

COUNTY:	STARK	
LOCATION:	S.R. 43 @ S.R. 183	
S.L.M.:	1.150	
24" STOP LINE:	38	L.F.
12" CROSSWALK LINE:		L.F.
DOTTED LINE:		L.F.
8" CHANNELIZING LINE:	325	L.F.
12" CHANNELIZING LINE:		L.F.
24" TRANSVERSE LINE (WT):		L.F.
24" TRANSVERSE LINE (YW):		L.F.
SYMBOL: 5 - LEFT TURN ARROWS		
5 - RIGHT TURN ARROWS		

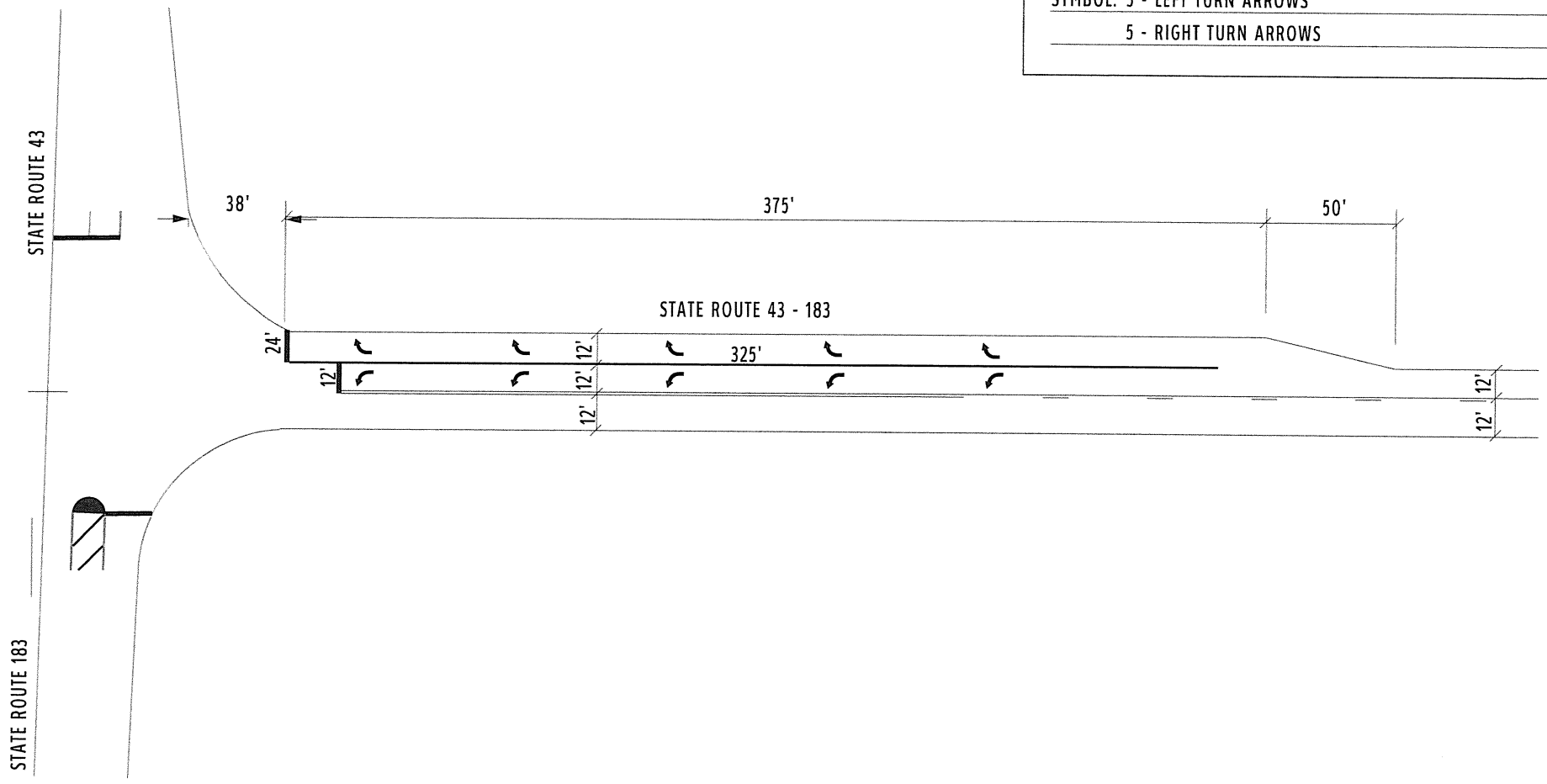

STATE ROUTE 43

STATE ROUTE 183

38'

375'

50'

STATE ROUTE 43 - 183

24'

325'

12'

12'

12'

12'

12'



COUNTY:	STARK	
LOCATION:	S.R. 43 @ S.R. 183	
S.L.M.:	1.150	
24" STOP LINE:	27	L.F.
12" CROSSWALK LINE:		L.F.
DOTTED LINE:		L.F.
8" CHANNELIZING LINE:	215	L.F.
12" CHANNELIZING LINE:		L.F.
24" TRANSVERSE LINE (WT):		L.F.
24" TRANSVERSE LINE (YW):		L.F.
SYMBOL: 6 - LEFT TURN ARROWS		

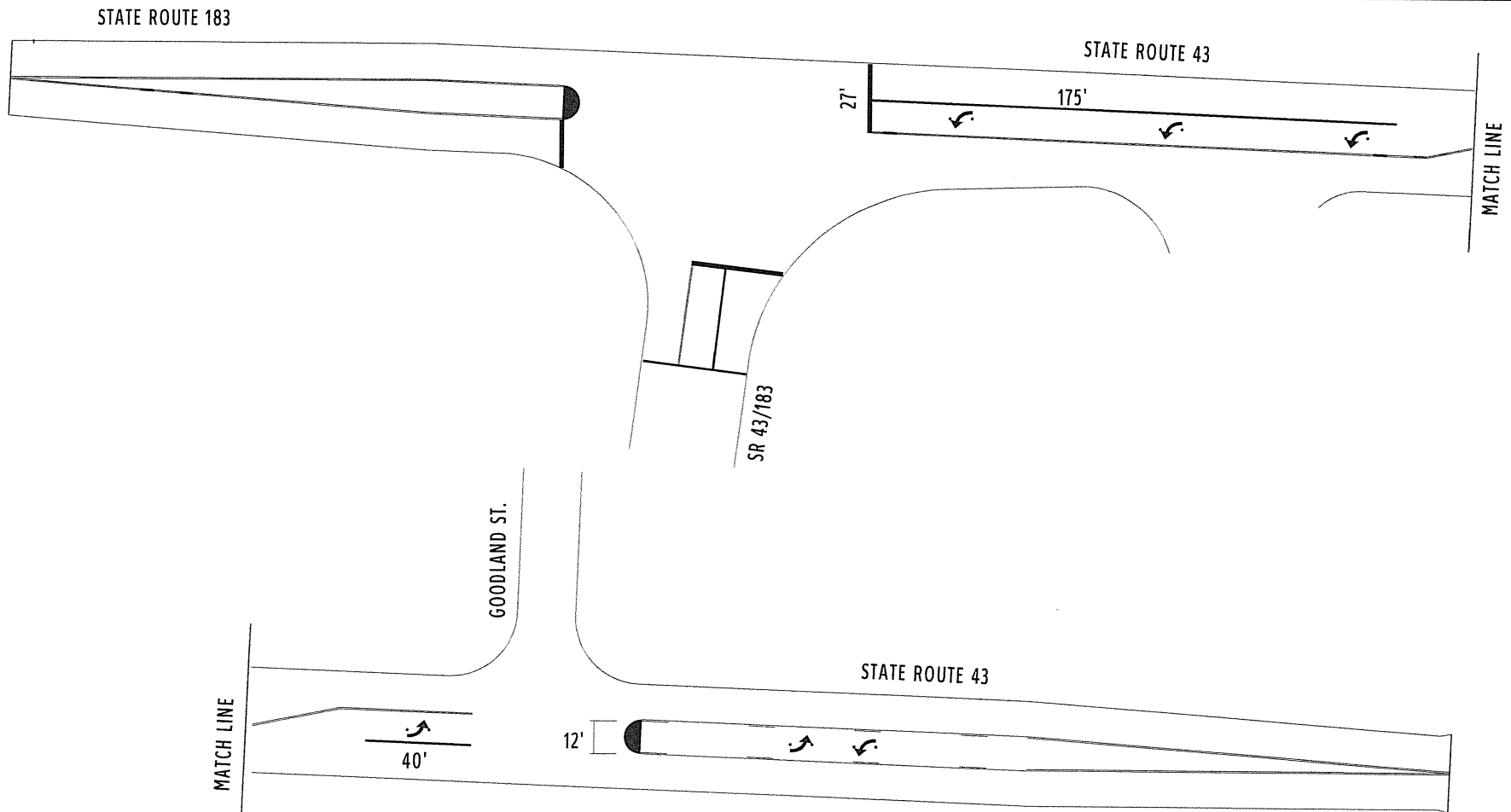

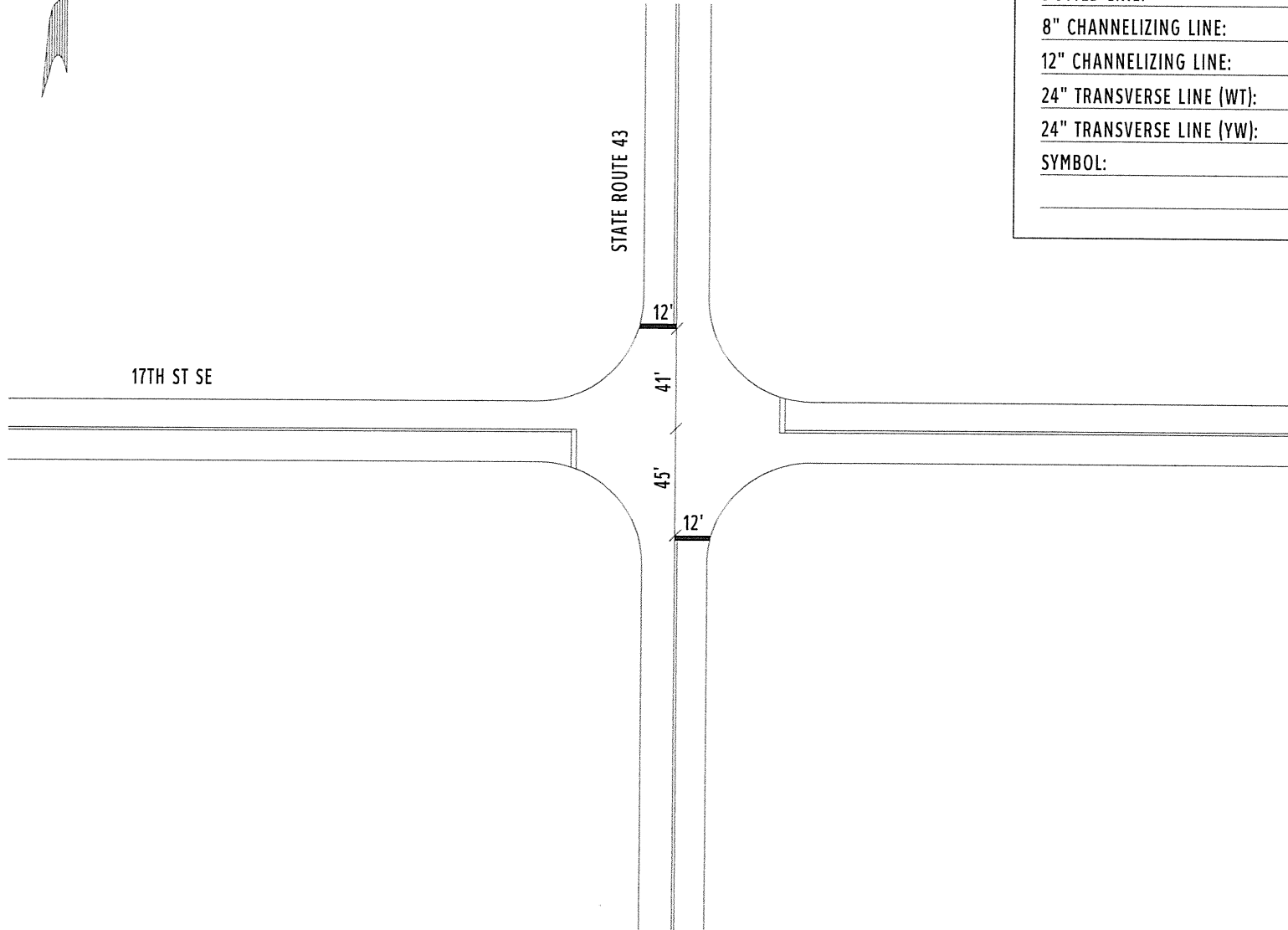

COUNTY:	STARK	
LOCATION:	S.R. 43 @ 17TH ST. SE	
S.L.M.:	10.26	
24" STOP LINE:	24	L.F.
12" CROSSWALK LINE:		L.F.
DOTTED LINE:		L.F.
8" CHANNELIZING LINE:		L.F.
12" CHANNELIZING LINE:		L.F.
24" TRANSVERSE LINE (WT):		L.F.
24" TRANSVERSE LINE (YW):		L.F.
SYMBOL:		



COUNTY:	STARK	
LOCATION:	S.R. 43 @ WHEELING & LAKE ERIE RXR	
S.L.M.:	10.544	
24" STOP LINE:	24	L.F.
12" CROSSWALK LINE:		L.F.
DOTTED LINE:		L.F.
8" CHANNELIZING LINE:		L.F.
12" CHANNELIZING LINE:		L.F.
24" TRANSVERSE LINE (WT):		L.F.
24" TRANSVERSE LINE (YW):		L.F.
SYMBOL: 2 - RXR SYMBOLS		

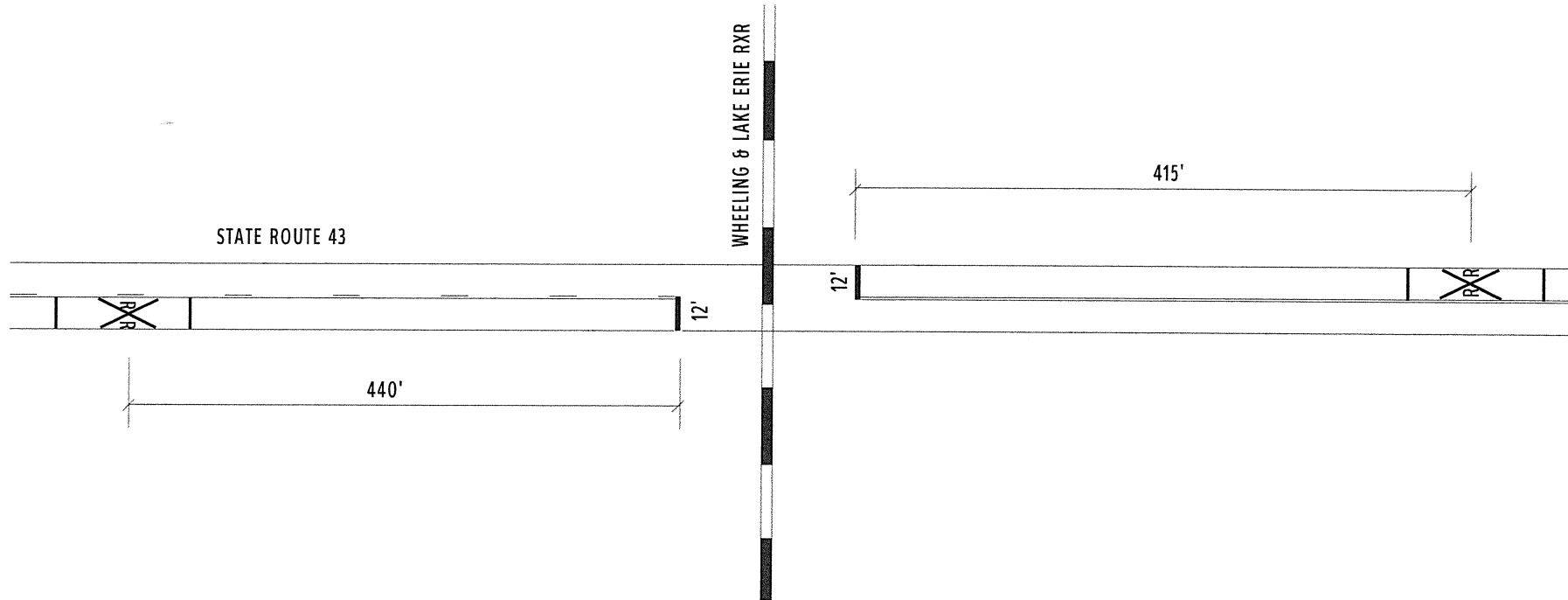

COUNTY:	STARK		
LOCATION:	S.R. 43 @ ED STEIN RD. / 14TH ST		
S.L.M.:	10.645		
24" STOP LINE:			L.F.
12" CROSSWALK LINE:			L.F.
DOTTED LINE:			L.F.
8" CHANNELIZING LINE:	140		L.F.
12" CHANNELIZING LINE:			L.F.
24" TRANSVERSE LINE (WT):			L.F.
24" TRANSVERSE LINE (YW):			L.F.
SYMBOL: 5 - LEFT TURN ARROWS, 60 L.F. YW CENTERLINE			
113 S.F. ISLAND MKGS, 57 S.F. ISLAND MKGS			

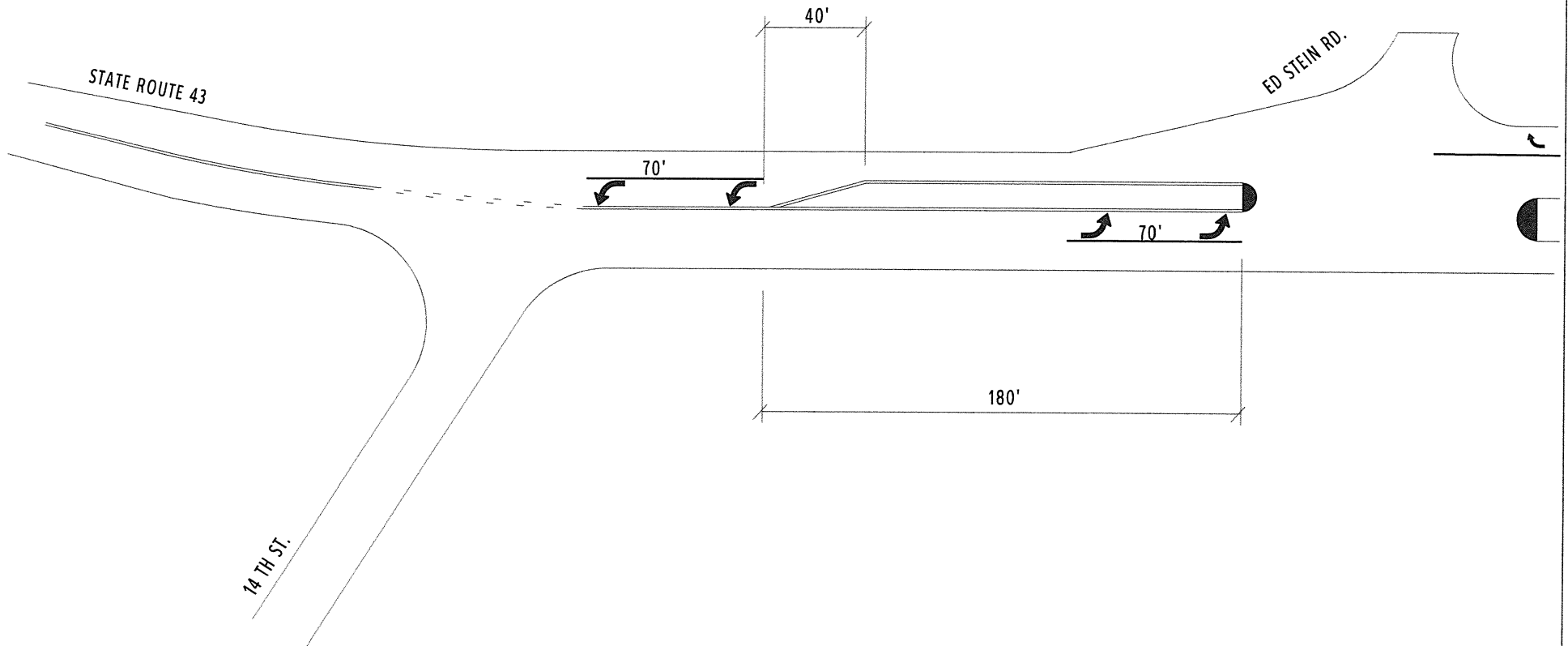

COUNTY:	STARK	
LOCATION:	S.R. 43 @ U.S. ROUTE 30 RAMPS	
S.L.M.:	10.76	
24" STOP LINE:		L.F.
12" CROSSWALK LINE:		L.F.
DOTTED LINE:		L.F.
8" CHANNELIZING LINE:	345	L.F.
12" CHANNELIZING LINE:		L.F.
24" TRANSVERSE LINE (WT):		L.F.
24" TRANSVERSE LINE (YW):		L.F.
SYMBOL:	3 - LEFT TURN ARROWS, 1 - RIGHT TURN ARROW	
	113 S.F. ISLAND MARKINGS	



STATE ROUTE 43

215'

130'

CITY OF CANTON CORP

U.S. 30 WB RAMP

U.S. 30 E RAMP

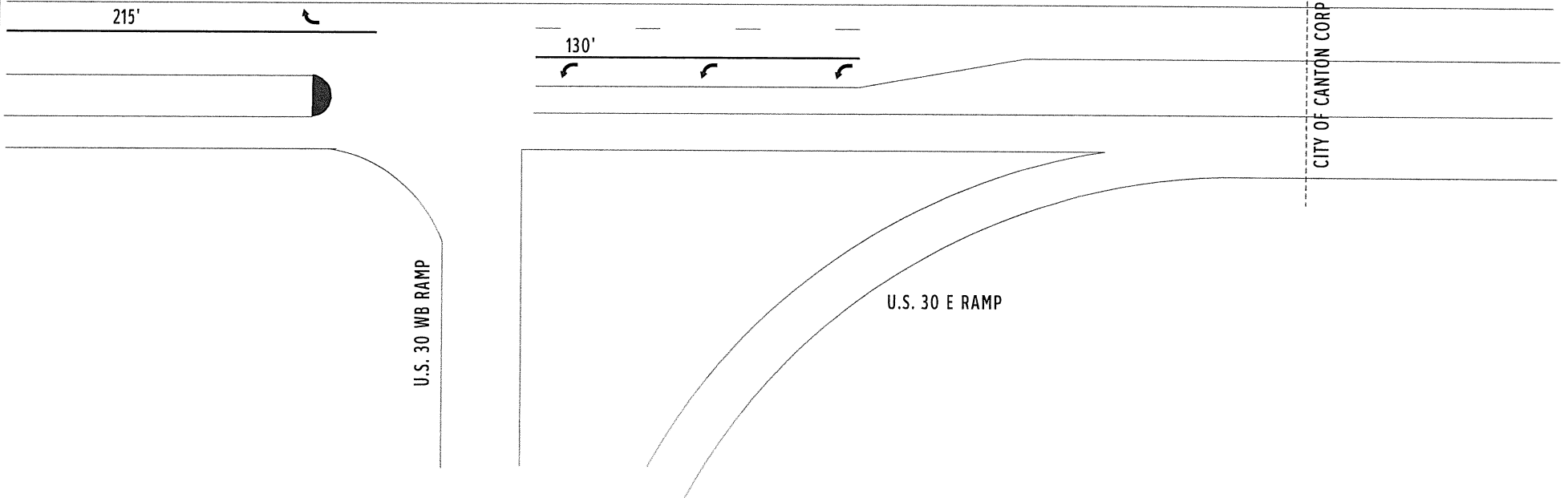

COUNTY:	STARK	
LOCATION:	S.R. 43 @ 55TH ST.	
S.L.M.:	17.200	
24" STOP LINE:		L.F.
12" CROSSWALK LINE:		L.F.
DOTTED LINE:		L.F.
8" CHANNELIZING LINE:	400	L.F.
12" CHANNELIZING LINE:		L.F.
24" TRANSVERSE LINE (WT):		L.F.
24" TRANSVERSE LINE (YW):		L.F.
SYMBOL: 6 - LEFT TURN ARROWS		

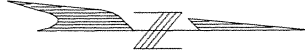

55th Street NW

STATE ROUTE 43

400'

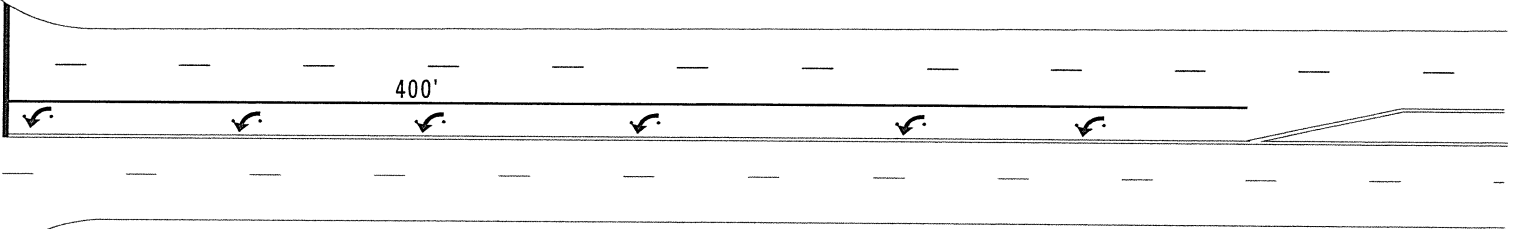



COUNTY:	STARK
LOCATION:	S.R. 43 @ 2-WAY LEFT
S.L.M.:	17.35-17.50
24" STOP LINE:	L.F.
12" CROSSWALK LINE:	L.F.
DOTTED LINE:	L.F.
8" CHANNELIZING LINE:	L.F.
12" CHANNELIZING LINE:	L.F.
24" TRANSVERSE LINE (WT):	L.F.
24" TRANSVERSE LINE (YW):	L.F.
SYMBOL: 6 - LEFT TURN ARROWS	

OAKPARK ST.

STATE ROUTE 43

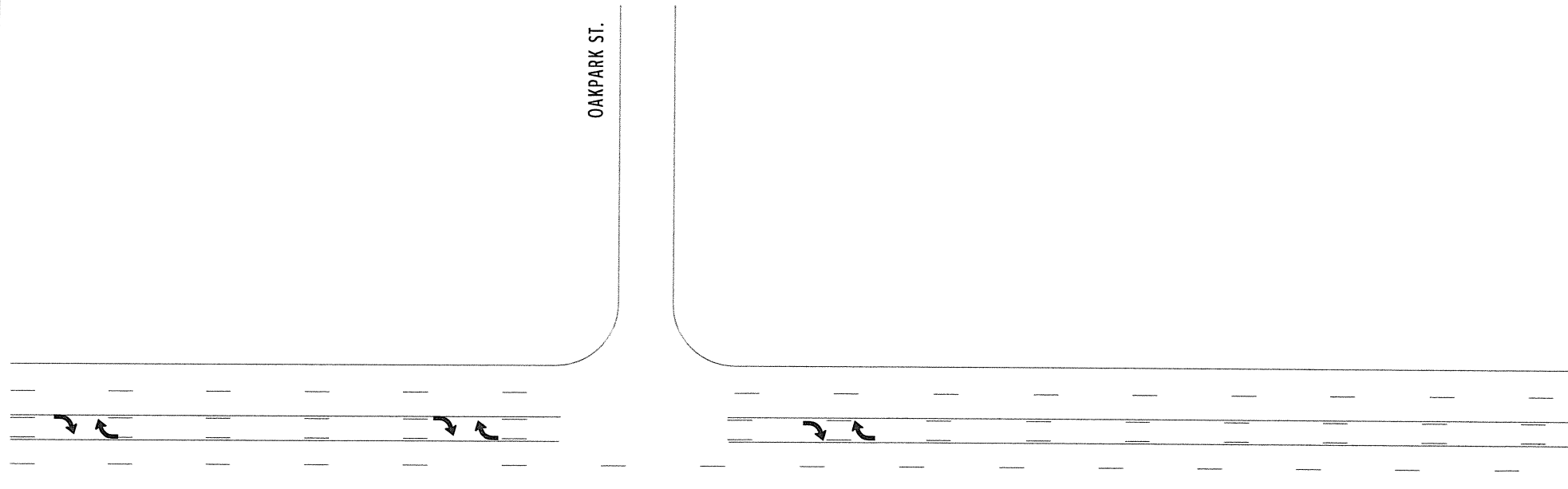



COUNTY:	STARK
LOCATION:	S.R. 43 @ 2-WAY LEFT
S.L.M.:	17.50-17.65
24" STOP LINE:	L.F.
12" CROSSWALK LINE:	L.F.
DOTTED LINE:	L.F.
8" CHANNELIZING LINE:	L.F.
12" CHANNELIZING LINE:	L.F.
24" TRANSVERSE LINE (WT):	L.F.
24" TRANSVERSE LINE (YW):	L.F.
SYMBOL: 6 - LEFT TURN ARROWS	

STATE ROUTE 43

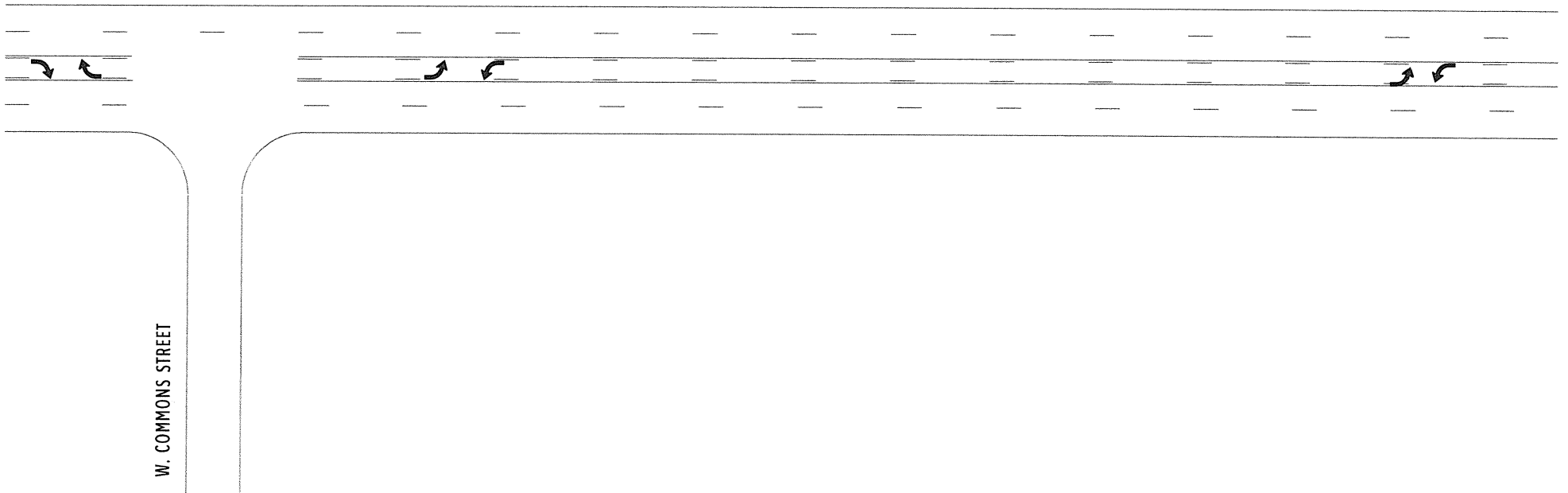

W. COMMONS STREET



COUNTY:	STARK	
LOCATION:	S.R. 43 @ SCHNEIDER ST. NW	
S.L.M.:	17.74	
24" STOP LINE:	70	L.F.
12" CROSSWALK LINE:		L.F.
DOTTED LINE:		L.F.
8" CHANNELIZING LINE:	650	L.F.
12" CHANNELIZING LINE:		L.F.
24" TRANSVERSE LINE (WT):		L.F.
24" TRANSVERSE LINE (YW):		L.F.
SYMBOL: 11 - LEFT TURN ARROWS		

STATE ROUTE 43

400'

36'

60'

SCHNEIDER ST NW

60'

34'

250'

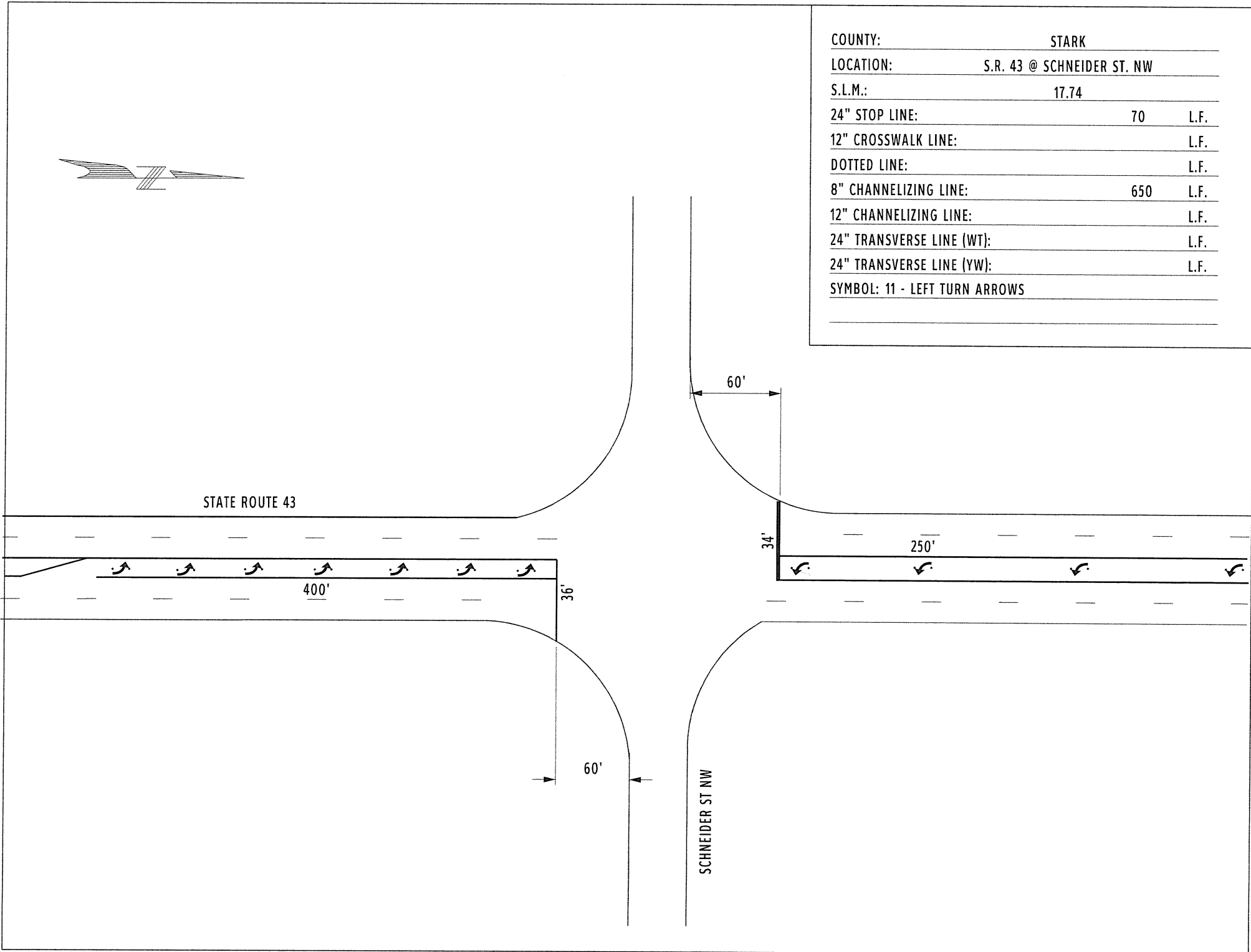



HUNTING VALLEY ST.

COUNTY:	STARK
LOCATION:	S.R. 43 @ TWO-WAY LEFT
S.L.M.:	17.85 - 18.05
24" STOP LINE:	L.F.
12" CROSSWALK LINE:	L.F.
DOTTED LINE:	L.F.
8" CHANNELIZING LINE:	L.F.
12" CHANNELIZING LINE:	L.F.
24" TRANSVERSE LINE (WT):	L.F.
24" TRANSVERSE LINE (YW):	L.F.
SYMBOL: 10 - LEFT UTRN ARORWS	

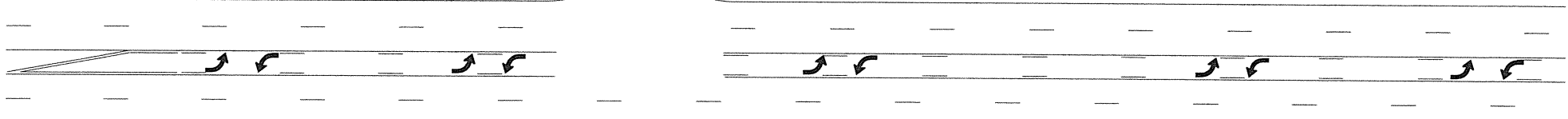

STATE ROUTE 43

MCDOWELL ST.



PHILZER ST.

GROVE ST. NW

GROVE ST. NE

STATE ROUTE 43

COUNTY:	STARK
LOCATION:	S.R. 43 @ TWO-WAY LEFT
S.L.M.:	18.05-18.20
24" STOP LINE:	L.F.
12" CROSSWALK LINE:	L.F.
DOTTED LINE:	L.F.
8" CHANNELIZING LINE:	L.F.
12" CHANNELIZING LINE:	L.F.
24" TRANSVERSE LINE (WT):	L.F.
24" TRANSVERSE LINE (YW):	L.F.
SYMBOL: 10 - LEFT TURN ARROWS	

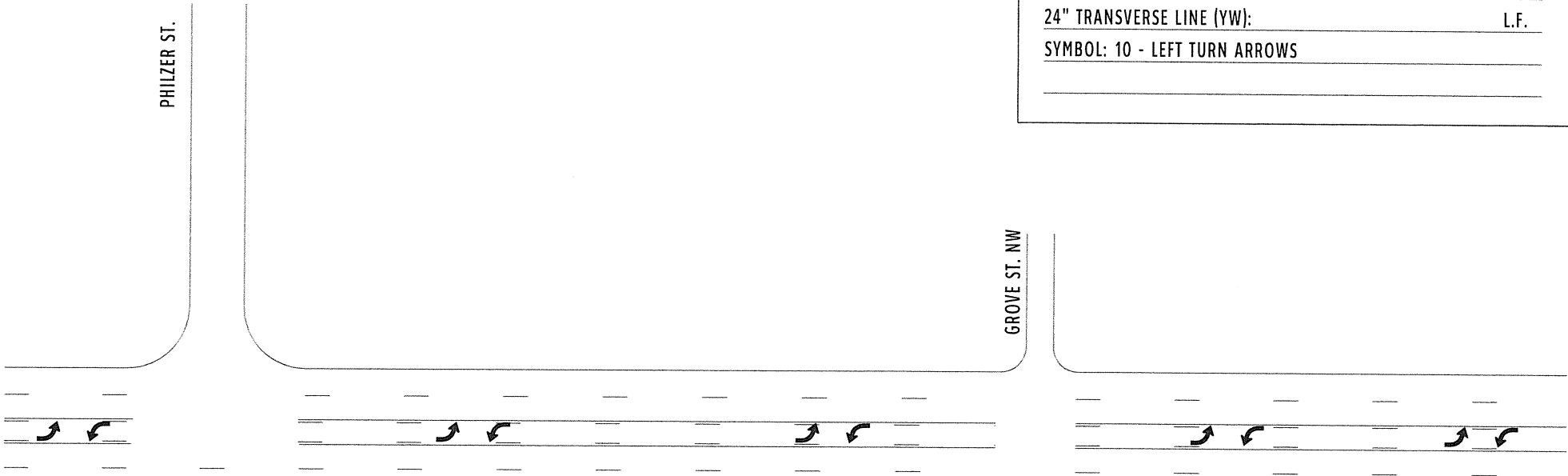



COUNTY:	STARK	
LOCATION:	S.R. 43 @ EASTON RD.	
S.L.M.:	18.273	
24" STOP LINE:	72	L.F.
12" CROSSWALK LINE:	280	L.F.
DOTTED LINE:		L.F.
8" CHANNELIZING LINE:	405	L.F.
12" CHANNELIZING LINE:		L.F.
24" TRANSVERSE LINE (WT):		L.F.
24" TRANSVERSE LINE (YW):		L.F.
SYMBOL: 8 - LEFT TURN ARROWS		

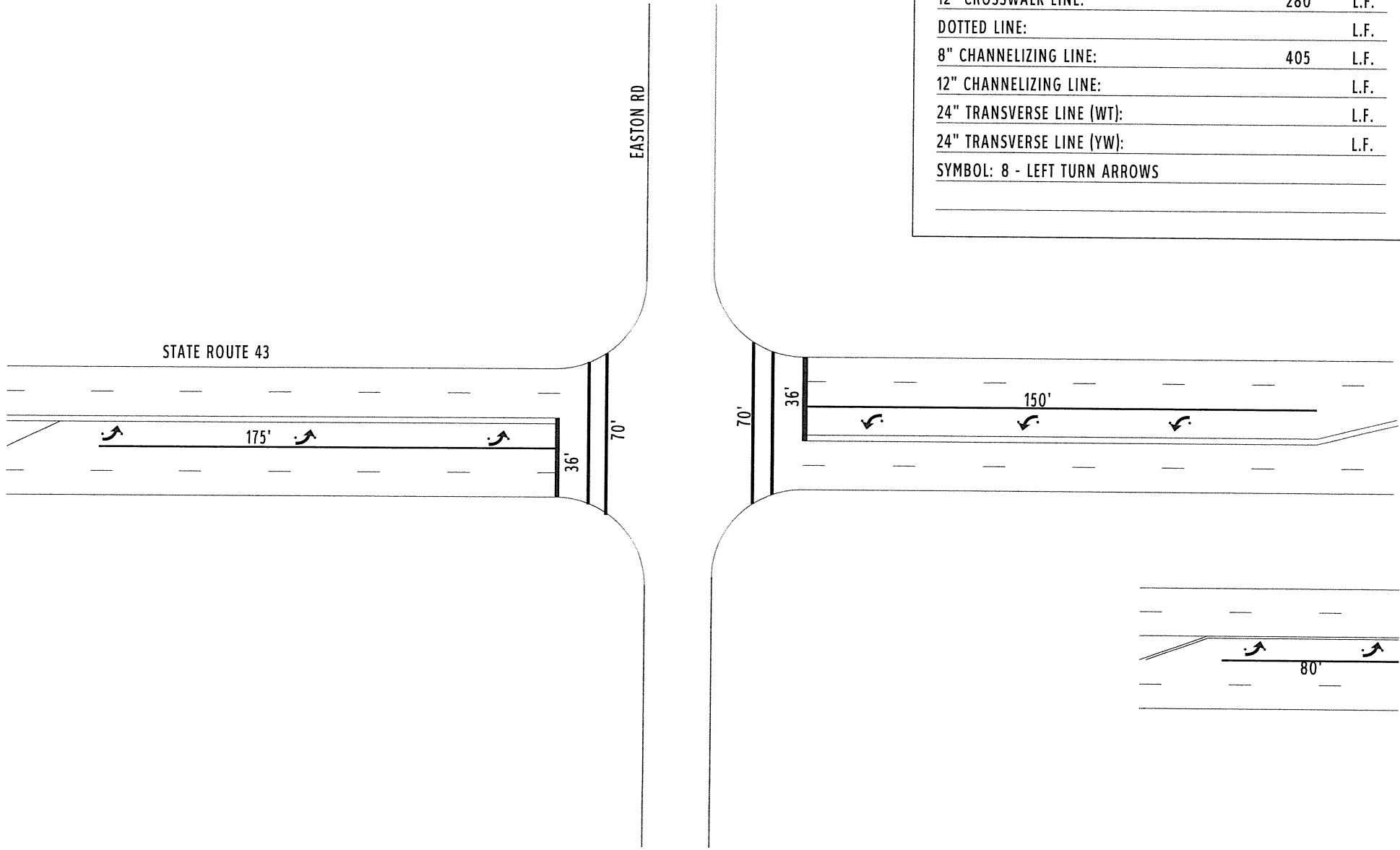



COUNTY:	STARK
LOCATION:	S.R. 43 @ TWO-WAY LEFT
S.L.M.:	18.38-18.55
24" STOP LINE:	L.F.
12" CROSSWALK LINE:	L.F.
DOTTED LINE:	L.F.
8" CHANNELIZING LINE:	L.F.
12" CHANNELIZING LINE:	L.F.
24" TRANSVERSE LINE (WT):	L.F.
24" TRANSVERSE LINE (YW):	L.F.
SYMBOL: 8 - LEFT TURN ARROWS	

DRIVEWAY

WYNSTONE CIRCLE

STATE ROUTE 43

STONE CROSSING ST. NE

10' 10' 10'

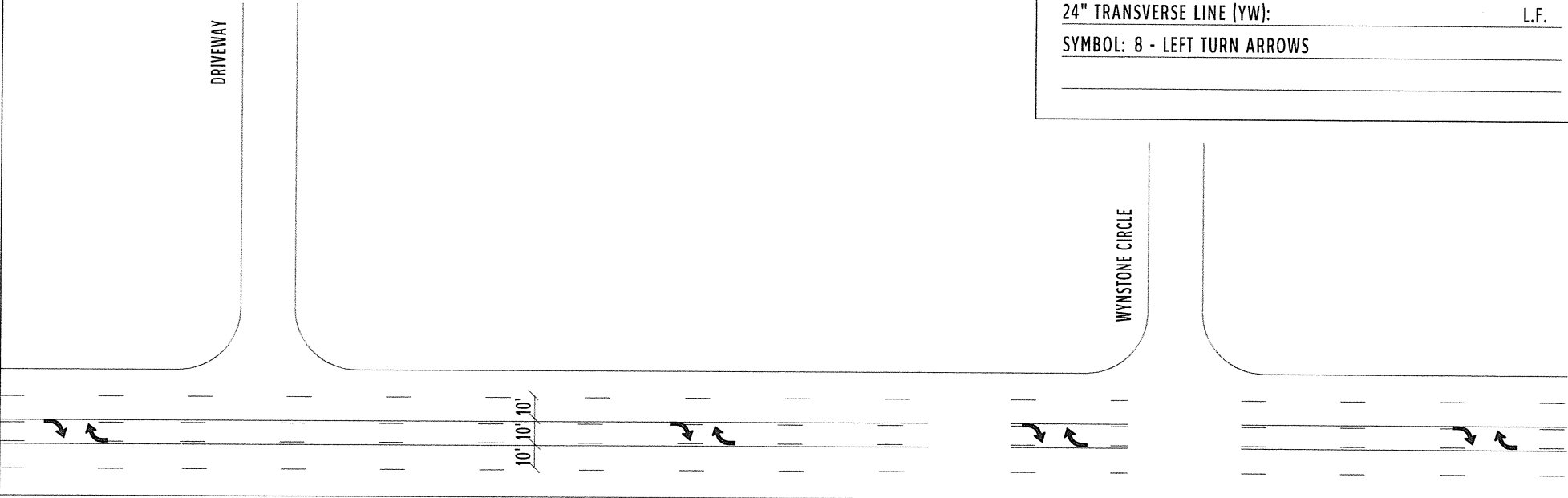

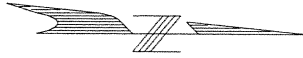

COUNTY:	STARK
LOCATION:	S.R. 43 @ TWO-WAY LEFT
S.L.M.:	18.55-18.77
24" STOP LINE:	L.F.
12" CROSSWALK LINE:	L.F.
DOTTED LINE:	L.F.
8" CHANNELIZING LINE:	L.F.
12" CHANNELIZING LINE:	L.F.
24" TRANSVERSE LINE (WT):	L.F.
24" TRANSVERSE LINE (YW):	L.F.
SYMBOL: 8 - LEFT TURN ARROWS	

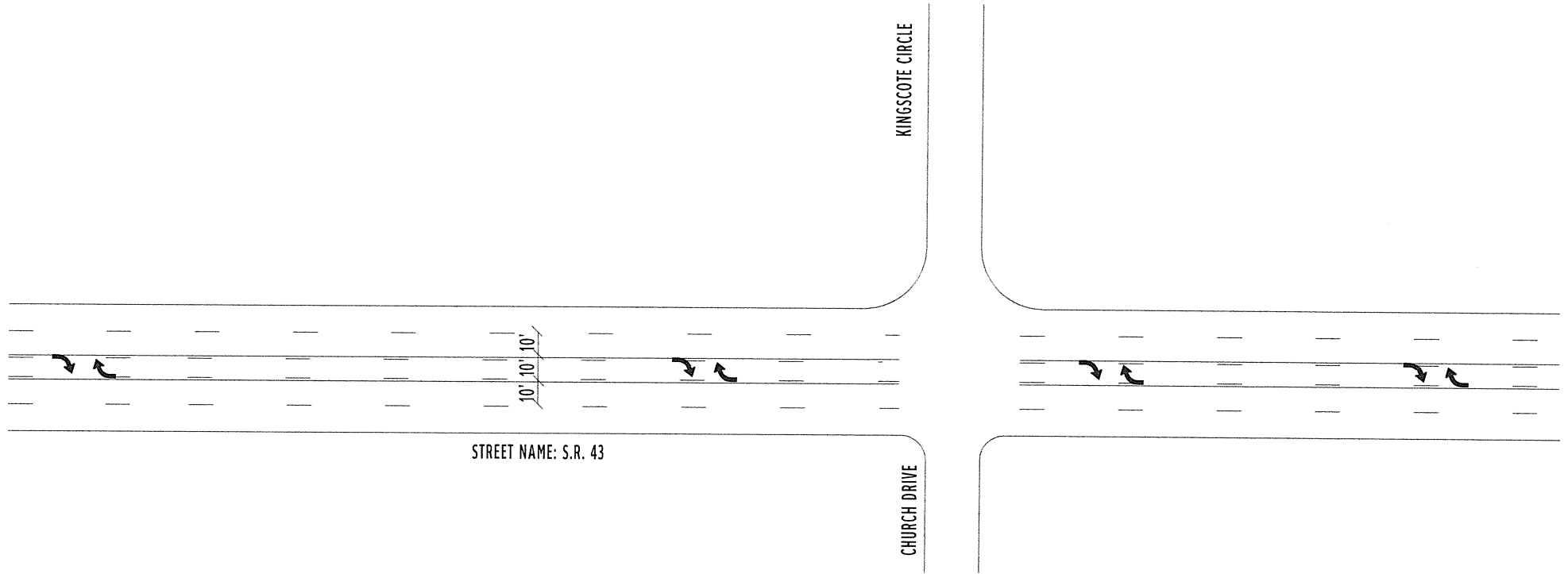



AMARILLO ST.

CHURCH DRIVE

STATE ROUTE 43

COUNTY:	STARK
LOCATION:	S.R. 43 @ TWO-WAY LEFT
S.L.M.:	18.77-19.03
24" STOP LINE:	L.F.
12" CROSSWALK LINE:	L.F.
DOTTED LINE:	L.F.
8" CHANNELIZING LINE:	L.F.
12" CHANNELIZING LINE:	L.F.
24" TRANSVERSE LINE (WT):	L.F.
24" TRANSVERSE LINE (YW):	L.F.
SYMBOL: 6 - LEFT TURN ARROWS	



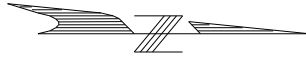

STREET NAME: MARKLEY ST.

STREET NAME: S.R. 43

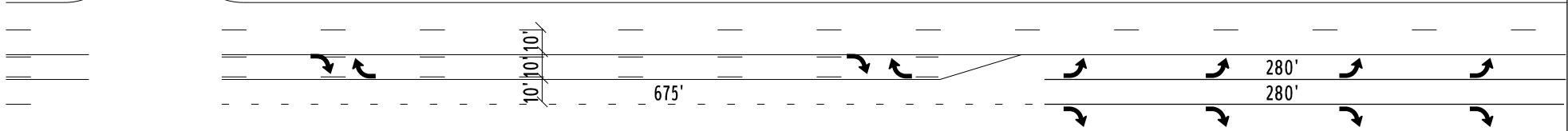

COUNTY:	STARK
LOCATION:	S.R. 43 @ TWO-WAY LEFT
S.L.M.:	19.03-19.25
24" STOP LINE:	L.F.
12" CROSSWALK LINE:	L.F.
DOTTED LINE:	675 L.F.
8" CHANNELIZING LINE:	L.F.
12" CHANNELIZING LINE:	560 L.F.
24" TRANSVERSE LINE (WT):	L.F.
24" TRANSVERSE LINE (YW):	L.F.
SYMBOL: 4 - LEFT TURN ARROWS	
6 - RIGHT TURN ARROWS	

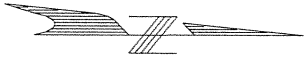

APPLEGROVE ST.

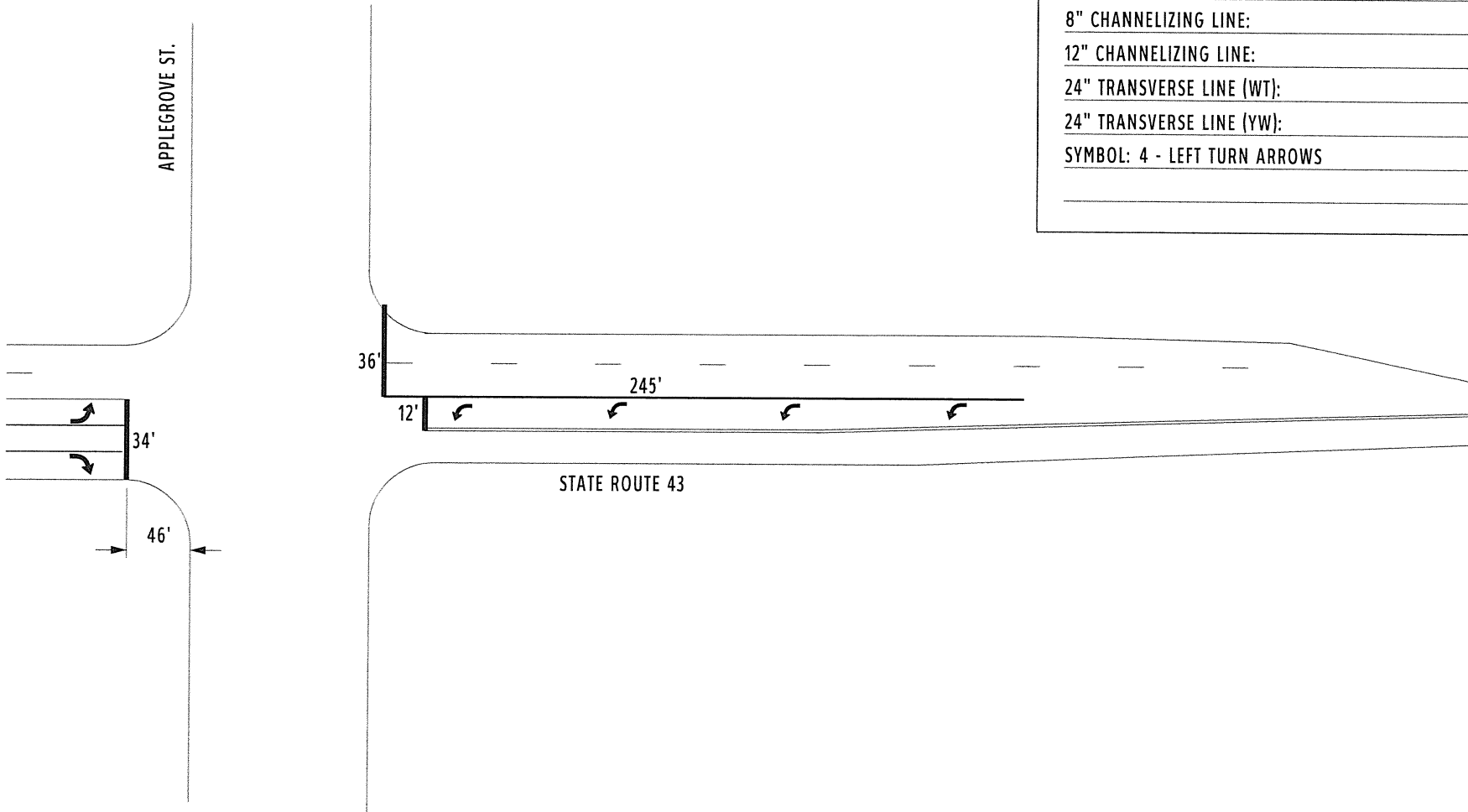

COUNTY:	STARK	
LOCATION:	S.R. 43 @ APPLGROVE ST.	
S.L.M.:	19.25	
24" STOP LINE:	72	L.F.
12" CROSSWALK LINE:		L.F.
DOTTED LINE:		L.F.
8" CHANNELIZING LINE:	245	L.F.
12" CHANNELIZING LINE:		L.F.
24" TRANSVERSE LINE (WT):		L.F.
24" TRANSVERSE LINE (YW):		L.F.
SYMBOL: 4 - LEFT TURN ARROWS		

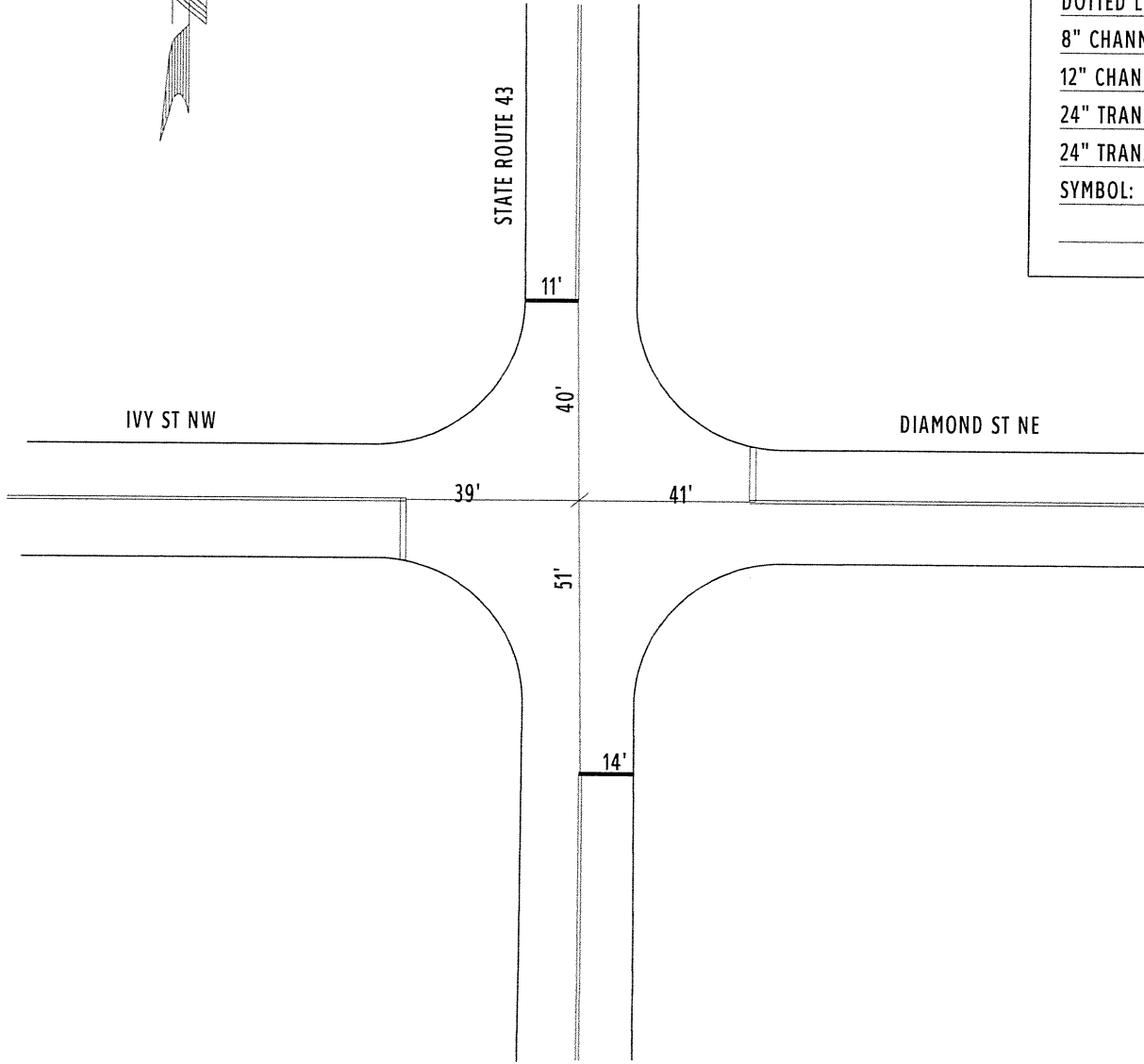

COUNTY:	STARK	
LOCATION:	SR 43 @ DIAMOND ST NE / IVY ST NW	
S.L.M.:	19.760	
24" STOP LINE:	25	L.F.
12" CROSSWALK LINE:		L.F.
DOTTED LINE:		L.F.
8" CHANNELIZING LINE:		L.F.
12" CHANNELIZING LINE:		L.F.
24" TRANSVERSE LINE (WT):		L.F.
24" TRANSVERSE LINE (YW):		L.F.
SYMBOL:		

COUNTY:	STARK
LOCATION:	S.R. 43 @ LANNER ST NW
S.L.M.:	20.193
24" STOP LINE:	L.F.
12" CROSSWALK LINE:	L.F.
DOTTED LINE:	L.F.
8" CHANNELIZING LINE:	L.F.
12" CHANNELIZING LINE:	L.F.
24" TRANSVERSE LINE (WT):	L.F.
24" TRANSVERSE LINE (YW):	L.F.
SYMBOL: 3 - LEFT TURN ARROWS	
25 S.F. ISLAND MARKINGS	

LANNER ST. NW

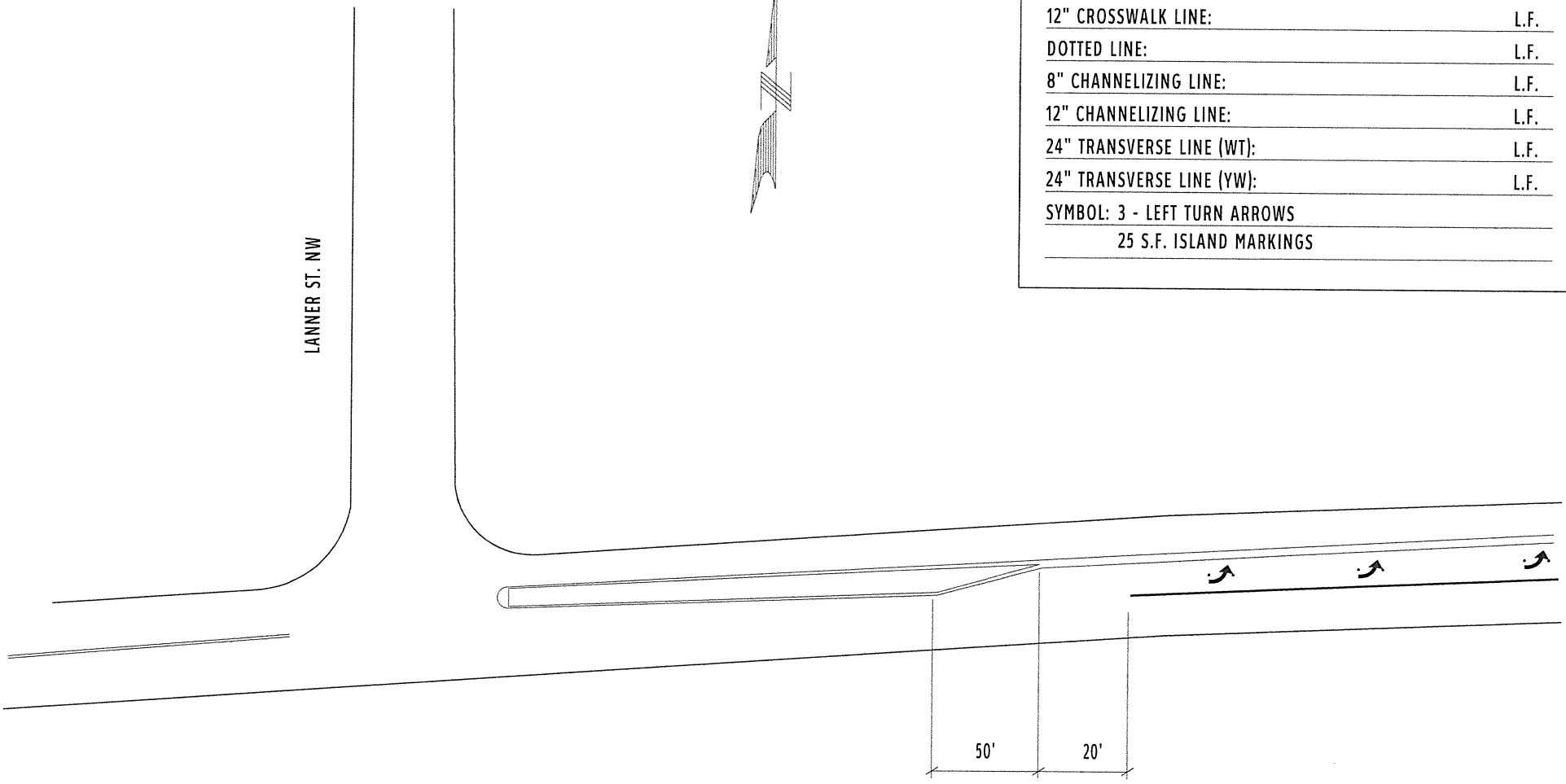

COUNTY:	STARK	
LOCATION:	S.R. 43 @ MARKET AVE NW	
S.L.M.:	20.193	
24" STOP LINE:		L.F.
12" CROSSWALK LINE:		L.F.
DOTTED LINE:		L.F.
8" CHANNELIZING LINE:	305	L.F.
12" CHANNELIZING LINE:		L.F.
24" TRANSVERSE LINE (WT):		L.F.
24" TRANSVERSE LINE (YW):		L.F.
SYMBOL: 2 - LEFT TURN ARROWS		
	57 S.F. ISLAND MARKINGS	

MARKET AVE. N

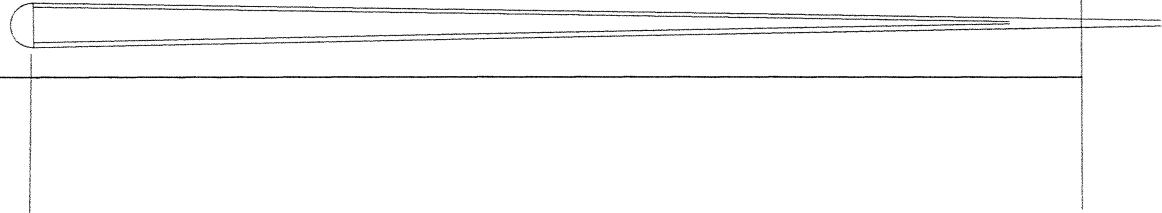
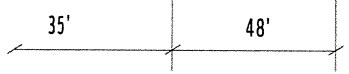
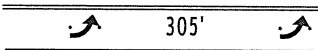

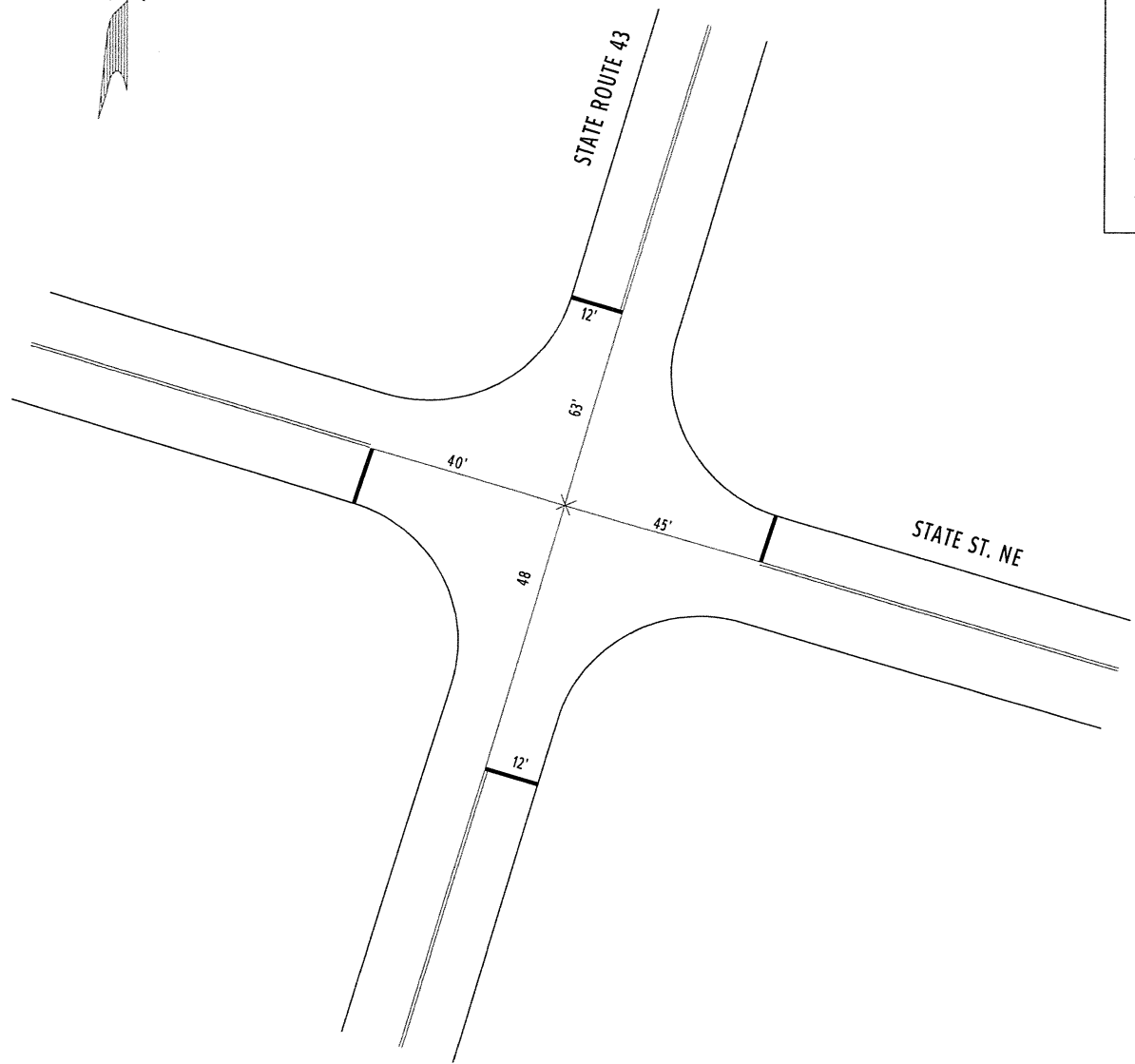

COUNTY:	STARK	
LOCATION:	S.R. 43 @ STATE RD. NE	
S.L.M.:	21.401	
24" STOP LINE:	24	L.F.
12" CROSSWALK LINE:		L.F.
DOTTED LINE:		L.F.
8" CHANNELIZING LINE:		L.F.
12" CHANNELIZING LINE:		L.F.
24" TRANSVERSE LINE (WT):		L.F.
24" TRANSVERSE LINE (YW):		L.F.
SYMBOL:		

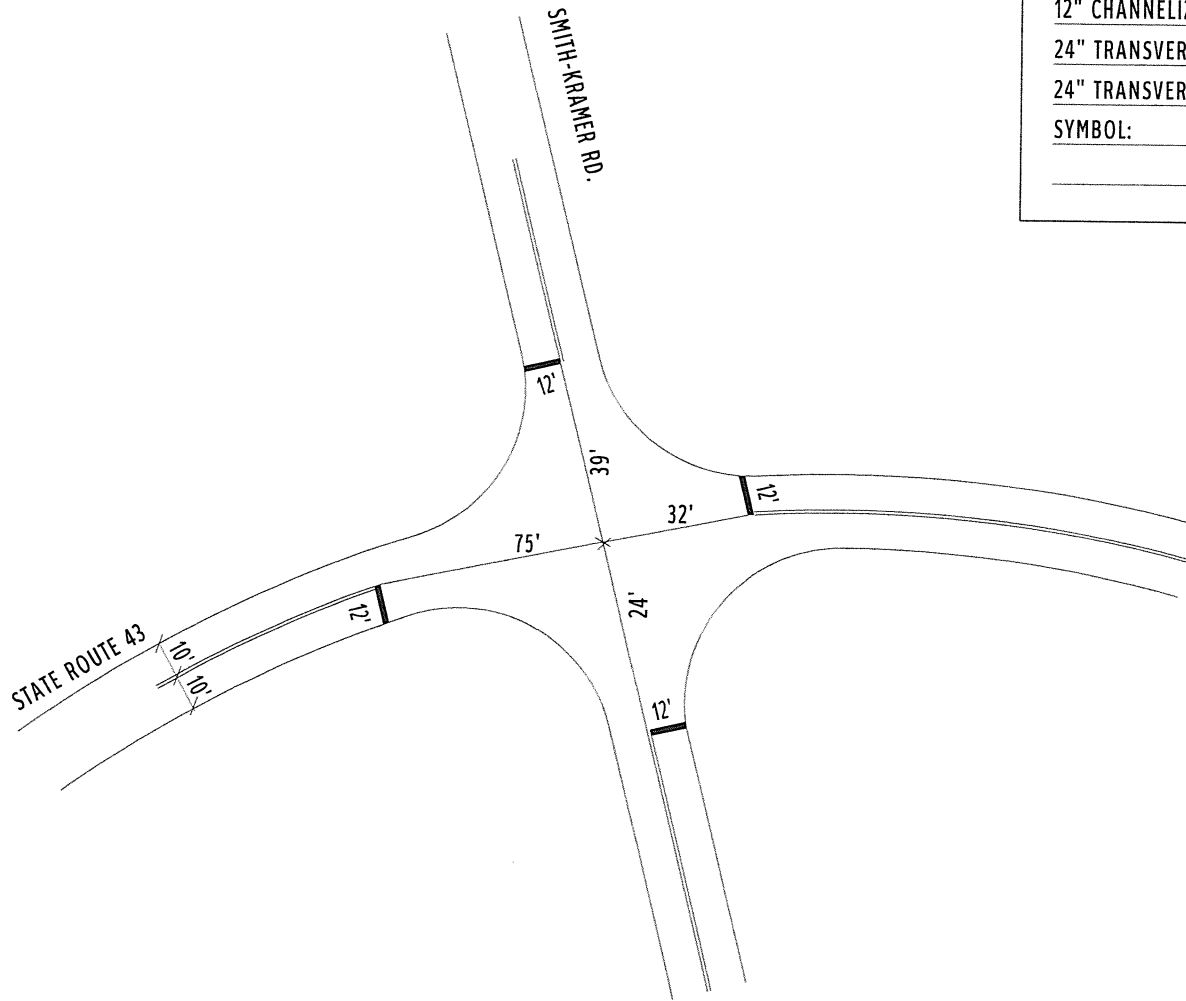
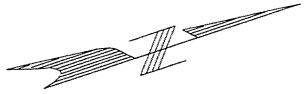

COUNTY:	STARK	
LOCATION:	S.R. 43 @ SMITH KRAMER RD.	
S.L.M.:	23.188	
24" STOP LINE:	24	L.F.
12" CROSSWALK LINE:		L.F.
DOTTED LINE:		L.F.
8" CHANNELIZING LINE:		L.F.
12" CHANNELIZING LINE:		L.F.
24" TRANSVERSE LINE (WT):		L.F.
24" TRANSVERSE LINE (YW):		L.F.
SYMBOL:		