

STRAIN POLE TABLE

REFERENCE SHEET NO.*	STATION & OFFSET*	POLE NO.	DESIGN NO.	POLE HEIGHT (FT.)	FOUNDATION ELEV.*	SPAN WIRE ATTACHED HEIGHT*	CABLE ENTRANCE DISTANCE BELOW SPAN WIRE ATTACHMENT (IN.)	INDEX LINE ANGLE (DEG.)	ANGLES (DEG.) FROM INDEX LINE					
									PEDESTRIAN SIGNALS	PEDESTRIAN PUSH BUTTONS	POWER SERVICE	CABLE ENTRANCE	BRACKET ARM	2" CAPPED
P.117	936+81.8, 53.1' LT	SP-1	13	34	980.0	28.5	12	244	24 / 114	-	-	119	119	-
P.117	936+80.4, 48.4' RT	SP-2	13	34	979.0	29.0	12	180	180 / 267	-	-	182	270	-
P.117	937+84.4, 58.3' LT	SP-3	13	35	979.0	29.5	12	265	92	-	-	91	187	-
P.117	937+89.7, 50.4' RT	SP-4	13	35	979.0	29.5	12	180	181	-	275	273	178	-
P.117	936+87.8, 44.9' LT	PS-1	PEDESTAL	5	-	-	-	244	-	0	-	-	-	-
P.117	936+89.5, 44.0' RT	PS-2	PEDESTAL	5	-	-	-	180	-	288	-	-	-	-

*See TEM Section 441-8

Notes:

1. All angles are measured clockwise.
2. The index line goes through the center of the handhole.

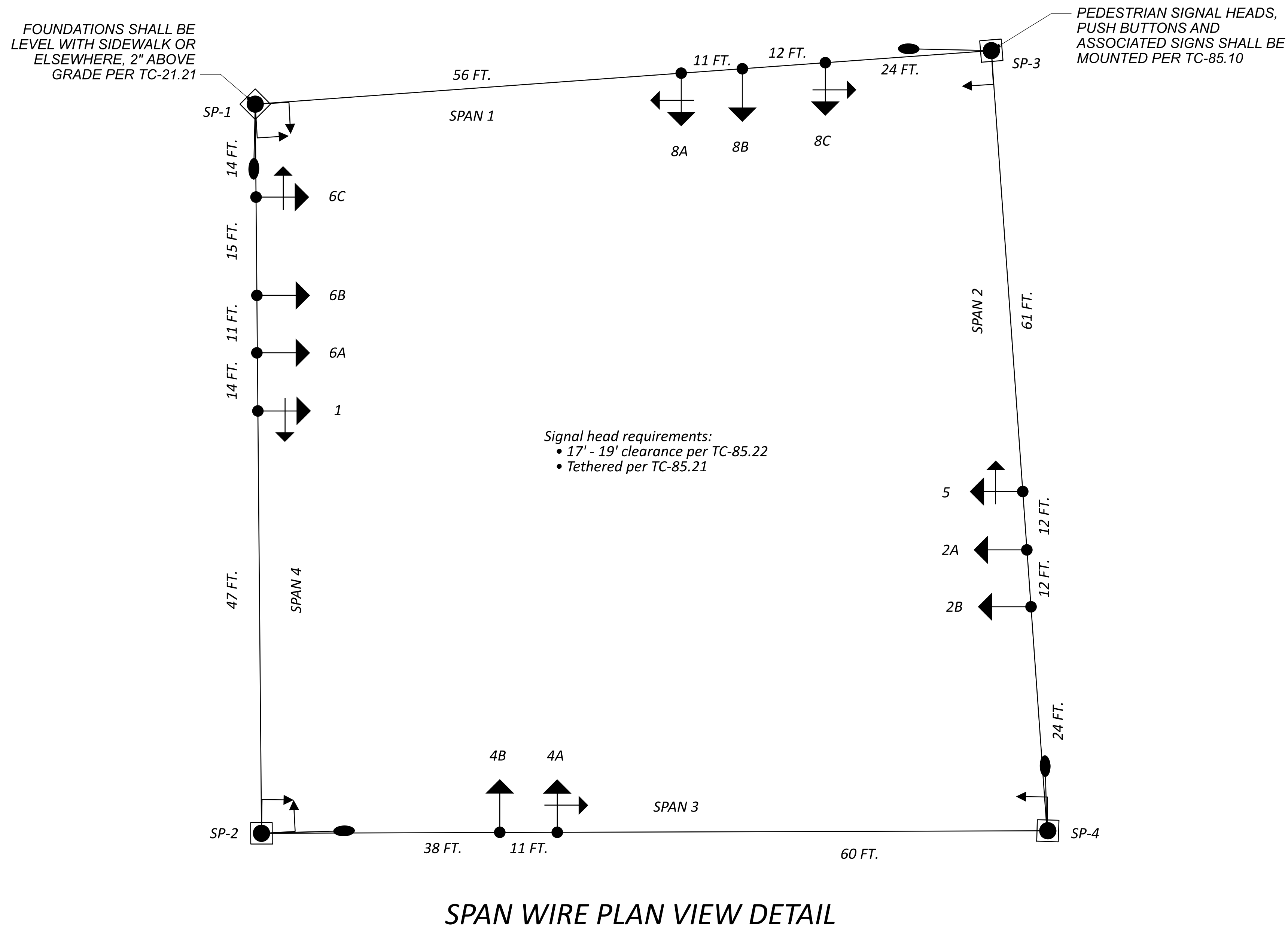

SPAN WIRE PLAN VIEW DETAIL

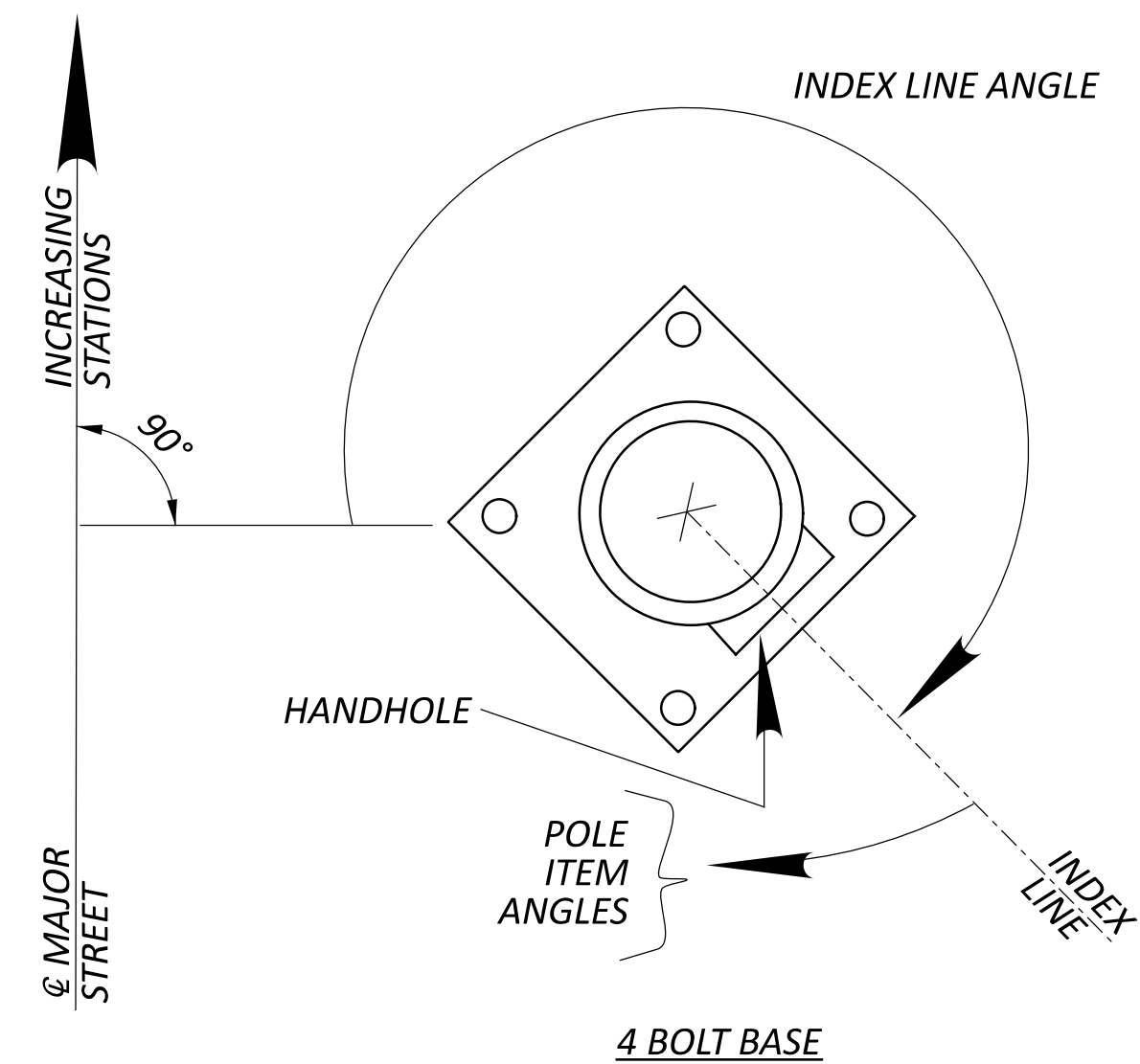

Note:

- Index line passes through the center of the handhole

POLE ORIENTATION

MAR-095-17.90

MODEL: Sheet PAPER SIZE: 34x22 (in.) DATE: 3/24/2025 TIME: 2:59:54 PM USER: moraleslovo P:\PR602\1411148\8\400-Engineering\Signals\Sheets\114818_CD002.dgn

SPAN WIRE DETAILS
SR-95 & JAMES WAY/WELCOME WAY

DESIGN AGENCY

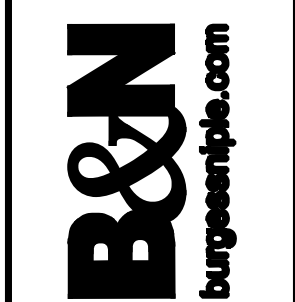

DESIGNER	RML
REVIEWER	JTP
PROJECT ID	09-06-24
	114818
SHEET	TOTAL
P.120	P.135

STRAIN POLE TABLE

REFERENCE SHEET NO.*	STATION & OFFSET*	POLE NO.	DESIGN NO.	POLE HEIGHT (FT.)	FOUNDATION ELEV.*	SPAN WIRE ATTACHED HEIGHT*	CABLE ENTRANCE DISTANCE BELOW SPAN WIRE ATTACHMENT (IN.)	INDEX LINE ANGLE (DEG.)	ANGLES (DEG.) FROM INDEX LINE					
									PEDESTRIAN SIGNALS	PEDESTRIAN PUSH BUTTONS	POWER SERVICE	CABLE ENTRANCE	BRACKET ARM	2" CAPPED
P.122	941+81.8, 52.3' LT	SP-1	12	37	980.0	31.5	12	180	173	-	-	135	182	-
P.122	942+06.0, 67.9' RT	SP-2	12	36	977.5	31.0	12	180	182	-	90	206	249	-
P.122	942+73.3, 62.5' LT	SP-3	12	35	979.5	30.0	12	270	84	-	-	118	173	-
P.122	942+88.7, 61.3' RT	SP-4	12	36	979.0	30.5	12	180	177	-	-	137	180	-

*See TEM Section 441-8

Notes:

1. All angles are measured clockwise.
2. The index line goes through the center of the handhole.

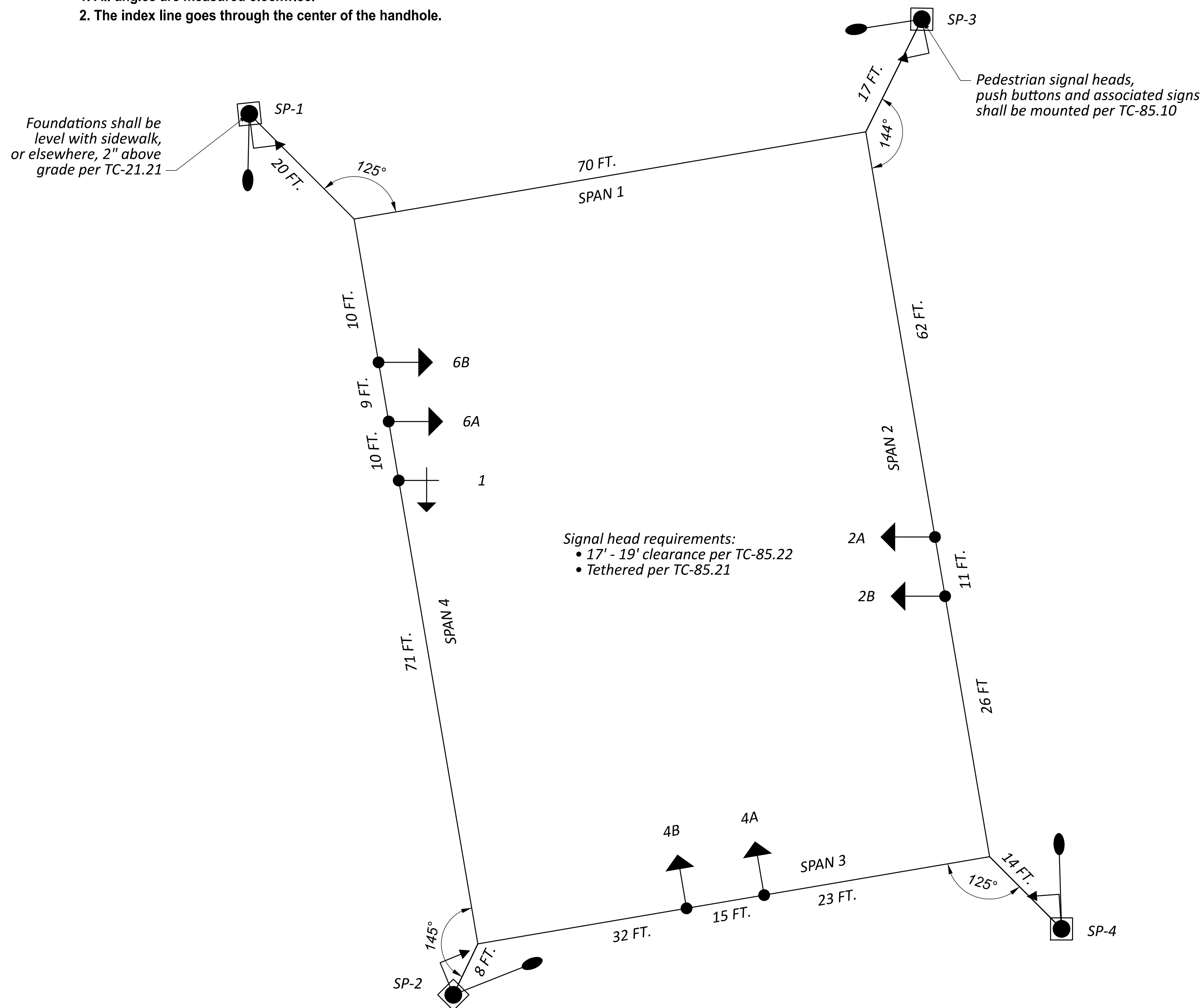

SPAN WIRE PLAN VIEW DETAIL

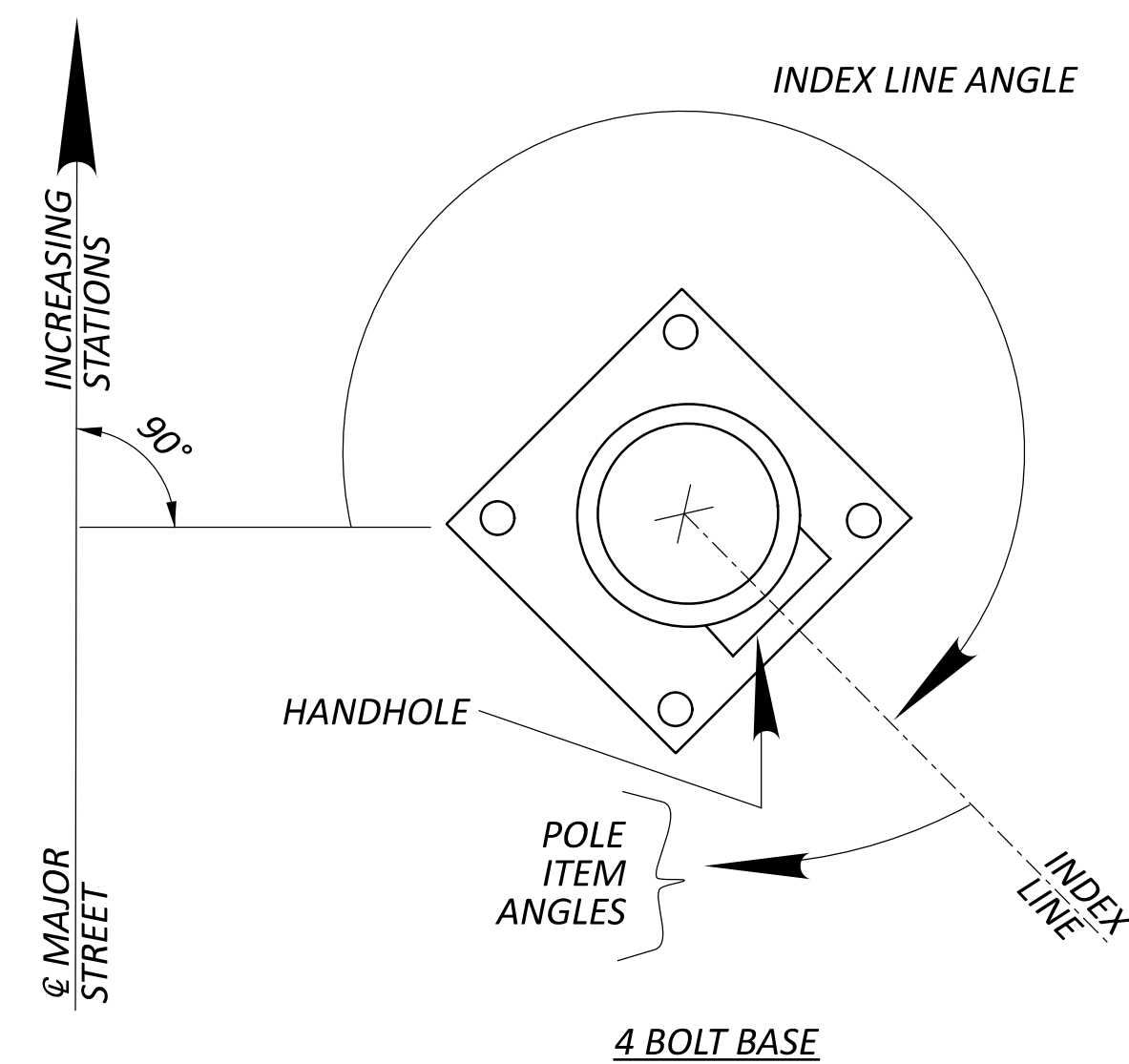

Note:

- Index line passes through the center of the handhole

POLE ORIENTATION

MAR-095-17.90

MODEL: Sheet PAPER SIZE: 34x22 (in.) DATE: 3/24/2025 TIME: 3:00:06 PM USER: moraleslovas
P:\PR602\1411148\8\400-Engineering\Signals\Sheets\114818_CD005.dgn

SPAN WIRE DETAILS
SR-95 & US-23 SOUTHBOUND RAMP

DESIGN AGENCY



DESIGNER

RML

REVIEWER

JTP 09-06-24

PROJECT ID

114818

SHEET TOTAL

P.125 P.135

STRAIN POLE TABLE

REFERENCE SHEET NO.*	STATION & OFFSET*	POLE NO.	DESIGN NO.	POLE HEIGHT (FT.)	FOUNDATION ELEV.*	SPAN WIRE ATTACHED HEIGHT*	CABLE ENTRANCE DISTANCE BELOW SPAN WIRE ATTACHMENT (IN.)	INDEX LINE ANGLE (DEG.)	ANGLES (DEG.) FROM INDEX LINE					
									PEDESTRIAN SIGNALS	PEDESTRIAN PUSH BUTTONS	POWER SERVICE	CABLE ENTRANCE	BRACKET ARM	2" CAPPED
P.127	948+30.7, 59.8' LT	SP-1	12	36	981.0	31.0	12	183	180	-	-	140	180	-
P.127	948+40.5, 61.0' RT	SP-2	12	35	980.5	28.0	12	270	88	-	-	124	180	-
P.127	949+18.8, 54.1' LT	SP-3	12	36	979.5	31.0	12	270	93	-	-	124	180	-
P.127	949+19.7, 56.6' RT	SP-4	12	36	979.0	30.5	12	90	177	-	58	233	270	-

*See TEM Section 441-8

Notes:

1. All angles are measured clockwise.
2. The index line goes through the center of the handhole.

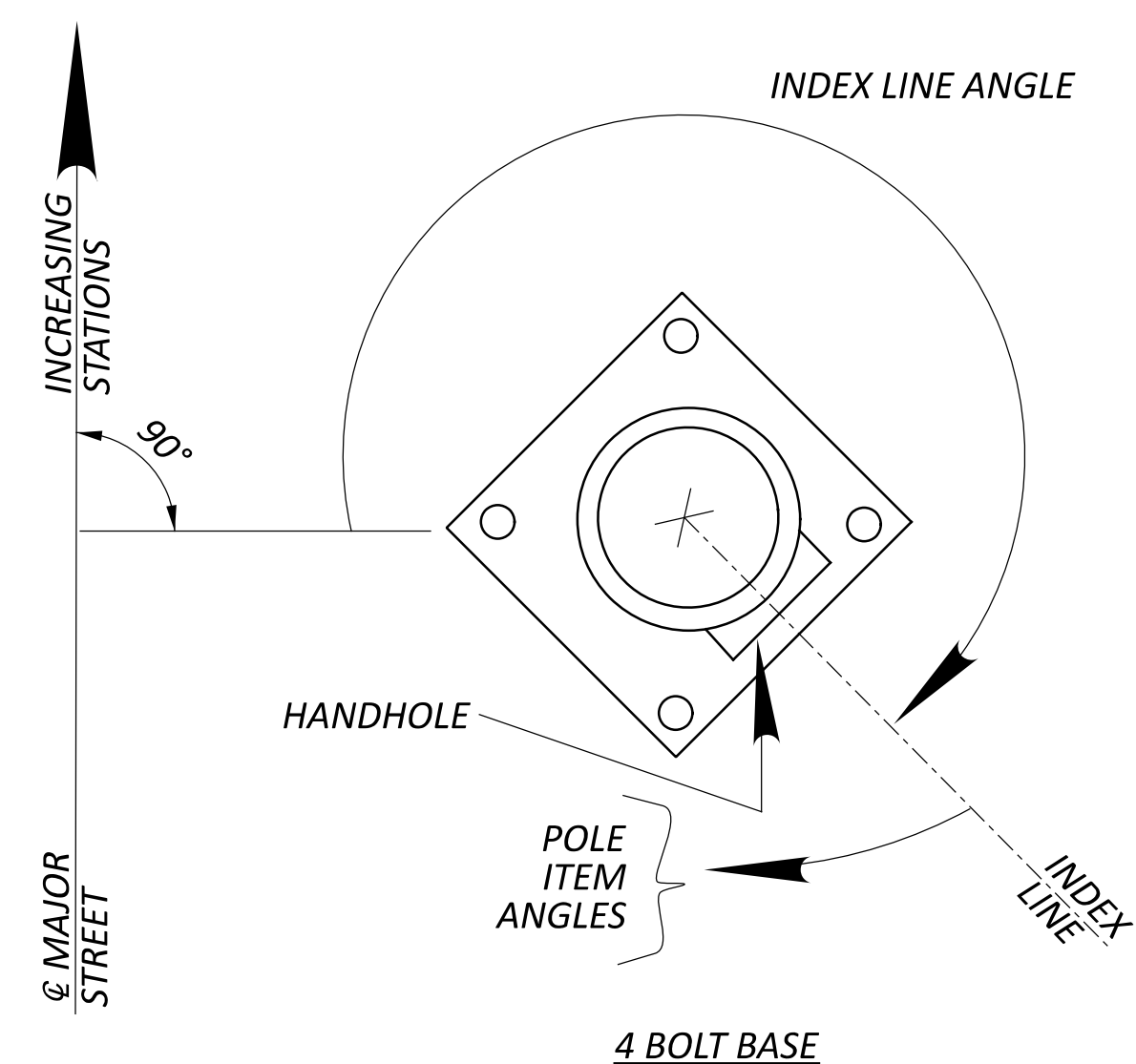
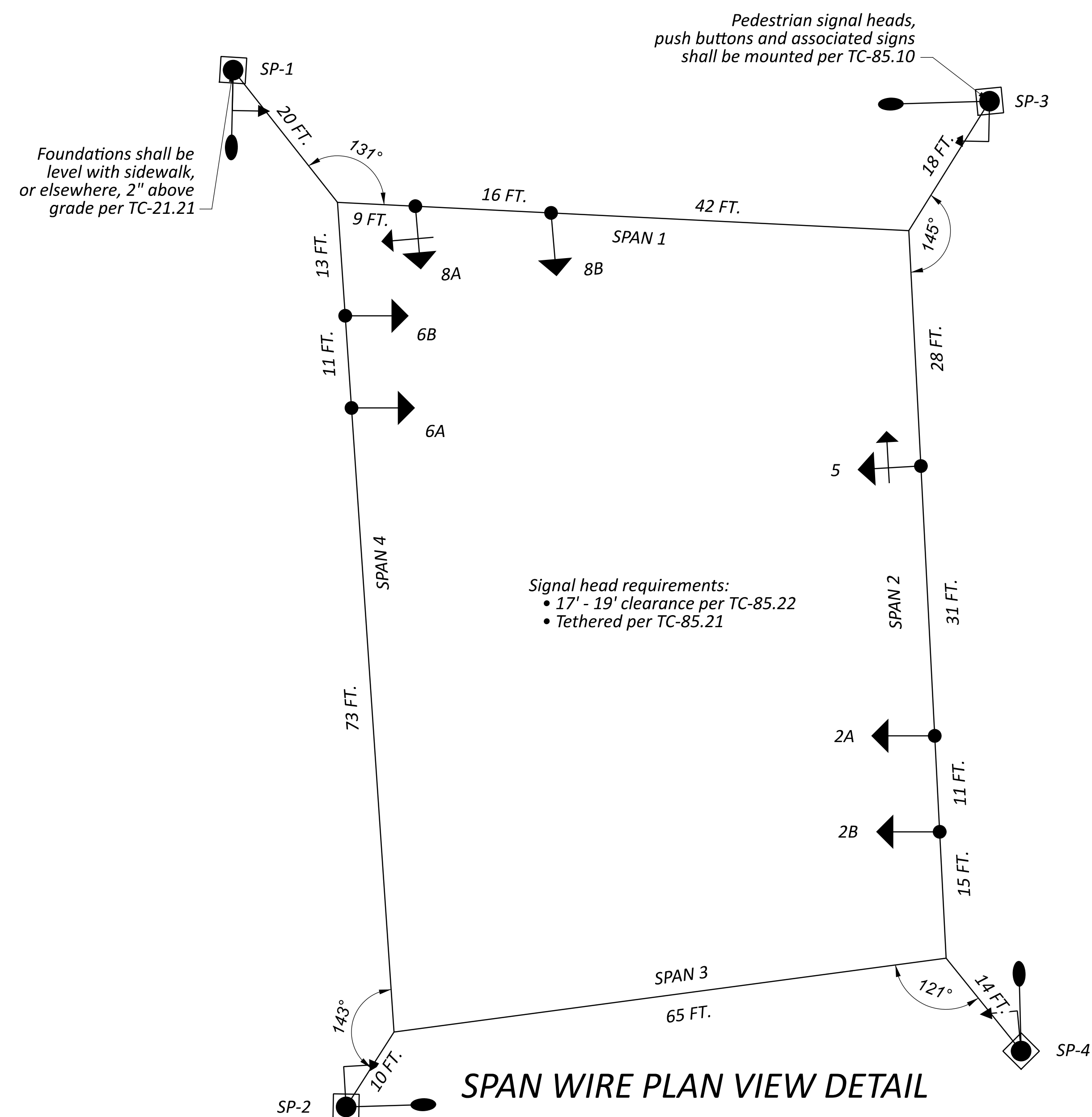

Note:

- Index line passes through the center of the handhole

POLE ORIENTATION

MAR-095-17.90

MODEL: Sheet PAPER SIZE: 34x22 (in.) DATE: 3/24/2025 TIME: 3:00:17 PM USER: moraleslovas
P:\PR602\1411148\8\400-Engineering\Signals\Sheets\114818_CD008.dgn

SPAN WIRE DETAILS
SR-95 & US-23 NORTHBOUND RAMP

DESIGN AGENCY



DESIGNER	RML
REVIEWER	JTP
PROJECT ID	09-06-24
	114818
SHEET	TOTAL
P.130	P.135

STRAIN POLE TABLE

REFERENCE SHEET NO.*	STATION & OFFSET*	POLE NO.	DESIGN NO.	POLE HEIGHT (FT.)	FOUNDATION ELEV.*	SPAN WIRE ATTACHED HEIGHT*	CABLE ENTRANCE DISTANCE BELOW SPAN WIRE ATTACHMENT (IN.)	INDEX LINE ANGLE (DEG.)	ANGLES (DEG.) FROM INDEX LINE					
									PEDESTRIAN SIGNALS	PEDESTRIAN PUSH BUTTONS	POWER SERVICE	CABLE ENTRANCE	BRACKET ARM	2" CAPPED
P.132	952+16.1, 67.6' LT	SP-1	13	36	980.0	30.5	12	90	271	-	-	236	273	-
P.132	952+12.6, 55.9' RT	SP-2	13	36	981.0	30.5	12	180	182	-	334	214	271	-
P.132	952+96.4, 67.2' LT	SP-3	13	35	981.0	29.5	12	180	94 / 181	-	-	215	268	-
P.132	952+99.3, 54.1' RT	SP-4	13	35	982.0	29.5	12	180	177 / 272	-	-	145	181	-
P.132	953+12.2, 40.9' LT	PS-1	PEDESTAL	5	-	-	-	180	-	270	-	-	-	-
P.132	953+12.3, 44.2' RT	PS-2	PEDESTAL	5	-	-	-	180	-	90	-	-	-	-

*See TEM Section 441-8

Notes:

1. All angles are measured clockwise.
2. The index line goes through the center of the handhole.

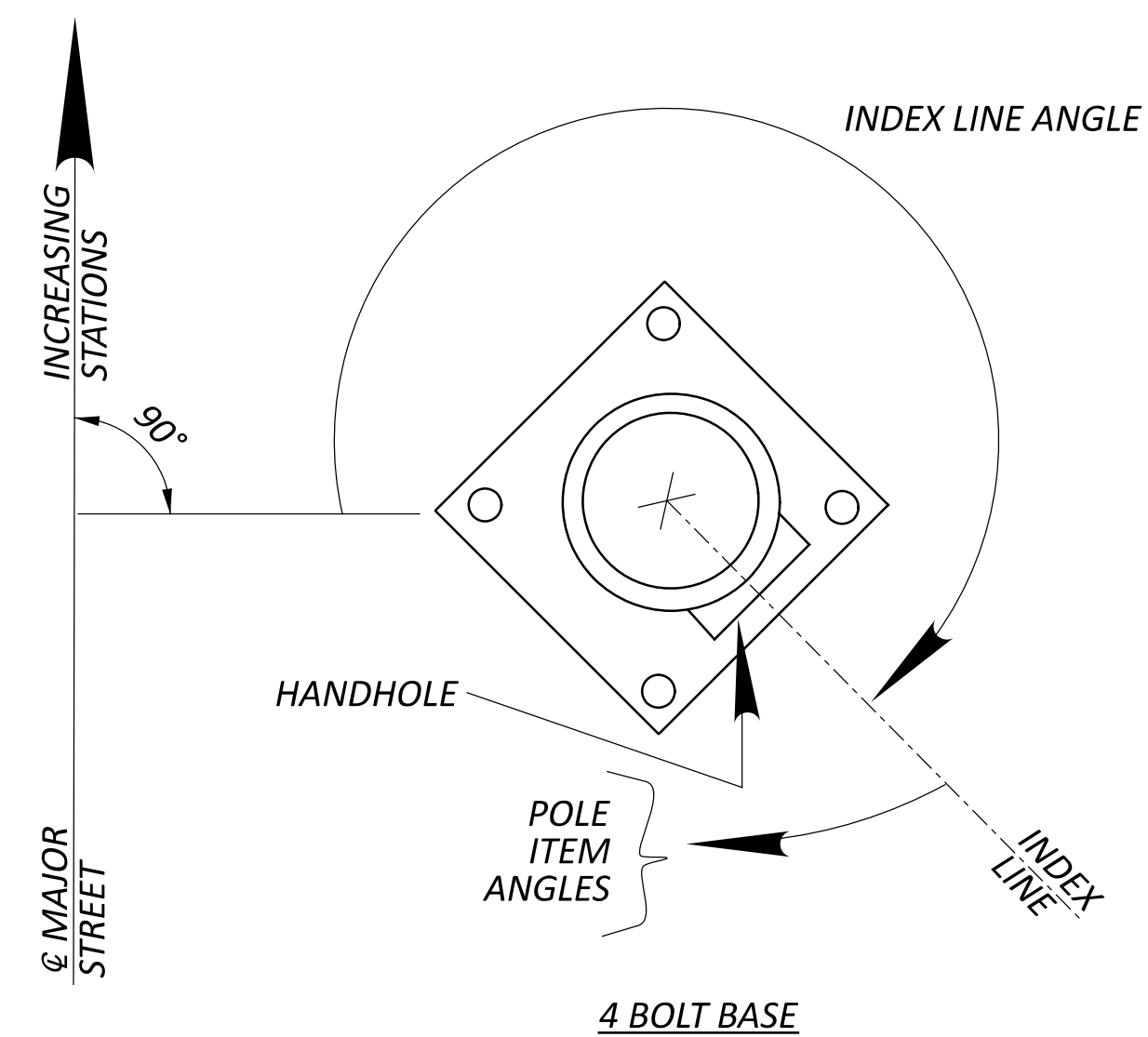
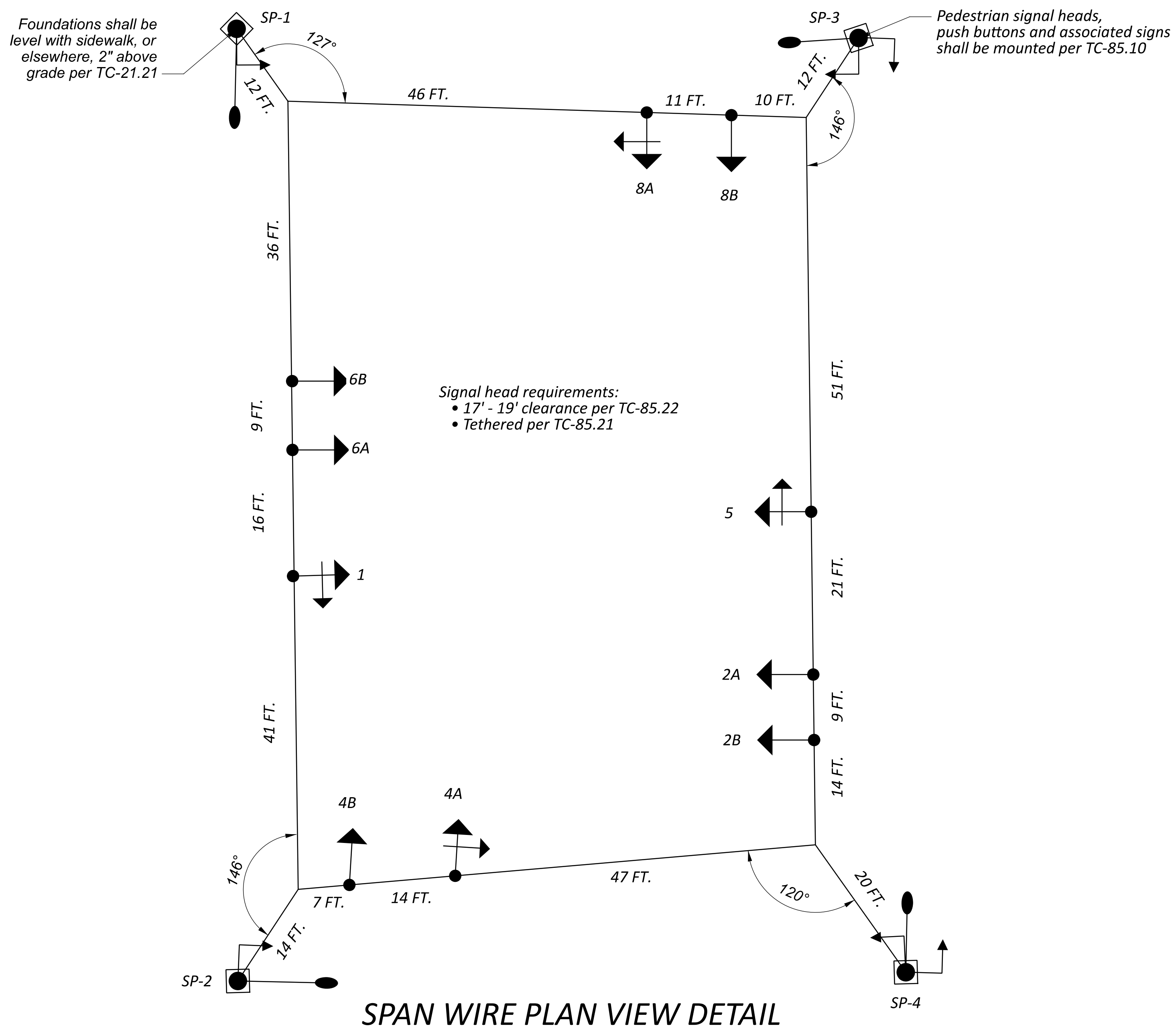

Note:

- Index line passes through the center of the handhole

MAR-095-17.90

MODEL: Sheet PAPER SIZE: 34x22 (in.) DATE: 3/24/2025 TIME: 3:00:27 PM USER: moraleslovas
 P:\PR602\1411148\8\400-Engineering\Signals\Sheets\114818_CD011.dgn

SPAN WIRE DETAILS
 SR-95 & POLE LANE ROAD

DESIGN AGENCY

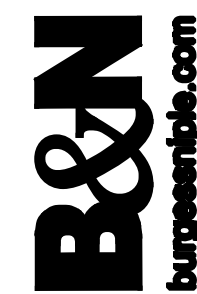

DESIGNER

RML

REVIEWER

JTP 09-06-24

PROJECT ID

114818

SHEET TOTAL

P.134 P.135