

TYPICAL A
US 30, S.L.M. 13.09 TO S.L.M. 13.47

* MINIMUM WIDTH UNLESS OTHERWISE DIRECTED BY THE ENGINEER

LEGEND

- | | |
|---|---|
| <ul style="list-style-type: none"> ① 254 3.00" PAVEMENT PLANING, ASPHALT CONCRETE ② 407 TACK COAT ③ 407 TACK COAT FOR INTERMEDIATE COURSE ④ 442 1.75" SUPERPAVE ASPHALT CONCRETE INTERMEDIATE COURSE, 19mm, TYPE B, (446), PG64-28 ⑤ 442 1.50" SUPERPAVE ASPHALT CONCRETE SURFACE COURSE, 12.5mm, TYPE B, (446), PG70-22M, AS PER PLAN ⑥ 617 2.00" COMPACTED AGGREGATE, TYPE A, AS PER PLAN | <ul style="list-style-type: none"> Ⓐ EXISTING ASPHALT CONCRETE PAVEMENT Ⓑ EXISTING PAVED SHOULDER Ⓒ EXISTING CONCRETE PAVEMENT |
|---|---|

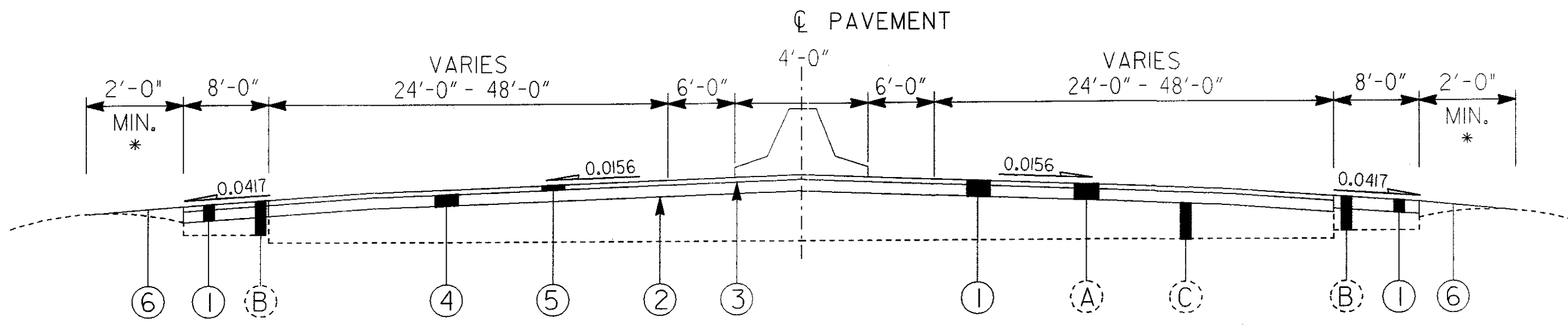

TYPICAL B
US 30, S.L.M. 13.47 TO S.L.M. 16.82

* MINIMUM WIDTH UNLESS OTHERWISE DIRECTED BY THE ENGINEER

LEGEND

- | | | | | | |
|---|-----|-------|---|---|------------------------------------|
| ① | 254 | 3.00" | PAVEMENT PLANING, ASPHALT CONCRETE | Ⓐ | EXISTING ASPHALT CONCRETE PAVEMENT |
| ② | 407 | | TACK COAT | Ⓑ | EXISTING PAVED SHOULDER |
| ③ | 407 | | TACK COAT FOR INTERMEDIATE COURSE | Ⓒ | EXISTING CONCRETE PAVEMENT |
| ④ | 442 | 1.75" | SUPERPAVE ASPHALT CONCRETE INTERMEDIATE COURSE, 19mm, TYPE B, (446), PG64-28 | | |
| ⑤ | 442 | 1.50" | SUPERPAVE ASPHALT CONCRETE SURFACE COURSE, 12.5mm, TYPE B, (446), PG70-22M, AS PER PLAN | | |
| ⑥ | 617 | 2.00" | COMPACTED AGGREGATE, TYPE A, AS PER PLAN | | |

PROFILE AND ALIGNMENT FOR RESURFACING PROJECTS:

THE PROPOSED PAVEMENT RESURFACING SHALL FOLLOW THE ALIGNMENT AND PROFILE OF THE EXISTING PAVEMENT. THE PROPOSED ASPHALT CONCRETE OVERLAY SHALL HAVE A UNIFORM THICKNESS OF 3.25" (MAINLINE) AND 1.5" (RAMPS) OR BE AS SHOWN ON THE TYPICAL SECTIONS.

CONTINGENCY QUANTITIES:

THE CONTRACTOR SHALL NOT ORDER MATERIALS OR PERFORM WORK FOR ITEMS DESIGNATED BY PLAN NOTE TO BE USED "AS DIRECTED BY THE ENGINEER" UNLESS AUTHORIZED BY THE ENGINEER. THE ACTUAL WORK LOCATIONS AND QUANTITIES USED FOR SUCH ITEMS SHALL BE INCORPORATED INTO THE FINAL CHANGE ORDER GOVERNING COMPLETION OF THIS PROJECT.

CONVERSION OF STANDARD CONSTRUCTION DRAWINGS:

THE METRIC STANDARD DRAWINGS REFERENCED IN THIS PLAN SHALL BE CONVERTED TO ENGLISH UNITS USING THE SI (METRIC) TO ENGLISH CONVERSION FACTORS PROVIDED IN SECTION 109.011 OF THE 1997 CONSTRUCTION AND MATERIALS SPECIFICATIONS. THE APPENDIX OF ASTM E 380 SHALL BE UTILIZED FOR ANY ADDITIONAL CONVERSION FACTORS REQUIRED. CONVERSIONS SHALL BE APPROPRIATELY PRECISE AND SHALL REFLECT STANDARD INDUSTRY ENGLISH VALUES WHERE SUITABLE.

UTILITIES:

BECAUSE OF THE NATURE OF THIS PROJECT, THE EXACT LOCATION OF EACH GUARDRAIL REPLACEMENT IS NOT KNOWN. THE CONTRACTOR SHALL USE THE FOLLOWING PROCEDURE AT EACH LOCATION WHERE WORK IS PERFORMED, IN ACCORDANCE WITH SECTIONS 105.06 AND 107.17 IN THE CONSTRUCTION SPECIFICATIONS:

THE CONTRACTOR SHALL NOTIFY THE PROJECT ENGINEER, THE OHIO UTILITIES PROTECTION SERVICE [OUPS], THE OIL AND GAS PRODUCERS UNDERGROUND PROTECTION SERVICE [OGPUPS], NON-MEMBER UTILITY OWNERS AND THE OHIO DEPARTMENT OF TRANSPORTATION [ODOT] DISTRICT 4 HEADQUARTERS AT LEAST TWO [2] WORKING DAYS PRIOR TO BEGINNING WORK AT ANY LOCATION.

- OUPS: 1-800-362-2764 [CONTACT NON-MEMBERS DIRECTLY]
- OGPUPS: 1-800-925-0988
- ODOT , DISTRICT 4: 330-297-0801 EXT. 305

THE LOCATION OF EXISTING UNDERGROUND UTILITIES ARE NOT SHOWN ON THE PLANS, BUT CAN BE OBTAINED FROM THE OWNERS OF THE UTILITIES.

FEATHERING AT BRIDGES

THE PROPOSED OVERLAY ON THE MAINLINE WILL RESULT IN A 1/4" DIFFERENCE HIGHER THAN THE EXISTING SURFACE OF THE BRIDGES. THE CONTRACTOR SHALL PROVIDE 25 FT. FEATHERS TO THE BRIDGE APPROACHES, AS DIRECTED BY THE ENGINEER.

ITEM 203 - EXCAVATION

THE FOLLOWING QUANTITY HAS BEEN PROVIDED FOR PAVEMENT REMOVAL OUTSIDE THE LIMITS OF ITEM 603 IN THE AREA OF STORM SEWER REPLACEMENT:

ITEM 203 - EXCAVATION 100 CU. YDS.

THE ABOVE QUANTITY IS BASED ON A PAVEMENT THICKNESS OF 18 INCHES.

ITEM 407 TACK COAT:

ITEM 407 TACK COAT FOR INTERMEDIATE COURSE:

THE RATE OF APPLICATION OF THE ITEM 407 TACK COAT SHALL BE SUBJECT TO ADJUSTMENT, AS DIRECTED BY THE ENGINEER. PLAN QUANTITIES INDICATE AN AVERAGE APPLICATION RATE OF 0.075 GALS./S.Y. OF TACK COAT AND AN AVERAGE RATE OF 0.15 GALS./S.Y. OF TACK COAT FOR INTERMEDIATE COURSE FOR ESTIMATING PURPOSES ONLY.

THE CONTRACTOR SHALL BE RESPONSIBLE FOR REMOVING ALL DIRT, VEGETATION, ETC., AS PER 407.04, TO EXPOSE THE EXISTING PAVED SHOULDER AT NO ADDITIONAL COST TO THE STATE.

ITEM 631- REMOVAL OF BALLAST AND DISPOSAL

THE CONTRACTOR SHALL REMOVE AND DISPOSE OF THE ABANDONED BALLASTS FROM EXISTING SUPPORTS, AS DIRECTED BY THE ENGINEER. THIS WORK SHALL BE PAID FOR AT THE CONTRACT PRICE FOR ITEM 631- REMOVAL OF BALLAST AND DISPOSAL, 20 EACH.

ITEM 442 ASPHALT CONCRETE SURFACE COURSE, 12.5mm,

TYPE B (446), PG70-22M, AS PER PLAN:

THE REQUIREMENTS OF 441, 446 AND SUPPLEMENTAL SPECIFICATIONS 908 SHALL APPLY; DEVIATIONS FROM THESE ARE AS FOLLOWS:

THE COMBINATION OF NEW AGGREGATES, NEW ASPHALT BINDER, AND RECLAIMED MATERIAL SHALL BE AS REQUIRED TO PRODUCE A COMPOSITION CONTAINING A MINIMUM OF 6.2% NEW ASPHALT BINDER RESULTING IN A MINIMUM TOTAL BINDER OF 6.9%.

ANY PERCENTAGE OF RECLAIMED MATERIAL PROPOSED FOR USE SHALL BE INCLUDED IN THE MIX DESIGN PROCESS TO ESTABLISH THE JOB MIX FORMULA (JMF) IN ACCORDANCE WITH 858.03.

MATERIALS: THE MATERIALS SHALL BE:

AGGREGATES	703.05*
ASPHALT BINDER	SS-908

*THE VIRGIN COARSE AGGREGATE PORTION OF THE MIXTURE SHALL BE AIR COOLED BLAST FURNACE SLAG AND MEET THE REQUIREMENTS OF 703.05.

ONLY RECLAIMED PAVEMENT FROM THIS PROJECT OR AN APPROVED EQUAL DETERMINED BY THE DISTRICT ENGINEER OF TESTS WILL BE PERMITTED FOR USE IN THIS ITEM.

ITEM 605 - 6" SHALLOW PIPE UNDERDRAINS

A CONTINGENCY QUANTITY HAS BEEN PROVIDED FOR THIS ITEM TO REPAIR UNDERDRAINS DAMAGED DURING EXCAVATION FOR STORM SEWER REPLACEMENT AS DIRECTED BY THE ENGINEER.

THE FOLLOWING CONTINGENCY QUANTITY HAS BEEN CARRIED TO THE GENERAL SUMMARY:

ITEM 605 - 6" SHALLOW PIPE UNDERDRAINS 60 FT

GRADING AND FILLING OPERATIONS

THE PLACEMENT OF COMPACTED AGGREGATE SHALL NOT EXTEND PAST THE EXISTING GRADED SHOULDERS. NO EXCAVATION, GRADINGS, OR FILLING OPERATIONS SHALL BE PERFORMED IN ANY WETLANDS OR STREAMS, UNLESS THE REQUIRED STATE AND/OR FEDERAL PERMITS HAVE BEEN OBTAINED IN ACCORDANCE WITH ALL APPLICABLE STATE AND/OR FEDERAL LAWS AND REGULATIONS. UNDER NO CIRCUMSTANCES SHALL THE CONTRACTOR STORE EQUIPMENT AND/OR MATERIALS IN ANY WETLANDS OR STREAMS.

ITEM 617 - COMPACTED AGGREGATE,

TYPE A, AS PER PLAN

UPON COMPLETION OF THE PAVING OPERATION, OR NO LONGER THAN 48 HOURS IN AREAS OF LOW BERM EXCEEDING 2" FROM PLAN TYPICAL, THE CONTRACTOR SHALL PLACE ITEM 617 COMPACTED AGGREGATE ADJACENT TO THE PAVED BERM. MATERIAL SHALL BE 90% LIMESTONE WITH NO SHALE EXCEEDING 5%. CRUSHED LIMESTONE SHALL MEET THE GRADATION AND OTHER MATERIAL REQUIREMENTS OF CMS 411.02. METHOD OF MEASUREMENT SHALL BE AS PER 411.04. PLACEMENT AND COMPACTION SHALL MEET REQUIREMENTS OF ITEM 617. ALL MATERIALS, LABOR EQUIPMENT, TOOLS, AND INCIDENTALS NECESSARY TO COMPLETE THE WORK SHALL BE INCLUDED IN THE UNIT PRICE FOR ITEM 617 COMPACTED AGGREGATE, TYPE A, AS PER PLAN.

PAVEMENT RESTORATION FOR PIPE INSTALLATIONS

THE FOLLOWING QUANTITY HAS BEEN PROVIDED FOR PAVEMENT RESTORATION FOLLOWING INSTALLATION OF PIPES UNDER ITEM 603.

ITEM 301 ASPHALT CONCRETE BASE, PG64-28	13 CU. YDS.
ITEM 304 AGGREGATE BASE	7 CU. YDS.
ITEM 407 TACK COAT	1 GAL.

THE ABOVE QUANTITY IS BASED ON A 301 THICKNESS OF 12 INCHES, 304 THICKNESS OF 6 INCHES AND A PAVEMENT RESTORATION WIDTH OF 30 FEET. THE 407 TACK COAT QUANTITY IS BASED ON A RATE OF 0.075 GAL/SQ. YD.

PROVIDE ANY MATERIALS USED OUTSIDE THE LIMITS STATED ABOVE AT NO ADDITIONAL COST.

PAVED SHOULDERS

ITEM 442 ASPHALT CONCRETE FOR SHOULDERS MAY BE PLACED IN THE SAME OPERATION AS THE ADJACENT PAVEMENT OVERLAY.

ITEM 503 - UNCLASSIFIED EXCAVATION

A CONTINGENCY QUANTITY HAS BEEN PROVIDED FOR THIS ITEM TO EXCAVATE UNSUITABLE MATERIAL IN THE AREA OF STORM SEWER REPLACEMENT TO BE USED AS DIRECTED BY THE ENGINEER.

THE FOLLOWING CONTINGENCY QUANTITY HAS BEEN CARRIED TO THE GENERAL SUMMARY:

ITEM 503 - UNCLASSIFIED EXCAVATION 150 CU. YDS.

ITEM 606 - IMPACT ATTENUATOR, TYPE 2-98 [(OS9006Y), (UNIDIRECTIONAL)], AS PER PLAN

ITEM 606 - IMPACT ATTENUATOR, TYPE 2-98 [(OS6906Y), (UNIDIRECTIONAL)], AS PER PLAN

THIS ITEM SHALL CONSIST OF FURNISHING AND INSTALLING A QUADGUARD IMPACT ATTENUATOR MANUFACTURED BY ENERGY ABSORPTION SYSTEMS, INC., ONE EAST WACKER DRIVE, CHICAGO, IL 60601 (TELEPHONE: 312-467-6750).

INSTALLATION WILL INCLUDE THE REMOVAL AND DISPOSAL OF EXISTING HEX-FOAM SANDWICH SYSTEM ATTENUATOR AND REUSE OF EXISTING CONCRETE BACKUP AND PAD.

INSTALLATION SHALL BE AT THE LOCATIONS SPECIFIED IN THE PLANS, IN ACCORDANCE WITH THE MANUFACTURER'S SPECIFICATIONS AS DETAILED ON THE FOLLOWING PRE-APPROVED SHOP DRAWINGS:

DWG. NO.	DRAWING NAME	DWG./REV. DATE	ODOT APPROVAL DATE
QFCBCVR-U	QUADGUARD SYSTEM W/ 69" & 90" CONCRETE BACKUPS	9/4/97 Rev. D	3/6/98
35-40-20	DEFLECTOR ASSEMBLY, CONCRETE BACKUP RETROFIT, QG	11/14/97 Rev. B	7/31/98
35-40-03	QUADGUARD SYSTEM BACKUP ASSEMBLY, TS, QG	3/19/99 Rev. F	8/27/99
35-40-08 2 SHEETS	QUADGUARD SYSTEM CONCRETE BACKUP, QG ON GRADE & ON EXISTING CONCRETE STRUCTURE	10/14/97 Rev. F 10/14/97 Rev. F	8/27/99 8/27/99
35-40-21 2 SHEETS	TRANSITION ASSEMBLY QUAD-BEAM TO W-BEAM	11/6/97 Rev. B 7/14/97 Rev. A	8/27/99 8/27/99
35-40-15	QUADGUARD SYSTEM END SHOE ASSEMBLY, QG	9/11/98 Rev. F	8/27/99

WHEN BI-DIRECTIONAL DESIGNS ARE SPECIFIED, THE CONTRACTOR SHALL SUPPLY APPROPRIATE TRANSITIONS.

PAYMENT FOR THE ABOVE WORK SHALL BE MADE AT THE UNIT PRICE BID FOR ITEM 606, IMPACT ATTENUATOR, TYPE 2-98 (MODEL NO.), (UNIDIRECTIONAL OR BIDIRECTIONAL), EACH, AND SHALL INCLUDE ALL LABOR, TOOLS, EQUIPMENT AND MATERIALS NECESSARY TO CONSTRUCT A COMPLETE AND FUNCTIONAL IMPACT ATTENUATOR SYSTEM, INCLUDING ALL RELATED BACKUPS, TRANSITIONS, HARDWARE AND GRADING, NOT SEPARATELY SPECIFIED, AS REQUIRED BY THE MANUFACTURER.

INSTALLATION SHALL BE AT THE FOLLOWING LOCATIONS IN THE PLANS.

- SLM - 14.74 GORE AREA BETWEEN RAMP US 30 E/B AND I-77
- SLM - 14.88 GORE AREA BETWEEN US 30 E/B AT SPLIT OF I-77 S/B AND N/B
- SLM - 15.22 GORE AREA BETWEEN RAMP US 30 W/B AND I-77
- SLM - 15.00 GORE AREA BETWEEN RAMP FROM I-77 N/B TO US 30 W/B
- SLM - 14.99 GORE AREA BETWEEN RAMP FROM I-77 S/B TO US 30 W/B

** SLM - 15.02 ON RAMP TO I-77 S/B FROM US 30 W/B
(THIS ONE WILL BE USING THE MODEL # QS6906Y)

ITEM 606 - IMPACT ATTENUATOR, TYPE 2-98 [(OS9006Y), (UNIDIRECTIONAL)], AS PER PLAN, (CONT.)

ITEM 606 - IMPACT ATTENUATOR, TYPE 2-98 [(OS6906Y), (UNIDIRECTIONAL)], AS PER PLAN, (CONT.)

THE FOLLOWING CONTINGENCY QUANTITIES HAVE BEEN CARRIED TO THE GENERAL SUMMARY:

ITEM 606 - IMPACT ATTENUATOR, TYPE 2-98 [(OS9006Y), (UNIDIRECTIONAL)], AS PER PLAN, 5 EA.

ITEM 606 - IMPACT ATTENUATOR, TYPE 2-98 [(OS6906Y), (UNIDIRECTIONAL)], AS PER PLAN, 1 EA.

ITEM 606 - DEFLECTOR ASSEMBLY, CONCRETE BACKUP RETROFIT, QG 6 EA.

ITEM 606 - GUARDRAIL MISC.: ANCHOR ASSEMBLY REBUILT, TYPE E

THIS ITEM OF WORK IS TO BE USED TO RECONSTRUCT AN EXISTING INSTALLATION OF AN ET-2000, OPTION "B", GUARDRAIL END TERMINAL AS MANUFACTURED BY SYRO STEEL COMPANY, 1170 N. STATE STREET, GIRARD, OHIO 44420 (TELEPHONE: 330-545-4373), AS DIRECTED BY THE ENGINEER. THE UNIT BID PRICE SHALL INCLUDE ALL LABOR, TOOLS, MATERIALS AND EQUIPMENT TO REMOVE AND REPLACE DAMAGED "W-SHAPED" RAIL PANEL(S) AND ANY NUMBER OF THE BREAK-AWAY WOODEN POSTS AND ASSOCIATED HARDWARE (BOLTS, NUTS, AND WASHERS), STEEL FOUNDATION TUBES, OFFSET STRUT CHANNEL, AND THE CABLE ASSEMBLY. NEED FOR REPLACING THE EXTRUDER END COMPONENT SHALL BE CAUSE TO REPLACE THE ANCHOR ASSEMBLY UNDER THE REFERENCE FOR NEW TYPE E ANCHOR. ALL REPAIR AND REPLACEMENT ITEMS SHALL BE AS PER THE MANUFACTURERS PLANS AND SPECIFICATIONS. THE LOCATION AND OFFSET SHALL BE AS DIRECTED BY THE ENGINEER. PAYMENT FOR THIS ITEM SHALL INCLUDE ALL LABOR, TOOLS, EQUIPMENT AND MATERIALS NECESSARY TO REBUILD A COMPLETE AND FUNCTIONAL ANCHOR ASSEMBLY SYSTEM, INCLUDING ALL RELATED HARDWARE, NOT SEPARATELY SPECIFIED, AS REQUIRED BY THE MANUFACTURER AND INCLUDED IN THE UNIT PRICE BID FOR EACH, ITEM 606 GUARDRAIL MISC.: ANCHOR ASSEMBLY REBUILT, TYPE E.

THE FOLLOWING CONTINGENCY QUANTITY HAS BEEN CARRIED TO THE GENERAL SUMMARY:

ITEM 606 - GUARDRAIL MISC.: ANCHOR ASSEMBLY REBUILT, TYPE E 2 EA.

ITEM 606 - GUARDRAIL, TYPE 5, AS PER PLAN

ITEM 606 - ANCHOR ASSEMBLY, TYPE T, AS PER PLAN

A CONTINGENCY QUANTITY HAS BEEN PROVIDED FOR THESE ITEMS TO BE USED AS DIRECTED BY THE ENGINEER ON THE RAMP AT SLM 15.02, THE ON RAMP TO I-77 S/B AND TO I-77 N/B FROM US 30 W/B. PAYMENT FOR THIS WORK SHALL INCLUDE ALL LABOR, TOOLS, EQUIPMENT AND MATERIAL NECESSARY TO DRILL THROUGH CONCRETE AND TO BUILD A COMPLETE AND FUNCTIONAL GUARDRAIL RUN.

THE FOLLOWING CONTINGENCY QUANTITIES HAVE BEEN CARRIED TO THE GENERAL SUMMARY:

ITEM 606 - GUARDRAIL, TYPE 5, AS PER PLAN 75 FT.
ITEM 606 - ANCHOR ASSEMBLY, TYPE T, AS PER PLAN 2 EA.

ITEM 613 - LOW STRENGTH MORTAR BACKFILL, TYPE 2

A CONTINGENCY QUANTITY HAS BEEN PROVIDED FOR THIS ITEM TO BACKFILL THE AREAS EXCAVATED IN THE AREA OF STORM SEWER REPLACEMENT TO BE USED AS DIRECTED BY THE ENGINEER.

THE FOLLOWING CONTINGENCY QUANTITY HAS BEEN CARRIED TO THE GENERAL SUMMARY:

ITEM 613 LOW STRENGTH MORTAR BACKFILL, TYPE 2 184 CU. YDS.

MAINTENANCE OF TRAFFIC

THIS ITEM SHALL CONSIST OF MAINTENANCE OF TRAFFIC ON EXISTING ROADWAYS AND RAMPS IN ACCORDANCE WITH THE OHIO MANUAL OF UNIFORM TRAFFIC CONTROL DEVICES FOR STREETS AND HIGHWAYS, CURRENT EDITION, LATEST REVISION, THE SPECIFICATIONS AND THE FOLLOWING:

1. A MINIMUM OF ONE ELEVEN FOOT LANE IN EACH DIRECTION SHALL BE MAINTAINED ON THE EXISTING PAVEMENT OR COMPLETED PAVEMENT DURING CONSTRUCTION OF THE WORK. ON RAMPS A MINIMUM OF ONE TEN FOOT LANE SHALL BE MAINTAINED.
2. THE CONTRACTOR SHALL INFORM THE DISTRICT OFFICE (330) 297-0801 EXT 209, EIGHTEEN (18) DAYS PRIOR TO THE BEGINNING OF WORK.
3. CONES SHALL NOT BE ACCEPTABLE TRAFFIC CONTROL DEVICES FOR LANE RESTRICTIONS OR LANE REDUCTIONS THAT ARE IN OPERATION ONE-HALF HOUR AFTER SUNSET OR ONE HALF-HOUR BEFORE SUNRISE. ALL NIGHTTIME LANE RESTRICTIONS SHALL REQUIRE DRUMS OR BARRICADES AT A MAXIMUM SPACING OF FIFTY (50) FEET. WEIGHTED CHANNELIZERS MAY BE USED IN ACCORDANCE WITH THE ADDITIONAL NOTE HEREIN.
4. LANE RESTRICTIONS OR LANE REDUCTIONS SHALL NOT BE PERMITTED AFTER NORMAL WORKING HOURS. NORMAL WORKING HOURS SHALL BE THOSE HOURS DURING WHICH THE CONTRACTOR HAS A FULL COMPLEMENT OF EMPLOYEES AND EQUIPMENT ACTIVELY REMOVING AND/OR PLACING PAVEMENT MATERIALS.
5. THE CONTRACTOR SHALL FURNISH, ERECT, MAINTAIN AND SUBSEQUENTLY REMOVE ALL FLAGS, BARRICADES, SIGNS, SIGN SUPPORTS AND FURNISH AND MAINTAIN ALL FLAGGERS, WATCHERS AND INCIDENTALS RELATED THERETO.
6. ALL FULL DEPTH PAVEMENT REMOVAL AND REPLACEMENT OPERATIONS SHALL BE COMPLETED THE SAME DAY THE EXCAVATION IS MADE. IF THE CONTRACTOR CANNOT COMPLETE THE WORK, THE EXCAVATION SHALL BE BACKFILLED OR PROTECTED AS PER THE "DROPOFFS IN WORK ZONES" SHEET.
7. UNDER NO CIRCUMSTANCES SHALL THE CONTRACTOR BE PERMITTED TO HAVE SUCCESSIVE WORK ZONES UNLESS THE DISTANCE BETWEEN THE DRUMS, BARRICADES OR CONES EXCEEDS TWO (2) MILES RURAL OR ONE (1) MILE URBAN.
8. IN ADDITION TO THE REQUIREMENTS OF 614 WORK ZONE PAVEMENT MARKINGS (614.11), AT THE END OF EACH DAY OF WORK, THE CONTRACTOR SHALL REPLACE (WITH TEMPORARY MARKINGS) ALL LANE, STOP OR CHANNELIZING LINES THAT WERE REMOVED OR COVERED DURING THE PAVEMENT REMOVAL OR PLACEMENT OPERATIONS. QUANTITIES FOR SUCH REPLACEMENT ARE CARRIED AS PART OF THE ITEMS LISTED UNDER 614 WORK ZONE PAVEMENT MARKINGS.
9. A QUANTITY OF 20 CU. YDS. OF 614 ASPHALT CONCRETE FOR MAINTAINING TRAFFIC SHALL BE PROVIDED FOR USE IN MAINTAINING PAVEMENT, SHOULDERS AND OTHER LOCATIONS PRIOR TO RESURFACING, AS DIRECTED BY THE ENGINEER.
10. PRIOR TO OPENING TO TRAFFIC, EACH LANE SHALL BE IN A SAFE, PASSABLE CONDITION. ALL TRANSVERSE JOINTS SHALL EXTEND ACROSS THE FULL LANE AND SHOULDER WIDTH AND EACH LANE SHALL BE FREE FROM UNEVEN LONGITUDINAL JOINTS. THE CONTRACTOR SHALL PROVIDE ASPHALT WEDGES FOR TRANSVERSE JOINTS WHEREVER THERE ARE PAVEMENT ELEVATION DIFFERENCES.
11. A QUANTITY OF ITEM 614 WORK ZONE MARKING SIGN HAS BEEN INCLUDED IN THE PLAN. THIS QUANTITY SHALL INCLUDE, BUT NOT BE LIMITED TO, THE FOLLOWING SIGNS: OW-62 [BUMP], OW-167 [NO EDGE LINES], OW-171 [UNEVEN LANES SYMBOL]. THESE QUANTITIES SHALL BE AS PER 614.04.

THE FOLLOWING QUANTITIES SHALL BE USED FOR THE MAINTENANCE OF TRAFFIC ON THIS PROJECT:

ITEM 614 WORK ZONE LANE LINE, CLASS I	33.0 MILE
ITEM 614 WORK ZONE STOP LINE, CLASS I	408 FT.
ITEM 614 WORK ZONE CHANNELIZING LINE, CLASS I	7,434 FT.
ITEM 614 WORK ZONE MARKING SIGN	20 EACH

WEIGHTED CHANNELIZERS

THE WEIGHTED CHANNELIZER SHALL BE PREDOMINATELY ORANGE IN COLOR AND SHALL BE MADE OF A LIGHTWEIGHT, FLEXIBLE, AND DEFORMABLE MATERIAL. THEY SHALL BE AT LEAST 42 INCHES IN HEIGHT WITH A WEIGHTED BASE. THEY MAY HAVE A "HANDLE" OR LIFTING DEVICE WHICH EXTENDS ABOVE THE 42" MINIMUM HEIGHT.

THE MARKINGS ON THE WEIGHTED CHANNELIZER SHALL BE HORIZONTAL, CIRCUMFERENTIAL, ALTERNATING ORANGE AND WHITE RETROREFLECTIVE STRIPES 6 INCHES WIDE. EACH WEIGHTED CHANNELIZER SHALL HAVE A MINIMUM OF TWO ORANGE AND TWO WHITE STRIPES. ANY NON-RETROREFLECTIVE SPACES BETWEEN THE HORIZONTAL ORANGE AND WHITE STRIPES SHALL NOT EXCEED 2 INCHES WIDE. THE WEIGHTED CHANNELIZER SHALL HAVE A 4-INCH MINIMUM WIDTH, REGARDLESS OF ORIENTATION.

ON FREEWAYS AND MULTILANE HIGHWAYS:
 USE OF WEIGHTED CHANNELIZERS ON FREEWAYS AND MULTILANE HIGHWAYS SHALL BE LIMITED TO SHORT-TERM OPERATION, GENERALLY TWELVE HOURS OR LESS, FOR EITHER DAY OR NIGHT. UPON COMPLETION OF WORK WITHIN THE ABOVE NOTED TIME PERIOD, THE WEIGHTED CHANNELIZERS SHALL BE REMOVED. THE WEIGHTED CHANNELIZERS MAY AGAIN BE PLACED ON THE HIGHWAY WHEN THE WORK IS TO RESUME ON THE FOLLOWING DAY OR NIGHT. ANY LANE CLOSURE USING CHANNELIZATION DEVICES, EXPECTED TO REMAIN FOR MORE THAN TWELVE HOURS, SHALL REQUIRE THE USE OF DRUMS OR BARRIERS.

WHEN USED AT NIGHT, WEIGHTED CHANNELIZERS SHALL ONLY BE PLACED IN THE "TANGENT AREA". THE "TANGENT AREA" IS DEFINED AS THE AREA AFTER THE TRANSITION TAPER WHERE THE WORK TAKES PLACE. DRUMS SHALL BE USED IN THE TRANSITION TAPERS FOR NIGHT OPERATIONS.

ON OTHER HIGHWAYS:
 THERE ARE NO DURATIONS OF WORK RESTRICTIONS FOR USE OF WEIGHTED CHANNELIZERS ON ALL OTHER TYPES OF HIGHWAYS, DAY OR NIGHT. ON THESE ROADWAYS THE WEIGHTED CHANNELIZER MAY BE USED IN THE TRANSITION TAPERS AS WELL AS IN THE TANGENT AREAS, DAY OR NIGHT.

MAXIMUM SPACING OF THE WEIGHTED CHANNELIZER SHALL BE 40 FEET.

STEPS SHOULD BE TAKEN TO ENSURE THAT THE WEIGHTED CHANNELIZERS WILL NOT BE BLOWN OVER OR DISPLACED BY WIND OR MOVING TRAFFIC. BALLASTS SHOULD NOT PRESENT A HAZARD IF THE WEIGHTED CHANNELIZERS ARE INADVERTENTLY STRUCK, NOR SHOULD THEY AFFECT THE VISIBILITY OF THE WEIGHTED CHANNELIZERS. ALL BALLASTS USED SHOULD BE IN ACCORDANCE WITH THE MANUFACTURER'S SPECIFICATIONS.

ADVANCE NOTICE TO PAVE

THE CONTRACTOR SHALL SUBMIT FOR APPROVAL TO THE DISTRICT CONSTRUCTION ENGINEER A DETAILED SCHEDULE 15 DAYS PRIOR TO THE PLACEMENT OF THE OVERLAY COURSES, ON HOW THEY PROPOSE TO PROSECUTE THE PAVING OPERATIONS. THE DETAILS SHALL SHOW THE ORDER OF PERFORMANCE OF EACH STAGE (START TO FINISH) OF THE WORK INCLUDING THE MAINTENANCE OF TRAFFIC THAT WILL BE USED.

CONTRACTOR'S EQUIPMENT - OPERATION AND STORAGE

A QUALIFIED FLAGGER SHALL BE EMPLOYED WHERE THE CONTRACTOR'S EQUIPMENT MUST MERGE WITH THE TRAFFIC STREAM. THE CONTRACTOR'S EQUIPMENT SHALL BE EQUIPPED WITH AT LEAST ONE AMBER FLASHING LIGHT. PAVERS, ROLLERS AND OTHER EQUIPMENT MAY BE PARKED IN AREAS ALONG THE HIGHWAY WHEN PAVING OPERATIONS ARE SCHEDULED TO CONTINUE WITHIN THE NEXT WORKDAY. OTHERWISE, THE EQUIPMENT SHALL BE STORED AT A STORAGE AREA OUTSIDE THE R/W, THE LOCATION OF WHICH SHALL HAVE PRIOR APPROVAL OF THE ENGINEER. WHEN PARKING ALONG THE HIGHWAY, THE EQUIPMENT SHALL BE PLACED AND DELINEATED AS PER 614.03. NO EQUIPMENT SHALL BE PARKED IN THE MEDIAN OF THE HIGHWAY. ADEQUATE BARRICADES AND LIGHTS SHALL BE PLACED ON THE PAVEMENT SIDE OF THE EQUIPMENT TO IDENTIFY THE LIMITS OF THE EQUIPMENT. ALL OTHER EQUIPMENT, INCLUDING PRIVATE VEHICLES, SHALL BE STORED AT THE APPROVED CONTRACTOR'S STORAGE AREA. NO EQUIPMENT SHALL BE PARKED ON PRIVATE PROPERTY UNLESS PRIOR APPROVAL OF THE OWNER AND THE PROJECT ENGINEER/SUPERVISOR HAS BEEN GRANTED.

WINTER TRAFFIC LIMITATIONS

ALL EXISTING LANES SHALL BE OPEN TO TRAFFIC BETWEEN NOVEMBER 15 AND APRIL 1. NOVEMBER 14 SHALL BE CONSIDERED TO CONSTITUTE AN INTERIM COMPLETION DATE AND LIQUIDATED DAMAGES AS SPECIFIED IN 108.07 SHALL BE ASSESSED FOR EACH CALENDAR DAY THAT THE ROADWAY REMAINS CLOSED TO TRAFFIC BEYOND THE SPECIFIED LIMIT. THE CONTRACTOR MAY CLOSE LANES PRIOR TO APRIL 1 WITH WRITTEN APPROVAL FROM THE DISTRICT CONSTRUCTION ENGINEER.

TRAFFIC CONTROL INSPECTOR

THE CONTRACTOR SHALL DESIGNATE AN INDIVIDUAL OTHER THAN THE SUPERINTENDENT AND SUBJECT TO THE APPROVAL OF THE ENGINEER, TO CONTINUOUSLY INSPECT ALL TRAFFIC CONTROL DEVICES WHENEVER CONSTRUCTION WORK IS BEING PERFORMED WITHIN THE WORK LIMITS OF THE PROJECT. THE DESIGNATED INDIVIDUAL SHALL ALSO INSPECT ALL TRAFFIC DEVICES AT THE BEGINNING AND AT THE END OF EACH WORK DAY. THE DESIGNATED INDIVIDUAL OR A QUALIFIED REPRESENTATIVE SHALL ALSO BE AVAILABLE ON AN AROUND THE CLOCK BASIS TO REPAIR AND/OR REPLACE DAMAGED OR MISSING TRAFFIC CONTROL DEVICES. THESE INDIVIDUALS SHALL BE EQUIPPED WITH CELLULAR PHONES AND THEIR NAMES AND PHONE NUMBERS SHALL BE GIVEN TO THE PROJECT ENGINEER AT THE PRE-CONSTRUCTION MEETING. THE DESIGNATED INDIVIDUAL MAY HAVE OTHER CONSTRUCTION RELATED DUTIES AS LONG AS IMMEDIATE ATTENTION IS GIVEN TO TRAFFIC CONTROL. PAYMENT FOR THE SERVICES OF THE TRAFFIC CONTROL INSPECTOR SHALL BE INCLUDED IN THE LUMP SUM PRICE BID FOR ITEM 614 MAINTAINING TRAFFIC.

DAILY WORK LIMITATIONS - US-30

THE CONTRACTOR MAY ONLY CLOSE ONE LANE OF TRAFFIC ON US-30 DURING THE FOLLOWING TIMES:

SR-297 TO CHERRY ST.
 MONDAY - FRIDAY 7:00PM TO 6:00AM
 SATURDAY - SUNDAY ANYTIME (AS APPROVED BY THE ENGINEER)

CHERRY ST. TO END OF PROJECT
 MONDAY - FRIDAY 9:00AM TO 3:00PM AND 6:00PM TO 7:00AM
 SATURDAY - SUNDAY ANYTIME

AT ALL OTHER TIMES ALL LANES OF TRAFFIC SHALL REMAIN OPEN. SHOULD THE CONTRACTOR FAIL TO MEET ANY OF THESE REQUIREMENTS, THE CONTRACTOR SHALL BE ASSESSED LIQUIDATED DAMAGES IN THE AMOUNT OF \$500.00 PER ONE-HALF HOUR OF OVERRUN.

I:\Projects\23759\23759m.dgn 14-MAY-2003 8:57AM ctfiber10

ITEM 614 - MAINTAINING TRAFFIC

NO WORK SHALL BE PERFORMED AND ALL EXISTING LANES SHALL BE OPEN TO TRAFFIC DURING THE FOLLOWING DESIGNATED HOLIDAYS OR EVENTS:

CHRISTMAS	NEW YEARS
MEMORIAL DAY	FOURTH OF JULY
LABOR DAY	THANKSGIVING

THE PERIOD OF TIME THAT THE LANES ARE TO BE OPEN DEPENDS ON THE DAY OF THE WEEK ON WHICH THE HOLIDAY OR EVENT FALLS. THE FOLLOWING SCHEDULE SHALL BE USED TO DETERMINE THIS PERIOD:

DAY OF THE WEEK	TIME ALL LANES MUST BE OPEN TO TRAFFIC
SUNDAY	12:00N FRIDAY THROUGH 12:00N MONDAY
MONDAY	12:00N FRIDAY THROUGH 12:00N TUESDAY
TUESDAY	12:00N MONDAY THROUGH 12:00N WEDNESDAY
WEDNESDAY	12:00N TUESDAY THROUGH 12:00N THURSDAY
THURSDAY	12:00N WEDNESDAY THROUGH 12:00N MONDAY
FRIDAY	12:00N THURSDAY THROUGH 12:00N MONDAY
SATURDAY	12:00N FRIDAY THROUGH 12:00N MONDAY

NO EXTENSIONS OF TIME SHALL BE GRANTED FOR DELAYS IN MATERIAL DELIVERIES, UNLESS SUCH DELAYS ARE INDUSTRY-WIDE, OR FOR LABOR STRIKES, UNLESS SUCH STRIKES ARE AREA-WIDE.

SHOULD THE CONTRACTOR FAIL TO MEET ANY OF THESE REQUIREMENTS, THE CONTRACTOR SHALL BE ASSESSED LIQUIDATED DAMAGES IN ACCORDANCE WITH 108.07.

FLOODLIGHTING

FLOODLIGHTING OF THE WORK SITE FOR OPERATIONS CONDUCTED DURING NIGHT TIME PERIODS SHALL BE ACCOMPLISHED SO THAT THE LIGHTS DO NOT CAUSE GLARE TO THE DRIVERS ON THE ROADWAY. TO ENSURE THE ADEQUACY OF THE FLOODLIGHT PLACEMENT, THE CONTRACTOR AND THE ENGINEER SHALL DRIVE THROUGH THE WORK SITE EACH NIGHT WHEN THE LIGHTING IS IN PLACE AND OPERATIVE PRIOR TO COMMENCING ANY WORK. IF GLARE IS DETECTED, THE LIGHT PLACEMENT AND SHIELDING SHALL BE ADJUSTED TO THE SATISFACTION OF THE ENGINEER BEFORE WORK PROCEEDS.

PAYMENT FOR ALL LABOR, EQUIPMENT AND MATERIALS SHALL BE INCLUDED IN THE LUMP SUM CONTRACT PRICE FOR ITEM 614 - MAINTAINING TRAFFIC.

COOPERATION BETWEEN CONTRACTORS

THE CONTRACTOR SHALL BE ADVISED THAT OTHER PROJECTS MAY BE ONGOING IN AREAS IMMEDIATELY ADJACENT TO AND WITHIN THE PROJECT LIMITS OF THIS PROJECT. THE CONTRACTOR SHALL SCHEDULE HIS WORK SO AS TO CAUSE A MINIMUM OF DELAY OR CONFLICT WITH THE OTHER PROJECT(S). IN ACCORDANCE WITH 105.08, THE CONTRACTOR SHALL ARRANGE WITH THE OTHER CONTRACTORS A MUTUALLY ACCEPTABLE WORK SCHEDULE SUBJECT TO THE APPROVAL OF THE ENGINEER. THE CONTRACTOR SHALL RECEIVE DAILY APPROVAL FROM THE ENGINEER PRIOR TO COMMENCING ANY OPERATIONS. ANY CONFLICT BETWEEN CONTRACTORS INVOLVING WORK SCHEDULES, WORK AREA OR COOPERATION SHALL BE RESOLVED BY THE ENGINEER. COMPENSATION FOR THE ABOVE COOPERATION SHALL BE INCIDENTAL TO THE VARIOUS PAY ITEMS INCLUDED WITHIN THIS PROJECT.

ITEM 614 PORTABLE CHANGEABLE MESSAGE SIGN, AS PER PLAN

THE CONTRACTOR SHALL FURNISH, INSTALL, MAINTAIN AND REMOVE, WHEN NO LONGER NEEDED, 2 PORTABLE CHANGEABLE MESSAGE SIGNS [PCMS], ON SITE, FOR THE DURATION OF TIME SPECIFIED IN THIS NOTE. EACH SIGN SHALL BE OF A TYPE SHOWN ON A LIST OF APPROVED PCMS UNITS MAINTAINED BY THE DIRECTOR. THE CLASS 1 UNITS SHALL HAVE A MINIMUM LEGIBILITY DISTANCE OF 1,250 FEET.

EACH SIGN SHALL BE TRAILER MOUNTED AND EQUIPPED WITH A FUNCTIONAL DIMMING MECHANISM TO DIM THE SIGN DURING DARKNESS AND A TAMPER AND VANDAL PROOF ENCLOSURE. EACH SIGN SHALL BE PROVIDED WITH APPROPRIATE TRAINING AND OPERATION INSTRUCTIONS TO ENABLE ON-SITE PERSONNEL TO OPERATE AND TROUBLESHOOT THE UNIT. THE SIGN SHALL ALSO BE CAPABLE OF BEING POWERED BY AN ELECTRICAL SERVICE DROP FROM A LOCAL UTILITY COMPANY.

PLACEMENT, OPERATION, MAINTENANCE AND ALL ACTIVATION OF THE SIGNS BY THE CONTRACTOR SHALL BE AS DIRECTED BY THE ENGINEER. THE PCMS SHALL BE LOCATED IN A HIGHLY VISIBLE POSITION YET PROTECTED FROM TRAFFIC. THE PCMS SHOULD NOT BE LOCATED IN THE MEDIAN OF THE HIGHWAY UNLESS IT IS PROTECTED FROM BOTH DIRECTIONS OF TRAFFIC. THE PCMS SHOULD BE LOCATED BEHIND GUARDRAIL WHEREVER POSSIBLE. THE CONTRACTOR SHALL, AT THE DIRECTION OF THE ENGINEER, RELOCATE THE PCMS TO IMPROVE THE VISIBILITY OR ACCOMMODATE CHANGED CONDITIONS. WHEN NOT IN USE, THE PCMS WILL BE OFF, FACING AWAY FROM ALL TRAFFIC AND SHALL DISPLAY ONE OR MORE HIGH INTENSITY YELLOW REFLECTIVE SHEETING SURFACES OF 9-INCH BY 15-INCH MINIMUM SIZE FACING TRAFFIC.

THE ENGINEER SHALL BE PROVIDED ACCESS TO EACH SIGN UNIT AND SHALL BE PROVIDED WITH APPROPRIATE TRAINING AND OPERATION INSTRUCTIONS TO ENABLE PERSONNEL TO OPERATE AND TROUBLESHOOT THE UNIT AND TO REVISE SIGN MESSAGES, IF NECESSARY.

ALL MESSAGES TO BE DISPLAYED ON THE SIGN WILL BE PROVIDED BY THE CONTRACTOR. A LIST OF ALL PROPOSED PREPROGRAMMED MESSAGES WILL BE GIVEN TO THE ENGINEER PRIOR TO CONSTRUCTION. THE SIGN SHALL HAVE TWO DIFFERENT MEMORIES [PROM AND RAM] AND CAPABILITY TO STORE UP TO 99 MESSAGES IN EACH MEMORY. THE SIGN LEGEND SHALL BE CAPABLE OF BEING CHANGED IN THE FIELD. IN ORDER TO CONVEY A MAXIMUM OF INFORMATION AT A SINGLE GLANCE, ONLY THREE LINE PRESENTATION FORMATS WITH A MAXIMUM OF SIX MESSAGE PHASES WILL BE PERMITTED. NORMALLY, ONLY A MAXIMUM OF THREE MESSAGE PHASES SHOULD BE EMPLOYED. PCMS FORMAT SHALL PERMIT THE COMPLETE MESSAGE FOR EACH PHASE TO BE READ AT LEAST ONCE.

THE PCMS SHALL CONTAIN AN ACCURATE CLOCK AND PROGRAMMING LOGIC WHICH WILL ALLOW THE SIGN TO BE ACTIVATED, DEACTIVATED OR MESSAGES CHANGED AUTOMATICALLY AT DIFFERENT TIMES OF THE DAY FOR DIFFERENT DAYS OF THE WEEK.

THE PCMS SHALL CONTAIN A CELLULAR TELEPHONE DATA LINK WHICH WILL [IN ACTIVE CELLULAR AREAS] ALLOW REMOTE SIGN ACTIVATION, DEACTIVATION, MESSAGE CHANGES, MESSAGE ADDITIONS AND REVISIONS TO TIME OF DAY PROGRAMS. THE SYSTEM SHALL ALSO PERMIT VERIFICATION OF CURRENT AND PROGRAMMED MESSAGES.

THE PCMS UNIT SHALL BE MAINTAINED IN GOOD WORKING ORDER BY THE CONTRACTOR IN ACCORDANCE WITH THE PROVISIONS OF 614. THE CONTRACTOR SHALL PRIOR TO ACTIVATING THE UNIT, MAKE ARRANGEMENTS WITH AN AUTHORIZED SERVICE AGENT FOR THE PCMS TO ASSURE PROMPT SERVICE IN THE EVENT OF FAILURE. ANY FAILURE SHALL NOT RESULT IN THE SIGN BEING OUT OF SERVICE FOR MORE THAN 12 HOURS INCLUDING WEEKENDS. FAILURE TO COMPLY MAY RESULT IN AN ORDER TO STOP WORK AND OPEN ALL TRAFFIC LANES AND/OR IN THE DEPARTMENT TAKING APPROPRIATE ACTION TO SAFELY CONTROL TRAFFIC AND THE ENTIRE COST TO CONTROL TRAFFIC ACCRUED BY THE DEPARTMENT WILL BE DEDUCTED FROM MONEYS DUE, OR TO BECOME DUE THE CONTRACTOR ON HIS CONTRACT.

THE CONTRACTOR SHALL BE RESPONSIBLE FOR 24 HOURS PER DAY OPERATION AND MAINTENANCE OF THESE SIGNS ON THE PROJECT FOR THE DURATION OF THE PHASES. THE REQUIREMENT TO FURNISH, INSTALL, MAINTAIN AND REMOVE A PCMS UNIT ON THIS PROJECT SHALL NOT IN ANY WAY RELIEVE THE CONTRACTOR OF HIS RESPONSIBILITIES AS OUTLINED IN 614.02.

PAYMENT FOR THE ABOVE DESCRIBED ITEM SHALL BE AT THE CONTRACT UNIT PRICE BID FOR EACH SIGN MONTH OF ITEM 614 PORTABLE CHANGEABLE MESSAGE SIGN, AS PER PLAN AND SHALL INCLUDE ALL LABOR, MATERIALS, EQUIPMENT, FUELS, LUBRICATING OILS, SOFTWARE, HARDWARE AND INCIDENTALS TO PERFORM THE ABOVE DESCRIBED WORK.

ITEM 614 PORTABLE CHANGEABLE MESSAGE SIGN, AS PER PLAN
4 SIGN MONTH

ITEM 614 - LAW ENFORCEMENT OFFICER (WITH PATROL CAR)

IN ADDITION TO THE REQUIREMENTS OF 614 AND THE LATEST EDITION OF THE OHIO MANUAL OF UNIFORM TRAFFIC CONTROL DEVICES (OMUTCD), A UNIFORMED LAW ENFORCEMENT OFFICER (AND OFFICIAL PATROL CAR WITH WORKING TOP MOUNTED EMERGENCY FLASHING LIGHTS) SHALL BE PROVIDED FOR CONTROLLING TRAFFIC FOR THE FOLLOWING TASKS:

FOR LANE CLOSURES: DURING INITIAL SET-UP PERIODS, TEAR-DOWN PERIODS, SUBSTANTIAL SHIFTS OF A CLOSURE POINT, OR WHEN NEW LANE CLOSURE ARRANGEMENTS ARE INITIATED.

LAW ENFORCEMENT OFFICERS (LEO'S) SHOULD NOT BE USED WHERE THE OMUTCD INTENDS THAT FLAGGERS BE USED. THE LEO'S ARE CONSIDERED TO BE EMPLOYED BY THE CONTRACTOR AND THE CONTRACTOR SHALL BE RESPONSIBLE FOR THEIR ACTIONS. ALTHOUGH THEY ARE EMPLOYED BY THE CONTRACTOR, THE PROJECT ENGINEER SHALL HAVE CONTROL OVER THEIR PLACEMENT. THE OFFICIAL CAR SHALL BE A PUBLIC SAFETY VEHICLE AS REQUIRED BY THE OHIO REVISED CODE.

THE CONTRACTOR SHALL MAKE ARRANGEMENTS FOR THESE SERVICES WITH:

CANTON PATROL POST
4710 SHUFFEL ROAD
NORTH CANTON, OHIO 44720
PHONE: 330-433-6200

IF AFTER CONTACTING THE OHIO HIGHWAY PATROL, IT IS DETERMINED THAT THEY CANNOT SUPPLY THE LEO, THEN AN AUTHORIZED MUNICIPAL OR COUNTY POLICE OFFICER WITH A MARKED AND FLASHER-LIGHT EQUIPPED OFFICIAL POLICE OR PATROL CAR SHALL BE PROVIDED.

LAW ENFORCEMENT OFFICERS (WITH PATROL CAR) REQUIRED BY THE TRAFFIC MAINTENANCE TASKS ABOVE SHALL BE PAID FOR ON A UNIT PRICE (HOURLY) BASIS UNDER ITEM 614 - LAW ENFORCEMENT OFFICER (WITH PATROL CAR). THE FOLLOWING ESTIMATED QUANTITY HAS BEEN CARRIED TO THE GENERAL SUMMARY:

ITEM 614 - LAW ENFORCEMENT OFFICER WITH PATROL CAR 400 HOURS

THE HOURS PAID SHALL INCLUDE MINIMUM SHOW-UP TIME REQUIRED BY THE LAW ENFORCEMENT AGENCY INVOLVED.

IF THE CONTRACTOR WISHES TO UTILIZE LEO'S FOR FLAGGING AND TRAFFIC CONTROL OTHER THAN FOR THAT REQUIRED IN THESE PLANS, HE MAY DO SO AT HIS OWN EXPENSE. PAYMENT FOR THE EXCESS ABOVE CONTRACT REQUIREMENTS WILL BE INCLUDED UNDER ITEM 614 MAINTAINING TRAFFIC.

LOOP DETECTOR REPLACEMENT

THE CONTRACTOR SHALL CONTACT THE DISTRICT OFFICE (330-297-0801 EXT 386) THREE WORKING DAYS PRIOR TO ANY PLANING OR TRENCHING AT THE INTERSECTIONS/LOCATIONS LISTED BELOW. LOOP DETECTORS DISTURBED BY PAVEMENT PLANING OR TRENCHING SHALL BE ABANDONED IN PLACE. THE LOOP DETECTOR WIRE WILL BE CUT INTO THE PAVEMENT AFTER THE PROPOSED SURFACE COURSE HAS BEEN PLACED. EACH DETECTOR SHALL BE REPLACED IN KIND, AT THE SAME LOCATION AS EXISTING. THE QUANTITIES LISTED BELOW HAVE BEEN CARRIED TO THE GENERAL SUMMARY. THE NEW LOOP DETECTOR WIRES SHALL BE RUN INTO THE EXISTING CONTROL BOX OR THE EXISTING PULLBOX. INCLUDED IN THIS ITEM IS THE POURED EPOXY TYPE CABLE SPLICE KIT CONFORMING TO 725.15 THAT MUST BE USED IN MAKING THESE CONNECTIONS.

ALL NECESSARY MATERIAL, LABOR, SPLICE KITS AND EQUIPMENT SHALL BE INCIDENTAL TO PAYMENT OF THESE ITEMS.

ITEM 632 DETECTOR LOOP 28 EACH

US-30 EASTBOUND, EXIT RAMP R
AND HARRISON: 1 EACH, 8' x 24'; 1 EACH, 9' x 25'

US-30 EASTBOUND MAINLINE,
SLM 13.81 (ATR 756): 6 EACH, 6' x 8'

US-30 EASTBOUND MAINLINE,
SLM 16.25 (ATR 556): 6 EACH, 6' x 8'

US-30 WESTBOUND MAINLINE,
SLM 13.81 (ATR 756): 6 EACH, 6' x 8'

US-30 WESTBOUND MAINLINE,
SLM 16.25 (ATR 556): 6 EACH, 6' x 8'

US-30 WESTBOUND, EXIT RAMP O
AND RAFF: 1 EACH, 6' x 8'; 1 EACH, 9' x 20'

I:\Projects\23759\23759mm.dgn 14-MAY-2003 8:58AM cflbertio

CALCULATED
M J H
CHECKED
M J H

MAINTENANCE OF TRAFFIC GENERAL NOTES

STA - 30-13.10

8
32

GENERAL NOTES

1. It is intended that this drawing be used for treatment of drop-offs that develop during construction operations, and that are not otherwise provided for in the construction plans. Where the plans do not provide specific items for labor, equipment, or materials to implement the drop-off treatments specified herein, they shall be included for payment in the lump sum bid for Item 614 - Maintaining Traffic.

2. While the need for certain advisory signing is noted herein, it is not intended that this be indicative of all signing that may be required to advise or warn motorist, and all requirements of the Ohio Manual of Uniform Traffic Control Devices (OMUTCD) must be fulfilled.

3. In urban or otherwise heavily developed areas where pedestrians and/or bicyclists may be present in significant numbers, additional signing and protective measures other than those shown herein may be required.

4. The drop-off treatment selected for use at any given location shall be appropriate for the prevailing conditions at the site.

5. Where concrete barrier is specified, it shall be in accordance with Standard Construction Drawing RM-4.2 and Item 622.

6. When drums are specified for a drop-off condition, a minimum number of four drums shall be used. Spacing shall be as indicated in the plans or as specified in the OMUTCD.

7. When OW-151 (Low Shoulder) signs or OW-171 (Uneven Lanes symbol), OWP-171 (uneven lane plaque), and OC-53 (Maintain Present Lane) signs are required, they shall be placed 750' in advance of the condition, on all intersecting entrance ramps within the limits of the condition and immediately beyond all intersecting roadways within the limits of the condition. When the drop-off condition extends more than one-half mile, additional signs shall be erected at intervals of a maximum of one mile.

8. For locations, such as at ramps, lane shifts, lane closures, etc., where traffic is required to negotiate any difference in elevation between pavements, the Optional Wedge Treatment shall be provided.

9. Portable concrete barrier shall be placed on the same level as the traffic surface and shall not encroach on lane width(s) designated as the minimum required for traffic use. Where drums are used, and their presence would reduce traveled lane widths to less than 10', drums may be placed on the opposite level from that of traffic provided the drop-off depth does not exceed 5" and approval is granted by the Project Engineer.

10. Pavement Repairs (or similar work):

a. Lengths greater than 60 feet - utilize appropriate treatment from Condition 1.

b. Lengths of 60 feet or less - repairs shall be affected in accordance with Item 255.08. Drums may be used as a separator adjacent to the traveled lane.

CONDITION 1

1. These treatments are to be used for resurfacing, pavement planing excavation, etc., between, beside or within traveled lanes.

Distance From Traveled Lane	D (in)	Treatment
1FT-12FT	$\leq 1\frac{1}{2}$	Erect OW-171, AND OWP-171.
1FT-12FT	$>1\frac{1}{2}-3$	1. Lane closure utilizing drums* as shown below. (use only on 3 or more lanes) - or - 2. Optional Wedge Treatment.
1FT-12FT	3 - 5	Lane closure utilizing drums as shown below
1FT-12FT	5 - 12	Lane closure utilizing portable concrete barrier as shown below.
>12FT-20FT	12 - 24	Lane closure utilizing drums as shown below
>12FT-20FT	>24	Lane closure utilizing portable concrete barrier as shown below.

*Cones may be used for daytime only conditions.

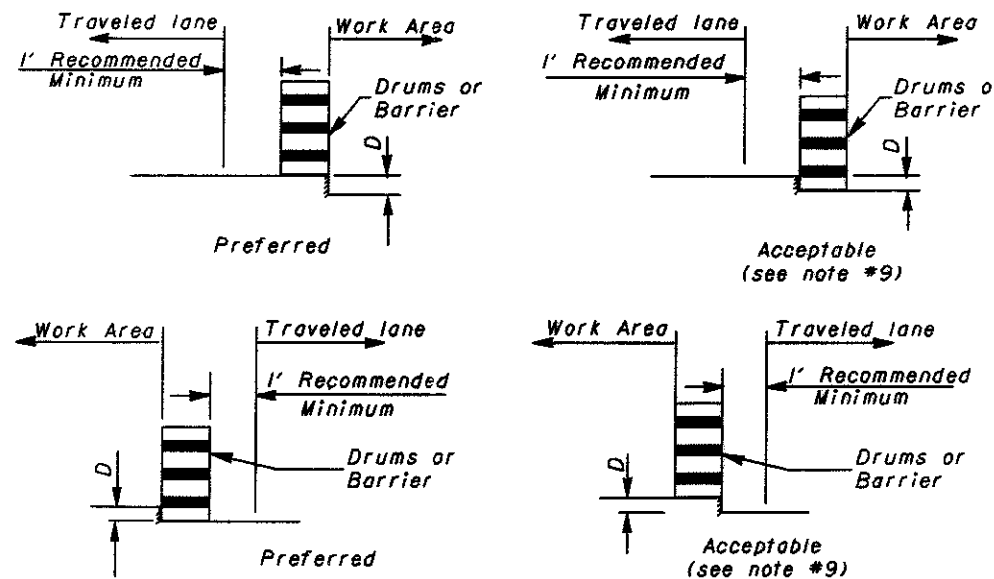

OPTIONAL WEDGE TREATMENT

(MILLING OR RESURFACING)

1. This treatment may be used when permitted for Condition 1 only.
2. OW-171, OWP-171, and OC-53 signs required.

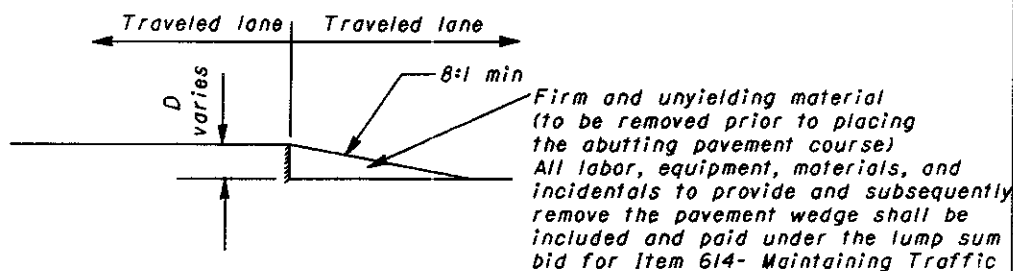

CONDITION II

DROPOFFS WITHIN GRADED SHOULDER AREA
[except for linear grading areas]

The treatments indicated below are for use in conjunction with resurfacing, planing, or excavation within the graded shoulder area.

Distance From Traveled Lane	D (in)	Treatment
1FT-12FT	$\leq 1\frac{1}{2}$	1.) If edgelines are present, no treatment necessary. or 2.) Erect OW-171, OWP-171, and OC-53 signs
1FT-12FT	$>1\frac{1}{2}-5$	1) If min. lane widths* requirements can be met, maintain lanes utilizing drums as shown below. - or - 2) If min. lane width* requirements cannot be met, close adjacent lane utilizing drums. (use only on 3 or more lanes) - or - 3) Optional shoulder treatment
>12FT-30FT	≤ 24	Shoulder closure utilizing drums as shown below
>12FT-30FT	>24	Shoulder closure utilizing portable concrete barrier as shown below.

*Minimum lane widths shall be 10' unless otherwise specified in the plans.

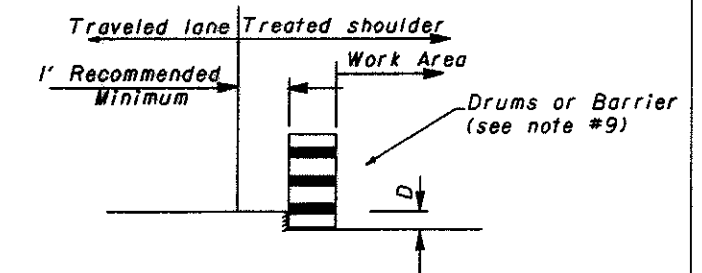

OPTIONAL SHOULDER TREATMENT

1. This treatment shall not be used within a bituminous shoulder where a hot longitudinal joint per 401.15 is required.
2. OW-151 signs required.

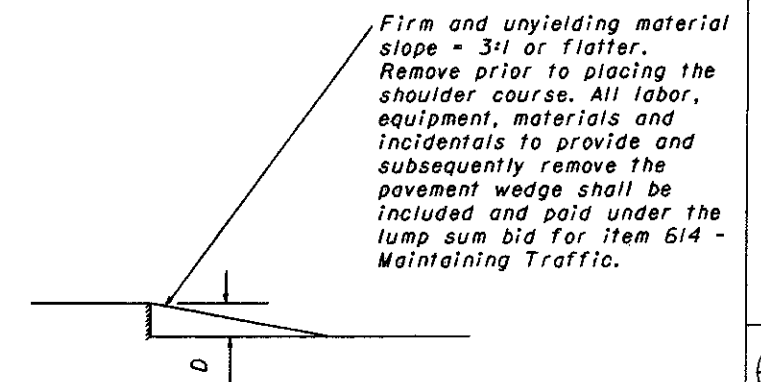

SHEET NUMBER										ITEM	ITEM EXT.	GRAND TOTAL	UNIT	DESCRIPTION	SEE SHEET NO.
4	5	12	13	14	15	16	17	31							
ROADWAY															
							76			202	35200	76	FT	PIPE REMOVED, OVER 24"	
100						50				203	10000	150	CU YD	EXCAVATION	
	75									606	13001	75	FT	GUARDRAIL, TYPE 5, AS PER PLAN	5
	2									606	26501	2	EACH	ANCHOR ASSEMBLY, TYPE T, AS PER PLAN	5
	5									606	60021	5	EACH	IMPACT ATTENUATOR, TYPE 2-98, [(QS9006Y),(UNIDIRECTIONAL)], AS PER PLAN	5
	1									606	60021	1	EACH	IMPACT ATTENUATOR, TYPE 2-98, [(QS6906Y),(UNIDIRECTIONAL)], AS PER PLAN	5
	2									606	98100	2	EACH	GUARDRAIL, MISC.: ANCHOR ASSEMBLY REBUILT, TYPE E	5
	6									606	60600	6	EACH	QUADGARD WHEEL DEFLECTOR ASSEMBLY	
DRAINAGE															
							76			603	19400	76	FT	42" CONDUIT, TYPE B, 706.02	
60										605	11100	60	FT	6" SHALLOW PIPE UNDERDRAINS	
						75				605	31100	75	FT	AGGREGATE DRAINS	
	184									613	41300	184	CU YD	LOW STRENGTH MORTAR BACKFILL (TYPE 2)	
PAVEMENT															
						750				251	01002	750	CU YD	PARTIAL DEPTH PAVEMENT REPAIR	
						150				253	02000	150	CU YD	PAVEMENT REPAIR	
		89651	59058	77911	42367					254	01000	268,987	SO YD	PAVEMENT PLANING, ASPHALT CONCRETE	
13										301	46010	13	CU YD	ASPHALT CONCRETE BASE, PG64-28	
7						50				304	20000	57	CU YD	AGGREGATE BASE	
1		6729	4436	5849	4623					407	10000	21637	GALLON	TACK COAT	
		13452	1736	11691	3820					407	14000	30699	GALLON	TACK COAT FOR INTERMEDIATE COURSE	
		3739	2468	3252	1772					442	10051	11231	CU YD	ASPHALT CONCRETE SURFACE COURSE, 12.5 MM, TYPE B (446),PG70-22M, AS PER PLAN	4
		4367	565	3793	1241					442	10150	9966	CU YD	ASPHALT CONCRETE INTERMEDIATE COURSE, 19MM, TYPE B (446),PG64-28	
		209	444	181	217					617	10101	1051	CU YD	COMPACTED AGGREGATE, TYPE A, AS PER PLAN	4
		5.62	0.66	4.68	1.52					618	40600	12.48	MILE	RUMBLE STRIPS, TYPE 2 (ASPHALT CONCRETE)	
LIGHTING															
							33			631	84000	33	EACH	SIGN SERVICE	
							62			631	84300	62	EACH	SIGN WIRED	
							33			631	85100	33	EACH	DISCONNECT SWITCH WITH ENCLOSURE, TYPE X	
							2			631	87102	2	EACH	BALLAST, TYPE CMRI-100-480	
							73			631	87202	73	EACH	BALLAST, TYPE CMRI-175-480	
							36			631	87302	36	EACH	BALLAST, TYPE CMRI-250-480	
							2			631	89100	2	EACH	MERCURY VAPOR LUMINAIRE, TYPE TC-31.21 WITH 100 WATT LAMP	
							73			631	89200	73	EACH	MERCURY VAPOR LUMINAIRE, TYPE TC-31.21 WITH 175 WATT LAMP	
							36			631	89300	36	EACH	MERCURY VAPOR LUMINAIRE, TYPE TC-31.21 WITH 250 WATT LAMP	
							111			631	94200	111	EACH	REMOVAL OF LUMINAIRE AND DISPOSAL	
							62			631	94406	62	EACH	REMOVAL OF SIGNS WIRED	
							62			631	94408	62	EACH	REMOVAL OF SIGN WIRING AND DISPOSAL	
							33			631	94412	33	EACH	REMOVAL OF SIGN SERVICE AND DISPOSAL	

GENERAL SUMMARY

STA-30-13.10

SHEET NUMBER						ITEM	ITEM EXT.	GRAND TOTAL	UNIT	DESCRIPTION	SEE SHEET NO.
4	6	7	8	18	30						
						TRAFFIC SURVEILLANCE					
					313.50	630	03100	313.50	FT	GROUND MOUNTED SUPPORT, NO. 3 POST	
					304.56	630	80102	304.56	SO FT	SIGN, FLAT SHEET, TYPE G	
					8019.50	630	80224	8019.50	SO FT	SIGN, OVERHEAD EXTRUSHEET, TYPE G	
					18	630	84900	18	EACH	REMOVAL OF GROUND MOUNTED SIGN AND DISPOSAL	
					6	630	86002	6	EACH	REMOVAL OF GROUND MOUNTED POST SUPPORT AND DISPOSAL	
					2	630	86310	2	EACH	REMOVAL OF STRUCTURE MOUNTED SIGN AND DISPOSAL	
					61	630	87400	61	EACH	REMOVAL OF OVERHEAD MOUNTED SIGN AND DISPOSAL	
						TRAFFIC CONTROL					
				17.18		646	10000	17.18	MILE	EDGE LINE	
				11.0		646	10100	11.0	MILE	LANE LINE	
				2478		646	10300	2478	LIN FT	CHANNELIZING LINE	
				136		646	10400	136	LIN FT	STOP LINE	
				528		646	10500	528	FT	CROSSWALK LINE, 12"	
				1022		646	10600	1022	LIN FT	TRANSVERSE LINE	
				4		646	20300	4	EACH	LANE ARROW	
				2		646	20410	2	EACH	WORD ON PAVEMENT, 96"	
						STRUCTURES					
						503	21100	158	CU YD	UNCLASSIFIED EXCAVATION	
						MAINTENANCE OF TRAFFIC					
	400					614	11100	400	HOUR	LAW ENFORCEMENT OFFICER WITH PATROL CAR	7
20						614	12460	20	EACH	WORK ZONE MARKING SIGN	
20						614	13000	20	CU YD	ASPHALT CONCRETE FOR MAINTAINING TRAFFIC	
	4					614	18601	4	SIGN MNTH	PORTABLE CHANGEABLE MESSAGE SIGN, AS PER PLAN	7
33.0						614	20000	9.54	MILE	WORK ZONE LANE LINE, CLASS 1	
7434						614	23000	8453	LIN FT	WORK ZONE CHANNELIZING LINE, CLASS 1	
408						614	26000	107	LIN. FT.	WORK ZONE STOP LINE, CLASS 1	
						614	11000	LUMP		MAINTAINING TRAFFIC	
						623	10000	LUMP		CONSTRUCTION LAYOUT STAKES	
						624	10000	LUMP		MOBILIZATION	
						619	16010	10	MONTH	FIELD OFFICE, TYPE B	

GENERAL SUMMARY

STA-30-13.10

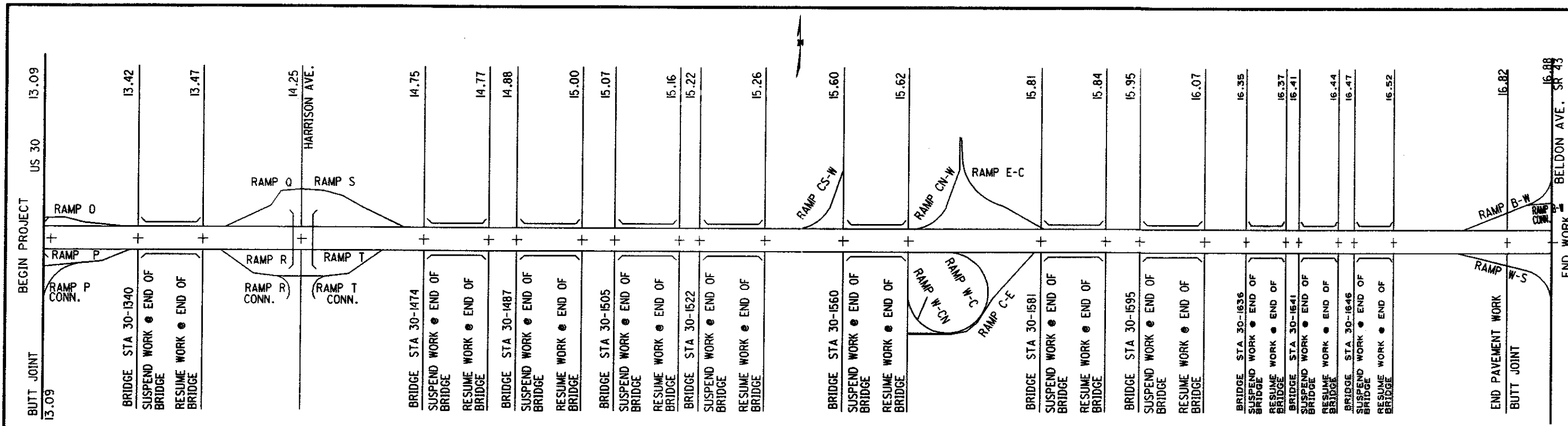

US - 30 EASTBOUND

** NOTE: PAVEMENT AREAS ARE TAKEN FROM THE ORIGINAL PLANS.

NO SCALE

PAVEMENT DATA

NOI-TACOL	ROUTE (E/B)	LOG POINT TO LOG POINT	LENGTH		WP FEET (AVG.)	TYPICAL #	SHOULDER WIDTH FEET (RT<)	EXISTING TYPE PAVEMENT	PAVEMENT AREA ** SQ. YDS.	ITEM 442 ASPHALT CONCRETE				254 PAVEMENT PLANING, BITUMINOUS 3.00 IN. AVG. ** SQ. YD.	617 COMPACTED AGGREGATE TYPE A, AS PER PLAN (2.00") (AVG.) CU. YD.	618 RUMBLE STRIPS TYPE 2, (ASPHALT) MILE		
			MILES	LIN. FT.						407 TACK COAT @ 0.075 gal./s.y. GAL.	407 TACK COAT FOR INTERMEDIATE COURSE @ 0.15 gal./s.y. GAL.	442 ASPHALT CONCRETE INTERMEDIATE COURSE, 19mm TYPE B (446), PG64-28					442 ASPHALT CONCRETE SURFACE COURSE, 12.5 mm, TYPE B (446), PG70-22M, AS PER PLAN	
												AVG. THICK INCHES 1.75"	CU. YD.				AVG. THICK INCHES 1.50"	CU. YD.
I	US 30	13.09 - 13.36	0.27	1415	24	A	12	ASPHALT	5660	425	849		276		236	5660	35	0.54
I	US 30	13.36 - 13.42	0.06	318	42	A	13	ASPHALT	1922	144	288		94		80	1922	8	0.12
I	US 30	13.47 - 13.90	0.43	2275	36	B	14	ASPHALT	12704	953	1906		618		530	12704	28	0.86
I	US 30	13.90 - 14.04	0.14	742	62	B	14	ASPHALT	6218	467	933		303		259	6218	9	0.28
I	US 30	14.04 - 14.40	0.36	1879	36	B	14	ASPHALT	10435	783	1566		508		435	10435	23	0.72
I	US 30	14.40 - 14.50	0.10	520	55	B	14	ASPHALT	3958	297	594		193		165	3958	7	0.20
I	US 30	14.50 - 14.75	0.25	1324	57	B	14	ASPHALT	10441	783	1566		508		435	10441	17	0.50
I	US 30	14.77 - 14.88	0.11	596	24	B	14	ASPHALT	2516	189	378		123		105	2516	8	0.22
I	US 30	15.00 - 15.07	0.07	395	24	B	14	ASPHALT	1669	125	250		82		70	1669	5	0.14
I	US 30	15.16 - 15.22	0.06	310	36	B	14	ASPHALT	1723	130	259		84		72	1723	4	0.12
I	US 30	15.26 - 15.35	0.09	459	57	B	14	ASPHALT	3667	275	550		179		153	3667	6	0.18
I	US 30	15.35 - 15.60	0.25	1306	49	B	14	ASPHALT	9140	686	1371		445		381	9140	16	0.50
I	US 30	15.62 - 15.67	0.05	267	62	B	14	ASPHALT	2237	168	336		109		94	2237	4	0.10
I	US 30	15.67 - 15.81	0.14	744	36	B	14	ASPHALT	4129	310	620		201		172	4129	10	0.28
I	US 30	15.84 - 15.95	0.11	557	49	B	14	ASPHALT	3863	290	580		188		161	3863	7	0.22
I	US 30	16.07 - 16.35	0.28	1487	36	B	14	ASPHALT	8259	620	1239		402		344	8259	19	0.56
I	US 30	16.37 - 16.41	0.04	200	36	B	14	ASPHALT	1110	84	167		54		47	1110	3	0.08
	TOTAL US 30 - THIS SHEET		2.81	14794					89651	6729	13452		4367		3739	89651	209	5.62

PLAN NO. 12
 STA-30-13.10 32
 ASPHALT CONCRETE
 CALCULATED C.J.T. CHECKED D.Y.

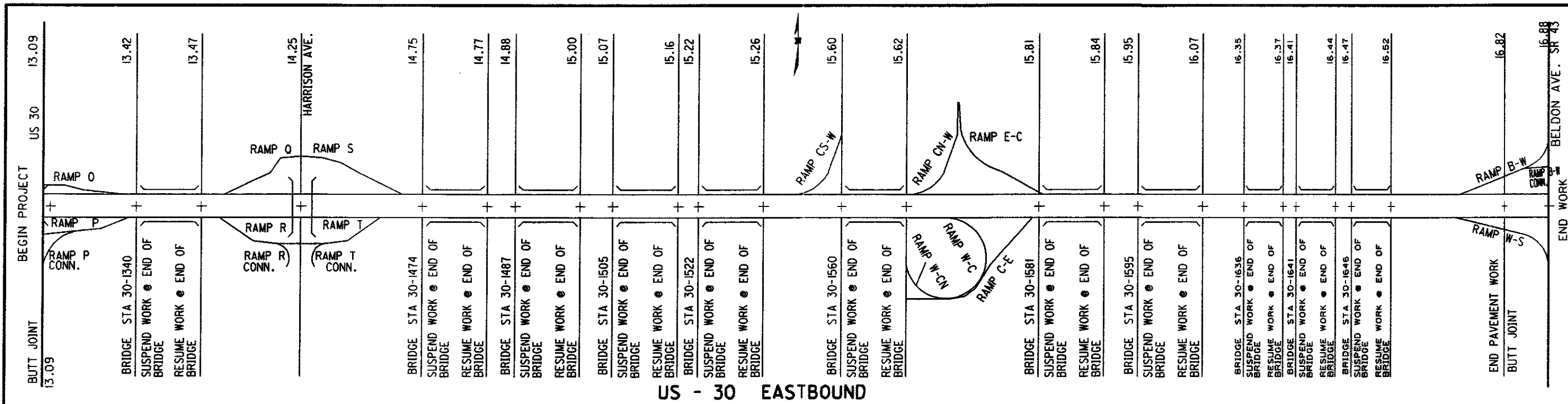

US - 30 EASTBOUND

** NOTE: PAVEMENT AREAS ARE TAKEN FROM THE ORIGINAL PLANS.

NO SCALE

PAVEMENT DATA

NO.	ROUTE	LOG POINT TO LOG POINT	LENGTH		WP FEET (AVG.)	TYPICAL #	SHOULDER WIDTH FEET (RT<)	EXISTING TYPE PAVEMENT	PAVEMENT AREA ** SQ.YDS.	407		ITEM 442 ASPHALT CONCRETE				254		617		618	
			MILES	LIN. FT.						TACK COAT @ 0.075 gal./s.y.	TACK COAT FOR INTERMEDIATE COURSE @ 0.15 gal./s.y.	442 ASPHALT CONCRETE INTERMEDIATE COURSE, 19mm TYPE B (446), PG64-28		442 ASPHALT CONCRETE SURFACE COURSE, 12.5 mm, TYPE B (446), PG70-22M, AS PER PLAN		PAVEMENT PLANING, BITUMINOUS 1.50 IN. AVG. ** SQ.YD.	PAVEMENT PLANING, BITUMINOUS 3.00 IN. AVG. ** SQ.YD.	COMPACTED AGGREGATE TYPE A, AS PER PLAN (2.00") (AVG.) CU.YD.	RUMBLE STRIPS TYPE 2, (ASPHALT) MILE		
												AVG. THICK INCHES 1.75"	CU. YD.	AVG. THICK INCHES 1.50"	CU. YD.						
I	US 30	16.44 - 16.47	0.03	144	36	B	14	ASPHALT	797	60	120		39	34		797	2	0.06			
I	US 30	16.52 - 16.58	0.06	296	36	B	14	ASPHALT	1645	124	247		80	69		1645	4	0.12			
I	US 30	16.58 - 16.60	0.02	100	42	B	14	ASPHALT	623	47	94		31	26		623	2	0.04			
I	US 30	16.60 - 16.73	0.13	700	62	B	14	ASPHALT	5873	441	881		286	245		5873	9	0.26			
I	US 30	16.73 - 16.82	0.09	461	36	B	14	ASPHALT	2562	192	384		125	107		2562	6	0.18			
I	US 30	EXTRA AREA	0.02	100	6			ASPHALT	67	5	10		4	3		67	2				
I	US 30	TOTAL RAMP "P"	0.45	2396	16	B	6	ASPHALT	5128	385				214	5128		60				
I	US 30	TOTAL RAMP "R"	0.33	1731	16	B	6	ASPHALT	4606	346				192	4606		43				
I	US 30	TOTAL RAMP "T"	0.20	1048	16	B	6	ASPHALT	3328	250				139	3328		26				
I	US 30	TOTAL RAMP "W-C"	0.20	1056	24	B	6	ASPHALT	3418	257				143	3418		26				
I	US 30	TOTAL RAMP "C-E"	0.21	1119	16	B	6	ASPHALT	2744	206				115	2744		28				
I	US 30	TOTAL RAMP "W-S"	0.17	919	16	B	6	ASPHALT	2185	164				91	2185		23				
I	US 30	E/B TO I 77 S/B	0.17	921	16	B	10	ASPHALT	2792	210				117	2792		25				
I	US 30	E/B TO I 77 N/B	0.22	1173	18	B	10	ASPHALT	3307	248				138	3307		31				
I	US 30	E/B FROM I 77 S/B	0.14	728	16	B	10	ASPHALT	2121	159				89	2121		20				
I	US 30	E/B FROM I 77 N/B	0.25	1332	16	B	10	ASPHALT	3847	289				161	3847		36				
I	US 30	W/B FROM I 77 N/B	0.18	931	18	B	10	ASPHALT	2896	218				121	2896		25				
I	US 30	W/B TO I 77 N/B	0.13	691	30	B	10	ASPHALT	3071	231				128	3071		18				
I	US 30	W/B TO I 77 S/B	0.18	972	16	B	10	ASPHALT	3519	264				147	3519		26				
I	US 30	W/B FROM I 77 S/B	0.23	1195	16	B	10	ASPHALT	4529	340				189	4529		32				
TOTAL US 30 - THIS SHEET			3.41	18013					59058	4436	1736		565	2468	47491	11567	444	0.66			

CALCULATED BY CJT
 CHECKED BY DY
 PLAN NO.
ASPHALT CONCRETE
 STA-30-13.10
 13
 32

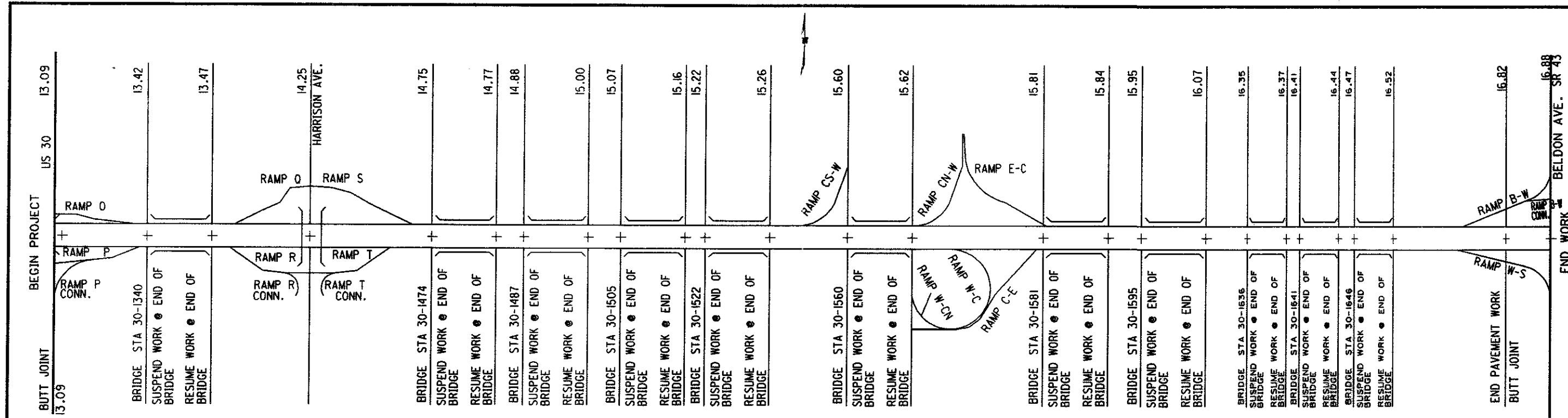

US - 30 WESTBOUND

** NOTE: PAVEMENT AREAS ARE TAKEN FROM THE ORIGINAL PLANS.

NO SCALE

PAVEMENT DATA

LOCATION	ROUTE (W/B)	LOG POINT TO LOG POINT	LENGTH		WP FEET (AVG.)	TYPICAL #	SHOULDER WIDTH FEET (RT<)	EXISTING TYPE PAVEMENT	PAVEMENT AREA ** SQ.YDS.	407	407	ITEM 442 ASPHALT CONCRETE				254	617	618
			TACK COAT ● 0.075 gal./s.y.	TACK COAT FOR INTERMEDIATE COURSE ● 0.15 gal./s.y.						442 ASPHALT CONCRETE INTERMEDIATE COURSE, 19mm TYPE B (446), PG64-28		442 ASPHALT CONCRETE SURFACE COURSE, 12.5 mm, TYPE B (446), PG70-22M, AS PER PLAN		PAVEMENT PLANING, BITUMINOUS 3.00 IN. AVG. ** SQ.YD.	COMPACTED AGGREGATE TYPE A, AS PER PLAN (2.00") (AVG.) CU.YD.	RUMBLE STRIPS TYPE 2, (ASPHALT) MILE		
			GAL.	GAL.						AVG. THICK INCHES 1.75"	CU. YD.	AVG. THICK INCHES 1.50"	CU.YD.					
I	US 30	13.09 - 13.31	0.22	1168	24	A	12	ASPHALT	4671	351	701		227	195	4671	29	0.44	
I	US 30	13.31 - 13.41	0.10	540	47	A	13	ASPHALT	3570	268	536		174	149	3570	14	0.20	
I	US 30	13.47 - 14.08	0.61	3244	36	B	14	ASPHALT	19412	1456	2912		944	809	19412	40	1.22	
I	US 30	14.08 - 14.12	0.04	232	42	B	14	ASPHALT	1444	109	217		71	61	1444	3	0.08	
I	US 30	14.12 - 14.39	0.27	1448	36	B	14	ASPHALT	8041	603	1206		391	335	8041	18	0.54	
I	US 30	14.39 - 14.44	0.05	271	62	B	14	ASPHALT	2271	171	341		111	95	2271	4	0.10	
I	US 30	14.44 - 14.75	0.29	1543	56	B	14	ASPHALT	11915	894	1788		580	497	11915	19	0.58	
I	US 30	14.77 - 14.88	0.11	596	36	B	14	ASPHALT	3311	249	497		161	138	3311	8	0.22	
I	US 30	15.00 - 15.02	0.02	93	62	B	14	ASPHALT	779	59	117		38	33	779	2	0.04	
I	US 30	15.02 - 15.07	0.05	303	36	B	14	ASPHALT	1680	126	252		82	70	1680	4	0.10	
I	US 30	15.17 - 15.22	0.05	285	36	B	14	ASPHALT	1584	119	238		77	66	1584	4	0.10	
I	US 30	15.26 - 15.45	0.19	1011	60	B	14	ASPHALT	8311	624	1247		404	347	8311	13	0.38	
I	US 30	15.45 - 15.47	0.02	100	61	B	14	ASPHALT	828	62	124		41	35	828	2	0.04	
I	US 30	15.47 - 15.60	0.13	654	42	B	14	ASPHALT	4065	305	610		198	170	4065	8	0.26	
I	US 30	15.62 - 15.65	0.03	172	55	B	14	ASPHALT	1305	98	196		64	55	1305	2	0.06	
I	US 30	15.65 - 15.81	0.16	821	36	B	14	ASPHALT	4558	342	684		222	190	4558	10	0.32	
I	US 30	15.81 - 15.81	0.00	18	68	B	14	ASPHALT	166	13	25		8	7	166	1	0.03	
		TOTAL US 30 - THIS SHEET	2.34	12499					77911	5849	11691		3793	3252	77911	181	4.68	

ASPHALT CONCRETE

STA-30-13.10

PLAN NO.

CALCULATED
CJT
CHECKED
DY

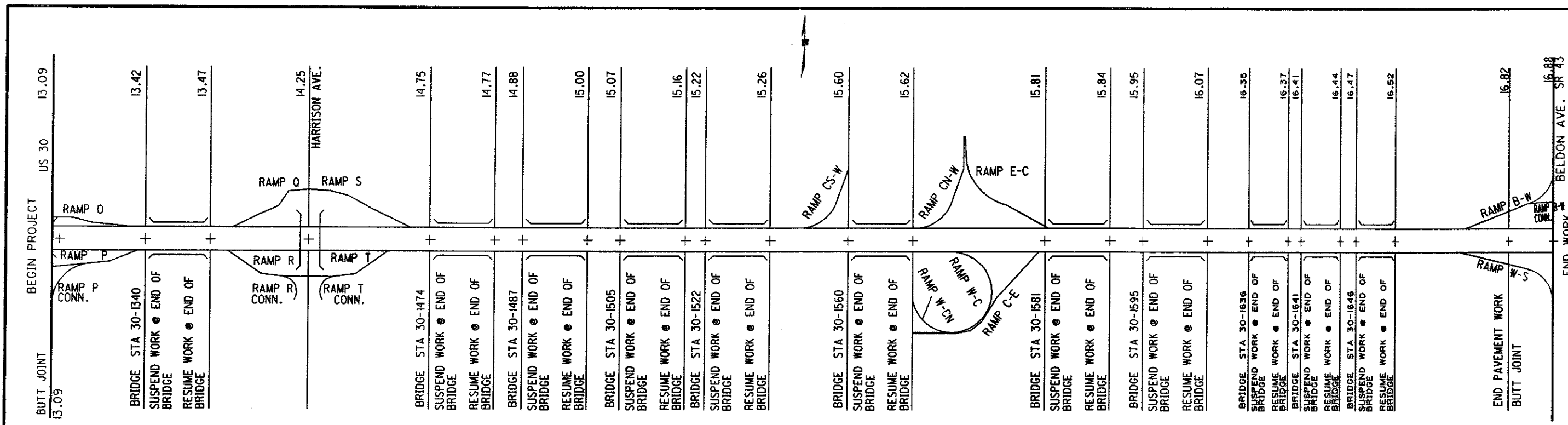

US - 30 WESTBOUND

** NOTE: PAVEMENT AREAS ARE TAKEN FROM THE ORIGINAL PLANS.

NO SCALE

PAVEMENT DATA

LOCATION	ROUTE (W/B)	LOG POINT TO LOG POINT	LENGTH		WP FEET (AVG.)	TYPICAL #	SHOULDER WIDTH FEET (RT<)	EXISTING TYPE PAVEMENT	PAVEMENT AREA ** SQ. YDS.	407		ITEM 442 ASPHALT CONCRETE				254		617		618	
			MILES	LIN. FT.						TACK COAT @ 0.075 gal./s.y.	TACK COAT FOR INTERMEDIATE COURSE @ 0.15 gal./s.y.	442 ASPHALT CONCRETE INTERMEDIATE COURSE, 19mm TYPE B (446), PG64-28		442 ASPHALT CONCRETE SURFACE COURSE, 12.5 mm, TYPE B (446), PG70-22M, AS PER PLAN		PAVEMENT PLANING, BITUMINOUS 1.50 IN. AVG. ** SQ. YD.	PAVEMENT PLANING, BITUMINOUS 3.00 IN. AVG. ** SQ. YD.	COMPACTED AGGREGATE TYPE A, AS PER PLAN (2.00") (AVG.) CU. YD.	RUMBLE STRIPS TYPE 2, (ASPHALT) MILE		
												AVG. THICK INCHES 1.75"	CU. YD.	AVG. THICK INCHES 1.50"	CU. YD.						
I	US 30	15.84 - 15.92	0.08	408	48	B	14	ASPHALT	2807	211	422		137		117		2807	5	0.16		
I	US 30	15.92 - 15.95	0.03	149	42	B	14	ASPHALT	926	70	139		45		39		926	2	0.06		
I	US 30	16.07 - 16.35	0.28	1487	36	B	14	ASPHALT	8259	620	1239		402		345		8259	19	0.56		
I	US 30	16.37 - 16.41	0.04	200	36	B	14	ASPHALT	1110	84	167		54		47		1110	3	0.08		
I	US 30	16.44 - 16.47	0.03	144	36	B	14	ASPHALT	797	60	120		39		34		797	2	0.06		
I	US 30	16.52 - 16.67	0.15	782	52	B	14	ASPHALT	5687	427	853		277		237		5687	10	0.30		
I	US 30	16.67 - 16.71	0.04	220	43	B	14	ASPHALT	1389	104	208		68		58		1389	3	0.08		
I	US 30	16.71 - 16.82	0.11	557	36	B	14	ASPHALT	3091	232	464		151		129		3091	7	0.22		
I	US 30	EXTRA AREA	0.61	1000	13			ASPHALT	1389	104	208		68		58		1389	13			
I	US 30	TOTAL RAMP "O"	0.22	1182	16	B	6	ASPHALT	3445	259					144	3445		30			
I	US 30	TOTAL RAMP "Q"	0.16	840	16	B	6	ASPHALT	2178	164					91	2178		21			
I	US 30	TOTAL RAMP "S"	0.16	823	20	B	6	ASPHALT	2543	191					106	2543		21			
I	US 30	TOTAL RAMP "CS-W"	0.13	664	16	B	6	ASPHALT	1715	129					72	1715		17			
I	US 30	TOTAL RAMP "CN-W"	0.14	736	16	B	6	ASPHALT	1828	137					77	1828		19			
I	US 30	TOTAL RAMP "E-C"	0.14	707	16	B	6	ASPHALT	1838	138					77	1838		18			
I	US 30	TOTAL RAMP "B-W"	0.21	1095	16	B	6	ASPHALT	3365	253					14	3365		27			
		TOTAL US 30 - THIS SHEET	2.53	10994					42367	4623	3820		1241		1772	16912	25455	217	1.52		

PLAN NO. **ASPHALT CONCRETE** STA-30-13.10
 CALCULATOR: CJT
 CHECKED: DY
 15
 32

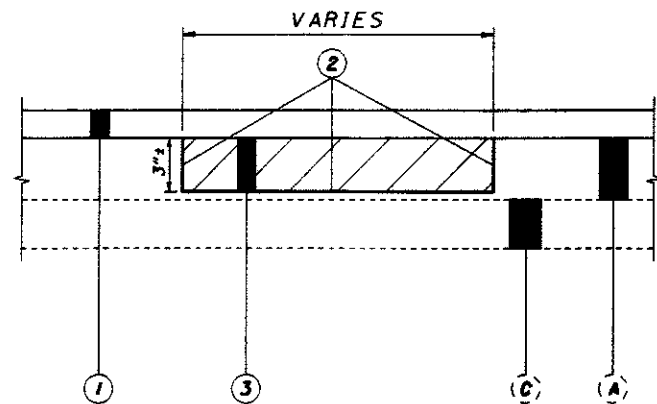

US 30

ITEM 251 PARTIAL DEPTH PAVEMENT REPAIR

A QUANTITY OF THIS ITEM SHALL BE PROVIDED FOR USE AS DIRECTED BY THE ENGINEER. THE ITEM SHALL CONSIST OF REPAIRING EXISTING LOCATIONS EXHIBITING SURFACE DETERIORATION AND PLACING 3.00"± OF ITEM 448 ASPHALT CONCRETE, TYPE I. THE ASPHALT CONCRETE SHALL BE COMPACTED WITH A TYPE I PNEUMATIC TIRE ROLLER AND A STEEL WHEEL ROLLER AS PER 401.11.

PAYMENT SHALL BE BASED ON THE ACTUAL NUMBER OF CUBIC YARDS OF PAVEMENT REPAIR.

ITEM 251 PARTIAL DEPTH PAVEMENT REPAIR

750 CU.YD.

LEGEND

- ① 448 PROPOSED OVERLAY
- ② 407 TACK COAT
- ②A 253 SAWING CUT
- ③ 251 3"± PARTIAL DEPTH PAVEMENT REPAIR
- ④ 253 12"± PAVEMENT REPAIR
- ⑤ 203 6" AVG. EXCAVATION NOT INCLUDING EMBANKMENT CONSTRUCTION
- ⑥ 304 6" AVG. AGGREGATE BASE
- (A) EXISTING ASPHALT PAVEMENT
- (B) EXISTING SUBBASE
- (C) EXISTING CONCRETE PAVEMENT

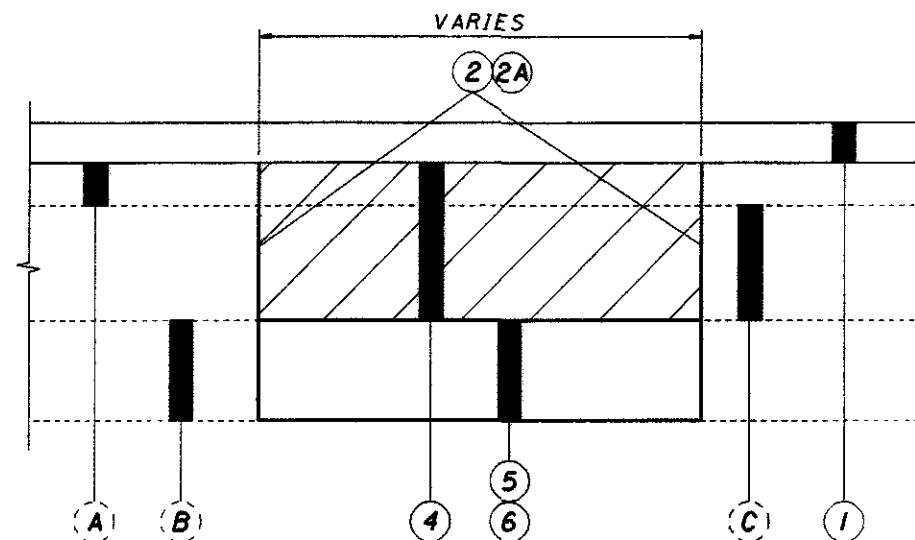

ITEM 253 PAVEMENT REPAIR:

A QUANTITY OF THIS ITEM SHALL BE PROVIDED FOR USE AS DIRECTED BY THE ENGINEER. THIS ITEM SHALL CONSIST OF REMOVING DETERIORATED PAVEMENT FULL DEPTH AND PLACING 12"± 301 BITUMINOUS AGGREGATE BASE. THE MAXIMUM COMPACTED DEPTH OF ANY ONE LAYER SHALL BE 6.00 INCHES.

PAYMENT SHALL BE BASED ON THE ACTUAL NUMBER OF CUBIC YARDS OF PAVEMENT REMOVED AND REPLACED TO THE LIMITS DESIGNATED BY THE ENGINEER. THE FOLLOWING ESTIMATED QUANTITY HAS BEEN CARRIED TO THE GENERAL SUMMARY.

ITEM 253 PAVEMENT REPAIR

150 CU. YDS.

ITEM 203 EXCAVATION

THIS ITEM OF WORK SHALL CONSIST OF REMOVING AND DISPOSING OF ALL UNSUITABLE MATERIAL BY EXCAVATING THE EXISTING SUBGRADE AND SUBBASE TO AN AVERAGE DEPTH OF 6" OR AS DIRECTED BY THE ENGINEER. EXACT LIMITS OF REMOVAL SHALL BE DETERMINED BY THE ENGINEER. ALL EQUIPMENT, LABOR, TOOLS, AND INCIDENTALS NECESSARY TO COMPLETE THIS ITEM SHALL BE INCLUDED IN THE UNIT PRICE BID FOR ITEM 203 EXCAVATION. THE FOLLOWING ESTIMATED QUANTITY HAS BEEN CARRIED TO THE GENERAL SUMMARY:

ITEM 203 EXCAVATION

50 CU. YDS.

ITEM 304 AGGREGATE BASE

THE FOLLOWING ESTIMATED QUANTITY HAS BEEN PROVIDED AND SHALL BE USED AS DIRECTED BY THE ENGINEER TO BACKFILL AREAS WHICH WERE EXCAVATED UNDER ITEM 203 EXCAVATION NOT INCLUDING EMBANKMENT CONSTRUCTION.

ITEM 304 AGGREGATE BASE

50 CU. YDS.

ITEM 605 AGGREGATE DRAINS

THE FOLLOWING ESTIMATED QUANTITY HAS BEEN PROVIDED AND SHALL BE USED, IN CONJUNCTION WITH ITEM 203, AND AS DIRECTED BY THE ENGINEER, AT AREAS WHERE UNSUITABLE SUBGRADE HAS BEEN EXCAVATED AND REPLACED WITH ITEM 304 AGGREGATE BASE.

ITEM 605 AGGREGATE DRAINS

75 LIN. FT.

CALCULATED
PLAN NO.
CUT
CHECKED
DY

PAVEMENT REPAIR

STA-30-13.10

16
32

calberic@004CD0282476 - 227888ba.m - Wednesday January 22 2003 07:26:53 AM EST



Total This Route = Yellow: Solid _____, Yellow: Dash _____, White: Dash _____
Equivalent Yellow _____

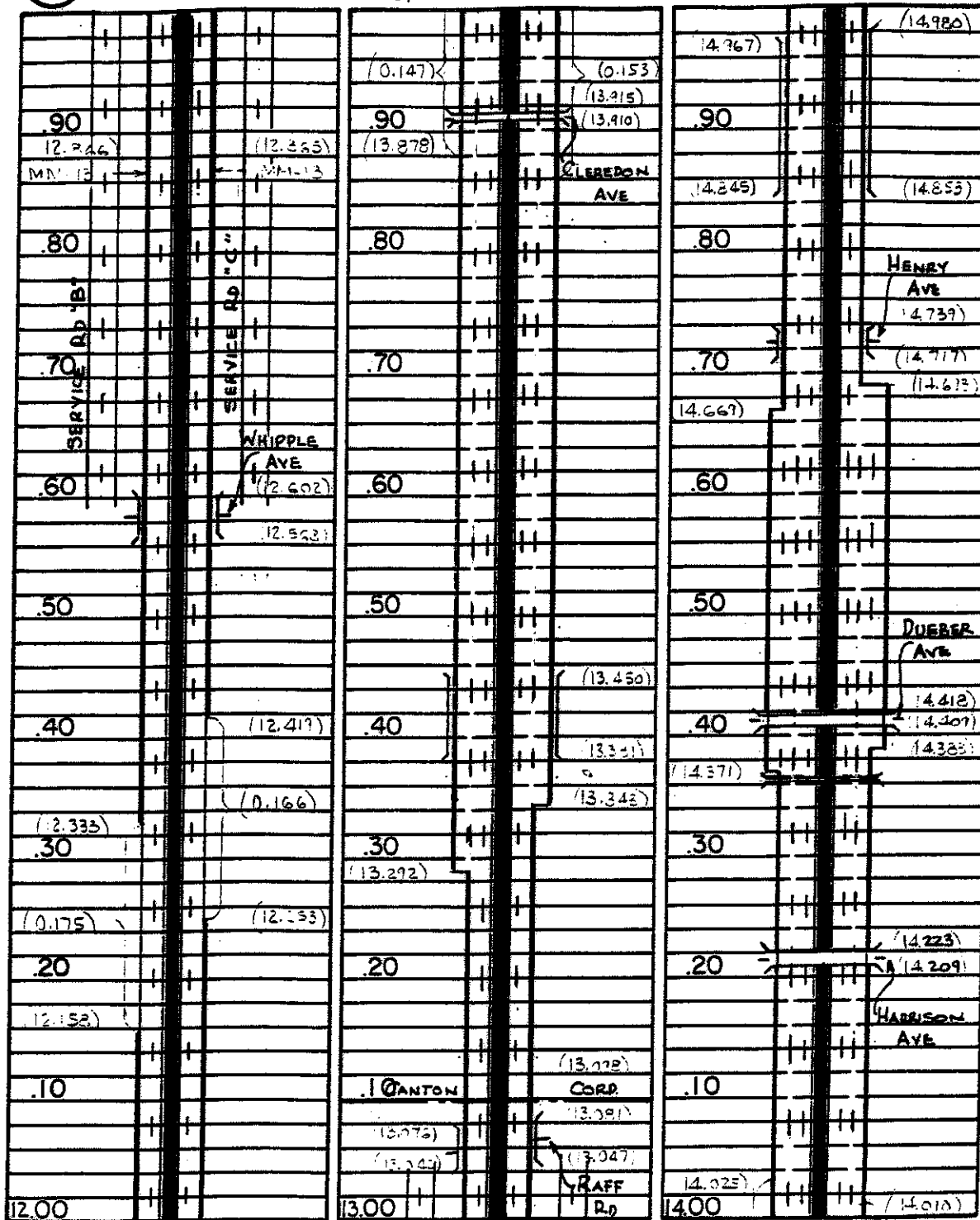

Yellow: Solid _____ Dash _____ Yellow: Solid _____ Dash _____ Yellow: Solid _____ Dash _____

TOTAL YELLOW THIS PAGE: SOLID _____, DASH _____, EQUIVALENT LINE _____



Total This Route = Yellow: Solid _____, Yellow: Dash _____, White: Dash _____
Equivalent Yellow _____

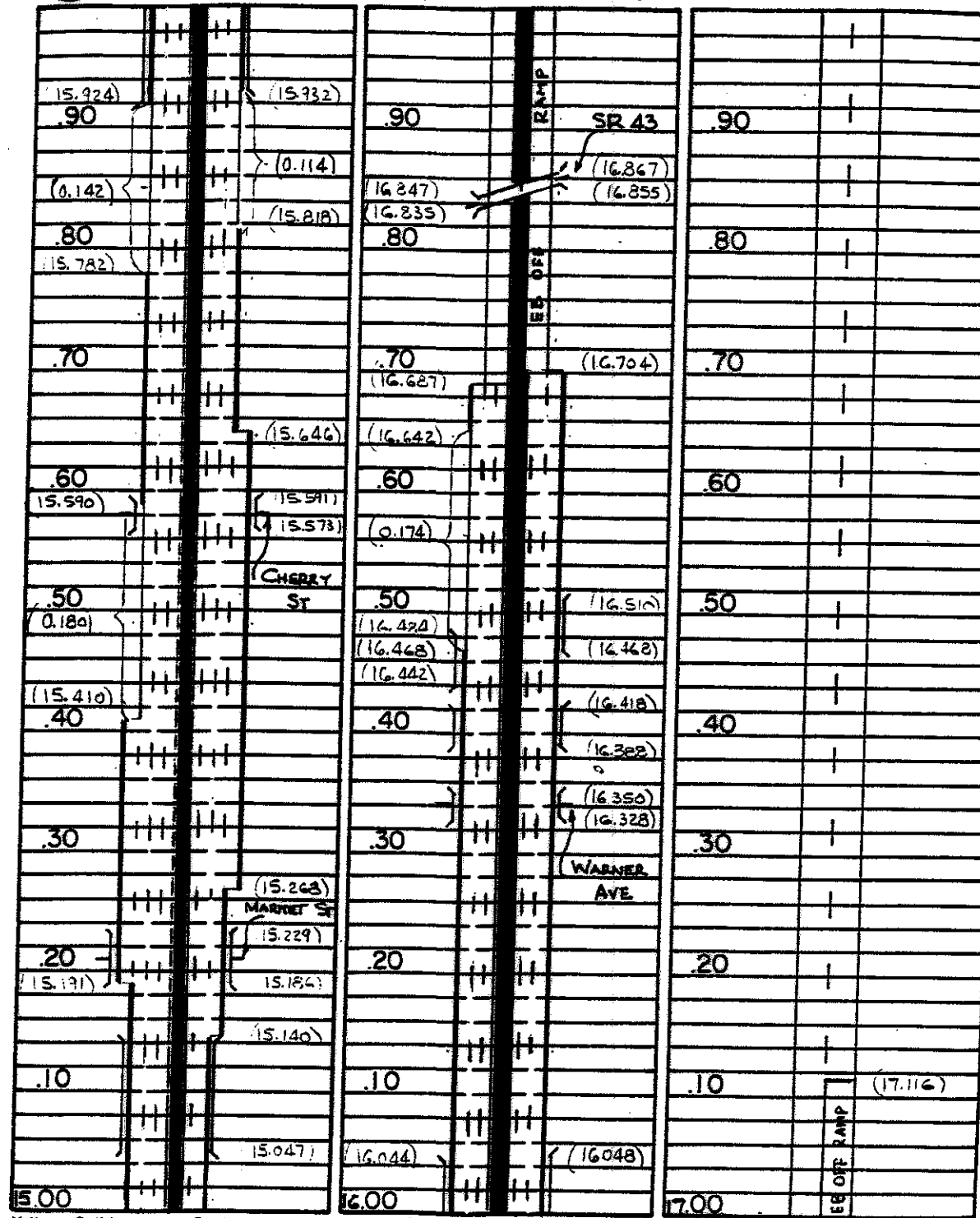

Yellow: Solid _____ Dash _____ Yellow: Solid _____ Dash _____ Yellow: Solid _____ Dash _____

TOTAL YELLOW THIS PAGE: SOLID _____, DASH _____, EQUIVALENT LINE _____

CALCULATED
TAD
CHECKED
DAY

PLAN NO. _____

PAVEMENT MARKING DETAILS

STA-30-13.10

AUXILIARY PAVEMENT MARKING

COUNTY STARK

LOCATION US 30 & RAFF RD.

PAVEMENT SURFACE TYPE _____

INTERSECTION TOTALS _____ LIN. FT.

24" STOP LINE _____ LIN. FT.

12" CROSSWALK LINE _____ LIN. FT.

8" CHANNELIZING LINE 755 LIN. FT.

SYMBOLS and LEGENDS _____

24" TRANSVERSE LINE 378 LIN. FT.

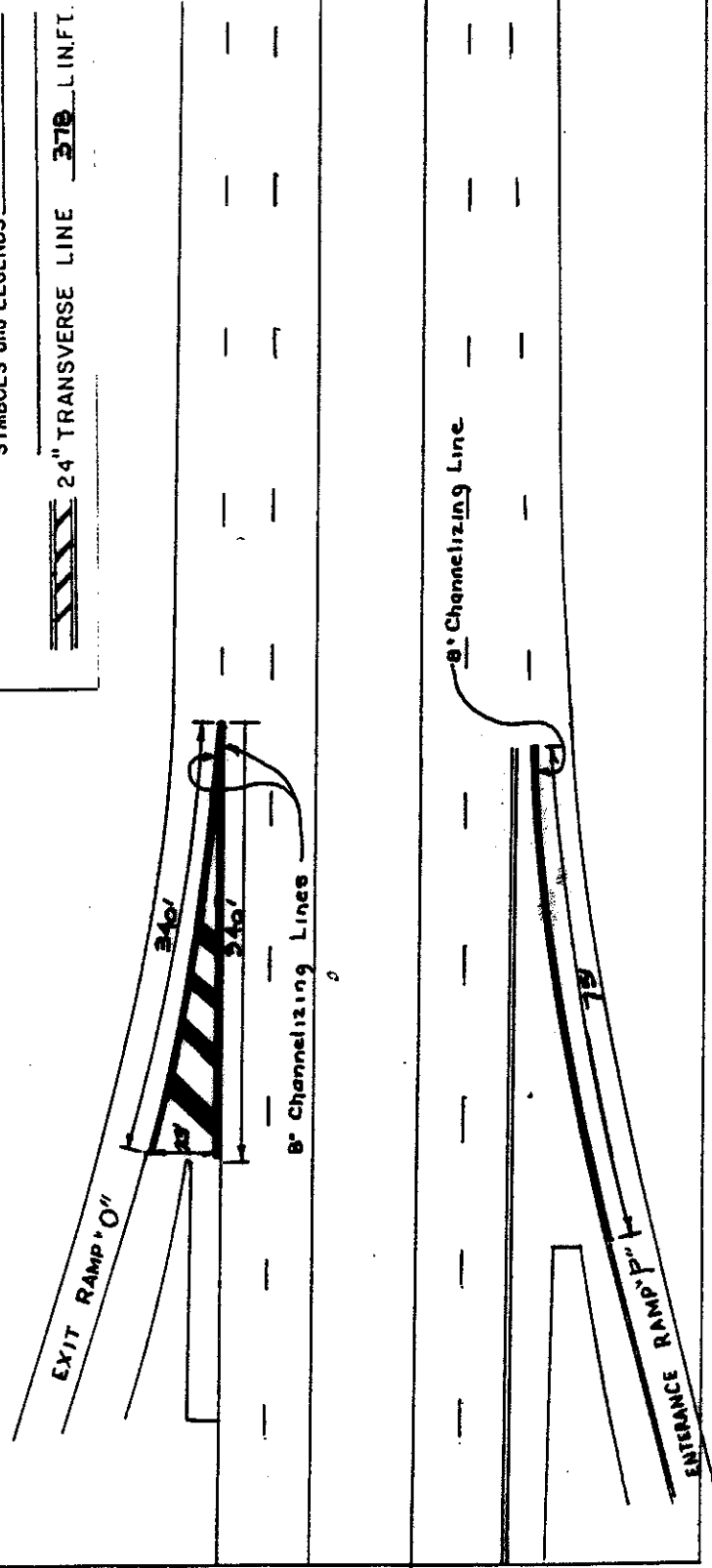

AUXILIARY PAVEMENT MARKING

COUNTY STARK

LOCATION US 30 & HARRISON AVE

PAVEMENT SURFACE TYPE _____

INTERSECTION TOTALS _____ LIN. FT.

24" STOP LINE _____ LIN. FT.

12" CROSSWALK LINE _____ LIN. FT.

8" CHANNELIZING LINE 613 LIN. FT.

SYMBOLS and LEGENDS _____

24" TRANSVERSE LINE 234 LIN. FT.

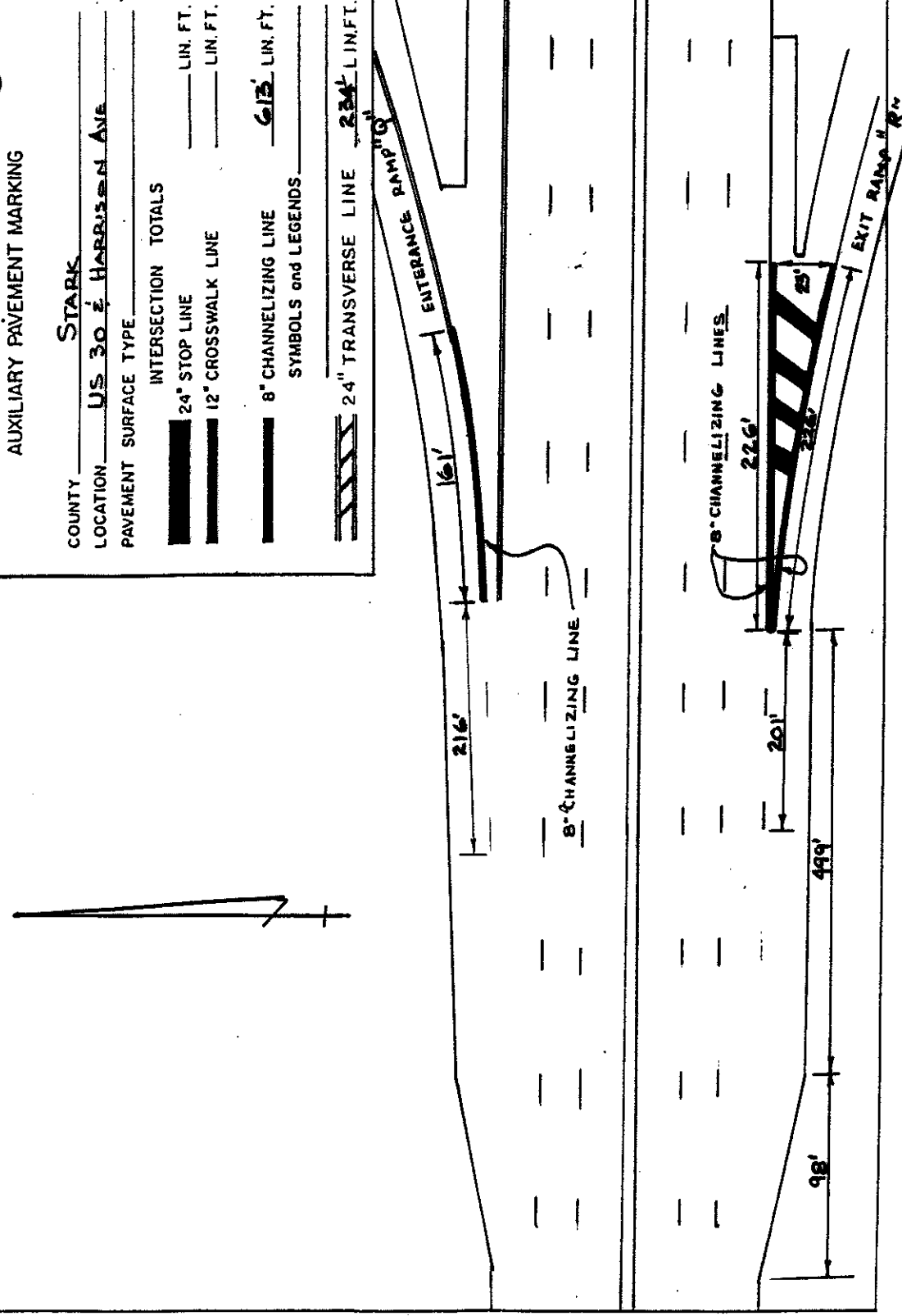

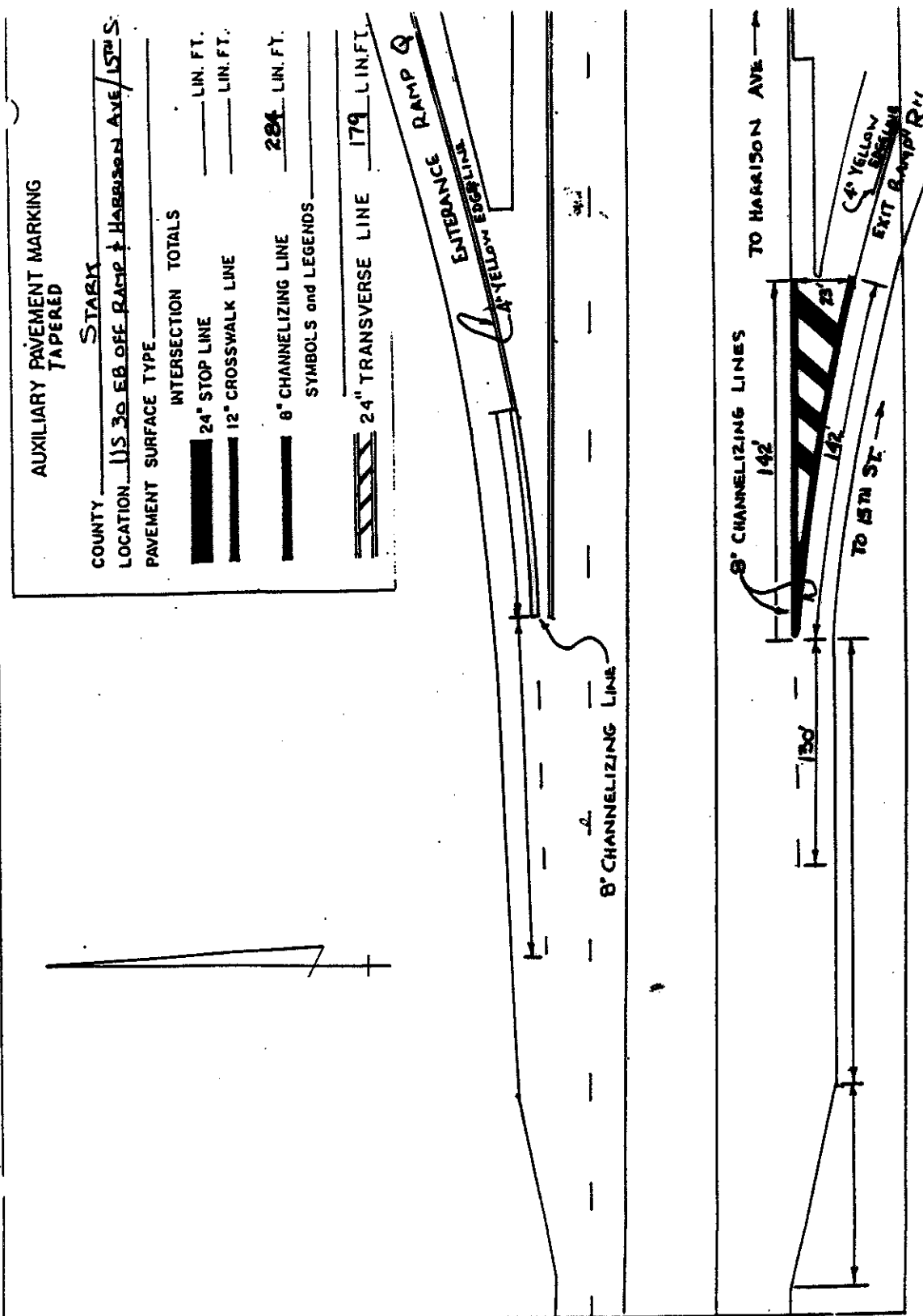

**AUXILIARY PAVEMENT MARKING
TAPERED**

COUNTY STARK
 LOCATION US 30 EB OFF RAMP & HARRISON AVE / 15TH ST

PAVEMENT SURFACE TYPE _____

INTERSECTION TOTALS _____ LIN. FT.
 _____ LIN. FT.

24" STOP LINE _____ LIN. FT.
 12" CROSSWALK LINE _____ LIN. FT.

8" CHANNELIZING LINE _____ LIN. FT.
 SYMBOLS and LEGENDS _____

24" TRANSVERSE LINE _____ LIN. FT.

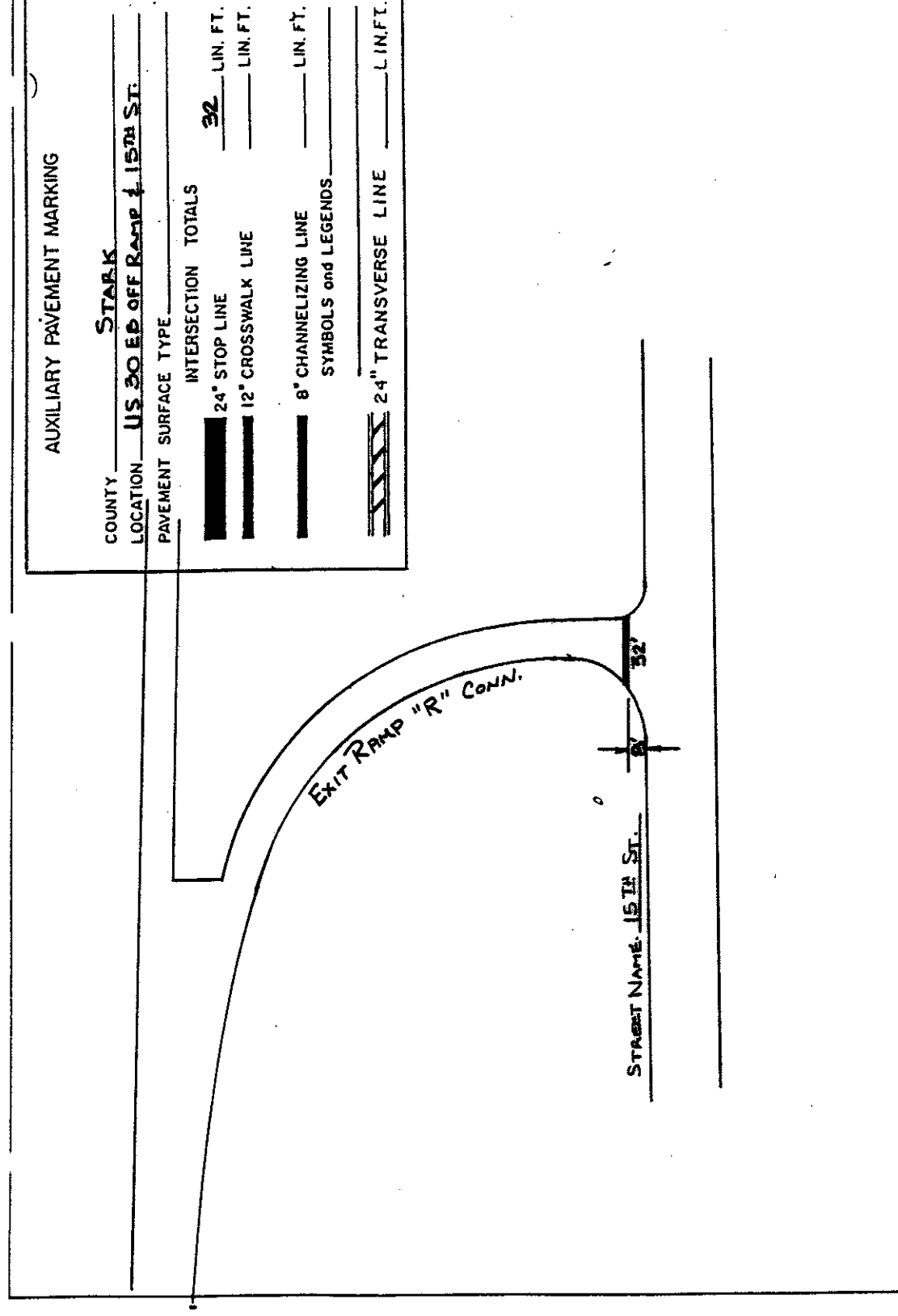

AUXILIARY PAVEMENT MARKING

COUNTY STARK
 LOCATION US 30 EB OFF RAMP & 15TH ST

PAVEMENT SURFACE TYPE _____

INTERSECTION TOTALS _____ LIN. FT.
 _____ LIN. FT.

24" STOP LINE _____ LIN. FT.
 12" CROSSWALK LINE _____ LIN. FT.

8" CHANNELIZING LINE _____ LIN. FT.
 SYMBOLS and LEGENDS _____

24" TRANSVERSE LINE _____ LIN. FT.

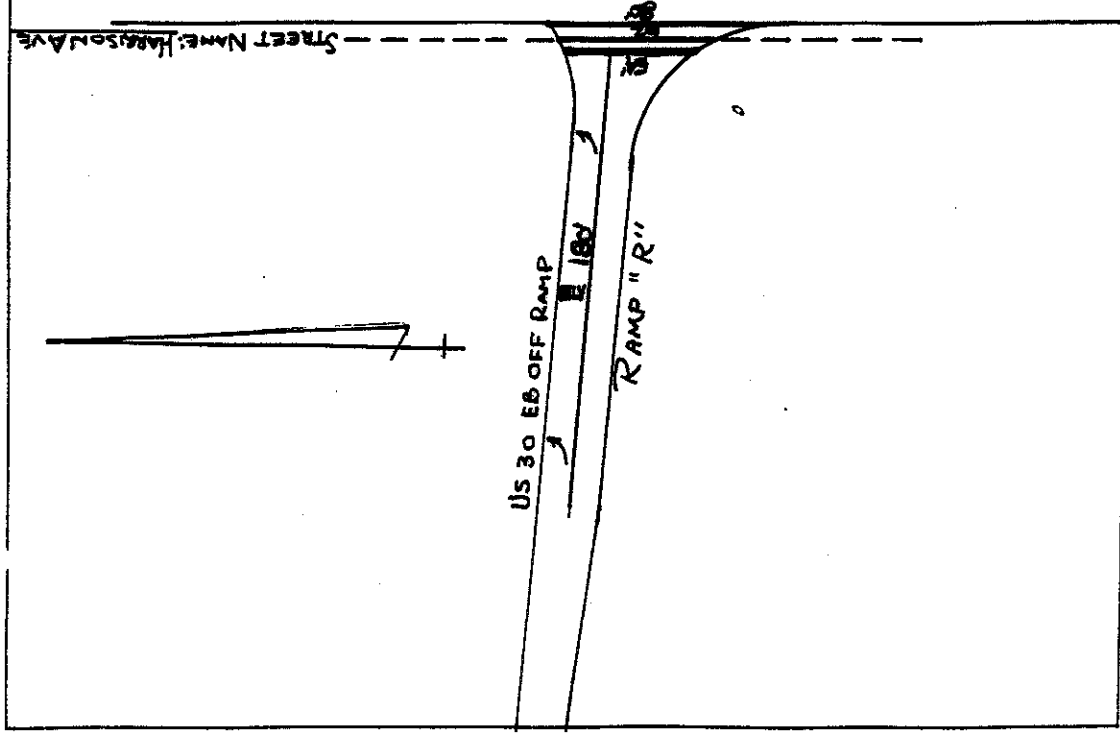

AUXILIARY PAVEMENT MARKING

COUNTY STARK
 LOCATION US 30 EB Ramps & Harrison Ave
 PAVEMENT SURFACE TYPE _____
 INTERSECTION TOTALS
 24" STOP LINE 54 LIN. FT.
 12" CROSSWALK LINE 276 LIN. FT.
 8" CHANNELIZING LINE 180 LIN. FT.
 SYMBOLS and LEGENDS _____
 24" TRANSVERSE LINE _____ LIN. FT.

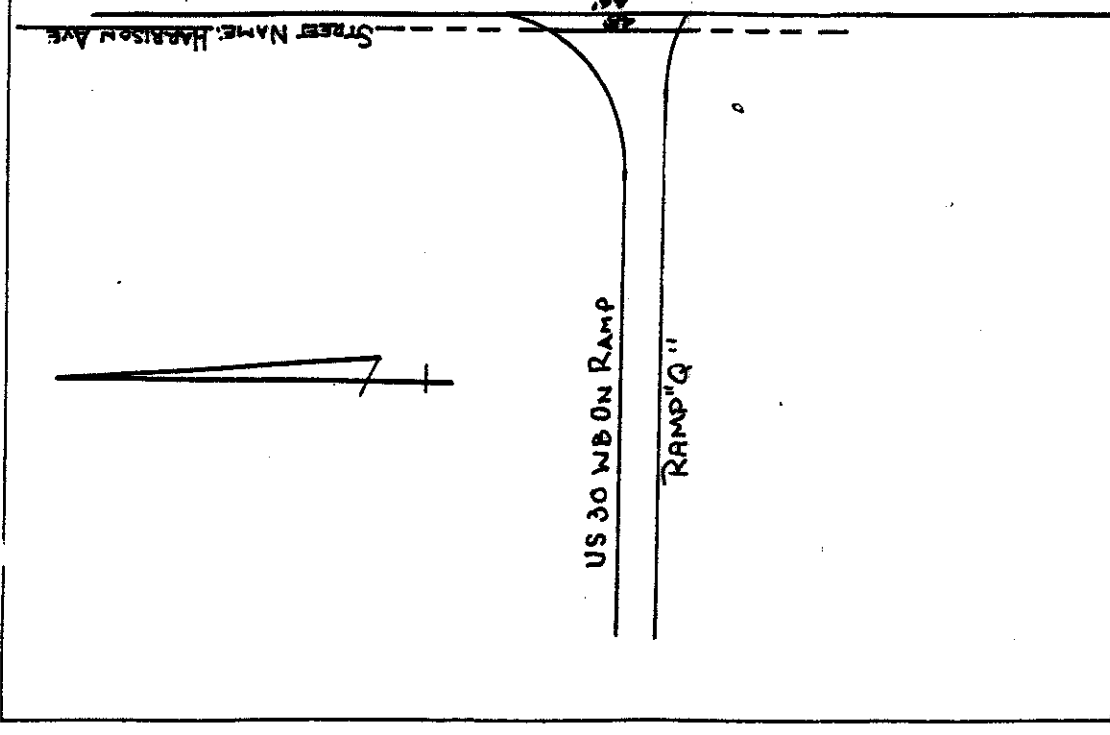
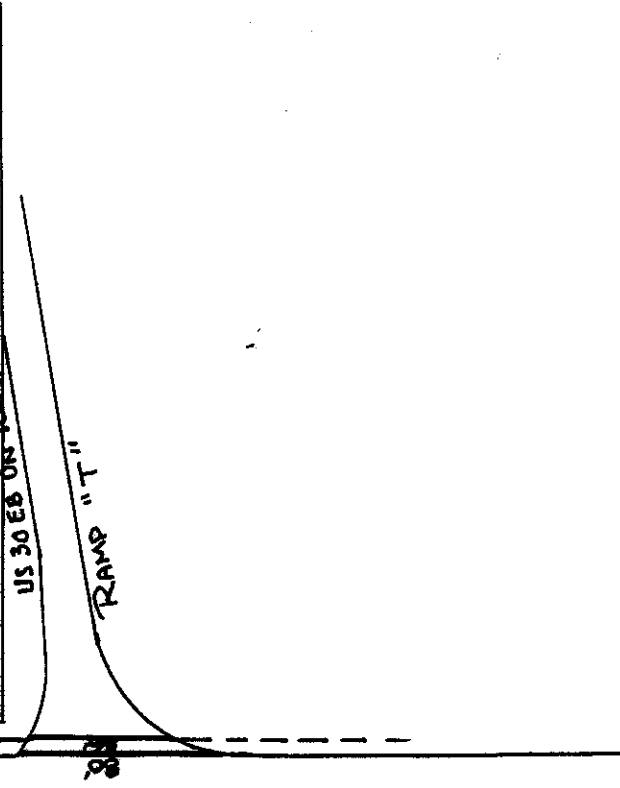

AUXILIARY PAVEMENT MARKING

COUNTY STARK
 LOCATION US 30 WB Ramps & Harrison Ave
 PAVEMENT SURFACE TYPE _____
 INTERSECTION TOTALS
 24" STOP LINE 50 LIN. FT.
 12" CROSSWALK LINE 250 LIN. FT.
 8" CHANNELIZING LINE 160 LIN. FT.
 SYMBOLS and LEGENDS _____
 24" TRANSVERSE LINE _____ LIN. FT.

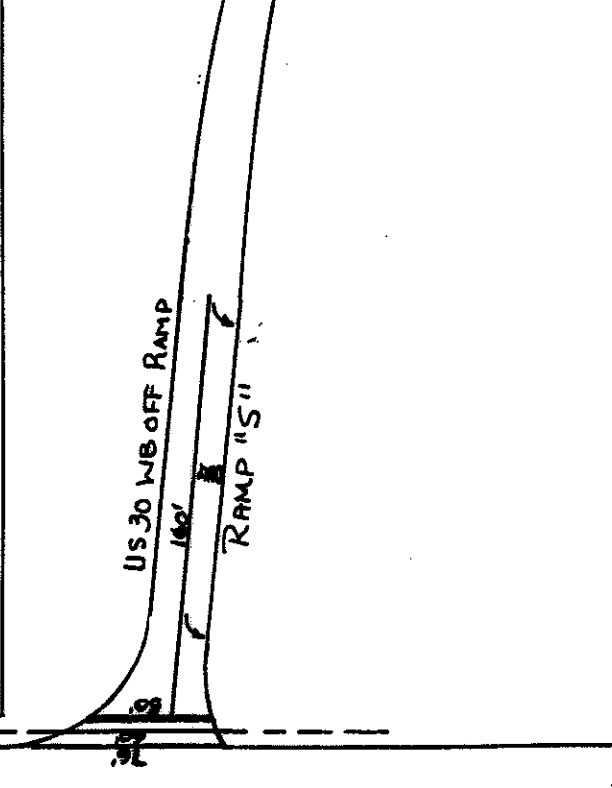

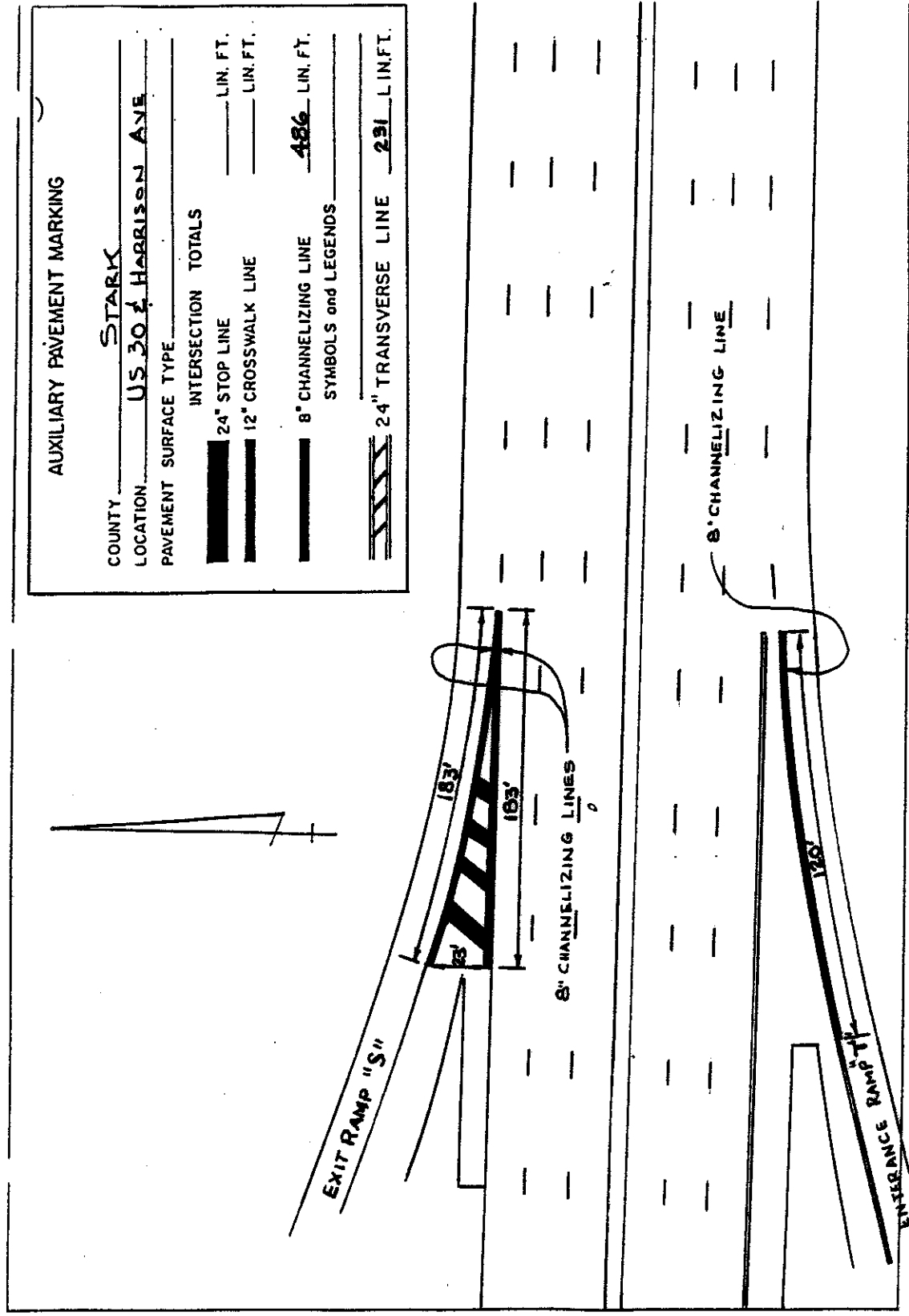

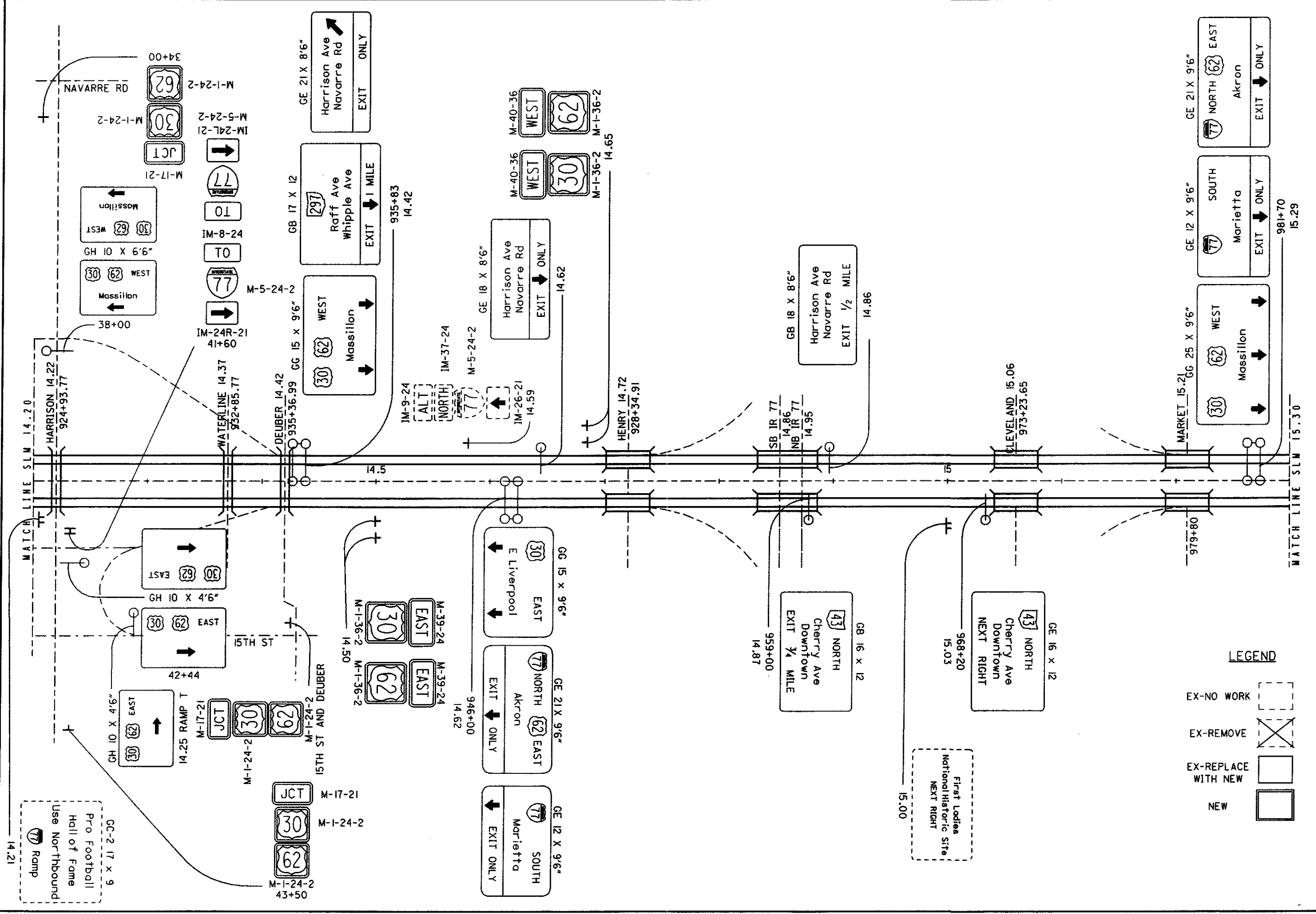

GC-2 17 X 9
Pro Football
Hall of Fame
Use Northbound
Ramp

- LEGEND**
- EX-NO WORK
 - EX-REMOVE X
 - EX-REPLACE WITH NEW X
 - NEW

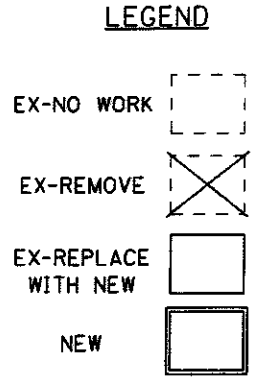
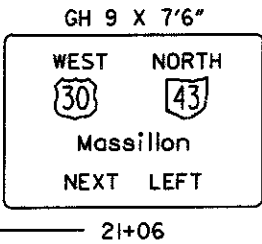
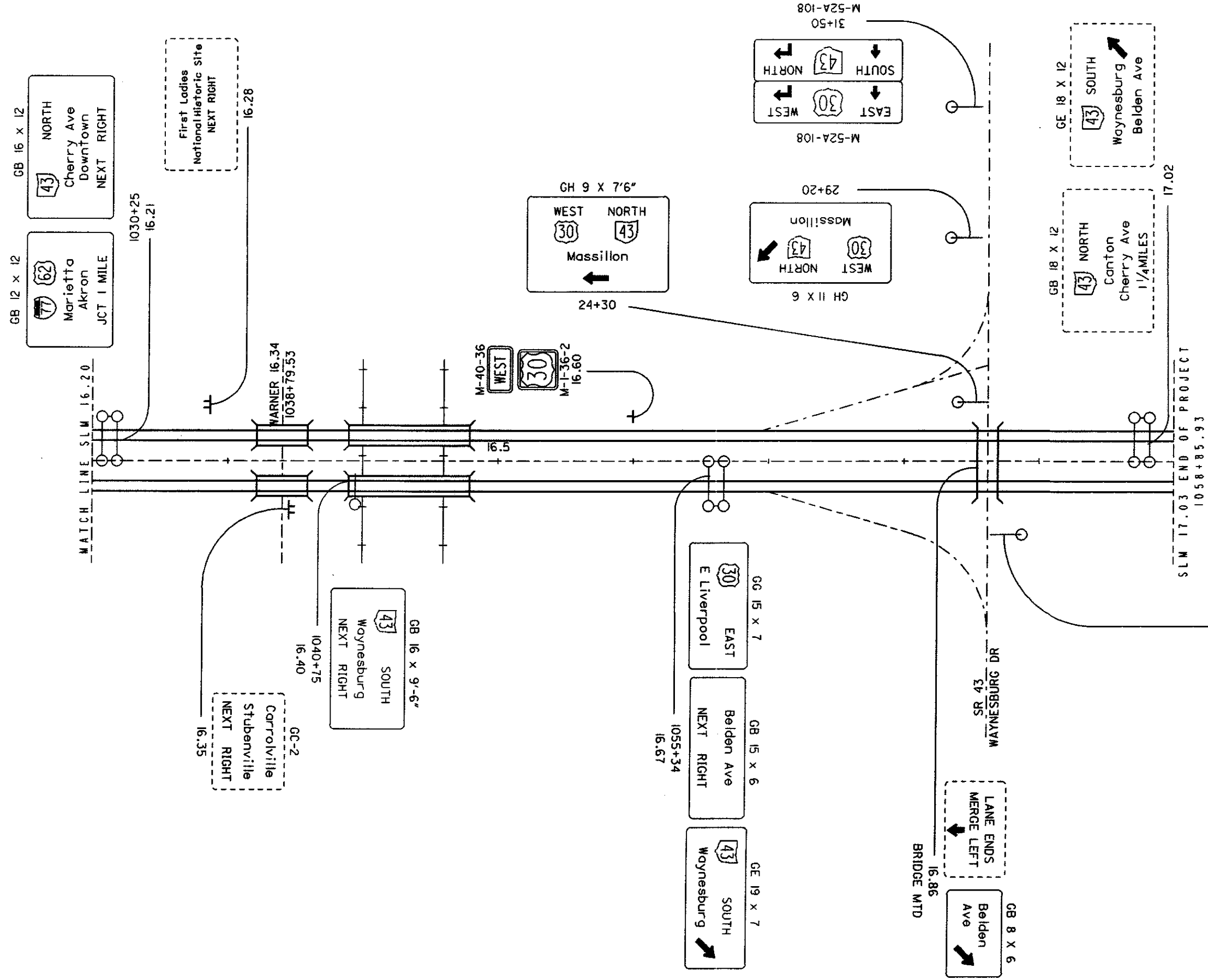

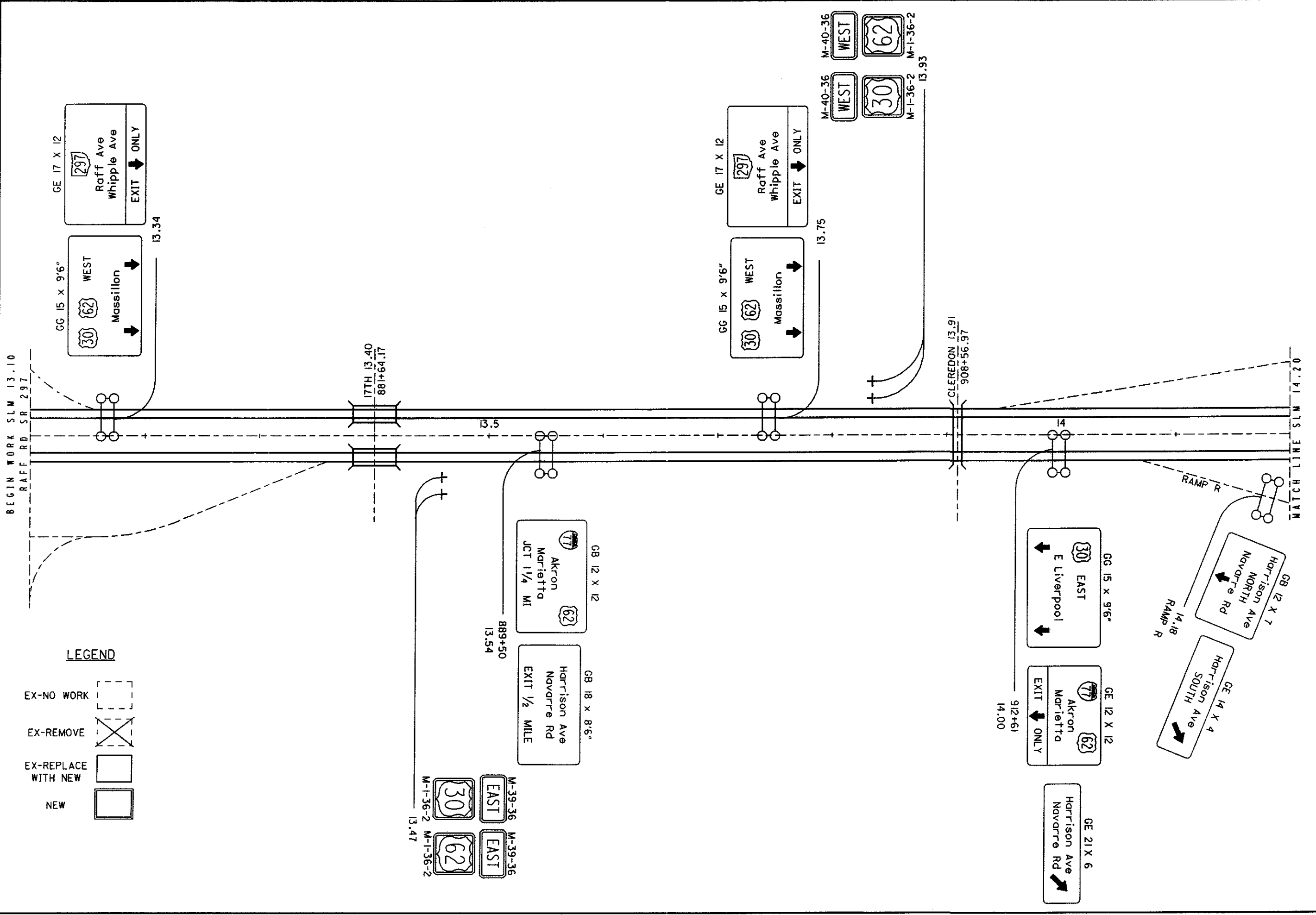

E:\Project\23159\231591p.dgn 14-MAY-2003 7:54AM c:\tiberio

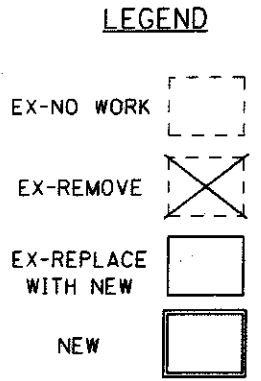
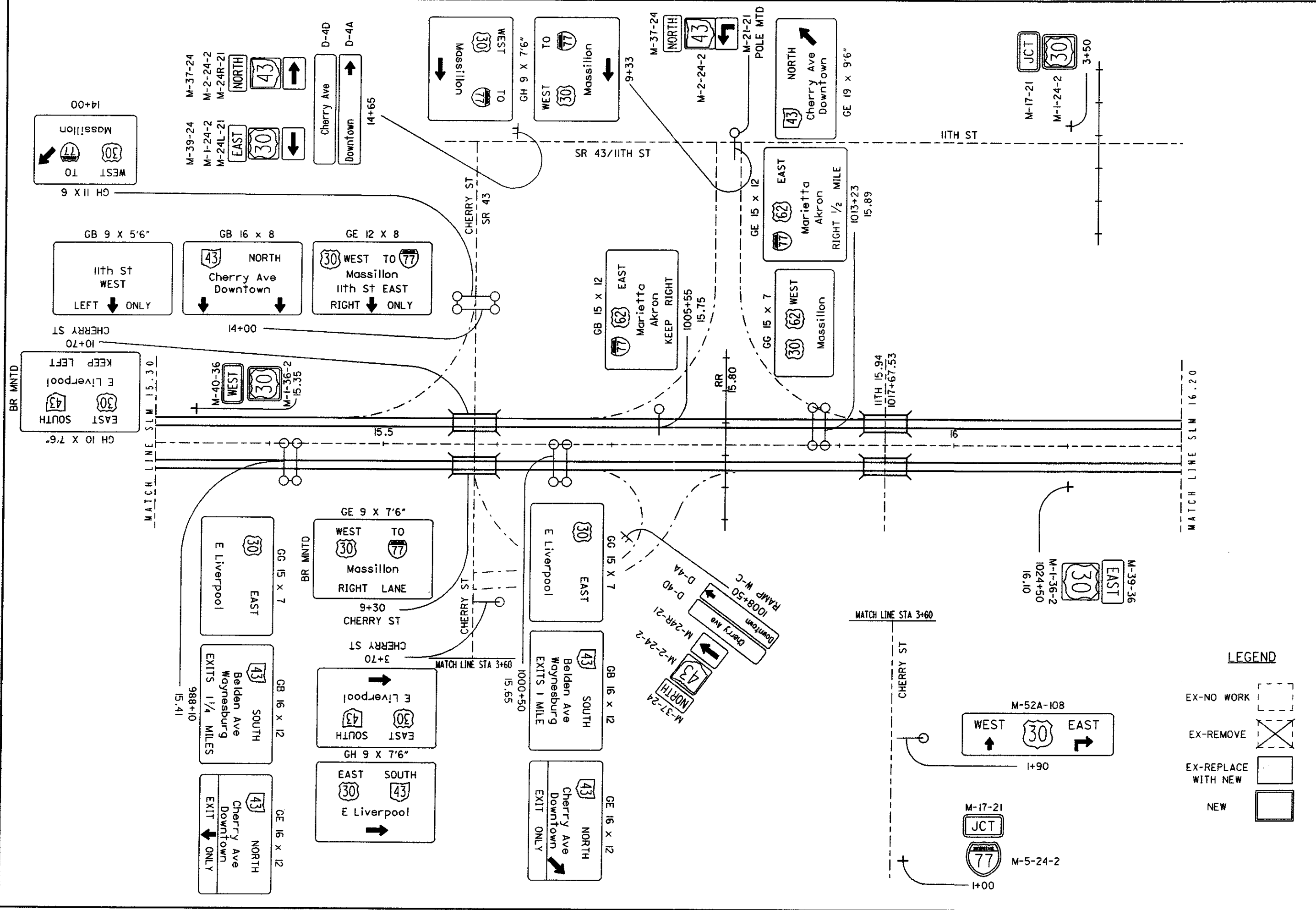

STA-30-13.10

SIGNING PLAN

SLM 15.30 TO SLM 16.20

27
32

CALCULATED T.P. _____
 CHECKED K.G. _____

0 0.04 0.08 0.16 0.32 0.64
 HORIZONTAL SCALE IN MILES

SHEET NO.	SLM	SIDE	CODE	SIZE (INCHES)	ITEM 630																	
					SIGNS FLATSHEET TYPE G	SIGNS EXTRUSHEET TYPE G	GROUND MOUNTED SUPPORT, NO. 3 POST	REMOVAL OF GROUND MOUNTED SIGN AND DISPOSAL	REMOVAL OF GROUND MOUNTED POST SUPPORT AND DISPOSAL	REMOVAL OF STRUCTURE MOUNTED SIGN AND DISPOSAL												REMOVAL OF OVERHEAD MOUNTED SIGN AND DISPOSAL
					SO.FT.	SO.FT.	FT.	EACH	EACH	EACH												EACH
	SHEET #																					
	13.34	LT	GG	180 X 120		150																
		LT	GE	204 X 150		212.5																
	13.47	RT	M-39-36	36 X 18	4.5		15															
		RT	M-1-36-2	36 X 36	9																	
		RT	M-39-36	36 X 18	4.5		15															
		RT	M-1-36-2	36 X 36	9																	
	13.54	RT	GB	144 X 150		150																
		RT	GB	216 X 108		162																
	13.75	LT	GG	180 X 120		150																
		LT	GE	204 X 150		212.5																
	13.93	LT	M-40-36	36 X 18	4.5		15															
		LT	M-1-36-2	36 X 36	9																	
		LT	M-40-36	36 X 18	4.5		15															
		LT	M-1-36-2	36 X 36	9																	
	14.00	RT	GG	180 X 120		150																
		RT	GE	144 X 150		150																
		RT	GE	252 X 78		136.5																
	14.18 RAMP R	RT	GB	144 X 90		90																
		RT	GE	168 X 54		63																
	SHEET #																					
	14.42	LT	GG	180 X 120		150																
		LT	GB	204 X 150		212.5																
		LT	GE	252 X 108		189																
	14.50	RT	M-39-36	36 X 18	4.5		15															
		RT	M-1-36-2	36 X 36	9																	
		RT	M-39-36	36 X 18	4.5		15															
		RT	M-1-36-2	36 X 36	9																	
	14.62	RT	GG	180 X 120		150																
		RT	GE	252 X 120		210																
		RT	GE	144 X 120		120																
	14.62	LT	GE	216 X 108		162																
	14.65	LT	M-39-36	36 X 18	4.5		15															
		LT	M-1-36-2	36 X 36	9																	
		LT	M-40-36	36 X 18	4.5		15															
		LT	M-1-36-2	36 X 36	9																	
	14.86	LT	GB	216 X 108		162																
	14.87	RT	GB	192 X 150		200																
	15.03	RT	GE	192 X 150		200																
	15.29	LT	GG	300 X 120		250																
		LT	GE	144 X 120		120																
		LT	GE	252 X 120		210																
	34+00 HARRISON	RT	M-17-21	21 X 15	2.19		15.75															
		RT	M-1-24-2	24 X 24	4																	
		RT	M-1-24-2	24 X 24	4																	
	38+00 HARRISON	RT	GH	120 X 84		70																
		RT	GH	120 X 84		70																
	41+60 HARRISON	LT	IM-8-24	24 X 12	2																	
		LT	M-5-24-2	24 X 24	4																	
		LT	IM-24-21	21 X 15	2.19		14.75															
		LT	IM-8-24	24 X 12	2																	
		LT	M-5-24-2	24 X 24	4																	
		LT	IM-24-21	21 X 15	2.19																	
	42+44 HARRISON	LT	GH	120 X 60		50																
		LT	GH	120 X 60		50																
	43+50 HARRISON	LT	M-17-21	21 X 15	2.19																	
		LT	M-1-24-2	24 X 24	4		15.75															
		LT	M-1-24-2	24 X 24	4																	
TOTALS CARRIED TO SUB SUMMARY					144.73	4202	166.25				28											

CALCULATED TP
 CHECKED TK
SIGNING SUBSUMMARY
STA -30-13.10
 28
 32

SHEET NO.	SLM	SIDE	CODE	SIZE (INCHES)	ITEM 630																
					SIGNS FLATSHEET TYPE G SQ.FT.	SIGNS EXTRUSHEET TYPE G SQ.FT.	GROUND MOUNTED SUPPORT, NO. 3 POST FT.	REMOVAL OF GROUND MOUNTED SIGN AND DISPOSAL EACH	REMOVAL OF GROUND MOUNTED POST SUPPORT AND DISPOSAL EACH	REMOVAL OF STRUCTURE MOUNTED SIGN AND DISPOSAL EACH	REMOVAL OF OVERHEAD MOUNTED SIGN AND DISPOSAL EACH										
SHEET #																					
14.25 RAMP T	RT	GH		120 X 60		50															
15TH ST/DEUBER	RT	M-17-21		21 X 15	2.19																
	RT	M-1-24-2		24 X 24	4		15.75														
	RT	M-1-24-2		24 X 24	4																
SHEET #																					
15.35	LT	M-40-36		36 X 18	4.5		15														
	LT	M-1-36-2		36 X 36	9																
15.41	RT	GG		180 X 90				112.5													
	RT	GB		192 X 150				200													
	RT	GE		192 X 150				200													
15.65	RT	GG		180 X 90				112.5													
	RT	GB		192 X 150				200													
	RT	GE		192 X 150				200													
15.75	LT	GB		180 X 150				187.5													
15.89	LT	GG		180 X 90				112.5													
	LT	GE		180 X 150				187.5													
	LT	GE		228 X 120				190													
16.10	RT	M-39-36		36 X 18	4.5		15														
	RT	M-1-36-2		36 X 36	9																
1+00 CHERRY ST	RT	M-17-21		21 X 15	2.19		13.75														
	RT	M-5-24-2		24 X 24	4																
1+90 CHERRY ST	RT	M-52A-108		108 X 30				22.5													
3+70 CHERRY ST	RT	GH		108 X 96				72													
	RT	GH		108 X 96				72													
9+30 CHERRY ST	MED	GE		108 X 96				72													
10+70 CHERRY ST	MED	GE		108 X 96				72													
14+00 CHERRY ST	RT	GB		108 X 72				54													
	RT	GB		192 X 102				136													
	RT	GE		144 X 102				102													
	LT	GH		132 X 78				71.5													
3+50 I1TH ST	RT	M-17-21		21 X 15	2.19		13.75														
	RT	M-1-24-2		24 X 24	4																
9+33 I1TH ST	RT	M-37-24		24 X 12	2																
	RT	M-1-24-2		24 X 24	4																
	RT	M-21-21		21 X 15	2.19																
9+33 I1TH ST	RT	GH		108 X 96				72													
	RT	GH		108 X 96				72													
14+65 I1TH ST	RT	M-39-24		24 X 12	2																
	RT	M-1-24-2		24 X 24	4																
	RT	M-24-21		21 X 15	2.19																
	RT	M-37-24		24 X 12	2																
	RT	M-2-24-2		24 X 24	4																
	RT	M-24-21		21 X 15	2.19																
	RT	D-4D		96 X 24	16		18.5/18.5		2												
	RT	D-4A		96 X 24	16																
1008+50 RAMP W-C	RT	M-37-24		24 X 12	2																
	RT	M-2-24-2		24 X 24	4																
	RT	M-24-21		21 X 15	2.19																
	RT	D-4D		96 X 24	16		18.5/18.5		2												
	RT	D-4A		96 X 24	16																
SHEET #																					
16.21	LT	GB		144 X 150				150													
	LT	GB		192 X 150				200													
16.40	RT	GB		192 X 120				160													
16.60	LT	M-40-36		36 X 18	4.5		15														
	LT	M-1-36-2		36 X 36	9																
TOTALS CARRIED TO SUB SUMMARY					159.83	3080.5	147.25	18	6	2	23										

CALCULATED TP
 CHECKED TK
SIGNING SUBSUMMARY
STA -30-13.10
 29
 32

SHEET NO.	SLM	SIDE	CODE	SIZE (INCHES)	ITEM 630																
					SIGNS FLATSHEET TYPE G SQ.FT.	SIGNS EXTRUSHEET TYPE G SQ.FT.	GROUND MOUNTED SUPPORT, NO. 3 POST FT.	REMOVAL OF GROUND MOUNTED SIGN AND DISPOSAL EACH	REMOVAL OF GROUND MOUNTED POST SUPPORT AND DISPOSAL EACH	REMOVAL OF STRUCTURE MOUNTED SIGN AND DISPOSAL EACH	REMOVAL OF OVERHEAD MOUNTED SIGN AND DISPOSAL EACH										
	SHEET #																				
	16.67	RT	GC	180 X 90		112.5															
		RT	GB	180 X 78		97.5															
		RT	GE	228 X 90		142.5															
	16.86	RT	GB	96 X 78		52															
	21+06 SR 43	RT	GH	108 X 96		72															
	24+30 SR 43	LT	GH	108 X 96		72															
		LT	GH	132 X 78		72															
	29+20 SR 43	LT	GH	108 X 30		71.5															
	31+50 SR 43	LT	M-52A-108	108 X 30		22.5															
		LT	M-52A-108			22.5															
	TOTAL SHEET NO. 28				144.73	4202	166.25					28									
	TOTAL SHEET NO. 29				159.83	3080.5	147.25	18	6	2		23									
	TOTAL THIS SHEET					737						10									
	TOTALS CARRIED TO SUB SUMMARY				304.56	8019.5	313.5	18	6	2		61									

CALCULATED	TP
	TK
SIGNING SUBSUMMARY	
STA - 30-13.10	
30 32	

