

The Great Lakes Construction Co.

**TRANSMITTAL
No. 173**

10737 Medallion Drive
Cincinnati, Ohio 45241

PROJECT: ODOT 150085 HAM 71-1.34

DATE: October 26, 2017

TO: ODOT District 8
505 South SR 741
Lebanon, OH 45036

REF: Linear Heat System User Manual
Line Item: #378.00

ATTN: Marvin Lennon

WE ARE SENDING		SUBMITTED FOR:		ACTION TAKEN:	
<input type="checkbox"/>	Shop Drawings	<input type="checkbox"/>	Approval	<input type="checkbox"/>	Approved as Submitted
<input type="checkbox"/>	Letter	<input checked="" type="checkbox"/>	Your Use	<input type="checkbox"/>	Approved as Needed
<input type="checkbox"/>	Prints	<input type="checkbox"/>	As Requested	<input type="checkbox"/>	Returned after Loan
<input type="checkbox"/>	Change Order	<input type="checkbox"/>	Review and Comment	<input type="checkbox"/>	Resubmit
<input type="checkbox"/>	Plans	<input type="checkbox"/>		<input checked="" type="checkbox"/>	Submit
<input type="checkbox"/>	Samples	SENT VIA:		<input type="checkbox"/>	Returned
<input type="checkbox"/>	Specifications	<input checked="" type="checkbox"/>	Attached	<input type="checkbox"/>	Returned for Correction
<input checked="" type="checkbox"/>	Other: User Manual	<input type="checkbox"/>	Separate Cover:	<input type="checkbox"/>	Due Date:

<u>SUBMITTAL</u>	<u>COPIES</u>	<u>DATE</u>	<u>DESCRIPTION</u>
TR85.15-173	1 pdf	10/26/2017	Linear Heat User Manual Per Sheet 511/555, Section 3.3A

REMARKS

CC: Joe Smithson, ODOT D8
Darryl Meadows, CFD

Signed:



Jacob D. Elmore.



FiberSystem 8000

User's Guide

B-Version

Notices

© The Protectowire Company, Inc.

No part of this manual may be reproduced in any form or by any means (including electronic storage and retrieval or translation into a foreign language) without prior agreement and written consent from The Protectowire Company, Inc. as governed by US and international copyright laws.

Subject Matter

The material in this document is subject to change without notice.

The Protectowire Company, Inc. makes no warranty of any kind with regard to this printed material, including, but not limited to, the implied warranties of merchantability and fitness for a particular purpose.

The Protectowire Company, Inc. shall not be liable for errors contained herein or for incidental or consequential damages in con-

Printing History

New editions are complete revisions of the guide reflecting alterations in the functionality of the instrument. Updates are occasionally made to the guide between editions. The date on the back page changes when an updated guide is published. To find out the current revision of the guide, or to purchase an updated guide, contact Protectowire Company, Inc. representative.

Warranty

This The Protectowire Company, Inc. instrument product is warranted against defects in material and workmanship for a period of one year from date of shipment. During the warranty period, The Protectowire Company, Inc. will, at its option, either repair or replace products that prove to be defective.

For warranty service or repair, this product must be returned to a service facility designated by The Protectowire Company, Inc.. Buyer shall prepay shipping charges to The Protectowire Company, Inc. and The Protectowire Company, Inc. shall pay shipping charges to return the product to Buyer. However, Buyer shall pay all shipping charges, duties, and taxes for products returned to The Protectowire Company, Inc. from another country.

The Protectowire Company, Inc. warrants that its software and firmware designated by Protectowire.

Limitation of Warranty

The foregoing warranty shall not apply to defects resulting from improper or inadequate maintenance by Buyer, Buyer-supplied software or interfacing, unauthorized modification or misuse, operation outside of the environmental specifications for the product, or improper site preparation or maintenance.

No other warranty is expressed or implied. The Protectowire Company, Inc. specifically disclaims the implied warranties of merchant ability and Fitness for a particular purpose.

Exclusive Remedies

The remedies provided herein are Buyer's sole and exclusive remedies. The Protectowire Company, Inc. shall not be liable for any direct, indirect, special, incidental, or consequential damages whether based on contract, tort, or any other legal

Assistance

Product maintenance agreements and other customer assistance agreements are available for The Protectowire Company, Inc. products. For any assistance contact

Certification

The Protectowire Company, Inc. certifies that this product met its published specifications at the time of shipment from the factory.

The Protectowire Company, Inc. further certifies that its calibration measurements are traceable to the United States National Institute of Standards and Technology, NIST (formerly the United States National Bureau of Standards, NBS) to the extent allowed by the Institutes's calibration facility, and to the calibration facilities of other International Standards Organization members.

ISO 9001 Certification

Produced to ISO 9001 international quality system standard as part of our objective of continually increasing customer satisfaction through improved process control.

Getting Started	5
<hr/>	
Introduction & Measurement Principle	6
General Safety Considerations	8
Safety Symbols	8
Setting up the FIBERSYSTEM 8000 System	14
Setting up the Hardware	14
Installing the Software	15
Connecting to the Controlling PC	16
Front, Rear and Connection Panels of the FIBERSYSTEM 8000 Instrument	18
Terminating the Sensor Cable	20
Connecting to the Output Relays and Input Lines	21
Making Measurements	25
<hr/>	
Starting the FIBERSYSTEM 8000 Instrument	26
Troubleshooting and Maintenance	27
<hr/>	
Cleaning	28
Safety Precautions	28
What do I need for Proper Cleaning?	28
Cleaning FIBERSYSTEM 8000 Instrument Housings	29
Preserving Connectors	29
Cleaning the Optical Connectors and Adapters	29
Replacing the Fuse	32
Checking the Operation of the FIBERSYSTEM 8000 system	33
Returning the Instrument for Service	35
The Protectowire Company, Inc. Contact	35
Specifications and Regulatory Information	36
<hr/>	
Introduction	37
Definition of Terms	38
References	44
Angled Connector Specifications	45
Specifications	46

Ordering Information	48
Index	49

1 Getting Started

Introduction & Measurement Principle.	6
General Safety Considerations	8
Setting up the FIBERSYSTEM 8000 System	14
Front, Rear and Connection Panels of the FIBERSYSTEM 8000 Instrument	18
Terminating the Sensor Cable	20
Connecting to the Output Relays and Input Lines.	21

Introduction & Measurement Principle

The Protectowire Company, Inc. FIBERSYSTEM 8000 PTS (Protectowire Temperature Sensing) Series is optimized and certified for fire detection applications. The instrument can be configured for various alarm criteria and can be connected to a fire control panel using the relay inputs and outputs. It is categorized as a DTS (Distributed Temperature Sensing) System which are optical fibers functioning as linear sensors. For the purposes of this manual these two acronyms (PTS and DTS) are used interchangeably.

The Protectowire Company, Inc.'s distributed temperature measurement is based on the proven Raman-Optical Time-Domain-Reflectometry (OTDR) technique. An optical laser pulse propagating through the fiber gets scattered light back to the transmitting end, where it is analyzed. The intensity of the Raman signals is a measure for the temperature along the fiber.

The backscattered light is spread across a range of wavelengths. Some of these wavelengths are affected by temperature changes while others are immune. By very accurately measuring the Difference in the signal intensity of the backscattered light an Accurate temperature measurement can be made.

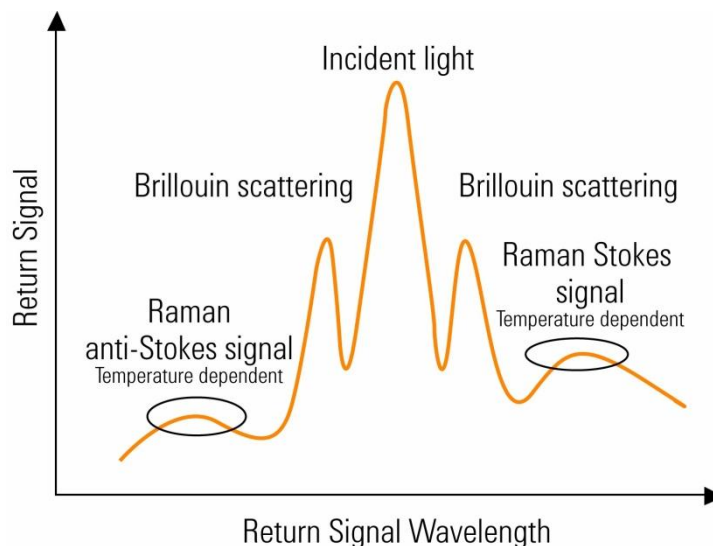

The local position of the temperature is determined by measuring the arrival timing of the returning light pulse similar to a radar echo showing the distance of a car or plane.

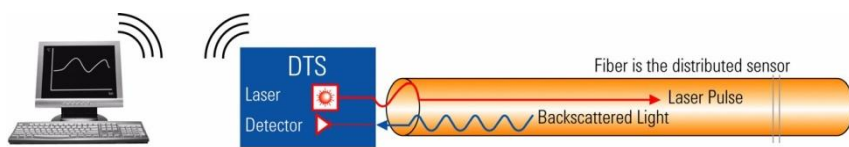

The temperature resolution is dependent on several factors: Measurement time, spatial resolution, the length of the fiber, the loss of the fiber, splices or connectors.

General Safety Considerations

This product has been designed and tested in accordance with the standards listed on the manufacturer's Declaration of Conformity, and has been supplied in a safe condition. The documentation contains information and warnings that must be followed by the user to ensure safe operation and to maintain the product in a safe condition.

Safety Symbols

CAUTION

The *caution* sign denotes a hazard. It calls attention to a procedure which, if not correctly performed or adhered to, could result in damage to or destruction of the product. Do not proceed beyond a caution sign until the indicated conditions are fully understood and met.

WARNING

The *warning* sign denotes a hazard. It calls attention to a procedure which, if not correctly performed or adhered to, could result in injury or loss of life. Do not proceed beyond a warning sign until the indicated conditions are fully understood and met.

Instrument Markings



The instruction manual symbol. The product is marked with this warning symbol when it is necessary for the user to refer to the instructions in the manual.

In this case, this is to change the fuse. Please refer to “Replacing the Fuse” on page 38.



The laser radiation symbol. This warning symbol is marked on products which have a laser output.



The DC (direct current) symbol is used to indicate the input power connecting terminal.



Certification Marking as VdS certified fire detector (linear heat detector).



Certification Marking as UL certified fire detector (linear heat detector).



This symbol indicates the earth connecting terminal.



The ON symbol is used to show that the power switch is in the on position, and the instrument is in operating mode.



The stand-by symbol is used to show the power switch is in the stand-by position and the instrument is in stand-by mode.



Conformity Marking of the European Union



General Recycling Mark for plastic parts used in the product

WARNING

If this product is not used as specified, the protection provided by the equipment could be impaired. This product must be used in a normal condition (in which all means for protection are intact) only.

WARNING

Operator access to the inside of the instrument is limited to the procedures described in “Setting up the FIBERSYSTEM 8000 System” in chapter 1. Other areas and parts inside the instrument are not for service by the operator. Refer servicing to qualified service

WARNING

To prevent electrical shock, disconnect the instrument from the power source before cleaning. Use a dry cloth or one slightly dampened with water to clean the external case parts.

Do not open the card cage inside the FIBERSYSTEM 8000, or attempt to clean it internally.

WARNING

Using controls or adjustments or performing procedures other than those specified in the documentation supplied with your equipment can result in hazardous radiation exposure.

CAUTION

This product complies with IEC Pollution Degree 2.

CAUTION

When installing the instrument using power supply, make sure the detachable power cord is readily identifiable and is easily reached by the operator.

CAUTION

Do not connect a light source to the optical output or the connected fiber to prevent potential interferences or damages of optical or opto-electrical components.

CAUTION

For operation of the instrument use a power supply certified in compliance with EN54-22 and certified to UL/ULC for UL/ULC compliance.

Please note, the The Protectowire Company, Inc. AC/DC adapter A1011A (18V DC, 3.5 A) is not suitable for certified fire detection application.

Laser Safety Information

The laser source specified by this user guide is classified according to IEC 60825-1 (2007).

The laser source complies with 21 CFR 1040.10 except for deviations pursuant to Laser Notice No. 50, dated 2001-July-26

	FIBERSYSTEM 8000 unit
Laser type	Semiconductor Laser
Wavelength	1064 nm
Max. average output power ¹	17 mW
Beam waist diameter	50 µm
Numerical aperture	0.2
Laser class according to IEC 60825-1 (2001)	1M
Max. permissible average output power ²	20 mW

¹ Max. average output power means the highest possible average power that the laser source can produce at its output.

² Max. permissible average output power is the highest optical power that is permitted within the appropriate IEC laser class.

According to IEC Laser class 1M the laser activity and the laser power is not dangerous for the user as long as no optical instruments like magnifying glasses or microscopes are used.

Laser class 1M label



The instrument has built-in safety circuitry, which will disable the optical output in the case of a fault condition.

WARNING

Please pay attention to the following laser safety warnings:

- Even the laser power of the FIBERSYSTEM 8000 instrument does not generate direct danger for your eyesight we suggest not to look into the end of an optical cable attached to the optical output when the device is operational.
 - The use of optical instruments with this product will increase the hazard to your eyes.
 - Refer servicing *only* to qualified and authorized personnel.
-

Environmental Information

This product complies with the WEEE Directive (2002/96/EC) marking requirements. The affixed label indicates that you must not discard this electrical/ electronic product in domestic household waste.

Product Category: With reference to the equipment types in the WEEE Directive Annex I, this product is classed as a "Monitoring and Control instrumentation" product.



Do not dispose in domestic household waste.

For product disposal you can return it to The Protectowire Company, Inc. after arrangement. Please contact your local Protectowire distributor for details.

Setting up the FIBERSYSTEM 8000 System

Setting up the Hardware

1. At receipt of shipment.

- a) Inspect the shipping containers for damage.

If the shipment was damaged, contact the carrier, then contact The Protectowire Company, Inc..

Keep the shipping containers and cushioning material and use it for further shipping e.g. in case of Service & Support needs.

- b) Verify that you received the options and accessories that you ordered. Compare the package contents with the bill of order.

If anything is missing or defective, please contact The Protectowire Company, Inc..

WARNING

To avoid the possibility of injury or death, you must observe the following precautions before switching on the instrument.

- **Do not remove protective covers while the instrument is powered.**
- **Do not open the inner card cage. Component replacement and internal adjustments must be made only by qualified service personnel.**
- **Instruments that appear damaged or defective should be made inoperative and secured against unintended operation until they can be repaired by qualified service personnel.**
- **Defective, damaged, or malfunctioning instruments must be returned to The Protectowire Company, Inc.**

Do not operate the instrument in the presence of flammable gases or fumes. Operation of any electrical instrument in such an environment constitutes a safety hazard.

CAUTION

Before you connect any fiber-optic cable to the FIBERSYSTEM 8000 unit, please ensure the optical connectors have been properly cleaned.

Fiber-optic connectors are easily damaged when connected to dirty or damaged cables and accessories. When you use improper cleaning and handling techniques, you risk expensive instrument repairs, damaged cables, and bad measurements.

CAUTION

If the device was stored outside the operating temperature range, you should first wait for the device to acclimatize before turning it on.

2. Attach the FIBERSYSTEM 8000 to a fire safety certified power supply which provides the required safety extra-low voltage as specified. Reference controller Internal Wiring Diagram (IWD drawing) for precise connection points.

3. Switch on the power.

Installing the Software

1. Install the Agilent IO Libraries Suite from the supplied CD on the PC you would like to use to control the FIBERSYSTEM 8000 instrument.

If you are using the FIBERSYSTEM 8000 Configurator software to control the FIBERSYSTEM 8000 instrument, install this from the CD, too. (The FIBERSYSTEM 8000 Configurator software is the easiest way to configure the FIBERSYSTEM 8000 instrument).

Connecting to the Controlling PC

1. Connect the distributed temperature system to the controlling PC.

NOTE

When you connect a USB device, Windows will display a Found New Hardware Wizard. Because your USB device is an Agilent USBTMC instrument, you do not need to insert a CD when prompted by the wizard, because all the drivers you need have already been installed with the IO Libraries Suite. Simply click Next until the wizard completes.

If a second Found New Hardware Wizard appears, continue to click Next until that wizard completes as well. These wizards place the installed USB drivers in the appropriate locations for Windows to recognize your device.

If you are controlling the distributed temperature system over the LAN, you will need to first connect to the distributed temperature system via USB and set the IP address with the FIBERSYSTEM 8000 Configurator (see FIBERSYSTEM 8000 Configurator Guide), if DHCP is not activated or supported by the network.

DHCP:	enabled
IP-address:	0.0.0.0
Host name:	A-N4387B-xxxxxx where xxxxxx denote the last 6 digits of the serial number
Domain name:	The default domain name is an empty string.
Subnet Mask:	255.255.255.0
Default Gate- way:	0.0.0.0

To change these values:

- a) Run the “Agilent Connection Expert:” If the Agilent Connection Expert utility does not run automatically at this time, click the IO Control (IO icon in the Windows notification area) and then click Agilent Connection Expert.
- b) The Agilent Connection Expert will automatically detect most interfaces and instruments, and will assign names and other default configuration settings. If you want to change

these parameters, you can do so in the Agilent Connection Expert window.

- i Select the FIBERSYSTEM 8000 instrument or interface in the explorer pane in the center of the Agilent Connection Expert window.
- ii

The properties of the selected item appear in the properties pane on the right. When you right-click on an item in the explorer pane, you see a shortcut menu of actions that you may take on that item. These actions are also available from the menus at the top of the Agilent Connection Expert window. The most common actions are also listed in the Agilent Connection Expert's

You may also add instruments or interfaces manually to your test system configuration if the Agilent Connection Expert does not automatically detect the hardware (for example, if it is connected via Ethernet).

See the Agilent IO Libraries Suite Online Help for more information on the Agilent Connection Expert and on configuration changes.

c) Test instrument connections:

The Agilent Connection Expert will automatically send an identification query (*IDN?) to any instrument that has its auto-identify property set to Yes. (See the Agilent IO Libraries Suite Online Help if you want to turn this function off.)

When you see a green check mark on the icon representing an instrument, this means that the instrument has responded as expected. (Note that some instruments do not support the *IDN? query and will not respond appropriately.) The instrument's identification information is displayed in the properties pane on the right side of the Agilent Connection Expert window.

You can explicitly test the connections to your instruments, and exercise more of their functionality, by selecting Send commands to this instrument in the task guide or shortcut menu. This starts the Interactive IO utility, which allows you to send commands to your instruments and see their responses. Note that some commands (such as *TST?, instrument self-test) may take longer than Interactive IO's default timeout; you can modify the timeout in the Interactive IO window by selecting Interact > Options...

2. Continue with "Starting the FIBERSYSTEM 8000 Instrument" on page 32.

Front, Rear and Connection Panels of the FIBERSYSTEM

FIBERSYSTEM 8000 Indoor Housing

Frontpanel

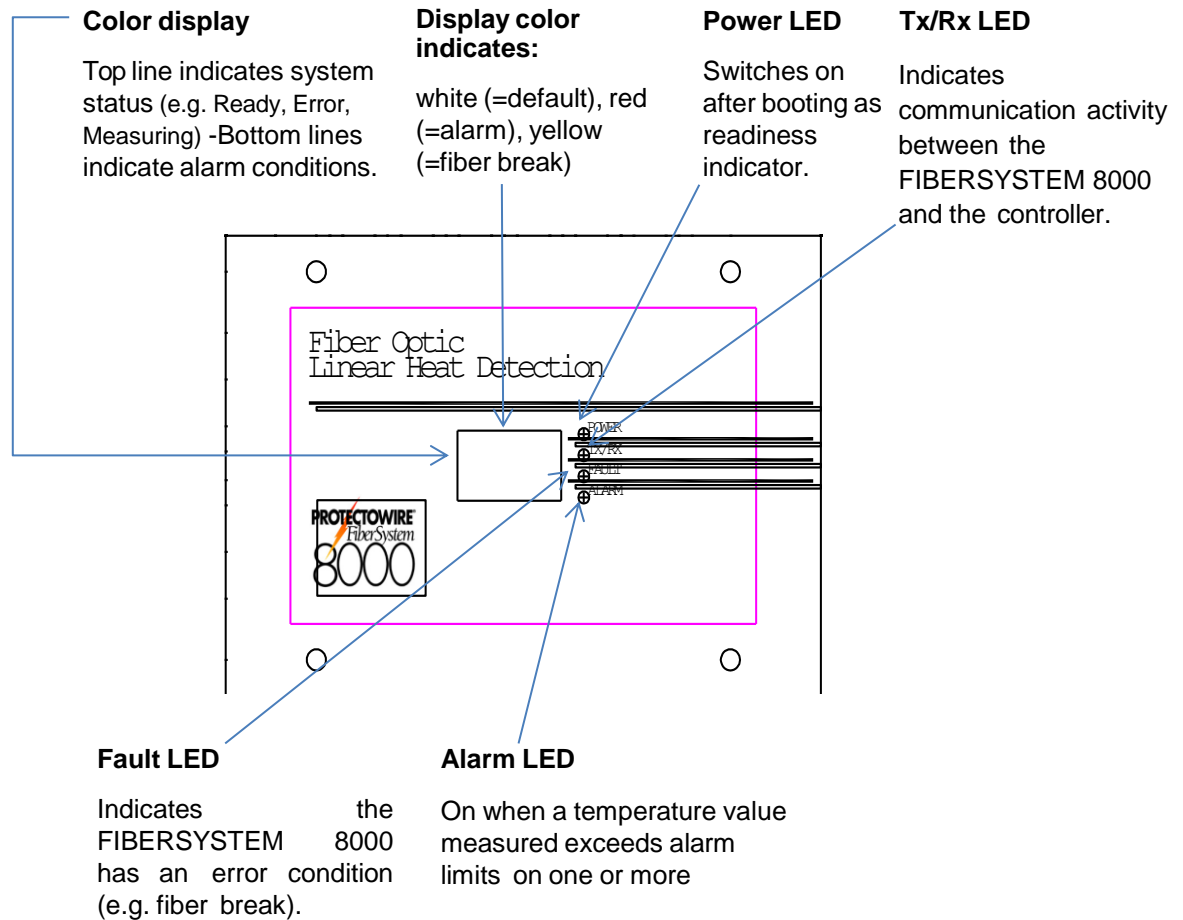

Cardcage
Bottom view

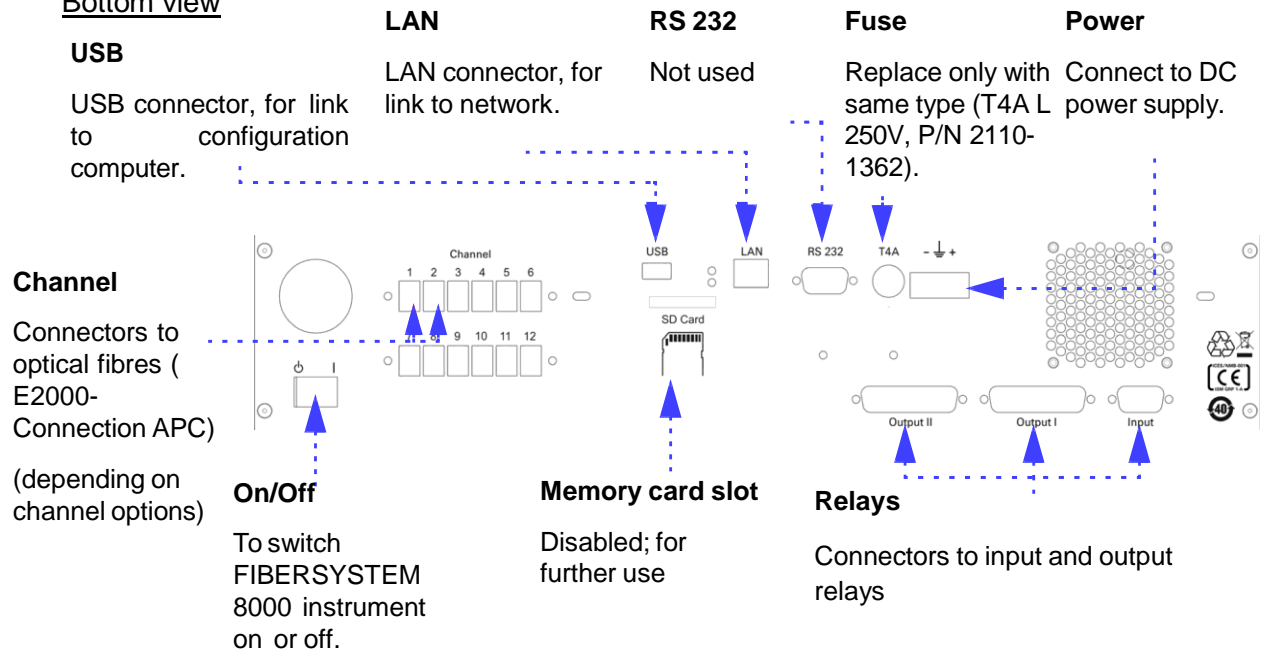

Terminating the Sensor Cable

To guarantee the specification throughout the whole measurement distance, we recommend excess cable of 20 m and a proper fiber termination (for low back reflection).

This can be achieved by ending the cable with a clean angled E2000 connector.

Acceptable alternatives are

- winding at least 5 loops with diameter smaller than 5 mm
- polishing an angle or cleaving of more than 14° to the cable end (and cleaning)
- immersing the (clean) end of the cable in index matching fluid
- any combination of winding, polishing and immersing according to this discription here.

Note: To terminate the sensor cable by polishing or immersing, a clean cable end is necessary.

Connecting to the Output Relays and Input Lines

The FIBERSYSTEM 8000 provides one fault relay and 43 alarm relay outputs (dry contacts) that are capable of notifying the user of alarm conditions.

- The fault relay is normally closed and in the event of an instrument failure or power outage open.
- The alarm relays are normally open and in the event of an alarm condition the contacts will be closed.

Reverse logic can also be programmed. The resulting ability to switch between these two states provides several options for the user. For example, the output can be used to operate external audible alarms or warning lamps.

Each relay circuit consists of an additional serial and parallel resistor as on the figure below.

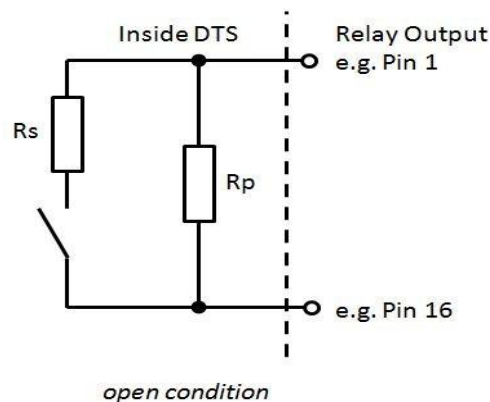

Available order options:

- Standard: $R_s = 0$ Ohm and $R_p =$ unequipped
- Equipped (on request): 1k / 10k with $R_s = 1$ kOhm and $R_p = 10$ kOhm

High density relay board with 43+1 outputs (Option-051)

Standard (without R_p and $R_s = 0$ Ohm):

Programmable relay outputs	44 (22 per connector)
Output connectors	2
Connector type	SUB-D 44pin female
Voltage range	Max. 30 V DC
Current range	Max. 1 A DC

Getting Started

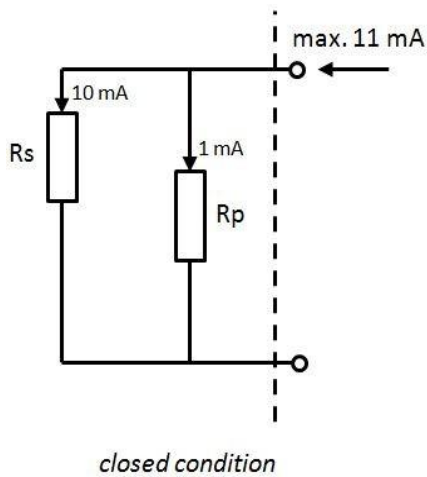

Equipped $R_s = 1\text{ k}\Omega$ and $R_p = 10\text{ k}\Omega$:

Current range	Max. 11 mA DC
Power Dissipation per Relay	Max. 100 mW

Use the HD (High Density) IO connection set (part number A1023A) or the HD relay connection set (part number A1024A) to connect the 44 outputs (option -051) of the internal relay board.

The A1024A (HD relay connection set) consists of:

- 2 x HD Relay Cable SUB-D 44 pins
- 1 x Relay Cable SUB-D 9 pins

The A1023A (HD IO connection set) consists of:

- 2 x HD Relay Cable SUB -D 44 pins
- 2 x HD Connection Box with 44 contacts
- 1 x Relay Cable SUB-D 9 pins
- 1 x Connection Box with 9 contacts

You can mount the connection boxes on a standard c-rail. The outputs contacts are numbered consecutively (1 to 44), with 2 relay outputs on each connector.

The mapping of the outputs is as follows:

Pin assignment connector box 1	
Output 1 - Error	Pin 1, 16
Output 2	Pin 2, 17
Output 3	Pin 3, 18
Output 4	Pin 4, 19
Output 5	Pin 5, 20
Pin assignment connector box 1	
Output 6	Pin 6, 21
Output 7	Pin 7, 22
Output 8	Pin 8, 23
Output 9	Pin 9, 24
Output 10	Pin 10, 25
Output 11	Pin 11, 26
Output 12	Pin 12, 27
Output 13	Pin 13, 28
Output 14	Pin 14, 29
Output 15	Pin 15, 30
Output 16	Pin 31, 32
Output 17	Pin 33, 34
Output 18	Pin 35, 36
Output 19	Pin 37, 38
Output 20	Pin 39, 40
Output 21	Pin 41, 42
Output 22	Pin 43, 44
Pin assignment connector box2	
Output 23	Pin 1, 16
Output 24	Pin 2, 17
Output 25	Pin 3, 18
Output 26	Pin 4, 19
Output 27	Pin 5, 20
Output 28	Pin 6, 21
Output 29	Pin 7, 22
Output 30	Pin 8, 23
Output 31	Pin 9, 24
Output 32	Pin 10, 25
Output 33	Pin 11, 26

Output 34	Pin 12, 27
Output 25	Pin 13, 28
Output 36	Pin 14, 29
Output 37	Pin 15, 30
Output 38	Pin 31, 32
Output 39	Pin 33, 34
Output 40	Pin 35, 36
Output 41	Pin 37, 38
Output 42	Pin 39, 40
Output 43	Pin 41, 42
Output 44	Pin 43, 44

Input to reset alarms

The FIBERSYSTEM 8000 also provides 4 opto-coupled inputs. The inputs are edge-sensitive and their polarity selectable by the user. The inputs can be configured to reset alarms that have already been detected.

Programmable opto-coupled inputs	4
Input connectors	1
Connector type	SUB-D 9 pin female
Input voltage range	12 to 30 V DC, nominal 24 V DC
Input current	5 to 15 mA DC, nominal 11 mA DC
Pin assignment connector 1	
Input 1	Pin 1
Input 2	Pin 2
Input 3	Pin 3
Input 4	Pin 4
GND	Pin 5, 6, 7, 8, 9



2 Making Measurements

Starting the FIBERSYSTEM 26

Starting the FIBERSYSTEM 8000 Instrument

1. Turn on the FIBERSYSTEM 8000 instrument.
2. Allow the instrument to warm up. All 4 LEDs turn on until display is started. Display will turn to white and display "Selftest". During the initial part of the selftest the TX/RX LED will stay on. The instrument is ready when Ready-LED will come on, the other LEDs are off and the word "Ready" is displayed in the upper part of the display. In the bottom line of the display the configured IP address is displayed.

Once the system has been turned on it can be controlled in one of two ways:

- Using the The Protectowire Company, Inc. FIBERSYSTEM 8000 Configurator software supplied with the system.
The User's Guide for the PC software is included on the CD supplied with the distributed temperature system.
- Using your own program. This can be written using SCPI commands.
- For the Programmer's Guide please contact The Protectowire Company, Inc..

NOTE

To get familiar with the instrument and measurement concept we recommend to use the FIBERSYSTEM 8000 Configurator. A Quick and Easy Course is provided on the support CD. It is a step by step course, which takes you through the basic operation.

3 Troubleshooting and Maintenance

This FIBERSYSTEM 8000 system should be serviced only by authorized

Cleaning	28
Replacing the Fuse	32
Checking the Operation of the FIBERSYSTEM 8000 system	33
Returning the Instrument for Service.	35

Cleaning

Safety Precautions

The Protectowire Company, Inc. assumes no liability for the customer's failure to comply with these requirements.

WARNING

Do not remove instrument covers when operating.

Ensure that the instrument is switched off throughout the cleaning procedures.

Even there is no direct danger for the eyesight because of the low laser power we suggest to not look directly into an optical device attached to an optical output when the device is operational.

Use of controls or adjustments or performance of procedures other than those specified may result in hazardous laser radiation exposure.

To prevent electrical shock, disconnect the instrument from the mains before cleaning. Use a dry cloth, or one slightly dampened with water, to clean the external case parts.

Do not open the card cage inside the FIBERSYSTEM 8000, or attempt to clean it internally.

Do not install parts or perform any unauthorized modification to optical devices.

Refer servicing only to qualified and authorized personnel.

What do I need for Proper Cleaning?

To clean the optical connectors and adapters on the FIBERSYSTEM 8000, we recommend

- Service adapter for E2000 (see following picture), article number N4385-43201 (one adapter is supplied with the instrument)
- Cleaning paper for connectors, article number N4385-88501 (package of 10 sheets, supplied with the instrument).

- For thorough connector cleaning, e.g. after touching the open connector end), perform wet cleaning using pure Isopropanol in combination with the cleaning paper.

Alternatives:

- Quick thorough cleaning of connectors: cartridge cleaning tools (such as OPTIPOP or CLETOP) or a card cleaner.
- Direct cleaning of the sensor plugs or for cleaning adapters: use a stick cleaner or the Diamond Ferrule Cleaner 2.5 (Diamond part number BCC 1030609).

Cleaning FIBERSYSTEM 8000 Instrument Housings

Use a dry and very soft cotton tissue to clean the instrument housing. In the case of heavy dirt, you can moisten the cotton tissue in water.

Preserving Connectors

Making connections

Before you make any connection ensure that all cables and connectors are clean. If they are dirty, use the appropriate cleaning procedure.

Sensor plug caps

Always make sure the dust cap on the E2000 connector tip closes when the connector is not in use.

Cleaning the Optical Connectors and Adapters

To clean the connector

1. Unplug the power supply.
2. The E2000 connector(s) on the FIBERSYSTEM 8000 are inside the enclosure.



To clean these connectors thoroughly, open the enclosure door.

3. Remove the connector from the panel adapter.
4. Open the dust cap on the connector tip using the E2000 service adapter.

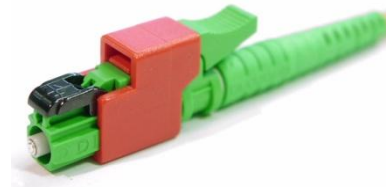

5. Clean the end face of the connector:
 - a) Gently rub the connector end against an absolute clean area of a cleaning paper. Be sure the paper is not contaminated by dust or fingerprints. We recommend to discard a sheet after giving it out of the hand.
 - b) For thorough cleaning, the dirt shall be wiped away using pure Isopropanol. Spill some drops Isopropanol on a small area of the cleaning paper. Gently rub the connector end over this location, then before the connector dries, rub it against a dry area.



- c) Alternately clean the end of the connector using a cartridge cleaner or card cleaner.
6. Remove the service adapter.
7. Reinsert the connector in the panel adapter.
8. When you have finished cleaning the connectors, put on the cover and screw it back into place.
9. Continue to clean the ferrule (see "To clean the adapter" on page 37)

To clean the adapter

If you are using stick cleaners,

1. Take a fresh stick cleaner
If you need to wet clean the adapter to remove heavy dirt, wet the stick cleaner with ethanol or propanol.
2. Use a small pointed object to press down the dust protector inside the adapter.
3. Insert the stick cleaner into the adapter.
4. Rotate the stick cleaner 3 or 4 turns.
5. Remove the stick cleaner and dispose of it.

If you are using a Diamond Ferrule Cleaner, follow the instructions that came with the device.



Replacing the Fuse

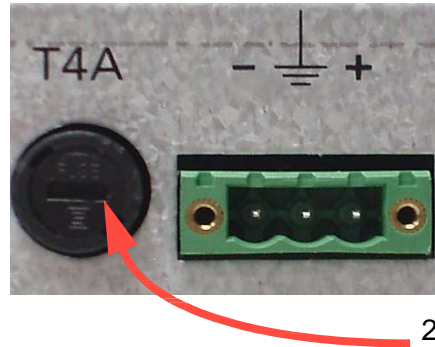

1. Unplug the power supply.
2. On the bottom of the card cage assembly, use a flat-tipped screwdriver to open the fuseholder.
3. Pull the fuse holder and fuse clear of the back panel.
4. Take the fuse out of the fuse cap and note the fuse rating.
5. Make sure the replacement fuse (4A, 250V, The Protectowire Company, Inc. part no. 312004) has the same rating.
6. Put the fuse into the fuse holder.
7. Put the fuse and fuse cap into the receptacle in the rear of the case and press it into place.

Checking the Operation of the

Set the measurement system

1. Power down the distributed temperature system.
2. Setup the hardware and connect the FIBERSYSTEM 8000 to the controlling PC (“Setting up the Hardware” on page 14)
3. Connect a fiber to the unit.
4. Switch-on the FIBERSYSTEM 8000
5. Observe boot process:

Observe the LED’s on the FIBERSYSTEM 8000 front panel while booting

- a) At the start of booting all LED’s are on for a few seconds.
- b) As booting continues, the display will turn on with white background and will initially show “Self test” in the top row.
- c) “Ready” in the top row and the Ready LED switched on to indicate the end of the boot process.
The FIBERSYSTEM 8000 is ready to use.

Check the following error conditions:

- All LEDs off: Check the power supply. Check the Power switch at the rear.
Check the fuse on the rear panel of the FIBERSYSTEM 8000 (“Replacing the Fuse” on page 38).
- The FIBERSYSTEM 8000 doesn’t finish the boot process or the error LED “**Fault**” is on:
Switch the FIBERSYSTEM 8000 off and on and try again.
- If the error conditions still exist, contact The Protectowire Company, Inc. for support.

Configure the FIBERSYSTEM

1. Setup the FIBERSYSTEM 8000 using the “Agilent Connection Expert” included in the Agilent IO Libraries (please refer to the information supplied with the IO Libraries)

The Agilent Connection Expert on your PC should find the FIBERSYSTEM 8000 and identify it with the identification query (*IDN?)

2. Start the Configurator Software
3. Setup and start a measurement with the FIBERSYSTEM 8000 Configurator software (please refer to the information supplied with the FIBERSYSTEM 8000 Configurator software)

If there is a measurement problem, check if the sensing fiber is correctly connected.

If you still have a problem, contact The Protectowire Company,

Check the sensing fiber

The sensor cable is verified in the “loss-trace” provided with a FIBERSYSTEM 8000 instrument.

- A typical loss-curve shows a continuous loss of signal power over distance

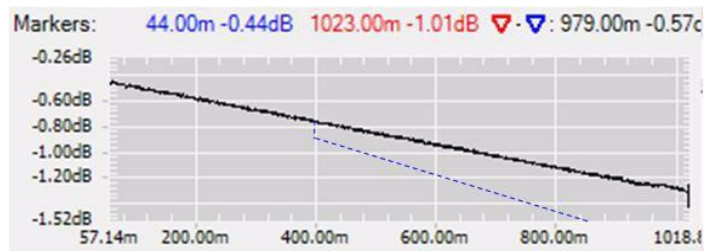

- Connections (plug-ins or splices) have to be seen as steps in the loss-curve (as in the picture above at 400 m)
- Changes to other fiber types can result in different gradient (in picture dashed blue)
- A fiber break results in a step to a low level in the loss-curve (like -80 dB)
- A typical connector loss is around 0.25 dB, a typical value for a splice is around 0.05 dB (at about 1064 nm, 50 um multimode fiber). For values higher than 0.4 dB (connector) or 0.1 dB (splice), one should consider to clean, repair or substitute the connector or to re-do the splice.

NOTE

A bad connection may cause high reflections that may disturb the measurement results in the proximity of the connection.

NOTE

Connection of two fiber types with different properties may cause a step in the loss trace (positive or negative, depending on the fiber properties), which is not caused by the connector.

Returning the Instrument for Service

NOTE

Before returning the instrument to the service center, you need to return it to the original status (for example, by re-splicing connectors), otherwise the return will be treated as a repair.

The Protectowire Company, Inc. aims to maximize the value you receive, while minimizing your risk and problems. We strive to ensure that you get the test and measurement capabilities you paid for and obtain the support you need. Every instrument and system we sell has a global warranty. Support is normally available for at least five years beyond the production life of the product.

Our Promise

Your FIBERSYSTEM 8000 will meet its advertised performance and functionality. When you use The Protectowire Company, Inc. equipment, we can verify that it works properly, help with product operation, and provide basic measurement assistance for the use of specified capabilities on request.

Your Advantage

The Protectowire Company, Inc. offers a wide range of additional expert services, which you can purchase according to your unique technical business needs. Solve problems efficiently and gain a competitive edge by contracting with us for calibration, extra-cost upgrades, out-of-warranty repairs, and on-site education and training, and other professional engineering services. Experienced The Protectowire Company, Inc. engineers and technicians worldwide can help you maximize your productivity, optimize the return on investment of your The Protectowire Company, Inc. instruments and systems, and obtain dependable measurement accuracy for the life of those products.

The Protectowire Company, Inc. Contact

For more information about The Protectowire Company, Inc. products, applications and services, please visit our web site:

- www.protectowire.com

or contact us by phone or fax:

- (tel) +001 781 826 3878
(fax) +001 781 826 2045

4 Specifications and Regulatory Information

Introduction	37
Definition of Terms.	38
Angled Connector Specifications.	45
Specifications	46

Introduction

This chapter contains specifications and characteristics for the Protectowire FIBERSYSTEM 8000 Fiber Optic Linear Heat Detector

Definition of Terms

Absolute accuracy (uncertainty)

When taking the difference between measured temperature and actual temperature of the sensing fiber, ΔT_i , over measurements i throughout operating temperature range and throughout sensing fiber temperature range, the Absolute accuracy (uncertainty) T_{Abs} is calculated as:

$$T_{Abs} = \text{StDev}_i\{\Delta T_i\}$$

“StDev_{*i*}” denotes the standard deviation over index i (over a sufficiently large sample base).

The statistics (standard deviation) is based on an ambient temperature evenly distributed over the operating temperature range and a sensing fiber temperature evenly distributed over the sensing fiber temperature range over measurements i .

Conditions: Uniform temperature distribution within the fiber. After calibration of the sensing fiber as specified. Other conditions as specified.

Note: Calibration of the sensing fiber adjusts the temperature difference ΔT_i , at the calibration points to zero.

Note: Any temperature offset or nonlinearity of the user's reference thermometer used for calibration of the sensing fiber leads to a corresponding temperature scale error of the FIBERSYSTEM 8000 unit.

Distance range

The maximum distance from the FIBERSYSTEM 8000 that can be covered by a measurement (e.g. along a bore hole, along a tunnel or along a power cable). The distance range depends on the sensor configuration (see “Single-ended” and “Dual-ended”).

Dynamic range

The maximum two-way loss within the sensing fiber to and from the measured point for which the FIBERSYSTEM 8000 unit is designed.

Note: The two-way loss in dB is twice the (one-way) loss of the sensing fiber from the FIBERSYSTEM 8000 unit system to the

Specifications and Regulatory Information

If not differently stated, Dynamic Range applies to spatial resolution 2 m and maximum channel option.

Measurement: the dynamic range value is derived from the specification assuming a sensing fiber with loss per kilometer as specified.

Fiber distance

The distance along the sensor fiber from the FIBERSYSTEM 8000 connector to a measurement point. A FIBERSYSTEM 8000 trace shows temperature or loss over fiber distance.

Intermediate update time - itut

Selectable parameter for the time until an intermediate temperature trace is available from the FIBERSYSTEM 8000. An intermediate trace shows the measurement progress during one measurement time - mtime (see Measurement time - mtime), but with limited temperature resolution (see Temperature resolution). It is intended to give a quick (unspecified) view to an installer. No alarm analysis is done on intermediate traces.

Note: Intermediate traces are not stored within the FIBERSYSTEM 8000 after completion of a measurement. They are continuously displayed, but not stored by the FIBERSYSTEM 8000 Configurator.

Internal data storage capability

Number of traces that can be simultaneously kept in the internal volatile memory of the FIBERSYSTEM 8000 unit.

Measurement time (per channel) - mtime

Selectable parameter for the time a FIBERSYSTEM 8000 acquires measurement data on one channel for calculating a temperature trace. In a repeated measurement, it is also the period between two measurements.

In dual-ended mode, it is the time per direction.

Note: mtime must be equal to itut (see Intermediate Update Time) or an integer multiple (e.g. mtime of 30 s with an itut of 10 s).

Minimum sampling interval

Specifies the minimum spatial distance of two consecutive result points in the measured temperature profile (see figure under Spatial Resolution).

Operating temperature and humidity range

Environmental temperature range and humidity range of the FIBERSYSTEM 8000 unit for which the specifications apply.

Conditions: All specifications apply for environmental temperature change max. $\pm 20^{\circ}\text{C}$ per hour.

Note: For a FIBERSYSTEM 8000 unit mounted in a rack the environmental conditions within the rack apply.

Note: For the temperature range of the sensing fiber see *Sensing fiber temperature range*.

Optical interface

Nominal properties of the optical port (sensor port) of the FIBERSYSTEM 8000 unit.

Reference sensing fiber

Fiber type as specified. Conditions: Fiber without contusions, sharp bends, splices and connectors (if not differently stated) that affect the light transmission.

Sensing fiber temperature range

Specifies the measurable temperature range for which the FIBERSYSTEM 8000 unit is designed.

Note: The actual temperature range of a sensing fiber depends on the sensing fiber type (e.g. coating).

Spatial resolution

Specifies the slope width of a measured step temperature profile ΔT (rising or falling). The slope width is defined as the spatial distance between the measured 10% and 90% levels of the slope, with 0% and 100% being the stationary temperature levels before or after the step, see figure.

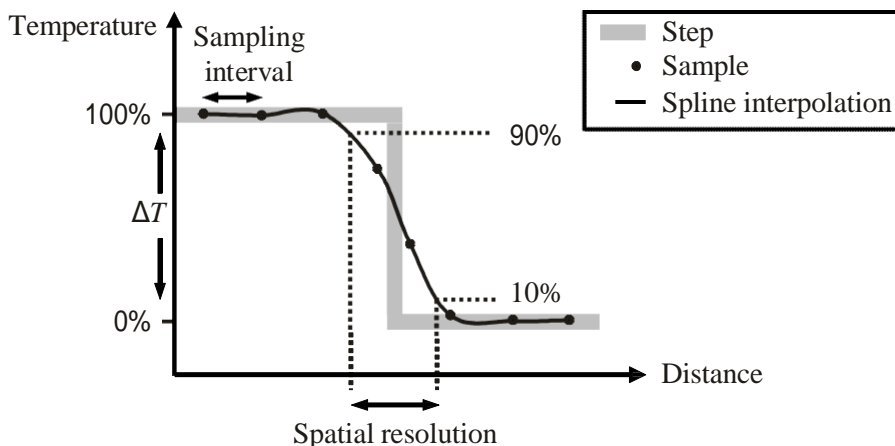

Measured temperature profile on a step temperature profile.

Spatial resolution does not include noise effects.

Conditions: Spatial resolution setting as specified. Sampling interval set to minimum. Other parameters as specified.

Measurement: An ideal step change in temperature of ΔT 10°C (rising or falling) is measured with the FIBERSYSTEM 8000 instrument. The points of the measured slope are connected using a cubic spline interpolation.

Specification

Specification describes a guaranteed product performance. Specifications are based on a coverage factor¹ of 2 (unless otherwise stated), corresponding to a level of confidence of >95%.

Generally all Specifications are valid at the stated operating conditions and measurement settings, for environmental temperature change $\Delta 20$ °C per hour, with a sensing fiber type as specified and with the sensing fiber spliced to the FIBERSYSTEM 8000 instrument.

Fiber length quantities (these are: distance range, fiber length, spatial resolution) are measured along the fiber. If the fiber is wound within a cable, a corresponding factor must be considered to transform from fiber length to cable length.

Temperature repeatability (standard deviation)

Specifies the variation of the measured temperature A_i in repeated measurements i at the same location within the sensing fiber under constant conditions. Temperature repeatability (standard deviation) T_{Rep} is calculated as:

$$T_{Rep} = \mathbf{StDev}\{ A_i \}$$

“StDev $\{i\}$ ” denotes the standard deviation over index i (over a sufficiently large sample base).

Temperature repeatability includes the effects from channel switching between repetitions.

Conditions: Constant properties of the sensing fiber, same temperature distribution within the sensing fiber between repetitions. Other parameters and conditions as specified.

Temperature repeatability throughout operating temperature range (standard deviation)

Same as “Temperature repeatability (standard deviation)”, but with the ambient temperature being allowed to change over repetitions. The statistics (standard deviation) is based on an ambient temperature evenly distributed over the operating temperature range over repetitions i .

Conditions: same as for “Temperature repeatability (standard deviation)”.

**Temperature resolution
(standard deviation over distance)**

Specifies the variations in the measured temperature at points i along the sensing fiber held at uniform temperature. Only higher spatial frequencies of the variations are considered. Higher frequency variations are calculated as the difference H_i between measured curve and smoothed curve. The smoothed curve is calculated as the average measured temperature within a smoothing window around each point i .

Temperature resolution $TRes$ is calculated as:

$$TRes = \text{StDev}_{\text{true},i} \{ H_i \}$$

$\text{StDev}_{\text{true},i}$ denotes the true standard deviation over points i .

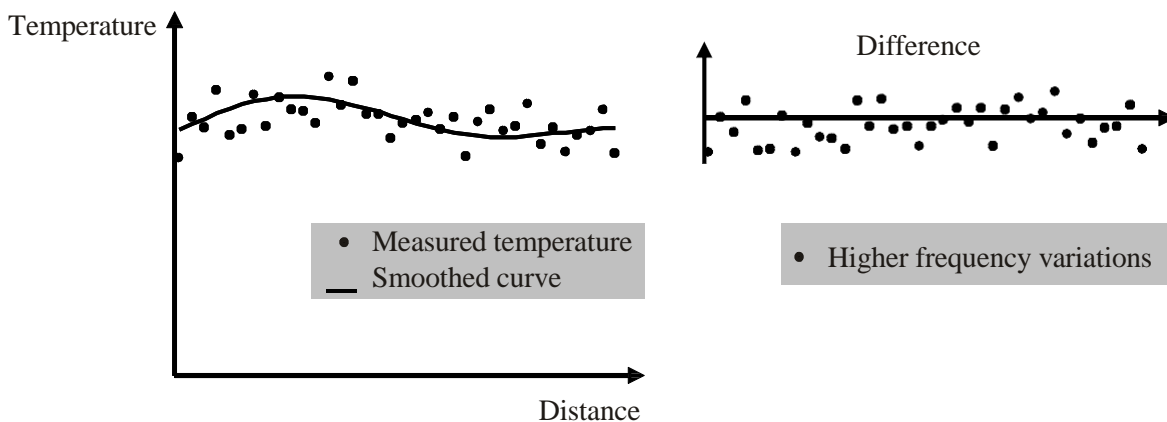

Conditions: Using a “Reference sensing fiber”. Sensing fiber with maximum length and loss as specified. Spatial resolution as specified.

Note: The true standard deviation is derived from the empirical standard deviations of repeated measurements. The empirical standard deviation of a single measurement may be higher or lower than the specified value.

Measurement: Smoothing window size $s = 50$ m (± 25 m around each point). Sampling resolution set to minimum (0.5 m).

Typical value

Typical value is a characteristic describing the product performance that is usually met, but not guaranteed.

References

(1) according to the “Guide to the Expression of Uncertainty in Measurement”, BIPM, IEC, ISO et al. (1993)

Angled Connector Specifications

Specifications require an angled connector at the optical interface.

Angled contact connectors help you to control return loss. With angled fiber endfaces, reflected light tends to reflect into the cladding, reducing the amount of light that reflects back to the source.

The contact connector on your distributed temperature system is an E2000 APC angled, you can only use a cable with angled connectors. Never connect a straight connector directly to an angled connector.

Specifications

Each FIBERSYSTEM 8000 instrument is individually tested and must pass defined test limits.

The test and specification process follows strict guidelines. Offering a thorough data sheet backed by stringent quality control measures guarantees best performance and application fit over time.

	PTS-8101...6 (N4387B -001...006)	PTS-8108 (N4387B-008)	PTS-8110 (N4387B-010)
Distance range	1 km – 6km	8 km	10 km
Minimum spacial resolution	0.75 m	0.75 m	0.75 m
Maximum sampling interval	0.25 m	0.25 m	0.25 m
Temperature resolution (standard deviation over distance) Measurement time: 30 Seconds Sampling Interval: 0.25 m to 1 m Spatial resolution: 2 m	0.6 deg. C	1.0 deg. C	2.0 deg. C
Temperature repeatability (standard deviation)	0.3 deg. C	0.3 deg. C	0.3 deg. C
Temperature repeatability throughout Operating temperature range (standard deviation)	1.5 deg. C	1.5 deg. C	1.5 deg. C
Absolute accuracy (uncertainty)	+/- 2.0 deg. C	+/- 2.0 deg. C	+/- 2.0 deg. C

Housing & Environmental Conditions

Operating temperature range	-10 °C to +60 °C	
Storage temperature range	-40 °C to +80 °C	
Operating humidity range	0 % to 95 % r.h. non condensing	
Dimensions (H x W x D)	88 x 448 x 364 mm ⁷	500 x 400 x 150 mm
Weight	9 kg	17 kg

Specifications and Regulatory Information

Supplementary Information

Sensing Fiber

Fibertypes	MM 50/125 μm graded index MM 62.5/125 μm graded index
Sensing temperature range	-273 °C to +1200 °C depending on sensor coating

Interfaces

Optical Connector	E2000 APC 8° angled
Number of channels	1 (N4387B-100) 2 (N4387B-200) 4 (N4387B-400)
Computer interface	USB, Ethernet (LAN)
Communication Protocol	SCPI; Modbus TCP/IP (Option N4387B-060)
Relay board (internal)	Volt-free contacts, 4 input 43+1 outputs (Option N4387B-051)
Power supply	10 V to 30 V DC ⁸
Power consumption Indoor Housing, Outdoor Housing	17 W typically, at 20 °C ambient temperature; < 40 W (entire operating conditions)

Other

Measurement times	10 s, 20 s or 30 s (selectable)
Available spatial resolution settings	0.5 m, 1 m, 2 m, 4 m, 6 m, 8 m (selectable)
Available measurement modes	Single ended; Dual ended (incl. fiber break recovery)
Internal data storage capability	120 traces total
Power supply (option) operating conditions	0 °C to +50 °C; non condensing, indoor use only
Laser class (IEC 60825-1:2001)	1M (eye-safe)

¹ Sensor fiber: multi-mode 50/125 μm , attenuation 0.9 dB/km @1064 nm (0.7 dB/km @1300 nm, 2.4 dB/km @850 nm), bandwidth: >300 MHz. Fiber within temperature range -5 °C to +90 °C. Sensing fiber end terminated and spliced to instrument. Instrument settings (if not stated differently):

- Measurement time: 10 min, intermediate update time: 30 s
- Sampling interval: 1 m; spatial resolution: 2 m
- Single ended measurement

² First 500 m of fiber, thereafter add 0.07 m/km to account for chromatic dispersion effects (600 MHz*km bandwidth). Dual-ended: 1.0 m + 0.04 m per km for chromatic dispersion.

³ For 1 channel option

⁴ Curve averaged over 50 m, measured at 2 km (option -002), or 4 km (other options).

⁵ After calibration of the sensing fiber at +20 °C and +65 °C. Average over first 50 m of the sensing fiber.

⁶ VdS compliance H01D or H02D, UL/ULC compliance H01D or HW2D.

⁷ For connectors in the back 500 mm installation depth recommended.

⁸ UL/ULC compliance requires 11.1 V to 30 V DC

5 Ordering Information

The Protectowire Company, Inc. offers a wide range of FIBERSYSTEM 8000 instruments, sensor cables, as well as other Accessories from The Protectowire Company, Inc. and it's Solution partners.

Detailed information available at: www.protectowire.com.

Index

A

Absolute accuracy (uncertainty) [38](#)
acclimatization [15](#)
Agilent Connection Expert [16](#)
Agilent IO Libraries Suite [15](#)

C

certification [2](#)
cleaning [28](#)
 disconnect from power [10](#)
concept [6](#)
connection
 testing [17](#)
connector
 see optical connector, relay

D

disposal [13](#)
Distance [39](#)
Distance range [38](#)
Dynamic range [38](#)

E

earth connection [9](#)
environmental information [13](#)

F

fuse
 replacing [32](#)

H

housing
 cleaning [28](#)

I

I/O configuration
 testing [17](#)
input connector [24](#)
 see also relay
instrument marking [9](#)
Internal data storage capability [41](#)
ISO 9001 [2](#)

L

LAN parameters
 changing [16](#)
 default [16](#)
laser source [11](#)

M

measurement concept [6](#)
Minimum sampling interval [40](#)

O

Operating temperature and humidity
range [40](#)
operation
 checking [33](#)
optical connector
 cleaning [28](#)
 preserving [34](#)

output connector [22-24](#)
 see also relay

P

PC
 connecting [16](#)
power supply
 attaching [15](#)

R

Raman effect [6](#)
relay
 connecting [21](#)
 connector pin assignment [22-24](#)
returning for service [35](#)

S

safety [8](#)
sensor fiber
 terminating [20](#)
service
 returning [37](#)
Spatial resolution [41](#)
specifications
 angled connector [45](#)

certification [2](#)

symbol on instrument [9](#)

T

Temperature repeatability (standard
deviation) [42](#)
Temperature repeatability throughout
operating temperature range (standard
deviation) [42](#)
Temperature resolution (standard
deviation over distance) [43](#)
terminating sensor fiber [20](#)
terms
 definition [40](#)

U

unpacking [14](#)

W

warm up [26](#)
warranty [2](#)

© 2011 The Protectowire Company Inc.
Man-2004 August 2013

The Protectowire Company, Inc
60 Washington Street
Pembroke, MA 02359
Tel: (781) 826-3878
Fax: (781) 826-2045
www.protectowire.com