

MICROFILMED
MAY 14 1984

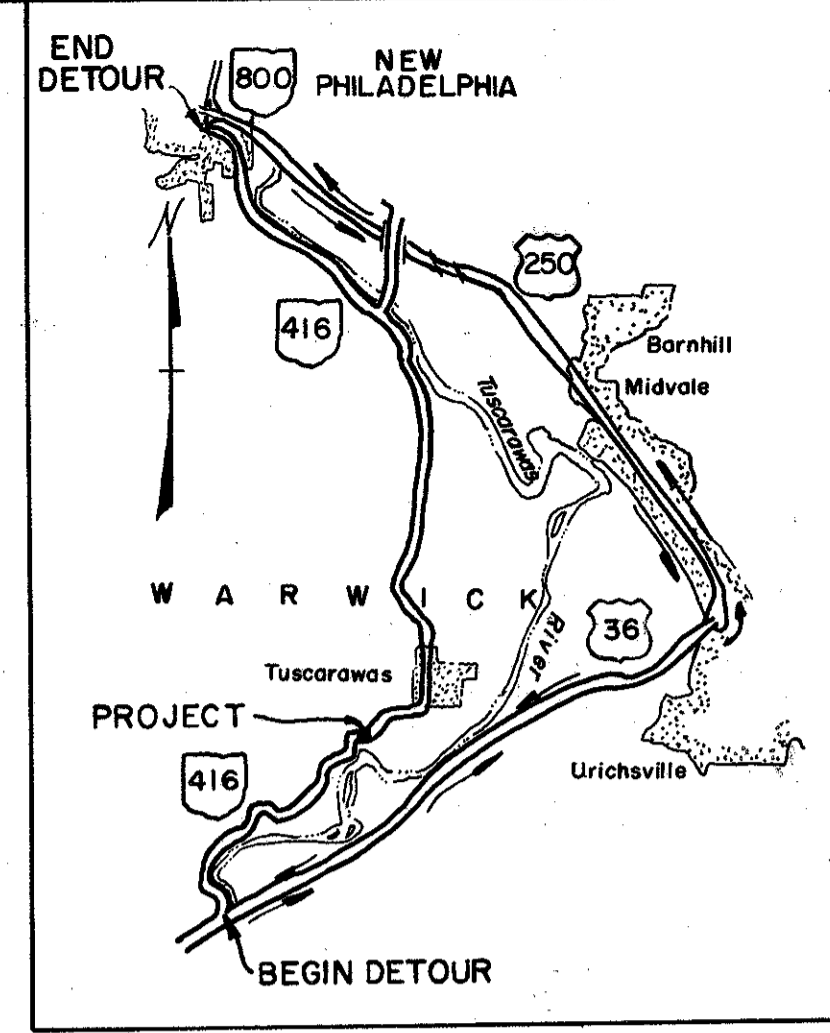

STATE OF OHIO DEPARTMENT OF TRANSPORTATION

OHIO	1
FHWA REGION	5
FEDERAL PROJECT	

TUS-416-00.00

MICROFILMED
AUG 31 1987

PLAN NO. BR-26-79

TUS-416-0.00 TUSCARAWAS COUNTY BR. NO. TUS-416-0313

CONVENTIONAL SIGNS

- | | | | | |
|--------------------------|-----------------|-------------------------------|---------------------------|---------|
| County Line | ----- | Limited Access (only) | ----- | LA |
| Township Line | ----- | Right of Way (only) | ----- | RW |
| Section Line | ----- | Limited Access & Right of Way | ----- | LA & RW |
| Corporation Line | ----- or ----- | Existing Right of Way | ----- | |
| Fence Line (existing) | -x-x- | Property Line | ----- (in existing fence) | -x-x- |
| Center Line | ----- | Railroad | ----- or ----- | |
| Trees | (to be removed) | Guardrail (existing) | ----- (proposed) | ----- |
| Utility Poles: Telephone | φ | | | |
| Power | φ | | | |
| Light | φ | | | |

INDEX OF SHEETS

Title Page	1
General Notes & Summary	2
Plan & Profile	3
Cross Sections	4
Drainage & Typical Section	5

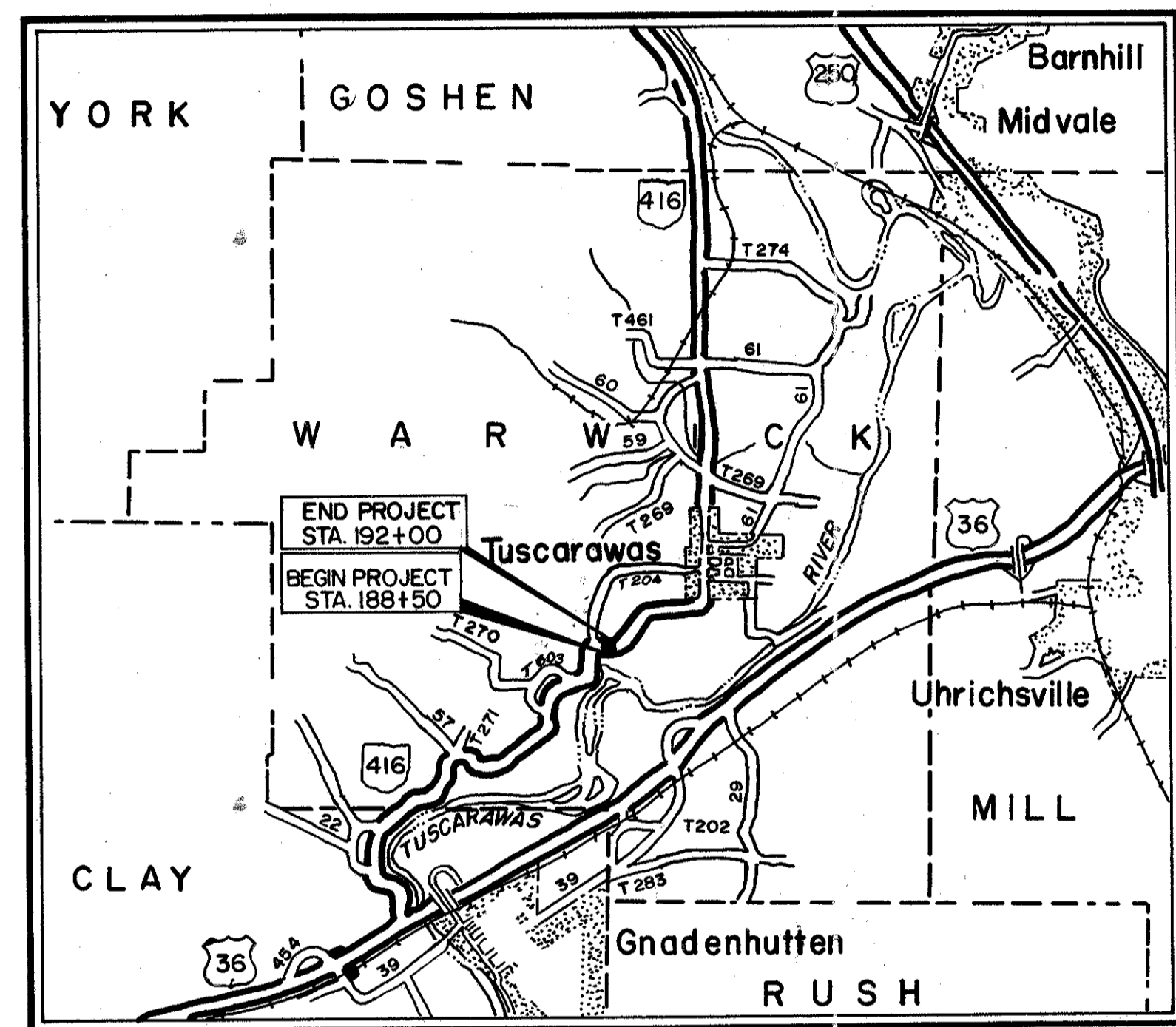

LOCATION MAP

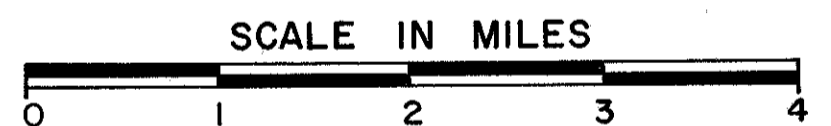

- Portion to be improved _____
- State & Federal Routes _____
- Other Roads _____

SCALES

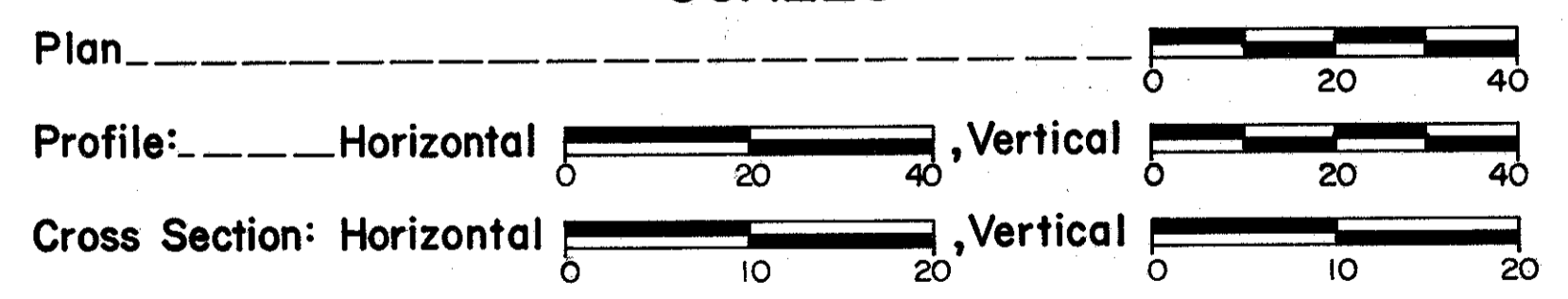

SUPPLEMENTAL SPECIFICATIONS	

SUPPLEMENTAL PRINTS OF STANDARD CONSTRUCTION DRAWINGS

Code	Date				
GR-1	12-6-76				
GR-2B	12-6-76				
GR-4	12-6-76				
MC-3	6-1-73				
SR-53	6-30-61				

Plan Prepared By: _____

SEAL

1979 SPECIFICATIONS

The standard specifications of the State of Ohio, Department of Transportation, including changes and supplemental specifications listed in the proposal shall govern this improvement.

The right of way for this improvement will be provided by the State of Ohio.

I hereby approve these plans and declare that the making of this improvement will require the highway to be closed to traffic and provisions for the maintenance and safety to traffic will be as set forth in these plans and estimates

Approved George E. Nelson
Date 4-17-79 District Deputy Director of Transportation

Approved Robert B. Pfeiffer
Date 4-18-79 Engineer, Bureau of Bridges and Structural Design

Approved C. Clark Street
Date 4-24-79 Chief Engineer, Planning and Design or Chief Engineer, Operations

Approved David L. Wein
Date 4-24-79 Director, Department of Transportation

DEPARTMENT OF TRANSPORTATION
FEDERAL HIGHWAY ADMINISTRATION

APPROVED: _____

DIVISION ADMINISTRATOR _____ DATE _____

SUMMARY

Item	Total	Unit	Description
201	Lump	Lump	Clearing and Grubbing
202	Lump	Lump	Portions of Structures Removed
202	625	Lin. ft.	Guardrail removed for Reuse or Storage
203	210	Cu. Yds	Excavation not including embankment construction
203	1016	Cu. Yds	Embankment
305	91	Sq. Yds.	Portland Cement concrete base, $t=9"$
404	2.5	Cu. Yds	Asphalt Concrete, AC-20
407	36	Gals.	Tack Coat, RT-2 or RT-3, MC-30 or MC-70 or Primer 20
407	0.5	Tons	Cover Aggregate
411	5.55	Cu. Yds	Stabilized crushed aggregate
601	75	Sq. Yds	Riprap, using 6" Reinforced Concrete Slab
601	21	Cu. Yds	Rock Channel protection, Type B, with bedding
602	51	Cu. Yds	Concrete masonry
603	61	Lin. ft.	16-7" X 10-1" Conduit, type A, 707.03, 0.128-0.249, installed as per plan.
606	512.5	Lin. ft.	Guardrail rebuilt, Type 5
606	4	Each	Anchor assembly, rebuilt
614	Lump	Lump	Maintaining traffic
619	Lump	Lump	Field office
659	0.15	Ton	Commercial Fertilizer
659	0.72	Ton	Agricultural liming
659	1609	Sq. Yd	Seeding and mulching
624	Lump	Lump	Mobilization

Station Log		Side	202	202	606	606
From	To		Guardrail Remove for Reuse Lin. ft.	Anchor Assembly Remove for Reuse Lin. ft.	Guardrail Type 5 rebuilt Lin. ft.	Anchor Assembly Rebuilt Each
188+77	191+89.5	Lt	262.5	50	262.5	2
188+79.5	191+79.5	Rt	262.5	50	250	2
Total Direct to General Summary (This sheet.)			525.0	100	512.5	4

GUARDRAIL OVER CONDUIT:

Where sufficient post depth is not available due to conduit, guardrail post directly over conduit shall be set in holes, and encased in a minimum of 4" thickness of Class C Concrete for the full depth of the post, or as detailed on Std. Dwg. GR-1 (dated 12-6-76) for inlet mounted post. The method shall be approved by The Engineer. Payment for the above shall be included in the unit price bid for Item 606-Guardrail Rebuilt, Type 5.

GUARDRAIL REMOVED FOR REUSE OR STORAGE

The existing guardrail, including rail element on structure, shall be carefully dismantled and stored for reuse, as portions of the proposed guardrail. All necessary labor, equipment and materials required shall be included in the unit price bid for Item 202, Guardrail removed for reuse and for Item 202, Anchor assembly removed for reuse.

STANDARD DRAWINGS:

Reference shall be made to Standard Drawings:
 GR-1 Dated 12-6-76 MC-3 Dated 6-1-73
 GR-2B Dated 12-6-76 SP-53 Dated 6-30-61
 GR-4 Dated 12-6-76

FHWA REGION	STATE	PROJECT	
5	OHIO		

2
5

TUS-416-00.00

GENERAL NOTES

WORK REQUIRED:

1. Remove portions of existing structure, as per plan.
2. Remove guardrail, as per plan.
3. Install conduit, as per plan.
4. Preform excavation and place embankment.
5. Place new pavement, as per plan.
6. Install rebuilt guardrail, as per plan.
7. Preform seeding and mulching.

REMOVAL OF TREES and STUMPS:

All trees and stumps specifically marked for removal within the construction limits shall be removed under the lump sum price bid for Item 201, Clearing and Grubbing. The following is an approximate estimate of the number and size of trees and stumps to be removed.

Size	No. Trees	No. Stumps
12"	1	0
24"	3	0

The above estimate is approximate and the State of Ohio reserves the right to order the removal of additional trees or stumps outside the construction limits but within the right of way and/or right of entry limits. Payment for the removal of these additional trees or stumps shall be included in the lump sum price bid for Item 201, Clearing and Grubbing.

SEEDING:

Quantities for seeding are calculated for soil area between work limits as shown on the cross-sections.

ROUNDING OF CORNERS:

The rounded corners, shown on the TYPICAL SECTION, apply to all cross sections even though otherwise shown on these plans.

LOCATION OF GUARDRAIL:

The location of guardrail runs as shown in these plans are subject to adjustment by the Engineer to assure that the planned installation will afford maximum protection for traffic.

PORTIONS OF STRUCTURE REMOVED:

The existing structure shall be removed under Lump Sum price bid for Item 202, Portions of structures removed. This removal includes asphalt wearing surface, 4" Creosote wood deck, 10-15" I beams, 2-15" Channels, railing posts and concrete back walls and wing walls to an elevation one foot below bottom of new concrete base and/or one foot below finished surface. These materials shall become the property of the contractor.

ITEM 603, 16-7" X 10-1" CONDUIT, TYPE A, 707.03, 0.128-0.249, Installed as per plan:

The State of Ohio will furnish the plates and part of the bolts. This material is available for pick-up by The Contractor at the Ohio Department of Transportation, Tuscarawas County Garage, County Road 21, New Philadelphia Ohio. The conduit was manufactured by The Armco Steel Corporation, Middletown, Ohio.

All necessary labor, hauling, loading, equipment and additional materials required to complete the installation of the conduit shall be included in the unit price bid per linear foot for Item 603, 16-7" X 10-1" Conduit, Type A, 707.03, 0.128-0.249, installed as per plan.

MAINTAINING TRAFFIC:

When no longer needed to maintain traffic portions of the existing structure shall be removed as per plan.

SP-53 ENDWALLS:

The left wall shall be Standard as per Std. Dwg. No SP-53 (dated 6-30-61) The right wall shall be Modified, as per plan. The height is to be increased to 11-2 and the base to 3-9". This will require two additional anchor bolts, one in each wing.

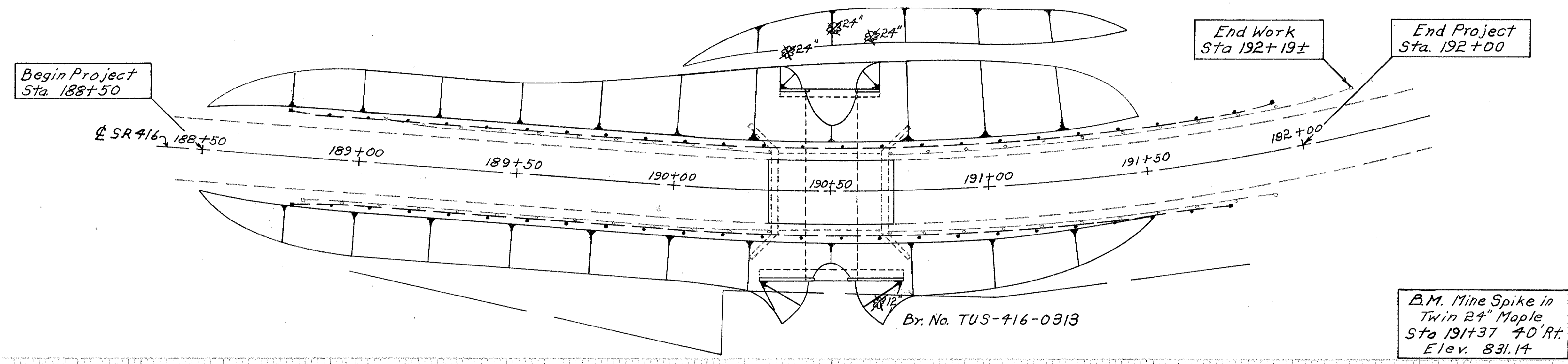
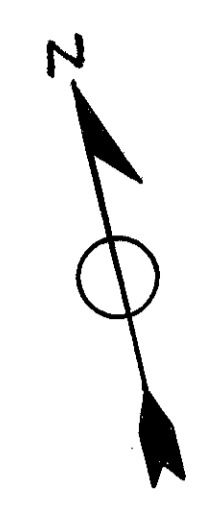

B.M. Mine Spike in
Twin 24" Maple
Sta 191+37 40' Rt.
Elev. 831.14

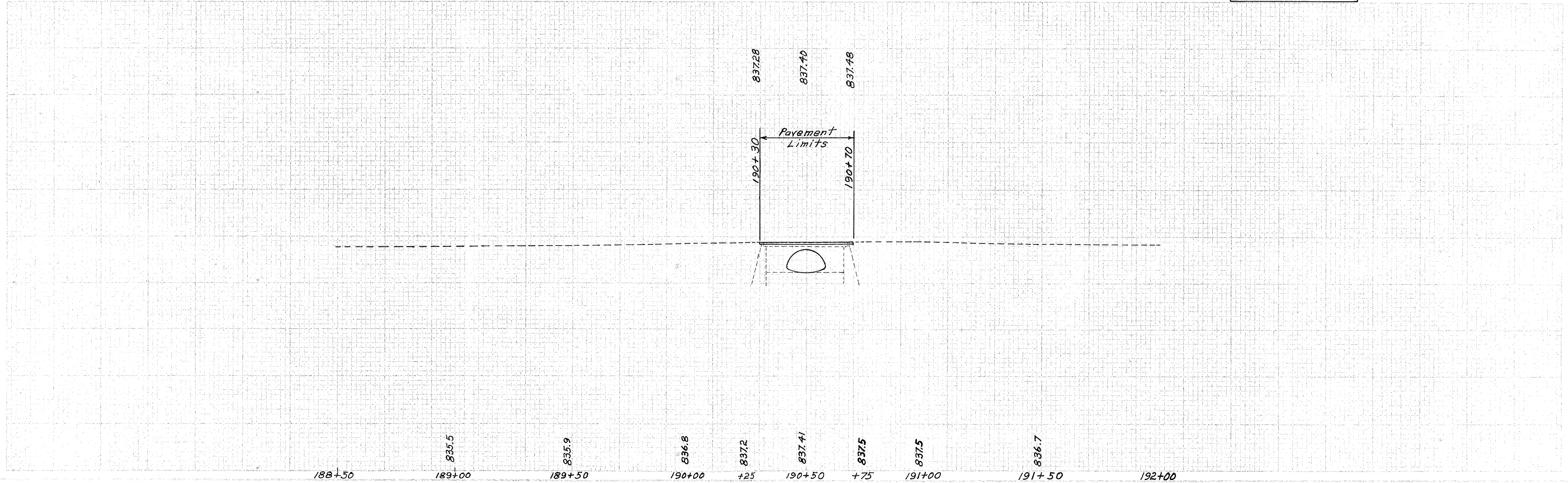

188+50 835.5
189+00 835.9
189+50 836.8
190+00 837.2
+25 837.4
190+50 837.5
+75 837.5
191+00 836.7
191+50
192+00

STATION 188+50 to 192+19 PLAN & PROFILE

Seeding Width	End Area Cut	Area Fill	Cu. Yds. Exc.	Cu. Yds. Emb.
0	0	0	0	0
214	30	89	30	89
77	32	96	32	96
222	39	119	39	119
83	52	160	52	160
171	51	444	51	444
40	58	712	58	712
158	42	377	42	377
74	33	103	33	103
179	26	75	26	75
55	24	58	24	58
278	22	108	22	108
45	0	59	0	59
256	47	46	47	46
0	131	43	131	43
0	0	0	0	0

TU5-416-00.00
Calc. J.G.M. Date 4-16-79
Chkd. J.L.O. Date 4-16-79

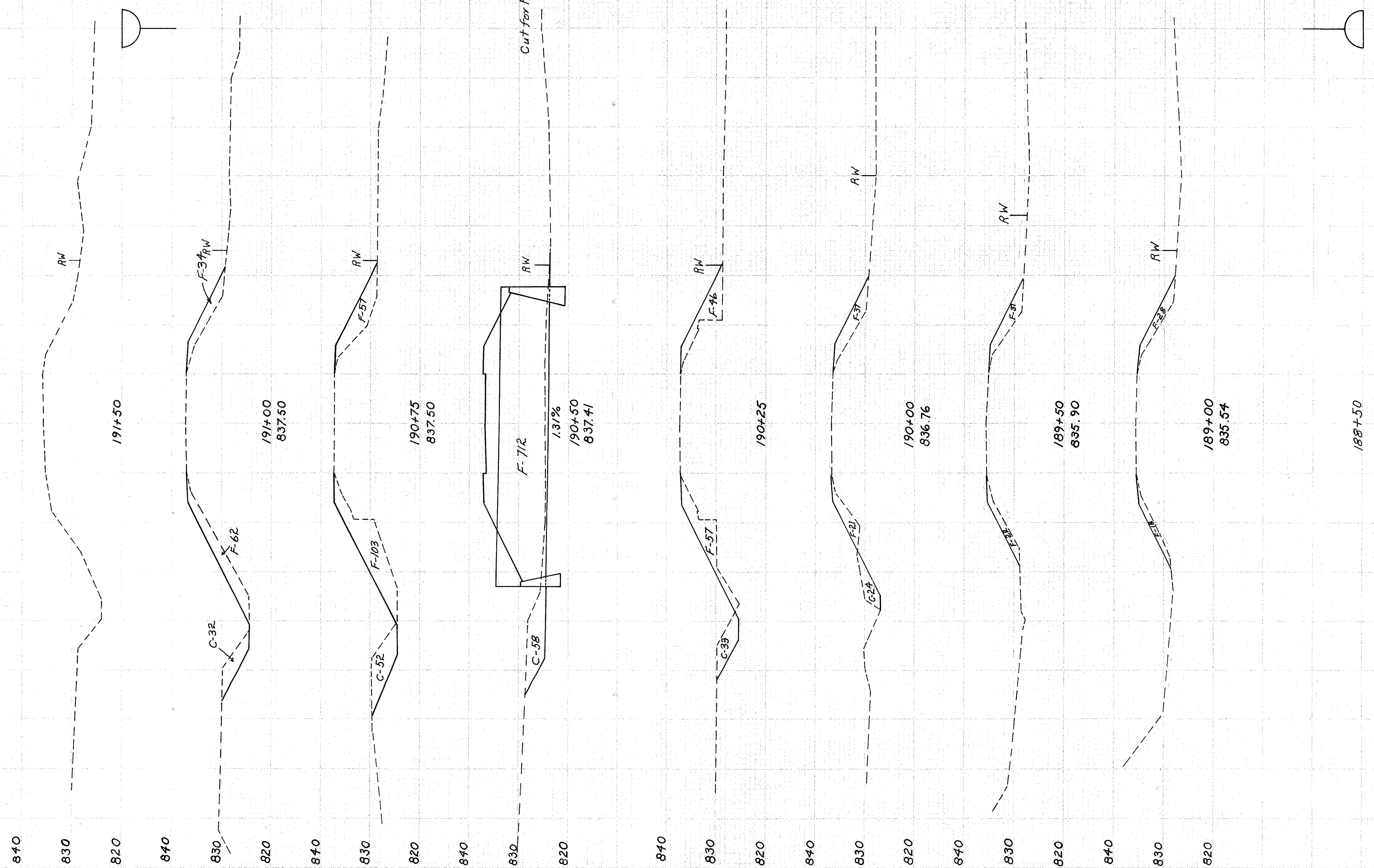

CROSS SECTIONS- Sta. 188+50 to Sta. 191+50

80 70 60 50 40 30 20 10 0 10 20 30 40 50 60 70 80

TU5-416-00.00

Calc. J.G.M. Date 4-16-79
Chkd. J.L.O. Date 4-16-79

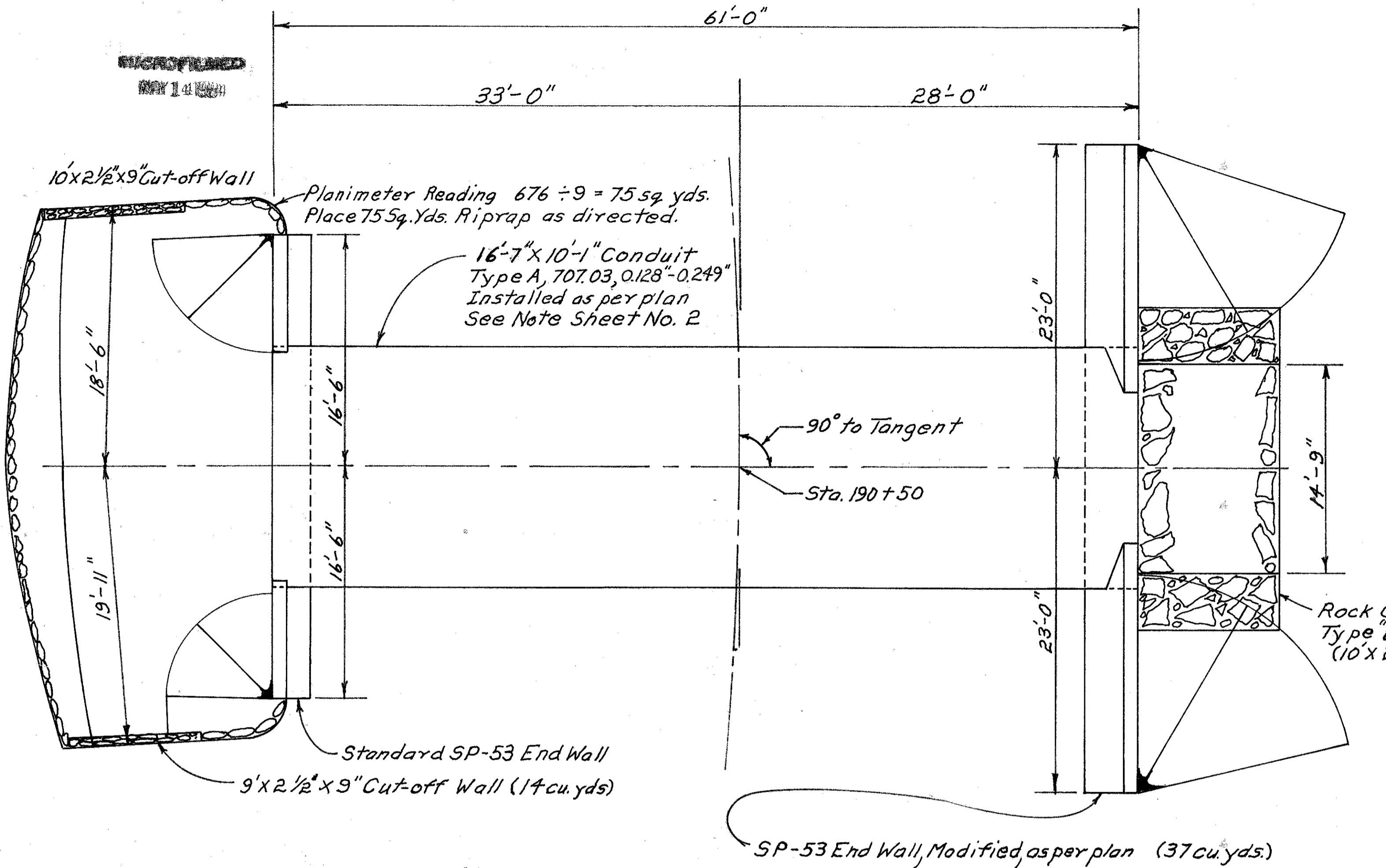

PLAN
Scale in Feet
0 3 6

Quantities, Carried to Summary Sheet 2
603 16'-7" x 10'-1" Conduit Type A, 707.03, 0.128'-0.249" 61 Lin. ft. as per plan
602 Concrete Masonry 51 Cu. Yds.
601 Riprap, Using 6" Reinforced Concrete Slab 75 Sq. Yds.
601 Rock Channel Protection, Type "B" (with bedding) 21 Cu. Yds.

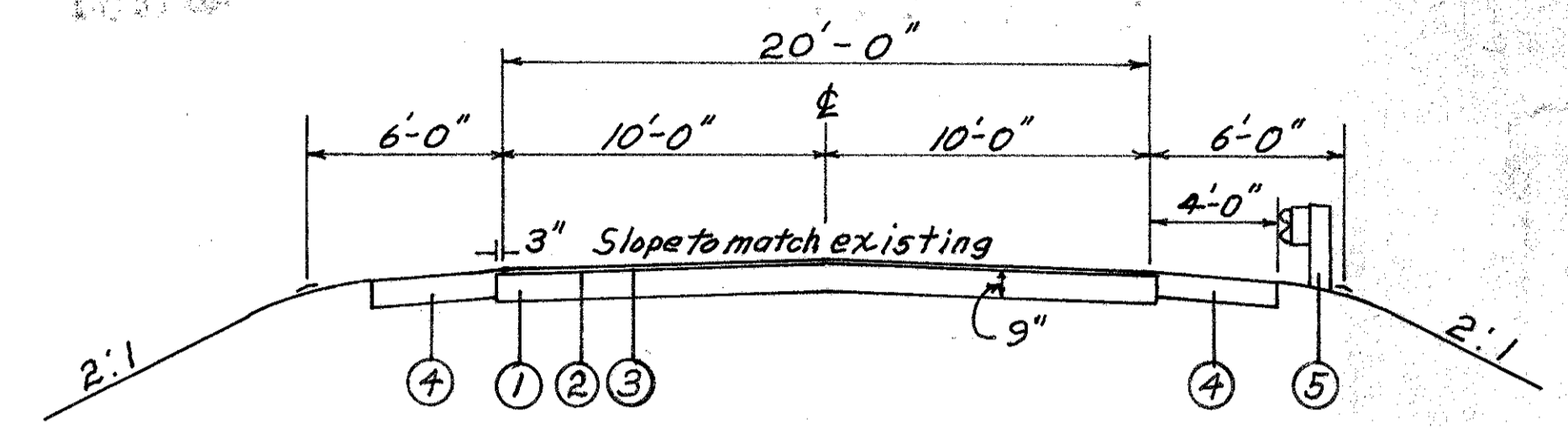

TYPICAL SECTION
Sta 190+30 to 190+70

- KEY**
- Item 305 Portland Cement Concrete Base (9")
 - Item 407 Tack Coat, Rt-2 or Rt-3, MC-30 or MC-70 or primer 20 applied at the rate of 0.40 gallons per square yard
 - Item 404 Asphalt Concrete (1") AC-20
 - Item 411 Stabilized crushed aggregate (6")
 - Item 606 Guardrail Type 5

Calculations.

SP-53 End Wall:
 $[(1.8333' \times 8.0417' \times 33') \div 27] - [(80.4^2 \times 1.5') \div 27] = 13.6 \text{ Cu. Yds. Concrete Masonry}$
 SP-53 End Wall, Modified:
 $[(2.375' \times 11.1667' \times 46') \div 27] - [(118.7^2 \times 1.75') \div 27] = 37.49 \text{ Cu. Yds. Concrete Masonry}$
 Pavement: carried to Sheet 2
 $(40' \times 20.5') \div 9 = 91.11 \text{ Sq. Yds. Concrete Base } \pm 9''$
 $(40' \times 20' \times 0.833) \div 27 = 2.468 \text{ Cu. Yds. 404 Asphalt Concrete}$
 $[2(40' \times 3.75' \times 0.5')] \div 27 = 5.55 \text{ Cu. Yds. Stabilized crushed aggregate}$
 $[(40' \times 20') \div 9] \times 0.4 = 35.6 \text{ Gals., 407 Tack Coat}$

EXISTING STRUCTURE
 Type: Steel Beam
 Length: 1-Span @ 34'-4" %c brg.
 Roadway: 22'-10" f/f railing
 Deck: Creosoted Timber
 Wearing Surface: Asphalt Concrete
 Alignment: Tan. rear -8% C. forward

PROPOSED STRUCTURE
 Type: Sectional Plate Pipe-Arch
 Culvert with Headwalls
 Span: 16'-7"
 Roadway: 28'-0" f/f guardrail
 Wearing Surface: Asphalt Concrete
 Alignment: Tangent @ \pm
 Skew: 0°

Drainage Area = 420 Ac.
 $Q_{25} = 325 \text{ cfs}$
 $Q_{100} = 512 \text{ cfs}$
 100 Year High Water = 5.80 ft.

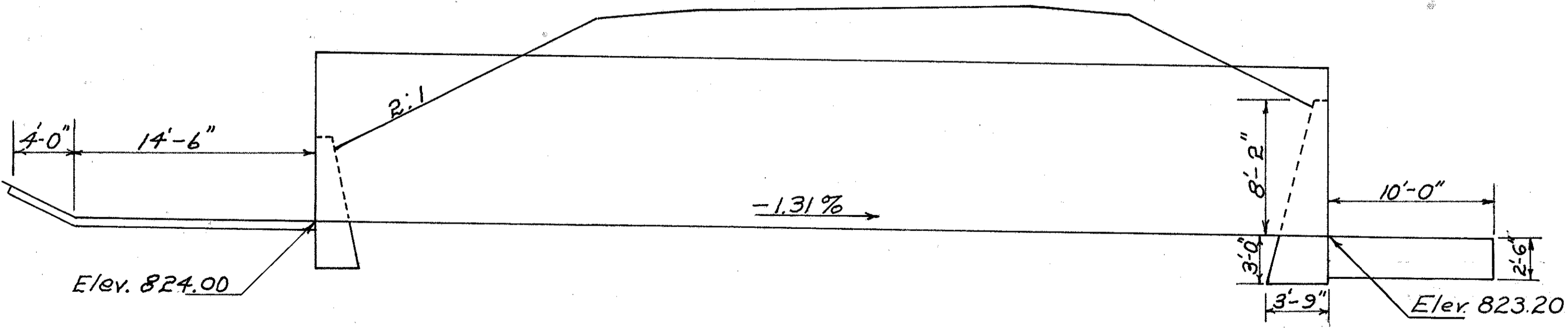

CROSS SECTION
Scale in Feet
0 3 6