



OpenRoads Designer: Drainage and Utilities

Overview

Drainage and utilities, such as culverts, catch basins, manholes, telephone, water, gas lines, etc., must be defined in the 3D model to display this information on the roadway profile and cross sections. This guide will provide an over view of the process to model Drainage and Utility features in 3D, using the OpenRoads Drainage and Utility tools.

This guide will go over the modeling side of the Drainage and Utility tools. There is a separate guide for running analytics on drainage networks that is currently in development.

Configuration and setup

All of the features set up for Drainage and Utility have been created within the OHDOT_Features_DrainageAndUtilities.dgnlib file. This file also contains all the settings for a [Drainage & Utility Project](#), such as prototypes, catalogs, storm events, scenarios, flex tables, and default design constraints. The 2D and 3D cells that are used with the feature definitions are defined in the OHDOT_DraiangeAndUtilities.cel file. These cells should not be placed directly using the place cell tool. They are made specifically for use with the Drainage and utilities feature definitions.

Drainage & Utility Project

A Drainage & Utility Project contains all the settings for drainage and utilities. This includes prototypes, catalogs, storm events, scenarios, flex tables, and default design constraints.

Whenever a Drainage and Utilities tool is used a Drainage & Utility Project is created within that file, if one does not already exist. This Drainage & Utility Project is a copy of all the Drainage and Utility settings that are set up in the OHDOT_Features_DrainageAndUtilities.dgnlib. Please note this means that any future updates to the OHDOT_Features_DrainageAndUtilities.dgnlib will not be used/applied to this file since the Drainage & Utility Project is already created. This does not copy all the feature definitions within the OHDOT_Features_DrainageAndUtilities.dgnlib file as those get copied into the file as they are used.

Drainage and Utility Features

Feature Definitions are currently defined as the following 3 different feature definition types

- Nodes – consists of point like features for example Catch Basins, Headwalls, Manholes...
- Conduit -consists of linear like features for example Gas line, Fiber Optic Line, and Culverts
- Drainage Area- consists of polygon like features for example catchment areas, ponds...

Use the OpenRoads Standards tab of Explorer within ORD to see the available feature definitions



Modeling Existing Drainage and Utility Features

Majority of the time existing Drainage and Utility features will be displayed within the survey fieldbook (FB) file. It is important to understand these graphics from the survey fieldbook are not truly modeled and are not using the Drainage and Utilities Feature Definitions. But these graphics can be used to help create your Drainage and Utility model.

Creating Drainage and Utility models should be done within separate files. For Drainage a “BD” drainage basemap design file should be created and for Utility a “BU” Utility basemap design file should be used.

The **OHDOT Create Design Files** application can be used to create these files.

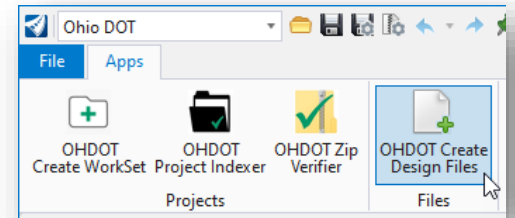
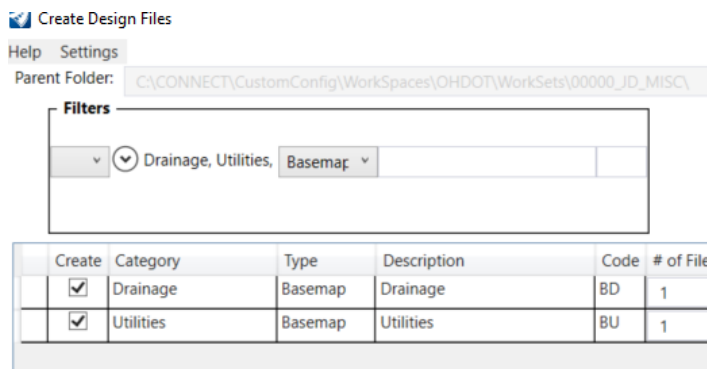

If existing drainage or utility graphics are contained with the projects Survey Fieldbook then the **Extract From Graphic** tool can be used to create existing drainage or utility models.

Extract From Graphic



The **Drainage and Utilities > Layout > Extract From Graphic** tool is used to extract 3D information from a 2D plan view graphic.

The first time a Subsurface Utility command is selected, the software prompts the user to create a utility model in the design file if one has not been previously created. Select **Yes** when prompted as shown below.

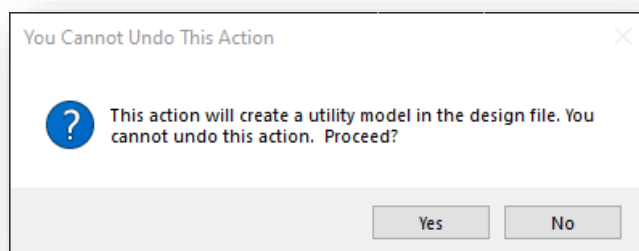

After the utility model has been created, the user must reselect the Drainage & Utility command to initiate the command.

The **Extract Utilities from Graphic** dialog is shown at left below.

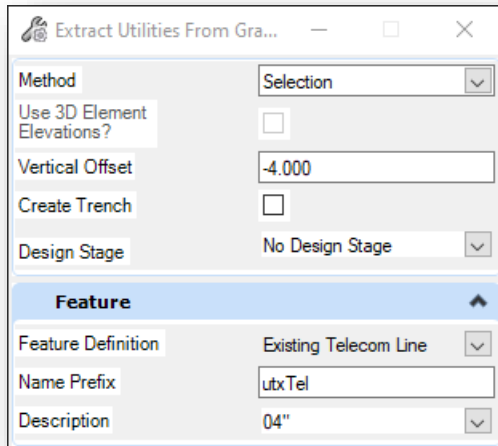

Method

The elements that will be used to create the 3D model can be selected, using the **Selection** option, either by selecting a single element or by a selection set, or by use of a **Graphical Filter**, which creates 3D utility models for many different types of utility types as defined in the filter group.

When the **Method** parameter is set to **Selection**, the dialog inputs are as follows:

- **Vertical Offset** – Defines the depth of the utility like under the selected surface.
 - **NOTE:** The depth value is assumed to be the depth to the top of the utility line.
- **Create trench** – Defines whether to create the trench defined in feature definition. Currently, ODOT does not provide feature definitions for trenching.
- **Design Stage** – Selection of OpenRoads design stage which defines settings applied to the trench corridor, such as stroking tolerances
- **Feature Definition** – Assigns the selected feature definition to the resulting utility features
- **Name Prefix** – The prefix that is used to name the created 3D utility element
- **Description** – Pick list for the utility size

When the Method parameter is set to Graphical Filter, the dialog inputs are as follows:

- **Vertical Offset** – Defines the depth of the utility like under the selected surface.
 - **NOTE:** The depth value is assumed to be the depth to the top of the utility line.
- **Create trench** – Defines whether to create the trench defined in feature definition. Currently, ODOT does not provide feature definitions for trenching.
- **Select Filter-** defines which filter or filter group to use to extract utilities.
- **Design Stage** – Selection of OpenRoads design stage which defines settings applied to the trench corridor, such as stroking tolerances

Filter Manager

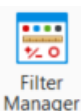

Filter Manager is set up with several filters and filter groups to make utility extraction easier. The OHDOT workspace has 4 main filter groups, imaged below. Each filter group is set up to extract existing features from graphics. For example, the All Catch Basins filter group will find all existing catch basin cells.

Filters are not set up for extracting drainage pipes as there is not currently a reliable way to extract the correct pipe size & material.

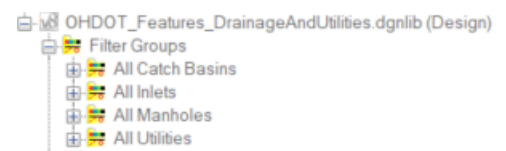

Utility line filters have default depths below the surface as defined by the table below.



Utility Lines	Default Depth	Default Size
Cable, TV, Telecom, Fiber Optic Lines	-2	2"
Electrical Lines	-2.5	2"
Gas Lines	-3	6"
Water Lines	-4.5	6"
Oil Lines	5	6"

Extracting Utility Features

- To extract utility lines, you can use the **Extract From Graphic** tool in the select mode or the filter mode.

In the **Selection Method**,

- Set the Desired Feature Definition, Feature Name (Name Prefix), and size (Description).
- Select the element(s) to be extracted to create the utility model
- These selected utility elements may result from survey processes, GIS graphic data, OpenRoads Geometry or other sources. But, in every case the elements are DGN graphic elements. In the example below, a MicroStation SmartLine was used to draw the telephone line graphics

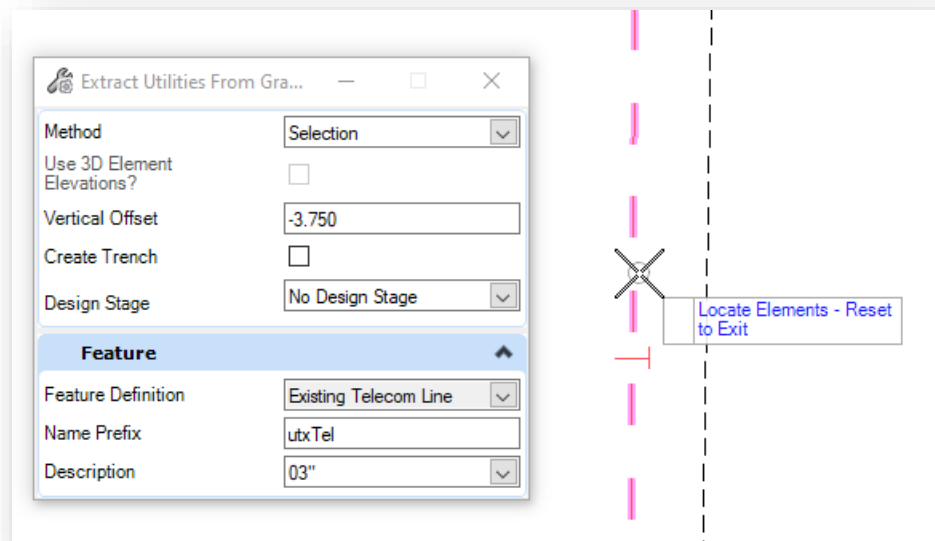

- Issue a reset comment (right-click) to complete the selection process
- When prompted, select the surface that will be used for the utility extraction. Reset (right-click) to use the active terrain model.



Select Surface or Reset to use Active Terrain Model

- Set the depth below the terrain to create the utility.



- Follow the prompts to accept the remaining options to complete the extraction process.

Tip 1: When extracting from a surface, keep the utility line graphics within the limits of the surface. If the plan view graphics for the utility line extend beyond the surface boundary the software will assume an elevation of zero for that portion of the utility line.

In the **Filter Method**,

- The Feature Definition, Feature Name (Name Prefix), and size (Description) will be grayed out since its being set within the filter.
- Select the desired filter (All Utilities), data point (left-click) to accept filter.

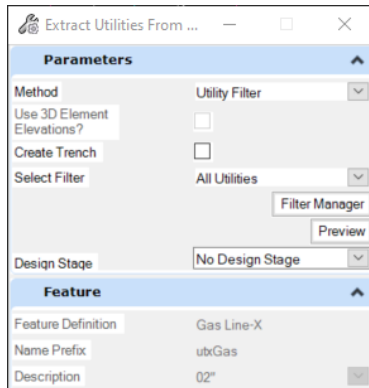

- When prompted, select the surface that will be used for the utility extraction. Reset (right-click) to use the active terrain model.

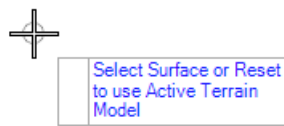

- Follow the prompts to accept the remaining options to complete the extraction process.

Tip 2: After extraction turn off display of elements used to extract utilities as the extracted utilities have a plan view display.

NOTE: You can always check over the extracted utilities and change pipe sizes and vertical offsets. Water lines and Gas lines will need to be checked to ensure proper pipe sizes and inverts. Sanitary lines are not included with the All Utilities filter and should follow the same process as the following section, Extracting Drainage Features.

When should I use the Selection Mode versus the Filter method?

Both methods offer different benefits. In the selection mode you get to specify the desired depths for each extraction but for each feature a different extraction is required. Where as the filter method can extract all utilities in one extraction, but the user does not get to specify depths but rather default depths are used.

Editing Utility Profiles

After the utility is extracted it was a uniform depth under the surface. This depth can be changed in the utility properties.

Utility	
Start Node	CN-7
Stop Node	CN-8
Start Invert	968.349
Stop Invert	982.720
Diameter	0.167'
Single Gradient	False
Vertical Offset	-2.000

But if more accurate data is known at certain locations of the utility the profile can be edited to account for the more accurate data by following the below steps.



Caution should be taken with the direction the utility was extracted, it could be going the opposition direction of your centerline.

- Open the profile view of the utility.
- You could draw a new profile and make it active but if you want to utilize some of the current profile then follow the rest of the steps below
- Select the profile and convert to Profile Rule

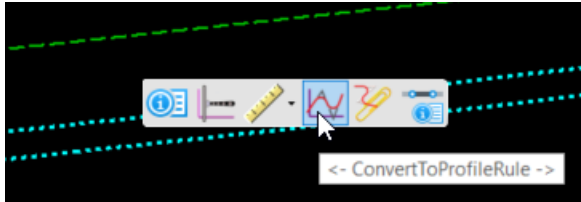

- Now profile the profile again and select create best fit profile

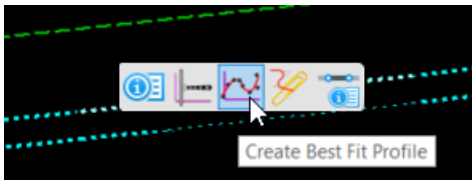

- Click through the prompts taking the defaults for the best fit profile (note the a feature definition does not matter as later on when it becomes the active profile it will automatically get set to the utility feature definition).

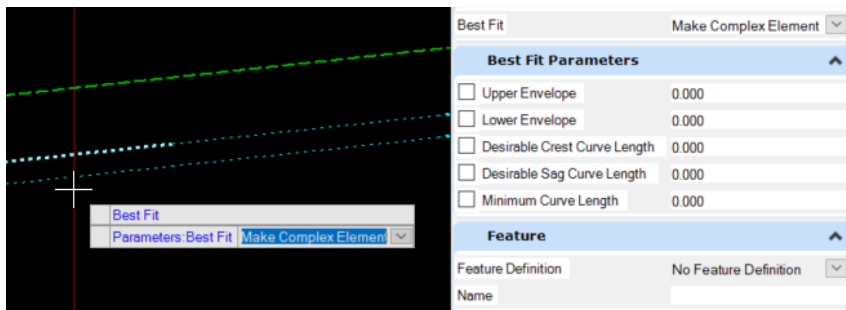

- Now select the newly created profile and convert to profile rule

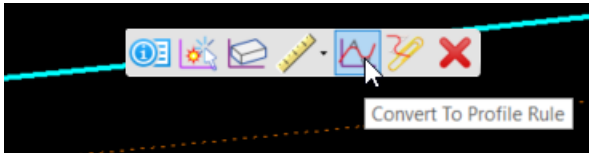

- The newly created profile is now editable and can be modified as needed. While moving/inserting vertexes civil accu-draw can be used with profile offset ordinate to specify a depth below existing ground.

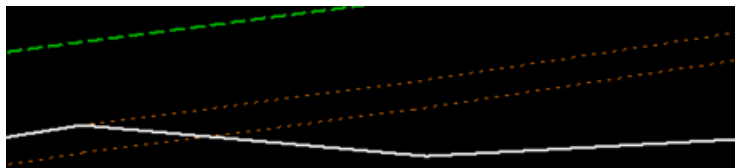



- Once modifications are complete make the new profile the active profile. You will notice the profile will automatically get assigned the utility feature definition.

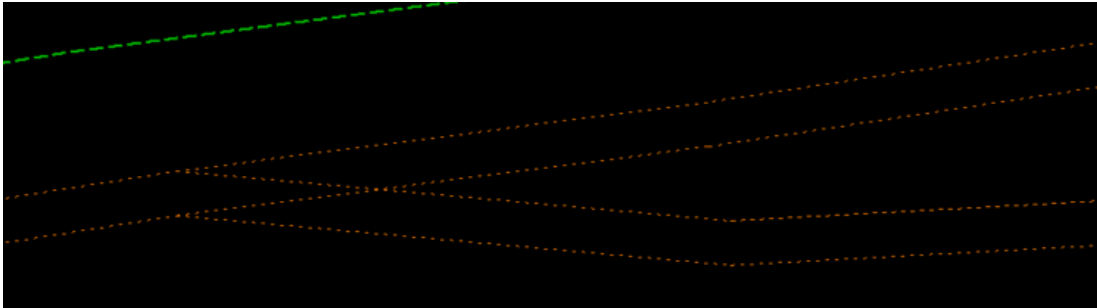

Extracting Drainage Features

Extracting drainage features is a little more involved than extracting Utilities. There are so many variations of pipe sizes and materials that the Extract from graphics tool is not feasible to extract pipes. You can however use the Extract from graphics tool to extract the nodes. Nodes are required at each end of a conduit. Manholes, catch basins, Inlets are considered Nodes.

Typically, the existing drainage manholes, catch basins and inlets will be displayed in the survey fieldbook file as 2d cells. These cells can be used with the extract from graphics tools to create your drainage model.

During extraction the node (manhole, catch basin, inlet) invert elevation can be extracted at the same time. This is only possible if the survey fieldbook collected an additional point to represent the invert. This point will have a FLINE cell. If this point is not present then a default invert for the node is used and will have to be set correctly after extraction.

Notes:

- Drainage models should be extracted within a drainage basemap (BD).
- Use the 2D seed file to create the drainage basemap. The **Subsurface Utilities** software will generate a separate 3D model in the drainage basemap design file for the 3D drainage information
- The file is created in the **400-Engineering\Drainage\Basemaps** folder

Extracting 3D Drainage Nodes

The following actions can be used to create a

Take the following steps to extract the Drainage Nodes.

1. Select the **Extract from Graphics** tool.
2. Set the **Method** to **Utility Filter**. Several filters are provided in the OHDOT CADD Standards for individual drainage items as well as groups of items.
3. Use the **Select Filter** item to choose **All Catch Basins** filter. This filter is configured to extract only the drainage cells for the catch basins and not the pipes. The pipes will be extracted individually as a separate process.
4. Toggle on the **Use 3D Element Elevations** option.



5. Accept the options as you are prompted on the cursor to initiate the extraction process.

Note: The **Design Stage** item is not relevant to this process.

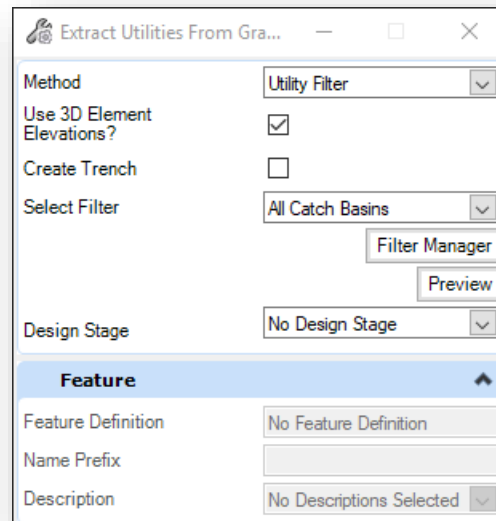

The 3D drainage structures are extracted using the elevation of the cells mapped by the Survey process. As each drainage structure is processed, the extraction process will search for a **FLINE** feature to establish the depth of the drainage structure. If a **FLINE** feature is not found, the depth is set using a default value.

If the drainage basemap was created with a 2D seed file, which is the recommended best practice, **the Extract Utilities from Graphics** process will create a new model named **Design-3D** containing the 3D drainage structures. This new model is automatically attached as a reference to the current 2D model.

In addition to the 3D model, a 2D graphic is placed in the current 2D model for each extracted drainage structure nodes. This graphic is linked to the 3D model and can be used to make edits to the drainage structure.

In the example below, the reference file display of the survey basemap and the Design-3D model has been turned off to show the 2D graphic that is placed for one of the drainage structures.

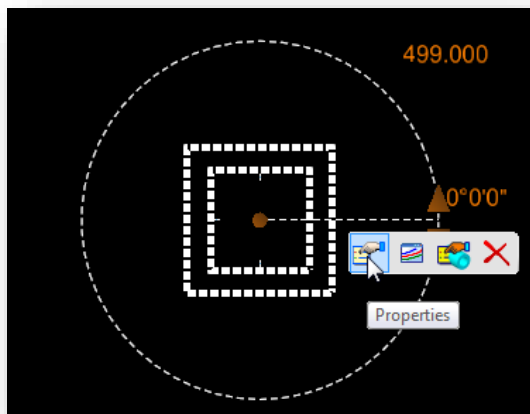

Selecting the graphic reveals a pop-up menu that can be used to make edits to the drainage structure as well as two rules (**Node Top Elevation**, and **Node Rotation**) that can be edited by selecting the displayed text.

The extracted drainage structures do not take into account the rotation angle of the original cells and are placed at a zero degree rotation. The example at left below shows the original cell as referenced from the Survey basemap, and the 2D cell that was placed as part of the utility extraction process. It is necessary to rotate each structure manually.

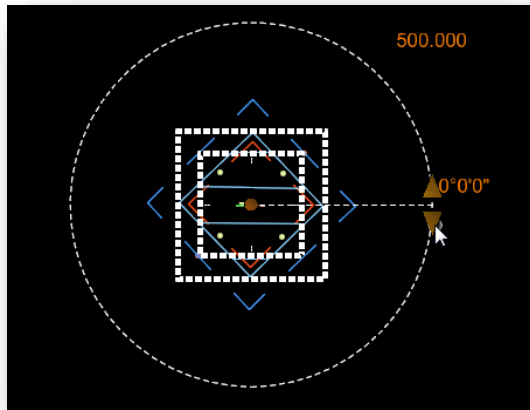

Once the 2D node is selected, parameters for the rotation of the 3D structure are displayed as shown at left. The angle can be keyed-in by selecting the angle text, or the 3D structure can be rotated by selecting one of the rotation arrows.

Typically, it is best to get the rotation angle of the original cell and use that value to key-in the rotation angle for the drainage node as described on the following page.

Take the following steps to key-in the rotation angle for the drainage structure:

- ✓ Change the **Angle Readout** as shown below by selecting **File > Settings > File > Design File Settings**

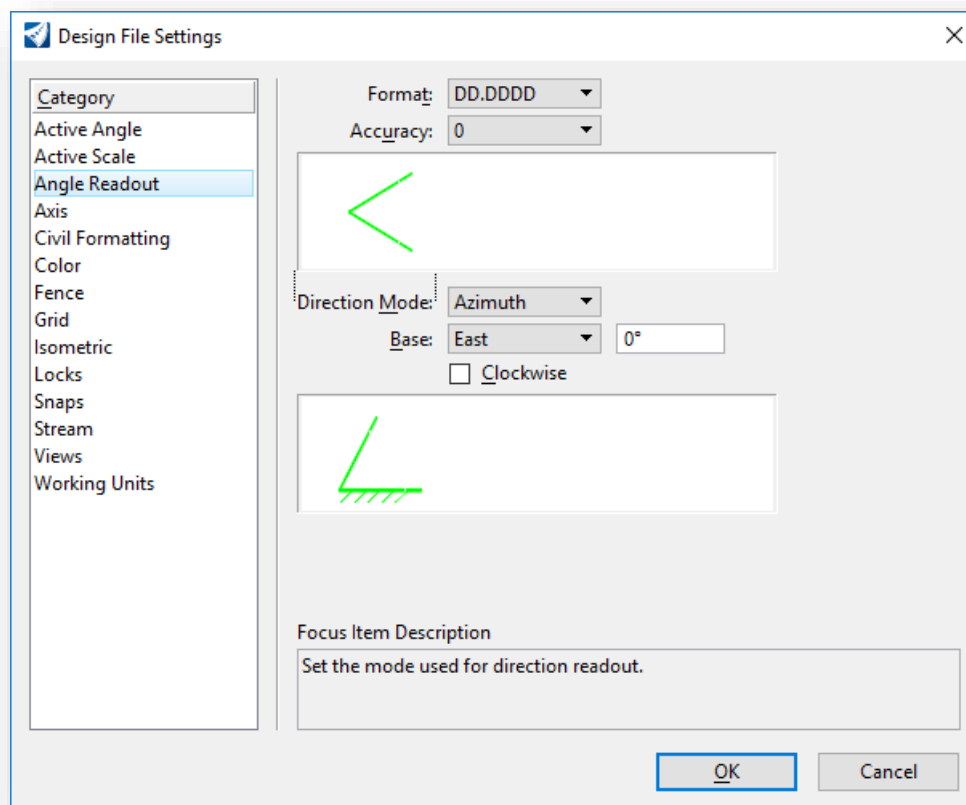

- ✓ Use the MicroStation **Element Information** command to get the rotation angle of the original cell as shown below.

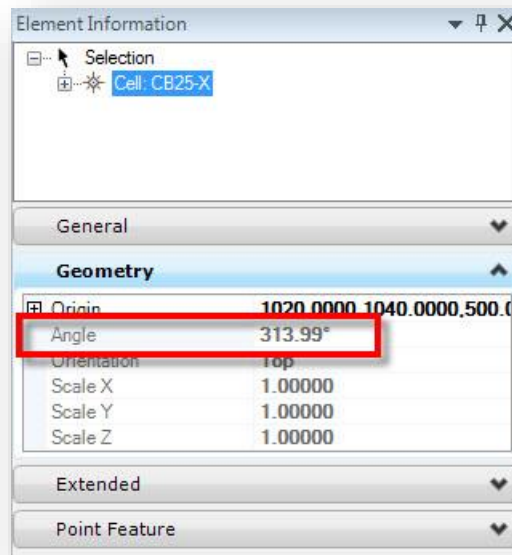

- ✓ Select the drainage node graphic and choose the **Properties** command from the pop-up menu. The **Rotation** can be modified as shown below. The graphics for the node in the 3D model are updated as changes are made to the properties.

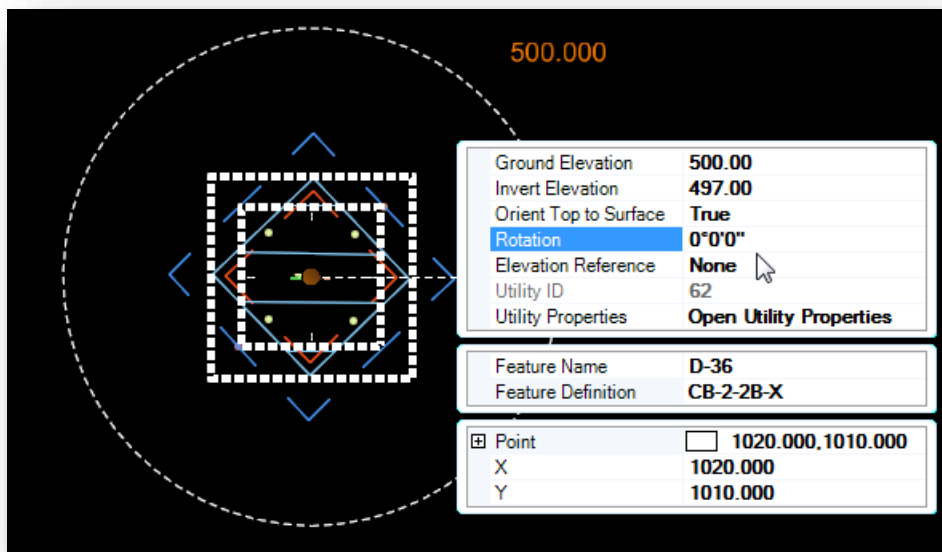

After extracting the drainage structures and rotating them into place we are ready to extract the pipes.

After extracting the graphics, If the FLINE cell was not found or does not exist it is necessary to select each structure and manually key-in the **Invert Elevation** value. An example is shown below.

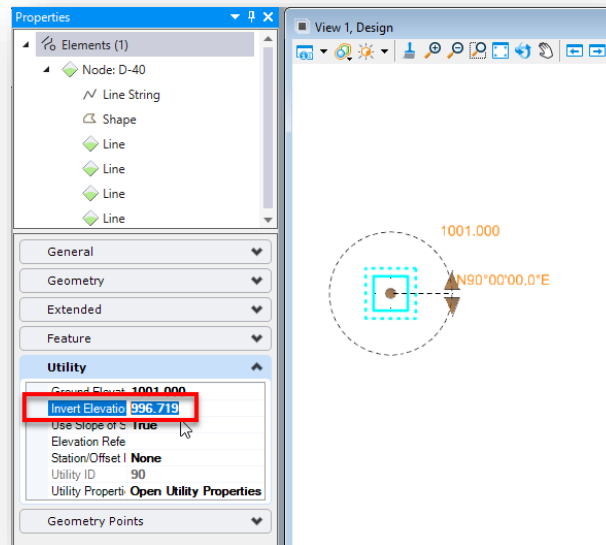

Note: The Filters are set up to search within a 12foot buffer of the cell. There is a chance that the process could not find the FLINE cell or find and use the wrong FLINE cell. Each structure should be verified the correct invert elevation is set.

Repeat the process using the All Inlets and All Manholes filter groups.

Extracting Drainage Links

The **Extract Utilities from Graphics** command could be configured to extract pipe information; however, as of this writing the current release of the software will not connect the extracted pipes to the previously extracted nodes. Even though it is more cumbersome, it is better to place each pipe manually as a “link” using the **Place Conduit** command, shown below.

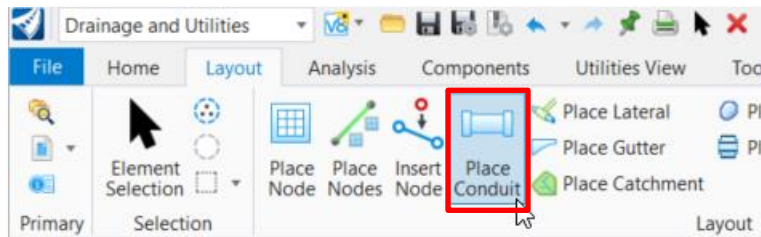

The dialog shown below is opened.

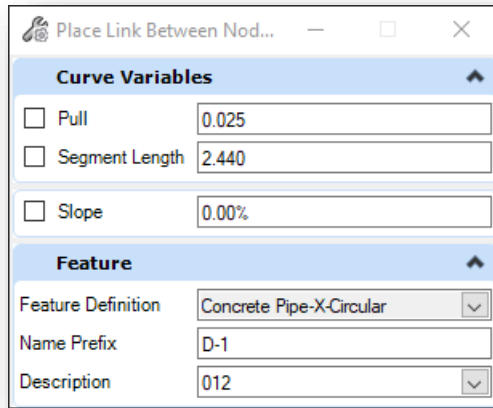

General information for the command can be found by selecting **Drainage and Utilities > Help > Help Contents** from the MicroStation ribbon menu.

The **Feature Definition** is used to select the pipe type.

The **Description** item is used to select the pipe size.

The **Name Prefix** is used to name each pipe and is incremented as you extract the pipes.

When the command is selected, you are prompted to **Select Start Node**.

The ODOT 3D drainage items have specific connection regions on each side of rectangular structures. Circular structures have a circular connection region. When the first node is selected, the link starts from one of the connection regions. Follow the prompts to select the second node.

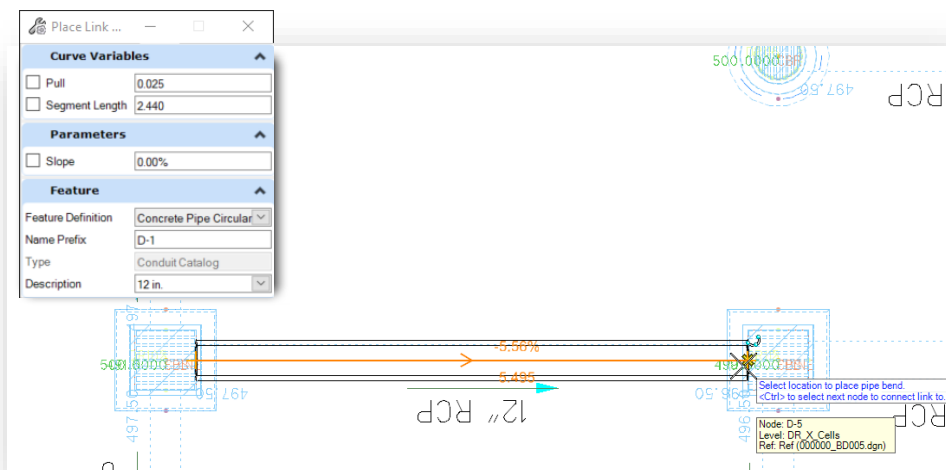

A line is placed in the current 3D model that can be used to modify the link. The extruded 3D link is placed in the 3D model as shown below.

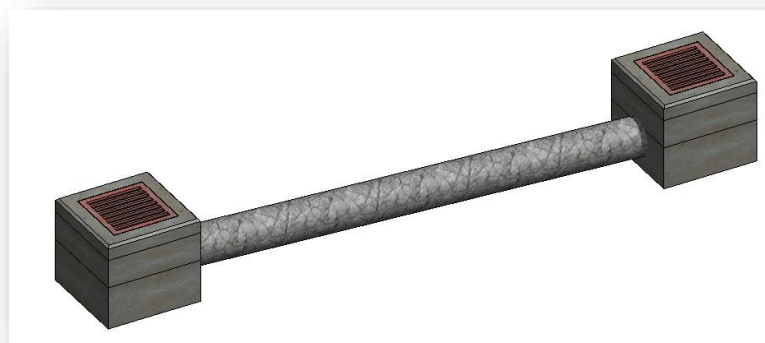



The link is placed at the lowest elevation of the selected nodes. The elevation values can be edited by selecting the link in either the 2D or the 3D model, and then choosing the **Properties** icon from the pop-up menu.

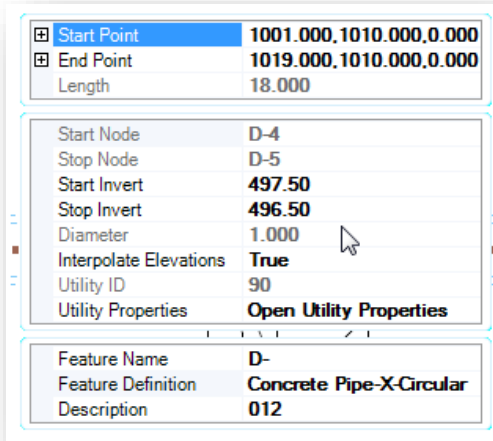

From the *Properties* menu, shown at left, the **Start Invert** and **Stop Invert** values can be edited if necessary to set the correct elevations for the pipe.

Note: Sanitary manholes and conduits should be extracted following the same methods outlined in this section.

Connecting Links to FDO or PIO Points

The field codes PIO (pipe inlet or outlet) and FDO (for direction only) can both be used to designate the end of a pipe. PIO is used to designate an inlet or outlet point for an open pipe of culvert. FDO (for direction only), is used to designate the direction of a pipe when the other end cannot be located.

There must be a node defined at the PIO and FDO locations to place a link in the design file using the PIO and FDO points. The **Place Node** command is used to place nodes at the PIO and FDO locations.

The command is selected from the **Drainage and Utilities** WorkFlow as shown below.

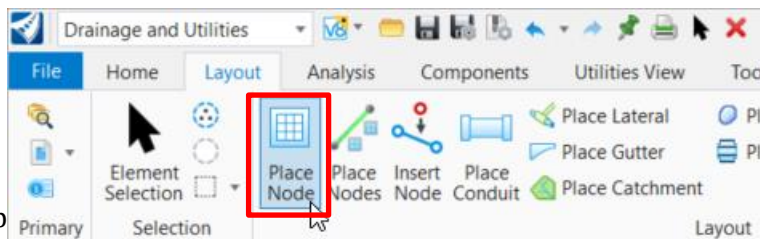

Take the following step

- Select the **Place Node** command
- Set the **Feature Definition** to the **GenericNode-X** item
- When prompted as shown below, issue a reset (right-click) to type in the elevation for the node

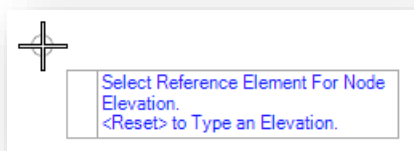

- Type in the **Elevation** for the node
- Enter a data point for the node location by snapping to the PIO or FDO point



- A triangle is placed in the 2D and the 3D models at the location of the node. The direction of the triangle is irrelevant

The extracted node for the PIO and FDO points is placed as a triangle at each point on the level SC_Scratch1 as shown at right.



The **Place Conduit** command described in the previous section is used to place the 3D pipes between the nodes.

Tip: There is also a PIO filter that can be used with the **Extract from Graphics** tool instead.

Box Culverts

The graphics for existing storm water utilities are normally placed in a 2D model in the drainage (BD) basemap design file. The **Drainage and Utilities** software is used to place the box culvert in a 2D model. The software will automatically generate the 3D model for the box culvert.

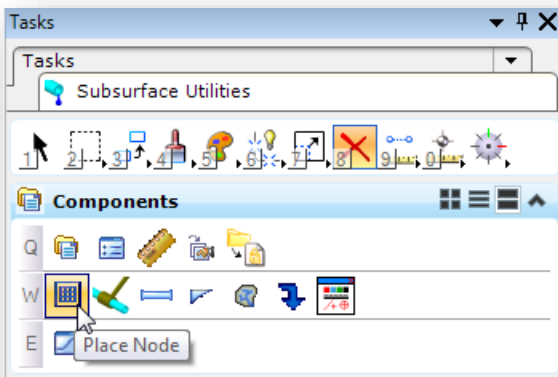

After creating a drainage basemap design file, attach the survey basemap as a reference file to view the culvert shots. Box culverts are surveyed using the **CULV** field code to take a shot at the invert elevation at each end of the culvert.

Box culverts are placed as a link by the **Drainage and Utilities** software by use of the **Connect Conduit Between Nodes** command. A node must first be placed at each end of the proposed box culvert in the design file by use of the **Place Node** command. The generic headwall feature definition is used to define the location of each end of the box culvert.

Select the **Place Node** command from the task list as shown below.

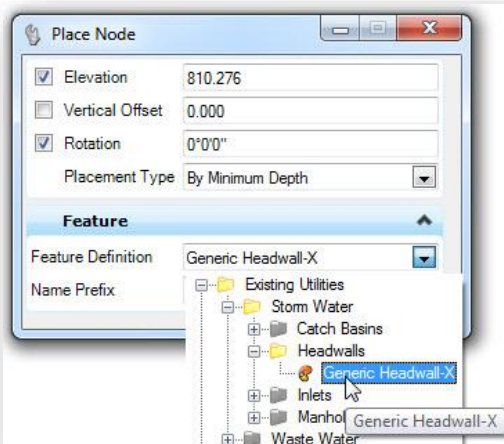

Place a node at each end of the box culvert using the **Generic Headwall-X** feature definition as shown above.

The user is prompted to select a reference element for the node elevation as shown below.

Nodes can be placed at a specific elevation, or relative to the selected surface or a corridor model. Issue a **Reset** to type an elevation.

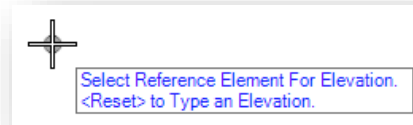

After the elevation reference is defined, the user is prompted to set the **Placement Type**.

The **By Minimum Depth** option is used to set the initial depth using a default value. The invert elevation can be edited after placement if necessary.

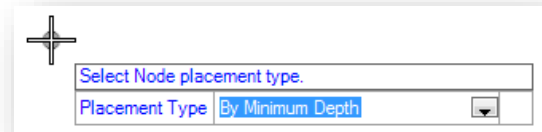

Next the user is prompted to set the location of the node. Place the node at the location of the CULV survey point.

The generic headwall node is placed using a triangle symbol on the level SC_Scratch1 as shown at right. The direction of the triangle, defined by the **Rotation** parameter, is irrelevant to the flow direction of any links connected to the node.

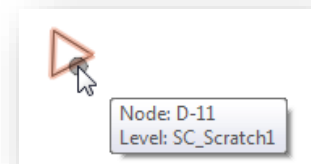

After the headwall points have been placed at each end of the culvert, the box culvert is placed using the **Connect Conduit Between Nodes** command

shown below.

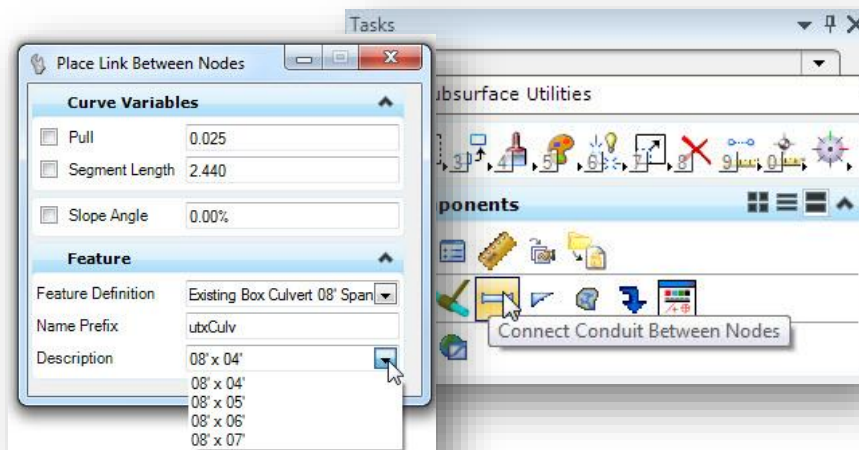

Feature definitions for existing and proposed box culverts are provided in the ODOT standards. The available features for existing box culverts are shown on the following page. The span and rise for each available culvert feature is defined by the **Description** field as shown at right above.

Available culvert sizes are based on the **Figure 1008-14** of the **ODOT Location and Design Manual – Volume 2, Drainage Design**.

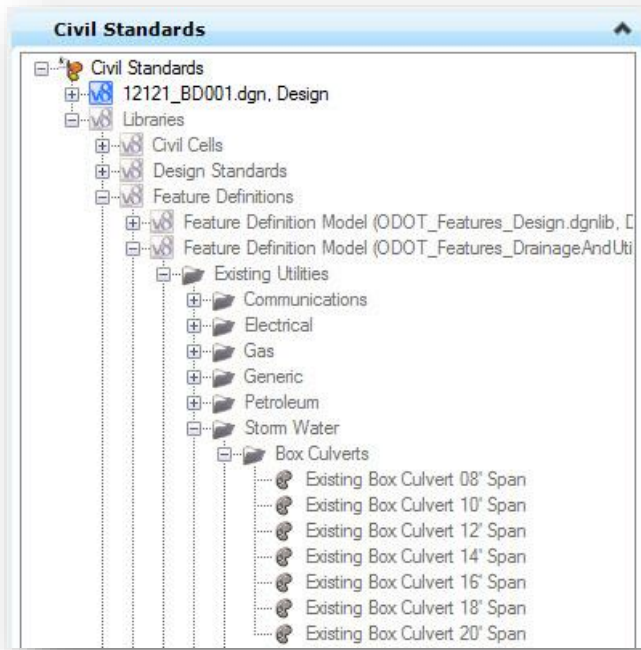

The culvert is placed by selecting each node as shown below.

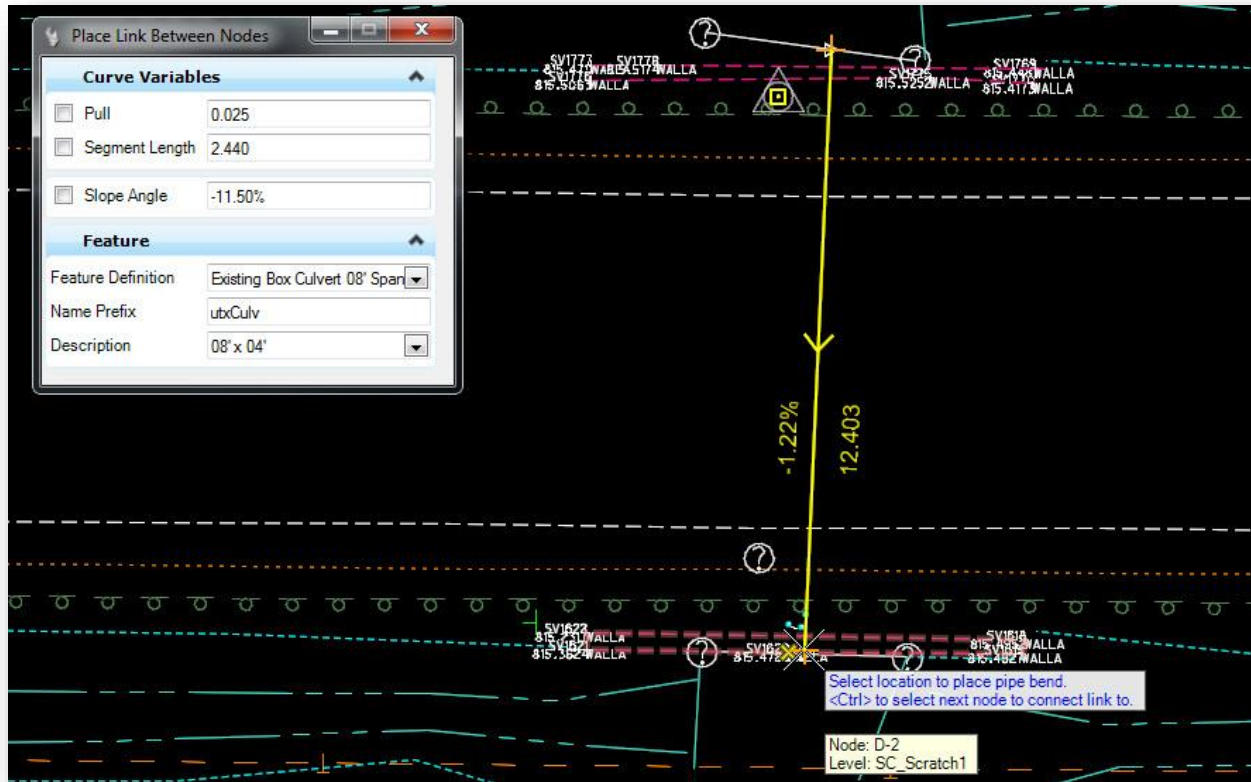



Two sets of graphics are drawn for the box culvert as shown below.

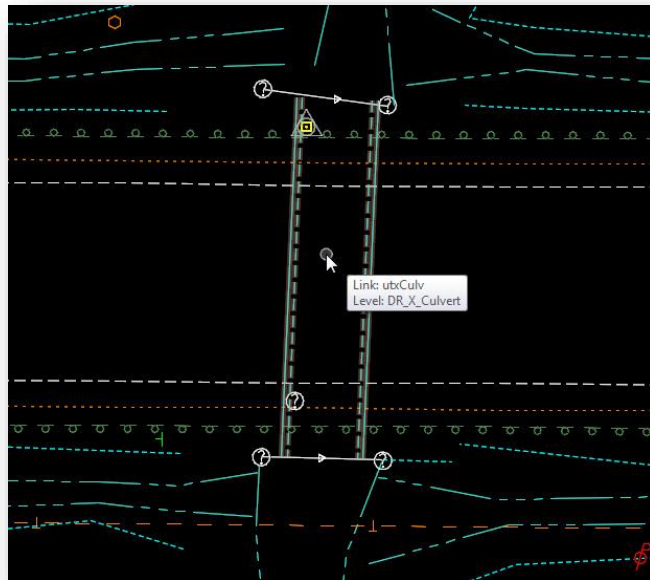

The culvert is drawn as a custom line style in the 2D model as shown at left. The 2D model can be referenced back to the survey basemap (BE file) if desired, or attached as a reference by the design personnel.

The Subsurface Utility software also creates a 3D model in the drainage basemap named “design-3d” containing the 3D model of the box culvert as shown below.

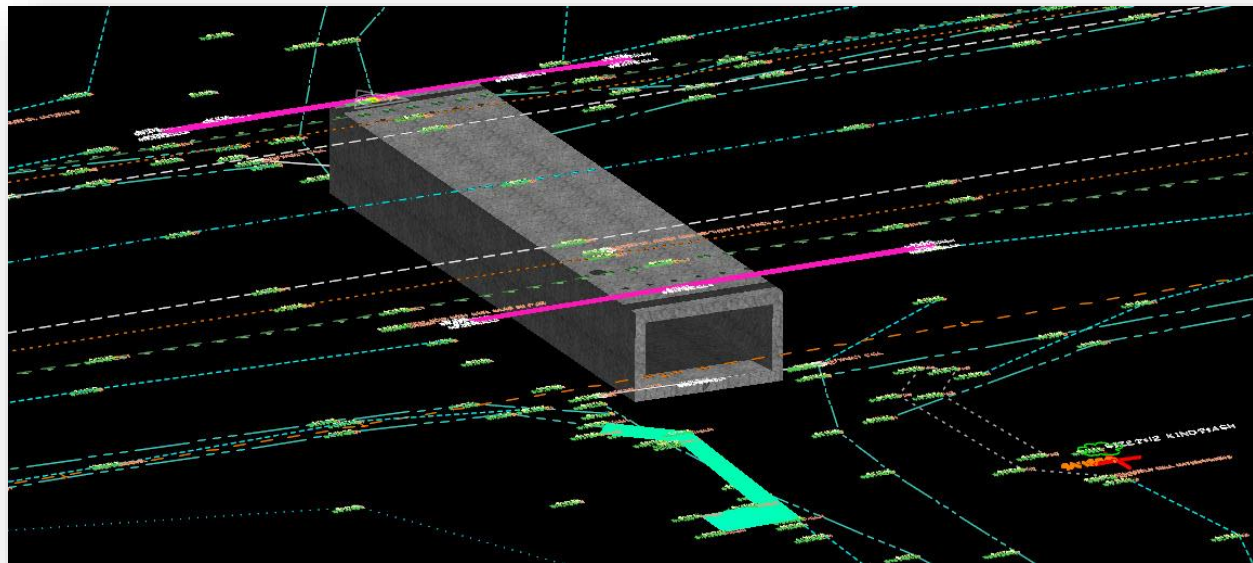

Modeling Proposed Drainage Features

Creating a proposed drainage model is somewhat like modeling existing drainage features but the extract from graphics tool is not relevant.



Modeling the drainage features should be done within a drainage basemap “BD” file. If the proposed network will attach to the existing modeled network, then the proposed network MUST be created in the same file as the modeled existing network.

In order to place conduit, the ends of that conduit must have nodes. So, the first step is to place the nodes.

Placing Nodes

The **Place Node** and **Place Nodes** tools can be used to place Drainage nodes like Manholes, Catch Basins, Inlets and headwalls.

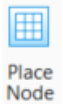

The **Place Node** tool offers a couple different ways to place nodes. The workflow is listed below

- Set the desired feature definition and Name Prefix.

Tip: The feature name (name prefix) can be used to annotate call outs.

- In the heads up prompt you can select an element to be used for the grate/rim elevation or reset click (right click) to key in the elevation.

Tip: If placing curb/curb & gutter catch basins, use the CURB_GUTTER element as the elevation reference.

- Next if a reference element as selected you can enter a vertical offset from that reference element. If a reference element was not selected, you can enter the desired elevation.

Tip: When entering a vertical offset value don't forget the negative sign to offset below the selected element. Also basic calculations are supported for example to vertically offset 0.5" below the reference element you can enter -0.5/12.

Note: Don't forget about catch basin depressions when placing catch basins for curb/curb & gutter.

- Next enter a data point (left click) at the location you want the node to be placed.

Tip: Use **civil accu-draw** station-offset ordinate to place the node at a desired station and offset.

- Next you can specify the rotation of the node. There are two options, absolute or relative to alignment. Data point (left click) to accept the selected rotation mode.
- If relative to alignment is selected as the rotation mode the user is prompted to select the alignment to base the rotation off of, then can enter the desired rotation and data point (left click) to complete the placement of the node.

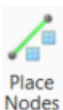

The **Place Nodes** tool can be used to place a series of node at a given interval as well as place conduits between the nodes at the same time. The workflow is listed below.



- First fill out the tools dialog as desired
 - Check on Create conduits and set the feature definition, name prefix, and description (size) to desired values. Note only one feature and size can be set and will be used for all conduit placed. If conduits are not desired, then uncheck the create conduits checkbox. The name prefix will increment the number for each conduit placed.
 - Set the feature definition and name prefix to the desired feature for the node. The name prefix will increment the number for each node placed.
- The first prompt is to select the element to use as a reference for the locations of the nodes. This will typically be your centerline. Select the desired element.
- Next in the heads up prompt you can select an element to be used for the grate/rim elevation or reset click (right click) to key in the elevation. If keying in an elevation, the same elevation will be used for all notes being placed where as using an element for the reference elevation will use the elevation of that reference element at the given location of the nodes.

Node Location	
Node Location Reference	
<input type="checkbox"/> Vertical Offset	0.000
<input checked="" type="checkbox"/> Interval	100.000
Lock To Start	<input type="checkbox"/>
<input type="checkbox"/> Start Station	30.329'
Lock To End	<input type="checkbox"/>
<input type="checkbox"/> End Station	241.916'
<input checked="" type="checkbox"/> Offset	0.000

Relative Rotation	
<input checked="" type="checkbox"/> Relative Rotation	N00°00'00.0"E

Conduits	
Create Conduits	<input checked="" type="checkbox"/>
Conduit Feature Definition	Type B-Round Concrete_Clay_Plastic
Conduit Name Prefix	D-1
Type	Conduit Catalog
Description	12 in.

Feature	
Feature Definition	CB-3 CurbGutter-P
Name Prefix	D-1

Tip: If placing curb/curb & gutter catch basins, use the CURB_GUTTER element as the elevation reference.

- Next if a reference element was selected for node elevation you can enter a vertical offset from that reference element. This is not shown in the heads up prompt and needs to be entered into the tools dialog. If a reference element was not selected, you can enter the desired elevation.

Tip: When entering a vertical offset value don't forget the negative sign to offset below the selected element. Also basic calculations are supported for example to vertically offset 0.5" below the reference element you can enter -0.5/12.

Note: Don't forget about catch basin depressions when placing catch basins for curb/curb & gutter.

- Next specify the desired interval to place the nodes. And issue a Data Point (left click) to accept value
- Next enter in the start station which is the station location of the first node, the station value is based off the first element reference you selected with this tool, which is the reference element to be used for node location. Issue a Data point to accept the value.
- Next enter the end station which is the station location of the last node, the station value is based off the first element reference you selected with this tool, which is the reference element to be used for node location. Issue a Data point to accept the value.

Note: If the end location ends at the exact station of an interval the value might need to be bumped up slightly for the software to place a node at that location, the view window will show the nodes as a preview which can be used to see where the nodes will be placed.



- Next enter in the desired offset. This is the offset from the selected element used for the node location. Issue a data point to accept the value.
- Next specify the desired relative rotation of the node. This is relative to the selected element used for the node location. Issue a data point to accept the value.
- Issue a final data point to finish placing the nodes and conduits.

Placing Conduit

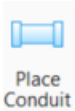

In order to place conduit a node must exist at each end of the conduit. Think of a conduit as a link between two nodes. A link can't exist between two nodes if there are not two nodes.

The workflow for placing conduit is listed below.

- Set the desired Feature Definition and Description (size)
- Select the start node where the start of the conduit will connect to the node.
 - There are connection regions defined on the nodes to specify the locations the conduit can connect to. In general the connection regions are to the inside boundary of the node. Square nodes have connection regions at the center of each side while circular nodes have the connection region all around the inside edge.
- Select the end node where the end of the conduit will connect to the node
 - In rare situation a curve or bend can be introduced while placing the pipe by holding down the alt key or ctrl key while selecting the end node.

Curve Variables	
<input type="checkbox"/> Pull	0.025
<input type="checkbox"/> Segment Length	2.440

Parameters	
<input type="checkbox"/> Slope	0.00%

Feature	
Feature Definition	Type B-Round Concrete_Clay_Plastic
Name Prefix	D-1
Type	Conduit Catalog
Description	12 in.

Reviewing and Editing Nodes and Links

After the nodes and links have been created, it is good practice to review the values for accuracy. The parameters of the 3D drainage information can be edited by using the MicroStation **Element Selection** tool to select a node or link, and then choosing the **Properties** icon from the pop-up menu as shown below.

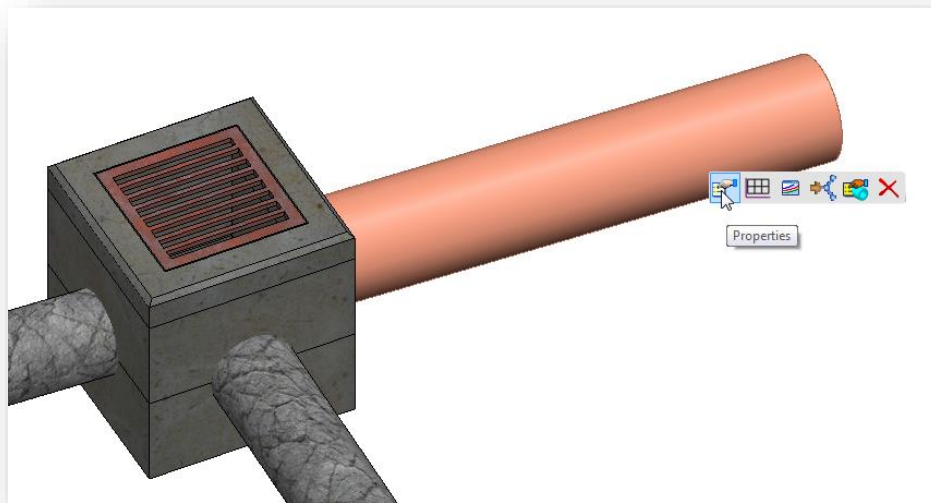

The parameters are shown below. Note that the invert values for a link cannot be edited if the link was extracted from graphics.

Conduit Properties

Start Point	1030.000,1040.000,0.000
End Point	1030.000,1030.000,0.000
Length	10.000
Start Node	D-21
Stop Node	D-20
Start Invert	499.75
Stop Invert	500.00
Diameter	1.000
Interpolate Elevations	True
Utility ID	145
Utility Properties	Open Utility Properties
Feature Name	D-1
Feature Definition	Concrete Pipe-X-Circular
Description	012

Node Properties

Origin	1020.000,1010.000,497
Angle	N90°0'0"E
Orientation	Top
Scale X	1.00000
Scale Y	1.00000
Scale Z	1.00000
Ground Elevation	499.00
Invert Elevation	496.00
Orient Top to Surface	True
Rotation	0°0'0"
Elevation Reference	None
Utility ID	30
Utility Properties	Open Utility Properties
Feature Name	D-4
Feature Definition	CB-2-2B-X
Point	<input type="checkbox"/> 1020.000,1010.000
X	1020.000
Y	1010.000



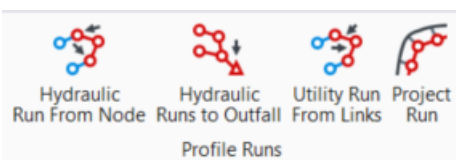

Currently the Node invert elevation will automatically change to match the lowest connected conduit invert elevation. Until this behavior is addressed by the software it is best practice to set all pipe begin and end invert elevations then set the node invert.

Creating Profile Runs



There are several tools available to help with creating profile runs. Profile runs can be created to view profiles of Drainage and Utility networks. Profile Runs can be as short as one pipe or "run" the whole drainage network.



Setting	Description
 Hydraulic Run From Node	Creates a profile run from a selected node to the outfall, or between two selected nodes. This tool only works on hydraulic (i.e. storm or sanitary) networks.
 Hydraulic Runs to Outfall	Creates a profile run for every path, from the most upstream nodes to the outfall. These paths are sometimes known as trunks or branches. This tool only works on hydraulic (i.e. storm or sanitary) systems.
 Utility Run From Links	Creates a profile run from selected links, for any type of utility (e.g. storm, communications, electric, etc.) The links must be consecutive, without gaps between them.
 Project Run	Projects a profile run created using the tools above onto a linear element, which could be a road centerline, or another profile run.

The **Hydraulic Run From Node** and **Hydraulic Runs to Outfall** tools are great for a more automated profile run creation process and the **Utility Run From Links** tool is a more manual process. This Guide will cover the process for using **Utility Run From Links** tool.

Profile Runs must be created in the model containing the Drainage or Utility Network as well as the profile run can only include connected conduits (as in no branches or jumps in the network).

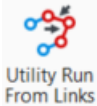

Follow the process below to create a Profile run using the **Utility Run From Links** Tool.

- Select the desired feature definition within the toolbox (there are ProfileRun1, ProfileRun2, ProfileRun3, and ProfileRun4 feature definitions created for this purpose.

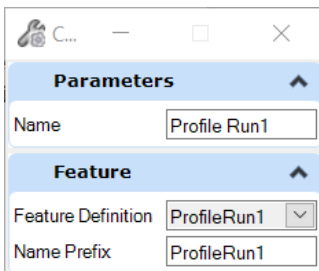

- Graphically select the first conduit desired to be included within the profile.
- Continue selecting conduits to be included within the profile.
- When done selecting conduit reset click (right click) to accept selection.

Profile runs can be found from within the Drainage and Utilities Model Tab of Explorer in the profile Runs section.

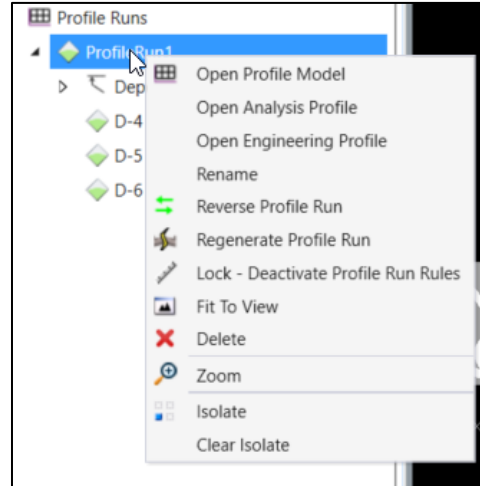
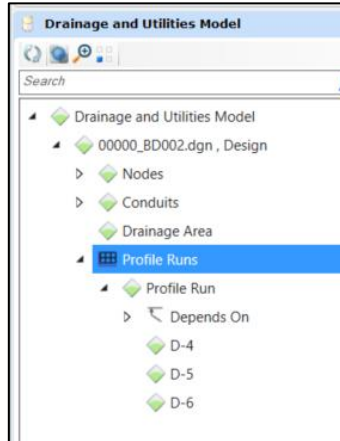

There are several options in the right click menu of a profile run, as shown above. The profile run will also have linear element in the 2d plan view to represent the profile run. If using the ProfileRun1-4 feature definitions then the 3d plan view graphic will be on the SC_ProfileRun1-4 level(s). note that the priority on this levels is set to be under the DR_P_Storm_Sewer level so it might be covered up by that level.

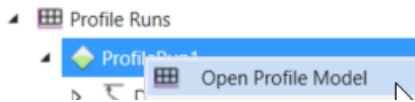

Use the Open profile model tool to open the Profile Run's Profile. After selecting this tool simply click inside the view window that you want the profile view to be displayed in.

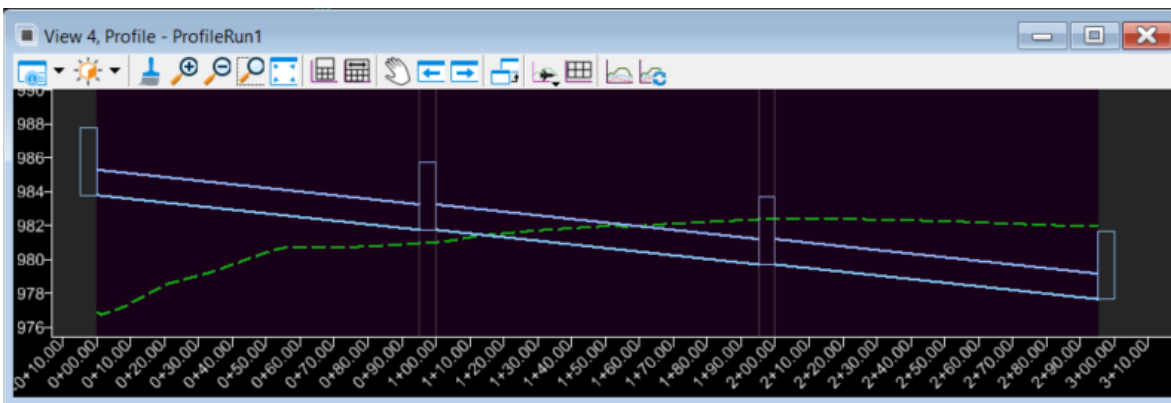

Some of the display settings for viewing Profile Runs are controlled via User Preferences > View Options - Civil.

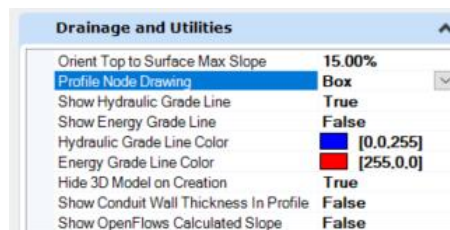



Showing Proposed Ground on Profile Runs

In the profile view of a profile run the active terrain will automatically be displayed along with the drainage network itself. But the proposed ground is not shown. Take the following steps to add proposed ground to the profile run.

A Profile run typically will be within the extents of a corridor. The Corridor top mesh can be used to project its top elevation online the profile run. The corridor has design stages set up so that the top mesh is display when the design stage is set to Final w/Meshes. If you do not see the CM_Corridor_Top_Mesh level in use in the 3d Design model of your corridor file then you need to open that file, select the corridor graphic and change the corridor feature definition to Final w/Meshes as imaged below.

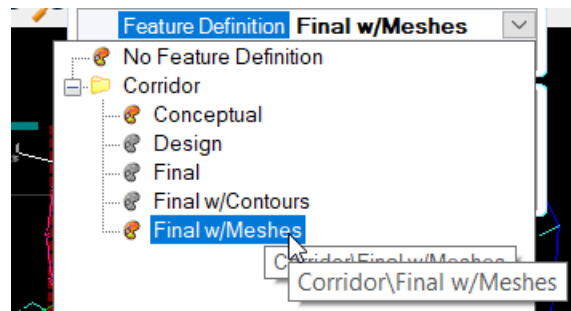

You can use the **Profile from Surface** tool to generate a dynamic profile from a surface.

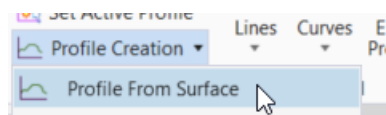

- When using this tool set the feature definition to Linear/Profiles/PF_P_Grade_Line.
- Select the profile run (not the conduit feature, but the actual profile run) that you want to create the proposed ground profile for.

- You can select multiple profile runs if desired.
- Reset click (right click) to accept selection and move on to the next step.
- Next select the surface to create the profile from. (You can select this from the view with the 3D model displayed)

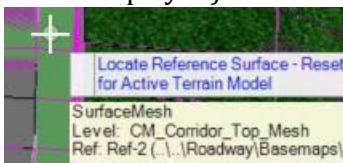

- Reset click to end surface selection after you have selected the desired surface
- Alt to lock to start and click to accept
- Alt to lock to end and click to accept
- Set point selection to all and click to accept
- Set profile adjustment to none and click to accept
- Set Draping options to Triangles and click to accept
- Set Horizontal offsets to 0 and click to accept
- Set vertical offsets to 0 and click to accept

The profile is rules to the surface so if the surface changes this profile will automatically update with the changes.

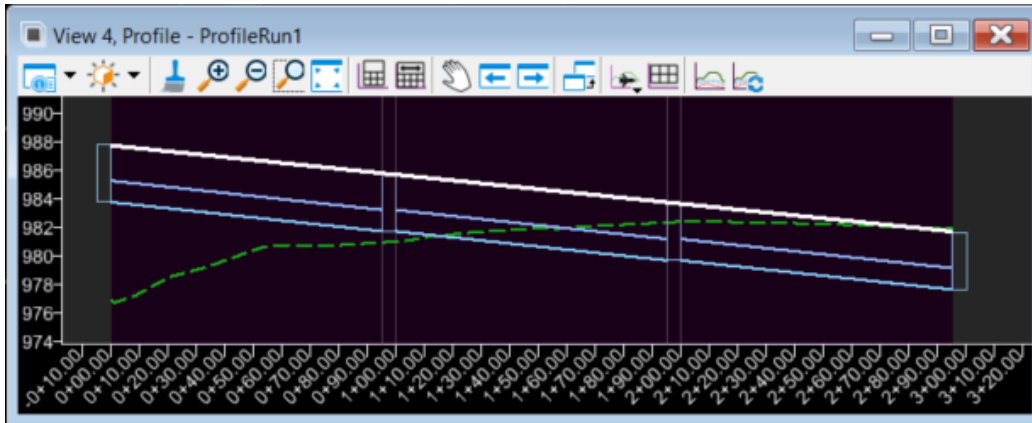

Deleting projected profile runs

If a profile run was projected onto a centerline on accident or no longer is needed you can open the project view and delete the conduit and profile run graphic but you will notice that the nodes can not be deleted. This is a bug. The work around is to regenerate the profile run. This can be done from Explorer as shown in the image below.

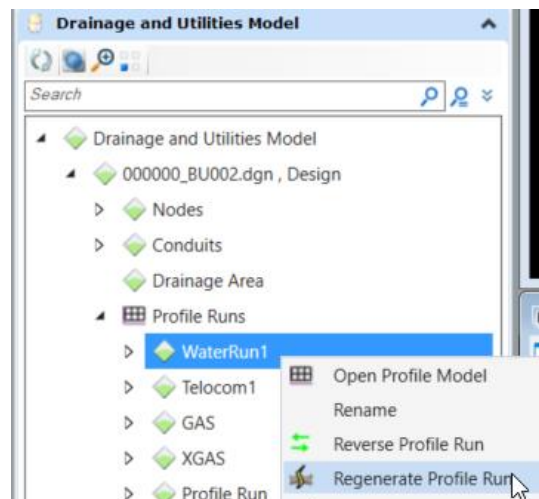

Create Profile Run Sheets

When putting together a plan set containing drainage there are a couple of options for how to display the drainage information. See L&D Vol. 3 section 1310.2 for details. One of the options is to show drainage information on a storm sewer profile sheet. This section will outline the steps to create these sheets.

Storm Sewer profile sheets should be created within the Drainage Profile (DF) file. Use the Create Design files application to create a Drainage Profile sheet file. Note that Named boundaries will be placed to create these sheets and as outlined in chapter 800, the named boundaries can be placed in the same file the sheets are generated in or a container file. For this example, we will put the named boundaries in the same file the sheets are generated in.

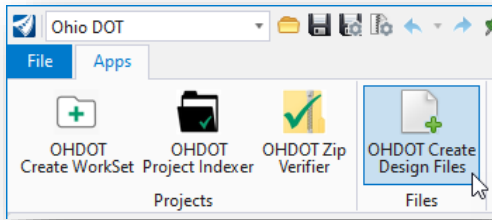

- Create a Drainage Profile sheet, don't forget to change the seed to 123456_DesignSeed2d.dgn



- After creating the file, add all desired references. This is typically the Fieldbook, alignment, corridors, and Drainage basemap files.
- Open the profile view of the Profile Run you would like to create a Storm Sewer Profile Sheet of.



- Select the **Place Named Boundary** tool and set the mode to profile, and the Drawing seed to either Pro-Pro or Profile Only. Pro-Pro seed will stack two named boundaries on top of each other in one sheet where as Profile Only will take up the whole sheet for one named boundary.
- Set the scale to the desired value.
- Data point inside the Profile view to select the view to place the named boundaries.
- Data point to set the start location for the first named boundary.
- Data point to set the end location for the last named boundary.
- Check on the Create drawing check box.

Tip: there is a check box for Whole Conduits Only

- Data point to accept and place the named boundary

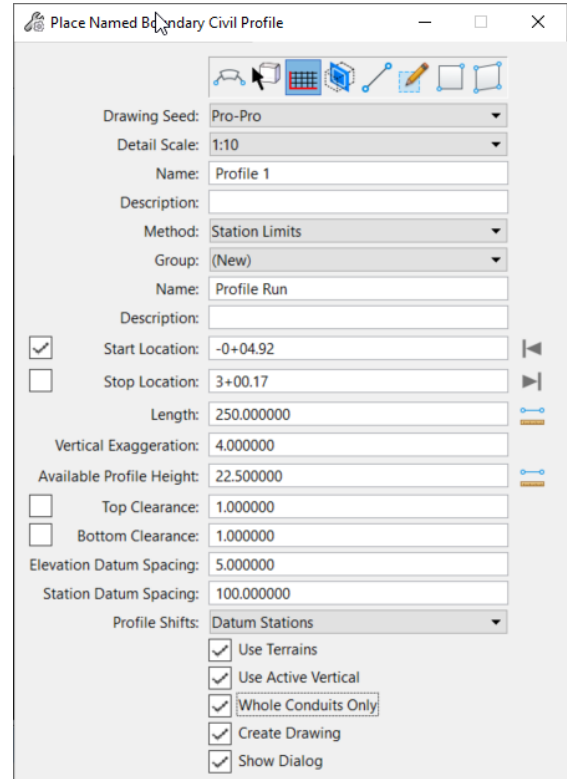



- In the create Drawing dialog that opens make sure to set the drawing model scale to match the scale set in the place named boundary dialog.

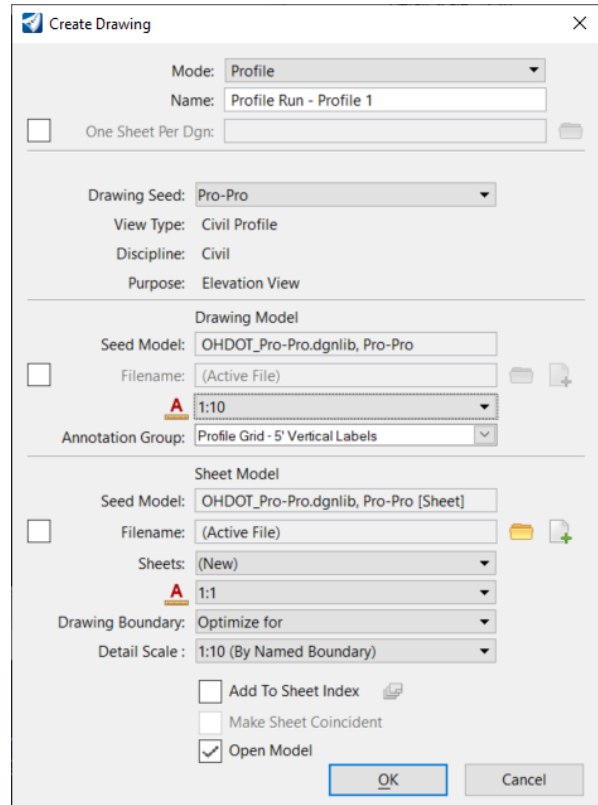

This will create a drawing model for each named boundary and sheet models. Annotation is placed in the drawing model.

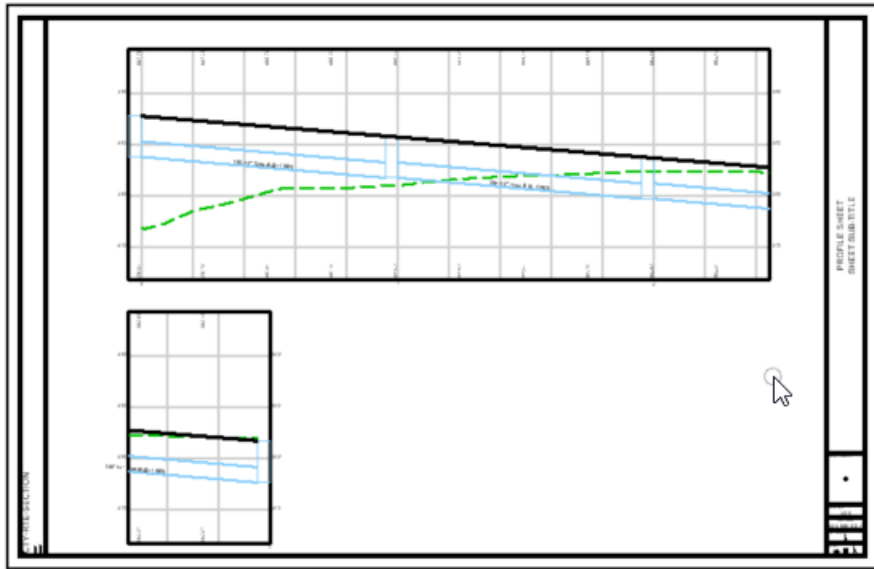

Tip: You can bulk create profile sheets for all profile runs by adding them to a selection set before starting the Place Named Boundary tool. There is a Graphical filter named Profile Runs which can be used with the **Select by Graphical Filter** Tool to help create the selection set.



Creating Profile Run sheets for divided highways

This Section is currently under development.

Setting up Drainage to show on Plan and Profile Sheets

In order to have a drainage network to show up in the profile section of a centerline profile it first needs to be modeled using the Drainage and Utilities tools outlined in the [Modeling Proposed Drainage Features](#) section of this guide. After it is modeled a profile run can be created as outlined in the [Creating Profile Runs](#) section of this guide, and these profile runs can be projected onto the centerline profile. Crossing pipes can also be shown with the use of the 3d cut tool. This section will outline the steps to set this up.

Projecting profile runs



Profile runs can be projected onto other profiles with the **Project Run** tool. This projection can be done either from within the drainage basemap file or from a file that has referenced in the drainage basemap. Currently it is recommended to project profile runs onto alignments from within the drainage basemap. The following steps outline how to project profile runs.

- Open the Drainage Basemap (BD) containing the drainage network you want to project to your center line alignment's profile
- Select the Project Run tool.
- Set the Feature Definition to one of the ProfileRun features (typically the same feature definition you created the profile runs with). Leaving the feature set to No Feature Definition will put a projection on the default level.
- Select the profile run you want to project
- Select the alignment you want to project the profile run onto.
- Open the profile view of the alignment to verify the profile run has been projected.

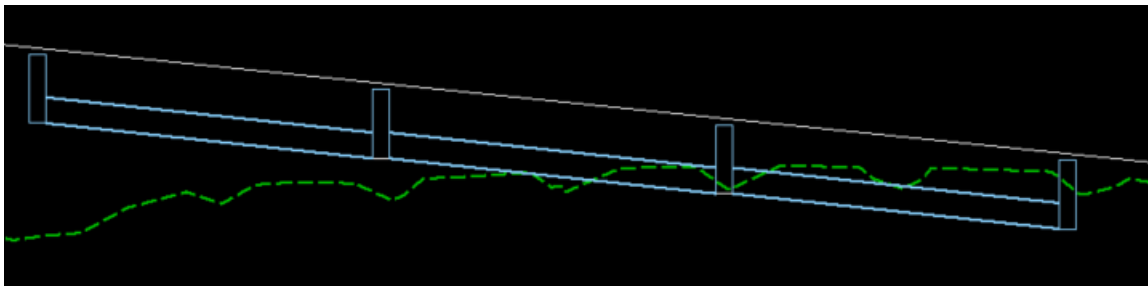
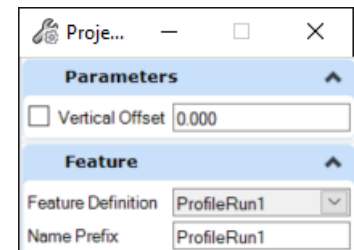

The profile run is projected perpendicular onto the alignment's profile. Notice if you turn off the DR_P_Storm_Sewer level you will see the Profile run element on the SC_ProfileRun1 level.

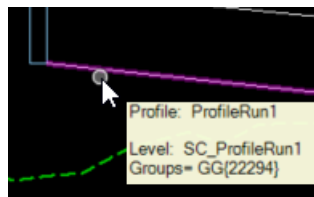

Showing Crossing Features

The previous section showed how to project a profile run onto an alignment but if there is a pipe crossing the road that is not shown. The create 3D cut tool can be used to show this crossing pipe.



- Select the create 3D cut button from within the Alignment' profile view.

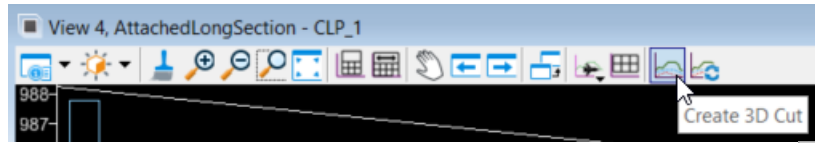

- Data point to accept the placement method as corners
- Data point in the profile view at one corner to start the area of the 3d cut
- Next data point in the profile view at the opposite corner to create the 3d cut area.

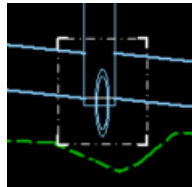
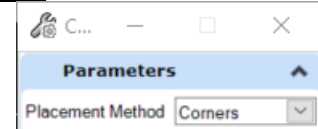

This process can be repeated for any number of 3d cut areas needed. Note that these areas can be selected and changed in size. You must hit the refresh 3d Cut button to update the graphics within the 3d cut area anytime a change it made included level display. This is a static 3d cut so changes to the model would require a refresh to the 3d cut as well.



Setting up Utilities to show on Plan and Profile Sheets

In order to have utilities show up in the profile section of a centerline profile it first needs to be modeled using the Drainage and Utilities tools outlined in the Extracting Utility Features section of this guide. After it is modeled its profile can be projected onto the centerline profile. Crossing utilities can also be shown with the use of the 3d cut tool. This section will outline the steps to set this up.

Projecting Profiles

The following steps show how to project utility profiles onto centerline profiles. ***This is a workaround workflow to using profile runs until some defects/enhancements are addressed with ORD. Utility text favorites for annotation will not be able to be used with this workflow! See alternative workflow for projecting profiles section for more info.***

Currently in order to project a utility profile onto the centerline profile you have to be within the file that contains the centerline element. This is typically a BK file.

1. Open the file containing the centerline alignment that the plan and profile sheet will be based upon.
2. Add a reference to the utility basemap.
3. Select the Project Profile To Element Tool
4. Select the appropriate feature definition

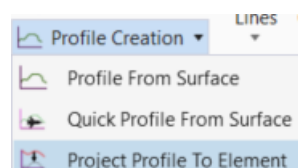

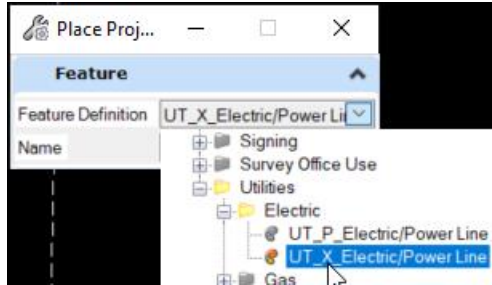

5. Select the Utility you want to project

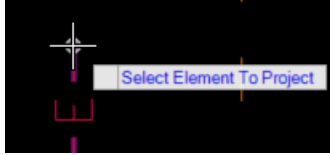

6. Select the Centerline you want to project onto



7. Open Profile View of centerline to verify the utility profile was projected.

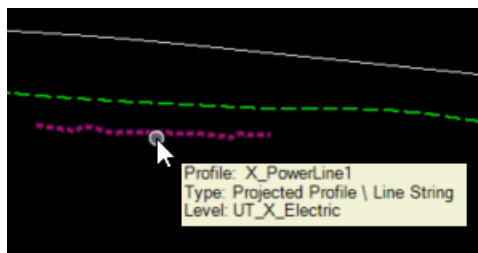

Note: The Utility feature definitions are set up to project the top of the conduit (not the invert) whereas Sanitary and Drainage project the bottom (invert).

Alternative workflow for projecting Utility Profiles

This workflow will project utilities onto centerline profile. This will allow for easier annotation of utilities with the use of text favorites, but the projection will show two lines (top and bottom of conduit). Typically for small diameter utilities we only show one line. There is currently a bug where the profile run graphic does not follow the profile of the pipe. When this is fixed this will be the preferred workflow.

In order to have an utility network show up in the profile section of a centerline profile it first needs to be modeled using the Drainage and Utilities tools outlined in the [Extracting Utility Features](#) section of this guide. After it is modeled a profile run can be created as outlined in the [Creating Profile Runs](#) section of this guide, and these profile runs can be projected onto the centerline profile. This section will outline the steps to set this up.

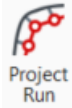

Profile runs can be projected onto other profiles with the **Project Run** tool. This projection can be done either from within the utility basemap file or from a file that has referenced in the utility basemap. Currently it is recommended to project profile runs onto alignments from within the utility basemap. The following steps outline how to project profile runs.

- Open the Utility Basemap (BU) containing the utility network you want to project to your center line alignment's profile
- Select the Project Run tool.
- Set the Feature Definition to one of the ProfileRun features (typically the same feature definition you created the profile runs with). Leaving the feature set to No Feature Definition will put a projection on the default level.
- Select the profile run you want to project
- Select the alignment you want to project the profile run onto.
- Open the profile view of the alignment to verify the profile run has been projected.

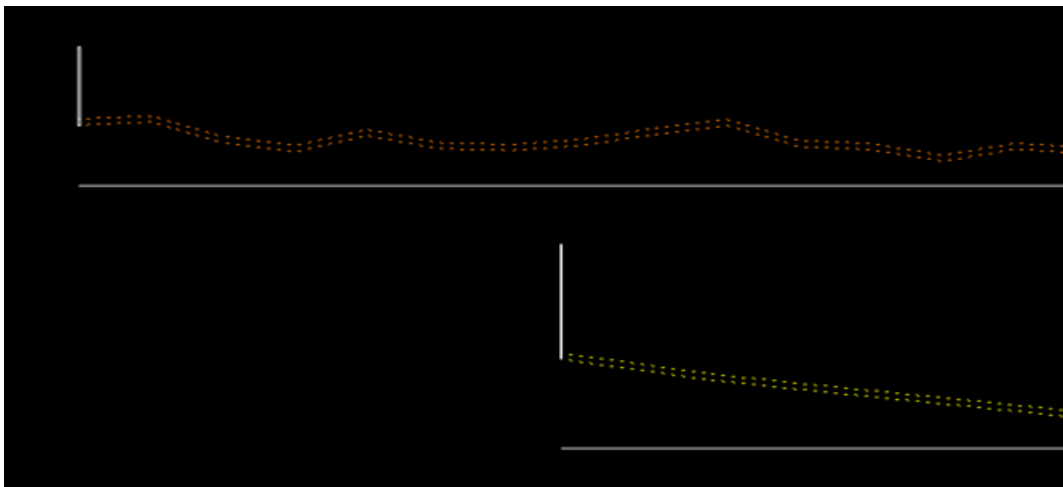
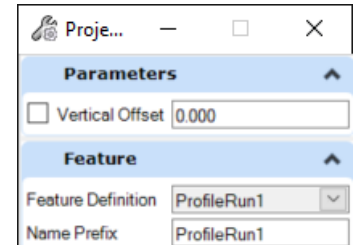

The profile run is projected perpendicular onto the alignment's profile. Since all conduit must connect to a node, you will notice nodes draw in, these are on the Default level and should be turned off. Also notice the profile run graphic and the bug that is does not follow the utility profile. This need turned off as well. This graphic will be on the SC_ProfileRun1 level is the ProfileRun1 feature definition was used. Also notice the two lines for the top and bottom of the conduit. In a future release of ORD when the profile run graphic is fixed to follow the conduit profile, the workflow will be to turn off the conduit and leave the profile run graphic on. The [Showing Drainage and Utilities on Plan and Profile](#) Section will show how to get these projected utilities to show up on profile sheets with the use of the attach all profile views button.

Showing Crossing Features

The previous section showed how to project a utility's profile onto an alignment but if there is a utility crossing the road that is not shown. The create 3D cut tool can be used to show this crossing utility.

- Open the Utilities Basemap.



- Select the create 3D cut button from within the Alignment' profile view.

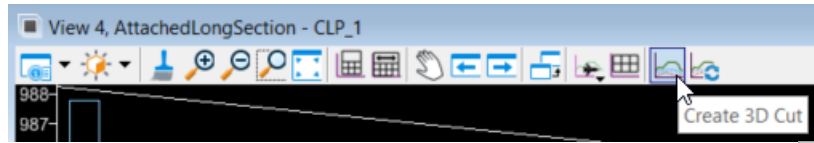

- Data point to accept the placement method as corners
- Data point in the profile view at one corner to start the area of the 3d cut
- Next data point in the profile view at the opposite corner to create the 3d cut area.

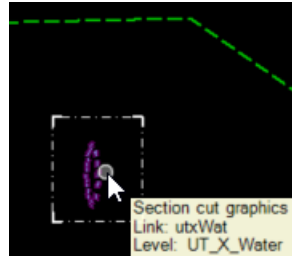
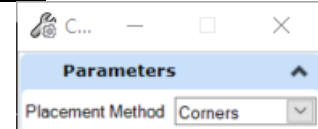

This process can be repeated for any number of 3d cut areas needed. Note that these areas can be selected and changed in size. You must hit the refresh 3d Cut button to update the graphics within the 3d cut area anytime a change it made included level display. This is a static 3d cut so changes to the model would require a refresh to the 3d cut as well.

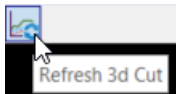

Showing Drainage and Utilities on Plan and Profile sheets

The previous two sections showed how to set up drainage and utilities for plan and profile sheets. Now that the set up is done this section will show the steps for showing these features on a plan and profile sheet.

Note that Named boundaries will be placed to create these sheets and as outlined in chapter 800, the named boundaries can be placed in the same file the sheets are generated in or a container file. For this example, we will put the named boundaries in the same file the sheets are generated in. First, we will need to create a plan and profile sheet file to set up for our plan and profile sheet.

- Create a Plan and Profile sheet, don't forget to change the seed to 123456_DesignSeed2d.dgn

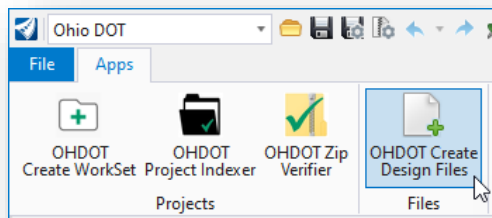

<input checked="" type="checkbox"/>	Roadway	Sheet	Plan and Profile or Plan	GP	1	400-Engineering\Roadway\Sheets\	123456_GP	001	Plan&Profile	1:20	OHDOT_SheetSeed2d.dgn
-------------------------------------	---------	-------	--------------------------	----	---	---------------------------------	-----------	-----	--------------	------	-----------------------



- After creating the file, add all desired references. This is typically the Fieldbook, alignment, corridors, Right of Way basemap, Drainage basemap, and Utility basemap files.
- Open the profile view of the alignment that the plan and profile sheet will be based off of.
 - Select the Attach All Profile Views button from within the profile view window. This will attach the profile view for any references that have drawn content for this profile view within that reference file.

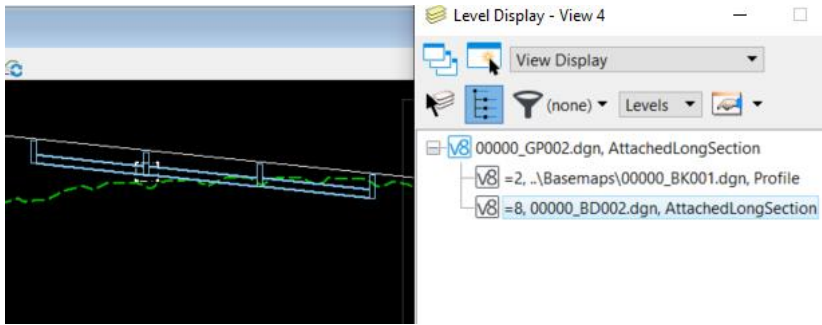
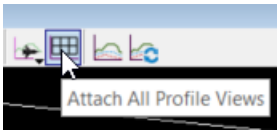

- Select the **Place Named Boundary** tool and set the mode to Civil Plan, and the Drawing seed to either Plan-Pro - PLAN.
- Set the scale to the desired value.
- Select the Center Line alignment which will be used to create named boundaries along.
- Key in or data point at the station you want the first named boundary to start at.
- Key in or data point at the station you want the last named boundary to end at.
- Before issuing a final data point to place the plan view named boundaries make sure to check off create drawing, as we don't want to create the drawings until we set up our profile named boundaries.
- Now data point in the view window to accept and place the plan view named boundaries
- Select the **Place Named Boundary** tool again and this time set the mode to Civil Profile, and the Drawing seed to either Plan-Pro - Profile.
- Set the scale to the same set when placing the plan view named boundaries.
- Set the Method to From Plan Group and set the plan group to the group that was just created with the plan view named boundaries. this is typically the name of the selected alignment.
- Data point inside the view window containing your profile view.

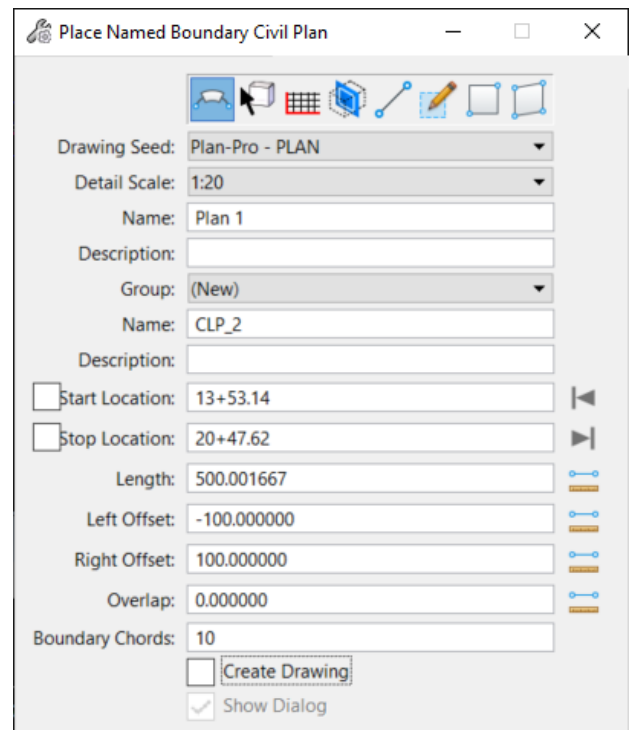



- The profile named boundaries should now be shown in the profile view window. These are temporary graphics.
- Before issuing the final data point make sure to check on the Create Drawing and show dialog checkboxes since now we are ready to generate the sheets.
- Now data point in the profile view to place the profile Named boundaries.
- Since Create Drawing was checked on the software will not start generating the sheets. Since Show Dialog is checked on a dialog will show up where you can review/edit settings for the sheet creation.
- Below shows the screen shot of the create drawing dialog. Make sure the Drawing model annotation scales match the scale you selected when placing the named boundaries, make sure the sheet model annotation scale is 1:1 and the sheet model detail scale matches the scale you selected when placing the named boundaries. Select OK and the software will generate the sheets.

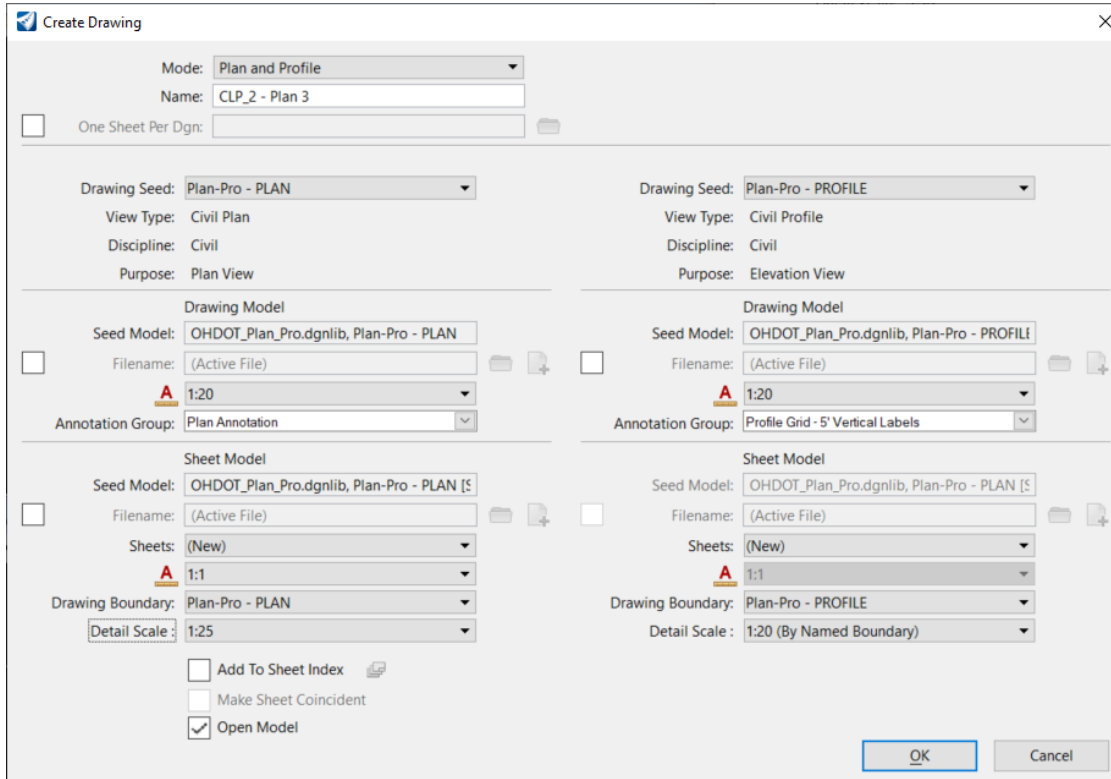
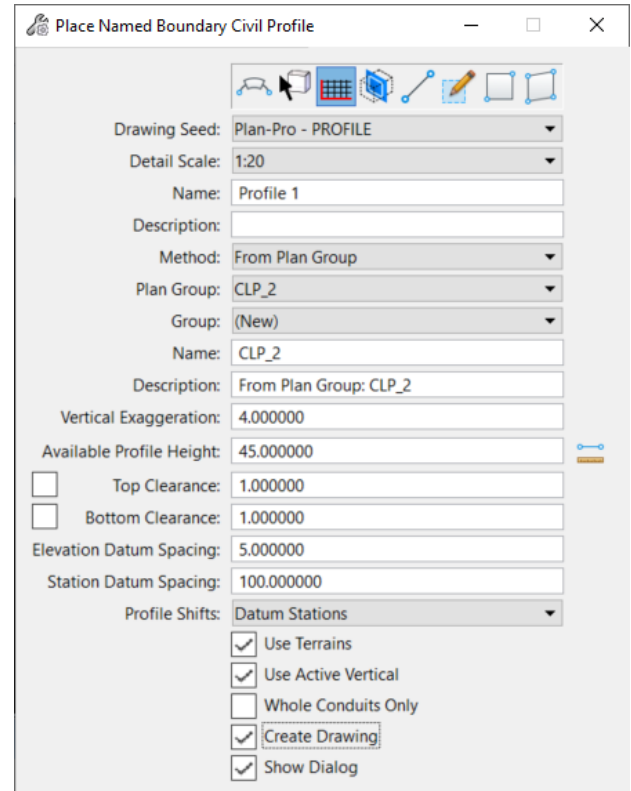

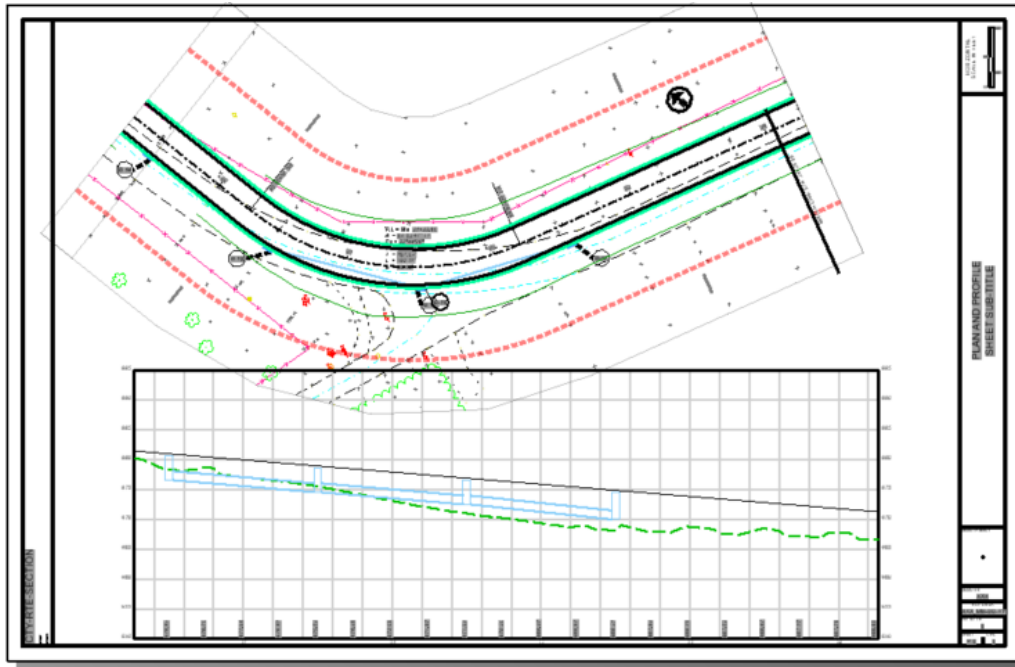

Showing Drainage and Utilities on Cross Sections

This section will explain how drainage and utility features are shown on cross section sheets. Refer to Chapter 800 of this guide for details on creating cross section sheets.

As long as you have modeled the drainage and utilities as outlined in this chapter with using the drainage and utilities tool then your drainage and utilities should be modeled in 3D. When cross sections are generated, the graphics that are displayed on the cross sections are a slice of the 3D model. This means that when you cut cross sections if a drainage or utility feature is in 3d model at the location of the cross section then it will be displayed on the cross section.

If you want to show drainage nodes on cross sections then a section cross must be cut at the location of the node.

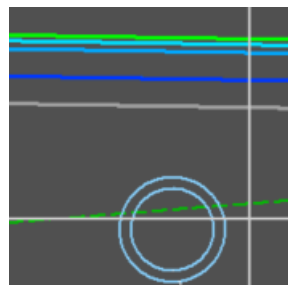
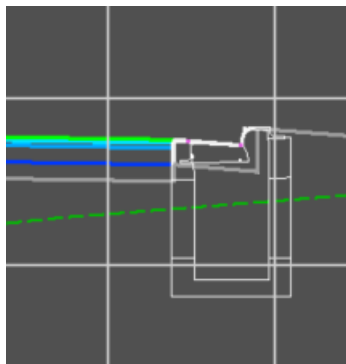



Annotating Drainage and Utility Features

Several things have been set up to assist in the process of annotating drainage and utility features. Annotation of drainage and utility features starts with Text Favorites. Text Favorites are basically predefined text that contains text fields. These text fields are placeholders for property values. The properties can come from element properties, model properties, file properties, etc.

An excel file can be found within the OHDOT cadd standards that provides more detail on what text favorites are available for Drainage and Utilities and example of each one. The screen shot below shows some of the text favorites.

\\.\WorkSpaces\OHDOT\Standards\OHDOT Utilities\Documentation\Drainage and Utilities Text Favorites.xlsx

****PLEASE NOTE CURRENTLY ANNOTATION FOR DRAINAGE AND UTILITY FEATURES DOES NOT WORK ACROSS A REFERENCE. WITH ORD 2020 R3. YOU CAN ANNOTATION ACROSS A REFERENCE WHILE YOU ARE IN THE FILE BUT WILL NEED TO COPY/PASTE THE TEXT FIELDS DOWN TO STATIC TEXT FOR PRINTING. THIS SHOULD BE FIXED IN AN UPCOMING RELEASE OF ORD. IF USING A VERSION PREVIOUS TO ORD 2020 R3 THEN ANNOTATION WILL NOT WORK ACROSS A REFERENCE. IF USING ORD 2020 R3 THEN SEE [ANNOTATING IN ORD 2020 R3](#) SECTION FOR WORKFLOW.****



Text Favorite Name	Format	Example	Requirements
FeatureName	<i>Feature Name</i>	D-2	
Plan DrainagePipe-P	Size Type	18" TYPE B	Conduit
Profile DrainagePipe-P	Length-Size Type @ Slope	100'-12" TYPE B @ -1.98%	Conduit
Profile DrainagePipe-X	<i>EX. Size Type</i>	<i>EX. 12" RCP</i>	Conduit
Profile/XS DrainageNode-P	STA XX+XX.XX, Offset Type, GRATE ELEV XXXX.XX	STA 386+50.00, 12.00' CB-3, GRATE ELEV 1003.65	Catch Basin & CivilAccuDraw
Profile/XS DrainageNode-P_Unformatted	STA XXXX.XX, Offset Type, GRATE ELEV XXXX.XX	STA 38650.00, 12.00' CB-3, GRATE ELEV 1003.65	Catch Basin & Storm Feature
Profile/XS DrainageNode-P-MH	STA XX+XX.XX, Offset Type, RIM ELEV XXXX.XX	STA 386+50.00, 12.00' MH-1, RIM ELEV 1003.65	Manhole & CivilAccuDraw
Profile/XS DrainageNode-P-MH_Unformatted	STA XXXX.XX, Offset Type, RIM ELEV XXXX.XX	STA 38650.00, 12.00' MH-1, RIM ELEV 1003.65	Manhole & Storm Feature
Profile/XS DrainageNode-P-PipeEnd	Size (direction) Elev at end of pipe	18" (N) 1002.13	Conduit
Profile/XS DrainageNode-P-PipeStart	Size (direction) Elev at start of pipe	18" (S) 1003.14	Conduit
Profile/XS DrainageNode-X	<i>STA XX+XX.XX, Offset EX. Type, GRATE ELEV XXXX.XX</i>	<i>STA 386+50.00, 12.00' EX. CB, GRATE ELEV 1003.65</i>	Catch Basin & CivilAccuDraw
Profile/XS DrainageNode-X_Unformatted	<i>STA XXXX.XX, Offset EX. Type, GRATE ELEV XXXX.XX</i>	<i>STA 38650.00, 12.00' EX. CB, GRATE ELEV 1003.65</i>	Catch Basin & Storm Feature
Profile/XS DrainageNode-X-MH	<i>STA XX+XX.XX, Offset EX. Type, RIM ELEV XXXX.XX</i>	<i>STA 386+50.00, 12.00' EX. MH, RIM ELEV 1003.65</i>	Manhole & CivilAccuDraw
Profile/XS DrainageNode-X-MH_Unformatted	<i>STA XXXX.XX, Offset EX. Type, RIM ELEV XXXX.XX</i>	<i>STA 38650.00, 12.00' EX. CB, RIM ELEV 1003.65</i>	Manhole & Storm Feature
Profile/XS DrainageNode-X-PipeEnd	<i>EX. Size direction Elev at end of pipe</i>	<i>EX. 12" PVC N 1002.13</i>	Conduit
Profile/XS DrainageNode-X-PipeStart	<i>EX. Size direction Elev at start of pipe</i>	<i>EX. 12" PVC S 1003.14</i>	Conduit
Profile/XS SanNode-P-MH_Unformatted	STA XXXX.XX, Offset Type, RIM ELEV XXXX.XX	STA 38650.00, 12.00' MH-1, RIM ELEV 1003.65	Manhole & Sanitary Feature
Profile/XS SanNode-X-MH_Unformatted	<i>STA XXXX.XX, Offset EX. Type, RIM ELEV XXXX.XX</i>	<i>STA 38650.00, 12.00' EX. CB, RIM ELEV 1003.65</i>	Manhole & Sanitary Feature
XS DrainagePipe-P	Size Type	12" Type B	Conduit
XS DrainagePipe-X	<i>EX. Size Type</i>	<i>EX. 12" STORM</i>	Conduit
Util-Comm-P-SizeType	Size Type	6" FIBER OPTIC	communication
Util-Comm-P-Type	Type	FIBER OPTIC	communication
Util-Comm-X-SizeType	<i>EX. Size Type</i>	<i>EX. 6" FIBER OPTIC</i>	communication
Util-Comm-X-Type	<i>EX. Type</i>	<i>EX. FIBER OPTIC</i>	communication
Util-Elec-P-SizeType	Size Type	6" ELECTRIC	Electrical
Util-Elec-P-Type	Type	ELECTRIC	Electrical
Util-Elec-X-SizeType	<i>EX. Size Type</i>	<i>EX. 6" ELECTRIC</i>	Electrical
Util-Elec-X-Type	<i>EX. Type</i>	<i>EX. ELECTRIC</i>	Electrical
Util-Gas-P-SizeType	Size Type	6" GAS	Gas
Util-Gas-P-Type	Type	GAS	Gas
Util-Gas-X-SizeType	<i>EX. Size Type</i>	<i>EX. 6" GAS</i>	Gas
Util-Gas-X-Type	<i>EX. Type</i>	<i>EX. GAS</i>	Gas
Util-Oil-X-SizeType	<i>EX. Size Type</i>	<i>EX. 6" OIL</i>	POL
Util-Oil-X-Type	<i>EX. Type</i>	<i>EX. OIL</i>	POL
Util-Water-P-SizeType	Size Type	6" WATER	Water
Util-Water-P-Type	Type	WATER	Water
Util-Water-X-SizeType	<i>EX. Size Type</i>	<i>EX. 6" WATER</i>	Water
Util-Water-X-Type	<i>EX. Type</i>	<i>EX. WATER</i>	Water

Typically, annotation should be done in the drawing models.



There are several tools available to assist in placing annotation.



Place Label: can place cells or text favorites with or without a leader line.

Element Annotation: if the element has an annotation group defined then element annotation will annotate the element.

Remove Element Annotation: removes the annotation that’s associated with the element.

Model Annotation: annotates the entire drawing model.

Remove Model Annotation: Removes all annotation from the model that was.

Plan View Drainage Annotation

Call outs

There are many ways to annotate a cell out. One way is to use `_Lbl_Pln_FeatureName` cell with the **Place Label** tool. This cell uses the Plan – Feature Name Text favorite and puts a circle around it. The Plan – Feature Name text favorite will display the feature name of the specified feature.

When using the place label tool make sure to select the element or the label will not get associated to that element and won’t be able to pull properties from the element.

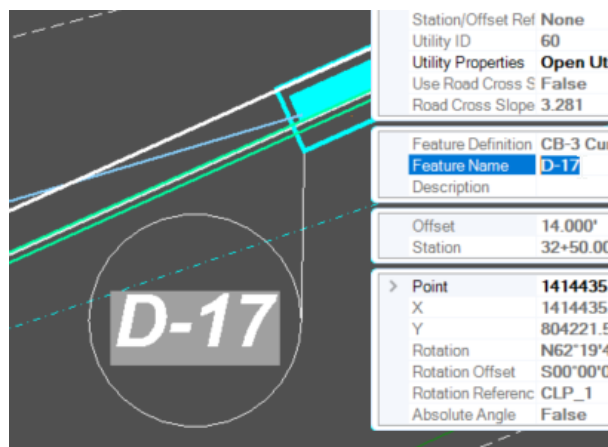

Note: Element annotation has been defined for Proposed Catch Basins, Manholes, and Inlets to place these call outs.

Plan View Drainage Pipe Annotation

Pipe Annotation has been defined on all proposed conduit. This means  **Annotate Element** can be used. This will place a flow arrow in the direction of flow for the pipe as well as the size and type. Note that the type is coming from the Notes drainage property which has been preset on the feature definition.

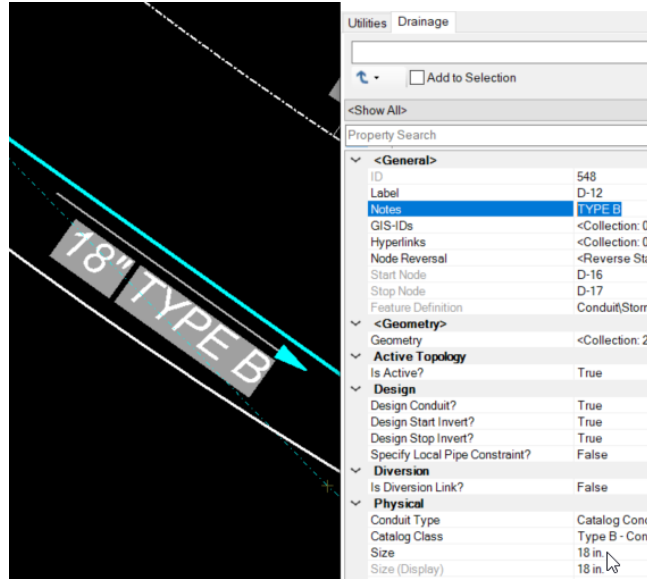

** While annotation should typically be placed within drawing models. There are currently some bugs in the software, and it is best to place these pipe annotation in the Drainage Basemap file. **

Profile View Drainage Annotation

When profile sheets are generated, features that have annotation groups defined will automatically get annotated. Both node and pipe annotations for profile view have annotation groups defined so these elements should auto annotate. Note that more work needs to be done to the node annotation.

Node Annotation

As mentioned above node annotation should be auto-annotated during sheet creation. The **Model annotation** and **Element annotation** tools could be used as well. But the annotation is missing the information about the connecting pipes. Currently this cannot be auto-annotated. Follow the below steps to add in the annotation for each pipe that connects to the node.

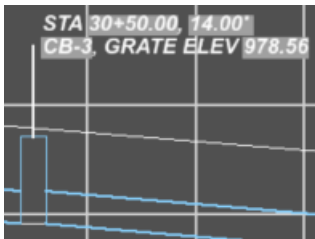

- Double click on text element or use **edit text** tool to open the text editor for the node annotation.
- Within the text editor insert a text favorite for the connected pipe.

There are two text favorites to choose from for proposed nodes

- Profile/XS DrainageNode-P-PipeEnd
- Profile/XS DrainageNode-P-PipeStart

The Profile/XS DrainageNode-P-PipeEnd will pull the end of the pipe invert elevation while the Profile/XS DrainageNode-P-PipeStart pulls the start of the pipe invert elevation.

NOTE: the pipe start/end locations represents the order/direction the pipe was drawn in not necessarily the direction of flow. Care must be taken to select the correct text favorite.

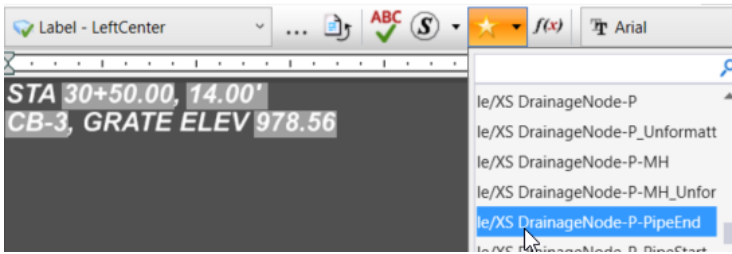

- After selecting the text favorite, it will be inserted into the text editor dialog. But the fields within the text favorite still need to be assigned to an element in order to know the property values to display. To do this you simply right click on the field and select reassign then select the element to assign the field to. Repeat this for all the fields.

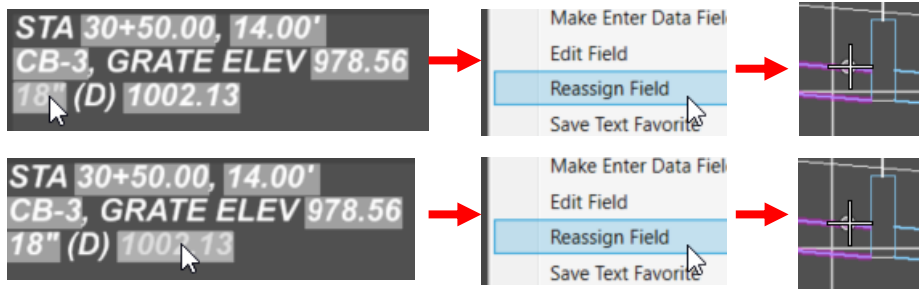

- The (D) standards for direction and has to be manually typed in. This is the direction the pipe is going away from the node.



- Repeat the above two steps for any additional pipes connected to that node making sure to select the appropriate text favorite for each pipe.

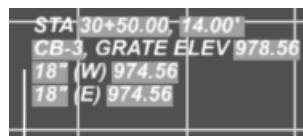

This process is the same for existing drainage nodes with the exception that the Profile/XS DrainageNode-X-PipeEnd and Profile/XS DrainageNode-X-PipeStart should be used instead.

Additional Info

The auto annotation of nodes is using the Profile/XS DrainageNode-P or Profile/XS DrainageNode-P-MH text favorites (Profile/XS DrainageNode-X, and Profile/XS DrainageNode-X-MH text favorites for existing). You could use the **Place Label** tool with these text favorites to achieve the same annotation.



The type field in the annotation is coming from the Notes drainage property as imaged below.

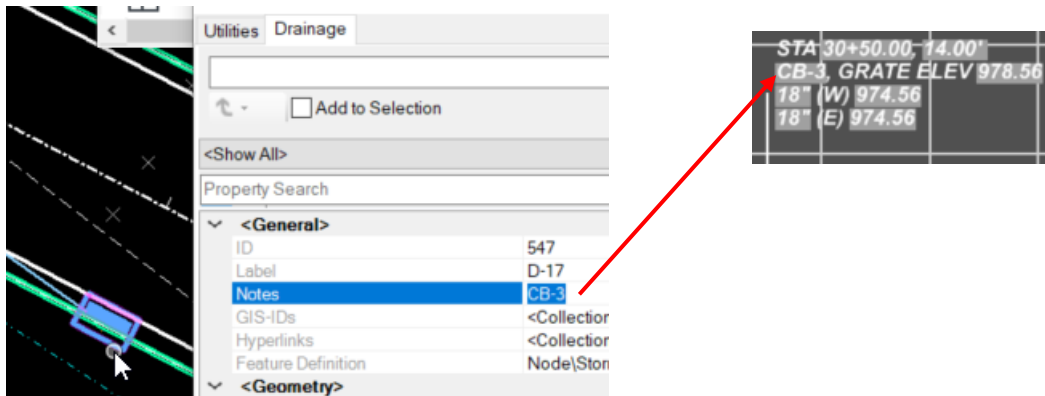

STATION AND OFFSET ANNOTATION

Point Constraints	
Offset	14.000'
Station	32+50.00

The Station and offset values are coming from a point constraint property that has been applied to the node. These point constraint properties are only added if the node was placed using civil accu-draw station-offset ordinate or the **Place Nodes** tool. If the node was not placed using one of the above two mentioned

methods then the annotation will no have a station or offset property to get the value from and will be blank. If this is the case, you can either use civil accudraw station-offset ordinate while moving the node (to the same spot) to apply the needed point constraints or below lists an **alternative workaround** to annotating station and offset.

- In the Drainage basemap select all the drainage nodes and open the Properties dialog.
- In the properties dialog select the three horizontal dots in the Station/Offset Reference property.
- Now select the desired alignment to use that the station/offset reference.
Station/Offset Reference CLP_1
- Now go back to the Profile Drawing model.

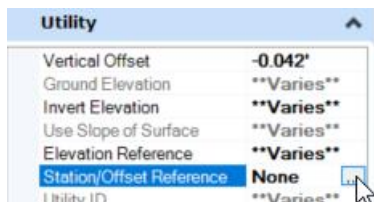

- Additional text favorites have been set up to use the Station/Offset Reference properties instead of the point constraint properties, but there are limitations to the formatting of these text favorites. The text favorites available are Profile/XS DrainageNode-P_Unformatted, Profile/XS DrainageNode-P-MH_Unformatted, and Profile/XS SanNode-P-MH_Unformatted (Profile/XS DrainageNode-X_Unformatted,, Profile/XS DrainageNode-X-MH_Unformatted, Profile/XS SanNode-X-MH_Unformatted text favorites for existing).
- Use the Place label tool and select the Profile/XS DrainageNode-P_Unformatted text favorite for inlet nodes, Profile/XS DrainageNode-P-MH_Unformatted text favorite for storm manholes, or Profile/XS SanNode-P-MH_Unformatted text favorite for sanitary manholes.
- After placing the label you will notice that the station value is not formatted correctly, this is a current limitation of the software that will eventually get fixed.





- Edit the text element and type over the station text field to format it as desired. Note that this will make the station value static and if the node is moved the value will **not** dynamically update.



- Follow the [Node Annotation](#) section for the steps on annotation the connecting pipes.

Pipe Annotation

As mentioned above pipe annotation should be auto annotated when profile sheets are generated.



Model Annotation and **Element Annotation** tools could be used as well. This auto-annotation is using the Profile DrainagePipe-P text favorite (Profile DrainagePipe-X text favorite for existing). You could use the **Place Label** tool to achieve the same annotation.

The Length value in this text field is the center of node to center of node length. The slope value is also based off the center of node to center of node length. Just as in the plan view annotation the Type is coming from Notes Drainage Property.

Cross Section View Drainage Annotation

Cross section drainage annotation is very similar to Profile drainage annotation except that element annotation tool will not work for cross sections and currently nothing is auto annotated.

Cross section annotation should be done in the drawing models that are created from named boundaries.

Node Annotation

Unlike Profiles, drainage networks are not projected to the nearest cross section. If you want to show a drainage node on a cross section then a cross section must be cut at that location. The same text favorites that are used to annotate nodes in a profile view are used to annotate nodes in a cross section view. Please follow the [Profile View Drainage Annotation – Node Annotation Section](#) for the workflow.

When annotating connecting pipes (as outlined in the Profile View Drainage Annotation – Node Annotation Section) there is a good chance that the connecting pipe will not be visible on the cross section making it hard to pull annotation values for that pipe. Follow the steps below to temporary display the connecting pipes in order to set up the connecting pipe annotation.

- Select the 3d named boundary from the 3D model for the cross section containing the drainage node that has connecting pipes that are not visible and change the Forward or Back Depth properties. This will widen the cross section slice to show a thicker section of the 3D. the Forward depth will widen the named boundary in the up station direction. The value needs to be great enough to get the named boundary to cut where the pipe is.

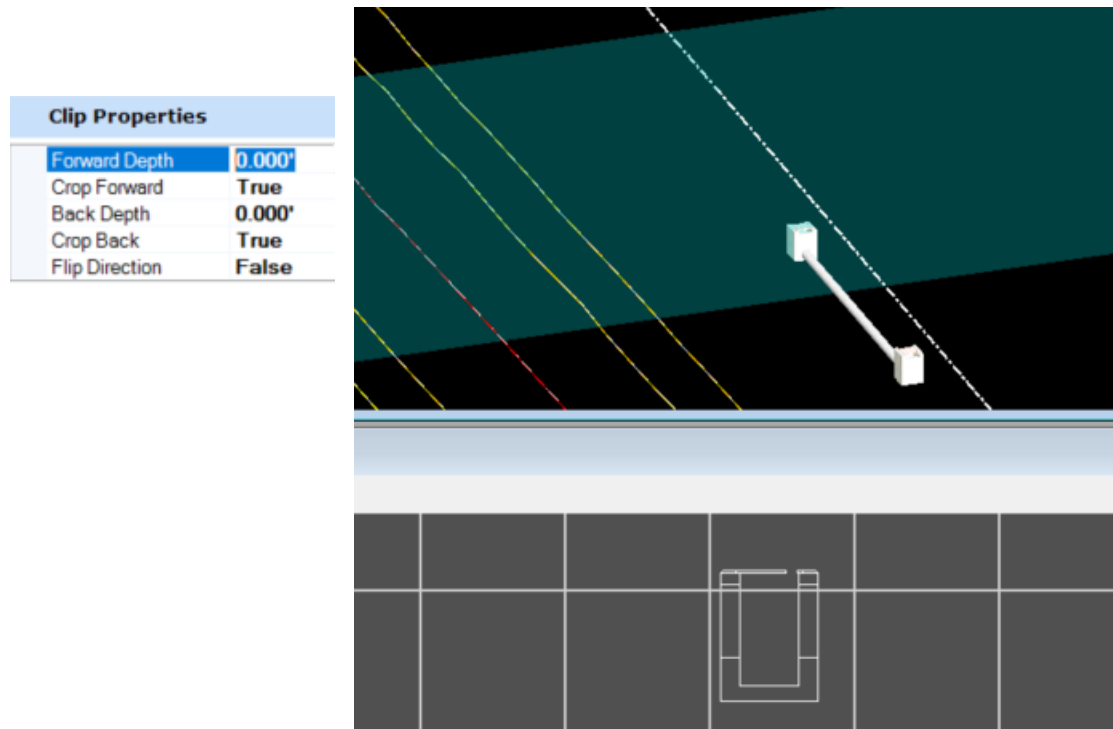

- After the value is updated notice how the connecting pipe shows up in the cross section view. Now the connection pipe annotation can be added to the node. (follow the steps outlined in the [Profile View Drainage Annotation – Node Annotation Section](#)).

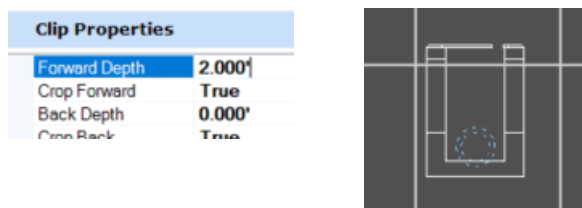

- Change the Forward/Back depth back to zero. And repeat of the other side if needed.

Pipe Annotation

Pipes will only be shown in the cross section if that pipe is crossing the Cross section named boundary.

The following steps outline how to annotate these pipes.

- Select the **Place Label** Tool. Set the text to Text Favorite and use the XS DrainagePipe-X for existing pipes and XS DrainagePipe-P for proposed pipes.
- Select the pipe and place the annotation

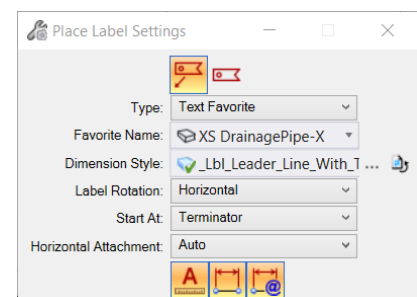
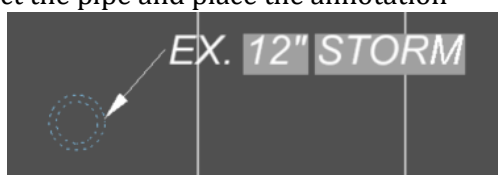

Just as in the plan view and profile view annotation the Type is coming from Notes Drainage Property.



Profile View Utility Annotation

While there are several text favorites set up for utility annotation, these will not work if the workflow outlined in the [Setting up Utilities to show on Plan and Profile Sheets - Projecting Profiles](#) section. This is because that workflow is just creating profiles using regular linear feature definitions and NOT an actual conduit feature definition, meaning that none of the utility properties exist on those elements. This workflow is used because currently projecting the actual utility shows two lines (the top and bottom of the conduit). Typically, we only show one line for these utilities as the diameter is small and two lines adds a lot of unneeded clutter. If you would like to use text favorites to annotate utilities, then follow the [alternative workflow for projecting utilities](#) section.

- If the [Setting up Utilities to show on Plan and Profile Sheets - Projecting Profiles](#) section was used to show utility profiles on centerline profile then annotation will be manual using the **Place Note** tool.

By hovering over the element you can see what feature/level it is on to know what utility it is

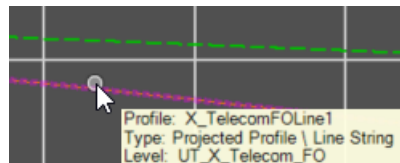

Then use the place note tool to place the annotation as shown in the screen shot below.

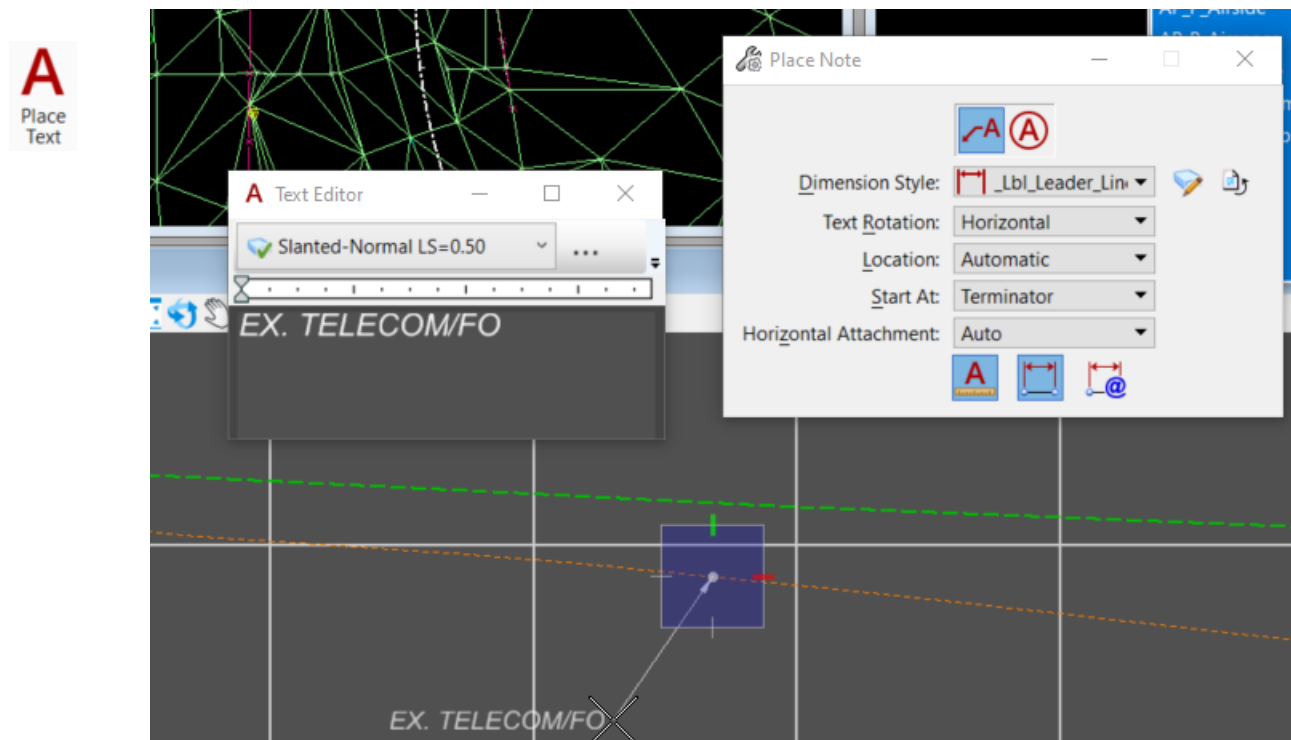

- If the [Alternative workflow for projecting utilities](#) section was used to show utility profiles on centerline profile then annotation can be dynamically pulled from the utility properties using text favorites with the **Place Label** Tool . (remember if your missing the projected utility runs to use the Attach all profile views button).



Remember before annotating Drainage & Utility features that the Drainage & Utility Project needs to be created in this project so that the drainage & Utility properties can be accessed. This is done easily by simply opening the Utility properties of any of the Drainage and Utility elements that are referenced into the file.

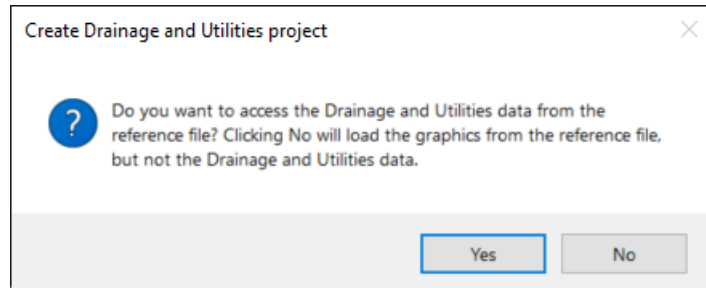
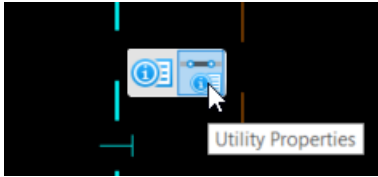

Now simply use **Place Label** tool. Note the different text favorites available for utilities.

Text favorites are specific to the utility type. For each type there is a text favorite for annotating just the utility type and another for the utility size and type.

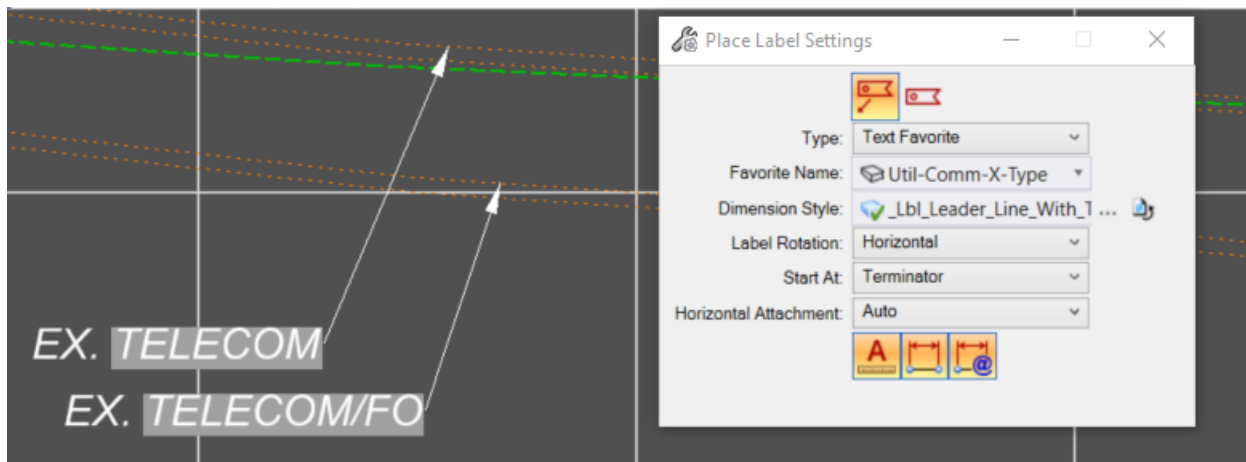

The Utility text favorites are pulling the Network Type (User Defined) property. This has been predefined on the utility feature definitions with appropriate values.

Utility Data	
Owner	
Operational Status	In Service
Network Type	User Defined
Network Type (User Defined)	TELECOM
Function	Segmented Cable
Conduit Type	Cable

Currently this method does show a line for the top and bottom of the utility. You could also follow this workflow [Setting up Utilities to show on Plan and Profile Sheets - Projecting Profiles](#) to show utility as one line in addition to this workflow, [Alternative workflow for projecting utilities](#) to use with the text favorites and turn off levels from the utility run projections.



Cross Section View Utility Annotation

Cross section utility annotation is very similar to Profile Utility annotation.

Cross section annotation should be done in the drawing models that are created from named boundaries.

Use The **Place Label** Tool with the Utility text favorites to annotate Utilities in cross section drawing models.

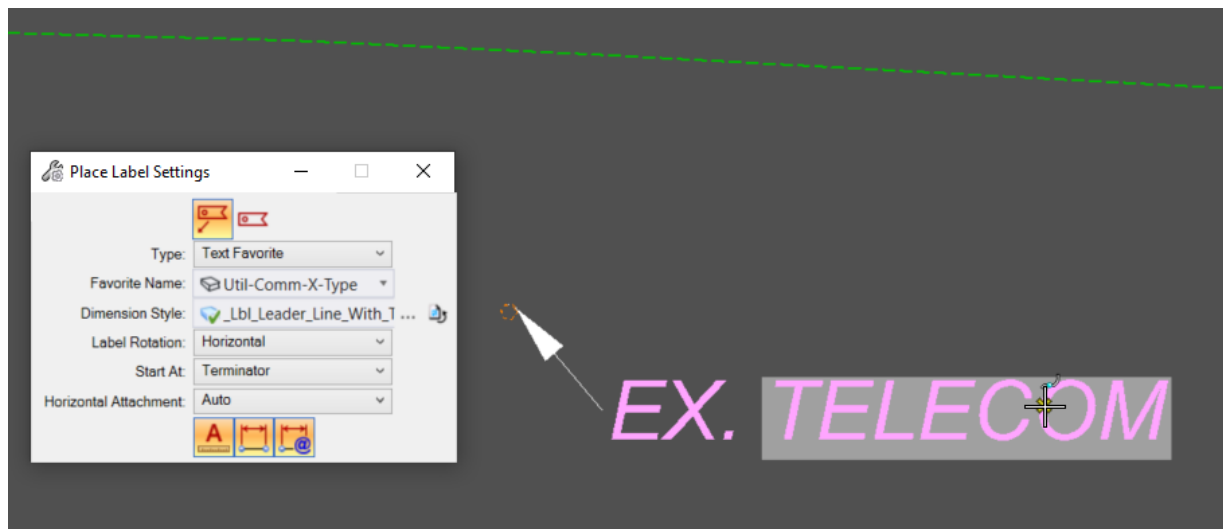

See the [Profile View Utility Annotation](#) Section for more details in the Utility Text Favorites.

Annotation in ORD 2020 R3

With ORD 2020 R3 it is possible to annotate drainage and utility features across a reference. There are still some bugs that will be fixed in a future release of ORD. For now in order to annotate Drainage & Utility features across a reference you first have to open the utility properties of any referenced in node/conduit. You will be prompted with the below dialog. Select yes and it will then expose the Drainage & Utility properties from the reference, which can then be used within text favorites.

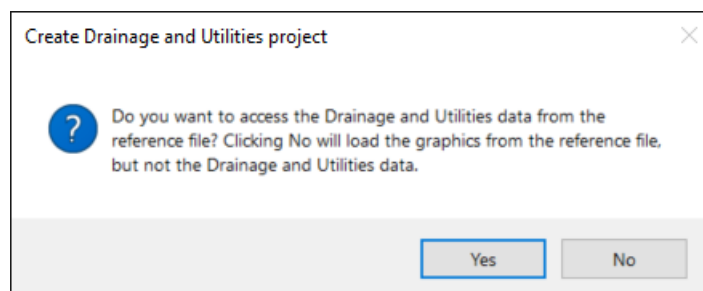
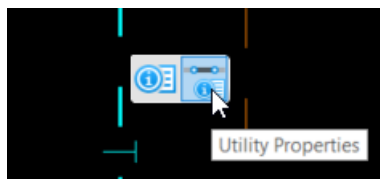



There are two major bugs when annotates Drainage and Utility features across a reference in ORD 2020 R3.

1. Auto-Annotation (element/model annotation) does not associate fields in text favorites to the actual element. (it does not work).

To fix this, every field within the text favorite needs to be re-assigned to the element.

2. Annotation values do not hold after you close and reopen the file.

The workaround for this is to change the fields to static text. This will make it so the values **WILL NOT** update if the Drainage & Utility network changes.

After you close and reopen the file, you will notice that the Drainage & Utility annotation are blank.



To fix this you have to again open the Utility properties.

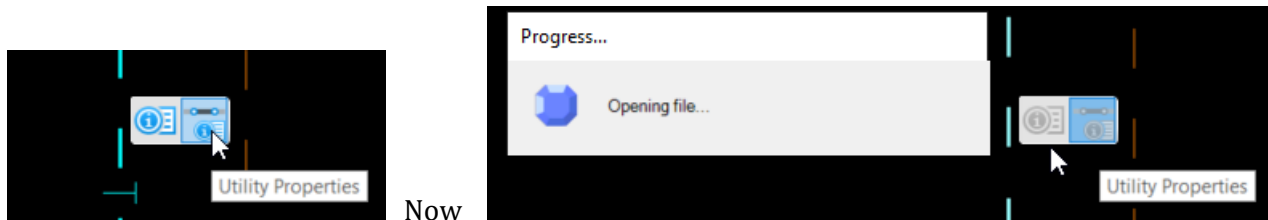

Now the text field should refresh, and the annotation will have the correct values.



When printing sheets to PDF this does have the possibility to print to PDF without the values. To alleviate this possibility, you can copy and paste the text fields down to static text.

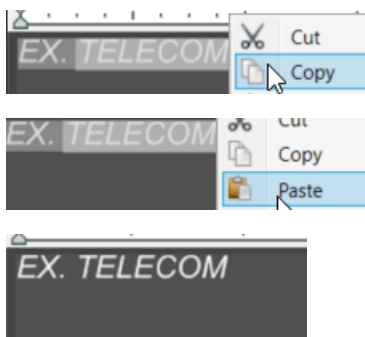



OpenRoads Software Version

This document was prepared using the following software version:

OpenRoads Designer CONNECT Edition – 2020 Release 3 Update 9 – Version 10.09.00.91

Contacts

For any questions, suggestions, or problems with this document please contact the ODOT Office of CADD and Mapping Services by use of the following form on the ODOT website:

https://odot.formstack.com/forms/cadd_servicerequest
