

MICROFILMED
MAY 2 1982

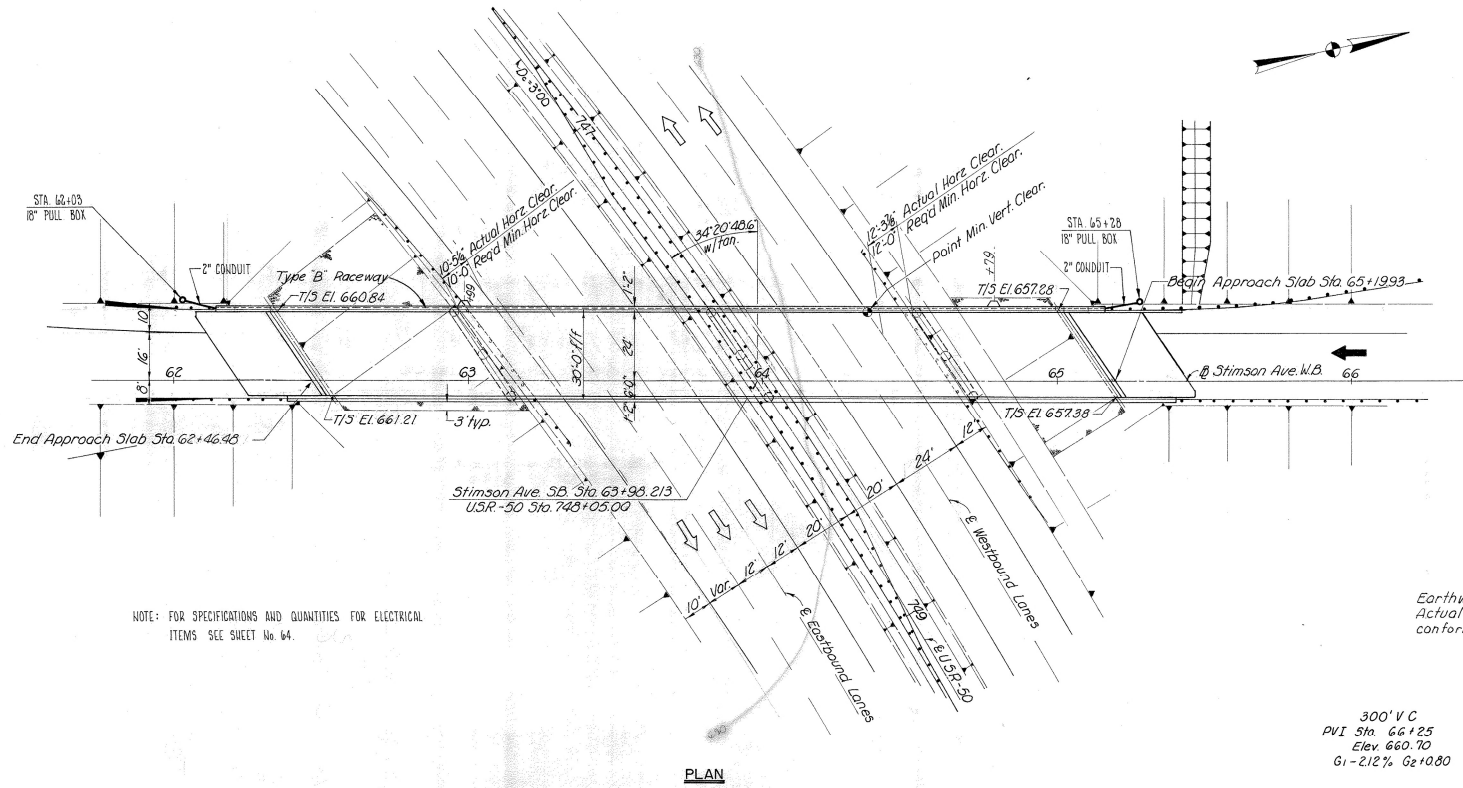

NOTE: FOR SPECIFICATIONS AND QUANTITIES FOR ELECTRICAL ITEMS SEE SHEET No. 64.

Earthwork slopes are schematic. Actual earthwork slopes shall conform to plan cross-sections.

300' V C
PVI Sta. 66+25
Elev. 660.70
G1 -2.12% G2+0.80

PLAN

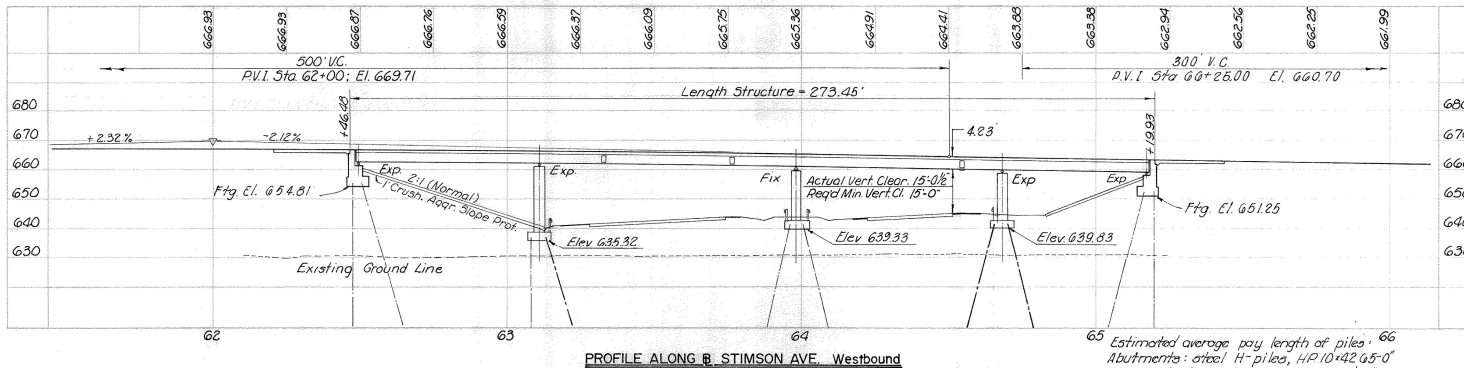

PROFILE ALONG @ STIMSON AVE. Westbound

Estimated average pay length of piles:
Abutments: steel H-piles, HP 10x42 0.5'-0"
Piers: steel H-piles, HP 12x53, 50'-0"

PROPOSED STRUCTURE

TYPE: Continuous steel beam bridge with reinf. conc. deck and substructure
SPANS: 61'-6"; 87'-6"; 70'-0"; 49'-0" 9% bridge
ROADWAY: 30'-0" flt of parapets
LOADING: HS 20-44
WEARING SURFACE: 1 1/2" Asphalt Concrete
SKEW: 34° 20' 43.6" RF
APPROACH SLAB: 43'-1"-72 (25'-0" long)
ALIGNMENT: tangent
SUPERELEVATION: none
AVERAGE DAILY TRAFFIC: 1150 (1990)

FRANKLIN ENGINEERING, LIMITED
Consulting Engineers
COLUMBUS, OHIO

SITE PLAN

BRIDGE NO. ATH-33-1597
under STIMSON AVE. Westbound

ATHENS COUNTY OHIO USR-33

DESIGNED	DRAWN	TRACED	CHECKED	REVIEWED	DATE	REVISION
JA	WLB					1/18

MICROFILMED
MAY 1982

FED. RD. DIVISION	STATE	PROJECT
2	OHIO	

74
93

ATH - 33-1593

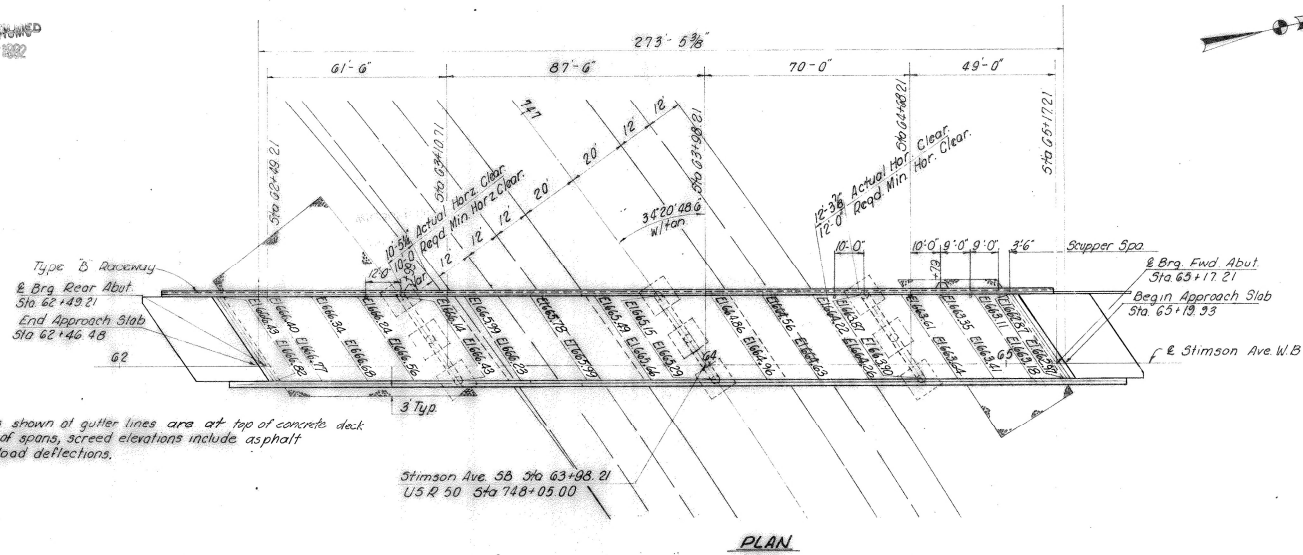

NOTE: Elevations shown at gutter lines are at top of concrete deck and at quarter points of spans, screed elevations include asphalt and concrete dead load deflections.

Stimson Ave. SB Sta 63+08.21
U.S.R. 50 Sta 748+05.00

PLAN

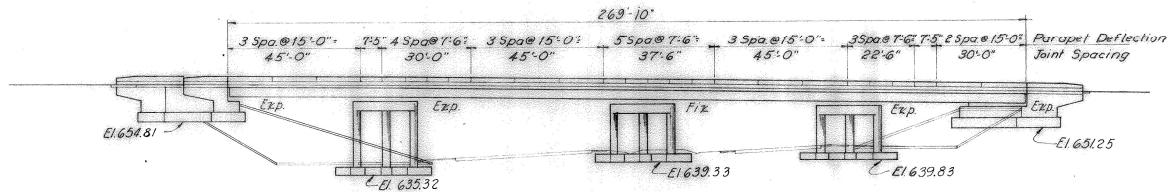

ELEVATION

Piles are not shown

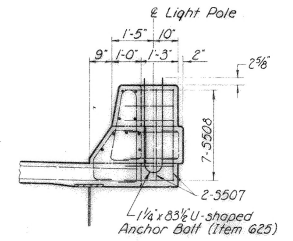
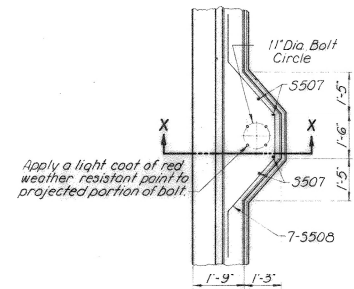

SECTION X-X
LIGHT POLE PILASTER

FRANKLIN ENGINEERING, LIMITED Consulting Engineers		COLUMBUS, OHIO	
GENERAL PLAN			
BRIDGE N° ATH-33-1597 UNDER STIMMON AVENUE W.B.			
ATHENS COUNTY		USR 93	
DESIGNED	DRAWN	TRACED	CHECKED
M.C.			
REVIEWED	DATE	REVISED	
	4/12/70		

ESTIMATED QUANTITIES				SUPER.	PIERS	ABUT.	GEN'L
ITEM	TOTAL	UNIT	DESCRIPTION				
503	406	Cu Yds	Unclassified Excavation		192	214	
505	Lump	Sum	Test Pile				Lump
507	1300	Lin Ft	Steel H Piles HP 10 x 42			1300	
507	2400	Lin Ft	Steel H Piles HP 12 x 53		2400		
509	138,037	Lbs.	Reinforcing Steel	86,971	38,545	12,521	
511	155	Cu Yds	Class "C" Concrete, Abutment			155	
511	296	Cu Yds	Class "C" Concrete, Superstructure	296			
511	73	Cu Yds	Class "C" Concrete, Pier above Footing		73		
511	100	Cu Yds	Class "C" Concrete, Pier Footing		100		
513	241,818	Lbs.	Structural Steel	241,818			
514	241,818	Lbs	Field Painting of Structural Steel	241,818			
506	Lump	Sum	Pile Test Load				Lump
506	1	Each	Subsequent pile test load.				1
518	6	Each	Scuppers, including supports	6			
518	41	Cu Yds	Porous Backfill			41	
518	62	Lin Ft	6" Perf. Helical Corrugated Metal Pipe, including specials (707.01)			62	
518	76	Lin Ft	6" Non-Perf. Helical Corrugated Metal Pipe (707.01)			76	
518	546	Lin Ft	Subdrainage for wearing course	546			
601	522	Sq Yds	Crushed Aggregate Slope Protection for Lighting Hema See Sheet 64				522
625							
808	296	Units	Chemical Admixture for Concrete, Type A, B or D	296			
404	24	C.Y.	Asphalt Concrete (70-85 or AC-20)	24			
Special	12	C.Y.	Sand Asphalt (See proposal note)	12			
Special	853	S.Y.	Membrane Waterproofing, Sheet Type (see proposal note)	853			

GENERAL NOTES

REFERENCE shall be made to Standard Drawings AS-1-72 (6-30-72), BR-1-67 (11-17-71) sheet number 1 of 3, RB-1-55 (2-2-59), SD-1-69 (6-12-69) sheet numbers 1, 2, 3, 4 of 4, and Supplemental Specification 008 (1-1-71) and 836 (1-1-71).

DESIGN SPECIFICATIONS - This structure conforms to "Standard Specifications for Highway Bridges", adopted by the Am. Assoc. of State Hwy. Officials, 1969, including the Ohio Supplement to these Specifications.

DESIGN DATA:

Design Loading - HS 20-44

Concrete Class "C" - Unit Stress 1200 psi. for Superstructure.
Unit Stress 1333 psi. for Substructure.

Structural Steel - ASTM A36, Unit Stress 20,000 psi.

Reinforcing Steel - ASTM A615, A616 or A617, Unit Stress 20,000 psi.
Spiral Reinforcement may be plain bars ASTM A82, A306, A499 or A615. (If bars in accordance with ASTM A616 are provided, they shall be subject to bend tests as per AASHTO designation M42-70.)

EMBANKMENT CONSTRUCTION - The embankments shall be constructed to the level of the subgrade for a minimum distance of 200 feet back of the abutments. After a waiting period of not less than 30 days, excavation may be made for the abutments and piers.

PILES shall be driven by a hammer of not less than 11,000 foot pounds per blow to firm contact with bedrock. If the length of penetration is approximately equal to the depth of bedrock, according to the bridge foundation investigation report, the firm contact shall be considered as obtained when the capacity according to the formula in SD-7.05 is not less than the following value for a pile hammer of the indicated energy rating.

Abutment Piles:

37 tons per pile using an 11,000 ft. lb. hammer.

35 tons per pile using a 15,000 ft. lb. or greater hammer.

Pier Piles:

62 tons per pile using an 11,000 ft. lb. hammer.

79 tons per pile using a 15,000 ft. lb. or greater hammer.

If the energy rating of the hammer is between the ratings as shown above, the required formula capacity shall be determined by interpolation. The design load is 35 tons per pile for the abutment piles and 50 tons per pile for pier piles.

UTILITY LINES - All expense involved in relocating the affected utility lines shall be borne by the owners. The Contractor and the Owners are requested to cooperate by arranging their work in such a manner that inconvenience to either would be held to a minimum.

FOR LIGHTING DETAILS not shown, see sheet no. 64.

DECK FINISHING: Texturing of the Deck Surface as provided in 431.09 shall not be done.

ITEM SPECIAL - SAND-ASPHALT:

A layer of Sand-Asphalt shall be used to protect the protective membrane. Traffic will not be permitted on the membrane until a protective layer of sand-asphalt has been placed and compacted. The sand-asphalt shall be mixed hot using natural sand, 70% 0/6, and asphalt cement, 70/100. The asphalt grade and content shall be established by the contractor within a range of 8.5 to 10.5 percent of the total mix. The sand-asphalt shall be placed on the membrane by means of a pneumatic tired mechanical spreader and compacted by rolling to produce a reasonably smooth surface. The quantity placed shall be as necessary to level irregularities and cover the surface with a compacted layer 1/2 in thickness. Turning movements of equipment used to place the sand-asphalt shall not be made on the membrane. Basis of Payment: The accepted quantity of sand-asphalt will be paid for at the contract unit price per cubic yard, which price and payment shall be full compensation for furnishing and placing all materials.

Payment will be made under:

ITEM	UNIT	DESCRIPTION
Special	Cu Yds	Sand-Asphalt.

* The sand-asphalt mixture temperature on arrival at the project site shall be as determined by the Engineer.

FRANKLIN ENGINEERING, LIMITED		Consulting Engineers		OHIO	
COLUMBUS,					
ESTIMATED QUANTITIES & GENERAL NOTES					
BRIDGE NO. ATH-33-1591					
UNDER STIMMONS AVENUE W.B.					
ATHENS COUNTY			OSK 33		
ISSUED	CHG	TRACED	CHECKED	REVIEWED	DATE
M.G.			940	JF	9/2/70

FED. RD. DIVISION	STATE	PROJECT	76
2	OHIO		93

ATH-33-15.93

MICROFILMED
MAY 1982

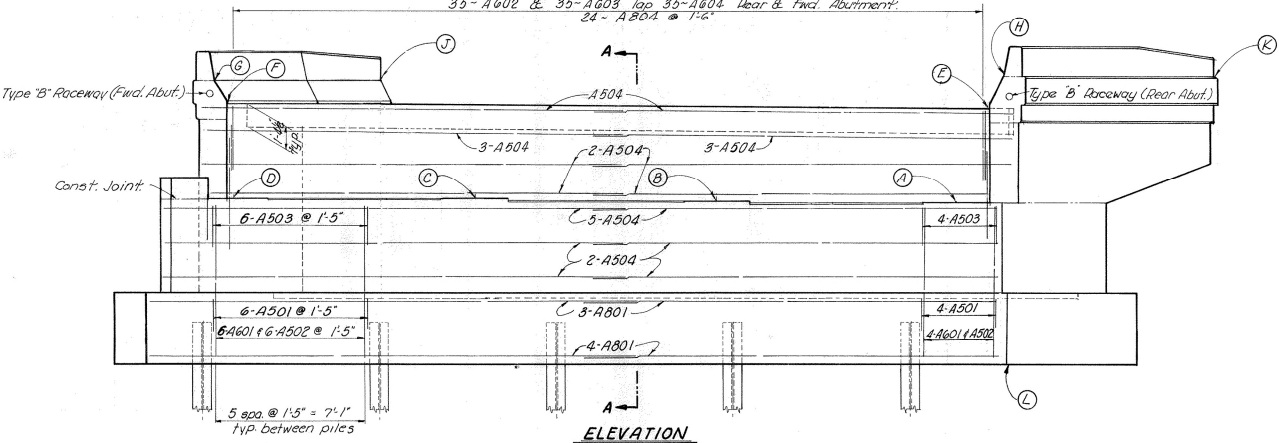
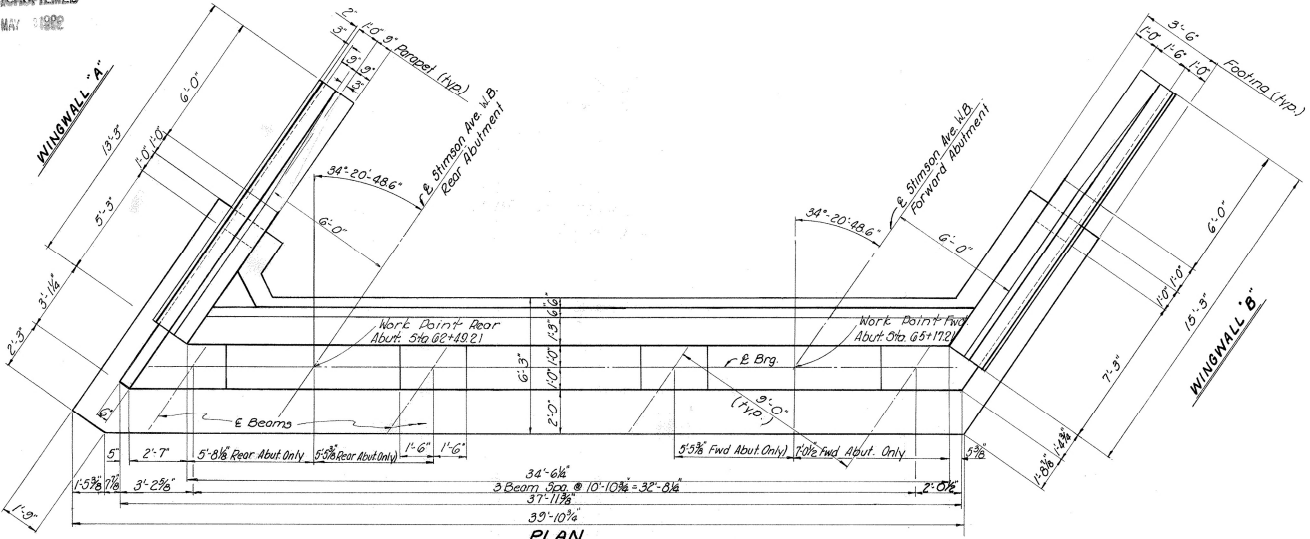
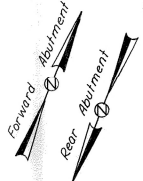

POROUS BACKFILL: 1.5 ft. thick shall extend up to the plane of the subgrade and laterally to the ends of the wingwalls.

Note: All longitudinal bars above footing are A504 unless noted.

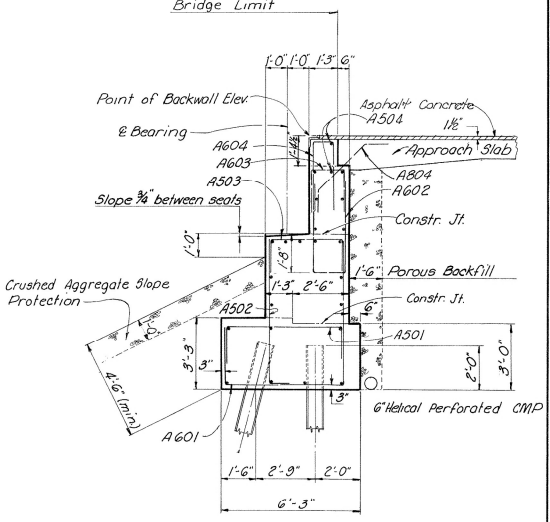

Note: All longitudinal bars in footing are A801

TABLE OF ELEVATIONS

Points	A	B	C	D	E	F	G	H	J	K	L
Rear Abutment	661.84	661.96	662.09	662.21	666.56	666.95	668.20	667.81	668.25	667.81	654.81
Forward Abutment	658.38	658.34	658.31	658.28	663.07	662.97	664.22	664.32	663.97	664.09	651.25

FRANKLIN ENGINEERING, LIMITED
Consulting Engineers
COLUMBUS, OHIO

ABUTMENT DETAILS
BRIDGE N° ATH-33-1597
UNDER STIMSON AVENUE W.B.

ATHENS COUNTY USR.33

DESIGNED	DRAWN	TRACED	CHECKED	REVIEWED	DATE	REVISED
M.C.					4/12/70	

MICROFILMED
MAY 1982

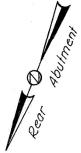

FED. RD. DIVISION	STATE	PROJECT	17 95
2	OHIO		

ATH-33-15.93

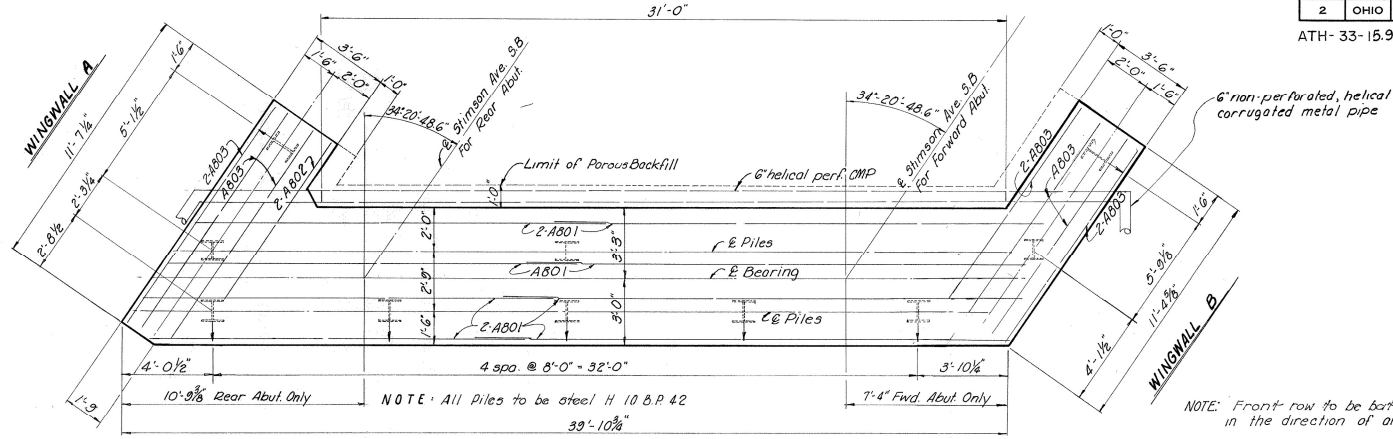

NOTE: Front row to be battered 1:4 in the direction of arrows shown

FOOTING PLAN

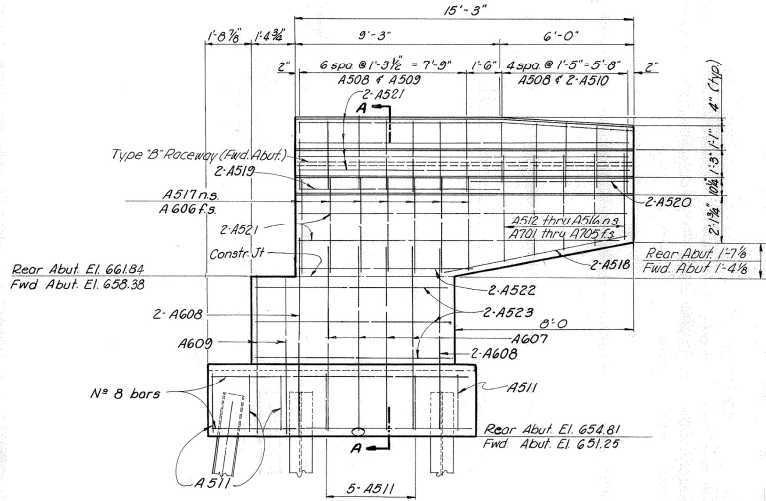

WINGWALL B

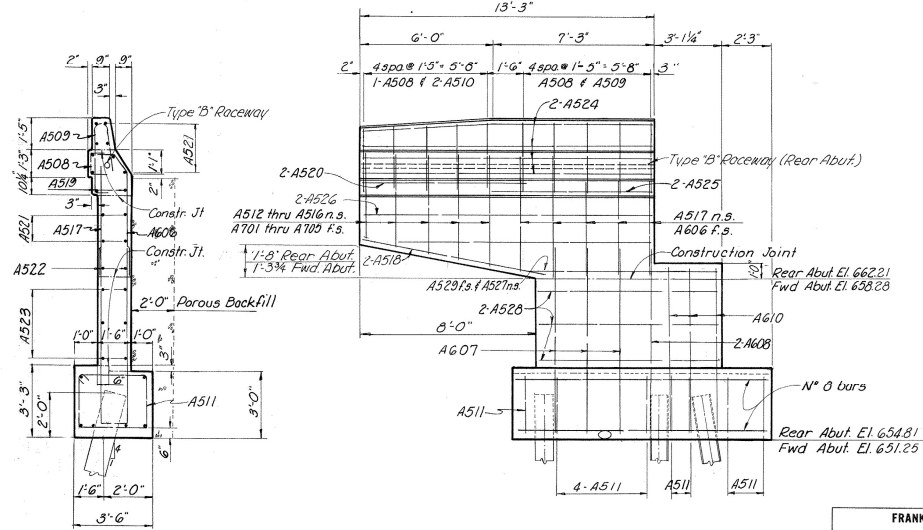

SECTION A-A

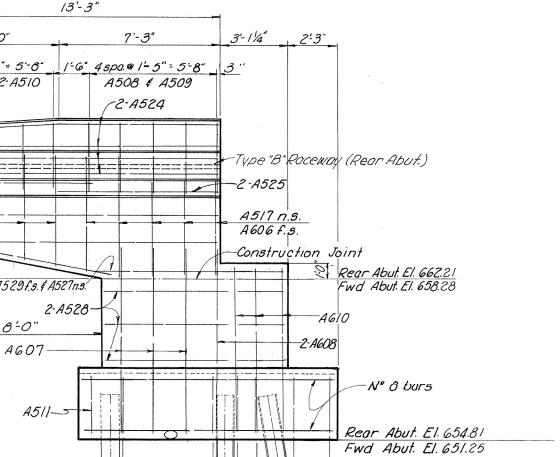

WINGWALL A

5 / 8

FRANKLIN ENGINEERING, LIMITED Consulting Engineers		COLUMBUS, OHIO	
WINGWALL AND FOOTING DETAILS			
BRIDGE NO. ATH-33-15.97			
UNDER STIMSON AVENUE W.B.			
ATHENS COUNTY	DESIGNED	DRAWN	DATE
CONTRACT	CHECKED	REVIEWED	DATE

MICROFILMED
MAY 1982

FED. RD. DIVISION	STATE	PROJECT
2	OHIO	

78
93

ATH-33-1593

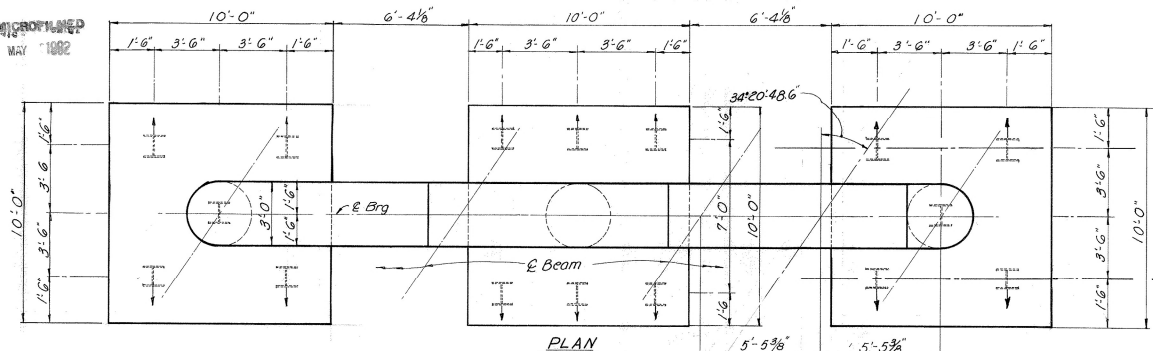

Batter this row
Rear, Center, & Forward Piers

TABLE OF ELEVATIONS

	A	B	C	D	E
Rear Pier	660.97	661.06	661.15	661.24	639.32
Center Pier	660.00	660.04	660.08	660.12	639.33
Forward Pier	658.87	658.88	658.89	658.90	639.83

See General Plan for pier layout

Batter this row
Center & Forward Piers

CENTER PIER: Special care shall be taken in placing reinforcing steel in the vicinity of the bridge seat so as to avoid interference with the drilling of anchor bolt holes.

All Piles are to be HP 12x53
For structure grounding see Standard Construction Drawing HL-4. (Center Pier)

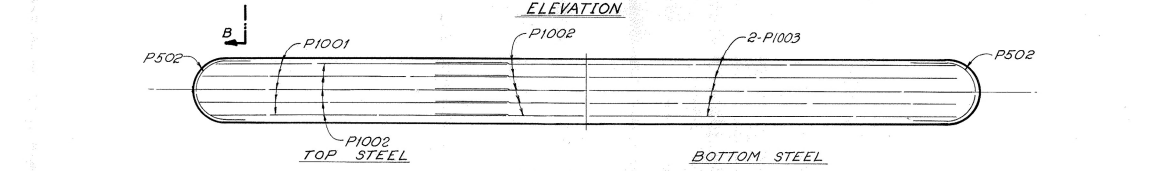
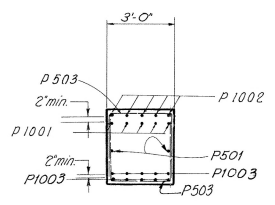
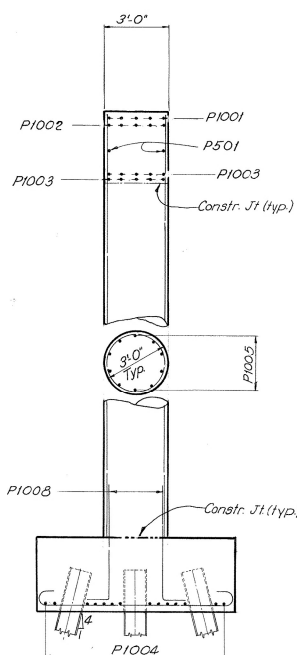
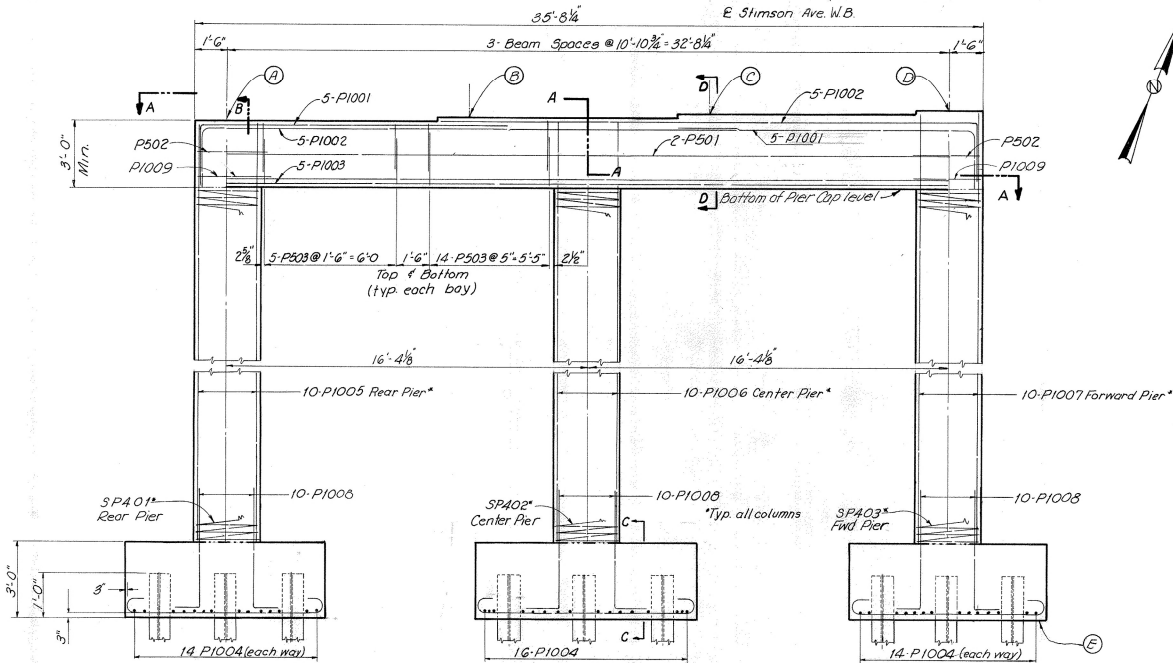

SECTION B-B

SECTION C-C

SECTION A-A

FRANKLIN ENGINEERING, LIMITED
Consulting Engineers
COLUMBUS, OHIO

PIER DETAILS
BRIDGE No. ATH-33-1597
under Stimson Avenue W.B.

ATHENS COUNTY US R-33

DESIGNED	DRAWN	TRACED	CHECKED	REVIEWED	DATE	REVISION
M.C.			4.6.0	J.P.	5/27	

MICROFILMED
MAY 1982

* Deck SLAB DEPTH: The distance shown from top of deck slab to top of steel beam is the design dimension, the quantity of deck concrete to be paid for shall be based on this dimension, even though deviation from it may be necessary because the top flange of the beam may not have the exact camber or conformation required to place it parallel to the finished grade.

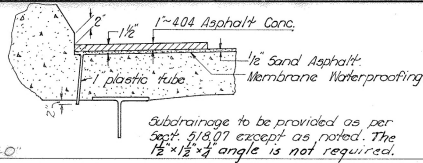

FED. NO. DIVISION	STATE	PROJECT
2	OHIO	

19
93

ATH-33-1593

	X	Y	Z
Beam 1	6 3/4"	8 3/4"	4 1/4"
Beam 2	6 1/4"	3 1/4"	3 1/4"
Beam 3	6"	7 3/4"	3 1/4"
Beam 4	5 7/8"	7 1/4"	2 1/4"

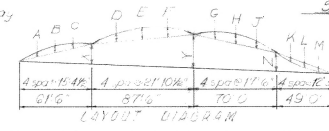
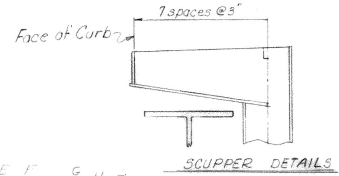

LOCATION	SPAN 1		SPAN 2		SPAN 3		SPAN 4	
	1/8 FT	1/8 FT	1/8 FT	1/8 FT	1/8 FT	1/8 FT	1/8 FT	1/8 FT
Deflection due to weight of steel	1/16"	1/16"	0	3/16"	1/4"	1/4"	0	0
Deflection due to remaining dead load	3/16"	1/8"	0	5/16"	3/8"	3/8"	-1/8"	-1/8"
Adjustment required for vertical curve	3/8"	1/2"	3/8"	3/4"	1"	3/4"	3/8"	3/8"
Required Shop Camber	3/8"	1/16"	3/8"	1 1/4"	1 3/8"	1 1/8"	3/8"	1/4"

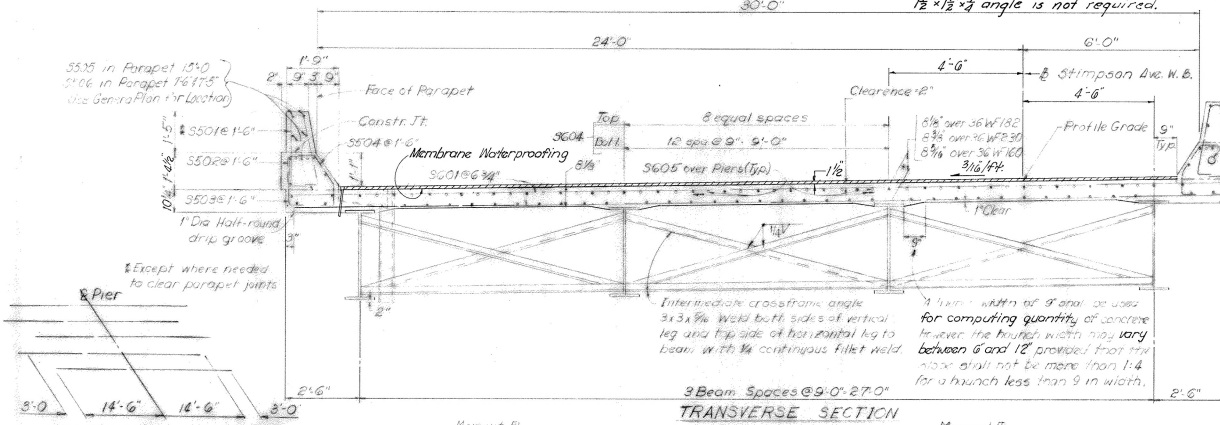

DIAGRAM SHOWING STAGGER OF 5605 BARS OVER PIERS

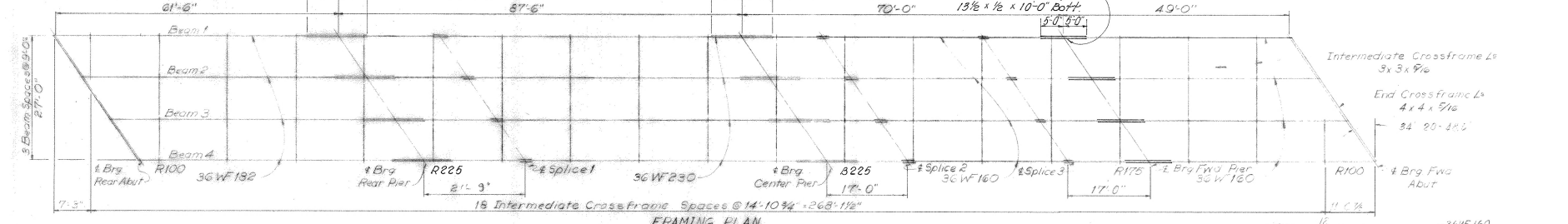
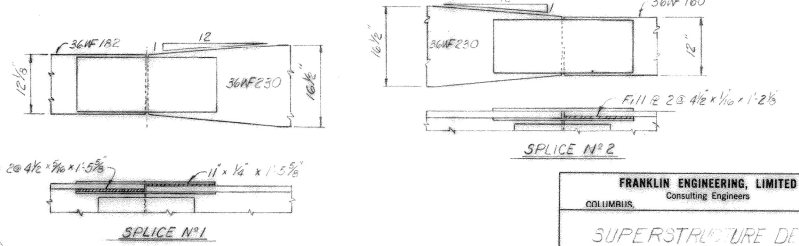
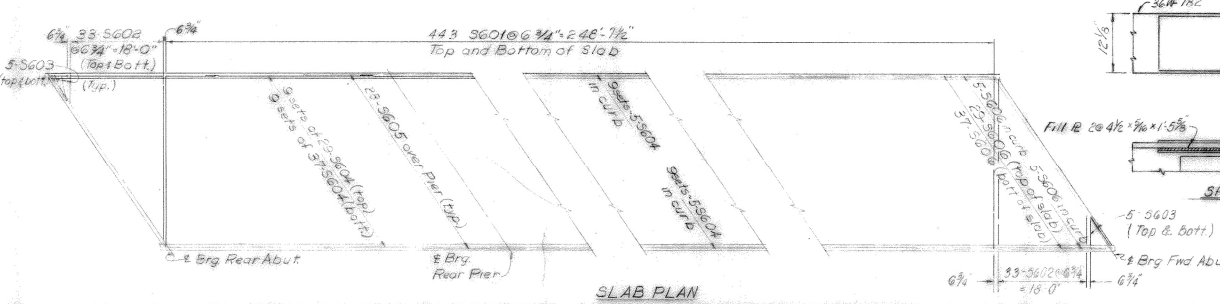

DIAGRAM SHOWING STAGGER OF 5603 BARS OVER PIERS



For Splice No. 3 and additional details, see ord. Diag. 3.0-1-39 Sheet 4 of 4

FRANKLIN ENGINEERING, LIMITED
Consulting Engineers OHIO

SUPERSTRUCTURE DETAILS
BRIDGE NRATH-33-1597
under Stimson Avenue W.B.

ATHENS COUNTY USR 33

DESIGNED	DRAWN	TRACED	CHECKED	REVIEWED	DATE	REVISED
M.G.	ES	ES	ES	ES	7/2/70	

