

CB21-48 BOX BEAM SHEAR REINFORCING SPACING

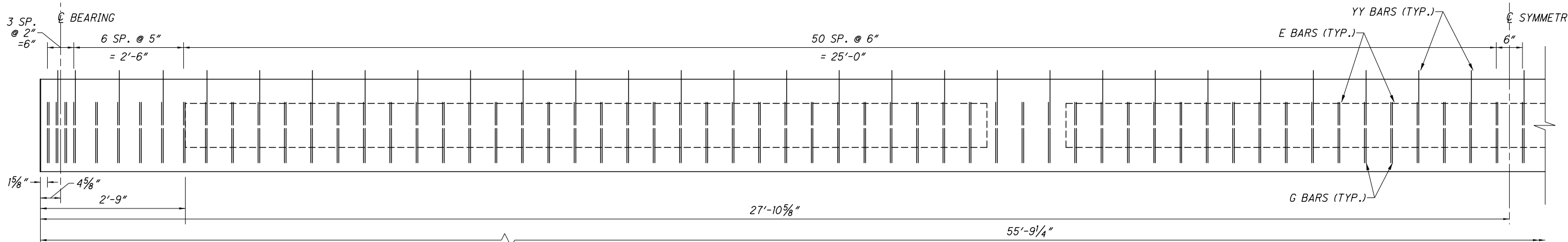

CB21-36 BOX BEAM SHEAR REINFORCING SPACING

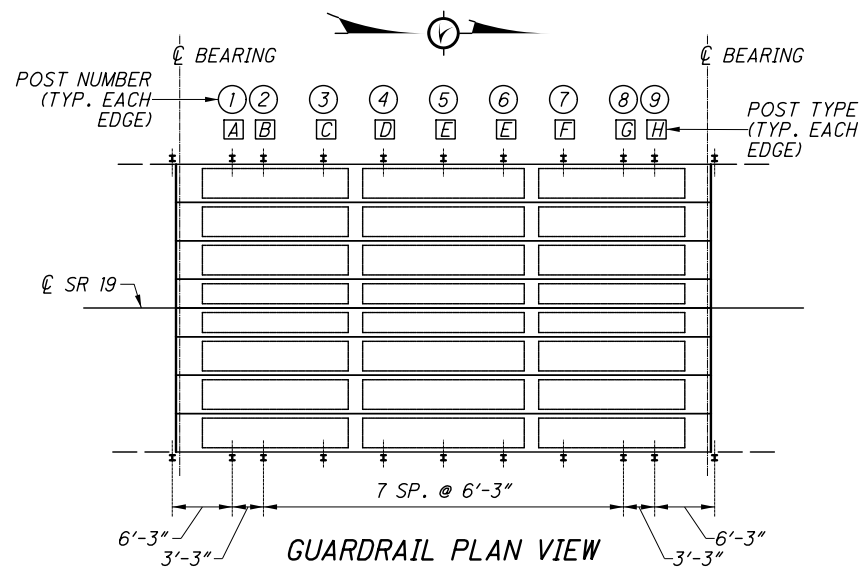

POST TYPE AND LENGTH			
POST NO.	ESTIMATED SLAB THICKNESS	POST TYPE	POST LENGTH
1	8"	A	4' - 7"
2	7 3/4"	B	4' - 3/4"
3	7 5/16"	C	4' - 5/16"
4	7"	D	4' - 6"
5	6 13/16"	E	4' - 5 13/16"
6	6 3/4"	E	4' - 5 3/4"
7	6 7/8"	F	4' - 5 7/8"
8	7 1/8"	G	4' - 6 1/8"
9	7 5/16"	H	4' - 6 5/16"

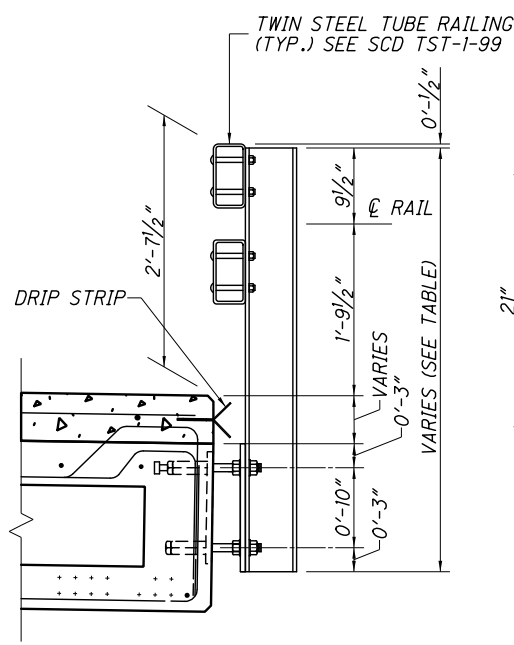

TWIN STEEL TUBE RAIL DETAIL

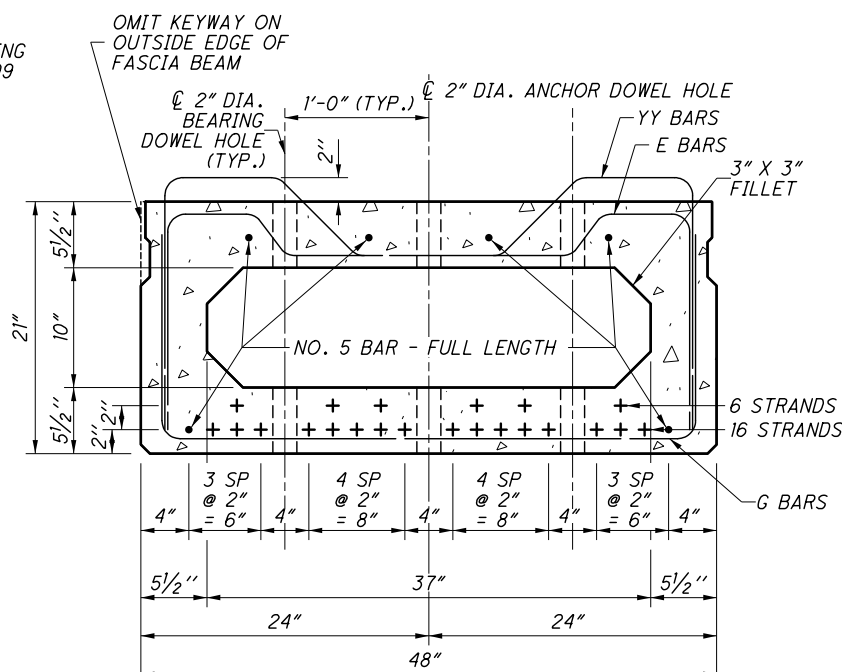

CB21-48 BEAM SECTION

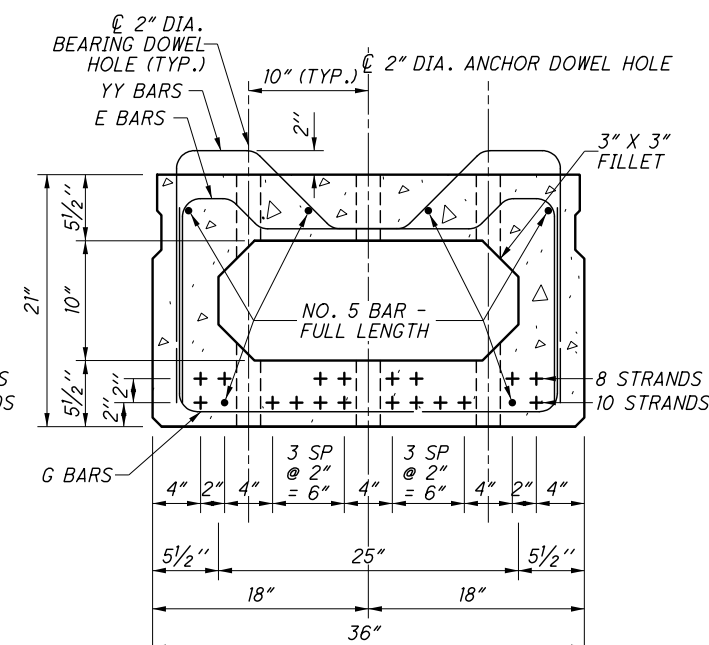

CB21-36 BEAM SECTION

NOTES

- ADDITIONAL BOX BEAM DETAILS: SEE SCD PSBD-2-07.
- ADDITIONAL RAILING DETAILS: SEE SCD TST-1-99.
- ADDITIONAL STEEL DRIP STRIP DETAILS: SEE SCD DS-1-92.

LEGEND

- + - 1/2" (0.153 SQ. IN.) PRESTRESSED STRAND FULLY BONDED