

# **SPECIAL PROVISIONS**

---

---

## **WATERWAY PERMITS CONDITIONS**

**C-R-S: CUY-77-00.42 (Part 1) and  
SUM-77-32.27 (Part 2)**

**PID: 104983**

**Date: October 5, 2022**

1. Waterway Permits Time Restrictions:

Section 404 Regional General Permit A (Linear Transportation) (RGP A) is authorized for CUY-77-00.42 (Part 1) and SUM-77-32.27 (Part 2), PID 104983. A copy of the RGP A and United States Army Corps of Engineers (USACE) authorization letter (USACE ID #LRH-2022-00694-CUY-Chippewa Creek) shall be kept at the work site at all times and made available to all contractors and subcontractors. The permit is effective starting: October 5, 2022 The permit expires: October 24, 2024.

For authorized work in aquatic resources (including streams, wetlands, jurisdictional ditches, captured streams, lakes, ponds), the Department will consider the Contractor’s submission of a reauthorization to the waterway permit expiration date based on project constraints. If more than one permit is authorized for the project, then all permits become invalid once the first permit expires. In order for the request to be considered, the Contractor must submit a justification to the Engineer at least 90 days prior to the waterway permit expiration date. The Engineer will submit the request for a time extension to the Ohio Department of Transportation, Office of Environmental Services, Waterway Permits Unit (ODOT-OES-WPU) for consideration and coordination with the U.S. Army Corps of Engineers (USACE), Ohio Environmental Protection Agency (OEPA), U.S. Coast Guard (USCG), U.S. Fish and Wildlife Service (USFWS), and Ohio Department of Natural Resources (ODNR) as appropriate.

2. Deviations From Permitted Construction Activities:

No deviation from the requirements for work in aquatic resources depicted in the plans, Special Provisions, and/or Working Drawings may be made unless a modification has been submitted to ODOT-OES-WPU and approved by the appropriate agencies (i.e., USACE, OEPA, USCG, ODNR, and USFWS).

NOTE: Plan sheets submitted with the Pre-Construction Notification were approved by the USACE in accordance with RGP A are included in these Special Provisions.

For emergency situations resulting in unanticipated impacts to aquatic resources, provide notification (verbal or written) to the Engineer as soon as possible following discovery of the situation. Written notification to the Engineer and notification to the ODOT-OES-WPU (614-466-2159) must be made within 24 hours.

For non-emergency situations, notify the Engineer in writing for submission to the ODOT-OES-WPU (614-466-2159) for consideration and coordination with the appropriate agencies. Notification must be made at least 90 days prior to planned, non-permitted activities. Consideration of the requested deviation is at the discretion of the Director and must be coordinated with the appropriate regulatory agencies.

3. In-Stream Work Restrictions:

Work in the following aquatic resources is further restricted as follows:

Stream Name /Description	Location	Work restriction dates (No in-stream work permitted)
Stream A	STA 66+00-69+00	None
Stream D	STA 76+20	None

\*Restriction dates do not apply if the stream has been dewatered prior to April 15.

In-stream work has been defined as the placement and/or removal of fill materials (temporary or

permanent) below ordinary high water of a stream. Examples of “fill” include, but are not limited to: bridge piers, abutments, culverts, rock channel protection, scour protection, and temporary access fills.

Fills placed within a stream identified in the above table (outside of the work restriction dates) can continue to be worked from during the work restriction dates, but cannot be expanded, removed, or otherwise modified (below ordinary high water) until once again outside of the work restriction dates.

#### 4. Materials:

Materials utilized in or adjacent to aquatic resources for temporary or permanent fill or bank protection shall consist of suitable material free from toxic contaminants in other than trace quantities. Asphalt products are specifically excluded for use as fill. Chromated Copper Arsenate (CCA), creosote, and other pressure treated lumber shall not be used in structures that are placed in aquatic resources.

#### 5. Cultural Resources:

Per CMS 107.10, if archeological sites, historical sites, or human remains are discovered, cease all work in the immediate area and notify the Engineer who will immediately contact the ODOT-District Environmental Coordinator and ODOT-OES-Cultural Resource Section at 614-466-2159. In the event of human remains are identified by OES-Cultural Resources Section, the Engineer shall also contact the Cuyahoga Sheriff’s Office at (216) 443-6000 or the Summit Sheriff’s Office at (330) 643-2122.

#### 6. Aquatic Resource Demarcation:

The table attached includes detailed fill quantities authorized within the aquatic resources. Aquatic resources not authorized for impact by these Special Provisions shall be demarcated in the field as per SS 832 prior to site disturbance. The fence shall remain in place and be maintained throughout the construction process. Following the completion of the project, the fence and posts shall be removed.

Tables 3 and 4 are attached and include detailed fill quantities that are authorized within the aquatic resources.

#### 7. Spill containment:

Provide and Maintain an Oil Spill Kit with a minimum capacity of 65 gallons. The Spill Kit shall contain:

- 6 - 3 in. X 8 ft. Oil only socks
- 4 - 18 in. X18 in. Oil only pillows
- 2 - 5 in. X 10ft. Booms
- 50 - 16in. X 20 in. Oil only pads
- 10- Disposable Bags
- 1 - 65 Gallon drum with lid
- 25 pounds of Granular Oil Absorbent

The Oil Spill Kit shall be located within 150 feet of any equipment working in a stream or wetland. The oil Spill Kit shall be maintained for the life of the contract. Any materials utilized during the project will be replaced within 48 hours. All costs associated with furnishing and maintaining the above referenced spill containment kit is incidental to work.

**8. Blasting:**

State law requires notification to the Ohio Department of Natural Resources should blasting be required within or near stream channels (See ORC 1533.58 & CMS 107.09). Notify the Engineer, in writing, a minimum of 30 days in advance of blasting, for submission to ODOT-OES-WPU (614-466-2159) for coordination with ODNR.

**9. Project Inspection:**

Inspection of Work may include inspection by representatives of other government agencies or railroad corporations that pay a portion of the cost of the Work or regulate the Work through State and Federal law. Comments from the representatives of these agencies shall be directed to the Engineer who will immediately contact the ODOT-District Environmental Coordinator and ODOT-OES-WPU at 614-466-2159.

**10. Temporary Access Fills:****Special Provisions Notes:****Definitions:****Hydraulic Opening**

The cross-sectional area allowing an unimpeded discharge equal to twice the highest monthly flow without producing a rise in the backwater above the Ordinary High Water Mark (OHWM).

**Standard Temporary Discharge**

Discharge equal to twice the *highest monthly flow* without producing a rise in the backwater above the OHWM. The U.S. Geologic Service publication "Techniques for estimating Selected Streamflow Characteristics of Rural Unregulated Streams in Ohio" provides equations that estimate monthly flow for Ohio Waterways. These flows are also available in a web application by USGS StreamStats, (<https://water.usgs.gov/osw/streamstats/ohio.html>). The highest monthly flow is the highest monthly mean discharge occurring in a 12-month period from January to December.

**Average Monthly Flow**

The average monthly flow represents the estimated "normal" flow.

**Temporary Access Fills (TAFs)**

Include, but are not limited to, dewatering fills, causeways, cofferdams, access pads, temporary bridges, etc. below the OHWM.

**Requirements**

21 calendar days prior to the initiation of any in-stream work, provide the Engineer with Working Drawings that include:

- Plan view drawing (50 scale or less) showing the location of all TAFs proposed for use on the project
- Scaled cross section and profile drawing showing the OHWM and the proposed hydraulic opening.
- Identify the minimum diameter size, placement location and thickness of non-erodible Dumped Rock Fill material on the plan and profile.
- Calculations analyzing the hydraulic impacts of the TAF on the waterway. Include in the

calculations an analysis of the hydraulic opening sized adequately to pass the Standard Temporary Discharge without producing a rise in backwater above the OHWM. Include, in the analysis, calculated channel velocities adjacent to the TAF, culvert exit velocities, calculated headwater and tailwater elevations, and any additional appropriate calculations to assess potential impacts to the waterway during normal and anticipated high flow (twice the highest monthly flow) events.

- A description of all temporary material to be placed below the OHWM elevation.
- A description of the installation and staging of all temporary fill over the life of the contract.
- Identify the protection methods and/or structural Best Management Practices for minimizing impacts to the waterway.
- Volume of temporary fill below the OHWM elevation.
- A description of the diversion ditches, equipment, conduits or means for maintaining normal flows in the waterway.
- A description of the removal of all temporary fill and restoration of the channel and all areas impacted by the TAFs.
- A schedule outlining the timing of the placement and removal of all temporary fill.
- Have competent individuals prepare and check the Working Drawings and hydraulic calculations. Provide a cover sheet containing the preparer(s) and checker(s): First Name, Last Name and Initials. The preparer(s) and checker(s) shall not be the same individual. Have an Ohio Registered Engineer review, approve, sign, seal and date the Working Drawings and hydraulic calculations according to ORC 4733 and OAC 4733-35. Include the following statement on the Working Drawings: "These Working Drawings were prepared in compliance with the terms of these Special Provisions and all contract documents."

Do not begin in-stream work until the Engineer has accepted the Working Drawings and hydraulic calculations.

The design and construction of the Contractor's TAF must minimize impacts to water bodies, stream banks, stream beds, and riparian zones to the maximum extent practicable.

Fording of waterways and other aquatic resources is prohibited.

Construct TAFs in such a manner that will maintain flows, minimize upstream flooding, and avoid overtopping the TAF on a regular basis. ***TAFs shall be designed and constructed so that the hydraulic opening provides capacity for a discharge equal to twice the highest monthly flow without producing a rise in the backwater above the (OHWM).***

If the Contractor proposes a TAF which does not meet all the requirements of these Special Provisions, the Contractor must submit a request in writing for a modified TAF to the Engineer. The request must include all Working Drawings and hydraulic calculations required by these Special Provisions. The Department makes no guarantee to grant the request. The Contractor's proposed TAF request will be coordinated by OES with the USACE and the OEPA, as appropriate. The time frame allowed for the coordination of the contractor's proposed TAF will be a minimum of 60 days.

Installation of any temporary fill without appropriate authorization is strictly prohibited. All direct coordination with the USACE and/or OEPA will be performed through OES.

### **TAFs Construction and Payment**

Begin planning and installing causeways and access fills as early in construction as possible to avoid conflicts with these Special Provisions or other environmental commitments that have been included in the construction plans.

TAFs in Streams and Rivers may include, but are not limited to, causeways, cofferdams, access pads, sheet piling, temporary bridges, etc. The Contractor must make every attempt to minimize disturbance

to waterbodies, stream banks, stream beds and riparian zones during the construction, maintenance, and removal of the TAF. Construct the TAFs as narrow as practical. Install in-stream conduits parallel to the stream banks. Make the TAFs in shallow areas rather than deep pools where possible. Minimize clearing, grubbing, and excavation of stream banks, and approach sections. Construct the TAFs as to not cause erosion or allow sediment deposits in the waterway.

Prior to the initiation of any in-stream work, establish a monument upstream of the proposed TAF to visually monitor the water elevation in the waterway where the fill is permitted. Maintain the monument throughout the project. Provide a visual mark on the monument that identifies the elevation 1 foot above the OHWM. Ensure that the monument can be read from the bank of the waterway. Have this elevation set and certified by an Ohio Registered Surveyor. All costs associated with furnishing and maintaining the above referenced monument is incidental to the work.

Should the surface water elevation exceed the elevation 1 foot above OHWM, the Department will compensate the Contractor for repair of any resulting damage to the TAF up to the elevation of 1 foot above the OHWM, except as noted. The Department will recognize this event as an excusable, non-compensable delay in accordance with Section 108.06 B. of the Construction & Materials Specifications.

Follow the requirements in Item 502 for Structures for Maintaining Traffic and in Item 503 for Cofferdams and Excavation Bracing and any modifications to these items as shown in the plans. The Department will not pay for repair and maintenance of TAFs associated with Items 502 and 503 as a result of surface water elevation exceeding 1 foot above the OHWM. Compensation for damages associated with waterway flows will be provided as described in Items 502 and 503.

Construct the TAFs, not including Items 502 and 503, to a water elevation at least 1 foot (0.3 m) above the OHWM. If more than one-third the width of the stream is filled, then use culvert pipes to allow the movement of aquatic life. Ensure that any ponding of water behind the TAF will not damage property, flood roadways, or threaten human health and safety.

The following minimum requirements apply to TAFs where culverts are used.

- A. Furnish culverts on the existing stream bottom.
- B. Avoid a drop in water elevation at the downstream end of the culvert that would result in an adverse impact to the waterway.
- C. Furnish a sufficient number of culverts in addition to stream openings to provide a discharge equal to twice the highest monthly flow without producing a rise in the backwater above the OHWM.
- D. Furnish culverts with a minimum diameter of 18 inches (0.5 m).

All TAFs must be constructed of suitable materials. Causeways and access fills must be encapsulated with clean, non-erodible, nontoxic Dumped Rock Fill, Type A, B, C, or D, meeting the requirements of C&MS 703.19.B. Utilize appropriately sized Dumped Rock Fill determined by the Contractor's engineer for encapsulating the sides of the TAF. Encapsulate all sides of the TAF with the non-erodible material. For causeways, contractors may use clean aggregate meeting C&MS 703.01 Size Number 1 and 2 for creating a working surface above the OHWM. Extend the non-erodible encapsulating material to at least the elevation of the top of the working surface. Extend clean aggregate up the slope from the original stream bank for 50 feet (10 m) to remove erodible material and prevent tracking from equipment onto the TAF.

When the work requiring TAF is complete, all portions of the TAF (including all rock and culverts) will be removed in its entirety. Do not dispose of TAF material in other aquatic resources or where erosion into another aquatic resource is possible. The stream bottom affected by the TAFs will be restored to its pre-construction elevations. The TAFs will not be paid as a separate item but will be included by the Contractor as part of the total project cost.

Unless specific TAF compensation is included in the plans, all environmental protection and control

associated with the authorized activities, are incidental to the work within the boundaries of the aquatic resources.

11. Excavation Activities:

Excavated material will be placed at an upland site and disposed of in such a manner that sediment and runoff to streams and other aquatic resources is controlled and minimized. Additionally, no more than incidental fallback into jurisdictional waters of the U.S. is permitted during the excavation process. If any changes to the proposed work are deemed necessary, notify the Engineer who will immediately contact the ODOT-District Environmental Coordinator and ODOT-OES-WPU at 614-466-2159

12. Temporary Fill Activities:

Temporary fill in Wetland A and Wetland D is not authorized for this project. Temporary fill includes, but is not limited to, causeways, work pads, cofferdams, sheet piling, temporary bridges, and construction equipment. Any unauthorized temporary impacts that occur will be in violation of Section 404 and 401 of the Clean Water Act.

13. Construction Completion Certification:

Upon completion of the work, notify the Engineer. The USACE Construction Completion Certification must be completed and signed by the Engineer then provided via US mail or email to:

Waterway Permits Program Manager  
ODOT - Office of Environmental Services  
1980 West Broad Street, Mail Stop 4170  
Columbus, Ohio 43223  
Adrienne.Earley@dot.ohio.gov

A copy of the certification has been attached to these Special Provisions.

14. Demolition Debris:

The intentional discharge of demolition debris from any structure (including but not limited to bridges, culverts, abutments, wing walls, piers) is not authorized for this project. If any demolition debris inadvertently falls into aquatic resources, it must be removed immediately. Notify the Engineer immediately in writing of any inadvertent fill discharged into aquatic resources. The Engineer will immediately contact ODOT-OES-WPU at 614-466-2159 if any unintentional discharge occurs.

TABLE 3. STREAM DISCHARGE AND FILL QUANTITIES

Stream	Station	Description of Impacts	Length (LF)	Width (LF)	Depth (LF)	Existing Culvert	Permanent Fill Below OHWM									Total Permanent Fill			Total Temporary Fill			Total Impact Length
							Proposed Concrete (Includes Culvert, Piers, Walls, Abutments, etc.)			Proposed RCP			Proposed Earthen, Granular, or Embankment Fill									
							Length (LF)	Length (LF)	Area (AC)	Volume (CY)	Length (LF)	Area (AC)	Volume (CY)	Length (LF)	Area (AC)	Volume (CY)	Length (LF)	Area (AC)	Volume (CY)	Length (LF)	Area (AC)	Volume (CY)
Stream A (CUY-77-00.42)	STA 66+00 to STA 69+00	Stream grading for ramp reconfiguration	1,256	3	2.5	517	NA	NA	NA	NA	NA	NA	230	0.016	63.8	230	0.016	63.8	0	0	0	230
Stream A (CUY-77-00.42)	Ramp B-1 STA 4+28	Culvert extension with added capacity and TAF, RCP Type A	1,256	3	2.5	517	15	0.001	5	12	0.001	6.67	NA	NA	NA	27	0.002	11.67	15	0.001	4.02	42
Stream D (CUY-77-00.42)	STA 76+20	Culvert extension with added capacity and TAF; RCP Type A	3,809	2.7	1.75	2,739	31	0.004	6.9	17	0.001	60	NA	NA	NA	48	0.005	76.9	31	0.004	11.25	79
SUM:						3773	46	0.005	11.9	29	0.002	66.67	230	0.016	63.8	305	0.023	152.37	46	0.005	15.27	351

LF = linear feet; AC = acres; CY = cubic yards; RCP = rock channel protection or the like (specify if different, i.e.. concrete block matting); NA = Not Applicable

TABLE 4. WETLAND DISCHARGE AND FILL QUANTITIES

Wetland	Station	Description of Impacts	Acreage (AC)	Depth (LF)	Permanent Fill Within Wetland Boundary		Total Permanent Fill		Total Impact Acreage
					Proposed Earthen, Granular, or Embankment Fill				
					Area (AC)	Volume (CY)	Area (AC)	Volume (CY)	Area (AC)
Wetland A (CUY-77-00.42)	STA 68+20	Clean earthen fill due to roadway realignment	0.61	1	0.084	136.1	0.084	136.1	0.084
Wetland D (SUM-77-32.27)	STA 10010+00 Ramp G	Clean earthen fill due to grading for ramp reconfiguration	0.4	1	0.014	22.6	0.014	22.6	0.014
SUM:					0.098	158.7	0.098	158.7	0.098

LF = linear feet; AC = acres; CY = cubic yards; RCP = rock channel protection or the like (specify if different, i.e.. concrete block matting); NA = Not Applicable



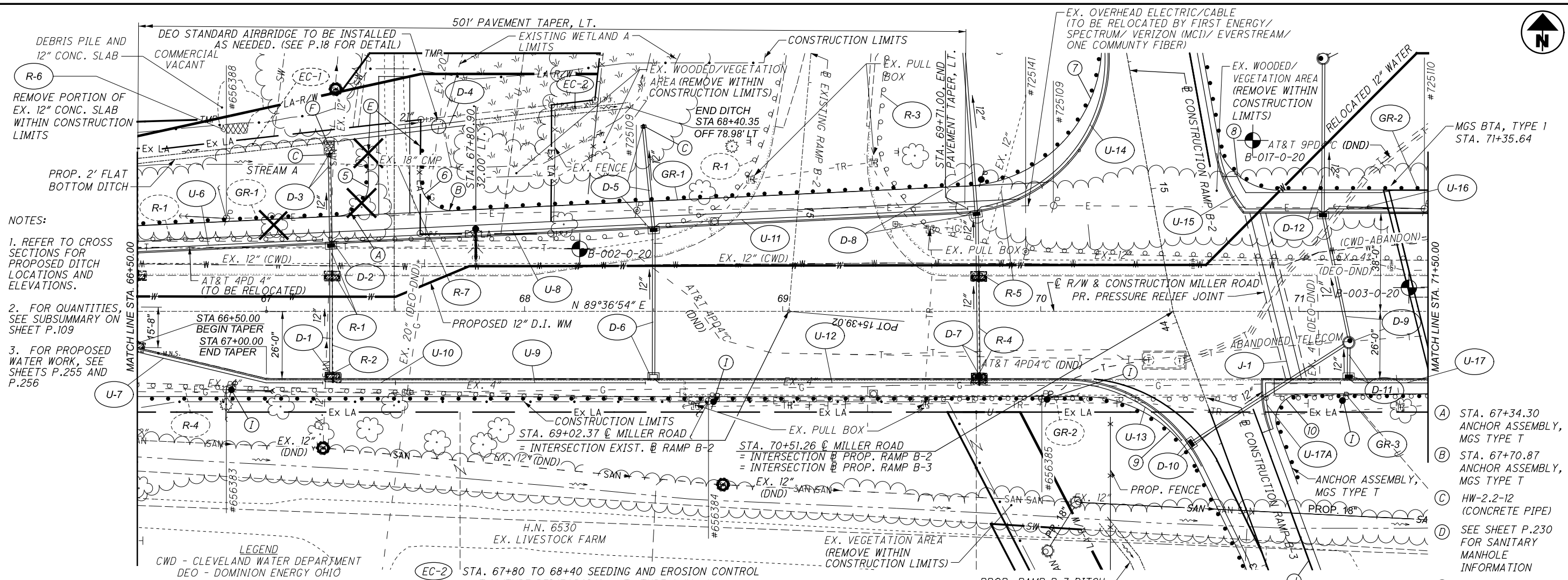

- NOTES:
1. REFER TO CROSS SECTIONS FOR PROPOSED DITCH LOCATIONS AND ELEVATIONS.
  2. FOR QUANTITIES, SEE SUBSUMMARY ON SHEET P.109
  3. FOR PROPOSED WATER WORK, SEE SHEETS P.255 AND P.256

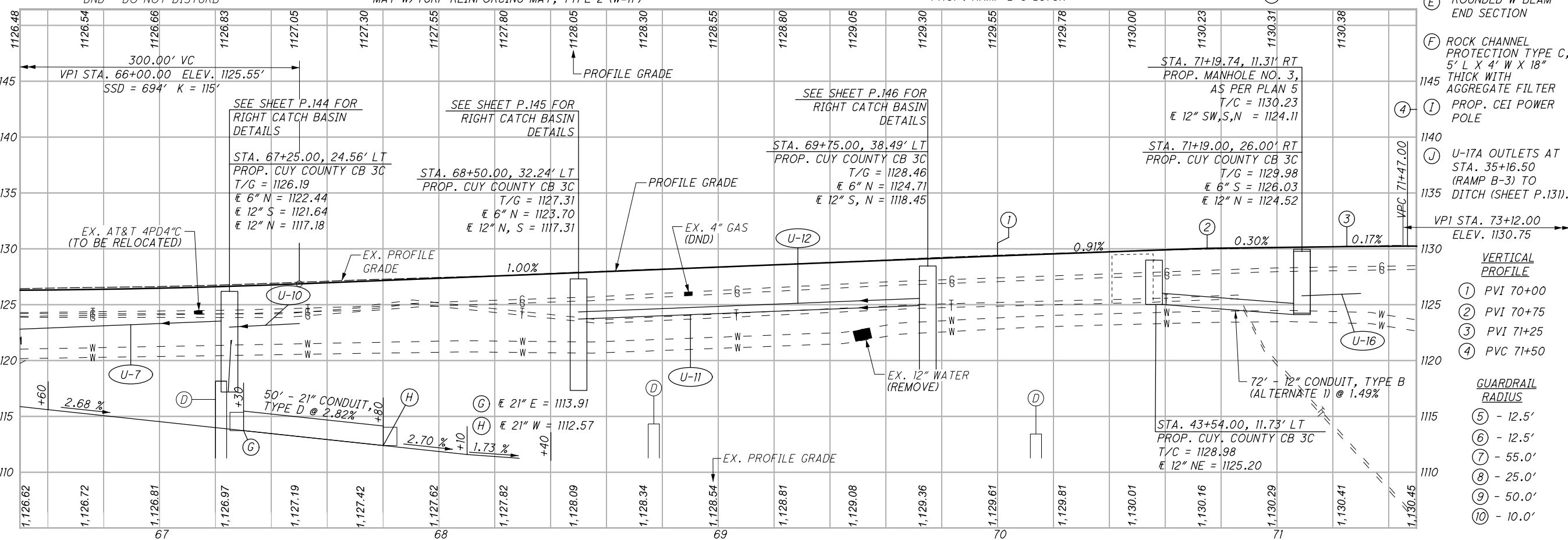

- (A) STA. 67+34.30 ANCHOR ASSEMBLY, MGS TYPE T
  - (B) STA. 67+70.87 ANCHOR ASSEMBLY, MGS TYPE T
  - (C) HW-2.2-12 (CONCRETE PIPE)
  - (D) SEE SHEET P.230 FOR SANITARY MANHOLE INFORMATION
  - (E) ROUNDED W-BEAM END SECTION
  - (F) ROCK CHANNEL PROTECTION TYPE C, 5' L X 4' W X 18" THICK WITH AGGREGATE FILTER
  - (I) PROP. CEI POWER POLE
  - (J) U-17A OUTLETS AT STA. 35+16.50 (RAMP B-3) TO DITCH (SHEET P.131).
- VERTICAL PROFILE
- (1) PVI 70+00
  - (2) PVI 70+75
  - (3) PVI 71+25
  - (4) PVC 71+50
- GUARDRAIL RADIUS
- (5) - 12.5'
  - (6) - 12.5'
  - (7) - 55.0'
  - (8) - 25.0'
  - (9) - 50.0'
  - (10) - 10.0'



PLAN AND PROFILE - MILLER ROAD (WETLAND A & STREAM A)  
STA. 66+50 TO STA. 71+50

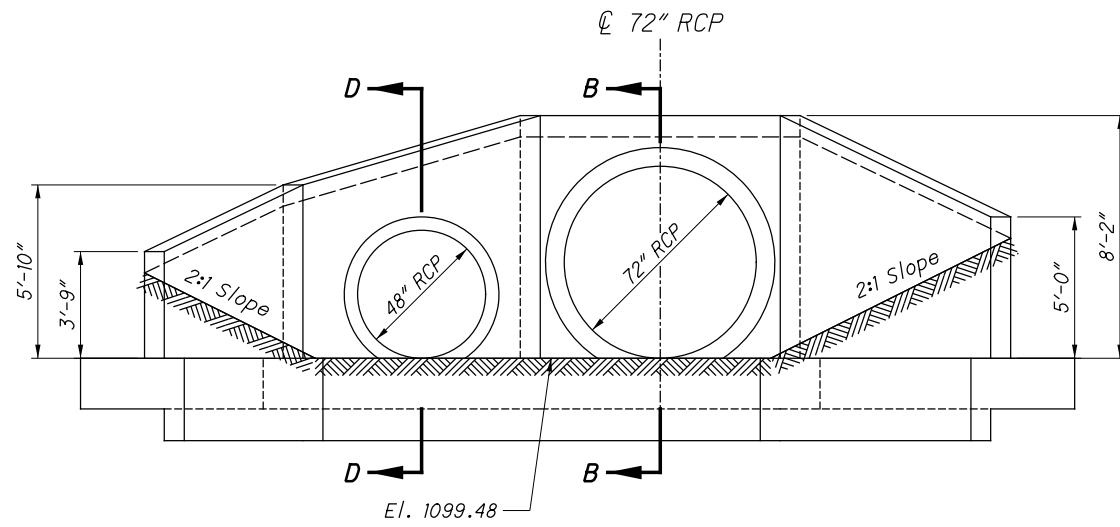

ELEVATION VIEW

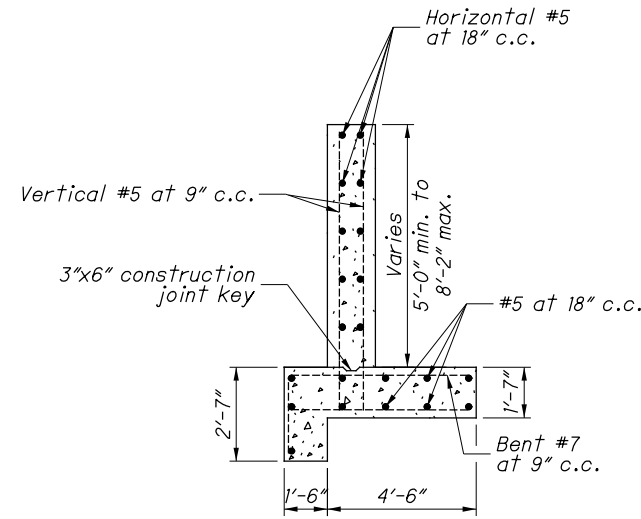

SECTION A-A

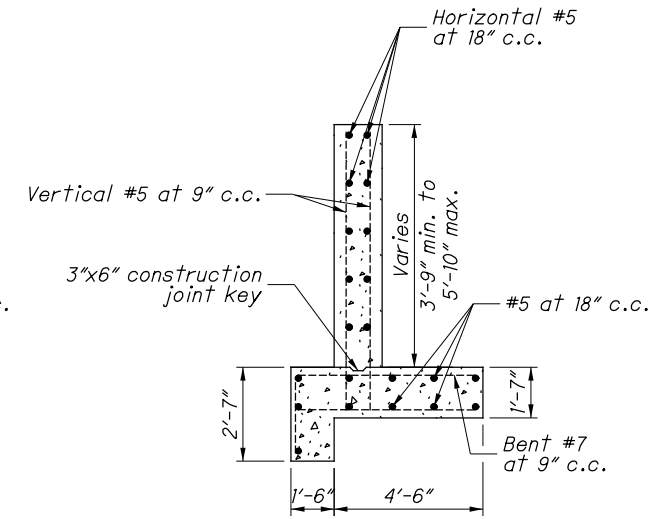

SECTION C-C

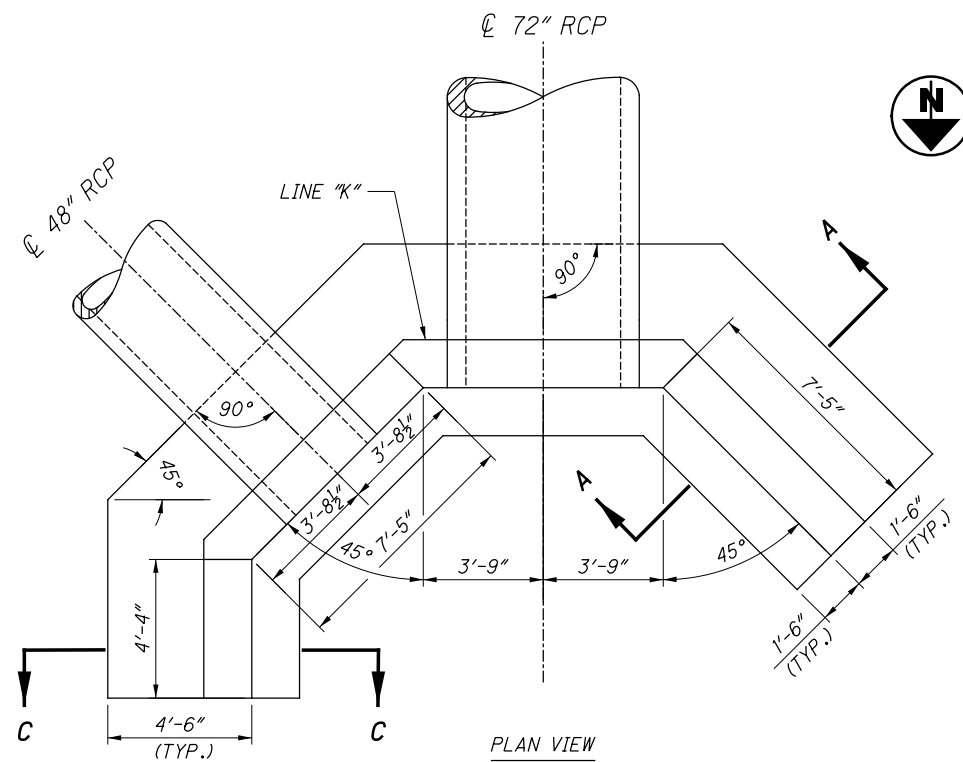

PLAN VIEW

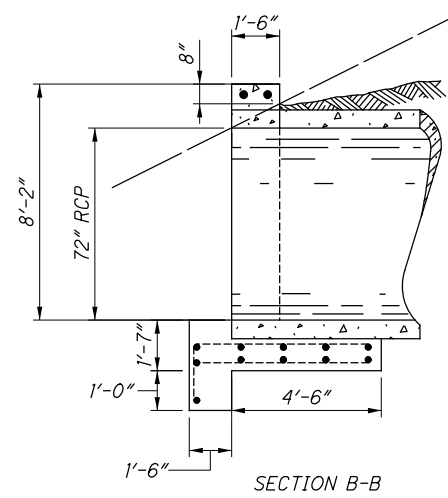

SECTION B-B

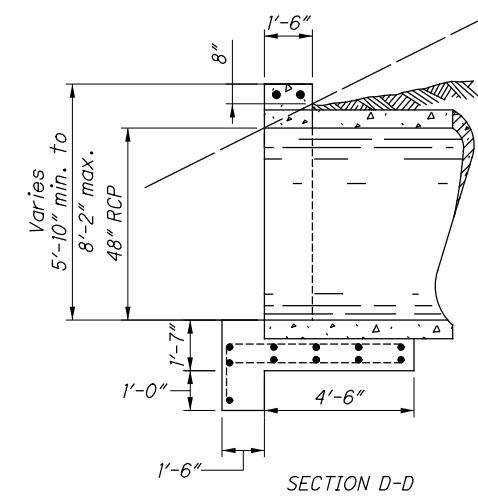

SECTION D-D

NOTES:

- This drawing provides details to supplement the standard drawing. For headwall reinforcing steel and details not shown, refer to standard drawing HW-1.1.

ESTIMATED QUANTITIES			
ITEM	QUANTITY	UNIT	DESCRIPTION
202	16	FT	PIPE REMOVED, OVER 24"
202	2	EACH	HEADWALL REMOVED
601	60	CY	ROCK CHANNEL PROTECTION, TYPE A WITH AGGREGATE FILTER
602	46	CY	CONCRETE MASONRY
611	31	FT	72" CONDUIT, TYPE A, 706.02
625	2	EACH	CONDUIT, MISC.: BENTONITE CLAY DAM

**HYDRAULIC DATA**

DRAINAGE AREA = 97.11 ACRES  
 Q (25) = 270 CFS V (25) = 9.9 FT/S HW (25) = 1106.47 FT  
 Q (100) = 345 CFS V (100) = 12.2 FT/S HW (100) = 1108.06 FT  
 ORDINARY HIGH WATER MARK: 1100.5'±  
 DESIGN SERVICE LIFE: N/A (EXISTING CULVERT)  
 ABRASION LEVEL: 1  
 CFN: 1989648



EX. DUMPED ROCK

ROCK CHANNEL PROTECTION TYPE A, 36" THICK WITH AGGREGATE FILTER

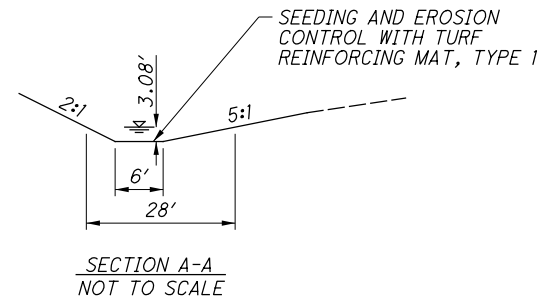

**NOTES:**

1. CONTRACTOR TO EXTEND 18" RCP THROUGH WINGWALL AND ADJUST WINGWALL REINFORCING STEEL AS NECESSARY TO ACCOMMODATE THE 18" RCP.
2. SEE SHEET P.223 FOR HEADWALL DETAIL.

- ① EX. 30" RCP
- ② EX. 32" X 48" RCP  
EX. 32" X 48" RCP  
EX. 24" RCP
- ③ EX. 18" RCP

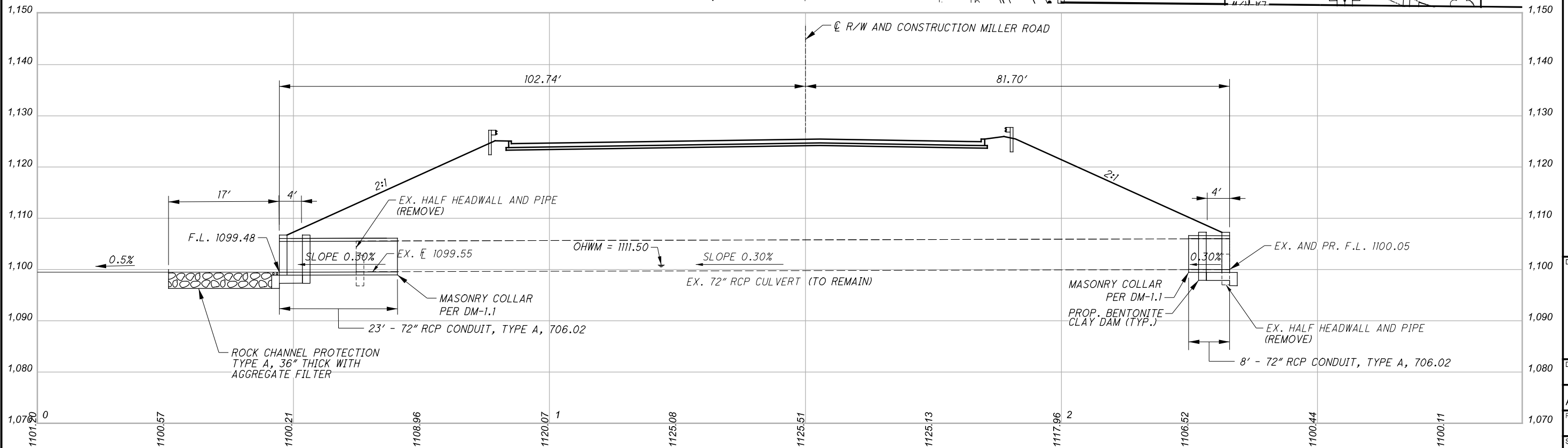
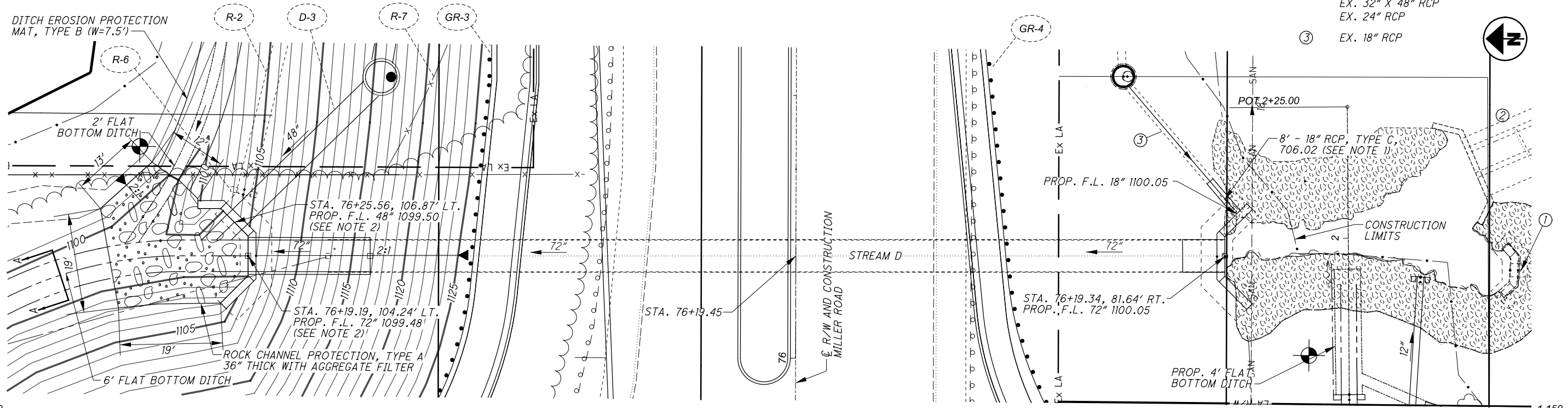
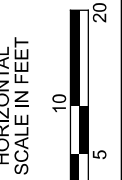

**CULVERT DETAIL (STREAM D)  
 MILLER ROAD STA. 76+20**

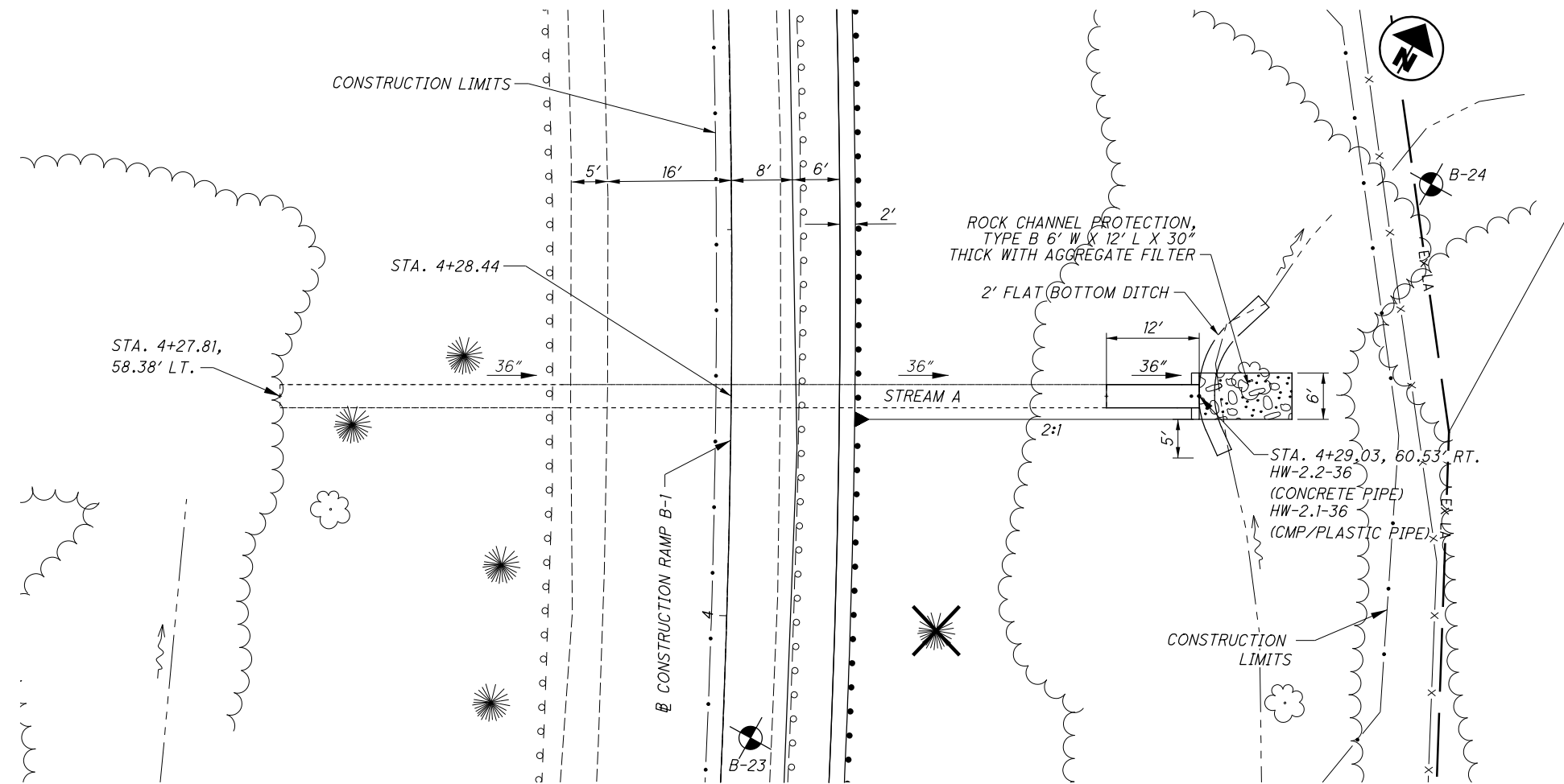

ESTIMATED QUANTITIES			
ITEM	QUANTITY	UNIT	DESCRIPTION
202	4	FT	PIPE REMOVED, OVER 24"
202	1	EACH	HEADWALL REMOVED
601	6.67	CY	ROCK CHANNEL PROTECTION, TYPE B 30" THICK WITH AGGREGATE FILTER
602	0.69	CY	CONCRETE MASONRY
611	15	FT	36" CONDUIT, TYPE A, AS PER PLAN, 706.02

**CURVE DATA**  
 P.I. = Sta. 3+08.29  
 $\Delta = 16^\circ 32' 50''$  RT  
 $D_c = 04^\circ 00' 00''$   
 $R = 1,432.39'$   
 $T = 208.29'$   
 $L = 413.68'$   
 $E = 15.06'$

NOTE: PROPOSED CONDUIT EXTENSION MUST MATCH EXISTING CONDUIT MATERIAL IN KIND.

**HYDRAULIC DATA**

DRAINAGE AREA = 24.19 ACRES  
 $Q(25) = 44.67$  CFS     $V(25) = 6.38$  FT/S     $HW(25) = 1101.54$  FT  
 $Q(100) = 54.23$  CFS     $V(100) = 7.73$  FT/S     $HW(100) = 1103.87$  FT  
 ORDINARY HIGH WATER MARK: 1100.5  
 DESIGN SERVICE LIFE: N/A  
 ABRASION LEVEL: 1  
 CFN: 1841856

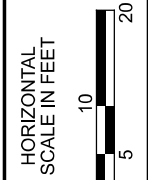
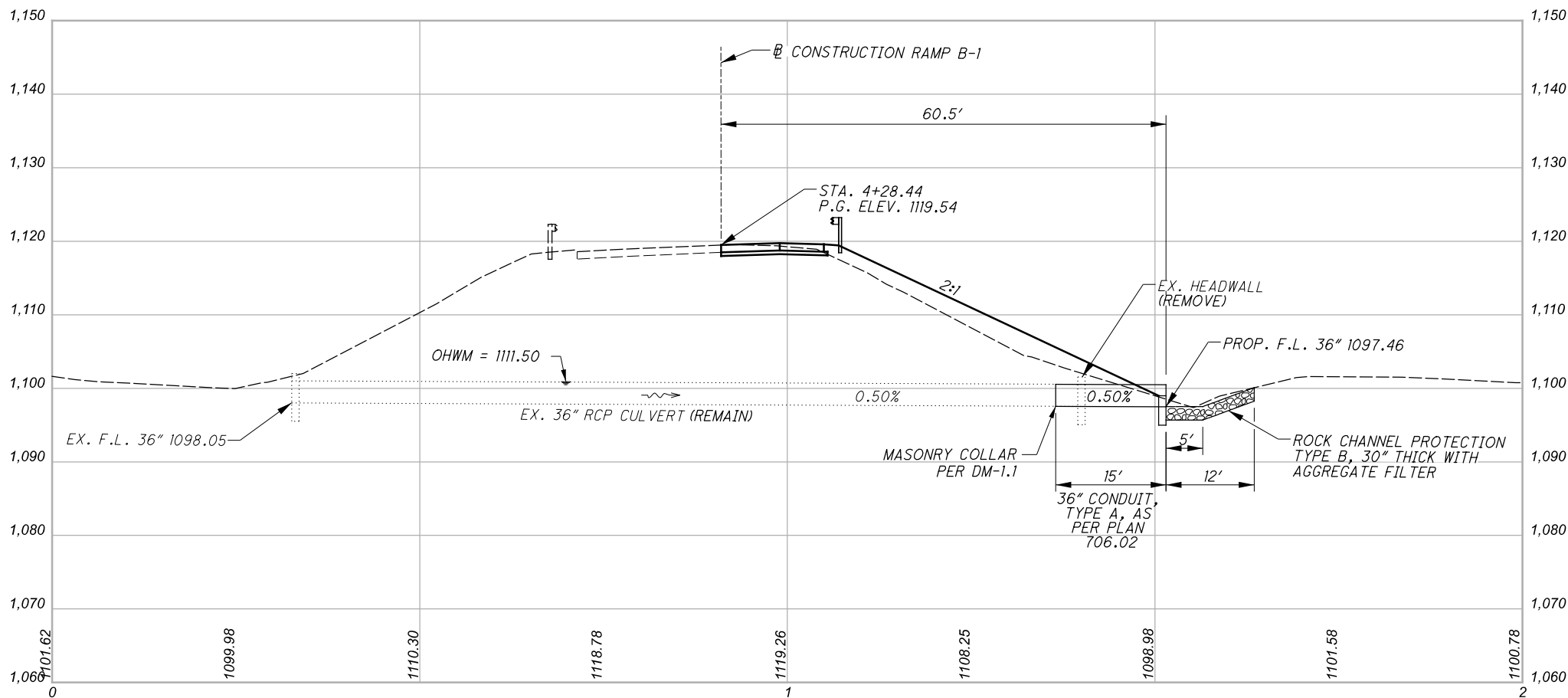

CULVERT DETAIL (STREAM A)  
 RAMP B-1 STA. 4+28

DESIGN AGENCY  
**EUTHENICS**  
 625 Walnut Dr., Cleveland, OH 44130

DESIGNER: DTB  
 REVIEWER: ARP 03/01/22  
 PROJECT ID: 104983  
 SHEET: P.224 TOTAL: P.445

CROSS REFERENCES	SHEET(S)
IR-77 PLAN AND PROFILE	84
SR-21 RAMP G PROFILE	90
SUPERELEVATION TABLES	179 - 184
TYPICAL SECTIONS	12
INTERCHANGE DETAILS	187 - 189
STORM SEWER DETAILS	191 - 193
TRAFFIC CONTROL	204 - 218
CULVERT DETAIL	190
PROJECT SITE PLAN	82
GENERAL SUMMARY	74 - 76
UNDERDRAIN SUBSUMMARY	196 - 197

FOR RAMP CURVE INFORMATION SEE SHEET 3

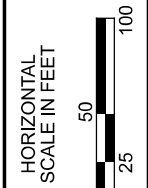

SUM-77-32.27

MODEL: I:\05\_GP401\_PAPER\SIZE: I:\x\lin.) DATE: 7/25/2022 TIME: 9:55:10 AM USER: edues  
 pw:\gfn\p-w\ent\ty.com\gfn\p-w\0\Documents\Projects\67490\04983-40-Engineering-GP401.dgn

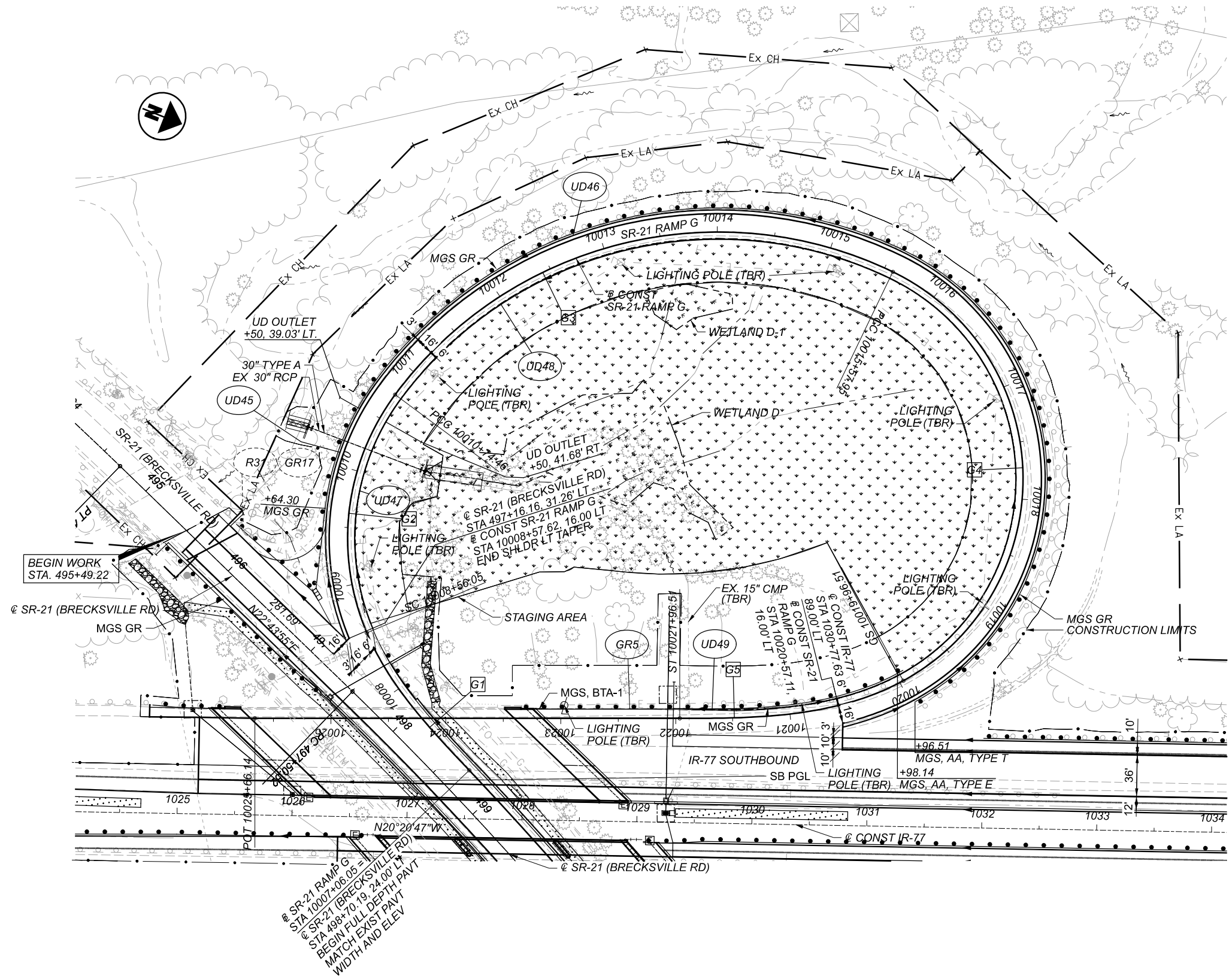

PLAN SHEET  
 SR-21 (BRECKSVILLE ROAD) - RAMP G

LEGEND

- ITEM 601 ROCK CHANNEL PROTECTION TYPE C W/ GEOTEXTILE FABRIC (7.5' WIDE)
- ITEM 670 DITCH EROSION PROTECTION (7.5' WIDE)
- VEGETATED FILTER STRIP

DESIGN AGENCY	
<b>Gannett Fleming</b>	
ENGINEERS AND ARCHITECTS, P.C. 2500 Corporate Exchange Drive Columbus, OH 43221	
DESIGNER	TQD
REVIEWER	DRJ 05/03/22
PROJECT ID	104983 (PRT 2)
SHEET	TOTAL
89	312



**US Army Corps of Engineers  
Huntington District**

Permit Number: 2022-00694-CUY

Name of Permittee: Ohio Department of Transportation

Date of Issuance: September 30, 2022

Upon completion of the activity authorized by this permit and any mitigation required by the permit, sign this certification and return it to the following address:

U.S. Army Corps of Engineers - Huntington District  
Building 10/ Section 10  
PO Box 3990  
Columbus, OH 43218-3990

Please note that your permitted activity is subject to a compliance inspection by an U.S. Army Corps of Engineers representative. If you fail to comply with this permit you are subject to permit suspension, modification, or revocation.

I hereby certify that the work authorized by the above-referenced permit has been completed in accordance with the terms and conditions of the said permit, and required mitigation was completed in accordance with the permit conditions.

\_\_\_\_\_  
Signature of Permittee

\_\_\_\_\_  
Date