



Osborn Engineering
1100 Superior Avenue - Suite 300
Cleveland, Ohio 44114

Project		CUY-77-04.79 PID 106239		Job Ref.		J20170056.000	
Section				Structure Estimated Quantities			
Sheet no./rev.				1			
Calc. by	Date	Chk'd by	Date	App'd by	Date		
EIW	03/22/24	PJW/SMK	03/22/24				

Item 202 – PORTIONS OF STRUCTURE REMOVED, OVER 20 FOOT SPAN, AS PER PLAN (LUMP SUM)

Below calculations performed for use in Estimated Quantities Form (D-2), not itemized in project plans.

Existing Concrete Deck, Sidewalk & parapet area (CAD) (SF); $A_{sup_ex} = 41.5$
Existing Deck limits (ft); $L_{sup_ex} = 280.67$

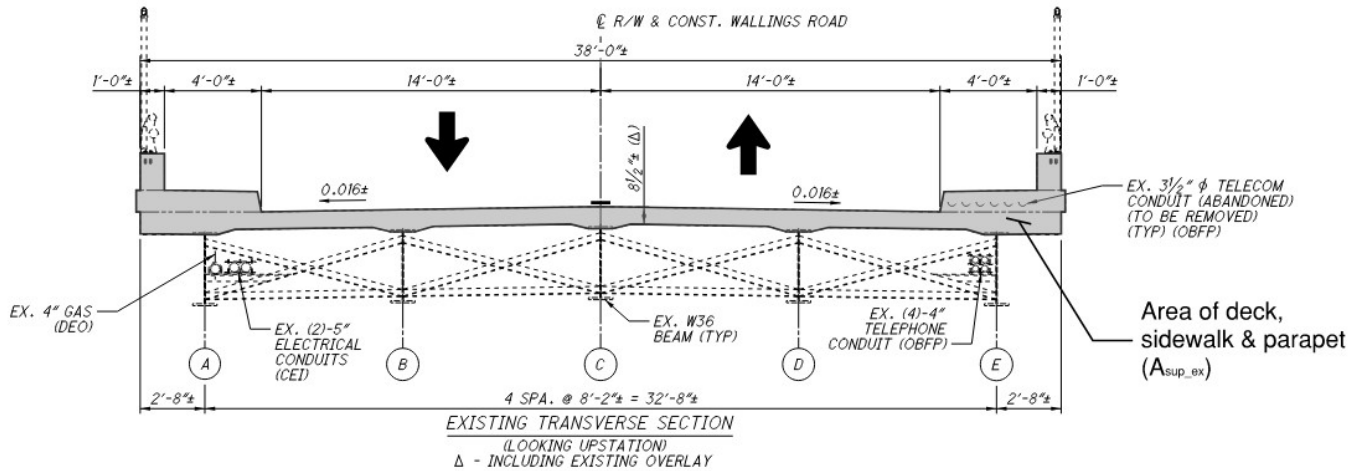

Existing backwall area removed (CAD) (SF); $A_{back_ex} = 190.5 + 189 = 379.500$
Existing backwall thickness (ft); $t_{back_ex} = 1.75$

Existing breastwall area removed (CAD) (SF); $A_{brstwall_ex} = 58 + 52.5 = 110.500$
Existing breastwall thickness (ft); $t_{brstwall_ex} = 3.75$

Existing wingwall area removed (CAD) (SF); $A_{ww_ex} = 2 \times (49 + 54.5) = 207.000$
Existing wingwall thickness (ft); $t_{ww_ex} = 1.5$

Existing sidewalk & parapet over wingwall area (CAD) (SF); $A_{walk_ex} = 10$
Existing sidewalk length outside abutment limits (ft); $L_{walk_ex} = 4 \times 13.75 = 55.000$

Total volume of concrete removed (CY); $T_{202_conc} = \text{ceiling}((A_{sup_ex} \times L_{sup_ex} + A_{back_ex} \times t_{back_ex} + A_{brstwall_ex} \times t_{brstwall_ex} + A_{ww_ex} \times t_{ww_ex}) / 27, 1) = 483.000$

Existing steel beam removed weight (lb); $W_{stl_ex} = 5 \times (160 \times 71.25 \times 2 + 194 \times 138) = 247860.000$

Unit weight of steel plates (lb/ft³); $W_{stl} = 490$

Existing moment plates removed weight (lb); $W_{pl_ex} = 5 \times W_{stl} \times (2 \times 10.5 \times 1 \times 27 + 2 \times 13.5 \times .875 \times 27 + 10.5 \times 1.125 \times 24 + 13.5 \times 1 \times 24) / 144 = 30835.547$

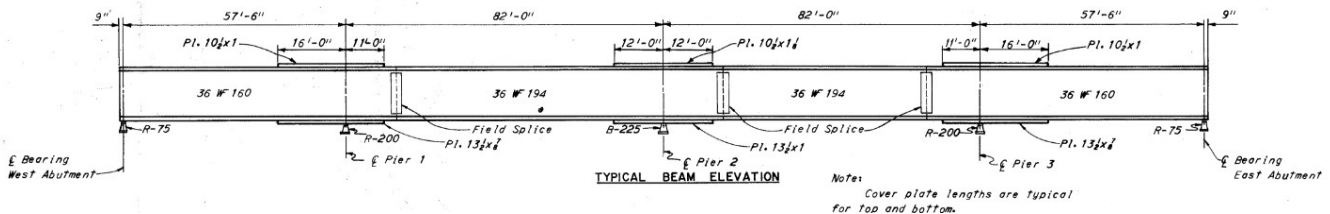

Existing crossframe removed weight (L3x3x5/16 + 5% increase for bolts, utility supports, etc.) (lb); $W_{CF_ex} = 1.05 \times 20 \times (6.1 \times (2 \times 8.4 + 8.1) + 7.2 \times 3) = 3643.290$



Osborn Engineering
1100 Superior Avenue - Suite 300
Cleveland, Ohio 44114

Project		CUY-77-04.79 PID 106239		Job Ref.		J20170056.000					
Section				Structure Estimated Quantities				Sheet no./rev.		2	
Calc. by		Date		Chk'd by		Date		App'd by		Date	
EIW		03/22/24		PJW/SMK		03/22/24					

Total weight of steel removed (LB); $T_{202_stl} = \text{ceiling}(W_{stl_ex} + W_{pl_ex} + W_{CF_ex}, 1) = 282339.000$

Pipe removal (1-DEO, 2-CEI, 10-AT&T) (ft); $T_{202_pipe} = \text{ceiling}(L_{sup_ex} \times (1 + 2 + 10), 1) = 3649.000$

Fence & railing removal (both sides) (ft); $T_{202_fence} = \text{ceiling}((L_{sup_ex} + 2 \times 15.17) \times 2, 1) = 623.000$



Osborn Engineering
1100 Superior Avenue - Suite 300
Cleveland, Ohio 44114

Project		CUY-77-04.79 PID 106239		Job Ref.		J20170056.000	
Section				Structure Estimated Quantities			
Sheet no./rev.		3					
Calc. by	Date	Chk'd by	Date	App'd by	Date		
EIW	03/22/24	PJW/SMK	03/22/24				

Item 202 – Approach Slab Removed

Existing Approach slab width (ft); $W_{ex_app} = 28$
Existing approach slab length (ft); $L_{ex_app} = 25$

Total Area of 202 (SY); $T_{ex_app} = \text{ceiling}(2 \times W_{ex_app} \times L_{ex_app} / 9, 1) = 156.000$

PLAN SPLITS:

02/SAF/BR – 156 SY

04/NFP/BR – DOMINION ENERGY OHIO 0 SY



Osborn Engineering
1100 Superior Avenue - Suite 300
Cleveland, Ohio 44114

Project				Job Ref.	
CUY-77-04.79 PID 106239				J20170056.000	
Section				Sheet no./rev.	
Structure Estimated Quantities				4	
Calc. by	Date	Chk'd by	Date	App'd by	Date
EIW	03/22/24	PJW/SMK	03/22/24		

Item 503 – Unclassified Excavation

*Unclassified excavation includes areas required to be excavated for the removal of backwalls and excavation required for new, widened abutments and pier column footings.

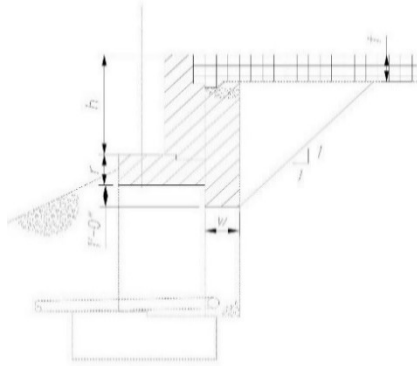

Excavation for removal of existing backwalls & beam seats (no shale)

Offset for new porous backfill (ft); $W_{PB} = 2$

Existing approach slab thickness (ft); $t_{ex_app} = 1.0833$

Average existing backwall height – RA (ft); $h_{avg_RAex} = 4.88$

Average existing seat removal – RA (ft); $r_{seat_RAex} = 1.52$

Average existing backwall height – FA (ft); $h_{avg_FAex} = 4.82$

Average existing seat removal – FA (ft); $r_{seat_FAex} = 1.37$

Existing Abutment length (ft); $L_{abut_ex} = 37.67$

Abutment width between wingwalls (ft); $L_{abut_wtw} = 34.67$

Area of 503 at rear abutment (sq ft); $A_{503_RAbw} = (W_{PB} \times (h_{avg_RAex} + r_{seat_RAex} + 1 - t_{ex_app})) + 0.5 \times (h_{avg_RAex} + r_{seat_RAex} + 1 - t_{ex_app})^2 = 32.584$

Area of 503 at forward abutment (sq ft); $A_{503_FAbw} = (W_{PB} \times (h_{avg_FAex} + r_{seat_FAex} + 1 - t_{ex_app})) + 0.5 \times (h_{avg_FAex} + r_{seat_FAex} + 1 - t_{ex_app})^2 = 30.859$

TOTAL VOLUME backwalls & seats (CY);; $T_{503_bw} = ceiling((A_{503_RAbw} + A_{503_FAbw}) \times L_{abut_wtw} / 27,1) = 82.000$

Excavation for widened abutments and wingwalls:

REV. 9/9/24

Excludes shale excavation at RA based on t/rock elevation of 1074.50 at Boring B-1. See calculation below for volume of shale anticipated at RA.



Osborn Engineering
1100 Superior Avenue - Suite 300
Cleveland, Ohio 44114

Project		CUY-77-04.79 PID 106239		Job Ref.		J20170056.000			
Section				Structure Estimated Quantities					
				Sheet no./rev.				5	
Calc. by	Date	Chk'd by	Date	App'd by	Date				
EIW	03/22/24	PJW/SMK	03/22/24						

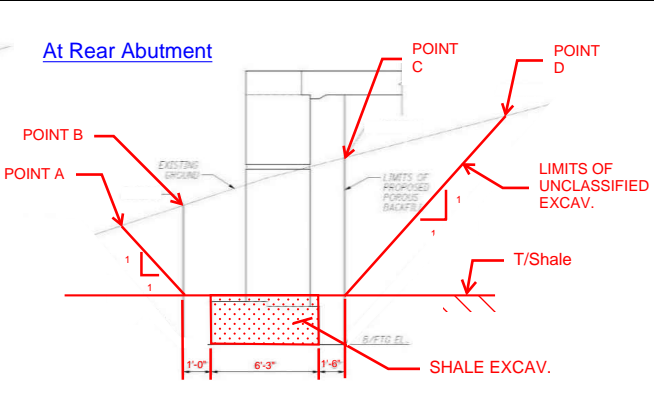
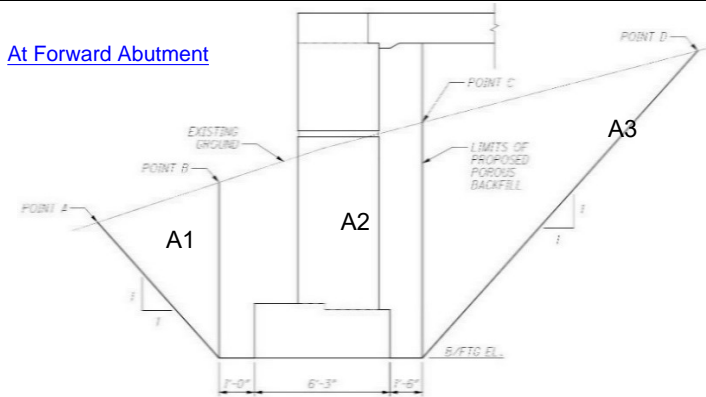

Proposed B/Ftg RA (ft); $EL_{ftg_RA} = 1071.35$
 Proposed B/Ftg FA (ft); $EL_{ftg_FA} = 1062.95$
 Proposed T/Shale RA (ft); $EL_{shale_RA} = 1074.5$

*Avg elevations below taken from CAD at 3 pts along abutments
 Avg. elevation Point A at RA (ft); $EL_{ptA_RA} = 1075.50$
 Avg. elevation Point A at FA (ft); $EL_{ptA_FA} = (1069.74 + 1067.74 + 1067.62)/3 = 1068.367$
 Avg. elevation Point B at RA (ft); $EL_{ptB_RA} = 1078.00$
 Avg. elevation Point B at FA (ft); $EL_{ptB_FA} = 1071.00$
 Avg. elevation Point C at RA (ft); $EL_{ptC_RA} = 1081.50$
 Avg. elevation Point C at FA (ft); $EL_{ptC_FA} = 1073.00$
 Avg. elevation at Point D at RA (ft); $EL_{ptD_RA} = (1084.11 + 1086 + 1084.02) / 3 = 1084.710$
 Avg. elevation at Point D at FA (ft); $EL_{ptD_FA} = (1073 + 1075 + 1074.95)/3 = 1074.317$

Limit of excavation behind RA (ft); $X_{RA} = (EL_{ptD_RA} - EL_{shale_RA}) = 10.210$
 Limit of excavation behind FA (ft); $X_{FA} = (EL_{ptD_FA} - EL_{ftg_FA}) = 11.367$
 Limit of excavation front RA (ft); $f_{RA} = (EL_{ptA_RA} - EL_{shale_RA}) = 1.000$
 Limit of excavation front FA (ft); $f_{FA} = (EL_{ptA_FA} - EL_{ftg_FA}) = 5.417$
 Excavation limit behind abutment footing (ft); $e_{behind} = 1.5$
 Excavation limit in front abutment footing (ft); $e_{front} = 1.0$
 Abutment footing width (ft); $W_{foot} = 6.25$

Excavation area RA - (sq ft); $A_{503_RA} = (0.5 \times (EL_{ptB_RA} - EL_{shale_RA}) \times f_{RA}) + ((e_{behind} + e_{front} + W_{foot}) \times ((EL_{ptB_RA} + EL_{ptC_RA})/2 - EL_{shale_RA})) + 0.5 \times (X_{RA}^2) - 0.5 \times (X_{RA} \times (EL_{ptD_RA} - EL_{ptC_RA})) = 83.93$

Excavation area FA - trapezoid (sq ft); $A_{503_FA} = (0.5 \times (EL_{ptB_FA} - EL_{ftg_FA}) \times f_{FA}) + ((e_{behind} + e_{front} + W_{foot}) \times ((EL_{ptB_FA} + EL_{ptC_FA})/2 - EL_{ftg_FA})) + 0.5 \times (X_{FA}^2) - 0.5 \times (X_{FA} \times (EL_{ptD_FA} - EL_{ptC_FA})) = 158.107$

Length of new abutment RA (ft); $L_{abut_RA} = \text{ceiling}(28.67 + 12.33, 1) = 41.000$
 Length of new abutment FA (ft); $L_{abut_FA} = \text{ceiling}(25.67 + 12.33, 1) = 38.000$

TOTAL VOLUME new abutments (CY); (excluding shale)
 $T_{503_abut} = \text{ceiling}(((A_{503_RA} \times L_{abut_RA}) + (A_{503_FA} \times L_{abut_FA})) / 27, 1) = 350.00$



Osborn Engineering
1100 Superior Avenue - Suite 300
Cleveland, Ohio 44114

Project		CUY-77-04.79 PID 106239		Job Ref.		J20170056.000	
Section		Structure Estimated Quantities		Sheet no./rev.		6	
Calc. by	Date	Chk'd by	Date	App'd by	Date		
EIW	03/22/24	PJW/SMK	03/22/24				

Excavation for new piers:

REV. 9/9/24

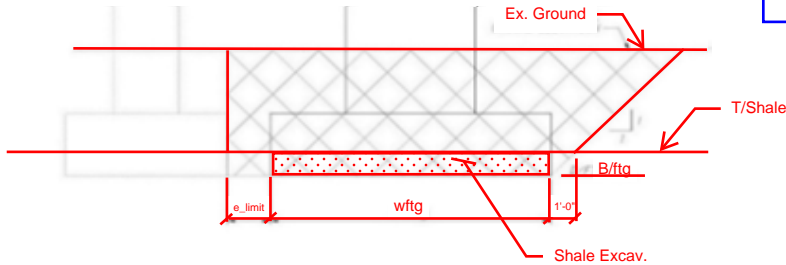

Proposed B/Ftg P1 (ft);	EL _{ftg_P1} = 1056.35
Proposed B/Ftg P2 (ft);	EL _{ftg_P2} = 1057.85
Proposed B/Ftg P3 (ft);	EL _{ftg_P3} = 1052.35
Avg. existing ground elevation at P1 (ft);	EL _{GL_P1} = 1060.32
Avg. existing ground elevation at P2 (ft);	EL _{GL_P2} = 1060.90
Avg. existing ground elevation at P3 (ft);	EL _{GL_P3} = 1055.76
T/Rock @ P1 (ft);	EL _{TR_P1} = 1057.2
T/Rock @ P2 (ft)(*assumed 1.1' above b/ftg);	EL _{TR_P2} = EL _{ftg_P2} + 1.1 = 1058.950
T/Rock @ P3 (ft);	EL _{TR_P3} = 1053.7

Excavation limit to existing pier footing at P1 (ft);	e _{limit_P1} = 2.5 + 1.00 to 1:1 slope = 3.5
Excavation limit to existing pier footing at P2 (ft);	e _{limit_P2} = 3.25 + 1.00 to 1:1 slope = 4.25
Excavation limit to existing pier footing at P3 (ft);	e _{limit_P3} = 2.5 + 1.00 to 1:1 slope = 3.5

Footing length at P1 (CL road) (ft);;	L _{P1_ftg} = 10
Footing width at P1 (ft);;	W _{P1_ftg} = 12
Footing length at P2 (ft);;	L _{P2_ftg} = 10
Footing width at P2 (ft);;	W _{P2_ftg} = 12
Footing length at P3 (ft);;	L _{P3_ftg} = 10
Footing width at P3 (ft);;	W _{P3_ftg} = 12

Total Excavation Area: (excluding shale excavation)

Cross-section Area at P1 (sq ft);	ACS _{P1} = ((W _{P1_ftg} + e _{limit_P1}) × (EL _{GL_P1} - EL _{TR_P1})) + (0.5 × (EL _{GL_P1} - EL _{TR_P1}) ²) = 53.227
Add'l Area at P1 along width (sq ft);	A _{width_P1} = 2 × 0.5 × (EL _{GL_P1} - EL _{TR_P1}) ² + (1.00 + 1.00) × (EL _{GL_P1} - EL _{TR_P1}) = 15.974
Volume at P1 (cu ft);	V _{503_P1} = (ACS _{P1} × L _{P1_ftg}) + (A _{width_P1} × W _{P1_ftg}) = 723.55
Cross-section Area at P2 (sq ft);	ACS _{P2} = ((W _{P2_ftg} + e _{limit_P2}) × (EL _{GL_P2} - EL _{TR_P2})) + (0.5 × (EL _{GL_P2} - EL _{TR_P2}) ²) = 33.589
Add'l Area at P2 along width (sq ft);	A _{width_P2} = 2 × 0.5 × (EL _{GL_P2} - EL _{TR_P2}) ² + (1.00 + 1.00) × (EL _{GL_P2} - EL _{TR_P2}) = 7.703
Volume at P2 (cu ft);	V _{503_P2} = (ACS _{P2} × L _{P2_ftg}) + (A _{width_P2} × W _{P2_ftg}) = 428.33
Cross-section Area at P3 (sq ft);	ACS _{P3} = ((W _{P3_ftg} + e _{limit_P3}) × (EL _{GL_P3} - EL _{TR_P3})) + (0.5 × (EL _{GL_P3} - EL _{TR_P3}) ²) = 33.93
Add'l Area at P3 along width (sq ft);	A _{width_P3} = 2 × 0.5 × (EL _{GL_P3} - EL _{TR_P3}) ² + (1.00 + 1.00) × (EL _{GL_P3} - EL _{TR_P3}) = 8.364
Volume at P3 (cu ft);	V _{503_P3} = (ACS _{P3} × L _{P3_ftg}) + (A _{width_P3} × W _{P3_ftg}) = 439.67



Osborn Engineering
1100 Superior Avenue - Suite 300
Cleveland, Ohio 44114

Project CUY-77-04.79 PID 106239				Job Ref. J20170056.000	
Section Structure Estimated Quantities				Sheet no./rev. 7	
Calc. by EIW	Date 03/22/24	Chk'd by PJW/SMK	Date 03/22/24	App'd by	Date

Shale Excavation Area:

Volume at P1 (cu ft); $V_{503_P1R} = W_{P1_ftg} \times L_{P1_ftg} \times (EL_{TR_P1} - EL_{ftg_P1}) = 102.000$

Volume at P2 (cu ft); $V_{503_P2R} = W_{P2_ftg} \times L_{P2_ftg} \times (EL_{TR_P2} - EL_{ftg_P2}) = 132.000$

Volume at P3 (cu ft); $V_{503_P3R} = W_{P3_ftg} \times L_{P3_ftg} \times (EL_{TR_P3} - EL_{ftg_P3}) = 162.000$

TOTAL VOLUME OF SHALE at piers (CY);; $T_{503_pier_SHALE} = ceiling((V_{503_P1R} + V_{503_P2R} + V_{503_P3R}) / 27, 1) = 15.000$

TOTAL VOLUME OF SHALE at rear abutment (CY) (See below); $T_{503_RA_SHALE} = 30\text{ CY}$

TOTAL VOLUME OF OTHER EXCAVATION at piers (CY);; $T_{503_pier} = ceiling((V_{503_P1} + V_{503_P2} + V_{503_P3}) / 27 = 59.00$

TOTAL VOLUME OF SHALE EXCAVATION (rev) (CY); $T_{503_SHALE} = T_{503_PIER_SHALE} + T_{503_RA_SHALE} = 45\text{ CY}$

TOTAL VOLUME OF OTHER EXCAVATION (rev) (CY); $T_{503_OTHER} = T_{503_pier} + T_{503_abut} + T_{503_bw} = 491\text{ CY}$

PLAN SPLITS:

02/SAF/BR –

491 CY OTHER EXCAVATION
45 CY SHALE EXCAVATION

04/NFP/BR – DOMINION ENERGY OHIO

0 CY

Shale Excavation Quantity Revision at Rear Abutment - 9/9/24:

At Rear Abutment - T/Rock El. = 1074.5
B/Footing El. = 1071.35

Shale Excavation Area = (6.25') x (1074.5 - 1071.35) = 19.7 SF

Length of new abutment RA (ft); $L_{abut_RA} = 41.00'$

Volume of shale excavation (cu yd);
 $T_{503_RA_SHALE} = 19.7\text{ sf} \times 41' / 27 = 30\text{ CY}$

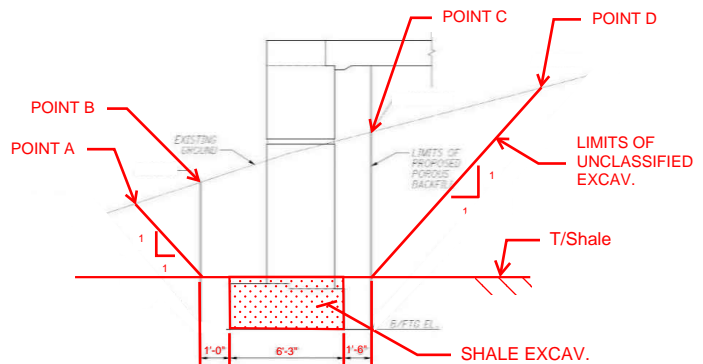

Excavation limit behind abutment footing (ft); $e_{behind} = 1.5$
Excavation limit in front abutment footing (ft); $e_{front} = 1.0$
Abutment footing width (ft); $W_{foot} = 6.25$



Tedds
 Osborn Engineering
 1100 Superior Avenue - Suite 300
 Cleveland, Ohio 44114

Project CUY-77-04.79 PID 106239				Job Ref. J20170056.000	
Section Structure Estimated Quantities				Sheet no./rev. 8	
Calc. by EIW	Date 03/22/24	Chk'd by PJW/SMK	Date 03/22/24	App'd by	Date

ITEM 509 – EXPOXY-COATED REINFORCING STEEL, AS PER PLAN (rev. 06/2024)

Abutments

Abutment & wingwall rebar total (lb); $T_{509_abut} = 8125$

Piers

Pier rebar (lb); $T_{509_pier} = 16552$

Superstructure

Deck & diaphragm (lb); $T_{509_super} = 142347$

Parapet

Parapet rebar (lb); $T_{509_par} = 13076$

TOTAL WEIGHT OF REINFORCING STEEL (LB); $T_{509} = \text{ceiling}(T_{509_abut} + T_{509_pier} + T_{509_super} + T_{509_par}, 1) = 180100.00$

PLAN SPLITS:

02/SAF/BR – 180100 LB

04/NFP/BR – DOMINION ENERGY OHIO 0 LB



Osborn Engineering
1100 Superior Avenue - Suite 300
Cleveland, Ohio 44114

Project		CUY-77-04.79 PID 106239		Job Ref.		J20170056.000					
Section				Structure Estimated Quantities				Sheet no./rev.		9	
Calc. by		Date		Chk'd by		Date		App'd by		Date	
EIW		03/22/24		PJW/SMK		03/22/24					

ITEM 509 – REINFORCING STEEL, REPLACEMENT OF EXISTING REINFORCING STEEL, AS PER PLAN

TOTAL WEIGHT OF REPLACEMENT STEEL (LB) = 500 LB

PLAN SPLITS:

02/SAF/BR –	500 LB
04/NFP/BR – DOMINION ENERGY OHIO	0 LB



Osborn Engineering
1100 Superior Avenue - Suite 300
Cleveland, Ohio 44114

Project				Job Ref.	
CUY-77-04.79 PID 106239				J20170056.000	
Section				Sheet no./rev.	
Structure Estimated Quantities				10	
Calc. by	Date	Chk'd by	Date	App'd by	Date
EIW	03/22/24	PJW/SMK	03/22/24		

ITEM 510 – DOWEL HOLES WITH NON-SHRINK, NONMETALLIC GROUT

Abutments

Bar Marks doweled: A501, A503, A504, A509, A510, A511, A512, A530, A540, A602, A604, A605

Total Abutment dowels (each); $T_{510_abut} = 12 + 6+6+16+4+144+40+8+4+8+4+4 = 256.000$

Piers

Bar Marks doweled: P501, P502, P503

Pier dowels (each); $T_{510_pier} = 68 + 48 + 88 = 204.000$

TOTAL NUMBER OF DOWELS (EACH); $T_{510} = T_{510_abut} + T_{510_pier} = 460.000$

PLAN SPLITS:

02/SAF/BR – 460 EACH

04/NFP/BR – DOMINION ENERGY OHIO 0 EACH



Osborn Engineering
1100 Superior Avenue - Suite 300
Cleveland, Ohio 44114

Project				Job Ref.	
CUY-77-04.79 PID 106239				J20170056.000	
Section				Sheet no./rev.	
Structure Estimated Quantities				11	
Calc. by	Date	Chk'd by	Date	App'd by	Date
EIW	03/22/24	PJW/SMK	03/22/24		

ITEM 511 – SEMI-INTEGRAL DIAPHRAGM GUIDE

* 2 per abutment

TOTAL NUMBER OF DIAPHRAGM GUIDES (EACH);

T_{511guide} = 4

PLAN SPLITS:

02/SAF/BR – 4 EACH
04/NFP/BR – DOMINION ENERGY OHIO 0 EACH



Osborn Engineering
1100 Superior Avenue - Suite 300
Cleveland, Ohio 44114

Project		CUY-77-04.79 PID 106239		Job Ref.		J20170056.000			
Section				Structure Estimated Quantities					
				Sheet no./rev.				12	
Calc. by	Date	Chk'd by	Date	App'd by	Date				
EIW	03/22/24	PJW/SMK	03/22/24						

ITEM 511 – CLASS QC2 CONCRETE WITH QC/QA, BRIDGE DECK, AS PER PLAN

REV. 12/12/2022

Primary Deck

Proposed deck width (ft); $W_{deck} = 54.3333$
 Proposed bridge limits (ft); $L_{deck} = 283.17$
 Proposed deck thickness (in); $t_{deck} = 8.5$

Volume of primary deck (cu ft); $V_{deck} = (W_{deck} \times L_{deck} \times t_{deck} / 12) = 10898.105$

Sidewalk

Sidewalk width (ft); $W_{walk} = 6$
 Parapet width (including formliner) (ft); $W_{bar} = 1.16667$
 Sidewalk overhang (ft); $over = 2/12 = 0.167$
 Curb height (ft); $curb = 8/12 = 0.667$
 Sidewalk cross-slope (ft/ft); $CROSS_{walk} = 0.02$

Average walk thickness (ft); $t_{walk_avg} = curb + CROSS_{walk} \times W_{walk} / 2 = 0.727$

Walk thickness under parapet (ft); $t_{walk_bar} = curb + CROSS_{walk} \times W_{walk} = 0.787$

Volume of sidewalk (cu ft); $V_{walk} = 2 \times L_{deck} \times (t_{walk_avg} \times W_{walk} + t_{walk_bar} \times (W_{bar} + over)) = 3063.272$

Haunches

Average haunch (all beams) (in); $h_{avg} = 2.09$

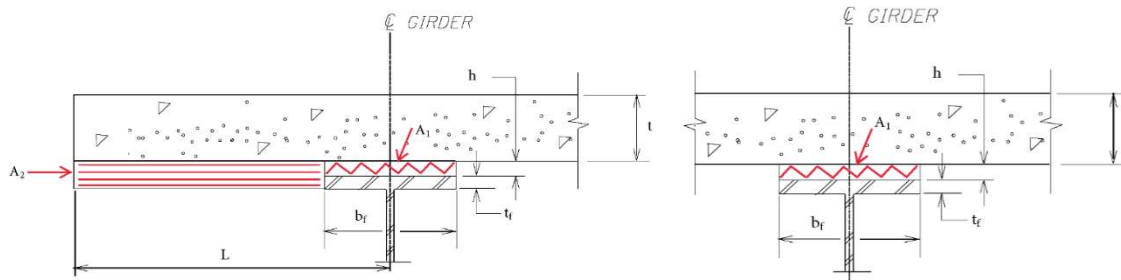

Average flange width (ft); $b_f = 1.01$

Average flange thickness (weighted over length) (in); $t_r = ((1.18 \times (71.813+71.823)) + (1.57 \times (86.0625+49.969))) / (279.668) = 1.370$

Fascia overhang (ft); $L_{fascia} = 2.6667$

Number of interior beams (each); $N_{int} = 5$

Number of fascia beams (each); $N_{ext} = 2$

Haunch volume – interior beams [A1] (cu ft); $V_{haunch_int} = b_f \times (h_{avg}/12) \times L_{deck} \times N_{int} = 249.060$

Haunch volume – fascia beams [A1+A2] (cu ft); $V_{haunch_ext} = L_{deck} \times N_{ext} \times ((b_f \times h_{avg}/12) + (L_{fascia} - b_f / 2) \times (h_{avg} + t_r)/12) = 452.587$



Osborn Engineering
1100 Superior Avenue - Suite 300
Cleveland, Ohio 44114

Project CUY-77-04.79 PID 106239				Job Ref. J20170056.000	
Section Structure Estimated Quantities				Sheet no./rev. 13	
Calc. by EIW	Date 03/22/24	Chk'd by PJW/SMK	Date 03/22/24	App'd by	Date

Abutment Diaphragms

Proposed abutment stem width (ft);

$$W_{stem} = 3.750$$

Abutment length (ft);

$$L_{abut} = 54.67$$

W36x182 beam CS Area (sq ft / ft);

$$A_{36x182} = 53.6/144 = 0.372$$

W36x182 beam height (ft);

$$h_{36x182} = 36.3/12 = 3.025$$

Beam length into diaphragm (ft);

$$L_{diaph_stl} = 2$$

Proposed approach slab thickness (ft);

$$t_{app} = 15/12 = 1.250$$

Haunch at abutments (in);

$$h_{h_abut} = 2.39$$

Average diaphragm height (ft);

$$h_{diaph} = (t_{deck} + h_{h_abut})/12 + h_{36x182} + (13.471-4.471)/12 = 4.683$$

Diaphragm Volume (not including deck concrete) (cu ft); $V_{diaph} = 2 \times (W_{stem} \times (h_{diaph} - (t_{deck} + h_{avg})/12) \times L_{abut} - A_{36x182} \times L_{diaph_stl} \times (N_{int} + N_{ext})) = 1547.673$

TOTAL VOLUME OF CONCRETE (CU YD); $T_{deck} = ceiling((V_{deck} + V_{walk} + V_{haunch_int} + V_{haunch_ext} + V_{diaph})/ 27, 1) = 601.000$

PLAN SPLITS:

02/SAF/BR –

601 CY

04/NFP/BR – DOMINION ENERGY OHIO

0 CY



Osborn Engineering
1100 Superior Avenue - Suite 300
Cleveland, Ohio 44114

Project		CUY-77-04.79 PID 106239		Job Ref.		J20170056.000			
Section				Structure Estimated Quantities		Sheet no./rev.		14	
Calc. by	Date	Chk'd by	Date	App'd by	Date				
EIW	03/22/24	PJW/SMK	03/22/24						

ITEM 511 – CLASS QC2 CONCRETE WITH QC/QA, BRIDGE DECK (PARAPET)

Proposed bridge limits (ft);; $L_{deck} = 283.170$

Parapet length past limits (ft);; $L_{parapet} = 12$

Parapet width (ft);; $W_{bar} = 1.167$

Parapet height (ft);; $h_{bar} = 2 + 8/12 = 2.667$

Parapet area (sq ft);; $A_{bar} = W_{bar} \times h_{bar} = 3.111$

TOTAL VOLUME OF CONCRETE (CU YD);; $T_{bar} = \text{ceiling}(A_{bar} \times ((2 \times L_{deck}) + (L_{parapet} \times 4)) / 27, 1) = 71.000$

PLAN SPLITS:

02/SAF/BR;

$T_{bar} = 71.000$

04/NFP/BR – DOMINION ENERGY OHIO;

0 CY



Osborn Engineering
1100 Superior Avenue - Suite 300
Cleveland, Ohio 44114

Project CUY-77-04.79 PID 106239				Job Ref. J20170056.000	
Section Structure Estimated Quantities				Sheet no./rev. 15	
Calc. by EIW	Date 03/22/24	Chk'd by PJW/SMK	Date 03/22/24	App'd by	Date

ITEM 511 – CLASS QC1 CONCRETE WITH QC/QA, ABUTMENT INCLUDING FOOTING

REV. 12/2/2022

Footings

Footing width (ft); $W_{abut_foot} = 6.25$
 Average footing height (ft); $H_{abut_foot} = 2.13$
 Total footing length (ft); $L_{abut_foot} = 21.667 + 5.333 + 12.333 + 25.667 = 65.000$

Vol for footing (cu ft); $V_{abut_foot} = W_{abut_foot} \times H_{abut_foot} \times L_{abut_foot} = 865.313$

Abutment – Stem

Stem width (ft); $W_{stem} = 3.750$
 Full height stem area RA (CAD) (sf); $A_{FHstem_RA} = 112.7$
 Seat modified stem area RA (CAD) (sf); $A_{SMstem_RA} = 53.4$
 Full height stem area FA (CAD) (sf); $A_{FHstem_FA} = 77.2$
 Seat modified stem area FA (CAD) (sf); $A_{SMstem_FA} = 51.0$

Vol for stem (cu ft); $V_{stem} = W_{stem} \times (A_{FHstem_RA} + A_{SMstem_RA} + A_{FHstem_FA} + A_{SMstem_FA}) = 1103.625$

Wingwalls

Wingwall width (ft); $W_{wingwall} = 3.25$

 NW WW Area (CAD) (sf); $A_{NW_ww} = 132.2$
 SW WW Area (CAD) (sf); $A_{SW_ww} = 129.8$
 NE WW Area (CAD) (sf); $A_{NE_ww} = 97.6$
 SE WW Area (CAD) (sf); $A_{SE_ww} = 87.8$

Vol for NW wingwall (cu ft); $V_{nw} = W_{wingwall} \times A_{NW_ww} = 429.650$
 Vol for NE wingwall (cu ft); $V_{ne} = W_{wingwall} \times A_{NE_ww} = 317.200$
 Vol for SW wingwall (cu ft); $V_{sw} = W_{wingwall} \times A_{SW_ww} = 421.850$
 Vol for SE wingwall (cu ft); $V_{se} = W_{wingwall} \times A_{SE_ww} = 285.350$

Vol of concrete for abutments (CY); $T_{abut} = ceiling((V_{abut_foot} + V_{stem} + V_{sw} + V_{se} + V_{nw} + V_{ne}) / 27, 1) = 127.000$

Contingency for fill of over-excavation at abutment footings:

*Estimated quantity if needed if rock is lower than existing footings. Estimate uses difference in t/rock boring elevations and b/footing elevations per existing plans over full area of proposed footings at abutments.

Abutment footing extension area (including wingwalls) RA (sf); $A_{ftg_RA} = W_{abut_foot} \times (21.667 + 5.333) = 168.750$
 Abutment footing extension area (including wingwalls) FA (sf); $A_{ftg_FA} = W_{abut_foot} \times (12.333 + 25.667) = 237.500$

Difference in B/Ftg and T/Rock Elevations:

RA; $\Delta_{RA} = 0$
 FA; $\Delta_{FA} = 1062.95 - 1060.50 = 2.450$

Total Concrete Contingency – Abutments (CY); $T_{contin_abut} = ceiling((A_{ftg_RA} \times \Delta_{RA} + A_{ftg_FA} \times \Delta_{FA}) / 27, 1) = 22.000$

Total Concrete Volume at abutments (CY); $T_{abut_tot} = T_{abut} + T_{contin_abut} = 149.000$



Osborn Engineering
1100 Superior Avenue - Suite 300
Cleveland, Ohio 44114

Project		CUY-77-04.79 PID 106239		Job Ref.		J20170056.000					
Section				Structure Estimated Quantities				Sheet no./rev.		16	
Calc. by		Date		Chk'd by		Date		App'd by		Date	
EIW		03/22/24		PJW/SMK		03/22/24					

PLAN SPLITS:

02/SAF/BR -;

T_{abut_tot} = 149.000

04/NFP/BR - DOMINION ENERGY OHIO

0 CY



Osborn Engineering
1100 Superior Avenue - Suite 300
Cleveland, Ohio 44114

Project		CUY-77-04.79 PID 106239		Job Ref.		J20170056.000			
Section				Structure Estimated Quantities					
				Sheet no./rev.				17	
Calc. by	Date	Chk'd by	Date	App'd by	Date				
EIW	03/22/24	PJW/SMK	03/22/24						

ITEM 511 – CLASS QC1 CONCRETE WITH QC/QA, PIER ABOVE FOOTINGS

Existing Cap Modifications

Cap plan area (CAD) (sf); $A_{plan_cap} = 105.0$
 Avg. seat modification thickness (P1) (ft); $t_{seat_P1} = 0.99$
 Avg. seat modification thickness (P2) (ft); $t_{seat_P2} = 1.15$
 Avg. seat modification thickness (P3) (ft); $t_{seat_P3} = 1.15$

Vol for cap seat modifications (cu ft); $V_{cap_seat} = A_{plan_cap} \times (t_{seat_P1} + t_{seat_P2} + t_{seat_P3}) = 345.45$

New Pier

Column – capsule shaped

Column radius (ft); $r_{col} = 1.5$
 Column straight length (ft); $a_{col} = 3$
 Column height pier 1 (ft); $H_{col1} = 14.79$
 Column height pier 2 (ft); $H_{col2} = 10.18$
 Column height pier 3 (ft); $H_{col3} = 12.64$

Hammerhead pier cap

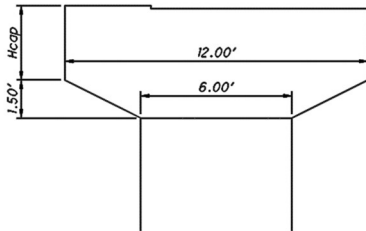

Cap width (ft); $W_{cap_new} = 3$
 Cap length (ft); $L_{cap_new} = 12$
 New cap area P1 (CAD) (ft); $A_{cap1} = 49.7$
 New cap area P2 (CAD) (ft); $A_{cap2} = 49.7$
 New cap area P3 (CAD) (ft); $A_{cap3} = 49.7$

Vol for 3 hammerhead caps (cu ft); $V_{cap_new} = W_{cap_new} \times (A_{cap1} + A_{cap2} + A_{cap3}) = 447.300$

Vol for 3 columns (cu ft); $V_{col} = (\pi \times r_{col}^2 + 2 \times r_{col} \times a_{col}) \times (H_{col1} + H_{col2} + H_{col3}) = 604.339$

Total Vol of concrete for piers above footings (CY); $T_{piers} = ceiling((V_{cap_seat} + V_{cap_new} + V_{col}) / 27, 1) = 52.00$

PLAN SPLITS:

02/SAF/BR – BRIDGE WIDENING; $T_{piers} = 52.00$
 04/NFP/BR – DOMINION ENERGY OHIO 0 CY



Osborn Engineering
1100 Superior Avenue - Suite 300
Cleveland, Ohio 44114

Project CUY-77-04.79 PID 106239				Job Ref. J20170056.000	
Section Structure Estimated Quantities				Sheet no./rev. 18	
Calc. by EIW	Date 03/22/24	Chk'd by PJW/SMK	Date 03/22/24	App'd by	Date

ITEM 511 – CLASS QC1 CONCRETE WITH QC/QA, FOOTING

REV. 12/2/2022

New Pier

Footing

Footing area P1 (sq ft); $A_{foot_P1} = 12 \times 10 = 120.000$
 Footing area P2 (sq ft); $A_{foot_P2} = 12 \times 10 = 120.000$
 Footing area P3 (sq ft); $A_{foot_P3} = 12 \times 10 = 120.000$

Footing height (ft); $H_{pier_foot} = 3$

Vol for 3 footings (cu ft); $V_{pier_foot} = H_{pier_foot} \times (A_{foot_P1} + A_{foot_P2} + A_{foot_P3}) = 1080.000$

Total Vol of concrete for pier footings (CY);; $T_{piers_footing} = ceiling((V_{pier_foot}) / 27, 1) = 40.000$

Contingency for fill of over-excavation at pier footings:

*Estimated quantity if needed if rock is lower than existing footings. Estimate uses difference in t/rock boring elevations and b/footing elevations per existing plans over full area of proposed footings at piers.

New Footing area P1 (sq ft); $A_{foot_P1} = 120.000$
 New Footing area P2 (sq ft); $A_{foot_P2} = 120.000$
 New Footing area P3 (sq ft); $A_{foot_P3} = 120.000$

Difference in B/Ftg and T/Rock Elevations:

P1; $\Delta P1 = 0$
 P2; $\Delta P2 = 1057.85 - 1054.20 = 3.650$
 P3; $\Delta P3 = 0$

Total Contingency Volume – Piers (CY); $T_{contin_piers} = ceiling((A_{foot_P1} \times \Delta P1 + A_{foot_P2} \times \Delta P2 + A_{foot_P3} \times \Delta P3) / 27, 1) = 17.000$

Total Concrete Volume – Pier Footing (CY); $T_{footing_total} = T_{piers_footing} + T_{contin_piers} = 57.000$



Osborn Engineering
1100 Superior Avenue - Suite 300
Cleveland, Ohio 44114

Project				Job Ref.	
CUY-77-04.79 PID 106239				J20170056.000	
Section				Sheet no./rev.	
Structure Estimated Quantities				19	
Calc. by	Date	Chk'd by	Date	App'd by	Date
EIW	03/22/24	PJW/SMK	03/22/24		

ITEM 511 – CONCRETE MISC.: 8” PVC CASING PIPE, 748.02

***Casing pipe sleeve for Dominion gas line through abutment diaphragm & under approach slab.*

Total Length of Casing Pipe (ft); $T_{\text{pipe}} = \text{ceiling}(2 \times (1.5 + 3.75 + 25 + 2), 1) = 65.000$

PLAN SPLITS:

02/SAF/BR;

0

04/NFP/BR DOMINION ENERGY OHIO;

$T_{\text{pipe}} = 65.000$



Osborn Engineering
1100 Superior Avenue - Suite 300
Cleveland, Ohio 44114

Project		CUY-77-04.79 PID 106239		Job Ref.		J20170056.000	
Section				Structure Estimated Quantities			
				Sheet no./rev.			
				20			
Calc. by	Date	Chk'd by	Date	App'd by	Date		
EIW	03/22/24	PJW/SMK	03/22/24				

ITEM 512 – SEALING CONCRETE SURFACES (EPOXY-URETHANE)

Abutments

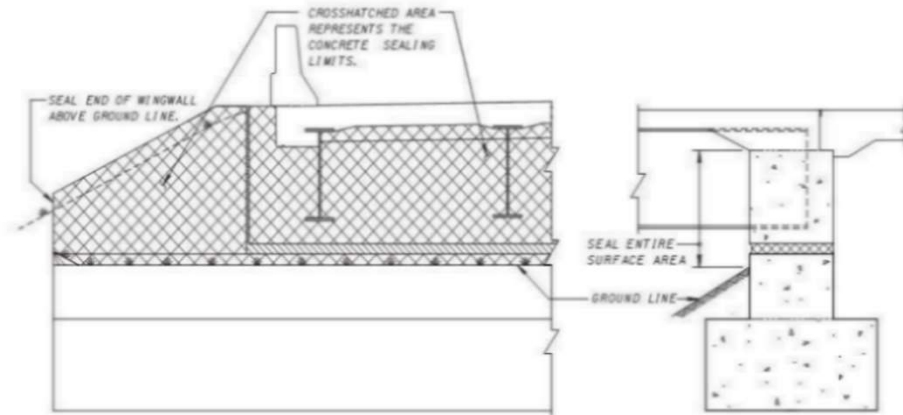

ABUTMENT SEALING LIMITS
(FOR SEMI-INTEGRAL ABUTMENT STEEL BEAM BRIDGE)

Diaphragm height (ft);	$h_{diaph} = 4.700$
Bearing height (ft);	$h_{brg} = 4.297 / 12 = 0.358$
Proposed approach slab thickness (ft);	$t_{app} = 1.250$
T/ Slope RA (ft);	$EL_{SP_RA} = 1079.73$
T/ Slope FA (ft);	$EL_{SP_FA} = 1069.24$
RA average beam seat elevation (ft);	$EL_{BS_RA} = 1080.43$
FA average beam seat elevation (ft);	$EL_{BS_FA} = 1069.94$
Beam seat-to-ground clearance RA (ft);	$h_{clr_RA} = (EL_{BS_RA} - EL_{SP_RA}) = 0.700$
Beam seat-to-ground clearance FA (ft);	$h_{clr_FA} = (EL_{BS_FA} - EL_{SP_FA}) = 0.700$
Abutment sealed height RA (ft);	$H_{512_A_RA} = h_{diaph} - t_{app} + h_{brg} + h_{clr_RA} = 4.508$
Abutment sealed height FA (ft);	$H_{512_A_FA} = h_{diaph} - t_{app} + h_{brg} + h_{clr_FA} = 4.508$
Abutment length (ft);	$L_{abut} = 54.670$
Total abutment area (sq ft);	$A_{512_abut} = (H_{512_A_RA} + H_{512_A_FA}) \times L_{abut} = 492.877$



Osborn Engineering
1100 Superior Avenue - Suite 300
Cleveland, Ohio 44114

Project CUY-77-04.79 PID 106239				Job Ref. J20170056.000	
Section Structure Estimated Quantities				Sheet no./rev. 21	
Calc. by EIW	Date 03/22/24	Chk'd by PJW/SMK	Date 03/22/24	App'd by	Date

Wingwalls

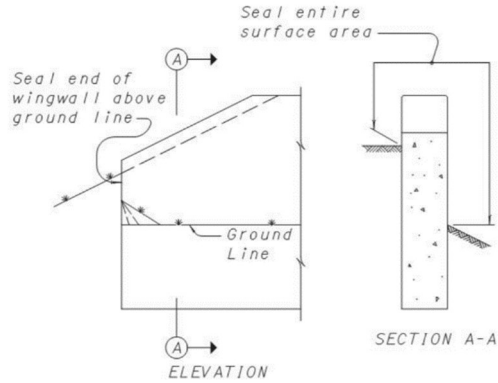

ITS WINGWALL SEALING LIMITS (STRAIGHT WING ABUTMENT)

*Wingwall sealing areas measured in CAD. Generally equation is as follows:

$$\text{Area} = \text{Highway side face} + \text{Embankment side face} + \text{Top area} + \text{End Area}$$

SW Wingwall elevation area (CAD) (sq ft);

$$A_{512_SW} = 52.0 + 11.8 + 46.7 + 3.7 = \mathbf{114.200}$$

SE Wingwall elevation area (CAD) (sq ft);

$$A_{512_SE} = 38.0 + 6.5 + 30.0 + 4.3 = \mathbf{78.800}$$

NW Wingwall elevation area (CAD) (sq ft);

$$A_{512_NW} = 53.57 + 11.9 + 46.7 + 3.7 = \mathbf{115.870}$$

NE Wingwall elevation area (CAD) (sq ft);

$$A_{512_NE} = 49.4 + 12.4 + 43.8 + 3.8 = \mathbf{109.400}$$

Total wingwall area (sq ft);

$$A_{512_ww} = A_{512_SW} + A_{512_SE} + A_{512_NW} + A_{512_NE} = \mathbf{418.270}$$

Piers

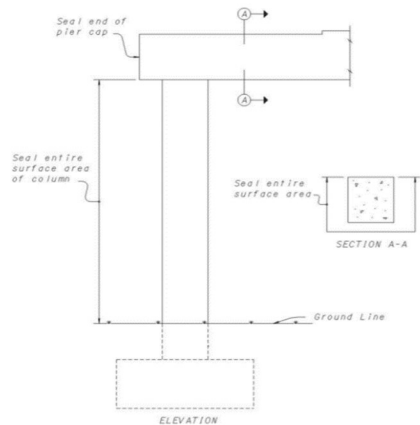

Sealing of existing piers:

Ex pier cap length (ft);

$$L_{cap_ex} = 35.667$$

Ex. Cap width (ft);

$$W_{cap_ex} = 3$$

Ex. Column diameter (ft);

$$D_{col_ex} = 3$$

Pier 1:



Osborn Engineering
1100 Superior Avenue - Suite 300
Cleveland, Ohio 44114

Project		CUY-77-04.79 PID 106239		Job Ref.		J20170056.000			
Section				Structure Estimated Quantities					
				Sheet no./rev.				22	
Calc. by	Date	Chk'd by	Date	App'd by	Date				
EIW	03/22/24	PJW/SMK	03/22/24						

Existing Pier -

Ex P1 Cap area between end radii (CAD) (sf); $A_{EP1_cap1} = 150.6$
 Avg. P1 cap height @ ends (ft); $H_{cap_EP1} = 4.54$
 P1 Cap end areas (sf); $A_{EP1_cap2} = H_{cap_EP1} \times \pi \times D_{col_ex} = 42.788$
 Bottom of Pier cap area (CAD) (sf); $A_{excap_bott} = 83.9$
 Average column height (to ground) (ft); $H_{excol1_seal} = 13.9$
 Total column area (sf); $AP1_excol = 3 \times \pi \times D_{col_ex} \times H_{excol1_seal} = 393.013$
 Total area ex. Pier 1 (sf); $AP1_ex = A_{EP1_cap1} + A_{EP1_cap2} + A_{excap_bott} + AP1_excol = 670.302$

New Pier -

Extended cap height pier 1 (ft); $H_{cap1} = 2.880$
 Cap elevation area (sq ft); $A_{cap1} = 49.700$
 Cap end area (sq ft); $A_{end1} = H_{cap1} \times W_{cap_new} = 8.640$
 Cap underneath area (sq ft); $A_{under1} = (\sqrt{(1.5^2 + 3^2)}) \times W_{cap_new} = 10.062$
 Total cap area (sq ft); $AP1_cap = 2 \times (A_{cap1} + A_{end1} + A_{under1}) = 136.805$
 Average column height (to ground) (ft); $H_{col1_seal} = 13.8$
 Total column area (sq ft); $AP1_col = (2 \times \pi \times r_{col} + (2 \times a_{col})) \times H_{col1_seal} = 212.862$
 Total area new Pier 1 (sq ft); $AP1_new = AP1_cap + AP1_col = 349.667$

Pier 2:

Existing Pier -

Ex P2 Cap area between end radii (CAD) (sf); $A_{EP2_cap1} = 153.9$
 Avg. P2 cap height @ ends (ft); $H_{cap_EP2} = 4.64$
 P2 Cap end areas (sf); $A_{EP2_cap2} = H_{cap_EP2} \times \pi \times D_{col_ex} = 43.731$
 Bottom of Pier cap area (CAD) (sf); $A_{excap_bott} = 83.900$
 Average column height (to ground) (ft); $H_{excol2_seal} = 10.2$
 Total column area (sf); $AP2_excol = 3 \times \pi \times D_{col_ex} \times H_{excol2_seal} = 288.398$
 Total area ex. Pier 2 (sf); $AP2_ex = A_{EP2_cap1} + A_{EP2_cap2} + A_{excap_bott} + AP2_excol = 569.929$

New Pier -

Extended cap height pier 2 (ft); $H_{cap2} = 2.880$
 Cap elevation area (sq ft); $A_{cap2} = 49.700$
 Cap end area (sq ft); $A_{end2} = H_{cap2} \times W_{cap_new} = 8.640$
 Cap underneath area (sq ft); $A_{under2} = (\sqrt{(1.5^2 + 3^2)}) \times W_{cap_new} = 10.062$
 Total cap area (sq ft); $AP2_cap = 2 \times (A_{cap2} + A_{end2} + A_{under2}) = 136.805$
 Average column height (to top of footing) (ft); $H_{col2_seal} = 10.2$
 Total column area (sq ft); $AP2_col = (2 \times \pi \times r_{col} + (2 \times a_{col})) \times H_{col2_seal} = 157.333$
 Total area new Pier 2 (sq ft); $AP2_new = AP2_cap + AP2_col = 294.137$

Pier 3:

Existing Pier -

Ex P3 Cap area between end radii (CAD) (sf); $A_{EP3_cap1} = 154.2$
 Avg. P2 cap height @ ends (ft); $H_{cap_EP3} = 4.65$
 P3 Cap end areas (sf); $A_{EP3_cap2} = H_{cap_EP3} \times \pi \times D_{col_ex} = 43.825$



Osborn Engineering
1100 Superior Avenue - Suite 300
Cleveland, Ohio 44114

Project		CUY-77-04.79 PID 106239		Job Ref.		J20170056.000			
Section				Structure Estimated Quantities					
				Sheet no./rev.				23	
Calc. by	Date	Chk'd by	Date	App'd by	Date				
EIW	03/22/24	PJW/SMK	03/22/24						

Bottom of Pier cap area (CAD) (sf); $A_{excap_bott} = 83.900$
 Average column height (to ground) (ft); $H_{excol3_seal} = 12.3$
 Total column area (sf); $AP3_excol = 3 \times \pi \times D_{col_ex} \times H_{excol3_seal} = 347.774$
 Total area ex. Pier 3 (sf); $AP3_ex = A_{EP3_cap1} + A_{EP3_cap2} + A_{excap_bott} + AP3_excol = 629.700$

New Pier -

Extended cap height pier 3 (ft); $H_{cap3} = 2.880$
 Cap elevation area (sq ft); $A_{cap3} = 49.700$
 Cap end area (sq ft); $A_{end3} = H_{cap3} \times W_{cap_new} = 8.640$
 Cap underneath area (sq ft); $A_{under3} = (\sqrt{1.5^2 + 3^2}) \times W_{cap_new} = 10.062$
 Total cap area (sq ft); $AP3_cap = 2 \times (A_{cap3} + A_{end3} + A_{under3}) = 136.805$
 Average column height (to top of footing) (ft); $H_{col3_seal} = 12.25$
 Total column area (sq ft); $AP3_col = (2 \times \pi \times r_{col} + (2 \times a_{col})) \times H_{col3_seal} = 188.954$
 Total area new Pier 3 (sq ft); $AP3_new = AP3_cap + AP3_col = 325.758$
 Total pier area (sq ft); $A_{512_pier} = AP1_ex + AP1_new + AP2_ex + AP2_new + AP3_ex + AP3_new = 2839.492$

Deck and Parapet (on bridge deck)

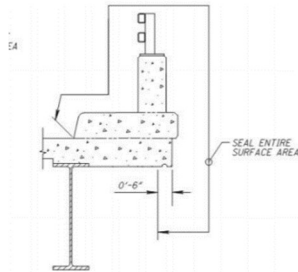

CONCRETE DECKS WITH CURBS,
SIDEWALKS AND PARAPET

**** ODOT D12 preference is to seal to the edge of the beam flange ****

**** Sidealk is calculated separately for non-epoxy sealer ****

Parapet height (ft); $h_{bar} = 2.667$
 Parapet width (ft); $w_{bar} = 1.167$
 Proposed bridge limits (ft); $L_{deck} = 283.170$
 Parapet perimeter (ft); $perim_{bar} = h_{bar} \times 2 + w_{bar} = 6.500$
 Average haunch (all beams) (in); $h_{avg} = 2.150$
 Average flange thickness (weighted over length) (in); $t_f = 1.231$
 Width of deck overhang sealed (ft); $w_{fascia} = (L_{fascia} - b_f / 2) = 2.161$
 Sealing perimeter (ft); $P_{deck} = perim_{bar} + over + t_{walk_bar} + over + (h_{avg} + t_f + t_{deck}) / 12 + w_{fascia} = 10.771$
 Total sealing area on bridge deck (sq ft); $A_{512_deck} = P_{deck} \times L_{deck} \times 2 = 6099.856$

Parapets (on approach slabs)



Osborn Engineering
1100 Superior Avenue - Suite 300
Cleveland, Ohio 44114

Project CUY-77-04.79 PID 106239				Job Ref. J20170056.000	
Section Structure Estimated Quantities				Sheet no./rev. 24	
Calc. by EIW	Date 03/22/24	Chk'd by P JW/SMK	Date 03/22/24	App'd by	Date

*Parapet and walk perimeter only

Perimeter of parapet (ft); $\text{perim}_{\text{bar}} = 6.500$
 Thickness of sidewalk at barrier; $t_{\text{walk_bar}} = 0.787$
 Length of parapet on approach slabs (ft); $L_{\text{parapet}} = 12.000$
 End area of parapet transition (sq ft); $A_{\text{par_end}} = w_{\text{bar}} \times h_{\text{bar}} = 3.111$

Total sealing area of parapets on approaches (sq ft); $A_{512_par} = 4 \times (A_{\text{par_end}} + (\text{perim}_{\text{bar}} + t_{\text{walk_bar}}) \times L_{\text{parapet}}) = 362.205$

TOTAL AREA OF SEALING (SY);; $T_{512} = \text{ceiling}((A_{512_abut} + A_{512_ww} + A_{512_pier} + A_{512_deck} + A_{512_par}) / 9, 1) = 1135.000$

PLAN SPLITS:

02/SAF/BR -; $T_{512} = 1135.000$

04/NFP/BR - DOMINION ENERGY OHIO None



Osborn Engineering
1100 Superior Avenue - Suite 300
Cleveland, Ohio 44114

Project CUY-77-04.79 PID 106239				Job Ref. J20170056.000	
Section Structure Estimated Quantities				Sheet no./rev. 25	
Calc. by EIW	Date 03/22/24	Chk'd by PJW/SMK	Date 03/22/24	App'd by	Date

ITEM 512 – SEALING CONCRETE SURFACES (NON-EPOXY)

Sealing perimeter with parapet (ft);
Length of parapet on approach slabs (ft);;

$$P_{walk_bar} = curb + W_{walk} = \mathbf{6.667}$$

$$L_{parapet} = \mathbf{12.000}$$

Sealing perimeter without parapet (ft);
Length of approach slabs (ft);

$$P_{walk_nobar} = curb + W_{walk} + W_{bar} + over + t_{walk_bar} = \mathbf{8.787}$$

$$L_{app} = \mathbf{25}$$

Total sealing area on bridge deck (SF);
Total sealing area on approach slabs (SF);

$$A_{non epoxy_deck} = P_{walk_bar} \times L_{deck} \times 2 = \mathbf{3775.600}$$

$$A_{non epoxy_AS} = 4 \times (P_{walk_bar} \times L_{parapet}) + (P_{walk_nobar} \times (L_{app} - L_{parapet})) =$$

434.227

TOTAL AREA OF SEALING (SY);

$$\mathbf{T_{512_NON} = ceiling((A_{non epoxy_deck} + A_{non epoxy_AS}) / 9, 1) = 468.000}$$

PLAN SPLITS:

02/SAF/BR –;
04/NFP/BR – DOMINION ENERGY OHIO

$$\mathbf{T_{512_NON} = 468.000}$$

0 SY



Osborn Engineering
1100 Superior Avenue - Suite 300
Cleveland, Ohio 44114

Project CUY-77-04.79 PID 106239				Job Ref. J20170056.000	
Section Structure Estimated Quantities				Sheet no./rev. 26	
Calc. by EIW	Date 03/22/24	Chk'd by P JW/SMK	Date 03/22/24	App'd by	Date

ITEM 512 – TYPE 2 WATERPROOFING

REV. 06/2024

*3'-0" wide at vertical and horizontal new-to-existing abutment stem joints, vertical construction joints in diaphragms, construction joints at wingwalls.

Width of waterproofing (ft);

$$W_{Type2} = 3$$

Total joint lengths at new-to-existing stems (RA) (ft);

$$L_{joint_RA} = 49.3 + 1.0 + 1.0 = 51.300$$

Total joint lengths at new-to-existing stems (FA) (ft);

$$L_{joint_FA} = 45.2 + 1.0 + 0.9 = 47.100$$

Total joint lengths at wingwalls (ft);

$$L_{joint_WW} = (13+13+12+9) = 47.000$$

Total Area of Type 2 Waterproofing (SY);

$$A_{Type2} = \text{ceiling}(W_{Type2} \times (L_{joint_RA} + L_{joint_FA} + L_{joint_WW}) / 9, 1) = 49.000$$

PLAN SPLITS:

02/SAF/BR –;

$$A_{Type2} = 49.000$$

04/NFP/BR – DOMINION ENERGY OHIO

$$0 \text{ SY}$$



Osborn Engineering
1100 Superior Avenue - Suite 300
Cleveland, Ohio 44114

Project		CUY-77-04.79 PID 106239		Job Ref.		J20170056.000			
Section				Structure Estimated Quantities					
				Sheet no./rev.				27	
Calc. by	Date	Chk'd by	Date	App'd by	Date				
EIW	03/22/24	PJW/SMK	03/22/24						

ITEM 513 – STRUCTURAL STEEL MEMBERS, LEVEL 3

REV. 1/5/2023

Main Steel Members

Length from CL brg to first field splice (ft); $L_{sp1} = 71.8125$
 Length from splice to splice (ft); $L_{sp2} = 86.0625$
 Length from splice to splice (ft); $L_{sp3} = 49.97$
 Length from splice to CL brg (ft); $L_{sp4} = 71.83$

Number of interior beams (each); $N_{int} = 5.000$
 Number of fascia beams (each); $N_{ext} = 2.000$
 Total Number of beams (each); $N_{beams} = N_{int} + N_{ext} = 7.000$

Unit Weight of W36x232 (lb/ft); $W_{36x232} = 232$
 Unit Weight of W36x182 (lb/ft); $W_{36x182} = 182$
 Unit weight of field splice 232 to 182 (lb/splice); $W_{splice_1} = 740$
 Unit weight of field splice 232 to 232 (lb/splice); $W_{splice_2} = 1010$

Total Weight of Main Steel Members (lb); $W_{stl_main} = N_{beams} \times (2 \times W_{splice_1} + W_{splice_2} + W_{36x232} \times (L_{sp2} + L_{sp3}) + W_{36x182} \times (L_{sp1} + L_{sp4} + 2.5)) = 424532.325$

Standard Crossframes

*Per GSD-1-19 Designer Supplement, estimated quantities are to assume the use of Type A Crossframes

*For 2'-8" overhang and 8'-2" beam spacing, angles will be L4x4x7/16 and the alternate connection plates will be used.

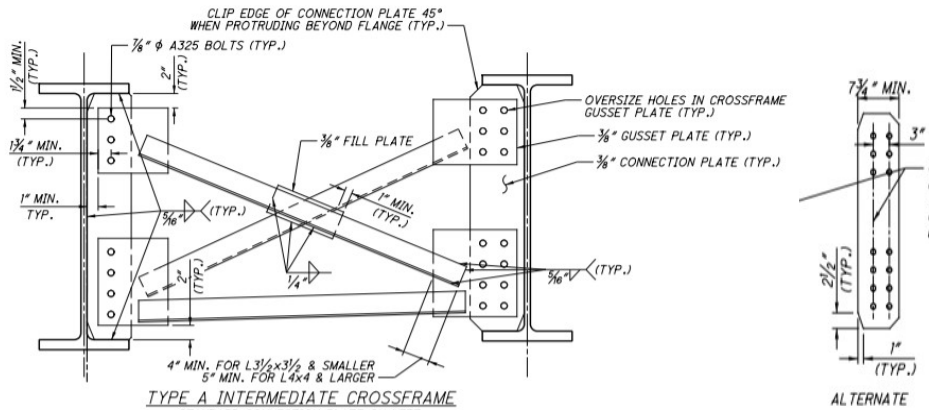

Gusset & Connection plate thickness (in); $t_{pl} = 0.375$
 Connection plate width (in); $W_{conn} = 7.75$
 Unit weight of L4x4x7/16 angles (lb/ft); $W_{4x4} = 11.3$
 Leg length of angles (in); $l_a = 4$
 Typical clear distance (in); $clr = 1$
 Typical bolt spacing (in); $spa_b = 3$
 Bolt horizontal edge distance (in); $edge_h = 1.75$
 Bolt vertical edge distance (in); $edge_v = 1.5$
 Unit weight of steel plates (lb/ft³); $W_{stl} = 490$
 Beam spacing (ft); $S_{bm} = 8.1667$

Project		CUY-77-04.79 PID 106239		Job Ref.		J20170056.000			
Section				Structure Estimated Quantities					
				Sheet no./rev.				28	
Calc. by	Date	Chk'd by	Date	App'd by	Date				
EIW	03/22/24	PJW/SMK	03/22/24						

W36x232 beam height (ft); $h_{36x232} = 37.1/12 = 3.092$
W36x232 flange width (ft); $b_{f_{36x232}} = 12.1/12 = 1.008$
W36x232 flange thickness (ft); $t_{f_{36x232}} = 1.57/12 = 0.131$
W36x232 web thickness (ft); $t_{w_{36x232}} = 0.87/12 = 0.073$

W36x182 beam height (ft); $h_{36x182} = 3.025$
W36x182 flange width (ft); $b_{f_{36x182}} = 12.1/12 = 1.008$
W36x182 flange thickness (ft); $t_{f_{36x182}} = 1.18/12 = 0.098$
W36x182 web thickness (ft); $t_{w_{36x182}} = 0.725/12 = 0.060$

****Gusset plate area extend horizontally 6" past connection plate to achieve 5" weld on bottom horizontal angle****

Bottom gusset plate area (sq ft); $A_{bg} = (6+W_{conn} - clr) \times ((3 \times spab) + 2 \times edge_v) / 144 = 1.063$

Top gusset plate area (sq ft); $A_{tg} = (6+W_{conn} - clr) \times ((2 \times spab) + 2 \times edge_v) / 144 = 0.797$

Connection plate area (sq ft); $A_{conn} = W_{conn} / 12 \times (h_{36x232} - 2 \times t_{f_{36x232}}) = 1.828$

Horizontal angle length (ft); $L_{a_h} = S_{bm} - t_{w_{36x232}} - 2 \times (W_{conn} + clr) / 12 = 6.636$

Diagonal angle vertical dimension (ft); $vert_{dia} = h_{36x232} - 2 \times t_{f_{36x232}} - (2 + clr + l_a + clr) / 12 - (2 + clr + l_a) / 12 = 1.580$

Diagonal angle length (ft); $L_{a_{dia}} = \sqrt{(L_{a_h})^2 + (vert_{dia})^2} = 6.821$

Weight per standard cross-frame (lb); $W_{cf} = 1.05 \times (W_{4x4} \times (L_{a_h} + 2 \times L_{a_{dia}}) + 2 \times W_{stl} \times t_{pl} \times (A_{bg} + A_{tg} + A_{conn})) / 12 = 359.169$

(*includes 5% for fill plate and bolts*)

Total number of standard crossframes; $N_{scf} = 19 \times 4 = 76.000$

Total standard crossframe weight (lb); $W_{stl_scf} = N_{scf} \times W_{cf} = 27296.807$

Special Utility Crossframe Type 1

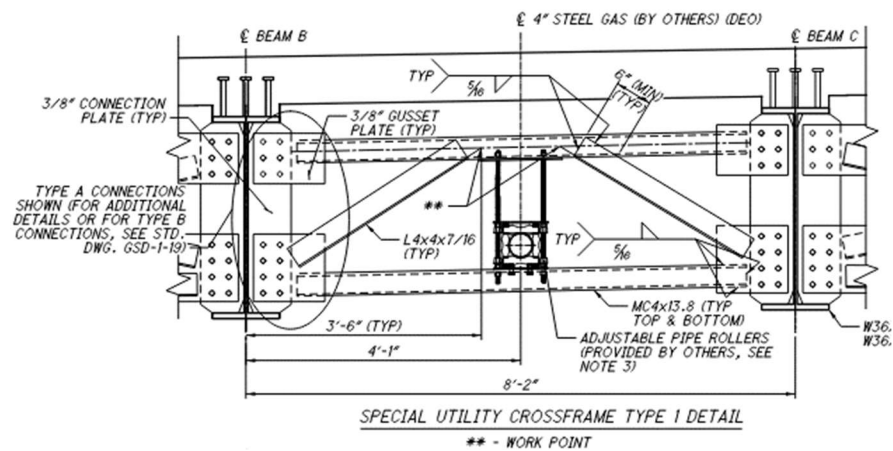

Unit weight MC4x13.8;

$W_{MC4} = 13.8$



Osborn Engineering
1100 Superior Avenue - Suite 300
Cleveland, Ohio 44114

Project		CUY-77-04.79 PID 106239		Job Ref. J20170056.000	
Section		Structure Estimated Quantities		Sheet no./rev. 29	
Calc. by EIW	Date 03/22/24	Chk'd by PJW/SMK	Date 03/22/24	App'd by	Date

Bottom gusset plate area (sq ft); $A_{bg1} = (6+W_{conn} - clr) \times ((3 \times spa_b) + 2 \times edge_v) / 144 = 1.063$

Top gusset plate area (sq ft); $A_{tg1} = (6+W_{conn} - clr) \times ((2 \times spa_b) + 2 \times edge_v) / 144 = 0.797$

Connection plate area (sq ft); $A_{conn1} = W_{conn} / 12 \times (h_{36x232} - 2 \times t_{f_{36x232}}) = 1.828$

Horizontal channel length (ft); $L_{c_h} = S_{bm} - t_{w_{36x232}} - 2 \times (W_{conn} + clr) / 12 = 6.636$

Diagonal angle length (ft) (CAD); $L_{a_dia1} = 3$

Weight per utility cross-frame Type 1 (lb); $W_{ucf1} = 1.05 \times (W_{4x4} \times (2 \times L_{a_dia1}) + 2 \times W_{MC4} \times L_{c_h} + 2 \times W_{stl} \times t_{pl} \times (A_{bg1} + A_{tg1} + A_{conn1}) / 12) = 382.060$

(*includes 5% for fill plate and bolts*)

Total number of Utility Type 1 crossframes; $N_{ucf1} = 19 \times (1) = 19.000$

Total Utility Type 1 crossframes weight (lb); $W_{stl_ucf1} = N_{ucf1} \times W_{ucf1} = 7259.144$

Special Utility Crossframe Type 2

*Similar to standard crossframe, except only a horizontal MC4x13.8 member

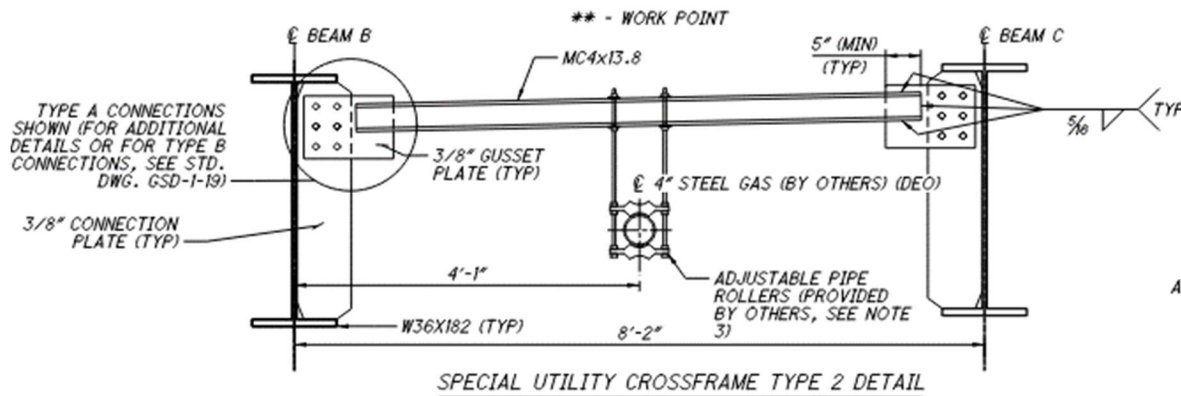

Weight per utility cross-frame Type 2 (lb); $W_{ucf2} = 1.05 \times (W_{MC4} \times L_{c_h} + 2 \times W_{stl} \times t_{pl} \times (A_{tg1} + A_{conn1}) / 12) = 180.550$

Total number of Utility Type 2 crossframes; $N_{ucf2} = 2$

Total Utility Type 2 crossframes weight (lb); $W_{stl_ucf2} = N_{ucf2} \times W_{ucf2} = 361.101$



Osborn Engineering
1100 Superior Avenue - Suite 300
Cleveland, Ohio 44114

Project		CUY-77-04.79 PID 106239		Job Ref.		J20170056.000	
Section				Structure Estimated Quantities			
Calc. by				Date		Chk'd by	
EIW				03/22/24		PJW/SMK	
Date				03/22/24		App'd by	
						Date	

Special Utility Crossframe Type 3

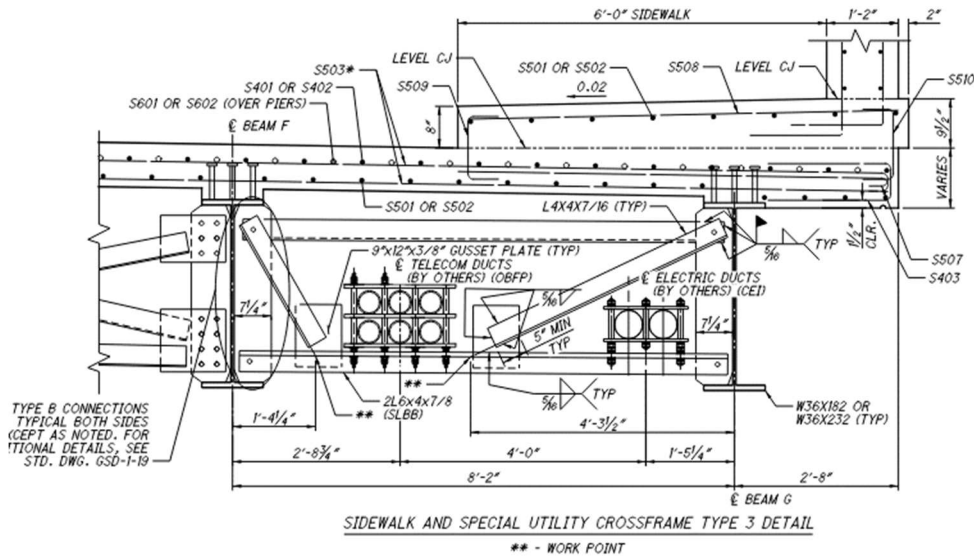

Gusset & Connection plate thickness (in); $t_{pl} = 0.375$

Connection plate width (in); $W_{conn3} = 7.25$

Bottom gusset plate area 1(sq ft); $A_{bg3} = (9 \times 12) / 144 = 0.750$

Connection plate area (sq ft); $A_{conn3} = W_{conn3} / 12 \times (h_{36 \times 232} - 2 \times t_{f_{36 \times 232}}) = 1.710$

Unit weight 2L6x4x7/8 (lb/ft); $W_{2L} = 54.4$

Horizontal member length (ft); $L_{a_{h3}} = S_{bm} - t_{w_{36 \times 232}} - 2 \times clr / 12 = 7.928$

Left diagonal length (CAD) (ft); $L_{diag3_{lt}} = 2.25$

Right diagonal length (CAD) (ft); $L_{diag3_{rt}} = 4.16$

Weight per Utility Type 3 cross-frame (lb); $W_{ucf3} = 1.05 \times (W_{4 \times 4} \times (L_{a_{h3}} + L_{diag3_{lt}} + L_{diag3_{rt}}) + W_{2L} \times L_{a_{h3}} + 2 \times W_{stl} \times t_{pl} \times (A_{bg3} + A_{conn3}) / 12) = 702.033$

(*includes 5% for fill plate and bolts*)

Total number of Special Type 3 crossframes; $N_{ucf3} = 19 \times (1) = 19.000$

Total Utility Type 3 crossframes weight (lb); $W_{stl_ucf3} = N_{ucf3} \times W_{ucf3} = 13338.631$

TOTAL WEIGHT OF STEEL (LB); $T_{513} = \text{ceiling}(W_{stl_main} + W_{stl_scf} + W_{stl_ucf1} + W_{stl_ucf2} + W_{stl_ucf3}, 1) = 472789.000$

PLAN SPLITS:

02/SAF/BR -;

04/NFP/BR - DOMINION ENERGY OHIO

*Includes Special Utility Support crossframes (Type 2)

; $T_{513} - W_{stl_ucf2} = 472427.899$

$W_{stl_ucf2} = 361.101$



Osborn Engineering
1100 Superior Avenue - Suite 300
Cleveland, Ohio 44114

Project		CUY-77-04.79 PID 106239		Job Ref.		J20170056.000			
Section				Structure Estimated Quantities		Sheet no./rev.		31	
Calc. by	Date	Chk'd by	Date	App'd by	Date				
EIW	03/22/24	PJW/SMK	03/22/24						

ITEM 513 – WELDED SHEAR STUD CONNECTORS

Studs per location; stud = 3

Studs per beam; N_{stud} = 378

Number of interior beams (each); N_{int} = 5.000

Number of fascia beams (each); N_{ext} = 2.000

TOTAL NUMBER OF SHEAR STUDS (EA); T_{stud} = stud × N_{stud} × (N_{int} + N_{ext}) = 7938.000

PLAN SPLITS:

02/SAF/BR –; T_{stud} = 7938.000

04/NFP/BR – DOMINION ENERGY OHIO 0 each



Osborn Engineering
1100 Superior Avenue - Suite 300
Cleveland, Ohio 44114

Project				Job Ref.	
CUY-77-04.79 PID 106239				J20170056.000	
Section				Sheet no./rev.	
Structure Estimated Quantities				32	
Calc. by	Date	Chk'd by	Date	App'd by	Date
EIW	03/22/24	PJW/SMK	03/22/24		

ITEM 514 – FIELD PAINTING STRUCTURAL STEEL, INTERMEDIATE COAT

REV. 12/2/2022

ITEM 514 – FIELD PAINTING STRUCTURAL STEEL, FINISH COAT

REV. 12/2/2022

Number of interior beams (each);; $N_{int} = 5.000$
 Number of fascia beams (each);; $N_{ext} = 2.000$
 W36x182 beam height (ft);; $h_{36x182} = 3.025$
 W36x182 flange width (ft);; $b_{f_{36x182}} = 1.008$
 W36x182 flange thickness (ft);; $t_{f_{36x182}} = 0.098$
 W36x182 web thickness (ft);; $t_{w_{36x182}} = 0.060$

W36x232 beam height (ft);; $h_{36x232} = 3.092$
 W36x232 flange width (ft);; $b_{f_{36x232}} = 1.008$
 W36x232 flange thickness (ft);; $t_{f_{36x232}} = 0.131$
 W36x232 web thickness (ft);; $t_{w_{36x232}} = 0.073$

Length from CL brg to first field splice (ft);; $L_{sp1} = 71.813$
 Length from splice to splice (ft);; $L_{sp2} = 86.063$
 Length from splice to splice (ft);; $L_{sp3} = 49.970$
 Length from splice to CL brg (ft);; $L_{sp4} = 71.830$

W36x182 Beam Section

Length of W36x182 between abutment diaphragms per beam line (ft);; $L_{36x182} = L_{sp1} + L_{sp4} - 2 \times 1.5 = 140.642$
 W36x182 perimeter (ft);; $P_{36x182} = 3 \times b_{f_{36x182}} + 2 \times h_{36x182} = 9.075$

W36x232 Beam Section

Length of W36x232 between splices per beam line (ft);; $L_{36x232} = L_{sp2} + L_{sp3} = 136.033$
 W36x232 perimeter (ft);; $P_{36x232} = 3 \times b_{f_{36x232}} + 2 \times h_{36x232} = 9.208$

Total Painting – main steel members (sq ft);; $T_{514_main} = N_{beams} \times (P_{36x232} \times L_{36x232} + P_{36x182} \times L_{36x182}) = 17702.743$

Standard Crossframes

From Steel weight calc

Bottom gusset plate area (sq ft);; $A_{bg} = 1.063$
 Top gusset plate area (sq ft);; $A_{tg} = 0.797$
 Connection plate area (sq ft);; $A_{conn} = 1.828$
 Gusset & Connection plate thickness (in);; $t_{pl} = 0.375$
 Leg length of angles (in);; $l_a = 4.000$
 Horizontal angle length (ft);; $L_{a_h} = 6.636$
 Diagonal angle length (ft);; $L_{a_dia} = 6.821$
 Total number of standard crossframes;; $N_{scf} = 76.000$

Perimeter of L4x4x7/16 angles (ft);; $P_{4x4} = (4+4+0.4375+3.5625+3.5625+0.4375) / 12 = 1.333$



Osborn Engineering
1100 Superior Avenue - Suite 300
Cleveland, Ohio 44114

Project		CUY-77-04.79 PID 106239		Job Ref.		J20170056.000			
Section				Structure Estimated Quantities					
				Sheet no./rev.				33	
Calc. by	Date	Chk'd by	Date	App'd by	Date				
EIW	03/22/24	PJW/SMK	03/22/24						

****Assumes 1/2 of the front face of each connection plate and half the back face of gusset plates are overlapping, overlap of angle and gusset plate not considered, plate edge thickness not considered****

Painted area of crossframe gusset and connection plates (sq ft); $A_{514_pl} = 2 \times 1.5 \times A_{conn} + 1.5 \times 2 \times A_{bg} + 1.5 \times 2 \times A_{tg} =$

11.061

Painted area of crossframe angle members (sq ft); $A_{514_a} = P_{4x4} \times (L_{a_h} + 2 \times L_{a_dia}) - 6 \times l_a \times 5 / 144 = \mathbf{26.205}$

Total Painting – standard crossframe members (sq ft); $T_{514_scf} = N_{scf} \times (A_{514_pl} + A_{514_a}) = \mathbf{2832.221}$

Type 1 Utility Crossframes

From Steel weight calc

Total number of Type 1 utility crossframes; $N_{ucf1} = \mathbf{19.000}$

Bottom gusset plate area (sq ft); $A_{bg1} = \mathbf{1.063}$

Top gusset plate area (sq ft); $A_{tg1} = \mathbf{0.797}$

Connection plate area (sq ft); $A_{conn} = \mathbf{1.828}$

Horizontal channel length (ft); $L_{c_h} = \mathbf{6.636}$

Diagonal angle length (ft) (CAD); $L_{a_dia1} = \mathbf{3.000}$

Perimeter of L4x4x7/16 angles (ft); $P_{4x4} = (4+4+0.4375+3.5625+3.5625+0.4375) / 12 = \mathbf{1.333}$

Perimeter of MC4x13.2 (ft); $P_{MC4} = (2.5+4+2.5+.5+2+3+2+0.5)/12 = \mathbf{1.417}$

****Assumes 1/2 of the front face of each connection plate and half the back face of gusset plates are overlapping, overlap of angle and gusset plate not considered, plate edge thickness not considered****

Painted area of crossframe gusset and connection plates (sq ft); $A_{514_pl1} = 2 \times 1.5 \times A_{conn} + 1.5 \times 2 \times A_{bg1} + 1.5 \times 2 \times A_{tg1} =$

11.061

Painted area of crossframe angle & channel members (sq ft); $A_{514_a1} = P_{4x4} \times (2 \times L_{a_dia1}) + 2 \times P_{MC4} \times L_{c_h} - 2 \times l_a \times 5 / 144 - 4 \times 4 \times 5 / 144 = \mathbf{25.968}$

Total Painting – Type 1 utility crossframe members (sq ft); $T_{514_ucf1} = N_{ucf1} \times (A_{514_pl1} + A_{514_a1}) = \mathbf{703.561}$

Type 2 Utility Crossframes

From Steel weight calc

Total number of Type 2 utility crossframes;; $N_{ucf2} = \mathbf{2.000}$

Painted area of crossframe gusset and connection plates (sq ft); $A_{514_pl2} = 4 \times A_{conn} + 0.5 \times 2 \times A_{tg} = \mathbf{8.108}$

Painted area of crossframe angle members (sq ft); $A_{514_a2} = P_{MC4} \times L_{c_h} - 2 \times 4 \times 5 / 144 = \mathbf{9.123}$

Total Painting – Type 2 utility crossframe members (sq ft); $T_{514_ucf2} = N_{ucf2} \times (A_{514_pl2} + A_{514_a2}) = \mathbf{34.461}$

Type 3 Utility Crossframes

From Steel weight calc

Bottom gusset plate area (sq ft); $A_{bg3} = \mathbf{0.750}$

Connection plate area (sq ft); $A_{conn3} = \mathbf{1.710}$



Osborn Engineering
1100 Superior Avenue - Suite 300
Cleveland, Ohio 44114

Project CUY-77-04.79 PID 106239				Job Ref. J20170056.000	
Section Structure Estimated Quantities				Sheet no./rev. 34	
Calc. by EIW	Date 03/22/24	Chk'd by P JW/SMK	Date 03/22/24	App'd by	Date

Horizontal member length (ft); $L_{a_h3} = S_{bm} - t_{w_36 \times 232} - 2 \times clr / 12 = 7.928$

Left diagonal length (CAD) (ft); $L_{diag3_lt} = 2.25$

Right diagonal length (CAD) (ft); $L_{diag3_rt} = 4.16$

Total number of Type 3 crossframes;; $N_{ucf3} = 19.000$

Perimeter of L4x4x7/16 angles (ft);; $P_{4 \times 4} = 1.333$

Exposed Perimeter of 2L6x4x7/8 (ft); $P_{2L} = 2.667$

****Overlap of angle and gusset plate not considered, plate edge thickness not considered****

Painted area of crossframe gusset and connection plates (sq ft); $A_{514_pl3} = 4 \times A_{conn3} + 4 \times A_{bg3} = 9.839$

Painted area of crossframe angle members (sq ft); $A_{514_a3} = P_{4 \times 4} \times (L_{a_h3} + L_{diag3_lt} + L_{diag3_rt}) + P_{2L} \times L_{a_h3} - 8 \times l_a \times 5 / 144 = 39.148$

Total Painting – Type 3 crossframe members (sq ft); $T_{514_ucf3} = N_{ucf3} \times (A_{514_pl3} + A_{514_a3}) = 930.762$

TOTAL AREA OF PAINTING (SQ FT); $T_{514} = \text{ceiling}(T_{514_main} + T_{514_scf} + T_{514_ucf1} + T_{514_ucf2} + T_{514_ucf3}, 1) = 22204.000$

PLAN SPLITS:

02/SAF/BR –; $T_{514} = 22204.000$

04/NFP/BR – DOMINION ENERGY OHIO 0 SF



Osborn Engineering
1100 Superior Avenue - Suite 300
Cleveland, Ohio 44114

Project CUY-77-04.79 PID 106239				Job Ref. J20170056.000	
Section Structure Estimated Quantities				Sheet no./rev. 35	
Calc. by EIW	Date 03/22/24	Chk'd by PJW/SMK	Date 03/22/24	App'd by	Date

ITEM 514 – FINAL INSPECTION REPAIR

*Per CMS, one location per 150 linear foot of girder

Length of beams (ft); $L_{beam} = L_{sp1} + L_{sp2} + L_{sp3} + L_{sp4} = 279.675$

Number of interior beams (each); $N_{int} = 5.000$

Number of fascia beams (each); $N_{ext} = 2.000$

Number of locations per beam line (each); $N_{inspec} = ceiling(L_{beam} / 150, 1) = 2.000$

TOTAL NUMBER OF INSPECTION LOCATIONS (EA); $T_{insp} = (N_{int} + N_{ext}) \times N_{inspec} = 14.000$

PLAN SPLITS:

02/SAF/BR –; $T_{insp} = 14.000$

04/NFP/BR – DOMINION ENERGY OHIO 0 SF



Osborn Engineering
1100 Superior Avenue - Suite 300
Cleveland, Ohio 44114

Project		CUY-77-04.79 PID 106239		Job Ref.		J20170056.000			
Section				Structure Estimated Quantities		Sheet no./rev.		36	
Calc. by	Date	Chk'd by	Date	App'd by	Date				
EIW	03/22/24	PJW/SMK	03/22/24						

ITEM 516 – ARMORLESS PREFORMED JOINT SEAL

**Measured as length of sleeper slab along the bridge skew.*

Width of approach slabs at ends (ft); $W_{app} = (40 + 2 \times (7.1667 + 2/12)) = 54.667$

Bridge skew; $\Theta = 0$

Seal length along skew (ft); $PJS = W_{app} / \cos(\Theta) = 54.667$

TOTAL SEAL LENGTH (FT); $L_{SEAL} = \text{ceiling}(2 \times PJS, 1) = 110.000$

PLAN SPLITS:

02/SAF/BR –; $L_{SEAL} = 110.000$

04/NFP/BR – DOMINION ENERGY OHIO 0 FT



Osborn Engineering
1100 Superior Avenue - Suite 300
Cleveland, Ohio 44114

Project		CUY-77-04.79 PID 106239		Job Ref.		J20170056.000			
Section				Structure Estimated Quantities		Sheet no./rev.		37	
Calc. by	Date	Chk'd by	Date	App'd by	Date				
EIW	03/22/24	PJW/SMK	03/22/24						

ITEM 516 – 1” PREFORMED EXPANSION JOINT FILLER

**Located between approach and bridge-mounted parapet*

Typical parapet section area (sq ft); $A_{par} = 3.111$
Bridge skew; $\Theta = 0.000$
Parapet area along skew (ft); $A_{par_skew} = A_{par} / \cos(\Theta) = 3.111$

TOTAL PEJF AREA (SQ FT); $L_{PEJF_1} = \text{ceiling}(A_{par_skew} \times 4, 1) = 13.000$

PLAN SPLITS:

02/SAF/BR –; $L_{PEJF_1} = 13.000$
04/NFP/BR – DOMINION ENERGY OHIO 0 FT



Osborn Engineering
1100 Superior Avenue - Suite 300
Cleveland, Ohio 44114

Project CUY-77-04.79 PID 106239				Job Ref. J20170056.000	
Section Structure Estimated Quantities				Sheet no./rev. 38	
Calc. by EIW	Date 03/22/24	Chk'd by PJW/SMK	Date 03/22/24	App'd by	Date

ITEM 516 – 2” PREFORMED EXPANSION JOINT FILLER

**Located between wingwall and abutment diaphragm*

Width of wingwall (ft); $W_{wingwall} = 3.250$
 Bridge skew; $\Theta = 0.000$
 Wingwall width along skew (ft); $W_{WW_skew} = W_{wingwall} / \cos(\Theta) = 3.250$

NW WW El. PEJF (Ft); $EL_{pejf_NW} = 1086.27$
 NE WW El. at PEJF (Ft); $EL_{pejf_NE} = 1075.79$
 SW WW El. at PEJF (Ft); $EL_{pejf_SW} = 1086.08$
 SE WW El. at PEJF (Ft); $EL_{pejf_SE} = 1075.59$

Beam seat at NW WW elevation (ft); $EL_{BS_NW} = 1080.42$
 Beam seat at NE WW elevation (ft); $EL_{BS_NE} = 1069.94$
 Beam seat at SW WW elevation (ft); $EL_{BS_SW} = 1080.23$
 Beam seat at SE WW elevation (ft); $EL_{BS_SE} = 1069.74$

NW WW height at PEJF (Ft); $h_{pejf_NW} = EL_{pejf_NW} - EL_{BS_NW} = 5.850$
 NE WW height at PEJF (Ft); $h_{pejf_NE} = EL_{pejf_NE} - EL_{BS_NE} = 5.850$
 SW WW height at PEJF (Ft); $h_{pejf_SW} = EL_{pejf_SW} - EL_{BS_SW} = 5.850$
 SE WW height at PEJF (Ft); $h_{pejf_SE} = EL_{pejf_SE} - EL_{BS_SE} = 5.850$

TOTAL PEJF AREA (SQ FT); $L_{PEJF_2} = \text{ceiling}(W_{WW_skew} \times (h_{pejf_NW} + h_{pejf_NE} + h_{pejf_SW} + h_{pejf_SE}), 1) =$
77.000

PLAN SPLITS:

02/SAF/BR –; $L_{PEJF_2} = 77.000$
 04/NFP/BR – DOMINION ENERGY OHIO 0 FT



Osborn Engineering
1100 Superior Avenue - Suite 300
Cleveland, Ohio 44114

Project		CUY-77-04.79 PID 106239		Job Ref.		J20170056.000			
Section				Structure Estimated Quantities		Sheet no./rev.		39	
Calc. by	Date	Chk'd by	Date	App'd by	Date				
EIW	03/22/24	PJW/SMK	03/22/24						

ITEM 516 – SEMI-INTEGRAL EXPANSION JOINT SEAL

Abutment length (ft);

$$L_{abut} = 54.670$$

Length of seal (ft);

$$L_{exp_jt_seal} = L_{abut} + 4/12 + 3 = 58.003$$

Total Length of Semi-integral expansion joint seal (FT);

$$L_{jt_seal} = \text{ceiling}(2 \times L_{exp_jt_seal}, 1) = 117.000$$

PLAN SPLITS:

02/SAF/BR –;

$$L_{jt_seal} = 117.000$$

04/NFP/BR – DOMINION ENERGY OHIO

$$0 \text{ FT}$$



Osborn Engineering
1100 Superior Avenue - Suite 300
Cleveland, Ohio 44114

Project				Job Ref.	
CUY-77-04.79 PID 106239				J20170056.000	
Section				Sheet no./rev.	
Structure Estimated Quantities				40	
Calc. by	Date	Chk'd by	Date	App'd by	Date
EIW	03/22/24	PJW/SMK	03/22/24		

ITEM 516 – ELASTOMERIC BEARING WITH INTERNAL LAMINATES AND LOAD PLATE (NEOPRENE)

Total Number of beams (each); $N_{beams} = 7.000$

TOTAL NUMBER OF ABUTMENT BEARINGS(EA); $T_{BRG_abut} = N_{beams} \times 2 = 14.000$

TOTAL NUMBER OF PIER BEARINGS(EA); $T_{BRG_pier} = N_{beams} \times 3 = 21.000$

PLAN SPLITS:

02/SAF/BR –

ABUTMENT;

$T_{BRG_abut} = 14.000$

PIER;

$T_{BRG_pier} = 21.000$

04/NFP/BR – DOMINION ENERGY OHIO

0 SF



Osborn Engineering
1100 Superior Avenue - Suite 300
Cleveland, Ohio 44114

Project CUY-77-04.79 PID 106239				Job Ref. J20170056.000	
Section Structure Estimated Quantities				Sheet no./rev. 41	
Calc. by EIW	Date 03/22/24	Chk'd by PJW/SMK	Date 03/22/24	App'd by	Date

ITEM 518 – POROUS BACKFILL WITH GEOTEXTILE FABRIC

- * Item includes 2'-0" thick porous backfill behind backwalls and wingwalls
- * New porous backfill behind existing abutment to remain extends 1' below construction joint
- * New porous backfill behind new abutment sections extends to top of footing.

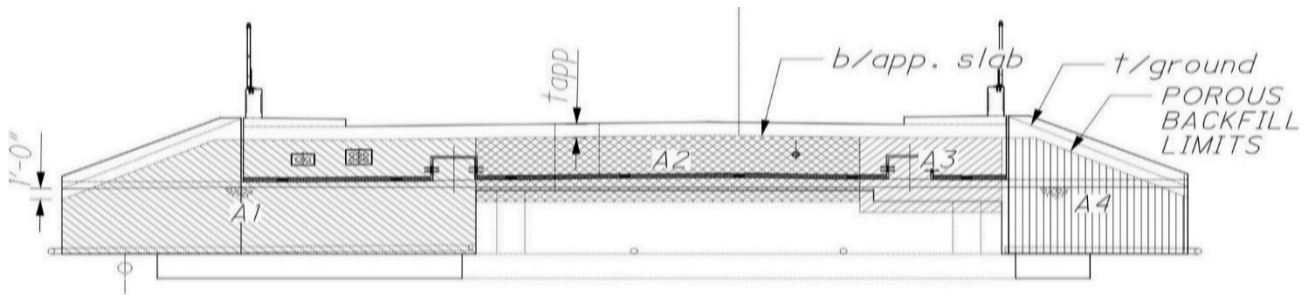

Proposed approach slab thickness (ft); $t_{app} = 1.250$
 Porous backfill thickness (ft); $t_{518} = 2$

Rear Abutment

Area 1 (CAD) (sf); $A1_{RA} = 280.6$
 Area 2 (CAD) (sf); $A2_{RA} = 162.9$
 Area 3 (CAD) (sf); $A3_{RA} = 69.5$
 Area 4 (CAD) (sf); $A4_{RA} = 111.9$

Fwd Abutment

Area 1 (CAD) (sf); $A1_{FA} = 208.4$
 Area 2 (CAD) (sf); $A2_{FA} = 161.6$
 Area 3 (CAD) (sf); $A3_{FA} = 69.0$
 Area 4 (CAD) (sf); $A4_{FA} = 77.3$

New porous backfill vol behind RA (cu ft); $V_{518_RA} = t_{518} \times (A1_{RA} + A2_{RA} + A3_{RA} + A4_{RA}) = 1249.800$

New porous backfill vol behind ex FA (cu ft); $V_{518_FA} = t_{518} \times (A1_{FA} + A2_{FA} + A3_{FA} + A4_{FA}) = 1032.600$

TOTAL VOL POROUS BACKFILL (CY); $T_{518} = \text{ceiling}((V_{518_RA} + V_{518_FA}) / 27, 1) = 85.000$

PLAN SPLITS:

02/SAF/BR –; $T_{518} = 85.000$

04/NFP/BR – DOMINION ENERGY OHIO 0 CY



Osborn Engineering
1100 Superior Avenue - Suite 300
Cleveland, Ohio 44114

Project		CUY-77-04.79 PID 106239		Job Ref.		J20170056.000			
Section				Structure Estimated Quantities		Sheet no./rev.		42	
Calc. by	Date	Chk'd by	Date	App'd by	Date				
EIW	03/22/24	PJW/SMK	03/22/24						

ITEM 518 – 6” PERFORATED CORRUGATED PLASTIC PIPE

*To run behind abutments and wingwalls

New full height stem length (ft); $L_{stem} = 16.833$
SE wingwall length (ft); $L_{se} = 5.833$
SW wingwall length (ft); $L_{sw} = 12.833$
NE wingwall length (ft); $L_{ne} = 11.833$
NW wingwall length (ft); $L_{nw} = 12.833$

TOTAL LENGTH PCPP (FT); $T_{PCPP} = ceiling(2 \times L_{stem} + L_{se} + L_{sw} + L_{ne} + L_{nw}, 1) = 77.000$

PLAN SPLITS:

02/SAF/BR –; $T_{PCPP} = 77.000$
04/NFP/BR – DOMINION ENERGY OHIO $0 FT$



Osborn Engineering
1100 Superior Avenue - Suite 300
Cleveland, Ohio 44114

Project		CUY-77-04.79 PID 106239		Job Ref.		J20170056.000			
Section				Structure Estimated Quantities		Sheet no./rev.		43	
Calc. by	Date	Chk'd by	Date	App'd by	Date				
EIW	03/22/24	PJW/SMK	03/22/24						

ITEM 518 – 6” NON-PERFORATED CORRUGATED PLASTIC PIPE, INCLUDING SPECIALS

*From ends of wingwalls to outlet in slope.

NW Wingwall (ft); $NP_{nw} = 14.34$
NE Wingwall (ft); $NP_{ne} = 15.49$
SW Wingwall (ft); $NP_{sw} = 14.91$
SE Wingwall (ft); $NP_{se} = 23.42$

TOTAL LENGTH NPCPP (FT); $T_{NPCPP} = \text{ceiling}(NP_{nw} + NP_{ne} + NP_{sw} + NP_{se}, 5) = 70.000$

PLAN SPLITS:

02/SAF/BR –; $T_{NPCPP} = 70.000$
04/NFP/BR – DOMINION ENERGY OHIO 0 FT



Osborn Engineering
1100 Superior Avenue - Suite 300
Cleveland, Ohio 44114

Project		CUY-77-04.79 PID 106239		Job Ref.		J20170056.000			
Section				Structure Estimated Quantities		Sheet no./rev.		44	
Calc. by	Date	Chk'd by	Date	App'd by	Date				
EIW	03/22/24	PJW/SMK	03/22/24						

ITEM 519 – PATCHING CONCRETE STRUCTURE, AS PER PLAN

*From repair plan

TOTAL PATCHING AREA (SF); $T_{patch} = 10$

PLAN SPLITS:

02/SAF/BR –; $T_{patch} = 10.000$

04/NFP/BR – DOMINION ENERGY OHIO 0 SF



Osborn Engineering
1100 Superior Avenue - Suite 300
Cleveland, Ohio 44114

Project		CUY-77-04.79 PID 106239		Job Ref.		J20170056.000			
Section				Structure Estimated Quantities		Sheet no./rev.		45	
Calc. by	Date	Chk'd by	Date	App'd by	Date				
EIW	03/22/24	PJW/SMK	03/22/24						

ITEM 526 – REINFORCED CONCRETE APPROACH SLABS WITH QC/QA (T=15”), AS PER PLAN

*Approach slabs with integral sidewalk

Length of approach slabs (ft); $L_{app} = 25$
Proposed approach slab width (ft); $w_{app} = 54.667$

TOTAL APPROACH SLAB AREA (SQ YD); $A_{app} = \text{ceiling}(2 \times (L_{app} \times w_{app}) / 9, 1) = 304.000$

PLAN SPLITS:

02/SAF/BR –; $A_{app} = 304.000$
04/NFP/BR – DOMINION ENERGY OHIO 0 FT



Tedds

Osborn Engineering

1100 Superior Avenue - Suite 300

Cleveland, Ohio 44114

Project				Job Ref.	
CUY-77-04.79 PID 106239				J20170056.000	
Section				Sheet no./rev.	
Structure Estimated Quantities				46	
Calc. by	Date	Chk'd by	Date	App'd by	Date
EIW	03/22/24	PJW/SMK	03/22/24		

ITEM 526 – TYPE C INSTALLATION, AS PER PLAN

*See calculation for Item 516 – Armorless Preformed Joint Seal

TOTAL INSTALLATION LENGTH (FT);

$L_{install} = L_{SEAL} = 110.000$

PLAN SPLITS:

02/SAF/BR –;

$L_{install} = 110.000$

04/NFP/BR – DOMINION ENERGY OHIO

0 FT



Osborn Engineering
1100 Superior Avenue - Suite 300
Cleveland, Ohio 44114

Project		CUY-77-04.79 PID 106239		Job Ref.		J20170056.000					
Section				Structure Estimated Quantities				Sheet no./rev.		47	
Calc. by		Date		Chk'd by		Date		App'd by		Date	
EIW		03/22/24		PJW/SMK		03/22/24					

ITEM 601 – CRUSHED AGGREGATE SLOPE PROTECTION

*Areas from Bridge Site Plan taken on a 2:1 slope at RA and 3:1 slope at FA

Rear Abutment Plan Area (SF); $A_{601_RA_plan} = (48.5 \times 3 + 43.33 \times 19.5) = 990.435$

Rear Abutment Adjusted Area (SF); $A_{601_RA} = \sqrt{(A_{601_RA_plan}^2 + (A_{601_RA_plan} / 2)^2)} = 1107.340$

Fwd Abutment Plan Area (SF); $A_{601_FA_plan} = (44.67 \times 3 + 46.67 \times 19.5) = 1044.075$

Fwd Abutment Adjusted Area (SF); $A_{601_FA} = \sqrt{(A_{601_FA_plan}^2 + (A_{601_FA_plan} / 3)^2)} = 1100.552$

Total Area of Crushed Aggregate Slope Protection (SY); $A_{601_TOTAL} = ceiling((A_{601_RA} + A_{601_FA}) / 9, 1) = 246.000$



Osborn Engineering
1100 Superior Avenue - Suite 300
Cleveland, Ohio 44114

Project CUY-77-04.79 PID 106239				Job Ref. J20170056.000	
Section Structure Estimated Quantities				Sheet no./rev. 48	
Calc. by EIW	Date 03/22/24	Chk'd by PJW/SMK	Date 03/22/24	App'd by	Date

ITEM 607 – VANDAL PROTECTION FENCE, 6' STRAIGHT, COATED FABRIC, AS PER PLAN

*Measured from end fence post to end fence post. See deck plan.

Proposed fence limit (ft); $L_{fence} = 10 + 2.67 + 2.33 + 135 + 2.54 + 2.46 + 135 + 2.33 + 2.67 + 10 =$
305.000

TOTAL LENGTH OF FENCE (FT); $T_{VPF} = \text{ceiling}(2 \times L_{fence}, 1) = 610.000$

PLAN SPLITS:

02/SAF/BR –; $T_{VPF} = 610.000$
04/NFP/BR – DOMINION ENERGY OHIO 0 FT