

COUNTY:	PORTAGE	
LOCATION:	U.S ROUTE 224 @ S.R. 532	
S.L.M.:	0.00	
24" STOP LINE:	30	L.F.
12" CROSSWALK LINE:		L.F.
DOTTED LINE:		L.F.
8" CHANNELIZING LINE:	120	L.F.
12" CHANNELIZING LINE:		L.F.
24" TRANSVERSE LINE (WT):		L.F.
24" TRANSVERSE LINE (YW):		L.F.
SYMBOL: 3 - LEFT TURN ARROWS		

COUNTY:	PORTAGE	
LOCATION:	U.S. ROUTE 224 @ MARTIN RD.	
S.L.M.:	0.553	
24" STOP LINE:		L.F.
12" CROSSWALK LINE:		L.F.
DOTTED LINE:		L.F.
8" CHANNELIZING LINE:	585	L.F.
12" CHANNELIZING LINE:		L.F.
24" TRANSVERSE LINE (WT):		L.F.
24" TRANSVERSE LINE (YW):		L.F.
SYMBOL: 8 - LEFT TURN ARROWS		



MARTIN RD.

U.S. ROUTE 224

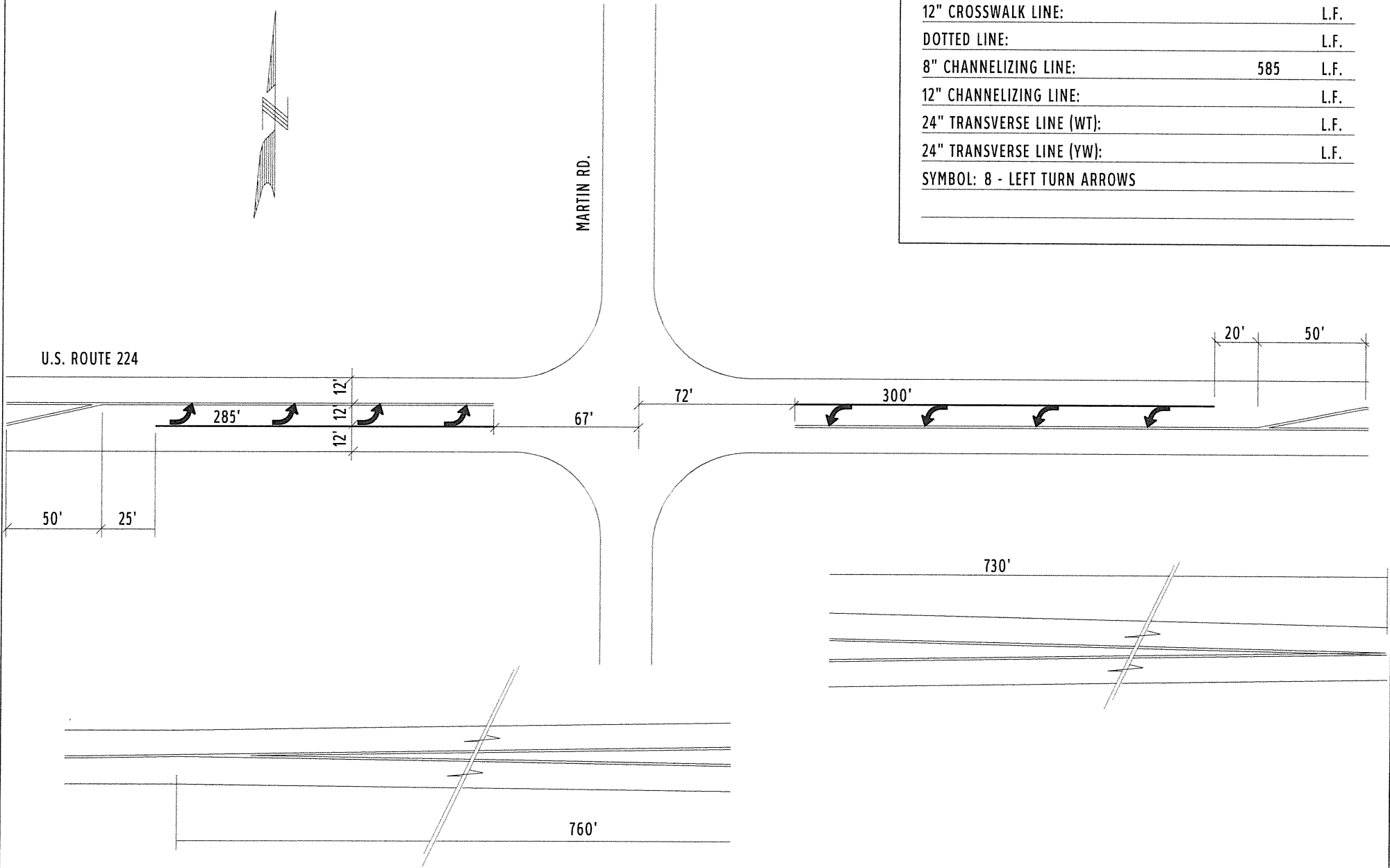



U.S. ROUTE 224

STATE ROUTE 43

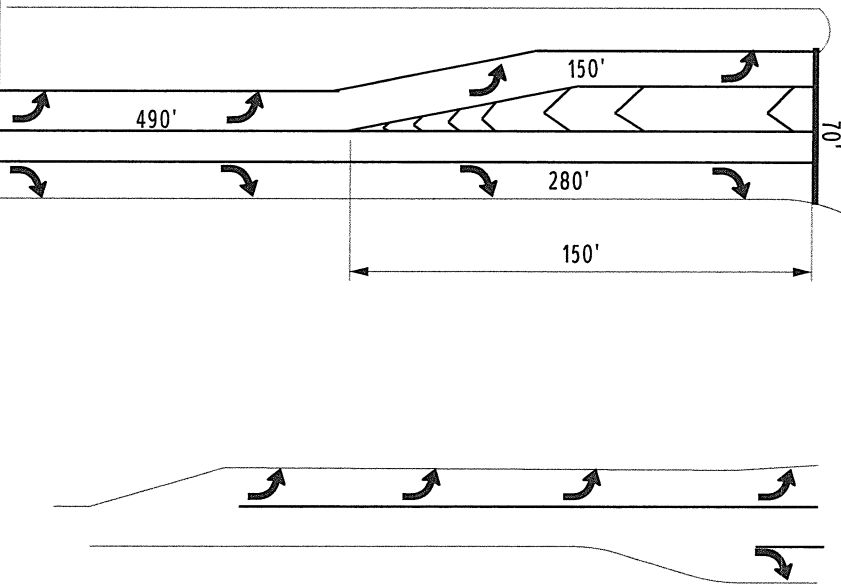

COUNTY:	PORTAGE	
LOCATION:	U.S. ROUTE 224 @ S.R. 43	
S.L.M.:	2.420	
24" STOP LINE:	140	L.F.
12" CROSSWALK LINE:		L.F.
DOTTED LINE:		L.F.
8" CHANNELIZING LINE:	1960	L.F.
12" CHANNELIZING LINE:		L.F.
24" TRANSVERSE LINE (WT):	200	L.F.
24" TRANSVERSE LINE (YW):		L.F.
SYMBOL: 17 - LEFT TURN ARROWS		
11 - RIGHT TURN ARROWS		

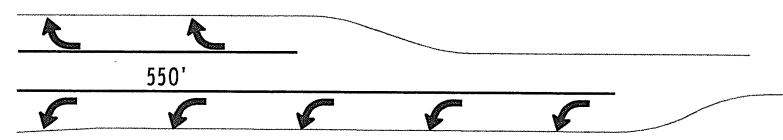
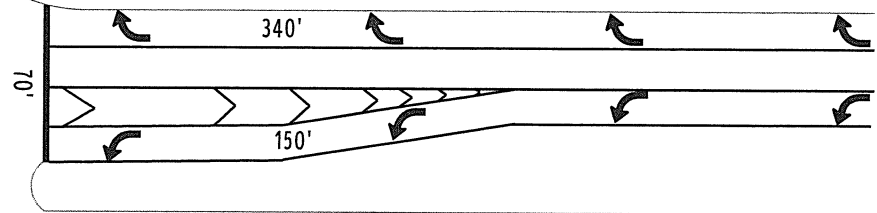

COUNTY:	PORTAGE
LOCATION:	U.S. ROUTE 224 @ CONGRESS LAKE RD.
S.L.M.:	3.364
24" STOP LINE:	L.F.
12" CROSSWALK LINE:	L.F.
DOTTED LINE:	L.F.
8" CHANNELIZING LINE:	550 L.F.
12" CHANNELIZING LINE:	L.F.
24" TRANSVERSE LINE (WT):	L.F.
24" TRANSVERSE LINE (YW):	L.F.
SYMBOL: 6 - LEFT TURN ARROWS	

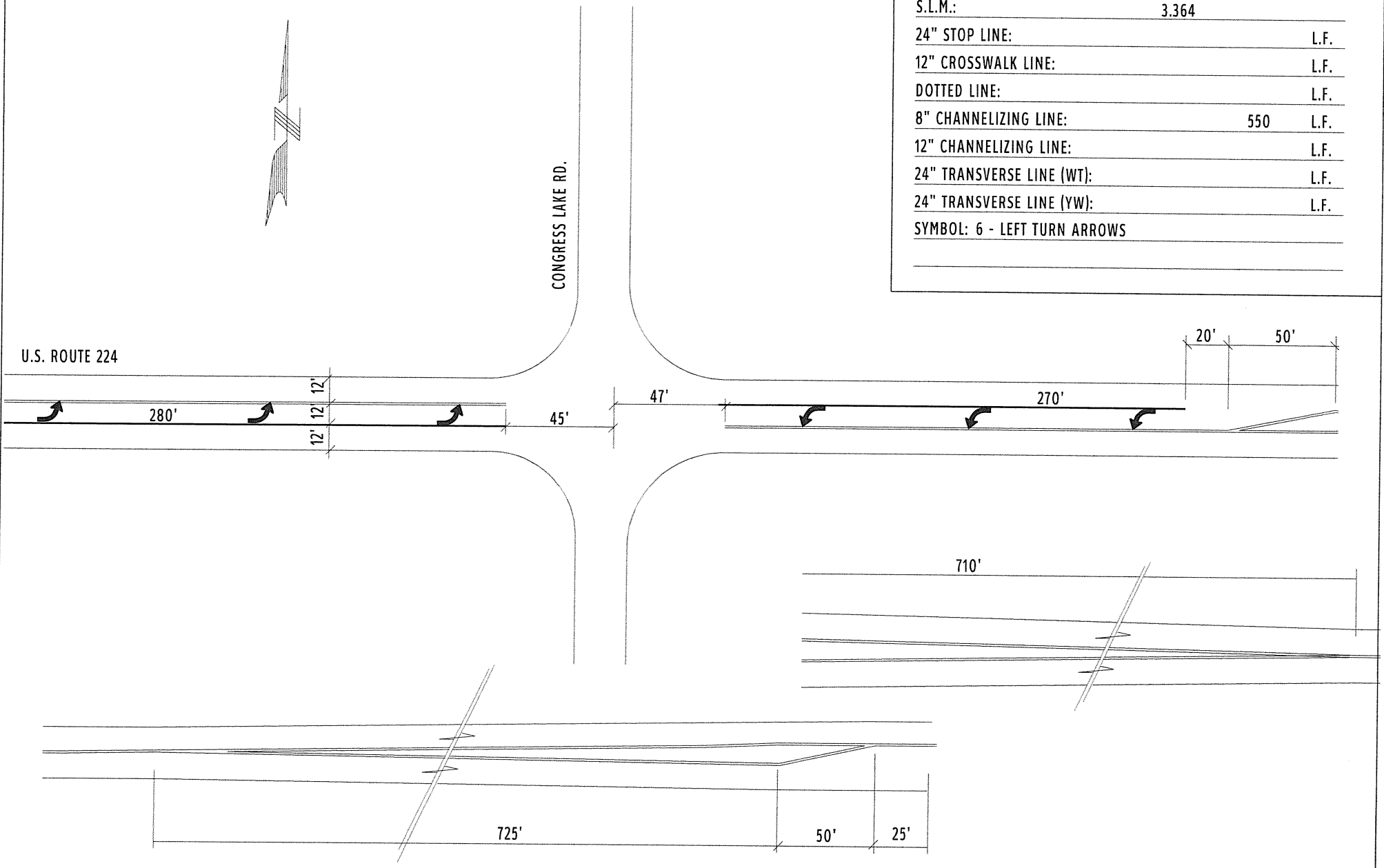

COUNTY:	PORTAGE	
LOCATION:	U.S. ROUTE 224 @ WATERLOO RD.	
S.L.M.:	6.242	
24" STOP LINE:		L.F.
12" CROSSWALK LINE:		L.F.
DOTTED LINE:		L.F.
8" CHANNELIZING LINE:	645	L.F.
12" CHANNELIZING LINE:		L.F.
24" TRANSVERSE LINE (WT):		L.F.
24" TRANSVERSE LINE (YW):		L.F.
SYMBOL: 6 - LEFT TURN ARROWS		

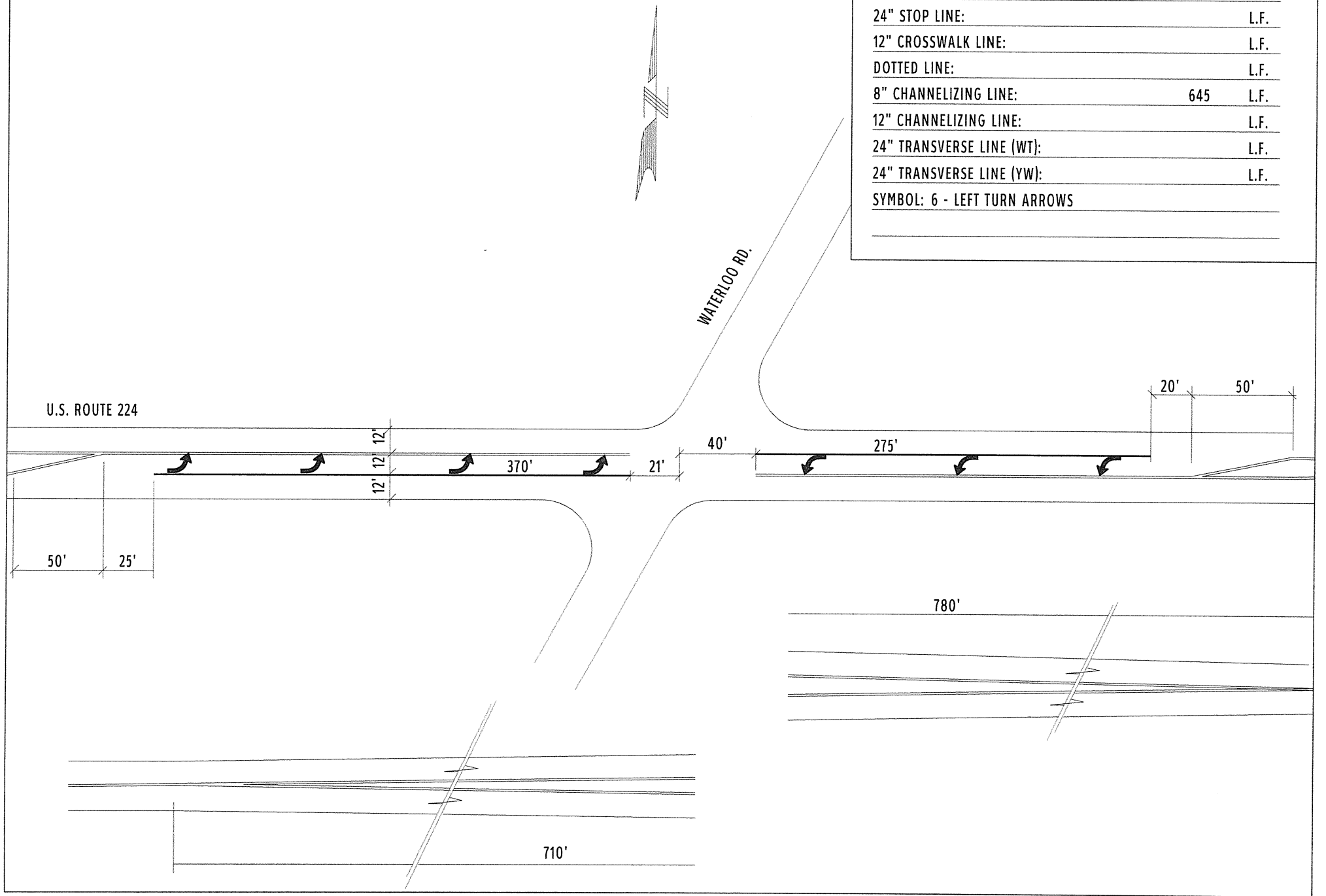

U.S. ROUTE 224

WATERLOO RD.

12'  
12'

370'

21'

40'

275'

20'

50'

50'

25'

780'

710'



COUNTY:	PORTAGE	
LOCATION:	U.S. ROUTE 224 @ S.R. 44	
S.L.M.:	7.692	
24" STOP LINE:	104	L.F.
12" CROSSWALK LINE:		L.F.
DOTTED LINE:		L.F.
8" CHANNELIZING LINE:	1890	L.F.
12" CHANNELIZING LINE:		L.F.
24" TRANSVERSE LINE (WT):	210	L.F.
24" TRANSVERSE LINE (YW):		L.F.
SYMBOL: 12 - LEFT TURN ARROWS		
8 - RIGHT TURN ARROWS		

STATE ROUTE 44

U.S. ROUTE 224

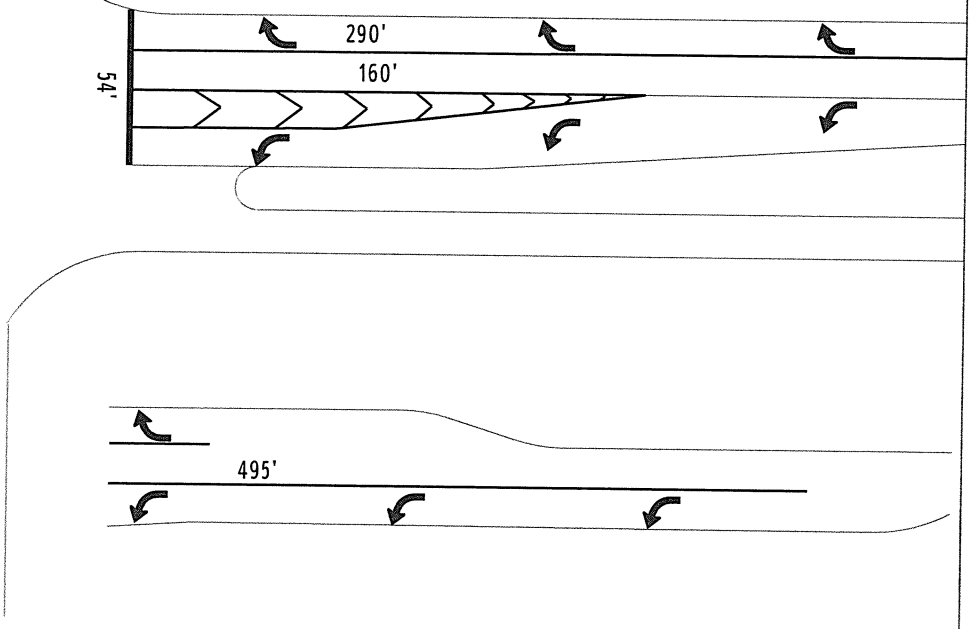
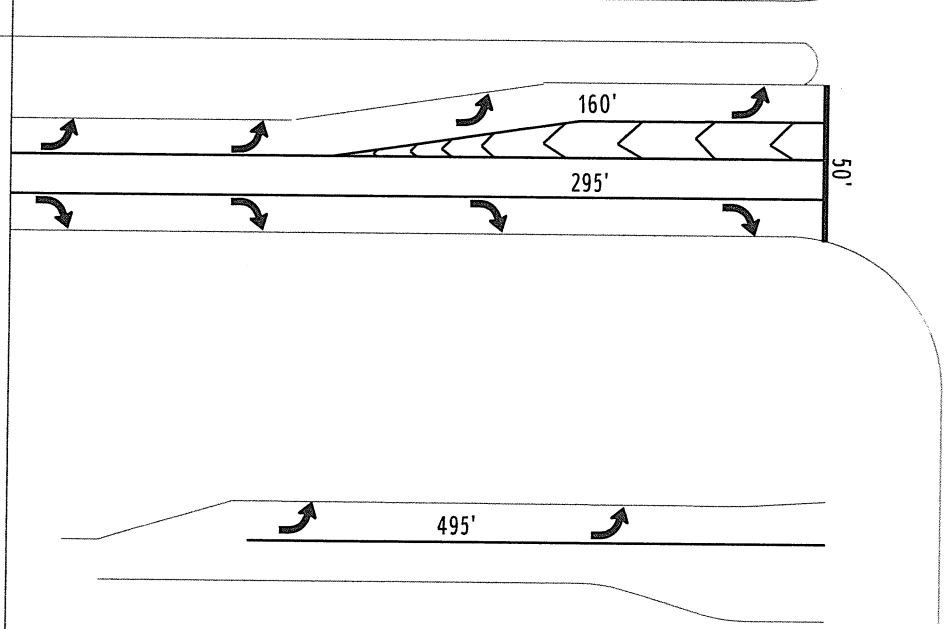

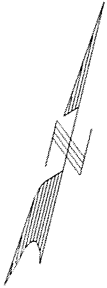

COUNTY:	PORTAGE
LOCATION:	U.S. ROUTE 224 @ TRANSITION 4-WAY
S.L.M.:	9.15
24" STOP LINE:	L.F.
12" CROSSWALK LINE:	L.F.
DOTTED LINE:	540 L.F.
8" CHANNELIZING LINE:	L.F.
12" CHANNELIZING LINE:	L.F.
24" TRANSVERSE LINE (WT):	L.F.
24" TRANSVERSE LINE (YW):	L.F.
SYMBOL: 2 - MERGE ARROWS	

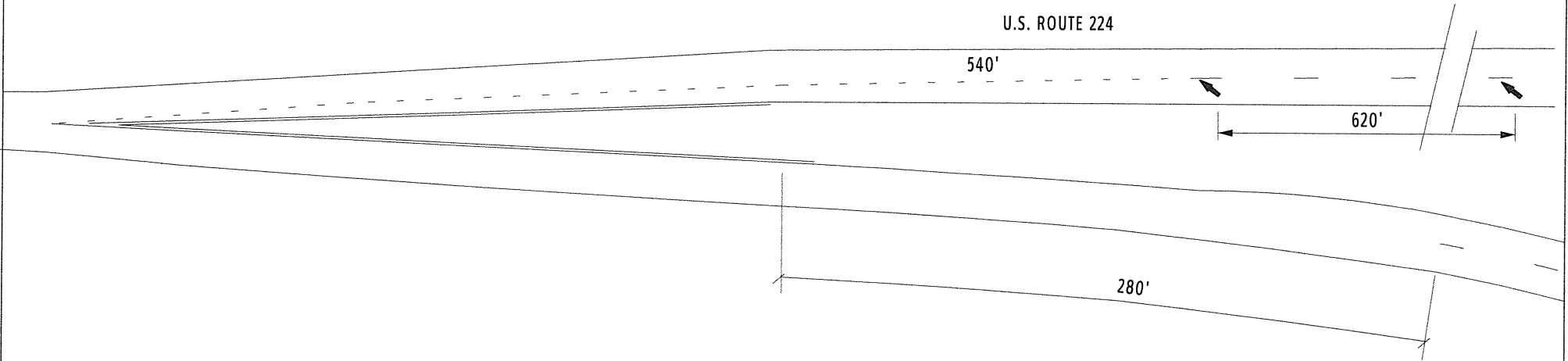

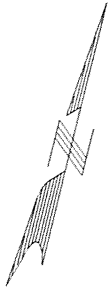

COUNTY:	PORTAGE
LOCATION:	U.S. ROUTE 224 @ TRANSITION 4-WAY
S.L.M.:	9.69
24" STOP LINE:	L.F.
12" CROSSWALK LINE:	L.F.
DOTTED LINE:	285 L.F.
8" CHANNELIZING LINE:	L.F.
12" CHANNELIZING LINE:	L.F.
24" TRANSVERSE LINE (WT):	L.F.
24" TRANSVERSE LINE (YW):	L.F.
SYMBOL: 2 - MERGE ARROWS	

U.S. ROUTE 224

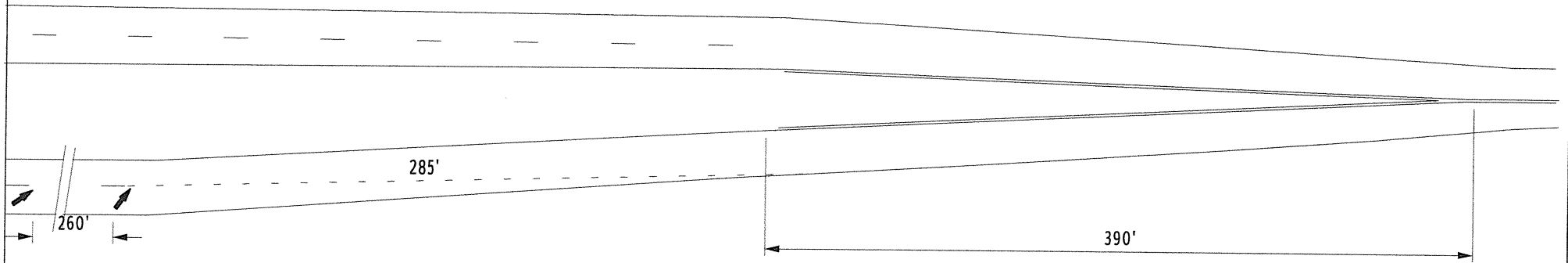



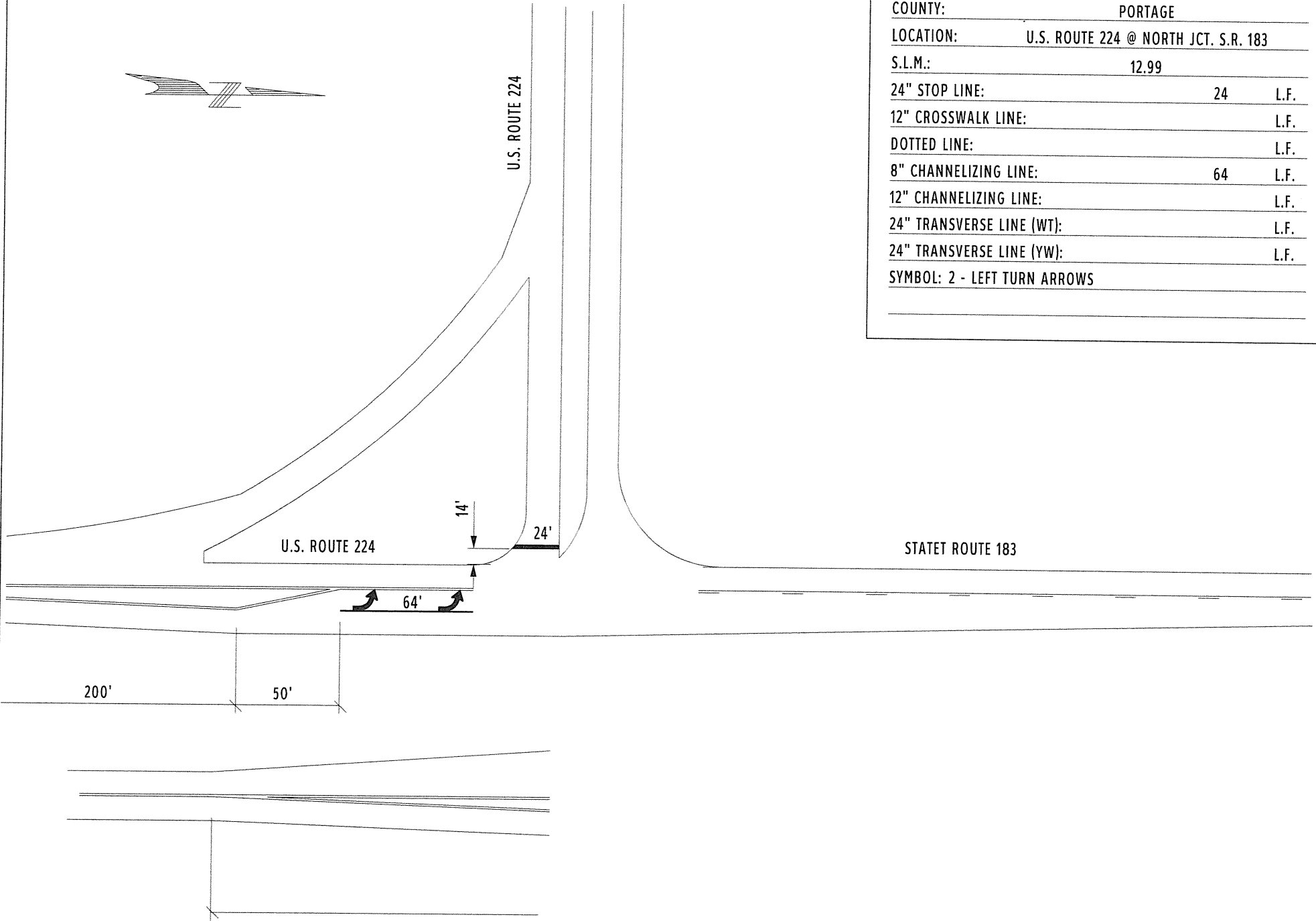

COUNTY:	PORTAGE	
LOCATION:	U.S. ROUTE 224 @ NORTH JCT. S.R. 183	
S.L.M.:	12.99	
24" STOP LINE:	24	L.F.
12" CROSSWALK LINE:		L.F.
DOTTED LINE:		L.F.
8" CHANNELIZING LINE:	64	L.F.
12" CHANNELIZING LINE:		L.F.
24" TRANSVERSE LINE (WT):		L.F.
24" TRANSVERSE LINE (YW):		L.F.
SYMBOL: 2 - LEFT TURN ARROWS		

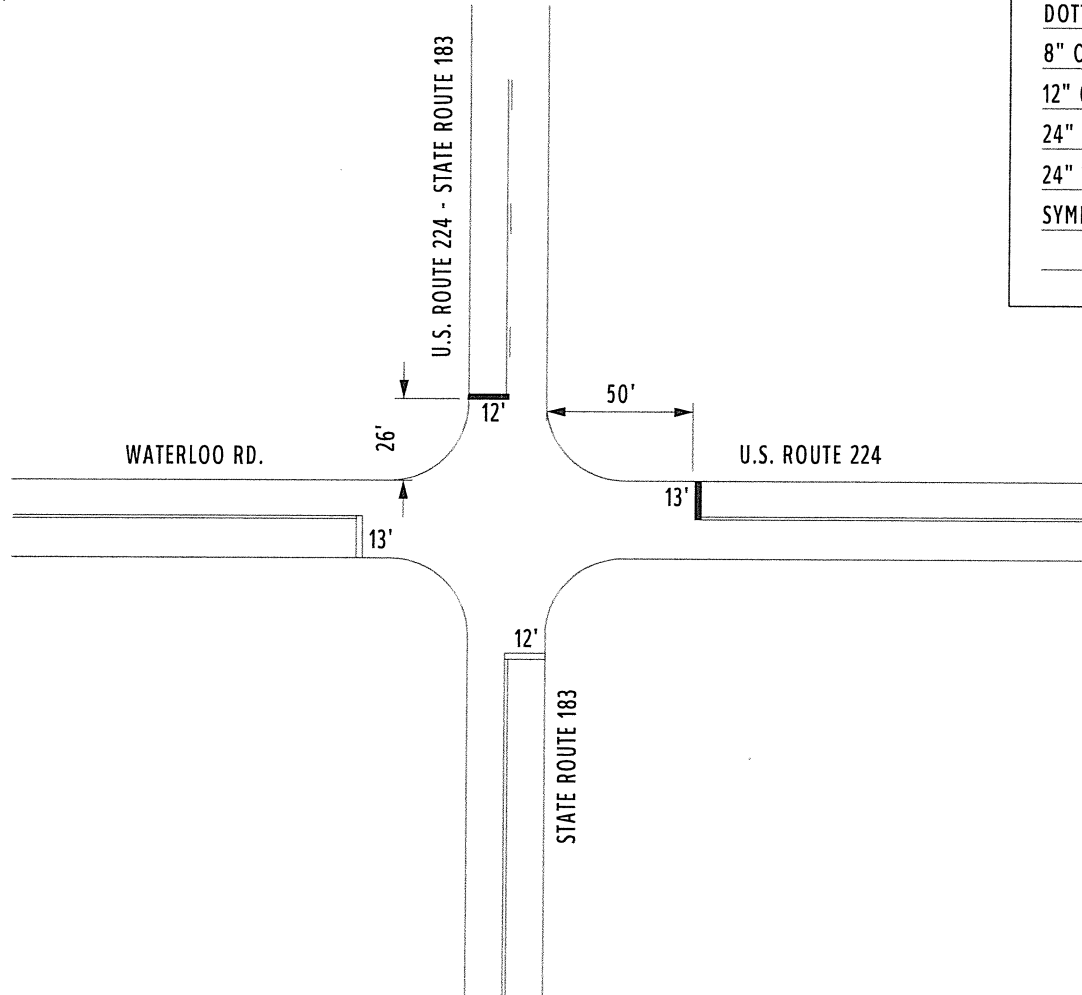

COUNTY:	PORTAGE	
LOCATION:	U.S. ROUTE 224 @ S.R. 183/WATERLOO RD.	
S.L.M.:	13.50	
24" STOP LINE:	25	L.F.
12" CROSSWALK LINE:		L.F.
DOTTED LINE:		L.F.
8" CHANNELIZING LINE:		L.F.
12" CHANNELIZING LINE:		L.F.
24" TRANSVERSE LINE (WT):		L.F.
24" TRANSVERSE LINE (YW):		L.F.
SYMBOL:		



S.R. 14-S.R. 225

34'

U.S. ROUTE 224  
U.S. ROUTE 225

22'

12'

DEERFIELD CIRCLE

STATE ROUTE 14

38'

12'

22'

U.S. ROUTE 224

COUNTY:	PORTAGE		
LOCATION:	U.S. ROUTE 224 @ DEERFIELD CIRCLE (S.R. 14)		
S.I.M.:	18.632		
24" STOP LINE:	44	L.F.	
12" CROSSWALK LINE:			L.F.
DOTTED LINE:			L.F.
8" CHANNELIZING LINE:			L.F.
12" CHANNELIZING LINE:			L.F.
24" TRANSVERSE LINE (WT):			L.F.
24" TRANSVERSE LINE (YW):			L.F.
SYMBOL:			