

STATE OF OHIO
DEPARTMENT OF TRANSPORTATION

FAI-33-17.44

**HOCKING AND BERNE TOWNSHIPS
FAIRFIELD COUNTY**

PROJECT DESCRIPTION
ASPHALT CONCRETE RESURFACING AND RELATED WORK
ON U.S. 33 IN FAIRFIELD COUNTY ALONG WITH DECK
SEALING OF VARIOUS STRUCTURES.

PROJECT EARTH DISTURBED AREA: N/A (MAINTENANCE)
ESTIMATED CONTRACTOR EARTH DISTURBED AREA: N/A (MAINTENANCE)
NOTICE OF INTENT EARTH DISTURBED AREA: N/A (MAINTENANCE)

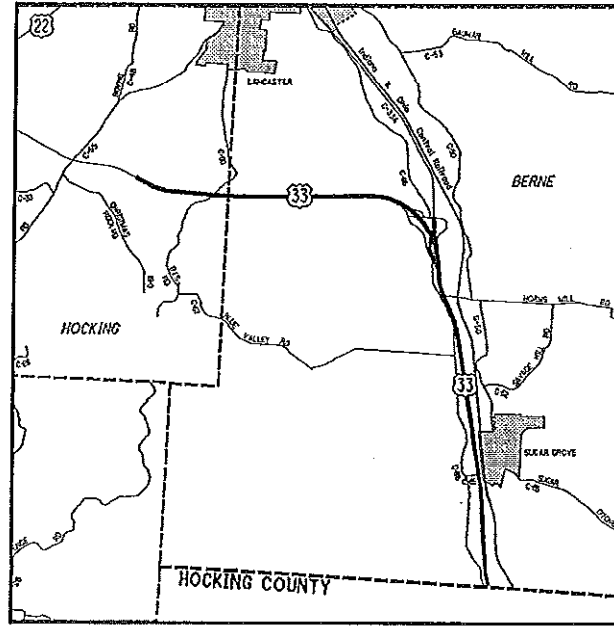

LOCATION MAP

LATITUDE: 39° 39' 30" LONGITUDE: 82° 33' 37"

PORTION TO BE IMPROVED -----

DESIGN DESIGNATION	U.S. 33
FUNCTIONAL CLASSIFICATION	RPA
OPENING YEAR ADT (2017)	23,000
DESIGN YEAR ADT (2029)	25,000
DESIGN HOURLY VOLUME (2029)	2,500
DIRECTIONAL DISTRIBUTION	69%
TRUCKS (24 HOUR B&C)	11%
DESIGN SPEED	70 MPH
LEGAL SPEED	60/70 MPH

RPA - RURAL PRINCIPAL ARTERIAL

DESIGN EXCEPTIONS
NONE

UNDERGROUND UTILITIES
CONTACT BOTH SERVICES TWO WORKING DAYS
BEFORE YOU DIG.

Call Before You Dig
1-800-362-2764
(Non-members must be called directly)

OIL & GAS PRODUCERS
UNDERGROUND PROTECTION SERVICE
1-800-925-0988

PLAN PREPARED BY:
OHIO DEPARTMENT OF TRANSPORTATION
DISTRICT 5 PLANNING & ENGINEERING

INDEX OF SHEETS

TITLE SHEET 1
GENERAL NOTES 2-3
MAINTENANCE OF TRAFFIC 4-7
PAVEMENT DATA 8-9
SHOULDER DATA 10
EXTRA AREA DATA 11
BRIDGE TREATMENT DATA 12-14
PAVEMENT MARKING DATA 15-19
RAISED PAVEMENT MARKER DATA 20
SIGNAL PLAN (SHARP RD.) 21
GENERAL SUMMARY 22-23

LOCATION	PLAN SPLIT	COUNTY	ROUTE	BEGIN SLM	END SLM	LENGTH MILES	CITY/VILLAGE
1	1	FAI	33	17.44	24.86	7.42	

2016 SPECIFICATIONS

THE STANDARD SPECIFICATIONS OF THE STATE OF OHIO, DEPARTMENT OF TRANSPORTATION, INCLUDING CHANGES AND SUPPLEMENTAL SPECIFICATIONS LISTED IN THE PROPOSAL SHALL GOVERN THIS IMPROVEMENT.

I HEREBY APPROVE THESE PLANS AND DECLARE THAT THE MAKING OF THIS IMPROVEMENT WILL NOT REQUIRE THE CLOSING TO TRAFFIC OF THE HIGHWAY AND THAT THAT PROVISIONS FOR THE MAINTENANCE AND SAFETY OF TRAFFIC WILL BE AS SET FORTH ON THE PLANS AND ESTIMATES.

ENGINEER'S SEAL		STANDARD CONSTRUCTION DRAWINGS				SUPPLEMENTAL SPECIFICATIONS	
<p>SIGNED: <i>Jason Scott Lutz</i> DATE: 2/24/17</p>	BP-3.1	7/18/14	TC-65.10	1/17/14	800	1/20/17	
	BP-9.1	7/19/13	TC-65.11	7/15/16	806	3/2/15	
			TC-71.10	7/15/16	808	1/29/16	
	MT-95.30	7/15/16	TC-72.20	7/15/16	809	4/15/16	
	MT-97.10	7/18/14			832	1/17/14	
	MT-98.10	7/18/14			842	7/17/15	
	MT-98.28	7/18/14			875	1/17/14	
	MT-99.20	7/19/13			908	1/29/16	
	MT-101.90	7/17/15					
	MT-105.10	7/19/13					
				SPECIAL PROVISIONS			

APPROVED: *[Signature]*
DATE: 2/23/17 DISTRICT DEPUTY DIRECTOR

APPROVED: *[Signature]*
DATE: 3-7-17 DIRECTOR, DEPARTMENT OF TRANSPORTATION

FAI - US 33-17.44
 170385 PID - 93015
 Dist 5 6/2/2017
 Contract Proposal Available @ www.Contracts.dot.state.oh.us/home

FEDERAL PROJECT NO. E150(643)
 PID NO. 93015
 CONSTRUCTION PROJECT NO.
 RAILROAD INVOLVEMENT NONE
 FAI-33-17.44
 1/23

UTILITIES

THERE ARE NO UNDERGROUND UTILITIES SHOWN ON THIS PLAN. THE NATURE OF THE WORK REQUIRED BY THIS PROJECT WILL NOT AFFECT ANY KNOWN UNDERGROUND UTILITIES THAT EXIST UNDER OR ADJACENT TO THE WORK AREA.

CONTINGENCY QUANTITIES

THE CONTRACTOR SHALL NOT ORDER MATERIALS OR PERFORM WORK FOR ITEMS DESIGNATED BY PLAN NOTE TO BE USED "AS DIRECTED BY THE ENGINEER" UNLESS AUTHORIZED BY THE ENGINEER. THE ACTUAL WORK LOCATIONS AND QUANTITIES USED FOR SUCH ITEMS SHALL BE INCORPORATED INTO THE FINAL CHANGE ORDER GOVERNING COMPLETION OF THIS PROJECT.

PAVEMENT MARKINGS

STOP LINES, CROSSWALK LINES, CHANNELIZING LINES, ETC., SHOWN IN THE PLANS ARE TAKEN FROM EXISTING MARKINGS. IT SHALL BE THE CONTRACTOR'S RESPONSIBILITY TO DOCUMENT EXISTING MARKING LOCATIONS (i.e. BY USE OF VIDEO, PICTURES) AND PLACE NEW PAVEMENT MARKINGS AS NEAR AS POSSIBLE TO THE EXISTING LOCATIONS UNLESS OTHERWISE DIRECTED BY THE ENGINEER. DOCUMENTATION OF PAVEMENT MARKING SHALL BE SUPPLIED TO THE ENGINEER BEFORE COMMENCEMENT OF ANY OPERATION WHICH WILL REMOVE/OBLITERATE MARKINGS.

ITEM 209, LINEAR GRADING

IN ORDER TO PROVIDE POSITIVE DRAINAGE FROM THE ROADWAY SURFACE TO THE SHOULDER BREAK, THE EXISTING ROADWAY SHOULDERS SHALL BE GRADED AND SHAPED USING A GRADER OF ADEQUATE SIZE, TO PERFORM THE WORK, TO THE SATISFACTION OF THE ENGINEER.

ALL EXCESS MATERIAL REMAINING AROUND GUARDRAIL AND OTHER AREAS AFTER THE GRADER WORK IS COMPLETED AND NOT DISPOSED OF ON THE SITE, SHALL BE REMOVED AND DISPOSED OF BY THE CONTRACTOR. ALL EQUIPMENT, LABOR, OR INCIDENTALS REQUIRED TO COMPLETE THIS ITEM SHALL BE INCLUDED FOR PAYMENT IN THE UNIT PRICE BID FOR ITEM 209 LINEAR GRADING.

THIS WORK MAY BE INTERMITTENT AND SPREAD THROUGHOUT THE PROJECT LIMITS, AS DIRECTED BY THE ENGINEER. THE CONTRACTOR WILL ONLY BE PAID FOR INTERSECTIONS AND GAPS IF THEY ARE WITHIN THE LIMITS OF A SECTION MARKED BY THE ENGINEER FOR GRADING.

AREAS WITH GUARDRAIL SHALL NOT BE EXCLUDED FROM LINEAR GRADING.

ALL LINEAR GRADING WORK SHALL BE DONE BEFORE PLACING THE ASPHALT SURFACE COURSE.

ALL MATERIALS, LABOR, EQUIPMENT, TOOLS, TRAFFIC CONTROL AND INCIDENTALS NEEDED TO COMPLETE THE WORK DESCRIBED ABOVE SHALL BE INCLUDED FOR PAYMENT IN THE UNIT PRICE BID FOR ITEM 209, LINEAR GRADING.

**ITEM 209, LINEAR GRADING
LOCATION 1: 31.36 MILE**

ITEM 253, PAVEMENT REPAIR

ALL REPAIRS SHALL TAKE PLACE PRIOR TO THE PLANING/PAVING OPERATIONS. THE INTENT OF THIS OPERATION IS TO REPAIR THOSE AREAS OF PAVEMENT WHICH HAVE COMPLETELY FAILED (PUMPING OF SUB-BASE MATERIAL) AND NOT TO CORRECT SURFACE IRREGULARITIES. DEPTH OF EXCAVATION SHALL BE **7 INCHES**. THE MINIMUM WIDTH SHALL BE **4 FEET**. AFTER EXCAVATION HAS BEEN COMPLETED, THE FACE OF THE REPAIR SHALL BE COATED WITH ITEM 407 TACK COAT. REPLACEMENT MATERIAL WILL BE 6" OF ITEM 301, ASPHALT CONCRETE BASE, PG64-22 (PLACED AND COMPACTED AS DIRECTED).

REPAIR QUANTITIES MAY BE USED ON THE MAINLINE PAVEMENT OR ON PAVED SHOULDERS. ALL EXCAVATION, MATERIALS, LABOR, EQUIPMENT, TOOLS, TRAFFIC CONTROL AND INCIDENTALS NEEDED TO COMPLETE THE WORK DESCRIBED ABOVE SHALL BE PAID FOR UNDER ITEM 253 PAVEMENT REPAIR.

ALL MATERIALS, LABOR, EQUIPMENT, TOOLS, TRAFFIC CONTROL AND INCIDENTALS NEEDED TO COMPLETE THE WORK DESCRIBED ABOVE SHALL BE INCLUDED FOR PAYMENT IN THE UNIT PRICE BID FOR ITEM 253, PAVEMENT REPAIR.

**ITEM 253, PAVEMENT REPAIR
LOCATION 1: 100 CY**

ITEM 254, PAVEMENT PLANING, ASPHALT CONCRETE

DEPTH OF PLANING ON U.S. 33, IS **1.5"**, AS SHOWN ON THE **PAVEMENT DATA SHEET**. PLANING SHALL BE FULL WIDTH OF PAVEMENT, INCLUDING PAVED SHOULDERS.

THE ROADWAY SHALL BE PLANED SUCH THAT POSITIVE DRAINAGE IS CREATED FROM THE CENTER LINE TO THE EDGE OF PAVEMENT IN TANGENT SECTIONS AND SHALL FOLLOW EXISTING SUPERELEVATIONS WHERE APPLICABLE. ALL REQUIREMENTS OF ITEM 254 SHALL APPLY.

ITEM 407, NON-TRACKING TACK COAT

THE RATE OF APPLICATION OF THE ITEM 407, NON-TRACKING TACK COAT SHALL BE PER **CMS TABLE 407.06-1** AND SUBJECT TO ADJUSTMENT AS DIRECTED BY THE ENGINEER. PLAN QUANTITIES INDICATE AN AVERAGE APPLICATION RATE OF **0.08 GAL/SY** FOR TACK COAT UNDER THE SURFACE COURSE, (FOR ESTIMATING PURPOSES ONLY).

ITEM 408, PRIME COAT, AS PER PLAN

THE CONTRACTOR SHALL APPLY ONE COAT OF MC-70 (AS PER SECTION 702) AT A RATE OF 0.40 GAL/SY TO THE COMPLETED AGGREGATE SHOULDER (ITEM 617) AS DIRECTED BY THE ENGINEER. THE CONTRACTOR SHALL PROVIDE A SHIELD TO PREVENT THE SPRAYING OR DRIFTING OF LIQUID BITUMINOUS MATERIAL ONTO THE EDGE OF PAVEMENT OR EDGE LINE. THE ATTENTION OF THE CONTRACTOR IS DIRECTED TO 107.10 OF THE SPECIFICATIONS.

ITEM 516, 2" DEEP JOINT SEALER, AS PER PLAN (A)

THE CONTRACTOR SHALL PLACE A 1" X 2.0" DEEP BEAD OF JOINT SEALER (AS PER 705.04) AT THE LOCATIONS SHOWN IN PLANS. THE CONTRACTOR SHALL SAW CUT A CHANNEL FOR THE JOINT SEALER. THE COST FOR SAW CUTTING THE CHANNEL FOR THE JOINT SEALER SHALL BE INCLUDED FOR PAYMENT WITH ITEM 516, 2" DEEP JOINT SEALER, AS PER PLAN (A).

ITEM 617, COMPACTED AGGREGATE, AS PER PLAN

ALL AGGREGATE SHALL BE 100% CRUSHED LIMESTONE. ALL QUALITY REQUIREMENTS EXCEPT SHALE SHALL BE WAIVED. OTHER GRADATION REQUIREMENTS SHALL BE AS SPECIFIED EXCEPT THE INDEX SHALL BE WAIVED. IF SO PERMITTED, THE CONTRACTOR MAY USE ASPHALT CONCRETE PAVEMENT (RACP MEETING REQUIREMENTS OF 617.02) IN LIEU OF CRUSHED LIMESTONE.

ITEM 617, SHOULDER PREPARATION SHALL BE PERFORMED ON ALL AREAS TO LOOSEN SUBBASE AND REMOVE VEGETATION PRIOR TO PLACEMENT OF COMPACTED AGGREGATE. AGGREGATE SHOULDERS SHALL BE SLOPED TO PROVIDE POSITIVE DRAINAGE FROM ROADWAY.

SHOULDER PREPARATION SHALL BE INCLUDED FOR PAYMENT IN THE UNIT PRICE BID FOR ITEM 617, COMPACTED AGGREGATE, AS PER PLAN.

ITEM 621, RAISED PAVEMENT MARKER REMOVED

RPM REMOVAL SHALL NOT OCCUR SOONER THAN 10 DAYS PRIOR TO RESURFACING OF THE ROADWAY. ALL RPM'S REMOVED SHALL BECOME THE PROPERTY OF THE CONTRACTOR.

ITEM 806, ASPHALT CONCRETE SURFACE COURSE, 12.5MM, TYPE A, AS PER PLAN

ALL THE REQUIREMENTS OF **CMS 442** AND **SS 806** SHALL APPLY EXCEPT A **PG 88-22M** BINDER SHALL BE USED FOR THE SURFACE COURSE.

SS 875.02 HOT APPLIED ASPHALTIC JOINT ADHESIVE SHALL BE APPLIED TO THE VERTICAL FACE OF ALL COLD JOINTS ON THE PROJECT.

PAYMENT SHALL BE INCLUDED IN THE UNIT BID PRICE FOR ITEM 806, ASPHALT CONCRETE SURFACE COURSE, 12.5MM, TYPE A, AS PER PLAN.

ASPHALT CUTBACK JOINT

THE FOLLOWING QUANTITY IS BEING CARRIED TO GENERAL SUMMARY FOR THE ADDITIONAL ASPHALT CONCRETE NEEDED TO PERFORM A CUTBACK JOINT TO HELP MEET **SS 806** DENSITY SPECIFICATIONS. IF A CUTBACK JOINT IS NOT PERFORMED THEN THE BELOW QUANTITY SHALL BE NON-PERFORMED.

E.B. LANES = ((24.86 - 17.44) X 5280' X 0.5' X (1.5"/12)))/27 = 91 CY
W.B. LANES = ((24.86 - 17.44) X 5280' X 0.5' X (1.5"/12)))/27 = 91 CY
RAMP M = (2,870.61 X 0.5' X (1.5"/12)))/27 = 7 CY
RAMP N = (1,569.70 X 0.5' X (1.5"/12)))/27 = 4 CY

**ITEM 806, ASPHALT CONCRETE SURFACE COURSE, 12.5 MM, TYPE A
LOCATION 1: 193 CY**

I:\ProjectData\FAI\93015\Design\Roadway\Sheets\93015_GNOC1.dgn 16-FEB-2017 5:51PM jlutzi

CALCULATED
JLS
CHECKED
JSL

GENERAL NOTES

FAI-33-17.44

2
23

ITEM 809. STOP-BAR RADAR DETECTION

THIS ITEM OF WORK SHALL CONSIST OF FURNISHING AND INSTALLING A WAVETRONIX SMARTSENSOR MATRIX DETECTION UNIT AT THE LOCATIONS SHOWN ON SHEET 21. THE DETECTION UNIT SHALL INCLUDE THE FOLLOWING:

1. POWER SHALL BE PROVIDED FROM THE TRAFFIC CABINET.
2. ALL REQUIRED INPUTS CARDS SHALL BE INCLUDED IN THE TRAFFIC CABINET AND SHALL BE COMPATIBLE WITH CALTRANS, NEMA TS1 AND NEMA TS2 DETECTOR RACKS. THE CARDS SHALL PROVIDE TRUE PRESENCE DETECTOR CALLS OR CONTACT CLOSURE TO THE TRAFFIC CONTROLLER.
3. THE UNIT SHALL BE MOUNTED DIRECTLY TO A POLE OR MAST ARM, AS RECOMMENDED BY THE MANUFACTURER. CABLE(S) SHALL BE PROVIDED AS REQUIRED AND RECOMMENDED BY THE MANUFACTURER.
4. SURGE PROTECTION DEVICES, AS RECOMMENDED BY THE MANUFACTURER SHALL BE INCLUDED BOTH AT THE POLE WHERE THE UNIT IS LOCATED TO PROTECT THE UNIT AND IN THE TRAFFIC CABINET TO PROTECT THE CABINET ELECTRONICS.
5. THE MANUFACTURER'S REPRESENTATIVE SHALL BE ON SITE DURING INSTALLATION AND TESTING AND SHALL PROVIDE ONSITE TRAINING ON THE SETUP, OPERATION AND MAINTENANCE OF THE UNIT.
6. A SERIAL TO ETHERNET COMMUNICATIONS MODULE AND ETHERNET CABLE (MINIMUM 7 FEET).
7. THE POWER SUPPLY AND COMMUNICATION MODULES SHALL BE SECURED TO A SINGLE PANEL THAT CAN BE MOUNTED INTERIOR TO THE TRAFFIC CABINET. THE PANEL SHALL INCLUDE MODULAR-PLUG STYLE CONNECTIONS FOR UP TO FOUR (4) SENSOR CABLES. ADDITIONAL SENSORS MAY BE HARD-WIRED TO THE COMMUNICATION MODULES, AS NECESSARY.

PAYMENT FOR ITEM 809 STOP-BAR RADAR DETECTION SHALL BE MADE AT THE CONTRACT UNIT PRICE FOR EACH UNIT, COMPLETE AND IN PLACE INCLUDING ALL REQUIRED CABINET HARDWARE, MOUNTING BRACKETS, CABLES, CONDUIT AND CONNECTIONS TESTED AND ACCEPTED.

ITEM 809. STOP BAR RADAR DETECTION
LOCATION 1: 4 EACH

i:\ProjectData\FAI\93015\Design\Roadway\Sheets\93015_GNOC2.dgn 16-FEB-2017 5:51PM jjut1

CALCULATED
JLS
CHECKED
JSL

GENERAL NOTES

FAI-33-17.44

3
23

ITEM 614, MAINTAINING TRAFFIC

A MINIMUM OF ONE LANE OF TRAFFIC IN EACH DIRECTION SHALL BE MAINTAINED AT ALL TIMES ON U.S. 33.

AREAS THAT ARE PLANED SHALL NOT BE OPENED TO TRAFFIC. ALL PLANED AREAS MUST BE INLAID WITH A PROPOSED COURSE OF ITEM 442, ASPHALT CONCRETE PRIOR TO BEING OPENED TO TRAFFIC.

OVERNIGHT CLOSURES MUST MEET SPECIFICATIONS AS OUTLINED IN THE CONSTRUCTION AND MAINTENANCE OPERATIONS SECTION OF THE OHIO MANUAL OF UNIFORM TRAFFIC CONTROL DEVICES FOR STREETS AND HIGHWAYS. THE ROADWAY SHALL NOT BE OPENED TO TRAFFIC WITHOUT EITHER THE PERMANENT OR WORK ZONE MARKINGS IN PLACE.

LANE CLOSURES WILL BE ACCOMPLISHED IN ACCORDANCE WITH THE STANDARD DRAWINGS LISTED ON THE TITLE SHEET AND **SHALL BE NO LONGER THAN 2 MILES**, UNLESS DIRECTED BY THE ENGINEER, IN CONSIDERATION OF THE TRAFFIC FLOW. LANE CLOSURES SHALL ONLY OCCUR DURING CONTRACTOR WORK HOURS.

LENGTH AND DURATION OF LANE CLOSURES AND RESTRICTIONS SHALL BE AT THE APPROVAL OF THE ENGINEER. IT IS THE INTENT TO MINIMIZE THE IMPACT TO THE TRAVELING PUBLIC. LANE CLOSURES OR RESTRICTIONS OVER SEGMENTS OF THE PROJECT, IN WHICH NO WORK IS ANTICIPATED WITHIN A REASONABLE TIME FRAME, AS DETERMINED BY THE ENGINEER, SHALL NOT BE PERMITTED. THE LEVEL OF UTILIZATION OF MAINTENANCE OF TRAFFIC DEVICES SHALL BE COMMENSURATE WITH THE WORK IN PROGRESS.

THE CONTRACTOR WILL HAVE ON SITE AND IN WORKING AND OR SUITABLE CONDITION; ALL EQUIPMENT, TOOLS, LABORERS, LEO'S, TRAFFIC CONTROL DEVICES AND INCIDENTALS NECESSARY TO EFFICIENTLY PERFORM THE CLOSURE BEFORE INITIALIZING THE LANE CLOSURE.

ALL WORK AND TRAFFIC CONTROL DEVICES SHALL BE IN ACCORDANCE WITH CMS 614 AND OTHER APPLICABLE PORTIONS OF THE SPECIFICATIONS, AS WELL AS THE OHIO MANUAL OF UNIFORM TRAFFIC CONTROL DEVICES. PAYMENT FOR ALL LABOR, EQUIPMENT AND MATERIALS SHALL BE INCLUDED IN THE LUMP SUM CONTRACT PRICE FOR ITEM 614, MAINTAINING TRAFFIC, UNLESS SEPARATELY ITEMIZED IN THE PLAN.

NOTIFICATION OF ROAD CLOSURE OR RESTRICTIONS

THE CONTRACTOR WILL ADVISE THE PROJECT ENGINEER A MINIMUM OF TWENTY ONE (21) DAYS PRIOR TO THE FOLLOWING: THE START OF CONSTRUCTION ACTIVITIES, LANE RESTRICTIONS, LANE CLOSURES, AND OR ROAD CLOSURES. THE PROJECT ENGINEER WILL FORWARD THIS INFORMATION TO THE FOLLOWING:

DISTRICT PUBLIC INFORMATION OFFICER (PIO) BY FAX AT (614) 887-4510 OR EMAIL AT D05.PIO@DOT.STATE.OH.US

DISTRICT PERMIT SECTION BY FAX AT (614) 887-4525 OR EMAIL AT BRIAN.BOSCH@DOT.STATE.OH.US

CENTRAL OFFICE SPECIAL HAUL PERMITS SECTION BY FAX AT (614) 728-4099 OR EMAIL AT HAULING.PERMITS@DOT.STATE.OH.US

THE PIO WILL, IN TURN, NOTIFY THE PUBLIC, THE LOCAL EMERGENCY SERVICES, AFFECTED SCHOOLS AND BUSINESSES, AND ANY OTHER IMPACTED LOCAL PUBLIC AGENCY OF ANY OF THE ABOVE MENTIONED ITEMS, VIA MEDIA SOURCES.

LANES OPEN DURING HOLIDAYS OR SPECIAL EVENTS

NO WORK SHALL BE PERFORMED AND ALL EXISTING LANES ON U.S. 33 SHALL BE OPENED TO TRAFFIC DURING THE FOLLOWING DESIGNATED HOLIDAYS OR EVENTS:

MEMORIAL DAY, FOURTH OF JULY, LABOR DAY, THANKSGIVING, CHRISTMAS, NEW YEARS, EASTER

THE PERIOD OF TIME THAT THE LANES ARE TO BE OPEN DEPENDS ON THE DAY OF THE WEEK ON WHICH THE HOLIDAY OR EVENT FALLS. THE FOLLOWING SCHEDULE SHALL BE USED TO DETERMINE THIS PERIOD:

DAY OF WEEK	TIME ALL LANES MUST BE OPEN TO TRAFFIC
SUNDAY	12:00N FRIDAY THROUGH 6:00AM MONDAY
MONDAY	12:00N FRIDAY THROUGH 6:00AM TUESDAY
TUESDAY	12:00N MONDAY THROUGH 6:00AM WEDNESDAY
WEDNESDAY	12:00N TUESDAY THROUGH 6:00AM THURSDAY
THURSDAY	12:00N WEDNESDAY THROUGH 6:00AM FRIDAY
THURSDAY (THANKSGIVING)	12:00N WEDNESDAY THROUGH 6:00AM MONDAY
FRIDAY	12:00N THURSDAY THROUGH 6:00AM MONDAY
SATURDAY	12:00N FRIDAY THROUGH 6:00AM MONDAY

NO EXTENSIONS OF TIME SHALL BE GRANTED FOR DELAYS IN MATERIAL DELIVERIES, UNLESS SUCH DELAYS ARE INDUSTRY-WIDE, OR FOR LABOR STRIKES, UNLESS SUCH STRIKES ARE AREA-WIDE.

SHOULD THE CONTRACTOR FAIL TO MEET ANY OF THESE REQUIREMENTS, THE CONTRACTOR SHALL BE ASSESSED A DISINCENTIVE OF \$75 FOR EACH MINUTE THE ABOVE DESCRIBED LANE AND/OR RAMP CLOSURE RESTRICTIONS ARE VIOLATED.

COOPERATION BETWEEN CONTRACTORS

THE STATE OF OHIO HAS CONTRACTED PROJECT **FAI-33-8.08 PID 93009**, WHICH MAY BE CONSTRUCTED CONCURRENTLY WITH THIS PROJECT. IT IS IMPERATIVE THAT THE CONTRACTORS COOPERATE FULLY WITH EACH OTHER AS OUTLINED IN SECTION 105.08 OF THE CMS MANUAL. ALL MAINTENANCE OF TRAFFIC SHALL BE COORDINATED BETWEEN PROJECTS AND NOT CONFLICT WITH ONE ANOTHER.

DROP-OFFS IN WORK ZONES

DROP-OFFS THAT DEVELOP DURING CONSTRUCTION OPERATIONS AND THAT ARE NOT OTHERWISE PROVIDED FOR IN THE PLANS SHALL BE TREATED AS SHOWN ON STANDARD DRAWING MT-101.90. WHERE THE PLANS DO NOT PROVIDE SPECIFIC ITEMS FOR LABOR, EQUIPMENT, OR MATERIALS TO IMPLEMENT THE DROP-OFF TREATMENTS SPECIFIED, THEY SHALL BE INCLUDED FOR PAYMENT IN THE **LUMP SUM BID FOR ITEM 614, MAINTAINING TRAFFIC**.

ITEM 614, WORK ZONE PAVEMENT MARKINGS

THE CONTRACTOR SHALL PLACE ALL WORK ZONE PAVEMENT MARKINGS IN ACCORDANCE WITH **CMS 614.11** AND STANDARD DRAWING **MT-99.20** UNLESS OTHERWISE DIRECTED BY THE ENGINEER. THE QUANTITIES BELOW ARE FOR PLACEMENT OF TEMPORARY MARKINGS ON THE SURFACE COURSE.

ITEM 614, WORK ZONE LANE LINE, CLASS III, 642 PAINT
LOCATION 1: 17.78 MILE

ITEM 614, WORK ZONE EDGE LINE, CLASS III, 642 PAINT
LOCATION 1: 31.36 MILE

ITEM 614, WORK ZONE CHANNELIZING LINE, CLASS III, 642 PAINT
LOCATION 1: 5,014 FT

ITEM 614, WORK ZONE MARKING SIGNS

THE CONTRACTOR SHALL ERECT A "GROOVED PAVEMENT" SIGN 250 FEET IN ADVANCE OF ANY SECTION OF ROADWAY WHERE TRAFFIC MUST TRAVEL ON A PLANED SURFACE. ENSURE THESE SIGNS ARE IN PLACE BEFORE OPENING THE ROADWAY TO TRAFFIC. ERECT THESE SIGNS ON EACH ENTRANCE RAMP AND AT INTERSECTIONS OF THROUGH ROUTES TO WARN TRAFFIC OF THIS SURFACE CONDITION. "GROOVED PAVEMENT" SIGNS SHALL BE INCLUDED FOR PAYMENT WITH THE **LUMP SUM BID FOR ITEM 614, MAINTAINING TRAFFIC** AS PER CMS SECTION 614.055.

i:\ProjectData\FAI\93015\Design\Roadway\Sheets\93015_MNO01.dgn 24-MAR-2017 3:57PM jltz1

MAINTENANCE OF TRAFFIC NOTES

FAI-33-17.44

CALCULATED
JLS
CHECKED
JSL

ITEM 614. LAW ENFORCEMENT OFFICER WITH PATROL CAR FOR ASSISTANCE

USE OF LAW ENFORCEMENT OFFICERS (LEOS) BY CONTRACTORS OTHER THAN THE USES SPECIFIED IN THIS NOTE WILL NOT BE PERMITTED AT PROJECT COST. LEOS SHOULD NOT BE USED WHERE THE OHIO MANUAL OF UNIFORM TRAFFIC CONTROL DEVICES (OMUTCD) INTENDS THAT FLAGGERS BE USED.

IN ADDITION TO THE REQUIREMENTS OF C&MS 614 AND THE OMUTCD, A UNIFORMED LEO WITH AN OFFICIAL PATROL CAR (CAR WITH TOP-MOUNTED EMERGENCY FLASHING LIGHTS AND COMPLETE MARKINGS OF THE APPROPRIATE LAW ENFORCEMENT AGENCY) SHOULD BE PROVIDED FOR CONTROLLING TRAFFIC FOR THE FOLLOWING TASKS, **AS DIRECTED BY THE ENGINEER**:

- FOR LANE CLOSURES: DURING INITIAL SET-UP PERIODS, TEAR DOWN PERIODS, SUBSTANTIAL SHIFTS OF A CLOSURE POINT OR WHEN NEW LANE CLOSURE ARRANGEMENTS ARE INITIATED.

IN GENERAL, LEOS SHOULD BE POSITIONED AT THE POINT OF LANE RESTRICTION OR ROAD CLOSURE AND TO MANUALLY CONTROL TRAFFIC MOVEMENTS THROUGH INTERSECTIONS IN WORK ZONES.

LEOS SHOULD NOT FORGO THEIR TRAFFIC CONTROL RESPONSIBILITIES TO APPREHEND MOTORISTS FOR ROUTINE TRAFFIC VIOLATIONS. HOWEVER, IF A MOTORIST'S ACTIONS ARE CONSIDERED TO BE RECKLESS, THEN PURSUIT OF THE MOTORIST IS APPROPRIATE.

THE LEOS WORK AT THE DIRECTION OF THE CONTRACTOR. THE CONTRACTOR IS RESPONSIBLE FOR SECURING THE SERVICES OF THE LEOS AND COMMUNICATING THE INTENTIONS OF THE PLANS WITH RESPECT TO DUTIES OF THE LEOS. THE ENGINEER SHALL HAVE FINAL CONTROL OVER THE LEOS' DUTIES AND PLACEMENT, AND WILL RESOLVE ANY ISSUES THAT MAY ARISE BETWEEN THE TWO PARTIES.

THE LEO SHALL REPORT IN TO THE CONTRACTOR PRIOR TO THE START OF THE SHIFT TO RECEIVE INSTRUCTIONS REGARDING SPECIFIC WORK ASSIGNMENTS DURING HIS/HER SHIFT. THE LEO IS EXPECTED TO STAY AT THE PROJECT SITE FOR THE ENTIRE DURATION OF HIS/HER SHIFT. THE LEO SHALL REPORT TO THE CONTRACTOR AT THE END OF HIS/HER SHIFT. ONCE THE LEO HAS COMPLETED THE DUTIES DESCRIBED ABOVE AND STILL HAS TIME REMAINING ON HIS/HER SHIFT, THE LEO MAY BE ASKED TO PATROL THROUGH THE WORK ZONE (WITH FLASHING LIGHTS OFF) OR BE PLACED AT A LOCATION TO DETER MOTORISTS FROM SPEEDING. SHOULD IT BE NECESSARY TO LEAVE THE PROJECT SITE, THE LEO SHALL NOTIFY THE ENGINEER. THE CONTRACTOR SHALL PROVIDE THE LEO WITH A TWO-WAY COMMUNICATION DEVICE WHICH SHALL BE RETURNED TO THE CONTRACTOR AT THE END OF HIS/HER SHIFT.

LAW ENFORCEMENT OFFICERS (WITH PATROL CAR) REQUIRED BY THE TRAFFIC MAINTENANCE TASKS ABOVE SHALL BE PAID FOR ON A UNIT PRICE (HOURLY) BASIS UNDER ITEM 614, LAW ENFORCEMENT OFFICER (WITH PATROL CAR) FOR ASSISTANCE.

THE HOURS PAID SHALL INCLUDE MINIMUM SHOW-UP TIME REQUIRED BY THE LAW ENFORCEMENT AGENCY INVOLVED.

ANY ADDITIONAL COSTS (ADMINISTRATIVE OR OTHERWISE) INCURRED BY THE CONTRACTOR TO OBTAIN THE SERVICES OF A LEO ARE INCLUDED WITH THE BID UNIT PRICE FOR ITEM 614, LAW ENFORCEMENT OFFICER WITH PATROL CAR FOR ASSISTANCE.

ITEM 614 LAW ENFORCEMENT OFFICER WITH PATROL CAR FOR ASSISTANCE
LOCATION 1: 250 HOUR

ITEM 614. WORK ZONE SPEED ZONES (WZSZS)

THE FOLLOWING WORK ZONE SPEED ZONE (WZSZ) SPEED LIMIT REVISION(S) HAVE BEEN APPROVED FOR USE ON THIS PROJECT WHEN WORK ZONE CONDITIONS AND FACTORS ARE MET AS DESCRIBED BELOW:

WZSZ REVISION NUMBER	COUNTY & ROUTE	DIRECTION
WZ-30591	FAI-33-17.44 to 21.15	EB/WB
WZ-30592	FAI-33-21.15 to 24.86	EB/WB
WZ-55231	HOC-33-0.00 to 00.25	EB/WB

POTENTIAL WZSZ LOCATIONS SHALL HAVE AN ORIGINAL (PRE-CONSTRUCTION) POSTED SPEED LIMIT OF ≥ 55 MPH. A QUALIFYING WORK ZONE CONDITION OF AT LEAST 0.5 MILE IN LENGTH, AN EXPECTED WORK DURATION OF AT LEAST THREE HOURS, AND A WORK ZONE CONDITION IN PLACE THAT REDUCES THE EXISTING FUNCTIONALITY OF THE TRAVEL LANES OR SHOULDERS (I.E., LANE CLOSURE, LANE SHIFT, CROSSOVER, CONTRAFLOW AND/OR SHOULDER CLOSURE). THE LENGTH OF THE WORK ZONE CONDITION IS MEASURED FROM THE BEGINNING OF THE TAPER FOR THE SUBJECT WORK ZONE CONDITION IMPACTING THE TRAVEL LANES AND/OR SHOULDER TO THE END OF THE DOWNSTREAM TAPER, WHERE DRIVERS ARE RETURNED TO TYPICAL ALIGNMENT. AN EXPECTED WORK DURATION OF AT LEAST THREE HOURS IS REQUIRED TO BALANCE THE ADDITIONAL EXPOSURE CREATED BY INSTALLING AND REMOVING WZSZ SIGNING WITH THE TIME NEEDED TO COMPLETE THE WORK.

IF THE WORK ZONE MEETS THESE MINIMUM CRITERIA, IT SHALL BE ANALYZED FURTHER USING TABLE 1 BELOW TO DETERMINE IF AND WHEN IT QUALIFIES FOR A SPEED LIMIT REDUCTION. DEPENDING ON THE ORIGINAL POSTED SPEED LIMIT, THE TYPE OF TEMPORARY TRAFFIC CONTROL USED, AND WHETHER OR NOT WORKERS ARE PRESENT, A WARRANTED WZSZ WILL VARY IN THE APPROVED SPEED LIMIT TO BE POSTED OVER TIME.

C&MS ITEM 614, PARAGRAPH 614.02(B), INDICATES THAT TWO DIRECTIONS OF A DIVIDED HIGHWAY ARE CONSIDERED SEPARATE HIGHWAY SECTIONS. THEREFORE, IF THE WORK ON A MULTI-LANE DIVIDED HIGHWAY IS LIMITED TO ONLY ONE DIRECTION, A SPEED LIMIT REDUCTION IN THE DIRECTION OF THE WORK DOES NOT AUTOMATICALLY CONSTITUTE A SPEED LIMIT REDUCTION IN THE OPPOSITE DIRECTION. EACH DIRECTION SHALL BE ANALYZED INDEPENDENTLY FROM EACH OTHER.

ALL WZSZS FLUCTUATE BETWEEN TWO APPROVED REDUCED SPEED LIMITS OR BETWEEN AN APPROVED REDUCED SPEED LIMIT AND THE ORIGINAL POSTED SPEED LIMIT. ONLY ONE OF TWO SIGNING STRATEGIES SHALL BE USED TO IMPLEMENT A WZSZ.

WZSZS USING DSL SIGN ASSEMBLIES SHALL BE IN ACCORDANCE WITH THIS NOTE, SUPPLEMENTAL SPECIFICATIONS 808, 908 AND TRAFFIC SCD **MT-104.10**

ONLY ONE WARRANTED SPEED LIMIT APPLIES AT ANY ONE TIME; SPEED LIMIT REDUCTIONS ARE NOT CUMULATIVE. WZSZS SHALL NOT BE USED FOR MOVING/MOBILE ACTIVITIES, AS DEFINED IN OMUTCD PART 6.

ITEM 614. WORK ZONE SPEED ZONES (WZSZS) (cont'd.)

WHEN LOOKING UP THE WARRANTED WORK ZONE SPEED LIMITS, ALWAYS USE THE ORIGINAL, PRE-CONSTRUCTION, POSTED SPEED LIMIT. DO NOT USE A PRIOR OR CURRENT WORK ZONE SPEED LIMIT AS A LOOK UP VALUE IN THE TABLE. POSITIVE PROTECTION IS GENERALLY REGARDED AS PORTABLE BARRIER OR OTHER RIGID BARRIER IN USE ALONG THE WORK AREA WITHIN THE SUBJECT WARRANTED WORK ZONE CONDITION. WITHOUT POSITIVE PROTECTION IS GENERALLY REGARDED AS USING DRUMS, CONES, SHADOW VEHICLE, ETC., ALONG THE WORK AREA WITHIN THE SUBJECT WARRANTED WORK ZONE CONDITION. WORKERS ARE CONSIDERED AS BEING PRESENT WHEN ON-SITE, WORKING WITHIN THE SUBJECT WARRANTED WORK ZONE CONDITION. WHEN THE WORK ZONE CONDITION REDUCING THE EXISTING FUNCTIONALITY OF THE TRAVEL LANES OR SHOULDERS IS REMOVED, THE SPEED LIMIT DISPLAYED SHALL RETURN TO THE ORIGINAL POSTED SPEED LIMIT.

TABLE 1: WARRANTED WORK ZONE SPEED LIMITS (MPH) FOR WORK ZONES ON HIGH-SPEED (≥ 55 MPH) MULTI-LANE HIGHWAYS.

ORIGINAL POSTED SPEED LIMIT	WITH POSITIVE PROTECTION		WITHOUT POSITIVE PROTECTION	
	WORKERS PRESENT	WORKERS NOT PRESENT	WORKERS PRESENT	WORKERS NOT PRESENT
70	60	65	55	65
65	55	60	50	60
60	55	60	50	60
55	50	55	45	55

A TOTAL OF 3 DSL SIGN ASSEMBLIES WILL BE REQUIRED FOR THIS PROJECT.

(2 MILE RESURFACING WORK ZONE)
U.S. 33 EB & WB: 3 DSL x 2 MONTHS = 6 SNMT

ITEM 614, DIGITAL SPEED LIMIT (DSL) SIGN ASSEMBLY
LOCATION 1: 6 SNMT

ITEM 614, PORTABLE CHANGEABLE MESSAGE SIGN, AS PER PLAN

THE CONTRACTOR SHALL FURNISH, INSTALL, MAINTAIN AND REMOVE, WHEN NO LONGER NEEDED, A CHANGEABLE MESSAGE SIGN, ON SITE, FOR THE DURATION OF THE PROJECT. THE SIGN SHALL BE OF A TYPE SHOWN ON A LIST OF APPROVED PCMS UNITS AVAILABLE ON THE OFFICE OF MATERIALS MANAGEMENT WEB PAGE. THE LIST CONTAINS CLASS A AND B UNITS WITH MINIMUM LEGIBILITY DISTANCES OF 650 FEET AND 475 FEET, RESPECTIVELY.

EACH SIGN SHALL BE TRAILER-MOUNTED AND EQUIPPED WITH A FUNCTIONAL DIMMING MECHANISM, TO DIM THE SIGN DURING DARKNESS, AND A TAMPER AND VANDAL PROOF ENCLOSURE. EACH SIGN SHALL BE PROVIDED WITH APPROPRIATE TRAINING AND OPERATION INSTRUCTIONS TO ENABLE ON-SITE PERSONNEL TO OPERATE AND TROUBLESHOOT THE UNIT. THE SIGN SHALL ALSO BE CAPABLE OF BEING POWERED BY AN ELECTRICAL SERVICE DROP FROM A LOCAL UTILITY COMPANY. THE PCMS SHALL BE DELINEATED IN ACCORDANCE WITH C&MS 614.03.

THE PROBABLE PCMS LOCATIONS AND WORK LIMITS FOR THOSE LOCATIONS ARE SHOWN ON SHEET(S) OF THE PLAN. PLACEMENT, OPERATION, MAINTENANCE AND ALL ACTIVATION OF THE SIGNS BY THE CONTRACTOR SHALL BE AS DIRECTED BY THE ENGINEER. THE PCMS SHALL BE LOCATED IN A HIGHLY VISIBLE POSITION YET PROTECTED FROM TRAFFIC. THE CONTRACTOR SHALL, AT THE DIRECTION OF THE ENGINEER, RELOCATE THE PCMS TO IMPROVE VISIBILITY OR ACCOMMODATE CHANGED CONDITIONS. WHEN NOT IN USE, THE PCMS SHALL BE TURNED OFF. ADDITIONALLY, WHEN NOT IN USE FOR EXTENDED PERIODS OF TIME, THE PCMS SHALL BE TURNED, FACING AWAY FROM ALL TRAFFIC.

THE ENGINEER SHALL BE PROVIDED ACCESS TO EACH SIGN UNIT AND SHALL BE PROVIDED WITH APPROPRIATE TRAINING AND OPERATION INSTRUCTIONS TO ENABLE ODOT PERSONNEL TO OPERATE AND TROUBLESHOOT THE UNIT, AND TO REVISE SIGN MESSAGES, IF NECESSARY.

THE CONTRACTOR SHALL IMPLEMENT A SYSTEM WHEREBY CHANGEABLE MESSAGES WILL BE IMPLEMENTED WITHIN 2 HOURS FOLLOWING TELEPHONE NOTIFICATION FROM THE PROJECT ENGINEER TO A DESIGNATED PHONE.

ALL MESSAGES TO BE DISPLAYED ON THE SIGN WILL BE PROVIDED BY THE ENGINEER. A LIST OF ALL REQUIRED PRE-PROGRAMMED MESSAGES WILL BE GIVEN TO THE CONTRACTOR AT THE PROJECT PRECONSTRUCTION CONFERENCE. THE SIGN SHALL HAVE THE CAPABILITY TO STORE UP TO 99 MESSAGES. MESSAGE MEMORY OR PRE-PROGRAMMED DISPLAYS SHALL NOT BE LOST AS A RESULT OF POWER FAILURES TO THE ON-BOARD COMPUTER. THE SIGN LEGEND SHALL BE CAPABLE OF BEING CHANGED IN THE FIELD. THREE-LINE PRESENTATION FORMATS WITH UP TO SIX MESSAGE PHASES SHALL BE SUPPORTED. PCMS FORMAT SHALL PERMIT THE COMPLETE MESSAGE FOR EACH PHASE TO BE READ AT LEAST TWICE.

THE PCMS SHALL CONTAIN AN ACCURATE CLOCK AND PROGRAMMING LOGIC WHICH WILL ALLOW THE SIGN TO BE ACTIVATED, DEACTIVATED OR MESSAGES CHANGED AUTOMATICALLY AT DIFFERENT TIMES OF THE DAY FOR DIFFERENT DAYS OF THE WEEK.

THE PCMS UNIT SHALL BE MAINTAINED IN GOOD WORKING ORDER BY THE CONTRACTOR IN ACCORDANCE WITH THE PROVISIONS OF C&MS 614.07. THE CONTRACTOR SHALL, PRIOR TO ACTIVATING THE UNIT, MAKE ARRANGEMENTS, WITH AN AUTHORIZED SERVICE AGENT FOR THE PCMS, TO ASSURE PROMPT SERVICE IN THE EVENT OF FAILURE. ANY FAILURE SHALL NOT RESULT IN THE SIGN BEING OUT OF SERVICE FOR MORE THAN 12 HOURS, INCLUDING WEEKENDS. FAILURE TO COMPLY MAY RESULT IN AN ORDER TO STOP WORK AND OPEN ALL TRAFFIC LANES AND/OR IN THE DEPARTMENT TAKING APPROPRIATE ACTION TO SAFELY CONTROL TRAFFIC. THE ENTIRE COST TO CONTROL TRAFFIC, ACCRUED BY THE DEPARTMENT DUE TO THE CONTRACTOR'S NONCOMPLIANCE, WILL BE DEDUCTED FROM MONEYS DUE, OR TO BECOME DUE THE CONTRACTOR ON HIS CONTRACT.

ITEM 614, PORTABLE CHANGEABLE MESSAGE SIGN, AS PER PLAN (cont'd.)

THE CONTRACTOR SHALL BE RESPONSIBLE FOR 24-HOUR-PER-DAY OPERATION AND MAINTENANCE OF THESE SIGNS ON THE PROJECT FOR THE DURATION OF THE PHASES WHEN THE PLAN REQUIRES THEIR USE.

PAYMENT FOR THE ABOVE DESCRIBED ITEM SHALL BE AT THE CONTRACT UNIT PRICE. PAYMENT SHALL INCLUDE ALL LABOR, MATERIALS, EQUIPMENT, FUELS, LUBRICATING OILS, SOFTWARE, HARDWARE AND INCIDENTALS TO PERFORM THE ABOVE DESCRIBED WORK.

A TOTAL OF 2 PCMS SHALL BE REQUIRED FOR THIS PROJECT.
2 SIGNS x 60 DAYS = 120 DAY (U.S. 33 PAVING)

**ITEM 614, PORTABLE CHANGEABLE MESSAGE SIGN, AS PER PLAN
LOCATION 1: 120 DAY**

I:\ProjectData\FAI\93015\Design\Roadway\Sheets\93015_MNO03.dgn 16-FEB-2017 5:51PM jutzl

CALCULATED
JLS
CHECKED
JSL

MAINTENANCE OF TRAFFIC NOTES

FAI-33-17.44

6
23

SEQUENCE OF OPERATIONS

IT IS THE INTENT OF THIS SEQUENCE OF OPERATIONS TO PROVIDE A WORK AREA FOR THE CONTRACTOR WHILE ALSO MAINTAINING TRAFFIC IN A MANNER WHICH IS SAFE FOR THE TRAVELING PUBLIC. IT MAY BE NECESSARY FOR THE CONTRACTOR TO ALTERNATE BETWEEN PHASES IN ORDER TO MEET WORK RESTRICTIONS FOUND IN ODOT'S "DROP-OFFS IN WORK ZONES" STANDARD DRAWING MT-101.90.

IF THE CONTRACTOR SO ELECTS, HE/SHE MAY SUBMIT ALTERNATE METHODS FOR THE MAINTENANCE OF TRAFFIC, PROVIDED THE INTENT OF THE ABOVE PROVISIONS ARE FOLLOWED AND NO ADDITIONAL INCONVENIENCE TO THE TRAVELING PUBLIC RESULTS THEREFROM. NO ALTERNATE PLAN SHALL BE PLACED INTO EFFECT UNTIL APPROVAL HAS BEEN GRANTED, IN WRITING, BY THE ENGINEER.

ALL FULL DEPTH PAVEMENT REPAIRS SHALL BE COMPLETED PRIOR TO PLANING.

ALL WORK NOT SPECIFIED IN THE SEQUENCE OF OPERATIONS CAN BE COMPLETED ANYTIME DURING THE DURATION OF THE PROJECT AT THE APPROVAL OF THE ENGINEER.

PHASE 1: BEGIN PROJECT TO END PROJECT

- (1) INSTALL NECESSARY TRAFFIC CONTROL DEVICES, CLOSE OUTSIDE LANE AND MAINTAIN TRAFFIC BY USE OF THE INSIDE LANE AND PAVED SHOULDER.
- (2) FILL IN RUMBLE STRIPS ON OUTSIDE SHOULDER WITH ITEM 441, INTERMEDIATE COURSE, TYPE 1 TO ALLOW FOR MAINTAINING TRAFFIC ON SHOULDER.
- (3) REMOVE TRAFFIC CONTROL DEVICES FOR CLOSING INSIDE LANE.

PHASE 2: BEGIN PROJECT TO END PROJECT

- (1) INSTALL NECESSARY TRAFFIC CONTROL DEVICES, CLOSE INSIDE LANE AND MAINTAIN TRAFFIC BY USE OF THE OUTSIDE LANE AND PAVED SHOULDER.
- (2) PLANE INSIDE LANE AND SHOULDER AT 1.5 INCHES.
- (3) PLACE 1.5 INCHES OF ITEM 806, ASPHALT CONCRETE SURFACE COURSE ON INSIDE LANE AND SHOULDER PER TYPICAL SECTION.
- (4) REMOVE TRAFFIC CONTROL DEVICES FOR CLOSING INSIDE LANE.

PHASE 3: BEGIN PROJECT TO END PROJECT

- (1) INSTALL NECESSARY TRAFFIC CONTROL DEVICES, CLOSE OUTSIDE LANE, AND MAINTAIN TRAFFIC BY USE OF THE INSIDE LANE AND PAVED SHOULDER.
- (2) PLANE OUTSIDE LANE AND SHOULDER AT 1.5 INCHES.
- (3) PLACE 1.5 INCHES OF ITEM 806, ASPHALT CONCRETE SURFACE COURSE ON OUTSIDE LANE AND SHOULDER PER TYPICAL SECTION.
- (4) REMOVE TRAFFIC CONTROL DEVICES FOR CLOSING OUTSIDE LANE.

PHASE 4: BEGIN PROJECT TO END PROJECT

- (1) INSTALL NECESSARY TRAFFIC CONTROL DEVICES TO MAINTAIN TRAFFIC FOR TURN LANES, RAMPS, AND INTERSECTIONS.
- (2) PLANE TURN LANES, RAMP AREAS, AND INTERSECTIONS AT 1.5 INCHES.
- (3) PLACE 1.5 INCHES OF ITEM 806, ASPHALT CONCRETE SURFACE COURSE ON TURN LANES AND RAMP AREAS.
- (4) REMOVE TRAFFIC CONTROL DEVICES. INSTALL "GROOVED PAVEMENT" SIGNS AT INTERSECTIONS.

PHASE 5: BEGIN PROJECT TO END PROJECT

- (1) INSTALL NECESSARY TRAFFIC CONTROL DEVICES TO MAINTAIN TRAFFIC FOR INTERSECTIONS.
- (2) PLACE 1.5 INCHES OF ITEM 441, ASPHALT CONCRETE SURFACE COURSE PG64-22 AT INTERSECTIONS.
- (3) REMOVE TRAFFIC CONTROL DEVICES.

PHASE 6: BEGIN PROJECT TO END PROJECT

- (1) PLACE COMPACTED AGGREGATE, INSTALL RUMBLE STRIPS, AND PLACE ALL PERMANENT PAVEMENT MARKINGS AND RAISED PAVEMENT MARKERS. OPEN ROADWAY TO UNRESTRICTED TRAFFIC.

ALL TEMPORARY OR PERMANENT PAVEMENT MARKINGS SHALL BE IN PLACE BEFORE ANY PAVEMENT IS OPENED TO TRAFFIC.

ITEM 441, ASPHALT CONCRETE INTERMEDIATE COURSE, TYPE 1, (448)

THIS ITEM SHALL BE USED TO FILL IN RUMBLE STRIPS FOR MAINTAINING TRAFFIC AS DESCRIBED IN PHASE 1 ABOVE. AVERAGE THICKNESS FOR CALCULATION PURPOSES IS 0.75 INCHES. THE FOLLOWING QUANTITY HAS BEEN CARRIED TO THE GENERAL SUMMARY.

$(17.44 - 24.86) \times 5,280 = 39,177.6'$
 $(2(39,178' \times 2.0' \times (0.75"/12))) / 27 = 362.8 \text{ CY}$

ITEM 441, ASPHALT CONCRETE INTERMEDIATE COURSE, TYPE 1, (448)
LOCATION 1: 363 CY

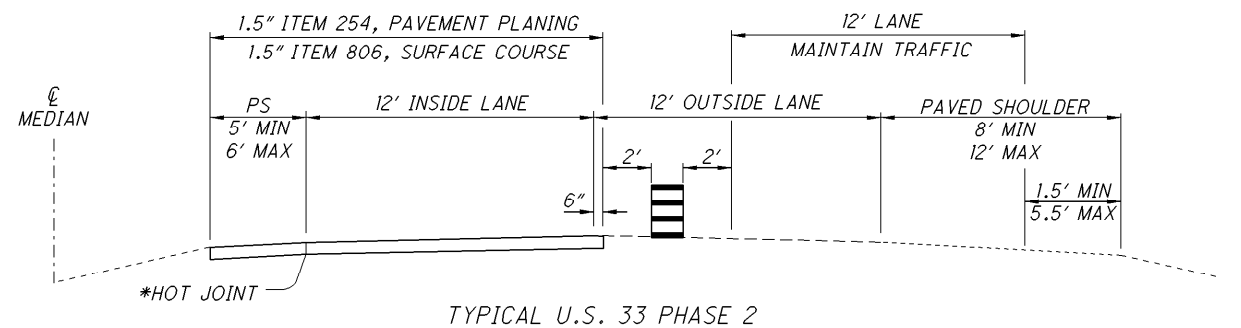
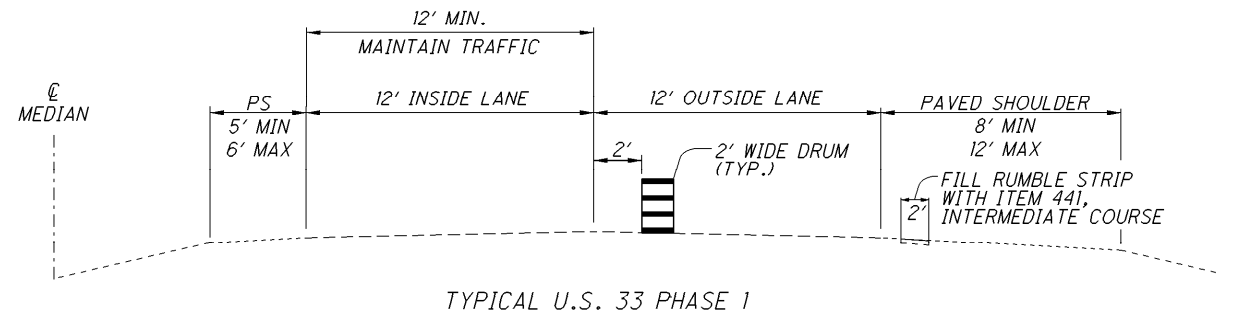

* A COLD JOINT MAY BE CONSTRUCTED AT RAMPS AND TURN LANES WHERE PAVING WIDTH INCREASES SET PAVER LIMITS

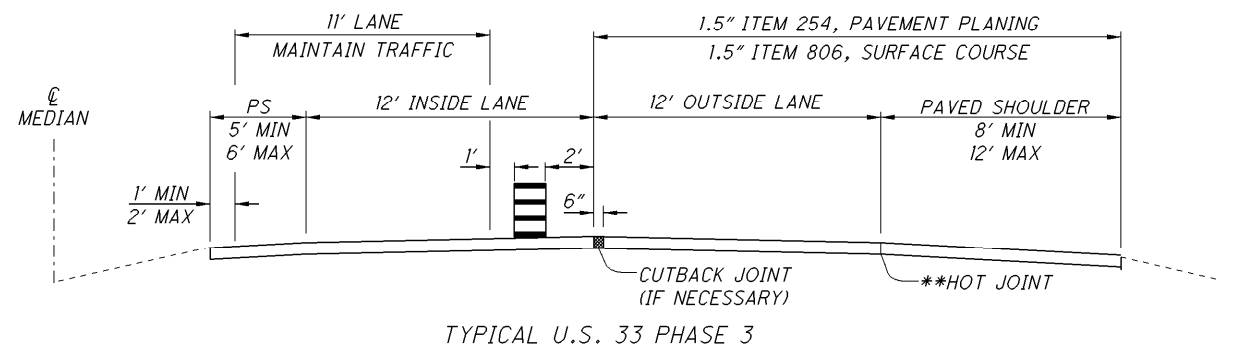

* SHOULDER WIDTH VARIES IN RAMP AND TURN LANE AREAS
 * A COLD JOINT MAY BE CONSTRUCTED AT RAMPS AND TURN LANES WHERE PAVING WIDTH INCREASES SET PAVER LIMITS

CALCULATED
JLS
CHECKED
JSL

SEQUENCE OF OPERATIONS

FAI-33-17.44

I:\ProjectData\FAN\93015\Design\Roadway\Sheets\93015_MN004.dgn jlutzi 16-FEB-2017 5:51PM

LEGEND FOR STRAIGHT LINE DIAGRAMS

STANDARD SURFACE CLASSIFICATIONS		STANDARD BASE CLASSIFICATIONS	
CODE	DESCRIPTION	CODE	DESCRIPTION
B	Brick	F	Crack and Seat - Concrete
D	Reinforced Concrete (1)	H	Rubblize and Roll - Concrete
E	Plain Concrete (1)	I	Aggregate Base 304 or Traffic Compacted
G	Bituminous Concrete, Such as 404, 412, 805, 807, 826, 827, or 829.	K	Water Bound Macadam Such as 303
I	409 Seal Coat on Penetration Macadam or 303 Water Bound Macadam.	L	Plant Mix Bituminous Concrete 301, 302, 806, or Penetration Macadam
K	Open Graded Bituminous Cold Mix 405 or Bituminous Road Mix 406.	N	Plain Concrete
L	Surface Seal with Cover, Such as 409 over Traffic Compacted or Stabilized. (2)	P	Reinforced Concrete
S	Wood - Bridge Deck (1)	R	Brick - Flexible
Z	Right-of-Way Only	T	Brick - Rigid
		D	Reinforced Concrete (3)
		E	Plain Concrete (3)

- Notes:
- (1) No base entry necessary.
 - (2) Classified as wearing surface only on stabilized or traffic bound.
 - (3) Concrete overlay resurfaced with bituminous material.

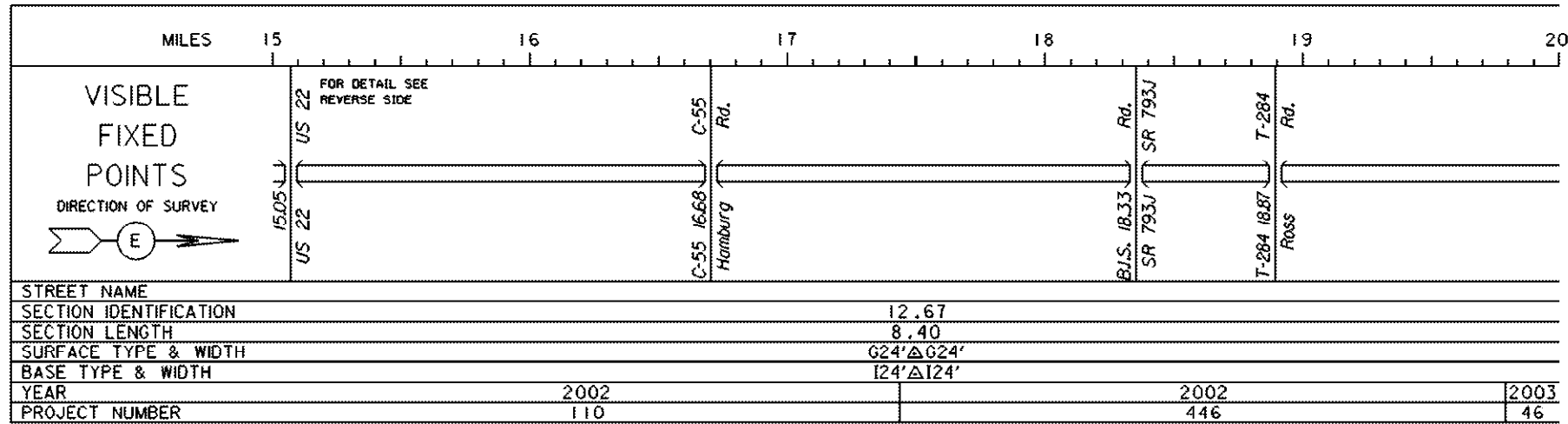

BEGIN WORK 17.44

U.S. 33 (Fai. Co.) Location 1

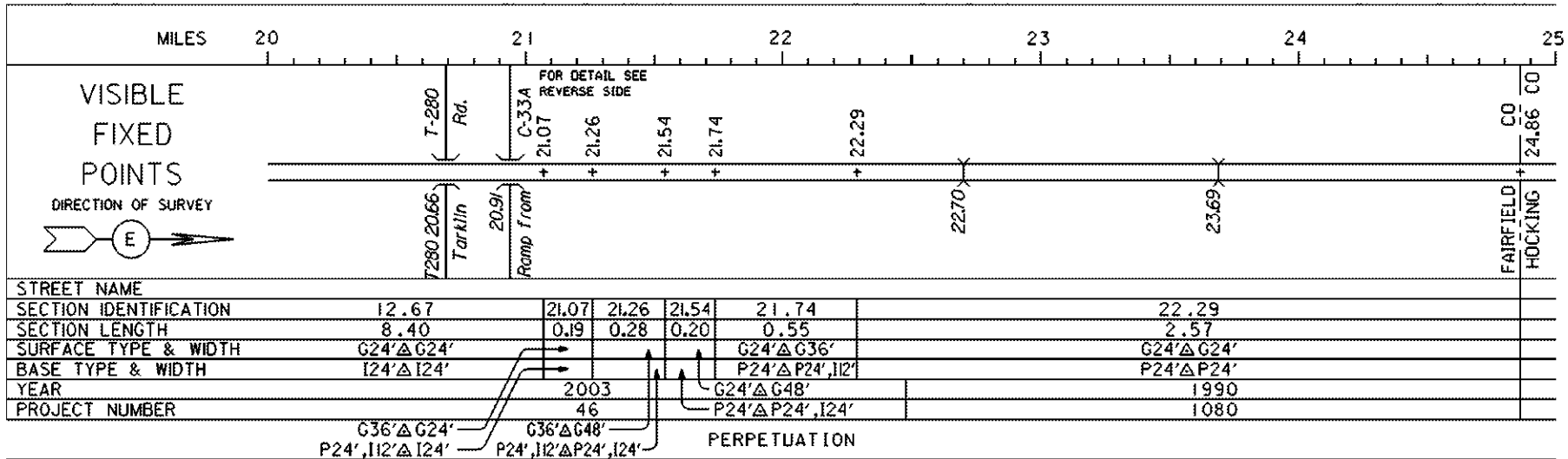

U.S. 33 (Fai. Co.) Location 1

END WORK 24.86

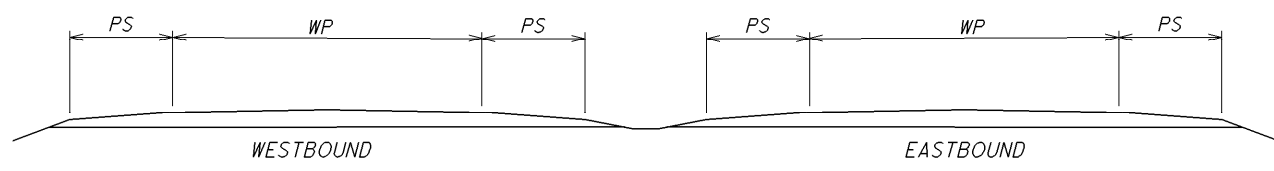

WP = WIDTH OF PAVEMENT
PS = PAVED SHOULDER

TYPICAL 1

Pavement Data														
Location	County	Route	Begin Log Point (SLM)	End Log Point (SLM)	Length		Pavement Width (FT)	Typical	Pavement Area (SY)	254	407	442	806	
					Miles	Lin. Ft.				PAVEMENT PLANING, ASPHALT CONCRETE, 1.50"	NON-TRACKING TACK COAT (@ 0.08 Gal/SY)	ANTI-SEGREGATION EQUIPMENT	Thickness	SURFACE COURSE, 12.5 MM TYPE A, AS PER PLAN
										SY	GAL	CY	Inches	CY
1	Fai.	U.S. 33 E.B.	17.44	24.86	7.42	39,177.60	24.0	1	104,473.6	104,473.6	8,357.9	4,353.1	1.50	4,353.1
			21.36	21.74	0.38	2,006.40	24.0	1	5,350.4	5,350.4	428.1	223.0	1.50	223.0
			21.74	21.87	0.13	686.40	18.0 (Avg.)	1	1,372.8	1,372.8	109.9	57.2	1.50	57.2
			21.87	22.28	0.41	2,164.80	12.0	1	2,886.4	2,886.4	231.0	120.3	1.50	120.3
			22.28	22.44	0.16	844.80	6.0 (Avg.)	1	563.2	563.2	45.1	23.5	1.50	23.5
			Ramp M (Ramp from U.S. 33 BR)		0.54	2,870.61	24.0	1	7,655.0	7,655.0	612.4	319.0	1.50	319.0
1	Fai.	U.S. 33 W.B.	24.86	17.44	7.42	39,177.60	24.0	1	104,473.6	104,473.6	8,357.9	4,353.1	1.50	4,353.1
			21.58	21.57	0.01	52.80	6.0 (Avg.)	1	35.2	35.2	2.9	1.5	1.50	1.5
			21.57	21.15	0.42	2,217.60	12.0	1	2,956.8	2,956.8	236.6	123.2	1.50	123.2
			Ramp N (Ramp to U.S. 33 BR)		0.30	1,569.70	24.0	1	4,185.9	4,185.9	334.9	174.5	1.50	174.5
Bridge Deductions (Bridge Length x Pavement Width)									(4,996.5)	(4,996.5)	(399.7)	(208.1)	1.50	(208.1)
Sub-Totals									228,956.4	18,317.0	9,540.3		9,540.3	
Location 1 Totals (Carried to General Summary)									228,957	18,317	9,541		9,541	

I:\ProjectData\FAI\93015\Design\Roadway\Sheets\93015_G0001.dgn 16-FEB-2017 5:51PM jlutzi

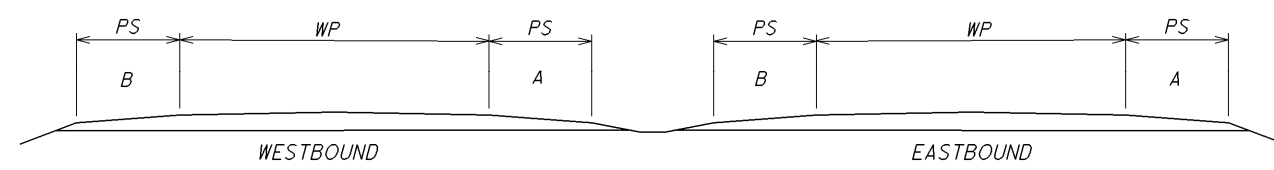

WP = WIDTH OF PAVEMENT
PS = PAVED SHOULDER

TYPICAL 1

Shoulder Data																				
Location	County	Route	Begin Log Point (SLM)	End Log Point (SLM)	Length		Typical	Shoulder Width (FT.) (Widths are Average Throughout Section)		Shoulder Area (SY)	254	407	408	Thickness	806	Thickness	617	618		
					Miles	Lin. Ft.		A	B		PAVEMENT PLANING, ASPHALT CONCRETE, 1.50"	NON-TRACKING TACK COAT (@ 0.08 Gal/SY)	PRIME COAT, AS PER PLAN (@ 0.40 Gal/SY)		SURFACE COURSE, 12.5 MM, TYPE A, AS PER PLAN		COMPACTED AGGREGATE, AS PER PLAN (2' Width)	RUMBLE STRIPS (ASPHALT CONCRETE)		
								SY	GAL		GAL	Inches	CY		Inches		CY	MILE		
1	Fai.	U.S. 33 E.B.	17.44	21.67	4.23	22,334.40	1	10.0		24,816.0	24,816.0	1,985.3	1,985.3	1.50	1,034.0	2.00	275.7	4.23		
			21.67	21.80	0.13	686.40	1	12.0		915.2	915.2	73.3	61.1	1.50	38.2	2.00	8.5	0.13		
			21.80	22.44	0.64	3,379.20	1	10.0		3,754.7	3,754.7	300.4	300.4	1.50	156.5	2.00	41.7	0.64		
			22.44	24.86	2.42	12,777.60	1	8.0		11,357.9	11,357.9	908.7	1,135.8	1.50	473.3	2.00	157.7	2.42		
		17.44	21.20	3.76	19,852.80	1		6.0	13,235.2	13,235.2	1,058.9	1,764.7	1.50	551.5	2.00	245.1	3.76			
		21.20	22.34	1.14	6,019.20	1		10.0	6,688.0	6,688.0	535.1	535.1	1.50	278.7	2.00	74.3	1.14			
		22.34	24.86	2.52	13,305.60	1		5.0	7,392.0	7,392.0	591.4	1,182.8	1.50	308.0	2.00	164.3	2.52			
					Ramp M (Ramp from U.S. 33 BR)		0.54	2,870.61	1	10.0	3,189.6	3,189.6	255.2	255.2	1.50	132.9	2.00	35.4	0.54	
					Ramp M (Ramp from U.S. 33 BR)		0.54	2,870.61	1	6.0	1,913.7	1,913.7	153.1	255.2	1.50	79.8	2.00	35.4	0.54	
				U.S. 33 W.B.	24.86	21.62	3.24	17,107.20	1	8.0	15,206.4	15,206.4	1,216.6	1,520.7	1.50	633.6	2.00	211.2	3.24	
					21.62	21.57	0.05	264.00	1	10.0	293.3	293.3	23.5	23.5	1.50	12.3	2.00	3.3	0.05	
			21.57	21.10	0.47	2,481.60	1	12.0	3,308.8	3,308.8	264.8	220.6	1.50	137.9	2.00	30.6	0.47			
			21.10	17.44	3.66	19,324.80	1	10.0	21,472.0	21,472.0	1,717.8	1,717.8	1.50	894.7	2.00	238.6	3.66			
			24.86	21.62	3.24	17,107.20	1		9,504.0	9,504.0	760.4	1,520.7	1.50	396.0	2.00	211.2	3.24			
			21.62	17.44	4.18	22,070.40	1		14,713.6	14,713.6	1,177.1	1,961.9	1.50	613.1	2.00	272.5	4.18			
			Ramp N (Ramp to U.S. 33 BR)		0.30	1,569.70	1	12.0	2,092.9	2,092.9	167.5	139.6	1.50	87.3	2.00	19.4	0.30			
			Ramp N (Ramp to U.S. 33 BR)		0.30	1,569.70	1	6.0	1,046.5	1,046.5	83.8	139.6	1.50	43.7	2.00	19.4	0.30			
			Bridge Deductions (Bridge Length x Shoulder Width)							(3,331.0)	(3,331.0)	(266.4)	(130.9)	1.50	(138.7)	2.00	(18.2)	(0.28)		
			Sub-Totals								115,803.5	11,006.5	14,589.1		5,732.8		2,026.1	31.08		
			Location 1 Totals (Carried to General Summary)								115,804	11,007	14,590		5,733		2,027	31.08		

SHOULDER DATA

FAI-33-17.44

i:\ProjectData\FAI\93015_Design\Roadway\Sheets\93015_G0002.dgn 16-FEB-2017 5:51PM jljtzl

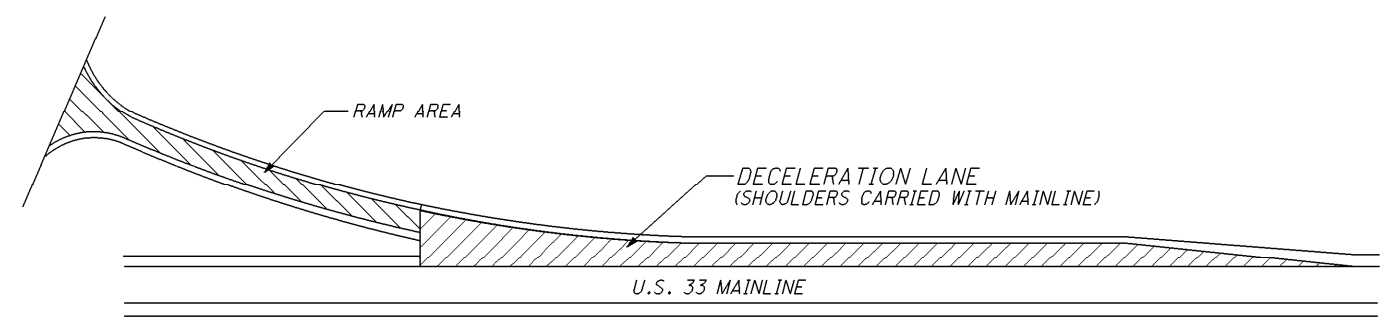
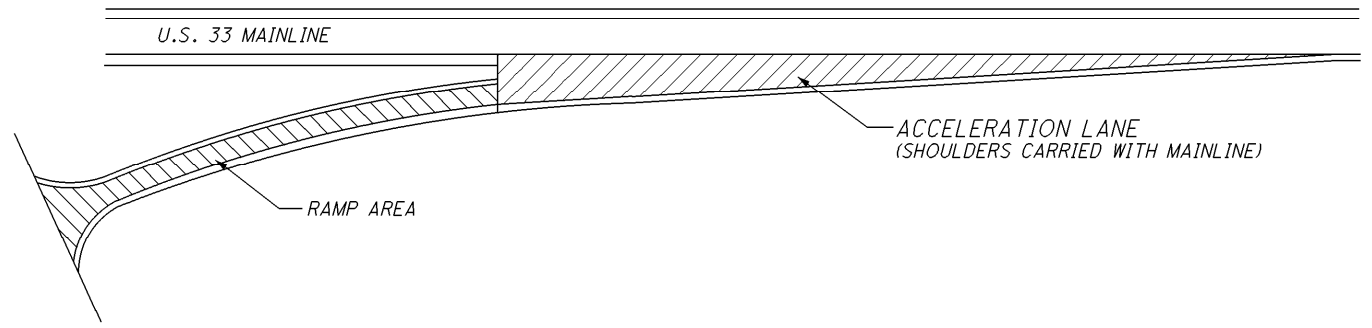

Extra Area Data

Location	County	Route	Description	Ramp/Turn Lanes (FT)		Extra Area (SY) (* - Area by Computer)	202	254	407	441		442	806	
				Width	Length		WEARING COURSE REMOVED	PAVEMENT PLANING, ASPHALT CONCRETE, 1.50"	NON-TRACKING TACK COAT (@ 0.08 Gal/SY)	Thickness	ASPHALT CONCRETE SURFACE COURSE, TYPE 1, (448) PG 64-22	ANTI-SEGREGATION EQUIPMENT	Thickness	SURFACE COURSE, 12.5 MM, TYPE A, ASPER PLAN
							SY	SY	GAL	Inches	CY	CY	Inches	CY
1	Fai.	U.S. 33	Median Crossover @ S.L.M. 18.11			318.4 (*)	318.4		25.5	1.50	13.3			
			Median Crossover @ S.L.M. 18.56			318.4 (*)	318.4		25.5	1.50	13.3			
			Median Crossover @ S.L.M. 19.99			318.4 (*)	318.4		25.5	1.50	13.3			
			Median Crossover @ S.L.M. 22.47			318.4 (*)	318.4		25.5	1.50	13.3			
			Median Crossover @ S.L.M. 22.97			318.4 (*)	318.4		25.5	1.50	13.3			
			Median Crossover @ S.L.M. 23.96			318.4 (*)	318.4		25.5	1.50	13.3			
			Median Crossover @ S.L.M. 24.32			318.4 (*)	318.4		25.5	1.50	13.3			
			Median Crossover @ S.L.M. 24.64			318.4 (*)	318.4		25.5	1.50	13.3			
		U.S. 33 E.B.	Deceleration Lane to Tarkiln Rd. (Ramp K)	Varies	Varies	1,686.3 (*)		1,686.3	135.0			70.3	1.50	70.3
			Acceleration Area from U.S. 33 BR (Ramp M)	Varies	Varies	1,367.2 (*)		1,367.2	109.4			57.0	1.50	57.0
			Left Turn Lane at Main St.	Varies	Varies	1,307.6 (*)		1,307.6	104.7			54.5	1.50	54.5
			Sharp Rd.			486.5 (*)	486.5		39.0	1.50	20.3			
		U.S. 33 W.B.	Left Turn Lane at Sharp Rd.	Varies	Varies	541.7 (*)		541.7	43.4			22.6	1.50	22.6
			Main St.			446.6 (*)	446.6		35.8	1.50	18.7			
			Deceleration Area to U.S. 33 BR (Ramp N)	Varies	Varies	3,778.2 (*)		3,778.2	302.3			157.5	1.50	157.5
			Ramp N Left Turn Lane to Tarkiln Rd.	Varies	Varies	917.7 (*)		917.7	73.5			38.3	1.50	38.3
			Acceleration Lane from Tarkiln Rd. (Ramp L)	Varies	Varies	2,088.4 (*)		2,088.4	167.1			87.1	1.50	87.1
Sub-Totals							3,480.3	8,681.0	973.6		145.4	361.9		361.9
Location 1 Totals (Carried to General Summary)							3,481	8,681	974		146	362		362

DETAIL 1

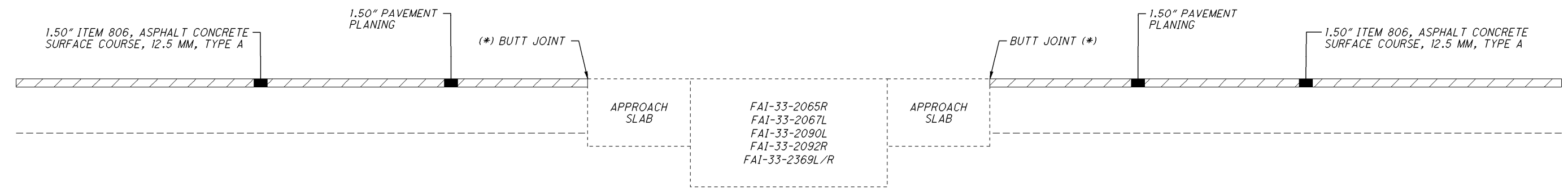

BUTT JOINTS AT APPROACH SLABS

(*) - ITEM 516, 2" DEEP JOINT SEALER, AS PER PLAN (A)

 - ITEM 254, PAVEMENT PLANING, ASPHALT CONCRETE

DETAIL 2

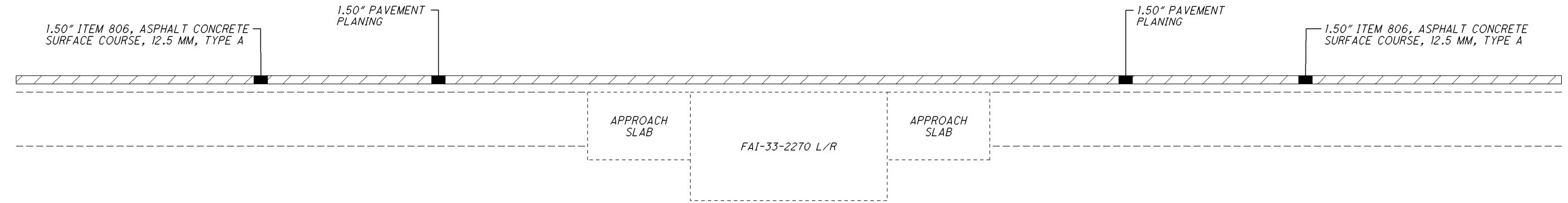

MILL AND FILL SAME AS ROADWAY

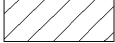
 - ITEM 254, PAVEMENT PLANING, ASPHALT CONCRETE

i:\ProjectData\FAI\93015\Design\Roadway\Sheets\93015_SN001.dgn 16-FEB-2017 5:51PM jlut1

PROJECT LOCATIONS								BRIDGE		PAVEMENT MARKINGS				
								512	516	646	646	646	646	
LOCATION	COUNTY	ROUTE	BRIDGE NUMBER	SFN	LATITUDE	LONGITUDE	FEATURES INTERSECTED	SEALING CONCRETE BRIDGE DECKS WITH HMWM, AS PER PLAN		2" DEEP JOINT SEALER, AS PER PLAN (B)	EDGE LINE, 6"	LANE LINE, 6"	CENTERLINE	REMOVAL OF PAVEMENT MARKING
								DECK/BACK WALL	APPROACH SLAB					
								SQ YD	SQ YD					
1	FAI	US 33	20.65R	2300915	39.664622	-82.564355	EB US 33 OVER TARKIN ROAD	955	289	155	0.08	0.04		0.12
2	FAI	US 33	20.67L	2300958	39.664622	-82.563991	WB US 33 OVER TARKIN ROAD	916	289	155	0.08	0.04		0.12
3	FAI	US 33	20.90L	2301008	39.661805	-82.561330	WB US 33 OVER CR 33A	1689	289	160	0.13	0.06		0.19
4	FAI	US 33	20.92R	2300974	39.661533	-82.561427	EB US 33 OVER CR 33A	1689	289	160	0.13	0.06		0.19
5	FAI	US 33	23.69L	2301083	39.622383	-82.550744	HOCKING RIVER	659	222	92	0.08	0.04		0.12
6	FAI	US 33	23.69R	2301113	39.622461	-82.550988	HOCKING RIVER	659	222	92	0.08	0.04		0.12
7	FAI	CR 90	1.78	2300834	39.667886	-82.606663	US 33 UNDER BIS ROAD	1412	200	94	0.15		0.08	0.23
8	FAI	TR 284	0.66	2300869	39.667541	-82.596499	US 33 UNDER ROSS RD T284	1132	200	94	0.13		0.06	0.19
SUB-TOTAL								9111	2000	1002	0.86	0.28	0.14	1.28
TOTAL								11111						

EXISTING STRUCTURE VERIFICATION

DETAILS AND DIMENSIONS SHOWN ON THESE PLANS PERTAINING TO THE EXISTING STRUCTURE HAVE BEEN OBTAINED FROM PLANS OF THE EXISTING STRUCTURE AND FROM FIELD OBSERVATIONS AND MEASUREMENTS. CONSEQUENTLY, THEY ARE INDICATIVE OF THE EXISTING STRUCTURE AND THE PROPOSED WORK BUT THEY SHALL BE CONSIDERED TENTATIVE AND APPROXIMATE. THE CONTRACTOR IS REFERRED TO CMS SECTIONS 102.05 AND 105.02.

BASE CONTRACT BID PRICES UPON A RECOGNITION OF THE UNCERTAINTIES DESCRIBED ABOVE AND UPON A PREBID EXAMINATION OF THE EXISTING STRUCTURE. HOWEVER, THE DEPARTMENT WILL PAY FOR ALL PROJECT WORK BASED UPON ACTUAL DETAILS AND DIMENSIONS THAT HAVE BEEN VERIFIED IN THE FIELD.

PERMANENT PAVEMENT MARKINGS

THE FOLLOWING PAVEMENT MARKING AND REMOVAL ITEMS HAVE BEEN CARRIED TO THE GENERAL SUMMARY AND ARE TO BE USED AS DIRECTED BY THE ENGINEER.

ITEM 512, SEALING CONCRETE BRIDGE DECKS WITH HMWM RESIN, AS PER PLAN

THIS WORK CONSISTS OF SEALING CONCRETE DECKS WITH HMWM AS PER CMS 512.04 AND 705.25. CONTRACTOR SHALL ENSURE ALL DIRT AND DEBRIS IS CLEARED FROM BRIDGE AND EXPANSION JOINTS PRIOR TO SEALING AND ALL OTHER WORK SHALL BE DONE PRIOR TO SEALING THE BRIDGE DECK. REMOVE ALL PERMANENT PAVEMENT MARKINGS PRIOR TO SEALING THE DECK. PERFORM ALL CONCRETE PATCHING REQUIREMENTS PRIOR TO SEALING THE DECK. CONTRACTOR SHALL ENSURE THAT HMWM IS NOT APPLIED TO THE EXPANSION JOINTS OF THE BRIDGE. THE ABOVE WORK SHALL BE INCLUDED IN THE CONTRACT BID PRICE FOR ITEM 512, SEALING CONCRETE BRIDGE DECKS WITH HMWM RESIN, AS PER PLAN.

THE FOLLOWING TABLE SHOWS THE ESTIMATED QUANTITIES OF ITEM 512, SEALING CONCRETE BRIDGE DECKS WITH HMWM RESIN, AS PER PLAN.

ITEM 516, 2" DEEP JOINT SEALER, AS PER PLAN (B)

PERFORM THE FOLLOWING WORK PRIOR TO THE SEALING HAS BEEN PERFORMED ON THE BRIDGE DECK. FOR THE LOCATIONS PROVIDED REMOVE ANY COMPRESSION SEAL, FOREIGN MATERIAL, AND DEBRIS FROM THE EXISTING JOINT BETWEEN THE APPROACH SLAB AND ABUTMENT BACKWALL. ANY SPALLS ADJACENT TO THE JOINT LESS THAN OR EQUAL TO 3" SHALL BE CLEANED AND SEALED WITH THE JOINT. FOR SPALLS GREATER THAN 3" SEE ITEM 511, CLASS QC2 CONCRETE, MISC.: ACCELERATING ADMIXTURE NOTE. IF ONLY A SAWCUT EXISTS AT THIS LOCATION, PERFORM A NEW SAWCUT TO ESTABLISH A 1" WIDE BY 2" DEEP JOINT ALONG THIS INTERFACE. ONCE THE JOINT HAS BEEN OPENED OR CREATED, AIRBLAST THOROUGHLY PRIOR TO PLACEMENT OF HOT APPLIED JOINT SEALER AS PER 705.04 AS DIRECTED BY THE ENGINEER. PAYMENT FOR ALL LABOR, EQUIPMENT, AND MATERIALS SHALL BE INCLUDED IN THE UNIT PRICE BID FOR ITEM 516, JOINT SEALER, AS PER PLAN (B).

ITEM 511, CLASS QC2 CONCRETE, MISC.: ACCELERATING ADMIXTURE

TO EXPEDITE WORK, CLASS QC2 CONCRETE WITH AN ACCELERATING ADMIXTURE SIKA RAPID-1 OR ANY APPROVED EQUIVALENT ADMIXTURE SHALL BE USED IN ALL REPAIR LOCATIONS TO ACHIEVE 3,000 PSI COMPRESSIVE STRENGTH IN 12 HRS. USE A NON-CHLORIDE ACCELERATING ADMIXTURE AND PROVIDE DOCUMENTATION THAT THE MIX WILL PROVIDE THE STRENGTH IN THE SPECIFIED TIME.

THIS ITEM SHALL CONFORM TO CMS 511 WITH THE FOLLOWING CONDITIONS AND REVISIONS:

AT LEAST 5 DAYS PRIOR TO CONSTRUCTION, THE CONTRACTOR SHALL SUBMIT TO THE ENGINEER FOR APPROVAL A SCHEDULE OF REPAIR WORK ITEMS TO BE COMPLETED. THE SCHEDULE SHALL INCLUDE A BREAKDOWN OF ALL MAJOR WORK ACTIVITIES ON AN HOURLY BASIS. REPAIR WORK SHALL NOT BEGIN UNTIL THE SCHEDULE IS APPROVED BY THE ENGINEER.

THE CONTRACTOR SHALL CONTINUE THE WET CURE FOR THE MAXIMUM NUMBER OF HOURS POSSIBLE DURING THE PERMITTED LANE CLOSURE. THE CLOCK STARTS FOR THE WET CURE WHEN THE CONCRETE PLACEMENT IS COMPLETE.

TRAFFIC WILL NOT BE PERMITTED ON THE FINISHED CONCRETE SURFACE UNTIL AFTER COMPLETION OF A 12 HOUR MINIMUM WET CURE AND AFTER TWO TEST BEAMS HAVE ATTAINED AN AVERAGE MODULUS OF RUPTURE OF 400 PSI.

PAYMENT FOR ALL OF THE ABOVE DESCRIBED LABOR, EQUIPMENT, AND MATERIALS WILL BE MADE AT THE CONTRACT PRICE BID FOR ITEM 511, CLASS QC2 CONCRETE, MISC.: ACCELERATING ADMIXTURE.

AN ESTIMATED QUANTITY OF 2 CY HAS BEEN CARRIED TO THE GENERAL SUMMARY TO BE USED AS DIRECTED BY THE ENGINEER.

ITEM 516, 2" DEEP JOINT SEALER, AS PER PLAN (B)

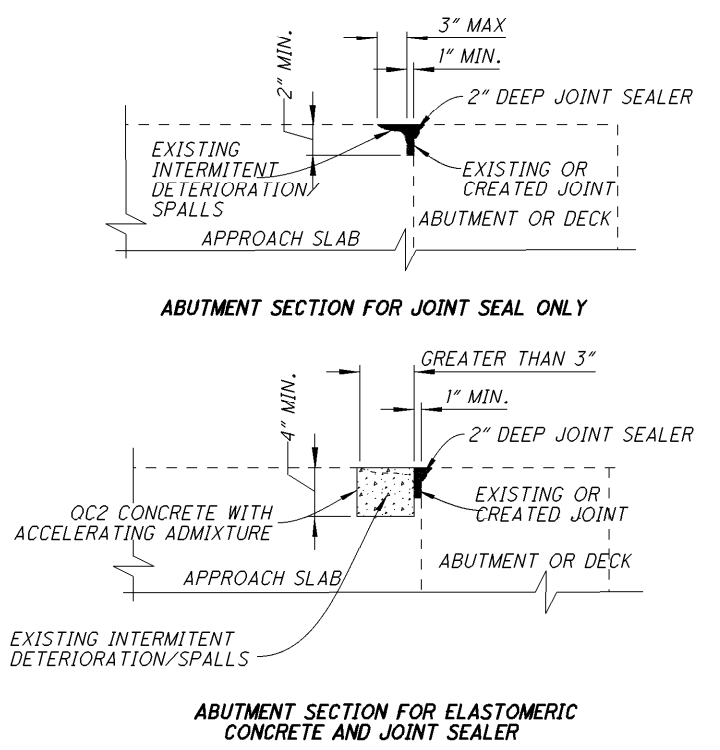

I:\FAI\93015\Design\Roadway\Sheets\93015_SN001.dgn

Edge Line Data													
Location	County	Route	Begin Log Point (SLM)	End Log Point (SLM)	Length (Miles)	Information Only						644	Remarks
						White Edge Line (Quantities)			Yellow Edge Line (Quantities)			EDGE LINE, 6"	
						Total Miles	Highway Miles	Ramp Miles	Total Miles	Highway Miles	Ramp Miles		
											MILE		
1	Fai.	U.S. 33 E.B.	17.44	24.86	7.42	7.42	7.42		7.42	7.42		14.84	4 Lane Divided
			Ramp M (Ramp from U.S. 33 BR)		0.54	0.54		0.54	0.54		0.54		1.08
		U.S. 33 W.B.	24.86	17.44	7.42	7.42	7.42		7.42	7.42		14.84	4 Lane Divided
		Ramp N (Ramp to U.S. 33 BR)		0.30	0.30		0.30	0.30		0.30		0.60	2 Lane Ramp
Location 1 Total (Carried to General Summary)											31.36		

Lane Line Data												
Location	County	Route	Begin Log Point (SLM)	End Log Point (SLM)	Length (Miles)	Information Only			644		Remarks	
						Lane Line (Quantities)			LANE LINE, 6"	CENTER LINE		
						Total Miles	Highway Miles	Ramp Miles				
											MILE	MILE
1	Fai.	U.S. 33 E.B.	17.44	24.86	7.42	7.42	7.42		7.42		4 Lane Divided	
			21.36	21.74	0.38	1.14	1.14		1.14		2 Additional Lanes	
			21.74	22.28	0.54	0.54	0.54		0.54		1 Additional Lane	
			Ramp M (Ramp from U.S. 33 BR)		0.54	0.54	0.54		0.54		2 Lane Ramp	
			Sharp Rd.		0.03					0.03	Double Solid Center Line/Sharp Rd. Approach	
		U.S. 33 W.B.	24.86	17.44	7.42	7.42	7.42		7.42		4 Lane Divided	
			21.57	21.15	0.42	0.42	0.42		0.42		Additional Lane	
		Ramp N (Ramp to U.S. 33 BR)		0.30	0.30	0.30		0.30		2 Lane Ramp		
		Main St.		0.02					0.02	Double Solid Center Line/Main St. Approach		
Location 1 Total (Carried to General Summary)											17.78	0.05

I:\ProjectData\FAI\93015\Design\Roadway\Sheets\93015_T00C2.dgn 16-FEB-2017 5:51PM jutzl

Auxiliary Marking Data														
Location	County	Route	Description	Side	644							Remarks		
					CHANNELIZING LINE, 12"	STOP LINE (24")	TRANSVERSE/ DIAGONAL LINE (24")		ISLAND MARKING	LANE ARROW			WORD ON PAVEMENT "ONLY"	DOTTED LINE, 6"
							White FT	FT		White FT	Yellow FT			
1	Fai.	U.S. 33 E.B.	Deceleration Lane to Tarkiln Rd. (Ramp K)		800								Place per TC-72.20	
			Acceleration Area from U.S. 33 BR (Ramp M)		1,100								2 Lane Drops. Place per TC-72.20	
			Lt. Turn Lane to Main St. (Sugar Grove)	Lt.	771	59	273	72	10	4		1	Place at Existing Location	
			Sharp Rd.	Rt.		22							Place at Existing Location	
		U.S. 33 W.B.	Lt. Turn Lane to Sharp Rd.	Lt.	275	43	26			2		1	Place at Existing Location	
			Main St.	Rt.		21							Place at Existing Location	
			Deceleration Area to U.S. 33 BR (Ramp N)		290								Place at Existing Location	
			Ramp N Turn Lane	Lt.	548	54	96	79		3		1	Ramp N Left Turn Lane to Tarkiln Rd.	
			Acceleration Lane from Tarkiln Rd. (Ramp L)		1,230								Place per TC-72.20	
Sub-Totals							395	151		9		3		
Location 1 Totals (Carried to General Summary)					5,014	199	546		10	9		3	2,245	

CALCULATED
JLS
CHECKED
JSL

PAVEMENT MARKING DATA (AUXILIARY)

FAI-33-17.44

I:\ProjectData\FAI\93015\Design\Roadway\Sheets\93015_TP001.dgn 16-FEB-2017 6:04PM jjutz1

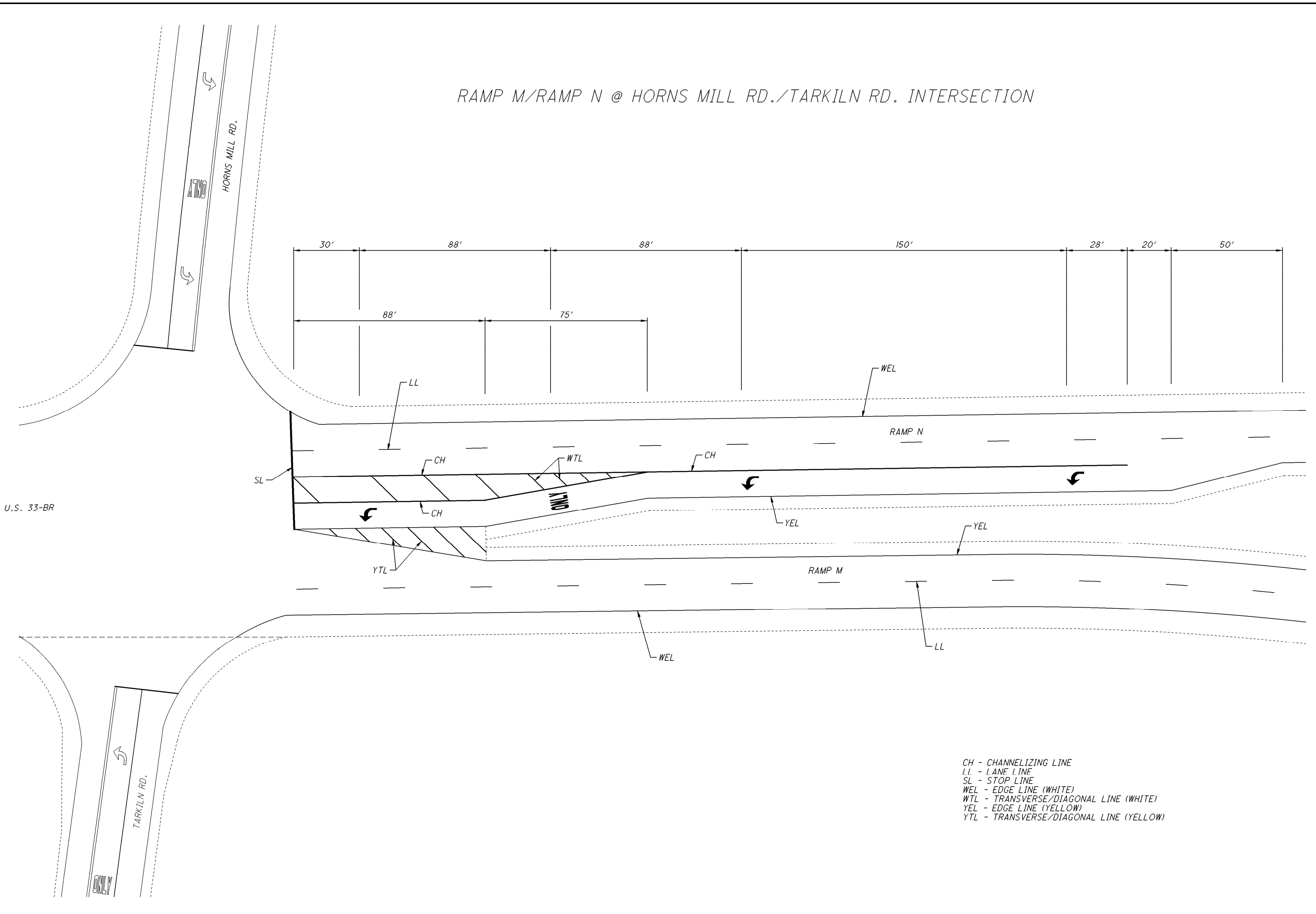

- CH - CHANNELIZING LINE
- LL - LANE LINE
- SL - STOP LINE
- WEL - EDGE LINE (WHITE)
- WTL - TRANSVERSE/DIAGONAL LINE (WHITE)
- YEL - EDGE LINE (YELLOW)
- YTL - TRANSVERSE/DIAGONAL LINE (YELLOW)

CALCULATED
JLS
CHECKED
JSL

PAVEMENT MARKING DETAILS

FAI-33-17.44

17
23



CALCULATED
JLS
CHECKED
JSL

U.S. 33 @ SHARP RD./MAIN ST. INTERSECTION

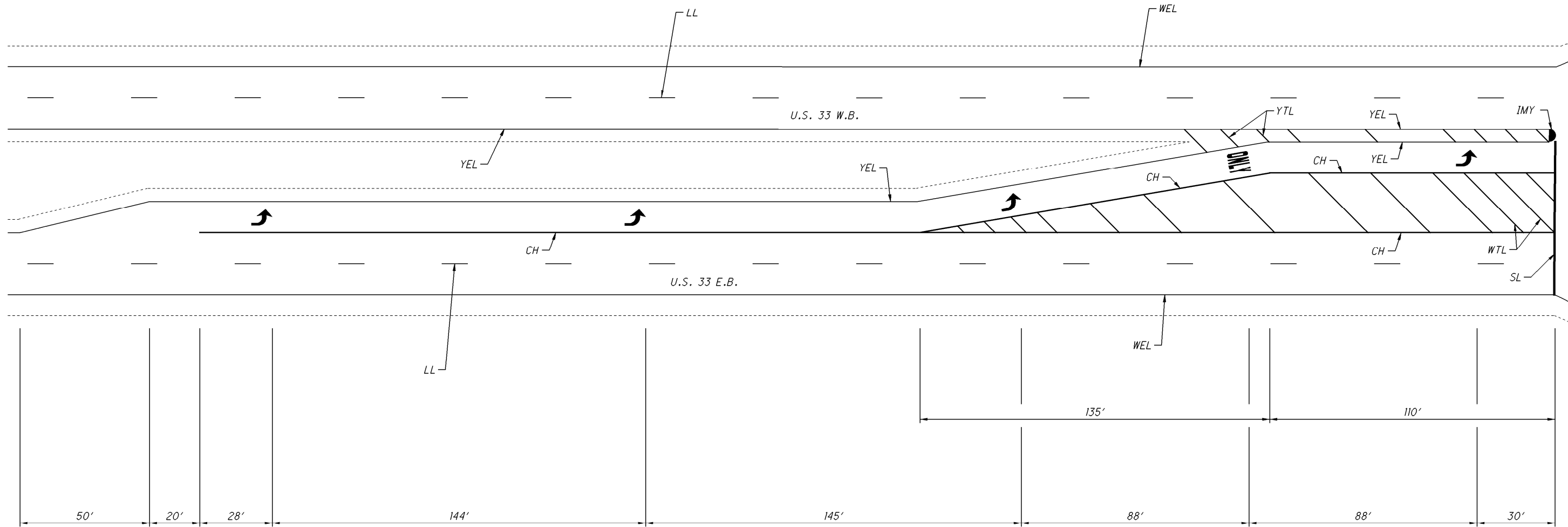

- CH - CHANNELIZING LINE
- IMY - ISLAND MARKING (YELLOW)
- LL - LANE LINE
- SL - STOP LINE
- WEL - EDGE LINE (WHITE)
- WTL - TRANSVERSE/DIAGONAL LINE (WHITE)
- YEL - EDGE LINE (YELLOW)
- YTL - TRANSVERSE/DIAGONAL LINE (YELLOW)

i:\ProjectData\FAI\93015\Design\Roadway\Sheets\93015_TP002.dgn 16-FEB-2017 6:04PM jutz1

PAVEMENT MARKING DETAILS

FAI-33-17.44

18
23

I:\ProjectData\FAI\93015\Design\Roadway\Sheets\93015_TP003.dgn 16-FEB-2017 6:05PM jutz1

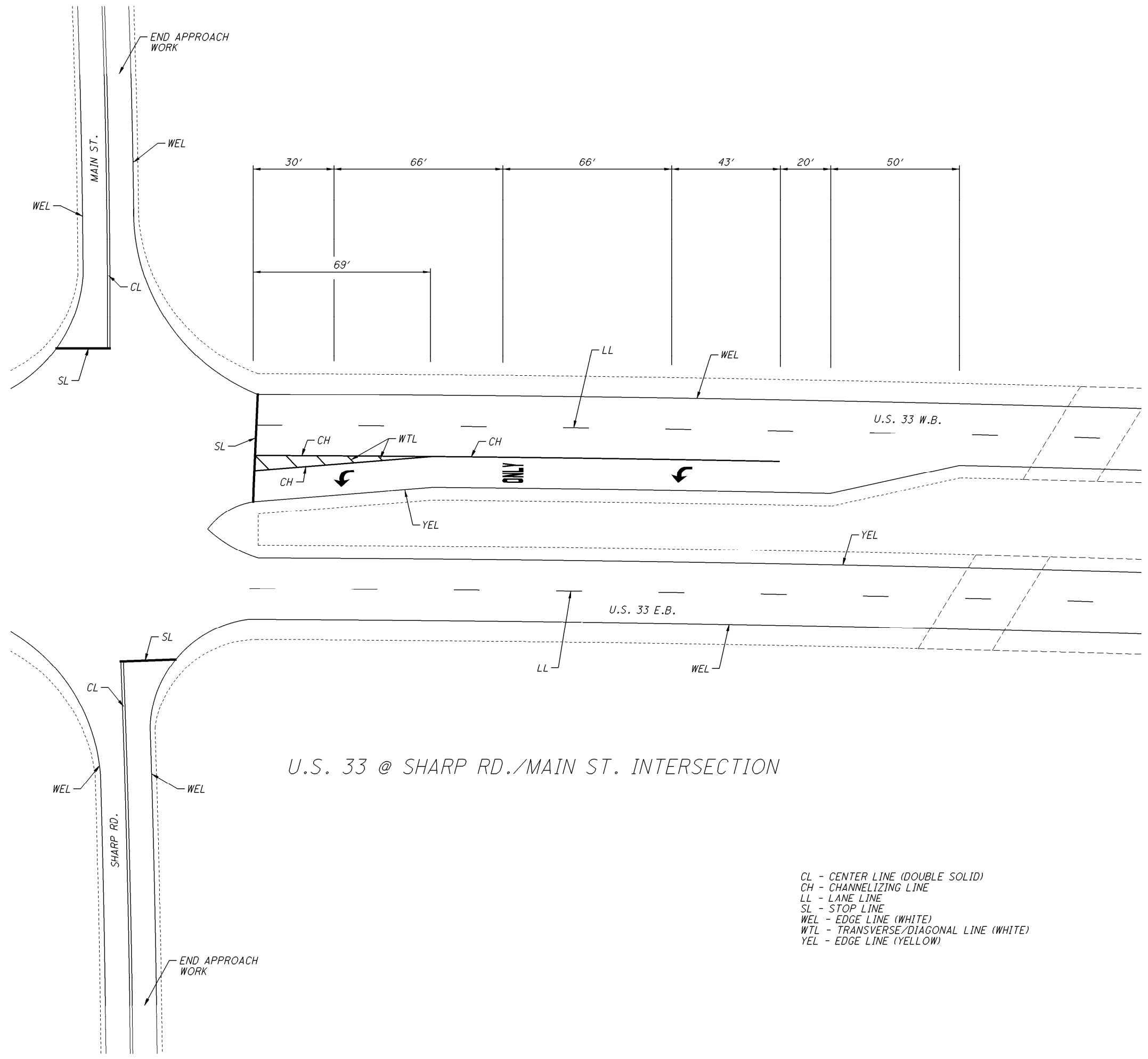

U.S. 33 @ SHARP RD./MAIN ST. INTERSECTION

- CL - CENTER LINE (DOUBLE SOLID)
- CH - CHANNELIZING LINE
- LL - LANE LINE
- SL - STOP LINE
- WEL - EDGE LINE (WHITE)
- WTL - TRANSVERSE/DIAGONAL LINE (WHITE)
- YEL - EDGE LINE (YELLOW)

CALCULATED	JLS
CHECKED	JSL

PAVEMENT MARKING DETAILS

FAI-33-17.44

Detail	
1	Tapered Acceleration Lane
2	Deceleration Lane
3	Multilane Divided/Controlled Access
4	4 Lane Divided to 2 Lane Transition
5	4 Lane Undivided to 2 Lane Transition
6	One Lane Bridge
7	Stop Approach

Detail	
8	Thru Approach
9	Two-Way Left Turn Lane
10	Approach with Left Turn Lane
11	Horizontal Curve 40' Spacing (Note 2)
12	Horizontal Curve Alt. (Note 3)
Gap	Center Line at 80' Typical Spacing
Rem	See Remarks

Raised Pavement Marker Data														
L o c a t i o n	C o u n t y	R o u t e	B e g i n L o g P o i n t (SLM)	E n d L o g P o i n t (SLM)	L e n g t h		D e t a i l	621		P r i s m a t i c R e t r o - R e f l e c t o r C o l o r s				R e m a r k s
								R P M	R A I S E D P A V E M E N T M A R K E R R E M O V E D	I n f o r m a t i o n O n l y				
										O n e - W a y		T w o - W a y		
										W h i t e	Y e l l o	W h i t e/ R e d	Y e l l o/ R e d	
				E A C H	E A C H									
1	Fai.	U.S. 33 E.B.	17.44	24.86	7.42	39,177.6	Rem	327	327			327		120' Spacing on Lane Line
			21.36	21.74	0.38	2,006.4	Rem	34	34			34		120' Spacing on Lane Lines (Additional Lanes)
			21.74	22.28	0.54	2,851.2	Rem	24	24			24		120' Spacing on Lane Line (Additional Lane)
			Deceleration Lane to Tarkiln Rd. (Ramp K)		800.0		2	20	20			20		
			Acceleration Area from U.S. 33 BR (Ramp M)		550.0		1	14	14			14		
			Ramp M (Ramp from U.S. 33 BR)		2,870.6		Rem	24	24			24		120' Spacing on Lane Line
			Lt. Turn Lane				10	24	24			21	3	Lt. Turn Lane to Main St. (Sugar Grove)/40' Spacing
		U.S. 33 W.B.	24.86	17.44	7.42	39,177.6	Rem	327	327			327		120' Spacing on Lane Line
			Lt. Turn Lane				10	8	8			8		Lt. Turn Lane to Sharp Rd./40' Spacing
			Deceleration Area to U.S. 33 BR (Ramp N)		290.0		2	8	8			8		
			Ramp N (Ramp to U.S. 33 BR)		1,569.7		Rem	14	14			14		120' Spacing on Lane Line
			Ramp N Turn Lane				10	18	18			15	3	Ramp N Left Turn Lane to Tarkiln Rd./40' Spacing
			Acceleration Lane from Tarkiln Rd. (Ramp L)		521.0		1	16	16			16		
			Sub-Totals									852	6	
			Location 1 Totals (Carried to General Summary)					858	858					

I:\ProjectData\FAI\93015\Design\Roadway\Sheets\93015_T00C3.dgn 16-FEB-2017 5:51PM jutzl

I:\ProjectData\FAI\93015\Design\Roadway\Sheets\93015_CP001.dgn 16-FEB-2017 5:57PM jlutzi

LEGEND

EX TRAFFIC SIGNAL, 3 UNIT HEAD, 12"	
EX TRAFFIC SIGNAL, 3 UNIT HEAD, 12" WITH ARROWS	
EX SIGNAL SUPPORT POLE	
EX CONTROLLER CABINET AND WORK PAD (332)	
EX DILEMMA ZONE RADAR DETECTION UNIT	
PR DILEMMA ZONE RADAR DETECTION UNIT	
PR STOP BAR RADAR DETECTION UNIT	
RADAR UNIT DETECTION ZONE	

NOTES: ABANDON ALL EXISTING LOOPS
SEE SHEET 3 FOR QUANTITIES

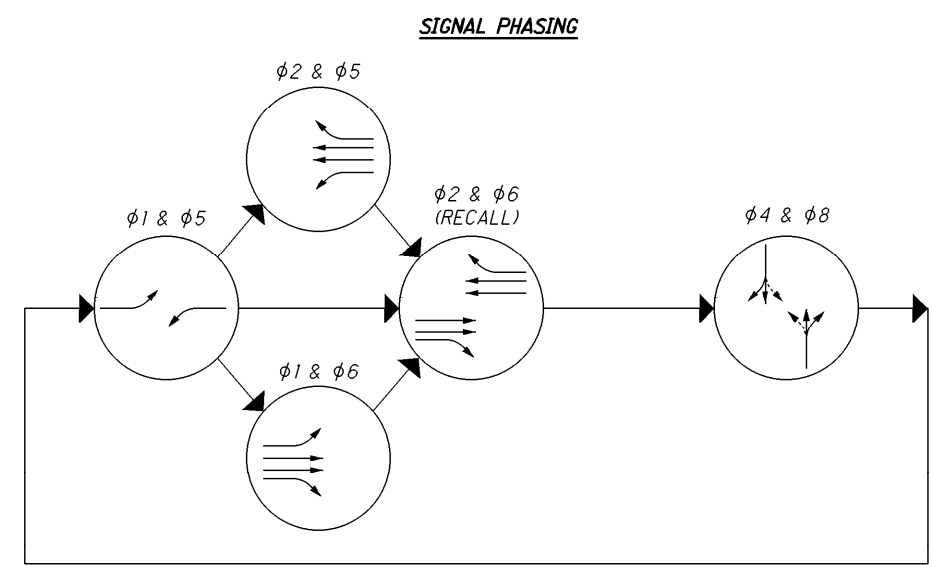
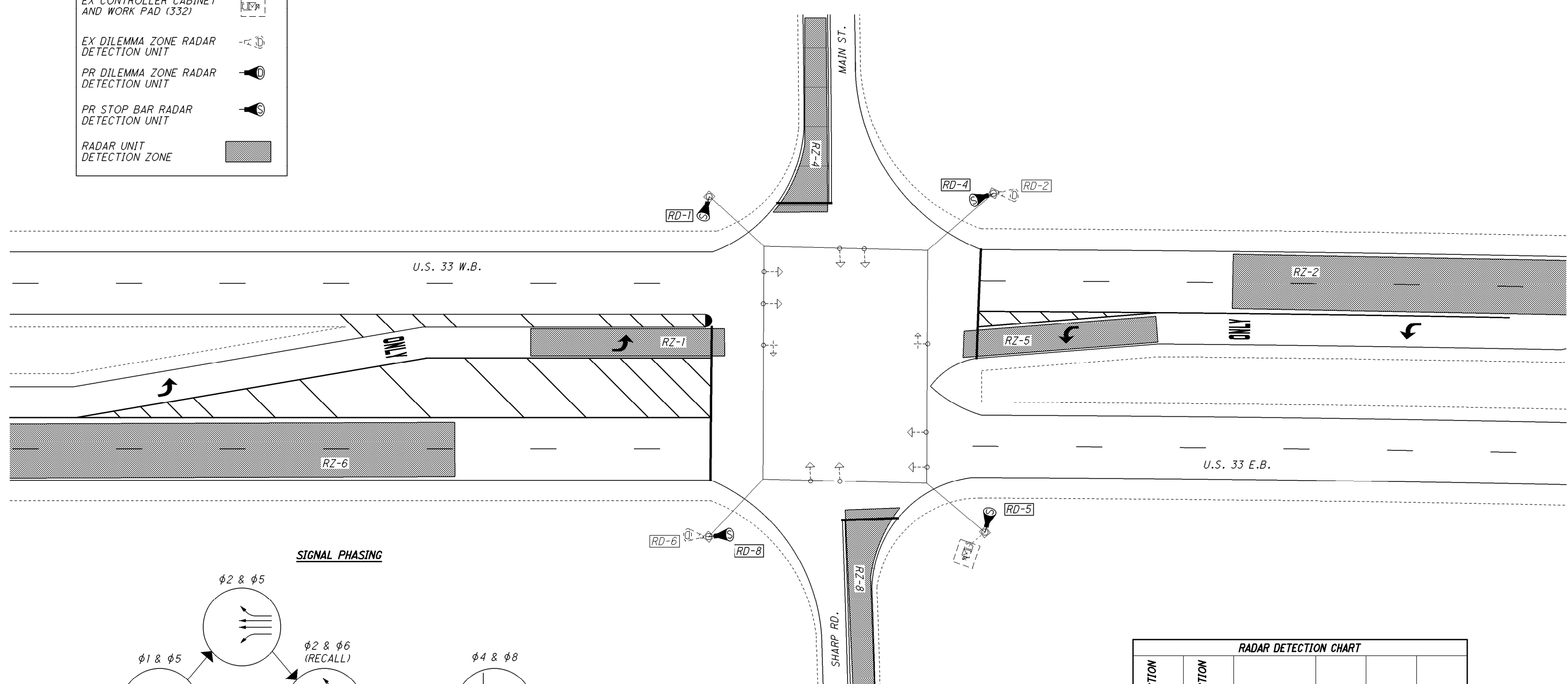

RADAR DETECTION CHART

RADAR DETECTION UNIT NO.	RADAR DETECTION ZONE	RADAR TYPE	DELAY (SEC.)	EXTENSION (SEC.)	ASSOCIATED CONTROLLER PHASE
RD-1	RZ-1	STOP BAR			1
RD-2	RZ-2	DILEMMA (EX)		2.0-7.5	2
RD-4	RZ-4	STOP BAR	8		4
RD-5	RZ-5	STOP BAR			5
RD-6	RZ-6	DILEMMA (EX)		2.0-7.5	6
RD-8	RZ-8	STOP BAR	8		8

CALCULATED JLS
CHECKED JLS

0 10 20 40
HORIZONTAL SCALE IN FEET

**TRAFFIC SIGNAL PLAN
U.S. 33 AND SHARP RD. / MAIN ST.**

FAI-33-17.44

