

BEGIN/END TRANSITION DETAIL

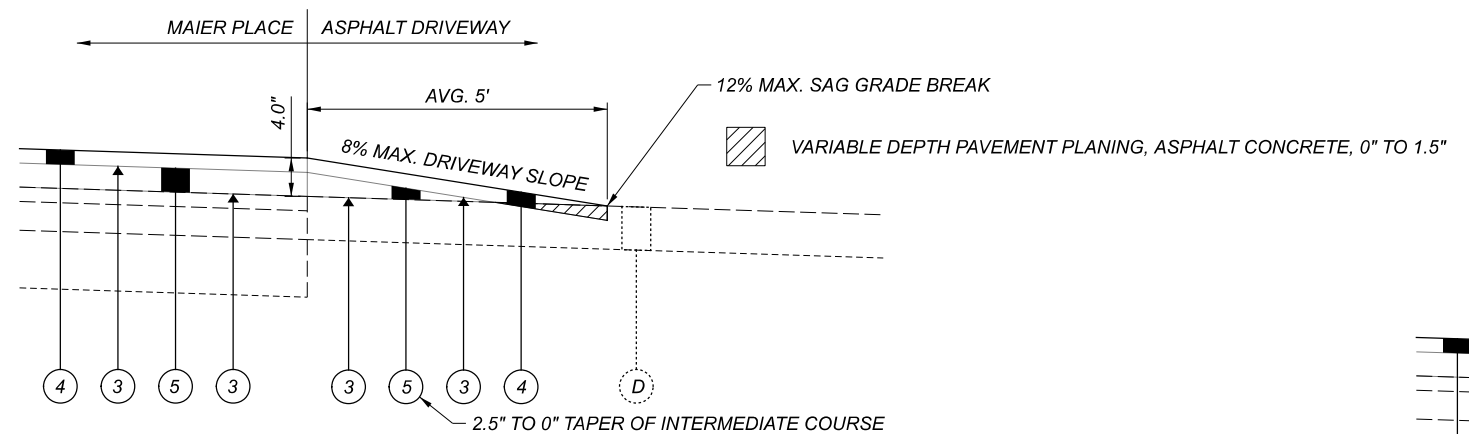

ASPHALT DRIVEWAY TRANSITION DETAIL

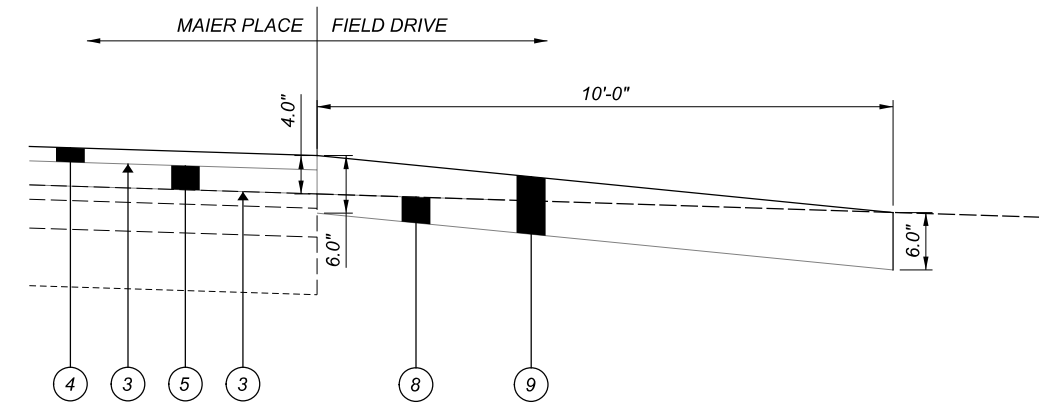

AGGREGATE (FIELD DRIVE) DRIVEWAY TRANSITION DETAIL

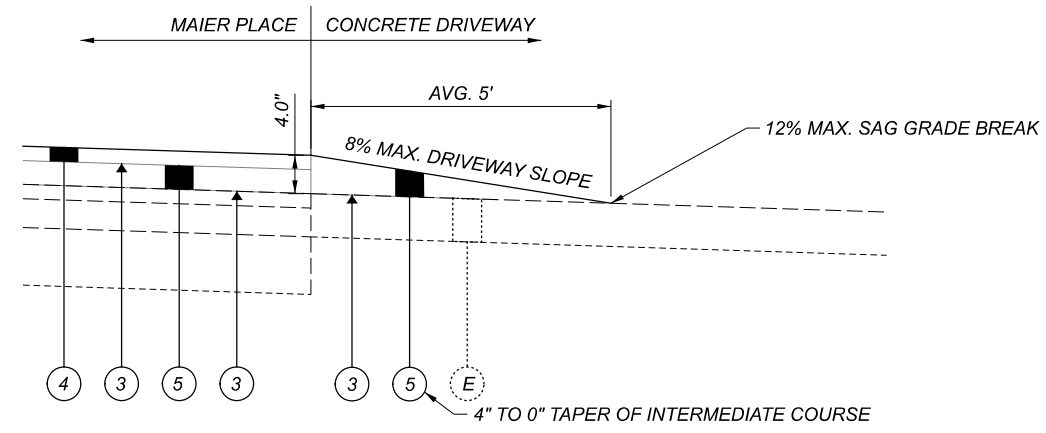

CONCRETE DRIVEWAY TRANSITION DETAIL

LEGEND

- (A) EXISTING 1.5" ASPHALT CONCRETE SURFACE
- (B) EXISTING 3" ASPHALT CONCRETE BASE
- (C) EXISTING 6" AGGREGATE BASE
- (D) EXISTING ASPHALT DRIVEWAY
- (E) EXISTING CONCRETE DRIVEWAY
- (1) ITEM 203 - EMBANKMENT, AS PER PLAN
- (2) ITEM 209 - PREPARING SUBGRADE FOR SHOULDER PAVING
- (3) ITEM 407 - NON-TRACKING TACK COAT (RATE AS PER CMS TABLE 407.06-1)
- (4) ITEM 442 - 1.5" ASPHALT CONCRETE SURFACE COURSE, 12.5 MM, TYPE A (446)
- (5) ITEM 442 - 2.5" ASPHALT CONCRETE INTERMEDIATE COURSE, 19 MM, TYPE A (448)
- (6) ITEM 617 - 4.0" COMPACTED AGGREGATE, AS PER PLAN
- (7) ITEM 659 - SEEDING AND MULCHING, CLASS 4B
- (8) ITEM 203 - EXCAVATION
- (9) ITEM 411 - STABILIZED CRUSHED AGGREGATE



NOTIFICATION OF CONSTRUCTION INITIATION:

AT LEAST FOURTEEN DAYS PRIOR TO STARTING INITIAL CONSTRUCTION ACTIVITIES, THE CONTRACTOR SHALL ADVISE THE DISTRICT OFFICE OF COMMUNICATIONS VIA EMAIL AT d06.pio@dot.ohio.gov, THE DISTRICT WORK ZONE TRAFFIC MANAGER VIA EMAIL AT d06.mot@dot.ohio.gov AND THE CENTRAL OFFICE SPECIAL HAUL PERMITS SECTION BY FAX AT (614)728-4099 OF THE ANTICIPATED START DATE OF ANY CONSTRUCTION ACTIVITIES, INCLUDING BUT NOT LIMITED TO THE PLACING OF WORK ZONE SIGNS. THIS NOTIFICATION SHALL ALSO INCLUDE THE PROJECT NUMBER, PID, NAME AND PHONE NUMBER OF THE CONTRACTOR, A POINT OF CONTACT AND THE ANTICIPATED IMPACT ON TRAFFIC. THE CONTRACTOR WILL IMMEDIATELY INFORM THE DISTRICT OFFICE OF COMMUNICATIONS AND THE DISTRICT WORK ZONE TRAFFIC MANAGER OF ANY AND ALL DELAYS AND/OR CHANGES REGARDING THE CONSTRUCTION INITIATION DATE.

GENERAL:

THE CONTRACTOR SHALL SUBMIT IN WRITING A SCHEDULE OF OPERATIONS TO THE ENGINEER (SEE 108.02) AND RECEIVE APPROVAL IN WRITING BEFORE WORK IS STARTED ON THIS PROJECT. ALL TRAFFIC CONTROL DEVICES SHALL BE FURNISHED, ERECTED, MAINTAINED, AND REMOVED BY THE CONTRACTOR IN ACCORDANCE WITH THE OHIO MANUAL OF UNIFORM TRAFFIC CONTROL DEVICES.

ALIGNMENT AND PROFILE:

THIS PROJECT INVOLVES RAISING THE EXISTING PAVEMENT ELEVATIONS BY 4.0" WHILE MAINTAINING THE EXISTING ALIGNMENT. PAVEMENT OF THE PROPOSED PAVEMENT SHALL BE AS SHOWN ON THE TYPICAL SECTIONS.

CONTRACTOR'S EQUIPMENT - OPERATION AND STORAGE:

THE CONTRACTOR'S EQUIPMENT SHALL BE OPERATED IN THE DIRECTION OF TRAFFIC WHERE PRACTICAL. EQUIPMENT SHALL HAVE AT LEAST ONE AMBER FLASHING LIGHT. WHEN PARKED ALONG THE HIGHWAY, THE EQUIPMENT SHALL BE LOCATED EITHER A MINIMUM OF THIRTY FEET FROM THE EDGE OF PAVEMENT OR SIX FEET BEHIND GUARDRAIL WITH A MINIMUM OF 125 FEET OF GUARDRAIL PRECEDING THE EQUIPMENT. ALL OTHER EQUIPMENT, INCLUDING PRIVATE VEHICLES, SHALL BE STORED AT AN APPROVED CONTRACTOR'S STORAGE AREA.

REMOVAL ITEMS:

UNLESS OTHERWISE INSTRUCTED, ASPHALT AND MISCELLANEOUS HARDWARE DESIGNATED FOR REMOVAL BECOME PROPERTY OF THE CONTRACTOR AND SHALL BE DISPOSED OF. PAYMENT FOR THE ABOVE ITEM SHALL BE INCLUDED IN THE UNIT PRICE BID FOR THE REMOVED ITEM.

WORK LIMITS:

THE WORK LIMITS SHOWN ON THESE PLANS ARE FOR PHYSICAL CONSTRUCTION ONLY. THE INSTALLATION AND OPERATION OF ALL TEMPORARY TRAFFIC CONTROL AND TEMPORARY TRAFFIC CONTROL DEVICES REQUIRED BY THESE PLANS SHALL BE PROVIDED BY THE CONTRACTOR WHETHER INSIDE OR OUTSIDE THESE WORK LIMITS.

CONTINGENCY QUANTITIES:

THE CONTRACTOR SHALL NOT ORDER MATERIALS OR PERFORM WORK FOR ITEMS DESIGNATED BY PLAN NOTE TO BE USED "AS DIRECTED BY THE ENGINEER" UNLESS AUTHORIZED BY THE ENGINEER. THE ACTUAL WORK LOCATIONS AND QUANTITIES USED FOR SUCH ITEMS SHALL BE INCORPORATED INTO THE FINAL CHANGE ORDER GOVERNING COMPLETION OF THIS PROJECT,

UTILITIES:

UTILITY IMPACTS ARE NOT ANTICIPATED WITH THIS PROJECT. THE ODOT CONTRACTOR IS REQUIRED TO CONTACT OHIO811 A MINIMUM OF 48 HOURS EXCLUDING WEEKENDS AND HOLIDAYS TO PERMIT ALL UNDERGROUND UTILITIES AN OPPORTUNITY TO MARK THEIR LINES AND TO ENSURE ALL UTILITIES ARE MARKED PRIOR TO BEGINNING WORK. IT IS ALSO THE ODOT CONTRACTOR'S RESPONSIBILITY TO CONTACT ALL NON-MEMBERS OF OHIO811 DIRECTLY A MINIMUM OF 48 HOURS NOTICE EXCLUDING WEEKENDS AND HOLIDAYS PRIOR TO EXCAVATION OCCURRING AT ANY LOCATIONS TO PROVIDE THEM WITH THE SAME OPPORTUNITY.

IF THERE IS A UTILITY MARKING WITHIN THE TOLERANCE ZONE OF A UTILITY LOCATE FROM THE PROPOSED GUARDRAIL PLACEMENT IT IS THE ODOT CONTRACTORS RESPONSIBILITY TO DIRECTLY CONTACT THE IMPACTED UTILITY AND WORK WITH THEM TO FIND A SOLUTION THAT DOES NOT CHANGE THE GUARDRAIL PLACEMENT OR DAMAGE THE EXISTING UTILITY. NO UTILITY RELOCATION WILL BE REIMBURSED NOR WILL DELAY CLAIMS BE PERMISSIBLE BASED ON LACK OF COORDINATION BETWEEN THE ODOT CONTRACTOR AND THE IMPACTED UTILITY.

BELOW IS A LIST OF UTILITIES LOCATED WITHIN THE PROJECT AREA TOGETHER WITH THEIR RESPECTIVE OWNERS.

<p>AEP OHIO 700 MORRISON RD GAHANNA, OH 43230 PAUL PAXTON 740.348.5322 ptpaxton@aep.com</p> <p>AT&T - OHIO 111 NORTH FOURTH ST ROOM 802 COLUMBUS, OH 43215 CHRIS MORRIS 614.223.4176 cm6828@att.com</p> <p>COLUMBIA GAS OF OHIO 3550 JOHNNY APPLESEED COURT COLUMBUS, OH 43231 ROB CALDWELL 614.818.2104 rcaldwell@nisource.com</p> <p>COLUMBUS DEPT. OF UTILITIES DIVISION OF POWER 3500 INDIANOLA AVE COLUMBUS, OH 43215 GARY WILFONG 614.645.2756 gdwilfong@columbus.gov</p>	<p>COLUMBUS DEPT. OF UTILITIES DIVISION OF SEWERAGE AND DRAINAGE 1250 FAIRWOOD AVE COLUMBUS, OH 43215 GREG FEDNER 614.645.8072 gfedner@columbus.gov</p> <p>COLUMBUS DEPT. OF UTILITIES DIVISION OF WATER 910 DUBLIN RD COLUMBUS, OH 43215 TIM HUFFMAN 614.645.8567 tehuffman@columbus.gov</p> <p>LUMEN 441 WEST BROAD ST PATASKALA, OH 43062 JEFF SCHOONOVER 330.262.1128 Jeffrey.L.Schoonover@centurylink.com</p> <p>SPECTRUM 3760 INTERCHANGE DR COLUMBUS, OH 43204 SAM LUTZ 614.481.5047 samuel.lutz@charter.com</p>
---	--

ITEM 203 - EMBANKMENT, AS PER PLAN:

THIS ITEM HAS BEEN PROVIDED TO BUILD UP THE FORESLOPE WITHIN THE EXISTING RAIN GARDEN FROM STA. 31+54.58 TO STA. 33+59.44 ON THE LEFT SIDE OF THE ROADWAY. THE SOIL FOR EMBANKMENT, AS PER PLAN, SHALL BE A UNIFORM MIX, FREE OF STONES, STUMPS, ROOTS OR OTHER SIMILAR OBJECTS LARGER THAN TWO INCHES. NO OTHER MATERIALS OR SUBSTANCES SHALL BE MIXED OR DUMPED WITHIN THE RAIN GARDEN AREA THAT MAY BE HARMFUL TO PLANT GROWTH, OR PROVE A HINDRANCE TO THE PLANTING OR MAINTENANCE OPERATIONS. THE SOIL SHALL BE FREE OF BERMUDA GRASS, QUACKGRASS, JOHNSON GRASS, OR OTHER NOXIOUS WEEDS. THE SOIL SHALL CONSIST OF A MIXTURE OF SAND, TOPSOIL, AND COMPOST WITH A PH RANGE OF 5.5 AND 6.5. IN ADDITION, THE SOIL SHALL HAVE INFILTRATION RATES NO LESS THAN 0.5 INCHES PER HOUR, ACHIEVED THROUGH THE FOLLOWING STANDARDS:

- A. 4 PARTS SAND (PER C&MS 703.06)
- B. 2 PARTS TOPSOIL (PER C&MS 659.05)
- C. 2 PARTS COMPOST (PER C&MS 659.06)

ITEM 202 - GUARDRAIL REMOVED, AS PER PLAN:

ITEM 202 - ANCHOR ASSEMBLY REMOVED, TYPE A, A.P.P.: IN ADDITION TO THE REQUIREMENTS OF ITEM 202, REMOVAL OF SPECIFIED GUARDRAIL ITEMS SHALL INCLUDE BUT NOT BE LIMITED TO ANY ATTACHED POSTS, SIGNS AND DELINEATORS (NOT OTHERWISE SPECIFIED).

CONCRETE FOUNDATIONS SHALL BE REMOVED TO 1 FOOT BELOW EXISTING GRADE.

ALL HOLES AND VOIDS REMAINING AFTER REMOVAL OF GUARDRAIL POSTS AND FOUNDATIONS SHALL BE FILLED WITH NATURAL SOILS CONFORMING TO C&MS 203.02.I. THE HOLES SHALL BE FILLED DURING THE SAME WORK SHIFT AS WHEN THEY WERE REMOVED. FILL MATERIAL CONTAINING SOD SHALL NOT BE USED. ALL FILL MATERIAL SHALL BE APPROVED BY THE ENGINEER. MATERIAL PLACED IN HOLES SHALL BE THOROUGHLY COMPACTED AND LEVELED OFF AS DIRECTED BY THE ENGINEER. PAYMENT FOR THE ABOVE SHALL BE INCLUDED IN THE UNIT PRICE BID FOR THE APPLICABLE GUARDRAIL REMOVAL ITEM.

ITEM 606 - GUARDRAIL REBUILT, TYPE 5, AS PER PLAN

ITEM 606 - ANCHOR ASSEMBLY REBUILT, TYPE B, A.P.P.

ITEM 606 - ANCHOR ASSEMBLY REBUILT, TYPE T, A.P.P.:

THE INTENT OF REBUILDING THE TYPE 5 GUARDRAIL AND ANCHOR ASSEMBLIES IS TO MEET THE HEIGHT REQUIREMENTS OF GR-1.1 AFTER THE ASPHALT OVERLAY IS PLACED.

THE EXISTING POST HOLES SHALL BE USED TO ELIMINATE THE NEED FOR EXCAVATION. BACKFILL THE HOLES WITH CLEAN FILL TO ALLOW FOR THE REINSTALLATION OF THE POSTS TO MEET HEIGHT REQUIREMENTS.

NO HAZARD SHALL BE LEFT UNPROTECTED EXCEPT FOR THE ACTUAL TIME NECESSARY TO REMOVE AND STORE THE EXISTING GUARDRAIL, PREPARE THE SITE, AND REBUILD THE GUARDRAIL IN A CONTINUOUS OPERATION.

PAYMENT SHALL BE MADE AT THE UNIT PRICE BID FOR EACH ITEM AND SHALL BE FULL COMPENSATION FOR ALL SERVICES, MATERIALS, LABOR, EQUIPMENT, TOOLS, AND INCIDENTALS, INCLUDING REMOVAL AND STORAGE, NECESSARY TO COMPLETE THIS ITEM.

ENVIRONMENTAL STUDIES INDICATED THAN AN OEPA VOLUNTARY ACTION PROGRAM WAS TAKEN IN THE AREA OF THE GUARDRAIL REBUILT ITEMS. AS PART OF THIS ACTION, THE VOLUNTEER PLACED A CLEAN 2 FOOT SOIL CAP BETWEEN STA. 10+40.15 LEFT TO STA. 13+09.24 LEFT. IF THE CONTRACTOR ELECTS TO DO ANY EXCAVATION WORK OTHER THAN PULLING THE POST AND REPLACING THEM IN THE EXISTING HOLES WITHIN THESE LIMITS, THE CONTRACTOR NEEDS TO FOLLOW THE RISK MITIGATION PLAN AS REQUIRED IN OEPA'S COVENANT NOT TO SUE FOR THIS PROPERTY. ANY COSTS TO FOLLOW THIS PLAN WOULD BE INCIDENTAL AND INCLUDED IN THE UNIT PRICE FOR THE ITEMS LISTED ABOVE.

RESTORATION OF RAIN GARDEN:

THE BELOW ITEMS ARE PROVIDED TO RESTORE THE RAIN GARDEN LOCATED ON THE LEFT SIDE OF MAIER PLACE FROM STA. 31+54.58 TO STA. 33+59.44 AFTER EMBANKMENT, AS PER PLAN, HAS BEEN PLACED. NO FERTILIZER SHALL BE USED WITHIN THE RAIN GARDEN.

THE FOLLOWING ITEMS HAVE BEEN PROVIDED AND CARRIED TO THE GENERAL SUMMARY:

ITEM 659 - TOPSOIL	= 11 CY
ITEM 659 - SEEDING AND MULCHING, CLASS 4B	= 119 SY
ITEM 659 - REPAIR SEEDING AND MULCHING	= 6 SY
ITEM 659 - INTER-SEEDING	= 6 SY
ITEM 659 - WATER	= 1 MGAL

ITEM 251 - PARTIAL DEPTH PAVEMENT REPAIR (ASPHALT CONCRETE BASE), AS PER PLAN:

ALL REPAIR AREAS SHALL BE DETERMINED BY THE PROJECT ENGINEER BEFORE THE BEGINNING OF WORK. REPAIRS SHALL CONSIST OF REMOVING 4.5" OF PAVEMENT AND PLACING 4.5" OF ITEM 301 - ASPHALT CONCRETE BASE, PG64-22, AS DETAILED ON SHEET P.6. WORK SHALL BE PERFORMED PRIOR TO THE RESURFACING.

THE FOLLOWING QUANTITY HAS BEEN PROVIDED FOR USE AS DIRECTED BY THE ENGINEER AND CARRIED TO THE GENERAL SUMMARY:

ITEM 251 - PARTIAL DEPTH PAVEMENT REPAIR (ASPHALT CONCRETE BASE), AS PER PLAN	= 80 SY
---	---------

ITEM 617 - COMPACTED AGGREGATE, AS PER PLAN:

ALL AGGREGATE SHALL BE 100% CRUSHED LIMESTONE. ALL QUALITY REQUIREMENTS EXCEPT SHALE SHALL BE WAIVED. OTHER GRADATION REQUIREMENTS SHALL BE AS SPECIFIED EXCEPT THE PLASTICITY INDEX SHALL BE WAIVED. IF SO PERMITTED, THE CONTRACTOR MAY USE RECYCLED ASPHALT CONCRETE PAVEMENT (RACP MEETING REQUIREMENTS OF 617.02) IN LIEU OF CRUSHED LIMESTONE.

BEFORE PLACING COMPACTED AGGREGATE, THE EXISTING SURFACE SHALL BE LOOSE AND FREE OF VEGETATION. IF NOT, THE CONTRACTOR SHALL PERFORM SHOULDER PREPARATION AS PER 617.04. PAYMENT FOR SHOULDER PREPARATION OUTSIDE OF THE SAFETY EDGE AREA SHALL BE INCLUDED IN THE COST OF ITEM 617 - COMPACTED AGGREGATE, AS PER PLAN.

ITEM 617 - WATER:

THE FOLLOWING QUANTITY HAS BEEN PROVIDED AND HAS BEEN CARRIED TO THE GENERAL SUMMARY:

ITEM 617 - WATER	= 1 MGAL
------------------	----------

DESIGN AGENCY



DESIGNER

KLM

REVIEWER

DKR MM-DD-YY

PROJECT ID

114815

SHEET TOTAL

P.15 | 30

LOCATION						DESIGN				QUANTITIES												REMARKS				
SHEET	COUNTY	ROUTE	BEGIN STATION	END STATION	SIDE	TYPICAL DETAIL	LENGTH FT	AVG. WIDTH FT	PAVEMENT AREA SY	203		209		254		407		441		442		442		617		
										EXCAVATION		PREPARING SUBGRADE FOR SHOULDER PAVING		PAVEMENT PLANING, ASPHALT CONCRETE, VARIABLE		NON-TRACKING TACK COAT		STABILIZED CRUSHED AGGREGATE		ASPHALT CONCRETE SURFACE COURSE, 12.5 MM, TYPE A (446)		ASPHALT CONCRETE INTERMEDIATE COURSE, 19 MM, TYPE A (448)		COMPACTED AGGREGATE, AS PER PLAN		
										AVG. DEPTH IN	CY	STA	STA	AVG. DEPTH IN	DEPTH SY	GAL	IN	CY	AVG. DEPTH IN	CY	AVG. DEPTH IN	CY	AVG. DEPTH IN	CY	AVG. DEPTH IN	CY
P.23	FRA	MAIER	0+12.33	0+72.33		1	60	28.3	189					2.00	189	26				1.5	8	2.5	13	4.0	4	BEGIN PROJECT TRANSITION
P.23	FRA	MAIER	0+72.33	3+05.58		1	233	23.2	602							84				1.5	25	2.5	42	4.0	18	
P.23	FRA	MAIER	3+05.58	5+09.66		1	204	23.0	522							73				1.5	22	2.5	36	4.0	16	
P.24	FRA	MAIER	5+09.66	5+61.69		1	52	23.0	133							19				1.5	6	2.5	9	4.0	4	
P.24	FRA	MAIER	5+61.69	7+36.22		1	175	22.8	441							62				1.5	18	2.5	31	4.0	12	
P.24	FRA	MAIER	7+36.22	10+40.15		2	304	22.7	768							108				1.5	32	2.5	53	4.0	32	EXTRA COMP. AGG. FOR GUARDRAIL
P.25	FRA	MAIER	10+40.15	13+09.24		2	269	22.7	680							95				1.5	28	2.5	47	4.0	42	EXTRA COMP. AGG. FOR GUARDRAIL
P.25	FRA	MAIER	13+09.24	28+37.57		1	1528	22.8	3863							541				1.5	161	2.5	268	4.0	114	
P.28	FRA	MAIER	28+37.57	29+02.89		1	65	22.6	164							23				1.5	7	2.5	11	4.0	4	
P.28	FRA	MAIER	29+02.89	30+63.59		1	161	22.5	402							56				1.5	17	2.5	28	4.0	12	
P.29	FRA	MAIER	30+63.59	30+95.38		1	32	24.8	87							12				1.5	4	2.5	6	4.0	2	
P.29	FRA	MAIER	30+95.38	33+12.57		1	217	24.0	579							81				1.5	24	2.5	40	4.0	8	COMPACTED AGGREGATE ON RT SIDE ONLY
P.29	FRA	MAIER	33+12.57	33+72.57		1	60	24.5	163							23				1.5	7	2.5	11	4.0	2	END PROJECT TRANSITION; COMP. AGG. ON RT SIDE ONLY
EXTRA AREAS																										
P.23	FRA	MAIER	0+12.33	0+42.33	LT		30																2.0	1	ADDITIONAL AGGREGATE FOR DROP-OFF	
P.25	FRA	MAIER	13+80.00	19+00.00	RT		520																1.0	5	ADDITIONAL AGGREGATE FOR DROP-OFF	
P.29	FRA	MAIER	29+74.97	30+85.68	LT	1	111	12.7	157							22				1.5	7	2.5	11			PARKING
		MAIER	0+12.33	33+72.57	LT/RT	1/2	3360	0.6	436			67.2				37				2.0	24					SAFETY EDGE
DRIVES																										
P.23	FRA	MAIER	2+82.16		RT	3	40.6	5.0	23							0.75	23	3		1.5	1	1.3	1			DRIVE 1, ASPHALT
P.24	FRA	MAIER	5+36.68		RT	3	39.5	5.0	22							0.75	22	3		1.5	1	1.3	1			DRIVE 2, ASPHALT
P.25	FRA	MAIER	14+15.00		RT	3	18.7	10.0	21	4.0	2								6.0	4						DRIVE 12, AGGREGATE
P.26	FRA	MAIER	15+80.00		RT	3	18.7	10.0	21	4.0	2								6.0	4						DRIVE 13, AGGREGATE
P.27	FRA	MAIER	20+00.91		LT	3	49.9	5.0	28							0.75	28	4		1.5	1	1.3	1			DRIVE 3, ASPHALT
P.27	FRA	MAIER	20+07.52		RT	3	37.3	5.0	21							0.75	21	3		1.5	1	1.3	1			DRIVE 4, ASPHALT
P.27	FRA	MAIER	21+42.71		RT	3	43.9	5.0	24							0.75	24	3		1.5	1	1.3	1			DRIVE 5, ASPHALT
P.27	FRA	MAIER	21+47.89		LT	3	43.0	5.0	24									3				2.0	1			DRIVE 6, CONCRETE
P.27	FRA	MAIER	21+95.73		LT	3	30.5	5.0	17							0.75	17	2		1.5	1	1.3	1			DRIVE 7, ASPHALT
P.27	FRA	MAIER	22+97.33		RT	3	71.7	5.0	40							0.75	40	6		1.5	2	1.3	1			DRIVE 8, ASPHALT
P.28	FRA	MAIER	24+85.77		LT	3	65.9	5.0	37							0.75	37	5		1.5	2	1.3	1			DRIVE 9, ASPHALT
P.29	FRA	MAIER	30+30.64		RT	3	62.3	5.0	35							0.75	35	5		1.5	1	1.3	1			DRIVE 10, ASPHALT
P.29	FRA	MAIER	31+40.10		LT	3	35.9	5.0	20							0.75	20	3		1.5	1	1.3	1			DRIVE 11, ASPHALT
TOTAL CARRIED TO GENERAL SUMMARY										4	67.2	619	1302	8	402	617	276									

PAVEMENT SUBSUMMARY

DESIGN AGENCY	
DESIGNER	KLM
REVIEWER	DKR MM-DD-YY
PROJECT ID	114815
SHEET	P.21
TOTAL	30

DO NOT DISTURB OR BURY EXISTING FEATURES OUTSIDE OF THE ROADWAY,
 INCLUDING BUT NOT LIMITED TO: SIGNS, POLES, UTILITY BOXES, VAULT COVERS
 HYDRANTS, MANHOLES, HEADWALLS

SEE SHEETS P.21, P.22 AND P.30 FOR QUANTITIES.

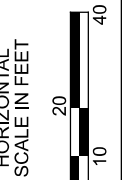

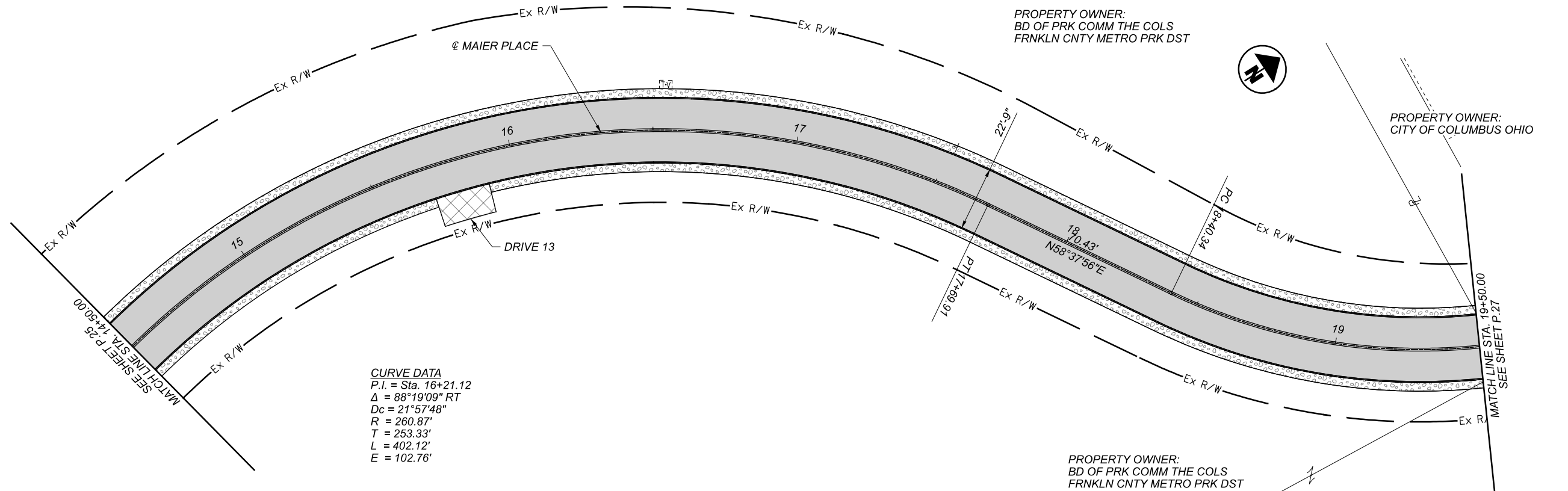

UTILITY NOTE:
 DO NOT DISTURB EXISTING UTILITIES.
 WATER, STORM, AND ELECTRIC ARE OWNED BY CITY OF COLUMBUS

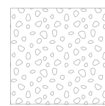

CURVE DATA
 P.I. = Sta. 16+21.12
 $\Delta = 88^\circ 19' 09''$ RT
 $D_c = 21^\circ 57' 48''$
 $R = 260.87'$
 $T = 253.33'$
 $L = 402.12'$
 $E = 102.76'$

CURVE DATA
 P.I. = Sta. 19+41.59
 $\Delta = 54^\circ 03' 43''$ LT
 $D_c = 28^\circ 52' 12''$
 $R = 198.46'$
 $T = 101.26'$
 $L = 187.26'$
 $E = 24.34'$

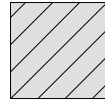
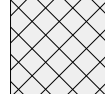
-  ITEM 617 - COMPACTED AGGREGATE,
AS PER PLAN
-  4" ASPHALT OVERLAY
-  OVERLAY TRANSITION
-  DRIVEWAY TRANSITION

ROADWAY PLAN
 STA. 14+50 TO STA. 19+50



DESIGNER	KLM
REVIEWER	DKR MM-DD-YY
PROJECT ID	114815
SHEET	TOTAL
P.26	30