

# STATE OF OHIO DEPARTMENT OF TRANSPORTATION

## GAL-7-19.94

GREEN TOWNSHIP  
GALLIA COUNTY



**LOCATION MAP**

LATITUDE: 82°13'22" LONGITUDE: 38°46'56"



PORTION TO BE IMPROVED	-----	=====
INTERSTATE HIGHWAY	-----	=====
FEDERAL ROUTES	-----	=====
STATE ROUTES	-----	=====
COUNTY & TOWNSHIP ROADS	-----	=====
OTHER ROADS	-----	=====

**DESIGN DESIGNATION**

CURRENT ADT (2025)	-----	6,600
DESIGN YEAR ADT (2045)	-----	6,800
DESIGN HOURLY VOLUME (2045)	-----	750
DIRECTIONAL DISTRIBUTION	-----	63.4%
TRUCKS (24 HOUR B&C)	-----	7%
DESIGN SPEED	-----	55
LEGAL SPEED	-----	55
DESIGN FUNCTIONAL CLASSIFICATION:		
RURAL ARTERIAL	-----	
NHS PROJECT	-----	YES

**DESIGN EXCEPTIONS**

NONE

**ADA DESIGN WAIVERS**

NONE

**UNDERGROUND UTILITIES**  
Contact Two Working Days  
Before You Dig

**OHIO811.org**  
Before You Dig

OHIO811, 8-1-1, or 1-800-362-2764  
(Non members must be called directly)

PLAN PREPARED BY:  
OHIO DEPARTMENT OF  
TRANSPORTATION PLANNING  
AND ENGINEERING - DISTRICT 10

**INDEX OF SHEETS:**

TITLE SHEET	1
TYPICAL SECTION	2
GENERAL NOTES	3-4
MAINTENANCE OF TRAFFIC	5-7
GENERAL SUMMARY	8-9
CALCULATIONS	10
PLAN AND PROFILE (S.R. 7)	11-12
PLAN AND PROFILE (FIELD DRIVE)	13
CROSS SECTIONS	14-24
CULVERT DETAILS	25
DRILLED SHAFT PROFILE	26
DRILLED SHAFT DETAILS	27-31
GEOTECHNICAL PROFILE - LANDSLIDE	32-48

STANDARD CONSTRUCTION DRAWINGS				SUPPLEMENTAL SPECIFICATIONS	SPECIAL PROVISIONS
BP-3.1	1/19/24	MT-96.20	7/21/23	800-2023 7/19/24	
		MT-96.26	1/18/19	832 7/21/23	
DM-1.1	7/17/20	MT-97.10	4/19/19	902 7/19/19	
DM-1.2	7/16/21	MT-101.70	4/21/23		
DM-4.3	1/15/16	MT-101.75	7/21/23		
DM-4.4	1/15/16	MT-101.90	7/17/20		
MGS-1.1	7/16/21	TC-65.10	1/17/14		
MGS-2.1	1/19/18	TC-65.11	1/19/24		
MGS-2.3	1/20/23				
MGS-4.2	7/19/13				
MGS-4.3	1/18/13				
RM-4.2	4/17/20				
MT-96.11	7/21/23				

**FEDERAL PROJECT NUMBER**

E240998

**RAILROAD INVOLVEMENT**

NONE

**PROJECT DESCRIPTION**

A LANDSLIDE REPAIR CONSISTING OF A 446FT DRILLED SHAFT RETAINING WALL AND CULVERT REPLACEMENT.

**EARTH DISTURBED AREAS**

PROJECT EARTH DISTURBED AREA:	0.32 ACRES
ESTIMATED CONTRACTOR EARTH DISTURBED AREA:	0.10 ACRES
NOTICE OF INTENT EARTH DISTURBED AREA:	0.42 ACRES

**2023 SPECIFICATIONS**

THE STANDARD SPECIFICATIONS OF THE STATE OF OHIO, DEPARTMENT OF TRANSPORTATION, INCLUDING SUPPLEMENTAL SPECIFICATIONS LISTED IN THE PLANS, CHANGES LISTED IN THE PROPOSAL, AND THE SUPPLEMENTAL SPECIFICATION 800 VERSION INDICATED ON THE PROPOSAL SHALL GOVERN THIS IMPROVEMENT.

I HEREBY APPROVE THESE PLANS AND DECLARE THAT THE MAKING OF THIS IMPROVEMENT WILL NOT REQUIRE THE CLOSING TO TRAFFIC OF THE HIGHWAY AND THAT PROVISIONS FOR THE MAINTENANCE AND SAFETY OF TRAFFIC WILL BE AS SET FORTH ON THE PLANS AND ESTIMATES.

Rich Oster  
District 10 Deputy Director

Pamela Boratyn  
Director, Department of Transportation

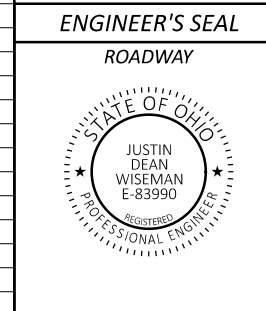

TITLE SHEET

DESIGN AGENCY	
DESIGNER	JDW
REVIEWER	XXX MM-DD-YY
PROJECT ID	115533
SHEET TOTAL	P.01 P.48

GAL-7-19.94

MODEL: Sheet PAPER: 17x11 (in.) DATE: 10/23/2024 TIME: 7:54:31 AM USER: jwiseman pwc:\ohio\dot-pw\dot-bentley.com\shoto\dot-pw\dot-02\Documents\01 Active Projects\District 10\Gallia\115533\400-Engineering\Roadway\Sheets\115533\_GT001.dgn

# CL PAVEMENT OFFSET FROM CL ROW SR 7

STATION	OFFSET
1066+00.00	0.67' LT
1066+25.00	0.47' LT
1066+50.00	0.29' RT
1066+75.00	0.23' RT
1067+00.00	0.67' RT
1067+25.00	1.03' RT
1067+50.00	1.50' RT
1067+75.00	1.58' RT
1068+00.00	1.70' RT
1068+25.00	1.71' RT
1068+50.00	1.29' RT
1068+75.00	1.55' RT
1069+00.00	1.40' RT
1069+25.00	1.27' RT
1069+50.00	0.78' RT
1069+75.00	1.33' RT
1070+00.00	0.80' RT
1070+25.00	0.90' RT
1070+50.00	0.11' RT
1070+75.00	0.06' LT
1071+00.00	0.20' LT
1071+25.00	0.33' LT
1071+50.00	0.72' LT
1071+75.00	0.56' LT
1072+00.00	0.53' LT

NOTES:

- # - STRIPE LANES AT 12.5' WIDTH (MATCH EXISTING)
- \* - MAXIMUM LIFT THICKNESS 1.5"
- \*\* - MAXIMUM LIFT THICKNESS 6"; MINIMUM LIFT THICKNESS 3"

EXISTING LEGEND

- (A) 9" EXISTING PORTLAND CONCRETE
- (B) 15" EXISTING ASPHALT CONCRETE
- (C) EXISTING DRIVEWAY ASPHALT CONCRETE

PROPOSED LEGEND

- 1 ITEM 441 - 1.5" ASPHALT CONCRETE SURFACE, TYPE 1, (448), PG64-22\*
- 2 ITEM 441 - 1.5" ASPHALT CONCRETE INTERMEDIATE COURSE, TYPE 1, (448)\*
- 3 ITEM 441 - ASPHALT CONCRETE INTERMEDIATE COURSE, TYPE 1 (449), (VARIABLE THICKNESS)\*
- 4 ITEM 441 - 3" ASPHALT CONCRETE SURFACE COURSE, TYPE 1, (449), (DRIVEWAYS)\*
- 5 ITEM 301 - 9" ASPHALT CONCRETE BASE, PG64-22\*\*
- 6 ITEM 304 - 6" AGGREGATE BASE
- 7 ITEM 304 - AGGREGATE BASE (VARIABLE THICKNESS)
- 8 ITEM 407 - NON-TRACKING TACK COAT
- 9 ITEM 254 - PAVEMENT PLANING, ASPHALT CONCRETE, AS PER PLAN
- 10 ITEM 202 - PAVEMENT REMOVED
- 11 ITEM 617 - 3" COMPACTED AGGREGATE & ITEM 408 - PRIME COAT (0.4 GAL/SY)
- 12 ITEM 659 - SEEDING AND MULCHING
- 13 ITEM 204 - SUBGRADE COMPACTION
- 14 ITEM 605 - 4" BASE PIPE UNDERDRAIN
- 15 ITEM 606 - GUARDRAIL, TYPE MGS
- 16 ITEM 606 - GUARDRAIL, TYPE MGS WITH LONG POSTS
- 17 ITEM 518 - POROUS BACKFILL WITH GEOTEXTILE FABRIC

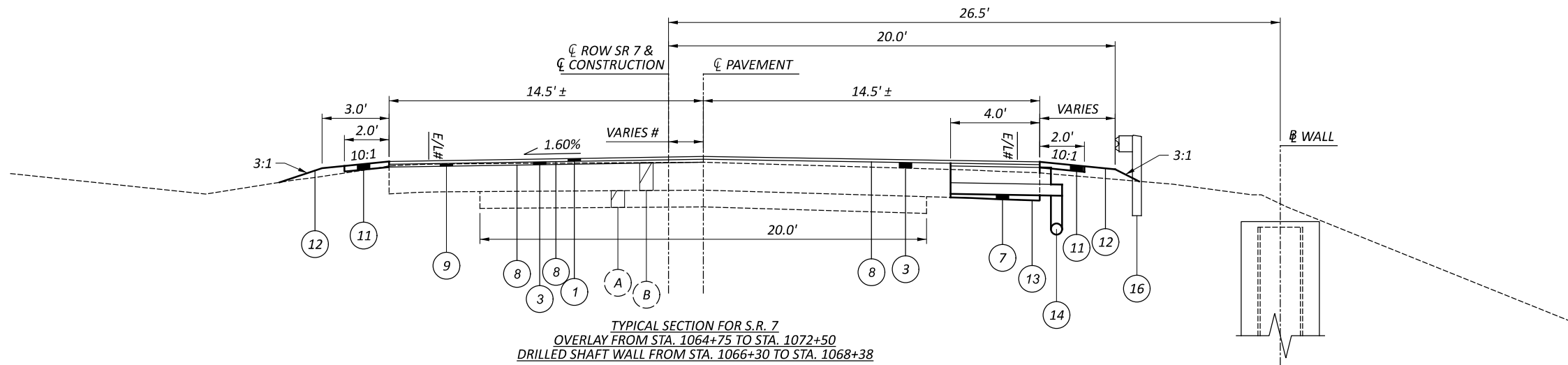

TYPICAL SECTION FOR S.R. 7  
OVERLAY FROM STA. 1064+75 TO STA. 1072+50  
DRILLED SHAFT WALL FROM STA. 1066+30 TO STA. 1068+38

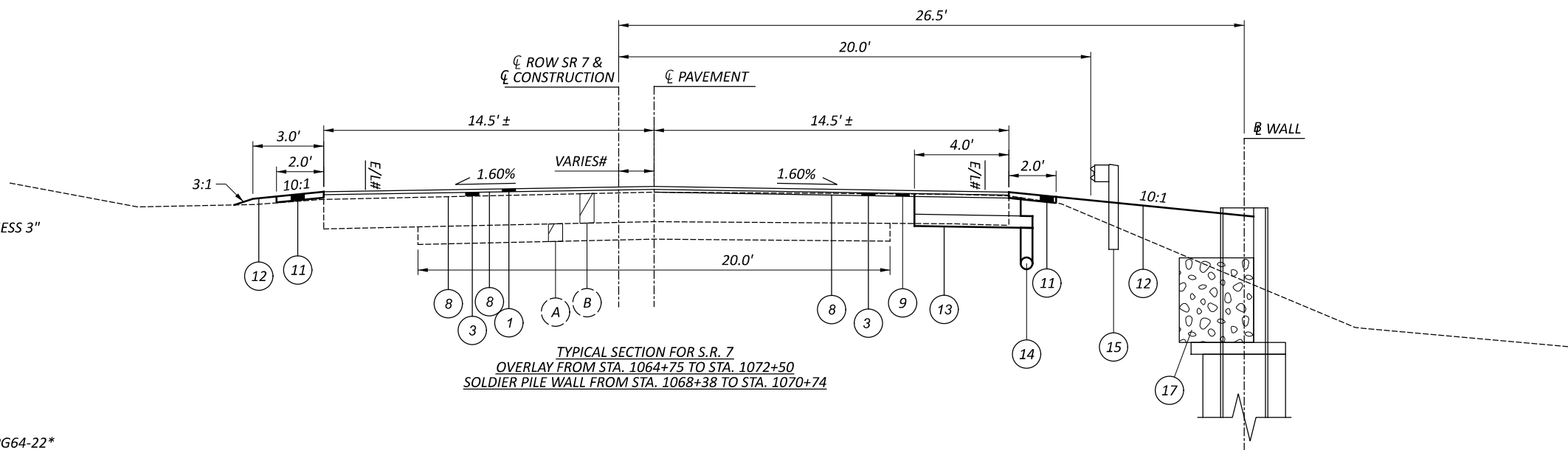

TYPICAL SECTION FOR S.R. 7  
OVERLAY FROM STA. 1064+75 TO STA. 1072+50  
SOLDIER PILE WALL FROM STA. 1068+38 TO STA. 1070+74

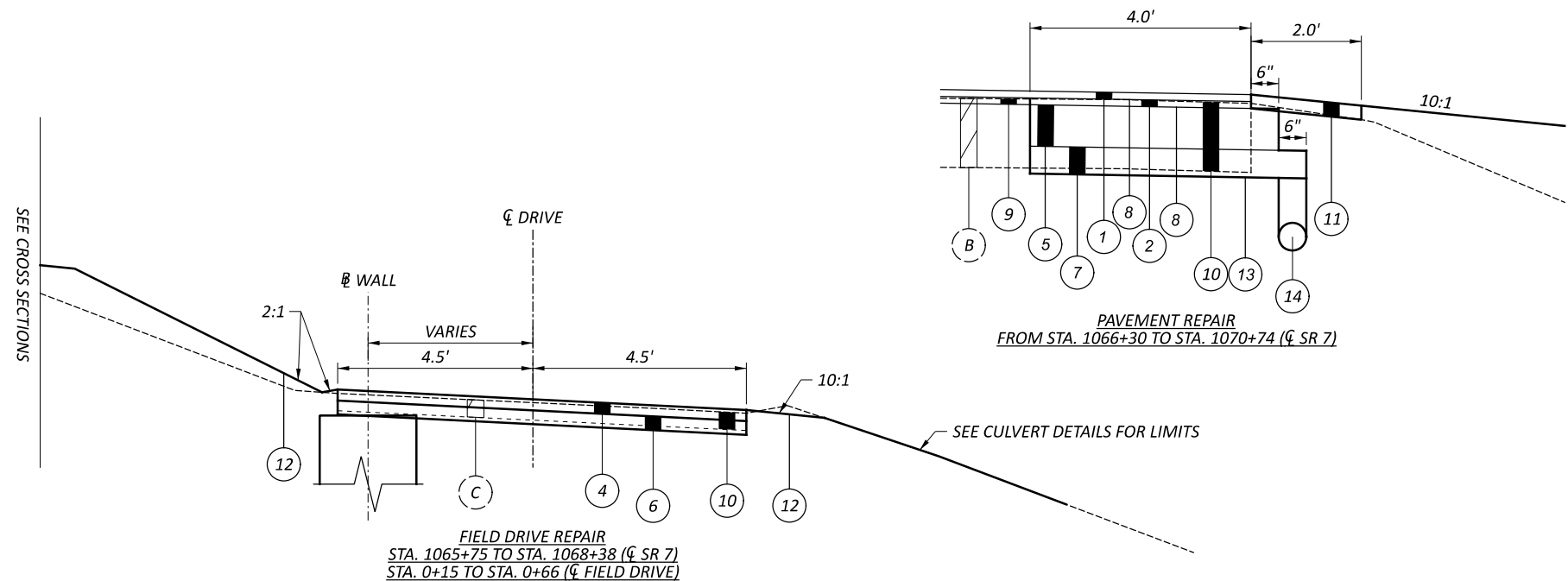

FIELD DRIVE REPAIR  
STA. 1065+75 TO STA. 1068+38 (CL SR 7)  
STA. 0+15 TO STA. 0+66 (CL FIELD DRIVE)

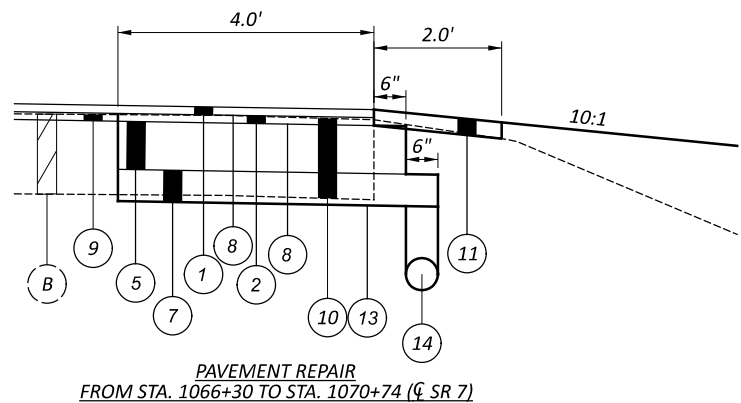

PAVEMENT REPAIR  
FROM STA. 1066+30 TO STA. 1070+74 (CL SR 7)

TYPICAL SECTION

DESIGN AGENCY



DESIGNER

JDW

REVIEWER

XXX MM-DD-YY

PROJECT ID

115533

SHEET TOTAL

P.02 P.48

**UTILITIES**

UTILITIES WERE NOT MARKED AT THE TIME OF THE SURVEY. LISTED BELOW ARE ALL UTILITIES LOCATED WITHIN THE PROJECT CONSTRUCTION LIMITS TOGETHER WITH THEIR RESPECTIVE OWNERS:

AMERICAN ELECTRIC POWER  
38831 SR 7  
REEDSVILLE, OH 45769  
CLARKE SAUNDERS 614-312-5807

A&T  
160 NORTH SIXTH STREET  
ZANESVILLE, OH 43701  
BARRETT TAMASOVICH 740-454-3552

COLUMBIA GAS OF OHIO  
843 PIATT AVENUE  
CHILLICOTHE, OH 45601  
TIFFANY WOODYARD 740-772-9131

SUDDENLINK  
1737 EAST SEVENTH STREET  
PARKERSBURG, WV 26101  
BILL BROWN 304-865-4067

CITY OF GALLIPOLIS  
518 2ND AVENUE  
GALLIPOLIS, OH 45631  
740-441-6006

**CLEARING AND GRUBBING**

THE DEPARTMENT HAS NOT MARKED INDIVIDUAL TREES AND STUMPS FOR REMOVAL. UNLESS SPECIFICALLY DESIGNATED AS "DO NOT DISTURB" IN THE PLANS, REMOVE ALL TREES AND STUMPS WITHIN THE CONSTRUCTION LIMITS UNDER THE LUMP SUM BID FOR ITEM 201 CLEARING AND GRUBBING.

**ITEM 659 - SEEDING AND MULCHING**

SEEDING AND MULCHING SHALL BE APPLIED TO ALL AREAS OF EXPOSED SOIL BETWEEN THE RIGHT-OF-WAY LINES, AND WITHIN THE CONSTRUCTION LIMITS FOR AREAS OUTSIDE THE RIGHT-OF-WAY LINES COVERED BY WORK AGREEMENT OR SLOPE EASEMENT. QUANTITY CALCULATIONS FOR SEEDING AND MULCHING ARE BASED ON THESE LIMITS.

**CONTINGENCY QUANTITIES**

THE CONTRACTOR SHALL NOT ORDER MATERIALS OR PERFORM WORK FOR ITEMS DESIGNATED BY PLAN NOTE TO BE USED "AS DIRECTED BY THE ENGINEER" UNLESS AUTHORIZED BY THE ENGINEER. THE ACTUAL WORK LOCATIONS AND QUANTITIES USED FOR SUCH ITEMS SHALL BE INCORPORATED INTO THE FINAL CHANGE ORDER GOVERNING COMPLETION OF THIS PROJECT.

**WORK LIMITS**

THE WORK LIMITS SHOWN ON THESE PLANS ARE FOR PHYSICAL CONSTRUCTION ONLY. PROVIDE THE INSTALLATION AND OPERATION OF ALL WORK ZONE TRAFFIC CONTROL DEVICES REQUIRED BY THESE PLANS WHETHER INSIDE OR OUTSIDE THESE WORK LIMITS.

**NOTIFICATION OF TRAFFIC RESTRICTIONS**

THROUGHOUT THE DURATION OF THE PROJECT, THE CONTRACTOR SHALL NOTIFY THE PROJECT ENGINEER IN WRITING OF ALL TRAFFIC RESTRICTIONS AND UPCOMING MAINTENANCE OF TRAFFIC CHANGES. THE CONTRACTOR SHALL ENSURE THE WRITING OF ALL TRAFFIC RESTRICTIONS AND UPCOMING MAINTENANCE OF TRAFFIC CHANGES. THE CONTRACTOR SHALL ENSURE THE WRITTEN NOTIFICATION IS SUBMITTED IN A TIMELY MANNER TO ALLOW THE PROJECT ENGINEER TO MEET THE REQUIRED TIME FRAMES SET FORTH IN THE TABLE BELOW TO INFORM THE SPECIAL HAULING PERMITS SECTION (HAULING.PERMITS@DOT.OHIO.GOV) AND THE DISTRICT PUBLIC INFORMATION OFFICE (PIO). THIS NOTIFICATION SHALL BE RECEIVED BY THE PROJECT ENGINEER PRIOR TO THE PHYSICAL SETUP OF ANY APPLICABLE SIGNS OR MESSAGE BOARDS.

INFORMATION SHOULD INCLUDE, BUT IS NOT LIMITED TO, ALL CONSTRUCTION ACTIVITIES THAT IMPACT OR INTERFERE WITH TRAFFIC AND SHALL LIST THE SPECIFIC LOCATION, TYPE OF WORK, ROAD STATUS, DATE AND TIME OF RESTRICTION, DURATION OF RESTRICTION, NUMBER OF LANES MAINTAINED, NUMBER OF LANES CLOSED, MINIMUM VERTICAL CLEARANCE, MINIMUM WIDTH OF DRIVABLE PAVEMENT, DETOUR ROUTES, IF APPLICABLE, AND ANY OTHER INFORMATION REQUESTED BY THE PROJECT ENGINEER.

NOTIFICATION TIME TABLE		
ITEM	DURATION OF CLOSURE	NOTICE DUE TO PERMITS AND PIO
RAMP & ROAD CLOSURES	>= 2 WEEKS	21 CALENDAR DAYS PRIOR TO CLOSURE
	> 12 HOURS & < 2 WEEKS	14 CALENDAR DAYS PRIOR TO CLOSURE
	< 12 HOURS	4 CALENDAR DAYS PRIOR TO CLOSURE
LANE CLOSURES & RESTRICTIONS	>= 2 WEEKS	14 CALENDAR DAYS PRIOR TO CLOSURE
	< 2 WEEKS	5 BUSINESS DAYS PRIOR TO CLOSURE
START OF CONSTRUCTION & TRAFFIC PATTERN CHANGES	N/A	14 CALENDAR DAYS PRIOR TO IMPLEMENTATION

ANY UNFORESEEN CONDITIONS NOT SPECIFIED IN THE PLANS REQUIRING TRAFFIC RESTRICTIONS SHALL ALSO BE REPORTED TO THE PROJECT ENGINEER USING THE NOTIFICATION TIME TABLE.

THE PROJECT ENGINEER WILL FORWARD THIS INFORMATION TO THE FOLLOWING:

DISTRICT PUBLIC INFORMATION OFFICER (PIO):  
ASHLEY RITTENHOUSE  
FAX: (740) 373-3953  
EMAIL: ASHLEY.RITTENHOUSE@DOT.OHIO.GOV

DISTRICT PERMIT SECTION:  
STEPHEN WELLS  
FAX: (740) 373-3953  
EMAIL: STEPHEN.WELLS@DOT.OHIO.GOV

CENTRAL OFFICE SPECIAL HAUL PERMITS SECTION:  
FAX: (614) 728-4099  
EMAIL: HAULING.PERMITS@DOT.OHIO.GOV

THE PIO WILL, IN TURN, NOTIFY THE PUBLIC, THE LOCAL EMERGENCY SERVICES, AFFECTED SCHOOLS AND BUSINESSES, AND ANY OTHER IMPACTED LOCAL PUBLIC AGENCY OF THE ABOVE MENTIONED ITEMS VIA MEDIA SOURCES.

**ITEM 524 - DRILLED SHAFTS, 36" DIAMETER, ABOVE BEDROCK, AS PER PLAN**

**ITEM 524 - DRILLED SHAFTS, 42" DIAMETER, ABOVE BEDROCK, AS PER PLAN**

**ITEM 524 - DRILLED SHAFTS, 42" DIAMETER, INTO BEDROCK, AS PER PLAN**

THIS WORK CONSISTS OF FURNISHING AND INSTALLING DRILLED SHAFTS FOR SOLDIER PILE AND LAGGING WALLS. THE DRILLED SHAFTS ARE REINFORCED WITH SOLDIER PILES INSTEAD OF REINFORCING STEEL CAGES. THE SOLDIER PILES EXTEND ABOVE THE TOP OF THE DRILLED SHAFT. FURNISH AND INSTALL DRILLED SHAFTS IN ACCORDANCE WITH CMS 524 EXCEPT AS MODIFIED AND SUPPLEMENTED BELOW.

EXCAVATE THE HOLE FOR THE DRILLED SHAFTS WITHIN 3 INCHES OF THE PLAN LOCATION IN THE HORIZONTAL PLANE. IF FIELD CONDITIONS INDICATE GREATER DEPTHS, NOTIFY THE ENGINEER FOR FURTHER EVALUATION.

PLACE THE SOLDIER PILE VERTICALLY WITHIN THE HOLE SO IT IS NOT INCLINED MORE THAN 1" BETWEEN THE TOP AND BOTTOM. PLACE THE SOLDIER PILE SO THAT THE FLANGES ARE PARALLEL TO THE CENTERLINE OF CONSTRUCTION. DO NOT ALLOW THE ORIENTATION OF THE FLANGES TO VARY BY MORE THAN 10 DEGREES. SUPPORT THE SOLDIER PILE SO THAT IT DOES NOT MOVE DURING CONCRETE PLACEMENT.

USE CLASS QC1 CONCRETE ACCORDING TO CMS 511. PLACE CONCRETE TO THE ELEVATION FOR THE BOTTOM OF THE PRECAST LAGGING. THE CONTRACTOR MAY PLACE CONCRETE USING THE FREE FALL METHOD PROVIDED THE DEPTH OF WATER IS LESS THAN 6 INCHES AND THE CONCRETE FALLS WITHOUT STRIKING THE SIDES OF THE HOLE. POURING CONCRETE ALONG THE WEB OF THE SOLDIER PILE IS ACCEPTABLE.

CHECK THE POSITION, THE VERTICAL ALIGNMENT AND ORIENTATION OF THE SOLDIER PILE IMMEDIATELY AFTER CONCRETE PLACEMENT. MAKE CORRECTIONS AS NECESSARY TO MEET THE ABOVE TOLERANCES.

PLACE PRECAST LAGGING SO THAT THE SOLDIER PILE FLANGE OVERLAPS THE END OF THE LAGGING BY AT LEAST 3 INCHES AT BOTH ENDS OF THE LAGGING.

SEQUENCE OF INSTALLATION  
THE INSTALLATION SEQUENCE SHALL BE SUCH THAT NO KING PILE IS INSTALLED ADJACENT TO EITHER AN OPEN KING PILE EXCAVATION OR A KING PILE IN WHICH THE CONCRETE HAS LESS THAN A 48 HOUR CURE. INSTALLING THE SHAFTS IN AN ALTERNATING SEQUENCE OR ANY OTHER SEQUENCE THAT MEETS THIS CRITERIA IS PERMISSIBLE.

PROTECTION OF UNATTENDED OPEN SHAFTS  
CARE SHALL BE EXERCISED AS TO COVER UNATTENDED OPEN SHAFTS. TEMPORARY COVERS SHALL BE OF ADEQUATE STRENGTH TO PREVENT A PERSON OR ANIMAL FROM FALLING IN. NO DRILLED SHAFT EXCAVATION SHALL BE LEFT UN-POURED OVERNIGHT

THE CONTRACTOR SHALL BE RESPONSIBLE FOR THE MEANS AND METHODS USED TO CONSTRUCT THE DRILLED SHAFTS AND PLACE CONCRETE PANELS. ANY TEMPORARY GRADING, EXCAVATION, EMBANKMENT, AGGREGATE, DRAINAGE, SHEETING, ETC. NEEDED TO COMPLETE THE WORK AREA SHALL BE INCLUDED IN THE BID PRICE FOR THE DRILLED SHAFTS. THE COST OF ANY EXCAVATION AND SUBSEQUENT REPLACEMENT OF EMBANKMENT (PER ITEM 203 EMBANKMENT) SHALL BE INCLUDED IN THE VARIOUS BID ITEMS FOR THE DRILLED SHAFTS AND CONCRETE PANELS. NO SEPARATE PAYMENT WILL BE MADE.

PAYMENT IS FULL COMPENSATION FOR CONSTRUCTING THE DRILLED SHAFTS, INCLUDING FURNISHING AND PLACING CONCRETE AND REMOVAL OF CONCRETE FROM AROUND THE SOLDIER PILE IN ORDER TO PLACE PRECAST LAGGING. PAYMENT FOR SOIL OVERBURDEN DRILLING, WHICH IS GROUND LEVEL TO THE TOP OF THE SHAFT, SHALL BE INCLUSIVE OF ITEM 524 DRILLED SHAFTS, 36" DIAMETER, ABOVE BEDROCK AS PER PLAN AND ITEM 524 DRILLED SHAFTS, 42" DIAMETER, ABOVE BEDROCK AS PER PLAN.

MEASUREMENT FOR PAYMENT FOR DRILLED SHAFTS ABOVE BEDROCK, AS PER PLAN, WILL BE MEASURED ALONG THE AXIS OF THE DRILLED SHAFT FROM THE TOP OF THE SHAFT TO THE TOP OF BEDROCK, AS DETERMINED BY THE ENGINEER. MEASUREMENT FOR PAYMENT FOR DRILLED SHAFTS INTO BEDROCK, AS PER PLAN, WILL BE LIMITED TO THE DISTANCE BETWEEN THE TOP OF BEDROCK AND THE BOTTOM OF THE DRILLED SHAFT, AS DETERMINED BY THE ENGINEER.

**CONNECTION BETWEEN EXISTING AND PROPOSED GUARDRAIL**

WHEN IT IS NECESSARY TO SPLICE PROPOSED GUARDRAIL TO EXISTING GUARDRAIL, ONLY THE EXISTING GUARDRAIL SHALL BE CUT, DRILLED, OR PUNCHED. THE CONNECTION SHALL BE MADE USING A W-BEAM, BEAM SPLICE AS SHOWN IN AASHTO M 180-12, EXCEPT THE BEAM WASHERS ARE NOT TO BE USED. PAYMENT SHALL BE INCLUDED IN THE CONTRACT PRICE FOR THE RESPECTIVE GUARDRAIL ITEMS.

**ITEM 254 - PAVEMENT PLANING, ASPHALT CONCRETE, AS PER PLAN**

DUE TO THE ACTIVE NATURE OF THE LANDSLIDE, PAVEMENT OVERLAYS HAVE BEEN PLACED AFTER THE SURVEY WAS PERFORMED. IT IS ANTICIPATED THAT PAVEMENT PLANING MAY BE NECESSARY TO OBTAIN THE PROPOSED CROSS-SLOPE.

DESIGN AGENCY



DESIGNER  
JDW

REVIEWER

XXX MM-DD-YY

PROJECT ID

115533

SHEET TOTAL

P.03 P.48

**ENDANGERED BAT HABITAT REMOVAL**

THE PROJECT IS LOCATED WITHIN THE KNOWN HABITAT RANGES OF THE FEDERALLY LISTED AND PROTECTED INDIANA BAT AND NORTHERN LONG-EARED BAT. NO TREES SHALL BE REMOVED UNDER THIS PROJECT FROM APRIL 1 THROUGH SEPTEMBER 30. ALL NECESSARY TREE REMOVAL SHALL OCCUR FROM OCTOBER 1 THROUGH MARCH 31. THIS REQUIREMENT IS NECESSARY TO AVOID AND MINIMIZE IMPACTS TO THESE SPECIES AS REQUIRED BY THE ENDANGERED SPECIES ACT. FOR THE PURPOSES OF THIS NOTE, A TREE IS DEFINED AS A LIVE, DYING, OR DEAD WOODY PLANT, WITH A TRUNK THREE INCHES OR GREATER IN DIAMETER AT A HEIGHT OF 4.5 FEET ABOVE THE GROUND SURFACE, AND WITH A MINIMUM HEIGHT OF 13 FEET.

**ITEM SPECIAL - RETAINING WALL, PRECAST CONCRETE LAGGING**

THIS WORK CONSISTS OF FURNISHING AND PLACING PRECAST REINFORCED CONCRETE PANELS BETWEEN THE SOLDIER PILES TO FUNCTION AS LAGGING FOR THE RETAINING WALL. PROVIDE PRECAST CONCRETE LAGGING FROM A PRECAST CONCRETE MANUFACTURER CERTIFIED UNDER SUPPLEMENT 1073. PROVIDE CONCRETE WITH A 28-DAY DESIGN STRENGTH OF AT LEAST 4000 PSI ACCORDING TO CMS 499. PROVIDE EPOXY COATED REINFORCING STEEL ACCORDING TO CMS 709.00. IN LIEU OF EPOXY COATING, A CORROSION INHIBITING CONCRETE ADMIXTURE MAY BE USED AT THE SPECIFIED DOSAGE RATE. A QUALIFIED PRODUCT LIST OF CORROSION INHIBITING ADMIXTURES IS ON FILE AT THE LABORATORY. MANUFACTURERS SHOULD RECOGNIZE THAT THE CORROSION INHIBITOR MAY AFFECT THE STRENGTH, ENTRAINED AIR CONTENT, WORKABILITY, ETC. OF THEIR CONCRETE MIXES. THE MANUFACTURER'S CHOICE TO USE ONE OF THESE CORROSION INHIBITORS DOES NOT ALLEVIATE MEETING ALL DESIGN REQUIREMENTS. DO NOT ALLOW THE DIMENSIONS OF THE REINFORCING STEEL TO VARY BY MORE THAN 1/4 INCH. PERMANENTLY MARK EACH PANEL TO INDICATE THE FACE TO BE PLACED AGAINST THE SOIL. PLACE THE PANEL BETWEEN THE FLANGES OF THE SOLDIER PILES AND BEARING AGAINST THE FLANGES ON THE EXPOSED SIDE OF THE WALL.

THE DEPARTMENT WILL PAY FOR PRECAST LAGGING AT THE CONTRACT UNIT PRICE PER SQUARE FOOT FOR ITEM SPECIAL, RETAINING WALL, PRECAST CONCRETE LAGGING.

**ITEM 507 - STEEL PILES, MISC.: SOLDIER PILES W27X146**

THIS WORK CONSISTS OF FURNISHING AND PLACING STEEL SOLDIER PILES INTO DRILLED HOLES. FURNISH SOLDIER PILES CONSISTING OF STRUCTURAL STEEL MEMBERS THAT MEET THE PLAN REQUIREMENTS AND CONFORM TO ASTM A572, GRADE 50. DO NOT FIELD WELD OR SPLICE STEEL SOLDIER PILES; WITH PANEL SEATS BEING THE EXCEPTION.

MEASUREMENT FOR PAYMENT WILL BE LIMITED TO THE DISTANCE BETWEEN THE TOP OF WALL ELEVATION AND THE BOTTOM OF THE DRILLED SHAFT, AS DETERMINED BY THE ENGINEER. THE DEPARTMENT WILL PAY FOR SOLDIER PILES AT THE CONTRACT UNIT PRICE PER FOOT OF ITEM 507 - STEEL PILES, MISC.: SOLDIER PILES - W27X146

**CONTROL POINTS**

STATION	OFFSET	NORTHING	EASTING	ELEVATION	FEATURE
1063+67.44	16.03' LT	284,546.553	2,047,572.212	555.363	IRON PIN
1067+90.70	16.66' LT	284,967.993	2,047,521.206	556.007	IRON PIN
1073+48.13	15.67' RT	285,524.944	2,047,498.038	564.875	IRON PIN

**SURVEYING POSITIONAL PARAMETERS**

USE THE FOLLOWING VERTICAL AND HORIZONTAL POSITIONING PARAMETERS FOR ALL SURVEYING:

VERTICAL POSITIONING  
ORTHOMETRIC HEIGHT DATUM: NAVD88  
GEOID: GEOID18

HORIZONTAL POSITIONING  
REFERENCE FRAME: NAD83 (2011) (epoch 2010.0)  
ELLIPSOID: GRS80  
MAP PROJECTION: LAMBERT CONFORMAL CONIC  
COORDINATE SYSTEM: OHIO STATE PLANE, SOUTH ZONE  
COMBINED SCALE FACTOR: N/A

UNITS:  
FURNISH UNITS IN U.S. SURVEY FEET. USE THE FOLLOWING CONVERSION FACTOR: 1 METER = 3.280833333 U.S. SURVEY FEET.

**STAKEOUT COORDINATES FOR S.R. 7**

STATION	NORTHING	EASTING
POT 1054+80.81	283,660.060	2,047,594.629
POT 1073+41.31	285,518.808	2,047,513.985

**ITEM 511 CLASS QC1 CONCRETE, FOOTING, AS PER PLAN**

ALL REQUIREMENTS OF CMS 511 SHALL BE FOLLOWED, EXCEPT THE CONTRACTOR WILL BE PERMITTED TO LOAD THE CONCRETE PAD ONE DAY AFTER PLACEMENT.

**ITEM 524 DRILLED SHAFTS, MISC.: PERMANENT CASING**

PERMANENT CASING, PER CMS 524.06, SHALL BE USED, AS SHOWN ON SHEETS 30 AND 31, FOR THE INSTALLATION OF DRILLED SHAFTS. PERMANENT CASING CONSTRUCTION SHALL BE PER CMS 524.04D.

PAYMENT IS FULL COMPENSATION FOR FURNISHING AND PLACING THE PERMANENT CASING.

**COORDINATES FOR KING PILES**

DRILLED SHAFT NO.	CENTERLINE OF WALL STATION	NORTHING	EASTING
1	11+50.61	284810.73	2047571.23
2	11+56.36	284816.48	2047570.98
3	11+62.11	284822.22	2047570.73
4	11+67.86	284827.97	2047570.48
5	11+73.61	284833.71	2047570.23
6	11+79.36	284839.46	2047569.98
7	11+85.11	284845.20	2047569.74
8	11+90.86	284850.95	2047569.49
9	11+96.61	284856.69	2047569.24
10	12+02.36	284862.43	2047568.99
11	12+08.11	284868.18	2047568.74
12	12+13.86	284873.92	2047568.49
13	12+19.61	284879.67	2047568.24
14	12+25.36	284885.41	2047567.99
15	12+31.11	284891.16	2047567.74
16	12+36.86	284896.90	2047567.49
17	12+42.61	284902.65	2047567.24
18	12+48.36	284908.39	2047566.99
19	12+54.11	284914.14	2047566.74
20	12+59.86	284919.88	2047566.50
21	12+65.61	284925.62	2047566.25
22	12+71.36	284931.37	2047566.00
23	12+77.11	284937.11	2047565.75
24	12+82.86	284942.86	2047565.50
25	12+88.61	284948.60	2047565.25
26	12+94.36	284954.35	2047565.00
27	13+00.11	284960.09	2047564.75
28	13+05.86	284965.84	2047564.50
29	13+11.61	284971.58	2047564.25
30	13+17.36	284977.33	2047564.00
31	13+23.11	284983.07	2047563.75
32	13+28.86	284988.82	2047563.50
33	13+34.61	284994.56	2047563.26
34	13+40.36	285000.30	2047563.01
35	13+46.11	285006.05	2047562.76
36	13+51.86	285011.79	2047562.51
37	13+57.61	285017.54	2047562.26
38	13+63.36	285023.28	2047562.01
39	13+69.11	285029.03	2047561.76

**COORDINATES FOR KING PILES (CONT.)**

DRILLED SHAFT NO.	CENTERLINE OF WALL STATION	NORTHING	EASTING
40	13+74.86	285034.77	2047561.51
41	13+80.61	285040.52	2047561.26
42	13+86.36	285046.26	2047561.01
43	13+92.11	285052.01	2047560.76
44	13+97.86	285057.75	2047560.51
45	14+03.61	285063.50	2047560.26
46	14+09.36	285069.24	2047560.02
47	14+15.11	285074.98	2047559.77
48	14+20.86	285080.73	2047559.52
49	14+26.61	285086.47	2047559.27
50	14+32.36	285092.22	2047559.02
51	14+38.11	285097.96	2047558.77
52	14+43.86	285103.71	2047558.52
53	14+49.61	285109.45	2047558.27
54	14+55.36	285115.20	2047558.02
55	14+61.11	285120.94	2047557.77
56	14+66.86	285126.69	2047557.52
57	14+72.61	285132.43	2047557.27
58	14+78.36	285138.17	2047557.02
59	14+84.11	285143.92	2047556.78
60	14+89.86	285149.66	2047556.53
61	14+95.61	285155.41	2047556.28
62	15+01.36	285161.15	2047556.03
63	15+07.11	285166.90	2047555.78
64	15+12.86	285172.64	2047555.53
65	15+18.61	285178.39	2047555.28
66	15+24.36	285184.13	2047555.03
67	15+30.11	285189.88	2047554.78
68	15+35.86	285195.62	2047554.53
69	15+41.61	285201.37	2047554.28
70	15+47.36	285207.11	2047554.03
71	15+53.11	285212.85	2047553.78
72	15+58.86	285218.60	2047553.54
73	15+64.61	285224.34	2047553.29
74	15+70.36	285230.09	2047553.04
75	15+76.11	285235.83	2047552.79
76	15+81.86	285241.58	2047552.54
77	15+87.61	285247.32	2047552.29
78	15+93.36	285253.07	2047552.04

**SUPERELEVATION TABLE**

P.I. STATION N/A DC = N/A

LEFT SIDE					CENTERLINE CONTROL		RIGHT SIDE					REMARKS
EDGE ELEVATION	TRANSITION RATE	ELEVATION CORRECTION	CROSS SLOPE	WIDTH	STATION	PROFILE GRADE	WIDTH	CROSS SLOPE	ELEVATION CORRECTION	TRANSITION RATE	EDGE ELEVATION	
556.28	-	-0.253	-0.0202	12.5	1066 + 00.00	556.53	12.5	-0.0140	-0.18	-	556.36	MATCH EX.
556.56	952	-0.226	-0.0181	12.5	1066 + 25.00	556.79	12.5	-0.0150	-0.19	-2000	556.60	-
556.79	952	-0.200	-0.0160	12.5	1066 + 50.00	556.99	12.5	-0.0160	-0.20	-2000	556.79	N.C. (RT/LT)
-	-	-	-	-	- + -	-	-	-	-	-	-	N.C. (RT/LT)
671.64	-	-0.200	-0.0160	12.5	1070 + 75.00	671.84	12.5	-0.0160	-0.20	-	671.64	N.C. (RT/LT)
673.08	5000	-0.195	-0.0156	12.5	1071 + 00.00	673.27	12.5	-0.0174	-0.22	-1429	673.05	MATCH EX. (RT)
561.81	5000	-0.190	-0.0152	12.5	1071 + 25.00	562.00	-	-	-	-	-	MATCH EX.

DESIGN AGENCY



DESIGNER

JDW

REVIEWER

XXX MM-DD-YY

PROJECT ID

115533

SHEET

P.04

TOTAL

P.48

GENERAL NOTES

**ITEM 614, MAINTAINING TRAFFIC**

A MINIMUM OF ONE LANE OF TRAFFIC SHALL BE MAINTAINED AT ALL TIMES BY USE OF THE EXISTING PAVEMENT, THE COMPLETED PAVEMENT, ITEM 615 PAVEMENT FOR MAINTAINING TRAFFIC, AND ITEM 615 ROADS FOR MAINTAINING TRAFFIC.

LENGTH AND DURATION OF LANE CLOSURES AND RESTRICTIONS SHALL BE AT THE APPROVAL OF THE ENGINEER. IT IS THE INTENT TO MINIMIZE THE IMPACT TO THE TRAVELING PUBLIC. LANE CLOSURES OR RESTRICTIONS OVER SEGMENTS OF THE PROJECT IN WHICH NO WORK IS ANTICIPATED WITHIN A REASONABLE TIME FRAME, AS DETERMINED BY THE ENGINEER, SHALL NOT BE PERMITTED. THE LEVEL OF UTILIZATION OF MAINTENANCE OF TRAFFIC DEVICES SHALL BE COMMENSURATE WITH THE WORK IN PROGRESS.

ALL WORK AND TRAFFIC CONTROL DEVICES SHALL BE IN ACCORDANCE WITH C&MS 614 AND OTHER APPLICABLE PORTIONS OF THE SPECIFICATIONS, AS WELL AS THE OHIO MANUAL OF UNIFORM TRAFFIC CONTROL DEVICES. PAYMENT FOR ALL LABOR, EQUIPMENT AND MATERIALS SHALL BE INCLUDED IN THE LUMP SUM CONTRACT PRICE FOR ITEM 614, MAINTAINING TRAFFIC, UNLESS SEPARATELY ITEMIZED IN THE PLAN.

**ITEM 614, WORK ZONE IMPACT ATTENUATOR FOR 24" WIDE HAZARDS (BIDIRECTIONAL)**

THIS ITEM SHALL CONSIST OF FURNISHING AND INSTALLING A NON-GATING IMPACT ATTENUATOR. FURNISH AN IMPACT ATTENUATOR FROM THE OFFICE OF ROADWAY ENGINEERING'S APPROVED LIST FOR WORK ZONE IMPACT ATTENUATORS, FROM THE ROADWAY STANDARDS APPROVED PRODUCTS WEB PAGE.

INSTALLATION SHALL BE AT THE LOCATIONS SPECIFIED IN THE PLANS IN ACCORDANCE WITH THE MANUFACTURER'S SPECIFICATIONS.

THE CONTRACTOR SHALL REPAIR OR REPLACE A DAMAGED UNIT WITHIN 24 HOURS OF A DAMAGING IMPACT.

WHEN BIDIRECTIONAL DESIGNS ARE SPECIFIED, THE CONTRACTOR SHALL SUPPLY APPROPRIATE TRANSITIONS.

WHEN GATING IMPACT ATTENUATORS ARE DESIRED, THE CONTRACTOR SHALL SUBMIT DOCUMENTATION TO THE ENGINEER FOR ACCEPTANCE.

THE COST FOR THE ADDITIONAL BARRIER REQUIRED FOR A GATING IMPACT ATTENUATOR SHALL BE INCLUDED IN THE COST OF THE GATING IMPACT ATTENUATOR.

PAYMENT FOR THE ABOVE WORK SHALL BE MADE AT THE UNIT PRICE BID AND SHALL INCLUDE ALL LABOR, TOOLS, EQUIPMENT AND MATERIALS NECESSARY TO CONSTRUCT AND MAINTAIN A COMPLETE AND FUNCTIONAL IMPACT ATTENUATOR SYSTEM, INCLUDING ALL RELATED BACKUPS, TRANSITIONS, LEVELING PADS, HARDWARE AND GRADING, NOT SEPARATELY SPECIFIED, AS REQUIRED BY THE MANUFACTURER.

**ITEM 614, BARRIER REFLECTORS AND/OR OBJECT MARKERS**

BARRIER REFLECTORS AND/OR OBJECT MARKERS SHALL BE INSTALLED ON ALL PORTABLE BARRIER (PB) USED FOR TRAFFIC CONTROL. BARRIER REFLECTORS, OBJECT MARKERS AND THEIR INSTALLATION SHALL CONFORM TO CMS 626, EXCEPT THAT THE SPACING SHALL BE 50 FEET

**LIGHTING**

LIGHTING SHALL BE PROVIDED AT EACH END OF THE LANE CLOSURE FOR THE CLOSING OF ONE LANE OF A TWO LANE HIGHWAY.

LIGHTING SHALL BE BY CONVENTIONAL METHODS, WITH LUMINAIRE ARMS ATTACHED TO THE SIGNAL SUPPORTS. AREA ILLUMINATION SHALL BE PROVIDED BY USING AN 8000-LUMEN LED, 150 WATT MINIMUM HIGH PRESSURE SODIUM LUMINARIES OR 250 WATT MINIMUM MERCURY LUMINARIES. THE MINIMUM HEIGHT OF THE LUMINAIRE SHALL BE 27 FT FROM THE GROUND SURFACE.

PAYMENT FOR LIGHTING SHALL INCLUDE DELIVERY, ERECTION, MAINTENANCE AND REMOVAL AS CALLED FOR IN THE PLANS. PAYMENT SHALL BE PER EACH.

ITEM 614 - WORK ZONE LIGHTING SYSTEM 1 EACH QUANTITY CARRIED TO THE GENERAL SUMMARY.

**SEQUENCE OF CONSTRUCTION**

**PHASE 1:**

1. WHILE USING FLAGGERS, INSTALL PORTABLE BARRIERS, IMPACT ATTENUATORS, SIGNALS, DELINEATORS, AND SIGNS TO PERFORM PART-WIDTH CONSTRUCTION OF THE PROPOSED CONDUIT AND PAVEMENT FOR MAINTAINING TRAFFIC. WORK PERFORMED SHALL BE IN ACCORDANCE WITH SCD'S MT-96.11, MT-96.20, MT-96.26, MT-97.10, MT-101.70, AND MT-101.75.
2. REMOVE PAVEMENT AND INSTALL PROPOSED CONDUIT, WHILE MAINTAINING DRAINAGE THROUGH THE EXISTING CONDUIT.
3. PLACE LOW STRENGTH MORTAR BACKFILL AND PLACE PROPOSED PAVEMENT TO MATCH EXISTING PROFILE AND INSTALL TEMPORARY PAVEMENT.

**PHASE 2:**

1. WHILE USING FLAGGERS, MOVE PORTABLE BARRIERS, IMPACT ATTENUATORS, DELINEATORS, SIGNS, AND PLACE PAVEMENT MARKINGS FOR INSTALLING THE DRILLED SHAFT WALL. WORK PERFORMED SHALL BE IN ACCORDANCE WITH SCD'S MT-96.11, MT-96.20, MT-96.26, MT-97.10, MT-101.70, AND MT-101.75.
2. CONSTRUCT DRILLED SHAFT, SOLDIER PILE WALL.
3. COMPLETE PART-WIDTH CONSTRUCTION OF CULVERT, PERTINENT LOW STRENGTH MORTAR BACKFILL, PLUG AND FILL EXISTING CONDUIT, AND PAVEMENT REPLACEMENT.
4. PERFORM PAVEMENT REPAIR.

**PHASE 3:**

1. WHILE USING FLAGGERS, REMOVE PORTABLE BARRIERS, INSTALL BARRELS, DELINEATORS, AND SIGNS TO PLACE PAVEMENT OVERLAY, PAVEMENT MARKINGS AND GUARDRAIL. WORK PERFORMED SHALL BE IN ACCORDANCE WITH SCD'S MT-96.11, MT-96.20, MT-96.26, MT-97.10, MT-101.70, AND MT-101.75.
2. COMPLETE PAVEMENT REPLACEMENT, OVERLAY, FINAL MARKINGS, AND INSTALL GUARDRAIL.
3. USING FLAGGERS REMOVE MAINTENANCE OF TRAFFIC DEVICES.

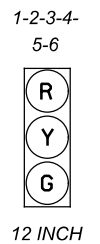

**SIGNAL INDICATORS**

**COLOR SEQUENCE CHART**

INDICATORS FACINGS	No	Ø1			Ø2			Ø3		
		1	2	3	1	2	3	1	2	3
NORTH BOUND SR 7	1	G	Y	R	R	R	R	R	R	R
	2	G	Y	R	R	R	R	R	R	R
SOUTH BOUND SR 7	3	R	R	R	G	Y	R	R	R	R
	4	R	R	R	G	Y	R	R	R	R
DRIVEWAY AT STA. 1071+10	5	R	R	R	R	R	R	G	Y	R
	6	R	R	R	R	R	R	G	Y	R

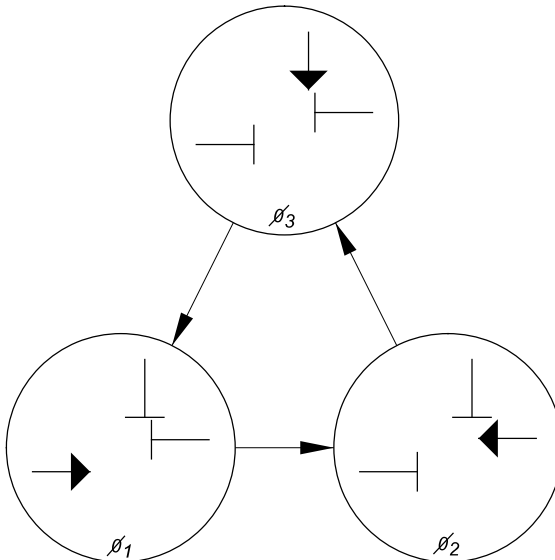

**PHASING DIAGRAM**

**TIMING CHART**

INTERVAL	Ø1			Ø2			Ø3		
	1	2	3	1	2	3	1	2	3
<b>GREEN</b>	36			36			3		
<b>YELLOW CHANGE</b>		3			3			3	
<b>ALL RED CLEARANCE</b>			24			24			18
<b>CYCLE LENGTH</b>	150								

DESIGN AGENCY



DESIGNER  
JDW

REVIEWER

XXX MM-DD-YY

PROJECT ID  
115533

SHEET TOTAL  
P.05 P.48

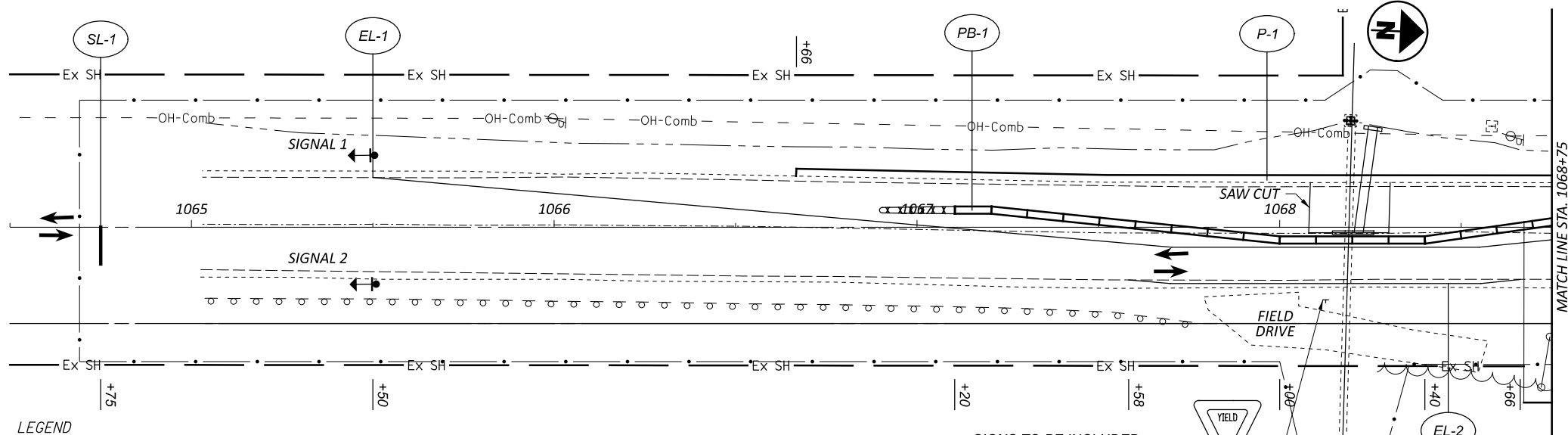

**LEGEND**

- WORK ZONE IMPACT ATTENUATOR
- PORTABLE BARRIER
- DRUMS

**NOTE:**  
 - CONTRACTOR SHALL MAINTAIN ACCESS TO MAILBOX.  
 - REFER TO STANDARD CONSTRUCTION DRAWING MT-96.11 FOR SIGN PLACEMENT AND FURTHER DETAILS.

**CONSTRUCTION SEQUENCE**

- WHILE USING FLAGGERS, INSTALL THE PORTABLE BARRIER (PB), WORK ZONE IMPACT ATTENUATORS, TEMPORARY PAVEMENT MARKINGS, AND TRAFFIC SIGNALS AS SHOWN ON THIS SHEET.
- USING SIGNALS, MAINTAIN TWO WAY, ONE LANE TRAFFIC IN THE NORTH BOUND LANE OF S.R. 7.
- CONSTRUCT PARTIAL WIDTH OF PROPOSED CONDUIT, WHILE USING THE EXISTING CONDUIT TO MAINTAIN DRAINAGE DURING PHASE 1.
- PLACE PROPOSED PAVEMENT AND TEMPORARY PAVEMENT FOR PHASE 2.

\* - CONTRACTOR WILL BE RESPONSIBLE FOR MAINTAINING SHOULDER ACCESS. LABOR AND MATERIAL WILL BE INCLUDED WITH PAYMENT IN ITEM 614 - MAINTAINING TRAFFIC.

PB-1 #	PORTABLE BARRIER LOCATIONS	
	STATION	OFFSET
	1067+10	5.6' LT
	1067+20	5.6' LT
	1068+00	1.8' RT
	1068+40	2.0' RT
	1069+49	12.8' LT
	1069+59	12.8' LT

THE PB OFFSETS ARE FROM THE  $\zeta$  OF PAVEMENT TO THE CENTER OF THE PB

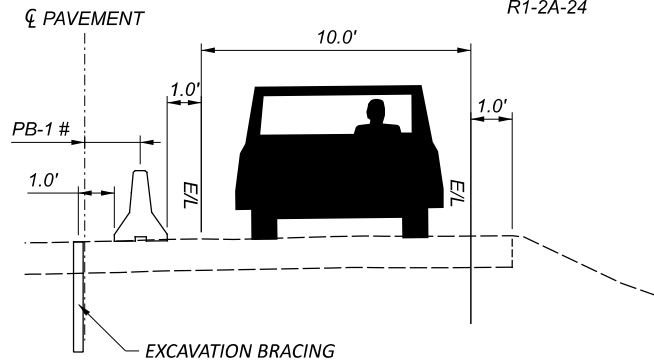

**TYPICAL SECTION FOR MAINTAINING TRAFFIC FROM STA. 1064+75 TO STA. 1072+50**

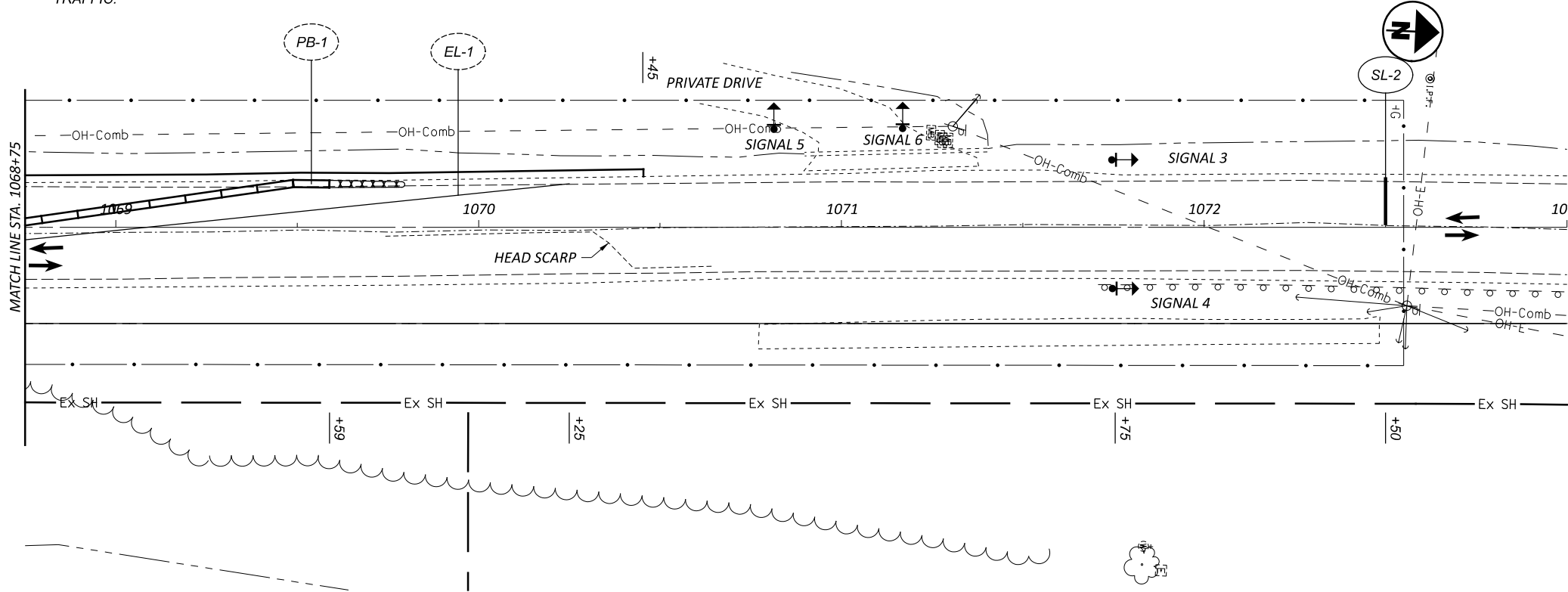

REF NO.	STATION		SIDE	ITEM	UNIT	TOTALS CARRIED TO GENERAL SUMMARY	
	FROM	TO				AMOUNT	CUMULATIVE
EL-1	1065+50	1070+25	LT/RT				
EL-2	1067+58	1068+66	RT				
SL-1	1064+75		RT				
SL-2	1072+50		LT				
PB-1	1067+10	1069+59	LT/RT			250	
P-1	1066+66	1070+45	RT			85	
				ROADS FOR MAINT. TRAFFIC	LUMP		LUMP
				PAVEMENT FOR MAINT. TRAFFIC, TYPE B	SY		85
				PORTABLE BARRIER	FEET		250
				WORK ZONE IMPACT ATTEN.	EACH		2
				BARRIER REFLECTOR, TYPE 1	EACH		5
				OBJECT MARKER, TWO WAY	EACH		5
				WORK ZONE STOP LINE	FEET		24
				WORK ZONE EDGE LINE, CLASS 1	MILE	0.09 0.02	0.11
				ROADS FOR MAINT. TRAFFIC	LUMP		LUMP
				PAVEMENT FOR MAINT. TRAFFIC, TYPE B	SY		85
				PORTABLE BARRIER	FEET		250
<b>TOTALS CARRIED TO GENERAL SUMMARY</b>							

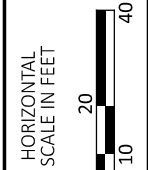

**MAINTENANCE OF TRAFFIC PHASE 1**

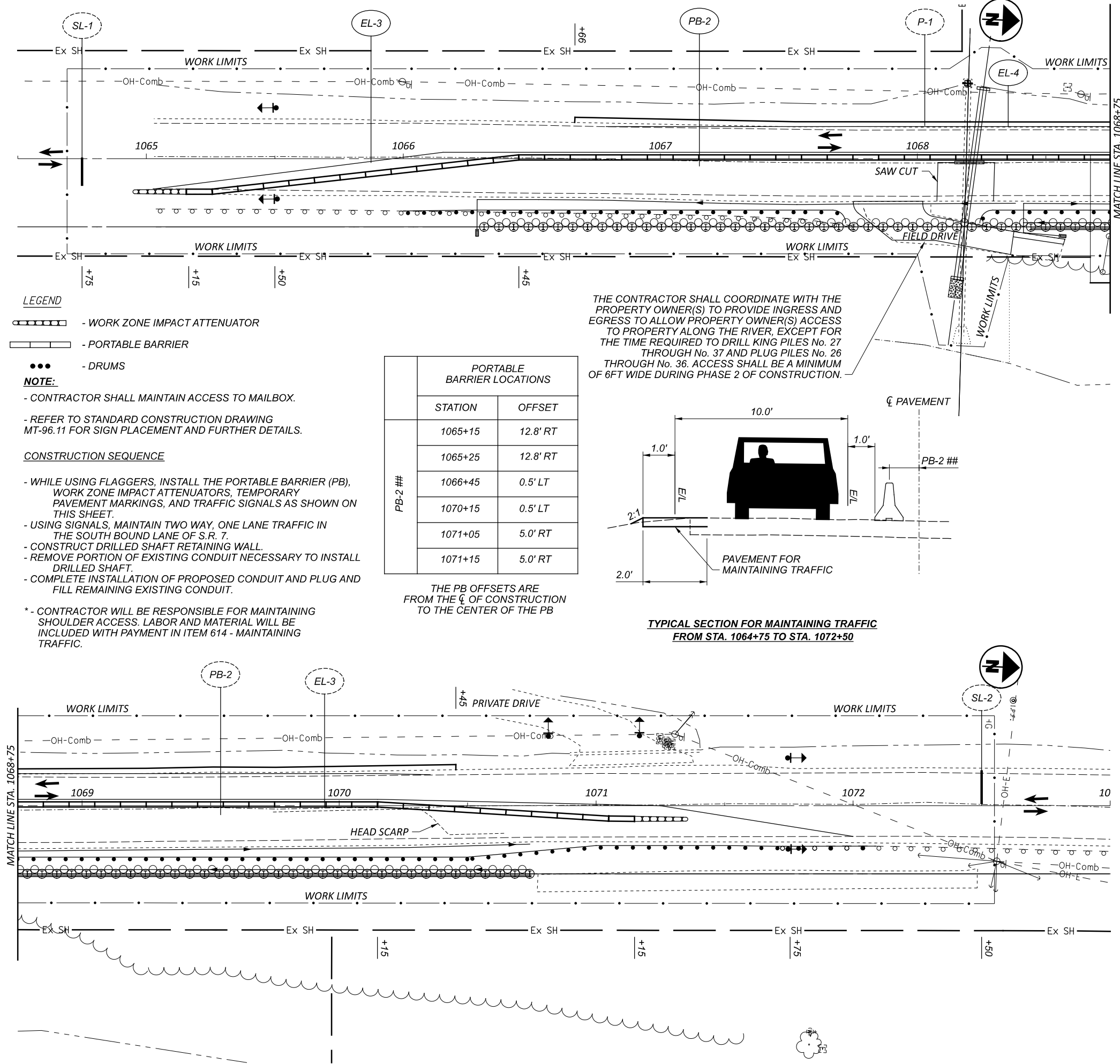

**LEGEND**

- WORK ZONE IMPACT ATTENUATOR
- PORTABLE BARRIER
- DRUMS

**NOTE:**

- CONTRACTOR SHALL MAINTAIN ACCESS TO MAILBOX.
- REFER TO STANDARD CONSTRUCTION DRAWING MT-96.11 FOR SIGN PLACEMENT AND FURTHER DETAILS.

**CONSTRUCTION SEQUENCE**

- WHILE USING FLAGGERS, INSTALL THE PORTABLE BARRIER (PB), WORK ZONE IMPACT ATTENUATORS, TEMPORARY PAVEMENT MARKINGS, AND TRAFFIC SIGNALS AS SHOWN ON THIS SHEET.
  - USING SIGNALS, MAINTAIN TWO WAY, ONE LANE TRAFFIC IN THE SOUTH BOUND LANE OF S.R. 7.
  - CONSTRUCT DRILLED SHAFT RETAINING WALL.
  - REMOVE PORTION OF EXISTING CONDUIT NECESSARY TO INSTALL DRILLED SHAFT.
  - COMPLETE INSTALLATION OF PROPOSED CONDUIT AND PLUG AND FILL REMAINING EXISTING CONDUIT.
- \* - CONTRACTOR WILL BE RESPONSIBLE FOR MAINTAINING SHOULDER ACCESS. LABOR AND MATERIAL WILL BE INCLUDED WITH PAYMENT IN ITEM 614 - MAINTAINING TRAFFIC.

PB-2 ##	PORTABLE BARRIER LOCATIONS	
	STATION	OFFSET
	1065+15	12.8' RT
	1065+25	12.8' RT
	1066+45	0.5' LT
	1070+15	0.5' LT
	1071+05	5.0' RT
	1071+15	5.0' RT

THE PB OFFSETS ARE FROM THE CL OF CONSTRUCTION TO THE CENTER OF THE PB

THE CONTRACTOR SHALL COORDINATE WITH THE PROPERTY OWNER(S) TO PROVIDE INGRESS AND EGRESS TO ALLOW PROPERTY OWNER(S) ACCESS TO PROPERTY ALONG THE RIVER, EXCEPT FOR THE TIME REQUIRED TO DRILL KING PILES No. 27 THROUGH No. 37 AND PLUG PILES No. 26 THROUGH No. 36. ACCESS SHALL BE A MINIMUM OF 6FT WIDE DURING PHASE 2 OF CONSTRUCTION.

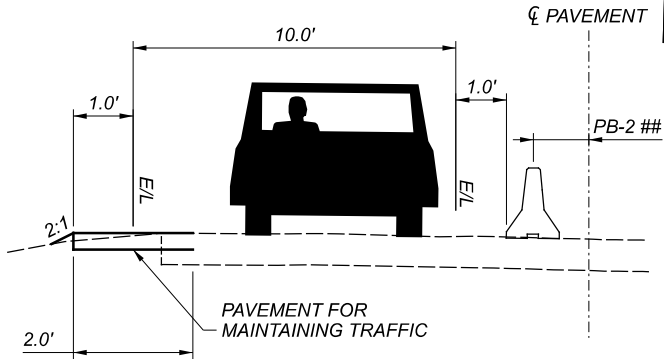

**TYPICAL SECTION FOR MAINTAINING TRAFFIC FROM STA. 1064+75 TO STA. 1072+50**

REF NO.	STATION		SIDE	ITEM	UNIT	AMOUNT	REMARKS
	FROM	TO					
EL-3	1065+50	1070+25	LT/RT				
EL-4	1066+78	1070+35	RT				
PB-2	1067+10	1069+59	LT/RT			600	
P-1	1067+81	1068+57	RT				
				622	PORTABLE BARRIER	FEET	
				615	ROADS FOR MAINT TRAFFIC	LUMP	
				614	WORK ZONE EDGE LINE, CLASS 1	MILE	0.13 0.07
				614	OBJECT MARKER, TWO WAY	EACH	12
				614	BARRIER REFLECTOR, TYPE 1	EACH	12
				614	WORK ZONE IMPACT ATTEN.	EACH	2
<b>TOTALS CARRIED TO GENERAL SUMMARY</b>							



**MAINTENANCE OF TRAFFIC PHASE 2**

DESIGN AGENCY



DESIGNER: JDW  
 REVIEWER: XXX MM-DD-YY  
 PROJECT ID: 115533  
 SHEET: P.07 TOTAL: P.48

SHEET NUM.										PART.			ITEM	ITEM EXT	GRAND TOTAL	UNIT	DESCRIPTION	SEE SHEET NO.
10	12	13	25	30						01/NHS/06	02/NHS/17							
<b>ROADWAY</b>																		
										LUMP	LUMP		201	11000	LS	CLEARING AND GRUBBING	3	
		76	62							76	62		202	23001	138	SY	PAVEMENT REMOVED, AS PER PLAN	13, 25
			5								5		202	35100	5	FT	PIPE REMOVED, 24" DIAMETER AND UNDER	
	214									214			202	38000	214	FT	GUARDRAIL REMOVED	
	2									2			202	42206	2	EACH	ANCHOR ASSEMBLY REMOVED	
			1								1		202	58100	1	EACH	CATCH BASIN REMOVED	
			93								93		SPECIAL	20270000	93	FT	FILL AND PLUG EXISTING CONDUIT 24"	25
	1									1			202	98100	1	EACH	REMOVAL MISC.:STAND PIPE	12
			1								1		202	98100	1	EACH	REMOVAL MISC.:CONCRETE OUTLET APRON	25
156										156			203	10000	156	CY	EXCAVATION	
236										236			203	20000	236	CY	EMBANKMENT	
273		76								349			204	10000	349	SY	SUBGRADE COMPACTION	
254										254			254	01001	254	SY	PAVEMENT PLANING, ASPHALT CONCRETE, AS PER PLAN VARIABLE DEPTH	3
	200									200			606	15050	200	FT	GUARDRAIL, TYPE MGS	
	337.5									337.5			606	15100	337.5	FT	GUARDRAIL, TYPE MGS WITH LONG POSTS	
	2									2			606	20050	2	EACH	ROUNDED END SECTION	
	2									2			606	26550	2	EACH	ANCHOR ASSEMBLY, MGS TYPE T	
<b>EROSION CONTROL</b>																		
			3								3		601	32100	3	CY	ROCK CHANNEL PROTECTION, TYPE B WITH FILTER	
1,544										1,544			659	10000	1,544	SY	SEEDING AND MULCHING	
0.21										0.21			659	20000	0.21	TON	COMMERCIAL FERTILIZER	
0.32										0.32			659	31000	0.32	ACRE	LIME	
4.17										4.17			659	35000	4.17	MGAL	WATER	
										3,000	2,000		832	30000	5,000	EACH	EROSION CONTROL	
<b>DRAINAGE</b>																		
			56								56		511	52110	56	CY	CLASS QC MS CONCRETE	
			1.2								1.2		602	20000	1.2	CY	CONCRETE MASONRY	
	443									443			605	06000	443	FT	4" BASE PIPE UNDERDRAINS	
			75								75		611	13200	75	FT	30" CONDUIT, TYPE A	
	2									2			611	99710	2	EACH	PRECAST REINFORCED CONCRETE OUTLET	
<b>PAVEMENT</b>																		
56			16							56	16		301	56000	72	CY	ASPHALT CONCRETE BASE, PG64-22, (449)	
56		26	11							82	11		304	20000	93	CY	AGGREGATE BASE	
207			4							207	4		407	20000	211	GAL	NON-TRACKING TACK COAT	
138										138			408	10000	138	GAL	PRIME COAT	
106										106			441	50000	106	CY	ASPHALT CONCRETE SURFACE COURSE, TYPE 1, (448), PG64-22	
9			3							9	3		441	50200	12	CY	ASPHALT CONCRETE INTERMEDIATE COURSE, TYPE 1, (448)	
68										68			441	70200	68	CY	ASPHALT CONCRETE INTERMEDIATE COURSE, TYPE 1, (449)	
		7								7			441	70500	7	CY	ASPHALT CONCRETE SURFACE COURSE, TYPE 1, (449), (DRIVEWAYS)	
29										29			617	10100	29	CY	COMPACTED AGGREGATE	
<b>TRAFFIC CONTROL</b>																		
20										20			621	00100	20	EACH	RPM	
20										20			621	54000	20	EACH	RAISED PAVEMENT MARKER REMOVED	
	12									12			626	00110	12	EACH	BARRIER REFLECTOR, TYPE 2(BIDIRECTIONAL)	
0.3										0.3			642	00104	0.3	MILE	EDGE LINE, 6", TYPE 1	
0.15										0.15			642	00300	0.15	MILE	CENTER LINE, TYPE 1	
<b>RETAINING WALLS</b>																		
				3,706						3,706			507	00400	3,706	FT	STEEL PILES, MISC.:SOLDIER PILES, W27X146	3,4,26-31
20										20			511	46511	20	CY	CLASS QC1 CONCRETE, FOOTING, AS PER PLAN	4
137										137			518	21200	137	CY	POROUS BACKFILL WITH GEOTEXTILE FABRIC	
	233									233			518	40000	233	FT	6" PERFORATED CORRUGATED PLASTIC PIPE	
	38									38			518	40012	38	FT	6" NON-PERFORATED CORRUGATED PLASTIC PIPE	

GENERAL SUMMARY

DESIGN AGENCY



DESIGNER  
JDW

REVIEWER  
XXX MM-DD-YY

PROJECT ID  
115533

SHEET TOTAL  
P.08 P.48



SHEET NUM.										PART.			ITEM	ITEM EXT	GRAND TOTAL	UNIT	DESCRIPTION	SEE SHEET NO.
5	6	7	25	27	30	31				01/NHS/06	02/NHS/17							
						950				950			524	94703	950	FT	<b>RETAINING WALLS (CONTINUED)</b> DRILLED SHAFTS, 36" DIAMETER, ABOVE BEDROCK, AS PER PLAN	3,4,26-31
					2,664					2,664			524	94803	2,664	FT	DRILLED SHAFTS, 42" DIAMETER, ABOVE BEDROCK, AS PER PLAN	3,4,26-31
					780					780			524	94805	780	FT	DRILLED SHAFTS, 42" DIAMETER, INTO BEDROCK, AS PER PLAN	3,4,26-31
						3				3			524	95000	3	FT	DRILLED SHAFTS, MISC.:EXTENSION	3,4,26-31
						950				950			524	95000	950	FT	DRILLED SHAFTS, MISC.:36" PERMANENT CASING	3,4,26-31
					2,664					2,664			524	95000	2,664	FT	DRILLED SHAFTS, MISC.:42" PERMANENT CASING	3,4,26-31
				1,320						1,320			SPECIAL	53051010	1,320	SF	RETAINING WALL, PRECAST CONCRETE LAGGING	3,4,26-31
			LUMP								LUMP		503	11100	LS		<b>MISCELLANEOUS STRUCTURE</b> COFFERDAMS AND EXCAVATION BRACING	
																	<b>MAINTENANCE OF TRAFFIC</b>	
1	2	2								4			614	12384	4	EACH	WORK ZONE IMPACT ATTENUATOR, 24" WIDE HAZARDS, (BIDIRECTIONAL)	
	5	12								1			614	12740	1	EACH	WORK ZONE LIGHTING SYSTEM	
										17			614	13310	17	EACH	BARRIER REFLECTOR, TYPE 1(BIDIRECTIONAL)	
	5	12								17			614	13360	17	EACH	OBJECT MARKER, TWO WAY	
	0.11	0.2								0.31			614	22010	0.31	MILE	WORK ZONE EDGE LINE, CLASS I, 6"	
	24									24			614	26000	24	FT	WORK ZONE STOP LINE, CLASS I	
	LUMP	LUMP								LUMP	LUMP		615	10000	LS		ROADS FOR MAINTAINING TRAFFIC	
	85									85			615	25000	85	SY	PAVEMENT FOR MAINTAINING TRAFFIC, CLASS B	
	250	600								850			622	41100	850	FT	PORTABLE BARRIER, UNANCHORED	
																	<b>INCIDENTALS</b>	
										LUMP	LUMP		614	11000	LS		MAINTAINING TRAFFIC	
										LUMP	LUMP		623	10000	LS		CONSTRUCTION LAYOUT STAKES AND SURVEYING	
										LUMP	LUMP		624	10000	LS		MOBILIZATION	

GENERAL SUMMARY

DESIGN AGENCY



DESIGNER  
JDW

REVIEWER  
XXX MM-DD-YY

PROJECT ID  
115533

SHEET TOTAL  
P.09 P.48

**ITEM 441 - ASPHALT CONCRETE SURFACE COURSE, TYPE 1, (448), PG64-22**

(OVERLAY)  
 STA. 1064+75 TO STA. 1072+50  
 775 FT x AVG. 29.5 FT x (1.5 IN/12)/27 = 105.8 CY

**A TOTAL OF 106 CY TO BE CARRIED TO THE GENERAL SUMMARY.**

**ITEM 441 - ASPHALT CONCRETE INTERMEDIATE COURSE, TYPE 1, (448)**

(PAVEMENT REPAIR)  
 STA. 1066+28 TO STA. 1070+74  
 446 FT x 4.0 FT x (1.5 IN/12)/27 = 8.3 CY

**A TOTAL OF 9 CY TO BE CARRIED TO THE GENERAL SUMMARY.**

**ITEM 441 - ASPHALT CONCRETE INTERMEDIATE COURSE, TYPE 1, (449)**

(LEVELING COURSE - LEFT LANE)  
 STA. 1066+25 TO STA. 1067+00  
 75 FT x AVG. 14.1 FT x (AVG. 1.9 IN/12)/27 = 6.2 CY  
 STA. 1067+00 TO STA. 1068+08  
 108 FT x AVG. 12.5 FT x (1.5 IN/12)/27 = 6.3 CY  
 STA. 1068+08 TO STA. 1068+30  
 SEE CULVERT DETAILS  
 STA. 1068+30 TO STA. 1069+00  
 70 FT x AVG. 12.4 FT x (AVG. 2.6 IN/12)/27 = 7.0 CY  
 STA. 1069+00 TO STA. 1070+00  
 100 FT x AVG. 13.0 FT x (1.5 IN/12)/27 = 6.0 CY  
 STA. 1070+00 TO STA. 1070+50  
 50 FT x AVG. 13.9 FT x (AVG. 2.1 IN/12)/27 = 4.5 CY

(LEVELING COURSE - RIGHT LANE)  
 STA. 1066+25 TO STA. 1068+08  
 183 FT x AVG. 12.4 FT x (AVG. 2.6 IN/12)/27 = 18.2 CY  
 STA. 1068+08 TO STA. 1068+30  
 SEE CULVERT DETAILS  
 STA. 1068+30 TO STA. 1068+75  
 45 FT x AVG. 12.5 FT x (AVG. 1.9 IN/12)/27 = 3.3 CY  
 STA. 1068+75 TO STA. 1069+50  
 75 FT x AVG. 12.5 FT x (1.5 IN/12)/27 = 4.3 CY  
 STA. 1069+50 TO STA. 1070+75  
 125 FT x AVG. 11.3 FT x (AVG. 2.6 IN/12)/27 = 11.3 CY

**A TOTAL OF 68 CY TO BE CARRIED TO THE GENERAL SUMMARY.**

**ITEM 304 - AGGREGATE BASE**

(PAVEMENT REPAIR)  
 STA. 1066+28 TO STA. 1070+74  
 446 FT x 5.0 FT x (6 IN/12)/27 = 41.3 CY

(VARIABLE THICKNESS)  
 STA. 1066+28 TO STA. 1068+75  
 247 FT x 4.0 FT x (AVG. 3.0 IN/12)/27 = 9.1 CY  
 STA. 1069+50 TO STA. 1070+74  
 124 FT x 4.0 FT x (AVG. 3.0 IN/12)/27 = 4.6 CY

**A TOTAL OF 56 CY TO BE CARRIED TO THE GENERAL SUMMARY.**

**ITEM 301 - ASPHALT CONCRETE BASE, PG64-22**

(PAVEMENT REPAIR)  
 STA. 1066+28 TO STA. 1070+74  
 446 FT x 4.5 FT x (9 IN/12)/27 = 55.8 CY

**A TOTAL OF 56 CY TO BE CARRIED TO THE GENERAL SUMMARY.**

**ITEM 407 - NON-TRACKING TACK COAT**  
 RATE = 0.08 GAL/SY (APPLIED ONTO EXISTING PAVEMENT)

(OVERLAY - APPLIED TO EXISTING PAVEMENT)  
 STA. 1064+75 TO STA. 1066+28  
 153 FT x 29.5 FT / 9 x 0.08 = 40.1 GAL.  
 STA. 1066+28 TO STA. 1068+08  
 180 FT x 25.5 FT / 9 x 0.08 = 40.8 GAL.  
 STA. 1068+30 TO STA. 1070+74  
 244 FT x 25.5 FT / 9 x 0.08 = 55.3 GAL.  
 STA. 1070+74 TO STA. 1072+50  
 176 FT x 29.5 FT / 9 x 0.08 = 46.2 GAL.

RATE = 0.05 GAL/SY (APPLIED ONTO LEVELING COURSES)

(APPLIED TO PAVEMENT REPAIR, ASPHALT CONC. BASE)  
 STA. 1066+28 TO STA. 1070+74  
 446 FT x 4.5 FT / 9 x 0.05 = 11.2 GAL.

(OVERLAY - APPLIED TO PAVEMENT REPAIR, INTERMEDIATE)  
 STA. 1066+28 TO STA. 1070+74  
 446 FT x 4.0 FT / 9 x 0.05 = 9.9 GAL.

(OVERLAY - APPLIED TO PAVEMENT FOR CULVERT REPLACEMENT)  
 STA. 1068+08 TO STA. 1068+30  
 22 FT x 25.5 FT / 9 x 0.05 = 3.1 GAL.

**A TOTAL OF 207 GAL TO BE CARRIED TO THE GENERAL SUMMARY.**

**ITEM 204 - SUBGRADE COMPACTION**

(PAVEMENT REPAIR)  
 STA. 1066+28 TO STA. 1070+74  
 446 FT x 5.5 FT / (9 SY/SF) = 272.6 SY

**A TOTAL OF 273 SY TO BE CARRIED TO THE GENERAL SUMMARY.**

**ITEM 642 - EDGE LINE**

STA. 1064+75 TO STA. 1072+50  
 2 X 775 FT / 5280 FT = 0.30 MILE

**A TOTAL OF 0.30 MILE TO BE CARRIED TO THE GENERAL SUMMARY.**

**ITEM 642 - CENTERLINE**

STA. 1064+75 TO STA. 1072+50  
 775 FT / 5280 FT = 0.15 MILE

**A TOTAL OF 0.15 MILE TO BE CARRIED TO THE GENERAL SUMMARY.**

**ITEM 511 - CLASS QC1 CONCRETE, FOOTING, AS PER PLAN**

STA. 1068+44 TO STA. 1070+74  
 230 FT x 4.0 FT x (6 IN / (12 IN/FT)) / (27 CF/CY) = 19.2 CY

**A TOTAL OF 20 CY TO BE CARRIED TO THE GENERAL SUMMARY.**

**ITEM 254 - PAVEMENT PLANING, ASPHALT CONCRETE, AS PER PLAN**

(VARIABLE THICKNESS)  
 STA. 1064+75 TO STA. 1072+50  
 775 FT x AVG. 29.5 FT x 10% / 9 = 254.0 SY

**A TOTAL OF 254 SY TO BE CARRIED TO THE GENERAL SUMMARY.**

SHEET NO.	EARTHWORK, SEEDING AND MULCHING		
	ITEM 203	ITEM 203	ITEM 659
	EXCAVATION	EMBANKMENT	SEEDING AND MULCHING
	CY	CY	SY
14	3	5	77
15	12	14	163
16	14	6	151
17	17	11	135
18	49	23	262
19	14	27	144
20	14	27	130
21	18	65	224
22	12	47	161
23	3	11	97
24	0	0	0
TOTALS	156	236	1544

**SEEDING AND MULCHING**

THE FOLLOWING QUANTITIES ARE PROVIDED TO PROMOTE GROWTH AND CARE OF PERMANENT SEEDED AREAS:

659 - SEEDING AND MULCHING = 1544 SQ. YD.

659 - COMMERCIAL FERTILIZER 1544 SY x 1 TON/7410 SY = 0.209 TON

659 - LIME 1544 SQ. YD. x 9 / 43,560 = 0.32 ACRES

659 - WATER 1544 SY x 0.0027M. GAL/SY = 4.17 M. GAL.

**TOTALS TO BE CARRIED TO THE GENERAL SUMMARY.**

**ITEM 621 - RPM / RPM REMOVED**

STA. 1064+75 TO STA. 1072+50  
 775 FT / 40 FT SPACING = 20 EA

**A TOTAL OF 20 EA TO BE CARRIED TO THE GENERAL SUMMARY.**

**ITEM 408 - PRIME COAT**

STA. 1064+75 TO STA. 1072+50  
 2 x 775 FT x 2 FT / (9 SY/SF) X (0.4 GAL/SY) = 137.8 GAL

**A TOTAL OF 138 GAL TO BE CARRIED TO THE GENERAL SUMMARY.**

**ITEM 617 - COMPACTED AGGREGATE**

STA. 1064+75 TO STA. 1072+50  
 2 x 775 FT x 2 FT x (3 IN / 12) / 27 = 228.7 CY

**A TOTAL OF 29 CY TO BE CARRIED TO THE GENERAL SUMMARY.**

ITEM 518 - POROUS BACKFILL W/ FABRIC				
STATION BASELINE OF WALL	HEIGHT	DEPTH	AREA	VOLUME
	FEET	FEET	SQ. FT.	CU. FT.
13+63.36				
	1.07	3.5	3.745	
	4.53	3.5	15.855	56.35
13+69.11				
	4.53	3.5	15.855	
	4.53	3.5	15.855	3464.32
15+87.61				
	4.53	3.5	15.855	
	1.13	3.5	42.9	168.92
15+93.36				
TOTAL (CY) CARRIED TO GENERAL SUMMARY				137

DESIGN AGENCY



DESIGNER  
 JDW

REVIEWER

XXX MM-DD-YY

PROJECT ID  
 115533

SHEET TOTAL  
 P.10 P.48

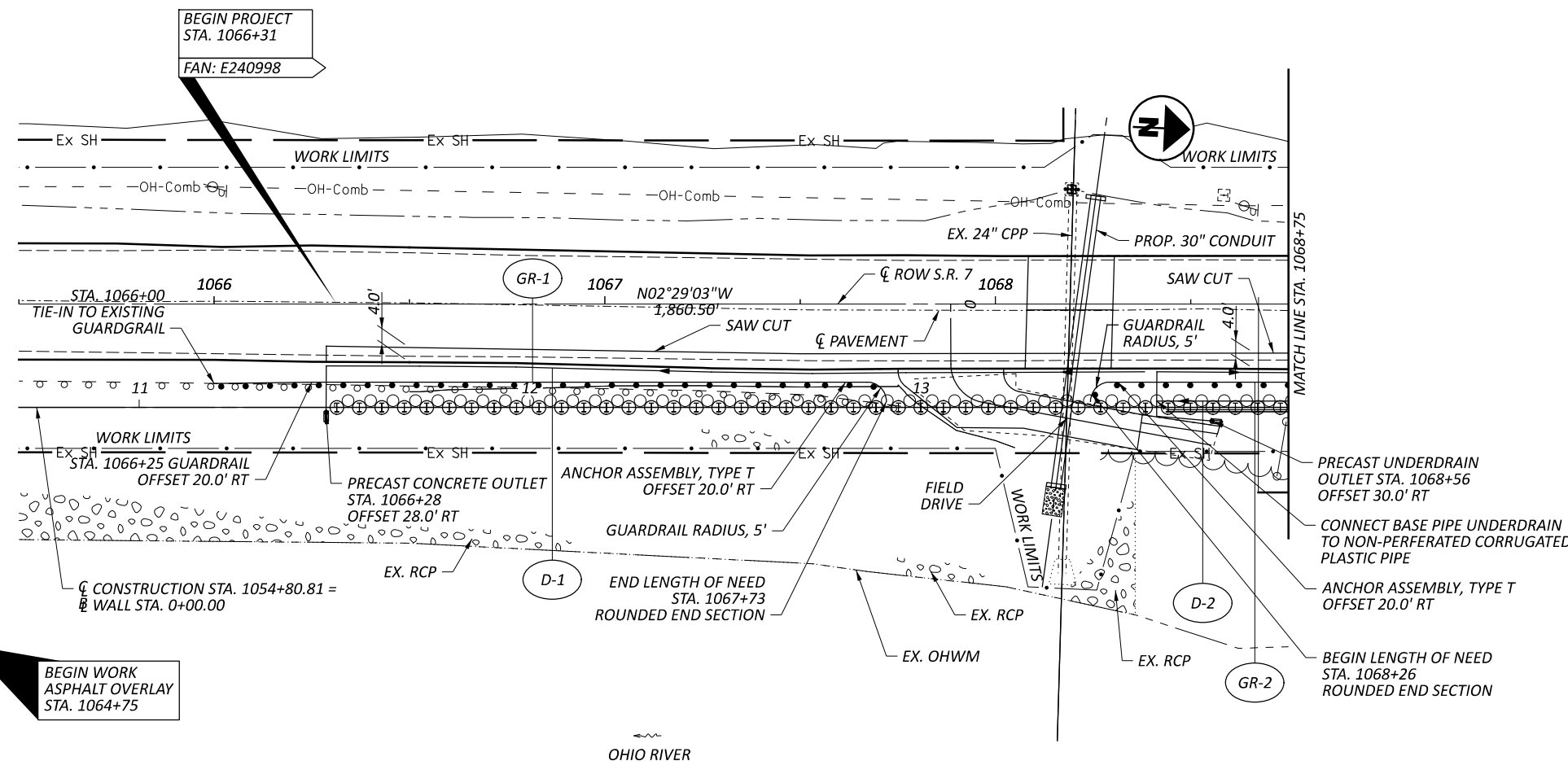

**NOTE:**

USE GUARDRAIL, TYPE MGS WITH LONG POSTS FROM STA. 1066+00 TO STA. 1067+73 AND FROM STA. 1068+26 TO STA. 1068+50

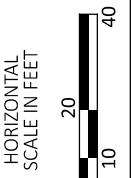

BEGIN WORK ASPHALT OVERLAY STA. 1064+75

BANK PROTECTION EASEMENT

OHIO RIVER

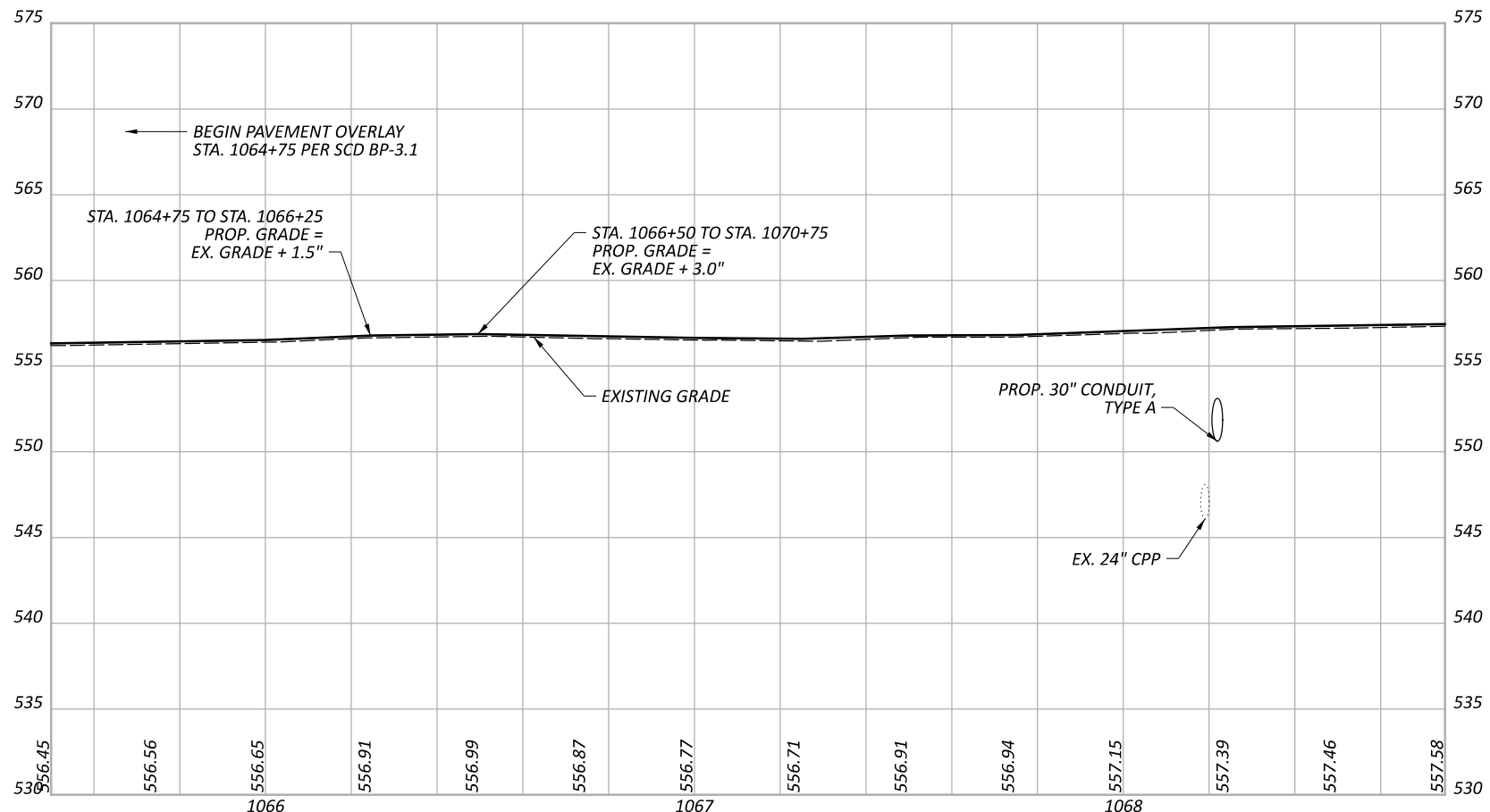

PLAN AND PROFILE  
 STA 1065+50 TO STA 1068+75

DESIGN AGENCY



DESIGNER  
 JDW

REVIEWER  
 XXX MM-DD-YY

PROJECT ID  
 115533

SHEET TOTAL  
 P.11 P.48

**NOTE:**  
 USE GUARDRAIL, TYPE MGS WITH LONG POSTS  
 FROM STA. 1070+50 TO STA. 1072+09

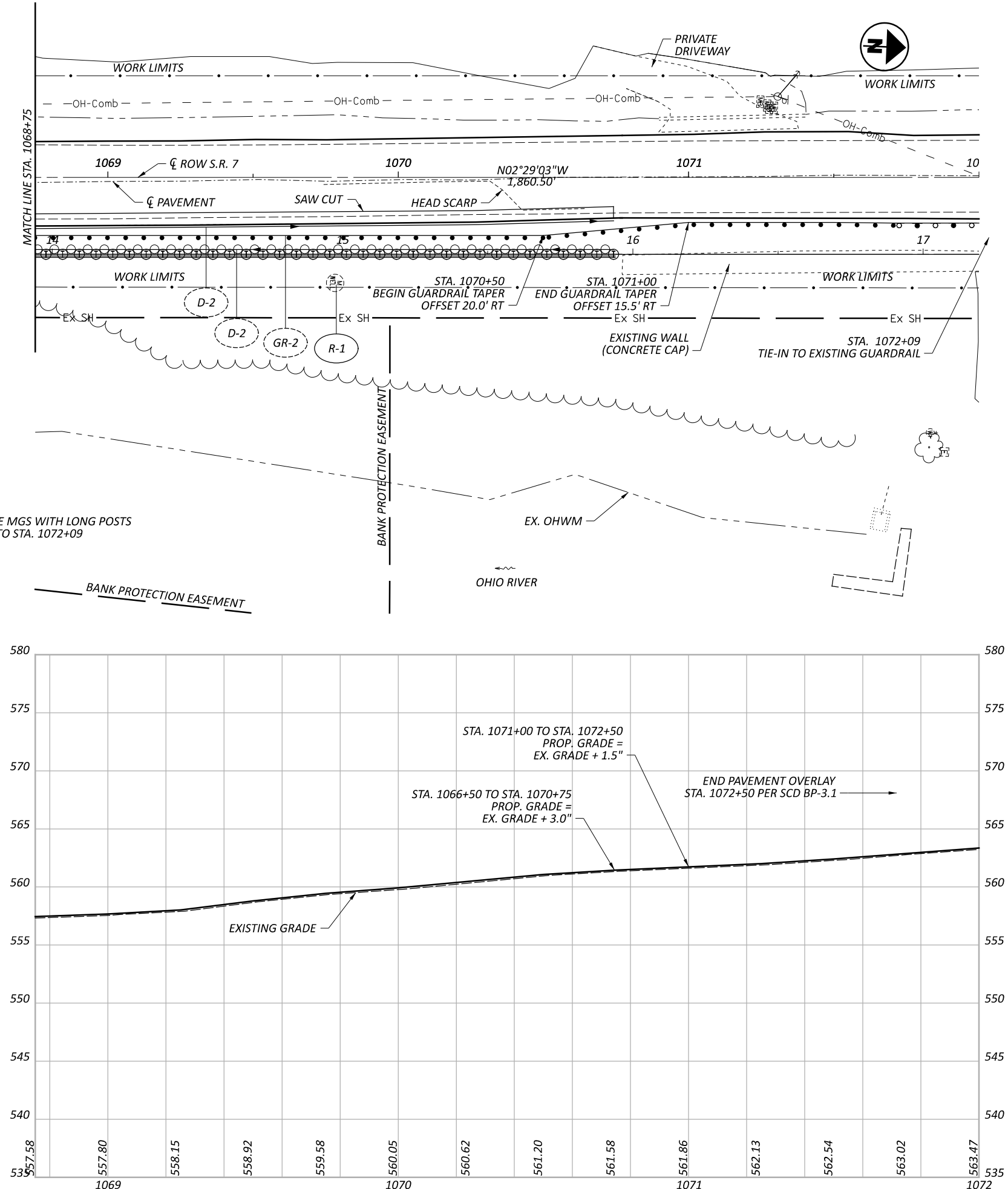

REF NO.	STATION		SIDE	REMOVAL, MISC. STAND PIPE	GUARDRAIL REMOVED	ANCHOR ASSEMBLY REMOVED	6" PERF. CORR. PLASTIC PIPE	6" NON-PERF. CORR. PLASTIC PIPE	4" BASEPIPE UNDERDRAIN	GUARDRAIL, TYPE MGS	GUARDRAIL, TYPE MGS W/LONG POSTS	ANCHOR ASSEMBLY, TYPE T	ROUNDED END SECTION	PRECAST RE-INFORCED CONC. OUTLET	BARRIER REFLECTOR, TYPE 2
	FROM	TO													
D-1	1066+28	1068+38	RT												
D-2	1068+41	1070+74	RT				233	210						1	
GR-1	1066+00	1067+73	RT		176	1					162.5	1			4
GR-2	1068+24	1072+09	RT		38	1				200	175	1	1		8
R-1	1069+78		RT	1											
<b>TOTALS CARRIED TO GENERAL SUMMARY</b>					1	214	2	443	200	337.5	2	2	2	12	

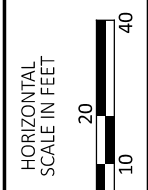

PLAN AND PROFILE  
 STA 1068+75 TO STA 1072+00

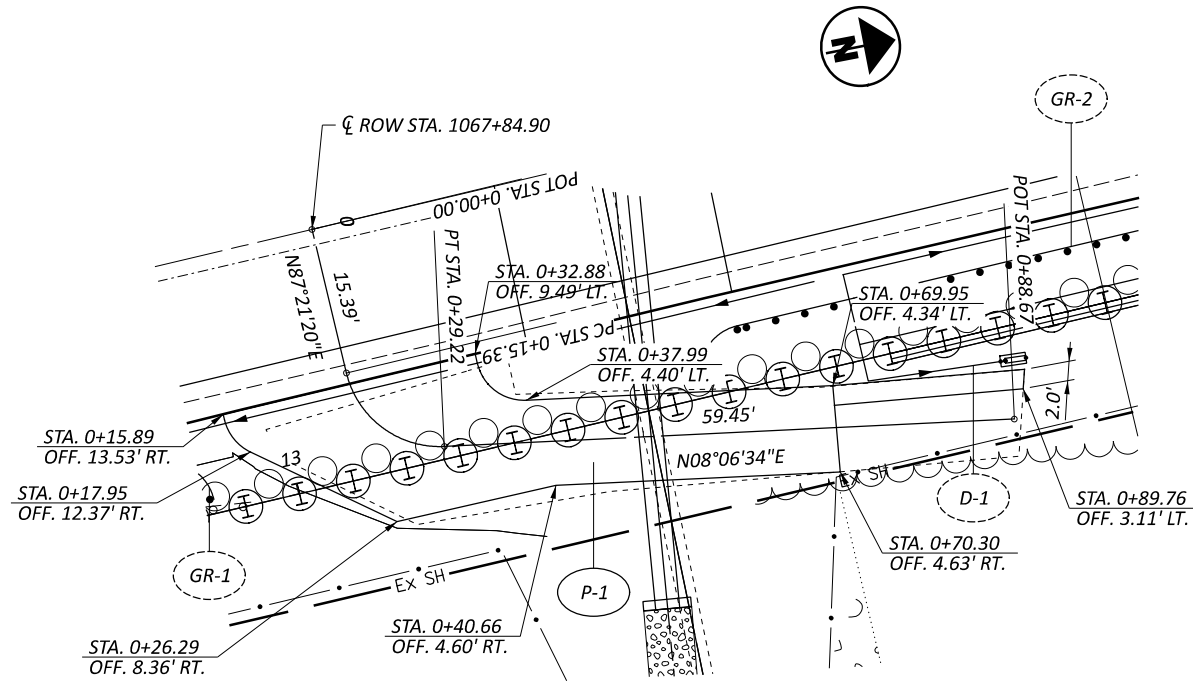

**DRIVEWAY CURVE DATA**  
 P.I. = STA. 0+23.67  
 $\Delta = 79^{\circ}14'47''$  LT  
 $D_c = 212^{\circ}57'28''$   
 $R = 10.00'$   
 $T = 8.28'$   
 $L = 13.83'$   
 $E = 2.98'$

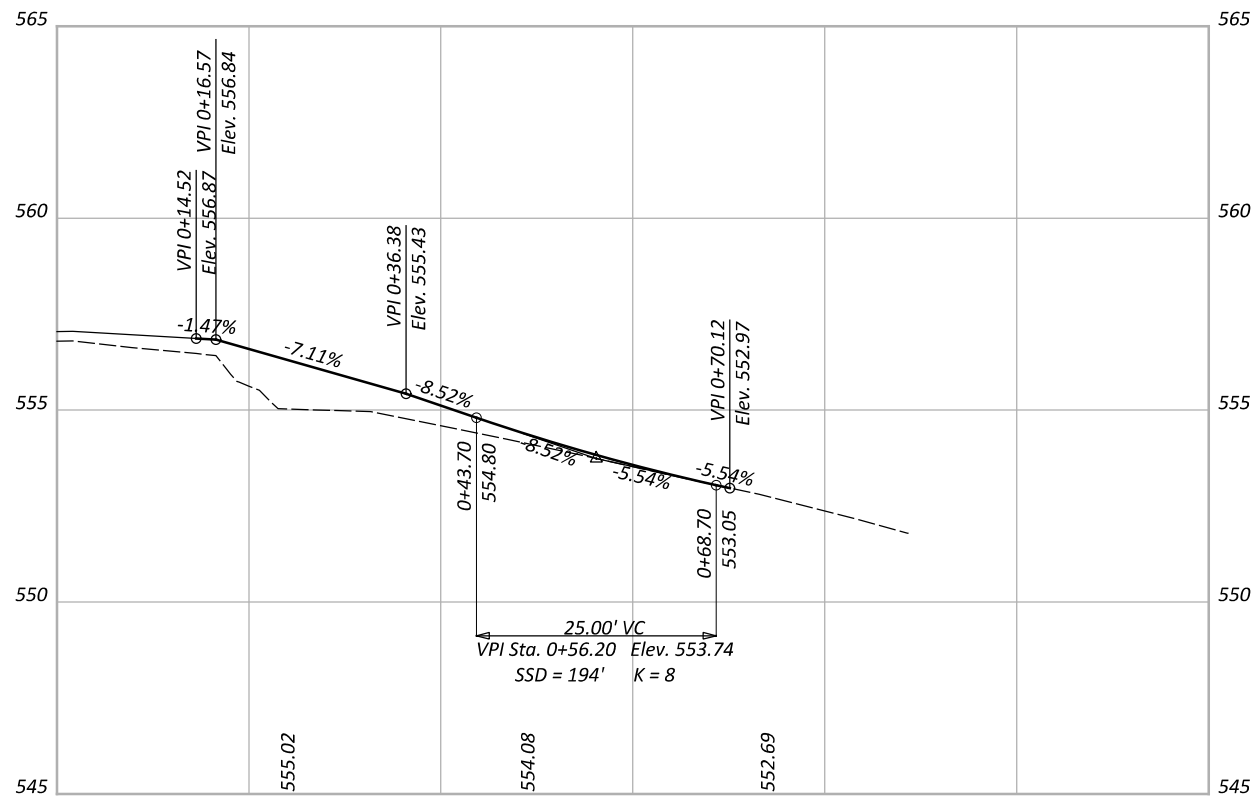

**ITEM 202 - PAVEMENT REMOVED, AS PER PLAN**  
 THIS ITEM CONSISTS OF REMOVING THE EXISTING ASPHALT PAVEMENT FROM STA. 0+15 TO STA. 0+86. THE DEPTH OF THE PAVEMENT IS UNKNOWN. THE DRIVE PAVEMENT IS ESTIMATED TO BE LESS THAN 10" THICK. THE CONTRACTOR SHALL REMOVE PAVEMENT AS SHOWN, REGARDLESS OF THE DEPTH ENCOUNTERED IN THE FIELD.

ALL EQUIPMENT, MATERIALS, INCIDENTALS, PAVEMENT SAWING, AND LABOR REQUIRED TO PERFORM THE WORK OUTLINED ABOVE SHALL BE INCLUDED FOR PAYMENT UNDER:

ITEM 202 - PAVEMENT REMOVED, AS PER PLAN - SY

**ITEM 441 - ASPHALT CONCRETE SURFACE COURSE, TYPE 1, (449), PG64-22, (DRIVEWAYS)**

(DRIVEWAY STA. 1067+89)  
 STA. 0+15 TO STA. 0+66  
 $637 \text{ SF (AREA FROM CADD)} \times (3.0 \text{ IN}/12)/27 = 5.9 \text{ CY}$   
 STA. 0+66 TO STA. 0+86  
 $2.0 \text{ FT} \times 20.0 \text{ FT} \times (3.0 \text{ IN}/12)/27 = 0.4 \text{ CY}$

**A TOTAL OF 7 CY TO BE CARRIED TO THE GENERAL SUMMARY.**

**ITEM 304 - AGGREGATE BASE**

(DRIVEWAY STA. 1067+89)  
 STA. 0+15 TO STA. 0+66  
 $637 \text{ SF (AREA FROM CADD)} \times (12.0 \text{ IN}/12)/27 = 23.6 \text{ CY}$   
 STA. 0+66 TO STA. 0+86  
 $2.0 \text{ FT} \times 20.0 \text{ FT} \times (12.0 \text{ IN}/12)/27 = 1.5 \text{ CY}$

**A TOTAL OF 26 CY TO BE CARRIED TO THE GENERAL SUMMARY.**

**ITEM 204 - SUBGRADE COMPACTION**

(DRIVEWAY STA. 1067+89)  
 STA. 0+15 TO STA. 0+66  
 $637 \text{ SF (AREA FROM CADD)} / (9 \text{ SY/SF}) = 70.8 \text{ SY}$   
 STA. 0+66 TO STA. 0+86  
 $2.0 \text{ FT} \times 20.0 \text{ FT} / (9 \text{ SF/SY}) = 4.4 \text{ SY}$

**A TOTAL OF 76 SY TO BE CARRIED TO THE GENERAL SUMMARY.**

**ITEM 202 - PAVEMENT REMOVED, AS PER PLAN**

(DRIVEWAY STA. 1067+89)  
 STA. 0+15 TO STA. 0+66  
 $621 \text{ SF (AREA FROM CADD)} / (9 \text{ SY/SF}) = 70.8 \text{ SY}$   
 STA. 0+66 TO STA. 0+86  
 $2.0 \text{ FT} \times 20.0 \text{ FT} / (9 \text{ SF/SY}) = 4.4 \text{ SY}$

**A TOTAL OF 76 SY TO BE CARRIED TO THE GENERAL SUMMARY.**

**ITEM 407 - NON-TRACKING TACK COAT**

(DRIVEWAY STA. 1067+89)  
 STA. 0+15 TO STA. 0+66  
 $637 \text{ SF (AREA FROM CADD)} / 9 \times (0.05 \text{ GAL/SY}) = 3.5 \text{ GAL}$   
 STA. 0+66 TO STA. 0+86  
 $2.0 \text{ FT} \times 20.0 \text{ FT} / 9 \times (0.05 \text{ GAL/SY}) = 0.2 \text{ GAL}$

**A TOTAL OF 4 GAL TO BE CARRIED TO THE GENERAL SUMMARY.**

REF NO.	STATION	SIDE	PAVEMENT REMOVED, APP		SUBGRADE COMPACTION	AGGREGATE BASE	ASPHALT CONC. SURF. COURSE, TYPE 1	TOTALS CARRIED TO GENERAL SUMMARY
			EACH	FT				
P-1	FROM 0+14 TO 0+86	RT/LT	76	76	76	26	7	76
<b>TOTALS CARRIED TO GENERAL SUMMARY</b>								76



PLAN AND PROFILE: FIELD DRIVE  
 STA. 1067+84.90

DESIGN AGENCY



DESIGNER  
 JDW

REVIEWER

XXX MM-DD-YY

PROJECT ID

115533

SHEET TOTAL

P.13 P.48

SEEDING	
END WIDTH	SO. YDS.
	49

10	
28	
10	
77	

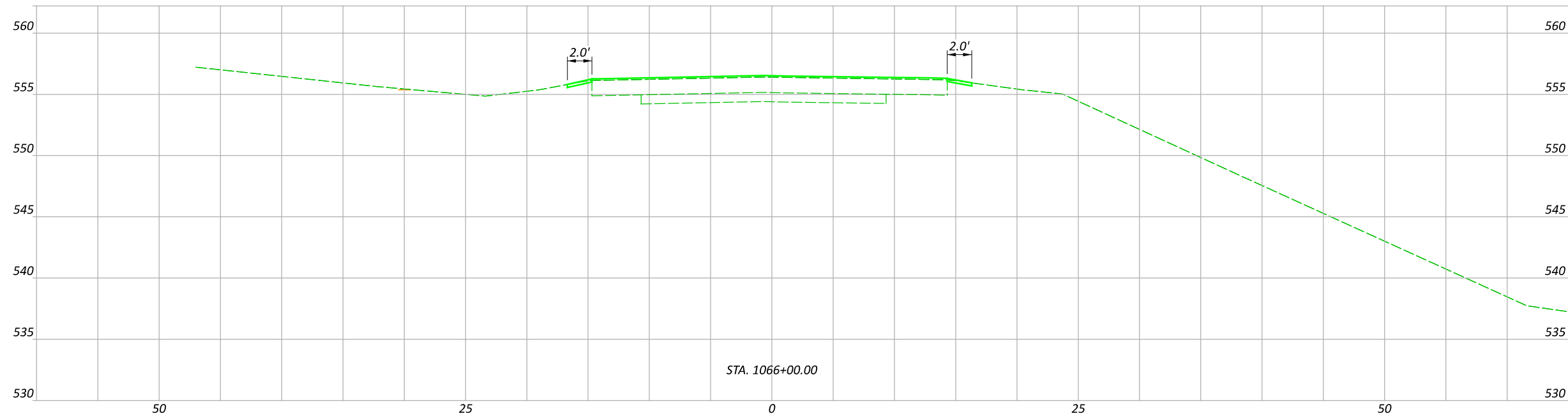
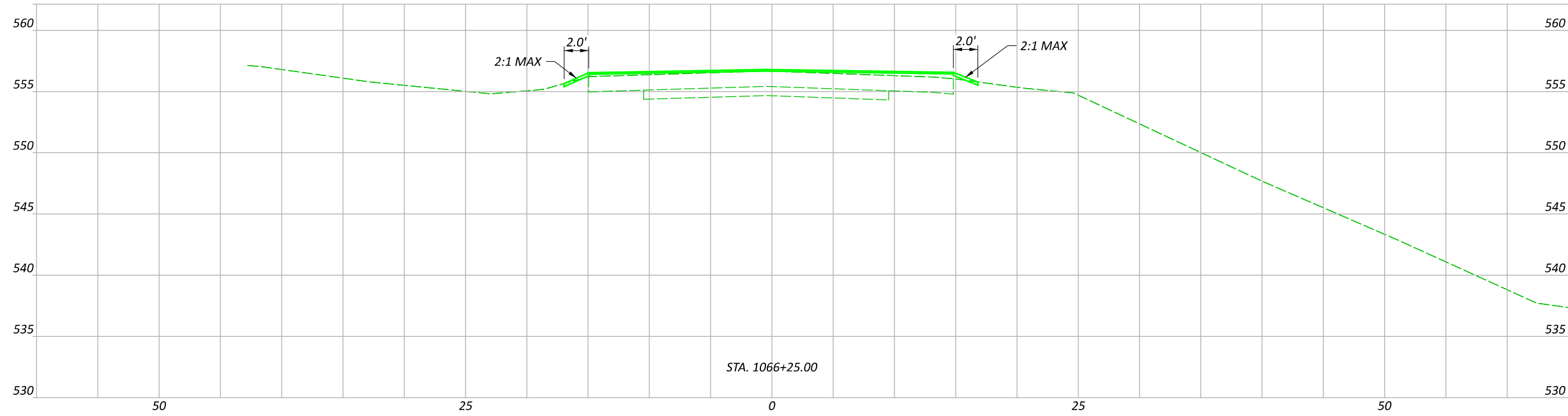

END AREA		VOLUME	
CUT	FILL	CUT	FILL
		3	5
0	0		
		0	0
0	0		
		3	5

CROSS SECTIONS  
 FROM STA. 1066+00 TO STA. 1066+25

DESIGN AGENCY



DESIGNER  
 JDW

REVIEWER  
 XXX MM-DD-YY

PROJECT ID  
 115533

SHEET	TOTAL
P.14	P.48

SEEDING	
END WIDTH	SO. YDS.
85	
31	
78	
25	
163	

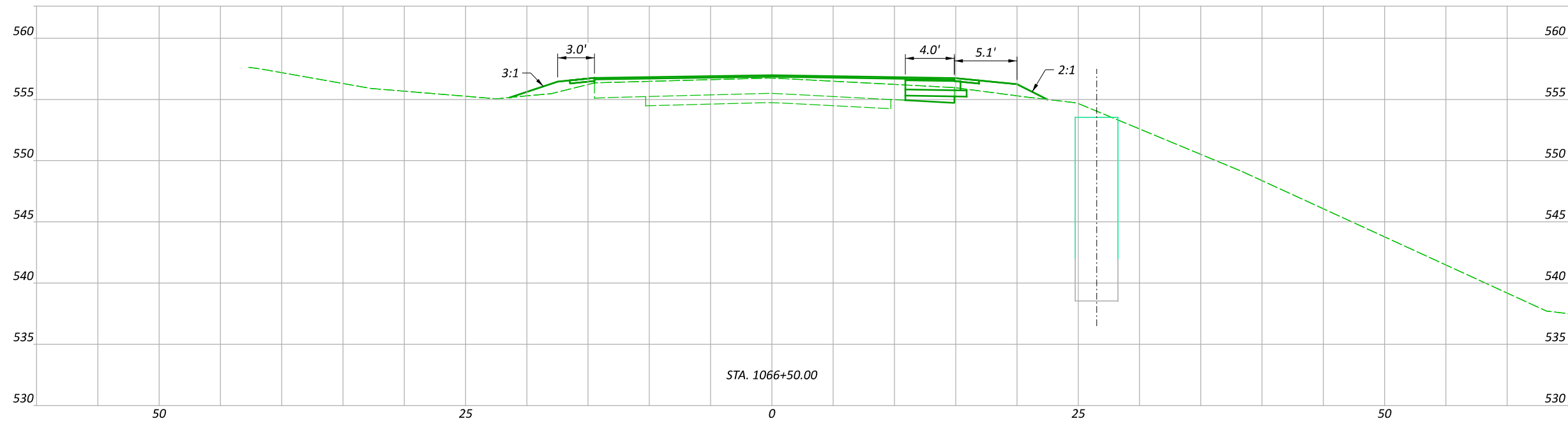
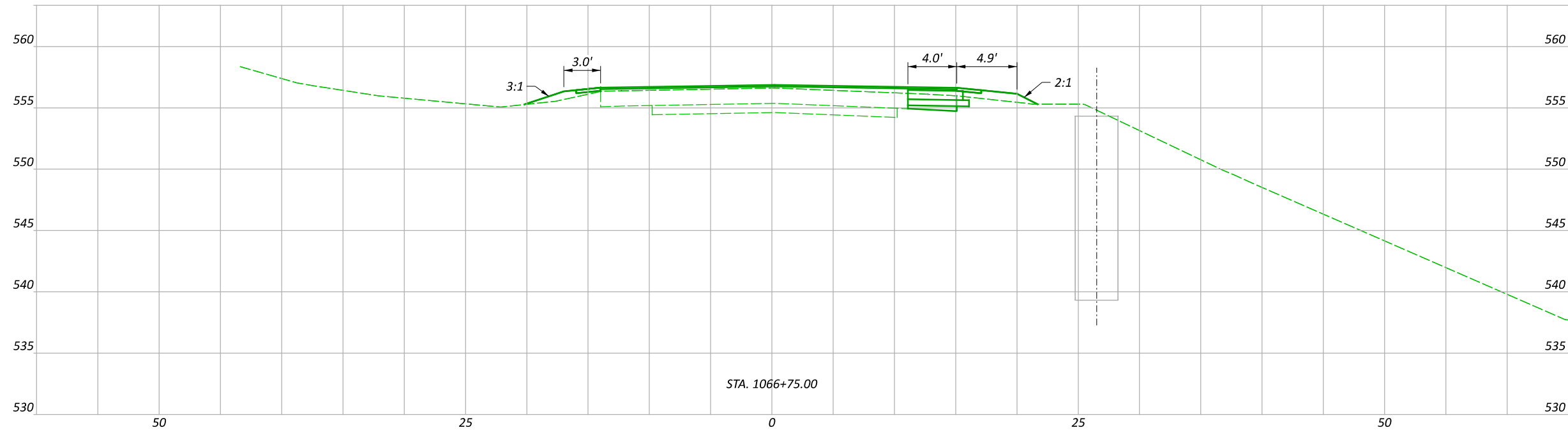

END WIDTH	END AREA		VOLUME	
	CUT	FILL	CUT	FILL
85			6	6
31	6	7		
78			6	8
25	6	10		
163			12	14

CROSS SECTIONS  
 FROM STA. 1066+50 TO STA. 1066+75

DESIGN AGENCY  
  
 DESIGNER  
 JDW  
 REVIEWER  
 XXX MM-DD-YY  
 PROJECT ID  
 115533  
 SHEET TOTAL  
 P.15 P.48

SEEDING	
END WIDTH	SO. YDS.
73	
26	
78	
30	
151	

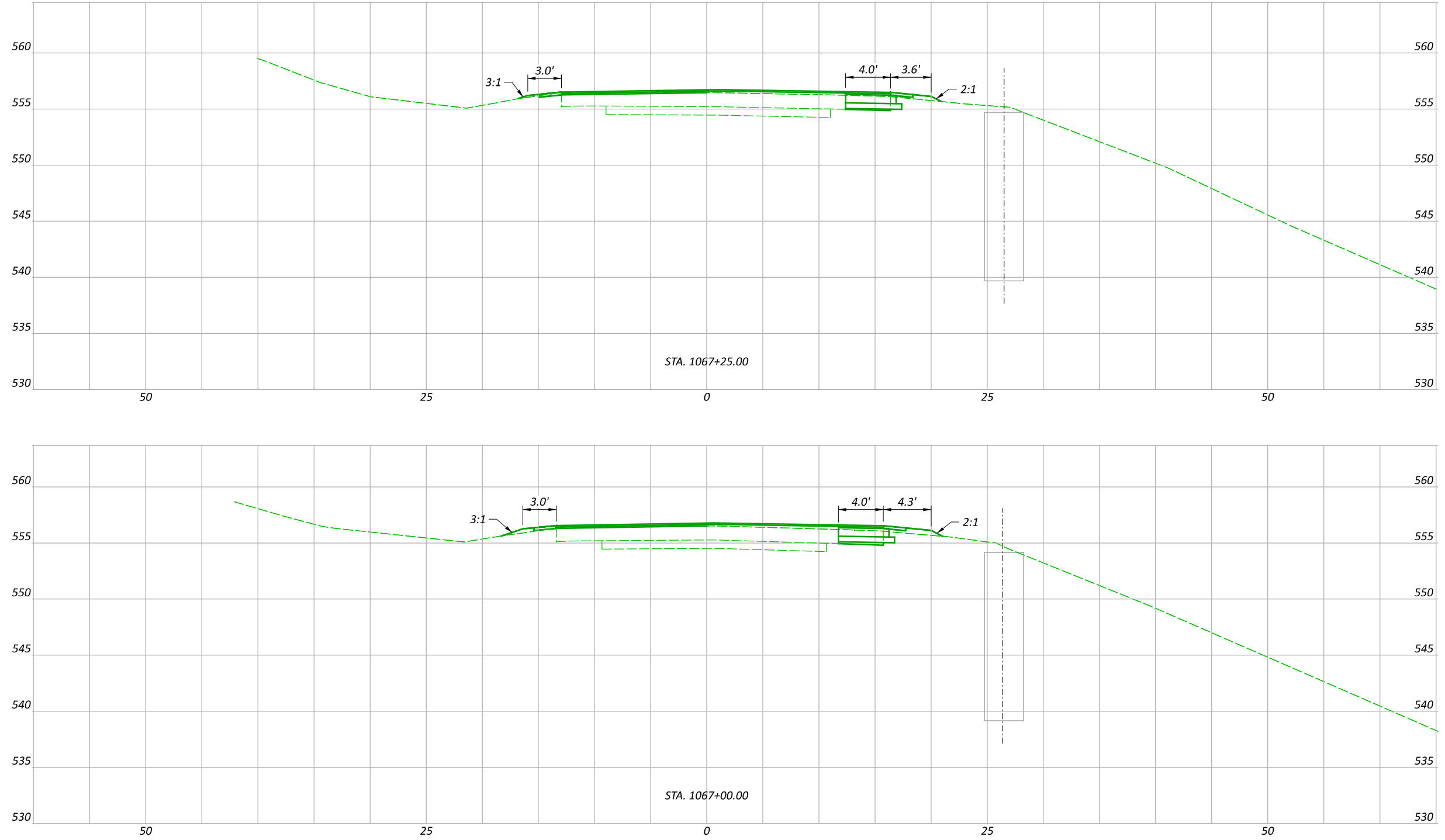

END AREA		VOLUME	
CUT	FILL	CUT	FILL
		7	3
7	2		
		7	3
6	4		
		14	6

CROSS SECTIONS  
 FROM STA. 1067+00 TO STA. 1067+25

DESIGN AGENCY  
  
 DESIGNER  
 JDW  
 REVIEWER  
 XXX MM-DD-YY  
 PROJECT ID  
 115533  
 SHEET TOTAL  
 P.16 P.48



SEEDING	
END WIDTH	SO. YDS.
62	
73	
26	
135	

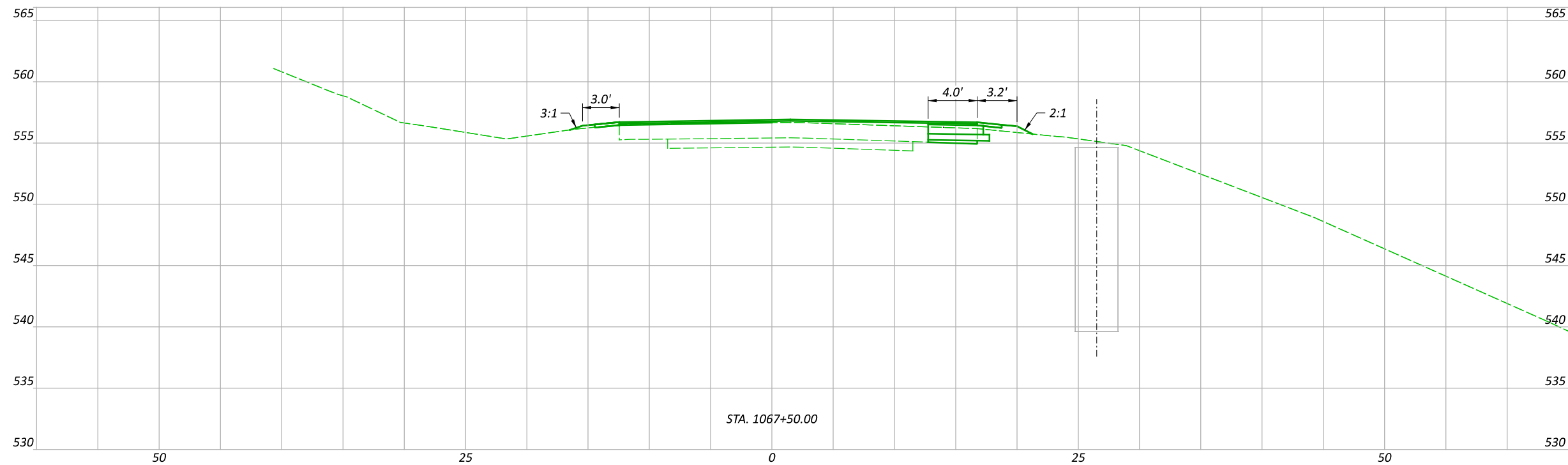
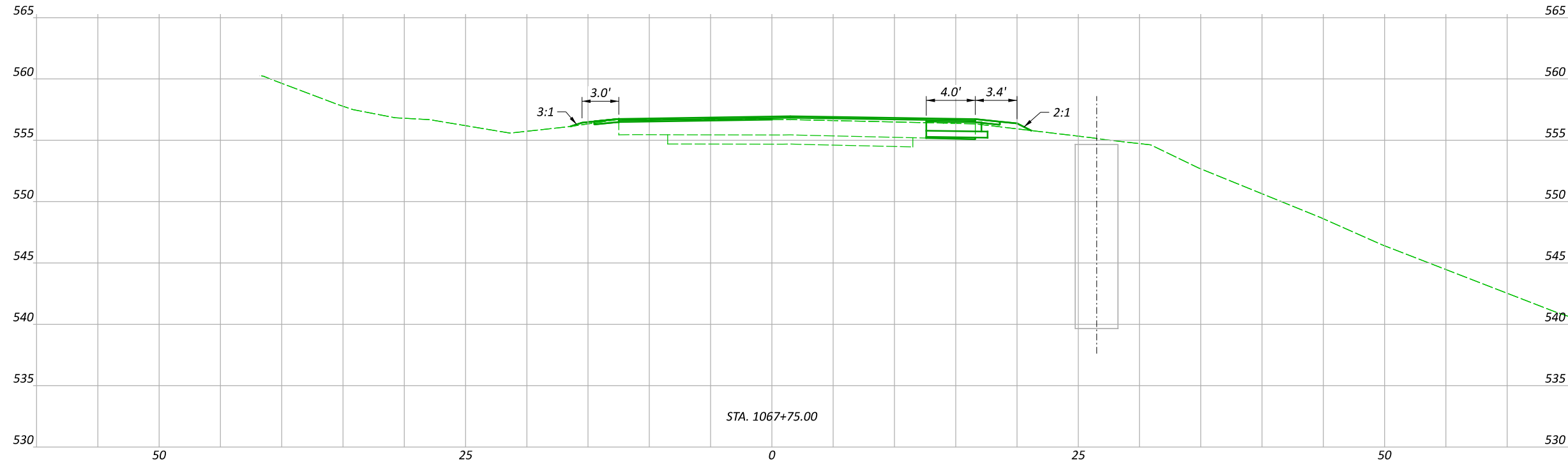

END AREA	VOLUME				
		CUT	FILL	CUT	FILL
7	3	10	8		
		7	3		
6	3				
		17	11		

CROSS SECTIONS  
 FROM STA. 1067+50 TO STA. 1067+75

DESIGN AGENCY  
  
 DESIGNER  
 JDW  
 REVIEWER  
 XXX MM-DD-YY  
 PROJECT ID  
 115533  
 SHEET TOTAL  
 P.17 P.48

SEEDING	
END WIDTH	SO. YDS.
	138

71

124

18

262

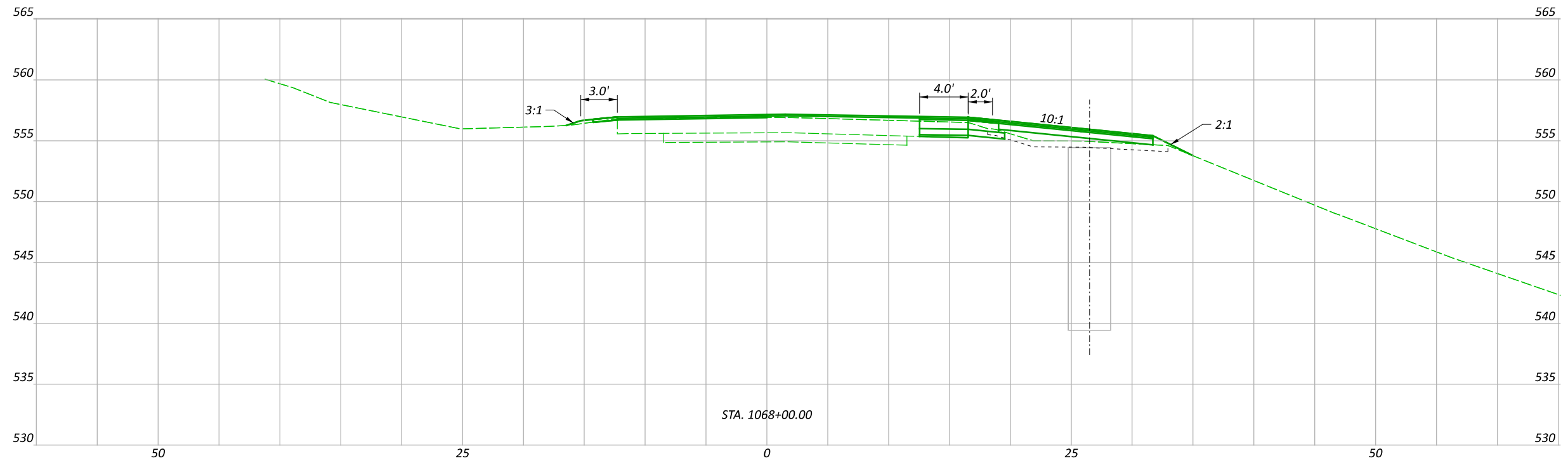
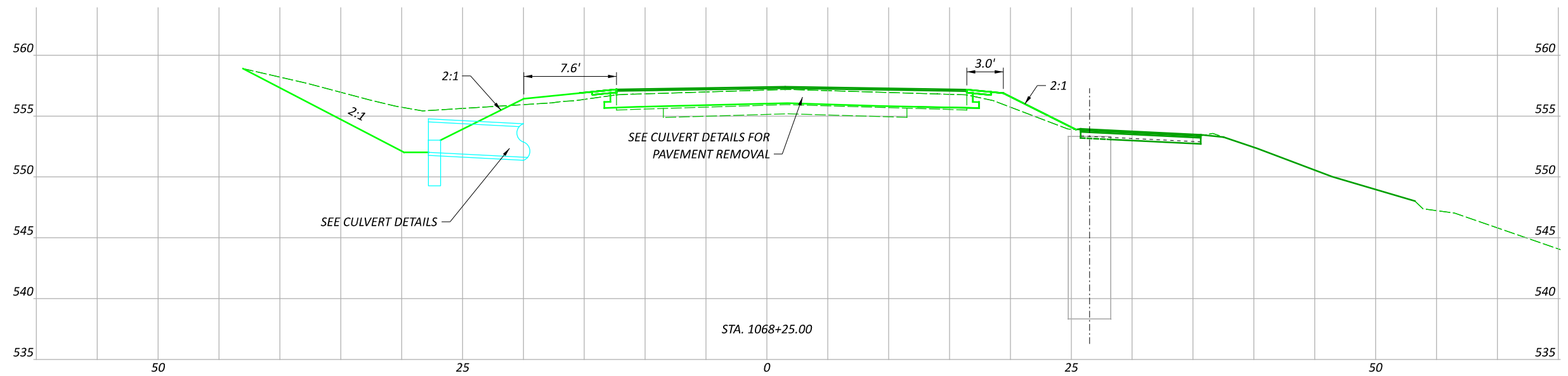

END WIDTH	END AREA		VOLUME	
	CUT	FILL	CUT	FILL
71	41	10	23	12
124			26	11
18	14	13		
262			49	23

CROSS SECTIONS  
 FROM STA. 1068+00 TO STA. 1068+25

DESIGN AGENCY  
  
 DESIGNER  
 JDW  
 REVIEWER  
 XXX MM-DD-YY  
 PROJECT ID  
 115533  
 SHEET TOTAL  
 P.18 P.48

SEEDING	
END WIDTH	SO. YDS.
70	
25	
74	
28	
144	

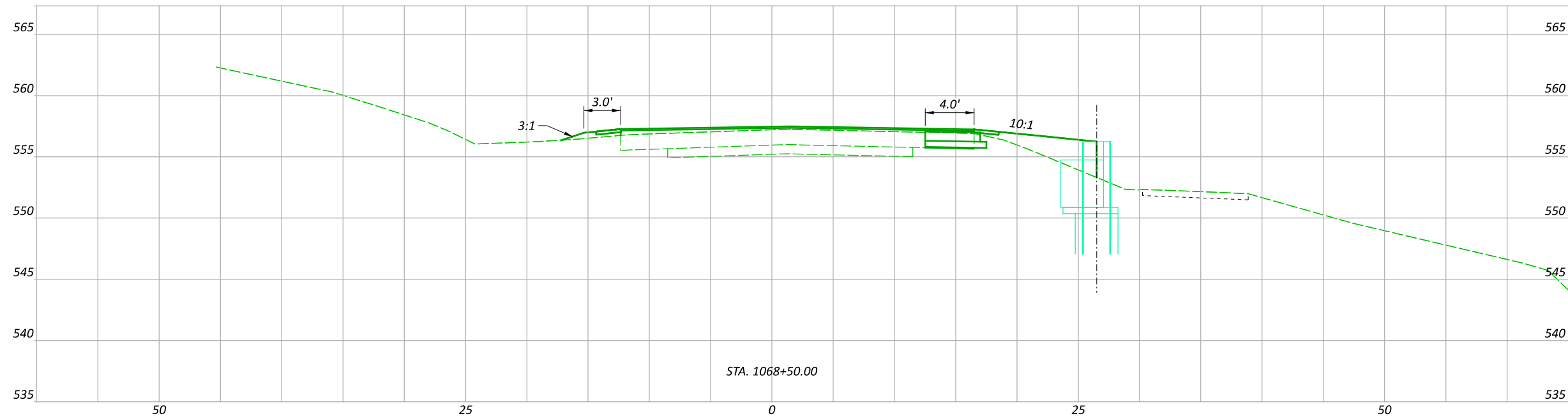
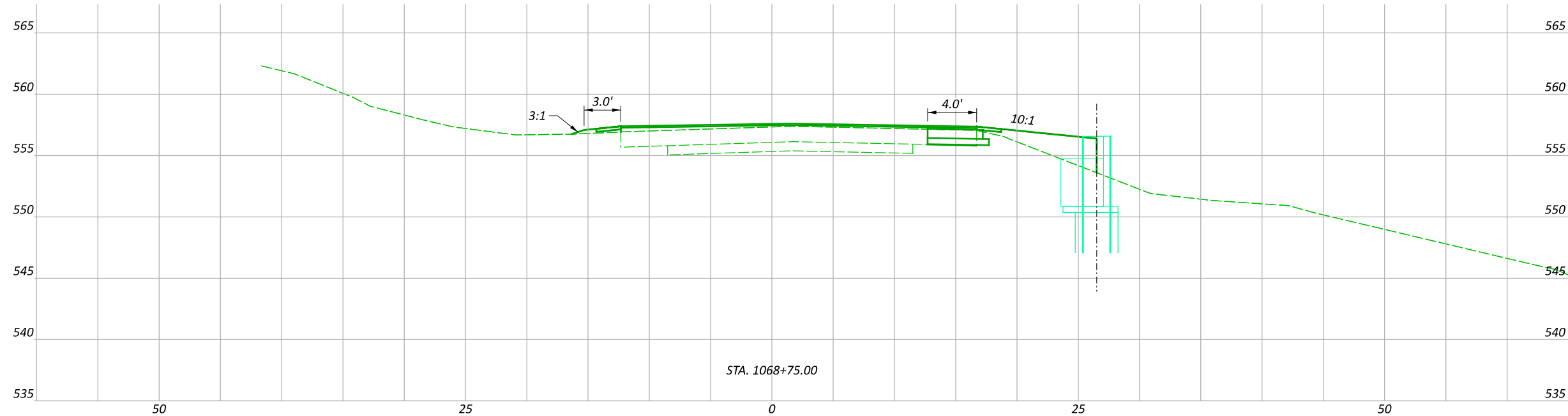

END	AREA		VOLUME	
	CUT	FILL	CUT	FILL
			7	13
	7	15		
			7	14
	7	15		
			14	27

CROSS SECTIONS  
 FROM STA. 1068+50 TO STA. 1068+75

DESIGN AGENCY



DESIGNER  
 JDW

REVIEWER  
 XXX MM-DD-YY

PROJECT ID  
 115533

SHEET TOTAL  
 P.19 P.48

SEEDING	
END WIDTH	SQ. YDS.
66	
21	
64	
25	
130	

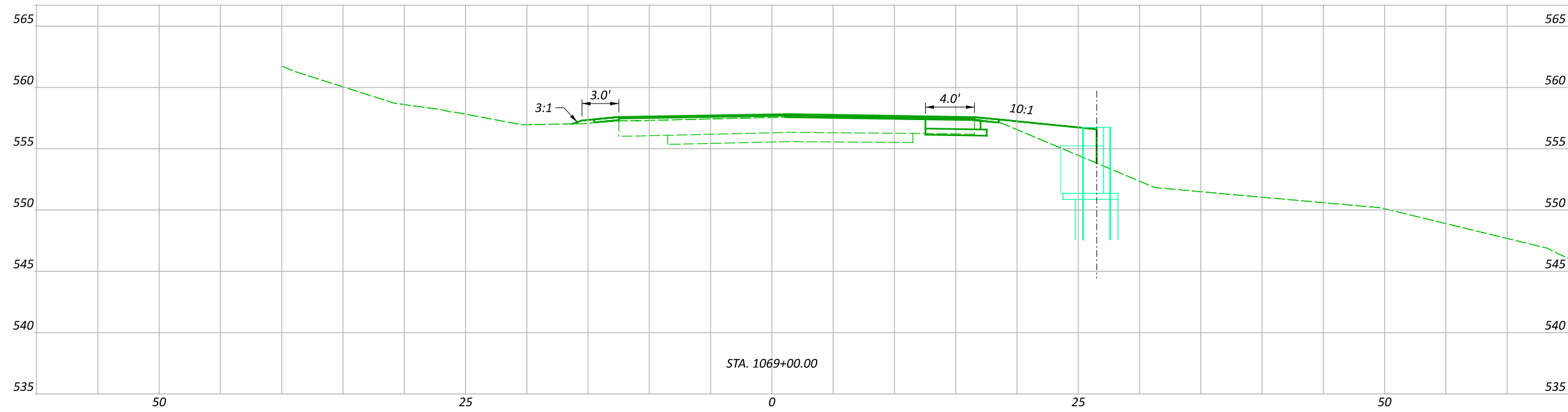
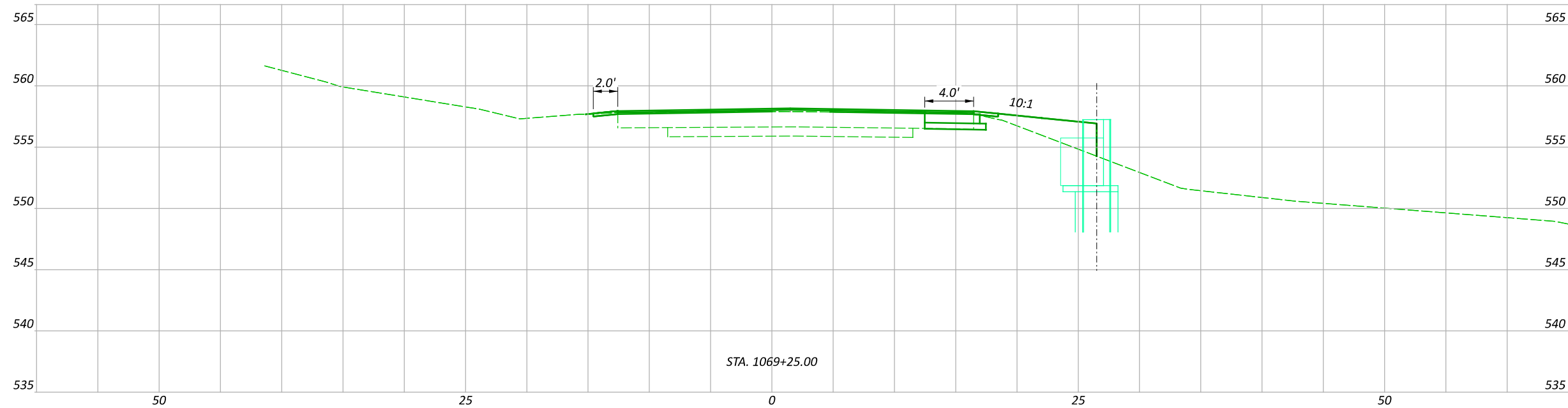

END WIDTH	END AREA		VOLUME	
	CUT	FILL	CUT	FILL
66			7	15
21			7	12
64			7	12
25			7	12
130			14	27

CROSS SECTIONS  
 FROM STA. 1069+00 TO STA. 1069+25

DESIGN AGENCY  
  
 DESIGNER: JDW  
 REVIEWER: XXX MM-DD-YY  
 PROJECT ID: 115533  
 SHEET: P.20 TOTAL: P.48

SEEDING	END WIDTH		SQ. YDS.
	77	74	
	27	74	77
	26	73	74
	26	224	77

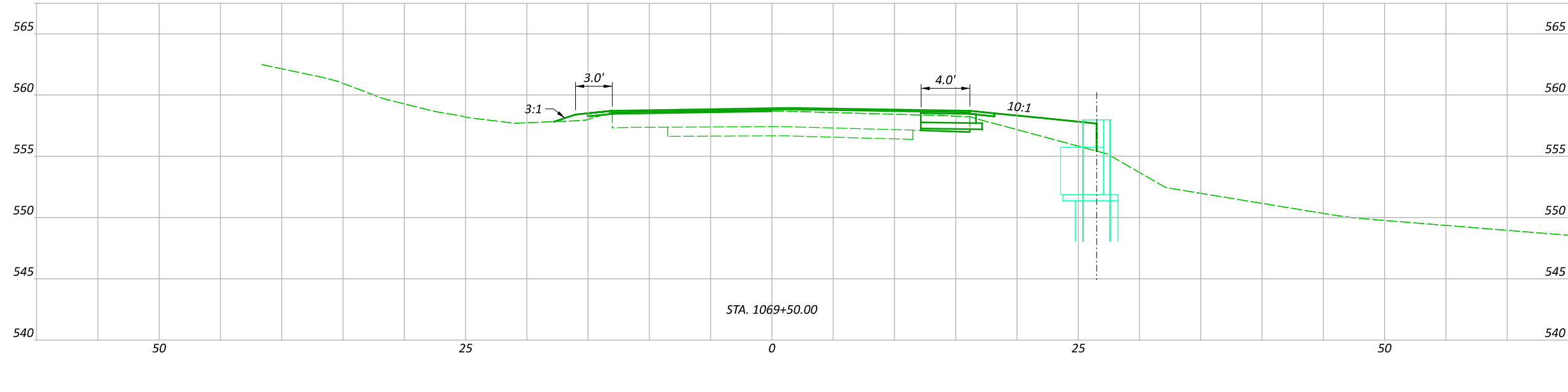
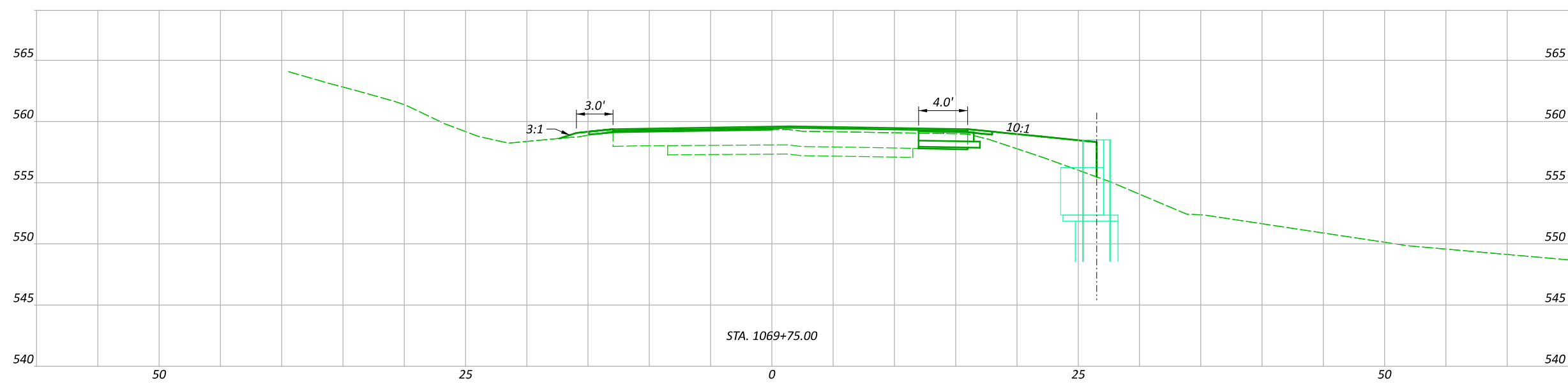
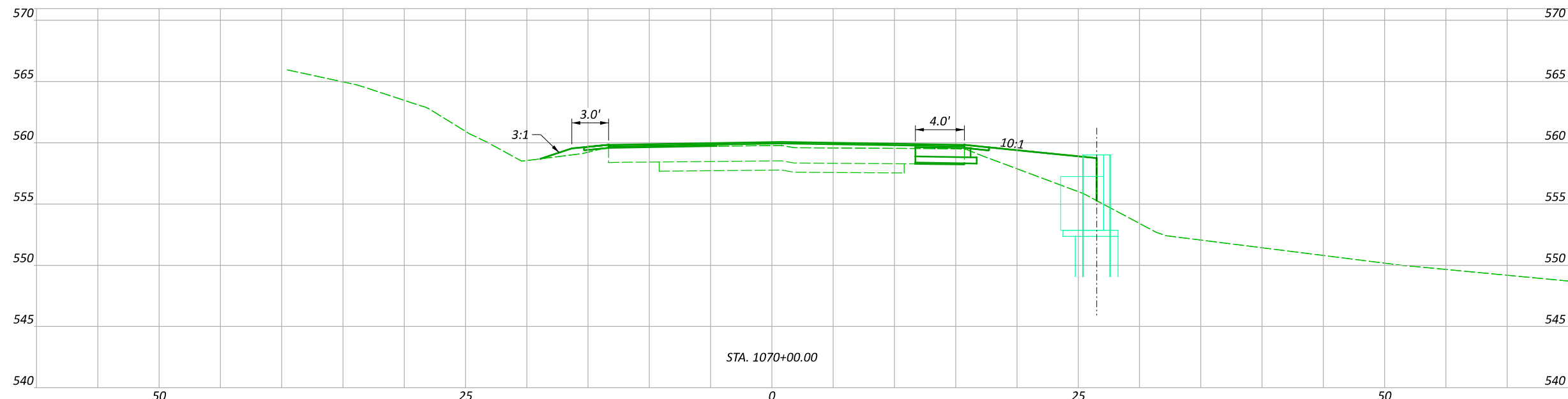

END AREA	VOLUME	
	CUT	FILL
6	29	25
6	18	22
6	19	18
18	65	65

CROSS SECTIONS  
 FROM STA. 1069+50 TO STA. 1070+00

DESIGN AGENCY  
  
 DESIGNER  
 JDW  
 REVIEWER  
 XXX MM-DD-YY  
 PROJECT ID  
 115533  
 SHEET TOTAL  
 P.21 P.48

SEEDING	
END WIDTH	SO. YDS.
81	
29	
80	
28	
161	

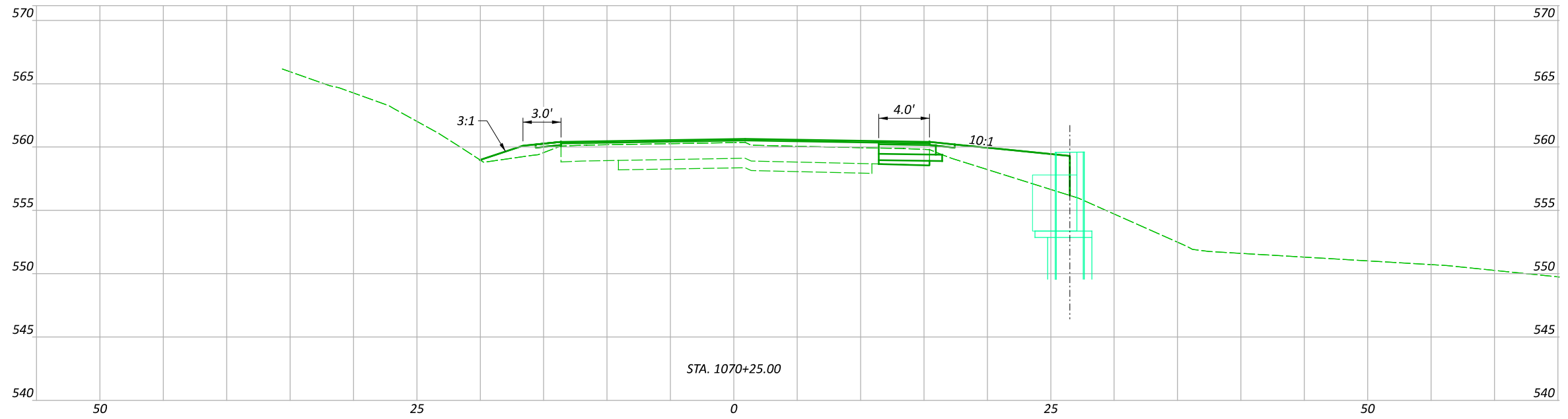
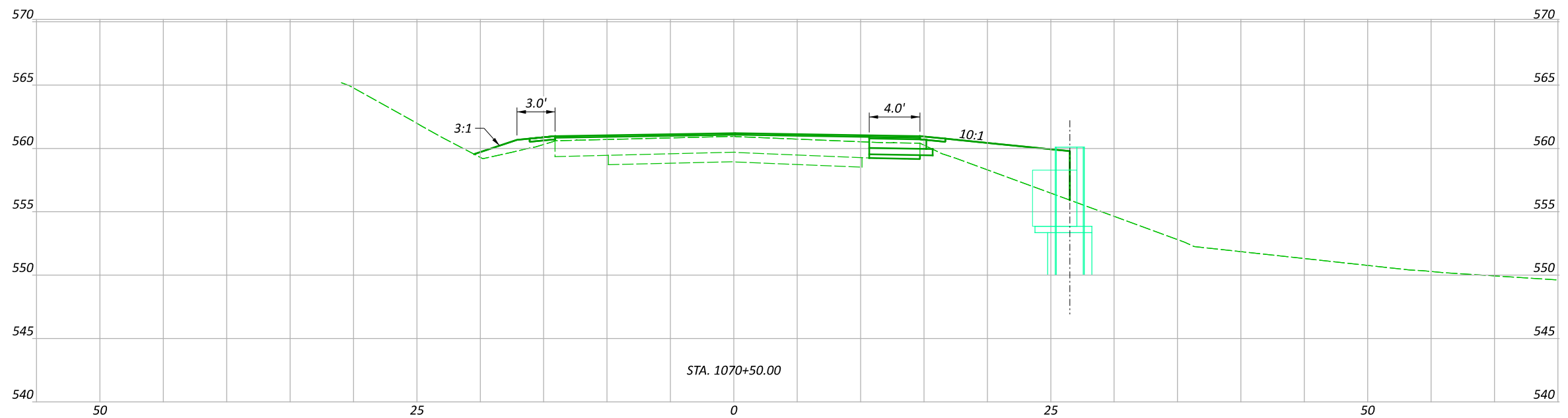

END AREA		VOLUME	
CUT	FILL	CUT	FILL
		6	23
6	27		
		6	24
6	23		
		12	47

CROSS SECTIONS  
 FROM STA. 1070+25 TO STA. 1070+50

DESIGN AGENCY  
  
 DESIGNER  
 JDW  
 REVIEWER  
 XXX MM-DD-YY  
 PROJECT ID  
 115533  
 SHEET TOTAL  
 P.22 P.48

SEEDING	
END WIDTH	SQ. YDS.
14	
10	
28	
10	
55	
29	
97	

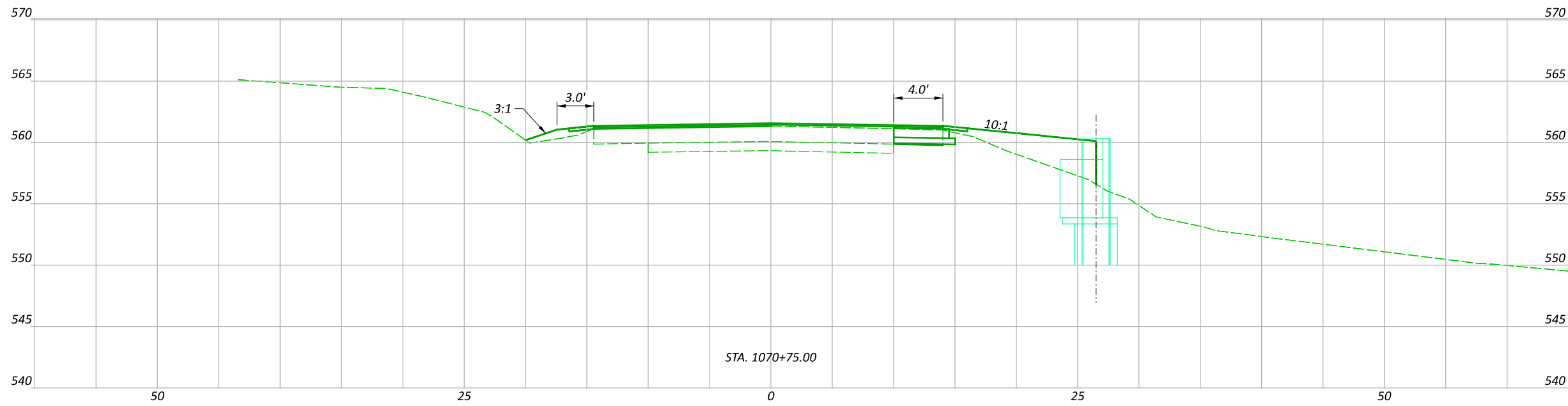
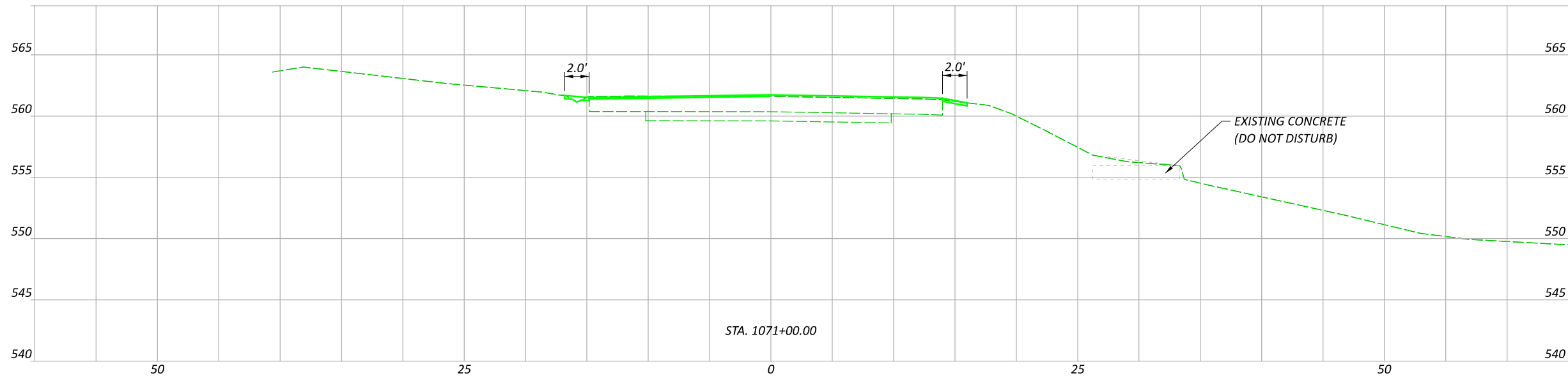
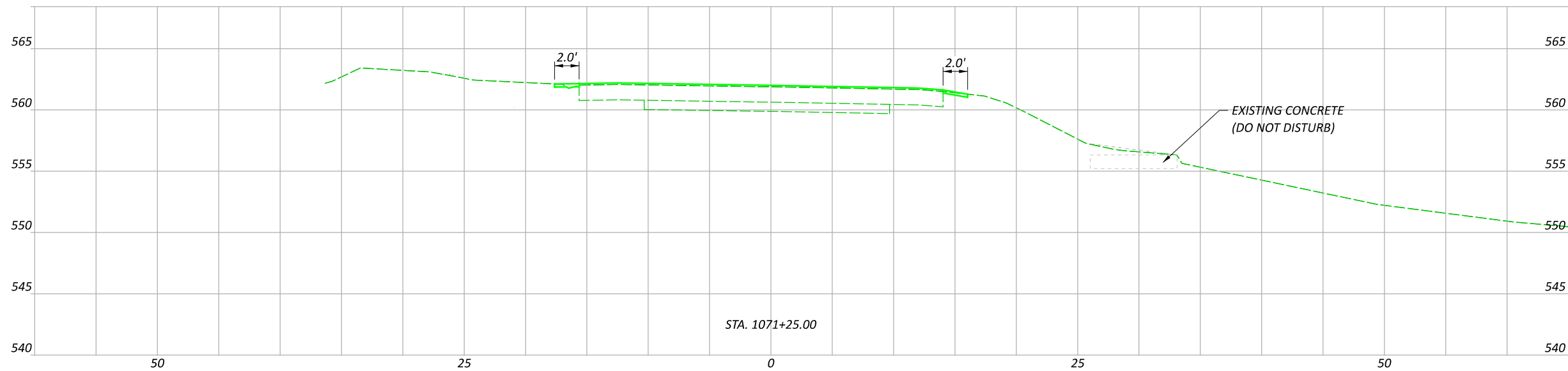

END AREA		VOLUME	
CUT	FILL	CUT	FILL
0	0	0	0
0	0	0	0
0	0	3	11
6	22	3	11
		TOTAL	TOTAL
		P.23	P.48

CROSS SECTIONS  
 FROM STA. 1070+75 TO STA. 1071+25

DESIGN AGENCY  
  
 DESIGNER  
 JDW  
 REVIEWER  
 XXX MM-DD-YY  
 PROJECT ID  
 115533  
 SHEET TOTAL  
 P.23 P.48

SEEDING	
END WIDTH	SO. YDS.
0	
0	
0	

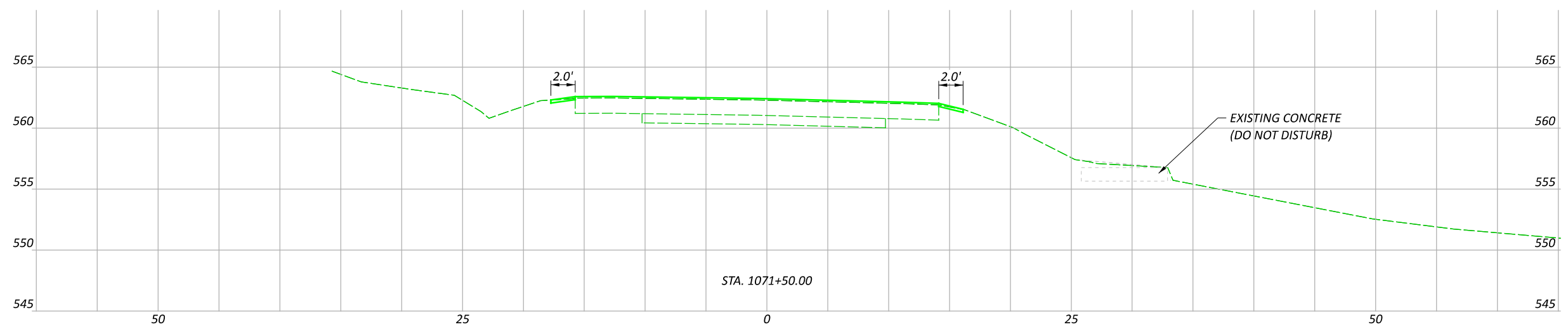
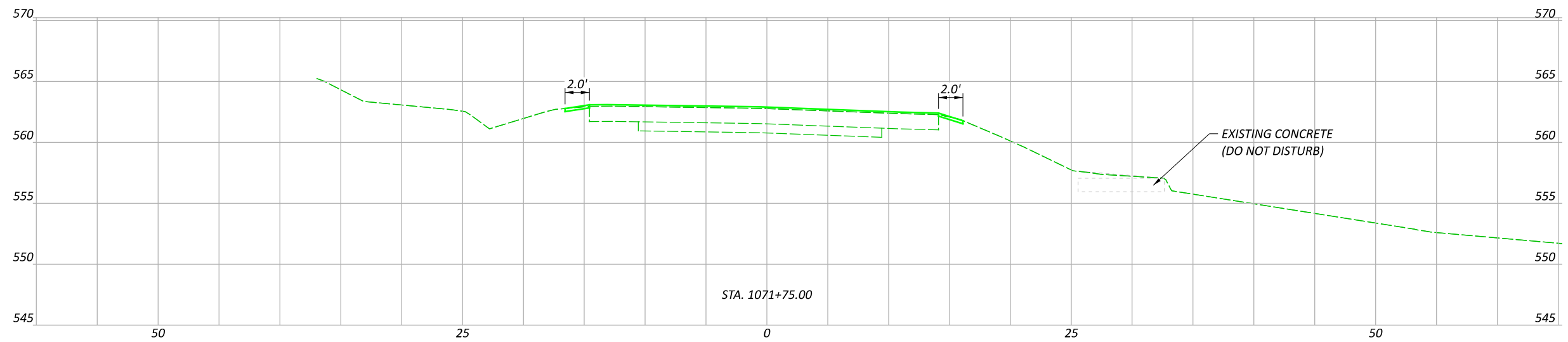

END AREA		VOLUME	
CUT	FILL	CUT	FILL
0	0	0	0
0	0	0	0
0	0	0	0
0	0	0	0

CROSS SECTIONS  
FROM STA. 1071+50 TO STA. 1071+75

DESIGN AGENCY



DESIGNER  
JDW

REVIEWER  
XXX MM-DD-YY

PROJECT ID  
115533

SHEET TOTAL  
P.24 P.48



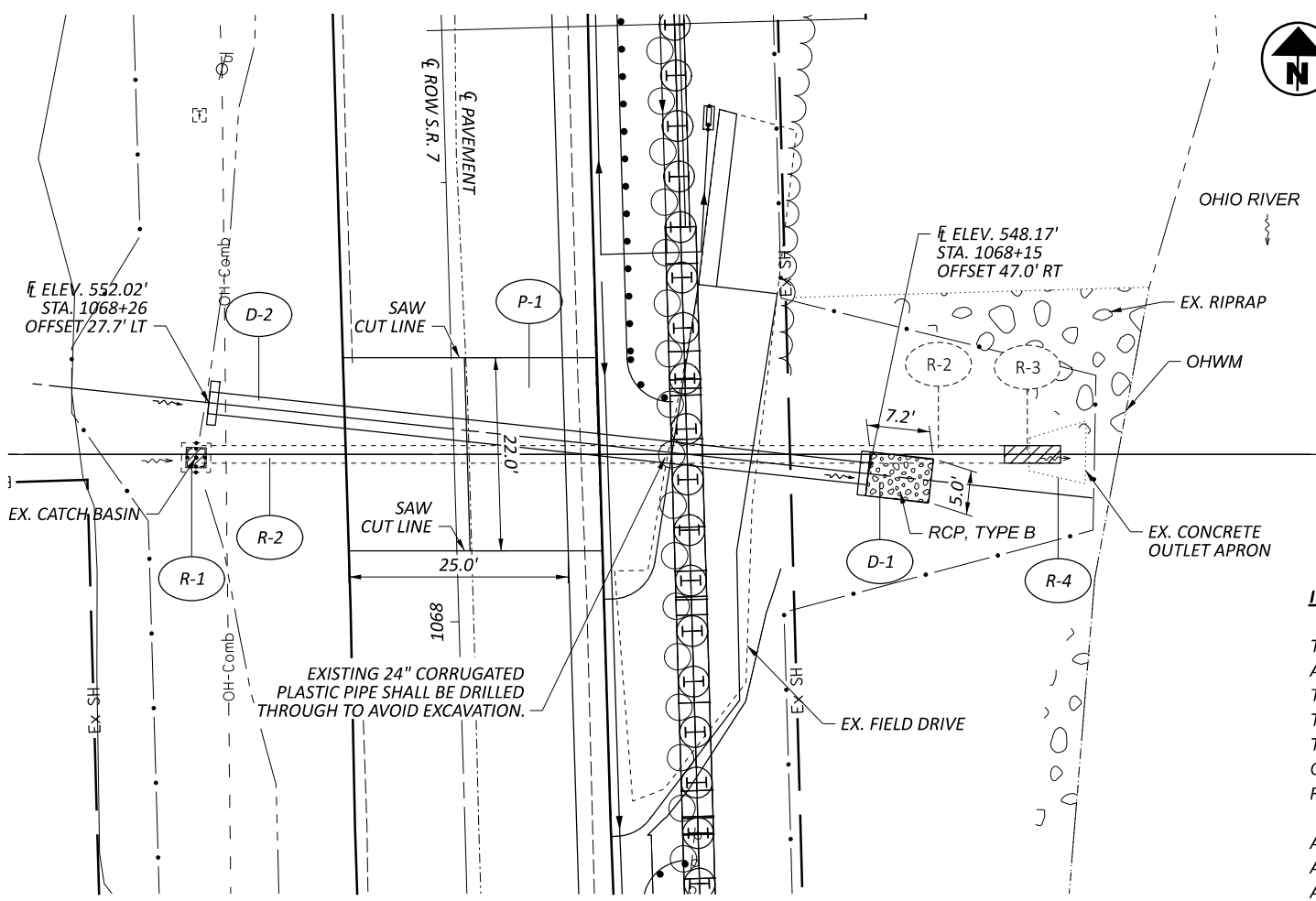

**ITEM 601 - RCP, TYPE B WITH FILTER, AS PER PLAN**

WORK SHALL BE DONE IN ACCORDANCE WITH CMS 601 FOR ITEM 601 - RCP, TYPE B WITH FILTER, APP. EXCEPT THE MATERIAL SHALL BE OBTAINED FROM THE EXISTING RIPRAP THAT IS EXCAVATED TO INSTALL THE PROPOSED CONDUIT AND OR THE EXISTING CONCRETE APRON.

**ITEM 202 - REMOVAL, MISC.: CONCRETE OUTLET APRON**

EXISTING CONCRETE OUTLET APRON SHALL BE BROKEN AND LEFT IN PLACE UNLESS IT IS NEEDED FOR ITEM 601 - ROCK CHANNEL PROTECTION TYPE B WITH FILTER, AS PER PLAN. EACH BROKEN PIECE SHALL NOT EXCEED 2 FOOT IN SIZE. EXPOSED CONCRETE REINFORCING IN THE CONCRETE SHALL BE REMOVED, SUCH THAT NO PIECE OF REINFORCING EXTENDS BEYOND 2 INCHES FROM THE CONCRETE SURFACE.

**ITEM 202 - PAVEMENT REMOVED, AS PER PLAN**

THIS ITEM CONSISTS OF REMOVING THE EXISTING ASPHALT AND CONCRETE PAVEMENT FROM STA. 1068+08 TO STA. 1068+30. THE DEPTH OF THE PAVEMENT MAY VARY. SOIL BORINGS INDICATE THE ASPHALT PAVEMENT TO BE APPROXIMATELY 15" THICK AND THE CONCRETE PAVEMENT TO BE APPROXIMATELY 10". THE CONTRACTOR SHALL REMOVE PAVEMENT AS SHOWN, REGARDLESS OF THE DEPTH ENCOUNTERED IN THE FIELD.

ALL EQUIPMENT, MATERIALS, INCIDENTALS, PAVEMENT SAWING, AND LABOR REQUIRED TO PERFORM THE WORK OUTLINED ABOVE SHALL BE INCLUDED FOR PAYMENT UNDER:

ITEM 202 - PAVEMENT REMOVED, AS PER PLAN - SY

**CALCULATIONS:**  
**ITEM 441 - ASPHALT CONCRETE INTERMEDIATE COURSE, TYPE 1, (448) PG64-22, 1.5"**

- 25.0 FT x 22.0 FT x (T=1.5IN)/12/27 = 2.5 CU. YDS.
- ITEM 301 - ASPHALT CONCRETE BASE PG64-22, (449) 9"**  
25.5 FT x 22.0 FT x (T=9IN)/12/27 = 15.6 CU. YDS.
- ITEM 304 - AGGREGATE BASE, 6"**  
26.0 FT x 22.0 FT x (T=6 IN)/12/27 = 10.6 CU. YDS.
- ITEM 511 - CLASS QC MS CONCRETE (12.3 FT LT TO 16.4 FT RT)**  
(A=51.8 SQ. FT.) x (L=12.3'+16.4')/27 = 55.1 CU. YDS.
- ITEM 407 - NON-TRACKING TACK COAT**  
25.0 FT x 22.0 FT / 9 x 0.05 = 3.1 GAL
- ITEM 601 - ROCK CHANNEL PROTECTION, TYPE B, W/ FILTER**  
7.2 FT x 5.0 FT x 2.0 FT / 27 = 2.7 CY
- ITEM 202 - PAVEMENT REMOVED, APP**  
25.0 FT x 22.0 FT / (9 SF/SY) = 61.1 SY

**ESTIMATED QUANTITIES**

REF.	ITEM	QUANTITY	UNIT	DESCRIPTION
R-1	202	1	EACH	CATCH BASIN REMOVED
R-4	202	1	EACH	REMOVAL, MISC.: CONC. OUTLET APRON
R-2	202	93	FT	FILL AND PLUG EXISTING CONDUIT, 24"
R-3	202	5	FT	PIPE REMOVED, 24" DIAMETER AND UNDER
P-1	202	62	SY	PAVEMENT REMOVED, APP
P-1	301	16	CY	9" ASPHALT CONC. BASE PG64-22
P-1	304	11	CY	6" AGGREGATE BASE
P-1	407	4	GAL	NON-TRACKING TACK
P-1	441	3	CY	1.5" ASPHALT CONC. INT. COURSE (448)
D-1	601	3	CY	RCP, TYPE B WITH FILTER, APP
D-2	602	1.2	CY	CONCRETE MASONRY
D-2	611	75	FT	30" CONDUIT, TYPE A
D-2	503	LUMP	LS	COFFERDAMS AND EXCAVATION BRACING
P-1	511	56	CY	CLASS QC MS CONCRETE

**HYDRAULIC DATA**

DRAINAGE AREA = 12.2 ACRES  
 Q (4%) = 20.7 CFS      V (4%) = 13.1 FT/S      HW (4%) = 554.3 FT  
 Q (10%) = 17.7 CFS      V (10%) = 12.6 FT/S      HW (10%) = 554.1 FT  
 ORDINARY HIGH WATER MARK: N/A  
 DESIGN SERVICE LIFE: 20 YEARS  
 ABRASION LEVEL: N/A  
 pH: 7

**EXISTING STRUCTURE**

TYPE: CORRUGATED PLASTIC PIPE  
 SIZE: 24"  
 SKEW: 01° 39' 59" L.F.  
 ALIGNMENT: TANGENT  
 DATE BUILT: UNKNOWN  
 CONDITION: POOR  
 CFN: 1981270

**PROPOSED STRUCTURE**

TYPE: 75' - 30" CONDUIT, TYPE A  
 SKEW: 07° 49' 34" L.F.  
 ALIGNMENT: TANGENT  
 CFN: 1996556

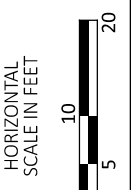
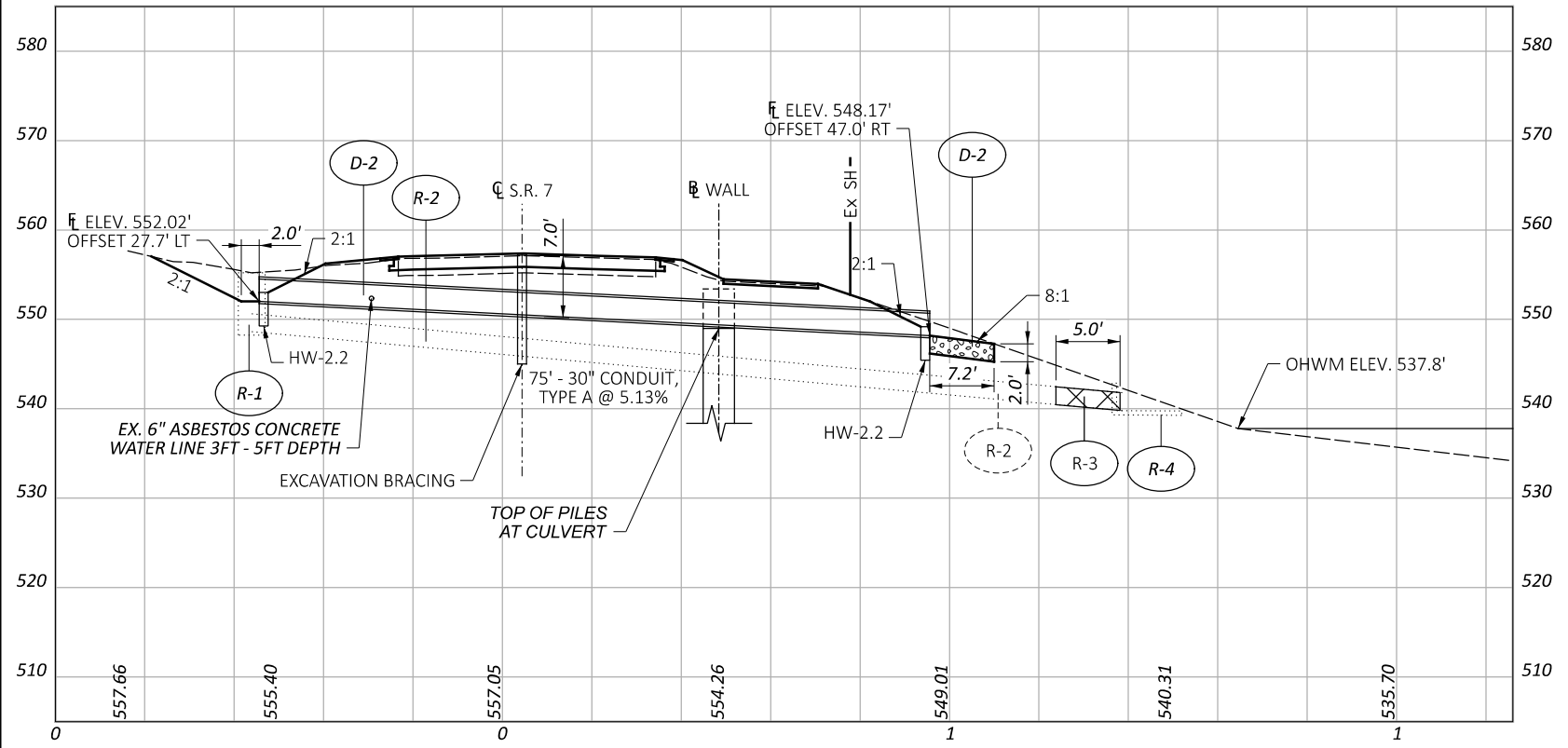

CULVERT DETAILS  
STA. 1068+21

DESIGN AGENCY



DESIGNER  
JDW

REVIEWER  
XXX MM-DD-YY

PROJECT ID  
115533

SUBSET	TOTAL
0	0

SHEET	TOTAL
P.25	P.48

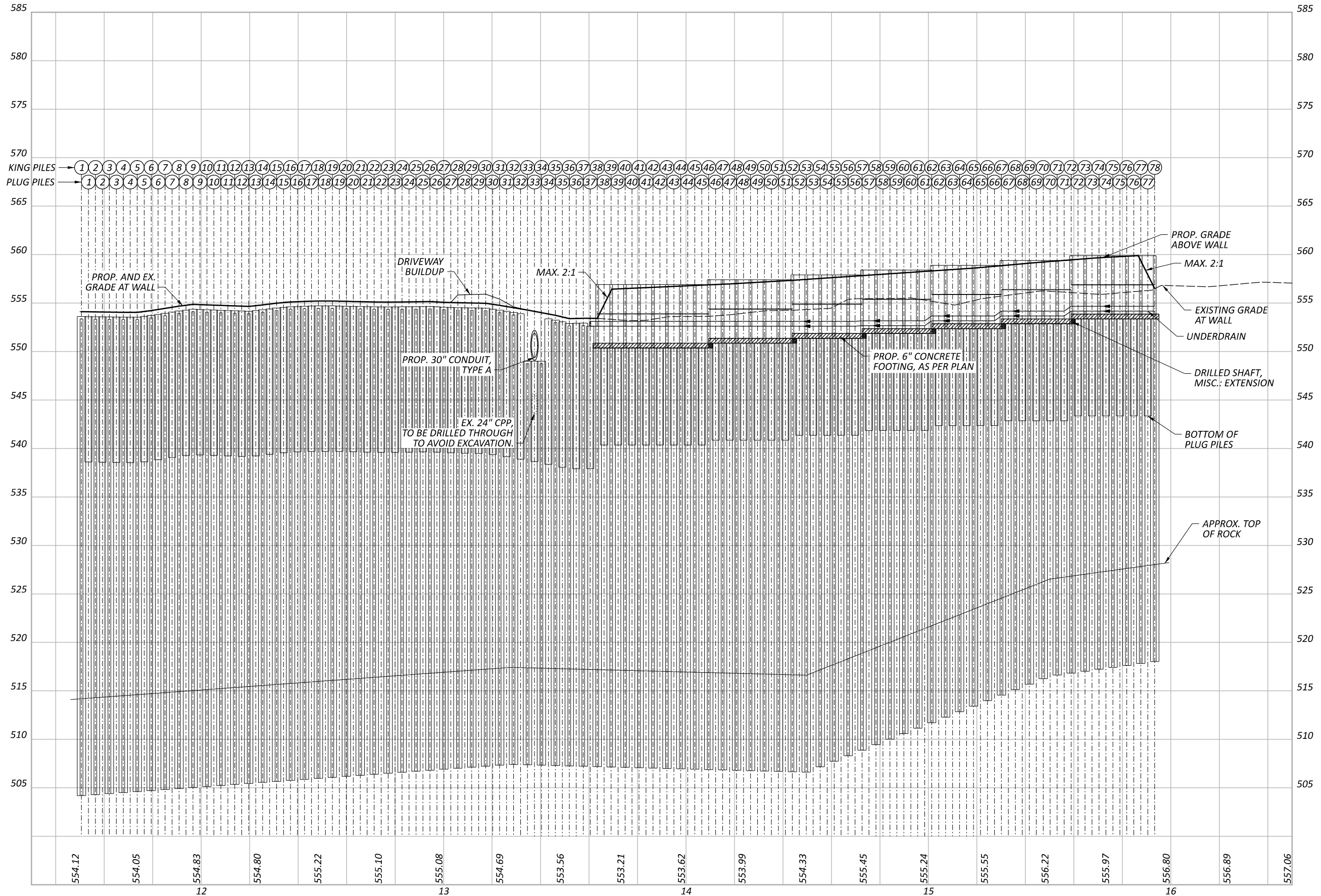

DRILLED SHAFT DETAILS  
 WALL PROFILE

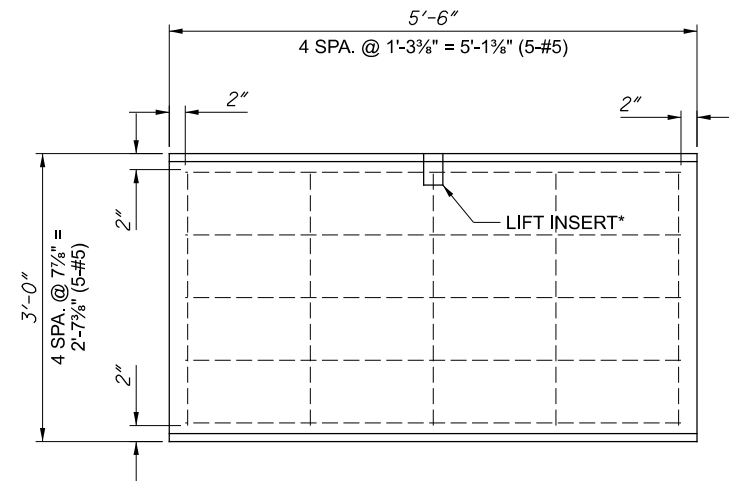

**PRE-CAST CONCRETE PANEL A**  
 TOTAL REQUIRED = 80, QUANTITY CARRIED TO GENERAL SUMMARY

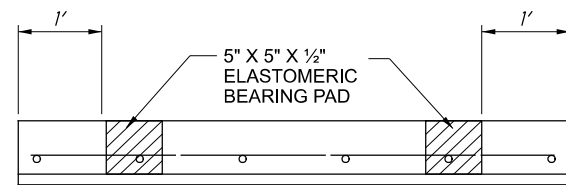
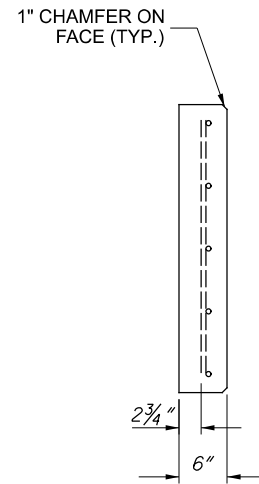

ELASTOMERIC BEARING PAD TYPICAL DETAIL.\*\*

**NOTES:**

- \* PRECAST PANEL MANUFACTURER TO DESIGN LIFT INSERT. MANUFACTURER TO DETERMINE NUMBER OF INSERTS FOR EACH PANEL.
- \*\* PRICE OF ELASTOMERIC BEARING PADS SHALL BE INCLUDED IN THE UNIT PRICE OF THE PRECAST CONCRETE PANELS.

**CALCULATIONS**

ITEM 530 - SPECIAL - RETAINING WALL, PRECAST CONCRETE LAGGING  
 A = 80 EACH X (3.0 FT X 5.5 FT) = 1,320 SF  
 A TOTAL OF 1,320 SF TO BE CARRIED TO THE GENERAL SUMMARY.

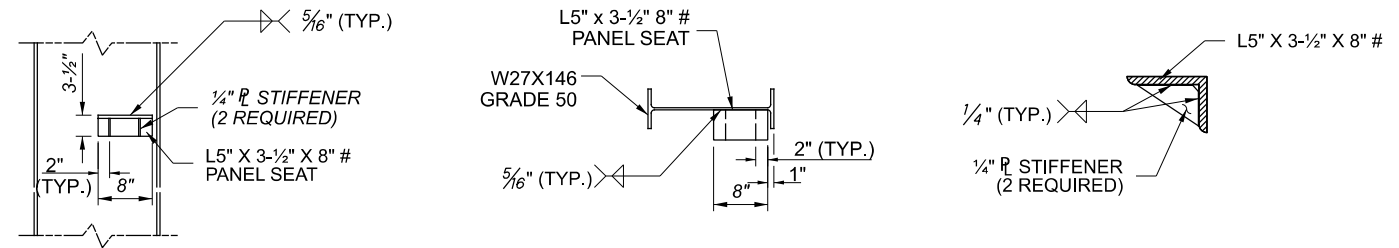

**PANEL SEAT DETAIL.**

# PANEL SEAT, STIFFENERS FOR PANEL SEAT STEEL IS INCLUDED IN PAYMENT FOR ITEM 507 - SOLDIER PILE, MISC.: SOLDIER PILES W27X146.

**NOTE:**  
 THE PANEL SEAT MAY BE NON-PERFORMED IF THE CONCRETE FOOTING IS PLACED PRIOR TO THE PRECAST CONCRETE LAGGING.

IF THE PRECAST CONCRETE LAGGING IS TO BE PLACED PRIOR TO THE CONCRETE FOOTING THEN THE PANELS SEATS SHALL BE PLACED ON EACH BEAM, FOR EITHER SIDE OF THE PRECAST CONCRETE LAGGING.



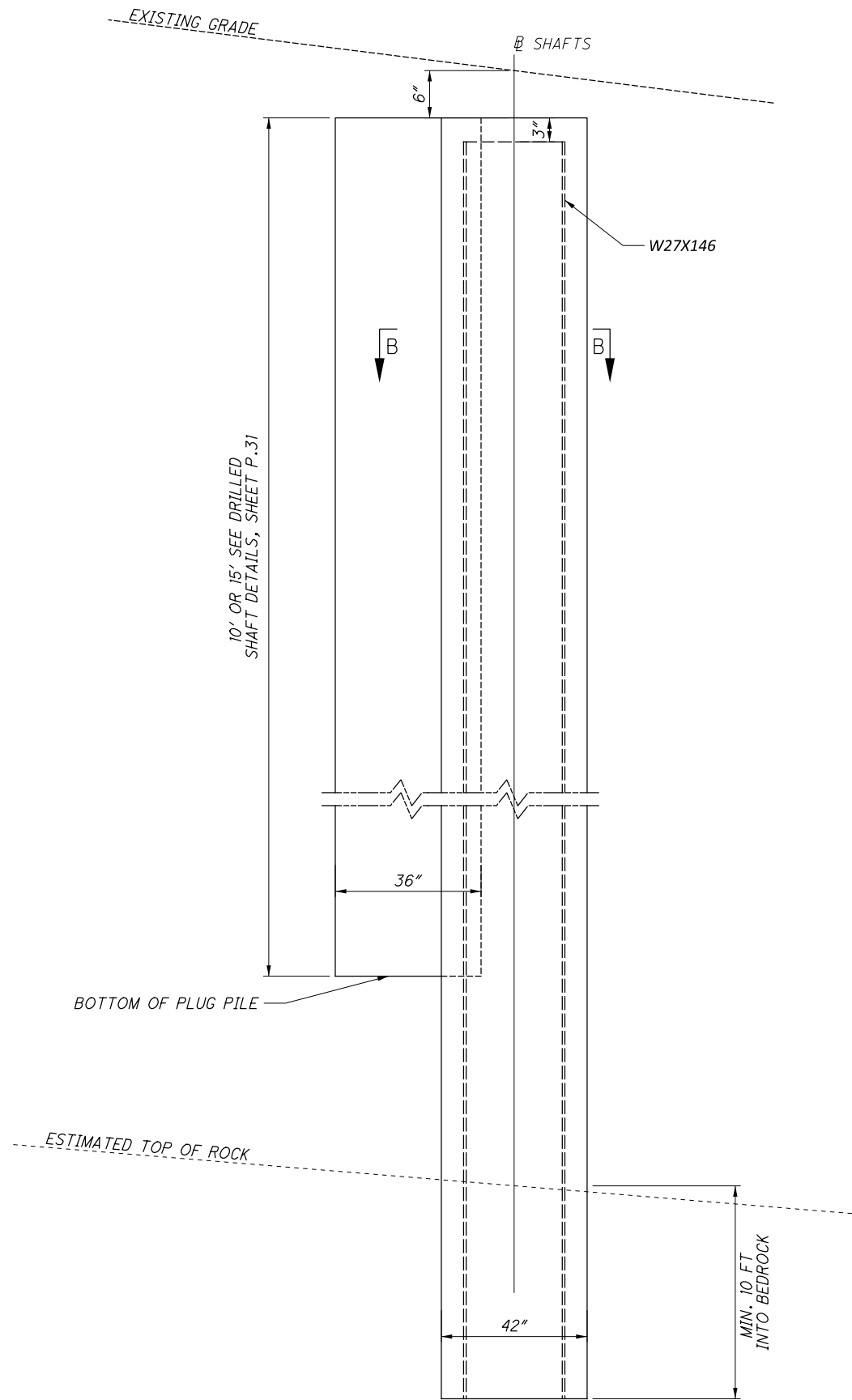
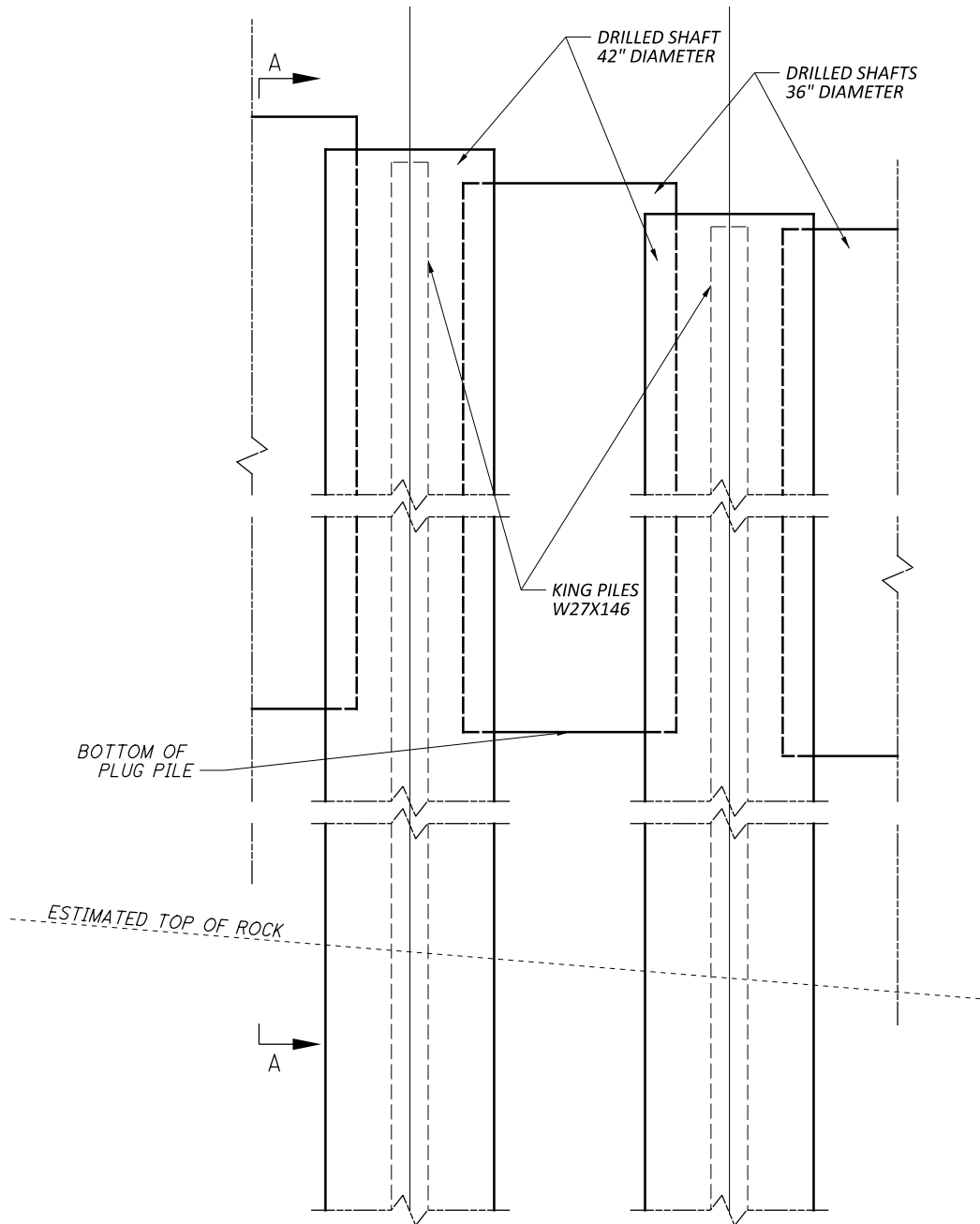
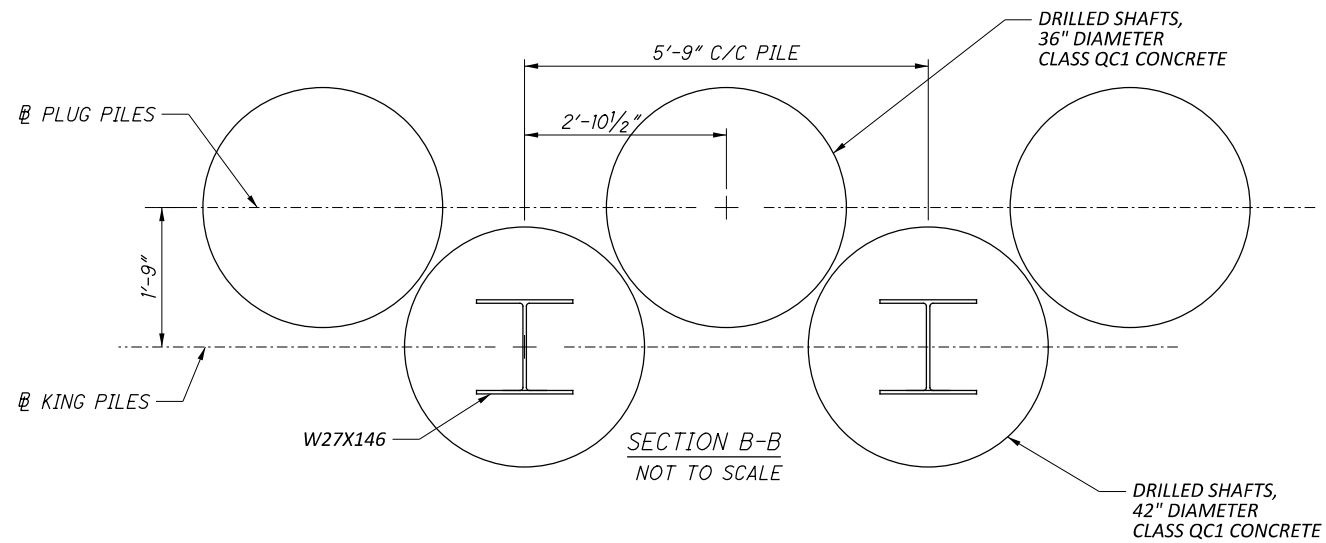

DRILLED SHAFT DETAILS

DESIGN AGENCY



DESIGNER

JDW

REVIEWER

XXX MM-DD-YY

PROJECT ID

115533

SHEET TOTAL

P.28 | P.48

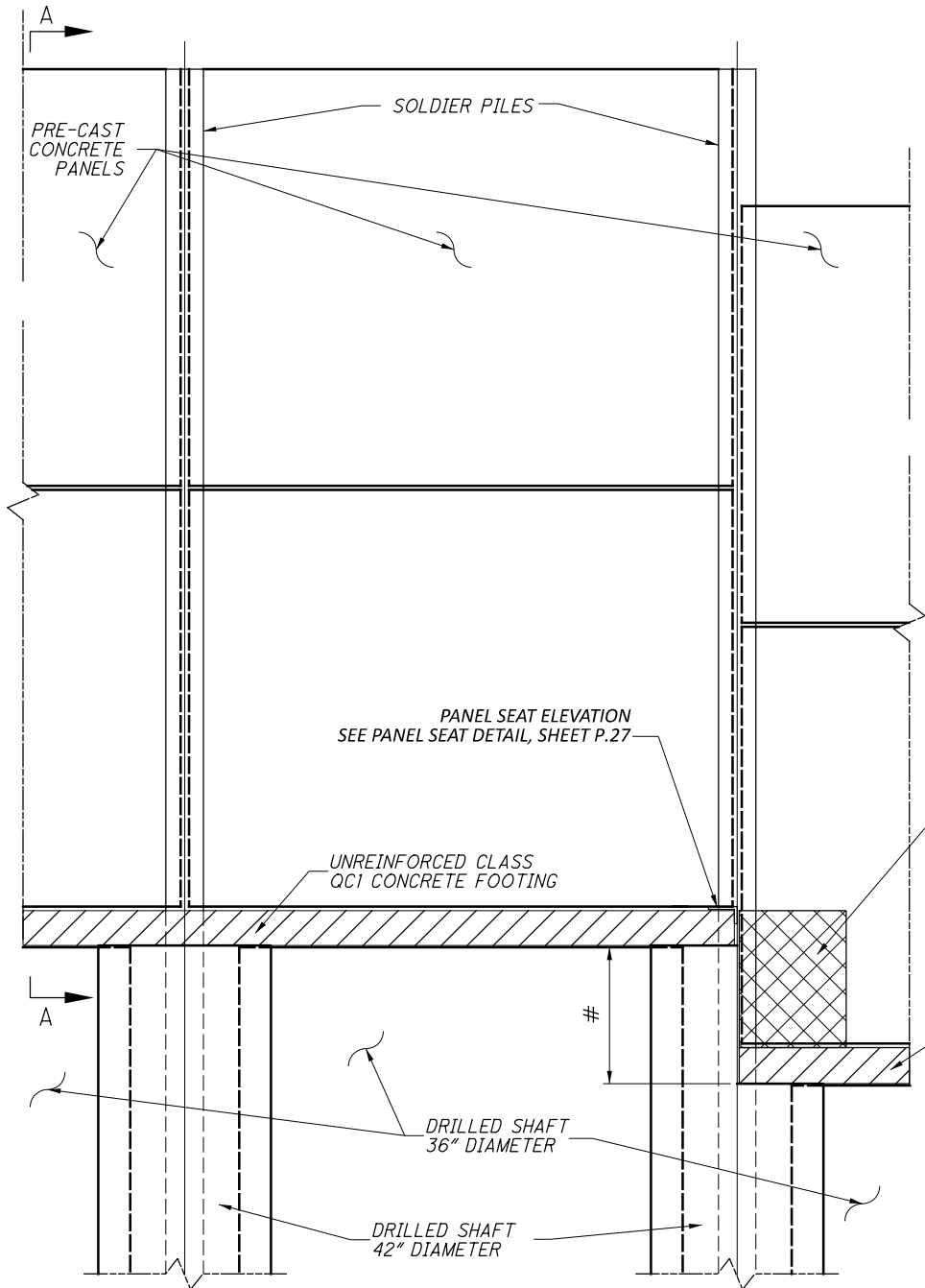
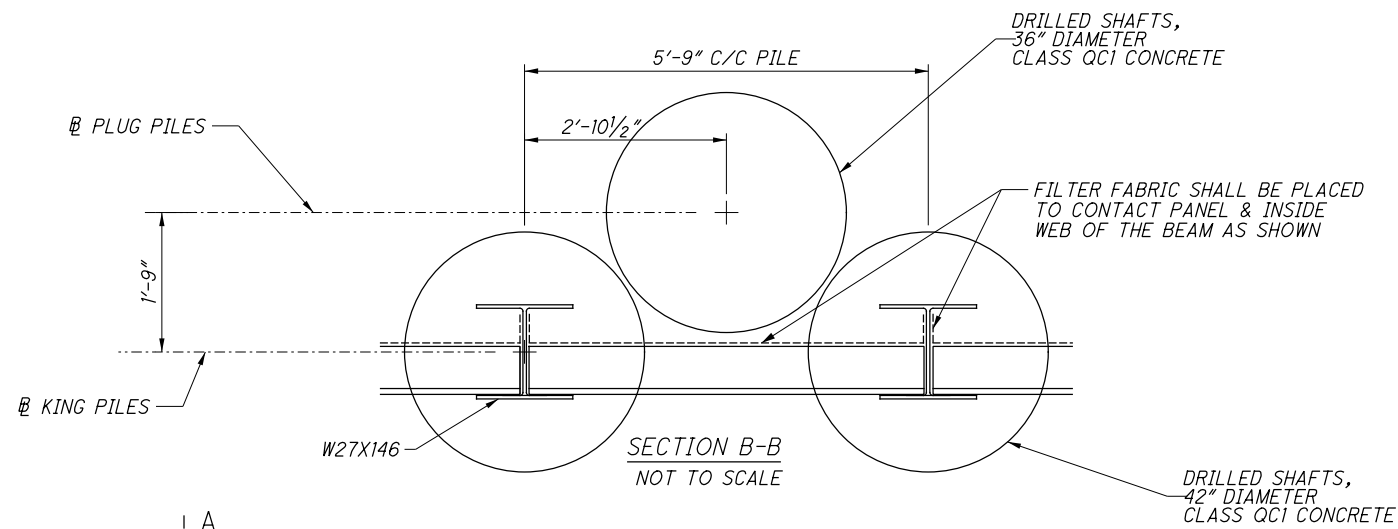

BLOCK OUT DRILLED SHAFT CONCRETE WITH FOAM INSULATION OR SIMILAR TO PROVIDE SUPPORT TO THE LOWER PANEL. THE COST TO BLOCK OUT THE DRILLED SHAFT WILL BE INCLUDED FOR PAYMENT UNDER ITEM 524 - DRILLED SHAFT, 42" DIAMETER, ABOVE BEDROCK, AS PER PLAN.

NOTE:  
# - ITEM 524 - DRILLED SHAFTS, MISC.: EXTENSION. QUANTITIES ARE INCLUDED IN DRILLED SHAFT DETAILS, SHEET P.30

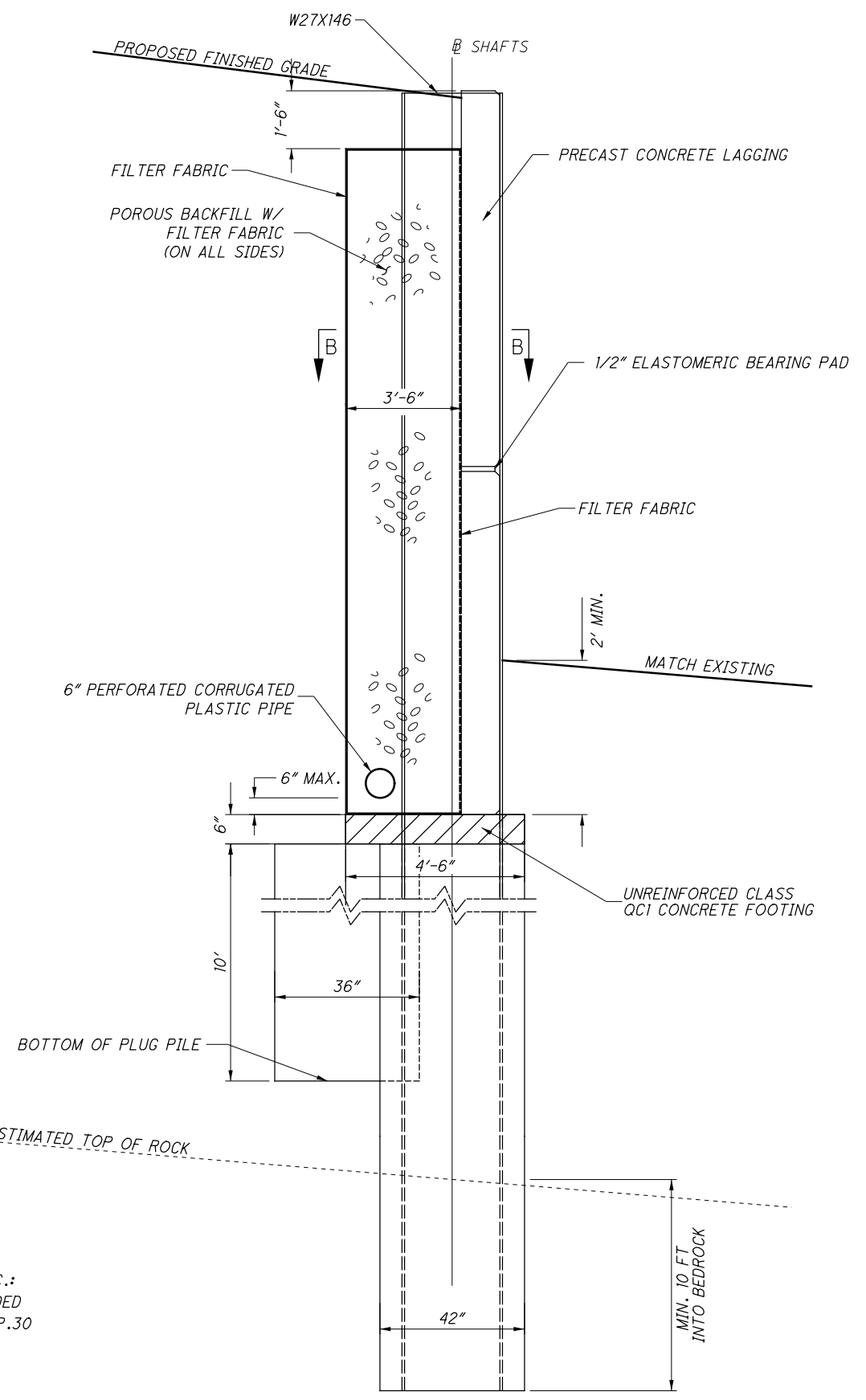

DRILLED SHAFT DETAILS

DESIGN AGENCY	
DESIGNER	JDW
REVIEWER	
PROJECT ID	115533
SHEET TOTAL	P.29 P.48

**GAL-7-19.94**

MODEL: SHEET 4 DRILLED SHAFT SUMMARY PAPER SIZE: 17x11 (in.) DATE: 10/23/2024 TIME: 7:51:35 AM USER: jwbseman  
 pwc:\hobolc-pw-bentley.com\shitolc-pw-02\Documents\01 Active Projects\Distrid 10\Galla\115533\400-Engineering\Roadway\Sheets\115533\_WD001.dgn

**DRILLED SHAFT SUMMARY (KING PILE)**

SHAFT No.	CENTERLINE DRILLED SHAFT (KING PILE) STA.	CENTERLINE OFFSET	BOTTOM ELEVATION OF SHAFT	TOP ELEVATION OF SHAFT	TOP OF BEAM	TOP ELEVATION OF LAGGING	ESTIMATED TOP OF ROCK ELEVATION	ITEM 524: 42" DIA. DRILLED SHAFTS INTO BEDROCK		ITEM 524: 42" DIA. DRILLED SHAFTS ABOVE BEDROCK	ITEM 524: DRILLED SHAFTS, MISC.: 42" STEEL CASING		ITEM 507: STEEL PILES, MISC.: SOLDIER PILES W27X146
								FEET	FEET		FEET	FEET	
1	11+50.61	26.50	RT	504.19	553.60	553.35	514.19	10.00	39.41	39.41	39.41	39.41	49.16
2	11+56.36	26.50	RT	504.29	553.60	553.35	514.29	10.00	39.31	39.31	39.31	39.31	49.06
3	11+62.11	26.50	RT	504.40	553.60	553.35	514.40	10.00	39.20	39.20	39.20	39.20	48.95
4	11+67.86	26.50	RT	504.50	553.50	553.25	514.50	10.00	39.00	39.00	39.00	39.00	48.75
5	11+73.61	26.50	RT	504.61	553.50	553.25	514.61	10.00	38.89	38.89	38.89	38.89	48.64
6	11+79.36	26.50	RT	504.71	553.70	553.45	514.71	10.00	38.99	38.99	38.99	38.99	48.74
7	11+85.11	26.50	RT	504.82	554.00	553.75	514.82	10.00	39.18	39.18	39.18	39.18	48.93
8	11+90.86	26.50	RT	504.92	553.20	552.95	514.92	10.00	38.28	38.28	38.28	38.28	48.03
9	11+96.61	26.50	RT	505.03	554.40	554.15	515.03	10.00	39.37	39.37	39.37	39.37	49.12
10	12+02.36	26.50	RT	505.13	554.30	554.05	515.13	10.00	39.17	39.17	39.17	39.17	48.92
11	12+08.11	26.50	RT	505.24	554.30	554.05	515.24	10.00	39.06	39.06	39.06	39.06	48.81
12	12+13.86	26.50	RT	505.34	554.20	553.95	515.34	10.00	38.86	38.86	38.86	38.86	48.61
13	12+19.61	26.50	RT	505.45	554.20	553.95	515.45	10.00	38.75	38.75	38.75	38.75	48.50
14	12+25.36	26.50	RT	505.55	554.30	554.05	515.55	10.00	38.75	38.75	38.75	38.75	48.50
15	12+31.11	26.50	RT	505.66	554.50	554.25	515.66	10.00	38.84	38.84	38.84	38.84	48.59
16	12+36.86	26.50	RT	505.76	554.60	554.35	515.76	10.00	38.84	38.84	38.84	38.84	48.59
17	12+42.61	26.50	RT	505.87	554.70	554.45	515.87	10.00	38.83	38.83	38.83	38.83	48.58
18	12+48.36	26.50	RT	505.97	554.70	554.45	515.97	10.00	38.73	38.73	38.73	38.73	48.48
19	12+54.11	26.50	RT	506.08	554.70	554.45	516.08	10.00	38.62	38.62	38.62	38.62	48.37
20	12+59.86	26.50	RT	506.18	554.70	554.45	516.18	10.00	38.52	38.52	38.52	38.52	48.27
21	12+65.61	26.50	RT	506.29	554.60	554.35	516.29	10.00	38.31	38.31	38.31	38.31	48.06
22	12+71.36	26.50	RT	506.39	554.60	554.35	516.39	10.00	38.21	38.21	38.21	38.21	47.96
23	12+77.11	26.50	RT	506.50	554.60	554.35	516.50	10.00	38.10	38.10	38.10	38.10	47.85
24	12+82.86	26.50	RT	506.60	554.60	554.35	516.60	10.00	38.00	38.00	38.00	38.00	47.75
25	12+88.61	26.50	RT	506.71	554.60	554.35	516.71	10.00	37.89	37.89	37.89	37.89	47.64
26	12+94.36	26.50	RT	506.81	554.70	554.45	516.81	10.00	37.89	37.89	37.89	37.89	47.64
27	13+00.11	26.50	RT	506.92	554.60	554.35	516.92	10.00	37.68	37.68	37.68	37.68	47.43
28	13+05.86	26.50	RT	507.02	554.50	554.25	517.02	10.00	37.48	37.48	37.48	37.48	47.23
29	13+11.61	26.50	RT	507.13	554.50	554.25	517.13	10.00	37.37	37.37	37.37	37.37	47.12
30	13+17.36	26.50	RT	507.23	554.50	554.25	517.23	10.00	37.27	37.27	37.27	37.27	47.02
31	13+23.11	26.50	RT	507.33	554.30	554.05	517.33	10.00	36.97	36.97	36.97	36.97	46.72
32	13+28.86	26.50	RT	507.41	554.00	553.75	517.41	10.00	36.59	36.59	36.59	36.59	46.34
33	13+34.61	26.50	RT	507.37	549.00	548.75	517.37	10.00	31.63	31.63	31.63	31.63	41.38
34	13+40.36	26.50	RT	507.33	549.00	548.75	517.33	10.00	31.67	31.67	31.67	31.67	41.42
35	13+46.11	26.50	RT	507.30	553.20	552.95	517.30	10.00	35.90	35.90	35.90	35.90	45.65
36	13+51.86	26.50	RT	507.26	552.90	552.65	517.26	10.00	35.64	35.64	35.64	35.64	45.39
37	13+57.61	26.50	RT	507.22	552.90	552.65	517.22	10.00	35.68	35.68	35.68	35.68	45.43
38	13+63.36	26.50	RT	507.18	550.36	-	556.90	10.00	33.18	33.18	33.18	33.18	49.72
39	13+69.11	26.50	RT	507.15	550.36	-	556.90	10.00	33.21	33.21	33.21	33.21	49.75
40	13+74.86	26.50	RT	507.11	550.36	-	556.90	10.00	33.25	33.25	33.25	33.25	49.79
41	13+80.61	26.50	RT	507.07	550.36	-	556.90	10.00	33.29	33.29	33.29	33.29	49.83
42	13+86.36	26.50	RT	507.03	550.36	-	556.90	10.00	33.33	33.33	33.33	33.33	49.87
43	13+92.11	26.50	RT	506.99	550.36	-	556.90	10.00	33.37	33.37	33.37	33.37	49.91
44	13+97.86	26.50	RT	506.96	550.36	-	556.90	10.00	33.40	33.40	33.40	33.40	49.94
45	14+03.61	26.50	RT	506.92	550.36	-	556.90	10.00	33.44	33.44	33.44	33.44	49.98
46	14+09.36	26.50	RT	506.88	550.36	-	557.40	10.00	33.48	33.48	33.48	33.48	50.52
47	14+15.11	26.50	RT	506.84	550.86	-	557.40	10.00	34.02	34.02	34.02	34.02	50.56
48	14+20.86	26.50	RT	506.81	550.86	-	557.40	10.00	34.05	34.05	34.05	34.05	50.59
49	14+26.61	26.50	RT	506.77	550.86	-	557.40	10.00	34.09	34.09	34.09	34.09	50.63
50	14+32.36	26.50	RT	506.73	550.86	-	557.40	10.00	34.13	34.13	34.13	34.13	50.67
51	14+38.11	26.50	RT	506.69	550.86	-	557.40	10.00	34.17	34.17	34.17	34.17	50.71
52	14+43.86	26.50	RT	506.66	550.86	-	557.90	10.00	34.20	34.20	34.20	34.20	51.24
53	14+49.61	26.50	RT	506.62	551.36	-	557.90	10.00	34.74	34.74	34.74	34.74	51.28
54	14+55.36	26.50	RT	507.17	551.36	-	557.90	10.00	34.19	34.19	34.19	34.19	50.73
55	14+61.11	26.50	RT	507.74	551.36	-	557.90	10.00	33.62	33.62	33.62	33.62	50.16
56	14+66.86	26.50	RT	508.31	551.36	-	557.90	10.00	33.05	33.05	33.05	33.05	49.59
57	14+72.61	26.50	RT	508.88	551.36	-	558.40	10.00	32.48	32.48	32.48	32.48	49.52
58	14+78.36	26.50	RT	509.45	551.86	-	558.40	10.00	32.41	32.41	32.41	32.41	48.95
59	14+84.11	26.50	RT	510.01	551.86	-	558.40	10.00	31.85	31.85	31.85	31.85	48.39
60	14+89.86	26.50	RT	510.58	551.86	-	558.40	10.00	31.28	31.28	31.28	31.28	47.82
61	14+95.61	26.50	RT	511.15	551.86	-	558.40	10.00	30.71	30.71	30.71	30.71	47.25
62	15+01.36	26.50	RT	511.72	551.86	-	558.90	10.00	30.14	30.14	30.14	30.14	47.18
63	15+07.11	26.50	RT	512.28	552.36	-	558.90	10.00	30.08	30.08	30.08	30.08	46.62
64	15+12.86	26.50	RT	512.85	552.36	-	558.90	10.00	29.51	29.51	29.51	29.51	46.05
65	15+18.61	26.50	RT	513.42	552.36	-	558.90	10.00	28.94	28.94	28.94	28.94	45.48
66	15+24.36	26.50	RT	513.99	552.36	-	558.90	10.00	28.37	28.37	28.37	28.37	44.91
67	15+30.11	26.50	RT	514.56	552.36	-	559.40	10.00	27.80	27.80	27.80	27.80	44.84
68	15+35.86	26.50	RT	515.12	552.86	-	559.40	10.00	27.74	27.74	27.74	27.74	44.28
69	15+41.61	26.50	RT	515.69	552.86	-	559.40	10.00	27.17	27.17	27.17	27.17	43.71
70	15+47.36	26.50	RT	516.26	552.86	-	559.40	10.00	26.60	26.60	26.60	26.60	43.14
71	15+53.11	26.50	RT	516.83	552.86	-	559.40	10.00	26.23	26.23	26.23	26.23	42.77
72	15+58.86	26.50	RT	516.82	552.86	-	559.90	10.00	26.04	26.04	26.04	26.04	43.08
73	15+64.61	26.50	RT	517.02	553.36	-	559.90	10.00	26.34	26.34	26.34	26.34	42.88
74	15+70.36	26.50	RT	517.22	553.36	-	559.90	10.00	26.14	26.14	26.14	26.14	42.68
75	15+76.11	26.50	RT	517.42	553.36	-	559.90	10.00	25.94	25.94	25.94	25.94	42.48
76	15+81.86	26.50	RT	517.62	553.36	-	559.90	10.00	25.74	25.74	25.74	25.74	42.28
77	15+87.61	26.50	RT	517.82	553.36	-	559.90	10.00	25.54	25.54	25.54	25.54	42.08
78	15+93.36	26.50	RT	518.02	553.36	-	559.90	10.00	25.34	25.34	25.34	25.34	41.88

TOTALS CARRIED TO GENERAL SUMMARY

780.00	2663.46	3.00	2663.46	3705.35
--------	---------	------	---------	---------

DESIGN AGENCY



DESIGNER  
**JDW**  
 REVIEWER  
**XXX MM-DD-YY**  
 PROJECT ID  
**115533**  
 SHEET TOTAL  
**P.30 P.48**

**DRILLED SHAFT DETAILS**

DRILLED SHAFT SUMMARY (PLUG PILE)

SHAFT No.	CENTERLINE DRILLED SHAFT (PLUG PILE) STA.	CENTERLINE OFFSET	BOTTOM ELEVATION OF SHAFT	TOP ELEVATION OF SHAFT	ITEM 524: 36" DIA. DRILLED SHAFTS ABOVE BEDROCK	ITEM 524: DRILLED SHAFTS, MISC.: 36" STEEL CASING
1	11+53.48	24.75 RT	538.60	553.60	15.00	15.00
2	11+59.23	24.75 RT	538.60	553.60	15.00	15.00
3	11+64.98	24.75 RT	538.60	553.60	15.00	15.00
4	11+70.73	24.75 RT	538.50	553.50	15.00	15.00
5	11+76.48	24.75 RT	538.60	553.60	15.00	15.00
6	11+82.23	24.75 RT	538.80	553.80	15.00	15.00
7	11+87.98	24.75 RT	539.10	554.10	15.00	15.00
8	11+93.73	24.75 RT	539.30	554.30	15.00	15.00
9	11+99.48	24.75 RT	539.30	554.30	15.00	15.00
10	12+05.23	24.75 RT	539.30	554.30	15.00	15.00
11	12+10.98	24.75 RT	539.20	554.20	15.00	15.00
12	12+16.73	24.75 RT	539.20	554.20	15.00	15.00
13	12+22.48	24.75 RT	539.20	554.20	15.00	15.00
14	12+28.23	24.75 RT	539.40	554.40	15.00	15.00
15	12+33.98	24.75 RT	539.60	554.60	15.00	15.00
16	12+39.73	24.75 RT	539.60	554.60	15.00	15.00
17	12+45.48	24.75 RT	539.70	554.70	15.00	15.00
18	12+51.23	24.75 RT	539.70	554.70	15.00	15.00
19	12+56.98	24.75 RT	539.70	554.70	15.00	15.00
20	12+62.73	24.75 RT	539.70	554.70	15.00	15.00
21	12+68.48	24.75 RT	539.60	554.60	15.00	15.00
22	12+74.23	24.75 RT	539.60	554.60	15.00	15.00
23	12+79.98	24.75 RT	539.60	554.60	15.00	15.00
24	12+85.73	24.75 RT	539.60	554.60	15.00	15.00
25	12+91.48	24.75 RT	539.60	554.60	15.00	15.00
26	12+97.23	24.75 RT	539.60	554.60	15.00	15.00
27	13+02.98	24.75 RT	539.60	554.60	15.00	15.00
28	13+08.73	24.75 RT	539.50	554.50	15.00	15.00
29	13+14.48	24.75 RT	539.50	554.50	15.00	15.00
30	13+20.23	24.75 RT	539.40	554.40	15.00	15.00
31	13+25.98	24.75 RT	539.10	554.10	15.00	15.00
32	13+31.73	24.75 RT	538.90	553.90	15.00	15.00
33	13+37.48	24.75 RT	539.00	549.00	10.00	10.00
34	13+43.23	24.75 RT	538.40	553.40	15.00	15.00
35	13+48.98	24.75 RT	538.10	553.10	15.00	15.00
36	13+54.73	24.75 RT	537.90	552.90	15.00	15.00
37	13+60.48	24.75 RT	537.61	552.61	15.00	15.00
38	13+66.23	24.75 RT	540.36	550.36	10.00	10.00
39	13+71.98	24.75 RT	540.36	550.36	10.00	10.00
40	13+77.73	24.75 RT	540.36	550.36	10.00	10.00
41	13+83.48	24.75 RT	540.36	550.36	10.00	10.00
42	13+89.23	24.75 RT	540.36	550.36	10.00	10.00
43	13+94.98	24.75 RT	540.36	550.36	10.00	10.00
44	14+00.73	24.75 RT	540.36	550.36	10.00	10.00
45	14+06.48	24.75 RT	540.36	550.36	10.00	10.00
46	14+12.23	24.75 RT	540.86	550.86	10.00	10.00
47	14+17.98	24.75 RT	540.86	550.86	10.00	10.00
48	14+23.73	24.75 RT	540.86	550.86	10.00	10.00
49	14+29.48	24.75 RT	540.86	550.86	10.00	10.00
50	14+35.23	24.75 RT	540.86	550.86	10.00	10.00
51	14+40.98	24.75 RT	540.86	550.86	10.00	10.00
52	14+46.73	24.75 RT	541.36	551.36	10.00	10.00
53	14+52.48	24.75 RT	541.36	551.36	10.00	10.00
54	14+58.23	24.75 RT	541.36	551.36	10.00	10.00
55	14+63.98	24.75 RT	541.36	551.36	10.00	10.00
56	14+69.73	24.75 RT	541.36	551.36	10.00	10.00
57	14+75.48	24.75 RT	541.86	551.86	10.00	10.00
58	14+81.23	24.75 RT	541.86	551.86	10.00	10.00
59	14+86.98	24.75 RT	541.86	551.86	10.00	10.00
60	14+92.73	24.75 RT	541.86	551.86	10.00	10.00
61	14+98.48	24.75 RT	541.86	551.86	10.00	10.00
62	15+04.23	24.75 RT	542.36	552.36	10.00	10.00
63	15+09.98	24.75 RT	542.36	552.36	10.00	10.00
64	15+15.73	24.75 RT	542.36	552.36	10.00	10.00
65	15+21.48	24.75 RT	542.36	552.36	10.00	10.00
66	15+27.23	24.75 RT	542.36	552.36	10.00	10.00
67	15+32.98	24.75 RT	542.86	552.86	10.00	10.00
68	15+38.73	24.75 RT	542.86	552.86	10.00	10.00
69	15+44.48	24.75 RT	542.86	552.86	10.00	10.00
70	15+50.23	24.75 RT	542.86	552.86	10.00	10.00
71	15+55.98	24.75 RT	542.86	552.86	10.00	10.00
72	15+61.73	24.75 RT	543.36	553.36	10.00	10.00
73	15+67.48	24.75 RT	543.36	553.36	10.00	10.00
74	15+73.23	24.75 RT	543.36	553.36	10.00	10.00
75	15+78.98	24.75 RT	543.36	553.36	10.00	10.00
76	15+84.73	24.75 RT	543.36	553.36	10.00	10.00
77	15+90.48	24.75 RT	543.36	553.36	10.00	10.00
<b>TOTAL</b>					<b>950.00</b>	<b>950.00</b>

DESIGN AGENCY



DESIGNER  
JDW

REVIEWER

XXX MM-DD-YY

PROJECT ID

115533

SHEET

P.31

TOTAL

P.48

DRILLED SHAFT DETAILS

**PROJECT DESCRIPTION**

THE PROJECT CONSISTS OF REPAIRING A LANDSLIDE UTILIZING A 446 FT DRILLED SHAFT RETAINING WALL AND DUMPED ROCK FILL.

**HISTORIC RECORDS**

NO HISTORICAL GEOTECHNICAL RECORDS WERE FOUND FOR THIS PROJECT. HISTORICAL DOCUMENTATION FOR SR7 INDICATES THAT ACTIVE SLOPE INSTABILITY HAS BEEN PRESENT THROUGHOUT THE AREA PRIOR TO THE 1930'S.

**GEOLOGY**

THE PROJECT IS LOCATED WITHIN THE NON-GLACIATED MARIETTA PLATEAU PHYSIOGRAPHIC REGION WHICH IS CHARACTERIZED AS A HIGH RELIEF DISSECTED PLATEAU. THIN RESIDUAL SOILS ARE LOCATED ALONG THE RIDGE TOPS AND HILLSIDES, AND THIN TO THICK COLLUVIAL SOILS ARE LOCATED AT THE BASE OF THE HILLS. ALONG MAJOR STREAM VALLEYS LACUSTRINE DEPOSITS WITH OUTWASH SOILS ARE PRESENT. THE OHIO DEPARTMENT OF NATURAL RESOURCES (ODNR) INTERACTIVE GEOLOGIC MAP INDICATES THAT THE MAJORITY OF THE PROJECT AREA IS COMPRISED OF ALLUVIAL SOILS, ASSOCIATED WITH THE OHIO RIVER VALLEY, AT THE GROUND SURFACE. THE OVERBURDEN SOILS ARE UNDERLAIN BY PENNSYLVANIAN-AGED SHALE, SILTSTONE, SANDSTONE, CONGLOMERATE, AND SUBORDINATE AMOUNTS OF LIMESTONE, CLAY, FLINT, AND COAL FROM THE CONEMAUGH GROUP.

**RECONNAISSANCE**

INITIAL FIELD RECONNAISSANCE WAS COMPLETED BY DISTRICT PERSONNEL ON JULY 12, 2021. THE ROADWAY WAS NOTED AS BEING PATCHED AND WAVY. CRACKING WAS NOTED WITHIN THE PAVEMENT INDICATING A HEAD SCARP DUE TO SLOPE INSTABILITY BELOW THE ROADWAY. AT THE WEST END OF THE PAVEMENT PATCH AND EXTENDING FURTHER WEST DUMP ROCK PLACED FOR RIVERBANK STABILIZATION IS PRESENT. AT THE EAST END OF THE PAVEMENT PATCH, A CONCRETE CAP IS PRESENT BEING SUPPORTED BY STEEL PILES. THE BASE OF THE CAP HAS BEEN EXPOSED AT THE WESTERN END ALLOWING FOR THE PILES TO BE VISIBLE. A PAVED DRIVEWAY IS PRESENT WITHIN THE AREA OF THE PAVEMENT PATCH LEADING TO A GRASSY FIELD BELOW THE ROADWAY. THE EASTERN END OF THE PROJECT HAS A STEEP, SHORT EMBANKMENT SUPPORTING THE ROADWAY. ABOVE THE ROADWAY IS A GENTLY RISING GRASSY HILLSIDE TRANSITIONING INTO A STEEPER WOODED SLOPE. THE RIPARIAN CORRIDOR AT THE EDGE OF THE OHIO RIVER IS WOODED. GENERALLY, THE SURROUNDING LAND USE IS FALLOW, GRASSY, AGRICULTURAL LAND.

**SUBSURFACE EXPLORATION**

MULTIPLE PHASES WERE PERFORMED FOR THE GEOTECHNICAL EXPLORATION. INITIALLY FOUR (4) BORINGS, B-001-0-21 THROUGH B-004-0-21, WERE COMPLETED BETWEEN AUGUST 3 AND 19, 2021, UTILIZING A TRUCK MOUNTED CME 55 ROTARY DRILL, USING 3 1/4-INCH I.D. HOLLOW STEM AUGERS. AN ADDITIONAL BORING, B-003-1-22, WAS COMPLETED BETWEEN MAY 31 AND JUNE 7, 2022, UTILIZING A TRACK MOUNTED CME 850R, USING 3 1/4-INCH I.D. HOLLOW STEM AUGERS. AUGERS WERE ADVANCED THROUGH THE OVERBURDEN SOILS INTO WEATHERED BEDROCK WITH DISTURBED SAMPLES COLLECTED IN ACCORDANCE WITH THE STANDARD PENETRATION TEST (AASHTO T206) AT CONTINUOUS AND 2.5-FOOT INTERVALS. THE HAMMER SYSTEMS USED WERE CALIBRATED ON APRIL 15, 2020, WITH AN AVERAGE DRILL ROD ENERGY RATIO (ER) OF 84% FOR THE CME 55 AND ON APRIL 19, 2021, WITH THE ER CAPPED AT 90% FOR THE CME 850 AS PER SGE 404.3. THE BORINGS WERE ADVANCED INTO BEDROCK AND SAMPLED (AASHTO T225) USING AN N SERIES WIRELINE CORE BARREL, WATER METHOD.

AN ELECTRICAL RESISTIVITY IMAGING (ER) SURVEY WAS COMPLETED WITHIN THE VICINITY OF THE CONCRETE CAP AS AN ATTEMPT TO DELINEATE THE EXTENT OF THE CAP. A SECOND ER SURVEY WAS CONDUCTED TO HELP DETERMINE THE LOCATION OF A CULVERT AND THE CULVERT OUTLET WITHIN THE PROJECT AREA. THE ER DATA WAS COLLECTED WITH AN ADVANCED GEOSCIENCES INC. (AGI) SUPERSTING R8 CONTROL UNIT. FOR THE FIRST ER SURVEY, 34 ELECTRODES WERE SPACED APPROXIMATELY 5 FEET APART, WHILE THE SECOND SURVEY UTILIZED 24 ELECTRODES SPACED APPROXIMATELY 5 FEET APART. THE ELECTRODES WERE USED TO MEASURE THE POTENTIAL FIELD WITH DIPOLE-DIPOLE AND STRONG GRADIENT ARRAYS. THE DATA WAS PROCESSED, AND SURFACE ELEVATION CORRECTED USING AGI'S EARTHIMAGER 2D SOFTWARE.

**EXPLORATION FINDINGS**

BORINGS B-001-0-21 THROUGH B-004-0-21 WERE COMPLETED WITHIN THE EXISTING ROADWAY ENCOUNTERING 12 TO 18-INCHES OF ASPHALT UNDERLAIN BY 8 TO 10-INCHES OF CONCRETE. BENEATH THE SURFACE MATERIALS THE BORINGS ENCOUNTERED PREDOMINANTLY COHESIVE SOILS CONSISTING OF SANDY SILT (A-4a), SILT (A-4b), SILT AND CLAY (A-6a), SILTY CLAY (A-6b), AND CLAY (A-7-6) RANGING FROM VERY SOFT TO HARD IN CONSISTENCY AND DAMP TO WET IN CONDITION. MODERATELY ORGANIC SOILS WERE ENCOUNTERED IN B-001-0-21 BETWEEN ELEVATIONS (EL.) 547.8 AND 542.8 FEET (FT) AND WITHIN B-003-0-21 BETWEEN EL. 546.0 AND 544.5 FT. ADDITIONALLY, NON-COHESIVE SOILS WERE ENCOUNTERED WITHIN ISOLATED AREAS WITHIN THESE BORINGS. MEDIUM DENSE SILT (A-4b) WAS ENCOUNTERED BETWEEN EL. 529.1 AND 522.8 FT IN WET CONDITION WITHIN B-001-0-21. WITHIN B-002-0-21 VERY DENSE STONE FRAGMENTS WITH SAND AND SILT (A-2-4) AND LOOSE COARSE AND FINE SAND (A-3a) WERE ENCOUNTERED BETWEEN EL. 533.1 AND 531.3 FT AND 525.3 AND 523.8 FT, RESPECTIVELY. BEDROCK WAS ENCOUNTERED IN ALL FOUR BORINGS BETWEEN EL. 517.8 AND 529.5 FT WHICH WAS SLIGHTLY VARIABLE, BUT, GENERALLY, RAISED TO THE EAST. THE FIRST ENCOUNTERED BEDROCK CONSISTED OF SANDSTONE WHICH WAS TYPICALLY HIGHLY TO MODERATELY WEATHERED AND WEAK TO SLIGHTLY STRONG. B-003-0-21 FIRST ENCOUNTERED A MODERATELY WEATHERED, VERY WEAK SHALE INSTEAD OF SANDSTONE. B-004-0-21 ENCOUNTERED A SILTSTONE LAYER BENEATH THE SANDSTONE, WHICH WAS MODERATELY WEATHERED, SLIGHTLY STRONG, AND CONTAINED CLAY SEAMS. CLAYSTONE WAS ENCOUNTERED IN ALL FOUR BORINGS BETWEEN EL. 515.3 AND 520.4 FT WITH A SLIGHTLY VARIABLE SURFACE. THIS STRATUM WAS TYPICALLY MODERATELY WEATHERED AND VERY WEAK. UNCONFINED COMPRESSIVE STRENGTH TESTING RESULTS RANGED FROM 27 TO 33 AND FROM 88 TO 338 PSI WITH CONFINING PRESSURE ADDED. ALL BORINGS WERE TERMINATED WITHIN CLAYSTONE. B-001-0-21 AND B-004-0-21 WERE REPORTED AS BEING DRY PRIOR TO INTRODUCTION OF CORE WATER. B-002-0-21 AND B-003-0-21 ENCOUNTERED FREE WATER WHILE DRILLING AT EL. 525.3 AND 527.0 FT., RESPECTIVELY WITH B-002-0-21 HAVING A WATER LEVEL AT COMPLETION, INCLUDING CORE WATER, AT EL. 538.6 FT.

LEGEND		ODOT CLASS	CLASSIFIED MECH./VISUAL	
DESCRIPTION				
	STONE FRAGMENTS WITH SAND AND SILT	A-2-4	1	1
	COARSE AND FINE SAND	A-3a	3	3
	SANDY SILT	A-4a	8	2
	SILT	A-4b	5	6
	SILT AND CLAY	A-6a	10	15
	SILTY CLAY	A-6b	9	18
	CLAY	A-7-6	5	11
	TOTAL		41	56
	BOULDERS	VISUAL		
	CLAYSTONE	VISUAL		
	SANDSTONE	VISUAL		
	SHALE	VISUAL		
	SILTSTONE	VISUAL		
	PAVEMENT OR BASE = X = APPROXIMATE THICKNESS	VISUAL		
	SOD AND TOPSOIL = X = APPROXIMATE THICKNESS	VISUAL		
	BORING LOCATION - PLAN VIEW.			
	DRIVE SAMPLE AND/OR ROCK CORE BORING PLOTTED TO VERTICAL SCALE ONLY. HORIZONTAL BAR INDICATES A CHANGE IN STRATIGRAPHY.			
WC	INDICATES WATER CONTENT IN PERCENT.			
N <sub>60</sub>	INDICATES STANDARD PENETRATION RESISTANCE NORMALIZED TO 60% DRILL ROD ENERGY RATIO.			
X/D"	NUMBER OF BLOWS FOR STANDARD PENETRATION TEST (SPT): X/D" = NUMBER OF BLOWS (UNCORRECTED) FOR D" OF PENETRATION AT REFUSAL.			
	INDICATES WATER AT COMPLETION.			
	INDICATES FREE WATER ELEVATION.			
	INDICATES A PLASTIC MATERIAL WITH A MOISTURE CONTENT EQUAL TO OR GREATER THAN THE LIQUID LIMIT MINUS 3.			
	INDICATES A NON-PLASTIC MATERIAL WITH A MOISTURE CONTENT GREATER THAN 25 % OR GREATER THAN 19 % WITH A WET APPEARANCE.			
	INDICATES UNIT WEIGHT OF ROCK.			
LOI	INDICATES ORGANIC CONTENT BY LOSS ON IGNITION, AASHTO T267.			
QU	INDICATES UNCONFINED COMPRESSION TEST, ASTM D7012. (ROCK)			
SS	INDICATES A SPLIT SPOON SAMPLE.			
NQ	"N" SERIES ROCK CORE BARREL OF "Q" WIRELINE BIT SIZE.			
NP	INDICATES A NON-PLASTIC SAMPLE.			
TR	INDICATES TOP OF ROCK ELEVATION.			

**EXPLORATION FINDINGS CONTINUED, SEE SHEET 2.**

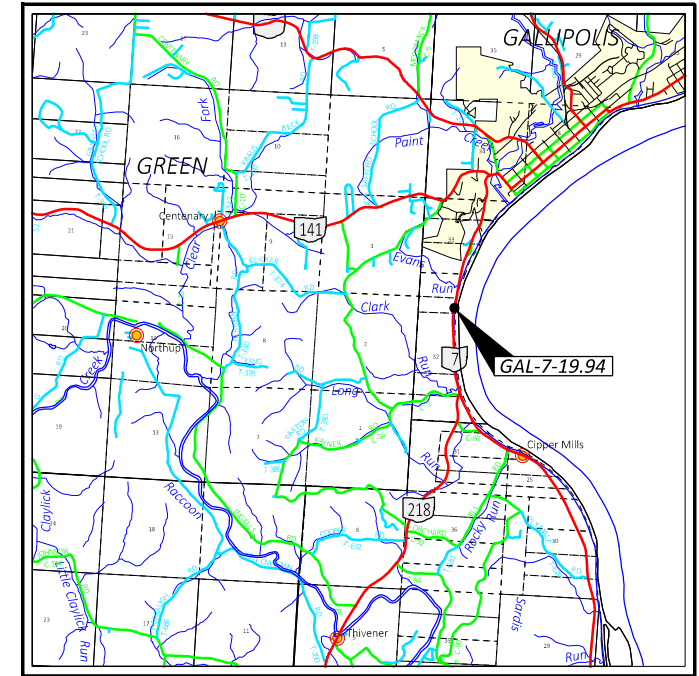

LOCATION MAP  
SCALE IN MILES



**PARTICLE SIZE DEFINITIONS**

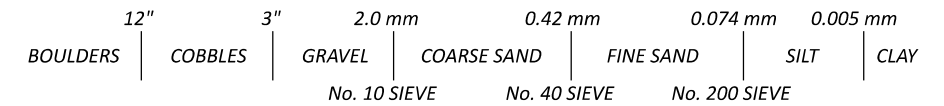

INDEX OF SHEETS				
EXPLORATION NOTES CONT., SHEET 2.				
LOCATION FROM STA.	TO STA.	PLAN VIEW SHEET	PROFILE SHEET	CROSS SECTION SHEET
SR 7				
106+00	117+50	3	3	-
117+50	122+50	4	4	-
121+85.55		-	-	5
BORING LOGS & ROCK CORE REPORTS, SHEETS 6 - 16.				
INCLINOMETER AND ER LINES DATA, SHEET 17.				

RECON. - AM 07/12/21  
 DRILLING - KAM 08/03/21 - 08/11/21  
 AMJ 08/11/21 - 08/19/21  
 DML 05/31/22 - 06/07/22  
 DRAWN - AJC 08/23/24  
 REVIEWED - SAT 08/23/24

GAL-7-19.94

MODEL: Sheet PAPER: 17x11 (in.) DATE: 10/23/2024 TIME: 7:41:29 AM USER: wiseman  
 p:\ohio\dot-pw-bentley.com\ohio\dot-pw-02\Documents\01.Active Projects\District 10\Gallia\115533\400-Engineering\Geotechnical\Sheets\115533\_YC001.dgn

GEOTECHNICAL PROFILE - LANDSLIDE

DESIGN AGENCY  
  
 DESIGNER  
 AJC  
 REVIEWER  
 SAT 08/23/24  
 PROJECT ID  
 115533  
 SUBSET TOTAL  
 1 17  
 SHEET TOTAL  
 P.32 P.48



**EXPLORATION FINDINGS (CONT.)**

BORINGS B-001-0-21 THROUGH B-004-0-21 WERE COMPLETED WITHIN THE EXISTING ROADWAY ENCOUNTERING 12 TO 18-INCHES OF ASPHALT UNDERLAIN BY 8 TO 10-INCHES OF CONCRETE. BENEATH THE SURFACE MATERIALS THE BORINGS ENCOUNTERED PREDOMINANTLY COHESIVE SOILS CONSISTING OF SANDY SILT (A-4a), SILT (A-4b), SILT AND CLAY (A-6a), SILTY CLAY (A-6b), AND CLAY (A-7-6) RANGING FROM VERY SOFT TO HARD IN CONSISTENCY AND DAMP TO WET IN CONDITION. MODERATELY ORGANIC SOILS WERE ENCOUNTERED IN B-001-0-21 BETWEEN ELEVATIONS (EL.) 547.8 AND 542.8 FEET (FT) AND WITHIN B-003-0-21 BETWEEN EL. 546.0 AND 544.5 FT. ADDITIONALLY, NON-COHESIVE SOILS WERE ENCOUNTERED WITHIN ISOLATED AREAS WITHIN THESE BORINGS. MEDIUM DENSE SILT (A-4b) WAS ENCOUNTERED BETWEEN EL. 529.1 AND 522.8 FT IN WET CONDITION WITHIN B-001-0-21. WITHIN B-002-0-21 VERY DENSE STONE FRAGMENTS WITH SAND AND SILT (A-2-4) AND LOOSE COARSE AND FINE SAND (A-3a) WERE ENCOUNTERED BETWEEN EL. 533.1 AND 531.3 FT AND 525.3 AND 523.8 FT, RESPECTIVELY. BEDROCK WAS ENCOUNTERED IN ALL FOUR BORINGS BETWEEN EL. 517.8 AND 529.5 FT WHICH WAS SLIGHTLY VARIABLE, BUT, GENERALLY, RAISED TO THE EAST. THE FIRST ENCOUNTERED BEDROCK CONSISTED OF SANDSTONE WHICH WAS TYPICALLY HIGHLY TO MODERATELY WEATHERED AND WEAK TO SLIGHTLY STRONG. B-003-0-21 FIRST ENCOUNTERED A MODERATELY WEATHERED, VERY WEAK SHALE INSTEAD OF SANDSTONE. B-004-0-21 ENCOUNTERED A SILTSTONE LAYER BENEATH THE SANDSTONE, WHICH WAS MODERATELY WEATHERED, SLIGHTLY STRONG, AND CONTAINED CLAY SEAMS. CLAYSTONE WAS ENCOUNTERED IN ALL FOUR BORINGS BETWEEN EL. 515.3 AND 520.4 FT WITH A SLIGHTLY VARIABLE SURFACE. THIS STRATUM WAS TYPICALLY MODERATELY WEATHERED AND VERY WEAK. UNCONFINED COMPRESSIVE STRENGTH TESTING RESULTS RANGED FROM 27 TO 33 AND FROM 88 TO 338 PSI WITH CONFINING PRESSURE ADDED. ALL BORINGS WERE TERMINATED WITHIN CLAYSTONE. B-001-0-21 AND B-004-0-21 WERE REPORTED AS BEING DRY PRIOR TO INTRODUCTION OF CORE WATER. B-002-0-21 AND B-003-0-21 ENCOUNTERED FREE WATER WHILE DRILLING AT EL. 525.3 AND 527.0 FT., RESPECTIVELY WITH B-002-0-21 HAVING A WATER LEVEL AT COMPLETION, INCLUDING CORE WATER, AT EL. 538.6 FT.

BORING B-003-1-22 WAS COMPLETED BELOW THE ROADWAY, TOWARD THE RIVER, WITHIN THE GRASSY FIELD ENCOUNTERING 12-INCHES OF TOPSOIL UNDERLAIN BY COHESIVE SOILS CONSISTING OF SANDY SILT (A-4a) AND SILTY CLAY (A-6b) IN STIFF TO VERY STIFF CONSISTENCY AND DAMP CONDITION. MEDIUM DENSE SILT (A-4b) WAS ENCOUNTERED AT EL. 529.3 FT. UNDERLAIN BY VERY LOOSE COARSE AND FINE SAND (A-3a) WHICH CONTAINED ELEVATED HYDROSTATIC HEAD CONDITIONS RESULTING IN HEAVING SANDS THAT EXTENDED TO EL. 518.3 FT. SEVERELY WEATHERED CLAYSTONE BEDROCK WHICH WAS VERY WEAK TO WEAK WAS FIRST ENCOUNTERED AT EL. 514.8 FT. AND WAS SPLIT SPOON SAMPLED TO EL. 505.8 FT WHERE IT BECAME HIGHLY TO MODERATELY WEATHERED AND WAS CORED. COMPRESSIVE STRENGTH TEST RESULTS OF 14 AND 48 PSI WERE OBTAINED FROM REPRESENTATIVE SAMPLES. SANDSTONE WAS ENCOUNTERED AT EL. 489.3 FT. IN MODERATELY WEATHERED CONDITION AND STRONG WITH AN UNCONFINED COMPRESSIVE STRENGTH TEST RESULT OF 8,255 PSI INTO WHICH THE BORING WAS TERMINATED. UPON COMPLETION OF SAMPLING ACTIVITIES AN INCLINOMETER CASING WAS INSTALLED WITHIN THE BOREHOLE. READING OF THE INCLINOMETER INDICATES A FAILURE ZONE AROUND EL. 526 FT.

THE ER SURVEYS WERE COMPLETED BELOW THE ROADWAY IN AN ATTEMPT TO LOCATE THE EXTENT OF THE PREVIOUSLY INSTALLED STRUCTURE LOCATED AT THE EAST END OF THE PROJECT AND A CULVERT OUTLET WITHIN THE PROJECT AREA. BASED ON THE RESULTS OF THE FIRST ER LINE, IT DOES NOT APPEAR THAT THE CAP AND PILES EXTEND SOUTH BEYOND WHAT IS EXPOSED AT THE SURFACE. THE RESULTS OF THE SECOND ER LINE WERE ABLE TO DELINEATE THE OUTLET OF THE EXISTING CULVERT TO BE ROUGHLY 83.09 FT EAST OF STA.1071+05 S.R. 7 AT EL 424 FT.

**SPECIFICATIONS**

THIS GEOTECHNICAL EXPLORATION WAS PERFORMED IN ACCORDANCE WITH THE STATE OF OHIO, DEPARTMENT OF TRANSPORTATION, OFFICE OF GEOTECHNICAL ENGINEERING, SPECIFICATIONS FOR GEOTECHNICAL EXPLORATIONS, DATED JULY 2021.

**AVAILABLE INFORMATION**

THE SOIL, BEDROCK, AND GROUNDWATER INFORMATION COLLECTED FOR THIS SUBSURFACE EXPLORATION THAT CAN BE CONVENIENTLY DISPLAYED ON THE GEOTECHNICAL PROFILE SHEETS HAS BEEN PRESENTED. GEOTECHNICAL REPORTS, IF PREPARED, ARE AVAILABLE FOR REVIEW ON THE OFFICE OF CONTRACT SALES WEBSITE.

BEDROCK TEST SUMMARY				
EXPLOR. ID	SAMPLE DEPTH	SAMPLE ELEVATION	LITHOLOGY	QU (psi)
B-001-0-21	41.6' - 42.0'	514.7' - 514.3'	CLAYSTONE	27
B-001-0-21	45.3' - 45.7'	511.0' - 510.6'	CLAYSTONE	185
B-001-0-21	55.0' - 55.4'	501.3' - 500.9'	CLAYSTONE	88
B-003-0-21	44.4' - 44.8'	513.6' - 513.2'	CLAYSTONE	33
B-003-0-21	45.0' - 45.4'	513.0' - 512.6'	CLAYSTONE	338
B-003-1-22	54.6' - 55.0'	497.7' - 497.3'	CLAYSTONE	48
B-003-1-22	57.4' - 57.8'	494.9' - 494.5'	CLAYSTONE	14
B-003-1-22	63.9' - 64.3'	488.4' - 488.0'	SANDSTONE	8,255

ORGANIC CONTENT BY LOSS ON IGNITION TEST				
EXPLOR. ID	SAMPLE ID	SAMPLE DEPTH	SAMPLE ELEVATION	LOI (%)
B-001-0-21	SS-4	8.50' - 10.00'	547.8' - 546.3'	4.2
B-001-0-21	SS-5	11.00' - 12.50'	545.3' - 543.8'	4.2
B-003-0-21	SS-7	12.00' - 13.50'	546.0' - 544.5'	6.2

DESIGN AGENCY



DESIGNER

AJC

REVIEWER

SAT 08/23/24

PROJECT ID

115533

SUBSET TOTAL

2 17

SHEET TOTAL

P.33 P.48

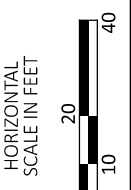
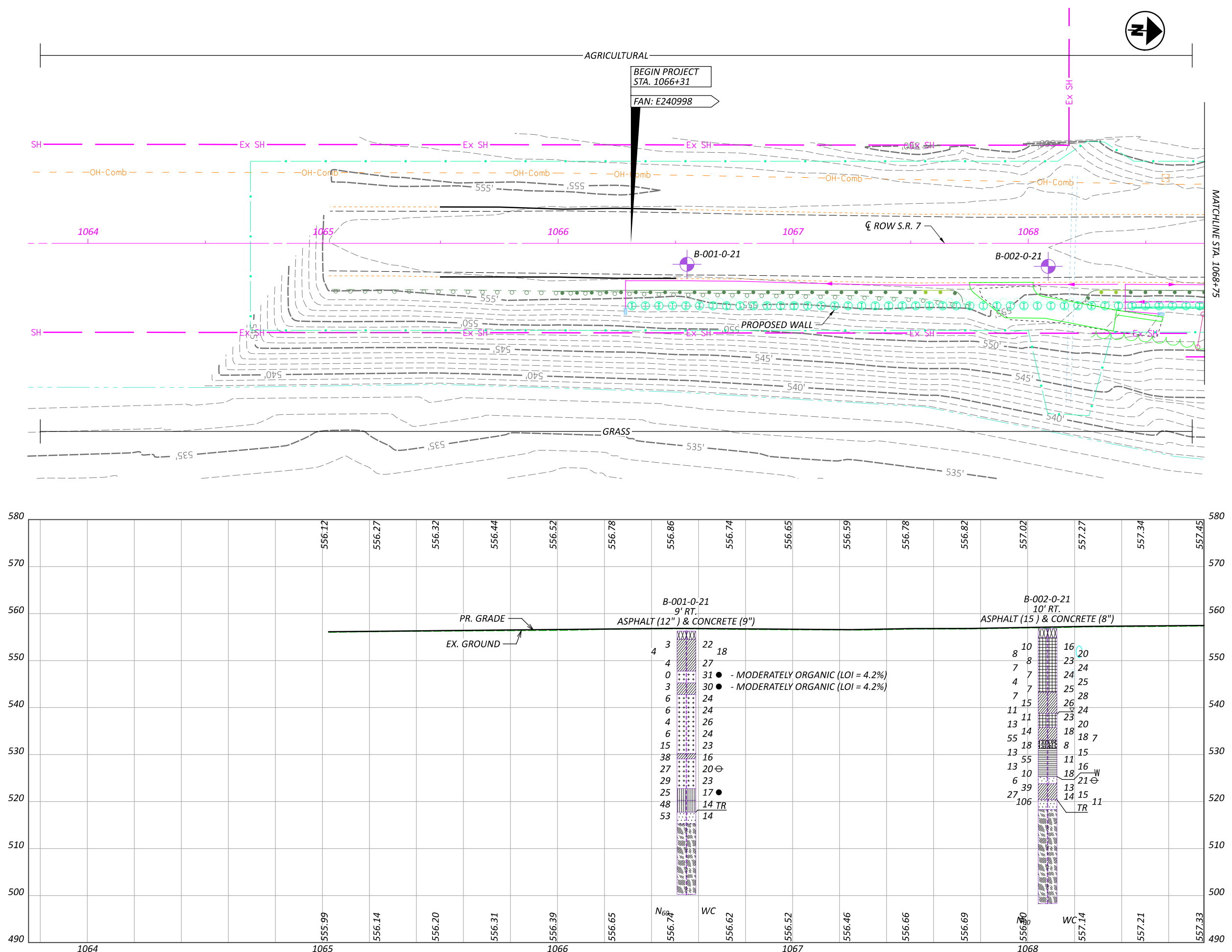

**GEOTECHNICAL PROFILE - LANDSLIDE  
 STA. 1063+75 TO STA. 1068+75 - S.R. 7**

DESIGN AGENCY



DESIGNER

AJC

REVIEWER

SAT 08/23/24

PROJECT ID

115533

SUBSET TOTAL

3 17

SHEET TOTAL

P.34 P.48

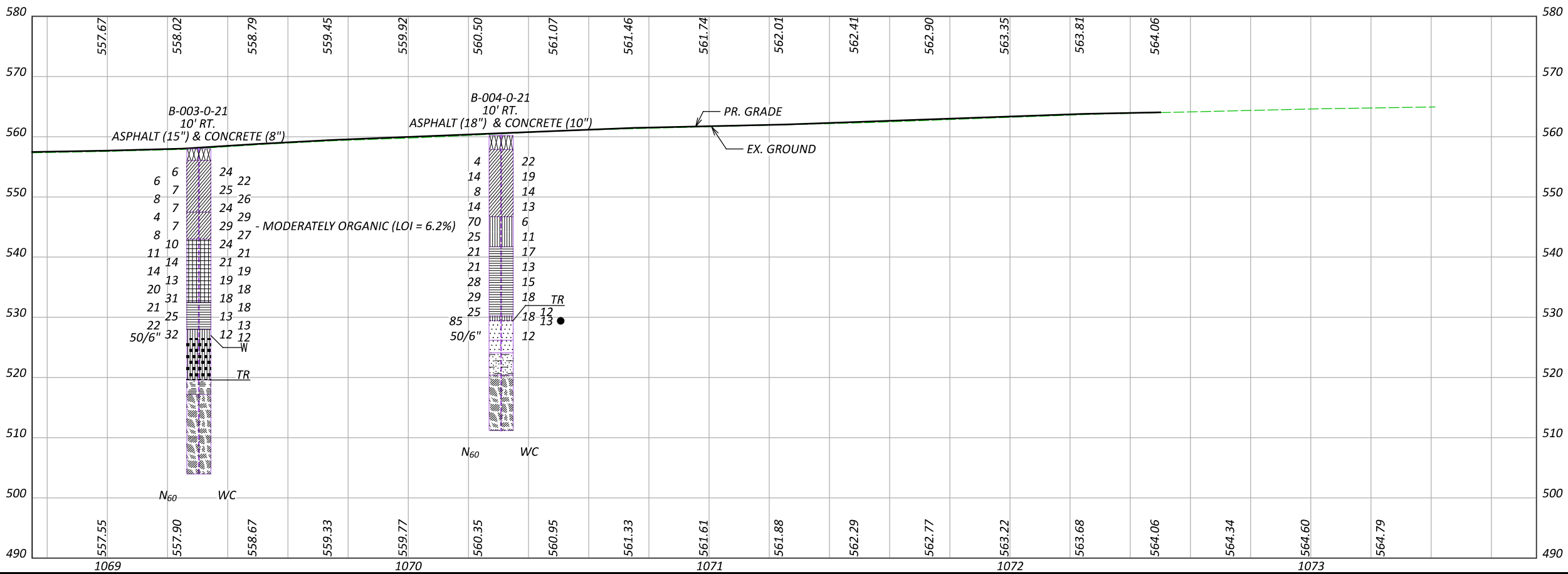
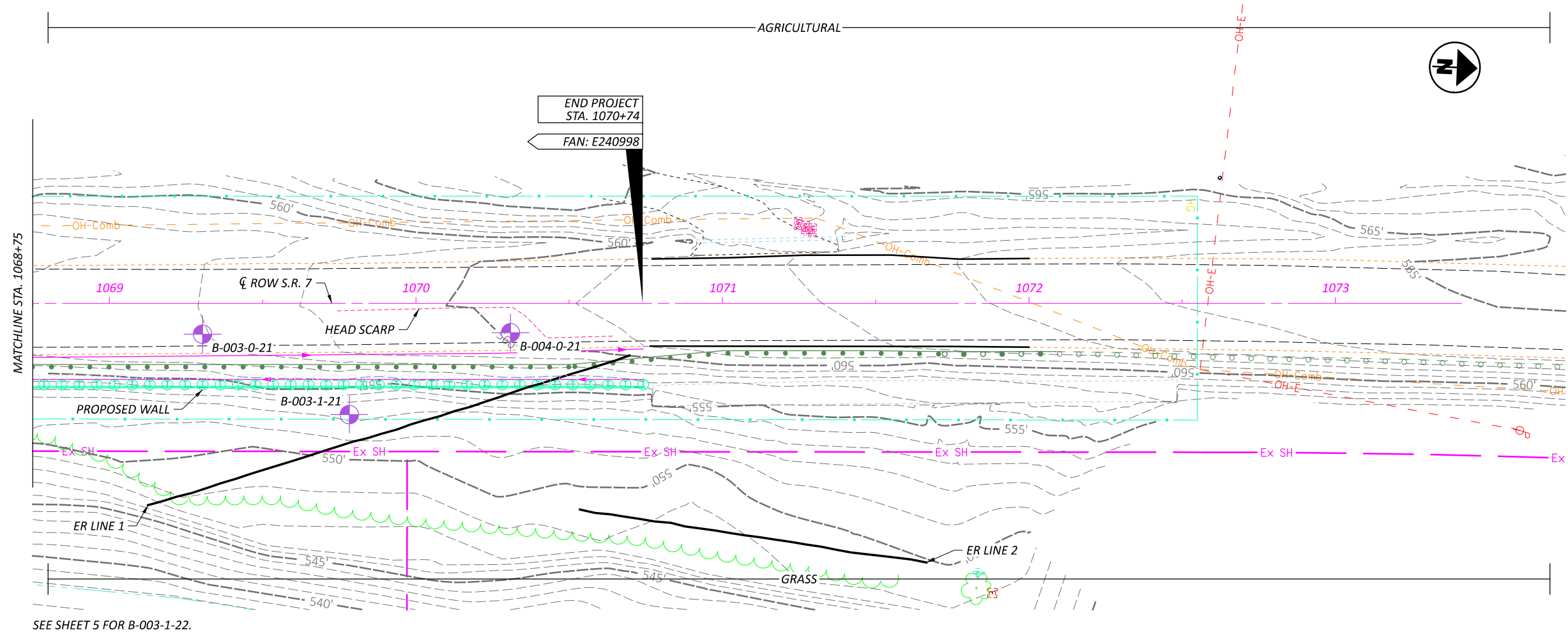

SEE SHEET 5 FOR B-003-1-22.

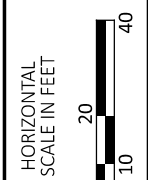

**GEOTECHNICAL PROFILE - LANDSLIDE**  
STA. 1068+75 TO STA. 1073+75 - S.R. 7

DESIGN AGENCY



DESIGNER

AJC

REVIEWER

SAT 08/23/24

PROJECT ID

115533

SUBSET TOTAL

4 17

SHEET TOTAL

P.35 P.48

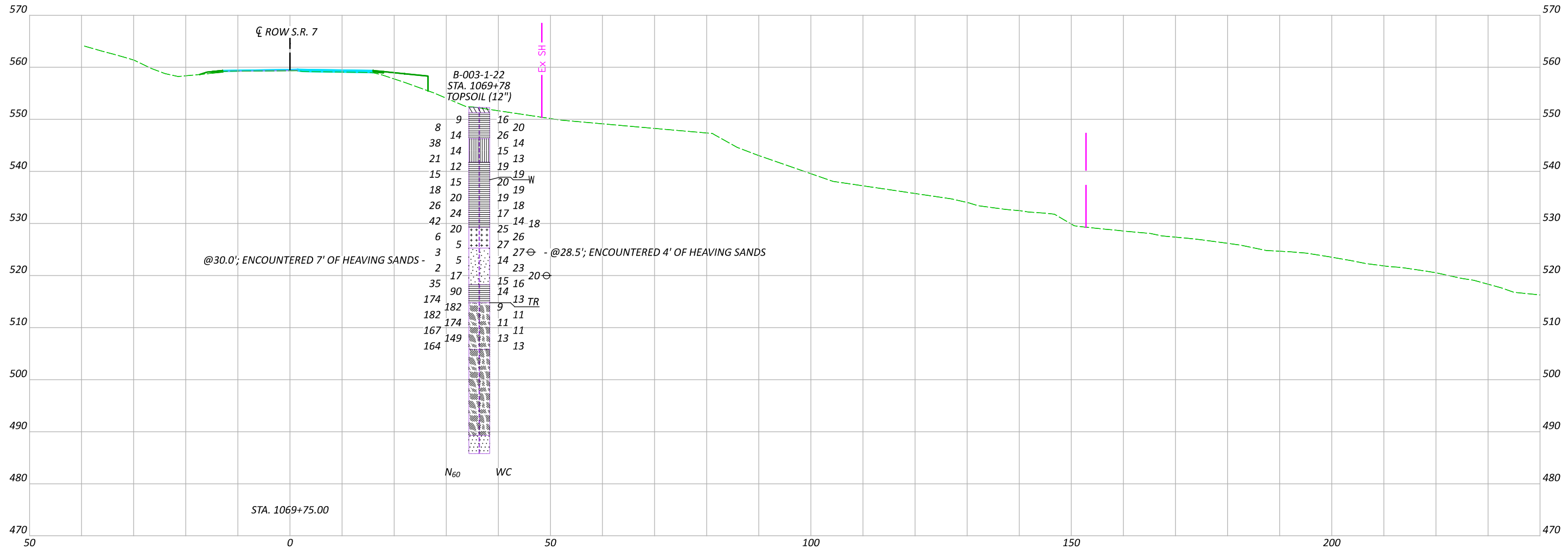

GEOTECHNICAL PROFILE - LANDSLIDE  
 CROSS SECTION STA. 1069+75 - S.R. 7

DESIGN AGENCY	
DESIGNER	
AJC	
REVIEWER	
SAT 08/23/24	
PROJECT ID	
115533	
SUBSET	TOTAL
5	17
SHEET	TOTAL
P.36	P.48

**GAL-7-19.94**

MODEL SHEET PAPER SIZE: 17x11 (in.) DATE: 10/23/2024 TIME: 7:41:59 AM USER: wiseman  
 p:\ohiodot-pw\entire\ohiodot-pw-02\Documents\01\_Active Projects\District 10\Gallia\115533\400-Engineering\Geotechnical\Sheets\115533\_YL001.dgn

PROJECT: GAL-7-19.94  
 TYPE: LANDSLIDE  
 PID: 115533 SFN:  
 START: 8/11/21 END: 8/19/21

DRILLING FIRM / OPERATOR: ODOT / CAREY  
 SAMPLING FIRM / LOGGER: ODOT / AJ  
 DRILLING METHOD: 3.25" HSA / NQ2  
 SAMPLING METHOD: SPT / NQ2

DRILL RIG: CME 55 TRUCK  
 HAMMER: CME AUTOMATIC  
 CALIBRATION DATE: 4/15/20  
 ENERGY RATIO (%): 84

STATION / OFFSET: 1066+55.9' RT.  
 ALIGNMENT: CL SR 7  
 ELEVATION: 556.3 (ft) EOB: 56.0 ft.  
 LAT / LONG: 38.781706, -82.222695

EXPLORATION ID  
 B-001-0-21  
 PAGE  
 1 OF 1

**MATERIAL DESCRIPTION AND NOTES**

DEPTH (ft)	ELEV. (ft)	DESCRIPTION	SPT/ RQD	N <sub>60</sub>	REC (%)	SAMPLE ID	HP (tsf)	GR	CS	FS	SI	CL	LL	PL	PI	WC	ODOT CLASS (GI)
1	556.3	ASPHALT (12") & CONCRETE (9")															
2	554.5	SOFT, RED AND BROWN, SILT AND CLAY, LITTLE GRAVEL, LITTLE SAND, MOIST	0	3	44	SS-1	0.50	15	3	8	31	43	37	22	15	22	A-6a (10)
3			1														
4		@3.5'; DAMP	1	4	50	SS-2	0.50	-	-	-	-	-	-	-	-	18	A-6a (V)
5			2														
6		@6.0'; MOIST	0	4	50	SS-3	0.50	-	-	-	-	-	-	-	-	27	A-6a (V)
7			2														
8	547.8																
9		VERY SOFT, GRAY OXIDIZING TO BROWN, SILT, SOME CLAY, LITTLE SAND, MODERATELY ORGANIC (LOI = 4.2%), WET	0	0	94	SS-4	0.25	0	1	13	61	25	27	18	9	31	A-4b (8)
10			0														
11	545.3																
12		SOFT, GRAY OXIDIZING TO BROWN, SILT AND CLAY, LITTLE SAND, TRACE GRAVEL, MODERATELY ORGANIC (LOI = 4.2%), MOIST	0	3	78	SS-5	0.50	7	2	8	48	35	33	20	13	30	A-6a (9)
13			2														
14	542.8																
15		MEDIUM STIFF, BROWN, SILT, SOME CLAY, TRACE SAND, MOIST	0	6	67	SS-6	0.50	-	-	-	-	-	-	-	-	24	A-4b (V)
16			2														
17		@18.5'; SOFT	0	6	100	SS-7	0.50	0	0	2	70	28	29	21	8	24	A-4b (8)
18			2														
19		@21.0'; VERY STIFF	1	4	100	SS-8	0.50	-	-	-	-	-	-	-	-	26	A-4b (V)
20			2														
21			1	6	100	SS-9	2.50	0	0	5	71	24	28	19	9	24	A-4b (8)
22			2														
23			2	5	100	SS-10	3.00	-	-	-	-	-	-	-	-	23	A-4b (V)
24			6														
25	530.3																
26		HARD, RED AND GRAY, SILT AND CLAY, TRACE SAND, TRACE GRAVEL, DAMP	6	38	83	SS-11	4.50	3	0	3	38	56	37	23	14	16	A-6a (10)
27	529.1		14														
28		MEDIUM DENSE, GRAY, SILT, "AND" SAND, LITTLE CLAY, WET	9	10	56	SS-12	-	0	10	29	50	11	NP	NP	NP	20	A-4b (5)
29			9														
30			5	29	50	SS-13	-	-	-	-	-	-	-	-	-	23	A-4b (V)
31			12														
32			4	7	78	SS-14	-	8	16	39	21	16	18	13	5	17	A-4a (0)
33			11														
34	522.8																
35		VERY STIFF, BROWN AND GRAY, SANDY SILT, "AND" STONE FRAGMENTS, LITTLE CLAY, DAMP	8	17	89	SS-15	3.00	2	14	32	16	23	15	8	14		A-4a (3)
36			17														
37			12	53	100	SS-16	4.50	-	-	-	-	-	-	-	-	14	Rock (V)
38	517.8		23														
39		SANDSTONE, BROWN AND GRAY, MODERATELY WEATHERED, WEAK, LAMINATED TO VERY THIN BEDDED, SLIGHTLY ARENACEOUS.	77		97	NQ2-1											CORE
40			44														
41	515.3																
42		CLAYSTONE, RED WITH GRAY, MODERATELY WEATHERED, VERY WEAK, MEDIUM BEDDED, BLOCKY, GOOD; RQD 63%, REC 88%. @ 41.6' - 42.0'; $\gamma = 135$ pcf; $Q_u = 27$ psi	57		67	NQ2-2											CORE
43			49														
44		@48.2'; HIGH ANGLE FRACTURE - SLICKENSIDED.	55		100	NQ2-3											CORE
45			54														
46		@53.9'; HIGH ANGLE FRACTURE - SLICKENSIDED.	55														
47			55														
48		@ 45.3' - 45.7'; $\gamma = 144$ pcf; $Q_u = 185$ psi, (ASTM 7012 METHOD C WITH CONFINING PRESSURE) @46.0'; GRAY @46.7'; RED WITH GRAY.															
49																	
50		@ 55.0' - 55.4'; $\gamma = 143$ pcf; $Q_u = 88$ psi, (ASTM 7012 METHOD C WITH CONFINING PRESSURE)															
51																	
52																	
53																	
54																	
55																	
56	500.3																

NOTES: LAT/LONG/ELEV FROM DISTRICT SURVEY GRADE INSTRUMENTS. HOLE DRY BEFORE CORING.

ABANDONMENT METHODS, MATERIALS, QUANTITIES: AUGER CUTTINGS MIXED WITH 25 LB. BENTONITE CHIPS



DESIGN AGENCY  
 AIC  
 REVIEWER  
 SAT 08/23/24  
 PROJECT ID  
 115533  
 SUBSET TOTAL  
 6 17  
 SHEET TOTAL  
 P.37 P.48

**GEOTECHNICAL PROFILE - LANDSLIDE  
 BORING LOG FOR B-001-0-21**

**GAL-7-19.94**

MODEL SHEET PAPER SIZE: 17x11 (in.) DATE: 10/23/2024 TIME: 7:42:10 AM USER: wiseman  
 pw:\ohiodot-pw.bentley.com\ohiodot-pw-02\Documents\01.Active Projects\District 10\Galila\115533\400-Engineering\Geotechnical\Sheets\115533\_YU002.dgn

PROJECT: GAL-7-19.94	DRILLING FIRM / OPERATOR: ODOT / CAREY	STATION / OFFSET: 1068+09, 10' RT.	EXPLORATION ID
TYPE: LANDSLIDE	SAMPLING FIRM / LOGGER: ODOT / MCLEISH	ALIGNMENT: CL SR 7	B-002-0-21
PID: 115533 SFN:	DRILLING METHOD: 3.25" HSA / NQ2	ELEVATION: 556.8 (ft) EOB: 58.5 ft.	PAGE
START: 8/9/21 END: 8/11/21	SAMPLING METHOD: SPT / NQ2	LAT / LONG: 38.782127, -82.222714	1 OF 1
<b>MATERIAL DESCRIPTION AND NOTES</b>		GRADATION (%):	BACK FILL
		GR CS FS SI CL LL PL PI WC	ODOT CLASS (GI)

DEPTH (ft)	ELEV. (ft)	DESCRIPTION	SPT / RQD	N <sub>60</sub>	REC (%)	SAMPLE ID	HP (tsf)	GR	CS	FS	SI	CL	LL	PL	PI	WC	ODOT CLASS (GI)
1	556.8	ASPHALT (15') & CONCRETE (8')															
2	554.9	MEDIUM STIFF, REDDISH BROWN, CLAY, AND GRAVEL AND STONE FRAGMENTS, SOME SILT, LITTLE SAND, (NOT ENOUGH MATERIAL TO TEST), DAMP	2	10	28	SS-1	0.50									16	A-7-6 (V)
3			3	4													
4			4														
5		@4.5'; NOT ENOUGH MATERIAL TO TEST	1	3	33	SS-2	0.50									20	A-7-6 (V)
6		@6.0'; LITTLE GRAVEL AND STONE FRAGMENTS, MOIST	3	8	100	SS-3	0.50	10	8	11	28	43	42	21	21	23	A-7-6 (12)
7			3	3													
8			1	2	7	SS-4	0.50									24	A-7-6 (V)
9			2	3	7	SS-5	0.50									24	A-7-6 (V)
10			3	2	56												
11		@10.5'; SOFT	0	1	4	SS-6	0.50	13	6	8	29	44	41	22	19	25	A-7-6 (11)
12		@12.0'; MEDIUM STIFF, REDDISH BROWN AND GRAYISH BROWN	1	2	7	SS-7	0.50									25	A-7-6 (V)
13			2	3	100												
14	543.3	MEDIUM STIFF, GRAYISH BROWN, SILT AND CLAY, LITTLE SAND, TRACE STONE FRAGMENTS, MOIST	1	2	7	SS-8	0.50	3	11	43	40	36	21	15		28	A-6a (10)
15		@15.0'; STIFF	1	4	15	SS-9	2.00									26	A-6a (V)
16			4	7	100												
17			2	3	11	SS-10	1.00									24	A-6a (V)
18	538.8	STIFF, BROWN, CLAY, SOME SILT, LITTLE SAND, DAMP	3	5	11	SS-11	2.00	0	5	6	35	54	46	24	22	23	A-7-6 (14)
19			3	5	100												
20			2	3	13	SS-12	2.00									20	A-7-6 (V)
21			2	6	14	SS-13	2.00									18	A-6a (V)
22	535.8	STIFF, BROWN, SILT AND CLAY, SOME SAND, TRACE STONE FRAGMENTS, DAMP	4	6	100												
23			9	18	55	SS-14A	2.00	8	10	11	34	37	36	23	13	18	A-6a (8)
24	533.1	VERY DENSE, BROWN, STONE FRAGMENTS WITH SAND AND SILT, LITTLE CLAY, DAMP	12	21	28	SS-14B	2.75	47	9	13	20	11	25	21	4	7	A-2-4 (0)
25	531.3		6	7												8	A-2-4 (V)
26			3	4	13	SS-16	2.50	9	8	10	35	38	40	22	18	15	A-6b (11)
27			9	15	55	SS-17	3.00									11	A-6b (V)
28		@27.0'; SOME STONE FRAGMENTS	15	24	22											16	A-6b (V)
29			10	5	13	SS-18	1.00									18	A-6b (V)
30			2	3	10	SS-19	3.50									18	A-6b (V)
31	525.3		3	4	6	SS-20	-	11	26	47	10	6	NP	NP	NP	21	A-3a (0)
32		LOOSE, BROWN, COARSE AND FINE SAND, LITTLE STONE FRAGMENTS, LITTLE SILT, TRACE CLAY, WET	0	0	4												
33	523.8	VERY STIFF, REDDISH BROWN, SILT AND CLAY, LITTLE SAND, TRACE STONE FRAGMENTS, DAMP	9	14	39	SS-21	3.00									13	A-6a (V)
34			14	14	44												
35			3	7	27	SS-22	3.00	8	4	7	36	45	33	21	12	15	A-6a (9)
36	520.4	SANDSTONE, GRAY, MODERATELY WEATHERED, WEAK, VERY FINE GRAINED.	19	12	56	SS-23A	2.75									14	A-6a (V)
37			27	49	100	SS-23B	-									11	Rock (V)
38	518.3	CLAYSTONE, GRAY, MODERATELY WEATHERED, VERY WEAK, MEDIUM, BLOCKY, GOOD; RQD 52%, REC 86%.															
39		@40.4'; VARIEGATED RED, GRAY AND YELLOWISH BROWN.															
40		@44.8'; GRAY, CONTAINS LITHIC FRAGMENTS.	77		97	NQ2-1											CORE
41																	
42			39		39	NQ2-2											CORE
43																	
44																	
45																	
46			57		83	NQ2-3											CORE
47																	
48																	
49			58		100	NQ2-4											CORE
50																	
51			0		100	NQ2-5											CORE
52																	
53			29		100	NQ2-6											CORE
54																	
55			75		96	NQ2-7											CORE
56																	
57			71		92	NQ2-8											CORE
58	498.3																CORE

NOTES: LAT/LONG/ELEV FROM OGE HANDHELD GPS UNIT. HOLE COLLAPSED AT 30.9 FT AFTER PULLING AUGERS  
 ABANDONMENT METHODS, MATERIALS, QUANTITIES: AUGER CUTTINGS MIXED WITH 50 LB. BENTONITE CHIPS

DESIGN AGENCY  
  
 DESIGNER  
 AIC  
 REVIEWER  
 SAT 08/23/24  
 PROJECT ID  
 115533  
 SUBSET TOTAL  
 7 17  
 SHEET TOTAL  
 P.38 P.48

**GEOTECHNICAL PROFILE - LANDSLIDE  
 BORING LOG FOR B-002-0-21**

STANDARD ODOT BORING LOG (11 X 17) - OH DOT GDT - 8/20/24 11:34 - X:\GINT\PROJ\PROJECTS\2021\COMPLET\FT600888.GPJ

**GAL-7-19.94**

MODEL SHEET PAPER SIZE: 17x11 (in.) DATE: 10/23/2024 TIME: 7:42:22 AM USER: wiseman  
 pw:\ohiodot-pw\entley.com\ohiodot-pw-02\Documents\01\_Active Projects\District 10\Galila\115533\400-Engineering\Geotechnical\Sheets\115533\_YL003.dgn

PROJECT: GAL-7-19.94 DRILLING FIRM / OPERATOR: ODOT / CAREY ODOT / CAREY EXPLORATION ID B-003-0-21  
 TYPE: LANDSLIDE SAMPLING FIRM / LOGGER: ODOT / MCLEISH ODOT / MCLEISH  
 PID: 115533 SFN: DRILLING METHOD: 3.25" HSA / NQ2 SPT / NQ2 DEPTHS 1-53 ELEV. 558.0  
 START: 8/4/21 END: 8/9/21 SPT / NQ2  
 DRILL RIG: CME 55 TRUCK STATION / OFFSET: 1069+30, 10' RT. CL SR 7  
 HAMMER: CME AUTOMATIC ALIGNMENT: ELEVATION: 558.0 (ft) EOB: 54.0 ft  
 CALIBRATION DATE: 4/15/20 ENERGY RATIO (%): 84 LAT / LONG: 38.782462, -82.222730  
 ODOT CLASS (GI) WC  
 BACK FILL

**MATERIAL DESCRIPTION AND NOTES**

DEPTH (ft)	ELEV. (ft)	DESCRIPTION	SPT/ RQD	N <sub>60</sub>	REC (%)	SAMPLE ID	HP (tsf)	GR	CS	FS	SI	CL	LL	PL	PI	WC	ODOT CLASS (GI)
1	558.0	ASPHALT (15") & CONCRETE (8")															
2	556.1	MEDIUM STIFF, REDDISH BROWN, SILT AND CLAY, LITTLE SAND, TRACE GRAVEL AND STONE FRAGMENTS, MOIST	1	6	28	SS-1	0.50	6	3	12	31	48	35	20	15	24	A-6a (10)
3			2	6	44	SS-2	0.50	-	-	-	-	-	-	-	-	22	A-6a (V)
4			2	7	50	SS-3	0.50	-	-	-	-	-	-	-	-	25	A-6a (V)
5			3	8	56	SS-4	1.50	2	2	6	45	45	33	19	14	26	A-6a (10)
6			1	7	100	SS-5	1.50	-	-	-	-	-	-	-	-	24	A-6a (V)
7			2	4	100	SS-6	0.25	-	-	-	-	-	-	-	-	29	A-6a (V)
8	547.5	SOFT, GRAYISH BROWN, SILT AND CLAY, LITTLE SAND, TRACE STONE FRAGMENTS, MOIST	0	7	89	SS-7	0.25	1	3	11	43	42	36	21	15	29	A-6a (10)
9			2	8	22	SS-8	0.25	-	-	-	-	-	-	-	-	27	A-6a (V)
10			3	10	89	SS-9	0.50	3	1	2	21	73	58	20	38	24	A-7-6 (20)
11			4	11	100	SS-10	1.50	-	-	-	-	-	-	-	-	21	A-7-6 (V)
12			4	14	89	SS-11	1.00	-	-	-	-	-	-	-	-	21	A-7-6 (V)
13			2	14	56	SS-12	1.50	1	1	3	32	63	43	21	22	19	A-7-6 (13)
14			4	13	100	SS-13	1.50	-	-	-	-	-	-	-	-	19	A-7-6 (V)
15			2	20	83	SS-14	2.00	-	-	-	-	-	-	-	-	18	A-7-6 (V)
16			8	31	56	SS-15	2.50	-	-	-	-	-	-	-	-	18	A-7-6 (V)
17	532.5	VERY STIFF, RED, SILTY CLAY, TRACE SAND, TRACE STONE FRAGMENTS, DAMP	3	21	78	SS-16	2.00	2	1	2	33	62	37	21	16	18	A-6b (10)
18			6	25	94	SS-17	2.00	-	-	-	-	-	-	-	-	13	A-6b (V)
19			8	22	100	SS-18	2.50	-	-	-	-	-	-	-	-	13	A-6b (V)
20			8	32	78	SS-19	2.00	25	8	25	21	21	19	14	5	12	A-4a (1)
21			11	32	100	SS-20	-	-	-	-	-	-	-	-	-	12	A-4a (V)
22			12	-	-	-	-	-	-	-	-	-	-	-	-	-	-
23			50	-	-	-	-	-	-	-	-	-	-	-	-	-	-
24																	
25																	
26																	
27																	
28																	
29																	
30																	
31	527.0	VERY STIFF, BROWN AND GRAY, SANDY SILT, SOME STONE FRAGMENTS, SOME CLAY, DAMP	0	50	50	NQ2-1											CORE
32																	
33																	
34																	
35																	
36																	
37																	
38	519.6	SHALE, GRAY, MODERATELY WEATHERED, VERY WEAK, LAMINATED TO VERY THIN BEDDED, POORLY FISSILE, BLOCKY, GOOD; RQD 0%, REC 100%.															
39																	
40																	
41	517.2	CLAYSTONE, VARIEGATED YELLOWISH BROWN, GRAY AND RED, MODERATELY WEATHERED, VERY WEAK, MEDIUM BEDDED, BLOCKY, GOOD; RQD 44%, REC 85%.	23		100	NQ2-2											CORE
42																	
43																	
44																	
45																	
46																	
47			53		92	NQ2-3											CORE
48																	
49																	
50																	
51																	
52			38		68	NQ2-4											CORE
53																	
54	504.0																

NOTES: LAT/LONG/ELEV FROM OGE HANDHELD GPS UNIT.

ABANDONMENT METHODS, MATERIALS, QUANTITIES: AUGER CUTTINGS MIXED WITH 50 LB. BENTONITE CHIPS

DESIGN AGENCY  
  
 DESIGNER  
 AIC  
 REVIEWER  
 SAT 08/23/24  
 PROJECT ID  
 115533  
 SUBSET TOTAL  
 8 17  
 SHEET TOTAL  
 P.39 P.48

**GEOTECHNICAL PROFILE - LANDSLIDE BORING LOG FOR B-003-0-21**

STANDARD ODOT BORING LOG (11 X 17) - OH DOT GDT - 8/20/24 11:34 - X:\GINT\PROJECTS\2021\COMPLETION\888.GPJ

**GAL-7-19.94**

MODEL SHEET PAPER SIZE: 17x11 (in.) DATE: 10/23/2024 TIME: 7:42:34 AM USER: wiseman  
 p:\ghodot-pw\entire\ghodot-pw-02\Documents\01\_Active Projects\District 10\Galila\115533\400-Engineering\Geotechnical\Sheets\115533\_YL004.dgn

PROJECT: GAL-7-19.94 TYPE: LANDSLIDE PID: 115533 SFN: START: 5/31/22 END: 6/7/22	DRILLING FIRM / OPERATOR: ODOT / MCINTOSH SAMPLING FIRM / LOGGER: ODOT / LEWIS DRILLING METHOD: 3.75" HSA / NQ2 SAMPLING METHOD: SPT / NQ2	MATERIAL DESCRIPTION AND NOTES	ELEV. 552.3	DEPTH 1	GRADATION (%)										REC SAMPLE ID (tsf)	SPT/ RQD N <sub>60</sub>	ENERGY RATIO (%)	CALIBRATION DATE: 4/19/21 90*	HAMMER: CME AUTOMATIC ELEVATION: 552.3 (ft) EOB: 66.5 ft. LAT / LONG: 38.782596, -82.222645	STATION / OFFSET: 1069+78, 36' RT. ALIGNMENT: CL SR 7 ELEVATION: 552.3 (ft) EOB: 66.5 ft. LAT / LONG: 38.782596, -82.222645	EXPLORATION ID B-003-1-22			
					GR	CS	FS	SI	CL	LL	PL	WC	ODOT CLASS (GI)	INCL.										
<b>TOPSOIL (12")</b>					1																			
VERY STIFF, RED, SILTY CLAY, LITTLE STONE FRAGMENTS, LITTLE SAND, DAMP					2																			
@3.0'; STIFF, MOIST					3																			
VERY STIFF, RED AND BROWN, SANDY SILT, SOME STONE FRAGMENTS, LITTLE CLAY, DAMP					4																			
@7.5'; STIFF, RED					5																			
STIFF, BROWN AND GRAY, SILTY CLAY, LITTLE STONE FRAGMENTS, TRACE SAND, DAMP					6																			
@13.5'; RED					7																			
@15.0'; VERY STIFF					8																			
@18.0'; TRACE STONE FRAGMENTS					9																			
MEDIUM DENSE, BROWN, SILT, SOME SAND, TRACE CLAY, WET @24.0'; LOOSE, GRAY					10																			
VERY LOOSE, BROWN, COARSE AND FINE SAND, LITTLE SILT, TRACE CLAY, WET @28.5'; LOOSE; 4' OF HEAVING SAND ENCOUNTERED @30.0'; VERY LOOSE, 7' OF HEAVING SAND ENCOUNTERED @31.5'; MEDIUM DENSE, TRACE STONE FRAGMENTS					11																			
HARD, GRAY AND BLACK, SILTY CLAY, TRACE SAND, TRACE STONE FRAGMENTS, RESIDUAL SOIL, DAMP @34.5'; BROWN AND GRAY @36.0'; RED AND GRAY					12																			
CLAYSTONE, RED AND GRAY, SEVERELY WEATHERED, VERY WEAK TO WEAK					13																			
CLAYSTONE, REDDISH BROWN, HIGHLY TO MODERATELY WEATHERED, VERY WEAK TO WEAK, THIN BEDDED; RQD 20%, REC 94% @48.5' - 48.6'; HIGH ANGLE FRACTURE @51.1'; VARIEGATED RED AND GRAY. @54.6' - 55.0'; γ = 148 pcf; Qu = 48 psi @57.4' - 57.8'; γ = 151 pcf; Qu = 14 psi @58.9'; SLIGHTLY STRONG.					14																			

STANDARD ODOT BORING LOG (11 X 17) - OH DOT GDT - R/2124 07 49 - X:\GINT\PROJ\JECTS\2022 COMPLETION\971 GP1

**GEOTECHNICAL PROFILE - LANDSLIDE  
BORING LOG FOR B-003-1-22**

DESIGN AGENCY  
  
 DESIGNER  
**AJC**  
 REVIEWER  
 SAT 08/23/24  
 PROJECT ID  
**115533**  
 SUBSET TOTAL  
 9 17  
 SHEET TOTAL  
 P.40 P.48



**GAL-7-19.94**

MODEL SHEET PAPER SIZE: 17x11 (in.) DATE: 10/23/2024 TIME: 7:42:44 AM USER: wiseman  
 pw:\ohiodot-pw.bentley.com\ohiodot-pw-02\Documents\01.Active Projects\District 10\Gallia\115533\400-Engineering\Geotechnical\Sheets\115533\_YL005.dgn

PID: 115533	SFN:	PROJECT: GAL-7-19.94	STATION / OFFSET: 1069+78.36' RT.	START: 5/31/22	END: 6/7/22	PG 2 OF 2	B-003-1-22					
MATERIAL DESCRIPTION AND NOTES		ELEV.	DEPTHS	SPT/ RQD	REC (%)	HP (tsf)	GRADATION (%)	ATTERBERG	WC	ODOT CLASS (GI)	INCL.	
<b>CLAYSTONE</b> , REDDISH BROWN, HIGHLY TO MODERATELY WEATHERED, VERY WEAK TO WEAK, THIN BEDDED; RQD 20%, REC 94%. <i>(continued)</i> @60.1' - 60.2': SLICKENSIDED HIGH ANGLE FRACTURE @61.0': BROWNISH BLACK @61.7': LIGHT GRAY, WEAK. <b>SANDSTONE</b> , GRAYISH BLACK, MODERATELY WEATHERED, STRONG, VERY FINE GRAINED, ARGILLACEOUS; RQD 56%, REC 100%. @ 63.9' - 64.3': $\gamma = 166$ pcf; $Q_u = 8,255$ psi		492.3	61	21	100					CORE		
			62									
		489.3	63	81	100						CORE	
			64									
		485.8	65	17	100					CORE		
			66									
			EOB									

NOTES: LAT/LONG/ELEV FROM DISTRICT SURVEY GRADE INSTRUMENTS.

ABANDONMENT METHODS, MATERIALS, QUANTITIES: TREMIED 120 GAL. BENTONITE CEMENT GROUT

DESIGN AGENCY



DESIGNER  
AJC

REVIEWER  
SAT 08/23/24

PROJECT ID  
115533

SUBSET TOTAL  
10 17

SHEET TOTAL  
P.41 P.48

**GEOTECHNICAL PROFILE - LANDSLIDE  
BORING LOG FOR B-003-1-22 (CONT.)**

**GAL-7-19.94**

MODEL SHEET PAPER SIZE: 17x11 (in.) DATE: 10/23/2024 TIME: 7:42:52 AM USER: wiseman  
 pw:\ohiodot-pw.bentley.com\ohiodot-pw-02\Documents\01.Active Projects\District 10\Gallia\115533\400-Engineering\Geotechnical\Sheets\115533\_YU006.dgn

PROJECT: GAL-7-19.94 DRILLING FIRM / OPERATOR: ODOT / CAREY EXPLORATION ID B-004-0-21  
 TYPE: LANDSLIDE SAMPLING FIRM / LOGGER: ODOT / MCLEISH  
 PID: 115533 SFN: DRILLING METHOD: 3.25" HSA / NQ2  
 START: 8/3/21 END: 8/4/21 SAMPLING METHOD: SPT / NQ2  
 DRILL RIG: CME 55 TRUCK STATION / OFFSET: 1070+31, 10' RT.  
 HAMMER: CME AUTOMATIC ALIGNMENT: CL SR 7  
 CALIBRATION DATE: 4/15/20 ELEVATION: 560.2 (ft) EOB: 49.0 ft.  
 ENERGY RATIO (%): 84 LAT / LONG: 38.782737, -82.222746

**MATERIAL DESCRIPTION AND NOTES**

DEPTH (ft)	ELEV.	DEPTHS	SPT/ RQD	REC (%)	SAMPLE ID	HP (tsf)	GR	CS	FS	SI	CL	LL	PL	WC	ODOT CLASS (GI)	BACK FILL
1	560.2															
2																
3																
4	557.9		4	28	SS-1	0.25	3	2	12	44	39	29	18	11	22	A-6a (8)
5			1													
6			2													
7			5	6	SS-2	2.00	-	-	-	-	-	-	-	-	19	A-6a (V)
8			5													
9			4	8	SS-3	1.00	-	-	-	-	-	-	-	-	14	A-6a (V)
10			2													
11			4	14	SS-4	1.50	-	-	-	-	-	-	-	-	13	A-6a (V)
12			5													
13			5													
14	546.7		31	70	SS-5	-	0	12	21	43	24	27	18	9	6	A-4a (6)
15			29													
16			21													
17			5	25	SS-6	-	2	17	14	39	28	30	20	10	11	A-4a (6)
18			7													
19			11													
20			3	21	SS-7	2.00	3	5	6	30	56	40	23	17	17	A-6b (11)
21			6													
22			9													
23			5	21	SS-8	2.50	1	0	2	31	66	35	18	17	13	A-6b (11)
24			6													
25			9													
26			3	28	SS-9	2.50	-	-	-	-	-	-	-	-	15	A-6b (V)
27			8													
28			12													
29			5	29	SS-10	2.50	2	0	2	30	66	39	21	18	18	A-6b (11)
30			9													
31			12													
32			3	25	SS-11	-	-	-	-	-	-	-	-	-	12	A-6b (V)
33			7													
34	530.2		11													
35			3	85	SS-12A	1.00	8	3	26	41	22	21	14	7	18	A-4a (6)
36			19													
37			42													
38			50													
39			0	100	NQ2-1											CORE
40																
41																
42			40	100	NQ2-2											CORE
43																
44																
45																
46																
47			32	100	NQ2-3											CORE
48																
49	511.2															

NOTES: LAT/LONG/ELEV FROM OGE HANDHELD GPS UNIT. HOLE DRY BEFORE CORING.  
 ABANDONMENT METHODS, MATERIALS, QUANTITIES: AUGER CUTTINGS MIXED WITH 50 LB. BENTONITE CHIPS



DESIGN AGENCY  
**AIC**  
 REVIEWER  
 SAT 08/23/24  
 PROJECT ID  
 115533  
 SUBSET TOTAL  
 11 17  
 SHEET TOTAL  
 P.42 P.48

**GEOTECHNICAL PROFILE - LANDSLIDE  
 BORING LOG FOR B-004-0-21**



Office of Geotechnical Engineering

B-001-0-21



Run #:	Depth	Recovery	RQD
NQ2-1	41.0'	58/60	46/60
NQ2-2	46.0'	40/60	34/60
GAL-7-19.94 PID 115533			



Office of Geotechnical Engineering

B-001-0-21



Run #:	Depth	Recovery	RQD
NQ2-3	51.0'	60/60	33/60
	56.0'	100%	55%
GAL-7-19.94 PID 115533			

DESIGN AGENCY



DESIGNER  
AJC

REVIEWER  
SAT 08/23/24

PROJECT ID  
115533

SUBSET	TOTAL
12	17

SHEET	TOTAL
P.43	P.48



Office of Geotechnical Engineering

B-002-0-21

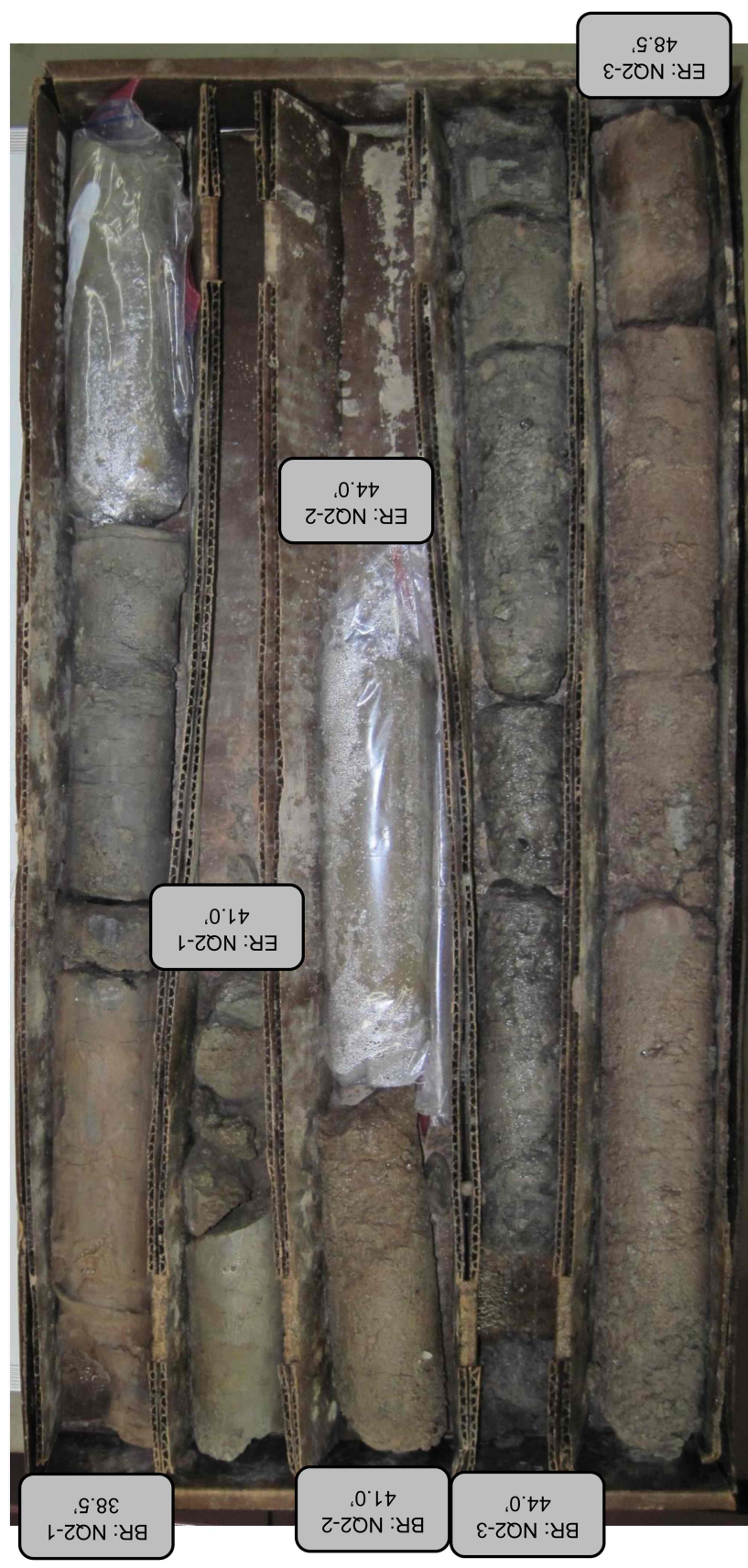

Run #:	Depth	Recovery	RQD
NQ2-1	38.5'	29/30	23/30
NQ2-2	41.0'	14/36	14/36
NQ2-3	44.0'	45/54	31/54
GAL-7-19.94 PID 115533			
		97%	77%
		39%	39%
		83%	57%



Office of Geotechnical Engineering

B-002-0-21



Run #:	Depth	Recovery	RQD
NQ2-4	48.5'	24/24	14/24
NQ2-5	50.5'	24/24	0/24
NQ2-6	52.5'	24/24	7/24
NQ2-7	54.5'	23/24	18/24
NQ2-8	56.5'	22/24	17/24
GAL-7-19.94 PID 115533			
		100%	58%
		100%	0%
		100%	29%
		96%	75%
		92%	71%

DESIGN AGENCY



DESIGNER

AJC

REVIEWER

SAT 08/23/24

PROJECT ID

115533

SUBSET TOTAL

13 17

SHEET TOTAL

P.44 P.48



Office of Geotechnical Engineering

B-003-0-21



Run #:	Depth	Recovery	RQD
NQ2-1	34.0'	30/60	0/60
NQ2-2	39.0'	60/60	14/60
GAL-7-19.94 PID 115533			



Office of Geotechnical Engineering

B-003-0-21



Run #:	Depth	Recovery	RQD
NQ2-3	44.0'	55/60	32/60
NQ2-4	49.0'	41/60	23/60
GAL-7-19.94 PID 115533			

DESIGN AGENCY



DESIGNER

AJC

REVIEWER

SAT 08/23/24

PROJECT ID

115533

SUBSET TOTAL

14 17

SHEET TOTAL

P.45 P.48



Office of Geotechnical Engineering

B-003-1-22



Run #:	Depth	Recovery	RQD
NQ2-1	46.5'	24/24	0/24
NQ2-2	48.5'	24/24	0/24
NQ2-3	50.5'	23/24	0/24
NQ2-4	52.5'	15/24	64/24
NQ2-5	54.5'	24/24	10/24

GAL-7-19.94 PID 115533



Office of Geotechnical Engineering

B-003-1-22



Run #:	Depth	Recovery	RQD
NQ2-6	56.5'	23/24	18/24
NQ2-7	58.5'	23/24	0/24
NQ2-8	60.5'	24/24	5/24
NQ2-9	62.5'	24/24	19.5/24
NQ2-10	64.5'	24/24	4/24

GAL-7-19.94 PID 115533

DESIGN AGENCY



DESIGNER

AJC

REVIEWER

SAT 08/23/24

PROJECT ID

115533

SUBSET TOTAL

15 17

SHEET TOTAL

P.46 P.48

GEOTECHNICAL PROFILE - LANDSLIDE  
 ROCK CORE PHOTOS FOR B-003-1-21



Office of Geotechnical Engineering

B-004-0-21



BR: NQ2-1  
34.0'

ER: NQ2-2  
44.0'

Run #:	Depth	Recovery	RQD
NQ2-1	34.0'	60/60	0/60
NQ2-2	39.0'	60/60	24/60
GAL-7-19.94 PID 115533			
		100%	0%
		100%	40%



Office of Geotechnical Engineering

B-004-0-21



BR: NQ2-3  
44.0'

ER: NQ2-3  
49.0'

Run #:	Depth	Recovery	RQD
NQ2-3	44.0'	60/60	19/60
GAL-7-19.94 PID 115533			
		100%	32%

DESIGN AGENCY



DESIGNER  
AJC

REVIEWER  
SAT 08/23/24

PROJECT ID  
115533

SUBSET	TOTAL
16	17

SHEET	TOTAL
P.47	P.48

GEOTECHNICAL PROFILE - LANDSLIDE  
 ROCK CORE PHOTOS FOR B-004-0-21

Borehole : B-003-1-22  
 Project : Inclinometer  
 Location : GAL-7-19.94  
 Northing :  
 Easting :  
 Collar :

Spiral Correction : N/A  
 Collar Elevation : 0.0 feet  
 Borehole Total Depth : 66.0 feet  
 A+ Groove Azimuth :  
 Base Reading : 2022 Jun 10 06:13  
 Applied Azimuth : -5.0 degrees

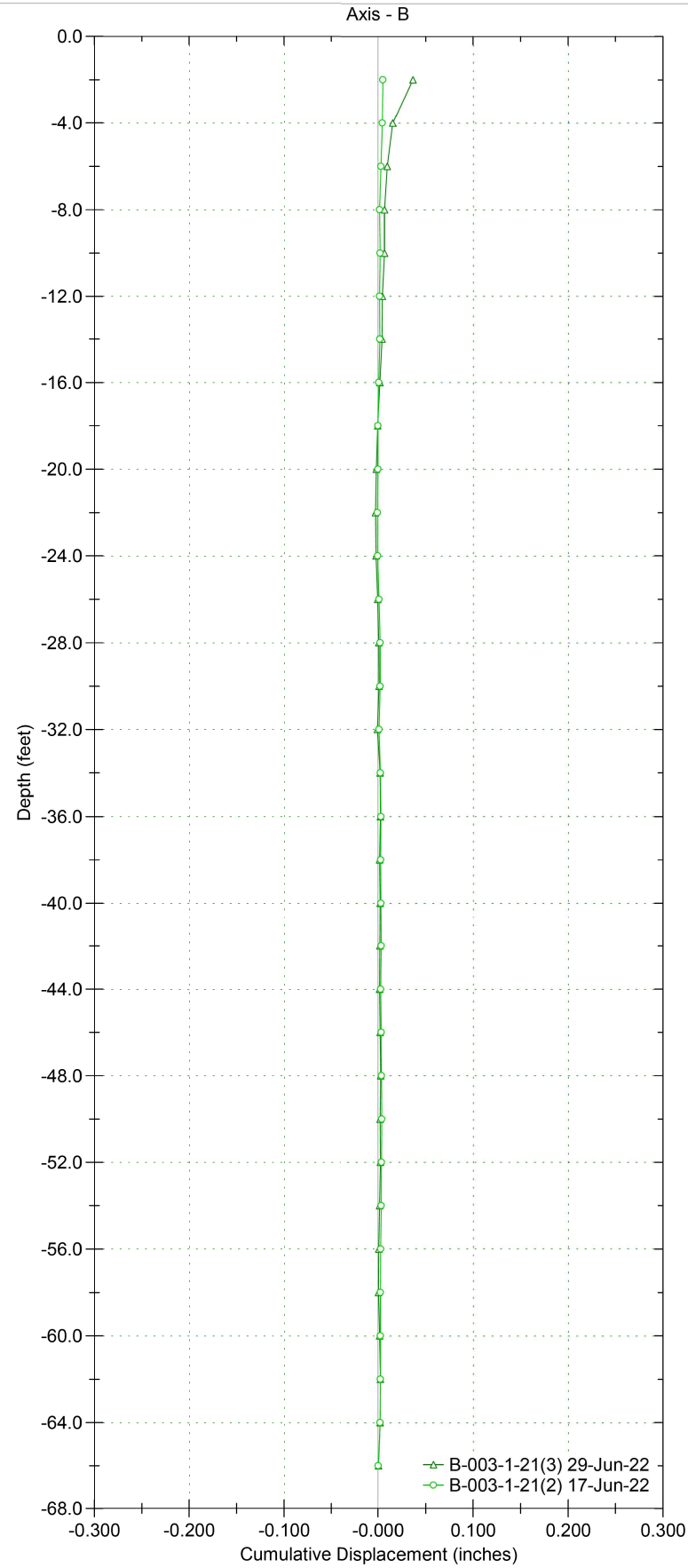
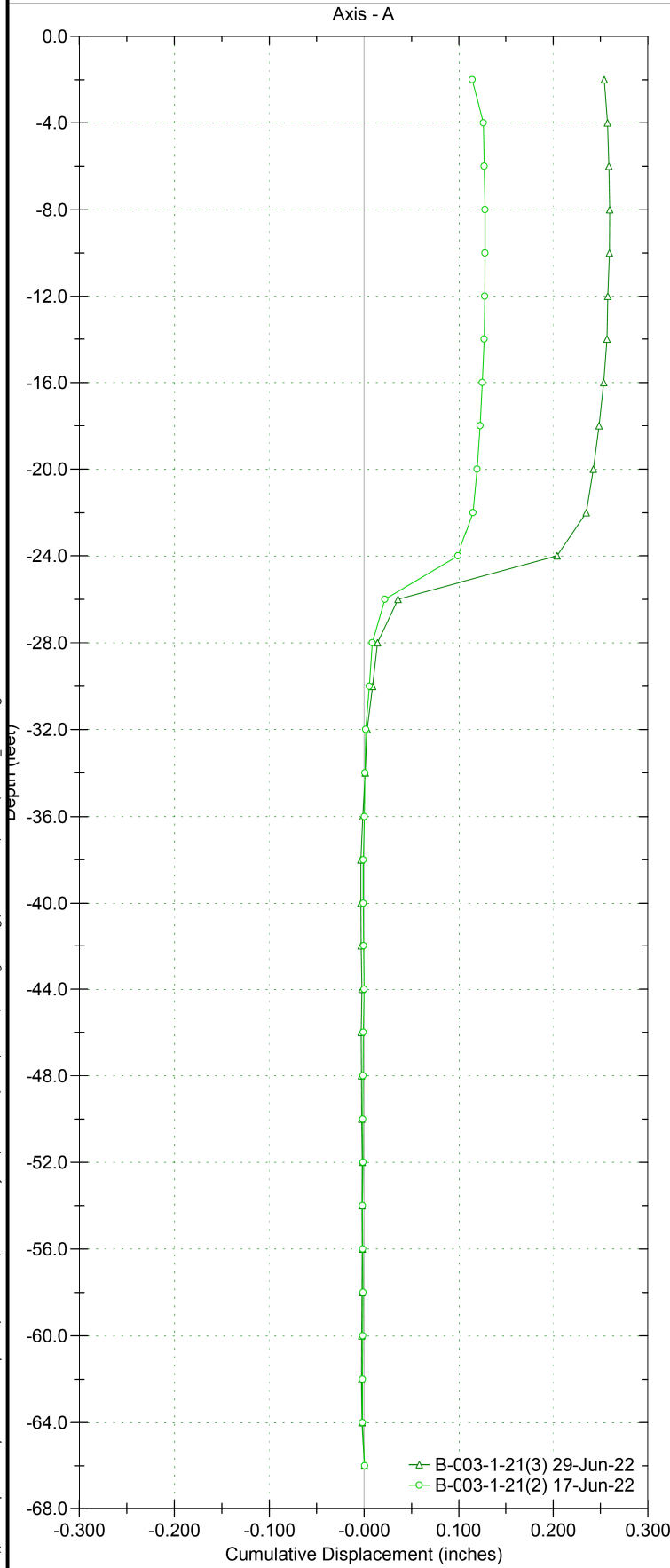

GAL-7-19.94 ER Survey Line 1 Inverted Resistivity Section

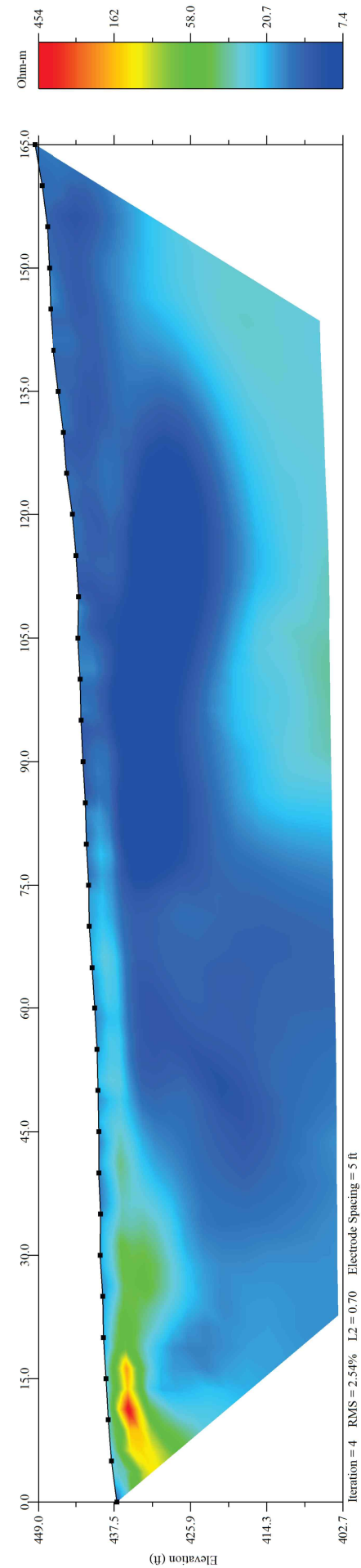

GAL-7-19.94 ER Survey Line 2 Inverted Resistivity Section

