

STATE OF OHIO DEPARTMENT OF TRANSPORTATION

GEA-87-15.93

Middlefield Village
Middlefield Township
GEAUGA COUNTY

FEDERAL PROJECT NUMBER

E191(582)

RAILROAD INVOLVEMENT

None

PROJECT DESCRIPTION

The project consists of the resurfacing of SR-87 (Kinsman Road) from the West Corporation Line to Hayes Road in the Village of Middlefield and Middlefield Township.

EARTH DISTURBED AREAS

PROJECT EARTH DISTURBED AREA: N/A Maintenance Project
ESTIMATED CONTRACTOR EARTH DISTURBED AREA: N/A Maintenance Project
NOTICE OF INTENT EARTH DISTURBED AREA: N/A Maintenance Project

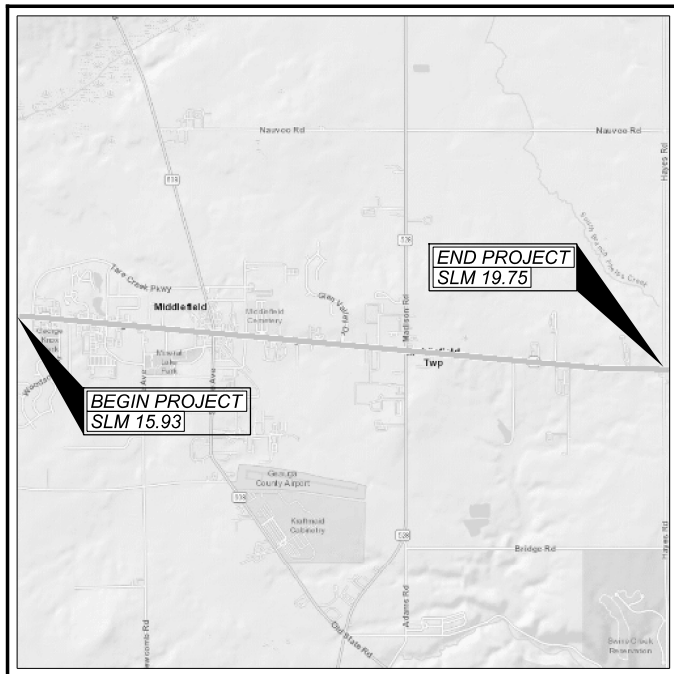

LOCATION MAP

LATITUDE: 41°27'38" N LONGITUDE: 81°02'58" W



PORTION TO BE IMPROVED	=====
INTERSTATE HIGHWAY	=====
FEDERAL ROUTES	=====
STATE ROUTES	=====
COUNTY & TOWNSHIP ROADS	=====
OTHER ROADS	=====

DESIGN DESIGNATION

	SLM 15.34-16.62	SLM 16.62-17.08	SLM 17.08-18.20	SLM 18.20-19.75
CURRENT ADT (2021)	9,700	8,700	7,100	5,600
DESIGN YEAR ADT (2042)	11,000	9,100	7,500	6,900
DESIGN HOURLY VOLUME (2042)	1,100	900	800	700
DIRECTIONAL DISTRIBUTION	0.53	0.53	0.60	0.60
TRUCKS (24 HOUR B&C)	0.03	0.03	0.03	0.03
DESIGN SPEED	25/35	25/35	35/50	50
LEGAL SPEED	25/35	25/35	35/50	50
DESIGN FUNCTIONAL CLASSIFICATION:				
MAJOR COLLECTOR				
NHS PROJECT				No

DESIGN EXCEPTIONS

No

ADA DESIGN WAIVERS

REQUIRED

UNDERGROUND UTILITIES
Contact Two Working Days
Before You Dig

OHIO811.org
Before You Dig

OHIO 811, 8-1-1, or 1-800-362-2764
(Non members must be called directly)

PLAN PREPARED BY:
ODOT - District 12
Planning and Engineering
5500 Transportation Blvd.
Garfield Heights, OH 44125

ENGINEER'S SEAL:

SIGNED: *E.M. Kallio*
DATE: 11-23-2021

INDEX OF SHEETS:

Title Sheet	1
Schematic Plans	2-4
Typical Sections	5-6
General Notes	7-10
Maintenance of Traffic Notes	11-13
General Summary	14-15
Subsummaries	
Pavement Subsummaries	16
Pavement Marking Subsummary	17-18
Curb Ramp Subsummary	19
General Plans	20-27
Pavement Details	28

2019 SPECIFICATIONS

THE STANDARD SPECIFICATIONS OF THE STATE OF OHIO, DEPARTMENT OF TRANSPORTATION, INCLUDING SUPPLEMENTAL SPECIFICATIONS LISTED IN THE PLANS AND CHANGES LISTED IN THE PROPOSAL SHALL GOVERN THIS IMPROVEMENT.

STANDARD CONSTRUCTION DRAWINGS						SUPPLEMENTAL SPECIFICATIONS	SPECIAL PROVISIONS
BP-3.1	1/17/20	MT-95.10	7/21/17	TC-41.20	10/18/13	800-2019 01/21/22	
BP-3.2	1/18/19	MT-95.50	7/21/17	TC-65.10	1/17/14	821 4/20/12	
BP-7.1	7/17/20	MT-95.60	4/19/19	TC-65.11	7/21/17	832 10/19/18	
		MT-95.61	4/19/19	TC-71.10	7/16/21	875 1/18/19	
		MT-97.10	4/19/19	TC-74.10	7/16/21		
		MT-97.12	1/20/17	TC-82.10	7/19/19	921 4/20/12	
		MT-99.20	4/19/19				
		MT-101.90	7/17/20				
		MT-105.10	1/17/20				
		MT-110.10	7/19/13				

APPROVED
DATE 11/17/21
DISTRICT DEPUTY DIRECTOR

APPROVED _____
DATE _____ DIRECTOR, DEPARTMENT OF TRANSPORTATION

Title Sheet

DESIGN AGENCY



DESIGNER
JDA

REVIEWER

EMK 11/01/21

PROJECT ID

108104

SHEET TOTAL

1 | 28

GEA-87-15.93

MODEL: Sheet PAPER: 17x11 (in.) DATE: 11/24/2021 TIME: 4:49:24 PM USER: jalbrng1 pwc:\ohio\dot-pw-bentley.com\shado\pww-02\Documents\01 Active Projects\District 12\Gaugau\108104\400-Engineering\Roadway\Sheets\108104_GT001.dgn

REF. NO.	SHEET NO.	PLAN SPLIT NO.	STATION TO STATION		CORNER	Description	202	253	608	608										
			WALK REMOVED	PAVEMENT REPAIR			4" CONCRETE WALK	CURB RAMP, AS PER PLAN												
			Intersection	Description			SF	CY	SF	SF										
CR-1	20	1	Market Square	Across Driveway	SW	RMP0007947														
CR-2	20	1	Market Square	Across Driveway	SE	RMP0007949														
CR-3	20	1	Market Square	Across SR-87	SE															
CR-4	20	1	Ames Plaza Drive	Across Driveway	NE	No Work														
CR-5	20	1	Ames Plaza Drive	Across SR-87	NE	No Work														
CR-6	20	1	Woodsong Drive		SW			4.00												
CR-7	20	1	Woodsong Drive		SE	No Work														
CR-8	20	1	Crestwood Dr		SW	No Work														
CR-9	20	1	Crestwood Dr		SE	No Work														
CR-10	20	1	NorthView Drive		NW	RMP0007948														
CR-11	20	1	NorthView Drive		NE	No Work														
CR-12	21	1	Springdale Ave	Across SR-87	NW	TYPE A2	25		25	76										
CR-13	21	1	Springdale Ave	Across SR-87	SW	TYPE A2	50		50	71										
CR-14	21	1	Springdale Ave	Across Springdale	SW	TYPE C1	50		50	36										
CR-15	21	1	Springdale Ave	Across Springdale	SE	TYPE B3				93										
CR-16	21	1	Springdale Ave	Across Springdale	NW	TYPE C1	25		25	104										
CR-17	21	1	Springdale Ave	Across Springdale	NE	TYPE C1				130										
CR-18	21	1	Springdale Ave	Across SR-87	NE	TYPE A1				61										
CR-19	21	1	Springdale Ave	Across SR-87	SE	No Work														
CR-20	21	1	Elmwood Street		NW	No Work														
CR-21	21	1	Elmwood Street		NE	TYPE B3	50		50	30										
CR-22	21	1	Lake Avenue		SW	No Work														
CR-23	21	1	Lake Avenue		SE	RMP0007950														
CR-24	21	1	Lake Avenue	Across SR-87	SE	No Work														
CR-25	21	1	Lake Avenue	Across SR-87	NE		75		75											
CR-26	21	1	Standish Ave		NW	No Work														
CR-27	21	1	Standish Ave		NE	No Work														
CR-28	21	1	Linda Ave	Across SR-87	SW	No Work														
CR-29	21	1	Linda Ave	Across SR-87	NW	No Work														
CR-30	21	1	Linda Ave		SW	No Work														
CR-31	21	1	Linda Ave		SE	No Work														
CR-32	22	1	Thompson Ave		NW	TYPE C1	55		55	60										
CR-33	22	1	Thompson Ave		SW	No Work														
CR-34	22	1	Thompson Ave		NE	No Work														
CR-35	22	1	Thompson Ave		SE	No Work														
CR-36	23	1	Hilcrest Ave		NW	No Work														
CR-37	23	1	Hilcrest Ave		NE	No Work														
CR-38	23	1	Lenny Ave		SW	No Work														
CR-39	23	1	Lenny Ave		SE	No Work														
CR-40	23	1	Glen Valley Drive		NW	TYPE C1	50		50	75										
CR-41	24	1	Glen Valley Drive		NE	TYPE C1	50		50	110										
SUBTOTALS							430	4	430	846										

Curb Ramp Subsummary

DESIGN AGENCY

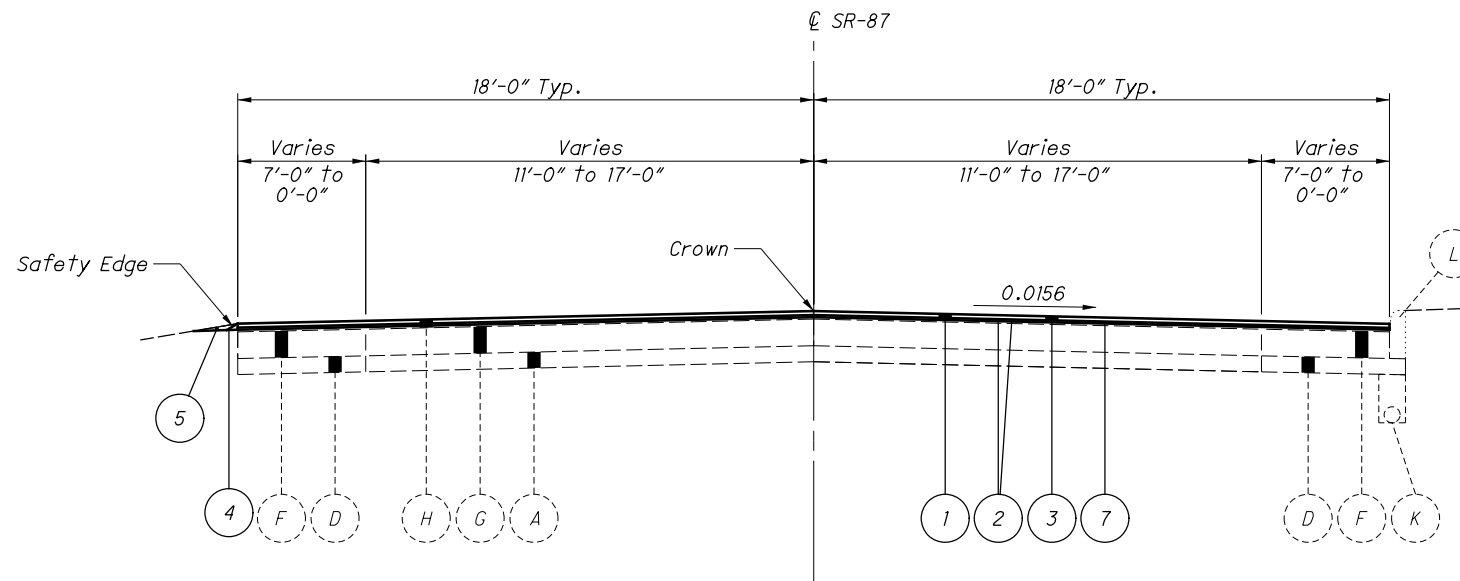
 DESIGNER
 JDA
 REVIEWER
 EMK 11/01/21
 PROJECT ID
 108104
 SHEET TOTAL
 19 | 28

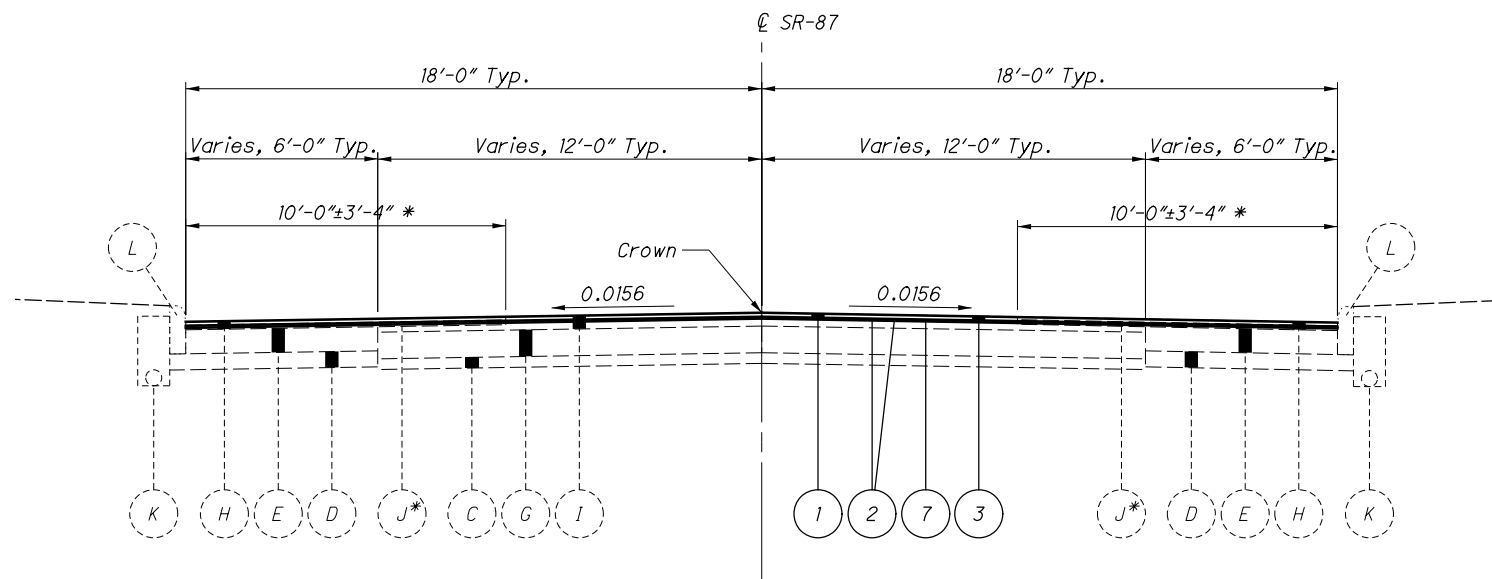

Sta. 0+00.00 to Sta. 4+48.87



Sta. 4+48.87 to Sta. 45+57.35

* Pavement Overlay Composite Fabric at 3" Depth
 Sta. 6+45.02 to Sta. 15+96.27

PROPOSED LEGEND

- 1 Item 254 - Pavement Planing, Asphalt Concrete, As Per Plan, 2-1/2"
- 2 Item 407 - Non-Tracking Tack Coat
- 3 Item 441 - Asphalt Concrete, Surface Course, Type 1, (446), As Per Plan, 1-1/2"
- 4 Item 209 - Linear Grading, As Per Plan
- 5 Item 617 - Compacted Aggregate, As Per Plan
- 6 Item 254 - Pavement Planing, Asphalt Concrete, As Per Plan, 1-1/2"
- 7 Item 441 - Asphalt Concrete Intermediate Course, Type 1, PG64-22, (448), As Per Plan, 1"

EXISTING LEGEND

- A Subbase, Varies
- B 10"± Macadam Base
- C 4"± Aggregate Base
- D 6"± Aggregate Base
- E 9"± Asphalt Concrete Base
- F 10"± Asphalt Concrete Base
- G 8"-10"± Reinforced Concrete Base
- H 3"± Asphalt Concrete Overlay
- I Asphalt Concrete Overlay, Varies
- J Pavement Overlay Composite Fabric
- K Underdrain
- L Curb

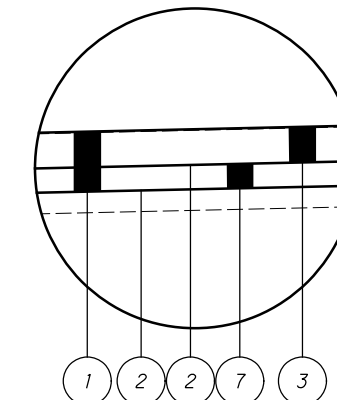

Proposed Pavement Build Up
 Sta. 0+00.00 to Sta. 86+50.00



Pavement

Profile and Alignment

Place the proposed pavement to follow the alignment of the existing pavement. Previous construction plans showing the original alignment are available for inspection at the ODOT District 12 office. Place the proposed asphalt concrete as shown on the typical sections. The intent of the plans is to maintain the existing profile.

Planing Requirements

The duration of time between planing the asphalt and placing the surface course shall be kept to a minimum. In no instance shall this time exceed 10 calendar days. The time limit shall begin on the first day of planing, and shall continue based on calendar days, minus any bad weather days, until completion of the asphalt concrete surface course. This is to ensure that the potential degradation of the exposed pavement due to traffic is kept to a minimum.

In the event that the time between exposing the existing pavement and placing the asphalt surface course exceeds 10 calendar days, liquidated damages as per 108.07 of the C&MS shall be assessed.

Asphalt Concrete Surface Course Sealing Requirements

In addition to the gutter sealing requirements specified on SCD BP-3.1 and in CMS 401.15, after completion of the surface course, the Contractor shall use a certified 702.01 PG binder to seal the following locations:

- All castings, including but not limited to: monuments, manholes, water valves, catch basins, curb inlets.
- Butt joints and feather joints including bridge approaches.
- Forward joint for driveway asphalt and trailing joint when butting to existing asphalt drive.
- Perimeter of all pavement repairs or other asphalt inlays when pavement repairs/inlays are not overlaid with an asphalt concrete surface course.
- All cold longitudinal joints between paved shoulders and guardrail asphalt.

The width of the sealer shall be 2 to 3 inches.

Any additional costs associated with the work identified in this note shall be included in the appropriate asphalt concrete surface course item of work.

Item 251 – Partial Depth Pavement Repair (441), As per Plan

This item shall be used to repair unsound, cold patch, or pop-out areas of longitudinal and transverse joints as directed by the Engineer. This work shall be performed prior to the planing operation. The depth of the repair shall be 3" below the top of the existing asphalt surface. The width of the repair shall be 12" centered over the existing joint.

Use replacement materials conforming to the requirements of Item 441, Type 2.

The following estimated quantity has been carried to the General Summary:

Item 251 – Partial Depth Pavement Repair.....**1,600 SY**

Item 253 – Pavement Repair

This work item is for use as directed by the Engineer for the purpose of pavement repair. All labor and material necessary to perform this work and section 250 of the CMS shall be included for payment under Item 253.

Depth of pavement repair removal shall typically be 5" measured after the pavement has been planed. The depth of repair shall be as directed by the Engineer if unsound material is encountered after the removal of the 5".

Use replacement materials conforming to the requirements of Item 301.

The following item has been carried to the General Summary for use as directed by the Engineer:

Item 253 – Pavement Repair..... **560 CY**

Item 254 – Pavement Planing, Asphalt Concrete, As Per Plan

This item shall be used to remove the existing asphalt overlay full width at an average depth of 1-1/2" and 2-1/2" as specified in the plans. Areas which have transverse wedges (butt joints) are to be removed in two passes as required for maintaining traffic. No additional payment shall be made for the second pass.

Item 441 – Asphalt Concrete Surface Course, Type 1, (446), As Per Plan

The coarse virgin aggregate for this item shall consist of a blend of 60% min. air cooled blast furnace slag (ACBFS) or Trap Rock from Ontario with limestone comprising the remaining percentage.

Use a PG70-22M binder for this item.

Additional requirements for IDEAL-CT:

Follow all requirements of the specifications with the addition of the following:

Perform the IDEAL-CT for the mix design submittal per Supplement 1033 on the JMF asphalt binder content determined from the design air voids and ensure the minimum in the table below is met for the mix type. The IDEAL-CT only needs to be ran for mix design acceptance.

Provide results per Supplement 1033 with the mix design. Supply six gyratory compacted specimens to the height mentioned in Supplement 1033 for the mix type specified. Allow more than two weeks for mix design review and preliminary approval due to OMM verifying the mix.

Mix Type	Minimum CTindex
Item 442 (Superpave) 9.5 mm	80
Item 442 (Superpave) 12.5 mm (Surface)	80
Item 442 (Superpave) 12.5 mm (Intermediate)	70
Item 442 (Superpave) 19 mm (Intermediate)	60
Item 441 (Marshall) Type 1 Surface Mixes	80
Item 441 (Marshall) Type 1 Intermediate Mixes	80
Item 441 (Marshall) Type 2 Intermediate Mixes	60
Item 302 (Marshall) Mixes	60

Item – 441 Asphalt Concrete Intermediate Course, Type 1, (448), As Per Plan, PG64-22

Requirements for IDEAL-CT:

Follow all requirements of the specifications with the addition of the following:

Perform the IDEAL-CT for the mix design submittal per Supplement 1033 on the JMF asphalt binder content determined from the design air voids and ensure the minimum in the table below is met for the mix type. The IDEAL-CT only needs to be ran for mix design acceptance.

Provide results per Supplement 1033 with the mix design. Supply six gyratory compacted specimens to the height mentioned in Supplement 1033 for the mix type specified. Allow more than two weeks for mix design review and preliminary approval due to OMM verifying the mix.

Mix Type	Minimum CTindex
Item 442 (Superpave) 9.5 mm	80
Item 442 (Superpave) 12.5 mm (Surface)	80
Item 442 (Superpave) 12.5 mm (Intermediate)	70
Item 442 (Superpave) 19 mm (Intermediate)	60
Item 441 (Marshall) Type 1 Surface Mixes	80
Item 441 (Marshall) Type 1 Intermediate Mixes	80
Item 441 (Marshall) Type 2 Intermediate Mixes	60
Item 302 (Marshall) Mixes	60

Item 617 – Compacted Aggregate, As Per Plan

This item is a contingency that shall be used as directed by the Engineer to fill any remaining low areas after Item 209 – Linear Grading, As Per Plan, has been completed. Material shall be limited to reclaimed asphalt concrete pavement.

The actual depth used will vary depending upon existing conditions. For estimating purposes, an average depth of one inch (1.0") at one foot width will be used. Water, if needed, shall be applied as per 617.05 and included for payment under Item 617 – Compacted Aggregate, As Per Plan.



Item 608 - Curb Ramp, As Per Plan

Under this pay item The Contractor shall be responsible for laying out and constructing American With Disabilities Act (ADA) compliant curb ramps and landing that conform to the Ohio Department of Transportation Curb Ramp Standard Drawings and Special Provisions. O.D.O.T. Standard Drawing BP-7.1 shall be used as a base for the construction of the curb ramps.

The curb ramp type is subject to adjustment and/or change due to field conditions and shall be determined in the field based on best fit to field conditions. Contractor shall be responsible for verifying type of curb ramp proposed in the plans. No additional payment shall be made if the curb ramp type is changed or for field adjustments necessary for the complete installation of the curb ramp.

Any newly constructed curb ramp not meeting ADA requirements will be removed and replaced by the Contractor, at their cost, to the satisfaction of the O.D.O.T. Project Engineer.

Payment shall be measured in Square Feet for curb ramp areas as indicated on the O.D.O.T. Standard Drawing BP-7.1. Payment shall include all labor, equipment, and materials necessary to construct the new curb ramp, complete in place.

Payment includes existing ramp/sidewalk removals, surveying, construction layout, form work, replacement of bedding, placement of sidewalk and curb concrete for new ramps, and placement of new detectable warning within the proposed ramp areas.

All saw cutting, appurtenances, and other work necessary for the complete installation of the ramp is considered incidental to this item.

All topsoil, seeding, and mulching required adjacent to the curb ramp shall be considered incidental to this item.

Seeding Mix shall conform to ODOT CMS 659.08 High Quality Seeds, Class I.

Curb Ramps at intersection corners are shown on the plans for estimating purposes. Work beyond the limits of the curb ramp area shall be paid under separate pay items.

Truncated Domes are included with the cost of Item 608 - Curb Ramps, As Per Plan.

As Directed by the Engineer, Additional walk needed beyond the curb ramp area, will be paid for under Item 608 – 4" Concrete Walk, As Per Plan.

ADA Waiver

An approved ADA Design Waiver is required on this project. The following features listed below cannot feasibly be constructed to meet ADA guidelines.

ADA Design Waiver

ADA Feature	Approval Date
RMP 0007947	11/17/2021
RMP 0007948	11/17/2021
RMP 0007949	11/17/2021
RMP 0007950	11/17/2021

Traffic Control

Item 621 – Raised Pavement Marker Removed

This item shall include the removal and disposal of RPMs.

The following estimated quantity has been carried to the General Summary:
 Item 621 – Raised Pavement Marker Removed..... **111 Each**

Item 632 – Detector Loop, As Per Plan

All stop line inductance detector loops shown in the plans shall be the powerhead configuration shown on TC-82.10. The width shall be as specified on TC-82.10 and the length shall match the existing detector loop length, with a maximum length of 35'. The stop line detector loops shall not be wired to any other loops and shall have their own detector channel. The location of these loops shall be such that the powerhead is located at the stop line, not past it.

All dilemma zone inductance detector loops called for in the plans shall be the Angular Design Detection (A.D.D.) loop as shown on TC-82.10. Dimensions shall be as specified on TC-82.10.

System loops shall be as depicted in the plans. All stop line detection shall be tested for a bicycle target and all dilemma detection zones shall be tested for a motorcycle target. Install detector loops in the surface course within 72 hours of its placement.

When replacing the loop detectors, the loop detector wire shall be replaced to the pull box or pole, whichever is applicable, under Item 632 and TC-82.10. The new cable splice kits shall be included in this pay item.

The Contractor shall contact the Project Engineer and Keith Hamilton, (216) 584-2220, District 12 Traffic Engineer, seven (7) days prior to planing through an intersection to adjust signal operation as needed.

The District 12 Traffic Engineer shall concur with the location of the replacement loops. The following estimated quantity has been carried to the General Summary for use as described above:

Item 632 – Detector Loop, As Per Plan..... **18 Each**

Detection Maintenance

If vehicle detection becomes unexpectedly disabled, requires modification, or is scheduled to be temporarily removed during the construction project, the Contractor shall immediately notify the Project Engineer and District Traffic Engineer.

If the loss of vehicle detection is known prior to the start of construction, it shall be discussed at the preconstruction meeting. At such time, the District Traffic Engineer shall advise the Project Engineer and Contractor on the appropriate action to rectify any loss of vehicle detection. This may include placing the traffic signal on minimum or maximum recall, modifying the minimum green times, and removing the malfunctioning detection from service. Where non-intrusive detection (i.e. video, radar) already exists, the Contractor shall insure that detection is operating and maintained by reconfiguring the detection units accordingly during all construction phases. This is to avoid the signal from maxing out the effected signal phase and creating unnecessary delays.

Locations where non-intrusive detection is proposed and the existing vehicle detection is to be abandon, the non-intrusive vehicle detection shall be installed, configured and made fully functional prior to the existing detection being disabled. The Contractor shall continue to maintain and modify the detection until final acceptance of the traffic signal. This is to ensure vehicle detection remains fully functional throughout construction.

REFERENCE NO.	LOCATION	632	632
		6' X 35' POWERHEAD DETECTOR LOOP	4.5' X 9' ANGULAR DESIGN DETECTION LOOP
		EACH	EACH
L-1	SR-87 EB near Ames Plaza/Market Square Through Lane, 200' West of Stop Line		1
L-2	SR-87 EB at Ames Plaza/Market Square Left Turn Lane at Stop Line	1	
L-3	SR-87 WB at Ames Plaza/Market Square Left Turn Lane at Stop Line	1	
L-4	SR-87 WB near Ames Plaza/Market Square Through Lane, 200' East of Stop Line		1
L-5	SR-87 EB at Springdale Avenue Left Turn Lane at Stop Line	1	
L-6	SR-87 EB at Springdale Avenue Through Lane at Stop Line	1	
L-7	SR-87 WB at Springdale Avenue Through Lane at Stop Line	1	
L-8	SR-87 WB at Springdale Avenue Left Turn Lane at Stop Line	1	
L-9	SR-87 WB near Springdale Avenue Through Lane, 150' East of Stop Line		1
L-10	SR-87 WB at Lake Avenue Left Turn Lane at Stop Line	1	
L-11	SR-87 EB near SR-528 Through Lane, 250' West of Stop Line		1
L-12	SR-87 WB near SR-528 Through Lane, 350' East of Stop Line		1
L-13	SR-528 NB at SR-87 Through Lane at Stop Line	2	
L-14	SR-528 SB at SR-87 Through Lane at Stop Line	2	
	Extra for Damaged Apron Loops, Use As Directed by the Engineer	2	
SUBTOTALS		13	5
TOTAL CARRIED TO GEN. SUMMARY		18	

General Notes

DESIGN AGENCY



DESIGNER
JDA

REVIEWER
EMK 11/01/21

PROJECT ID
108104

SHEET TOTAL
10 | 28

SHEET NUM.												PART.		ITEM	ITEM	GRAND	UNIT	DESCRIPTION	SEE SHEET NO.
7-10	7-10	11-13		16-17	18							01/STR/PV		EXT	TOTAL				
ROADWAY																			
												430		202	30000	430	SF	WALK REMOVED	
				3.86								3.86		209	60500	3.86	MILE	LINEAR GRADING	
				3.86								3.86		209	72050	3.86	MILE	PREPARING SUBGRADE FOR SHOULDER PAVING	
												430		608	10000	430	SF	4" CONCRETE WALK	
												846		608	52001	846	SF	CURB RAMP, AS PER PLAN	
8	8											8		623	39501	8	EACH	MONUMENT BOX ADJUSTED TO GRADE, AS PER PLAN	8
1	1											1		623	39600	1	EACH	MONUMENT BOX RECONSTRUCTED TO GRADE	
EROSION CONTROL																			
												1,000		832	30000	1,000	EACH	EROSION CONTROL	
DRAINAGE																			
7	7											7		611	98630	7	EACH	CATCH BASIN ADJUSTED TO GRADE	
65	65											65		611	98631	65	EACH	CATCH BASIN ADJUSTED TO GRADE, AS PER PLAN	8
20	20											20		611	99655	20	EACH	MANHOLE ADJUSTED TO GRADE, AS PER PLAN	8
2	2											2		611	99660	2	EACH	MANHOLE RECONSTRUCTED TO GRADE	
15,000	15,000											15,000		SPECIAL	61199820	15,000	LB	MISCELLANEOUS METAL	8
20	20											20		638	10801	20	EACH	VALVE BOX ADJUSTED TO GRADE, AS PER PLAN	8
PAVEMENT																			
1,600	1,600											1,600		251	01001	1,600	SY	PARTIAL DEPTH PAVEMENT REPAIR (441), AS PER PLAN	9
560	560											564		253	02000	564	CY	PAVEMENT REPAIR	
				30,082								30,082		254	01001	30,082	SY	PAVEMENT PLANING, ASPHALT CONCRETE, AS PER PLAN, 1.5"	9
				36,807								36,807		254	01001	36,807	SY	PAVEMENT PLANING, ASPHALT CONCRETE, AS PER PLAN, 2.5"	9
				9,699								9,699		407	20000	9,699	GAL	NON-TRACKING TACK COAT	
				2,784								2,784		441	10101	2,784	CY	ASPHALT CONCRETE SURFACE COURSE, TYPE 1, (446), AS PER PLAN, 1.5"	9
				110								110		441	50101	110	CY	ASPHALT CONCRETE SURFACE COURSE, TYPE 1, (448), AS PER PLAN, PG64-22, 1.5"	9
				1,765								1,765		441	50201	1,765	CY	ASPHALT CONCRETE INTERMEDIATE COURSE, TYPE 1, (448), AS PER PLAN, PG64-22, 1.0"	9
				9								9		441	50400	9	CY	ASPHALT CONCRETE SURFACE COURSE, TYPE 1, (448), (DRIVEWAYS), 1.5"	
				252								252		617	10101	252	CY	COMPACTED AGGREGATE, AS PER PLAN	8
				6,517								6,517		875	10000	6,517	LB	LONGITUDINAL JOINT ADHESIVE	
TRAFFIC CONTROL																			
					147							147		621	00100	147	EACH	RPM (YELLOW/YELLOW)	
111	111											111		621	54000	111	EACH	RAISED PAVEMENT MARKER REMOVED	
				33	1							34		643	01300	34	EACH	LANE ARROW	
				58	210							268		644	01200	268	FT	PARKING LOT STALL MARKING	
				0.09	4.36							4.45		646	10010	4.45	MILE	EDGE LINE, 6"	
				1.2	2.46							3.66		646	10200	3.66	MILE	CENTER LINE	
				1,152	43							1,195		646	10300	1,195	FT	CHANNELIZING LINE, 8"	
				98	91							189		646	10400	189	FT	STOP LINE	
				292	1,153							1,445		646	10510	1,445	FT	CROSSWALK LINE, 12"	
				585	32							617		646	10600	617	FT	TRANSVERSE/DIAGONAL LINE	
				242								242		646	10800	242	SF	ISLAND MARKING	
TRAFFIC SIGNALS																			
18	18											18		632	26501	18	EACH	DETECTOR LOOP, AS PER PLAN	11

General Summary

DESIGN AGENCY



DESIGNER

JDA

REVIEWER

EMK 11/01/21

PROJECT ID

108104

SHEET

14

TOTAL

28

SHEET NUM.												PART.	ITEM	ITEM	GRAND	UNIT	DESCRIPTION	SEE
7-10	11-13		16-17	18										EXT	TOTAL			SHEET NO.

General Summary

DESIGN AGENCY



DESIGNER
JDA

REVIEWER
EMK 11/01/22

PROJECT ID
108104

SHEET TOTAL
15 | 28

REF. NO.	SHEET NO.	PLAN SPLIT NO.	STATION TO STATION		LENGTH	BEGIN WIDTH	ENDING WIDTH	AVERAGE WIDTH	AREA	254	254	441	441	407	441	441	209	209	617	875	
										PAVEMENT PLANING, ASPHALT CONCRETE, AS PER PLAN, 2.5"	PAVEMENT PLANING, ASPHALT CONCRETE, AS PER PLAN, 1.5"	ASPHALT CONCRETE INTERMEDIATE COURSE, TYPE 1, (448), AS PER PLAN, PG64-22, 1.0"	ASPHALT CONCRETE SURFACE COURSE, TYPE 1, (446), AS PER PLAN, 1.5"	NON-TRACKING TACK COAT	ASPHALT CONCRETE SURFACE COURSE, TYPE 1, (448), AS PER PLAN, PG64-22, 1.5"	ASPHALT CONCRETE SURFACE COURSE, TYPE 1, (448), (DRIVEWAYS), 1.5"	LINEAR GRADING	PREPARING SUBGRADE FOR SHOULDER PAVING	COMPACTED AGGREGATE, AS PER PLAN	LONGITUDINAL JOINT ADHESIVE	
					FT.	FT.	FT.	FT.	SQ. YD.	SY	SY	CY	CY	GAL	CY	CY	MILE	MILE	CY	LB	
S.R. 87 - Curbed Section																					
	1		0+00.00	4+48.87	449	24	34	29.0	1446	1446		41	61	217			0.09			113	
	1		4+48.87	5+05.00	56	34	36	35.0	218	218		7	10	33						29	
	1		5+05.00	44+07.00	3902	36	36	36.0	15608	15608		434	651	2341						1951	
	1		44+07.00	45+51.43	144	36	26	31.0	497	497		14	21	75						73	
	1		45+51.43	54+11.50	860	26	24	25.0	2389	2389		67	100	358						216	
	1		54+11.50	55+04.38	93	24.0	24.0	24.0	248	248		7	11	37						24	
	1		55+04.38	55+94.33	90	34.5	45	39.8	397	397		12	17	60						23	
	1		55+94.33	56+14.16	20	45	45	45.0	99	99		3	5	15						5	
Bridge No. GEA-87-1703																					
	1		56+35.69	58+15.12	179	45	46.5	45.8	912	912		26	38	137						90	
Suspend Resurfacing																					
	1		62+10.01	63+53.25	143	45	48	46.5	740	740		21	31	111						72	
	1		63+53.25	66+73.28	320	45	48	46.5	1653	1653		46	69	248						161	
	1		66+73.28	67+21.21	48	38	38	38.0	202	202		6	9	30						24	
	1		67+21.21	67+34.84	14	38	28	33.0	50	50		2	3	8						7	
	1		67+34.84	80+07.81	1273	28	28	28.0	3960	3960		110	165	594						319	
	1		80+07.81	86+50.00	642	28	26	27.0	1927	1927		54	81	289						161	
	1		86+50.00	100+59.11	1409	26	26	26.0	4071	4071		114	170	611						353	
Transition Section																					
	1		100+59.11	100+89.11	30	26	26	26.0	87	87		3	4	13						8	
S.R. 87 - Non-Curbed Section																					
	1		100+89.11	200+23.48	9934	26	26	26.0	28699	28699		798	1196	4305			3.77			2484	
Safety Edge																					
	1		0+00.00	4+48.87	449			0.5	25				4					0.09	6		
	1		100+89.11	200+23.48	9934			1.0	1104				138					3.77	246		
Intersection Extra Areas																					
	1		Tare Creek Parkway, 4+49 LT.		15		136	CAD AREA	157	157				13	7					34	
	1		Ames Plaza, 9+00 RT.		10		106	CAD AREA	103	103				9	5					27	
	1		Market Square, 9+00 LT.		15		98	CAD AREA	84	84				7	4					25	
	1		Crestwood Drive, 15+13 RT.		24		61	CAD AREA	52	52				4	3					16	
	1		Northview Drive, 20+91 LT.		15		84	CAD AREA	85	85				7	4					21	
	1		Springdale Avenue, 26+79 LT & RT.		15 (x2)		200	CAD AREA	205	205				17	9					50	
	1		Elmwood Street, 30+48 LT.		15		65	CAD AREA	64	64				5	3					17	
	1		Lake Avenue, 38+38 RT.		15		96	CAD AREA	94	94				8	4					24	
	1		Standish Avenue, 44+07 LT.		15		54	CAD AREA	55	55				5	3					14	
	1		Linda Avenue, 45+53 RT.		18		47	CAD AREA	53	53				5	3					12	
	1		Thompson Avenue, 69+93 LT. & RT.		15 (x2)		170	CAD AREA	157	157				13	7					43	
	1		Lenny Avenue, 85+91 RT.		22		70	CAD AREA	79	79				7	4					0	
	1		SR-528, 119+54 LT. & RT.		90 (x2)		250	CAD AREA	1115	1115	1115			95	47					63	
	1		Hayes Road, 199+86 LT. & RT.		15 (x2)		160	CAD AREA	146		146			12	7					40	
	1		Driveways - Asphalt		5' Avg				122		122			10						9	
SUBTOTALS										36807	30082		1765	2784	9699	110	9	3.86	3.86	252	6517
TOTALS CARRIED TO GENERAL SUMMARY										36807	30082		1765	2784	9699	110	9	3.86	3.86	252	6517

DESIGN AGENCY

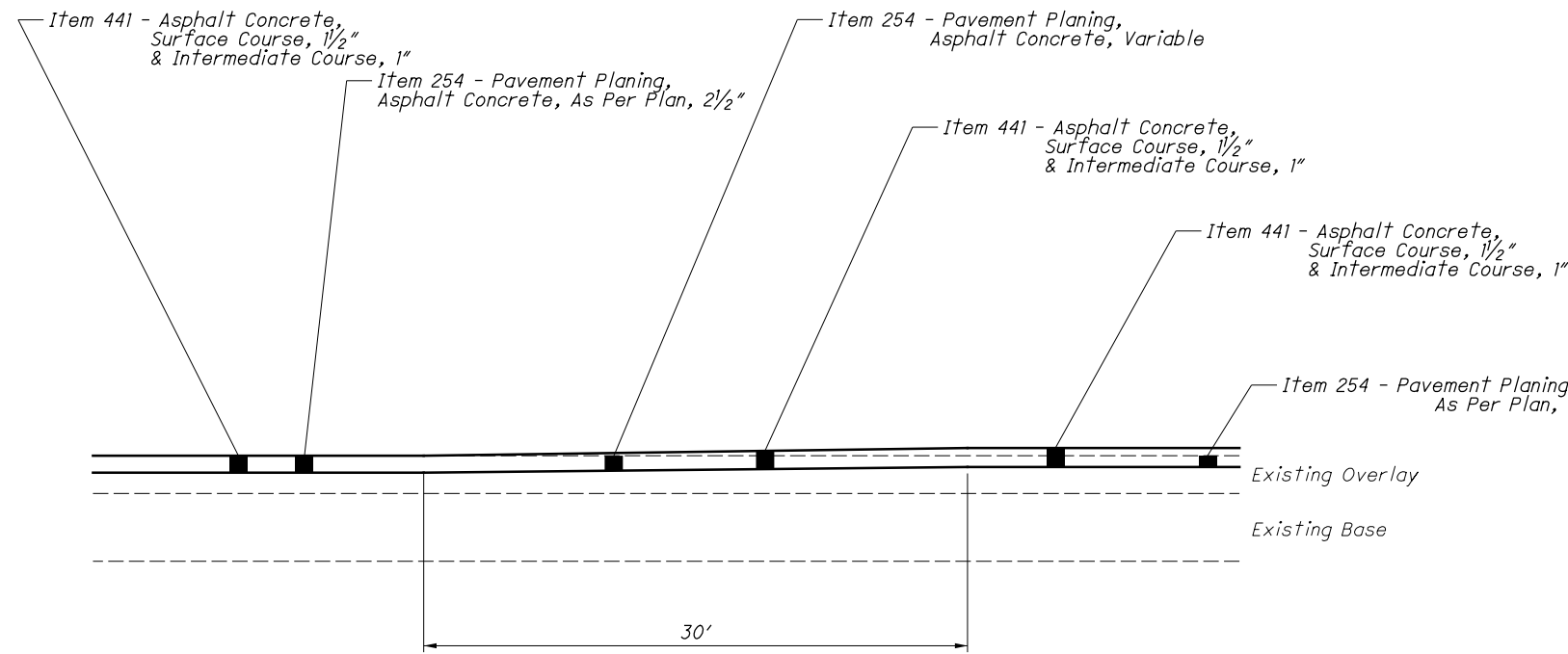
 DESIGNER
 JDA
 REVIEWER
 EMK 11/01/21
 PROJECT ID
 108104
 SHEET TOTAL
 16 28

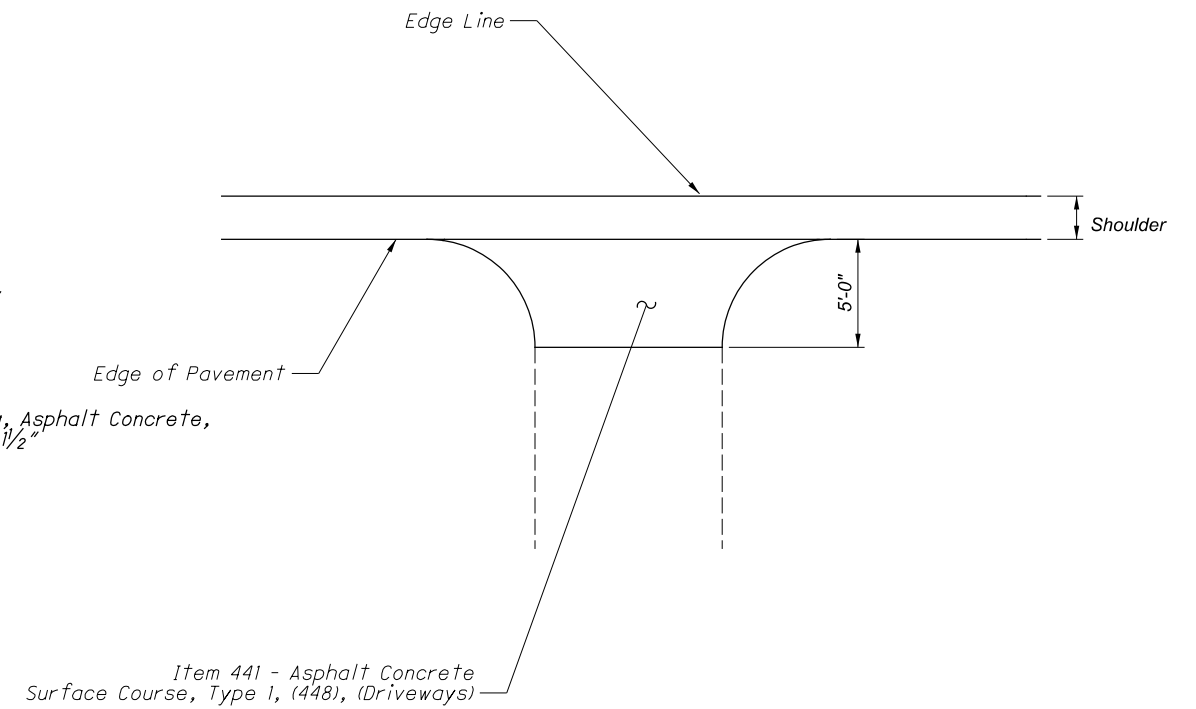

TRANSITION BETWEEN 2 1/2" PLANING & 1/2" PLANING
 Sta. 100+59.11 to Sta. 100+89.11

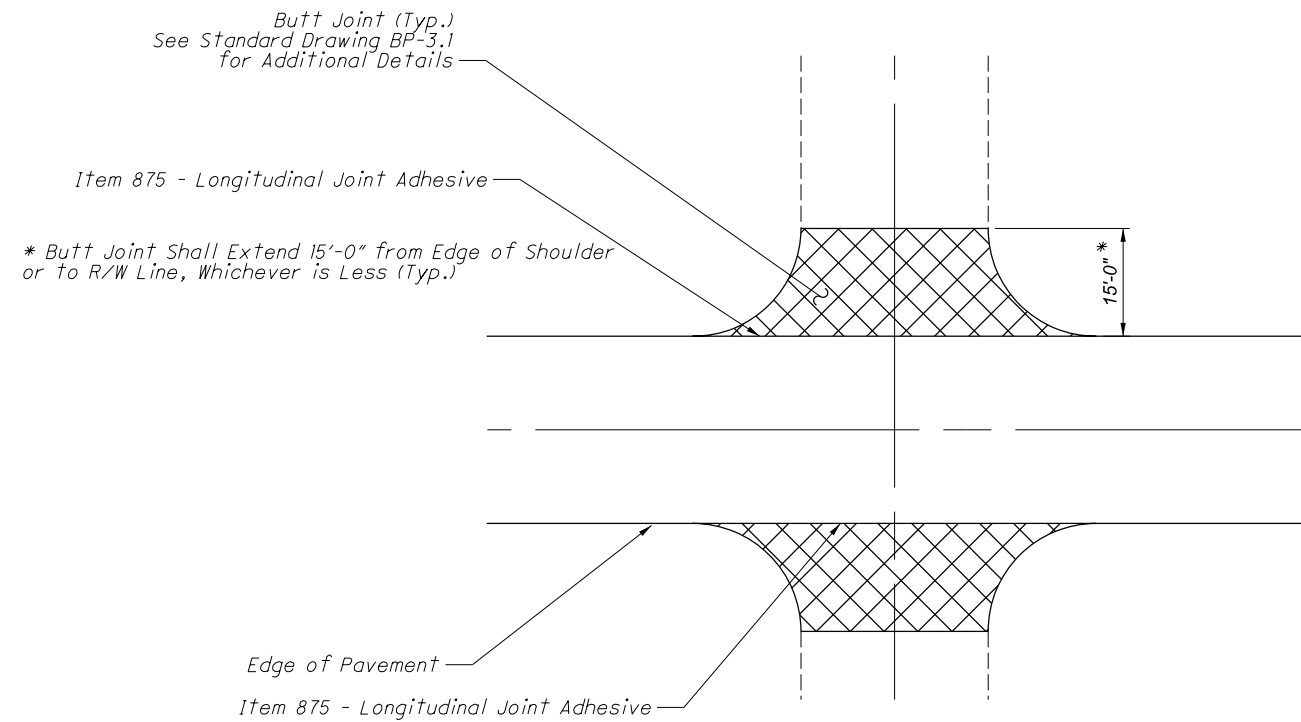

DRIVEWAY APRON DETAIL



TYPICAL ASPHALT INTERSECTION DETAIL
 CONCRETE INTERSECTION SIMILAR
 BUTT JOINT SHALL END AT EXISTING JOINT IN CONCRETE PAVEMENT

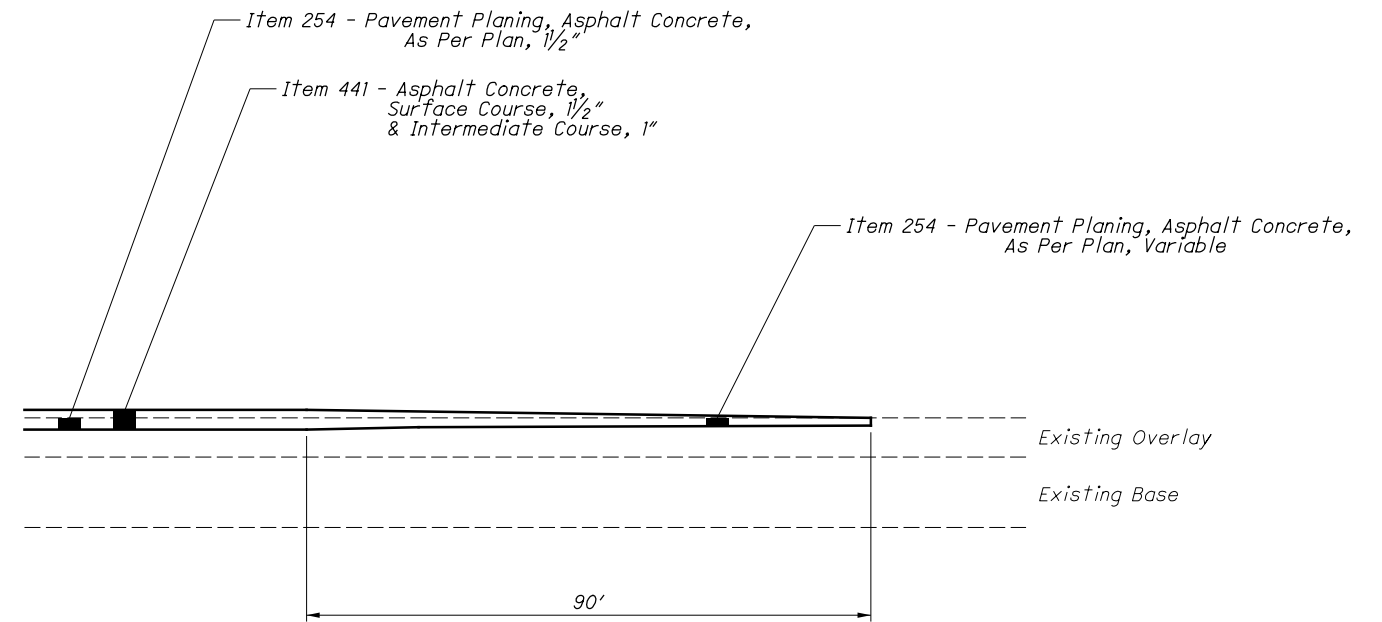

1/2" PLANING MEETING EXISTING PAVEMENT
 SR-528 Intersection Aprons
 End Project @ County Line

