

CONTINGENCY QUANTITIES

THE CONTRACTOR SHALL NOT ORDER MATERIALS OR PERFORM WORK LISTED IN THE GENERAL SUMMARY FOR ITEMS DESIGNATED BY PLAN NOTE TO BE USED "AS DIRECTED BY THE ENGINEER UNLESS AUTHORIZED BY THE ENGINEER". THE ACTUAL WORK LOCATIONS AND QUANTITIES USED AT THE ENGINEER'S DIRECTION SHALL BE MADE A MATTER OF RECORD BY INCORPORATION INTO THE FINAL CHANGE ORDER GOVERNING COMPLETION OF THE PROJECT.

PERMANENT PAVEMENT MARKINGS

THE CONTRACTOR SHALL REFERENCE ALL PAVEMENT MARKINGS INCLUDING AUXILIARY PAVEMENT MARKINGS BEFORE THE START OF THE RESURFACING OPERATION. THIS WILL BE NECESSARY TO ASSURE THE CORRECT PLACEMENT OF MARKINGS IN ORIGINAL LOCATIONS (EXCEPT WHERE NOTED). FOR CENTER LINE MARKINGS, THE CONTRACTOR SHALL INSTALL THE PASSING/NO PASSING ZONE MARKINGS ACCORDING TO THE CURRENT CENTER LINE LOGS AVAILABLE AT

<http://www.dot.state.oh.us/Divisions/Operations/Traffic/miscellaneous/Pages/CenterlinePassingandNoPassingZoneLogs.aspx>

PAYMENT FOR THIS OPERATION SHALL BE INCLUDED WITH EACH RESPECTIVE PAVEMENT MARKING ITEM.

INTERIM COMPLETION OF WORK

ON OR BEFORE THE INTERIM COMPLETION DATE OF 11/15/2022, THE CONTRACTOR SHALL COMPLETE ALL WORK AT BRIDGE No.: GRE-72-1876 AND BRIDGE No.: GRE-72-1883, REQUIRED TO BE PERFORMED WHILE ONE LANE/TWO WAY TRAFFIC IS TO BE MAINTAINED WITH THE USE OF TEMPORARY TRAFFIC SIGNALS AS SHOWN ON SHEETS 9 & 10 AND RESTORE THE ROADWAY TO THE EXISTING LANE CONFIGURATION WITH ALL PERMANENT PAVEMENT MARKINGS INSTALLED. THE CONTRACT WILL BE SUBJECT TO DAILY DISINCENTIVES FOR FAILURE TO COMPLETE ALL REQUIRED WORK AND ALL INCIDENTALS RELATED TO THE WORK, AS OUTLINED IN THE TABLE INCLUDED IN THIS NOTE. APPLICATION OF THE DISINCENTIVES WILL BE BASED ON THE OVERALL CONTRACT AMOUNT. DAILY DISINCENTIVES ARE APPLICABLE TO THE WORK REQUIRED TO THE INTERIM COMPLETION DATE ONLY. THE CONTRACT IS STILL SUBJECT TO LIQUIDATED DAMAGES AS OUTLINED IN CMS 108.07 FOR THE REMAINDER OF THE CONTRACT.

DISINCENTIVE CONTRACT TABLE			
DESCRIPTION OR LOCATION OF CRITICAL WORK	COMPLETION DATE	TIME PERIOD	DISINCENTIVE \$ PER TIME PERIOD
COMPLETE ALL WORK USING ONE LANE-TWO WAY TRAFFIC WITH TEMPORARY SIGNALS	11/15/2022	DAY	\$3,000

ITEM 254- PAVEMENT PLANING, ASPHALT CONCRETE

THE PLANING SHALL BE SCHEDULED SO AS TO BE COVERED BY THE INTERMEDIATE COURSE FOR SR 72 WORK PRIOR TO REOPENING THE LANE TO TRAFFIC. THE COST OF THE ABOVE SHALL BE INCLUDED IN THE UNIT BID PRICE FOR THE RESPECTIVE ITEM. A DISINCENTIVE IN THE AMOUNT OF \$3,000 SHALL BE ASSESSED FOR EACH DAY, OR PORTION THEREOF, A PLANED SURFACE IS OPEN TO TRAFFIC.

ADJUST DEPTH OF PLANING AT NECESSARY BRIDGE APPROACH SLABS. PLAIN PAVEMENT TO PROVIDE SMOOTH TRANSITIONS AT BRIDGE(S).

INTERSECTIONS AND DRIVES

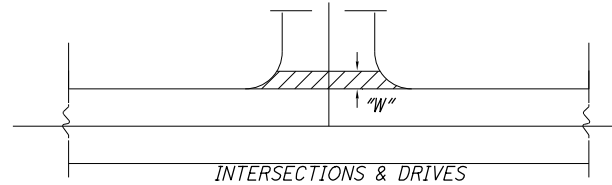

INTERSECTION AND DRIVES QUANTITIES ARE INCLUDED IN THE ASPHALT CONCRETE QUANTITIES. INTERSECTION QUANTITIES HAVE BEEN ESTIMATED AT 15' MEASURED FROM EDGE OF PAVED SHOULDER, DRIVE QUANTITIES HAVE BEEN ESTIMATED AT 3' "W" MEASURED FROM EDGE OF PAVED SHOULDER.

PERFORM WORK PER SPECIFIED OFFSET LIMITS UNLESS THERE IS AN EXISTING JOINT LOCATED CLOSER TO THE EDGE OF PAVED SHOULDER, IN WHICH CASE END WORK AT SAID JOINT, EXCEPT WHERE NOTED BELOW.

ITEM 623- CONSTRUCTION LAYOUT STAKES, AS PER PLAN

PRIOR TO THE START OF ROADWAY OPERATION, THE CONTRACTOR SHALL REFERENCE THE LENGTH OF THE PROJECT ON BOTH SIDES OF THE ROADWAY, IN A MANNER SATISFACTORY TO THE ENGINEER. THE PAVEMENT SHALL BE REFERENCED IN 1000' FEET INCREMENTS, OR IN INCREMENTS ACCEPTABLE TO THE ENGINEER, IN A SEMIPERMANENT CONDITION.

ITEM 253- PAVEMENT REPAIR

AN ESTIMATED QUANTITY OF 1600 CU YDS OF ITEM 253- PAVEMENT REPAIR HAS BEEN CARRIED TO THE GENERAL SUMMARY TO BE USED AS DIRECTED BY THE ENGINEER. THIS OPERATION SHALL BE PERFORMED BEFORE PAVEMENT PLANING OF ROADWAY.

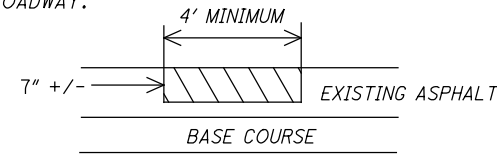

EXISTING DETERIORATED ASPHALT SHALL BE REMOVED TO A MAXIMUM DEPTH OF 7" INCHES OR AS DIRECTED BY THE ENGINEER AND REPLACED WITH ITEM 301, ASPHALT CONCRETE BASE SHALL BE COMPACTED AS PER 401.15 AND IN APPROXIMATELY EQUAL LAYERS. THE LOCATIONS AND SIZE OF THE REPAIRS SHALL BE DETERMINED BY THE ENGINEER.

ITEM 621- RAISED PAVEMENT MARKINGS

ITEM 621- RPM, Y/Y.....270 EA
THE FOLLOWING QUANTITIES HAVE BEEN CARRIED TO THE GENERAL SUMMARY:
ITEM 621- RPM270 EA
ITEM 621- RPM REMOVED.....270 EA

MANHOLES AND VALVES ADJUSTED TO GRADE (PRIVATELY OWNED)
ALL MANHOLE AND VALVES ENCOUNTERED IN AREAS THAT REQUIRE GRADE ADJUSTMENT WILL BE PERFORMED PRIOR TO THE APPLICATION OF THE SURFACE COURSE BY THE UTILITY OWNER. CONTACT THE UTILITY OWNER 2 WEEKS PRIOR TO WHEN THE ADJUSTMENTS ARE TO BE COMPLETED.

ITEM 611 - MANHOLE ADJUSTED TO GRADE

THIS WORK SHALL CONSIST OF ADJUSTING MANHOLES TO GRADE PRIOR TO THE APPLICATION OF THE SURFACE COURSE AS DIRECTED BY THE ENGINEER. THE FOLLOWING QUANTITY HAS BEEN CARRIED TO THE GENERAL SUMMARY:

ITEM 611 - MANHOLE ADJUSTED TO GRADE..... 13 EA.

ITEM 638 - VALVE BOX ADJUSTED TO GRADE

THIS WORK SHALL CONSIST OF ADJUSTING VALVE BOXES TO GRADE PRIOR TO THE APPLICATION OF THE SURFACE COURSE AS DIRECTED BY THE ENGINEER. THE FOLLOWING QUANTITY HAS BEEN CARRIED TO THE GENERAL SUMMARY:

ITEM 638 - VALVE BOX ADJUSTED TO GRADE..... 7 EA.

ITEM 611 - CATCH BASIN ADJUSTED TO GRADE

THIS WORK SHALL CONSIST OF ADJUSTING CATCH BASINS TO GRADE PRIOR TO THE APPLICATION OF THE SURFACE COURSE AS DIRECTED BY THE ENGINEER. THE FOLLOWING QUANTITY HAS BEEN CARRIED TO THE GENERAL SUMMARY:

ITEM 611 - CATCH BASIN ADJUSTED TO GRADE..... 13 EACH

UTILITY COORDINATION

AT&T TRANSMISSION
MICHAEL DIEDERICH
7555 E. PLEASANT VALLEY RD. SUITE 140
INDEPENDENCE, OH 44131
216-750-0135 (MICHAEL DIEDERICH)
md4145@att.com

CENTERPOINT ENERGY
DON SPECHT
6500 CLYO ROAD
CENTERVILLE, OHIO 45459
PUBLICPROJECT@CENTERPOINTENERGY.COM
937-312-2533 (DON SPECHT)

DAYTON POWER & LIGHT
WILLIAM WARD
1900 DRYDEN RD
DAYTON, OH 45439
937-554-9063 (WILLIAM WARD)
William.Ward@aes.com

GREENE COUNTY WATER AND SEWER
GREENE COUNTY SANITARY ENG. DEPT.
667 DAYTON XENIA RD
XENIA OH, 45385
SED PM@co.greene.oh.us

CHARTER COMMUNICATIONS (SPECTRUM)
CHRISTOPHER BOOKSH
3691 TURNER ROAD
DAYTON, OHIO 45459
DL-Southern-Ohio-Outside-Plant@charter.com
513-631-1594 (Chris Booksh)
christopher.booksh@charter.com

GUARDRAIL POST

THIS PROJECT REQUIRES THE INSTALLATION OF NEW GUARDRAIL POSTS. SURVEY WORK HAS NOT BEEN PERFORMED ON THIS PROJECT, NOR HAVE THE UTILITY LOCATIONS BEEN CONFIRMED IN THE FIELD. IN ADDITION TO CMS 105.07, IF, DURING THE COURSE OF INSTALLING ANY NEW GUARDRAIL COMPONENT, IT IS DETERMINED THAT A UTILITY CONFLICT MAY RESULT, THE CONTRACTOR IS TO NOTIFY THE PROJECT ENGINEER IMMEDIATELY. UTILITIES ARE NOT BE RELOCATED AS A RESULT OF THIS OPERATION. ADJUSTMENTS TO THE PROPOSED GUARDRAIL WILL ACCOMMODATE THE EXISTING UTILITY. THE CONTRACTOR IS RESPONSIBLE FOR INSTALLING THE GUARDRAIL VIA MEANS THAT WOULD BE COMPLIANT WITH THE IMPACTED UTILITY'S SAFETY GUIDELINES AS WELL AS STILL MEETING ODOT'S DESIGN CRITERIA. ANY MINOR ADJUSTMENTS MADE TO THE PROPOSED GUARDRAIL INSTALLATIONS SHALL BE INCIDENTAL TO PAY ITEM 606.

ADA WAIVER

AN APPROVED ADA DESIGN WAIVER IS REQUIRED ON THIS PROJECT. THE FOLLOWING FEATURES LISTED BELOW CANNOT FEASIBLY BE CONSTRUCTED TO MEET ADA GUIDELINES.

ADA DESIGN WAIVER			
ADA FEATURE	APPROVAL DATE	SHEET NUMBER	REFERENCE NUMBER
RPM0008159	01/04/22	SHEET 20	C-21
RPM0008160	01/06/22	SHEET 25	C-21

CURB RAMP PAY ITEM CLARIFICATION

AT NEW OR REPLACED CURB RAMPS, NEW CURB OR CURB/GUTTER HAS BEEN QUANTIFIED AND INCLUDED WITH THE CURB RAMP PAY ITEM. CURB OR CURB/GUTTER IS ONLY PAID SEPARATELY WHERE WALK IS PROPOSED.

THE SURFACE COURSE OF THE 2 FOOT PAVEMENT REPLACEMENT AT THE CURB RAMP LOCATIONS SHALL BE PERFORMED CONTIGUOUSLY WITH THE ROADWAY SURFACE COURSE.

I:\ProjectData\GRE\94174_GRE-SR72-14.48_Design\Roadway\Sheets\94174_GN001.dgn Sheet 4/6/2022 8:49:25 AM jdavis4

CALCULATED
JED
CHECKED
JDO

GENERAL NOTES

GRE - SR 72-14.48

3
48

ENVIRONMENTAL NOTES

- 1. STREAM UNT-1 TO LMR, LOCATED WEST OF SR-72 AND SOUTH OF THE LITTLE MIAMI RIVER, WILL NOT BE IMPACTED DURING CONSTRUCTION. THE CONTRACTOR IS NOT PERMITTED TO TOUCH OR IMPACT THIS STREAM IN ANY WAY AND SHALL OBTAIN THEIR OWN PERMIT IF THEY WISH TO TOUCH OR IMPACT THE STREAM.
- 2. THIS PROJECT IS LOCATED IN OR NEAR A DRINKING WATER PROTECTION AREA. IN ORDER TO MINIMIZE THE POTENTIAL FOR CONTAMINATION, THE CONTRACTOR SHALL NOT PERFORM PROJECT RELATED REFUELING AND VEHICLE MAINTENANCE ACTIVITIES ON SR-72 FROM SLM 15.72-16.04 AND SLM 18.73-19. THE CONTRACTOR SHALL IMMEDIATELY TAKE STEPS TO MITIGATE ANY EVENT, SUCH AS A SPILL OF FUELS, OILS, OR CHEMICALS, THAT COULD THREATEN TO CONTAMINATE THE DRINKING WATER SUPPLY. ANY SUCH SPILL OR EVENT SHALL BE REPORTED IMMEDIATELY TO THE GREENE COUNTY DISASTER SERVICES AT (937)-562-5994. IF THE SPILL IS A REPORTABLE AMOUNT (PER OHIO EPA'S RELEASE REPORTING REQUIREMENTS), THE CONTRACTOR SHALL CONTACT MIAMI TOWNSHIP FIRE-RESCUE STATION 82 AT (937)-767-7842 OR THE OHIO EPA'S SPILLS HOTLINE 1-800-282-9378 FOR CLEAN-UP OF THE SPILL.
- 3. THE CONTRACTOR SHALL NOT DISCHARGE TOXIC OR HAZARDOUS MATERIALS SUCH AS SEALANTS, PAINT, SOLVENTS, CLEANING AGENTS, EARTHEN MATERIALS, WASTE-WATER, FUELS OR DEBRIS OF ANY KIND TO A SCENIC RIVER, ITS TRIBUTARIES, OR DRAINAGE WAYS. IF REFUELING OF IMMOBILE EQUIPMENT IS NECESSARY WITHIN THE FLOODPLAIN OR NEAR ANY TRIBUTARY DRAINAGE WAYS, DITCHES, OR STREAM, THE CONTRACTOR SHALL PROVIDE SECONDARY CONTAINMENT WITH ENOUGH CAPACITY TO COMPLETELY CONTAIN AND COLLECT ALL POTENTIAL LIQUID WASTES IN THE EVENT OF A SPILL.
- 4. ANY AND ALL CONSTRUCTION DEBRIS, EARTHEN DEBRIS, EXCESS ASPHALT OR CONCRETE, WOOD DEBRIS FROM CLEARING, EXCESS FILL MATERIAL, AND TRASH SHOULD BE DISPOSED OF AT AN APPROVED UPLAND SITE OR LAND FILL ABOVE FEMA 100-YEAR FLOOD ELEVATIONS. DISPOSAL OF ANY SUCH MATERIALS WITHIN 1000 FEET OF THE LITTLE MIAMI SCENIC RIVER IS PROHIBITED.
- 5. IN ACCORDANCE WITH ORC 3750.06, REPORTABLE SPILLS MUST BE REPORTED TO THE LOCAL FIRE DEPARTMENT (911); THE LOCAL EMERGENCY COORDINATOR (330-627-2141), AND THE OHIO SPILL LINE (1-800-282-9378).
- 6. THE CONTRACTOR SHALL KEEP ALL IDLE EQUIPMENT, FUELS, LUBRICANTS, AND ANY STORAGE FOR/OF POTENTIALLY TOXIC OR HAZARDOUS MATERIALS OUT OF THE FEMA DESIGNATED SPECIAL FLOOD HAZARD AREA AND NOT WITHIN 1000 FEET OF THE LITTLE MIAMI SCENIC RIVER.
- 7. THE CONTRACTOR SHALL NOTIFY THE PROJECT ENGINEER 40 DAYS PRIOR TO WORK WITHIN 1000 FEET OF THE LITTLE MIAMI SCENIC RIVER. THE PROJECT ENGINEER SHALL NOTIFY THE DISTRICT ENVIRONMENTAL COORDINATOR 35 DAYS PRIOR TO WORK WITHIN 1000 FEET OF THE SCENIC RIVER. IF COORDINATION WITH ODNR HAS NOT ALREADY OCCURRED, AND THE PROJECT REQUIRES NOTIFICATION TO THE SCENIC RIVER MANGER PRIOR TO CONSTRUCTION PER THE SCENIC RIVER MOA, THE DISTRICT ENVIRONMENTAL COORDINATOR SHALL COORDINATE WITH ODNR SCENIC RIVERS 30 DAYS PRIOR TO ANY WORK WITHIN 1000 FEET OF LITTLE MIAMI SCENIC RIVER.
- 8. WHEN CUTTING AND CLEARING OF ANY VEGETATION WITHIN 1000 FEET OF THE LITTLE MIAMI RIVER, THE CONTRACTOR SHALL LIMIT THE AMOUNT OF VEGETATION BEING CLEARED TO THE ABSOLUTE MINIMUM NECESSARY TO ACCOMPLISH THE GOAL OF THE PROJECT. VERTICAL PRUNING OF TREES IS PERMITTED IF ANY OVERHANGING LIMBS CAUSE A SAFETY HAZARD OR OBSTRUCT VIEW. THE CONTRACTOR SHALL NOT USE A FLAIL MOWER FOR VERTICAL PRUNING. THE CONTRACTOR MUST AVOID GIRDLING OR SCUFFING TREE TRUNKS.

9. IF ANY PAINTING, WELDING, SAND AND/OR WATER BLASTING (CLEANING) AT OR OVER THE LITTLE MIAMI RIVER, THEN THE CONTRACTOR SHALL UTILIZE APPROPRIATE APRONS TO PROVIDE FOR COMPLETE CONTAINMENT OF ALL PAINT, WELDING SLAG AND/OR SEALANT OVER SPRAY AND OTHER DEBRIS. APRONS, APPROPRIATE FALSEWORK, OR OTHER BARRIERS SHALL BE UTILIZED ON ALL DECK REPLACEMENT PROJECTS TO PREVENT THE DISCHARGE OF CONCRETE, ASPHALT OR OTHER DEBRIS TO A DESIGNATED SCENIC RIVER. ALL DEBRIS COLLECTED SHALL BE DISPOSED OF AT AN APPROVED UPLAND SITE OR LAND FILL ABOVE FEMA 100-YEAR FLOOD ELEVATIONS. DISPOSAL OF ANY SUCH MATERIALS WITHIN 1000 FEET OF THE LITTLE MIAMI RIVER IS PROHIBITED.

10. FILL MATERIAL USED BELOW OHWM OF THE LITTLE MIAMI RIVER SHALL BE RELATIVELY FREE FROM FINE PARTICULATE MATTER AND FREE FROM TOXIC CONTAMINANTS OTHER THAN IN TRACE QUANTITIES AND SHALL BE KEPT TO THE MINIMUM AMOUNT NECESSARY. BROKEN CONCRETE OR ASPHALT ARE SPECIFICALLY PROHIBITED FROM USE AS FILL BELOW THE OHWM OR ON ANY PORTION OF THE SCENIC RIVER STREAM BANKS. APPLICABLE IN-STREAM WORK RESTRICTION DATES WILL BE INCORPORATED INTO THE SPECIAL PROVISIONS.

11. ACCESS TO THE CHANNEL SHALL BE CONFINED TO ONE STREAM BANK WHENEVER POSSIBLE. THE STREAM BOTTOMS AND BANKS AFFECTED BY THE CAUSEWAY AND ACCESS FILLS WILL BE RESTORED TO ITS PRE-CONSTRUCTION ELEVATIONS.

12. THE CONTRACTOR SHALL MAKE EVERY ATTEMPT TO CONDUCT IN-STREAM WORK USING WATER DIVERSIONS SUCH AS SHEET PILING, MEMBRANE DAMS, ETC. THAT DO NOT REQUIRE THE PLACEMENT OF EARTHEN FILL.

13. THE CONTRACTOR SHALL NOT DISCHARGE WASTEWATER OF ANY KIND INTO THE LITTLE MIAMI RIVER OR ANY OF ITS TRIBUTARY STREAMS, DRAINAGE WAYS, OR DITCHES. IF DEWATERING IS NECESSARY TO FACILITATE IN-STREAM WORK OR PIER CONSTRUCTION, PUMP ALL WASTEWATER ONTO A VEGETATED AREA A SUFFICIENT DISTANCE FROM THE RIVER TO ALLOW FOR COMPLETE INFILTRATION. IF DISCHARGE TO A VEGETATED AREA IS NOT FEASIBLE, THEN WASTEWATER SHALL BE DISCHARGED INTO A SEDIMENT FILTER BAG OR INTO A TEMPORARY DETENTION/RETENTION POND OR APPROPRIATE SEDIMENT CONTROL WITH A SUFFICIENT RETENTION PERIOD THAT PERMITS THE SETTLING OF ALL SUSPENDED SOLIDS. THE CONTRACTOR SHALL PUMP ALL WATER TO AN AREA WITHIN THE PROJECT LIMITS OR AN AREA CLEARED BY THE CONTRACTOR.

14. ENSURE IMPACTS TO THE FEDERALLY LISTED AND PROTECTED INDIANA BAT AND NORTHERN LONG-EARED BAT AND THE STATE LISTED AND PROTECTED LITTLE BROWN BAT AND TRICOLORED BAT ARE AVOIDED AND MINIMIZED. DO NOT REMOVE TREES FROM [APRIL 1 THROUGH SEPTEMBER 30]. PERFORM ALL NECESSARY TREE REMOVAL FROM [OCTOBER 1 THROUGH MARCH 31]. DEMARCAT E CLEARING LIMITS IN THE FIELD TO AVOID ANY UNAUTHORIZED TREE CLEARING. FOR THE PURPOSES OF THIS NOTE, A TREE IS DEFINED AS A LIVE, DYING, OR DEAD WOODY PLANT, WITH A TRUNK THREE INCHES OR GREATER IN DIAMETER AT A HEIGHT OF 4.5 FEET ABOVE THE GROUND SURFACE, AND WITH A MINIMUM HEIGHT OF 13 FEET.

15. ANY DISTURBED AREAS WITHIN 1,000 FEET OF THE SCENIC RIVER THAT WILL BE REVEGETATED SHALL BE REVEGETATED BY THE CONTRACTOR WITH NATIVE GRASSES AND WILDFLOWERS (CMS ITEM 659.09) OR SIMILAR SEED MIXES COMPOSED OF NATIVE HERBS AND GRASSES.

ITEM SPECIAL - CONSULTANT FOR CONCRETE QUALITY CONTROL INCLUDING TESTING AND INSPECTION

ALL CONCRETE SHALL BE TESTED. ALL TESTING, INSPECTION AND QUALITY CONTROL FOR CONCRETE, NOT INCLUDED UNDER QC/QA PAY ITEMS, SHALL BE THE RESPONSIBILITY OF THE CONTRACTOR. THE CONTRACTOR SHALL PROVIDE A CONCRETE TESTING CONSULTANT WITH PREVIOUS EXPERIENCE AND FAMILIARITY IN ODOT PROCEDURES, CONCRETE TESTING REQUIREMENTS AND CONCRETE TESTING DOCUMENTATION. AT LEAST 30 DAYS PRIOR TO CONCRETE PLACEMENT, SUBMIT TO THE ENGINEER FOR APPROVAL, THE PROPOSED CONCRETE TESTING CONSULTANT ALONG WITH THE RESUMES OF THE PROPOSED TESTING PERSONNEL.

TESTING CONCRETE FOR STRUCTURES AND PORTLAND CEMENT CONCRETE PAVEMENT SHALL BE PERFORMED AS OUTLINED IN CMS SPECIFICATIONS 455 RESPECTIVELY.

THROUGH THE CONTRACTOR, THE CONSULTANT SHALL BE RESPONSIBLE FOR ENSURING THAT ALL CONCRETE PLACED IS IN ACCORDANCE WITH THE SPECIFICATIONS. SUCH WORK SHALL BE IN ACCORDANCE WITH THE APPLICABLE CONSTRUCTION AND MATERIAL SPECIFICATIONS AND THE ODOT CONSTRUCTION INSPECTION MANUAL OF PROCEDURES FOR CONCRETE. THE CONCRETE CONSULTANT SHALL PROVIDE THE NECESSARY TRAINED TECHNICIAN(S), ALL EQUIPMENT, AND SHALL FURNISH THE PROJECT ENGINEER WITH TWO (2) COPIES OF ALL TEST RESULTS WITHIN 24 HOURS AFTER COMPLETION OF CONCRETE PLACEMENT.

THE TECHNICIAN SHALL BE ACI LEVEL 1 CERTIFIED AND WILL BE REQUIRED TO DEMONSTRATE HIS/HER COMPETENCE AND EXPERIENCE LEVELS TO THE ENGINEER PRIOR TO BEGINNING WORK. THE ENGINEER WILL ORDER THE CONTRACTOR TO REPLACE ANY TECHNICIAN THAT IS NOT VERSED IN THE REQUIRED TESTING PROCEDURE.

THE TECHNICIAN SHALL VERBALLY NOTIFY THE ODOT PROJECT ENGINEER OF ANY FAILING TEST AND SHALL SUBMIT FOLLOW-UP WRITTEN NOTIFICATION TO THE PROJECT ENGINEER OF REMEDIAL ACTION(S) TAKEN. TESTS SHALL BE TAKEN AS SPECIFIED WITHIN THE CONSTRUCTION AND MATERIAL SPECIFICATIONS, CONCRETE MANUAL OR APPROPRIATE SUPPLEMENTAL SPECIFICATION AS LISTED IN THE PROPOSAL GOVERNING THE PROJECT. IT SHALL BE THE SOLE RESPONSIBILITY OF THE CONTRACTOR TO MAKE IMMEDIATE CORRECTIONS OR ADJUSTMENTS TO THE CONCRETE MIX VIA DIRECT COMMUNICATION WITH THE CONCRETE SUPPLIER'S PLANT PERSONNEL TO MAINTAIN UNINTERRUPTED COMPLIANCE WITH THE SPECIFICATIONS UPON NOTIFICATION OF CONCRETE MIX NON-COMPLIANCE BY THE CONSULTANT TECHNICIAN. THE PROJECT ENGINEER MAY REQUIRE MORE FREQUENT TESTING AS CONDITIONS WARRANT.

UPON COMPLETION OF DAILY CONCRETE PLACEMENT(S), THE CONCRETE CONSULTANT SHALL PROVIDE THE PROJECT ENGINEER WITH DAILY TEST REPORTS, TE-45'S, INSPECTORS DAILY REPORT AND SUPPORTING DOCUMENTATION FOR EACH ITEM OF CONCRETE WORK PERFORMED SEPARATED BY MIX DESIGN. SUBSEQUENTLY, UPON COMPLETION OF AN ENTIRE CONCRETE SPECIFICATION ITEM, THE CONCRETE CONSULTANT SHALL ALSO PROVIDE THE PROJECT ENGINEER WITH TWO (2) COPIES OF AN ADDITIONAL INSPECTION REPORT BY A REGISTERED PROFESSIONAL ENGINEER, STATE OF OHIO, WHICH CONTAINS THE TESTING-RESULTS SUMMARY FOR EACH ITEM BY CONTRACT REFERENCE NUMBER AND THE CONSULTANT'S CONCLUSIONS RELATIVE TO SPECIFICATION COMPLIANCE FOR ALL CONCRETE-TESTING WORK.

THE ODOT PROJECT ENGINEER RESERVES THE RIGHT TO MAKE UNANNOUNCED QUALITY-CONTROL TESTS TO VERIFY PROCEDURES USED AND RESULTS BEING OBTAINED BY THE CONTRACTOR.

THE CONCRETE TECHNICIAN SHALL WORK UNDER THE DIRECTION OF A REGISTERED PROFESSIONAL ENGINEER, STATE OF OHIO, WHO WILL MONITOR THE CONCRETE TEST RESULTS. THE FINAL INSPECTION REPORTS FOR EACH COMPLETED ITEM SHALL BE SIGNED BY A REGISTERED PROFESSIONAL ENGINEER, STATE OF OHIO, CERTIFYING THAT ALL CONCRETE TESTS PROVIDED BY THE CONTRACTOR MET APPLICABLE CONTRACT REQUIREMENTS. A FINAL REPORT ISSUED BY THE

CONSULTING FIRM SHALL CONTAIN A CERTIFIED STATEMENT OF COMPLIANCE WITH ODOT SPECIFICATIONS AND ANY OTHER CONCLUSIONS REGARDING THE CONCRETE MATERIALS INCORPORATED INTO THE PROJECT. SUCH STATEMENT SHALL BE SIGNED BY A REGISTERED PROFESSIONAL ENGINEER, STATE OF OHIO. AND, THE CONCRETE CONSULTANT SHALL BE REQUIRED TO ATTEND MONTHLY PROGRESS MEETINGS AS REQUIRED BY THE PROJECT ENGINEER.

ADDITIONALLY, THE CONTRACTOR SHALL BE REQUIRED TO KEEP A POSTED LIST OF BEAM AND CYLINDER IDENTIFICATION NUMBERS FOR THE PURPOSE OF IDENTIFYING THE CORRESPONDING PLACEMENT LOCATION AND CONCRETE SPECIFICATION ITEM.

PAYMENT SHALL BE BID AS LUMP SUM FOR ITEM SPECIAL MISC.: CONSULTANT FOR CONCRETE QUALITY CONTROL INCLUDING TESTING AND INSPECTION. THE ITEM WILL BE PAID FOR AS FOLLOWS:
 UPON APPROVAL OF CONSULTANT 20%
 PROGRESSIVE EQUIVALENT PAYMENTS 50%
 UPON SUBMISSION OF FINAL REPORT 30%.

THE TECHNICIAN SHALL HAVE THE FULL EFFECT AND AUTHORITY OF AN ODOT PROJECT INSPECTOR IN DETERMINING ACCEPTABILITY OF MATERIAL AND CONCRETE PLACEMENT PRACTICES.

CALCULATED
JED
CHECKED
JDO

GENERAL NOTES

GRE - SR 72-14.48

I:\Project\Dat\GRE\94174_GRE-SR72-14.48_Design\Roadway\Sheets\94174_GN002.dgn Sheet 4/8/2022 11:31:31PM jdavisa

I:\ProjectData\GRE_94174\GRE-SR72-14.48\Design\Roadway\Sheets\94174_C-201.dgn Sheet 4/6/2022 10:54:56 AM Jdavls4

- ① ITEM 253 - PAVEMENT REPAIR, (B)
- ② ITEM 407 - NON-TRACKING TACK COAT
- ③ ITEM 301 - 6" ASPHALT CONCRETE BASE, PG 64-22, 2 - 3" LIFTS
- ④ ITEM 304 - 6" AGGREGATE BASE
- ⑤ ITEM 608 - CURB RAMP
- Ⓐ EXISTING ASPHALT SECTION

TYPICAL SECTION

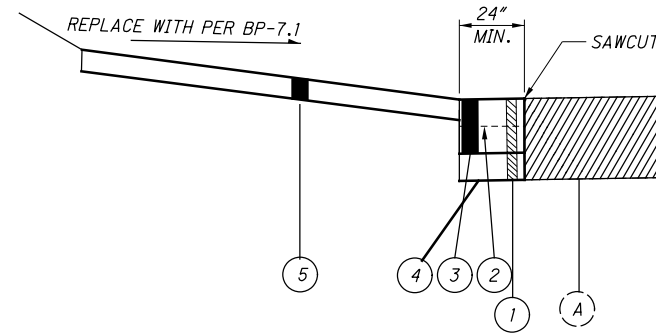

COUNTY	ROUTE	LOGPOINT OR INTERSECTING STREETNAME	REFERENCE NO.	202			253		608		609		ADDITIONAL NOTES		
				PAVEMENT REMOVED	WALK REMOVED	CURB & GUTTER REMOVED	CURB REMOVED	PAVEMENT REPAIR B	4" CONCRETE WALK	CURB RAMP	CURB TYPE 6	CURB TYPE 4-C			
				SQ YD	SQ FT	FEET	FEET	CU YD	SQ FT	SQ FT	FEET	FEET			
GRE	72	REGENCY N	C-1		70.0	4.0		1			70.0				
GRE	72	REGENCY S	C-2		70.0	4.0		1			70.0				
GRE	72	WILMINGTON PK N	C-3		48.0			1	16.0		32.0				
GRE	72	WILMINGTON PK S	C-4		48.0			1	16.0		32.0				
GRE	72	MAPLE ST NE	C-5		16.0			1			16.0				
GRE	72	MAPLE ST SE	C-6		16.0			1			16.0				
GRE	72	PARKVIEW ST S	C-7		20.0			1			20.0				
GRE	72	BIKE PATH WEST	C-8	1							30.0				
GRE	72	EAST ST N	C-9		60.0		8.0	1	30.0		30.0		8.0		
GRE	72	E NORTH ST SE	C-10		16.0			1			16.0				
GRE	72	W NORTH ST NW	C-11		16.0			1			16.0				
GRE	72	W NORTH ST NW	C-12		16.0			1			16.0				
GRE	72	W NORTH ST SW	C-13		16.0			1			16.0				
GRE	72	E ELM ST NE	C-14	1	30.3			1			41.0				
GRE	72	E ELM ST SE	C-15	1	25.0			1			35.0				
GRE	72	W ELM ST NW	C-16		45.0			1			45.0				
GRE	72	W ELM ST SW	C-17		52.5			1			52.5				
GRE	72	W CHURCH ST NE	C-18		80.0		12.0	2	50.0		55.0		13.0		
GRE	72	W CHURCH ST NE	C-18A		105.0		16.0	1	25.0		50.0				
GRE	72	W CHURCH SE	C-19		25.0			1			25.0				
GRE	72	COLLEGE ST SW	C-20	1	43.0		4.0	1			43.0		4.0		
GRE	72	COLLEGE ST NE	C-21		45.5			1			45.5				
GRE	72	COLLEGE ST SE	C-22		145.5			1	50.0		145.0				
GRE	72	ORR ST NE	C-23, C-23A		120.0		10.0	1			120.0		4.0		
GRE	72	ORR ST NW	C-24		33.0			1			33.0				
GRE	72	ORR ST SE	C-25		110.3		14.0	1	44.0		66.0				
GRE	72	ORR ST SE	C-25A		40.0		8.0	1	39.0		40.0		7.0		
GRE	72	ORR ST SW	C-26		33.0			1			33.0				
GRE	72	CENTER ST NE	C-27		30.5			1	20.0		10.5				
GRE	72	CENTER ST SE	C-28		60.0		2.0	1	30.0		30.0		6.0		
GRE	72	KYLE DR	C-29		117.0			1	72.0		45.0				
			CONTINGENCY						50.0						
TOTALS CARRIED TO GENERAL SUMMARY				4	1553	8	74	31		442	1295		7	35	

CALCULATED
JED
CHECKED
JDO

CURB RAMP QUANTITIES

GRE-SR 72-14.48

GENERAL NOTES:

REFERENCE SHALL BE MADE TO THE FOLLOWING STANDARD DRAWINGS:

DBR-3-11 DATED 07-15-11
PIS GR-1.1 DATED 01-18-13
PIS GR-2.1 DATED 01-18-13
PIS GR-3.4 DATED 07-20-18
PIS GR-4.2 DATED 01-18-13
PIS GR-5.1 DATED 01-18-13

REFERENCE SHALL BE MADE TO THE FOLLOWING SUPPLEMENTAL SPECIFICATIONS:

800 DATED 1-21-22
843 DATED 10-18-19
844 DATED 4-20-18
846 DATED 4-17-15
848 DATED 1-15-21

REFERENCE SHALL BE MADE TO THE FOLLOWING PROPOSAL NOTE:

512 DATED 1-15-16

DESIGN DATA:

CONCRETE CLASS QC5 - COMPRESSIVE STRENGTH 4.5 KSI

REINFORCING STEEL - GRADE 60 MINIMUM YIELD STRENGTH 60 KSI

DESIGN SPECIFICATIONS

THIS STRUCTURE CONFORMS TO THE 8TH EDITION OF THE LRFD BRIDGE DESIGN SPECIFICATIONS ADOPTED BY THE AMERICAN ASSOCIATION OF STATE HIGHWAY AND TRANSPORTATION OFFICIALS, 2017 AND THE ODOT BRIDGE DESIGN MANUAL, 2020.

EXISTING STRUCTURE VERIFICATION

DETAILS AND DIMENSIONS SHOWN ON THESE PLANS PERTAINING TO THE EXISTING STRUCTURE HAVE BEEN OBTAINED FROM PLANS OF THE EXISTING STRUCTURE AND FROM FIELD OBSERVATIONS AND MEASUREMENTS. CONSEQUENTLY, THEY ARE INDICATIVE OF THE EXISTING STRUCTURE AND THE PROPOSED WORK, BUT THEY SHALL BE CONSIDERED TENTATIVE AND APPROXIMATE. THE CONTRACTOR IS REFERRED TO CMS SECTION 102.05 AND 105.02.

BASE CONTRACT BID PRICES UPON A RECOGNITION OF THE UNCERTAINTIES DESCRIBED ABOVE AND UPON A PREBID EXAMINATION OF THE EXISTING STRUCTURE. HOWEVER, THE DEPARTMENT WILL PAY FOR ALL PROJECT WORK BASED UPON ACTUAL DETAILS AND DIMENSIONS THAT HAVE BEEN VERIFIED IN THE FIELD.

UTILITIES

LISTED BELOW ARE ALL UTILITIES LOCATED WITHIN THE PROJECT CONSTRUCTION LIMITS TOGETHER WITH THEIR RESPECTIVE OWNERS:

DAYTON POWER AND LIGHT
1900 DRYDEN RD
DAYTON, OH 45439
937-554-9063 (WILLIAM WARD)
WILLIAM.WARD@AES.COM

CENTERPOINT ENERGY COMPANY (VECTREN)
6500 CLYO ROAD
CENTERVILLE, OHIO 45459
937-312-2533 (DON SPECHT)
PUBLICPROJECT@CENTERPOINTENERGY.COM

ATT OHIO
7201 FAR HILLS AVE.
DAYTON OHIO 45459
937-296-3588 (HOWARD LAUDERMILK)
HL1596@ATT.COM

GREENE COUNTY WATER AND SEWER
GREENE COUNTY SANITARY ENG. DEPT.
ATTN: PROJECT MANAGEMENT
667 DAYTON XENIA RD
XENIA OH, 45385
SED.PM@CO.GREENE.OH.US

CHARTER COMMUNICATIONS
3691 TURNER RD
DAYTON, OHIO 45415
DL-SOUTHERN-OHIO-OUTSIDE-PLANT@CHARTER.COM
937-631-1594 (CHRIS BOOKSH)
CHRISTOPHER.BOOKSH@CHARTER.COM

ITEM SPECIAL - PATCHING CONCRETE STRUCTURE (BOTTOM OF BRIDGE DECK):

PATCH CONCRETE WITH TROWELABLE MORTAR PER SUPPLEMENTAL SPECIFICATION 843. INSTALL EMBEDDED GALVANIZED ANODES PER SUPPLEMENTAL SPECIFICATION 844. ANODES SHALL BE PLACED UNIFORMLY AT 24" SPACING EACH WAY.

MEASUREMENT AND PAYMENT:

THE PLAN QUANTITIES INCLUDE A 50% INCREASE OF THE FIELD MEASURED QUANTITIES. THE ACCEPTED QUANTITIES FOR THE COMPLETED WORK AS DESCRIBED WILL BE MEASURED AND PAID BY ITEM 519 - PATCHING CONCRETE STRUCTURE, AS PER PLAN.

ITEM 509 - REINFORCING STEEL, REPLACEMENT OF REINFORCING STEEL, AS PER PLAN

REPLACEMENT OF ALL EXISTING REINFORCING BARS DEEMED BY THE ENGINEER TO BE UNUSABLE BECAUSE OF CORROSION. THE DEPARTMENT WILL MEASURE THE REPLACEMENT REINFORCING STEEL BY THE NUMBER OF POUNDS ACCEPTED IN PLACE.

REPLACE ALL EXISTING REINFORCING STEEL BARS WHICH ARE TO BE INCORPORATED INTO THE NEW WORK AND ARE DEEMED BY THE ENGINEER TO BE MADE UNUSABLE BY CONCRETE REMOVAL OPERATIONS WITH NEW EPOXY COATED REINFORCING STEEL OF THE SAME SIZE AND COATING AT NO COST TO THE DEPARTMENT.

ADDITIONAL QUANTITIES HAVE BEEN PROVIDED FOR DOWEL HOLES, IF NEEDED, TO EMBED THE REPLACEMENT REINFORCING INTO THE EXISTING STRUCTURE. PAYMENT FOR DOWEL HOLES SHALL BE MADE AT THE BID UNIT PRICE FOR ITEM 510 DOWEL HOLES WITH NONSHRINK, NONMETALLIC GROUT.

ITEM 519 - PATCHING CONCRETE STRUCTURES, AS PER PLAN:

ESTIMATED QUANTITIES ARE BASED ON THE MOST RECENT IN-DEPTH INSPECTION OF THE STRUCTURE. AREAS TO BE PATCHED HAVE BEEN DETAILED IN THE PLANS.

IT IS POSSIBLE THAT ADDITIONAL AREAS REQUIRING PATCHING MAY HAVE DEVELOPED SINCE THE MOST RECENT INSPECTION OF THE STRUCTURE. THEREFORE, THE CONTRACTOR SHALL SOUND THE SURROUNDING PERIMETER OF THE AREA TO BE PATCHED AND PATCH NEW AREAS APPROVED BY THE ENGINEER THAT HAVE NOT BEEN DETAILED IN THE PLANS.

MEASUREMENT AND PAYMENT:

THE PLAN QUANTITIES INCLUDE A 50% INCREASE OF THE FIELD MEASURED QUANTITIES. THE ACCEPTED QUANTITIES FOR THE COMPLETED WORK AS DESCRIBED WILL BE MEASURED AND PAID BY ITEM 519 - PATCHING CONCRETE STRUCTURE.

ITEM 843 - PATCHING CONCRETE STRUCTURES WITH TROWELABLE MORTAR, AS PER PLAN:

ESTIMATED QUANTITIES ARE BASED ON THE MOST RECENT IN-DEPTH INSPECTION OF THE STRUCTURE. AREAS TO BE PATCHED HAVE BEEN DETAILED IN THE PLANS.

IT IS POSSIBLE THAT ADDITIONAL AREAS REQUIRING PATCHING MAY HAVE DEVELOPED SINCE THE MOST RECENT INSPECTION OF THE STRUCTURE. THEREFORE, THE CONTRACTOR SHALL SOUND THE SURROUNDING PERIMETER OF THE AREA TO BE PATCHED AND PATCH NEW AREAS APPROVED BY THE ENGINEER THAT HAVE NOT BEEN DETAILED IN THE PLANS.

MEASUREMENT AND PAYMENT:

THE PLAN QUANTITIES INCLUDE A 50% INCREASE OF THE FIELD MEASURED QUANTITIES. THE ACCEPTED QUANTITIES FOR THE COMPLETED WORK AS DESCRIBED WILL BE MEASURED AND PAID BY ITEM 843 - PATCHING CONCRETE STRUCTURES WITH TROWELABLE MORTAR, AS PER PLAN.

ITEM 606 - BRIDGE TERMINAL ASSEMBLY, TYPE 4, AS PER PLAN:

THIS PART ITEM SHALL INCLUDE THE COST TO FURNISH AND INSTALL ALL GUARDRAIL COMPONENTS (NORMAL AND EXTRA) OF THE 25' LONG BRIDGE TERMINAL ASSEMBLY, TYPE 4 AS SEEN ON THE PLAN INSERT SHEET.

ITEM 606 - ANCHOR ASSEMBLY, MGS TYPE E:

THIS ITEM SHALL CONSIST OF FURNISHING AND INSTALLING ANY OF THE GUARDRAIL END TERMINALS FOR TYPE MGS GUARDRAIL AS LISTED ON ROADWAY ENGINEERING'S WEB PAGE UNDER ROADSIDE SAFETY DEVICES FOR APPROVED GUARDRAIL END TREATMENTS. INSTALLATION SHALL BE AT THE LOCATIONS SPECIFIED IN THE PLANS, IN ACCORDANCE WITH THE MANUFACTURER'S SPECIFICATIONS.

THE FACE OF THE TYPE E IMPACT HEAD SHALL BE COVERED WITH A SHEET OF TYPE J, ASTM D4956 TYPE XI REFLECTIVE SHEETING, PER CMS 730.193.

REFER TO THE MANUFACTURER'S INSTRUCTIONS REGARDING THE INSTALLATION OF, AND THE GRADING AROUND THE FOUNDATION TUBES AND GROUND STRUT. THE TOP OF ANY FOUNDATION TUBES SHOULD BE AN APPROPRIATE DEPTH BELOW THE LEVEL LINE IN ORDER TO MAINTAIN THE FINISHED GUARDRAIL HEIGHT OF 31 INCHES FROM THE EDGE OF THE SHOULDER.

ON-SITE GRADING IS REQUIRED IF THE TOP OF THE FOUNDATION TUBES OR TOP OF THE GROUND STRUT DOES PROJECT MORE THAN 4 INCHES ABOVE THE GROUND LINE.

PAYMENT FOR THE ABOVE WORK SHALL BE MADE AT THE UNIT PRICE BID FOR ITEM 606, ANCHOR ASSEMBLY, MGS TYPE E, EACH, AND SHALL INCLUDE ALL LABOR, TOOLS, EQUIPMENT AND MATERIALS NECESSARY TO CONSTRUCT A COMPLETE AND FUNCTIONAL ANCHOR ASSEMBLY SYSTEM, INCLUDING ALL RELATED TRANSITIONS, REFLECTIVE SHEETING, HARDWARE, GRADING, EMBANKMENT AND EXCAVATION NOT SEPERATELY SPECIFIED, AS REQUIRED BY THE MANUFACTURER.

ITEM 606 - ANCHOR ASSEMBLY, TYPE E:

THIS ITEM SHALL CONSIST OF FURNISHING AND INSTALLING ANY OF THE GUARDRAIL END TERMINALS AS LISTED ON ROADWAY ENGINEERING'S WEB PAGE UNDER ROADSIDE SAFETY DEVICES FOR APPROVED GUARDRAIL END TREATMENTS. INSTALLATION SHALL BE AT THE LOCATIONS SPECIFIED IN THE PLANS, IN ACCORDANCE WITH THE MANUFACTURER'S SPECIFICATIONS.

THE FACE OF THE TYPE E IMPACT HEAD SHALL BE COVERED WITH A SHEET OF TYPE G REFLECTIVE SHEETING, PER CMS 730.19.

REFER TO THE MANUFACTURER'S INSTRUCTIONS REGARDING THE INSTALLATION OF, AND THE GRADING AROUND THE FOUNDATION TUBES AND GROUND STRUT. THE TOP OF ANY FOUNDATION TUBES SHOULD BE LESS THAN 4 INCHES ABOVE THE GROUND. THE PLACEMENT OF THE FOUNDATION TUBES SHOULD BE AN APPROPRIATE DEPTH BELOW THE LEVEL LINE IN ORDER TO MAINTAIN THE FINISHED GUARDRAIL HEIGHT OF 27.75 INCHES FROM THE EDGE OF THE SHOULDER.

ON-SITE GRADING IS REQUIRED IF THE TOP OF THE FOUNDATION TUBES OR TOP OF THE GROUND STRUT DOES PROJECT MORE THAN 4 INCHES ABOVE THE GROUND LINE.

PAYMENT FOR THE ABOVE WORK SHALL BE MADE AT THE UNIT PRICE BID FOR ITEM 606, ANCHOR ASSEMBLY, TYPE E, EACH, AND SHALL INCLUDE ALL LABOR, TOOLS, EQUIPMENT AND MATERIALS NECESSARY TO CONSTRUCT A COMPLETE AND FUNCTIONAL ANCHOR ASSEMBLY SYSTEM, INCLUDING ALL RELATED TRANSITIONS, REFLECTIVE SHEETING, HARDWARE, GRADING, EMBANKMENT AND EXCAVATION NOT SEPERATELY SPECIFIED, AS REQUIRED BY THE MANUFACTURER.

ITEM 844 - CONCRETE PATCHING WITH GALVANIC ANODE PROTECTION, AS PER PLAN:

ESTIMATED QUANTITIES ARE BASED ON THE MOST RECENT IN-DEPTH INSPECTION OF THE STRUCTURE. AREAS REQUIRING CONCRETE PATCHING WITH GALVANIC ANODE PROTECTION HAVE BEEN DETAILED IN THE PLANS.

IT IS POSSIBLE THAT ADDITIONAL AREAS REQUIRING CONCRETE PATCHING WITH GALVANIC ANODE PROTECTION MAY HAVE DEVELOPED SINCE THE MOST RECENT INSPECTION OF THE STRUCTURE. THEREFORE, THE CONTRACTOR SHALL SOUND THE SURROUNDING PERIMETER OF THE AREA TO BE PATCHED AND PATCH NEW AREAS APPROVED BY THE ENGINEER THAT HAVE NOT BEEN DETAILED IN THE PLANS.

INSTALL EMBEDDED GALVANIZED ANODES PER SUPPLEMENTAL SPECIFICATION 844. ANODES SHALL BE PLACED UNIFORMLY AT 24" SPACING EACH WAY.

SEE CMS 519 FOR ABUTMENT PATCHING REQUIREMENTS. SEE SUPPLEMENTAL SPECIFICATION 843 FOR SLAB PATCHING REQUIREMENTS.

MEASUREMENT AND PAYMENT:

THE PLAN QUANTITIES INCLUDE A 50% INCREASE OF THE FIELD MEASURED QUANTITIES. THE ACCEPTED QUANTITIES FOR THE COMPLETED WORK AS DESCRIBED WILL BE MEASURED AND PAID BY ITEM 844 - CONCRETE PATCHING WITH GALVANIC ANODE PROTECTION, AS PER PLAN.

ITEM 846 - POLYMER MODIFIED ASPHALT EXPANSION JOINT SYSTEM, AS PER PLAN:

THIS ITEM INCLUDES ALL THE WORK NECESSARY FOR REMOVAL OF EXISTING POLYMER MODIFIED ASPHALT EXPANSION JOINT SYSTEM, AS WELL AS ADDITIONAL MATERIAL REMOVAL NECESSARY TO INSTALL THE NEW POLYMER MODIFIED ASPHALT EXPANSION JOINT SYSTEM. THIS ITEM SHALL BE COMPLETED AT THE LOCATIONS SPECIFIED ON THE PLANS.

PAYMENT FOR THIS WORK SHALL INCLUDE ALL EQUIPMENT, TOOLS, MATERIALS AND LABOR NECESSARY TO PERFORM THIS TASK.

TEMPORARY ACCESS FILL

COFFERDAMS AND EXCAVATION BRACING INSTALLED FOR THE PROJECT ARE FOR DEWATERING THE WORK AREA. COFFERDAMS AND EXCAVATION BRACING DESIGN, CONSTRUCTION, AND REIMBURSEMENT FOR DAMAGE IS BASED ON CMS 503. THE CONTRACTOR MUST COMPLY WITH THE IN-STREAM RESTRICTION IN THE SPECIAL PROVISIONS - WATERWAY PERMIT. ADDING FILL TO THE STREAM TO DEWATER THE WORK AREA REQUIRES A TEMPORARY ACCESS (TAF) SUBMISSION PER THE SPECIAL PROVISIONS. FILLING AN EXCAVATED AREA AFTERWARDS IS CONSIDERED A PERMANENT FILL AND MAY VIOLATE THE WATERWAY PERMIT'S THRESHOLDS OF IMPACTS.

AS STATED IN THE SPECIAL PROVISIONS, THE TAF WILL NOT BE PAID AS A SEPARATE ITEM BUT WILL BE INCLUDED BY THE CONTRACT AS PART OF THE TOTAL PROJECT COST.

MAINTENANCE OF TRAFFIC

MAINTAIN ONE 12 FOOT LANE OF TWO-WAY TRAFFIC USING TEMPORARY SIGNALS. INCLUDE BOTH GRE-72-1876 AND GRE-72-1883 IN THE SAME SIGNALIZED LANE CLOSURE. SEE ROADWAY PLANS FOR MORE DETAILS.

P:\PR59330\GRE\94174\Design\Structures\GRE072_1876C\Sheets\94174_SFN2902079_SNO01.dgn Sheet 4/5/2022 11:20:34 AM anslnf

DESIGN AGENCY	BURGESS & NIPLÉ	525 VINE ST. CINCINNATI, OHIO
DATE	3/19/21	
REVIEWED	XAC	STRUCTURE FILE NUMBER 2902079/2902109
DRAWN	JDG	REVISID
DESIGNED	JDG	CHECKED
		SJA
STRUCTURE GENERAL NOTES		
BRIDGE NO. GRE-72-1876 AND BRIDGE NO. GRE-72-1883 OVER LITTLE MIAMI RIVER		
GRE - 72 - 14 - 48		
PID No. 94174		
1 / 13		
27		
48		

P:\PR59330\GRE\94174\Design\Structures\GRE072_1876\Sheets\94174_SF2902079_50001.dgn Sheet 4/4/2022 3:00:13 PM ansln

GRE-72-1876 ESTIMATED BRIDGE QUANTITIES							CALC.	DATE	CHK'D	DATE
ITEM	ITEM EXT.	TOTAL	UNIT	DESCRIPTION	ABUT.	PIERS	SUPER.	GENERAL	SHT. REF.	
202	38000	206	FT	GUARDRAIL REMOVED				206		
254	01000	73	SY	PAVEMENT PLANING, ASPHALT CONCRETE (2 1/2")				73		
407	13900	6	GAL	TACK COAT, 702.13				6		
441	50101	5	CY	ASPHALT CONCRETE SURFACE COURSE, TYPE 1 (448), PG76-22M, (2 1/2"), AS PER PLAN				5	2/13	
503	11100	LS		COFFERDAMS AND EXCAVATION BRACING						
509	20001	100	LB	REINFORCING STEEL, REPLACEMENT OF EXISTING REINFORCING STEEL, AS PER PLAN				100	1/13	
510	10000	10	EACH	DOWEL HOLES WITH NONSHRINK, NONMETALLIC GROUT				10	1/13	
512	10100	357	SY	SEALING OF CONCRETE SURFACES (EPOXY-URETHANE)	152	159	46			
512	10600	27	FT	CONCRETE REPAIR BY EPOXY INJECTION	27					
512	74000	187	SY	REMOVAL OF EXISTING COATINGS FROM CONCRETE SURFACES	152		35			
517	75600	227	FT	DEEP BEAM BRIDGE RETROFIT RAILING			227			
519	11101	146	SF	PATCHING CONCRETE STRUCTURE, AS PER PLAN		146			1/13	
519	12200	11	SY	PATCHING CONCRETE BRIDGE DECK, TYPE A (SEE PROPOSAL NOTE)				11		
SPECIAL	519-11600	108	SF	PATCHING CONCRETE STRUCTURE (BOTTOM OF BRIDGE DECK)			108		2/13	
606	13000	112.5	FT	GUARDRAIL, TYPE 5				112.5		
606	15100	150	FT	GUARDRAIL, TYPE MGS WITH LONG POSTS				150		
606	26150	3	EACH	ANCHOR ASSEMBLY, MGS TYPE E (NCHRP 350 OR MASH 2016)				3		
606	26500	1	EACH	ANCHOR ASSEMBLY, TYPE T				1		
606	35141	4	EACH	BRIDGE TERMINAL ASSEMBLY, TYPE 4, AS PER PLAN				4	1/13	
626	00110	12	EACH	BARRIER REFLECTOR, TYPE 2 BIDERICTIONAL				12		
843	50001	50	SF	PATCHING CONCRETE STRUCTURES WITH TROWELABLE MORTAR, AS PER PLAN		5	45		1/13	
844	10001	829	SF	CONCRETE PATCHING WITH GALVANIC ANODE PROTECTION, AS PER PLAN	829				1/13	
846	00111	24	CF	POLYMER MODIFIED ASPHALT EXPANSION JOINT SYSTEM, AS PER PLAN				24	1/13	
848	10200	442	SY	SUPERPLASTICIZED DENSE CONCRETE OVERLAY USING HYDRODEMOLITION (2 1/4" THICK)			442			
848	20000	449	SY	SURFACE PREPARATION USING HYDRODEMOLITION			449			
848	30200	4	CY	SUPERPLASTICIZED DENSE CONCRETE OVERLAY (VARIABLE THICKNESS), MATERIAL ONLY			4			
848	50000	13	SY	HAND CHIPPING			13			
848	50100	LS		TEST SLAB						
848	50320	449	SY	EXISTING CONCRETE OVERLAY REMOVED (1 3/4" NOMINAL THICKNESS)			449			

GRE-72-1883 ESTIMATED BRIDGE QUANTITIES							CALC.	DATE	CHK'D	DATE
ITEM	ITEM EXT.	TOTAL	UNIT	DESCRIPTION	ABUT.	PIERS	SUPER.	GENERAL	SHT. REF.	
202	38000	140	FT	GUARDRAIL REMOVED				140		
503	11100	LS		COFFERDAMS AND EXCAVATION BRACING						
509	20001	100	LB	REINFORCING STEEL, REPLACEMENT OF EXISTING REINFORCING STEEL, AS PER PLAN				100	1/13	
510	10000	10	EACH	DOWEL HOLES WITH NONSHRINK, NONMETALLIC GROUT				10	1/13	
512	10100	131	SY	SEALING OF CONCRETE SURFACES (EPOXY-URETHANE)	121		10			
512	10600	27	FT	CONCRETE REPAIR BY EPOXY INJECTION	27					
512	73500	171	SY	TREATING CONCRETE BRIDGE DECKS WITH GRAVITY FED RESIN				171		
512	74000	128	SY	REMOVAL OF EXISTING COATINGS FROM CONCRETE SURFACES	121		7			
517	75600	75	FT	DEEP BEAM BRIDGE RETROFIT RAILING			75			
SPECIAL	519-11600	99	SF	PATCHING CONCRETE STRUCTURE (BOTTOM OF BRIDGE DECK)			99		2/13	
606	13000	143.75	FT	GUARDRAIL, TYPE 5				143.75		
606	15050	50	FT	GUARDRAIL, TYPE MGS				50		
606	17900	1	EACH	GUARDRAIL POST				1		
606	26100	1	EACH	ANCHOR ASSEMBLY, TYPE E				1		
606	26150	1	EACH	ANCHOR ASSEMBLY, MGS TYPE E (NCHRP 350 OR MASH 2016)				1		
606	26500	2	EACH	ANCHOR ASSEMBLY, TYPE T				2		
606	35141	3	EACH	BRIDGE TERMINAL ASSEMBLY, TYPE 4, AS PER PLAN				3	1/13	
626	00110	12	EACH	BARRIER REFLECTOR, TYPE 2 BIDERICTIONAL				12		
843	50001	9	SF	PATCHING CONCRETE STRUCTURES WITH TROWELABLE MORTAR, AS PER PLAN			9		1/13	
844	10001	136	SF	CONCRETE PATCHING WITH GALVANIC ANODE PROTECTION, AS PER PLAN	136				2/13	
846	00111	30	CF	POLYMER MODIFIED ASPHALT EXPANSION JOINT SYSTEM, AS PER PLAN				30	1/13	
848	10200	113	SY	SUPERPLASTICIZED DENSE CONCRETE OVERLAY USING HYDRODEMOLITION (2 3/4" THICK)			113			
848	20000	120	SY	SURFACE PREPARATION USING HYDRODEMOLITION			120			
848	30200	1	CY	SUPERPLASTICIZED DENSE CONCRETE OVERLAY (VARIABLE THICKNESS), MATERIAL ONLY			1			
848	50000	4	SY	HAND CHIPPING			4			
848	50100	LS		TEST SLAB						
848	50320	120	SY	EXISTING CONCRETE OVERLAY REMOVED (1 3/4" NOMINAL THICKNESS)			120			

ESTIMATED QUANTITIES

BRIDGE NO. GRE-72-1876 AND BRIDGE NO. GRE-72-1883
OVER LITTLE MIAMI RIVER

GRE - 72 - 14.48
PID No. 94174

2 / 13

28
48

DESIGN AGENCY
BURGESS & NIPLE
525 VINE ST. CINCINNATI, OHIO

DATE
3/19/21

REVIEWED
XAC

DRAWN
JDG

DESIGNED
JDG

STRUCTURE FILE NUMBER
2902079/2902109

REVISED
SJA

CHECKED
SJA

P:\PR59330\GRE\94174\Design\Structures\GRE072_1876C\Sheets\94174_SF2902079_SMO05.dgn Sheet 4/4/2022 3:01:03 PM ansin

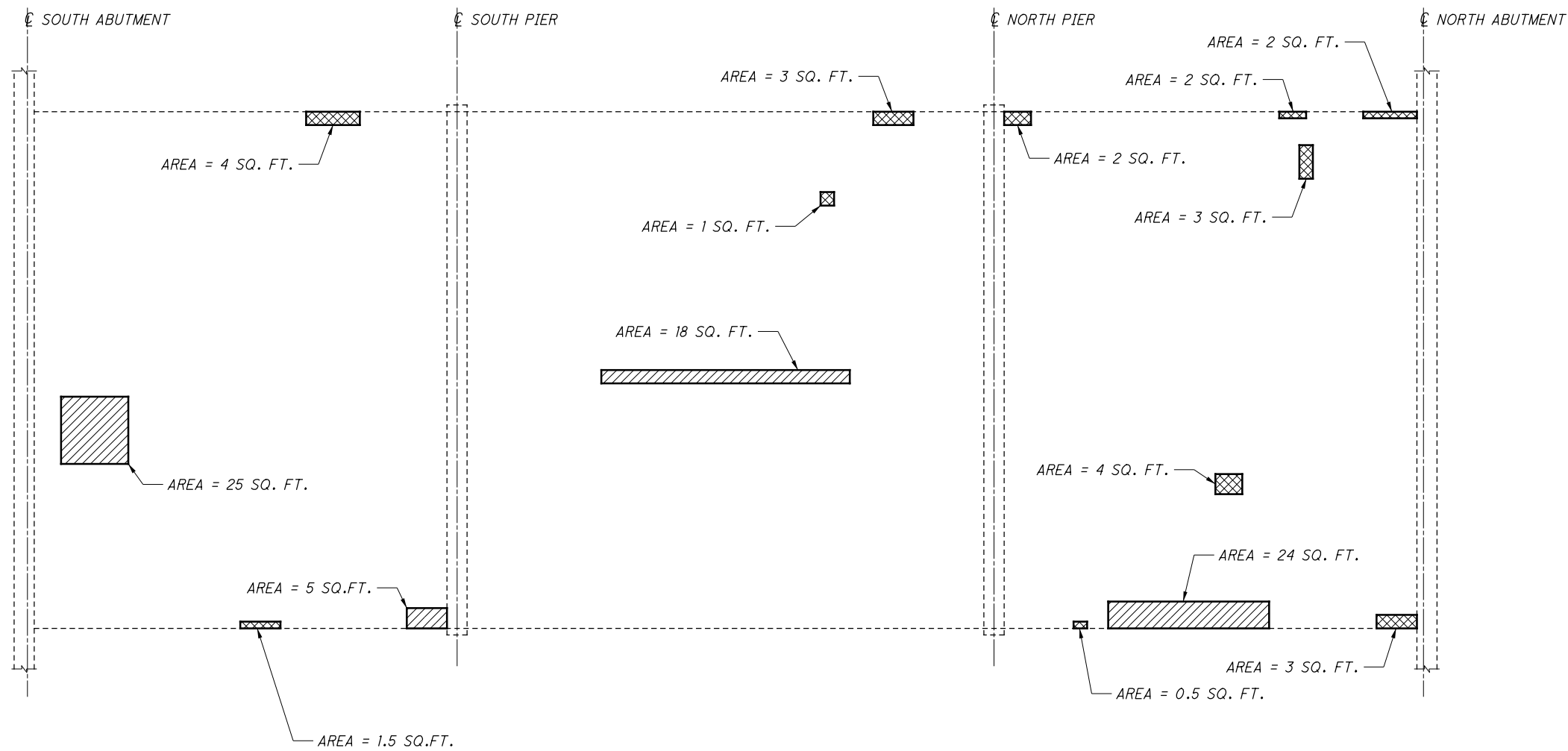

DECK PLAN
(PATCHING SHOWN IS TO THE UNDERSIDE OF DECK)

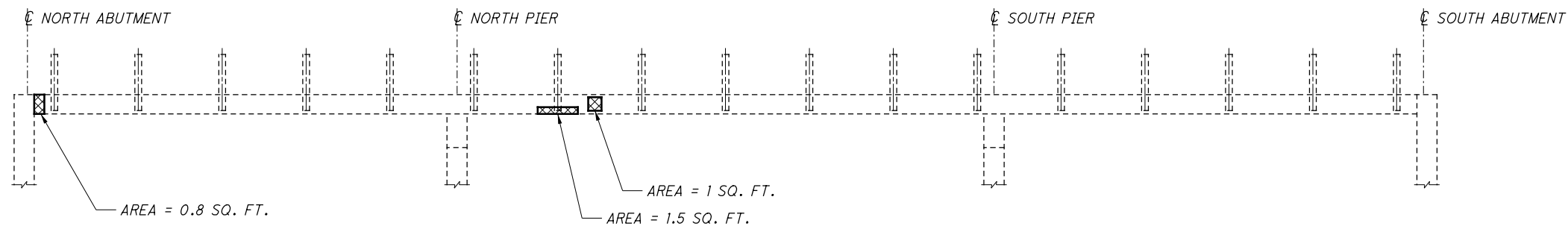

WEST EDGE OF DECK

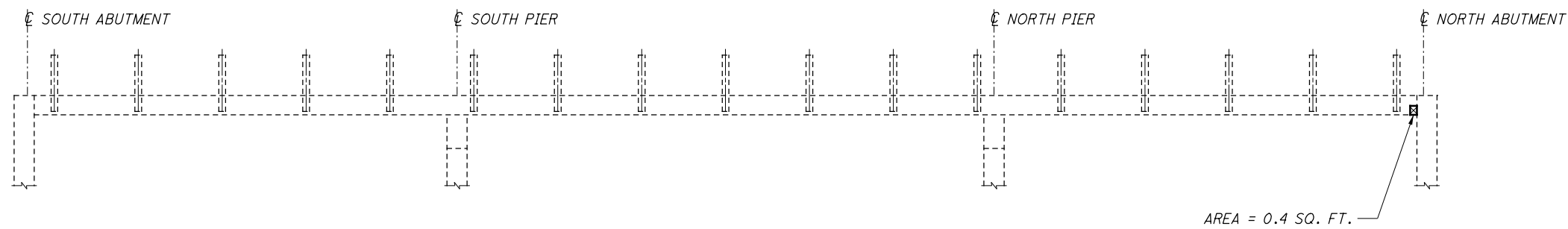

EAST EDGE OF DECK

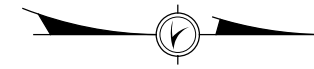

SUMMARY OF REPAIR QUANTITIES		
REPAIR TYPE	* FIELD MEASURED QUANTITY	** PLAN QUANTITY
ITEM 843 PATCHING	30 SF	45 SF
ITEM SPECIAL PATCHING	72 SF	108 SF

* FROM FIELD INSPECTION CONDUCTED MARCH 2021
 ** PLAN QUANTITIES HAVE BEEN INCREASED BY 50% FOR ADDITIONAL DETERIORATION

LEGEND:

- LIMITS OF PATCHING PER ITEM SPECIAL - PATCHING CONCRETE STRUCTURE (BOTTOM OF BRIDGE DECK)
- LIMITS OF PATCHING PER ITEM 843 - PATCHING CONCRETE STRUCTURES WITH TROWELABLE MORTAR, AS PER PLAN

NOTES:

1. REMOVE EXISTING CONCRETE SEALER FROM DECK EDGES. SEAL DECK EDGES WITH EPOXY-URETHANE SEALER, FEDERAL COLOR 17778 (OFF WHITE).

P:\PR59330\GRE\94174\Design\Structures\GRE072_1883C\Sheets\94174_SFN290209_SM003.dgn Sheet 4/4/2022 3:02:08 PM ansin

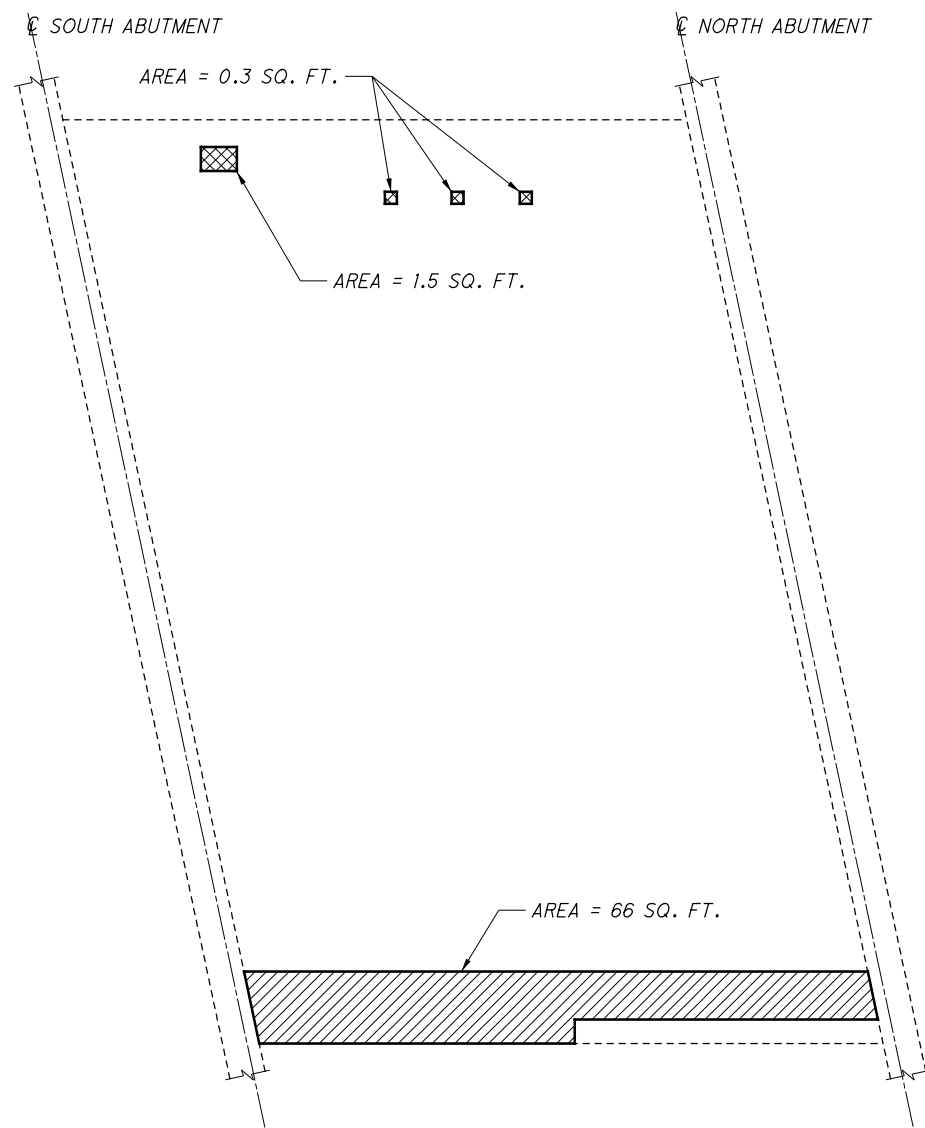

DECK PLAN
(PATCHING SHOWN IS TO THE UNDERSIDE OF DECK)

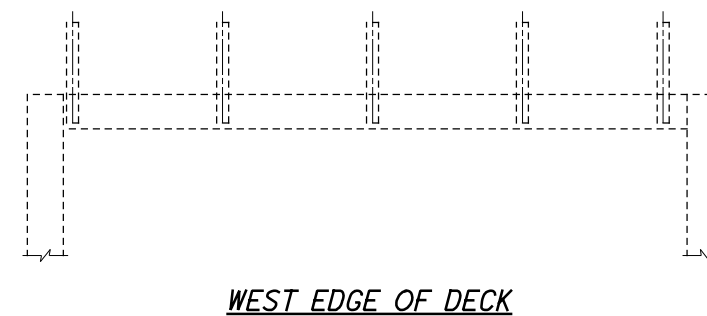

WEST EDGE OF DECK

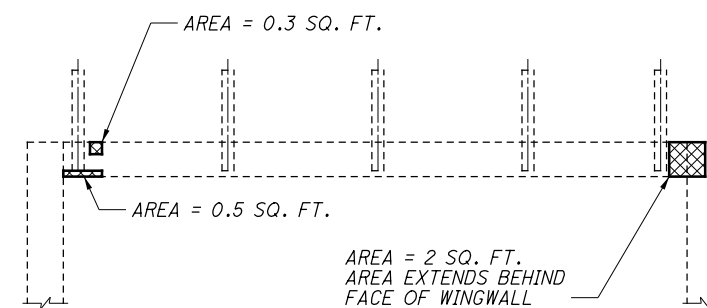

EAST EDGE OF DECK

SUMMARY OF REPAIR QUANTITIES		
REPAIR TYPE	* FIELD MEASURED QUANTITY	** PLAN QUANTITY
ITEM 843 PATCHING	6 SF	9 SF
ITEM SPECIAL PATCHING	66 SF	99 SF

* FROM FIELD INSPECTION CONDUCTED MARCH 2021
** PLAN QUANTITIES HAVE BEEN INCREASED BY 50% FOR ADDITIONAL DETEIORATION

LEGEND:

- LIMITS OF PATCHING PER ITEM SPECIAL - PATCHING CONCRETE STRUCTURE (BOTTOM OF BRIDGE DECK)
- LIMITS OF PATCHING PER ITEM 843 - PATCHING CONCRETE STRUCTURES WITH TROWELABLE MORTAR, AS PER PLAN

NOTES:

1. REMOVE EXISTING CONCRETE SEALER FROM DECK EDGES. SEAL DECK EDGES WITH EPOXY-URETHANE SEALER, FEDERAL COLOR 17778 (OFF WHITE).

GRE - 72 - 14 - 48	PID No. 94174	BRIDGE NO. GRE-72-1883 OVER THE TAIL RACE OF THE LITTLE MIAMI RIVER	DESIGN AGENCY BURGESS & NIPLÉ 525 VINE ST. CINCINNATI, OHIO
13 / 13	39 / 48		REVIEWED DATE XAC 5/25/21 STRUCTURE FILE NUMBER 2902079
DESIGNED JDG	DRAWN JDG	CHECKED SJA	REVISED SJA