

SCENIC RIVER PLAN NOTES

THE CONTRACTOR SHALL NOT DISCHARGE TOXIC OR HAZARDOUS MATERIALS SUCH AS SEALANTS, PAINT, SOLVENTS, CLEANING AGENTS, EARTHEN MATERIALS, WASTE-WATER, FUELS OR DEBRIS OF ANY KIND TO A SCENIC RIVER, ITS TRIBUTARIES, OR DRAINAGE WAYS. IF REFUELING OF IMMOBILE EQUIPMENT IS NECESSARY WITHIN THE FLOODPLAIN OR NEAR ANY TRIBUTARY DRAINAGE WAYS, DITCHES, OR STREAM, THE CONTRACTOR SHALL PROVIDE SECONDARY CONTAINMENT WITH ENOUGH CAPACITY TO COMPLETELY CONTAIN AND COLLECT ALL POTENTIAL LIQUID WASTES IN THE EVENT OF A SPILL.

ANY AND ALL CONSTRUCTION DEBRIS, EARTHEN DEBRIS, EXCESS ASPHALT OR CONCRETE, WOOD DEBRIS FROM CLEARING, EXCESS FILL MATERIAL, AND TRASH SHOULD BE DISPOSED OF AT AN APPROVED UPLAND SITE OR LAND FILL ABOVE FEMA 100-YEAR FLOOD ELEVATIONS. DISPOSAL OF ANY SUCH MATERIALS WITHIN 1000 FEET OF THE LITTLE MIAMI RIVER IS PROHIBITED.

IN ACCORDANCE WITH ORC 3750.06, REPORTABLE SPILLS MUST BE REPORTED TO THE LOCAL FIRE DEPARTMENT (911); THE LOCAL EMERGENCY COORDINATOR (937) 224-8938, AND THE OHIO SPILL LINE (1-800-282-9378).

THE CONTRACTOR SHALL KEEP ALL IDLE EQUIPMENT, FUELS, LUBRICANTS, AND ANY STORAGE FOR/OF POTENTIAL TOXIC OR HAZARDOUS MATERIALS OUT OF THE FEMA DESIGNATED SPECIAL FLOOD HAZARD AREA AND NOT WITHIN 1000 FEET OF THE LITTLE MIAMI RIVER.

THE CONTRACTOR SHALL NOTIFY THE PROJECT ENGINEER 40 DAYS PRIOR TO WORK WITHIN 1000 FEET OF THE LITTLE MIAMI RIVER. THE PROJECT ENGINEER SHALL NOTIFY THE DISTRICT ENVIRONMENTAL COORDINATOR 35 DAYS PRIOR TO WORK WITHIN 1000 FEET OF THE SCENIC RIVER. IF COORDINATION WITH ODNR HAS NOT ALREADY OCCURED, AND THE PROJECT REQUIRES NOTIFICATION TO THE SCENIC RIVER MANGER PRIOR TO CONSTRUCTION PER THE SCENIC RIVER MOA, THE DISTRICT ENVIRONMENTAL COORDINATOR SHALL COORDINATE WITH ODNR SCENIC RIVERS 30 DAYS PRIOR TO ANY WORK WITHIN 1000 FEET OF THE LITTLE MIAMI RIVER.

THE CONTRACTOR SHALL DEVELOP AND IMPLEMENT A SEDIMENT AND EROSION CONTROL PLAN BEFORE EARTHWORK COMMENCES. THE PLAN SHALL INCLUDE A LIST OF APPLICABLE BMPS, PER SS 832 THAT WILL BE USED THROUGHOUT THE PROJECT, SUCH AS PERIMETER CONTROLS AND/OR SEEDING AND MULCHING, AND MUST BE SUBMITTED TO THE PROJECT ENGINEER FOR REVIEW AND ACCEPTANCE. SEDIMENT AND EROSION CONTROLS SHALL BE PROPERLY INSTALLED AND MAINTAINED THROUGHOUT THE DURATION OF THE PROJECT. STRAW BALES SHALL NOT BE PERMITTED AS A FORM OF SEDIMENT CONTROL. ALL TEMPORARY SEDIMENT AND EROSION CONTROLS SHALL BE REMOVED UPON STABILIZATION OF THE PROJECT AREA. PARTICULAR ATTENTION SHALL BE GIVEN TO ANY DRAINAGE WAYS, UNPROTECTED SLOPES, DITCHES, AND STREAMS THAT COULD CONVEY SEDIMENT LAND WATERS DIRECTLY TO THE LITTLE MIAMI RIVER.

THE CONTRACTOR SHALL MAINTAIN ALL DITCHES FOR THE ORIGINAL INTENDED FUNCTION AND RESTORE IT TO THE ORIGINAL DESIGN CONFIGURATION, UNLESS THE DITCH LINE WILL BE MODIFIED FOR WATER QUALITY ISSUES SUCH AS STORM WATER CONTROL OR MITIGATION. THE CONTRACTOR SHALL SEED AND PROTECT ALL DENUDED DITCHES WITH NATURAL EROSION CONTROL MATTING OR SOD IMMEDIATELY UPON COMPLETION OF EARTHWORK

WHEN CUTTING AND CLEARING OF ANY VEGETATION WITHIN 1000 FEET OF THE LITTLE MIAMI RIVER, THE CONTRACTOR SHALL LIMIT THE AMOUNT OF VEGETATION BEING CLEARED TO THE ABSOLUTE MINIMUM NECESSARY TO ACCOMPLISH THE GOAL OF THE PROJECT. VERTICAL PRUNING OF TREES IS PERMITTED IF ANY OVERHANGING LIMBS CAUSE A SAFETY HAZARD OR OBSTRUCT VIEW. THE CONTRACTOR SHALL NOT USE A FLAIL MOWER FOR VERTICAL PRUNING. THE CONTRACTOR MUST AVOID GIRDLING OR SCUFFING TREE TRUNKS.

BAT HABITAT CUTTING RESTRICTIONS

THE PROJECT IS LOCATED WITHIN THE KNOW HABITAT RANGES OF THE FEDERALLY LISTED AND PROTECTED INDIANA BAT AND NORTHERN LONG-EARED BAT. THE CONTRACTOR SHALL NOT REMOVE TREES UNDER THIS PROJECT FROM APRIL 1 THROUGH SEPTEMBER 30. ALL NECESSARY TREE REMOVAL SHALL OCCUR FROM OCTOBER 1 THROUGH MARCH 31. THE CONTRACTOR SHALL DEMARCAT E CLEARING LIMITS IN THE FIELD TO AVOID ANY UNAUTHORIZED TREE CLEARING. THIS REQUIREMENT IS NECESSARY TO AVOID AND MINIMIZE IMPACTS TO THESE SPECIES AS REQUIRED BY THE ENDANGERED SPECIES ACT. FOR THE PURPOSES OF THIS NOTE, A TREE IS DEFINED AS A LIVE, DYING, OR DEAD WOODY PLANT, WITH A TRUNK THREE INCHES OR GREATER IN DIAMETER AT A HEIGHT OF 4.5 FEET ABOVE THE GROUND SURFACE, AND WITH A MINIMUM HEIGHT OF 13 FEET.

ITEM SPECIAL STRUCTURES: CONSULTANT FOR CONCRETE QUALITY CONTROL INCLUDING TESTING AND INSPECTION

ALL CONCRETE SHALL BE TESTED. ALL TESTING, INSPECTION AND QUALITY CONTROL FOR CONCRETE, NOT INCLUDED UNDER QC/QA PAY ITEMS, SHALL BE THE RESPONSIBILITY OF THE CONTRACTOR. THE CONTRACTOR SHALL PROVIDE A CONCRETE TESTING CONSULTANT WITH PREVIOUS EXPERIENCE AND FAMILIARITY IN ODOT PROCEDURES, CONCRETE TESTING REQUIREMENTS AND CONCRETE TESTING DOCUMENTATION. AT LEAST 30 DAYS PRIOR TO CONCRETE PLACEMENT, SUBMIT TO THE ENGINEER FOR APPROVAL, THE PROPOSED CONCRETE TESTING CONSULTANT ALONG WITH THE RESUMES OF THE PROPOSED TESTING PERSONNEL.

TESTING CONCRETE FOR STRUCTURES AND PORTLAND CEMENT CONCRETE PAVEMENT SHALL BE PERFORMED AS OUTLINED IN CONSTRUCTION AND MATERIAL SPECIFICATIONS 455.

THROUGH THE CONTRACTOR, THE CONSULTANT SHALL BE RESPONSIBLE FOR ENSURING THAT ALL CONCRETE PLACED IS IN ACCORDANCE WITH THE SPECIFICATIONS. SUCH WORK SHALL BE IN ACCORDANCE WITH THE APPLICABLE CONSTRUCTION AND MATERIAL SPECIFICATIONS AND THE ODOT CONSTRUCTION INSPECTION MANUAL OF PROCEDURES FOR CONCRETE. THE CONCRETE CONSULTANT SHALL PROVIDE THE NECESSARY TRAINED TECHNICIAN(S) AND EQUIPMENT AND SHALL FURNISH THE PROJECT ENGINEER WITH TWO (2) COPIES OF ALL TEST RESULTS WITHIN 24 HOURS AFTER COMPLETION OF CONCRETE PLACEMENT.

THE TECHNICIANS SHALL BE ACI LEVEL 1 CERTIFIED AND WILL BE REQUIRED TO DEMONSTRATE HIS/HER COMPETENCE AND EXPERIENCE LEVELS TO THE ENGINEER PRIOR TO BEGINNING WORK. THE ENGINEER WILL ORDER THE CONTRACTOR TO REPLACE ANY TECHNICIAN THAT IS NOT VERSED IN THE REQUIRED TESTING PROCEDURE.

THE TECHNICIAN SHALL VERBALLY NOTIFY THE ODOT PROJECT ENGINEER OF ANY FAILING TESTS AND SHALL SUBMIT FOLLOW-UP WRITTEN NOTIFICATION TO THE PROJECT ENGINEER OF REMEDIAL ACTION(S) TAKEN. TESTS SHALL BE TAKEN AS SPECIFIED WITHIN THE CONSTRUCTION AND MATERIAL SPECIFICATIONS, CONCRETE MANUAL OR APPROPRIATE SUPPLEMENTAL SPECIFICATION AS LISTED IN THE PROPOSAL GOVERNING THE PROJECT. IT SHALL BE THE SOLE RESPONSIBILITY OF THE CONTRACTOR TO MAKE IMMEDIATE CORRECTIONS OR ADJUSTMENTS TO THE CONCRETE MIX VIA DIRECT COMMUNICATION WITH THE CONCRETE SUPPLIER'S PLANT PERSONNEL TO MAINTAIN UNINTERRUPTED COMPLIANCE WITH THE SPECIFICATIONS UPON NOTIFICATION OF CONCRETE MIX NON-COMPLIANCE BY THE CONSULTANT TECHNICIAN. THE PROJECT ENGINEER MAY REQUIRE MORE FREQUENT TESTING AS CONDITIONS WARRANT.

UPON COMPLETION OF DAILY CONCRETE PLACEMENT(S), THE CONCRETE CONSULTANT SHALL PROVIDE THE PROJECT ENGINEER WITH DAILY TEST REPORTS, TE-45'S, INSPECTORS DAILY REPORT AND SUPPORTING DOCUMENTATION FOR EACH ITEM OF CONCRETE WORK PERFORMED SEPARATED BY MIX DESIGN. SUBSEQUENTLY, UPON COMPLETION OF AN ENTIRE CONCRETE SPECIFICATION ITEM, THE CONCRETE CONSULTANT SHALL ALSO PROVIDE THE PROJECT ENGINEER WITH TWO (2) COPIES OF AN ADDITIONAL INSPECTION REPORT BY A REGISTERED PROFESSIONAL ENGINEER, STATE OF OHIO, WHICH CONTAINS THE TESTING RESULTS SUMMARY FOR EACH ITEM BY CONTRACT REFERENCE NUMBER AND THE CONSULTANT'S CONCLUSIONS RELATIVE TO SPECIFICATION COMPLIANCE FOR ALL CONCRETE TESTING WORK.

THE ODOT PROJECT ENGINEER RESERVES THE RIGHT TO MAKE UNANNOUNCED QUALITY-CONTROL TESTS TO VERIFY PROCEDURES USED AND RESULTS BEING OBTAINED BY THE CONTRACTOR. THE CONCRETE TECHNICIAN SHALL WORK UNDER THE DIRECTION OF A REGISTERED PROFESSIONAL ENGINEER, STATE OF OHIO, WHO WILL MONITOR THE CONCRETE TEST RESULTS. THE FINAL INSPECTION REPORTS FOR EACH COMPLETED ITEM SHALL BE SIGNED BY A REGISTERED PROFESSIONAL ENGINEER, STATE OF OHIO, CERTIFYING THAT ALL CONCRETE TESTS PROVIDED BY THE CONTRACTOR MET APPLICABLE CONTRACT REQUIREMENTS. A FINAL REPORT ISSUED BY THE CONSULTING FIRM SHALL CONTAIN A CERTIFIED STATEMENT OF COMPLIANCE WITH ODOT SPECIFICATIONS AND ANY OTHER CONCLUSIONS REGARDING THE CONCRETE MATERIALS INCORPORATED INTO THE PROJECT. SUCH STATEMENT SHALL BE SIGNED BY A REGISTERED PROFESSIONAL ENGINEER, STATE OF OHIO. AND, THE CONCRETE CONSULTANT SHALL BE REQUIRED TO ATTEND MONTHLY PROGRESS MEETINGS AS REQUIRED BY THE PROJECT ENGINEER.

ADDITIONALLY, THE CONTRACTOR SHALL BE REQUIRED TO KEEP A POSTED LIST OF BEAM AND CYLINDER IDENTIFICATION NUMBERS FOR THE PURPOSE OF IDENTIFYING THE CORRESPONDING PLACEMENT LOCATION AND CONCRETE SPECIFICATION ITEM.

PAYMENT SHALL BE BID AS LUMP SUM FOR ITEM SPECIAL STRUCTURES: CONSULTANT FOR CONCRETE QUALITY CONTROL INCLUDING TESTING AND INSPECTION. THE ITEM WILL BE PAID FOR AS FOLLOWS:

UPON APPROVAL OF CONSULTANT 20%
PROGRESSIVE EQUIVALENT PAYMENTS 50%
UPON SUBMISSION OF FINAL REPORT 30%

THE TECHNICIAN SHALL HAVE THE FULL EFFECT AND AUTHORITY OF AN ODOT PROJECT INSPECTOR IN DETERMINING ACCEPTABILITY OF MATERIAL AND CONCRETE PLACEMENT PRACTICES.

I:\ProjectData\HAM\10176_HAM-275-34.70\Design\Roadway\Sheets\10176_GN002.dgn_Sheet 1/20/2021 2:22:08 PM asadowks

CALCULATED
AWS
CHECKED
XXX

GENERAL NOTES

HAM - 275 - 34.70

3A
16

I:\ProjectData\HAM\10176_HAM-275-34.70\Design\Roadway\Sheets\10176_G000.dgn Sheet 1/25/2021 10:55:40 AM asadowsk

SHEET NUM.									PART.	ITEM	ITEM	GRAND	UNIT	DESCRIPTION	SEE SHEET NO.
3	4	5	9	12	14	15	16		01/IMS/OT	EXT	TOTAL				
ROADWAY															
LS									LS	201	11000	LS		CLEARING AND GRUBBING	
782									782	203	10000	782	CY	EXCAVATION	
249									249	203	20000	249	CY	EMBANKMENT	
									LS	878	25000	LS		INSPECTION AND COMPACTION TESTING OF UNBOUND MATERIALS	
EROSION CONTROL															
			1,408						1,408	601	21100	1,408	SY	SLOPE PROTECTION, MISC.:SEEDING AND EROSION CONTROL WITH TURF REINFORCING MAT, TYPE 3 & PERCUSSION DRIVEN EARTH ANCHORS	9
			16						16	601	34200	16	CY	ROCK CHANNEL PROTECTION, TYPE C WITHOUT FILTER	
			250						250	601	37501	250	FT	PAVED GUTTER, TYPE 1-2, AS PER PLAN	3
			27						27	601	38500	27	FT	PAVED GUTTER, TYPE 3	
2,617									2,617	659	10000	2,617	SY	SEEDING AND MULCHING	
0.36									0.36	659	20000	0.36	TON	COMMERCIAL FERTILIZER	
0.55									0.55	659	31000	0.55	ACRE	LIME	
15									15	659	35000	15	MGAL	WATER	
			235						235	670	00710	235	SY	DITCH EROSION PROTECTION MAT, TYPE A	
									LS	832	15000	LS		STORM WATER POLLUTION PREVENTION PLAN	
									LS	832	15002	LS		STORM WATER POLLUTION PREVENTION INSPECTIONS	
									LS	832	15010	LS		STORM WATER POLLUTION PREVENTION INSPECTION SOFTWARE	
5,000									5,000	832	30000	5,000	EACH	EROSION CONTROL	
DRAINAGE															
			1						1	611	98635	1	EACH	CATCH BASIN RECONSTRUCTED TO GRADE, AS PER PLAN	3
TRAFFIC CONTROL															
	0.17								0.17	642	00100	0.17	MILE	EDGE LINE, 4", TYPE 1	
RETAINING WALLS															
							1,070		1,070	507	00400	1,070	FT	STEEL PILES, MISC.: SOLDIER PILES W24x131	12
				74					74	518	21101	74	CY	POROUS BACKFILL, AS PER PLAN	12
							180		180	524	94703	180	FT	DRILLED SHAFTS, 36" DIAMETER, ABOVE BEDROCK, AS PER PLAN	12
							500		500	524	94705	500	FT	DRILLED SHAFTS, 36" DIAMETER, INTO BEDROCK, AS PER PLAN	12
							178		178	524	95000	178	FT	DRILLED SHAFTS, MISC.: PLUG PILE 36" DIA. UNREINFORCED	12
									LS	SPECIAL	53000200	LS		STRUCTURES: CONSULTANT FOR CONCRETE QUALITY CONTROL INCLUDING TESTING AND INSPECTION	3A
						56			56	610	50000	56	EACH	RETAINING WALL, MISC.: PRECAST CONCRETE PANEL 1	12
						87			87	610	50000	87	EACH	RETAINING WALL, MISC.: PRECAST CONCRETE PANEL 2	12
				1,900					1,900	610	50010	1,900	SF	RETAINING WALL, MISC.:TEMPORARY HARDWOOD LAGGING	12
MAINTENANCE OF TRAFFIC															
		90							90	614	11630	90	FT	INCREASED BARRIER DELINEATION	
		1							1	614	12380	1	EACH	WORK ZONE IMPACT ATTENUATOR, 24" WIDE HAZARDS (UNIDIRECTIONAL)	4
		8							8	614	13310	8	EACH	BARRIER REFLECTOR, TYPE 1, ONE-WAY	
		8							8	614	13350	8	EACH	OBJECT MARKER, ONE WAY	
	6								6	614	18601	6	SNMT	PORTABLE CHANGEABLE MESSAGE SIGN, AS PER PLAN	4
		0.17							0.17	614	22110	0.17	MILE	WORK ZONE EDGE LINE, CLASS I, 6", 642 PAINT	
		400							400	622	41100	400	FT	PORTABLE BARRIER, UNANCHORED	
INCIDENTALS															
	LS								LS	614	11000	LS		MAINTAINING TRAFFIC	
									LS	623	10000	LS		CONSTRUCTION LAYOUT STAKES AND SURVEYING	
									LS	624	10000	LS		MOBILIZATION	

GENERAL SUMMARY

HAM - 275 - 34.70

CALCULATED	EDA	CHECKED	SNS
------------	-----	---------	-----

GENERAL NOTES

DESIGN SPECIFICATIONS

DESIGN SPECIFICATIONS: THIS STRUCTURE CONFORMS TO THE "LRFD BRIDGE DESIGN SPECIFICATIONS" ADOPTED BY THE AMERICAN ASSOCIATION OF STATE HIGHWAY AND TRANSPORTATION OFFICIALS, 2017 AND THE ODOT BRIDGE DESIGN MANUAL, 2020.

DESIGN DATA:

CONCRETE CLASS QC1 - COMPRESSIVE STRENGTH 4.0 KSI (CONCRETE LAGGING)
CONCRETE CLASS QC5 - COMPRESSIVE STRENGTH 4.5 KSI (DRILLED SHAFT)
STRUCTURAL STEEL - ASTM A572 GRADE 50
YIELD STRENGTH - 50 KSI
REINFORCING STEEL - ASTM A615 OR A996 GRADE 60
MIN. YIELD STRENGTH - 60 KSI
STEEL SHEAR CONNECTORS, NUTS, PLATES - ASTM A572, GRADE 36
YIELD STRENGTH - 36 KSI

ITEM 507 - STEEL PILES, MISC.: SOLDIER PILES W24X131

THIS WORK CONSISTS OF FURNISHING AND PLACING STEEL SOLDIER PILES INTO DRILLED HOLES. FURNISH SOLDIER PILES CONSISTING OF STRUCTURAL STEEL MEMBERS THAT MEET THE PLAN REQUIREMENTS AND CONFORM TO ASTM A572, GRADE 50. DO NOT FIELD WELD OR SPLICE THOSE PARTS OF THE STEEL SOLDIER PILES THAT WILL BE ABOVE GROUND.

THE INDIVIDUAL LENGTHS SHOWN IN THE DRILLED SHAFT SUMMARY TABLES AND THE TOTAL LENGTHS SHOWN IN THE ESTIMATED QUANTITIES ARE CALCULATED FROM THE ESTIMATED TOP OF ROCK ELEVATIONS AND THE ACTUAL LENGTH OF EACH STEEL BEAM MAY VARY. THE CONTRACTOR SHOULD ANTICIPATE THAT THE STEEL BEAMS WILL NEED TO BE TRIMMED OR SPLICED TO THE ACTUAL TOP OF THE ROCK. THE CONTRACTOR MAY WANT TO ORDER ADDITIONAL LENGTH OF EACH TYPE OF STEEL BEAM FOR SPLICING.

MEASUREMENT FOR PAYMENT WILL BE LIMITED TO THE DISTANCE BETWEEN THE TOP OF WALL ELEVATION AND THE BOTTOM OF THE DRILLED SHAFT, AS DETERMINED BY THE ENGINEER. THE DEPARTMENT WILL PAY FOR SOLDIER PILES AT THE CONTRACT UNIT PRICE PER FOOT OF ITEM 507 - STEEL PILES, MISC.: SOLDIER PILES W24X131

ITEM 518 POROUS BACK FILL, AS PER PLAN

THE #8 COURSE AGGREGATE USED TO FILL BETWEEN THE HARD WOOD LAGGING AND THE CONCRTE LAGGING PANNELS ALONG WITH ALL LABOUR, MATERIALS AND EQUIPMENT NECESSARY TO INSTALL IT IN PLACE IS PAID FOR UNDER ITEM 518 POROUS BACKFILL, AS PER PLAN

ITEM 524 - DRILLED SHAFTS, 36" DIAMETER, ABOVE BEDROCK, AS PER PLAN

ITEM 524 - DRILLED SHAFTS, 36" DIAMETER, INTO BEDROCK, AS PER PLAN

THIS WORK CONSISTS OF FURNISHING AND INSTALLING DRILLED SHAFTS FOR SOLDIER PILE AND LAGGING WALLS. THE DRILLED SHAFTS ARE REINFORCED WITH SOLDIER PILES INSTEAD OF REINFORCING STEEL CAGES. THE SOLDIER PILES EXTEND ABOVE THE TOP OF THE DRILLED SHAFT. FURNISH AND INSTALL DRILLED SHAFTS IN ACCORDANCE WITH CMS 524 EXCEPT AS MODIFIED AND SUPPLEMENTED BELOW.

EXCAVATE THE HOLE FOR THE DRILLED SHAFTS WITHIN 3 INCHES OF THE PLAN LOCATION IN THE HORIZONTAL PLANE. IF FIELD CONDITIONS INDICATE GREATER DEPTHS, NOTIFY THE ENGINEER FOR FURTHER EVALUATION.

PLACE THE SOLDIER PILE VERTICALLY WITHIN THE HOLE SO IT IS NOT INCLINED MORE THAN 1" BETWEEN THE TOP AND BOTTOM. PLACE THE SOLDIER PILE SO THAT THE FLANGES ARE PARALLEL TO THE CENTERLINE OF CONSTRUCTION. DO NOT ALLOW THE ORIENTATION OF THE FLANGES TO VARY BY MORE THAN 10 DEGREES. SUPPORT THE SOLDIER PILE SO THAT IT DOES NOT MOVE DURING CONCRETE PLACEMENT.

USE CLASS QC5 CONCRETE ACCORDING TO CMS 511. THE CONTRACTOR MAY PLACE CONCRETE USING THE FREE FALL METHOD PROVIDED THE DEPTH OF WATER IS LESS THAN 6 INCHES AND THE CONCRETE FALLS WITHOUT STRIKING THE SIDES OF THE HOLE. POURING CONCRETE ALONG THE WEB OF THE SOLDIER PILE IS ACCEPTABLE.

CHECK THE POSITION, THE VERTICAL ALIGNMENT AND ORIENTATION OF THE SOLDIER PILE IMMEDIATELY AFTER CONCRETE PLACEMENT. MAKE CORRECTIONS AS NECESSARY TO MEET THE ABOVE TOLERANCES.

PLACE PRECAST LAGGING SO THAT THE SOLDIER PILE FLANGE OVERLAPS THE END OF THE LAGGING BY AT LEAST 3 INCHES AT BOTH ENDS OF THE LAGGING.

THE INSTALLATION SEQUENCE SHALL BE SUCH THAT NO DRILLED SHAFT IS INSTALLED ADJACENT TO EITHER AN OPEN DRILLED SHAFT EXCAVATION OR A DRILLED SHAFT IN WHICH THE CONCRETE HAS LESS THAN A 48 HOUR CURE. INSTALLING THE SHAFTS IN AN ALTERNATING SEQUENCE OR ANY OTHER SEQUENCE THAT MEETS THIS CRITERIA IS PERMISSIBLE.

CARE SHALL BE EXERCISED AS TO COVERING UNATTENDED OPEN SHAFTS. TEMPORARY COVERS SHALL BE OF ADEQUATE STRENGTH TO PREVENT A PERSON OR ANIMAL FROM FALLING IN. NO DRILLED SHAFT EXCAVATION SHALL BE LEFT UN-POURED OVERNIGHT.

THE CONTRACTOR SHALL BE RESPONSIBLE FOR THE MEANS AND METHODS USED TO CONSTRUCT THE DRILLED SHAFTS AND PLACE CONCRETE PANELS. ANY TEMPORARY GRADING, EXCAVATION, EMBANKMENT, AGGREGATE, DRAINAGE, CASING, SHEETING, ETC. NEEDED TO COMPLETE THE WORK AREA SHALL BE INCLUDED IN THE BID PRICE FOR THE DRILLED SHAFTS. THE COST OF ANY EXCAVATION AND SUBSEQUENT REPLACEMENT OF EMBANKMENT (PER ITEM 203 EMBANKMENT) SHALL BE INCLUDED IN THE VARIOUS BID ITEMS FOR THE DRILLED SHAFTS AND CONCRETE PANELS. NO SEPARATE PAYMENT WILL BE MADE.

PAYMENT IS FULL COMPENSATION FOR CONSTRUCTING THE DRILLED SHAFTS, INCLUDING FURNISHING AND PLACING CONCRETE AND ITEM 613 LSM BACKFILL FROM TOP OF THE CONCRETE TO THE EXSISTING GROUND SURFACE AT THE C/L OF THE PILE AND REMOVAL OF CONCRETE FROM AROUND THE SOLDIER PILE IN ORDER TO PLACE PRECAST LAGGING. PAYMENT FOR SOIL OVERBURDEN DRILLING, WHICH IS GROUND LEVEL TO THE TOP OF THE SHAFT, SHALL BE INCLUSIVE OF ITEM 524 DRILLED SHAFTS, 36" DIAMETER, ABOVE BEDROCK, APP

MEASUREMENT FOR PAYMENT FOR DRILLED SHAFTS ABOVE BEDROCK, AS PER PLAN, WILL BE MEASURED ALONG THE AXIS OF THE DRILLED SHAFT FROM THE TOP OF THE SHAFT TO THE TOP OF BEDROCK, AS DETERMINED BY THE ENGINEER. MEASUREMENT FOR PAYMENT FOR DRILLED SHAFTS INTO BEDROCK, AS PER PLAN, WILL BE LIMITED TO THE DISTANCE BETWEEN THE TOP OF BEDROCK AND THE BOTTOM OF THE DRILLED SHAFT, AS DETERMINED BY THE ENGINEER.

ITEM 524, DRILLED SHAFTS, MISC.: PLUG PILE, 36" DIAMETER, UNREINFORCED

THE SHAFTS ARE TO BE UNREINFORCED NON-STRUCTURAL "PLUG PILES" SERVING THE PURPOSE OF LAGGING.

THIS WORK SHALL BE AS PER ITEM 524 EXCEPT A REINFORCING CAGE WILL NOT BE USED IN THE SHAFT. EACH PLUG PILE SHALL BE CENTERED BETWEEN EACH REINFORCED 36" DIAMETER DRILLED SHAFT AND DRILLED TO THE TOP OF BEDROCK AND BACKFILLED WITH UNREINFORCED CLASS QC5 CONCRETE.

CASING MAY BE REQUIRED FOR THE CONSTRUCTION OF THE PLUG PILES. ADJACENT PLUG PILES SHALL NOT BE OPEN SIMULTANEOUSLY. PLUG PILES SHALL NOT BE DRILLED UNTIL THE CONCRETE IN ADJACENT PLUG PILES OR DRILLED SHAFTS HAS CURED 48 HOURS.

PAYMENT FOR LABOR, EQUIPMENT AND MATERIALS FOR THE ABOVE SHALL BE INCLUDED IN THE PER FOOT CONTRACT PRICE FOR ITEM 524, DRILLED SHAFTS, MISC.: PLUG PILE, 36" DIAMETER, UNREINFORCED, AS PER PLAN.

**ITEM 610 RETAINING WALL, MISC.: PRECAST CONCRETE PANEL 1
ITEM 610 RETAINING WALL, MISC.: PRECAST CONCRETE PANEL 2**

THIS WORK CONSISTS OF FURNISHING AND PLACING PRECAST REINFORCED CONCRETE PANELS BETWEEN THE SOLDIER PILES TO FUNCTION AS LAGGING FOR THE RETAINING WALL. PROVIDE PRECAST CONCRETE LAGGING FROM A PRECAST CONCRETE MANUFACTURER CERTIFIED UNDER SUPPLEMENT 1073. PROVIDE CONCRETE WITH A 28-DAY DESIGN STRENGTH OF AT LEAST 4000 PSI ACCORDING TO CMS 499. PROVIDE EPOXY COATED REINFORCING STEEL ACCORDING TO CMS 709.00. IN LIEU OF EPOXY COATING, A CORROSION INHIBITING CONCRETE ADMIXTURE MAY BE USED AT THE SPECIFIED DOSAGE RATE. A QUALIFIED PRODUCT LIST OF CORROSION INHIBITING ADMIXTURES IS ON FILE AT THE LABORATORY. MANUFACTURERS SHOULD RECOGNIZE THAT THE CORROSION INHIBITOR MAY AFFECT THE STRENGTH, ENTRAINED AIR CONTENT, WORKABILITY, ETC. OF THEIR CONCRETE MIXES. THE MANUFACTURER'S CHOICE TO USE ONE OF THESE CORROSION INHIBITORS DOES NOT ALLEVIATE MEETING ALL DESIGN REQUIREMENTS. DO NOT ALLOW THE DIMENSIONS OF THE REINFORCING STEEL TO VARY BY MORE THAN 1/4 INCH. PERMANENTLY MARK EACH PANEL TO INDICATE THE FACE TO BE PLACED AGAINST THE SOIL. PLACE THE PANEL BETWEEN THE FLANGES OF THE SOLDIER PILES AND BEARING AGAINST THE FLANGES ON THE EXPOSED SIDE OF THE WALL.

SEAL EACH PANEL PER ITEM 512 EPOXY URETHENE SEALER, COLOR 17778 TO THE LIMITS INDICATED IN THE PLANS. SEAL PANELS PRIOR TO DELIVERY TO THE SITE.

THE DEPARTMENT WILL PAY FOR PRECAST LAGGING AT THE CONTRACT UNIT PRICE PER EACH FOR ITEM SPECIAL, STRUCTURES PRECAST CONCRETE PANEL 1 OR PANEL 2.

ITEM 610, RETAINING WALL, MISC.: TEMPORARY HARDWOOD LAGGING

THIS ITEM CONSISTS OF FURNISHING AND INSTALLING UNTREATED HARDWOOD LAGGING TO SERVE AS TEMPORARY LAGGING FOR THE SOLDIER PILE WALL. THE LAGGING SHALL CONSIST OF HARDWOOD WITH NOMINAL 3"x8" DIMENSIONS. PAYMENT FOR THE HARDWOOD LAGGING INCLUDES MATERIAL SUPPLY, NON-DEGRADABLE SPACERS BETWEEN THE LAGGING BOARDS AND INSTALLATION AS INDICATED IN THE PROJECT PLANS. LAGGING SHALL BE PLACED IN A TOP-DOWN MANNER SUCH THAT NO MORE THAN 3 FEET OF UNSUPPORTED EXCAVATION IS EXPOSED. EXCAVATION FOR PLACEMENT OF THE LAGGING SHALL BE PERFORMED IN SUCH A MANNER THAT THE LAGGING IS TIGHT AGAINST THE EXCAVATED FACE. ANY VOIDS BEHIND THE LAGGING SHALL BE BACKFILLED WITH NO. 57 CRUSHED CARBONATE STONE AS DIRECTED BY THE ENGINEER. REDUCE UNSUPPORTED HEIGHT AS NECESSARY TO PREVENT CAVING AND SLOUGHING OF THE SOILS BETWEEN THE SOLDIER PILES. PROVIDE 1/4" TO 3/8" HORIZONTAL JOINT SPACING BETWEEN THE LAGGING BOARDS TO PERMIT DRAINAGE. CONNECT THE LAGGING TO THE SOLDIER PILES USING THREADED SHEAR CONNECTORS, LAGGING WASHERS AND NUTS PROVIDED AND INSTALLED PER CMS 513. LAGGING PLATES AND NUTS SHALL BE ASTM A 709 GRADE 36, YIELD STRENGTH 36,000 PSI OR GREATER.

A QUANTITY OF 1900 SF HAS BEEN CARRIED TO THE GENERAL SUMMARY FOR THIS WORK.

I:\ProjectData\HAM\10176_HAM-275-34.70\Design\Structures\Wall\Sheets\10176_WALL001_GN002.dgn Sheet 1/25/2021 12:23:35 PM asadowsk

CALCULATED
EDA
CHECKED
MRS

DRILLED SHAFT WALL NOTES

HAM-275-34.70

12
16

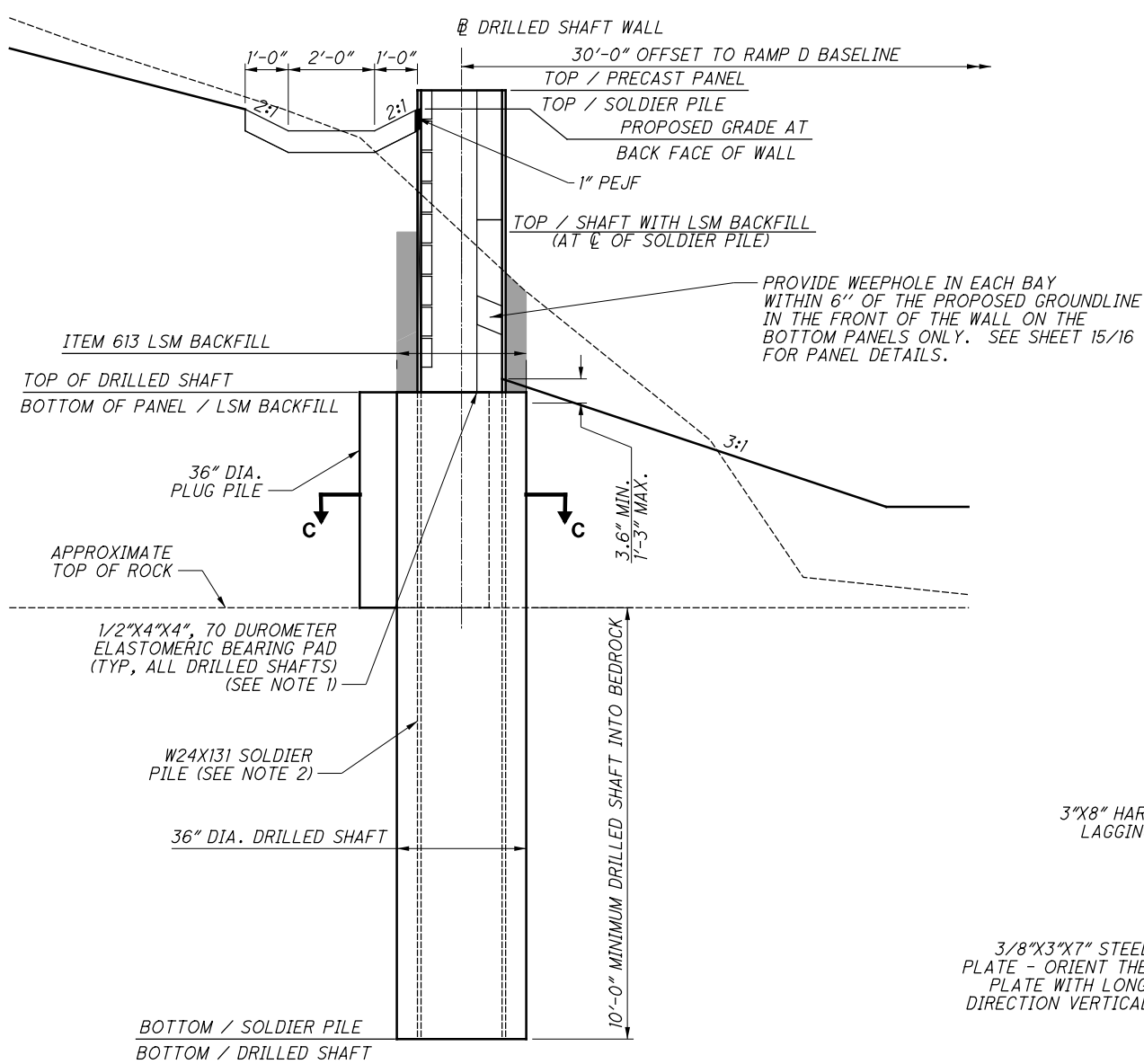

DRILLED SHAFT WALL SECTION

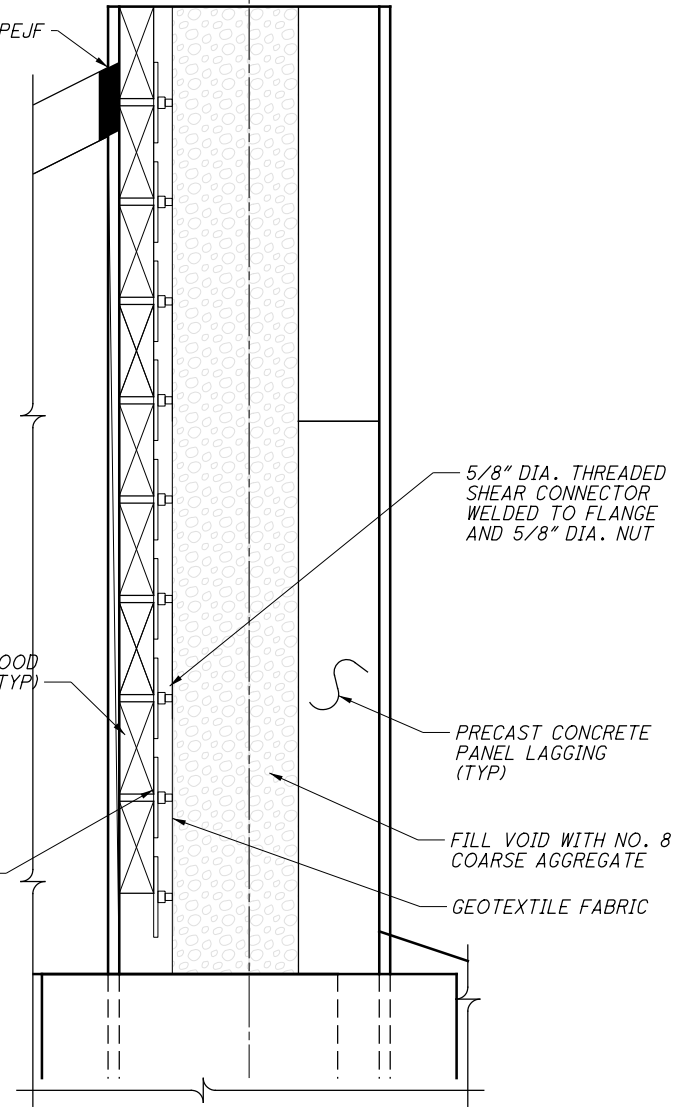

SECTION B-B

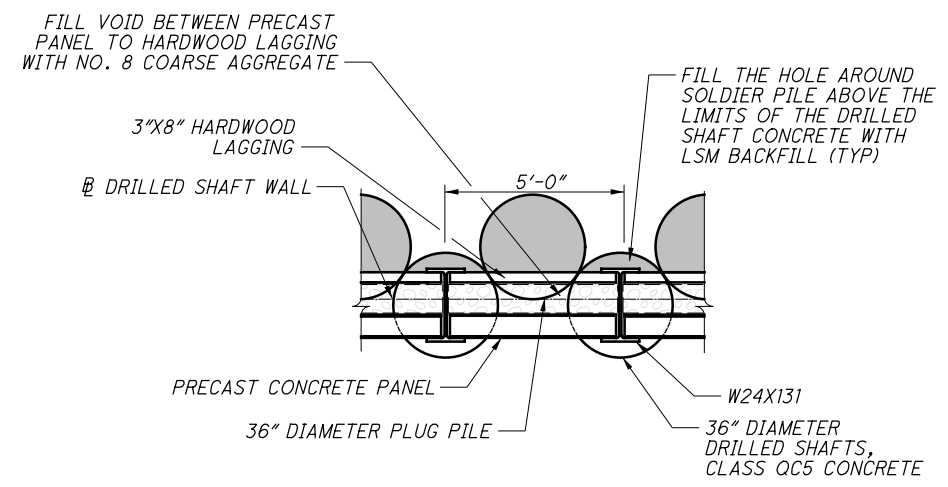

SECTION A-A

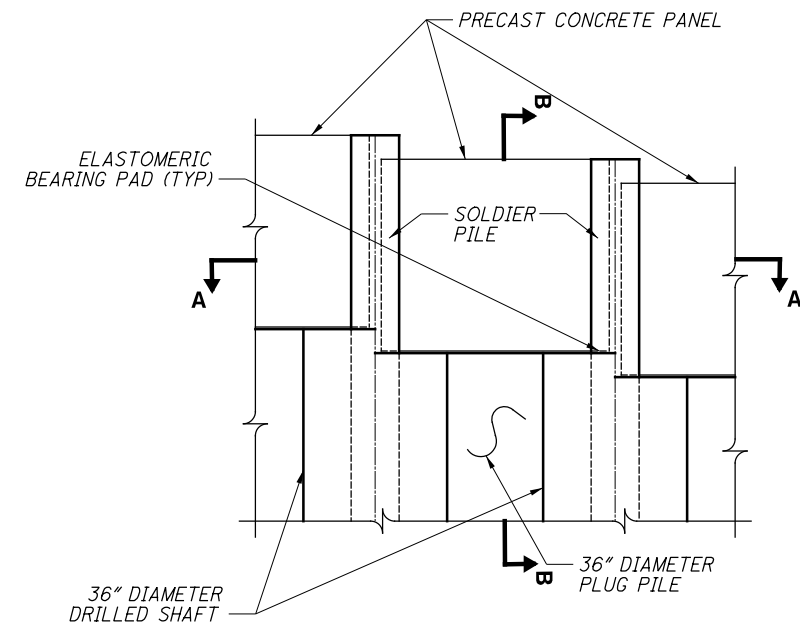

WALL ELEVATION

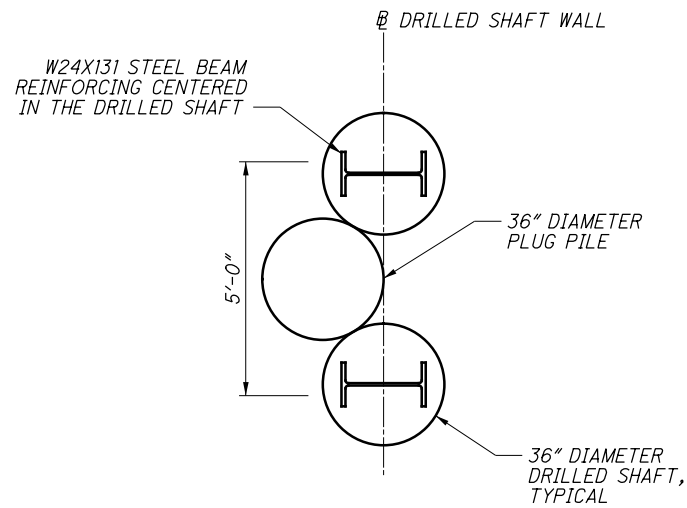

SECTION C-C

ITEM 518, POROUS BACKFILL, AS PER PLAN
1900 SF OF WALL x 12.625"/12/27 CF/CY = 74 CY
QUANTITY CARRIED TO GENERAL SUMMARY

- NOTES:
- ELASTOMERIC BEARINGS ARE INCLUDED WITH ITEM 610, RETAINING WALL, MISC.: PRECAST CONCRETE PANEL FOR PAYMENT
 - STEEL SOLDIER PILES SHALL BE GALVANIZED ABOVE THE QC5 CONCRETE.
 - SECURE PRECAST CONCRETE PANELS AGAINST PILE FLANGE UNTIL VOID IS FILLED WITH AGGREGATE.

I:\ProjectData\HAM\10176_HAM-275-34.70\Design\Structures\Wall\Sheets\10176_WALL001_DM001.dgn Sheet 1/25/2021 12:31:32 PM asadowsk

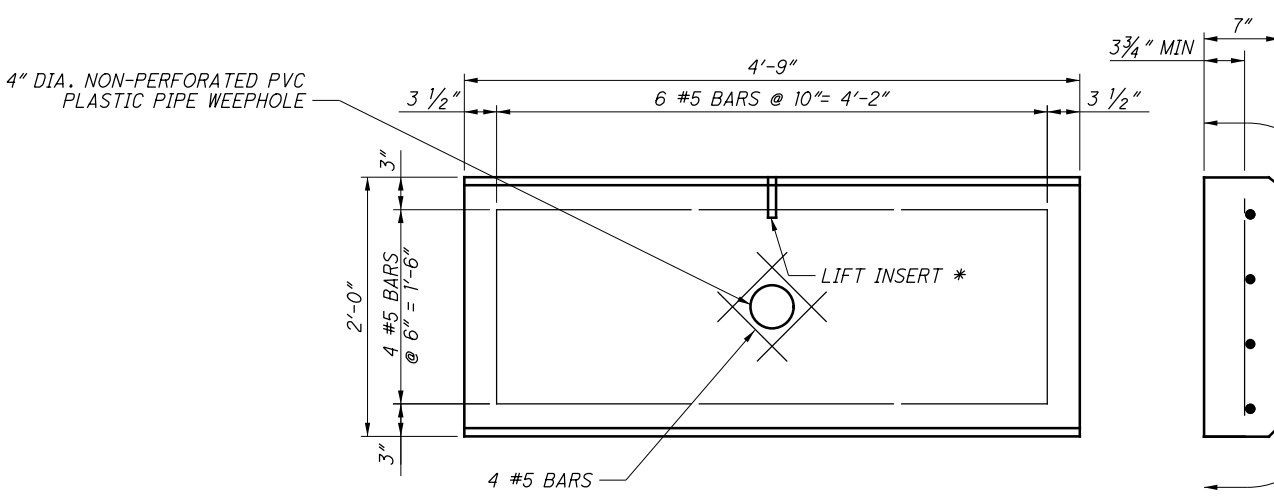

PRECAST CONCRETE PANEL 1

TOTAL REQUIRED = 56
QUANTITY CARRIED TO GENERAL SUMMARY

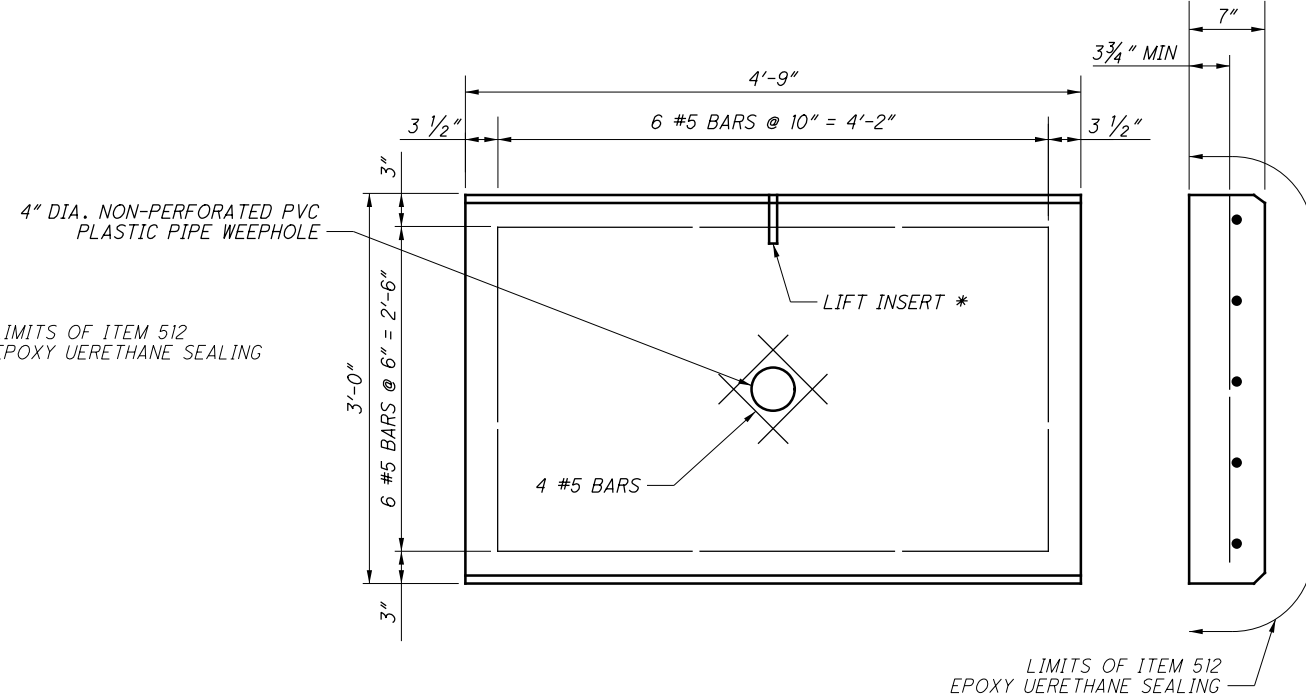

PRECAST CONCRETE PANEL 2

TOTAL REQUIRED = 87
QUANTITY CARRIED TO GENERAL SUMMARY

NOTE:
PROVIDE WEEPHOLES ONLY ON THE BOTTOM PANELS.
LOCATE WEEPHOLE OUTLET WITHIN 6" OF THE
PROPOSED FINISH GRADE IN FRONT OF THE WALL

* LIFT INSERT LOCATION AND DESIGN TO BE DETERMINED
BY THE PRECAST PANEL MANUFACTURER.

WALL DETAILS

HAM-275-34.70

I:\ProjectData\HAM\10176_HAM-275-34.70\Design\Structures\Wall\Sheets\10176_WALL00_DM002.dgn Sheet 1/25/2021 10:07:17 PM asadowsk