

NOTES:

1. ALL QUANTITIES CARRIED TO SHEET 12

LOCATION	ITEM	DESCRIPTION	UNIT	QUANTITY		TOTAL
				LEFT	RIGHT	
U	202	GUARDRAIL REMOVED	FT	100		100
G	202	GUARDRAIL REMOVED FOR REUSE	FT		25	25
R	202	ANCHOR ASSEMBLY REMOVED FOR REUSE, TYPE E	EACH	2	2	4
[Hatched Box]	203	EMBANKMENT, AS PER PLAN	CY		2	2
P	209	RESHAPING UNDER GUARDRAIL	STATION	1.5	1.25	2.75
B	606	GUARDRAIL, TYPE 5	FT	100		100
T	606	GUARDRAIL REBUILT, TYPE 5	FT		25	25
E	606	ANCHOR ASSEMBLY REBUILT, TYPE E	EACH	2	2	4
AA	626	BARRIER REFLECTOR	EACH	3	1	4

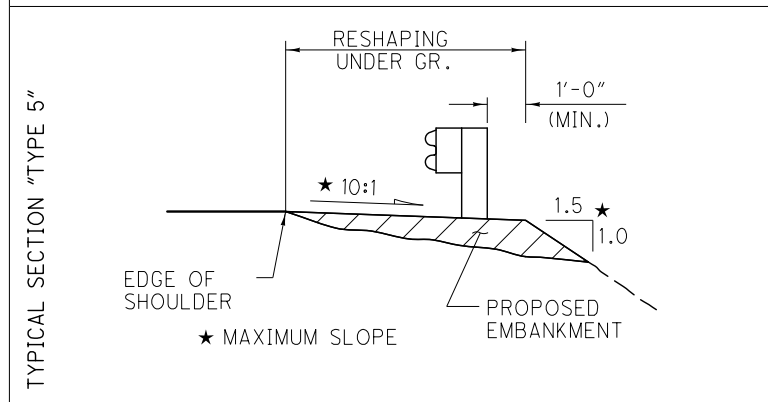
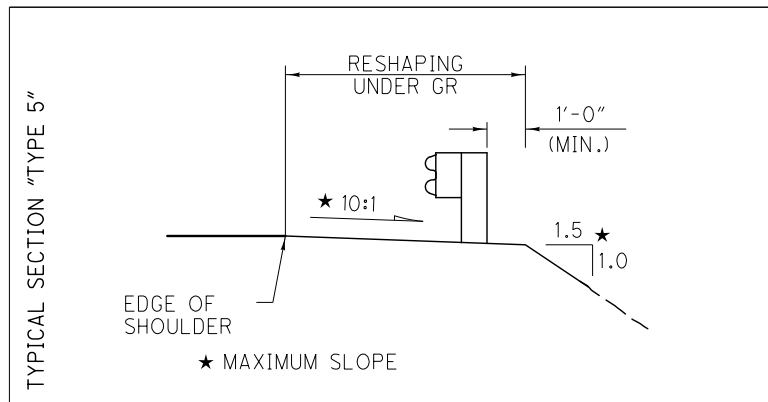

I:\projects\88767\roadway\sheets\88767GR001.dgn