

**NOTES:**

1. ALL QUANTITIES CARRIED TO SHEET 12
2. STAGGER GUARDRAIL POSTS TO AVOID DAMAGING CULVERT.
3. WATERLINE CROSSES ROADWAY SOUTH OF CULVERT. LOCATION UNKNOWN.

| LOCATION | ITEM | DESCRIPTION                               | UNIT    | QUANTITY |       | TOTAL |
|----------|------|---|---------|----------|-------|-------|
|          |      |   |         | LEFT     | RIGHT |       |
| (A)      | 202  | GUARDRAIL REMOVED FOR REUSE               | FT      | 112.5    | 100   | 212.5 |
| (D)      | 202  | ANCHOR ASSEMBLY REMOVED, TYPE A           | EACH    | 1        | 1     | 2     |
| (P)      | 202  | ANCHOR ASSEMBLY REMOVED FOR REUSE, TYPE A | EACH    | 1        | 1     | 2     |
|          | 203  | EMBANKMENT, AS PER PLAN                   | CY      | 26       | 24    | 50    |
| (C)      | 209  | RESHAPING UNDER GUARDRAIL                 | STATION | 2.38     | 2.14  | 4.52  |
| (F)      | 606  | GUARDRAIL, TYPE 5                         | FT      | 75       | 92.5  | 167.5 |
| (T)      | 606  | GUARDRAIL REBUILT, TYPE 5                 | FT      | 112.5    | 100   | 212.5 |
| (B)      | 606  | ANCHOR ASSEMBLY, TYPE A                   | EACH    | 1        |       | 1     |
| (M)      | 606  | ANCHOR ASSEMBLY, TYPE T                   | EACH    |          | 1     | 1     |
| (N)      | 606  | ANCHOR ASSEMBLY REBUILT, TYPE A           | EACH    | 1        | 1     | 2     |
| (AA)     | 626  | BARRIER REFLECTOR                         | EACH    | 3        | 3     | 6     |

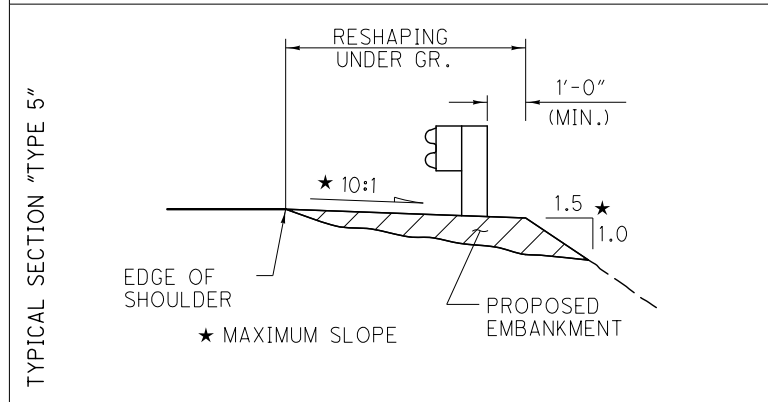
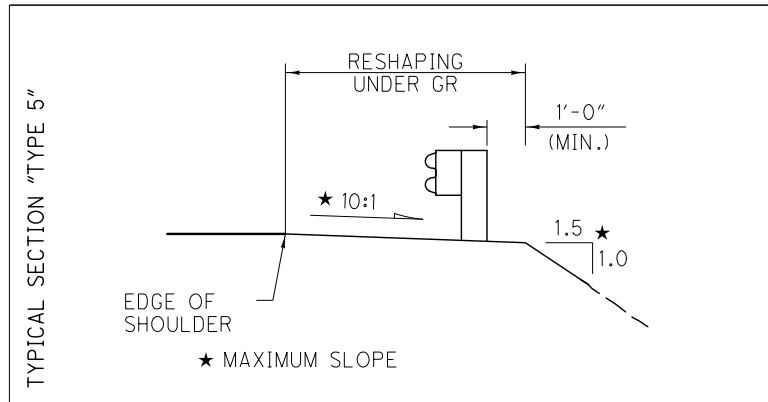

I:\projects\88767\roadway\sheets\88767GR001.dgn