

I:\ProjectData\LIC\93109\Design\Roadway\Sheets\93109_CS002.dgn_Sheet 1/21/2021 4:42 PM jlu+zl

LOCATION 1B SHEET TOTALS												ITEM	ITEM EXT.	GRAND TOTAL	UNIT	DESCRIPTION	
2	4	5	6	7	9	10	11	12	13	14	33						
						2,760							202	23500	2,760	SY	ROADWAY WEARING COURSE REMOVED
100													253	01000	100	CY	PAVEMENT PAVEMENT REPAIR
				123,756	26,307								254	01000	150,063	SY	PAVEMENT PLANING, ASPHALT CONCRETE , 3.00"
				16,090	3,421	222							407	20000	19,733	GAL	NON-TRACKING TACK COAT
					2,986								408	10001	2,986	GAL	PRIME COAT, AS PER PLAN
						97							441	50000	97	CY	ASPHALT CONCRETE SURFACE COURSE, TYPE 1, (448), PG64-22
				10,315									442	00100	10,315	CY	ANTI-SEGREGATION EQUIPMENT
				5,158	1,097								442	10000	6,255	CY	ASPHALT CONCRETE SURFACE COURSE, 12.5 MM, TYPE A (446)
				5,158	1,097								442	10101	6,255	CY	ASPHALT CONCRETE INTERMEDIATE COURSE, 19 MM, TYPE A (446), AS PER PLAN (PG64-22/PG64-28)
					415								617	10101	415	CY	COMPACTED AGGREGATE, AS PER PLAN
																	TRAFFIC CONTROL
												1,150	621	00100	1,150	EACH	RPM
												1,150	621	54000	1,150	EACH	RAISED PAVEMENT MARKER REMOVED
							6.56						644	00104	6.56	MILE	EDGE LINE, 6"
								6.56					644	00204	6.56	MILE	LANE LINE, 6"
									8.09				644	00300	8.09	MILE	CENTER LINE
										6,668			644	00404	6,668	FT	CHANNELIZING LINE, 12"
										835			644	00500	835	FT	STOP LINE
										2,770			644	00700	2,770	FT	TRANSVERSE/DIAGONAL LINE
										64			644	01300	64	EACH	LANE ARROW
											23		644	01410	23	EACH	WORD ON PAVEMENT, 96"
											793		644	01510	793	FT	DOTTED LINE, 6"
																	MAINTENANCE OF TRAFFIC
		100											614	11110	100	HOUR	LAW ENFORCEMENT OFFICER WITH PATROL CAR FOR ASSISTANCE
	15												614	12460	15	EACH	WORK ZONE MARKING SIGN
			10										614	18601	10	SNMT	PORTABLE CHANGEABLE MESSAGE SIGN, AS PER PLAN
	8.40												614	20100	8.40	MILE	WORK ZONE LANE LINE, CLASS I, 4", 642 PAINT
	8.40												614	20550	8.40	MILE	WORK ZONE LANE LINE, CLASS III, 4", 642 PAINT
	7.98												614	21100	7.98	MILE	WORK ZONE CENTER LINE, CLASS I, 642 PAINT
	7.98												614	21550	7.98	MILE	WORK ZONE CENTER LINE, CLASS III, 642 PAINT
	6,668												614	23200	6,668	FT	WORK ZONE CHANNELIZING LINE, CLASS I, 8", 642 PAINT
	6,668												614	23680	6,668	FT	WORK ZONE CHANNELIZING LINE, CLASS III, 8", 642 PAINT
	733												614	26200	733	FT	WORK ZONE STOP LINE, CLASS I, 642 PAINT
	733												614	26610	733	FT	WORK ZONE STOP LINE, CLASS III, 642 PAINT
		10											808	18700	10	SNMT	DIGITAL SPEED LIMIT (DSL) SIGN ASSEMBLY

CALCULATED LIME CHECKED JSL
LOCATION 1B SUB-SUMMARY
LIC-40-0.00
 36
 442

I:\ProjectData\LIC\93109\Design\Roadway\Sheets\93109_CS004.dgn_Sheet 1/21/2021 4:20:26 PM jlu tzl

LOCATION 1C SHEET TOTALS										ITEM	ITEM EXT.	GRAND TOTAL	UNIT	DESCRIPTION
69	73	157	159	161	342	364	365	366	367					
						804				202	35100	804	FT	PIPE REMOVED, 24" AND UNDER
						12				202	58100	12	EACH	CATCH BASIN REMOVED
						279				SPECIAL	20270000	279	FT	FILL AND PLUG EXISTING CONDUIT, 15"
				2			2			602	20000	4	CY	CONCRETE MASONRY
								6,396	6,380	605	11100	12,776	FT	6" SHALLOW PIPE UNDERDRAINS
20								200	200	605	13300	420	FT	6" UNCLASSIFIED PIPE UNDERDRAINS
								7,583	7,563	605	14000	15,146	FT	6" BASE PIPE UNDERDRAINS
20										605	31100	20	FT	AGGREGATE DRAINS
20										611	00100	20	FT	4" CONDUIT, TYPE B
40										611	00900	40	FT	6" CONDUIT, TYPE B
								528	541	611	00510	1,069	FT	6" CONDUIT, TYPE F FOR UNDERDRAIN OUTLETS
20										611	01400	20	FT	6" CONDUIT, TYPE E
40										611	01500	40	FT	6" CONDUIT, TYPE F
							189			611	05900	189	FT	15" CONDUIT, TYPE B
				181						611	06400	181	FT	15" CONDUIT, TYPE D
							5			611	07400	5	FT	18" CONDUIT, TYPE B
							199			611	12100	199	FT	27" CONDUIT, TYPE C
							1,075			611	97010	1,075	FT	SLOTTED DRAIN, TYPE 2 , 12"
							8			611	98410	8	EACH	CATCH BASIN, NO. 8
							6			611	98630	6	EACH	CATCH BASIN ADJUSTED TO GRADE
							5			611	98631	5	EACH	CATCH BASIN ADJUSTED TO GRADE, AS PER PLAN
2								1	1	611	99710	4	EACH	PRECAST REINFORCED CONCRETE OUTLET
				35						625	29600	35	FT	TRENCH IN PAVED AREA, TYPE B
	100									253	02000	100	CY	PAVEMENT REPAIR
	3,500									254	01000	3,500	SY	PAVEMENT PLANING, ASPHALT CONCRETE , 1.25"
		2,288	2,846							254	01000	5,134	SY	PAVEMENT PLANING, ASPHALT CONCRETE , VARIABLE (3.00" MAX)
				394						254	01000	394	SY	PAVEMENT PLANING, ASPHALT CONCRETE , VARIABLE (5.00" MAX)
		4,827	4,919	158						301	46000	9,904	CY	ASPHALT CONCRETE BASE, PG64-22
					19					301	48000	19	CY	ASPHALT CONCRETE BASE, PG64-22 (DRIVEWAYS)
		4,931	4,950	110						304	20000	9,991	CY	AGGREGATE BASE
	280	3,071	3,136	113	10					407	20000	6,610	GAL	NON-TRACKING TACK COAT
	250	684	681							408	10001	1,615	GAL	PRIME COAT, AS PER PLAN
					34					411	10000	34	CY	STABILIZED CRUSHED AGGREGATE
	125			36	6					441	50000	167	CY	ASPHALT CONCRETE SURFACE COURSE, TYPE 1, (448), PG64-22
		2,080	2,133							442	00100	4,213	CY	ANTI-SEGREGATION EQUIPMENT
		1,280	1,307							442	10000	2,587	CY	ASPHALT CONCRETE SURFACE COURSE, 12.5 MM, TYPE A (446)
		1,280	1,307							442	10101	2,587	CY	ASPHALT CONCRETE INTERMEDIATE COURSE, 19 MM, TYPE A (446), AS PER PLAN (PG64-22/PG64-28)
	25	160	160							617	10101	345	CY	COMPACTED AGGREGATE, AS PER PLAN

CALCULATED	PTB	CHECKED	JSL
LOCATION 1C SUB-SUMMARY			
LIC-40-0.00			
38 442			

I:\ProjectData\LIC\93109\Design\Roadway\Sheets\93109_CS010.dgn Sheet 1/28/2021 4:27 PM jlu7zi

LOCATION 1D SHEET TOTALS										ITEM	ITEM EXT.	GRAND TOTAL	UNIT	DESCRIPTION
4	5	6	70	72	73	75	89	90	92					
						3,314				410	13001	3,314	CY	MAINTENANCE OF TRAFFIC TRAFFIC COMPACTED SURFACE, TYPE C, AS PER PLAN
	100						40	4	54	614	11110	100	HOUR	LAW ENFORCEMENT OFFICER WITH PATROL CAR FOR ASSISTANCE
										614	12384	98	EACH	WORK ZONE IMPACT ATTENUATOR, 24" WIDE HAZARDS, (BIDIRECTIONAL)
8										614	12460	8	EACH	WORK ZONE MARKING SIGN
					10					614	12600	10	EACH	REPLACEMENT DRUM
							307	41	306	614	13310	654	EACH	BARRIER REFLECTOR, TYPE 1, BIDIRECTIONAL
							307	41	306	614	13360	654	EACH	OBJECT MARKER, TWO WAY
		60								614	18601	60	SNMT	PORTABLE CHANGEABLE MESSAGE SIGN, AS PER PLAN
6.17										614	20100	6.17	MILE	WORK ZONE LANE LINE, CLASS I, 4", 642 PAINT
6.17										614	20550	6.17	MILE	WORK ZONE LANE LINE, CLASS III, 4", 642 PAINT
							3.33	0.60	3.40	614	21050	7.33	MILE	WORK ZONE CENTER LINE, CLASS I, 807 PAINT
5.64					2.00					614	21100	7.64	MILE	WORK ZONE CENTER LINE, CLASS I, 642 PAINT
5.64										614	21550	5.64	MILE	WORK ZONE CENTER LINE, CLASS III, 642 PAINT
							6.52	0.41	6.51	614	22056	13.44	MILE	WORK ZONE EDGE LINE, CLASS I, 6", 807 PAINT
							242	1,203	1,075	614	23100	2,520	FT	WORK ZONE CHANNELIZING LINE, CLASS I, 8", 807 PAINT
3,903										614	23200	3,903	FT	WORK ZONE CHANNELIZING LINE, CLASS I, 8", 642 PAINT
3,903										614	23680	3,903	FT	WORK ZONE CHANNELIZING LINE, CLASS III, 8", 642 PAINT
							365		330	614	24100	695	FT	WORK ZONE DOTTED LINE, CLASS I, 4", 807 PAINT
158					25		59	91	101	614	26200	434	FT	WORK ZONE STOP LINE, CLASS I, 642 PAINT
158										614	26610	158	FT	WORK ZONE STOP LINE, CLASS III, 642 PAINT
							8	23	24	614	30200	55	EACH	WORK ZONE ARROW, CLASS I, 642 PAINT
			650				6,994			615	25001	7,644	SY	PAVEMENT FOR MAINTAINING TRAFFIC, CLASS B, AS PER PLAN
				75						616	10000	75	MGAL	WATER
							15,440	2,050	14,855	622	41100	32,345	FT	PORTABLE BARRIER, UNANCHORED
	120									808	18700	120	SNMT	DIGITAL SPEED LIMIT (DSL) SIGN ASSEMBLY

CALCULATED
PTB
CHECKED
JSL

LOCATION 1D SUB-SUMMARY

LIC-40-0.00

I:\ProjectData\LIC_93109\Design\Roadway\Sheets\93109_CG001.dgn Sheet 2/4/2021 4:40:06 PM jlutzi

LOCATION TOTALS					PLAN SPLITS					ITEM	ITEM EXT.	GRAND TOTAL	UNIT	DESCRIPTION	SEE SHEET
LOC. 1A	LOC. 1B	LOC. 1C	LOC. 1D	LOC. 1D SCHOOL	01/S>2/ PV/REYN	02/S>2/ PV	03/S>2/ PV	04/STR/ PV	05/STR/ OT/SLSD						
							LS	LS		201	11000	LS	LS	CLEARING AND GRUBBING	
		51,578	117,989				51,578	117,989		202	23000	169,567	SY	PAVEMENT REMOVED	
			232					232		202	23001	232	SY	PAVEMENT REMOVED, AS PER PLAN	
1,092	2,760				1,092	2,760				202	23500	3,852	SY	WEARING COURSE REMOVED	
			33					33		202	32000	33	FT	CURB REMOVED	
		2,859	4,882				2,859	4,882		202	38000	7,741	FT	GUARDRAIL REMOVED	
			1					1		202	98100	1	EACH	REMOVAL MISC.: PRIVATE SIGN AND LANDSCAPING	68
		12,194	21,181	186			12,194	21,181	186	203	10000	33,561	CY	EXCAVATION	
		4,852	5,874				4,852	5,874		203	20000	10,726	CY	EMBANKMENT	
		305	2,528				305	2,528		204	10000	2,833	SY	SUBGRADE COMPACTION	
			18,159					18,159		204	20000	18,159	CY	EMBANKMENT	
		31	62	2			31	62	2	204	45000	95	HOUR	PROOF ROLLING	
		1,738	3,681	48			1,738	3,681	48	206	10500	5,467	TON	CEMENT	
		57,506	121,859	1,543			57,506	121,859	1,543	206	11000	180,908	SY	CURING COAT	
		57,506	121,859	1,543			57,506	121,859	1,543	206	15020	180,908	SY	CEMENT STABILIZED SUBGRADE, 14 INCHES DEEP	
							LS	LS		206	30000		LS	MIXTURE DESIGN FOR CHEMICALLY STABILIZED SOILS	
		3,537.5	6,525.0				3,537.5	6,525.0		606	15050	10,062.5	FT	GUARDRAIL, TYPE MGS	
		4	10				4	10		606	26150	14	EACH	ANCHOR ASSEMBLY, MGS TYPE E (NCHRP 350/MASH 2016)	
		4	20				4	20		606	26500	24	EACH	ANCHOR ASSEMBLY, TYPE T	
				166					166	609	26001	166	FT	CURB, TYPE 6, AS PER PLAN	65
		41	84				41	84		626	00110	125	EACH	BARRIER REFLECTOR, TYPE 2 (ONE-WAY)	
		1	25				1	25		SPECIAL	69050100	26	EACH	MAILBOX SUPPORT SYSTEM, SINGLE	71
			18					18		SPECIAL	69050200	18	EACH	MAILBOX SUPPORT SYSTEM, DOUBLE	71
		2	78				2	78		SPECIAL	69050350	80	EACH	MAILBOX REMOVED AND RESET	71
							LS	LS		878	25000	LS	LS	INSPECTION AND COMPACTION TESTING OF UNBOUND MATERIALS	
		9	55				9	55		601	21050	64	SY	TIED CONCRETE BLOCK MAT WITH TYPE 1 UNDERLAYMENT	
		2,043	518	4			2,043	518	4	653	10001	2,565	CY	TOPSOIL FURNISHED AND PLACED, AS PER PLAN	68
		2	2				2	2		659	00100	4	EACH	SOIL ANALYSIS TEST	
		47,223	45,288				47,223	45,288		659	00510	92,511	SY	SEEDING AND MULCHING, CLASS 2	
		2,361	2,268				2,361	2,268		659	14000	4,629	SY	REPAIR SEEDING AND MULCHING	
		2,361	2,268				2,361	2,268		659	15000	4,629	SY	INTER-SEEDING	
		6.59	6.33				6.59	6.33		659	20000	12.92	TON	COMMERCIAL FERTILIZER	
		9.76	9.37				9.76	9.37		659	31000	19.13	ACRE	LIME	
		261	251				261	251		659	35000	512	MGAL	WATER	
			4,167					4,167		670	00520	4,167	SY	SLOPE EROSION PROTECTION MAT, TYPE B	
		4,119	484				4,119	484		670	00720	4,603	SY	DITCH EROSION PROTECTION MAT, TYPE B	
							LS	LS		832	15000	LS	LS	STORM WATER POLLUTION PREVENTION PLAN	
							LS	LS		832	15002	LS	LS	STORM WATER POLLUTION PREVENTION INSPECTIONS	
							LS	LS		832	15010	LS	LS	STORM WATER POLLUTION PREVENTION INSPECTION SOFTWARE	
							250,000	250,000		832	30000	500,000	EACH	EROSION CONTROL	

CALCULATED	PTB	CHECKED	JSL
GENERAL SUMMARY			
LIC-40-0.00			
46 442			

I:\ProjectData\LIC\93109\Design\Roadway\Sheets\93109_GG002.dgn_Sheet 1/21/2021 4:18:15 PM jlu7z

LOCATION TOTALS					PLAN SPLITS					ITEM	ITEM EXT.	GRAND TOTAL	UNIT	DESCRIPTION	SEE SHEET
LOC. 1A	LOC. 1B	LOC. 1C	LOC. 1D	LOC. 1D SCHOOL	01/S>2/ PV/REYN	02/S>2/ PV	03/S>2/ PV	04/STR/ PV	05/STR/ OT/SLSD						
		804	578				804	578		202	35100	1,382	FT	PIPE REMOVED, 24" AND UNDER	
			119					119		202	35200	119	FT	PIPE REMOVED, OVER 24"	
		12	1				12	1		202	58100	13	EACH	CATCH BASIN REMOVED	
		279					279			SPECIAL	20270000	279	FT	FILL AND PLUG EXISTING CONDUIT, 15"	68
		4	4				4	4		602	20000	8	CY	CONCRETE MASONRY	
			12,776					12,776		605	11100	12,776	FT	6" SHALLOW PIPE UNDERDRAINS	
		420	250				420	250		605	13300	670	FT	6" UNCLASSIFIED PIPE UNDERDRAINS	
		15,146	33,034				15,146	33,034		605	14000	48,180	FT	6" BASE PIPE UNDERDRAINS	
		20	50				20	50		605	31100	70	FT	AGGREGATE DRAINS	
		20	50				20	50		611	00100	70	FT	4" CONDUIT, TYPE B	
		40	100				40	100		611	00900	140	FT	6" CONDUIT, TYPE B	
		1,069	679				1,069	679		611	00510	1,748	FT	6" CONDUIT, TYPE F FOR UNDERDRAIN OUTLETS	
		20	50				20	50		611	01400	70	FT	6" CONDUIT, TYPE E	
		40	100				40	100		611	01500	140	FT	6" CONDUIT, TYPE F	
			140					140		611	05700	140	FT	15" CONDUIT, TYPE A	
		189					189			611	05900	189	FT	15" CONDUIT, TYPE B	
		181	149				181	149		611	06400	330	FT	15" CONDUIT, TYPE D	
			146					146		611	07200	146	FT	18" CONDUIT, TYPE A	
		5					5			611	07400	5	FT	18" CONDUIT, TYPE B	
			186					186		611	10400	186	FT	24" CONDUIT, TYPE B	
		199					199			611	12100	199	FT	27" CONDUIT, TYPE C	
			120					120		611	13200	120	FT	30" CONDUIT, TYPE A	
		1,075					1,075			611	97010	1,075	FT	SLOTTED DRAIN, TYPE 2 , 12"	68
		8					8			611	98410	8	EACH	CATCH BASIN, NO. 8	
			1					1		611	98470	1	EACH	CATCH BASIN, NO. 2-2B	
		6	5				6	5		611	98630	11	EACH	CATCH BASIN ADJUSTED TO GRADE	
		5					5			611	98631	5	EACH	CATCH BASIN ADJUSTED TO GRADE, AS PER PLAN	68
		4	32				4	32		611	99710	36	EACH	PRECAST REINFORCED CONCRETE OUTLET	
		35					35			625	29600	35	FT	TRENCH IN PAVED AREA, TYPE B	

CALCULATED	PTB	CHECKED	JSL
GENERAL SUMMARY			
LIC-40-0.00			
47 442			

I:\ProjectData\LIC\93109\Design\Roadway\Sheets\93109_GG003.dgn_Sheet 1/28/2021 4:40:43 PM jlwzlj

LOCATION TOTALS					PLAN SPLITS					ITEM	ITEM EXT.	GRAND TOTAL	UNIT	DESCRIPTION	SEE SHEET
LOC. 1A	LOC. 1B	LOC. 1C	LOC. 1D	LOC. 1D SCHOOL	01/S>2/ PV/REYN	02/S>2/ PV	03/S>2/ PV	04/STR/ PV	05/STR/ OT/SLSD						
			400					400		252	01500	400	FT	PAVEMENT FULL DEPTH PAVEMENT SAWING	
50	100	100	100		50	100	100	100		253	02000	350	CY	PAVEMENT REPAIR	
		3,500	3,500				3,500	3,500		254	01000	7,000	SY	PAVEMENT PLANING, ASPHALT CONCRETE , 1.25"	
59,495	150,063				59,495	150,063				254	01000	209,558	SY	PAVEMENT PLANING, ASPHALT CONCRETE , 3.00"	
		5,134					5,134			254	01000	5,134	SY	PAVEMENT PLANING, ASPHALT CONCRETE , VARIABLE (3.00" MAX)	
		394	549				394	549		254	01000	943	SY	PAVEMENT PLANING, ASPHALT CONCRETE , VARIABLE (5.00" MAX)	
		9,904	20,568	283			9,904	20,568	283	301	46000	30,755	CY	ASPHALT CONCRETE BASE, PG64-22	
		19	196				19	196		301	48000	215	CY	ASPHALT CONCRETE BASE, PG64-22 (DRIVEWAYS)	
		9,991	20,822	259			9,991	20,822	259	304	20000	31,072	CY	AGGREGATE BASE	
7,825	19,733	6,610	12,635	155	7,825	19,733	6,610	12,635	155	407	20000	46,958	GAL	NON-TRACKING TACK COAT	
1,517	2,986	1,615	3,204		1,517	2,986	1,615	3,204		408	10001	9,322	GAL	PRIME COAT, AS PER PLAN	2
		34	129				34	129		411	10000	163	CY	STABILIZED CRUSHED AGGREGATE	
39	97	167	227	18	39	97	167	227	18	441	50000	548	CY	ASPHALT CONCRETE SURFACE COURSE, TYPE 1, (448), PG64-22	
4,143	10,315	4,213	8,304	87	4,143	10,315	4,213	8,304	87	442	00100	27,062	CY	ANTI-SEGREGATION EQUIPMENT	
2,481	6,255	2,587	5,048	44	2,481	6,255	2,587	5,048	44	442	10000	16,415	CY	ASPHALT CONCRETE SURFACE COURSE, 12.5 MM, TYPE A (446)	
2,481	6,255	2,587	5,048	44	2,481	6,255	2,587	5,048	44	442	10101	16,415	CY	ASPHALT CONCRETE INTERMEDIATE COURSE, 19 MM, TYPE A (446), AS PER PLAN (PG64-22/PG64-28)	3
			65					65		452	10010	65	SY	6" NON-REINFORCED CONCRETE PAVEMENT, CLASS QC 1P (DRIVEWAYS)	
			230					230		452	12010	230	SY	8" NON-REINFORCED CONCRETE PAVEMENT, CLASS QC 1P (DRIVEWAYS)	
212	415	345	432		212	415	345	432		617	10101	1,404	CY	COMPACTED AGGREGATE, AS PER PLAN	2

CALCULATED	PTB	CHECKED	JSL
GENERAL SUMMARY			
LIC-40-0.00			
48 442			

I:\Project+Data\LIC\93109\Design\Roadway\Sheets\93109_CG006.dgn_Sheet 1/28/2021 4:42:15 PM jlu21

LOCATION TOTALS					PLAN SPLITS					ITEM	ITEM EXT.	GRAND TOTAL	UNIT	DESCRIPTION	SEE SHEET
LOC. 1A	LOC. 1B	LOC. 1C	LOC. 1D	LOC. 1D SCHOOL	01/S>2/ PV/REYN	02/S>2/ PV	03/S>2/ PV	04/STR/ PV	05/STR/ OT/SLSD						
MAINTENANCE OF TRAFFIC															
		433	3,314				433	3,314		410	13001	3,747	CY	TRAFFIC COMPACTED SURFACE, TYPE C, AS PER PLAN	75
50	100	150	100		50	100	150	100		614	11110	400	HOUR	LAW ENFORCEMENT OFFICER WITH PATROL CAR FOR ASSISTANCE	5
		18	98				18	98		614	12384	116	EACH	WORK ZONE IMPACT ATTENUATOR, 24" WIDE HAZARDS, (BIDIRECTIONAL)	73
							LS	LS		614	12421	LS	LS	DETOUR SIGNING, AS PER PLAN	73
4	15	4	8		4	15	4	8		614	12460	31	EACH	WORK ZONE MARKING SIGN	4
		50	10				50	10		614	12600	60	EACH	REPLACEMENT DRUM	73
		1					1			614	12756	1	EACH	WORK ZONE CROSSOVER LIGHTING SYSTEM	73
6					6					614	13000	6	CY	ASPHALT CONCRETE FOR MAINTAINING TRAFFIC	5
		294	654				294	654		614	13310	948	EACH	BARRIER REFLECTOR, TYPE 1, BIDIRECTIONAL	72
		294	654				294	654		614	13360	948	EACH	OBJECT MARKER, TWO WAY	72
2	10	60	60		2	10	60	60		614	18601	132	SNMT	PORTABLE CHANGEABLE MESSAGE SIGN, AS PER PLAN	6
		0.15					0.15			614	20056	0.15	MILE	WORK ZONE LANE LINE, CLASS I, 6", 807 PAINT	
2.78	8.40	2.94	6.17		2.78	8.40	2.94	6.17		614	20100	20.29	MILE	WORK ZONE LANE LINE, CLASS I, 4", 642 PAINT	
2.78	8.40	2.94	6.17		2.78	8.40	2.94	6.17		614	20550	20.29	MILE	WORK ZONE LANE LINE, CLASS III, 4", 642 PAINT	
		3.86	7.33				3.86	7.33		614	21050	11.19	MILE	WORK ZONE CENTER LINE, CLASS I, 807 PAINT	
2.22	7.98	3.20	7.64		2.22	7.98	3.20	7.64		614	21100	21.04	MILE	WORK ZONE CENTER LINE, CLASS I, 642 PAINT	
2.22	7.98	1.20	5.64		2.22	7.98	1.20	5.64		614	21550	17.04	MILE	WORK ZONE CENTER LINE, CLASS III, 642 PAINT	
		6.97	13.44				7	13		614	22056	20.41	MILE	WORK ZONE EDGE LINE, CLASS I, 6", 807 PAINT	
		2,624	2,520				2,624	2,520		614	23100	5,144	FT	WORK ZONE CHANNELIZING LINE, CLASS I, 8", 807 PAINT	
1,992	8,016	2,905	3,903		1,992	8,016	2,905	3,903		614	23200	16,816	FT	WORK ZONE CHANNELIZING LINE, CLASS I, 8", 642 PAINT	
1,992	8,016	2,905	3,903		1,992	8,016	2,905	3,903		614	23680	16,816	FT	WORK ZONE CHANNELIZING LINE, CLASS III, 8", 642 PAINT	
		1,987	695				1,987	695		614	24100	2,682	FT	WORK ZONE DOTTED LINE, CLASS I, 4", 807 PAINT	
131	733	551	434		131	733	551	434		614	26200	1,849	FT	WORK ZONE STOP LINE, CLASS I, 642 PAINT	
131	733	160	158		131	733	160	158		614	26610	1,182	FT	WORK ZONE STOP LINE, CLASS III, 642 PAINT	
		45	55				45	55		614	30200	100	EACH	WORK ZONE ARROW, CLASS I, 642 PAINT	
							LS	LS		615	10000	LS	LS	ROADS FOR MAINTAINING TRAFFIC	72
		3,342	7,644				3,342	7,644		615	25001	10,986	SY	PAVEMENT FOR MAINTAINING TRAFFIC, CLASS B, AS PER PLAN	73
		50	75				50	75		616	10000	125	MGAL	WATER	85
		14,930	32,345				14,930	32,345		622	41100	47,275	FT	PORTABLE BARRIER, UNANCHORED	
6	10	120	120		6	10	120	120		808	18700	256	SNMT	DIGITAL SPEED LIMIT (DSL) SIGN ASSEMBLY	5
INCIDENTALS															
					LS	LS	LS	LS	LS	108	10000	LS	LS	CPM PROGRESS SCHEDULE	
					LS	LS	LS	LS	LS	614	11000	LS	LS	MAINTAINING TRAFFIC	
					2	4.5	10	19	0.5	619	16020	36	MNTH	FIELD OFFICE, TYPE C	
					LS	LS	LS	LS	LS	623	10001	LS	LS	CONSTRUCTION LAYOUT STAKES AND SURVEYING, AS PER PLAN	69
					LS	LS	LS	LS	LS	624	10000	LS	LS	MOBILIZATION	

CALCULATED
PTB
CHECKED
JSL

GENERAL SUMMARY

LIC-40-0.00

- 1 TAPERS FROM 39' AT STA. 1081+50 TO 12' AT STA. 1094+89.43
- 2 SMOKE RD. RIGHT TURN LANE
TAPERS FROM 37.5' AT STA. 1093+51.5 TO 36' AT STA. 1094+83.54
36' FROM STA. 1094+83.54 TO STA. 1096+96.5
TAPERS FROM 36' AT STA. 1096+96.5 TO 24' AT STA. 1097+46.5
- 3 SCHOOL DR. RIGHT TURN LANE
36' FROM STA. 1108+26 TO STA. 1111+91
TAPERS FROM 36' AT STA. 1111+91 TO 24' AT STA. 1112+41
- 4 4' FROM STA. 1094+83.54 TO STA. 1111+91
TAPERS FROM 4' AT STA. 1111+91 TO 6' AT STA. 1112+41
- 5 8' FROM STA. 1094+83.54 TO STA. 1111+91
TAPERS FROM 8' AT STA. 1111+91 TO 12' AT STA. 1112+41
- 6 TAPERS FROM 24' AT STA. 1256+93.59 TO 19.5' AT STA. 1259+50
- 7 TAPERS FROM 24' AT STA. 1255+33.05 TO 18.22' AT STA. 1259+50
- 8 TAPERS FROM 6' AT STA. 1259+00 TO 7.5' AT STA. 1259+50

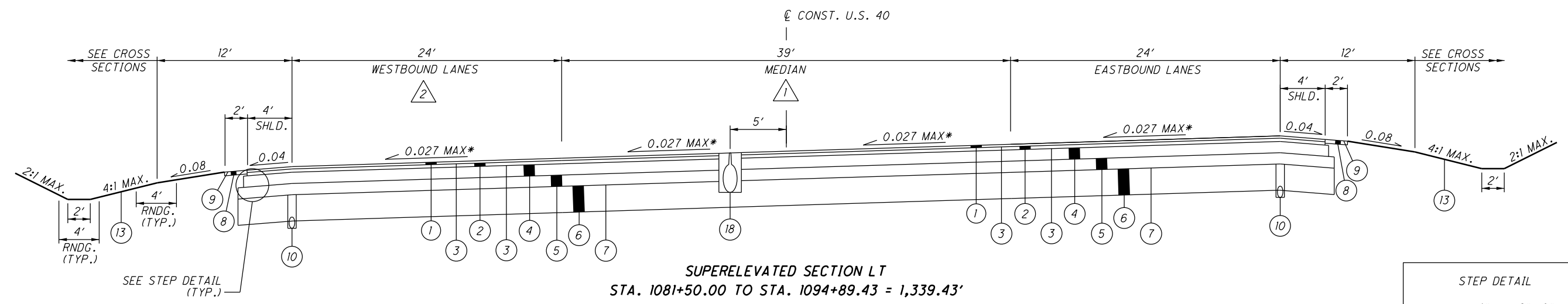

* SEE SUPERELEVATION TABLES

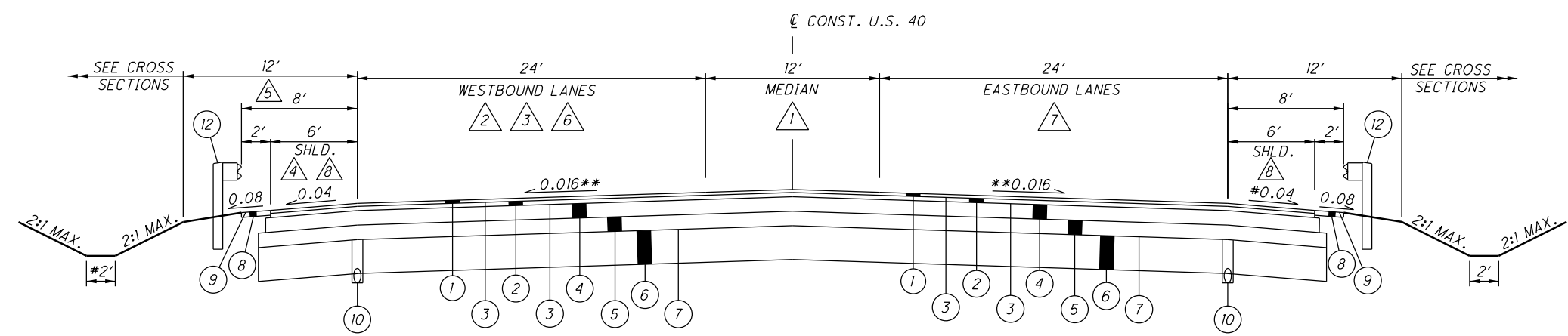

7' DITCH BOTTOM FROM STA. 1246+00 TO STA. 1249+00 LT

** TRANSITION FROM 0.016 AT STA. 1259+00 TO 0.0194 AT STA. 1259+50 LT

0.016 FROM STA. 1254+50 TO STA. 1259+50

** TRANSITION FROM 0.016 AT STA. 1259+00 TO 0.0071 AT STA. 1259+50 RT

- | | | |
|---|---|---|
| <ul style="list-style-type: none"> 1 ITEM 442, 1.50" ASPHALT CONCRETE SURFACE COURSE, 12.5 MM, TYPE A (446) 2 ITEM 442, 1.50" ASPHALT CONCRETE INTERMEDIATE COURSE, 19 MM, TYPE A (446), AS PER PLAN 3 ITEM 407, NON-TRACKING TACK COAT (RATE PER 407.06-1) 4 ITEM 301, 6" ASPHALT CONCRETE BASE 5 ITEM 304, 6" AGGREGATE BASE | <ul style="list-style-type: none"> 6 ITEM 206, CEMENT STABILIZED SUBGRADE, 14 INCHES DEEP 7 ITEM 204, PROOF ROLLING 8 ITEM 617, 2" COMPACTED AGGREGATE, AS PER PLAN 9 ITEM 408, PRIME COAT, AS PER PLAN 10 ITEM 605, 6" BASE PIPE UNDERDRAINS (18" DEEP) | <ul style="list-style-type: none"> 11 ITEM 605, 6" SHALLOW PIPE UNDERDRAINS (30" DEEP) 12 ITEM 606, GUARDRAIL, TYPE MGS 13 ITEM 659, SEEDING AND MULCHING, CLASS 2 14 ITEM 653, TOPSOIL, FURNISHED AND PLACED, AS PER PLAN 15 ITEM 670, DITCH EROSION PROTECTION MAT, TYPE B |
| <ul style="list-style-type: none"> 16 ITEM 254, VARIABLE PAVEMENT PLANING (3" MAX.) 17 ITEM 301, VARIABLE ASPHALT CONCRETE BASE (6" MAX.) 18 ITEM 611, SLOTTED DRAIN, TYPE 2 (12" OPENING) 19 ITEM 609, CURB, TYPE 6, AS PER PLAN | | |

I:\ProjectData\LIC-93109\Design\Roadway\Sheets\93109_C0008.dgn_Sheet 2/4/2021 12:49:20 PM jjutzi

ITEM 611, MANHOLE ADJUSTED TO GRADE, AS PER PLAN

ALL MANHOLES ADJUSTED TO GRADE, **AS DIRECTED BY THE ENGINEER**, SHALL MEET THE SOUTHWEST LICKING COMMUNITY WATER AND SEWER DISTRICT CONSTRUCTION MATERIAL SPECIFICATIONS STANDARD DRAWINGS SA.S.-2, SA.S.-3 AND SA.S.-4. SEE SPECIAL PROVISIONS FOR STANDARD DRAWINGS.

CONTRACTOR SHALL NOTIFY THE SOUTHWEST LICKING COMMUNITY WATER AND SEWER DISTRICT NO LESS THAN 48 HOURS PRIOR TO EXCAVATION.

PAYMENT FOR THIS ITEM SHALL BE MADE AT THE UNIT CONTRACT BID PRICE FOR EACH ITEM MANHOLE ADJUSTED TO GRADE, AS PER PLAN AND SHALL INCLUDE ALL LABOR, EQUIPMENT, MATERIALS, AND INCIDENTALS NECESSARY TO CONSTRUCT THIS ITEM TO THE SATISFACTION OF THE ENGINEER AND THE SOUTHWEST LICKING COMMUNITY WATER AND SEWER DISTRICT.

ITEM 611, MANHOLE ADJUSTED TO GRADE, AS PER PLAN

LOCATION 1C: 4 EACH
LOCATION 1D: 35 EACH

ITEM 638, VALVE BOX ADJUSTED TO GRADE, AS PER PLAN

ALL VALVE BOXES ADJUSTED TO GRADE OR PLACED WITHIN THE PROJECT PAVEMENT LIMITS, **AS DIRECTED BY THE ENGINEER**, SHALL MEET THE SOUTHWEST LICKING COMMUNITY WATER AND SEWER DISTRICT CONSTRUCTION MATERIAL SPECIFICATIONS STANDARD DRAWINGS W-14 FOR NON-TRAFFIC TYPE AND W-15 FOR TRAFFIC TYPE. SEE SPECIAL PROVISIONS FOR STANDARD DRAWINGS.

CONTRACTOR SHALL NOTIFY THE SOUTHWEST LICKING COMMUNITY WATER AND SEWER DISTRICT NO LESS THAN 48 HOURS PRIOR TO EXCAVATION.

PAYMENT FOR THIS ITEM SHALL BE MADE AT THE UNIT CONTRACT BID PRICE FOR EACH ITEM VALVE BOX ADJUSTED TO GRADE, AS PER PLAN AND SHALL INCLUDE ALL LABOR, EQUIPMENT, MATERIALS, AND INCIDENTALS NECESSARY TO CONSTRUCT THIS ITEM TO THE SATISFACTION OF THE ENGINEER AND THE SOUTHWEST LICKING COMMUNITY WATER AND SEWER DISTRICT.

ITEM 638, VALVE BOX ADJUSTED TO GRADE, AS PER PLAN

LOCATION 1C: 5 EACH
LOCATION 1D: 18 EACH

ITEM 638, FIRE HYDRANT ADJUSTED TO GRADE, AS PER PLAN

ALL FIRE HYDRANTS RELOCATED OR ADJUSTED TO GRADE, **AS DIRECTED BY THE ENGINEER**, SHALL MEET THE SOUTHWEST LICKING COMMUNITY WATER AND SEWER DISTRICT CONSTRUCTION MATERIAL SPECIFICATIONS STANDARD DRAWINGS W-18, W-20, W-21, W-22, AND W-23. ALL VALVE BOXES FOR FIRE HYDRANTS RELOCATED OR ADJUSTED TO GRADE SHALL MEET THE SOUTHWEST LICKING COMMUNITY WATER AND SEWER DISTRICT CONSTRUCTION MATERIAL SPECIFICATIONS STANDARD DRAWINGS W-14 FOR NON-TRAFFIC TYPE AND W-15 FOR TRAFFIC TYPE. SEE SPECIAL PROVISIONS FOR STANDARD DRAWINGS.

CONTRACTOR SHALL NOTIFY THE SOUTHWEST LICKING COMMUNITY WATER AND SEWER DISTRICT NO LESS THAN 48 HOURS PRIOR TO EXCAVATION.

PAYMENT FOR THIS ITEM SHALL BE MADE AT THE UNIT CONTRACT BID PRICE FOR EACH ITEM FIRE HYDRANT RELOCATED OR ADJUSTED TO GRADE, AS PER PLAN AND SHALL INCLUDE ALL LABOR, EQUIPMENT, MATERIALS, AND INCIDENTALS NECESSARY TO CONSTRUCT THIS ITEM TO THE SATISFACTION OF THE ENGINEER AND THE SOUTHWEST LICKING COMMUNITY WATER AND SEWER DISTRICT.

ITEM 638, FIRE HYDRANT ADJUSTED TO GRADE, AS PER PLAN

LOCATION 1C: 2 EACH
LOCATION 1D: 32 EACH

PAVEMENT RESTORATION FOR CULVERT INSTALLATION

THE FOLLOWING QUANTITIES SHALL BE USED WHEN OPEN CUTTING PAVEMENT FOR CULVERT INSTALLATION AT STA. 1097+28, 1110+20, 1115+23, AND 1141+20.5. PAVEMENT SHALL BE RESTORED TO THE EXISTING ELEVATION UNTIL FINAL FULL DEPTH PAVEMENT CAN BE PLACED.

THE CONTRACTOR IS RESPONSIBLE FOR PERFORMING SAFE EXCAVATION AND EARTHWORK PER OSHA REGULATIONS. THE EXCAVATION LIMITS SHOWN BELOW ARE FOR ESTIMATED PURPOSES ONLY AND SHALL BE ADJUSTED TO MATCH THE LIMITS APPROVED IN THE 611 INSTALLATION PLAN, AS DIRECTED BY THE ENGINEER.

SEE SHEETS 152-153 FOR EXISTING PAVEMENT REMOVAL QUANTITIES.

PAYMENT FOR THE ITEMS BELOW SHALL BE MADE AT THE UNIT PRICE BID AND SHALL INCLUDE ALL LABOR, EQUIPMENT, AND INCIDENTALS REQUIRED TO COMPLETE THE WORK AS DESCRIBED HEREIN.



ITEM 252, FULL DEPTH PAVEMENT SAWING

LOCATION 1D: 400 FEET

ITEM 615, PAVEMENT FOR MAINTAINING TRAFFIC, CLASS B, AS PER PLAN

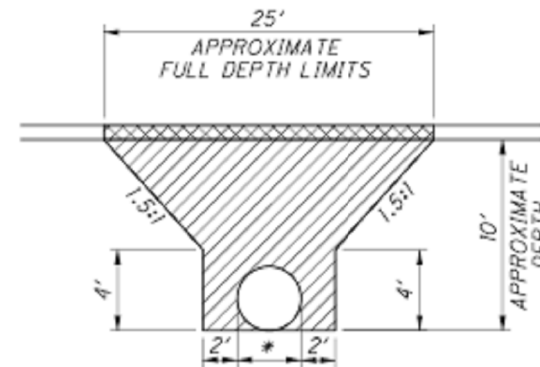
LOCATION 1D: 650 SQ. YD.



-  ITEM 615, PAVEMENT FOR MAINTAINING TRAFFIC, CLASS B, AS PER PLAN
-  BACKFILL PER ITEM 611 INSTALLATION PLAN

CALCULATED
PTB
CHECKED
JSL

GENERAL NOTES (FULL DEPTH)

LIC-40-0.00

ITEM 614, DETOUR SIGNING, AS PER PLAN

THE CONTRACTOR SHALL SUPPLY, ERECT, MAINTAIN, AND REMOVE ALL DETOUR SIGNING AS SHOWN IN THE PLANS.

PAYMENT FOR ALL LABOR, EQUIPMENT, MATERIAL AND INCIDENTALS TO PERFORM THIS WORK SHALL BE INCLUDED IN THE LUMP SUM BID FOR ITEM 614, DETOUR SIGNING, AS PER PLAN.

ITEM 614, REPLACEMENT DRUM

DRUMS FURNISHED BY THE CONTRACTOR IN ACCORDANCE WITH THE REQUIREMENTS OF THE PLANS, SPECIFICATIONS AND PROPOSAL WHICH BECOME DAMAGED BY TRAFFIC FOR REASONS BEYOND THE CONTROL OF THE CONTRACTOR SHALL BE REPLACED IN KIND WHEN ORDERED BY THE ENGINEER. REPLACEMENT DRUMS SHALL BE NEW.

PAYMENT FOR THE NEW DRUMS SHALL BE MADE AT THE CONTRACT PRICE PER EACH FOR ITEM 614, REPLACEMENT DRUM, AND SHALL INCLUDE THE COST OF REMOVING AND DISPOSING OF THE DAMAGED DRUM AND PROVIDING AND MAINTAINING THE REPLACEMENT DRUM IN ACCORDANCE WITH THE CONTRACT REQUIREMENTS FOR THE ORIGINAL DRUM.

ITEM 614, REPLACEMENT DRUM
LOCATION 1C: 50 EACH
LOCATION 1D: 10 EACH

ITEM 614, WORK ZONE IMPACT ATTENUATOR FOR 24" WIDE HAZARDS (BIDIRECTIONAL)

THIS ITEM SHALL CONSIST OF FURNISHING AND INSTALLING A NON-GATING IMPACT ATTENUATOR. FURNISH AN IMPACT ATTENUATOR FROM THE OFFICE OF ROADWAY ENGINEERING'S APPROVED LIST FOR WORK ZONE IMPACT ATTENUATORS, FROM THE ROADWAY STANDARDS APPROVED PRODUCTS WEB PAGE.

INSTALLATION SHALL BE AT THE LOCATIONS SPECIFIED IN THE PLANS IN ACCORDANCE WITH THE MANUFACTURER'S SPECIFICATIONS.

THE CONTRACTOR SHALL REPAIR OR REPLACE A DAMAGED UNIT WITHIN 24 HOURS OF A DAMAGING IMPACT.

WHEN BIDIRECTIONAL DESIGNS ARE SPECIFIED, THE CONTRACTOR SHALL SUPPLY APPROPRIATE TRANSITIONS.

WHEN GATING IMPACT ATTENUATORS ARE DESIRED, THE CONTRACTOR SHALL SUBMIT DOCUMENTATION TO THE ENGINEER FOR ACCEPTANCE.

THE COST FOR THE ADDITIONAL BARRIER REQUIRED FOR A GATING IMPACT ATTENUATOR SHALL BE INCLUDED IN THE COST OF THE GATING IMPACT ATTENUATOR.

UNANCHORED IMPACT ATTENUATORS SHALL BE USED WHEN PLACED ON NEW PAVEMENT.

PAYMENT FOR THE ABOVE WORK SHALL BE MADE AT THE UNIT PRICE BID AND SHALL INCLUDE ALL LABOR, TOOLS, EQUIPMENT AND MATERIALS NECESSARY TO CONSTRUCT AND MAINTAIN A COMPLETE AND FUNCTIONAL IMPACT ATTENUATOR SYSTEM, INCLUDING ALL RELATED BACKUPS, TRANSITIONS, LEVELING PADS, HARDWARE AND GRADING, NOT SEPARATELY SPECIFIED, AS REQUIRED BY THE MANUFACTURER.

ITEM 615, PAVEMENT FOR MAINTAINING TRAFFIC, CLASS B, AS PER PLAN

IN ADDITION TO THE PAVEMENT BUILDUPS SHOWN IN CMS 615.05, THE FOLLOWING ASPHALT BUILDUP MAY ALSO BE USED, AS DIRECTED BY THE ENGINEER:

- ITEM 441, 1.25" ASPHALT CONCRETE SURFACE COURSE, TYPE I, (448), PG64-22
- ITEM 407, NON-TRACKING TACK COAT (APPLIED AT A RATE OF 0.05 GAL./ SQ. YD.)
- ITEM 301, **7.5" ASPHALT CONCRETE BASE, PG64-22

**** THICKNESS MAY BE REDUCED TO 6" AT LOCATIONS NOT UNDER LIVE TRAFFIC**

THE CONTRACTOR SHALL PROVIDE AND MAINTAIN A SAFE DRIVING SURFACE THROUGHOUT THE USE OF THE PAVEMENT.

PAYMENT SHALL BE MADE AT THE UNIT PRICE BID AND INCLUDE ALL LABOR, EQUIPMENT, AND INCIDENTALS NECESSARY TO COMPLETE THE ITEM.

ITEM 614, WORK ZONE CROSSOVER LIGHTING SYSTEM

THIS WORK SHALL CONSIST OF FURNISHING, ERECTING, OPERATING, MAINTAINING AND REMOVING A WORK ZONE LIGHTING SYSTEM FOR A SINGLE CROSSOVER, OR OVERLAPPING A PAIR OF CROSSOVERS. THE SYSTEM SHALL BE AS SHOWN ON STANDARD DRAWING MT-100.00. THE CONTRACTOR SHALL ARRANGE AND PAY FOR POWER. ALL MATERIALS AND CONSTRUCTION SHALL COMPLY WITH APPLICABLE PORTIONS OF 625 AND 725 EXCEPT: THE PERFORMANCE TEST OF 625.19F, AND CERTIFIED DRAWING REQUIREMENT OF 625.04, ARE WAIVED AND USED MATERIALS IN GOOD CONDITION ARE ACCEPTABLE.

POLES WHICH ARE NOT PROTECTED BY GUARDRAIL OR PORTABLE BARRIER SHALL BE LOCATED OUTSIDE THE CLEAR ZONE AND SHOULD BE LOCATED AT LEAST 30 FEET (PREFERABLY 40 FEET) FROM THE EDGE OF PAVEMENT WHEN POSSIBLE. ADDITIONAL POLE LINES, CABLES AND APPURTENANCES NECESSARY TO FURNISH POWER TO THE LIGHTING SYSTEM SHALL BE INCLUDED IN THIS ITEM. SERVICE POLES SHALL BE POSITIONED WITH THE SAME CONSTRAINTS AS THE LIGHTING POLES AS A MINIMUM.

PAYMENT WILL BE MADE AT THE UNIT PRICE PER EACH FOR ITEM 614, WORK ZONE CROSSOVER LIGHTING SYSTEM THROUGHOUT ALL PHASES OF WORK WHEN THE CROSSOVER ROADWAYS ARE USED.

ITEM 614, WORK ZONE CROSSOVER LIGHTING SYSTEM
LOCATION 1C: 1 EACH

DESIGNATED LOCAL DETOUR ROUTE

IN ADDITION TO THE OFFICIAL STATE SIGNED DETOUR ROUTE, LOCAL ROUTES HAVE BEEN DETERMINED TO BE THE SECONDARY, UNSIGNED DETOUR ROUTE OR "DESIGNATED LOCAL DETOUR ROUTE." THE ROUTES SHOWN ON SHEETS 78 AND 81. DURING THE TIME THAT TRAFFIC IS DETOURED, THE CONTRACTOR SHALL MAINTAIN THIS ROUTE IN A CONDITION WHICH IS REASONABLY SMOOTH AND FREE FROM HOLES, RUTS, RIDGES, BUMPS, DUST AND STANDING WATER. ONCE THE DETOUR IS REMOVED AND TRAFFIC RETURNED TO ITS NORMAL PATTERN, THE DESIGNATED LOCAL DETOUR ROUTE SHALL BE RESTORED TO A CONDITION THAT IS EQUIVALENT TO THAT WHICH EXISTED PRIOR TO ITS USE FOR THIS PURPOSE. ALL SUCH WORK SHALL BE PERFORMED WHEN AND AS DETERMINED BY THE ENGINEER.

THE FOLLOWING ESTIMATED QUANTITIES HAVE BEEN CARRIED TO THE LOCATION SUB-SUMMARIES FOR USE AS DETERMINED BY THE ENGINEER TO MAINTAIN AND SUBSEQUENTLY RESTORE THE DESIGNATED LOCAL DETOUR ROUTES SHOWN IN THE PLANS.

ITEM 253, PAVEMENT REPAIR
LOCATION 1C: 100 CU. YD.
LOCATION 1D: 100 CU. YD.

ITEM 254, PAVEMENT PLANING, ASPHALT CONCRETE, 1.25"
LOCATION 1C: 3,500 SQ. YD.
LOCATION 1D: 3,500 SQ. YD.

ITEM 441, ASPHALT CONCRETE SURFACE COURSE, TYPE 1, PG 64-22
LOCATION 1C: 125 CU. YD.
LOCATION 1D: 125 CU. YD.

ITEM 407, NON-TRACKING TACK COAT
LOCATION 1C: 280 GAL.
LOCATION 1D: 280 GAL.

ITEM 408, PRIME COAT, AS PER PLAN
LOCATION 1C: 250 GAL.
LOCATION 1D: 250 GAL.

ITEM 617, COMPACTED AGGREGATE, AS PER PLAN
LOCATION 1C: 25 CU. YD.
LOCATION 1D: 25 CU. YD.

ITEM 614, WORK ZONE CENTER LINE, CLASS I, 642 PAINT
LOCATION 1C: 2.0 MILE
LOCATION 1D: 2.0 MILE

ITEM 614, WORK ZONE STOP LINE, CLASS I, 642 PAINT
LOCATION 1C: 25 FEET
LOCATION 1D: 25 FEET

CALCULATED
LIME
CHECKED
JSL

MAINTENANCE OF TRAFFIC NOTES (FULL DEPTH)

LIC-40-0.00

MAINTAINING EXISTING DRIVES

THE CONTRACTOR SHALL MAINTAIN ACCESS TO ALL RESIDENT AND COMMERCIAL DRIVES TO THE FULLEST EXTENT POSSIBLE. IT IS UNDERSTOOD THAT FOR SHORT PERIODS OF TIME, THE FULL ACCESS TO A DRIVEWAY MAY NOT BE POSSIBLE. THE CONTRACTOR SHALL MAKE ACCOMMODATIONS TO THE RESIDENT/BUSINESS OWNER SO THAT DURING THESE SHORT INTERVALS, THE HOME/BUSINESS OWNER CAN STILL HAVE ACCESS TO PARK NEAR THEIR RESIDENCE/BUSINESS.

PROPERTIES WITH MULTIPLE ACCESS POINTS: WORK AT ONE DRIVE AT A TIME. PROPERTIES WITH A SINGLE ACCESS POINT: MAINTAIN ACCESS TO PROPERTY AT ALL TIMES USING ONE OF THE FOLLOWING METHODS: REPLACE DRIVEWAY USING PART WIDTH CONSTRUCTION, BACKFILL OPEN EXCAVATION WITH ITEM 410 AGGREGATE FOR TEMPORARY ACCESS, OR USE STEEL PLATES TO SPAN OVER OPEN EXCAVATIONS AND OR CONCRETE NOT OUT OF CURE BEFORE ACCESS TO A DRIVEWAY IS INTERRUPTED, THE CONTRACTOR SHALL GIVE PRIOR NOTICE TO THE OCCUPANT OF THE PROPERTY 72 HOURS BEFORE THE WORK IS STARTED. THE CONTRACTOR SHALL BE RESPONSIBLE TO ENSURE THAT U.S. MAIL OR ANY OTHER DELIVERY WITHIN THE PROJECT LIMITS IS NOT DISRUPTED BY CONSTRUCTION OPERATIONS.

THE DEPARTMENT WILL ONLY PAY FOR ITEM 411, TRAFFIC COMPACTED SURFACE, TYPE C ONE TIME PER PHASE OF CONSTRUCTION. ALL LABOR AND EQUIPMENT REQUIRED TO MOVE THE TRAFFIC COMPACTED AGGREGATE MULTIPLE TIMES DURING A PHASE SHALL BE AT THE COST OF THE CONTRACTOR.

THE FOLLOWING ESTIMATED QUANTITIES HAVE BEEN INCLUDED IN THE LOCATION SUB-SUMMARIES FOR USE AS DIRECTED BY THE ENGINEER TO MAINTAIN AND RESTORE EXISTING DRIVES AS DESCRIBED ABOVE AND AS DETAILED ON THIS SHEET.

	LOCATION IC	LOCATION ID
PHASE 1	257	1,065
PHASE 2	86	1,579
CONTINGENCY	90	670

ITEM 410, TRAFFIC COMPACTED SURFACE, TYPE C, AS PER PLAN
 LOCATION IC: 433 CU. YD.
 LOCATION ID: 3,314 CU. YD.

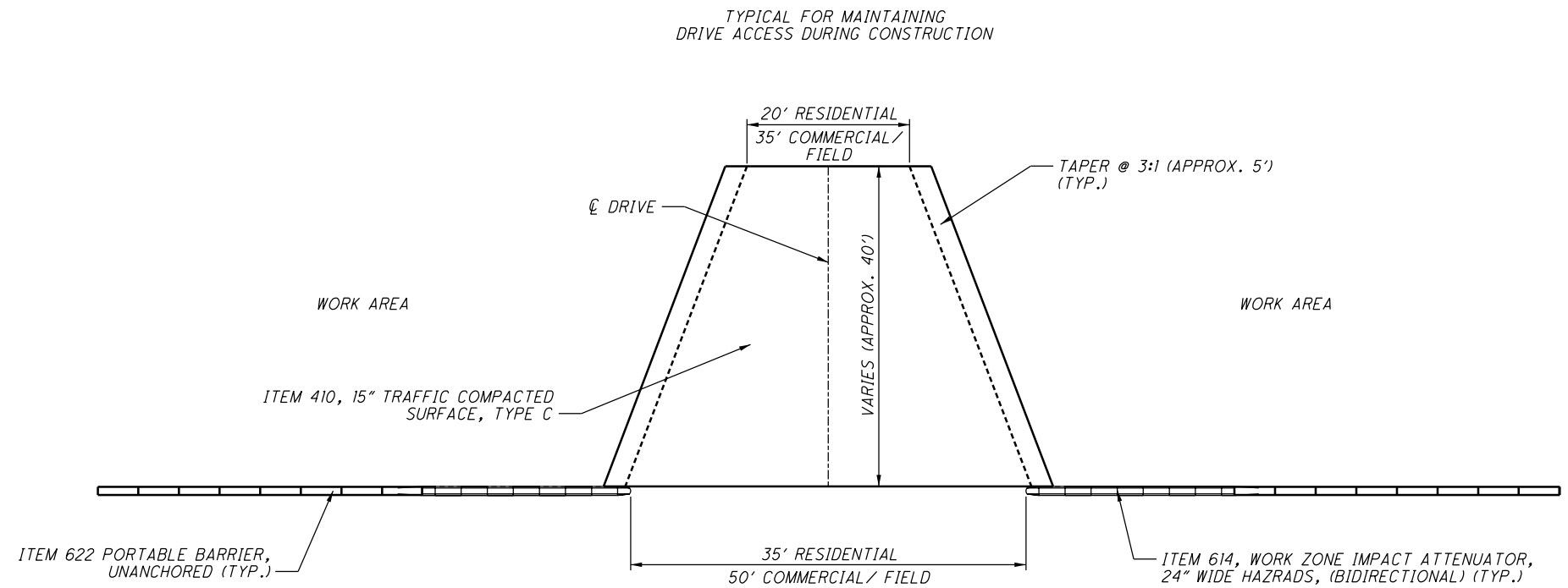

I:\ProjectData\LIC\93109\Design\MOT\Sheets\93109_MN007.dgn_Sheet 1/29/2021 11:54:26 PM jlutzi

CALCULATED
 PTB
 CHECKED
 JSL

MAINTAINING EXISTING DRIVES

LIC-40-0.00

①
 DETOUR EAST
 MI-4-36-2
 M5-1-30

⑥
 DETOUR WEST
 MI-4-36-2
 M5-1-30

②
 DETOUR EAST
 MI-4-36-2
 M6-1-30

⑦
 DETOUR WEST
 MI-4-36-2
 M6-1-30

③
 DETOUR EAST
 MI-4-36-2
 M5-1-30

⑧
 DETOUR WEST
 MI-4-36-2
 M5-1-30

④
 DETOUR EAST
 MI-4-36-2
 M6-1-30

⑨
 DETOUR WEST
 MI-4-36-2
 M6-1-30

⑤
 DETOUR EAST
 MI-4-36-2
 M5-2-30

⑩
 DETOUR WEST
 MI-4-36-2
 M5-2-30

PLACE AT BEGINNING OF DECELERATION LANE

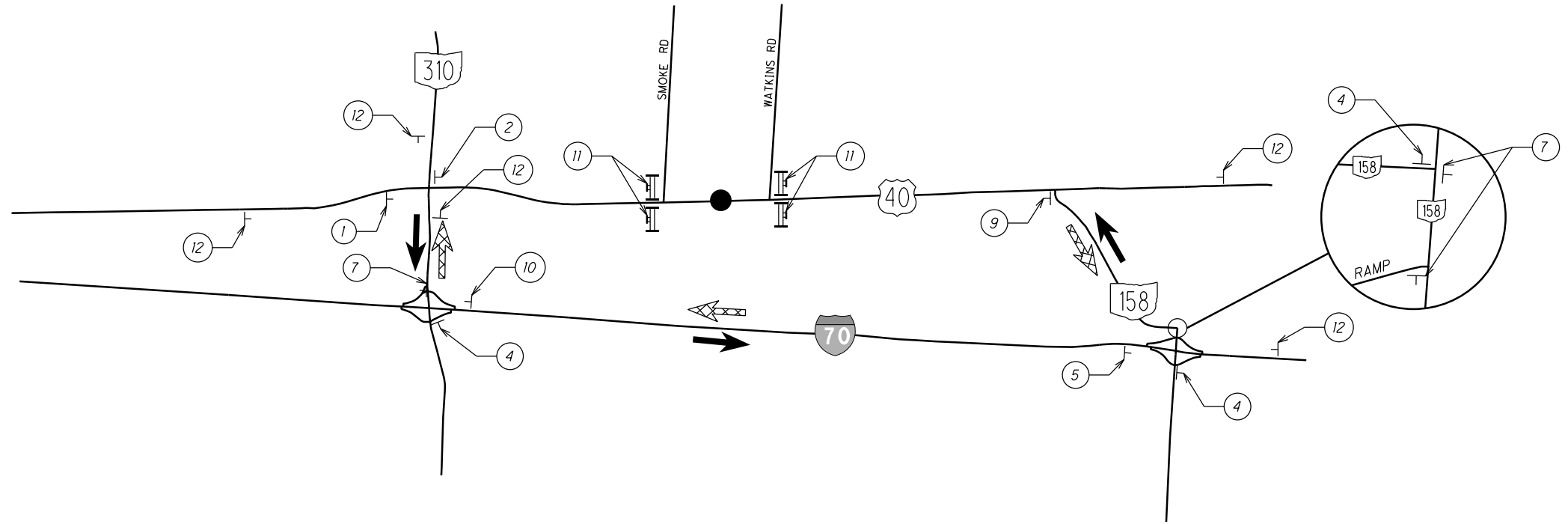

LEGEND

- WORK AREA
- ← U.S. 40 EB DETOUR
- U.S. 40 WB DETOUR

⑪
 ROAD CLOSED
 R11-2-48
 MOUNT ON TYPE 3 BARRICADE
 PLACE ON BOTH EB AND WB LANES

⑫
 PORTABLE CHANGEABLE MESSAGE SIGN

US 40 CLOSED BETWEEN

SMOKE AND WATKINS

SCREEN 1 SCREEN 2
 PLACE MINIMUM 1/2 MILE PRIOR TO INTERSECTION/ EXIT

①
 DETOUR NORTH
 310
 M4-8-30
 M3-1-30
 MI-5-36-3
 M5-1-30

⑥
 DETOUR SOUTH
 310
 M4-8-30
 M3-3-30
 MI-5-36-3
 M5-1-30

②
 DETOUR NORTH
 310
 M4-8-30
 M3-1-30
 MI-5-36-3
 M6-1-30

⑦
 DETOUR SOUTH
 310
 M4-8-30
 M3-3-30
 MI-5-36-3
 M6-1-30

③
 DETOUR NORTH
 310
 M4-8-30
 M3-1-30
 MI-5-36-3
 M5-1-30

⑧
 DETOUR SOUTH
 310
 M4-8-30
 M3-3-30
 MI-5-36-3
 M5-1-30

④
 DETOUR NORTH
 310
 M4-8-30
 M3-1-30
 MI-5-36-3
 M6-1-30

⑨
 DETOUR SOUTH
 310
 M4-8-30
 M3-3-30
 MI-5-36-3
 M6-1-30

⑤
 DETOUR NORTH
 310
 M4-8-30
 M3-1-30
 MI-5-36-3
 M6-3-30

⑩
 DETOUR SOUTH
 310
 M4-8-30
 M3-3-30
 MI-5-36-3
 M6-3-30

⑪
 ROAD CLOSED
 3 MILES AHEAD
 LOCAL TRAFFIC ONLY
 R11-3A-60
 DETOUR
 M4-10R-48
 MOUNT ON TYPE 3 BARRICADE
 PLACE ON SHOULDER

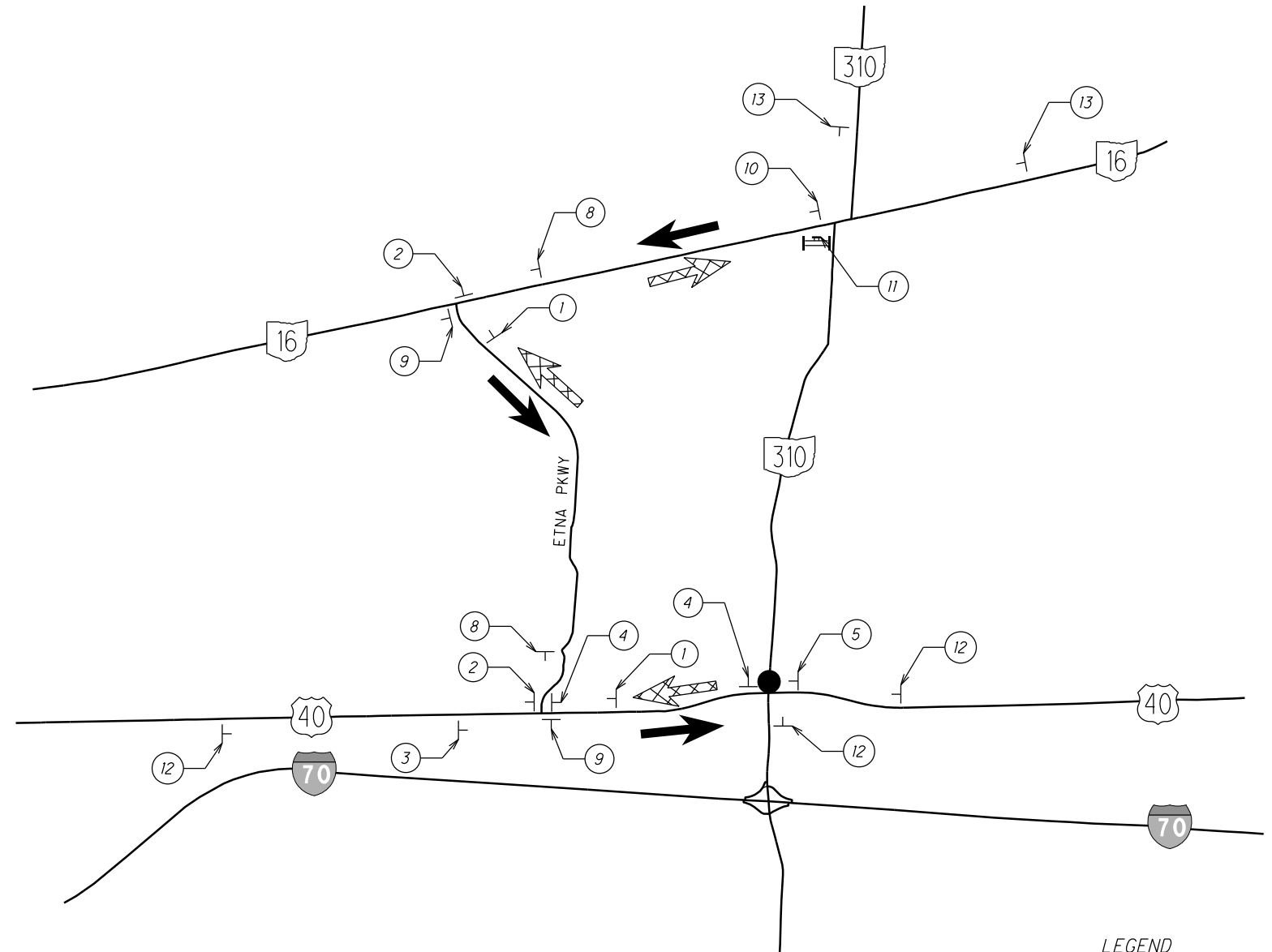

LEGEND

- WORK AREA
- ↔ S.R. 310 NB DETOUR
- ← S.R. 310 SB DETOUR

⑫
 PORTABLE CHANGEABLE
 MESSAGE SIGN
 SR 310NB
 CLOSED
 USE
 ETNA
 PKWY
 SCREEN 1 SCREEN 2
 PLACE MINIMUM 1/2 MILE
 PRIOR TO INTERSECTION

⑬
 PORTABLE CHANGEABLE
 MESSAGE SIGN
 SR 310
 CLOSED
 AT US 40
 USE
 ETNA
 PKWY
 SCREEN 1 SCREEN 2
 PLACE MINIMUM 1/2 MILE
 PRIOR TO INTERSECTION

1
 DETOUR NORTH
 310
 →

M4-8-30
 M3-1-30
 MI-5-36-3
 M5-1-30

6
 DETOUR SOUTH
 310
 →

M4-8-30
 M3-3-30
 MI-5-36-3
 M5-1-30

2
 DETOUR NORTH
 310
 →

M4-8-30
 M3-1-30
 MI-5-36-3
 M6-1-30

7
 DETOUR SOUTH
 310
 →

M4-8-30
 M3-3-30
 MI-5-36-3
 M6-1-30

3
 DETOUR NORTH
 310
 ←

M4-8-30
 M3-1-30
 MI-5-36-3
 M5-1-30

8
 DETOUR SOUTH
 310
 ←

M4-8-30
 M3-3-30
 MI-5-36-3
 M5-1-30

4
 DETOUR NORTH
 310
 ←

M4-8-30
 M3-1-30
 MI-5-36-3
 M6-1-30

9
 DETOUR SOUTH
 310
 ←

M4-8-30
 M3-3-30
 MI-5-36-3
 M6-1-30

5
 DETOUR NORTH
 310
 ↗

M4-8-30
 M3-1-30
 MI-5-36-3
 M5-2-30

10
 DETOUR SOUTH
 310
 ↗

M4-8-30
 M3-3-30
 MI-5-36-3
 M5-2-30

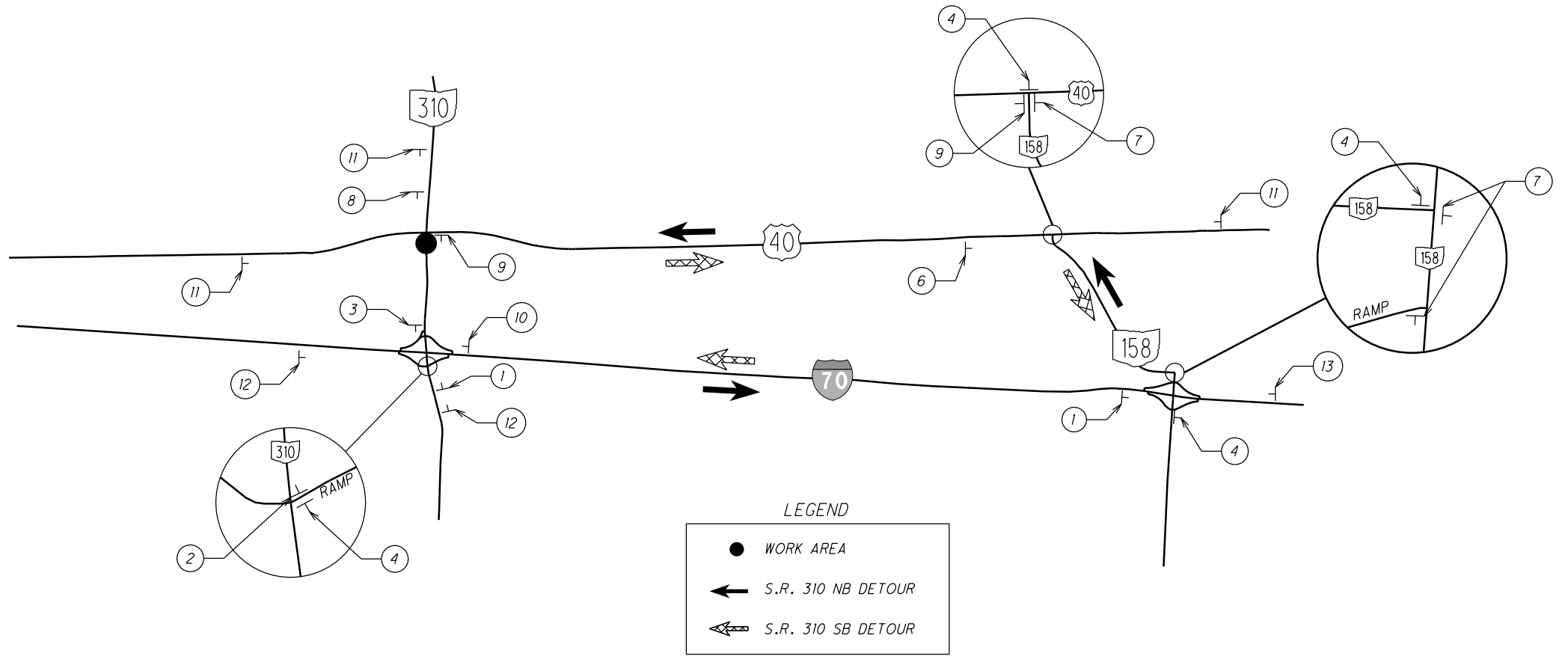

11
 PORTABLE CHANGEABLE MESSAGE SIGN

SR 310 CLOSED AT US 40	USE SR 158 TO IR 70
SCREEN 1	SCREEN 2

PLACE MINIMUM 1/2 MILE PRIOR TO INTERSECTION/ EXIT

13
 PORTABLE CHANGEABLE MESSAGE SIGN

SR 310 CLOSED AT US 40	USE SR 158 TO US 40
SCREEN 1	SCREEN 2

PLACE MINIMUM 1/2 MILE PRIOR TO INTERSECTION/ EXIT

12
 PORTABLE CHANGEABLE MESSAGE SIGN

SR 310 CLOSED AT US 40	USE IR 70 TO SR 158
SCREEN 1	SCREEN 2

PLACE MINIMUM 1/2 MILE PRIOR TO INTERSECTION/ EXIT

I:\ProjectData\LIC\93109\Design\MOT\Sheets\93109_MD005.dgn Sheet 1/21/2021 3:53:32 PM jlutzi

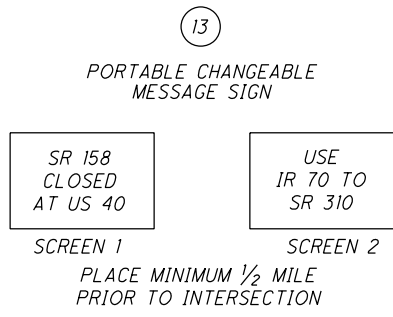
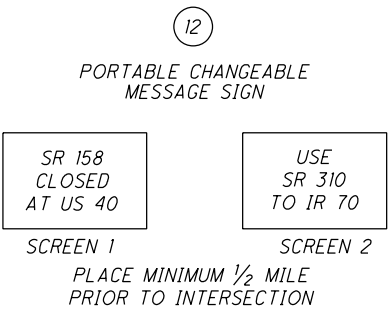
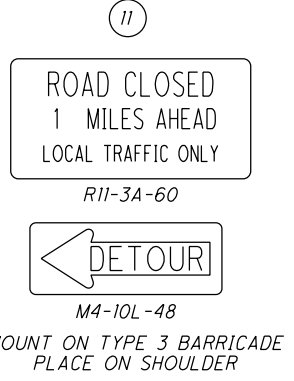
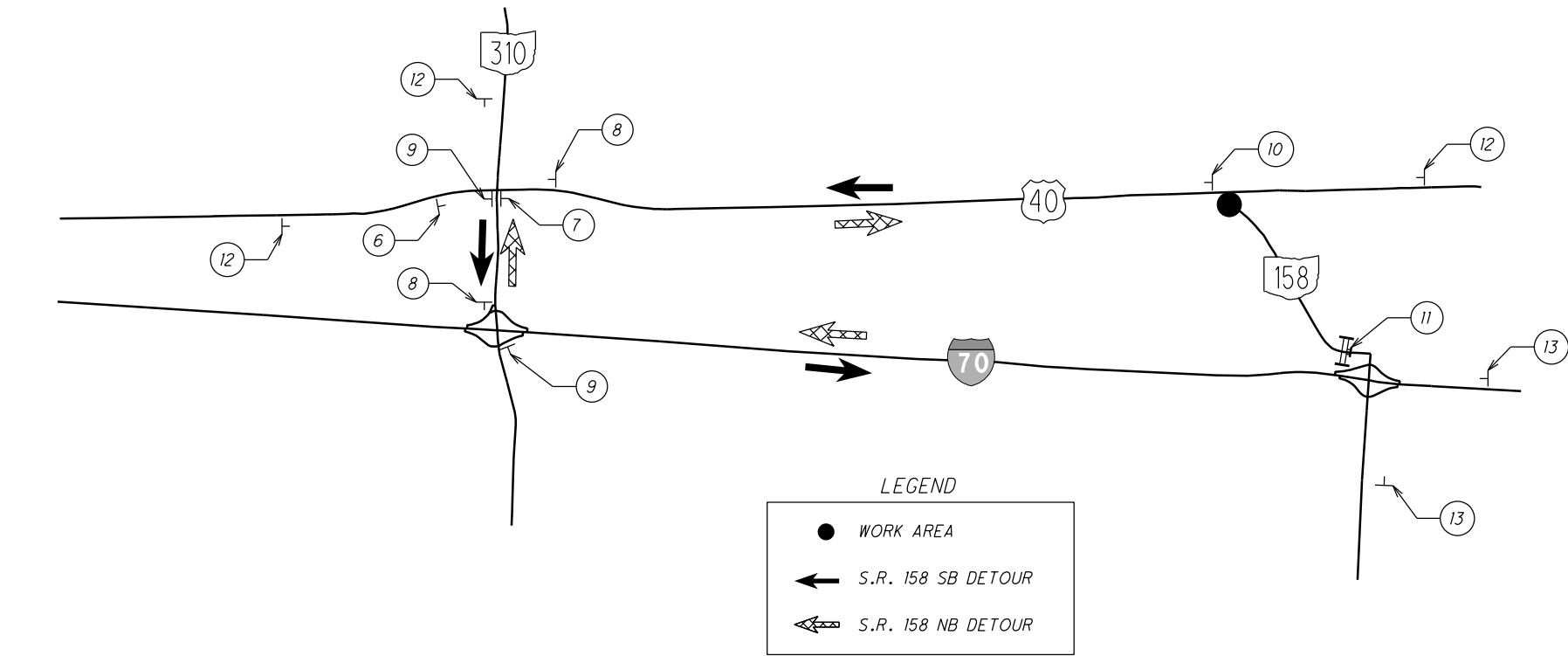
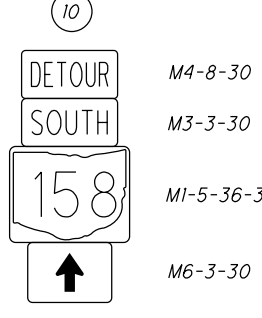
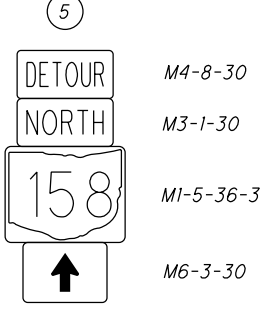
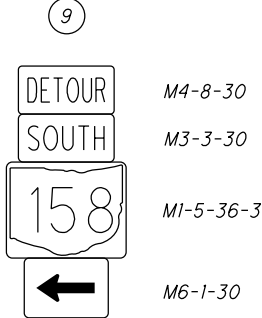
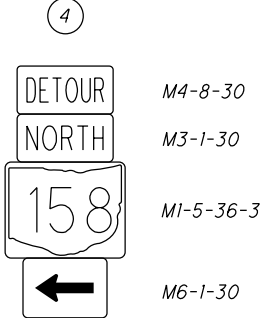
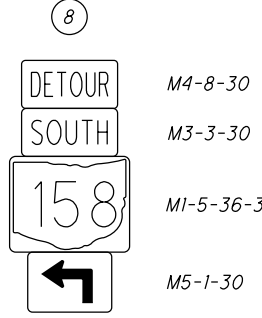
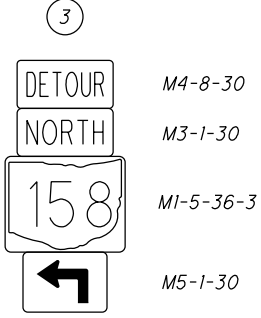
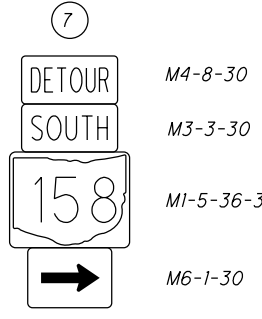
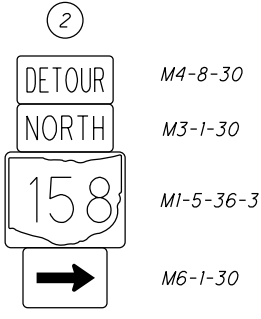
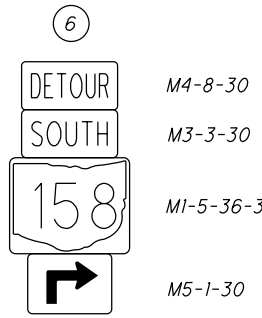
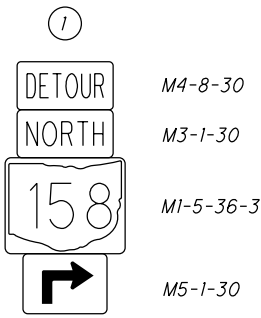

CALCULATED
PTB
CHECKED
JSL

DETOUR MAP
PHASE 2 (S.R. 158 DETOUR)

LIC-40-0.00

Location (Station to Station) Sta. 3081+57.90 (WB PGL) = Sta. 1081+50 (CL) Sta. 2081+41.81 (EB PGL) = Sta. 1081+50 (CL)	Side	202					
		PAVEMENT REMOVED (6" ASPHALT, 9" REINFORCED CONCRETE)	PAVEMENT REMOVED (9" ASPHALT, 9" REINFORCED CONCRETE)	PAVEMENT REMOVED (6" ASPHALT, 10" NON-REINFORCED CONCRETE)	PAVEMENT REMOVED (16" ASPHALT, 10" NON-REINFORCED CONCRETE)	PAVEMENT REMOVED, AS PER PLAN	GUARDRAIL REMOVED
		SY	SY	SY	SY	SY	FT
Phase 2 Split 03/S>2/PV							
2016+69.16 to 2081+41.81	CL	21,460.0					
1081+50.00 to 1093+36.00	Rt.	4,220.0					
2017+52.00 to 2028+06.30	Rt.						1,153
2071+99.50 to 2075+90.60	Rt.						392
Sub-Totals		25,680.0					1,545.0
Totals Carried to Location 1c (Full Depth) Summary		25,680.0					1,545
Phase 2 Split 04/S>2/PV							
1093+36.00 to 1095+63.33	Rt.	730.0					
1095+63.33 to 1096+50.00	Rt.			280.0			
1096+50.00 to 1259+50.00	Rt.				57,390.00		
1221+35.00	Rt.					23.2	
1240+08.00	Rt.					67.3	
1245+65.00	Rt.					27.5	
1114+29.30 to 1115+94.10	Rt.						165
1127+04.00 to 1130+69.10	Rt.						366
1154+81.00 to 1156+21.40	Rt.						141
1166+33.00 to 1167+98.40	Rt.						166
1179+51.10 to 1181+41.60	Rt.						191
1189+04.40 to 1191+44.60	Rt.						241
1215+07.70 to 1216+23.20	Rt.						116
1227+71.70 to 1229+23.00	Rt.						152
Sub-Totals		730.0		280.0	57,390.0	118.0	1,538.0
Totals Carried to Location 1d (Full Depth) Summary		58,400.0				118	1,538

REMOVAL CALCULATIONS (FULL DEPTH)

LIC-40-0.00

Reference No.	Location (Station to Station) Sta. 3081+57.90 (WB PGL) = Sta. 1081+50 (CL) Sta. 2081+41.81 (EB PGL) = Sta. 1081+50 (CL)	Side	606			626
			GUARDRAIL, TYPE MGS	ANCHOR ASSEMBLY, MGS TYPE E (NCHRP 350 OR MASH 2016)	ANCHOR ASSEMBLY, TYPE T	BARRIER REFLECTOR, TYPE 2 (ONE-WAY)
			FEET	EACH	EACH	EACH
GR-1	2017+63.60 to 2028+97.70	Rt.	1,225.0	1	1	14
GR-2	2070+32.10 to 2076+44.60	Rt.	550.0	1	1	7
GR-3	3019+06.20 to 3031+43.10	Lt.	1,175.0	1	1	13
GR-4	3074+05.20 to 3080+55.50	Lt.	587.5	1	1	7
Totals Carried to Location 1c (Full Depth) Summary			3,537.5	4	4	41
GR-5	1126+97.40 to 1131+74.82	Rt.	437.5		2	6
GR-6	1127+30.63 to 1134+91.46	Lt.	700.0	1	1	8
GR-7	1151+84.90 to 1159+47.60	Lt.	700.0	1	1	8
GR-8	1152+62.50 to 1157+12.50	Rt.	387.5	1	1	5
GR-9	1161+83.89 to 1168+98.80	Lt.	687.5		2	8
GR-10	1162+87.42 to 1168+70.96	Rt.	537.5		2	7
GR-11	1175+85.00 to 1183+79.00	Lt.	775.0		2	9
GR-12	1178+43.80 to 1182+06.30	Rt.	300.0	1	1	4
GR-13	1184+05.60 to 1187+37.00	Lt.	275.0	1	1	4
GR-14	1188+26.80 to 1191+89.30	Rt.	300.0	1	1	4
GR-15	1189+30.00 to 1193+17.50	Lt.	325.0	1	1	5
GR-16	1213+24.80 to 1216+86.71	Rt.	300.0	1	1	4
GR-17	1214+52.59 to 1218+15.09	Lt.	300.0	1	1	4
GR-18	1226+37.50 to 1230+12.50	Lt.	312.5	1	1	5
GR-19	1227+71.70 to 1230+15.70	Rt.	187.5		2	3
Totals Carried to Location 1d (Full Depth) Summary			6,525.0	10	20	84