

DATE: 19-Nov-09 10:50  
 FILE: J:\Job\6087 MAH-170-4.80\Plan\_Sheet\ODOT STD.DWG\_LA11.dgn  
 SCALE: 1" = 10'

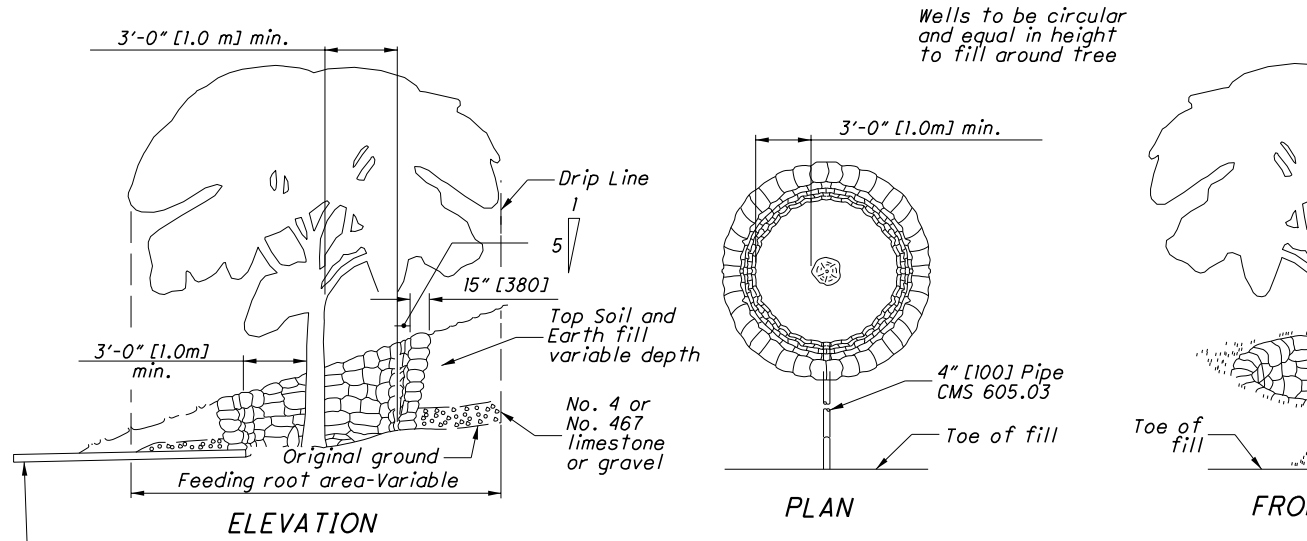

**RIPRAP AND AGGREGATE FOR TREE PROTECTION AND AERATION IN FILL**

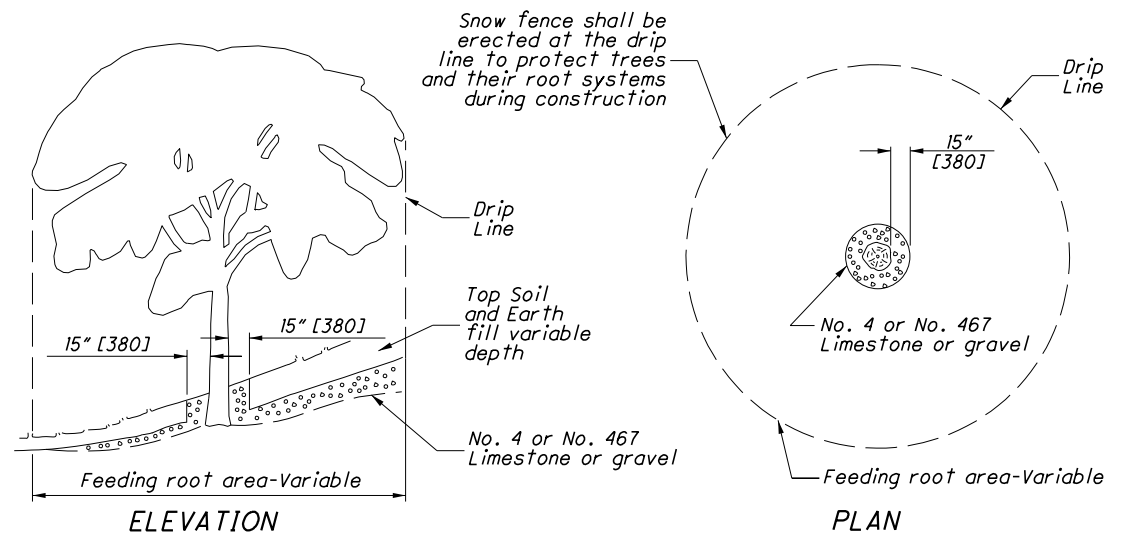

**AGGREGATE FOR TREE ROOT PROTECTION IN FILL**

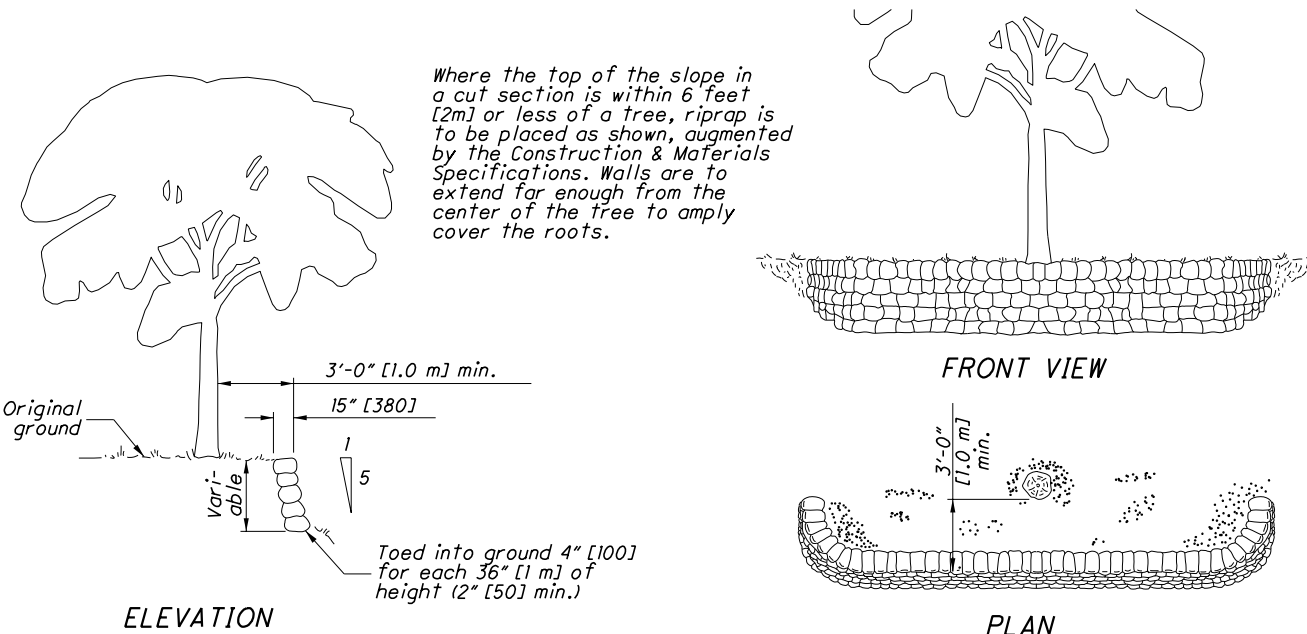

**RIPRIP FOR TREE PROTECTION IN CUT**

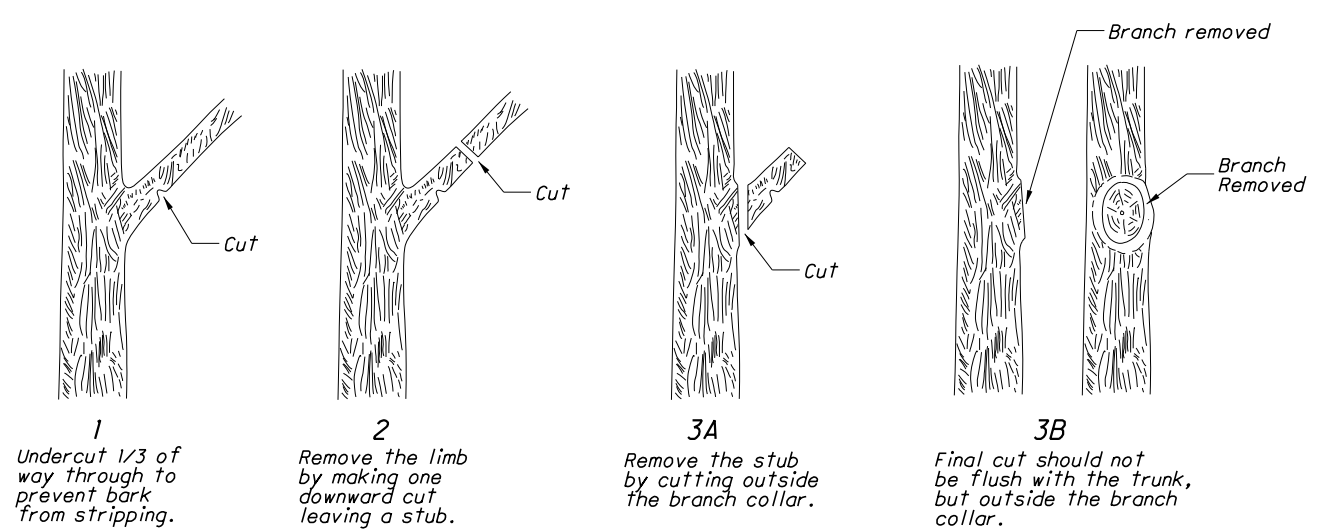

**PROPER REMOVAL OF BRANCHES**

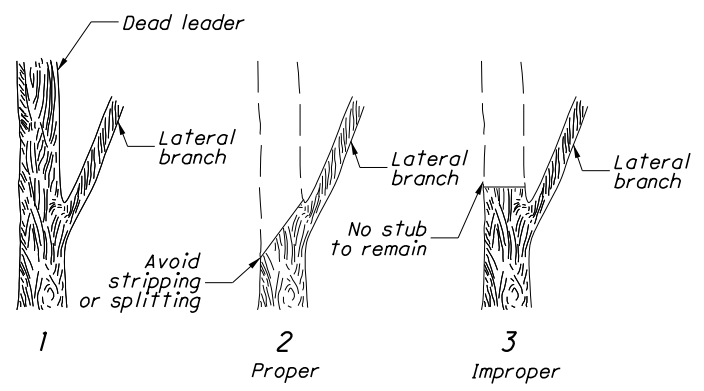

**PART OF LEADER OR BRANCH TO BE REMOVED**

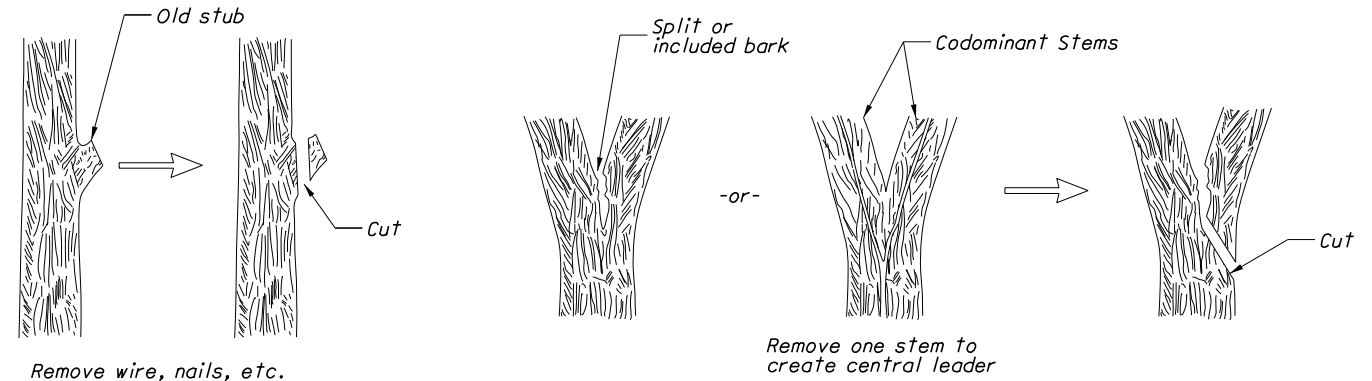

**REMOVING STUBS**

**PROPER CROTCH TREATMENT**

**PRUNING**

THIS DRAWING REPLACES LA-1, IM DATED 9-6-95.

STATE OF OHIO DEPARTMENT OF TRANSPORTATION	7-28-00
Signed Larry F. Sutherland	DATE
ADMINISTRATOR	
STUDIOS ENGINEER	M. Evans
ALL METRIC DIMENSIONS ( IN BRACKETS ) ARE IN MILLIMETERS UNLESS OTHERWISE NOTED.	
OFFICE OF ROADWAY ENGINEERING	
STANDARD ROADWAY CONSTRUCTION DRAWING	
TREE WELLS AND PRUNING	
SCD NUMBER	LA-1.1
1 / 1	

**MAH-170-4.80**

**ODOT STANDARD CONSTRUCTION DRAWINGS**

CALCULATED  
 MJT  
 CHECKED  
 DTB