

GRASS MEDIAN TYPICAL SECTION
STA. 489+00 TO STA. 495+00
STA. 685+00 TO STA. 689+50

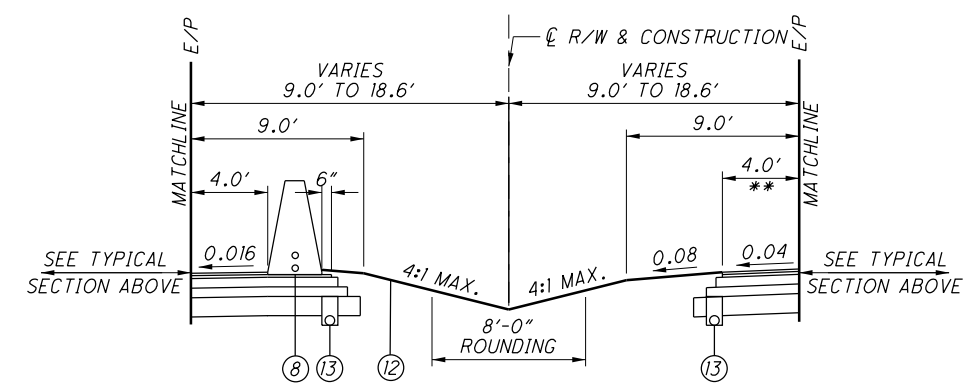

GRASS MEDIAN TYPICAL SECTION - WITH BARRIER
STA. 495+00 TO STA. 500+76.38
STA. 679+09.77 TO STA. 685+00 (MIRROR TYPICAL)

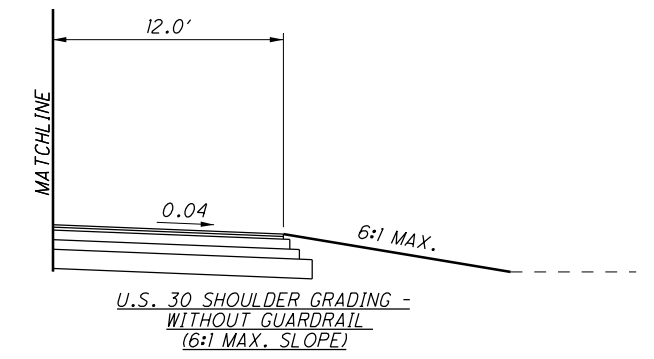

U.S. 30 SHOULDER GRADING - WITHOUT GUARDRAIL
(6:1 MAX. SLOPE)

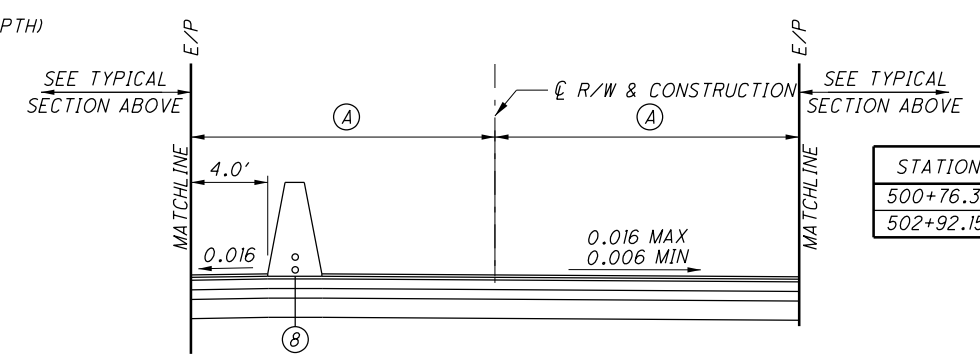

PAVED MEDIAN TYPICAL SECTION - WITH BARRIER DETAIL 1
STA. 500+76.38 TO STA. 502+92.15

STATION	(A)
500+76.38	9.0'
502+92.15	5.4'

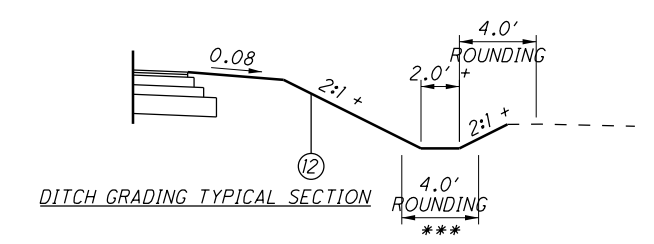

DITCH GRADING TYPICAL SECTION

PROPOSED ITEM LEGEND

- ① ITEM 442 - 1 1/2" ASPHALT CONCRETE SURFACE COURSE, 12.5MM, TYPE A (447) (SEE NOTE 3)
- ② ITEM 442 - 1 3/4" ASPHALT CONCRETE INTERMEDIATE COURSE, 19MM, TYPE A (446), AS PER PLAN
- ③ ITEM 302 - 6" ASPHALT CONCRETE BASE, PG64-22, AS PER PLAN
- ④ ITEM 304 - 6" AGGREGATE BASE
- ⑤ ITEM 407 - NON-TRACKING TACK COAT
- ⑥ ITEM 407 - TACK COAT
- ⑦ ITEM 526 - REINFORCED CONCRETE APPROACH SLABS (T=13")
- ⑧ ITEM 622 - CONCRETE BARRIER, SINGLE SLOPE, TYPE B1 (WITH TWO 4" RACEWAYS)
- ⑨ ITEM 606 - GUARDRAIL, TYPE MGS
- ⑩ ITEM 204 - SUBGRADE COMPACTION
- ⑪ ITEM 609 - CURB, TYPE 6
- ⑫ ITEM 659 - SEEDING AND MULCHING
- ⑬ ITEM 605 - 6" BASE PIPE UNDERDRAIN WITH GEOTEXTILE FABRIC, 707.31 OR 707.41 (18" NORMAL DEPTH)
- ⑭ ITEM 452 - 10.5" NON-REINFORCED CONCRETE PAVEMENT, CLASS QCIP WITH QC/OA
- ⑮ ITEM 206 - CEMENT STABILIZED SUBGRADE, 12 INCHES DEEP
- ⑯ ITEM 206 - CURING COAT
- ⑰ ITEM 609 - 6" CONCRETE TRAFFIC ISLAND
- ⑱ ITEM 526 - REINFORCED CONCRETE APPROACH SLABS (T=15")
- ⑲ ITEM 608 - 4" CONCRETE WALK
- ⑳ ITEM 609 - CURB, TYPE 4-C
- ㉑ ITEM 254 - PAVEMENT PLANING, ASPHALT CONCRETE (SEE TYPICALS FOR DEPTH)
- ㉒ ITEM 617 - COMPACTED AGGREGATE (AVERAGE THICKNESS - 2")
- ㉓ ITEM 442 - ASPHALT CONCRETE INTERMEDIATE COURSE, 19MM, TYPE A (448), AS PER PLAN (VARIABLE THICKNESS - SEE TYPICALS FOR DEPTH)
- ㉔ ITEM 202 - WEARING COURSE REMOVED
- ㉕ ITEM 442 - 2 1/2" ASPHALT CONCRETE INTERMEDIATE COURSE, 19MM, TYPE A (446), AS PER PLAN
- ㉖ ITEM 442 - ASPHALT CONCRETE INTERMEDIATE COURSE, 19MM, TYPE A (448), AS PER PLAN (VARIABLE THICKNESS - 1 3/4" TO 2 1/2")
- ㉗ ITEM 305 - 9" CONCRETE BASE, CLASS QCIP
- ㉘ ITEM 516 - 1" PREFORMED EXPANSION JOINT FILLER
- ㉙ ITEM 622 - CONCRETE BARRIER, SINGLE SLOPE, TYPE D
- ㉚ ITEM 622 - CONCRETE BARRIER, SINGLE SLOPE, TYPE D, AS PER PLAN
- ㉛ ITEM 622 - CONCRETE BARRIER, SINGLE SLOPE, TYPE C1 (WITH 4" RACEWAY)
- ㉜ ITEM 608 - 4" CONCRETE MEDIAN
- ㉝ ITEM 302 - ASPHALT CONCRETE BASE, PG64-22 (VARIABLE THICKNESS - SEE TYPICALS FOR DEPTH)
- ㉞ ITEM 302 - 6" ASPHALT CONCRETE BASE, PG64-22
- ㉟ ITEM 442 - ASPHALT CONCRETE SURFACE COURSE, 12.5 MM, TYPE A (448)

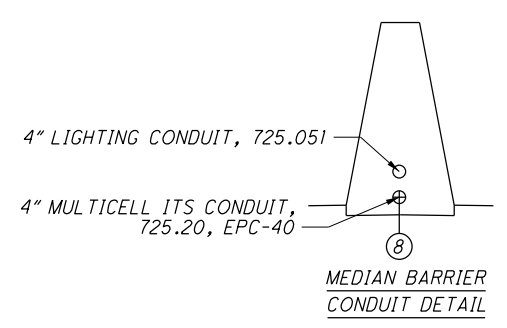

MEDIAN BARRIER CONDUIT DETAIL

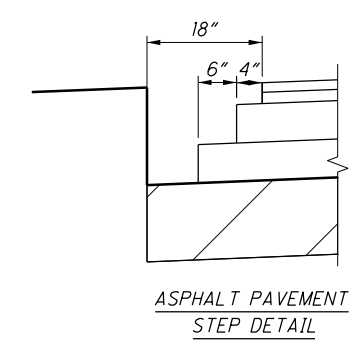

ASPHALT PAVEMENT STEP DETAIL

NOTE:

- 1. SEE SHEET 26 FOR LEGEND OF EXISTING PAVEMENT.
- 2. FOR SPEED CHANGE LANE TYPICAL SECTION SEE SHEET 18.
- 3. THE CONTRACTOR SHALL PROVIDE ANTI-SEGREGATION EQUIPMENT FOR ASPHALT SURFACE COURSE.
- * TRANSITION CROSS-SLOPE FROM 0.016 TO -0.016 (SLOPE TOWARDS OUTSIDE SHOULDER) FROM STA. 494+00 TO STA. 495+00 AND STA. 685+00 TO STA. 686+00
- ** TRANSITION SHOULDER CROSS-SLOPE FROM -0.04 TO +0.009 FROM STA. 500+26.45 TO STA. 500+76.45
- *** VEGETATED BIOFILTERS SHALL NOT BE ROUNDED. REFER TO SITE PLAN FOR LOCATIONS.
- + OR AS SHOWN ON CROSS SECTIONS
- ** THIS UNDERDRAIN MAY BE SHIFTED TOWARDS THE OUTSIDE OF THE SHOULDER AS DIRECTED BY THE ENGINEER, TO ACCOUNT FOR EQUIPMENT TOLERANCES.

M:\15074\93455\Design\Roadway\Sheets\93455\0001.dgn 3/25/2020 11:08:23 AM kja282

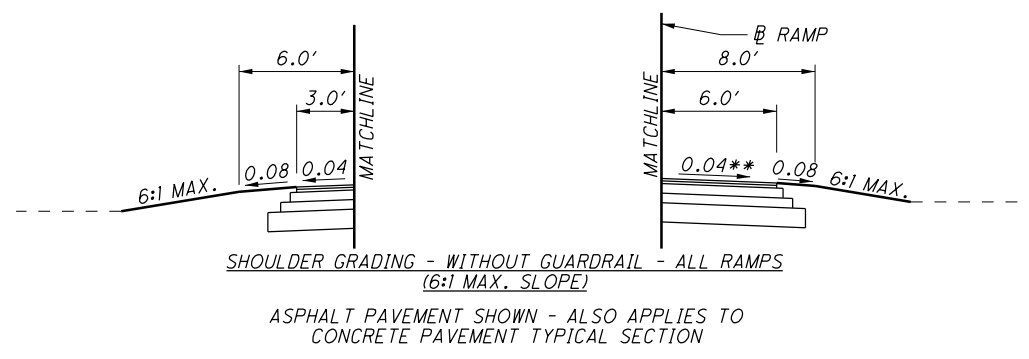
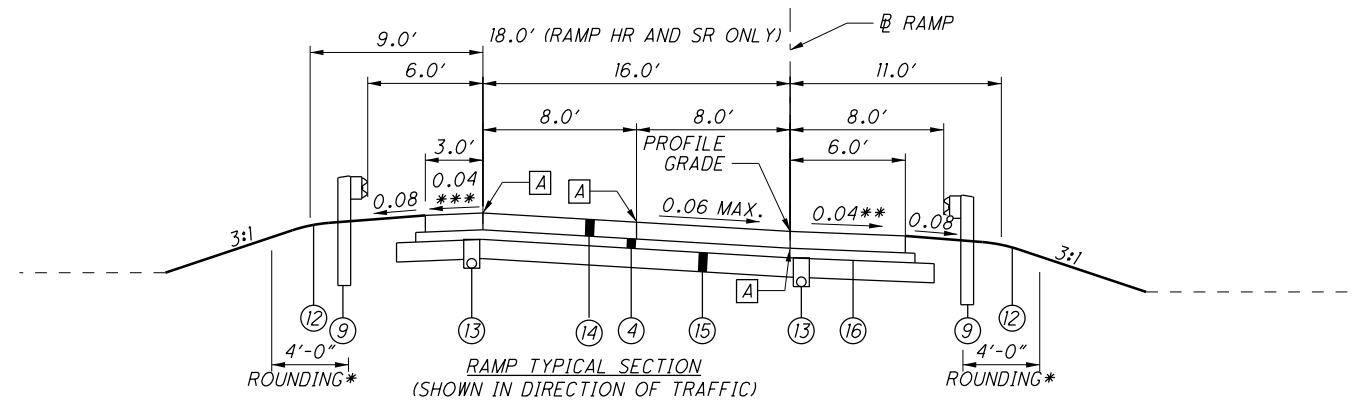

RAMPS - S.R. 39		RAMPS - S.R. 545	
G	STA. 360+49.82 TO STA. 371+51.92	SR	STA. 448+66.53 TO STA. 451+35.36
HL	STA. 458+19.27 TO STA. 462+35.71	SL	STA. 348+70.60 TO STA. 351+65.74
HR	STA. 259+77.68 TO STA. 263+94.48		
I	STA. 169+95.32 TO STA. 173+97.70		

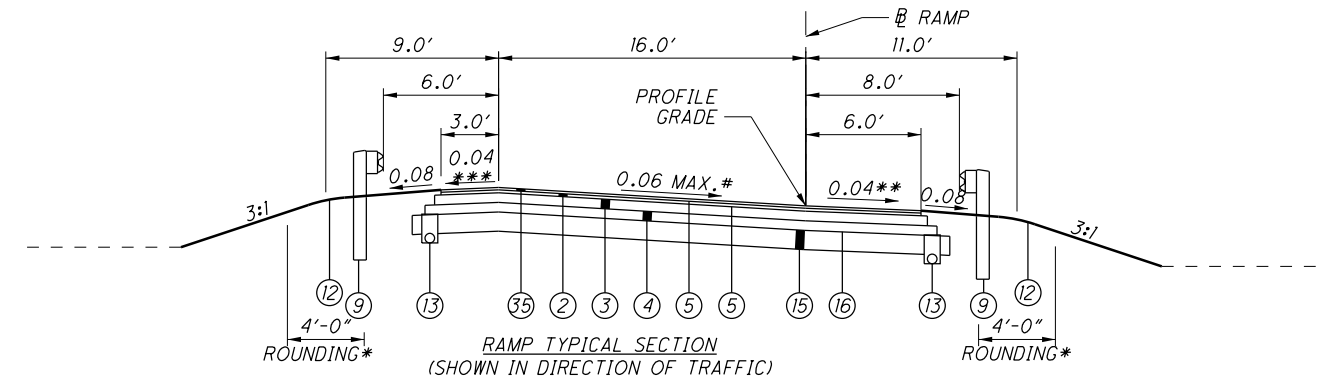

RAMPS - TRIMBLE RD.		RAMPS - FIFTH AVE.	
A	STA. 7+17.34 TO STA. 8+60	A	STA. 174+24.14 TO STA. 180+00
B	STA. 17+17.34 TO STA. 18+00	B	STA. 369+50 TO STA. 372+37.77
C	STA. 19+95.01 TO STA. 21+50.95	C	STA. 375+25 TO STA. 375+39.32
D	STA. 9+95.01 TO STA. 11+80	D	STA. 474+50.25 TO STA. 480+50

RAMPS - S.R. 13	
C	STA. 10+89.43 TO STA. 12+50.00
D	STA. 18+00.00 TO STA. 19+41.32

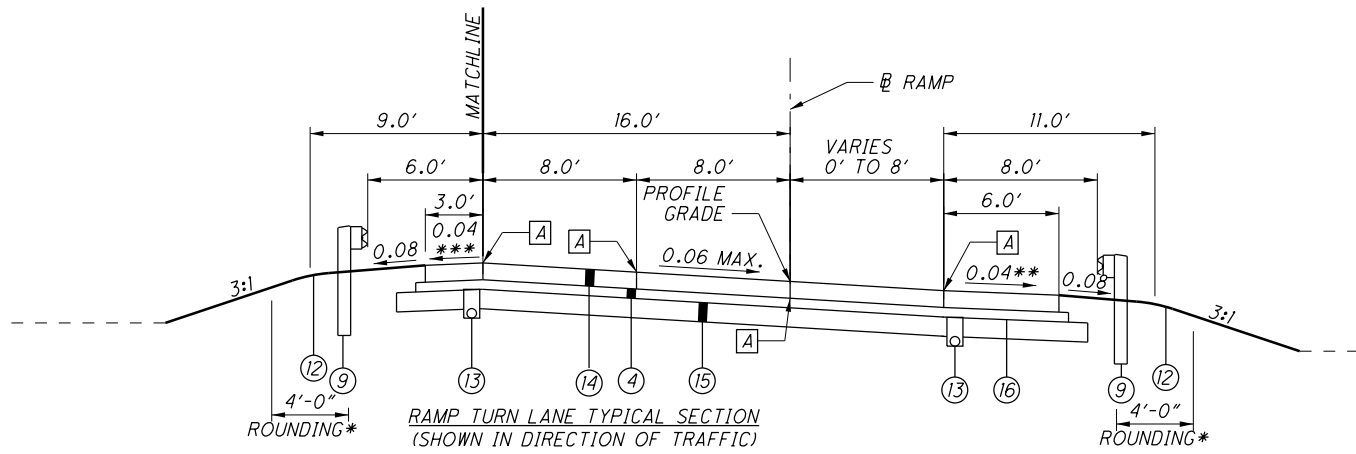

RAMPS - S.R. 13/S.R. 545	
W	STA. 136+36.23 TO STA. 140+67.38
X	STA. 238+42.64 TO STA. 241+42.86

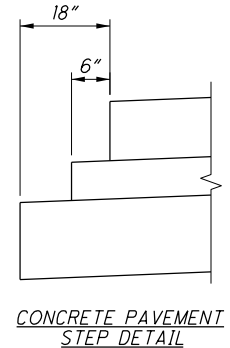
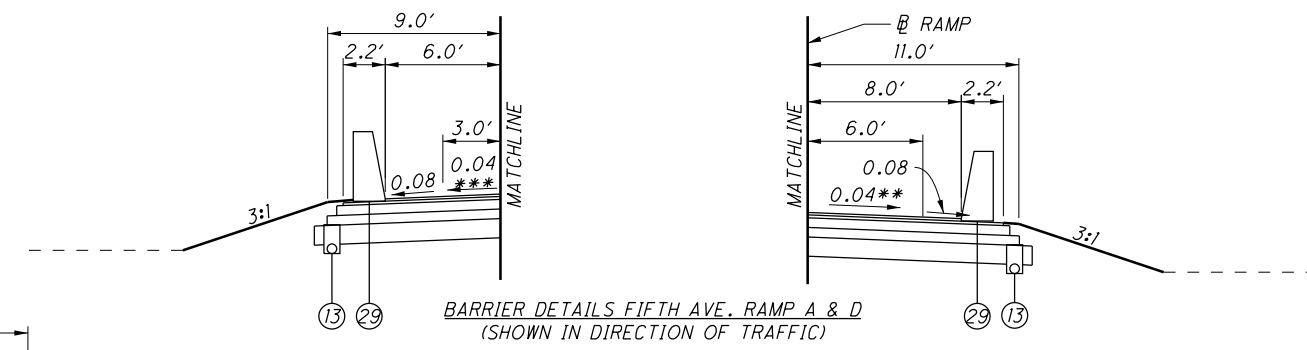
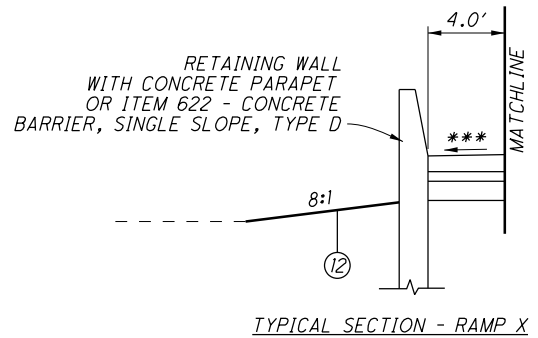

# CROSS SLOPE TABLE			
RAMP	STATION	CROSS SLOPE	DESCRIPTION
FIFTH AVE. RAMP A	179+90	0.060	
FIFTH AVE. RAMP A	180+00	0.057	MATCH EXISTING
FIFTH AVE. RAMP B	369+50	0.047	MATCH EXISTING
FIFTH AVE. RAMP B	369+85	0.060	
FIFTH AVE. RAMP D	480+25	0.060	
FIFTH AVE. RAMP D	480+50	0.050	MATCH EXISTING

- NOTE:**
- SEE SHEET 12 FOR LEGEND.
 - FOR SPEED CHANGE LANE TYPICAL SECTION SEE SHEET 18.
 - SEE SHEET 12 FOR DITCH GRADING TYPICAL SECTION.
- * ROUNDRING SHALL BE 10'-0" WHEN NO BARRIER IS NEEDED
 - ** LOW SIDE OF SUPER-SHOULDER CROSS SLOPE 0.04 OR RATE OF SUPER IF GREATER
 - *** HIGH SIDE OF SUPER-SHOULDER CROSS SLOPE 0.04 OR LESS NOT TO EXCEED 7% BREAK
 - **** FROM STA. 462+35.71 TO STA. 462+48.39 AND FROM STA. 465+65.56 TO STA. 465+78.56 CONTINUE THE CONCRETE PAVEMENT ACROSS THE MEDIAN. BEGIN ITEM 609 - CONCRETE TRAFFIC ISLAND AT STA. 462+48.39.
- [A] TIED LONGITUDINAL JOINT PER BP-2.1

M:\15074\93455\Design\Roadway\Sheets\93455C\Y0006.dgn 3/25/2020 11:13:18 AM kj0282

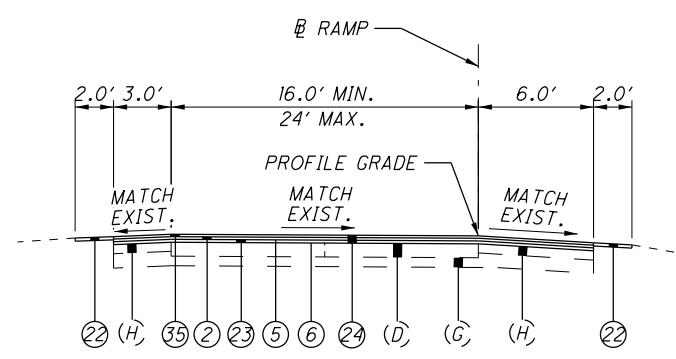

RAMP RESURFACING TYPICAL SECTION
(SHOWN IN DIRECTION OF TRAFFIC)

RAMPS - TRIMBLE RD.#

A	STA. 8+60 TO STA. 10+45
B	STA. 18+00 TO STA. 19+15
C	STA. 21+50.95 TO STA. 22+25
D	STA. 11+80 TO STA. 13+50

TRIMBLE RD. RAMPS
EXISTING ASPHALT THICKNESS
RAMP A - ±5"
RAMP B - ±3"
RAMP C - ±2"
RAMP D - ±4"

② ASPHALT CONCRETE INTERMEDIATE COURSE THICKNESS *

TRIMBLE RAMP	STA	THICKNESS	TO	STA	THICKNESS
A	8+60	5.25"		10+45	0"
B	18+00	3.25"		19+15	0"
C	21+50.95	2"		22+25	0"
D	11+80	4.75"		13+50	0"

* CONTRACTOR SHALL VERIFY EXISTING ASPHALT OVERLAY THICKNESS IN THE FIELD. WEDGE COURSE THICKNESS AND LENGTH MAY BE ADJUSTED IN THE FIELD PER REQUIREMENTS OF BP-3.1.

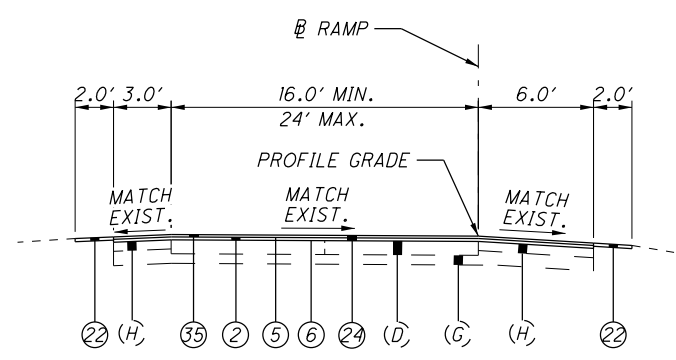

RAMP RESURFACING TYPICAL SECTION
(SHOWN IN DIRECTION OF TRAFFIC)

RAMPS - TRIMBLE RD.#

A	STA. 10+45 TO STA. 13+33.08
B	STA. 19+15 TO STA. 23+28.07
C	STA. 22+25 TO STA. 26+67.65
D	STA. 13+50 TO STA. 16+81.17

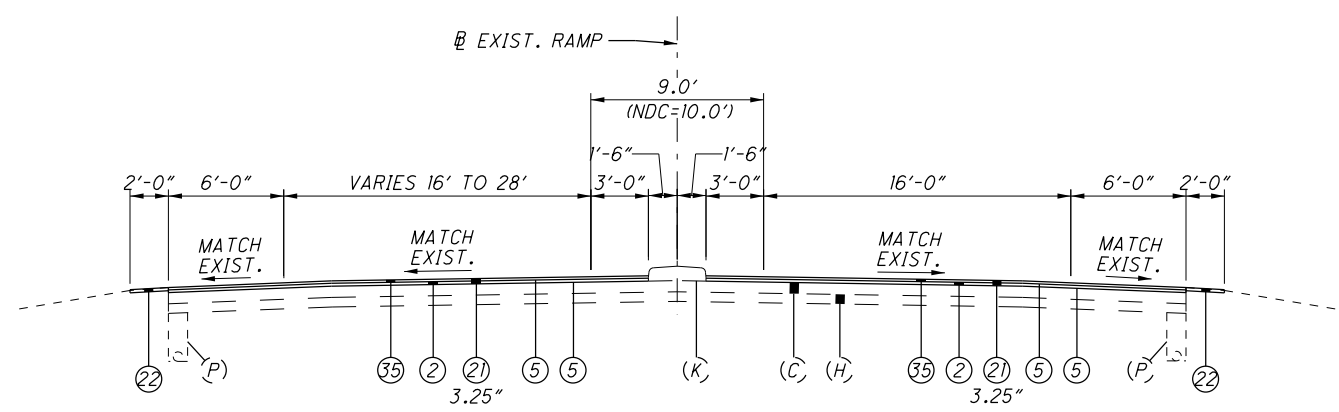

RAMP RESURFACING TYPICAL SECTION
(SHOWN IN DIRECTION OF TRAFFIC)

RAMPS - S.R. 13

CD	STA. 10+26.07 TO STA. 14+44.07
----	--------------------------------

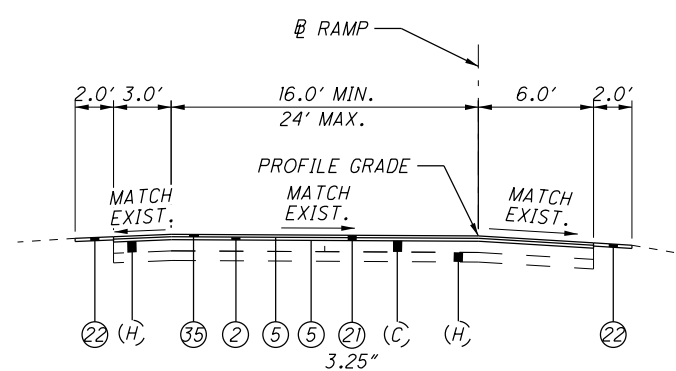

RAMP RESURFACING TYPICAL SECTION
(SHOWN IN DIRECTION OF TRAFFIC)

RAMPS - S.R. 13

CE	STA. 8+86.20 TO STA. 12+54.37
C	STA. 12+50 TO STA. 14+43.15
D	STA. 14+44.07 TO STA. 18+00

- NOTE:
- SEE SHEET 12 FOR LEGEND.
 - SEE SHEET 26 FOR EXISTING LEGEND.
- # THE INTENT IS TO REMOVE THE EXISTING ASPHALT TO THE TOP SURFACE OF THE EXISTING CONCRETE PAVEMENT.

M:\15074\93455\Design\Roadway\Sheets\93455C\Y0008.dgn 3/25/2020 11:17:34 AM kjp282

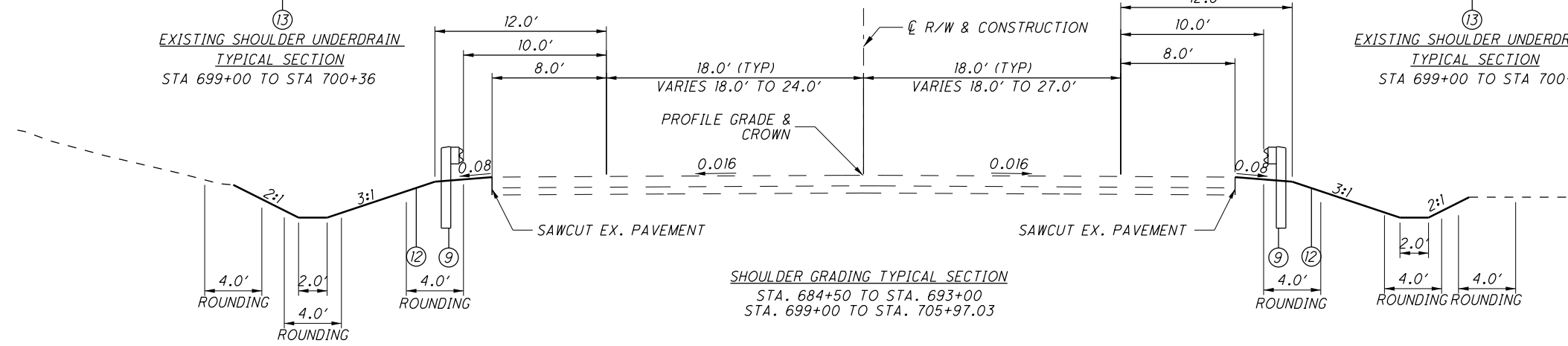
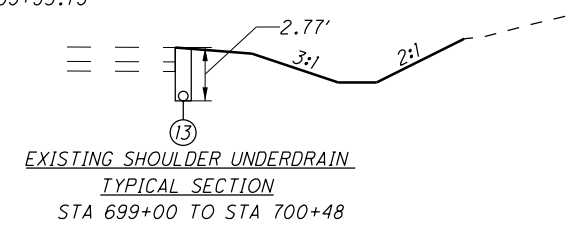
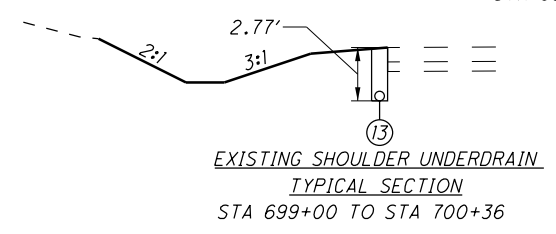
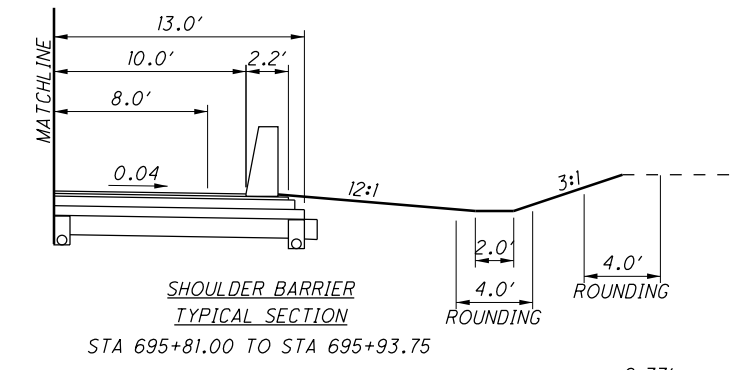
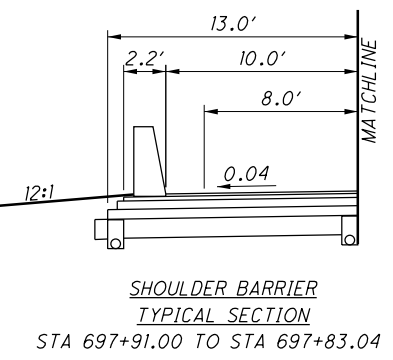
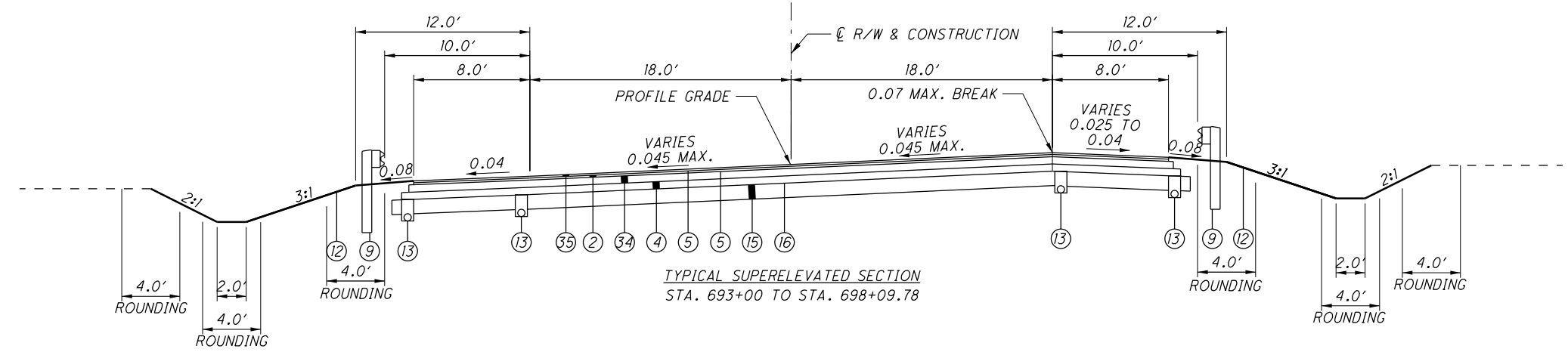
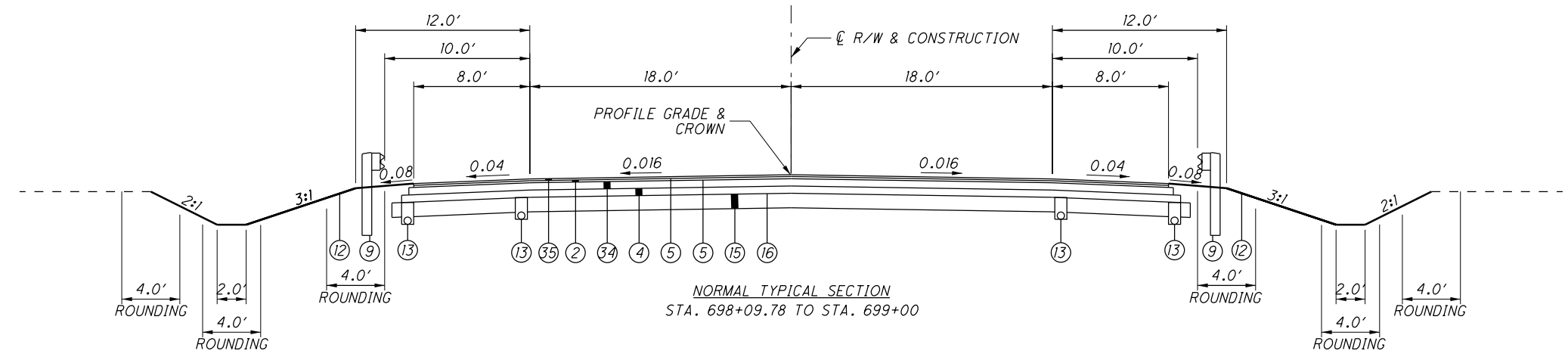

- NOTE:**
1. SEE SHEET 12 FOR LEGEND.
 2. FOR EXISTING PAVEMENT DETAILS SEE SHEET 26.

M:\15074\93455\Design\Roadway\Sheets\93455C\Y0009.dgn 3/25/2020 11:27:53 AM kjo282

STATION	B	
	LEFT	RIGHT
101+16.19	0.00'	99.00'
101+50	10.5'	109.50'
102+00	10.5'	82.67'
102+50	10.5'	19.83'
103+00	10.5'	14.27'
103+18.50	10.5'	12.63'

* LONGVIEW AVE. W ONLY
 ** RELOCATED LONGVIEW AVE. ONLY

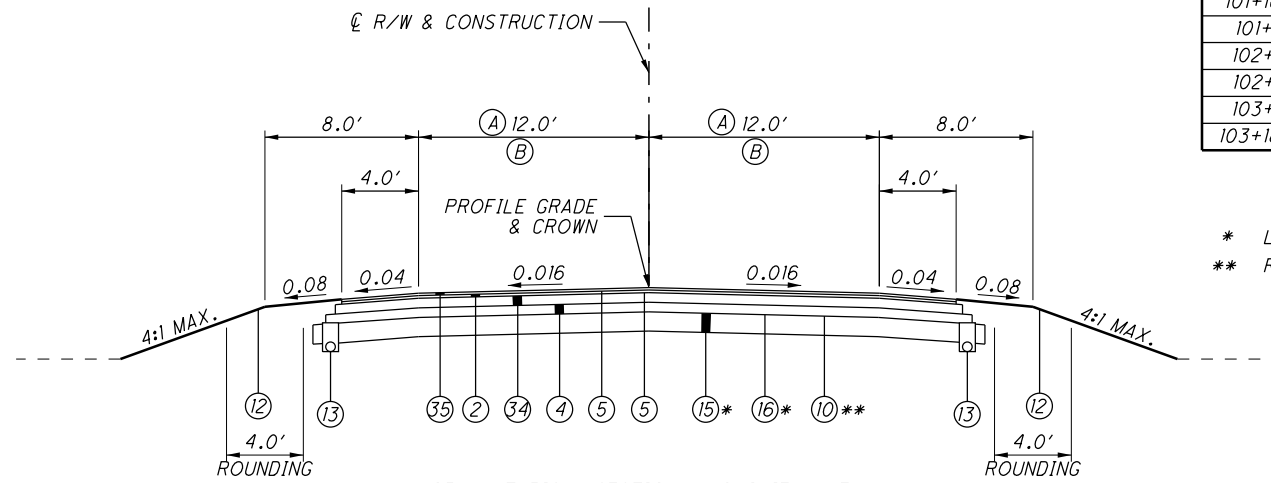

NORMAL TYPICAL SECTION - LONGVIEW AVE. W
 & RELOCATED LONGVIEW AVE.

B STA. 101+16.09 TO STA. 103+18.50
 A STA. 302+75 TO STA. 302+94.16
 STA. 308+14.89 TO STA. 308+94.86

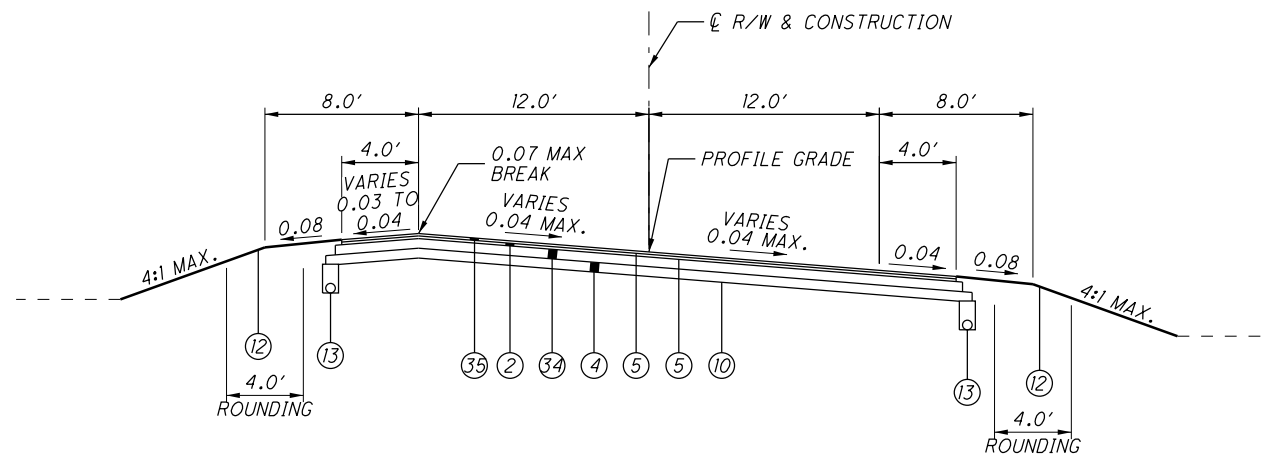

SUPERELEVATED TYPICAL SECTION - RELOCATED LONGVIEW AVE.

STA. 302+94.16 TO STA. 308+14.89
 STA. 308+94.86 TO STA. 309+86.31

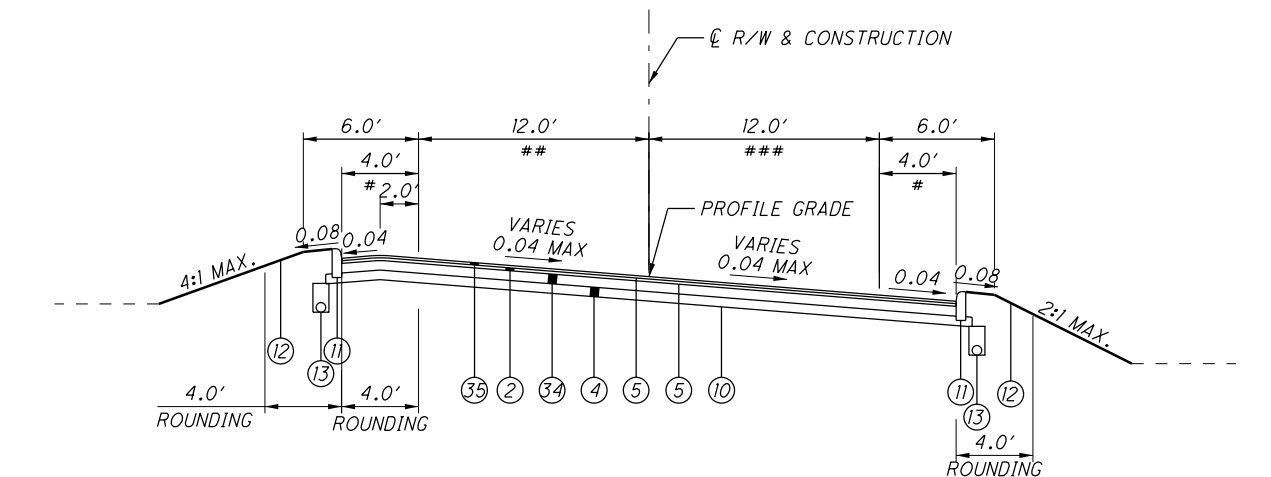

SUPERELEVATED TYPICAL SECTION WITH CURB - RELOCATED LONGVIEW AVE.

STA. 309+86.31 TO STA. 311+30 # VARIES 1.0' TO 2.0' LT, 4.0' TO 2.1' RT
 STA. 311+30 TO STA. 311+75 ## VARIES 12.0' TO 10.5'
 ### VARIES 12.0' TO 13.5'

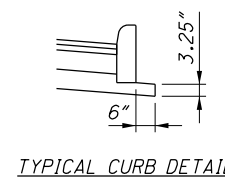

TYPICAL CURB DETAIL

NOTE:

1. SEE SHEET 12 FOR LEGEND.
2. SEE SHEET 12 FOR STANDARD DITCH GRADING TYPICAL SECTION.

M:\15074\93455\Design\Roadway\Sheets\93455C\Y0010.dgn 3/25/2020 11:42:06 AM kja282

CALCULATED
 CHECKED

TYPICAL SECTIONS - LONGVIEW AVE.

RIC-30-9.26

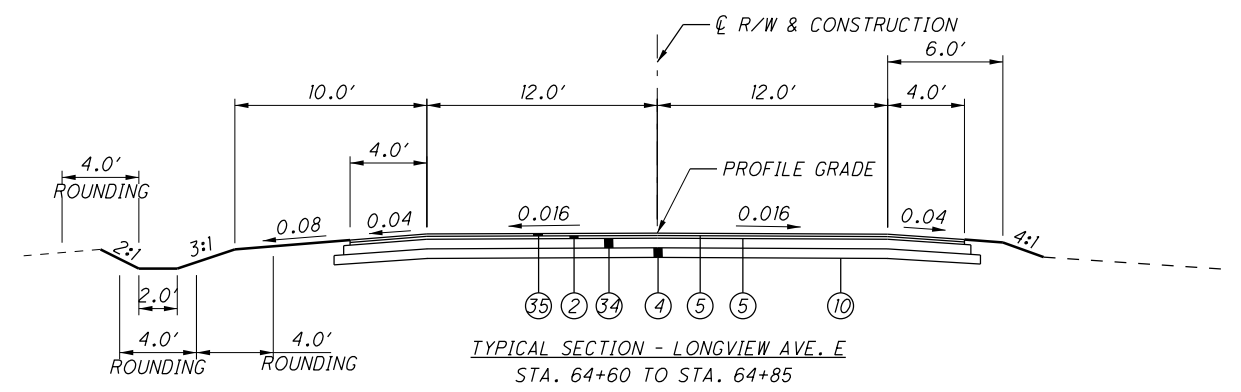
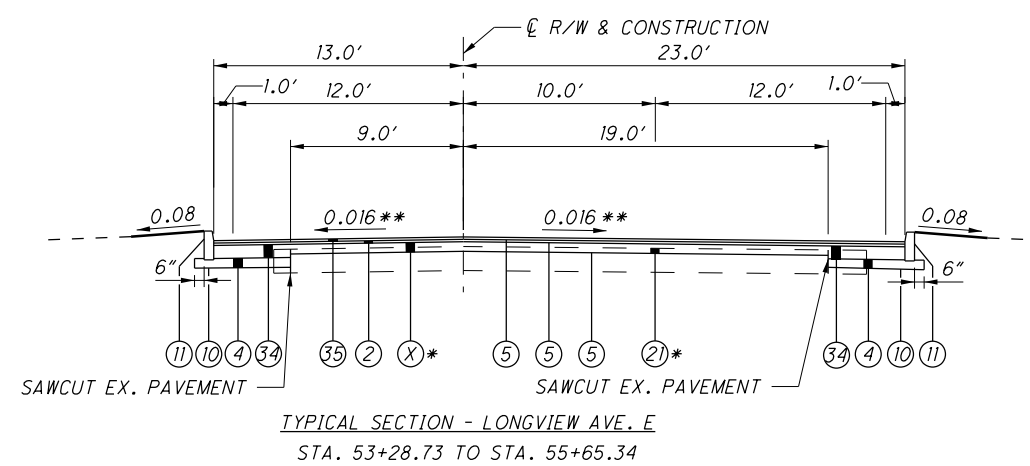

STATION	CROSS SLOPE LEFT	CROSS SLOPE RIGHT
54+50	-0.016	-0.016
54+75	-0.016	-0.014
55+00	-0.016	-0.007
55+25	-0.016	0.000
55+50	-0.017	0.007
55+75	-0.011	0.003
56+00	-0.019	-0.004
56+25	-0.019	-0.010
56+50	-0.010	-0.007
56+75	-0.011	-0.009
57+00	-0.011	-0.007
57+25	-0.003	-0.007
57+50	-0.007	-0.002
57+75	-0.015	-0.007
58+00	-0.002	-0.005
58+25	0.002	-0.003
58+50	-0.011	0.001
58+75	-0.016	-0.005
59+00	-0.016	-0.012
59+25	-0.016	-0.016

** SEE THE INTERSECTION DETAILS, MISCELLANEOUS DETAILS, SUPERELEVATION TABLES, AND THE TABLE ON THIS SHEET.

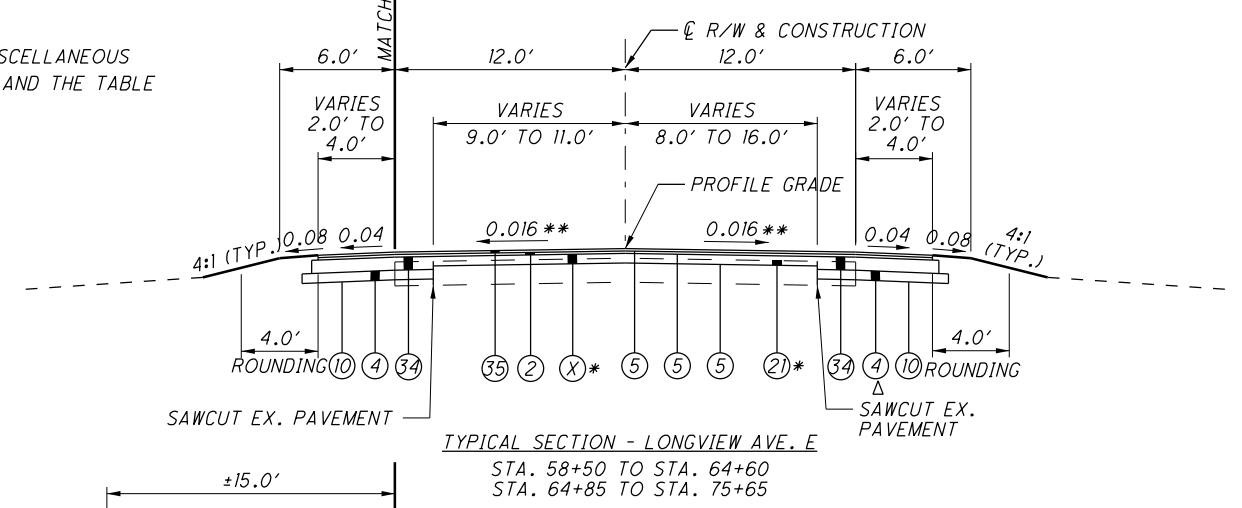
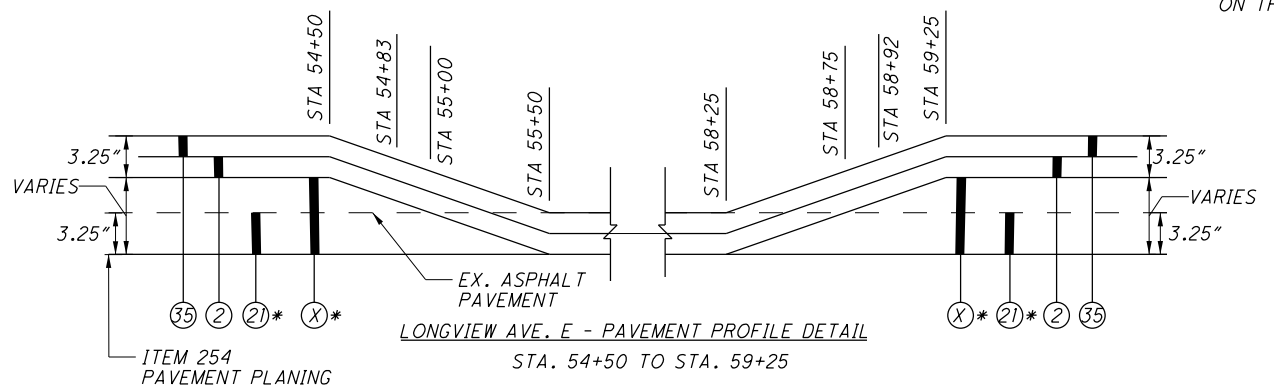
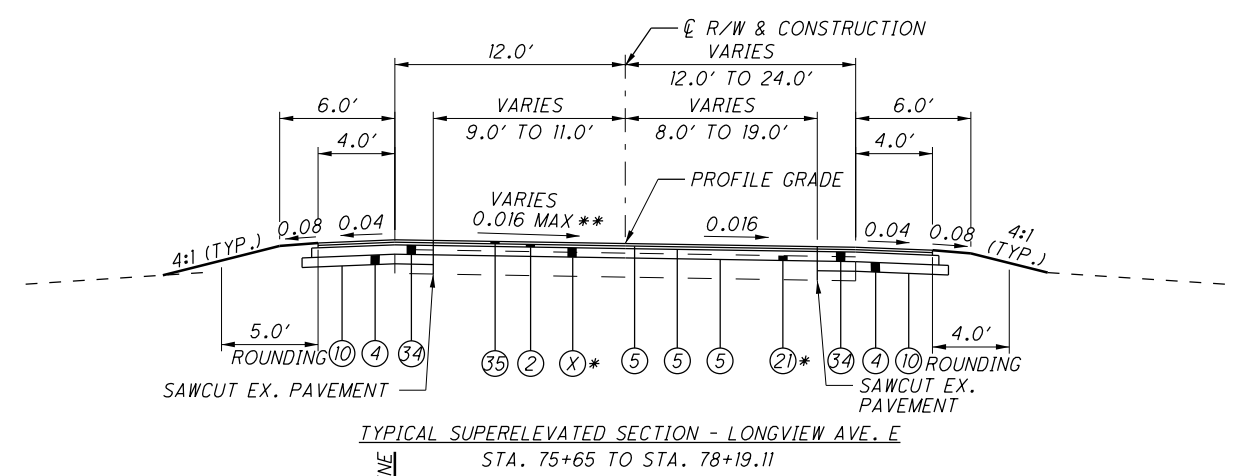
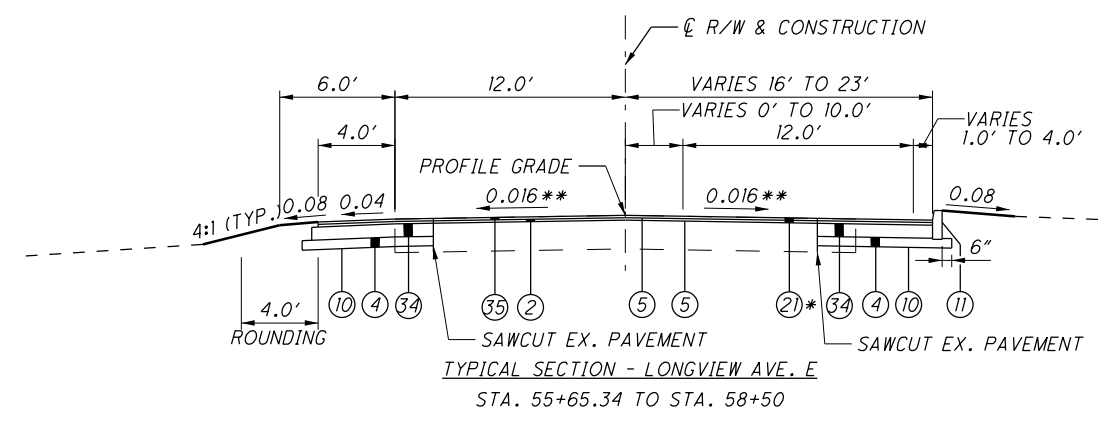

Δ NO FULL DEPTH PAVEMENT ON THE RIGHT SHOULDER FROM STATION 58+50 TO STATION 62+00.

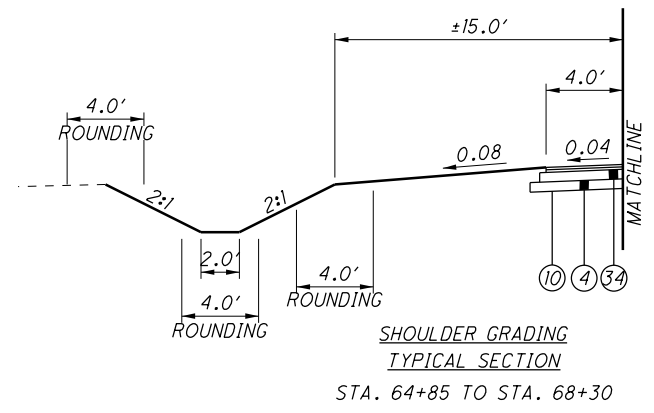

* NOTES:

- SEE SHEET 12 FOR LEGEND.
- PLANE 3.25" AT THE CENTERLINE WITH A CROSS SLOPE OF -0.016 EXCEPT WHERE NOTED ON THIS SHEET.
- BALLOON (X) IS EITHER AN ITEM 442 SCRATCH COURSE OR ITEM 302 ASPHALT CONCRETE BASE COURSE THAT VARIES IN THICKNESS AS SHOWN ON THE TABLE TO PROVIDE THE REQUIRED PAVEMENT SURFACE ELEVATIONS.
- SEE REFERENCE SPREADSHEET FOR ADDITIONAL INFORMATION.

BALLOON (X) DETAILS				
STATION	TO	STATION	THICKNESS	BALLOON
53+28.73		55+50	0"-6"	(23)
55+50		58+25	0"	-
58+25		59+00	0"-4.5"	(23)
59+00		64+60	4.5"-7.25"	(33)
64+85		65+50	4.25"-7.25"	(33)
65+50		72+50	0"-4.5"	(23)
72+50		77+50	4.5"-6"	(33)
77+50		78+19.11	0"-4.5"	(23)

STATION	SAWCUT OFFSET LEFT	STATION	SAWCUT OFFSET RIGHT
53+24.40	VARIES	53+19.83	VARIES
53+70.40	9.0'	53+58.64	19.0'
57+00	9.0'	57+28.50	19.0'
57+50	10.0'	58+00	14.0'
68+50	10.0'	58+50 (BACK)	14.0'
69+00	11.0'	58+50 (AHEAD)	16.0'
75+50	11.0'	62+00 (BACK)	16.0'
76+00	10.0'	62+00 (AHEAD)	14.0'
77+00	10.0'	67+50	8.0'
77+60	11.0'	75+50	8.0'
		76+00	12.0'
		77+80	12.0'

TRANSITION SAWCUT LINE BETWEEN THE OFFSETS SHOWN IN THE ABOVE TABLE.

M:\15074\93455\Design\Roadway\Sheets\93455C\Y0011.dgn 3/25/2020 11:46:59 AM kjo282

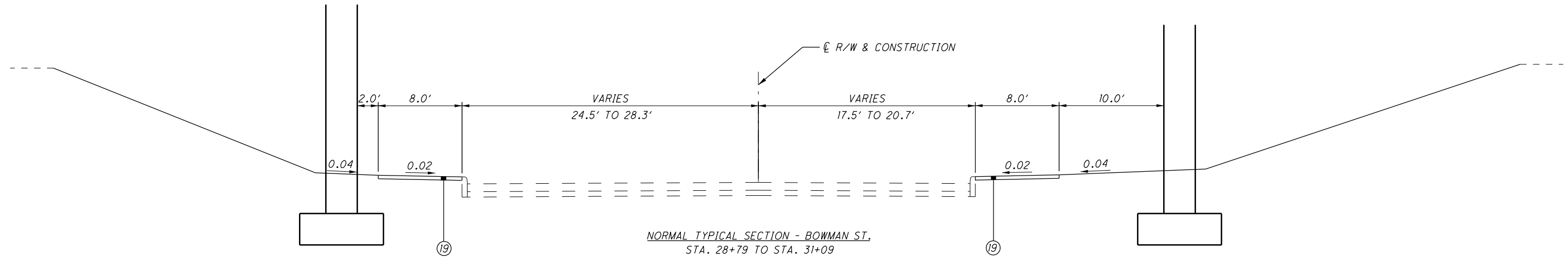

NORMAL TYPICAL SECTION - BOWMAN ST.
STA. 28+79 TO STA. 31+09

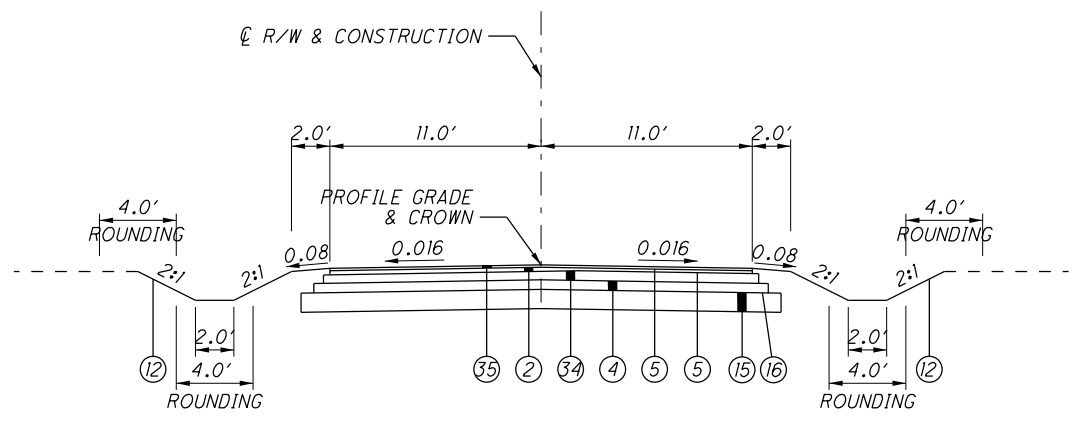

NORMAL TYPICAL SECTION - WISE AVE.
STA 20+25.09 TO STA 31+65

NOTE:
1. SEE SHEET 12 FOR LEGEND.

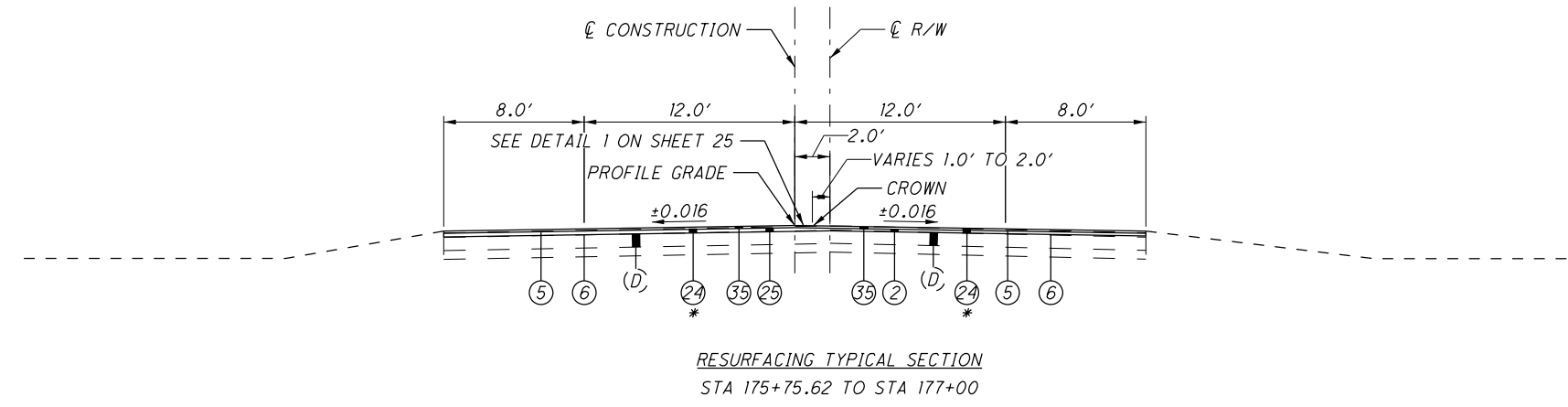
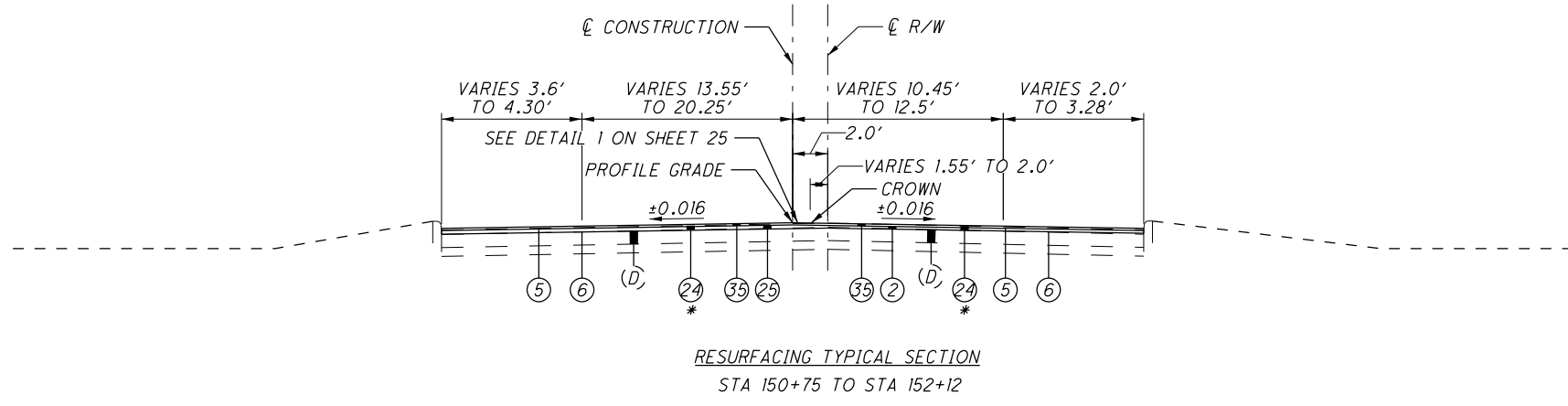
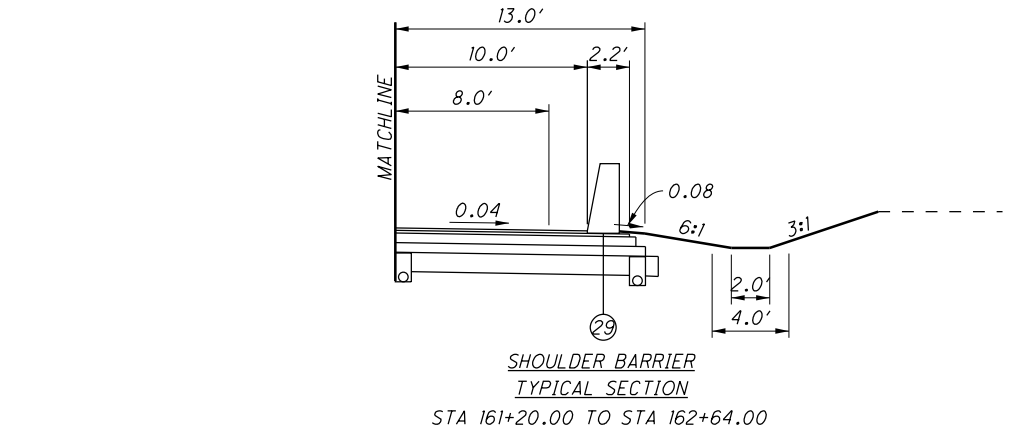
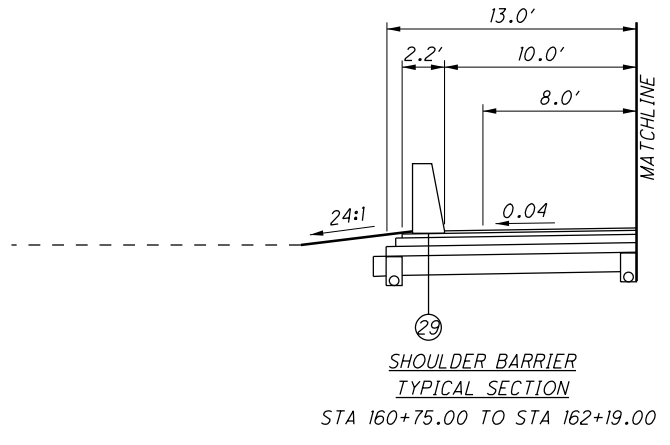
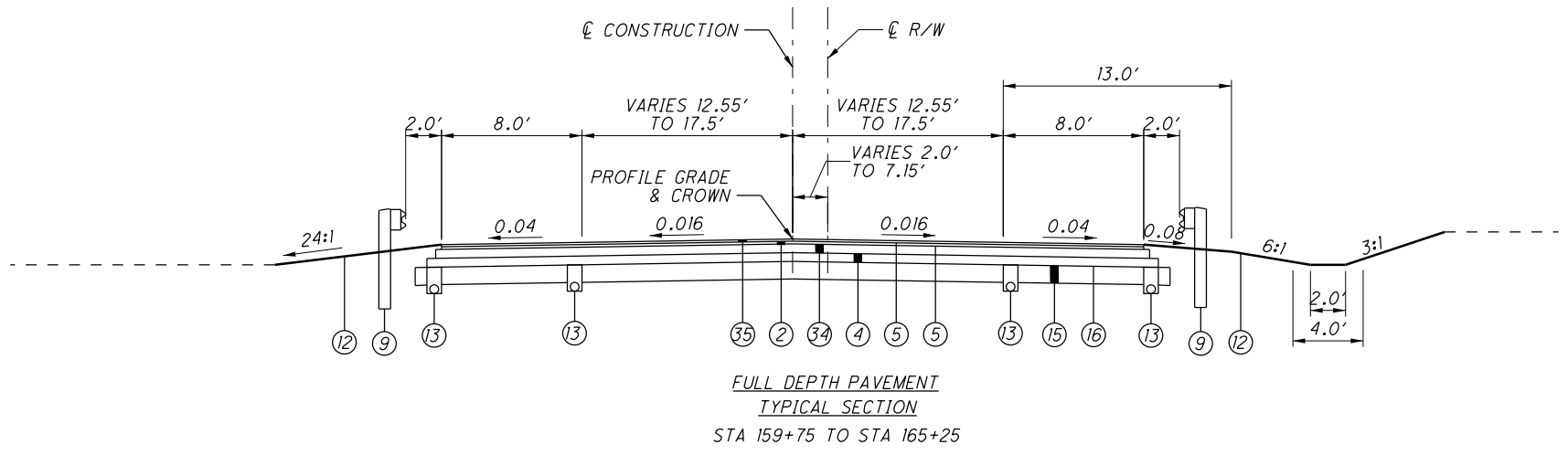

NOTE:

1. SEE SHEET 12 FOR PROPOSED ITEM LEGEND.
 2. SEE SHEET 26 FOR EXISTING ITEM LEGEND.
- * THE CONTRACTOR SHALL MILL OFF THE EXISTING ASPHALT OVERLAY TO EXISTING CONCRETE PAVEMENT THEN RESURFACE WITH ASPHALT SURFACE AND INTERMEDIATE COURSE.

M:\15074\93455\Design\Roadway\Sheets\93455C\Y0013.dgn 3/25/2020 11:53:18 AM kjo282

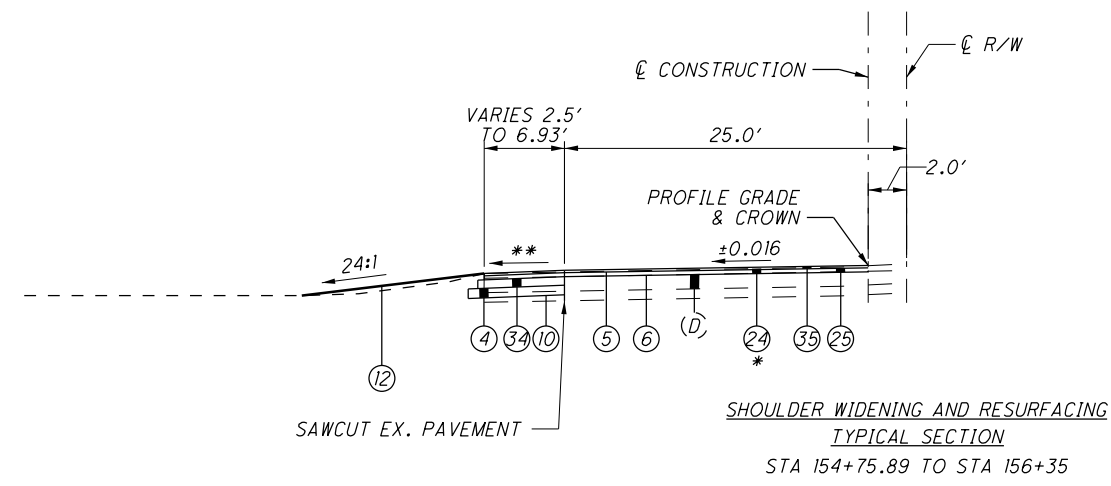

** - VARIES
±0.016 IN LANE AREAS
±0.04 IN SHOULDER AREAS

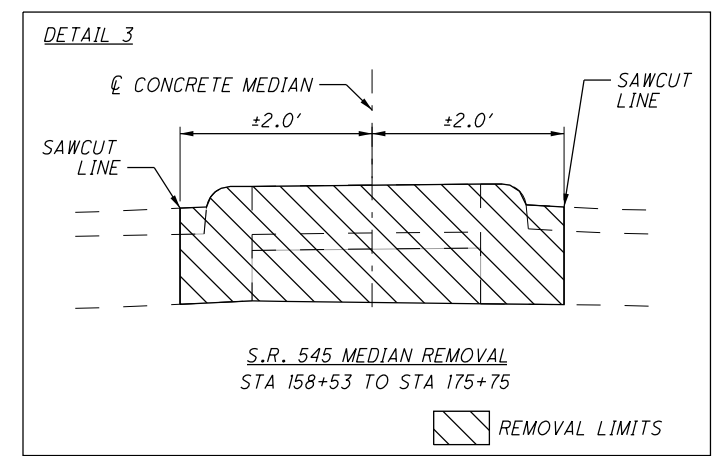
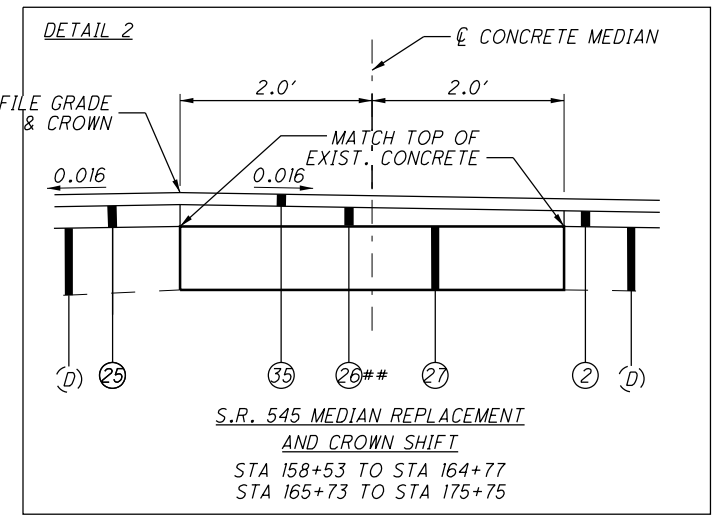
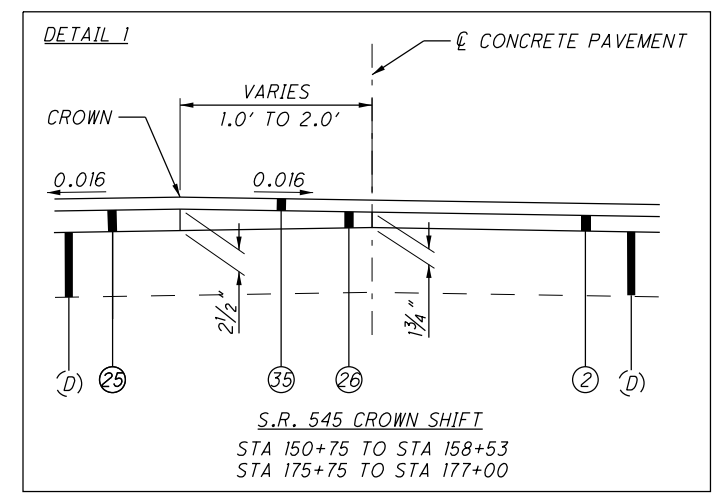
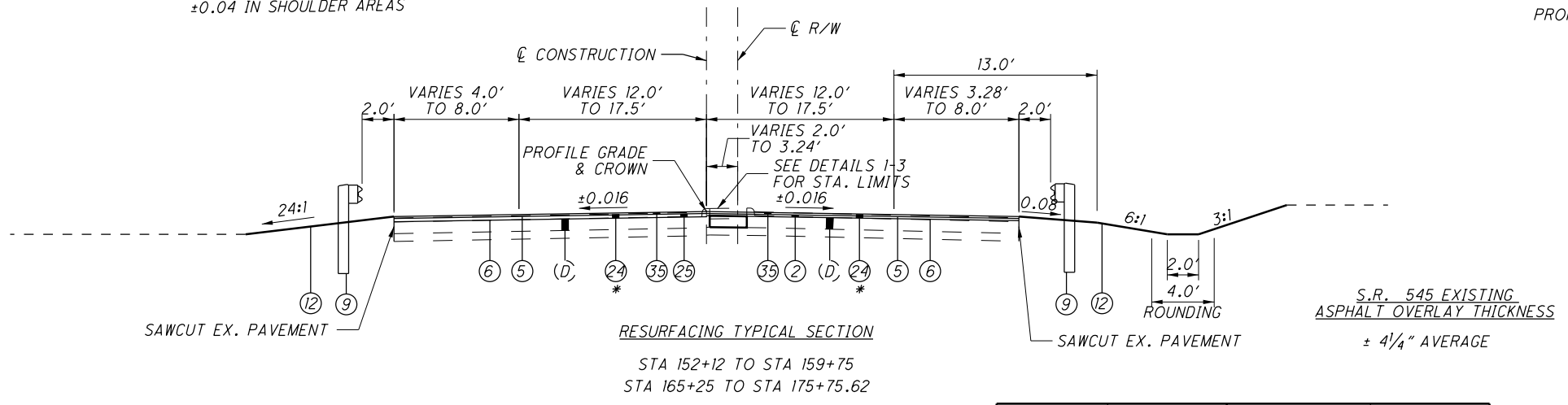

- NOTE:**
- SEE SHEET 12 FOR PROPOSED ITEM LEGEND.
 - SEE SHEET 26 FOR EXISTING ITEM LEGEND.
- * THE CONTRACTOR SHALL MILL OFF THE EXISTING ASPHALT OVERLAY TO EXISTING CONCRETE PAVEMENT THEN RESURFACE WITH ASPHALT SURFACE AND INTERMEDIATE COURSE. THE EXISTING ASPHALT OVERLAY THICKNESS IS ESTIMATED AT ± 4.25\"
- ** TRANSITION (26) FROM 2 1/2\"

STATION	SAWCUT OFFSET LEFT	STATION	SAWCUT OFFSET RIGHT
152+77	28.01'	152+70#	26.15'
152+77	23' (AHEAD)	152+76	20.5'
153+50	23'	154+50	20.5'
153+95.60**	61.61'	155+00	20.0'
154+18.60**	81.61'	155+11.50	20.0'
154+50	23'	155+21.31#	29.81'
156+35	23' (BACK)	155+72.36#	30.64'
156+35	26.41' (AHEAD)	155+83	20.0'
159+25	20.0'	157+30	20.0'
159+50	20.0'	157+51.5#	29.46'
159+75	21.00' (BACK)	158+26#	30.09'
165+25	17.5' (AHEAD)	158+40	20.0'
166+42.02	17.5' (BACK)	159+25	20.0'
166+42.02	25.5' (AHEAD)	159+75	21.00' (BACK)
166+50	25.5'	165+25	25.5' (AHEAD)
169+00	20.0'	166+50	25.5'
175+40.15	20.0'	169+00	20.0'
175+71.63	25.25'	175+02.30	20.0'
		175+09.96#	38.91'
		175+21.96#	39.79'
		175+29.60	20.0'
		177+00	20.0'
		177+10.28	24.23'

** - NO SAWCUT ACROSS LONGVIEW INTERSECTION
- NO SAWCUT ACROSS DRIVE APPROACHES

M:\15074\93455\Design\Roadway\Sheets\93455C\Y0014.dgn 3/25/2020 12:05:38 PM kja282

PHASING	614	614		614	614	614	614		614	614	614	614		614	614	614	614								
	INCREASED BARRIER DELINEATION	WORK ZONE IMPACT ATTENUATOR (UNIDIRECTIONAL)		WORK ZONE RAISED PAVEMENT MARKER	WORK ZONE RAISED PAVEMENT MARKER	WORK ZONE RAISED PAVEMENT MARKER, AS PER PLAN	WORK ZONE RAISED PAVEMENT MARKER, AS PER PLAN		BARRIER REFLECTOR, TYPE 1, ONE WAY	BARRIER REFLECTOR, TYPE 1, BIDIRECTIONAL	OBJECT MARKER, ONE WAY	OBJECT MARKER, TWO WAY		WORK ZONE LANE LINE, CLASS 1, 6", 642 PAINT	WORK ZONE CENTER LINE, CLASS 1, 642 PAINT	WORK ZONE EDGE LINE, CLASS 1, 6", 642 PAINT	WORK ZONE EDGE LINE, CLASS 1, 6", 642 PAINT								
	FT	EACH		YELLOW EACH	WHITE EACH	YELLOW EACH	WHITE EACH		EACH	EACH	EACH	EACH		MILE	MILE	WHITE MILE	YELLOW MILE								
PHASE 1	16,800	24		507	1,120				574	209	574	209		1.67	4.54	11.96	3.32								
PHASE 2	19,260	4		400	954				386		386			3.52		4.23	4.90								
PHASE 3	96,547	8		779	1,358				1,958		891	534		4.21		17.55	17.94								
PHASE 4	23,845	7		587	1,198				476		476			4.22		17.51	17.62								
PHASE 5	20,800	2		635	1,691				416		416			8.33		10.85	10.80								
PHASE 5A	140	1				193	638		3		3														
PHASE 6	75,815	4		262	696				1,517		448	535		4.92		15.44	15.88								
PHASE 7	18,256	9		345	779				555		555			4.92		18.28	16.25								
TOTALS CARRIED TO GENERAL SUMMARY	271,463	59		3,515	7,796	193	638		5,885	209	3,749	1,278		31.79	4.54	95.82	86.71								

PHASING	614	614	614	614	614	614	614	614	614	614	622	622	622	642	642	642	642	642	642	642
	WORK ZONE CHANNELIZING LINE, CLASS I, 8", 642 PAINT FT	WORK ZONE CHANNELIZING LINE, CLASS I, 12", 642 PAINT FT	WORK ZONE DOTTED LINE, CLASS I, 642 PAINT FT	WORK ZONE TRANSVERSE/DIAGONAL LINE, CLASS I, 642 PAINT FT	WORK ZONE STOP LINE, CLASS I, 642 PAINT FT	WORK ZONE CROSSWALK LINE, CLASS I, 642 PAINT FT	WORK ZONE GORE MARKING, CLASS II, 642 PAINT FT	WORK ZONE ARROW, CLASS I, 642 PAINT EACH	PORTABLE BARRIER, 50", AS PER PLAN FT	PORTABLE BARRIER, 50", BRIDGE MOUNTED, AS PER PLAN FT	PORTABLE BARRIER, "Y" CONNECTOR EACH	LANE LINE, 6", TYPE I MILE	EDGE LINE, 6", TYPE I WHITE MILE	EDGE LINE, 6", TYPE I YELLOW MILE	CHANNELIZING LINE, 8", TYPE I FT	CHANNELIZING LINE, 12", TYPE I FT	DOTTED LINE, 6", TYPE I FT			
PHASE 1	12,641	3,220	3,959	354	554	420	30	50	17,480	180										
PHASE 2	12,668		2,969						19,260											
PHASE 3	17,514	1,025	9,785				12		70,104	1180	1									
PHASE 4	18,098	1,025	13,617				12		23,265	580	2									
PHASE 5	22,823		10,190						20,800											
PHASE 5A									140			10.29	10.58	11.04	3,786	13,042	14,182			
PHASE 6	12,972	1,000	14,117				12		48,095	990										
PHASE 7	16,896	1,000	13,193				12		26,581	640	4									
TOTALS CARRIED TO GENERAL SUMMARY	113,612	7,270	67,830	354	554	420	78	50	225,725	3570	7	10.29	21.62	11.04	3,786	13,042	14,182			

SUBSUMMARY MAINTENANCE OF TRAFFIC	CALCULATED
	BAD CHECKED AFS
RIC - 30 - 9 . 26	
67 1669	

M:\5074_93455\Design\M0T\Sheet\93455\M00502.dgn 3/27/2020 8:44:17 AM K1a282

REF NO.	SHEET NO.	STATION TO STATION		614	614		614	614			614	614		614	614	614	614	614	622		
				INCREASED BARRIER DELINEATION FT	WORK ZONE IMPACT ATTENUATOR (UNIDIRECTIONAL) EACH		WORK ZONE RAISED PAVEMENT MARKER (YELLOW) EACH	WORK ZONE RAISED PAVEMENT MARKER (WHITE) EACH		BARRIER REFLECTOR, TYPE I, ONE WAY EACH	OBJECT MARKER, ONE WAY EACH		WORK ZONE LANE LINE, CLASS I, 6", 642 PAINT MILE		WORK ZONE EDGE LINE, CLASS I, 6", 642 PAINT (WHITE) MILE	WORK ZONE EDGE LINE, CLASS I, 6", 642 PAINT (YELLOW) MILE	WORK ZONE CHANNELIZING LINE, CLASS I, 8", 642 PAINT FT		WORK ZONE DOTTED LINE, CLASS I, 642 PAINT FT		PORTABLE BARRIER, 50", AS PER PLAN FT
EL-511	233-255	681+50	TO																		
LL-501	233-255	445+20																			
CHL-517	233-255	540+35																			
LL-502	233-255	556+00																			
CHL-518	233-255	599+50																			
LL-503	233-255	614+50																			
CHL-519	233-255	624+00																			
LL-504	233-255	637+00																			
CHL-520	233-255	652+00																			
LL-505	233-255	665+00																			
CHL-521	233-255	700+00																			
LL-506	233-255	710+20																			
IA-501	233-255	552+60																			
PB-501	233-255	552+60																			
EL-512	233-255	444+23																			
RPM-512	233-255	444+23																			
RPM-513	233-255	541+50																			
RPM-514	233-255	558+00																			
RPM-515	233-255	599+62																			
RPM-516	233-255	614+50																			
RPM-517	233-255	624+00																			
RPM-518	233-255	640+82																			
RPM-519	233-255	697+50																			
PB-502	233-255	553+50																			
IA-502	233-255	698+60																			
LL-507	233-255	444+23																			
CHL-522	233-255	541+50																			
LL-508	233-255	558+00																			
CHL-523	233-255	599+62																			
LL-509	233-255	614+50																			
CHL-524	233-255	624+00																			
LL-510	233-255	640+82																			
CHL-525	233-255	697+50																			
EL-513	233-255	444+23																			
CHL-526	233-255	489+00																			
CHL-527	233-255	489+00																			
DL-509	233-255	491+53																			
EL-514	233-255	489+00																			
CHL-528	233-255	504+67																			
CHL-529	233-255	504+67																			
EL-515	233-255	511+89																			
CHL-530	233-255	525+35																			
CHL-531	233-255	525+35																			
DL-510	233-255	527+64																			
EL-516	233-255	525+35																			
CHL-532	233-255	563+93																			
CHL-533	233-255	563+93																			
DL-511	233-255	564+80																			
EL-517	233-255	563+93																			
SUBTOTALS CARRIED TO SHEET 262				20,800	2		296	768			416	416		7.90	4.40	5.42	15,107		2,430		20,800

MAINTENANCE OF TRAFFIC ESTIMATED QUANTITIES
PHASE 5

RIC-30-9.26

CALCULATED
BAD
CHECKED
AFS

261
1669

M:\5074\93455\Design\M0T\Sheets\93455\M00503.dgn 3/27/2020 8:49:26 AM k.ja282

REF NO.	SHEET NO.	STATION TO STATION				614	614	614	614	614	614	614	614	614	614	614	614	622
						INCREASED BARRIER DELINEATION FT	WORK ZONE IMPACT ATTENUATOR (UNIDIRECTIONAL) EACH	WORK ZONE RAISED PAVEMENT MARKER (YELLOW) EACH	WORK ZONE RAISED PAVEMENT MARKER (WHITE) EACH	BARRIER REFLECTOR, TYPE I, ONE WAY EACH	OBJECT MARKER, ONE WAY EACH	WORK ZONE LANE LINE, CLASS I, 6", 642 PAINT MILE	WORK ZONE EDGE LINE, CLASS I, 6", 642 PAINT (WHITE) MILE	WORK ZONE EDGE LINE, CLASS I, 6", 642 PAINT (YELLOW) MILE	WORK ZONE CHANNELIZING LINE, CLASS I, 8", 642 PAINT FT	WORK ZONE DOTTED LINE, CLASS I, 642 PAINT FT	PORTABLE BARRIER, 50", AS PER PLAN FT	
CHL-534	233-255	633+33	TO	633+77														
CHL-535	233-255	633+33		633+77														
DL-512	233-255	633+77		636+72														
EL-518	233-255	633+00		651+31														
CHL-536	233-255	651+31		651+51														
CHL-537	233-255	651+31		651+51														
DL-513	233-255	651+51		655+89														
EL-519	233-255	651+01		674+50														
DL-514	233-255	664+51		670+07														
CHL-538	233-255	670+07		674+50														
CHL-539	233-255	670+07		674+50														
EL-520	233-255	674+50		686+51														
CHL-540	233-255	686+51		689+50														
CHL-541	233-255	686+51		689+50														
DL-515	233-255	689+50		695+00														
EL-521	233-255	686+38		730+62														
DL-516	233-255	550+00		556+95														
RPM-520	233-255	550+00		558+00														
EL-522	233-255	550+00		558+20														
CHL-542	233-255	556+95		558+20														
CHL-543	233-255	556+95		558+20														
LL-516	245-246	707+70		730+62														
RPM-530	245-246	707+70		730+62														
SUBTOTALS THIS SHEET								61			0.43	2.02		1,862		3,134		
SUBTOTALS SHEET 260							339	862				4.43	5.38	5,854		4,626		
SUBTOTALS SHEET 261					20,800	2	296	768	416	416	7.90	4.40	5.42	15,107		2,430		20,800
PHASE 5 TOTALS CARRIED TO SHEET 264					20,800	2	635	1691	416	416	8.33	10.85	10.80	22823		10,190		20800

**MAINTENANCE OF TRAFFIC ESTIMATED QUANTITIES
PHASE 5**

RIC-30-9.26

CALCULATED
BAD
CHECKED
AFS

262
1669

M:\5074\93455\Design\MOT\Sheets\93455\M00505.dgn 3/27/2020 8:52:04 AM kja282

REF NO.	SHEET NO.	STATION TO STATION				614	614	614	614	614	614	614	614	614	614	614	622	642	642	642	642	642	642	
						INCREASED BARRIER DELINEATION FT	WORK ZONE IMPACT ATTENUATOR (UNIDIRECTIONAL) EACH	WORK ZONE RAISED PAVEMENT MARKER (YELLOW) EACH	WORK ZONE RAISED PAVEMENT MARKER (WHITE) EACH	WORK ZONE RAISED PAVEMENT MARKER, AS PER PLAN (YELLOW) EACH	WORK ZONE RAISED PAVEMENT MARKER, AS PER PLAN (WHITE) EACH	BARRIER REFLECTOR, TYPE I, ONE WAY EACH	OBJECT MARKER, ONE WAY EACH	WORK ZONE LANE LINE, CLASS I, 6", 642 PAINT MILE	WORK ZONE EDGE LINE, CLASS I, 6", 642 PAINT MILE	WORK ZONE EDGE LINE, CLASS I, 6", 642 PAINT MILE	WORK ZONE CHANNELIZING LINE, CLASS I, 8", 642 PAINT FT	WORK ZONE CHANNELIZING LINE, CLASS I, 12", 642 PAINT FT	WORK ZONE DOTTED LINE, CLASS I, 642 PAINT FT	PORTABLE BARRIER, 50", AS PER PLAN FT	LANE LINE, 6", TYPE I MILE	EDGE LINE, 6", TYPE I (WHITE) MILE	EDGE LINE, 6", TYPE I (YELLOW) MILE	CHANNELIZING LINE, 8", TYPE I FT
DL-524	247-254	557+66	TO	561+38																			372	
CHL-561	247-254	561+38		561+92																			54	
CHL-562	247-254	561+38		561+92																			54	
EL-535	247-254	561+92		575+34														0.25						
CHL-563	247-254	575+34		580+91																			557	
CHL-564	247-254	575+34		580+91																			557	
EL-536	247-254	573+85		575+34															0.03					
EL-537	247-254	573+85		630+30														1.07						
DL-525	247-254	580+91		586+61																			570	
CHL-565		NOT USED																						
RPM-524	247-254	599+50		614+00						13														
LL-513	247-254	614+00		629+29													0.29							
DL-526	247-254	612+50		626+61																			1,411	
RPM-525	247-254	614+00		629+29						14														
CHL-566	247-254	626+61		630+30																			369	
CHL-567	247-254	629+29		630+30																			101	
EL-538	247-254	630+30		675+73														0.86						
CHL-568	247-254	629+29		640+00																	1,071			
RPM-526	247-254	629+29		640+00				55	109															
LL-514	247-254	640+00		654+50													0.27							
RPM-527	247-254	640+00		654+50						13														
RPM-528	247-254	654+50		666+00				59	117															
CHL-569	247-254	654+50		666+00																			1,150	
LL-515	247-254	666+00		710+20													0.84							
RPM-529	247-254	666+00		710+20						38														
DL-527	247-254	667+09		669+18																			209	
CHL-570	247-254	669+18		675+73																			655	
CHL-571	247-254	669+18		675+73																			655	
EL-539	247-254	675+73		681+50														0.11						
EL-540	247-254	681+50		710+20														0.54						
CHL-572	247-254	681+50		689+74																			824	
CHL-573	247-254	681+50		689+74																			824	
DL-528	247-254	689+74		695+84																			610	
SUBTOTALS THIS SHEET									114	304							1.40	2.83	0.03	2,221	4,650	3,172		
SUBTOTALS SHEET 263					140	1			79	334	3	3				140	4.22	3.53	6.34	1,565	3,756	6,922		
PHASE 5A FROM OFFICE CALCULATIONS																	4.67	4.22	4.67	0	4636	4088		
PHASE 5A TOTALS CARRIED TO SHEET 66-67					140	1			193	638	3	3				140	10.29	10.58	11.04	3,786	13,042	14,182		
PHASE 5 TOTALS CARRIED TO SHEET 66-67					20,800	2	635	1,691			416	416	8.33	10.85	10.80	22,823		10,190	20,800					

MAINTENANCE OF TRAFFIC ESTIMATED QUANTITIES PHASE 5

RIC-30-9.26

CALCULATED
BAD
CHECKED
AFS

SHEET NUM.													PART.				ITEM	ITEM EXT	GRAND TOTAL	UNIT	DESCRIPTION	SEE SHEET NO.
32-38B	40-65	66-67	369-371	380-383	390	395	918	959	991	1510-1511	1531-1585	OFFICE CALCS	01/NHS/BR	02/NHS/PV	03/NHS/BR	04/NHS/BR						
				45.8										45.8			602	20000	45.8	CY	CONCRETE MASONRY	
					2,525									2,525			605	13410	2,525	FT	6" UNCLASSIFIED PIPE UNDERDRAINS WITH GEOTEXTILE FABRIC	
					93,656									93,656			605	14020	93,656	FT	6" BASE PIPE UNDERDRAINS WITH GEOTEXTILE FABRIC	
					2,807			18						2,825			611	00510	2,825	FT	6" CONDUIT, TYPE F FOR UNDERDRAIN OUTLETS	
				22										22			611	02000	22	FT	8" CONDUIT, TYPE C	
				147										147			611	04400	147	FT	12" CONDUIT, TYPE B	
				182										182			611	04600	182	FT	12" CONDUIT, TYPE C	
				79										79			611	04900	79	FT	12" CONDUIT, TYPE D	
				77										77			611	05700	77	FT	15" CONDUIT, TYPE A	
				2,227										2,227			611	05900	2,227	FT	15" CONDUIT, TYPE B	
				204										204			611	06100	204	FT	15" CONDUIT, TYPE C	
				362										362			611	06700	362	FT	15" CONDUIT, TYPE F, 707.50 TYPE C OR 707.21	
				227										227			611	07400	227	FT	18" CONDUIT, TYPE B	
				306										306			611	07600	306	FT	18" CONDUIT, TYPE C	
				24										24			611	09100	24	FT	21" CONDUIT, TYPE C	
				27										27			611	09400	27	FT	21" CONDUIT, TYPE D	
				103										103			611	10200	103	FT	24" CONDUIT, TYPE A	
				275										275			611	10400	275	FT	24" CONDUIT, TYPE B	
				61										61			611	10600	61	FT	24" CONDUIT, TYPE C	
				96										96			611	11200	96	FT	24" CONDUIT, TYPE F, 707.50 TYPE C OR 707.21	
				228										228			611	11900	228	FT	27" CONDUIT, TYPE B	
				131										131			611	13200	131	FT	30" CONDUIT, TYPE A	
				92										92			611	13400	92	FT	30" CONDUIT, TYPE B	
				253										253			611	16400	253	FT	36" CONDUIT, TYPE B	
				71										71			611	16600	71	FT	36" CONDUIT, TYPE C	
				98										98			611	19400	98	FT	42" CONDUIT, TYPE B	
				164										164			611	20900	164	FT	48" CONDUIT, TYPE B	
				422										422			611	21100	422	FT	48" CONDUIT, TYPE C	
				397										397			611	22400	397	FT	54" CONDUIT, TYPE B	
				88										88			611	52702	88	FT	29" X 45" CONDUIT, TYPE B, 706.04	
				54										54			611	52706	54	FT	29" X 45" CONDUIT, TYPE D, 706.04	
				147										147			611	53000	147	FT	38" X 60" CONDUIT, TYPE A, 706.04	
				137										137			611	96600	137	FT	CONDUIT, BORED OR JACKED, 15", TYPE B	
				196										196			611	96600	196	FT	CONDUIT, BORED OR JACKED, 18", TYPE B	
				181										181			611	96600	181	FT	CONDUIT, BORED OR JACKED, 21", TYPE C	
				133										133			611	96600	133	FT	CONDUIT, BORED OR JACKED, 30", TYPE A	
				241										241			611	96600	241	FT	CONDUIT, BORED OR JACKED, 30", TYPE B	
				392										392			611	96600	392	FT	CONDUIT, BORED OR JACKED, 36", TYPE B	
				246										246			611	96600	246	FT	CONDUIT, BORED OR JACKED, 42", TYPE A	
				182										182			611	96600	182	FT	CONDUIT, BORED OR JACKED, 48", TYPE A	
				389										389			611	96600	389	FT	CONDUIT, BORED OR JACKED, 54", TYPE A	
				265										265			611	96600	265	FT	CONDUIT, BORED OR JACKED, 66", TYPE A	
				229										229			611	96600	229	FT	CONDUIT, BORED OR JACKED, 66", TYPE B	
				234										234			611	96600	234	FT	CONDUIT, BORED OR JACKED, 78", TYPE A	
				4										4			611	98150	4	EACH	CATCH BASIN, NO. 3	
				11										11			611	98180	11	EACH	CATCH BASIN, NO. 3A	
				2										2			611	98270	2	EACH	CATCH BASIN, NO. 4A	
				5										5			611	98370	5	EACH	CATCH BASIN, NO. 6	
				26										26			611	98410	26	EACH	CATCH BASIN, NO. 8	
				9										9			611	98434	9	EACH	CATCH BASIN, NO. 8A	
				1										1			611	98470	1	EACH	CATCH BASIN, NO. 2-2B	
				1										1			611	98570	1	EACH	CATCH BASIN, NO. 2-5	
				2										2			611	98630	2	EACH	CATCH BASIN ADJUSTED TO GRADE	
				2										2			611	99114	2	EACH	INLET, NO. 3 FOR SINGLE SLOPE BARRIER, TYPE D	
				4										4			611	99140	4	EACH	INLET, NO. 4 FOR SINGLE SLOPE BARRIER, TYPE B1	
				9										9			611	99140	9	EACH	INLET, NO. 4 FOR SINGLE SLOPE BARRIER, TYPE B1, AS PER PLAN	34
				7										7			611	99574	7	EACH	MANHOLE, NO. 3	
				2										2			611	99654	2	EACH	MANHOLE ADJUSTED TO GRADE	
				2										2			611	99660	2	EACH	MANHOLE RECONSTRUCTED TO GRADE	
				60										62			611	99710	62	EACH	PRECAST REINFORCED CONCRETE OUTLET	

GENERAL SUMMARY

RIC - 30 - 9 . 26

M:\15074\93455\Design\Roadway\Sheets\93455\G0003.dgn 3/26/2020 11:05:05 AM kja282

SHEET NUM.												PART.				ITEM	ITEM EXT	GRAND TOTAL	UNIT	DESCRIPTION	SEE SHEET NO.	
32-38B	40-65	66-67	369-371	380-383	390	395	918	959	991	1510-1511	1531-1585	OFFICE CALCS	01/NHS/BR	02/NHS/PV	03/NHS/BR							04/NHS/BR
	34.52	21.62											5.62	50.52			642	00104	56.14	MILE	EDGE LINE, 6", TYPE 1	
	15.05	10.29											2.54	22.8			642	00204	25.34	MILE	LANE LINE, 6", TYPE 1	
		3,786												3,786			642	00400	3,786	FT	CHANNELIZING LINE, 8", TYPE 1	
	21,204	13,042											3,424.6	30,821.4			642	00404	34,246	FT	CHANNELIZING LINE, 12", TYPE 1	
	120													120			642	00500	120	FT	STOP LINE, TYPE 1	
	25,082	14,182											3,926.4	35,337.6			642	01510	39,264	FT	DOTTED LINE, 6", TYPE 1	
																					FOR ADDITIONAL TRAFFIC CONTROL QUANTITIES	1009
																					TRAFFIC SIGNALS	
																					FOR TRAFFIC SIGNALS ESTIMATED QUANTITIES	1147
																					RETAINING WALLS	
																					FOR RETAINING WALL 10B ESTIMATED QUANTITIES	974
																					FOR RETAINING WALL 7B ESTIMATED QUANTITIES	980
																					BUILDING DEMOLITION	
LS														LS			202	56001	LS		BUILDING DEMOLISHED, AS PER PLAN, PARCEL 208, PORTION OF BUILDING	38A
4														4			SPECIAL	69070100	4	SF	ASBESTOS ABATEMENT, WINDOW GLAZING COMPOUND	38A
50														50			SPECIAL	69070100	50	SF	ASBESTOS ABATEMENT, DRYWALL SYSTEMS	38A
1														1			SPECIAL	69070100	1	SF	ASBESTOS ABATEMENT, ELECTRICAL BACKING PLATE	38A
20														20			SPECIAL	69070100	20	SF	ASBESTOS ABATEMENT, RESIDUAL FLASHING	38A
																					NOISE BARRIERS	
								3,190						3,190			605	11101	3,190	FT	6" SHALLOW PIPE UNDERDRAINS, AS PER PLAN	960
								73,704						73,704			SPECIAL	60610210	73,704	SF	NOISE BARRIER (REFLECTIVE)	959
																					STRUCTURES OVER 20 FOOT SPAN	
																					FOR RIC-30-0982 ESTIMATED QUANTITIES	1200
																					FOR RIC-30-1074 ESTIMATED QUANTITIES	1207
																					FOR RIC-30-1135 ESTIMATED QUANTITIES	1273
																					FOR RIC-30-1156 ESTIMATED QUANTITIES	1329
																					FOR RIC-30-1212 ESTIMATED QUANTITIES	1335
																					FOR RIC-30-1219 ESTIMATED QUANTITIES	1347
																					FOR RIC-30-1236 ESTIMATED QUANTITIES	1428
																					FOR RIC-30-1283 ESTIMATED QUANTITIES	1507
																					MAINTENANCE OF TRAFFIC	
	10													10			410	12000	10	CY	TRAFFIC COMPACTED SURFACE, TYPE A OR B	
	275													275			606	98000	275	FT	GUARDRAIL, MISC.: MEDIAN BARRIER PROTECTION	61
	2,500																614	11110	2,500	hour	LAW ENFORCEMENT OFFICER WITH PATROL CAR FOR ASSISTANCE	
	58,662	271,463												33,013	297,112		614	11630	330,125	FT	INCREASED BARRIER DELINEATION	
		59													59		614	12336	59	EACH	WORK ZONE IMPACT ATTENUATOR (UNIDIRECTIONAL)	
	1														1		614	12338	1	EACH	WORK ZONE IMPACT ATTENUATOR (BIDIRECTIONAL)	
	LS													LS			614	12420	LS		DETOUR SIGNING	
	20													20			614	12484	20	EACH	WORK ZONE INCREASED PENALTIES SIGN	
	20													20			614	12500	20	EACH	REPLACEMENT SIGN	
	100												10	90			614	12600	100	EACH	REPLACEMENT DRUM	
	2													2			614	12756	2	EACH	WORK ZONE CROSSOVER LIGHTING SYSTEM	
		11,311												1,131	10,180		614	12800	11,311	EACH	WORK ZONE RAISED PAVEMENT MARKER	
	197	831												103	925		614	12801	1,028	EACH	WORK ZONE RAISED PAVEMENT MARKER, AS PER PLAN	45
71	310														381		614	13000	381	CY	ASPHALT CONCRETE FOR MAINTAINING TRAFFIC	
	1,203	5,885												709	6,379		614	13310	7,088	EACH	BARRIER REFLECTOR, TYPE 1, ONE WAY	
		209												21	188		614	13310	209	EACH	BARRIER REFLECTOR, TYPE 1, BIDIRECTIONAL	
	507													51	456		614	13318	507	EACH	BARRIER REFLECTOR, TYPE 5, ONE WAY	
	631	3,749												438	3,942		614	13350	4,380	EACH	OBJECT MARKER, ONE WAY	
	656	1,278												193	1,741		614	13360	1,934	EACH	OBJECT MARKER, TWO WAY	
	750,000													750,000			614	18000	750,000	EACH	MAINTAINING TRAFFIC, MISC.: BRIDGE DECK AND PAVEMENT PATCHING	48
	16													16			614	18000	16	EACH	MAINTAINING TRAFFIC, MISC.: EMERGENCY ACCESS GATE SYSTEMS	48
	90													90			614	18601	90	SNMT	PORTABLE CHANGEABLE MESSAGE SIGN, AS PER PLAN	44
		31.79												3.18	28.61		614	20110	31.79	MILE	WORK ZONE LANE LINE, CLASS 1, 6", 642 PAINT	
		4.54												0.45	4.09		614	21100	4.54	MILE	WORK ZONE CENTER LINE, CLASS 1, 642 PAINT	
		182.53												18.26	164.27		614	22110	182.53	MILE	WORK ZONE EDGE LINE, CLASS 1, 6", 642 PAINT	

GENERAL SUMMARY

RIC-30-9.26

356
1669

M:\5074\93455\Design\Roadway\Sheets\93455\G0005.dgn 3/27/2020 9:00:58 AM kja282

M:\5074_93455\Design\Drainage\Sheets\93455DS1001.dgn 3/26/2020 11:56:52 AM k_ja282

REF NO.	SHEET NO.	STATION TO STATION			SIDE	OUTLET				FOR INFORMATION ONLY																
						STATION	OFFSET	ELEVATION	OUTLET DETAIL #	601	605	605	611	BENDS AND BRANCHES												
						TIED CONCRETE BLOCK MAT, TYPE	6" UNCLASSIFIED PIPE UNDERDRAINS WITH GEOTEXTILE FABRIC	6" BASE PIPE UNDERDRAINS WITH GEOTEXTILE FABRIC	6" CONDUIT, TYPE F FOR UNDERDRAIN OUTLETS	PRECAST REINFORCED CONCRETE OUTLET	6" X 6" TEE	6" X 6" CROSS	6" X 90° BEND	6" X 45° BEND							6" X 22 1/2° BEND	6" X 11 1/4° BEND	6" X 6" X 6" WYE			
						SY	FT	FT	FT	EACH	NO.	NO.	NO.	NO.							NO.	NO.	NO.			
		US 30	TO																							
U1	410	489+00		494+25	RT																					
U2	410	489+00		494+25	RT	494+25	84.02	1288.40	3	2																
U3	410	489+00		494+39	RT	494+39	0.00	1287.00	5																	
U4	410	489+00		494+38	LT	494+39	0.00	1287.00	5																	
U5	410	489+02		495+00	LT	495+00	85.96	1287.84	3	2																
U6	410	489+03		495+00	LT																					
U7	410	494+26		500+76	RT																					
U8	410	494+26		500+76	RT	500+54	65.33	1284.53	3	2																
U9	410	494+53		500+76	RT	500+60	1.00	1286.20	5																	
U10	410	494+38		500+76	LT	500+60	1.00	1286.20	5																	
U11	410	495+01		505+05	LT	505+05	75.86	1284.32	3	2																
U12	410	495+01		505+05	LT																					
U1	412	500+77		504+86	RT																					
U2	412	500+77		504+86	RT	504+86	62.96	1284.48	3	2																
U3	412	505+34		7+16 (RAMP A)	RT																					
U4	412	505+34		7+16 (RAMP A)	RT	505+34	61.41	1284.54	3	2																
U5	412	505+36		8+46 (RAMP D)	LT	505+36	75.69	1284.36	3	2																
U6	412	505+36		8+46 (RAMP D)	LT																					
U1	414	511+89		514+49	LT				1																	
U2	414	511+89		514+49	LT																					
U5	414	512+41		514+99	RT	7+00	32.85	1283.60	1																	
U6	414	512+41		514+99	RT																					
U7	414	514+50		522+33	LT	514+50	59.33	1285.89	8																	
U8	414	514+50		522+33	LT																					
U9	414	515+00		522+33	RT																					
U10	414	515+00		522+33	RT	515+00	58.55	1285.86	8																	
U1	416	522+34		525+88	RT	19+94	18.55	1286.1	2	2																
U2	416	522+34		525+88	RT																					
U3	416	522+34		525+35	LT	17+17	20.47	1286.41	2	2																
U4	416	522+34		525+35	LT																					
U5	416	18+00 (RAMP C)		530+50	RT																					
U6	416	18+00 (RAMP C)		530+50	RT	530+50	68.58	1286.64	3	2																
U11	416	529+07		530+50	LT	530+50	60.66	1286.49	3	2																
U12	416	529+07		530+50	LT																					
U13	416	530+51		536+18	RT																					
U14	416	530+51		536+18	RT	536+18	65.77	1278.71	13	2																
U15	416	530+51		536+00	LT	536+00	66.75	1278.96	3	2																
U16	416	530+51		536+00	LT																					
U1	418	536+19		546+34	RT																					
U2	418	536+19		546+34	RT	546+34	68.71	1260.22	13	2																
U3	418	536+01		545+85	LT	545+85	65.65	1260.52	3	2																
U4	418	536+01		545+85	LT																					
SUBTOTALS CARRIED TO SHEET 390										30	1700	21779	664	15	29	2	19	5	0	4	0					

CALCULATED
 ACB
 CHECKED
 SDS

UNDERDRAIN SUBSUMMARY

RIC - 30 - 9 . 26

 384
 1669

M:\5074\93455\Design\Drainage\Sheets\93455\SDS1002.dgn 3/26/2020 12:26:37 PM k.ja282

REF NO.	SHEET NO.	STATION TO STATION			SIDE	OUTLET				FOR INFORMATION ONLY															
						STATION	OFFSET	ELEVATION	OUTLET DETAIL #						BENDS AND BRANCHES										
										601 TIED CONCRETE BLOCK MAT, TYPE SY	605 6" UNCLASSIFIED PIPE UNDERDRAINS WITH GEOTEXTILE FABRIC FT	605 6" BASE PIPE UNDERDRAINS WITH GEOTEXTILE FABRIC FT	611 6" CONDUIT, TYPE F FOR UNDERDRAIN OUTLETS FT	611 PRECAST REINFORCED CONCRETE OUTLET EACH	6" X 6" TEE NO.	6" X 6" CROSS NO.	6" X 90° BEND NO.	6" X 45° BEND NO.	6" X 22 1/2° BEND NO.	6" X 11 1/4° BEND NO.	6" X 6" X 6" WYE NO.				
			TO																						
U5	420	544+68		547+50	RT	547+50	0.00	1257.92	6A																
U6	420	545+86		548+00	LT	548+00	57.89	1255.96	3	2				1			1								
U7	420	545+86		548+00	LT																				
U8	420	546+35		550+46	RT																				
U9	420	546+35		550+46	RT	550+46	58.27	1252.34	13	2				2			1								
U10	420	547+55		549+50	RT	549+50	0.00	1254.15	6A																
U11	420	548+01		457+50 (RAMP HL)	LT	457+50	19.84	1243.88	4	2	150			1	1		1								
U12	420	548+01		457+50 (RAMP HL)	LT						149														
U13	420	549+55		551+50	RT	551+50	0.00	1250.40	6A																
U14	420	550+47		555+95	RT																				
U15	420	550+47		555+95	RT	555+95	87.95	1243.86	13A	2				1	1	2									
U16	420	551+55		553+50	RT	553+50	0.00	1246.66	6A																
U17	420	553+55		555+00	RT	555+00	0.00	1244.82	6A																
U1	422	555+05		556+00	RT	556+00	0.00	1244.49	6																
U2	422	556+00		556+77	RT	556+00	0.00	1244.49	6																
U3	422	558+22		563+93	LT	458+19	18.86	1244.25	1	2															
U4	422	558+22		563+93	LT																				
U5	422	560+51		566+76	RT																				
U6	422	560+51		566+87	RT	360+50	27.68	1247.37	1	2															
U1	424	569+65		570+75	RT																				
U2	424	569+65		570+75	RT	569+65	55.63	1273.06	3	2															
U3	424	568+87		570+75	LT	568+14	69.17	1271.77	11	2															
U4	424	568+80		570+75	LT																				
U7	424	570+76		578+00	LT	578+00	58.70	1260.55	3	2															
U8	424	570+76		578+00	LT																				
U9	424	570+76		573+96	RT																				
U10	424	570+76		573+96	RT	173+98	19.34	1268.96	3	2															
U11	424	173+99 (RAMP I)		578+00	RT																				
U12	424	173+99 (RAMP I)		578+00	RT	578+00	70.62	1260.42	3	2															
U1	426	578+01		584+00	LT	584+00	53.95	1242.88	3	2															
U2	426	578+01		584+00	LT																				
U3	426	578+01		583+00	RT																				
U4	426	578+01		583+00	RT	583+00	60.62	1245.78	3	2															
U5	426	583+01		589+74	RT	589+74	53.95	1232.41	3	2															
U6	426	583+01		589+74	RT																				
U9	426	584+54		587+50	LT	587+50	0.00	1235.83	6A																
U10	426	584+01		589+50	LT	589+50	53.94	1234.28	3	2															
U13	426	584+01		589+50	LT																				
U14	426	587+55		589+00	LT	589+00	0.00	1233.96	6A																
SUBTOTALS CARRIED TO SHEET 390										30	299	16058	588	15	20	3	12	12	0	3	1				

CALCULATED ACB CHECKED SDS	UNDERDRAIN SUBSUMMARY

M:\5074\33455\Design\Drainage\Sheets\93455SDS1004.dgn 3/26/2020 1:32:21 PM kja282

REF NO.	SHEET NO.	STATION TO STATION			SIDE	OUTLET				601 TIED CONCRETE BLOCK MAT, TYPE 1 SY	605 6" UNCLASSIFIED PIPE UNDERDRAINS WITH GEOTEXTILE FABRIC FT	605 6" BASE PIPE UNDERDRAINS WITH GEOTEXTILE FABRIC FT	611 6" CONDUIT, TYPE F FOR UNDERDRAIN OUTLETS FT	611 PRECAST REINFORCED CONCRETE OUTLET EACH	FOR INFORMATION ONLY																					
						STATION	OFFSET	ELEVATION	OUTLET DETAIL #						BENDS AND BRANCHES																					
															6" X 6" TEE NO.	6" X 6" CROSS NO.	6" X 90° BEND NO.	6" X 45° BEND NO.	6" X 22 1/2° BEND NO.	6" X 11 1/4° BEND NO.	6" X 6" X 6" WYE NO.															
			TO																																	
U1	442	654+40		655+69	RT						129																									
U2	442	654+40		655+69	RT	654+19	74.65	1244.70	3	2	129	36	1	1		1	1																			
U3	442	655+05		665+00	LT	655+05	62.04	1248.39	3	2	997	21	1	1		1	1																			
U4	442	655+05		665+00	LT						997										2															
U5	442	655+70		665+00	RT	655+69	61.87	1250.30	8		927	19		1		1																				
U6	442	655+70		665+00	RT						928										4															
U1	444	665+01		174+24 (RAMP A)	RT						923																									
U2	444	665+01		174+24 (RAMP A)	RT	174+24	37.13	1251.7	3	2	924	34	1	1		1	1																			
U7	444	665+01		474+50 (RAMP D)	LT	474+50	27.67	1250.78	3	2	950	25	1	1		1	1																			
U8	444	665+01		474+50 (RAMP D)	LT						950																									
U9	444	674+25		683+20	RT						895																									
U10	444	674+25		683+20	RT	372+37	22.48	1230.15	2	2	895	59	1	3	1	1																				
U11	444	674+51		683+61	LT						910																									
U12	444	674+51		683+61	LT	683+65	63.00	1230.00	10		910	24		1	1		1																			
U1	446	678+70		683+61	LT	683+65	0.00	1231.00	16		491	14		1			1																			
U2	446	678+70		683+61	RT	683+65	0.00	1231.00	16		491	14		1			1																			
U3	446	683+61		686+52	LT						291																									
U4	446	683+61		686+52	LT						291																									
U5	446	683+61		689+50	LT						589																									
U6	446	683+61		689+50	RT						589																									
		LONGVIEW AVE W																																		
U1	454	101+10		102+50	LT	102+55	39.90	1255.32	4	2	144	58	1	1		2	1																			
U2	454	100+85		101+50	RT	101+50	125.26	1255.99	4	2	158	9	1	1																						
U3	454	101+50		102+49	RT						142																									
U4	454	102+50		103+18.50	RT						69																									
U5	454	102+50		103+18.50	LT						69																									
		SR 39																																		
U1	460	693+00		696+70	LT	696+70	26.25	1247.92			366																									
U2	460	693+00		696+70	LT	696+70	26.25	1247.92			367	8		1																						
U3	460	693+00		696+87	RT	696+87	26.25	1248.56			390	8		1																						
U4	460	693+00		696+87	RT	696+87	26.25	1248.24			391																									
U5	462	696+70		700+36	LT	696+70	26.25	1248.24			366																									
U6	462	696+70		699+00	LT						230																									
U7	462	696+87		699+00	RT						213																									
U8	462	696+87		700+48	RT	696+87	26.25	1248.34			361																									
		RELOCATED LONGVIEW AVE																																		
U1	468	302+75		311+25	LT	311+25	16.00	1239.60			871																									
U2	468	302+75		311+25	RT	311+25	16.00	1239.60			829																									
U3	471	311+25		311+75	LT	311+25	16.00	1239.60			50																									
U4	471	311+25		311+75	RT	311+25	16.00	1239.60			50																									
SUBTOTALS CARRIED TO SHEET 390												14	138	19134	329	7	15	2	8	5	6	0	1													

CALCULATED
 UNDERDRAIN SUBSUMMARY
 387
 1669

REF NO.	SHEET NO.	STATION TO STATION		SIDE	OUTLET				601	605	605	611	611	FOR INFORMATION ONLY											
					STATION	OFFSET	ELEVATION	OUTLET DETAIL #	TIED CONCRETE BLOCK MAT, TYPE 1	6" UNCLASSIFIED PIPE UNDERDRAINS WITH GEOTEXTILE FABRIC	6" BASE PIPE UNDERDRAINS WITH GEOTEXTILE FABRIC	6" CONDUIT, TYPE F FOR UNDERDRAIN OUTLETS	PRECAST REINFORCED CONCRETE OUTLET	BENDS AND BRANCHES											
									SY	FT	FT	FT	EACH	6" X 6" TEE NO.	6" X 6" CROSS NO.	6" X 90° BEND NO.	6" X 45° BEND NO.	6" X 22 1/2° BEND NO.	6" X 11 1/4° BEND NO.	6" X 6" X 6" WYE NO.					
		SR 545	TO																						
U1	497	159+75		165+25	RT					550															
U2	497	159+75		165+25	RT					550															
U3	497	159+75		164+89	LT					524															
U4	497	159+75		163+88	LT	159+13	26.47	1216.82		413	107				3		1	1							
		TRIMBLE RAMP A																							
U1	507	7+17		8+60	RT					143															
U2	507	7+17		8+60	LT					143															
		TRIMBLE RAMP B																							
U1	510	13+47		17+17	RT					369															
U2	510	13+47		17+17	RT					368															
U3	512	17+17		18+00	LT					83															
U4	512	17+17		18+00	RT					83															
		TRIMBLE RAMP C																							
U1	517	18+00		19+95	LT					194															
U2	517	18+00		19+95	LT					194															
U3	517	19+95		21+51	LT					156															
U4	517	19+95		21+51	RT					157															
		TRIMBLE RAMP D																							
U1	520	8+52		9+50	LT					98															
U2	520	8+52		9+50	LT					98															
U3	520	9+50		9+94	LT				44																
U4	520	9+50		11+80	LT				70	160															
U5	520	9+95		11+80	RT				25	160															
		SR 39 RAMP G																							
U1	525	555+95 (US 30)		360+49	RT					454															
U2	525	555+95 (US 30)		360+49	RT					453															
U3	525	360+50		365+25	RT					474															
U4	525	360+50		364+50	LT					407															
U1	527	364+51		368+00	LT	368+00	29.92	1254.96	3	2	347	11	1			1									
U2	529	365+26		369+50	RT	369+50	18.70	1255.33	3	2	425	16	1			1									
U4	529	368+01		371+31	LT					125	186														
U1	531	369+51		371+13	RT					164	54				1		2								
U3	531	371+13		371+36	RT					32												1			
		SR 39 RAMP H																							
U1	533	458+19 (RAMP HL)		465+50	LT					751															
U2	533	261+50 (RAMP HR)		465+50	RT					468															
		SR 39 RAMP HL																							
U2	535	457+50		458+18	LT					68															
U3	535	457+50		458+18	LT					69															
U4	535	458+19		462+19	RT					418															
SUBTOTALS CARRIED TO SHEET 390										4	264	9159	188	2	4	0	3	3	0	0	1				

UNDERDRAIN SUBSUMMARY

RIC - 30 - 9.26

CALCULATED	ACB
CHECKED	SDS

388
1669

M:\5074\93455\Design\Drainage\Sheets\93455DS1006.dgn 3/26/2020 1:37:44 PM kja282

REF NO.	SHEET NO.	STATION TO STATION		SIDE	OUTLET				601 TIED CONCRETE BLOCK MAT, TYPE SY	605 6" UNCLASSIFIED PIPE UNDERDRAINS WITH GEOTEXTILE FABRIC FT	605 6" BASE PIPE UNDERDRAINS WITH GEOTEXTILE FABRIC FT	611 6" CONDUIT, TYPE F FOR UNDERDRAIN OUTLETS FT	611 PRECAST REINFORCED CONCRETE OUTLET EACH	FOR INFORMATION ONLY								
					STATION	OFFSET	ELEVATION	OUTLET DETAIL #						BENDS AND BRANCHES								
														6" X 6" TEE NO.	6" X 6" CROSS NO.	6" X 90° BEND NO.	6" X 45° BEND NO.	6" X 22 1/2° BEND NO.	6" X 11 1/4° BEND NO.	6" X 6" X 6" WYE NO.		
		SR 39 RAMP HR		TO																		
U1	539	259+93	261+50	RT	261+50	24.61	1247.17	10			172	42		1	1							
U3	539	261+50	263+94	RT							259											
U4	539	261+50	263+93	LT							244											
U1	541	263+94	265+82	LT							187											
U2	541	263+94	266+05	LT	263+94	20.47	1259.99	3	2		210	18	1	1		1						
U5	541	265+85	265+97	LT	265+85	10.00	1266.45	6A			9	3				1						
		SR 39 RAMP I																				
U1	544	170+21	173+97	LT							386											
U2	544	170+36	173+97	RT							362	63				1	2		1			
		SR 13 RAMP C																				
U1	549	9+30	12+25	LT						50	237											
U2	549	10+88	12+25	RT	12+25	21.14	1144.88	3	2		151	38	1	1		1						
		SR 13 RAMP D																				
U1	553	18+00	19+42	RT	18+00	25.82	1146.98	3	2		150	43	1	1		1						
		RAMP W																				
U1	558	136+36	138+00	RT							162											
U2	558	136+36	138+00	LT							168											
U3	560	138+01	140+67	LT							285	17		1		1						
U4	560	138+01	67+25 (LONGVIEW W)	RT	67+25	31.36	1148.78	3	2		477	12	1		1							
		RAMP X																				
U1	562	238+43	241+43	LT							321	17		1		1						
U2	562	236+67 (Ramp Y)	643+20 (US 30)	RT	237+00	45.21	1156.24	10			654	35		1		1						
		RAMP Y																				
U1	565	69+50 (LONGVIEW W)	236+67	RT							92											
		SR 545 RAMP SL																				
U1	567	348+71	357+60 (RAMP S)	LT							956											
U2	567	348+71	351+00	RT							241											
U3	567	351+01	351+70 (RAMP S)	RT	351+70	2.00	1225.45	5			67	3			1							
		SR 545 RAMP SR																				
U1	569	449+00	452+33	LT							332											
U2	569	449+00	451+35	RT	449+00	18.88	1223.93	10	2		258	35	1	1	1							
U3	569	448+67	449+00	RT							36											
U4	569	357+28 (Ramp S)	449+00	LT							554											
		FIFTH RAMP A																				
U1	577	174+25	180+00	RT							569	73		1	1	1	1	1				
U2	577	174+24	180+00	LT							591											
		FIFTH RAMP B																				
U1	583	369+50	372+38	LT							37											
U2	583	369+50	372+38	RT							37											
U3	583	372+38	378+68	RT							631											
U4	583	372+38	378+68	RT							631											
		SUBTOTALS CARRIED TO SHEET 390																				
											10	124	9906	399	5	9	2	8	6	1	0	2

	CALCULATED ACB CHECKED SDS
UNDERDRAIN SUBSUMMARY	
RIC-30-9.26	
389 1669	

M:\15074_93455\Design\Drainage\Sheets\93455DS1007.dgn 3/26/2020 1:41:01PM kjq282

REF NO.	SHEET NO.	STATION TO STATION		SIDE	OUTLET				601	605	605	611	611	FOR INFORMATION ONLY										
					STATION	OFFSET	ELEVATION	OUTLET DETAIL #	TIED CONCRETE BLOCK MAT, TYPE	6" UNCLASSIFIED PIPE UNDERDRAINS WITH GEOTEXTILE FABRIC	6" BASE PIPE UNDERDRAINS WITH GEOTEXTILE FABRIC	6" CONDUIT, TYPE F FOR UNDERDRAIN OUTLETS	PRECAST REINFORCED CONCRETE OUTLET	BENDS AND BRANCHES										
									SY	FT	FT	FT	EACH	6" X 6" TEE	6" X 6" CROSS	6" X 90° BEND	6" X 45° BEND	6" X 22 1/2° BEND	6" X 11 1/4° BEND	6" X 6" X 6" WYE				
									NO.	NO.	NO.	NO.	NO.	NO.	NO.	NO.	NO.	NO.	NO.					
FIFTH RAMP C		TO																						
U1	588	375+25	375+40	RT																				
U2	588	375+25	378+37	LT																				
U3	588	375+25	378+37	LT	375+25	19.77	1232.64	1	2				2		1									
FIFTH RAMP D																								
U1	590	474+51	477+45	LT	477+45	18.32	1241.70	4	2				1											
U2	590	474+50	478+00	RT	447+99	31.89	1241.00	10					1											
U3	592	477+45	480+50	LT																				
U4	592	478+00	480+50	RT																				
SUBTOTALS								4		1852	58	2	4	0	1	0	0	0	0					
SHEET 384								30	1700	21779	664	15	29	2	19	5	0	4	0					
SHEET 385								30	299	16058	588	15	20	3	12	12	0	3	1					
SHEET 386								28		15768	581	14	22	1	15	6	3	1	0					
SHEET 387								14	138	19134	329	7	15	2	8	5	6	0	1					
SHEET 388								4	264	9159	188	2	4	0	3	3	0	0	1					
SHEET 389								10	124	9906	399	5	9	2	8	6	1	0	2					
TOTALS CARRIED TO GENERAL SUMMARY								120	2525	93656	2807	60	103	10	66	37	10	8	5					

UNDERDRAIN SUBSUMMARY								
<table style="width: 100%;"> <tr> <td>CALCULATED</td> <td>_____</td> </tr> <tr> <td>ACB</td> <td>_____</td> </tr> <tr> <td>CHECKED</td> <td>_____</td> </tr> <tr> <td>SDS</td> <td>_____</td> </tr> </table>	CALCULATED	_____	ACB	_____	CHECKED	_____	SDS	_____
CALCULATED	_____							
ACB	_____							
CHECKED	_____							
SDS	_____							
RIC - 30 - 9 . 26								
<table style="margin: 0 auto; border: 1px solid black; border-radius: 50%; padding: 5px;"> <tr> <td style="text-align: center;">390</td> </tr> <tr> <td style="text-align: center;">1669</td> </tr> </table>	390	1669						
390								
1669								

M:\15074\93455\Design\Drainage\Sheets\93455DC0012.dgn 3/26/2020 10:49:29 AM jjm278

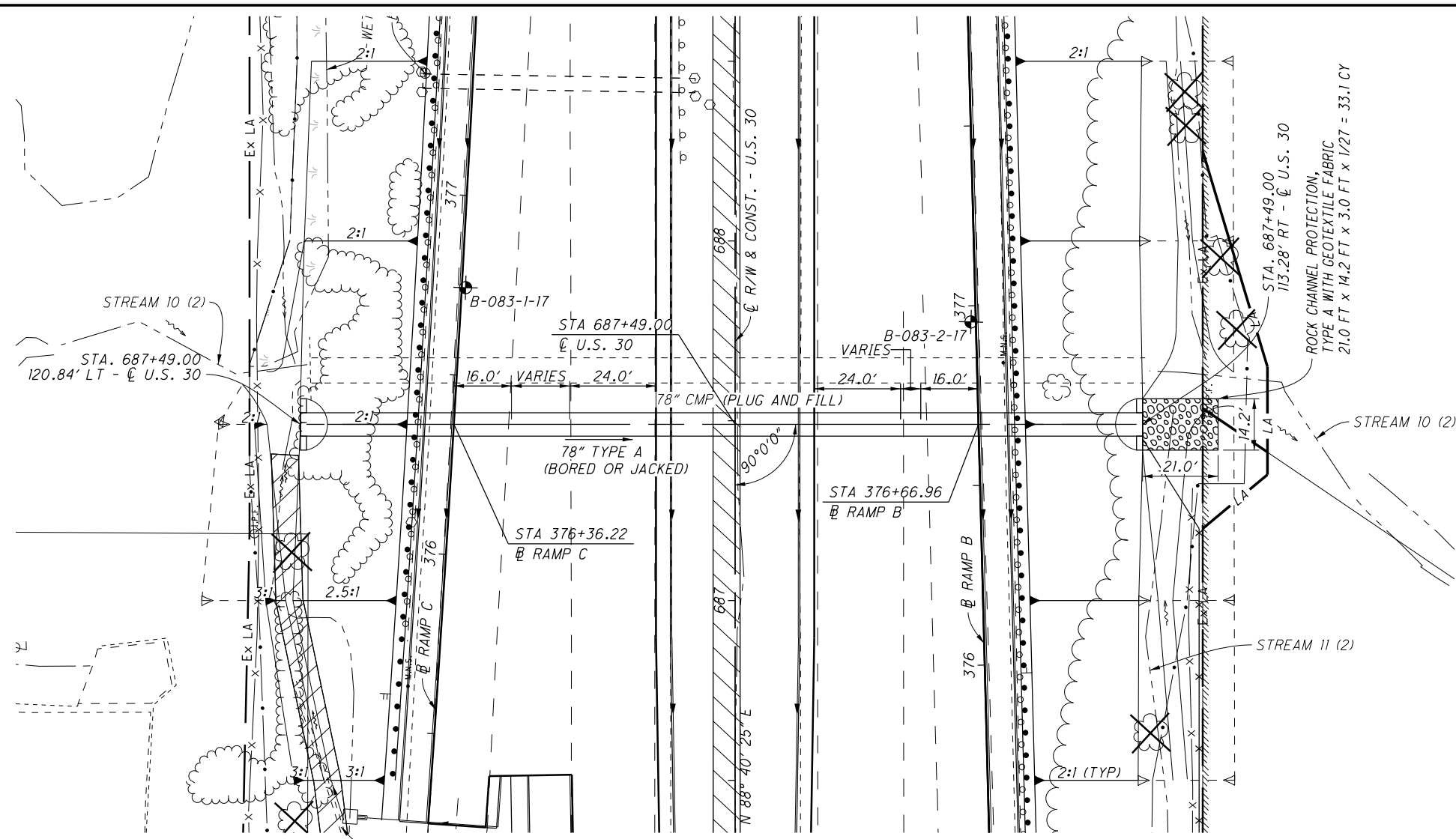

PLAN

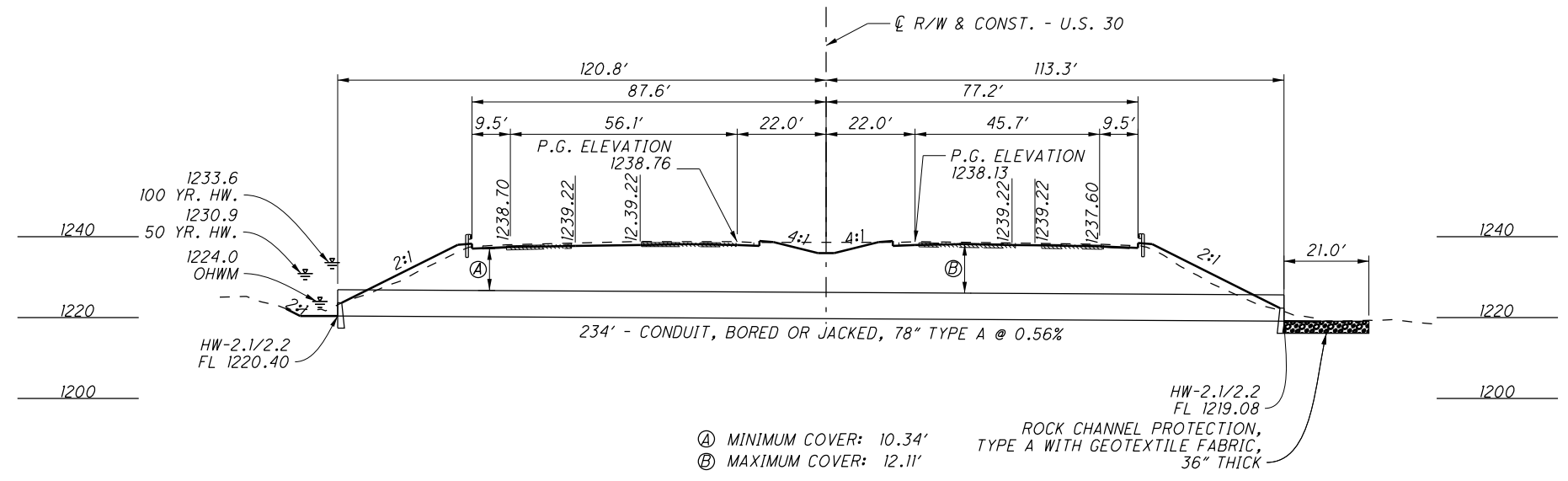

**PROFILE ALONG CULVERT
STA. 687+49**

LEGEND

- SEEDING AND EROSION PROTECTION WITH TURF REINFORCING MAT, TYPE 2
- PROJECT BORING LOCATION
- ROCK CHANNEL PROTECTION

HYDRAULIC DATA

DRAINAGE AREA = 499 ACRES
 Q (50) = 381 CFS V (50) = 13.5 FT/S
 Q (100) = 443 CFS V (100) = 15.7 FT/S
 DESIGN SERVICE LIFE: 75 YRS
 ph: 7.7
 ABRASION LEVEL 3

EXISTING STRUCTURE	
TYPE:	78" CMP
SKEW:	0° 43' 48"
ALIGNMENT:	TANGENT
DATE BUILT:	1956
CULVERT FILE NUMBER:	1874368
COORDINATES:	LATITUDE N40°46'45" LONGITUDE W82°29'29"

PROPOSED STRUCTURE	
TYPE:	CONDUIT, BORED OR JACKED, 78" TYPE A
ALIGNMENT:	TANGENT
CULVERT FILE NUMBER:	1981075
COORDINATES:	LATITUDE N40°46'45" LONGITUDE W82°29'29"

QUANTITIES CARRIED TO SHEETS 380-383.

ESTIMATED QUANTITIES			
ITEM	QUANTITY	UNIT	DESCRIPTION
601	33.1	CY	ROCK CHANNEL PROTECTION, TYPE A WITH GEOTEXTILE FABRIC
602	6.74	CY	CONCRETE MASONRY
611	234	FT	CONDUIT, BORED OR JACKED, 78", TYPE A

**CULVERT DETAIL - U.S. 30
STA 687+49**

RIC-30-9.26

950
1669

Z:\2014 pro\14-003-01 RIC-30 Lighting\CAD\Projects\CAD\Lighting\93455\lighting\93455\93455L001.dgn 27-MAR-2020 11:20AM JordanS

SHEET NUM.												PART.	ITEM	ITEM	GRAND	UNIT	DESCRIPTION	SEE
1151	1152	1153	1154	1155	1156	1157	1158	1159	1160	1161	1162	02/NHS/ PV	EXT	TOTAL		SHEET		
36	42	44	34	38	38	38	28	22	12			332	625	00450	332	EACH	CONNECTION, FUSED PULL APART	
9	6	3	6	3	6	9	6	3	6			57	625	00470	57	EACH	CONNECTION, UNFUSED BOLTED	
9	12	12	15	6	3	15	30	51	21			174	625	00480	174	EACH	CONNECTION, UNFUSED PERMANENT	
	8	1				1						10	625	10490	10	EACH	LIGHT POLE, CONVENTIONAL, DAVIT STYLE, DESIGN AT12B40	
4	4	2	8	3		1	7	8	2			39	625	10490	39	EACH	LIGHT POLE, CONVENTIONAL, DAVIT STYLE, DESIGN AT15B40	
	2					3	3	3	4			15	625	10490	15	EACH	LIGHT POLE, CONVENTIONAL, DAVIT STYLE, DESIGN AT18B40	
			7									7	625	10490	7	EACH	LIGHT POLE, CONVENTIONAL, DAVIT STYLE, DESIGN AT20B40	
10	7	19	2	16	11	6	4					75	625	10494	75	EACH	LIGHT POLE, LOW MAST, DESIGN ALM40	
4												4	625	10494	4	EACH	LIGHT POLE, LOW MAST, DESIGN ATLM40	
				4	4		4					12	625	10614	12	EACH	LIGHT POLE ANCHOR BOLTS ON STRUCTURE	
8	14	3	15	3		5	10	11	6			75	625	14100	75	EACH	LIGHT POLE FOUNDATION, 24" X 8' DEEP	
10	7	19	2	15	10	6	3					72	625	14300	72	EACH	MEDIAN LIGHT POLE FOUNDATION, 8' DEEP	
6,507	3,537	10,605	2,049	9,078	11,274	3,387	4,722	2,064	2,646			55,869	625	23200	55,869	FT	NO. 4 AWG 2400 VOLT DISTRIBUTION CABLE	
2,340	3,096	2,766	2,820	2,415	2,520	2,811	2,157	1,842	1,026			23,793	625	23400	23,793	FT	NO. 10 AWG POLE AND BRACKET CABLE	
1,510	2,034	317	1,896	470	187	2,363	1,344	2,700	1,246			14,067	625	24320	14,067	FT	1-1/2" DUCT CABLE WITH THREE NO. 4 AWG 2400 VOLT CABLES	
227	84	176	242	167	51	144	292	608	285			2,276	625	25500	2,276	FT	CONDUIT, 3", 725.04	
										1,734	199	1,933	625	25910	1,933	FT	CONDUIT CLEANED AND CABLES REMOVED	
4	14	3	15	3		13	10	11	6			79	625	26253	79	EACH	LUMINAIRE, CONVENTIONAL, SOLID STATE (LED), AS PER PLAN, 130W, TYPE III, 480V	
14	7	19	2	16	11	6	4					79	625	26273	79	EACH	LUMINAIRE, LOW MAST, SOLID STATE (LED), AS PER PLAN, 209W, TYPE V, 480V	
					8							8	625	26273	8	EACH	LUMINAIRE, LOW MAST, SOLID STATE (LED), AS PER PLAN, 319W, TYPE V, 480V	
									8			8	625	27503	8	EACH	LUMINAIRE, UNDERPASS, SOLID STATE (LED), AS PER PLAN, 39W, TYPE III, 480V	
1,632	1,869	453	1,988	592	228	2,357	1,521	3,143	1,466			15,249	625	29000	15,249	FT	TRENCH	
				2	2		3					7	625	29910	7	EACH	TRANSITION JUNCTION BOX	
2	1	1	2	1	2	2	2	1	2			16	625	29930	16	EACH	MEDIAN JUNCTION BOX	
3			3	2	1	1	2	5	1			18	625	30700	18	EACH	PULL BOX, 725.08, 18"	
	2	2	2			1	4	6	3			20	625	30706	20	EACH	PULL BOX, 725.08, 24"	
										3		3	625	31510	3	EACH	PULL BOX REMOVED	
18	21	22	17	18	11	11	13	11	6			148	625	32000	148	EACH	GROUND ROD	
				1	1		2					4	625	33000	4	EACH	STRUCTURE GROUNDING SYSTEM	
1				1	1	1		2				6	625	34001	6	EACH	POWER SERVICE, AS PER PLAN	
1,632	1,869	453	1,988	592	228	2,357	1,521	3,143	1,466			15,249	625	36000	15,249	FT	PLASTIC CAUTION TAPE	
									4			4	625	37100	4	EACH	SERVICE TO UNDERPASS LIGHTING	
										2	2	4	625	39520	4	EACH	PULL BOX CLEANED	
												LS	SPECIAL	62540000	LS		MAINTAIN EXISTING LIGHTING	
										8	13	21	625	75400	21	EACH	LIGHT POLE REMOVED	
										8	13	21	625	75500	21	EACH	LIGHT POLE FOUNDATION REMOVED	
										44	47	91	625	75506	91	EACH	LUMINAIRE REMOVED	
										1		1	625	75510	1	EACH	POWER SERVICE REMOVED	
										20	13	33	625	75801	33	EACH	DISCONNECT CIRCUIT, AS PER PLAN	
1				1	1	1		2				6	625	76000	6	EACH	ARC FLASH CALCULATIONS AND LABEL, FOR EACH POWER SERVICE	
												4	625	98000	4	EACH	LIGHTING, MISC.: SERVICE TO UNDERPASS LIGHTING, REMOVED	

LIGHTING GENERAL SUMMARY

RIC-30-9.26

1150
1669

CALCULATED
TRL
CHECKED
JCS

SEE
SHEET
NO.

SHEET NO.	SIDE	ROADWAY	STATION TO STATION	CIRCUIT NODES	625	625	625	625	625	625	625	625	625	625	625	625	625	625	625	625	625							
					CONNECTION, FUSED PULL APART	CONNECTION, UNFUSED PERMANENT	CONNECTION, UNFUSED BOLTED	LIGHT POLE, CONVENTIONAL, DAVIT STYLE, DESIGN AT12B40	LIGHT POLE, CONVENTIONAL, DAVIT STYLE, DESIGN AT15B40	LIGHT POLE, LOW MAST, DESIGN ALM40	LIGHT POLE FOUNDATION, 24" X 8' DEEP	MEDIAN LIGHT POLE FOUNDATION, 24" X 8' DEEP	NO. 4 AWG 2400 VOLT DISTRIBUTION CABLE	NO. 10 AWG POLE AND BRACKET CABLE	1-1/2" DUCT CABLE WITH THREE NO. 4 AWG 2400 VOLT CABLES	CONDUIT, 3", 725.04	LUMINAIRE, CONV., SOLID STATE (LED), APP, 130W, TYPE III, 480V	LUMINAIRE, LOW MAST, SOLID STATE (LED), APP, 209W, TYPE V, 480V	TRENCH	PULL BOX, 725.08, 24"	MEDIAN JUNCTION BOX	GROUND ROD	PLASTIC CAUTION TAPE					
				* = MATCH LINE	EACH	EACH	EACH	EACH	EACH	EACH	EACH	EACH	FT	FT	FT	FT	EACH	EACH	FT	EACH	EACH	EACH	FT					
1177	CL	U.S. 30	STA. 525+47.4 TO STA. 526+41.1	MJB-3 TO AB-16									312															
1177	CL	U.S. 30	STA. 526+41.1 TO STA. 528+17.5	AB-16 TO AB-17	2				1		1		120						1			1						
1177	CL	U.S. 30	STA. 528+17.5 TO STA. 529+95.5	AB-17 TO AB-18	2				1		1		120						1			1						
1177	CL	U.S. 30	STA. 529+95.5 TO STA. 531+74.1	AB-18 TO AB-19	2				1		1		120						1			1						
1177	CL	U.S. 30	STA. 531+74.1 TO STA. 533+51.4	AB-19 TO AB-20	2				1		1		120						1			1						
1177	CL	U.S. 30	STA. 533+51.4 TO STA. 535+29.3	AB-20 TO AB-21	2				1		1		120						1			1						
1177	CL	U.S. 30	STA. 535+29.3 TO STA. 537+00	AB-21 TO *	2				1		1		120						1			1						
1177	CL/RT	US 30 / RAMP C	STA. 525+47.4 TO STA. 20+33.1	MJB-3 TO PB-6									294			88			88					88				
1177	RT	RAMP C	STA. 20+33.1 TO STA. 20+85.0	PB-6			6												1									
1177	RT	RAMP C	STA. 20+85.0 TO STA. 20+33.1	* TO PB-6											59				54						54			
1177	RT	RAMP C	STA. 20+33.1 TO STA. 19+71.9	PB-6 TO AB-7										71				61								61		
1177	RT	RAMP C	STA. 19+71.9 TO STA. 537+00	AB-7	2			1			1		156				1					1						
1178	CL	U.S. 30	STA. 537+00 TO STA. 537+06.7	* TO AB-22									51															
1178	CL	U.S. 30	STA. 537+06.7 TO STA. 538+85.0	AB-22 TO AB-23	2				1		1		120						1			1						
1178	CL	U.S. 30	STA. 538+85.0 TO STA. 540+62.5	AB-23 TO AB-24	2				1		1		120						1			1						
1178	CL	U.S. 30	STA. 540+62.5 TO STA. 542+39.3	AB-24 TO AB-25	2				1		1		120						1			1						
1178	CL	U.S. 30	STA. 542+39.3 TO STA. 544+18.0	AB-25 TO AB-26	2				1		1		120						1			1						
1178	CL	U.S. 30	STA. 544+18.0 TO STA. 545+95.9	AB-26 TO AB-27	2				1		1		120						1			1						
1178	CL	U.S. 30	STA. 545+95.9 TO STA. 547+75.6	AB-27 TO AB-28	2				1		1		120						1			1						
1178	CL	U.S. 30	STA. 547+75.6 TO STA. 549+87.5	AB-28	2				1		1		120						1			1						
1179	CL	U.S. 30	STA. 549+87.5 TO STA. 551+77.9	BD-25	2				1		1		120						1			1						
1179	CL	U.S. 30	STA. 551+77.9 TO STA. 553+84.8	BD-25 TO BD-24	2				1		1		600						1			1						
1179	CL	U.S. 30	STA. 553+84.8 TO STA. 555+60.3	BD-24 TO BD-23	2				1		1		120						1			1						
1179	CL	U.S. 30	STA. 555+60.3 TO STA. 557+37.5	BD-23 TO BD-22	2				1		1		558						1			1						
1179	CL	U.S. 30	STA. 557+37.5 TO STA. 558+20.0	BD-22 TO BD-21	2				1		1		120						1			1						
1179	CL	U.S. 30	STA. 558+20.0 TO STA. 558+92.1	BD-21 TO MJB-4	2				1		1		120						1			1						
1179	CL	U.S. 30	STA. 558+92.1 TO STA. 559+00	MJB-4 TO BD-20	2				1		1		249						1			1						
1179	CL	U.S. 30	STA. 559+00 TO STA. 458+28.7	BD-20 TO *	2				1		1		39						1			1						
1179	CL/LT	US 30 / RAMP HL	STA. 458+28.7 TO STA. 457+33.7	MJB-4 TO PB-7									294			88			88					88				
1179	LT	RAMP HL	STA. 457+33.7 TO STA. 458+28.7	PB-7			6												1									
1179	LT	RAMP HL	STA. 458+28.7 TO STA. 457+33.7	PB-7 TO BD-9										103					93					93				
1179	LT	RAMP HL	STA. 457+33.7 TO STA. 458+28.7	BD-9	2				1		1		165					1				1						
1179	LT	RAMP HL	STA. 458+28.7 TO STA. 458+70.1	PB-7 TO BD-8										50					40					40				
1179	LT	RAMP HL	STA. 458+70.1 TO STA. 459+00	BD-8	2				1		1		165					1				1						
1179	LT	RAMP HL	STA. 459+00 TO STA. 458+28.7	BD-8 TO *										34					29					29				
TOTALS CARRIED TO LIGHTING GENERAL SUMMARY					44	12	3	1	2	19	3	19	10605	2766	317	176	3	19	453	2	1	22	453					

LIGHTING SUBSUMMARY

CALCULATED TRL CHECKED JCS

RIC - 30 - 9 . 26

1153
1669

Z:\2014 pro\14-003-01 RIC-30 Lighting\CAD\Projects\CAD\Lighting\93455\Lighting\93455_S003.dgn 27-MAR-2020 11:20AM Jordans

Z:\2014 pro\14-003-01 RIC-30 Lighting\CAD\Projects\CAD\Lighting\93455\lighting\93455\S010.dgn 27-MAR-2020 11:20AM Jordans

SHEET NO.	SIDE	ROADWAY	STATION TO STATION	CIRCUIT NODES	625	625	625	625	625	625	625	625	625	625	625	625	625	625	625	625	625	625	625								
					CONNECTION, FUSED PULL APART	CONNECTION, UNFUSED PERMANENT	CONNECTION, UNFUSED BOLTED	LIGHT POLE, CONVENTIONAL, DAVIT STYLE, DESIGN AT16B40	LIGHT POLE, CONVENTIONAL, DAVIT STYLE, DESIGN AT18B40	LIGHT POLE FOUNDATION, 24" X 8" DEEP	NO. 4 AWG 2400 VOLT DISTRIBUTION CABLE	NO. 10 AWG POLE AND BRACKET CABLE	1-1/2" DUCT CABLE WITH THREE NO. 4 AWG 2400 VOLT CABLES	CONDUIT, 3", 725.04	LUMINAIRE, CONV., SOLID STATE (LED), APP. 130W, TYPE III, 480V	LUMINAIRE, UNDERPASS, SOLID STATE (LED), APP. 39W, TYPE III, 480V	TRENCH	PULL BOX, 725.08, 18"	PULL BOX, 725.08, 24"	MEDIAN JUNCTION BOX	GROUND ROD	PLASTIC CAUTION TAPE	SERVICE TO UNDERPASS LIGHTING								
* = MATCH LINE					EACH	EACH	EACH	EACH	EACH	EACH	FT	FT	FT	FT	EACH	EACH	FT	EACH	EACH	EACH	EACH	FT	EACH								
1190	RT	U.S. 30	STA. 683.00 TO STA. 683+09.8	* TO FL-7										15			10					10									
1190	RT	U.S. 30	STA. 683+09.8	FL-7	2				1	1	174				1					1											
1190	RT	U.S. 30	STA. 683+09.8 TO STA. 683+51.0	FL-7 TO PB-35										51			41					41									
1190	RT	U.S. 30	STA. 683+51.0	PB-35			6												1												
1190	RT	U.S. 30	STA. 683+51.0 TO STA. 685+44.8	PB-35 TO FL-8										204			194					194									
1190	RT	U.S. 30	STA. 685+44.8	FL-8	2				1	1	174				1							1									
1190	RT	U.S. 30	STA. 683+51.0 TO STA. 683+50.1	PB-35 TO MJB-14							282						84					84									
1190	RT	U.S. 30	STA. 683+50.1	MJB-14																1											
1190	RT	U.S. 30	STA. 683+50.1 TO STA. 684+96.2	MJB-14 TO MJB-15							486																				
1190	RT	U.S. 30	STA. 684+96.2	MJB-15					3											1											
1190	RT/℄	U.S. 30	STA+684+96.2 TO STA. 685+71.6	MJB-15 TO PB-36							276						82					82									
1190	℄	U.S. 30	STA. 685+71.6	PB-36					3										1												
1190	℄/RT	U.S. 30/RAMP C	STA. 685+71.6 TO STA. 374+61.5	PB-36 TO PB-37							228						76					76									
1190	RT	RAMP C	STA. 374+61.5	PB-37					6											1											
1190	RT	RAMP C	STA. 374+61.5 STA. 374+36.3	PB-37 TO FL-9								36					26					26									
1190	RT	RAMP C	STA. 374+36.3	FL-9	2				1	1	174				1							1									
1190	RT/LT	RAMP C	STA.. 374+61.5 TO STA. 374+19.1	PB-37 TO PB-38							159						43					43									
1190	LT	RAMP C	STA. 374+19.1	PB-38					6												1										
1190	LT	RAMP C	STA. 374+19.1 TO STA. 374+00.0	PB-38 TO FL-10										70			60					60									
1190	LT	RAMP C	STA. 374+00.0	FL-10	2				1	1	174				1							1									
1190	LT	RAMP C	STA. 374+19.1 TO STA. 375+79.3	PB-38 TO FL-11										130			120					120									
1190	LT	RAMP C	STA. 375+79.3	FL-11	2				1	1	165				1						1										
1190	LT	RAMP C	STA. 375+79.3 TO STA. 383+10.7	FL-11 TO FL-12										740			730					730									
1190	LT	RAMP C	STA. 383+10.7	FL-12	2				1	1	165				1							1									
1190	RT	U.S. 30/S.R. 13	STA. 901+43.3 TO STA. 901+06.0	DG-1 TO EX.PB							141																				
1190	RT	S.R. 13	STA. 901+06.0	EX.PB																											
1190	RT	S.R. 13	STA. 901+06.0 TO STA. 900+30.8	EX.PB TO EX.PB							282																				
1191	RT	S.R. 13	STA. 900+30.8	EX PB																											
1191	RT	S.R. 13	STA. 900+30.8 TO STA. 900+20.0	EX-PB TO UP							63																				
1191	RT	S.R. 13	STA. 900+20.0	UNDERPASS																											
1191	RT	S.R. 13	STA. 900+30.8 TO STA. 900+40.2	EX-PB TO UP							60																				
1191	RT	S.R. 13	STA. 900+40.2	UNDERPASS																											
1191	RT/LT	S.R. 13	STA. 901+0.60 TO STA. 900+89.9	EX.PB TO EX.PB							297																				
1191	LT	S.R. 13	STA. 900+89.9 TO STA. 900+18.6	EX.PB TO EX.PB							252																				
1191	LT	S.R. 13	STA. 900+18.6	EX PB																											
1191	LT	S.R. 13	STA. 900+18.6 TO STA. 900+07.7	EX-PB TO UP							63																				
1191	LT	S.R. 13	STA. 900+07.7	UNDERPASS																											
1191	LT	S.R. 13	STA. 900+18.6 TO STA. 900+27.9	EX-PB TO UP							57																				
1191	LT	S.R. 13	STA. 900+27.9	UNDERPASS																											
TOTALS CARRIED TO LIGHTING GENERAL SUMMARY					12	21	6	2	4	6	2646	1026	1246	285	6	8	1466	1	3	2	6	1466	4								

CALCULATED TRL
 CHECKED JCS

LIGHTING SUBSUMMARY

RIC-30-9.26

1160
 1669

STANDARD DRAWINGS

REFER TO THE FOLLOWING STANDARD BRIDGE DRAWINGS:

AS-1-15	REVISED	7-17-15
AS-2-15	REVISED	1-18-19
GSD-1-19	DATED	1-18-19
PCB-91	REVISED	1-18-13
SBR-1-13	REVISED	7-20-18
SBR-2-13	REVISED	7-20-18
SICD-1-96	REVISED	7-18-14
SICD-2-14	DATED	7-18-14
VPF-1-90	REVISED	7-20-18

DESIGN SPECIFICATIONS

THIS STRUCTURE CONFORMS TO THE "LRFD BRIDGE DESIGN SPECIFICATIONS" ADOPTED BY THE AMERICAN ASSOCIATION OF STATE HIGHWAY AND TRANSPORTATION OFFICIALS, 2017, 8TH EDITION AND THE ODOT BRIDGE DESIGN MANUAL, 2019.

OPERATIONAL IMPORTANCE

A LOAD MODIFIER OF 1.0 HAS BEEN ASSUMED FOR THE DESIGN OF THIS STRUCTURE IN ACCORDANCE WITH THE AASHTO LRFD BRIDGE DESIGN SPECIFICATIONS, ARTICLE 1.3.5 AND THE ODOT BRIDGE DESIGN MANUAL, 2019.

DESIGN LOADING

HL-93
FUTURE WEARING SURFACE (FWS) OF 0.060 KIPS/FT².

DESIGN DATA

CONCRETE CLASS QC2 WITH QC/OA - COMPRESSIVE STRENGTH 4.5 KSI (SUPERSTRUCTURE)

CONCRETE CLASS QC1 WITH QC/OA - COMPRESSIVE STRENGTH 4.0 KSI (SUBSTRUCTURE)

REINFORCING STEEL - MINIMUM YIELD STRENGTH 60 KSI

STRUCTURAL STEEL - ASTM A709 GRADE 50 - YIELD STRENGTH 50 KSI

STEEL H-PILES - ASTM A572 - YIELD STRENGTH 50 KSI

DECK PROTECTION METHOD

EPOXY COATED REINFORCING STEEL
2 1/2" CONCRETE COVER

MONOLITHIC WEARING SURFACE

MONOLITHIC WEARING SURFACE IS ASSUMED, FOR DESIGN PURPOSES, TO BE 1 INCH THICK.

ITEM 202, PORTIONS OF STRUCTURE REMOVED, OVER 20 FOOT SPAN, AS PER PLAN:

THIS ITEM SHALL INCLUDE THE ELEMENTS INDICATED IN THE PLANS AND GENERAL NOTES AND THAT ARE NOT SEPARATELY LISTED FOR PAYMENT, EXCEPT FOR WEARING COURSE REMOVAL. ITEMS TO BE REMOVED INCLUDE ALL EXISTING MATERIALS BEING REPLACED BY NEW CONSTRUCTION AND MISCELLANEOUS ITEMS THAT ARE NOT SHOWN TO BE INCORPORATED INTO THE FINAL CONSTRUCTION AND ARE DIRECTED TO BE REMOVED BY THE ENGINEER. THE USE OF EXPLOSIVES, HEADACHE BALLS AND/OR HOE-RAMS WILL NOT BE PERMITTED. THE METHOD OF REMOVAL AND THE WEIGHT OF HAMMER SHALL BE APPROVED BY THE ENGINEER. PERFORM ALL WORK IN A MANNER THAT WILL NOT CUT, ELONGATE OR DAMAGE THE EXISTING REINFORCING STEEL TO BE PRESERVED. CHIPPING HAMMERS SHALL NOT BE HEAVIER THAN THE NOMINAL 90-POUND CLASS. PNEUMATIC HAMMERS SHALL NOT BE PLACED IN DIRECT CONTACT WITH REINFORCING STEEL THAT IS TO BE RETAINED IN THE REBUILT STRUCTURE. SUBMIT CONSTRUCTION PLANS ACCORDING TO C&MS 501.05

ITEM 203 EMBANKMENT, AS PER PLAN

PLACE AND COMPACT EMBANKMENT MATERIAL IN 6 INCH LIFTS FOR THE CONSTRUCTION OF THE APPROACH EMBANKMENT BETWEEN STATIONS 564+75 TO 570+75.

PILE DRIVING CONSTRAINTS

PRIOR TO DRIVING PILES, CONSTRUCT THE SPILL THROUGH SLOPES AND THE BRIDGE APPROACH EMBANKMENT BEHIND THE ABUTMENTS UP TO THE LEVEL OF THE SUBGRADE ELEVATION FOR A MINIMUM DISTANCE OF 200 FEET BEHIND EACH ABUTMENT. DO NOT BEGIN THE EXCAVATION FOR THE ABUTMENT FOOTINGS AND THE INSTALLATION OF THE ABUTMENT AND THE PIER PILES, UNTIL AFTER THE ABOVE REQUIRED EMBANKMENT HAS BEEN CONSTRUCTED.

ITEM 503, COFFERDAMS AND EXCAVATION BRACING, AS PER PLAN

THE DESIGN SHOWN ON THE PLANS FOR TEMPORARY SUPPORT OF EXCAVATION IS ONE REPRESENTATIVE DESIGN THAT MAY BE USED TO CONSTRUCT THE PROJECT. THE CONTRACTOR MAY CONSTRUCT THE DESIGN SHOWN ON THE PLANS OR PREPARE AN ALTERNATE DESIGN TO SUPPORT THE SIDES OF EXCAVATION. IF CONSTRUCTING AN ALTERNATE DESIGN FOR TEMPORARY SUPPORT OF EXCAVATION, PREPARE AND PROVIDE PLANS IN ACCORDANCE WITH C&MS 501.05. THE DEPARTMENT WILL PAY FOR THE TEMPORARY SUPPORT OF EXCAVATION AT THE CONTRACT LUMP SUM PRICE FOR COFFERDAMS AND EXCAVATION BRACING. NO ADDITIONAL PAYMENT WILL BE MADE FOR PROVIDING AN ALTERNATE DESIGN.

DECK PLACEMENT ASSUMPTIONS

THE FOLLOWING ASSUMPTIONS OF CONSTRUCTION MEANS AND METHODS WERE MADE FOR THE ANALYSIS AND DESIGN OF THE SUPERSTRUCTURE. THE CONTRACTOR IS RESPONSIBLE FOR THE DESIGN OF THE FALSEWORK SUPPORT SYSTEM WITHIN THESE PARAMETERS AND WILL ASSUME RESPONSIBILITY FOR SUPERSTRUCTURE ANALYSIS FOR DEVIATION FROM THESE DESIGN ASSUMPTIONS.

AN EIGHT WHEEL FINISHING MACHINE WITH A MAXIMUM WHEEL LOAD OF 2.42 KIPS.

A MINIMUM OUT-TO-OUT WHEEL SPACING AT EACH END OF THE MACHINE OF 103".

A MAXIMUM SPACING OF OVERHANG FALSEWORK BRACKETS OF 48".

A MAXIMUM DISTANCE FROM THE CENTERLINE OF THE FASCIA GIRDER TO THE FACE OF THE SAFETY HANDRAIL OF 65".

PILES TO BEDROCK

DRIVE PILES TO REFUSAL ON BEDROCK. THE DEPARTMENT WILL CONSIDER REFUSAL TO BE OBTAINED WHEN THE PILE PENETRATION IS AN INCH OR LESS AFTER RECEIVING AT LEAST 20 BLOWS FROM THE PILE HAMMER. SELECT THE HAMMER SIZE TO ACHIEVE THE REQUIRED DEPTH TO BEDROCK AND REFUSAL.

THE TOTAL FACTORED LOAD IS 125 KIPS PER PILE FOR THE ABUTMENT PILES. THE TOTAL FACTORED LOAD IS 262 KIPS PER PILE FOR THE PIER NO. 1 PILES.

ABUTMENT PILES: (HP 10X42)
70 PILES 45 FEET LONG, ORDER LENGTH

PIER NO. 1 PILES (HP 10X42)
36 PILES 35 FEET LONG, ORDER LENGTH

PIER NO. 2 PILES (HP 10X42)
36 PILES 20 FEET LONG, ORDER LENGTH

STRUCTURE PAINTING: ALL BRIDGE FINISH COATS SHALL BE THE SAME COLOR.

INSTALLATION OF MULTI-CELL CONDUIT ON STRUCTURES
ONE MULTI-CELL CONDUIT IS CONTINUOUS FOR THE ENTIRE PROJECT. THE SECOND MULTI-CELL CONDUIT SHALL BE PLACED ONLY WITHIN THE LIMITS OF THE BRIDGES AND APPROACH SLABS AND SHALL TERMINATE AT A JUNCTION BOX AS SHOWN IN STANDARD DRAWING HL-30.33.

ABBREVIATIONS

- ABUT. - ABUTMENT
- APPR. - APPROACH
- BRG. - BEARING
- BOT. - BOTTOM
- CONST. JT. - CONSTRUCTION JOINT
- CLR. - CLEAR
- CONST. - CONSTRUCTION
- CORR. - CORRUGATED
- DIA. - DIAMETER
- DIM. - DIMENSION
- DWG. - DRAWING
- EL. - ELEVATION
- E.F. - EACH FACE
- EXIST. - EXISTING
- F.A. - FORWARD ABUTMENT
- FWD. - FORWARD
- F.F. - FRONT FACE
- FT. - FEET
- LBS. - POUNDS
- MAX. - MAXIMUM
- MEAS. - MEASURED
- MIN. - MINIMUM
- OPT. - OPTIONAL
- P.E.J.F. - PREFORMED EXPANSION JOINT FILLER
- R.A. - REAR ABUTMENT
- R.F. - REAR FACE
- REQ'D. - REQUIRED
- SPA. - SPACING
- STA. - STATION
- T.O.S. - TOP OF SLOPE
- TYP. - TYPICAL
- U.O.N. - UNLESS OTHERWISE NOTED
- VAR. - VARIES
- W/ - WITH

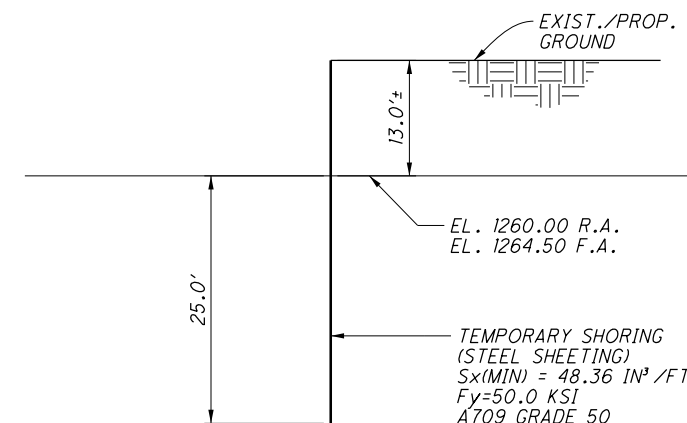

**SECTION A-A
TEMPORARY SHORING DETAIL**
NOTE: SEE SHEET [2/66] FOR LOCATION.

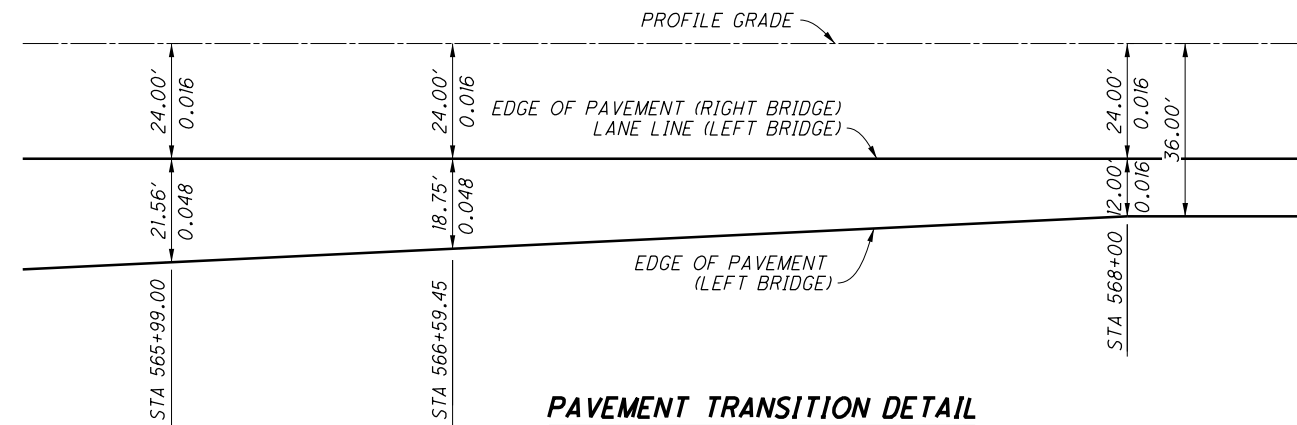

PAVEMENT TRANSITION DETAIL

M:\15074\93455\Design\Structures\RIC030_1074C\Sheets\030_1074CSN001.dgn 3/26/2020 8:34:01 PM toc230

DESIGN AGENCY
ENGINEERING ASSOCIATES, INC.
835 EAGLE PASS - WOOSTER, OHIO 44691
TELEPHONE: (330) 345-6556
FAX: (330) 345-8077



DATE 9-24-19
REVIEWED SDS
STRUCTURE FILE NUMBER 7001119

DRAWN TAC
CHECKED BDH

GENERAL NOTES
BRIDGE NO. RIC-30-1074
OVER S.R. 39

RIC-30-9-26
PID No. 93455

3 / 66

1206
1669

CALC: TAC DATE: 5/7/2019
 CHECKED: RLE DATE: 5/21/2019

ESTIMATED QUANTITIES

ITEM	EXTENSION	TOTAL 01/NHS/BR	UNIT	DESCRIPTION	ABUT.	PIERS	SUPER.	GEN.	SEE	SHEET
202	11203	LS		PORTIONS OF STRUCTURE REMOVED, OVER 20 FOOT SPAN, AS PER PLAN				LS		3 / 66
202	22900	311	SY	APPROACH SLAB REMOVED				311		
202	23500	311	SY	WEARING COURSE REMOVED				311		
202	98200	124	FT	REMOVAL MISC.:STEEL PILE (HPI2x53)	54	70				17 / 66 & 18 / 66
503	11101	LS		COFFERDAMS AND EXCAVATION BRACING, AS PER PLAN				LS		3 / 66
503	21100	1174	CY	UNCLASSIFIED EXCAVATION	747	427				
505	11100	LS		PILE DRIVING EQUIPMENT MOBILIZATION				LS		
507	00101	5130	FT	STEEL PILES HPI0X42, FURNISHED, AS PER PLAN	3150	1980				17 / 66 & 18 / 66
507	00151	4420	FT	STEEL PILES HPI0X42, DRIVEN, AS PER PLAN	2800	1620				17 / 66 & 18 / 66
507	93300	142	EACH	STEEL POINTS OR SHOES				142		
509	10000	304979	LB	EPOXY COATED REINFORCING STEEL	38719	67518	198742			
511	21523	878	CY	CLASS QC2 CONCRETE WITH QC/QA, SUPERSTRUCTURE, AS PER PLAN			878			35 / 66 & 44 / 66
511	33500	4	EACH	SEMI-INTEGRAL DIAPHRAGM GUIDE			4			
511	41012	206	CY	CLASS QC1 CONCRETE WITH QC/QA, PIER ABOVE FOOTINGS		206				
511	44112	178	CY	CLASS QC1 CONCRETE WITH QC/QA, ABUTMENT NOT INCLUDING FOOTING	178					
511	46512	360	CY	CLASS QC1 CONCRETE WITH QC/QA, FOOTING	232	128				
512	10100	1590	SY	SEALING OF CONCRETE SURFACES (EPOXY-URETHANE)	93	606	804	87		
512	10300	408	SY	SEALING CONCRETE BRIDGE DECKS WITH HMMW RESIN			368	40		
512	33000	27	SY	TYPE 2 WATERPROOFING	27					
513	10260	603922	LB	STRUCTURAL STEEL MEMBERS, LEVEL 3			603922			
513	20000	11466	EACH	WELDED STUD SHEAR CONNECTORS			11466			
514	00800	603922	LB	FIELD PAINTING STRUCTURAL STEEL, INTERMEDIATE COAT			603922			
514	00851	603922	LB	FIELD PAINTING STRUCTURAL STEEL, FINISH COAT, AS PER PLAN			603922			3 / 66
514	10000	29	EACH	FINAL INSPECTION REPAIR			29			
516	10010	264	FT	ARMORLESS PREFORMED JOINT SEAL				264		
516	13600	32	SF	1" PREFORMED EXPANSION JOINT FILLER			32			
516	13900	624	SF	2" PREFORMED EXPANSION JOINT FILLER			181	443		
516	14020	333	FT	SEMI-INTEGRAL ABUTMENT EXPANSION JOINT SEAL	333					
516	44101	26	EACH	ELASTOMERIC BEARING WITH INTERNAL LAMINATES AND LOAD PLATE (NEOPRENE), AS PER PLAN 2 13/16"x1'-2 1/2"x1'-5" W/ † x1'-3 1/2"x1'-6" BEVELED LOAD PLATE		26				31 / 66
516	44101	26	EACH	ELASTOMERIC BEARING WITH INTERNAL LAMINATES AND LOAD PLATE (NEOPRENE), AS PER PLAN 2 15/16"x1'-0"x1'-1" W/ 1 5/8"x1'-1"x1'-2" BEVELED LOAD PLATE	26					31 / 66
518	21200	185	CY	POROUS BACKFILL WITH GEOTEXTILE FABRIC	185					
518	40000	348	FT	6" PERFORATED CORRUGATED PLASTIC PIPE	348					
518	40010	62	FT	6" NON-PERFORATED CORRUGATED PLASTIC PIPE, INCLUDING SPECIALS	62					
526	25001	666	SY	REINFORCED CONCRETE APPROACH SLABS (T=15"), AS PER PLAN				666		48 / 66 THRU 53 / 66
526	90030	274	FT	TYPE C INSTALLATION				274		
601	21000	1501	SY	CONCRETE SLOPE PROTECTION				1501		
607	39900	354	FT	VANDAL PROTECTION FENCE, 6' STRAIGHT, COATED FABRIC			354			

DESIGN AGENCY
ENGINEERING ASSOCIATES, INC.
 895 EAGLE PASS - WOOSTER, OHIO 44691
 TELEPHONE: (330) 345-6656
 FAX: (330) 345-8077

DATE
 9-24-19
 STRUCTURE FILE NUMBER
 700119

REVIEWED
 SDS
 DRAWN
 TAC
 CHECKED
 BDH

ESTIMATED QUANTITIES
 BRIDGE NO. RIC-30-1074
 OVER S.R. 39

RIC-30-9-26
 PID No. 93455

4 / 66

1207
 1669

M:\15074\93455\Design\Structures\RIC030_1074C\Sheets\030_1074CS0001.dgn 3/27/2020 12:39:27 PM kjo282

M:\15074\93455\Design\Structures\RIC030_1074C\Sheets\030_1074CST001.dgn 3/27/2020 9:38:20 AM toc230

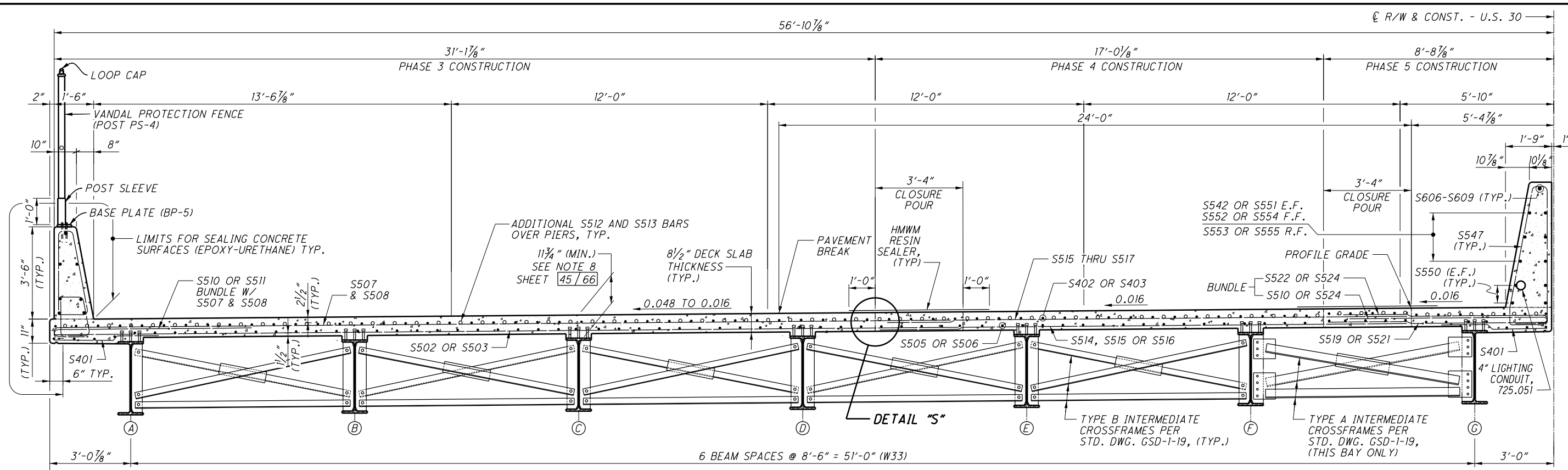

TRANSVERSE SECTION

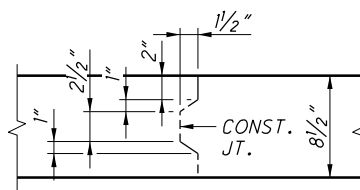
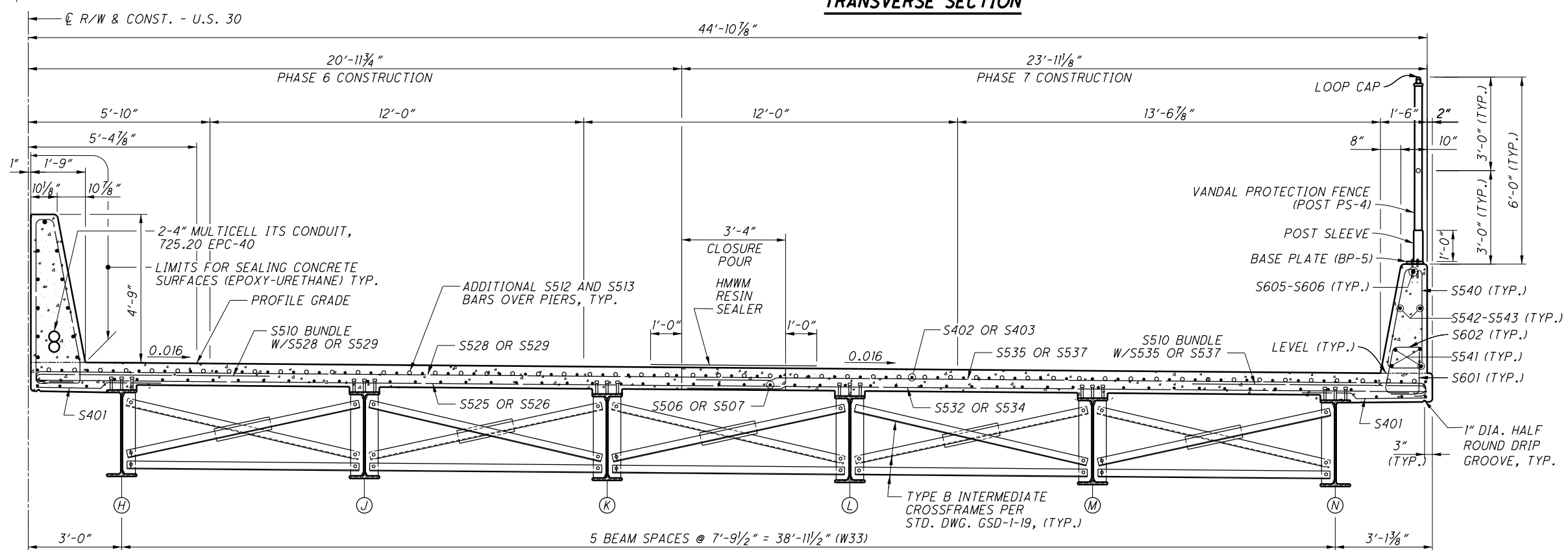

**CONST. JOINT DETAIL
DETAIL "S" (TYPICAL)**

TRANSVERSE SECTION

- NOTES**
- FOR ABBREVIATIONS SEE SHEET 3/66.
 - FOR SLAB PLAN SEE SHEET 45/66 AND 46/66.
 - FOR SCREED ELEVATIONS SEE SHEET 41/66.
 - FOR BARRIER MEDIAN AND RAILING DETAILS SEE SHEETS 47/66 THRU 50/66.
 - MINIMUM BAR LAPS:
NO. 4 BAR = 1'-11"
NO. 5 BARS = 2'-5"
NO. 5 BARS = 3'-0" S502, S504, S514, S516, S519, S525, S527, S532 & S533
NO. 6 BAR = 3'-7"
 - 4" LIGHTING CONDUIT, 725.051, AND 4" MULTICELL ITS CONDUIT, 725.20 EPC-40, AND JUNCTION BOXES WHERE REQUIRED SHALL BE PLACED IN THE MEDIAN BARRIER AS SHOWN IN THE PLANS. THE COST OF PLACEMENT, MATERIALS, EQUIPMENT AND LABOR SHALL BE CONSIDERED INCIDENTAL AND INCLUDED FOR PAYMENT IN ITEM 511.
- THE CLOSURE POUR SHALL BE SEALED WITH HIGH MOLECULAR WEIGHT METHACRYLATE (HMWM) RESIN IN ACCORDANCE OF ITEM 512. THE RESIN SHALL COVER THE ENTIRE CLOSURE POUR SECTION AND OVERLAP EACH CONSTRUCTION JOINT 1'-0".

DESIGN AGENCY: ENGINEERING ASSOCIATES, INC.
 895 EAGLE PASS - WOOSTER, OHIO 44691
 TELEPHONE: (330) 345-6556
 FAX: (330) 345-9077

DATE: 9-24-19
 SDS: 9-24-19
 STRUCTURE FILE NUMBER: 700119

DRAWN: RLE
 CHECKED: BDH

DESIGNED: HK

TRANSVERSE SECTION
 BRIDGE NO. RIC-30-1074
 OVER S.R. 39

RIC-30-9.26
 PID No. 93455

44/66
 1247
 1669

M:\15074\93455\Design\Structures\RIC030_1074C\Sheets\030_1074CSA004.dgn 3/27/2020 11:01:42 AM toc230

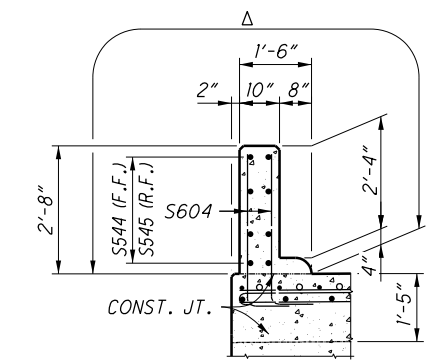

SECTION EE-EE

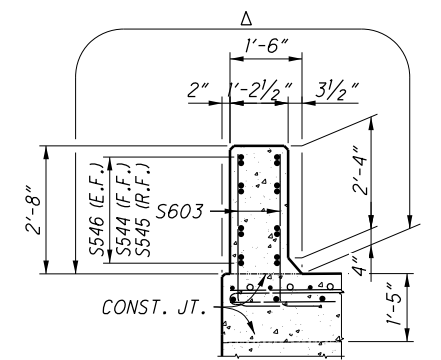

SECTION FF-FF

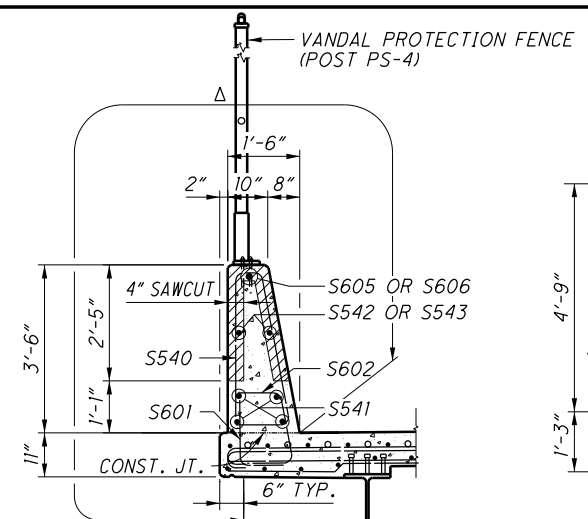

SECTION GG-GG

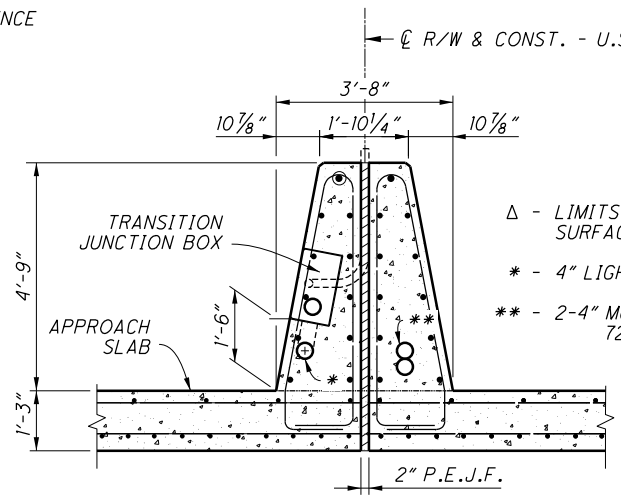

SECTION AF-AF

- LEGEND**
- Δ - LIMITS FOR SEALING CONCRETE SURFACES (EPOXY-URETHANE) TYP.
 - * - 4" LIGHTING CONDUIT, 725.051
 - ** - 2-4" MULTICELL ITS CONDUIT, 725.20 EPC-40

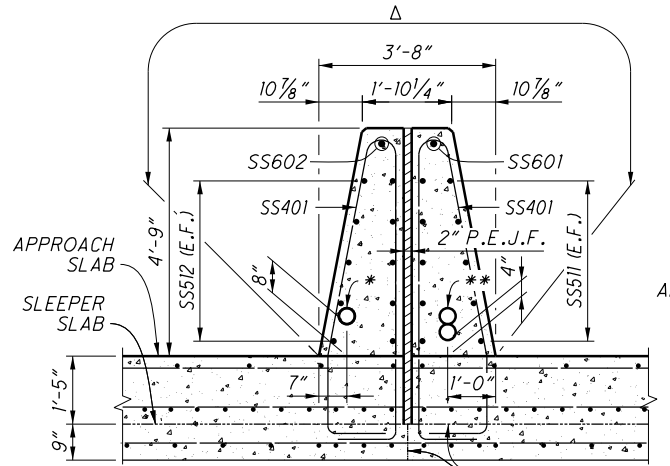

SECTION HH-HH

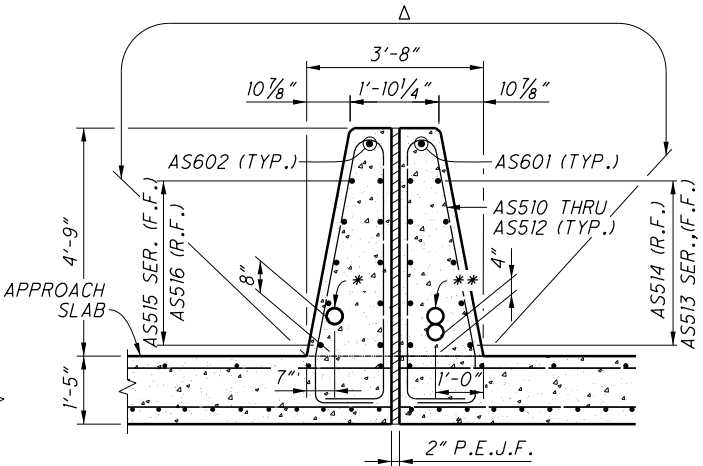

SECTION JJ-JJ

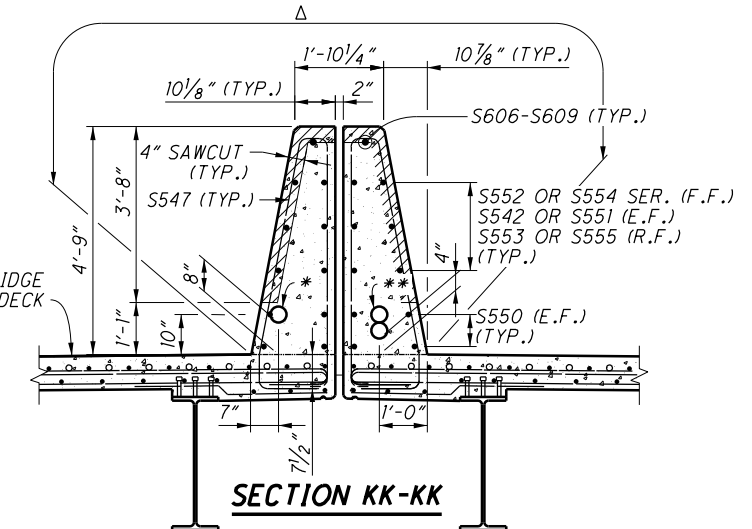

SECTION KK-KK

- NOTES**
1. FOR ABBREVIATIONS SEE SHEET 3/66.
 2. FOR LOCATIONS OF SECTIONS EE-EE, FF-FF & GG-GG SEE SHEET 47/66.
 3. FOR LOCATIONS OF SECTIONS HH-HH, JJ-JJ, KK-KK, AF-AF & DETAILS "B" & "C" SEE SHEETS 48/66 & 49/66.
 4. FOR DETAILS NOT SHOWN SEE STANDARD DRAWING SBR-1-13 AND SBR-2-13.
 5. 4" LIGHTING CONDUIT, 725.051, AND 4" MULTICELL ITS CONDUIT, 725.20 EPC-40, AND JUNCTION BOXES WHERE REQUIRED SHALL BE PLACED IN THE MEDIAN BARRIER AS SHOWN IN THE PLANS. THE COST OF PLACEMENT, MATERIALS, EQUIPMENT AND LABOR SHALL BE CONSIDERED INCIDENTAL AND INCLUDED FOR PAYMENT IN ITEM 526 REINFORCED CONCRETE APPROACH SLABS, AS PER PLAN.

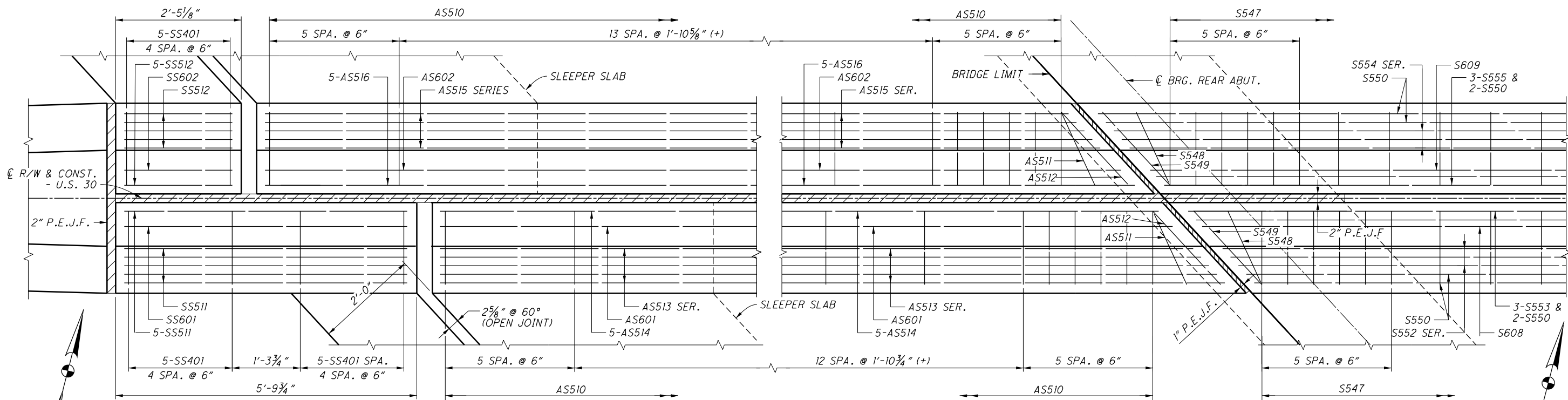

SLEEPER SLAB

DETAIL "B" APPROACH SLAB

APPROACH SLAB

DETAIL "C"

BRIDGE

(MEDIAN RAILING AT SLEEPER SLAB)
REAR APPROACH SHOWN-FORWARD SIMILAR BY ROTATION

(MEDIAN RAILING AT ABUTMENT)
REAR ABUTMENT SHOWN-FORWARD SIMILAR BY ROTATION

DESIGN AGENCY: ENGINEERING ASSOCIATES, INC.
 895 EAGLE PASS - WOOSTER, OHIO 44691
 TELEPHONE: (330) 345-6556
 FAX: (330) 345-8077

DATE: 9-24-19
 SDS: 9-24-19
 STRUCTURE FILE NUMBER: 700119

DESIGNED: HK
 CHECKED: BDH

BRIDGE RAILING DETAILS
 BRIDGE NO. RIC-30-1074
 OVER S.R. 39

RIC-30-9-26
 PID No. 93455

50/66
 1253
 1669

M:\15074\93455\Design\Structures\RIC030_1074C\Sheets\030_1074CSA005.dgn 3/27/2020 11:15:37 AM toc230

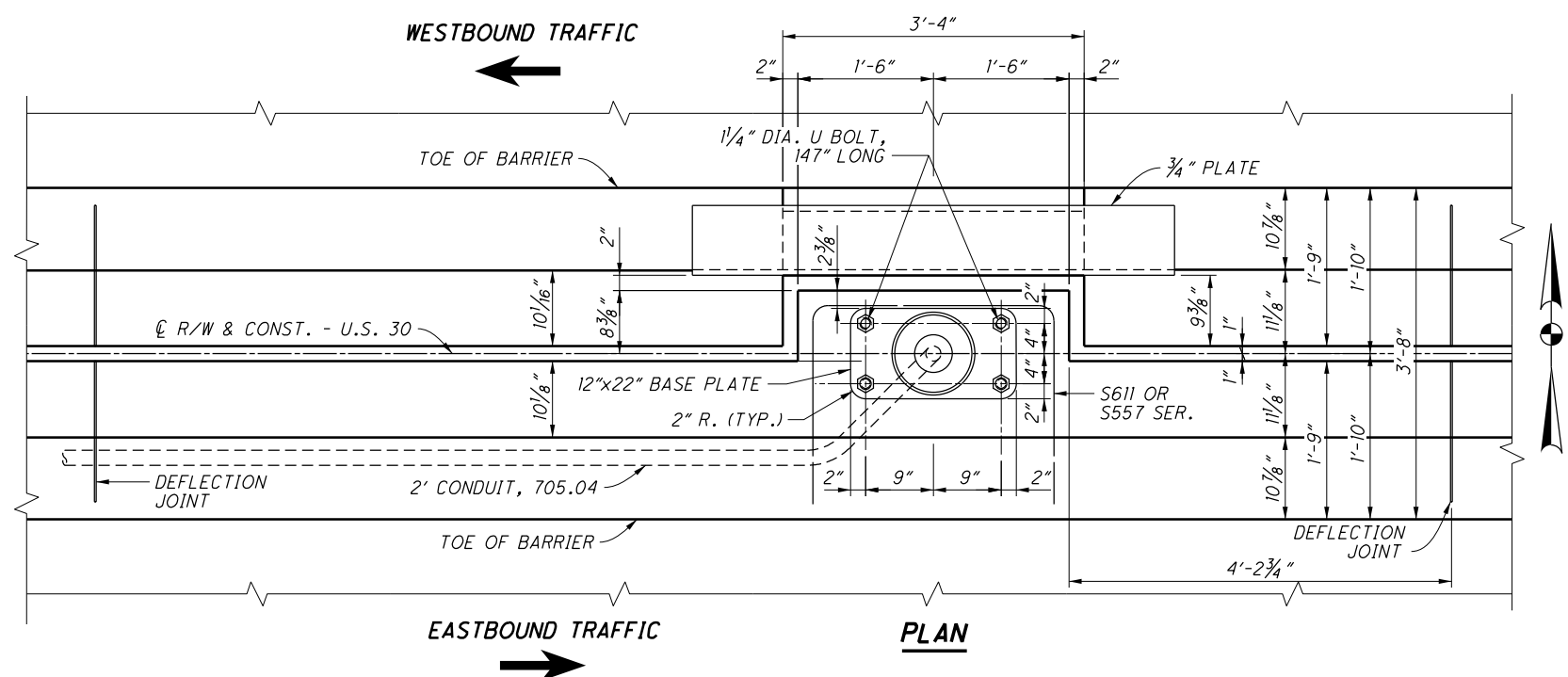

PLAN

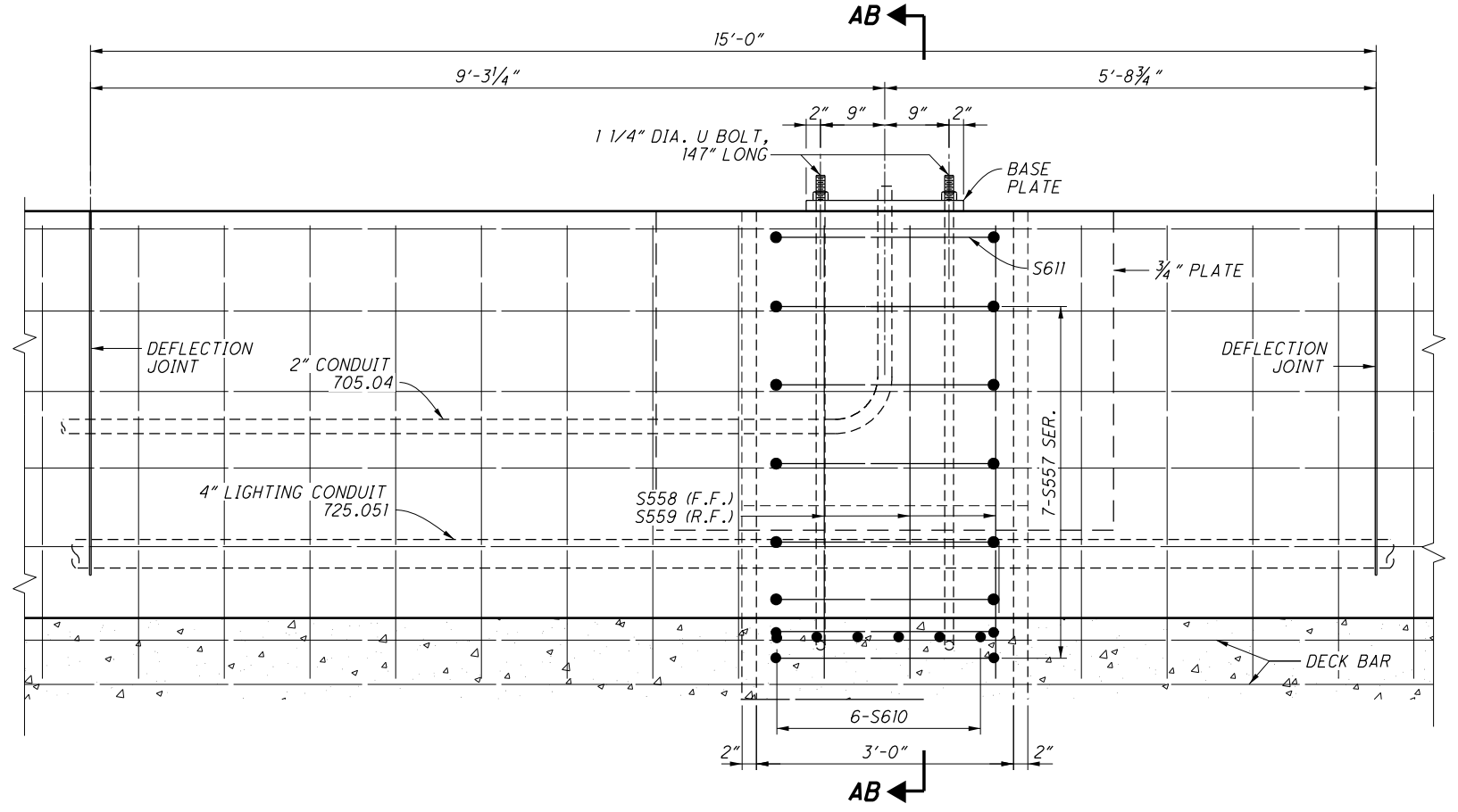

ELEVATION

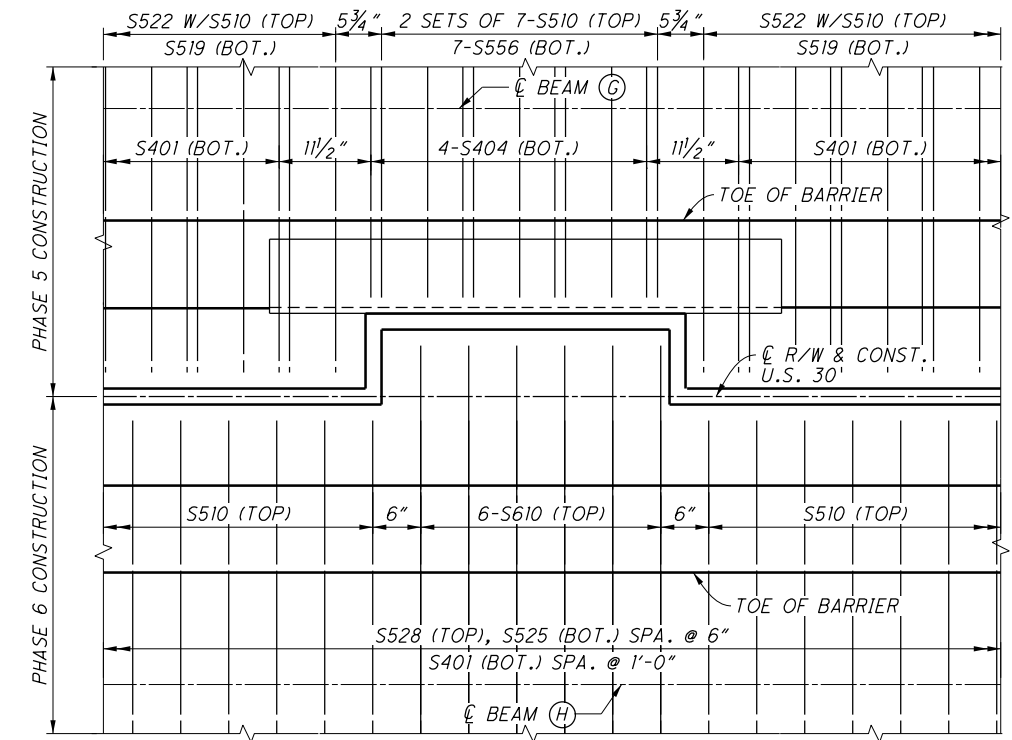

SLAB REINFORCING PLAN

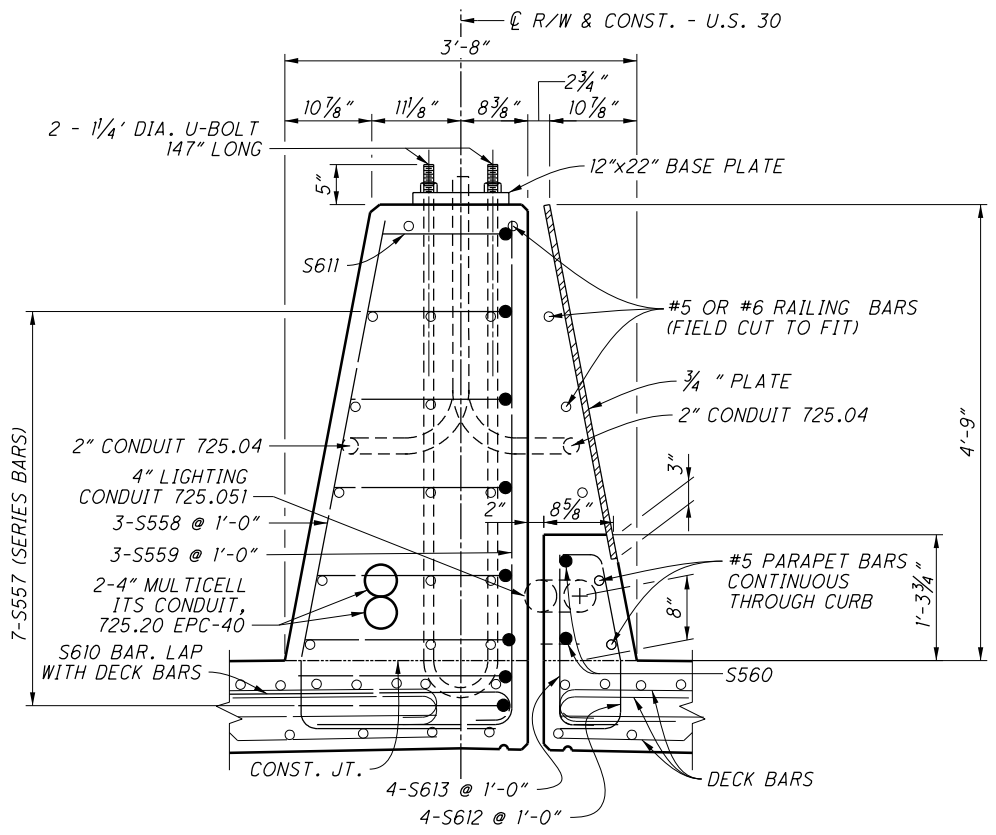

SECTION AB-AB

NOTES

1. MATERIALS: STEEL PLATES SHALL BE ASTM A709, GR. 50. PLATES SHALL BE METALIZED OR GALVANIZED PER 516.03.
2. PAYMENT FOR THE MATERIAL AND INSTALLATION OF MEDIAN BARRIER PLATES AND FASTENERS SHALL BE INCLUDED AS INCIDENTAL TO ITEM 511 - CLASS OC2 CONCRETE WITH OC/OA, SUPERSTRUCTURE, AS PER PLAN.
3. FOR LIGHT SUPPORT LOCATION SEE SHEET 1180
1669.

MEDIAN BARRIER AT LIGHT SUPPORT STA. 567+98.50
BRIDGE NO. RIC-30-1074
OVER S.R. 39

DESIGNED	HK	CHECKED	BDH
DRAWN	TAC	REVISED	---
REVIEWED	SDS	STRUCTURE FILE NUMBER	700119
DATE	9-24-19	DESIGN AGENCY	ENGINEERING ASSOCIATES, INC. 895 EAGLE PASS - WOOSTER, OHIO 44691 TELEPHONE: (330) 345-6556 FAX: (330) 345-8077

RIC-30-9.26
PID No. 93455

50A/66

1253A
1669

M:\15074\93455\Design\Structures\RIC030_1074C\Sheets\030_1074CSA006.dgn 3/26/2020 8:24:46 PM tac230

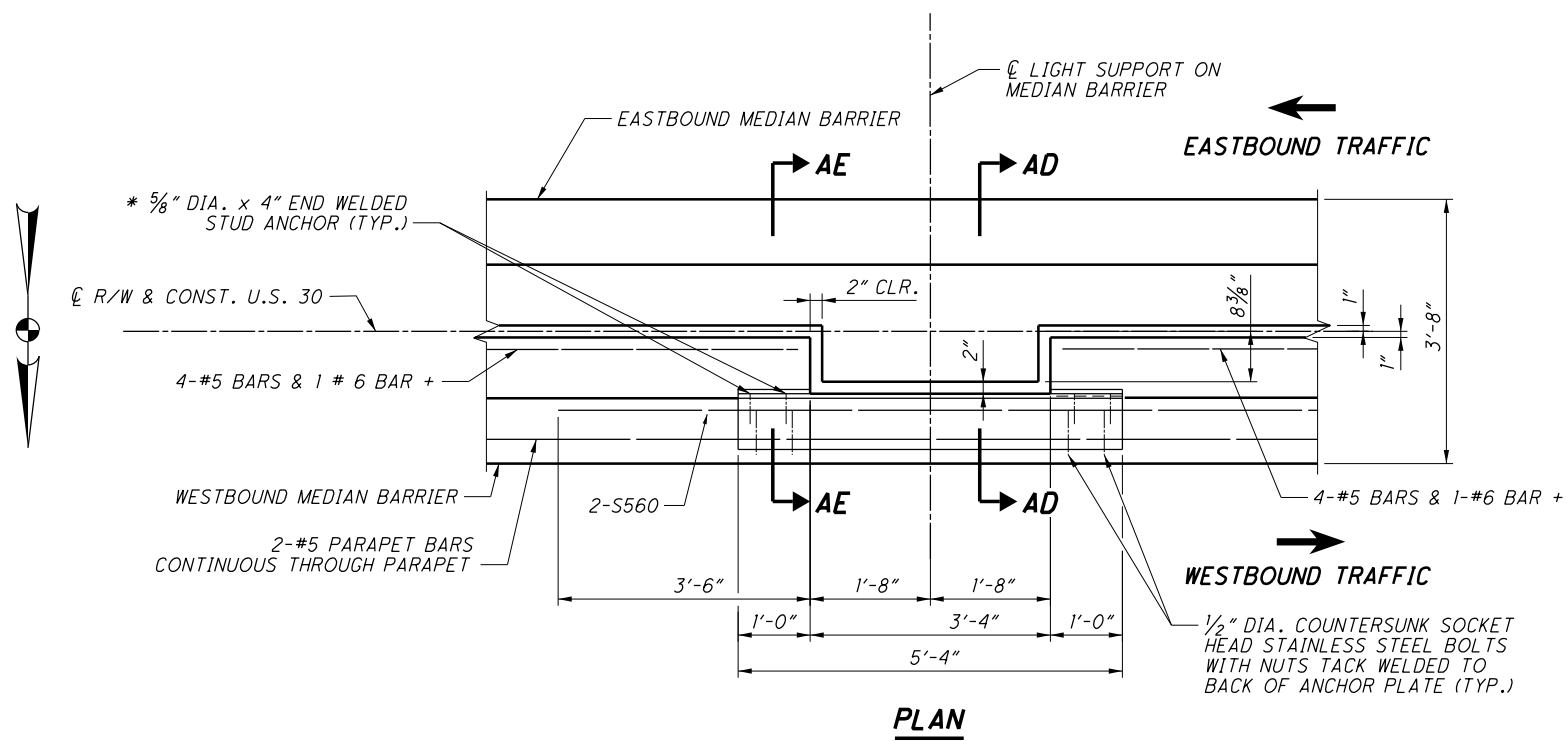

PLAN

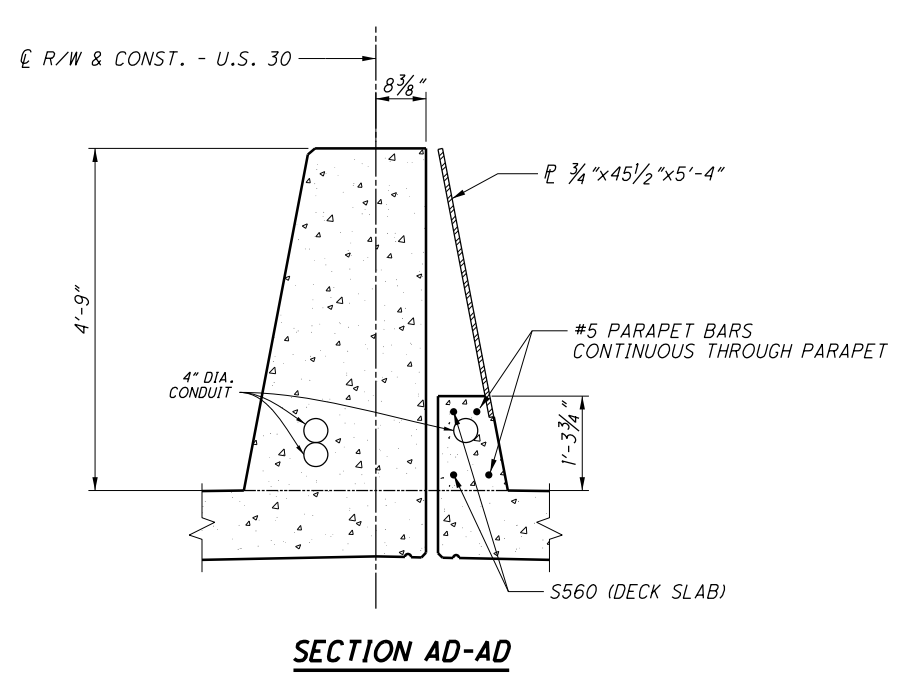

SECTION AD-AD

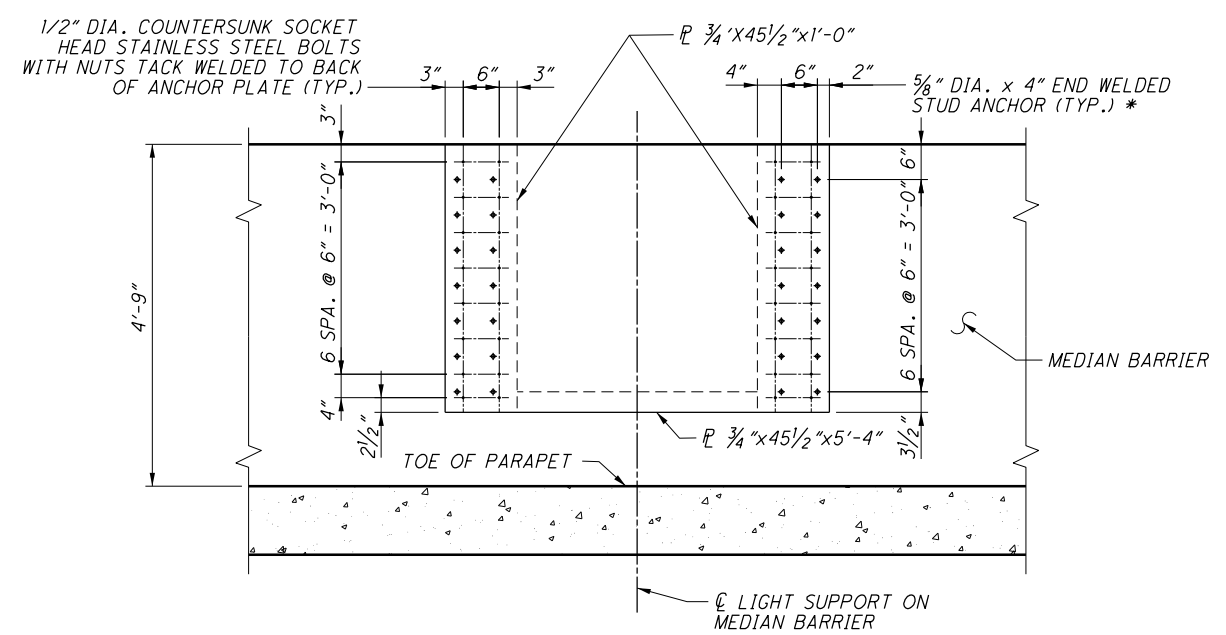

ELEVATION

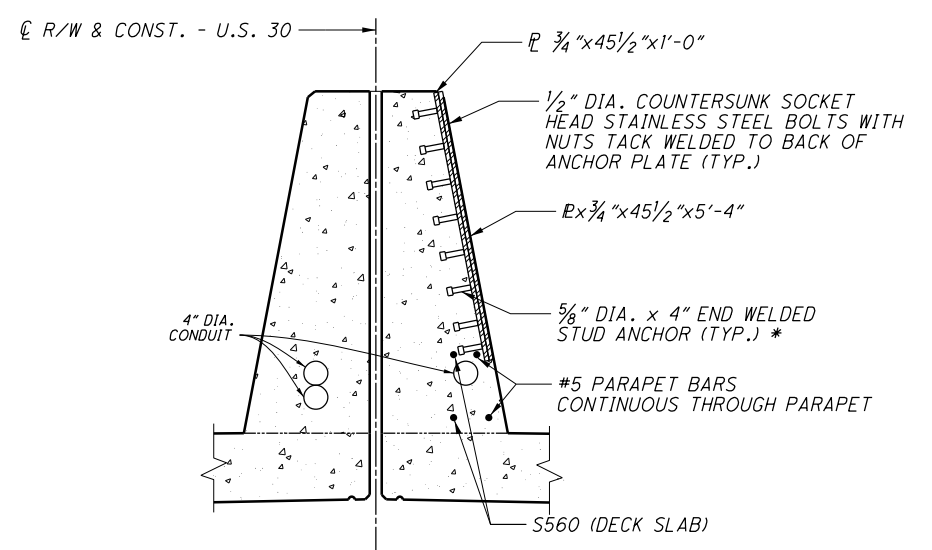

SECTION AE-AE

PLATE AT LIGHT SUPPORT

LEGEND

- * - WELDED WITH AUTOMATICALLY TIMED STUD WELDING EQUIPMENT OR 5/16" MINIMUM FILLET WELD ALL AROUND
- + - FIELD CUT OR ADJUST LAP TO FIT GAP

NOTES

1. ADDITIONAL NOTES SEE SHEETS 504/66 .

<p>RIC-30-9.26 PID No. 93455</p>	<p>MEDIAN BARRIER AT LIGHT SUPPORT DETAILS BRIDGE NO. RIC-30-1074 OVER S.R. 39</p>	<p>DESIGNED: HK CHECKED: BDH</p>	<p>DRAWN: RLE RLE</p>	<p>REVIEWED: SDS SDS</p>	<p>DATE: 9-24-19 9-24-19</p>	<p>STRUCTURE FILE NUMBER: 700119 FILE NUMBER: 700119</p>	<p>DESIGN AGENCY: ENGINEERING ASSOCIATES, INC. 895 EAGLE PASS - WOOSTER, OHIO 44691 TELEPHONE: (330) 345-6556 FAX: (330) 345-8077</p>
---	---	--------------------------------------	---------------------------	------------------------------	----------------------------------	--	--

M:\15074\93455\Design\Structures\RIC030_1074C\Sheets\030_1074CSD005.dgn 3/26/2020 8:27:58 PM tac230

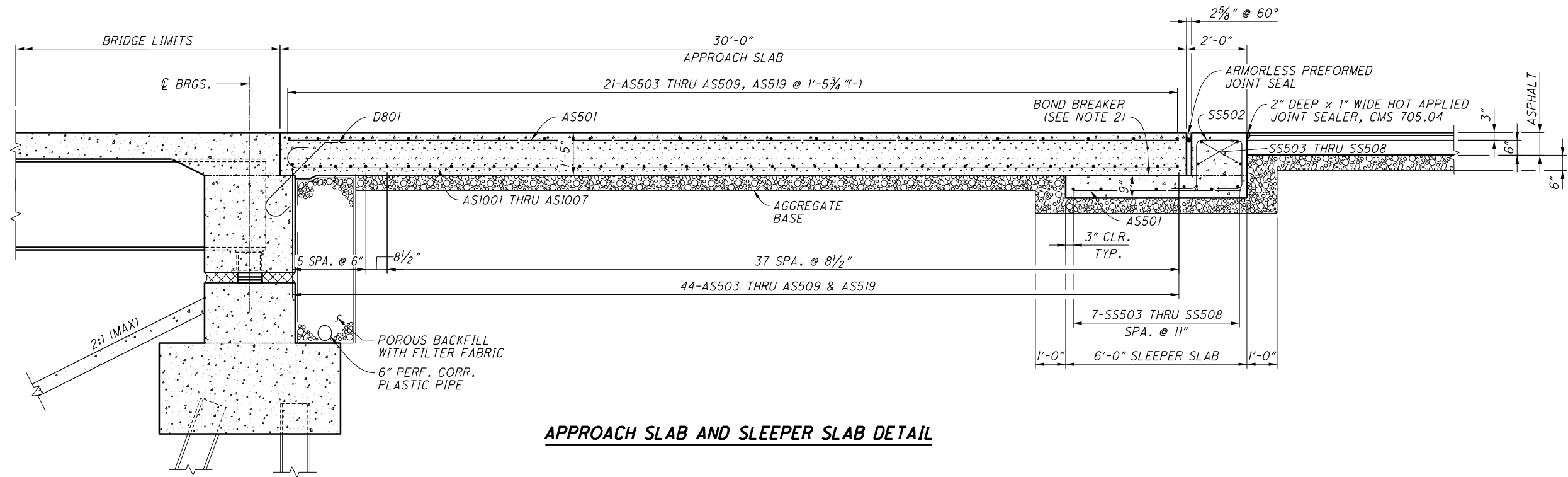

APPROACH SLAB AND SLEEPER SLAB DETAIL

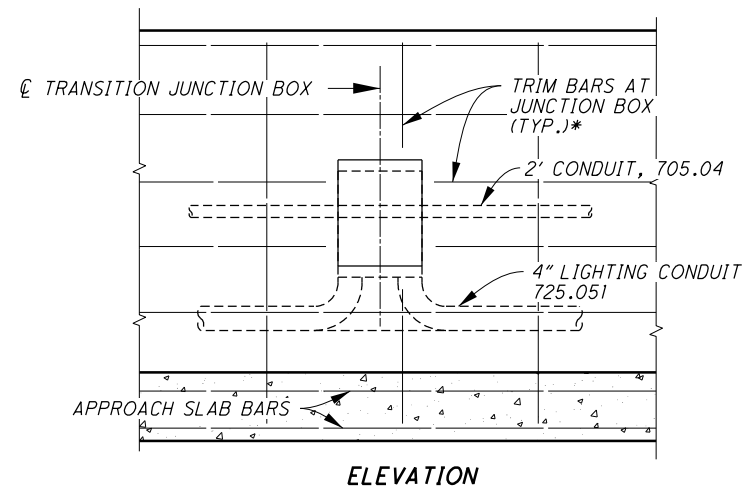
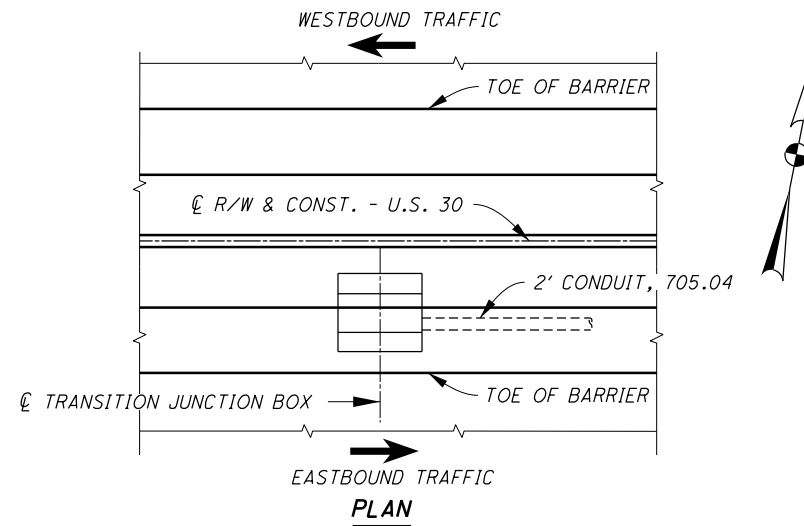

TRANSITION JUNCTION BOX DETAIL

LEGEND

* - CUT OR ADJUST BARS AS NEEDED TO AVOID JUNCTION BOX IN BARRIER

NOTES

1. FOR ABBREVIATIONS SEE SHEET 3/66.
2. APPLY BOND BREAKER TO THE ENTIRE TOP SURFACE OF THE CONCRETE SLEEPER SLAB.
3. FOR ADDITIONAL NOTES NOT SHOWN SEE STANDARD DRAWING AS-2-15 SHEET 14/14.

DESIGN AGENCY
ENGINEERING ASSOCIATES, INC.
 895 EAGLE PASS - WOOSTER, OHIO 44691
 TELEPHONE: (330) 345-6556
 FAX: (330) 345-8077

DESIGNED	HK	CHECKED	BDH
DRAWN	TAC	REVISED	---
REVIEWED	SDS	STRUCTURE FILE NUMBER	7001119
DATE	9-24-19		

APPROACH SLAB DETAILS
 BRIDGE NO. RIC-30-1074
 OVER S.R. 39

RIC-30-9-26
PID No. 93455

STANDARD DRAWINGS

REFER TO THE FOLLOWING STANDARD BRIDGE DRAWINGS:

AS-1-15	REVISED	7-17-15
AS-2-15	REVISED	1-18-19
GSD-1-19	DATED	1-18-19
PCB-91	REVISED	1-18-13
SBR-1-13	REVISED	7-20-18
SBR-2-13	REVISED	7-20-18
SICD-1-96	REVISED	7-18-14
SICD-2-14	DATED	7-18-14
VPF-1-90	REVISED	7-20-18

DESIGN SPECIFICATIONS

THIS STRUCTURE CONFORMS TO THE "LRFD BRIDGE DESIGN SPECIFICATIONS" ADOPTED BY THE AMERICAN ASSOCIATION OF STATE HIGHWAY AND TRANSPORTATION OFFICIALS, 2017, 8TH EDITION AND THE ODOT BRIDGE DESIGN MANUAL, 2019.

OPERATIONAL IMPORTANCE

A LOAD MODIFIER OF 1.0 HAS BEEN ASSUMED FOR THE DESIGN OF THIS STRUCTURE IN ACCORDANCE WITH THE AASHTO LRFD BRIDGE DESIGN SPECIFICATIONS, ARTICLE 1.3.5 AND THE ODOT BRIDGE DESIGN MANUAL, 2019.

DESIGN LOADING

HL-93
FUTURE WEARING SURFACE (FWS) OF 0.060 KIPS/FT².

DESIGN DATA

CONCRETE CLASS QC2 WITH QC/OA - COMPRESSIVE STRENGTH 4.5 KSI (SUPERSTRUCTURE)

CONCRETE CLASS QCI WITH QC/OA - COMPRESSIVE STRENGTH 4.0 KSI (SUBSTRUCTURE)

CONCRETE CLASS QC5 - COMPRESSIVE STRENGTH 4.5 KSI (DRILLED SHAFT)

REINFORCING STEEL - MINIMUM YIELD STRENGTH 60 KSI

STRUCTURAL STEEL - ASTM A709 GRADE 50 - YIELD STRENGTH 50 KSI

STEEL H-PILES - ASTM A572 - YIELD STRENGTH 50 KSI

DECK PROTECTION METHOD

EPOXY COATED REINFORCING STEEL
2 1/2" CONCRETE COVER

MONOLITHIC WEARING SURFACE

MONOLITHIC WEARING SURFACE IS ASSUMED, FOR DESIGN PURPOSES, TO BE 1 INCH THICK.

ITEM 202, PORTIONS OF STRUCTURE REMOVED, OVER 20 FOOT SPAN, AS PER PLAN:

THIS ITEM SHALL INCLUDE THE ELEMENTS INDICATED IN THE PLANS AND GENERAL NOTES AND THAT ARE NOT SEPARATELY LISTED FOR PAYMENT, EXCEPT FOR WEARING COURSE REMOVAL. ITEMS TO BE REMOVED INCLUDE ALL EXISTING MATERIALS BEING REPLACED BY NEW CONSTRUCTION AND MISCELLANEOUS ITEMS THAT ARE NOT SHOWN TO BE INCORPORATED INTO THE FINAL CONSTRUCTION AND ARE DIRECTED TO BE REMOVED BY THE ENGINEER. THE USE OF EXPLOSIVES, HEADACHE BALLS AND/OR HOE-RAMS WILL NOT BE PERMITTED. THE METHOD OF REMOVAL AND THE WEIGHT OF HAMMER SHALL BE APPROVED BY THE ENGINEER. PERFORM ALL WORK IN A MANNER THAT WILL NOT CUT, ELONGATE OR DAMAGE THE EXISTING REINFORCING STEEL TO BE PRESERVED. CHIPPING HAMMERS SHALL NOT BE HEAVIER THAN THE NOMINAL 90-POUND CLASS. PNEUMATIC HAMMERS SHALL NOT BE PLACED IN DIRECT CONTACT WITH REINFORCING STEEL THAT IS TO BE RETAINED IN THE REBUILT STRUCTURE. SUBMIT CONSTRUCTION PLANS ACCORDING TO C&MS 501.05

SUBSTRUCTURE CONCRETE REMOVAL:

REMOVE CONCRETE BY MEANS OF APPROVED PNEUMATIC HAMMERS EMPLOYING POINTED AND BLUNT CHISEL TOOLS. HYDRAULIC HOE-RAM TYPE HAMMERS WILL NOT BE PERMITTED. THE WEIGHT OF THE HAMMER SHALL NOT BE MORE THAN 35 POUNDS FOR REMOVAL WITHIN 18 INCHES OF PORTIONS TO BE PRESERVED. OUTSIDE THE 18 INCH LIMIT, THE CONTRACTOR MAY USE HAMMERS NOT EXCEEDING 90 POUNDS UPON THE APPROVAL OF THE ENGINEER. DO NOT PLACE PNEUMATIC HAMMERS IN DIRECT CONTACT WITH REINFORCING STEEL THAT IS TO BE RETAINED IN THE REBUILT STRUCTURE.

ITEM 203 EMBANKMENT, AS PER PLAN

PLACE AND COMPACT EMBANKMENT MATERIAL IN 6 INCH LIFTS FOR THE CONSTRUCTION OF THE APPROACH EMBANKMENT BETWEEN STATIONS 597+50 TO 602+50.

PILES TO BEDROCK

DRIVE PILES TO REFUSAL ON BEDROCK. THE DEPARTMENT WILL CONSIDER REFUSAL TO BE OBTAINED WHEN THE PILE PENETRATION IS AN INCH OR LESS AFTER RECEIVING AT LEAST 20 BLOWS FROM THE PILE HAMMER. SELECT THE HAMMER SIZE TO ACHIEVE THE REQUIRED DEPTH TO BEDROCK AND REFUSAL.

THE TOTAL FACTORED LOAD IS 132 KIPS PER PILE FOR THE ABUTMENT PILES.

REAR ABUTMENT PILES: (HP 10X42)
23 PILES 50 FEET LONG, ORDER LENGTH

FORWARD ABUTMENT PILES: (HP 10X42)
23 PILES 60 FEET LONG, ORDER LENGTH

PILE SPLICES

IN LIEU OF USING THE FULL PENETRATION BUTT WELDS SPECIFIED IN CMS 507.09 TO SPLICE STEEL H-PILES, THE CONTRACTOR MAY USE A MANUFACTURED H-PILE SPLICER. FURNISH SPLICERS FROM THE FOLLOWING MANUFACTURER:

ASSOCIATED PILE AND FITTING CORPORATION
8 WOOD HOLLOW RD. PLAZA 1
PARSIPPANY, NEW JERSEY 07054

INSTALL AND WELD THE SPLICER TO THE PILE SECTIONS IN ACCORDANCE WITH THE MANUFACTURER'S WRITTEN ASSEMBLY PROCEDURE SUPPLIED TO THE ENGINEER BEFORE THE WELDING IS PERFORMED.

ITEM 503, COFFERDAMS AND EXCAVATION BRACING, AS PER PLAN

THE DESIGN SHOWN ON THE PLANS FOR TEMPORARY SUPPORT OF EXCAVATION IS ONE REPRESENTATIVE DESIGN THAT MAY BE USED TO CONSTRUCT THE PROJECT. THE CONTRACTOR MAY CONSTRUCT THE DESIGN SHOWN ON THE PLANS OR PREPARE AN ALTERNATE DESIGN TO SUPPORT THE SIDES OF EXCAVATION. IF CONSTRUCTING AN ALTERNATE DESIGN FOR TEMPORARY SUPPORT OF EXCAVATION, PREPARE AND PROVIDE PLANS IN ACCORDANCE WITH C&MS 501.05. THE DEPARTMENT WILL PAY FOR THE TEMPORARY SUPPORT OF EXCAVATION AT THE CONTRACT LUMP SUM PRICE FOR COFFERDAMS AND EXCAVATION BRACING. NO ADDITIONAL PAYMENT WILL BE MADE FOR PROVIDING AN ALTERNATE DESIGN.

DECK PLACEMENT ASSUMPTIONS

THE FOLLOWING ASSUMPTIONS OF CONSTRUCTION MEANS AND METHODS WERE MADE FOR THE ANALYSIS AND DESIGN OF THE SUPERSTRUCTURE. THE CONTRACTOR IS RESPONSIBLE FOR THE DESIGN OF THE FALSEWORK SUPPORT SYSTEM WITHIN THESE PARAMETERS AND WILL ASSUME RESPONSIBILITY FOR SUPERSTRUCTURE ANALYSIS FOR DEVIATION FROM THESE DESIGN ASSUMPTIONS.

AN EIGHT WHEEL FINISHING MACHINE WITH A MAXIMUM WHEEL LOAD OF 2.3 KIPS.

A MINIMUM OUT-TO-OUT WHEEL SPACING AT EACH END OF THE MACHINE OF 103".

A MAXIMUM SPACING OF OVERHANG FALSEWORK BRACKETS OF 48".

A MAXIMUM DISTANCE FROM THE CENTERLINE OF THE FASCIA GIRDER TO THE FACE OF THE SAFETY HANDRAIL OF 65".

MECHANICAL CONNECTORS:

AN APPROVED TYPE OF MECHANICAL CONNECTOR FOR REINFORCING BARS SHALL BE PROVIDED. INSTALLATION OF CONNECTORS SHALL CONFORM WITH MANUFACTURER'S RECOMMENDED PROCEDURES.

CONNECTORS USED WITH EPOXY COATED BARS SHALL BE EPOXY COATED. COATINGS USED SHALL CONFORM TO THE SAME SPECIFICATION. COATINGS WHICH HAVE BEEN DAMAGED OR WHICH OTHERWISE DO NOT MEET SPECIFICATION WITH RESPECT TO COLOR, CONTINUITY, AND UNIFORMITY MAY BE REPAIRED AS DIRECTED BY THE ENGINEER OR THEY SHALL BE REPLACED WITH MATERIAL WHICH MEET THE SPECIFICATIONS. CONNECTORS SHALL BE INCLUDED IN ITEM 509 FOR PAYMENT.

REINFORCING STEEL LENGTHS IN THE TABLES FOR BARS THAT ARE TO BE MECHANICALLY SPLICED ASSUME AN END TO END TYPE CONNECTOR WILL BE USED. IF THE CONTRACTOR ELECTS TO USE ANOTHER TYPE OF CONNECTOR THE FABRICATOR SHALL BE DIRECTED TO MAKE ADJUSTMENTS TO THE REINFORCING STEEL LENGTHS ACCORDINGLY.

DRILLED SHAFTS:

THE MAXIMUM FACTORED LOAD TO BE SUPPORTED BY EACH DRILLED SHAFT IS 265 KIPS AT THE PIERS. THIS LOAD IS RESISTED BY SIDE RESISTANCE WITHIN A PORTION OF THE BEDROCK SOCKET AND ALSO BY TIP RESISTANCE. THE FACTORED RESISTANCE DEVELOPED BY SIDE RESISTANCE IS 0 KIPS, ASSUMED TO ACT ALONG THE BOTTOM 0 FEET OF THE BEDROCK SOCKET FOR THE PIERS. THE FACTORED RESISTANCE PROVIDED BY THE DRILLED SHAFT TIP IS 2400 KIPS.

CUT LINE CONSTRUCTION JOINT PREPARATION:

SAW CUT BOUNDARIES OF PROPOSED CONCRETE REMOVALS 1 INCH DEEP. REMOVE CONCRETE TO A ROUGH SURFACE. LEAVE THE EXISTING REINFORCING STEEL, IF REQUIRED IN THE PLANS, IN PLACE. INSTALL DOWEL BARS IF SPECIFIED. PRIOR TO CONCRETE PLACEMENT ABRASIVELY CLEAN JOINT SURFACES AND EXISTING EXPOSED REINFORCEMENT TO REMOVE LOOSE AND DISINTEGRATED CONCRETE AND LOOSE RUST. THOROUGHLY CLEAN THE JOINT SURFACE AND EXPOSED REINFORCEMENT OF ALL DIRT, DUST, RUST OR OTHER FOREIGN MATERIAL BY THE USE OF WATER, AIR UNDER PRESSURE, OR OTHER METHODS THAT PRODUCE SATISFACTORY RESULTS. EXISTING REINFORCING STEEL DOES NOT HAVE TO HAVE A BRIGHT STEEL FINISH BUT REMOVE ALL PACK AND LOOSE RUST. THOROUGHLY DRENCH EXISTING CONCRETE SURFACES WITH CLEAN WATER AND ALLOW TO DRY TO A DAMP CONDITION BEFORE PLACING CONCRETE.

STRUCTURE PAINTING: ALL BRIDGE FINISH COATS SHALL BE THE SAME COLOR.

INSTALLATION OF MULTI-CELL CONDUIT ON STRUCTURES

ONE MULTI-CELL CONDUIT IS CONTINUOUS FOR THE ENTIRE PROJECT. THE SECOND MULTI-CELL CONDUIT SHALL BE PLACED ONLY WITHIN THE LIMITS OF THE BRIDGES AND APPROACH SLABS AND SHALL TERMINATE AT A JUNCTION BOX AS SHOWN IN STANDARD DRAWING HL-30.33.

ABBREVIATIONS

ABUT.	-	ABUTMENT
APPR.	-	APPROACH
BRG.	-	BEARING
BOT.	-	BOTTOM
CONST. JT.	-	CONSTRUCTION JOINT
CLR.	-	CLEAR
CONST.	-	CONSTRUCTION
CORR.	-	CORRUGATED
DIA.	-	DIAMETER
DIM.	-	DIMENSION
DWG.	-	DRAWING
EL.	-	ELEVATION
E.F.	-	EACH FACE
EXIST.	-	EXISTING
F.A.	-	FORWARD ABUTMENT
FWD.	-	FORWARD
F.F.	-	FRONT FACE
FT.	-	FEET
LBS.	-	POUNDS
MAX.	-	MAXIMUM
MEAS.	-	MEASURED
MIN.	-	MINIMUM
OPT.	-	OPTIONAL
P.E.J.F.	-	PERFORMED EXPANSION JOINT FILLER
R.A.	-	REAR ABUTMENT
R.F.	-	REAR FACE
REQ'D.	-	REQUIRED
SPA.	-	SPACING
STA.	-	STATION
T.O.S.	-	TOP OF SLOPE
TYP.	-	TYPICAL
U.O.N.	-	UNLESS OTHERWISE NOTED
VAR.	-	VARIES
W/	-	WITH

GENERAL NOTES
BRIDGE NO. RIC-30-1135
BOWMAN STREET

RIC-30-9-26
PID No. 93455

3 / 56

1272
1669

DESIGN AGENCY
ENGINEERING ASSOCIATES, INC.
935 EAGLE PASS - WOOSTER, OHIO 44691
TELEPHONE: (330) 345-6556
FAX: (330) 345-9077



DATE 9-24-19
SDS
STRUCTURE FILE NUMBER 7001143

DRAWN TAC
CHECKED BDH

M:\15074\93455\Design\Structures\RIC030_1135C\Sheets\030_1135CSQ001.dgn 3/27/2020 11:08:31 AM kjo282

CALC:	RLE	DATE:	5/28/2019
CHECKED:	TAC	DATE:	6/1/2019

ESTIMATED QUANTITIES

ITEM	EXTENSION	TOTAL 01/NHS/BR	UNIT	DESCRIPTION	ABUT.	PIERS	SUPER.	GEN.	SEE	SHEET
202	11203	LS		PORTIONS OF STRUCTURE REMOVED, OVER 20 FOOT SPAN, AS PER PLAN				LS		3 / 56
202	22900	258	SY	APPROACH SLAB REMOVED				258		
202	23500	258	SY	WEARING COURSE REMOVED				258		
503	11101	LS		COFFERDAMS AND EXCAVATION BRACING, AS PER PLAN				LS		3 / 56
503	21100	384	CY	UNCLASSIFIED EXCAVATION	384					
504	11100	3840	SF	STEEL SHEET PILING LEFT IN PLACE, Sx = 34.8 IN ³ /FT				3840		
505	11100	LS		PILE DRIVING EQUIPMENT MOBILIZATION				LS		
507	00100	2530	FT	STEEL PILES HPI0X42, FURNISHED	2530					
507	00150	2300	FT	STEEL PILES HPI0X42, DRIVEN	2300					
509	10001	199496	LB	EPOXY COATED REINFORCING STEEL, AS PER PLAN	21843	30975	146678			23 / 56
510	10000	40	EACH	DOWEL HOLES WITH NONSHRINK, NONMETALLIC GROUT	24	16				
511	21523	645	CY	CLASS OC2 CONCRETE WITH OC/OA, SUPERSTRUCTURE, AS PER PLAN			645			5 / 56 & 33 / 56 & 40 / 56
511	33500	4	EACH	SEMI-INTEGRAL DIAPHRAGM GUIDE			4			
511	41012	153	CY	CLASS OC1 CONCRETE WITH OC/OA, PIER ABOVE FOOTINGS		153				
511	44112	85	CY	CLASS OC1 CONCRETE WITH OC/OA, ABUTMENT NOT INCLUDING FOOTING	85					
511	46512	148	CY	CLASS OC1 CONCRETE WITH OC/OA, FOOTING	148					
512	10100	1155	SY	SEALING OF CONCRETE SURFACES (EPOXY-URETHANE)	48	397	654	56		
512	10300	233	SY	SEALING CONCRETE BRIDGE DECKS WITH HMWM RESIN			204	29		
512	33000	16	SY	TYPE 2 WATERPROOFING	16					
513	10260	371800	LB	STRUCTURAL STEEL MEMBERS, LEVEL 3			371800			
513	20000	8676	EACH	WELDED STUD SHEAR CONNECTORS			8676			
514	00800	371800	LB	FIELD PAINTING STRUCTURAL STEEL, INTERMEDIATE COAT			371800			
514	00851	371800	LB	FIELD PAINTING STRUCTURAL STEEL, FINISH COAT, AS PER PLAN			371800			3 / 56
514	10000	19	EACH	FINAL INSPECTION REPAIR			19			
516	10010	176	FT	ARMORLESS PREFORMED JOINT SEAL				176		
516	13600	26	SF	1" PREFORMED EXPANSION JOINT FILLER			26			
516	13900	285	SF	2" PREFORMED EXPANSION JOINT FILLER			60	225		
516	14020	261	FT	SEMI-INTEGRAL ABUTMENT EXPANSION JOINT SEAL	261					
516	44101	24	EACH	ELASTOMERIC BEARING WITH INTERNAL LAMINATES AND LOAD PLATE (NEOPRENE), AS PER PLAN 2 13/16"x1'-2"x1'-5" W/ 1 x1'-3"x1'-6" BEVELED LOAD PLATE		24				28 / 56
516	44101	24	EACH	ELASTOMERIC BEARING WITH INTERNAL LAMINATES AND LOAD PLATE (NEOPRENE), AS PER PLAN 2 1/2"x11"x1'-0" W/ 1 5/8"x1'-0"x1'-1" BEVELED LOAD PLATE	24					28 / 56
518	21200	97	CY	POROUS BACKFILL WITH GEOTEXTILE FABRIC	97					
518	40001	220	FT	6" PERFORATED CORRUGATED PLASTIC PIPE, AS PER PLAN	220					15 / 56 & 19 / 56
518	40010	22	FT	6" NON-PERFORATED CORRUGATED PLASTIC PIPE, INCLUDING SPECIALS	22					
524	95434	84	FT	DRILLED SHAFTS, 36" DIAMETER, INTO BEDROCK WITH OC/OA		84				
524	95442	278	FT	DRILLED SHAFTS, 42" DIAMETER, ABOVE BEDROCK WITH OC/OA		278				
526	15001	390	SY	REINFORCED CONCRETE APPROACH SLABS (T=13"), AS PER PLAN				390		43 / 56 THRU 47 / 56
526	90030	176	FT	TYPE C INSTALLATION				176		
601	21000	932	SY	CONCRETE SLOPE PROTECTION				932		
607	39900	289	FT	VANDAL PROTECTION FENCE, 6' STRAIGHT, COATED FABRIC			289			

DESIGN AGENCY
ENGINEERING ASSOCIATES, INC.
8955 EAGLE PASS - WOOSTER, OHIO 44691
TELEPHONE: (330) 345-6556
FAX: (330) 345-8077



DATE: 9-24-19
REVIEWED: SDS
STRUCTURE FILE NUMBER: 7001143

DRAWN: TAC
REVISOR: XXX

DESIGNED: HK
CHECKED: BDH

ESTIMATED QUANTITIES
BRIDGE NO. RIC-30-1135
OVER BOWMAN STREET

RIC-30-9-26
PID No. 93455

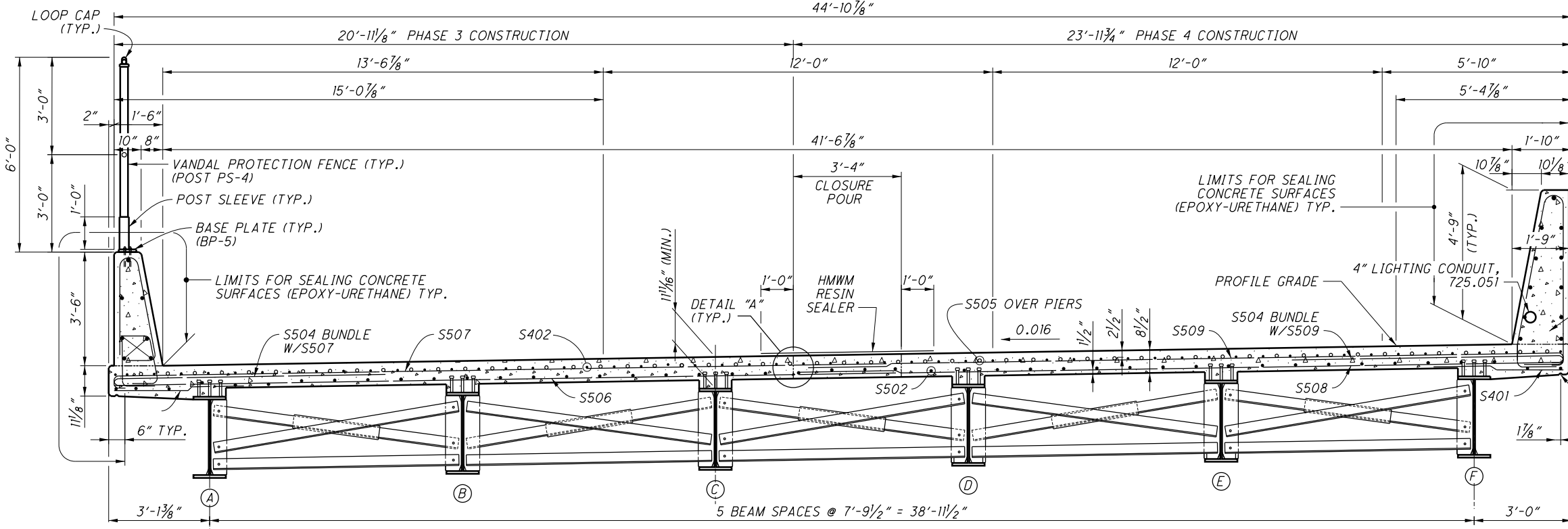

TRANSVERSE SECTION
(WESTBOUND LANES)

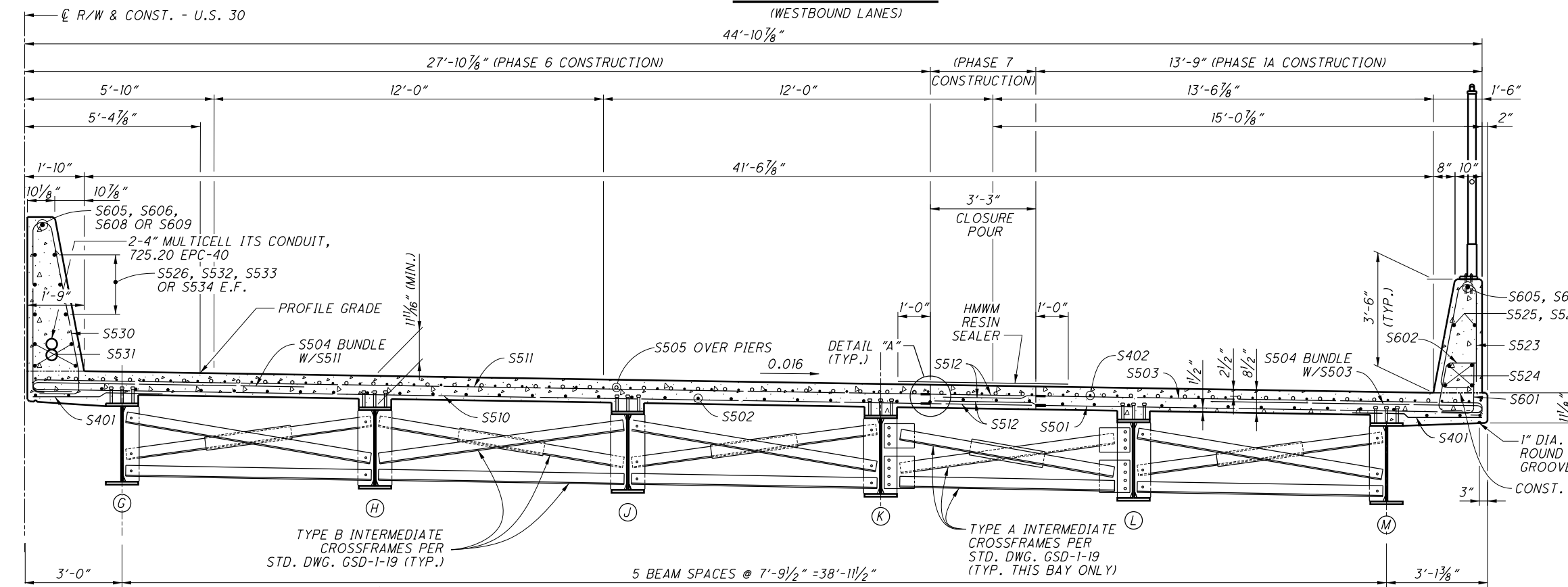

TRANSVERSE SECTION
(EASTBOUND LANES)

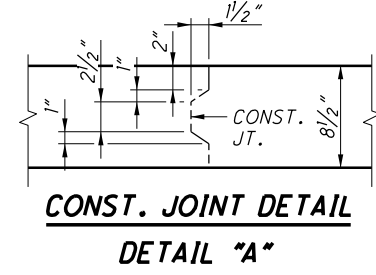

CONST. JOINT DETAIL
DETAIL "A"

LIMITS FOR SEALING
CONCRETE SURFACES
(EPOXY-URETHANE) TYP.

PROFILE GRADE

NOTES

1. FOR SLAB PLAN SEE SHEET 41/56.
2. FOR ABBREVIATIONS SEE SHEET 3/56.
3. MINIMUM REINFORCING STEEL SPLICE LENGTH UNLESS OTHERWISE NOTED:
NO. 4 BAR = 1'-11"
NO. 5 BAR = 2'-5"
NO. 5 BAR = 3'-0" (BOTTOM OF SLAB)
NO. 6 BAR = 3'-7"
4. FOR BARRIER MEDIAN AND RAILING DETAILS SEE SHEETS 42/56 THRU 45/56.
5. THE CLOSURE POUR SHALL BE SEALED WITH HIGH MOLECULAR WEIGHT METHACRYLATE (HMWM) RESIN IN ACCORDANCE OF ITEM 512. THE RESIN SHALL COVER THE ENTIRE CLOSURE POUR SECTION AND OVERLAP EACH CONSTRUCTION JOINT 1'-0"
6. 4" LIGHTING CONDUIT, 725.051, AND 4" MULTICELL ITS CONDUIT, 725.20 EPC-40, AND JUNCTION BOXES WHERE REQUIRED SHALL BE PLACED IN THE MEDIAN BARRIER AS SHOWN IN THE PLANS. THE COST OF PLACEMENT, MATERIALS, EQUIPMENT AND LABOR SHALL BE CONSIDERED INCIDENTAL AND INCLUDED FOR PAYMENT IN ITEM 511 CLASS OC2 CONCRETE WITH OC/OA SUPERSTRUCTURE, AS PER PLAN.

LEGEND

— DENOTES MECHANICAL CONNECTOR

DESIGN AGENCY: ENGINEERING ASSOCIATES, INC.
 8955 EAGLE PASS - WOOSTER, OHIO 44691
 TELEPHONE: (330) 345-6556
 FAX: (330) 345-3077

DATE: 9-24-19
 STRUCTURE FILE NUMBER: 700143

DESIGNED: HK
 CHECKED: BDH

DRAWN: TAC
 REVISED: ---

BRIDGE NO.: RIC-30-1135
 OVER BOWMAN STREET

RIC-30-9-26
 PID No. 93455

40/56
 1309
 1669

M:\15074\93455\Design\Structures\RIC030_1135\CS\01.dgn 3/27/2020 10:11:47 AM tac230

M:\15074\93455\Design\Structures\RIC030_1135C\Sheets\030_1135CSA004.dgn 3/27/2020 10:15:22 AM toc230

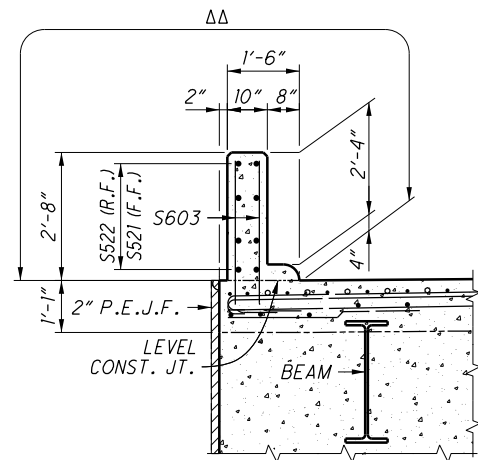

SECTION D-D

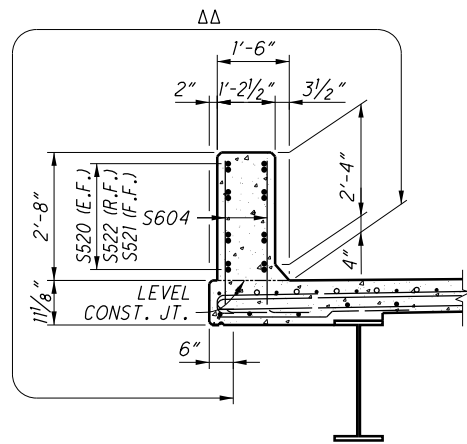

SECTION E-E

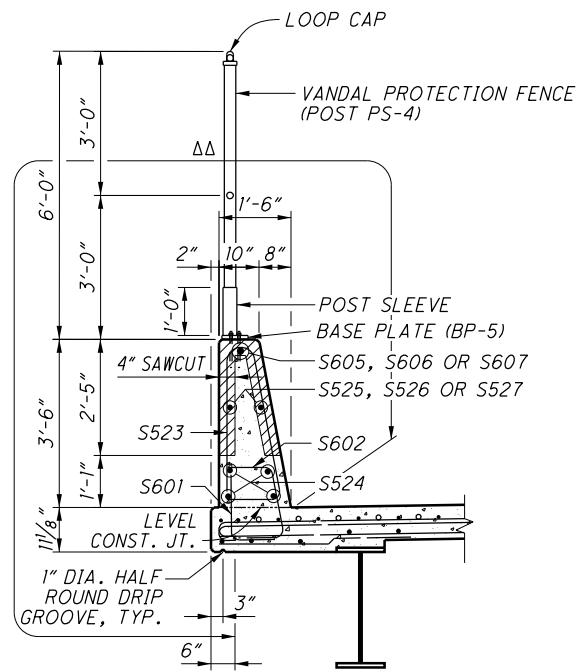

SECTION F-F

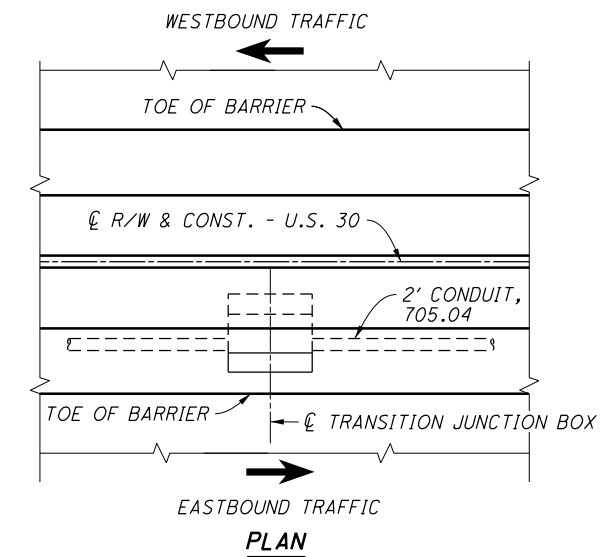

PLAN

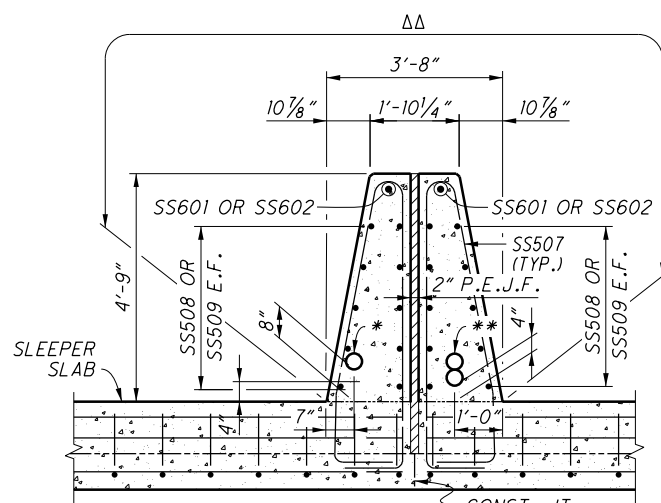

SECTION DD-DD

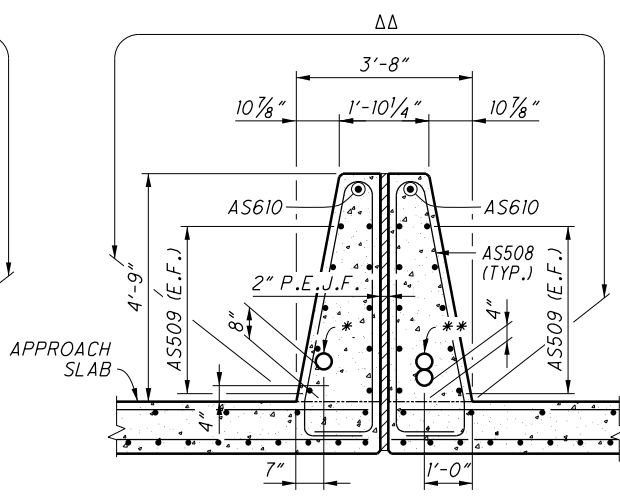

SECTION EE-EE

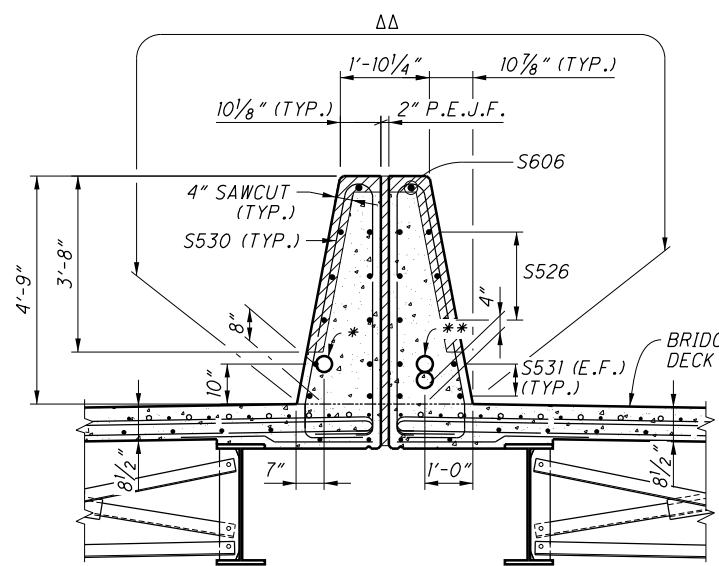

SECTION FF-FF

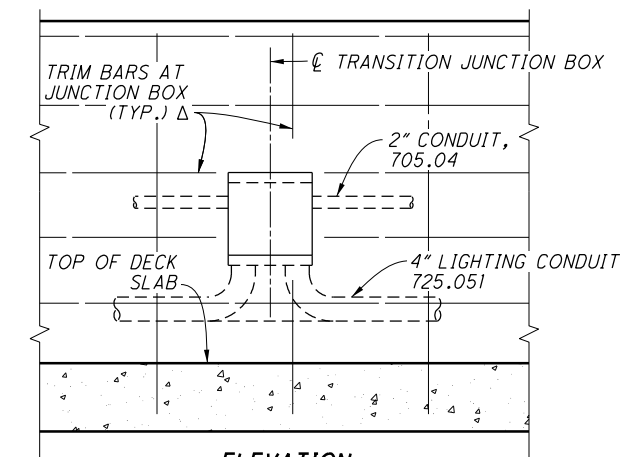

TRANSITION JUNCTION BOX DETAILS

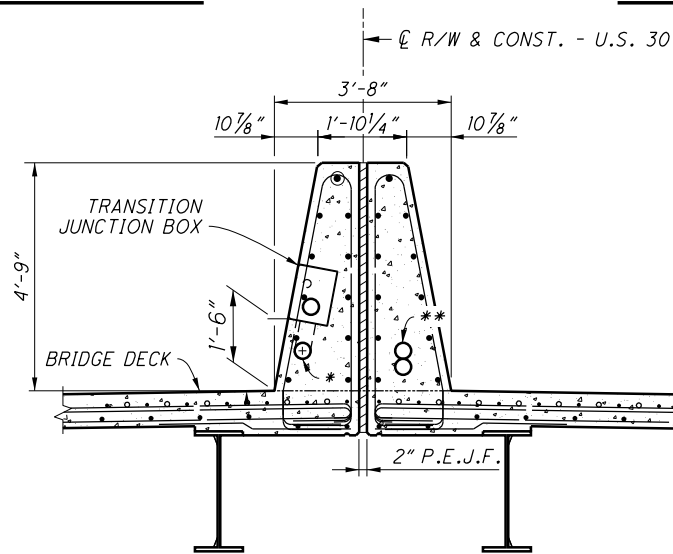

SECTION AF-AF

LEGEND

- Δ - CUT OR ADJUST BARS AS NEEDED TO AVOID JUNCTION BOX IN BARRIER
- ΔΔ - LIMITS FOR SEALING CONCRETE SURFACES (EPOXY-URETHANE)
- * - 4" LIGHTING CONDUIT, 725.051
- ** - 2-4" MULTICELL ITS CONDUIT, 725.20 EPC-40

NOTES

1. FOR ABBREVIATIONS SEE SHEET 3/56.
2. FOR LOCATIONS OF SECTIONS D-D, E-E & F-F SEE SHEET 42/56.
3. FOR LOCATIONS OF SECTIONS DD-DD, EE-EE, FF-FF & AF-AF SEE SHEETS 43/56 & 44/56.
4. 4" LIGHTING CONDUIT, 725.051, AND 4" MULTICELL ITS CONDUIT, 725.20 EPC-40, AND JUNCTION BOXES WHERE REQUIRED SHALL BE PLACED IN THE MEDIAN BARRIER AS SHOWN IN THE PLANS. THE COST OF PLACEMENT, MATERIALS, EQUIPMENT AND LABOR SHALL BE CONSIDERED INCIDENTAL AND INCLUDED FOR PAYMENT IN ITEM 526 REINFORCED CONCRETE APPROACH SLABS, AS PER PLAN.

M:\15074\93455\Design\Structures\RIC030_1135C\Sheets\030_1135CSA005.dgn 3/27/2020 10:19:23 AM toc230

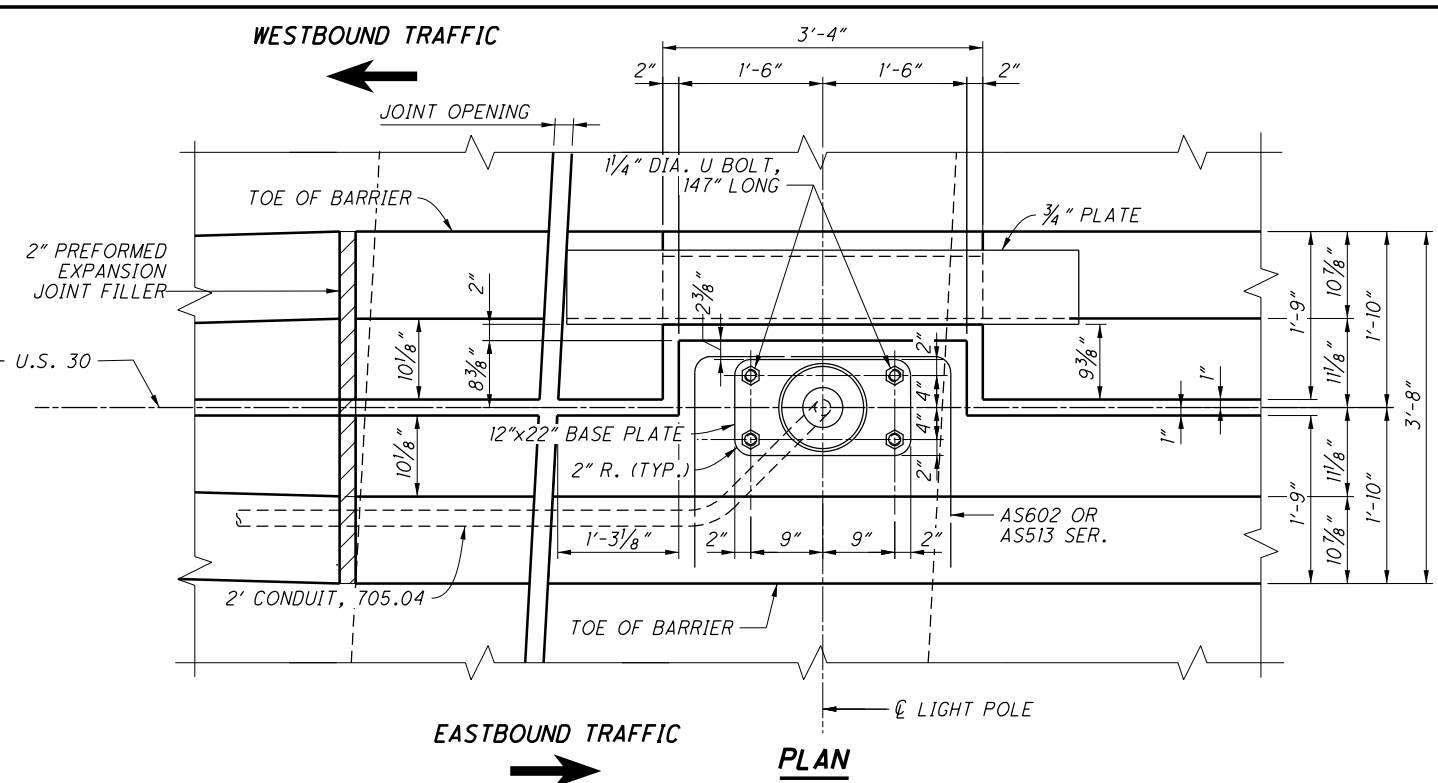

PLAN

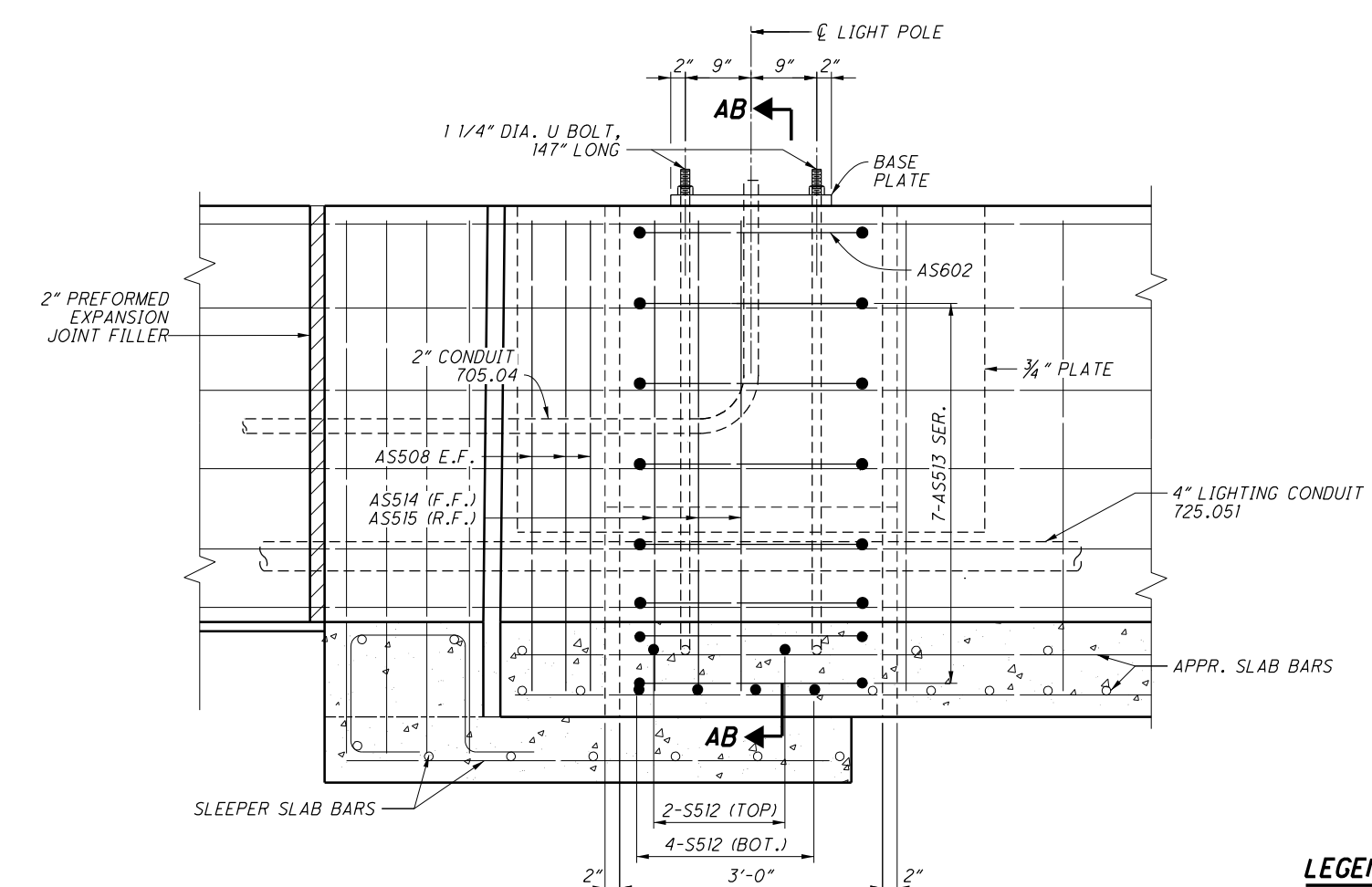

ELEVATION

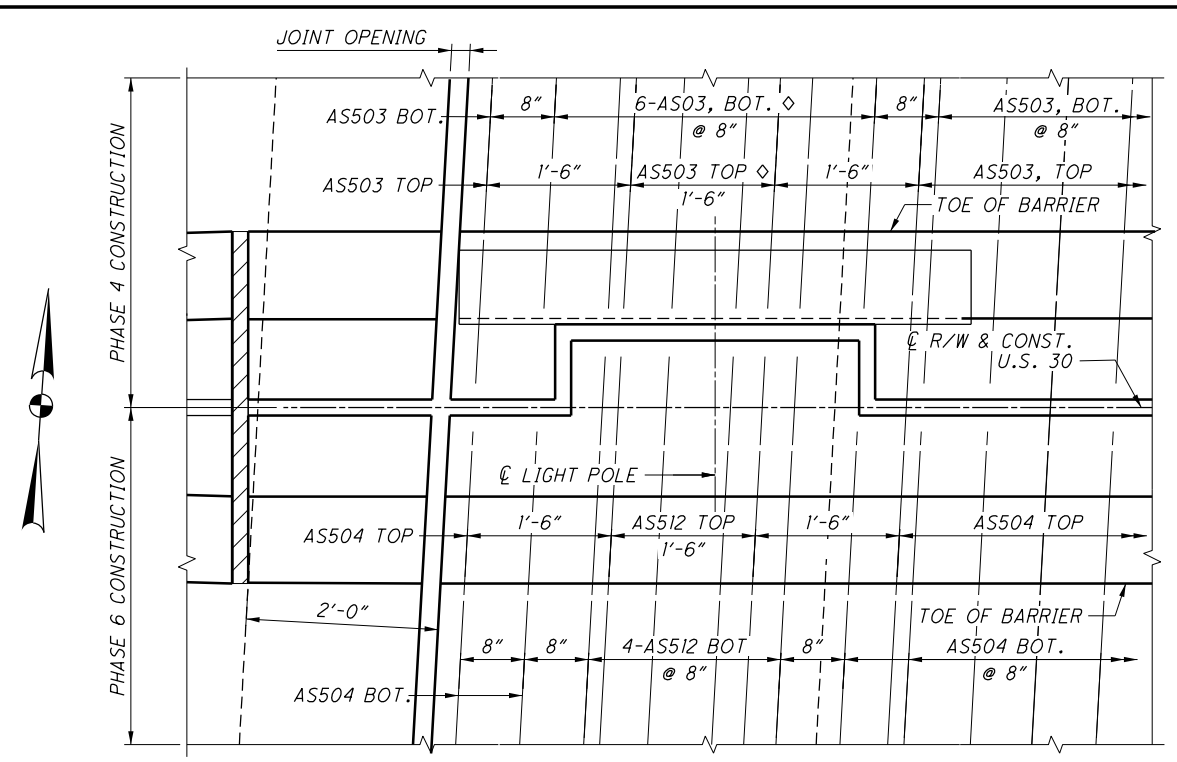

SLAB REINFORCING PLAN

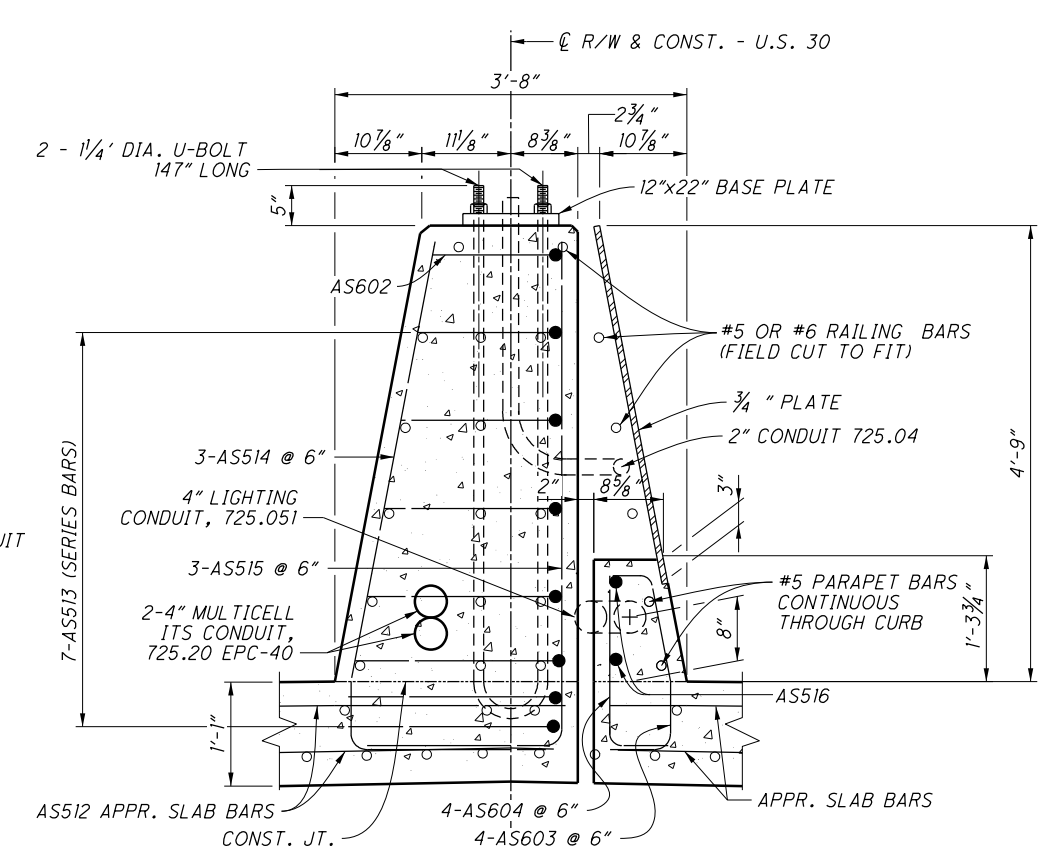

SECTION AB-AB

LEGEND

◇ - FIELD CUT SLAB BARS

NOTES

1. MATERIALS: STEEL PLATES SHALL BE ASTM A709, GR. 50. PLATES SHALL BE METALIZED OR GALVANIZED PER 516.03.
2. PAYMENT FOR THE MATERIAL AND INSTALLATION OF MEDIAN BARRIER PLATES AND FASTENERS SHALL BE INCLUDED AS INCIDENTAL TO ITEM 511 - CLASS QC2 CONCRETE WITH QC/OA, SUPERSTRUCTURE, AS PER PLAN.
3. FOR LIGHT SUPPORT LOCATION SEE SHEET 1183/1669.

DESIGN AGENCY: **ENGINEERING ASSOCIATES, INC.**
 895 EAGLE PASS - WOOSTER, OHIO 44691
 TELEPHONE: (330) 345-6556
 FAX: (330) 345-3077

DATE: 9-24-19
 SDS
 STRUCTURE FILE NUMBER: 7001143

DESIGNED: HK
 CHECKED: BDH

DRAWN: TAC
 REVISIONS: ---

BRIDGE NO. RIC-30-1135
 OVER BOWMAN STREET

RIC-30-9-26
PID No. 93455

45A/56

1314A
 1669

M:\15074\93455\Design\Structures\RIC030_1135C\Sheets\030_1135CSA006.dgn 3/27/2020 10:23:15 AM toc230

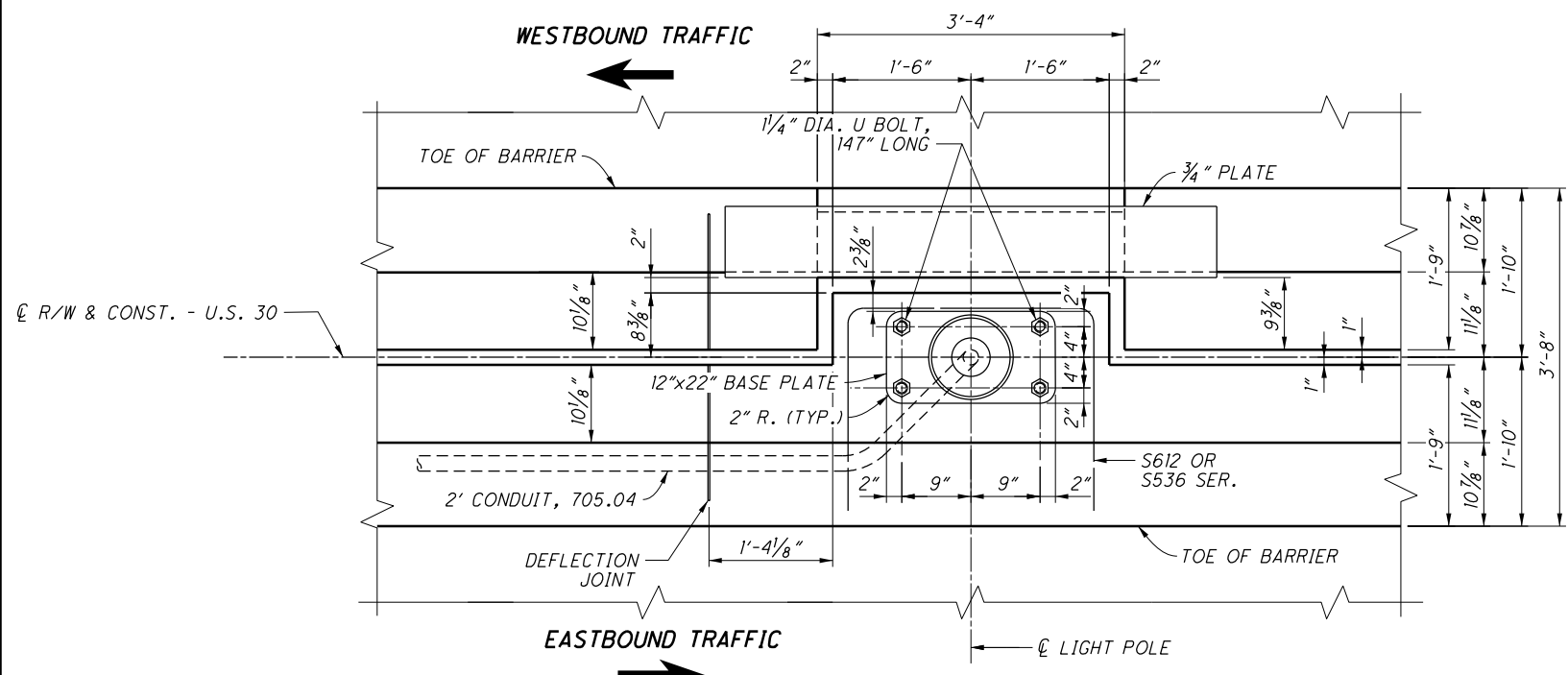

PLAN

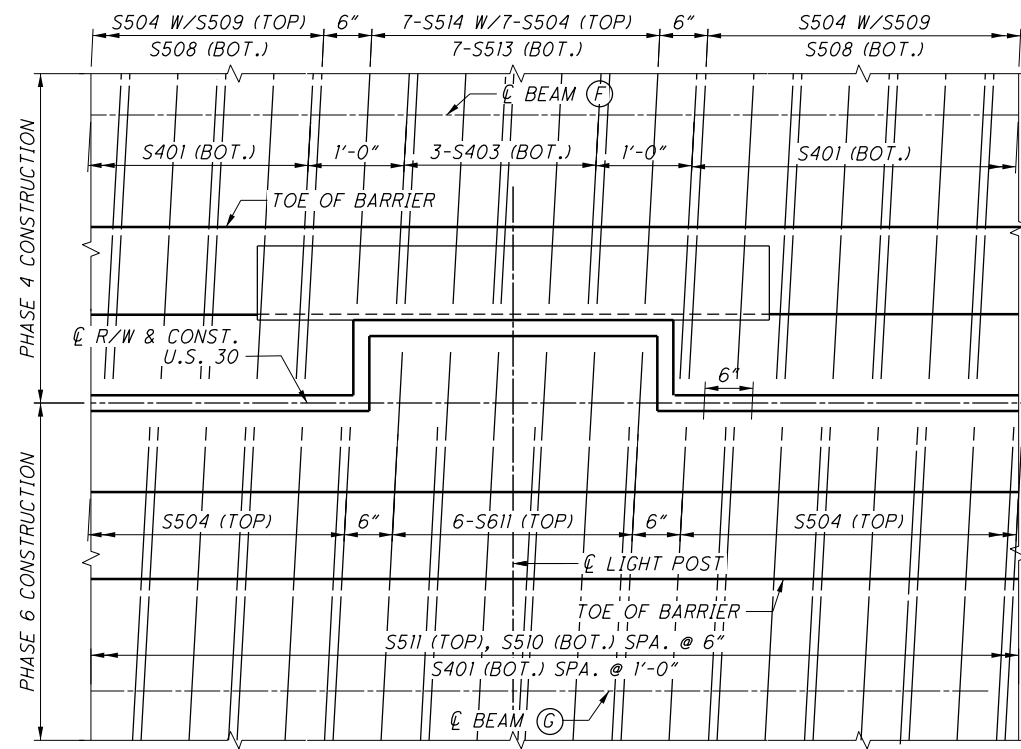

SLAB REINFORCING PLAN

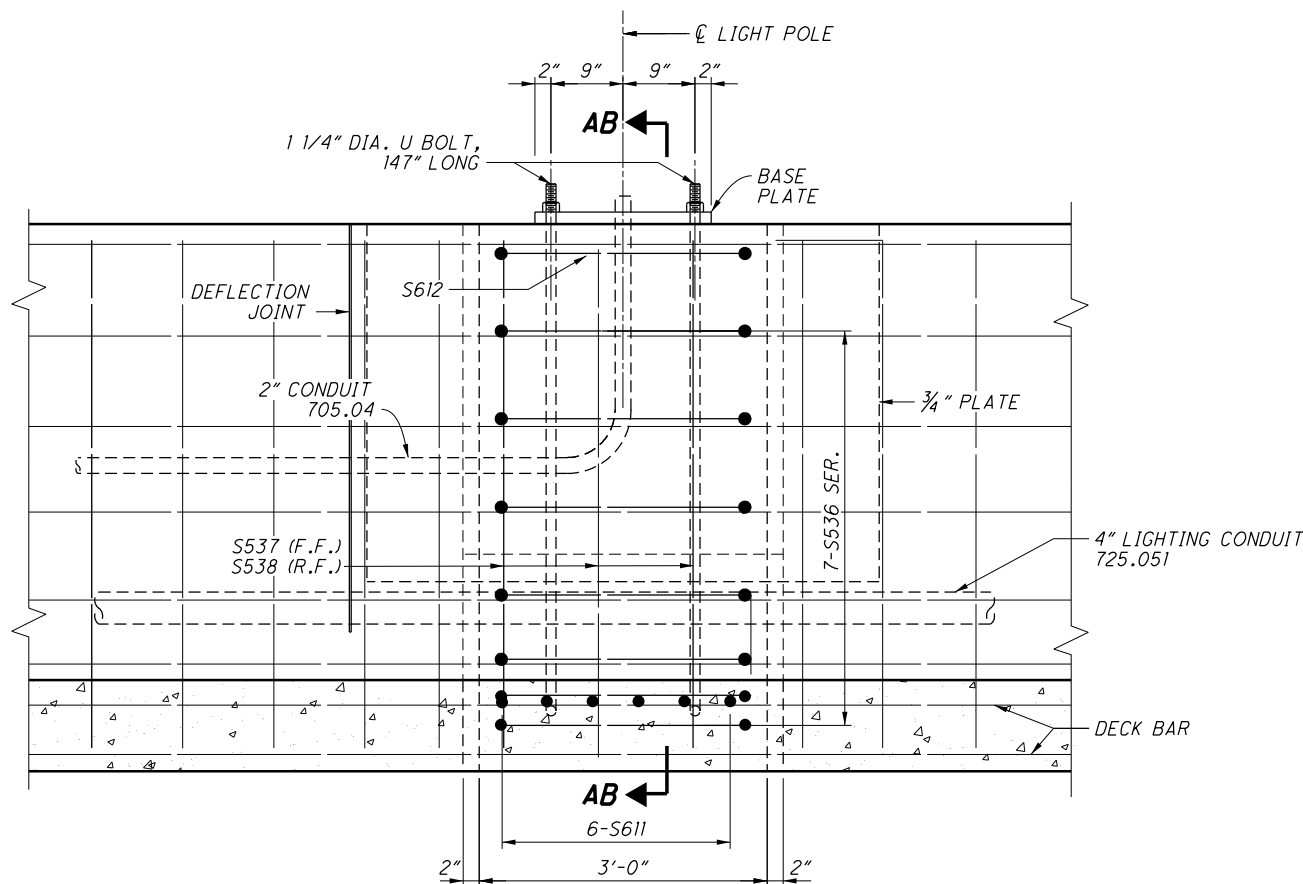

ELEVATION

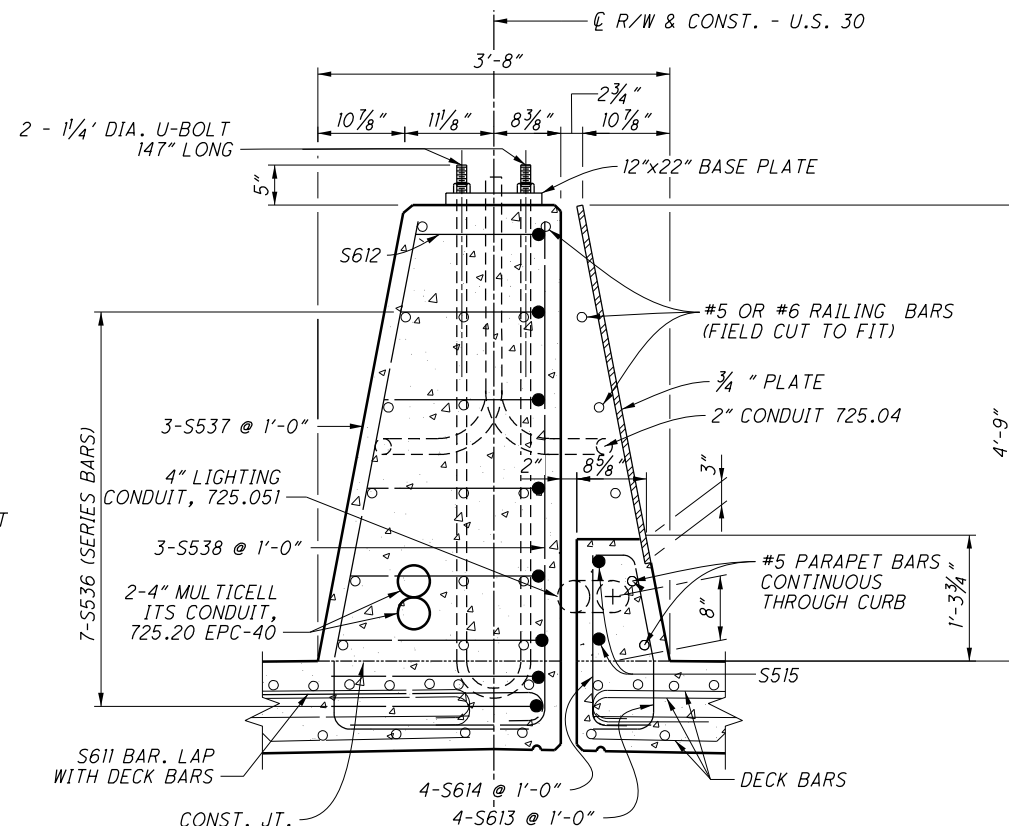

SECTION AB-AB

NOTES

- 1. MATERIALS: STEEL PLATES SHALL BE ASTM A709, GR. 50. PLATES SHALL BE METALIZED OR GALVANIZED PER 516.03.
2. PAYMENT FOR THE MATERIAL AND INSTALLATION OF MEDIAN BARRIER PLATES AND FASTENERS SHALL BE INCLUDED AS INCIDENTAL TO ITEM 511 - CLASS OC2 CONCRETE WITH OC/OA, SUPERSTRUCTURE, AS PER PLAN.
3. FOR LIGHT SUPPORT LOCATION SEE SHEET 1183/1669.

Project information block including Design Agency (Engineering Associates, Inc.), Date (9-24-19), Stationing (600+76.75), Bridge No. (RIC-30-1135), and drawing identifiers (RIC-30-9.26, PID No. 93455, 45B/56).

M:\15074\93455\Design\Structures\RIC030_1135C\Sheets\030_1135CSA007.dgn 3/26/2020 9:51:39 PM tac230

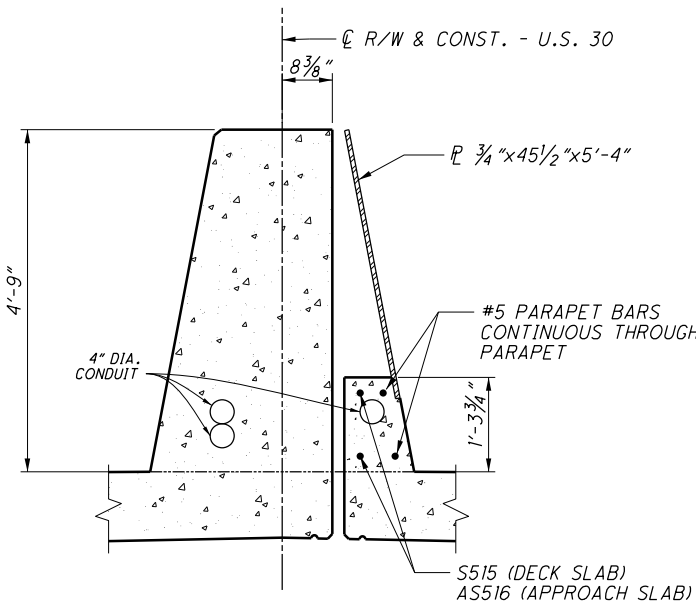

SECTION AD-AD

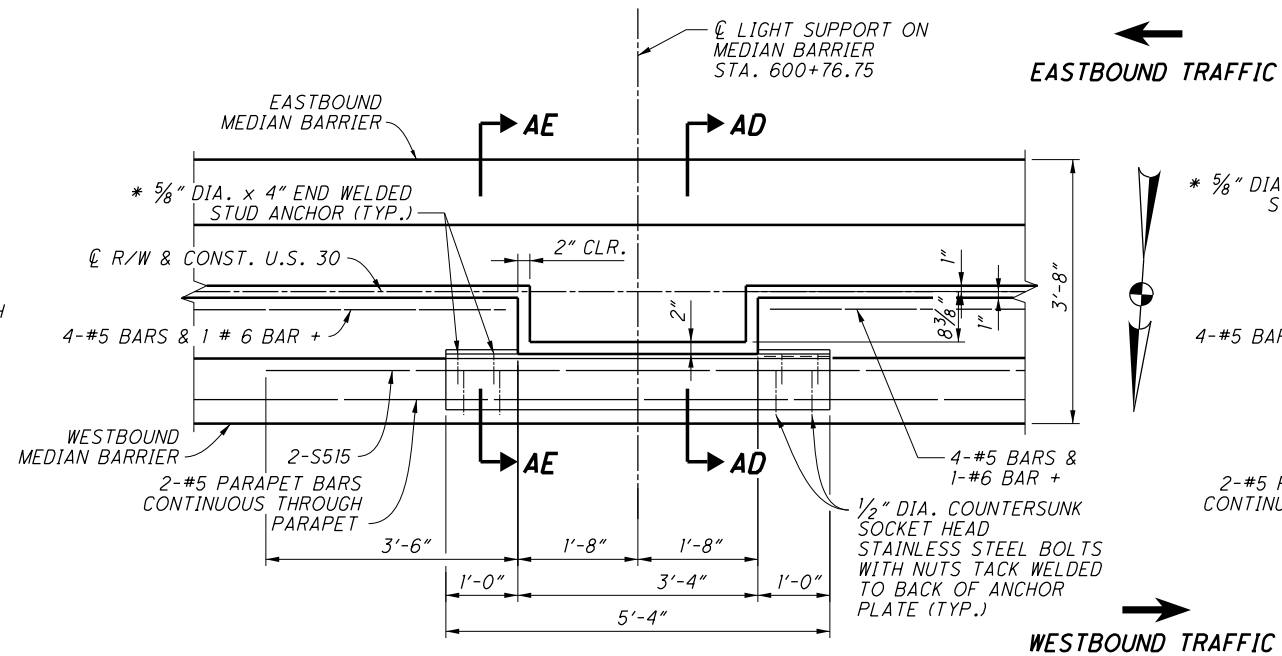

PLAN

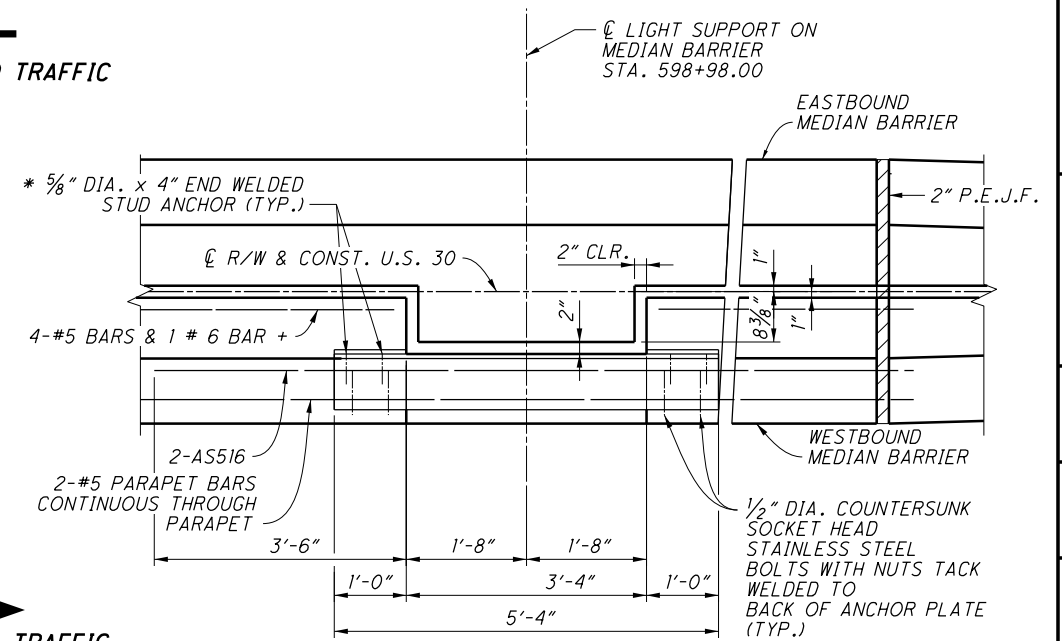

PLAN

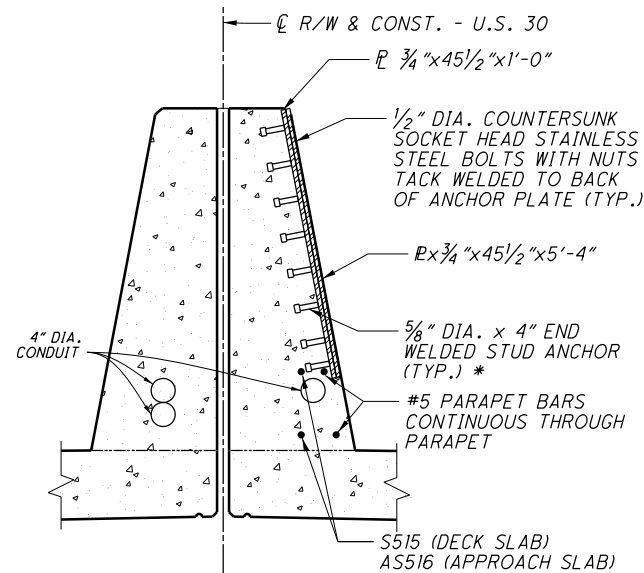

SECTION AE-AE

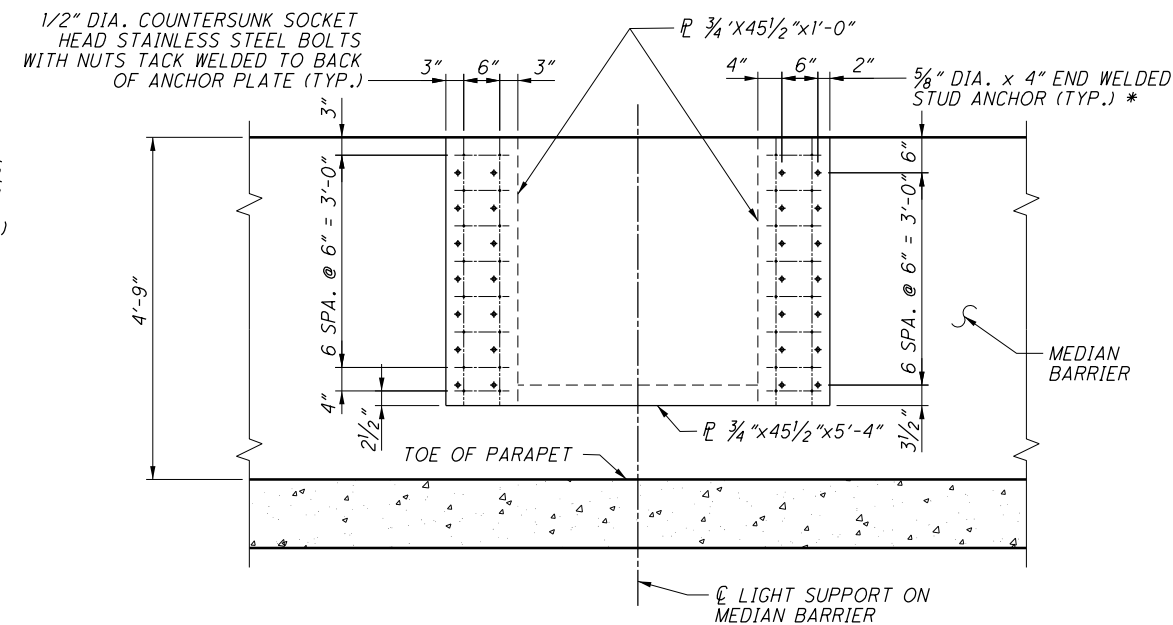

ELEVATION

PLATE AT LIGHT SUPPORT

LEGEND

- * - WELDED WITH AUTOMATICALLY TIMED STUD WELDING EQUIPMENT OR 5/16" MINIMUM FILLET WELD ALL AROUND
- + - FIELD CUT OR ADJUST LAP TO FIT GAP

NOTES

1. ADDITIONAL NOTES SEE SHEETS 45A/56 & 45B/56.

M:\15074\93455\Design\Structures\RIC030_1219C\Sheets\030_1219C\SG001.dgn 3/25/2020 2:34:51PM tac230

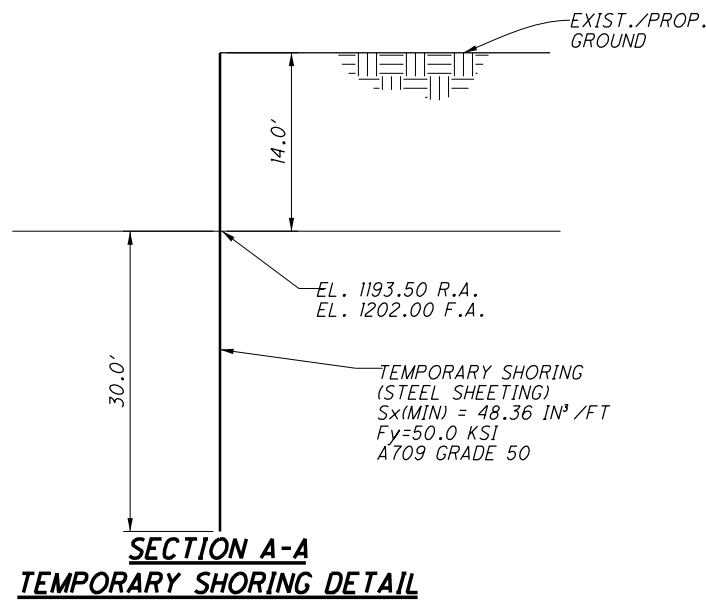
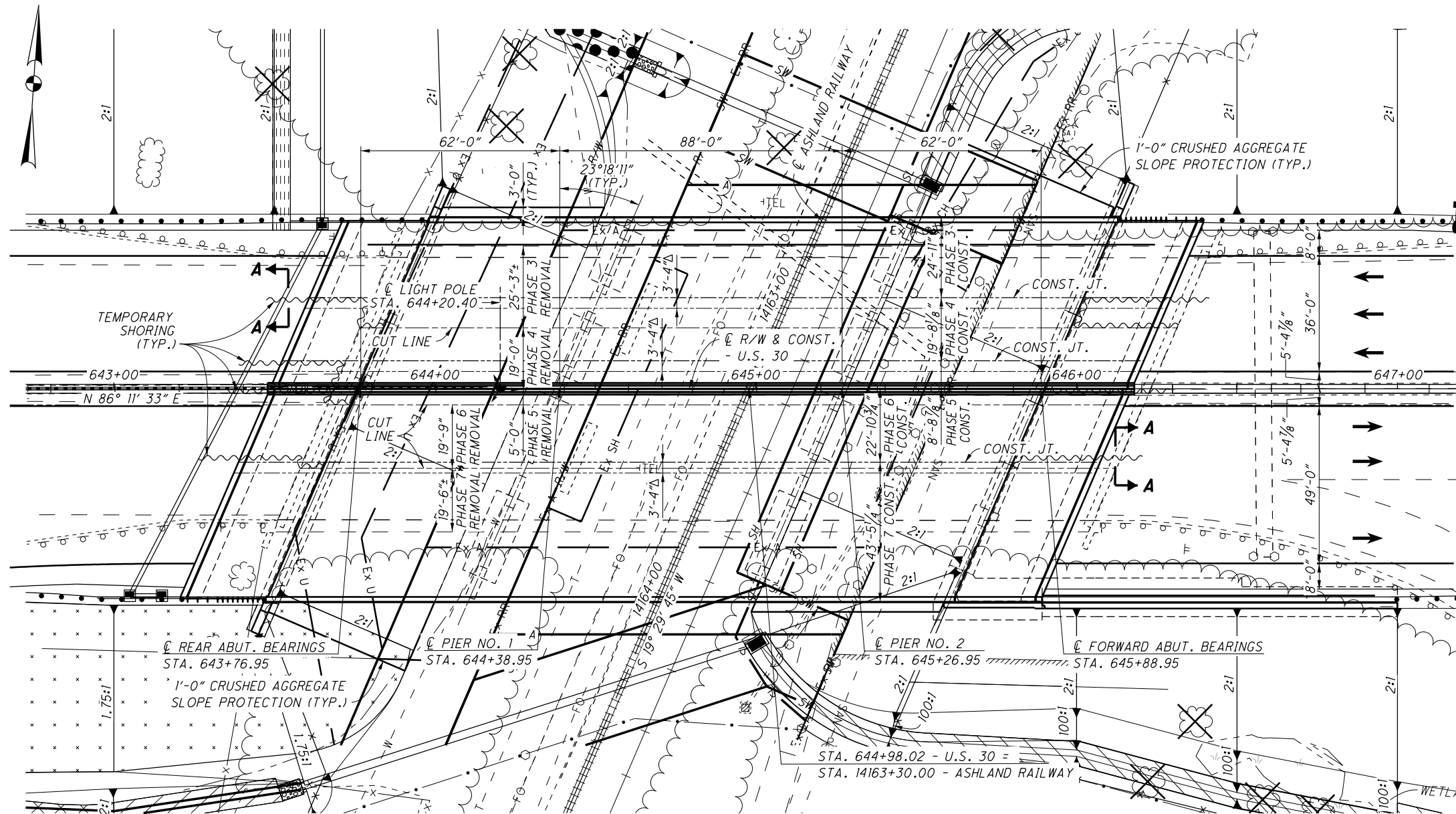

LEGEND
 Δ - CLOSURE POUR

NOTES

1. FOR ABBREVIATIONS AND SECTION SEE SHEET 3/79 .

ITEM 203 EMBANKMENT, AS PER PLAN
 PLACE AND COMPACT EMBANKMENT MATERIAL IN 6 INCH LIFTS FOR THE CONSTRUCTION OF THE APPROACH EMBANKMENT BETWEEN STATIONS 642+50 TO 647+00.

EMBANKMENT AT THE FORWARD ABUTMENT IS TO BE PLACED AT THE ELEVATION SHOWN IN THE PLANS AS SOON AS POSSIBLE. SETTLEMENT OF THE PROPOSED EMBANKMENT IS TO BE MONITORED BY SETTLEMENT PLATFORMS AND DOCUMENTED BY THE CONTRACTOR.

ITEM 503, COFFERDAMS AND EXCAVATION BRACING, AS PER PLAN

THE DESIGN SHOWN ON THE PLANS FOR TEMPORARY SUPPORT OF EXCAVATION IS ONE REPRESENTATIVE DESIGN THAT MAY BE USED TO CONSTRUCT THE PROJECT. THE CONTRACTOR MAY CONSTRUCT THE DESIGN SHOWN ON THE PLANS OR PREPARE AN ALTERNATE DESIGN TO SUPPORT THE SIDES OF EXCAVATION. IF CONSTRUCTING AN ALTERNATE DESIGN FOR TEMPORARY SUPPORT OF EXCAVATION, PREPARE AND PROVIDE PLANS IN ACCORDANCE WITH C&MS 501.05. THE DEPARTMENT WILL PAY FOR THE TEMPORARY SUPPORT OF EXCAVATION AT THE CONTRACT LUMP SUM PRICE FOR COFFERDAMS AND EXCAVATION BRACING. NO ADDITIONAL PAYMENT WILL BE MADE FOR PROVIDING AN ALTERNATE DESIGN.

GENERAL PLAN & NOTES

BRIDGE NO. RIC-30-1219
 OVER ASHLAND RAILWAY

RIC-30-9.26
 PID No. 93455

2 / 79

1345
 1669

DESIGN AGENCY
ENGINEERING ASSOCIATES, INC.
 895 EAGLE PASS - WOOSTER, OHIO 44691
 TELEPHONE: (330) 345-6556
 FAX: (330) 345-8077

DATE 9-24-19
 REVIEWED SDS
 DRAWN TAC
 CHECKED HK
 DESIGNED BDH
 STRUCTURE FILE NUMBER 7001232

STANDARD DRAWINGS

REFER TO THE FOLLOWING STANDARD BRIDGE DRAWINGS:

AS-1-15	REVISED	7-17-15
AS-2-15	REVISED	1-18-19
GSD-1-19	DATED	1-18-19
PCB-91	REVISED	1-18-13
SBR-1-13	REVISED	7-20-18
SBR-2-13	REVISED	7-20-18
SICD-1-96	REVISED	7-18-14
SICD-2-14	DATED	7-18-14
VPF-1-90	REVISED	7-20-18

DESIGN SPECIFICATIONS

THIS STRUCTURE CONFORMS TO THE "LRFD BRIDGE DESIGN SPECIFICATIONS" ADOPTED BY THE AMERICAN ASSOCIATION OF STATE HIGHWAY AND TRANSPORTATION OFFICIALS, 2017, 8TH EDITION AND THE ODOT BRIDGE DESIGN MANUAL, 2019.

OPERATIONAL IMPORTANCE

A LOAD MODIFIER OF 1.0 HAS BEEN ASSUMED FOR THE DESIGN OF THIS STRUCTURE IN ACCORDANCE WITH THE AASHTO LRFD BRIDGE DESIGN SPECIFICATIONS, ARTICLE 1.3.5 AND THE ODOT BRIDGE DESIGN MANUAL, 2019.

DESIGN LOADING

HL-93
FUTURE WEARING SURFACE (FWS) OF 0.060 KIPS/FT².

DESIGN DATA

CONCRETE CLASS OC2 WITH OC/OA - COMPRESSIVE STRENGTH 4.5 KSI (SUPERSTRUCTURE)

CONCRETE CLASS OCI WITH OC/OA - COMPRESSIVE STRENGTH 4.0 KSI (SUBSTRUCTURE)

REINFORCING STEEL - MINIMUM YIELD STRENGTH 60 KSI

STRUCTURAL STEEL - ASTM A709 GRADE 50 - YIELD STRENGTH 50 KSI

DECK PROTECTION METHOD

EPOXY COATED REINFORCING STEEL
2 1/2" CONCRETE COVER

MONOLITHIC WEARING SURFACE

MONOLITHIC WEARING SURFACE IS ASSUMED, FOR DESIGN PURPOSES, TO BE 1 INCH THICK.

ITEM 202, PORTIONS OF STRUCTURE REMOVED, OVER 20 FOOT SPAN, AS PER PLAN:

THIS ITEM SHALL INCLUDE THE ELEMENTS INDICATED IN THE PLANS AND GENERAL NOTES AND THAT ARE NOT SEPARATELY LISTED FOR PAYMENT, EXCEPT FOR WEARING COURSE REMOVAL. ITEMS TO BE REMOVED INCLUDE ALL EXISTING MATERIALS BEING REPLACED BY NEW CONSTRUCTION AND MISCELLANEOUS ITEMS THAT ARE NOT SHOWN TO BE INCORPORATED INTO THE FINAL CONSTRUCTION AND ARE DIRECTED TO BE REMOVED BY THE ENGINEER. THE USE OF EXPLOSIVES, HEADACHE BALLS AND/OR HOE-RAMS WILL NOT BE PERMITTED. THE METHOD OF REMOVAL AND THE WEIGHT OF HAMMER SHALL BE APPROVED BY THE ENGINEER. PERFORM ALL WORK IN A MANNER THAT WILL NOT CUT, ELONGATE OR DAMAGE THE EXISTING REINFORCING STEEL TO BE PRESERVED. CHIPPING HAMMERS SHALL NOT BE HEAVIER THAN THE NOMINAL 90-POUND CLASS. PNEUMATIC HAMMERS SHALL NOT BE PLACED IN DIRECT CONTACT WITH REINFORCING STEEL THAT IS TO BE RETAINED IN THE REBUILT STRUCTURE. SUBMIT CONSTRUCTION PLANS ACCORDING TO C&MS 501.05

PILES DRIVEN TO TIP ELEVATION FOR SOIL/PILE SETUP

THE ULTIMATE BEARING VALUE IS 220 KIPS PER PILE FOR THE ABUTMENT PILES. THE ULTIMATE BEARING VALUE AT PIERS IS 352.0 KIPS PER PILE LEFT BRIDGE AND 338.5 KIPS PER PILE RIGHT BRIDGE. PART OF THE ULTIMATE BEARING VALUE WILL BE ACHIEVED THROUGH PILE/SOIL SETUP, WHICH IS A TIME DEPENDENT INCREASE IN RESISTANCE THAT OCCURS IN SOME SOILS.

NOTIFY THE ENGINEER AT LEAST 5 DAYS BEFORE DRIVING PILES SO THAT THE ENGINEER CAN NOTIFY THE DISTRICT GEOTECHNICAL ENGINEER, THE OFFICE OF CONSTRUCTION ADMINISTRATION, AND THE OFFICE OF GEOTECHNICAL ENGINEERING.

DRIVE THE FIRST TWO PILES IN EACH SUBSTRUCTURE TO THE TIP ELEVATION GIVEN BELOW FOR THE SUBSTRUCTURE, DRIVE THE THIRD AND FOURTH PILES TO 75% AND 85% OF THE LENGTH OF THE FIRST TWO PILES. PERFORM DYNAMIC LOAD TESTING ON ALL FOUR PILES WHILE DRIVING. AFTER DRIVING THE FOUR PILES, CEASE ALL DRIVING OPERATIONS AT THE SUBSTRUCTURE FOR A MINIMUM OF 7 DAYS. INCLUDE THE WAITING PERIOD AS A SEPARATE ACTIVITY IN THE PROGRESS SCHEDULE. AFTER THE WAITING PERIOD, PERFORM PILE RESTRIKES ON THE FOUR PILES (TWO RESTRIKE ITEMS). SUBMIT ALL TEST RESULTS TO THE ENGINEER. THE ENGINEER WILL REVIEW THE TEST RESULTS AND ESTABLISH DRIVING CRITERIA FOR THE PILING IN THE SUBSTRUCTURE WITH THE ASSISTANCE OF THE DISTRICT GEOTECHNICAL ENGINEER, AND THE OFFICE OF GEOTECHNICAL ENGINEERING.

THE DRIVING CRITERIA WITH PILE SETUP SHALL BE PERFORMED FOR THE FIRST STAGE OF BRIDGE CONSTRUCTION. THE CONTRACTOR SHALL NOT ORDER PILES FOR SUBSEQUENT PHASES UNTIL AFTER THE DRIVING CRITERIA HAS BEEN ESTABLISHED WITH SETUP. THE DEPARTMENT WILL ADJUST THE FURNISHED PILE QUANTITIES BASED ON THE RESTRIKE TEST RESULTS.

IF THE DYNAMIC LOAD TESTING INDICATES A PILE HAS ACHIEVED THE ULTIMATE BEARING VALUE ABOVE THE TIP ELEVATION DURING THE INITIAL DRIVING, (BEFORE THE WAITING PERIOD), STOP DRIVING AND NOTIFY THE ENGINEER. IF THE RESTRIKE TEST RESULTS ON THE FOUR PILES INDICATE THAT A PILE DID NOT ACHIEVE THE REQUIRED ULTIMATE BEARING VALUE, DRIVE THE PILE TO THE ESTABLISHED DRIVING CRITERIA. SPLICING OF THE PILES BEYOND THE ESTIMATED LENGTH PROVIDED IN THE PLANS WILL BE PAID BY THE DEPARTMENT UNDER CMS 109.05 WITH A NEGOTIATED PRICE PER SPLICE.

LEFT BRIDGE:	NO. OF PILES	PILE TIP ELEV.	ORDER LENGTH
REAR ABUTMENT	14	1142.9	60'
PIER NO. 1	30	1104.1	75'
PIER NO. 2	30	1104.7	80'
FORWARD ABUTMENT	14	1149.8	60'

RIGHT BRIDGE:	NO. OF PILES	PILE TIP ELEV.	ORDER LENGTH
REAR ABUTMENT	17	1142.9	60'
PIER NO. 1	36	1106.9	80'
PIER NO. 2	36	1109.3	75'
FORWARD ABUTMENT	28	1149.8	60'

ABUTMENT PILES: (12" DIA. C-I-P CONCRETE)
1 DYNAMIC LOAD TEST
PIER PILES: (16" DIA. C-I-P CONCRETE)
1 STATIC LOAD TEST
2 DYNAMIC LOAD TESTS
2 RESTRIKES

PILE DRIVING CONSTRAINTS

PILE DRIVING MAY NOT BEGIN UNTIL SUFFICIENT EMBANKMENT SETTLEMENT HAS OCCURRED AS DOCUMENTED BY THE SETTLEMENT PLATFORMS. THE ANTICIPATED WAITING PERIOD TO PERMIT SUFFICIENT EMBANKMENT SETTLEMENT IS 30 DAYS. THE DISTRICT GEOTECHNICAL ENGINEER MAY REDUCE OR EXTEND THE WAITING PERIOD BASED ON THE MAGNITUDE AND RATE OF THE EMBANKMENT SETTLEMENT AS DETERMINED BY THE SETTLEMENT PLATFORMS. THE SETTLEMENT WAITING PERIOD BEGINS ONCE THE APPROACH EMBANKMENT REACHES THE DESIGN SUBGRADE LEVEL FOR A MINIMUM DISTANCE OF 200 FEET BEHIND EACH ABUTMENT. BEGIN PILE DRIVING ONLY FOLLOWING TERMINATION OF THE SETTLEMENT MONITORING WAITING PERIOD BY THE DISTRICT GEOTECHNICAL ENGINEER.

ITEM 507 - CAST-IN-PLACE REINFORCED CONCRETE PILES, AS PER PLAN

MINIMUM PIPE PILE WALL THICKNESS IS 0.375".

FOR ENCASED PILES, PILE SLEEVE MATERIAL SHALL BE CORRUGATED POLYETHYLENE SMOOTH LINED PIPE CONFORMING TO EITHER 707.33 OR ASTM F2648, OR PVC CORRUGATED SMOOTH INTERIOR PIPE CONFORMING TO 707.42. INSIDE DIAMETER OF SLEEVE SHALL BE 14 INCHES. THE ESTIMATED SLEEVE LENGTH SHALL BE 15 FEET.

IF FURNISHING PLASTIC PIPE MANUFACTURED FROM RECYCLED POLYETHYLENE, SUBMIT CERTIFIED TEST DATA THAT SHOWS THE PIPE CONFORMS WITH ASTM F2648. CLEARLY MARK ALL PIPE MANUFACTURED FROM RECYCLED POLYETHYLENE SO THAT IT IS USED ONLY FOR PILE SLEEVES ON THE PROJECT.

AFTER PILES ARE DRIVEN, SLEEVES ARE TO BE FILLED WITH GRANULAR MATERIAL CONFORMING TO 703.11, STRUCTURAL BACKFILL TYPE 2, EXCEPT 100 PERCENT OF THE MATERIAL SHALL PASS THROUGH A 3/4-INCH SIEVE.

FOR ITEM SPECIAL, SETTLEMENT PLATFORM SEE SHEET 1335/1669.

SETTLEMENT PLATFORM LOCATIONS			
POINT	STATION	OFFSET	CONSTRUCTED IN STAGE
1	645+94.24	41.36' LT	-
2	645+82.37	13.81' LT	-
3	645+70.51	13.75' RT	-
4	645+58.64	41.30' RT	-

DECK PLACEMENT ASSUMPTIONS

THE FOLLOWING ASSUMPTIONS OF CONSTRUCTION MEANS AND METHODS WERE MADE FOR THE ANALYSIS AND DESIGN OF THE SUPERSTRUCTURE. THE CONTRACTOR IS RESPONSIBLE FOR THE DESIGN OF THE FALSEWORK SUPPORT SYSTEM WITHIN THESE PARAMETERS AND WILL ASSUME RESPONSIBILITY FOR SUPERSTRUCTURE ANALYSIS FOR DEVIATION FROM THESE DESIGN ASSUMPTIONS.

AN EIGHT WHEEL FINISHING MACHINE WITH A MAXIMUM WHEEL LOAD OF 2.38 KIPS.

A MINIMUM OUT-TO-OUT WHEEL SPACING AT EACH END OF THE MACHINE OF 103".

A MAXIMUM SPACING OF OVERHANG FALSEWORK BRACKETS OF 48".

A MAXIMUM DISTANCE FROM THE CENTERLINE OF THE FASCIA GIRDER TO THE FACE OF THE SAFETY HANDRAIL OF 65".

STRUCTURE PAINTING: ALL BRIDGE FINISH COATS SHALL BE THE SAME COLOR.

INSTALLATION OF MULTI-CELL CONDUIT ON STRUCTURES

ONE MULTI-CELL CONDUIT IS CONTINUOUS FOR THE ENTIRE PROJECT. THE SECOND MULTI-CELL CONDUIT SHALL BE PLACED ONLY WITHIN THE LIMITS OF THE BRIDGES AND APPROACH SLABS AND SHALL TERMINATE AT A JUNCTION BOX AS SHOWN IN STANDARD DRAWING HL-30.33.

ABBREVIATIONS

- ABUT. - ABUTMENT
- APPR. - APPROACH
- BRG. - BEARING
- BOT. - BOTTOM
- CONST. JT. - CONSTRUCTION JOINT
- CLR. - CLEAR
- CONST. - CONSTRUCTION
- CORR. - CORRUGATED
- DIA. - DIAMETER
- DIM. - DIMENSION
- DWG. - DRAWING
- EL. - ELEVATION
- E.F. - EACH FACE
- EXIST. - EXISTING
- F.A. - FORWARD ABUTMENT
- FWD. - FORWARD
- F.F. - FRONT FACE
- FT. - FEET
- LBS. - POUNDS
- MAX. - MAXIMUM
- MEAS. - MEASURED
- MIN. - MINIMUM
- OPT. - OPTIONAL
- P.E.J.F. - PREFORMED EXPANSION JOINT FILLER
- R.A. - REAR ABUTMENT
- R.F. - REAR FACE
- REQ'D. - REQUIRED
- SPA. - SPACING
- STA. - STATION
- T.O.S. - TOP OF SLOPE
- TYP. - TYPICAL
- U.O.N. - UNLESS OTHERWISE NOTED
- VAR. - VARIES
- W/ - WITH

M:\15074\93455\Design\Structures\RIC030_1219C\Sheets\030_1219CSN001.dgn 3/27/2020 8:59:57 AM toc230



CALC: HK DATE: 6/28/2019
 CHECKED: TAC DATE: 6/28/2019

ESTIMATED QUANTITIES

ITEM	EXTENSION	TOTAL 01/NHS/BR	UNIT	DESCRIPTION	ABUT.	PIERS	SUPER.	GEN.	SEE	SHEET
202	11203	LS		PORTIONS OF STRUCTURE REMOVED, OVER 20 FOOT SPAN, AS PER PLAN				LS		3/79
202	22900	411	SY	APPROACH SLAB REMOVED				411		
202	23500	411	SY	WEARING COURSE REMOVED				411		
SPECIAL	20365000	4	EACH	SETTLEMENT PLATFORM				4		3/79
503	11101	LS		COFFERDAMS AND EXCAVATION BRACING, AS PER PLAN				LS		2/79
503	21100	1967	CY	UNCLASSIFIED EXCAVATION	810	1157				
505	11100	LS		PILE DRIVING EQUIPMENT MOBILIZATION				LS		
506	11100	LS		STATIC LOAD TEST		LS				
507	00501	4015	FT	12" CAST-IN-PLACE REINFORCED CONCRETE PILES, DRIVEN, AS PER PLAN	4015					3/79 & 23/79
507	00551	4380	FT	12" CAST-IN-PLACE REINFORCED CONCRETE PILES, FURNISHED, AS PER PLAN	4380					3/79 & 23/79
507	00701	9570	FT	16" CAST-IN-PLACE REINFORCED CONCRETE PILES, DRIVEN, AS PER PLAN		9570				3/79
507	00751	10230	FT	16" CAST-IN-PLACE REINFORCED CONCRETE PILES, FURNISHED, AS PER PLAN		10230				3/79
509	10000	411193	LB	EPOXY COATED REINFORCING STEEL	42869	136266	232058			
511	21523	1026	CY	CLASS OC2 CONCRETE WITH OC/OA, SUPERSTRUCTURE, AS PER PLAN			1026			42/79, 52/79, 53/79 & 61/79
511	33500	4	EACH	SEMI-INTEGRAL DIAPHRAGM GUIDE			4			
511	41012	437	CY	CLASS OC1 CONCRETE WITH OC/OA, PIER ABOVE FOOTINGS		437				
511	44112	203	CY	CLASS OC1 CONCRETE WITH OC/OA, ABUTMENT NOT INCLUDING FOOTING	203					
511	46512	496	CY	CLASS OC1 CONCRETE WITH OC/OA, FOOTING	256	240				
512	10100	2037	SY	SEALING OF CONCRETE SURFACES (EPOXY-URETHANE)	237	982	723	95		
512	10300	414	SY	SEALING CONCRETE BRIDGE DECKS WITH HMMM RESIN			381	33		
512	33000	42	SY	TYPE 2 WATERPROOFING	42					
513	10260	754305	LB	STRUCTURAL STEEL MEMBERS, LEVEL 3			754305			
513	20000	11778	EACH	WELDED STUD SHEAR CONNECTORS			11778			
514	00800	754305	LB	FIELD PAINTING STRUCTURAL STEEL, INTERMEDIATE COAT			754305			
514	00851	754305	LB	FIELD PAINTING STRUCTURAL STEEL, FINISH COAT, AS PER PLAN			754305			3/79
514	10000	31	EACH	FINAL INSPECTION REPAIR			31			
516	10010	249	FT	ARMORLESS PREFORMED JOINT SEAL				249		
516	13600	75	SF	1" PREFORMED EXPANSION JOINT FILLER			75			
516	13900	646	SF	2" PREFORMED EXPANSION JOINT FILLER			245	401		
516	14020	300	FT	SEMI-INTEGRAL ABUTMENT EXPANSION JOINT SEAL	300					
516	44101	28	EACH	ELASTOMERIC BEARING WITH INTERNAL LAMINATES AND LOAD PLATE (NEOPRENE), AS PER PLAN 3 1/8"x1'-4"x1'-7" WITH 2 3/8" (AVG)x1'-5"x1'-8" BEVELED LOAD PLATE		28				38/79
516	44101	28	EACH	ELASTOMERIC BEARING WITH INTERNAL LAMINATES AND LOAD PLATE (NEOPRENE), AS PER PLAN 2 1/2"x1'-0"x1'-2" WITH 1 3/4" (AVG)x1'-1"x1'-3" BEVELED LOAD PLATE	28					38/79
518	21200	225	CY	POROUS BACKFILL WITH GEOTEXTILE FABRIC	225					
518	40000	320	FT	6" PERFORATED CORRUGATED PLASTIC PIPE	320					
518	40010	45	FT	6" NON-PERFORATED CORRUGATED PLASTIC PIPE, INCLUDING SPECIALS	45					
523	20000	3	EACH	DYNAMIC LOAD TESTING	1	2				
523	20500	2	EACH	RESTRIKE		2				
526	25001	657	SY	REINFORCED CONCRETE APPROACH SLABS (T=15"), AS PER PLAN				657		60/79, 63/79 THRU 65/79
526	90030	258	FT	TYPE C INSTALLATION				258		
601	20010	612	CY	CRUSHED AGGREGATE SLOPE PROTECTION				612		

DESIGN AGENCY
 ENGINEERING ASSOCIATES, INC.
 8955 EAGLE PASS - WOOSTER, OHIO 44691
 TELEPHONE: (330) 345-6556
 FAX: (330) 345-8077

DATE
 9-24-19
 STRUCTURE FILE NUMBER
 7001232

DESIGNED
 HK
 CHECKED
 BDH

DRAWN
 TAC
 REVISED

REVIEWED
 SDS
 STRUCTURE FILE NUMBER
 7001232

ESTIMATED QUANTITIES
 BRIDGE NO. RIC-30-1219
 OVER ASHLAND RAILWAY

DESIGNED
 HK
 CHECKED
 BDH

DESIGNED
 HK
 CHECKED
 BDH

DESIGNED
 HK
 CHECKED
 BDH

4/79
 1347
 1669

M:\15074\93455\Design\Structures\RIC030_1219C\Sheets\030_1219CSQ001.dgn 3/27/2020 11:25:58 AM kja282

M:\15074\93455\Design\Structures\RIC030_1219C\Sheets\030_1219CST001.dgn 3/27/2020 8:54:53 AM tac230

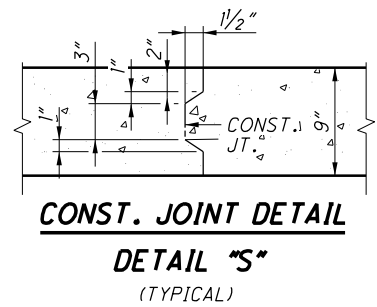
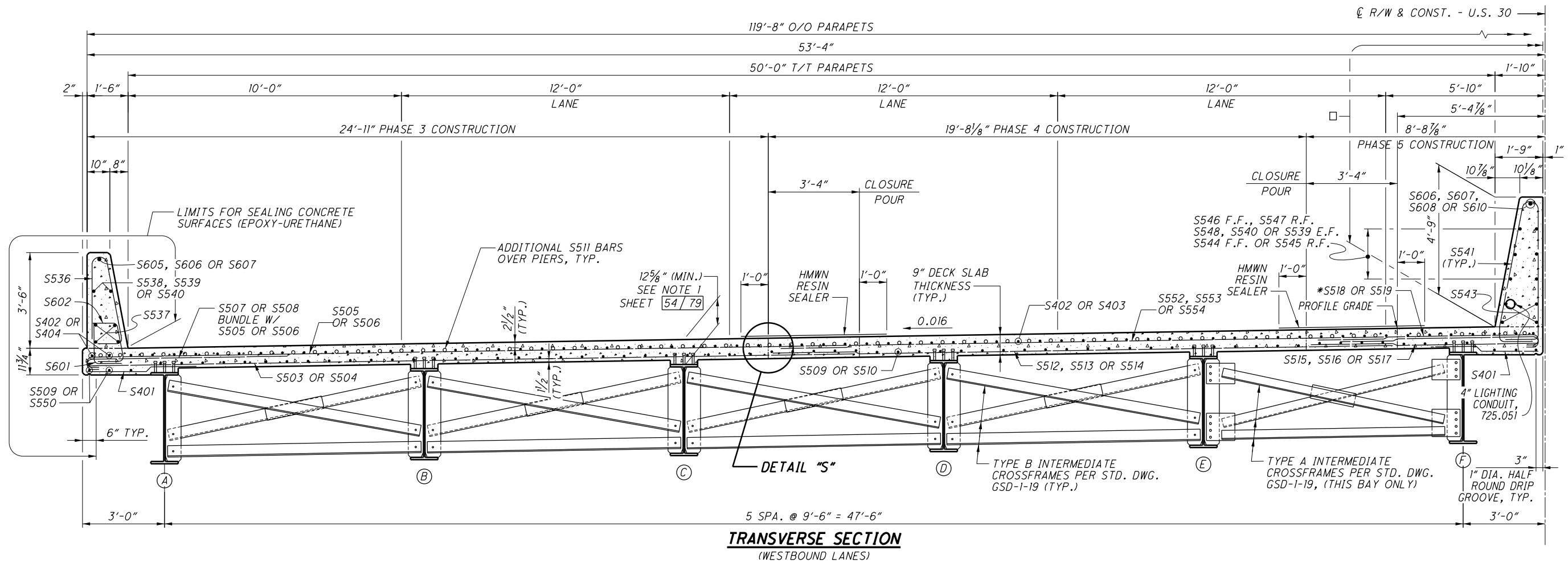

LEGEND

- - LIMITS FOR SEALING CONCRETE SURFACES (EPOXY-URETHANE)
- * - S507 OR S553 BUNDLE W/S518 OR S519

NOTES

1. MINIMUM REINFORCING STEEL SPLICE LENGTH UNLESS OTHERWISE NOTED:
NO. 5 BAR = 2'-5"
S502 THRU S504,
S509 & S510,
S512 THRU S517 = 3'-0" (BOTTOM OF SLAB)
2. FOR RAILING AND MEDIAN BARRIER DETAILS SEE SHEET [56/79] THRU [60/79].
3. FOR SLAB PLAN - LEFT (WESTBOUND) SEE SHEET [54/79].
4. FOR ABBREVIATIONS SEE SHEET [3/79].
5. 4" LIGHTING CONDUIT, 725.051, AND 4" MULTICELL ITS CONDUIT, 725.20 EPC-40, AND JUNCTION BOXES WHERE REQUIRED SHALL BE PLACED IN THE MEDIAN BARRIER AS SHOWN IN THE PLANS. THE COST OF PLACEMENT, MATERIALS, EQUIPMENT AND LABOR SHALL BE CONSIDERED INCIDENTAL AND INCLUDED FOR PAYMENT IN ITEM 511 CLASS OC2 CONCRETE WITH OC/QA SUPERSTRUCTURE, AS PER PLAN.

<p>DESIGN AGENCY ENGINEERING ASSOCIATES, INC. 895 EAGLE PASS - WOOSTER, OHIO 44691 TELEPHONE: (330) 345-6556 FAX: (330) 345-8077</p>	<p>DATE 9-24-19</p>	<p>REVIEWED SDS</p>	<p>STRUCTURE FILE NUMBER 7001232</p>	<p>DESIGNED HK</p>	<p>CHECKED BDH</p>
<p>TRANSVERSE SECTION - LEFT (WESTBOUND)</p>					
<p>BRIDGE NO. RIC-30-1219 OVER ASHLAND RAILWAY</p>					
<p>RIC-30-9-26 PID No. 93455</p>					
<p>52 / 79</p>					
<p>1395 1669</p>					

M:\15074\93455\Design\Structures\RIC030_1219C\Sheets\030_1219CST002.dgn 3/27/2020 8:56:52 AM tac230

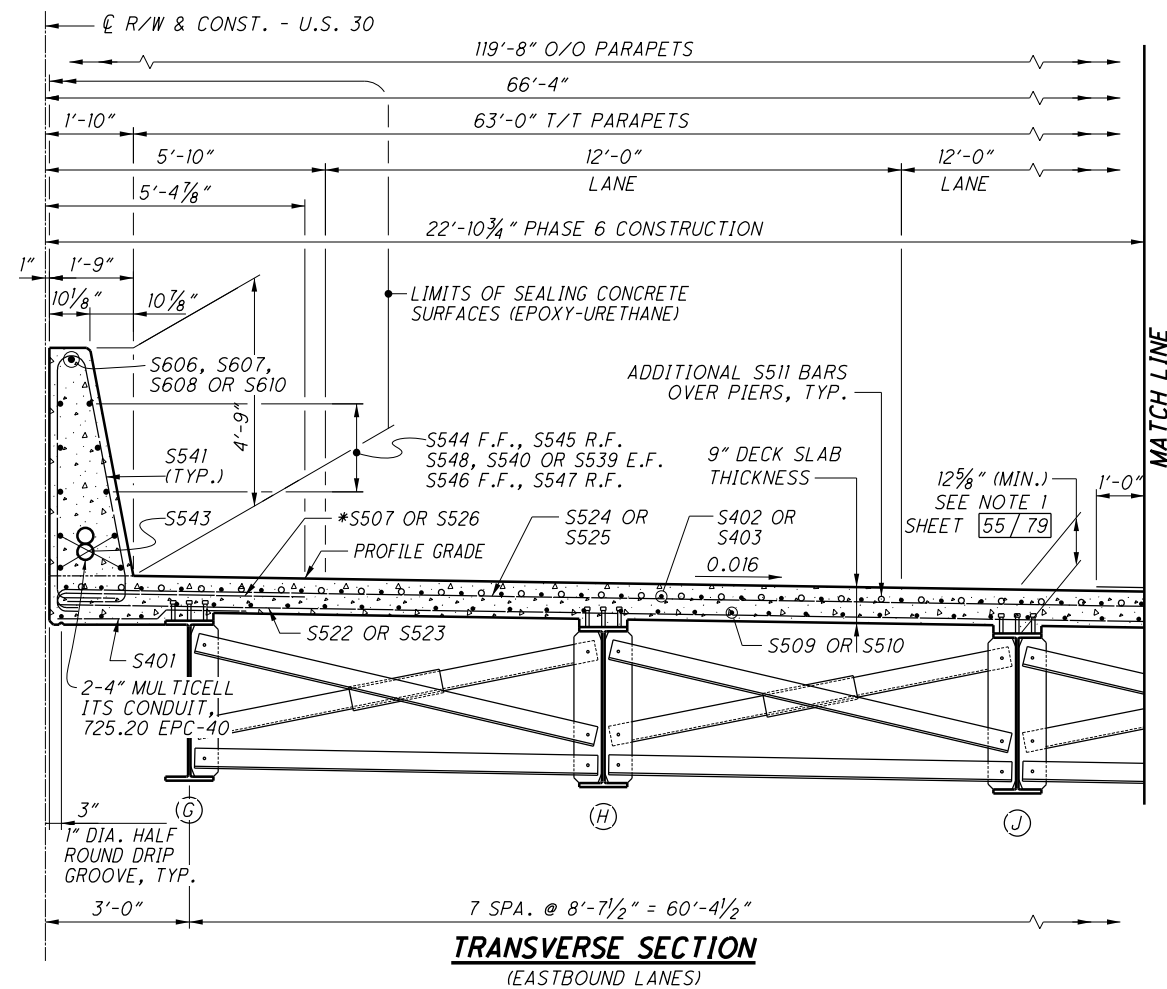

TRANSVERSE SECTION
(EASTBOUND LANES)

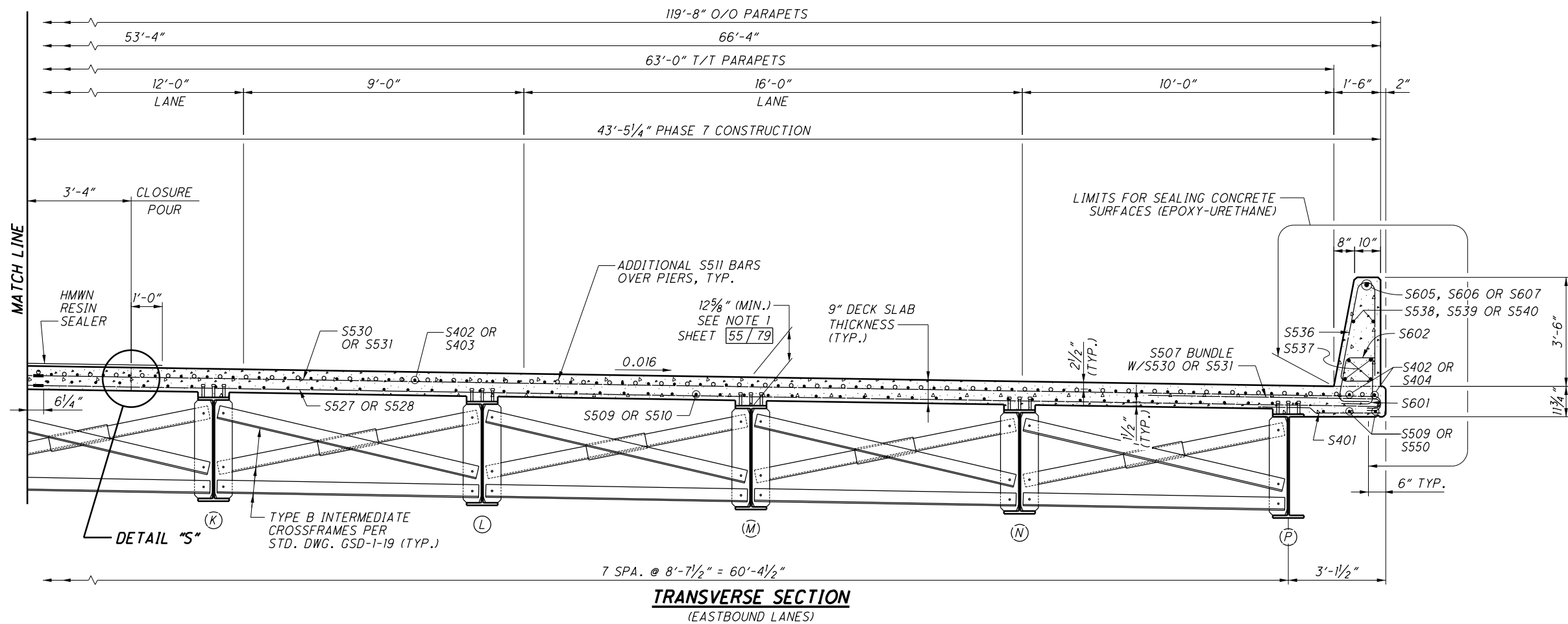

TRANSVERSE SECTION
(EASTBOUND LANES)

LEGEND

* - S507 & S526 BUNDLE WITH S524 OR S525

NOTES

1. MINIMUM REINFORCING STEEL SPLICE LENGTH UNLESS OTHERWISE NOTED:
NO. 5 BAR = 2'-5"
S521 THRU S523, S527 THRU S529 = 3'-0" (BOTTOM OF SLAB)
2. FOR RAILING AND MEDIAN BARRIER DETAILS SEE SHEET 56/79 THRU 60/79.
3. FOR SLAB PLAN - RIGHT (EASTBOUND) SEE SHEET 55/79.
4. FOR ABBREVIATIONS SEE SHEET 3/79.
5. FOR DETAIL "S" SEE SHEET 52/79.
6. 4" LIGHTING CONDUIT, 725.051, AND 4" MULTICELL ITS CONDUIT, 725.20 EPC-40, AND JUNCTION BOXES WHERE REQUIRED SHALL BE PLACED IN THE MEDIAN BARRIER AS SHOWN IN THE PLANS. THE COST OF PLACEMENT, MATERIALS, EQUIPMENT AND LABOR SHALL BE CONSIDERED INCIDENTAL AND INCLUDED FOR PAYMENT IN ITEM 511 CLASS QC2 CONCRETE WITH QC/OA SUPERSTRUCTURE, AS PER PLAN.

DESIGN AGENCY: ENGINEERING ASSOCIATES, INC.
 895 EAGLE PASS - WOOSTER, OHIO 44691
 TELEPHONE: (330) 345-6556
 FAX: (330) 345-8077

DESIGNED: HK
 CHECKED: BDH

DRAWN: RLE
 REVISION: ---

REVIEWED: SDS
 DATE: 9-24-19
 STRUCTURE FILE NUMBER: 7001232

BRIDGE NO. RIC-30-1219
 OVER ASHLAND RAILWAY

RIC-30-9-26
 PID No. 93455

53/79

1396
 1669

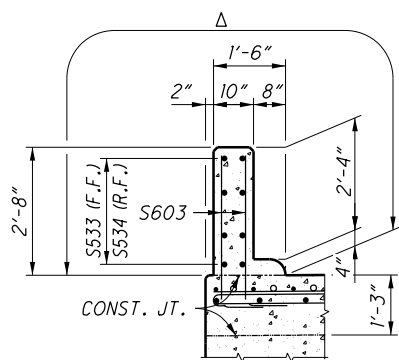

SECTION NN-NN

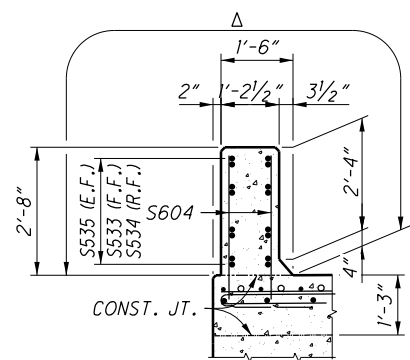

SECTION OO-00

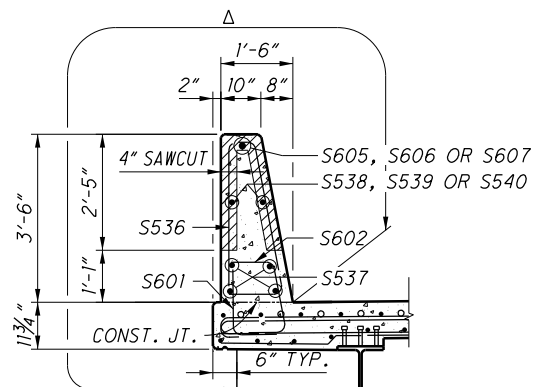

SECTION PP-PP

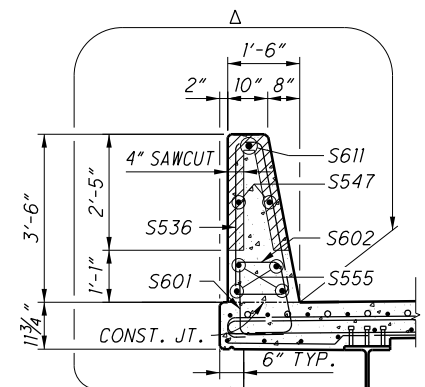

SECTION PPP-PPP

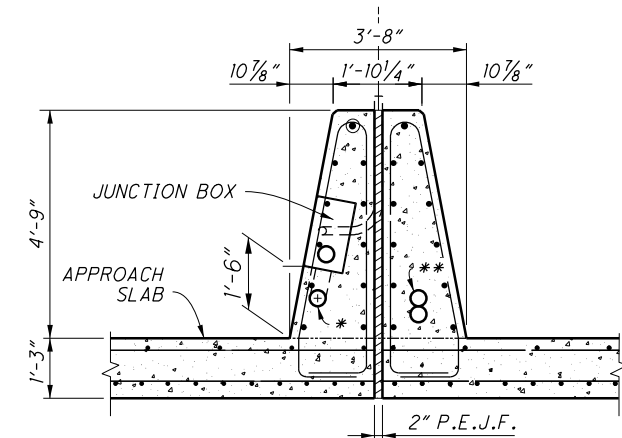

SECTION AF-AF

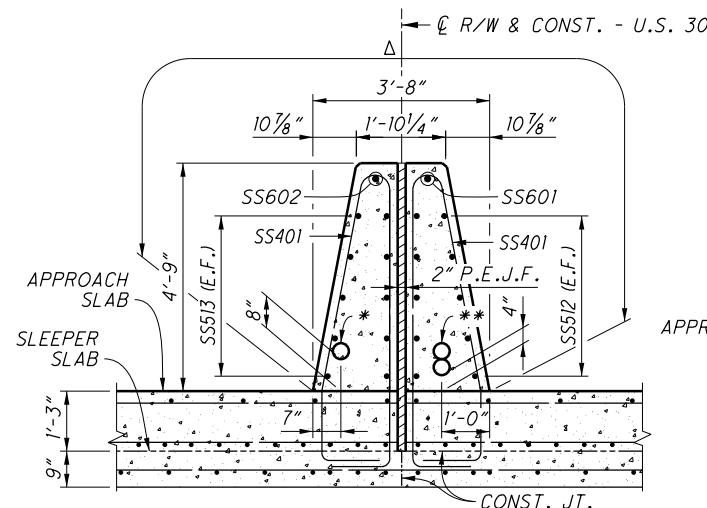

SECTION RR-RR

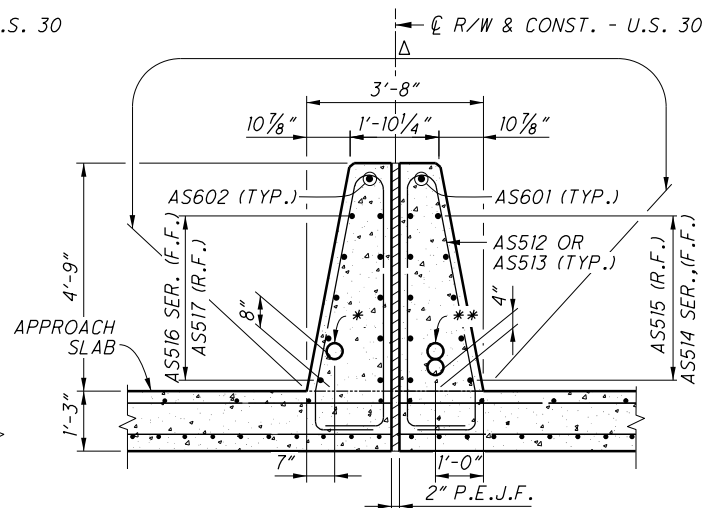

SECTION SS-SS

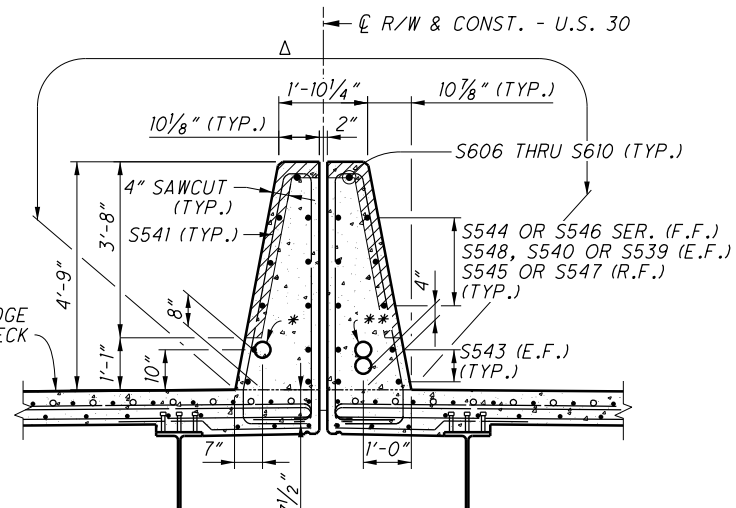

SECTION TT-TT

NOTES

- FOR ABBREVIATIONS SEE SHEET **3/79**.
- FOR LOCATIONS OF SECTIONS NN-NN THRU PP-PP SEE SHEETS **56/79** & **57/79**.
- FOR LOCATIONS OF SECTIONS RR-RR THRU TT-TT, AF-AF & DETAILS "H" & "J" SEE SHEETS **58/79** & **59/79**.
- FOR DETAILS NOT SHOWN SEE STANDARD DRAWING SBR-1-13 AND SBR-2-13.
- 4" LIGHTING CONDUIT, 725.051, AND 4" MULTICELL ITS CONDUIT, 725.20 EPC-40, AND JUNCTION BOXES WHERE REQUIRED SHALL BE PLACED IN THE MEDIAN BARRIER AS SHOWN IN THE PLANS. THE COST OF PLACEMENT, MATERIALS, EQUIPMENT AND LABOR SHALL BE CONSIDERED INCIDENTAL AND INCLUDED FOR PAYMENT IN ITEM 526 REINFORCED CONCRETE APPROACH SLABS, AS PER PLAN.

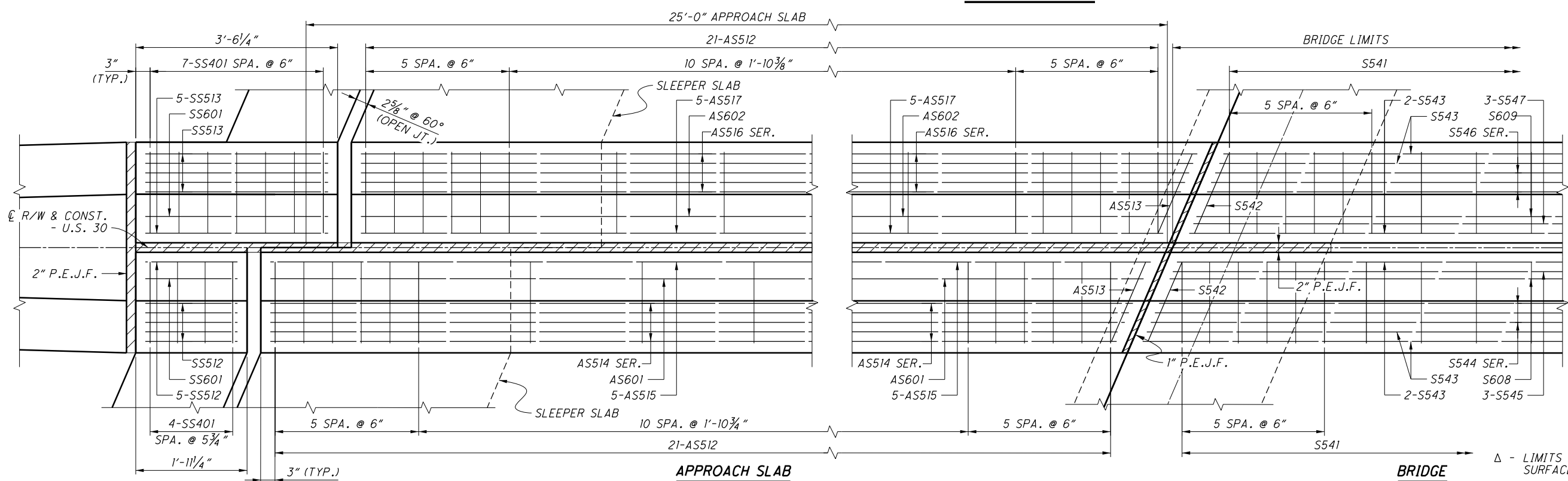

DETAIL "H"

(MEDIAN RAILING AT SLEEPER SLAB)
REAR APPROACH SHOWN-FORWARD SIMILAR BY ROTATION

DETAIL "J"

(MEDIAN RAILING AT ABUTMENT)

LEGEND

- Δ - LIMITS FOR SEALING CONCRETE SURFACES (EPOXY-URETHANE) TYP.
- * - 4" LIGHTING CONDUIT, 725.051
- ** - 2-4" MULTICELL ITS CONDUIT, 725.20 EPC-40

M:\15074\93455\Design\Structures\RIC030_1219C\Sheets\030_1219CSA005.dgn 3/27/2020 10:03:17 AM toc230

DESIGN AGENCY: ENGINEERING ASSOCIATES, INC.
 895 EAGLE PASS - WOOSTER, OHIO 44691
 TELEPHONE: (330) 345-6556
 FAX: (330) 345-8077

DATE: 9-24-19
 REVIEWED: SDS
 STRUCTURE FILE NUMBER: 7001232

DRAWN: TAC
 CHECKED: BDH

DESIGNED: HK

BRIDGE RAILING DETAILS
 BRIDGE NO. RIC-30-1219
 OVER ASHLAND RAILWAY

RIC-30-9-26
 PID No. 93455

60/79
 1403
 1669

M:\15074\93455\Design\Structures\RIC030_1219C\Sheets\030_1219CSA006.dgn 3/27/2020 10:01:26 AM tac230

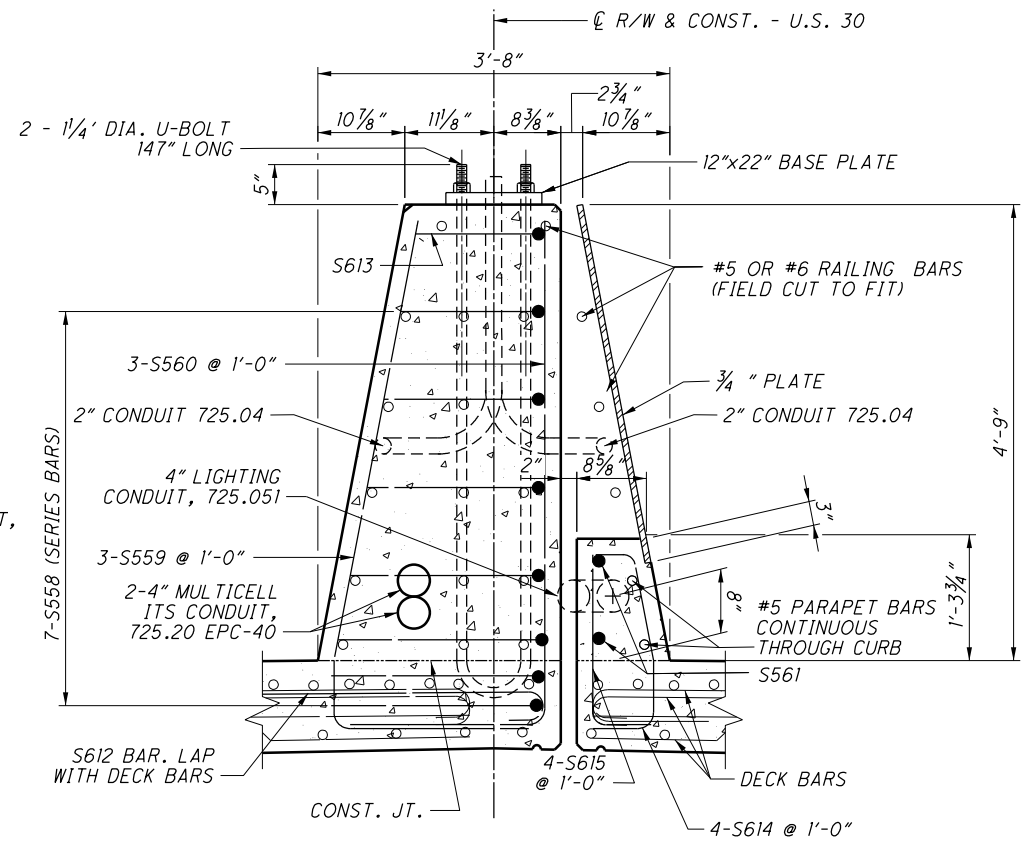
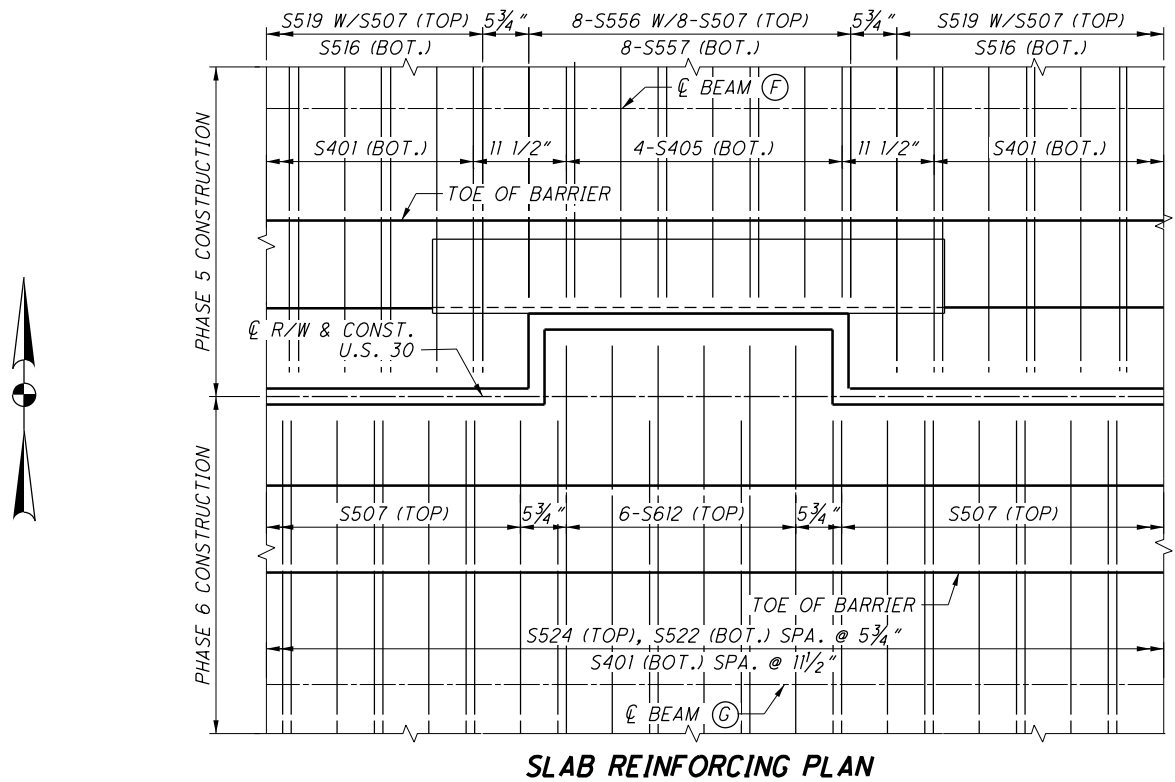
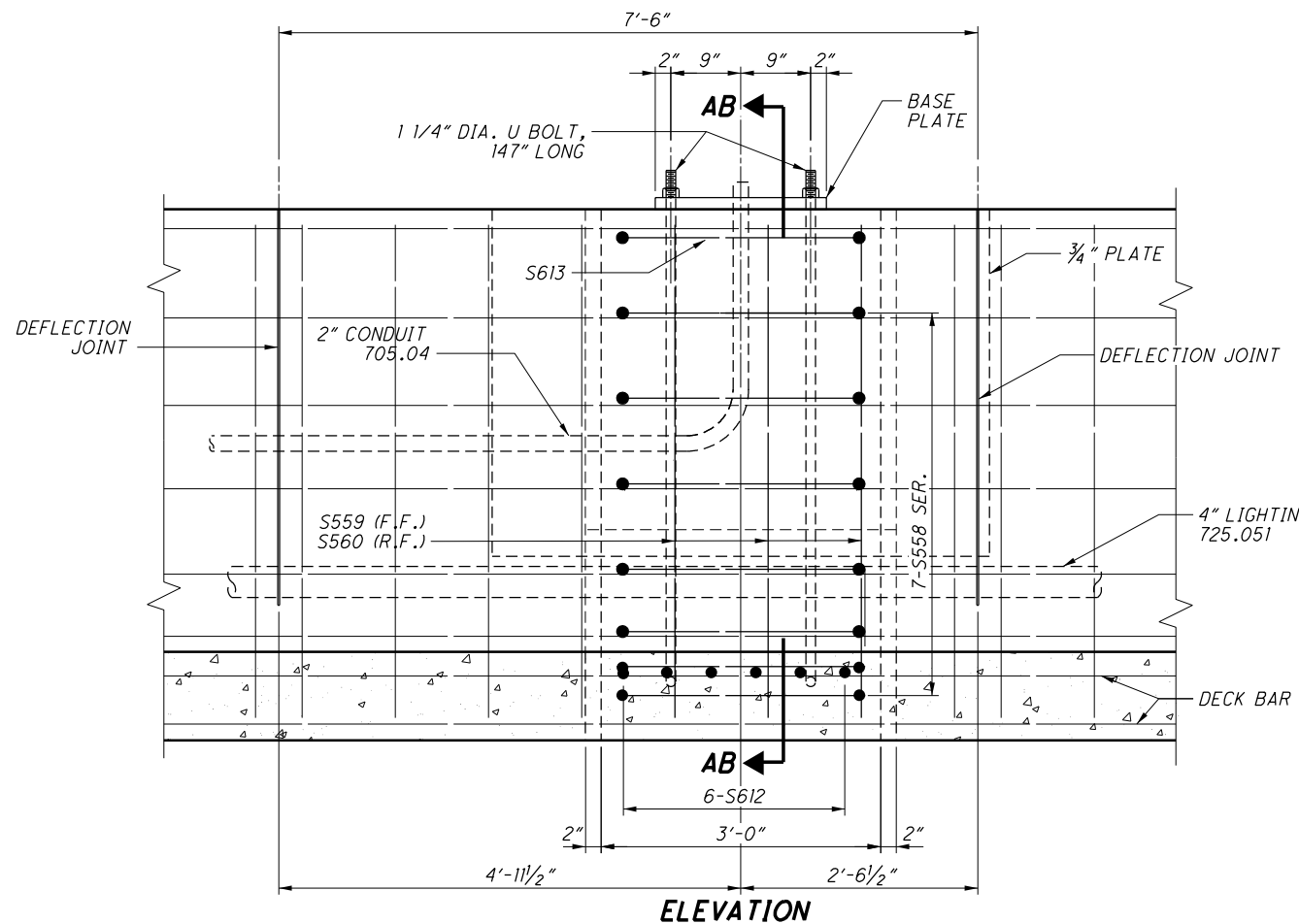
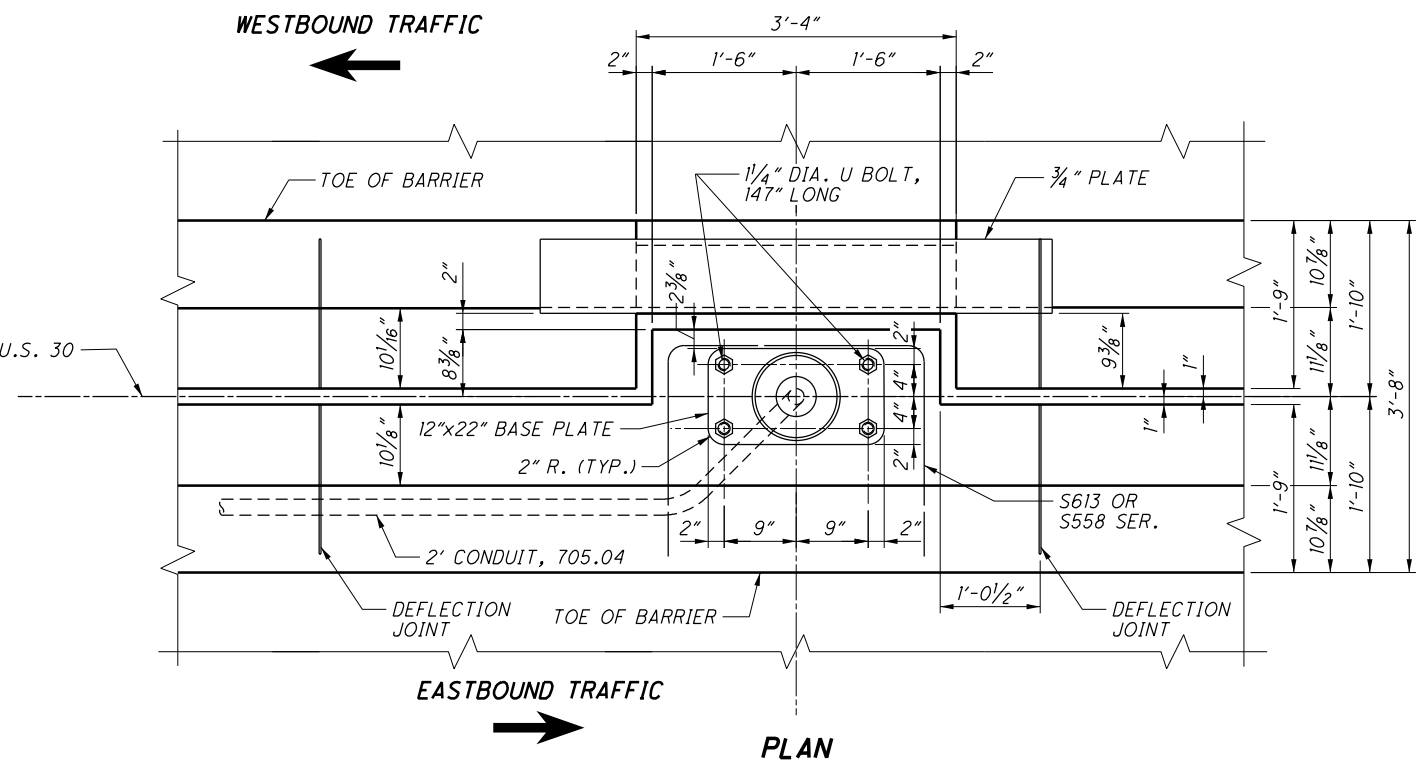

NOTES

1. MATERIALS: STEEL PLATES SHALL BE ASTM A709, GR. 50. PLATES SHALL BE METALIZED OR GALVANIZED PER 516.03.
2. PAYMENT FOR THE MATERIAL AND INSTALLATION OF MEDIAN BARRIER PLATES AND FASTENERS SHALL BE INCLUDED AS INCIDENTAL TO ITEM 511 - CLASS OC2 CONCRETE WITH OC/OA, SUPERSTRUCTURE, AS PER PLAN.
3. FOR LIGHT SUPPORT LOCATION SEE SHEET 1187/1669.

DESIGN AGENCY
ENGINEERING ASSOCIATES, INC.
935 EAGLE PASS - WOOSTER, OHIO 44691
TELEPHONE: (330) 345-6556
FAX: (330) 345-8077

EA

DATE: 9-24-19
REVIEWED: SDS
DESIGNED: HK
DRAWN: TAC
CHECKED: BDH

BRIDGE NO. RIC-30-1219
OVER ASHLAND RAILWAY

RIC-30-9.26
PID No. 93455

7001232

MEDIAN BARRIER AT LIGHT SUPPORT STA. 644+20.40

61 / 79

1404
1669

M:\15074\93455\Design\Structures\RIC030_1219C\Sheets\030_1219CSA007.dgn 3/27/2020 9:19:18 AM toc230

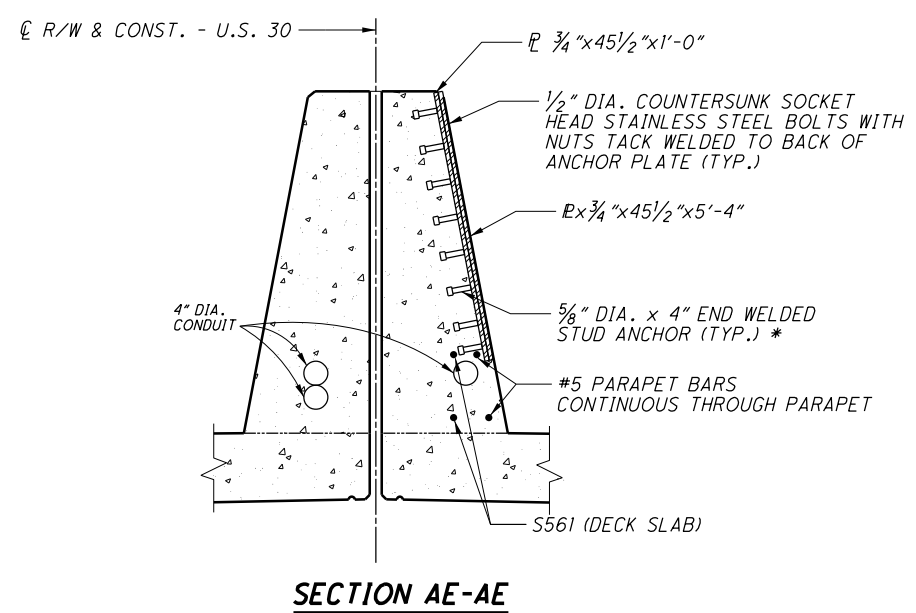
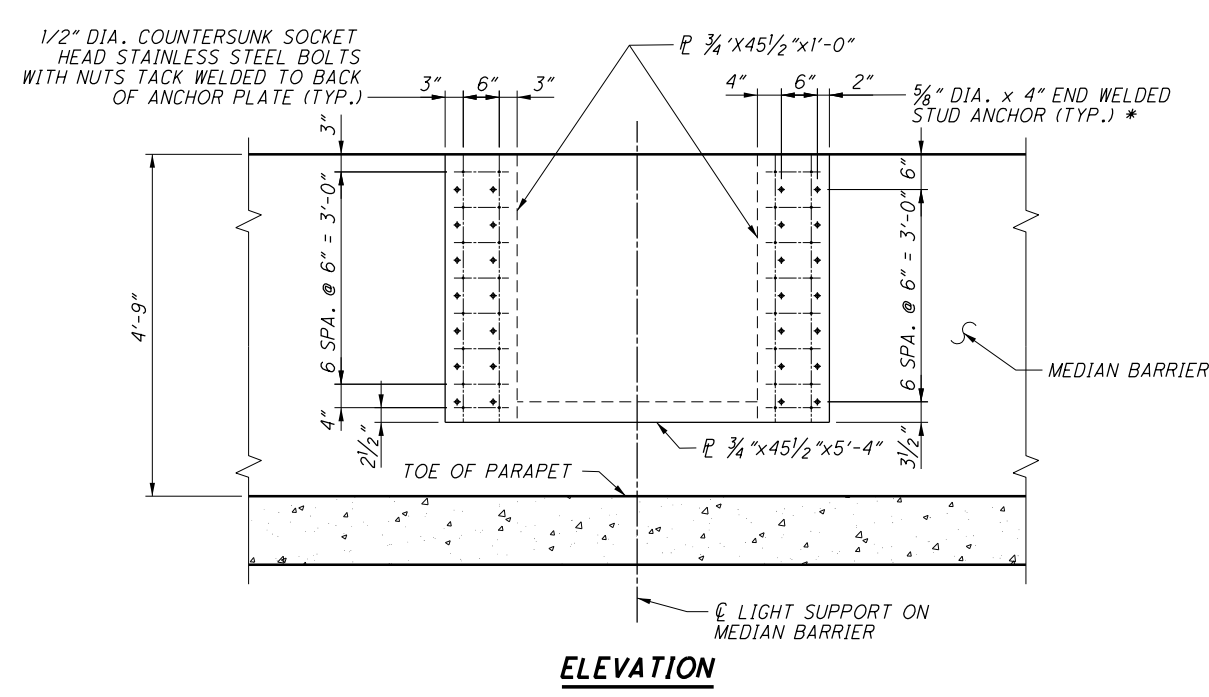
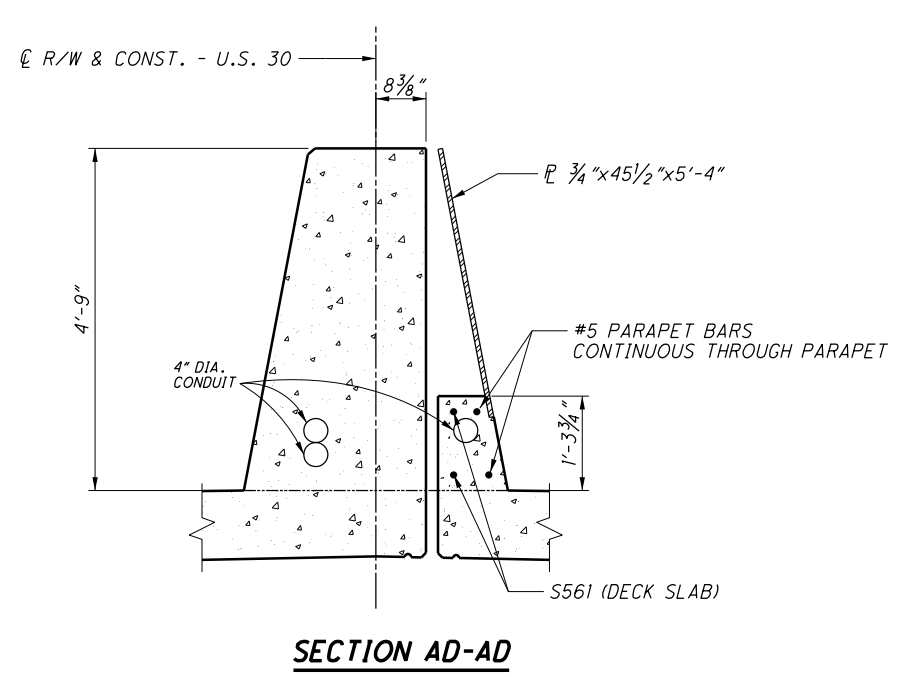
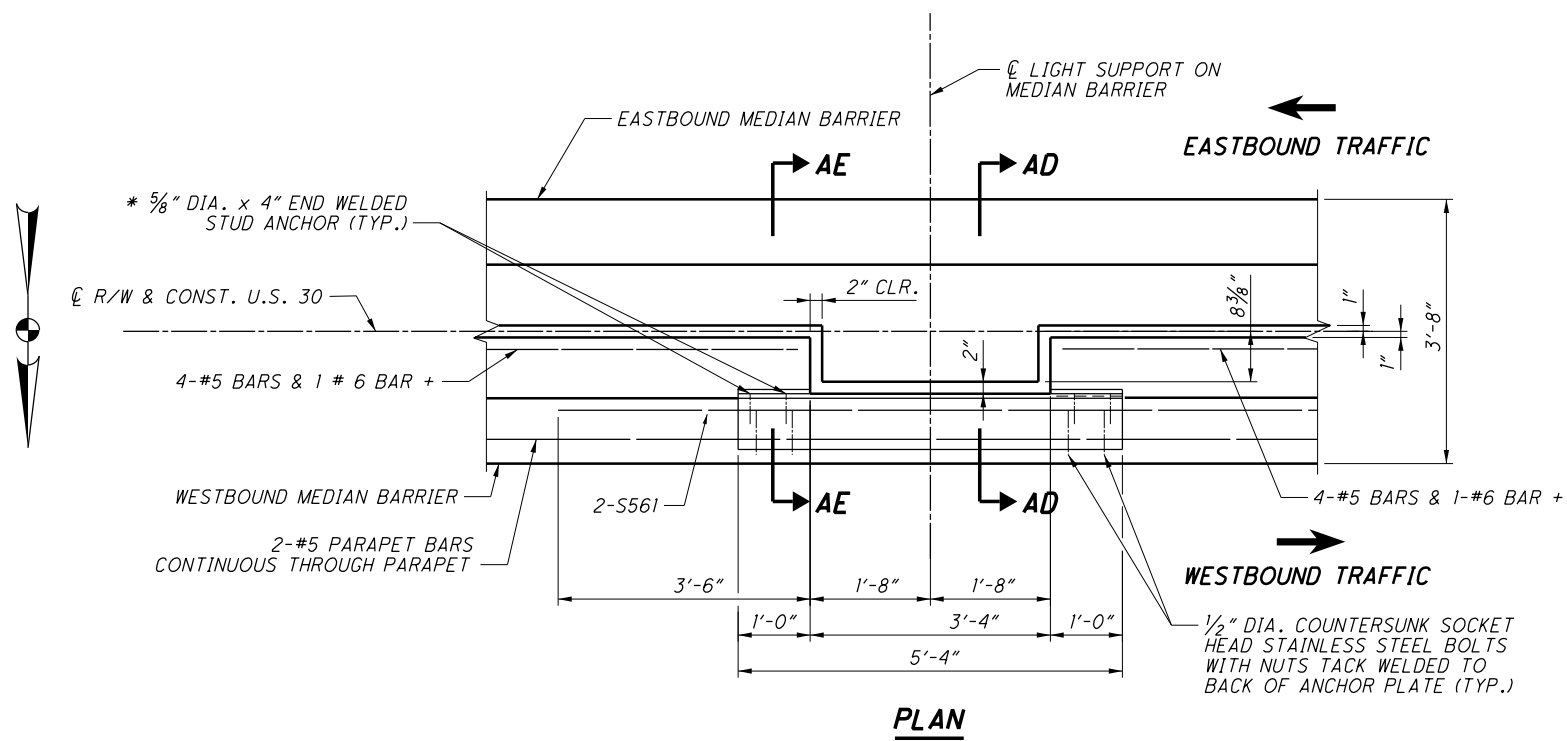

PLATE AT LIGHT SUPPORT

LEGEND

- * - WELDED WITH AUTOMATICALLY TIMED STUD WELDING EQUIPMENT OR 5/16" MINIMUM FILLET WELD ALL AROUND
- + - FIELD CUT OR ADJUST LAP TO FIT GAP

NOTES

1. ADDITIONAL NOTES SEE SHEETS 61/79 .

DESIGN AGENCY		ENGINEERING ASSOCIATES, INC.	
DESIGNED BY		BRIDGE NO. RIC-30-1219	
DRAWN		OVER ASHLAND RAILWAY	
CHKD	BDH	DATE	9-24-19
REVISED	---	REVIEWED	SDS
FILE NUMBER	7001232	STRUCTURE FILE NUMBER	---
PHONE	---	TELEPHONE	---
FAX	---	FAX	---

STANDARD DRAWINGS

REFER TO THE FOLLOWING STANDARD BRIDGE DRAWINGS:

AS-1-15	REVISED	7-17-15
AS-2-15	REVISED	1-18-19
GSD-1-19	DATED	1-18-19
PCB-91	REVISED	1-18-13
SBR-1-13	REVISED	7-20-18
SBR-2-13	REVISED	7-20-18
SICD-1-96	REVISED	7-18-14
SICD-2-14	DATED	7-18-14
VPF-1-90	REVISED	7-20-18

DESIGN SPECIFICATIONS

THIS STRUCTURE CONFORMS TO THE "LRFD BRIDGE DESIGN SPECIFICATIONS" ADOPTED BY THE AMERICAN ASSOCIATION OF STATE HIGHWAY AND TRANSPORTATION OFFICIALS, 2017, 8TH EDITION AND THE ODOT BRIDGE DESIGN MANUAL, 2019.

OPERATIONAL IMPORTANCE

A LOAD MODIFIER OF 1.0 HAS BEEN ASSUMED FOR THE DESIGN OF THIS STRUCTURE IN ACCORDANCE WITH THE AASHTO LRFD BRIDGE DESIGN SPECIFICATIONS, ARTICLE 1.3.5 AND THE ODOT BRIDGE DESIGN MANUAL, 2019.

DESIGN LOADING

HL-93
FUTURE WEARING SURFACE (FWS) OF 0.060 KIPS/FT².

DESIGN DATA

CONCRETE CLASS QC2 WITH QC/QA - COMPRESSIVE STRENGTH 4.5 KSI (SUPERSTRUCTURE)

CONCRETE CLASS QC1 WITH QC/QA - COMPRESSIVE STRENGTH 4.0 KSI (SUBSTRUCTURE)

REINFORCING STEEL - MINIMUM YIELD STRENGTH 60 KSI

STRUCTURAL STEEL - ASTM A709 GRADE 50 - YIELD STRENGTH 50 KSI

STEEL H-PILES - ASTM A572 - YIELD STRENGTH 50 KSI

DECK PROTECTION METHOD

EPOXY COATED REINFORCING STEEL
2 1/2" CONCRETE COVER

MONOLITHIC WEARING SURFACE

MONOLITHIC WEARING SURFACE IS ASSUMED, FOR DESIGN PURPOSES, TO BE 1 INCH THICK.

ITEM 202, PORTIONS OF STRUCTURE REMOVED, OVER 20 FOOT SPAN, AS PER PLAN:

THIS ITEM SHALL INCLUDE THE ELEMENTS INDICATED IN THE PLANS AND GENERAL NOTES AND THAT ARE NOT SEPARATELY LISTED FOR PAYMENT, EXCEPT FOR WEARING COURSE REMOVAL. ITEMS TO BE REMOVED INCLUDE ALL EXISTING MATERIALS BEING REPLACED BY NEW CONSTRUCTION AND MISCELLANEOUS ITEMS THAT ARE NOT SHOWN TO BE INCORPORATED INTO THE FINAL CONSTRUCTION AND ARE DIRECTED TO BE REMOVED BY THE ENGINEER. THE USE OF EXPLOSIVES, HEADACHE BALLS AND/OR HOE-RAMS WILL NOT BE PERMITTED. THE METHOD OF REMOVAL AND THE WEIGHT OF HAMMER SHALL BE APPROVED BY THE ENGINEER. PERFORM ALL WORK IN A MANNER THAT WILL NOT CUT, ELONGATE OR DAMAGE THE EXISTING REINFORCING STEEL TO BE PRESERVED. CHIPPING HAMMERS SHALL NOT BE HEAVIER THAN THE NOMINAL 90-POUND CLASS. PNEUMATIC HAMMERS SHALL NOT BE PLACED IN DIRECT CONTACT WITH REINFORCING STEEL THAT IS TO BE RETAINED IN THE REBUILT STRUCTURE. SUBMIT CONSTRUCTION PLANS ACCORDING TO C&MS 501.05

ITEM 203 EMBANKMENT, AS PER PLAN

PLACE AND COMPACT EMBANKMENT MATERIAL IN 6 INCH LIFTS FOR THE CONSTRUCTION OF THE APPROACH EMBANKMENT BETWEEN STATIONS 650+50 TO 656+50.

PILE DRIVING CONSTRAINTS

PRIOR TO DRIVING PILES, CONSTRUCT THE SPILL THROUGH SLOPES AND THE BRIDGE APPROACH EMBANKMENT BEHIND THE ABUTMENTS UP TO THE LEVEL OF THE SUBGRADE ELEVATION FOR A MINIMUM DISTANCE OF 200 FEET BEHIND EACH ABUTMENT. DO NOT BEGIN THE EXCAVATION FOR THE ABUTMENT FOOTINGS AND THE INSTALLATION OF THE ABUTMENT AND THE PIER PILES, UNTIL AFTER THE ABOVE REQUIRED EMBANKMENT HAS BEEN CONSTRUCTED.

PILES TO BEDROCK

DRIVE PILES TO REFUSAL ON BEDROCK. THE DEPARTMENT WILL CONSIDER REFUSAL TO BE OBTAINED WHEN THE PILE PENETRATION IS AN INCH OR LESS AFTER RECEIVING AT LEAST 20 BLOWS FROM THE PILE HAMMER. SELECT THE HAMMER SIZE TO ACHIEVE THE REQUIRED DEPTH TO BEDROCK AND REFUSAL.

THE TOTAL FACTORED LOAD IS 125 KIPS PER PILE FOR THE ABUTMENT PILES. THE TOTAL FACTORED LOAD IS 235 KIPS PER PILE FOR THE PIER PILES.

	LEFT BRIDGE		RIGHT BRIDGE	
	NO. OF PILES	ORDER LENGTH	NO. OF PILES	ORDER LENGTH
REAR ABUTMENT	22	65 FT	23	65 FT
PIER NO. 1	17	50 FT	22	45 FT
PIER NO. 2	16	35 FT	20	35 FT
FORWARD ABUTMENT	17	40 FT	18	45 FT

PILE SPLICES

IN LIEU OF USING THE FULL PENETRATION BUTT WELDS SPECIFIED IN CMS 507.09 TO SPLICE STEEL H-PILES, THE CONTRACTOR MAY USE A MANUFACTURED H-PILE SPLICER. FURNISH SPLICERS FROM THE FOLLOWING MANUFACTURER:

ASSOCIATED PILE AND FITTING CORPORATION
8 WOOD HOLLOW RD. PLAZA 1
PARSIPPANY, NEW JERSEY 07054

INSTALL AND WELD THE SPLICER TO THE PILE SECTIONS IN ACCORDANCE WITH THE MANUFACTURER'S WRITTEN ASSEMBLY PROCEDURE SUPPLIED TO THE ENGINEER BEFORE THE WELDING IS PERFORMED.

ITEM 503, COFFERDAMS AND EXCAVATION BRACING, AS PER PLAN

THE DESIGN SHOWN ON THE PLANS FOR TEMPORARY SUPPORT OF EXCAVATION IS ONE REPRESENTATIVE DESIGN THAT MAY BE USED TO CONSTRUCT THE PROJECT. THE CONTRACTOR MAY CONSTRUCT THE DESIGN SHOWN ON THE PLANS OR PREPARE AN ALTERNATE DESIGN TO SUPPORT THE SIDES OF EXCAVATION. IF CONSTRUCTING AN ALTERNATE DESIGN FOR TEMPORARY SUPPORT OF EXCAVATION, PREPARE AND PROVIDE PLANS IN ACCORDANCE WITH C&MS 501.05. THE DEPARTMENT WILL PAY FOR THE TEMPORARY SUPPORT OF EXCAVATION AT THE CONTRACT LUMP SUM PRICE FOR COFFERDAMS AND EXCAVATION BRACING. NO ADDITIONAL PAYMENT WILL BE MADE FOR PROVIDING AN ALTERNATE DESIGN.

DECK PLACEMENT ASSUMPTIONS

THE FOLLOWING ASSUMPTIONS OF CONSTRUCTION MEANS AND METHODS WERE MADE FOR THE ANALYSIS AND DESIGN OF THE SUPERSTRUCTURE. THE CONTRACTOR IS RESPONSIBLE FOR THE DESIGN OF THE FALSEWORK SUPPORT SYSTEM WITHIN THESE PARAMETERS AND WILL ASSUME RESPONSIBILITY FOR SUPERSTRUCTURE ANALYSIS FOR DEVIATION FROM THESE DESIGN ASSUMPTIONS.

AN EIGHT WHEEL FINISHING MACHINE WITH A MAXIMUM WHEEL LOAD OF 2.34 KIPS.

A MINIMUM OUT-TO-OUT WHEEL SPACING AT EACH END OF THE MACHINE OF 103".

A MAXIMUM SPACING OF OVERHANG FALSEWORK BRACKETS OF 48".

A MAXIMUM DISTANCE FROM THE CENTERLINE OF THE FASCIA GIRDER TO THE FACE OF THE SAFETY HANDRAIL OF 65".

STRUCTURE PAINTING: ALL BRIDGE FINISH COATS SHALL BE THE SAME COLOR.

UTILITIES TO REMAIN: EXISTING TELEPHONE DUCT SHALL NOT BE DISTURBED.

INSTALLATION OF MULTI-CELL CONDUIT ON STRUCTURES

ONE MULTI-CELL CONDUIT IS CONTINUOUS FOR THE ENTIRE PROJECT. THE SECOND MULTI-CELL CONDUIT SHALL BE PLACED ONLY WITHIN THE LIMITS OF THE BRIDGES AND APPROACH SLABS AND SHALL TERMINATE AT A JUNCTION BOX AS SHOWN IN STANDARD DRAWING HL-30.33.

- ABUT. - ABUTMENT
- APPR. - APPROACH
- BRG. - BEARING
- BOT. - BOTTOM
- CONST. JT. - CONSTRUCTION JOINT
- CLR. - CLEAR
- CONST. - CONSTRUCTION
- CORR. - CORRUGATED
- DIA. - DIAMETER
- DIM. - DIMENSION
- DWG. - DRAWING
- EL. - ELEVATION
- E.F. - EACH FACE
- EXIST. - EXISTING
- F.A. - FORWARD ABUTMENT
- FWD. - FORWARD
- F.F. - FRONT FACE
- FT. - FEET
- LBS. - POUNDS
- MAX. - MAXIMUM
- MEAS. - MEASURED
- MIN. - MINIMUM
- OPT. - OPTIONAL
- P.E.J.F. - PERFORMED EXPANSION JOINT FILLER
- R.A. - REAR ABUTMENT
- R.F. - REAR FACE
- REQ'D. - REQUIRED
- SPA. - SPACING
- STA. - STATION
- T.O.S. - TOP OF SLOPE
- TYP. - TYPICAL
- U.O.N. - UNLESS OTHERWISE NOTED
- VAR. - VARIES
- W/ - WITH

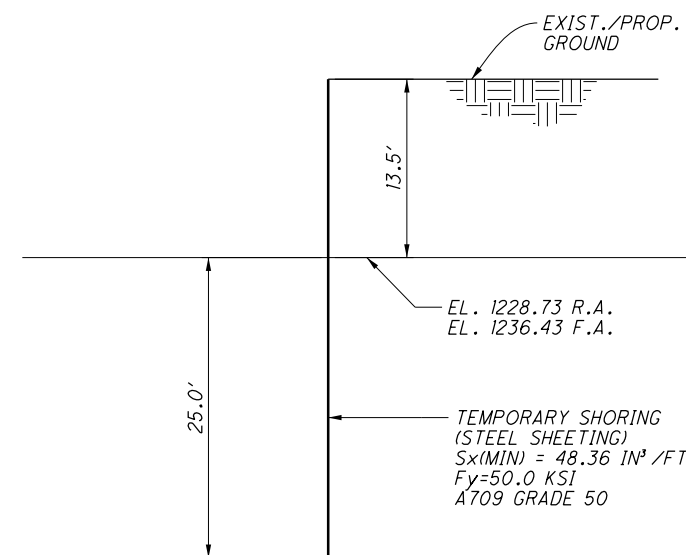

**SECTION A-A
TEMPORARY SHORING DETAIL**

NOTE: SEE SHEET 2 / 73 FOR LOCATION

M:\15074\93455\Design\Structures\RIC030_1236C\Sheets\030_1236CSN001.dgn 3/27/2020 11:06:54 AM toc230

DESIGN AGENCY: ENGINEERING ASSOCIATES, INC.
 8955 EAGLE PASS - WOOSTER, OHIO 44691
 TELEPHONE: (330) 345-6556
 FAX: (330) 345-8077

DATE: 9-24-19
 STRUCTURE FILE NUMBER: 7001267

DESIGNED: HK
 CHECKED: BDH

DESIGN REVIEWED: SDS
 TAC: REVISED

GENERAL NOTES
 BRIDGE NO. RIC-30-1236
 OVER S.R. 545

RIC-30-9-26
 PID No. 93455

3 / 73

1427
 1669

M:\15074\93455\Design\Structures\RIC030_1236C\Sheets\030_1236CS0001.dgn 3/27/2020 11:31:41 AM kje282

CALC: BDH DATE: 8/30/2019
 CHECKED: HK DATE: 8/30/2019

ESTIMATED QUANTITIES

ITEM	EXTENSION	TOTAL 01/NHS/BR	UNIT	DESCRIPTION	ABUT.	PIERS	SUPER.	GEN.	SEE	SHEET
202	11203	LS		PORTIONS OF STRUCTURE REMOVED, OVER 20 FOOT SPAN, AS PER PLAN				LS		3/73
202	22900	347	SY	APPROACH SLAB REMOVED				347		
202	23500	167	SY	WEARING COURSE REMOVED				167		
503	11101	LS		COFFERDAMS AND EXCAVATION BRACING, AS PER PLAN				LS		3/73
503	21100	1693	CY	UNCLASSIFIED EXCAVATION	1234	459				
505	11100	LS		PILE DRIVING EQUIPMENT MOBILIZATION				LS		
507	00100	7515	FT	STEEL PILES HPI0X42, FURNISHED	4415	3100				
507	00150	6740	FT	STEEL PILES HPI0X42, DRIVEN	4015	2725				
507	92200	585	FT	PREBORED HOLES		585				
509	10000	294385	LB	EPOXY COATED REINFORCING STEEL	39137	56695	198553			
511	21523	943	CY	CLASS OC2 CONCRETE WITH OC/OA, SUPERSTRUCTURE, AS PER PLAN	122		821		35/73, 36/73, 46/73 & 47/73	
511	33500	4	EACH	SEMI-INTEGRAL DIAPHRAGM GUIDE			4			
511	41012	189	CY	CLASS OC1 CONCRETE WITH OC/OA, PIER ABOVE FOOTINGS		189				
511	44112	190	CY	CLASS OC1 CONCRETE WITH OC/OA, ABUTMENT NOT INCLUDING FOOTING	190					
511	46512	357	CY	CLASS OC1 CONCRETE WITH OC/OA, FOOTING	226	131				
512	10100	1539	SY	SEALING OF CONCRETE SURFACES (EPOXY-URETHANE)	82	561	823	73		
512	10300	369	SY	SEALING CONCRETE BRIDGE DECKS WITH HMWM RESIN			335	34		
512	33000	35	SY	TYPE 2 WATERPROOFING	35					
513	10260	560936	LB	STRUCTURAL STEEL MEMBERS, LEVEL 3			560936			
513	20000	10335	EACH	WELDED STUD SHEAR CONNECTORS			10335			
514	00800	560936	LB	FIELD PAINTING STRUCTURAL STEEL, INTERMEDIATE COAT			560936			
514	00851	560936	LB	FIELD PAINTING STRUCTURAL STEEL, FINISH COAT, AS PER PLAN			560936		3/73	
514	10000	25	EACH	FINAL INSPECTION REPAIR			25			
516	10010	256	FT	ARMORLESS PREFORMED JOINT SEAL				256		
516	13600	30	SF	1" PREFORMED EXPANSION JOINT FILLER			30			
516	13900	787	SF	2" PREFORMED EXPANSION JOINT FILLER			230	557		
516	14020	279	FT	SEMI-INTEGRAL ABUTMENT EXPANSION JOINT SEAL	279					
516	44101	26	EACH	ELASTOMERIC BEARING WITH INTERNAL LAMINATES AND LOAD PLATE (NEOPRENE), AS PER PLAN 2 1/2"x1'-0"x1'-2" W/ 1 1/2"x1'-1"x1'-3" BEVELED LOAD PLATE	26					32/73
516	44101	26	EACH	ELASTOMERIC BEARING WITH INTERNAL LAMINATES AND LOAD PLATE (NEOPRENE), AS PER PLAN 3 1/8"x1'-3"x1'-6" W/ 2 5/16"(AVG)x1'-4"x1'-7" BEVELED LOAD PLATE		26				32/73
518	21200	190	CY	POROUS BACKFILL WITH GEOTEXTILE FABRIC	190					
518	40000	339	FT	6" PERFORATED CORRUGATED PLASTIC PIPE	339					
518	40010	66	FT	6" NON-PERFORATED CORRUGATED PLASTIC PIPE, INCLUDING SPECIALS	66					
526	25001	617	SY	REINFORCED CONCRETE APPROACH SLABS (T=15"), AS PER PLAN				617		53/73 THRU 58/73
526	90030	267	FT	TYPE C INSTALLATION				267		
601	21000	1154	SY	CONCRETE SLOPE PROTECTION				1154		
607	39900	320	FT	VANDAL PROTECTION FENCE, 6' STRAIGHT, COATED FABRIC			320			

DESIGN AGENCY
 ENGINEERING ASSOCIATES, INC.
 8955 EAGLE PASS - WOOSTER, OHIO 44691
 TELEPHONE: (330) 345-6556
 FAX: (330) 345-8077

DATE: 9-24-19
 REVIEWED: SDS
 STRUCTURE FILE NUMBER: 7001267
 DRAWN: TAC
 CHECKED: BDH

ESTIMATED QUANTITIES
 BRIDGE NO. RIC-30-1236
 OVER S.R. 545

RIC-30-9-26
 PID No. 93455

4/73

1428
 1669

M:\15074\93455\Design\Structures\RIC030_1236C\Sheets\030_1236CST001.dgn 3/27/2020 11:23:55 AM toc230

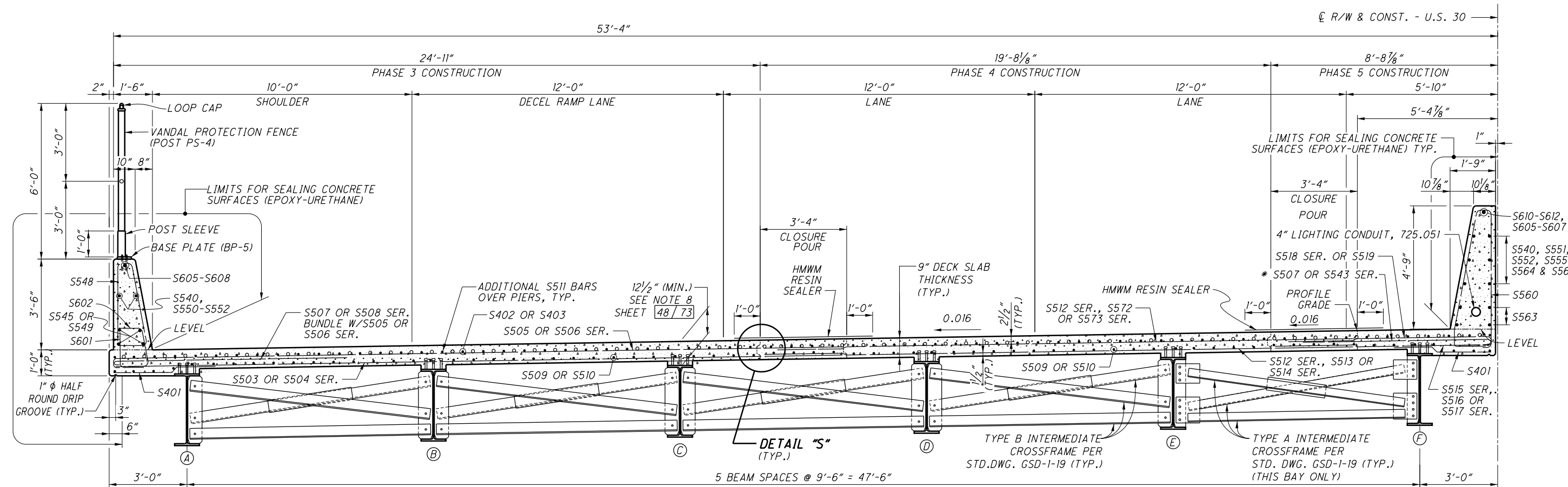

TRANSVERSE SECTION
(WESTBOUND LANES)

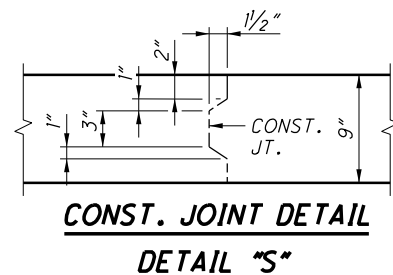

CONST. JOINT DETAIL
DETAIL "S"

LEGEND

* - S507 & S543 BUNDLE W/S518 SER., OR S519

NOTES

1. FOR ABBREVIATIONS SEE SHEET 3/73 .
2. FOR NOTES SEE SHEETS 48/73 THRU 50/73 .
3. FOR EASTBOUND TRANSVERSE SECTION SEE 47/73 .
4. 4" LIGHTING CONDUIT, 725.051, AND 4" MULTICELL ITS CONDUIT, 725.20 EPC-40, AND JUNCTION BOXES WHERE REQUIRED SHALL BE PLACED IN THE MEDIAN BARRIER AS SHOWN IN THE PLANS. THE COST OF PLACEMENT, MATERIALS, EQUIPMENT AND LABOR SHALL BE CONSIDERED INCIDENTAL AND INCLUDED FOR PAYMENT IN ITEM 511 CLASS OC2 CONCRETE WITH OC/OA SUPERSTRUCTURE, AS PER PLAN.

DESIGN AGENCY ENGINEERING ASSOCIATES, INC. 895 EAGLE PASS - WOOSTER, OHIO 44691 TELEPHONE: (330) 345-6556 FAX: (330) 345-8077	
DATE 9-24-19	DESIGNED BDH
REVIEWED SDS	CHECKED BDH
DRAWN RLE	STRUCTURE FILE NUMBER 7001267
<p>TRANSVERSE SECTION - LEFT (WESTBOUND) BRIDGE NO. RIC-30-1236 OVER S.R. 545</p>	
<p>RIC-30-9.26 PID No. 93455</p>	
<p>46/73</p>	
<p>1470 1669</p>	

M:\15074\93455\Design\Structures\RIC030_1236C\Sheets\030_1236CST002.dgn 3/27/2020 11:29:07 AM toc230

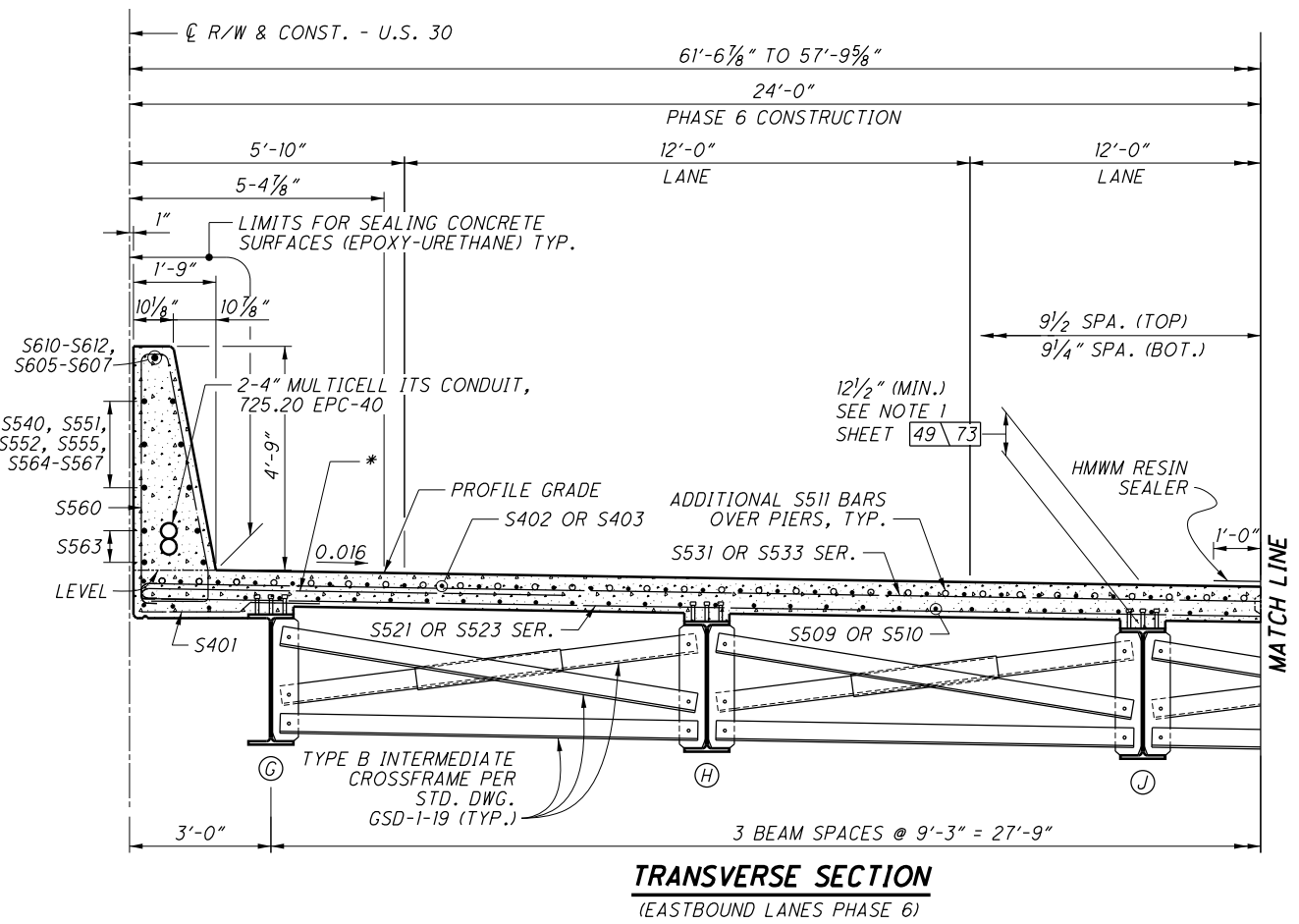

TRANSVERSE SECTION
(EASTBOUND LANES PHASE 6)

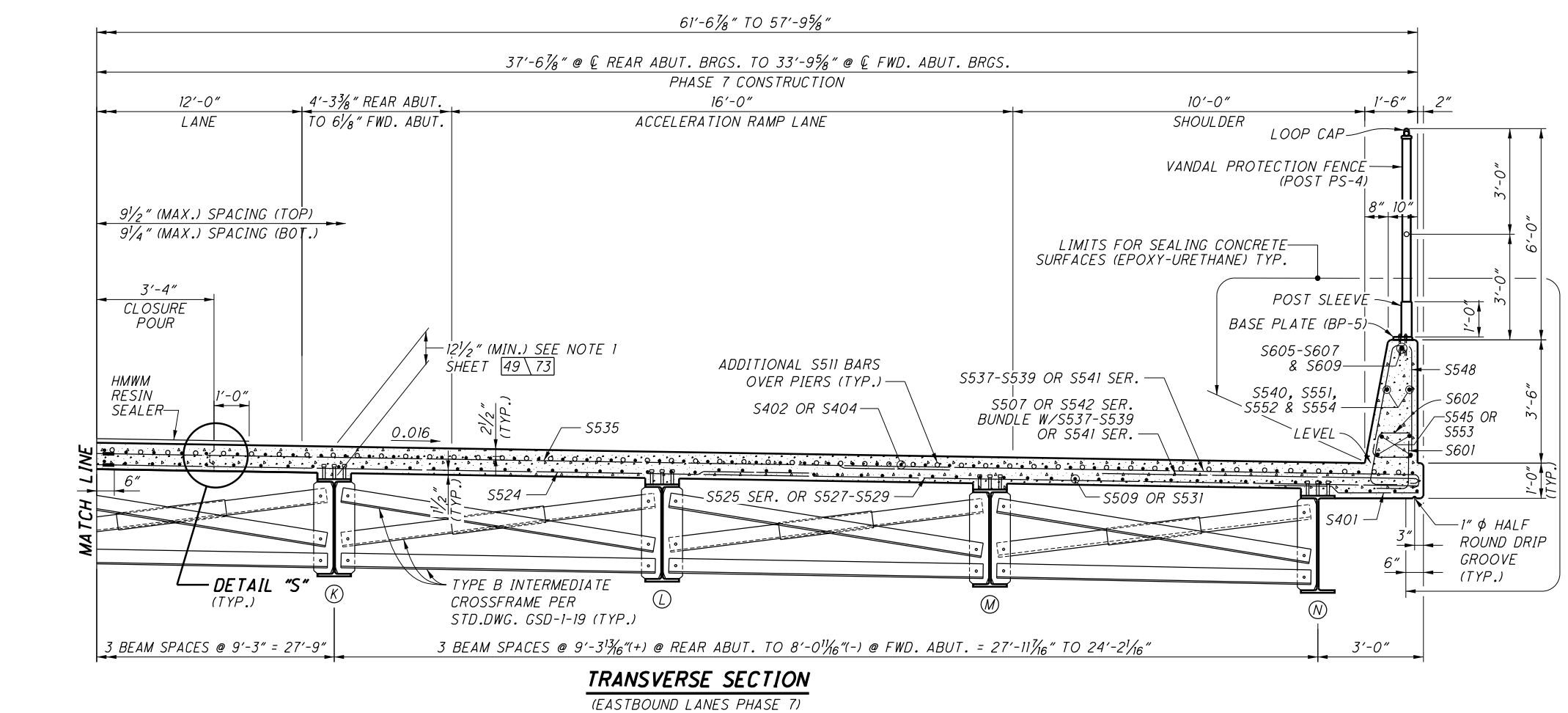

TRANSVERSE SECTION
(EASTBOUND LANES PHASE 7)

LEGEND

— DENOTES MECHANICAL REBAR CONNECTOR

* - S507 & S534 SER. BUNDLE W/S531 OR S533 SER.

- NOTES**
- FOR ABBREVIATIONS SEE SHEET 3/73.
 - FOR NOTES SEE SHEETS 48/73 THRU 50/73.
 - FOR WESTBOUND TRANSVERSE SECTION & DETAIL "S" SEE 46/73.
 - 4" LIGHTING CONDUIT, 725.051, AND 4" MULTICELL ITS CONDUIT, 725.20 EPC-40, AND JUNCTION BOXES WHERE REQUIRED SHALL BE PLACED IN THE MEDIAN BARRIER AS SHOWN IN THE PLANS. THE COST OF PLACEMENT, MATERIALS, EQUIPMENT AND LABOR SHALL BE CONSIDERED INCIDENTAL AND INCLUDED FOR PAYMENT IN ITEM 511 CLASS OC2 CONCRETE WITH OC/OA SUPERSTRUCTURE, AS PER PLAN.

DESIGN AGENCY: ENGINEERING ASSOCIATES, INC.
 8955 EAGLE PASS - WOOSTER, OHIO 44691
 TELEPHONE: (330) 345-6556
 FAX: (330) 345-8077

DATE: 9-24-19
 REVIEWED: SDS
 STRUCTURE FILE NUMBER: 7001267

DRAWN: RLE
 REVISION: REVISED

DESIGNED: HK
 CHECKED: BDH

TRANSVERSE SECTION - RIGHT (EASTBOUND)
 BRIDGE NO. RIC-30-1236
 OVER S.R. 545

RIC-30-9-26
 PID No. 93455

47/73

1471
 1669

M:\15074\93455\Design\Structures\RIC030-1236C\Sheets\030_1236CSA005.dgn 3/27/2020 11:51:14 AM toc230

LEGEND

- △ - LIMITS FOR SEALING CONCRETE SURFACES (EPOXY-URETHANE) TYP.
- * - 4" LIGHTING CONDUIT, 725.051
- ** - 2-4" MULTICELL ITS CONDUIT, 725.20 EPC-40

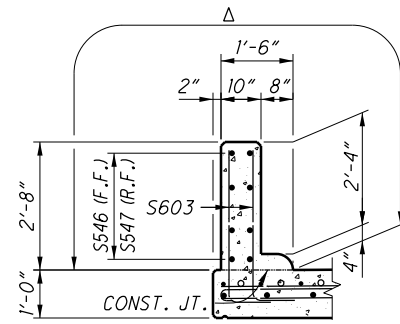

SECTION EE-EE

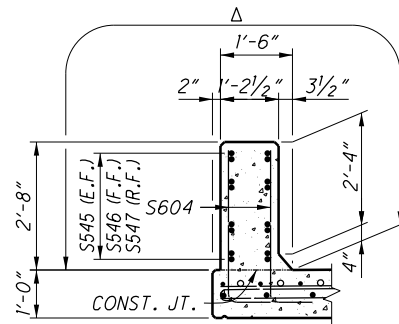

SECTION FF-FF

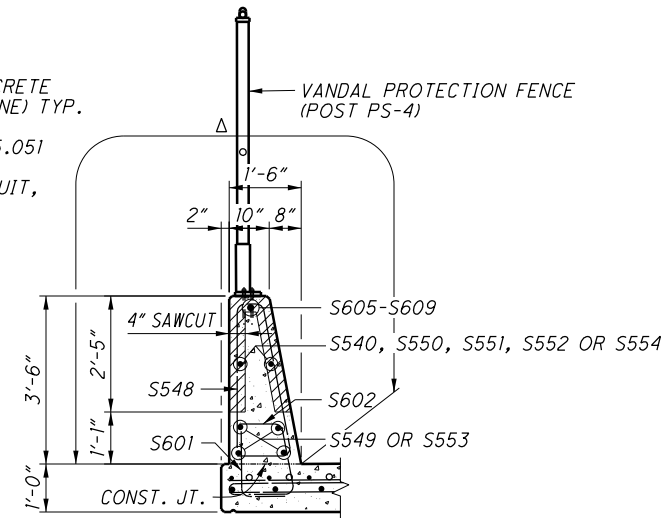

SECTION GG-GG

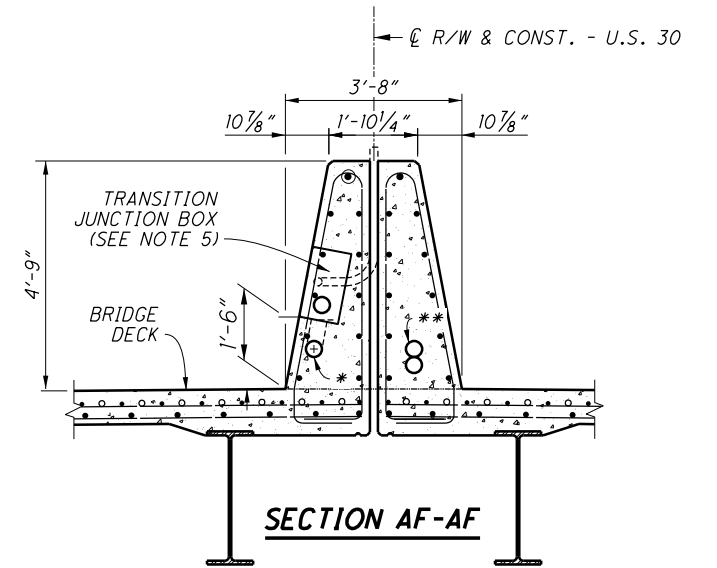

NOTES

1. FOR ABBREVIATIONS SEE SHEET 3/73 .
2. FOR LOCATIONS OF SECTIONS EE-EE, FF-FF & GG-GG SEE SHEET 51/73 & 52/73 .
3. FOR LOCATIONS OF SECTIONS HH-HH, JJ-JJ, KK-KK & DETAILS "B" & "C" SEE SHEETS 53/73 & 54/73 .
4. FOR DETAILS NOT SHOWN SEE STANDARD DRAWING SBR-1-13 AND SBR-2-13.
5. FOR ADDITIONAL DETAILS OF TRANSITION JUNCTION BOX SEE SHEET 58/73 .
6. 4" LIGHTING CONDUIT, 725.051, AND 4" MULTICELL ITS CONDUIT, 725.20 EPC-40, AND JUNCTION BOXES WHERE REQUIRED SHALL BE PLACED IN THE MEDIAN BARRIER AS SHOWN IN THE PLANS. THE COST OF PLACEMENT, MATERIALS, EQUIPMENT AND LABOR SHALL BE CONSIDERED INCIDENTAL AND INCLUDED FOR PAYMENT IN ITEM 526 REINFORCED CONCRETE APPROACH SLABS, AS PER PLAN.

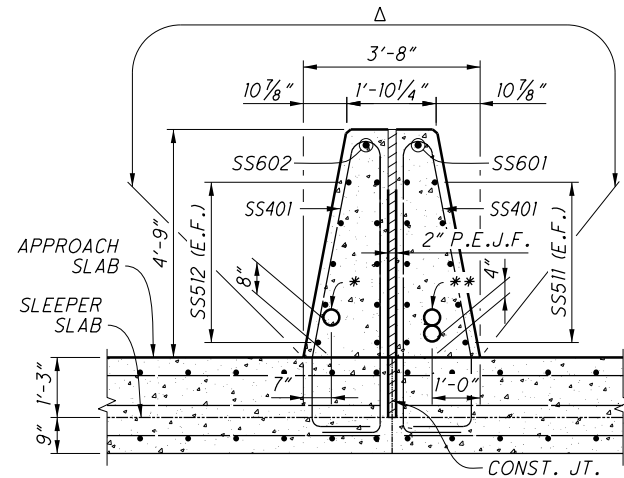

SECTION HH-HH

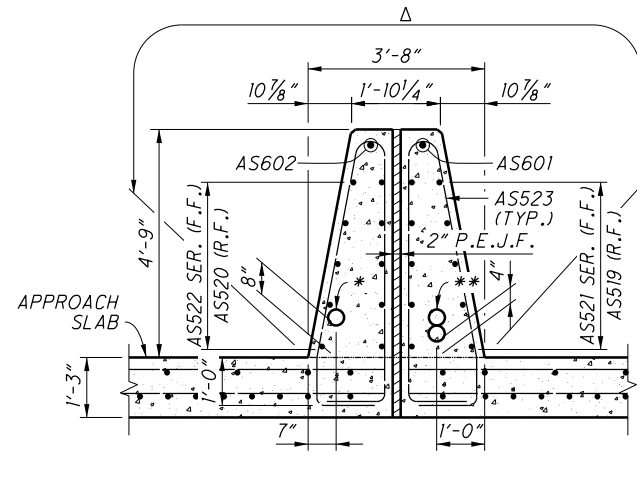

SECTION JJ-JJ

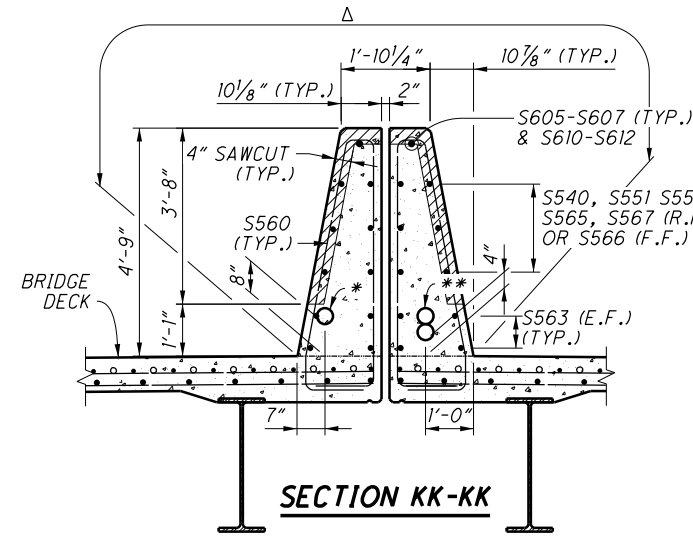

SECTION KK-KK

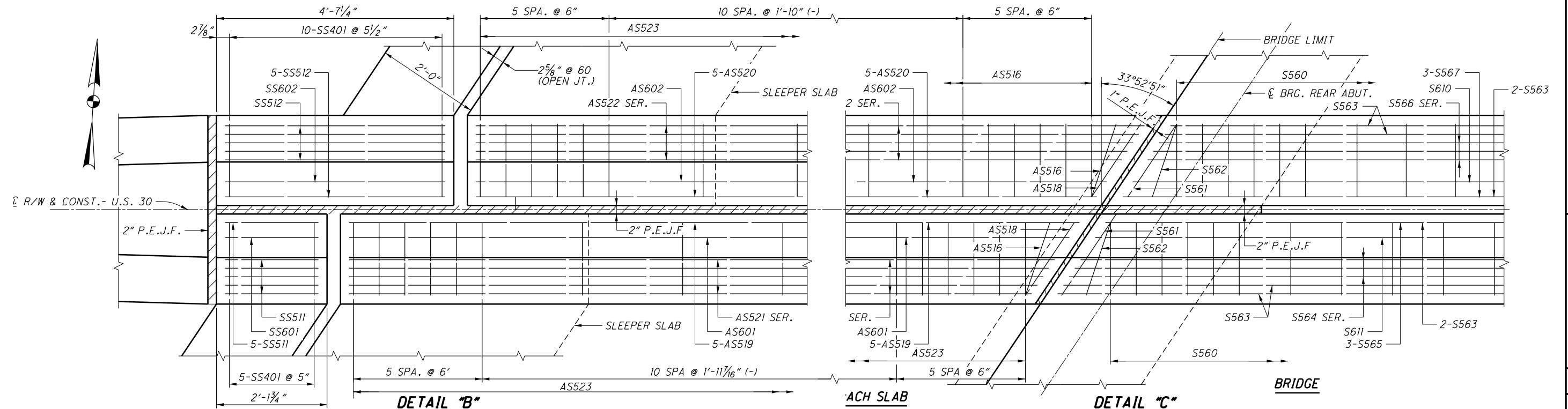

DETAIL "B"

(MEDIAN RAILING AT APPROACH SLAB)
(REAR APPROACH SHOWN-FORWARD SIMILAR BY ROTATION)

DETAIL "C"

(MEDIAN RAILING AT ABUTMENT)
(REAR ABUTMENT SHOWN - FORWARD ABUTMENT SIMILAR BY ROTATION)

DESIGNED HK	DRAWN TAC	REVIEWED SDS	DATE 9-24-19	DESIGN AGENCY ENGINEERING ASSOCIATES, INC. 935 EAGLE PASS - WOODSTER, OHIO 44681 TELEPHONE: (330) 345-6556 FAX: (330) 345-8077
CHECKED BDH	REVISED	STRUCTURE FILE NUMBER 7001267	STRUCTURE FILE NUMBER 7001267	PROJECT NO. RIC-30-9-26 BRIDGE NO. RIC-30-1236 OVER S.R. 545
				BRIDGE RAILING DETAILS
			55 / 73	(1479) (1669)

M:\15074\93455\Design\Structures\RIC030_1236C\Sheets\030_1236CSD006.dgn 3/27/2020 11:54:14 AM toc230

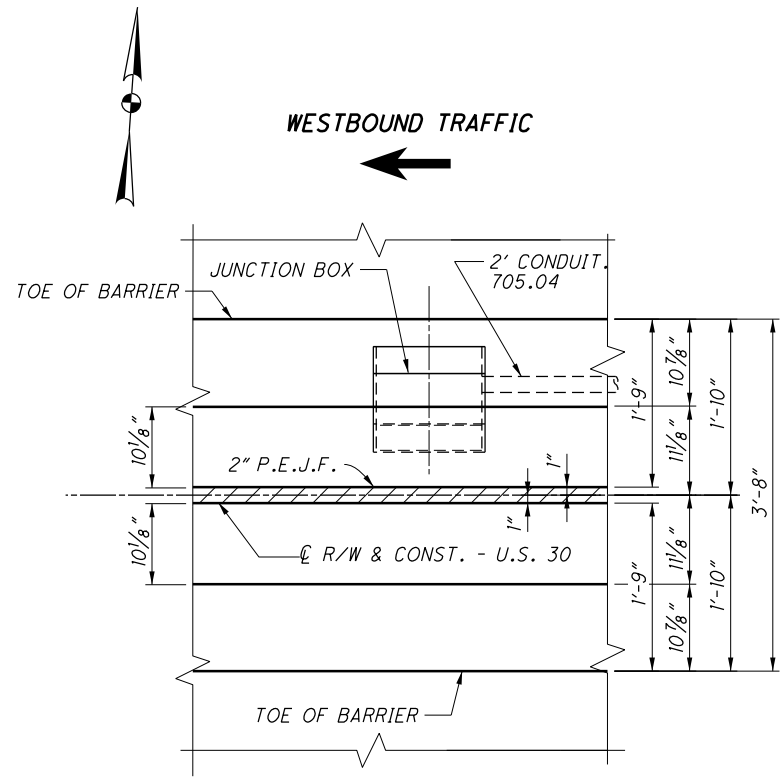

PLAN

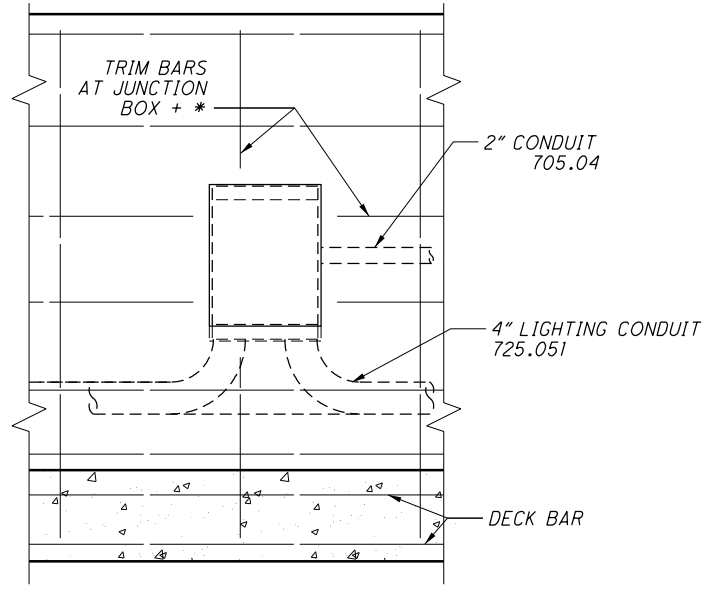

**ELEVATION
JUNCTION BOX DETAIL**

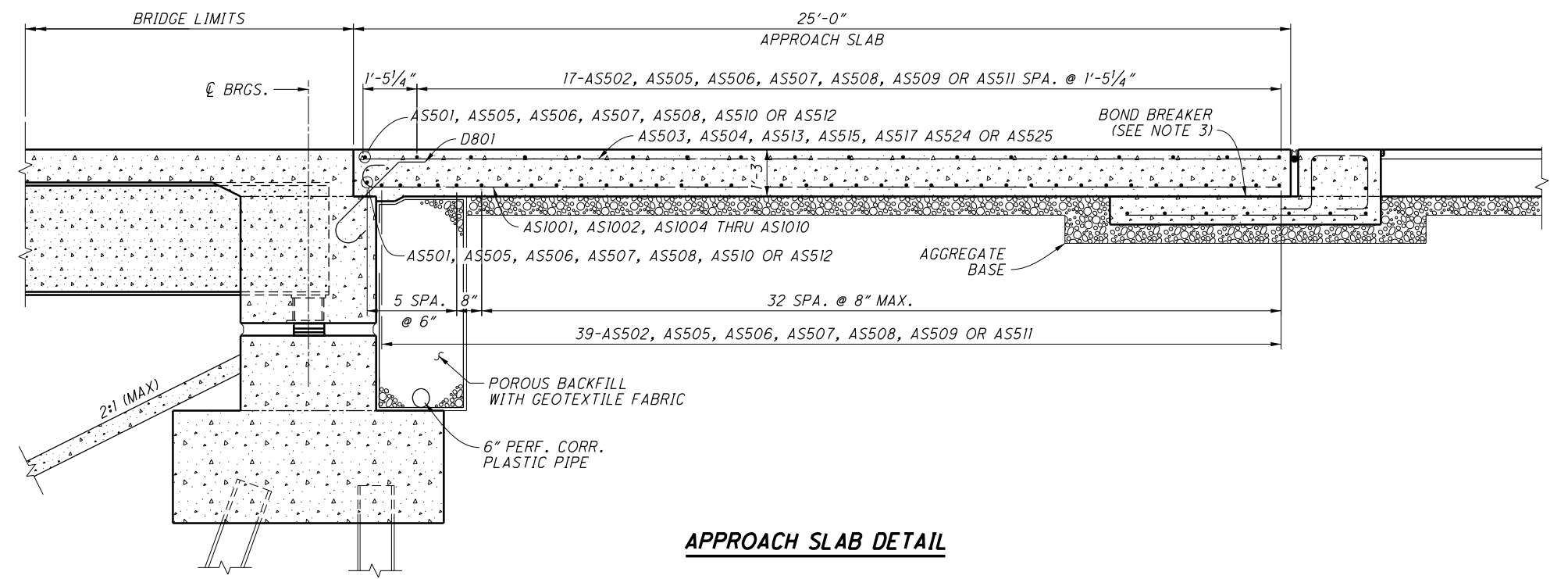

APPROACH SLAB DETAIL

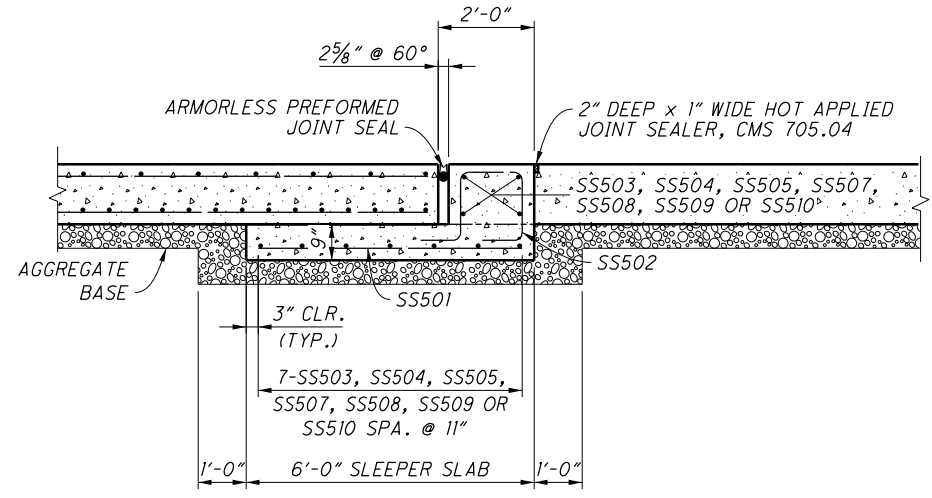

**SLEEPER SLAB DETAIL
SECTION LL-LL**

- LEGEND**
- + ADJUST BARS AS NEEDED TO AVOID JUNCTION BOX IN BARRIER
 - * CUT BAR AS NEEDED TO AVOID JUNCTION BOX IN BARRIER

NOTES

1. FOR ABBREVIATIONS SEE SHEET 3/73 .
2. FOR LOCATION OF SECTION LL-LL SEE SHEETS 56/73 & 57/73 .
3. APPLY BOND BREAKER TO THE ENTIRE TOP SURFACE OF THE CONCRETE SLEEPER SLAB.
4. FOR ADDITIONAL NOTES NOT SHOWN SEE STANDARD DRAWING AS-2-15, 4/14 .

<p>RIC-30-9.26</p>	<p>BRIDGE NO. RIC-30-1236 OVER S.R. 545</p>	<p>APPROACH SLAB DETAILS</p>	<p>DESIGN AGENCY ENGINEERING ASSOCIATES, INC. 935 EAGLE PASS - WOOSTER, OHIO 44691 TELEPHONE: (330) 345-6556 FAX: (330) 345-8077</p>
<p>PID No. 93455</p>	<p>DESIGNED HK</p>	<p>DRAWN TAC</p>	<p>REVIEWED SDS</p>
<p>58/73</p>	<p>CHECKED BDH</p>	<p>REVISED ---</p>	<p>DATE 9-24-19</p>
<p>1482 1669</p>	<p>STRUCTURE FILE NUMBER 7001267</p>	<p>FILE NUMBER ---</p>	<p>DESIGNER ---</p>