

ROUNDING

THE ROUNDING AT SLOPE BREAKPOINTS SHOWN ON THE TYPICAL SECTIONS APPLIES TO ALL CROSS-SECTIONS.

UTILITIES

LISTED BELOW ARE ALL UTILITIES LOCATED WITHIN THE PROJECT CONSTRUCTION LIMITS TOGETHER WITH THEIR RESPECTIVE OWNERS:

COLUMBIA GAS OF OHIO (NISOURCE)
NATHAN BEINING, ASSOCIATE FIELD ENGINEER 2
1800 BROAD AVENUE
FINDLAY, OHIO 45840
(419) 427-3206 (OFFICE)
(419) 266-7092 (CELL)

TOLEDO EDISON COMPANY (FIRSTENERGY)
RICH HAAS
1717 ASHLAND ROAD
MANSFIELD, OHIO 44905
(419) 521-6275

VILLAGE OF GREEN SPRINGS, OHIO
JOHN MILLER, VILLAGE ADMINISTRATOR
120 CATHERINE STREET
P.O. BOX 356
GREEN SPRINGS, OHIO 44836
(419) 603-8150

BENTON RIDGE TELEPHONE COMPANY
C/O COMMUNITY FIBER SOLUTIONS, INC. (CFSP)
NICK SAYRE, NETWORK TECHNICIAN
1805 N. DIXIE HWY.
LIMA, OHIO 45801
(567) 204-8627

SPECTRUM (FORMALLY CHARTER COMMUNICATIONS)
3760 INTERCHANGE DRIVE
COLUMBUS, OHIO 43204
(614) 255-6349

CENTURYLINK
GEORGE McELVAIN
700 W. MINERAL AVENUE
FLOOR UTAH ROOM D27-34
LITTLETON, COLORADO 80120
(303) 992-9931

UTILITIES

THE LOCATION OF THE UNDERGROUND UTILITIES SHOWN ON THE PLANS ARE AS OBTAINED FROM THE OWNERS AS REQUIRED BY SECTION 153.64 O.R.C.

CONSTRUCTION NOISE

ACTIVITIES AND LAND USE ADJACENT TO THIS PROJECT MAY BE AFFECTED BY CONSTRUCTION NOISE. IN ORDER TO MINIMIZE ANY ADVERSE CONSTRUCTION NOISE IMPACTS, DO NOT OPERATE POWER-OPERATED CONSTRUCTION-TYPE DEVICES BETWEEN THE HOURS OF 8:00 PM AND 7:00 AM. IN ADDITION, DO NOT OPERATE AT ANY TIME ANY DEVICE IN SUCH A MANNER THAT THE NOISE CREATED SUBSTANTIALLY EXCEEDS THE NOISE CUSTOMARILY AND NECESSARILY ATTENDANT TO THE REASONABLE AND EFFICIENT PERFORMANCE OF SUCH EQUIPMENT.

SURVEYING PARAMETERS

PRIMARY PROJECT CONTROL MONUMENTS GOVERN ALL POSITIONING ON ODOT PROJECTS. SEE THIS SHEET OF THE PLANS FOR A TABLE CONTAINING PROJECT CONTROL INFORMATION.

USE THE FOLLOWING PROJECT CONTROL, VERTICAL POSITIONING, AND HORIZONTAL POSITIONING PARAMETERS FOR ALL SURVEYING:

PROJECT CONTROL

POSITIONING METHOD: ODOT VRS
MONUMNET TYPE: B

VERTICAL POSITIONING

ORTHOMETRIC HEIGHT DATUM: NAVD 88
GEOID: GEOID 12A

HORIZONTAL POSITIONING

REFERENCE FRAME: NAD 83(2011)
ELLIPSOID: GRS80
MAP PROJECTION: LAMBERT CONFORMAL CONIC
COORDINATE SYSTEM: OHIO STATE PLANE - NORTH ZONE
COMBINED SCALE FACTOR: 0.99991753
PROJECT ADJUSTMENT FACTOR (PAF) = 1.00008248
ORIGIN OF COORDINATE SYSTEM: 0,0

USE THE POSITIONING METHODS AND MONUMENT TYPE USED IN THE ORIGINAL SURVEY TO RESTORE ALL MONUMENTS RELATED TO PRIMARY PROJECT CONTROL THAT ARE DAMAGED OR DESTROYED BY CONSTRUCTION ACTIVITIES. RESTORE THE DAMAGED OR DESTROYED MONUMENTS IN ACCORDANCE WITH CMS 623.

UNITS ARE IN U.S. SURVEY FEET.

CONSTRUCTION LIMITS

CONSTRUCTIONLIMITS SHOWN ON THESE PLANS ARE FOR PHYSICAL CONSTRUCTION ONLY. PROVIDE THE INSTALLATION AND OPERATION OF ALL WORK ZONE TRAFFIC CONTROL AND WORK ZONE TRAFFIC CONTROL DEVICES REQUIRED BY THESE PLANS WHETHER INSIDE OR OUTSIDE CONSTRUCTION LIMITS.

CLEARING AND GRUBBING

THERE ARE SOME TREES THAT ARE NOT SHOWN IN THE PLANS, BUT ARE WITHIN THE CONSTRUCTION LIMITS THAT MAY REQUIRE REMOVAL BY THE CONTRACTOR. THE CONTRACTOR SHALL ONLY REMOVE THOSE TREES THAT ARE NECESSARY TO COMPLETE THE WORK WITHIN THE CONSTRUCTION LIMITS. TREES NOT REQUIRING REMOVAL IN ORDER TO PERFORM THE WORK SHALL REMAIN AND NOT DISTURBED. THE LUMP SUM QUANTITY INCLUDED IN THE GENERAL SUMMARY FOR ITEM 201- CLEARING AND GRUBBING SHALL INCLUDE TREES NOT SHOWN, BUT MAY REQUIRE REMOVAL. ALL PROVISIONS AS SET FORTH IN THE SPECIFICATIONS UNDER THIS ITEM ARE INCLUDED IN THE LUMP SUM PRICE BID FOR ITEM 201 - CLEARING AND GRUBBING. CLEARING AND GRUBBING ACTIVITIES SHALL BE COMPLETED BY THE ITERIM CONTRACT COMPLETION DATE OF 12/31/20, SO AS TO ALLOW UTILITIES TIME TO RELOCATE THEIR FACILITIES PRIOR TO THE ROAD CLOSURE. DAMAGES IN THE AMOUNT OF \$2,000 PER DAY SHALL BE ASSESSED FOR EACH CALENDAR DAY BEYOND 12/31/20 THAT THE TREES ARE NOT CLEARED.

ENDANGERED BAT HABITAT REMOVAL

THIS PROJECT IS LOCATED WITHIN THE KNOWN HABITAT RANGES OF THE FEDERALLY LISTED AND PROTECTED INDIANA BAT AND NORTHERN LONG-EARED BAT. NO TREES SHALL BE REMOVED UNDER THIS PROJECT FROM APRIL 1 THROUGH SEPTEMBER 30. ALL NECESSARY TREE REMOVAL SHALL OCCUR FROM OCTOBER 1 THROUGH MARCH 31. THIS REQUIREMENT IS NECESSARY TO AVOID AND MINIMIZE IMPACTS TO THESE SPECIES AS REQUIRED BY THE ENDANGERED SPECIES ACT. FOR THE PURPOSES OF THIS NOTE, A TREE IS DEFINED AS: A LIVE, DYING, OR DEAD WOODY PLANT, WITH A TRUNK THREE INCHES OR GREATER IN DIAMETER AT A HEIGHT OF 4.5 FEET ABOVE THE GROUND SURFACE, AND WITH A MINIMUM HEIGHT OF 13 FEET.

CHANNEL EMBANKMENTS

FILL AND SLOPE PORTIONS OF THE EXISTING CHANNEL TO DRAIN AS SHOWN IN THESE PLANS. IN CHANNEL EMBANKMENT AREAS WHICH WILL NOT SUPPORT ANY PORTION OF THE NEW ROAD BED OR STRUCTURAL EMBANKMENTS, THE CONTRACTOR MAY UTILIZE EMBANKMENT METHODS MEETING THE FOLLOWING REQUIREMENTS:

CLEAR ALL WEEDS AND BRUSH IN AREAS WHERE CHANNEL EMBANKMENTS ARE TO BE PLACED. PLACE THE MATERIAL IN 8-INCH LOOSE LIFTS. THE ENGINEER MAY INCREASE THE LIFT THICKNESS IN ORDER TO BRIDGE THE SOFT OR WET FOUNDATIONS DEPENDING ON THE STABILITY OF THE FOUNDATION. THE ENGINEER MAY INCREASE THE LIFT THICKNESS UP TO 24 INCHES TO OBTAIN STABILITY AT THE TOP OF THE LIFT.

SUPPLEMENTAL SPECIFICATION 879 QC/QA EMBANKMENT SHALL APPLY FOR EMBANKMENT CONSTRUCTION.

PAYMENT FOR ALL OF THE ABOVE SHALL BE INCLUDED IN THE CONTRACT UNIT PRICE FOR ITEM 203, EMBANKMENT.

AIRWAY/HIGHWAY CLEARANCE FOR AIRPORTS AND HELIPORTS

THIS PROJECT HAS BEEN IDENTIFIED AS BEING WITHIN THE INFLUENCE AREA OF A PUBLIC USE AIRPORT OR HELIPORT. NO TEMPORARY STRUCTURES OR CONSTRUCTION EQUIPMENT AT MAXIMUM OPERATING HEIGHT SHALL EXCEED A HEIGHT OF 100 FT. IF ANY TEMPORARY STRUCTURES OR CONSTRUCTION EQUIPMENT WILL EXCEED THIS HEIGHT, FURTHER COORDINATION WITH THE FEDERAL AVIATION ADMINISTRATION (FAA), AND ODOT OFFICE OF AVIATION, WILL BE NECESSARY PRIOR TO ERECTING SUCH TEMPORARY STRUCTURES OR OPERATING SUCH EQUIPMENT ON THE PROJECT. THE CONTRACTOR WILL BE REQUIRED TO SUBMIT FORM 7460-1 TO THE FAA. NOTIFY THE ODOT OFFICE OF AVIATION WHEN SUBMITTING AN FAA FORM 7460-1.

NO TEMPORARY STRUCTURES OR CONSTRUCTION EQUIPMENT SHALL EXCEED THE PERMISSIBLE HEIGHT, UNTIL A COPY OF THE FAA APPROVAL AND ODOT OFFICE OF AVIATION PERMIT HAS BEEN FURNISHED TO THE PROJECT ENGINEER.

EXPRESS PROCESSING CENTER
THE FEDERAL AVIATION ADMINISTRATION
SOUTHWEST REGIONAL OFFICE
AIR TRAFFIC AIRSPACE BRANCH ASW-520
2601 MEACHAN BLVD.
FORT WORTH, TX 76137-4298

OHIO DEPARTMENT OF TRANSPORTATION
OFFICE OF AVIATION
2829 WEST DUBLIN-GRANVILLE ROAD
COLUMBUS, OHIO 43235
614-387-2346

FENCE LENGTHS

THE LENGTHS OF FENCE SHOWN IN THE PLANS ARE HORIZONTAL DIMENSIONS. MEASUREMENTS OF THE FINAL QUANTITIES WILL BE IN ACCORDANCE WITH ITEM 607.

EXCAVATION FOR PROPOSED CULVERT

CONSTRUCT THE SUBGRADE AS FOLLOWS AND IN THE FOLLOWING SEQUENCE:

1. EXCAVATE TO REMOVE THE EXISTING STONE ARCH CULVERT TO INSTALL THE NEW FOUR-SIDED BOX CULVERT, BACKFILLING THE EXCAVATED AREA REPLACING UNSUITABLE SUBGRADE MATERIAL. UNSUITABLE SUBGRADE INCLUDES UNSUITABLE SOIL (A-4B, A-2-5, A-5, A-7-5, AND SOIL WITH A LIQUID LIMIT GREATER THAN 65) AND ANY COAL, SHALE, OR ROCK WHICH NEEDS TO BE REMOVED ACCORDING TO 204.05.
2. BACKFILL THE EXCAVATED AREA IN ACCORDANCE WITH 204.03 TO WITHIN THE LIMITS OF THE SUBGRADE SPECIFIED (BENEATH ITEM 304 AGGREGATE BASE).
3. FINE GRADE THE SUBGRADE TO THE SPECIFIED GRADE.

ALL EXCAVATIONS SHOULD BE CONSTRUCTED IN ACCORDANCE WITH APPLICABLE LOCAL, STATE, AND FEDERAL SAFETY REGULATIONS INCLUDING THE CURRENT OSHA EXCAVATION AND TRENCH SAFETY STANDARDS (29CFR PART 1926).

THE QUANTITIES FOR EXCAVATING THE UNSUITABLE SUBGRADE AND UNSTABLE SUBGRADE ARE BOTH PAID UNDER ITEM 204 EXCAVATION.

PROPOSED 8" WATER MAIN CROSSING

INSTALLATION OF THE WATER LINE CROSSING 1,338' NORTH OF THE PROJECT SHALL BE MADE PRIOR TO ANY WORK TO REPLACE THE CULVERT. THE WATER LINE CROSSING SHALL BE INSTALLED AND FULLY OPERATIONAL BEFORE ANY WORK CAN BE PERFORMED ON THE REST OF CONSTRUCTION ON THE PROJECT.

MAINTENANCE OF TRAFFIC TO INSTALL THE WATER LINE CROSSING SHALL BE PERFORMED IMPLEMENTING PART-WIDTH CONSTRUCTION, PER ODOT STD DRAWING MT-97.10-FLAGGERS CLOSING 1-LANE OF A 2 LANE (FOR STATIONARY OPERATIONS). THE CONTRACTOR WILL BE ALLOWED ONE (1) WEEK TO COMPLETE THE INSTALLATION OF THE CROSSING FROM THE INITIAL START DATE TO INSTALL THE CROSSING. DAMAGES IN THE AMOUNT OF \$500 PER DAY SHALL BE ASSESSED FOR EACH CALENDAR DAY BEYOND 1 WEEK TO INSTALL THE CROSSING.

ITEM 631 - SCHOOL SPEED LIMIT SIGN ASSEMBLY, MISC.: REMOVAL, STORAGE AND REINSTALLATION

THE CONTRACTOR SHALL REMOVE THE POLE, SIGN AND SCHOOL FLASHER ASSEMBLY LOCATION AT STATION 12+39 RT PRIOR TO STARTING WORK ON THE PROJECT. WHEN WORK ON THE PROJECT NO LONGER CONFLICTS WITH THE SCHOOL FLASHER ASSEMBLY, IT SHALL BE REINSTALLED IN THE SAME LOCATION. ALL COSTS ASSOCIATED WITH THE REMOVAL, STORAGE AND REINSTALLATION OF THE SCHOOL FLASHER ASSEMBLY SHALL BE INCLUDED WITH ITEM 631 - SCHOOL SPEED LIMIT SIGN ASSEMBLY, MISC.: REMOVAL STORAGE AND REINSTALLATION, AS PER PLAN. TOLEDO EDISON WILL DISCONNECT POWER SERVICE TO THIS SIGN ASSEMBLY PRIOR TO THE START OF THE PROJECT AND WILL RECONNECT THE POWER ONCE THE SIGN ASSEMBLY IS REINSTALLED.

S:\Projects\SAN019\01329\Design\Roadway\Sheets\01329_GN001.dgn Sheet 10/22/2020 11:24:57 PM REGuser

CALCULATED
LI
CHECKED
PA

GENERAL NOTES

SAN-19-0.24

S:\Projects\SAN09\01329\Design\Roadway\Sheets\01329_GS001.dgn Sheet 10/23/2020 10:09:25 AM REGuser

REF NO.	SHEET NO.	STATION		SIDE	202		509	511	611			202		204	301	304	407	441	441	511	609	659	659	638						
		FROM	TO		PIPE REMOVED 24" AND UNDER	MANHOLE REMOVED	EPOXY COATED REINFORCING STEEL	CLASS QC1 CONCRETE MISC	10" CONDUIT, TYPE B (DIP, 748.01)	10" CONDUIT, TYPE C (DIP, 748.01)	MANHOLE, NO. 3, AS PER PLAN (INCL. BY-PASS PUMPING)	PAVEMENT REMOVED, AS PER PLAN	CURB REMOVED	SUBGRADE COMPACTION	ASPHALT CONCRETE BASE, PG64-22	AGGREGATE BASE	NON-TRACKING TACK COAT	ASPHALT CONCRETE SURFACE COURSE, TYPE 1, (448), PG64-22	ASPHALT CONCRETE INTERMEDIATE COURSE, TYPE 1, (448)	CLASS QC1 CONCRETE, MISC.:	CURB, TYPE 6	SEEDING AND MULCHING	COMMERCIAL FERTILIZER	6" WATER MAIN DUCTILE IRON PIPE ANSI CLASS 53, MECHANICAL JOINTS AND FITTINGS	8" WATER MAIN DUCTILE IRON PIPE ANSI CLASS 53, MECHANICAL JOINTS AND FITTINGS	POLYETHYLENE ENCASEMENT	8" GATE VALVE AND VALVE BOX	6" X 6" TAPPING SLEEVE, VALVE AND VALVE BOX	8" X 8" TAPPING SLEEVE, VALVE AND VALVE BOX	
PROPOSED 10" SANITARY SEWER					LF	EA	LBS	CY	LF	LF	EA	SY	LF	SY	CY	CY	GAL	CY	CY	CY	LF	SY	SY	LF	LF	LF	EA	EA	EA	
R-2	12			CR	211																									
R-7	12			RT		1																								
R-8	12			RT		1																								
R-9	12			LT		1																								
P-4	19	1+00.00	1+35.00	LT						35																				
P-5	19	1+35.00	2+47.00	CR					112																					
P-6	19	2+47.00	2+65.00	RT						18																				
P-7	19	2+65.00	2+89.94	RT						25																				
PS-1	19		2+47.00	RT			412.5	2.9																						
PS-2	19		2+65.00	RT			412.5	2.9																						
S-1	17/19		1+00.00	LT						1																				
S-2	19		1+35.00	LT						1																				
S-3	19		2+89.94	RT						1																				
PROPOSED 8" WATER MAIN RELOCATION																														
WW-1	20	10+05.00	11+74.00	LT															14					169	169					
WW-2	20		10+20.00	LT																							1			
WW-3	20		11+59.00	LT																							1			
R-10	20	10+05.00	11+74.00	LT	155																									
PROPOSED 8" WATER MAIN CROSSING																														
WW-4			APPROXIMATELY 1,338' N. OF OF THE PROJECT ON SR 19	CR							13	8	9	3	2	2	1	1		8	22	0.01	7	33	40		1	1		
TOTALS CARRIED TO GENERAL SUMMARY					366	3	825	6	112	78	3	13	8	9	3	2	2	1	1	14	8	22	0.01	7	202	209	2	1	1	

SUBSUMMARIES

CALCULATED
LI
CHECKED
PA

SAN - 19 - 0.24

DESIGN SPECIFICATIONS

THIS STRUCTURE CONFORMS TO THE "LRFD BRIDGE DESIGN SPECIFICATIONS" ADOPTED BY THE AMERICAN ASSOCIATION OF STATE HIGHWAY AND TRANSPORTATION OFFICIALS, 8TH EDITION, INCLUDING THE INTERIM SPECIFICATIONS AND THE ODOT BRIDGE DESIGN MANUAL, 2007.

DESIGN LOADING

DESIGN LOADING: HL-93

FUTURE WEARING SURFACE (FWS) OF 0.060 KIPS/SQ.FT.

DESIGN DATA (CAST-IN-PLACE STRUCTURE)

CONCRETE CLASS QC1 - COMPRESSIVE STRENGTH 4,000 PSI (FOOTINGS, WINGWALLS, AND FORESLOPE WALLS).

REINFORCING STEEL - ASTM A615, A616, OR A617 GRADE 60, MINIMUM YIELD STRENGTH 60,000 PSI (ALL REINFORCING SHALL BE EPOXY COATED).

INTERNAL ANGLE OF FRICTION OF BACKFILL SOIL, $\phi_w = 35^\circ$
 TOTAL UNIT WEIGHT OF BACKFILL SOIL = 120 PCF
 UNIT WEIGHT OF COMPACTED GRANULAR SOIL = 130 PCF
 INTERNAL ANGLE OF FRICTION (DRAINED), FOUNDATION SOIL, $\phi_s = 28^\circ$

UNDRAINED SHEAR STRENGTH (COHESIVE), FOUNDATION SOIL, $S_u = 1500$ PSF

UNIT WEIGHT OF CONCRETE = 150 PCF

SLOPE OF BACKFILL $\geq 2:1$ (WINGWALLS NOS. 1, 2, & 3)

HEIGHT OF LIVE LOAD SURCHARGE = 2 FT (WINGWALL NO. 4)

EXISTING STRUCTURE VERIFICATION

DETAILS AND DIMENSIONS SHOWN ON THESE PLANS PERTAINING TO THE EXISTING STRUCTURE HAVE BEEN OBTAINED FROM FIELD OBSERVATIONS AND MEASUREMENTS. CONSEQUENTLY, THEY ARE INDICATIVE OF THE EXISTING STRUCTURE AND THE PROPOSED WORK BUT THEY SHALL BE CONSIDERED TENTATIVE AND APPROXIMATE. THE CONTRACTOR IS REFERRED TO CMS SECTIONS 102.05 AND 105.02.

BASE CONTRACT BID PRICES UPON A RECOGNITION OF THE UNCERTAINTIES DESCRIBED ABOVE AND UPON A PREBID EXAMINATION OF THE EXISTING STRUCTURE. HOWEVER, THE DEPARTMENT WILL PAY FOR ALL PROJECT WORK BASED UPON ACTUAL DETAILS AND DIMENSIONS WHICH HAVE BEEN VERIFIED IN THE FIELD.

BACKFILL LIMITATION

WHEN THE DESIGN HEIGHT IS GREATER THAN 10 FT, THE BACKFILL BEHIND THE WINGWALLS SHALL NOT BE PLACED HIGHER THAN THE ELEVATION OF THE SOIL ABOVE THE TOE. THEN THE SOIL ABOVE THE TOE IS AT ITS FINISHED ELEVATION, THE REMAINDER OF THE BACKFILL MAY BE PLACED.

FORESLOPE WALL ANCHOR DOWELS

PROVIDE ANCHOR DOWELS PER CMS 510 WITH NONSHRINK, NONMETALLIC GROUT CONFORMING TO CMS 705.20 AND TO A DEPTH SPECIFIED ON SHEETS 3/8 AND 4/8. PAYMENT FOR DOWEL HOLES, GROUT AND INSTALLATION SHALL BE INCLUDED WITH ITEM 510 DOWEL HOLES WITH NONSHRINK, NONMETALLIC GROUT.

THREADED INSERTS OR NON-PROTRUDING MECHANICAL CONNECTORS CAPABLE OF DEVELOPING AT LEAST 125 PERCENT OF THE SPECIFIED YIELD STRENGTH OF THE REINFORCEMENT SHOWN ARE AN ACCEPTABLE ALTERNATIVE TO RESIN BONDING. MAINTAIN A MINIMUM COVER OF 3 INCHES AT THE BOTTOM OF THE CULVERT SLAB. MECHANICAL CONNECTORS SHALL HAVE AN "L-SHAPED" BAR INSIDE THE CULVERT WITH A MINIMUM HORIZONTAL LENGTH OF 12 INCHES. THE DEPARTMENT WILL CONSIDER PAYMENT FOR INSERTS OR MECHANICAL CONNECTORS AS INCIDENTAL TO ITEM 611.

POROUS BACKFILL WITH FILTER FABRIC

POROUS BACKFILL 2'-0" THICK SHALL BE PLACED BEHIND THE WINGWALLS ONLY AND SHALL BE PLACED 6" BELOW THE EMBANKMENT SURFACE AND EXTEND 6" BELOW WEEPHOLES. GEOTEXTILE FABRIC TYPE A SHALL BE PLACED BETWEEN THE POROUS BACKFILL AND REPLACED EXCAVATION ADJACENT TO THE STRUCTURE. IT SHALL TURN UNDER THE BOTTOM OF THE POROUS BACKFILL AND RETURN 6" ABOVE THE TOP ELEVATION OF THE WEEPHOLE.

WEEPHOLES SHALL BE PLACED 6" TO 12" ABOVE THE NORMAL WATER ELEVATION OR GROUND LINE AND SHALL HAVE A MAXIMUM SPACING OF 10'-0". A MINIMUM OF ONE WEEPHOLE SHALL BE PROVIDED PER WINGWALL.

PERFORMED EXPANSION JOINT FILLER

PERFORMED EXPANSION JOINT FILLER (PEJF) CONFORMING TO CMS 705.03, 1 INCH THICK, SHALL BE PLACED ABOVE THE FOOTING BETWEEN THE SIDES OF THE BOX CULVERT AND THE ENDS OF THE WINGWALLS. PAYMENT FOR MATERIALS AND INSTALLATION SHALL BE INCLUDED WITH ITEM 516 - 1" PERFORMED EXPANSION JOINT FILLER.

SEALING OF FORESLOPE WALL AND WINGWALL

ALL EXPOSED FORESLOPE WALL AND WINGWALL CONCRETE SHALL BE SEALED WITH NON-EPOXY SEALER. THE LIMITS SHALL BE AS SHOWN IN THE DIAGRAMS BELOW. PAYMENT FOR THE NON-EPOXY SEALER SHALL BE PER ITEM 512 - SEALING OF CONCRETE SURFACES.

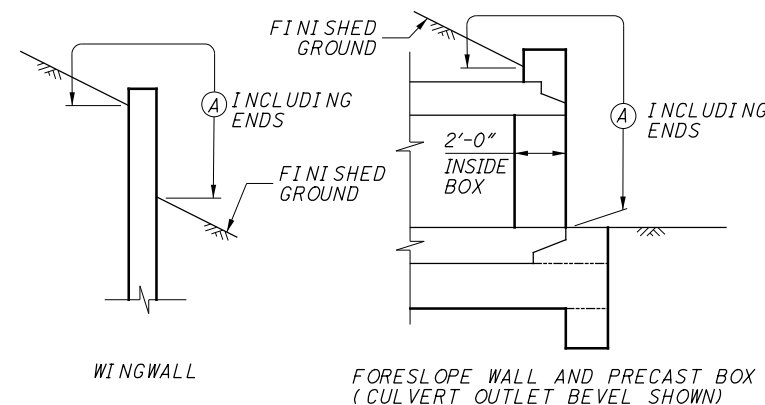

LIMITS OF ITEM 512-SEALING CONCRETE SURFACES
 (A) - SEAL ENTIRE CONCRETE SURFACE AREA

WATERPROOFING

TYPE 2 WATERPROOFING, PER CMS 512 AND 711.25, SHALL EXTEND VERTICALLY DOWN THE ENTIRE SIDES OF THE PRECAST CULVERT SECTIONS FOR ALL PORTIONS OF THE CULVERT WHICH SHALL BE IN CONTACT WITH THE BACKFILL. PAYMENT FOR THE MEMBRANE WATERPROOFING SHALL BE AT THE CONTRACT PRICE BID PER SQUARE YARD FOR ITEM 512 - TYPE 2 WATERPROOFING.

IF PAVEMENT IS NOT PLACED DIRECTLY ON TOP OF THE CULVERT, TYPE 2 WATERPROOFING, PER CMS 512 AND 711.25 SHALL BE APPLIED TO THE ENTIRE TOP SURFACE OF THE PRECAST CULVERT SECTIONS AND SHALL EXTEND ONE FOOT VERTICALLY DOWN THE SIDES FOR ALL PORTIONS OF THE CULVERT WHICH SHALL BE IN CONTACT WITH THE BACKFILL. PAYMENT FOR THE MEMBRANE WATERPROOFING SHALL BE AT THE CONTRACT PRICE BID PER SQUARE YARD FOR ITEM 512 - TYPE 2 WATERPROOFING.

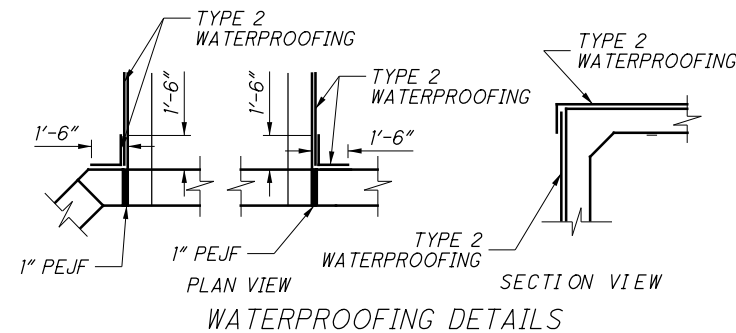

ITEM 611 - CONDUIT, TYPE A, 706.05, AS PER PLAN

ALL EQUIPMENT, MATERIAL, AND LABOR REQUIRED TO INSTALL THE TYPE A PRECAST REINFORCED CONCRETE BOX SECTION SHALL BE PAID FOR UNDER THIS ITEM AND SHALL BE DESIGNED PER THE "LRFD BRIDGE DESIGN SPECIFICATIONS" ADOPTED BY THE AMERICAN ASSOCIATION OF STATE HIGHWAY AND TRANSPORTATION OFFICIALS, 8TH EDITION, INCLUDING THE INTERIM SPECIFICATIONS AND THE ODOT BRIDGE DESIGN MANUAL, 2007.

THE MANUFACTURER OF THE BOX SHALL PROVIDE A LOAD RATING WITH THE BOX SHOP DRAWINGS FOR APPROVAL BY THE ENGINEER. THE LOAD RATING SHALL MEET AASHTO HL-93, ALL OHIO LEGAL LOADS AND FHWA SPECIAL HAULING VEHICLES.

PAYMENT FOR REINFORCING STEEL FOR THE BOX CULVERT SHALL BE INCIDENTAL TO ITEM 611 12'x6' CONDUIT, TYPE A, 706.05, AS PER PLAN.

ABBREVIATIONS

- CLR. - CLEARANCE
- CONST. - CONSTRUCTION
- C.J. - CONSTRUCTION JOINT
- E.F. - EACH FACE
- ELEV. - ELEVATION
- EQ. - EQUAL
- EX. - EXISTING
- LT. - LEFT
- MAX. - MAXIMUM
- MIN. - MINIMUM
- NO. - NUMBER
- PEJF - PERFORMED EXPANSION JOINT FILLER
- RT. - RIGHT
- R/W - RIGHT-OF-WAY
- SER. - SERIES
- S.P.A. - SPACING
- S.R. - STATE ROUTE
- STA. - STATION
- T&B - TOP & BOTTOM
- TYP. - TYPICAL
- W/ - WITH

ESTIMATED QUANTITIES

ITEM	ITEM EXT.	TOTAL	UNIT	DESCRIPTION
202	11000	LS		STRUCTURE REMOVED
202	98000	LS		REMOVAL MISC. (PORTIONS OF EX. RETAINING WALL)
203	35120	129	CY	GRANULAR MATERIAL, TYPE C
503	11100	LS		COFFERDAMS AND EXCAVATION BRACING
503	21300	LS		UNCLASSIFIED EXCAVATION
509	10000	6,458	LB	EPOXY COATED REINFORCING STEEL
510	10000	28	EACH	DOWEL HOLES WITH NONSHRINK, NONMETALLIC GROUT
511	46010	21	CY	CLASS QC1 CONCRETE, RETAINING WALL/WINGWALL NOT INCLUDING FOOTING
511	46510	54	CY	CLASS QC1 CONCRETE, FOOTING
512	10050	57	SY	SEALING OF CONCRETE SURFACES (NON-EPOXY)
512	33000	390	SY	TYPE 2 WATERPROOFING
516	13600	38	SF	1" PERFORMED EXPANSION JOINT FILLER
518	21200	18	CY	POROUS BACKFILL WITH GEOTEXTILE FABRIC (TYPE A)
601	11000	26	SY	RIPRAP, TYPE D
601	32100	208	CY	ROCK CHANNEL PROTECTION, TYPE B WITH FILTER
601	34100	4	CY	ROCK CHANNEL PROTECTION, TYPE B WITHOUT FILTER
611	95801	108	FT	12' X 6' CONDUIT TYPE A, 706.05, AS PER PLAN
613	41250	440	CY	LOW STRENGTH MORTAR BACKFILL (TYPE 1)

S:\Projects\SAN09\101329\Design\Drawings\Sheets\101329_DN001.dgn Sheet 10/23/2020 10:51:20 AM REGuser

GENERAL NOTES & ESTIMATED QUANTITIES

SAN-19-0.24
PID No. 101329

2 / 8

23
34

DESIGN AGENCY
REBEY ENGINEERING GROUP, INC.
10000 WOODBURN BLVD., SUITE 500
COLUMBUS, OHIO 43215
PH. NO. (614) 221-8009
FAX NO. (614) 221-9889

DATE
05/14/19
REVIEWED
AE
DRAWN
JDS
CHECKED
LJ
DESIGNED
LI
STRUCTURE FILE NUMBER
7201096
REVISION NUMBER
XXX
PA