

STATE OF OHIO
DEPARTMENT OF TRANSPORTATION

STA-44/173-14.67/0.00

**MARLBORO, NIMISHILLEN, LEXINGTON
& WASHINGTON TOWNSHIP
STARK COUNTY**

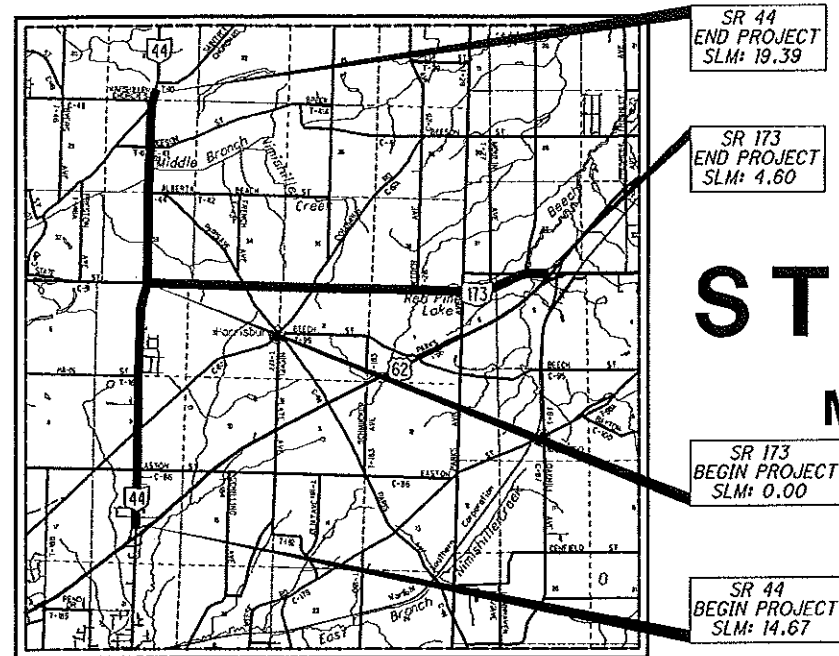

LOCATION MAP

LATITUDE: 40°54'06" LONGITUDE: 81°15'19"

SCALE IN MILES

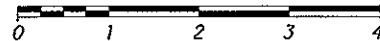

PORTION TO BE IMPROVED	
INTERSTATE HIGHWAY	
FEDERAL ROUTES	
STATE ROUTES	
COUNTY & TOWNSHIP ROADS	
OTHER ROADS	

INDEX OF SHEETS:

TITLE SHEET	1
TYPICAL SECTIONS	2
SAFETY EDGE	3
GENERAL NOTES	4-12, 5A
MAINTENANCE OF TRAFFIC	13-14
GENERAL SUMMARY	15-16
PAVEMENT CALCULATIONS	17-18, 18A
RAISED PAVEMENT MARKERS	19
PAVEMENT MARKINGS	20
STRUCTURES	21-26

PROJECT DESCRIPTION

RESURFACING OF 4.72 MILES OF SR 44 AND 4.60 MILES OF SR 173. ALSO, MINOR BRIDGE WORK ON VARIES STRUCTURES ON SR 44, SR 173 AND US 62T

EARTH DISTURBED AREAS

PROJECT EDA:	N/A (MAINTENANCE PROJECT)
ESTIMATED CONTRACTOR EDA:	0.25 ACRES
NOTICE OF INTENT EDA:	N/A (MAINTENANCE PROJECT)

2016 SPECIFICATIONS

THE STANDARD SPECIFICATIONS OF THE STATE OF OHIO, DEPARTMENT OF TRANSPORTATION, INCLUDING SUPPLEMENTAL SPECIFICATIONS LISTED IN THE PLANS AND CHANGES LISTED IN THE PROPOSAL SHALL GOVERN THIS IMPROVEMENT.

I HEREBY APPROVED THESE PLANS AND DECLARE THAT THE MAKING OF THIS IMPROVEMENT WILL NOT REQUIRE THE CLOSING TO TRAFFIC OF THE HIGHWAY AND THAT PROVISIONS FOR THE MAINTENANCE AND SAFETY OF TRAFFIC WILL BE AS SET FORTH ON THE PLANS AND ESTIMATES.

DESIGN DESIGNATION

DESIGN FUNCTIONAL CLASSIFICATION:
SR 44 SLM: 14.67 - 17.19: PRINCIPAL ARTERIAL
SR 44 SLM: 17.19 - 19.39: MINOR ARTERIAL
SR 173 SLM: 0.00 - 4.60: MAJOR COLLECTOR

NHS PROJECT ----- YES (SR 44 SLM 14.67 - 16.46)/ NO

DESIGN EXCEPTIONS

NONE

UNDERGROUND UTILITIES
CONTACT BOTH SERVICES TWO WORKING DAYS BEFORE YOU DIG.

Call Before You Dig
1-800-362-2764

(Non-members must be called directly)

OIL & GAS PRODUCERS UNDERGROUND PROTECTION SERVICE
1-800-925-0988

PLAN PREPARED BY:
ODOT - DISTRICT 4 PLANNING & ENGINEERING
2088 SOUTH ARLINGTON RD.
AKRON, OH 44306

ENGINEERS SEAL:

SIGNED: *Matthew Chaney*
DATE: 2-1-18

STANDARD CONSTRUCTION DRAWINGS				SUPPLEMENTAL SPECIFICATIONS	SPECIAL PROVISIONS
BP-3.1	7/18/14	TC-41.20	10/18/13	800	4/20/18 WPC 1/12/18
BP-4.1	7/19/13	TC-52.10	10/18/13	821	4/20/12
		TC-52.20	7/21/17	921	4/20/12
DM-4.3	1/15/16	TC-65.10	1/17/14	832	1/17/14
DM-4.4	1/15/16	TC-65.11	7/21/17		
		TC-71.10	1/20/17		
MT-95.30	7/21/17				
MT-95.31	7/21/17	MGS-1.1	7/21/17		
MT-95.32	7/21/17	MGS-2.1	7/19/13		
MT-97.10	7/18/14	MGS-4.2	7/19/13		
MT-97.11	1/20/17				
MT-97.12	1/20/17				
MT-99.20	7/21/17				
MT-101.90	7/21/17				
MT-105.10	7/19/13				

APPROVED
DATE 2/1/18 *[Signature]* DISTRICT DEPUTY DIRECTOR

APPROVED
DATE 5/2-18 *[Signature]* DIRECTOR DEPARTMENT OF TRANSPORTATION

STA - SR-SR 44/SR 153/SR 173-14.67/
180432 PID - 98392 Contract Proposal Available @
Dist 4 7/11/2018 www.contracts.dot.state.oh.us/home

FEDERAL PROJECT NO.
E161(229)

PID NO.
98392

CONSTRUCTION PROJECT NO.

RAILROAD INVOLVEMENT
NONE

STA-44/173
14.67/0.00

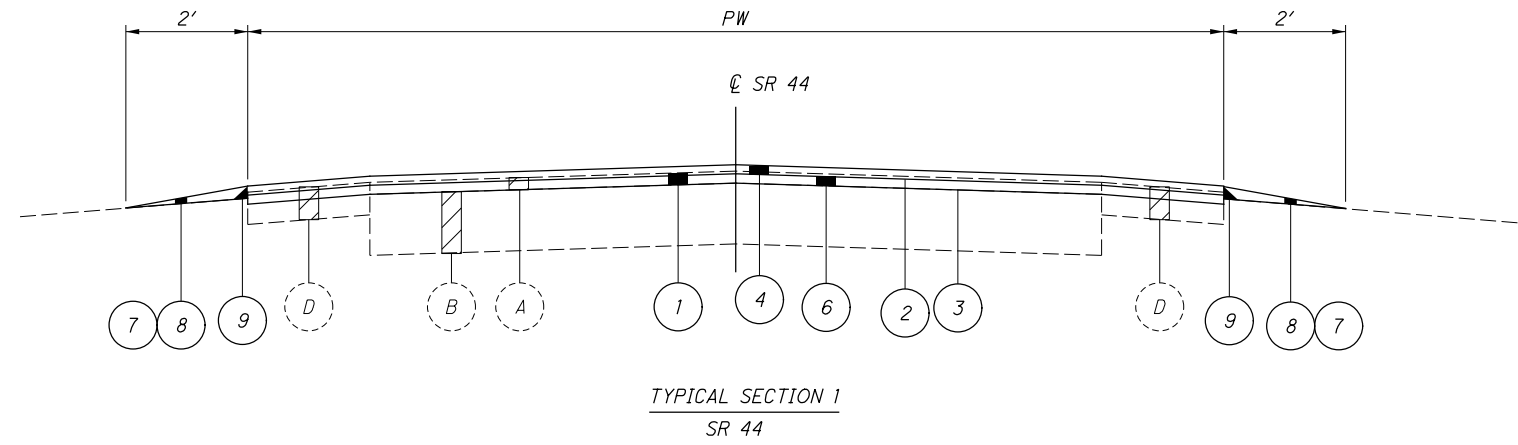

TYPICAL SECTION 1				
ROUTE	SLM		PW (FEET)	LENGTH (MILES)
	FROM	TO		
44	14.67	14.97	30	0.3
44	14.97	15.51	32	0.54
44	15.51	15.57	41	0.06
44	15.57	16.46	27	0.89
44	16.46	16.92	27	0.46
44	16.92	17.31	30	0.39
44	17.31	19.39	27	2.08

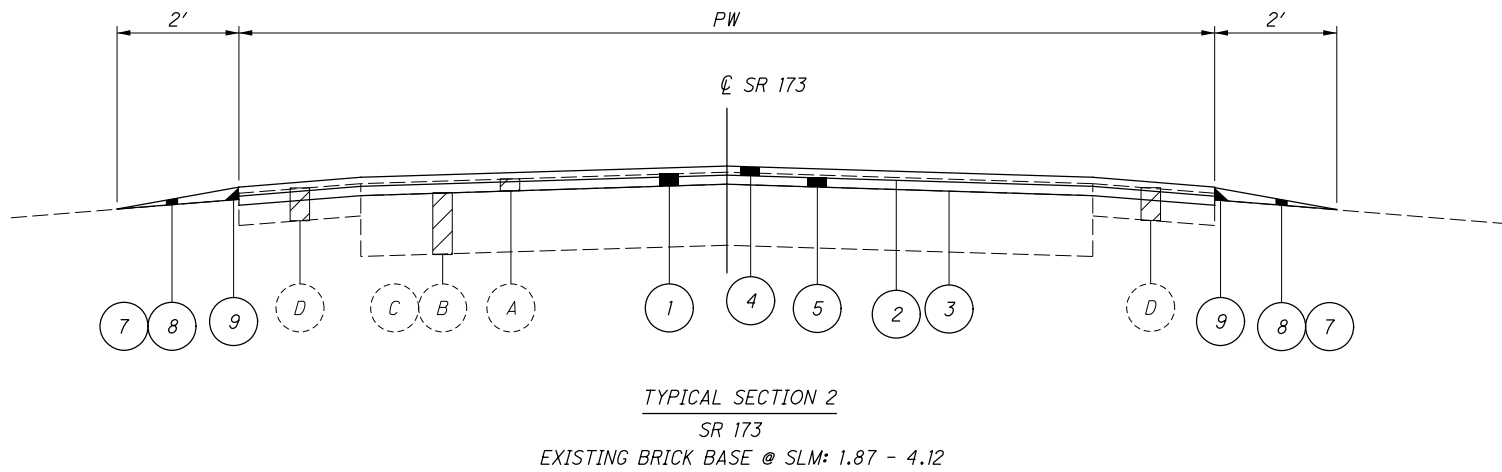

TYPICAL SECTION 2				
ROUTE	SLM		PW (FEET)	LENGTH (MILES)
	FROM	TO		
173	0.00	1.72	28	1.72
173	1.72	1.98	32	0.26
173	1.98	4.25	28	2.27
173	4.27	4.43	50	0.16
173	4.43	4.47	70	0.04
173	4.53	4.60	70	0.07

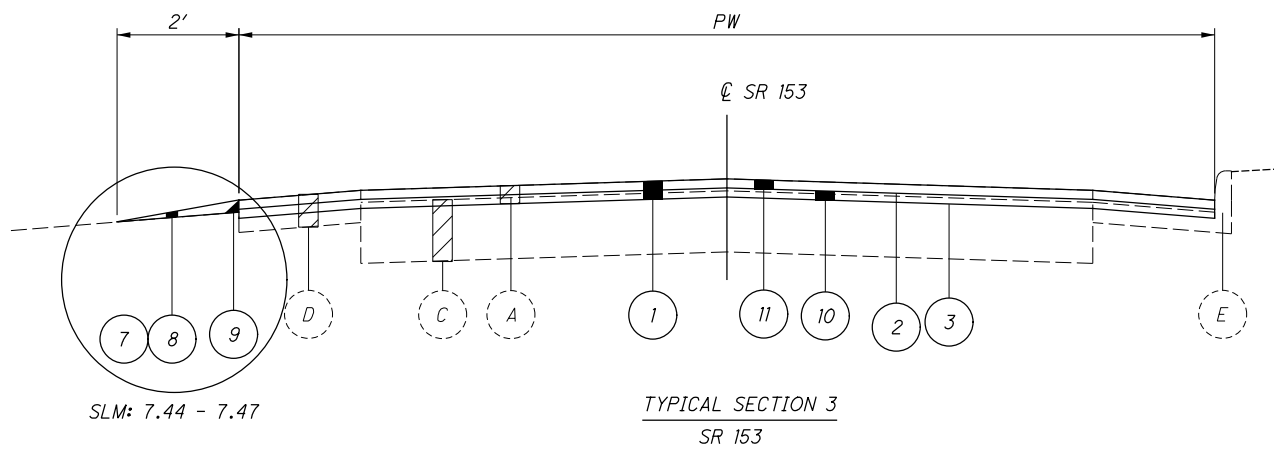

TYPICAL SECTION 3				
ROUTE	SLM		PW (FEET)	LENGTH (MILES)
	FROM	TO		
153	6.25	6.33	48	0.08
153	6.33	6.40	38	0.07
153	6.40	7.47	32	1.07

LEGEND

- | | | |
|--|---|---|
| <ul style="list-style-type: none"> 1 254, PAVEMENT PLANNING, ASPHALT CONCRETE (T=2") 2 407, NON-TRACKING TACK COAT @ 0.06 GAL/SY 3 407, NON-TRACKING TACK COAT @ 0.09 GAL/SY 4 441, ASPHALT CONCRETE SURFACE COURSE, TYPE 1 (446), AS PER PLAN (PG70-22M) (T=1 1/4") 5 441, ASPHALT CONCRETE INTERMEDIATE COURSE, TYPE 1 (448) (T=1 1/4") 6 441, ASPHALT CONCRETE INTERMEDIATE COURSE, TYPE 2 (446) (T=1 3/4") | <ul style="list-style-type: none"> 7 408, PRIME COAT, AS PER PLAN @ 0.40 GAL/SY 8 617, COMPACTED AGGREGATE, AS PER PLAN (T = 2") 9 SAFETY EDGE, SEE SHEET 3 FOR DETAIL 10 441, ASPHALT CONCRETE INTERMEDIATE COURSE, TYPE 1 (448) (T=1") 11 424, FINE GRADED POLYMER ASPHALT CONCRETE, TYPE B, AS PER PLAN (T=1") [LESS THAN 1500 TRUCK ADT] | <ul style="list-style-type: none"> A EXISTING ASPHALT CONCRETE B EXISTING BITUMINOUS CONCRETE BASE C EXISTING BRICK BASE D EXISTING SHOULDER E EXISTING CURB/CURB & GUTTER |
|--|---|---|

SAFETY EDGE (ASPHALT CONCRETE)

IN ADDITION TO THE REQUIREMENTS OF 401.12, ATTACH A DEVICE TO THE SCREED OF THE PAVER THAT CONFINES THE MATERIAL AT THE END GATE AND EXTRUDES THE ASPHALT MATERIAL IN SUCH A WAY THAT RESULTS IN A COMPACTED WEDGE SHAPE PAVEMENT EDGE OF APPROXIMATELY 30 DEGREES (NOT STEEPER THAN 40 DEGREES). ENSURE THE DEVICE MAINTAINS CONTACT WITH THE EXISTING SURFACE, AND ALLOW FOR AUTOMATIC TRANSITION TO CROSS ROADS, DRIVEWAYS AND OBSTRUCTIONS. DO NOT USE CONVENTIONAL SINGLE PLATE STRIKE OFF.

CONSTRUCTION OF SAFETY EDGE CAN BE OMITTED AT LOCATIONS WHERE EXISTING WIDTH OF GRADED SHOULDER OR BERM IS LESS THAN 12". PROJECTS WITH VARYING CONDITIONS SHOULD USE SAFETY EDGE WHERE POSSIBLE. PLAN PREPARATION HAS MADE EVERY REASONABLE ATTEMPT TO IDENTIFY POSSIBLE SAFETY EDGE LOCATIONS.

USE THE TRANSTECH SHOULDER WEDGE MAKER, THE CARLSON SAFETY EDGE END GATE, THE ADVANT-EDGER, THE TROXLER SAFETY SLOPE OR A SIMILAR APPROVED-EQUAL DEVICE THAT PRODUCES THE SAME WEDGE CONSOLIDATION RESULTS. CONTACT INFORMATION FOR THESE WEDGE SHAPE COMPACTION DEVICES IS THE FOLLOWING:

TRANSTECH SYSTEMS, INC.
1594 STATE STREET
SCHENECTADY, NY 12304
1-800-724-6306
WWW.TRANSTECHSYS.COM

ADVANT-EDGE PAVING EQUIPMENT LLC
P.O. BOX 9163
NISKAYUNA, NY 12309-0163
518-280-6090
WWW.ADVANTAEDGEPAVING.COM

CARLSON SAFETY EDGE END GATE
18425 50TH AVENUE EAST
TACOMA, WA 98446
253-875-8000

TROXLER ELECTRONIC LABORATORIES, INC.
3008 E. CORNWALLIS RD.
RESEARCH TRIANGLE PARK, NC 27709
1-877-TROXLER
WWW.TROXLERLABS.COM

IF ELECTING TO USE A SIMILAR DEVICE, PROVIDE PROOF THAT THE DEVICE HAS BEEN USED ON PREVIOUS PROJECTS WITH ACCEPTABLE RESULTS OR CONSTRUCT A TEST SECTION PRIOR TO THE BEGINNING OF WORK AND DEMONSTRATE WEDGE COMPACTION TO THE SATISFACTION OF THE ENGINEER. SHORT SECTIONS OF HANDWORK WILL BE ALLOWED WHEN NECESSARY FOR TRANSITIONS AND TURNOUTS OR OTHERWISE AUTHORIZED BY THE ENGINEER.

IN ADDITION TO THE REQUIREMENTS OF 401.16, MAKE THE FIRST ROLLER PASS 8 TO 12 INCHES AWAY FROM TAPERED EDGE. DO NOT ROLL THE TAPER.

ITEM 209, PREPARING SUBGRADE FOR SHOULDER PAVING, AS PER PLAN.

PREPARE THE SHOULDER FOR PAVING A CONSISTENT SAFETY EDGE IN BOTH THICKNESS AND WIDTH.

PRIOR TO PAVING THE SAFETY EDGE, GRADE AN AREA 10 INCHES WIDE, BEGINNING AT THE EDGE OF THE PAVED ROADWAY, TO PROVIDE A LEVEL SURFACE FREE OF VEGETATION FOR CONSTRUCTION OF THE SAFETY EDGE. IF NECESSARY, EXCAVATE THE GRADED AREA TO THE DEPTH NECESSARY TO CONSTRUCT THE SAFETY EDGE. THE MATERIAL REMOVED DURING THIS PROCESS SHOULD BE REMOVED IMMEDIATELY. COMPACT THE GRADED SHOULDER ACCORDING TO 617.05, OR AS DIRECTED BY THE ENGINEER.

NOTES:

1.) SAFETY EDGES ARE REQUIRED AT THE OUTSIDE EDGES OF THE PAVED ROADWAY (EDGE OF TRAVEL LANE OR EDGE OF PAVED SHOULDER).

2.) CONSTRUCT THE SAFETY EDGE THE FULL ASPHALT CONCRETE OVERLAY THICKNESS OR 2.5" WHICHEVER IS GREATER, NOT TO EXCEED THE MAXIMUM SAFETY EDGE THICKNESS OF 6". CONSTRUCT A NEAR-VERTICAL FACE BELOW THE SAFETY EDGE FOR THICKNESS GREATER THAN 6".

3.) BLADE AND SHAPE EXISTING SHOULDER MATERIAL TO FORM A UNIFORM SURFACE UNDER THE SAFETY EDGE PRIOR TO PLACEMENT OF THE ASPHALT CONCRETE OVERLAY.

* 40° MAX

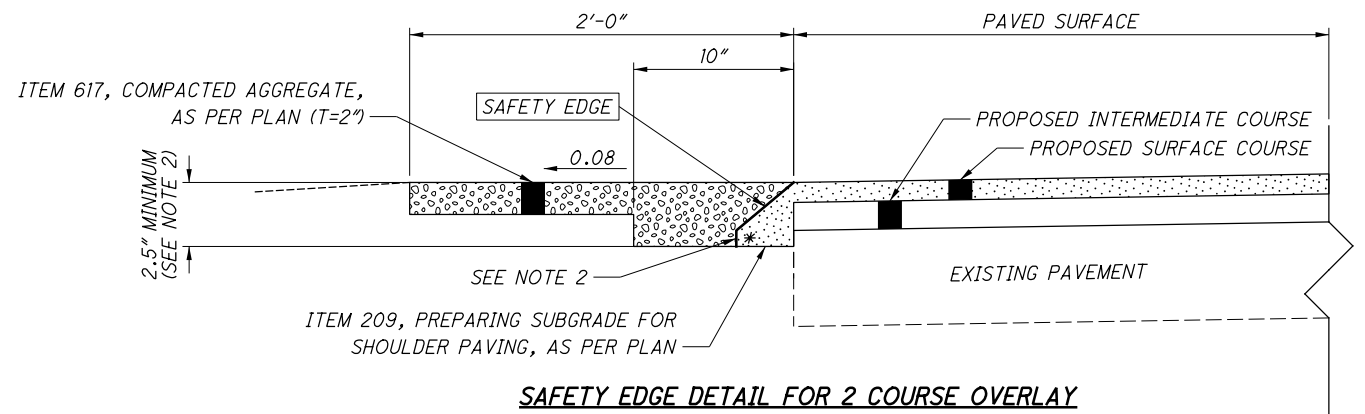

SAFETY EDGE DETAIL FOR 2 COURSE OVERLAY

ESTIMATED QUANTITIES

ROUTE	SAFETY EDGE THICKNESS (IN.)	S.L.M TO S.L.M.		SIDE	209	441	424	
		STA	TO		PREPARING SUBGRADE FOR SHOULDER PAVING, AS PER PLAN	ASPHALT CONCRETE SURFACE COURSE, TYPE 1, (446), AS PER PLAN (PG 70-22M)	FINE GRADED POLYMER ASPHALT CONCRETE, TYPE B, AS PER PLAN	
44	2.5	14.67	TO	16.46	L/R	189.0	18.20	
44	2.5	16.46	TO	19.39	L/R	309.4	29.79	
173	2.5	0.00	TO	4.25	L/R	448.8	43.22	
173	2.5	4.27	TO	4.43	L/R	16.9	1.63	
173	2.5	4.43	TO	4.47	L/R	4.2	0.41	
173	2.5	4.53	TO	4.60	L/R	7.4	0.71	
153	2.5	7.44	TO	7.47	L	1.6	0.15	
TOTALS CARRIED TO GENERAL SUMMARY						978	94	1

I:\ProjectData\STA\98392_44-173_14.67-0\Design\Roadway\Sheets\98392_Safety Edge_Detail.dgn Sheet 5/8/2018 9:21:47 AM pdinh

UTILITIES

THE CONTRACTOR SHALL USE THE FOLLOWING PROCEDURE AT EACH LOCATION WHERE WORK IS PERFORMED, IN ACCORDANCE WITH SECTIONS 105.07 AND 107.16 IN THE CONSTRUCTION AND MATERIALS SPECIFICATIONS.

THE CONTRACTOR SHALL NOTIFY THE PROJECT ENGINEER, THE OHIO UTILITIES PROTECTION SERVICE (OUPS), THE OHIO & GAS PROCEDURES UNDERGROUND PROTECTION SERVICE (OGPUPS), THE OHIO DEPARTMENT OF TRANSPORTATION DISTRICT 4 HEAD-QUARTERS AND ALL NON REGISTERED UTILITY OWNERS AT LEAST TWO (2) WORKING DAYS PRIOR TO COMMENCING CONSTRUCTION IN ALL AREAS.

OUPS 1-800-362-2764 (CONTACT LIMITED BASIS PARTICIPANTS DIRECTLY)
 OGPUPS 1-800-925-0988
 ODOT 330-786-3100 MIKE SIMPKINS

THE LOCATION OF EXISTING UNDERGROUND UTILITIES ARE NOT SHOWN ON THE PLANS, BUT CAN BE OBTAINED FROM THE OWNERS OF THE UTILITIES. THE CONTRACTOR IS RESPONSIBLE FOR ANY DAMAGE TO UTILITIES.

AEP ATTN: Ray Zitney 301 Cleveland Avenue, SW P.O. Box 24400 Canton, Ohio 44701 330-438-7718	AT&T The Ohio Bell Telephone Company ATTN: Cindy Zuchegno 50 W. Bowery St. 4th Floor Akron, OH 44308 330-384-3561
Charter Communications ATTN: Michael Meyer 5520 Whipple Ave. NE. North Canton, OH 44720 216-575-8016 ext. 12165554261	Columbia Gas of Ohio ATTN: Chris Robinson 1020 W. State St. Salem, OH 44460 Cell: 419-957-6633
Dominion Energy Ohio ATTN: Bill Snyder 320 Springside Drive Akron, OH 44333 330-664-2781	Enervest Operating L.L.C. ATTN: Troy Valasek 125 State Route 43 Suite 100 Hartville, OH 44632 330-587-1009
Ohio Edison ATTN: David Miller 1910 W. Market Street Building #1 Akron, OH 44313 330-436-4055	Range Resources - Appalachia, LLC ATTN: Ed Haas 125 State Route 43 P.O. Box 550 Hartville, OH 44632

WORK LIMITS

THE WORK LIMITS SHOWN ON THESE PLANS ARE FOR PHYSICAL CONSTRUCTION ONLY. PROVIDE THE INSTALLATION AND OPERATION OF ALL WORK ZONE TRAFFIC CONTROL AND WORK ZONE TRAFFIC CONTROL DEVICES REQUIRED BY THESE PLANS WHETHER INSIDE OR OUTSIDE THESE WORK LIMITS.

PAVEMENT MARKING LANE WIDTHS

THE NORMAL LANE WIDTH FOR THE PAVEMENT MARKINGS ON THIS PROJECT SHALL BE AS FOLLOWS:

ROUTE	S.L.M. TO S.L.M.	LANE WIDTH
SR 44	14.67 19.39	10'
SR 173	0.00 1.85	10'
SR 173	1.85 4.60	12'

PROFILE AND ALIGNMENT

PLACE THE PROPOSED PAVEMENT TO FOLLOW THE ALIGNMENT AND PROFILE OF THE EXISTING PAVEMENT. PLACE THE PROPOSED ASPHALT CONCRETE OVERLAY AS SHOWN ON THE TYPICAL SECTIONS.

INTERSECTIONS (SR 44 & SR 173)

INTERSECTIONS WILL BE RESURFACED 10 FT BEYOND THE EDGE LINE, UNLESS OTHERWISE DIRECTED BY THE ENGINEER OR INDICATED IN THE PLAN. INTERSECTIONS SHALL BE PAVED AFTER COMPLETION OF THE SURFACE COURSE OR WITH THE MAINLINE PAVEMENT IF THIS CAN BE ACCOMPLISHED WITHOUT CHANGING THE VELOCITY AND DIRECTION OF THE PAVER. USE THE SAME ASPHALT CONCRETE AS THE MAINLINE PAVEMENT. A BUTT JOINT, AS PER STANDARD CONSTRUCTION DRAWING BP-3.1, SHALL BE USED TO PROVIDE A SMOOTH TRANSITION TO THE EXISTING PAVEMENT. ANY GRADING OR PRIME NECESSARY TO ACCOMPLISH THIS WORK SHALL BE INCLUDED IN THE COST OF THE ASPHALT SURFACE COURSE.

PAVED MAILBOX APPROACHES

ALL EXISTING MAIL BOX APPROACHES WILL BE PAVED WITH ASPHALT CONCRETE AS PER TYPICAL SHOWN OR AS NEAR AS PRACTICAL. AGGREGATE APPROACHES SHALL HAVE A 2 IN. MIN. THICKNESS; IMPROVED APPROACHES SHALL HAVE A 2 IN. MIN. THICKNESS. THE CONTRACTOR SHALL PAVE THE MAILBOX APPROACHES WITH THE MAINLINE AND SHOULDERS, ALL GRADING, TACK, TOOLS, EQUIPMENT, MATERIAL AND INCIDENTALS REQUIRED TO LAYOUT AND CONSTRUCT THE MAILBOX APPROACHES SHALL BE INCLUDED IN THE UNIT BID FOR ITEM 441, ASPHALT CONCRETE SURFACE COURSE, TYPE 1, (446) AS PER PLAN (PG70-22M), ITEM 441, ASPHALT CONCRETE INTERMEDIATE COURSE, TYPE 1 (446) & ITEM 441, ASPHALT CONCRETE INTERMEDIATE COURSE, TYPE 2 (446)

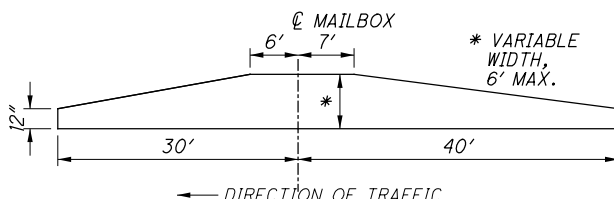

ITEM 441 - ASPHALT CONCRETE SURFACE COURSE, TYPE 1 (446), AS PER PLAN (PG70-22M)

703.05 DO NOT USE COARSE AGGREGATE FROM A SOURCE DESIGNATED 'SR' OR 'SRH' ACCORDING TO THE OFFICE OF MATERIALS MANAGEMENT (OMM) IN ANY JOB MIX FORMULA (JMF) FOR THIS ITEM.

ITEM 203 - EXCAVATION (FOR PAVEMENT REPAIR)

THIS ITEM OF WORK SHALL CONSIST OF REMOVING AND DISPOSING OF ALL UNSUITABLE MATERIAL BY EXCAVATING THE EXISTING SUBGRADE AND SUBBASE TO AN AVERAGE DEPTH OF 6 INCHES OR AS DIRECTED BY THE ENGINEER. EXACT LIMITS OF REMOVAL SHALL BE DETERMINED BY THE ENGINEER. ALL EQUIPMENT, LABOR, TOOLS, AND INCIDENTALS NECESSARY TO COMPLETE THIS ITEM SHALL BE INCLUDED IN THE UNIT PRICE BID FOR ITEM 203 EXCAVATION (FOR PAVEMENT REPAIR). THE FOLLOWING ESTIMATED QUANTITY HAS BEEN CARRIED TO THE GENERAL SUMMARY:
 203, EXCAVATION (FOR PAVEMENT REPAIR) 110 CU YD

ITEM 251 - PARTIAL DEPTH PAVEMENT REPAIR

A QUANTITY OF THIS ITEM SHALL BE PROVIDED FOR USE AS DIRECTED BY THE ENGINEER. THE ITEM SHALL CONSIST OF REPAIRING EXISTING LOCATIONS EXHIBITING SURFACE DETERIORATION AND PLACING ITEM 441 ASPHALT CONCRETE, TYPE 2. THE ASPHALT CONCRETE SHALL BE COMPACTED WITH A TYPE 1 PNEUMATIC TIRE ROLLER AND A STEEL WHEEL ROLLER AS PER 401.13. IT IS NOT THE INTENT TO REPAIR EVERY DETERIORATED AREA WITHIN THE PROJECT. THE ENGINEER SHALL DETERMINE WHICH AREAS ARE TO BE REPAIRED. UNLESS OTHERWISE DIRECTED BY THE ENGINEER, THIS ITEM SHALL BE PERFORMED AFTER THE COMPLETION OF MAINLINE PAVEMENT PLANING. ALSO, THIS ITEM SHALL COMMENCE WITHIN 7 DAYS OF THE COMPLETION OF MAINLINE PAVEMENT PLANING. PAYMENT SHALL BE BASED ON THE ACTUAL NUMBER OF SQUARE YARDS OF PAVEMENT REPAIR. THE FOLLOWING ESTIMATED QUANTITY HAS BEEN CARRIED TO THE GENERAL SUMMARY:

251, PARTIAL DEPTH PAVEMENT REPAIR, 7400 SQ. YD.	
(SR 44 SLM 14.67 - 16.46	1200 SQ. YD.)
(SR 44 SLM 16.46 - 19.39	2000 SQ. YD.)
(SR 173 SLM 0.00 - 4.43	3100 SQ. YD.)
(SR 173 SLM 4.43 - 4.60	100 SQ. YD.)
(SR 153 SLM 6.25 - 7.47	1000 SQ. YD.)

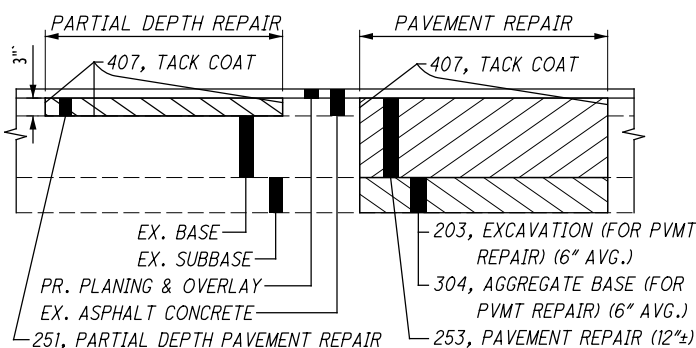

ITEM 253 - PAVEMENT REPAIR

A QUANTITY OF THIS ITEM SHALL BE PROVIDED FOR USE AS DIRECTED BY THE ENGINEER. THIS ITEM SHALL CONSIST OF CUTTING AND REMOVING DETERIORATED PAVEMENT FULL DEPTH AND PLACING 12"± 301 ASPHALT CONCRETE BASE, PG64-22. THE MAXIMUM COMPACTED DEPTH OF ANY ONE LAYER SHALL BE 6 INCHES. UNLESS OTHERWISE DIRECTED BY THE ENGINEER, THIS ITEM SHALL BE PERFORMED AFTER THE COMPLETION OF MAINLINE PAVEMENT PLANING. ALSO, THIS ITEM SHALL COMMENCE WITHIN 7 DAYS OF THE COMPLETION OF MAINLINE PAVEMENT PLANING. IT IS NOT THE INTENT TO REPAIR EVERY DETERIORATED AREA WITHIN THE PROJECT. THE ENGINEER SHALL DETERMINE WHICH AREAS ARE TO BE REPAIRED. PAYMENT SHALL BE BASED ON THE ACTUAL NUMBER OF SQUARE YARDS OF PAVEMENT REMOVED AND REPLACED TO THE LIMITS DESIGNATED BY THE ENGINEER. THE FOLLOWING ESTIMATED QUANTITY HAS BEEN CARRIED TO THE GENERAL SUMMARY:

253, PAVEMENT REPAIR (SR 44 & SR 173),	600 SQ. YD.
253, PAVEMENT REPAIR (SR 153),	50 SQ. YD.
255, FULL DEPTH PAVEMENT SAWING,	3040 FT

ITEM 304 - AGGREGATE BASE (FOR PAVEMENT REPAIR)

THE FOLLOWING ESTIMATED QUANTITY HAS BEEN PROVIDED AND SHALL BE USED AS DIRECTED BY THE ENGINEER TO BACKFILL AREAS WHICH WERE EXCAVATED UNDER ITEM 203 EXCAVATION (FOR PAVEMENT REPAIR). THE FOLLOWING ESTIMATED QUANTITY HAS BEEN CARRIED TO THE GENERAL SUMMARY:
 304, AGGREGATE BASE (FOR PAVEMENT REPAIR) 110 CU YD

ITEM 408 - PRIME COAT, AS PER PLAN

APPLY "MC-70" AT A RATE OF 0.4 GALLONS PER SQUARE YARD, OR AS DETERMINED BY THE ENGINEER, TO THE COMPLETED COMPACTED AGGREGATE SHOULDER.

ITEM 617 - COMPACTED AGGREGATE, AS PER PLAN

IN LOW SHOULDER AREAS EXCEEDING 1", AND ADJACENT TO THE SAFETY EDGE, OR AS DIRECTED BY THE ENGINEER, RECYCLED ASPHALT PAVEMENT (RAP) SHALL BE USED IN AREAS ADJACENT TO THE PAVED BERM. THE RAP SHALL HAVE A MINIMUM PG CONTENT OF 4.5% AND MEET THE FOLLOWING GRADATION. ONCE THE STOCKPILE MEETS THE GRADATION, THE PG CONTENT OF THE RAP SHALL BE DETERMINED PER 441.03. THE RAP ANALYSIS MUST BE SUBMITTED TO THE ENGINEER FOR APPROVAL 2 WEEKS PRIOR TO USE. METHOD OF MEASUREMENT SHALL BE AS PER 617.06. PLACEMENT AND COMPACTION SHALL MEET THE REQUIREMENTS OF ITEM 617. ALL MATERIALS, LABOR, EQUIPMENT, TOOLS AND INCIDENTALS NECESSARY TO COMPLETE THE WORK SHALL BE INCLUDED IN THE UNIT PRICE BID FOR ITEM 617 COMPACTED AGGREGATE, AS PER PLAN.

MODIFIED GRADATION SHALL APPLY:

SIEVE	TOTAL PERCENT PASSING
1-1/2"	100
3/4"	50-100
NO. 4	35-70
NO. 30	9-33
NO. 200	0-13

DRIVEWAYS

THE CONTRACTOR WILL NOT BE PERMITTED TO LEAVE A DIFFERENCE IN ELEVATION BETWEEN THE MAINLINE ASPHALT SURFACE COURSE AND THE EXISTING DRIVEWAYS. IF APPROVED BY THE ENGINEER, AN ASPHALT WEDGE WITH A WIDTH OF APPROX 6' MAY BE PLACED EITHER ON THE ROADWAY SHOULDER OR DRIVEWAY DEPENDENT UPON WHICH SIDE IS HIGH. A QUANTITY OF MAINLINE SURFACE COURSE ASPHALT HAS BEEN PROVIDED IN THE CALCULATIONS AND GENERAL SUMMARY TO PERFORM THIS ITEM OF WORK.

CALCULATED
PD
CHECKED
MAC

GENERAL NOTES

STA - 44 / 153 / 173
14.67 / 6.25 / 0.00

ITEM SPECIAL - VOID REDUCING ASPHALT MEMBRANE (VRAM)

GENERAL. AS PART OF THIS PROJECT, THE CONTRACTOR WILL BE REQUIRED TO CONSTRUCT SECTIONS OF COLD LONGITUDINAL JOINTS USING VOID REDUCING ASPHALT MEMBRANE (VRAM) MATERIAL AT SPECIFIED LOCATIONS. PROVIDE ADDITIONAL CORES SAMPLES, LOOSE MIX SAMPLES AND LIQUID MATERIAL SAMPLES AS DIRECTED BY THE ENGINEER. CONSTRUCT ALL SURFACE COURSE COLD LONGITUDINAL JOINTS ON SR 44 SLM: 14.67 - 19.39 & SR 173 SLM: 0.00- 4.60, USING VRAM MATERIAL AND CONFORMING WITH THE FOLLOWING REQUIREMENTS.

MATERIALS.

PROVIDE J-BAND PRODUCED BY ASPHALT MATERIALS, INC. OR OTHER APPROVED ASPHALT MATERIAL AS FOLLOWS:

PROVIDE A BASE ASPHALT MODIFIED WITH STYRENE-BUTADIENE DIBLOCK OR TRIBLOCK COPOLYMER WITHOUT OIL EXTENSION, OR A STYRENE-BUTADIENE RUBBER ELASTOMERS. DO NOT USE AIR BLOWN ASPHALT, ACID MODIFICATION, OR OTHER MODIFIERS.

Test	Test Requirement	Test Method
Dynamic shear @ 82°C (unaged), G*/sin δ, kPa	1.00 min.	AASHTO T 315
Creep stiffness @ -18°C (unaged), Stiffness (S), MPa m-value	300 max. 0.300 min.	AASHTO T 313
Ash, %	6.0 max.	AASHTO T 111
Elastic Recovery, 100 mm elongation, cut immediately, 25°C, %	58 min.	AASHTO T301
Separation of Polymer, Difference in °C of the softening point (ring and ball)	3 max.	ASTM D7173, AASHTO T53
Migration of VRAM, %	50-75	ITM XYZ

EQUIPMENT. WHEN A PRESSURE DISTRIBUTOR IS USED TO APPLY THE VRAM, EQUIP THE DISTRIBUTOR WITH A HEATING AND RECIRCULATING SYSTEM ALONG WITH A FUNCTIONING AUGER AGITATING SYSTEM OR VERTICAL SHAFT MIXER IN THE HAULING TANK TO PREVENT LOCALIZED OVERHEATING.

WHEN A MELTER KETTLE IS USED TO TRANSPORT AND APPLY THE VRAM, USE ONLY OIL JACKETED DOUBLE-BOILER MELTER KETTLES WITH AGITATING AND RECIRCULATING SYSTEMS. MATERIAL FROM THE KETTLE MAY BE DISPENSED THROUGH A PRESSURE FEED WAND WITH AN APPLICATOR SHOE OR THROUGH A PRESSURE FEED WAND INTO A HAND-OPERATED 'THERMAL PUSH CART.'

PREPARATION OF SURFACE. PRIOR TO PLACING VRAM, CLEAN THE PAVEMENT SURFACE AREA TO BE TREATED OF ALL FOREIGN MATERIALS DEEMED DETRIMENTAL BY THE ENGINEER. ONLY APPLY VRAM TO SURFACES THAT ARE DRY AND CLEANED OF ALL DUST, DEBRIS, AND ANY SUBSTANCES THAT WILL PREVENT THE VRAM FROM ADHERING. THE VRAM MAY BE PLACED BEFORE OR AFTER THE TACK COAT PLACEMENT. WHEN PLACED AFTER THE TACK COAT, ENSURE THE TACK COAT IS FULLY CURED PRIOR TO PLACEMENT OF THE VRAM.

APPLICATION OF VRAM. APPLY VRAM TO COLD LONGITUDINAL JOINTS UNDER SURFACE COURSES. ONLY APPLY VRAM WHEN THE PAVEMENT SURFACE TEMPERATURE AND THE AMBIENT TEMPERATURE ARE A MINIMUM OF 40°F AND RISING.

APPLY VRAM MATERIAL ON COLD LONGITUDINAL JOINT AS DETAILED BELOW:

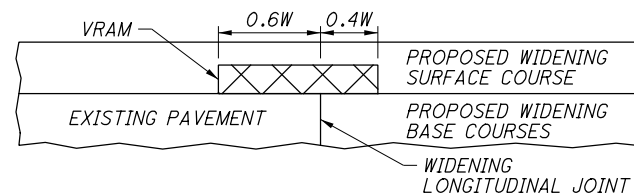

APPLY VRAM AT THE WIDTH AND APPLICATION RATE REQUIRED ACCORDING TO THE FOLLOWING TABLE:

VRAM Application Rate Table		
Overlay Thickness, (in.)	VRAM Width, "W", (in.)	Application Rate ^[1] , (lb/ft)
HMA Mixtures ^[2]		
1	15	0.95
1 1/4	15	1.09
1 1/2	15	1.22
1 3/4	15	1.36
2	15	1.49
2 1/4	15	1.62
2 1/2	15	1.76
2 3/4	15	1.89
3	15	2.03
3 1/4	15	2.16
3 1/2	15	2.30
3 3/4	15	2.43
4	15	2.57
SMA Mixtures ^[2]		
1 1/2	12	0.83
1 3/4	12	0.92
2	12	1.00

[1] THE APPLICATION RATE HAS A SURFACE DEMAND FOR LIQUID INCLUDED WITHIN IT. THE NOMINAL THICKNESS OF THE VRAM MAY TAPER FROM THE CENTER OF THE APPLICATION TO A LESSER THICKNESS ON THE EDGE OF THE APPLICATION. THE WIDTH AND WEIGHT/FOOT SHALL BE MAINTAINED.

[2] IN THE EVENT OF A JOINT BETWEEN AN SMA AND HMA MIXTURE, THE SMA APPLICATION RATE WILL BE USED.

APPLY VRAM IN A SINGLE PASS WITH A PRESSURE DISTRIBUTOR, MELTER KETTLE, OR HAND APPLIED FROM A ROLL, FOR ASPHALT COURSES UP TO 2 IN. (50 MM) IN THICKNESS. APPLY VRAM IN TWO PASSES FOR ASPHALT COURSES BETWEEN 2 AND 4 IN. (50 AND 100 MM) IN THICKNESS. ENSURE THE APPLIED WIDTH OF VRAM IS WITHIN 1.5 IN. (38 MM) OF THE WIDTH SPECIFIED. IF THE VRAM FLOWS MORE THAN 2 IN. (50 MM) FROM THE INITIAL PLACEMENT WIDTH, IMMEDIATELY STOP PLACEMENT OF VRAM AND PERFORM CORRECTIVE ACTIONS. COORDINATE THE APPLICATION OF VRAM AND PLACEMENT OF THE ASPHALT MIXTURE TO ENSURE THE CENTER OF THE VRAM APPLICATION IS WITHIN 2.0 IN. (50 MM) OF THE CENTER OF THE ASPHALT PAVEMENT COLD JOINT BEING CONSTRUCTED.

IF THE VRAM MATERIAL WILL BE EXPOSED TO TRAFFIC PRIOR TO CLOSING THE LONGITUDINAL JOINT, SHIFT THE LOCATION OF THE CENTERLINE OF THE VRAM MATERIAL ABOUT THE JOINT CENTERLINE SUCH THAT NO MORE THAN A NOMINAL 6 IN (152 MM) OF MATERIAL IS EXPOSED. DO NOT OPEN TO TRAFFIC IF WIDTH OF EXPOSED VRAM MATERIAL IS GREATER THAN 6 IN. (152 MM).

IF THE PAVING OPERATION ONLY ALLOWS VRAM TO BE PLACED ON ONE SIDE OF THE COLD LONGITUDINAL JOINT AT A TIME, COAT THE VERTICAL FACE OF THE COLD LONGITUDINAL JOINT WITH VRAM MATERIAL IN ADDITION TO THE REQUIREMENTS ABOVE. DO NOT SEAL THE FACE OF COLD LONGITUDINAL JOINTS AS REQUIRED PER 401.17 WHEN USING VRAM FOR THE COLD LONGITUDINAL JOINT.

FURNISH A BILL OF LADING FOR EACH TANKER SUPPLYING MATERIAL TO THE PROJECT. VERIFY THE APPLICATION RATE OF VRAM WITHIN THE FIRST 1000 FT. (305 M) OF THE DAYS SCHEDULED APPLICATION LENGTH AND EVERY 6000 FT. (1829 M) THE REMAINDER OF THE DAY. FOR PROJECTS LESS THAN 3000 FT. (914 M), THE RATE WILL BE VERIFIED ONCE. PLACE A SUITABLE PAPER OR PAN AT A RANDOM LOCATION IN THE PATH OF THE PLACEMENT FOR THE VRAM. AFTER APPLICATION OF THE VRAM, PICK UP THE PAPER OR PAN AND OBTAIN THE WEIGHT OF MATERIAL. CALCULATE THE WEIGHT PER FOOT OF VRAM. ENSURE THE ACTUAL WEIGHT PER FOOT OF VRAM IS WITHIN 15 PERCENT OF THE TARGET WEIGHT/FOOT FROM THE VRAM APPLICATION RATE TABLE. REPLACE THE VRAM IN THE AREAS WHERE THE SAMPLES ARE TAKEN.

WHEN BEGINNING PLACEMENT OF A RUN OF VRAM, USE A SUITABLE RELEASE PAPER TO COVER PREVIOUS VRAM APPLICATION TO PREVENT DOUBLING UP OF THICKNESS OF VRAM.

THE VRAM MUST BE SUITABLE FOR CONSTRUCTION TRAFFIC TO DRIVE ON WITHOUT PICKUP OR TRACKING WITHIN 30 MINUTES OF PLACEMENT. IF PICKUP OR TRACKING OCCURS, IMMEDIATELY STOP PLACEMENT OF VRAM AND REPAIR DAMAGED AREAS.

PRIOR TO START OF PAVING, ENSURE THE PAVER END PLATE AND ANY GRADE CONTROL DEVICES ARE ADEQUATELY RAISED ABOVE THE FINISHED HEIGHT OF THE VRAM.

IMMEDIATELY STOP PLACEMENT OF ASPHALT MIXTURE AND VRAM IF FLUSHING IS NOTED IN THE ASPHALT SURFACE. DO NOT CONTINUE PLACEMENT OF THE ASPHALT MIXTURE UNTIL THE ISSUE IS CORRECTED.

METHOD OF MEASUREMENT. THE DEPARTMENT WILL MEASURE VRAM BY THE NUMBER OF FEET COMPLETED AND ACCEPTED IN PLACE.

BASIS OF PAYMENT. DEPARTMENT WILL PAY FOR ACCEPTED QUANTITIES AT THE CONTRACT PRICE AS FOLLOWS:

ITEM 690, SPECIAL - VOID REDUCING ASPHALT MEMBRANE (VRAM), 52212 FT

ITEM 606 - GUARDRAIL

THIS WORK WILL CONSIST OF REMOVING AND REPLACING GUARDRAIL ON THE FOLLOWING LOCATIONS.

REPAIRS WILL BE PAID FOR AT THE UNIT BID PRICE FOR THE FOLLOWING ITEMS. THIS PRICE WILL INCLUDE THE COST FOR LABOR, EQUIPMENT, AND ALL INCIDENTALS REQUIRED TO COMPLETE THIS WORK.

STA-173-0315 (ALL GUARDRAIL)		
202, GUARDRAIL REMOVED		1125 FT
606, GUARDRAIL, TYPE MGS		962.5 FT
606, ANCHOR ASSEMBLY, MGS TYPE T		1 EACH
606, ANCHOR ASSEMBLY, MGS TYPE E		3 EACH
626, BARRIER REFLECTOR, TYPE 2		12 EACH

STA-173-0427 (APPROACH GUARDRAIL AT ALL CORNERS)		
202, GUARDRAIL REMOVED		400 FT
606, GUARDRAIL, TYPE 5		275 FT
606, ANCHOR ASSEMBLY, TYPE T		2 EACH
606, ANCHOR ASSEMBLY, TYPE E		2 EACH
626, BARRIER REFLECTOR, TYPE 2		8 EACH

ITEM 606 - ANCHOR ASSEMBLY, MGS TYPE E

THIS ITEM SHALL CONSIST OF FURNISHING AND INSTALLING ANY OF THE GUARDRAIL END TERMINALS FOR TYPE MGS GUARDRAIL AS LISTED ON ROADWAY ENGINEERING'S WEB PAGE UNDER ROADSIDE SAFETY DEVICES FOR APPROVED GUARDRAIL END TREATMENTS. INSTALLATION SHALL BE AT THE LOCATIONS SPECIFIED IN THE PLANS, IN ACCORDANCE WITH THE MANUFACTURER'S SPECIFICATIONS.

THE FACE OF THE TYPE E IMPACT HEAD SHALL BE COVERED WITH A SHEET OF TYPE G REFLECTIVE SHEETING, PER CMS 730.19.

REFER TO THE MANUFACTURER'S INSTRUCTIONS REGARDING THE INSTALLATION OF, AND THE GRADING AROUND THE FOUNDATION TUBES AND GROUND STRUT. THE TOP OF ANY FOUNDATION TUBE SHOULD BE LESS THAN 4 INCHES ABOVE THE GROUND. THE PLACEMENT OF THE FOUNDATION TUBES SHOULD BE AN APPROPRIATE DEPTH BELOW THE LEVEL LINE IN ORDER TO MAINTAIN THE FINISHED GUARDRAIL HEIGHT OF 31 INCHES FROM THE EDGE OF THE SHOULDER.

ON-SITE GRADING IS REQUIRED IF THE TOP OF THE FOUNDATION TUBES OR TOP OF THE GROUND STRUT DOES PROJECT MORE THAN 4 INCHES ABOVE THE GROUND LINE.

PAYMENT FOR THE ABOVE WORK SHALL BE MADE AT THE UNIT PRICE BID FOR ITEM 606, ANCHOR ASSEMBLY, MGS TYPE E, EACH, AND SHALL INCLUDE ALL LABOR, TOOLS, EQUIPMENT AND MATERIALS NECESSARY TO CONSTRUCT A COMPLETE AND FUNCTIONAL ANCHOR ASSEMBLY SYSTEM, INCLUDING ALL RELATED TRANSITIONS, REFLECTIVE SHEETING, HARDWARE, GRADING, EMBANKMENT AND EXCAVATION NOT SEPARATELY SPECIFIED, AS REQUIRED BY THE MANUFACTURER.

ITEM 606 - ANCHOR ASSEMBLY, TYPE E

THIS ITEM SHALL CONSIST OF FURNISHING AND INSTALLING ANY OF THE GUARDRAIL END TERMINALS AS LISTED ON ROADWAY ENGINEERING'S WEB PAGE UNDER ROADSIDE SAFETY DEVICES FOR APPROVED GUARDRAIL END TREATMENTS. INSTALLATION SHALL BE AT THE LOCATIONS SPECIFIED IN THE PLANS, IN ACCORDANCE WITH THE MANUFACTURER'S SPECIFICATIONS.

THE FACE OF THE TYPE E IMPACT HEAD SHALL BE COVERED WITH A SHEET OF TYPE G REFLECTIVE SHEETING, PER CMS 730.19.

REFER TO THE MANUFACTURER'S INSTRUCTIONS REGARDING THE INSTALLATION OF, AND THE GRADING AROUND THE FOUNDATION TUBES AND GROUND STRUT. THE TOP OF ANY FOUNDATION TUBE SHOULD BE LESS THAN 4 INCHES ABOVE THE GROUND. THE PLACEMENT OF THE FOUNDATION TUBES SHOULD BE AN APPROPRIATE DEPTH BELOW THE LEVEL LINE IN ORDER TO MAINTAIN THE FINISHED GUARDRAIL HEIGHT OF 27.75 INCHES FROM THE EDGE OF THE SHOULDER.

ON-SITE GRADING IS REQUIRED IF THE TOP OF THE FOUNDATION TUBES OR TOP OF THE GROUND STRUT DOES PROJECT MORE THAN 4 INCHES ABOVE THE GROUND LINE.

PAYMENT FOR THE ABOVE WORK SHALL BE MADE AT THE UNIT PRICE BID FOR ITEM 606, ANCHOR ASSEMBLY TYPE E, EACH, AND SHALL INCLUDE ALL LABOR, TOOLS, EQUIPMENT AND MATERIALS NECESSARY TO CONSTRUCT A COMPLETE AND FUNCTIONAL ANCHOR ASSEMBLY SYSTEM, INCLUDING ALL RELATED TRANSITIONS, REFLECTIVE SHEETING, HARDWARE, GRADING, EMBANKMENT AND EXCAVATION NOT SEPARATELY SPECIFIED, AS REQUIRED BY THE MANUFACTURER.

I:\ProjectData\STA_98392_44-173_14.67-0\Design\Roadway\Sheets\98392_001.dgn Sheet 2 5/8/2018 9:21:55 AM pd/nh

I:\ProjectData\STA_98392_44-173_14.67-0\Design\Roadway\Sheets\98392_001.dgn Sheet 3 5/8/2018 9:21:58 AM pdinh

**MONUMENT BOX ADJUSTED TO GRADE
MANHOLE ADJUSTED TO GRADE
VALVE BOX ADJUSTED TO GRADE**

IN ADDITION TO THE REQUIREMENTS OF CMS 611.10.D FOR MANHOLES, 623.05 FOR MONUMENT BOXES, OR 638.18 FOR VALVE BOXES, THE CONTRACTOR WILL MAKE A CLEAN CIRCULAR CUT AROUND THE CASTING (A MINIMUM OF 1'-0" OUTSIDE OF THE CASTING) AND ADJUST THE CASTING TO GRADE (ACCORDING TO THE TOLERANCES AS SHOWN ON STANDARD CONSTRUCTION DRAWING BP-3.1) AFTER THE PAVEMENT SURFACE COURSE HAS BEEN PLACED

CMS 499 CLASS QCMS CONCRETE (DYE THE CONCRETE SUCH THAT ITS COLOR CLOSELY MATCHES THE COLOR OF THE SURROUNDING PAVEMENT) WILL BE USED FOR BACKFILLING THE FULL PAVEMENT SECTION AND THE JOINT BETWEEN THE ASPHALT AND CONCRETE WILL BE SEALED WITH CMS 702.01 PG BINDER. EPOXY COATED REBAR SHALL BE PLACED IN THE CONCRETE AT 6" MAXIMUM ON CENTER AND A MINIMUM OF 3.5" CLEARANCE FROM THE TOP, BOTTOM AND SIDES. THE CONCRETE WILL BE VIBERATED SUFFICIENTLY TO ELOMINATE AIR POCKETS UNDER THE FRAME.

PAYMENT WILL INCLUDE REMOVAL OF THE EXISTING MATERIAL, INSTALLATION OF THE NEW CASTING, AND ALL LABOR REQUIRED TO COMPLETE THIS ITEM OF WORK AS DESCRIBED.

THE FOLLOWING QUANTITIES HAVE BEEN CARRIED TO THE GENERAL SUMMARY:

- ITEM 623, MONUMENT BOX ADJUSTED TO GRADE, 51 EACH
- ITEM 611, MANHOLE ADJUSTED TO GRADE, 11 EACH
- ITEM 638, VALVE BOX ADJUSTED TO GRADE, 9 EACH

CATCH BASIN ADJUSTED TO GRADE

THE CONTRACTOR SHALL ADJUST CATCH BASINS TO GRADE. THE FOLLOWING QUANTITY HAS BEEN CARRIED TO THE GENERAL SUMMARY:

- ITEM 611, CATCH BASIN ADJUSTED TO GRADE, 12 EACH

ITEM 424 - FINE GRADED POLYMER ASPHALT CONCRETE, TYPE B, AS PER PLAN

703.05 DO NOT USE FINE AGGREGATE FROM A SOURCE DESIGNATED 'SR' OR 'SRH' ACCORDING TO THE OFFICE OF MATERIALS MANAGEMENT (OMM) IN ANY JOB MIX FORMULA (JMF) FOR THIS ITEM.

CURB REPAIR (SR 153)

THE FOLLOWING QUANTITY HAS BEEN CARRIED TO THE GENERAL SUMMARY TO BE USED AS DIRECTED BY THE ENGINEER TO REPAIR CURB ON SR 153

- ITEM 202 - CURB REMOVED 100 FT
- ITEM 609 - CURB, TYPE 2-A 100 FT

CALCULATED
PD
CHECKED
MAC

GENERAL NOTES

**STA - 44 / 153 / 173
14.67 / 6.25 / 0.00**

NOTES

GENERAL: Components shown on this drawing are used in a variety of guardrail systems. See individual guardrail drawing for specific applications.

See CMS 606 for guardrail specifications not covered on these drawings.

Refer to AASHTO M 180 for dimensional details of W-Beam and Thrie-Beam rail elements, related buffer and end sections, beam splices, post and splice bolts, nuts, and Type 1 W-Beam to Thrie-Beam Transition sections.

RAIL ELEMENTS: W-Beam Rail has an effective length of 12'-6" unless otherwise specified, with $\frac{3}{4}$ " x $2\frac{1}{2}$ " post bolt slots on 6'-3" centers regardless of post spacing. Field punch or drill bolt holes or slots for irregularly spaced posts as specified in CMS 606.04.

RAIL SPLICES: Lap splices between two rail elements or between a rail and terminal connector in the direction of traffic. Lap the buffer or flared end sections in the direction of traffic.

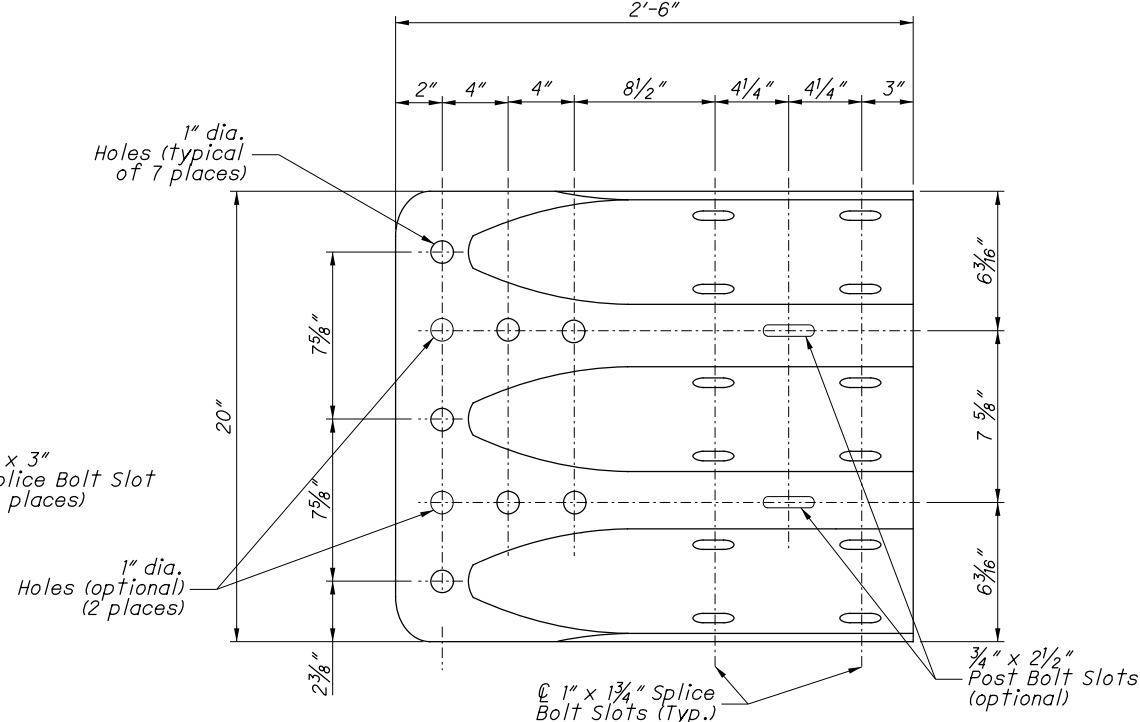
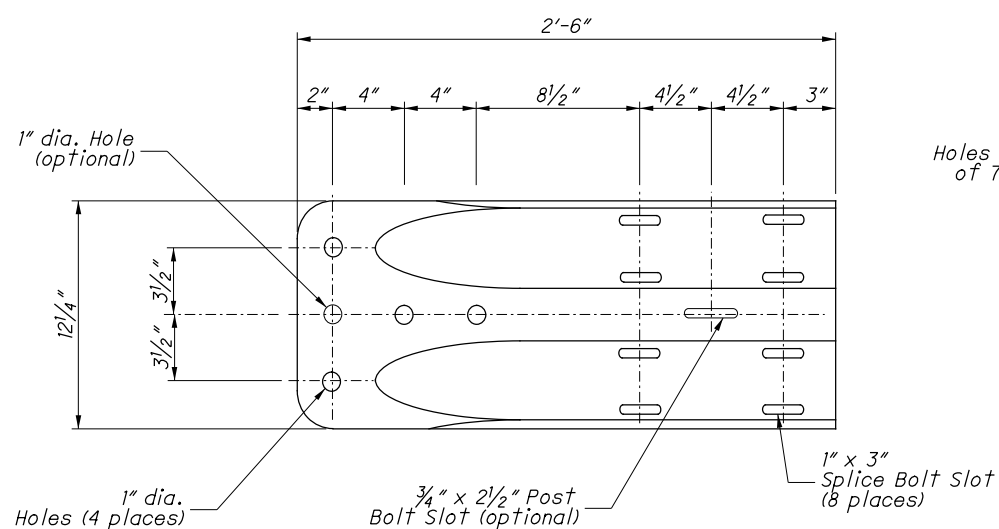
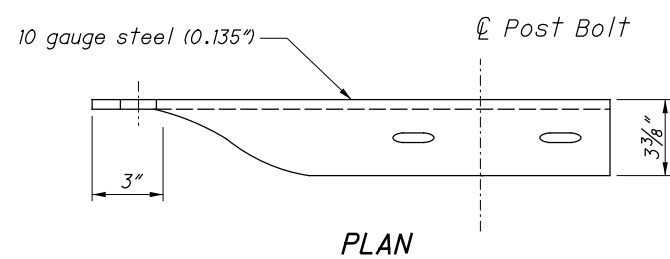
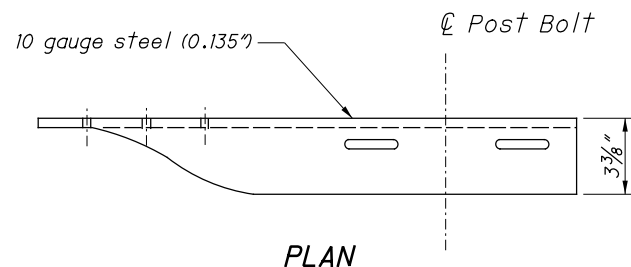

**ELEVATION
W-BEAM TERMINAL CONNECTOR**

**ELEVATION
THRIE-BEAM TERMINAL CONNECTOR**

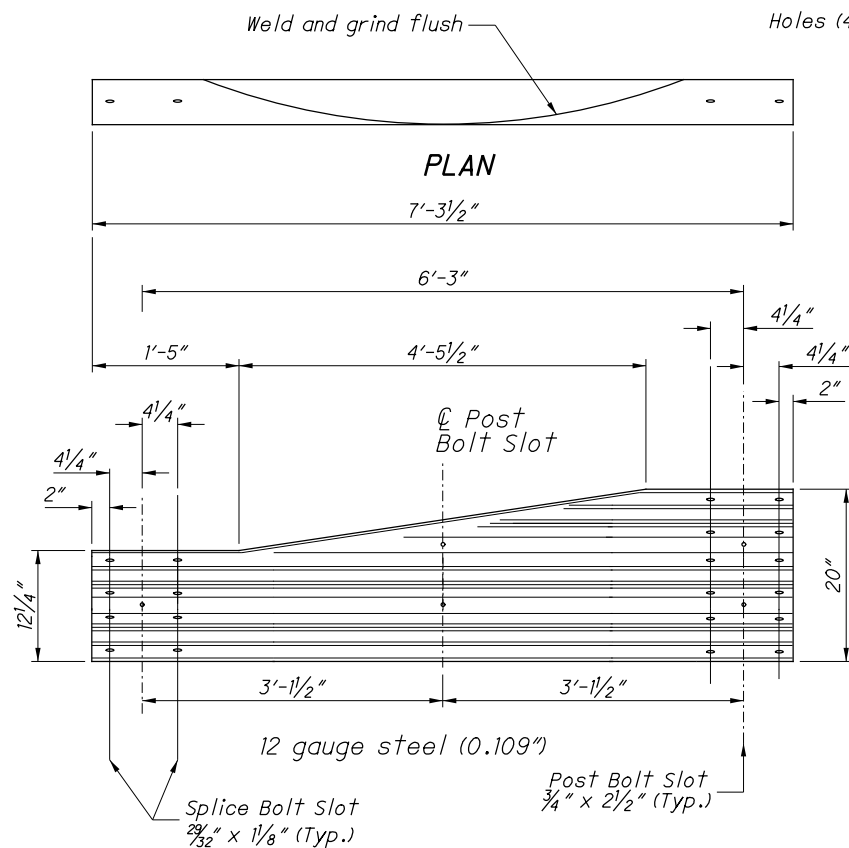

**ELEVATION
TYPE 2 TRANSITION SECTION
(Asymmetric W to Thrie-Beam)**

For details of Type 1 Transition Section (Symmetric), refer to AASHTO M 180, Figure 4.

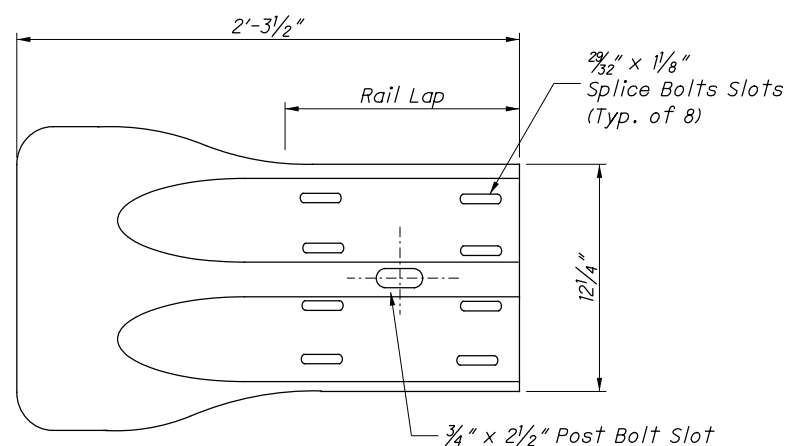
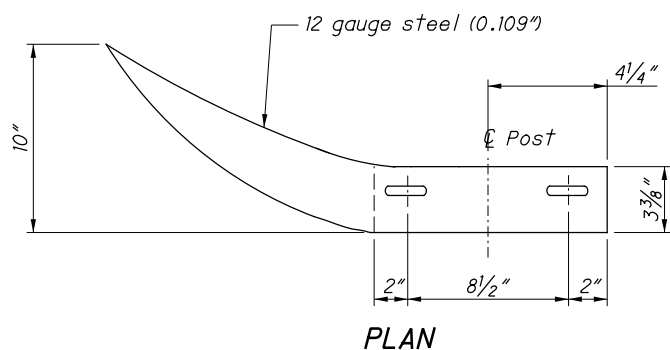

**ELEVATION
W-BEAM FLARED END SECTION**

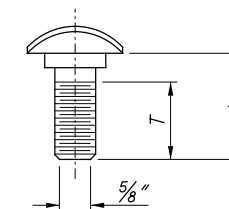

GUARDRAIL BOLT (For Post and Splice Bolts)		
L	T min.	Bolt Use
18" (Standard Rail)	4"	Type 5: WP/WB, PB
26" (Barrier Rail)		
10"	4"	Type 5: SP/WB, PB
1 1/4"	1 1/8"	Splice Bolt

WP = Wood Post WB = Wood Blockout
SP = Steel Post PB = Plastic Blockout

Longer Bolt may be needed for round Wood Post larger than 8" dia.

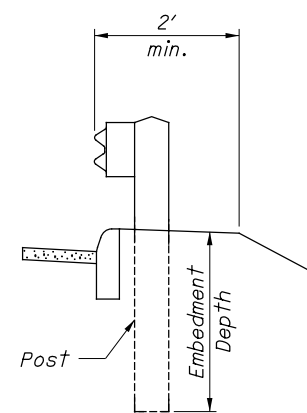

DETAIL A

See POST EMBEDMENT DEPTH Note

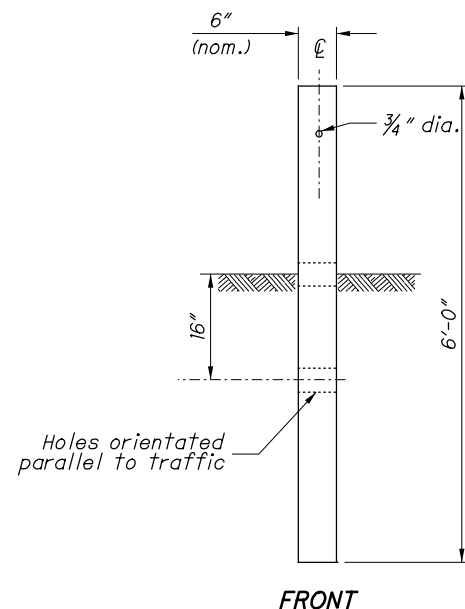

FRONT

SIDE

TYPE 1 BREAKAWAY CRT POST

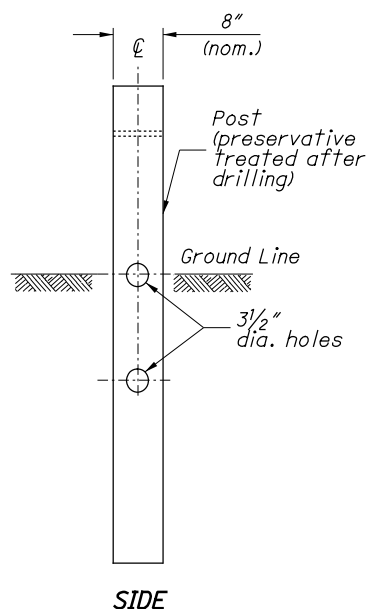

FRONT

SIDE

TYPE 2 BREAKAWAY CRT POST

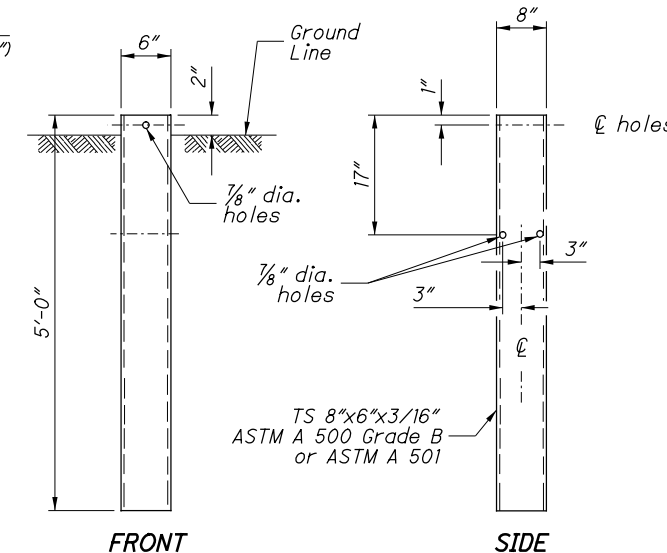

FRONT

SIDE

STEEL GROUND TUBE

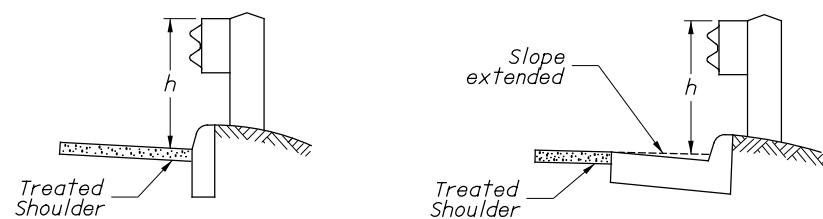
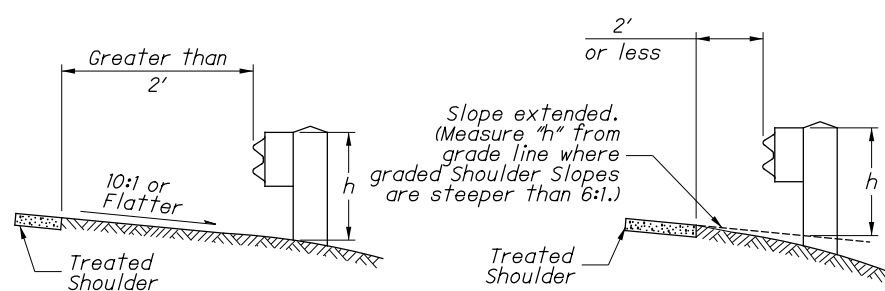
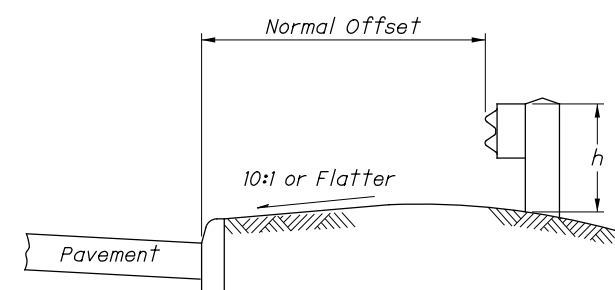

h = Standard Height (See GUARDRAIL HEIGHT Note)

MEASURING GUARDRAIL HEIGHT

NOTES

GUARDRAIL HEIGHT: For initial installation, construct the guardrail within $\pm 1"$ of the standard height, h , or **29"** to the top of W-Beam rail. (See MEASURING GUARDRAIL HEIGHT Detail.)

When subsequent projects, such as resurfacings, affect the height of existing guardrail, the finished height is to be within $\pm 2.5"$ of the standard height.

POST EMBEDMENT DEPTH: Standard embedment is 3'-5" min. Where less than 2' of graded shoulder width (10:1 or flatter) exists, measured from the face of the guardrail (see DETAIL "A"), use longer posts so that a minimum of 5'-5" embedment depth is provided. Payment for the longer posts will be made at the unit price bid for **ITEM 606 - GUARDRAIL POST, 9', Each.**

SPECIAL POST MOUNTINGS: Install posts located over a drainage inlet or structure as shown in the FOOTING ANCHOR Detail, or anchor per the details shown on **SCD GR-2.2.**

Install posts located over a footing with a cover of less than 2'-6" with a footing anchor as detailed here. (A plate, as detailed on SECTION B-B of **SCD GR-2.2,** may be used as an alternative attachment method.) Where the cover is between 2'-6" and 3'-5", the footing anchor may be omitted and the post encased instead with 4" (min.) of concrete.

Do not drive posts located over a culvert with less than 4'-3" of cover; instead set in drilled or dug holes. Where the available post embedment depth is less than 3'-5", encase the post with a minimum of 4" concrete.

All costs associated with special post mountings are included in the unit price bid of Item 606 Guardrail of the type specified in the plans.

ANCHORS: Holes and grouting shall comply with CMS 510. Use either cement or non-shrink, nonmetallic grout.

Expansion shield anchors as specified in CMS 712.01 may be substituted except where concrete deterioration has occurred, as determined by the Engineer. Where self-drilling anchors are used, drill the holes with the expansion shield (not by a drill bit) and install the shield flush with the concrete surface.

PROTECTIVE COATING: In lieu of the complying with CMS 710.06, coat expansion shields, anchors and concrete insert anchor assemblies embedded in concrete in accordance with ASTM A 153 or be of stainless steel. Any bolts screwed into these devices shall meet CMS 710.06. (See sheet 3 for Concrete Insert Anchor Assembly Detail.)

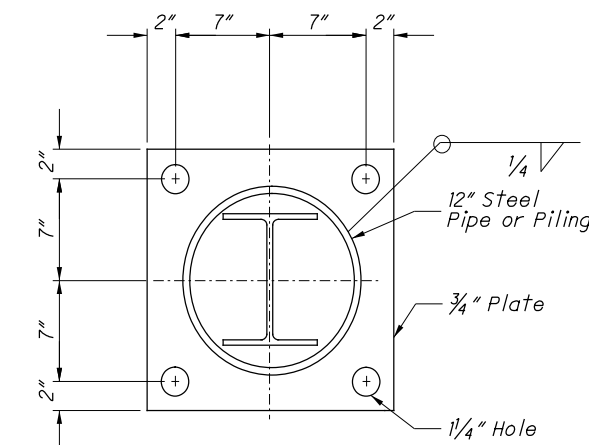

Footing Anchor and hardware need not be galvanized

SECTION A-A

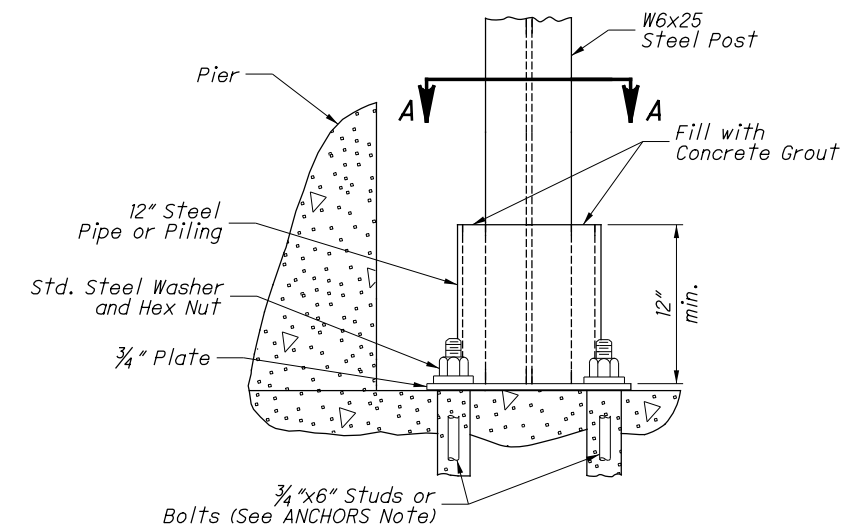

ELEVATION FOOTING ANCHOR

See SPECIAL POST MOUNTINGS Note.

I:\ProjectData\STA\98392_44-173_14.67-0\Design\Roadway\Sheets\98392_GR-1.1_01-18-2013.dgn Sheet 2 5/8/2018 9:21:59 AM pdinh

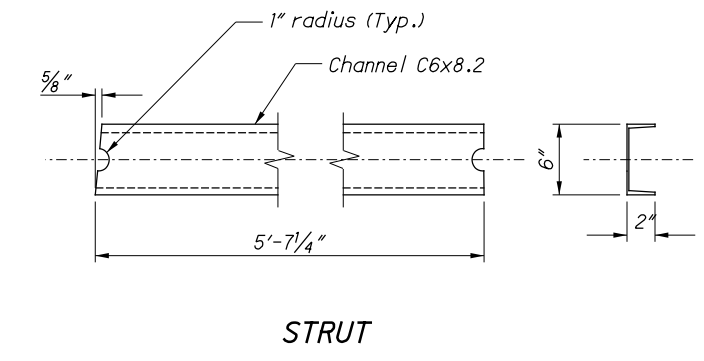
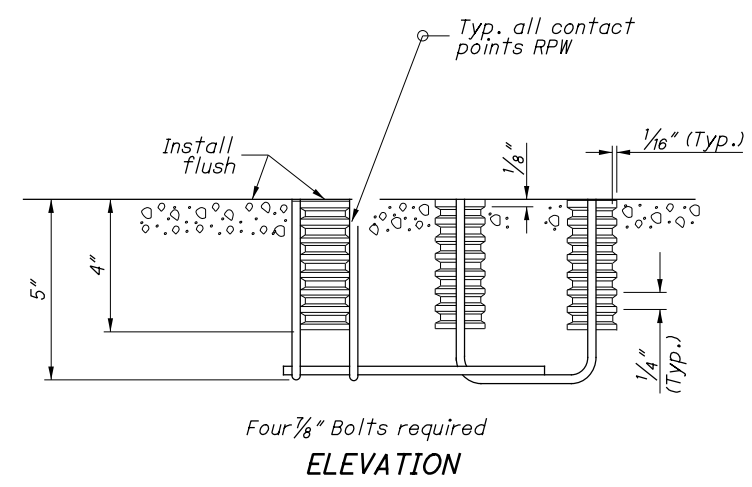
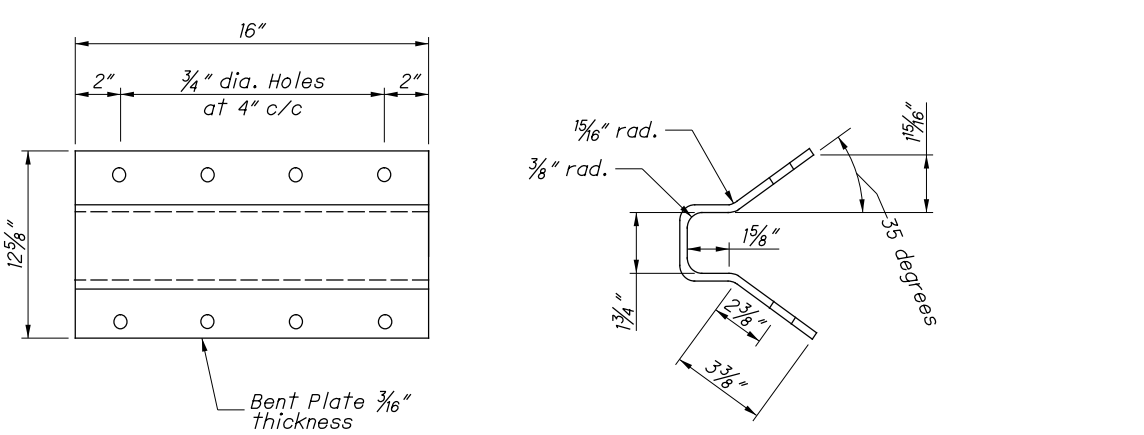
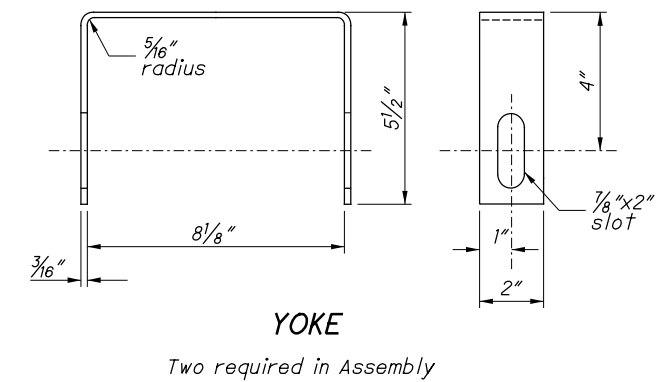
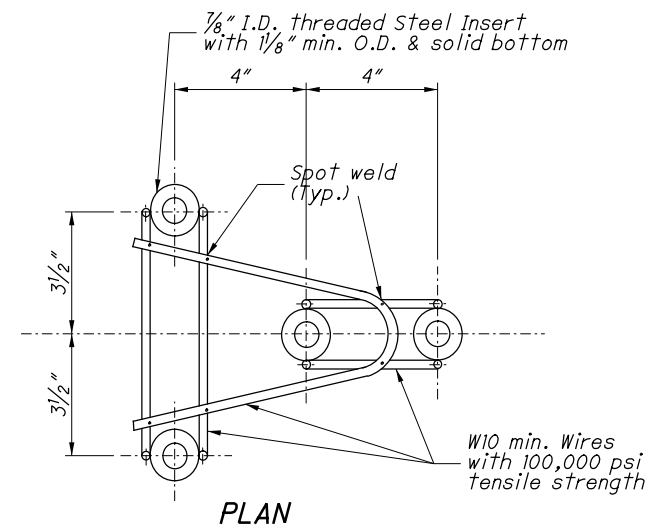
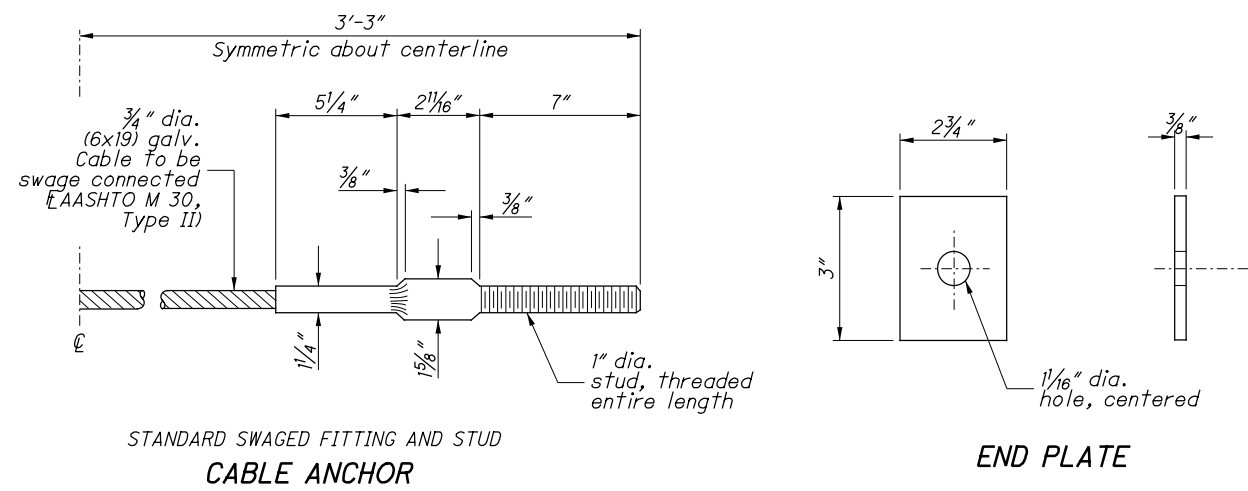

CONCRETE INSERT ANCHOR ASSEMBLY (W-BEAM ONLY)
 See ANCHORS and PROTECTIVE COATINGS Notes on Sheet 2

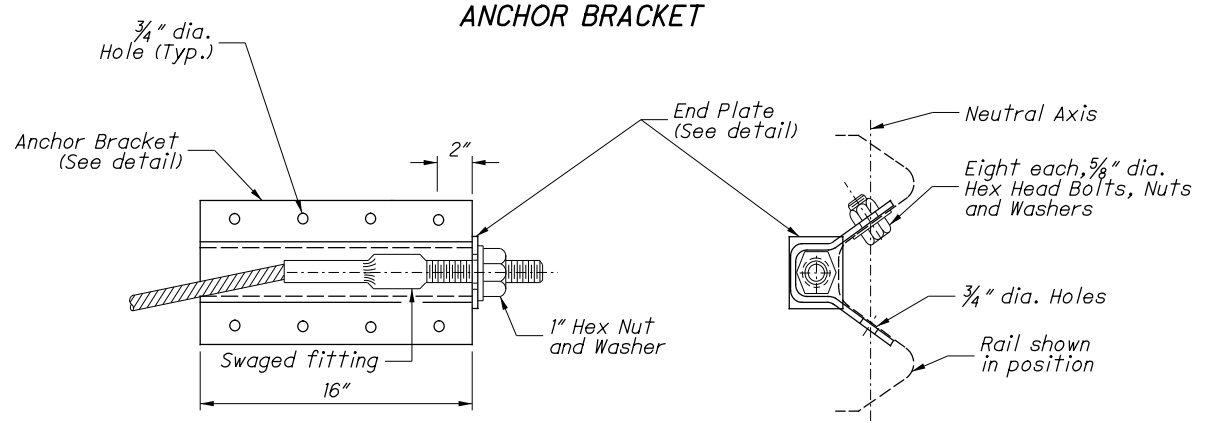
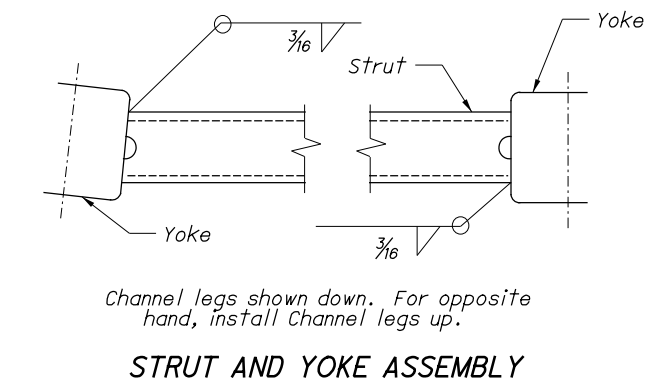

ANCHOR BRACKET ASSEMBLY DETAILS

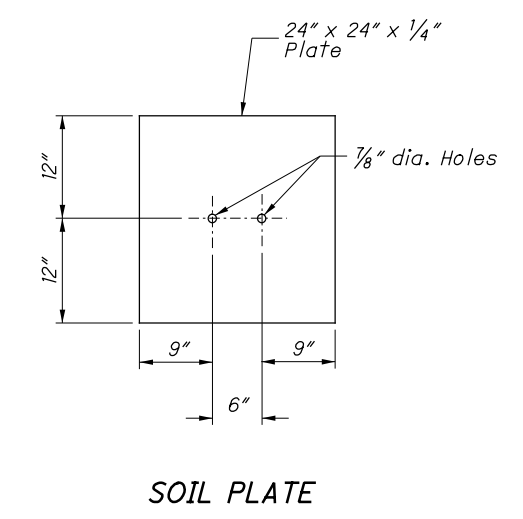
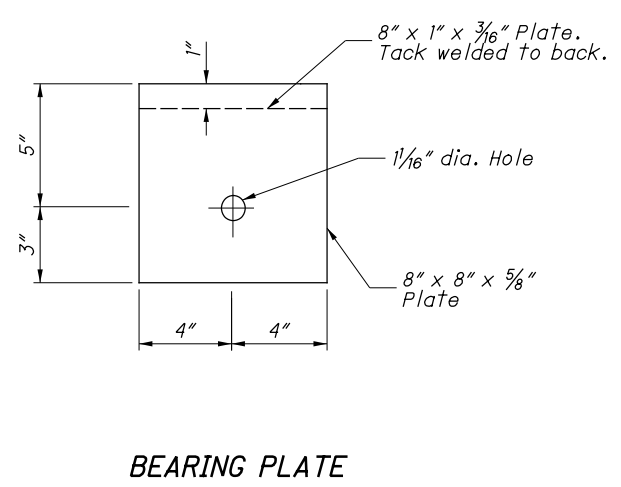
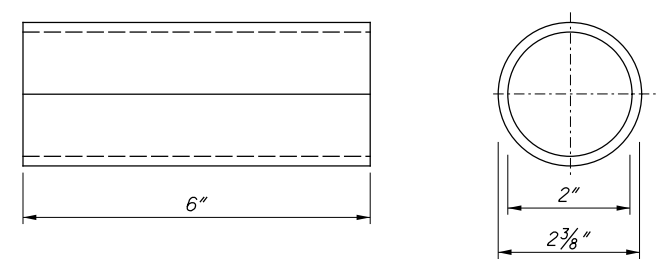

I:\ProjectData\STA\98392_44-173_14.67-0\Design\Roadway\Sheets\98392_GR-1.1_01-18-2013.dgn Sheet 3 5/8/2018 9:21:59 AM pdinh

I:\ProjectData\STA\98392_44-173_14.67-0\Design\Roadway\Sheets\98392_TYPE 5_GUARDRAIL_PIS.dgn Sheet 1 5/8/2018 9:22:00 AM pdmjh

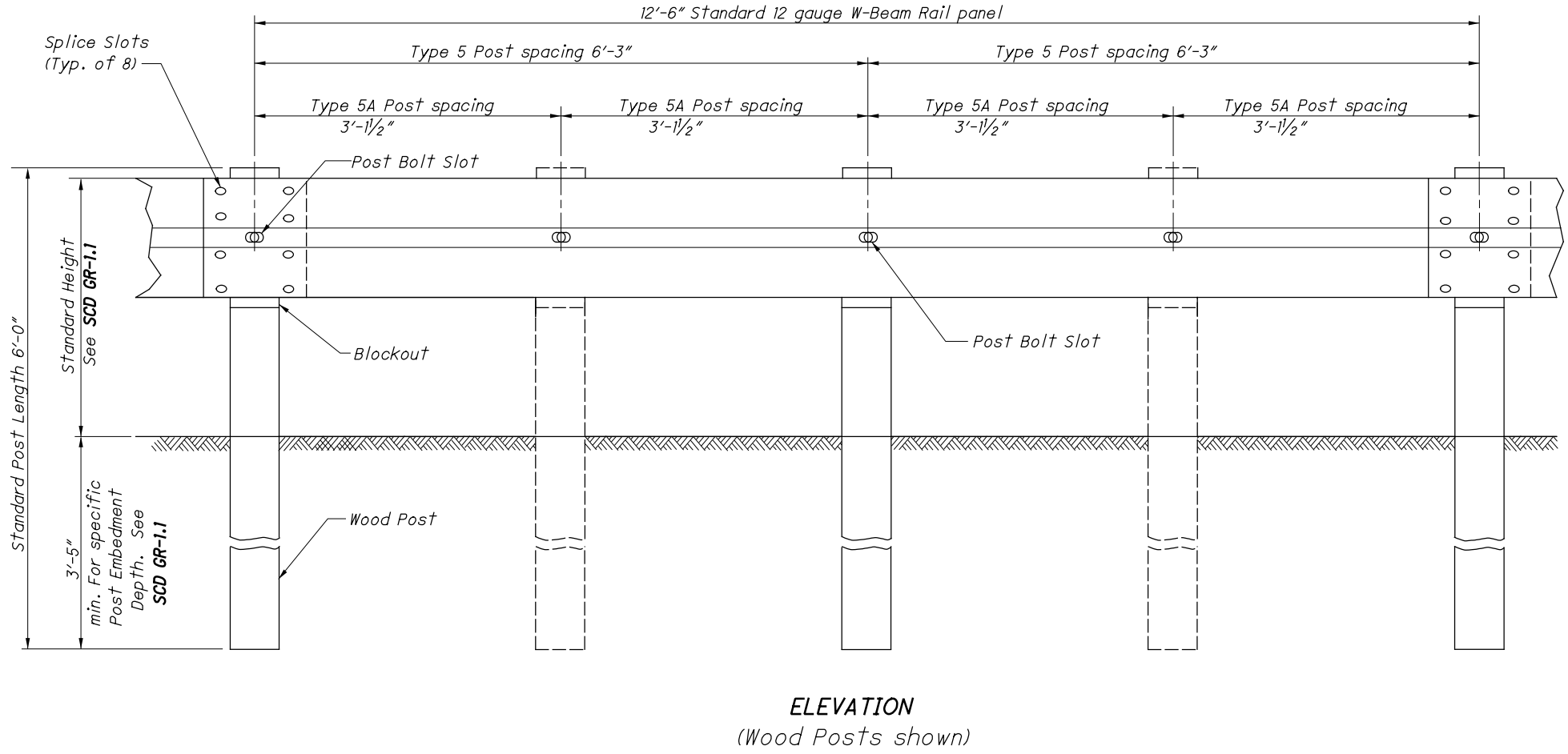
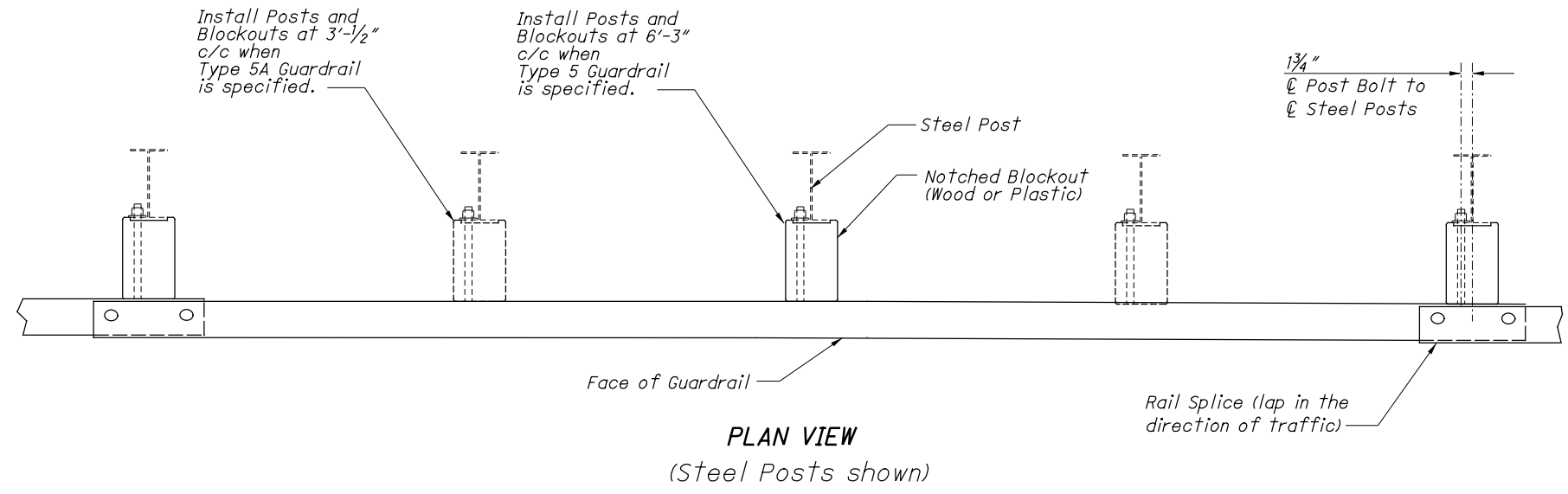

NOTES

RAIL: Use W-Beam rail meeting AASHTO M 180 Type II Class A, as specified in CMS 606.

POSTS: Posts may be constructed of wood or steel. Wood posts may be round or 6"x8" square-sawed.

Use round wood posts on runs of single-sided rail. The round posts shall be 8"±1 in diameter at the top and not more than 3" larger at the butt with a uniform taper.

Fabricated wood posts with square ends. Posts shall be pressure-treated as per CMS 710.14. Bore bolt holes and, if required, trim the tops of posts after the posts are set.

Steel posts are to be W6x9 or W6x8.5 galvanized steel. Use the same type of post throughout the length of the project unless otherwise specified in the plans or permitted by the Engineer.

All posts are 6'-0" long unless specified otherwise in the Contract Document. Posts may be set in drilled holes or may be driven to grade.

WELDED BEAM POSTS: Welded beam guardrail posts may be used for Item 606, Guardrail, provided the web and flange sizes are as shown here. Welding of the web to the flanges must comply with ASTM A 769, Class 1, using Grade 36 steel [250 MPa yield point] with the following exceptions:

- Sec. 7.2 Test reports of tensile properties for each lot shall accompany each shipment.
- Sec. 12 Beams that have imperfections repaired by welding shall not be accepted for use in Item 606.
- Sec. 13 Random samples shall be tested by the Department from materials delivered to the project site, or other locations designated by the Laboratory.

ALTERNATE POSTS: Engineered guardrail posts having met NCHRP 350 criteria, and listed on the **Office of Materials Management's** Approved List are permitted as an equal alternate when installed according to the Manufacturer's instructions and within the limitations shown on the Approved List.

BLOCKOUTS: Blockout dimensions are dependent on post used. Wood Blockouts are to be pressure treated as specified in CMS 710.14. Bore bolt holes. Approved alternate blockouts may be used in lieu of the wood blockouts shown. The approved list is maintained by the **Office of Roadway Engineering**.

WASHERS: Install appropriate sized standard galvanized steel washers on the nut side of bolts installed on wood posts.

DELINEATION: For barrier reflectors, see CMS 626.

MISCELLANEOUS: For other guardrail details, see SCD GR-1.1.

STEEL BEAM POSTS (English)				
Size	Beam depth	Flange width	Flange thickness	Web thickness
Rolled W6x8.5	5.8"	3.94"	0.193"	0.170"
Rolled W6x9	5.9"	3.94"	0.215"	0.170"
Welded 6x8.5	6.0"	3.94"	0.193"	0.170"
Welded 6x9	6.0"	3.94"	0.215"	0.170"

I:\ProjectData\STA\98392_44-173_14.67-0\Design\Roadway\Sheets\98392_TYPE 5_GUARDRAIL_PIS.dgn Sheet 2 5/8/2018 9:22:00 AM pdnh

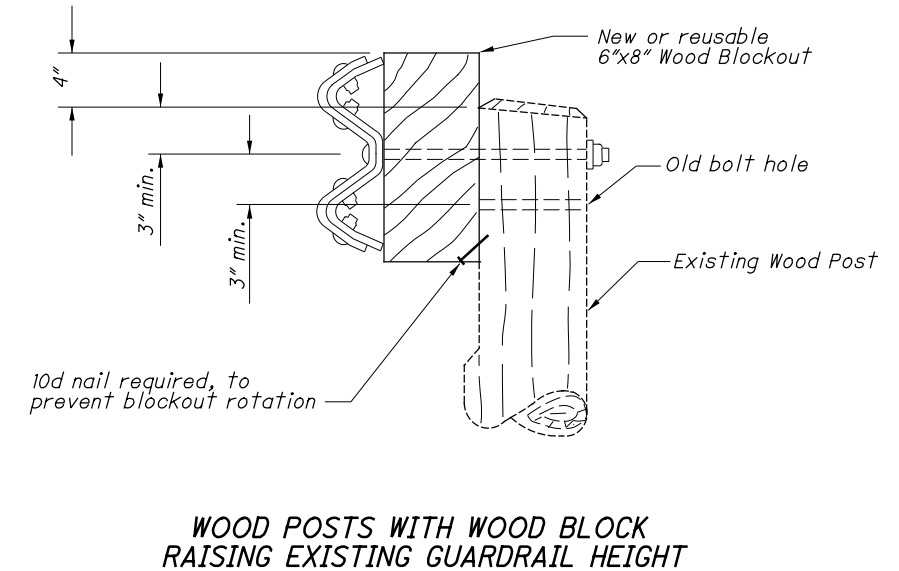
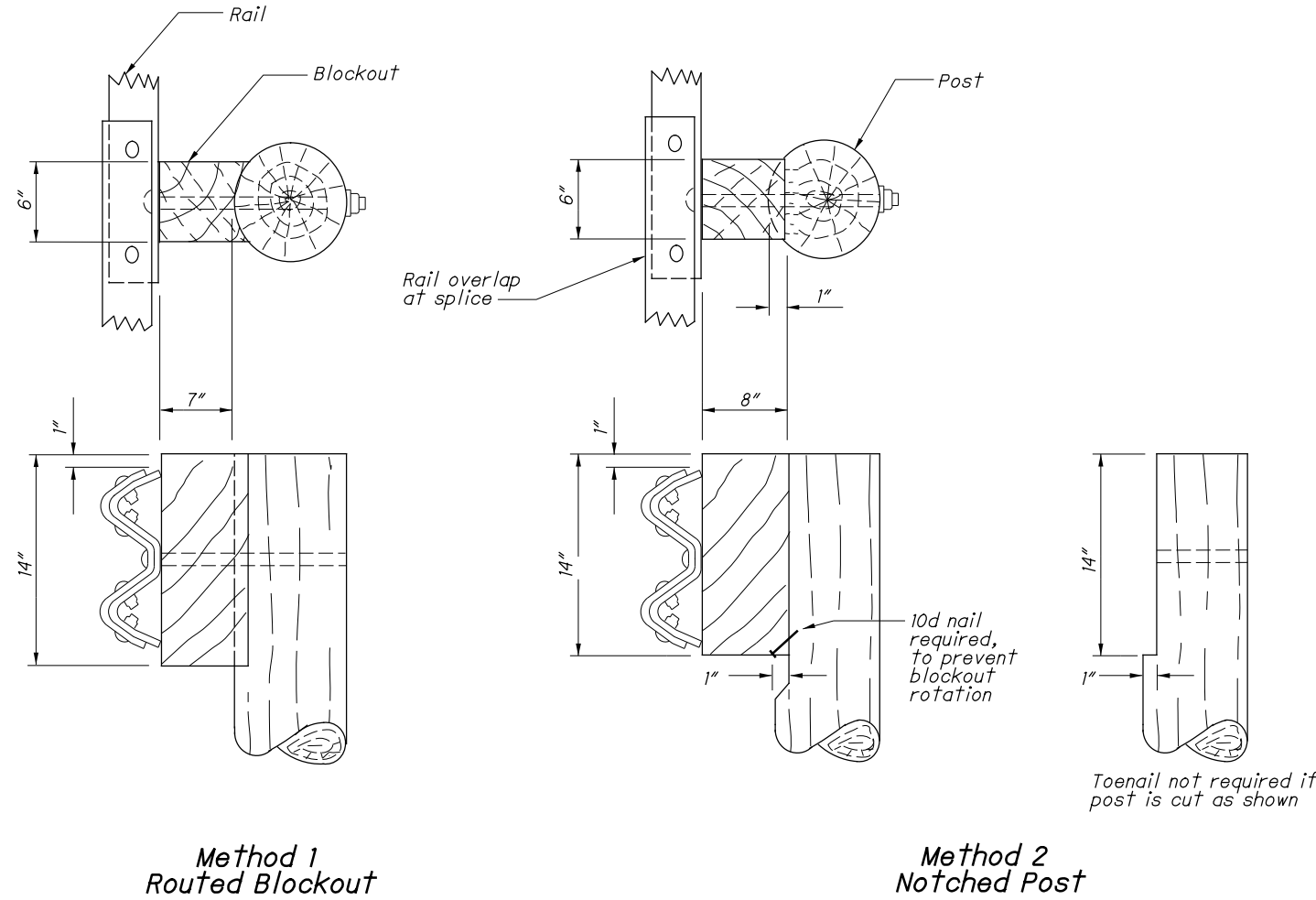
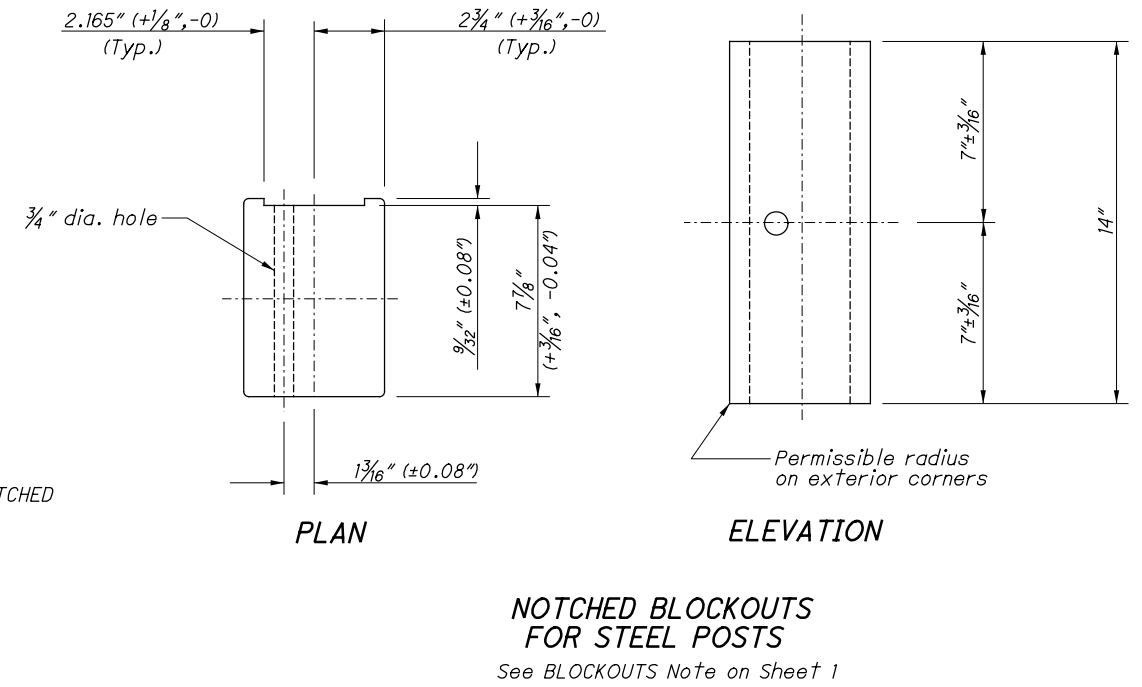
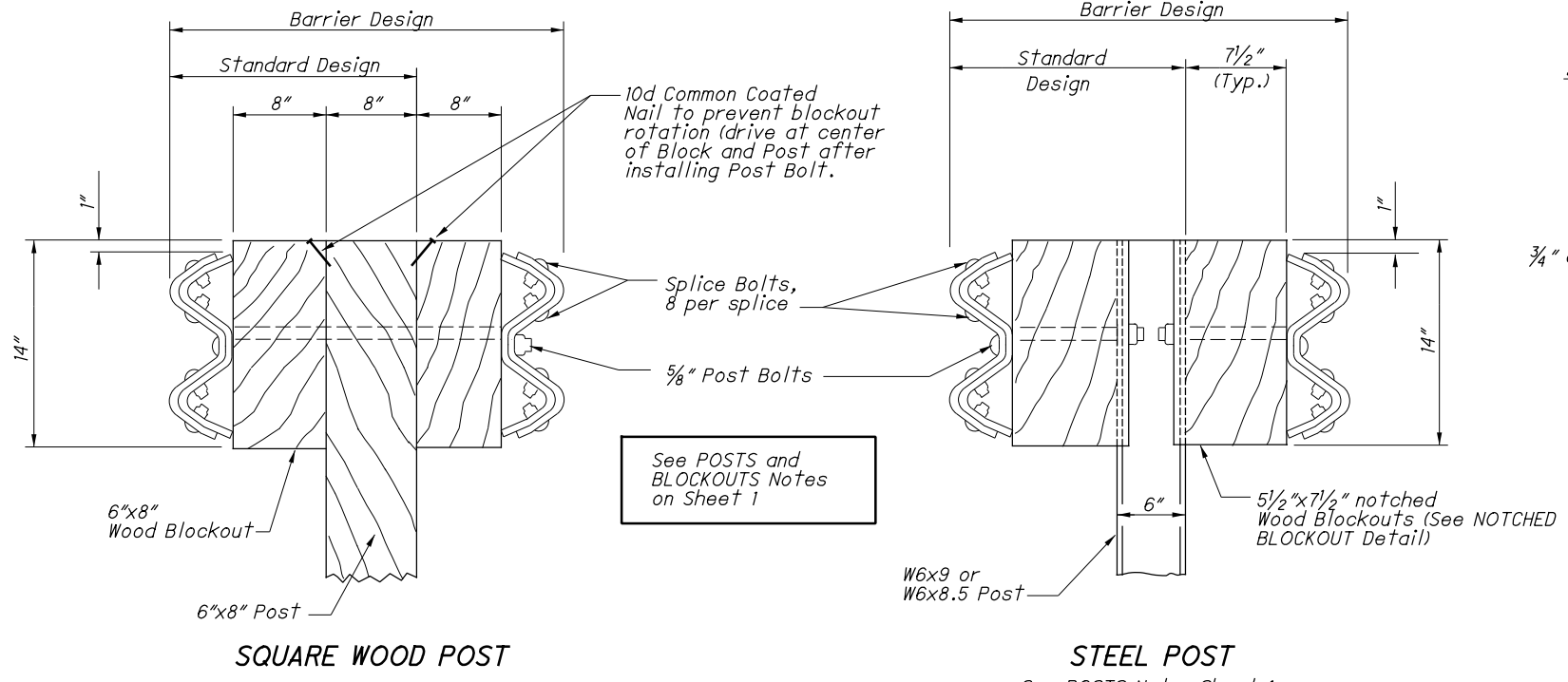

Alternate methods of placing the Blockouts on round Posts may be submitted for consideration and approved by the Engineer.

ROUND WOOD POSTS
Single Sided runs only (Standard Design)

NOTES

APPLICATION: Use Type T Anchor Assemblies on the trailing end of guardrail runs, located outside of the clear zone of opposing traffic. The assembly is 12'-6" long, none of which can be considered the Length of Need for the guardrail run.

For termination requirements at driveways, see DRIVEWAY OPENING Detail on Sheet 2. For side road approaches and Terminals at Structures, see Location & Design Manual, Volume 1, Figure 603-3.

ANCHORING OPTIONS: Contractor may choose either the foundation tube (shown on this Sheet) or the concrete footing option (Sheet 2) to construct this anchor assembly.

If the foundation tube option is chosen, the contractor will take proper care to insure that the Soil Plate fasteners are not broken during the driving process.

Concrete footings may be cast-in-place or precast. Compact fill after placing precast unit.

MATERIALS: See SCD GR-1.1 for parts used on this anchor, including the CRT Breakaway Posts, Steel Ground Tube, Post Sleeve, Cable Anchor and Bracket Assembly.

Bearing Plate and Soil Plate is ASTM A709 Grade 36. Steel Ground Tube shall be ASTM A500, Grade B, and meet CMS 707.10. All angles, channels and plates shall meet CMS 711.01. All structural steel shall be galvanized as specified in CMS 711.02. All bolt washers indicated are standard galvanized steel of the appropriate size.

Concrete shall be class C.

Components on this anchor that are not detailed on SCD GR-1.1 include: 1) 12'-6" W-Beam Terminal Rail (standard part RWM14a), and 2) W-Beam Rounded End Section (RWE03a). For complete details and specifications, see part descriptions in the AASHTO/AGC/ARTBA Standardized Hardware Guide.

POSTS: Post No. 1 may be an 8'-0" long Steel Ground Tube without a Soil Plate in lieu of the 5'-0" tube with Soil Plate.

Post No. 2 can be W6x9 (or W6x8.5) with notched wood blockouts or a standard Type 5 post and blockout. Recycled plastic blockouts are permitted.

PAYMENT: All labor and materials, including the W-Beam Rounded End Section and the W-Beam Terminal Rail for the 12'-6" anchor assembly shall be included in the unit price bid for Item 606 - Anchor Assembly, Type T, Each.

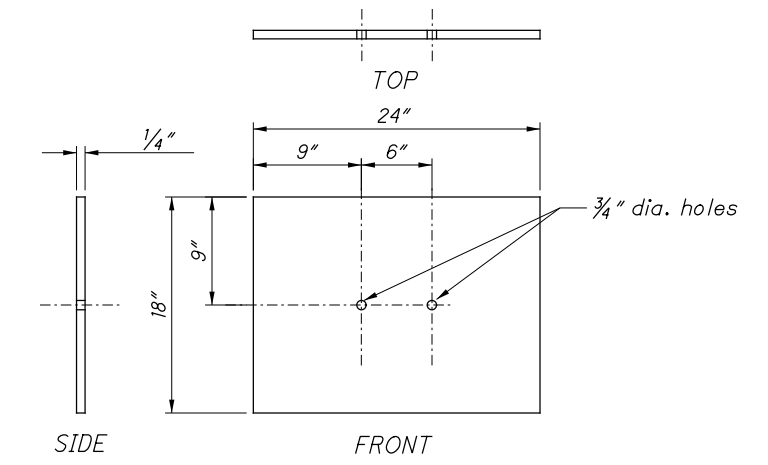
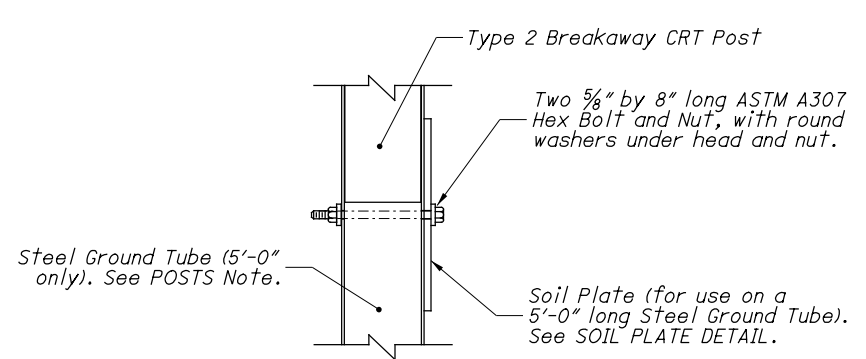
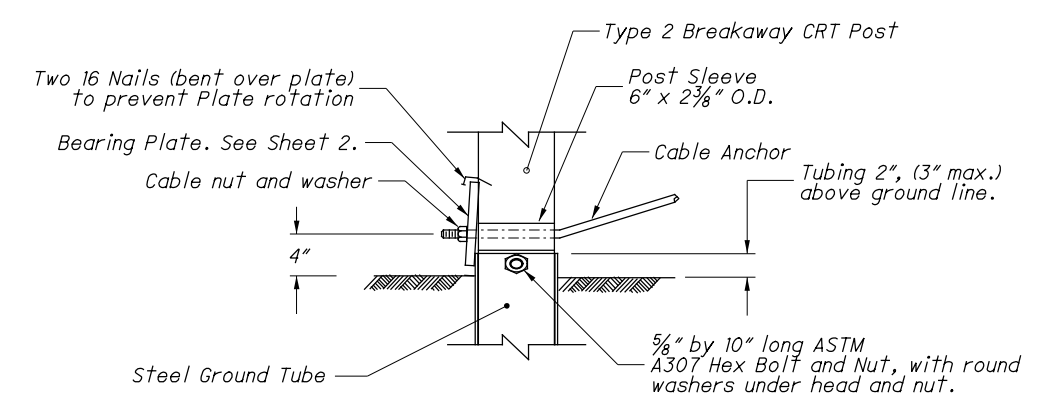
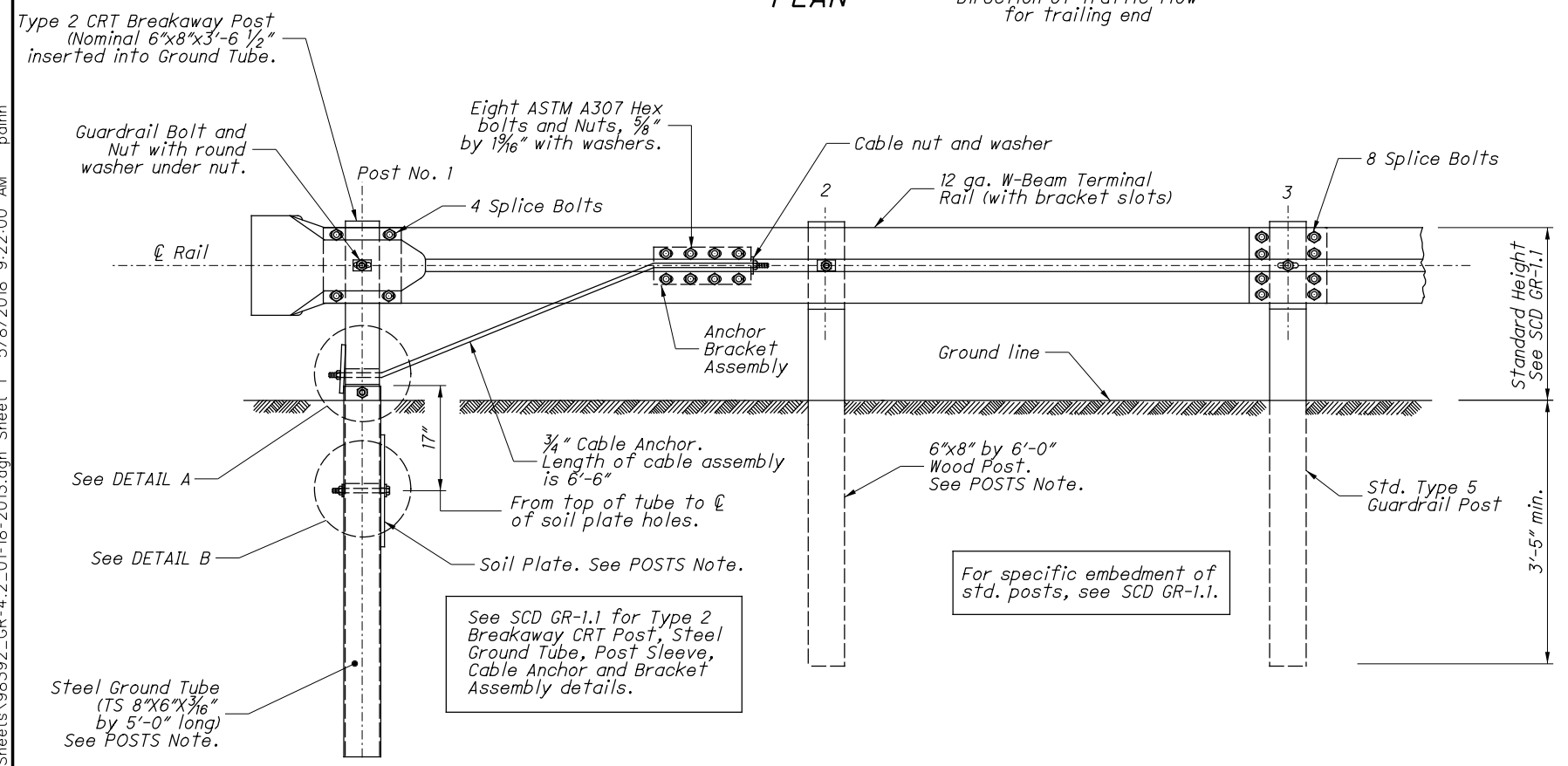
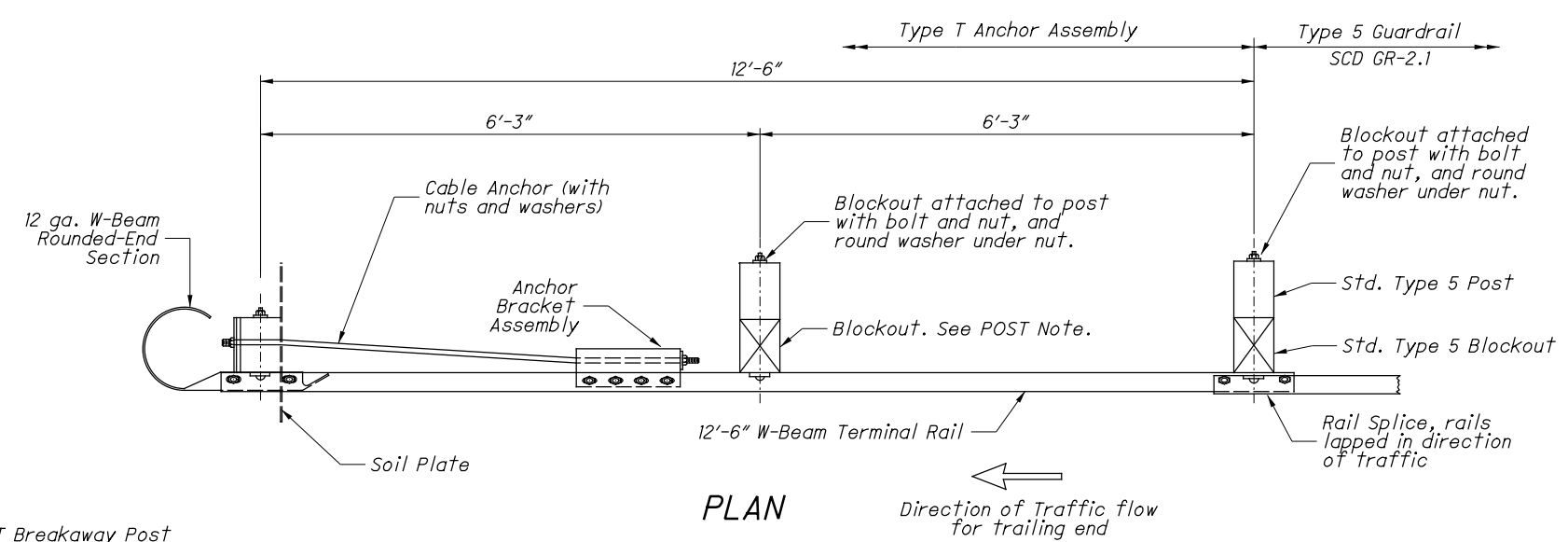

I:\ProjectData\STA\98392_44-173_14.67-0\Design\Roadway\Sheets\98392_GR-4.2_01-18-2013.dgn Sheet 1 5/8/2018 9:22:00 AM pdinh

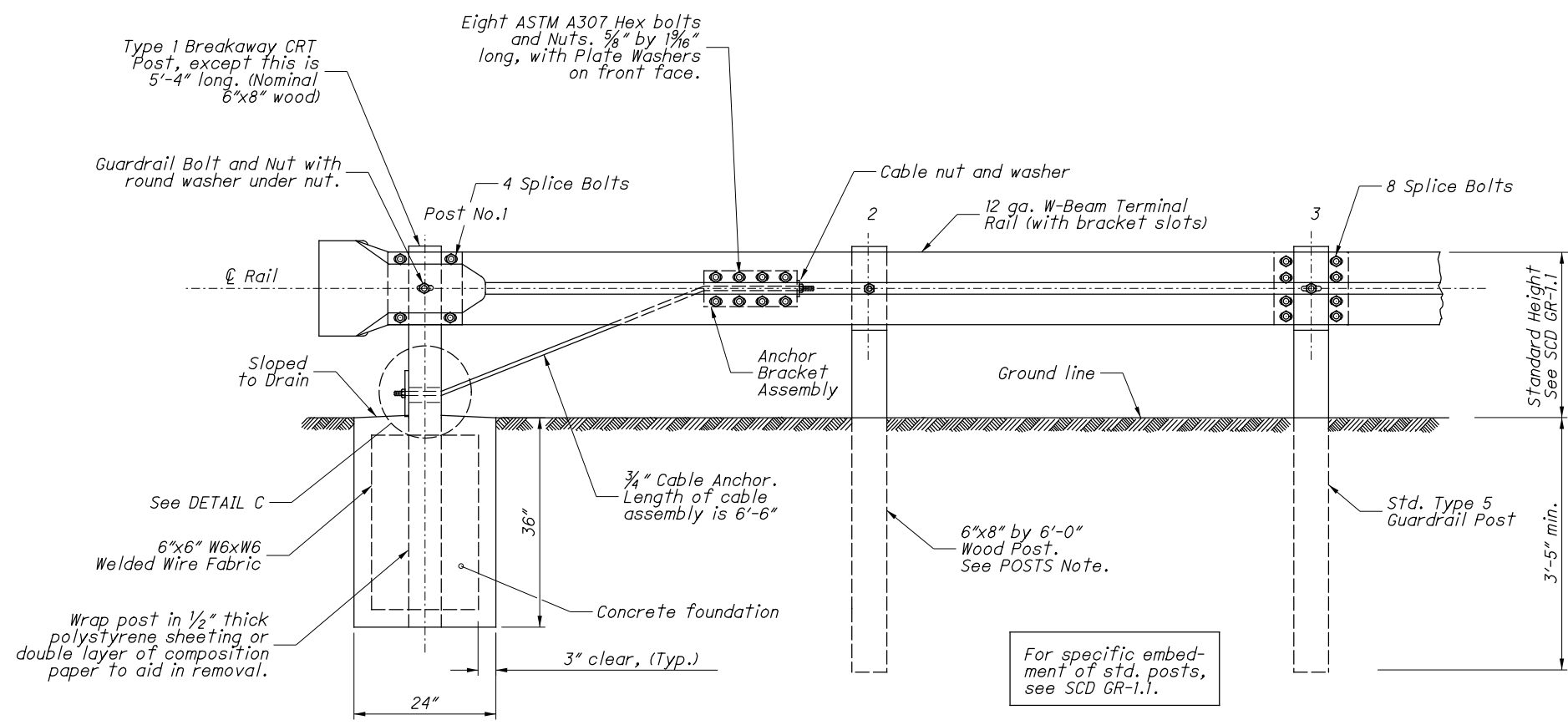
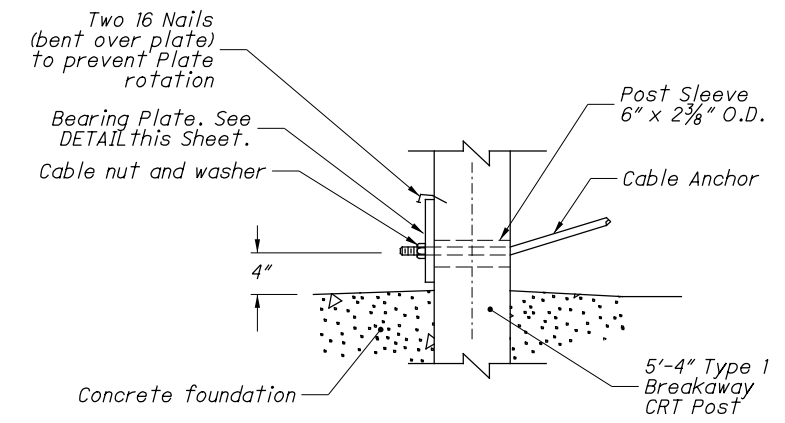
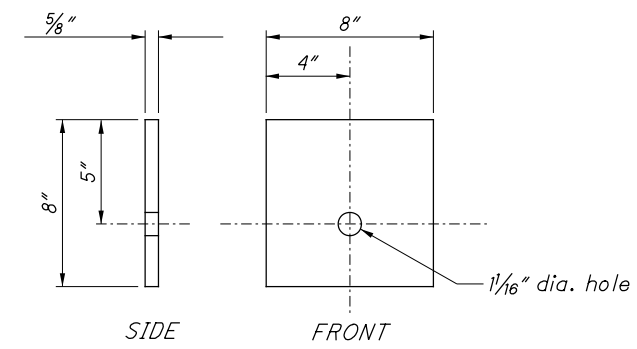
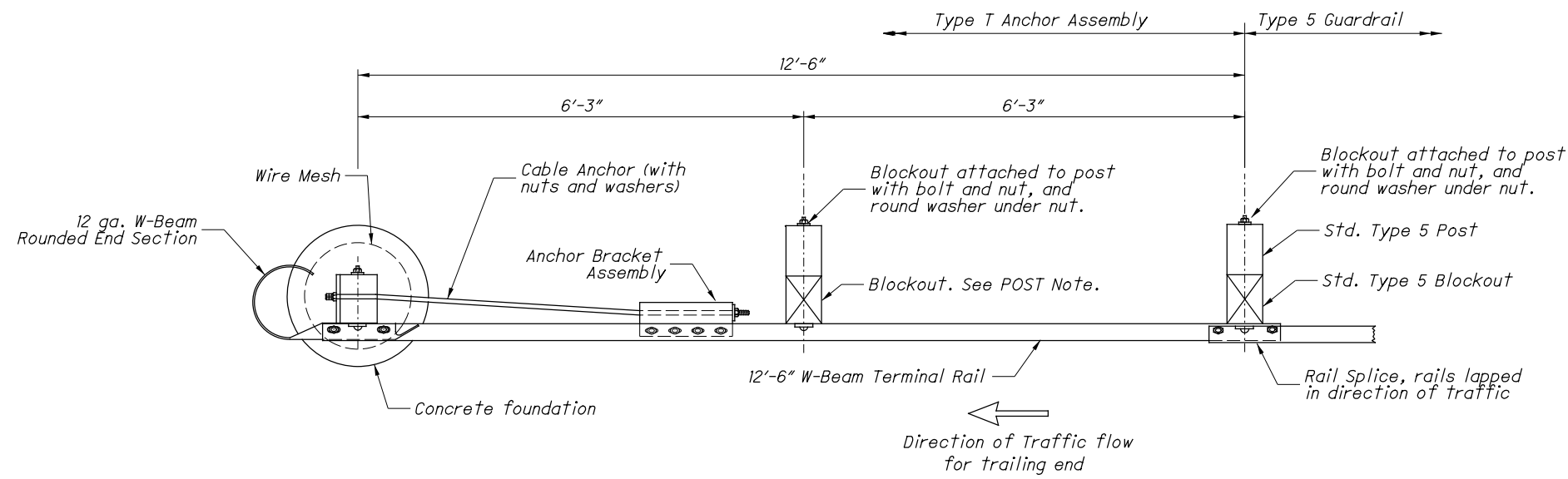

See SCD GR-1.1 for Type 1 Breakaway CRT Post, Steel Ground Tube, Post Sleeve, Cable Anchor and Bracket Assembly details.

For specific embedment of std. posts, see SCD GR-1.1.

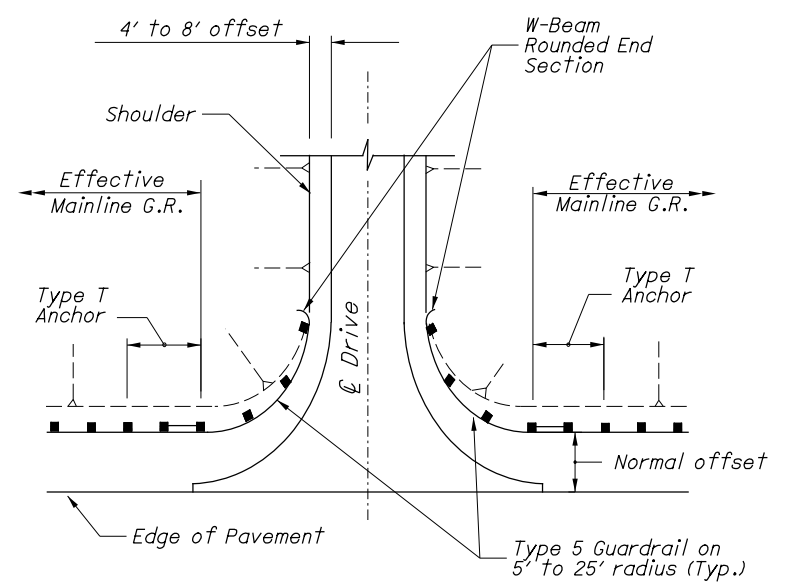

I:\ProjectData\STA\98392_44-173_14.67-0\Design\Roadway\Sheets\98392_GR-4.2_01-18-2013.dgn Sheet 2 5/8/2018 9:22:01 AM pdnh

MAINTENANCE OF TRAFFIC

THIS ITEM SHALL CONSIST OF MAINTENANCE OF TRAFFIC ON EXISTING ROADWAYS AND RAMPS IN ACCORDANCE WITH THE OHIO MANUAL OF UNIFORM TRAFFIC CONTROL DEVICES FOR STREETS AND HIGHWAYS, CURRENT EDITION, LATEST REVISION, THE SPECIFICATIONS AND THE FOLLOWING:

1. TWO LANE SECTIONS: A MINIMUM OF ONE TEN FOOT BI-DIRECTIONAL LANE SHALL BE MAINTAINED ON THE EXISTING PAVEMENT AND COMPLETED PAVEMENT DURING CONSTRUCTION OF THE WORK.

FOUR LANE SECTIONS: A MINIMUM OF ONE TEN FOOT LANE IN EACH DIRECTION SHALL BE MAINTAINED ON THE EXISTING PAVEMENT AND COMPLETED PAVEMENT DURING CONSTRUCTION OF THE WORK.

2. THE CONTRACTOR SHALL INFORM THE DISTRICT OFFICE (330) 786-2208, EIGHTEEN (18) DAYS PRIOR TO THE BEGINNING OF WORK.

3. ALL FULL DEPTH PAVEMENT REMOVAL AND REPLACEMENT OPERATIONS SHALL BE COMPLETED THE SAME DAY THE EXCAVATION IS MADE. IF THE CONTRACTOR CANNOT COMPLETE THE WORK, THE EXCAVATION SHALL BE BACKFILLED OR PROTECTED AS PER STANDARD CONSTRUCTION DRAWING MT-101.90.

4. UNDER NO CIRCUMSTANCES SHALL THE CONTRACTOR BE PERMITTED TO HAVE SUCCESSIVE WORK ZONES UNLESS THE DISTANCE BETWEEN THE DRUMS, BARRICADES OR CONES EXCEEDS TWO (2) MILES.

5. ONLY DURING OFF-PEAK PERIODS (ie ANY PERIOD OTHER THAN 6-8AM AND 3-6PM) SHALL THE CONTRACTOR INSTALL AND SUBSEQUENTLY RESET ALL TRAFFIC CONTROL NECESSARY FOR THE WORK ZONE FOR EACH CONSTRUCTION PHASE.

6. IN ADDITION TO THE REQUIREMENTS OF 614.11 WORK ZONE PAVEMENT MARKINGS, AT THE END OF EACH DAY OF WORK, THE CONTRACTOR SHALL REPLACE (WITH WORK ZONE MARKINGS) ALL LANE, CENTER, STOP OR CHANNELIZING LINES THAT WERE REMOVED OR COVERED DURING THE PAVEMENT REMOVAL OR PLACEMENT OPERATIONS. QUANTITIES FOR SUCH PLACEMENT ARE CARRIED AS PART OF THE ITEMS LISTED UNDER 614 WORK ZONE PAVEMENT MARKINGS.

7. A QUANTITY OF 20 CU. YDS. OF ITEM 614 ASPHALT CONCRETE FOR MAINTAINING TRAFFIC SHALL BE PROVIDED FOR USE IN MAINTAINING PAVEMENT, SHOULDERS AND OTHER LOCATIONS AS DIRECTED BY THE ENGINEER.

8. PRIOR TO OPENING TO TRAFFIC EACH LANE SHALL BE IN A SAFE, PASSABLE CONDITION. ALL TRANSVERSE JOINTS SHALL EXTEND ACROSS THE FULL LANE AND SHOULDER WIDTH AND EACH LANE SHALL BE FREE FROM UNEVEN LONGITUDINAL JOINTS. THE CONTRACTOR SHALL PROVIDE ASPHALT WEDGES FOR TRANSVERSE JOINTS WHEREVER THERE ARE PAVEMENT ELEVATION DIFFERENCES.

9. THE CONTRACTOR SHALL PLACE THE SIGNS: W8-1 [BUMP] PER OMUTCD 2C.28; W8-11 [UNEVEN LANES] PER OMUCTD 6F.45; AND W6-3 [TWO-WAY TRAFFIC] PER OMUTCD 6F.32. PAYMENT FOR THESE SIGNS SHALL BE INCIDENTAL TO THE LUMP SUM ITEM 614-MAINTAINING TRAFFIC. A QUANTITY OF ITEM 614 WORK ZONE MARKING SIGNS HAS BEEN INCLUDED IN THE PLANS PER CMS 614.04.

THE FOLLOWING QUANTITIES SHALL BE USED FOR THE MAINTENANCE OF TRAFFIC ON THIS PROJECT:

PHASE I - PLANED SURFACE (SR 44)
 614, WORK ZONE CENTER LINE, CLASS I, 4.72 MILE
 614, WORK ZONE STOP LINE, CLASS 1, 85 FT
 614, WORK ZONE CHANNELIZING LINE, CLASS 1, 8", 125 FT
 614, WORK ZONE MARKING SIGN, (ALL PHASES) 36 EACH

PHASE II - INTERMEDIATE COURSE (SR 44)
 614, WORK ZONE CENTER LINE, CLASS I, 4.72 MILE
 614, WORK ZONE STOP LINE, CLASS 1, 85 FT
 614, WORK ZONE CHANNELIZING LINE, CLASS 1, 8", 125 FT

PHASE III - SURFACE COURSE (SR 44)
 614, WORK ZONE CENTERLINE, CLASS III, 642 PAINT 4.72 MILE
 614, WORK ZONE STOP LINE, CLASS III, 642 PAINT 85 FT
 614, WORK ZONE CHANNELIZING LINE, CLASS III, 8", 642 PAINT 125 FT

PHASE I - PLANED SURFACE (SR 173)
 614, WORK ZONE CENTER LINE, CLASS I, 4.60 MILE
 614, WORK ZONE LANE LINE, CLASS I, 6", 0.18 MILE
 614, WORK ZONE STOP LINE, CLASS 1, 58 FT
 614, WORK ZONE CHANNELIZING LINE, CLASS 1, 8", 652 FT

PHASE II - INTERMEDIATE COURSE (SR 173)
 614, WORK ZONE CENTER LINE, CLASS I, 4.60 MILE
 614, WORK ZONE LANE LINE, CLASS I, 6", 0.18 MILE
 614, WORK ZONE STOP LINE, CLASS 1, 58 FT
 614, WORK ZONE CHANNELIZING LINE, CLASS 1, 8", 652 FT

PHASE III - SURFACE COURSE (SR 173)
 614, WORK ZONE CENTERLINE, CLASS III, 642 PAINT 4.60 MILE
 614, WORK ZONE LANE LINE, CLASS III, 642 PAINT 0.18 MILE
 614, WORK ZONE STOP LINE, CLASS III, 642 PAINT 58 FT
 614, WORK ZONE CHANNELIZING LINE, CLASS III, 8", 642 PAINT 652 FT

PHASE I- PLANNED SURFACE (SR 153)
 614, WORK ZONE CENTER LINE CLASS I, 1.31 MILES
 614, WORK ZONE STOP LINE, CLASS I, 120 FT
 614, WORK ZONE CHANNELIZING LINE, CLASS I, 643 FT

PHASE II- INTERMEDIATE COURSE (SR 153)
 614, WORK ZONE CENTER LINE CLASS I, 1.31 MILES
 614, WORK ZONE STOP LINE, CLASS I, 120 FT
 614, WORK ZONE CHANNELIZING LINE, CLASS I, 643 FT

PHASE III- SURFACE COURSE (SR 153)
 614, WORK ZONE CENTER LINE CLASS III, 642 PAINT, 1.31 MILES
 614, WORK ZONE STOP LINE, CLASS III, 642 PAINT, 120 FT
 614, WORK ZONE CHANNELIZING LINE, CLASS III, 642 PAINT, 643 FT

TO BE USED AS DIRECTED BY THE ENGINEER
 614, WORK ZONE EDGE LINE, CLASS III, 6" 642 PAINT 55.92 MILE

ITEM 614, MAINTAINING TRAFFIC (LANES OPEN DURING HOLIDAYS OR SPECIAL EVENTS)

NO WORK SHALL BE PERFORMED AND ALL EXISTING LANES SHALL BE OPEN TO TRAFFIC DURING THE FOLLOWING DESIGNATED HOLIDAYS OR EVENTS:

CHRISTMAS	FOURTH OF JULY
NEW YEARS	LABOR DAY
MEMORIAL DAY	THANKSGIVING
CONSTITUTION DAY- CITY OF LOUISVILLE (9/23/18)	

THE PERIOD OF TIME THAT THE LANES ARE TO BE OPEN DEPENDS ON THE DAY OF THE WEEK ON WHICH THE HOLIDAY OR EVENT FALLS. THE FOLLOWING SCHEDULE SHALL BE USED TO DETERMINE THIS PERIOD:

DAY OF HOLIDAY OR EVENT	TIME ALL LANES MUST BE OPEN TO TRAFFIC
SUNDAY	12:00N FRIDAY THROUGH 6:00 AM MONDAY
MONDAY	12:00N FRIDAY THROUGH 6:00 AM TUESDAY
TUESDAY	12:00N MONDAY THROUGH 6:00 AM WEDNESDAY
WEDNESDAY	12:00N TUESDAY THROUGH 6:00 AM THURSDAY
THURSDAY	12:00N WEDNESDAY THROUGH 6:00 AM FRIDAY
THURSDAY (THANKSGIVING ONLY)	6:00 AM WEDNESDAY THROUGH 6:00 AM MONDAY
FRIDAY	12:00N THURSDAY THROUGH 6:00 AM MONDAY
SATURDAY	12:00N FRIDAY THROUGH 6:00 AM MONDAY

SHOULD THE CONTRACTOR FAIL TO MEET ANY OF THESE REQUIREMENTS, THE CONTRACTOR SHALL BE ASSESSED A DISINCENTIVE IN THE AMOUNT OF \$3000 FOR EACH HOUR THE ABOVE DESCRIBED LANE CLOSURE RESTRICTIONS ARE VIOLATED.

TRAFFIC CONTROL INSPECTOR

THE CONTRACTOR SHALL DESIGNATE AN INDIVIDUAL OTHER THAN THE SUPERINTENDENT AND SUBJECT TO THE APPROVAL OF THE ENGINEER, TO CONTINUOUSLY INSPECT ALL TRAFFIC CONTROL DEVICES WHENEVER CONSTRUCTION WORK IS BEING PERFORMED WITHIN THE WORK LIMITS OF THE PROJECT. THE DESIGNATED INDIVIDUAL SHALL ALSO INSPECT ALL TRAFFIC DEVICES AT THE BEGINNING AND AT THE END OF EACH WORK DAY. THE DESIGNATED INDIVIDUAL OR A QUALIFIED REPRESENTATIVE SHALL ALSO BE AVAILABLE ON AN AROUND THE CLOCK BASIS TO REPAIR AND/OR REPLACE DAMAGED OR MISSING TRAFFIC CONTROL DEVICES. THESE INDIVIDUALS SHALL BE EQUIPPED WITH CELLULAR PHONES AND THEIR NAMES AND PHONE NUMBERS SHALL BE GIVEN TO THE PROJECT ENGINEER AT THE PRE-CONSTRUCTION MEETING. THE DESIGNATED INDIVIDUAL MAY HAVE OTHER CONSTRUCTION RELATED DUTIES AS LONG AS IMMEDIATE ATTENTION IS GIVEN TO TRAFFIC CONTROL. PAYMENT FOR THE SERVICES OF THE TRAFFIC CONTROL INSPECTOR SHALL BE INCLUDED IN THE LUMP SUM PRICE BID FOR ITEM 614 MAINTAINING TRAFFIC.

ADVANCED NOTICE TO PAVE

THE CONTRACTOR SHALL SUBMIT FOR APPROVAL TO THE DISTRICT CONSTRUCTION ENGINEER A DETAILED SCHEDULE 15 DAYS PRIOR TO THE PLACEMENT OF THE OVERLAY COURSES, ON HOW THEY PROPOSE TO PROSECUTE THE PAVING OPERATIONS. THE DETAILS SHALL SHOW THE ORDER OF PERFORMANCE OF EACH STAGE (START TO FINISH) OF THE WORK INCLUDING THE MAINTENANCE OF TRAFFIC THAT WILL BE USED.

TIME LIMITATION, TRAFFIC ON A MILLED SURFACE

THE MAXIMUM ALLOWABLE TIME FOR TRAFFIC TO BE PLACED ON A MILLED SURFACE SHALL BE 7 CONSECUTIVE CALENDAR DAYS. SHOULD THE CONTRACTOR FAIL TO MEET THIS REQUIREMENT, THE CONTRACTOR SHALL BE ASSESSED A DISINCENTIVE IN THE AMOUNT OF \$1500 PER DAY THAT THE TRAFFIC IS PLACED ON A MILLED SURFACE BEYOND THE SPECIFIED LIMIT.

NOTIFICATION OF TRAFFIC RESTRICTIONS

THROUGHOUT THE DURATION OF THE PROJECT, THE CONTRACTOR SHALL NOTIFY THE PROJECT ENGINEER IN WRITING OF ALL TRAFFIC RESTRICTIONS AND UPCOMING MAINTENANCE OF TRAFFIC CHANGES. THE CONTRACTOR SHALL ENSURE THE WRITTEN NOTIFICATION IS SUBMITTED IN A TIMELY MANNER TO ALLOW THE PROJECT ENGINEER TO MEET THE REQUIRED TIME FRAMES SET FORTH IN THE TABLE BELOW TO INFORM SPECIAL HAULING PERMITS SECTION (HAULING.PERMITS@DOT.OHIO.GOV) AND THE DISTRICT PUBLIC INFORMATION OFFICE (PIO). THIS NOTIFICATION SHALL BE RECEIVED BY THE PROJECT ENGINEER PRIOR TO THE PHYSICAL SETUP OF ANY APPLICABLE SIGNS OR MESSAGE BOARDS.

INFORMATION SHOULD INCLUDE, BUT IS NOT LIMITED TO, ALL CONSTRUCTION ACTIVITIES THAT IMPACT OR INTERFERE WITH TRAFFIC AND SHALL LIST THE SPECIFIC LOCATION, TYPE OF WORK, ROAD STATUS, DATE AND TIME OF RESTRICTION, DURATION OF RESTRICTION, NUMBER OF LANES MAINTAINED, NUMBER OF LANES CLOSED, MINIMUM VERTICAL CLEARANCE, MINIMUM WIDTH OF DRIVABLE PAVEMENT, DETOUR ROUTES, IF APPLICABLE, AND ANY OTHER INFORMATION REQUESTED BY THE PROJECT ENGINEER.

NOTIFICATION TIME TABLE		
ITEM	DURATION OF CLOSURE	NOTICE DUE TO PERMITS & PIO
ROAD & RAMP CLOSURES	>= 2 WEEKS	21 CALENDAR DAYS PRIOR TO CLOSURE
	> 12 HOURS & < 2 WEEKS	14 CALENDAR DAYS PRIOR TO CLOSURE
	< 12 HOURS	4 BUSINESS DAYS PRIOR TO CLOSURE
LANE CLOSURES & RESTRICTIONS	>= 2 WEEKS	14 CALENDAR DAYS PRIOR TO CLOSURE
	< 2 WEEKS	2 BUSINESS DAYS PRIOR TO CLOSURE
START OF CONSTRUCTION & TRAFFIC PATTERNS CHANGES	N/A	14 CALENDAR DAYS PRIOR TO IMPLEMENTATION

ANY UNFORESEEN CONDITIONS NOT SPECIFIED IN THE PLANS REQUIRING TRAFFIC RESTRICTIONS SHALL ALSO BE REPORTED TO THE PROJECT ENGINEER USING THE NOTIFICATION TIME TABLE.

LANE CLOSURES (US - 62T)

DURATION OF LANE CLOSURES AND RESTRICTIONS SHALL BE AS PER THE PERMITTED LANE CLOSURE CHART. THE PERMITTED LANE CLOSURE CHART USED FOR THIS PROJECT SHALL BE THE MOST CURRENT CHART AVAILABLE ON THE DATE THIS PROJECT SELLS.

THE CHART CAN BE FOUND AT:
<http://plcm.dot.state.oh.us>

SHOULD THE CONTRACTOR FAIL TO MEET ANY OF THE REQUIREMENTS IN THE CHART, THE CONTRACTOR SHALL BE ASSESSED DISINCENTIVES IN THE AMOUNT OF \$2500 PER HOUR OR PORTION THEREOF THAT THE LANE REDUCTION REMAINS BEYOND THE SPECIFIED LIMIT.

ITEM 614 - LAW ENFORCEMENT OFFICER (WITH PATROL CAR) FOR ASSISTANCE DURING CONSTRUCTION OPERATIONS

USE OF LAW ENFORCEMENT OFFICERS (LEOS) BY CONTRACTORS OTHER THAN THE USES SPECIFIED BELOW WILL NOT BE PERMITTED AT PROJECT COST. LEOS SHOULD NOT BE USED WHERE THE OMTCD INTENDS THAT FLAGGERS BE USED.

IN ADDITION TO THE REQUIREMENTS OF C&MS 614 AND THE OMTCD, A UNIFORMED LEO WITH AN OFFICIAL PATROL CAR (CAR WITH TOP-MOUNTED EMERGENCY FLASHING LIGHTS AND COMPLETE MARKINGS OF THE APPROPRIATE LAW ENFORCEMENT AGENCY) SHALL BE PROVIDED FOR THE FOLLOWING TRAFFIC CONTROL TASKS:

DURING THE ENTIRE ADVANCE PREPARATION AND CLOSURE SEQUENCE WHERE COMPLETE BLOCKAGE OF TRAFFIC IS REQUIRED.

WHEN TRAFFIC NEEDS TO BE DIRECTED THROUGH AN ENERGIZED TRAFFIC SIGNAL CONTRARY TO THE SIGNAL DISPLAY (E.G., DIRECTING MOTORISTS THROUGH A RED LIGHT

IN ADDITION TO THE REQUIREMENT OF C&MS 614 AND THE OMTCD, A UNIFORMED LEO WITH AN OFFICIAL PATROL CAR (CAR WITH TOP-MOUNTED EMERGENCY FLASHING LIGHTS AND COMPLETE MARKINGS OF THE APPROPRIATE LAW ENFORCEMENT AGENCY) SHOULD BE PROVIDED FOR THE FOLLOWING TRAFFIC CONTROL TASKS AS APPROVED BY THE ENGINEER:

FOR LANE CLOSURES: DURING INITIAL SET-UP PERIODS, TEAR DOWN PERIODS, SUBSTANTIAL SHIFTS OF A CLOSURE POINT OR WHEN NEW LANE CLOSURE ARRANGEMENTS ARE INITIATED FOR LONG-TERM LANE CLOSURES/SHIFTS (FOR THE FIRST AND LAST DAY OF MAJOR CHANGES IN TRAFFIC CONTROL SETUP).

IN GENERAL, LEOS SHOULD BE POSITIONED IN ADVANCE OF AND ON THE SAME SIDE AS THE LANE RESTRICTION OR AT THE POINT OF ROAD CLOSURE, AND TO MANUALLY CONTROL TRAFFIC MOVEMENTS THROUGH SIGNALIZED INTERSECTIONS IN WORK ZONES.

LEOS SHOULD NOT FORGO THEIR TRAFFIC CONTROL RESPONSIBILITIES TO APPREHEND MOTORISTS FOR ROUTINE TRAFFIC VIOLATIONS. HOWEVER, IF A MOTORIST'S ACTIONS ARE CONSIDERED TO BE RECKLESS, THEN PURSUIT OF THE MOTORIST IS APPROPRIATE.

THE LEOS WORK AT THE DIRECTION OF THE CONTRACTOR. THE CONTRACTOR IS RESPONSIBLE FOR SECURING THE SERVICES OF THE LEOS WITH THE APPROPRIATE AGENCIES AND COMMUNICATING THE INTENTIONS OF THE PLANS WITH RESPECT TO DUTIES OF THE LEOS. THE ENGINEER SHALL HAVE FINAL CONTROL OVER THE LEOS' DUTIES AND PLACEMENT, AND WILL RESOLVE ANY ISSUES THAT MAY ARISE BETWEEN THE TWO PARTIES.

THE LEO SHALL REPORT IN TO THE CONTRACTOR PRIOR TO THE START OF THE SHIFT, IN ORDER TO RECEIVE INSTRUCTIONS REGARDING SPECIFIC WORK ASSIGNMENTS DURING HIS/HER SHIFT. THE LEO IS EXPECTED TO STAY AT THE PROJECT SITE FOR THE ENTIRE DURATION OF HIS/HER SHIFT. THE LEO SHALL REPORT TO THE CONTRACTOR AT THE END OF HIS/HER SHIFT. ONCE THE LEO HAS COMPLETED THE DUTIES DESCRIBED ABOVE AND STILL HAS TIME REMAINING ON HIS/HER SHIFT, THE LEO MAY BE ASKED TO PATROL THROUGH THE WORK ZONE (WITH FLASHING LIGHTS OFF) OR BE PLACED AT A LOCATION TO DETER MOTORISTS FROM SPEEDING. SHOULD IT BE NECESSARY TO LEAVE THE PROJECT SITE, THE LEO SHALL NOTIFY THE ENGINEER. THE CONTRACTOR SHALL PROVIDE THE LEO WITH A TWO-WAY COMMUNICATION DEVICE WHICH SHALL BE RETURNED TO THE CONTRACTOR AT THE END OF HIS/HER SHIFT.

LEOS (WITH PATROL CAR) REQUIRED BY THE TRAFFIC MAINTENANCE TASKS ABOVE SHALL BE PAID FOR ON A UNIT PRICE (HOURLY) BASIS UNDER ITEM 614, LAW ENFORCEMENT OFFICER (WITH PATROL CAR) FOR ASSISTANCE. THE FOLLOWING ESTIMATED QUANTITIES HAVE BEEN CARRIED TO THE GENERAL SUMMARY.

ITEM 614, LAW ENFORCEMENT OFFICER WITH PATROL CAR FOR ASSISTANCE 110 HOURS

THE HOURS PAID SHALL INCLUDE ANY MINIMUM SHOW-UP TIME REQUIRED BY THE LAW ENFORCEMENT AGENCY INVOLVED.

ANY ADDITIONAL COSTS (ADMINISTRATIVE OR OTHERWISE) INCURRED BY THE CONTRACTOR TO OBTAIN THE SERVICES OF AN LEO ARE INCLUDED WITH THE BID UNIT PRICE FOR ITEM 614, LAW ENFORCEMENT OFFICER WITH PATROL CAR FOR ASSISTANCE.

COOPERATION BETWEEN CONTRACTORS

THE CONTRACTOR SHALL BE ADVISED THAT PROJECTS STA-77/44-17.92/15.57 (PID: 102509), STA-62-35.72 (PID: 94127) STA-CULVERTS-FY2018 (PID 99798) AND STA-153/172-7.47/19.51 (PID 102413) MAY BE ONGOING IN AN AREA IMMEDIATELY ADJACENT TO AND WITHIN THE PROJECT LIMITS OF THIS PROJECT. THE CONTRACTOR SHALL SCHEDULE HIS WORK SO AS TO CAUSE A MINIMUM OF DELAY OR CONFLICT WITH THE OTHER PROJECTS. IN ACCORDANCE WITH 105.08, THE CONTRACTOR SHALL ARRANGE WITH THE OTHER CONTRACTORS APPROVAL OF THE ENGINEER. THE CONTRACTOR SHALL RECEIVE DAILY APPROVALS FROM THE ENGINEER PRIOR TO COMMENCING ANY OPERATIONS. ANY CONFLICT BETWEEN CONTRACTORS INVOLVING WORK SCHEDULES, WORK AREA, OR COOPERATION SHALL BE RESOLVED BY THE ENGINEER. COMPENSATION FOR THE ABOVE COOPERATION SHALL BE INCIDENTAL TO THE VARIOUS PAY ITEMS INCLUDED WITHIN THIS PROJECT.

INTERIM COMPLETION DATE

ALL PARTIAL DEPTH REPAIRS AND FULL DEPTH REPAIRS DONE ON SR-153 SHALL BE COMPLETED BY 9/20/18. ALL WORK DONE ON SR-153 SHALL BE COMPLETED BY 10/15/18. THE CONTRACTOR SHALL BE ASSESSED A DISINCENTIVE IN THE AMOUNT OF \$3,000 FOR EACH DAY OVER THE ABOVE STATED DATES.

ITEM 632 - DETECTOR LOOP, AS PER PLAN

THE CONTRACTOR SHALL CONTACT THE DISTRICT OFFICE (330-786-3146) THREE WORKING DAYS PRIOR TO ANY PLANING OR TRENCHING AT THE INTERSECTION OF SR 153 AND SR 44. LOOP DETECTORS DISTURBED BY PAVEMENT PLANING OR TRENCHING SHALL BE ABANDONED IN PLACE. THE LOOP DETECTOR WIRE WILL BE CUT INTO THE PAVEMENT AFTER THE PROPOSED SURFACE COURSE HAS BEEN PLACED. ALL STOP LINE INDUCTANCE DETECTOR LOOPS SHALL BE THE POWERHEAD CONFIGURATION SHOWN ON TC-82.10. THE WIDTH SHALL BE AS SPECIFIED ON TC-82.10 AND THE LENGTH SHALL BE AS SPECIFIED BELOW. THE LOCATION OF THESE LOOPS SHALL BE SUCH THAT THE POWERHEAD IS LOCATED AT THE STOP LINE, NOT PAST IT. ALL DILEMMA ZONE INDUCTANCE DETECTOR LOOPS CALLED FOR IN THE PLANS SHALL BE THE ANGULAR DESIGN DETECTION (ADD) LOOP AS SHOWN ON TC-82.10. DIMENSIONS SHALL BE AS SPECIFIED ON TC-82.10 AND THE LOOP SHALL BE PLACED AT THE SAME LOCATION AS THE EXISTING LOOPS.

THE QUANTITIES LISTED BELOW HAVE BEEN CARRIED TO THE GENERAL SUMMARY. THE NEW LOOP DETECTOR WIRES SHALL BE RUN INTO THE EXISTING CONTROL BOX OR THE EXISTING PULLBOX. INCLUDED IN THIS ITEM IS THE POURED EPOXY TYPE CABLE SPLICE KIT (CONFORMING TO 725.15E) THAT MUST BE USED IN MAKING THESE CONNECTIONS. ALL NECESSARY MATERIAL, LABOR, SPLICE KITS AND EQUIPMENT SHALL BE INCIDENTAL TO PAYMENT OF THESE ITEMS.

632 DETECTOR LOOP, AS PER PLAN, 2 EACH
(2 EACH, POWERHEAD (35FT))

I:\ProjectData\STA_98392_44-IT3_14.67-0\Design\Roadway\Sheets\98392_MN001.dgn Sheet2 5/8/2018 9:22:03 AM pdinh

CALCULATED
HKS
CHECKED
CNC

MAINTENANCE OF TRAFFIC GENERAL NOTES

STA - 44 / 153 / 173
14.67 / 6.25 / 0.00

14
26

I:\ProjectData\STA_98392_44-173_14.67-0\Design\Roadway\Sheets\98392_GC001.dgn Sheet 5/8/2018 9:23:06 AM pdinn

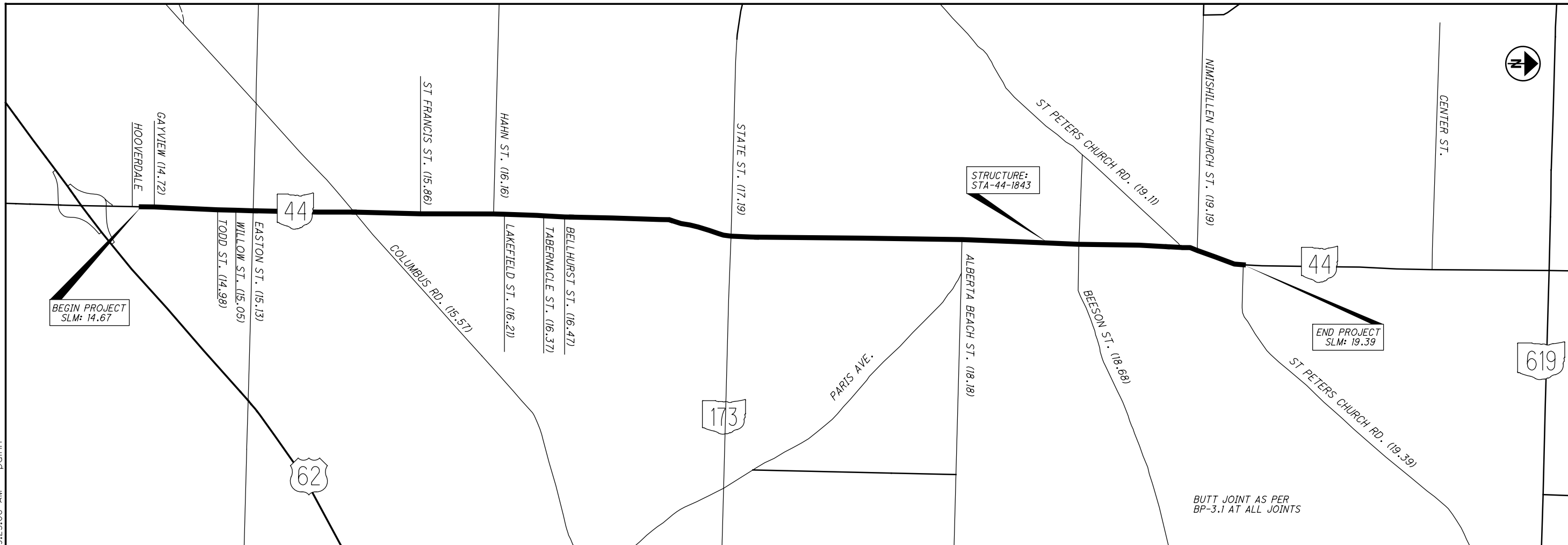

SLM RANGE			TYPICAL SECTION	SIDE	DISTANCE (D) FT	AVERAGE WIDTH (W) FT	SURFACE AREA (A) A=DxW/9 SY	CADD GENERATED AREA SY	254 PAVEMENT PLANING, ASPHALT CONCRETE (T=2") SY	407 NON-TRACKING TACK COAT @ 0.06 GAL/SY GAL	407 NON-TRACKING TACK COAT @ 0.09 GAL/SY GAL	441 ASPHALT CONCRETE SURFACE COURSE, TYPE 1, (446), AS PER PLAN PG70-22M (T=1.25") CY	441 ASPHALT CONCRETE INTERMEDIATE COURSE, TYPE 2, (446)(T=1.75") CY	617 COMPACTED AGGREGATE, AS PER PLAN (T=2") CY	408 PRIME COAT, AS PER PLAN @ 0.40 GAL/SY GAL
MAINLINE SR 44															
14.67	TO	14.97	1	1584.00	30.00	5280.00			5280.00	316.80	475.20	183.33	256.67	39.11	281.60
14.97	TO	15.51	1	2851.20	32.00	10137.60			10137.60	608.26	912.38	352.00	492.80	70.40	506.88
15.51	TO	15.57	1	316.80	41.00	1443.20			1443.20	86.59	129.89	50.11	70.16	7.82	56.32
15.57	TO	16.46	1	4699.20	27.00	14097.60			14097.60	845.86	1268.78	489.50	685.30	116.03	835.41
16.46	TO	16.92	1	2428.80	27.00	7286.40			7286.40	437.18	655.78	253.00	354.20	59.97	431.79
16.92	TO	17.31	1	2059.20	30.00	6864.00			6864.00	411.84	617.76	238.33	333.67	50.84	366.08
17.31	TO	19.39	1	10982.40	27.00	32947.20			32947.20	1976.83	2965.25	1144.00	1601.60	271.17	1952.43
INTERSECTIONS															
14.67	TO	16.46		10.00	VARIES		836.00		836.00	50.16	75.24	29.03	40.64		
16.46	TO	19.39		10.00	VARIES		694.00		694.00	41.64	62.46	24.10	33.74		
DRIVEWAYS															
14.67	TO	16.46		6.00	VARIES							15.00			
16.46	TO	19.39		6.00	VARIES							12.00			
MAILBOX APPROACHES															
14.67	TO	16.46					987.00		987.00			34.27	47.98		
16.46	TO	19.39					740.00		740.00			25.69	35.97		
SUBTOTALS									81313.00	4775.16	7162.74	2850.37	3952.72	615.35	4430.51
TOTALS CARRIED TO GENERAL SUMMARY									81313	4776	7163	2851	3953	616	4431

PAVEMENT CALCULATIONS (SR 44)

STA - 44 / 153 / 173
14.67 / 6.25 / 0.00

CALCULATED PD
CHECKED MAC

17
26

I:\ProjectData\STA_98392_44-173-0\Design\Roadway\Sheets\98392_RPM001.dgn Sheet 5/8/2018 9:23:56 AM pdinn

COUNTY	ROUTE	LOCATION		SECTION (S.L.M.)				621	621	621	621	RAISED PAVEMENT MARKER REMOVED	REMARKS			
		RPM (YELLOW/YELLOW)	RPM (WHITE/RED)					RPM (WHITE)	RPM (YELLOW/RED)	EACH	EACH			EACH	EACH	EACH
		FROM	TO													
STA	44	14.67	15.57					60	4	48		84	START OF PROJECT TO COLUMBUS RD			
STA	44	15.57	16.46					59		16		57	COLUMBUS RD TO BELLHURST ST			
STA	44	16.46	17.19					55		16		54	BELLHURST ST TO STATE ST			
STA	44	17.19	19.39					156		16		129	STATE ST TO END OF PROJECT			
STA	173	0.00	3.50					231		16		186	SR 44 TO PARKS AVE			
STA	173	3.50	4.43					109	3			84	PARKS AVE TO ON/OFF RAMPS FOR US 62			
STA	173	4.43	4.60					6	28			26	ON/OFF RAMPS FOR US 62 TO END OF PROJECT			
TOTALS CARRIED TO GENERAL SUMMARY													676	35	112	620

CALCULATED	PD
	CHECKED
MAC	
RAISED PAVEMENT MARKERS	
STA - 44 / 153 / 173	
14.67 / 6.25 / 0.00	
19	26

EDGE LINE

CTY	ROUTE	TRUE LOG	FROM	TRUE LOG	TO	WHITE EDGE LINE, 6"			YELLOW EDGE LINE, 6"			COMMENTS
						TOTAL	HIGHWAY	RAMP	TOTAL	HIGHWAY	RAMP	
STA	S.R. 44	14.67	GAYVIEW	16.46	BELLHURST ST. NE	3.58	3.58					
STA	S.R. 44	16.46	BELLHURST ST. NE	19.39	ST. PETERS CHURCH RD. NE	5.86	5.86					
STA	S.R. 173	0.00	S.R. 44	4.43	U.S. 62 ON/OFF RAMPS	8.86	8.86					
STA	S.R. 173	4.43	U.S. 62 ON/OFF RAMPS	4.60	U.S. 62	0.34	0.34					
TOTAL						18.64	18.64		0			

LANE LINE

CTY	ROUTE	TRUE LOG	FROM	TRUE LOG	TO	TOTAL MILES	6" LANE LINE		COMMENTS
							DASHED	SOLID	
STA	S.R. 173	4.43	U.S. 62 ON/OFF RAMPS	4.60	U.S. 62	0.18	0.18		
TOTAL						0.18	0.18		

CENTER LINE

CTY	ROUTE	TRUE LOG	FROM	TRUE LOG	TO	TOTAL MILES	EQUIVALENT SOLID LINE		COMMENTS
STA	S.R. 44	14.67	GAYVIEW	16.46	BELLHURST ST. NE	1.79	2.62		
STA	S.R. 44	16.46	BELLHURST ST. NE	19.39	ST. PETERS CHURCH RD. NE	2.93	4.28		
STA	S.R. 173	0.00	S.R. 44	4.43	U.S. 62 ON/OFF RAMPS	4.43	9.15		
STA	S.R. 173	4.43	U.S. 62 ON/OFF RAMPS	4.60	U.S. 62	0.17	0.35		
STA	S.R. 153	6.25	SR 44	7.47	LOUISVILLE CORP LIMIT	1.31	3.05		
TOTAL						10.63	19.45		

AUXILIARY

CTY	ROUTE LOCATION	TRUE LOG	CHANNEL LINE, 8"	CHANNEL LINE, 12"	STOP LINE	CROSS WALK LINES	TRANSVERSE DIAGONAL LINES		ISLAND MARKING	SYMBOL MARKINGS					LANE ARROWS			WORD ON PVMT ONLY		PARKING LOT STALL	COMMENTS
							WHITE	YELLOW		RxR	SCHOOL		TURN LEFT	TURN RIGHT	THRU	COMB.	REDUCT.	72"	96"		
											FT	FT									
STA	S.R. 44 @ EASTON ST.	15.150			28																
STA	S.R. 44 @ COLUMBUS RD	15.570	125		33										3						
STA	S.R. 44 @ S.R. 173	17.190			24																
STA	S.R. 173 @ S.R. 44	0.000			18																
STA	S.R. 173 @ U.S. 62	4.500	652		40		70	66	141				5	2							
STA	S.R. 153 @ SR 44	6.250	233		76	511	30						5							239	
STA	S.R. 153 @ WALNUT ST	6.450				167															
STA	S.R. 153 @ NICKEL PLATE ST	6.750	410		44	265							8								
TOTAL			1420		263	943	100	66	141			2	18	5						239	

PAVEMENT MARKINGS

STA - 44 / 153 / 173
14.67 / 6.25 / 0.00

I:\ProjectData\STA_98392_44-173_14.67-0\Design\Structures\STA44_1843\Sheets\98392_SN001.dgn Sheet 5/8/2018 9:24:59 AM pdinh

DESIGN SPECIFICATIONS

THIS STRUCTURE CONFORMS TO "STANDARD SPECIFICATIONS FOR HIGHWAY BRIDGES" ADOPTED BY THE AMERICAN ASSOCIATION OF STATE HIGHWAY AND TRANSPORTATION OFFICIALS, 17TH EDITION, INCLUDING THE 2002 INTERIM SPECIFICATIONS AND THE ODOT BRIDGE DESIGN MANUAL.

EXISTING STRUCTURE VERIFICATION

DETAILS AND DIMENSIONS SHOWN ON THESE PLANS PERTAINING TO THE EXISTING STRUCTURE HAVE BEEN OBTAINED FROM PLANS OF THE EXISTING STRUCTURE AND FROM FIELD OBSERVATIONS AND MEASUREMENTS. CONSEQUENTLY, THEY ARE INDICATIVE OF THE EXISTING STRUCTURE AND THE PROPOSED WORK BUT THEY SHALL BE CONSIDERED TENTATIVE AND APPROXIMATE. THE CONTRACTOR IS REFERRED TO CMS SECTIONS 102.05, 105.02 AND 513.04.

BASE CONTRACT BID PRICES UPON A RECOGNITION OF THE UNCERTAINTIES DESCRIBED ABOVE AND UPON A PREBID EXAMINATION OF THE EXISTING STRUCTURE. HOWEVER, THE DEPARTMENT WILL PAY FOR ALL PROJECT WORK BASED UPON ACTUAL DETAILS AND DIMENSIONS WHICH HAVE BEEN VERIFIED IN THE FIELD.

PROPOSED WORK

STA-44-1843 (OVER REED DITCH)
-CLEAN OUT CHANNEL AND REMOVE GRASS AND SAND BARS AT THE INLET AND OUTLET
-CLEARING AND GRUBBING 15' AROUND THE STRUCTURE TO REMOVE VEGETATION
-PROVIDE NEW STRUCTURE IDENTIFICATION SIGNS

STA-62T-0237 (UNDER BEESON STREET)
-SEAL WEARING SURFACE AND APPROACH SLABS WITH GRAVITY FED RESIN
-CLEARING AND GRUBBING 15' AROUND THE STRUCTURE TO REMOVE VEGETATION

STA-62T-0290 (UNDER VINE STREET)
-SEAL WEARING SURFACE AND APPROACH SLABS WITH GRAVITY FED RESIN
-CLEARING AND GRUBBING 15' AROUND THE STRUCTURE TO REMOVE VEGETATION

STA-173-0315 (BRANCH OF BEECH CREEK)
-REPAIR EROSION AT THE FORWARD AND REAR HEADWALLS
-CLEARING AND GRUBBING 15' AROUND THE STRUCTURE TO REMOVE VEGETATION
-PROVIDE NEW STRUCTURE IDENTIFICATION SIGNS

STA-173-0427 (OVER BEECH CREEK)
-PATCH ALL UNSOUND AREAS OF THE BRIDGE DECK AND APPROACH SLAB
-SEAL WEARING SURFACE AND APPROACH SLABS WITH GRAVITY FED RESIN
-PATCH ALL UNSOUND AREAS OF THE SUBSTRUCTURE
-SEAL PATCHED AREAS OF THE SUBSTRUCTURE WITH EPOXY-URETHANE
-REMOVE ALL SPALLED AREAS OF THE BOTTOM DECK FLOOR AND SEAL AREAS WITH EPOXY-URETHANE
-REPAIR SLOPE PROTECTION AT THE REAR RIGHT OF STRUCTURE
-CLEARING AND GRUBBING 15' AROUND THE STRUCTURE TO REMOVE VEGETATION
-PROVIDE NEW STRUCTURE IDENTIFICATION SIGNS

STA-173-0447 (OVER STA-62T-35.63)
-PATCH ALL UNSOUND AREAS OF THE BRIDGE DECK AND APPROACH SLAB
-SEAL WEARING SURFACE AND APPROACH SLABS WITH GRAVITY FED RESIN
-PATCH ALL UNSOUND AREAS OF THE SUBSTRUCTURE
-SEAL PATCHED AREAS OF THE SUBSTRUCTURE WITH EPOXY-URETHANE
-REMOVE ALL SPALLED AREAS OF THE BOTTOM DECK FLOOR AND SEAL AREAS WITH EPOXY-URETHANE
-CLEAN OUT EXISTING SCUPPERS
-CLEARING AND GRUBBING 15' AROUND THE STRUCTURE TO REMOVE VEGETATION
-PROVIDE NEW STRUCTURE IDENTIFICATION SIGNS

ITEM 202 - REMOVAL MISC.: CHANNEL CLEANOUT

THIS WORK WILL CONSIST OF RE-ESTABLISHING THE ORIGINAL CHANNEL PROFILE BY REMOVING SEDIMENT BUILDUP, VEGETATION, AND DEBRIS FROM THE EXISTING CHANNEL WITHIN STATE RIGHT-OF-WAY LIMITS AS SPECIFIED IN THE PLANS FOR STRUCTURE STA-44-1843. ANY TREES LOCATED WITHIN CHANNEL OR BANK LIMITS WILL BE INCLUDED UNDER ITEM 201, CLEARING AND GRUBBING. ALL MATERIALS REMOVED SHALL BE DISPOSED OF IN ACCORDANCE WITH 105.16 AND 105.17 OF THE CMS WITH THE APPROVAL OF THE ENGINEER. NO AREAS OF EXISTING CHANNEL PROTECTION SHALL BE REMOVED IN ORDER TO RESTORE THE ORIGINAL CHANNEL PROFILE. AFFECTED CHANNEL AREAS SHALL BE CLEANED OUT TO THE SATISFACTION OF THE ENGINEER.

CHANNEL CLEANOUT WILL BE PAID FOR AT THE UNIT PRICE BID FOR ITEM 202 REMOVAL MISC.: CHANNEL CLEANOUT. THIS PRICE WILL INCLUDE THE COST FOR LABOR, EQUIPMENT, AND ALL INCIDENTALS REQUIRED TO COMPLETE THE CHANNEL CLEANOUT.

ITEM 519 - PATCHING CONCRETE STRUCTURES, AS PER PLAN

PRIOR TO THE SURFACE CLEANING SPECIFIED IN 519.04 AND WITHIN 24 HOURS OF PLACING PATCHING MATERIAL, BLAST CLEAN ALL SURFACES TO BE PATCHED INCLUDING THE EXPOSED REINFORCING STEEL. ACCEPTABLE METHODS INCLUDE HIGH-PRESSURE WATER BLASTING WITH OR WITHOUT ABRASIVES IN THE WATER, ABRASIVE BLASTING WITH CONTAINMENT, OR VACUUM ABRASIVE BLASTING.

STRUCTURE IDENTIFICATION SIGNS

STRUCTURE IDENTIFICATION SIGNS (I-H25b) WILL BE PLACED ON EACH APPROACH OFF THE RIGHT SHOULDER, FACING TRAFFIC, AND BEHIND THE GUARDRAIL IF APPLICABLE. A QUANTITY OF ONE SIGN PER APPROACH WILL BE INSTALLED. THE SIGNS WILL HAVE A NON-REFLECTIVE WHITE SHEETING BACKGROUND.

THE SIGNS WILL BE MOUNTED ON NEW NO. 2 POSTS AND WILL BE INSTALLED AS PER STANDARD CONSTRUCTION DRAWING TC-41.20, MOST CURRENT REVISION. EACH POST WILL BE 7.5' IN LENGTH.

INSTALL SIGNS FOR THE FOLLOWING STRUCTURES:

STA-44-1843 (2 APPROACH)
STA-173-0315 (2 APPROACH)
STA-173-0427 (2 APPROACH)
STA-173-0447 (2 APPROACH)

THE FOLLOWING QUANTITIES HAVE BEEN INCLUDED FOR EACH APPROACH:
ITEM 630 - GROUND MOUNTED SUPPORT, NO. 2 POST, 7.5 FT
ITEM 630 - SIGN, FLAT SHEET, 730.20, 1 SQ FT
ITEM 630 - REMOVAL OF GROUND MOUNTED SIGN AND DISPOSAL, 1 EACH
ITEM 630 - REMOVAL OF GROUND MOUNTED POST SUPPORT AND DISPOSAL, 1 EACH

CORRECTING BRIDGE IDENTIFICATION SIGN NUMBERS:

SOME OF THE EXISTING BRIDGE NUMBER SIGNS HAVE INCORRECT BRIDGE NUMBERS ON THEM. THE FOLLOWING BRIDGE NUMBERS ARE THE CORRECT ONES AND WILL BE USED ON THE NEW BRIDGE IDENTIFICATION SIGNS.

STRUCTURE STA-173-0427 (SFN:7605536) THE EXISTING SIGN SHOWS 0425. THE CORRECT BRIDGE IDENTIFICATION NUMBER IS 0427.

ITEM 512 - SEALING OF CONCRETE SURFACES

THIS WORK SHALL CONSISTS OF SEALING PATCHED AREAS ON STRUCTURE STA-173-0427 AND STA-173-0447 WITH EPOXY-URETHANE. THE COLOR SHALL MATCH EXISTING CONCRETE SEAL ON THE STRUCTURE (PER CMS).

CLEARING AND GRUBBING

ALTHOUGH THERE ARE NO TREES OR STUMPS SPECIFICALLY MARKED FOR REMOVAL WITHIN THE LIMITS OF THE PROJECT, A LUMP SUM QUANTITY IS INCLUDED IN THE GENERAL SUMMARY FOR ITEM 201, CLEARING AND GRUBBING. ALL PROVISIONS AS SET FORTH IN THE SPECIFICATIONS UNDER THIS ITEM ARE INCLUDED IN THE LUMP SUM PRICE BID FOR ITEM 201, CLEARING AND GRUBBING.

ITEM 518 - SCUPPER MISC.: CLEANOUT

THIS WORK WILL CONSIST OF REMOVING ALL DEBRIS FROM ON TOP AND INSIDE OF THE SCUPPERS. SCUPPER CLEANOUT WILL BE PAID FOR AT THE UNIT PRICE BID FOR ITEM 518, SCUPPER MISC.: CLEANOUT. THIS PRICE WILL INCLUDE THE COST FOR LABOR, EQUIPMENT, AND ALL INCIDENTALS REQUIRED TO COMPLETE THIS WORK.

PAVEMENT MARKINGS

THE FOLLOWING QUANTITIES HAS BEEN PROVIDED FOR ALL STRUCTURES TO RESTRIPE AFTER TREATING THE DECK WITH GRAVITY FED RESIN.

ITEM 646, CENTER LINE 0.21 MILES
ITEM 646, EDGE LINE, 6" 0.41 MILES
ITEM 646, LANE LINE, 6" 0.19 MILES
ITEM 646, CHANNELIZING LINE, 8" 311 FT
ITEM 646, LANE ARROW 4 EACH

SPECIAL - STRUCTURE MISC.: CONCRETE SPALL REMOVAL

THIS WORK WILL CONSIST OF REMOVING ALL VISIBLY SPALLED AREAS OF THE DECK FLOOR BOTTOM OF STRUCTURES STA-173-0427 AND STA-173-0447 WITHOUT SOUNDING. AFTER SPALLED CONCRETE AREAS HAVE BEEN REMOVED SEAL AREAS WITH ITEM 512, SEALING OF CONCRETE SURFACES (EPOXY-URETHANE).

CONCRETE SPALL REMOVAL WILL BE PAID FOR AT THE UNIT PRICE BID FOR SPECIAL - STRUCTURE MISC.: CONCRETE SPALL REMOVAL. THIS PRICE WILL INCLUDE THE COST FOR LABOR, EQUIPMENT, AND ALL INCIDENTALS REQUIRED TO COMPLETE THIS WORK.

STA-173-0427:
SPEC, STRUCTURE MISC.: CONCRETE SPALL REMOVAL, 50 SY
512, SEALING OF CONCRETE SURFACES (EPOXY-URETHANE), 50 SY

STA-173-0447:
SPEC, STRUCTURE MISC.: CONCRETE SPALL REMOVAL, 50 SY
512, SEALING OF CONCRETE SURFACES (EPOXY-URETHANE), 50 SY

EROSION REPAIR

THIS WORK WILL CONSIST OF REPAIRING EROSION ON VARIES LOCATIONS ON THE FOLLOWING STRUCTURES

STA-173-0315 (FORWARD AND REAR HEADWALLS)
601, ROCK CHANNEL PROTECTION, TYPE B W/ GEOTEXTILE FABRIC 47 CY
STA-173-0427 (REAR RIGHT)
601, DUMPED ROCK FILL, TYPE B 20 CY

DESIGN AGENCY		ODOT DISTRICT 4	
REVIEWED		DATE	
XXX	MM/DD/YY	STRUCTURE FILE NUMBER	
DRAWN	PD	CHECKED	XXX
DESIGNED	PD	CHECKED	XXX
STRUCTURE GENERAL NOTES			
STA-44-1843, STA-62T-0237, STA-62T-0290, STA-173-0315 STA-173-0427, STA-173-0447			
STA-44-153/173		PID No. 98392	
14.67/6.25/0.00			
1/6		21/26	

I:\ProjectData\STA_98392_44-173_14.67-0\Design\Structures\STA44_1843\Sheets\98392_SN001.dgn Sheet 2 5/8/2018 9:25:00 AM pdinn

ENDANGERED BAT HABITAT REMOVAL

THE PROJECT IS LOCATED WITHIN THE KNOWN HABITAT RANGES OF THE FEDERALLY LISTED AND PROTECTED INDIANA BAT AND NORTHERN LONG-EARED BAT. NO TREES SHALL BE REMOVED UNDER THIS PROJECT FROM APRIL 1 THROUGH SEPTEMBER 30. ALL NECESSARY TREE REMOVAL SHALL OCCUR FROM OCTOBER 1 THROUGH MARCH 31. THIS REQUIREMENT IS NECESSARY TO AVOID AND MINIMIZE IMPACT TO THESE SPECIES AS REQUIRED BY THE ENDANGERED SPECIES ACT. FOR THE PURPOSES OF THIS NOTE, A TREE IS DEFINED AS A LIVE, DYING, OR DEAD WOODY PLANT, WITH A TRUNK THREE INCHES OR GREATER IN DIAMETER AT A HEIGHT OF 4.5 FEET ABOVE THE GROUND SURFACE, AND WITH A MINIMUM HEIGHT OF 13 FEET.

STREAM AVOIDANCE BEECH CREEK STA-173-0427/SFN 7605536

THE STA-173-0427 (SFN 7605536) BRIDGE SPANS BEECH CREEK. NO EXCAVATION, GRADING OR FILLING OPERATIONS RESULTING IN PERMANENT IMPACTS SHALL BE PERFORMED BELOW THE ORDINARY HIGH WATER MARK OF BEECH CREEK. USE OF TEMPORARY SCAFFOLDING TO ACCESS THE FORWARD ABUTMENT WALL MAY BE PERMITTED WITH APPROVAL OF THE PROJECT ENGINEER. UNDER NO CIRCUMSTANCES SHALL THE CONTRACTOR STORE OTHER EQUIPMENT AND/OR MATERIALS WITHIN BEECH CREEK.

CHANNEL CLEANOUT OPERATIONS - MIDDLE BRANCH OF NIMISHILLEN CREEK STA-44-1843/SFN 7601875

THE STA-44-1843 (SFN 7601875) BRIDGE SPANS THE MIDDLE BRANCH OF NIMISHILLEN CREEK CHANNEL AND WETLANDS ARE PRESENT EAST AND WEST OF THE STA-44-1843 BRIDGE. UNDER NO CIRCUMSTANCES SHALL THE CONTRACTOR PLACE ANY PERMANENT OR TEMPORARY FILL WITHIN THE MIDDLE BRANCH OF NIMISHILLEN CREEK AND/OR THE ABUTTING WETLANDS. UNDER NO CIRCUMSTANCES SHALL THE CONTRACTOR STORE EQUIPMENT AND/OR MATERIALS WITHIN THE MIDDLE BRANCH OF NIMISHILLEN CREEK CHANNEL AND/OR THE ABUTTING WETLANDS. WHEN USING A BUCKET-TYPE EXCAVATOR, THE EQUIPMENT IS TO BE STAGED ON THE BRIDGE OR ROAD AND NO MORE THAN INCIDENTAL FALLBACK IS AUTHORIZED. NO BANK SHAPING, STREAM RELOCATION OR CHANNELIZATION IS AUTHORIZED. WORK SHALL NOT CHANGE THE EXISTING CONTOUR OF THE STREAM FLOW LINE OR BANKS AND EXISTING ROCK CHANNEL PROTECTION SHOULD REMAIN IN PLACE. MATERIAL RESULTING FROM VEGETATION REMOVAL AND/OR REMOVAL OF ACCUMULATED SEDIMENT SHALL BE DIRECTLY LOADED INTO A TRUCK, REMOVED FROM THE SITE AND DISPOSED OF IN ACCORDANCE WITH 105.16 AND 105.17 OF THE CMS WITH APPROVAL OF THE ENGINEER. ALL WORK SHALL BE PERFORMED TO THE SATISFACTION OF THE PROJECT ENGINEER.

STREAM CHANNEL CLEANOUT AND DITCH EXCAVATION BEST MANAGEMENT PRACTICES

THE CONTRACTOR SHALL TAKE ALL PRECAUTIONS NECESSARY TO PREVENT ANY INCIDENTAL DISCHARGES ASSOCIATED WITH THE EXCAVATION AND HAULING OF MATERIAL FROM STREAMS AND DITCHES. ALL MATERIALS REMOVED FROM STREAMS AND/OR DITCHES MUST BE IMMEDIATELY REMOVED TO AN UPLAND SITE AND STABILIZED (I.E., SEED) TO PREVENT REDISTRIBUTION INTO ANY WATERS OF THE UNITED STATES. IMMEDIATE REMOVAL IS DEFINED BY THE UNITED STATES ARMY CORPS OF ENGINEERS AS DEPOSITING THE REMOVED MATERIALS DIRECTLY INTO A TRUCK AND REMOVING THE MATERIAL FROM THE SITE. PLACEMENT OF REMOVED MATERIALS INTO A WETLANDS OR ON THE BANKS OF A STREAM EVEN TEMPORARILY IS CONSIDERED A FILL AND REQUIRES A PERMIT ACTION.

A QUANTITY OF ITEM 832 CONSTRUCTION FENCE AND A QUANTITY OF ITEM 832 PERIMETER FILTER FABRIC FENCE HAVE BEEN INCLUDED IN THE GENERAL SUMMARY. THE CONSTRUCTION FENCE AND PERIMETER FILTER FABRIC FENCE SHALL BE INSTALLED ALONG THE PROPOSED CONSTRUCTION LIMITS AT THE STA-173-0427 (SFN 7605536) AND STA-44-1843 (SFN 7601875) BRIDGE LOCATIONS, AS DIRECTED BY THE PROJECT ENGINEER, PRIOR TO THE START OF ANY CONSTRUCTION ACTIVITIES WITHIN THE LIMITS AND ADJACENT AREA, INCLUDING ANY NECESSARY CLEARING AND GRUBBING ACTIVITIES. THE CONSTRUCTION FENCE AND PERIMETER FILTER FABRIC FENCE SHALL BE MAINTAINED BY THE CONTRACTOR THROUGHOUT PROJECT CONSTRUCTION AND SHALL BE REMOVED BY THE CONTRACTOR UPON PROJECT COMPLETION.

PAYMENT FOR ITEM 832 CONSTRUCTION FENCE AND ITEM 832, PERIMETER FILTER FABRIC FENCE WILL BE MADE UNDER ITEM 832, EROSION CONTROL.

WATERWAY PERMIT DETERMINATION (404/401) - ODOT PROJECTS

ALL PROJECTS INVOLVING JURISDICTIONAL WATERS OF THE UNITED STATES (STREAMS, RIVERS, NON-ISOLATED WETLANDS) AND/OR ISOLATED WETLANDS ARE SUBJECT TO REGULATION UNDER SECTIONS 404 AND 401 OF THE CLEAN WATER ACT, AND POSSIBLY OHIO EPA ISOLATED WETLAND LAW. THE WATERWAY PERMITS CONDITIONS VERIFIED FOR THE PROJECT HAVE BEEN INCORPORATED INTO THE PROJECT CONSTRUCTION PLAN AS SPECIAL PROVISIONS. THE PROJECT CONTRACTOR SHALL ADHERE TO ALL WATERWAY PERMIT TERMS AND CONDITIONS THROUGHOUT PROJECT CONSTRUCTION.

MECHANICAL EQUIPMENT OPERATION AT STREAM CHANNEL

THE MECHANICAL EQUIPMENT USED TO EXECUTE THE WORK AUTHORIZED HEREIN SHALL BE OPERATED IN SUCH A WAY AS TO MINIMIZE TURBIDITY THAT COULD DEGRADE WATER QUALITY AND ADVERSELY AFFECT AQUATIC PLANT AND ANIMAL LIFE.

STRUCTURE PAINTING/CONCRETE SEALING OPERATIONS

THE CONTRACTOR SHALL TAKE ALL PRECAUTIONS NECESSARY TO PREVENT EPOXY-URETHANE SEALER, PAINT OR OTHER MATERIALS USED TO REPAIR, CLEAN, PAINT, SEAL OR TREAT ANY STRUCTURE FROM ENTERING ANY STREAMS, WETLANDS OR OTHER WATERS OF THE UNITED STATES AND TAKE THE APPROPRIATE ACTIONS IN THE EVENT OF A RELEASE.

**STA-44-153/173
14.67/6.25/0.00
PID No. 98392**

STRUCTURE GENERAL NOTES
STA-44-1843, STA-62T-0237, STA-62T-0290, STA-173-0315
STA-173-0427, STA-173-0447

DESIGNED	PD	CHECKED	XXX
DRAWN	PD	REVISED	XXX
REVIEWED	XXX	STRUCTURE FILE NUMBER	XXX

DATE MM/DD/YY
STRUCTURE FILE NUMBER

DESIGN AGENCY
ODOT DISTRICT 4
PLANNING & ENGINEER

2/6
22/26

CALC: PD DATE: 12/4/2017
 CHECKED: DATE:

ESTIMATED QUANTITIES											
BRIDGE NO. / STRUCTURE FILE NO.							ITEM	EXTENSION	UNIT	DESCRIPTION	SEE SHEET
STA-44-1843 SFN 7601875 05/STR/BR	STA-62T-0237 SFN 7602472 04/NHS/BR	STA-62T-0290 SFN 7602480 04/NHS/BR	STA-173-0315 SFN 7605498 06/STR/BR	STA-173-0427 SFN 7605536 05/STR/BR	STA-173-0447 SFN 7602855 04/NHS/BR		201	11000		CLEARING AND GRUBBING	
LUMP 50	LUMP	LUMP	LUMP	LUMP	LUMP		202	98200	FT	REMOVAL MISC.: CHANNEL CLEANOUT	1/6
	2533	1281		75	75		512	10100	SY	SEALING OF CONCRETE SURFACES (EPOXY-URETHANE)	
				569	2131		512	73500	SY	TREATING CONCRETE BRIDGE DECKS WITH GRAVITY FED RESIN	
					16		518	12500	EACH	SCUPPER, MISC.: CLEANOUT	
				150	150		519	11101	SF	PATCHING CONCRETE STRUCTURE, AS PER PLAN	1/6
	25	15		7	22		519	12304	SY	PATCHING CONCRETE BRIDGE DECK - TYPE C	
				50	50		SPECIAL	53000800	SY	STRUCTURES MISC.: CONCRETE SPALL REMOVAL	
				47			601	32104	CY	ROCK CHANNEL PROTECTION, TYPE B WITH GEOTEXTILE FABRIC	
				20			601	26000	CY	DUMPED ROCK FILL, TYPE B	
15				15	15		630	02100	FT	GROUND MOUNTED SUPPORT, NO. 2 POST	
2				2	2		630	80100	SF	SIGN, FLAT SHEET	
				2	2		630	84900	EACH	REMOVAL OF GROUND MOUNTED SIGN AND DISPOSAL	
				2	2		630	86002	EACH	REMOVAL OF GROUND MOUNTED POST SUPPORT AND DISPOSAL	
	0.06	0.05		0.03	0.07		646	10200	MILE	CENTER LINE	
	0.12	0.1		0.05	0.14		646	10010	MILE	EDGE LINE, 6"	
	0.12				0.07		646	10110	MILE	LANE LINE, 6"	
					311		646	10300	FT	CHANNELIZING LINE, 8"	
					4		646	20300	EACH	LANE ARROW	

I:\ProjectData\STA_98392_44-173_14.67-0\Design\Structures\STA44_18431_Sheets\98392_SP001.dgn Sheet 2 5/8/2018 9:26:03 AM pdm

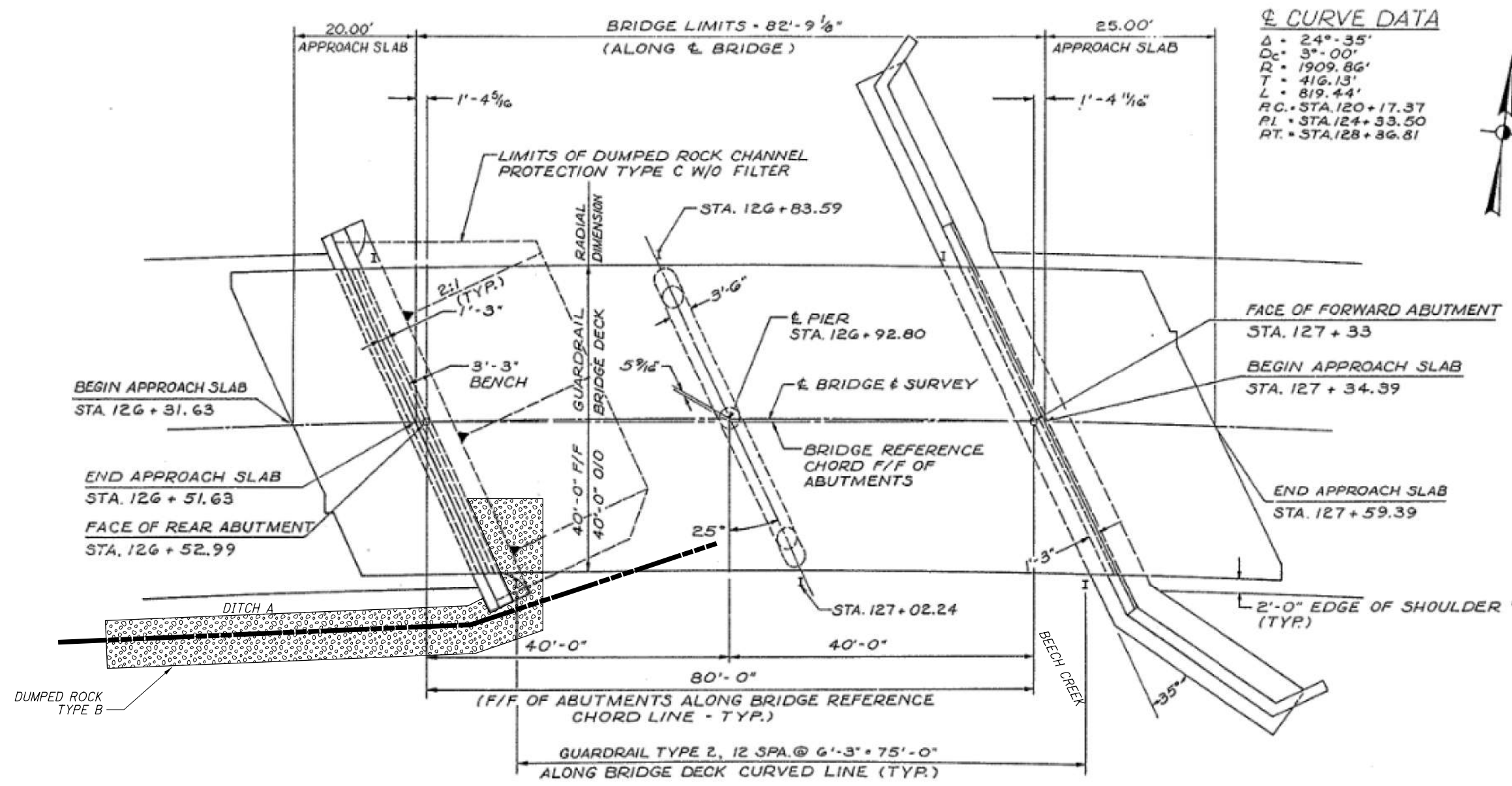

GENERAL PLAN

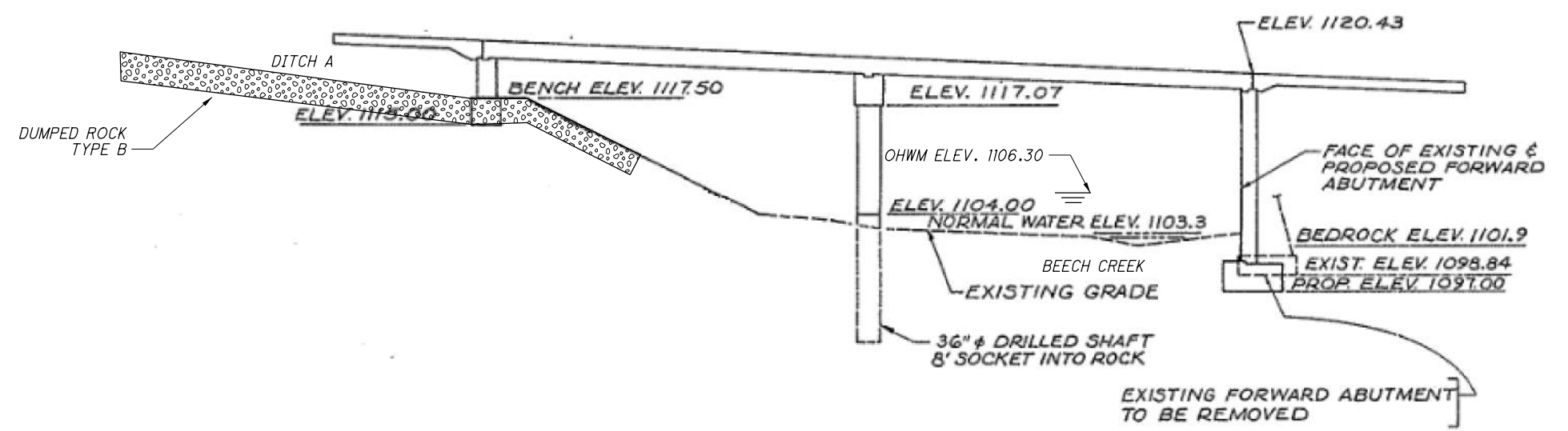

* DETAILS ON THIS SHEET ARE PROVIDED FOR REFERENCE ONLY, EXCEPT THE PROPOSED WORK OF DUMPED ROCK TYPE B

DESIGN AGENCY	ODOT DISTRICT 4
PLANNING & ENGINEER	
DATE	MM/DD/YY
REVIEWED	XXX
STRUCTURE FILE NUMBER	XXX
DRAWN	PD
REVISION	XXX
DESIGNED	PD
CHECKED	XXX
STRUCTURE SITE PLAN	
STA-173-0427	
OVER BEECH CREEK	
STA-44/153/173	
14.67/6.25/0.00	
PID No. 98392	
6/6	
26	
26	

SPECIAL PROVISIONS

WATERWAY PERMITS CONDITIONS

C-R-S: STA-44/173-
14.67/0.00

PID: 98392

Date: 1/12/18

1. Waterway Permits Time Restrictions:

Regional General Permit B is authorized for STA-44/173-14.67/0.00, PID 98392. A copy of the RGP shall be kept at the work site at all times and made available to all contractors and subcontractors. The permit is effective starting: January 12, 2018. The permit expires: October 24, 2019.

For authorized work in aquatic resources (including streams, wetlands, jurisdictional ditches, captured streams, lakes, ponds), the Department will consider the Contractor's submission of a reauthorization to the waterway permit expiration date based on project constraints. If more than one permit is authorized for the project, then all permits become invalid once the first permit expires. In order for the request to be considered, the Contractor must submit a justification to the Engineer at least 90 days prior to the waterway permit expiration date. The Engineer will submit the request for a time extension to the Ohio Department of Transportation, Office of Environmental Services, Waterway Permits Unit (ODOT-OES-WPU) for consideration and coordination with the U.S. Army Corps of Engineers (USACE), Ohio Environmental Protection Agency (OEPA), U.S. Coast Guard (USCG), U.S. Fish and Wildlife Service (USFWS), and Ohio Department of Natural Resources (ODNR) as appropriate.

2. Deviations From Permitted Construction Activities

No deviation from the requirements for work in aquatic resources depicted in the plans, Special Provisions, and/or Working Drawings may be made unless a modification has been submitted to ODOT-OES-WPU and approved by the appropriate agencies (i.e., USACE, OEPA, USCG, ODNR, and USFWS).

For emergency situations resulting in unanticipated impacts to aquatic resources, provide notification (verbal or written) to the Engineer as soon as possible following discovery of the situation. Written notification to the Engineer and notification to the ODOT-OES-WPU (614-466-7100) must be made within 24 hours.

For non-emergency situations, notify the Engineer in writing for submission to the ODOT-OES-WPU (614-466-7100) for consideration and coordination with the appropriate agencies. Notification must be made at least 90 days prior to planned, non-permitted activities. Consideration of the requested deviation is at the discretion of the Director and must be coordinated with the appropriate regulatory agencies.

3. In-Stream Work Restrictions

Work in the following aquatic resources is further restricted as follows:

Stream Name /Description	Location	Work restriction dates (No in-stream work permitted)
Tributary of Beech Creek (STA-173-3.15)	STA 159+44	None

In-stream work has been defined as the placement and/or removal of fill materials (temporary or permanent) below ordinary high water of a stream. Examples of "fill" include, but are not limited to: bridge piers, abutments, culverts, rock channel protection, scour protection, and temporary access fills.

Fills placed within a stream identified in the above table (outside of the work restriction dates) can continue to be worked from during the work restriction dates, but cannot be expanded, removed, or otherwise modified (below ordinary high water) until once again outside of the work restriction dates.

<p>4. Materials:</p> <p>Materials utilized in or adjacent to aquatic resources for temporary or permanent fill or bank protection shall consist of suitable material free from toxic contaminants in other than trace quantities. Broken asphalt is specifically excluded. Chromated Copper Arsenate (CCA), creosote, and other pressure treated lumber shall not be used in structures that are placed in aquatic resources.</p>										
<p>5. Cultural Resources</p> <p>Per CMS 107.10, if archeological sites, historical sites, or human remains are discovered, cease all work in the immediate area and notify the Engineer who will immediately contact the ODOT-District Environmental Coordinator and ODOT-OES-Cultural Resource Section at 614-466-7100. In the event of human remains are identified by OES-Cultural Resources Section, the Engineer shall also contact the Stark County Sheriff's Office at 330-430-3800.</p>										
<p>6. Aquatic Resource Demarcation:</p> <p>All aquatic resources indicated on the plans shall be demarcated in the field as per SS 832 prior to site disturbance. The remainder of the aquatic resources must be demarcated as to ensure avoidance. The fence shall remain in place and be maintained throughout the construction process. Following the completion of the project, the fence and posts shall be removed.</p> <table border="1"> <thead> <tr> <th>Resource ID</th> <th>Resource Location</th> <th>Impact Location</th> <th>Permanent Impact Amount</th> <th>Temporary Impact Amount</th> </tr> </thead> <tbody> <tr> <td>Tributary of Beech Creek</td> <td>STA-173-3.15</td> <td>STA 159+44</td> <td>30 feet (0.006 acre)</td> <td>0</td> </tr> </tbody> </table>	Resource ID	Resource Location	Impact Location	Permanent Impact Amount	Temporary Impact Amount	Tributary of Beech Creek	STA-173-3.15	STA 159+44	30 feet (0.006 acre)	0
Resource ID	Resource Location	Impact Location	Permanent Impact Amount	Temporary Impact Amount						
Tributary of Beech Creek	STA-173-3.15	STA 159+44	30 feet (0.006 acre)	0						
<p>7. Spill containment:</p> <p>Provide and Maintain an Oil Spill Kit with a minimum capacity of 65 gallons. The Spill Kit shall contain:</p> <ul style="list-style-type: none"> - 6 - 3 in. X 8 ft. Oil only socks - 4 - 18 in. X18 in. Oil only pillows - 2 - 5 in. X 10ft. Booms - 50 - 16in. X 20 in. Oil only pads - 10- Disposable Bags - 1- 65 Gallon drum with lid - 25 pounds of Granular Oil Absorbent <p>The Oil Spill Kit shall be located within 150 feet of any equipment working in a stream or wetland. The oil Spill Kit shall be maintained for the life of the contract. Any materials utilized during the project will be replaced within 48 hours. All costs associated with furnishing and maintaining the above referenced spill containment kit is incidental to work.</p>										

<p>8. Blasting:</p> <p>State law requires notification to the Ohio Department of Natural Resources should blasting be required within or near stream channels (See ORC 1533.58 & CMS 107.09). Notify the Engineer, in writing, a minimum of 30 days in advance of blasting, for submission to ODOT-OES-WPU (614-466-7100) for coordination with ODNR.</p>
<p>9. Bridge Inspection:</p> <p>Prior to the removal of bridge structures, the underside must be carefully examined for the presence of birds and bats. Should any birds or bats be found roosting on the underside of the bridge, the Contractor is required to notify the Engineer for coordination with ODOT-OES-WPU (614-466-7100).</p>
<p>10. Project Inspection:</p> <p>Inspection of Work may include inspection by representatives of other government agencies or railroad corporations that pay a portion of the cost of the Work or regulate the Work through State and Federal law. Comments from the representatives of these agencies shall be directed to the Engineer. Please forward a copy to ODOT-OES-WPU (614-466-7100).</p>
<p>11. Excavation Activities:</p> <p>Excavated material will be placed at an upland site and disposed of in such a manner that sediment and runoff to streams and other aquatic resources is controlled and minimized. Additionally, no more than incidental fallback into jurisdictional waters of the U.S. is permitted during the excavation process. If any changes to the proposed work are deemed necessary, you must notify and coordinate with the ODOT-OES-WPU (614-466-7100).</p>
<p>12. Temporary Fill Activities</p> <p>Temporary fill in streams is not authorized for this project. Temporary fill includes, but is not limited to, causeways, work pads, cofferdams, sheet piling, temporary bridges, and construction equipment. Any unauthorized temporary impacts that occur will be in violation of Section 404 and 401 of the Clean Water Act.</p>
<p>13. Demolition Debris:</p> <p>The intentional discharge of demolition debris from any structure (including but not limited to bridges, culverts, abutments, wing walls, piers) into Tributary of Beech Creek is not authorized for this project. If any demolition debris inadvertently falls into Tributary of Beech Creek, it must be removed immediately. Notify the Engineer immediately in writing of any inadvertent fill discharged into Tributary of Beech Creek. Also contact ODOT-OES-WPU at 614-466-7100 if any unintentional discharge occurs.</p>