

I:\ProjectData\WAR\00816\WAR-48-11.54\ProjAdmin\PlanPackage\Design\Roadway\Sheets\00816-CADDFiles\Design\Roadway\Sheets\00816-GG002.dgn Sheet 2/18/2022 11:22:34 AM gfreeman

SHEET NUM.										PART.		ITEM	ITEM EXT	GRAND TOTAL	UNIT	DESCRIPTION	SEE SHEET NO.		
28	29	30	57	58	63					01/S>2/BR	02/CMQ/OT								
	40											40	301	46000	40	CY	PAVEMENT (CONTINUED) ASPHALT CONCRETE BASE, PG64-22		
294	346											485	155	304	20000	640	CY	AGGREGATE BASE	
379	243											521	101	407	20000	622	GAL	NON-TRACKING TACK COAT	
103	71											145	29	441	50000	174	CY	ASPHALT CONCRETE SURFACE COURSE, TYPE 1, (448), PG64-22	
176	99											234	41	441	50200	275	CY	ASPHALT CONCRETE INTERMEDIATE COURSE, TYPE 1, (448)	
266	319											585		452	13010	585	SY	9" NON-REINFORCED CONCRETE PAVEMENT, CLASS QC IP	
		25										25		609	24510	25	FT	CURB, TYPE 4-C	
		748										748		609	26000	748	FT	CURB, TYPE 6	
																		TRAFFIC CONTROL	
			118									118		621	00100	118	EACH	RPM	
			80									80		621	54000	80	EACH	RAISED PAVEMENT MARKER REMOVED	
	21											21		626	00110	21	EACH	BARRIER REFLECTOR, TYPE 2, BIDIRECTIONAL	
				216.5								216.5		630	03100	216.5	FT	GROUND MOUNTED SUPPORT, NO. 3 POST	
				28								28		630	08004	28	FT	ONE WAY SUPPORT, NO. 3 POST	
				6								6		630	08600	6	EACH	SIGN POST REFLECTOR	
				100.5								100.5		630	80100	100.5	SF	SIGN, FLAT SHEET	
				25								25		630	84900	25	EACH	REMOVAL OF GROUND MOUNTED SIGN AND DISPOSAL	
				5								5		630	85100	5	EACH	REMOVAL OF GROUND MOUNTED SIGN AND REERECTION	
				21								21		630	86002	21	EACH	REMOVAL OF GROUND MOUNTED POST SUPPORT AND DISPOSAL	
			0.35									0.35		642	00100	0.35	MILE	EDGE LINE, 4", TYPE 1, WHITE	
			0.15									0.15		642	00300	0.15	MILE	CENTER LINE, TYPE 1, 4", DOUBLE SOLID, YELLOW	
			62									62		642	00400	62	FT	CHANNELIZING LINE, 8", TYPE 1, WHITE	
			4									4		642	01300	4	EACH	LANE ARROW, TYPE 1	
			0.07									0.07		644	00104	0.07	MILE	EDGE LINE, 6", WHITE	
			0.09									0.09		644	00104	0.09	MILE	EDGE LINE, 6", YELLOW	
			0.54									0.54		644	00200	0.54	MILE	LANE LINE, 4", WHITE	
			266									266		644	00400	266	FT	CHANNELIZING LINE, 8", WHITE	
			33									33		644	00500	33	FT	STOP LINE	
			112									112		644	00600	112	FT	CROSSWALK LINE	
			2									2		644	01300	2	EACH	LANE ARROW	
			0.11									0.11		646	10000	0.11	MILE	EDGE LINE, 4", WHITE	
			0.06									0.06		646	10200	0.06	MILE	CENTER LINE, 4", DOUBLE SOLID, YELLOW	
																		STRUCTURE REPAIR (WAR-48-1154)	
				LS								LS		202	11203	LS		PORTIONS OF STRUCTURE REMOVED, OVER 20 FOOT SPAN, AS PER PLAN	60
				134								134		202	22900	134	SY	APPROACH SLAB REMOVED	
				LS								LS		503	11100	LS		COFFERDAMS AND EXCAVATION BRACING	
				LS								LS		503	21300	LS		UNCLASSIFIED EXCAVATION	
					131,994							119,840	12,154	509	10000	131,994	LB	EPOXY COATED REINFORCING STEEL	
					100							100		509	20001	100	LB	REINFORCING STEEL, REPLACEMENT OF EXISTING REINFORCING STEEL, AS PER PLAN	61
					4,393							4,393		509	30020	4,393	FT	NO. 4 GFRP DEFORMED BARS	
					150							150		510	10001	150	EACH	DOWEL HOLES WITH NONSHRINK, NONMETALLIC GROUT, AS PER PLAN	61
					2							2		511	33501	2	EACH	SEMI-INTEGRAL DIAPHRAGM GUIDE, AS PER PLAN	61
					39							39		511	45712	39	CY	CLASS QC1 CONCRETE WITH QC/QA, ABUTMENT	
					93							93		511	53014	93	CY	CLASS QC3 CONCRETE, MISC.:PARAPET CONCRETE WITH QC/QA, AS PER PLAN	61
					114							114	114	511	53014	114	CY	CLASS QC3 CONCRETE, MISC.:SIDEWALK CONCRETE WITH QC/QA, AS PER PLAN	61
					370							370		511	53014	370	CY	CLASS QC3 CONCRETE, MISC.:SUPERSTRUCTURE CONCRETE WITH QC/QA, AS PER PLAN	61
					530							530		512	10050	530	SY	SEALING OF CONCRETE SURFACES (NON-EPOXY)	
					1,053							1,053		512	10100	1,053	SY	SEALING OF CONCRETE SURFACES (EPOXY-URETHANE)	
					121							121		512	10600	121	FT	CONCRETE REPAIR BY EPOXY INJECTION	
					13							13		512	33000	13	SY	TYPE 2 WATERPROOFING	
					151							151		512	74000	151	SY	REMOVAL OF EXISTING COATINGS FROM CONCRETE SURFACES	
					3,276							3,276		513	10201	3,276	LB	STRUCTURAL STEEL MEMBERS, LEVEL UF, AS PER PLAN	78
					2,628							2,628		513	20000	2,628	EACH	WELDED STUD SHEAR CONNECTORS	
					1							1		513	95000	1	FT	STRUCTURAL STEEL, MISC.:REPAIR OF DAMAGED MAIN MEMBER, COMPLETE PENETRATION WELDING	61

GENERAL SUMMARY

WAR-48-11.54  
PART 1



I:\ProjectData\WAR\100816\_WAR-48-11.54\ProjAdmin\PlanPackage\WAR-100816-CADDFiles\Design\Structures\00816-WAR048\_1154C\_S0003.dgn\_Sheet 2/18/2022 10:47:34 AM gFreeman

**ITEM 516 - JACKING AND TEMPORARY SUPPORT OF SUPERSTRUCTURE, AS PER PLAN:**

THIS WORK CONSISTS OF RAISING OR RE-POSITIONING EXISTING STRUCTURES TO THE DIMENSIONS AND REQUIREMENTS DEFINED IN THE PROJECT PLANS. SUBMIT CONSTRUCTION PLANS IN ACCORDANCE WITH C&MS 501.05.

IF, DURING THE JACKING OPERATIONS, DAMAGE TO THE STEEL GIRDERS AND CROSS FRAMES IS VISUALLY OBSERVED, IMMEDIATELY CEASE THE JACKING OPERATION AND INSTALL SUPPORTS TO THE SATISFACTION OF THE ENGINEER. ANALYZE THE DAMAGE AND SUBMIT A METHOD OF CORRECTION TO THE ENGINEER FOR APPROVAL. THE DEPARTMENT WILL NOT PAY FOR THE COST OF THIS REPAIR. THE BRIDGE BEARINGS SHALL BE FULLY SEATED AT ALL CONTACT AREAS. IF FULL SEATING IS NOT ATTAINED, SUBMIT A REPAIR PLAN TO THE ENGINEER. THE DEPARTMENT WILL NOT PAY FOR THE REPAIR COSTS TO ENSURE FULL SEATING ON BEARINGS.

DURING JACKING OPERATIONS THE BEAMS SHALL BE RAISED CONCURRENTLY AT EACH SUBSTRUCTURE UNIT. RAISING BEAMS DIFFERENTIALLY AT THE SUBSTRUCTURE UNITS WILL NOT BE ALLOWED. PROVIDE TEMPORARY LATERAL BRACING FOR THE BEAMS DURING JACKING AND SUPPORT OF THE EXISTING BEAMS UNTIL ABUTMENT DIAPHRAGMS ARE IN PLACE.

THE DEPARTMENT WILL MEASURE THIS WORK ON A LUMP SUM BASIS.

THE DEPARTMENT WILL PAY FOR THE ACCEPTED QUANTITIES AT THE CONTRACT PRICE FOR ITEM 516, JACKING AND TEMPORARY SUPPORT OF SUPERSTRUCTURE, AS PER PLAN.

**ITEM 518 - 6" NON-PERFORATED CORRUGATED PLASTIC PIPE, INCLUDING SPECIALS, AS PER PLAN:**

PAYMENT FOR ALL ITEMS SHOWN FOR PIPE TERMINATION ARE INCLUDED WITH ITEM 518 - 6" NON-PERFORATED CORRUGATED PLASTIC PIPE.

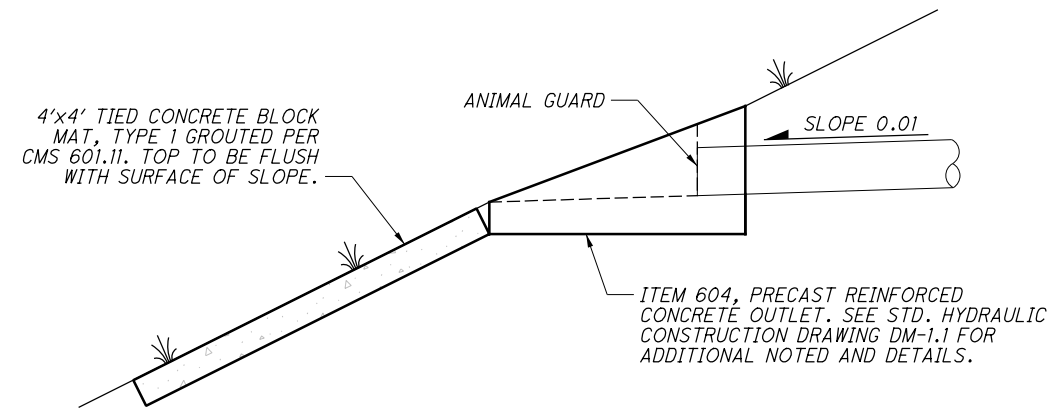

**ITEM 519 - PATCHING CONCRETE STRUCTURE, AS PER PLAN:**

PRIOR TO THE SURFACE CLEANING SPECIFIED IN 519.04 AND WITHIN 24 HOURS OF PLACING PATCHING MATERIAL, BLAST CLEAN ALL SURFACES TO BE PATCHED INCLUDING THE EXPOSED REINFORCING STEEL. ACCEPTABLE METHODS INCLUDE HIGH -PRESSURE WATER BLASTING WITH OR WITHOUT ABRASIVES IN THE WATER, ABRASIVE BLASTING WITH CONTAINMENT, OR VACUUM ABRASIVE BLASTING.

**PROPOSED WORK:**

- CONVERT EXISTING ABUTMENTS TO SEMI-INTEGRAL.
- REPLACE EXISTING ABUTMENT BEARINGS WITH ELASTOMERIC BEARINGS.
- REPLACE EXISTING PARAPETS WITH NEW SINGLE SLOPE DEFLECTOR PARAPETS.
- PATCH CONCRETE SURFACES PER ITEM 519.
- EPOXY INJECT SUBSTRUCTURE CRACKS PER ITEM 512.
- SEAL SUPERSTRUCTURE AND ABUTMENTS WITH EPOXY-URETHANE.
- REPLACE EXISTING APPROACH SLABS.

**ITEM 530 - SPECIAL - FORM LINER**

**DESCRIPTION:**

THIS ITEM SHALL INCLUDE MATERIALS, LABOR, TOOLS EQUIPMENT AND INCIDENTALS NECESSARY TO INCORPORATE DECORATIVE FORM LINER TO THE EXTERIOR FACE OF THE AESTHETIC HAUNCH AT THE ABUTMENTS AS SHOWN ON STRUCTURES SHEET 15 / 34.

THE ADDITIONAL THICKNESS OF THE DECORATIVE FORM LINER SHALL BE ADDED TO THE EXTERIOR FACE OF THE CONCRETE SURFACE. THE INCORPORATION OF THIS FORM LINER SHALL NOT RESULT IN ANY REDUCTION TO THE PROPOSED THICKNESS OF THE AESTHETIC HAUNCH AT THE ABUTMENT.

**FORM LINER:**

ACCEPTABLE FORM LINER MANUFACTURERS INCLUDE CUSTOMROCK FORM LINER, WWW.CUSTOMROCK.COM PHONE: 1-800-637-2447 OR APPROVED EQUAL.

ACCEPTABLE FORM LINER PATTERNS INCLUDE PATTERN #210 FRACTURED RIB - 3/4" DEEP 1.5" OC OR APPROVED EQUAL.

**ABBREVIATIONS:**

- ABUT. - ABUTMENT
- APPR. - APPROACH
- BOT. - BOTTOM
- BRG. - BEARING
- BTA - BRIDGE TERMINAL ASSEMBLY
- CL - CENTERLINE
- C/C - CENTER-TO-CENTER
- CLR. - CLEAR
- C.J. - CONSTRUCTION JOINT
- CONST. - CONSTRUCTION
- DIA. - DIAMETER
- DND - DO NOT DISTURB
- EA. - EACH
- ELEV. - ELEVATION
- E.F. - EACH FACE
- EST. - ESTIMATED
- EQ. - EQUAL
- EX. - EXISTING
- EXP. - EXPANSION
- F.A. - FORWARD ABUTMENT
- F.S. - FAR SIDE
- INC. - INCREMENT
- MAX. - MAXIMUM
- MIN. - MINIMUM
- NO. - NUMBER
- N.S. - NEAR SIDE
- NPCPP - NON-PERFORATED CORRUGATED PLASTIC PIPE
- O/O - OUT-TO-OUT
- PCPP - PERFORATED CORRUGATED PLASTIC PIPE
- PEJF - PREFORMED EXPANSION JOINT FILLER
- P - PLATE
- PROP. - PROPOSED
- R.A. - REAR ABUTMENT
- R.F. - RIGHT FORWARD
- R/W - RIGHT OF WAY
- SER. - SERIES
- SPA. - SPACES
- STA. - STATION
- TBR - TO BE REMOVED
- T/ - TOE OF
- T/T - TOE-TO-TOE
- TYP. - TYPICAL
- W/ - WITH

**GENERAL NOTES**

BRIDGE NO. WAR-48-1154  
E. TURTLE CREEK-UNION RD. (TR-77) OVER SR-48

WAR-48-11.54  
PART 1  
PID No. 100816

4 / 34

62  
92

DESIGN AGENCY  
WOLPERT  
CORPORATION  
100 EASTON OVAL  
SUITE 400  
COLUMBUS, OH 43219  
TEL: 614-776-6000  
FAX: 614-776-6225

DATE  
6/2021  
REVIEWED  
MAA  
STRUCTURE FILE NUMBER  
8301174

DRAWN  
KLD  
REVISED  
DESIGNED  
JYM  
CHECKED  
PES

I:\ProjectData\WAR\100816\_WAR-48-11.54\ProjAdmin\PlanPackage\WAR-100816-CADDFiles\Design\Structures\048\_1154C\_Sheets\048\_1154C\_5000.dgn Sheet 2/18/2022 11:37:40 AM g.freeman

ESTIMATED QUANTITIES

CALC BY: JYM DATE: 2/24/2021  
 CHECK BY: PJP DATE: 6/27/2021

ITEM	EXT	01/S>2/BR	02/CMQ/OT	TOTAL	UNIT	DESCRIPTION	ABUT.	PIERS	SUPER.	GEN.	SHEET
202	11203	LS		LS		PORTIONS OF STRUCTURE REMOVED, OVER 20 FOOT SPAN, AS PER PLAN				LS	2/34
202	22900	134		134	SY	APPROACH SLAB REMOVED				134	
503	11100	LS		LS		COFFERDAMS AND EXCAVATION BRACING				LS	
503	21300	LS		LS		UNCLASSIFIED EXCAVATION				LS	
509	10000	119840	12154	131,994	LB	EPOXY COATED REINFORCING STEEL	13057		118937		
509	20001	100		100	LB	REINFORCING STEEL, REPLACEMENT OF EXISTING REINFORCING STEEL, AS PER PLAN				100	3/34
509	30020	4,393		4,393	FT	NO. 4 GFRP DEFORMED BARS			4,393		
510	10001	150		150	EACH	DOWEL HOLES WITH NONSHRINK, NONMETALLIC GROUT, AS PER PLAN	150				3/34
511	33501	2		2	EACH	SEMI-INTEGRAL DIAPHRAGM GUIDE, AS PER PLAN	2				3/34
511	45712	39		39	CY	CLASS QC1 CONCRETE WITH QC/QA, ABUTMENT	39				
511	53014	370		370	CY	CLASS QC3 CONCRETE, MISC.: SUPERSTRUCTURE CONCRETE WITH QC/QA, AS PER PLAN			370		3/34
511	53014	93		93	CY	CLASS QC3 CONCRETE, MISC.: PARAPET CONCRETE WITH QC/QA, AS PER PLAN			77	16	3/34
511	53014		114	114	CY	CLASS QC3 CONCRETE, MISC.: SIDEWALK CONCRETE WITH QC/QA, AS PER PLAN			94	20	3/34
512	10050		530	530	SY	SEALING OF CONCRETE SURFACES (NON-EPOXY)			437	93	
512	10100	1,053		1,053	SY	SEALING OF CONCRETE SURFACES (EPOXY-URETHANE)	121	151	609		
512	10600	121		121	FT	CONCRETE REPAIR BY EPOXY INJECTION	101	20			
512	33000	13		13	SY	TYPE 2 WATERPROOFING	13				
512	74000	151		151	SY	REMOVAL OF EXISTING COATINGS FROM CONCRETE SURFACES	6	145			
513	10201	3,276		3,276	LB	STRUCTURAL STEEL MEMBERS, LEVEL UF, AS PER PLAN		3,276			20/34
513	20000	2,628		2,628	EACH	WELDED STUD SHEAR CONNECTORS			2,628		
513	95000	1		1	FT	STRUCTURAL STEEL MISC.: REPAIR OF DAMAGED MAIN MEMBER, COMPLETE PENETRATION WELDING			1		3/34
514	00050	2,805		2,805	SF	SURFACE PREPARATION OF EXISTING STRUCTURAL STEEL			2,805		3/34
514	00056	2,805		2,805	SF	FIELD PAINTING OF EXISTING STRUCTURAL STEEL, PRIME COAT			2,805		3/34
514	00060	2,868		2,868	SF	FIELD PAINTING OF STRUCTURAL STEEL, INTERMEDIATE COAT			2,868		
514	00066	2,868		2,868	SF	FIELD PAINTING OF STRUCTURAL STEEL, FINISH COAT			2,868		
514	00504	8		8	MAN HR	GRINDING FINIS, TEARS, SLIVERS ON EXISTING STRUCTURAL STEEL			8		
514	10000	3		3	EACH	FINAL INSPECTION REPAIR			3		
514	21001	LS		LS		FIELD PAINTING OF EXISTING DAMAGED STRUCTURAL STEEL, AS PER PLAN			LS		3/34
516	10000	107		107	FT	PREFORMED ELASTOMERIC COMPRESSION JOINT SEAL	107				
516	13600	18		18	SF	1" PREFORMED EXPANSION JOINT FILLER			18		
516	13900	158		158	SF	2" PREFORMED EXPANSION JOINT FILLER	158				
516	14020	107		107	FT	SEMI-INTEGRAL ABUTMENT EXPANSION JOINT SEAL	107				
516	44401	12		12	EACH	ELASTOMERIC BEARING WITH INTERNAL LAMINATES AND LOAD PLATE (NEOPRENE), AS PER PLAN (11.5"x16"x3.75" PAD WITH 12.5"x17"x1.25" PLATE)	12				19/34
516	44401	18		18	EACH	ELASTOMERIC BEARING WITH INTERNAL LAMINATES AND LOAD PLATE (NEOPRENE), AS PER PLAN (12"x19"x3.75" PAD WITH 13"x20"x1.25" PLATE)		18			20/34
516	47001	LS		LS		JACKING AND TEMPORARY SUPPORT OF SUPERSTRUCTURE, AS PER PLAN				LS	4/34
518	21200	110		110	CY	POROUS BACKFILL WITH GEOTEXTILE FABRIC	110				
518	40000	172		172	FT	6" PERFORATED CORRUGATED PLASTIC PIPE	172				
518	40010	65		65	FT	6" NON-PERFORATED CORRUGATED PLASTIC PIPE, INCLUDING SPECIALS	65				
519	11101	22		22	SF	PATCHING CONCRETE STRUCTURE, AS PER PLAN	14	8			4/34
526	25011	256		256	SY	REINFORCED CONCRETE APPROACH SLABS WITH QC/QA (T=15"), AS PER PLAN				256	3/34
526	90010	107		107	FT	TYPE A INSTALLATION				107	
SPECIAL	53000600	94		94	SF	STRUCTURES - FORM LINER	94				4/34
601	20000	412		412	SY	CRUSHED AGGREGATE SLOPE PROTECTION				412	
607	39910	242		242	FT	VANDAL PROTECTION FENCE, 8' STRAIGHT, COATED FABRIC			242		
607	39930	285		285	FT	VANDAL PROTECTION FENCE, 12' CURVED, COATED FABRIC			285		
846	00110	45		45	CF	POLYMER MODIFIED ASPHALT EXPANSION JOINT SYSTEM				45	
849	10000	LS		LS		DAMAGE ASSESSMENT			LS		
849	10500	LS		LS		SURFACE PREPARATION			LS		
849	10600	27		27	HOURL	REPAIRING DAMAGED MEMBERS BY GRINDING			27		
849	10700	LS		LS		STRAIGHTENING DAMAGED MEMBERS			LS		

DESIGN AGENCY: EASTON OVAL SUITE #100 COLUMBUS, OH 43219 T 614-776-8000 F 614-776-8225  
**WOOLPERT**  
 DATE: 6/2021  
 REVIEWED: MAA  
 DRAWN: JYM  
 CHECKED: JYM  
 DESIGNED: JYM  
 STRUCTURE FILE NUMBER: 8301174  
 ESTIMATED QUANTITIES  
 BRIDGE NO. WAR-48-1154  
 E. TURTLE CREEK-UNION RD. (TR-77) OVER SR-48  
 WAR-48-11.54  
 PART I  
 PID No. 100816  
 5/34  
 63  
 92

I:\ProjectData\WAR-48-11.54\ProjAdmin\PlanPackage\WAR-100816-CADDFiles\Design\Structures\00816-WAR048-1154C-Sheets\048-1154C-SR003.dgn Sheet 2/18/2022 11:17:10 AM gFreeman

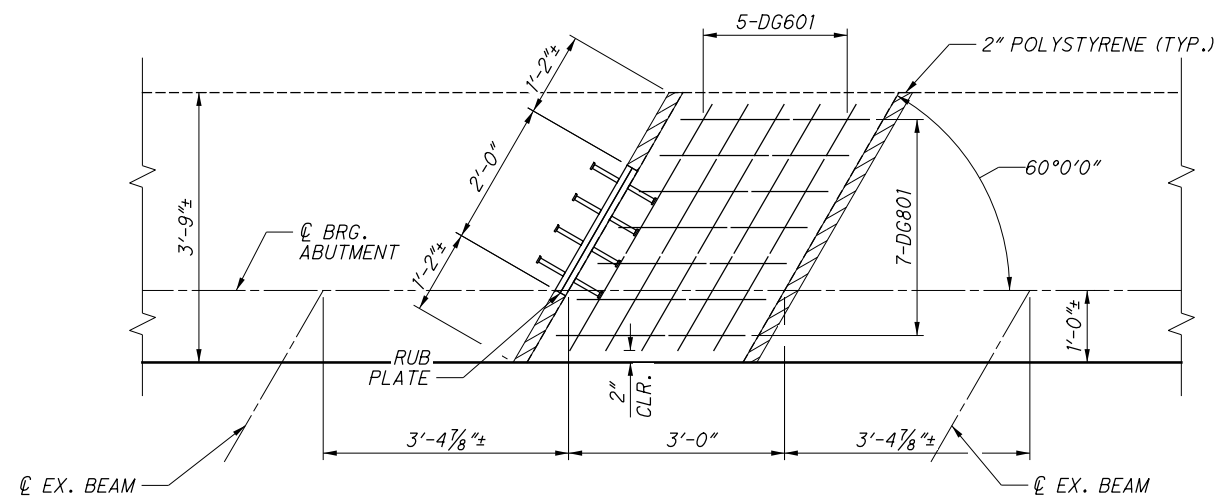

**DIAPHRAGM GUIDE PLAN**

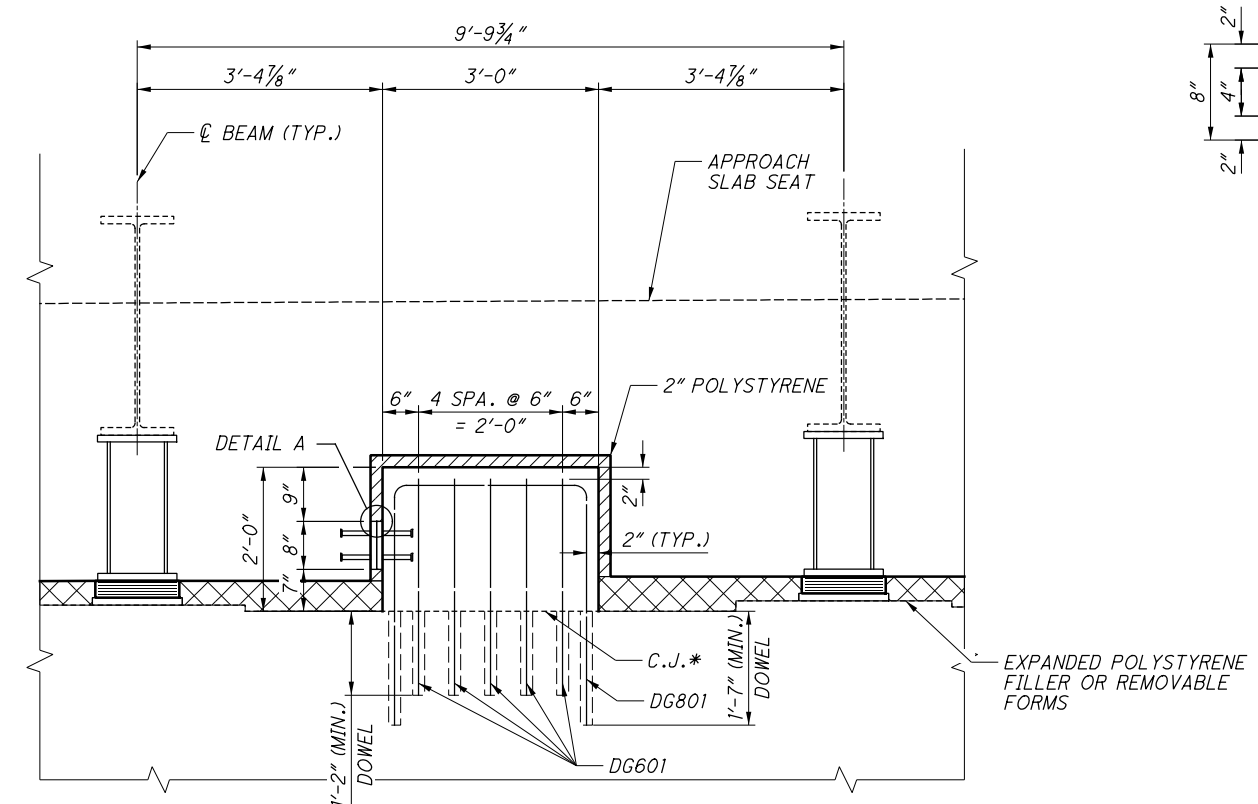

**DIAPHRAGM GUIDE ELEVATION**

(PLACE DG601 AND DG801 DOWELS TO AVOID INTERFERENCE WITH EXISTING BEAM SEAT REINFORCEMENT)

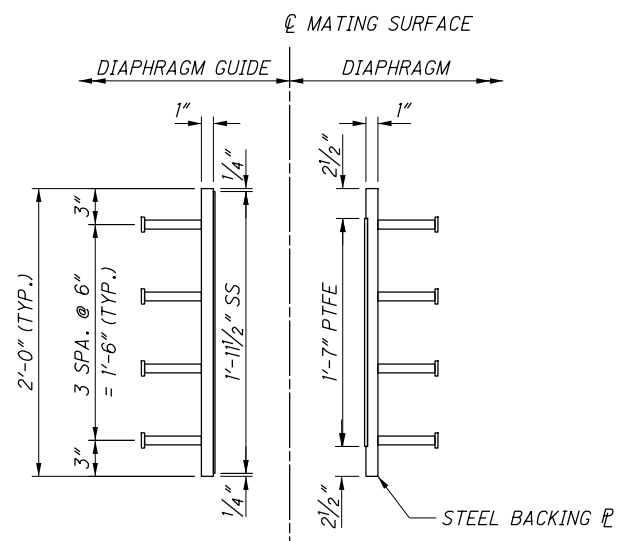

**TOP VIEW**

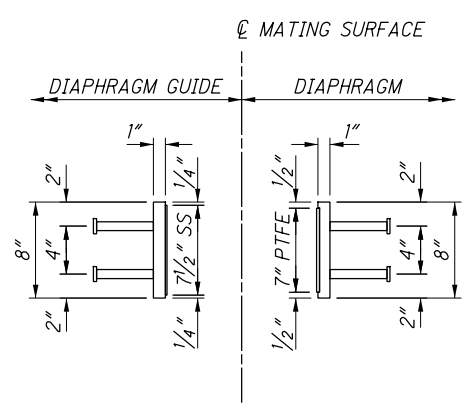

**END VIEW**

**RUB PLATE DETAILS**

SS = STAINLESS STEEL  
PTFE = POLYTETRAFLUORETHYLENE

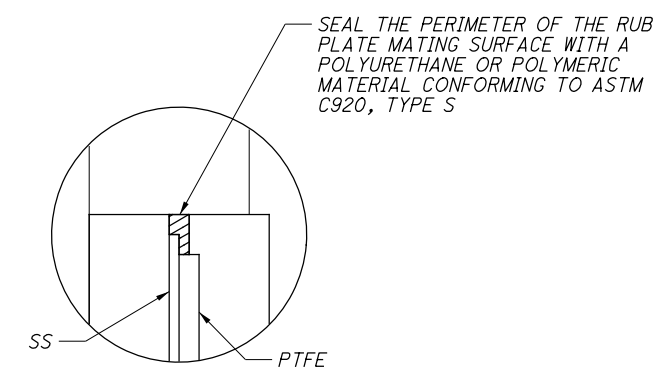

**DETAIL A**

**LEGEND:**

- \* THOROUGHLY ROUGHEN THE EXISTING SURFACE PER C&MS 511.09.B
- DOWEL ROD

**NOTES:**

- SEE SHEET 10/34 FOR REAR ABUTMENT PLAN AND ELEVATION.
- SEE SHEET 11/34 FOR FORWARD ABUTMENT PLAN AND ELEVATION.
- SEE SCD SICD-2-14 FOR ADDITIONAL DIAPHRAGM GUIDE DETAILS.

<b>WAR-48-11.54</b> <b>PART 1</b> PID No. 100816	<b>DIAPHRAGM GUIDE DETAILS</b> BRIDGE NO. WAR-48-1154 E. TURTLE CREEK-UNION RD. (TR-77) OVER SR-48	DESIGNED JYM	CHECKED PES	DRAWN JYM	REVISED MAA	REVIEWED MAA	DATE 6/2021	DESIGN AGENCY <b>WOOLPERT</b> EASTON OVAL SUITE 400 COLUMBUS, OH 43219 T 614-476-8000 F 614-476-8225
		STRUCTURE FILE NUMBER 8301174						

I:\ProjectData\WAR\100816\_WAR-48-11.54\ProjAdmin\PlanPackage\WAR-100816-CADDFiles\Design\Structures\00816\_WAR048\_1154C\_Sheets\048\_1154C\_MD001.dgn Sheet 2/18/2022 10:57:44 AM gfreeman

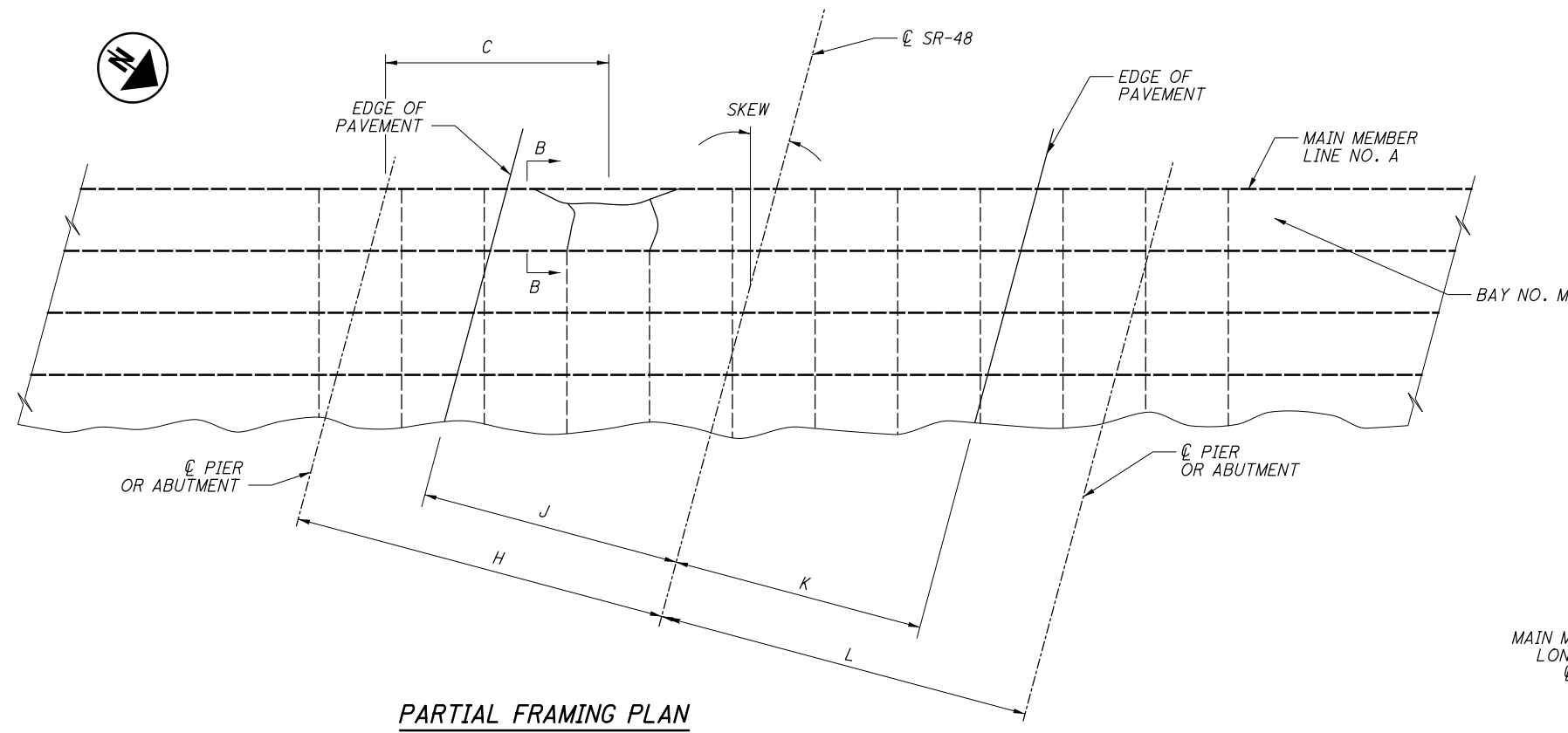

**PARTIAL FRAMING PLAN**

**NOTES:**

- SEE FRAMING PLAN ON SHEET 16/34 FOR SUBSTRUCTURE AND BEAM NUMBERING.
  - REMOVE CROSSFRAME MEMBERS FROM GIRDER WEB AS NECESSARY TO FACILITATE THE HEAT STRAIGHTENING OF THE PRIMARY MEMBER.  
FLAME OR SAW CUT THE EXISTING MEMBERS TO WITHIN 1/8 INCH OF THE EXISTING MAIN MATERIAL USING A MECHANICAL GUIDE ACCORDING TO C&MS 513.12 PROVIDE SHIELDING AS NECESSARY TO PREVENT DAMAGE TO MAIN OR SECONDARY MATERIALS THAT REMAIN. GRIND THE EXISTING MAIN OR SECONDARY MEMBER SMOOTH IN PREPARATION FOR COMPLETE PENETRATION OR FILLET WELDING. PROVIDE A SURFACE FINISH ACCORDING TO ANSI B46.1 OF 250 MIL (TO ACCOMMODATE THE PROPOSED REPLACEMENT MATERIALS)
- PAYMENT FOR THE WORK DESCRIBED ABOVE IS TO BE PAID UNDER THE LUMP SUM BID ITEM Item 202 - PORTIONS OF STRUCTURE REMOVED, OVER 20 FOOT SPAN, AS PER PLAN

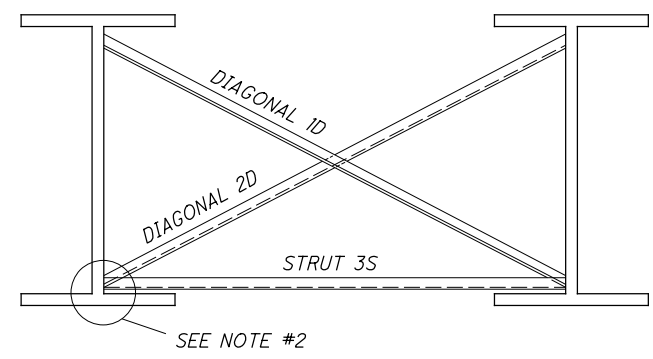

MAIN AND SECONDARY MEMBER DAMAGE IS NOT SHOWN. FOR CLARITY SEE SECTION A-A.  
**SECTION B-B**  
SECONDARY MEMBER BAY NO. M

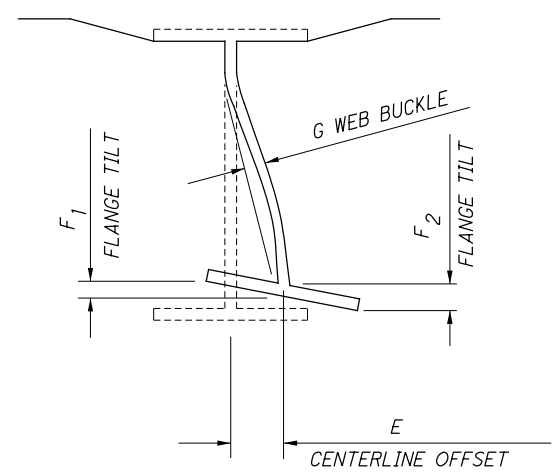

**SECTION A-A**  
NEGATIVE E VALUES ARE BENT LEFT  
NEGATIVE F VALUES ARE BENT DOWN  
NEGATIVE G VALUES ARE BENT LEFT

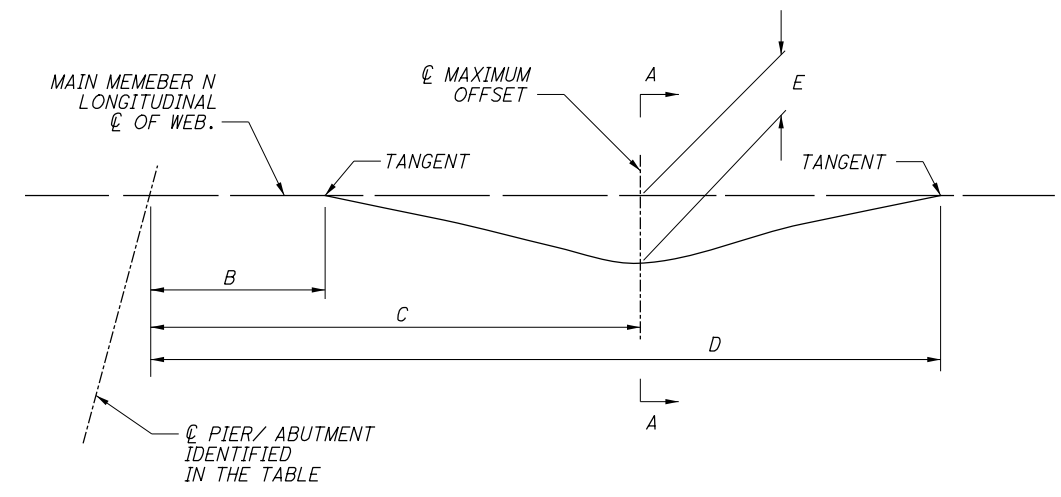

TABLE #1 DAMAGED MAIN MEMBERS TO BE HEAT STRAIGHTENED

DAMAGE AREA NO.	MEMBER LINE NO. A	PIER OR ABUT.	B	C	D	E	F1	F2	G
1	1	PIER 1	15'-8"		21'-6"		-3/8"	+1 15/16"	5/16"
2	2	PIER 1	19'-0"		20'-8"		-	+1/2"	
3	3	PIER 1	19'-1"		20'-11"		-	+1 1/4"	
4	5	PIER 1	18'-0"		21'-4"		+1 3/16	-1/8"	

DESIGN AGENCY: EASTON OVAL SUITE 400 COLUMBUS, OH 43219 T 614-76-8000 F 614-76-8225  
**WOOLPERT**  
DESIGN ENGINEERING INCORPORATED

DATE: 6/2021  
REVIEWED: MAA  
DRAWN: KLD  
CHECKED: PPS  
DESIGNED: KLD  
STRUCTURE FILE NUMBER: 8301174

**WAR-48-11.54 PART 1 PID No. 100816**

**COLLISION REPAIR AND HEAT STRAIGHTENING DETAILS**  
BRIDGE NO. WAR-48-1154  
E. TURTLE CREEK-UNION RD. (TR-77) OVER SR-48

17 / 34  
75  
92