

STATE OF OHIO
DEPARTMENT OF HIGHWAYS AND PUBLIC WORKS
DIVISION OF HIGHWAYS
BUREAU OF CONSTRUCTION

FED. AID DIST. NO.	STATE	FED. AID PROJECT	FISCAL YEAR
10	OHIO	498-A	1926-27

ICH.20 SECSG, H-2
LUCAS COUNTY.

TOLEDO-WAUSEON ROAD

I.C.H. NO. 20 SEC. G & H-2 PET. NO. 5404

LUCAS COUNTY

SWANTON, MONCLOVA AND SPRINGFIELD TWPS.

MAY
1926

Recd June 26/26

INDEX

Title Page	p. 1
Typical Cross Section	p. 2-(3) Inc.
Plans and Profile	p. 4-13 Inc.
Cross Sections	p. 14-23 Inc.
Structural Plans	p. 24-28 Inc.
Summary Sheet	p. 29-30 Inc.

CONVENTIONAL SIGNS

State Line	-----
County line	-----
Township line	-----
Section line	-----
Property line not fenced	-----
Center line	-----
City or Village line	-----
Fence	-----
Telephone or Telegraph	TTTTTTTT
Steam railroad	-----
Electric line	-----
Guard rail	-----
Drain pipe - new	-----
Drain pipe - old	-----

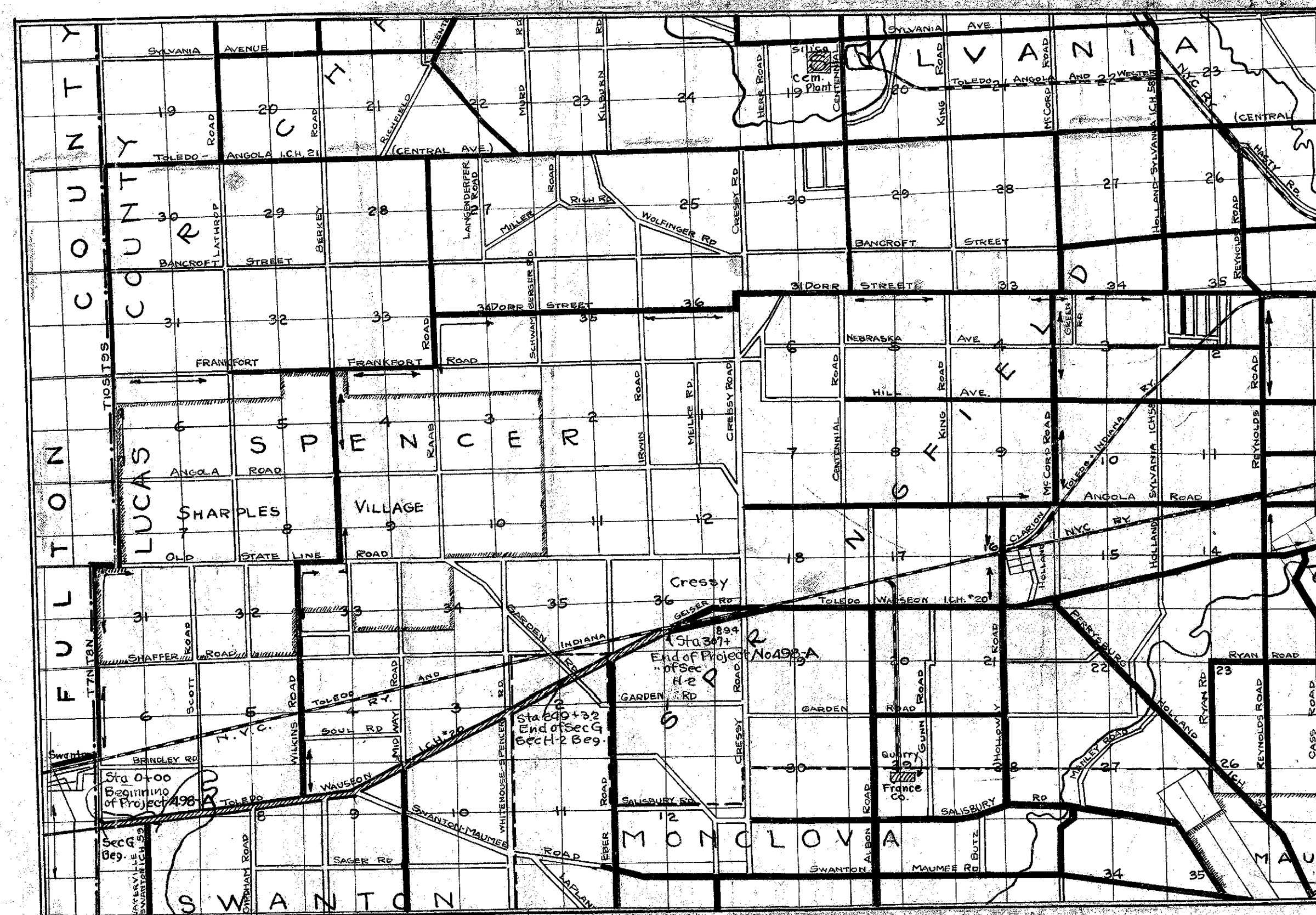
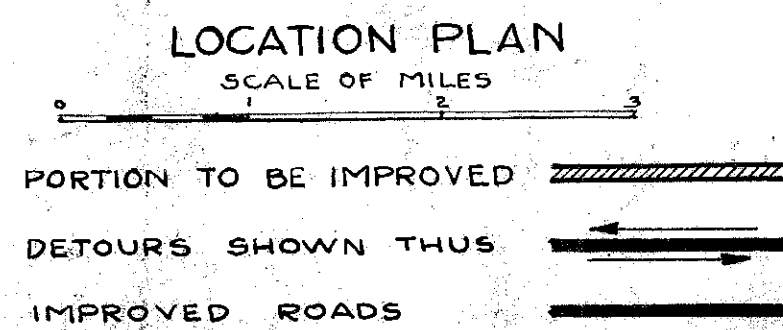

The Standard Specifications of the State of Ohio, Division of Highways in force on date of contract will govern this improvement.

I hereby approve these plans and declare that the making of this improvement will require the closing to traffic of the highway and that detours will be provided as shown on the plan and estimates.

We the Commissioners of Lucas County hereby approve these plans and certify that the right-of-way 60 feet wide is available for the construction, maintenance and repair of the above highway.

Ray E. Davis

R.E. Farnsworth

Date 6-28-1926 County Commissioners

Approved: *C. L. Sawyer*
Date, June 9, 1926 Resident Engineer

Approved: *M. J. Hynaban*
Date, 6-15-26. Resident Deputy
State Highway Commissioner

Approved: *Harry J. Kirk*
Date, 6-25-26 State Highway Engineer

Approved: *J. F. Schlessinger*
Date, 6-25-26 Director of Highways and
Public Works

Recommended for Approval: _____
Date, District Engineer
Bureau of Public Roads

Recommended for Approval: _____
Date, Chief Engineer
Bureau of Public Roads

Approved: _____
Date, Chief of Bureau

SCALES
Plans 1" = 50'
Profile (Vertical) 1" = 10'
Profile (Horizontal) 1" = 50'
Cross Sections 1" = 5'

CONSTRUCTION BUREAU
JUN 28 1926
GROUND PHOTOLAB

30 LUCAS 20 G+H-2
1926

FED RD DIST NO	STATE	FED AID PROJECT	FISCAL YEAR
10	OHIO	498-A	1926-27

I.C.H20 SECSG, H-2
LUCAS COUNTY.

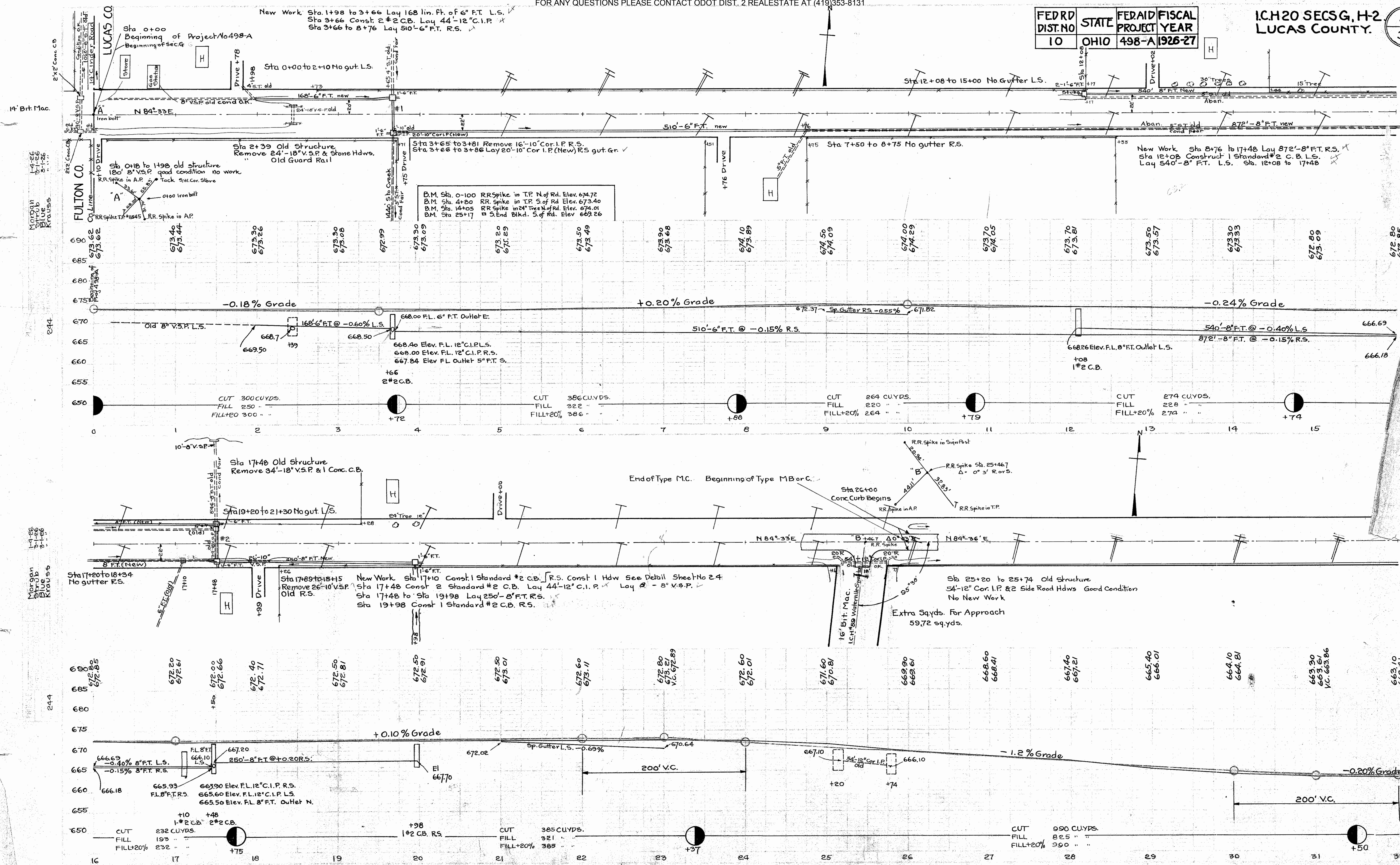

New Work Sta. 1+98 to 3+66 Lay 168 lin. Ft. of 6" FT. L.S.
 Sta 3+66 Const. 2 #2 C.B. Lay 44'-12" C.I.P.
 Sta 3+66 to 8+76 Lay 510'-6" FT. R.S.

Sta 0+00 Beginning of Project No 498-A
 Beginning of Sec. G

Sta 0+00 to 2+10 No gut L.S.

Sta 12+08 to 15+00 No Gutter L.S.

N 84°-33'E

Sta 2+39 Old Structure Remove 24'-18" V.S.P. & Stone Hdws. Old Guard Rail

Sta 3+65 to 3+81 Remove 16'-10" Cor. I.P. R.S.
 Sta 3+66 to 3+86 Lay 20'-10" Cor. I.P. (New) R.S. gut Gr.

Sta 7+50 to 8+75 No gutter R.S.

New Work Sta 8+76 to 17+48 Lay 872'-8" FT. R.S.
 Sta 12+08 Construct 1 Standard #2 C.B. L.S.
 Lay 540'-8" FT. L.S. Sta. 12+08 to 17+48

D.M. Sta. 0+100 RR Spike in T.P. N of Rd. Elev. 674.72
 D.M. Sta. 4+80 RR Spike in T.P. S of Rd. Elev. 673.40
 D.M. Sta. 14+05 RR Spike in 24" Tree N of Rd. Elev. 674.01
 D.M. Sta. 25+17 End Blvd. S. of Rd. Elev. 669.26

Sta 0+18 to 1+98 old structure 180' 8" V.S.P. good condition no work. RR spike in A.P. Tack SW. Cor. Stone

RR Spike in A.P. RR Spike in A.P.

-0.18% Grade

+0.20% Grade

-0.24% Grade

Old 8" V.S.P. L.S.

168'-6" FT. @ -0.60% L.S.

510'-6" FT. @ -0.15% R.S.

540'-8" FT. @ -0.40% L.S.

872'-8" FT. @ -0.15% R.S.

CUT 300 CUYDS.
 FILL 250 "

CUT 386 CUYDS.
 FILL 322 "

CUT 264 CUYDS.
 FILL 220 "

CUT 274 CUYDS.
 FILL 228 "

Sta 17+48 Old Structure Remove 34'-18" V.S.P. & 1 Conc. C.B.

Sta 19+20 to 21+30 No gut L.S.

End of Type M.C. Beginning of Type M Bar C.

Sta 26+00 Conc Curb Begins

RR Spike in Sign Post
 RR Spike Sta. 25+46.7
 RR Spike in T.P.

Sta 25+20 to 25+74 Old Structure 54'-12" Cor. I.P. & 2 Side Road Hdws. Good Condition No New Work

Extra Sqyds. For Approach 59.72 sqyds.

Sta 17+89 to 18+15 Remove 26'-10" V.S.P. Old R.S.

New Work Sta 17+10 Const. 1 Standard #2 C.B. R.S. Const. 1 Hdw See Detail Sheet No 24
 Sta 17+48 Const. 2 Standard #2 C.B. Lay 44'-12" C.I.P. Lay 8" V.S.P.
 Sta 17+48 to Sta 19+98 Lay 250'-8" FT. R.S.
 Sta 19+98 Const. 1 Standard #2 C.B. R.S.

+0.10% Grade

+0.20% Grade

-1.2% Grade

250'-8" FT. @ +0.20% R.S.

Sp. Gutter L.S. -0.69%

54'-13" Cor. I.P.

-0.20% Grade

665.93 Elev. FL. 8" FT. R.S.
 665.60 Elev. FL. 12" C.I.P. L.S.
 665.50 Elev. FL. 8" FT. Outlet N.

CUT 365 CUYDS.
 FILL 321 "

CUT 990 CUYDS.
 FILL 825 "

FED. RD DIST. NO	STATE	FED. AID PROJECT	FISCAL YEAR
10	OHIO	498-A	1926-27

Sta 36+06 New Work
Const. 2 Standard #2 C.B.
Lay 50'-12" C.I.P.

Old Structure 36+06
Remove 40'-12" V.S.P.
1-Brick C.B.

New Work Sta. 36+06 to 37+74 Lay 168'-8" V.S.P. L.S.
Sta. 36+06 to 37+74 Lay 168'-8" V.S.P. R.S.
Sta. 37+74 Construct 2 Standard #1 C.B.
Sta. 37+74 to 49+80 Lay 1206'-8" F.T. L.S.
Sta. 37+74 to 46+74 Lay 900'-8" F.T. R.S.

New Work Sta 41+20 Construct 2 Standard #1 C.B.
Sta 45+50 Const. 1 Standard #1 C.B. L.S.
Sta 46+74 to 56+50 Lay 976'-6" F.T. R.S.
Sta 46+74 Const. 1 Standard #1 C.B. R.S.

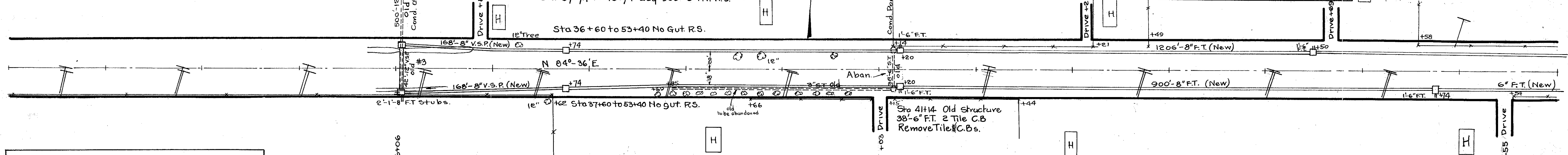

BM. Sta. 36+50 RR Spike in T.P. S. of Rd. Elev. 667.11
BM. Sta. 45+40 RR Spike in 36' Tree N. of Rd. Elev. 671.84
BM. Sta. 53+99 RR Spike in 18' Tree N. of Rd. Elev. 671.10
BM. Sta. 58+91 in Center N. Rail Bridge 394 Elev. 663.04
BM. Sta. 61+60 RR Spike in T.P. S. of Rd. Elev. 664.18

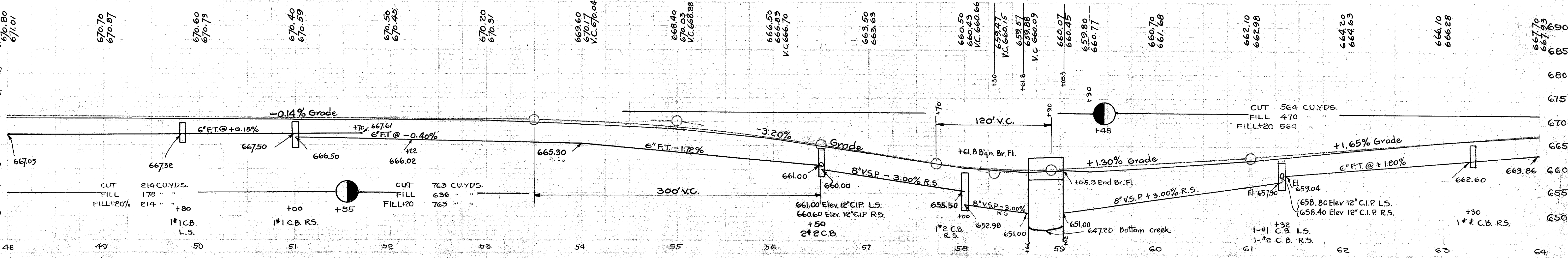
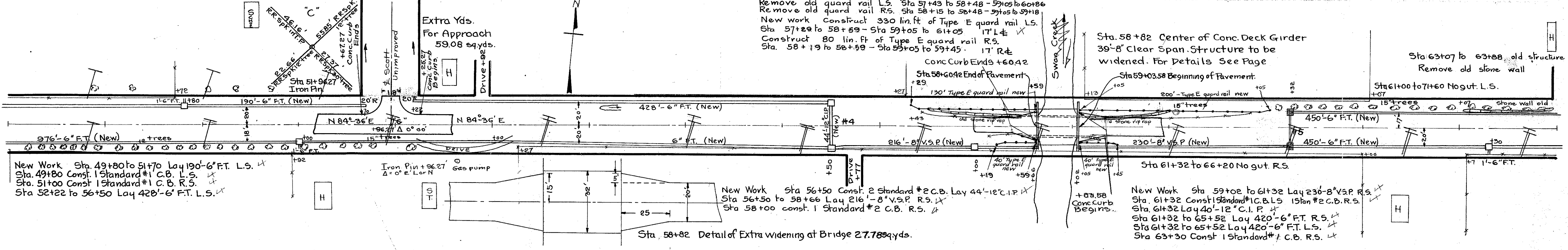
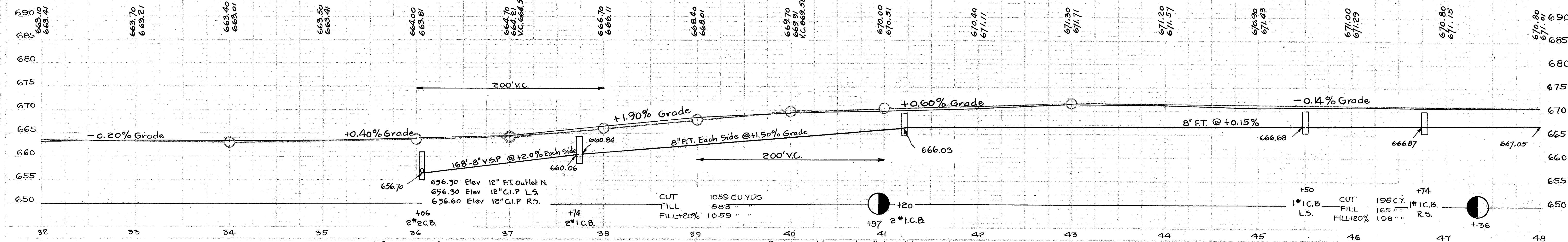

Morgan
Krauss

Morgan
Krauss

FED. RD. DIST. NO.	STATE	FED. AID PROJECT	FISCAL YEAR
10	OHIO	498-A	1926-27

I.C.H. 20 SECS. G, H-2
LUCAS COUNTY

6
30

New Work Sta 68+00 to 71+96 Lay 396'-6" FT. L.S.
Sta 71+64 Const. 1 Stan. #2 C.B. R.S.
Sta 71+64 to 71+96 Lay 44'-12" V.S.P. R.S.
Sta 71+96 Const 2 Stan. #2 C.B. Mod. 4x4
Sta 71+96 Lay 44'-30" C.I.P. (New)
Sta 71+96 to 72+06 Lay 10'-10" FT. (New) L.S.
Sta 71+96 to 73+12 Lay 116'-24" V.S.P. (New) R.S.
Sta 73+12 Const. 1 Stan. #2 C.B. Mod. R.S.
3x3 inside Dim.

New Work

Sta 73+70 Const. 1 Stan. #2 C.B. L.S.
Sta 73+70 to 81+08 Lay 738'-8" FT. (New) L.S.
Sta 78+68 to 81+08 Lay 240'-6" FT. (New) R.S.

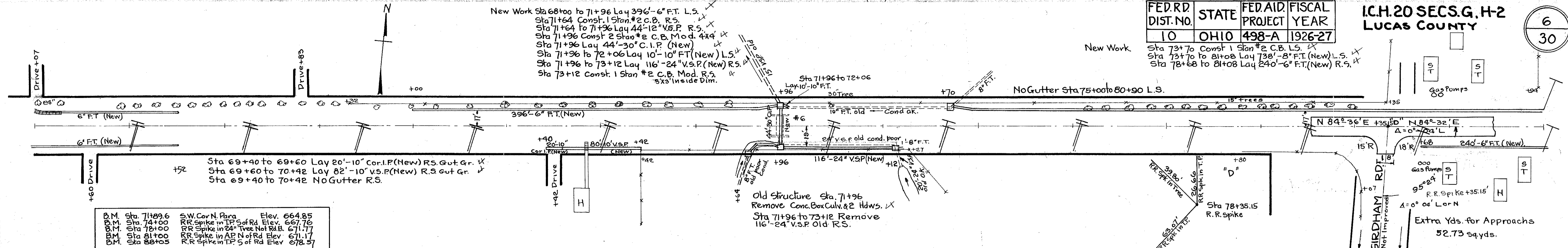

B.M. Sta. 71+89.6	S.W. Cor N. Para	Elev. 664.85
B.M. Sta. 74+00	RR Spike in T.P. S of Rd	Elev. 667.76
B.M. Sta. 78+00	RR Spike in 24" Tree Not Rd. El.	671.17
B.M. Sta. 81+00	RR Spike in A.P. N of Rd	Elev. 671.17
B.M. Sta. 88+05	RR Spike in T.P. S of Rd	Elev. 678.37

Morgan
Stub
Blue
Krauss

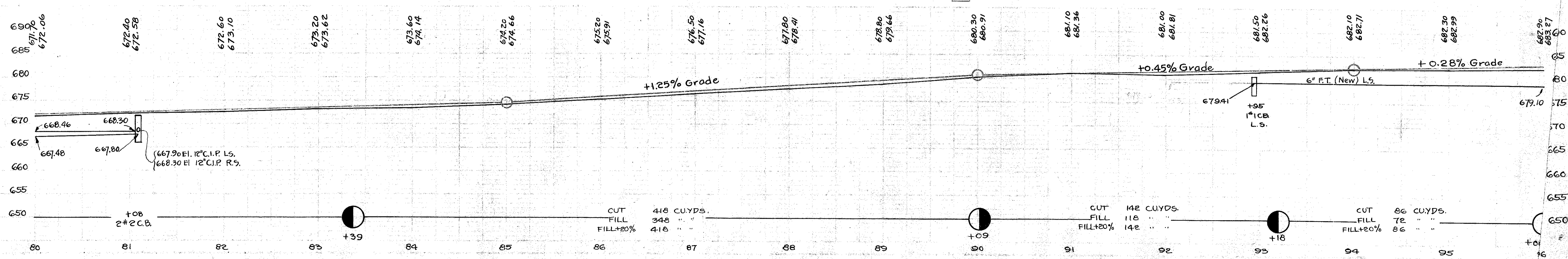
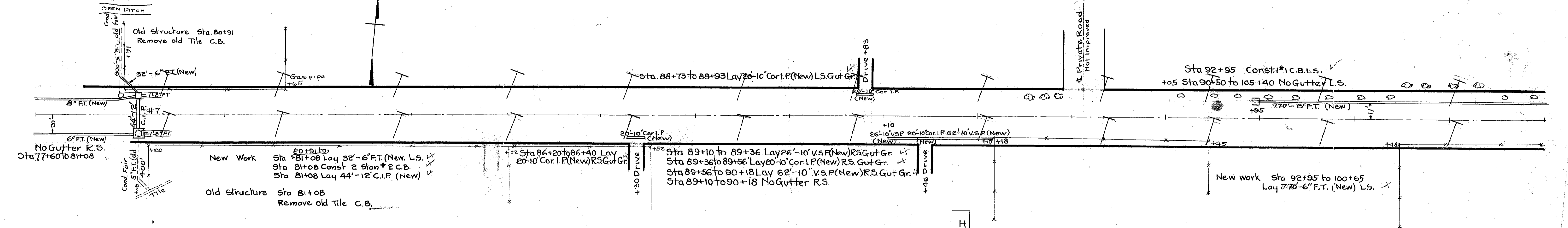
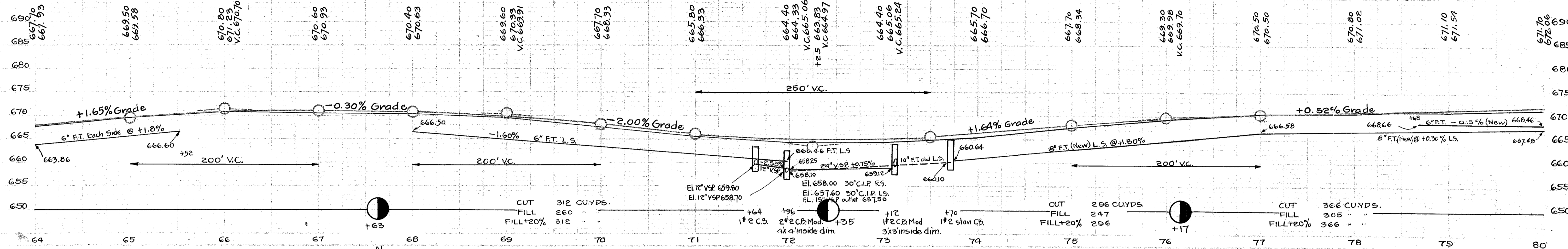

Morgan
Stub
Blue
Krauss

FED. RD. DIST. NO.	STATE	FED. AID PROJECT	FISCAL YEAR
10	OHIO	498-A	1926-27

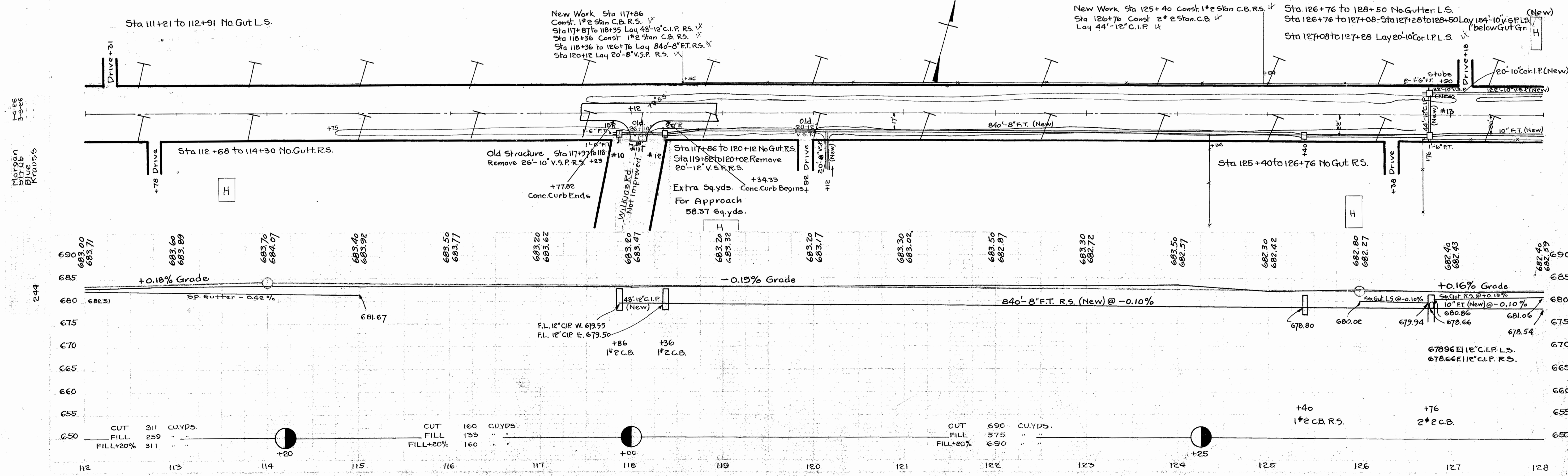
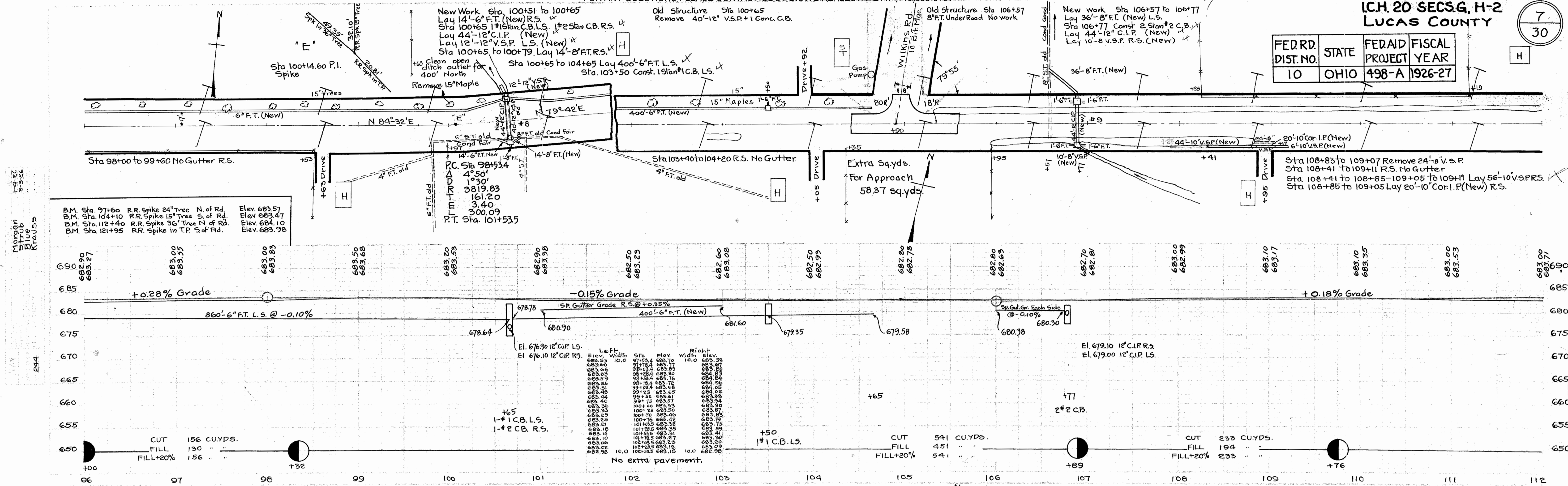

FED. RD. DIST. NO.	STATE	FED. AID PROJECT	FISCAL YEAR
10	OHIO	498-A	1926-27

New Work Sta 170+35 Const #2 Stan C.B. L.S. X
Sta 170+49 Const 19" x 2 C.B. R.S. X
Sta 170+35 to 170+49 Lay 46'-12" C.I.P. X
Sta 170+49 to 185+37 Lay 1488'-8" R.S. X

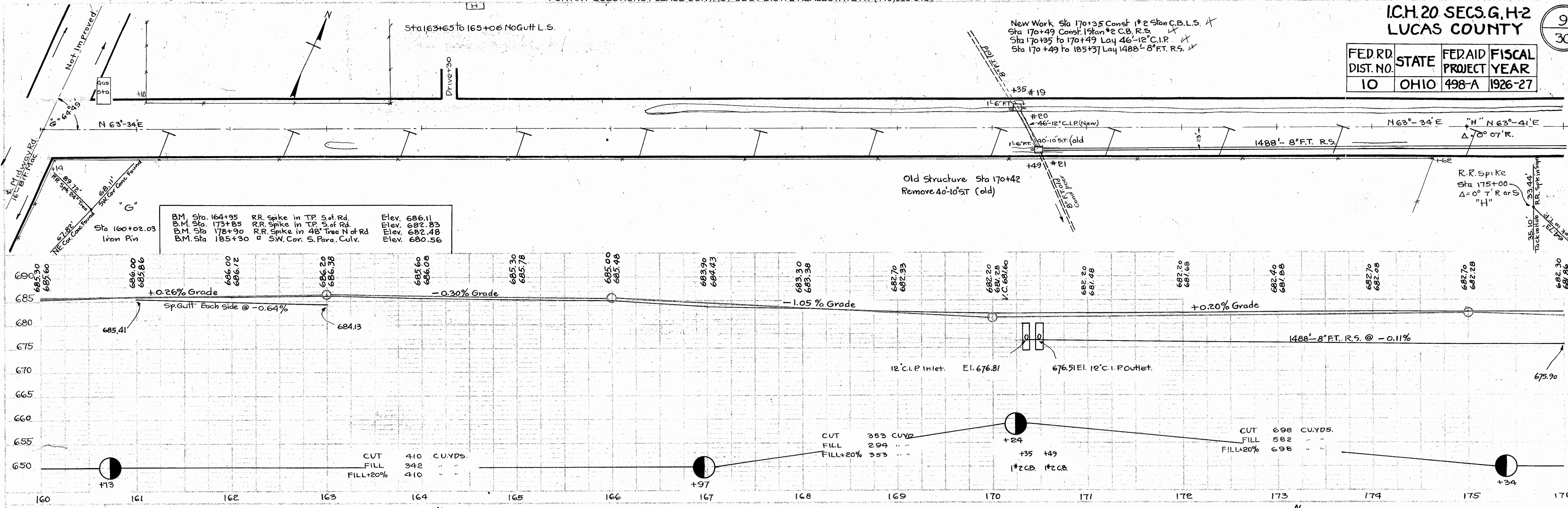

B.M. Sta. 164+95 Elev. 686.11
B.M. Sta. 173+85 Elev. 682.83
B.M. Sta. 178+90 Elev. 682.48
B.M. Sta. 185+30 Elev. 680.56

RR Spike in TP S of Rd. Elev. 686.11
RR Spike in TP S of Rd. Elev. 682.83
RR Spike in 48" Tree N of Rd. Elev. 682.48
SW. Cor. S. Para. Culv. Elev. 680.56

CUT	410	CUYDS.	
FILL	342	"	
FILL+20%	410	"	

CUT	353	CUYDS.	
FILL	294	"	
FILL+20%	353	"	

CUT	698	CUYDS.	
FILL	582	"	
FILL+20%	698	"	

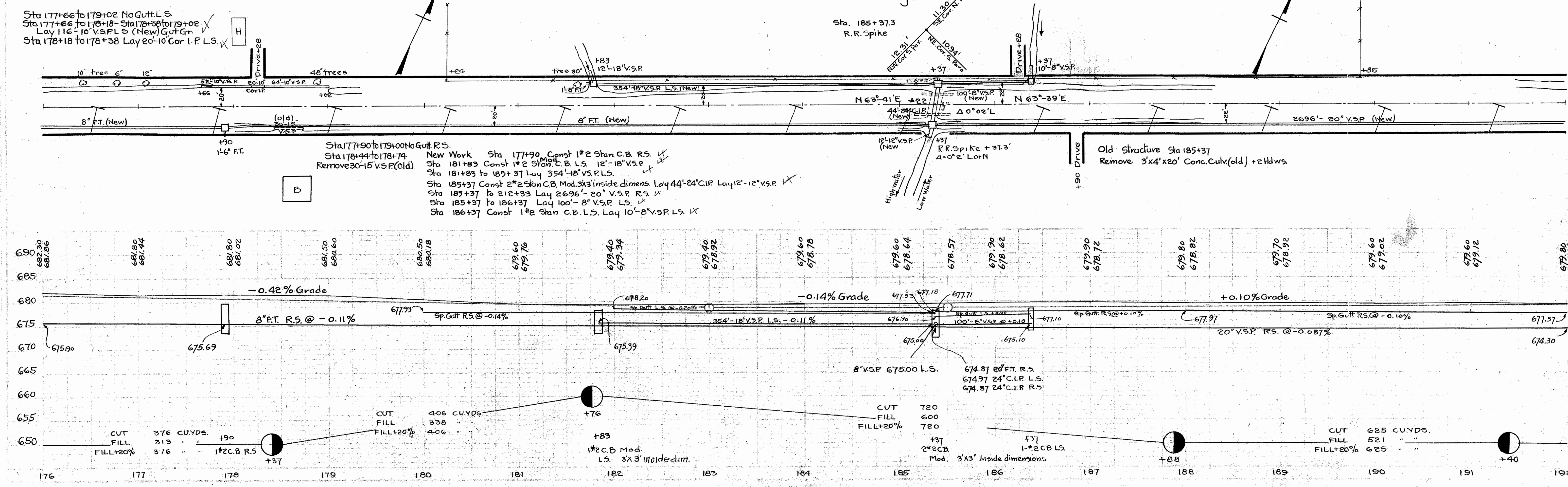

New Work Sta 177+90 Const #2 Stan C.B. R.S. X
Sta 181+83 Const #2 Stan C.B. L.S. 12'-18" V.S.P. X
Sta 181+83 to 185+37 Lay 354'-18" V.S.P. L.S. X
Sta 185+37 Const #2 Stan C.B. Mod. 3'x3' inside dimens. Lay 44'-24" C.I.P. Lay 12'-12" V.S.P. X
Sta 185+37 to 212+33 Lay 2696'-20" V.S.P. R.S. X
Sta 185+37 to 186+37 Lay 100'-8" V.S.P. L.S. X
Sta 186+37 Const #2 Stan C.B. L.S. Lay 10'-8" V.S.P. L.S. X

CUT	406	CUYDS.	
FILL	338	"	
FILL+20%	406	"	

CUT	720	CUYDS.	
FILL	600	"	
FILL+20%	720	"	

CUT	625	CUYDS.	
FILL	521	"	
FILL+20%	625	"	

IC.H.20 SECS.G.H-2
LUCAS COUNTY

10
30

FED. RD. DIST. NO.	STATE	FED. AID PROJECT	FISCAL YEAR
10	OHIO	498-A	1928-27

Sta 205+00 to 206+00 No Gutt. L.S.

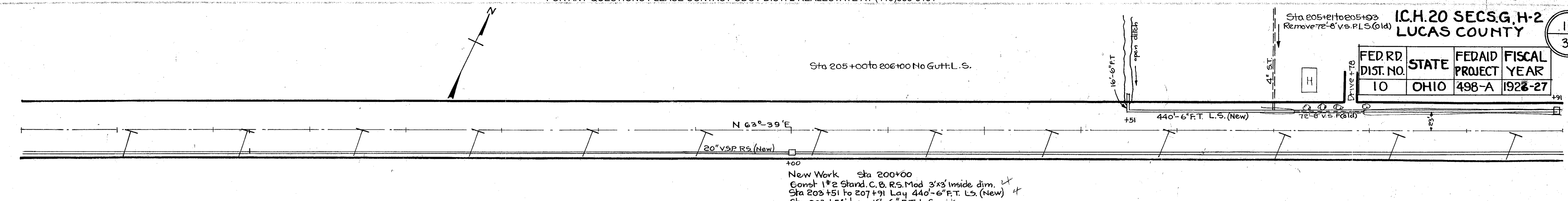

New Work Sta 200+00
Const 1# 2 Stan. C.B. R.S. Mod 3'x3' inside dim. ✓
Sta 203+51 to 207+91 Lay 440'-6" F.T. L.S. (New) ✓
Sta 203+51 Lay 16'-6" F.T. L.S. ✓
Sta 207+91 Const 1# 1 Stan. C.B. L.S. ✓
Sta 207+91 to 212+45 Lay 454'-8" F.T. L.S. (New) ✓

B.M. Sta. 194+00 R.R. Spike in T.P. S of Rd. Elev. 680.12
B.M. Sta. 205+30 R.R. Spike in 10' Tree N of Rd. Elev. 680.59
B.M. Sta. 216+ in Center of Conc. Hdwy S of Rd. Elev. 679.27

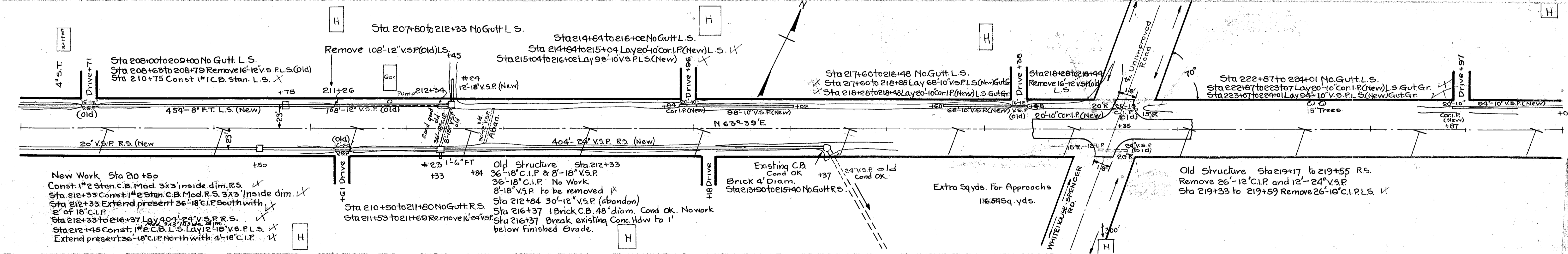
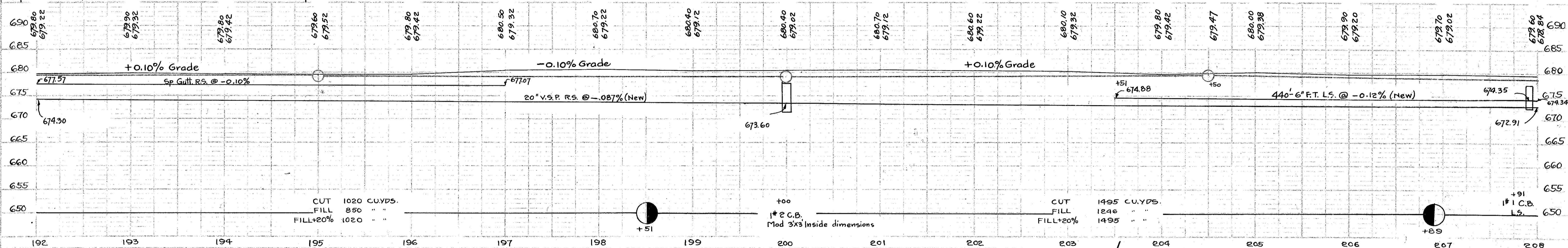

New Work Sta 210+50
Const 1# 2 Stan. C.B. Mod 3'x3' inside dim. R.S. ✓
Sta 212+33 Const 1# 2 Stan. C.B. Mod. R.S. 3'x3' Inside dim. ✓
Sta 212+33 Extend present 36'-18" C.I.P. South with 2' of 18" C.I.P. ✓
Sta 212+33 to 216+37 Lay 404'-24" V.S.P. R.S. ✓
Sta 212+45 Const 1# 2 C.B. L.S. Lay 12'-10" V.S.P.L.S. ✓
Extend present 36'-18" C.I.P. North with 4'-18" C.I.P. ✓

Old Structure Sta 212+33
36'-18" C.I.P. & 8'-18" V.S.P.
36'-18" C.I.P. No Work
8'-18" V.S.P. to be removed ✓
Sta 212+84 30'-12" V.S.P. (abandon)
Sta 216+37 1 Brick C.B. 48" diam. Cond OK. No work
Sta 216+37 Break existing Conc Hdwy to 1' below finished Grade.

Old Structure Sta 219+17 to 219+55 R.S.
Remove 26'-12" C.I.P. and 12'-24" V.S.P.
Sta 219+33 to 219+59 Remove 26'-10" C.I.P.L.S. ✓

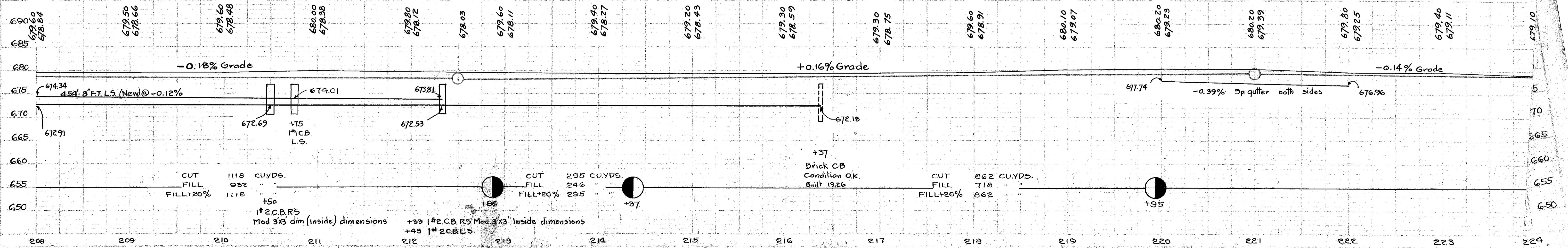

Morgan
Strub
Blue
Krauss
244

Morgan
Strub
Blue
Krauss
244

FED RD DIST. NO.	STATE	FED AID PROJECT	FISCAL YEAR
10	OHIO	498-A	1926-27

Morgan Stub Blue Knause 14-26 3-26 244

Morgan Stub Blue Knause 14-26 3-26 244

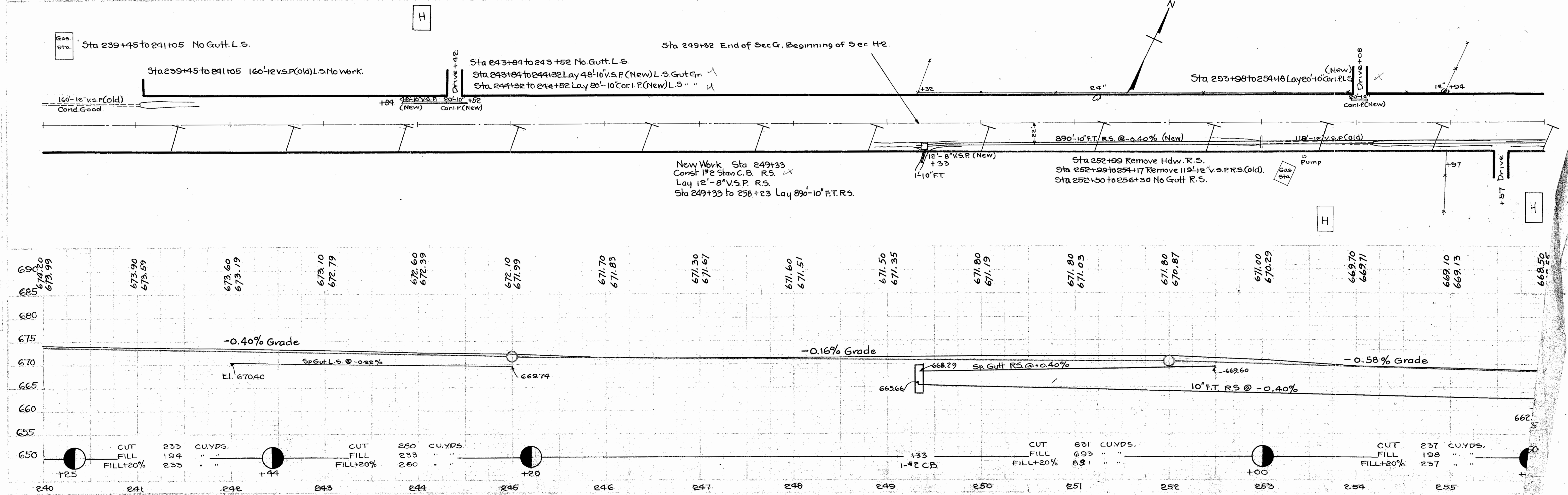
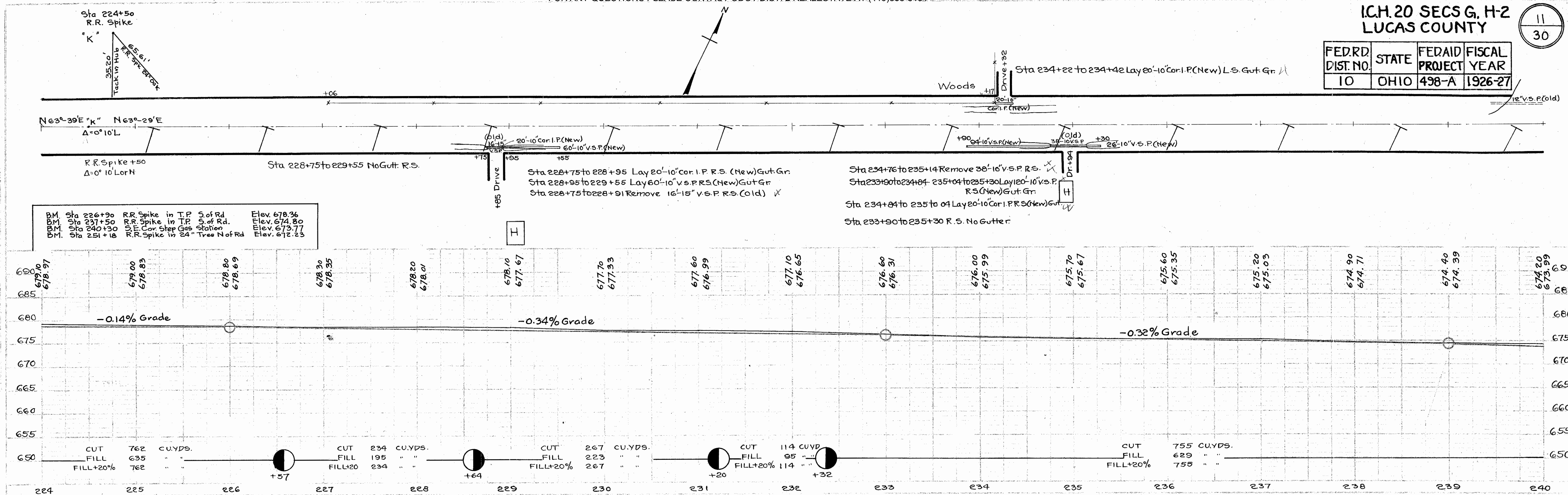

FED. RD. DIST. NO	STATE	FED. AID PROJECT	FISCAL YEAR
10	OHIO	498-A	1926-7

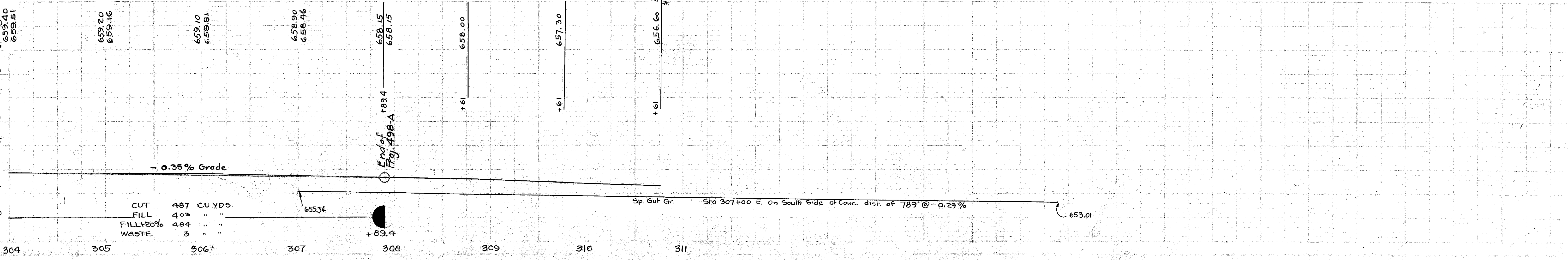
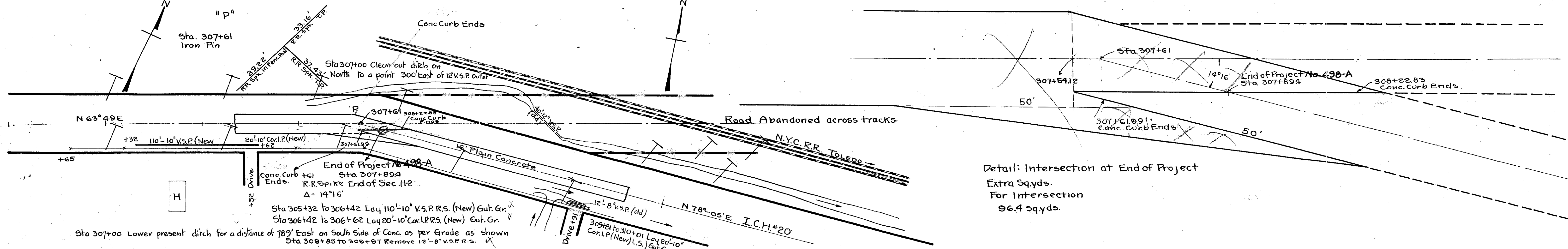
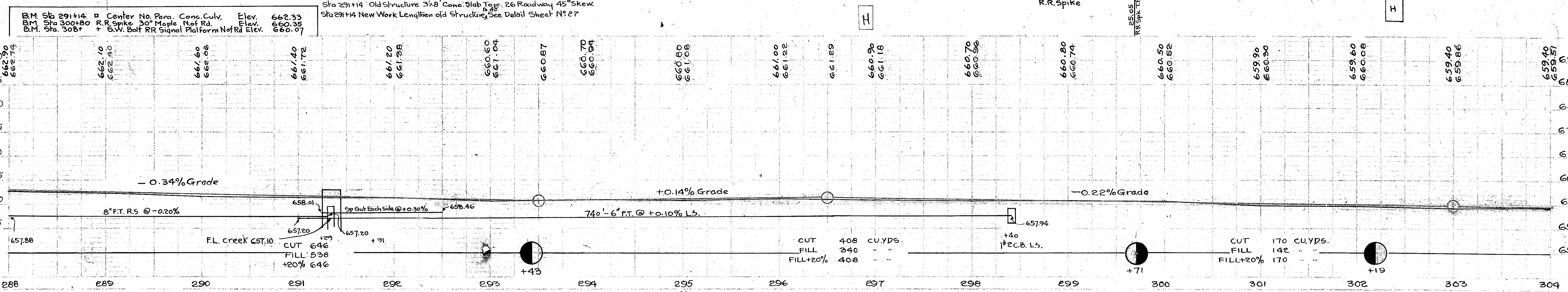
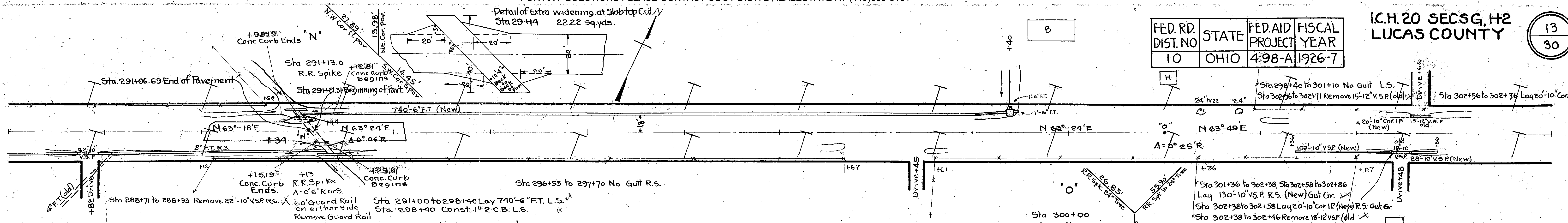

Morgan
1-4-26
5-9-26
R. RAUSE

244

Morgan
1-4-26
5-9-26
R. RAUSE

244

B.M. Sta 291+14	Center No. Para. Conc. Culv.	Elev.	662.33
B.M. Sta 300+80	R.R. Spike 30' Maple N of Rd.	Elev.	660.35
B.M. Sta. 308+	S.W. Bolt RR Signal Platform N of Rd	Elev.	660.07

Sta 291+14 Old Structure 3x8' Conc. Slab Top. 26' Roadway 45° Skew.
Sta 291+14 New Work Lengthen old Structure See Detail Sheet N° 27

Detail: Intersection at End of Project
Extra Sqyds.
For Intersection
96.4 Sqyds.

CUT	487	CU. YDS.
FILL	403	" "
FILL+20%	484	" "
WASTE	3	" "

FED. RD. DIST. NO.	STATE	FED AID PROJECT	FISCAL YEAR
10	OHIO	498-A	1926-7

I.C.H. 20 SECSG, H2 LUCAS COUNTY

12
30

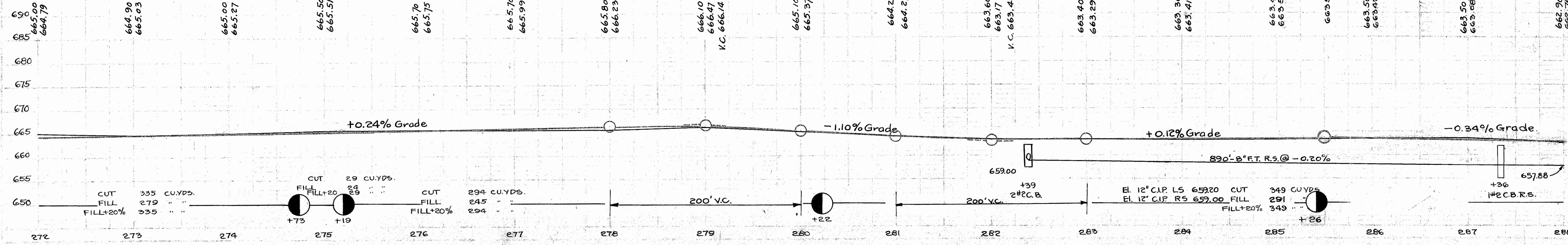
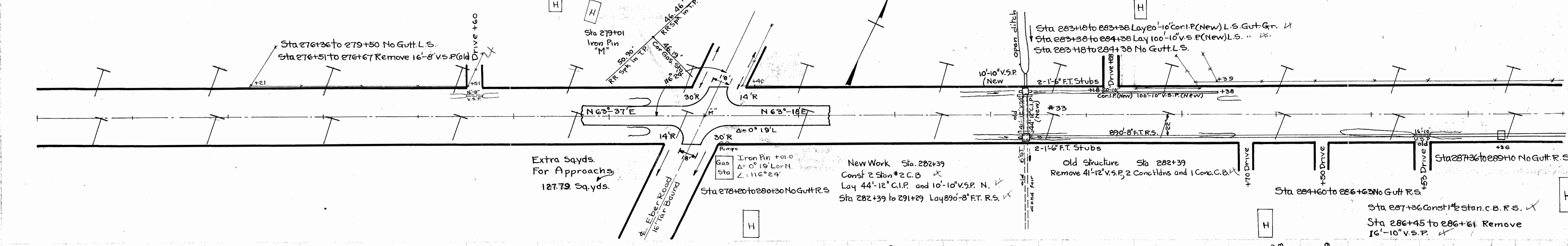
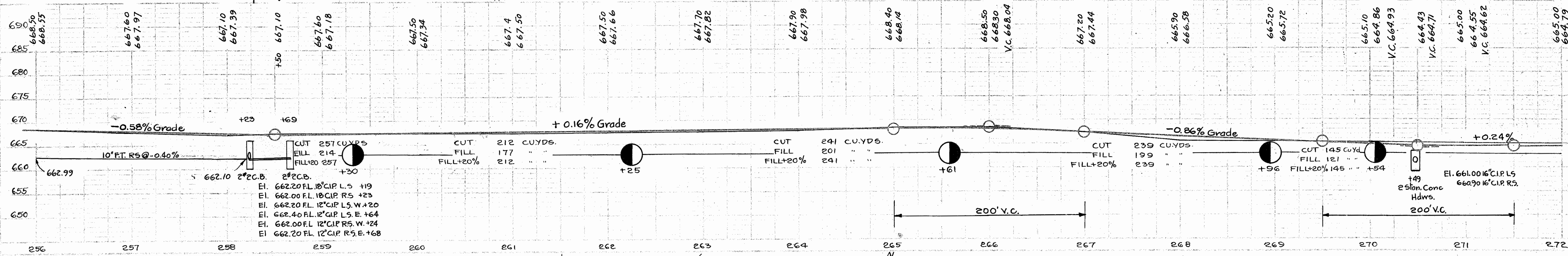
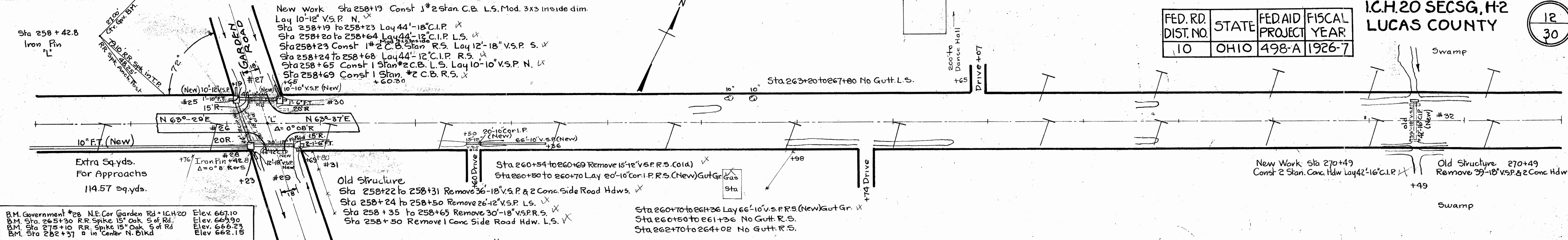

Morgan
Strub
Blue
Krause

Morgan
Strub
Blue
Krause