

CENTERLINE PLAT

LUC-24-3.42
 PROVIDENCE TOWNSHIP
 T-6-N, R-9-E
 SECTION 33 & 34
 LUCAS COUNTY, OHIO

CURVE INFORMATION
 @ CONST. - US 24
 P.I. Sta = 190+10.65
 $\Delta = 4^\circ 29' 28''$ (LT)
 $D_c = 0^\circ 17' 06''$
 $R = 20,104.54'$
 $T = 788.36'$
 $L = 1,575.92'$
 $E = 15.45'$

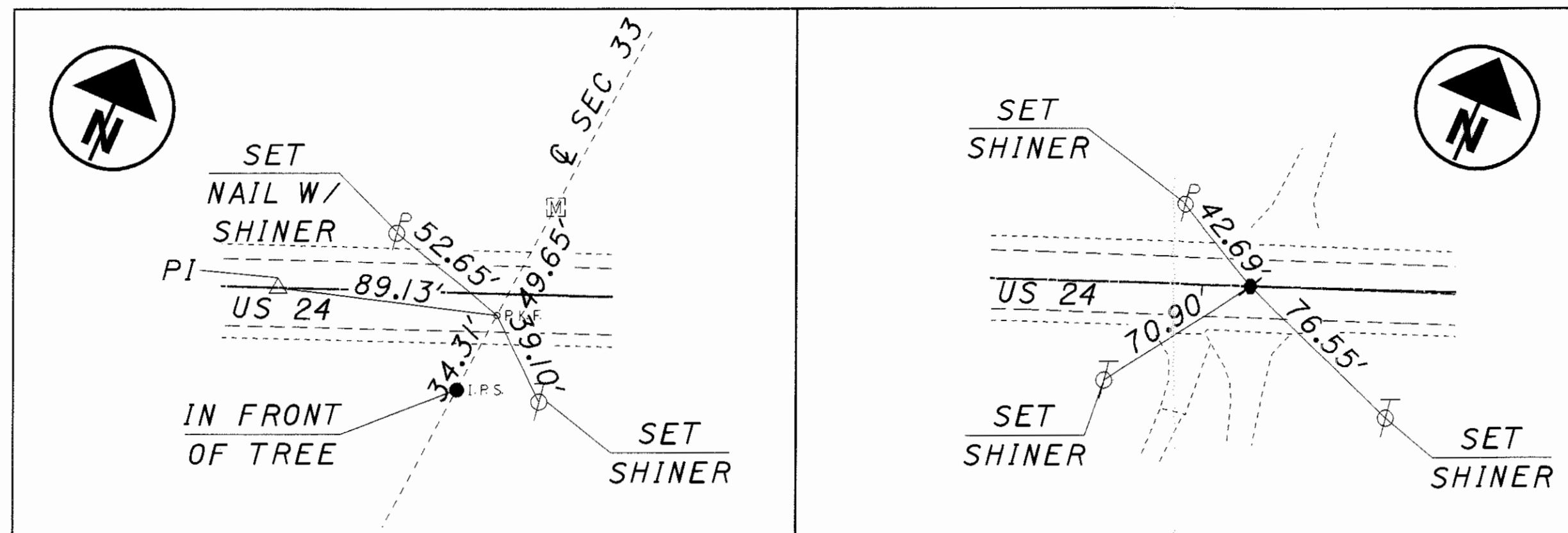
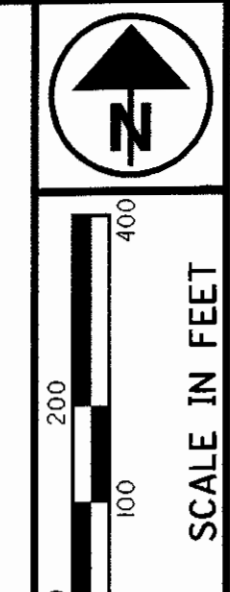

P.K. NAIL FOUND
 POT @ R/W - US 24
 STA. 160+38.11

R.R. SPIKE FOUND
 PI @ R/W - US 24
 STA. 180+65.20

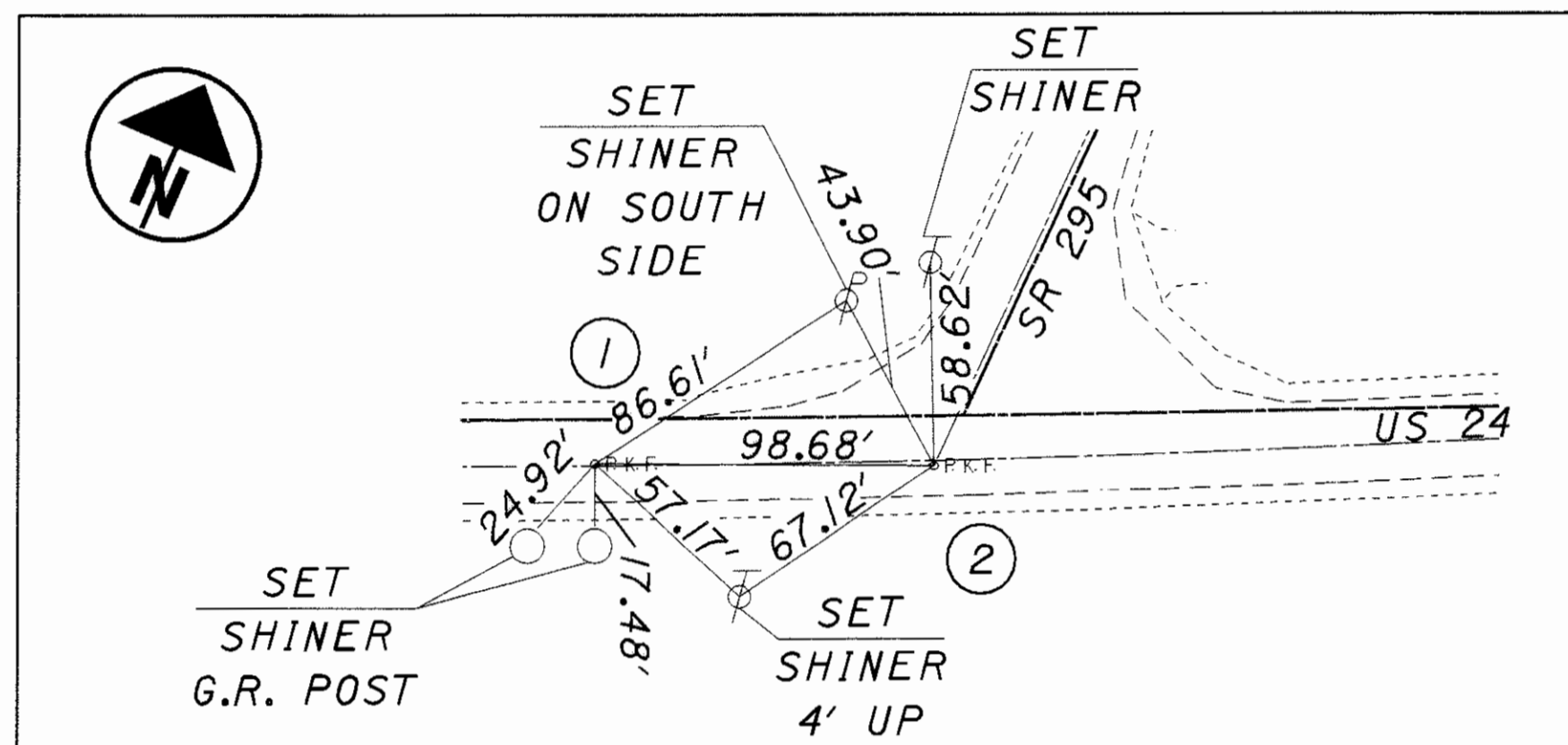

- ① P.K. NAIL FOUND
 STA. 189+13.94
 PI FOR @ OF R/W
 OF @ SURVEY - US 24
- ② P.K. NAIL FOUND
 STA. 0+00 OF @
 SURVEY - SR 295

POT STA. 160+18.11
 @ CONST. & @ R/W
 US 24 (P.K. Nail Fd.)

PI STA. 173+91.20
 (NO CURVE)
 @ DELTA = $-0^\circ 33' 31''$
 @ CONST. - US 24

BEGIN PROJECT
 STA. 180+59.00
 S.L.M. 3.42

CURVE INFORMATION - @ R/W US 24
 P.I. Sta = 189+13.94
 $\Delta = 4^\circ 54' 01''$ (LT)
 $D_c = 3^\circ 00' 00''$
 $R = 1,909.86'$
 $T = 81.72'$
 $L = 163.34'$
 $E = 1.75'$
 CHORD LENGTH = 163.29'
 CHORD BEARING = N $65^\circ 28' 11''$ E

NOTE: ALL RIGHT OF WAY SHALL BE REFERENCED FROM THE CENTERLINE R/W

NOTE: THE EXISTING R/W WIDTH AND LOCATION WERE DETERMINED USING THE FOLLOWING R/W PLANS LOCATED IN THE ODOT OFFICES IN BOWLING GREEN, OHIO Lucas County ICH 51, 1930 Luc-24-0.00, 1956

I HEREBY CERTIFY THAT THIS PLAT IS A TRUE DELINEATION OF A SURVEY MADE FOR THE OHIO DEPARTMENT OF TRANSPORTATION IN 2002 UNDER THE SUPERVISION OF STEVE HOFFMAN.

THE ESTABLISHMENT OF THE PROPERTY LINES AND EXISTING RIGHT OF WAY LINES SHOWN ON THIS PLAN AS OF THIS DATE WERE PERFORMED BY ME OR UNDER MY DIRECT SUPERVISION.

BY _____ SURVEYOR'S NAME
 SURVEYOR NO. _____ DATE _____

BASIS FOR BEARINGS:

ALL BEARINGS SHOWN ARE FOR PROJECT USE ONLY AND ARE USED TO DELINEATE ANGLES ONLY.

F.C.J. 3-20-03	Corrected sheet numbers
REV. BY	DATE
DATE COMPLETED	December 10, 2002

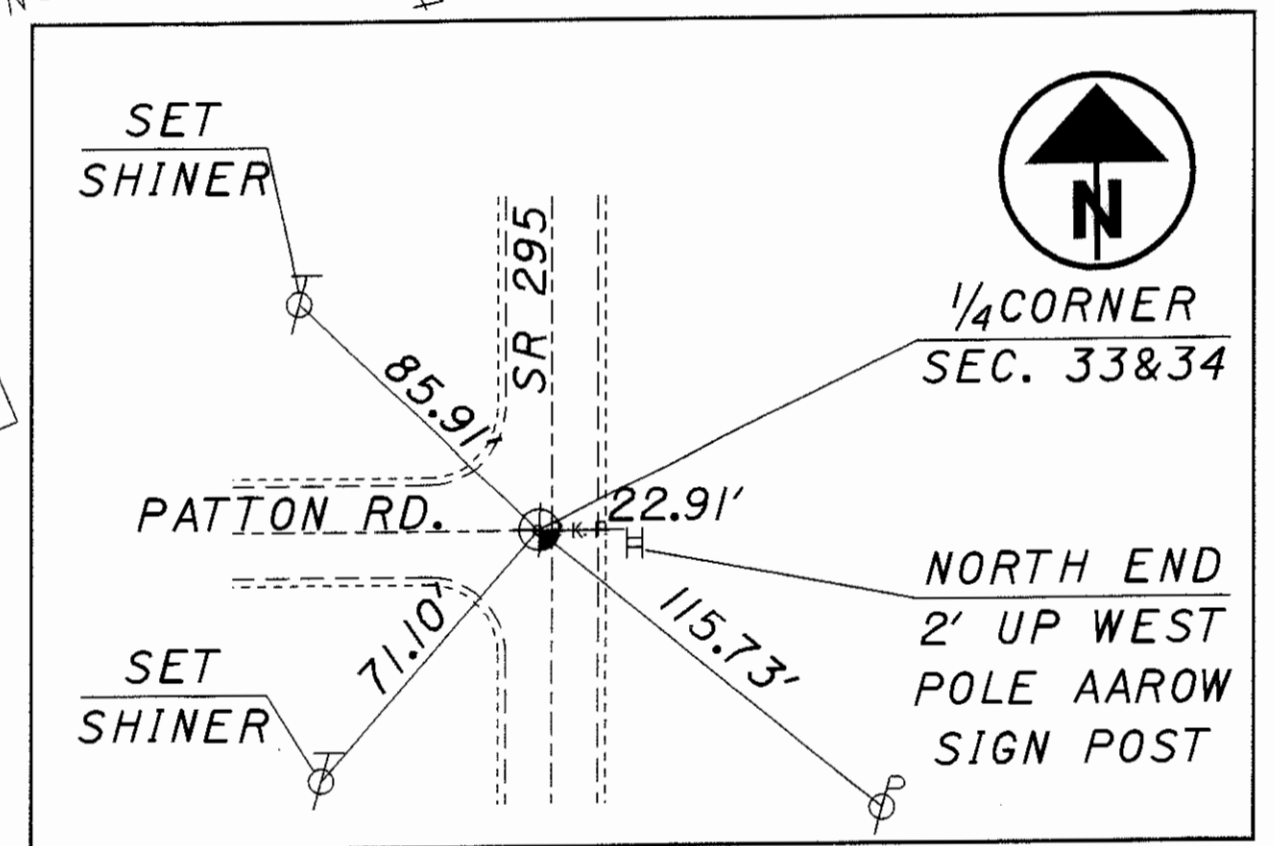

P.K. NAIL FOUND
 POT @ R/W - SR 295
 STA. 8+28.58

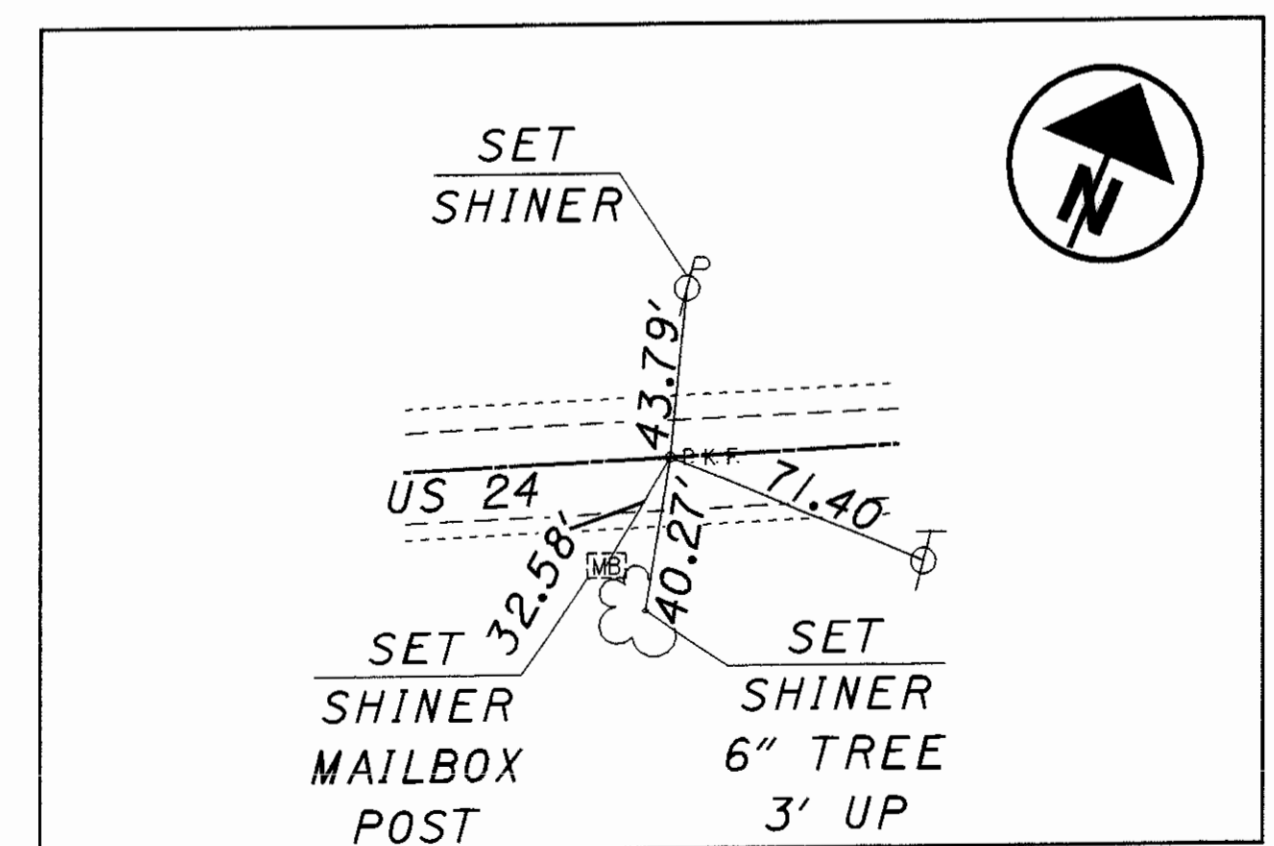

P.K. NAIL FOUND
 POT @ R/W - US 24
 STA. 207+45.20

SURVORS SEAL:

SIGNED _____ DATE _____

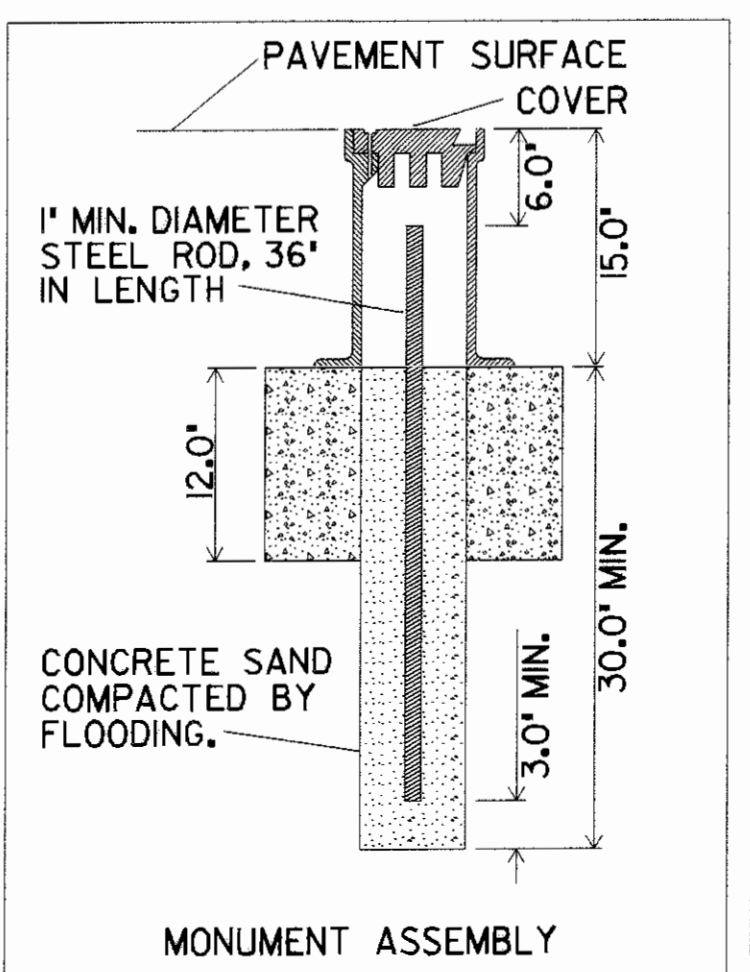

MONUMENTS TO BE SET DURING CONSTRUCTION				
LOCATED ON THE @ OF RIGHT OF WAY	COORDINATES		ADJUSTABLE @ MONUMENTS	ADJUSTABLE TO GRADE
	U.S. 24	NORTHING	EASTING	ITEM
PI STA. 180+65.20	4635.9109	9125.6711	/	ITEM 604E 38500
PI STA. 189+13.94	4954.8800	9912.1973	/	ITEM 604E 39500
POT STA. 190+12.37	4999.5794	9999.9954	/	
TOTAL TO GENERAL SUMMARY			3	

RECEIVED _____, 20____
 RECORDED _____, 20____
 BOOK _____ PAGE _____
 COUNTY RECORDER

PID NO. FCJ CAL 25377
 CENTERLINE PLAT
 LUC-24-3.42
 117/127

CONVENTIONAL SIGNS

- County Line _____
- Township Line _____
- Section Line _____
- Corporation Line _____ or _____
- Fence Line (existing) - - - - - (proposed) - - - - -
- Center Line _____
- Trees, Stumps (to be removed)
- Utility Poles: Telephone , Power , Light
- Limited Access (only) **LA** _____
- Right of Way (only) **R/W** _____
- Limited Access & Right of Way **LA-R/W** _____
- Exist. Right of Way **R/W** _____
- Temp. Right of Way **T ESMT** _____
- Slope Easement **SL ESMT** _____
- Utility Easement **U ESMT** _____
- Property Line _____ (in existing fence) - - - - -
- Railroad or _____
- Guardrail (existing) (proposed)
- Construction Limits _____

UTILITY NAMES

Adelphia
P.O. Box 405
Defiance, OH 43512
(419) 784-1992

Toledo Edison
300 Madison Ave.
Mailstop 1880
Toledo, OH 43652
(419) 249-5218

Grand Rapids,
Village of
P.O. Box 209
Grand Rapids, OH 43522
(419) 832-5305

Verizon Wireless
26935 Northwest Highway Suite 100
Southfield, MI 48034
(248) 915-3560

Suburban Natural Gas Co.
134 East Front Street
P.O. Box 130
Cygnet, OH 43413
(419) 655-2345

Lucas County Engineer
One Government Center
Toledo, OH 43604-2258
(419) 213-4540

STRUCTURE KEY

- RESIDENTIAL
- COMMERCIAL
- OUT-BUILDING

1 Charles A. Jeffers
51-17827

2 Elaine J. Niese, Trustee

3 David S Fox
51-20334

4 RICHARD L. & NANCY R.M. GUERNSEY

5 Richard H. Parthemer, Trustee

6 Robin R. Miller

7 Robert R. Ransom

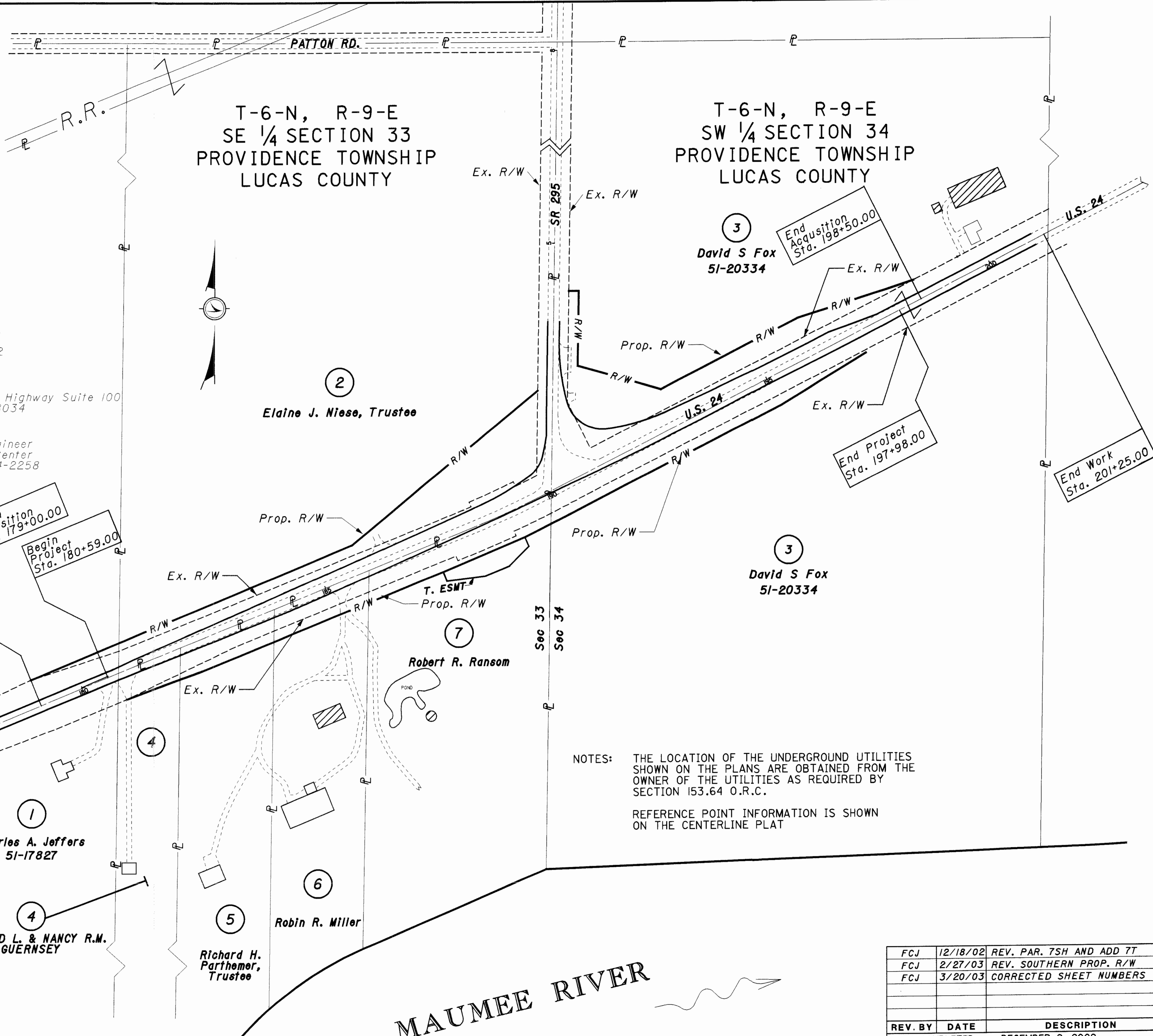

NOTES: THE LOCATION OF THE UNDERGROUND UTILITIES SHOWN ON THE PLANS ARE OBTAINED FROM THE OWNER OF THE UTILITIES AS REQUIRED BY SECTION 153.64 O.R.C.

REFERENCE POINT INFORMATION IS SHOWN ON THE CENTERLINE PLAT

FCJ	12/18/02	REV. PAR. TSH AND ADD TT
FCJ	2/27/03	REV. SOUTHERN PROP. R/W
FCJ	3/20/03	CORRECTED SHEET NUMBERS
REV. BY	DATE	DESCRIPTION
DATE COMPLETED	DECEMBER 9, 2002	

SCALE IN FEET
0 50 100 200

PID. NO. **25377**

R/W DESIGNER **FCJ**
R/W REVIEWER **CAL**

PROPERTY MAP

LUC-24-3.42

3 / 11

119
127

TOTAL NUMBER OF :

7 OWNERSHIPS 0 OWNERSHIPS WITH STRUCTURES INVOLVED
 9 PARCELS 2 OWNERSHIPS WITH "P" ITEMS
 0 TOTAL TAKES

NET RESIDUE = RECORD AREA - TOTAL PRO - NET TAKE

GRANTEE:

ALL RIGHT OF WAY ACQUIRED IN THE NAME OF
 THE STATE OF OHIO
 UNLESS OTHERWISE SHOWN.

ALL AREAS IN ACRES

PARCEL NO.	OWNER	SHEET NO.	OWNERS RECORD		AUDITOR'S PARCEL	RECORD AREA	TOTAL P.R.O.	GROSS TAKE	P.R.O. IN TAKE	NET TAKE	STRUC-TURE	NET RESIDUE		TYPE FUND	REMARKS AND PERSONALTY	AS ACQUIRED	
			BOOK	PAGE								LEFT	RIGHT			BOOK	PAGE
1-SH	CHARLES A. JEFFERS	5-6	1094	460	51-17827	30.48	1.697	0.234	0.199	0.035	(S)	28.748			Residue total of both sides old sign to be removed		
2-SH	ELAINE J. NIESE, TRUSTEE OF THE FLORENCE P. HARTMAN REVOCABLE LIVING TRUST DATED FEBRUARY 1, 2001 AND ROBERT E. HARTMAN, SUCCESSOR TRUSTEE	6-8&11	* 01-0062B01		51-17721	21.46	2.010	2.022	0.998	1.024		18.426					
3-SH	DAVID S. FOX	8-11	* 00-0520B02		51-20334	32.70	2.654	2.013	1.063	0.950							
3-SH1		8-11						0.927	0.641	0.286							
	TOTAL					32.70	2.654	2.940	1.704	1.236		28.810					
4-SH	RICHARD L. GUERNSEY and NANCEY R. M. GUERNSEY	6	* 99-0258D01		51-17824	2.40	0.160	0.176	0.160	0.016			2.224				
5-SH	RICHARD H. PARTHEMER, TRUSTEE OF THE RICHARD H. PARTHEMER REVOCABLE LIVING TRUST u/a/d/ JULY 20, 2000	6	* 00-0368A11		51-17814	2.61	0.196	0.279	0.196	0.083			2.331				
6-SH	ROBIN R. MILLER	6	* 98-0361C05		51-17801	2.60	0.187	0.280	0.187	0.093	(P)		2.321		Decorative brick light base to be removed		
7-SH	ROBERT R. RANSOM	6-7	2543	199	51-17787	5.06	0.394	0.542	0.394	0.148			4.518				
7-T		6						0.138		0.138					For grading & culvert installation		

* Denotes Microfiche Number

+ Denotes Encroachment

NOTE: UNDER NO CIRCUMSTANCES ARE TEMPORARY EASEMENTS TO BE USED FOR STORAGE OF MATERIAL OR EQUIPMENT BY THE CONTRACTOR UNLESS NOTED OTHERWISE.

NOTE: ALL TEMPORARY PARCELS TO BE OF 12 MONTH DURATION.

REV. BY	DATE	DESCRIPTION
F.C.J.	3-20-03	Corrected sheet numbers
C.A.L.	3-6-03	Correct PRO Parcel 5
C.A.L.	3-4-03	Correct Total PRO Parcel 6
C.A.L.	12-19-02	Revise 7-SH, add 7-T
DATE COMPLETED December 13, 2002		

FEDERAL PROJECT NO. 25377
 PID NO. 25377
 STATE JOB NO. 425730
 R/W RESTORER FCJ
 R/W REVIEWER CAL
SUMMARY OF ADDITIONAL RIGHT OF WAY
 LUC-24-3.42
 4/11
 120
 127

I:\projects\lucas\25377\03\dgn\rs001.dgn 21-MAR-2003 12:20 PM fjudson

NOTE: THE EXISTING R/W WIDTH AND LOCATION WERE DETERMINED USING R/W PLANS:
 -LUCAS COUNTY ICH. 51, 1930
 -LUC-24-0.00, 1956

NOTE: BURIED UTILITIES SHOWN OR NOT, ARE NOT WARRANTED. THE CONTRACTOR IS RESPONSIBLE FOR VERIFYING THE EXACT SIZE, DEPTH AND LOCATION OF ALL BURIED UTILITIES WITHIN THE CONSTRUCTION AREA PRIOR TO EXCAVATING.

T-6-N, R-9-E
 SECTION 33
 PROVIDENCE TOWNSHIP
 LUCAS COUNTY

SE 1/4
 SEC 33

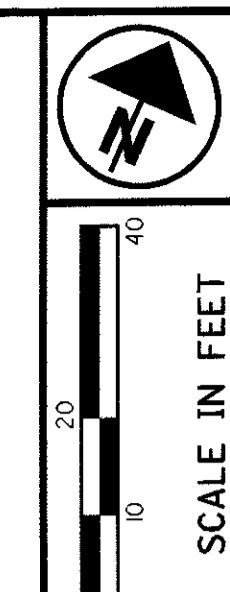

PID NO.
25377

FCJ
 CAL

RIGHT OF WAY PLAN - US 24
 STA. 178+50 TO STA. 184+00

LUC-24-3.42

REV. BY	DATE	DESCRIPTION
	December 10, 2002	

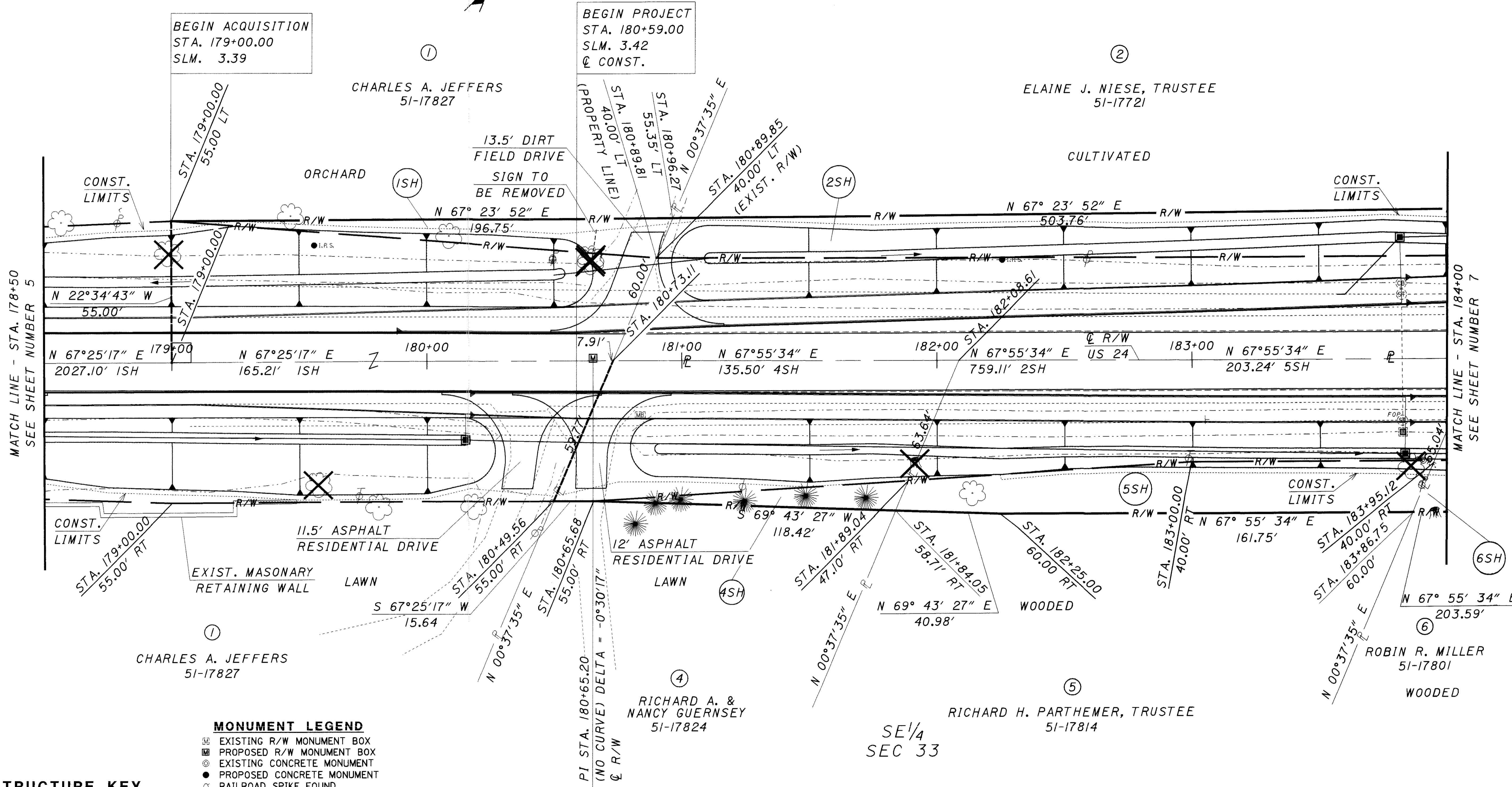

MONUMENT LEGEND

- ☒ EXISTING R/W MONUMENT BOX
- ☐ PROPOSED R/W MONUMENT BOX
- ⊙ EXISTING CONCRETE MONUMENT
- PROPOSED CONCRETE MONUMENT
- ⊕ RAILROAD SPIKE FOUND
- ⊖ RAILROAD SPIKE SET
- ⊙ IRON PIN FOUND
- ⊙ IRON PIN FOUND W/ ID CAP
- IRON PIN SET W/ ID CAP
- ⊙ IRON PIPE FOUND
- ⊙ IRON PIPE SET
- ⊙ P.K. NAIL FOUND
- P.K. NAIL SET

STRUCTURE KEY

- RESIDENTIAL
- COMMERCIAL
- ▨ OUT-BUILDING

I:\projects\lucas\25377.03\rdgm\p00124.dgn 21-MAR-2003 12:18 PM fjudson

NOTE: THE EXISTING R/W WIDTH AND LOCATION WERE DETERMINED USING R/W PLANS:
 -LUCAS COUNTY ICH. 51, 1930
 -LUC-24-0.00, 1956

NOTE: BURIED UTILITIES SHOWN OR NOT, ARE NOT WARRANTED. THE CONTRACTOR IS RESPONSIBLE FOR VERIFYING THE EXACT SIZE, DEPTH AND LOCATION OF ALL BURIED UTILITIES WITHIN THE CONSTRUCTION AREA PRIOR TO EXCAVATING.

T-6-N, R-9-E
 SECTION 33
 PROVIDENCE TOWNSHIP
 LUCAS COUNTY

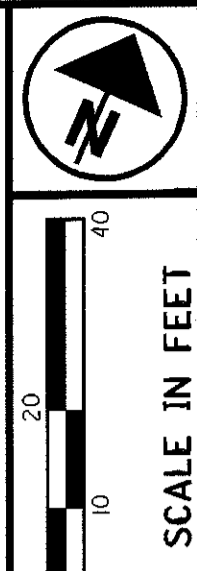

SE 1/4
 SEC 33

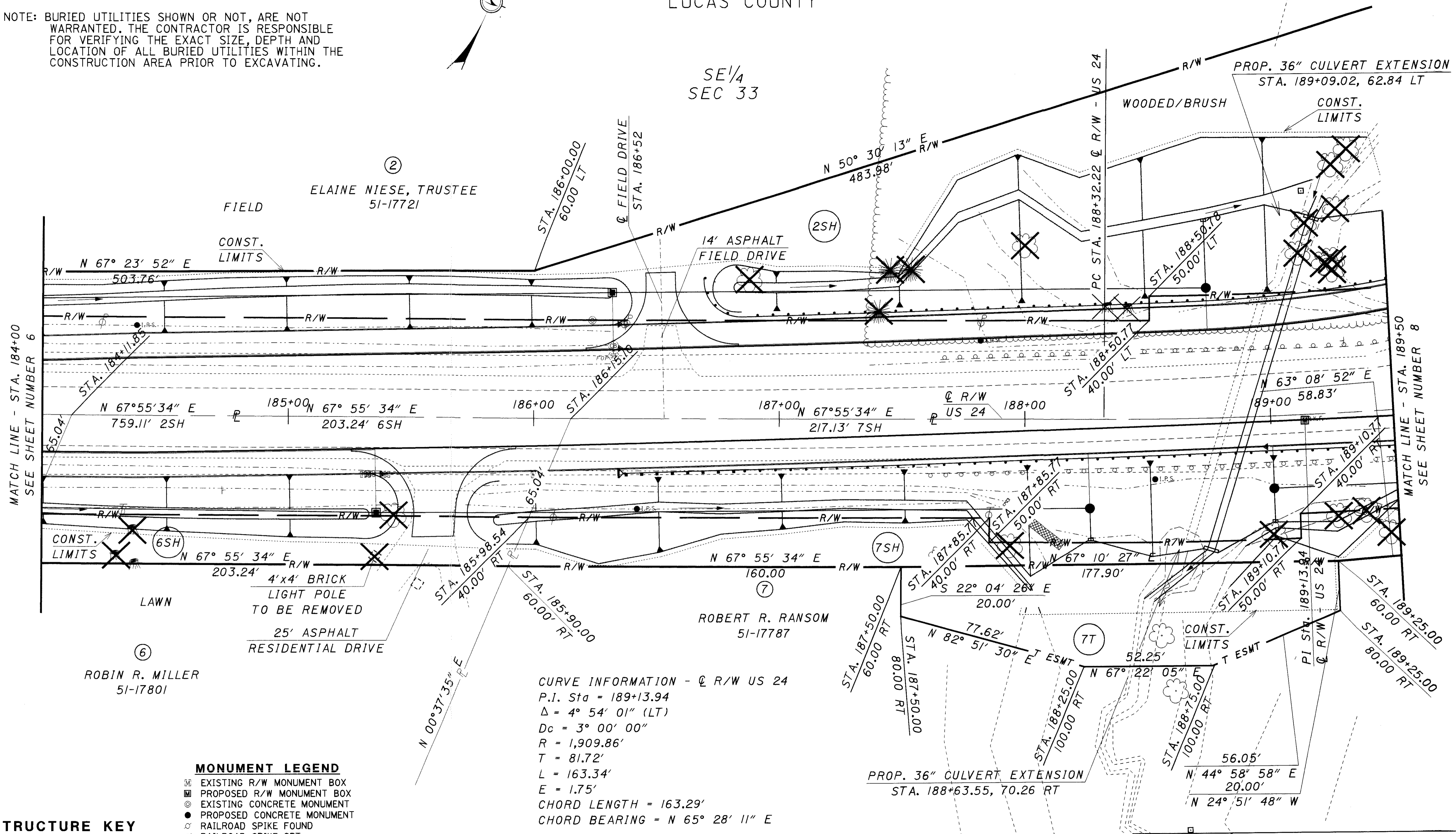

MATCH LINE - STA. 184+00
 SEE SHEET NUMBER 6

MATCH LINE - STA. 189+50
 SEE SHEET NUMBER 8

MONUMENT LEGEND

- ◻ EXISTING R/W MONUMENT BOX
- ◻ PROPOSED R/W MONUMENT BOX
- ⊙ EXISTING CONCRETE MONUMENT
- PROPOSED CONCRETE MONUMENT
- ⊙ RAILROAD SPIKE FOUND
- ⊙ RAILROAD SPIKE SET
- I.P.F. IRON PIN FOUND
- I.P.F. IRON PIN FOUND W/ ID CAP
- I.P.S. IRON PIN SET W/ ID CAP
- I.P.F. IRON PIPE FOUND
- I.P.S. IRON PIPE SET
- P.K. NAIL FOUND
- P.K. NAIL SET

STRUCTURE KEY

- ◻ RESIDENTIAL
- COMMERCIAL
- ▨ OUT-BUILDING

CURVE INFORMATION - C R/W US 24
 P.I. Sta = 189+13.94
 Δ = 4° 54' 01" (LT)
 Dc = 3° 00' 00"
 R = 1,909.86'
 T = 81.72'
 L = 163.34'
 E = 1.75'
 CHORD LENGTH = 163.29'
 CHORD BEARING = N 65° 28' 11" E

F.C.J.	12/18/02	REV. PAR. 7SH AND ADD 7T
F.C.J.	3-20-03	Corrected sheet numbers
REV. BY	DATE	DESCRIPTION
	December 10, 2002	

PID NO.
25377

R/W DESIGNER
FCJ
 R/W REVIEWER
CAL

RIGHT OF WAY PLAN - US 24
STA. 184+00 TO STA. 189+50

LUC-24-3.42

7/11

123
 127

I:\projects\lucas\25377\03\dgn\vrp00124.dgn 21-MAR-2003 12:18 PM f.ludson

NOTE: THE EXISTING R/W WIDTH AND LOCATION WERE DETERMINED USING R/W PLANS:
 -LUCAS COUNTY ICH. 51, 1930
 -LUC-24-0.00, 1956

NOTE: BURIED UTILITIES SHOWN OR NOT, ARE NOT WARRANTED. THE CONTRACTOR IS RESPONSIBLE FOR VERIFYING THE EXACT SIZE, DEPTH AND LOCATION OF ALL BURIED UTILITIES WITHIN THE CONSTRUCTION AREA PRIOR TO EXCAVATING.

T-6-N, R-9-E
 SECTION 33 & 34
 PROVIDENCE TOWNSHIP
 LUCAS COUNTY

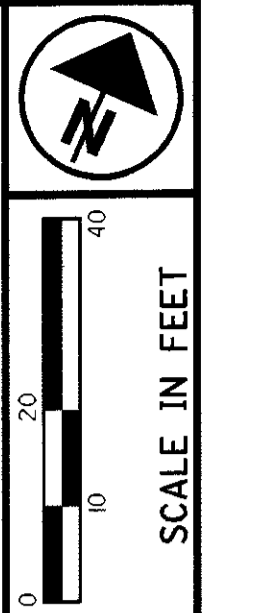
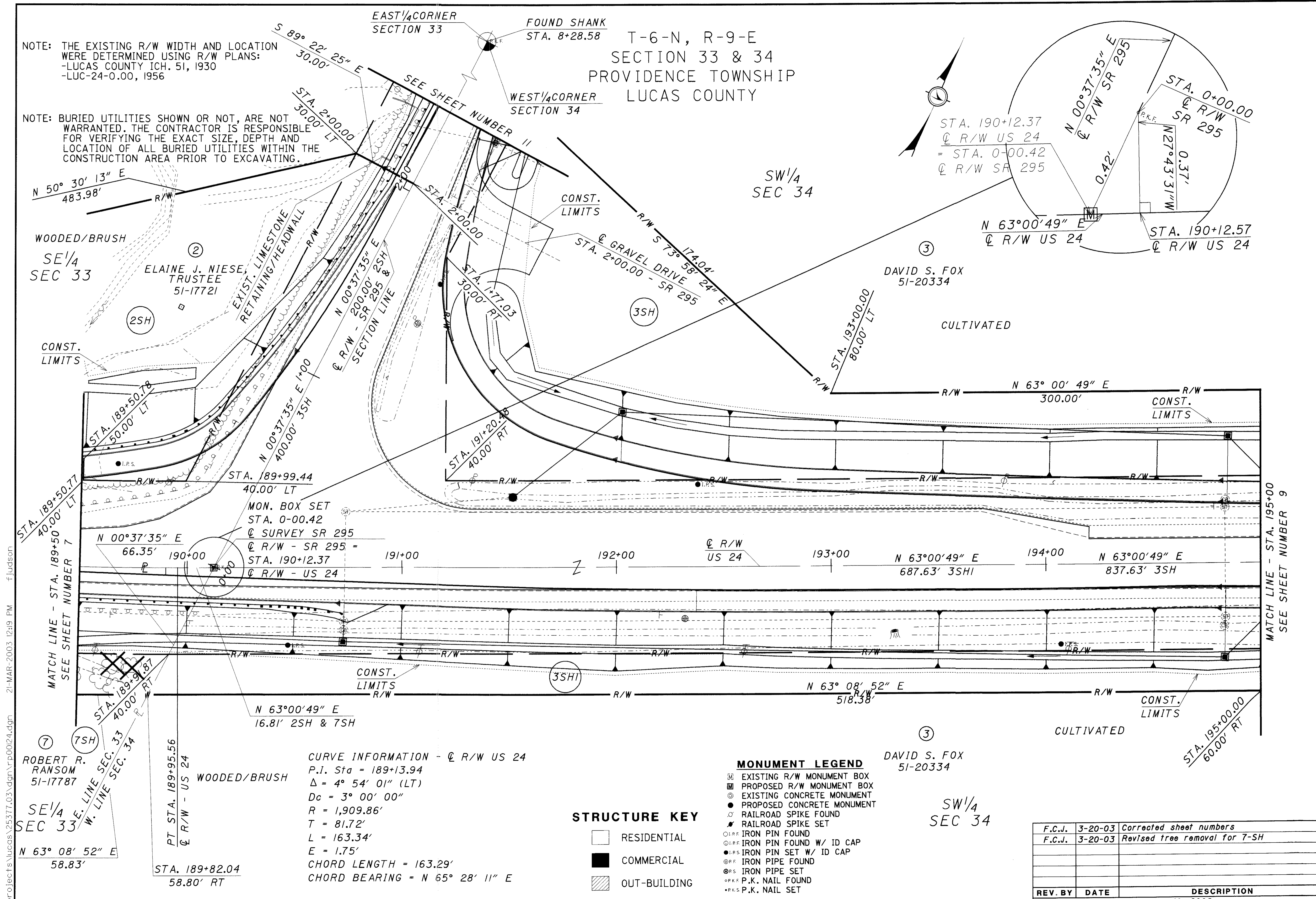

PID NO. **25377**

R/W DESIGNER **FCJ**
 R/W REVIEWER **CAL**

RIGHT OF WAY PLAN - US 24
STA. 189+50 TO STA. 195+00

LUC-24-3.42

I:\projects\lucas\25377\03\dgn\p00124.dgn 21-MAR-2003 12:19 PM fjudson

CURVE INFORMATION - @ R/W US 24
 P.I. Sta = 189+13.94
 $\Delta = 4^\circ 54' 01''$ (LT)
 $D_c = 3^\circ 00' 00''$
 $R = 1,909.86'$
 $T = 81.72'$
 $L = 163.34'$
 $E = 1.75'$
 CHORD LENGTH = 163.29'
 CHORD BEARING = N 65° 28' 11" E

STRUCTURE KEY

- RESIDENTIAL
- COMMERCIAL
- OUT-BUILDING

MONUMENT LEGEND

- EXISTING R/W MONUMENT BOX
- PROPOSED R/W MONUMENT BOX
- EXISTING CONCRETE MONUMENT
- PROPOSED CONCRETE MONUMENT
- RAILROAD SPIKE FOUND
- RAILROAD SPIKE SET
- IRON PIN FOUND
- IRON PIN FOUND W/ ID CAP
- IRON PIN SET W/ ID CAP
- IRON PIPE FOUND
- IRON PIPE SET
- P.K. NAIL FOUND
- P.K. NAIL SET

F.C.J.	3-20-03	Corrected sheet numbers
F.C.J.	3-20-03	Revised tree removal for 7-SH

REV. BY	DATE	DESCRIPTION
DATE COMPLETED		December 10, 2002

8 / 11
124
127

NOTE: THE EXISTING R/W WIDTH AND LOCATION WERE DETERMINED USING R/W PLANS:
 -LUCAS COUNTY ICH. 51, 1930
 -LUC-24-0.00, 1956

NOTE: BURIED UTILITIES SHOWN OR NOT, ARE NOT WARRANTED. THE CONTRACTOR IS RESPONSIBLE FOR VERIFYING THE EXACT SIZE, DEPTH AND LOCATION OF ALL BURIED UTILITIES WITHIN THE CONSTRUCTION AREA PRIOR TO EXCAVATING.

T-6-N, R-9-E
 SECTION 34
 PROVIDENCE TOWNSHIP
 LUCAS COUNTY

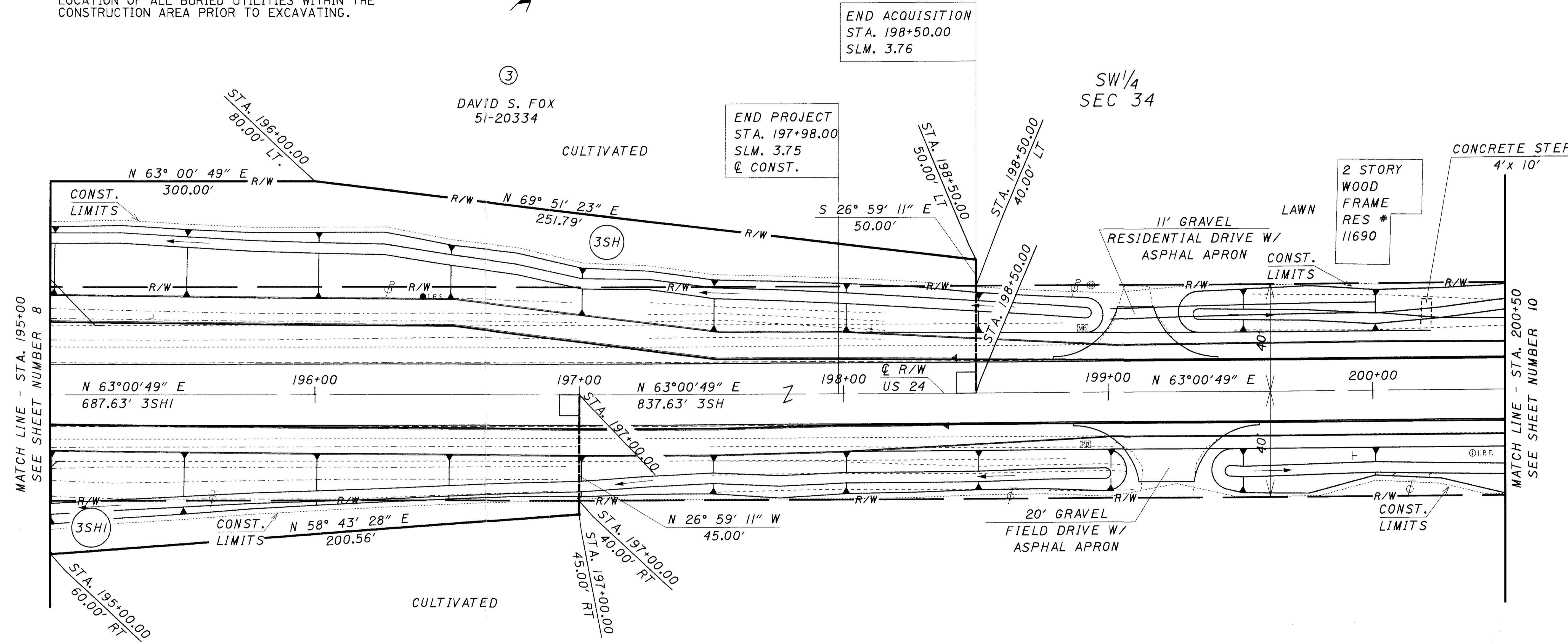
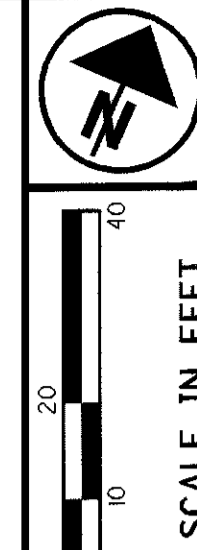

MATCH LINE - STA. 195+00
SEE SHEET NUMBER 8

MATCH LINE - STA. 200+50
SEE SHEET NUMBER 10

I:\projects\lucas\25377\03\vgm\p00124.dgn 21-MAR-2003 12:19 PM fjudson

STRUCTURE KEY

- RESIDENTIAL
- COMMERCIAL
- OUT-BUILDING

MONUMENT LEGEND

- EXISTING R/W MONUMENT BOX
- PROPOSED R/W MONUMENT BOX
- EXISTING CONCRETE MONUMENT
- PROPOSED CONCRETE MONUMENT
- RAILROAD SPIKE FOUND
- RAILROAD SPIKE SET
- IRON PIN FOUND
- IRON PIN FOUND W/ ID CAP
- IRON PIN SET W/ ID CAP
- IRON PIPE FOUND
- IRON PIPE SET
- P.K. NAIL FOUND
- P.K. NAIL SET

F.C.J.	3-20-03	Corrected sheet numbers
C.A.L.	3-6-03	Correct Bearing within Parcel 3-SH
REV. BY	DATE	DESCRIPTION
DATE COMPLETED	December 10, 2002	

PID NO.
25377

R/W DESIGNER
FCJ
R/W REVIEWER
CAL

RIGHT OF WAY PLAN - US 24
STA. 195+00 TO STA. 200+50

LUC-24-3.42

125
127

NOTE: THE EXISTING R/W WIDTH AND LOCATION WERE DETERMINED USING R/W PLANS:
 -LUCAS COUNTY ICH. 51, 1930
 -LUC-24-0.00, 1956

NOTE: BURIED UTILITIES SHOWN OR NOT, ARE NOT WARRANTED. THE CONTRACTOR IS RESPONSIBLE FOR VERIFYING THE EXACT SIZE, DEPTH AND LOCATION OF ALL BURIED UTILITIES WITHIN THE CONSTRUCTION AREA PRIOR TO EXCAVATING.

T-6-N, R-9-E
 SECTION 34
 PROVIDENCE TOWNSHIP
 LUCAS COUNTY

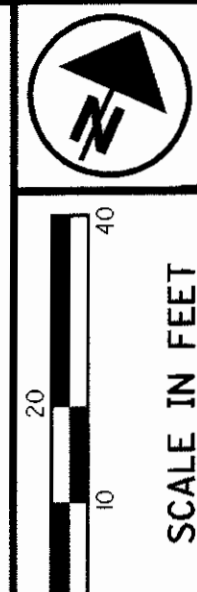

PID NO.
25377

FCJ
 CAL

RIGHT OF WAY PLAN - US 24
 STA. 200+50 TO STA. 206+00

LUC-24-3.42

10/11
 126
 127



END WORK
 STA. 201+25.00
 SLM. 3.81
 @ CONST.

SW 1/4
 SEC 34

DAVID S. FOX
 51-20334

CONST. LIMITS

R/W

N 00°37'35" E
 STA. 201+55.43
 40.00' LT

STA. 201+34.5

N 63°00'49" E 202+00

@ R/W
 US 24

203+00

204+00

205+00

PK NAIL SET
 STA. 207+45.00

MATCH LINE - STA. 200+50
 SEE SHEET NUMBER 9

CONST. LIMITS

R/W

STA. 201+13.58
 40.00' RT

N 00°37'35" E
 STA. 201+34.5

SW 1/4
 SEC 34

I:\projects\lucas\25377\03\dgn\fp0024.dgn 21-MAR-2003 12:19 PM f.judson

STRUCTURE KEY

- RESIDENTIAL
- COMMERCIAL
- OUT-BUILDING

MONUMENT LEGEND

- EXISTING R/W MONUMENT BOX
- PROPOSED R/W MONUMENT BOX
- EXISTING CONCRETE MONUMENT
- PROPOSED CONCRETE MONUMENT
- RAILROAD SPIKE FOUND
- RAILROAD SPIKE SET
- IRON PIN FOUND
- IRON PIN FOUND W/ ID CAP
- IRON PIN SET W/ ID CAP
- IRON PIPE FOUND
- IRON PIPE SET
- P.K. NAIL FOUND
- P.K. NAIL SET

F.C.J.	3-20-03	Corrected sheet numbers
REV. BY	DATE	DESCRIPTION
	December 10, 2002	

