

FED. RD. DIVISION	STATE	PROJECT
2	OHIO	

61
75

Woo 51 (157-175)
Woo 579 0.01

1
15

CENTERLINE SURVEY PLAT

WOODVILLE AND WILLISTON ROADS

ROUTE 51 SECTION (157-179)
ROUTE 579 SECTION 0.01

VILLAGE OF NORTHWOOD T8N R12E SECTION 34
LAKE TOWNSHIP T7N R12E SECTION 3
WOOD COUNTY, OHIO

Signed Raymond H. Rice
Date 12-13-1967
Raymond H. Rice
Division Deputy Director
Professional Engineer
Registration Number E00666

Monuments

Station	Standard Monument Assembly As Per Plan
48+57.60	1
56+45	1
13+01.88	1
4+98.41	1

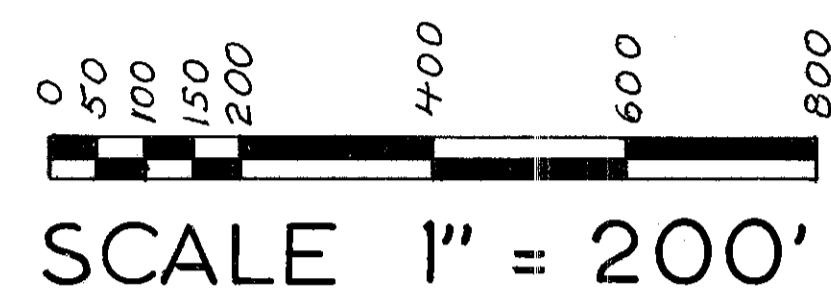

RECORDED IN
VOL. 13, PAGE 42
12-21-67

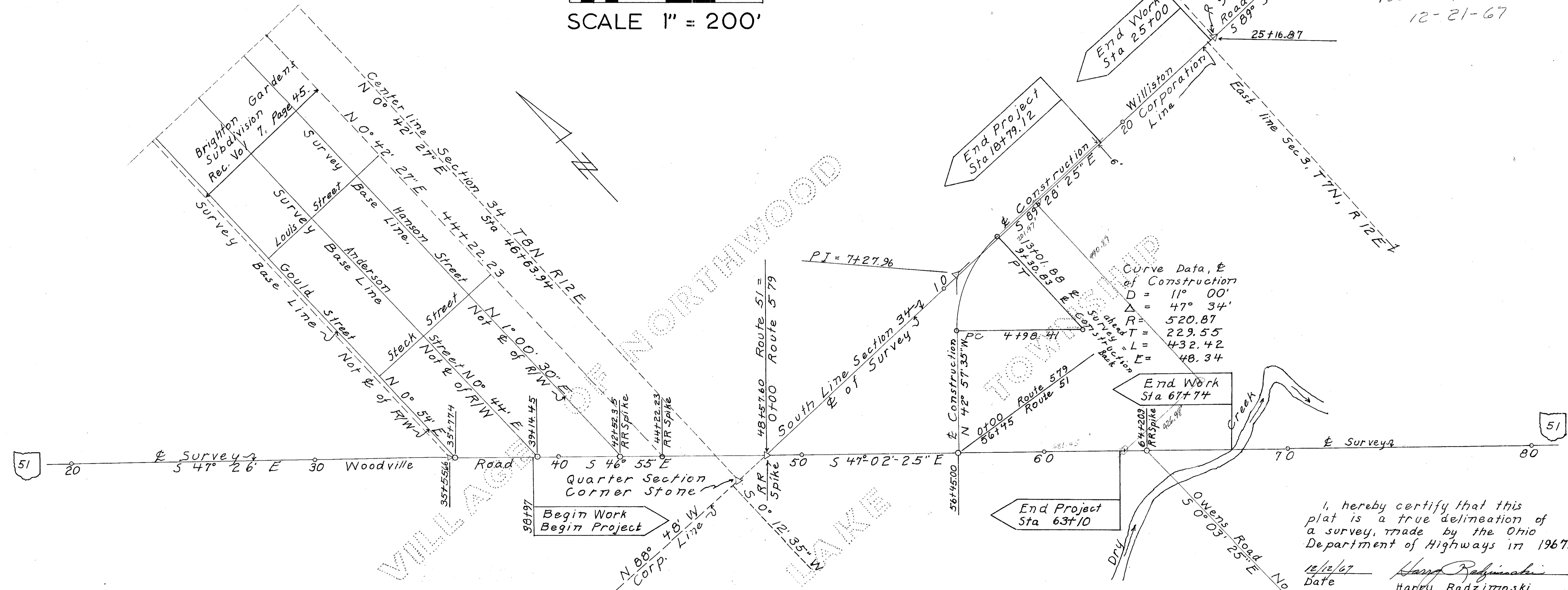

I, hereby certify that this plat is a true delineation of a survey, made by the Ohio Department of Highways in 1967.

Date 12/12/67
Harry Radzimoski
Harry Radzimoski
Registration Number S04401

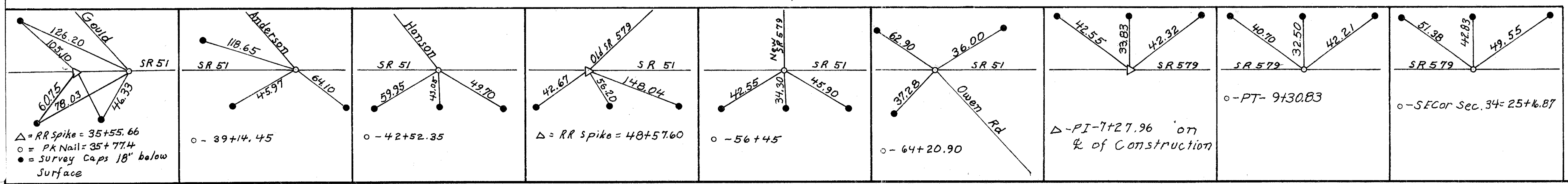

R.R. Spike at Plumley Road Intersection

R8051 #4 D-94

PROPERTY MAP

ROUTE 51 SEC. 1.57 ROUTE 579 SEC. 0.01
 VILLAGE OF NORTHWOOD and LAKE TOWNSHIP
 WOOD COUNTY, OHIO

FED. RD. DIVISION	STATE	PROJECT
2	OHIO	

Woo 51 Sec 1.57-1.75
 Woo 579 Sec. 0.01

62
75

2
15

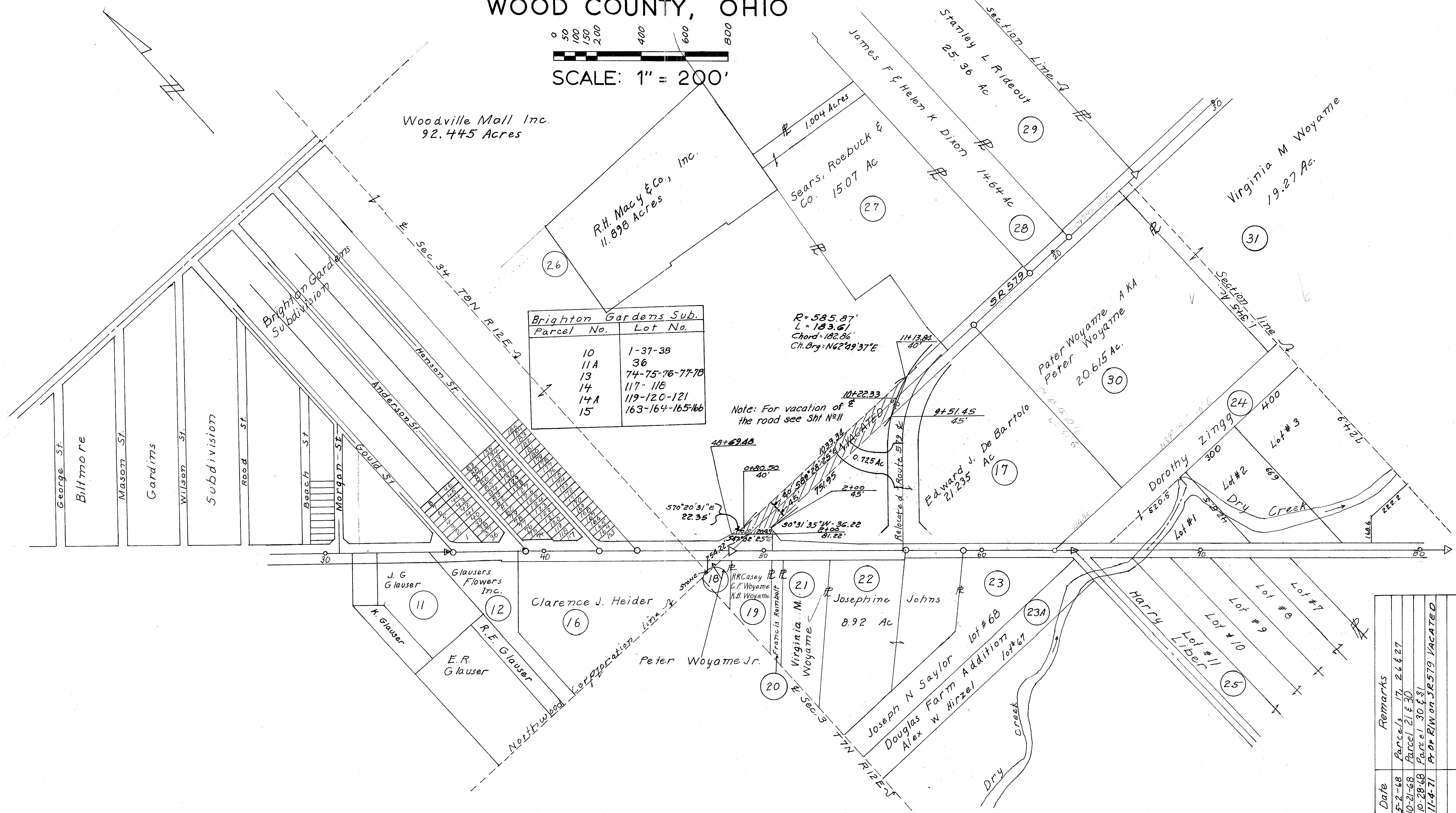
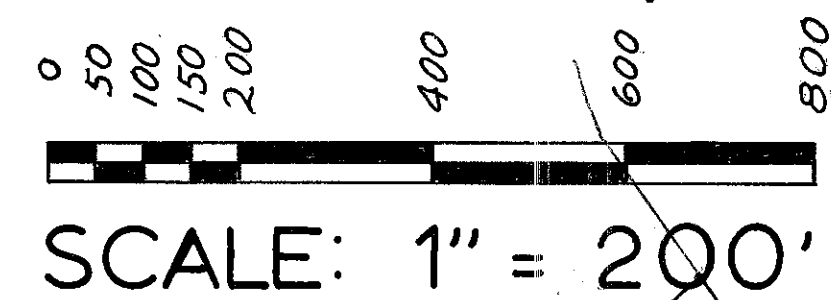

Date	Remarks
5-2-68	Parcel 17, 26 & 27
10-21-68	Parcel 21 & 30
10-28-68	Parcel 1, 30 & 31
11-4-71	PT OF R/W ON JR 579 VACATED

WOOD COUNTY OHIO

Number of Owners _____

FED. RD. DIVISION	STATE	PROJECT
2	OHIO	

Woo 51 (157-175)
Woo 579 0.01

63
75

3
15

SUMMARY OF ADDITIONAL RIGHT-OF-WAY REQUIRED

Parcel No.	Sheet No.	Owner	Deed		Deed Area	Total PFO	Total Take		PFO in Take		Net Take		Buildings or Structures	Net Residue		Remarks
			Vol.	Page			Acres	Sq Ft	Acres	Sq Ft	Acres	Sq Ft		Left	Right	
10	5	Mabel Frederick	210	375				0.00								
			187	536												
			187	536												
11	5	John G. Glauser						0.00								
11A	5	John G. Glauser & Ernest R. Glauser	253	627				0.00								
12	5-6	Glauser's Flowers Inc.	429	395				0.00								
13	6	George H. Dalling & Augusta Dalling	201	521	15,792.35 SF	99,701 SF		2,990.94								Deed Area Corrected
			213	358												
14WD	6	George Hasenfratz & Marie Hasenfratz	264	58	6,933.55 SF	832.71 SF		5837.30	832.71		5004.59	1+3 Under-ground tanks	0.00			Deed Area Corrected WA to remove building
14WA	6							1096.25								
14A	6	Nora M. Sahr	239	463	9,465.35 SF	0.00		127.55	0.00		127.55		9,337.75			Deed Area Corrected
			239	465												
15WD	6	Angelo Tollendo	430	548	14,386.00 SF	735.62 SF		9,890.91	735.62		9,155.29	1	4,495.09			Deed Area Corrected
15WA			430	181				772.0								
			333	414												
16	6-7	Clarence J. Heider	387	414	68,64 Ac	1822 Ac	1.090	47,463.67	0.835	36,368.1	0.255	11,095.57			66,563 Ac	
17	9-10-11 14-15	Edward J. DeBartolo	448	785	21.235	2.613	5.086		1.779		3.307		2.85	12.17		Add Deeds Book Vol 454 Page 544
			448	787									0.29			
			448	788												
			448	789												
18	7	Peter Woyame Jr.	374	65	0.585 Ac	0.179 Ac	0.213	9281.28	0.179	7798.26	0.034 Ac	1483.02	1		0.372 Ac	
18WA			375	28				1862.00								
19	7 8	Ruth R. Casey 1/3 Charles F. Woyame 1/3 Kenneth B. Woyame 1/3	423	416	1.479 Ac	0.189 Ac	0.231	10,049.05	0.189	8221.95	0.042	1827.10			1248 Ac	
															0.520 Ac	
20	8	Frances Reinbolt	374	64	0.587 Ac	0.055 Ac	0.067	2,928.75	0.055	2,396.25	0.012	532.50				
21	8	Virginia M. Woyame	459	909	2.492 Ac	0.185	0.229	9988.99	0.185	8,064.45	0.044	1,924.54			2263 Ac	
22	8-9	Josephine Johns	444	453	8.92 Ac	0.607 Ac	0.917	39,935.75	0.607	26,438.37	0.310	13,497.38			8,003 Ac	
23	9-10	Joseph N. Saylor & Anna Mae Saylor	415	20	5.30	0.428	0.670	29,182.57	0.428	18,643.66	0.242	10,538.91	1		4630	
23WA								2,114.00								
23A	10	Alex W. Hirzel et al	429	482	4.00	0.091	0.041	1774.55	0.031	1338.60	0.010	435.95			3,899	
24	10	Dorothy Zingg	378	348	4.5	0.272	0.632	27,532.71	0.272	11,848.95	0.360	15,683.76			3,868	
			339	620												
			339	618												

Date	Remarks
2/13/68	Revision Parcel-23A Alex W. Hirzell
5-2-68	Parcel 17
6-25-68	Change Area Parcel 22
9-11-68	Change Area Parcel 14WD, Add 14WA
10-21-68	Parcel 21

WOOD COUNTY OHIO

Number of Owners _____

FED. PROJ. DISTRICT	STATE	PROJECT
2	OHIO	

Woo 51 (157-175)
Woo 579 0.01

64
75

4
15

SUMMARY OF ADDITIONAL RIGHT-OF-WAY REQUIRED

Parcel No.	Sheet No.	OWNER	Deed		Deed Area	Total PRO	Total Take		PRO in Take		Net Take		Buildings or Structures	Net Residue		Remarks
			Vol.	Page			Acres	Sq Ft	Acres	Sq Ft	Acres	Sq Ft		Left	Right	
25	10	Harry LIBER	{ 417 413 }	{ 437 96 }	12.68	1.46	0.434	18,906.26	0.283	12,322.16	0.151	6,584.10			11.069	Deed Area Corrected
26 26A 26AWA 26B	6-7-11 12-15 14	Woodville Mall Inc.	{ 448 448 448 448 448 454 448 448 448 }	{ 835 844 848 849 847 687 544 846 845 842 }	92.445	1.847	0.879	38,288.18	0.557	24,273.5	0.322	4,014.66		89.942		Deed Area Corrected
27 27 WA & 27AWA	12	Sears Roebuck & Co.	448	689	16.078	0.528	0.821	35,758.5	0.528	22,980.15	0.293	12,778.36			15.257	
28 28WA	12	James F. Dixon Helen K. Dixon	{ 440 385 320 }	{ 907 572 502 }	14.636A	0.231A	0.358	15,600.0	0.231	10,049.25	0.127	5,550.75			14.278	
29	12-13	Stanley L. Rideout	{ 237 237 }	{ 258 256 }	25.364Ac	0.439Ac	0.413	18,009.07	0.318Ac	13,851.90	0.095	4,147.17			24.830	
30 30T	13	Peter Woyame AKA Peter Woyame	444 459 461	455 909 470	20.615	0.937	0.882	38,439.70	0.718	31,294.80	0.164	7,144.90			19.514	
31 31T		Virginia M. Woyame	461 459 444	471 909 455	20.615	0.966	0.0		0.0		0.0	3,148.88			19.649	

Date	Remarks
5-2-68	Parcel 26 & 27
7-18-68	Parcel 26
10-21-68	Parcel 30
10-28-68	Parcels 30 & 31

FED. RD. DIVISION	STATE	PROJECT
2	OHIO	

65
75

5
15

Woo 51 - (1.57-1.75)
Woo 579 - 0.01

E. U. B Church

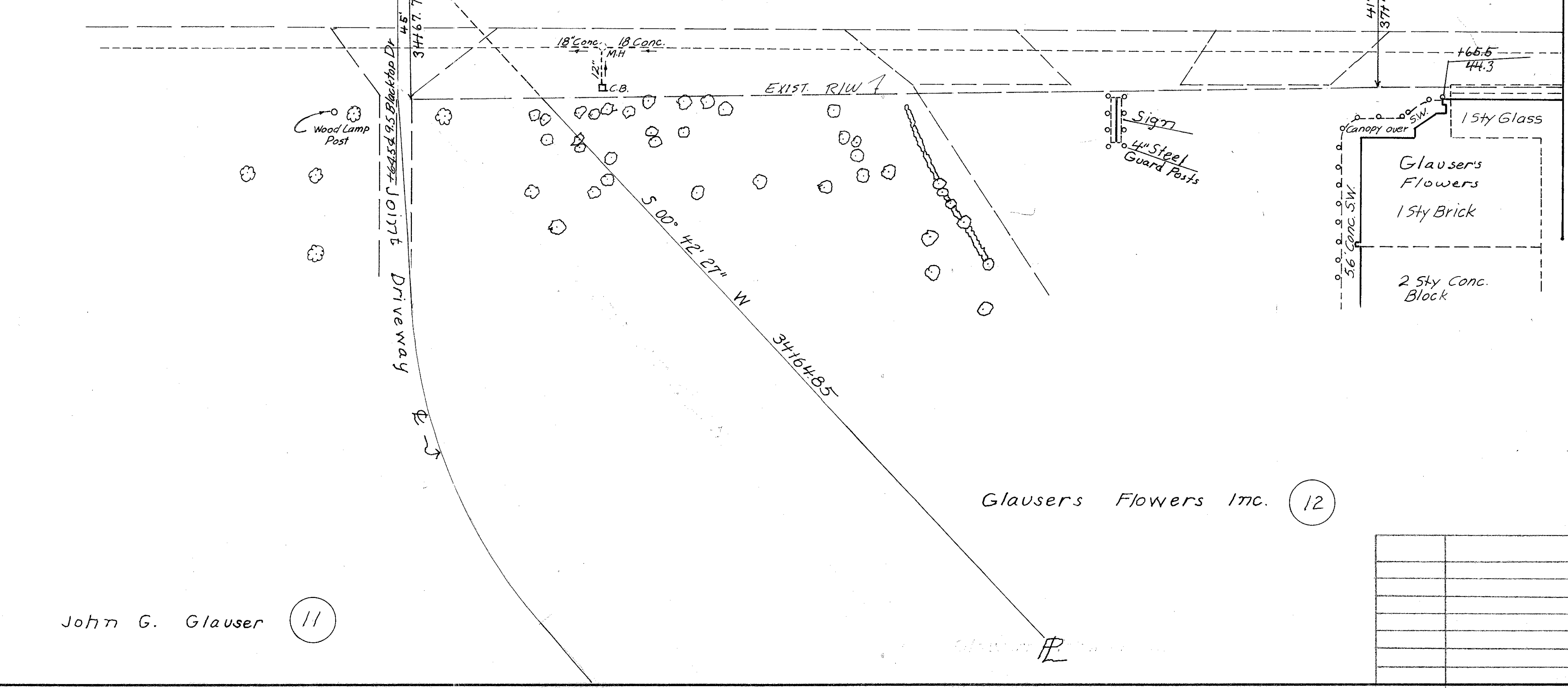
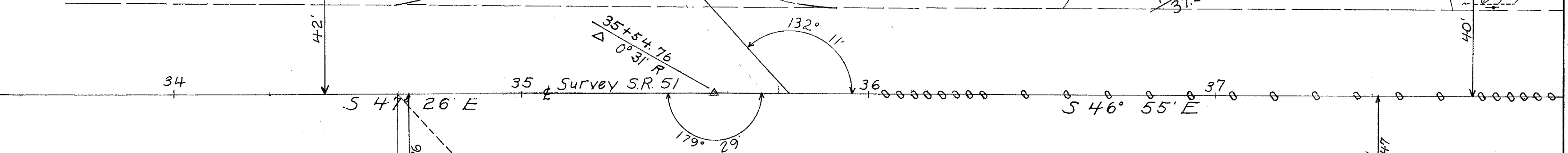
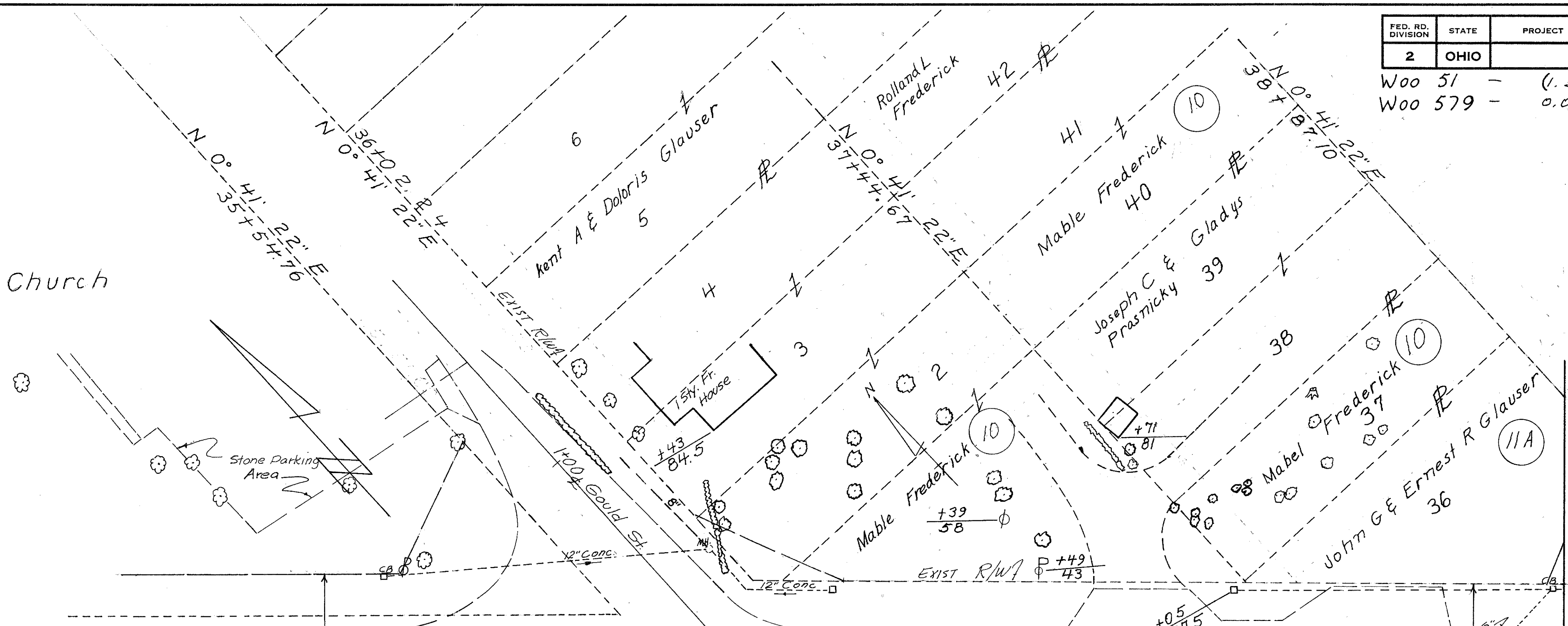

John G. Glauser 11

Glauser's Flowers Inc. 12

R/W 34+00 TO 38+00

FED. RD. DIVISION	STATE	PROJECT
2	OHIO	

Woo 51 (1.57-1.15)
Woo 579 0.01

Deed Area (Corrected)	14,386.00 SF
Total PRO	735.62 SF
Total Take	9,890.91 SF
PRO in Take	735.62 SF
Net Take	9,155.29 SF
Net Residue	4,495.09 SF

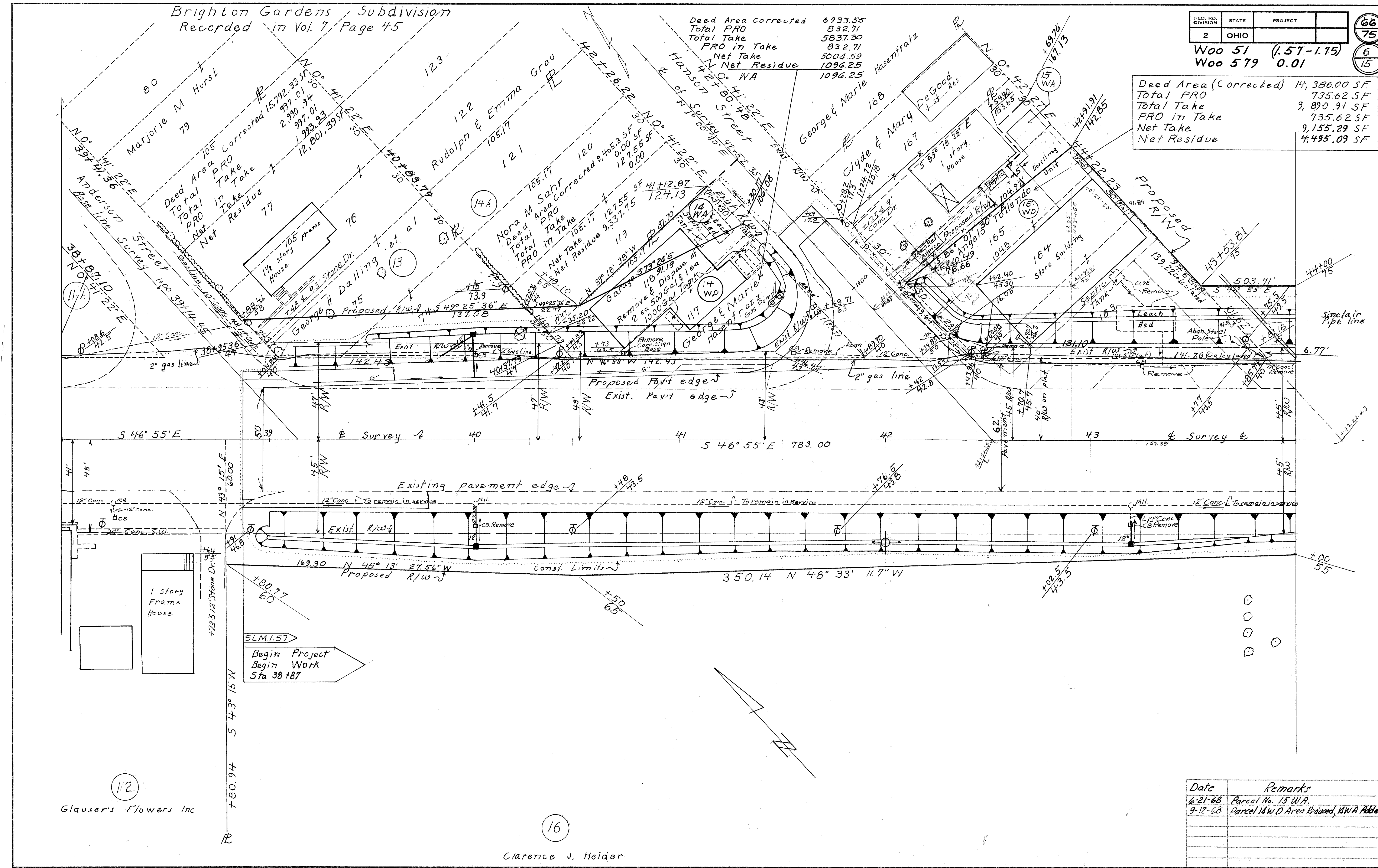

12
Glaser's Flowers Inc

16
Clarence J. Heider

Date	Remarks
6-21-68	Parcel No. 15 W.P.
9-12-68	Parcel 16 W.D Area Reopened, HWA Added

R/W STATION 38+00 to 44+00

Woodville Mall Inc.

(26)

Deed Area	92.445 Acres
Total PRO	1.847 Acres
26 Take	0.879 Acres
26a Take	0.372 Acres
26b Take	0.254 Acres
Total Take	1.505 Acres
PRO in Take	0.849 Acres
Net Take	0.656 Acres
Net Residue	89.942 Acres

FED. RD. DIVISION	STATE	PROJECT
2	OHIO	

Woo-51 (1.57-1.75)
Woo-579 0.01

(67/75)

(7/15)

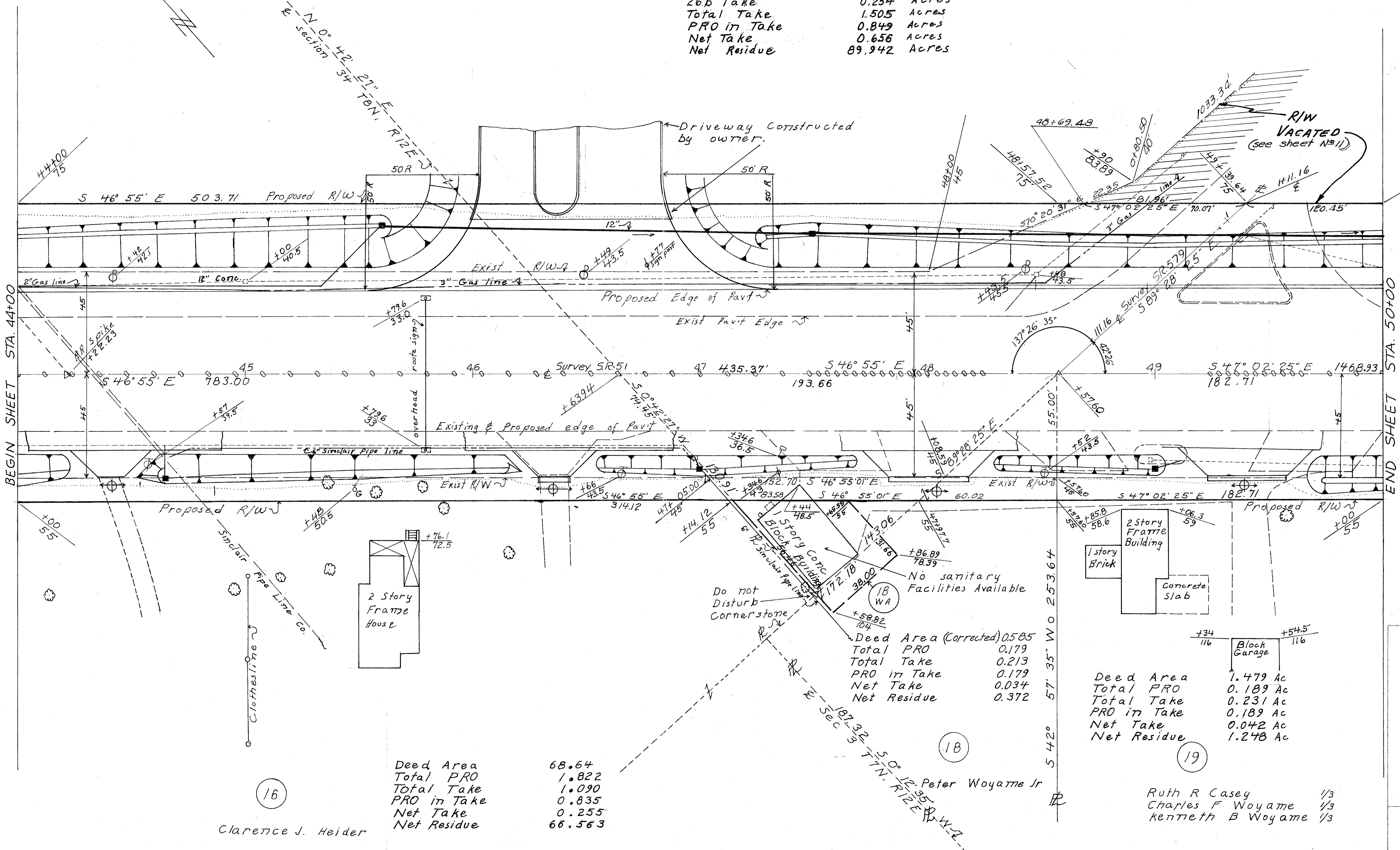

16

Deed Area	68.64
Total PRO	1.822
Total Take	1.090
PRO in Take	0.835
Net Take	0.255
Net Residue	66.563

Clarence J. Heider

18

Deed Area (Corrected)	0.585
Total PRO	0.179
Total Take	0.213
PRO in Take	0.179
Net Take	0.034
Net Residue	0.372

Peter Woyame Jr

19

Deed Area	1.479 Ac
Total PRO	0.189 Ac
Total Take	0.231 Ac
PRO in Take	0.189 Ac
Net Take	0.042 Ac
Net Residue	1.248 Ac

Ruth R Casey 1/3
Charles F Woyame 1/3
Kenneth B Woyame 1/3

Parcel 26
5-2-68
11-3-71 EXISTING R/W 52579 VACATED

FED. RD. DIVISION	STATE	PROJECT
2	OHIO	

W00-51-(1.57-1.75)
W00-579 0.01

Edward J. DeBartolo

17

Deed Area	21.235	Ac
Total PRO	2.613	Ac
Total Take	5.086	Ac
PRO in Take	1.779	Ac
Net Take	3.307	Ac
Net Residue left	2.85	Ac
Net Residue right	0.29	Ac
Net Residue Right	12.17	Ac

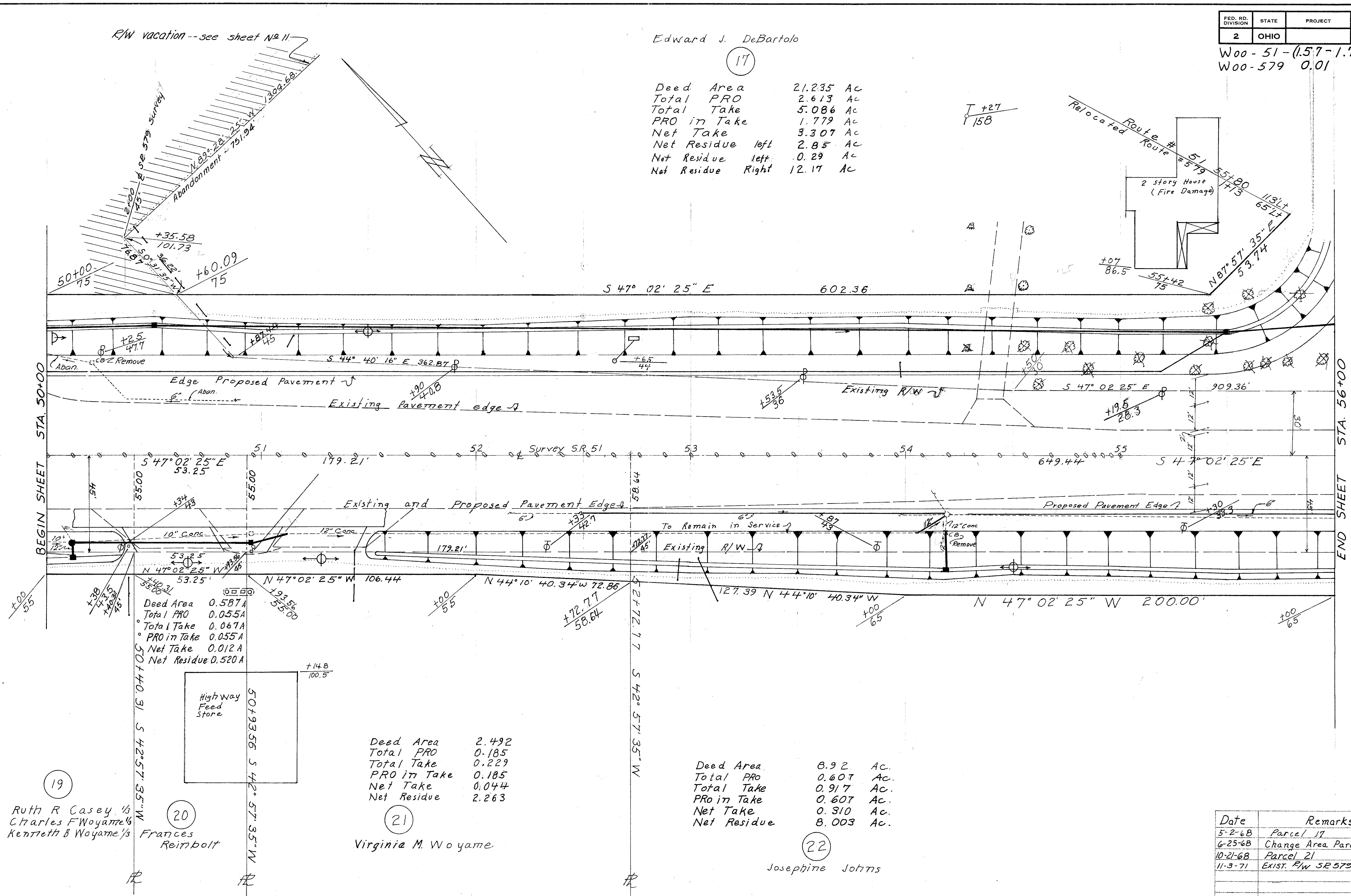
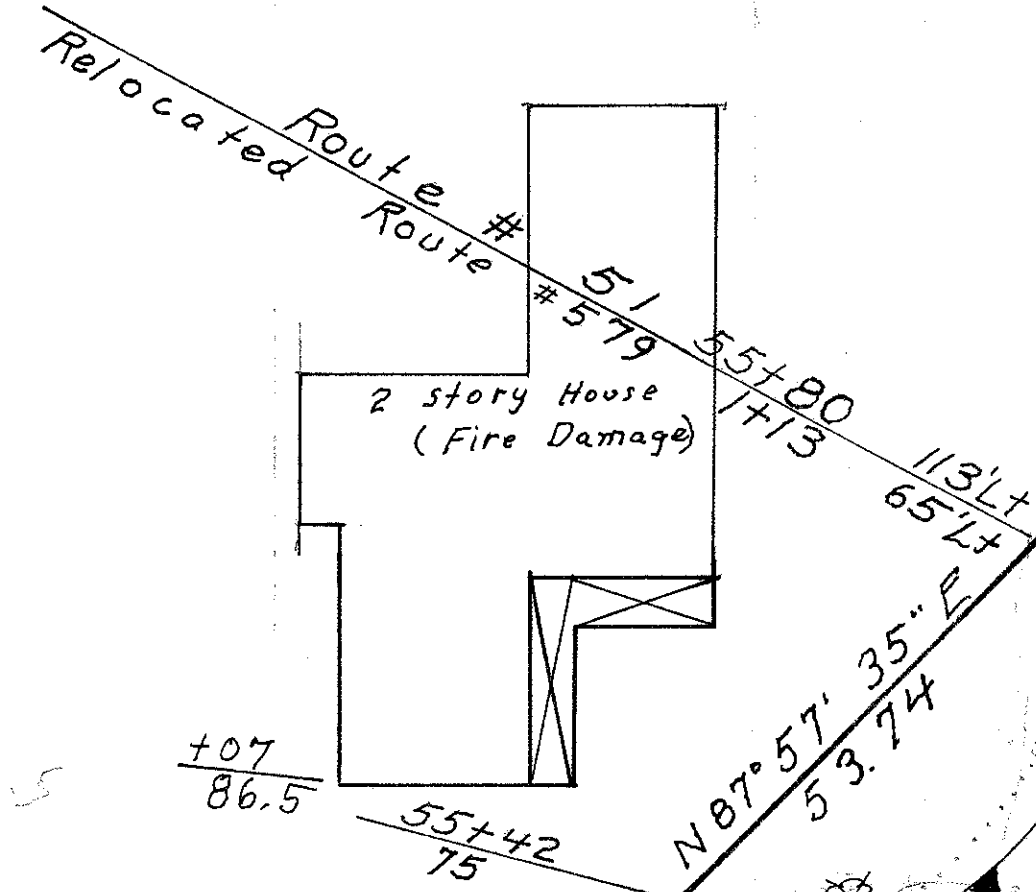

19

Deed Area	0.587A
Total PRO	0.055A
Total Take	0.067A
PRO in Take	0.055A
Net Take	0.012A
Net Residue	0.520A

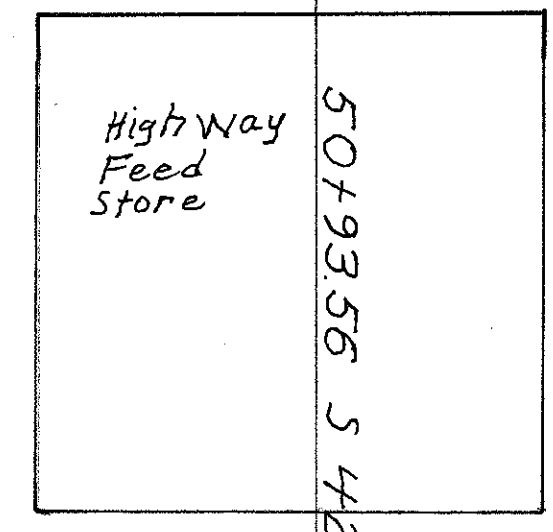

20

Deed Area	2.492
Total PRO	0.185
Total Take	0.229
PRO in Take	0.185
Net Take	0.044
Net Residue	2.263

21

Deed Area	8.92	Ac.
Total PRO	0.607	Ac.
Total Take	0.917	Ac.
PRO in Take	0.607	Ac.
Net Take	0.310	Ac.
Net Residue	8.003	Ac.

Ruth R Casey 1/3
Charles F Woyame 1/3
Kenneth B Woyame 1/3

Frances Reimbolt

Virginia M. Woyame

Josephine Johns

Date	Remarks
5-2-68	Parcel 17
6-25-68	Change Area Parcel 22
10-21-68	Parcel 21
11-3-71	EXIST. R/W SR 579 VACATED

FED. RD. DIVISION	STATE	PROJECT
2	OHIO	

Woo-51- (1.57-1.75)
Woo 579 0.01

69
75

9
15

Edward J. DeBartolo

17

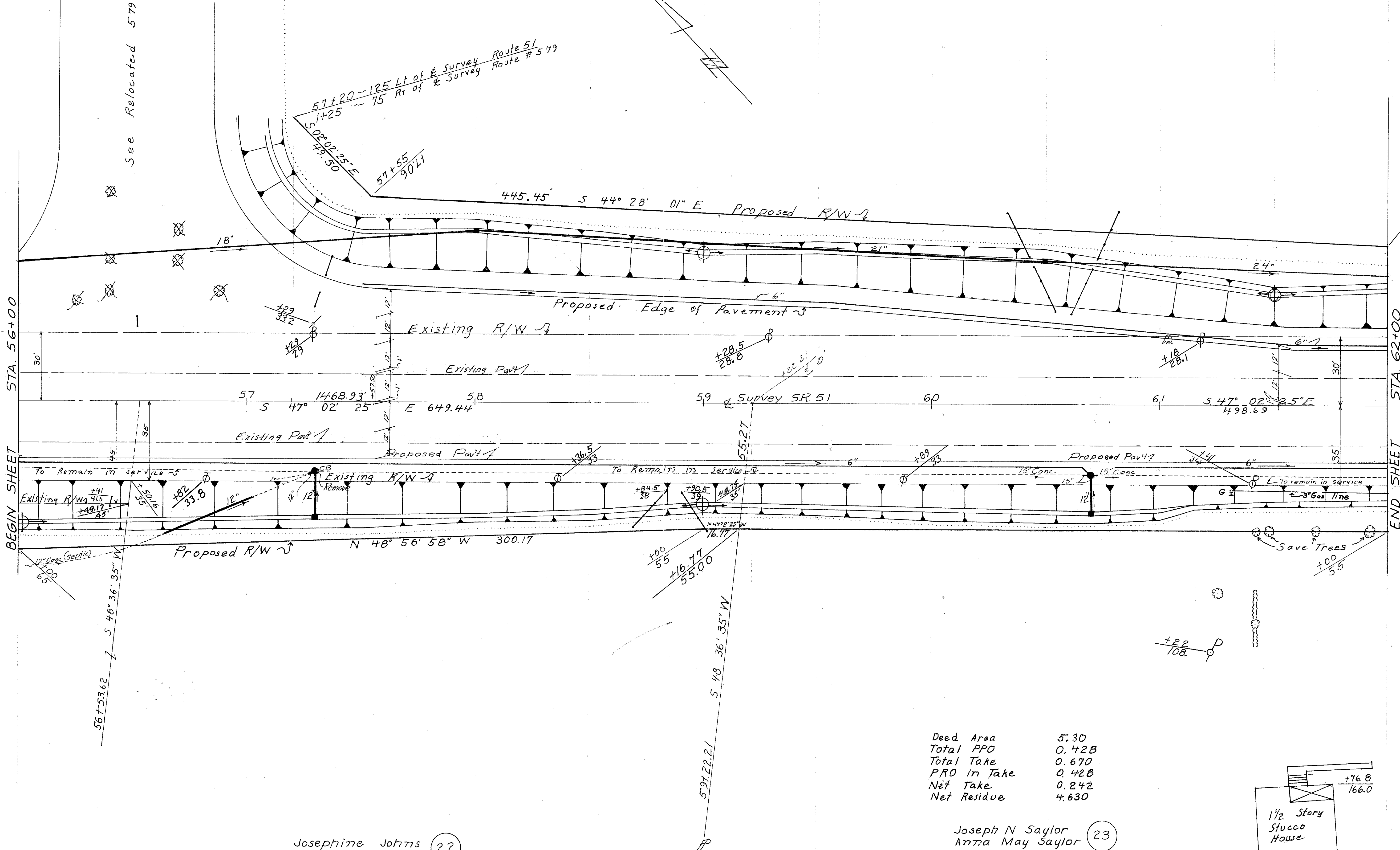

BEGIN SHEET
STA. 56+00

END SHEET
STA. 62+00

Deed Area	5.30
Total PPO	0.428
Total Take	0.670
PPO in Take	0.428
Net Take	0.242
Net Residue	4.630

Joseph N Saylor
Anna May Saylor

23

Josephine Johns

22

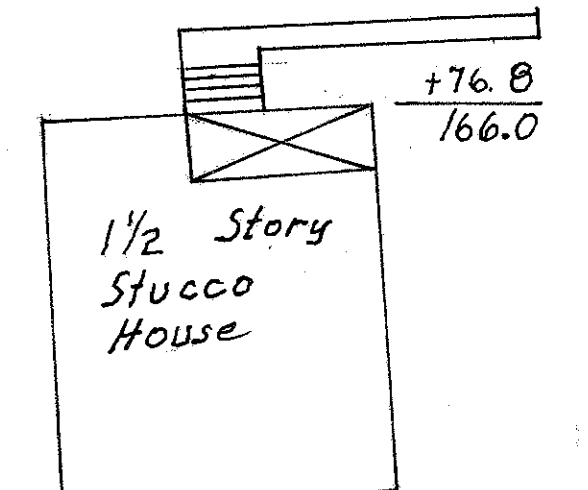

R/W STATION 56+00 To 62+00

Edward J. DeBartolo

17

FED. RD. DIVISION	STATE	PROJECT	70
2	OHIO		75

Woo-51 - (1.57-1.75)
Woo-579 0.01

10
15

Dorothy Zingg
4.5 Acres

Deed Area 4.500 Ac.
 Total PRO 0.272 Ac.
 Total Take 0.632 Ac.
 PRO in Take 0.272 Ac.
 Net Take 0.360 Ac.
 Net Residue 3.868 Ac.

End Project
Sta 63+10

End Work
Sta 67+74

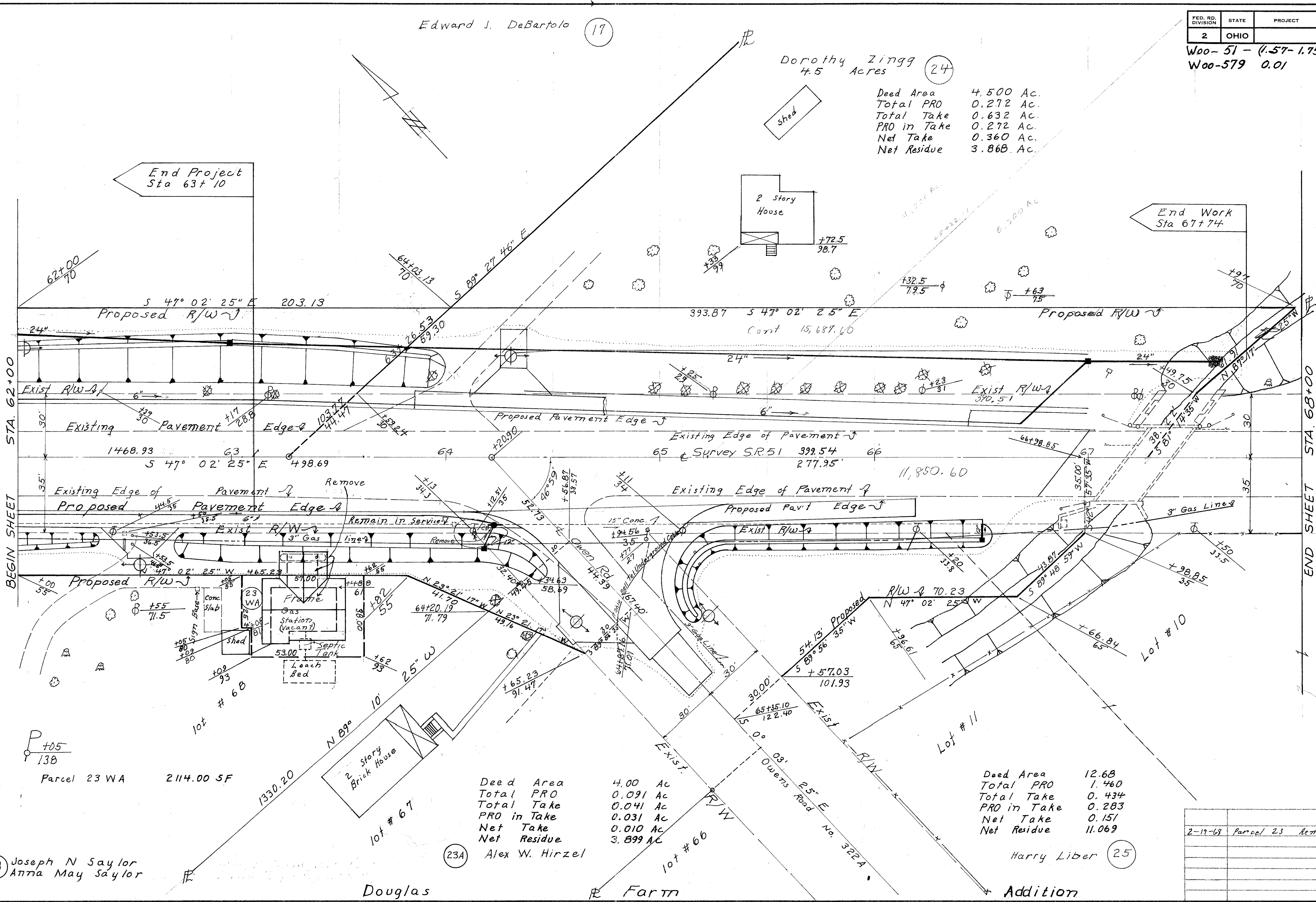

BEGIN SHEET STA. 62+00

END SHEET STA. 68+00

Deed Area 4.00 Ac
 Total PRO 0.091 Ac
 Total Take 0.041 Ac
 PRO in Take 0.031 Ac
 Net Take 0.010 Ac
 Net Residue 3.899 Ac

Deed Area 12.68
 Total PRO 1.460
 Total Take 0.434
 PRO in Take 0.283
 Net Take 0.151
 Net Residue 11.069

2-19-69	Parcel 23	Remove Tree

23 Joseph N Saylor
Anna May Saylor

23A Alex W. Hirzel

Harry Liber 25

Douglas

R Farm

Addition

R/W STATION 62+00 TO 68+00

FED. RD. DIVISION	STATE	PROJECT
2	OHIO	

Woo 51- (1.57-1.75)
Woo-579-0.01

71
75

11
15

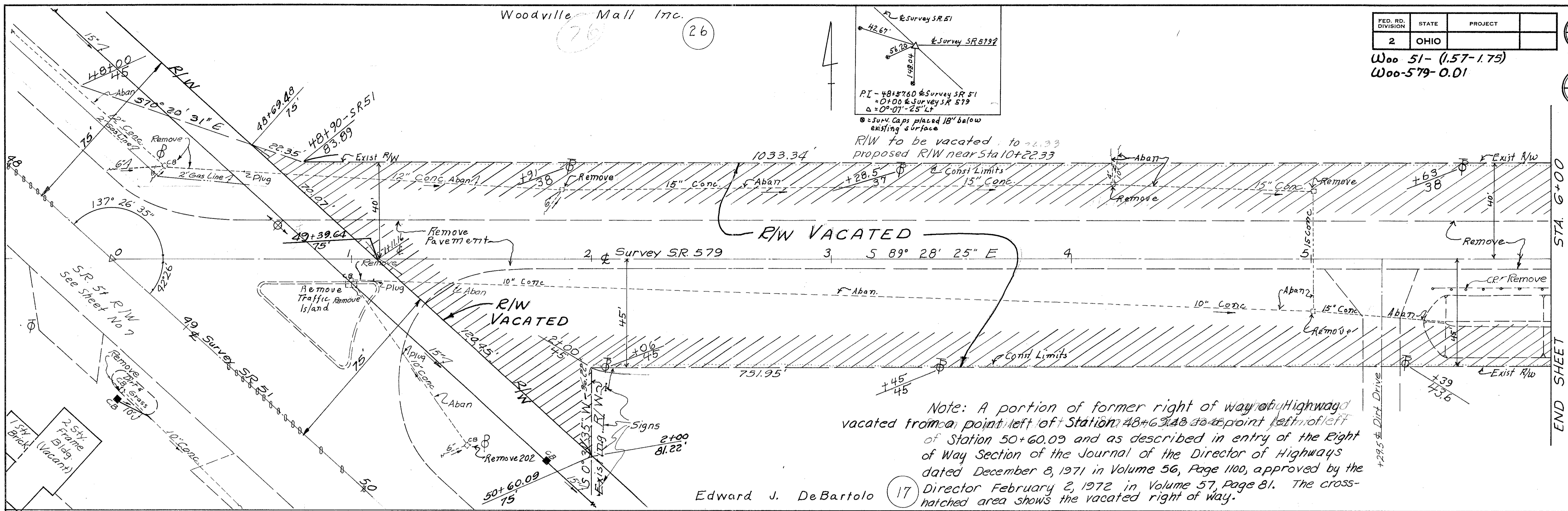

Note: A portion of former right of way of Highway vacated from a point left of Station 48+62.48 to a point left of Station 50+60.09 and as described in entry of the Right of Way Section of the Journal of the Director of Highways dated December 8, 1971 in Volume 56, Page 100, approved by the Director February 2, 1972 in Volume 57, Page 81. The cross-hatched area shows the vacated right of way.

Edward J. DeBartolo (17)

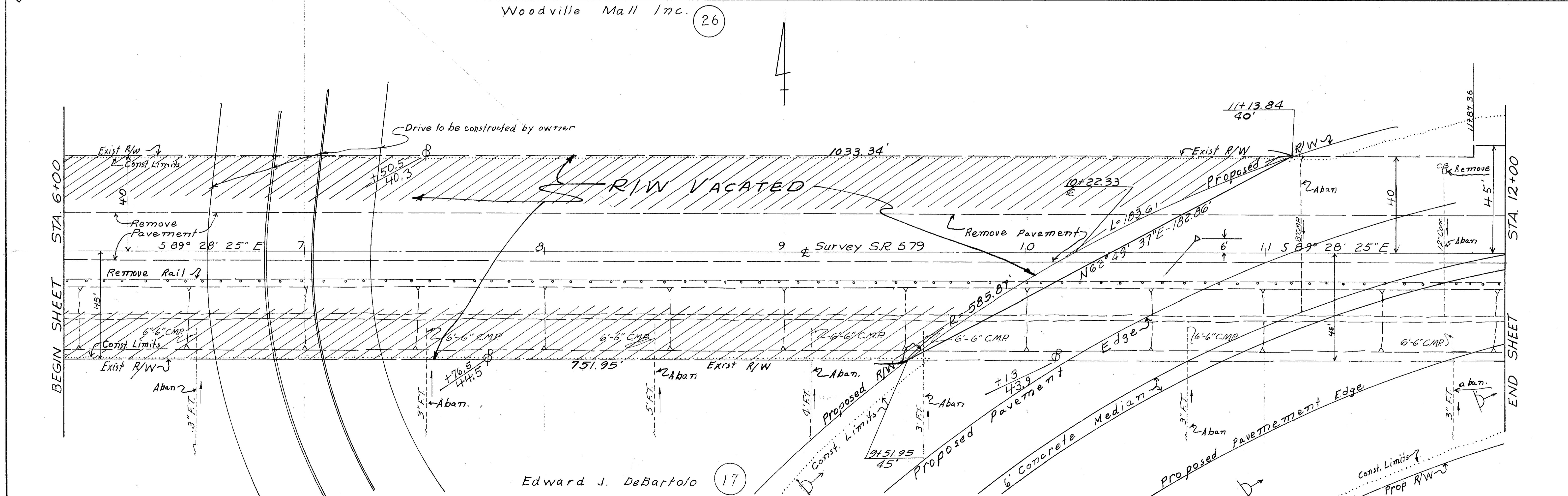

Edward J. DeBartolo (17)

11-4-71 EXISTING R/W SR 579 VACATED

Deed Area	16.078
Total PRO	0.528
Total Take	0.821
PRO in Take	0.528
Net Take	0.293
Net Residue	15.257

FED. RD. DIVISION	STATE	PROJECT
2	OHIO	

Woo 51- (1.57-1.75)
Woo 579- 0.01

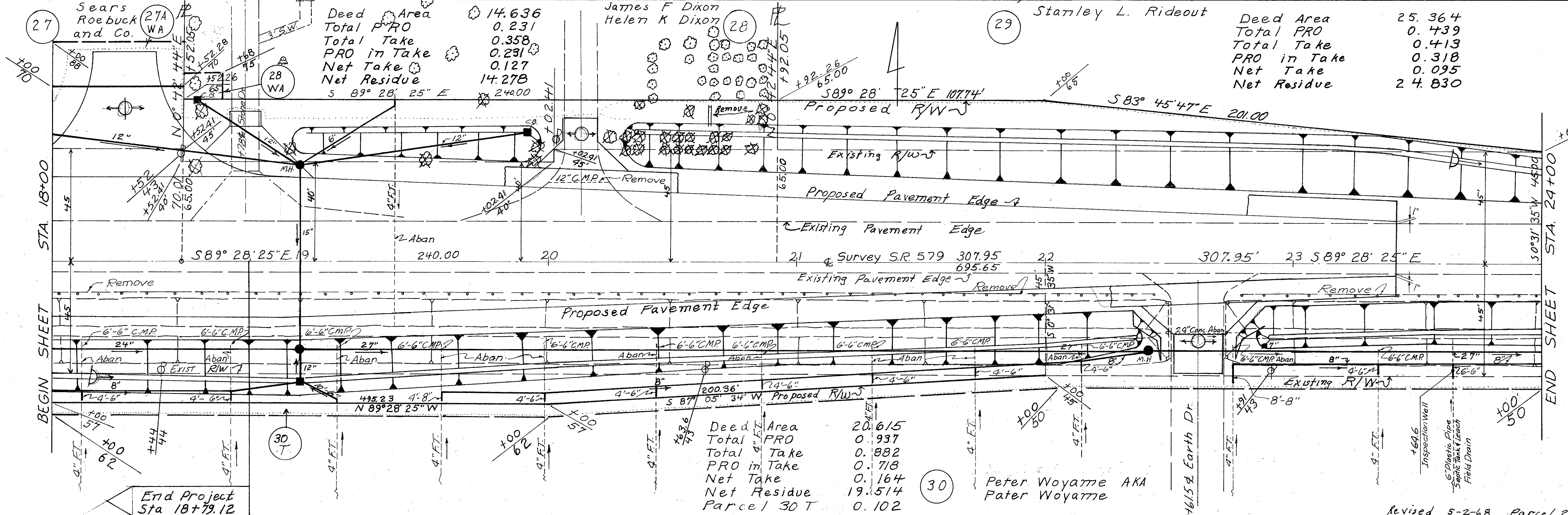
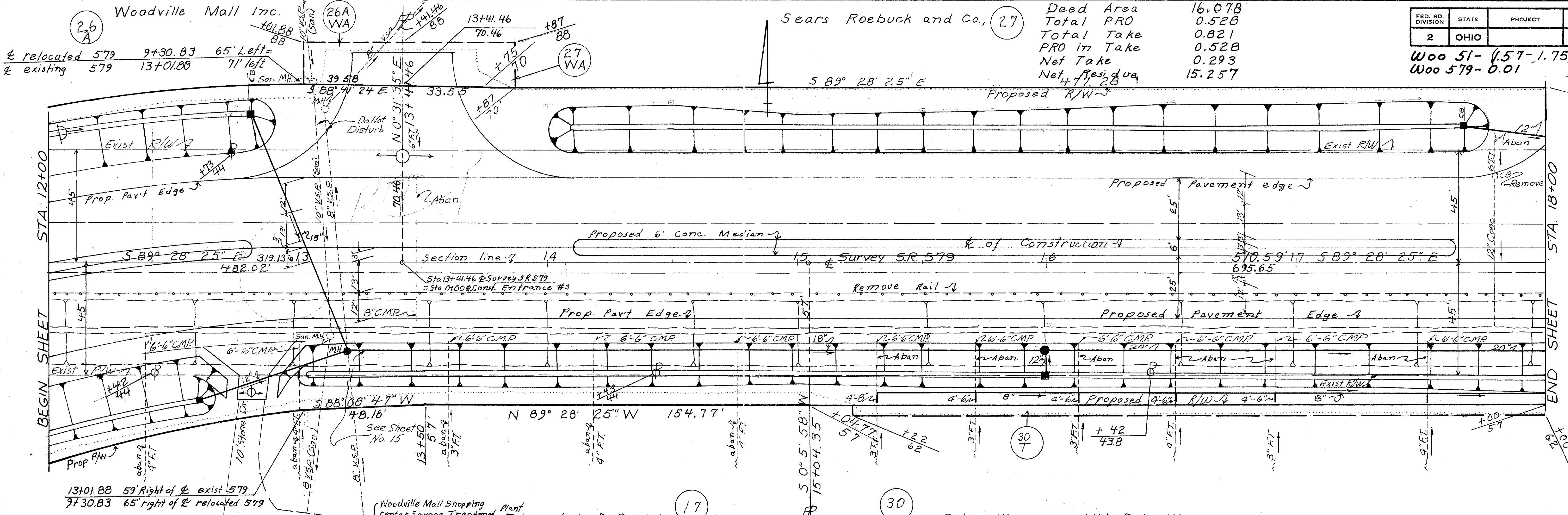

Deed Area	14.636
Total PRO	0.231
Total Take	0.358
PRO in Take	0.231
Net Take	0.127
Net Residue	14.278

Deed Area	25.364
Total PRO	0.439
Total Take	0.413
PRO in Take	0.318
Net Take	0.095
Net Residue	24.830

Deed Area	20.615
Total PRO	0.937
Total Take	0.882
PRO in Take	0.713
Net Take	0.164
Net Residue	19.514

Date	Remarks
10-21-68	Parcel 30
10-28-68	Parcel 30

Stanley L. Rideout

FED. RD. DIVISION	STATE	PROJECT
2	OHIO	

Woo-51-(1.57-1.75)
Woo-579-0.01

73
75

13
15

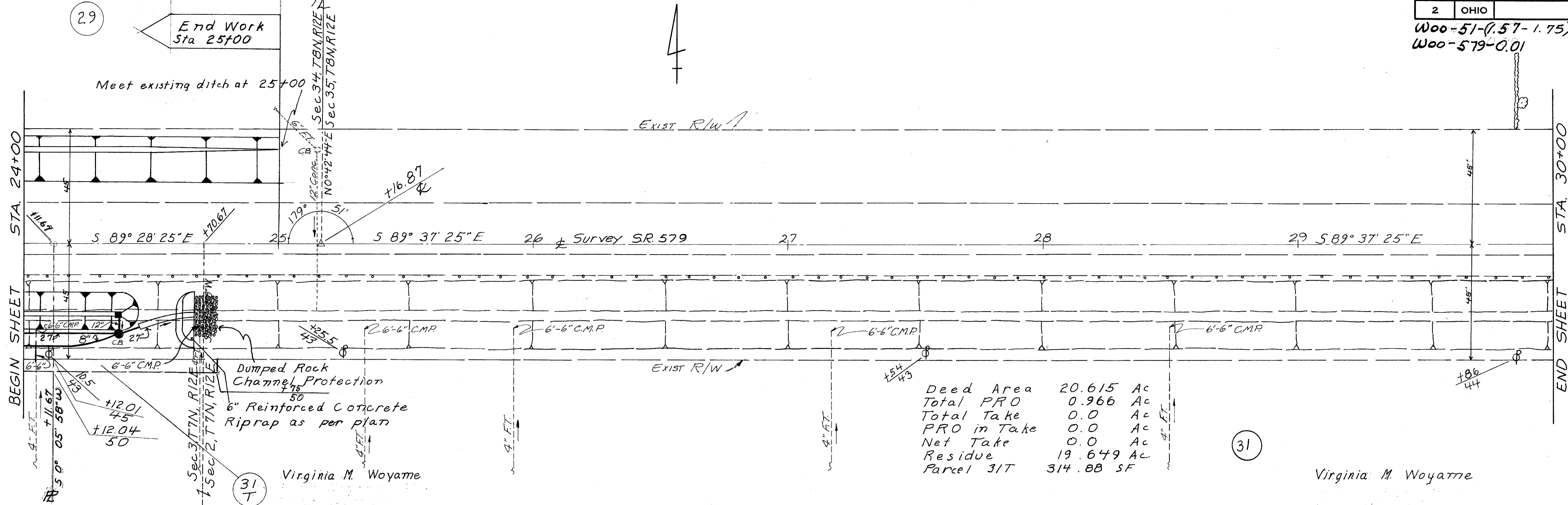

Deed Area	20.615	Ac
Total PRO	0.966	Ac
Total Take	0.0	Ac
PRO in Take	0.0	Ac
Net Take	0.0	Ac
Residue	19.649	Ac
Parcel 31T	314.88	SF

Virginia M. Woyame

Virginia M. Woyame

Date	Remarks
10-21-68	Parcel 30
10-28-68	Add Parcel 31T

S.R. 579 ~ STA. 24+00 to STA.

Edward J. DeBartolo (17)

Woodville Mall Inc.

Net Take 0.254 Ac
 PRO 17 Take 0.000 Ac
 Total Take 0.254 Ac
 See Sheet No. 7

FED. RD. DIVISION	STATE	PROJECT
2	OHIO	

Woo 51 - (1.57-1.75)
 Woo 579 - 0.01

74
75
14
15

Edward J. DeBartolo

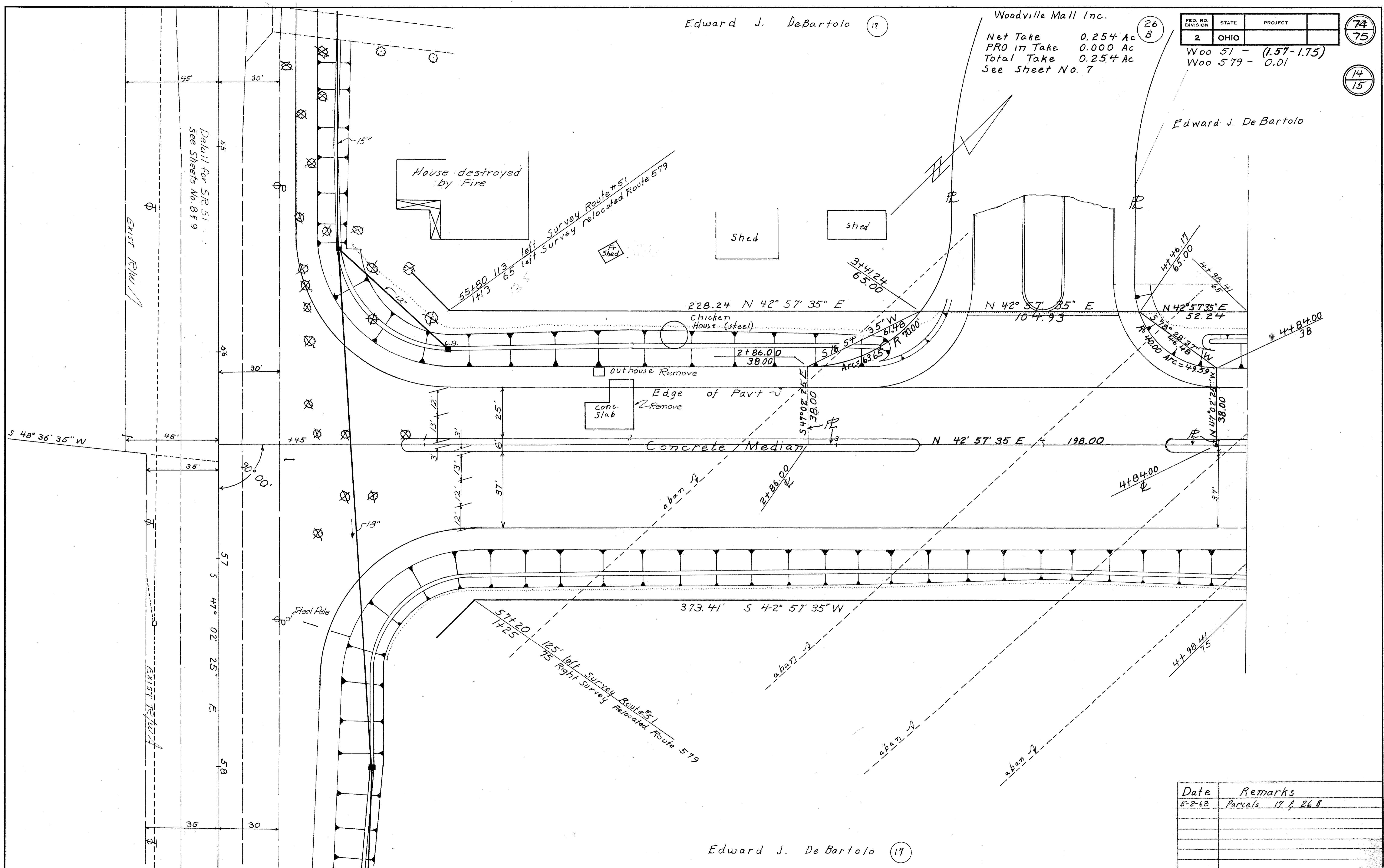

Edward J. DeBartolo (17)

Date	Remarks
5-2-68	Parcels 17 & 26.8

FED. RD. DIVISION	STATE	PROJECT
2	OHIO	

75
75

Woo 51 (1.57-1.75)
Woo 579 0.01

15
15

26
A Woodville Mall Inc.

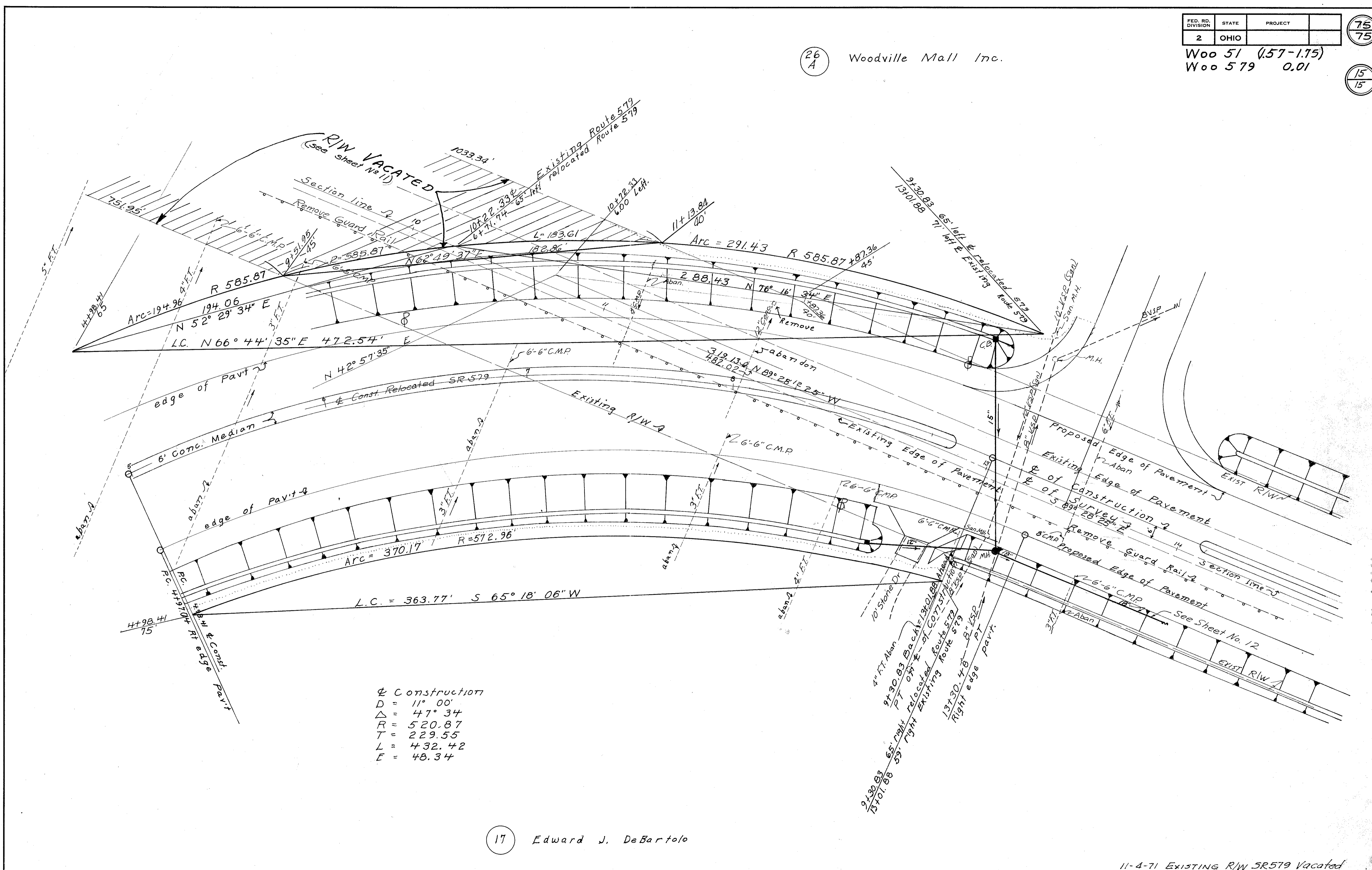

Construction
 D = 11° 00'
 Δ = 47° 34'
 R = 520.87
 T = 229.55
 L = 432.42
 E = 48.34

17 Edward J. DeBar tolo