

8005

STATE OF OHIO DEPARTMENT OF HIGHWAYS W00-6-(11.13-13.11) WOOD COUNTY CITY OF BOWLING GREEN

FED. RD. DIVISION	STATE	PROJECT	
2	OHIO	STATE	

W00-6 (11.13-13.11)

SEP 20 1962
GROUND PHOTOLAB

CONVENTIONAL SIGNS

County Line	-----
Township Line	- - - - -
Section Line	-----
Corporation Line	-----
Center Line	-----
Pole Line	⊕ ⊕ ⊕ ⊕ ⊕ ⊕ ⊕ ⊕ ⊕ ⊕ ⊕
Railroad	-----
Drainage	Exist ----- New -----

INDEX OF SHEETS

Title Sheet	1
Typical Sections	2-3
General Notes	4
General Summary	4
Catch Basin Detail	5
Sub Summaries	5-6
Calculations	7
Plan & Profile Sheets	8-17

LINE DATA

	PROJECT	LIN. FT.	MILES	WORK	LINE	MILE
Begin	587+7665			587+7665		
Suspend	624+052	3628.55		624+052	3,628.55	
Resume	624+140			624+140		
Suspend	641+80	1,766.00		641+962	1,782.20	
Resume	642+65			642+522		
Suspend	658+44	1,579.00		658+440	1,591.80	
Resume	658+76			658+76.0		
End	699+8175	4,105.75		699+81.75	4,105.75	
TOTAL		11,079.30	2.098		11,108.30	2.103

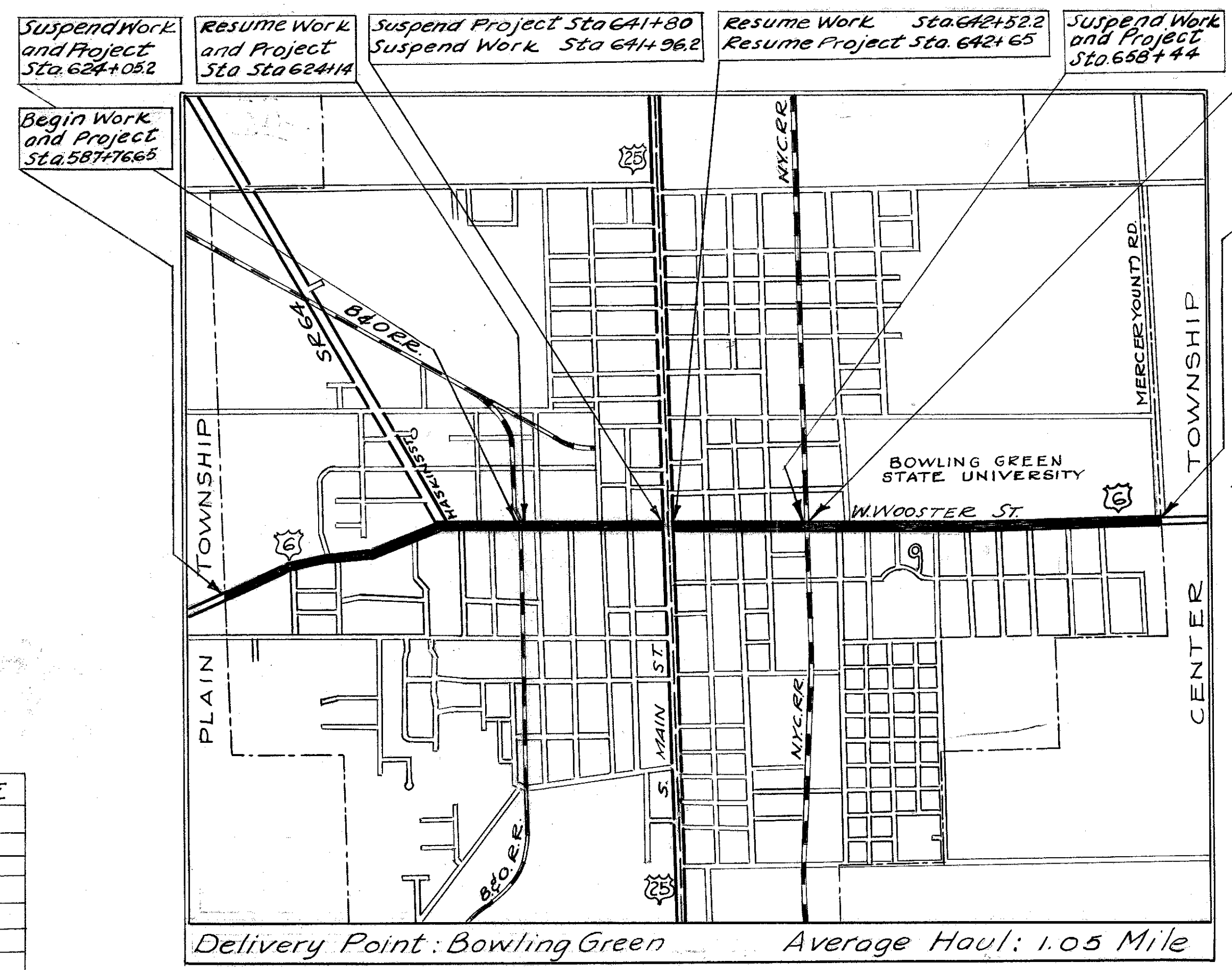

Delivery Point: Bowling Green Average Haul: 1.05 Mile

LOCATION MAP
Scale in feet
0 800 1200 2400 3600

Portion to be improved
State routes
Other streets

SCALE
Plan 1" = 50'
Profile Vertical 1" = 5'
Profile Horizontal 1" = 50'

The standard specifications of the State of Ohio Department of Highways, including changes and supplemental specifications listed in the proposal shall govern this improvement.
The right-of-way for this improvement will be provided by the State of Ohio.

I hereby approve these plans and declare the making of this improvement will not require the closing of the highway to traffic, and that provisions for the maintenance and safety of traffic will be as set forth on the plans and estimates.

Approved G. W. Luber
Date 4-22-60 Division Deputy Director

Approved Ray E. Yeager
Date 5-18-60 Deputy Director of Planning & Programming

Approved _____
Date _____ Engineer of Bridges

Approved W. M. Menden
Date 5-16-60 Engineer of Location and Design

Approved C. W. McCaughey
Date 5-16-60 Deputy Director of Design and Construction

Approved G. A. Berry
Date 5-19-60 First Assistant Director

Approved E. S. Preston
Date 5-20-60 Director of Highways

FILE NO WOOD COUNTY
SECS W00-6 (11.13) (13.11)
DATE OF LETTING CONTRACT _____

STANDARD DRAWINGS

I-8 M.H. No 1	1-26-59	B.T-50-70-71E*	10-1-47
I-1, 2, 3, 4, 5	4-24-58	B.T-71R	3-2-53
I-12	7-1-54	G-7.07	6-1-56
L-3	4-1-50	L.J. No 1	7-1-55
L-3-A	4-1-50	T.J.	5-1-56
R1-1	7-15-58		
T-35	1-2-56		

SUPPLEMENTAL SPECIFICATIONS

SEP 20 1962
GROUND PHOTOLAB

DEPARTMENT OF COMMERCE
BUREAU OF PUBLIC ROADS

DIVISION ENGINEER _____ DATE _____

P.I. Sta. 588+12.1
Δ = 11°26' Lt.

P.I. Sta. 596+05.3
Δ = 5°57' Rt.

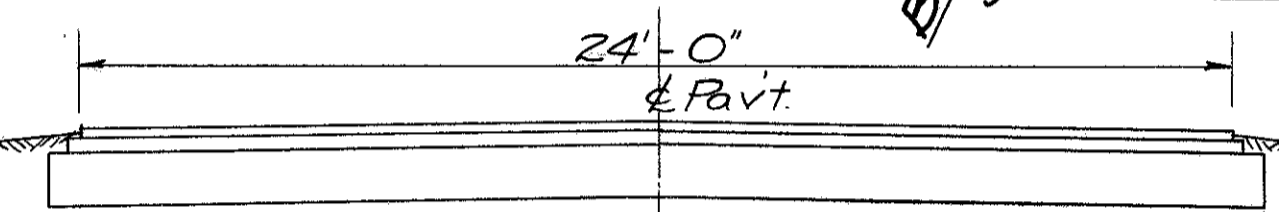
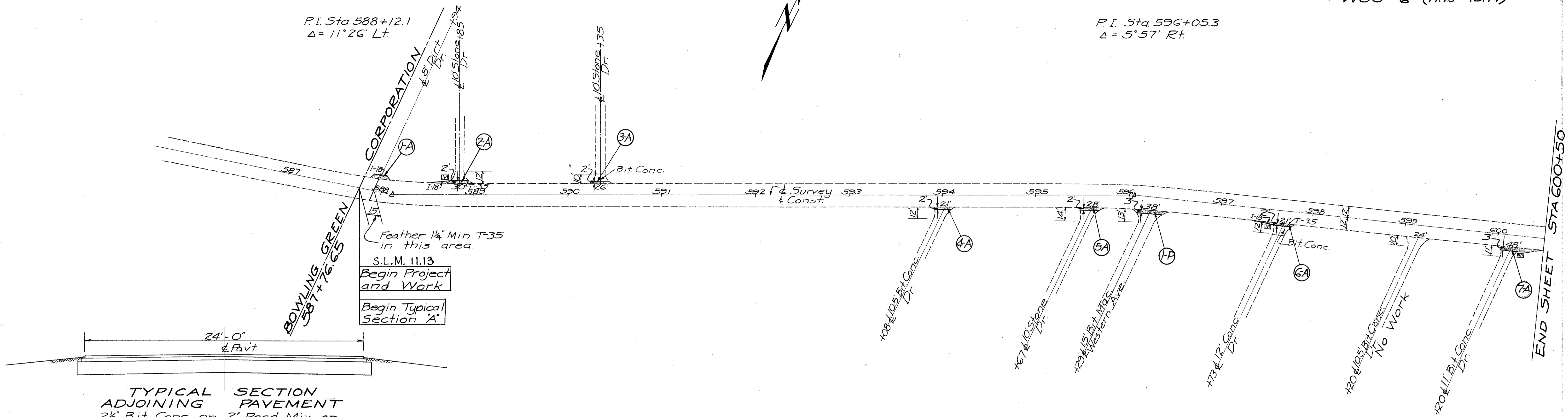

TYPICAL SECTION ADJOINING PAVEMENT
2½" Bit Conc. on 2" Road Mix on 10" Waterbound Macadam, 24' wide.

S.L.M. 11.13
Begin Project and Work
Begin Typical Section 'A'

B.M. bolt flange hydrant
Sta. 593+35
Elev. = 696.23

B.M. bolt flange hydrant
Sta. 597+75
Elev. = 692.66

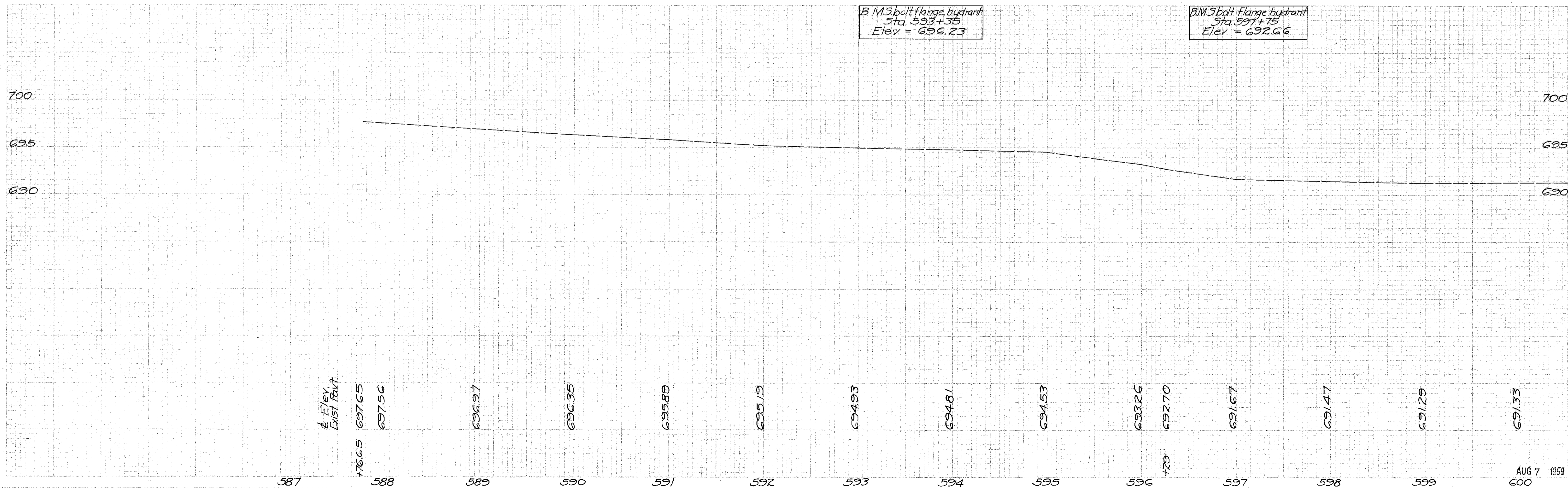

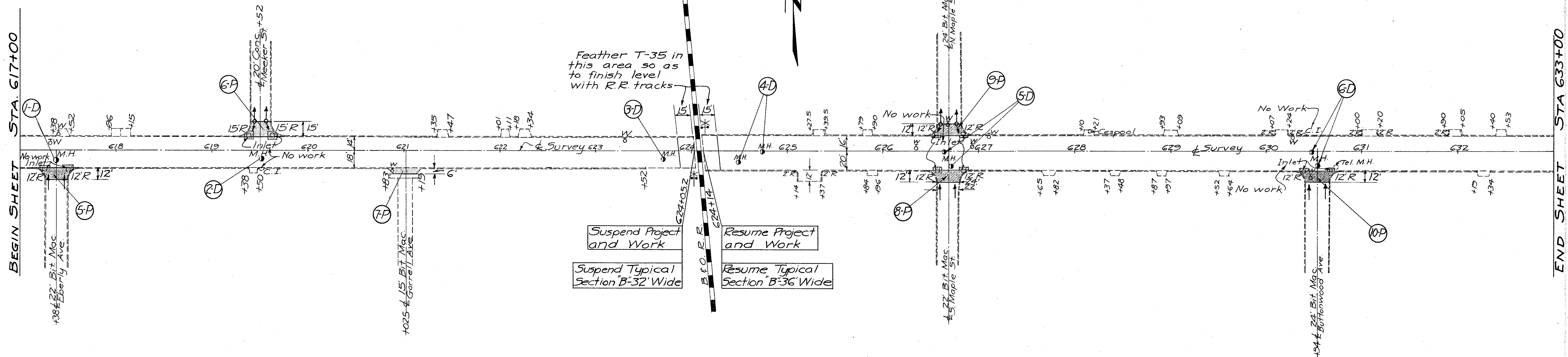

B.M. SW Cor. bot. step, house
Lt. & 608 W. Wooster
Elev. = 688.09

B.M. NE Cor. frdn. Rt. &
Avery Coal & Supply
Elev. = 688.94

B.M. SE Cor. bot. step, house
Lt. & 422 W. Wooster
Elev. = 691.03

B.M. SE Cor. bot. step, house
Lt. & 316 W. Wooster
Elev. = 692.39

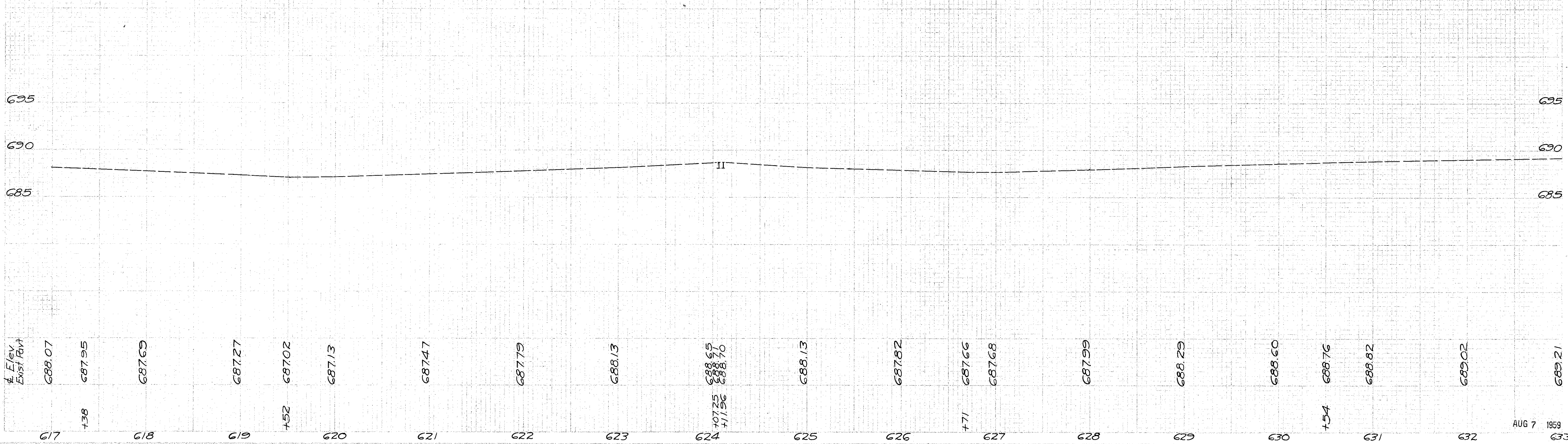

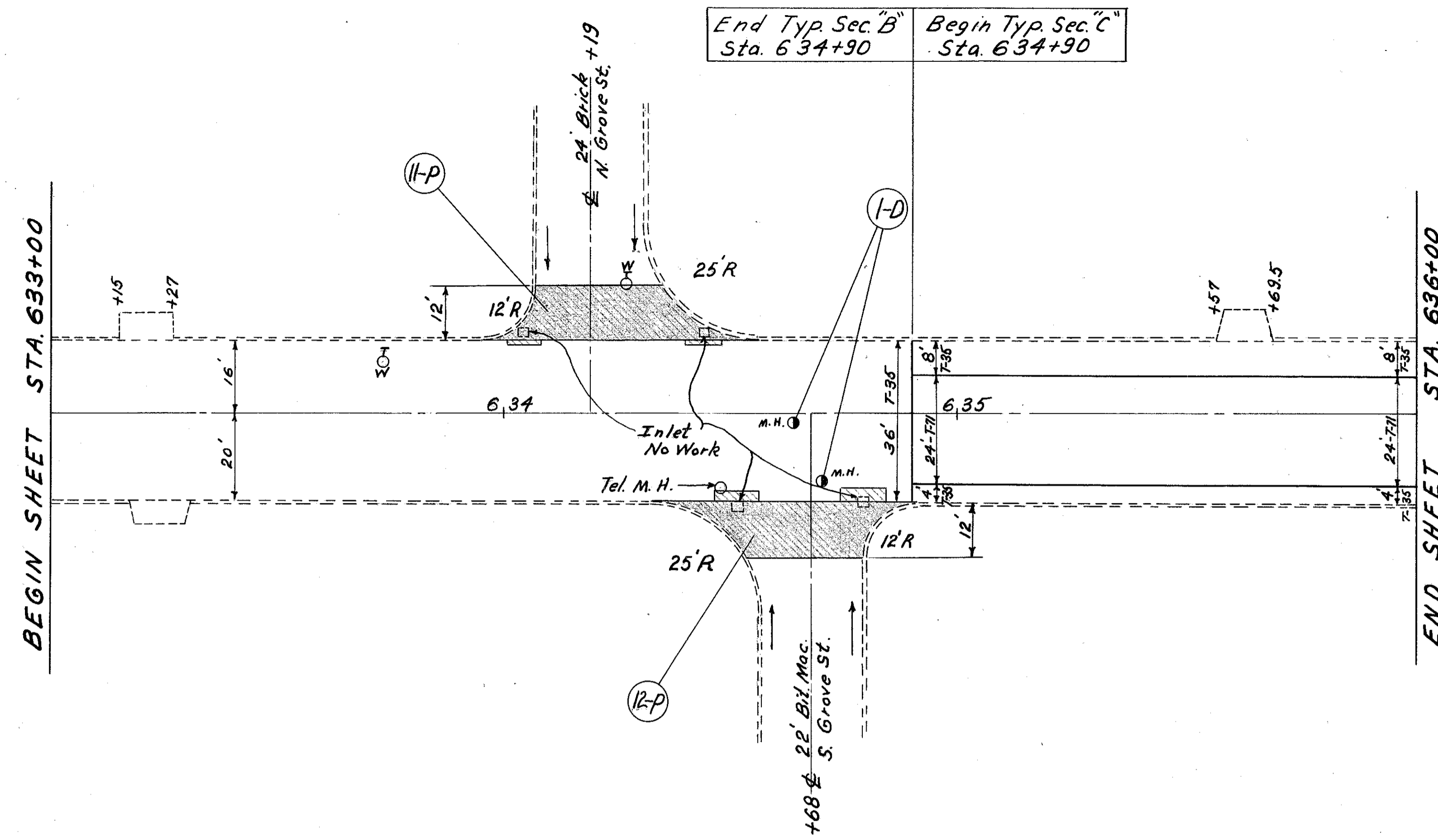

B.M. N.E. Cor. base light pole
 Rt. @ Sta. 635+52
 Elev. = 692.33

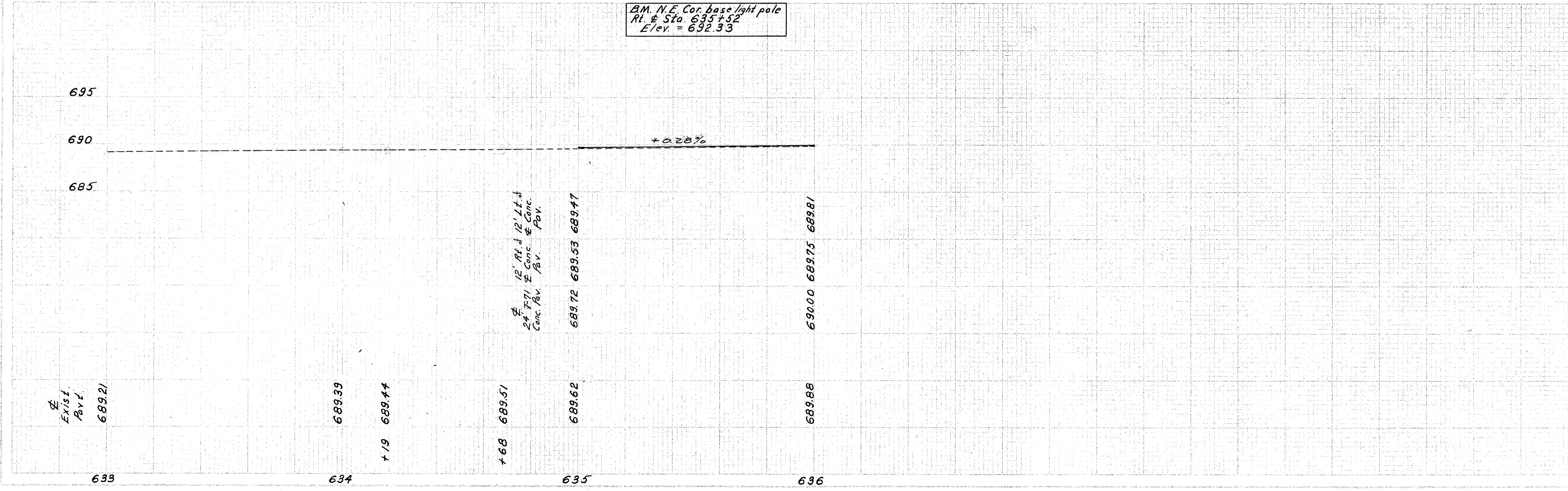

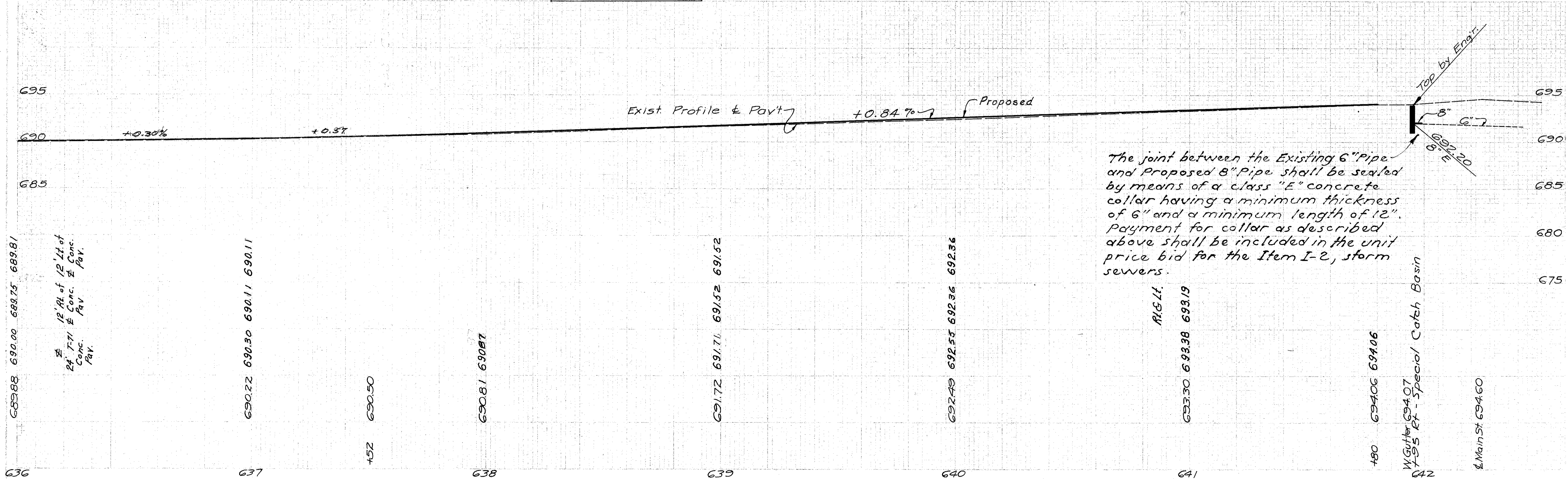
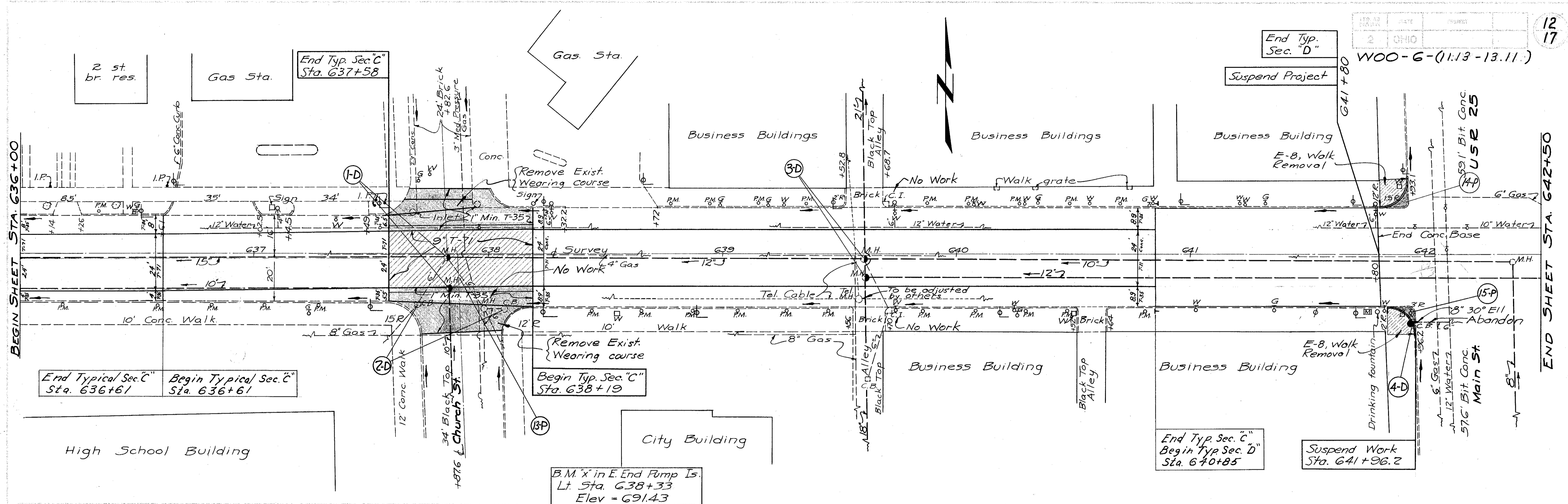

The joint between the Existing 6" Pipe and Proposed 8" Pipe shall be sealed by means of a class "E" concrete collar having a minimum thickness of 6" and a minimum length of 12". Payment for collar as described above shall be included in the unit price bid for the Item I-2, storm sewers.

Sta. 636+00 to Sta. 642+50

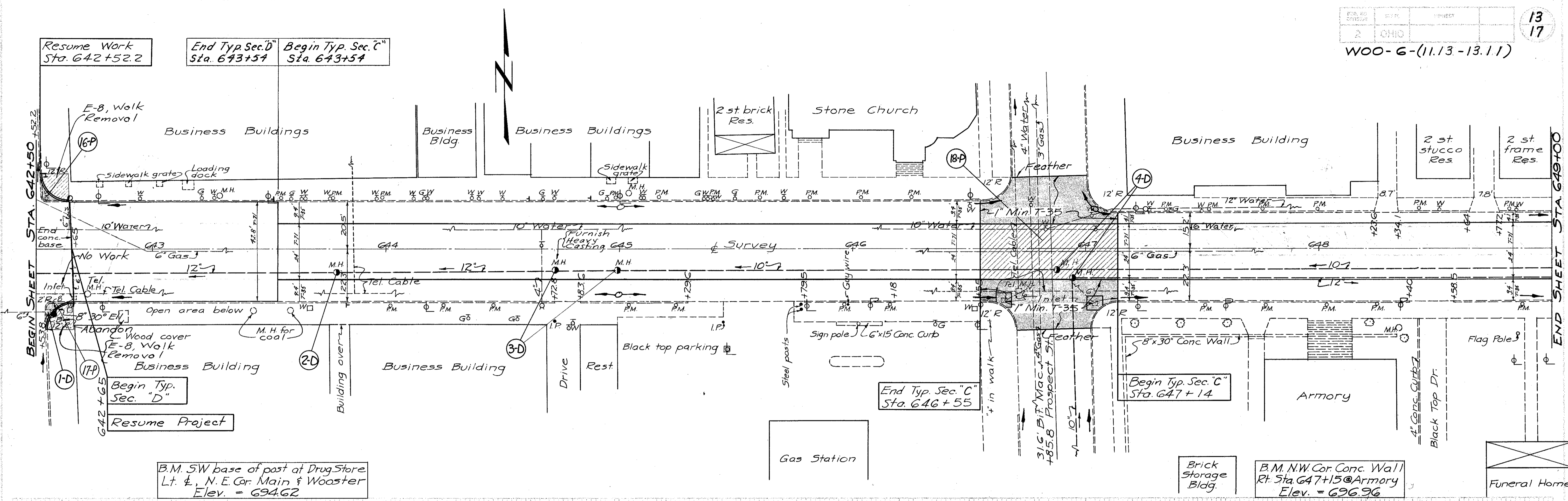

B.M. SW base of post at Drug Store
Lt. & N. E. Cor. Main & Wooster
Elev. = 694.62

Brick Storage Bldg.

B.M. N.W. Cor. Conc. Wall
Rt. Sta. 647+15 @ Armory
Elev. = 696.96

Funeral Home

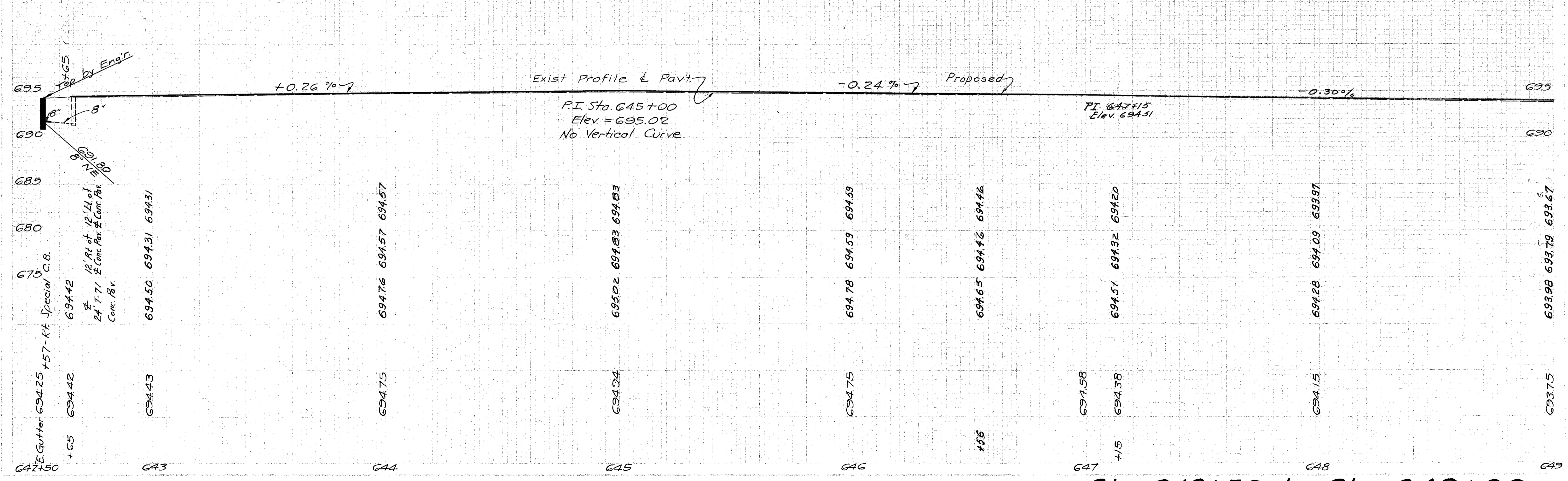

Sta. 642+50 to Sta. 649+00

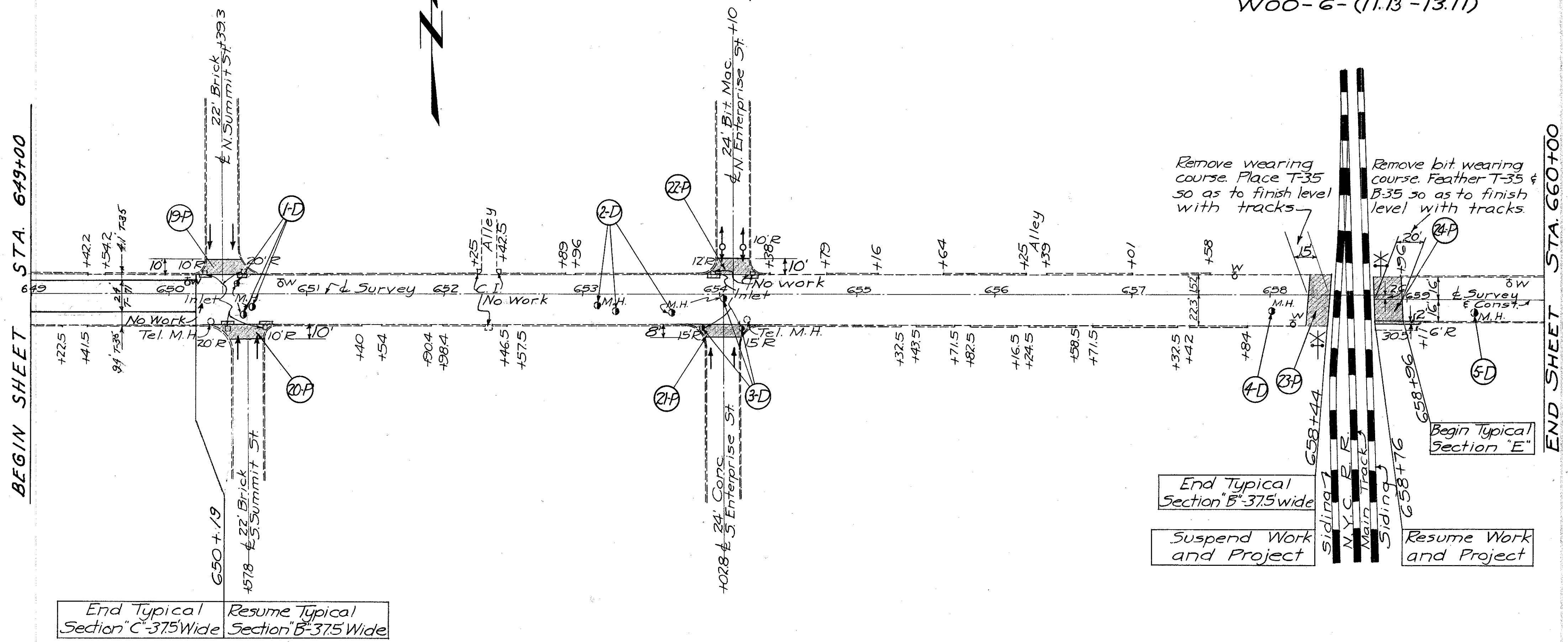

End Typical Section "C" 37.5 Wide Resume Typical Section "B" 37.5 Wide

End Typical Section "B" 37.5 wide
Suspend Work and Project
Resume Work and Project
Begin Typical Section "E"

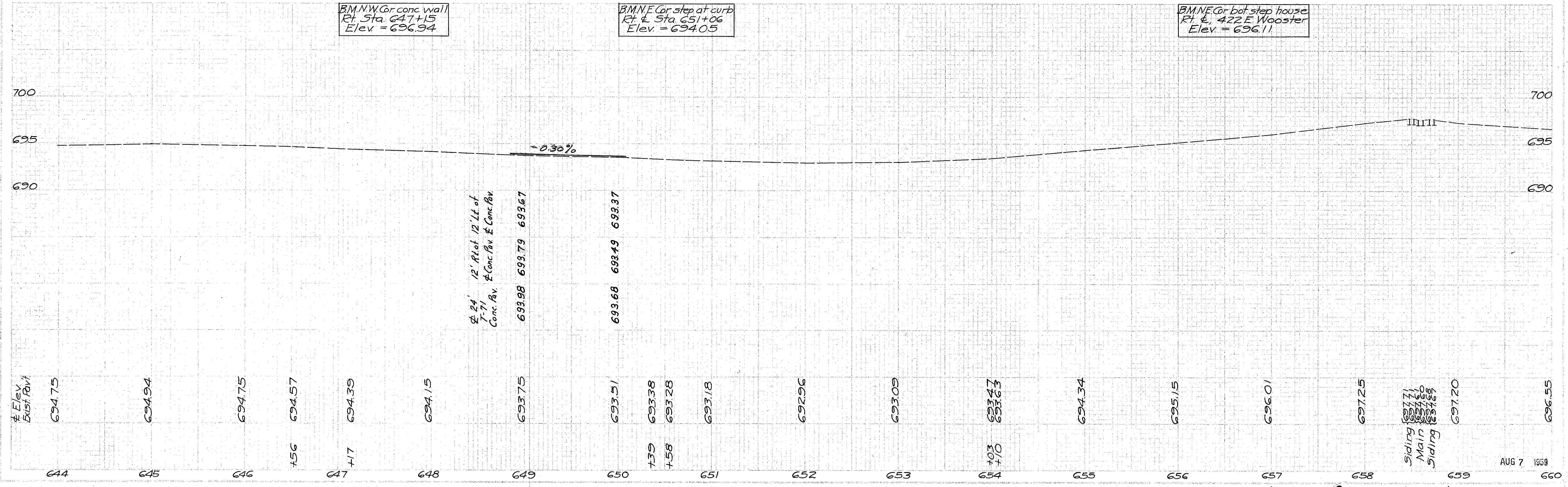

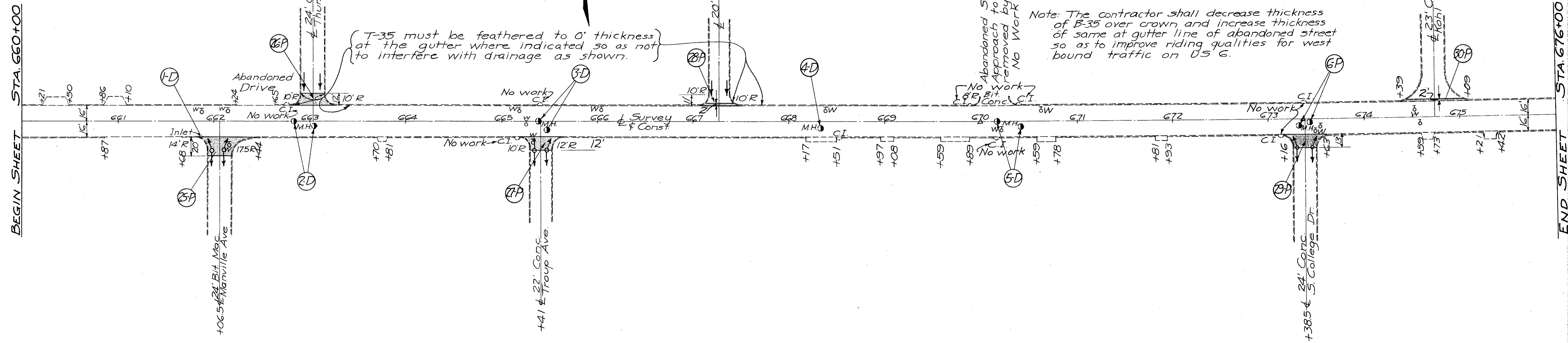

P.I. Sta. 670+00.50
Δ = 0° 31' Lt.

P.I. Sta. 673+36.90
Δ = 0° 35' Lt.

B.M. N.E. Cor. conc base
Hamblin Cleaners sign Rt. &
Elev. = 698.10

B.M. S.E. Cor. 1st step Dormitory
Lt. & Sta. 665+59
Elev. = 695.56

B.M. Top N. bolt flange hydrant
Rt. & Sta. 670+78
Elev. = 694.92

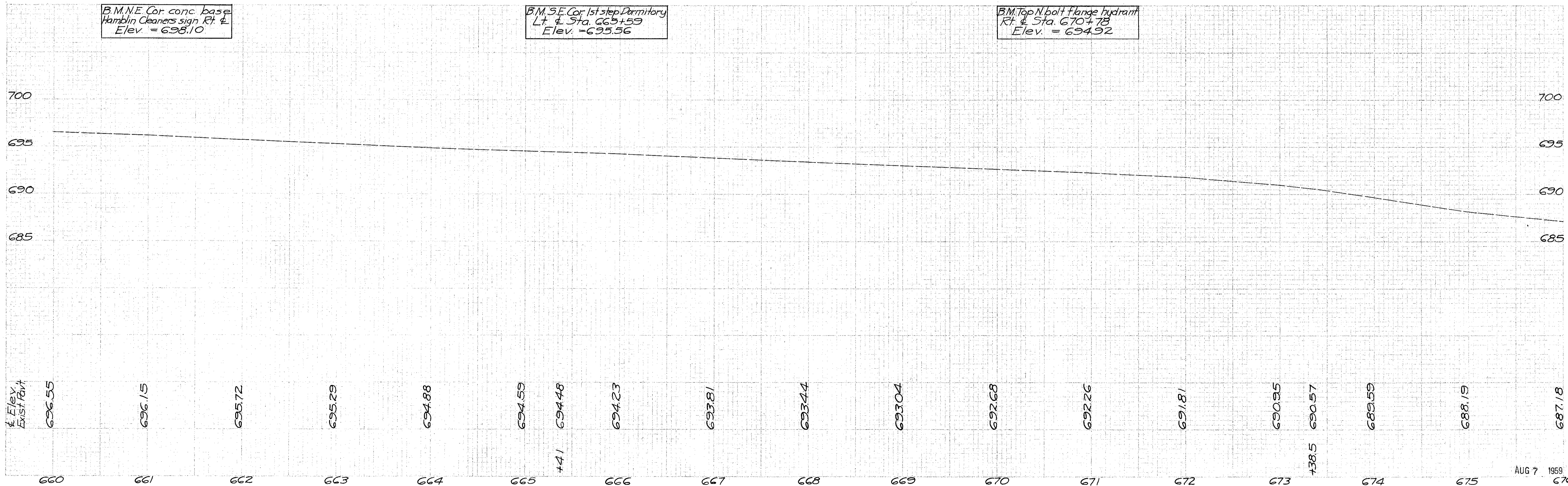

Sta. 660+00 to Sta. 676+00

Station	Elev.	Notes
676	687.18	
677	686.06	
+24	685.71	
678	684.76	
679	684.74	
680	685.04	
+86	685.30	
681	685.30	
682	685.46	
683	685.24	
684	684.99	
+53	684.89	
685	684.75	
686	684.33	
687	683.93	
688	683.57	
+83	683.37	
689	683.37	
690	682.98	
691	682.29	

B.M. NE Corner 1st step walk
 Rt. Sta. 676+02
 Elev = 688.09

B.M. NW 1/4 Power Pole
 Rt. Sta. 680+65
 Elev = 686.37

B.M. NW Bolt Flange hydrant
 Rt. Sta. 684+29
 Elev = 687.63

B.M. NW Corner 1st step house
 Rt. Sta. 689+54
 Elev = 684.54

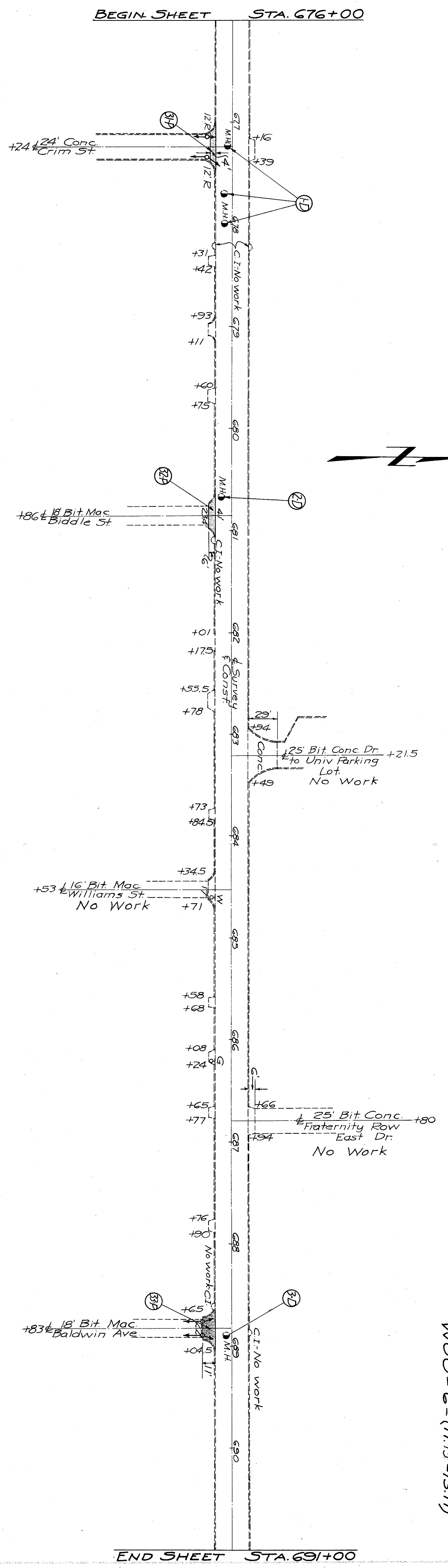

Sta. 676+00 to Sta. 691+00

AUG 7 1999

P.I. Sta. 691+85.8
Δ = 0°33' Lt.

BEGIN SHEET STA. 691+00

Note: Resurfacing of 2 1/4" min. west or back to 1/4" min. east or ahead shall be adjusted in 15' so as to give a smooth transition from one to the other

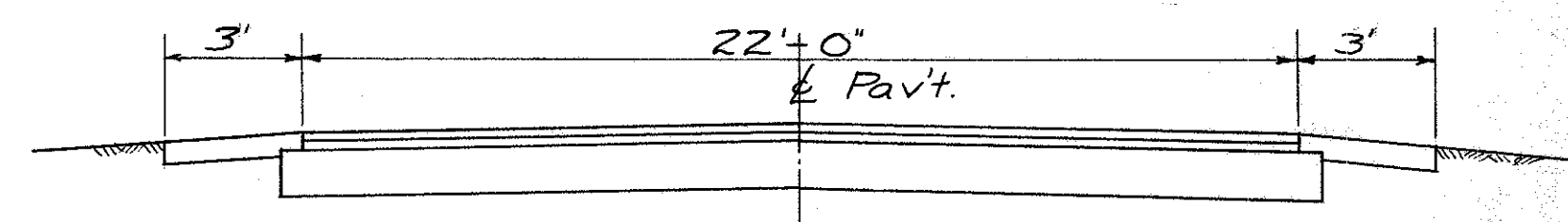
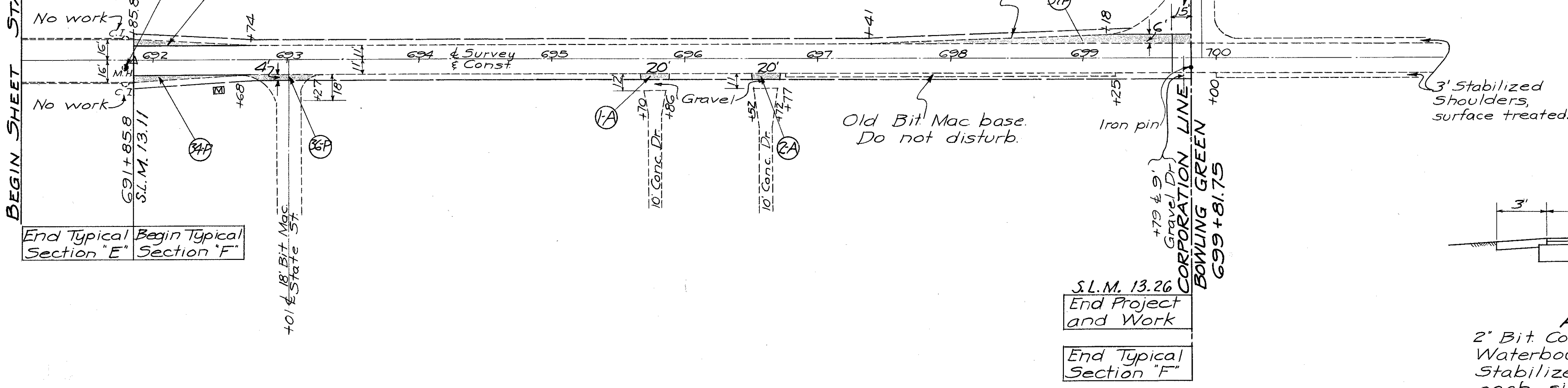

B.M. Bolt flange hydrant
Rt. Sta. 693+64
Elev. = 682.53

B.M. Spk Power Pole
Rt. Sta. 699+64
Elev. = 678.68

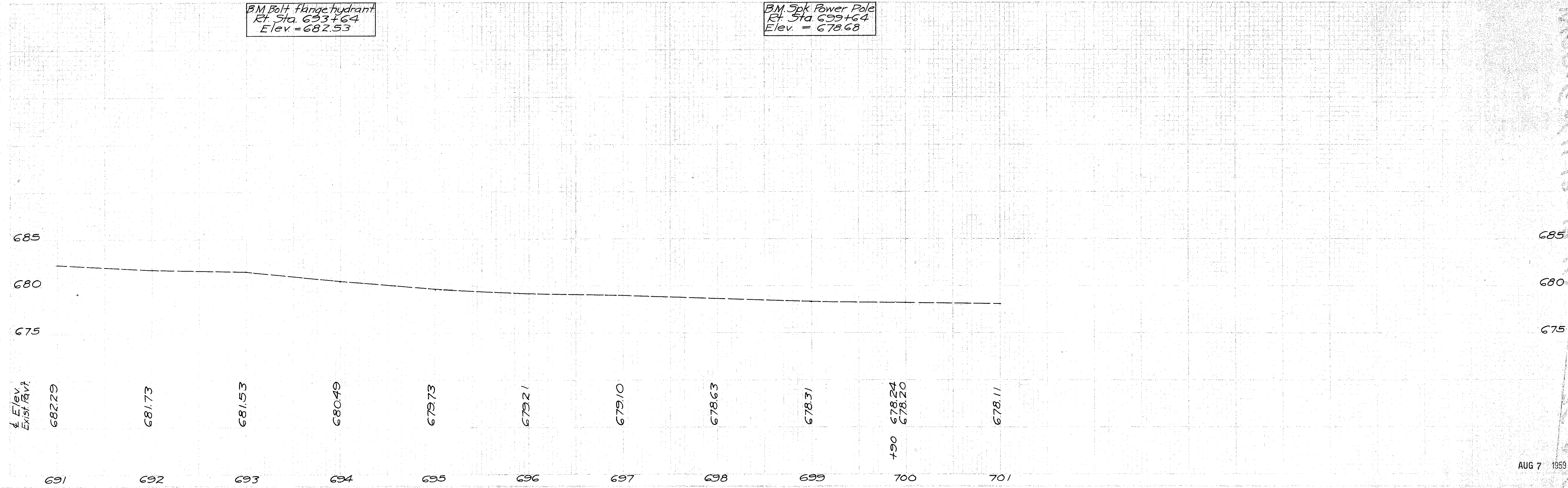

Sta. 691+00 to Sta. 699+81.75