

Released for Construction  
 Thomas J Powell, PE  
 05/28/2021

ISSUE RECORD:		
NO.	DATE	DESCRIPTION

STATE OF OHIO  
 DEPARTMENT OF TRANSPORTATION

**SUM-76-8.24**  
**SUM-77-9.74**  
**SUM-8-0.00**

CITY OF AKRON  
 SUMMIT COUNTY

PROJECT DESCRIPTION

THE AKRON CENTRAL INTERCHANGE PROJECT (PID 102329) INCLUDES RECONSTRUCTION OF IR-76 EB/WB PAVEMENT FROM SLM 11.05 (IR-76) TO SLM (IR-76) FOR APPROX. 1.16 MILES OF MAINLINE WORK. THIS PROJECT ALSO INCLUDES REPLACEMENT OF TWO FREEWAY STRUCTURES (RAMP N AND RAMP Q) ON NEW ALIGNMENTS, WIDENING OF TWO EXISTING BRIDGES (IR-76 EB OVER BROWN STREET AND IR-76 WB OVER INMAN STREET), CONSTRUCTION OF A NEW PEDESTRIAN/MULTI-USE OVERPASS SPANNING SR-8, AND CONSTRUCTION OF NOISE BARRIERS AT THE PERIMETER OF THE INTERCHANGE. PORTIONS OF SR-8, LANE O AND LANE S ARE TO BE RESURFACED. THE EXISTING IR-76 WB TO INMAN STREET AND IR-77 SB TO LOVERS LANE WILL BE REMOVED PERMANENTLY, AS WELL AS THE EXISTING LAFOLLETTE STREET BRIDGE OVER SR-8 (SUM-77-1184).

BUILDABLE UNIT 3B DESCRIPTION

THIS BUILDABLE UNIT SHOWS CONSTRUCTION OF THE INSIDE PORTION OF IR 76/77 FROM NORTH OF VERNON ODOM BOULEVARD TO WEST OF EAST AVENUE.

LIMITED ACCESS

THIS IMPROVEMENT IS ESPECIALLY DESIGNED FOR THROUGH TRAFFIC AND HAS BEEN DECLARED A LIMITED ACCESS HIGHWAY OR FREEWAY BY ACTION OF THE DIRECTOR IN ACCORDANCE WITH THE PROVISIONS OF SECTION 5511.02 OF THE OHIO REVISED CODE.

2019 SPECIFICATIONS

THE STANDARD SPECIFICATIONS OF THE STATE OF OHIO, DEPARTMENT OF TRANSPORTATION, INCLUDING SUPPLEMENTAL SPECIFICATIONS LISTED IN THE PLANS AND CHANGES LISTED IN THE PROPOSAL SHALL GOVERN THIS IMPROVEMENT.

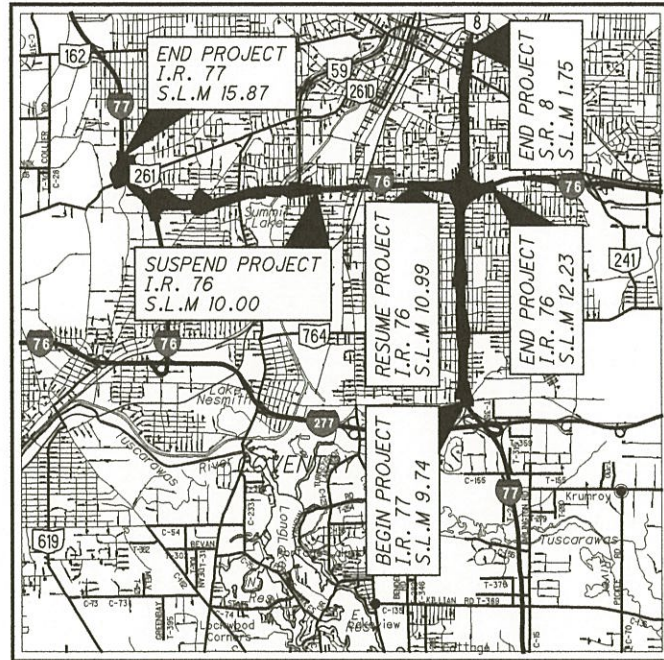

LOCATION MAP

LATITUDE: 41° 03' 43" LONGITUDE: 81° 30' 17"

SCALE IN MILES

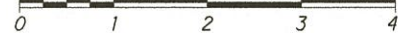

PORTION TO BE IMPROVED	=====
INTERSTATE HIGHWAY	=====
FEDERAL ROUTES	=====
STATE ROUTES	=====
COUNTY & TOWNSHIP ROADS	=====
OTHER ROADS	=====

DESIGN DESIGNATION

ROADWAY PLANS: SEE BU-34

NHS PROJECT ----- YES

DESIGN EXCEPTIONS

N/A

INDEX OF SHEETS:

TITLE SHEET	1
MOT NOTES	2 - 8
DETOUR PLANS	9 - 14
MAINTENANCE OF TRAFFIC	15 - 31

UNDERGROUND UTILITIES

Contact Two Working Days  
 Before You Dig



OHIO811, 8-1-1, or 1-800-362-2764  
 (Non-members must be called directly)

ENGINEERS SEAL:



SIGNED: [Signature]  
 DATE: 5/27/21

STANDARD CONSTRUCTION DRAWINGS				SUPPLEMENTAL SPECIFICATIONS	SPECIAL PROVISIONS
MT-95.40	1/17/20	MT-101.80	1/17/20	800-2020	7/17/20
MT-95.50	7/21/17	MT-101.90	7/17/20	821	4/20/12
MT-95.70	1/17/20	MT-102.10	1/17/20	829	1/20/17
MT-95.72	1/17/20	MT-103.10	1/19/18	831	10/21/16
MT-95.73	1/17/20	MT-105.10	1/17/20	839	1/17/20
MT-98.10	1/17/20				
MT-98.11	1/17/20	DM-1.3	7/18/14		
MT-98.21	1/17/20				
MT-98.29	1/17/20				
MT-99.30	1/17/20				
MT-99.50	1/17/20				
MT-99.60	7/15/16				
MT-100.00	1/15/16				
MT-101.60	1/17/20				
MT-101.70	1/17/20				
MT-101.75	1/17/20				



**BU-3B**  
**MOT**  
**PHASE 2B**  
**I-77/76**  
**VERNON ODOM BLVD TO**  
**WEST OF EAST AVE**  
**RFC PLANS**  
**May 27, 2021**

FEDERAL PROJECT NO.  
**E180(428)**

PID NO.  
**102329**

CONSTRUCTION PROJECT NO.  
**21-3000**

RAILROAD INVOLVEMENT  
**NONE**

**SUM-76/77/8-**  
**8.24/9.74/0.00**

d:\va\p\p\int\p\arsons.com\ohio state\Documents\DB-Akron\_Beltway\_Rehab\10 - Design\102329\_M01\Sheets\BU-3B\102329\_MNB\BU3B01.dgn Sheet 5/27/2021 6:56:49 AM apilpichuk

**ITEM 614, MAINTAINING TRAFFIC**

A MINIMUM OF TWO LANES OF TRAFFIC IN EACH DIRECTION SHALL BE MAINTAINED AT ALL TIMES BY USE OF THE EXISTING PAVEMENT, THE COMPLETED PAVEMENT, ITEM 502 STRUCTURE FOR MAINTAINING TRAFFIC, ITEM 615 PAVEMENT FOR MAINTAINING TRAFFIC, ITEM 615 ROADS FOR MAINTAINING TRAFFIC, AND TEMPORARY SURFACES USING ITEMS 410 AND 614.

A MINIMUM OF TWO LANES OF TRAFFIC IN EACH DIRECTION SHALL BE MAINTAINED AT ALL TIMES. A DISINCENTIVE SHALL BE ASSESSED IN THE AMOUNT OF \$3,000 PER HOUR FOR EACH HOUR THE ROADWAY REMAINS CLOSED TO TRAFFIC BEYOND THE SPECIFIED LIMIT.

LENGTH AND DURATION OF LANE CLOSURES AND RESTRICTIONS SHALL BE AT THE APPROVAL OF THE ENGINEER. IT IS THE INTENT TO MINIMIZE THE IMPACT TO THE TRAVELING PUBLIC. LANE CLOSURES OR RESTRICTIONS OVER SEGMENTS OF THE PROJECT IN WHICH NO WORK IS ANTICIPATED WITHIN A REASONABLE TIME FRAME, AS DETERMINED BY THE ENGINEER, SHALL NOT BE PERMITTED. THE LEVEL OF UTILIZATION OF MAINTENANCE OF TRAFFIC DEVICES SHALL BE COMMENSURATE WITH THE WORK IN PROGRESS.

NO WORK SHALL BE PERFORMED AND ALL EXISTING LANES SHALL BE OPEN TO TRAFFIC DURING THE FOLLOWING DESIGNATED HOLIDAYS OR EVENTS:

CHRISTMAS	FOURTH OF JULY
NEW YEARS	LABOR DAY
MEMORIAL DAY	THANKSGIVING
EASTER	

THE PERIOD OF TIME THAT THE LANES ARE TO BE OPEN DEPENDS ON THE DAY OF THE WEEK ON WHICH THE HOLIDAY OR EVENT FALLS. THE FOLLOWING SCHEDULE SHALL BE USED TO DETERMINE THIS PERIOD:

DAY OF HOLIDAY OR EVENT	TIME ALL LANES MUST BE OPEN FOR TRAFFIC
SUNDAY	12:00N FRIDAY THROUGH 6:00 AM MONDAY
MONDAY	12:00N FRIDAY THROUGH 6:00 AM TUESDAY
TUESDAY	12:00N MONDAY THROUGH 6:00 AM WEDNESDAY
WEDNESDAY	12:00N TUESDAY THROUGH 6:00 AM THURSDAY
THURSDAY	12:00N WEDNESDAY THROUGH 6:00 AM FRIDAY
THURSDAY (THANKSGIVING ONLY)	6:00 AM WEDNESDAY THROUGH 6:00 AM MONDAY
FRIDAY	12:00N THURSDAY THROUGH 6:00 AM MONDAY
SATURDAY	12:00N FRIDAY THROUGH 6:00 AM MONDAY

SHOULD THE CONTRACTOR FAIL TO MEET ANY OF THESE REQUIREMENTS, THE CONTRACTOR SHALL BE ASSESSED A DISINCENTIVE PER THE LANE VALUE CONTRACT.

NOTICE OF CLOSURE SIGNS (W20-H13) SHALL BE ERECTED BY THE CONTRACTOR PRIOR TO THE SCHEDULED ROAD OR RAMP CLOSURE IN ACCORDANCE WITH THE NOTICE OF CLOSURE TIME TABLE BELOW. AT THE APPROVAL OF THE ENGINEER, PORTABLE CHANGEABLE MESSAGE SIGNS MAY BE USED IN LIEU OF THE STANDARD FLATSHEET SIGN FOR CLOSURE DURATIONS OF LESS THAN 1 WEEK.

THE SIGNS SHALL BE ERECTED ON THE RIGHT-HAND SIDE OF THE ROAD/RAMP FACING TRAFFIC. THEY SHALL BE PLACED

**ITEM 614, MAINTAINING TRAFFIC (CONT'D)**

SO AS NOT TO INTERFERE WITH THE VISIBILITY OF ANY OTHER TRAFFIC CONTROL SIGNS. ON ROADWAYS, THEY SHOULD BE ERECTED AT OR NEAR THE POINT OF CLOSURE. THE SIGNS MAY BE ERECTED ANYWHERE ON RAMPS AS LONG AS THEY ARE VISIBLE TO THE MOTORISTS USING THE RAMP. ON ENTRANCE RAMPS, THE SIGN SHALL BE ERECTED WELL IN ADVANCE OF THE MERGE AREA TO AVOID DISTRACTING MOTORISTS.

NOTICE OF CLOSURE SIGN TIME TABLE		
ITEM	DURATION OF CLOSURE	SIGN DISPLAYED TO PUBLIC
RAMP & ROAD CLOSURES	>= 2 WEEKS	14 CALENDAR DAYS PRIOR TO CLOSURE
	> 12 HOURS & < 2 WEEKS	7 CALENDAR DAYS PRIOR TO CLOSURE
	< 12 HOURS	2 BUSINESS DAYS PRIOR TO CLOSURE

THE SIGN SHALL DISPLAY THE DATE OF THE CLOSURE IN MMM-DD FORMAT AND THE NUMBER OF DAYS OF THE CLOSURE. THE LAST LINE OF THE W20-H13 SIGN LISTS A PHONE NUMBER WHICH A MOTORIST MAY CALL FOR ADDITIONAL INFORMATION. THIS IS TO BE A SPECIFIC OFFICE WITHIN THE DISTRICT RATHER THAN THE GENERAL SWITCHBOARD NUMBER.

ALL WORK AND TRAFFIC CONTROL DEVICES SHALL BE IN ACCORDANCE WITH C&MS 614 AND OTHER APPLICABLE PORTIONS OF THE SPECIFICATIONS, AS WELL AS THE OHIO MANUAL OF UNIFORM TRAFFIC CONTROL DEVICES. PAYMENT FOR ALL LABOR, EQUIPMENT AND MATERIALS SHALL BE INCLUDED IN THE LUMP SUM CONTRACT PRICE FOR ITEM 614, MAINTAINING TRAFFIC, UNLESS SEPARATELY ITEMIZED IN THE PLAN.

**ITEM 614 - MAINTENANCE OF TRAFFIC (RESTRICTIONS)**

ALL EXISTING LANES OF TRAFFIC IN EACH DIRECTION SHALL BE MAINTAINED AT ALL TIMES, EXCEPT AS PERMITTED BY THE PERMITTED LANE CLOSURE TIMES NOTE AND THE MOTEC/PIAC APPROVED CLOSURES NOTE, BY USE OF THE EXISTING PAVEMENT, THE COMPLETED PAVEMENT, AND ITEM 615 PAVEMENT FOR MAINTAINING TRAFFIC CLASS A.

THE FOLLOWING CRITERIA SHALL BE USED IN DEVELOPMENT OF MAINTENANCE OF TRAFFIC PLANS FOR ALL ROADWAYS WITHIN THE PROJECT LIMITS:

- MINIMUM LANE WIDTH: 11 FEET\*
- MINIMUM BARRIER/CURB OFFSET: 2 FOOT\*
- MINIMUM EDGE OF PAVEMENT OFFSET: 2 FEET

\*THE MINIMUM BARRIER/CURB OFFSET MAY BE REDUCED TO 1 FOOT AND LANE WIDTH REDUCED TO 10 FEET WHEN NECESSARY IN SPOT LOCATIONS. SPOT LOCATIONS INCLUDE ON BRIDGE DECKS, ON APPROACH SLABS, BETWEEN BRIDGE PIERS AND ROADWAY SECTIONS WHERE TEMPORARY SLIVER FILLS COULD BE AVOIDED BY SAID ALLOWANCE. STANDARD TAPER RATES SHALL APPLY IN THE SHOULDER TRANSITION FROM 2 FOOT TO 1 FOOT; AND VICEVERSA.

BEFORE WORK BEGINS, THE CONTRACTOR SHALL SUBMIT TO THE ENGINEER THE NAME AND TELEPHONE NUMBER OF THE WORKSITE TRAFFIC SUPERVISOR(S) WHO CAN BE CONTACTED 24 HOURS A DAY BY THE OHIO DEPT. OF TRANSPORTATION AND ALL INTERESTED POLICE AGENCIES.

**NOTIFICATION OF TRAFFIC RESTRICTIONS**

Released for Construction  
 Thomas J Powell, PE  
 05/28/2021

THROUGHOUT THE DURATION OF THE PROJECT, THE CONTRACTOR SHALL NOTIFY THE PROJECT ENGINEER IN WRITING OF ALL TRAFFIC RESTRICTIONS AND UPCOMING MAINTENANCE OF TRAFFIC CHANGES. THE CONTRACTOR SHALL ENSURE THE WRITTEN NOTIFICATION IS SUBMITTED IN A TIMELY MANNER TO ALLOW THE PROJECT ENGINEER TO MEET THE REQUIRED TIME FRAMES SET FORTH IN THE TABLE BELOW TO INFORM SPECIAL HAULING PERMITS SECTION (HAULING.PERMITS@DOT.OHIO.GOV) AND THE DISTRICT PUBLIC INFORMATION OFFICE (PIO). THIS NOTIFICATION SHALL BE RECEIVED BY THE PROJECT ENGINEER PRIOR TO THE PHYSICAL SETUP OF ANY APPLICABLE SIGNS OR MESSAGE BOARDS.

INFORMATION SHOULD INCLUDE, BUT IS NOT LIMITED TO, ALL CONSTRUCTION ACTIVITIES THAT IMPACT OR INTERFERE WITH TRAFFIC AND SHALL LIST THE SPECIFIC LOCATION, TYPE OF WORK, ROAD STATUS, DATE AND TIME OF RESTRICTION, DURATION OF RESTRICTION, NUMBER OF LANES MAINTAINED, NUMBER OF LANES CLOSED, MINIMUM VERTICAL CLEARANCE, MINIMUM WIDTH OF DRIVABLE PAVEMENT, DETOUR ROUTES, IF APPLICABLE, AND ANY OTHER INFORMATION REQUESTED BY THE PROJECT ENGINEER.

NOTICE OF OFFICE OF COMMUNICATION TABLE		
ITEM	DURATION OF CLOSURE	NOTICE DUE TO PERMITS & PIO
RAMP & ROAD CLOSURES	>= 2 WEEKS	21 CALENDAR DAYS PRIOR TO CLOSURE
	> 12 HOURS & < 2 WEEKS	14 CALENDAR DAYS PRIOR TO CLOSURE
	<= 12 HOURS	4 BUSINESS DAYS PRIOR TO CLOSURE
LANE CLOSURES & RESTRICTIONS	>= 2 WEEKS	14 CALENDAR DAYS PRIOR TO CLOSURE
	< 2 WEEKS	5 BUSINESS DAYS PRIOR TO CLOSURE
START OF CONSTRUCTION & TRAFFIC PATTERN CHANGES	N/A	14 CALENDAR DAYS PRIOR TO CLOSURE

ANY UNFORESEEN CONDITIONS NOT SPECIFIED IN THE PLANS REQUIRING TRAFFIC RESTRICTIONS SHALL ALSO BE REPORTED TO THE PROJECT ENGINEER USING THE NOTIFICATION TIME TABLE.

**DETOUR NOTIFICATION CITY OF AKRON/SUMMIT COUNTY**

THE CONTRACTOR SHALL ADVISE THE ODOT DISTRICT OFFICE (330-786-3148) AND COUNTY/CITY EIGHTEEN (18) DAYS IN ADVANCE OF WHEN THE DETOUR ROUTE SHOULD BE IN EFFECT. ALL WORK ZONE DEVICES REQUIRED SHALL BE FURNISHED, ERECTED, MAINTAINED, AND SUBSEQUENTLY REMOVED BY THE CONTRACTOR. PAYMENT FOR ALL WORK ASSOCIATED WITH THE DETOUR SHALL BE INCLUDED UNDER THE LUMP SUM BID FOR ITEM 614, DETOUR SIGNING.

**WORK ZONE EGRESS WARNING SYSTEM**

THE CONTRACTOR SHALL FURNISH, INSTALL, AND MAINTAIN AN APPROVED WORK ZONE EGRESS WARNING SYSTEM (WZEWS) AS PER SUPPLEMENTAL SPECIFICATION 829.

THE PROBABLE INITIAL LOCATIONS OF THE WZEWS DEVICES ARE SHOWN IN THE PLAN. IT IS EXPECTED THAT THESE LOCATIONS WILL VARY BASED ON PLANNED OR UNPLANNED PHASE AND TRAFFIC PATTERN CHANGES. PLACEMENT, OPERATION, AND MAINTENANCE AND ALL ACTIVATION OF THE DEVICES BY THE CONTRACTOR SHALL BE DIRECTED BY THE ENGINEER.

**ISSUE RECORD:**

NO.	DATE	DESCRIPTION

**ITS MESSAGE BOARDS**

THE EXISTING ITS MESSAGE BOARDS IN THE VICINITY OF THE PROJECT WILL BE UTILIZED WHEN AVAILABLE TO PROVIDE SUPPLEMENTAL INFORMATION TO THE TRAVELING PUBLIC. THE CONTRACTOR WILL NOTIFY THE PROJECT ENGINEER ONE [1] WEEK IN ADVANCE OF ANY PHASE CHANGE ON SUM-76/77/8-8.42/9.47/0.00. THE PROJECT ENGINEER WILL COORDINATE WITH THE PROJECT ENGINEER TO GET THE ITS MESSAGE BOARDS ADJUSTED.

**ITEM 614 WORK ZONE PAVEMENT MARKINGS, AS PER PLAN**

IN ADDITION TO THE REQUIREMENTS OF 614.11, ALL CLASS 1 EDGE LINES, LANE LINES, CENTER LINES AND DOTTED LINES SHALL BE 6 INCHES WIDE AND CHANNELIZING MARKINGS SHALL BE 12 INCHES WIDE. THE APPLICATION RATES FOR THE 6 INCH LINES SHALL BE 1.5 TIMES THE RATES SPECIFIED FOR 4 INCH LINES IN TABLE 614.11-1.

**ITEM 614 WORK ZONE PAVEMENT MARKINGS, SPRAY THERMOPLASTIC, AS PER PLAN**

THE CONTRACTOR SHALL PLACE THE WORK ZONE PAVEMENT MARKINGS, SPRAY THERMOPLASTIC, AS PER PLAN PER ODOT SPECIFICATION 614.11 AND ODOT SPECIFICATION 648 WITH THE EXCEPTION ODOT SPECIFICATION 648.05 SHALL BE MODIFIED TO ALLOW PLACEMENT OF THE MATERIAL AT A TEMPERATURE OF NOT LESS THAN 35 DEGREES FAHRENHEIT.

**DELINEATION OF TEMPORARY AND PERMANENT GUARDRAIL**

BARRIER REFLECTORS SHALL BE INSTALLED ON ALL TEMPORARY GUARDRAIL USED FOR TRAFFIC CONTROL AND ON ALL PERMANENT GUARDRAIL LOCATED WITHIN 5 FEET OF THE EDGE OF THE ADJACENT TRAVEL LANE. BARRIER REFLECTORS SHALL CONFORM TO C&MS 626.

OBJECT MARKERS SHALL BE INSTALLED ON ALL TEMPORARY AND PERMANENT GUARDRAIL LOCATED WITHIN 5 FEET OF THE EDGE OF THE ADJACENT TRAVEL LANE. GUARDRAIL-MOUNTING OF OBJECT MARKERS SHALL BE MADE BY INSTALLING THE OBJECT MARKERS ON THE EXTENSION BLOCKS RATHER THAN DIRECTLY ONTO THE GUARDRAIL ITSELF. OBJECT MARKERS SHALL CONFORM TO C&MS 614.03 AND THE SPACING SHALL BE APPROXIMATELY 50 FEET.

**DUST CONTROL**

THE CONTRACTOR SHALL FURNISH AND APPLY WATER FOR DUST CONTROL AS DIRECTED BY THE ENGINEER.

**COOPERATION BETWEEN CONTRACTORS**

THE CONTRACTOR SHALL BE ADVISED THAT PROJECTS SUM-77/277/US224 VARIOUS (PID 106002), SUM-8-1.75 (PID 91710), D04 ITS MAINT FY 2021 (PID 113833), AND SUM-77-15.87 (PID 88937) MAY BE ONGOING IN AN AREA IMMEDIATELY ADJACENT TO AND WITHIN THE PROJECT LIMITS OF THIS PROJECT. THE CONTRACTOR SHALL SCHEDULE HIS WORK SO AS TO CAUSE A MINIMUM OF DELAY OR CONFLICT WITH THE OTHER PROJECTS. IN ACCORDANCE WITH 105.08, THE CONTRACTOR SHALL ARRANGE WITH THE OTHER CONTRACTORS APPROVAL OF THE ENGINEER. THE CONTRACTOR SHALL RECEIVE DAILY APPROVALS FROM THE ENGINEER PRIOR TO COMMENCING ANY OPERATIONS. ANY CONFLICT BETWEEN CONTRACTORS INVOLVING WORK SCHEDULES, WORK AREA, OR COOPERATION SHALL BE RESOLVED BY THE ENGINEER.

**MAINTENANCE OF TRAFFIC NOTES**

SUM-76/77/8-8.24/9.74/0.00

d:\VANVAIPWINTO\parsons.com:Ohio State\Documents\DB-Akron Beltway Rehab\10 - Design\102329\M01\Sheets\BU-3B\102329.MNB\3B002.dgn Sheet 5/27/2021 6:57:00 AM ap:ilipcnuk

**BRIDGE PAINTING EQUIPMENT ON SHOULDERS**

IF BRIDGE PAINTING EQUIPMENT IS TO REMAIN ON THE SHOULDERS WHEN THE CONTRACTOR IS NOT WORKING, IT SHALL BE PLACED BEHIND PORTABLE CONCRETE BARRIER (PCB) AND A WORK ZONE IMPACT ATTENUATOR (WZIA) SHALL PROTECT THE LEADING BLUNT END OF THE PCB (SEE OMTCD, FIGURE 6H-5 "SHOULDER CLOSURE ON FREEWAY" (TYPICAL APPLICATION 5)).

**ADVANCED NOTICE TO PAVE**

THE CONTRACTOR SHALL SUBMIT FOR APPROVAL TO THE DISTRICT CONSTRUCTION ENGINEER A DETAILED SCHEDULE 15 DAYS PRIOR TO THE PLACEMENT OF THE OVERLAY COURSES, ON HOW THEY PROPOSE TO PROSECUTE THE PAVING OPERATIONS. THE DETAILS SHALL SHOW THE ORDER OF PERFORMANCE OF EACH STAGE (START TO FINISH) OF THE WORK INCLUDING THE MAINTENANCE OF TRAFFIC THAT WILL BE USED.

**ITEM 615 - PAVEMENT FOR MAINTAINING TRAFFIC, CLASS A, AS PER PLAN**

IN ADDITION TO THE REQUIREMENTS OF 615

ON THIS PROJECT THE CLASS A PAVEMENT FOR MAINTAINING TRAFFIC SHALL BE 18 FEET WIDE AND THE ROADWAY WIDTH SHALL NOT BE LESS THAN 22 FEET OUT TO OUT OF SHOULDERS. THE EXISTING PAVEMENT/SHOULDER SHALL BE SAWCUT AS PER 203.04(E).

UPON COMPLETION OF THE PROJECT, THE CONTRACTOR SHALL REMOVE THE PAVEMENT FOR MAINTAINING TRAFFIC INCLUDING ANY TEMPORARY DRAINAGE FACILITIES. THE AFFECTED EXISTING EARTH MEDIAN AND PAVED SHOULDERS SHALL BE RESTORED TO THEIR ORIGINAL CONDITION AS DIRECTED BY THE ENGINEER AND AS PER 615.08.

PAVEMENT FOR MAINTAINING TRAFFIC SHALL NOT BE OPENED TO TRAFFIC UNTIL ALL WORK ZONE TRAFFIC CONTROL DEVICES, SIGNS, PAVEMENT MARKINGS AND PORTABLE CONCRETE BARRIERS HAVE BEEN ERECTED AND APPROVED BY THE ENGINEER.

**ITEM 615 PAVEMENT FOR MAINTAINING TRAFFIC, CLASS B, AS PER PLAN, TYPE 1**  
**ITEM 615 PAVEMENT FOR MAINTAINING TRAFFIC, CLASS B, AS PER PLAN, TYPE 2**  
**ITEM 615 PAVEMENT FOR MAINTAINING TRAFFIC, CLASS B, AS PER PLAN, TYPE 3**  
**ITEM 615 PAVEMENT FOR MAINTAINING TRAFFIC, CLASS B, AS PER PLAN, TYPE 4**

THIS ITEM SHALL BE UTILIZED FOR THE PAVEMENT REPAIRS NEEDED DURING THIS CONSTRUCTION PROCESS. ALL AREAS TO BE REPAIRED SHALL BE LOCATED BY THE ENGINEER. IT IS LIKELY THAT REPAIRS WILL BE NEEDED PRIOR TO EACH PHASE SWITCH. GREAT CARE SHALL BE TAKEN TO MAINTAIN THE EXISTING PAVEMENT CROSS SLOPE AS WELL AS ALL LONGITUDINAL SLOPES. THE TYPE OF REPAIR SHALL BE DETERMINED BY THE PROJECT ENGINEER. PAYMENT FOR ALL LABOR, EQUIPMENT AND MATERIALS REQUIRED FOR MAINTENANCE OF TRAFFIC FOR PAVEMENT REPAIRS SHALL BE INCLUDED IN THE LUMP SUM CONTRACT PRICE FOR ITEM 614, MAINTAINING TRAFFIC.

TYPE 1 - IS TO BE USED WHEN YOU NEED TO MILL & FILL AN AREA OF VARYING LENGTH AND HAVE AN AVERAGE WIDTH OF NOT LESS THAN 2 FEET.

TYPE 2 - IS TO BE USED FOR FIXING THE LONGITUDINAL JOINT ISSUES OF VARYING LENGTH AND HAVE A CONSISTENT WIDTH OF 2 FEET.

TYPE 3 - IS TO BE USED FOR DEEPER REPAIRS (POTHOLE) OF VARYING LENGTH AND WILL HAVE AN AVERAGE WIDTH OF NOT LESS THAN 4 FEET.

TYPE 4 - IS TO BE USED FOR COMPOSITE PAVEMENT REPAIRS OF VARYING LENGTH AND WILL HAVE AN AVERAGE WIDTH OF NOT LESS THAN 3 FEET.

**WET REFLECTIVE (WR) WORK ZONE PAVEMENT MARKINGS**

ALL CLASS I WORK ZONE PAVEMENT MARKINGS ON INTERSTATES AND MULTILANE HIGHWAYS EXPECTED TO BE IN PLACE LONGER THAN 14 DAYS SHOULD BE SPECIFIED AS WET REFLECTIVE BY REFERENCING EITHER WORK ZONE MARKING MATERIAL TYPE 807 (WET REFLECTIVE LIQUID APPLIED BINDER) OR 873 (WET REFLECTIVE REMOVABLE TAPE).

TO AVOID SCARRING ON THE FINAL SURFACE COURSE, WET REFLECTIVE REMOVABLE TAPE SHOULD BE SELECTED WHEN REMOVAL OF THE TEMPORARY MARKING FROM THE FINAL SURFACE COURSE IS NECESSARY PRIOR TO INSTALLATION OF THE PERMANENT MARKING.

IF THE WORK ZONE MARKING ON THE FINAL SURFACE COURSE IS IN THE LOCATION OF THE FINAL PERMANENT PAVEMENT MARKING AND THE FINAL PERMANENT PAVEMENT MARKING WILL BE A RECESSED MARKING, THE WORK ZONE MARKING DOES NOT NEED TO BE REMOVED PRIOR TO INSTALLATION OF THE PERMANENT MARKING.

**ITEM 614 MAINTAINING TRAFFIC MISC.: BRIDGE DECK PAVEMENT PATCHING**

Released for Construction  
By: James J Powell, PE  
05/28/2021

THIS WORK WILL BE AS DIRECTED BY THE ENGINEER AND WILL INCLUDE ALL ASSOCIATED MOT COSTS WITH THE ACTIVITY. THE FIXED AMOUNT SHOWN IN THE PROPOSAL IS INCLUDED (AS ANY OTHER BID ITEMS) IN THE TOTAL BID AMOUNT. THIS FIXED AMOUNT IS THE DEPARTMENT'S ESTIMATE OF THE TOTAL COST OF BRIDGE DECK AND PAVEMENT PATCHING WORK REQUIRED TO BE PERFORMED WITHIN THE WORK LIMITS AS DIRECTED BY THE ENGINEER. C&MS TABLE 104.02-2 DOES NOT APPLY TO REDUCTIONS IN THIS CONTRACT ITEM. FORCE ACCOUNT RECORDS SHALL BE KEPT TO TRACK AND ULTIMATELY DETERMINE THE AMOUNT OF THE PAY ITEM USED. THE WORK ITEM SHALL INCLUDE ALL WORK, AS DIRECTED BY THE ENGINEER, NEEDED TO RE-ESTABLISH A REASONABLY SAFE AND PASSABLE CONDITION OF THE DECK AND/OR PAVEMENT FOR THE DURATION OF THE REQUIRED UPCOMING MOT PHASES. THE CONTRACTOR SHALL MEET WITH THE ENGINEER TO ESTABLISH THE WORK AFTER EXECUTION OF THE CONTRACT. THE CONTRACTOR'S PROPOSED PHASING AND PHASING DURATIONS WILL ASSIST THE ENGINEER IN DETERMINING THE EXTENT OF THE WORK. THIS WORK IS ONLY INTENDED TO ESTABLISH A SAFE AND DRIVABLE CONDITION FOR THE DURATION OF THE PROJECT. THIS DOES NOT RELIEVE THE CONTRACTOR OF THE RESPONSIBILITIES OF 614.02B.

**ITEM 622 PORTABLE BARRIER PLACEMENT**

DURING THE PLACEMENT OF THE PORTABLE BARRIER, TRAFFIC WILL BE PROHIBITED FROM OCCUPYING THE TRAVEL LANE ADJACENT TO THE BARRIER. THE BARRIER WILL BE PLACED AT NIGHT PER THE WORK HOUR RESTRICTION NOTE AND IN ACCORDANCE WITH THE PERMITTED LANE CLOSURE MAP. THE CLOSURE OF THE ADJACENT LANE WILL BE PER THE STANDARD DRAWING MT-95.30.

THE CONTRACTOR WILL SUBMIT A PLAN TO THE ENGINEER FOR APPROVAL SEVEN (7) DAYS IN ADVANCE OF THE PLANNED LANE CLOSURE. WORK WILL NOT BEGIN UNTIL APPROVAL OF THE PLANS HAS BEEN GRANTED.

**SPECIAL - WORK ZONE GUARDRAIL**

THIS WORK AND MATERIALS SHALL COMPLY WITH ITEM 606 FOR PERMANENT GUARDRAIL, EXCEPT THAT USED TYPE 5 RAILS AND POSTS MAY BE USED IF IN GOOD CONDITION AND APPROVED BY THE ENGINEER. FOR EXISTING GUARDRAIL RUNS WHICH REQUIRE AN EXTENSION, THE EXISTING END TERMINAL ASSEMBLY SHALL BE REMOVED AND RESET TO THE NEW LOCATIONS, AS SHOWN ON THE PLANS. NEW RUNS, FOR BRIDGE PARAPET PROTECTION SHALL HAVE THE APPROPRIATE BRIDGE TERMINAL ASSEMBLIES INSTALLED. UPON COMPLETION OF THE PHASE WHICH REQUIRES THE TEMPORARY GUARDRAIL, ALL WORK ZONE GUARDRAIL SHALL BE REMOVED AND THE POST HOLES BACKFILLED (UNLESS PERMANENT GRADING TO BE PERFORMED LATER WOULD REPAIR THE HOLES), ALL TERMINAL ASSEMBLIES REMOVED, AND END TERMINAL ASSEMBLIES RESET TO THEIR ORIGINAL LOCATION.

**DRUM REQUIREMENTS**

IN ADDITION TO THE REQUIREMENTS OF THE PLANS, SPECIFICATION AND PROPOSAL, DRUMS FURNISHED BY THE CONTRACTOR SHALL BE NEW AND UNUSED AT THE TIME OF ARRIVAL ON THE PROJECT. ANY DRUMS BROUGHT ON THE PROJECT, WHICH HAVE PREVIOUSLY BEEN USED ELSEWHERE, WILL NOT BE ACCEPTED.

ISSUE RECORD:		
NO.	DATE	DESCRIPTION

**ITEM 622, PORTABLE BARRIER, 50", AS PER PLAN**

THIS WORK SHALL CONSIST OF FURNISHING, MAINTAINING, AND SUBSEQUENTLY REMOVING A 50-INCH PORTABLE BARRIER AT THE LOCATIONS SHOWN ON THE PLANS. FOR DETAILS, SEE SCD RM-4.1.

PORTABLE STEEL BARRIER IS AN APPROVED ALTERNATIVE TO PORTABLE CONCRETE BARRIER. FOR INFORMATION ON APPROVED VENDORS, SEE THE APPROVED PRODUCTS LIST MAINTAINED BY ROADWAY ENGINEERING.

PORTABLE BARRIER, 32 INCHES HIGH WITH AN 18-INCH MINIMUM HEIGHT GLARE SCREEN MAY BE USED AT THE OPTION OF THE CONTRACTOR. THE GLARE SCREEN SHALL BE CONSTRUCTED USING ONE OF THE SCREENS PROVIDED ON THE APPROVED LIST, AVAILABLE ON THE OFFICE OF ROADWAY ENGINEERING WEBSITE.

PADDLE OR INTERMITTENT TYPE GLARE SCREENS SHALL BE DESIGNED USING A 20 DEGREE CUT-OFF ANGLE BASED ON TANGENT ALIGNMENT. THAT SPACING SHALL BE USED THROUGHOUT THE BARRIER LENGTH WITHOUT REGARD TO BARRIER CURVATURE.

THE GLARE SCREEN SYSTEM SHALL BE SECURELY FASTENED TO THE 32-INCH PORTABLE BARRIER USING THE HARDWARE AND PROCEDURES SPECIFIED BY THE MANUFACTURER.

FOR DIRECTIONS ON HOW TO INSTALL THE GLARE SCREEN AND THE BARRIER, SEE THE MANUFACTURER'S INSTRUCTIONS.

**DELINEATION OF PORTABLE AND PERMANENT BARRIER**

BARRIER REFLECTORS AND OBJECT MARKERS SHALL BE INSTALLED ON ALL PORTABLE BARRIER (PB) USED FOR TRAFFIC CONTROL AND ON PERMANENT CONCRETE BARRIER (INCLUDING BRIDGE PARAPETS) LOCATED WITHIN 5 FEET OF THE EDGE OF THE ADJACENT TRAVEL LANE.

BARRIER REFLECTORS SHALL CONFORM TO C&MS 626, EXCEPT THAT THE SPACING SHALL BE AS PER TRAFFIC SCD MT-101.70. OBJECT MARKERS AND THEIR INSTALLATION SHALL CONFORM TO C&MS 614.03 AND SCD MT-101.70. WHEN THE PB CONTAINS GLARE SCREEN, ONE SET OF THREE VERTICAL STRIPES OF SHEETING SHALL BE CONSIDERED EQUIVALENT TO AN OBJECT MARKER, ONE-WAY.

INCREASED BARRIER DELINEATION, AS SPECIFIED HEREIN, SHALL BE INSTALLED ON ALL PB AND CONCRETE PERMANENT BARRIER LOCATED WITHIN 5 FEET OF THE EDGE OF THE TRAVELED LANE UNDER EITHER OF THE FOLLOWING CONDITIONS: ALONG TAPERS AND TRANSITION AREAS AND ALONG CURVES (OUTSIDE ONLY) WITH DEGREE OF CURVATURE GREATER THAN OR EQUAL TO 3 DEGREES.

THE INCREASED BARRIER DELINEATION SHALL CONSIST OF EITHER DELINEATION PANELS OR THE TRIPLE STACKING OF WORK ZONE BARRIER REFLECTORS.

DELINEATION PANELS SHALL CONSIST OF PANELS OF DELINEATION, APPROXIMATELY 34 INCHES LONG AND 6 INCHES WIDE AND SHALL BE "CRIMPED." PANELS SHALL BE INSTALLED AND SPACED PER TRAFFIC SCD MT-101.70.

TRIPLE-STACKED BARRIER REFLECTORS SHALL CONSIST OF ALIGNING THREE BARRIER REFLECTORS VERTICALLY, AT LOCATIONS WHERE A SINGLE BARRIER REFLECTOR WOULD BE OTHERWISE ATTACHED. THERE SHALL BE NO OPEN SPACE BETWEEN THE ADJACENT BARRIER REFLECTORS. THE TRIPLE-STACKED BARRIER REFLECTORS SHALL CONFORM TO C&MS 626, EXCEPT THAT THEY SHALL BE SPACED AND ALIGNED PER TRAFFIC SCD MT-101.70.

MAINTENANCE OF TRAFFIC NOTES

SUM-76 / 77 / 8-  
8.24 / 9.74 / 0.00

d:\VANVAOPWINTO\parsons.com\Ohio State\Documents\DB-Akron Beltway Rehab\10 - Design\102329\M01\Sheets\BU-3B\102329.MNBU3B003.dgn Sheet 5/27/2021 6:57:10 AM apilipchuk

**ITEM 614, WORK ZONE IMPACT ATTENUATOR FOR 24" WIDE HAZARDS (UNIDIRECTIONAL OR BIDIRECTIONAL)**

THIS ITEM SHALL CONSIST OF FURNISHING AND INSTALLING A NON-GATING IMPACT ATTENUATOR. FURNISH AN IMPACT ATTENUATOR FROM THE OFFICE OF ROADWAY ENGINEERING'S APPROVED LIST FOR WORK ZONE IMPACT ATTENUATORS, FROM THE ROADWAY STANDARDS APPROVED PRODUCTS WEB PAGE.

INSTALLATION SHALL BE AT THE LOCATIONS SPECIFIED IN THE PLANS IN ACCORDANCE WITH THE MANUFACTURER'S SPECIFICATIONS.

THE CONTRACTOR SHALL REPAIR OR REPLACE A DAMAGED UNIT WITHIN 24 HOURS OF A DAMAGING IMPACT.

WHEN BIDIRECTIONAL DESIGNS ARE SPECIFIED, THE CONTRACTOR SHALL SUPPLY APPROPRIATE TRANSITIONS.

WHEN GATING IMPACT ATTENUATORS ARE DESIRED, THE CONTRACTOR SHALL SUBMIT DOCUMENTATION TO THE ENGINEER FOR ACCEPTANCE.

**ITEM 614, WORK ZONE IMPACT ATTENUATOR FOR HAZARDS OVER 24" AND LESS THAN 36" WIDE (UNIDIRECTIONAL OR BIDIRECTIONAL)**

THIS ITEM SHALL CONSIST OF FURNISHING AND INSTALLING A NON-GATING IMPACT ATTENUATOR. FURNISH AN IMPACT ATTENUATOR FROM THE OFFICE OF ROADWAY ENGINEERING'S APPROVED LIST FOR WORK ZONE IMPACT ATTENUATORS, FROM THE ROADWAY STANDARDS APPROVED PRODUCTS WEB PAGE.

INSTALLATION SHALL BE AT THE LOCATIONS SPECIFIED IN THE PLANS, IN ACCORDANCE WITH THE MANUFACTURER'S SPECIFICATIONS. THE CONTRACTOR SHALL REPAIR OR REPLACE A DAMAGED UNIT WITHIN 24 HOURS OF A DAMAGING IMPACT.

WHEN BIDIRECTIONAL DESIGNS ARE SPECIFIED, THE CONTRACTOR SHALL SUPPLY APPROPRIATE TRANSITIONS.

**FLOODLIGHTING**

FLOODLIGHTING OF THE WORK SITE FOR OPERATIONS CONDUCTED DURING NIGHTTIME PERIODS SHALL BE ACCOMPLISHED SO THAT THE LIGHTS DO NOT CAUSE GLARE TO THE DRIVERS ON THE ROADWAY. TO ENSURE THE ADEQUACY OF THE FLOODLIGHT PLACEMENT, THE CONTRACTOR AND THE ENGINEER SHALL DRIVE THROUGH THE WORK SITE EACH NIGHT WHEN THE LIGHTING IS IN PLACE AND OPERATIVE PRIOR TO COMMENCING ANY WORK. IF GLARE IS DETECTED, THE LIGHT PLACEMENT AND SHIELDING SHALL BE ADJUSTED TO THE SATISFACTION OF THE ENGINEER BEFORE WORK PROCEEDS.

**ITEM 611 - 12", SLOTTED DRAIN, TYPE 2**

THIS ITEM SHALL CONSIST OF 12 INCH DIAMETER SLOTTED DRAIN ALUMINUM COATED STEEL CONDUIT 707.01 WITH 6 INCH TRAPEZOIDAL GALVANIZED SOLID BAR GRATE AS APPROVED BY THE ENGINEER.

**ITEM 614 - WORK ZONE RAISED PAVEMENT MARKER, AS PER PLAN**

WORK ZONE RAISED PAVEMENT MARKERS, AS PER PLAN, AND THEIR INSTALLATION SHALL CONFORM TO C&MS 614 OR C&MS 621 AS SPECIFIED HEREIN.

RAISED PAVEMENT MARKERS IN USE DURING THE SNOW-PLOWING SEASON SHALL CONFORM TO 621, EXCEPT FOR RAISED PAVEMENT MARKERS ON PERMANENT CONCRETE SURFACES. SEE ITEM 614 - WORK ZONE RAISED PAVEMENT MARKERS ON PERMANENT CONCRETE SURFACES NOTE BELOW.

RAISED PAVEMENT MARKERS IN USE DURING THE NON-SNOW-PLOW SEASON SHALL CONFORM TO EITHER 614 OR TO 621.

THE SNOW-PLOWING SEASON SHALL RUN FROM OCTOBER 15 THROUGH APRIL 1.

IF PROJECT DELAYS, NOT THE FAULT OF ODOT, CAUSE THE WORK TO EXTEND INTO THE SNOW-PLOWING SEASON, THE CONTRACTOR SHALL BE RESPONSIBLE FOR REPLACING WORK ZONE RAISED PAVEMENT MARKERS (WZRPMS) CONFORMING TO C&MS 614, WITH RAISED PAVEMENT MARKERS CONFORMING TO 621, AS DETERMINED BY THE ENGINEER, AT THE CONTRACTOR'S EXPENSE.

THIS ITEM SHALL INCLUDE PURCHASE, INSTALLATION AND REMOVAL OF ITEM 614 WORK ZONE RAISED PAVEMENT MARKER, AS PER PLAN, INCLUDING FILLING OF ANY DEPRESSIONS CREATED IN THE PAVEMENT AS PER C&MS 621.08.

RESURFACING OF THE TRANSITION AREAS SHALL BE PERFORMED AT THE TIME THAT THE SURFACE COURSE IS BEING APPLIED TO THE ENTIRE PROJECT. PRIOR TO APPLICATION OF THE SURFACE COURSE ON THE PROJECT, THE EXISTING PAVEMENT WITHIN THE TRANSITION AREA SHALL BE REMOVED TO A DEPTH NECESSARY TO REACH THE LEVEL OF THE INTERMEDIATE COURSE OF THE PAVEMENT, AS DETERMINED BY THE ENGINEER.

**ITEM 614 - WORK ZONE RAISED PAVEMENT MARKERS ON PERMANENT CONCRETE SURFACES**

RAISED PAVEMENT MARKERS IN WORK ZONES, INSTALLED ON PERMANENT CONCRETE SURFACES, SHALL BE ITEM 614 WORK ZONE RAISED PAVEMENT MARKERS. WZRPMS ARE INTENDED FOR USE ONLY DURING THE NON-SNOW-PLOWING SEASON. WZRPMS SHALL NOT BE PROVIDED DURING THE SNOW-PLOWING SEASON.

THE SNOW-PLOWING SEASON SHALL RUN FROM OCTOBER 15 THROUGH APRIL 1.

WHERE A TEMPORARY ALIGNMENT WILL REMAIN IN USE THROUGH THE WINTER, THE WZRPMS SHALL BE REMOVED PRIOR TO THE BEGINNING OF THE SNOW-PLOWING SEASON AND REPLACED APPROXIMATELY APRIL 1, OR AS OTHERWISE DETERMINED BY THE ENGINEER.

**ITEM 614 - LAW ENFORCEMENT OFFICER (WITH PATROL CAR) FOR ASSISTANCE DURING CONSTRUCTION OPERATIONS**

Released for Construction  
Number: Powell, PE  
05/28/2021

USE OF LAW ENFORCEMENT OFFICERS (LEOS) BY CONTRACTORS OTHER THAN THE USES SPECIFIED BELOW WILL NOT BE PERMITTED AT PROJECT COST. LEOS SHOULD NOT BE USED WHERE THE OMUTCD INTENDS THAT FLAGGERS BE USED.

IN ADDITION TO THE REQUIREMENTS OF C&MS 614 AND THE OMUTCD, A UNIFORMED LEO WITH AN OFFICIAL PATROL CAR (CAR WITH TOP-MOUNTED EMERGENCY FLASHING LIGHTS AND COMPLETE MARKINGS OF THE APPROPRIATE LAW ENFORCEMENT AGENCY) SHALL BE PROVIDED FOR THE FOLLOWING TRAFFIC CONTROL TASKS:

DURING THE ENTIRE ADVANCE PREPARATION AND CLOSURE SEQUENCE WHERE COMPLETE BLOCKAGE OF TRAFFIC IS REQUIRED.

DURING A TRAFFIC SIGNAL INSTALLATION WHEN IMPACTING THE NORMAL FUNCTION OF THE SIGNAL OR THE FLOW OF TRAFFIC, OR WHEN TRAFFIC NEEDS TO BE DIRECTED THROUGH AN ENERGIZED TRAFFIC SIGNAL CONTRARY TO THE SIGNAL DISPLAY (E.G., DIRECTING MOTORISTS THROUGH A RED LIGHT).

IN ADDITION TO THE REQUIREMENT OF C&MS 614 AND THE OMUTCD, A UNIFORMED LEO WITH AN OFFICIAL PATROL CAR (CAR WITH TOP-MOUNTED EMERGENCY FLASHING LIGHTS AND COMPLETE MARKINGS OF THE APPROPRIATE LAW ENFORCEMENT AGENCY) SHOULD BE PROVIDED FOR THE FOLLOWING TRAFFIC CONTROL TASKS AS APPROVED BY THE ENGINEER:

FOR LANE CLOSURES: DURING INITIAL SET-UP PERIODS, TEAR DOWN PERIODS, SUBSTANTIAL SHIFTS OF A CLOSURE POINT OR WHEN NEW LANE CLOSURE ARRANGEMENTS ARE INITIATED FOR LONG-TERM LANE CLOSURES/SHIFTS (FOR THE FIRST AND LAST DAY OF MAJOR CHANGES IN TRAFFIC CONTROL SETUP).

FOR OPERATIONS WITHOUT POSITIVE PROTECTION OCCURRING WITHIN 10 FEET OF AN OPEN TRAVELED LANE THAT MEET ALL OF THE FOLLOWING CRITERIA:

- ON A MULTI-LANE DIVIDED INTERSTATE, OTHER FREEWAY OR EXPRESSWAY; AND
- AN AUTHORIZED SPEED LIMIT OF 45 MPH OR GREATER THAT IS IN EFFECT AT THE TIME OF THE OPERATION; AND,
- AADT OF 50,000 (OR AADT OF 30,000 WITH 25% OR HIGHER PERCENT TRUCKS)

"WITHOUT POSITIVE PROTECTION" MEANS USE OF DRUMS, CONES, SHADOW VEHICLE, ETC, WITHOUT PROTECTION FROM PORTABLE BARRIER OR OTHER RIGID BARRIER ALONG THE WORK AREA. THIS PHRASE DOES NOT APPLY TO CASES WHERE POSITIVE PROTECTION IS REQUIRED. MOBILE OPERATIONS ARE REGARDED AS "WITHOUT POSITIVE PROTECTION". FOR WORK ZONES USING A COMBINATION OF BARRIER AND TEMPORARY TRAFFIC CONTROL DEVICES (CONES, DRUMS, ETC), THE DESIGNATION SHALL BE BASED UPON THE TYPE OF DEVICES USED IN THE AREA THAT WORKERS ARE LOCATED.

IF MULTIPLE ACTIVE LOCALIZED QUALIFYING WORK AREAS OCCUR WITHOUT POSITIVE PROTECTION, PER MAINLINE TRAFFIC DIRECTION, PROVIDE A UNIFORMED LEO AND OFFICIAL PATROL CAR IN ADVANCE OF:

- THE FIRST ACTIVE WORK AREA THAT DRIVERS WILL ENCOUNTER; OR
- THE ACTIVE WORK AREA Laterally CLOSEST TO THE OPEN TRAVELED LANE; OR

ISSUE RECORD:		
NO.	DATE	DESCRIPTION

**ITEM 614 - LAW ENFORCEMENT OFFICER (WITH PATROL CAR) FOR ASSISTANCE DURING CONSTRUCTION OPERATIONS (CONT'D)**

-OTHER LOCATION AS APPROVED BY THE ENGINEER. THE UNIFORMED LEO AND OFFICIAL PATROL CAR MAY RELOCATE AMONG THE LISTED LOCATIONS AS APPROPRIATE AS THE OPERATIONS PROCEED IN THE LOCALIZED QUALIFYING WORK AREAS.

IN GENERAL, LEOS SHOULD BE POSITIONED IN ADVANCE OF AND ON THE SAME SIDE AS THE LANE RESTRICTION (OR AT THE POINT OF ROAD CLOSURE), AND TO MANUALLY CONTROL TRAFFIC MOVEMENTS THROUGH SIGNALIZED INTERSECTIONS IN WORK ZONES.

LEOS SHOULD NOT FORGO THEIR TRAFFIC CONTROL RESPONSIBILITIES TO APPREHEND MOTORISTS FOR ROUTINE TRAFFIC VIOLATIONS. HOWEVER, IF A MOTORIST'S ACTIONS ARE CONSIDERED TO BE RECKLESS, THEN PURSUIT OF THE MOTORIST IS APPROPRIATE.

THE LEOS WORK AT THE DIRECTION OF THE CONTRACTOR. THE CONTRACTOR IS RESPONSIBLE FOR SECURING THE SERVICES OF THE LEOS WITH THE APPROPRIATE AGENCIES AND COMMUNICATING THE INTENTIONS OF THE PLANS WITH RESPECT TO DUTIES OF THE LEOS. THE ENGINEER SHALL HAVE FINAL CONTROL OVER THE LEOS' DUTIES AND PLACEMENT, AND WILL RESOLVE ANY ISSUES THAT MAY ARISE BETWEEN THE TWO PARTIES.

ENSURE PROVIDED LEOS HAVE BEEN TRAINED APPROPRIATE TO THE JOB DECISIONS THEY ARE REQUIRED TO MAKE WHILE ON THE PROJECT, IN ACCORDANCE WITH C&MS 614.03.

THE LEO SHALL REPORT IN TO THE CONTRACTOR PRIOR TO THE START OF THE SHIFT, IN ORDER TO RECEIVE INSTRUCTIONS REGARDING SPECIFIC WORK ASSIGNMENTS DURING HIS/HER SHIFT. THE LEO IS EXPECTED TO STAY AT THE PROJECT SITE FOR THE ENTIRE DURATION OF HIS/HER SHIFT. THE LEO SHALL REPORT TO THE CONTRACTOR AT THE END OF HIS/HER SHIFT. SHOULD IT BE NECESSARY TO LEAVE THE PROJECT SITE, THE LEO SHALL NOTIFY THE ENGINEER. THE CONTRACTOR SHALL PROVIDE THE LEO WITH A TWO-WAY COMMUNICATION DEVICE THAT SHALL BE RETURNED TO THE CONTRACTOR AT THE END OF HIS/HER SHIFT.

**CONCRETE MEDIAN BARRIER REPLACEMENT**

REMOVING, GRADING AND INSTALLING THE REPLACEMENT BARRIER IN A CONTINUOUS OPERATION SHALL BE LIMITED TO 250 LINEAR FEET AND SHALL AT ALL TIMES BE SUBJECT TO THE APPROVAL OF THE ENGINEER. THE ENGINEER SHALL BE SATISFIED THAT ALL INSTALLATIONS WILL AFFORD MAXIMUM PROTECTION FOR TRAFFIC.

**EARTHWORK FOR MAINTAINING TRAFFIC**

WHEN UNDERCUTS ARE NECESSARY FOR MAINLINE PAVEMENT OR EMBANKMENT CONSTRUCTION, EVALUATE THE NEED FOR TEMPORARY ROAD UNDERCUTS IF WITHIN A CLOSE PROXIMITY TO THE MAINLINE UNDERCUTS. A GEOTECHNICAL EVALUATION SHOULD BE CONSIDERED TO DETERMINE IF THE EXISTING SOIL CONDITIONS ARE ADEQUATE TO SUPPORT THE TEMPORARY ROAD. ADDITIONAL SOIL BORINGS ALONG THE TEMPORARY ROAD ARE NOT NORMALLY REQUIRED.

MAINTENANCE OF TRAFFIC NOTES

SUM-76 / 77 / 8-  
8.24 / 9.74 / 0.00

d:\VANVAIPWINTO\parsons.com\Ohio State\Documents\DB-Akron Beltway Rehab\10 - Design\102329\MO1\Sheets\BU-3B\102329\_MNBU3B004.dgn Sheet 5/27/2021 6:57:21 AM apilpchnuk

**SPECIAL, MAINTAIN EXISTING LIGHTING**

EXISTING ROADWAYS WHICH ARE TO REMAIN OPEN TO TRAFFIC DURING CONSTRUCTION OF THIS PROJECT AND WHICH ARE LIGHTED SHALL HAVE THE LIGHTING MAINTAINED AS DESCRIBED HEREIN.

BEFORE ANY WORK IS STARTED IN THE IMMEDIATE VICINITY OF THE EXISTING LIGHTING CIRCUITS, REPRESENTATIVES OF ODOT, THE MAINTAINING AGENCY AND THE CONTRACTOR SHALL MAKE A VISUAL INSPECTION OF THE EXISTING ROADWAY LIGHTING CIRCUITS TO BE MAINTAINED. DURING THIS INSPECTION, A WRITTEN RECORD OF THE CONDITION OF EXISTING LIGHTING SHALL BE MADE BY ODOT'S REPRESENTATIVE. THIS WRITTEN REPORT SHALL NOTE INDIVIDUAL LUMINAIRES WHICH ARE NOT IN WORKING ORDER, INDIVIDUAL POLES WHICH ARE NOT STANDING, AND INDIVIDUAL CIRCUITS WHICH ARE NOT IN WORKING ORDER. THE COMPLETED REPORT SHALL BE SIGNED BY THE REPRESENTATIVES OF ODOT, THE MAINTAINING AGENCY AND THE CONTRACTOR.

IF, AS A RESULT OF THIS INSPECTION, IT IS DETERMINED THAT THE CONDITION OF THE EXISTING SYSTEM IS BELOW THAT REQUIRED FOR THE SAFETY OF THE TRAVELING PUBLIC, THEN THE MAINTAINING AGENCY SHALL MAKE THE REPAIRS NECESSARY TO RETURN THE SYSTEM TO AN ACCEPTABLE CONDITION. FOLLOWING THESE REPAIRS, THE SYSTEM SHALL AGAIN BE INSPECTED AND A REPORT SHALL BE MADE AND SIGNED AS OUTLINED HEREIN.

WHEN THE EXISTING SYSTEM IS IN AN ACCEPTABLE CONDITION, IT SHALL BE TURNED OVER TO THE CONTRACTOR WHO SHALL THEN BE REQUIRED TO MAINTAIN THE EXISTING LIGHTING TO THE CONDITION OUTLINED IN THIS REPORT WITH THE EXCEPTION OF KNOCKDOWNS DUE TO TRAFFIC ACCIDENTS.

REPLACEMENT OF KNOCKED DOWN UNITS SHALL BE DONE ONLY WHEN THE ENGINEER HAS DETERMINED THAT THE REPLACEMENT OF THE KNOCKED DOWN UNIT IS NECESSARY AND SHALL BE PAID SEPARATELY ON A UNIT BASIS.

BETTERMENTS SHALL BE COVERED IN ITEMS OF WORK PERTAINING TO THE CONSTRUCTION OF PERMANENT IMPROVEMENT.

WHEN THE SEQUENCE OF CONSTRUCTION ACTIVITIES REQUIRES, OR SHOULD THE CONTRACTOR DESIRE, THE REMOVAL OF THE EXISTING LIGHTING BEFORE THE NEW LIGHTING IS OPERATIONAL, THE CONTRACTOR SHALL BE RESPONSIBLE FOR PROVIDING TEMPORARY LIGHTING OF THIS PORTION OF THE ROADWAY.

PRIOR TO INSTALLING SUCH LIGHTING, THE CONTRACTOR SHALL PREPARE AND SUBMIT FOUR SETS OF THE TEMPORARY LIGHTING PLAN TO THE ENGINEER FOR REVIEW AND APPROVAL.

THIS PLAN SHALL SHOW LOCATIONS OF POLES, LENGTHS OF BRACKET ARMS, STYLES OF LUMINAIRES, MOUNTING HEIGHTS, WIRING METHODS AND OTHER PERTINENT INFORMATION. THE TEMPORARY LIGHTING SHALL PROVIDE AN AVERAGE INITIAL INTENSITY OF 1.2 FOOTCANDLES WITH AN AVERAGE TO MINIMUM UNIFORMITY NOT TO EXCEED 3:1. MOUNTING HEIGHT OF TEMPORARY LUMINAIRES SHALL NOT BE LESS THAN 30 FEET, AND THE MINIMUM OVERHEAD CONDUCTOR CLEARANCE SHALL BE 20 FEET. TEMPORARY OVERHEAD CONSTRUCTION SHALL NOT BE LESS THAN GRADE "B" FOR STRENGTH REQUIREMENTS AS DEFINED BY THE NATIONAL ELECTRIC SAFETY CODE. WOOD POLES WITH OVERHEAD WIRING MAY BE USED. HOWEVER, TEMPORARY LIGHTING SHALL MEET FEDERAL AND STATE SAFETY CRITERIA. IF BREAKAWAY POLES ARE USED TO MEET THESE CRITERIA, THEN UNDERGROUND WIRING SHALL

**SPECIAL, MAINTAIN EXISTING LIGHTING (CONT'D)**

BE USED. RECONDITIONED OR USED MATERIALS MAY BE FURNISHED FOR TEMPORARY LIGHTING.

ALL MATERIALS NECESSARY TO COMPLETE THE TEMPORARY LIGHTING SHALL BE FURNISHED AND INSTALLED BY THE CONTRACTOR. WHEN NO LONGER NEEDED, THE TEMPORARY LIGHTING INSTALLATION SHALL BE REMOVED AND PROPERLY DISPOSED OF BY THE CONTRACTOR.

THE MAINTAINING AGENCY WILL PAY FOR ELECTRICAL ENERGY CONSUMED BY EXISTING POWER SERVICES AND BY PROPOSED PERMANENT POWER SERVICES AFTER ACCEPTANCE OF THE LIGHTING WORK. THE CONTRACTOR WILL PAY FOR ELECTRICAL ENERGY, INSTALLATION, REMOVAL AND MAINTENANCE OF ANY TEMPORARY POWER SERVICES.

**ITEM 614, PORTABLE CHANGEABLE MESSAGE SIGNS, AS PER PLAN**

THE CONTRACTOR SHALL FURNISH, INSTALL, MAINTAIN AND REMOVE, WHEN NO LONGER NEEDED, A CHANGEABLE MESSAGE SIGN. THE SIGN SHALL BE OF A TYPE SHOWN ON A LIST OF APPROVED PCMS UNITS AVAILABLE ON THE OFFICE OF MATERIALS MANAGEMENT WEB PAGE. THE LIST CONTAINS CLASS A AND B UNITS WITH MINIMUM LEGIBILITY DISTANCES OF 800 FEET AND 650 FEET, RESPECTIVELY.

EACH SIGN SHALL BE TRAILER-MOUNTED AND EQUIPPED WITH A FUNCTIONAL DIMMING MECHANISM, TO DIM THE SIGN DURING DARKNESS, AND A TAMPER AND VANDAL PROOF ENCLOSURE. EACH SIGN SHALL BE PROVIDED WITH APPROPRIATE TRAINING AND OPERATION INSTRUCTIONS TO ENABLE ON-SITE PERSONNEL TO OPERATE AND TROUBLESHOOT THE UNIT. THE SIGN SHALL ALSO BE CAPABLE OF BEING POWERED BY AN ELECTRICAL SERVICE DROP FROM A LOCAL UTILITY COMPANY. THE PCMS SHALL BE DELINEATED IN ACCORDANCE WITH C&MS 614.03.

THE PROBABLE PCMS LOCATIONS AND WORK LIMITS FOR THOSE LOCATIONS ARE SHOWN IN THE PLAN. PLACEMENT, OPERATION, MAINTENANCE AND ALL ACTIVATION OF THE SIGNS BY THE CONTRACTOR SHALL BE AS DIRECTED BY THE ENGINEER. THE PCMS SHALL BE LOCATED IN A HIGHLY VISIBLE POSITION YET PROTECTED FROM TRAFFIC. THE CONTRACTOR SHALL, AT THE DIRECTION OF THE ENGINEER, RELOCATE THE PCMS TO IMPROVE VISIBILITY OR ACCOMMODATE CHANGED CONDITIONS. WHEN NOT IN USE, THE PCMS SHALL BE TURNED OFF. ADDITIONALLY, WHEN NOT IN USE FOR EXTENDED PERIODS OF TIME, THE PCMS SHALL BE TURNED AWAY FROM ALL TRAFFIC.

THE ENGINEER SHALL BE PROVIDED ACCESS TO EACH SIGN UNIT AND SHALL BE PROVIDED WITH APPROPRIATE TRAINING AND OPERATION INSTRUCTIONS TO ENABLE ODOT PERSONNEL TO OPERATE AND TROUBLESHOOT THE UNIT, AND TO REVISE SIGN MESSAGES, IF NECESSARY.

ALL MESSAGES TO BE DISPLAYED ON THE SIGN WILL BE PROVIDED BY THE ENGINEER. A LIST OF ALL REQUIRED PRE-PROGRAMMED MESSAGES WILL BE GIVEN TO THE CONTRACTOR AT THE PROJECT PRECONSTRUCTION CONFERENCE. THE SIGN SHALL HAVE THE CAPABILITY TO STORE UP TO 99 MESSAGES. MESSAGE MEMORY OR PRE-PROGRAMMED DISPLAYS SHALL NOT BE LOST AS A RESULT OF POWER FAILURES TO THE ON-BOARD COMPUTER. THE SIGN LEGEND SHALL BE CAPABLE OF BEING CHANGED IN THE FIELD. THREE-LINE PRESENTATION FORMATS WITH UP TO SIX MESSAGE PHASES SHALL BE SUPPORTED. PCMS FORMAT SHALL PERMIT THE COMPLETE MESSAGE FOR EACH PHASE TO BE READ AT LEAST TWICE.

**ITEM 614, PORTABLE CHANGEABLE MESSAGE SIGNS, AS PER PLAN (CONT'D)**

Released for Construction  
JAMES R. NELL, PE  
05/28/2021

THE PCMS SHALL CONTAIN AN ACCURATE CLOCK AND PROGRAMMING LOGIC WHICH WILL ALLOW THE SIGN TO BE ACTIVATED, DEACTIVATED OR MESSAGES CHANGED AUTOMATICALLY AT DIFFERENT TIMES OF THE DAY FOR DIFFERENT DAYS OF THE WEEK.

THE PCMS SHALL CONTAIN A CELLULAR TELEPHONE DATA LINK WHICH WILL (IN ACTIVE CELLULAR PHONE AREAS) ALLOW REMOTE SIGN ACTIVATION, MESSAGE CHANGES, MESSAGE ADDITIONS AND REVISIONS TO TIME OF DAY PROGRAMS. THE SYSTEM SHALL ALSO PERMIT VERIFICATION OF CURRENT AND PROGRAMMED MESSAGES. ONE REMOTE DATA INPUT DEVICE (LAPTOP COMPUTER PLUS MODEM OR EQUIVALENT) SHALL BE FURNISHED FOR USE BY THE DISTRICT TRAFFIC ENGINEER, OR EQUIVALENT, AND SHALL BE INSURED AGAINST THEFT.) THE PCMS UNIT SHALL BE MAINTAINED IN GOOD WORKING ORDER BY THE CONTRACTOR IN ACCORDANCE WITH THE PROVISIONS OF C&MS 614.07. THE CONTRACTOR SHALL, PRIOR TO ACTIVATING THE UNIT, MAKE ARRANGEMENTS, WITH AN AUTHORIZED SERVICE AGENT FOR THE PCMS, TO ASSURE PROMPT SERVICE IN THE EVENT OF FAILURE. ANY FAILURE SHALL NOT RESULT IN THE SIGN BEING OUT OF SERVICE FOR MORE THAN 12 HOURS, INCLUDING WEEKENDS. FAILURE TO COMPLY MAY RESULT IN AN ORDER TO STOP WORK AND OPEN ALL TRAFFIC LANES AND/OR IN THE DEPARTMENT TAKING APPROPRIATE ACTION TO SAFELY CONTROL TRAFFIC. THE ENTIRE COST TO CONTROL TRAFFIC, ACCRUED BY THE DEPARTMENT DUE TO THE CONTRACTOR'S NONCOMPLIANCE, WILL BE DEDUCTED FROM MONEYS DUE, OR TO BECOME DUE THE CONTRACTOR ON HIS CONTRACT.

THE CONTRACTOR SHALL BE RESPONSIBLE FOR 24-HOUR-PER-DAY OPERATION AND MAINTENANCE OF THESE SIGNS ON THE PROJECT FOR THE DURATION OF THE PHASES WHEN THE PLAN REQUIRES THEIR USE.

**EXTRA ADVANCE WARNING SIGNS**

AN EXTRA ADVANCE WARNING SIGN GROUP CONSISTS OF TWO W20-1 (ROAD WORK AHEAD) SIGNS, TWO W20-5 (RIGHT/LEFT LANE CLOSED AHEAD) SIGNS WITH W16-3A DISTANCE PLATES, AND TWO W3-H7 (WATCH FOR STOPPED TRAFFIC) SIGNS AND REQUIRED WARNING LIGHTS.

THE CONTRACTOR SHALL PROVIDE, ERECT, MAINTAIN AND REMOVE EXTRA ADVANCE WARNING SIGN GROUPS AS SHOWN ON TRAFFIC SCD MT-95.50 AT THE LOCATIONS SHOWN IN THE PLANS IN ADVANCE OF THE LANE TAPERS WITH THE APPROPRIATE W16-3A DISTANCE PLATES.

ISSUE RECORD:		
NO.	DATE	DESCRIPTION

**ADVANCE WORK ZONE INFORMATION**

ADVANCE WORK ZONE INFORMATION SIGNS, AS USED IN THIS NOTE, ARE FIXED MESSAGE TYPES. THE SIGNS ARE TO BE LOCATED AT EXTREME DISTANCE FROM THE WORK AREA, AS SHOWN IN THE PLANS.

THE SIGNS SHALL BE BLACK ON ORANGE (INCLUDING A BLACK BORDER). THE LAYOUT SHALL BE IN CONFORMANCE WITH TEM CHAPTER 211.

WHEN REGULATORY INFORMATION IS PROVIDED, IT SHALL BE DISPLAYED SEPARATELY AS A STANDARD BLACK-ON-WHITE SIGN. MIXING OF BLACK-ON-WHITE REGULATORY INFORMATION ON A BLACK-ON-ORANGE INFORMATION SIGN IS PROHIBITED.

IF THE MOTORIST IS BEING DETOURED OR IF AN ALTERNATE ROUTE IS PROVIDED, THE ROUTE SHOULD BE SIGNED WITH ASSEMBLIES CONSISTING OF THE APPROPRIATE BLACK-ON-ORANGE DETOUR OR ALT MARKER WITH A STANDARD ROUTE MARKER AND ARROW PLATE. IF MORE TARGET VALUE IS DESIRED, THIS TRAIL BLAZER INFORMATION MAY BE SHOWN ON AN ORANGE PANEL (OMUTCD SECTION 2D.32).

ROUTE SIGN ASSEMBLIES SHALL BE SIZED ACCORDING TO THE TYPE OF ROAD ON WHICH THEY ARE LOCATED IN ACCORDANCE WITH THE OMUTCD.

SUPPORTS FOR SIGN INSTALLATIONS SHALL CONFORM TO ALL EXISTING STANDARDS FOR PERMANENT SIGNS. THESE SIGNS SHOULD NOT BE ATTACHED TO EXISTING SUPPORTS.

WHERE THE PLANS CALL FOR AN OVERLAY TO COVER A PORTION OF AN EXISTING SIGN, THE OVERLAY SHALL BE BLACK-ON-ORANGE. LETTER SIZES SHOULD BE THE SAME AS ON THE EXISTING SIGNS. WHEN LANE ARROWS ARE TO BE COVERED, A BLANK OVERLAY SHOULD BE PLACED OVER EACH OF THE AFFECTED ARROWS. WHEN A RAMP IS BEING CLOSED, RATHER THAN USING A BLANK OVERLAY TO COVER THE ENTIRE SIGN, THE LEGEND "EXIT CLOSED" (W20-H15) SHOULD BE USED ON A DIAGONAL OVERLAY (LOWER LEFT TO UPPER RIGHT) ON THE SIGN. THE SIZE OF LETTERING ON OVERLAYS AND THE SIZE OF THE OVERLAY ARE INDICATED IN THE PLANS. THE MINIMUM LETTER SIZE FOR THE DIAGONAL "EXIT CLOSED" (W20-H15) OVERLAY SHALL BE 12" C.

**ITEM 614, WORK ZONE CROSSOVER LIGHTING SYSTEM**

THIS WORK SHALL CONSIST OF FURNISHING, ERECTING, OPERATING, MAINTAINING AND REMOVING A WORK ZONE LIGHTING SYSTEM FOR A SINGLE CROSSOVER, OR OVERLAPPING A PAIR OF CROSSOVERS. THE SYSTEM SHALL BE AS SHOWN ON TRAFFIC SCD MT-100.00. ALL MATERIALS AND CONSTRUCTION SHALL COMPLY WITH APPLICABLE PORTIONS OF 625 AND 725 EXCEPT: THE PERFORMANCE TEST OF 625.19F, AND CERTIFIED DRAWING REQUIREMENT OF 625.04, ARE WAIVED AND USED MATERIALS IN GOOD CONDITION ARE ACCEPTABLE.

POLES WHICH ARE NOT PROTECTED BY GUARDRAIL OR PORTABLE BARRIER SHALL BE LOCATED OUTSIDE THE CLEAR ZONE, AND SHOULD BE LOCATED AT LEAST 30 FEET (PREFERABLY 40 FEET) FROM THE EDGE OF PAVEMENT WHEN POSSIBLE.

ADDITIONAL POLE LINES, CABLES AND APPURTENANCES NECESSARY TO FURNISH POWER TO THE LIGHTING SYSTEM SHALL BE INCLUDED IN THIS ITEM. SERVICE POLES SHALL BE POSITIONED WITH THE SAME CONSTRAINTS AS THE LIGHTING POLES AS A MINIMUM.

MAINTENANCE OF TRAFFIC NOTES

SUM-76 / 77 / 8-  
8.24 / 9.74 / 0.00

S:\STATE\PROJECTS\2021\05\27\20210527\31 AM - apilipchuk  
5/27/2021 6:57:31 AM - Design\02329\M0T\Sheets\BU-3B\02329\_MNB\BU3B005.dgn Sheet  
STATE STAMPS  
DATE  
FILE

**MAINTENANCE OF TRAFFIC SIGNAL/FLASHER INSTALLATION**

THE CONTRACTOR SHALL BE RESPONSIBLE FOR MAINTAINING TRAFFIC SIGNAL/FLASHER INSTALLATIONS WITHIN THE PROJECT UNDER THE FOLLOWING CONDITIONS:

1. EXISTING SIGNAL/FLASHER INSTALLATIONS WHICH THE PLANS REQUIRE THE CONTRACTOR TO ADJUST, MODIFY, ADD ONTO OR REMOVE, OR WHICH THE CONTRACTOR ACTUALLY ADJUSTS, MODIFIES OR OTHERWISE DISTURBS. THE CONTRACTOR SHALL BE RESPONSIBLE FOR THE ENTIRE INSTALLATION (AT AN INTERSECTION) FROM THE TIME HIS OPERATIONS FIRST DISTURB THE INSTALLATION UNTIL THE INSTALLATION HAS BEEN SUBSEQUENTLY REMOVED OR MODIFIED AND THE WORK IS ACCEPTED.
2. NEW OR REUSED SIGNAL/FLASHER INSTALLATIONS OR DEVICES, INSTALLED BY THE CONTRACTOR. THE CONTRACTOR SHALL BE RESPONSIBLE FOR MAINTENANCE OF THESE FROM THE TIME OF INSTALLATION UNTIL THE WORK IS ACCEPTED.

THE CONTRACTOR SHALL CORRECT AS QUICKLY AS POSSIBLE ALL OUTAGES OR MALFUNCTIONS. HE SHALL PROVIDE THE MAINTAINING AGENCY AND THE ENGINEER SUCH ADDRESSES AND PHONE NUMBERS WHERE HIS MAINTENANCE FORCES CAN BE CONTACTED. THE CONTRACTOR SHALL PROVIDE ONE OR MORE PERSONS TO RECEIVE ALL CALLS AND DISPATCH THE NECESSARY MAINTENANCE FORCES TO CORRECT OUTAGES. SUCH A PERSON OR PERSONS MAY BE USED TO PERFORM OTHER DUTIES AS LONG AS PROMPT ATTENTION IS GIVEN TO THESE CALLS AND A PERSON IS READILY AVAILABLE CONTINUOUSLY 24 HOURS A DAY, 7 DAYS A WEEK. ALL LAMP OUTAGES, CABLE OUTAGES, ELECTRICAL FAILURES, EQUIPMENT MALFUNCTIONS AND MISALIGNED SIGNAL HEADS SHALL BE CORRECTED TO THE SATISFACTION OF THE ENGINEER WITH THE SIGNAL BACK TO SERVICE WITHIN FOUR HOURS AFTER THE CONTRACTOR HAS BEEN NOTIFIED OF THE OUTAGE.

IN THE EVENT NEW SIGNALS ARE DAMAGED PRIOR TO ACCEPTANCE, ALL DAMAGED EQUIPMENT EXCEPT POLES AND CONTROL EQUIPMENT SHALL BE REPLACED BY THE CONTRACTOR TO THE SATISFACTION OF THE ENGINEER WITH THE SIGNAL BACK IN SERVICE WITHIN 8 HOURS AFTER THE CONTRACTOR'S NOTIFICATION OF THE OUTAGE. THE CONTRACTOR SHALL ARRANGE FOR FULL TRAFFIC CONTROL UNTIL THE SIGNAL IS BACK IN OPERATION. IF POLES AND/OR CONTROL EQUIPMENT ARE DAMAGED AND MUST BE REPLACED, THE CONTRACTOR SHALL MAKE TEMPORARY REPAIRS AS NECESSARY TO BRING THE SIGNAL BACK INTO FULL OPERATION WITHIN THE ALLOWED 8-HOUR PERIOD, AND SHALL MAKE PERMANENT REPAIRS OR REPLACEMENT AS SOON THEREAFTER AS POSSIBLE.

NONE OF THE ABOVE SHALL BE CONSTRUED AS COLLECTIVE OR CONSECUTIVE OUTAGE TIME PERIODS AT ANY ONE LOCATION. THAT IS, WHERE MORE THAN ONE OUTAGE OCCURS AT ANY ONE LOCATION THEN THE ALLOTTED TIME LIMIT SHALL BE FOR THE WORST SINGLE OUTAGE.

WHERE OUTAGES ARE THE DIRECT RESULT OF A VEHICLE ACCIDENT THE RESPONSE OF THE CONTRACTOR SHALL BE AS OUTLINED ABOVE. THE CONTRACTOR SHALL BE RESPONSIBLE FOR COLLECTION OF ANY COMPENSATION FOR THIS WORK FROM THOSE PARTIES RESPONSIBLE FOR THE DAMAGE.

WHERE THE CONTRACTOR HAS FAILED TO, OR CANNOT RESPOND TO, AN OUTAGE OR SIGNAL EQUIPMENT MALFUNCTION, AT THESE LOCATIONS WITHIN HIS RESPONSIBILITY, WITHIN PERIODS AS SPECIFIED ABOVE, THE ENGINEER MAY INVOKE THE PROVISIONS OF SECTION 105.15

**MAINTENANCE OF TRAFFIC SIGNAL/FLASHER INSTALLATION (CONT'D)**

AND ANY SUBSEQUENT BILLINGS TO THE STATE OR THE CITY OF AKRON FOR POLICE SERVICES AND MAINTENANCE SERVICES BY CITY FORCES SHALL BE DEDUCTED FROM MONIES DUE OR TO BECOME DUE THE CONTRACTOR IN ACCORDANCE WITH PROVISIONS OF SECTION 105.15.

THE CONTRACTOR SHALL PROVIDE THE MAINTENANCE SERVICE ENTIRELY WITH HIS FORCES OR HE MAY CHOOSE TO ENTER INTO A COOPERATIVE UNDERSTANDING WITH THE LOCAL MAINTAINING AGENCY TO PROVIDE THE MAINTENANCE. THE CONTRACTOR SHALL INFORM THE ENGINEER, IN WRITING, OF THE MAINTENANCE METHOD SELECTED.

THE CONTRACTOR SHALL BE RESPONSIBLE FOR ANY DAMAGE TO ANY TRAFFIC SIGNAL COMPONENTS REQUIRED TO BE HANDLED DURING THE RELOCATION OF POLES AND REVISIONS TO THE SIGNAL SYSTEM. WHEN A TRAFFIC SIGNAL MUST BE TAKEN OUT OF SERVICE BY THE CONTRACTOR, DUE TO CONSTRUCTION PROCEDURES, THIS OUTAGE SHALL NOT EXCEED 2 HOURS AND SHALL NOT INCLUDE THE HOURS OF 6 AM TO 9 AM AND 3 PM TO 6 PM. ANY SIGNALIZED INTERSECTION, WHERE THE SIGNAL IS OUT OF SERVICE DUE TO CONSTRUCTION PROCEDURES, OR DUE TO AN OUTAGE OR MALFUNCTION OF EQUIPMENT AS DESCRIBED ABOVE, SHALL BE PROTECTED, BY THE CONTRACTOR, BY THE INSTALLATION OF TEMPORARY "STOP" SIGNS, EXCEPT FOR THE FOLLOWING INTERSECTIONS WHICH SHALL BE PROTECTED BY OFF-DUTY CITY OF AKRON POLICE, HIRED BY THE CONTRACTOR:

SEE HAUL ROUTES REFERENCED IN CMOTP PLAN, BU-01.

ANY VEHICULAR TRAFFIC SIGNAL HEAD, EITHER NEW OR EXISTING WHICH WILL BE OUT OF OPERATION SHALL BE COVERED IN THE MANNER DESCRIBED IN 632.25.

THE CONTRACTOR SHALL MAINTAIN COMPLETE RECORDS OF MALFUNCTIONS INCLUDING:

1. TIME OF NOTIFICATION OF MALFUNCTION;
2. TIME OF WORK CREWS ARRIVAL TO CORRECT THE MALFUNCTION;
3. ACTIONS TAKEN TO CORRECT THE MALFUNCTION, INCLUDING A LIST OF PARTS REPAIRED OR REPLACED;
4. A DIAGNOSIS OF REASON FOR THE MALFUNCTION AND PROBABILITY OF REOCCURRENCE;
5. TIME OF COMPLETION OF THE REPAIR AND SYSTEM RESTORED TO FULL SERVICE.

A COPY OF THESE RECORDS SHALL BE PROVIDED TO THE ENGINEER WITHIN THREE (3) WORKING DAYS FOLLOWING COMPLETION OF EACH REPAIR.

**TRAFFIC INCIDENT MANAGEMENT (TIM) DURING MOT**

Released for Construction  
Thomas J Powell, PE  
05/28/2021

OHIO TIM IS OHIO'S TRAFFIC INCIDENT MANAGEMENT PROGRAM WHICH IS COMMITTED TO MAINTAINING THE SAFE AND EFFECTIVE FLOW OF TRAFFIC DURING EMERGENCIES AS TO PREVENT FURTHER DAMAGE, INJURY OR UNDUE DELAY OF THE MOTORING PUBLIC. IN ADDITION TO COMPLYING WITH THE PROVISION OF OMUTCD CHAPTER 6I, CONTROL OF TRAFFIC THROUGH TRAFFIC INCIDENT MANAGEMENT AREAS, THE CONTRACTOR SHALL ACTIVELY PARTICIPATE IN TIM PLANNING AND IMPLEMENTATION AS OUTLINED BELOW.

1. SUPERINTENDENT SHALL IDENTIFY THE INDIVIDUAL PERSONS ON THE PROJECT WHO WILL, OR MAY NEED TO, PERFORM THE DUTIES HEREIN. AT A MINIMUM, INCLUDE THE SUPERINTENDENT, FOREMEN AND SUPERVISORS (OR EQUIVALENT) AS WELL AS THE WORKSITE TRAFFIC SUPERVISOR (WTS; IF APPLICABLE TO THE PROJECT). THESE INDIVIDUALLY IDENTIFIED PERSONS SHALL COLLECTIVELY BE KNOWN AS CONTRACTOR TRAFFIC INCIDENT MANAGEMENT (TIM) CONTACTS. NOTIFY THE PROJECT ENGINEER OF THE CONTRACTOR TIM CONTACTS (ALONG WITH CONTACT INFORMATION FOR EACH) AT OR BEFORE THE PRECONSTRUCTION MEETING.
2. SUPERINTENDENT SHALL NOTIFY THE ENGINEER IMMEDIATELY IF ANY CONTRACTOR TIM CONTACT IS ADDED, REMOVED OR THE CONTACT INFORMATION CHANGES OVER THE COURSE OF THE PROJECT.
3. PRIOR TO THE FIRST DAY OF WORK IN THE FIELD, EACH CONTRACTOR TIM CONTACT ON THE PROJECT SHALL HAVE ATTENDED AND SUCCESSFULLY COMPLETED OHIO TIM TRAINING PROVIDED BY THE DEPARTMENT OR DESIGNEE. TRAINING INFORMATION CAN BE FOUND AT WWW.OHIOTIM.COM.
4. SUPERINTENDENT, AT A MINIMUM, SHALL ATTEND AND ACTIVELY PARTICIPATE IN A DEPARTMENT SCHEDULED TIM MEETING BEFORE CONSTRUCTION WORK BEGINS AND BEFORE EACH PHASE CHANGE. THESE MEETINGS WILL RESULT IN A DEPARTMENT ISSUED PROJECT SPECIFIC TRAFFIC INCIDENT MANAGEMENT PLAN (TIMP). AT THE TIM MEETINGS THE ATTENDING CONTRACTOR TIM CONTACTS SHALL:
  - A. COLLABORATE WITH ODOT AND SAFETY FORCES;
  - B. SHARE PROJECT SPECIFIC DETAILS THAT IMPACT TIM RESPONDERS; AND
  - C. RECOMMEND WAYS TO INCORPORATE NECESSARY EMERGENCY ACCESS AND OTHER TIM ELEMENTS FOR TIM RESPONDERS GIVEN PROJECT SPECIFIC WORK BEING COMPLETED AND PROJECT SPECIFIC PHASING.
5. CONTRACTOR TIM CONTACTS SHALL IMPLEMENT COMPONENTS OF THE RESULTING TIMP (SUCH AS APPROVED EMERGENCY INGRESS/EGRESS POINTS, ETC), AS DIRECTED BY THE ENGINEER IN ACCORDANCE WITH 109.05.
6. CONTRACTOR TIM CONTACTS SHALL PERFORM, AT A MINIMUM, THE FOLLOWING FUNCTIONS WHEN AN INCIDENT/CRASH OCCURS:
  - A. IF OBSERVED OR PRESENT WHEN OCCURS, CALL 911 AND THEN NOTIFY THE TRAFFIC MANAGEMENT CENTER (TMC) TO PROVIDE THE FOLLOWING:
    - I. LOCATION, INCLUDING MILEPOST NUMBER AND DIRECTION OF TRAVEL
    - II. NUMBER AND TYPE OF VEHICLES INVOLVED, IF KNOWN
    - III. ESTIMATED EXTENT OF DAMAGE OR INJURY, IF KNOWN

ISSUE RECORD:		
NO.	DATE	DESCRIPTION

**TRAFFIC INCIDENT MANAGEMENT (TIM) DURING MOT (CONT'D)**

- IV. ESTIMATED NUMBER OF PATIENTS INVOLVED, IF KNOWN
  - V. ANY POTENTIAL HAZARDOUS CONDITIONS, IF KNOWN
  - VI. THE PLACARD NUMBER ON ANY HAZARDOUS MATERIALS PLACARD FROM A SAFE DISTANCE, IF APPLICABLE AND VISIBLE
- B. FOLLOWING AN INCIDENT/CRASH:
- I. INITIATE TRAFFIC MANAGEMENT/PROVIDE TEMPORARY TRAFFIC CONTROL AS INDICATED IN THE TIMP, AS DIRECTED BY THE ENGINEER IN ACCORDANCE WITH 109.05.
  - II. RECOMMEND ROADWAY REPAIR NEEDS.
  - III. PROVIDE REPAIR RESOURCES AND INITIATE REPAIRS, AS DIRECTED BY THE ENGINEER IN ACCORDANCE WITH 109.05.
  - IV. ATTEND AND PARTICIPATE IN AN AFTER ACTION REVIEW (AAR).

MAINTENANCE OF TRAFFIC NOTES

SUM-76 / 77 / 8-  
8.24 / 9.74 / 0.00



Released for Construction  
 Thomas J Powell, PE  
 05/28/2021

ISSUE RECORD:		
NO.	DATE	DESCRIPTION

Table - Lane / Ramp Closure Matrix

Phase	Roadway/Ramp	Approximate Workzone Limits	Exist # Mainline Thru Lanes	Min. # MOT Mainline Thru Lanes	Required System Ramp Closure	Required Concurrent Local Ramp Closure	Maximum Lane/Ramp Closure Duration(s)	Concurrent 2-lane Operation Not Permissible	Concurrent Ramp Closure Not Permissible	Required Temporary Improvements
1A, 1B	8NB/SB	77 to Perkins St	3	PLCC	N/A	N/A	N/A	N/A	N/A	N/A
2A	77NB/77SB (construct outside improvements)	Vernon Odom Blvd to west of East Ave	6	4	76EB to 77NB 76EB to 76EB (at 77) 77SB to 76WB 277WB to 76EB 76EB to 76EB (at 277) 76WB/77NB to 76WB (permissible)	Kenmore Blvd to 76EB 22 <sup>nd</sup> St to 76WB (on ramps) 261 to 77SB	150-Day	77NB from Waterloo Rd to 8 77SB from Waterloo Rd to 8	77NB to 76WB 76EB to 77SB	Restripe 77SB to maintain 4 lanes south of Cole Ave to 277 (also applies to inside improvements)
2B	77NB/77SB (construct inside improvements)	Vernon Odom Blvd to west of East Ave	6	0	8SB to 76WB/77NB 77NB to 76WB/77NB	N/A		77NB from Waterloo Rd to 8 77SB from Waterloo Rd to 8	77NB to 76EB 76EB to 77SB	Restripe 76WB Ramp (at 77) to create 2 lane exit (merge to 1 lane on ramp)
5A	8SB to 76EB	Length of Ramps	N/A	N/A	Lane S	N/A	Lane S: 45-Day	N/A	N/A	N/A
5A	Ramp R (76EB to 8 NB)	Ramp	1	1	Yes	N/A	Ramp R: 75-Day	77NB from Waterloo Rd to 8	N/A	N/A
	Ramp N (76WB to 77 SB)	Ramp	1	1	Yes	N/A	Ramp N: 60-Day	76WB west of East Ave to Princeton St	N/A	N/A
4A, 4B, 5A	76EB	west of East Ave to Princeton St	3	2	76EB to 76EB (at 77) 76EB to 76EB (at 277) 76EB to 77SB	East Ave On-ramp (EB) South St On-ramp	640-Day	77NB from Waterloo Rd to 8 76 WB from East Ave to Princeton St	77NB to 76WB 77NB to 76EB	N/A
		Sumner St to Inman St bridge	2	1						
5A, 5B	77SB Ramp M (76EB to 77SB)	Waterloo Rd to 8	3	2	76EB to 77SB 77SB to 277WB 76EB to 76EB (at 77) 76EB to 76EB (at 277)	Wilbeth Rd On-ramp (SB) East Ave On-ramp (EB)	640-Day Wilbeth (210-Day) 77SB-277WB (210-Day*)	77NB from Waterloo Rd to 8	8SB to 76WB	(*) 76WB/77NB: Restripe to maintain 4 lanes from Main St to 76WB Off-ramp; Exit 2 lanes at 76WB Off-ramp (inside merge vicinity of Morse St overpass); Reduce 76EB-77NB ramp to 1 lane
4A, 4B	76EB	Allyn St to Ramp M	4							
3A	76WB	west of East Ave to Princeton St	3	2	77NB to 76WB 8SB to 76WB (inside work area) 59SB to 76WB (outside work area)	East Ave Off-ramp (outside work area)	640-Day 59SB to 76WB: 320-Day	76EB from East Ave to Princeton St	76EB to 77NB 77SB to 277WB	N/A
3A, 3B	77NB Ramp T (77NB to 76EB) Lane O (77NB to 76WB)	Waterloo Rd to 8	3	2	77NB to 76EB 77NB to 76WB	Waterloo Rd, Wilbeth Rd & Archwood Ave On-ramps (NB)	640-Day 77NB-76EB (210-Day) Service Ramps (210-Day)	77SB from Waterloo Rd to 8	76EB to 77NB 76EB to 76EB (at 77)	N/A
	76WB	Brown St to Sumner St	4							
5A, 6B	76WB	west of 8 (approx. STA 530+75) to Inman St	2	1	N/A	N/A	60-Day	77SB from Waterloo Rd to 8	76WB to 77SB (new flyover shall be open before lane reduction is permitted)	N/A
3A, 3B, 4A	76WB	East of Inman St	3	PLCC	N/A	N/A	N/A	N/A	N/A	N/A

MAINTENANCE OF TRAFFIC NOTES

SUM-76 / 77 / 8-  
8.24 / 9.74 / 0.00

p:\VANVAIPWINTO\parsons.com\Ohio State\Documents\DB-Akron\_Beltway\_Rehab\10 - Design\02329\MOT\Sheets\BU-3B\02329\_MNB\BU3B007.dgn Sheet 5/27/2021 6:57:52 AM aplilpchuk





\\VANVA01P\WIN101\parsons.com\Ohio State Documents\Beltway Akron\Rehab\10 - Design\102329\MOT\Sheets\BU-3B\102329\_MD022-77SB.dgn Sheet 5/27/2021 6:58:15 AM aplipchuk

Released for Construction  
Thomas J. Powell, PE  
05/28/2021

ISSUE RECORD:		
NO.	DATE	DESCRIPTION

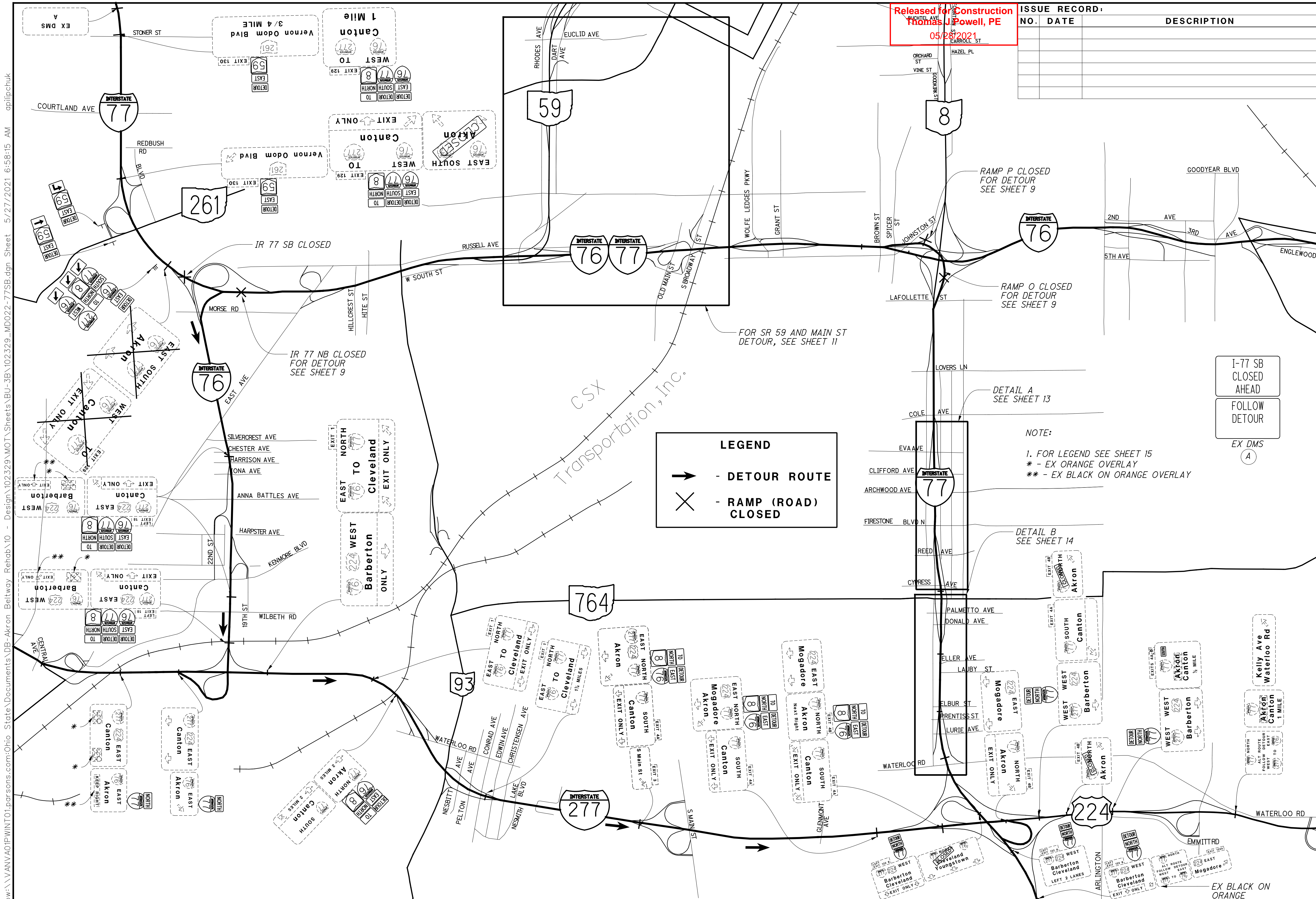

**LEGEND**

- ➔ - DETOUR ROUTE
- ✕ - RAMP (ROAD) CLOSED

**NOTE:**

- FOR LEGEND SEE SHEET 15
- \* - EX ORANGE OVERLAY
- \*\* - EX BLACK ON ORANGE OVERLAY

I-77 SB CLOSED AHEAD  
FOLLOW DETOUR  
EX DMS  
A

RAMP P CLOSED FOR DETOUR SEE SHEET 9

RAMP O CLOSED FOR DETOUR SEE SHEET 9

FOR SR 59 AND MAIN ST DETOUR, SEE SHEET 11

DETAIL A SEE SHEET 13

DETAIL B SEE SHEET 14

IR 77 SB CLOSURE (PHASE 2B) DETOUR MAP

SUM-76 / 77 / 8 - 8.24 / 9.74 / 0.00

10 / 31

USER: STIMESTAMPS DATE: 5/27/2021 6:58:26 AM apilipchuk

**1** DETOUR AHEAD  
W20-2-36

**2** DETOUR NORTH INTERSTATE 77  
M4-8-30 M3-1-36 M1-1-48-2 M5-1-30

**3** DETOUR NORTH INTERSTATE 77  
M4-8-30 M3-1-36 M1-1-48-2 M6-3-30

**4** DETOUR NORTH INTERSTATE 77  
M4-8-30 M3-1-36 M1-1-48-2 M5-1-30

**5** DETOUR NORTH INTERSTATE 77  
M4-8-30 M3-1-36 M1-1-48-2 M6-2-30

NOTES:  
1. FOR LEGEND SEE SHEET 15

Released for Construction  
Thomas J Powell, PE  
05/28/2021

ISSUE RECORD:		
NO.	DATE	DESCRIPTION

CALCULATED BER CHECKED AVP

0 750 1500  
375  
HORIZONTAL SCALE IN FEET

TO NORTH INTERSTATE 77

TO NORTH INTERSTATE 77

**LEGEND**

→ - DETOUR ROUTE

X - RAMP (ROAD) CLOSED

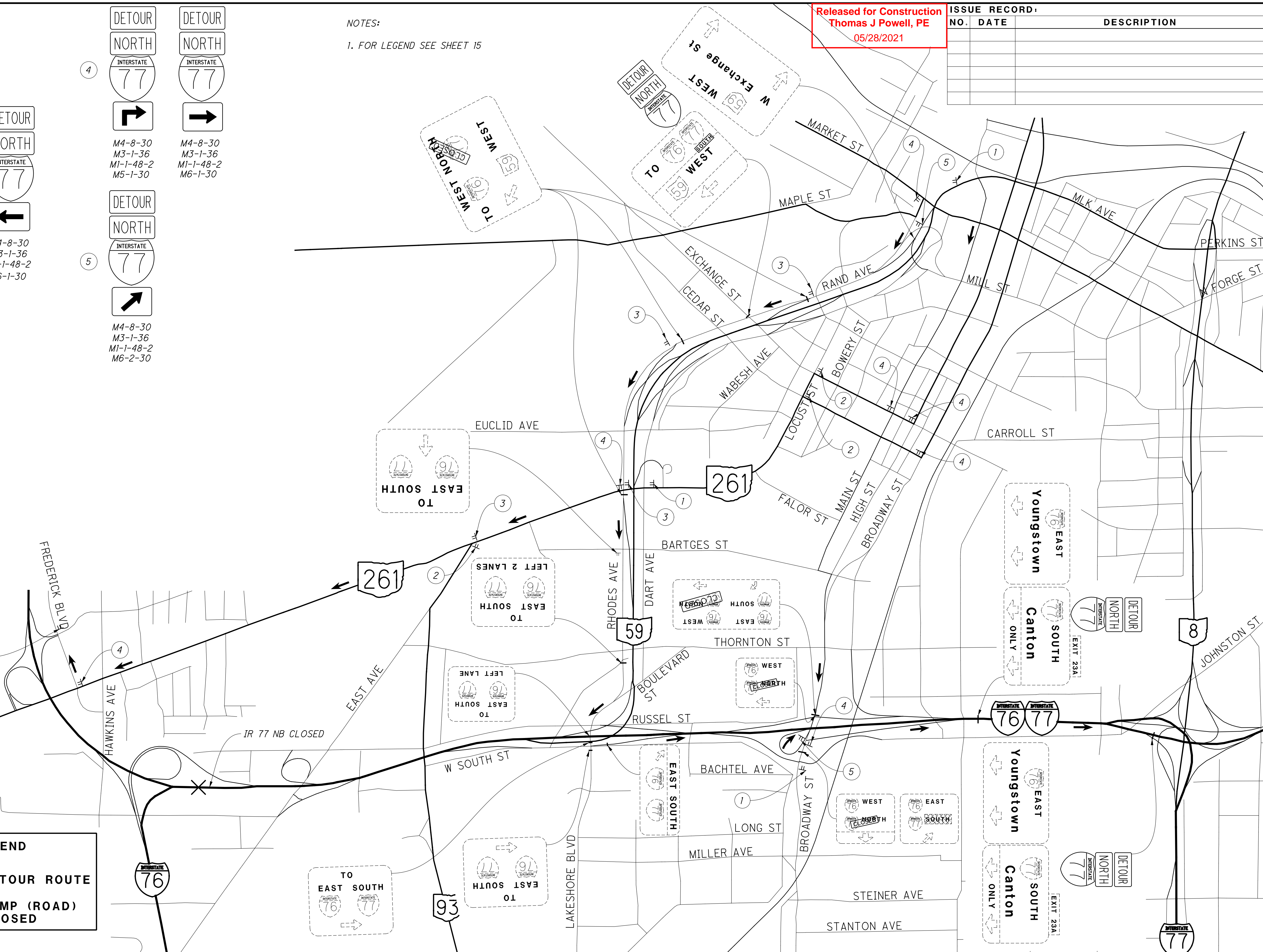

IR 77 NB DETOUR (PHASE 2B) DETOUR MAP

SUM-76 / 77 / 8 - 8.24 / 9.74 / 0.00

11 / 31



USER: STIMESTAMPS  
 SPATES: \VAOP\NTO\parsons.com:Ohio State\Documents\DB-Akron Beltway Rehab\0 - Design\02329\M0T\Sheets\BU-3B\02329-DETAIL A.dgn\_Sheet 5/27/2021 6:58:45 AM aplipchuk

Released for Construction  
 Thomas J Powell, PE  
 05/28/2021

ISSUE RECORD:		
NO.	DATE	DESCRIPTION

CALCULATED  
 BER  
 CHECKED  
 AVP

0 400 800  
 HORIZONTAL  
 SCALE IN FEET

**DETAIL A DETOUR (PHASE 2B)  
 DETOUR MAP**

**SUM-76/77/8-  
 8.24/9.74/0.00**

**LEGEND**

- DETOUR ROUTE  
 - RAMP (ROAD) CLOSED

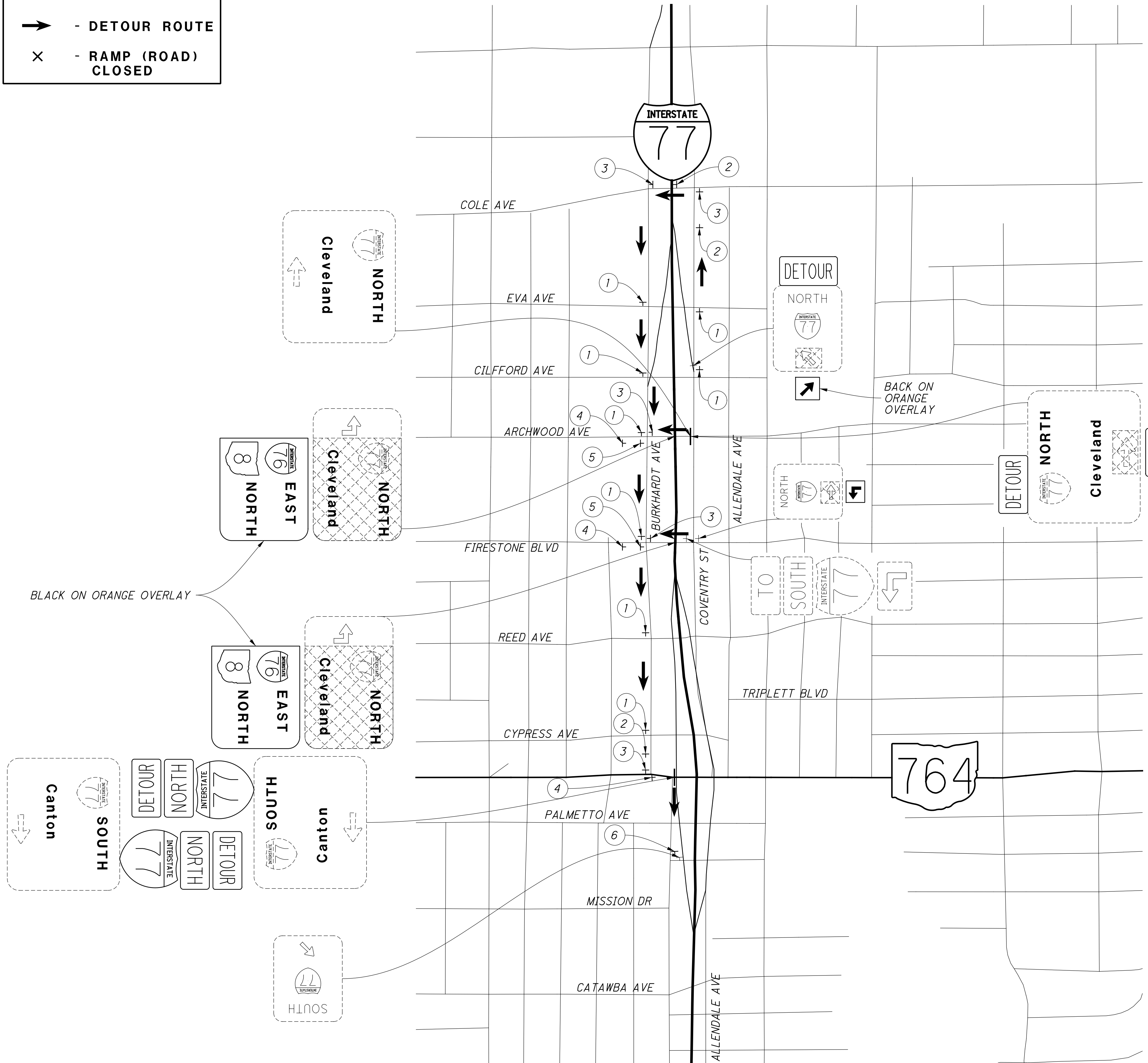

1

2

3

4

5

6

NOTES:  
 1. FOR LEGEND SEE SHEET 15  
 2. FOR SR 764 DETOUR, SEE SHEET 14  
 3. FOR OVERHEAD SIGNS ON IR 77, SEE SHEET 9

USER: STIMESTAMPS DATE: 05/27/2021 6:58:55 AM FILE: \\VAOP\PI\NTO\parsons.com:Ohio State\Documents\B-Akron Beltway Rehab\0 - Design\02329\M0T\Sheets\BU-3B\02329\_MD022-DETAIL B.dgn Sheet 5/27/2021 6:58:55 AM aplipchuk

**LEGEND**

→ - DETOUR ROUTE

X - RAMP (ROAD) CLOSED

BLACK ON ORANGE OVERLAY

Released for Construction  
 Thomas J Powell, PE  
 05/28/21  
 BLACK ON ORANGE OVERLAY

**ISSUE RECORD:**

NO.	DATE	DESCRIPTION

CALCULATED BER: \_\_\_\_\_  
 CHECKED AVP: \_\_\_\_\_

0 200 400 800  
 HORIZONTAL SCALE IN FEET

**DETAIL B DETOUR (PHASE 2B)  
 DETOUR MAP**

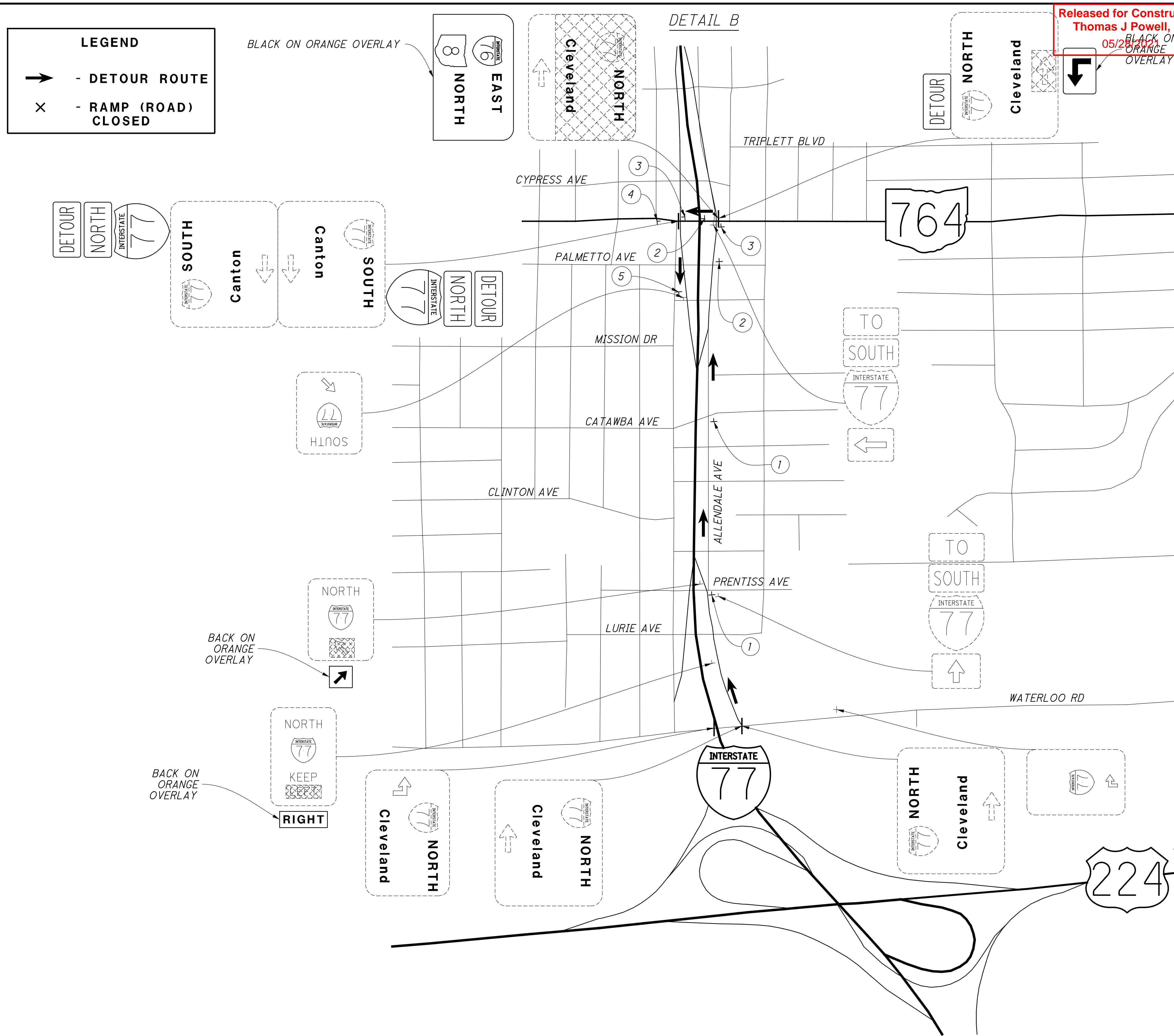

**DETOUR KEY SIGNS**

1.

2.

3.

4.

5.

BACK ON ORANGE OVERLAY

BACK ON ORANGE OVERLAY

- NOTES:**
- FOR LEGEND SEE SHEET 15
  - FOR OVERHEAD SIGNS ON IR 77, SEE SHEET 9

**DETOUR KEY SIGNS**

EAST WEST TO  
 M3-2-30 M3-4-30 M4-5-30  
  
 M1-1-30-2 M1-5-30-2

NOTE:  
 ALL ROUTE SHIELDS ON OVERHEAD SIGNS  
 SHALL BE 36" x 36" MINIMUM.

Released for Construction  
 Thomas J Powell, PE  
 05/28/2021

ISSUE RECORD:		
NO.	DATE	DESCRIPTION

CALCULATED  
 FGW  
 CHECKED  
 AVP

0 50 100  
 HORIZONTAL  
 SCALE IN FEET

NOTE:  
 1. ALL STATIONING TAKEN FROM  
 @ IR 76/IR 77 UNLESS OTHERWISE NOTED  
 2. FOR DRUM SPACING SEE MT-95.10, TABLE II  
 3. FOR PB FLARE RATE SEE MT-95.10, TABLE II

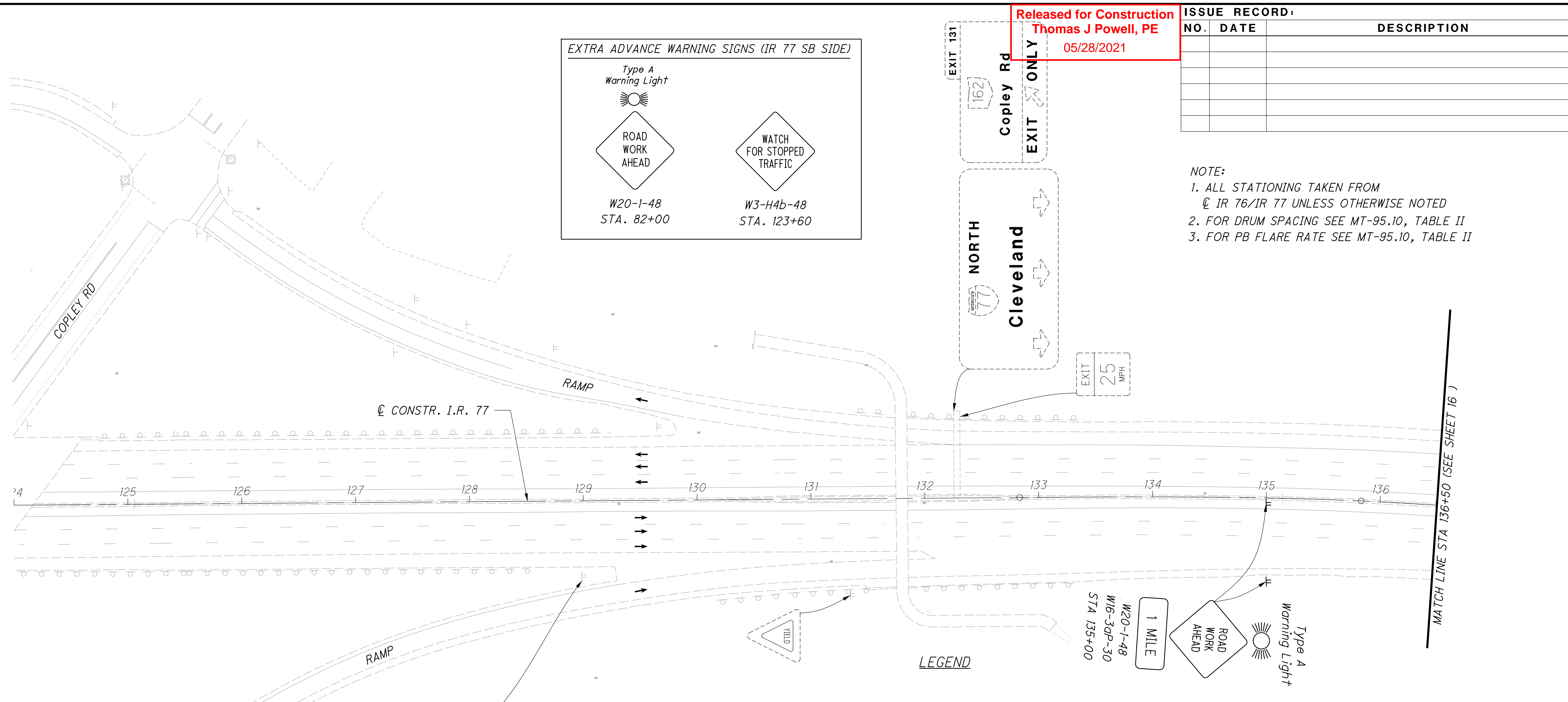

EXTRA ADVANCE WARNING SIGNS (IR 77 SB SIDE)

Type A Warning Light

ROAD WORK AHEAD  
 W20-1-48  
 STA. 82+00

WATCH FOR STOPPED TRAFFIC  
 W3-H4b-48  
 STA. 123+60

LEGEND

- PROPOSED WORK ZONE SIGN
- EXISTING SIGNS
- EXISTING COVERED SIGNS
- EXISTING SIGN TO BE REMOVED
- ITEM 614 - WORK ZONE EDGE LINE, WHITE (WEL)
- ITEM 614 - WORK ZONE LANE LINE (WLL)
- ITEM 614 - WORK ZONE EDGE LINE, YELLOW (WYL)
- ITEM 614 - WORK ZONE CHANNELIZING LINE (WCH)
- ITEM 614 - WORK ZONE DOTTED LINE (WDL)
- ITEM 614 - WORK ZONE TRANSVERSE LINE (WTL)
- ITEM 614 - SPECIAL - WORK ZONE GUARDRAIL (WGR)
- ITEM 611 - TEMPORARY DRAINAGE (TD)
- ITEM 614 - WORK ZONE IMPACT ATTENUATOR (ATT)
- ITEM 615 - TEMPORARY PAVEMENT FOR MAINTAINING TRAFFIC (TP)
- ITEM 622 - PORTABLE BARRIER (PB)
- ITEM 622 - PORTABLE BARRIER, "Y" CONNECTOR (YC)

MOT IR 77 PHASE 2B  
 STA 124+00 TO STA 136+50

SUM-76 / 77 / 8-  
 8.24 / 9.74 / 0.00

SUSER: STIMESTAMPS: 5/27/2021 6:59:24 AM apilipchuk  
 STATE: OHIO  
 FILE: \\VAOP\PI\NTO\parsons.com\Ohio State\Documents\DB-Akron Beltway Rehab\10 - Design\02329\M0T\Sheets\BU-3B\02329\_MP2B10\_Sheet

- NOTES:
1. FOR LEGEND SEE SHEET 15
  2. ALL STATIONING TAKEN FROM C I.R. 77 UNLESS OTHERWISE NOTED
  3. FOR DRUM SPACING SEE MT-95.10, TABLE II
  4. FOR PB FLARE RATE SEE MT-95.10, TABLE II

Released for Construction  
 Thomas J Powell, PE  
 05/28/2021

ISSUE RECORD:		
NO.	DATE	DESCRIPTION

CALCULATED  
 FGW  
 CHECKED  
 AVP

HORIZONTAL SCALE IN FEET

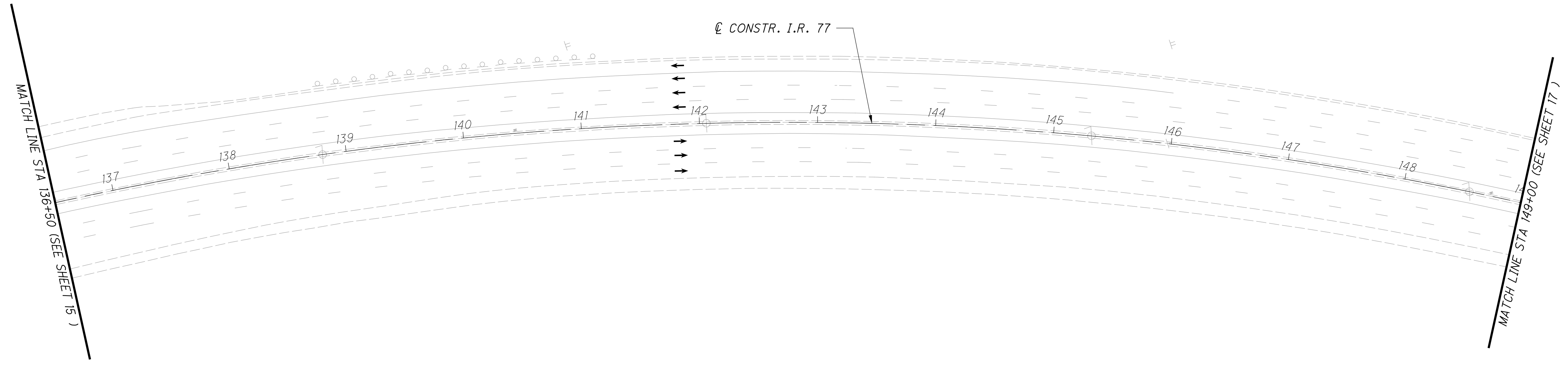

MOT IR 77 PHASE 2B  
 STA 136+50 TO STA 149+00

SUM-76 / 77 / 8-  
 8.24 / 9.74 / 0.00



Released for Construction  
 Thomas J Powell, PE  
 05/28/2021

ISSUE RECORD:		
NO.	DATE	DESCRIPTION

- NOTES:  
 1. FOR LEGEND SEE SHEET 15  
 2. ALL STATIONING TAKEN FROM C IR 77 UNLESS OTHERWISE NOTED  
 3. FOR DRUM SPACING SEE MT-95.10, TABLE II  
 4. FOR PB FLARE RATE SEE MT-95.10, TABLE II

CALCULATED  
 FGW  
 CHECKED  
 AVP

0 50 100  
 HORIZONTAL  
 SCALE IN FEET

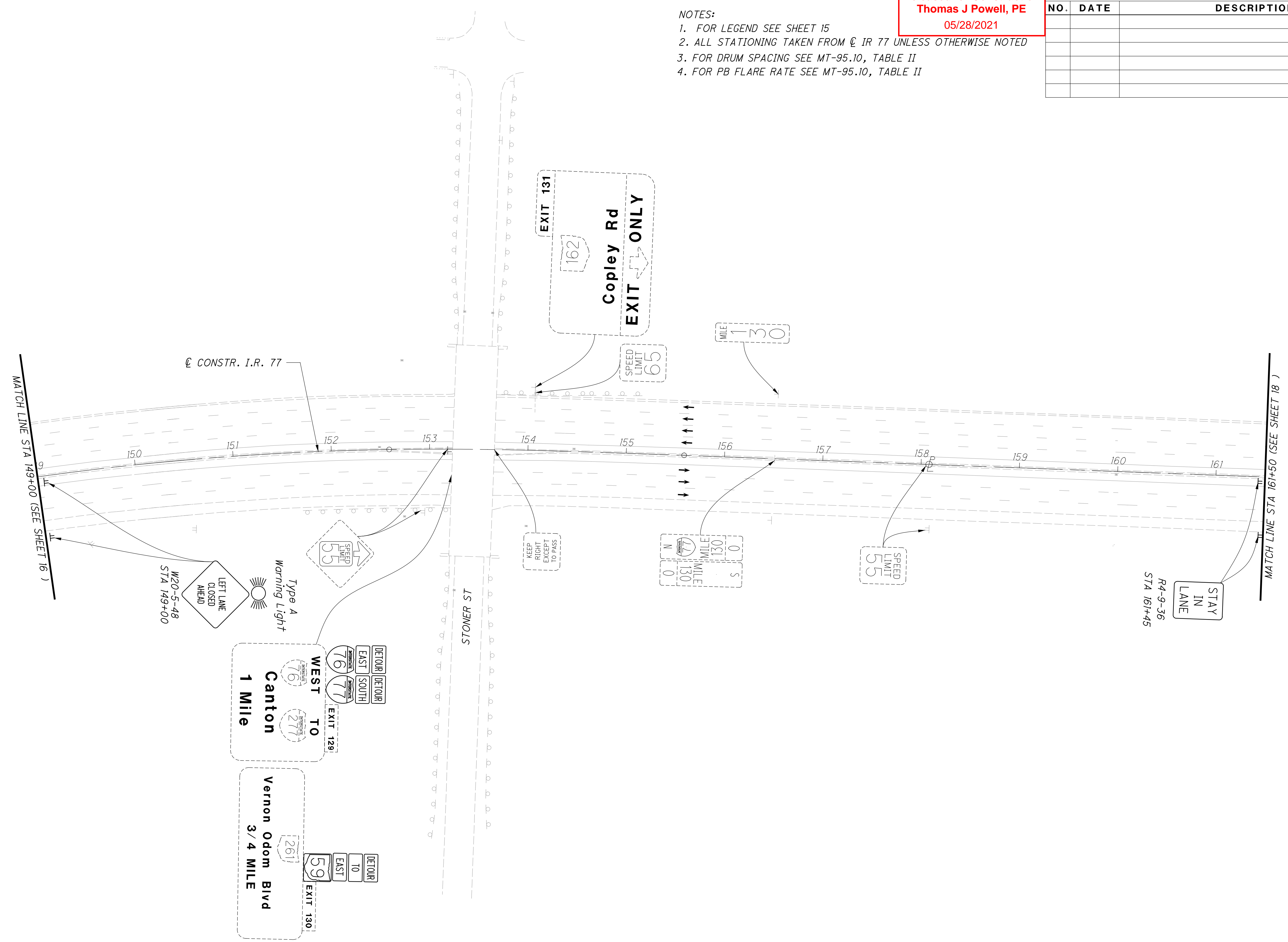

**MOT IR 77 PHASE 2B**  
**STA 149+00 TO STA 161+50**

**SUM-76 77 / 8-**  
**8.24 / 9.74 / 0.00**

Released for Construction  
 Thomas J Powell, PE  
 05/28/2021

ISSUE RECORD:		
NO.	DATE	DESCRIPTION

- NOTES:
- FOR LEGEND SEE SHEET 15
  - ALL STATIONING TAKEN FROM C I.R. 77 UNLESS OTHERWISE NOTED
  - FOR DRUM SPACING SEE MT-95.10, TABLE II
  - FOR PB FLARE RATE SEE MT-95.10, TABLE II

CALCULATED  
 FGW  
 CHECKED  
 AVP

0 50 100  
 HORIZONTAL  
 SCALE IN FEET

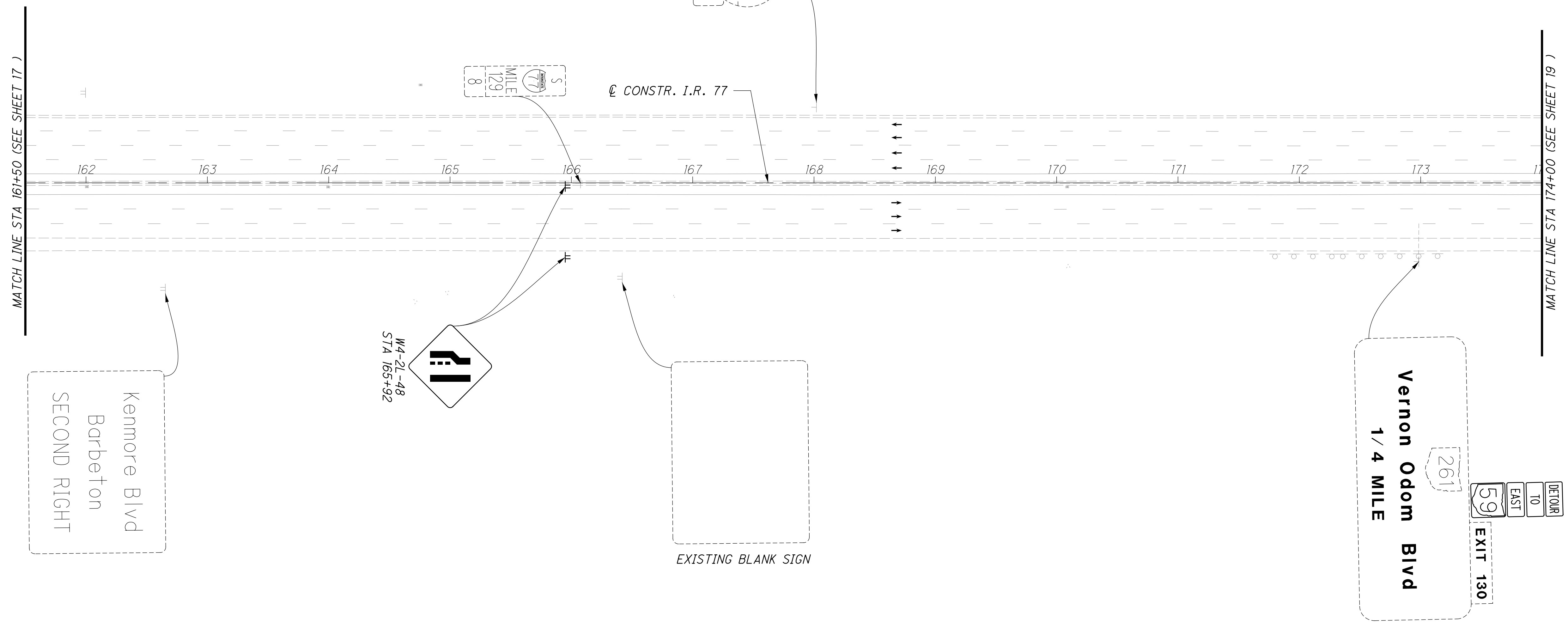

MOT IR 77 PHASE 2B  
 STA 161+50 TO STA 174+00

SUM-76 / 77 / 8-  
 8.24 / 9.74 / 0.00

p:\ANV\A01P\WINT01\parsons.com\Ohio\_State\Documents\DB-Akron Beltway Rehab\10 - Design\102329\MOT\Sheets\BU-3B\102329\_MP2B113\_Sheet 5/27/2021 7:00:07 AM apiljpcchuk

Released for Construction  
 Thomas J Powell, PE  
 05/28/2021

ISSUE RECORD:		
NO.	DATE	DESCRIPTION

- NOTES:
- FOR LEGEND SEE SHEET 15
  - ALL STATIONING TAKEN FROM  $\varnothing$  IR 77 UNLESS OTHERWISE NOTED
  - FOR DRUM SPACING SEE MT-95.10, TABLE II
  - FOR PB FLARE RATE SEE MT-95.10, TABLE II

CALCULATED  
 FGW  
 CHECKED  
 AVP

0 50 100  
 25  
 HORIZONTAL  
 SCALE IN FEET

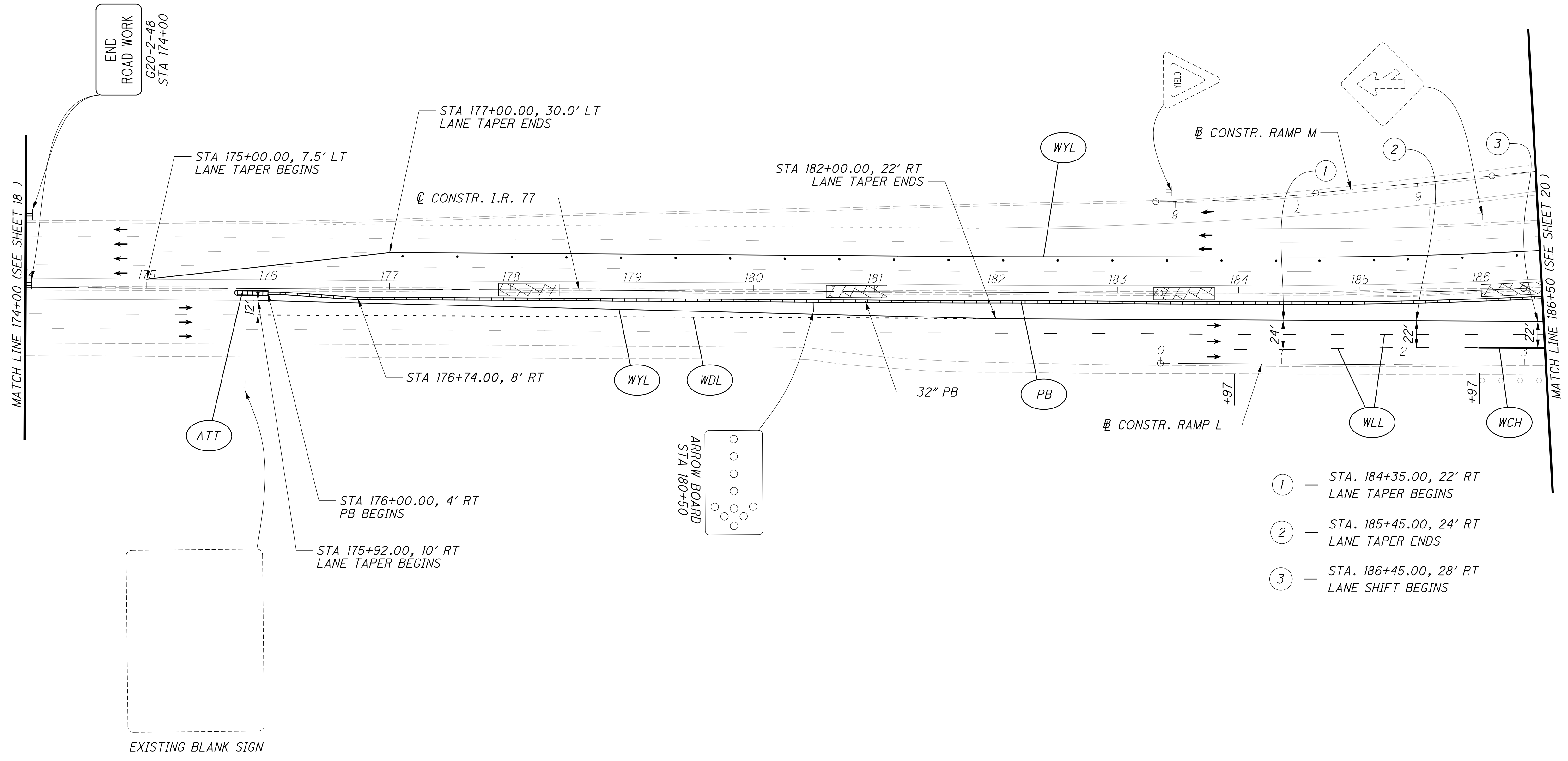

- ① — STA. 184+35.00, 22' RT LANE TAPER BEGINS
- ② — STA. 185+45.00, 24' RT LANE TAPER ENDS
- ③ — STA. 186+45.00, 28' RT LANE SHIFT BEGINS

MOT IR 77 PHASE 2B  
 STA 174+00 TO STA 186+50

SUM-76 / 77 / 8-  
 8.24 / 9.74 / 0.00

pw:\VANVA01PWINT01.parsons.com:Ohio State Documents\B-Akron Beltway Rehab\10 - Design\102329\MOT\Sheets\BU-3B\102329\_MP2B114\_Sheet 5/27/2021 7:00:22 AM apilipchuk

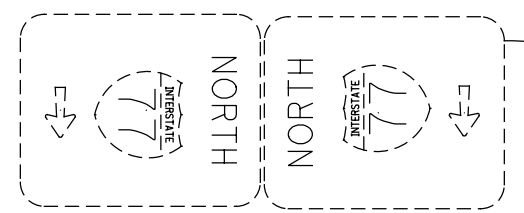

NOTES:  
 1. FOR LEGEND SEE SHEET 15  
 2. ALL STATIONING TAKEN FROM CL IR 77 UNLESS OTHERWISE NOTED  
 3. FOR DRUM SPACING SEE MT-95.10, TABLE II  
 4. FOR PB FLARE RATE SEE MT-95.10, TABLE II

Released for Construction  
 Thomas J Powell, PE

ISSUE RECORD:		
NO.	DATE	DESCRIPTION

CALCULATED  
 FGW  
 CHECKED  
 AVP

0 50 100  
 25  
 HORIZONTAL  
 SCALE IN FEET

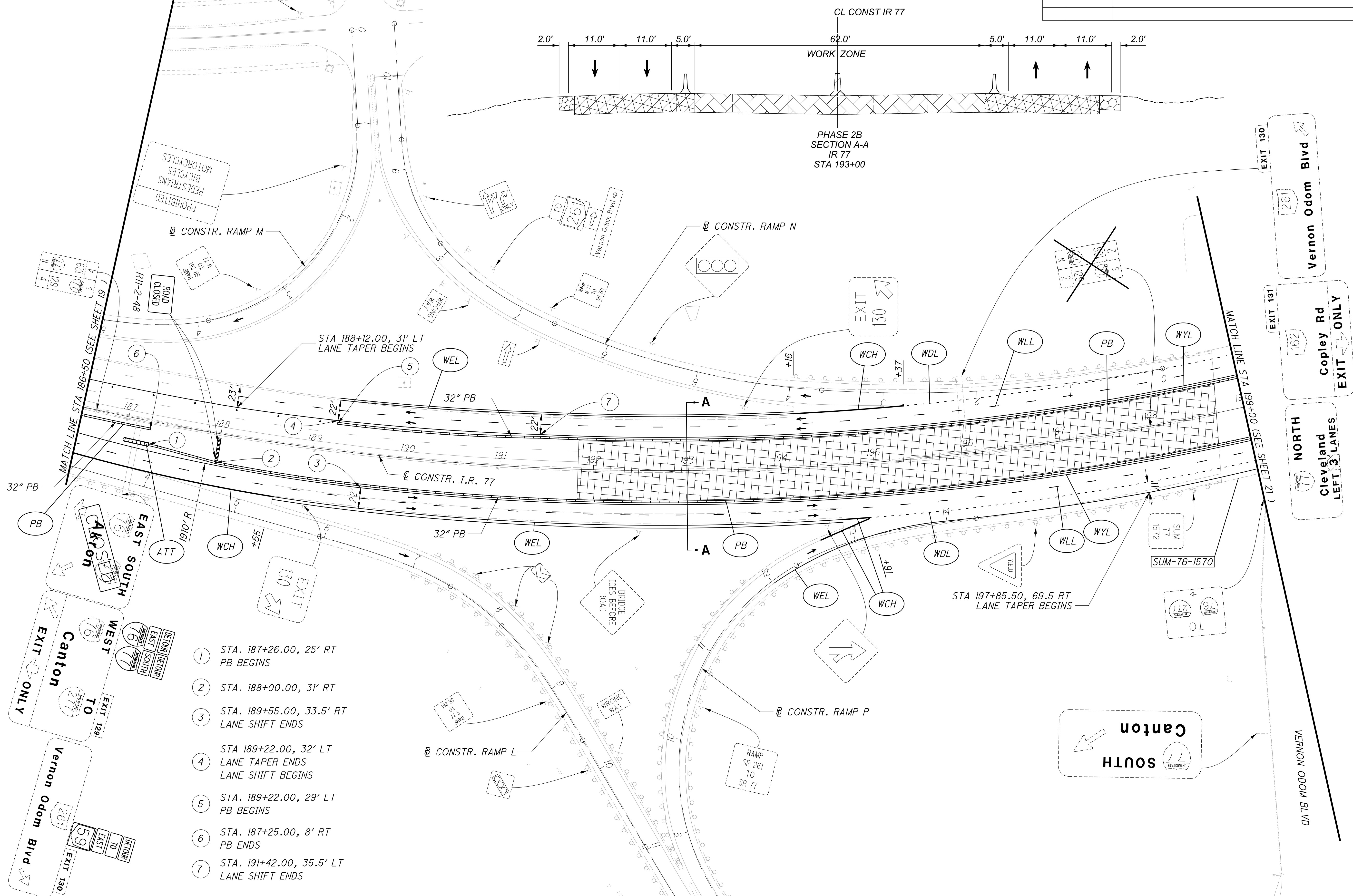

- 1 STA. 187+26.00, 25' RT PB BEGINS
- 2 STA. 188+00.00, 31' RT
- 3 STA. 189+55.00, 33.5' RT LANE SHIFT ENDS
- 4 STA. 189+22.00, 32' LT LANE TAPER ENDS LANE SHIFT BEGINS
- 5 STA. 189+22.00, 29' LT PB BEGINS
- 6 STA. 187+25.00, 8' RT PB ENDS
- 7 STA. 191+42.00, 35.5' LT LANE SHIFT ENDS

MOT IR 77 PHASE 2B  
 STA 186+50 TO STA 199+00

SUM-76 / 77 / 8-  
 8.24 / 9.74 / 0.00

20  
 31

pw:\VANVA01P\WINT01\parsons.com\Ohio\_State\Documents\DB-Akron Beltway Rehab\10 - Design\102329\MOT\Sheets\BU-3B\102329\_MP2B115\_Sheet 5/27/2021 7:00:38 AM apilipchuk

Released for Construction  
Thomas J Powell, PE  
05/28/2021

ISSUE RECORD:		
NO.	DATE	DESCRIPTION

- NOTES:
- FOR LEGEND SEE SHEET 15
  - ALL STATIONING TAKEN FROM C I.R. 77 UNLESS OTHERWISE NOTED
  - FOR DRUM SPACING SEE MT-95.10, TABLE II
  - FOR PB FLARE RATE SEE MT-95.10, TABLE II

CALCULATED  
FGW  
CHECKED  
AVP

0 50 100  
25  
HORIZONTAL  
SCALE IN FEET

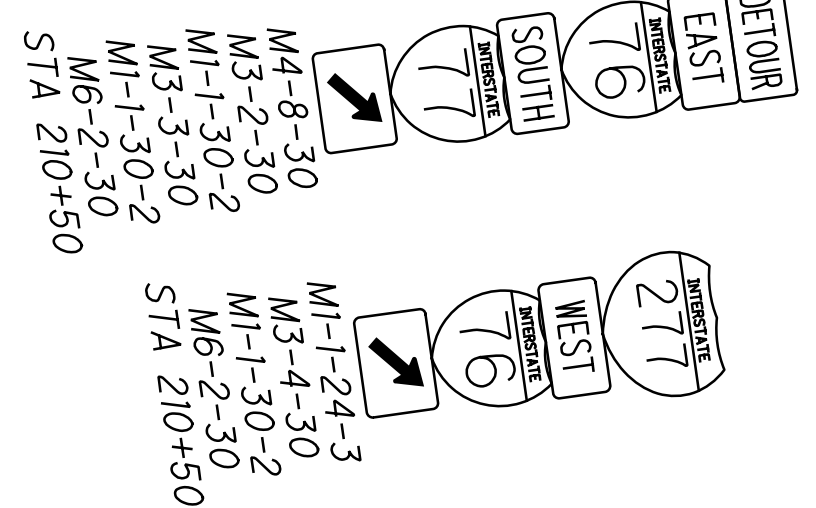
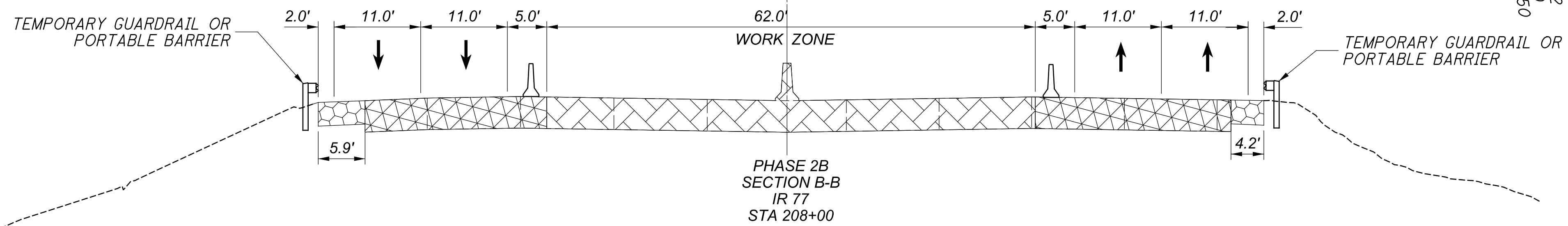
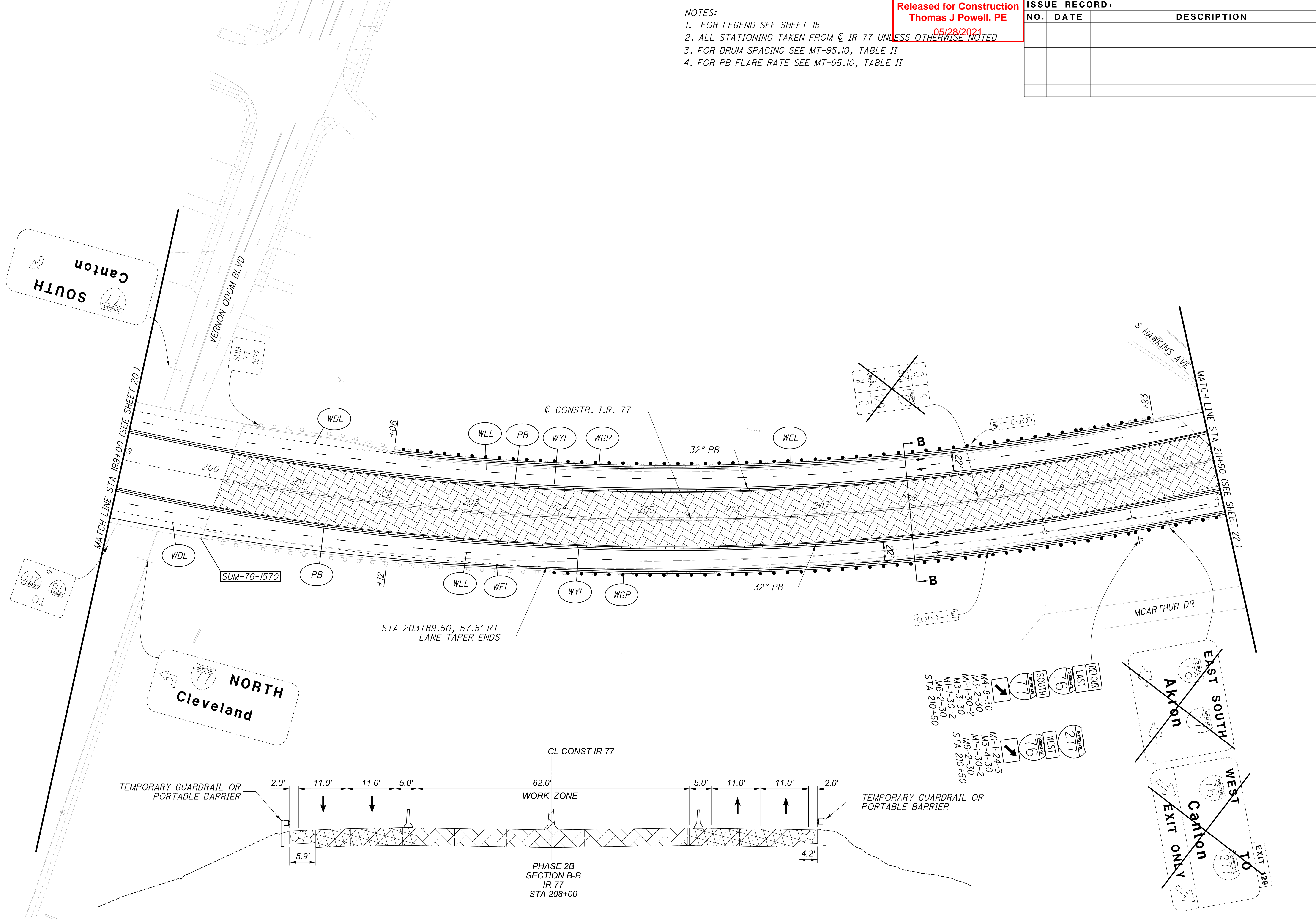

IR 77 PHASE 2B  
STA 199+00 TO STA 211+50

SUM-76 77 8-  
8.24/9.74/0.00

21  
31

pw:\VANVA01PWINT01.parsons.com:Ohio State Documents\DB-Akron Beltway Rehab\10 - Design\102329\MOT\Sheets\BU-3B\102329\_MP2B116\_Sheet 5/27/2021 7:00:53 AM apilipchuk

Released for Construction  
Thomas J Powell, PE  
05/28/2021

ISSUE RECORD:		
NO.	DATE	DESCRIPTION

- NOTES:
- FOR LEGEND SEE SHEET 15
  - ALL STATIONING TAKEN FROM C IR 77 UNLESS OTHERWISE NOTED
  - FOR DRUM SPACING SEE MT-95.10, TABLE II
  - FOR PB FLARE RATE SEE MT-95.10, TABLE II

CALCULATED  
FGW  
CHECKED  
AVP

0 50 100  
25  
HORIZONTAL  
SCALE IN FEET

- STA 3+00.00, 19.0' LT RAMP T LANE TAPER BEGINS
- STA 4+65.00, 24.0' LT RAMP T LANE TAPER ENDS
- STA 4+95.00, 27.0' LT RAMP T PB ENDS
- STA 221+73.50, 35.5' LT LANE TAPER BEGINS
- STA 7+94.50, 8.0' LT (RW) LANE TAPER ENDS

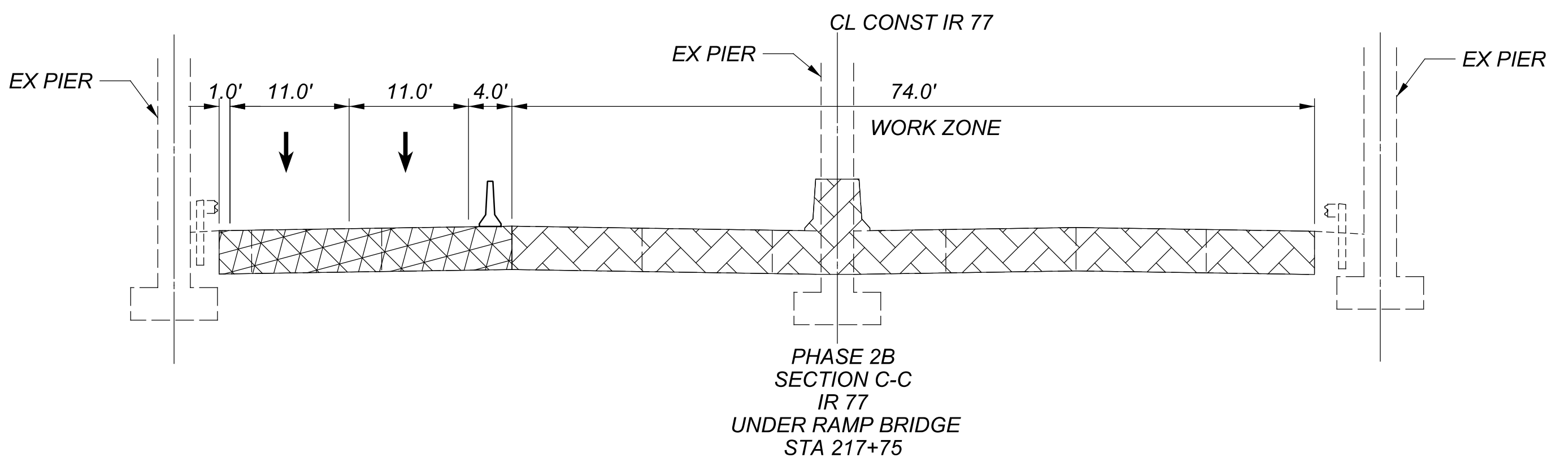
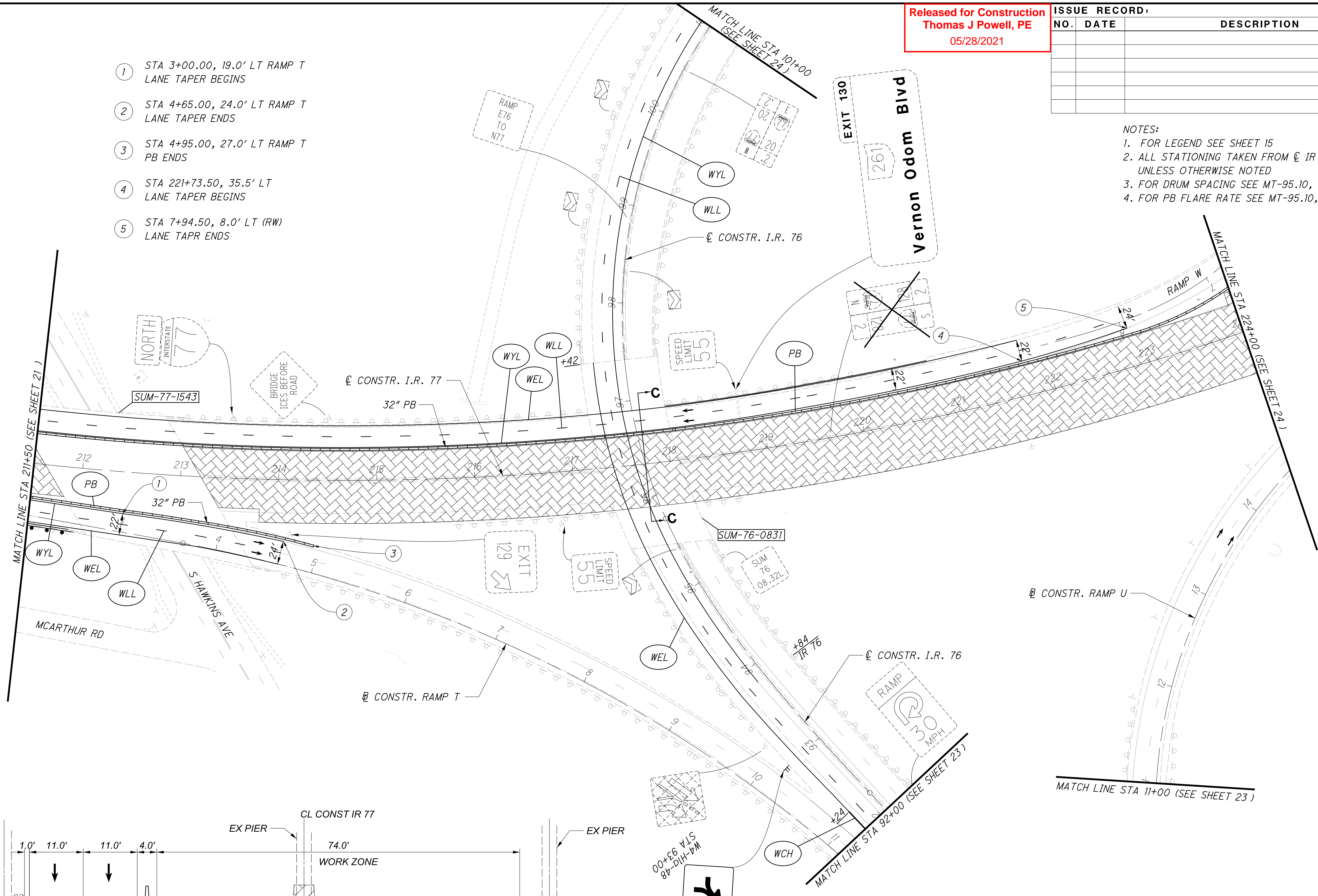

MOT IR 76 / IR 77 PHASE 2B  
STA 211+50 TO STA 224+00

SUM-76 / 77 / 8-  
8.24 / 9.74 / 0.00

pw:\VANVA01PWINT01\parsons.com:Ohio State\Documents\DB-Akron Beltway Rehab\10 - Design\102329\MOT\Sheets\BU-3B\102329\_MP2B16A.dgn Sheet 5/27/2021 7:01:09 AM aplipchuk

Released for Construction  
 Thomas J Powell, PE  
 05/28/2021

ISSUE RECORD:		
NO.	DATE	DESCRIPTION

- NOTES:
- FOR LEGEND SEE SHEET 15
  - ALL STATIONING TAKEN FROM  $\odot$  CONSTRUCTION IR 76 UNLESS OTHERWISE NOTED
  - FOR DRUM SPACING SEE MT-95.10, TABLE II
  - FOR PB FLARE RATE SEE MT-95.10, TABLE II

CALCULATED  
 FGW  
 CHECKED  
 AVP

0 50 100  
 25  
 HORIZONTAL  
 SCALE IN FEET

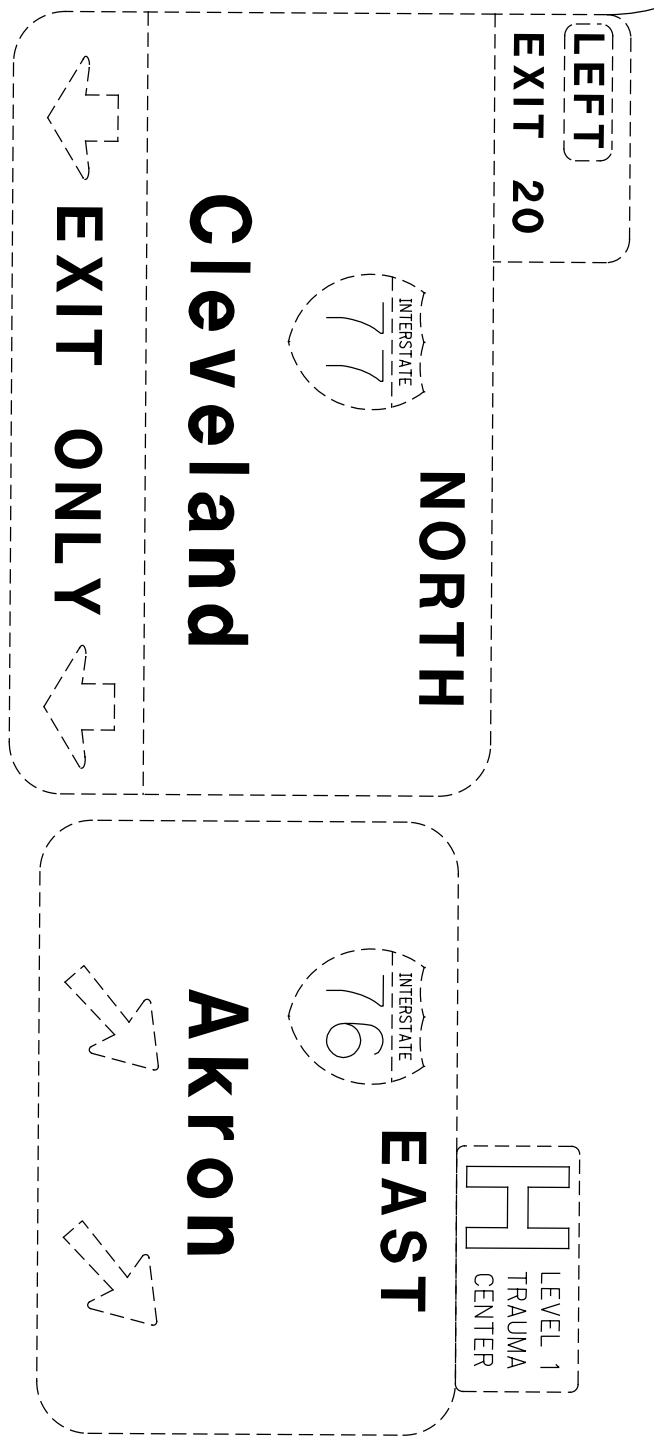
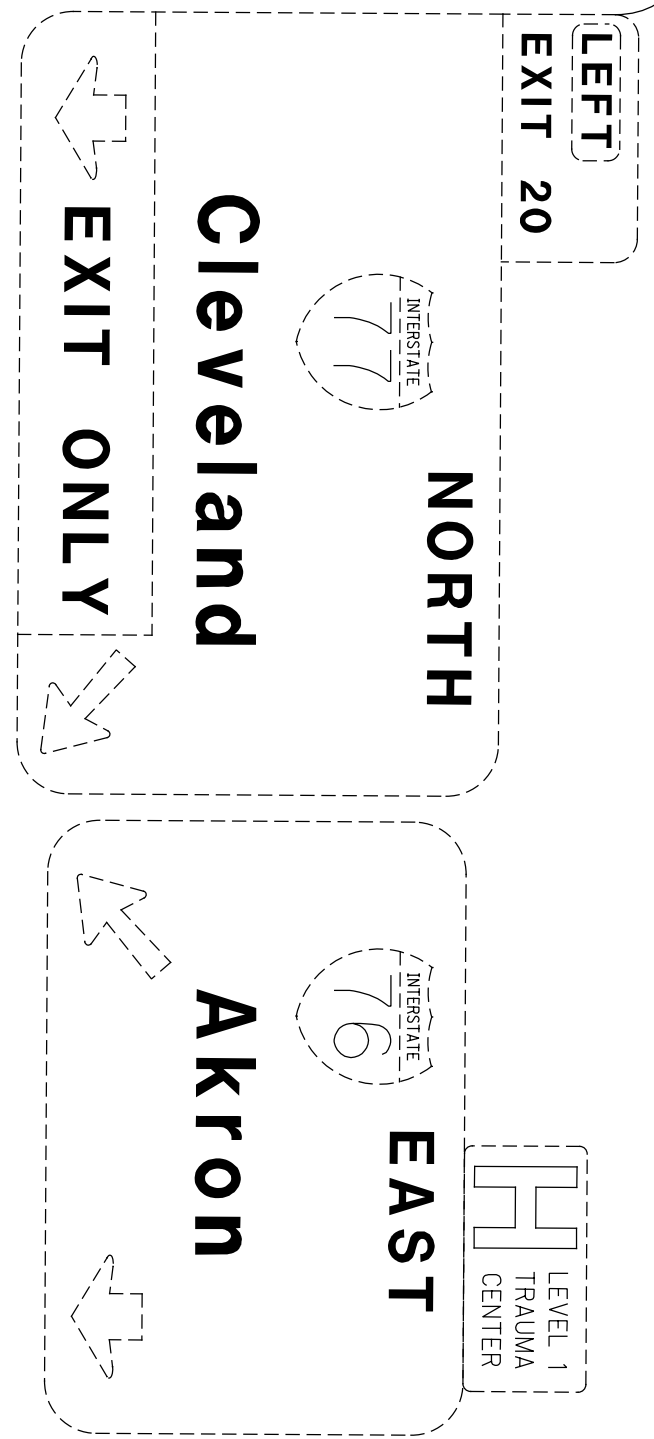
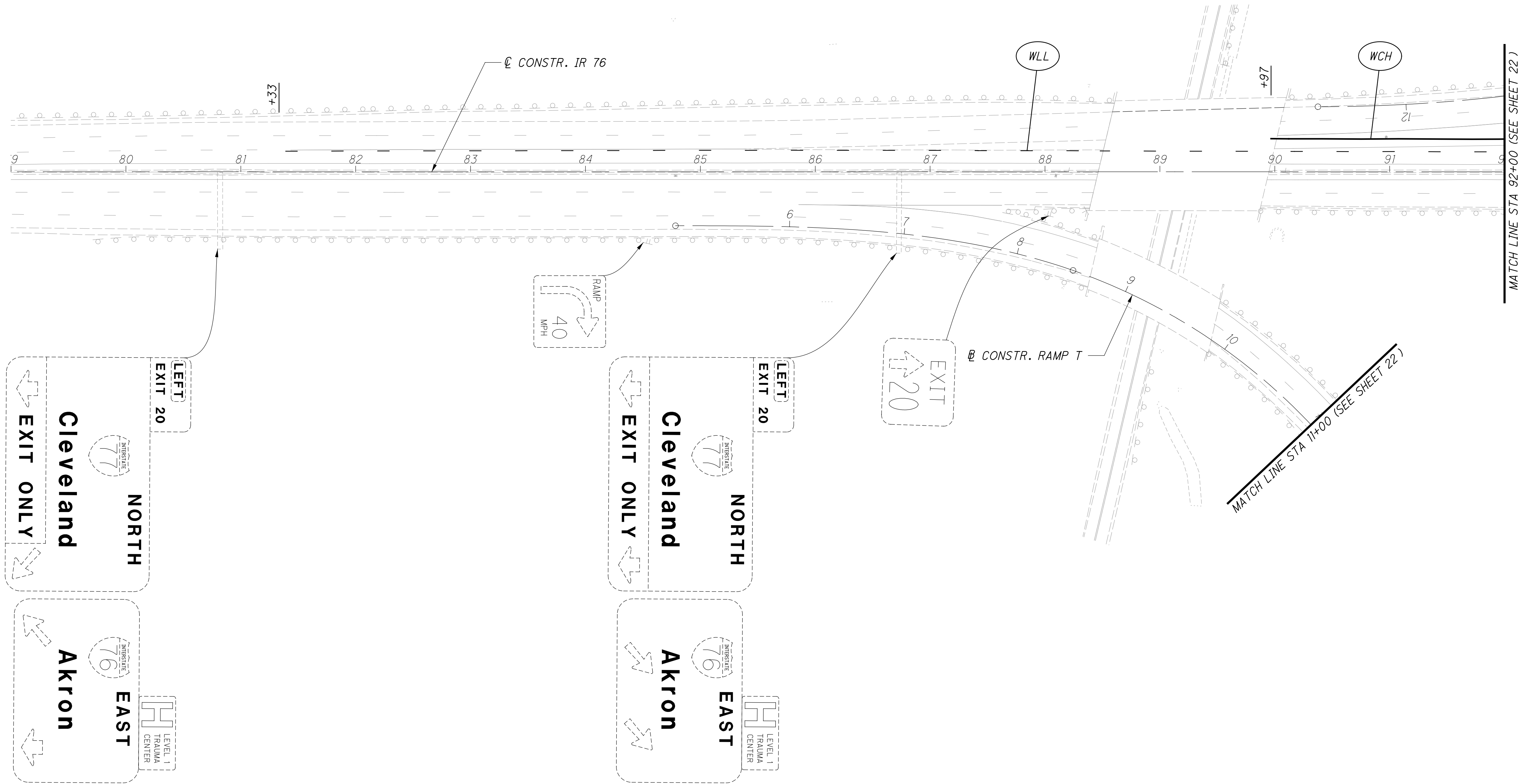

MOT IR 76 / IR 77 PHASE 2B  
 STA 79+00 TO STA 92+00

SUM-76 / 77 / 8-  
 8.24 / 9.74 / 0.00

23  
 31

pw:\VANVA01P\WINT01\parsons.com\Ohio\_State\Documents\DB-Akron Beltway Rehab\10 - Design\102329\MOT\Sheets\BU-3B\102329\_MP2B117\_Sheet 5/27/2021 7:01:25 AM aplipchuk

Released for Construction  
 Thomas J Powell, PE  
 05/28/2021

ISSUE RECORD:		
NO.	DATE	DESCRIPTION

- NOTES:
- FOR LEGEND SEE SHEET 15
  - ALL STATIONING TAKEN FROM  $\phi$  IR 76/ IR 77 UNLESS OTHERWISE NOTED
  - FOR DRUM SPACING SEE MT-95.10, TABLE II
  - FOR PB FLARE RATE SEE MT-95.10, TABLE II

CALCULATED  
 FGW  
 CHECKED  
 AVP

0 50 100  
 25  
 HORIZONTAL  
 SCALE IN FEET

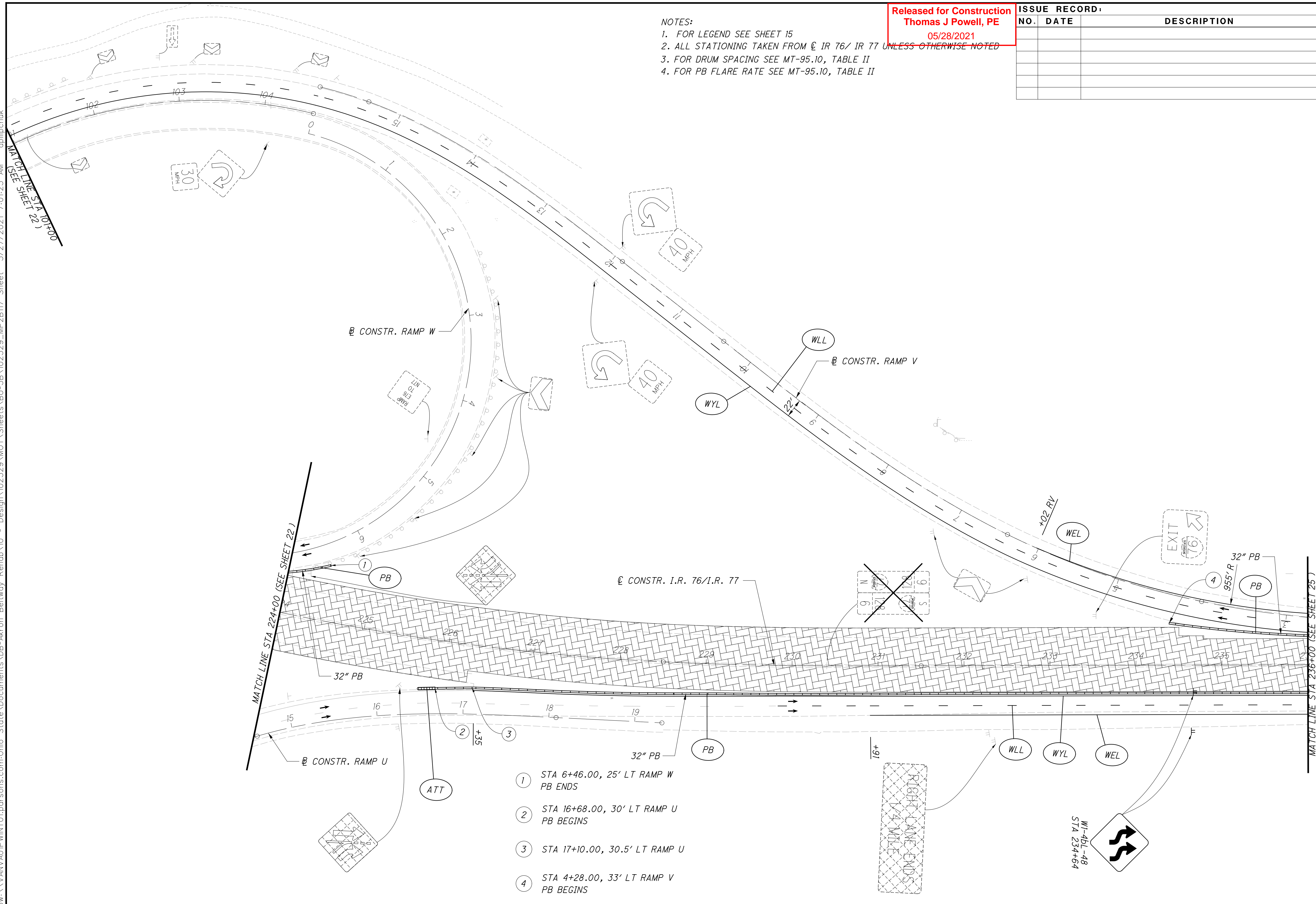

- STA 6+46.00, 25' LT RAMP W  
PB ENDS
- STA 16+68.00, 30' LT RAMP U  
PB BEGINS
- STA 17+10.00, 30.5' LT RAMP U
- STA 4+28.00, 33' LT RAMP V  
PB BEGINS

MOT IR 76 / IR 77 PHASE 2B  
 STA 224+00 TO STA 236+00

SUM-76 / 77 / 8 -  
 8.24 / 9.74 / 0.00

24  
 31



Released for Construction  
 Thomas J Powell, PE  
 05/28/2021

ISSUE RECORD:		
NO.	DATE	DESCRIPTION

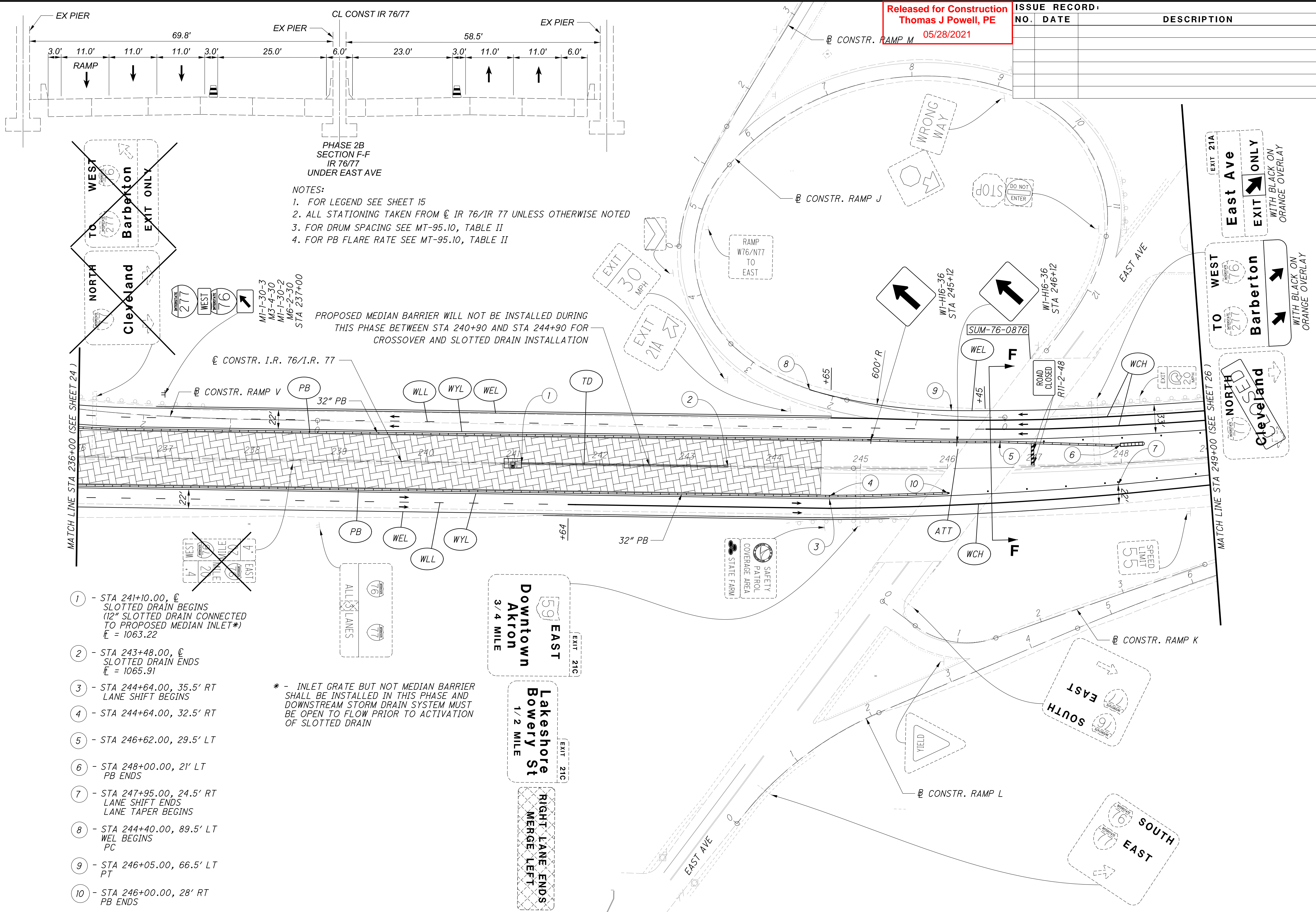
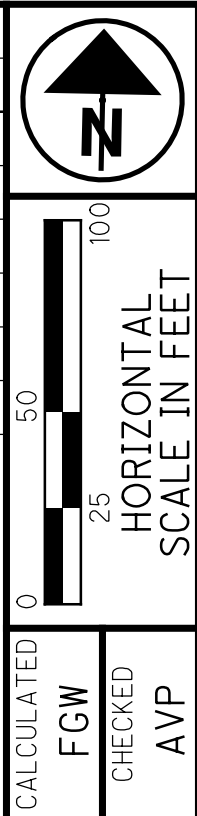

PHASE 2B SECTION F-F IR 76/77 UNDER EAST AVE

NOTES:  
 1. FOR LEGEND SEE SHEET 15  
 2. ALL STATIONING TAKEN FROM CL IR 76/IR 77 UNLESS OTHERWISE NOTED  
 3. FOR DRUM SPACING SEE MT-95.10, TABLE II  
 4. FOR PB FLARE RATE SEE MT-95.10, TABLE II

PROPOSED MEDIAN BARRIER WILL NOT BE INSTALLED DURING THIS PHASE BETWEEN STA 240+90 AND STA 244+90 FOR CROSSOVER AND SLOTTED DRAIN INSTALLATION

- 1 - STA 241+10.00, CL SLOTTED DRAIN BEGINS (12" SLOTTED DRAIN CONNECTED TO PROPOSED MEDIAN INLET\*) E = 1063.22
- 2 - STA 243+48.00, CL SLOTTED DRAIN ENDS E = 1065.91
- 3 - STA 244+64.00, 35.5' RT LANE SHIFT BEGINS
- 4 - STA 244+64.00, 32.5' RT
- 5 - STA 246+62.00, 29.5' LT
- 6 - STA 248+00.00, 21' LT PB ENDS
- 7 - STA 247+95.00, 24.5' RT LANE SHIFT ENDS LANE TAPER BEGINS
- 8 - STA 244+40.00, 89.5' LT WEL BEGINS PC
- 9 - STA 246+05.00, 66.5' LT PT
- 10 - STA 246+00.00, 28' RT PB ENDS

\* - INLET GRATE BUT NOT MEDIAN BARRIER SHALL BE INSTALLED IN THIS PHASE AND DOWNSTREAM STORM DRAIN SYSTEM MUST BE OPEN TO FLOW PRIOR TO ACTIVATION OF SLOTTED DRAIN

pw:\VANVA01P\WINT01\parsons.com:Ohio State\Documents\DB-Akron Beltway Rehab\10 - Design\102329\MOT\Sheets\BU-3B\102329\_MP2B118\_Sheet 5/27/2021 7:01:40 AM apljpbchuk

MOT IR 76 / IR 77 PHASE 2B  
 STA 236+00 TO STA 249+00

SUM-76 / 77 / 8-  
 8.24 / 9.74 / 0.00

pw:\ANV\A01P\WINT01\parsons.com\Ohio\_State\Documents\DB-Akron Beltway Rehab\10 - Design\102329\MOT\Sheets\BU-3B\102329\_MP2B119\_Sheet 5/27/2021 7:01:56 AM aplipchuk

Released for Construction  
 Thomas J Powell, PE  
 05/28/2021  
 UNLESS OTHERWISE NOTED

ISSUE RECORD:		
NO.	DATE	DESCRIPTION

- NOTES:
- FOR LEGEND SEE SHEET 15
  - ALL STATIONING TAKEN FROM  $\text{CL IR 76/IR 77}$  UNLESS OTHERWISE NOTED
  - FOR DRUM SPACING SEE MT-95.10, TABLE II
  - FOR PB FLARE RATE SEE MT-95.10, TABLE II

CALCULATED  
 FGW  
 CHECKED  
 AVP

0 50 100  
 HORIZONTAL  
 SCALE IN FEET

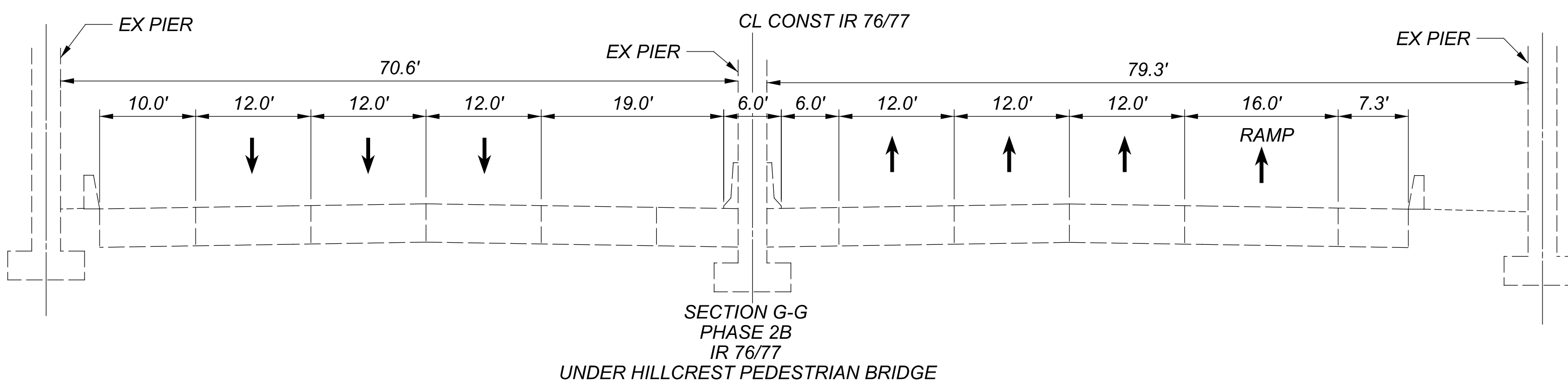
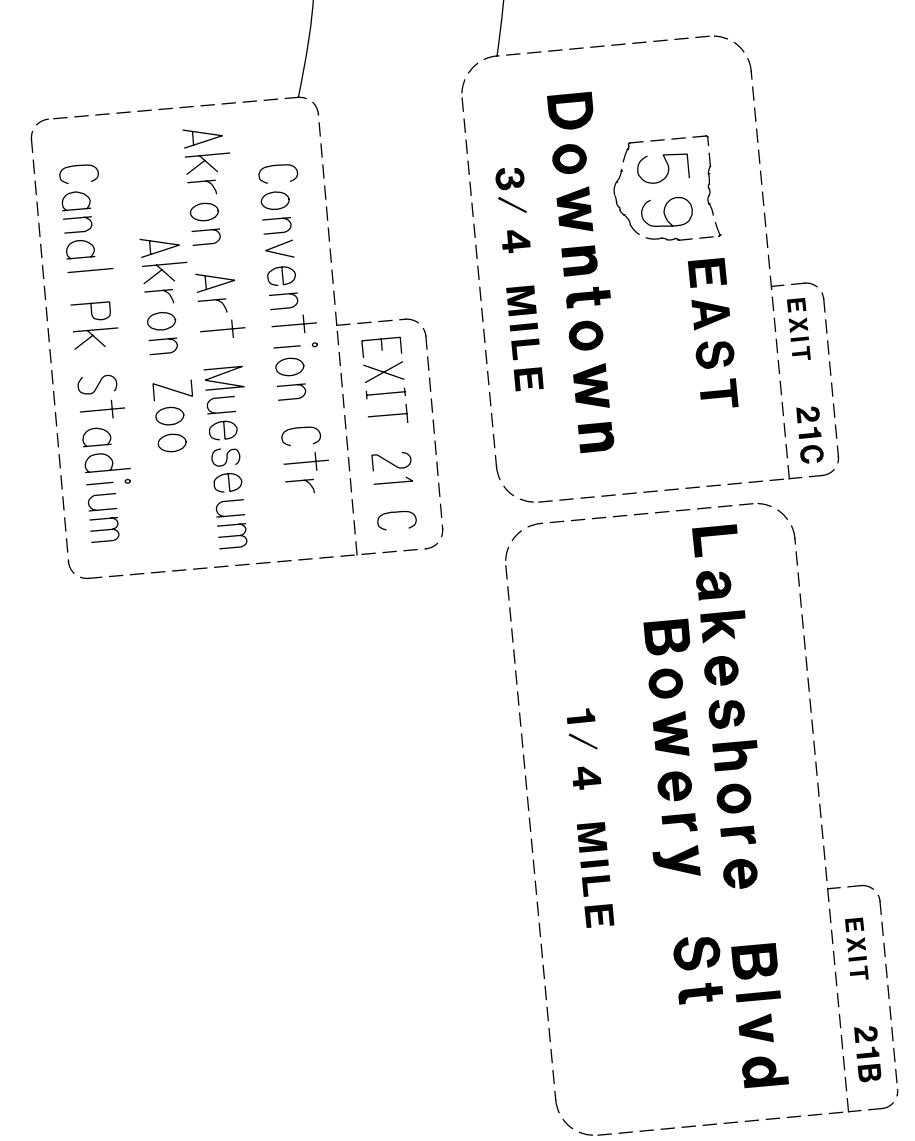
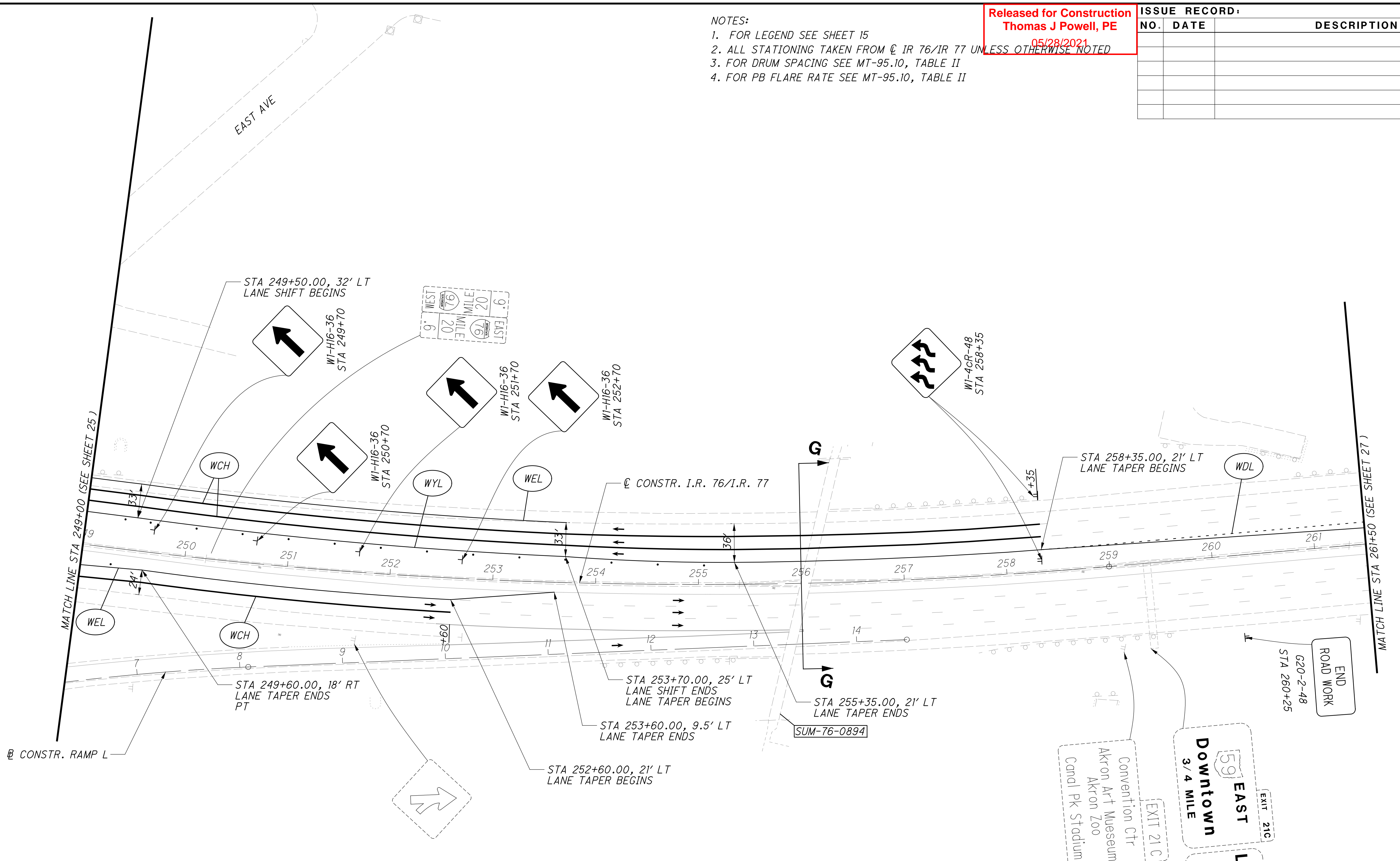

MOT IR 76 / IR 77 PHASE 2B  
 STA. 249+00 TO STA 261+50

SUM-76 / 77 / 8-  
 8.24 / 9.74 / 0.00

Released for Construction  
 Thomas J Powell, PE

ISSUE RECORD:		
NO.	DATE	DESCRIPTION

- NOTES:
- FOR LEGEND SEE SHEET 15 05/28/2021
  - ALL STATIONING TAKEN FROM C IR 76 / IR 77 UNLESS OTHERWISE NOTED
  - FOR DRUM SPACING SEE MT-95.10, TABLE II
  - FOR PB FLARE RATE SEE MT-95.10, TABLE II

CALCULATED  
 FGW  
 CHECKED  
 AVP

0 50 100  
 HORIZONTAL  
 SCALE IN FEET

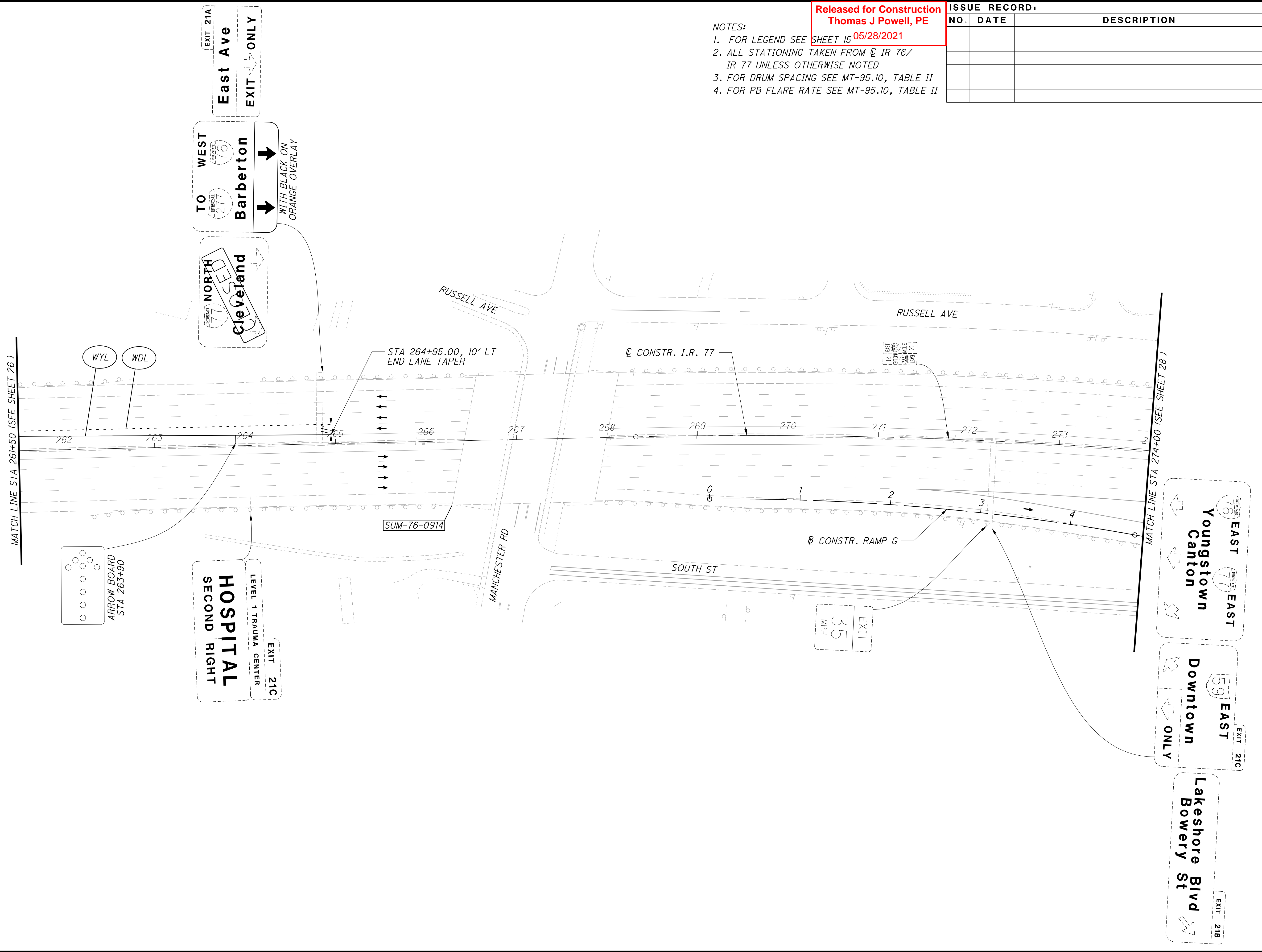

MOT IR 76 / IR 77 PHASE 2B  
 STA 261+50 TO STA 274+00

SUM-76 / 77 8-  
 8.24 / 9.74 / 0.00

27  
 31



\\VANVAIPWINTO\parsons.com\Ohio State\Documents\DB-Akron Beltway Rehab\0 - Design\02329\M0T\Sheets\BU-3B\02329\_MP2B22\_Sheet 5/27/2021 7:02:44 AM aplipchuk

Released for Construction  
Thomas J Powell, PE  
05/28/2021

ISSUE RECORD:		
NO.	DATE	DESCRIPTION

- NOTES:
- FOR LEGEND SEE SHEET 15
  - ALL STATIONING TAKEN FROM C IR 76/ IR 77 UNLESS OTHERWISE NOTED
  - FOR DRUM SPACING SEE MT-95.10, TABLE II
  - FOR PB FLARE RATE SEE MT-95.10, TABLE II

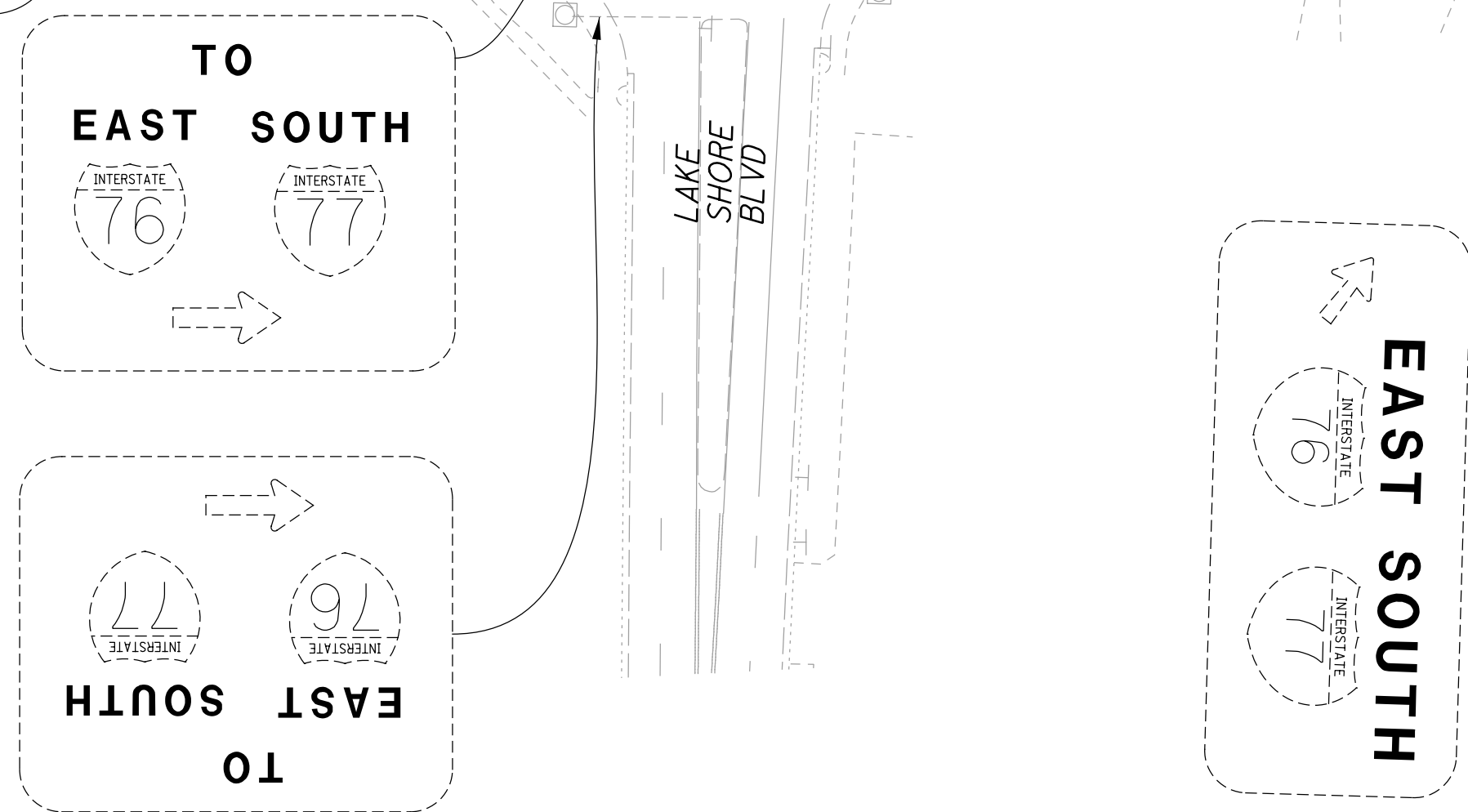
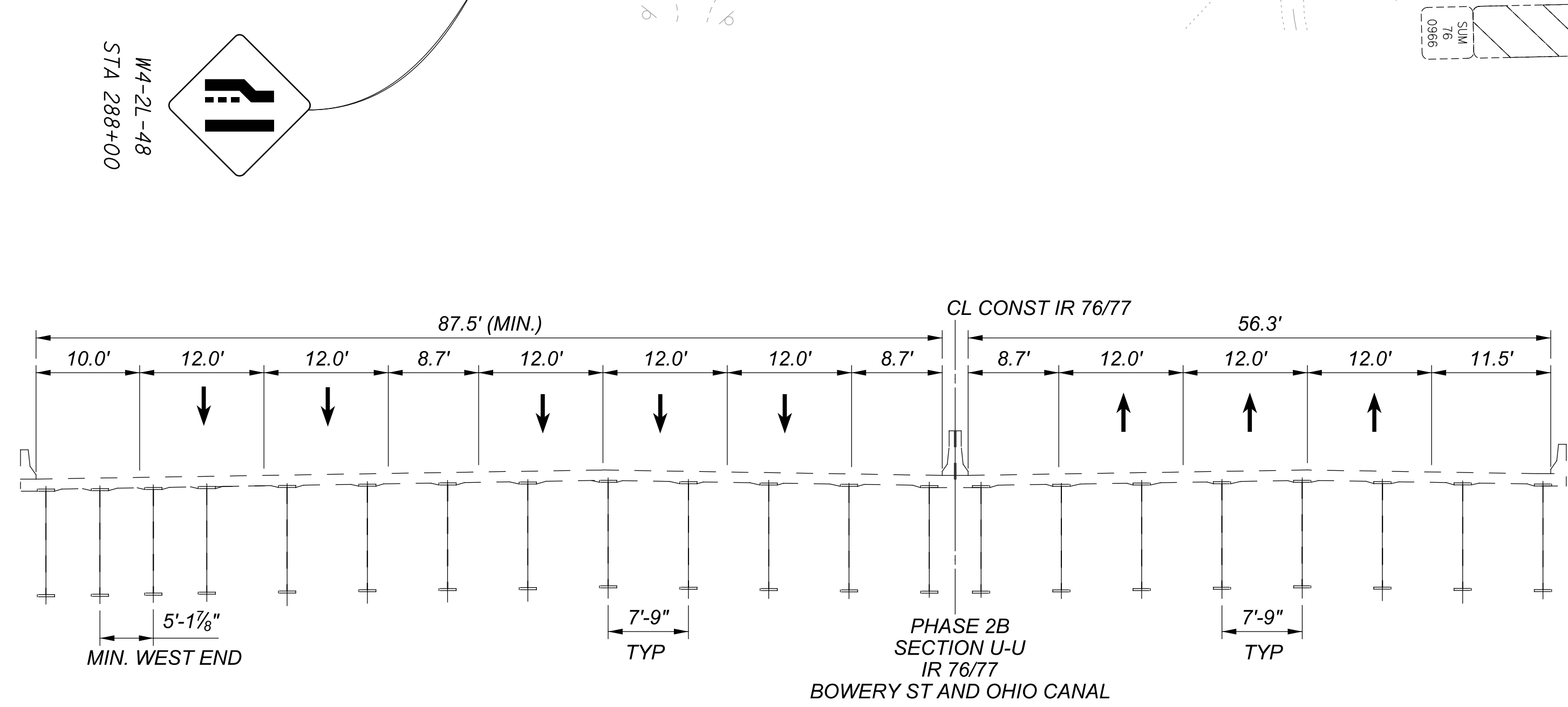
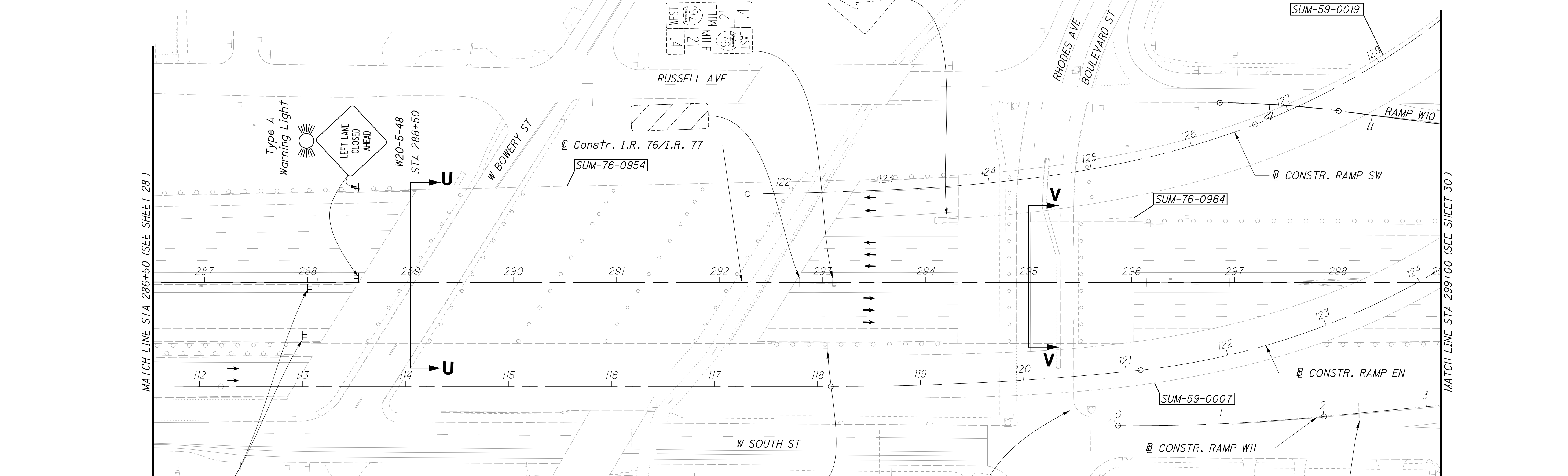
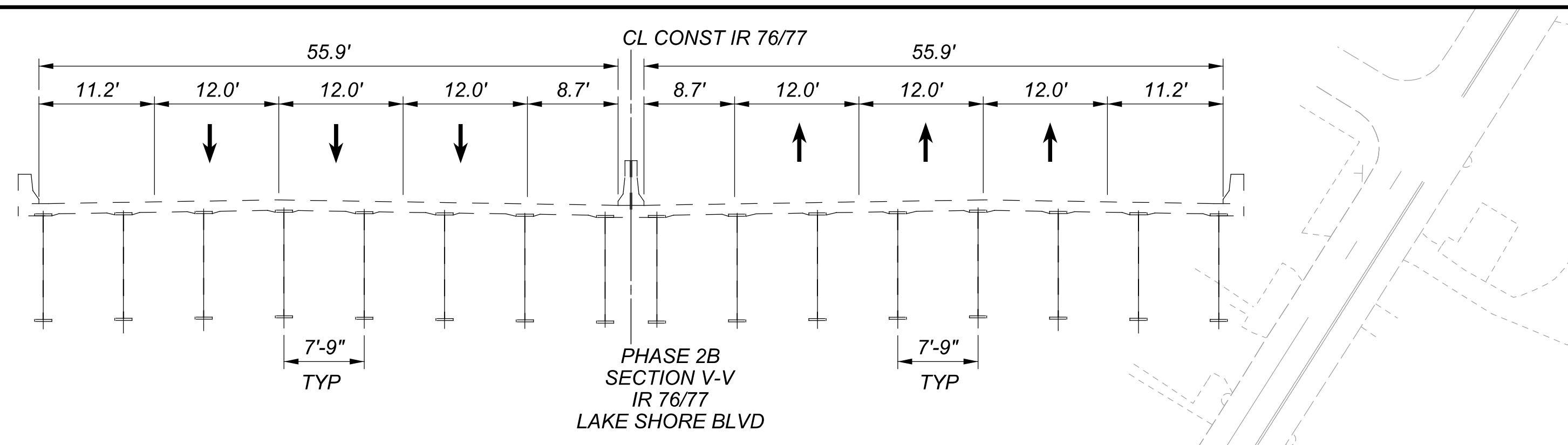
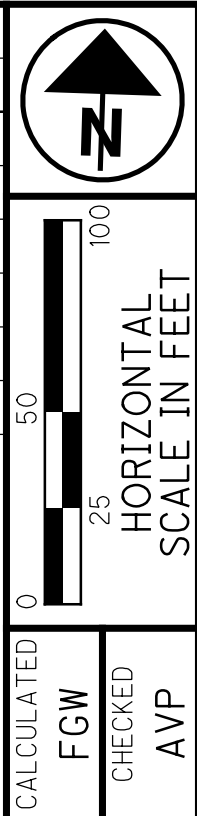

MOT IR 76 / IR 77 PHASE 2B  
STA 286+50 TO STA 299+00

SUM-76/77/8-  
8.24/9.74/0.00

29  
31

d:\va\vaipwintol\parsons.com\Ohio State\Documents\Ohio State\Documents\Akron Beltway Rehab\10 - Design\02329\M0T\Sheets\BU-3B\02329\_MP2B123\_Sheet 5/27/2021 7:03:00 AM aplipchuk

Released for Construction  
Thomas J Powell, PE  
05/28/2021

ISSUE RECORD:		
NO.	DATE	DESCRIPTION

- NOTES:
1. FOR LEGEND SEE SHEET 15
  2. ALL STATIONING TAKEN FROM C IR 76/IR 77 UNLESS OTHERWISE NOTED
  3. FOR DRUM SPACING SEE MT-95.10, TABLE II
  4. FOR PB FLARE RATE SEE MT-95.10, TABLE II

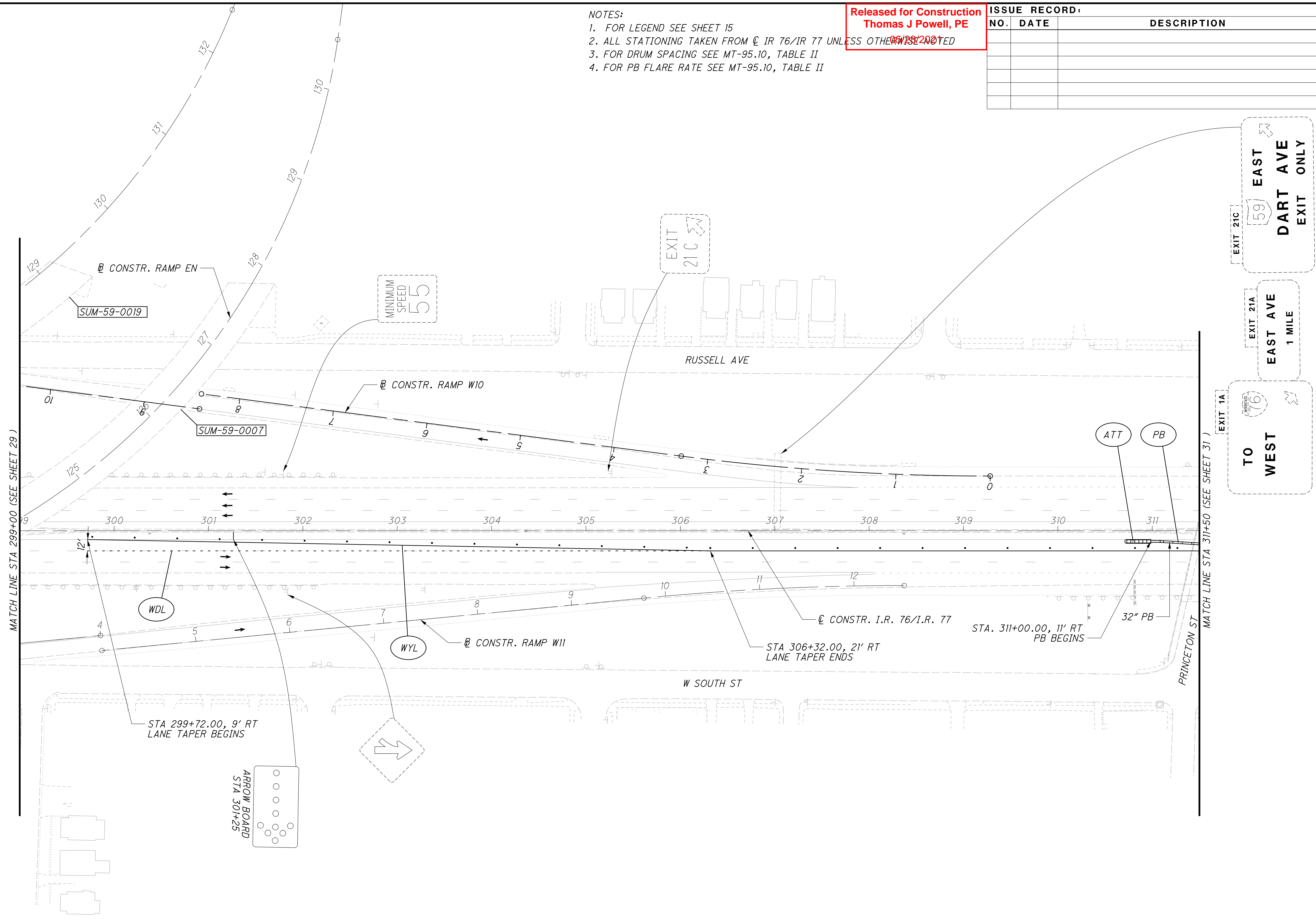
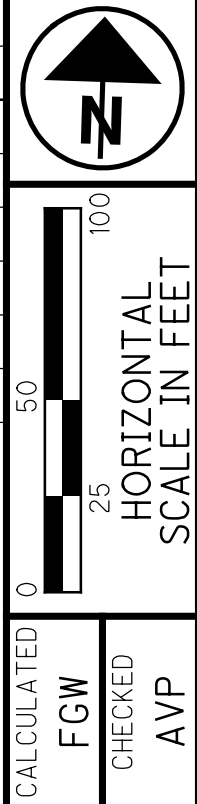

CALCULATED FGW CHECKED AVP

**MOT IR 76 / IR 77 PHASE 2B**  
**STA 299+00 TO STA 311+50**

**SUM-76 / 77 / 8-**  
**8.24 / 9.74 / 0.00**

30  
31

d:\va\vaipwintol\parsons.com\Ohio State\Documents\DB-Akron Beltway Rehab\0 - Design\02329\M0T\Sheets\BU-3B\02329\_MP2B124\_Sheet\_5/27/2021 7:03:13 AM apilpchnuk

Released for Construction  
 Thomas J Powell, PE  
 05/28/2021

ISSUE RECORD:		
NO.	DATE	DESCRIPTION

- NOTES:
- FOR LEGEND SEE SHEET 15
  - ALL STATIONING TAKEN FROM  $\text{CL IR 76/IR 77}$  UNLESS OTHERWISE NOTED
  - FOR DRUM SPACING SEE MT-95.10, TABLE II
  - FOR PB FLARE RATE SEE MT-95.10, TABLE II

- STA 312+22.00, 7' LT PB BEGINS
- STA 313+07,  $\text{CL}$  SLOTTED DRAIN BEGINS (12" SLOTTED DRAIN CONNECTED TO EXISTING INLET)  $\text{E} = 1011.23$
- STA 314+77,  $\text{CL}$  SLOTTED DRAIN ENDS  $\text{E} = 1012.24$

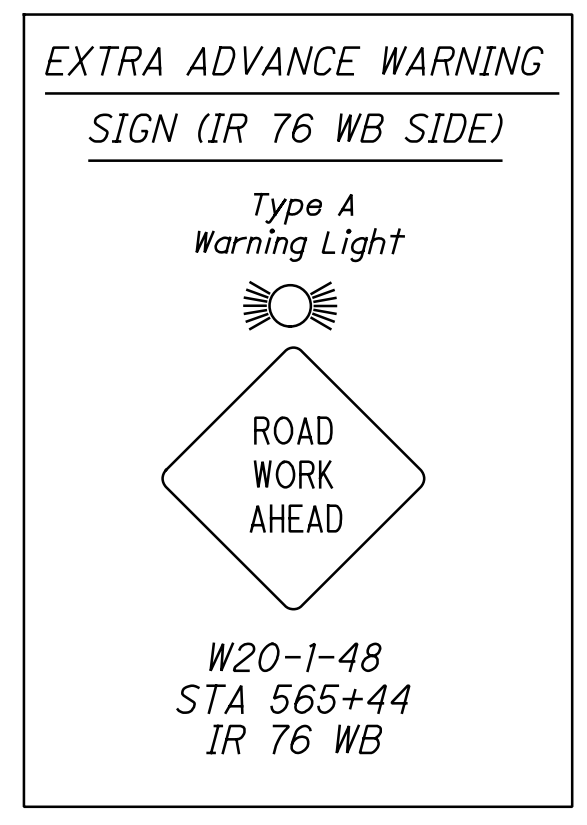
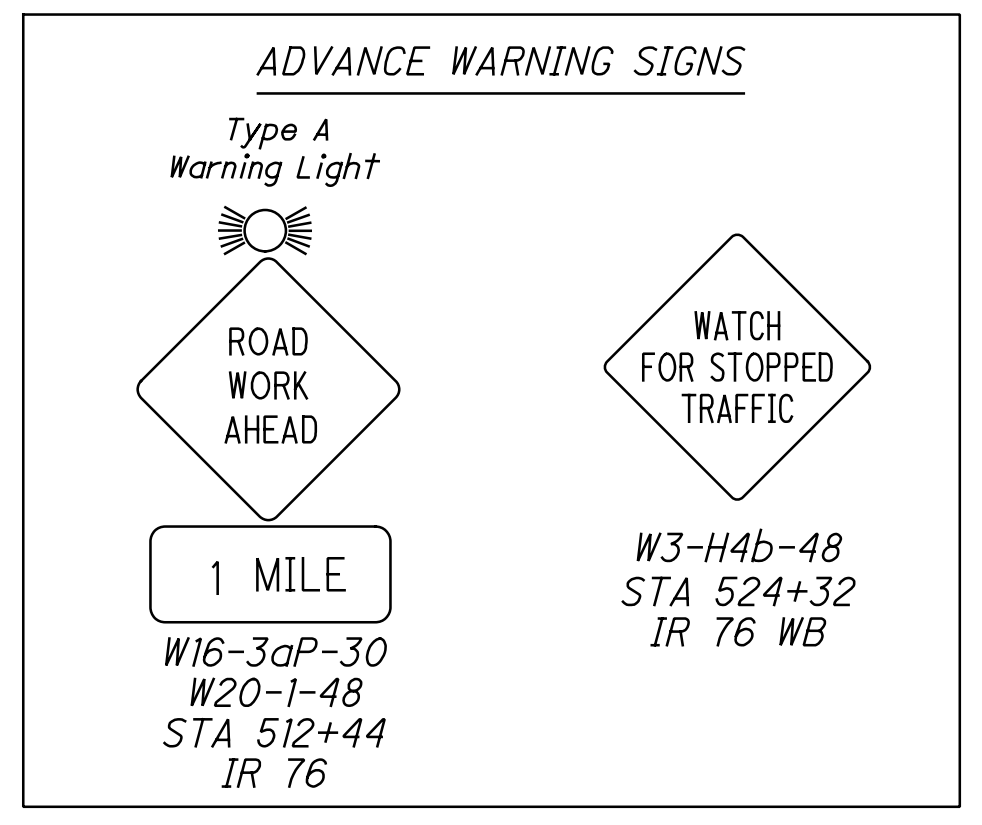
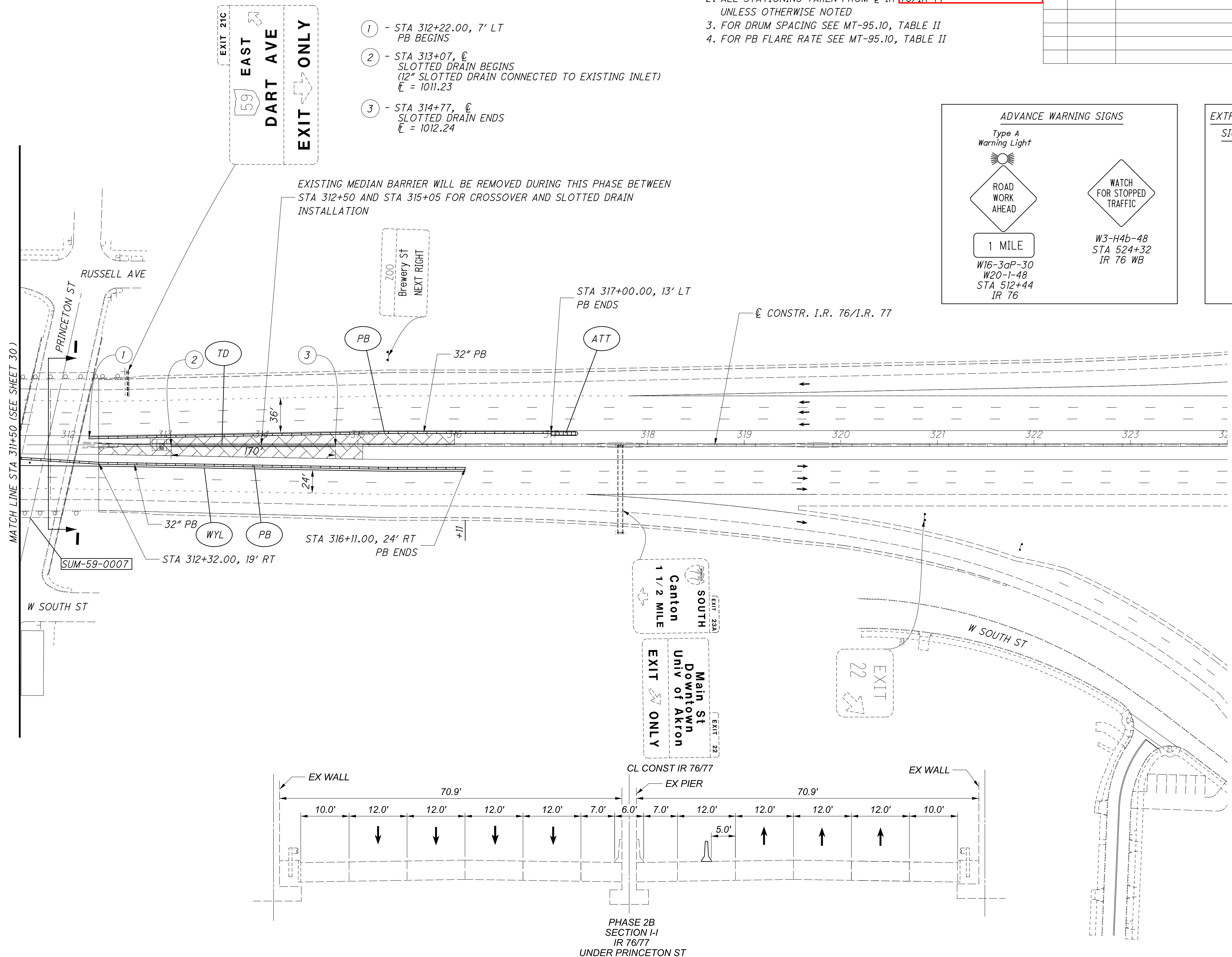

EXISTING MEDIAN BARRIER WILL BE REMOVED DURING THIS PHASE BETWEEN STA 312+50 AND STA 315+05 FOR CROSSOVER AND SLOTTED DRAIN INSTALLATION

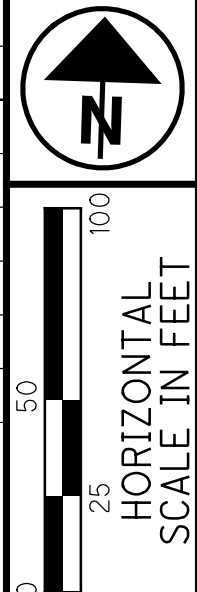
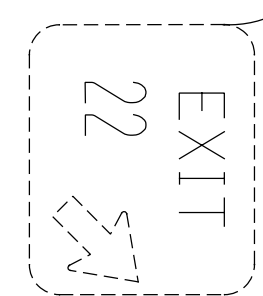
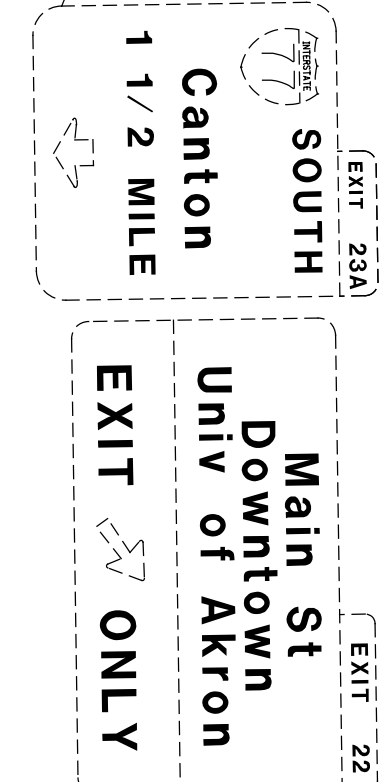
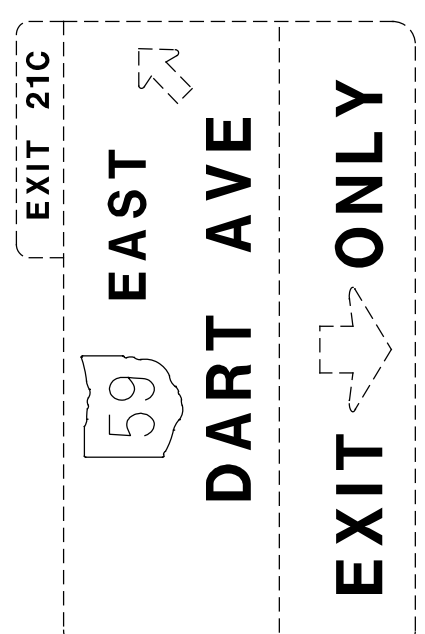

CALCULATED  
 FGW  
 CHECKED  
 AVP

MOT IR 76 / IR 77 PHASE 2B  
 STA 311+50 TO STA 324+00

SUM-76/77/8-  
 8.24/9.74/0.00