

Pedestrian Plan

The Village of
HEBRON
Crossroads of Ohio
Where Our Paths Connect

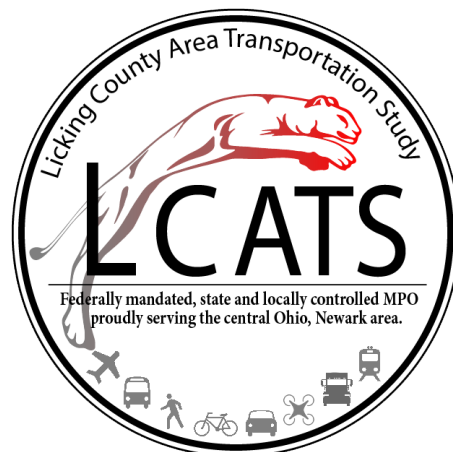

August 2020



Contents

Background.....	1
Methodology.....	1
Existing Conditions.....	2
Public Input.....	4
Recommended Treatments.....	4
Implementation.....	7
Appendix A: Map	
Appendix B: Public Input Survey	
Appendix C: Walk Audit Summary	
Appendix D: Pedestrian Counts	
Appendix E: Crosswalk Marking and Signing Guidelines	
Appendix F: Pedestrian Signal and Beacon Guidelines	
Appendix G: Additional Crosswalk Guidelines	
Appendix H: Bike Lane Design Guidelines	
Appendix I: Rectangular Rapid Flashing Beacon Guidelines	
Appendix J: ODOT Feasibility Correspondence	



Background

The Village of Hebron is located in southern Licking County in central Ohio. Hebron is historically a transportation hub, having been the intersection of the Ohio Canal, the National Road (US-40/Main Street), Ohio State Route (SR) 79 and the Ohio Electric Interurban Rail Line. Of these, only the National Road and Ohio SR-79 are still in use today, but the old rail line and evidence of the canal are still observable in downtown Hebron. None of these modes of transportation are useful without the oldest form of mobility: walking.

As part of an initiative to improve walking conditions and encourage healthier living, the Village of Hebron and a Health Educator from the Licking County Health Department (LCHD) wanted to examine the main pedestrian corridor in Hebron to discuss funding projects that would have a positive impact for local pedestrians. The Licking County Area Transportation Study's (LCATS) assistance was requested for a walk audit along the Main Street thoroughfare to help survey local conditions and provide recommendations for improvement. The methodologies, findings, and a proposed plan of action will be reported in this document, along with any relevant information pertaining to this plan.

Methodology

A walk audit was conducted by staff from the Village of Hebron, the LCHD and LCATS on June 9, 2020. This audit spanned the sidewalk through the Main Street Corridor from Arrowhead Drive to the Village Municipal Building. For the full summary of the walk audit, refer to Appendix C.

Surveying was conducted between June 10 and June 30, 2020 by the LCHD and the Village of Hebron to ascertain the public input for desired pedestrian projects from local residents. This survey was available online and in paper form. The complete survey results can be found in Appendix B.

Pedestrian counts were taken by LCATS staff July and August 2020 using Eco-Counter Mobile Multi and PYRO Range Boxes. To take counts, the boxes are affixed to posts near pedestrian facilities and use passive-infrared with precision lenses to sense pedestrians and cyclists that pass them. Refer to Appendix D for the pedestrian count data.

In August 2020, the Ohio Department of Transportation (ODOT) District 5 sent a signal electrician to look at the signalized intersection of Main and High Streets in order to gauge the feasibility of pedestrian signal heads at this location with the current signal hardware. The exchange can be in Appendix J.

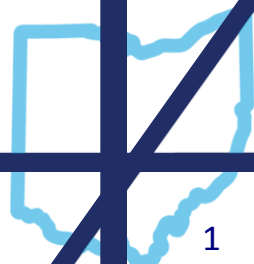

Existing Conditions

Hebron emphasizes walking as a regular means of transportation, which is fitting for a village approximately 3 square miles in area, with the vast majority of residents residing within the central 0.6 square miles of the village. Sidewalk and street crossings line the major east-west corridor along US-40 in the Village. These are comprised of signalized and unsignalized intersection crossings with the only sidewalk gaps along this corridor existing east of SR-79 on the north side of US-40 and west of the Village’s Municipal Complex/Library on both sides of US-40. The gap to the western end of Hebron along US-40 excludes some agricultural properties, and does not provide any marked or signalized crossings west of 9th Street. On the eastern end of the village, along the northern side of US-40, is a gap that creates an island crossing from the Arrowhead Drive intersection.



Figure 1: The crossing cutout on the north side of US-40 across from Arrowhead Drive is unconnected to any sidewalk on from either side

The state of the sidewalk along US-40 is generally well maintained; the sidewalk does have some spots of minor overgrowth and there are a few incongruities in elevation between sidewalk tiles or utility infrastructure. Although, there is clear evidence of maintenance; in most areas, there is no overgrowth and uneven sidewalk has been shaved down to smooth and level such tripping hazards. There are issues with the heading truncated domes: the vast majority of these crossing indicators are aimed diagonally and into the middle of intersections, rather than straight and directly across the street. This can be a major issue for individuals with visual impairments or those that require wheelchairs for mobility.

Along its major north-south corridor, High Street, Hebron has sidewalk between the southernmost residential neighborhood and businesses and industries on Enterprise Drive towards the northern side of the village. This sidewalk does not run the entire length of the village, but the only omissions are located near industrial facilities at the most extreme north and south ends of the municipal boundaries.

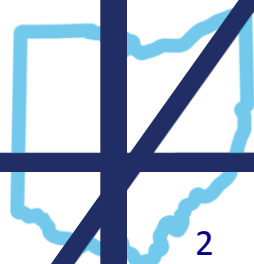

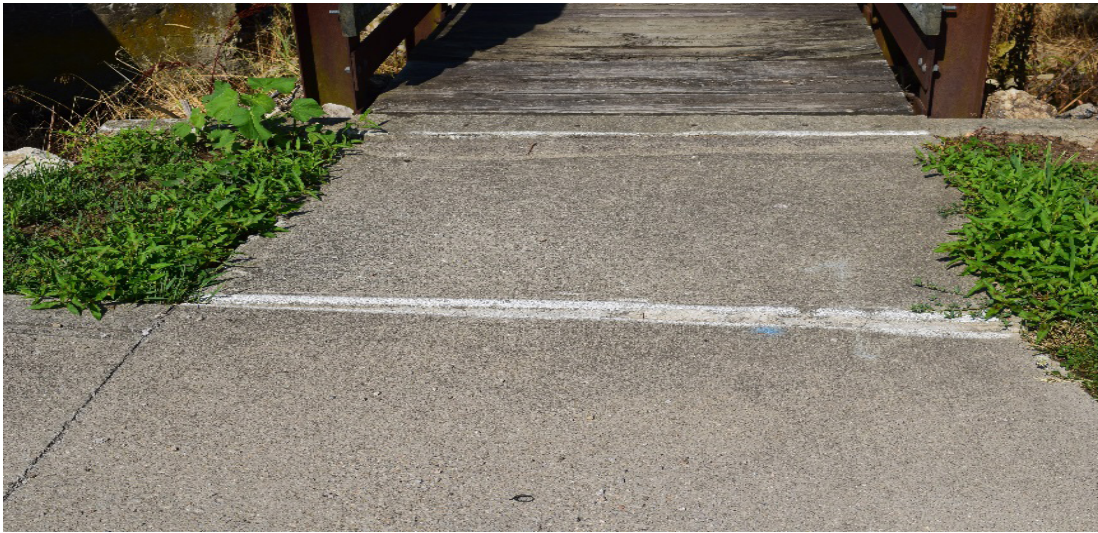

Figure 2: Segment of sidewalk that has been shaved and smoothed to remove unevenness and prevent a tripping hazard

Within central Hebron (both the north and south of US-40 between Wooster Street on the east and Lakewood Drive on the west), there exists several gaps of sidewalk or a total lack of it entirely in certain neighborhoods. The most notable absence of pedestrian infrastructure exists between Wooster Street and 4th Street. Only one side of three different residential blocks have sidewalk in that entire ten block area. 6th Street is also noticeably lacking sidewalk between Deacon and North Streets. Hamilton Avenue and Cully Street are completely devoid of sidewalk as well. There are some gaps on North Street and 8th Street north of North Street too. In total, there are over 250 residences that do not have direct access to sidewalk.

Hebron has two trail connections within its jurisdiction, one local and one regional. The northern end of the Ohio Canal Greenway, a regionally significant trail, is accessible from a parking lot along Canal Road, near the intersection of Cumberland Street, where Canal Park is located. This connection is currently not tied into the sidewalk network. The local trail path at Evans Park, Hebron's major athletic and recreational facilities, is connected into the Village's sidewalk network via 9th Street and Refugee Road.



Figure 3: Single cut curb crossing with truncated dome facing into middle of High and Main Streets intersection

See Appendix A for a map that contains the entire Village of Hebron and highlights its sidewalk and crossings along the Main Street Corridor.

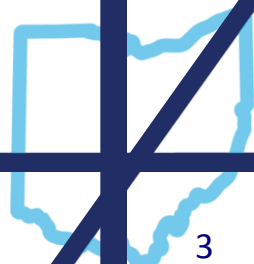

Public Input

In order to supplement the findings of the audit and the local knowledge provided by village administration, a survey was conducted. 56 participants completed the survey, which is over 2% of Hebron's population. The overwhelming majority of participants, 96.4%, walk at least once a month, and 78.5% walk at least once a week. About 80% of those surveyed consider walking to community destinations, such as schools, libraries, parks, and local businesses, to be important. When asked why they walked, survey participants responded with 91% for exercise.

28.6% of locals responded that they feel unsafe at certain intersections or streets. Several comments speak to the Main and High Streets intersection being a safety concern. Several individuals commented on sidewalk gaps throughout the village, and better sidewalk maintenance at particular locations.

Recommended Treatments

Based upon the walk audit and discussions with Hebron leadership regarding walkability issues within the village and taking into account public comments, LCATS has multiple recommendations. These range from maintaining sidewalk surfaces for evenness and removing any overgrowth, to installing pedestrian signal heads at signalized intersections, and include improving crosswalk visibility, removing redundant crosswalks, filling in sidewalk gaps, and narrowing sections of roadways to reduce motorists' speeds.



Figure 4: Utility pipe protrusion that creates a tripping hazard

One short term improvement is to correct the minor issues in sidewalk surface. As seen in *Figure 4* there are some spots with very minor overgrowth and utilities that are not level with the sidewalk surface. These fixes will help make the sidewalks safer for users, especially any users with impairments, as these minor dangers become much more severe for a wheelchair user or individual with sight impairment. Another important, albeit, more difficult improvement is to correct the misaligned truncated domes, such as the one referenced in *Figure 3*.

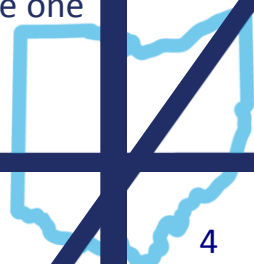

The next short term treatment would be to remove some of the striped crosswalk in segments where there are multiple crossings within a one- or two-block distance along the Main Street corridor. For example, there are six crosswalks in the two block between 6th and 8th Streets. The abundance of crossings is similar to sign pollution, in that when a motorist sees too many, they are prone to become overwhelmed and ignore them. This can become a big risk to pedestrians; simplifying the crossing zone into one location would be much safer for crossers. Additionally, the crossings that remain should be treated with high visibility striping and signage to ensure that motorists are forewarned of the pedestrian crossings and slowdown to accommodate them. The pedestrian counts taken at the crossings of Main Street, at Church Street and 8th Street, were both off-balance. These counts showed uneven numbers by heading, with more than twice as many pedestrians crossing southbound as there were northbound at Church Street and the opposite at 8th Street, where twice as many pedestrians crossed heading northbound as did southbound. This data shows how the multiplicity of crosswalks in a relatively short stretch allows pedestrians to cross at any of the marked crossings, rather than having to return to the crossing of origin for their trip. Again, this speaks to the potential dangers of maintaining motorists' awareness in a short road segment where crossings can occur at many locations.

Figure 5: Westward view of US-40 from mid-block crosswalk; there is a crosswalk at the eastern end of this same block (behind this vantage point) and two seen immediately at 7th Street, with the intersection crossings in the background at 8th Street



A Rectangular Rapid Flashing Beacon (RRFB), in combination with high visibility striping, would ensure pedestrian safety at the crossings that are most frequently utilized by school children. A RRFB would greatly assist in safe crossings for children commuting to and from school, particularly at known school bus stop locations and in proximity to the school. This would help ensure that motorists are aware of pedestrians and improve yielding compliance.

Additionally, as a means to better manage motorists' speeds, LCATS recommends narrowing the useable roadway width, with striping, to slow motorists down. The width of US-40 is 36 feet. This could easily accommodate a five foot bike lane in each direction while still maintaining the current two lanes of auto traffic. This bike lane would be a useful amenity to safely connect Hebron to the southern trailhead of the Buckeye Scenic Trail, which is a desirable regional connection.

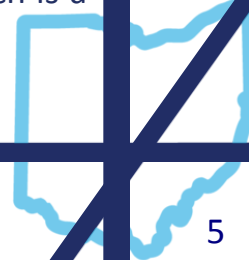



Figure 6: At 36', Main Street is very wide for a two lane roadway

As seen in *Figure 1*, the crosswalk across from Arrowhead Drive on US-40 is isolated. In its current state, it does not benefit pedestrians since it lacks any sidewalk connections. LCATS would recommend either connecting sidewalk to this crossing or removing it and creating a crossing further west that does tie into the sidewalk network. In general, LCATS would recommend filling in sidewalk gaps; like the aforementioned gap along the north side of US-40, as well as gaps throughout the residential neighborhoods of Hebron. While traffic volumes might be low enough for pedestrians to utilize the roadways, this is never an ideal situation. Pedestrians are much safer using separate infrastructure.

While the Main and High Streets intersection has a signalized crosswalk between its northwest and southwest corners, no other leg is signalized. As an improvement, LCATS recommends adding two pedestrian signal heads to the southwest and southeast corners to facilitate a safer crossing. This upgrade would provide a signalized east-west crossing in addition to the current north-south signal. According to ODOT signal electricians and engineers, the controller cabinet will require upgrades in order to facilitate these pedestrian signal heads at this intersection.

Finally, LCATS recommends creating a connection from Hebron's sidewalk network to the Ohio Canal Greenway trailhead, thereby tying into a larger regional network and utilizing existing community amenities to enrich local and regional walk- and bike-ability.

Design Guidelines

For the design guidelines pertaining to recommended treatments mentioned in the previous section of this document, please see Appendices E, F, G, H and I in full, and consult with ODOT District 5 where needed.

Implementation

The Village of Hebron and LCHD have agreed that funding from the Creating Healthy Communities (CHC) Grant will pay for paint to improve striping visibility at unsignalized crosswalks along Main Street and signage to accompany these crossing improvements. The Village of Hebron will be responsible for finding the appropriate contractor or for the Village of Hebron Public Works Department to redo the crosswalk striping improvements. Any additional costs for the hardware that exceeds the CHC Grant funding, will be budgeted for by the Village of Hebron.

For other recommended treatments listed in this document, the Village of Hebron will be the responsible for seeking appropriate funding. LCATS will assist in providing guidance, where needed, to the Village as it seeks to make these improvements in the future, but the Village will be responsible for planning, prioritizing, and pursuing funds for these projects. LCATS would recommend also seeking the assistance of ODOT District 5 in finding applicable funding and guidance in this process.





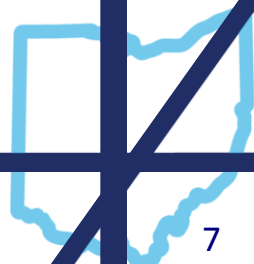

As a means of preliminary planning, LCATS has laid out the following table to assist with the prioritization of future projects:

Priority	Project	Range	Cost
High	Pedestrian Signal Heads	Long term	\$\$\$
High	RRFB at School Crossings	Short-long term	\$\$
High	Sidewalk Surface Maintenance	Short term	\$
High	High Visibility Striping at Crosswalks	Short term	S
Medium	Excessive Crossing Reduction	Short term	S
Medium	Sign Crosswalks (Not at signalized intersections)	Short term	\$
Medium	Truncated Domes/Curb ramps	Short-medium term	\$\$
Low	Add Bike Lanes	Short-long term	SS
Low	Fill Sidewalk Gaps	Medium-long term	SS
Low	Connect Sidewalk to Ohio Canal Greenway	Medium-long term	SS



VILLAGE OF HEBRON

Appendix A: Map

-  Pedestrian Counts
-  Sidewalk
-  Crosswalks
-  Local Trail
-  Regional Trail
-  Village Limits

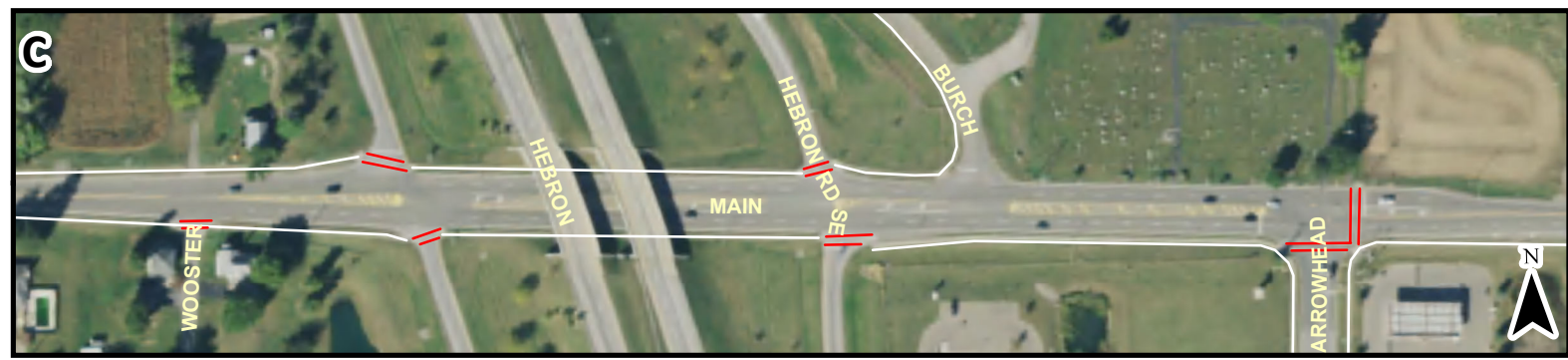
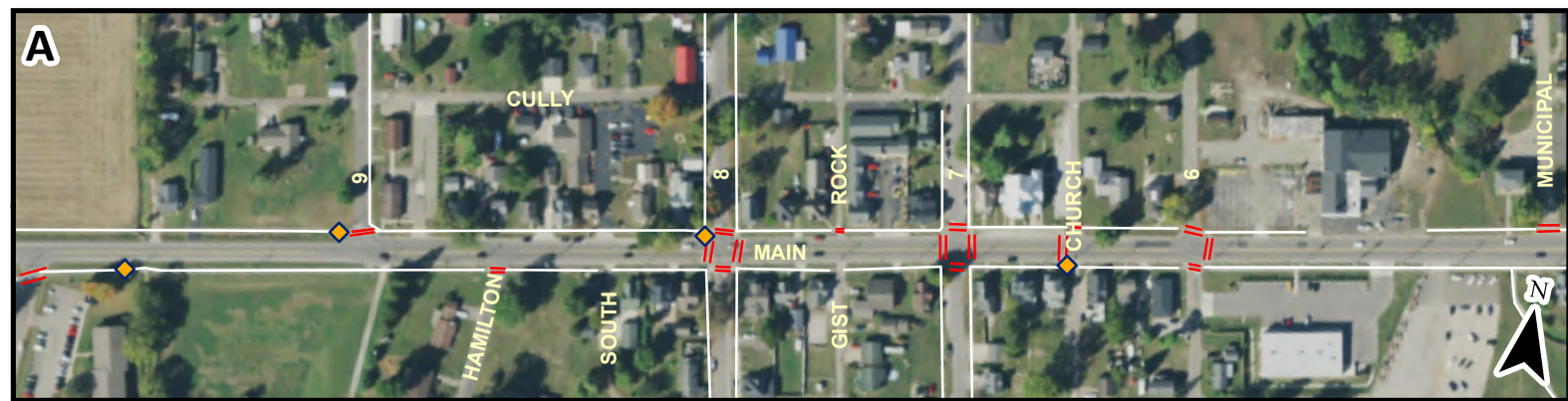
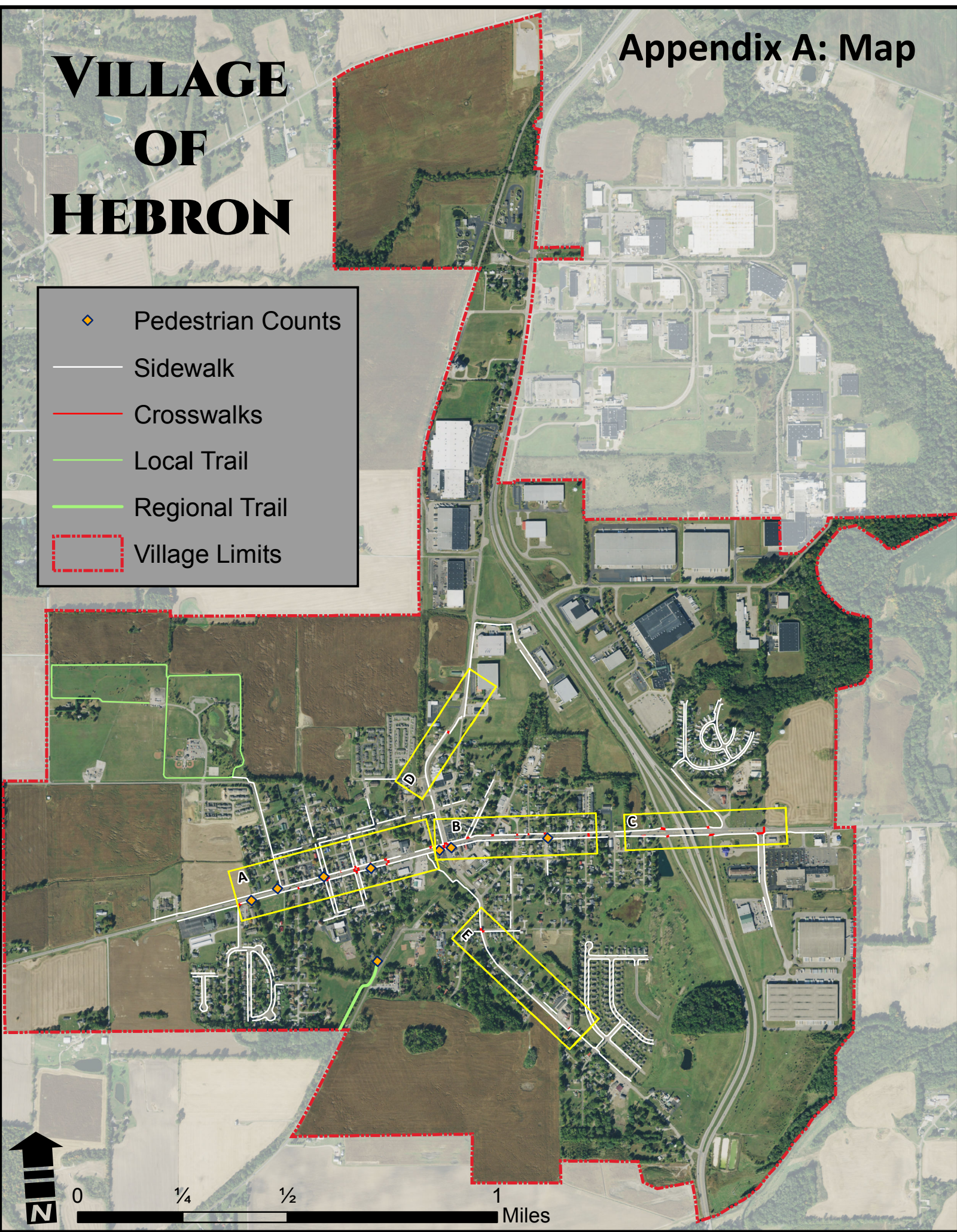

Appendix B: Public Input Survey

What is your age?

55 responses

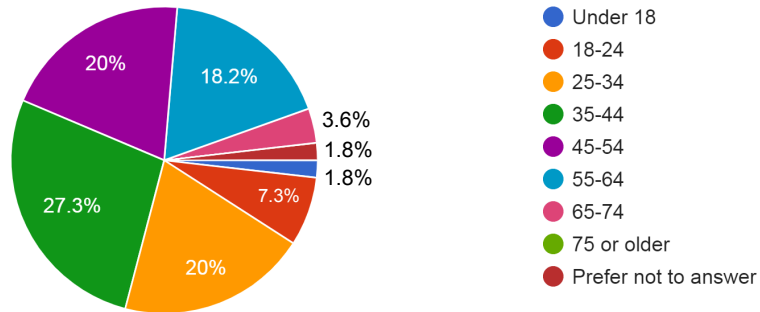

What is your gender?

55 responses

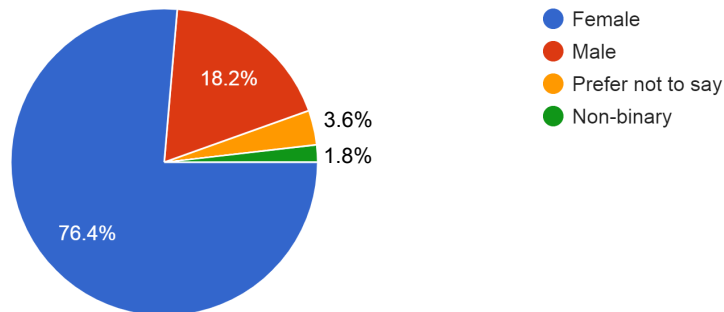

What race to you most identify with?

53 responses

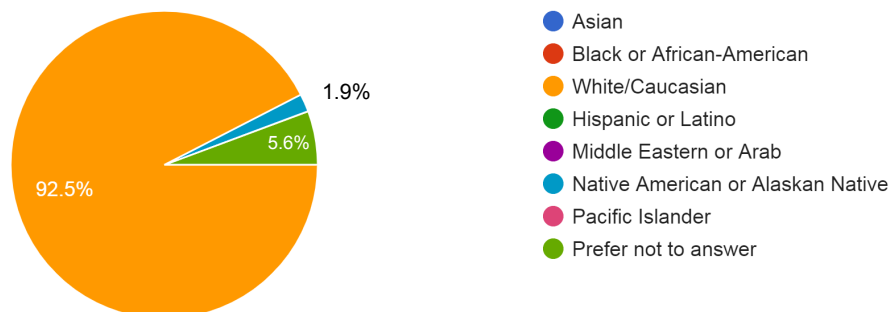

What is your estimated household income?

53 responses

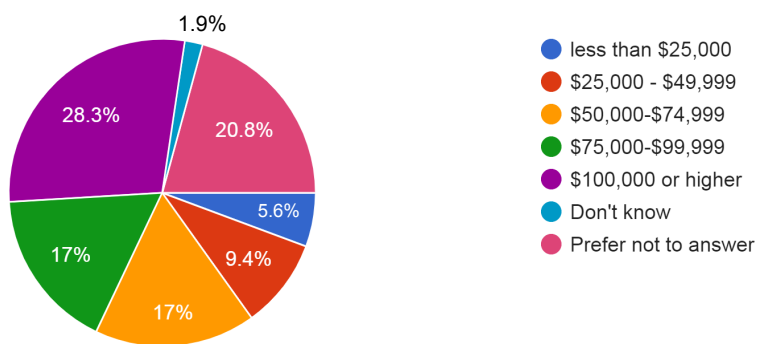

How often do you walk in your community (typically, when weather is appropriate)?

56 responses

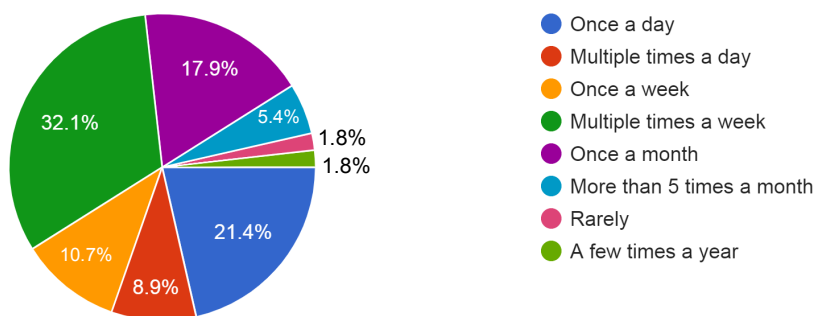

How important is it for you to walk to destinations (library, park, store, bank, school, etc.) in your community? 1 being very important, 5 being not important.

56 responses

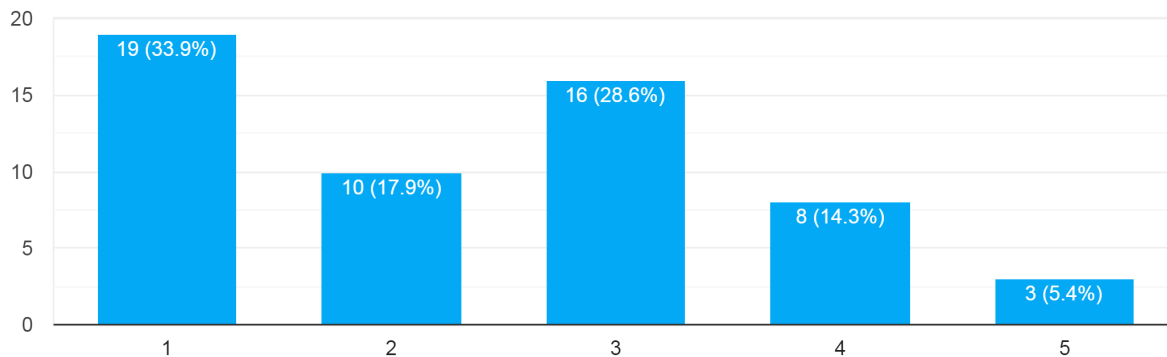

Why do you walk? (check all that apply)

56 responses

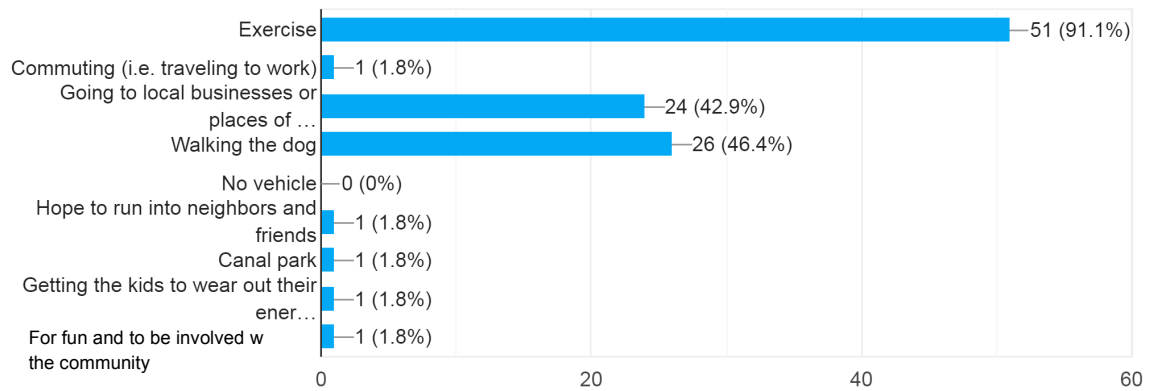

How important is walkability for you in the Village of Hebron? 1 being very important, 5 being least important.

56 responses

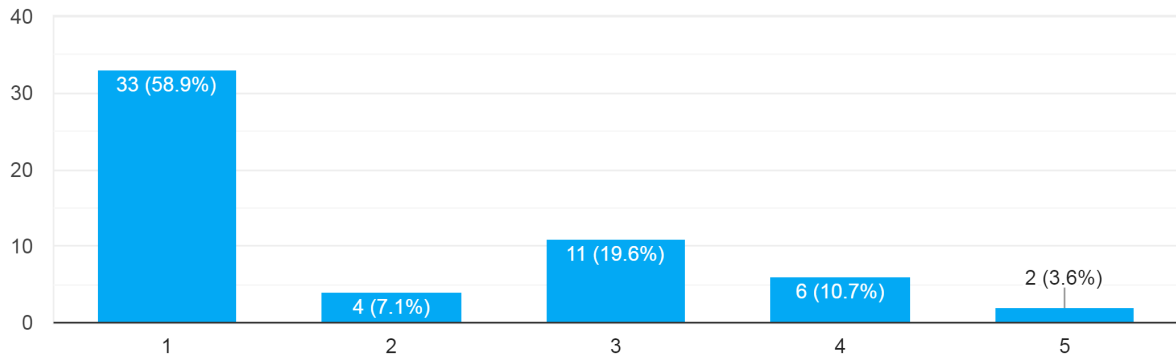

How easy is it for you to use the sidewalks in the current condition and locations? 1 being very easy, 5 being not easy.

56 responses

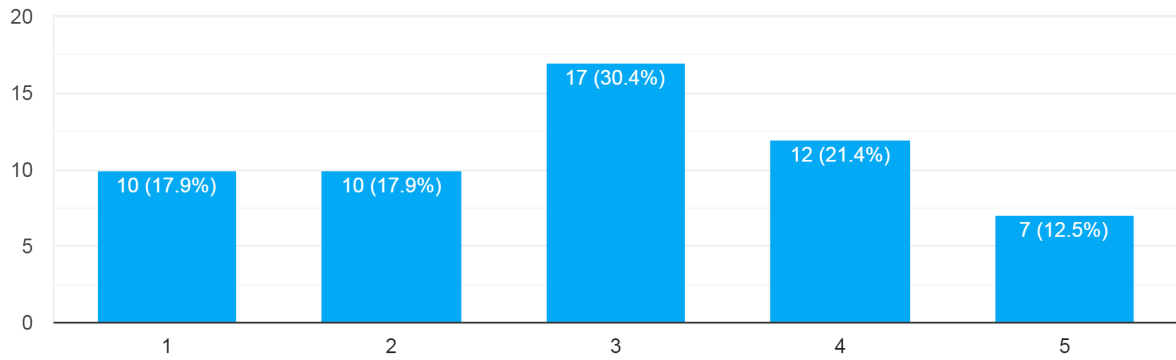

How safe do you feel crossing at intersections in town? 1 being very safe, 5 being not safe.

56 responses

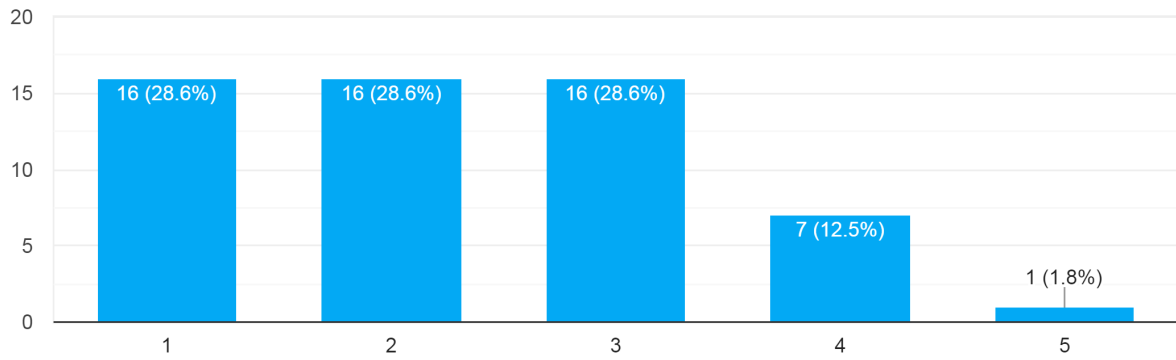

Are there particular intersections or streets where you feel unsafe?

56 responses

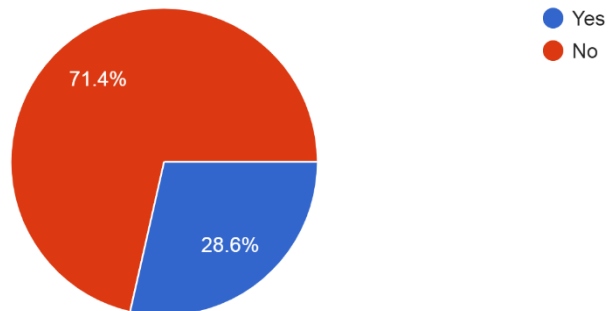

If yes, please specify the intersection(s) and/or streets you feel unsafe at and why:

16 responses

- Hamilton Ave, Pence St, Warden St, Deacon St
- Hamilton
- Those missing sidewalks like 5th, Parks, Broad, 2nd (TONS of through traffic and how everyone gets to softball and walking trail), Newark (how the East side travels to the post office), North (how many get to Evans).
- On Cumberland St from S high St to Canal Park has no sidewalks
- Any crosswalk on Main Street crossing by stop signs at side streets such as Lakewood drive and Hamilton Avenue...people fly up this streets and stop suddenly in the crosswalks with no concern for pedestrians
- North Street and intersection by Kroger
- Intersection by humans dari
- No sidewalks on Hamilton Street
- The main one near Haymans gets tricky because you have traffic both ways plus people pulling in and out of Haymans, the gas station, and the bank to watch for. Unsafe might not be the right word but that's where I am most cautious when walking.
- Cumberland and High. People don't stop at the crosswalk.
- East Main Street crosswalks due to drivers speeding and driver at 519 E main st peeling out of his driveway with tires squealing and they drive over the sidewalks so there is dirt and trash blocking the sidewalk.
- Ninth and North cars run stop signs all day long on Ninth at the North street intersection.
- The intersection of route 40 and high street can have a high volume of traffic. Sometimes difficult to navigate with people turning right and pulling in and out of businesses. I would recommend a no turning right sign and maybe some electronic crossing guards for pedestrians.

- A crosswalk at Lakewood Dr and Route 40 would be nice
- Crosswalk on south High Street, close to Lake Forest subdivision. No cars ever stop for pedestrians (even my kids) even when the lights are flashing.
- High st and Main st.

Do any of the following apply to you? (check all that apply)

56 responses

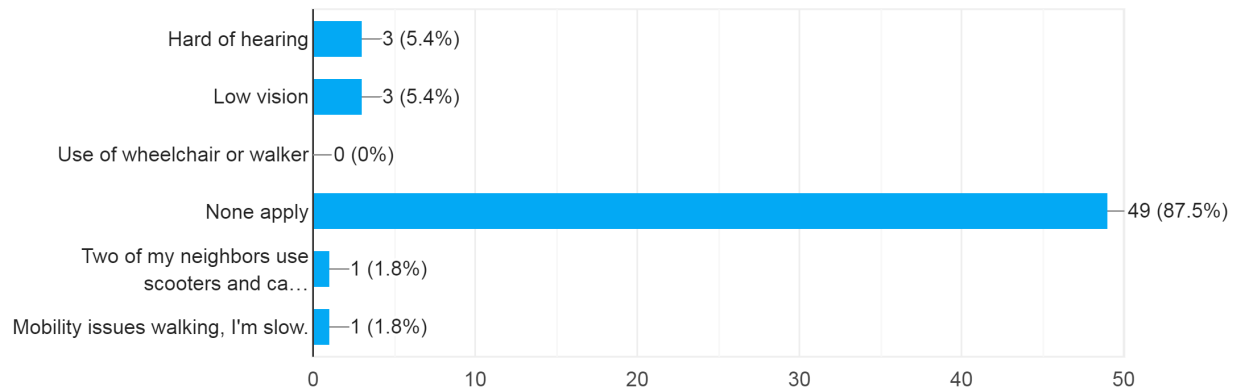

Please share any additional comments about walkability in the Village of Hebron.

19 responses

- We need better sidewalks in places and a crosswalk in front of the police station.
- Sidewalks need repaired. Not easy for strollers
- It would be nice for the end of S. High to have sidewalks, near 79.
- Hebron does a good job on this one suggestion would be sidewalks on Hamilton avenue
- Would love to see the sidewalks fixed on side streets such as North Street.
- North street sidewalks are practically nonexistent. There's a lot of foot traffic in the area, and it'd be nice if there were actual sidewalks through there.
- Na
- I would love for the bike trail to be connected to Lakewood schools parking lot, or even further to Harbor Hills neighborhood! It would be utilized so much more by residents if that were the case!
- I would like to see more sidewalks throughout the village.
- The drivers at 519 East Main Street use the sidewalk as their driveway. It has so much dirt and trash the people with wheelchairs have to go onto route 40 due to the rough terrain of built up dirt.
- Many sidewalks are in disrepair and need attention. The state and village teamed up and put in nice new sidewalks to McDonalds and down south High St. but no repairs or assistance for homeowners on North St for example. Should have helped the residents first, we pay the taxes.

- Seeing yards not being taken care of. Home owner or renter's mow 1 time a month back yards full of old wood boards/engines and other trash
- I would also like to share that more often than none that the sidewalk on the corner of north and refugee (going towards Evans park) is full of dirt and debris causing me to walk around and need to use the road versus the side walk. In addition the pink house on East Main Street is often blocking the side walk with either trash, dirt or vehicles. I have seen many including elderly not be able to use the sidewalk because of how the residents of that home take care of their property.
- It is nice to now be able to walk High St from 79 all the way to McDonalds. Overall, walkability is good. I just wish drivers had more consideration of people in the crosswalks. My wife has almost been hit twice while jogging, particularly at marked crosswalks.
- I love the lights along high st. The new sidewalk is awesome. Thank you
- I love walking in town when its nice out and I love the new sidewalks and street lights
- It is a beautiful place to live!
- I love walking through Hebron. I feel safe.
- North street is rough. So many kids walking it and having to trek through grass patches. Instead of a path to McDonald's, I would love to see a sidewalk on north street!

Appendix C: Walk Audit Summary

Village of Hebron
6/9/2020

Location:

Village of Hebron – Main St. Corridor. The walk audit was split into 2 routes: 1 route went from the Municipal Building to High Street, the 2nd route went from the Kroger intersection to High Street. The 2 groups met at High St.

Audited By:

Linda Nicodemus (Community Development), James Layton (Mayor), Greg Huss (LCATS), Alex Nouanesengsy (LCATS), Carrie McKee (LCHD)

Sidewalks

- Is a sidewalk present? Is it wide enough?
 - Yes, sidewalks are present down Main St. from the Municipal Building through town to the Kroger.
 - Sidewalks appear wide enough – but did not measure
- Is the sidewalk cracked or broken?
 - Overall, sidewalks down Main St. are in good condition. Not many issues with cracked or broken sidewalks, maybe some with elevation changes.
- Does the sidewalk have gaps or end suddenly?
 - No
 - There is a gap in sidewalk on the north side of US 40 between Arrowhead & Burch running alongside the cemetery. That is an important connection between the neighborhood to the north and Kroger to the south. However, there is sidewalk running along the west side of Burch and south side of US 40. Potential options include the addition of sidewalks on north side of US 40 to connect to crosswalk at Arrowhead or to create a modified mid-block crossing on the east side of Burch with RRFB and pedestrian island halfway across US 40.
- Are there trip hazards or accessibility issues?
 - Some areas of sidewalk change elevation which could be a hazard for someone using a mobility device or with a disability (i.e. – residents in village with cerebral palsy, using electric scooters (see photo), and visual impaired.).

- Small issues with uneven sidewalk between 4th & Buckeye. Sidewalks in great shape for the most part.
- SR 79 northbound exit at US 40, east side of crosswalk has truncated dome positioned facing north when it should be facing west to other side of crosswalk
- Issues throughout entire network with truncated domes facing toward middle of intersection instead of across the street. Out of ADA compliance.

Crossings

- Do marked *unsignalized* crossings feel safe?
 - Unsignalized crossings at 8th but traffic light – feels unsafe. Kids get dropped off for school. Potentially add signalized crossing here.
 - 6th and Main – no signal at corner of Dollar General. Communities down 6th come up 6th street (no sidewalks) to cross over and get to the Dollar General. Potentially add signalized crossing here.
 - High Street and Main St. – higher traffic and only 1 signal in 1 direction. Need to have signals with sound for all 4 directions. Truncated domes, but ramps point into the center of the intersection instead of across (this has been an issue for a visually impaired person in the area who had to learn how to cross correctly here).
 - Could work on improving other unsignalized crossings that have lower traffic with signage or piano key marked crossings to increase visualization for pedestrian crossings (i.e. 7th St. and Main). There was no pedestrian signage in the Village down Main St.
 - Main & Dennison features a marked crosswalk with truncated domes on east side of intersection. Crosswalk should be made more visible to vehicles, either by using piano key striping or signs. RRFB not necessary for this crossing.
- Do *signalized* crossings feel safe?
 - Only signalized crossing is at High Street, but only for one direction. More traffic at this intersection – signals needed for all 4 directions.
 - In addition to the need for ped heads at all 4 directions at Main & High, there is a need for sound features indicating it is safe to cross, for the visually impaired.
- Are there missing crosswalks?
 - There is not a marked crossing from the Municipal Building until 8th Street. People walk down to the Municipal Building to pay bills and access the library. Church across the street also offers food pantry. Look at an improved crossing at Lakewood Dr. Speed limit also increases to 50 at the Municipal Building – need marked crossing so vehicles know to slow down and pedestrians feel safe to cross.

- Throughout the village there are places that could use re-striping of crosswalks that have faded over the years. Specifically at the intersection of Main & High and US 40 & SR 79.
- Main & 5th serves as a heavily used crossing for pedestrians getting from the neighborhood on the north side of town to neighborhood on south side. It also serves as the geographic middle point between High and SR 79. Piano key style crosswalk, pedestrian crossing signs, and an RFB is recommended for this intersection. Truncated domes already present. However, the sidewalk present on east side of 5th going north is in poor condition and would need to be improved if an RFB is added. Culvert improvements on 5th a little further north would also need to be made in connection with the aforementioned upgrades.
- Do people have to walk more than 300ft for a safe place to cross the street?
 - See above.

Safety

- Does it feel safe to walk?
 - Yes, Village is well-maintained and feels safe. No signs of crime, graffiti, violence, trash
- Are there areas that seem dangerous?
 - Did not see anything on Main St. Empty car dealership lot is not as “visually appealing”, but does not seem unsafe.
 - The intersection of Main & High Streets has businesses with driveways that exit out very closer to the intersection itself. It creates an unsafe area for people not only walking along the sidewalk, but those that are stopped waiting for the traffic signal to cross the street.
- Is traffic too fast?
 - Closer to Municipal Building it increases to 50, in town it is 35. Most of the sidewalk is separated from the road.
 - The junction of US 40 & SR 79 has a larger amount of traffic, including vehicles traveling at faster speeds up to stop signs. While this creates a sense of less safety in the area, the infrastructure is in place to have as safe of an environment as possible.
 - For the entire stretch from High to Arrowhead, there seemed to be issues with speeding traffic. The roadway is extremely wide for a two-lane road there are areas where parking is restricted along Main Street. The addition of a marked bike lane could work in two ways: making use of extra space to create a new option for bicyclists through the community, and narrowing the road and therefore slowing traffic and creating a safer atmosphere for all pedestrians.

- Is it well lit?
 - Audit was conducted during the day

Community and Recreation

- Are other people out walking?
 - Gentleman was out riding his electric scooter from assisted living facility to the BP. People were out near High St. intersection walking. Very pedestrian friendly community – people enjoy and want to be able to get out and walk!
- Are there places to gather as a community?
 - Yes – green space at corner of High and Main - Also popular ice cream shop at opposite corner. Evans Park has wetlands with 1/8 mile paved walking trail – access to park off of Main St. Another playground is located off High Street.
- Are there playgrounds or parks?
 - Yes, Evans Park and a playground off High St.
- Are parks unsafe or unmaintained?
 - Did not visit parks – but Village maintains them.

Recommendations/High Priority(ies):

1. High Street intersection – needs signals (with sound) in all directions. Ramps need corrected to be ADA compliant.
2. Lakewood Dr. – no crossing currently. Need a crossing closer to Municipal Building for pedestrians to safely cross. There is not a crossing until 8th street.
3. 6th Street and Main – possibly add signal for access Dollar General.
4. 8th St Intersection – signals with sound in all directions
5. Reduce the number of crossings between 6th and 7th Streets
6. High visibility striping and in-street pedestrian crossing signage for all non-signalized crossings

Appendix D: Pedestrian Counts

This section is awaiting compilation upon completion of data retrieval.



Hebron Pedestrian Counts - Main Street East of High Street, South Side of Road

Data Collected by LCATS

07/20/2020

Portable Multi

Licking County Area Transportation Study

July 11, 2020 12:00 AM → July 20, 2020 12:00 AM

Daily Average Trips

Daily Average

40

Peak Day Trips

Peak Day

Tuesday
Jul 14, 2020

65

Total Trips by Hour

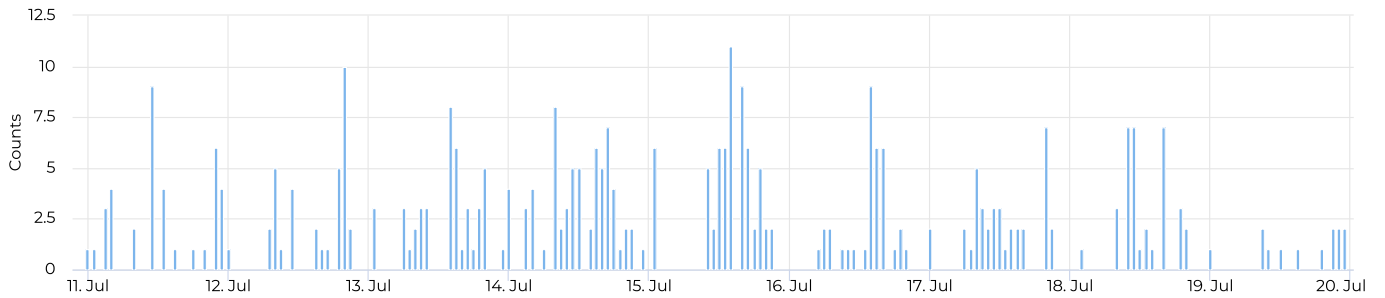

Key Figures Summary ↗

Site	Total	Average	Peak Count	Peak Period
Portable Multi	359	40	65	Tue Jul 14, 2020
Westbound	189	21	32	Tue Jul 14, 2020
Eastbound	170	19	33	Tue Jul 14, 2020



Hebron Pedestrian Counts - Main Street East of High Street, South Side of Road

Data Collected by LCATS

07/20/2020

Daily Average Trips

Daily Average

184

Peak Day Trips

Peak Day

Saturday
Jul 11, 2020

266

Total Trips by Hour

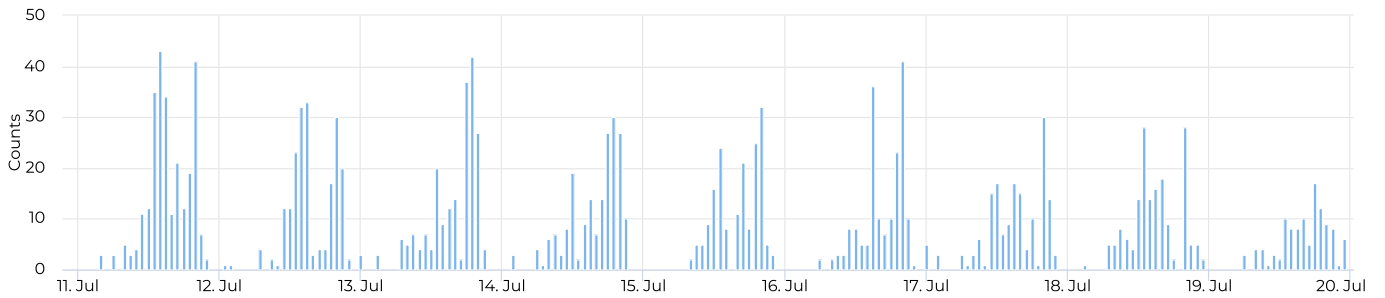

Key Figures Summary

Site	Total	Average	Peak Count	Peak Period
Mobile Ped	1,657	184	266	Sat Jul 11, 2020
Westbound	842	94	135	Sat Jul 11, 2020
Eastbound	815	91	131	Sat Jul 11, 2020



Hebron Pedestrian Counts - Main Street & 8th Street, NW Corner, Crossing Main Street

Data Collected by LCATS

07/31/2020

Portable Multi

Licking County Area Transportation Study

July 21, 2020 12:00 AM → July 28, 2020 12:00 AM

Daily Average Trips

Daily Average

11

Peak Day Trips

Peak Day

Friday
Jul 24, 2020

19

Total Trips by Hour

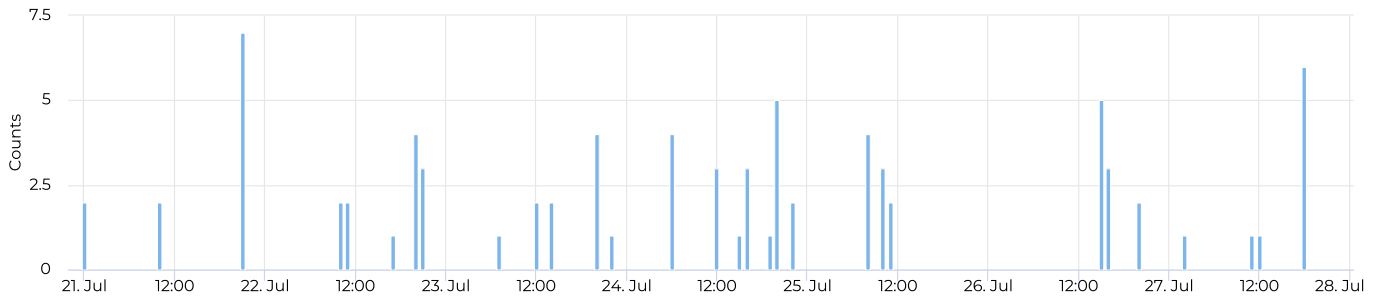

Key Figures Summary [↗](#)

Site	Total	Average	Peak Count	Peak Period
Portable Multi	80	11	19	Fri Jul 24, 2020
Northbound	54	8	15	Fri Jul 24, 2020
Southbound	26	4	7	Tue Jul 21, 2020



Hebron Pedestrian Counts - Main Street & Church Street, SW Corner, Crossing Main Street

Data Collected by LCATS

07/31/2020

Mobile Ped

Licking County Area Transportation Study

July 21, 2020 12:00 AM → July 28, 2020 12:00 AM

Daily Average Trips

Daily Average

6

Peak Day Trips

Peak Day

Tuesday
Jul 21, 2020

17

Total Trips by Hour

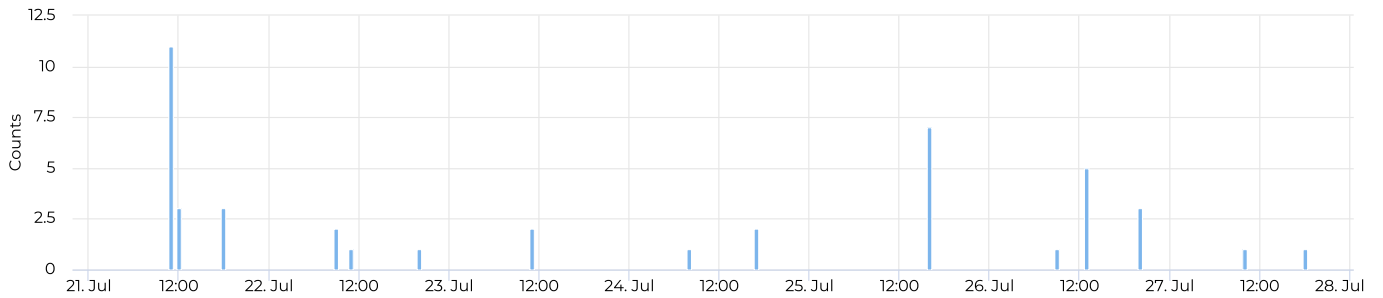

Key Figures Summary ↗

Site	Total	Average	Peak Count	Peak Period
Mobile Ped	44	6	17	Tue Jul 21, 2020
Southbound	31	4	11	Tue Jul 21, 2020
Northbound	13	2	6	Tue Jul 21, 2020



Main Street & N 9th Street, NW Corner, Crossing 9th

Data Collected by LCATS

Portable Multi

August 2, 2020 → August 9, 2020

Daily Average Trips

Daily Average

9

Peak Day Trips

Peak Day

Sunday
Aug 2, 2020

16

08/10/2020

Total Trips by Hour

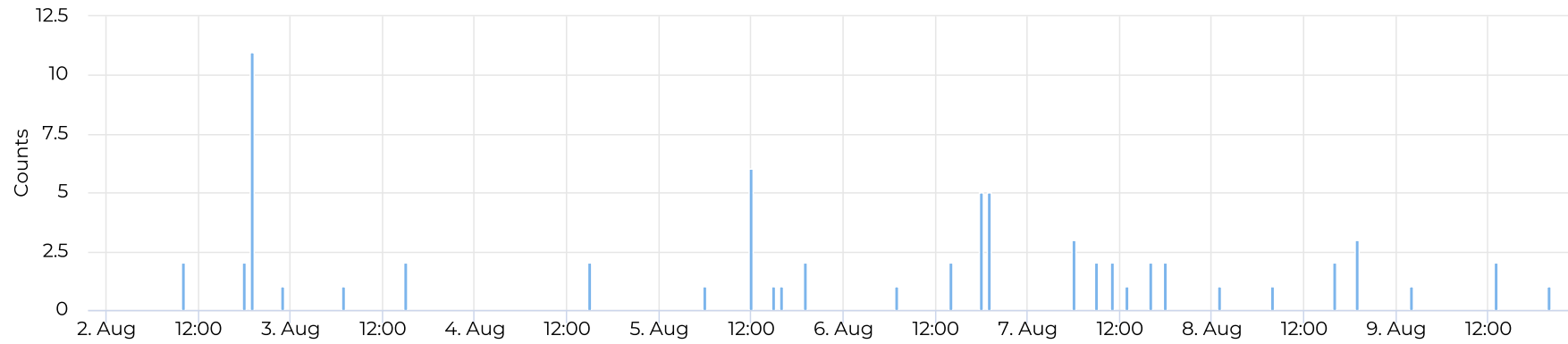

Key Figures Summary

Site	Total	Average	Peak Count	Peak Period
Portable Multi	68	9	16	Sun Aug 2, 2020
Westbound	44	6	13	Sun Aug 2, 2020
Eastbound	24	3	5	Wed Aug 5, 2020



Hebron Pedestrian Counts - Main Street Between Hamilton & Lakewood, South Side of Road

Data Collected by LCATS

09/10/2020

Daily Average Trips

Daily Average

30

Peak Day Trips

Peak Day

Saturday
Aug 22, 2020

73

Total Trips by Hour

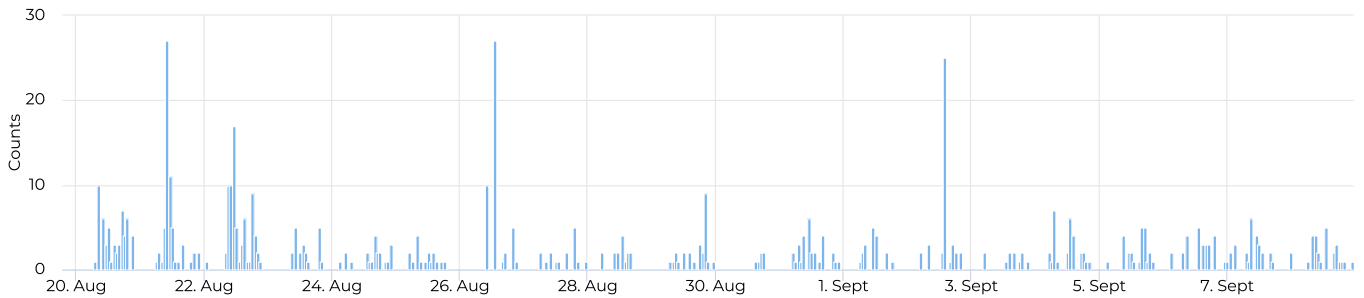

Key Figures Summary ↗

Site	Total	Average	Peak Count	Peak Period
Portable Multi	593	30	73	Sat Aug 22, 2020
Westbound	329	16	42	Sat Aug 22, 2020
Eastbound	264	13	31	Sat Aug 22, 2020



Hebron Pedestrian Counts - Southeast Corner of Main/5th, Crossing Main Street

Data Collected by LCATS

09/10/2020

Daily Average Trips

Daily Average

15

Peak Day Trips

Peak Day

Thursday
Sep 3, 2020

63

Total Trips by Hour

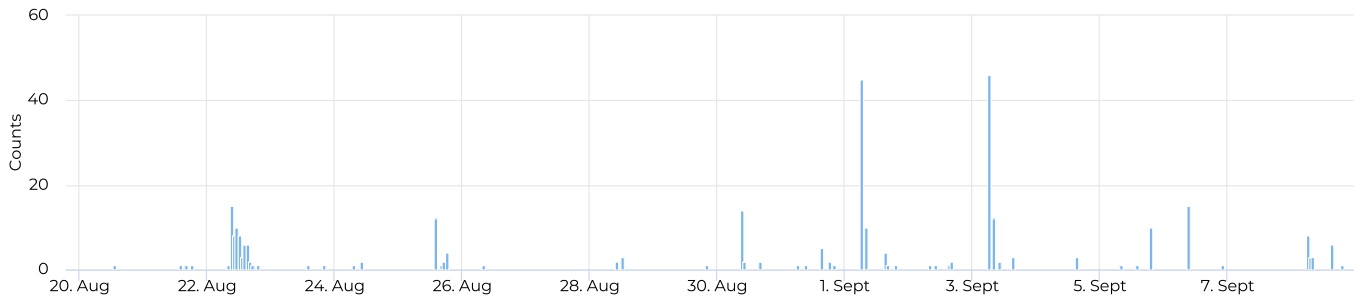

Key Figures Summary

Site	Total	Average	Peak Count	Peak Period
Mobile Ped	305	15	63	Thu Sep 3, 2020
Southbound	183	9	40	Sat Aug 22, 2020
Northbound	122	6	32	Tue Sep 1, 2020

Appendix E: Crosswalk Marking and Signing Guidelines

The following is an excerpt of Section 3B-18 from pages 430-431 of the 2012 Edition of the *Ohio Manual of Uniform Traffic Control Devices*.

Section 3B.18 Crosswalk Markings

Support:

01 Crosswalk markings provide guidance for pedestrians who are crossing roadways by defining and delineating paths on approaches to and within signalized intersections, and on approaches to other intersections where traffic stops.

02 In conjunction with signs and other measures, crosswalk markings help to alert road users of a designated pedestrian crossing point across roadways at locations that are not controlled by traffic control signals or STOP or YIELD signs.

03 At non-intersection locations, crosswalk markings legally establish the crosswalk.

Standard:

04 When crosswalk lines are used, they shall consist of solid white lines that mark the crosswalk. They shall be not less than 6 inches or greater than 24 inches in width.

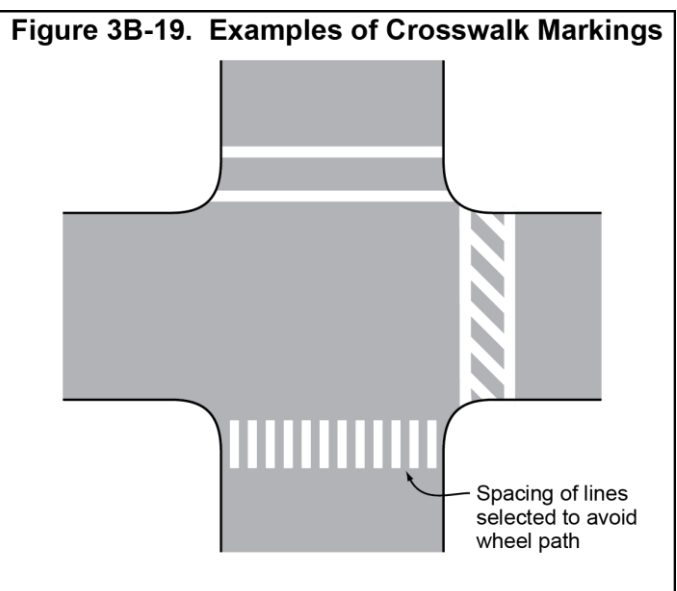

Guidance:

- 05 *If transverse lines are used to mark a crosswalk, the gap between the lines should not be less than 6 feet. If diagonal or longitudinal lines are used without transverse lines to mark a crosswalk, the crosswalk should be not less than 6 feet wide.*
- 06 *Crosswalk lines, if used on both sides of the crosswalk, should extend across the full width of pavement or to the edge of the intersecting crosswalk to discourage diagonal walking between crosswalks (see Figures 3B-17 and 3B-19).*
- 07 *At locations controlled by traffic control signals or on approaches controlled by STOP or YIELD signs, crosswalk lines should be installed where engineering judgment indicates they are needed to direct pedestrians to the proper crossing path(s).*
- 08 *Crosswalk lines should not be used indiscriminately. An engineering study should be performed before a marked crosswalk is installed at a location away from a traffic control signal or an approach controlled by a STOP or YIELD sign. The engineering study should consider the number of lanes, the presence of a median, the distance from adjacent signalized intersections, the pedestrian volumes and delays, the average daily traffic (ADT), the posted or statutory speed limit or 85th-percentile speed, the geometry of the location, the possible consolidation of multiple crossing points, the availability of street lighting, and other appropriate factors.*
- 09 *New marked crosswalks alone, without other measures designed to reduce traffic speeds, shorten crossing distances, enhance driver awareness of the crossing, and/or provide active warning of pedestrian presence, should not be installed across uncontrolled roadways where the speed limit exceeds 40 mph and either:*
- A. The roadway has four or more lanes of travel without a raised median or pedestrian refuge island and an ADT of 12,000 vehicles per day or greater; or*
 - B. The roadway has four or more lanes of travel with a raised median or pedestrian refuge island and an ADT of 15,000 vehicles per day or greater.*

Support:

- 10 Chapter 4F contains information on Pedestrian Hybrid Beacons. Section 4L.03 contains information regarding Warning Beacons to provide active warning of a pedestrian's presence. Section 4N.02 contains information regarding In-Roadway Warning Lights at crosswalks. Chapter 7D contains information regarding school crossing supervision.

Guidance:

- 11 Because non-intersection pedestrian crossings are generally unexpected by the road user, warning signs (see Section 2C.50) should be installed for all marked crosswalks at non-intersection locations and adequate visibility should be provided by parking prohibitions.

Support:

- 12 Section 3B.16 contains information regarding placement of stop line markings near crosswalk markings.

Option:

- 13 For added visibility, the area of the crosswalk may be marked with white diagonal lines at a 45-degree angle to the line of the crosswalk or with white longitudinal lines parallel to traffic flow as shown in Figure 3B-19.
- 14 When diagonal or longitudinal lines are used to mark a crosswalk, the transverse crosswalk lines may be omitted. This type of marking may be used at locations where substantial numbers of pedestrians cross without any other traffic control device, at locations where physical conditions are such that added visibility of the crosswalk is desired, or at places where a pedestrian crosswalk might not be expected.

Guidance:

- 15 *If used, the diagonal or longitudinal lines should be 10 to 24 inches wide and separated by gaps of 12 to 60 inches. The design of the lines and gaps should avoid the wheel paths if possible, and the gap between the lines should not exceed 2.5 times the width of the diagonal or longitudinal lines.*

The following are sections 2B.11 and 2B.12 from pages 66-68 of 2012 Edition of the *Ohio Manual of Uniform Traffic Control Devices*.

Section 2B.11 Yield Here To Pedestrians Signs (R1-5 Series)

Standard:

- 01 **Yield Here To Pedestrians (R1-5 or R1-5a) signs (see Figure 2B-2) shall be used if yield lines are used in advance of a marked crosswalk that crosses an uncontrolled multi-lane approach. The legend STATE LAW may be displayed at the top of the R1-5, or R1-5a.**

Guidance:

- 02 *If yield lines and Yield Here To Pedestrians signs are used in advance of a crosswalk that crosses an uncontrolled multi-lane approach, they should be placed 20 to 50 feet in advance of the nearest crosswalk line (see Section 3B.16 and Figure 3B-17), and parking should be prohibited in the area between the yield line and the crosswalk.*
- 03 *Yield lines and Yield Here To Pedestrians signs should not be used in advance of crosswalks that cross an approach to or departure from a roundabout.*

Option:

- 04 **Yield Here To Pedestrians signs may be used in advance of a crosswalk that crosses an uncontrolled multi-lane approach to indicate to road users where to yield even if yield lines are not used.**

Figure 2B-2. Unsignalized Pedestrian Crosswalk Signs

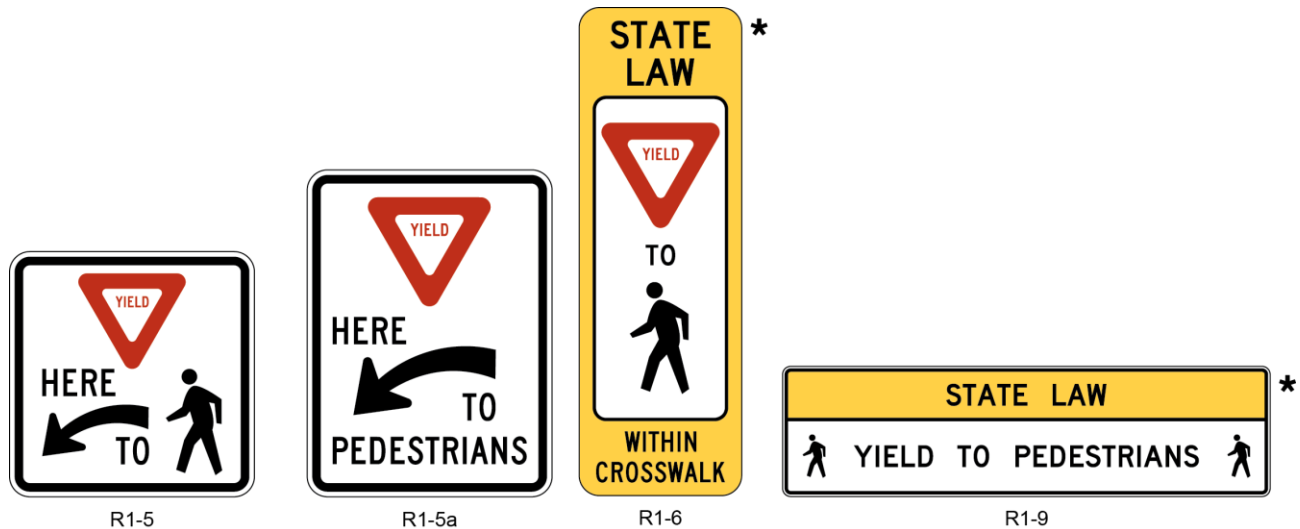

* The Legend STATE LAW is optional. A fluorescent yellow-green background color may be used instead of yellow for this sign.

05 A Pedestrian Crossing (W11-2) warning sign may be placed overhead or may be post-mounted with a diagonal downward pointing arrow (W16-7P) plaque at the crosswalk location where Yield Here To Pedestrians signs have been installed in advance of the crosswalk.

Standard:

06 **If a W11-2 sign has been post-mounted at the crosswalk location where a Yield Here To Pedestrians sign is used on the approach, the Yield Here To Pedestrians sign shall not be placed on the same post as or block the road user’s view of the W11-2 sign.**

Option:

07 An advance Pedestrian Crossing (W11-2) warning sign with an AHEAD or a distance supplemental plaque may be used in conjunction with a Yield Here To Pedestrians sign on the approach to the same crosswalk.

08 In-Street Pedestrian Crossing signs and Yield Here To Pedestrians signs may be used together at the same crosswalk.

Section 2B.12 In-Street and Overhead Pedestrian Crossing Signs (R1-6, R1-9)

Option:

01 The In-Street Pedestrian Crossing (R1-6) sign (see Figure 2B-2) or the Overhead Pedestrian Crossing (R1-9) sign (see Figure 2B-2) may be used to remind road users of laws regarding right-of-way at an unsignalized pedestrian crosswalk. The legend STATE LAW may be displayed at the top of the R1-6 and R1-9 signs. On the R1-6 sign, the legend YIELD may be used in conjunction with the appropriate YIELD sign symbol.

02 Highway agencies may develop and apply criteria for determining the applicability of In-Street Pedestrian Crossing signs.

Standard:

03 **If used, the In-Street Pedestrian Crossing sign shall be placed in the roadway at the crosswalk location on the center line, on a lane line, or on a median island. The In-Street Pedestrian Crossing sign shall not be post-mounted on the left-hand or right-hand side of the roadway.**

04 **If used, the Overhead Pedestrian Crossing sign shall be placed over the roadway at the crosswalk location.**

05 **An In-Street or Overhead Pedestrian Crossing sign shall not be placed in advance of the crosswalk to educate road users about the State law prior to reaching the crosswalk, nor shall it be installed as an educational display that is not near any crosswalk.**

Guidance:

06 *If an island (see Chapter 3I) is available, the In-Street Pedestrian Crossing sign, if used, should be placed on the island.*

Option:

07 If a Pedestrian Crossing (W11-2) warning sign is used in combination with an In-Street or an Overhead Pedestrian Crossing sign, the W11-2 sign with a diagonal downward pointing arrow (W16-7P) plaque may be post-mounted on the right-hand side of the roadway at the crosswalk location.

Standard:

08 **The In-Street Pedestrian Crossing sign and the Overhead Pedestrian Crossing sign shall not be used at signalized locations.**

09 **The In-Street Pedestrian Crossing sign shall have a black legend (except for the red YIELD sign symbol) and border on a white background, surrounded by an outer yellow or fluorescent yellow-green background area (see Figure 2B-2). The Overhead Pedestrian Crossing sign shall have a black legend and border on a yellow or fluorescent yellow-green background at the top of the sign and a black legend and border on a white background at the bottom of the sign (see Figure 2B-2).**

10 **Unless the In-Street Pedestrian Crossing sign is placed on a physical island, the sign support shall be designed to bend over and then bounce back to its normal vertical position when struck by a vehicle.**

Support:

11 Provisions of Section 2A.18 concerning mounting height are not applicable for the In-Street Pedestrian Crossing sign.

Standard:

12 **The top of an In-Street Pedestrian Crossing sign shall be a maximum of 4 feet above the pavement surface. The top of an In-Street Pedestrian Crossing sign placed in an island shall be a maximum of 4 feet above the island surface.**

Option:

13 The In-Street Pedestrian Crossing sign may be used seasonally to prevent damage in winter because of plowing operations, and may be removed at night if the pedestrian activity at night is minimal.

14 In-Street Pedestrian Crossing signs, Overhead Pedestrian Crossing signs, and Yield Here To Pedestrians signs may be used together at the same crosswalk.

Appendix E: Crosswalk Marking and Signing Guidelines

The following is an excerpt of Section 3B-18 from pages 430-431 of the 2012 Edition of the *Ohio Manual of Uniform Traffic Control Devices*.

Section 3B.18 Crosswalk Markings

Support:

01 Crosswalk markings provide guidance for pedestrians who are crossing roadways by defining and delineating paths on approaches to and within signalized intersections, and on approaches to other intersections where traffic stops.

02 In conjunction with signs and other measures, crosswalk markings help to alert road users of a designated pedestrian crossing point across roadways at locations that are not controlled by traffic control signals or STOP or YIELD signs.

03 At non-intersection locations, crosswalk markings legally establish the crosswalk.

Standard:

04 When crosswalk lines are used, they shall consist of solid white lines that mark the crosswalk. They shall be not less than 6 inches or greater than 24 inches in width.

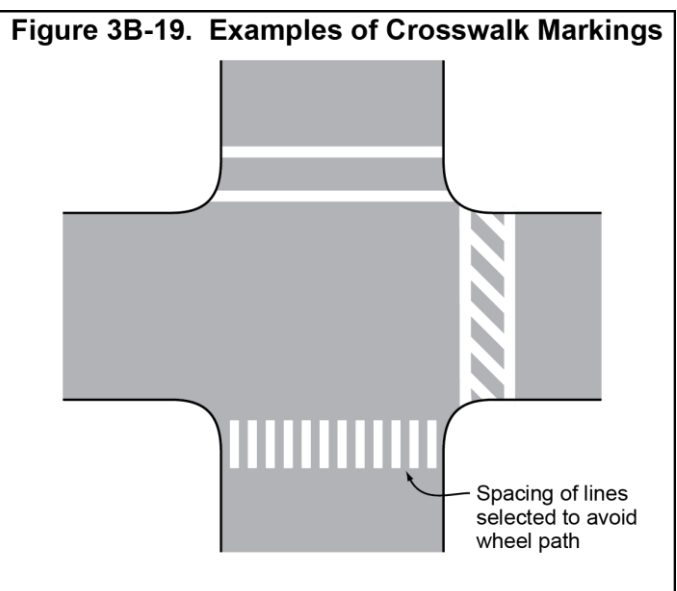

Guidance:

- 05 *If transverse lines are used to mark a crosswalk, the gap between the lines should not be less than 6 feet. If diagonal or longitudinal lines are used without transverse lines to mark a crosswalk, the crosswalk should be not less than 6 feet wide.*
- 06 *Crosswalk lines, if used on both sides of the crosswalk, should extend across the full width of pavement or to the edge of the intersecting crosswalk to discourage diagonal walking between crosswalks (see Figures 3B-17 and 3B-19).*
- 07 *At locations controlled by traffic control signals or on approaches controlled by STOP or YIELD signs, crosswalk lines should be installed where engineering judgment indicates they are needed to direct pedestrians to the proper crossing path(s).*
- 08 *Crosswalk lines should not be used indiscriminately. An engineering study should be performed before a marked crosswalk is installed at a location away from a traffic control signal or an approach controlled by a STOP or YIELD sign. The engineering study should consider the number of lanes, the presence of a median, the distance from adjacent signalized intersections, the pedestrian volumes and delays, the average daily traffic (ADT), the posted or statutory speed limit or 85th-percentile speed, the geometry of the location, the possible consolidation of multiple crossing points, the availability of street lighting, and other appropriate factors.*
- 09 *New marked crosswalks alone, without other measures designed to reduce traffic speeds, shorten crossing distances, enhance driver awareness of the crossing, and/or provide active warning of pedestrian presence, should not be installed across uncontrolled roadways where the speed limit exceeds 40 mph and either:*
- A. The roadway has four or more lanes of travel without a raised median or pedestrian refuge island and an ADT of 12,000 vehicles per day or greater; or*
 - B. The roadway has four or more lanes of travel with a raised median or pedestrian refuge island and an ADT of 15,000 vehicles per day or greater.*

Support:

- 10 Chapter 4F contains information on Pedestrian Hybrid Beacons. Section 4L.03 contains information regarding Warning Beacons to provide active warning of a pedestrian's presence. Section 4N.02 contains information regarding In-Roadway Warning Lights at crosswalks. Chapter 7D contains information regarding school crossing supervision.

Guidance:

- 11 Because non-intersection pedestrian crossings are generally unexpected by the road user, warning signs (see Section 2C.50) should be installed for all marked crosswalks at non-intersection locations and adequate visibility should be provided by parking prohibitions.

Support:

- 12 Section 3B.16 contains information regarding placement of stop line markings near crosswalk markings.

Option:

- 13 For added visibility, the area of the crosswalk may be marked with white diagonal lines at a 45-degree angle to the line of the crosswalk or with white longitudinal lines parallel to traffic flow as shown in Figure 3B-19.
- 14 When diagonal or longitudinal lines are used to mark a crosswalk, the transverse crosswalk lines may be omitted. This type of marking may be used at locations where substantial numbers of pedestrians cross without any other traffic control device, at locations where physical conditions are such that added visibility of the crosswalk is desired, or at places where a pedestrian crosswalk might not be expected.

Guidance:

- 15 *If used, the diagonal or longitudinal lines should be 10 to 24 inches wide and separated by gaps of 12 to 60 inches. The design of the lines and gaps should avoid the wheel paths if possible, and the gap between the lines should not exceed 2.5 times the width of the diagonal or longitudinal lines.*

The following are sections 2B.11 and 2B.12 from pages 66-68 of 2012 Edition of the *Ohio Manual of Uniform Traffic Control Devices*.

Section 2B.11 Yield Here To Pedestrians Signs (R1-5 Series)

Standard:

- 01 **Yield Here To Pedestrians (R1-5 or R1-5a) signs (see Figure 2B-2) shall be used if yield lines are used in advance of a marked crosswalk that crosses an uncontrolled multi-lane approach. The legend STATE LAW may be displayed at the top of the R1-5, or R1-5a.**

Guidance:

- 02 *If yield lines and Yield Here To Pedestrians signs are used in advance of a crosswalk that crosses an uncontrolled multi-lane approach, they should be placed 20 to 50 feet in advance of the nearest crosswalk line (see Section 3B.16 and Figure 3B-17), and parking should be prohibited in the area between the yield line and the crosswalk.*
- 03 *Yield lines and Yield Here To Pedestrians signs should not be used in advance of crosswalks that cross an approach to or departure from a roundabout.*

Option:

- 04 **Yield Here To Pedestrians signs may be used in advance of a crosswalk that crosses an uncontrolled multi-lane approach to indicate to road users where to yield even if yield lines are not used.**

Figure 2B-2. Unsignalized Pedestrian Crosswalk Signs

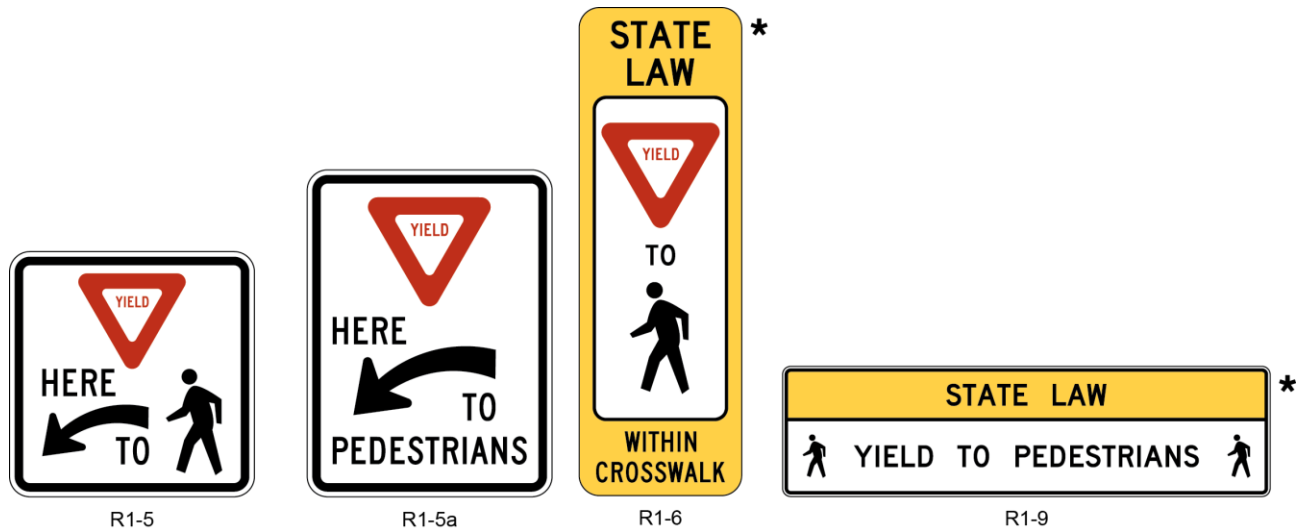

* The Legend STATE LAW is optional. A fluorescent yellow-green background color may be used instead of yellow for this sign.

05 A Pedestrian Crossing (W11-2) warning sign may be placed overhead or may be post-mounted with a diagonal downward pointing arrow (W16-7P) plaque at the crosswalk location where Yield Here To Pedestrians signs have been installed in advance of the crosswalk.

Standard:

06 **If a W11-2 sign has been post-mounted at the crosswalk location where a Yield Here To Pedestrians sign is used on the approach, the Yield Here To Pedestrians sign shall not be placed on the same post as or block the road user’s view of the W11-2 sign.**

Option:

07 An advance Pedestrian Crossing (W11-2) warning sign with an AHEAD or a distance supplemental plaque may be used in conjunction with a Yield Here To Pedestrians sign on the approach to the same crosswalk.

08 In-Street Pedestrian Crossing signs and Yield Here To Pedestrians signs may be used together at the same crosswalk.

Section 2B.12 In-Street and Overhead Pedestrian Crossing Signs (R1-6, R1-9)

Option:

01 The In-Street Pedestrian Crossing (R1-6) sign (see Figure 2B-2) or the Overhead Pedestrian Crossing (R1-9) sign (see Figure 2B-2) may be used to remind road users of laws regarding right-of-way at an unsignalized pedestrian crosswalk. The legend STATE LAW may be displayed at the top of the R1-6 and R1-9 signs. On the R1-6 sign, the legend YIELD may be used in conjunction with the appropriate YIELD sign symbol.

02 Highway agencies may develop and apply criteria for determining the applicability of In-Street Pedestrian Crossing signs.

Standard:

03 **If used, the In-Street Pedestrian Crossing sign shall be placed in the roadway at the crosswalk location on the center line, on a lane line, or on a median island. The In-Street Pedestrian Crossing sign shall not be post-mounted on the left-hand or right-hand side of the roadway.**

04 **If used, the Overhead Pedestrian Crossing sign shall be placed over the roadway at the crosswalk location.**

05 **An In-Street or Overhead Pedestrian Crossing sign shall not be placed in advance of the crosswalk to educate road users about the State law prior to reaching the crosswalk, nor shall it be installed as an educational display that is not near any crosswalk.**

Guidance:

06 *If an island (see Chapter 3I) is available, the In-Street Pedestrian Crossing sign, if used, should be placed on the island.*

Option:

07 If a Pedestrian Crossing (W11-2) warning sign is used in combination with an In-Street or an Overhead Pedestrian Crossing sign, the W11-2 sign with a diagonal downward pointing arrow (W16-7P) plaque may be post-mounted on the right-hand side of the roadway at the crosswalk location.

Standard:

08 **The In-Street Pedestrian Crossing sign and the Overhead Pedestrian Crossing sign shall not be used at signalized locations.**

09 **The In-Street Pedestrian Crossing sign shall have a black legend (except for the red YIELD sign symbol) and border on a white background, surrounded by an outer yellow or fluorescent yellow-green background area (see Figure 2B-2). The Overhead Pedestrian Crossing sign shall have a black legend and border on a yellow or fluorescent yellow-green background at the top of the sign and a black legend and border on a white background at the bottom of the sign (see Figure 2B-2).**

10 **Unless the In-Street Pedestrian Crossing sign is placed on a physical island, the sign support shall be designed to bend over and then bounce back to its normal vertical position when struck by a vehicle.**

Support:

11 Provisions of Section 2A.18 concerning mounting height are not applicable for the In-Street Pedestrian Crossing sign.

Standard:

12 **The top of an In-Street Pedestrian Crossing sign shall be a maximum of 4 feet above the pavement surface. The top of an In-Street Pedestrian Crossing sign placed in an island shall be a maximum of 4 feet above the island surface.**

Option:

13 The In-Street Pedestrian Crossing sign may be used seasonally to prevent damage in winter because of plowing operations, and may be removed at night if the pedestrian activity at night is minimal.

14 In-Street Pedestrian Crossing signs, Overhead Pedestrian Crossing signs, and Yield Here To Pedestrians signs may be used together at the same crosswalk.

Appendix F: Pedestrian Signal and Beacon Guidelines

The following are Chapters 4E, 4F, and 4G from pages 557-580 of the 2012 Edition of the *Ohio Manual of Uniform Traffic Control Devices*.

CHAPTER 4E. PEDESTRIAN CONTROL FEATURES

Section 4E.01 Pedestrian Signal Heads

Support:

- 01 Pedestrian signal heads provide special types of traffic signal indications exclusively intended for controlling pedestrian traffic. These signal indications consist of the illuminated symbols of a WALKING PERSON (symbolizing WALK) and an UPRAISED HAND (symbolizing DONT WALK).

Guidance:

- 02 *Engineering judgment should determine the need for separate pedestrian signal heads (see Section 4D.03) and accessible pedestrian signals (see Section 4E.09).*

Support:

- 03 Chapter 4F contains information regarding the use of pedestrian hybrid beacons and Chapter 4N contains information regarding the use of In-Roadway Warning Lights at unsignalized marked crosswalks.

Section 4E.02 Meaning of Pedestrian Signal Head Indications

Standard:

- 01 **As specified in 4511.14 of the Ohio Revised Code, pedestrian signal head indications shall have the following meanings**

- “(A) A steady walking person signal indication, which symbolizes “walk,” means that a pedestrian facing the signal indication is permitted to start to cross the roadway in the direction of the signal indication, possibly in conflict with turning vehicles. The pedestrian shall yield the right-of-way to vehicles lawfully within the intersection at the time that the walking person signal indication is first shown.**
- (B) A flashing upraised hand signal indication, which symbolizes “don’t walk,” means that a pedestrian shall not start to cross the roadway in the direction of the signal indication, but that any pedestrian who has already started to cross on a steady walking person signal indication shall proceed to the far side of the traveled way of the street or highway, unless otherwise directed by a traffic control device to proceed only to the median of a divided highway or only to some other island or pedestrian refuge area.**
- (C) A steady upraised hand signal indication means that a pedestrian shall not enter the roadway in the direction of the signal indication.**
- (D) Nothing in this section shall be construed to invalidate the continued use of pedestrian control signals utilizing the word “wait” if those signals were installed prior to March 28, 1985.**
- (E) A flashing walking person signal indication has no meaning and shall not be used.”**

Section 4E.03 Application of Pedestrian Signal Heads

Standard:

- 01 **Pedestrian signal heads shall be used in conjunction with vehicular traffic control signals under any of the following conditions:**
- A. If a traffic control signal is justified by an engineering study and meets either Warrant 4, Pedestrian Volume or Warrant 5, School Crossing (see Chapter 4C);**
 - B. If an exclusive signal phase is provided or made available for pedestrian movements in one or more directions, with all conflicting vehicular movements being stopped;**
 - C. At an established school crossing at any signalized location; and/or**
 - D. Where engineering judgment determines that multi-phase signal indications (as with split-phase timing) would tend to confuse or cause conflicts with pedestrians using a crosswalk guided only by vehicular signal indications.**

Guidance:

- 02 *Pedestrian signal heads should be used under any of the following conditions:*
- A. If it is necessary to assist pedestrians in deciding when to begin crossing the roadway in the chosen direction or if engineering judgment determines that pedestrian signal heads are justified to minimize vehicle-pedestrian conflicts;*

- B. *If pedestrians are permitted to cross a portion of a street, such as to or from a median of sufficient width for pedestrians to wait, during a particular interval but are not permitted to cross the remainder of the street during any part of the same interval; and/or*
- C. *If no vehicular signal indications are visible to pedestrians, or if the vehicular signal indications that are visible to pedestrians starting a crossing provide insufficient guidance for them to decide when to begin crossing the roadway in the chosen direction, such as on one-way streets, at T-intersections, or at multi-phase signal operations.*

Option:

03 Pedestrian signal heads may be used under other conditions based on engineering judgment.

Section 4E.04 Size, Design, and Illumination of Pedestrian Signal Head Indications

Standard:

01 **All new pedestrian signal head indications shall be displayed within a rectangular background and shall consist of symbolized messages (see Figure 4E-1), except that existing pedestrian signal head indications with lettered or outline style symbol messages shall be permitted to be retained for the remainder of their useful service life. The symbol designs that are set forth in the “Sign Designs and Markings Manual” (SDMM) (see Section 1A.11) shall be used. Each pedestrian signal head indication shall be independently displayed and emit a single color.**

02 **If a two-section pedestrian signal head is used, the UPRAISED HAND (symbolizing DONT WALK) signal section shall be mounted directly above the WALKING PERSON (symbolizing WALK) signal section. If a one-section pedestrian signal head is used, the symbols shall be either overlaid upon each other or arranged side-by-side with the UPRAISED HAND symbol to the left of the WALKING PERSON symbol, and a light source that can display each symbol independently shall be used.**

03 **The WALKING PERSON (symbolizing WALK) signal indication shall be white, conforming to the publication entitled “Pedestrian Traffic Control Signal Indications” (see Section 1A.11), with all except the symbol obscured by an opaque material.**

04 **The UPRAISED HAND (symbolizing DONT WALK) signal indication shall be Portland orange, conforming to the publication entitled “Pedestrian Traffic Control Signal Indications” (see Section 1A.11), with all except the symbol obscured by an opaque material.**

05 **When not illuminated, the WALKING PERSON (symbolizing WALK) and UPRAISED HAND (symbolizing DONT WALK) symbols shall not be readily visible to pedestrians at the far end of the crosswalk that the pedestrian signal head indications control.**

06 **For pedestrian signal head indications, the symbols shall be at least 6 inches high.**

07 **The light source of a flashing UPRAISED HAND (symbolizing DONT WALK) signal indication shall be flashed continuously at a rate of not less than 50 or more than 60 times per minute. The displayed period of each flash shall be a minimum 1/2 and a maximum of 2/3 of the total flash cycle.**

Guidance:

08 *Pedestrian signal head indications should be conspicuous and recognizable to pedestrians at all distances from the beginning of the controlled crosswalk to a point 10 feet from the end of the controlled crosswalk during both day and night.*

09 *For crosswalks where the pedestrian enters the crosswalk more than 100 feet from the pedestrian signal head indications, the symbols should be at least 9 inches high.*

10 *If the pedestrian signal indication is so bright that it causes excessive glare in nighttime conditions, some form of automatic dimming should be used to reduce the brilliance of the signal indication.*

Option:

11 **An animated eyes symbol may be added to a pedestrian signal head in order to prompt pedestrians to look for vehicles in the intersection during the time that the WALKING PERSON (symbolizing WALK) signal indication is displayed.**

Figure 4E-1. Typical Pedestrian Signal Indications

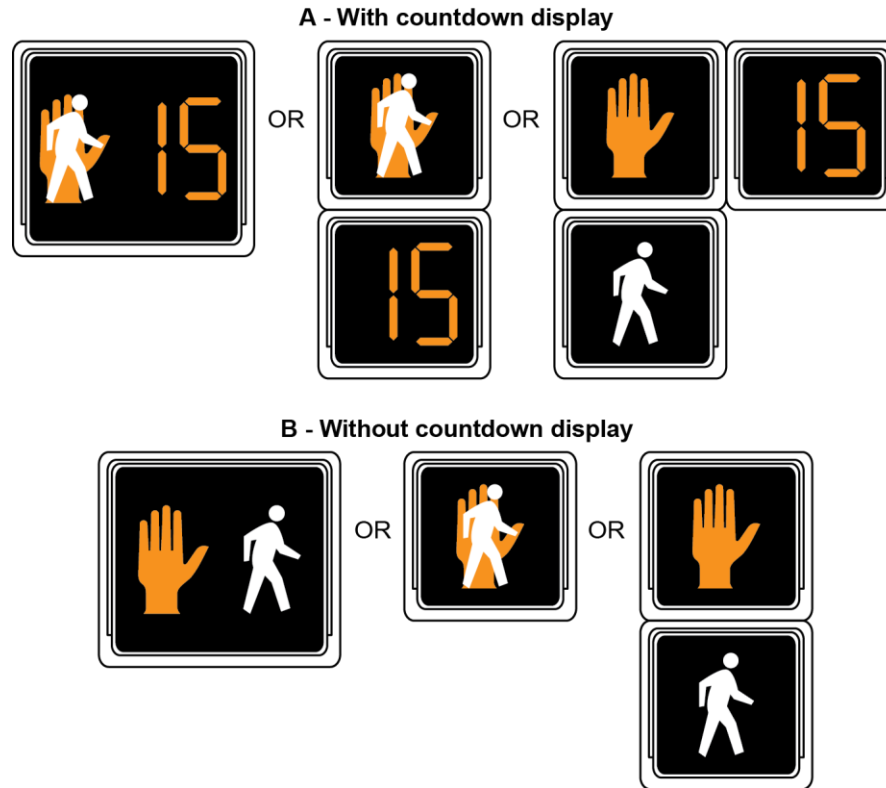

Standard:

- 12 If used, the animated eyes symbol shall consist of an outline of a pair of white steadily-illuminated eyes with white eyeballs that scan from side to side at a rate of approximately once per second. The animated eyes symbol shall be at least 12 inches wide with each eye having a width of at least 5 inches and a height of at least 2.5 inches. The animated eyes symbol shall be illuminated at the start of the walk interval and shall terminate at the end of the walk interval.

Section 4E.05 Location and Height of Pedestrian Signal Heads

Standard:

- 01 Pedestrian signal heads shall be mounted with the bottom of the signal housing including brackets not less than 7 feet or more than 10 feet above sidewalk level, and shall be positioned and adjusted to provide maximum visibility at the beginning of the controlled crosswalk.
- 02 If pedestrian signal heads are mounted on the same support as vehicular signal heads, there shall be a physical separation between them.

Section 4E.06 Pedestrian Intervals and Signal Phases

Standard:

- 01 At intersections equipped with pedestrian signal heads, the pedestrian signal indications shall be displayed except when the vehicular traffic control signal is being operated in the flashing mode. At those times, the pedestrian signal indications shall not be displayed.
- 02 When the pedestrian signal heads associated with a crosswalk are displaying either a steady WALKING PERSON (symbolizing WALK) or a flashing UPRaised HAND (symbolizing DONT WALK) signal indication, a steady or a flashing red signal indication shall be shown to any conflicting vehicular movement that is approaching the intersection or midblock location perpendicular or nearly perpendicular to the crosswalk.

03 When pedestrian signal heads are used, a WALKING PERSON (symbolizing WALK) signal indication shall be displayed only when pedestrians are permitted to leave the curb or shoulder.

04 A pedestrian change interval consisting of a flashing UPRAISED HAND (symbolizing DON'T WALK) signal indication shall begin immediately following the WALKING PERSON (symbolizing WALK) signal indication. Following the pedestrian change interval, a buffer interval consisting of a steady UPRAISED HAND (symbolizing DONT WALK) signal indication shall be displayed for at least 3 seconds prior to the release of any conflicting vehicular movement. The sum of the time of the pedestrian change interval and the buffer interval shall not be less than the calculated pedestrian clearance time (see Paragraphs 7 through 16). The buffer interval shall not begin later than the beginning of the red clearance interval, if used.

Option:

05 During the yellow change interval, the UPRAISED HAND (symbolizing DON'T WALK) signal indication may be displayed as either a flashing indication, a steady indication, or a flashing indication for an initial portion of the yellow change interval and a steady indication for the remainder of the interval.

Support:

06 Figure 4E-2 illustrates the pedestrian intervals and their possible relationships with associated vehicular signal phase intervals.

Guidance:

07 *Except as provided in Paragraph 8, the pedestrian clearance time should be sufficient to allow a pedestrian crossing in the crosswalk who left the curb or shoulder at the end of the WALKING PERSON (symbolizing WALK) signal indication to travel at a walking speed of 3.5 feet per second, to at least the far side of the traveled way or to a median of sufficient width for pedestrians to wait.*

Option:

08 A walking speed of up to 4 feet per second may be used to evaluate the sufficiency of the pedestrian clearance time at locations where an extended pushbutton press function has been installed to provide slower pedestrians an opportunity to request and receive a longer pedestrian clearance time. Passive pedestrian detection may also be used to automatically adjust the pedestrian clearance time based on the pedestrian's actual walking speed or actual clearance of the crosswalk.

09 The additional time provided by an extended pushbutton press to satisfy pedestrian clearance time needs may be added to either the walk interval or the pedestrian change interval.

Guidance:

10 *Where pedestrians who walk slower than 3.5 feet per second, or pedestrians who use wheelchairs, routinely use the crosswalk, a walking speed of less than 3.5 feet per second should be considered in determining the pedestrian clearance time.*

11 *Except as provided in Paragraph 12, the walk interval should be at least 7 seconds in length so that pedestrians will have adequate opportunity to leave the curb or shoulder before the pedestrian clearance time begins.*

Option:

12 If pedestrian volumes and characteristics do not require a 7-second walk interval, walk intervals as short as 4 seconds may be used.

Support:

13 The walk interval is intended for pedestrians to start their crossing. The pedestrian clearance time is intended to allow pedestrians who started crossing during the walk interval to complete their crossing. Longer walk intervals are often used when the duration of the vehicular green phase associated with the pedestrian crossing is long enough to allow it.

Guidance:

14 *The total of the walk interval and pedestrian clearance time should be sufficient to allow a pedestrian crossing in the crosswalk who left the pedestrian detector (or, if no pedestrian detector is present, a location 6 feet from the face of the curb or from the edge of the pavement) at the beginning of the WALKING PERSON (symbolizing WALK) signal indication to travel at a walking speed of 3 feet per second to the far side of the traveled way being crossed or to the median if a two-stage pedestrian crossing sequence is used.*

Figure 4E-2. Pedestrian Intervals

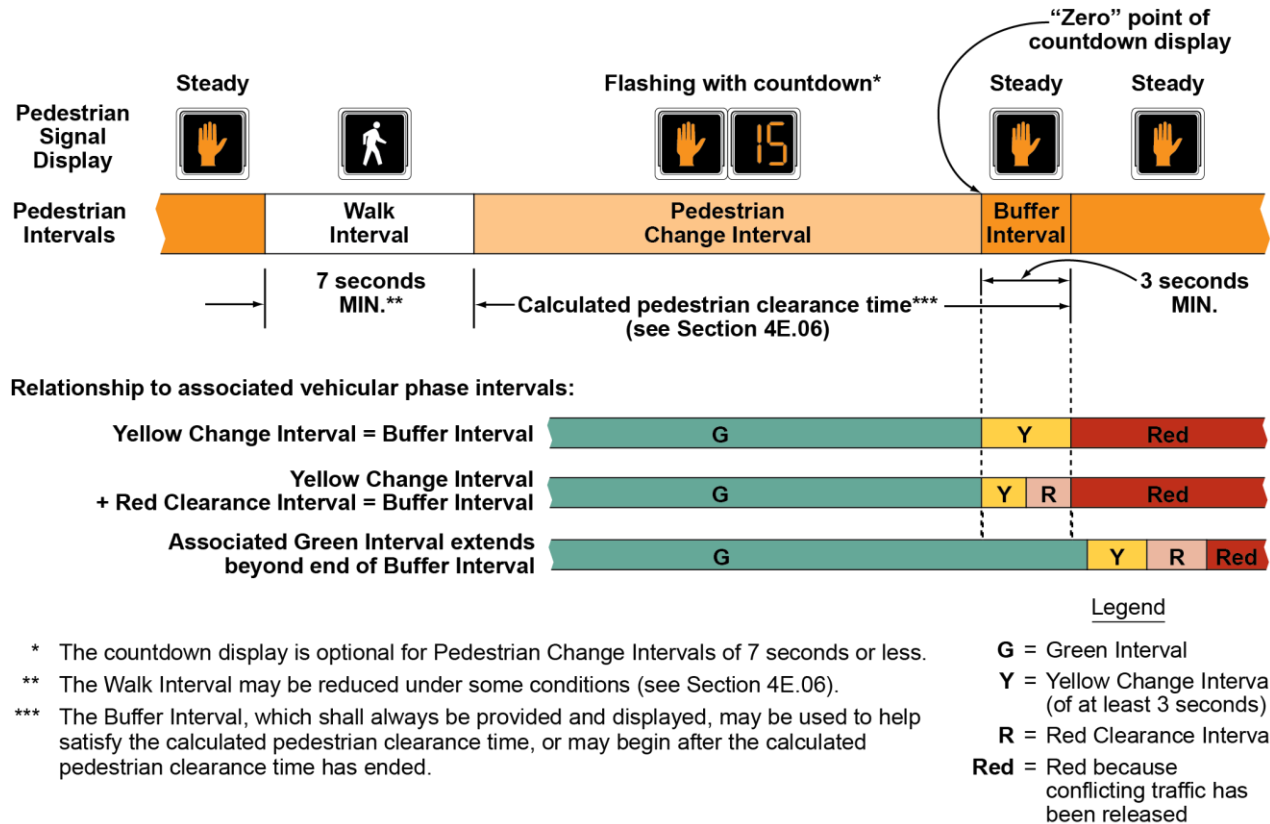

Any additional time that is required to satisfy the conditions of this paragraph should be added to the walk interval.

Option:

- 15 On a street with a median of sufficient width for pedestrians to wait, a pedestrian clearance time that allows the pedestrian to cross only from the curb or shoulder to the median may be provided.

Standard:

- 16 **Where the pedestrian clearance time is sufficient only for crossing from the curb or shoulder to a median of sufficient width for pedestrians to wait, median-mounted pedestrian signals (with pedestrian detectors if actuated operation is used) shall be provided (see Sections 4E.08 and 4E.09) and signing such as the R10-3d sign (see Section 2B.52) shall be provided to notify pedestrians to cross only to the median to await the next WALKING PERSON (symbolizing WALK) signal indication.**

Guidance:

- 17 *Where median-mounted pedestrian signals and detectors are provided, the use of accessible pedestrian signals (see Sections 4E.09 through 4E.13) should be considered.*

Option:

- 18 During the transition into preemption, the walk interval and the pedestrian change interval may be shortened or omitted as described in Section 4D.27.

- 19 At intersections with high pedestrian volumes and high conflicting turning vehicle volumes, a brief leading pedestrian interval, during which an advance WALKING PERSON (symbolizing WALK) indication is displayed for the crosswalk while red indications continue to be displayed to parallel through and/or turning traffic, may be used to reduce conflicts between pedestrians and turning vehicles.

Guidance:

- 20 *If a leading pedestrian interval is used, the use of accessible pedestrian signals (see Sections 4E.09 through 4E.13) should be considered.*

Support:

- 21 If a leading pedestrian interval is used without accessible features, pedestrians who are visually impaired can be expected to begin crossing at the onset of the vehicular movement when drivers are not expecting them to begin crossing.

Guidance:

- 22 *If a leading pedestrian interval is used, it should be at least 3 seconds in duration and should be timed to allow pedestrians to cross at least one lane of traffic or, in the case of a large corner radius, to travel far enough for pedestrians to establish their position ahead of the turning traffic before the turning traffic is released.*
- 23 *If a leading pedestrian interval is used, consideration should be given to prohibiting turns across the crosswalk during the leading pedestrian interval.*

Support:

- 24 At intersections with pedestrian volumes that are so high that drivers have difficulty finding an opportunity to turn across the crosswalk, the duration of the green interval for a parallel concurrent vehicular movement is sometimes intentionally set to extend beyond the pedestrian clearance time to provide turning drivers additional green time to make their turns while the pedestrian signal head is displaying a steady UPRAISED HAND (symbolizing DONT WALK) signal indication after pedestrians have had time to complete their crossings.

Section 4E.07 Countdown Pedestrian Signals

Standard:

- 01 **All pedestrian signal heads used at crosswalks where the pedestrian change interval is more than 7 second shall include a pedestrian change interval countdown display in order to inform pedestrians of the number of seconds remaining in the pedestrian change interval.**

Option:

- 02 Pedestrian signal heads used at crosswalks where the pedestrian change interval is 7 seconds or less may include a pedestrian change interval countdown display in order to inform pedestrians of the number of seconds remaining in the pedestrian change interval.

Standard:

- 03 **Where countdown pedestrian signals are used, the countdown shall always be displayed simultaneously with the flashing UPRAISED HAND (symbolizing DONT WALK) signal indication displayed for that crosswalk.**

- 04 **Countdown pedestrian signals shall consist of Portland orange numbers that are at least 6 inches in height on a black opaque background. The countdown pedestrian signal shall be located immediately adjacent to the associated UPRAISED HAND (symbolizing DONT WALK) pedestrian signal head indication (see Figure 4E-1).**

- 05 **The display of the number of remaining seconds shall begin only at the beginning of the pedestrian change interval (flashing UPRAISED HAND). After the countdown displays zero, the display shall remain dark until the beginning of the next countdown.**

- 06 **The countdown pedestrian signal shall display the number of seconds remaining until the termination of the pedestrian change interval (flashing UPRAISED HAND). Countdown displays shall not be used during the walk interval or during the red clearance interval of a concurrent vehicular phase.**

Guidance:

- 07 *If used with a pedestrian signal head that does not have a concurrent vehicular phase, the pedestrian change interval (flashing UPRAISED HAND) should be set to be approximately 4 seconds less than the required pedestrian clearance time (see Section 4E.06) and an additional clearance interval (during which a steady UPRAISED HAND is displayed) should be provided prior to the start of the conflicting vehicular phase.*
- 08 *For crosswalks where the pedestrian enters the crosswalk more than 100 feet from the countdown pedestrian signal display, the numbers should be at least 9 inches in height.*

09 *Because some technology includes the countdown pedestrian signal logic in a separate timing device that is independent of the timing in the traffic signal controller, care should be exercised by the engineer when timing changes are made to pedestrian change intervals.*

10 *If the pedestrian change interval is interrupted or shortened as a part of a transition into a preemption sequence (see Section 4E.06), the countdown pedestrian signal display should be discontinued and go dark immediately upon activation of the preemption transition.*

Section 4E.08 Pedestrian Detectors

Option:

01 Pedestrian detectors may be pushbuttons or passive detection devices.

Support:

02 Passive detection devices register the presence of a pedestrian in a position indicative of a desire to cross, without requiring the pedestrian to push a button. Some passive detection devices are capable of tracking the progress of a pedestrian as the pedestrian crosses the roadway for the purpose of extending or shortening the duration of certain pedestrian timing intervals.

03 The provisions in this Section place pedestrian pushbuttons within easy reach of pedestrians who are intending to cross each crosswalk and make it obvious which pushbutton is associated with each crosswalk. These provisions also position pushbutton poles in optimal locations for installation of accessible pedestrian signals (see Sections 4E.09 through 4E.13). Information regarding reach ranges can be found in the “Americans with Disabilities Act Accessibility Guidelines for Buildings and Facilities (ADAAG)” (see Section 1A.11).

Guidance:

04 *If pedestrian pushbuttons are used, they should be capable of easy activation and conveniently located near each end of the crosswalks. Except as provided in Paragraphs 5 and 6, pedestrian pushbuttons should be located to meet all of the following criteria (see Figure 4E-3):*

- A. *Unobstructed and adjacent to a level all-weather surface to provide access from a wheelchair;*
- B. *Where there is an all-weather surface, a wheelchair accessible route from the pushbutton to the ramp;*
- C. *Between the edge of the crosswalk line (extended) farthest from the center of the intersection and the side of a curb ramp (if present), but not greater than 5 feet from said crosswalk line;*
- D. *Between 1.5 and 6 feet from the edge of the curb, shoulder, or pavement;*
- E. *With the face of the pushbutton parallel to the crosswalk to be used; and*
- F. *At a mounting height of approximately 3.5 feet, but no more than 4 feet, above the sidewalk.*

05 *Where there are physical constraints that make it impractical to place the pedestrian pushbutton adjacent to a level all-weather surface, the surface should be as level as feasible.*

06 *Where there are physical constraints that make it impractical to place the pedestrian pushbutton between 1.5 and 6 feet from the edge of the curb, shoulder, or pavement, it should not be farther than 10 feet from the edge of curb, shoulder, or pavement.*

07 *Except as provided in Paragraph 8, where two pedestrian pushbuttons are provided on the same corner of a signalized location, the pushbuttons should be separated by a distance of at least 10 feet.*

Option:

08 Where there are physical constraints on a particular corner that make it impractical to provide the 10-foot separation between the two pedestrian pushbuttons, the pushbuttons may be placed closer together or on the same pole.

Support:

09 Figure 4E-4 shows typical pedestrian pushbutton locations for a variety of situations.

Standard:

10 **Signs (see Section 2B.52) shall be mounted adjacent to or integral with pedestrian pushbuttons, explaining their purpose and use.**

Figure 4E-3. Pushbutton Locations Area

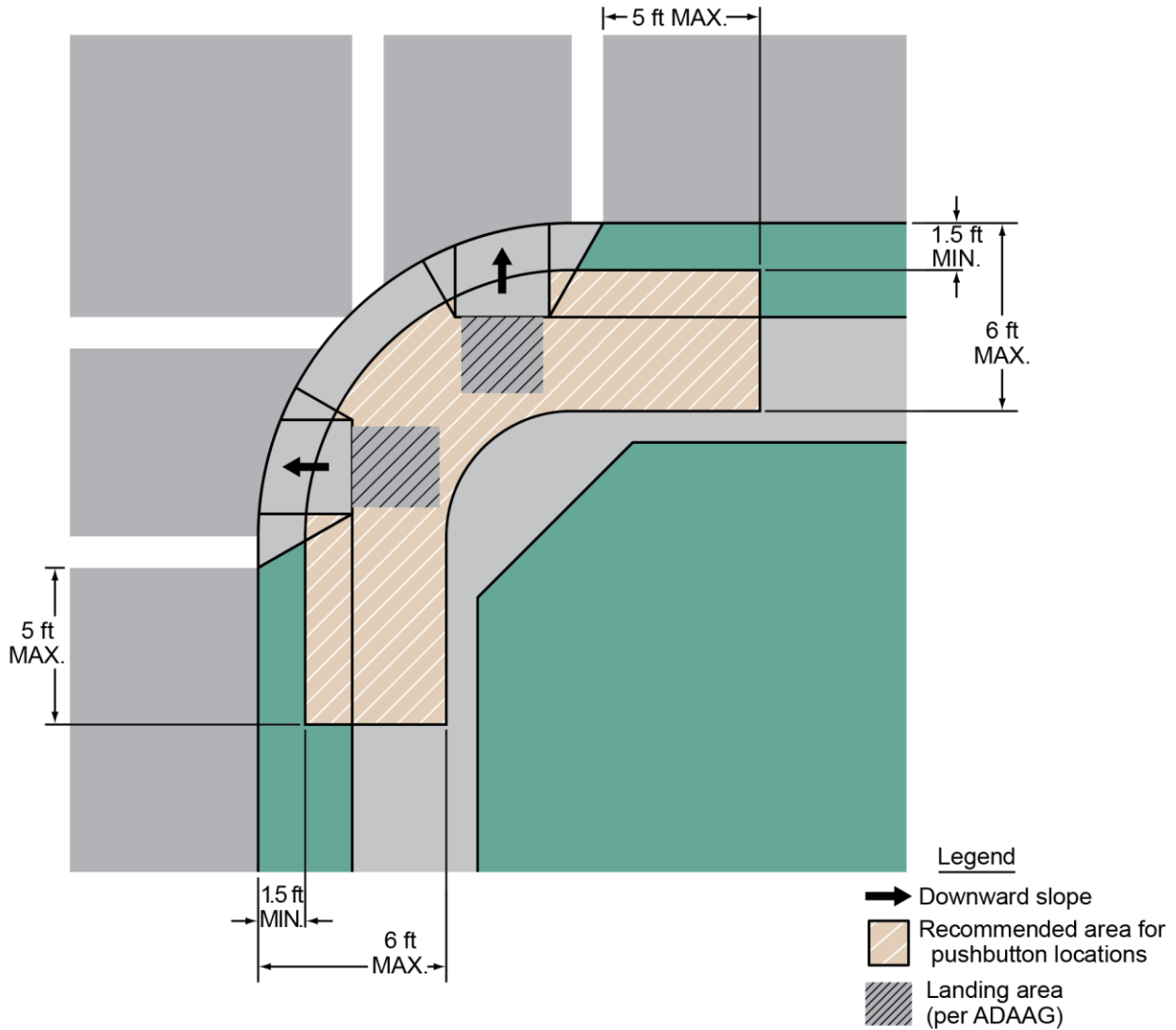

Notes:

1. Where there are constraints that make it impractical to place the pedestrian pushbutton between 1.5 feet and 6 feet from the edge of the curb, shoulder, or pavement, it should not be further than 10 feet from the edge of curb, shoulder, or pavement.
2. Two pedestrian pushbuttons on a corner should be separated by 10 feet.
3. This figure is not drawn to scale.
4. Figure 4E-4 shows typical pushbutton locations.

Option:

- 11 At certain locations, a supplemental sign in a more visible location may be used to call attention to the pedestrian pushbutton.

Standard:

- 12 **The positioning of pedestrian pushbuttons and the legends on the pedestrian pushbutton signs shall clearly indicate which crosswalk signal is actuated by each pedestrian pushbutton.**
- 13 **If the pedestrian clearance time is sufficient only to cross from the curb or shoulder to a median of sufficient width for pedestrians to wait and the signals are pedestrian actuated, an additional pedestrian detector shall be provided in the median.**

Figure 4E-4. Typical Pushbutton Locations (Sheet 1 of 2)

A - Parallel ramps with wide sidewalk

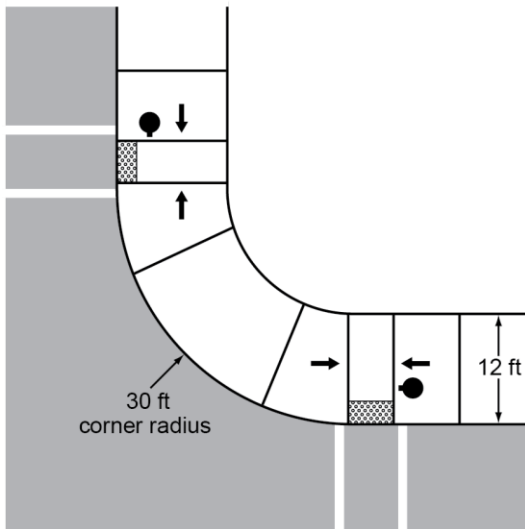

B - Parallel ramps with narrow sidewalk

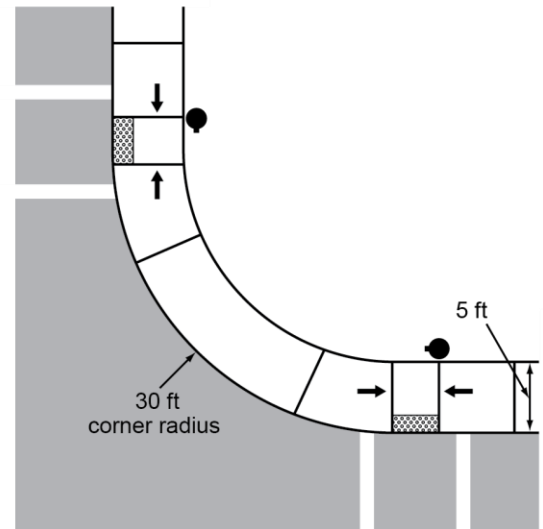

C - Parallel ramps with narrow sidewalk and tight corner radius

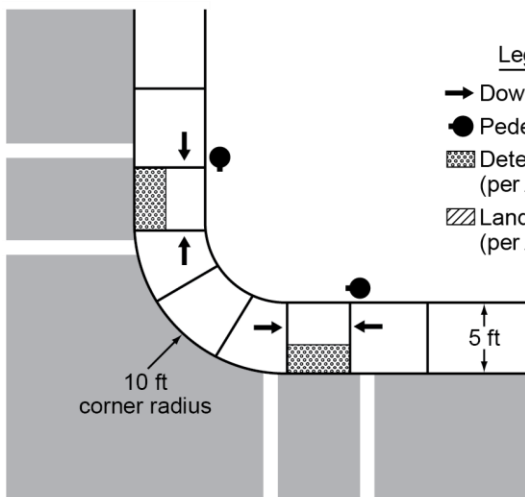

Legend

- Downward slope
- Pedestrian pushbutton
- ▨ Detectable warning (per ADAAG)
- ▩ Landing area (per ADAAG)

D - Perpendicular ramps with crosswalks far apart

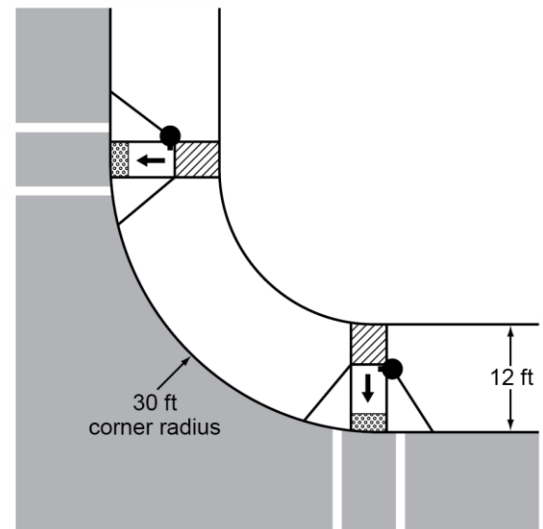

Notes:

1. This figure is not drawn to scale.
2. These drawings are intended to describe the typical locations for pedestrian pushbutton installations. They are not intended to be a guide for the design of curb cut ramps.
3. Figure 4E-3 shows the recommended area for pushbutton locations.

Guidance:

- 14 *The use of additional pedestrian detectors on islands or medians where a pedestrian might become stranded should be considered.*
- 15 If used, special purpose pushbuttons (to be operated only by authorized persons) should include a housing capable of being locked to prevent access by the general public and do not need an instructional sign.

Standard:

- 16 **If used, a pilot light or other means of indication installed with a pedestrian pushbutton shall not be illuminated until actuation. Once it is actuated, the pilot light shall remain illuminated until the pedestrian's green or WALKING PERSON (symbolizing WALK) signal indication is displayed.**

Figure 4E-4. Typical Pushbutton Locations (Sheet 2 of 2)

E - Perpendicular ramps with crosswalks close together

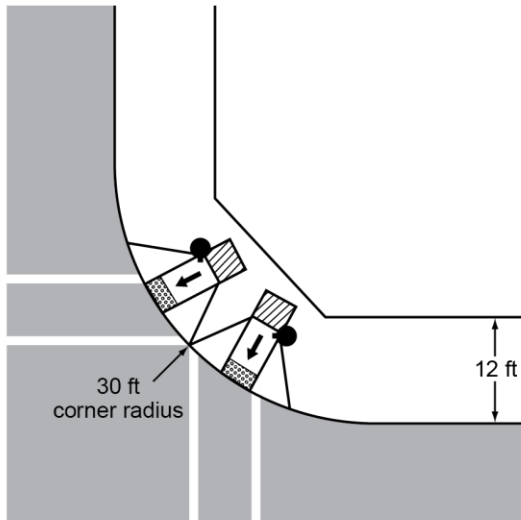

F - Perpendicular ramps with sidewalk set back from road with crosswalks far apart

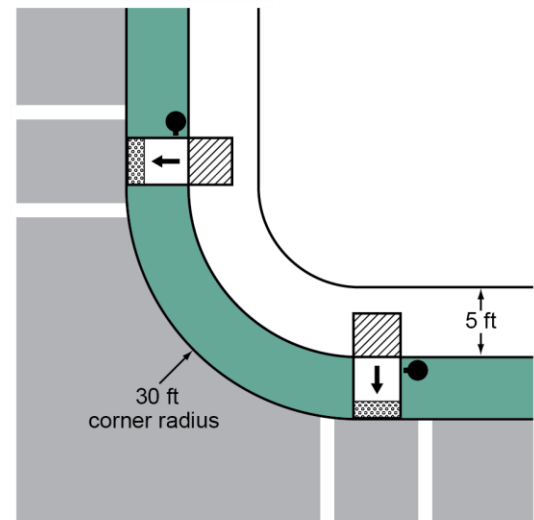

G - Perpendicular ramps with sidewalk set back from road with crosswalks close together

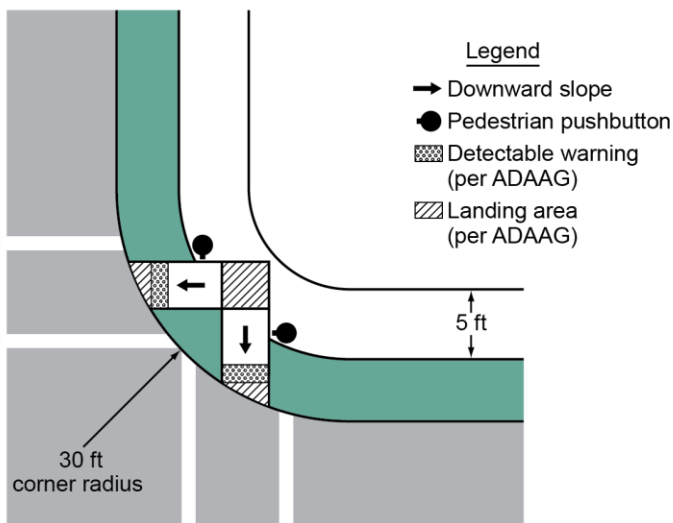

H - Perpendicular ramps with sidewalk set back from road with continuous sidewalk between ramps

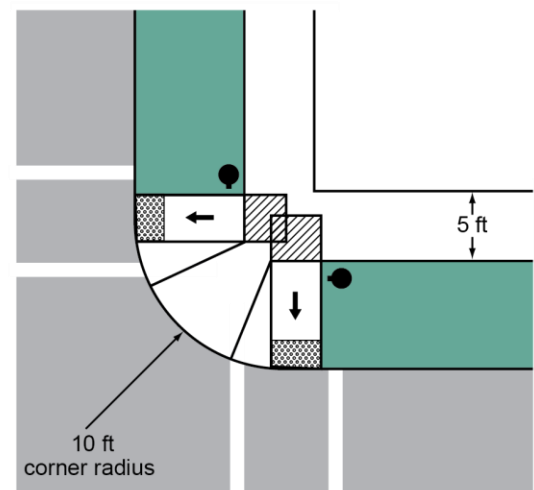

Notes:

1. This figure is not drawn to scale.
2. These drawings are intended to describe the typical locations for pedestrian pushbutton installations. They are not intended to be a guide for the design of curb cut ramps.
3. Figure 4E-3 shows the recommended area for pushbutton locations.

17 **If a pilot light is used at an accessible pedestrian signal location (see Sections 4E.09 through 4E.13), each actuation shall be accompanied by the speech message “wait.”**

Option:

18 At signalized locations with a demonstrated need and subject to equipment capabilities, pedestrians with special needs may be provided with additional crossing time by means of an extended pushbutton press.

Standard:

19 **If additional crossing time is provided by means of an extended pushbutton press, a PUSH BUTTON FOR 2 SECONDS FOR EXTRA CROSSING TIME (R10-32P) plaque (see Figure 2B-26) shall be mounted adjacent to or integral with the pedestrian pushbutton.**

Section 4E.09 Accessible Pedestrian Signals and Detectors - General

Support:

- 01 Accessible pedestrian signals and detectors provide information in non-visual formats (such as audible tones, speech messages, and/or vibrating surfaces).
- 02 The primary technique that pedestrians who have visual disabilities use to cross streets at signalized locations is to initiate their crossing when they hear the traffic in front of them stop and the traffic alongside them begin to move, which often corresponds to the onset of the green interval. The existing environment is often not sufficient to provide the information that pedestrians who have visual disabilities need to cross a roadway at a signalized location.

Guidance:

- 03 *If a particular signalized location presents difficulties for pedestrians who have visual disabilities to cross the roadway, an engineering study should be conducted that considers the needs of pedestrians in general, as well as the information needs of pedestrians with visual disabilities. The engineering study should consider the following factors:*
- A. Potential demand for accessible pedestrian signals;*
 - B. A request for accessible pedestrian signals;*
 - C. Traffic volumes during times when pedestrians might be present, including periods of low traffic volumes or high turn-on-red volumes;*
 - D. The complexity of traffic signal phasing (such as split phases, protected turn phases, leading pedestrian intervals, and exclusive pedestrian phases); and*
 - E. The complexity of intersection geometry.*

Support:

- 04 The factors that make crossing at a signalized location difficult for pedestrians who have visual disabilities include: increasingly quiet cars, right turn on red (which masks the beginning of the through phase), continuous right-turn movements, complex signal operations, traffic circles, and wide streets. Furthermore, low traffic volumes might make it difficult for pedestrians who have visual disabilities to discern signal phase changes.
- 05 Local organizations, providing support services to pedestrians who have visual and/or hearing disabilities, can often act as important advisors to the traffic engineer when consideration is being given to the installation of devices to assist such pedestrians. Additionally, orientation and mobility specialists or similar staff also might be able to provide a wide range of advice. The U.S. Access Board (www.access-board.gov) provides technical assistance for making pedestrian signal information available to persons with visual disabilities (see the Preface for the address for the U.S. Access Board).

Standard:

- 06 **When used, accessible pedestrian signals shall be used in combination with pedestrian signal timing. The information provided by an accessible pedestrian signal shall clearly indicate which pedestrian crossing is served by each device.**
- 07 **Under stop-and-go operation, accessible pedestrian signals shall not be limited in operation by the time of day or day of week.**

Option:

- 08 Accessible pedestrian signal detectors may be pushbuttons or passive detection devices.
- 09 At locations with pretimed traffic control signals or non-actuated approaches, pedestrian pushbuttons may be used to activate the accessible pedestrian signals.

Support:

- 10 Accessible pedestrian signals are typically integrated into the pedestrian detector (pushbutton), so the audible tones and/or messages come from the pushbutton housing. They have a pushbutton locator tone and tactile arrow, and can include audible beaconing and other special features.

Option:

- 11 The name of the street to be crossed may also be provided in accessible format, such as Braille or raised print. Tactile maps of crosswalks may also be provided.

Support:

- 12 Specifications regarding the use of Braille or raised print for traffic control devices can be found in the “Americans with Disabilities Act Accessibility Guidelines for Buildings and Facilities (ADAAG)” (see Section 1A.11).

Standard:

- 13 **At accessible pedestrian signal locations where pedestrian pushbuttons are used, each pushbutton shall activate both the walk interval and the accessible pedestrian signals.**

Section 4E.10 Accessible Pedestrian Signals and Detectors – Location

Support:

- 01 Accessible pedestrian signals that are located as close as possible to pedestrians waiting to cross the street provide the clearest and least ambiguous indication of which pedestrian crossing is served by a device.

Guidance:

- 02 *Pushbuttons for accessible pedestrian signals should be located in accordance with the provisions of Section 4E.08 and should be located as close as possible to the crosswalk line furthest from the center of the intersection and as close as possible to the curb ramp.*

Standard:

- 03 **If two accessible pedestrian pushbuttons are placed less than 10 feet apart or on the same pole, each accessible pedestrian pushbutton shall be provided with the following features (see Sections 4E.11 through 4E.13):**
- A. **A pushbutton locator tone,**
 - B. **A tactile arrow,**
 - C. **A speech walk message for the WALKING PERSON (symbolizing WALK) indication, and**
 - D. **A speech pushbutton information message.**
- 04 **If the pedestrian clearance time is sufficient only to cross from the curb or shoulder to a median of sufficient width for pedestrians to wait and accessible pedestrian detectors are used, an additional accessible pedestrian detector shall be provided in the median.**

Section 4E.11 Accessible Pedestrian Signals and Detectors – Walk Indications

Support:

- 01 Technology that provides different sounds for each non-concurrent signal phase has frequently been found to provide ambiguous information. Research indicates that a rapid tick tone for each crossing coming from accessible pedestrian signal devices on separated poles located close to each crosswalk provides unambiguous information to pedestrians who are blind or visually impaired. Vibrotactile indications provide information to pedestrians who are blind and deaf and are also used by pedestrians who are blind or who have low vision to confirm the walk signal in noisy situations.

Standard:

- 02 **Accessible pedestrian signals shall have both audible and vibrotactile walk indications.**
- 03 **Vibrotactile walk indications shall be provided by a tactile arrow on the pushbutton (see Section 4E.12) that vibrates during the walk interval.**
- 04 **Accessible pedestrian signals shall have an audible walk indication during the walk interval only. The audible walk indication shall be audible from the beginning of the associated crosswalk.**
- 05 **The accessible walk indication shall have the same duration as the pedestrian walk signal except when the pedestrian signal rests in walk.**

Guidance:

- 06 *If the pedestrian signal rests in walk, the accessible walk indication should be limited to the first 7 seconds of the walk interval. The accessible walk indication should be recalled by a button press during the walk interval provided that the crossing time remaining is greater than the pedestrian change interval.*

Standard:

- 07 **Where two accessible pedestrian signals are separated by a distance of at least 10 feet, the audible walk indication shall be a percussive tone. Where two accessible pedestrian signals on one corner are**

not separated by a distance of at least 10 feet, the audible walk indication shall be a speech walk message.

- 08 **Audible tone walk indications shall repeat at eight to ten ticks per second. Audible tones used as walk indications shall consist of multiple frequencies with a dominant component at 880 Hz.**

Guidance:

- 09 *The volume of audible walk indications and pushbutton locator tones (see Section 4E.12) should be set to be a maximum of 5 dBA louder than ambient sound, except when audible beaconing is provided in response to an extended pushbutton press.*

Standard:

- 10 **Automatic volume adjustment in response to ambient traffic sound level shall be provided up to a maximum volume of 100 dBA.**

Guidance:

- 11 *The sound level of audible walk indications and pushbutton locator tones should be adjusted to be low enough to avoid misleading pedestrians who have visual disabilities when the following conditions exist:*
- A. *Where there is an island that allows unsignalized right turns across a crosswalk between the island and the sidewalk.*
 - B. *Where multi-leg approaches or complex signal phasing require more than two pedestrian phases, such that it might be unclear which crosswalk is served by each audible tone.*
 - C. *At intersections where a diagonal pedestrian crossing is allowed, or where one street receives a WALKING PERSON (symbolizing WALK) signal indication simultaneously with another street.*

Option:

- 12 *An alert tone, which is a very brief burst of high-frequency sound at the beginning of the audible walk indication that rapidly decays to the frequency of the walk tone, may be used to alert pedestrians to the beginning of the walk interval.*

Support:

- 13 *An alert tone can be particularly useful if the walk tone is not easily audible in some traffic conditions.*
- 14 *Speech walk messages communicate to pedestrians which street has the walk interval. Speech messages might be either directly audible or transmitted, requiring a personal receiver to hear the message. To be a useful system, the words and their meaning need to be correctly understood by all users in the context of the street environment where they are used. Because of this, tones are the preferred means of providing audible walk indications except where two accessible pedestrian signals on one corner are not separated by a distance of at least 10 feet.*
- 15 *If speech walk messages are used, pedestrians have to know the names of the streets that they are crossing in order for the speech walk messages to be unambiguous. In getting directions to travel to a new location, pedestrians with visual disabilities do not always get the name of each street to be crossed. Therefore, it is desirable to give users of accessible pedestrian signals the name of the street controlled by the pushbutton. This can be done by means of a speech pushbutton information message (see Section 4E.13) during the flashing or steady UPRAISED HAND intervals, or by raised print and Braille labels on the pushbutton housing.*
- 16 *By combining the information from the pushbutton message or Braille label, the tactile arrow aligned in the direction of travel on the relevant crosswalk, and the speech walk message, pedestrians with visual disabilities are able to correctly respond to speech walk messages even if there are two pushbuttons on the same pole.*

Standard:

- 17 **If speech walk messages are used to communicate the walk interval, they shall provide a clear message that the walk interval is in effect, as well as to which crossing it applies. Speech walk messages shall be used only at intersections where it is technically infeasible to install two accessible pedestrian signals at one corner separated by a distance of at least 10 feet.**
- 18 **Speech walk messages that are used at intersections having pedestrian phasing that is concurrent with vehicular phasing shall be patterned after the model: “Broadway. Walk sign is on to cross Broadway.”**

19 **Speech walk messages that are used at intersections having exclusive pedestrian phasing shall be patterned after the model: “Walk sign is on for all crossings.”**

20 **Speech walk messages shall not contain any additional information, except they shall include designations such as “Street” or “Avenue” where this information is necessary to avoid ambiguity at a particular location.**

Guidance:

21 *Speech walk messages should not state or imply a command to the pedestrian, such as “Cross Broadway now.” Speech walk messages should not tell pedestrians that it is “safe to cross,” because it is always the pedestrian’s responsibility to check actual traffic conditions.*

Standard:

22 **A speech walk message is not required at times when the walk interval is not timing, but, if provided:**

A. It shall begin with the term “wait.”

B. It need not be repeated for the entire time that the walk interval is not timing.

23 **If a pilot light (see Section 4E.08) is used at an accessible pedestrian signal location, each actuation shall be accompanied by the speech message “wait.”**

Option:

24 Accessible pedestrian signals that provide speech walk messages may provide similar messages in languages other than English, if needed, except for the terms “walk sign” and “wait.”

Standard:

25 **Following the audible walk indication, accessible pedestrian signals shall revert to the pushbutton locator tone (see Section 4E.12) during the pedestrian change interval.**

Section 4E.12 Accessible Pedestrian Signals and Detectors – Tactile Arrows and Locator Tones

Standard:

01 **To enable pedestrians who have visual disabilities to distinguish and locate the appropriate pushbutton at an accessible pedestrian signal location, pushbuttons shall clearly indicate by means of tactile arrows which crosswalk signal is actuated by each pushbutton. Tactile arrows shall be located on the pushbutton, have high visual contrast (light on dark or dark on light), and shall be aligned parallel to the direction of travel on the associated crosswalk.**

02 **An accessible pedestrian pushbutton shall incorporate a locator tone.**

Support:

03 A pushbutton locator tone is a repeating sound that informs approaching pedestrians that a pushbutton to actuate pedestrian timing or receive additional information exists, and that enables pedestrians with visual disabilities to locate the pushbutton.

Standard:

04 **Pushbutton locator tones shall have a duration of 0.15 seconds or less and shall repeat at 1-second intervals.**

05 **Pushbutton locator tones shall be deactivated when the traffic control signal is operating in a flashing mode. This requirement shall not apply to traffic control signals or pedestrian hybrid beacons that are activated from a flashing or dark mode to a stop-and-go mode by pedestrian actuations.**

06 **Pushbutton locator tones shall be intensity responsive to ambient sound, and be audible 6 to 12 feet from the pushbutton, or to the building line, whichever is less.**

Support:

07 Section 4E.11 contains additional provisions regarding the volume and sound level of pushbutton locator tones.

Section 4E.13 Accessible Pedestrian Signals and Detectors – Extended Pushbutton Press Features

Option:

- 01 Pedestrians may be provided with additional features such as increased crossing time, audible beaoning, or a speech pushbutton information message as a result of an extended pushbutton press.

Standard:

- 02 **If an extended pushbutton press is used to provide any additional feature(s), a pushbutton press of less than one second shall actuate only the pedestrian timing and any associated accessible walk indication, and a pushbutton press of one second or more shall actuate the pedestrian timing, any associated accessible walk indication, and any additional feature(s).**

- 03 **If additional crossing time is provided by means of an extended pushbutton press, a PUSH BUTTON FOR 2 SECONDS FOR EXTRA CROSSING TIME (R10-32P) plaque (see Figure 2B-26) shall be mounted adjacent to or integral with the pedestrian pushbutton.**

Support:

- 04 Audible beaoning is the use of an audible signal in such a way that pedestrians with visual disabilities can home in on the signal that is located on the far end of the crosswalk as they cross the street.

- 05 Not all crosswalks at an intersection need audible beaoning; audible beaoning can actually cause confusion if used at all crosswalks at some intersections. Audible beaoning is not appropriate at locations with channelized turns or split phasing, because of the possibility of confusion.

Guidance:

- 06 *Audible beaoning should only be considered following an engineering study at:*
- A. *Crosswalks longer than 70 feet, unless they are divided by a median that has another accessible pedestrian signal with a locator tone;*
 - B. *Crosswalks that are skewed;*
 - C. *Intersections with irregular geometry, such as more than four legs;*
 - D. *Crosswalks where audible beaoning is requested by an individual with visual disabilities; or*
 - E. *Other locations where a study indicates audible beaoning would be beneficial.*

Option:

- 07 Audible beaoning may be provided in several ways, any of which are initiated by an extended pushbutton press.

Standard:

- 08 **If audible beaoning is used, the volume of the pushbutton locator tone during the pedestrian change interval of the called pedestrian phase shall be increased and operated in one of the following ways:**

- A. **The louder audible walk indication and louder locator tone comes from the far end of the crosswalk, as pedestrians cross the street,**
- B. **The louder locator tone comes from both ends of the crosswalk, or**
- C. **The louder locator tone comes from an additional speaker that is aimed at the center of the crosswalk and that is mounted on a pedestrian signal head.**

Option:

- 09 Speech pushbutton information messages may provide intersection identification, as well as information about unusual intersection signalization and geometry, such as notification regarding exclusive pedestrian phasing, leading pedestrian intervals, split phasing, diagonal crosswalks, and medians or islands.

Standard:

- 10 **If speech pushbutton information messages are made available by actuating the accessible pedestrian signal detector, they shall only be actuated when the walk interval is not timing. They shall begin with the term “Wait,” followed by intersection identification information modeled after: “Wait to cross Broadway at Grand.” If information on intersection signalization or geometry is also given, it shall follow the intersection identification information.**

Guidance:

- 11 *Speech pushbutton information messages should not be used to provide landmark information or to inform pedestrians with visual disabilities about detours or temporary traffic control situations.*

Support:

- 12 Additional information on the structure and wording of speech pushbutton information messages is included in ITE's "Electronic Toolbox for Making Intersections More Accessible for Pedestrians Who Are Blind or Visually Impaired," which is available at ITE's website (see the Preface).

CHAPTER 4F. PEDESTRIAN HYBRID BEACONS

Section 4F.01 Application of Pedestrian Hybrid Beacons

Support:

- 01 A pedestrian hybrid beacon is a special type of hybrid beacon used to warn and control traffic at an unsignalized location to assist pedestrians in crossing a street or highway at a marked crosswalk.

Option:

- 02 A pedestrian hybrid beacon may be considered for installation to facilitate pedestrian crossings at a location that does not meet traffic signal warrants (see Chapter 4C), or at a location that meets traffic signal warrants under Sections 4C.05 and/or 4C.06 but a decision is made to not install a traffic control signal.

Standard:

- 03 **If used, pedestrian hybrid beacons shall be used in conjunction with signs and pavement markings to warn and control traffic at locations where pedestrians enter or cross a street or highway. A pedestrian hybrid beacon shall only be installed at a marked crosswalk.**

Guidance:

- 04 *If one of the signal warrants of Chapter 4C is met and a traffic control signal is justified by an engineering study, and if a decision is made to install a traffic control signal, it should be installed based upon the provisions of Chapters 4D and 4E.*
- 05 *If a traffic control signal is not justified under the signal warrants of Chapter 4C and if gaps in traffic are not adequate to permit pedestrians to cross, or if the speed for vehicles approaching on the major street is too high to permit pedestrians to cross, or if pedestrian delay is excessive, the need for a pedestrian hybrid beacon should be considered on the basis of an engineering study that considers major-street volumes, speeds, widths, and gaps in conjunction with pedestrian volumes, walking speeds, and delay.*
- 06 *For a major street where the posted or statutory speed limit or the 85th-percentile speed is 35 mph or less, the need for a pedestrian hybrid beacon should be considered if the engineering study finds that the plotted point representing the vehicles per hour on the major street (total of both approaches) and the corresponding total of all pedestrians crossing the major street for 1 hour (any four consecutive 15-minute periods) of an average day falls above the applicable curve in Figure 4F-1 for the length of the crosswalk.*
- 07 *For a major street where the posted or statutory speed limit or the 85th-percentile speed exceeds 35 mph, the need for a pedestrian hybrid beacon should be considered if the engineering study finds that the plotted point representing the vehicles per hour on the major street (total of both approaches) and the corresponding total of all pedestrians crossing the major street for 1 hour (any four consecutive 15-minute periods) of an average day falls above the applicable curve in Figure 4F-2 for the length of the crosswalk.*
- 08 *For crosswalks that have lengths other than the four that are specifically shown in Figures 4F-1 and 4F-2, the values should be interpolated between the curves.*

Section 4F.02 Design of Pedestrian Hybrid Beacons

Standard:

- 01 **Except as otherwise provided in this Section, a pedestrian hybrid beacon shall meet the provisions of Chapters 4D and 4E.**
- 02 **A pedestrian hybrid beacon face shall consist of three signal sections, with a CIRCULAR YELLOW signal indication centered below two horizontally aligned CIRCULAR RED signal indications (see Figure 4F-3).**
- 03 **When an engineering study finds that installation of a pedestrian hybrid beacon is justified, then:**
- A. **At least two pedestrian hybrid beacon faces shall be installed for each approach of the major street,**
 - B. **A stop line shall be installed for each approach to the crosswalk,**
 - C. **A pedestrian signal head conforming to the provisions set forth in Chapter 4E shall be installed at each end of the marked crosswalk, and**
 - D. **The pedestrian hybrid beacon shall be pedestrian actuated.**

Figure 4F-1. Guidelines for the Installation of Pedestrian Hybrid Beacons on Low-Speed Roadways

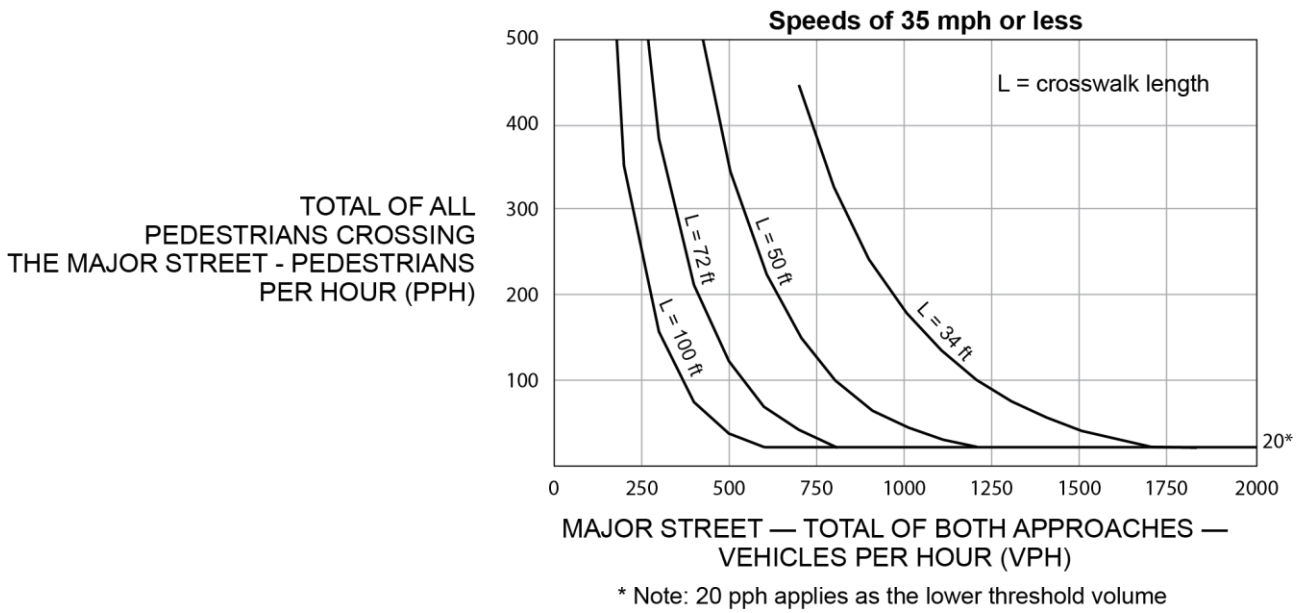

Figure 4F-2. Guidelines for the Installation of Pedestrian Hybrid Beacons on High-Speed Roadways

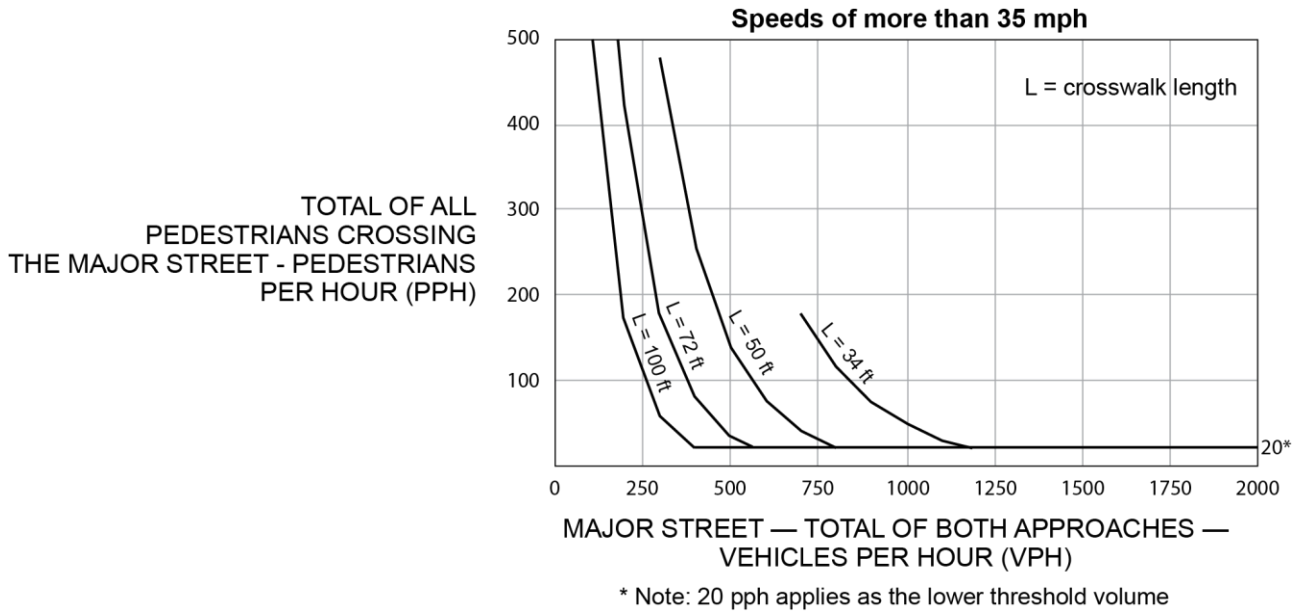
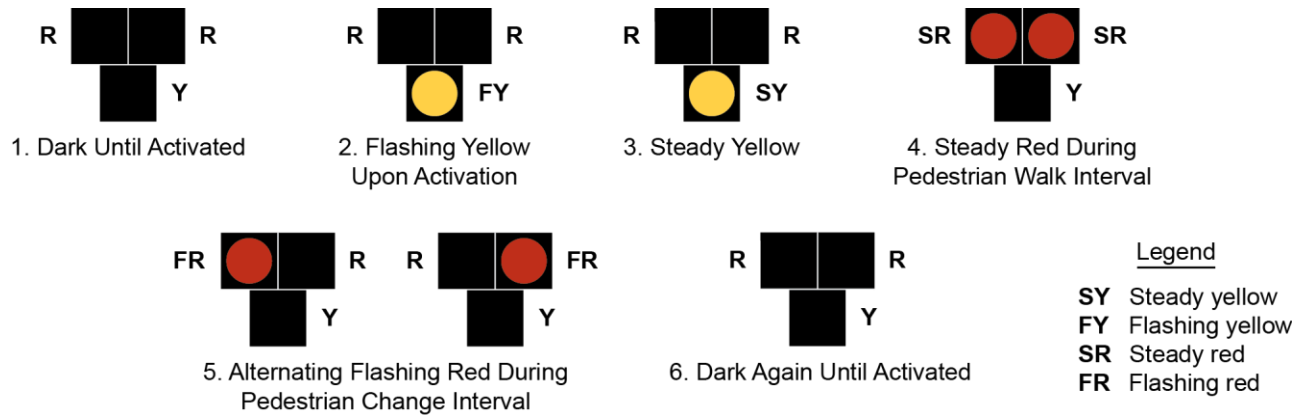

Figure 4F-3. Sequence for a Pedestrian Hybrid Beacon



Guidance:

- 04 When an engineering study finds that installation of a pedestrian hybrid beacon is justified, then:
 - A. The pedestrian hybrid beacon should be installed at least 100 feet from side streets or driveways that are controlled by STOP or YIELD signs,
 - B. Parking and other sight obstructions should be prohibited for at least 100 feet in advance of and at least 20 feet beyond the marked crosswalk, or site accommodations should be made through curb extensions or other techniques to provide adequate sight distance,
 - C. The installation should include suitable standard signs and pavement markings, and
 - D. If installed within a signal system, the pedestrian hybrid beacon should be coordinated.
- 05 On approaches having posted or statutory speed limits or 85th-percentile speeds in excess of 35 mph and on approaches having traffic or operating conditions that would tend to obscure visibility of roadside hybrid beacon face locations, both of the minimum of two pedestrian hybrid beacon faces should be installed over the roadway.
- 06 On multi-lane approaches having a posted or statutory speed limits or 85th-percentile speeds of 35 mph or less, either a pedestrian hybrid beacon face should be installed on each side of the approach (if a median of sufficient width exists) or at least one of the pedestrian hybrid beacon faces should be installed over the roadway.
- 07 A pedestrian hybrid beacon should comply with the signal face location provisions described in Sections 4D.11 through 4D.16.

Standard:

- 08 **A CROSSWALK STOP ON RED (symbolic circular red) (R10-23) sign (see Section 2B.53) shall be mounted adjacent to a pedestrian hybrid beacon face on each major street approach. If an overhead pedestrian hybrid beacon face is provided, the sign shall be mounted adjacent to the overhead signal face.**

Option:

- 09 A Pedestrian (W11-2) warning sign (see Section 2C.50) with an AHEAD (W16-9P) supplemental plaque may be placed in advance of a pedestrian hybrid beacon. A warning beacon may be installed to supplement the W11-2 sign.

Guidance:

- 10 If a warning beacon supplements a W11-2 sign in advance of a pedestrian hybrid beacon, it should be programmed to flash only when the pedestrian hybrid beacon is not in the dark mode.

Standard:

- 11 **If a warning beacon is installed to supplement the W11-2 sign, the design and location of the warning beacon shall comply with the provisions of Sections 4L.01 and 4L.03.**

Section 4F.03 Operation of Pedestrian Hybrid Beacons

Standard:

01 Pedestrian hybrid beacon indications shall be dark (not illuminated) during periods between actuations.

02 Upon actuation by a pedestrian, a pedestrian hybrid beacon face shall display a flashing CIRCULAR YELLOW signal indication, followed by a steady CIRCULAR YELLOW signal indication, followed by both steady CIRCULAR RED signal indications during the pedestrian walk interval, followed by alternating flashing CIRCULAR RED signal indications during the pedestrian change interval (see Figure 4F-3). Upon termination of the pedestrian change interval, the pedestrian hybrid beacon faces shall revert to a dark (not illuminated) condition.

03 Except as provided in Paragraph 4, the pedestrian signal heads shall continue to display a steady UPRAISED HAND (symbolizing DONT WALK) signal indication when the pedestrian hybrid beacon faces are either dark or displaying flashing or steady CIRCULAR YELLOW signal indications. The pedestrian signal heads shall display a WALKING PERSON (symbolizing WALK) signal indication when the pedestrian hybrid beacon faces are displaying steady CIRCULAR RED signal indications. The pedestrian signal heads shall display a flashing UPRAISED HAND (symbolizing DONT WALK) signal indication when the pedestrian hybrid beacon faces are displaying alternating flashing CIRCULAR RED signal indications. Upon termination of the pedestrian change interval, the pedestrian signal heads shall revert to a steady UPRAISED HAND (symbolizing DONT WALK) signal indication.

Option:

04 Where the pedestrian hybrid beacon is installed adjacent to a roundabout to facilitate crossings by pedestrians with visual disabilities and an engineering study determines that pedestrians without visual disabilities can be allowed to cross the roadway without actuating the pedestrian hybrid beacon, the pedestrian signal heads may be dark (not illuminated) when the pedestrian hybrid beacon faces are dark.

Guidance:

05 *The duration of the flashing yellow interval should be determined by engineering judgment.*

Standard:

06 **The duration of the steady yellow change interval shall be determined using engineering practices.**

Guidance:

07 *The steady yellow interval should have a minimum duration of 3 seconds and a maximum duration of 6 seconds (see Section 4D.26). The longer intervals should be reserved for use on approaches with higher speeds.*

CHAPTER 4G. TRAFFIC CONTROL SIGNALS AND HYBRID BEACONS FOR EMERGENCY VEHICLE ACCESS

Section 4G.01 Applications of Emergency-Vehicle Traffic Control Signals and Hybrid Beacons

Support:

01 An emergency-vehicle traffic control signal is a special traffic control signal that assigns the right-of-way to an authorized emergency vehicle.

Option:

02 An emergency-vehicle traffic control signal may be installed at a location that does not meet other traffic signal warrants such as at an intersection or other location to permit direct access from a building housing the emergency vehicle.

03 An emergency-vehicle hybrid beacon may be installed instead of an emergency-vehicle traffic control signal under conditions described in Section 4G.04.

Guidance:

04 *If a traffic control signal is not justified under the signal warrants of Chapter 4C and if gaps in traffic are not adequate to permit the timely entrance of emergency vehicles, or the stopping sight distance for vehicles approaching on the major street is insufficient for emergency vehicles, installing an emergency-vehicle traffic control signal should be considered. If one of the signal warrants of Chapter 4C is met and a traffic control signal is justified by an engineering study, and if a decision is made to install a traffic control signal, it should be based upon the provisions of Chapter 4D.*

05 *The sight distance determination should be based on the location of the visibility obstruction for the critical approach lane for each street or drive and the posted or statutory speed limit or 85th-percentile speed on the major street, whichever is higher.*

Section 4G.02 Design of Emergency-Vehicle Traffic Control Signals

Standard:

01 **Except as otherwise provided in this Section, an emergency-vehicle traffic control signal shall meet the requirements of this Manual.**

02 **An Emergency Vehicle (W11-8) sign (see Section 2C.49) with an EMERGENCY SIGNAL AHEAD (W11-12P) supplemental plaque shall be placed in advance of all emergency-vehicle traffic control signals. If a warning beacon is installed to supplement the W11-8 sign, the design and location of the beacon shall comply with the Standards of Sections 4L.01 and 4L.03.**

Guidance:

03 *At least one of the two signal faces for each approach on the major street should be located over the roadway.*

04 *The following size signal indications should be used for emergency-vehicle traffic control signals: 12-inch diameter for steady red and steady yellow circular signal indications and any arrow indications, and 8-inch diameter for green or flashing yellow circular signal indications.*

Standard:

05 **An EMERGENCY SIGNAL (R10-13) sign shall be mounted adjacent to a signal face on each major street approach (see Section 2B.53). If an overhead signal face is provided, the EMERGENCY SIGNAL sign shall be mounted adjacent to the overhead signal face.**

Option:

06 An approach that only serves emergency vehicles may be provided with only one signal face consisting of one or more signal sections.

07 Besides using an 8-inch diameter signal indication, other appropriate means to reduce the flashing yellow light output may be used.

Section 4G.03 Operation of Emergency-Vehicle Traffic Control Signals

Standard:

- 01 **Right-of-way for emergency vehicles at signalized locations operating in the steady (stop-and-go) mode shall be obtained as provided in Section 4D.27.**
- 02 **As a minimum, the signal indications, sequence, and manner of operation of an emergency-vehicle traffic control signal installed at a midblock location shall be as follows:**
- A. **The signal indication, between emergency-vehicle actuations, shall be either green or flashing yellow. If the flashing yellow signal indication is used instead of the green signal indication, it shall be displayed in the normal position of the green signal indication, while the steady red and steady yellow signal indications shall be displayed in their normal positions.**
 - B. **When an emergency vehicle actuation occurs, a steady yellow change interval followed by a steady red interval shall be displayed to traffic on the major street.**
 - C. **A yellow change interval is not required following the green interval for the emergency-vehicle driveway.**
- 03 **Emergency-vehicle traffic control signals located at intersections shall either be operated in the flashing mode between emergency-vehicle actuations (see Sections 4D.28 and 4D.30) or be full-actuated or semi-actuated to accommodate normal vehicular and pedestrian traffic on the streets.**
- 04 **Warning beacons, if used with an emergency-vehicle traffic control signal, shall be flashed only:**
- A. **For an appropriate time in advance of and during the steady yellow change interval for the major street; and**
 - B. **During the steady red interval for the major street.**

Guidance:

- 05 *The duration of the steady red interval for traffic on the major street should be determined by on-site test-run time studies, but should not exceed 1.5 times the time required for the emergency vehicle to clear the path of conflicting vehicles.*

Option:

- 06 **An emergency-vehicle traffic control signal sequence may be initiated manually from a local control point such as a fire station or law enforcement headquarters or from an emergency vehicle equipped for remote operation of the signal.**

Section 4G.04 Emergency-Vehicle Hybrid Beacons

Standard:

- 01 **Emergency-vehicle hybrid beacons shall be used only in conjunction with signs to warn and control traffic at an unsignalized location where emergency vehicles enter or cross a street or highway. Emergency-vehicle hybrid beacons shall be actuated only by authorized emergency or maintenance personnel.**

Guidance:

- 02 *Emergency-vehicle hybrid beacons should only be used when all of the following criteria are satisfied:*
- A. *The conditions justifying an emergency-vehicle traffic control signal (see Section 4G.01) are met; and*
 - B. *An engineering study, considering the road width, approach speeds, and other pertinent factors, determines that emergency-vehicle hybrid beacons can be designed and located in compliance with the requirements contained in this Section and in Section 4L.01, such that they effectively warn and control traffic at the location; and*
 - C. *The location is not at or within 100 feet from an intersection or driveway where the side road or driveway is controlled by a STOP or YIELD sign.*

Standard:

- 03 **Except as otherwise provided in this Section, an emergency-vehicle hybrid beacon shall meet the requirements of this Manual.**

Figure 4G-1. Sequence for an Emergency-Vehicle Hybrid Beacon

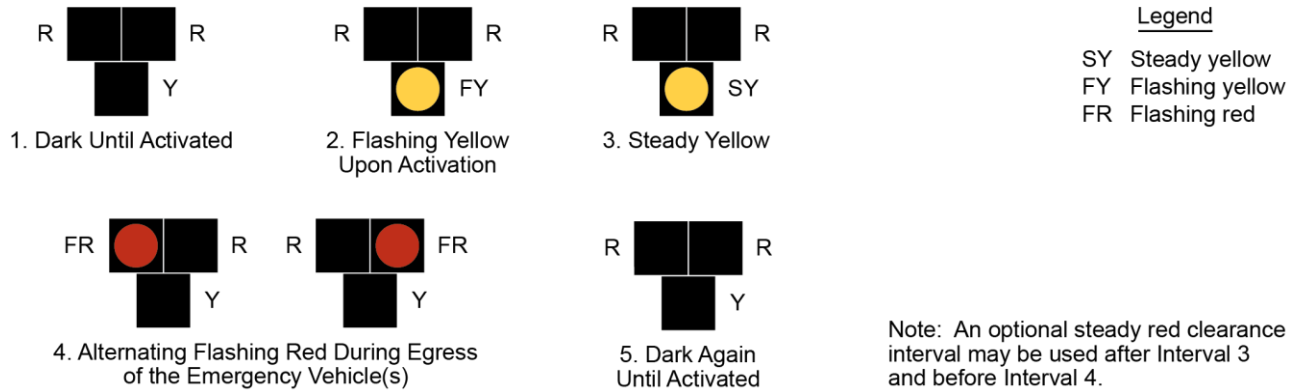

04 **An emergency-vehicle hybrid beacon face shall consist of three signal sections, with a CIRCULAR YELLOW signal indication centered below two horizontally aligned CIRCULAR RED signal indications (see Figure 4G-1).**

05 **Emergency-vehicle hybrid beacons shall be placed in a dark mode (no indications displayed) during periods between actuations.**

06 **Upon actuation by authorized emergency personnel, the emergency-vehicle hybrid beacon faces shall each display a flashing yellow signal indication, followed by a steady yellow change interval, prior to displaying two CIRCULAR RED signal indications in an alternating flashing array for a duration of time adequate for egress of the emergency vehicles. The alternating flashing red signal indications shall only be displayed when it is required that drivers on the major street stop and then proceed subject to the rules applicable after making a stop at a STOP sign. Upon termination of the flashing red signal indications, the emergency-vehicle hybrid beacons shall revert to a dark mode (no indications displayed) condition.**

Guidance:

07 *The duration of the flashing yellow interval should be determined by engineering judgment.*

Standard:

08 **The duration of the steady yellow change interval shall be determined using engineering practices.**

Guidance:

09 *The steady yellow change interval should have a minimum duration of 3 seconds and a maximum duration of 6 seconds (see Section 4D.26). The longer intervals should be reserved for use on approaches with higher speeds.*

Option:

10 A steady red clearance interval may be used after the steady yellow change interval.

11 Emergency-vehicle hybrid beacons may be equipped with a light or other display visible to the operator of the egressing emergency vehicle to provide confirmation that the beacons are operating.

12 Emergency-vehicle hybrid beacons may be supplemented with an advance warning sign, which may also be supplemented with a Warning Beacon (see Section 4L.03).

Guidance:

13 *If a Warning Beacon is used to supplement the advance warning sign, it should be programmed to flash only when the emergency-vehicle hybrid beacon is not in the dark mode.*

Standard:

14 **At least two emergency-vehicle hybrid beacon faces shall be installed for each approach of the major street and a stop line shall be installed for each approach of the major street.**

Guidance:

- 15 *On approaches having posted or statutory speed limits or 85th-percentile speeds in excess of 40 mph, and on approaches having traffic or operating conditions that would tend to obscure visibility of roadside beacon faces, both of the minimum of two emergency-vehicle hybrid beacon faces should be installed over the roadway.*
- 16 *On multi-lane approaches having posted or statutory speed limits or 85th-percentile speeds of 40 mph or less, either an emergency-vehicle hybrid beacon face should be installed on each side of the approach (if a median of sufficient width exists) or at least one of the emergency-vehicle hybrid beacon faces should be installed over the roadway.*
- 17 *An emergency-vehicle hybrid beacon should comply with the signal face location provisions described in Sections 4D.11 through 4D.16.*

Standard:

- 18 **Stop lines and EMERGENCY SIGNAL—STOP WHEN FLASHING RED (R10-14 or R10-14a) signs (see Figure 2B-27) shall be used with emergency-vehicle hybrid beacons.**

Option:

- 19 If needed for extra emphasis, a STOP HERE ON FLASHING RED (R10-14b) sign (see Section 2B.53) may be installed with an emergency-vehicle hybrid beacon.

Appendix G: Additional Crosswalk Guidelines

Yield Here to Pedestrians – Properly Signing Unsignalized Crosswalks in Ohio

In this Route of Navigation (RON) update, we discuss which signs shall or can be added to increase motorist awareness of an unsignalized crosswalk and the safety of pedestrians who use them.

Unsignalized Crosswalks

Crosswalks located at areas other than a signalized intersection or signalized mid-block crossing are unsignalized crosswalks. Unsignalized crosswalks have different signing protocols than signalized crosswalks, along with enhanced signage opportunities in order to improve safety for pedestrians in more heavily traveled corridors.

Yield vs. Stop for Pedestrians in Crosswalks

A point of confusion for many when determining what signage to install for an unsignalized crosswalk in Ohio is whether to install “Yield Here To Pedestrians” signs or “Stop Here For Pedestrians” signs. ¹ Ohio Law states:

*“When traffic control signals are not in place, not in operation, or are not clearly assigning the right-of-way, the driver of a vehicle, trackless trolley, or streetcar shall **yield** the right of way, slowing down or stopping if need be to so yield or if required by section 4511.132 of the Revised Code, to a pedestrian crossing the roadway within a crosswalk when the pedestrian is upon the half of the roadway upon which the vehicle is traveling, or when the pedestrian is approaching so closely from the opposite half of the roadway as to be in danger.” [Ohio Revised Code § 4511.46 \(A\)](#). ² [emphasis added]*

So when determining your signage needs for an unsignalized crosswalk in Ohio, make certain to select the signage which complies with Ohio’s law – the “Yield Here To Pedestrians” in crosswalk signs. The Ohio Manual of Uniform Traffic Control Devices (OMUTCD), in 2B.11 discusses the “Yield Here To Pedestrians” signage as displayed by the images shown in figure 1.

¹ Pedestrian Crossing: 50 State Summary, National Conference of State Legislatures website, available at: <http://www.ncsl.org/research/transportation/pedestrian-crossing-50-state-summary.aspx> (last visited on September 25, 2017).

² Available at: <http://codes.ohio.gov/orc/4511.46> (last visited on September 25, 2017).

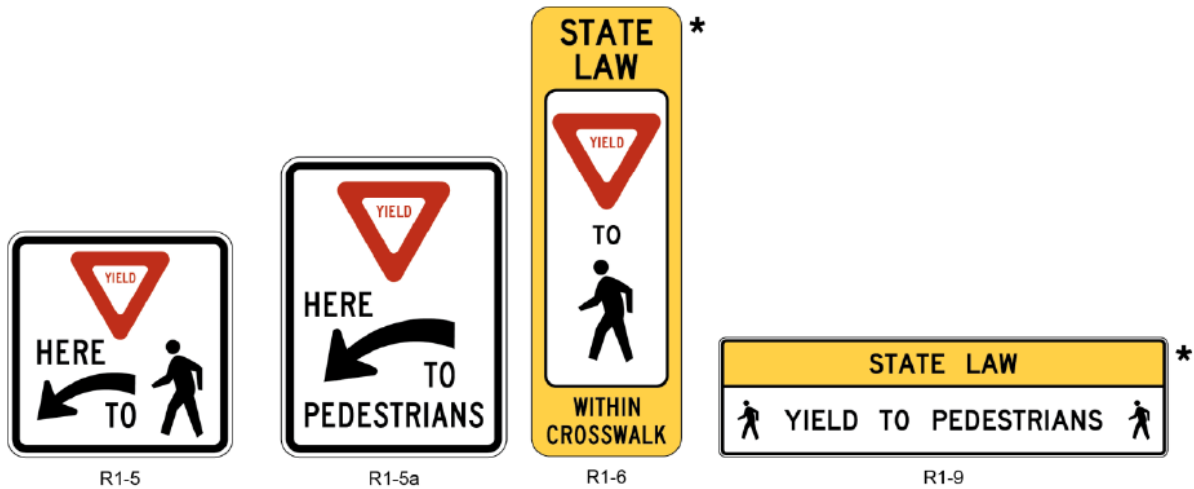

Figure 1 – R1-5 Signage Series, R1-6 and R1-9 Signage

(*The Legend STATE LAW is optional. A fluorescent yellow-green background color may be used instead of yellow for this sign.)

“Yield Here To Pedestrians (R1-5 or R1-5a) signs (see Figure 1) shall be used if yield lines are used in advance of a marked crosswalk that crosses an uncontrolled multi-lane approach. The legend STATE LAW may be displayed at the top of the R1-5, or R1-5a.” OMUTCD Section 2B.11 Standard [emphasis added]

“Yield Here To Pedestrians signs may be used in advance of a crosswalk that crosses an uncontrolled multi-lane approach to indicate to road users where to yield even if yield lines are not used.” OMUTCD Section 2B.11 Option

So in Figure 2, the use of the triangular markings in-front of the crosswalk as shown (the yield pavement markings) make usage of the “Yield Here To Pedestrians” signage mandatory for the unsignalized crosswalk. If the yield pavement markings were not present, the “Yield Here To Pedestrians” signage could still be installed to enhance safety, but the signage is not required.

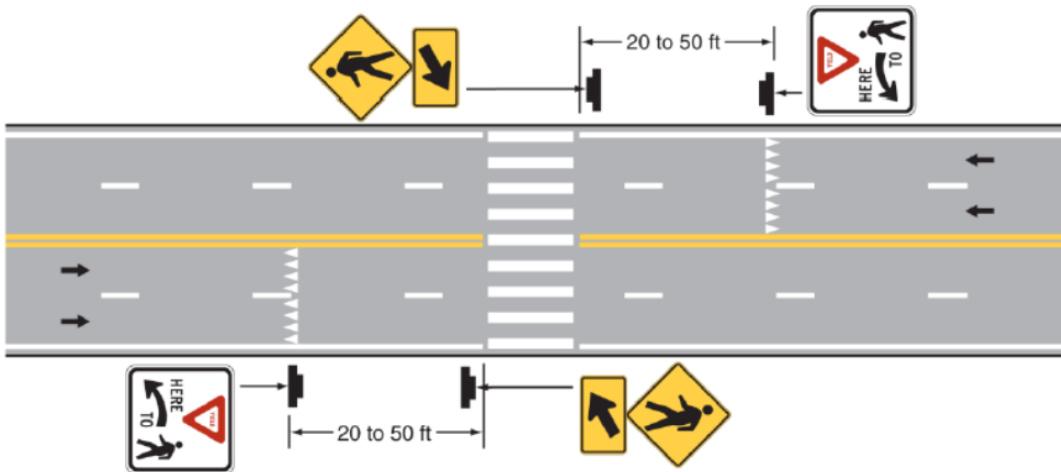

Figure 2 – Multi-lane Approach with Yield Markings in Front of the Unsignaled Crosswalk

Figure 2 also shows Pedestrian Crossing (W11-2) warning signs with diagonal downward pointing arrows (W16-7P) plaques at the unsignaled crosswalk location as per the option described below:

“A Pedestrian Crossing (W11-2) warning sign may be placed overhead or may be post-mounted with a diagonal downward pointing arrow (W16-7P) plaque at the crosswalk location where Yield Here To Pedestrians signs have been installed in advance of the crosswalk.” OMUTCD Section 2B.11 Option

Use of the yield lines and “Yield Here To Pedestrian” signs combination has further guidance you need to be aware of:

*“If yield lines and Yield Here To Pedestrians signs are used in advance of a crosswalk that crosses an uncontrolled multi-lane approach, they should be placed 20 to 50 feet in advance of the nearest crosswalk line (see Section 3B.16 [of the OMUTCD] and Figure 2 above), and parking should be **prohibited** in the area between the yield line and the crosswalk.*

Yield lines and Yield Here To Pedestrians signs should not be used in advance of crosswalks that cross an approach to or departure from a roundabout.” OMUTCD Section 2B.11 Guidance [emphasis added]

For additional information regarding use of Pedestrian Crossing (W11-2) warning signs, refer to OMUTCD Section 2C.50.

Crosswalk Visibility Enhancements

SAFE TRANSPORTATION FOR EVERY PEDESTRIAN

COUNTERMEASURE TECH SHEET

This example combines curb extensions, high-visibility markings, overhead lighting, and in-street signs on a two-lane roadway.



Poor lighting conditions, obstructions such as parked cars, and horizontal or vertical roadway curvature can reduce visibility at crosswalks, contributing to higher crash rates.



Crosswalk visibility enhancements help make crosswalks and/or pedestrians more visible and can help pedestrians decide where to cross.

Crosswalk visibility enhancements can reduce crashes by

23–48%



This group of countermeasures includes improved lighting, advance or in-street warning signage, pavement markings, and geometric design elements. Such features may be used in combination to indicate optimal or preferred locations for people to cross and to help reinforce the driver requirement to yield the right-of-way to pedestrians at crossing locations.

For multi-lane roadway crossings where vehicle AADTs are in excess of 10,000, a marked crosswalk alone is typically not sufficient (Zegeer, 2005). Under such conditions, more substantial crossing improvements are also needed to prevent an increase in pedestrian crash potential. Examples of more substantial treatments include the refuge island, PHB, and RRFB.

FEATURES:

- High visibility marking improves visibility of the crosswalk compared to the standard parallel lines.
- Parking restriction on the crosswalk approach improves the sightlines for motorists and pedestrians.
- Advance STOP or YIELD markings & signs reduce the risk of a multiple threat crash.
- Curb extension improves sight distance between drivers and pedestrians and narrows crossing distance.
- In street STOP or YIELD signs may improve driver yielding rates.

Crosswalk Visibility Enhancements

EDC-4 STEP: https://www.fhwa.dot.gov/innovation/everydaycounts/edc_4/step.cfm

High-visibility crosswalk marking. High-visibility crosswalks are preferred over parallel line crosswalks and should be provided at all established midblock pedestrian crossings. They should also be considered at uncontrolled intersections.

Parking restriction on the crosswalk approach. Parking restriction can include the removal of parking space markings, installation of new “parking prohibition” pavement markings or curb paint, and signs. The minimum setback is 20 feet in advance of the crosswalk where speeds are 25 mph or less, and 30 feet where speeds are between 26 and 35 mph.

Advance YIELD or STOP markings and signs.¹ The stop bar or “sharks teeth” yield markings are placed 20 to 50 feet in advance of a marked crosswalk to indicate where vehicles are required to stop or yield in compliance with the accompanying “STOP Here for Pedestrians” or “YIELD Here to Pedestrians” sign.

Curb extension. This treatment, also referred to as bulb-outs, extends the sidewalk or curb line out into the parking lane, which reduces the effective street width. Curb extensions must not extend into travel lanes and should not extend across bicycle lanes.

Improved nighttime lighting. Consideration should be given to placing lights in advance of midblock and intersection crosswalks on both approaches to illuminate the front of the pedestrian and avoid creating a silhouette.

In-street STOP or YIELD to pedestrian sign.² These signs serve to remind road users of laws regarding right-of-way, and they may be appropriate on 2-lane or 3-lane roads where speed limits are 30 mph or less. The sign can be placed in between travel lanes or in a median.

COST

Countermeasure	Range	Average
High visibility crosswalk marking	\$600-5,700 each	\$2,540 each
Lighting	<i>Varies based on fixture type and utility service agreement</i>	
Parking restriction	<i>Varies based on the required signs and pavement markings</i>	
Curb extension	\$2,000-20,000	\$13,000 each
Advance STOP/YIELD sign	N/A	\$300 each
Advance STOP/YIELD line	N/A	\$320 each
In-street STOP/YIELD sign	N/A	\$240 each

¹MUTCD section 2B.12 In-Street and Overhead Pedestrian Crossing Signs (R1-6, R1-6a, R1-9, and R1-9a)

²MUTCD reference: Section 2B.11 Yield Here To Pedestrians Signs and Stop Here For Pedestrians Signs (R1-5 Series)

References

Harkey, D.L., R. Srinivasan, J. Baek, F. Council, K. Eccles, N. Lefler, F. Gross, B. Persaud, C. Lyon, E. Hauer, and J. Bonneson. (2008). NCHRP Report 617: Crash Reduction Factors for Traffic Engineering and ITS Improvements. Transportation Research Board, Washington, D.C.

Zegeer, C., R. Srinivasan, B. Lan, D. Carter, S. Smith, C. Sundstrom, N.J. Thirsk, J. Zegeer, C. Lyon, E. Ferguson, and R. Van Houten. (2017). NCHRP Report 841: Development of Crash Modification Factors for Uncontrolled Pedestrian Crossing Treatments. Transportation Research Board, Washington, D.C.

Gibbons, R. B., Edwards, C., Williams, B., & Andersen, C. K. (2008). Informational Report on Lighting Design for Midblock Crosswalks. Report No. FHWA-HRT-08-053. Federal Highway Administration.

Bushell, M., Poole, B., Zegeer, C., & Rodriguez, D. (2013). Costs for Pedestrian and Bicyclist Infrastructure Improvements: A Resource for Researchers, Engineers, Planners, and the General Public. Pedestrian and Bicycle Information Center.

Federal Highway Administration. (2013). Multiple webpages in PEDSAFE: Pedestrian Safety Guide and Countermeasure Selection System:

- Marked Crosswalks and Enhancements: http://www.pedbikesafe.org/PEDSAFE/countermeasures_detail.cfm?CM_NUM=4
- Lighting and Illumination: http://www.pedbikesafe.org/PEDSAFE/countermeasures_detail.cfm?CM_NUM=8
- Parking Restrictions: http://www.pedbikesafe.org/PEDSAFE/countermeasures_detail.cfm?CM_NUM=9
- Curb Extensions: http://www.pedbikesafe.org/PEDSAFE/countermeasures_detail.cfm?CM_NUM=5
- Advance Stop/Yield Lines: http://www.pedbikesafe.org/PEDSAFE/countermeasures_detail.cfm?CM_NUM=13

Appendix H: Bike Lane Design Guidelines

FHWA COURSE ON BICYCLE
AND PEDESTRIAN TRANSPORTATION

L E S S O N 19

Bicycle Lanes

19.1 Purpose

The AASHTO *Guide for the Development of Bicycle Facilities* defines a bike lane as “a portion of a roadway which has been designated by striping, signing, and pavement markings for the preferential or exclusive use of bicyclists.” As levels of bicycling have increased in the United States, there has been a growing amount of support for bike lanes on urban and suburban roadways. Bike lanes are a preferred facility type in European countries, and in North America, nearly every major city has made an effort in recent years to install bicycle lanes, either as “pilot projects” (to test their success) or, in many cases, on larger networks of interconnecting roadways. Several small towns have led the way in establishing networks of bicycle lanes, particularly college towns where there are high levels of student bicycle commuters (e.g., University of California at Davis and University of Texas at Austin).

As a relatively new feature in the roadway cross-section, bike lane design has been the topic of much study in recent years. Bike lane design can be quite challenging in situations where the existing urban traffic patterns are complex and cross-sections are already constrained by heavy traffic

volumes. Designers throughout the country develop new and better solutions each year. This section includes excerpts from several sources, including Oregon’s *1995 Bicycle and Pedestrian Plan* and Philadelphia’s *Bicycle Network Plan*.

Note: The Europeans have pioneered innovative bike lane design solutions. Lesson 22 includes a description of European approaches that have been successful.

As with the other bicycle facility design issues covered in this manual, bike lane design is covered in



some detail by the AASHTO *Guide for the Development of Bicycle Facilities*. This text should be referenced for additional information.

19.2 Bicycle Lane Widths and Construction Standards

Bicycle lanes serve the needs of all types of cyclists in urban and suburban areas, providing them with their own travel lane on the street surface. The minimum width of a bike lane should be 1.5 meters (5 feet) against a curb or adjacent to a parking lane. On streets where the bike lane is adjacent to the curb and the curb includes a 1-foot to 2-foot gutter pan, bike lanes should be a minimum of 4 feet wide (width does not include the gutter pan, since bicyclists are typically unable to use this space).

Wider bike lanes are recommended on streets with higher motor vehicle speeds and traffic volumes, or where pedestrian traffic in the bike lane is anticipated. Width measurements are taken from the curb face to the bicycle lane stripe.

Since bicyclists usually tend to ride a distance of 0.8 meters to 1.1 meters (2.5 feet to 3.5 feet) from the curb face, it is very important that the pavement surface in this zone be smooth and free of structures. Drain inlets and manholes that extend into this area cause bicyclists to swerve, having the effect of reducing the usable width of the lane. Where these structures exist and the surface cannot be made smooth, bike



As a temporary solution, striping narrow lanes through intersections may be an option where space is limited.

lane width should be adjusted accordingly. Regular maintenance is critical for bike lanes (see text in this section).

Bike lanes should be constructed to normal full-depth pavement standards since motor vehicles will occasionally cross them, or may use them as a breakdown area.

19.3 Unmarked Lanes

Where the minimum widths listed above cannot be met, it may be possible to provide an unmarked lane. Studies have shown that the bicyclist's perceived level of comfort is higher when a striped area is provided; therefore, this method can raise the bicycle level of service for the street. An unmarked lane is a striped area of 0.6 m (2 ft) wide or more that contains no markings or signing that would denote it as a bike lane. "Share the Road" signs may be used to caution motorists to be alert for bicyclists.

It is important to recognize that this is a temporary solution. Particularly on busy streets, narrow unmarked lanes will not adequately serve the needs of the majority of bicyclists.

19.4 Location Within the Street Cross-Section

Bicycle lanes are always located on both sides of the road on two-way streets. Since bicyclists must periodically merge with motor vehicle traffic, bike lanes should not be separated from other motor vehicle lanes by curbs, parking lanes, or other obstructions. Two-way bike lanes on one side of two-way streets create hazardous conditions for bicyclists and are not recommended.

On one-way streets, bicycle lanes should be installed on the right-hand side, unless conflicts can be greatly reduced by installing the lane on the left-hand side. Left-side bicycle lanes on one-way streets may also be considered where there are frequent bus or trolley stops, unusually high numbers of right-turning motor vehicles, or if there is a significant number of left-turning bicyclists.

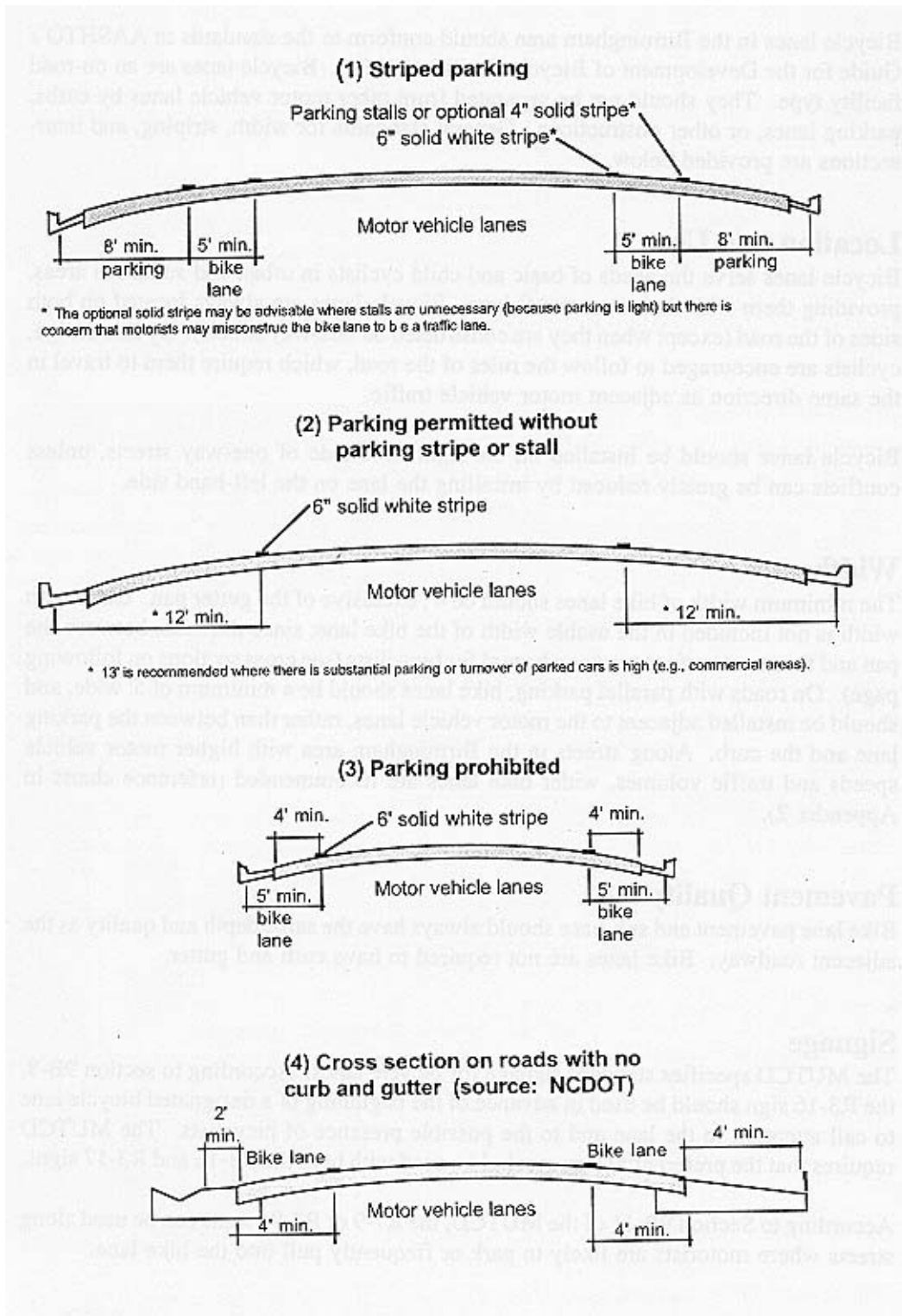

Bicycle lanes provided under different types of conditions. Source: AASHTO Guide for the Development of Bicycle Facilities, 1991.

19.5 Practices To Be Avoided

Two-Way Bike Lane

This creates a dangerous condition for bicyclists. It encourages illegal riding against traffic, causing several problems:

- At intersections and driveways, wrong-way riders approach from a direction where they are not visible to motorists.
- Bicyclists closest to the motor vehicle lane have opposing motor vehicle traffic on one side and opposing bicycle traffic on the other.
- Bicyclists are put into awkward positions when transitioning back to standard bikeways.

If constraints allow widening on only one side of the road, the centerline stripe may be shifted to allow for adequate travel lanes and bike lanes:

Continuous Right-Turn Lanes

This configuration is difficult for cyclists: Riding on the right puts them in conflict with right-turning cars, but riding on the left puts them in conflict with cars merging into and out of the right-turn lane. The best solution is to eliminate the continuous right-turn lane, consolidate accesses, and create well-defined intersections.

19.6 Contra-Flow Bike Lanes

Contra-flow bike lanes on a one-way street are not usually recommended. They may encourage cyclists

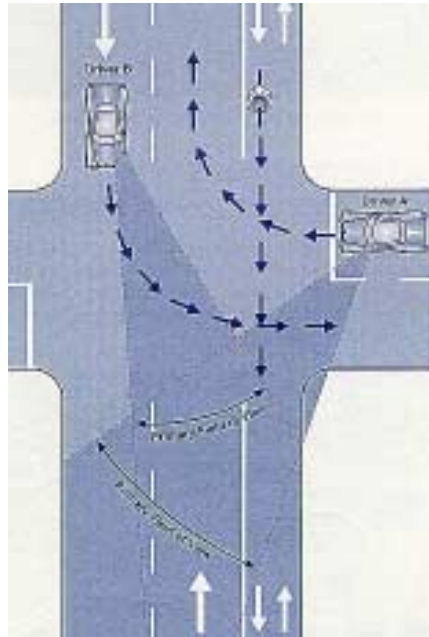

In both cases above, a wrong-way bicyclist is not in the driver's main field of vision.

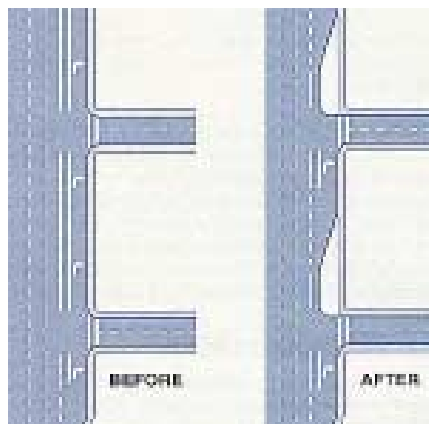

Continuous right-turn lane reconfigured to standard approaches.

to ride against traffic, which is contrary to the rules of the road and a leading cause of bicycle/motor vehicle crashes.

There are, however, special circumstances when this design may be advantageous:

- A contra-flow bike lane provides a substantial savings in out-of-direction travel.
- The contra-flow bike lane provides direct access to high-use destinations.
- Improved safety because of reduced conflicts on the longer route.
- There are few intersecting driveways, alleys, or streets on the side of the contra-flow lane.
- Bicyclists can safely and conveniently re-enter the traffic stream at either end of the section.
- A substantial number of cyclists are already using the street.
- There is sufficient street width to accommodate a bike lane.

A contra-flow bike lane may also be appropriate on a one-way residential street recently converted from a two-way street (especially where this change was made to calm traffic).

For a contra-flow bike lane to function well, these special features should be incorporated into the design:



Contra-flow bike lanes can provide direct access to high-use destinations.

- The contra-flow bike lane must be placed on the right side of the street (to motorists' left) and must be separated from oncoming traffic by a double yellow line. This indicates that the bicyclists are riding on the street legally, in a dedicated travel lane.
- Any intersecting alleys, major driveways, and streets must have signs indicating to motorists that they should expect two-way bicycle traffic.
- Existing traffic signals should be fitted with special signals for bicyclists; this can be achieved with either loop detectors or push buttons (these should be easily reached by bicyclists without having to dismount).

Note: Under no circumstances should a contra-flow bike lane be installed on a two-way street, even where the travel lanes are separated by a raised median.

19.7 Bike Lane Pavement Markings

The *Manual on Uniform Traffic Control Devices* (MUTCD) section 9C addresses standard bike lane markings. The stripe between the bicycle lane and the adjacent motor vehicle lane should be a 100-millimeter (4 inch) wide white line (minimum width). Six- to eight-inch-wide lines provide an even clearer division of space, and are highly recommended.

Where parking is allowed next to a bike lane, the parking area should be defined by parking space markings or a solid 100 millimeter (4 inch) wide stripe.

Care should be taken to use pavement striping that is durable, yet skid-resistant. Reflectors and raised markings in bike lanes can deflect a bicycle wheel, causing a bicyclist to lose control. If reflective pavement markers are needed for motorists, they should be installed on the motorist's side of the stripe, and have a beveled front edge.

While the 1988 edition of the MUTCD recommends the use of the diamond-

shaped preferential lane symbol in conjunction with bike lane signs, this symbol is often confusing for both the bicyclist and motorist. For this reason, subsequent editions of the MUTCD will probably eliminate the use of the diamond in bike lanes. The new standard pavement markings for bicycle lanes are the bicycle symbol (or the words BIKE LANE) and a directional arrow.

19.8 Bike Lane Signing

The *Manual on Uniform Traffic Control Devices* (MUTCD) section 9B addresses standard bike lane signing. According to section 9B-8, the R3-16 sign should be used in advance of the beginning of a



Bike lane signs should be replaced with bike lane stencils, with optional NO PARKING signs where needed.

designated bicycle lane to call attention to the lane and to the possible presence of bicyclists. In locations where bicycle lanes are ending, the same R3-16 sign should be used, with the word ENDS substituting for the word AHEAD. The R7-9 or R7-9a signs should be used along streets where motorists are likely to park or frequently pull into the bike lane.

19.9 Diagonal Parking

Diagonal parking causes conflicts with bicycle travel: Drivers backing out have poor visibility of oncoming cyclists and parked vehicles obscure other vehicles backing out. These factors require cyclists to ride close to the center of a travel lane, which is intimidating to inexperienced riders.

Where possible on one-way streets, diagonal parking should be limited to the left side, even if the street has no bike lane; on one-way streets with bike lanes, the bike lane should be placed adjacent to parallel parking (preferably on the right).

Bike lanes are not usually placed next to diagonal parking. However, should diagonal parking be required on a street planned for bike lanes, the following recommendations can help decrease potential conflicts:

- The parking bays must be long enough to accommodate most vehicles.
- A 200-millimeter- (8-inch-) wide stripe should separate the parking area from the bike lane.
- Enforcement may be needed to cite or remove vehicles encroaching on the bike lane.

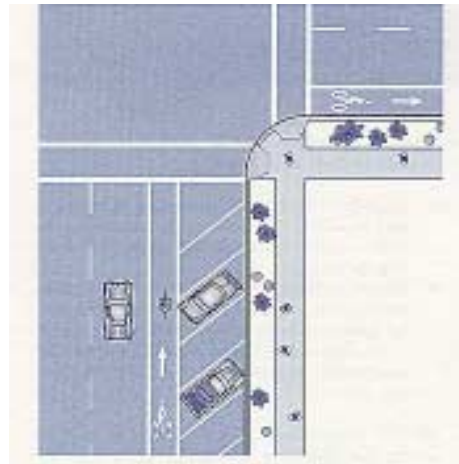

Bike lane next to diagonal parking, 8-inch stripe should separate the areas.

19.10 Bike Lane Design at Intersections

Intersections With Bus Stops

If there is a bus stop at the near side of the intersection, a broken line should extend the length of the bus stop (no less than 15 meters [50 feet]), and the solid white line should resume on the far side of the intersection, immediately after the crosswalk. If a bus stop is located on the far side of the intersection, the solid white

line on the far side of the intersection should be replaced with a broken line for a distance of at least 24 meters (80 feet) from the crosswalk (at this intersection, a broken line would still be required on the near side if there is right-turning traffic).

Intersections With Right-Turn Lanes

In general, right-turn lanes should be used only where warranted by a traffic study, as they present problems for both bicyclists and pedestrians:

- If right-turning cars and through bicyclists must cross paths.
- If the additional lane width adds to the pedestrian crossing distance.
- If right-turn moves are made easier for motorists, which may cause inattentive drivers to not notice pedestrians on the right.

The through bike lane to the left of a right-turn lane should be striped with two 100-millimeter- (4-in-) wide stripes and connected to the preceding bike lane with 0.9-meter (3-foot) dashes and 2.7-meter (9-foot) spaces. This allows turning motorists to cross the bike lane. A legend must be placed at the beginning of the through bike lane. Sign R4-4, BEGIN RIGHT TURN LANE, YIELD TO BIKES, may be placed at the beginning of the taper in areas where a through bike lane may not be expected.

Not all intersections can be widened to provide a right-turn lane. A bike lane to the left of right-turning cars should still be provided. One common configuration occurs where a right-turn lane is developed by dropping parking (see figure at right).

Another configuration occurs where a lane is dropped and turns into a right-turn lane.

Note: This is a difficult movement for bicyclists as they must merge left and find a gap in the traffic stream:

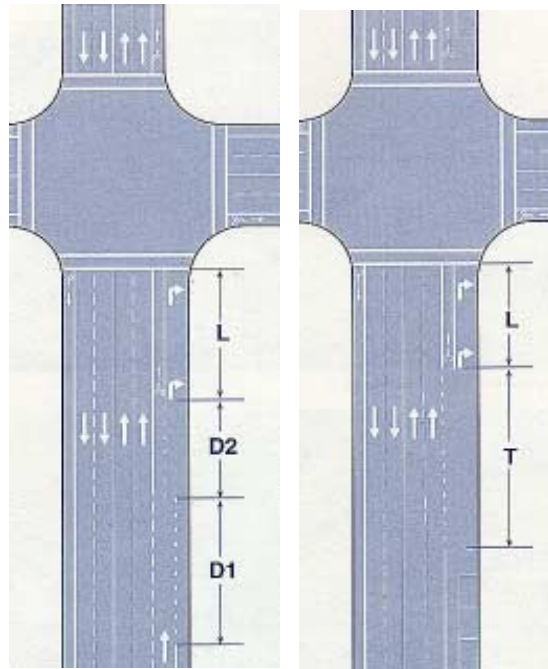

Above left: Bike lane left of right-turn lane developed by dropping a travel lane. Above right: Bike lane left of right-turn lane developed by dropping parking.

Offset Intersections

Care should be taken to ensure that motorists are not inadvertently encouraged to ride in the bike lane because of offset travel lanes. At intersections with offset lanes, dashed offset lane markings should continue through the intersection to direct traffic flow (MUTCD Section 3B-7).

Traffic Signal Actuation

It is highly recommended that new on-road bicycle facilities include traffic signals that detect bicycles for all actuated signal systems. *The Traffic Detector Handbook* (FHWA-IP-90-002) recommends several bicycle-sensitive loop configurations (loops are wires installed beneath the pavement surface that detect the presence of vehicles) that effectively detect bicycles. The quadrupole loop is the preferred solution for bike lanes, and the diagonal quadrupole loop is preferred for use in shared lanes.

Exception #1: Heavy Right Turns

If the major traffic movement at an intersection is to the right, and the straight through move leads to a minor side street, then the bike lane may be placed on the right and wrapped around the curve, assuming that the majority of cyclists will desire to turn right too. This often occurs where a highway is routed over local streets and the route is indirect.

Exception #2: Tee Intersections

At a Tee intersection, where the traffic split is approximately 50 percent turning right and 50 percent turning left, the bike lane should be dropped prior to the lane split to allow cyclists to position themselves in the correct lane. Where traffic volumes are very high, a left- and right-turning bike lane should be considered.

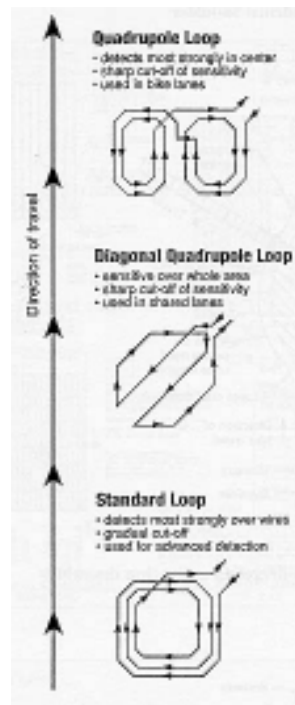

Different loop configurations: The quadrupole loop is recommended for bike lanes.

The quadrupole loop is the preferred solution for bike lanes, and the diagonal quadrupole loop is preferred for use in shared lanes.

One solution for existing intersection signals that do not respond to bicycles is to install a special pavement marking over the exact spot that a bicycle must stand in order to “trip” the signal.

Expressway Interchanges

Expressway interchanges often present barriers to bicycle circulation. Designs that encourage free-flowing motor vehicle traffic movements are the most difficult for pedestrians and bicyclists to negotiate.

At-Grade Crossings

Interchanges with access ramps connected to local streets at a right angle are easiest for bicyclists to negotiate. The intersection of the ramp and the street should follow established urban intersection designs. The main advantages are:

- The distance that pedestrians and bicyclists must cross at the ramps is minimized.
- Signalized intersections stop traffic.
- Visibility is enhanced.

If these configurations are unavoidable, mitigation measures should be sought. Special designs should be considered that allow pedestrians and bicyclists to cross ramps in locations with good visibility and where speeds are low.

Grade-Separated Crossings

Where it is not possible to accommodate pedestrians and bicyclists with at-grade crossings, grade separation should be considered. Grade-separated facilities are expensive; they add out-of-direction travel and will not be used if the added distance is too great. This can create problems if pedestrians and bicyclists ignore the facility and try to negotiate the interchange at grade with no sidewalks, bike lanes, or crosswalks.

In some instances, a separate path can be provided on only one side of the interchange, which leads to awkward crossing movements. Some bicyclists will be riding on a path facing traffic, creating difficulties when they must cross back to a bike lane or shoulder (clear and easy-to-follow directions must be given to guide bicyclists' movements that are inconsistent with standard bicycle operation).

To ensure proper use by bicyclists, structures must be open, with good visibility (especially underpasses).

Other Innovative Designs

These concepts are presented as examples of innovative solutions to bike lane design at freeway interchanges and intersections.

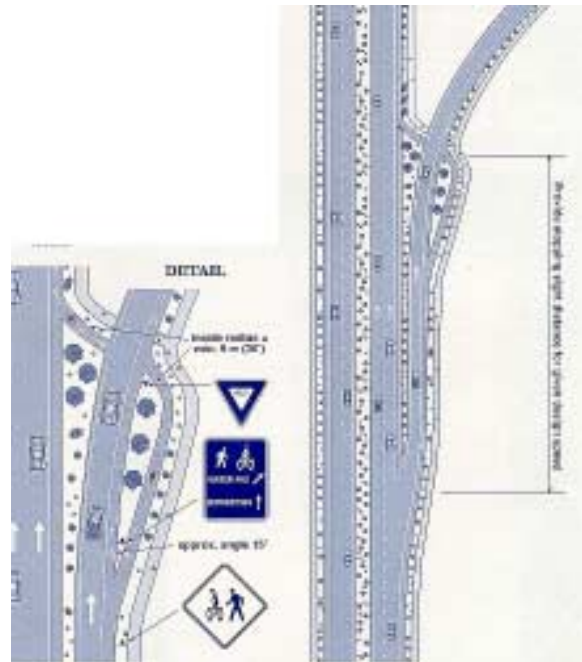

Exit ramp configuration for bike lane and sidewalks (urban design — not for use on limited-access freeways).

Traffic entering or exiting a roadway at high speeds creates difficulties for slower moving bicyclists. The following designs help alleviate these difficulties:

Right-Lane Merge

It is difficult for bicyclists to traverse the undefined area created by right-lane merge movements, because:

- The acute angle of the approach creates visibility problems.

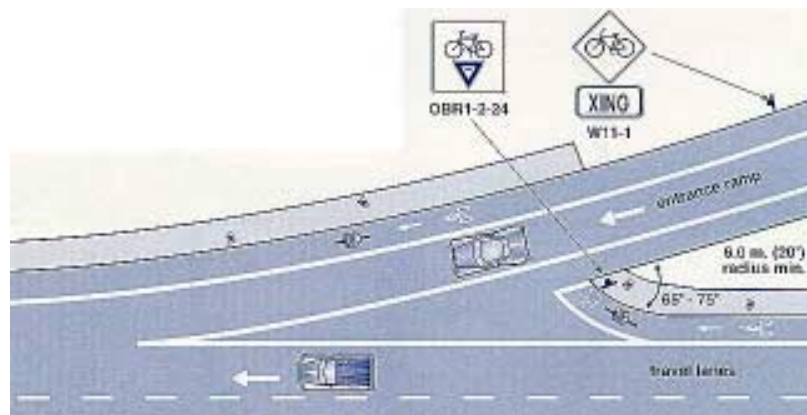

Right-lane merge — bike lane and sidewalk configuration (urban design — not for use on limited-access freeways).

- Motor vehicles are often accelerating to merge into traffic.
- The speed differential between cyclists and motorists is high.

The following design guides bicyclists in a manner that provides:

- A short distance across the ramp at close to a right angle.
- Improved sight distances in an area where traffic speeds are slower than farther downstream.
- A crossing in an area where drivers' attention is not entirely focused on merging with traffic.

Exit Ramps

Exit ramps present difficulties for bicyclists because:

- Motor vehicles exit at fairly high speeds.
- The acute angle creates visibility problems.
- Exiting drivers often do not use their right-turn signal, confusing pedestrians and bicyclists seeking a gap in the traffic.

The exit ramp design on the previous page guides bicyclists in a manner that provides:

- A short distance across the ramp, at close to a right angle.
- Improved sight distances in an area where traffic speeds are slower than farther upstream.
- A crossing in an area where the driver's attention is not distracted by other motor vehicles.

Dual Right-Turn Lanes

This situation is particularly difficult for bicyclists. Warrants for dual turn lanes should be used to ensure that they are provided only if absolutely necessary.

The design for single right-turn lanes allows bicyclists and motorists to cross paths in a predictable manner, but the addition of a lane from which cars may also turn adds complexity: Some drivers make a last minute decision to turn right from the center lane without signaling, catching bicyclists and pedestrians unaware.

Bicyclists and motorists should be guided to areas where movements are more predictable, so bicyclists and motorists can handle one conflict at a time, in a predictable manner. A curb cut provides bicyclists with access to the sidewalk, for those who prefer to proceed as pedestrians.

- Design A (see Figure 19-13) encourages cyclists to share the optional through-right-turn lane with motorists.
- Design B guides cyclists up to the intersection in a dedicated bike lane.
- Design C allows cyclists to choose a path themselves (this design is the AASHTO recommendation—simply dropping the bike lane prior to the intersection).

A.

B.

C.

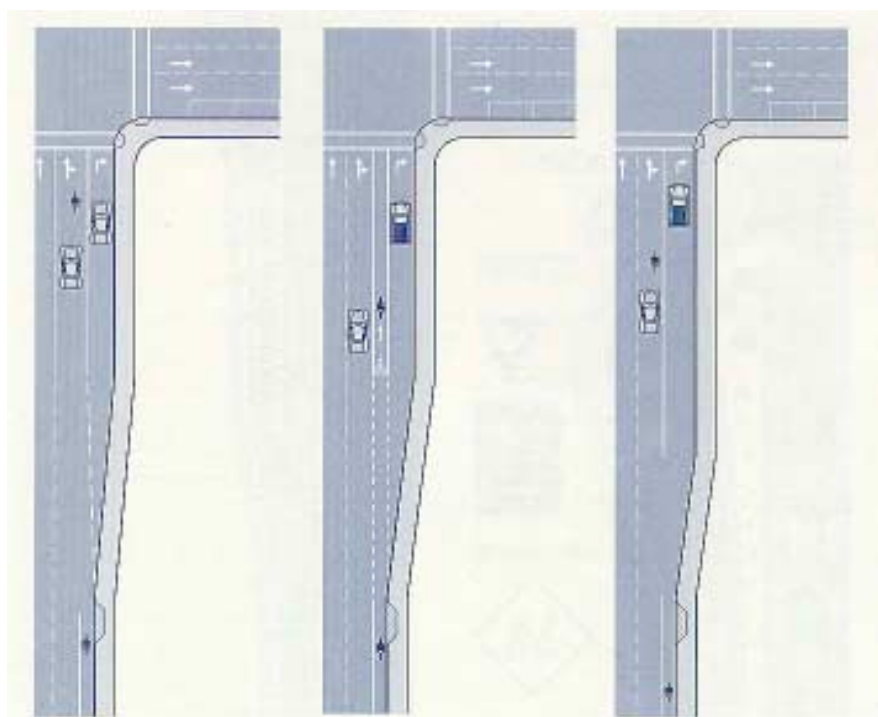

Bike lane through dual right-turn lanes.

A fourth design places an island between the right-turn lane and the optional through-right turn lane. This creates a more conventional intersection, separating the conflicts. This design is also better for pedestrians, as the island provides a refuge.

Engineering judgment should be used to determine which design is most appropriate for the situation.

Right-Turn Lane Without Room for a Bike Lane

On bike lane retrofit projects where there is insufficient room to mark a minimum 1.2-meter (4-foot) bike lane to the left of the right-turn lane, a right-turn lane may be marked and signed as a shared-use lane to encourage through-cyclists to occupy the left portion of the turn lane. This is most successful on slow-speed streets.

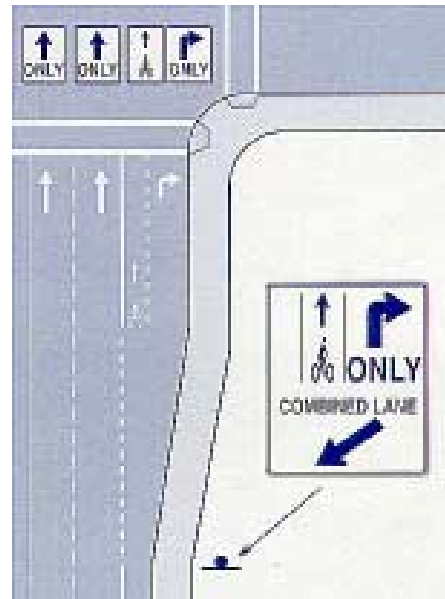

Joint use of a right-turn lane for through-bicyclist.

19.12 References

Text and graphics in this lesson were derived from the following sources:

Oregon Department of Transportation, *Oregon Bicycle and Pedestrian Plan*, 1995.

Philadelphia Department of Streets, *Philadelphia Bicycle Facility Design Guidelines*, 1998.

For more information on this topic, refer to:

AASHTO, *Guide for the Development of Bicycle Facilities*, latest edition.

ITE Technical Committee 6A-55, *Review of Planning and Design Standards for Bicycle Facilities*, 1997.

USDOT, *Manual on Uniform Traffic Control Devices*, Section 9, latest edition.

Appendix I: Rectangular Rapid Flashing Beacon Guidelines

Rectangular Rapid-Flashing Beacon (RRFB)

SAFE TRANSPORTATION
FOR EVERY PEDESTRIAN

COUNTERMEASURE TECH SHEET

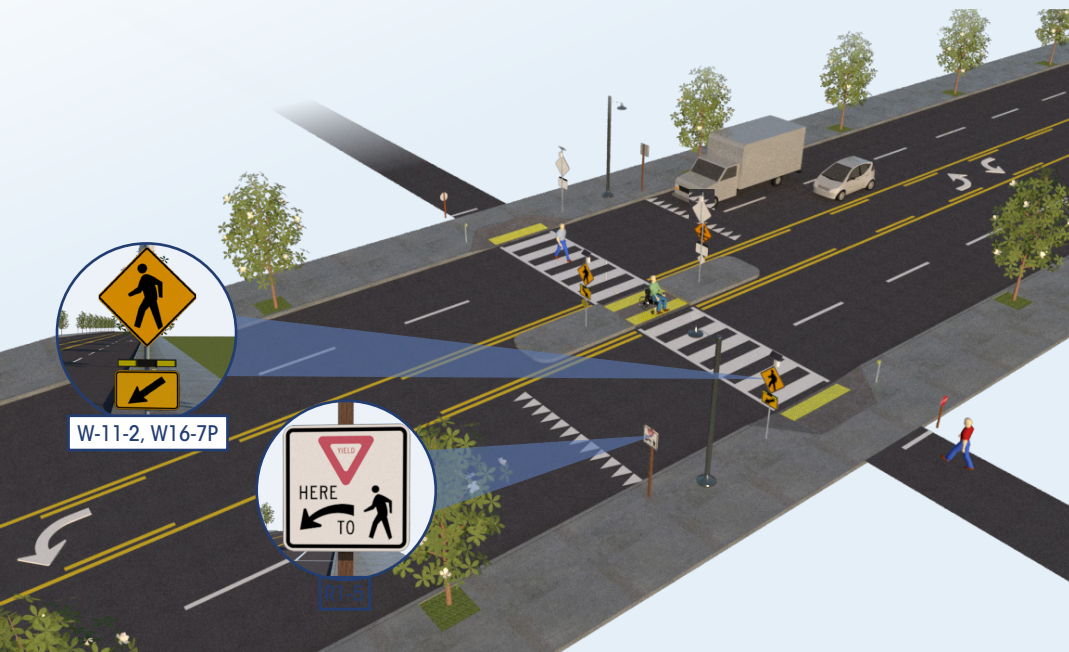

RRFBs are pedestrian-actuated conspicuity enhancements used in combination with a pedestrian, school, or trail crossing warning sign to improve safety at uncontrolled, marked crosswalks. The device includes two rectangular-shaped yellow indications, each with an LED-array-based light source, that flash with high frequency when activated.

The RRFB is a treatment option at many types of established pedestrian crossings. Research indicates RRFBs can result in motorist yielding rates as high as 98 percent at marked crosswalks. However, yielding rates as low as 19 percent have also been noted. Compliance rates varied most per the city location, posted speed limit, crossing distance, and whether the road was one- or two-way. RRFBs are particularly effective at multilane crossings with speed limits less than 40 mph. Consider the Pedestrian Hybrid Beacon (PHB) instead for roadways with higher speeds. FHWA's *Guide for Improving Pedestrian Safety at Uncontrolled Crossing Locations* (HSA-17-072) provides specific conditions where practitioners should strongly consider the PHB instead of the RRFB.

 Multiple lanes of traffic create challenges for pedestrians crossing at unsignalized locations.

 RRFBs can make crosswalks and/or pedestrians more visible at a marked crosswalk.

RRFBs can reduce pedestrian crashes by **47%**



FEATURES:

- Enhanced warning improves motorist yielding

OFTEN USED WITH:

- Crosswalk visibility enhancements
- Pedestrian refuge island
- Advance STOP or YIELD markings and signs

Rectangular Rapid-Flashing Beacon (RRFB)

EDC-4 STEP: https://www.fhwa.dot.gov/innovation/everydaycounts/edc_4/step.cfm



CONSIDERATIONS

FHWA has issued interim approval for the use of the RRFB (IA-21). State and local agencies must request and receive permission to use this interim approval before they can use the RRFB. IA-21 does not provide guidance or criteria based on number of lanes, speed, or traffic volumes.

RRFBs are placed on both ends of a crosswalk. If the crosswalk contains a pedestrian refuge island or other type of median, an RRFB should be placed to the right of the crosswalk and on the median (instead of the left side of the crosswalk).

RRFBs typically draw power from standalone solar panel units, but may also be wired to a traditional power source. IA-21 provides conditions for the use of accessible pedestrian features with the RRFB assembly. When RRFBs are not in common use in a community, consider conducting an outreach effort to educate the public and law enforcement officers on their purpose and use.

COST

The cost associated with RRFB installation ranges from \$4,500 to \$52,000 each, with the average cost estimated at \$22,250. These costs include the complete system installation with labor and materials.

References

MUTCD section 2B.12 In-Street and Overhead Pedestrian Crossing Signs (R1-6, R1-6a, R1-9, and R1-9a).

Fitzpatrick, K., M. Brewer, R. Avelar, and T. Lindheimer. "Will You Stop for Me? Roadway Design and Traffic Control Device Influences on Drivers Yielding to Pedestrians in a Crosswalk with a Rectangular Rapid-Flashing Beacon." Report No. TTI-CTS-0010. Texas A&M Transportation Institute, College Station, Texas. June 2016. <https://static.tti.tamu.edu/tti.tamu.edu/documents/TTI-CTS-0010.pdf>

Federal Highway Administration. (2018). MUTCD – Interim Approval for Optional Use of Pedestrian-Actuated Rectangular Rapid-Flashing Beacons at Uncontrolled Marked Crosswalks (IA-21). U.S. Department of Transportation, Washington, DC.

Federal Highway Administration. (2013). "Rectangular Rapid Flash Beacon" in PEDSAFE: Pedestrian Safety Guide and Countermeasure Selection System. Available: http://www.pedbikesafe.org/PEDSAFE/countermeasures_detail.cfm?CM_NUM=54

Bushell, M., Poole, B., Zegeer, C., & Rodriguez, D. (2013). Costs for Pedestrian and Bicyclist Infrastructure Improvements: A Resource for Researchers, Engineers, Planners, and the General Public. Pedestrian and Bicycle Information Center.



U.S. Department of Transportation
Federal Highway Administration

Memorandum

Subject: **INFORMATION:** MUTCD – Interim Approval for Optional Use of Pedestrian-Actuated Rectangular Rapid-Flashing Beacons at Uncontrolled Marked Crosswalks (IA-21) Date: March 20, 2018

From: Martin C. Knopp In Reply
Associate Administrator Refer HOTO-1
for Operations To:

To: Federal Lands Highway Division Directors
Division Administrators

Purpose: The purpose of this memorandum is to issue an Interim Approval for the optional use of Rectangular Rapid-Flashing Beacons (RRFB) as pedestrian-actuated conspicuity enhancements for pedestrian and school crossing warning signs under certain limited conditions. Interim Approval allows interim use, pending official rulemaking, of a new traffic control device, a revision to the application or manner of use of an existing traffic control device, or a provision not specifically described in the *Manual on Uniform Traffic Control Devices for Streets and Highways* (MUTCD). State and local agencies must request and receive permission to use this new Interim Approval, designated IA-21, from the Federal Highway Administration (FHWA) in accordance with the provisions of Section 1A.10 of the MUTCD before they can use the RRFB, even if prior approval had been given for Interim Approval 11 (IA-11), now terminated. The issuance of this new Interim Approval does not reinstate IA-11 either in whole or in part.

Background: The Florida Department of Transportation has requested that the FHWA issue an Interim Approval to allow the use of RRFBs as pedestrian-actuated conspicuity enhancements to supplement standard pedestrian and school crossing warning signs at uncontrolled marked crosswalks. The RRFB does not meet the current standards for flashing warning beacons as contained in the 2009 edition of the MUTCD, Chapter 4L, which requires a warning beacon to be circular in shape and either 8 or 12 inches in diameter, to flash at a rate of approximately once per second, and to be located no less than 12 inches outside the nearest edge of the warning sign it supplements. The RRFB uses rectangular-shaped high-intensity light-emitting-diode (LED)-based indications, flashes rapidly in a combination wig-wag and simultaneous flash pattern, and may be mounted immediately adjacent to the crossing sign.

Research on the RRFB: The City of St. Petersburg, Florida, experimented with the RRFB at 18 pedestrian crosswalks across uncontrolled approaches and submitted its final report in 2008. In addition to "before" data, the city collected "after" data at intervals for one year at all 18 sites and for two years at the first two implemented sites. For the first two sites, the city collected data for overhead and ground-mounted pedestrian crossing signs supplemented with standard circular yellow flashing warning beacons, for comparison purposes, before the RRFBs were installed. The data showed higher motorist yielding rates at crosswalks where the RRFBs had been installed in comparison to lower rates for standard warning beacons. The higher yielding rates were sustained even after two years of operation, and no identifiable negative effects were found. The St. Petersburg data also showed that drivers exhibit yielding behavior much farther in advance of crosswalks with RRFBs than with standard circular yellow flashing warning beacons.

In addition to the St. Petersburg locations, experimentation with RRFBs was also conducted at other uncontrolled marked crosswalks in Florida and other States. Data from locations other than St. Petersburg was limited, but did show results similar to those found in St. Petersburg.

The Texas Transportation Institute (TTI) conducted a Federally funded research project¹ that developed and tested a new flash pattern for the RRFB that was shown to be at least as effective as the flash pattern that was initially tested in St. Petersburg, Florida, and that showed that mounting the RRFB unit above the sign was at least as effective as mounting the RRFB unit below the sign. In this project, the results were generally favorable, however there was a wide range of yielding rates, with some as low as 19 percent. This broad range indicates that there might be certain factors or characteristics of locations at which the RRFB might not be effective.

A separate project² conducted by TTI examined data from multiple projects to determine various factors that influenced driver yielding rates at RRFB locations. In this project, the researchers found that intersection configuration, presence of a median refuge, crossing distance, approach to the crossing, and one-way vs. two-way traffic significantly affected the rate of driver yielding. Additional factors including posted speed limit, mounting of the beacons (overhead or roadside), and the type of crossing and sign—Pedestrian (W11-2) or School (S1-1) sign compared with the Trail Crossing (W11-15) sign—were also significant.

FHWA Evaluation of Results: The Office of Transportation Operations reviewed the available data in 2008 and considered the RRFB to be highly successful for the applications tested (uncontrolled marked crosswalks). The RRFB offers significant potential safety and cost benefits because it achieves high rates of compliance at a low relative cost in comparison to other more restrictive devices that provide comparable results, such as full midblock signalization or pedestrian hybrid beacons.

The FHWA granted interim approval status to the RRFB on July 16, 2008, and designated that action as Interim Approval 11 (IA-11).

The FHWA was later informed that the concept of the RRFB had been patented by a private company. Because patented traffic control devices are not allowed to be included in the MUTCD, are not allowed to be given interim approval status, and are not allowed to be a part of an official experiment, the FHWA terminated Interim Approval 11 on December 21, 2017.

The FHWA has confirmed that the patents on the RRFB device that was the subject of Interim Approval 11 have been expressly abandoned and the concept of the RRFB is now in the public domain. Because of this action, the RRFB is once again eligible for interim approval status and the FHWA is issuing this new Interim Approval for the RRFB.

Interim Approval 11 (IA-11) remains terminated. Agencies that previously had been approved to use RRFBs under IA-11 are not covered by this new Interim Approval to install new RRFBs. If agencies that had approval under IA-11 wish to continue to install new RRFBs, then they must submit a new request to the FHWA and agree to comply with the terms and conditions of IA-21.

This Interim Approval does not create a new mandate compelling installation of RRFBs, but will allow agencies to install this traffic control device, pending official MUTCD rulemaking, to provide a degree of enhanced pedestrian safety at uncontrolled marked crosswalks.

Conditions of Interim Approval: The FHWA will grant Interim Approval for the optional use of the RRFB as a pedestrian-actuated conspicuity enhancement to supplement standard pedestrian crossing or school crossing signs at uncontrolled marked crosswalks to any jurisdiction that submits a written request to the Office of Transportation Operations. A State may request

Interim Approval for all jurisdictions in that State. Jurisdictions using RRFBs under this Interim Approval must agree to the following:

- Comply with the Technical Conditions detailed in this memorandum;
- Maintain an inventory list of all locations at which the RRFB is installed; and
- Comply with all the conditions as listed in Paragraph 18 of Section 1A.10 of the MUTCD.

In addition, any agency that receives this approval must acknowledge agreement with the following:

- That an agency will furnish its list of locations where implemented if requested by FHWA;
- That FHWA has the right to rescind this Interim Approval at any time; and
- That issuance of this Interim Approval does not guarantee that the provisions, either in whole or part, will be adopted into the MUTCD.

1. General Conditions:

- a. Each RRFB unit shall consist of two rapidly flashed rectangular-shaped yellow indications with an LED-array-based light source, and shall be designed, located, and operated in accordance with the detailed requirements specified below.
- b. The use of RRFBs is optional. However, if an agency opts to use an RRFB under this Interim Approval, the following design and operational requirements shall apply, and shall take precedence over any conflicting provisions of the MUTCD for the approach on which RRFBs are used:

2. Allowable Uses:

- a. An RRFB shall only be installed to function as a pedestrian-actuated conspicuity enhancement.
- b. An RRFB shall only be used to supplement a post-mounted W11-2 (Pedestrian), S1-1 (School), or W11-15 (Trail) crossing warning sign with a diagonal downward arrow (W16-7P) plaque, or an overhead-mounted W11-2, S1-1, or W11-15 crossing warning sign, located at or immediately adjacent to an uncontrolled marked crosswalk.
- c. Except for crosswalks across the approach to or egress from a roundabout, an RRFB shall not be used for crosswalks across approaches controlled by YIELD signs, STOP signs, traffic control signals, or pedestrian hybrid beacons.
- d. In the event sight distance approaching the crosswalk at which RRFBs are used is less than deemed necessary by the engineer, an additional RRFB may be installed on that approach in advance of the crosswalk, as a pedestrian-actuated conspicuity enhancement to supplement a W11-2 (Pedestrian), S1-1 (School), or W11-15 (Trail) crossing warning sign with an AHEAD (W16-9P) or distance (W16-2P or W16-2aP) plaque. If an additional RRFB is installed on the approach in advance of the crosswalk, it shall be supplemental to and not a replacement for the RRFBs at the crosswalk itself.

3. Sign/Beacon Assembly Locations:

- a. For any approach on which RRFBs are used to supplement post-mounted signs, at least two W11-2, S1-1, or W11-15 crossing warning signs (each with an RRFB unit and a W16-7P plaque) shall be installed at the crosswalk, one on the right-hand side of the roadway and one on the left-hand side of the roadway. On a divided highway, the left-hand side assembly should be installed on the median, if practical, rather than on the far left-hand side of the highway.
- b. An RRFB unit shall not be installed independent of the crossing warning signs for the approach that the RRFB faces. If the RRFB unit is supplementing a post-mounted sign, the RRFB unit shall be installed on the same support as the associated W11-2, S1-1, or W11-15 crossing warning sign and plaque. If the

RRFB unit is supplementing an overhead-mounted sign, the RRFB unit shall be mounted directly below the bottom of the sign.

4. Beacon Dimensions and Placement in the Sign Assembly:

- a. Each RRFB shall consist of two rectangular-shaped yellow indications, each with an LED-array-based light source. The size of each RRFB indication shall be at least 5 inches wide by at least 2 inches high.
- b. The two RRFB indications for each RRFB unit shall be aligned horizontally, with the longer dimension horizontal and with a minimum space between the two indications of at least 7 inches, measured from the nearest edge of one indication to the nearest edge of the other indication.
- c. The outside edges of the RRFB indications, including any housings, shall not project beyond the outside edges of the W11-2, S1-1, or W11-15 sign that it supplements.
- d. As a specific exception to Paragraph 5 of Section 4L.01 of the 2009 MUTCD, the RRFB unit associated with a post-mounted sign and plaque may be located between and immediately adjacent to the bottom of the crossing warning sign and the top of the supplemental downward diagonal arrow plaque (or, in the case of a supplemental advance sign, the AHEAD or distance plaque) or within 12 inches above the crossing warning sign, rather than the recommended minimum of 12 inches above or below the sign assembly. (See the example photo that is shown below.)

5. Beacon Flashing Requirements:

- a. When actuated, the two yellow indications in each RRFB unit shall flash in a rapidly flashing sequence.
- b. As a specific exception to the requirements for the flash rate of beacons provided in Paragraph 3 of Section 4L.01, RRFBs shall use a much faster flash rate and shall provide 75 flashing sequences per minute. Except as provided in Condition 5f below, during each 800-millisecond flashing sequence, the left and right RRFB indications shall operate using the following sequence:

The RRFB indication on the left-hand side shall be illuminated for approximately 50 milliseconds.

Both RRFB indications shall be dark for approximately 50 milliseconds.

The RRFB indication on the right-hand side shall be illuminated for approximately 50 milliseconds.

Both RRFB indications shall be dark for approximately 50 milliseconds.

The RRFB indication on the left-hand side shall be illuminated for approximately 50 milliseconds.

Both RRFB indications shall be dark for approximately 50 milliseconds.

The RRFB indication on the right-hand side shall be illuminated for approximately 50 milliseconds.

Both RRFB indications shall be dark for approximately 50 milliseconds.

Both RRFB indications shall be illuminated for approximately 50 milliseconds.

Both RRFB indications shall be dark for approximately 50 milliseconds.

Both RRFB indications shall be illuminated for approximately 50 milliseconds.

Both RRFB indications shall be dark for approximately 250 milliseconds.

- c. The flash rate of each individual RRFB indication, as applied over the full flashing sequence, shall not be between 5 and 30 flashes per second to avoid frequencies that might cause seizures.
 - d. The light intensity of the yellow indications during daytime conditions shall meet the minimum specifications for Class 1 yellow peak luminous intensity in the Society of Automotive Engineers (SAE) Standard J595 (Directional Flashing Optical Warning Devices for Authorized Emergency, Maintenance, and Service Vehicles) dated January 2005.
 - e. To minimize excessive glare during nighttime conditions, an automatic signal dimming device should be used to reduce the brilliance of the RRFB indications during nighttime conditions.
 - f. Existing RRFB units that use the flashing sequence that was specified in the Interim Approval 11 memorandum and a subsequent interpretation (the RRFB indication on the left-hand side emits two slow pulses of light after which the RRFB indication on the right-hand side emits four rapid pulses of light followed by one long pulse of light) should be reprogrammed to the flash pattern specified above in Condition 5b as part of a systematic upgrading process, such as when the units are serviced or when the existing signs are replaced.
6. Beacon Operation:
- a. The RRFB shall be normally dark, shall initiate operation only upon pedestrian actuation, and shall cease operation at a predetermined time after the pedestrian actuation or, with passive detection, after the pedestrian clears the crosswalk.
 - b. All RRFB units associated with a given crosswalk (including those with an advance crossing sign, if used) shall, when actuated, simultaneously commence operation of their rapid-flashing indications and shall cease operation simultaneously.
 - c. If pedestrian pushbutton detectors (rather than passive detection) are used to actuate the RRFB indications, a Push Button To Turn On Warning Lights (R10-25) sign shall be installed explaining the purpose and use of the pedestrian pushbutton detector.
 - d. The duration of a predetermined period of operation of the RRFBs following each actuation should be based on the procedures provided in Section 4E.06 of the 2009 MUTCD for the timing of pedestrian clearance times for pedestrian signals.
 - e. The predetermined flash period shall be immediately initiated each and every time that a pedestrian is detected either through passive detection or as a result of a pedestrian pressing a pushbutton detector, including when pedestrians are detected while the RRFBs are already flashing and when pedestrians are detected immediately after the RRFBs have ceased flashing.
 - f. A small pilot light may be installed integral to the RRFB or pedestrian pushbutton detector to give confirmation that the RRFB is in operation.
7. Accessible Pedestrian Features:
- a. If a speech pushbutton information message is used in conjunction with an RRFB, a locator tone shall be provided.
 - b. If a speech pushbutton information message is used in conjunction with an RRFB, the audible information device shall not use vibrotactile indications or percussive indications.
 - c. If a speech pushbutton information message is used in conjunction with an RRFB, the message should say, "Yellow lights are flashing." The message should be spoken twice.

Any questions concerning this Interim Approval should be directed to Mr. Duane Thomas at duane.thomas@dot.gov.





Figure 1. Example of an RRFB dark (left) and illuminated during the flash period (center and right) mounted with W11-2 sign and W16-7P plaque at an uncontrolled marked crosswalk.





Figure 2. View of pilot light to pedestrian at shared-use path crossing with median refuge. Enlargement of pilot light at right.



Figure 3. Example of pedestrian pushbutton and R10-25 sign with pilot light for pedestrian actuation.

Appendix J: ODOT Feasibility Correspondence

The following are emails exchanged between LCATS and ODOT during July and August 2020.

Hi Ty and Josh,

LCATS has been working with the LC Health Department and Village of Hebron on local pedestrian improvements. The biggest part of this project is aiming to get pedestrian signal heads in at the Main and High intersection in the center of the village. Before this progresses any further, we wanted to get an expert out there to make sure that this would be compatible at the current signal/controller. We are also looking to discuss installation of these ped heads before we start allocating local funds for this project.

All the Best,
Alex Nouanesengsy

Alex – our Traffic Engineer (Brian Bosch) said he would stop by this week or next and let us know about the feasibility of installing pedestrian heads at the intersection of High Street/Main Street. Once I hear back from Brian – I'll forward the response.

Thanks,

Ty

Alex – please see excerpt below of the signal cabinet review. In short, the cabinet will need to be replaced to accommodate the pedestrian signal heads.

Yes, We did check it out and it is only a 2 phase cabinet (no approach monitoring) and there is only 1 slot left for a load switch to run the other 3 ped phases.

My suggestion would be to upgrade the cabinet and split the signal phases so that you can have approach monitoring and then you would also have 4 phases for each of the ped phases.

Ty Thompson, P.E.