

STATE OF OHIO
DEPARTMENT OF HIGHWAYS
MAD-40-3.08
MADISON COUNTY
SOMERFORD & DEER CREEK TWP'S.

PART I.









FOR PART 2, SEE PLANS FOR
MAD-40-(7.42-12.45)

LINE DATA

Begin Project 160+22.53
End Project 349+34.78
Gross Length 18,912.25 Ft.
No Additions or Deductions
Net Length of Project 18,912.25 Ft.
or 3.581 Mi.

Begin Work 160+01.26
End Work 350+63.78
Gross Length 19,062.52 Ft.
Add For Equation Sta. 78.73 Ft.
(161+01.26 Bk. = 160+22.53 Ah)
Net Length of Work 19,141.25 Ft.
or 3.625 Mi.

CONVENTIONAL SIGNS

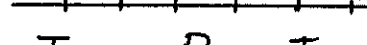
County Line 
Township Line 
Section Line 
Center Line 
Property Line 
City or Village Line 
Fence Line 
Steam Railroad 
Pole Line 

INDEX OF SHEETS





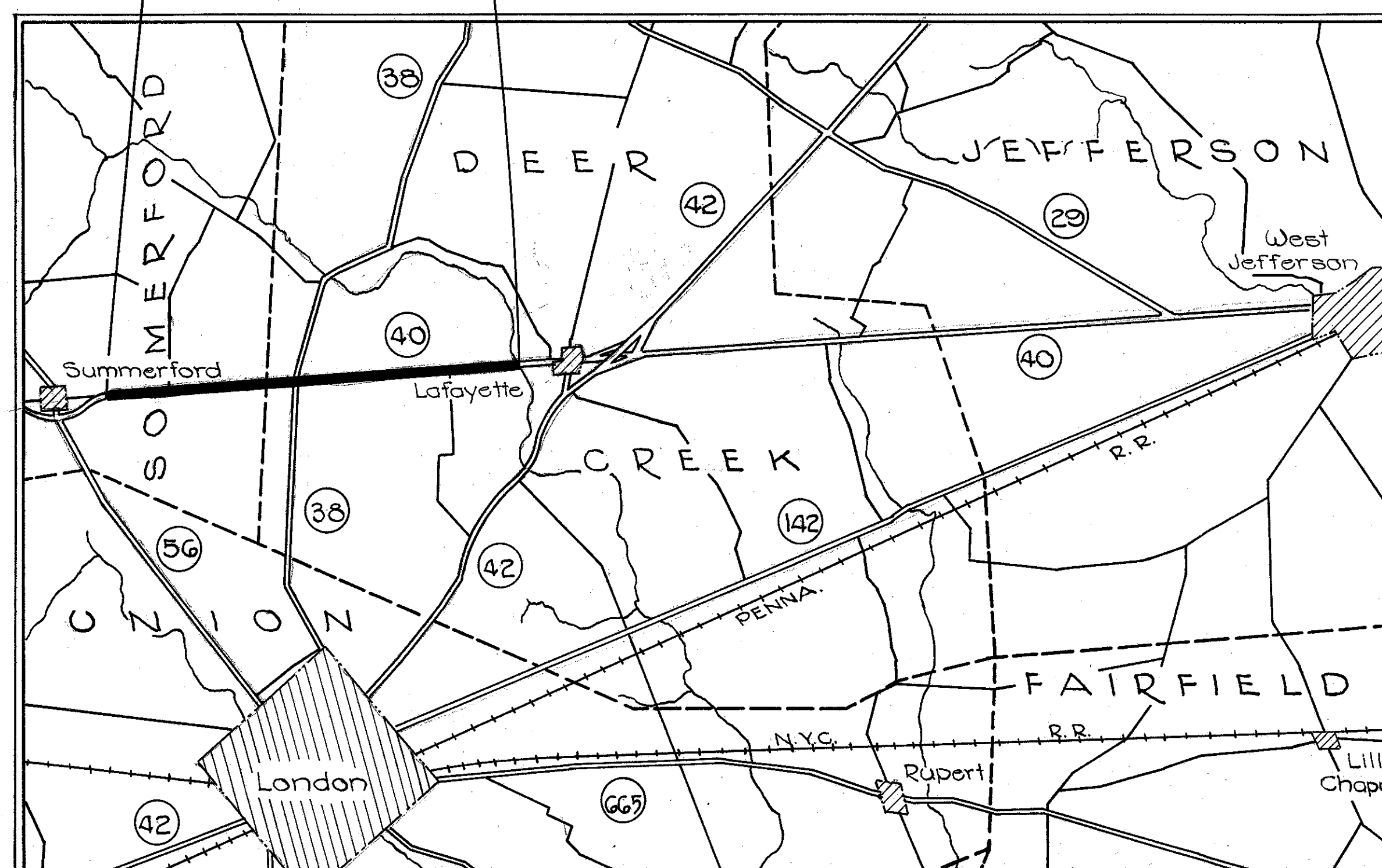

Title Sheet	1
Typical Section	2
General Notes	3
General Summary	3
Calculations	3
Plan & Profile	4-5
Special Details	6
Cross Sections	7-10

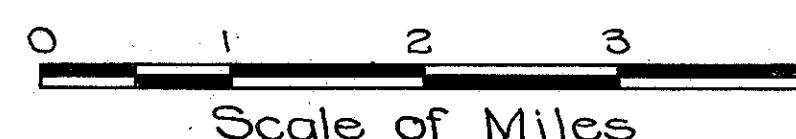
Begin Project Sta 160+22.53
End Project Sta 349+34.78

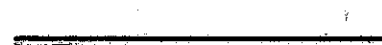

LOCATION PLAT

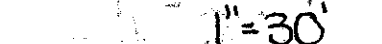

Portion to be Improved 
State Highways 
County Roads 
Plan 
Profile 
X-Sections, sheets 7-9 
X-Sections, sheet 10 

Horizontal 1"=300'
Vertical 1"=30'
Horizontal 1"=5'
Vertical 1"=0.5'
Horizontal 1"=5'
Vertical 1"=5'

NOV 6 1961
GROUND PHOTOLAP

SUPPLEMENTAL PRINTS OF STANDARD CONSTRUCTION DRAWINGS

T-35	1-2-56	L-3	4-1-50
RI-1	1-3-55	L-3-A	4-1-50
I-15, N° 1	8-1-55	I-15, N° 2	12-1-54
I-15, N° 2-A	7-2-56		
G-7.07	6-1-56		

SUPPLEMENTAL SPECIFICATIONS

B-115	Rev. 6-30-56
E-101	1-1-57

File No.	Madison County	MAD-40-3.08
Date of Letting		
Contract No.		

The Standard Specifications of the State of Ohio, Department of Highways, including changes and Supplemental Specifications listed in the proposal shall govern this improvement.

I hereby approve these plans and declare that the making of this improvement will not require the closing of the highway to traffic and that provisions for the maintenance and safety of traffic will be as set forth on the plans and estimates.

The right of way for this improvement will be provided by the State of Ohio.

Approved *E. W. Waldorf*
Date 3-7-57 Division Deputy Director

Approved *C. H. Mahoney*
Date 3-21-57 Deputy Director of Planning & Programming

Approved *W. J. Carrigan*
Date 3-18-57 Engineer of Bridges

Approved *P. E. Shultz*
Date 3-20-57 Engineer of Location & Design

Approved *P. S. Masten*
Date 3-20-57 Deputy Director of Design & Construction

Approved _____
Date _____ First Assistant Director

Approved *George J. Sherman*
Date 3/22/57 Acting Director of Highways.

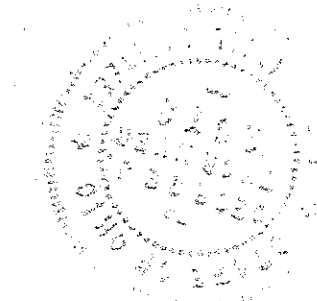

TYPICAL SECTION

TYPE T-35

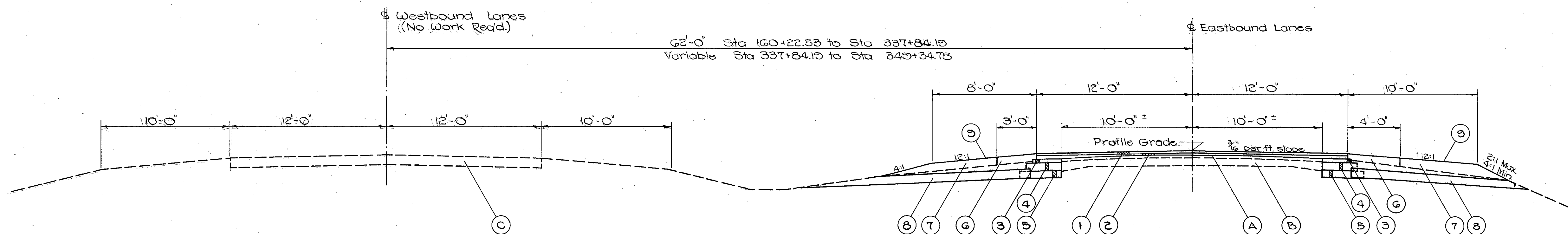

LIMITING STATIONS
Sta 160+22.53 to Sta 349+34.78 = 18,912.25 Lin. Ft.

Note: For details not shown reference is made to Standard Drawings RI-1 & T-35.

- | | |
|-----|--|
| (A) | Existing 2"± Bituminous Wearing Course |
| (B) | Existing 9"-7"-7"-9" Concrete Pavement, Plain |
| (C) | Existing 9" Portland Cement Concrete Pavement, Reinforced |
| (1) | Item T-35 1½" Asphaltic Concrete Surface Course (70-85), Type A |
| (2) | Item B-35 1¼" Minimum Asphaltic Concrete Leveling Course (70-85) |
| (3) | Item B-35 3" Asphaltic Concrete Leveling Course (70-85) |
| (4) | Item B-119 8" Crushed Aggregate Base Course |
| (5) | Item I-22 6" Subbase |
| (6) | Item I-18 Variable Depth Stabilized Crushed Aggregate Shoulders & Approaches |
| (7) | Embankment |
| (8) | Item I-9 Stone Underdrains, No. 2 |
| (9) | Item L-9 Seeding and Protecting |

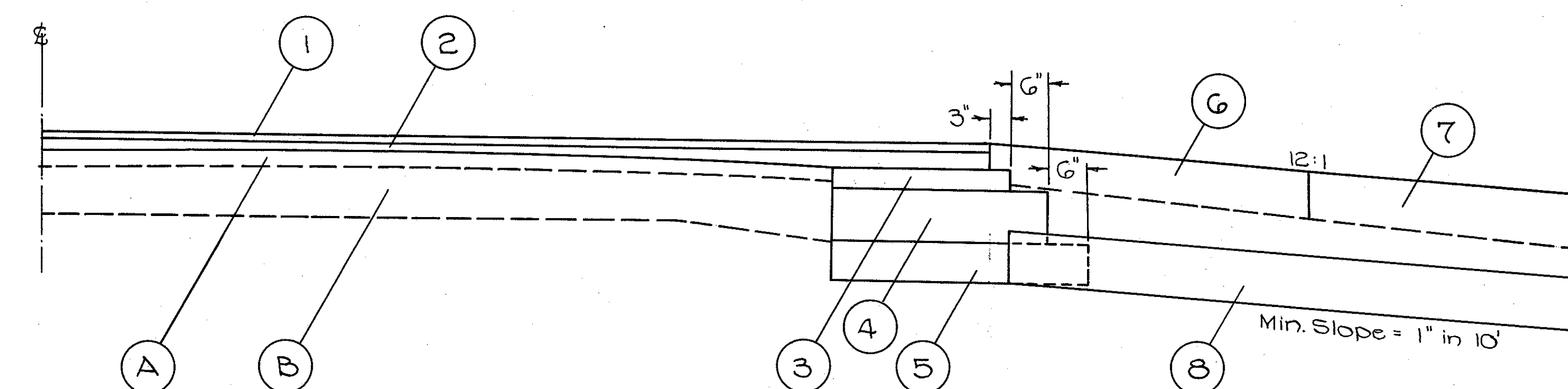

DETAIL OF BASE WIDENING

Note: Stone Underdrains to be placed at 100' intervals on both sides or as directed by the Engineer.

ESTIMATED QUANTITY
378 @ 14' = 5292 Lin. Ft.
(quantity carried to General Summary, sheet 3)

CALCULATIONS

T-35 Asphaltic Concrete Surface Course

1/2" T-35
 From Typical = 18,912.25 Lin. Ft.
 18,912.25 x 24 ÷ 9 = 50,432.66 Sq. Yd.
 50,432.66 x 1.50 ÷ 36 = 1,751.13 Cu. Yd.
 Total T-35 = 2101.4 Cu. Yd.

B-35 Asphaltic Concrete Leveling Course

1/4" B-35
 Quantity same as T-35 = 1,751.13 Cu. Yd.
 3" B-35
 From Typical = 18,912.25 Lin. Ft.
 18,912.25 x 2.25 ÷ 9 x 2 = 9,456.13 Sq. Yd.
 Deduct from sheet G = 343.6 Sq. Yd.
 9,112.53 Sq. Yd.
 9,112.53 x 3 ÷ 36 = 759.38 Cu. Yd.
 For Longitudinal & Crown Correction (180 cu.yd/mi.)
 From Typical = 18,912.25 Lin. Ft.
 18,912.25 ÷ 5,280 = 3.582 Mi.
 3.582 x 180 = 644.76 Cu. Yd.
 Total B-35 = 3,155.3 Cu. Yd.

B-119 Crushed Aggregate Base Course

8" B-119
 From Typical = 18,912.25 Lin. Ft.
 18,912.25 x 2.75 ÷ 9 x 2 = 11,557.48 Sq. Yd.
 Deduct from sheet G = 420.0 Sq. Yd.
 11,137.48 Sq. Yd.
 11,137.48 x 8 ÷ 36 = 2,475.00 Cu. Yd.
 Total B-119 = 2,475.0 Cu. Yd.

I-22 Subbase

6" I-22
 From Typical = 18,912.25 Lin. Ft.
 18,912.25 x 3.25 ÷ 9 x 2 = 13,658.84 Sq. Yd.
 Deduct from sheet G = 426.2 Sq. Yd.
 13,162.64 Sq. Yd.
 13,162.64 x 6 ÷ 36 = 2,193.77 Cu. Yd.
 Total I-22 = 2,193.8 Cu. Yd.

I-18 Stabilized Crushed Aggregate Shoulders & Approaches

Var. Depth I-18
 From sheet 7 = 1939.0 Cu. Yd.
 Deduct from sheet G = 343 Cu. Yd.
 Total I-18 = 1,904.7 Cu. Yd.

E-11 Water

Embankment = 5074 Cu. Yd.
 B-119 Total Embankment = 2482 Cu. Yd.
 I-22 = 2220 Cu. Yd.
 I-18 = 1937 Cu. Yd.
 Subgrade in Cuts = 2220 Cu. Yd.
 13,933 x 0.005 = 69.7 M. Gals.

L-9 Commercial Fertilizer

L-9 Seeding = 35,743 Sq. Yd.
 35,743 x 0.18 ÷ 2000 = 3.22 Tons
 Total L-9 = 3.2 Tons

E-4 Borrow

Embankment plus 25% Excavation = 5074 x 1.25 = 6343 Cu. Yd.
 Net Borrow = 5962 Cu. Yd.
 = 381 Cu. Yd.

GENERAL NOTES

PROFILE:-

The profile of the proposed surface course shall be approximately 2" above that of the existing pavement.

PAY QUANTITIES:-

All quantities are estimated and payment shall be made on actual quantities used as determined by final measurements.

STABILIZED SHOULDERS:-

Compaction of the Subgrade required by Sec. I-18.03 is hereby waived on this project.

TRAFFIC:-

Two-way traffic shall be maintained at all times. The requirements of Sec. T-35.23 and Sec. B-35.25 shall be strictly followed.

WIDENING:-

In areas where widening occurs on both sides of the existing pavement the contractor shall leave an open trench on but one side at a time. No work shall be performed on the opposite side until the base widening courses have been placed to the grade of the existing pavement.

UTILITIES:-

Any and all work required for public or private utilities shall be performed by and at the expense of their respective owners.

SEEDING AND PROTECTING:-

Quantities for seeding have been estimated for those areas where embankment is to be placed.

ITEMS T-35 & B-35:-

The 1/4" minimum thickness leveling course and the 1/2" surface course shall be laid using two pavers so that a hot longitudinal joint will be secured. (See note in proposal).

EARTHWORK :-

Benching, density requirements, and the removal of sod from the shoulders will not be required except between Sta. 346+00 and Sta 349+34.78. However Item E-101 Roadway Excavation shall include the thorough compaction of embankment in layers not exceeding eight inches compacted thickness, and shall include any operations of grading necessary to finish the shoulders and slopes substantially to the lines indicated on the typical section.

MAINTAINING TRAFFIC:-

The item "Maintaining Traffic" shall include furnishing lights, signs, barricades, and watchmen necessary to secure the flow of traffic 24 hours daily.

GENERAL SUMMARY

ITEM	SHEET 2	SHEET 3	SHEET 5	SHEET 6	SHEET 7	QUANTITY	UNIT	DESCRIPTION
ROADWAY AND DRAINAGE								
E-101					5962	5962	Cu. Yds.	Roadway Excavation, as per plan
E-4		381				381	Cu. Yds.	Borrow
E-8				526.8		527	Sq. Yds.	Removal and Disposal of Existing Wearing Course
E-8				100.0		100	Sq. Yds.	Removal and Disposal of Existing Pavement
E-11		69.7				70	M. Gals.	Water
I-9	5292					5292	Lin. Ft.	Stone Underdrains, N ^o 2
I-15			430			430	Lin. Ft.	Guard Rail Removed and Disposed of
I-15			300			300	Lin. Ft.	Guard Rail, Steel Beam Type (Deep)
I-18		1904.7		31.9		1937	Cu. Yds.	Stabilized Crushed Aggregate Shoulders and Approaches <i>as per plan</i>
L-9					35743	35743	Sq. Yds.	Seeding and Protecting
L-9		3.22				3.22	Tons	Commercial Fertilizer (10-G-4)
PAVEMENT								
T-35		2101.4		79.4		2181	Cu. Yds.	Asphaltic Concrete Surface Course, Type A(70-85) <i>As Per Plan</i>
B-35		3155.3		77.4		3233	Cu. Yds.	Asphaltic Concrete Leveling Course (70-85) <i>As Per Plan</i>
B-119		2475.0		6.7		2482	Cu. Yds.	Crushed Aggregate Base Course
I-22		2193.8		25.6		2220	Cu. Yds.	Subbase
B-35				584		584	Lin. Ft.	Sealing Vertical Face of Existing Pavement
S-3				415.7		416	Sq. Yds.	Waterproofing, Type "C"
T-30				160.9		161	Gals.	Bituminous Tack Coat: Sec. M 5.5, M5-2 or RS-1; or Sec. M-5.2, RC-1 or RC-2, as per Sec. T-30.02

FED. RD. DISTRICT	STATE	PROJECT
2	OHIO	

4
10

MAD-40-3.08

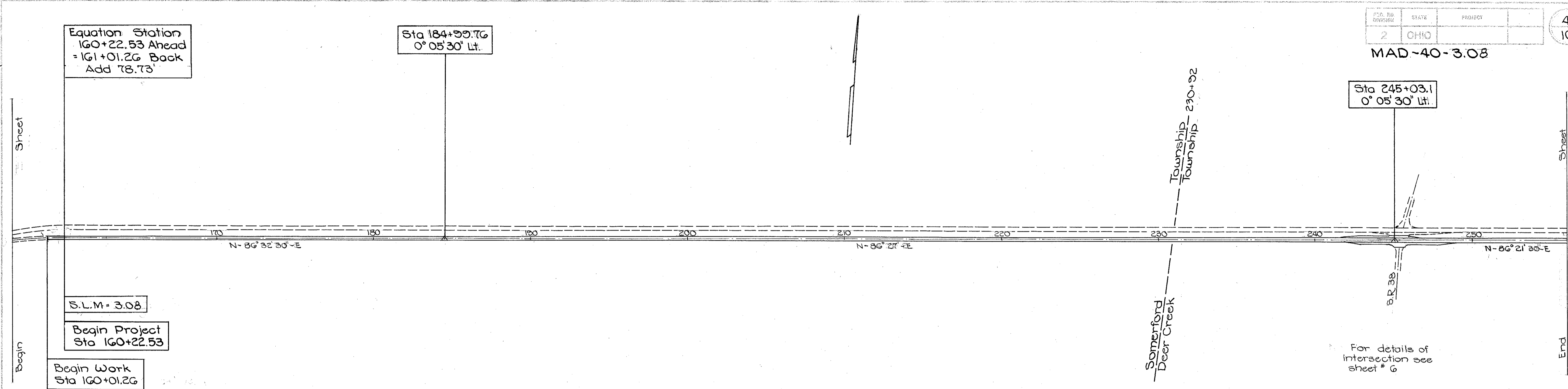

Equation Station
160+22.53 Ahead
= 161+01.26 Back
Add 78.73

Sta 184+99.76
0° 05' 30" Lt.

Sta 245+03.1
0° 05' 30" Lt.

S.L.M. = 3.08

Begin Project
Sta 160+22.53

Begin Work
Sta 160+01.26

For details of transition
see sheet # 6

For details of
intersection see
sheet # 6

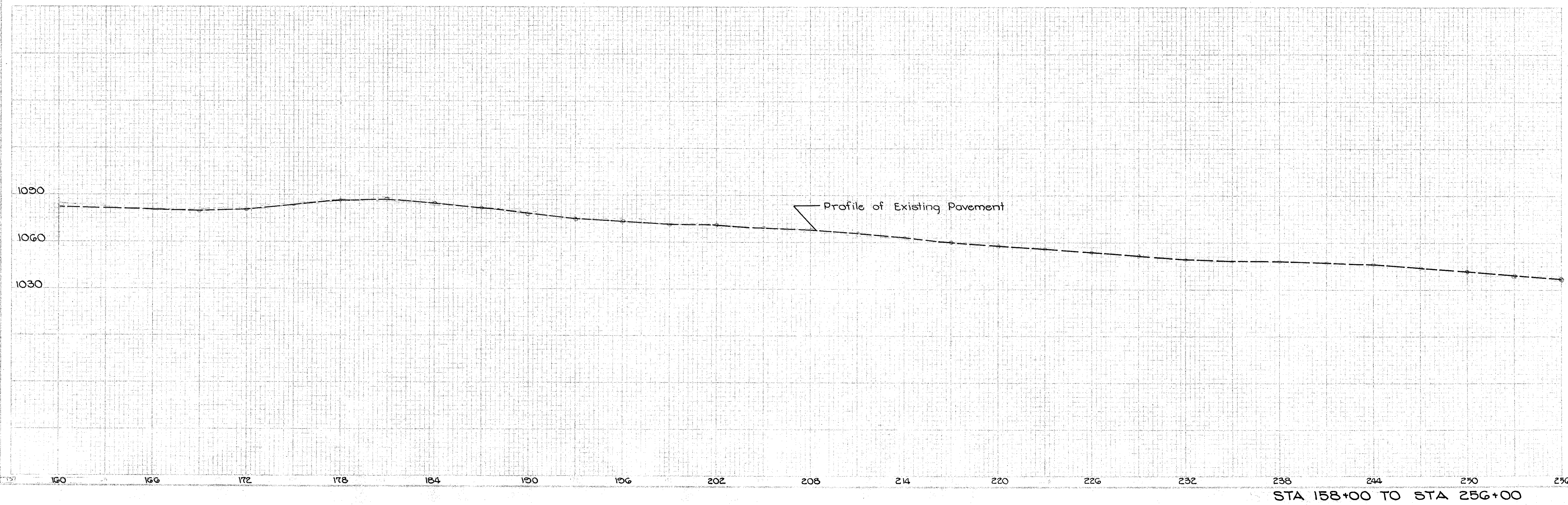

Profile of Existing Pavement

STA 158+00 TO STA 256+00

MAD-40-3.08

Sta 315+00.4
0°08'30" Lt.

For detail of
Structure see
sheet # G

MAD-40-0666

Sheet

Begin

Sheet

End

Ref. No.	Station		Side	RAIL	
	From	To		I-15 Guard Rail Removed & Dispose Lin. Ft.	I-15 Guard Rail Steel Beam (Deep) Lin. Ft.
1-G	345+04	349+34	Rt.	430	
2-G	346+32	349+32	Rt.		300
Totals				430	300

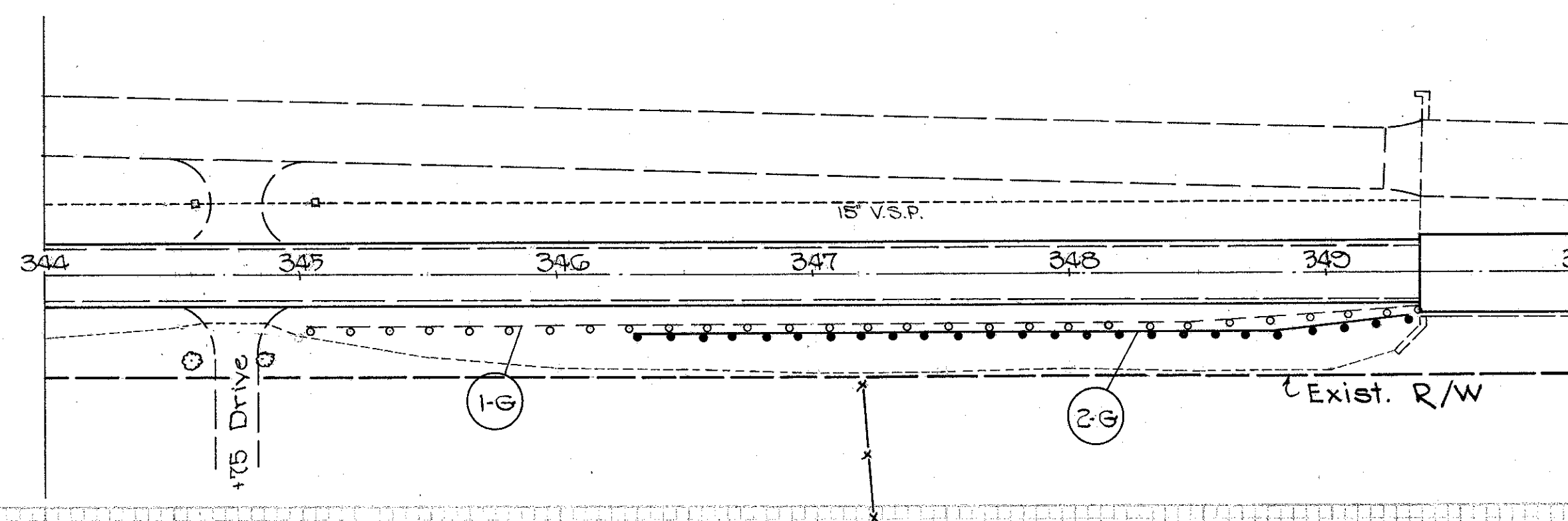

SLM = 6.66

End Project
Sta 349+34.78

End Work
Sta 350+63.78

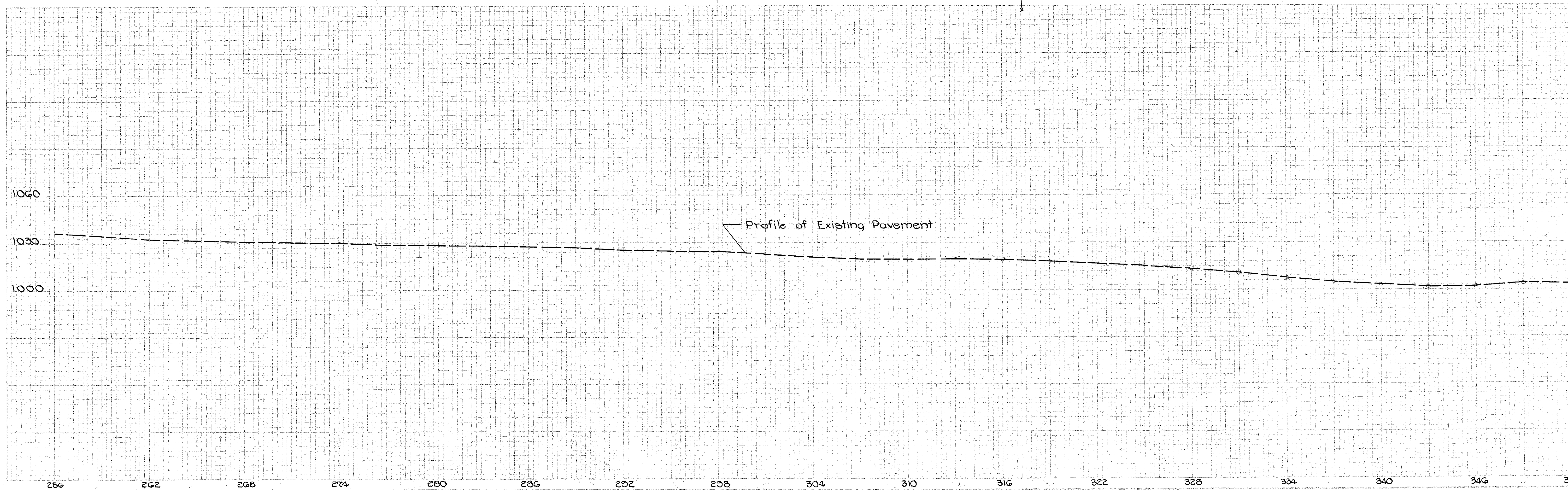

STA 256+00 TO STA 352+00

MAD-40-3.08

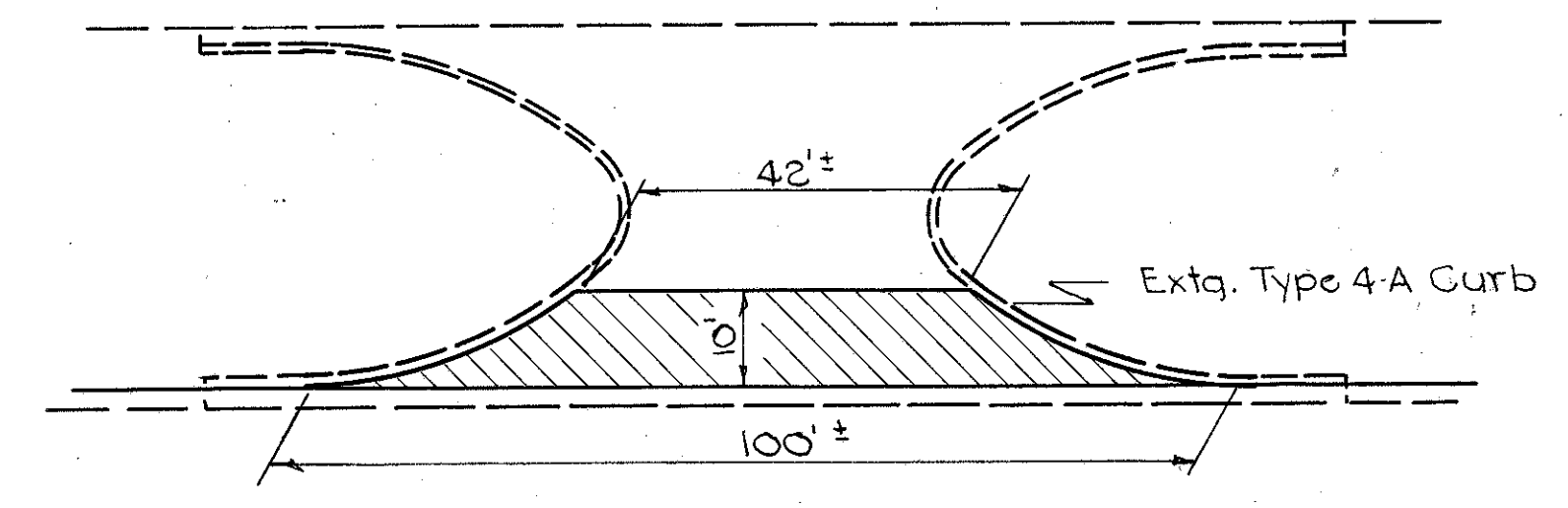

TYPICAL PAVED CROSSOVER (2)
Sta 183+55 & Sta 316+27

DETAIL OF TRANSITION (4)
Sta 160+01.26 to 161+01.26

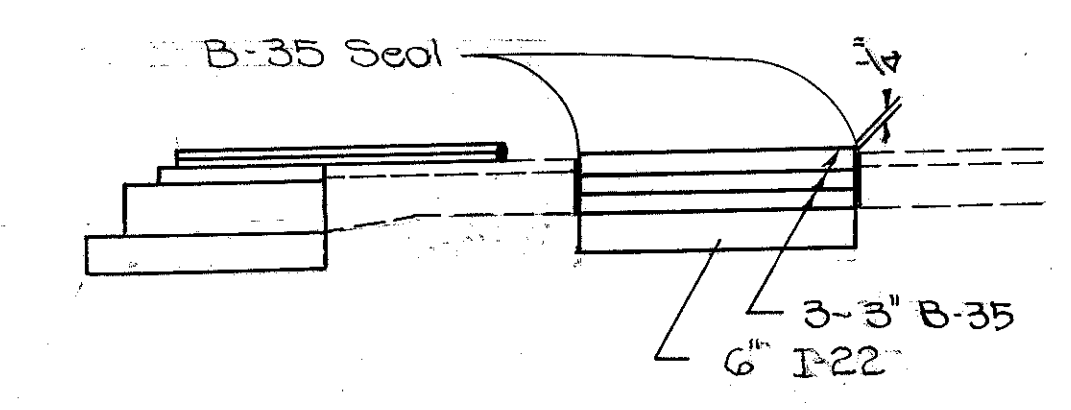
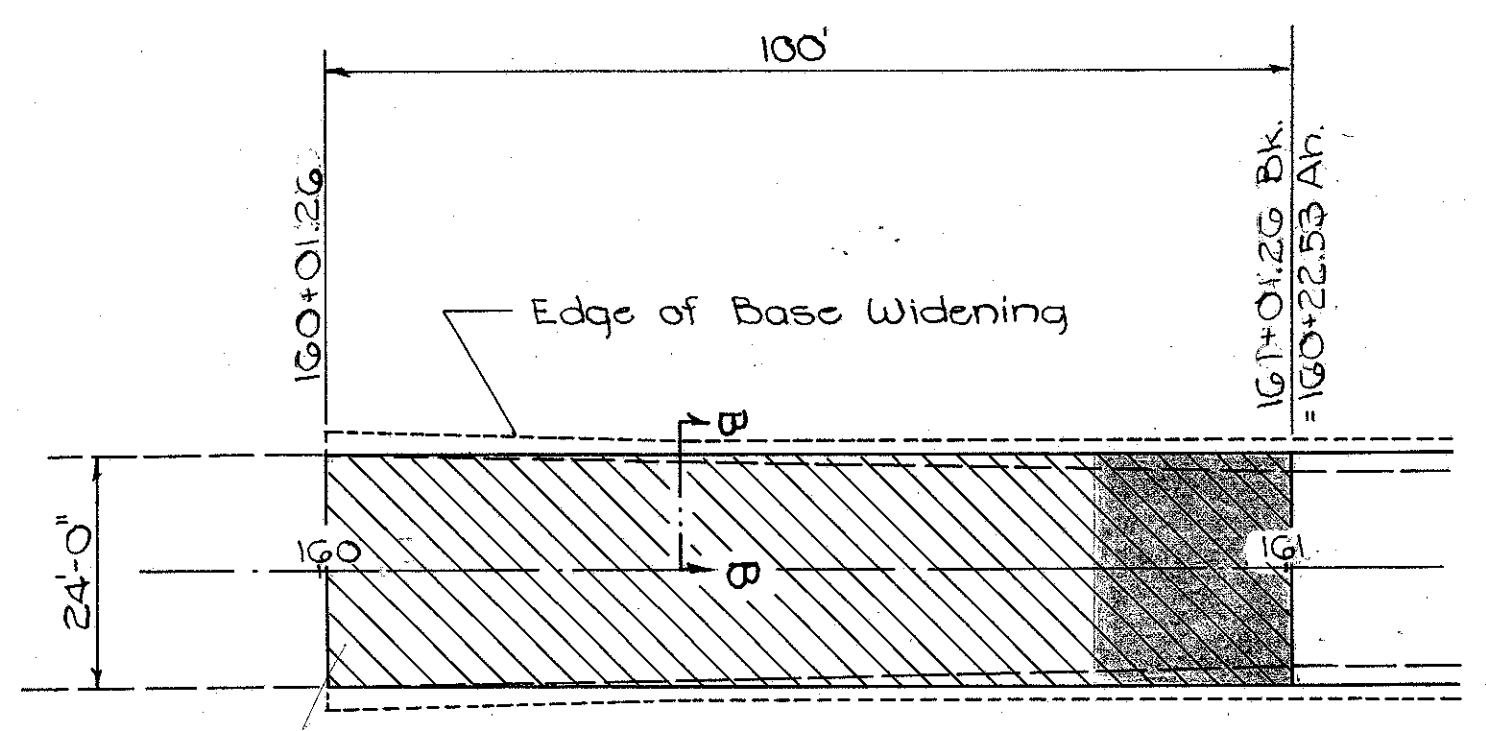

Base Replacement, if required, shall be at those locations determined by the Engineer.
Estimated: 100 Sq. Yds.

DETAIL OF BASE REPLACEMENT (7)

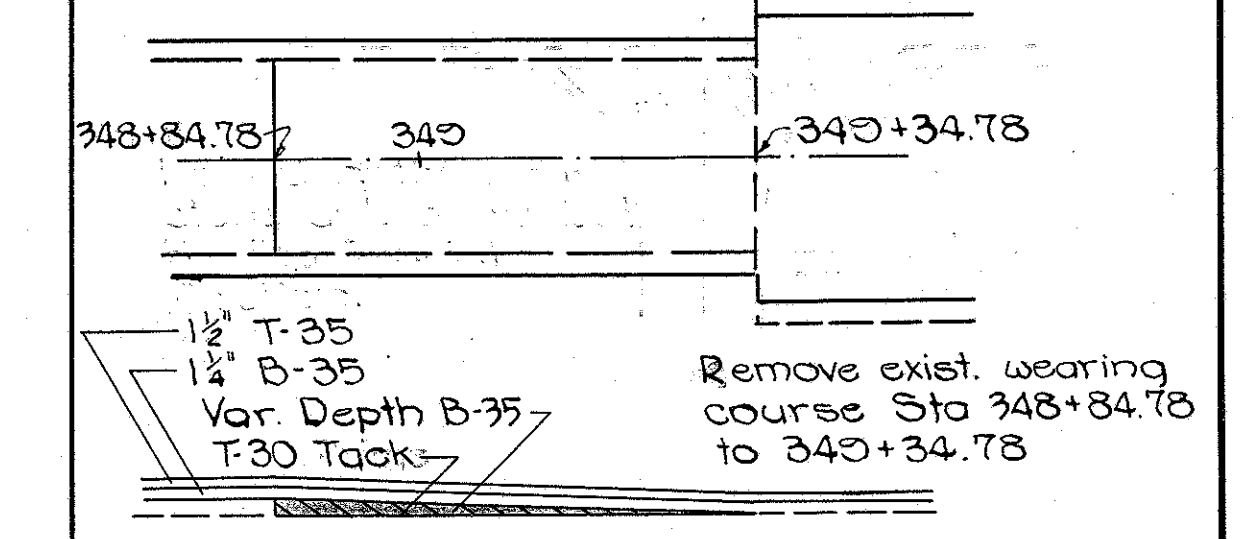

TRANSITION (6)
348+84.78 to 349+34.78

Note: The exist. 3" bituminous wearing surface shall be removed and the exist. conc. deck shall be thoroughly cleaned of all loose material, using air if necessary. Cost of this cleaning shall be included in unit cost bid for Item E-8.

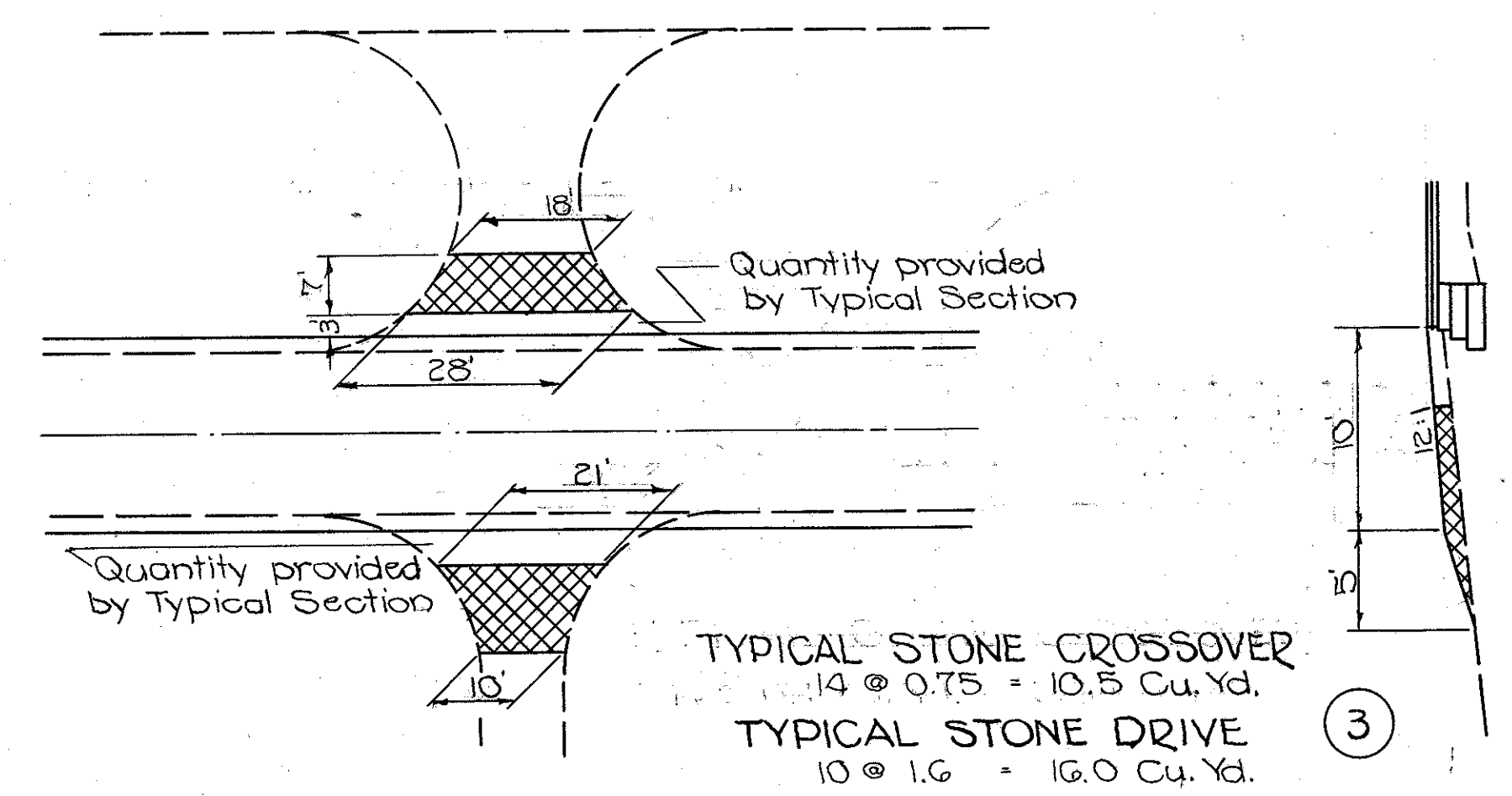

TYPICAL STONE CROSSOVER
14 @ 0.75 = 10.5 Cu. Yd.
TYPICAL STONE DRIVE
10 @ 1.6 = 16.0 Cu. Yd.

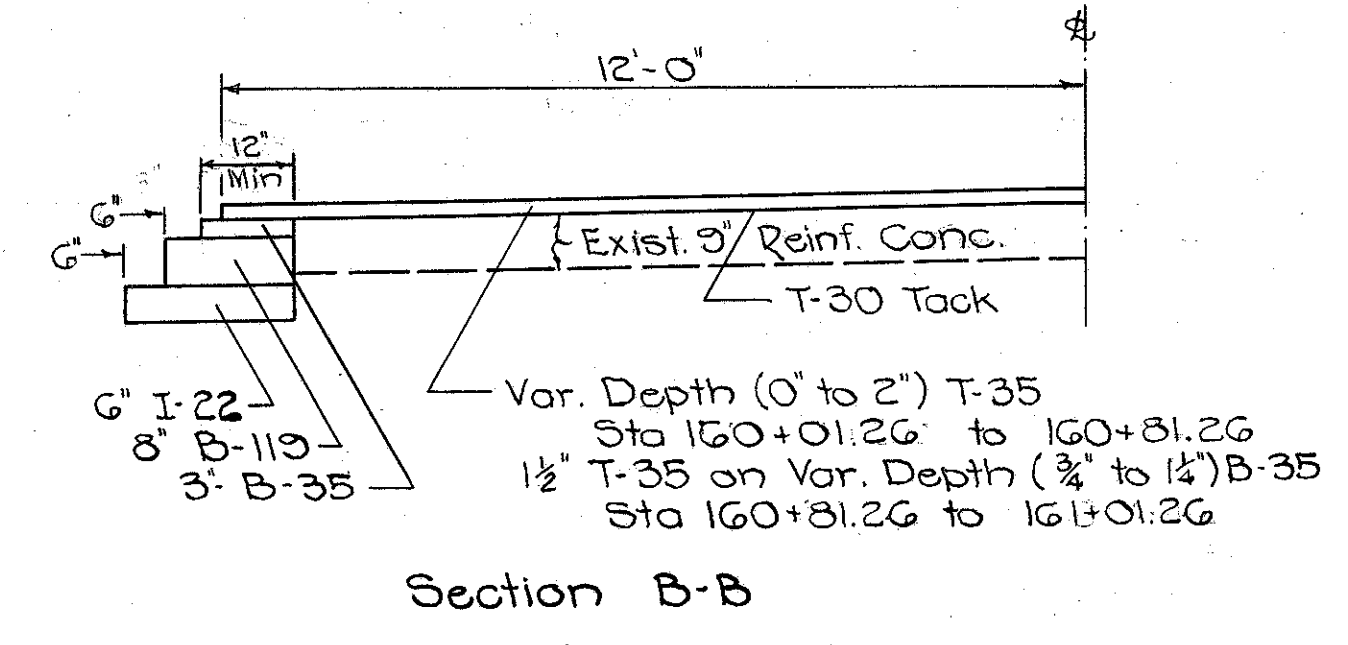

Section B-B

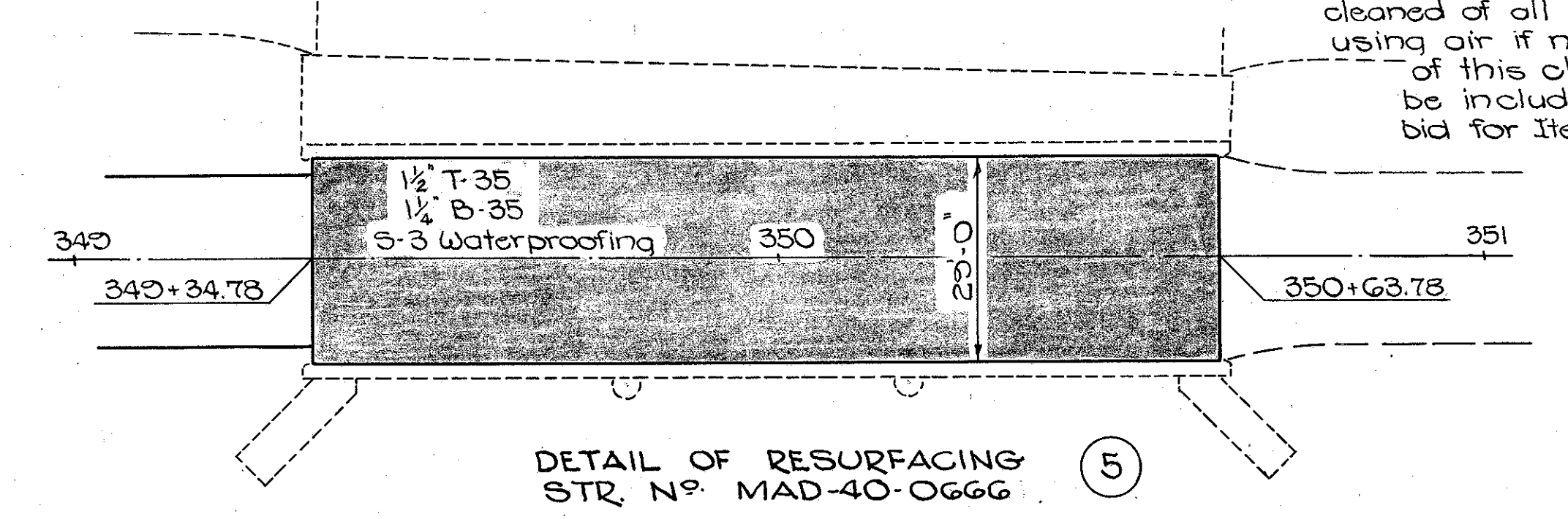

DETAIL OF RESURFACING STR. N° MAD-40-0666 (5)

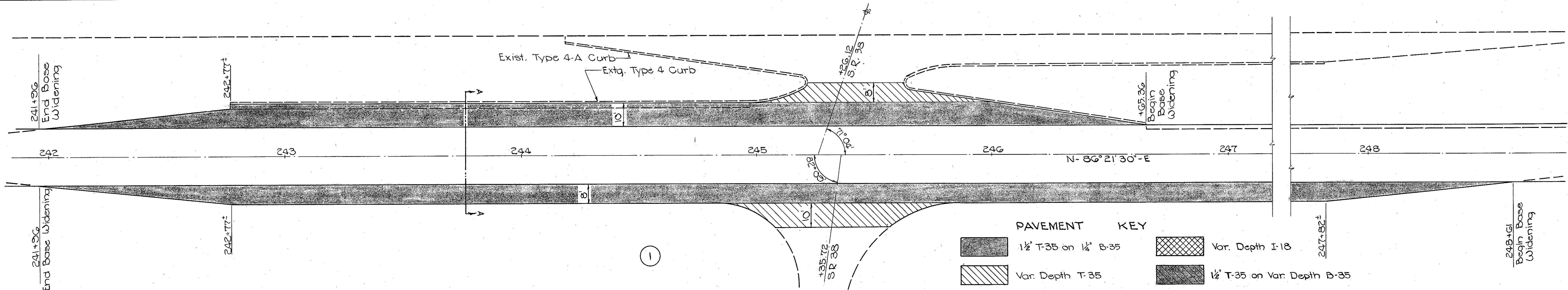

PAVEMENT KEY

	1 1/2" T-35 on 1/4" B-35		Var. Depth I-18
	Var. Depth T-35		1 1/2" T-35 on Var. Depth B-35

* See Standard Drawing T-35 for details.

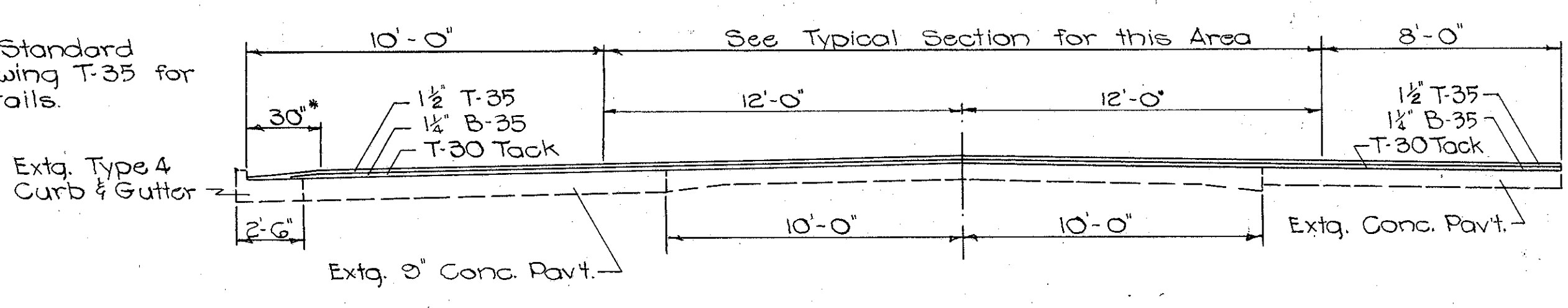

TYPICAL SECTION A-A

Reference Number	ESTIMATED QUANTITIES														
	B-35 Sealing Vertical Face of Exist. Pavt.	E-8 Remove & Dispose of Exist. Pavt.	T-35 Asphaltic Concrete Surface Course (70-85)	B-35 Asphaltic Concrete Leveling Course (70-85)	T-30 Bituminous Tack Coat 0.1 gal/sq. yd.	I-18 Crushed Aggregate Shoulder & Appr.	E-8 Remove & Dispose of Exist. Wearing Course	S-3 Water-proofing Type C	I-22 Subbase	B-119 Crushed Aggregate Base Course	Deduct				
	Lin. Ft.	Sq. Yd.	Cu. Yd.	Cu. Yd.	Gals.	Cu. Yd.	Sq. Yds.	Sq. Yds.	Cu. Yds.	Cu. Yds.	3" B-35 Asphaltic Concrete Leveling	8" B-119 Crushed Aggregate Base	6" I-22 Subbase	Var. Depth I-18 Stabilized Crushed Aggregate	
1			46.1	31.0	103.6						283.6	346.6	403.6	22.7	
2			6.6		15.8						60.0	73.4	86.6	11.6	
3						26.5									
4			9.4	4.1	24.4	5.4			8.0	6.7					
5			17.3	14.4			415.7	415.7							
6				2.9	11.1		111.1								
7		58.4	100.0	25.0					16.7						
Totals		58.4	100.0	79.4	77.4	160.9	31.9	526.8	415.7	25.6	6.7	343.6	420.0	496.2	34.3

General Summary, sheet # 3

Calculations, sheet # 3

I-18 END AREA CU. YD.	END AREA		I-18 END AREA CU. YD.
	CUT	FILL	
	2.3	8.5	8.0
	8.0		3.15
			2.63
	2.5	8.5	6.2
	10.0		3.15
			2.72
	3.2	8.5	8.5
	11.5		3.00
			3.28
	3.0	8.2	9.2
	10.0		3.13
			3.28
	2.9	8.7	8.5
	10.5		3.14
			2.82
	2.9	8.6	7.1
			2.19

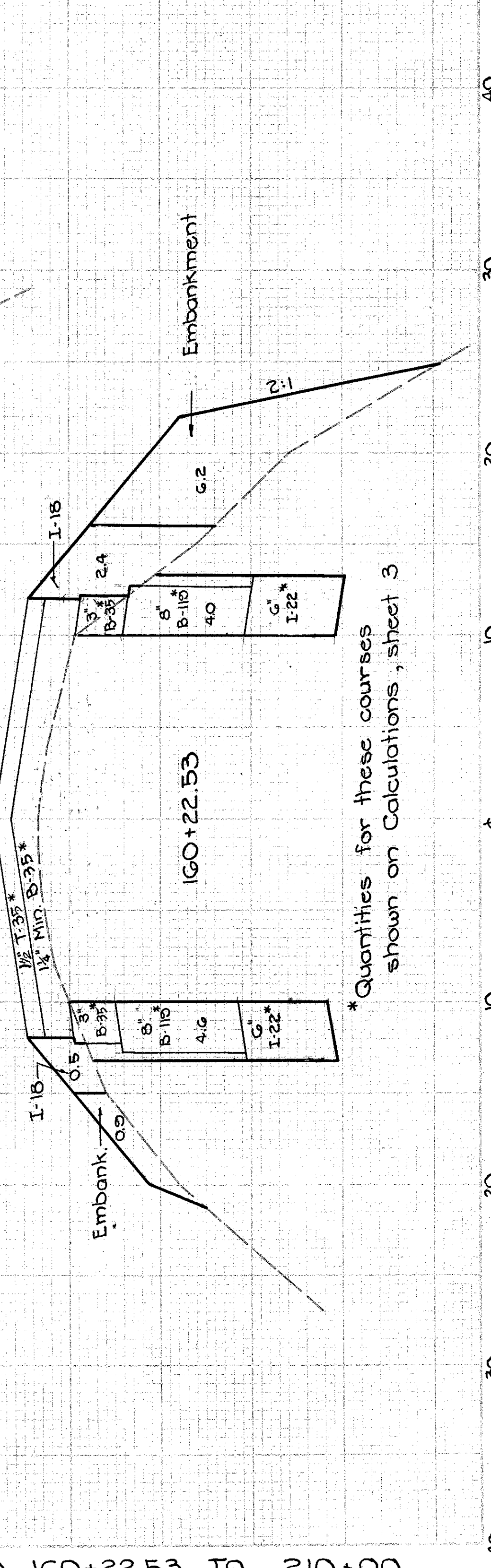
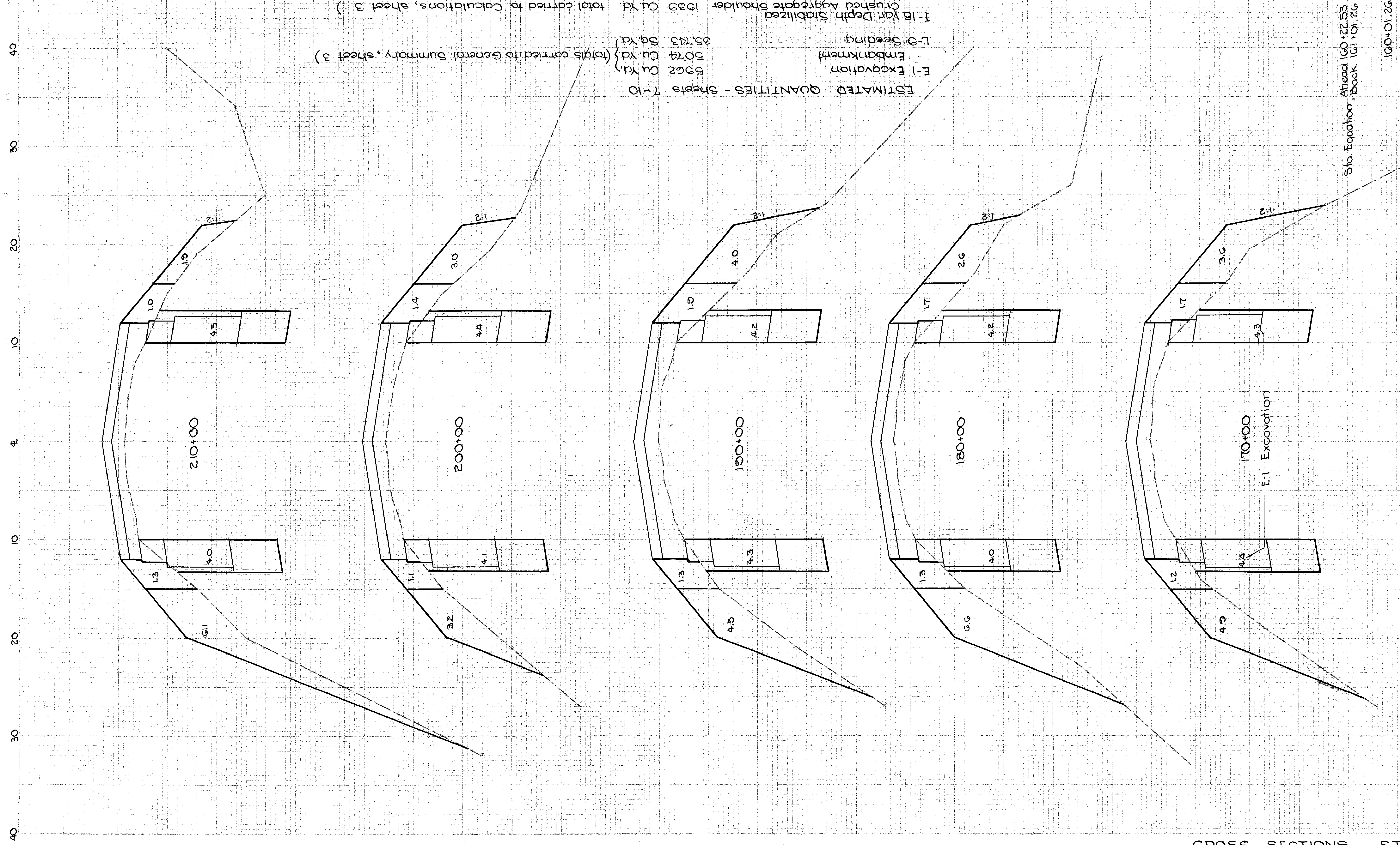

CROSS-SECTIONS STA 160+22.53 TO 210+00

I-18 END CUT AREA YD.	END AREA		CUT YD.	FILL YD.
	CUT	FILL		
3.0	8.3	8.6		
117			306	285
3.3	8.2	6.8		
112			302	261
3.1	8.5	7.3		
111			311	235
2.9	8.3	5.4		
93			317	178
2.1	8.8	4.2		
80			322	174
2.7	6.6	5.2		
98			317	244
2.3	8.5	8.0		

FEG. NO. 2	STATE OHIO	PROJECT MAD-40-3.08	SHEET NO. 10
---------------	---------------	------------------------	-----------------

MAD-40-3.08

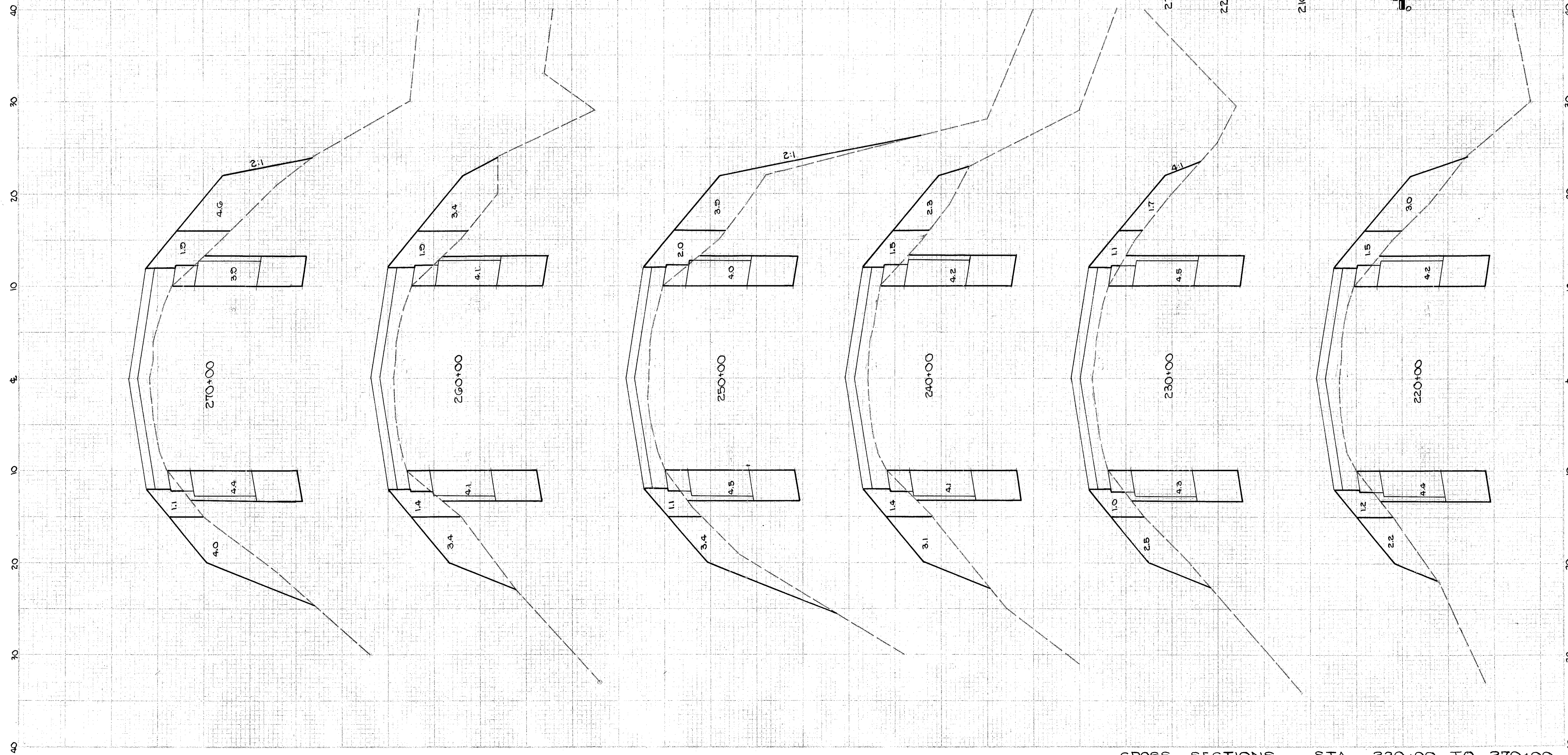
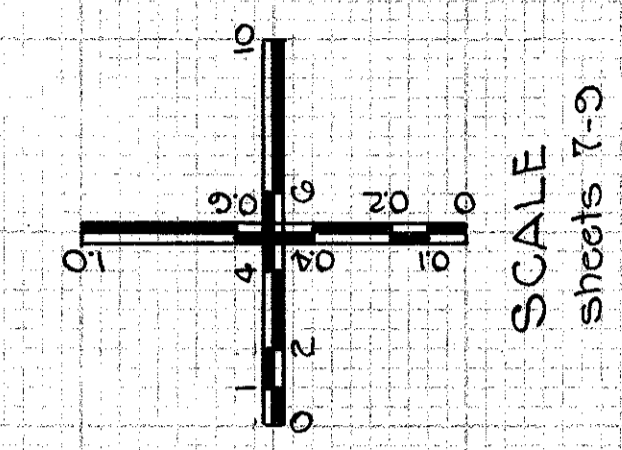

STA	I-10 END CO. AREA YD.	END AREA CUT	END AREA FILL	CO. YD. CUT	CO. YD. FILL
307 354	122	8.3	10.3		
317 290	102	8.3	8.2		
322 185	74	8.5	7.4		
319 206	82	8.5	8.6		
313 297	111	8.5	7.1		
313 263	107	8.4	6.8		
302 028	21	8.8	4.2		
300 000	32	8.4	6.8		

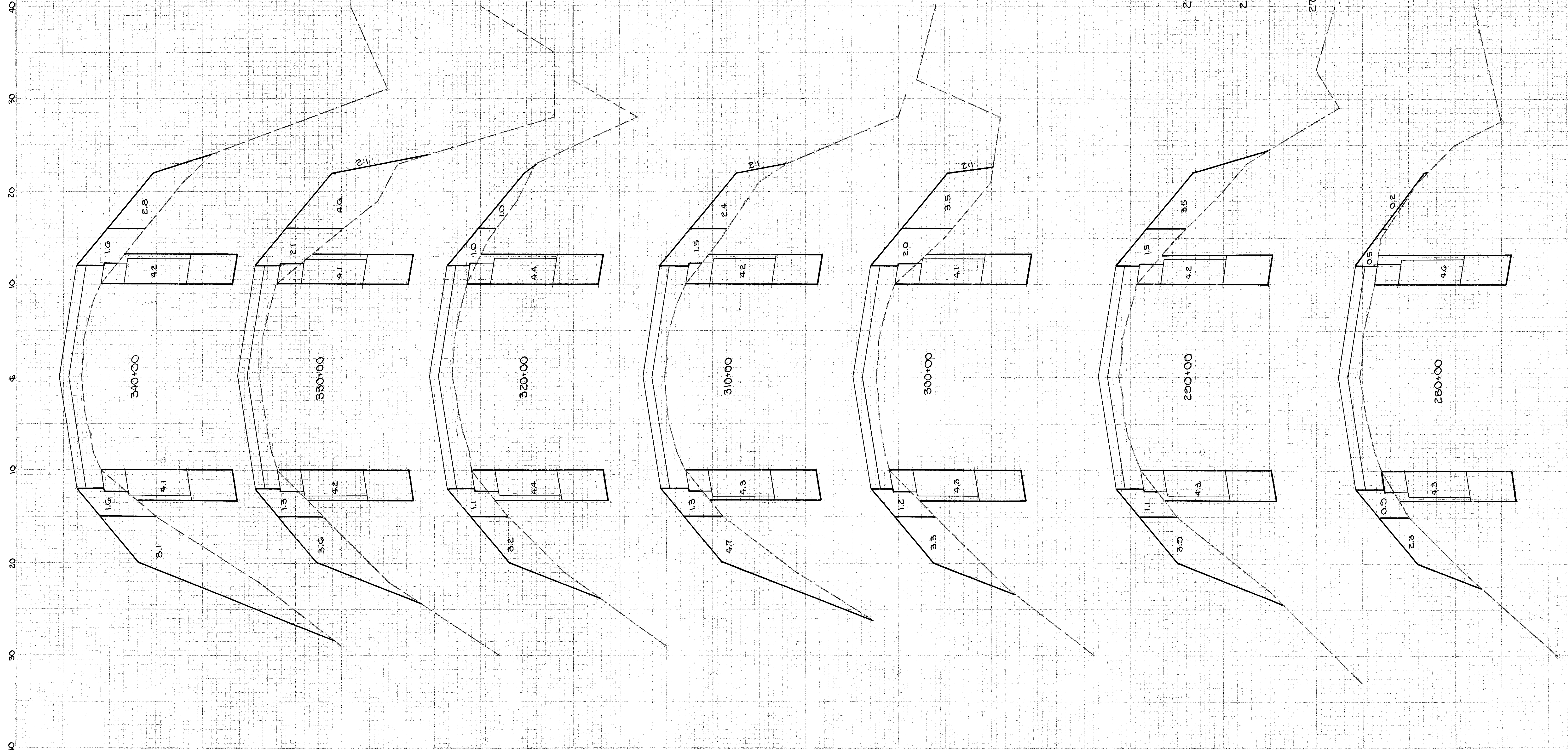

CROSS-SECTIONS STA 280+00 TO 340+00

MAD-40-3.08

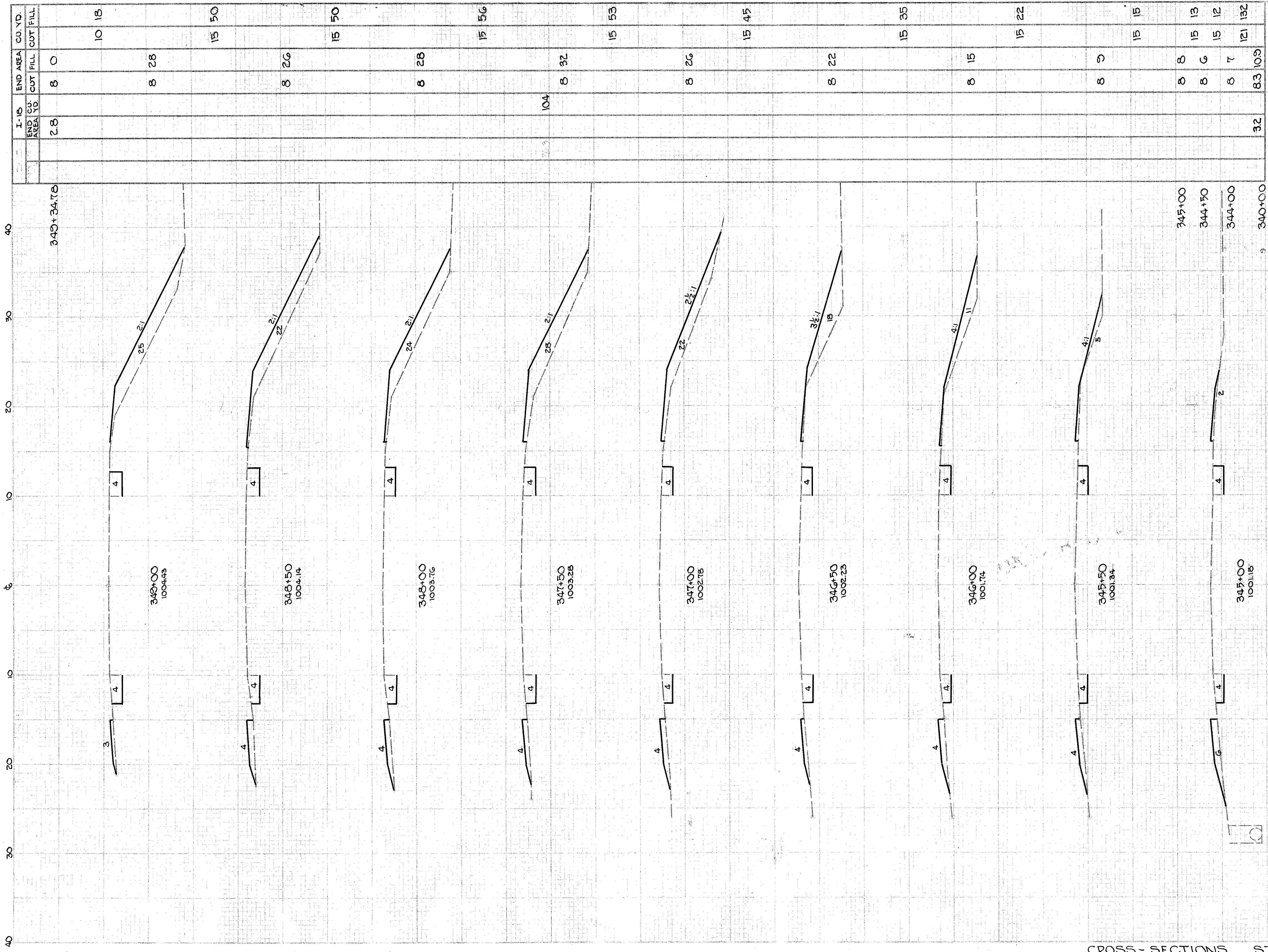

CROSS-SECTIONS STA 344+00 TO 349+00