

DIMENSION 'A'	
REAR ABUTMENT	
AMBIENT TEMPERATURE	
30° F	1.88
40° F	1.79
50° F	1.71
60° F	1.62
70° F	1.53
80° F	1.45
90° F	1.37

DIMENSION 'A'	
FORWARD ABUTMENT	
AMBIENT TEMPERATURE	
30° F	1.80
40° F	1.77
50° F	1.73
60° F	1.70
70° F	1.66
80° F	1.63
90° F	1.59

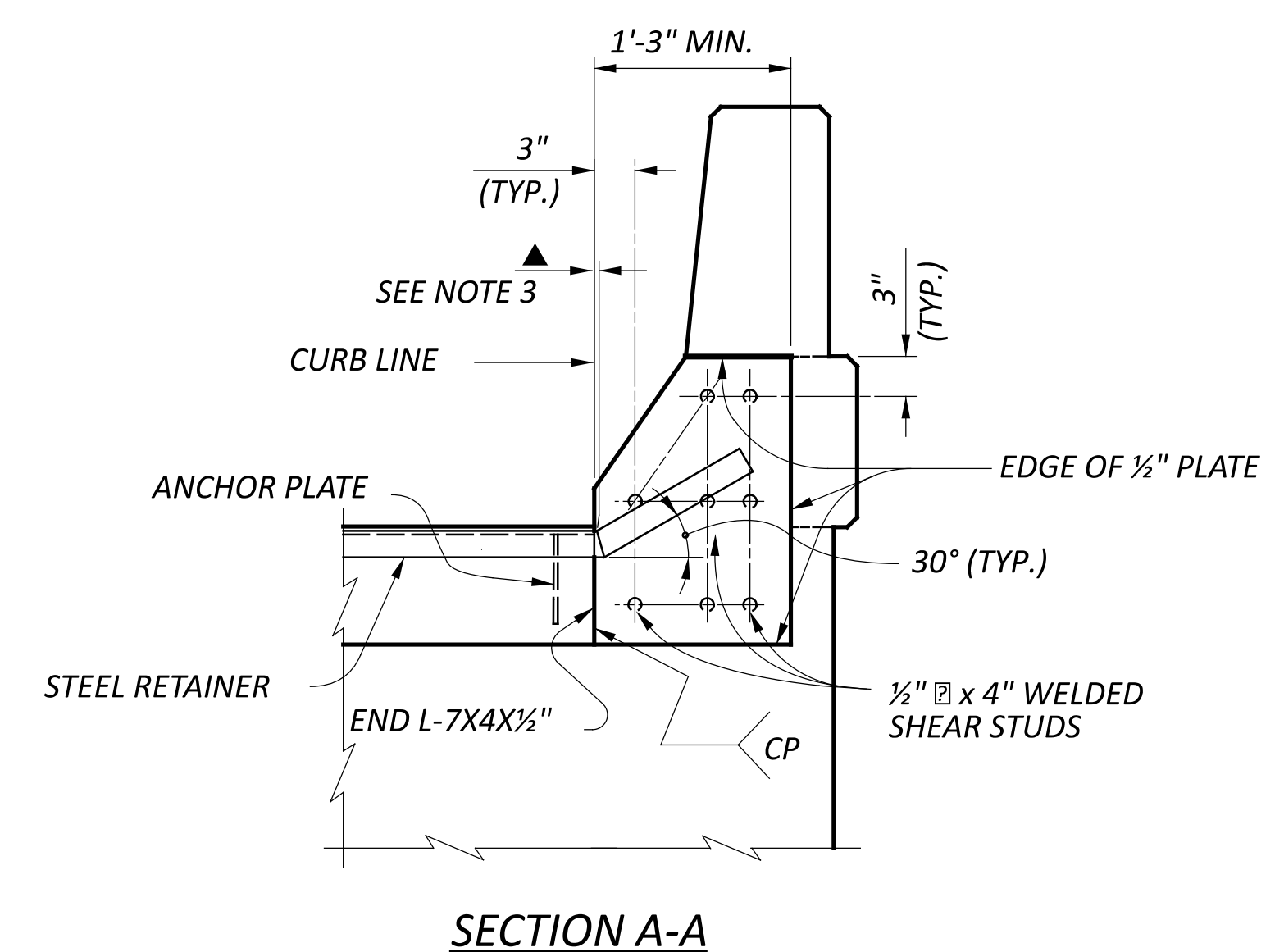
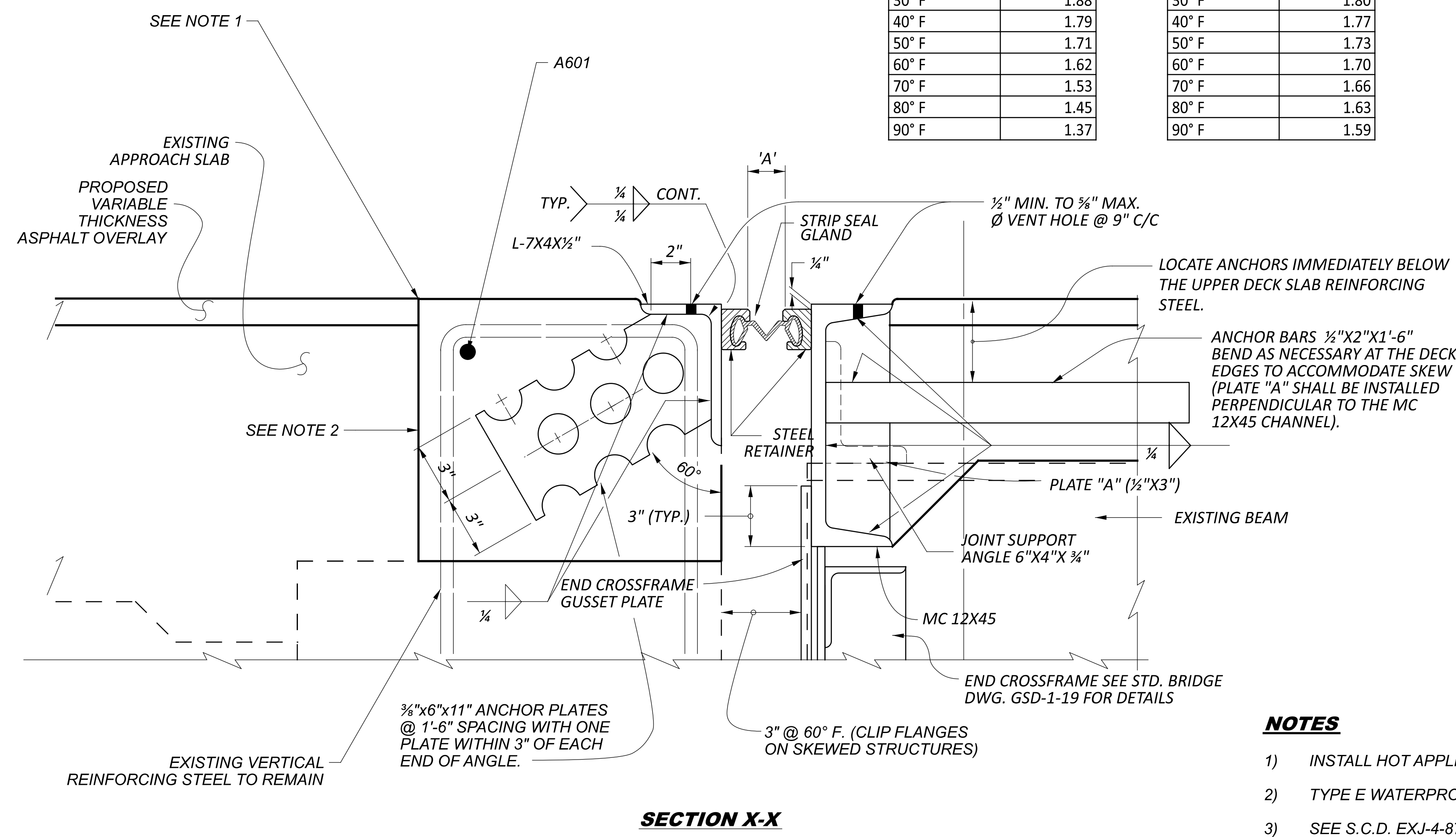

- NOTES**
- 1) INSTALL HOT APPLIED JOINT SEALER, 705.04 (2" DEEP x 1" WIDE)
 - 2) TYPE E WATERPROOFING
 - 3) SEE S.C.D. EXJ-4-87 & GSD-1-19 FOR ADDITIONAL DETAILS

EXPANSION JOINT DETAILS
 BRIDGE No.: HAM-52-3589
 U.S. 52 OVER KELLOGG AVE.

SFN	3105857
DESIGN AGENCY	
DESIGNER	CHECKER
GTF	AS
REVIEWER	
CAH MM-DD-YY	
PROJECT ID	119272
SUBSET	TOTAL
13	13
SHEET	TOTAL
42	42