

CONTINGENCY QUANTITIES

THE CONTRACTOR SHALL NOT ORDER MATERIALS OR PERFORM WORK LISTED IN THE GENERAL SUMMARY FOR ITEMS DESIGNATED BY PLAN NOTE TO BE USED "AS DIRECTED BY THE ENGINEER" UNLESS AUTHORIZED BY THE ENGINEER. THE ACTUAL WORK LOCATIONS AND QUANTITIES USED AT THE ENGINEER'S DIRECTION SHALL BE MADE A MATTER OF RECORD BY INCORPORATION INTO THE FINAL CHANGE ORDER GOVERNING COMPLETION OF THE PROJECT.

ITEM 254 - PAVEMENT PLANING, ASPHALT CONCRETE

THE SEGMENT 1 PAVEMENT PLANING SHALL BE SCHEDULED TO BE COVERED BY THE SURFACE COURSE PRIOR TO REOPENING THE LANE TO TRAFFIC, EXCEPT THE CONTRACTOR IS PERMITTED TO MILL AHEAD 1000 FEET BEYOND THE PLACED SURFACE COURSE. THE MILLED AHEAD SURFACE SHALL BE COVERED BY THE SURFACE COURSE ASPHALT WITHIN 72 HOURS OF BEING OPEN TO TRAFFIC. ADDITIONALLY, THE MILLED AHEAD SURFACE SHALL NOT BE LOCATED WITHIN AN INTERSECTION OR RAMP. THE MILLED AHEAD SURFACE SHALL BE SMOOTH, FREE OF DEBRIS, AND FREE OF POTHOLES.

THE SEGMENT 2 PAVEMENT PLANING SHALL BE SCHEDULED SUCH THAT THE MILLED SURFACE SHALL BE COVERED BY THE SURFACE COURSE ASPHALT WITHIN 72 HOURS OF BEING OPEN TO TRAFFIC. THE MILLED SURFACE SHALL BE SMOOTH, FREE OF DEBRIS, AND FREE OF POTHOLES.

A DISINCENTIVE IN THE AMOUNT OF \$9,300 SHALL BE ASSESSED FOR EACH DAY THE CONTRACTOR FAILS TO MEET ANY OF THESE REQUIREMENTS.

ITEM 251 - PARTIAL DEPTH PAVEMENT REPAIR (442)

THIS OPERATION SHALL BE PERFORMED BEFORE RESURFACING OF ROADWAY.

THE FOLLOWING QUANTITY IS GENERATED ON SHEETS P.007 & P.009 AND CARRIED TO THE GENERAL SUMMARY TO ADDRESS LOCATIONS REQUIRING PARTIAL DEPTH PAVEMENT REPAIR:

ITEM 251 - PARTIAL DEPTH PAVEMENT REPAIR (442) 341 CY

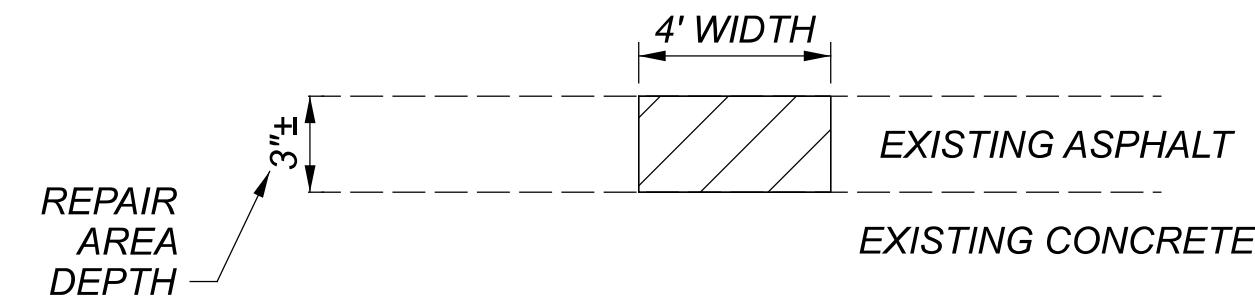

EXISTING DETERIORATED ASPHALT SHALL BE REMOVED TO A DEPTH OF 3"± AND MINIMUM WIDTH OF 4' OR AS DIRECTED BY THE ENGINEER. THIS WORK CONSISTS OF PARTIAL DEPTH REMOVAL OF EXISTING PAVEMENT IN AREAS EXHIBITING DETERIORATION AT THE SURFACE, APPLYING TACK COAT, AND PLACING AND COMPACTING ASPHALT CONCRETE. THE LOCATION AND SIZE OF THE REPAIR SHALL BE DETERMINED BY THE ENGINEER. THE EXISTING CONCRETE SURFACE SHALL NOT BE DISTURBED.

PLACE ITEM 442 - ASPHALT CONCRETE INTERMEDIATE COURSE, 12.5MM, TYPE A (449) INTO THE REPAIR.

ITEM 252 - FULL DEPTH RIGID PAVEMENT REMOVAL AND FLEXIBLE REPLACEMENT, AS PER PLAN

THIS ITEM SHALL CONSIST OF CUTTING AND REMOVING DETERIORATED PAVEMENT FULL DEPTH AND PLACING 10"-12"± ITEM 252 - FULL DEPTH RIGID PAVEMENT REMOVAL AND FLEXIBLE REPLACEMENT. IT IS NOT THE INTENT TO REPAIR EVERY DETERIORATED AREA WITHIN THE PROJECT. THE ENGINEER SHALL DETERMINE WHICH AREAS ARE TO BE REPAIRED. THIS ITEM SHALL COMMENCE WITHIN 7 DAYS OF THE BEGINNING OF MAINLINE PAVEMENT PLANING. PAYMENT SHALL BE BASED ON THE ACTUAL NUMBER OF SQUARE YARDS OF PAVEMENT REMOVED AND REPLACED TO THE LIMITS DESIGNATED BY THE ENGINEER.

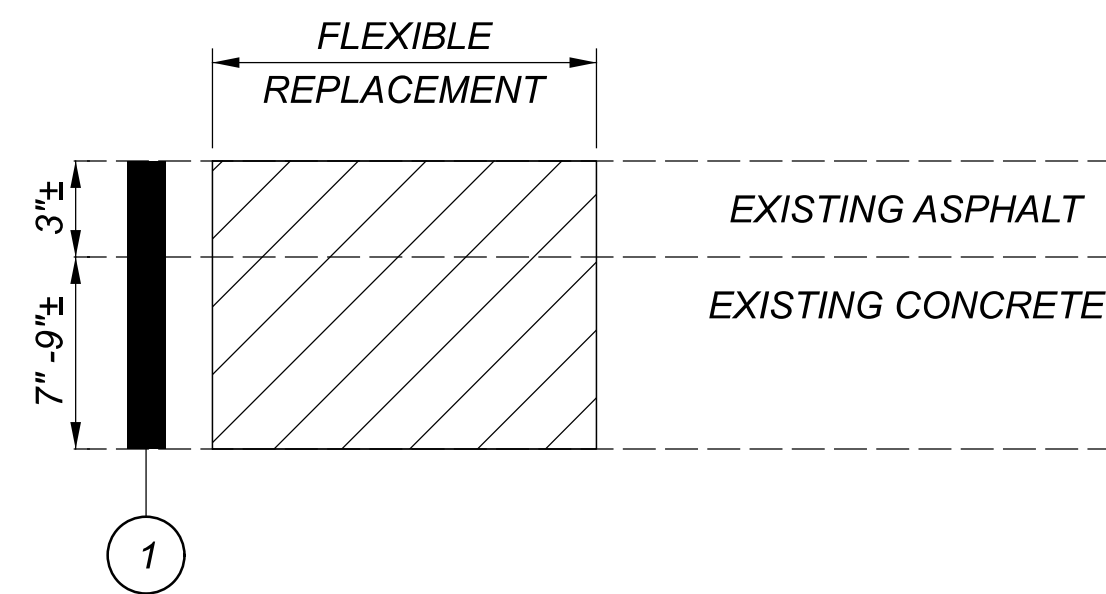

① ITEM 252 - PAVEMENT REPAIR (10"-12"±)

PLACE ITEM 301 - ASPHALT CONCRETE BASE (449) INTO THE REPAIR.