

BUT-75/VAR 5.22/VAR FEASIBILITY STUDY PID 117275

Prepared for:
Ohio Department of Transportation
505 South S.R. 741
Lebanon, Ohio 45036

Original: May 1, 2024

Revised: September 4, 2024

| REVIEW COMPLETE | |
|-----------------|--|
| PM | Katherine S. DeStefano, P.E. 09/17/2024 |
| BRIDGES | |
| CONSTRUCT | |
| DRAINAGE | Tami Brehm, P.E. 10/18/2024 |
| ENVIRON | |
| GEOTECH | |
| ITS | |
| MOT | |
| PAVEMENT | |
| ROADWAY | Katherine S. DeStefano, P.E. 09/17/2024 |
| R/W | Matthew Couch, 10/01/2024 |
| SURVEY | |
| TRAFFIC | Teri C. Scanlon, P.E. 09/30/2024 No comments |
| UTILITIES | Lucas W. Braun, P.E. 09/20/2024 No comments |
| OTHER | |
| OTHER | |

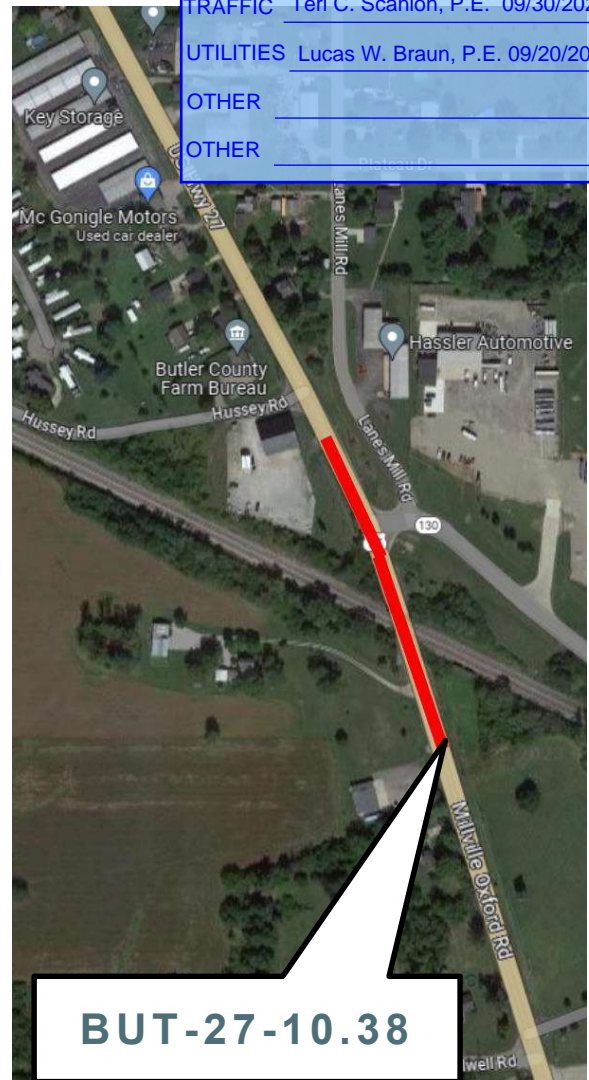

Contents

| | | |
|---------|---|----|
| 1.0 | INTRODUCTION | 1 |
| 2.0 | PURPOSE AND NEED SUMMARY | 1 |
| 3.0 | ALTERNATIVES CONSIDERED AND DISMISSED..... | 1 |
| 3.1 | BUT-4-23.90 Alternatives | 2 |
| 3.2 | BUT-27-10.38 Alternatives | 2 |
| 4.0 | KEY ISSUES | 2 |
| 4.1 | Traffic Analysis | 2 |
| 4.1.1 | Roadway Volumes | 2 |
| 4.1.2 | Safety | 3 |
| 4.2 | Roadway Information | 3 |
| 4.2.1 | Pavement Design | 3 |
| 4.2.2 | Bicycle and Pedestrian Features | 4 |
| 4.2.3 | Typical Sections..... | 4 |
| 4.2.4 | Horizontal & Vertical Alignments..... | 4 |
| 4.2.5 | Cross Sections..... | 5 |
| 4.2.6 | Lighting..... | 5 |
| 4.2.7 | Signing and Pavement Markings | 5 |
| 4.2.8 | Property Access and Driveways | 5 |
| 4.2.8.1 | BUT-4-23.90 Property Access and Driveways..... | 5 |
| 4.2.8.2 | BUT-27-10.38 Property Access and Driveways..... | 6 |
| 4.2.9 | Potential Design Exceptions | 6 |
| 4.3 | Roadway Design Criteria..... | 6 |
| 4.4 | BUT-4-23.90 Drainage | 6 |
| 4.4.1 | BUT-4-23.90 Flap Gate | 7 |
| 4.4.2 | BUT-4-23.90 Retention Pond | 12 |
| 4.4.3 | BUT-4-23.90 BMP | 13 |
| 4.5 | BUT-27-10.38 Drainage | 13 |
| 4.5.1 | BUT-27-10.38 BMP | 13 |
| 4.6 | BUT-4-23.90 Structural Considerations | 13 |
| 4.7 | BUT-27-10.38 Structural Considerations | 14 |
| 4.8 | BUT-4-23.90 Maintenance of Traffic (MOT) | 14 |

| | | |
|------|---|----|
| 4.9 | BUT-27-10.38 Maintenance of Traffic (MOT) | 18 |
| 4.10 | BUT-4-23.90 Right-of-Way (R/W) | 24 |
| 4.11 | BUT-27-10.38 Right-of-Way (R/W) | 24 |
| 4.12 | BUT-4-23.90 Geotechnical | 25 |
| 4.13 | BUT-27-10.38 Geotechnical | 25 |
| 4.14 | Utility Impacts | 25 |
| 4.15 | Railroad Coordination..... | 27 |
| 4.16 | BUT-4-23.90 Environmental Impacts..... | 27 |
| 4.17 | BUT-27-10.38 Environmental Impacts..... | 28 |
| 4.18 | BUT-4-23.90 Public Involvement..... | 29 |
| 4.19 | BUT-27-10.38 Public Involvement..... | 29 |
| 4.20 | BUT-4-23.90 Construction Cost Estimates..... | 29 |
| 4.21 | BUT-27-10.38 Construction Cost Estimates..... | 30 |
| 5.0 | COMPARISON OF ALTERNATIVES | 30 |
| 5.1 | BUT-4-23.90 | 30 |
| 5.2 | BUT-27-10.38 | 31 |
| 6.0 | CONCLUSION..... | 33 |
| 6.1 | BUT-4-23.90..... | 33 |
| 6.2 | BUT-27-10.38 | 33 |
| 7.0 | NEXT STEPS | 33 |

Figures

| | |
|--|----|
| Figure 1: Traffic Data Summary | 2 |
| Figure 2: Existing Roadway Information | 3 |
| Figure 3: Full Depth Pavement Design | 3 |
| Figure 4: Resurfacing Pavement Design | 4 |
| Figure 5: BUT-4 Driveway Impacts | 5 |
| Figure 6: BUT-27 Driveway Impacts | 6 |
| Figure 7: BUT-4 Flap Gate Plan View | 8 |
| Figure 8: BUT-4 Flap Gate Profile View | 8 |
| Figure 9: BUT-4 Flap Gate Section View | 9 |
| Figure 10: BUT-4 FEMA FIRMette | 9 |
| Figure 11: BUT-4 Flap Gate Options | 10 |
| Figure 12: BUT-4 Detour Summary | 15 |
| Figure 13: BUT-4 HCS Analysis Summary | 16 |
| Figure 14: BUT-4 Cost Comparison | 17 |
| Figure 15: BUT-27 Detour Summary | 19 |
| Figure 16: HCS Analysis (SR 130 Closed) | 20 |

| | |
|--|----|
| Figure 17: BUT-27 HCS Analysis (SR 130 Open) | 20 |
| Figure 18: BUT-27 Cost Comparison | 22 |
| Figure 19: BUT-4 R/W Needs | 24 |
| Figure 20: BUT-27 R/W Needs | 24 |
| Figure 21: BUT-4 Utility Information | 26 |
| Figure 22: BUT-27 Utility Information | 26 |
| Figure 23: BUT-4 Environmental Justice Populations | 28 |
| Figure 24: BUT-27 Environmental Justice Populations | 29 |
| Figure 25: BUT-4 Estimated Construction Costs | 29 |
| Figure 26: BUT-27 Estimated Construction Costs | 30 |
| Figure 27: BUT-4 Alternative Matrix | 30 |
| Figure 28: BUT-27 Alternative Matrix | 32 |

Appendices

| | |
|--|--|
| Appendix A: Design Criteria | |
| Appendix B: BUT-4 Drainage Area Map, Conduit Inventory and Calculations | |
| Appendix C: BUT-4 Preliminary Plan and Profile Sheets | |
| Appendix D: BUT-4 Representative Typical Sections | |
| Appendix E: BUT-4 Critical Cross Sections | |
| Appendix F: BUT-4 Drive Profiles | |
| Appendix G: BUT-4 Maintenance of Traffic Schematic, Typical Sections, Capacity Analysis and Road User Costs | |
| Appendix H: BUT-4 Preliminary Cost Estimate | |
| Appendix I: BUT-27 Drainage Area Map, Conduit Inventory and Calculations | |
| Appendix J: BUT-27 Preliminary Plan and Profile | |
| Appendix K: BUT-27 Representative Typical Sections | |
| Appendix L: BUT-27 Critical Cross Sections | |
| Appendix M: BUT-27 Drive Profiles | |
| Appendix N: BUT-27 Maintenance of Traffic Schematic, Typical Sections, Capacity Analysis and Road User Costs | |
| Appendix O: BUT-27 Preliminary Cost Estimate | |
| Appendix P: Business Plan Inflation Calculator | |
| Appendix Q: BUT-27 Justification for 15' Vertical Clearance | |

1.0 INTRODUCTION

Chagrin Valley Engineering (CVE) has been retained by the Ohio Department of Transportation (ODOT) District 8 office to provide a Feasibility Study for the pavement replacement and vertical clearance improvements underneath two (2) bridges located in Butler County, Ohio. The locations are US 27 under CSX Railroad (SFN 0900729) in Hanover Township and SR 4 under CSX Railroad (SFN 0900451) in Madison Township. These locations are here forth identified as the following: BUT-27-10.38 and BUT-4-23.90.

The vertical clearance improvement alternatives for BUT-4-23.90 to be analyzed include: existing vertical clearance (13.8'), 14.0', 14.5' and 15.0'.

The vertical clearance improvement alternatives for BUT-27-10.38 to be analyzed include: existing vertical clearance (14.0') and 14.5'.

The BUT-4-23.90 full depth pavement reconstruction project limits are from south of the SR 4 / Catalina Court (TR 80209) intersection for all options to north of the Madison Township Fire Station property at 6415 Germantown Road, for the 13.8' alternative and 14.0' alternative. Reconstruction limits for the 14.5' alternative end in the middle of the Madison Township Fire Station property at 6415 Germantown Road and the 15.0' option ends at the south end. Additionally, BUT-4 will be resurfaced to the north approach slab of the BUT-4-23179 (SFN 0900397) bridge over the Great Miami River, a distance of over 3000 feet to the south of the reconstruction limits. BUT-4 will be resurfaced to north of Catalina Court, with different ending distances depending on the vertical clearance alternative chosen.

The BUT-27-10.38 project limits include replacement of all of the existing concrete pavement from south of the US 27 / Hussey Road (TR 228) intersection to just north of 2143 Millville Oxford Road (US 27) for a distance of approximately 700 feet. There will be minor resurfacing on each end of the US 27 pavement reconstruction, ending at Sta. 18+27 (14.5' vertical clearance) or Sta. 17+27 (14.0' vertical clearance) which is north of the north radius return of Hussey Road (TR 228), and beginning at Sta. 5+50 on the south end. Included within the project limits is the US 27 / SR 130 (Old Oxford Road) intersection and will either include 63 feet (14.0' alternative) or 73 feet (14.5' alternative) of reconstruction or resurfacing on SR 130 (measured from the intersection with US 27) in order to tie into the new US 27 profile.

2.0 PURPOSE AND NEED SUMMARY

The purpose of this project is to improve the pavement condition and increase the vertical clearance for US 27 under the CSX Railroad (SFN 0900729) bridge in Hanover Township and SR 4 under the CSX Railroad (SFN 0900451) bridge in Madison Township. These improvements are necessary to increase overall safety for the traveling public by preventing future bridge impacts with passing vehicles at each location as well as eliminate the hazard of ponding water on the pavement at the BUT SR 4 structure. The US 27 pavement has a PCR of 69 and the SR 4 pavement has a PCR of 70 (south of the bridge) and 78 (north of the bridge). The PCR for SR 4 north of the bridge will improve since there is a project to resurface the road (BUT-4-24.00, PID 107580).

3.0 ALTERNATIVES CONSIDERED AND DISMISSED

ODOT provided the vertical clearance alternatives to be analyzed for each location as noted below.

3.1 BUT-4-23.90 Alternatives

The BUT-4-23.90 vertical clearance improvement alternatives analyzed include: existing vertical clearance (13.8’), 14.0’, 14.5’ and 15.0’. The No Build Alternative was not evaluated since the pavement needs to be replaced due to condition.

The 13.8’ vertical clearance improvement maintains the existing vertical clearance and requires pavement reconstruction from Sta. 1297+55 to Sta. 1299+28.00 for a distance of 173 feet.

The 14.0’ vertical clearance improvement alternative increases the vertical clearance to 14.0’ and requires pavement reconstruction from Sta. 1297+05 to Sta. 1300+65 for a distance of 360 feet.

The 14.5’ vertical clearance improvement alternative increases the vertical clearance to 14.5’ and requires pavement reconstruction from Sta. 1296+50 to Sta. 1301+18.50 for a distance of 468.50 feet.

The 15.0’ vertical clearance improvement alternative increases the vertical clearance to 15.0’ and requires pavement reconstruction from Sta. 1295+60 to Sta. 1301+18.50 for a distance of 558.50 feet.

3.2 BUT-27-10.38 Alternatives

The BUT-27-10.38 vertical clearance improvement alternatives analyzed include: existing vertical clearance (14.0’) and 14.5’. The No Build Alternative was not evaluated since the pavement needs to be replaced due to condition.

The 14.0’ vertical clearance improvement alternative maintains the vertical clearance to 14.0’ and requires pavement reconstruction from Sta. 7+40 to Sta. 14+50 for a distance of 710 feet.

The 14.5’ vertical clearance improvement alternative increases the vertical clearance to 14.5’ and requires pavement reconstruction from Sta. 7+40 to Sta. 15+50 for a distance of 810 feet.

4.0 KEY ISSUES

4.1 Traffic Analysis

4.1.1 Roadway Volumes

Traffic data for this project was developed by ODOT District 8 using the Traffic Forecast Management System (TFMS) Tool to calculate the average daily traffic (ADT), percentage of truck traffic, and other pertinent design designation information and summarized in **Figure 1**.

Figure 1: Traffic Data Summary

| Feature | BUT-4-23-24.44 | BUT-4-24.44-26.39 | BUT-27-6.87-10.46 | BUT-27-10.46-10.52 | BUT-130-0.00-2.85 |
|------------|----------------|-------------------|-------------------|--------------------|-------------------|
| ADT (2027) | 11,500 | 7,600 | 7,600 | 10,000 | 3,800 |
| ADT (2047) | 13,000 | 10,000 | 7,600 | 10,000 | 4,500 |
| DHV | 1,600 | 1,200 | 1,000 | 1,200 | 600 |

| | | | | | |
|-----|-------|-------|-------|-------|-------|
| K | 12.4% | 12.5% | 13.4% | 11.9% | 12.9% |
| D | 53.7% | 51.5% | 52.6% | 56.5% | 52.3% |
| T24 | 4.0% | 3.0% | 4.0% | 3.0% | 2.0% |

The traffic data was used to develop the roadway design criteria pertinent to each location. The criteria are based on various sections and figures in the L&D Manual, Volume One and establish the design parameters for the geometry, cross section, and other elements of the roadway.

4.1.2 Safety

A safety analysis was not part of the scope for this project.

4.2 Roadway Information

Existing roadway information is summarized in **Figure 2**:

Figure 2: Existing Roadway Information

| Feature | BUT-4-23.90 | BUT-27-10.38 |
|----------------------------------|--------------------------|--------------------------|
| Road Name | Germantown Road | Millville Oxford Road |
| Design Functional Classification | Urban Principal Arterial | Rural Principal Arterial |
| NHS System | Yes | Yes |
| Design Speed (MPH) | 45 | 50 |
| Legal Speed (MPH) | 45 | 45 |

4.2.1 Pavement Design

The proposed full depth pavement composition has been provided by ODOT and is the same for BUT-4-23.90 and BUT-27-10.38 and is summarized in **Figure 3** as follows:

Figure 3: Full Depth Pavement Design

| Depth | Item Number | Item Description |
|-------|-------------|---|
| 1.25" | 441 | Asphalt Concrete Surface Course, Type 1, (448), PG64-22 |
| N/A | 407 | Non-Tracking Tack Coat (0.055 GAL/SY) |
| 1.75" | 441 | Asphalt Concrete Intermediate Course, Type 2, (448) |
| N/A | 407 | Non-Tracking Tack Coat (0.055 GAL/SY) |
| 6" | 301 | Asphalt Concrete Base, PG64-22, (449) |

| | | |
|-----|-----|----------------|
| 6” | 304 | Aggregate Base |
| N/A | 204 | Geogrid |

Resurfacing typical sections are summarized in **Figure 4** as follows:

Figure 4: Resurfacing Pavement Design

| Depth | Item Number | Item Description |
|-------|-------------|--|
| 3” | 254 | Pavement Planing, Asphalt Concrete, 3” |
| 1.25” | 441 | Asphalt Concrete Surface Course, Type 1, (448), PG64-22 |
| N/A | 407 | Non-Tracking Tack Coat (0.055 GAL/SY) |
| 1.75” | 441 | Asphalt Concrete Intermediate Course, Type 2, (448) |
| N/A | 407 | Tack Coat, 702.13 (0.07 GAL/SQ YD) if over existing concrete or Non-Tracking Tack Coat (0.055 GAL/SY) if over existing asphalt |

4.2.2 Bicycle and Pedestrian Features

The BUT-4 location has existing narrow sidewalks that will be removed within the limits of the pavement reconstruction. The proposed condition will include 6’ sidewalks on each side of the road. The sidewalk on each side will be extended north to the southern radius return of Catalina Court and a new pedestrian crossing and curb ramps will be provided. Because of the proposed curb height, pedestrian handrail will be required for the 14.5’ and 15.0’ alternatives.

The BUT-27 location does not have any pedestrian features, there is no indication of pedestrians utilizing this roadway section, and therefore, there will not be any proposed pedestrian features incorporated into the improvements.

4.2.3 Typical Sections

The BUT-4 existing composite typical section has 3” of asphalt over 7” concrete with the limits of the pavement reconstruction. Reconstruction typical sections for BUT-4 are provided in **Appendix D**.

The BUT-27 existing concrete typical section has 10” reinforced concrete pavement over 6” aggregate base in the travel lanes and shoulders. The BUT-27 existing composite section has 5” of asphalt over 7” concrete in the travel lanes and 10” of asphalt over 6” of aggregate base in the shoulders. Reconstruction typical sections for BUT-27 are provided in **Appendix K**.

4.2.4 Horizontal & Vertical Alignments

The horizontal alignment for BUT-4 is unchanged and the vertical alignment for the various alternatives are shown on the plan and profile sheets. Plan and profile sheets for BUT-4 are provided in **Appendix C**.

The horizontal alignment for BUT-27 is unchanged and the vertical alignment for the various alternatives are shown on the plan and profile sheets. Plan and profile sheets for BUT-27 are provided in **Appendix J**.

4.2.5 Cross Sections

Critical cross sections for BUT-4 are shown for the various alternatives. Cross sections for BUT-4 were taken at the proposed sag point, a representative bridge section, point of minimum vertical clearance, just past the north abutment (a R/W pinch point) and location of new catch basins and are provided in **Appendix E**.

Critical cross sections for BUT-27 are shown for the various alternatives. Cross sections for BUT-27 were taken at the proposed sag point, a representative bridge section, point of minimum vertical clearance, just past the north abutment (at lateral R/W pinch points), existing 24” storm sewer crossing, and SR 130 intersection and are provided in **Appendix L**.

4.2.6 Lighting

There is no lighting on SR 4 within the reconstruction limits and none is proposed. Intersection lighting is present at the US 27 intersection with SR 130 and will not be disturbed.

4.2.7 Signing and Pavement Markings

The permanent pavement markings for BUT-4-23.90 and BUT-27-10.38 will be Item 644 – Thermoplastic on asphalt surfaces. Placement of proposed pavement markings and raised pavement markers (RPM) shall meet current ODOT design standards. Vertical clearance signs may need to be removed and replaced depending on the vertical clearance alternative selected. Other signs will not be replaced unless current signage does not meet recommended standards or signs are impacted by the proposed project.

4.2.8 Property Access and Driveways

4.2.8.1 BUT-4-23.90 Property Access and Driveways

Access to all drives will be maintained at all times. Driveway information for BUT-4-23.90 properties located within the project limits is summarized in **Figure 5**:

Figure 5: BUT-4 Driveway Impacts

| Station | Side | Address | Type | Impacts |
|------------|------|------------|--|--|
| 1295+63.91 | West | 6401 | Commercial asphalt drive. | Impacts in 15.0’ alternative. * |
| 1296+39.19 | East | No address | Field concrete drive apron only | Impacts in 15.0’ alternative. * |
| 1296+93.94 | West | 6415 | Commercial asphalt drive for fire station. Drive apron is concrete but only within the sidewalk. | Impacts in 14.5’ and 15.0’ alternatives. * |

| | | | | |
|------------|------|------|---------------------------------|--|
| 1297+92.34 | East | 6400 | Commercial concrete drive apron | Impacts in 14.0', 14.5' and 15.0' alternatives. * |
|------------|------|------|---------------------------------|--|

* ODOT’s commercial drive apron standards were impractical for the 14.5’ and 15.0’ alternatives.

4.2.8.2 BUT-27-10.38 Property Access and Driveways

Access to all drives will be maintained at all times. Driveway information for BUT-27-10.38 properties located within the project limits is summarized in **Figure 6**:

Figure 6: BUT-27 Driveway Impacts

| Station | Side | Address | Type | Impacts |
|----------|------|------------|---|--|
| 7+02.65 | West | 2143 | Commercial asphalt drive | No impacts in any alternative. |
| 7+50.54 | West | No address | Field asphalt drive apron only | No impacts in any alternative. |
| 8+90.48 | West | 2149 | Residential asphalt drive apron with gravel drive | No impacts in 14.5' alternative. Drive requires reconstruction in 14.0' alternative. |
| 14+92.27 | West | 2173 | Commercial concrete drive apron only | No impacts in 14' alternative. Impacted in 14.5' alternative. |

4.2.9 Potential Design Exceptions

CVE reviewed each location for potential design exceptions and the following design exceptions are anticipated:

SR 4 – This is classified as a low speed facility (design speed <50 mph) and no design exceptions are required.

US 27 – This is classified as a high speed facility (design speed ≥50 mph) and a design exception is required for shoulder width for either vertical clearance alternative.

4.3 Roadway Design Criteria

The roadway design criteria for each location is shown in **Appendix A**.

4.4 BUT-4-23.90 Drainage

The existing drainage system is comprised of a closed system with storm sewers, underdrains, a 68”x43” culvert located underneath the CSX Railroad bridge, and a retention pond located on the east side, south of the CSX Railroad bridge behind Amatulli Produce. East side catch basins north of the bridge drain across the road to the trunk line located on the west side in various locations.

The catch basin pair located at the proposed sag drain from the west side to the east side draining towards the trunk line now crossed over to the east into the retention pond. The project area north of the 68”x43” culvert drains to the retention pond and the project area south of the 68”x43” culvert drains south eventually outletting to the Great Miami River.

In the pavement reconstruction sections where the sidewalk is widened, the four existing catch basins located around the bridge will be removed and either replaced with a new catch basin, relocated to the proposed sag or replaced with a new manhole. The remaining impacted catch basins in the reconstruction limits for the respective options will be adjusted to grade and conduit will be cleaned or replaced as noted by ODOT in the project scope and labelled on the plans. New catch basins will be added at the sag point for each alternative. In the pavement resurfacing section, catch basins and inlets will not need to be reconstructed since they are either located in the curb and gutter (north of Trenton Franklin Road) or located in the median (south of Trenton Franklin Road) and will not be disturbed. All manholes located in the pavement will be adjusted to grade.

The drainage will be reconfigured on the west side south of Catalina Court to allow for the sidewalk to be constructed all the way to Catalina Court.

There are no Federal Emergency Management Agency (FEMA) Floodplains or wetlands within the project limits.

In the existing condition, there is a catch basin at Sta. 1298+30, 19.90’ LT that drains both east toward the retention pond and south toward the Great Miami River. In our proposed condition, this connection will be maintained so drainage can flow toward the retention pond and the Great Miami River. Additionally, the FEMA flood elevation at the Great Miami River is 649 and the roadway profile elevations are 652.35. No vertical clearance alternatives will impact any flooding from the Great Miami River.

We performed spread calculations and spread is violated in the existing condition within the resurfacing and reconstruction sections. We’ve added nominal additional impervious area with the sidewalk extension. We are proposing to add new catch basins north and south of the CSX Railroad bridge on each side of the road to help mitigate spread concerns. We chose CB-3’s instead of CB-3A’s to further reduce spread and limit bypass flow. However, there is still a spread violation at the 68”x43” culvert since we can not tie new storm sewer into the culvert.

We prepared representative cross sections and note the proposed pavement buildup conflicts with the existing 27” storm sewer that is currently plugged in the 14.5’ and 15.0’ alternatives. This conflict can be mitigated by removing the 27” plugged storm sewer.

There are no underdrains under the CSX Railroad bridge currently and none are proposed. We propose to include underdrains in the reconstruction sections up to the point where they can be drained without an additional excavation underneath the CSX Railroad bridge.

The drainage area map, conduit inventory and calculations are provided in **Appendix B**.

4.4.1 BUT-4-23.90 Flap Gate

The existing Calco Gate control structure is located within the existing manhole No. 2 at Sta.52+05.50 (from 1955 record plans) that is 54” (presumed square), 22’ deep and located within the pavement. The control structure is currently inoperable and has seized in the half-open position. ODOT owns the structure and requested options to address the inoperable gate. See **Figure 7** for plan view of the flap gate, **Figure 8** for profile view and **Figure 9** for section view.

Figure 7: BUT-4 Flap Gate Plan View

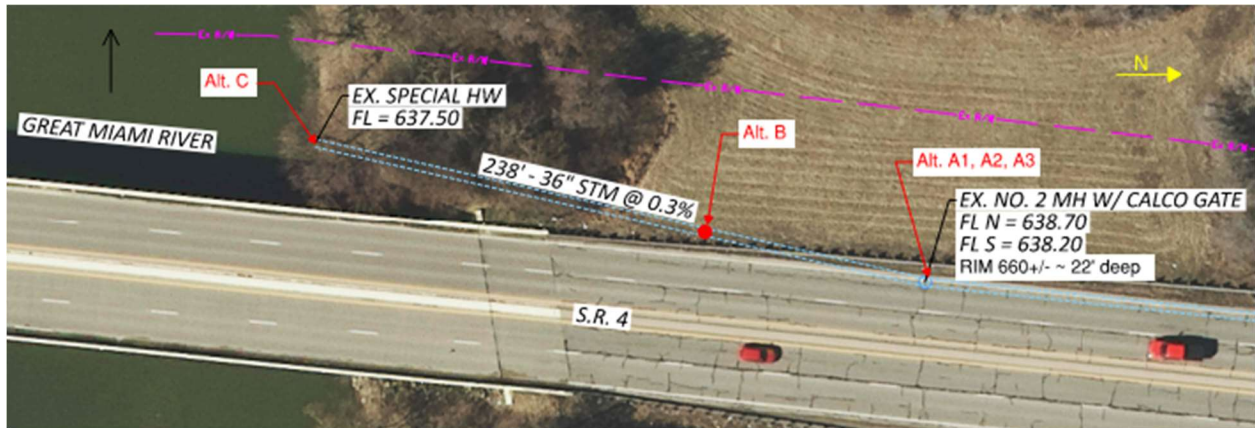

Figure 8: BUT-4 Flap Gate Profile View

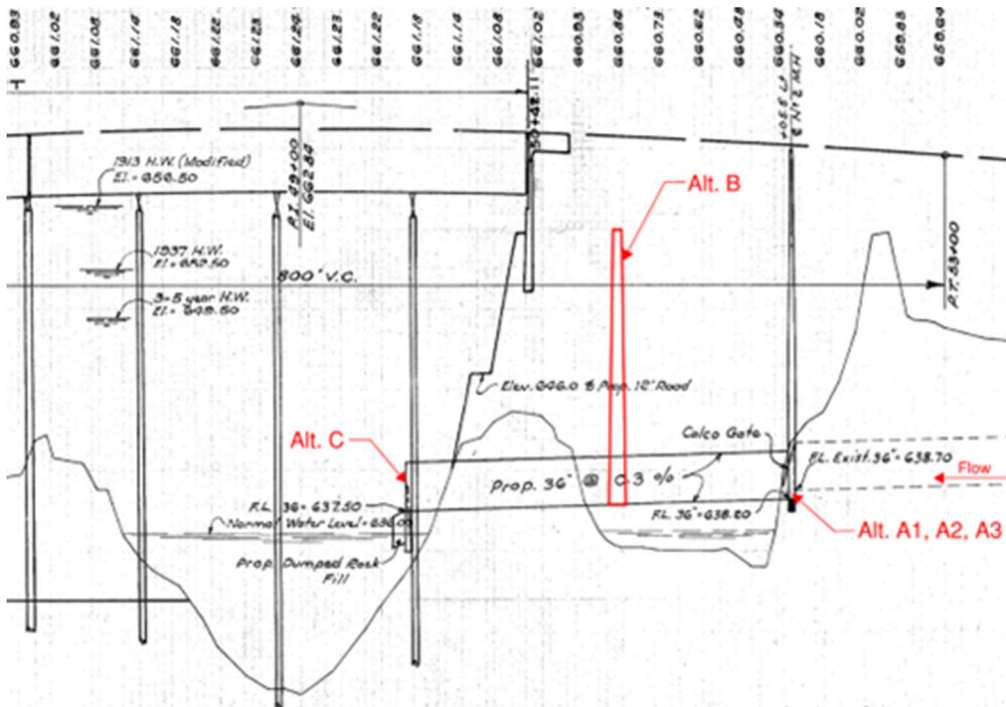
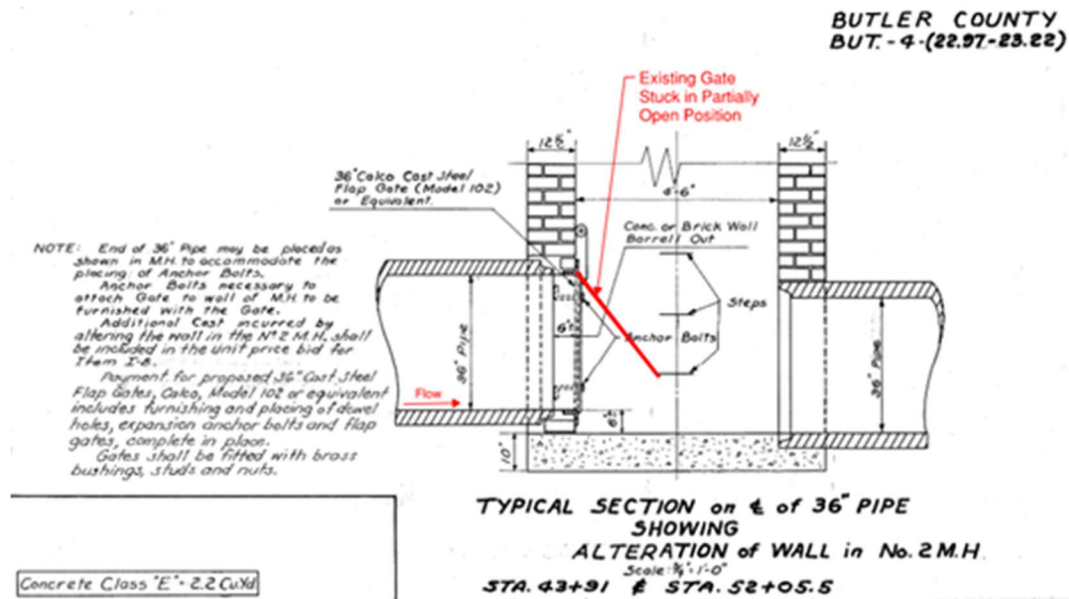
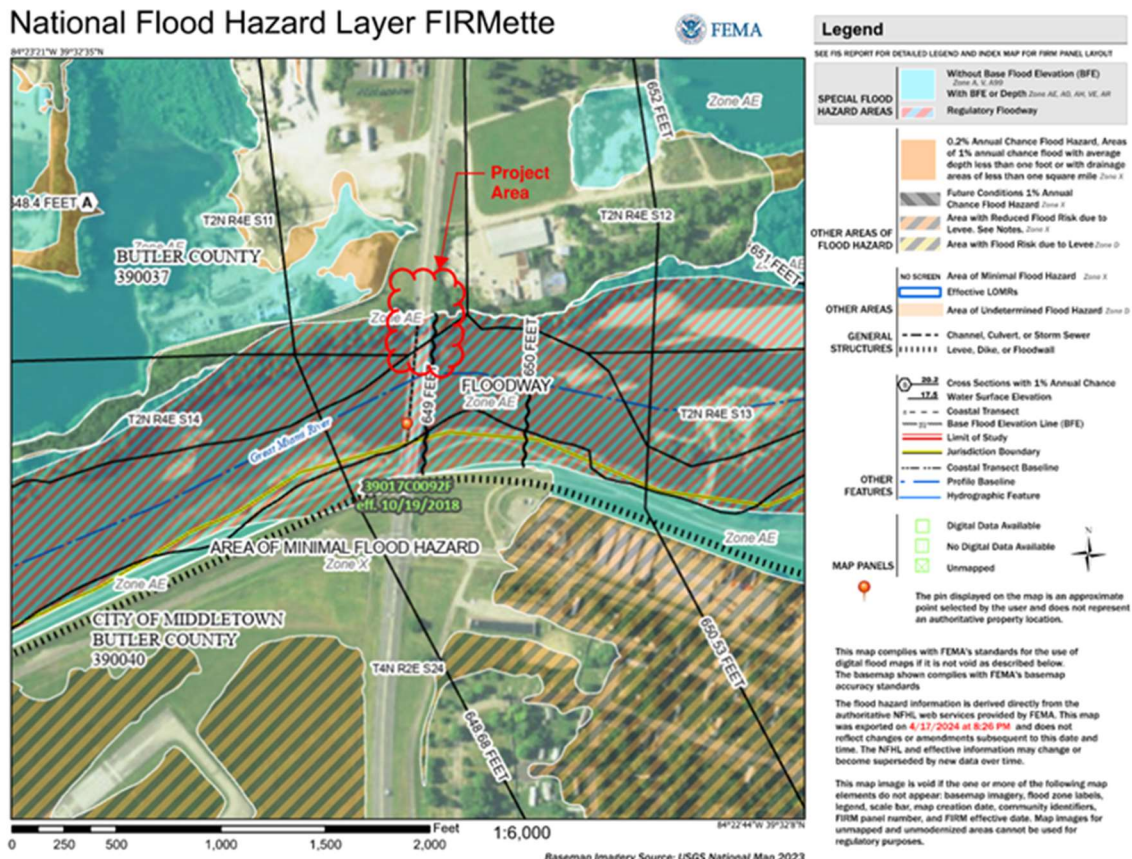

Figure 9: BUT-4 Flap Gate Section View



The ground slopes upward from the riverbank north toward existing MH No. 2 to elevations 651 and 652 within special flood hazard areas as shown in the FEMA FIRMette in **Figure 10**, providing localized surficial floodway storage regardless of the flap valve configuration on the 36" storm sewer.

Figure 10: BUT-4 FEMA FIRMette



The base flood elevation of 649 will remain approximately 3’ below the proposed elevation of SR 4 after it is lowered less than one foot at the sag under the CSX Railroad bridge to roughly new elevation 652.

Figure 11 details the various flap gate options.

Figure 11: BUT-4 Flap Gate Options

| Alt. | Description | Pros | Cons | Cost Estimate |
|------|--|--|--|---------------|
| A1 | Do nothing, allowing the existing Calco Flap Gate to remain as-is in the half-open position. | Flow from upstream tributary areas adequately passes through with river surface elevation less than 638.70, zero cost alternative. | Eventual failure on undetermined timeline, difficult to remove in 22’ deep structure, could ultimately obstruct storm flow from tributary upstream areas from reaching the river. | \$0 |
| A2 | Remove the existing Calco Flap Gate to eliminate the control structure. | Removal eliminates the risk of eventual failure and gate falling into the flow line. | Confined space construction, will not restrict water and debris from filling the 36” sewer during flooding events, work requires excavation and removal of the top manhole section, pavement replacement, MOT. | \$45,000 |

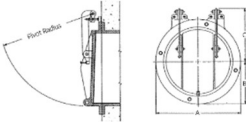
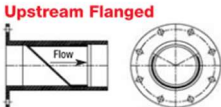
| Alt. | Description | Pros | Cons | Cost Estimate |
|------|--|--|---|---------------|
| A3 | <p>Replace the Calco Flap Gate with a new Mueller HydroGate Flap Gate in the existing structure</p>  | <p>Older technology, restores original functionality allowing dry weather flow to outlet to the river and to close during river flooding, restricting water and debris from filling the 36” sewer.</p> | <p>Confined space construction, heavy replacement unit, existing structure may have deterioration that could affect ability to mount the unit properly, work requires excavation and removal of the top manhole section, pavement replacement, MOT, higher maintenance cost, lower reliability.</p> | \$70,000 |
| B | <p>Install a new control structure manhole with TideFlex Inline Checkmate Valve at a location off the existing pavement.</p>  | <p>Newer technology, restores original functionality allowing dry weather flow to outlet to the river, and to close during river flooding, restricting water and debris from filling the 36” sewer, device installed within pipe, straightforward manhole construction, located outside the pavement, ~12’ deep for ease in continued O&M, no MOT required, out of sight and protected from floating debris in river, minimal maintenance.</p> | <p>Requires off-road access, recommend quarterly inspection of Checkmate valve, restoration of unpaved area, and includes cost of Alternative A2 to remove the existing Calco Flap Gate.</p> | \$110,000 |

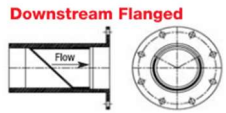
| Alt. | Description | Pros | Cons | Cost Estimate |
|------|--|---|---|---------------|
| C | Install a TideFlex Inline Checkmate Valve on the downstream 36” outfall to the Miami River.  | Newer technology, restores original functionality allowing dry weather to outlet to the river, and to close during river flooding, restricting water and debris from filling the 36” sewer, located outside the pavement, no MOT required, ease of installation, device installed within pipe, out of sight and protected from floating debris in river, minimal maintenance. | Difficult to access for O&M, recommend quarterly inspection of Checkmate valve, requires off-road or river access, installation adjacent to river may add additional cost if cofferdam required, and includes cost of Alternative A2 work to remove the existing Calco Flap Gate. | \$105,000 |

Of the Alternatives presented herein, Alternative A1 is not supported based upon the risk of eventual failure of the Calco Flap Gate and the difficulty in removing it from obstructing the flow line in an emergency situation. The remaining Alternatives A2, A3, B, and C, each require the removal of the existing Calco valve to eliminate its risk of failure. Alternative A2 is the preferred solution since the roadway elevation at the railroad bridge is over 3 feet higher than the Great Miami River 100 year base flood elevation and a backflow preventer is not needed to prevent the roadway from flooding.

ODOT will coordinate the disposition of the flap gate with the Miami Conservancy District (MCD).

4.4.2 BUT-4-23.90 Retention Pond

To clarify scope, the retention pond should be excavated to the original bond bottom elevation for its entire length, not just the smaller area that was excavated in 2013.

The retention pond will need to be excavated to remove the excess sediment that has accumulated since the last cleaning in 2013. According to the 1963 plans, the invert elevation of the 60” pipe that outlets to the retention pond is 645.20 and the elevation of the bottom depth of the retention pond is 644.50 which is an elevation difference of 0.7 feet.

The survey for this project indicated that the invert elevation of the 60” pipe that outlets to the retention pond is 644.65 and the elevation of the bottom depth of the retention pond bottom is 645.48 on the west side which is a positive elevation difference of 0.83 feet.

Since the 60” pipe invert elevations are different, it means there is a datum change of $645.20 - 644.65 = 0.55$ feet lower today than 1963. This datum change means that the bottom of pond elevation today should be $644.50 - 0.55 = 643.95$. The pond should be excavated to a bottom of elevation of 643.95 to remove the excess sediment.

4.4.3 BUT-4-23.90 BMP

An exact calculation will be performed during detailed design to determine earth disturbed area (EDA) for the Notice of Intent (NOI) application form and the need for Post Construction Best Management Practices (BMP) to be implemented on this project. Our preliminary calculations appear to indicate that the EDA is greater than 1 acre and will require BMP. We will discuss BMP options and locations during detailed design.

4.5 BUT-27-10.38 Drainage

The existing drainage system is comprised of an open and closed system with ditches, drive pipes, storm sewers, underdrains, and a 3'x3' culvert. West side catch basins north of SR 130 drain across the road to the trunk line on the east side of US 27. East side catch basins south of SR 130 drain across the road to the trunk line located in the west curb or shoulder of US 27. The project area drains to a 36" pipe in the southwest quadrant.

The proposed project will require reconstructing or adjusting to grade all catch basins where the curb and gutter is added. New catch basins will be added at the sag point for each alternative. Other catch basins and manholes located in the pavement will be adjusted to grade.

There are no Federal Emergency Management Agency (FEMA) Floodplains or wetlands within the project limits.

We performed spread calculations and there are no spread violations within the project limits.

We prepared representative cross sections and note the proposed pavement buildup conflicts with the 24" crossing pipe in the 14.5' alternative. This conflict can be mitigated by changing the pavement thickness on SR 130.

Proposed underdrains will generally match locations of existing underdrains.

The drainage area map, conduit inventory and calculations are provided in **Appendix I**.

4.5.1 BUT-27-10.38 BMP

An exact calculation will be performed during detailed design to determine earth disturbed area (EDA) for the Notice of Intent (NOI) application form and the need for Post Construction Best Management Practices (BMP) to be implemented on this project. Our preliminary calculations appear to indicate that the EDA is greater than 1 acre and will require BMP. We will discuss BMP options and locations during detailed design.

4.6 BUT-4-23.90 Structural Considerations

BUT-4 is underneath the CSX Railroad bridge (BUT-4-23.94, SFN 0900451, CSXT Bridge #BE-40.10). This bridge was built in 1941 and is a 71' long single span, steel beam, bridge on cast-in-place concrete abutments with spread footings. The bridge skew is 32.17 degrees right forward.

To mitigate any structural concerns, the proposed sidewalk will be constructed at the same elevation or higher as the existing sidewalk underneath the CSX Railroad bridge. In the 13.8' alternative, the maximum curb height is 6" and the back of walk elevation ends up 4" higher than existing on the left side and 6" higher on the right side. In the 14.0' alternative, the maximum curb height is 6" and the back of walk elevation ends up 1" higher than existing on the left side and 3" higher on the right side. In the 14.5' alternative, the maximum curb height is 1' and in the 15.0' alternative, the maximum curb height is 1.5', with both options matching the existing back of walk

elevation. The curb heights for the 14.5' and 15.0' alternatives are too high for an ODOT standard curb and will require a wall.

4.7 BUT-27-10.38 Structural Considerations

BUT-27 is underneath the CSX Railroad bridge (BUT-27-10.44, SFN 0900729, CSXT Bridge #BD-33.10). This bridge was built in 1938 and is a 70' long single span, steel beam, bridge on cast-in-place concrete abutments with spread footings. The bridge skew is 43.28 degrees left forward.

To mitigate any structural concerns, the proposed top of curb on the curb and gutter will be constructed at the same elevation as the existing curb and gutter underneath the CSX Railroad bridge. In the 14.0' alternative, the maximum curb height is 6" and in the 14.5' alternative, the maximum curb height is 10".

4.8 BUT-4-23.90 Maintenance of Traffic (MOT)

The existing pavement width is 46' which allows for part-width construction with two lanes of traffic maintained on one lane using temporary signals. MOT Typical Sections are provided in **Appendix G**.

Sequencing: We recommend sequencing the construction into two (2) Stages with the pavement reconstruction as Stage 1 and resurfacing to the Great Miami River as Stage 2. Stage 1 traffic can be maintained with a temporary signal located at Catalina Court (TR 80209) and the other temporary signal located south of the reconstruction limits. We suggest constructing the west side first in Stage 1, Phase 1 and the east side should be constructed next in Stage 1, Phase 2.

Stop Bars: The stop bar locations on the north side of SR 4 vary based on the reconstruction limits for each option. Stop bars are located at 50 foot offsets from the merging edge line on either end of the work zone as per ODOT Standard Drawing MT-96.11.

Drives: The drives located within the reconstruction limits will need to be constructed in a Sub-Phase and accommodations provided to maintain drive access at all times. Drives will be signalized to coordinate directional traffic movements and forbid conflicting traffic movements attributed to drive egress during one-lane maintenance of traffic.

Existing Walks: The existing sidewalks will be closed when the abutting pavement is being constructed. A pedestrian detour is possible at Trenton Franklin Road, however there is no crossing at Catalina Court and sidewalk closure signs will need to be posted instead.

Evaluation: The project site was evaluated for MOT schemes where two-way traffic would be maintained through the work zone using temporary signals, one direction of traffic would be detoured, or both directions of traffic would be detoured to allow for complete closure at the work zone. Highway Capacity Software (HCS) was used to perform the temporary traffic signal analysis and ODOT's Road User Cost (RUC) workbook was used in conjunction with Google Maps to analyze the detour route. AM and PM peak hours were analyzed for the site with data from ODOT count station 40409 to develop anticipated delays and performance metrics for the temporary signals. These were then compared to the expected delays associated with the detour route drive times. For the complete closure scenario, delay is calculated as the additional drive time of the detour route applied to all northbound and southbound vehicles.

Detour Route: The available state route detour for northbound or southbound traffic would be from SR 4 to SR 73 to SR 123 and back to SR 4 taking traffic through the Cities of Carlisle,

Franklin, and Middletown. This route passes by two emergency services buildings, crosses four at-grade railroad crossings, and passes through 11 signalized intersections. The typical drive time for this route is 16-18 minutes, although this would be expected to increase with additional traffic added to the route. The detour summary is shown in **Figure 12**. The ODOT Road User Cost workbook was utilized to determine the expected cost of the delay cost per day, which was found to be \$27,561 and \$21,539 for the northbound and southbound detour routes, respectively. The detailed route information and RUC sheets are contained within **Appendix G**. The local detour could be Trenton Franklin Road (CR 81) to Franklin Madison Road (TR 9) to Thomas Road (TR 91).

Figure 12: BUT-4 Detour Summary

| | Normal Route | | State Route Detour | |
|--------------------------|--------------|-----|--------------------|------|
| | NB | SB | NB | SB |
| Travel Direction | NB | SB | NB | SB |
| Length (mi) | 6.3 | 6.3 | 10.7 | 10.5 |
| Typical Drive Time (min) | 8 | 8 | 18 | 16 |
| Delay (min) | 0 | 0 | 10 | 8 |

Temporary Signal: At the north end of the project site, the temporary signal is expected to be installed at the intersection of OH 4 and Catalina Court. At the south end of the project site, the temporary signal is expected to be installed approximately 525 feet south of the railroad overpass.

Capacity Analysis: For the capacity analysis, AM and PM peak hours were analyzed with ODOT count station data to develop anticipated delays (per vehicle based on approach) and performance metrics for the temporary signals. HCS analysis is included in **Appendix G**. The resulting delays, as reported for the AM and PM peak hour, were then standardized for an average vehicle trip using the Hourly Percent by Vehicle Type spreadsheet (provided by ODOT) to compare to the expected delays at the signal equated to the additional drive times associated with the detour routes. This delay was calculated to be approximately 3 minutes for northbound and southbound trips, normalized for the average vehicle. The HCS Analysis Summary is shown in **Figure 13**:

Figure 13: BUT-4 HCS Analysis Summary

| Temporary Signal | AM Peak Hour | | PM Peak Hour | |
|---------------------------|--------------|-------|--------------|-------|
| | NB | SB | NB | SB |
| Approach Direction | NB | SB | NB | SB |
| WZ Length (ft) | 1200 | 1050 | 1200 | 1050 |
| Volume (veh) | 361 | 320 | 521 | 587 |
| V/C Ratio | 1.028 | 1.005 | 1.623 | 1.625 |
| Back of Queue* (ft) | 722 | 644 | 1629 | 1827 |
| Approach Delay (s/veh) | 111.2 | 108.9 | 353.0 | 350.5 |
| Level of Service (A to F) | F | F | F | F |
| | NB | | SB | |
| Standard Delay (min/veh) | 3.1 | | 3.1 | |

* 95th Percentile

Based on the analysis, AM peak hour queueing does not indicate conflict but in the 95th percentile of the PM peak hour, northbound traffic is anticipated to queue 1629 feet which passes the OH 4 / Trenton-Franklin Road intersection south of the project site, and southbound traffic is expected to queue 1827 feet which passes the TWSC intersection of OH 4 & Corlee Ln to the north of the site. In both instances, traffic backup from the temporary signal could impact the performance of adjacent local intersections.

Cost Comparison: As mentioned previously, ODOT’s RUC workbook was utilized to determine the expected cost associated with the additional drive time of the northbound and southbound state detour route. These costs were then directly compared to the additional drive time associated with the normalized northbound and southbound delay at the temporary signal. In both cases, delay cost per day was calculated using Average Daily Traffic (ADT), which was determined by dividing ODOT count station AADT by the corresponding ODOT seasonal adjustment factor. For delay comparison during the peak hours, northbound and southbound delays as output by HCS were compared to the additional drive time (northbound and southbound) needed to take the state route detour instead of the normal route during peak hours. Corresponding delay cost was calculated by applying User Cost to the peak hour volumes. The cost comparison is shown in **Figure 14** and detailed RUC sheets and delay analyses are contained in **Appendix G**.

Figure 14: BUT-4 Cost Comparison

| | Northbound | | Southbound | |
|--------------------------------|--------------|-----------|--------------|-----------|
| Vehicle Type | Car | B/C Truck | Car | B/C Truck |
| ADT | 5,690 | 237 | 5,541 | 238 |
| AM Peak Volume | 351 | 10 | 311 | 9 |
| PM Peak Volume | 513 | 8 | 578 | 9 |
| User Cost Per Vehicle Per Hour | \$26.13 | \$70.52 | \$26.13 | \$70.52 |
| | Northbound | | Southbound | |
| | Temp. Signal | SR Detour | Temp. Signal | SR Detour |
| AM Peak Delay (min/vehicle) | 1.9 | 13 | 1.8 | 8.5 |
| AM Peak Delay Cost | \$305 | \$2,140 | \$265 | \$1,241 |
| PM Peak Delay (min/vehicle) | 5.9 | 12.5 | 5.8 | 8.5 |
| PM Peak Delay Cost | \$1,370 | \$2,910 | \$1,532 | \$2,230 |
| Avg Vehicle Delay (min) | 3.1 | 10 | 3.1 | 8 |
| Avg Delay Cost Per Day | \$8,454 | \$27,561 | \$8,276 | \$21,539 |

Conclusions: Based on the temporary signal analysis, both northbound and southbound traffic are anticipated to have a standardized delay of approximately 3 minutes per vehicle. By comparison, the state route detour is anticipated to add an additional 8-10 minutes of drive time for the average vehicle, which equates to a delay savings per day of approximately \$19,100 for northbound traffic and \$13,300 for southbound traffic by using the temporary signal. Delay cost during the peak hours is also higher for the state route detour compared to the temporary signal. That said, queue analysis at the temporary signal indicates that backup in the PM peak hour may interfere with local traffic at the intersections directly north and south of the site. If complete closure were implemented, delay cost to detour all traffic would amount to approximately \$49,000 per day but would improve contractor access throughout the site, lower traffic impacts by reducing the overall construction duration to approximately 30 days, and mitigate the risk of wrong-way vehicles as posed by a directional closure. For these reasons, a complete closure is recommended at the work site with both northbound and southbound traffic detoured via SR 73 and SR 123. In order to accommodate the Madison Township Fire Station located on SR 4 (Germantown Road) south of Catalina Court, two-way emergency response will need to be coordinated through the project area.

4.9 BUT-27-10.38 Maintenance of Traffic (MOT)

The existing pavement width varies from 38' on the north end (north of SR 130) to 44' on the south end (south of SR 130). These widths allow for part-width construction with two lanes of traffic maintained on one lane using temporary signals. MOT Typical Sections are provided in **Appendix N**.

Sequencing: We recommend sequencing the construction into one (1) Phase with the pavement reconstruction. The west side (outlet side) of the new storm sewer lateral located at the new sag point should be constructed first in Phase 1 and the east side (inlet side) of the new storm sewer system should be constructed next in Phase 2.

Stop Bars: The stop bar locations on the north side of US 27 vary based on the reconstruction limits for each option. Stop bars are located at 50 foot offsets from the merging edge line on either end of the work zone as per ODOT Standard Drawing MT-96.11.

Drives: The drives located within the reconstruction limits will need to be constructed in a Sub-Phase and accommodations provided to maintain drive access at all times. Drives will be signalized to coordinate directional traffic movements and forbid conflicting traffic movements attributed to drive egress during one-lane maintenance of traffic.

Evaluation: The project site was evaluated for MOT schemes where two-way traffic would be maintained at the site using temporary signals, one direction of traffic would be detoured, or both directions of traffic would be detoured to allow for complete closure at the work zone. HCS was used to perform the traffic signal analysis and ODOT's Road User Cost (RUC) workbook was used in conjunction with Google Maps to analyze the detour route. Two state route detours were reviewed, and an additional analysis was conducted to determine whether SR 130 could remain open at OH 27 and to determine what additional delays would be incurred by traffic passing through the site. AM and PM peak hours were analyzed for the site with data from ODOT count station 3109 (US 27) and 13609 (SR 130) to develop anticipated delays and performance metrics for the temporary signals. These were then compared to the expected delays associated with the detour route drive times. For the complete closure scenario, delay is calculated as the additional drive time of the detour route applied to all northbound and southbound vehicles.

Detour Route: The primary state route detour (State Route Detour 1) for northbound or southbound US 27 traffic would be from US 27 to SR 129, to SR 177, to SR 73, and back to US 27 through Millville, Hamilton, & Oxford. This route passes by one emergency services building, crosses two at-grade railroad crossings, passes by three grade schools and Miami University, and passes through 30 signalized intersections. The typical drive time for this approximately 19-mile-long route is 30-35 minutes resulting in 10-15 minutes of delay per vehicle. The ODOT Road User Cost workbook was utilized to determine the expected cost of the delay cost per day, which was found to be \$28,849 and \$18,703 for the southbound and northbound detour routes, respectively. The detailed RUC sheets are contained within **Appendix N**. No local detours are anticipated to be signed for US 27 traffic. It should be noted that a recent intersection reconfiguration project at the intersection of SR 129 at SR 177 prohibits eastbound left turns from SR 129 to northbound SR 177, which increases the length and duration of the northbound detour route.

The secondary state route detour (State Route Detour 2) for northbound or southbound US 27 traffic would be from US 27 to SR 129 to SR 732 back to US 27 through Millville & Oxford. This

route passes by no emergency service buildings or schools, crosses one at-grade railroad crossing, and passes through 8 signalized intersections. While this route does avoid Miami University, it does pass through the middle of the City of Oxford. The typical drive time for this 15.6-mile-long route is 26 minutes resulting in 6 minutes of delay per vehicle. The detour summary is shown in **Figure 15**. The ODOT Road User Cost workbook was utilized to determine the expected cost of the delay cost per day, which was found to be \$11,540 and \$11,222 for the southbound and northbound detour routes, respectively. The detailed route information and RUC sheets are contained within **Appendix N**. This route could be shortened by utilizing Locust Street within Oxford - the at-grade crossing on Locust Street has been upgraded and is preempted whereas the at-grade crossing on OH 732 at E Chestnut has not – resulting in a similar travel time, but fewer turns and signalized intersections to navigate.

Figure 15: BUT-27 Detour Summary

| Travel Direction | Normal Route | | State Route Detour 1 | | State Route Detour 2 | |
|--------------------------|--------------|----|----------------------|------|----------------------|------|
| | NB | SB | NB | SB | NB | SB |
| Length (mi) | 11 | 11 | 18.6 | 18.2 | 15.6 | 15.6 |
| Typical Drive Time (min) | 20 | 20 | 30 | 35 | 26 | 26 |
| Delay (min) | 0 | 0 | 10 | 15 | 6 | 6 |

The primary state route detour for eastbound or westbound through traffic would be from SR 130 to SR 177 to SR 73 and back to US 27. This route does not pass by any emergency services buildings, passes by one grade school & Miami University, and passes through five signalized intersections. While this detour route is 10.2 miles long, the drive is typically two minutes shorter per vehicle than that of the primary route utilizing SR 130 to US 27 to travel to Oxford. Local traffic would be able to utilize several options for local detours:

- 1) SR 177 to Stillwell Beckett Road back to US 27
- 2) SR 130 to Lanes Mill Road to Stillwell Beckett Road back to US 27
- 3) SR 130 to Darrtown Road to Stillwell Beckett Road back to US 27

Each of the local detours adds 0-2 minutes of additional travel time, but relies on narrow, local roadways. Lanes Mill Road is approximately 22 feet wide. Stillwell Beckett Road is approximately 20 feet wide. The typical drive time for all three routes is 7-9 minutes, but would be expected to increase with additional traffic added to the routes.

Temporary Signal: At the north end of the project site, the temporary signal is expected to be installed just north of the intersection of US 27 and Hussey Road. At the south end, the temporary signal is expected to be installed approximately 500 feet south of the railroad bridge.

Capacity Analysis: For the capacity analysis, AM and PM peak hours were analyzed with ODOT count station data to develop anticipated delays (per vehicle based on approach) and performance metrics for the temporary signals. HCS analysis is included in **Appendix N**. The resulting delays, as reported for the AM and PM peak hour, were then standardized for an average vehicle trip using the Hourly Percent by Vehicle Type spreadsheet to compare to the expected delays at the signal equated to the additional drive times associated with the detour routes. This delay was calculated

to be approximately 90 seconds per vehicle with SR 130 closed and 3 minutes with SR 130 open for northbound and southbound trips, normalized for the average vehicle. The HCS Analysis Summary for SR 130 closed is shown in **Figure 16** and for SR 130 open is shown in **Figure 17**:

Figure 16: HCS Analysis (SR 130 Closed)

| Temporary Signal | AM Peak Hour | | PM Peak Hour | |
|---------------------------|--------------|-------|--------------|-------|
| | NB | SB | NB | SB |
| Approach Direction | NB | SB | NB | SB |
| WZ Length (ft) | 1295 | 1295 | 1295 | 1295 |
| Volume (veh) | 243 | 309 | 404 | 318 |
| V/C Ratio | 0.801 | 0.848 | 1.143 | 1.116 |
| Back of Queue* (ft) | 397 | 487 | 884 | 704 |
| Approach Delay (s/veh) | 71.6 | 71.9 | 149.2 | 147.8 |
| Level of Service (A to F) | E | E | F | F |
| | NB | | SB | |
| Standard Delay (min/veh) | 1.5 | | 1.4 | |

* 95th Percentile

Figure 17: BUT-27 HCS Analysis (SR 130 Open)

| Temporary Signal | AM Peak Hour | | PM Peak Hour | |
|---------------------------|--------------|-------|--------------|-------|
| | NB | SB | NB | SB |
| Approach Direction | NB | SB | NB | SB |
| WZ Length (ft) | 1295 | 1295 | 1295 | 1295 |
| Volume (veh) | 243 | 309 | 404 | 318 |
| V/C Ratio | 1.006 | 1.033 | 1.502 | 1.446 |
| Back of Queue* (ft) | 569 | 691 | 1289 | 999 |
| Approach Delay (s/veh) | 135.4 | 134.1 | 317.6 | 300.5 |
| Level of Service (A to F) | F | F | F | F |
| | NB | | SB | |
| Standard Delay (min/veh) | 3.0 | | 2.8 | |

* 95th Percentile

Based on the analysis, queueing does not indicate conflict with the SR 130 closure or in the AM peak hour with SR 130 open, but in the 95th percentile of the PM peak hour northbound traffic is anticipated to queue 1289 feet which passes the TWSC intersection of US 27 & Stillwell Road south of the project site. In this instance, traffic backup from the temporary signal could impact the performance of the adjacent local intersection.

Cost Comparison: As mentioned, ODOT’s RUC workbook was used to determine the expected cost associated with the extra drive time of the northbound and southbound state detour routes. These costs were then directly compared to the additional drive time associated with the normalized northbound and southbound delay at the temporary signal, with and without the closure of SR 130. In all cases, delay cost per day was calculated using Average Daily Traffic (ADT), which was determined by dividing ODOT count station AADT by the corresponding ODOT seasonal adjustment factor. For delay comparison during the peak hours, northbound and southbound delays as output by HCS were compared to the additional drive time (northbound and southbound) needed to take the state route detour instead of the normal route during peak hours. Corresponding delay cost was calculated by applying User Cost to the peak hour volumes. The cost comparison is shown in **Figure 18** and the detailed RUC sheets and delay analyses are contained in Appendix N.

Figure 18: BUT-27 Cost Comparison

| | Northbound | | Southbound | |
|--------------------------------|------------------|----------------|------------------|----------------|
| Vehicle Type | Car | B/C Truck | Car | B/C Truck |
| ADT | 3,680 | 228 | 3,888 | 196 |
| AM Peak Volume | 234 | 9 | 300 | 9 |
| PM Peak Volume | 393 | 11 | 311 | 7 |
| User Cost Per Vehicle Per Hour | \$26.13 | \$70.52 | \$26.13 | \$70.52 |
| | Northbound | | Southbound | |
| Temp. Signal | SR 130 Closed | SR 130 Open | SR 130 Closed | SR 130 Open |
| AM Peak Delay (min/vehicle) | 1.2 | 2.3 | 1.2 | 2.2 |
| AM Peak Delay Cost | \$134 | \$254 | \$169 | \$316 |
| PM Peak Delay (min/vehicle) | 2.5 | 5.3 | 2.5 | 5.0 |
| PM Peak Delay Cost | \$458 | \$974 | \$354 | \$720 |
| Avg Vehicle Delay (min) | 1.5 | 3.0 | 1.4 | 2.8 |
| Avg Delay Cost per Day | \$2,723 | \$5,599 | \$2,747 | \$5,434 |
| Detour | SR Detour 1 | SR Detour 2 | SR Detour 1 | SR Detour 2 |
| AM Peak Delay (min/vehicle) | 14.5 | 6.5 | 15.5 | 5 |
| AM Peak Delay Cost | \$1,631 | \$731 | \$2,189 | \$706 |
| PM Peak Delay (min/vehicle) | 17 | 4 | 13.5 | 4 |
| PM Peak Delay Cost | \$3,129 | \$736 | \$1,940 | \$575 |
| Avg Vehicle Delay (min) | 10 | 6 | 15 | 6 |
| Avg Delay Cost Per Day | \$18,703 | \$11,222 | \$28,849 | \$11,540 |

Conclusions: Based on the temporary signal analysis, both northbound and southbound traffic are anticipated to have a standardized delay of approximately 3 minutes per vehicle with OH 130 open

and 90 seconds with OH 130 closed. By comparison, state route detour 1 is expected to add 10-15 minutes of drive time for the average vehicle and state route detour 2 is expected to add 6 minutes. Relative to delay cost per day for detour 1, approximately \$16,000 northbound and \$26,000 southbound is saved using the temporary signal with OH 130 closed, and approximately \$13,000 northbound and \$23,500 southbound is saved using the temporary signal with OH 130 open. For detour 2 relative delay cost per day, approximately \$8,500 northbound and \$8,800 southbound is saved using the temporary signal with OH 130 closed, and approximately \$5,600 northbound and \$6,100 southbound is saved using the temporary signal with OH 130 open. As shown, delay cost for the overall day using detour 2 is significantly higher compared to the temporary signal, even though delay cost in the PM peak hour is slightly lower for detour 2 compared to the temporary signal with OH 130 open. That said, queue analysis at the temporary signal indicates that backup in the PM peak hour with OH 130 open may interfere with local traffic at the intersection directly south of the site. If complete closure were implemented, delay cost to detour all traffic would amount to approximately \$47,500 per day using state route detour 1 or \$22,800 per day using state route detour 2 but would improve contractor access throughout the site and lower traffic impacts by reducing the overall construction duration.

Based on this analysis and to avoid the risk of wrong-way vehicles as posed by a directional closure, it is recommended that traffic be maintained either with the use of a temporary signal at the work zone or with traffic detoured and complete closure at the site. A temporary signal (to maintain one lane of two-way traffic) would allow for part-width construction with a duration of approximately 3 to 4 months, whereas complete closure would result in a construction duration of approximately 30 days. Given the delay comparison as summarized in the previous table, temporary signal operation is improved with the closure of SR 130 and the use of state route detour 2 results in approximately half as much additional travel time per vehicle compared to state route detour 1. Applied to the respective construction duration, the temporary signal would result in an overall delay cost between approximately \$500,000 and \$665,000 but would avoid the need for vehicles to detour, and complete closure would result in an overall delay cost of approximately \$680,000 but would shorten the duration of traffic impacts. It is recommended that input from the Butler County Engineer's Office (BCEO), Miami University, local Fire and Police Department agencies, and public involvement be solicited with regard to a final design decision.

4.10 BUT-4-23.90 Right-of-Way (R/W)

R/W is anticipated for the following vertical clearance alternatives as shown in **Figure 19**:

Figure 19: BUT-4 R/W Needs

| Alternative | R/W Needed | Parcel # | Area | Cost |
|------------------------------|----------------|---|---------|------|
| 1 – 13.8’ Vertical Clearance | Yes, temporary | E2210020000024 for Madison Township. No parcel # for CSX Railroad property. 2 Parcels | 1260 SF | TBD* |
| 2 – 14.0’ Vertical Clearance | Yes, temporary | E2210020000024 for Madison Township. No parcel # for CSX Railroad property. 2 Parcels | 1240 SF | TBD* |
| 3 – 14.5’ Vertical Clearance | Yes, temporary | E2210020000024 and E2210020000025 for Madison Township. No parcel # for CSX Railroad property. 3 Parcels | 2185 SF | TBD* |
| 4 – 15.0’ Vertical Clearance | Yes, temporary | E2210020000024 and E2210020000025 for Madison Township. E2250091000004 for Poasttown First Church of God. No parcel # for CSX Railroad property. 4 Parcels | 3130 SF | TBD* |

* A construction agreement would be needed with CSX Railroad if R/W is to be acquired and those costs would be determined at a later date.

4.11 BUT-27-10.38 Right-of-Way (R/W)

R/W is anticipated for the following vertical clearance alternatives as shown in **Figure 20**:

Figure 20: BUT-27 R/W Needs

| Alternative | R/W Needed | Parcel # | Area | Cost |
|------------------------------|----------------|--|--------|------|
| 1 – 14.0’ Vertical Clearance | Yes, temporary | No parcel # for CSX Railroad property. 1 Parcel | 225 SF | TBD* |
| 2 – 14.5’ Vertical Clearance | Yes, temporary | No parcel # for CSX Railroad property. 1 Parcel | 315 SF | TBD* |

* A short 140’ long retaining wall is possible to eliminate the 2:1 slopes and avoid R/W just past the bridge on the west side. This wall could be extended to eliminate the 2:1 slopes even where R/W is not needed. A construction agreement would be needed with CSX Railroad if R/W is to be acquired and those costs would be determined at a later date.

4.12 BUT-4-23.90 Geotechnical

ODOT’s Central Office Geotechnical Section reviewed the BUT-4-23.94 location and provided the following comments:

“The posted clearance is 13’-7” and the desired clearance is 14’-0” to 14’-6”. The overpass is a single span railroad bridge on full height wall abutments. Resource International performed a roadway exploration immediately south of the bridge in 2002 (PID 14922, BUT-4-23.74), exhibiting predominantly medium dense to loose granular soils. With a maximum grade change of 1 foot and maximum excavation of 2.5-foot, the project should not have an effect on the stability (passive resistance) of the RR wall abutment foundations, assuming the soils within the frost zone (30”) were ignored in the original design. If the RR has a concern, the complete details of the abutment footing need to be made available, and the stability of the footing could be looked at considering the historic adjacent boring. Our opinion is that the planned subgrade treatment is warranted, and no new borings are necessary.”

4.13 BUT-27-10.38 Geotechnical

ODOT’s Central Office Geotechnical Section reviewed the BUT-27-10.46 location and provided the following comments:

“The existing clearance is 14’-0”, and the preferred new clearance is 14’-6”. The overpass is a single span railroad bridge on full height wall abutments. A roadway historic exploration was performed by ATEC in 1988 (BUT-27-10.40) with one boring south of the bridge and rest north. The borings exhibited A-6 soils overlying shallow shale bedrock (6.0 feet±) with no rock coring performed. Again, considering the fact that the planned excavation for this project will be less than 2 feet, we would expect the abutment foundation design to ignore the soil within the frost depth (30”), and therefore, the planned excavation to have no effect on the stability of the footing. If the RR has any concerns, they need to produce a detail of the abutment footing for analysis, and the stability can be looked at using the historic boring and some assumptions for the bedrock, if necessary. If there are any further concerns (which there shouldn’t be) a boring would be necessary to characterize the rock. The ATEC exploration included lab CBRs at 98% and 100% compaction and resulted in CBR values between 5 and 6. Our opinion is that the planned subgrade treatment is warranted, and no new borings are necessary.”

4.14 Utility Impacts

BG Engineering Group contacted Ohio Utilities Protection Service (OUPS) and obtained record utility plans for this project.

The Stage 1 plan sheets will be mailed to each utility within the project limits once a preferred alternative has been selected by ODOT. The utility responses will be collected and sent to ODOT. The comments will be addressed in detailed design. The utility impacts are the reduced over the 4” gas line and traffic signal conduit for the BUT-27-10.38 location.

Utility information for the BUT-4-23.90 location is summarized in **Figure 21**:

Figure 21: BUT-4 Utility Information

| Utility | Owner | Size | Location | Impacts and Comments |
|-----------------------|--------------------------|------|--------------------------|----------------------|
| Electric and Lighting | Duke Energy | N/A | Both sides | No impacts. |
| Water | Southwest Regional Water | 12" | West side | No impacts. |
| Telephone | AT&T Ohio | Unk. | East side under sidewalk | No impacts. |
| Cable | Charter Communications | N/A | Overhead on poles | No impacts. |
| Gas | Duke Energy | 8" | East side | No impacts. |
| Sanitary Sewer | N/A | N/A | N/A | N/A |

Utility information for the BUT-27-10.38 location is summarized in **Figure 22**:

Figure 22: BUT-27 Utility Information

| Utility | Owner | Size | Location | Impacts and Comments |
|-----------------------|---|----------|---|--|
| Electric and Lighting | Duke Energy | N/A | Both sides | No impacts. |
| Electric | Butler Rural Electric Cooperative, Inc. | N/A | SR 130 | No impacts. |
| Water | Southwest Regional Water | 8" | West side | No impacts. |
| Telephone | Altafiber (formerly Cincinnati Bell) | N/A | Overhead on poles | No impacts. |
| Cable | Charter Communications | N/A | Overhead on poles | No impacts. |
| Gas | Duke Energy | 8" 4" | 8" on west side; 4" on east side | Reduced cover over 4" in both alternates |
| Sanitary Sewer | N/A | N/A | N/A | N/A |
| Traffic Signal | ODOT District 8 | N/A | SR 130 intersection and along US 27. Pull | Signal to be upgraded to radar |

| | | | | |
|--|--|--|---|--|
| | | | boxes, 2” conduit and loop detectors on west side north of SR 130 and east side south of SR 130 | loop detectors can be abandoned. Adjust to grade for some pull boxes. Reduced cover over 2” conduit. |
|--|--|--|---|--|

4.15 Railroad Coordination

Railroad coordination will begin with submission of this Feasibility Study to CSX through the Ohio Rail Development Commission (ORDC).

4.16 BUT-4-23.90 Environmental Impacts

The following is a summary of environmental resources with the project area and anticipated involvement with those resources under the feasible build alternatives:

Streams and Wetlands: No streams or wetlands are anticipated within the project corridor.

Floodplain: The project corridor is not located within a designated special flood hazard area.

Threatened and Endangered Species: Butler County is within the known habitat ranges of the Indiana bat, northern long-eared bats, the tri-colored bat, the bald eagle, the rayed bean mussel, and the eastern massasauga rattlesnake. Habitat for these species is not anticipated to be present within the project corridors.

Cultural Resources: Within the project corridor, there are no National Historic Landmarks or sites that have been determined eligible for the National Register of Historic Places. Although not currently listed on the NRHP, the Madison Township Fire Department Station is adjacent to the proposed project and the building was likely constructed in the 1900s. Under all build alternatives, the project is not expected to have impacts to historic properties.

Section 4(f)/6(f) Resources: There are no publicly-owned recreational facilities or facilities funded with Land & Water Conservation Funds within or adjacent to the project corridors.

Air Quality: All build alternatives are expected to be exempt from analysis for mobile source air toxics. The project is not located in an area that is currently in non-attainment for criteria air pollutants under the National Ambient Air Quality Standards.

Noise Levels: None of the project corridors will shift travel lanes modestly closer to noise sensitive receptors. If necessary, a noise analysis and, if warranted and feasibility, consideration for noise abatement will be undertaken; however, a noise analysis is not anticipated.

Drinking Water Resources: This project is located within the boundaries of a designated sole source aquifer and a drinking water resource protection area. Under all build alternatives, a plan note to protect groundwater resources will be included in the project plans.

Farmland: A majority of this project is located within an urbanized area and is not likely to require coordination under the Farmland Protection Policy Act. Additionally, acquisition under this project is not anticipated to exceed the coordination thresholds of ORC 929.05.

Regulated Materials: Multiple properties of concern are located within the vicinity of the project corridor. Additional investigations may be warranted if the selected alternative’s footprint requires

involvement with the identified properties of concern. It is likely the involvement will be limited to a petroleum contaminated soils plan note.

Underserved Populations: US Census data indicate the following percentages of environmental justice populations within the corridor as shown in **Figure 23**. The project will not require relocations and right-of-way acquisition from private properties will be limited to non-residential properties. Under the build alternatives, the project is not expected to result in disproportionate adverse impacts to environmental justice populations.

Figure 23: BUT-4 Environmental Justice Populations

| | % Population by Block Group |
|------------|-----------------------------|
| Minority | 4 |
| Low-Income | 33 |

4.17 BUT-27-10.38 Environmental Impacts

The following is a summary of environmental resources with the project area and anticipated involvement with those resources under the feasible build alternatives:

Streams and Wetlands: No streams or wetlands are anticipated within the project corridor.

Floodplain: The project corridor is not located within a designated special flood hazard area.

Threatened and Endangered Species: Butler County is within the known habitat ranges of the Indiana bat, northern long-eared bats, the tri-colored bat, the bald eagle, the rayed bean mussel, and the eastern massasauga rattlesnake. Habitat for these species is not anticipated to be present within the project corridors.

Cultural Resources: Within the project corridor, there are no National Historic Landmarks or sites that have been determined eligible for the National Register of Historic Places. A cemetery may be in proximity to the proposed project. Under all build alternatives, the project is not expected to have impacts to historic properties.

Section 4(f)/6(f) Resources: There are no publicly-owned recreational facilities or facilities funded with Land & Water Conservation Funds within or adjacent to the project corridors.

Air Quality: All build alternatives are expected to be exempt from analysis for mobile source air toxics. The project is not located in an area that is currently in non-attainment for criteria air pollutants under the National Ambient Air Quality Standards.

Noise Levels: None of the project corridors will shift travel lanes modestly closer to noise sensitive receptors. If necessary, a noise analysis and, if warranted and feasibility, consideration for noise abatement will be undertaken; however, a noise analysis is not anticipated.

Drinking Water Resources: The project is not located within the boundaries of a designated sole source aquifer or a drinking water resource protection area.

Farmland: This project is not located entirely within an urbanized area and may require coordination under the Farmland Protection Policy Act. Additionally, acquisition under this project is not anticipated to exceed the coordination thresholds of ORC 929.05.

Regulated Materials: Two properties of concern are located within the vicinity of the project corridor. Additional investigations may be warranted if the selected alternative’s footprint requires involvement with the identified properties of concern. It is likely the involvement will be limited to a petroleum contaminated soils plan note.

Underserved Populations: US Census data indicate the following percentages of environmental justice populations within the corridor as shown in **Figure 24**. The project will not require relocations and right-of-way acquisition from private properties will be limited to non-residential properties. Under the build alternatives, the project is not expected to result in disproportionate adverse impacts to environmental justice populations.

Figure 24: BUT-27 Environmental Justice Populations

| | % Population by Block Group |
|------------|-----------------------------|
| Minority | 13 |
| Low-Income | 24 |

4.18 BUT-4-23.90 Public Involvement

Public involvement activities will occur after approval of the preferred alternate. Owners, occupants and other identified stakeholders will be notified of the project as part of ODOT’s public involvement process. Comments received from the public will be considered as design progresses.

4.19 BUT-27-10.38 Public Involvement

Public involvement activities will occur after approval of the preferred alternate. Owners, occupants and other identified stakeholders will be notified of the project as part of ODOT’s public involvement process. Comments received from the public will be considered as design progresses.

4.20 BUT-4-23.90 Construction Cost Estimates

The following planning level costs, shown in **Figure 25**, are expected for each vertical clearance alternative. Itemized cost estimates are provided in **Appendix H**.

Figure 25: BUT-4 Estimated Construction Costs

| Alternative | Total Construction Cost | % Greater than Cheapest Alternative |
|------------------------------|-------------------------|-------------------------------------|
| 1 – 13.8’ Vertical Clearance | \$1,770,000 | |
| 2 – 14.0’ Vertical Clearance | \$1,900,000 | 7.3% |
| 3 – 14.5’ Vertical Clearance | \$2,130,000 | 20.3% |
| 4 – 15.0’ Vertical Clearance | \$2,320,000 | 31.1% |

All alternative costs include a 30% design contingency for this stage of project development and an 17.1% inflation rate was included based on ODOT’s inflation calculator and an assumption that

the midpoint of construction will be 7/15/2027. ODOT’s inflation calculator is provided in **Appendix P**.

4.21 BUT-27-10.38 Construction Cost Estimates

The following planning level costs, shown in **Figure 26**, are expected for each vertical clearance alternative. Itemized cost estimates are provided in **Appendix O**.

Figure 26: BUT-27 Estimated Construction Costs

| Alternative | Total Construction Cost | % Greater than Cheapest Alternative |
|------------------------------|-------------------------|-------------------------------------|
| 1 – 14.0’ Vertical Clearance | \$1,240,000 | |
| 2 – 14.5’ Vertical Clearance | \$1,310,000 | 5.6% |

All alternative costs include a 30% design contingency for this stage of project development and an 17.1% inflation rate was included based on ODOT’s inflation calculator and an assumption that the midpoint of construction will be 7/15/2027. ODOT’s inflation calculator is provided in **Appendix P**.

I thought 15' is the preferred alternative for BUT-4-23.90?

5.0 COMPARISON OF ALTERNATIVES

5.1 BUT-4-23.90

The alternative matrix, as shown in **Figure 27**, evaluates each vertical clearance alternative. Based upon these established criteria, the 14.0’ vertical clearance alternative was selected as the preferred alternative.

Figure 27: BUT-4 Alternative Matrix

| Criteria | 1 – 13.8’ Vertical Clearance | 2 – 14.0’ Vertical Clearance | 3 – 14.5’ Vertical Clearance | 4 – 15.0’ Vertical Clearance |
|--------------------------------|------------------------------|-------------------------------|---|---|
| Vertical Clearance Improvement | No | Yes | Yes | Yes |
| Profile Reduction/Maximum Cut | None | 0.31’ lower than 13.8’ option | 0.85’ lower than 13.8’ alternative | 1.35’ lower than 13.8’ alternative |
| Curb Height at Bridge | 6” | 6” | 1.0’ which exceeds ODOT standard curb height, wall needed | 1.5’ which exceeds ODOT standard curb height, wall needed |

| | | | | |
|--|--------------------------|---|--|---|
| Pedestrian Handrail Required under Bridge? | No | No | Yes | Yes |
| Retaining Walls Needed | No | No | Yes | Yes |
| Railroad Impacts | None | None | None | None |
| Cover over Storm Sewers | Similar to 14.0' option. | Similar to 13.8' option. | Reduced generally about 6" more compared to 14.0' alternative | Reduced generally about 12" more compared to 14.0' alternative |
| Maintenance of Traffic | Shortest work zone. | 69.5' longer work zone on north end than 13.8' alternative. | 53.5' longer work zone on north end than 14.0' alternative. | Same work zone length as 14.5' alternative. |
| Drive Impacts | No drives. | One drive. | Two drives that are unable to be designed following ODOT's commercial drive design criteria. | Four drives that are unable to be designed following ODOT's commercial drive design criteria. |
| Utility Impacts | None | None | Yes, reduced cover over telephone | Yes, reduced cover over telephone |
| Right-of-Way Impacts | Yes | Yes | Yes | Yes |
| Construction Costs | \$1,770,000 | \$1,900,000 | \$2,130,000 | \$2,320,000 |

5.2 BUT-27-10.38

The alternative matrix, as shown in **Figure 28**, evaluates each vertical clearance alternative. Based upon these established criteria, the 14.5' vertical clearance alternative was selected as the preferred alternative.

Figure 28: BUT-27 Alternative Matrix

| Criteria | 1 – 14.0' Vertical Clearance | 2 – 14.5' Vertical Clearance |
|--------------------------------|---|---|
| Vertical Clearance Improvement | No | Yes |
| Profile Reduction/Maximum Cut | 3" Max. | 1.3' |
| Curb Height at Bridge | 6" | Varies 10" Max. |
| Railroad Impacts | None | None |
| SR 130 Impacts | Ties in before Lanes Mill Road at Sta. 200+63.21, but the grade break is only .15% below the max allowable grade break, so it does not improve it as much as the 14.5' alternative. | Ties in before Lanes Mill Road at Sta. 200+73.53 and improves the existing vertical geometry/grade breaks which currently exceed ODOT's maximum allowable grade breaks. |
| Cover over Storm Sewers | Maximum reduction of 0.4'. | Reduced generally about more 6" compared to 14.0' alternative |
| Maintenance of Traffic | 100' shorter work zone than 14.5' alternative | 100' longer work zone than 14.0' alternative. |
| Drive Impacts | One drive impacted at Sta. 8+90.48. Limited to apron work within R/W. | One drive impacted at Sta. 14+92.27. Limited to apron work within R/W. |
| Utility Impacts | 4" gas has reduced cover. 2" traffic signal conduit has reduced cover. | 4" gas has reduced cover. 2" traffic signal conduit is now into the aggregate base. |
| Right-of-Way (R/W) Impacts | Yes, on west side, north of bridge | Yes, on west side, north of bridge |
| Construction Costs | \$1,240,000 | \$1,310,000 |

This conflicts with
sheet 34

6.0 CONCLUSION

6.1 BUT-4-23.90

The 15.0' vertical clearance alternative was selected as the preferred alternative since it increases the vertical clearance from the existing condition.

6.2 BUT-27-10.38

The 15.0' vertical clearance alternative was selected as the preferred alternative since it increases the vertical clearance from the existing condition. This alternative was not studied during the feasibility study. However, see **Appendix Q** for justification for this alternative.

7.0 NEXT STEPS

Upon approval of this report by the District, CVE will prepare a contract modification for detailed design of this project to complete the construction plans.

The project schedule indicates the feasibility study being completed in October 2024, which is on schedule. Stage 1/2 design plans are expected in May of 2025, Stage 3 design plans are expected in April of 2026, and final plans in November of 2026.

Appendix A

Design Criteria

| BUT-75-05.22 PID 117275 - US 27/SR 4 DESIGN CRITERIA | | | | | | | |
|--|--|---|------------------------------|--------------------------------------|--------------------------------------|--------------------------------------|--------------------------------------|
| | ITEM | REMARKS | REF SECTION | US 27 (Millville Oxford Road) | | SR 4 (Germantown Road) | |
| | | | | PREFERRED | PROPOSED | PREFERRED | PROPOSED |
| DESIGN DESIGNATION | Design Functional Classification, FC | | L&D Vol. 1 101 | 03 Principal Arterial Other (Rural) | | 03 Principal Arterial Other (Urban) | |
| | Design Speed (mph) | | L&D Vol. 1 104 | 50 | | 45 | |
| | Legal Speed (mph) | | L&D Vol. 1 104 | 45 | | 45 | |
| | Managing Agency | | | ODOT | | ODOT | |
| | Location | | | Hanover Township | | Madison Township | |
| | Number of Lanes | | | 2 thru and a center turn lane | | 2 thru and a center turn lane | |
| | National Highway System (NHS) Project | | ODOT Roadway Inventory | Yes | | Yes | |
| | Federal Aid Primary (FAP) Route | | ODOT Roadway Inventory | Yes | | Yes | |
| | Current ADT (2027) | | ODOT TFMS Tool | 7600 | | 11550 | |
| | Design ADT (2047) | | ODOT TFMS Tool | 7600 | | 13000 | |
| | Design Hourly Volume (2047) | | ODOT TFMS Tool | 1000 | | 1600 | |
| | Directional Distribution, D | | ODOT TFMS Tool | 52.6% | | 53.7% | |
| | Trucks, T24 (24 Hour B&C) | | ODOT TFMS Tool | 4% | | 4% | |
| SIGHT DISTANCES | Stopping Sight Distance, SSD (ft) | | L&D Vol. 1 201-1 | 425' | 425' | 360' | 360' |
| | Minimum Passing Sight Distance, PSD (ft) | | L&D Vol. 1 201-3 | 800' | 800' | 700' | 700' |
| | Intersection Sight Distance - Passenger Car (Left) (ft) | | L&D Vol. 1 201-5 | 555' | 555' | 500' | 500' |
| | Intersection Sight Distance - Passenger Car (Right) (ft) | | L&D Vol. 1 201-5 | 480' | 480' | 430' | 430' |
| | Decision Sight Distance, DSD, stop (ft) | Rural Stop (A) and Urban Stop (B) | L&D Vol. 1 201-6 | 465' (A) | 465' (A) | 800' (B) | 800' (B) |
| | Decision Sight Distance, DSD, change (ft) | Speed/Path/Direction Change (Rural C, Urban E) | L&D Vol. 1 201-6 | 750' (C) | 750' (C) | 930' (E) | 930' (E) |
| HORIZONTAL DESIGN | Max. CL Deflection w/out Horizontal Curve | | L&D Vol. 1 202-1 | 1° 05' | 1° 05' | 1° 40' | 1° 40' |
| | Max. Degree of Curve | | L&D Vol. 1 202-2 | 7° 30' | 7° 30' | 8° 00' | 8° 00' |
| | Max. Degree of Curve w/out Superelevation | | L&D Vol. 1 202-3 | 0° 45' | 0° 45' | 5° 40' | 5° 40' |
| | Max. Superelevation Rate | | L&D Vol. 1 202-7 to 202-10 | 0.080 ft/ft | 0.080 ft/ft | 0.039 ft/ft | 0.039 ft/ft |
| | Max. Degree of Curve w/out Spiral | | L&D Vol. 1 202-11 | 4° 30' | 4° 30' | N/A | N/A |
| VERTICAL DESIGN | Terrain | | L&D Vol. 1 103.2 | Level | | Level | |
| | Maximum Grade | | L&D Vol. 1 203-1 | 4% | 4% | 6% | 6% |
| | Minimum Grade | | L&D Vol. 1 203.2.2 | 0.5% with Curb, 0.3% without Curb | 0.5% with Curb, 0.3% without Curb | 0.5% with Curb, 0.3% without Curb | 0.5% with Curb, 0.3% without Curb |
| | Max. Grade Break w/out Vertical Curve | | L&D Vol. 1 203-2 | 0.45% | 0.45% | 0.55% | 0.55% |
| | Minimum "K" value for crest vertical curve | | L&D Vol. 1 203-3 | 84 | 84 | 61 | 61 |
| | Minimum Sight Stopping Distance (SSD) for crest vertical curve | | L&D Vol. 1 203-3 | 425' | 425' | 360' | 360' |
| | Minimum "K" value for sag vertical curve | | L&D Vol. 1 203-6 | 96 | 96 | 79 | 79 |
| | Minimum Sight Stopping Distance (SSD) for sag vertical curve | | L&D Vol. 1 203-6 | 425' | 425' | 360' | 360' |
| | Minimum length of vertical curve (ft) | | L&D Vol. 1 203.3.3 & 203.3.4 | 150' | 150' | 135' | 135' |
| Minimum Vertical Clearance Over Roadway (ft) | | L&D Vol. 1 302-1 to 302-3 | 14' | 14' | 14' | 14' | |

| BUT-75-05.22 PID 117275 - US 27/SR 4 DESIGN CRITERIA | | | | | | | |
|--|----------------------------|--------------------------|---|---|---|---|----------|
| CROSS SECTION DESIGN | ITEM | REMARKS | REF SECTION | US 27 (Millville Oxford Road) | | SR 4 (Germantown Road) | |
| | | | | PREFERRED | PROPOSED | PREFERRED | PROPOSED |
| | | | | Minimum Lane Width (ft) | | L&D Vol. 1 301-2 & 301-4 | 12 |
| Treated Shoulder Width (Left) (ft) | | L&D Vol. 1 301-3 & 301-4 | 8' | 8' | 1'-2' Paved | 1'-2' Paved | |
| Treated Shoulder Width (Right) (ft) | | L&D Vol. 1 301-3 & 301-4 | 8' | 8' | 1'-2' Paved | 1'-2' Paved | |
| Curbed Shoulder Width (ft) | | L&D Vol. 1 301-4 | 8' | 8' | 1'-2' Paved | 1'-2' Paved | |
| Lateral Clearance Under Bridge | | L&D Vol. 1 302-3 | 13' | Match existing | 13' | Match existing | |
| Normal Cross Slope | | L&D Vol. 1 301.1.5 | 0.016 | 0.016 | 0.016 | 0.016 | |
| Pavement Transition Taper Rates | | L&D Vol. 1 301.1.4 | L=WS | L=WS | L=WS^2/60 | L=WS^2/60 | |
| Shoulder Transition Taper Rates | | L&D Vol. 1 301.2.3.2 | Decrease: 25:1 Increase: 5:1 | Decrease: 25:1 Increase: 5:1 | Decrease: 25:1 Increase: 5:1 | Decrease: 25:1 Increase: 5:1 | |
| Slope Treatment Adjacent to Curbed Streets | | L&D Vol. 1 307-6 | 4% Minimum 8% Maximum | 4% Minimum 8% Maximum | 4% Minimum 8% Maximum | 4% Minimum 8% Maximum | |
| Guardrail Offset (ft) | | L&D Vol. 1 301-3 | 10' | 10' | 10' | 10' | |
| Barrier Offset (ft) | | L&D Vol. 1 301-3 | 13' (Total Graded Width may be reduced as much as 3' where MGS Guardrail with longer posts is used) | 13' (Total Graded Width may be reduced as much as 3' where MGS Guardrail with longer posts is used) | 13' (Total Graded Width may be reduced as much as 3' where MGS Guardrail with longer posts is used) | 13' (Total Graded Width may be reduced as much as 3' where MGS Guardrail with longer posts is used) | |
| Grading Type | | L&D Vol. 1 307.2.1 | Clear Zone | Clear Zone | Clear Zone | Clear Zone | |
| Clear Zone (ft) | Foreslope 6:1 or Flatter | L&D Vol. 1 600-1 | 19 | 19 | 19 | 19 | |
| Clear Zone (ft) | Foreslope 6:1 to 4:1 | L&D Vol. 1 600-1 | 26 | 26 | 26 | 26 | |
| Clear Zone (ft) | Backslope 6:1 or Flatter | L&D Vol. 1 600-1 | 21 | 21 | 21 | 21 | |
| Clear Zone (ft) | Backslope 6:1 to 4:1 | L&D Vol. 1 600-1 | 19 | 19 | 19 | 19 | |
| Clear Zone (ft) | Backslope Steeper than 4:1 | L&D Vol. 1 600-1 | 15 | 15 | 15 | 15 | |
| Sidewalk Installations | | MDG 2.5.1.1 | N/A | N/A | Both sides | Both sides | |
| Walk Width (ft) | | MDG 4.3.2 | N/A | N/A | 6'-8' | 6' | |
| Walk Cross Slope | | MDG 3.6.4 | N/A | N/A | 1.56% | 1.56% | |
| Treelawn Width (ft) | | MDG 4.3.2 | N/A | N/A | 2'-6' | 0' | |

Design Manual Abbreviations:

MDG - Multimodal Design Guide

L&D Vol. 1 - Location and Design Manual, Volume 1

TFMS - Traffic Forecasting Management System

Appendix B

BUT-4 Drainage Area Map, Conduit Inventory and Calculations

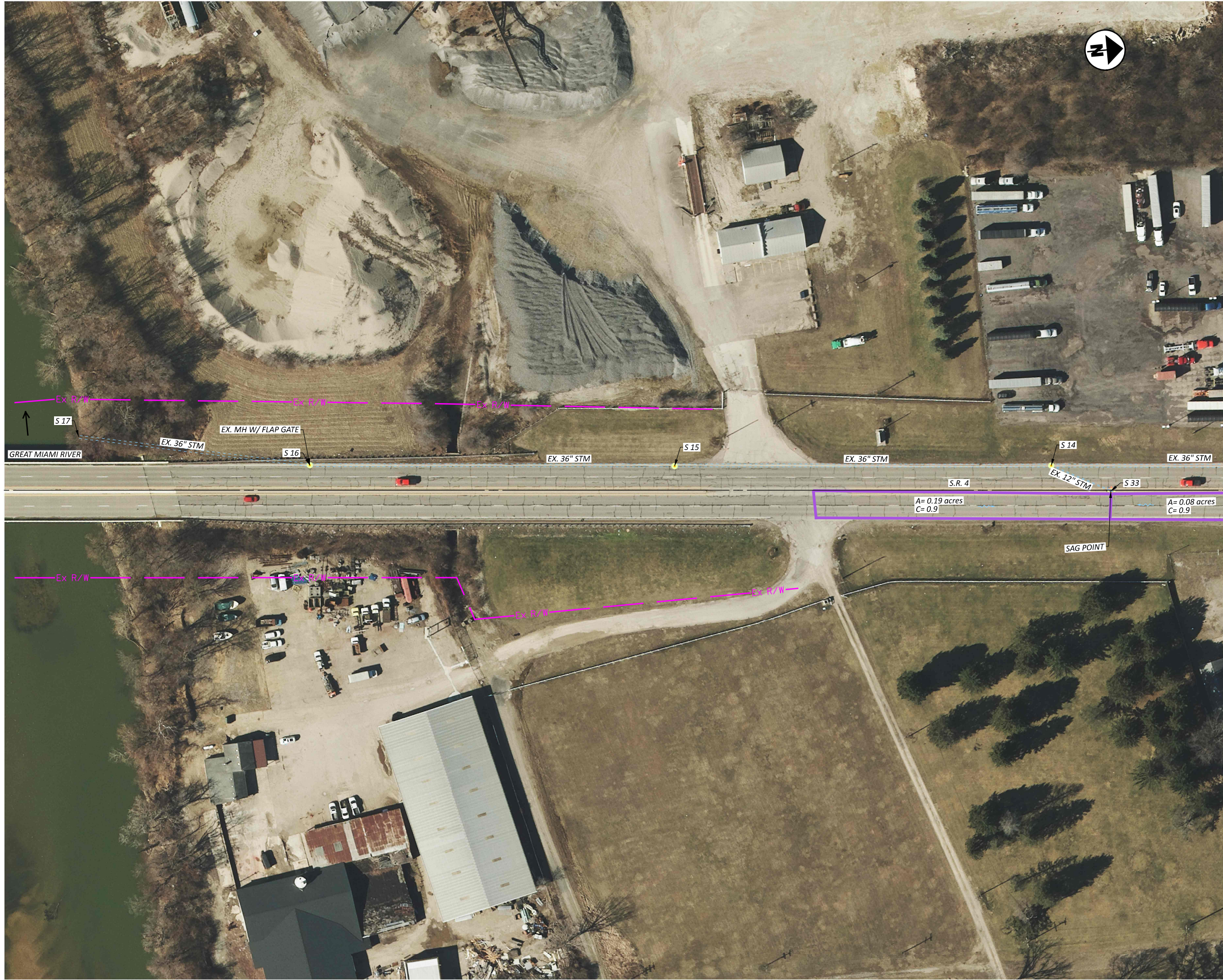

LEGEND:
 — EXISTING DRAINAGE AREA
 — PROPOSED DRAINAGE AREA

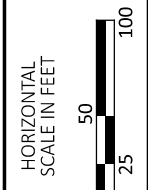

DRAINAGE AREA MAP
 BUT-4 - SHEET 1

DESIGN AGENCY



DESIGNER
 SAF

REVIEWER
 CWP 04-25-2024

PROJECT ID
 117275

| | |
|-------|-------|
| SHEET | TOTAL |
| P.1 | 5 |



LEGEND:

- EXISTING DRAINAGE AREA
- PROPOSED DRAINAGE AREA

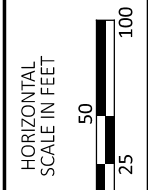

**DRAINAGE AREA MAP
 BUT-4 - SHEET 2**

DESIGN AGENCY



DESIGNER
 SAF

REVIEWER
 CWP 04-25-2024

PROJECT ID
 117275

| | |
|-------|-------|
| SHEET | TOTAL |
| P.2 | 5 |



LEGEND:
 — EXISTING DRAINAGE AREA
 — PROPOSED DRAINAGE AREA

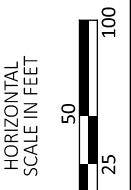

DRAINAGE AREA MAP
 BUT-4 - SHEET 3

DESIGN AGENCY



DESIGNER
 SAF

REVIEWER
 CWP 04-25-2024

PROJECT ID
 117275

| | |
|-------|-------|
| SHEET | TOTAL |
| P.3 | 5 |



DRAINAGE AREA MAP
 BUT-4 - SHEET 4

DESIGN AGENCY



DESIGNER
 SAF

REVIEWER
 CWP 04-25-2024

PROJECT ID
 117275

| | |
|-------|-------|
| SHEET | TOTAL |
| P.4 | 5 |

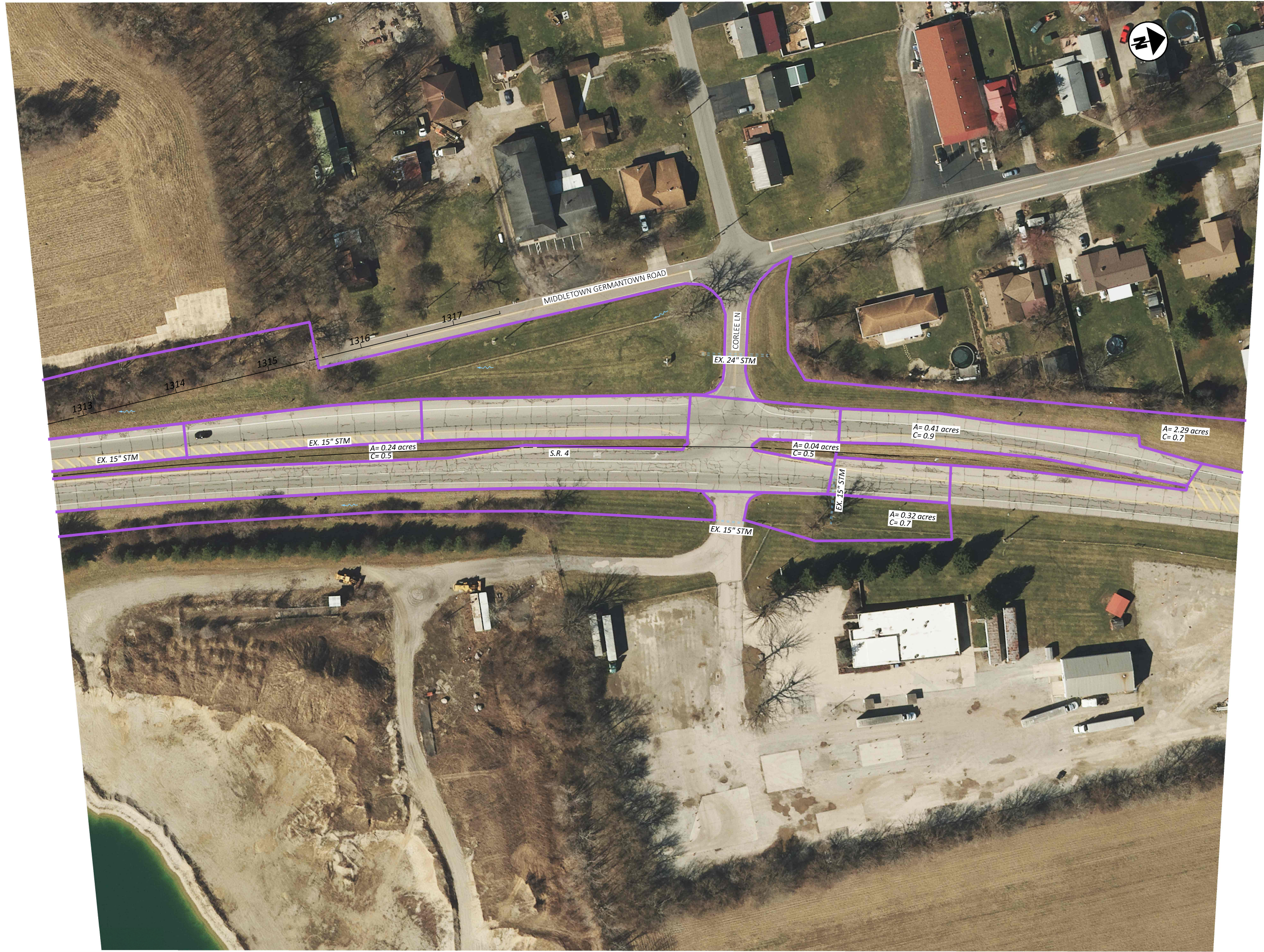

LEGEND:
— EXISTING DRAINAGE AREA
— PROPOSED DRAINAGE AREA

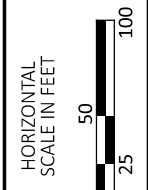

DRAINAGE AREA MAP
BUT-4 - SHEET 5

DESIGN AGENCY



DESIGNER
SAF

REVIEWER
CWP 04-25-2024

PROJECT ID
117275

| | |
|-------|-------|
| SHEET | TOTAL |
| P.5 | 5 |



INLET SPACING DESIGN

PID : 117275 **Date :** 04/25/2024 **Project :** BUT IR 75/VAR/5.22/VAR **Location :** SR-4

Description : Existing BUT-04 East Inlet Spacing

Designer : SAF

Rainfall Area: C **Storm Frequency (yr.) :** 5 **Total Allow. Spread (ft.) :** 6.00 * **Allowable Depth (ft.)** 0.42

| STATION | C.B. Type | GUTTER LENGTH (ft.) | RUNOFF COEF | AREA (acres) | CONC. TIME (min.) | GUTTER TIME (min.) | TIME USED (min.) | LONG. SLOPE (ft./ft.) | GUTT. SLOPE (ft./ft.) | PAVT. SLOPE (ft./ft.) | GUTT. WIDTH (ft.) | LOCAL DEPRESS. (ft.) | RAIN FALL (in./hrs.) | INTERCPTD FLOW (cfs.) | BYPASS FLOW (cfs.) | TOTAL FLOW (cfs.) | DEPTH FLOW (ft.) | PAVT. SPREAD (ft.) | |
|---------|-----------|---------------------|-------------|--------------|-------------------|--------------------|------------------|-----------------------|-----------------------|-----------------------|-------------------|----------------------|----------------------|-----------------------|--------------------|-------------------|------------------|--------------------|--------|
| 1301+71 | Begin | | | | | | | | | | | | | | | | | | |
| 1298+53 | CB-3 | 318.00 | 0.75 | 0.60 | 10.00 | 4.36 | 14.36 | 0.0043 | 0.0160 | 0.0160 | 0.00 | 0.0000 | 4.09 | ***** | ***** | 1.84 | 0.191 | 11.92 | Sag ** |
| 1288+43 | Begin | | | | | | | | | | | | | | | | | | |
| 1289+94 | CB-3 | 151.00 | 0.68 | 0.18 | 10.00 | 2.47 | 12.47 | 0.0032 | 0.0830 | 0.0160 | 2.00 | 0.1670 | 4.38 | 0.54 | 0.00 | 0.54 | 0.225 | 5.71 | |
| 1291+45 | CB-3 | 151.00 | 0.67 | 0.13 | 10.00 | 2.51 | 12.51 | 0.0032 | 0.0830 | 0.0160 | 2.00 | 0.1670 | 4.37 | 0.38 | 0.00 | 0.38 | 0.203 | 4.32 | |
| 1293+63 | CB-3 | 218.00 | 0.69 | 0.19 | 10.00 | 3.51 | 13.51 | 0.0033 | 0.0830 | 0.0160 | 2.00 | 0.1670 | 4.21 | 0.55 | 0.00 | 0.55 | 0.226 | 5.77 | |
| 1296+05 | CB-3 | 242.00 | 0.75 | 0.19 | 10.00 | 4.13 | 14.13 | 0.0029 | 0.0830 | 0.0160 | 2.00 | 0.1670 | 4.12 | 0.59 | 0.00 | 0.59 | 0.235 | 6.29 | *** |
| 1298+43 | CB-3 | 238.00 | 0.60 | 0.47 | 10.00 | 2.72 | 12.72 | 0.0060 | 0.0830 | 0.0160 | 2.00 | 0.1670 | 4.34 | 1.22 | 0.00 | 1.22 | 0.260 | 7.86 | *** |
| 1298+53 | CB-3 | 10.00 | 0.76 | 0.01 | 10.00 | 0.20 | 10.20 | 0.0060 | 0.0830 | 0.0160 | 2.00 | 0.1670 | 4.78 | ***** | ***** | 0.05 | 0.086 | 1.04 | End |

SUMP DATA

Total Flow (cfs) : 1.89

Ponded Depth (ft.) : 0.154

Spread on Pavement (ft.) : 2.83

*2 ft was added to spread limit since a 14' lane is proposed
 **Existing conditions violate spread within reconstruction limits
 ***Existing conditions violate spread within resurfacing limits



INLET SPACING DESIGN

PID : 117275 Date : 08/05/2024 Project : BUT IR 75/VAR/5.22/VAR Location : SR-4

Description : BUT-04 East Inlet Spacing

Designer : SAF

Rainfall Area: C

Storm Frequency (yr.) : 5

Total Allow. Spread (ft.) : 6.00*

Allowable Depth (ft.) 0.42

| STATION | C.B. Type | GUTTER LENGTH (ft.) | RUNOFF COEF | AREA (acres) | CONC. TIME (min.) | GUTTER TIME (min.) | TIME USED (min.) | LONG. SLOPE (ft./ft.) | GUTT. SLOPE (ft./ft.) | PAVT. SLOPE (ft./ft.) | GUTT. WIDTH (ft.) | LOCAL DEPRESS. (ft.) | RAIN FALL (in./hrs.) | INTERCPTD FLOW (cfs.) | BYPASS FLOW (cfs.) | TOTAL FLOW (cfs.) | DEPTH FLOW (ft.) | PAVT. SPREAD (ft.) |
|---------|-----------|---------------------|-------------|--------------|-------------------|--------------------|------------------|-----------------------|-----------------------|-----------------------|-------------------|----------------------|----------------------|-----------------------|--------------------|-------------------|------------------|--------------------|
| 1302+05 | Begin | | | | | | | | | | | | | | | | | |
| 1301+71 | CB-3 | 31.00 | 0.90 | 0.02 | 10.00 | 0.68 | 10.68 | 0.0094 | 0.0160 | 0.0160 | 0.00 | 0.0000 | 4.69 | 0.08 | 0.00 | 0.08 | 0.052 | 3.24 |
| 1301+25 | CB-3 | 46.00 | 0.78 | 0.06 | 10.00 | 0.80 | 10.80 | 0.0094 | 0.0160 | 0.0160 | 0.00 | 0.0000 | 4.67 | 0.20 | 0.02 | 0.22 | 0.074 | 4.63 |
| 1300+75 | CB-3 | 50.00 | 0.79 | 0.07 | 10.00 | 0.35 | 10.35 | 0.0940 | 0.0160 | 0.0160 | 0.00 | 0.0000 | 4.75 | 0.25 | 0.03 | 0.28 | 0.053 | 3.29 |
| 1300+25 | CB-3 | 50.00 | 0.80 | 0.06 | 10.00 | 0.35 | 10.35 | 0.0940 | 0.0160 | 0.0160 | 0.00 | 0.0000 | 4.75 | 0.23 | 0.02 | 0.26 | 0.051 | 3.18 |
| 1299+75 | CB-3 | 50.00 | 0.75 | 0.06 | 10.00 | 0.86 | 10.86 | 0.0094 | 0.0160 | 0.0160 | 0.00 | 0.0000 | 4.66 | 0.21 | 0.02 | 0.23 | 0.076 | 4.73 |
| 1299+25 | CB-3 | 50.00 | 0.71 | 0.16 | 10.00 | 0.69 | 10.69 | 0.0094 | 0.0160 | 0.0160 | 0.00 | 0.0000 | 4.69 | 0.43 | 0.13 | 0.55 | 0.105 | 6.54 ** |
| 1298+53 | CB-3 | 72.00 | 0.72 | 0.20 | 10.00 | 0.80 | 10.80 | 0.0094 | 0.0830 | 0.0160 | 1.38 | 0.1670 | 4.67 | ***** | ***** | 0.80 | 0.196 | 6.49 Sag ** |
| 1288+43 | Begin | | | | | | | | | | | | | | | | | |
| 1289+94 | CB-3 | 151.00 | 0.68 | 0.18 | 10.00 | 2.47 | 12.47 | 0.0032 | 0.0830 | 0.0160 | 2.00 | 0.1670 | 4.38 | 0.54 | 0.00 | 0.54 | 0.225 | 5.71 |
| 1291+45 | CB-3 | 151.00 | 0.67 | 0.13 | 10.00 | 2.51 | 12.51 | 0.0032 | 0.0830 | 0.0160 | 2.00 | 0.1670 | 4.37 | 0.38 | 0.00 | 0.38 | 0.203 | 4.32 |
| 1293+63 | CB-3 | 218.00 | 0.69 | 0.19 | 10.00 | 3.57 | 13.57 | 0.0032 | 0.0830 | 0.0160 | 2.00 | 0.1670 | 4.21 | 0.55 | 0.00 | 0.55 | 0.227 | 5.83 |
| 1296+05 | CB-3 | 242.00 | 0.75 | 0.19 | 10.00 | 2.47 | 12.47 | 0.0085 | 0.0830 | 0.0160 | 2.00 | 0.1670 | 4.38 | 0.62 | 0.00 | 0.62 | 0.203 | 4.34 |
| 1297+50 | CB-3 | 145.00 | 0.63 | 0.23 | 10.00 | 1.48 | 11.48 | 0.0085 | 0.0830 | 0.0160 | 2.00 | 0.1670 | 4.54 | 0.66 | 0.00 | 0.66 | 0.207 | 4.56 |
| 1298+43 | CB-3 | 68.00 | 0.73 | 0.24 | 10.00 | 0.69 | 10.69 | 0.0085 | 0.0830 | 0.0160 | 2.00 | 0.1670 | 4.69 | 0.82 | 0.00 | 0.82 | 0.221 | 5.45 |
| 1298+53 | CB-3 | 10.00 | 0.76 | 0.01 | 10.00 | 0.17 | 10.17 | 0.0085 | 0.0830 | 0.0160 | 2.00 | 0.1670 | 4.79 | ***** | ***** | 0.05 | 0.081 | 0.98 End |

*2 ft was added to spread limit since a 14' lane is proposed

**Note that catch basins have been added every 50' where feasible and in this area needed additional distance to avoid elliptical pipe crossing. Cannot add any additional basins



INLET SPACING DESIGN

| STATION | C.B. Type | GUTTER LENGTH (ft.) | RUNOFF COEF (ft.) | CONC. AREA (acres) | GUTTER TIME (min.) | TIME USED (min.) | LONG. SLOPE (ft./ft.) | GUTT. SLOPE (ft./ft.) | PAVT. SLOPE (ft./ft.) | GUTT. WIDTH (ft.) | LOCAL DEPRESS. (ft.) | RAIN FALL (in./hrs.) | INTERCPTD FLOW (cfs.) | BYPASS FLOW (cfs.) | TOTAL FLOW (cfs.) | DEPTH FLOW (ft.) | PAVT. SPREAD (ft.) |
|---------|--------------|---------------------------|-------------------------|--------------------------|--------------------------|------------------------|-----------------------------|-----------------------------|-----------------------------|-------------------------|----------------------------|----------------------------|-----------------------------|--------------------------|-------------------------|------------------------|--------------------------|
|---------|--------------|---------------------------|-------------------------|--------------------------|--------------------------|------------------------|-----------------------------|-----------------------------|-----------------------------|-------------------------|----------------------------|----------------------------|-----------------------------|--------------------------|-------------------------|------------------------|--------------------------|

SUMP DATA

Total Flow (cfs) : 0.85

Ponded Depth (ft.) : 0.074

Spread on Pavement (ft.) : 2.09



INLET SPACING DESIGN

PID : 117275 Date : 04/25/2024 Project : BUT IR 75/VAR/5.22/VAR Location : SR-4

Description : Existing BUT-04 West Inlet Spacing

Designer : SAF

Rainfall Area: C

Storm Frequency (yr.) : 5

Total Allow. Spread (ft.) : 6.00 *

Allowable Depth (ft.) 0.42

| STATION | C.B. Type | GUTTER LENGTH (ft.) | RUNOFF COEF | AREA (acres) | CONC. TIME (min.) | GUTTER TIME (min.) | TIME USED (min.) | LONG. SLOPE (ft./ft.) | GUTT. SLOPE (ft./ft.) | PAVT. SLOPE (ft./ft.) | GUTT. WIDTH (ft.) | LOCAL DEPRESS. (ft.) | RAIN FALL (in./hrs.) | INTERCPTD FLOW (cfs.) | BYPASS FLOW (cfs.) | TOTAL FLOW (cfs.) | DEPTH FLOW (ft.) | PAVT. SPREAD (ft.) |
|---------|-----------|---------------------|-------------|--------------|-------------------|--------------------|------------------|-----------------------|-----------------------|-----------------------|-------------------|----------------------|----------------------|-----------------------|--------------------|-------------------|------------------|--------------------|
| 1301+71 | Begin | | | | | | | | | | | | | | | | | |
| 1298+75 | CB-3 | 296.00 | 0.79 | 0.32 | 10.00 | 4.70 | 14.70 | 0.0043 | 0.0160 | 0.0160 | 0.00 | 0.0000 | 4.04 | 0.69 | 0.33 | 1.02 | 0.153 | 9.55 ** |
| 1298+32 | CB-3 | 43.00 | 0.77 | 0.06 | 10.00 | 0.61 | 10.68 | 0.0043 | 0.0830 | 0.0160 | 2.00 | 0.1670 | 4.69 | ***** | ***** | 0.55 | 0.217 | 5.20 Sag |
| 1288+33 | Begin | | | | | | | | | | | | | | | | | |
| 1290+00 | CB-3 | 167.00 | 0.81 | 0.17 | 10.00 | 2.72 | 12.72 | 0.0032 | 0.0830 | 0.0160 | 2.00 | 0.1670 | 4.34 | 0.60 | 0.00 | 0.60 | 0.232 | 6.16 *** |
| 1291+45 | CB-3 | 145.00 | 0.83 | 0.20 | 10.00 | 2.32 | 12.32 | 0.0032 | 0.0830 | 0.0160 | 2.00 | 0.1670 | 4.40 | 0.73 | 0.00 | 0.73 | 0.246 | 7.00 *** |
| 1293+63 | CB-3 | 218.00 | 0.71 | 0.33 | 10.00 | 3.32 | 13.32 | 0.0033 | 0.0830 | 0.0160 | 2.00 | 0.1670 | 4.24 | 0.99 | 0.00 | 0.99 | 0.266 | 8.27 *** |
| 1294+75 | CB-3A | 112.00 | 0.65 | 0.18 | 10.00 | 1.87 | 11.87 | 0.0031 | 0.0830 | 0.0160 | 2.00 | 0.1670 | 4.48 | 0.52 | 0.00 | 0.52 | 0.225 | 5.68 |
| 1296+05 | CB-3 | 130.00 | 0.90 | 0.25 | 10.00 | 2.09 | 12.09 | 0.0029 | 0.0830 | 0.0160 | 2.00 | 0.1670 | 4.44 | 1.00 | 0.00 | 1.00 | 0.271 | 8.58 *** |
| 1298+32 | CB-3 | 248.00 | 0.61 | 0.39 | 10.00 | 2.89 | 12.89 | 0.0060 | 0.0830 | 0.0160 | 2.00 | 0.1670 | 4.31 | ***** | ***** | 1.03 | 0.248 | 7.10 End ** |

SUMP DATA

Total Flow (cfs) : 1.57

Ponded Depth (ft.) : 0.132

Spread on Pavement (ft.) : 2.63

*2 ft was added to spread limit since a 14' lane is proposed
 **Existing conditions violate spread within reconstruction limits
 ***Existing conditions violate spread within resurfacing limits



INLET SPACING DESIGN

PID : 117275 Date : 08/06/2024 Project : BUT IR 75/VAR/5.22/VAR Location : SR-4

Description : BUT-04 West Inlet Spacing

Designer : SAF

Rainfall Area: C

Storm Frequency (yr.) : 5

Total Allow. Spread (ft.) : 6.00*

Allowable Depth (ft.) 0.42

| STATION | C.B. Type | GUTTER LENGTH (ft.) | RUNOFF COEF | AREA (acres) | CONC. TIME (min.) | GUTTER TIME (min.) | TIME USED (min.) | LONG. SLOPE (ft./ft.) | GUTT. SLOPE (ft./ft.) | PAVT. SLOPE (ft./ft.) | GUTT. WIDTH (ft.) | LOCAL DEPRESS. (ft.) | RAIN FALL (in./hrs.) | INTERCPTD FLOW (cfs.) | BYPASS FLOW (cfs.) | TOTAL FLOW (cfs.) | DEPTH FLOW (ft.) | PAVT. SPREAD (ft.) |
|---------|-----------|---------------------|-------------|--------------|-------------------|--------------------|------------------|-----------------------|-----------------------|-----------------------|-------------------|----------------------|----------------------|-----------------------|--------------------|-------------------|------------------|--------------------|
| 1301+71 | Begin | | | | | | | | | | | | | | | | | |
| 1301+25 | CB-3 | 46.00 | 0.79 | 0.05 | 10.00 | 0.84 | 10.84 | 0.0094 | 0.0160 | 0.0160 | 0.00 | 0.0000 | 4.66 | 0.18 | 0.01 | 0.18 | 0.069 | 4.34 |
| 1300+75 | CB-3 | 50.00 | 0.78 | 0.05 | 10.00 | 0.90 | 10.90 | 0.0094 | 0.0160 | 0.0160 | 0.00 | 0.0000 | 4.65 | 0.18 | 0.01 | 0.19 | 0.070 | 4.39 |
| 1300+25 | CB-3 | 50.00 | 0.78 | 0.05 | 10.00 | 0.90 | 10.90 | 0.0094 | 0.0160 | 0.0160 | 0.00 | 0.0000 | 4.65 | 0.18 | 0.01 | 0.19 | 0.070 | 4.40 |
| 1299+75 | CB-3 | 50.00 | 0.78 | 0.05 | 10.00 | 0.38 | 10.38 | 0.0940 | 0.0160 | 0.0160 | 0.00 | 0.0000 | 4.75 | 0.19 | 0.01 | 0.20 | 0.046 | 2.88 |
| 1299+25 | CB-3 | 50.00 | 0.78 | 0.05 | 10.00 | 0.90 | 10.90 | 0.0094 | 0.0160 | 0.0160 | 0.00 | 0.0000 | 4.65 | 0.18 | 0.01 | 0.19 | 0.070 | 4.40 |
| 1298+53 | CB-3 | 72.00 | 0.83 | 0.08 | 10.00 | 1.14 | 11.14 | 0.0094 | 0.0160 | 0.0160 | 0.00 | 0.0000 | 4.60 | ***** | ***** | 0.32 | 0.085 | 5.31 Sag |
| 1288+33 | Begin | | | | | | | | | | | | | | | | | |
| 1290+00 | CB-3 | 167.00 | 0.81 | 0.17 | 10.00 | 2.72 | 12.72 | 0.0032 | 0.0830 | 0.0160 | 2.00 | 0.1670 | 4.34 | 0.60 | 0.00 | 0.60 | 0.232 | 6.16 ** |
| 1291+45 | CB-3 | 145.00 | 0.83 | 0.20 | 10.00 | 2.32 | 12.32 | 0.0032 | 0.0830 | 0.0160 | 2.00 | 0.1670 | 4.40 | 0.73 | 0.00 | 0.73 | 0.246 | 7.00 ** |
| 1293+63 | CB-3 | 218.00 | 0.71 | 0.33 | 10.00 | 3.37 | 13.37 | 0.0032 | 0.0830 | 0.0160 | 2.00 | 0.1670 | 4.24 | 0.99 | 0.00 | 0.99 | 0.267 | 8.33 ** |
| 1294+75 | CB-3A | 112.00 | 0.65 | 0.18 | 10.00 | 1.84 | 11.84 | 0.0032 | 0.0830 | 0.0160 | 2.00 | 0.1670 | 4.48 | 0.52 | 0.00 | 0.52 | 0.224 | 5.62 |
| 1296+05 | CB-3 | 130.00 | 0.90 | 0.25 | 10.00 | 1.29 | 11.29 | 0.0085 | 0.0830 | 0.0160 | 2.00 | 0.1670 | 4.58 | 1.03 | 0.00 | 1.03 | 0.236 | 6.39 ** |
| 1297+50 | CB-3 | 145.00 | 0.62 | 0.26 | 10.00 | 1.47 | 11.47 | 0.0085 | 0.0830 | 0.0160 | 2.00 | 0.0000 | 4.54 | 0.73 | 0.00 | 0.73 | 0.214 | 4.98 |
| 1298+32 | CB-3 | 82.00 | 0.63 | 0.13 | 10.00 | 0.86 | 10.86 | 0.0085 | 0.0830 | 0.0160 | 2.00 | 0.0000 | 4.66 | 0.39 | 0.00 | 0.39 | 0.173 | 2.43 |
| 1298+53 | CB-3 | 21.00 | 0.63 | 0.03 | 10.00 | 0.31 | 10.31 | 0.0085 | 0.0830 | 0.0160 | 2.00 | 0.1670 | 4.76 | ***** | ***** | 0.09 | 0.100 | 1.21 End |

*2 ft was added to spread limit since a 14' lane is proposed

**Note that the allowable spread is exceeded however these inlets fall outside of the reconstruction limits



INLET SPACING DESIGN

| STATION | C.B. Type | GUTTER LENGTH (ft.) | RUNOFF COEF (ft.) | CONC. AREA (acres) | GUTTER TIME (min.) | TIME USED (min.) | LONG. SLOPE (ft./ft.) | GUTT. SLOPE (ft./ft.) | PAVT. SLOPE (ft./ft.) | GUTT. WIDTH (ft.) | LOCAL DEPRESS. (ft.) | RAIN FALL (in./hrs.) | INTERCPTD FLOW (cfs.) | BYPASS FLOW (cfs.) | TOTAL FLOW (cfs.) | DEPTH FLOW (ft.) | PAVT. SPREAD (ft.) |
|---------|--------------|---------------------------|-------------------------|--------------------------|--------------------------|------------------------|-----------------------------|-----------------------------|-----------------------------|-------------------------|----------------------------|----------------------------|-----------------------------|--------------------------|-------------------------|------------------------|--------------------------|
|---------|--------------|---------------------------|-------------------------|--------------------------|--------------------------|------------------------|-----------------------------|-----------------------------|-----------------------------|-------------------------|----------------------------|----------------------------|-----------------------------|--------------------------|-------------------------|------------------------|--------------------------|

SUMP DATA

Total Flow (cfs) : 0.41

Ponded Depth (ft.) : 0.028

Spread on Pavement (ft.) : 1.66



STORM SEWER SYSTEM

PID : 117275 Date : 04/25/2024 Project : BUT IR 75/VAR/5.22/VAR Location : SR-4

Description : Existing BUT-04 North Storm Sewer

Designer : SAF

Rainfall Area: C

Just Full Capacity Frequency (yrs.) : 10

Hydraulic Gradient Frequency (yrs.) : 50

Minimum Pipe Size : 0.00

Tailwater Elevation (ft.): 644.65

| JUNCTION From | STATION To | From To | ΔAREA | ΔCA | BEGIN TIME | RAINFALL | | DISCHARGE | | PIPE | | | F/L PIPE | MEAN | JUST FULL | FRICT | HYGR EL. | COVER | COVER | COVER | INLET TYPE 'n' |
|------------------|---------------|--------------------|-------------------|--------------|---------------|----------|-----------|-----------|-----------|-----------|-------|--------|------------------|----------|-----------|----------|------------------|------------------|----------|----------------|-------------------|
| | | | Σ AREA (acres) | Σ CA | | (min.) | (10 yrs.) | (50 yrs.) | (10 yrs.) | (50 yrs.) | DIAM. | LENGTH | SLOPE | IN / OUT | VEL | CAPACITY | SLOPE | IN / OUT | IN / OUT | MINUS HY GR | |
| N1 | N3 | 1301+71 begin | 0.56 0.56 | 0.46 0.46 | 15.00 | 4.47 | 5.49 | 2.0 | 2.5 | 12 | 61.0 | 0.0120 | 650.59 649.86 | 4.51 | 3.63 | 0.0066 | 651.46 651.06 | 652.27 653.22 | 0.81 | 0.68 | CB 2-5 0.015 |
| N3 | N4 | 1301+71 1301+72 | 8.30 8.86 | 6.37 6.82 | 15.23 | 4.44 | 5.49 | 30.3 | 37.5 | 27 | 7.0 | 0.0186 | 648.90 648.77 | 10.29 | 39.35 | 0.0195 | 651.06 650.92 | 653.22 652.58 | 2.16 | 2.07 | MH 3 0.015 |
| N4 | N7 | 1301+72 1299+15 | 1.17 10.03 | 0.85 7.67 | 15.24 | 4.44 | 5.36 | 34.1 | 41.1 | 48 | 257.0 | 0.0025 | 646.76 646.11 | 5.09 | 67.35 | 0.0011 | 649.35 649.07 | 652.58 652.64 | 3.23 | 1.82 | CB 2-2B 0.015 |
| N7 | N8 | 1299+15 1298+53 | 0.00 10.03 | 0.00 7.67 | 16.08 | 4.33 | 5.31 | 33.2 | 40.8 | 54 * | 89.0 | 0.0019 | 645.64 645.47 | 4.55 | 80.12 | 0.0006 | 648.69 648.64 | 652.64 655.37 | 3.95 | 2.50 | MH 1 0.015 |
| N15 | N16 | 1298+51 begin | 0.01 10.04 | 0.01 7.69 | 10.00 | 5.32 | 6.37 | 0.1 | 0.1 | 24 | 9.0 | 0.0533 | 647.70 647.22 | 2.42 | 48.71 | 0.0000 | 649.10 649.10 | 651.91 651.80 | 2.81 | 2.21 | CB 3 0.015 |
| S1 | N16 | 1298+32 begin | 0.39 10.43 | 0.24 7.92 | 10.00 | 5.32 | 6.37 | 1.3 | 1.5 | 24 | 44.0 | 0.0009 | 647.26 647.22 | 1.50 | 6.36 | 0.0001 | 649.10 649.10 | 652.00 651.80 | 2.90 | 2.74 | CB 3 0.015 |
| N16 | N8 | 1298+42 1298+53 | 0.47 10.90 | 0.28 8.21 | 10.49 | 5.22 | 6.37 | 2.8 | 3.4 | 36 | 19.0 | 0.0095 | 647.49 647.31 | 4.14 | 60.52 | 0.0000 | 649.10 649.10 | 651.80 655.37 | 2.70 | 1.31 | CB 3 0.015 |
| N8 | N9 | 1298+53 final | 0.00 10.90 | 0.00 8.21 | 16.40 | 4.29 | 5.22 | 35.2 | 42.8 | 60 | 232.0 | 0.0039 | 645.55 644.65 | 5.95 | 151.23 | 0.0004 | 648.15 648.06 | 655.37 649.65 | 7.22 | 4.82 | MH 1 0.015 |

**54" pipe size was used as an equivalent size to represent the 68"x43" elliptical pipe since it has the same approximate cross sectional area



STORM SEWER SYSTEM

PID : 117275 Date : 04/25/2024 Project : BUT IR 75/VAR/5.22/VAR Location : SR-4

Description : Proposed BUT-04 North Storm Sewer

Designer : SAF

Rainfall Area: C

Just Full Capacity Frequency (yrs.) : 10

Hydraulic Gradient Frequency (yrs.) : 50

Minimum Pipe Size : 0.00

Tailwater Elevation (ft.): 644.65

| JUNCTION | STATION | ΔAREA | ΔCA | BEGIN | RAINFALL | DISCHARGE | | PIPE | | | F/L PIPE | MEAN | JUST FULL | FRICT | HYGR EL. | COVER | COVER | COVER | INLET TYPE | | |
|----------|---------|---------|-------|--------|---------------------|---------------------|--------|-------|-----------|-------|----------|--------|-----------|-------|----------|----------|--------|--------|------------|------|--------|
| From | To | Σ AREA | Σ CA | TIME | INTENSITY | (cfs.) | (cfs.) | DIAM. | LENGTH | SLOPE | IN / OUT | VEL | CAPACITY | SLOPE | IN / OUT | IN / OUT | MINUS | MINUS | MANNING'S | | |
| | From To | (acres) | | (min.) | (10 yrs.) (50 yrs.) | (10 yrs.) (50 yrs.) | (in.) | (ft.) | (ft./ft.) | (ft.) | (fps.) | (cfs.) | (ft./ft.) | (ft.) | (ft.) | HY GR | CROWN | 'n' | | | |
| N1 | N2 | 1301+71 | 0.56 | 0.46 | 15.00 | 4.47 | 5.49 | 2.0 | 2.5 | 12 | 16.0 | 0.0119 | 650.59 | 4.49 | 3.62 | 0.0066 | 651.50 | 652.27 | 0.77 | 0.68 | CB 2-5 |
| | begin | 1301+71 | 0.56 | 0.46 | | | | | | | | | 650.40 | | | | 651.39 | 653.39 | | | 0.015 |
| N2 | N3 | 1301+71 | 0.02 | 0.02 | 15.06 | 4.47 | 5.49 | 2.1 | 2.6 | 12 | 45.0 | 0.0120 | 650.40 | 4.55 | 3.64 | 0.0072 | 651.39 | 653.39 | 2.00 | 1.99 | CB 3 |
| | | 1301+71 | 0.58 | 0.48 | | | | | | | | | 649.86 | | | | 651.07 | 653.22 | | | 0.015 |
| N3 | N4 | 1301+71 | 8.47 | 6.51 | 15.22 | 4.44 | 5.49 | 31.0 | 38.4 | 27 | 7.0 | 0.0186 | 648.90 | 10.32 | 39.35 | 0.0204 | 651.07 | 653.22 | 2.15 | 2.07 | CB 3 |
| | | 1301+72 | 9.05 | 6.98 | | | | | | | | | 648.77 | | | | 650.93 | 652.58 | | | 0.015 |
| N4 | N5 | 1301+72 | 1.00 | 0.71 | 15.24 | 4.44 | 5.47 | 34.2 | 42.1 | 48 | 47.0 | 0.0026 | 646.76 | 5.11 | 67.67 | 0.0011 | 649.66 | 652.58 | 2.92 | 1.82 | MH 3 |
| | | 1300+25 | 10.05 | 7.69 | | | | | | | | | 646.64 | | | | 649.61 | 653.71 | | | 0.015 |
| N13 | N14 | 1301+25 | 0.06 | 0.05 | 10.00 | 5.32 | 6.43 | 0.2 | 0.3 | 12 | 43.0 | 0.0100 | 650.14 | 2.35 | 3.32 | 0.0001 | 650.35 | 653.09 | 2.74 | 1.95 | CB 3 |
| | begin | 1301+25 | 10.11 | 7.74 | | | | | | | | | 649.71 | | | | 650.32 | 653.10 | | | 0.015 |
| N14 | N5 | 1301+25 | 0.05 | 0.04 | 10.30 | 5.26 | 6.42 | 0.5 | 0.6 | 12 | 6.5 | 0.0108 | 649.71 | 2.88 | 3.45 | 0.0003 | 650.30 | 653.10 | 2.80 | 2.39 | CB 3 |
| | | 1301+25 | 10.16 | 7.78 | | | | | | | | | 649.64 | | | | 650.29 | 653.71 | | | 0.015 |
| N5 | N6 | 1301+25 | 0.00 | 0.00 | 15.39 | 4.42 | 5.44 | 34.4 | 42.3 | 48 | 50.0 | 0.0024 | 646.64 | 5.00 | 65.60 | 0.0012 | 649.55 | 653.71 | 4.16 | 3.07 | MH BC |
| | | 1300+75 | 10.16 | 7.78 | | | | | | | | | 646.52 | | | | 649.49 | 653.29 | | | 0.015 |
| N15 | N16 | 1300+75 | 0.07 | 0.06 | 10.00 | 5.32 | 6.43 | 0.3 | 0.4 | 12 | 43.0 | 0.0100 | 650.02 | 2.49 | 3.32 | 0.0001 | 650.25 | 652.65 | 2.40 | 1.63 | CB 3 |
| | begin | 1300+75 | 10.23 | 7.83 | | | | | | | | | 649.59 | | | | 650.21 | 652.66 | | | 0.015 |



STORM SEWER SYSTEM

| JUNCTION | | STATION | ΔAREA | ΔCA | BEGIN | RAINFALL | | DISCHARGE | | PIPE | | | F/L PIPE | MEAN | JUST FULL | FRICT | HYGR EL. | COVER | COVER | COVER | INLET TYPE |
|----------|-----|--------------------|----------------|--------------|-------------|-----------|-----------|-----------|-----------|-------------|--------------|-----------------|------------------|------------|-----------------|-----------------|------------------|------------------|-------------|-------------|----------------|
| From | To | From To | Σ AREA (acres) | Σ CA | TIME (min.) | (10 yrs.) | (50 yrs.) | (10 yrs.) | (50 yrs.) | DIAM. (in.) | LENGTH (ft.) | SLOPE (ft./ft.) | IN / OUT (ft.) | VEL (fps.) | CAPACITY (cfs.) | SLOPE (ft./ft.) | IN / OUT (ft.) | IN / OUT (ft.) | MINUS HY GR | MINUS CROWN | MANNING'S 'n' |
| N16 | N6 | 1300+75 1300+75 | 0.05 10.28 | 0.04 7.87 | 10.29 | 5.26 | 6.42 | 0.5 | 0.6 | 12 | 6.5 | 0.0108 | 649.59 649.52 | 2.95 | 3.45 | 0.0004 | 650.18 650.18 | 652.66 653.29 | 2.48 | 2.07 | CB 3 0.015 |
| N6 | N7 | 1300+75 1300+25 | 0.00 10.28 | 0.00 7.87 | 15.56 | 4.40 | 5.42 | 34.6 | 42.6 | 48 | 50.0 | 0.0026 | 646.52 646.39 | 5.16 | 68.28 | 0.0012 | 649.42 649.37 | 653.29 652.91 | 3.87 | 2.77 | MH BC 0.015 |
| N17 | N18 | 1300+25 begin | 0.06 10.34 | 0.05 7.92 | 10.00 | 5.32 | 6.43 | 0.3 | 0.3 | 12 | 43.0 | 0.0100 | 649.89 649.46 | 2.38 | 3.32 | 0.0001 | 650.10 650.07 | 652.18 652.19 | 2.08 | 1.29 | CB 3 0.015 |
| N18 | N7 | 1300+25 1300+25 | 0.05 10.39 | 0.04 7.96 | 10.30 | 5.26 | 6.42 | 0.5 | 0.6 | 12 | 6.5 | 0.0108 | 649.46 649.39 | 2.90 | 3.45 | 0.0003 | 650.05 650.04 | 652.19 652.91 | 2.14 | 1.73 | CB 3 0.015 |
| N7 | N8 | 1300+25 1299+75 | 0.00 10.39 | 0.00 7.96 | 15.72 | 4.38 | 5.39 | 34.8 | 42.9 | 48 | 50.0 | 0.0024 | 646.39 646.27 | 5.01 | 65.60 | 0.0012 | 649.31 649.25 | 652.91 653.05 | 3.60 | 2.52 | MH BC 0.015 |
| N19 | N20 | 1299+75 begin | 0.06 10.45 | 0.05 8.01 | 10.00 | 5.32 | 6.43 | 0.2 | 0.3 | 12 | 42.0 | 0.0100 | 649.76 649.34 | 2.33 | 3.32 | 0.0001 | 649.97 649.95 | 651.72 651.72 | 1.75 | 0.96 | CB 3 0.015 |
| N20 | N8 | 1299+75 1299+75 | 0.05 10.50 | 0.04 8.04 | 10.30 | 5.26 | 6.42 | 0.4 | 0.5 | 12 | 6.5 | 0.0108 | 649.34 649.27 | 2.86 | 3.45 | 0.0003 | 649.92 649.92 | 651.72 653.05 | 1.80 | 1.38 | CB 3 0.015 |
| N8 | N9 | 1299+75 1299+25 | 0.00 10.50 | 0.00 8.04 | 15.88 | 4.35 | 5.37 | 35.0 | 43.2 | 48 | 50.0 | 0.0026 | 646.27 646.14 | 5.18 | 68.28 | 0.0012 | 649.18 649.12 | 653.05 652.62 | 3.87 | 2.78 | MH BC 0.015 |
| N21 | N22 | 1299+25 begin | 0.16 10.66 | 0.11 8.16 | 10.00 | 5.32 | 6.44 | 0.6 | 0.7 | 12 | 40.5 | 0.0099 | 649.61 649.21 | 3.03 | 3.30 | 0.0006 | 649.94 649.89 | 651.27 651.26 | 1.33 | 0.66 | CB 3 0.015 |
| N22 | N9 | 1299+25 1299+25 | 0.05 10.71 | 0.04 8.20 | 10.22 | 5.28 | 6.44 | 0.8 | 1.0 | 12 | 6.5 | 0.0108 | 649.21 649.14 | 3.41 | 3.45 | 0.0010 | 649.86 649.85 | 651.26 652.62 | 1.40 | 1.05 | CB 3 0.015 |
| N9 | N10 | 1299+25 1299+15 | 0.00 10.71 | 0.00 8.20 | 16.04 | 4.33 | 5.36 | 35.5 | 44.0 | 48 | 10.0 | 0.0030 | 646.14 646.11 | 5.48 | 73.35 | 0.0012 | 649.11 649.10 | 652.62 652.64 | 3.51 | 2.48 | MH BC 0.015 |



STORM SEWER SYSTEM

| JUNCTION | | STATION | | ΔAREA | ΔCA | BEGIN | RAINFALL | | DISCHARGE | | PIPE | | | F/L PIPE | MEAN | JUST FULL | FRICT | HYGR EL. | COVER | COVER | COVER | INLET TYPE |
|----------|-------|---------|----|---------|------|--------|-----------|-----------|-----------|-----------|--------|-------|-----------|----------|----------|-----------|-----------|----------|--------|-------|-----------|------------|
| From | To | From | To | Σ AREA | Σ CA | TIME | INTENSITY | (cfs.) | (cfs.) | DIAM. | LENGTH | SLOPE | IN / OUT | VEL | CAPACITY | SLOPE | IN / OUT | IN / OUT | MINUS | MINUS | MANNING'S | |
| | | | | (acres) | | (min.) | (10 yrs.) | (50 yrs.) | (10 yrs.) | (50 yrs.) | (in.) | (ft.) | (ft./ft.) | (ft.) | (fps.) | (cfs.) | (ft./ft.) | (ft.) | (ft.) | HY GR | CROWN | 'n' |
| N10 | N11 | 1299+15 | | 0.00 | 0.00 | 16.07 | 4.33 | 5.31 | 35.5 | 43.6 | 54 * | 89.0 | 0.0019 | 645.64 | 4.63 | 80.12 | 0.0007 | 648.73 | 652.64 | 3.91 | 2.50 | MH 1 |
| | | 1298+53 | | 10.71 | 8.20 | | | | | | | | | 645.47 | | | | 648.67 | 655.37 | | | 0.015 |
| N23 | N24 | 1298+53 | | 0.21 | 0.15 | 10.00 | 5.32 | 6.47 | 0.8 | 1.0 | 12 | 10.0 | 0.0450 | 648.70 | 5.64 | 7.05 | 0.0010 | 649.05 | 650.77 | 1.72 | 1.07 | CB 3 |
| | begin | 1298+43 | | 10.92 | 8.35 | | | | | | | | | 648.25 | | | | 649.04 | 650.82 | | | 0.015 |
| N24 | N11 | 1298+43 | | 0.24 | 0.18 | 10.03 | 5.32 | 6.47 | 1.7 | 2.1 | 36 | 19.0 | 0.0100 | 647.50 | 3.66 | 62.18 | 0.0000 | 649.04 | 650.49 | 1.45 | -0.01 | CB 3 |
| | | 1298+53 | | 11.16 | 8.52 | | | | | | | | | 647.31 | | | | 649.04 | 650.82 | | | 0.015 |
| N11 | N12 | 1298+53 | | 0.00 | 0.00 | 16.40 | 4.29 | 5.22 | 36.5 | 44.5 | 60 | 232.0 | 0.0039 | 645.55 | 6.02 | 151.23 | 0.0004 | 648.17 | 655.37 | 7.20 | 4.82 | MH 1 |
| | final | 1299+53 | | 11.16 | 8.52 | | | | | | | | | 644.65 | | | | 648.08 | 649.65 | | | 0.015 |

*54" pipe size was used as an equivalent size to represent the 68"x43" elliptical pipe since it has the same approximate cross sectional area



STORM SEWER SYSTEM

PID : 117275 Date : 08/06/2024 Project : BUT IR 75/VAR/5.22/VAR Location : SR-4

Description : Existing BUT-04 South Storm Sewer with 649.50 Tailwater

Designer : SAF

Rainfall Area: C

Just Full Capacity Frequency (yrs.) : 10

Hydraulic Gradient Frequency (yrs.) : 25

Minimum Pipe Size : 0.00

Tailwater Elevation (ft.): 649.50

| JUNCTION | STATION | ΔAREA | ΔCA | BEGIN | RAINFALL | DISCHARGE | | PIPE | | | F/L PIPE | MEAN | JUST FULL | FRICT | HYGR EL. | COVER | COVER | COVER | INLET TYPE | | |
|----------|---------|---------|------|--------|-----------|-----------|-----------|-------|--------|-----------|----------|--------|-----------|-----------|----------|----------|--------|--------|------------|-------|-------|
| From | To | Σ AREA | Σ CA | TIME | INTENSITY | (cfs.) | (cfs.) | DIAM. | LENGTH | SLOPE | IN / OUT | VEL | CAPACITY | SLOPE | IN / OUT | IN / OUT | MINUS | MINUS | MANNING'S | | |
| | | (acres) | | (min.) | (10 yrs.) | (25 yrs.) | (10 yrs.) | (in.) | (ft.) | (ft./ft.) | (ft.) | (fps.) | (cfs.) | (ft./ft.) | (ft.) | (ft.) | HY GR | CROWN | 'n' | | |
| S1 | S2 | 1298+32 | 0.00 | 0.00 | 10.00 | 5.32 | 3.86 | 0.0 | 0.0 | 27 | 227.0 | 0.0011 | 647.29 | 0.00 | 9.39 | 0.0000 | 650.08 | 652.02 | 1.94 | 2.48 | MH 3 |
| | begin | 1296+05 | 0.00 | | | | | | | | | | 647.05 | | | | 650.08 | 653.43 | | | 0.015 |
| S2 | S3 | 1296+05 | 0.44 | 0.37 | 10.00 | 5.32 | 3.86 | 2.0 | 1.4 | 36 | 131.0 | 0.0037 | 647.03 | 2.67 | 37.64 | 0.0000 | 650.08 | 653.43 | 3.35 | 3.40 | MH 3 |
| | | 1294+75 | 0.44 | 0.37 | | | | | | | | | 646.55 | | | | 650.08 | 653.35 | | | 0.015 |
| S3 | S4 | 1294+75 | 0.18 | 0.12 | 10.82 | 5.16 | 3.86 | 2.5 | 1.9 | 36 | 112.0 | 0.0037 | 646.55 | 2.87 | 37.62 | 0.0000 | 650.08 | 653.35 | 3.27 | 3.80 | MH 3 |
| | | 1293+63 | 0.62 | 0.48 | | | | | | | | | 646.14 | | | | 650.08 | 653.65 | | | 0.015 |
| S4 | S5 | 1293+63 | 0.52 | 0.36 | 11.47 | 5.04 | 3.86 | 4.3 | 3.3 | 36 | 219.0 | 0.0032 | 646.07 | 3.20 | 35.16 | 0.0000 | 650.08 | 653.65 | 3.57 | 4.58 | MH 3 |
| | | 1291+45 | 1.14 | 0.85 | | | | | | | | | 645.37 | | | | 650.08 | 654.31 | | | 0.015 |
| S5 | S6 | 1291+45 | 0.33 | 0.25 | 12.61 | 4.84 | 3.86 | 5.3 | 4.3 | 36 | 144.0 | 0.0023 | 645.36 | 3.03 | 29.77 | 0.0001 | 650.08 | 654.31 | 4.23 | 5.95 | MH 3 |
| | | 1290+02 | 1.47 | 1.10 | | | | | | | | | 645.03 | | | | 650.07 | 657.63 | | | 0.015 |
| S6 | S7 | 1290+02 | 0.35 | 0.26 | 13.40 | 4.71 | 3.86 | 6.4 | 5.3 | 36 | 135.0 | 0.0023 | 645.03 | 3.19 | 29.80 | 0.0001 | 650.07 | 657.63 | 7.56 | 9.60 | MH 3 |
| | | 1288+67 | 1.82 | 1.36 | | | | | | | | | 644.72 | | | | 650.06 | 658.06 | | | 0.015 |
| S7 | S8 | 1288+67 | 0.00 | 0.00 | 14.11 | 4.60 | 3.86 | 6.3 | 5.3 | 36 | 82.0 | 0.0023 | 644.72 | 3.18 | 29.93 | 0.0001 | 650.06 | 658.06 | 8.00 | 10.34 | MH 3 |
| | | 1287+85 | 1.82 | 1.36 | | | | | | | | | 644.53 | | | | 650.05 | 658.28 | | | 0.015 |
| S8 | S9 | 1287+85 | 0.34 | 0.27 | 14.54 | 4.54 | 3.86 | 7.4 | 6.3 | 36 | 87.0 | 0.0023 | 644.53 | 3.32 | 29.81 | 0.0001 | 650.05 | 658.28 | 8.23 | 10.75 | MH 2 |
| | | 1286+98 | 2.16 | 1.63 | | | | | | | | | 644.33 | | | | 650.04 | 656.65 | | | 0.015 |



STORM SEWER SYSTEM

| JUNCTION | | STATION | ΔAREA | ΔCA | BEGIN | RAINFALL | | DISCHARGE | | PIPE | | | F/L PIPE | MEAN | JUST FULL | FRICT | HYGR EL. | COVER | COVER | COVER | INLET TYPE |
|----------|-----|-----------------------------|----------------|--------------|-------------|-----------|-----------|-----------|-----------|-------------|--------------|-----------------|------------------|------------|-----------------|-----------------|------------------|------------------|-------------|-------------|----------------|
| From | To | From To | Σ AREA (acres) | Σ CA | TIME (min.) | (10 yrs.) | (25 yrs.) | (10 yrs.) | (25 yrs.) | DIAM. (in.) | LENGTH (ft.) | SLOPE (ft./ft.) | IN / OUT (ft.) | VEL (fps.) | CAPACITY (cfs.) | SLOPE (ft./ft.) | IN / OUT (ft.) | IN / OUT (ft.) | MINUS HY GR | MINUS CROWN | MANNING'S 'n' |
| S9 | S10 | 1286+98 1283+87 | 0.00 2.16 | 0.00 1.63 | 14.97 | 4.48 | 3.86 | 7.3 | 6.3 | 36 | 312.0 | 0.0023 | 644.33 643.61 | 3.31 | 29.87 | 0.0001 | 650.04 650.00 | 656.64 657.31 | 6.60 | 9.31 | MH 2 0.015 |
| S10 | S11 | 1283+87 1280+70 | 0.72 2.88 | 0.44 2.06 | 16.55 | 4.27 | 3.86 | 8.8 | 8.0 | 36 | 317.0 | 0.0023 | 643.61 642.88 | 3.49 | 29.84 | 0.0002 | 650.00 649.94 | 657.31 656.60 | 7.31 | 10.70 | MH 2 0.015 |
| S11 | S12 | 1280+70 1278+84 | 0.00 2.88 | 0.00 2.06 | 18.06 | 4.08 | 3.86 | 8.4 | 8.0 | 36 | 187.0 | 0.0023 | 642.88 642.45 | 3.44 | 29.82 | 0.0002 | 649.94 649.91 | 656.60 645.45 | 6.66 | 10.72 | MH 2 0.015 |
| S12 | S13 | 1278+84 1277+13 | 0.15 3.03 | 0.14 2.20 | 18.97 | 3.98 | 3.86 | 8.8 | 8.5 | 36 | 173.0 | 0.0041 | 642.45 641.74 | 4.29 | 39.84 | 0.0002 | 649.91 649.87 | 645.45 655.71 | -4.46 | 0.00 | MH BC 0.015 |
| S13 | S14 | 1277+13 1273+26 | 0.08 3.11 | 0.07 2.27 | 19.64 | 3.91 | 3.86 | 8.9 | 8.8 | 36 | 386.0 | 0.0026 | 641.73 640.74 | 3.63 | 31.49 | 0.0002 | 649.87 649.78 | 655.71 657.62 | 5.84 | 10.98 | MH 2 0.015 |
| S14 | S15 | 1273+26 1269+41 | 0.27 3.38 | 0.24 2.51 | 21.41 | 3.73 | 3.86 | 9.4 | 9.7 | 36 | 385.0 | 0.0026 | 640.73 639.74 | 3.69 | 31.53 | 0.0003 | 649.78 649.67 | 657.62 660.31 | 7.84 | 13.89 | MH 2 0.015 |
| S15 | S16 | 1269+41 1265+69 | 0.00 3.38 | 0.00 2.51 | 23.15 | 3.57 | 3.86 | 9.0 | 9.7 | 36 | 373.0 | 0.0028 | 639.73 638.70 | 3.74 | 32.68 | 0.0003 | 649.67 649.57 | 660.31 662.63 | 10.64 | 17.58 | MH 2 0.015 |
| S16 | S17 | 1265+69 final 1263+32 | 0.00 3.38 | 0.00 2.51 | 24.81 | 3.43 | 3.86 | 8.6 | 9.7 | 36 | 238.0 | 0.0029 | 638.20 637.50 | 3.79 | 33.72 | 0.0003 | 649.57 649.50 | 662.63 640.50 | 13.06 | 21.43 | MH 2 0.015 |

BC = BLIND CONNECTION (existing concrete collar)



STORM SEWER SYSTEM

PID : 117275 **Date :** 08/06/2024 **Project :** BUT IR 75/VAR/5.22/VAR **Location :** SR-4

Description : Existing BUT-04 South Storm Sewer with 652.50 Tailwater **Designer :** SAF

Rainfall Area: C **Just Full Capacity Frequency (yrs.) :** 10 **Hydraulic Gradient Frequency (yrs.) :** 25
Minimum Pipe Size : 0.00 **Tailwater Elevation (ft.):** 652.50

| JUNCTION From | STATION To | From To | ΔAREA Σ AREA (acres) | ΔCA Σ CA | BEGIN TIME (min.) | RAINFALL INTENSITY | | DISCHARGE | | PIPE | | | F/L PIPE IN / OUT (ft.) | MEAN VEL (fps.) | JUST FULL CAPACITY (cfs.) | FRICT SLOPE (ft./ft.) | HYGR EL. IN / OUT (ft.) | COVER IN / OUT (ft.) | COVER MINUS HY GR | COVER MINUS CROWN | INLET TYPE MANNING'S 'n' |
|------------------|---------------|--------------------|----------------------------|--------------|-------------------------|-----------------------|-----------|-----------|-----------|----------------|-----------------|--------------------|-------------------------------|-----------------------|---------------------------------|-----------------------------|-------------------------------|----------------------------|-------------------------|-------------------------|--------------------------------|
| | | | | | | (10 yrs.) | (25 yrs.) | (10 yrs.) | (25 yrs.) | DIAM. (in.) | LENGTH (ft.) | SLOPE (ft./ft.) | | | | | | | | | |
| S1 | S2 | 1298+32 begin | 0.00 0.00 | 0.00 | 10.00 | 5.32 | 3.86 | 0.0 | 0.0 | 27 | 227.0 | 0.0011 | 647.29 647.05 | 0.00 | 9.39 | 0.0000 | 653.08 653.08 | 652.02 653.43 | -1.06 | 2.48 | MH 3 0.015 |
| S2 | S3 | 1296+05 1294+75 | 0.44 0.44 | 0.37 0.37 | 10.00 | 5.32 | 3.86 | 2.0 | 1.4 | 36 | 131.0 | 0.0037 | 647.03 646.55 | 2.67 | 37.64 | 0.0000 | 653.08 653.08 | 653.43 653.35 | 0.35 | 3.40 | MH 3 0.015 |
| S3 | S4 | 1294+75 1293+63 | 0.18 0.62 | 0.12 0.48 | 10.82 | 5.16 | 3.86 | 2.5 | 1.9 | 36 | 112.0 | 0.0037 | 646.55 646.14 | 2.87 | 37.62 | 0.0000 | 653.08 653.08 | 653.35 653.65 | 0.27 | 3.80 | MH 3 0.015 |
| S4 | S5 | 1293+63 1291+45 | 0.52 1.14 | 0.36 0.85 | 11.47 | 5.04 | 3.86 | 4.3 | 3.3 | 36 | 219.0 | 0.0032 | 646.07 645.37 | 3.20 | 35.16 | 0.0000 | 653.08 653.08 | 653.65 654.31 | 0.57 | 4.58 | MH 3 0.015 |
| S5 | S6 | 1291+45 1290+02 | 0.33 1.47 | 0.25 1.10 | 12.61 | 4.84 | 3.86 | 5.3 | 4.3 | 36 | 144.0 | 0.0023 | 645.36 645.03 | 3.03 | 29.77 | 0.0001 | 653.08 653.07 | 654.31 657.63 | 1.23 | 5.95 | MH 3 0.015 |
| S6 | S7 | 1290+02 1288+67 | 0.35 1.82 | 0.26 1.36 | 13.40 | 4.71 | 3.86 | 6.4 | 5.3 | 36 | 135.0 | 0.0023 | 645.03 644.72 | 3.19 | 29.80 | 0.0001 | 653.07 653.06 | 657.63 658.06 | 4.56 | 9.60 | MH 3 0.015 |
| S7 | S8 | 1288+67 1287+85 | 0.00 1.82 | 0.00 1.36 | 14.11 | 4.60 | 3.86 | 6.3 | 5.3 | 36 | 82.0 | 0.0023 | 644.72 644.53 | 3.18 | 29.93 | 0.0001 | 653.06 653.05 | 658.06 658.28 | 5.00 | 10.34 | MH 3 0.015 |
| S8 | S9 | 1287+85 1286+98 | 0.34 2.16 | 0.27 1.63 | 14.54 | 4.54 | 3.86 | 7.4 | 6.3 | 36 | 87.0 | 0.0023 | 644.53 644.33 | 3.32 | 29.81 | 0.0001 | 653.05 653.04 | 658.28 656.65 | 5.23 | 10.75 | MH 2 0.015 |



STORM SEWER SYSTEM

| JUNCTION From | STATION To | From To | ΔAREA Σ AREA (acres) | ΔCA Σ CA | BEGIN TIME (min.) | RAINFALL INTENSITY | | DISCHARGE | | PIPE | | | F/L PIPE IN / OUT (ft.) | MEAN VEL (fps.) | JUST FULL CAPACITY (cfs.) | FRICT SLOPE (ft./ft.) | HYGR EL. IN / OUT (ft.) | COVER IN / OUT (ft.) | COVER MINUS HY GR | COVER MINUS CROWN | INLET TYPE MANNING'S 'n' |
|------------------|---------------|--------------------|----------------------------|--------------|-------------------------|--------------------|-----------|-----------|-----------|----------------|-----------------|--------------------|-------------------------------|-----------------------|---------------------------------|-----------------------------|-------------------------------|----------------------------|-------------------------|-------------------------|--------------------------------|
| | | | | | | (10 yrs.) | (25 yrs.) | (10 yrs.) | (25 yrs.) | DIAM. (in.) | LENGTH (ft.) | SLOPE (ft./ft.) | | | | | | | | | |
| S9 | S10 | 1286+98 1283+87 | 0.00 2.16 | 0.00 1.63 | 14.97 | 4.48 | 3.86 | 7.3 | 6.3 | 36 | 312.0 | 0.0023 | 644.33 643.61 | 3.31 | 29.87 | 0.0001 | 653.04 653.00 | 656.64 657.31 | 3.60 | 9.31 | MH 2 0.015 |
| S10 | S11 | 1283+87 1280+70 | 0.72 2.88 | 0.44 2.06 | 16.55 | 4.27 | 3.86 | 8.8 | 8.0 | 36 | 317.0 | 0.0023 | 643.61 642.88 | 3.49 | 29.84 | 0.0002 | 653.00 652.94 | 657.31 656.60 | 4.31 | 10.70 | MH 2 0.015 |
| S11 | S12 | 1280+70 1278+84 | 0.00 2.88 | 0.00 2.06 | 18.06 | 4.08 | 3.86 | 8.4 | 8.0 | 36 | 187.0 | 0.0023 | 642.88 642.45 | 3.44 | 29.82 | 0.0002 | 652.94 652.91 | 656.60 645.45 | 3.66 | 10.72 | MH 2 0.015 |
| S12 | S13 | 1278+84 1277+13 | 0.15 3.03 | 0.14 2.20 | 18.97 | 3.98 | 3.86 | 8.8 | 8.5 | 36 | 173.0 | 0.0041 | 642.45 641.74 | 4.29 | 39.84 | 0.0002 | 652.91 652.87 | 645.45 655.71 | -7.46 | 0.00 | MH BC 0.015 |
| S13 | S14 | 1277+13 1273+26 | 0.08 3.11 | 0.07 2.27 | 19.64 | 3.91 | 3.86 | 8.9 | 8.8 | 36 | 386.0 | 0.0026 | 641.73 640.74 | 3.63 | 31.49 | 0.0002 | 652.87 652.78 | 655.71 657.62 | 2.84 | 10.98 | MH 2 0.015 |
| S14 | S15 | 1273+26 1269+41 | 0.27 3.38 | 0.24 2.51 | 21.41 | 3.73 | 3.86 | 9.4 | 9.7 | 36 | 385.0 | 0.0026 | 640.73 639.74 | 3.69 | 31.53 | 0.0003 | 652.78 652.67 | 657.62 660.31 | 4.84 | 13.89 | MH 2 0.015 |
| S15 | S16 | 1269+41 1265+69 | 0.00 3.38 | 0.00 2.51 | 23.15 | 3.57 | 3.86 | 9.0 | 9.7 | 36 | 373.0 | 0.0028 | 639.73 638.70 | 3.74 | 32.68 | 0.0003 | 652.67 652.57 | 660.31 662.63 | 7.64 | 17.58 | MH 2 0.015 |
| S16 | S17 final | 1265+69 1263+32 | 0.00 3.38 | 0.00 2.51 | 24.81 | 3.43 | 3.86 | 8.6 | 9.7 | 36 | 238.0 | 0.0029 | 638.20 637.50 | 3.79 | 33.72 | 0.0003 | 652.57 652.50 | 662.63 640.50 | 10.06 | 21.43 | MH 2 0.015 |

BC = BLIND CONNECTION (existing concrete collar)



STORM SEWER SYSTEM

PID : 117275 **Date :** 04/25/2024 **Project :** BUT IR 75/VAR/5.22/VAR **Location :** SR-4

Description : Existing BUT-04 South Storm Sewer with Program Sizing Pipes

Designer : SAF

Rainfall Area: C

Just Full Capacity Frequency (yrs.) : 10

Hydraulic Gradient Frequency (yrs.) : 25

Minimum Pipe Size : 0.00

Tailwater Elevation (ft.): 637.50

| JUNCTION | | STATION | ΔAREA | ΔCA | BEGIN | RAINFALL | | DISCHARGE | | PIPE | | | F/L PIPE | MEAN | JUST FULL | FRICT | HYGR EL. | COVER | COVER | COVER | INLET TYPE |
|----------|----|--------------------|----------------|--------------|-------------|-----------|-----------|-----------|-----------|-------------|--------------|-----------------|------------------|------------|-----------------|-----------------|------------------|------------------|-------------|-------------|---------------|
| From | To | From To | Σ AREA (acres) | Σ CA | TIME (min.) | (10 yrs.) | (25 yrs.) | (10 yrs.) | (25 yrs.) | DIAM. (in.) | LENGTH (ft.) | SLOPE (ft./ft.) | IN / OUT (ft.) | VEL (fps.) | CAPACITY (cfs.) | SLOPE (ft./ft.) | IN / OUT (ft.) | IN / OUT (ft.) | MINUS HY GR | MINUS CROWN | MANNING'S 'n' |
| S1 | S2 | 1298+32 begin | 0.00 0.00 | 0.00 | 10.00 | 5.32 | 5.11 | 0.0 | 0.0 | 12 | 227.0 | 0.0011 | 647.29 647.05 | 0.00 | 1.08 | 0.0000 | 648.04 648.04 | 652.02 653.43 | 3.98 | 3.73 | MH 3 0.015 |
| S2 | S3 | 1296+05 1294+75 | 0.44 0.44 | 0.37 0.37 | 10.00 | 5.32 | 5.11 | 2.0 | 1.9 | 12 | 131.0 | 0.0037 | 647.03 646.55 | 2.70 | 2.01 | 0.0037 | 648.04 647.56 | 653.43 653.35 | 5.39 | 5.40 | MH 3 0.015 |
| S3 | S4 | 1294+75 1293+63 | 0.18 0.62 | 0.12 0.48 | 10.81 | 5.16 | 5.11 | 2.5 | 2.5 | 15 | 112.0 | 0.0037 | 646.55 646.14 | 3.02 | 3.64 | 0.0020 | 647.56 647.34 | 653.35 653.65 | 5.79 | 5.55 | MH 3 0.015 |
| S4 | S5 | 1293+63 1291+45 | 0.52 1.14 | 0.36 0.85 | 11.43 | 5.05 | 5.11 | 4.3 | 4.3 | 18 | 219.0 | 0.0032 | 646.07 645.37 | 3.26 | 5.54 | 0.0023 | 647.34 646.84 | 653.65 654.31 | 6.31 | 6.08 | MH 3 0.015 |
| S5 | S6 | 1291+45 1290+02 | 0.33 1.47 | 0.25 1.10 | 12.55 | 4.85 | 5.11 | 5.3 | 5.6 | 21 | 144.0 | 0.0023 | 645.36 645.03 | 3.05 | 7.07 | 0.0017 | 646.84 646.60 | 654.31 657.63 | 7.47 | 7.20 | MH 3 0.015 |
| S6 | S7 | 1290+02 1288+67 | 0.35 1.82 | 0.26 1.36 | 13.33 | 4.72 | 5.11 | 6.4 | 7.0 | 21 | 135.0 | 0.0023 | 645.03 644.72 | 3.12 | 7.08 | 0.0026 | 646.60 646.25 | 657.63 658.06 | 11.03 | 10.85 | MH 3 0.015 |
| S7 | S8 | 1288+67 1287+85 | 0.00 1.82 | 0.00 1.36 | 14.06 | 4.61 | 5.11 | 6.3 | 7.0 | 21 | 82.0 | 0.0023 | 644.72 644.53 | 3.13 | 7.11 | 0.0026 | 646.25 646.00 | 658.06 658.28 | 11.81 | 11.59 | MH 3 0.015 |
| S8 | S9 | 1287+85 1286+98 | 0.34 2.16 | 0.27 1.63 | 14.49 | 4.55 | 5.11 | 7.4 | 8.3 | 24 | 87.0 | 0.0023 | 644.53 644.33 | 3.32 | 10.11 | 0.0018 | 646.00 645.84 | 658.28 656.65 | 12.28 | 11.75 | MH 2 0.015 |



STORM SEWER SYSTEM

| JUNCTION From | STATION To | From To | ΔAREA Σ AREA (acres) | ΔCA Σ CA | BEGIN TIME (min.) | RAINFALL INTENSITY | | DISCHARGE | | PIPE | | | F/L PIPE IN / OUT (ft.) | MEAN VEL (fps.) | JUST FULL CAPACITY (cfs.) | FRICT SLOPE (ft./ft.) | HYGR EL. IN / OUT (ft.) | COVER IN / OUT (ft.) | COVER MINUS HY GR | COVER MINUS CROWN | INLET TYPE MANNING'S 'n' |
|------------------|---------------|--------------------|----------------------------|--------------|-------------------------|--------------------|-----------|-----------|-----------|----------------|-----------------|--------------------|-------------------------------|-----------------------|---------------------------------|-----------------------------|-------------------------------|----------------------------|-------------------------|-------------------------|--------------------------------|
| | | | | | | (10 yrs.) | (25 yrs.) | (10 yrs.) | (25 yrs.) | DIAM. (in.) | LENGTH (ft.) | SLOPE (ft./ft.) | | | | | | | | | |
| S9 | S10 | 1286+98 1283+87 | 0.00 2.16 | 0.00 1.63 | 14.93 | 4.48 | 4.56 | 7.3 | 7.4 | 24 | 312.0 | 0.0023 | 644.33 643.61 | 3.31 | 10.13 | 0.0014 | 645.69 645.25 | 656.64 657.31 | 10.95 | 10.31 | MH 2 0.015 |
| S10 | S11 | 1283+87 1280+70 | 0.72 2.88 | 0.44 2.06 | 16.50 | 4.27 | 4.56 | 8.8 | 9.4 | 24 | 317.0 | 0.0023 | 643.61 642.88 | 3.41 | 10.12 | 0.0023 | 645.25 644.52 | 657.31 656.60 | 12.06 | 11.70 | MH 2 0.015 |
| S11 | S12 | 1280+70 1278+84 | 0.00 2.88 | 0.00 2.06 | 18.05 | 4.08 | 4.56 | 8.4 | 9.4 | 24 | 187.0 | 0.0023 | 642.88 642.45 | 3.39 | 10.11 | 0.0023 | 644.52 644.00 | 656.60 644.45 | 12.08 | 11.72 | MH 2 0.015 |
| S12 | S13 | 1278+84 1277+13 | 0.15 3.03 | 0.14 2.20 | 18.97 | 3.98 | 4.48 | 8.8 | 9.8 | 24 | 173.0 | 0.0041 | 642.45 641.74 | 4.32 | 13.51 | 0.0025 | 643.78 643.30 | 644.45 655.71 | 0.67 | 0.00 | MH BC 0.015 |
| S13 | S14 | 1277+13 1273+26 | 0.08 3.11 | 0.07 2.27 | 19.64 | 3.91 | 3.95 | 8.9 | 9.0 | 24 | 386.0 | 0.0026 | 641.73 640.74 | 3.57 | 10.68 | 0.0021 | 643.22 642.37 | 655.71 657.62 | 12.49 | 11.98 | MH 2 0.015 |
| S14 | S15 | 1273+26 1269+41 | 0.27 3.38 | 0.24 2.51 | 21.44 | 3.73 | 3.95 | 9.4 | 9.9 | 24 | 385.0 | 0.0026 | 640.73 639.74 | 3.60 | 10.69 | 0.0026 | 642.37 641.31 | 657.62 660.31 | 15.25 | 14.89 | MH 2 0.015 |
| S15 | S16 | 1269+41 1265+69 | 0.00 3.38 | 0.00 2.51 | 23.22 | 3.57 | 3.95 | 9.0 | 9.9 | 24 | 373.0 | 0.0028 | 639.73 638.70 | 3.69 | 11.08 | 0.0026 | 641.31 640.26 | 660.31 662.63 | 19.00 | 18.58 | MH 2 0.015 |
| S16 | S17 final | 1265+69 1263+32 | 0.00 3.38 | 0.00 2.51 | 24.91 | 3.43 | 3.86 | 8.6 | 9.7 | 24 | 238.0 | 0.0029 | 638.20 637.50 | 3.77 | 11.44 | 0.0024 | 639.70 639.06 | 662.63 640.50 | 22.93 | 22.43 | MH 2 0.015 |

BC = BLIND CONNECTION (existing concrete collar)



STORM SEWER SYSTEM

PID : 117275 Date : 08/07/2024 Project : BUT IR 75/VAR/5.22/VAR Location : SR-4

Description : Prop BUT 4 South Storm Sewer with 649.50 Tailwater.pdf Designer : SAF

Rainfall Area: C Just Full Capacity Frequency (yrs.) : 10 Hydraulic Gradient Frequency (yrs.) : 25
 Minimum Pipe Size : 0.00 Tailwater Elevation (ft.): 649.50

| JUNCTION | STATION | ΔAREA | ΔCA | BEGIN | RAINFALL | DISCHARGE | | PIPE | | | F/L PIPE | MEAN | JUST FULL | FRICT | HYGR EL. | COVER | COVER | COVER | INLET TYPE | | |
|----------|---------|---------|------|--------|---------------------|---------------------|---------------------|-------|--------|-----------|----------|--------|-----------|-----------|----------|----------|--------|--------|------------|-------|------|
| From | To | Σ AREA | Σ CA | TIME | INTENSITY | (cfs.) | (cfs.) | DIAM. | LENGTH | SLOPE | IN / OUT | VEL | CAPACITY | SLOPE | IN / OUT | IN / OUT | MINUS | MINUS | MANNING'S | | |
| | | (acres) | | (min.) | (10 yrs.) (25 yrs.) | (10 yrs.) (25 yrs.) | (10 yrs.) (25 yrs.) | (in.) | (ft.) | (ft./ft.) | (ft.) | (fps.) | (cfs.) | (ft./ft.) | (ft.) | (ft.) | HY GR | CROWN | 'n' | | |
| S1 | S2 | 1298+53 | 0.11 | 0.08 | 10.00 | 5.32 | 3.75 | 0.4 | 0.3 | 27 | 21.0 | 0.0195 | 647.70 | 3.16 | 40.34 | 0.0000 | 650.33 | 650.99 | 0.66 | 1.04 | CB 3 |
| | begin | 1298+32 | 0.11 | 0.08 | | | | | | | | | 647.29 | | | | 650.33 | 650.87 | | 0.015 | |
| S2 | S3 | 1298+32 | 0.13 | 0.08 | 10.11 | 5.30 | 3.75 | 0.9 | 0.6 | 27 | 82.0 | 0.0009 | 647.29 | 1.30 | 8.44 | 0.0000 | 650.33 | 650.87 | 0.54 | 1.33 | CB 3 |
| | | 1297+50 | 0.24 | 0.16 | | | | | | | | | 647.22 | | | | 650.33 | 651.32 | | 0.015 | |
| S20 | S3 | 1297+50 | 0.23 | 0.14 | 10.00 | 5.32 | 3.75 | 0.8 | 0.5 | 12 | 43.0 | 0.0100 | 648.90 | 3.26 | 3.32 | 0.0003 | 650.34 | 651.32 | 0.98 | 1.42 | CB 3 |
| | begin | 1297+50 | 0.47 | 0.31 | | | | | | | | | 648.47 | | | | 650.33 | 651.32 | | 0.015 | |
| S3 | S4 | 1297+50 | 0.26 | 0.16 | 11.16 | 5.10 | 3.75 | 2.4 | 1.8 | 27 | 145.0 | 0.0012 | 647.22 | 1.94 | 9.89 | 0.0000 | 650.33 | 651.32 | 0.99 | 1.85 | CB 3 |
| | | 1296+05 | 0.73 | 0.47 | | | | | | | | | 647.05 | | | | 650.32 | 653.43 | | 0.015 | |
| S4 | S5 | 1296+05 | 0.44 | 0.37 | 12.41 | 4.87 | 3.75 | 4.1 | 3.1 | 36 | 131.0 | 0.0037 | 647.03 | 3.30 | 37.64 | 0.0000 | 650.32 | 653.43 | 3.11 | 3.40 | MH 3 |
| | | 1294+75 | 1.17 | 0.84 | | | | | | | | | 646.55 | | | | 650.32 | 653.35 | | 0.015 | |
| S5 | S6 | 1294+75 | 0.18 | 0.12 | 13.07 | 4.77 | 3.75 | 4.5 | 3.6 | 36 | 112.0 | 0.0037 | 646.55 | 3.41 | 37.62 | 0.0000 | 650.32 | 653.35 | 3.03 | 3.80 | MH 3 |
| | | 1293+63 | 1.35 | 0.95 | | | | | | | | | 646.14 | | | | 650.31 | 653.65 | | 0.015 | |
| S6 | S7 | 1293+63 | 0.52 | 0.36 | 13.62 | 4.68 | 3.75 | 6.2 | 4.9 | 36 | 219.0 | 0.0032 | 646.07 | 3.55 | 35.16 | 0.0001 | 650.31 | 653.65 | 3.34 | 4.58 | MH 3 |
| | | 1291+45 | 1.87 | 1.32 | | | | | | | | | 645.37 | | | | 650.30 | 654.31 | | 0.015 | |
| S7 | S8 | 1291+45 | 0.33 | 0.25 | 14.64 | 4.53 | 3.75 | 7.1 | 5.9 | 36 | 144.0 | 0.0023 | 645.36 | 3.28 | 29.77 | 0.0001 | 650.30 | 654.31 | 4.01 | 5.95 | MH 3 |
| | | 1290+02 | 2.20 | 1.57 | | | | | | | | | 645.03 | | | | 650.28 | 657.63 | | 0.015 | |



STORM SEWER SYSTEM

| JUNCTION | | STATION From To | ΔAREA ΣAREA (acres) | ΔCA ΣCA | BEGIN TIME (min.) | RAINFALL INTENSITY | | DISCHARGE | | PIPE | | | F/L PIPE IN / OUT (ft.) | MEAN VEL (fps.) | JUST FULL CAPACITY (cfs.) | FRICT SLOPE (ft./ft.) | HYGR EL. IN / OUT (ft.) | COVER IN / OUT (ft.) | COVER MINUS HY GR | COVER MINUS CROWN | INLET TYPE MANNING'S 'n' |
|----------|--------------|--------------------|---------------------------|--------------|-------------------------|--------------------|-----------|-----------|-----------|-------|-------|-----------|-------------------------------|-----------------------|---------------------------------|-----------------------------|-------------------------------|----------------------------|-------------------------|-------------------------|--------------------------------|
| From | To | | | | | (10 yrs.) | (25 yrs.) | (10 yrs.) | (25 yrs.) | (in.) | (ft.) | (ft./ft.) | | | | | | | | | |
| S8 | S9 | 1290+02 1288+67 | 0.35 2.55 | 0.26 1.83 | 15.37 | 4.42 | 3.75 | 8.1 | 6.9 | 36 | 135.0 | 0.0023 | 645.03 644.72 | 3.40 | 29.80 | 0.0001 | 650.28 650.26 | 657.63 658.06 | 7.35 | 9.60 | MH 3 0.015 |
| S9 | S10 | 1288+67 1287+85 | 0.00 2.55 | 0.00 1.83 | 16.04 | 4.33 | 3.75 | 7.9 | 6.9 | 36 | 82.0 | 0.0023 | 644.72 644.53 | 3.39 | 29.93 | 0.0001 | 650.26 650.25 | 658.06 658.28 | 7.80 | 10.34 | MH 3 0.015 |
| S10 | S11 | 1287+85 1286+98 | 0.34 2.89 | 0.27 2.10 | 16.44 | 4.28 | 3.75 | 9.0 | 7.8 | 36 | 87.0 | 0.0023 | 644.53 644.33 | 3.50 | 29.81 | 0.0002 | 650.25 650.24 | 658.28 656.65 | 8.03 | 10.75 | MH 2 0.015 |
| S11 | S12 | 1286+98 1283+87 | 0.00 2.89 | 0.00 2.10 | 16.85 | 4.23 | 3.75 | 8.9 | 7.8 | 36 | 312.0 | 0.0023 | 644.33 643.61 | 3.49 | 29.87 | 0.0002 | 650.24 650.18 | 656.64 657.31 | 6.40 | 9.31 | MH 2 0.015 |
| S12 | S13 | 1283+87 1280+70 | 0.72 3.61 | 0.44 2.53 | 18.34 | 4.05 | 3.75 | 10.3 | 9.5 | 36 | 317.0 | 0.0023 | 643.61 642.88 | 3.63 | 29.84 | 0.0003 | 650.18 650.09 | 657.31 656.60 | 7.13 | 10.70 | MH 2 0.015 |
| S13 | S14 | 1280+70 1278+84 | 0.00 3.61 | 0.00 2.53 | 19.80 | 3.89 | 3.75 | 9.9 | 9.5 | 36 | 187.0 | 0.0023 | 642.88 642.45 | 3.59 | 29.82 | 0.0003 | 650.09 650.04 | 656.60 645.45 | 6.51 | 10.72 | MH 2 0.015 |
| S14 | S15 | 1278+84 1277+13 | 0.15 3.76 | 0.14 2.67 | 20.67 | 3.80 | 3.75 | 10.1 | 10.0 | 36 | 173.0 | 0.0041 | 642.45 641.74 | 4.47 | 39.84 | 0.0003 | 650.04 649.99 | 645.45 655.71 | -4.59 | 0.00 | MH BC 0.015 |
| S15 | S16 | 1277+13 1273+26 | 0.08 3.84 | 0.07 2.74 | 21.31 | 3.74 | 3.75 | 10.2 | 10.3 | 36 | 386.0 | 0.0026 | 641.73 640.74 | 3.77 | 31.49 | 0.0003 | 649.99 649.87 | 655.71 657.62 | 5.72 | 10.98 | MH 2 0.015 |
| S16 | S17 | 1273+26 1269+41 | 0.27 4.11 | 0.24 2.98 | 23.02 | 3.58 | 3.75 | 10.7 | 11.2 | 36 | 385.0 | 0.0026 | 640.73 639.74 | 3.82 | 31.53 | 0.0004 | 649.87 649.73 | 657.62 660.31 | 7.75 | 13.89 | MH 2 0.015 |
| S17 | S18 | 1269+41 1265+69 | 0.00 4.11 | 0.00 2.98 | 24.70 | 3.44 | 3.75 | 10.3 | 11.2 | 36 | 373.0 | 0.0028 | 639.73 638.70 | 3.88 | 32.68 | 0.0004 | 649.73 649.59 | 660.31 662.63 | 10.58 | 17.58 | MH 2 0.015 |
| S18 | S19 final | 1265+69 1263+32 | 0.00 4.11 | 0.00 2.98 | 26.30 | 3.32 | 3.75 | 9.9 | 11.2 | 36 | 238.0 | 0.0029 | 638.20 637.50 | 3.93 | 33.72 | 0.0004 | 649.59 649.50 | 662.63 640.50 | 13.04 | 21.43 | MH 2 0.015 |



STORM SEWER SYSTEM

PID : 117275 Date : 08/07/2024 Project : BUT IR 75/VAR/5.22/VAR Location : SR-4

Description : Prop BUT 4 South Storm Sewer with 652.50 Tailwater.pdf

Designer : SAF

Rainfall Area: C

Just Full Capacity Frequency (yrs.) : 10

Hydraulic Gradient Frequency (yrs.) : 25

Minimum Pipe Size : 0.00

Tailwater Elevation (ft.): 652.50

| JUNCTION | STATION | ΔAREA | ΔCA | BEGIN | RAINFALL | DISCHARGE | | PIPE | | | F/L PIPE | MEAN | JUST FULL | FRICT | HYGR EL. | COVER | COVER | COVER | INLET TYPE | | |
|----------|---------|---------|------|--------|---------------------|---------------------|--------|-------|--------|-----------|----------|--------|-----------|-----------|----------|----------|--------|--------|------------|------|-------|
| From | To | Σ AREA | Σ CA | TIME | INTENSITY | (cfs.) | (cfs.) | DIAM. | LENGTH | SLOPE | IN / OUT | VEL | CAPACITY | SLOPE | IN / OUT | IN / OUT | MINUS | MINUS | MANNING'S | | |
| | From To | (acres) | | (min.) | (10 yrs.) (25 yrs.) | (10 yrs.) (25 yrs.) | | (in.) | (ft.) | (ft./ft.) | (ft.) | (fps.) | (cfs.) | (ft./ft.) | (ft.) | (ft.) | HY GR | CROWN | 'n' | | |
| S1 | S2 | 1298+53 | 0.11 | 0.08 | 10.00 | 5.32 | 3.75 | 0.4 | 0.3 | 27 | 21.0 | 0.0195 | 647.70 | 3.16 | 40.34 | 0.0000 | 653.33 | 650.99 | -2.34 | 1.04 | CB 3 |
| | begin | 1298+32 | 0.11 | 0.08 | | | | | | | | | 647.29 | | | | 653.33 | 650.87 | | | 0.015 |
| S2 | S3 | 1298+32 | 0.13 | 0.08 | 10.11 | 5.30 | 3.75 | 0.9 | 0.6 | 27 | 82.0 | 0.0009 | 647.29 | 1.30 | 8.44 | 0.0000 | 653.33 | 650.87 | -2.46 | 1.33 | CB 3 |
| | | 1297+50 | 0.24 | 0.16 | | | | | | | | | 647.22 | | | | 653.33 | 651.32 | | | 0.015 |
| S20 | S3 | 1297+50 | 0.23 | 0.14 | 10.00 | 5.32 | 3.75 | 0.8 | 0.5 | 12 | 43.0 | 0.0100 | 648.90 | 3.26 | 3.32 | 0.0003 | 653.34 | 651.32 | -2.02 | 1.42 | CB 3 |
| | begin | 1297+50 | 0.47 | 0.31 | | | | | | | | | 648.47 | | | | 653.33 | 651.32 | | | 0.015 |
| S3 | S4 | 1297+50 | 0.26 | 0.16 | 11.16 | 5.10 | 3.75 | 2.4 | 1.8 | 27 | 145.0 | 0.0012 | 647.22 | 1.94 | 9.89 | 0.0000 | 653.33 | 651.32 | -2.01 | 1.85 | CB 3 |
| | | 1296+05 | 0.73 | 0.47 | | | | | | | | | 647.05 | | | | 653.32 | 653.43 | | | 0.015 |
| S4 | S5 | 1296+05 | 0.44 | 0.37 | 12.41 | 4.87 | 3.75 | 4.1 | 3.1 | 36 | 131.0 | 0.0037 | 647.03 | 3.30 | 37.64 | 0.0000 | 653.32 | 653.43 | 0.11 | 3.40 | MH 3 |
| | | 1294+75 | 1.17 | 0.84 | | | | | | | | | 646.55 | | | | 653.32 | 653.35 | | | 0.015 |
| S5 | S6 | 1294+75 | 0.18 | 0.12 | 13.07 | 4.77 | 3.75 | 4.5 | 3.6 | 36 | 112.0 | 0.0037 | 646.55 | 3.41 | 37.62 | 0.0000 | 653.32 | 653.35 | 0.03 | 3.80 | MH 3 |
| | | 1293+63 | 1.35 | 0.95 | | | | | | | | | 646.14 | | | | 653.31 | 653.65 | | | 0.015 |
| S6 | S7 | 1293+63 | 0.52 | 0.36 | 13.62 | 4.68 | 3.75 | 6.2 | 4.9 | 36 | 219.0 | 0.0032 | 646.07 | 3.55 | 35.16 | 0.0001 | 653.31 | 653.65 | 0.34 | 4.58 | MH 3 |
| | | 1291+45 | 1.87 | 1.32 | | | | | | | | | 645.37 | | | | 653.30 | 654.31 | | | 0.015 |
| S7 | S8 | 1291+45 | 0.33 | 0.25 | 14.64 | 4.53 | 3.75 | 7.1 | 5.9 | 36 | 144.0 | 0.0023 | 645.36 | 3.28 | 29.77 | 0.0001 | 653.30 | 654.31 | 1.01 | 5.95 | MH 3 |
| | | 1290+02 | 2.20 | 1.57 | | | | | | | | | 645.03 | | | | 653.28 | 657.63 | | | 0.015 |



STORM SEWER SYSTEM

| JUNCTION From | STATION To | From To | ΔAREA ΣAREA (acres) | ΔCA ΣCA | BEGIN TIME (min.) | RAINFALL INTENSITY | | DISCHARGE | | PIPE | | | F/L PIPE IN / OUT (ft.) | MEAN VEL (fps.) | JUST FULL CAPACITY (cfs.) | FRICT SLOPE (ft./ft.) | HYGR EL. IN / OUT (ft.) | COVER IN / OUT (ft.) | COVER MINUS HY GR | COVER MINUS CROWN | INLET TYPE MANNING'S 'n' |
|------------------|---------------|--------------------|---------------------------|--------------|-------------------------|--------------------|-----------|-----------|-----------|----------------|-----------------|--------------------|-------------------------------|-----------------------|---------------------------------|-----------------------------|-------------------------------|----------------------------|-------------------------|-------------------------|--------------------------------|
| | | | | | | (10 yrs.) | (25 yrs.) | (10 yrs.) | (25 yrs.) | DIAM. (in.) | LENGTH (ft.) | SLOPE (ft./ft.) | | | | | | | | | |
| S8 | S9 | 1290+02 1288+67 | 0.35 2.55 | 0.26 1.83 | 15.37 | 4.42 | 3.75 | 8.1 | 6.9 | 36 | 135.0 | 0.0023 | 645.03 644.72 | 3.40 | 29.80 | 0.0001 | 653.28 653.26 | 657.63 658.06 | 4.35 | 9.60 | MH 3 0.015 |
| S9 | S10 | 1288+67 1287+85 | 0.00 2.55 | 0.00 1.83 | 16.04 | 4.33 | 3.75 | 7.9 | 6.9 | 36 | 82.0 | 0.0023 | 644.72 644.53 | 3.39 | 29.93 | 0.0001 | 653.26 653.25 | 658.06 658.28 | 4.80 | 10.34 | MH 3 0.015 |
| S10 | S11 | 1287+85 1286+98 | 0.34 2.89 | 0.27 2.10 | 16.44 | 4.28 | 3.75 | 9.0 | 7.8 | 36 | 87.0 | 0.0023 | 644.53 644.33 | 3.50 | 29.81 | 0.0002 | 653.25 653.24 | 658.28 656.65 | 5.03 | 10.75 | MH 2 0.015 |
| S11 | S12 | 1286+98 1283+87 | 0.00 2.89 | 0.00 2.10 | 16.85 | 4.23 | 3.75 | 8.9 | 7.8 | 36 | 312.0 | 0.0023 | 644.33 643.61 | 3.49 | 29.87 | 0.0002 | 653.24 653.18 | 656.64 657.31 | 3.40 | 9.31 | MH 2 0.015 |
| S12 | S13 | 1283+87 1280+70 | 0.72 3.61 | 0.44 2.53 | 18.34 | 4.05 | 3.75 | 10.3 | 9.5 | 36 | 317.0 | 0.0023 | 643.61 642.88 | 3.63 | 29.84 | 0.0003 | 653.18 653.09 | 657.31 656.60 | 4.13 | 10.70 | MH 2 0.015 |
| S13 | S14 | 1280+70 1278+84 | 0.00 3.61 | 0.00 2.53 | 19.80 | 3.89 | 3.75 | 9.9 | 9.5 | 36 | 187.0 | 0.0023 | 642.88 642.45 | 3.59 | 29.82 | 0.0003 | 653.09 653.04 | 656.60 645.45 | 3.51 | 10.72 | MH 2 0.015 |
| S14 | S15 | 1278+84 1277+13 | 0.15 3.76 | 0.14 2.67 | 20.67 | 3.80 | 3.75 | 10.1 | 10.0 | 36 | 173.0 | 0.0041 | 642.45 641.74 | 4.47 | 39.84 | 0.0003 | 653.04 652.99 | 645.45 655.71 | -7.59 | 0.00 | MH BC 0.015 |
| S15 | S16 | 1277+13 1273+26 | 0.08 3.84 | 0.07 2.74 | 21.31 | 3.74 | 3.75 | 10.2 | 10.3 | 36 | 386.0 | 0.0026 | 641.73 640.74 | 3.77 | 31.49 | 0.0003 | 652.99 652.87 | 655.71 657.62 | 2.72 | 10.98 | MH 2 0.015 |
| S16 | S17 | 1273+26 1269+41 | 0.27 4.11 | 0.24 2.98 | 23.02 | 3.58 | 3.75 | 10.7 | 11.2 | 36 | 385.0 | 0.0026 | 640.73 639.74 | 3.82 | 31.53 | 0.0004 | 652.87 652.73 | 657.62 660.31 | 4.75 | 13.89 | MH 2 0.015 |
| S17 | S18 | 1269+41 1265+69 | 0.00 4.11 | 0.00 2.98 | 24.70 | 3.44 | 3.75 | 10.3 | 11.2 | 36 | 373.0 | 0.0028 | 639.73 638.70 | 3.88 | 32.68 | 0.0004 | 652.73 652.59 | 660.31 662.63 | 7.58 | 17.58 | MH 2 0.015 |
| S18 | S19 final | 1265+69 1263+32 | 0.00 4.11 | 0.00 2.98 | 26.30 | 3.32 | 3.75 | 9.9 | 11.2 | 36 | 238.0 | 0.0029 | 638.20 637.50 | 3.93 | 33.72 | 0.0004 | 652.59 652.50 | 662.63 640.50 | 10.04 | 21.43 | MH 2 0.015 |

| CRS | CFN or SFN | Inlet Station | Inlet Offset | Outlet Station | Outlet Offset | Side | Inlet Structure | Inlet Survey Point # | Outlet Structure | Outlet Survey Point # | Size (in) | Length | Pipe Material | GA | Inventory Comments | Inspection Comments | ODOT Scope Disposition | Profile Work |
|--------------|------------|---|--|---|--|------|-----------------|----------------------|--|-----------------------|-----------|--------|----------------------|-----|--|---|--|--|
| BUT-4-23.359 | 0900427 | Outside survey limits (53+50 Original Plans) | Outside survey limits (59.25' RT Original Plans) | Outside survey limits (53+50 Original Plans) | Outside survey limits (59.25' LT Original Plans) | Both | Headwall | Not surveyed | Headwall | Not surveyed | 144x144 | 78.5 | 4 sided concrete box | 6 | N/A. This is a bridge. | N/A. This is a bridge. | No work | No work |
| N/A | N/A | Outside survey limits (60+25 Original Plans) | Outside survey limits (CL Original Plans) | Outside survey limits (59+62.40 Original Plans) | Outside survey limits (25' LT Original Plans) | LT | Catch Basin | Not surveyed | Manhole | Not surveyed | 12 | 64 | RCP | N/A | Median curb basin. Not in ODOT TIMS. | Not in ODOT TIMS. | No work | No work |
| BUT-4-23.543 | 1981381 | Outside survey limits (62+75 Original Plans) | Outside survey limits (CL Original Plans) | Outside survey limits (63+49.00 Original Plans) | Outside survey limits (25.5' LT Original Plans) | LT | Catch Basin | Not surveyed | Manhole | Not surveyed | 12 | 35 | RCP | 6 | Median curb basin | Misaligned section with slight joint separation. | No work | No work |
| BUT-4-23.590 | 1981389 | Outside survey limits (65+25.00 Original Plans) | Outside survey limits (CL Original Plans) | Outside survey limits (65+25.00 Original Plans) | Outside survey limits (43' LT Original Plans) | LT | Catch Basin | Not surveyed | Manhole in TIMS Collar in Original Plans | Not surveyed | 12 | 30 | RCP | 6 | Curb basin in the median. | Edge of curb basin broken off section misalignment with slight joint separation. | No work | No work |
| BUT-4-23.306 | 1981382 | 1296+04.00 | 22.11' LT | Outside survey limits (49+67.50 Original Plans) | Outside survey limits (55' LT Original Plans) | LT | Manhole | Not surveyed | Half Height Headwall | Not surveyed | 36 | 3200 | RCP | 7 | Culvert runs from manhole with cfn. 1981365 23.894 to the river. Passing thru several manholes in south bound curb lane. | Culvert has 770 ft. Of new plastic changes to concrete under Fairfield intersection. Water control gate stuck half open. Minor rocks randomly throughout. | Replace or remove gate. Determine the necessity of the gate and extent/frequency of flooding if it is removed. | No profile work, but CVE recommends removing gate and reconstructing a new gate. |
| BUT-4-23.796 | 1981367 | Outside survey limits (1289+93.78 Original Plans) | Outside survey limits (21.08' RT Original Plans) | Outside survey limits (1290+02.34 Original Plans) | Outside survey limits (33.41' LT Original Plans) | Both | Catch Basin | Not surveyed | Catch Basin | Not surveyed | 12 | 54 | RCP | 6 | Runs across main line older concrete new plastic extension. | Section minor misalignment. | No work | No work |
| BUT-4-23.827 | 1981355 | 1291+44.99 | 34.14' LT | 1291+45.72 | 21.96' RT | Both | Catch Basin | SV5003 | Catch Basin | SV5004 | 12 | 50 | RCP | 5 | Older concrete with newer plastic extension. | Culvert concrete section in middle of turn lane is rises up 3" no infiltration. | March 2024 Update: No work. Original: Replace section of bad pipe. Bridge Department to determine limits. | March 2024 Update: No work. Original: Replace pipe. |

| CRS | CFN or SFN | Inlet Station | Inlet Offset | Outlet Station | Outlet Offset | Side | Inlet Structure | Inlet Survey Point # | Outlet Structure | Outlet Survey Point # | Size (in) | Length | Pipe Material | GA | Inventory Comments | Inspection Comments | ODOT Scope Disposition | Profile Work |
|--------------|------------|---------------|--------------|----------------|---------------|------|-----------------|----------------------|------------------|-----------------------|-----------|--------|--------------------|----|---|---|---|-----------------------------------|
| BUT-4-23.869 | 1981366 | 1293+62.50 | 33.98' LT | 1293+63.34 | 21.94' LT | Both | Catch Basin | SV686 | Catch Basin | SV774 | 12 | 50 | RCP | 6 | Older concrete culvert with 2 extension of smooth plastic | Slight misalignment to the concrete sections. | No work | No work |
| BUT-4-23.888 | 1981354 | 1294+74.62 | 34.12' LT | 1294+75.14 | 18.93' LT | LT | Catch Basin | SV851 | Manhole | SV3074 | 12 | 13 | Corrugated Plastic | 8 | Runs from curb to center of lane | Null | No work | No work |
| BUT-4-23.918 | 1981365 | 1296+04.09 | 21.94' RT | 1296+04.00 | 22.11' LT | Both | Catch Basin | SV3247 | Catch Basin | SV3252 | 12 | 38 | RCP | 6 | Main line | Culvert is misaligned. | Clean pipe | Clean pipes |
| BUT-4-23.962 | 1981353 | 1298+28.47 | 19.97' LT | 1296+05.31 | 26.27' LT | LT | Catch Basin | SV3725 | Manhole | SV3253 | 24 | 220 | RCP | 7 | Running along white line /side walk. | Outlets in the Manhole, in front of Firehouse in the sidewalk. Inlet CB at the curb/gutter. | Clean concrete pipe. Clean plastic pipe and remove wood debris clogging CB/Manhole. | Clean pipes |
| BUT-4-23.968 | 1981352 | 1298+31.58 | 19.86' LT | 1298+42.23 | 22.79' RT | Both | Catch Basin | SV3724 | Catch Basin | SV3642 | 24 | 42 | RCP | 6 | Runs from catch basin across main line to catch basin. | Culvert is misaligned in the center left and right. | Replace catch basin. Clean pipes. | Replace catch basins. Clean pipes |
| BUT-4-23.969 | 1981351 | 1298+74.35 | 19.86' LT | 1298+31.58 | 19.86' LT | LT | Catch Basin | SV3746 | Catch Basin | SV3724 | 27 | 40 | RCP | 7 | Runs along white line south bound under railroad. | 1/3 full of sediment pavement around catch basin broken up. | Replace catch basin. Clean pipes. | Replace catch basins. Clean pipes |
| BUT-4-23.973 | 1981350 | 1299+14.96 | 27.16' LT | 1298+53.42 | 36.86' RT | Both | Manhole | SV3802 | Manhole | SV4768 | 68x43 | 84 | RCP | 7 | Runs at angle under railroad bridge. | Unseal cracks across pavement on the edge of where culvert cross. About 1/3 full of sediment. | Clean out 250'+/- of 60" pipe and the ODOT Owned 1800'+ detention basin along the railroad (constructed in 1963). | Clean pipes |
| BUT-4-24.025 | 1981343 | 1301+70.71 | 38.71' RT | 1301+71.18 | 22.48' LT | Both | Catch Basin | SV3992 | Catch Basin | SV4019 | 12 | 62 | RCP | 7 | Runs across main line in manhole then 5 feet into catch basin. | Runs across main line to manhole. | No work | No work |
| BUT-4-24.024 | 1981347 | 1302+82.04 | 23.58' LT | 1301+71.12 | 22.34' LT | LT | Manhole | SV4046 | Manhole | SV4019 | 30 | 104 | RCP | 7 | Runs south lane shoulder manhole to manhole then 5' to right to catch basin into 48" culvert under side walk. | Under right shoulder | No work | No work |
| BUT-4-24.025 | 1981349 | 1301+71.91 | 28.73' LT | 1299+14.90 | 27.13' LT | LT | Catch Basin | SV4018 | Manhole | SV3802 | 48 | 245 | RCP | 7 | Runs south from 42" culvert toward railroad bridge under side walk. | Runs south toward railroad bridge | Clean pipes | Clean pipes |
| BUT-4-24.043 | 1981348 | 1202+89.50 | 40.54' LT | 1301+71.91 | 28.73' LT | LT | Catch Basin | SV4047 | Catch Basin | SV4018 | 42 | 104 | RCP | 7 | Runs south toward rail road bridge under side walk. | Some minor debris in the inlet catch basin. | No work | No work |

Appendix C

BUT-4 Preliminary Plan and Profile Sheets

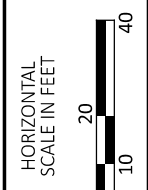
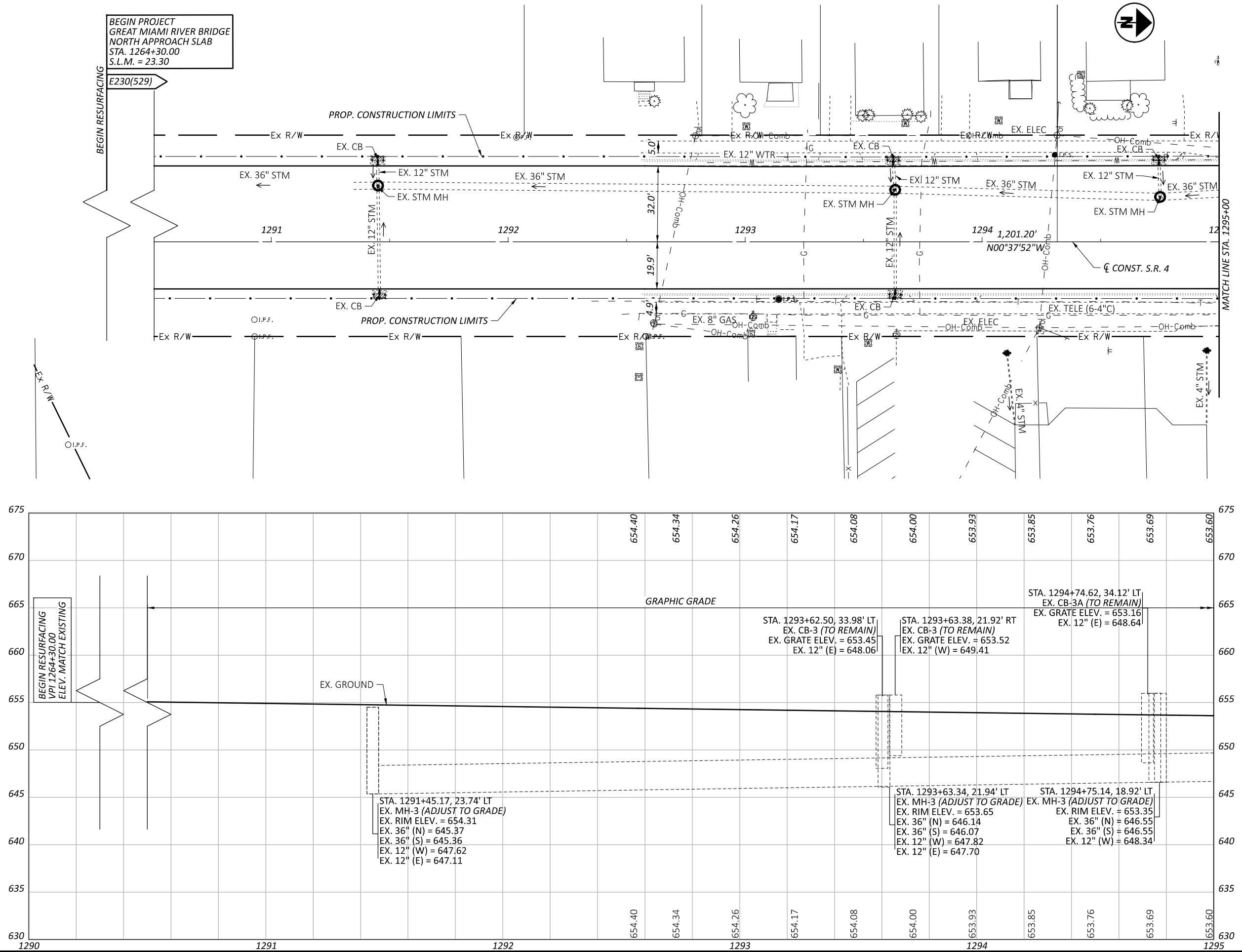

**PLAN AND PROFILE - ALL VERTICAL CLEARANCE OPTIONS
 S.R. 4 - BEGIN PROJECT TO STA. 1295+00.00**



| | |
|------------|----------------|
| DESIGNER | SAF |
| REVIEWER | CWP 04-29-2024 |
| PROJECT ID | 117275 |
| SHEET | P.1 |
| TOTAL | 3 |

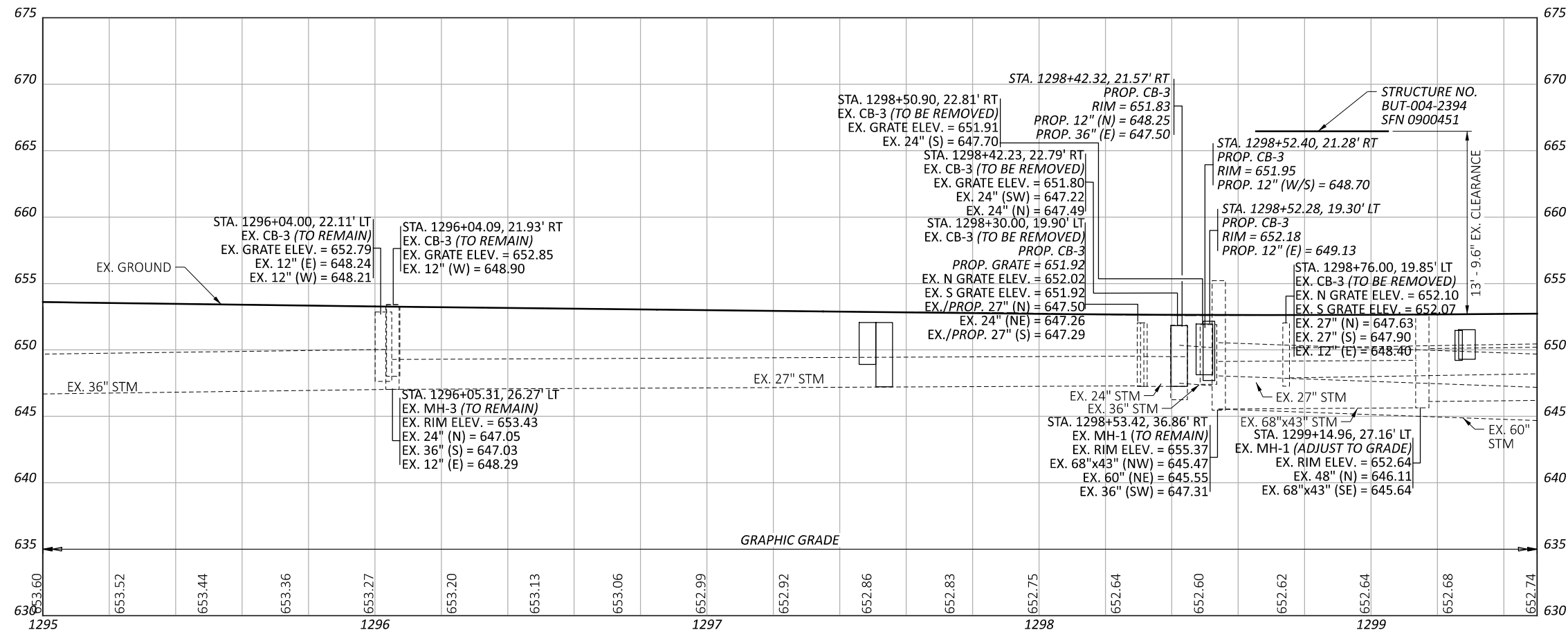
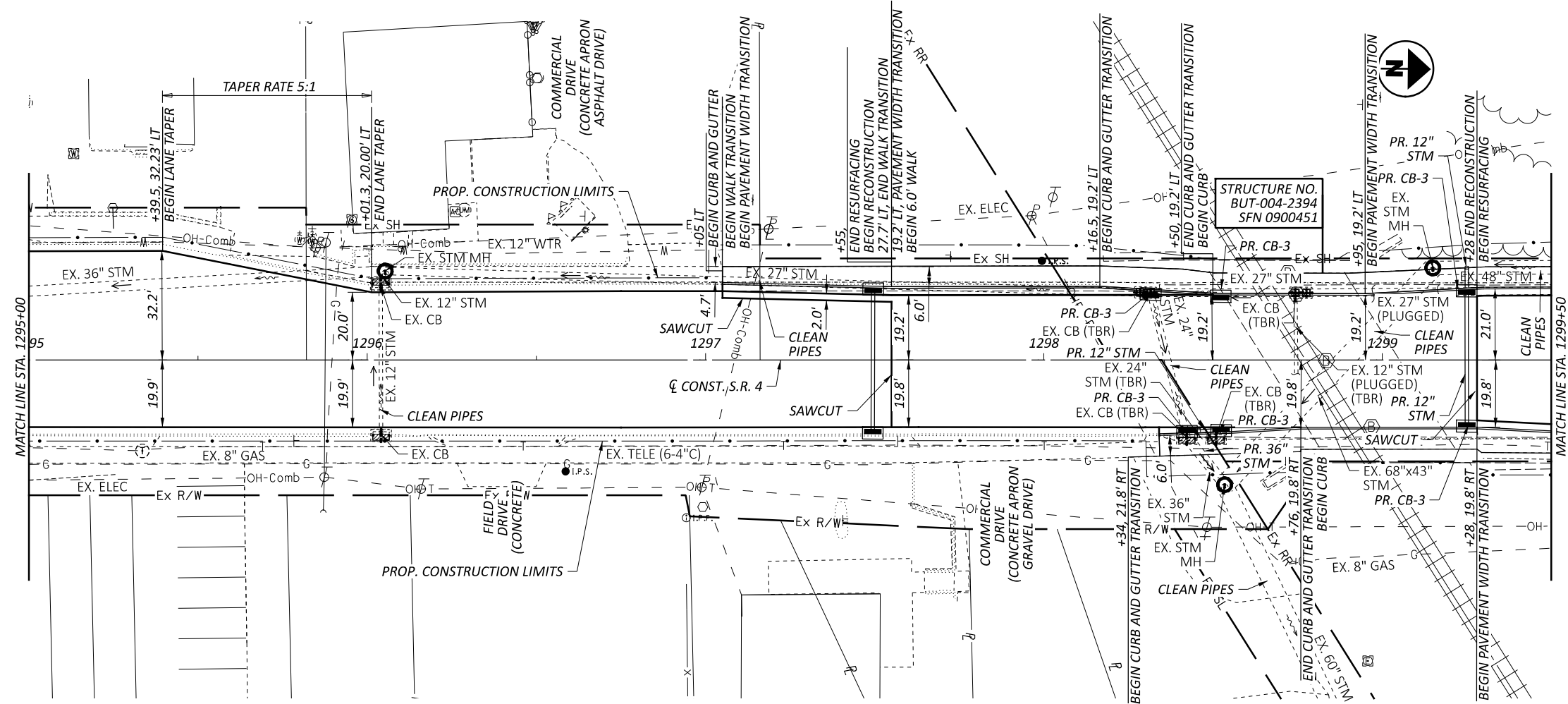

PLAN AND PROFILE - 13.8' VERTICAL CLEARANCE
 S.R. 4 - BEGIN TO STA. 1299+50.00

DESIGN AGENCY



DESIGNER

SAF

REVIEWER

CWP 04-29-2024

PROJECT ID

117275

SHEET TOTAL

P.2 3

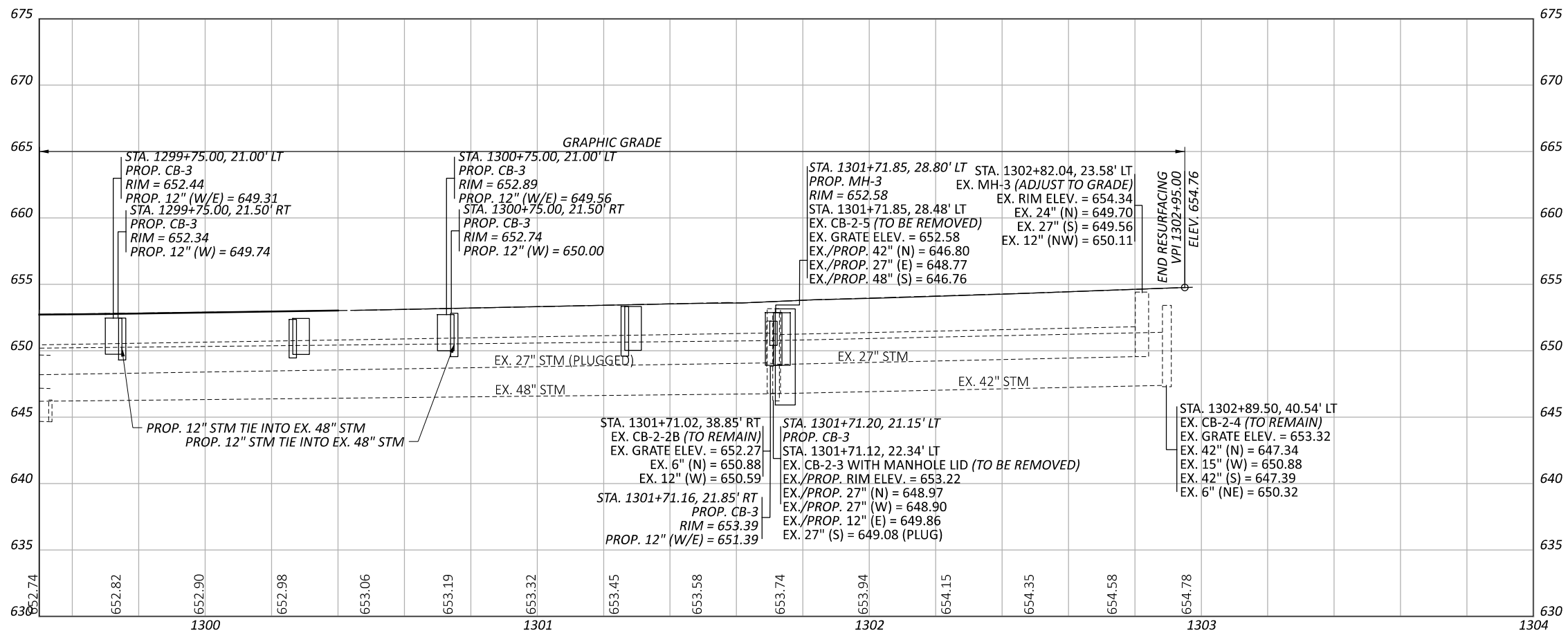
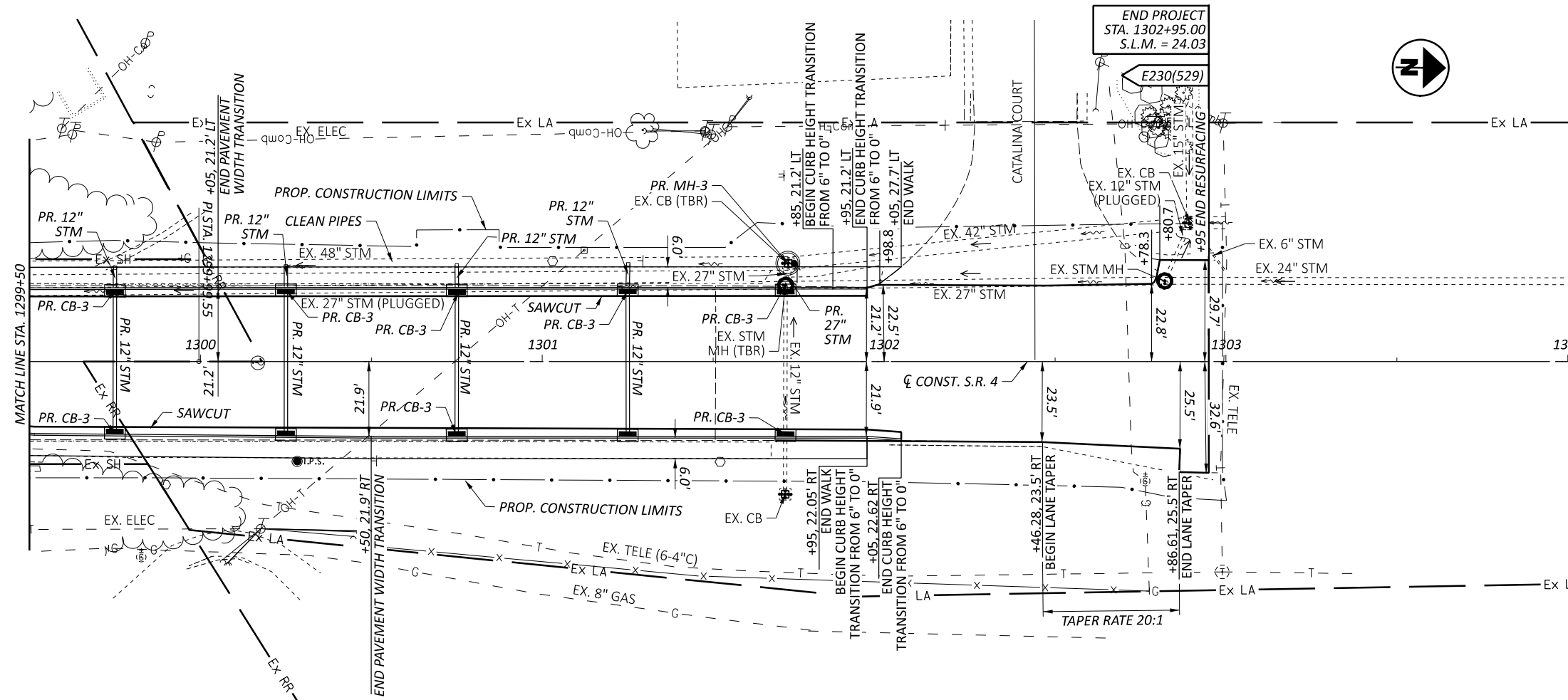

PLAN AND PROFILE - 13.8' VERTICAL CLEARANCE
 S.R. 4 - STA. 1299+50.00 TO END

DESIGN AGENCY



DESIGNER

SAF

REVIEWER

CWP 04-29-2024

PROJECT ID

117275

SHEET

P.3

TOTAL

3

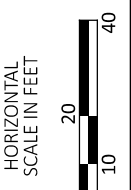
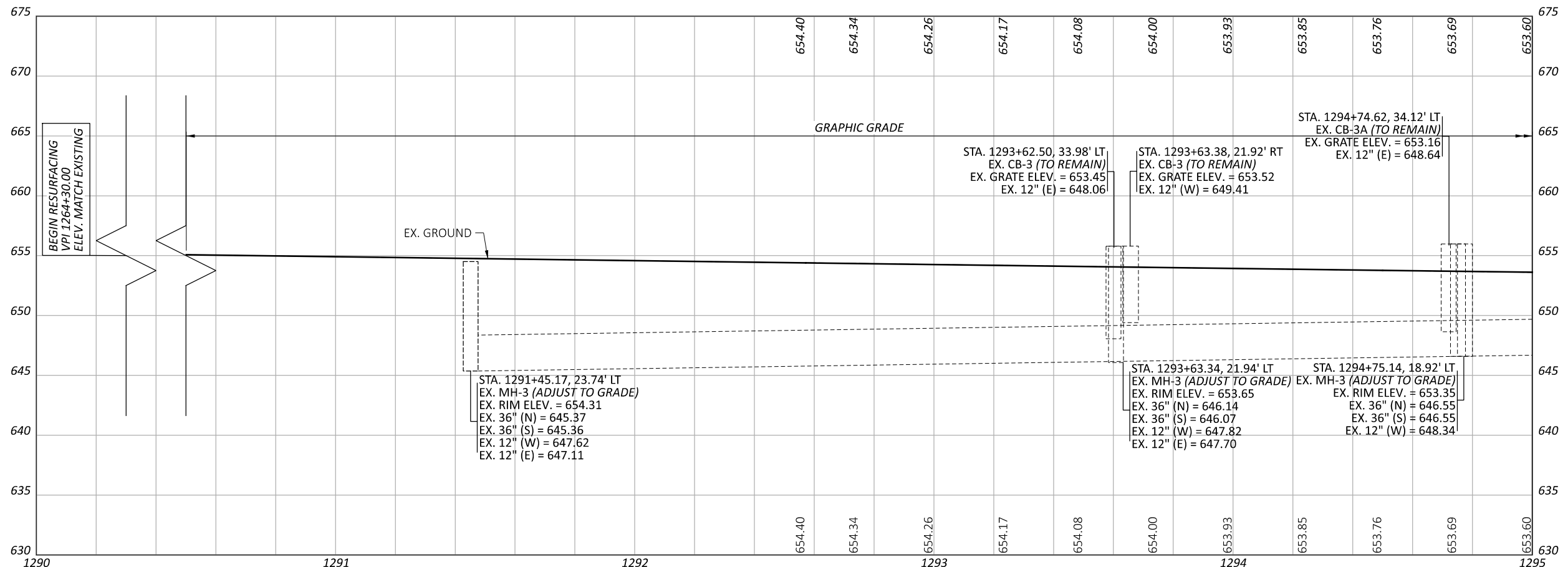
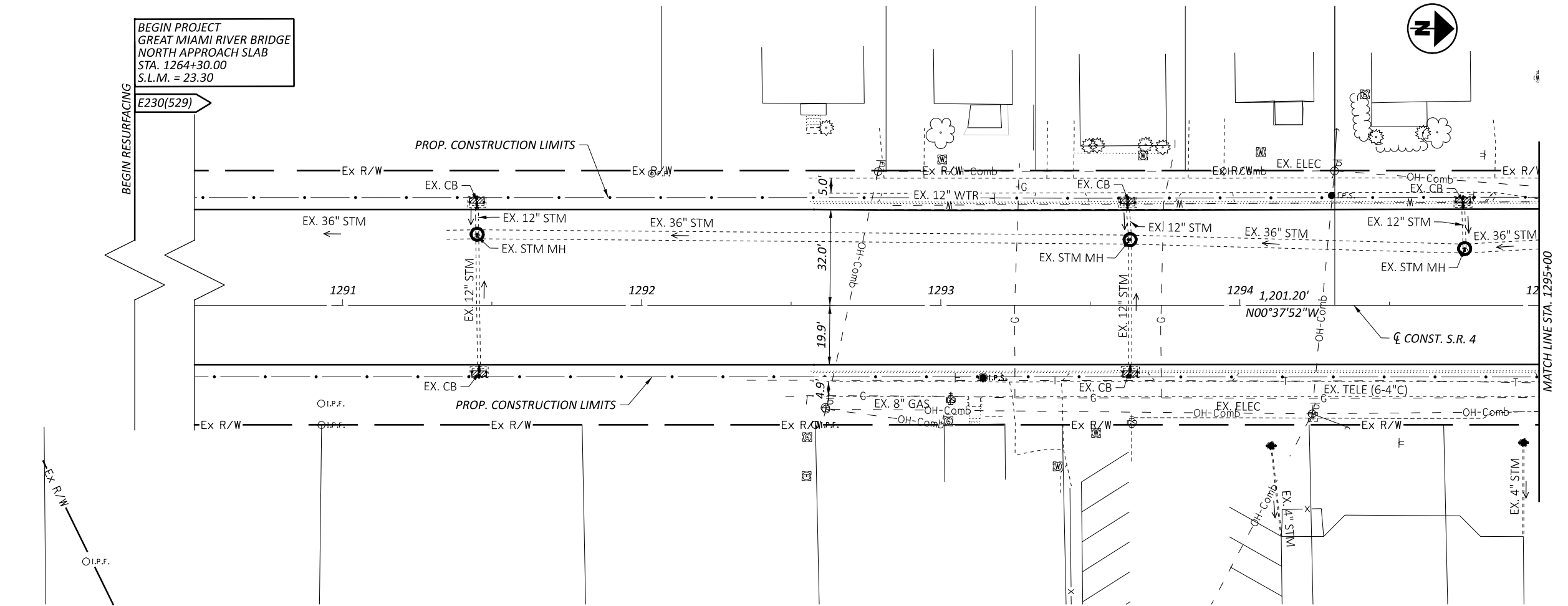

PLAN AND PROFILE - ALL VERTICAL CLEARANCE OPTIONS
S.R. 4 - BEGIN PROJECT TO STA. 1295+00.00

DESIGN AGENCY



DESIGNER

REVIEWER

PROJECT ID

SHEET TOTAL

P.1 3

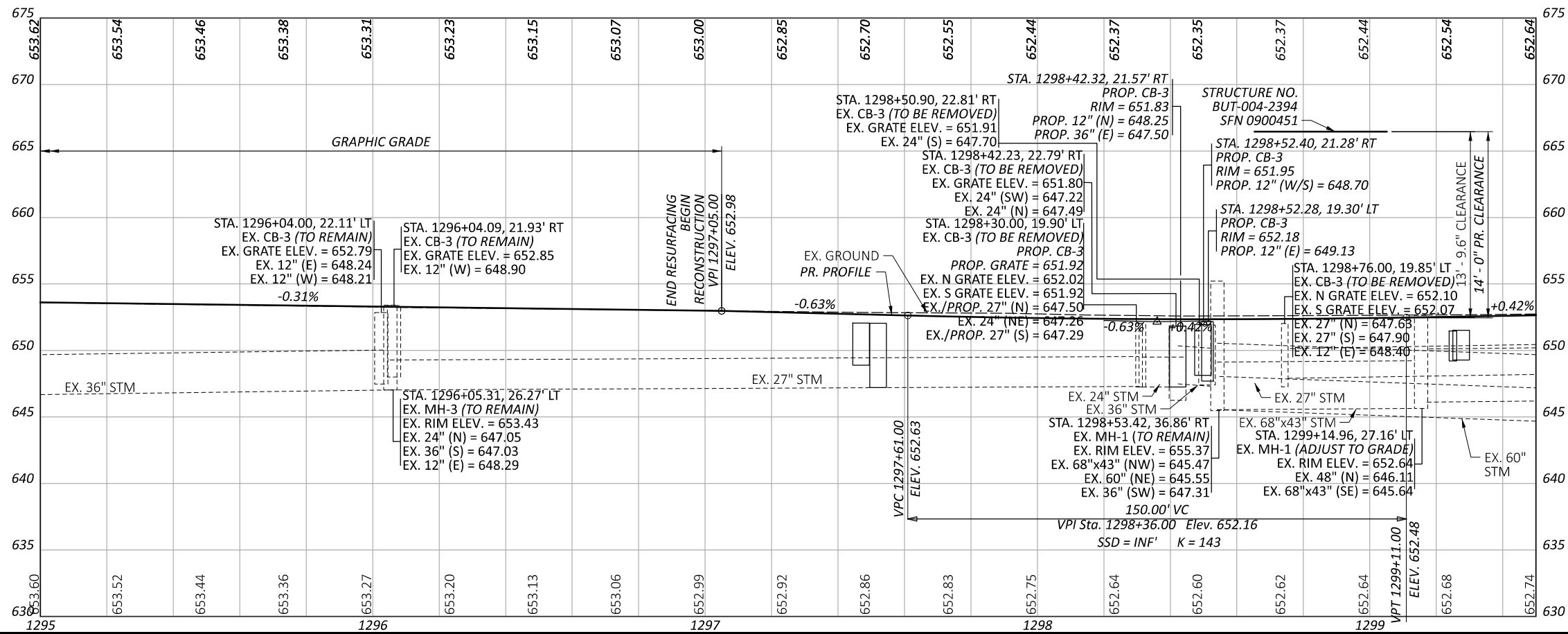
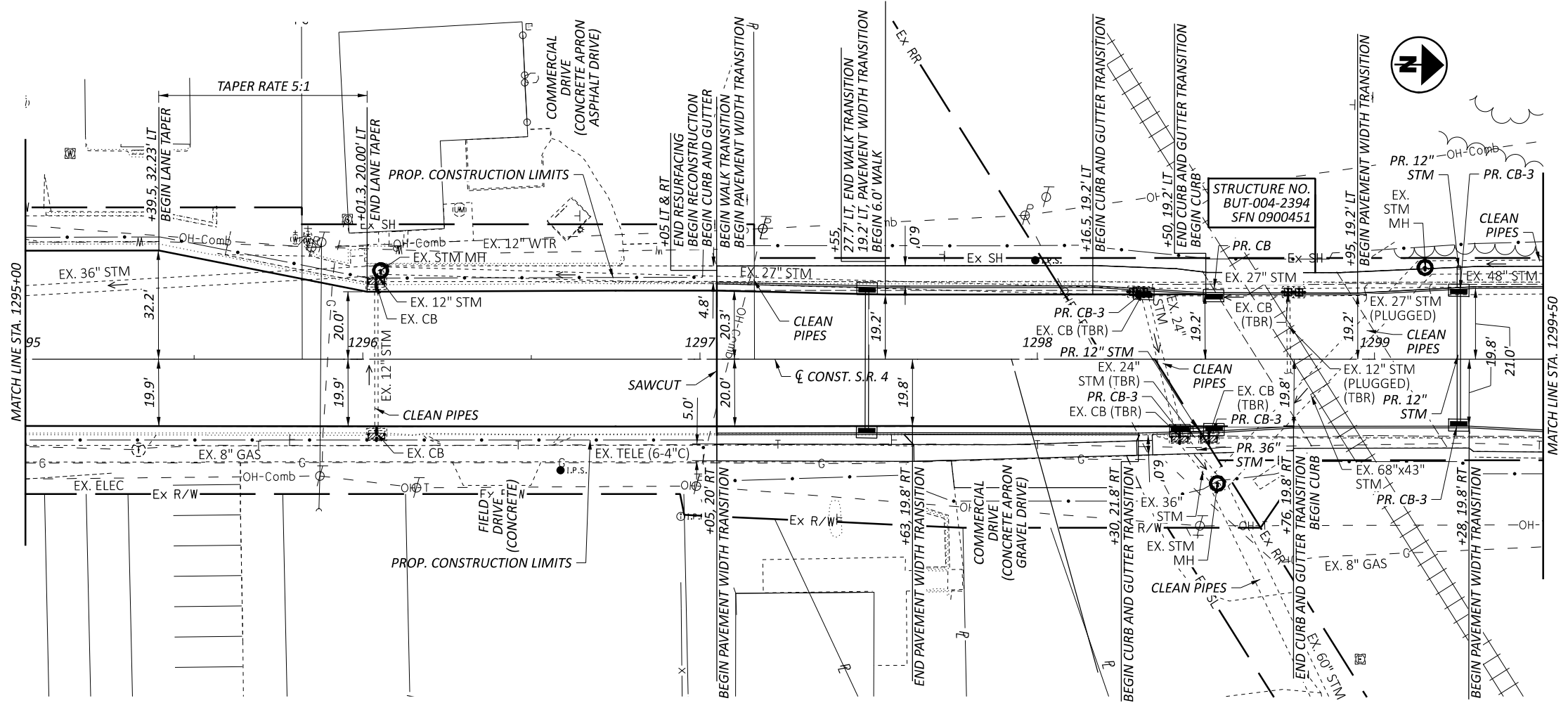

PLAN AND PROFILE - 14.0' VERTICAL CLEARANCE
 S.R. 4 - STA. 1295+00.00 TO STA. 1299+50.00

DESIGN AGENCY



| | |
|------------|----------------|
| DESIGNER | SAF |
| REVIEWER | CWP 04-29-2024 |
| PROJECT ID | 117275 |
| SHEET | P.2 |
| TOTAL | 3 |

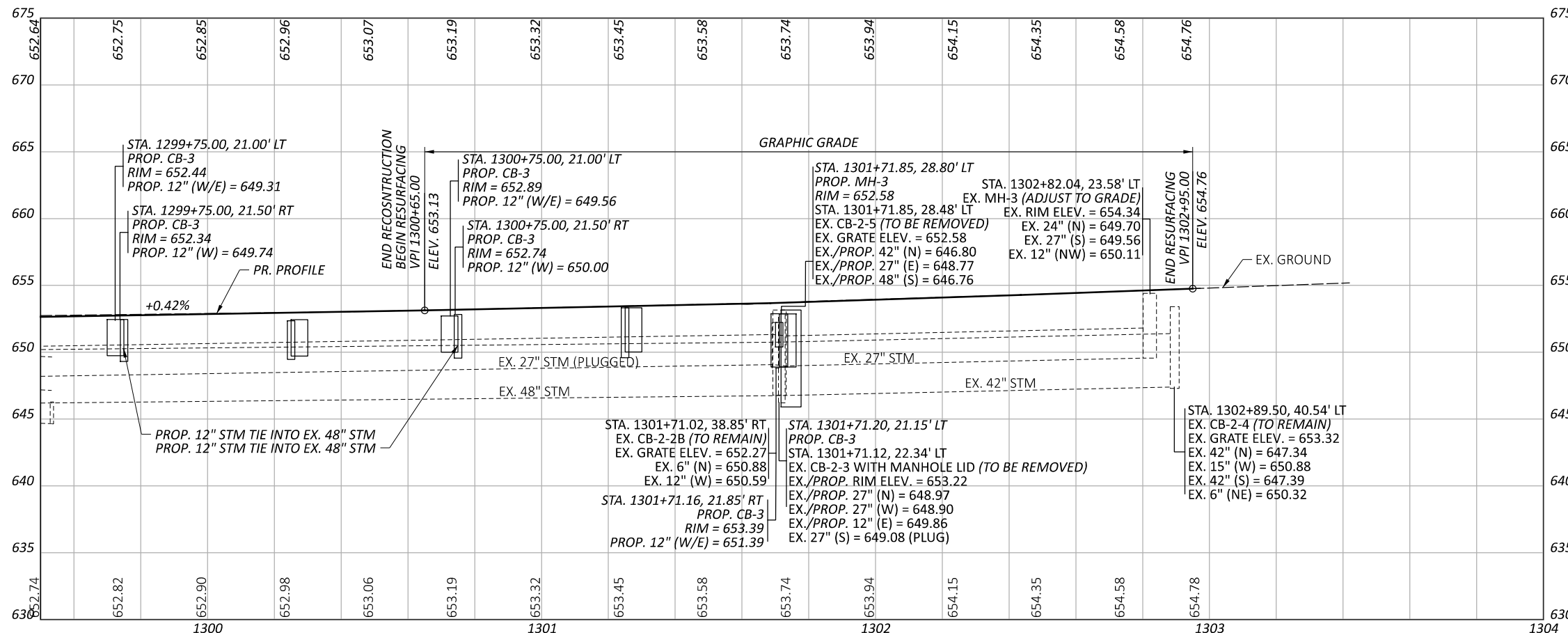
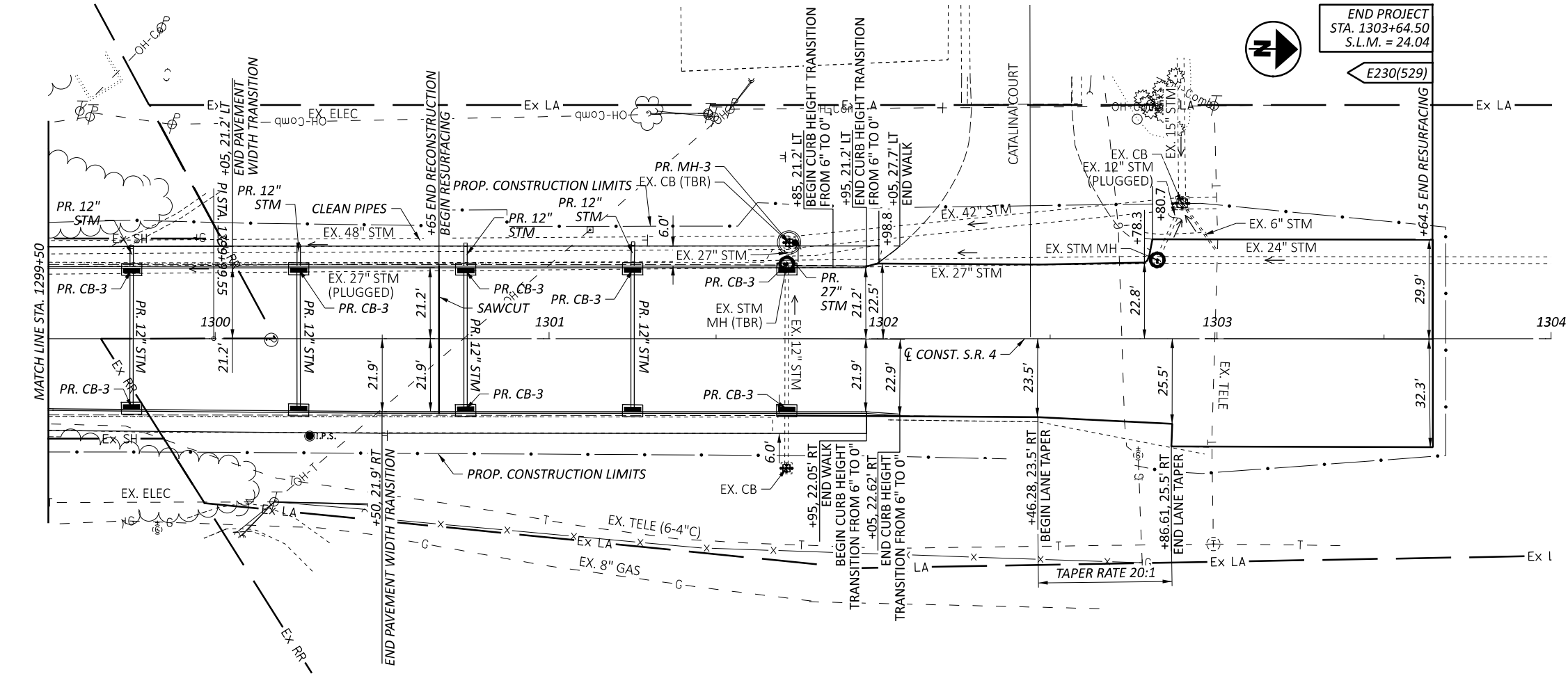

END PROJECT
 STA. 1303+64.50
 S.L.M. = 24.04

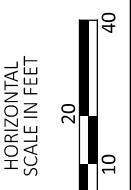

PLAN AND PROFILE - 14.0' VERTICAL CLEARANCE
 S.R. 4 - STA. 1299+50.00 TO END PROJECT

DESIGN AGENCY



DESIGNER
 SAF

REVIEWER
 CWP 04-29-2024

PROJECT ID
 117275

SHEET TOTAL
 P.3 3

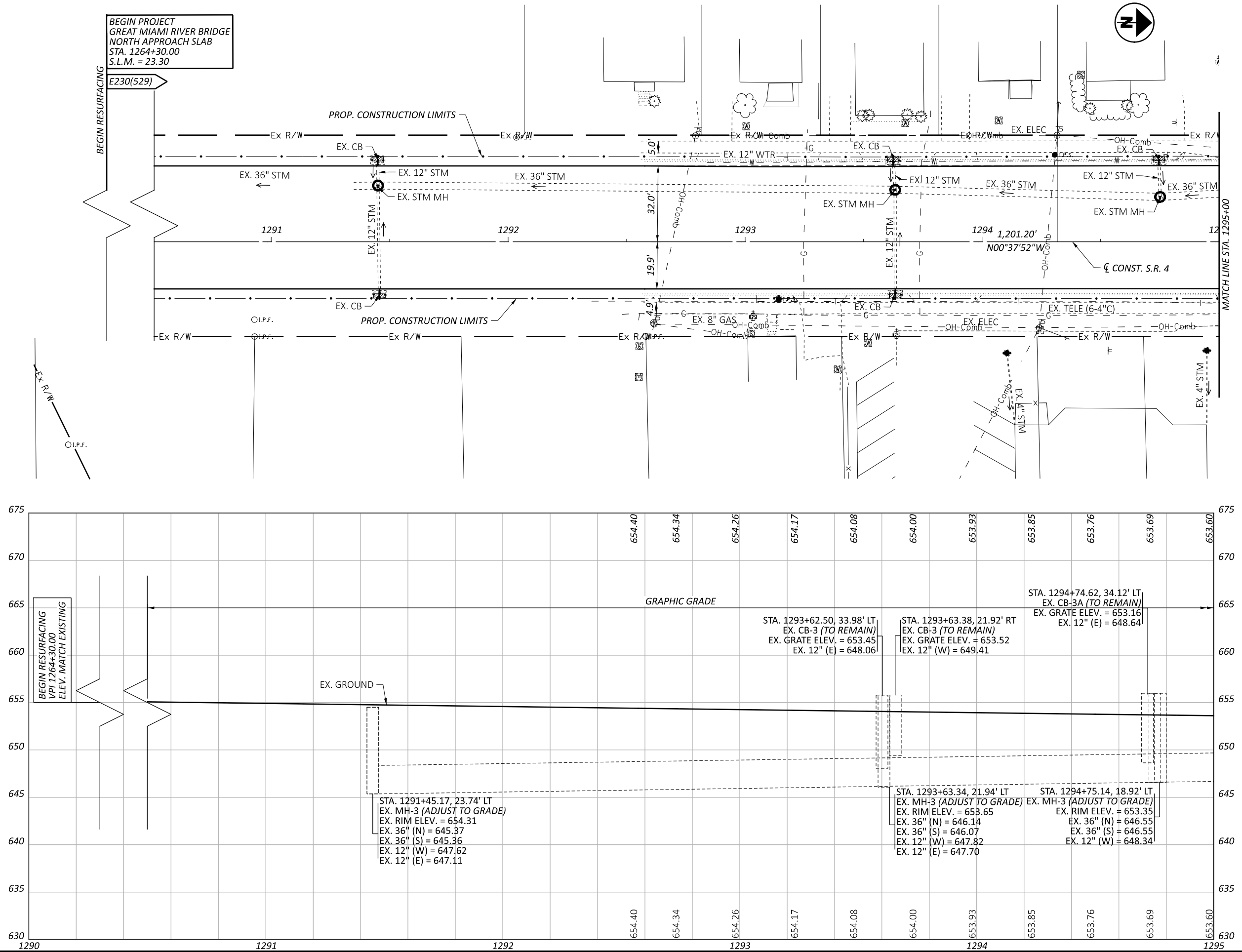

BEGIN PROJECT
 GREAT MIAMI RIVER BRIDGE
 NORTH APPROACH SLAB
 STA. 1264+30.00
 S.L.M. = 23.30

BEGIN RESURFACING

E230(529)

PROP. CONSTRUCTION LIMITS

PROP. CONSTRUCTION LIMITS

GRAPHIC GRADE

EX. GROUND

EX. R/W
 O.I.P.F.

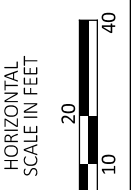

PLAN AND PROFILE - ALL VERTICAL CLEARANCE OPTIONS
 S.R. 4 - BEGIN PROJECT TO STA. 1295+00.00

DESIGN AGENCY



DESIGNER
 SAF

REVIEWER
 CWP 04-29-2024

PROJECT ID
 117275

SHEET TOTAL
 P.1 3

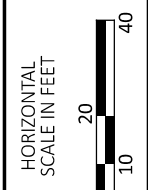
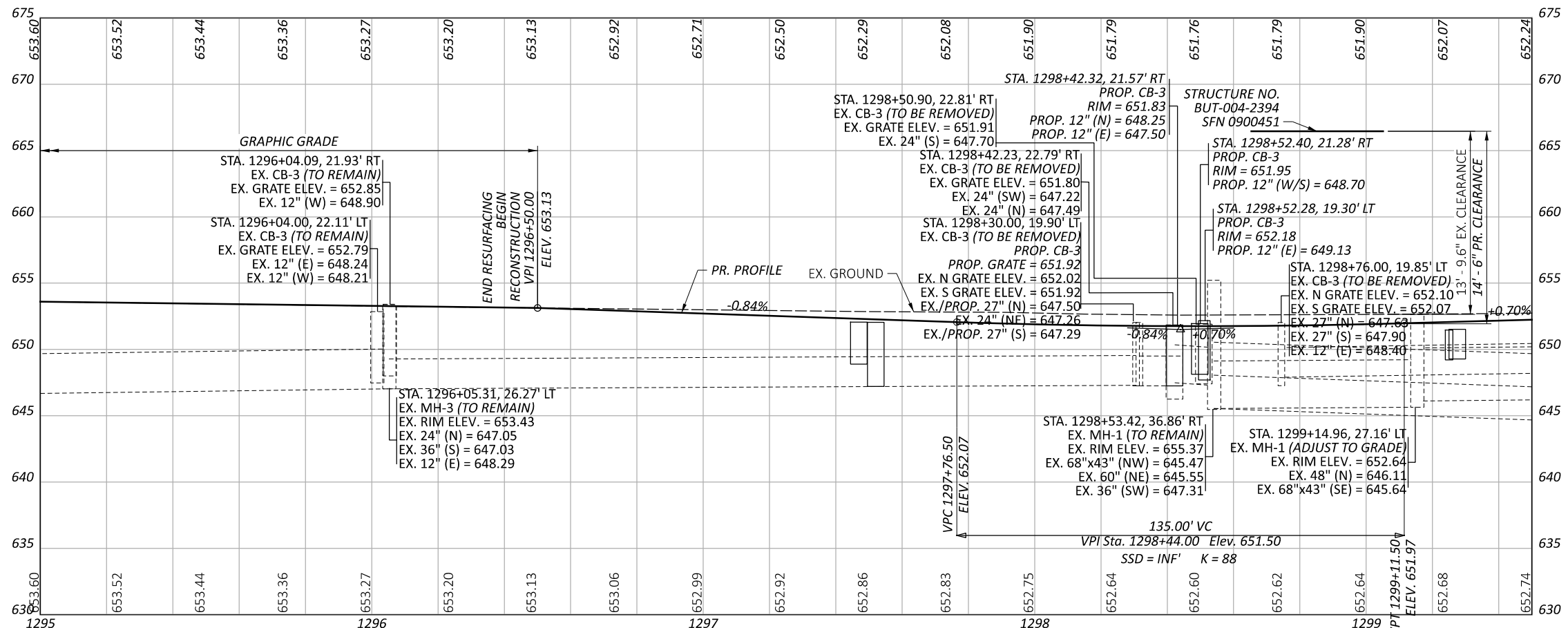
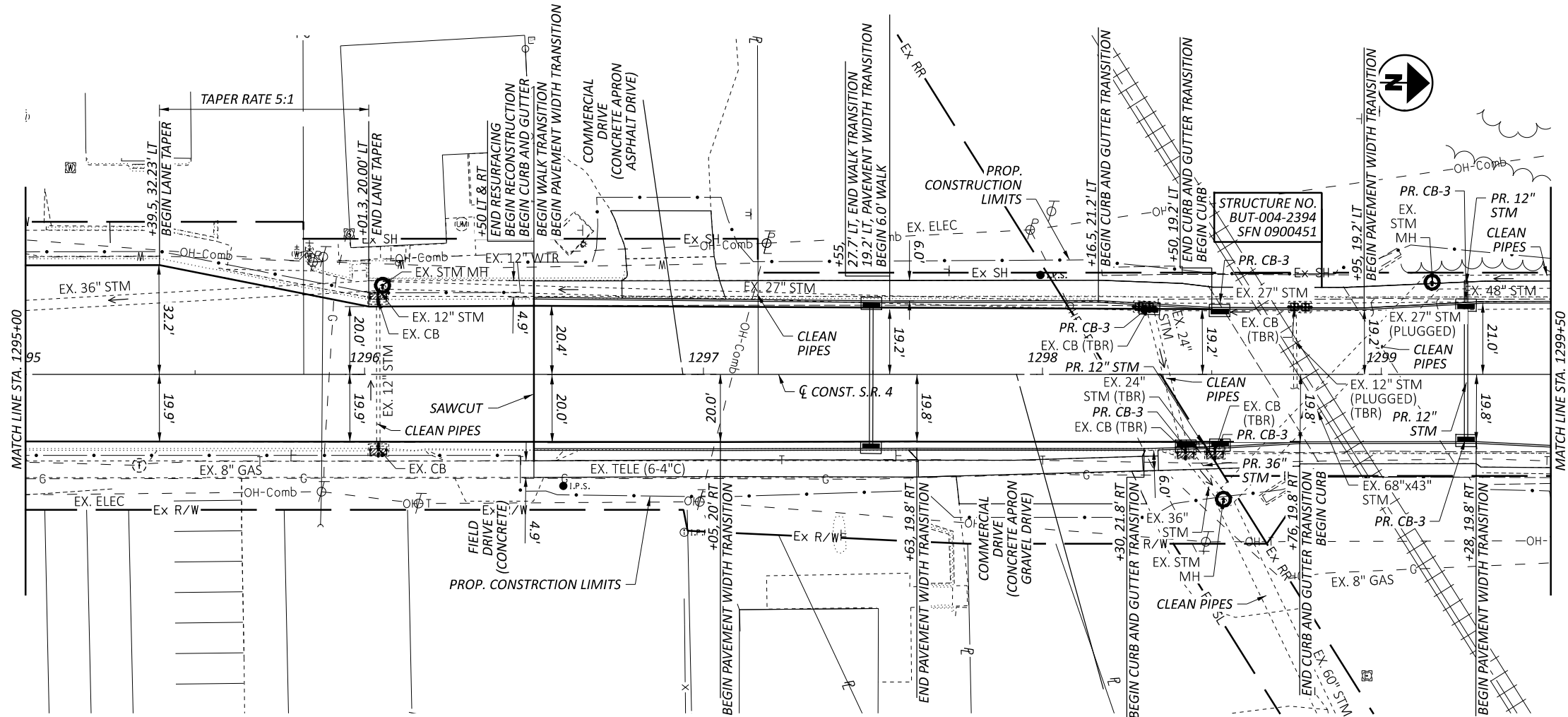

PLAN AND PROFILE - 14.5' VERTICAL CLEARANCE
S.R. 4 - BEGIN TO STA. 1299+50.00

DESIGN AGENCY



| | |
|------------|----------------|
| DESIGNER | SAF |
| REVIEWER | CWP 04-29-2024 |
| PROJECT ID | 117275 |
| SHEET | P.2 |
| TOTAL | 3 |

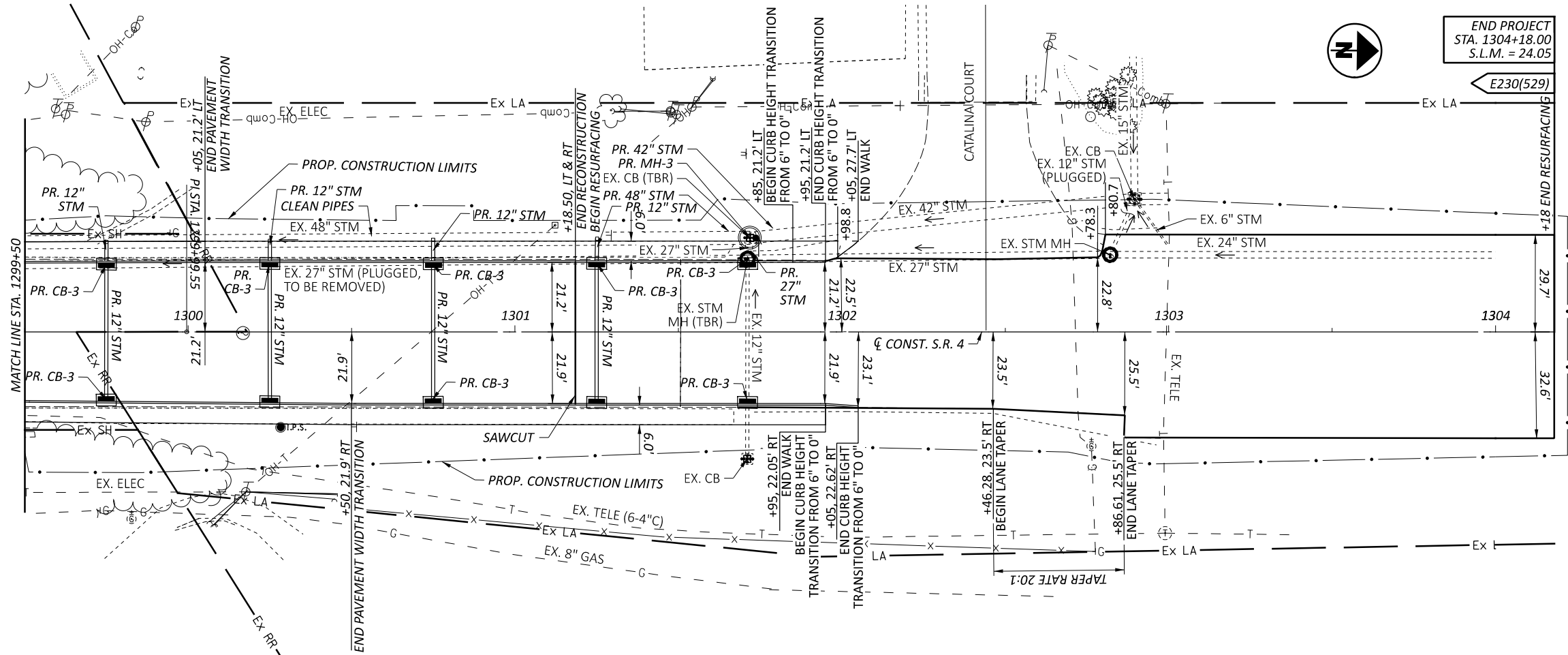

END PROJECT
 STA. 1304+18.00
 S.L.M. = 24.05

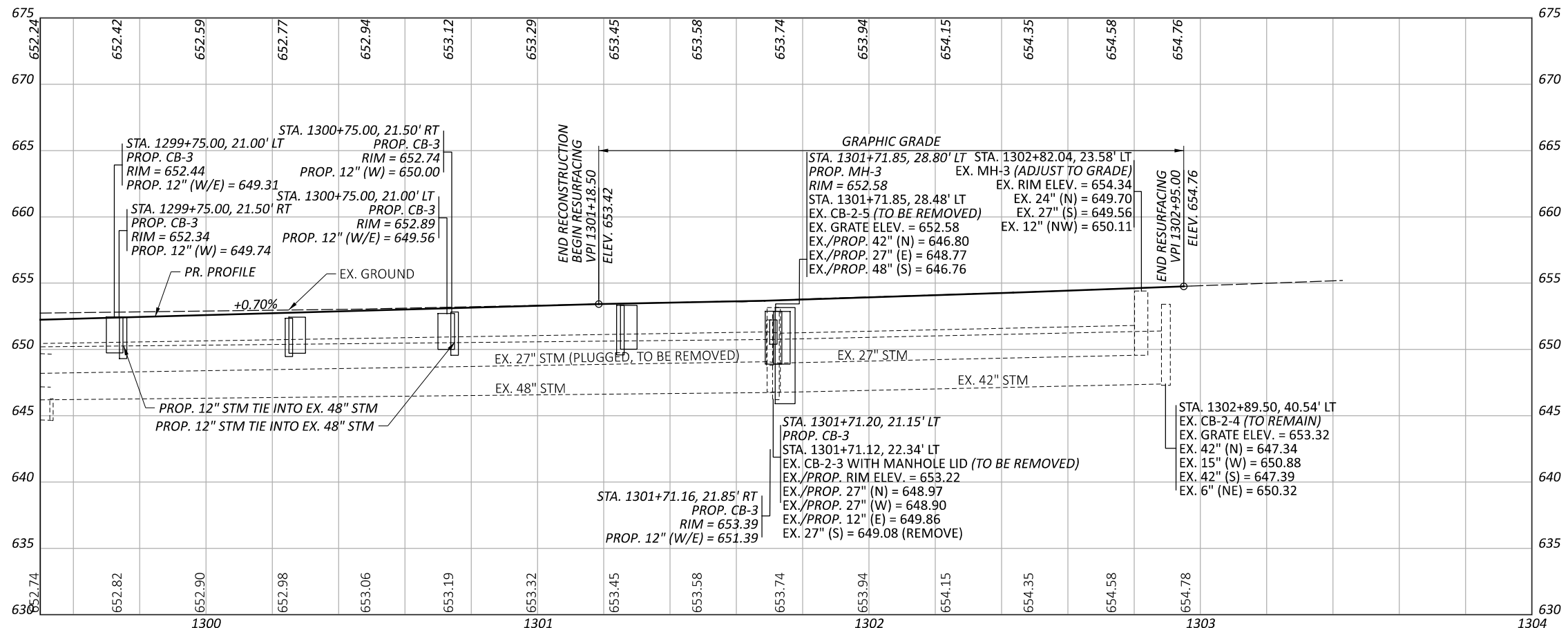
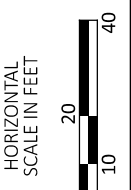

PLAN AND PROFILE - 14.5' VERTICAL CLEARANCE
 S.R. 4 - STA. 1299+50.00 TO END

DESIGN AGENCY



DESIGNER

SAF

REVIEWER

CWP 04-29-2024

PROJECT ID

117275

SHEET TOTAL

P.3 3

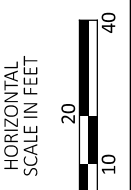
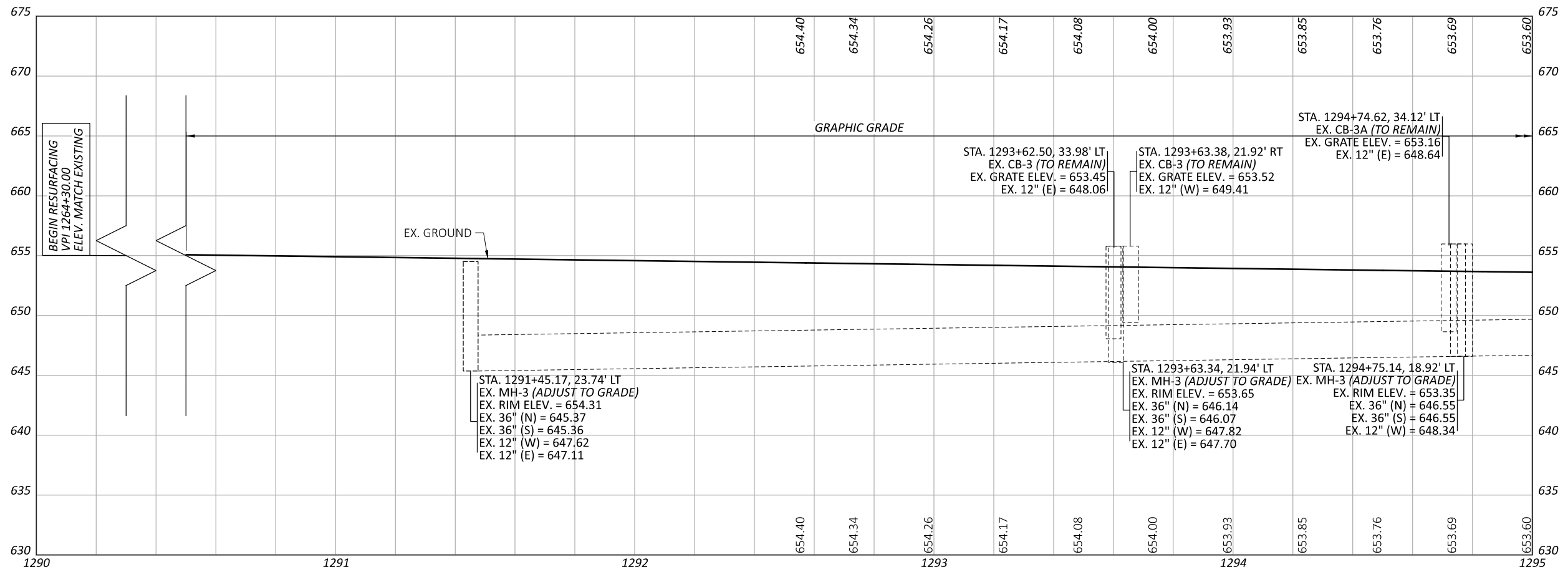
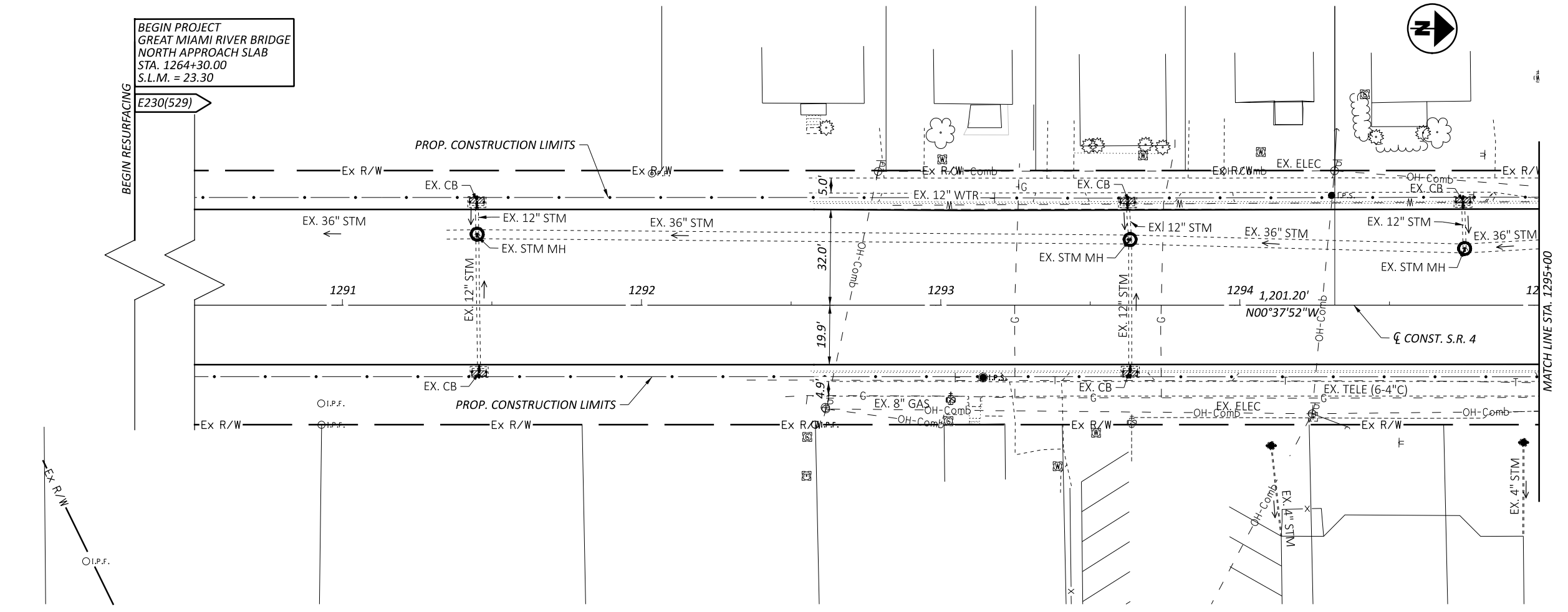

PLAN AND PROFILE - ALL VERTICAL CLEARANCE OPTIONS
 S.R. 4 - BEGIN PROJECT TO STA. 1295+00.00



| | |
|---------------|----------------|
| DESIGN AGENCY | |
| DESIGNER | SAF |
| REVIEWER | |
| PROJECT ID | CWP 04-29-2024 |
| | 117275 |
| SHEET | P.1 |
| TOTAL | 3 |

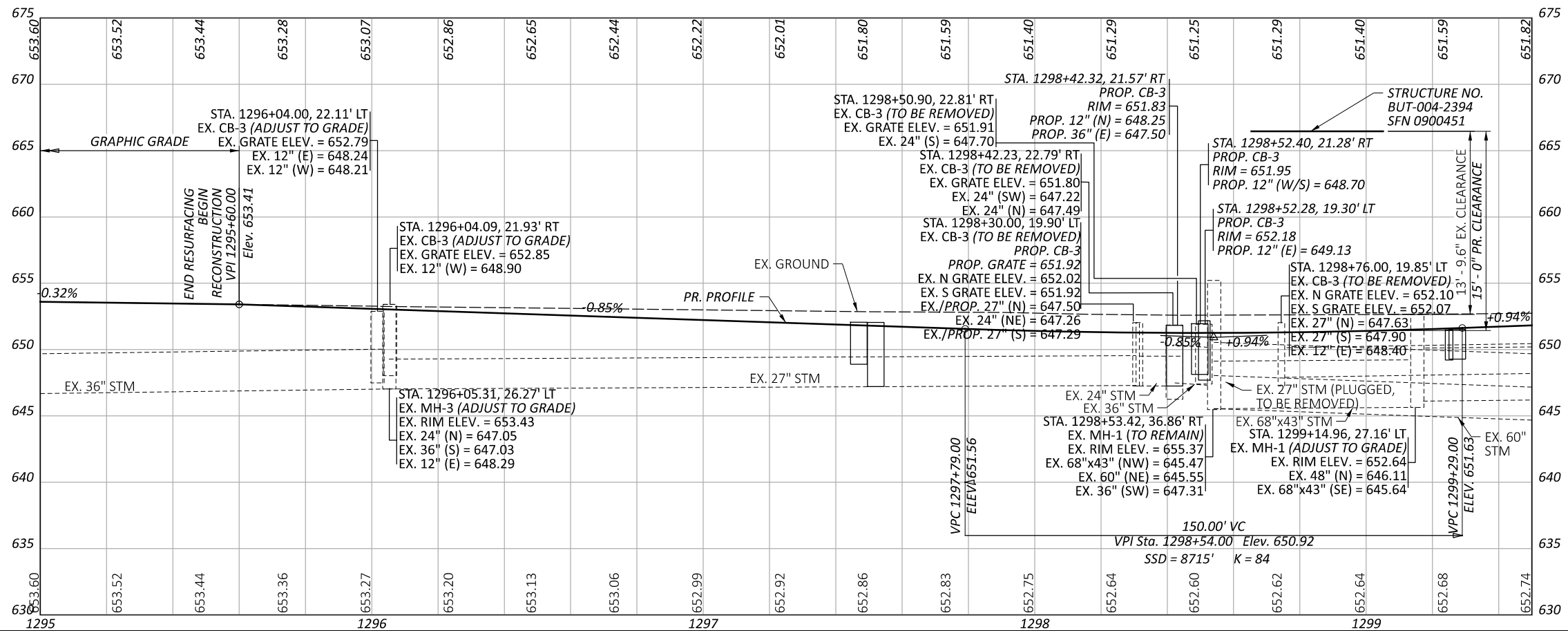
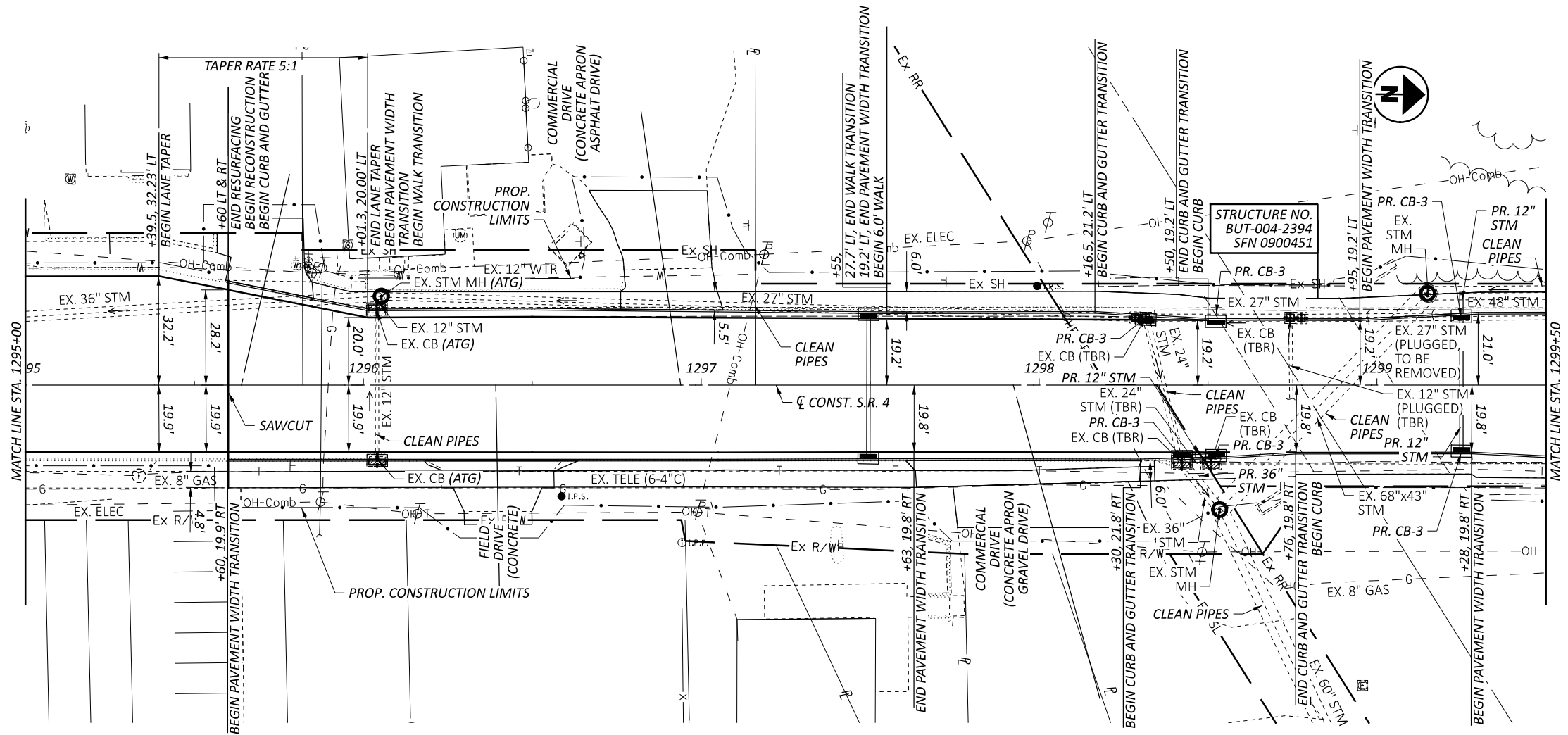

PLAN AND PROFILE - 15.0' VERTICAL CLEARANCE
S.R. 4 - BEGIN TO STA 1299+50.00

DESIGN AGENCY



| | |
|------------|----------------|
| DESIGNER | SAF |
| REVIEWER | CWP 04-29-2024 |
| PROJECT ID | 117275 |
| SHEET | P.2 |
| TOTAL | 3 |

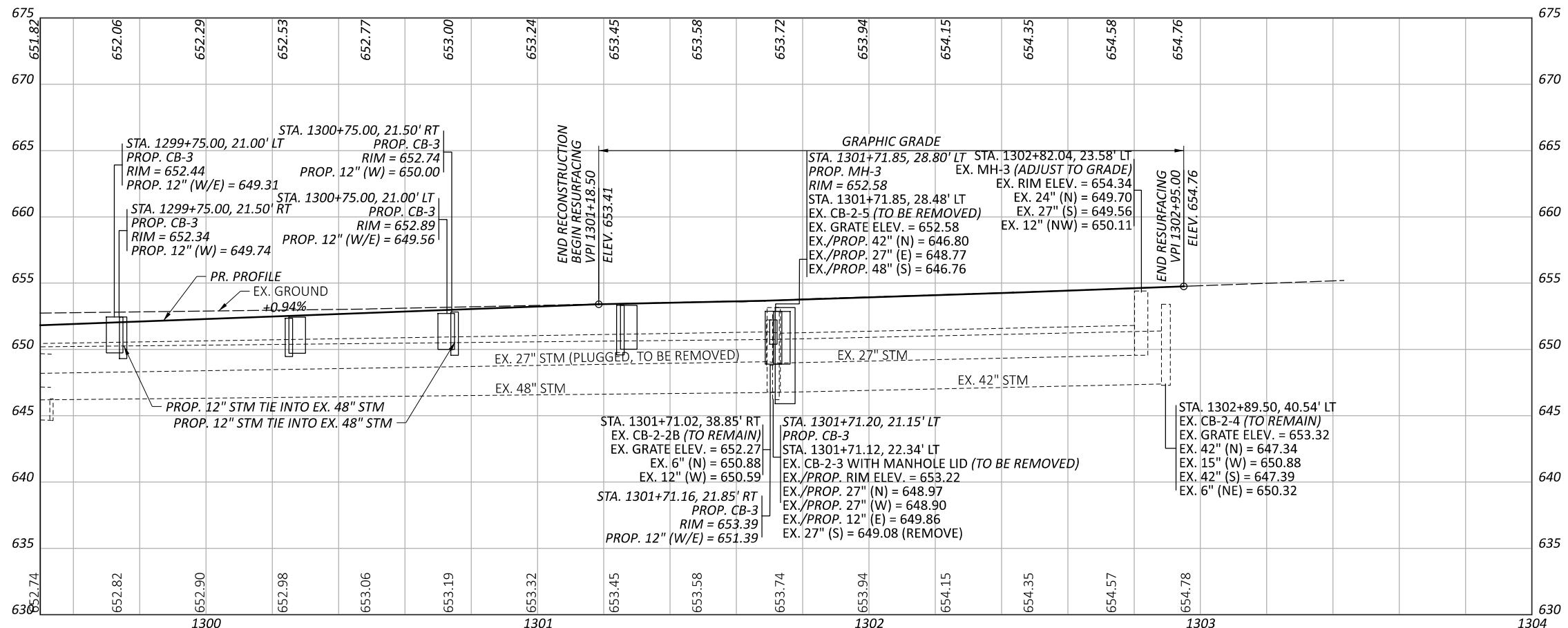
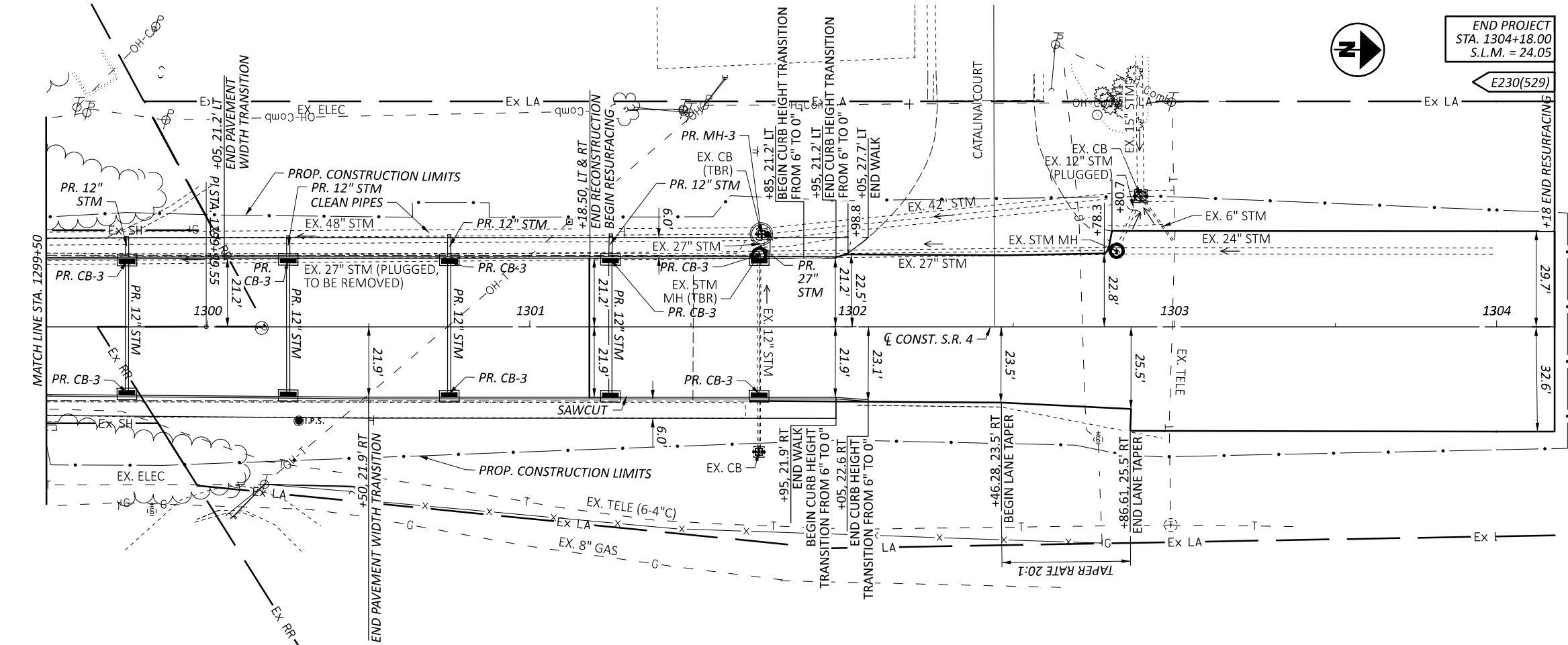

PLAN AND PROFILE - 15.0' VERTICAL CLEARANCE
 S.R. 4 - STA. 1299+50.00 TO END

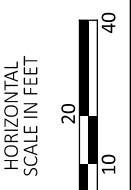

DESIGN AGENCY



DESIGNER
 SAF

REVIEWER
 CWP 04-29-2024

PROJECT ID
 117275

SHEET TOTAL
 P.3 3

Appendix D

BUT-4 Representative Typical Sections

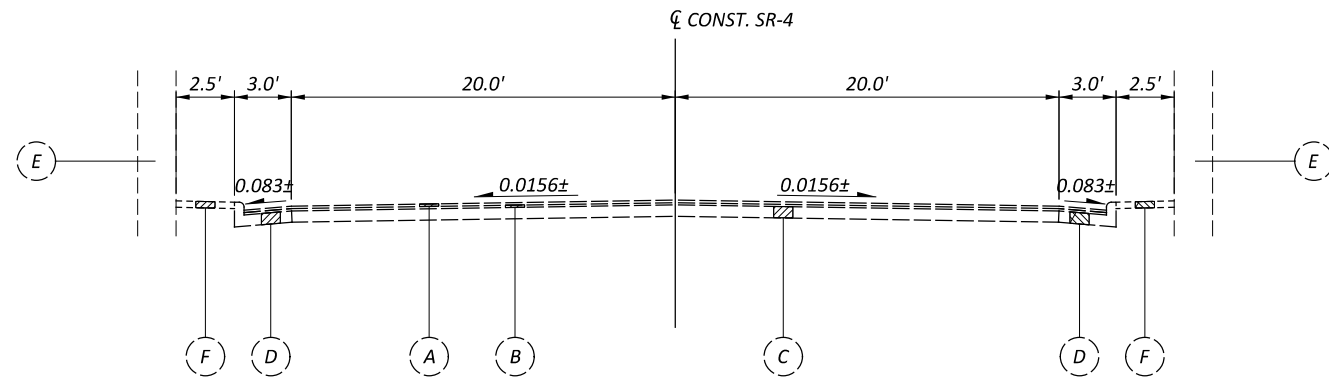

EXISTING REPRESENTATIVE NORMAL SECTION: SR-4

STA. 1298+85.23 (UNDER RAILROAD BRIDGE)

EXISTING LEGEND

- (A) 1.5" ASPHALT CONCRETE SURFACE COURSE
- (B) 1.5" ASPHALT CONCRETE INTERMEDIATE COURSE
- (C) 7" REINFORCED CONCRETE PAVEMENT
- (D) COMBINATION CURB AND GUTTER, TYPE 2 (MODIFIED, 3' WIDE)
- (E) BRIDGE ABUTMENT
- (F) 4" CONCRETE WALK

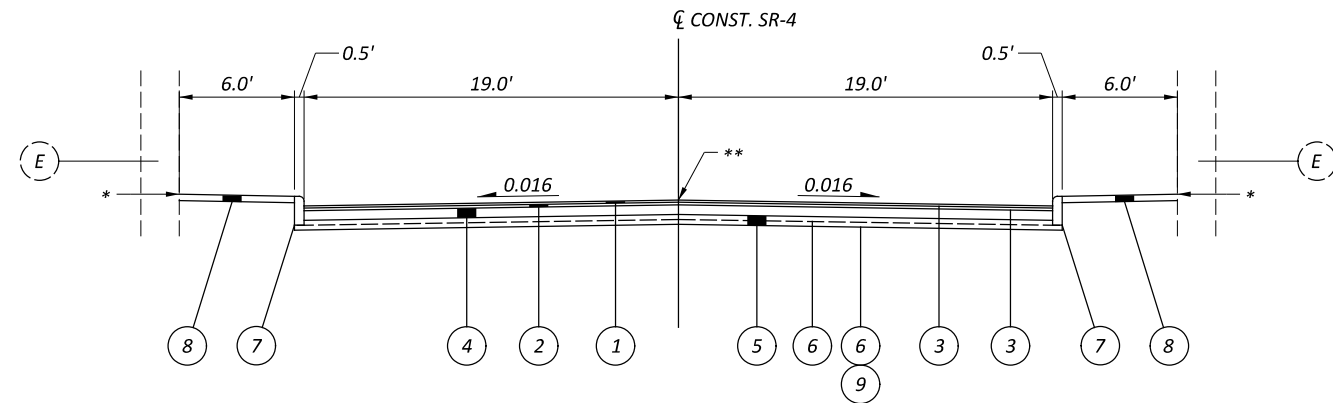

PROPOSED REPRESENTATIVE NORMAL SECTION: SR-4

STA. 1298+85.23 (UNDER RAILROAD BRIDGE)

PROPOSED LEGEND

- (1) ITEM 441 - 1.25" ASPHALT CONCRETE SURFACE COURSE, TYPE 1 (448), PG64-22
- (2) ITEM 441 - 1.75" ASPHALT CONCRETE INTERMEDIATE COURSE, TYPE 2, (448)
- (3) ITEM 407 - NON-TRACKING TACK COAT (0.055 GAL/SY)
- (4) ITEM 301 - 6" ASPHALT CONCRETE BASE, PG64-22 (449)
- (5) ITEM 304 - 6" AGGREGATE BASE
- (6) ITEM 204 - GEOGRID
- (7) ITEM 609 - CURB, TYPE 6
- (8) ITEM 608 - 4" CONCRETE WALK
- (9) ITEM 204 - PROOF ROLLING

* MATCH EXISTING TOP OF SIDEWALK ELEVATION

** PROPOSED IS 0.24' LOWER THAN EXISTING IN 14.0' OPTION, 0.8' LOWER THAN EXISTING IN 14.5' OPTION AND 1.3' LOWER THAN EXISTING IN 15.0' OPTION

DESIGN AGENCY



DESIGNER

CJD

REVIEWER

CWP 04-25-24

PROJECT ID

117275

SHEET TOTAL

P.1 | 1

Appendix E

BUT-4 Critical Cross Sections

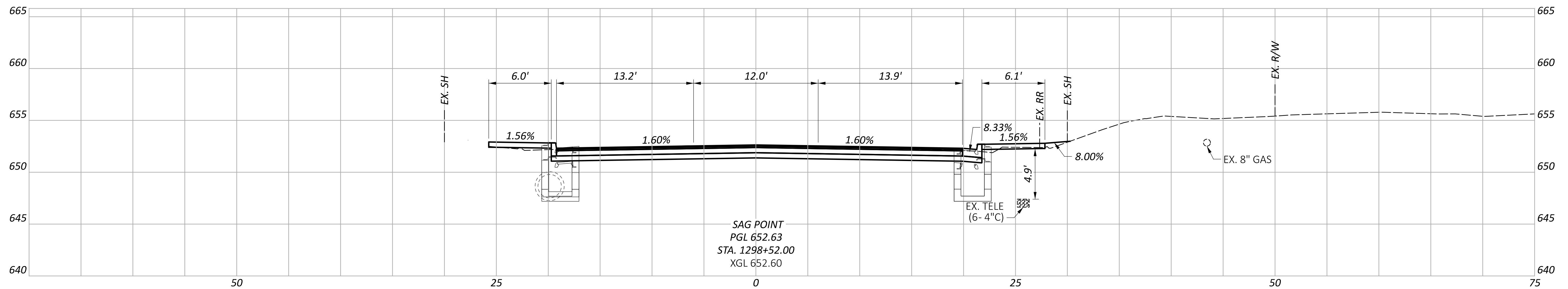
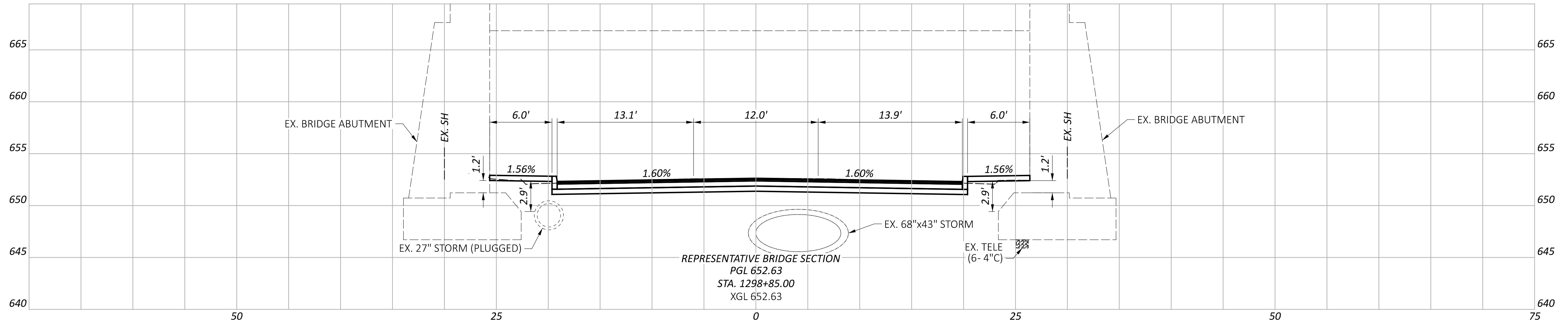
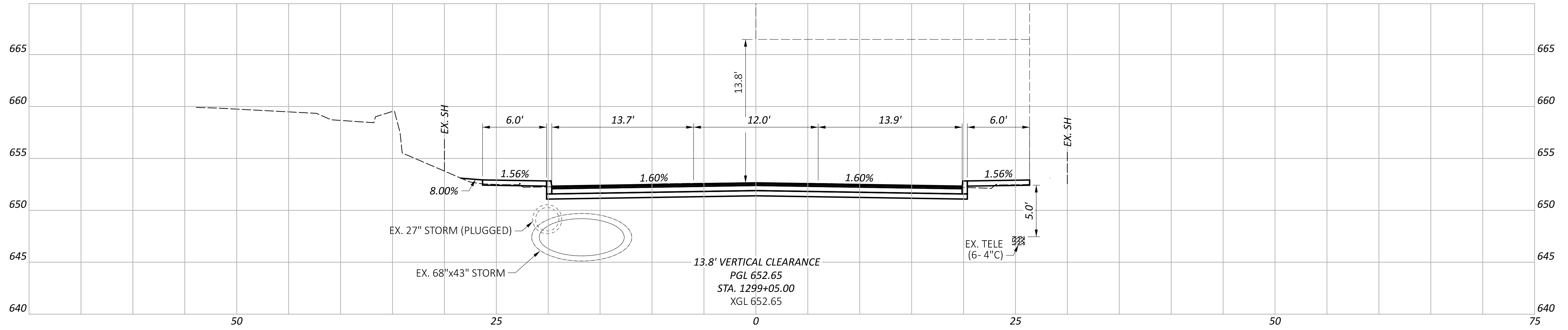

CROSS SECTIONS - SR 4- 13.8' (EX) CLEARANCE
STA. 1298+52.00, STA. 1298+85.00 AND STA. 1299+05.00

DESIGN AGENCY



CHAGRIN VALLEY
ENGINEERING, LTD.

DESIGNER
SAF

REVIEWER
CWP 04-29-2024

PROJECT ID
117275

SHEET TOTAL
P.1 3

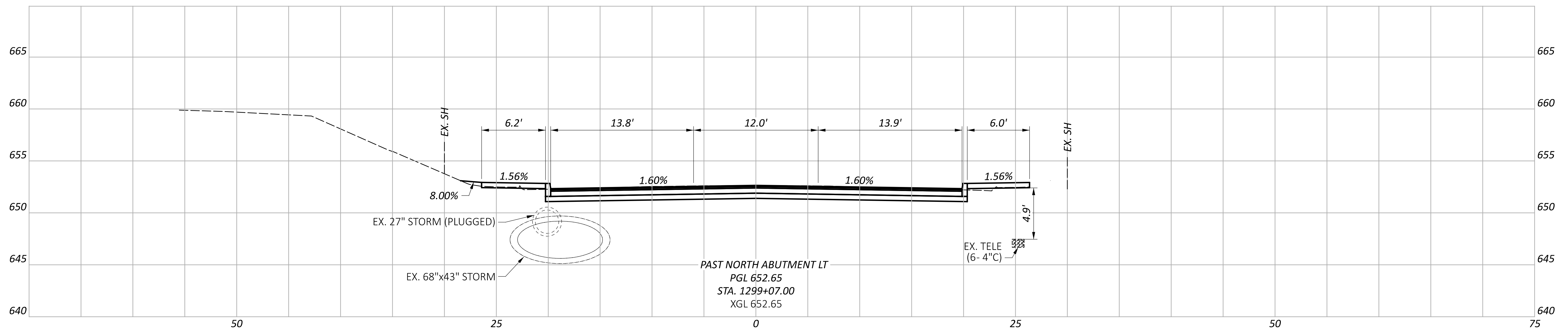
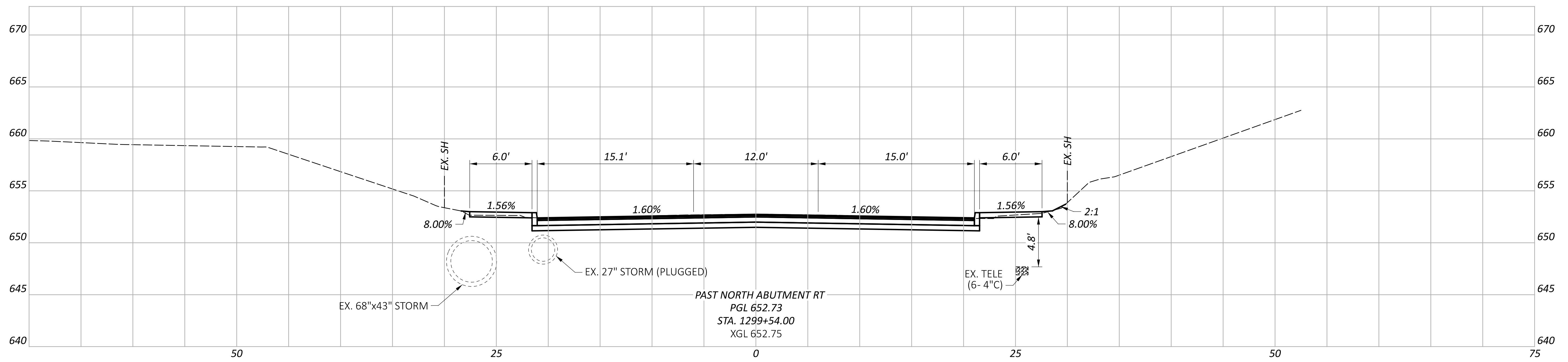

CROSS SECTIONS - SR 4 - 13.8' (EX) CLEARANCE
STA. 1299+07.00 AND STA. 1299+54.00

DESIGN AGENCY



DESIGNER
SAF

REVIEWER
CWP 04-29-2024

PROJECT ID
117275

SHEET TOTAL
P.2 3

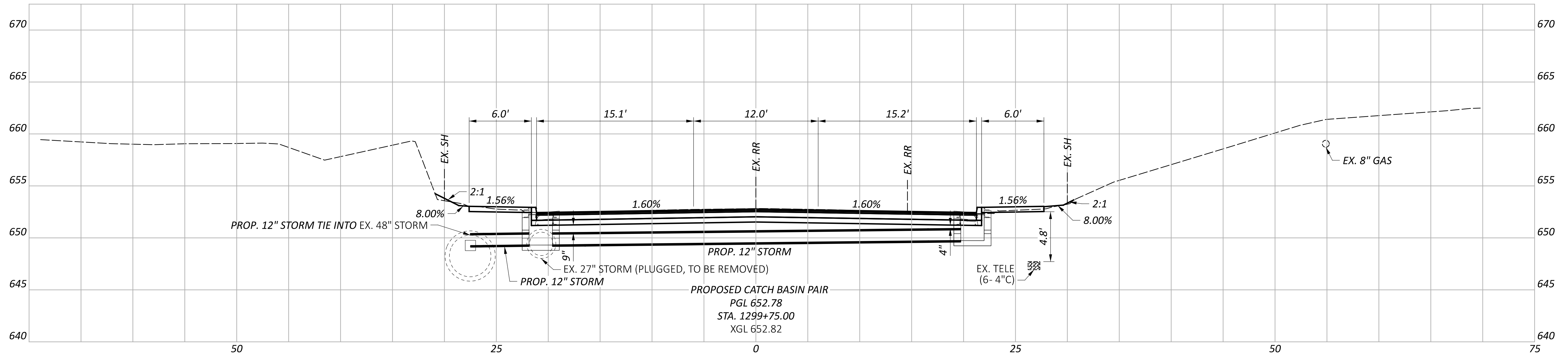

DESIGN AGENCY



DESIGNER
SAF

REVIEWER
CWP 04-29-2024

PROJECT ID
117275

| | |
|-------|-------|
| SHEET | TOTAL |
| P.3 | 3 |

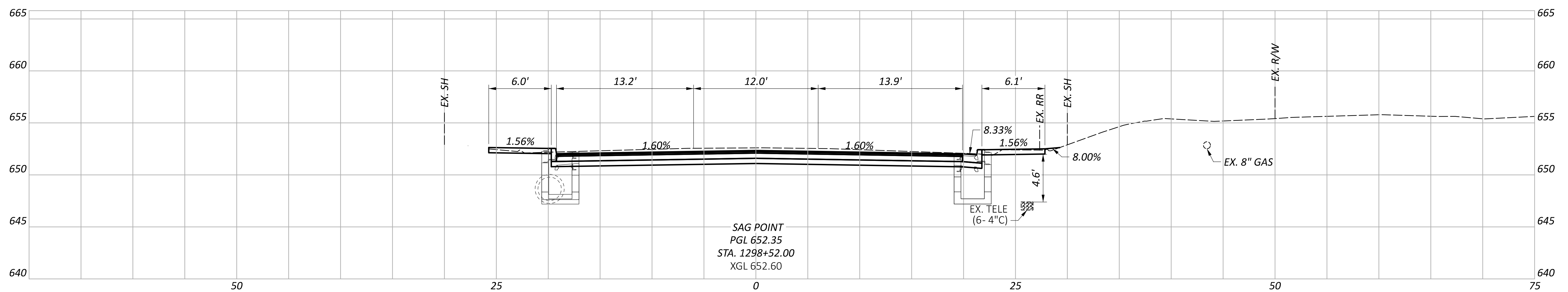
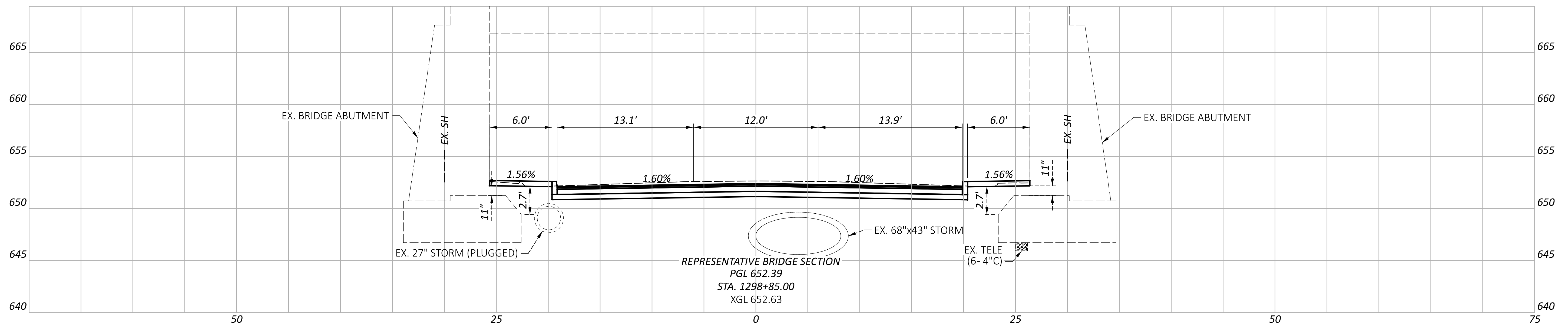
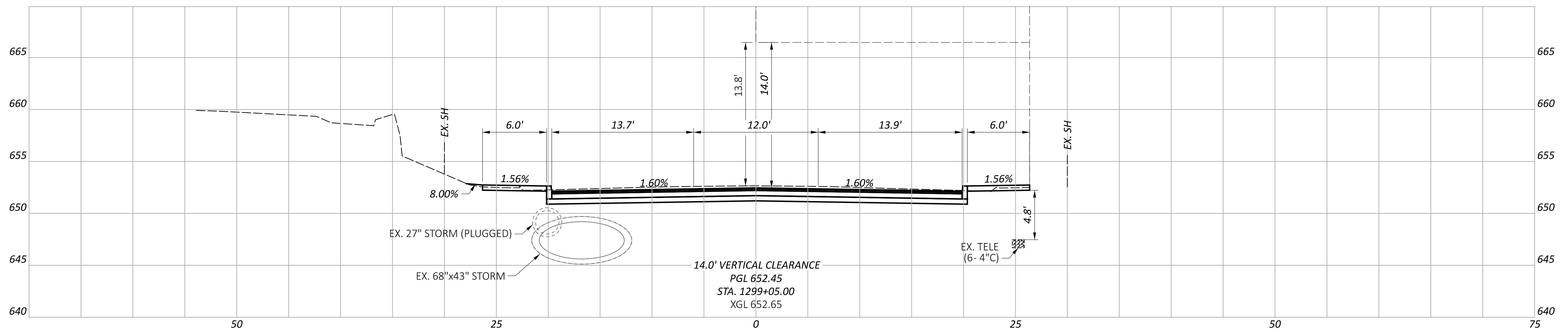

CROSS SECTIONS - SR 4 - 14.0' CLEARANCE
STA. 1298+52.00, STA. 1298+85.00 AND STA. 1299+05.00

DESIGN AGENCY



DESIGNER

SAF

REVIEWER

CWP 04-29-2024

PROJECT ID

117275

SHEET TOTAL

P.1 3

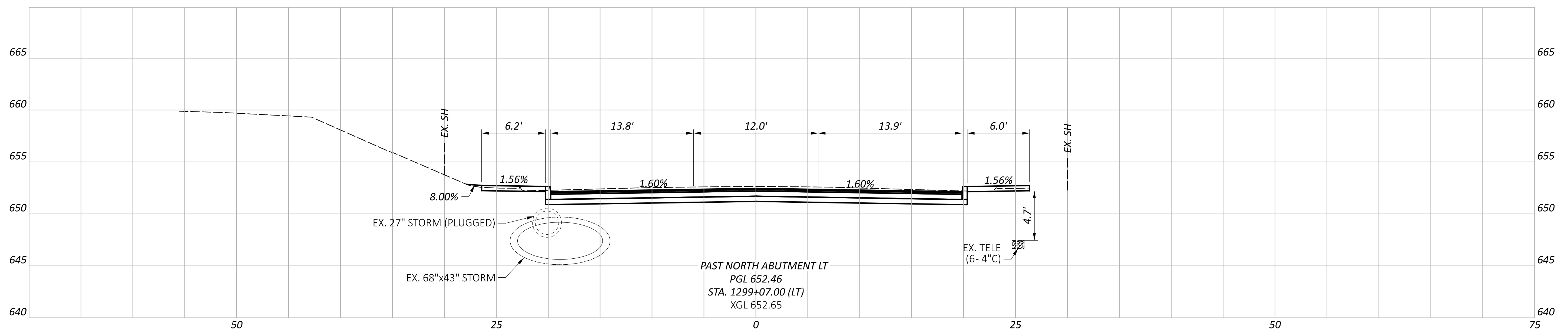
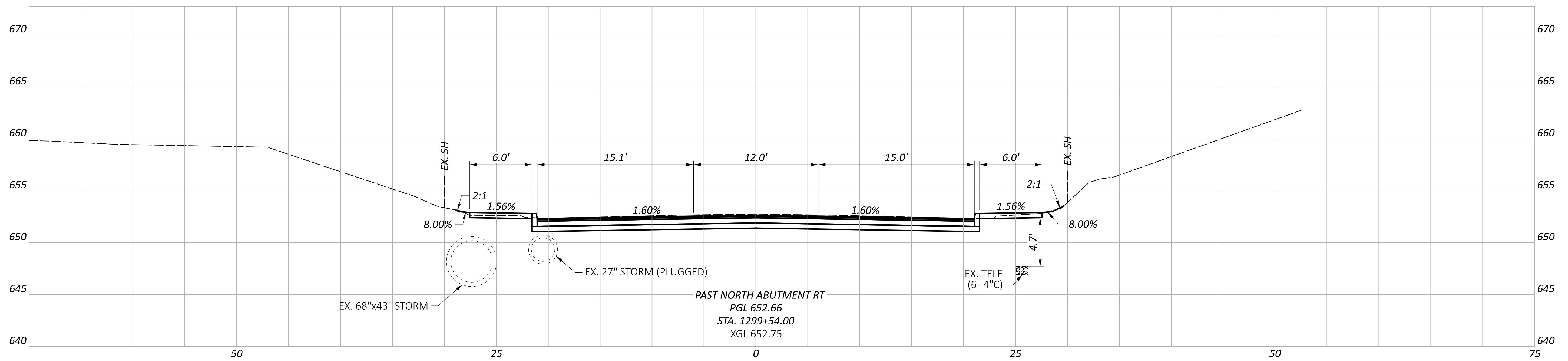

CROSS SECTIONS - SR 4 - 14.0' CLEARANCE
STA. 1299+07.00 AND STA. 1299+54.00

DESIGN AGENCY



DESIGNER
SAF

REVIEWER
CWP 04-29-2024

PROJECT ID
117275

SHEET TOTAL
P.2 3

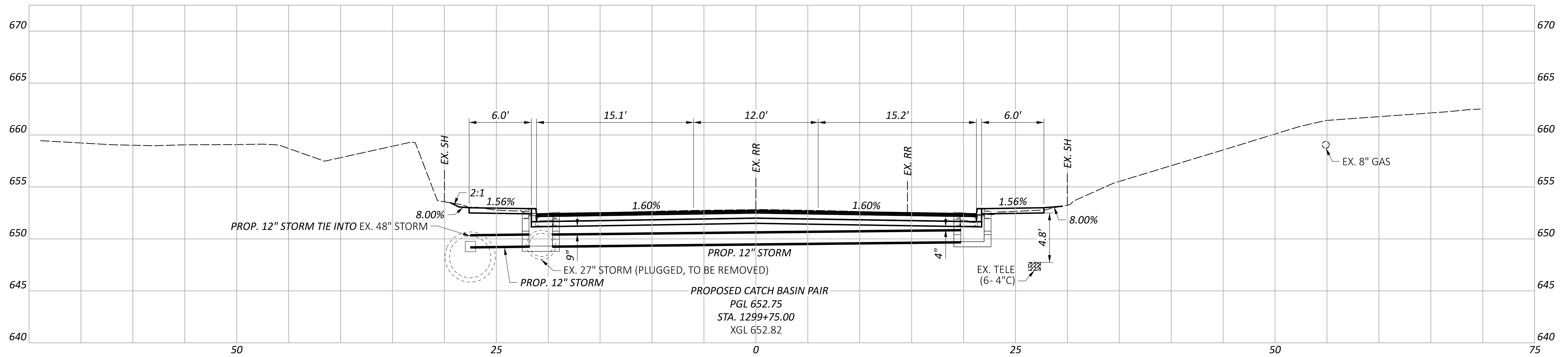

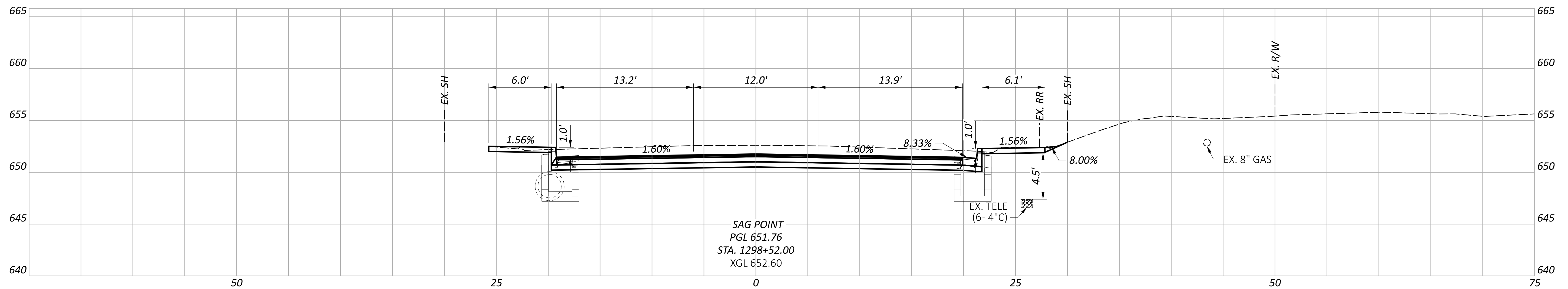
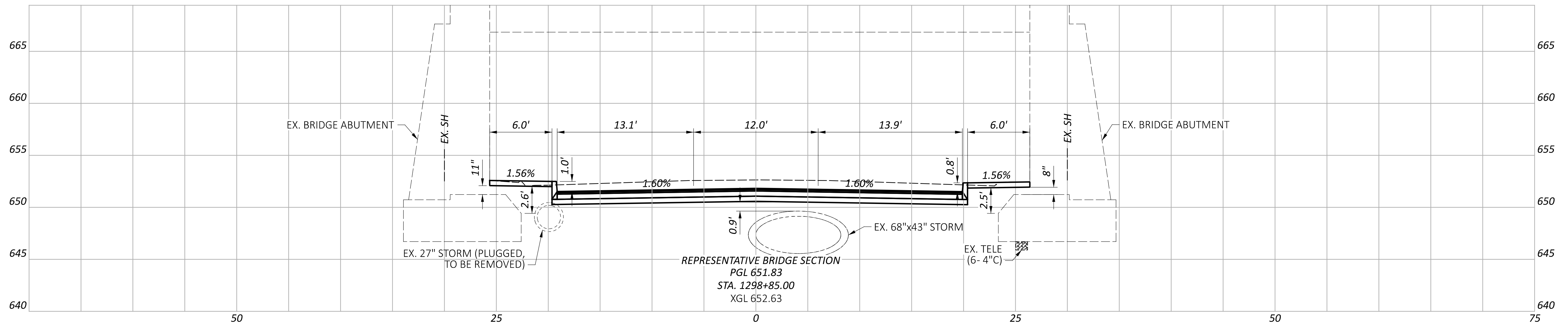
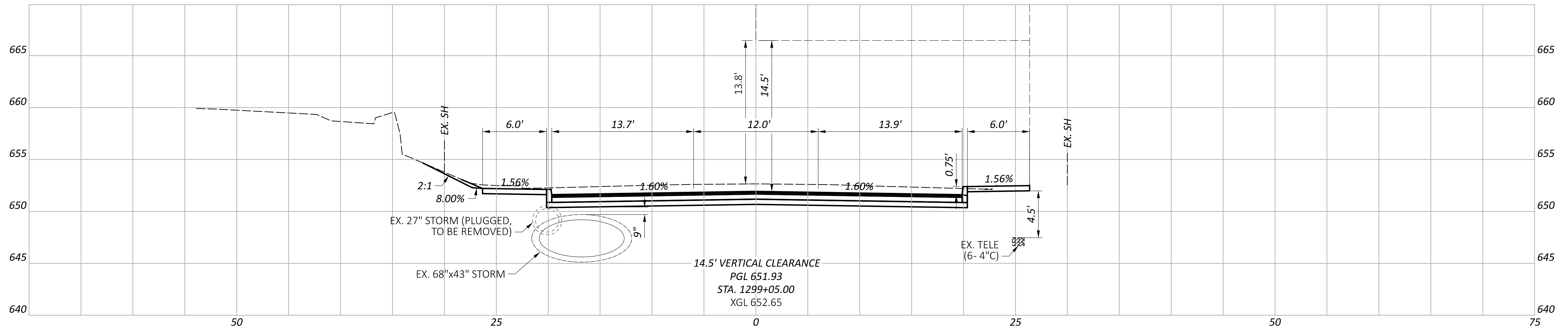

CROSS SECTIONS - SR 4 - 14.5' CLEARANCE
STA. 1298+52.00, STA. 1298+85.00 AND STA. 1299+05.00

DESIGN AGENCY



DESIGNER
SAF

REVIEWER
CWP 04-29-2024

PROJECT ID
117275

SHEET TOTAL
P.1 3

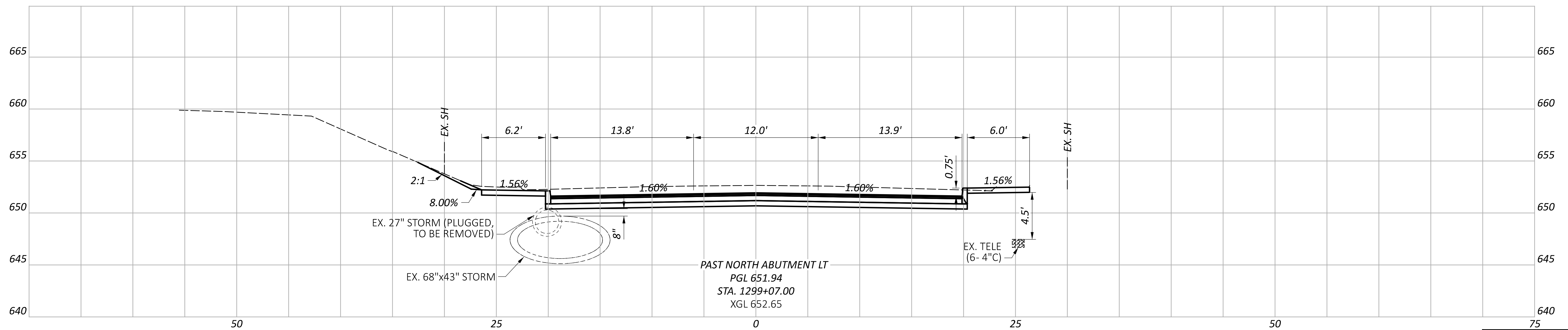
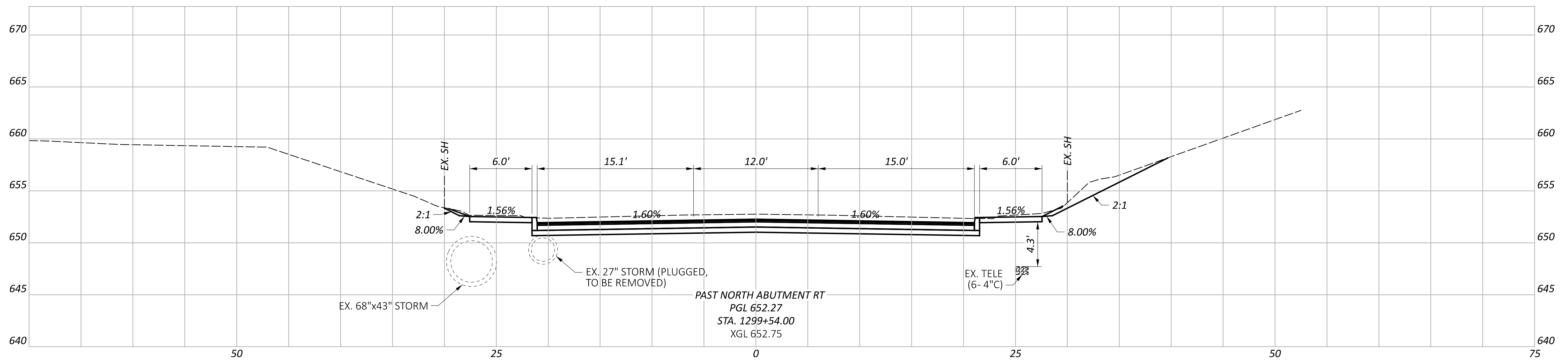

CROSS SECTIONS - SR 4 - 14.5' CLEARANCE
 STA. 1299+07.00 AND 1299+54.00

DESIGN AGENCY



DESIGNER

SAF

REVIEWER

CWVP 04-29-2024

PROJECT ID

117275

Sheet Totals

| | | |
|---------|-----|------|
| Seeding | Cut | Fill |
| | | |

SHEET TOTAL

| | |
|-----|---|
| P.2 | 3 |
|-----|---|

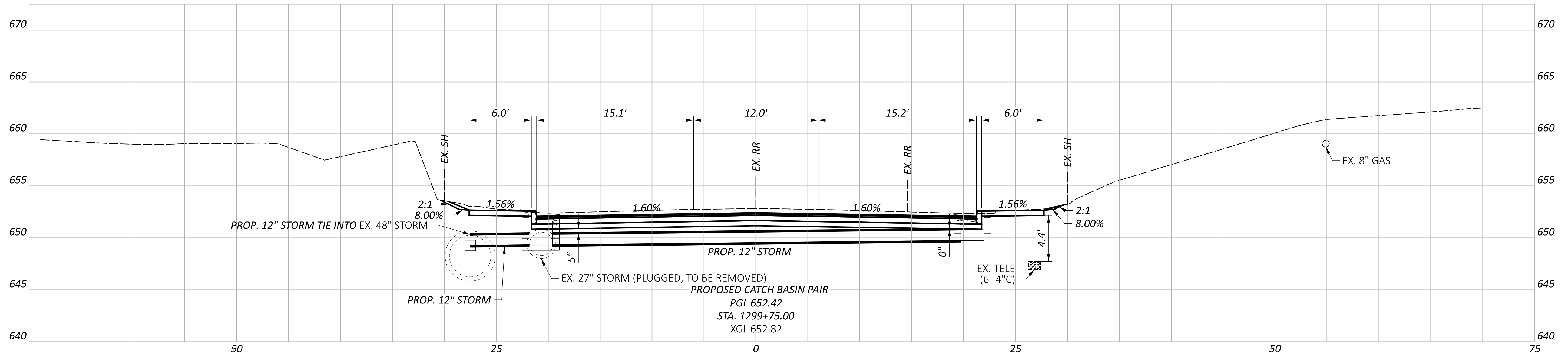

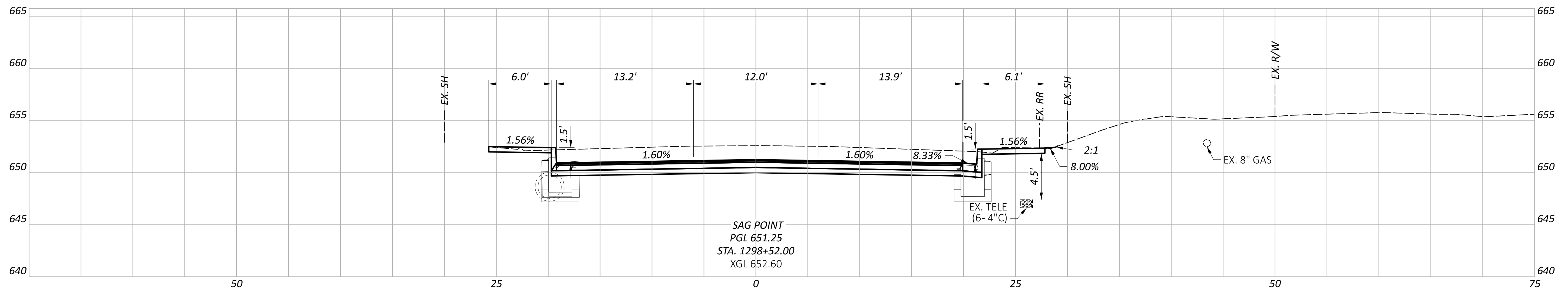
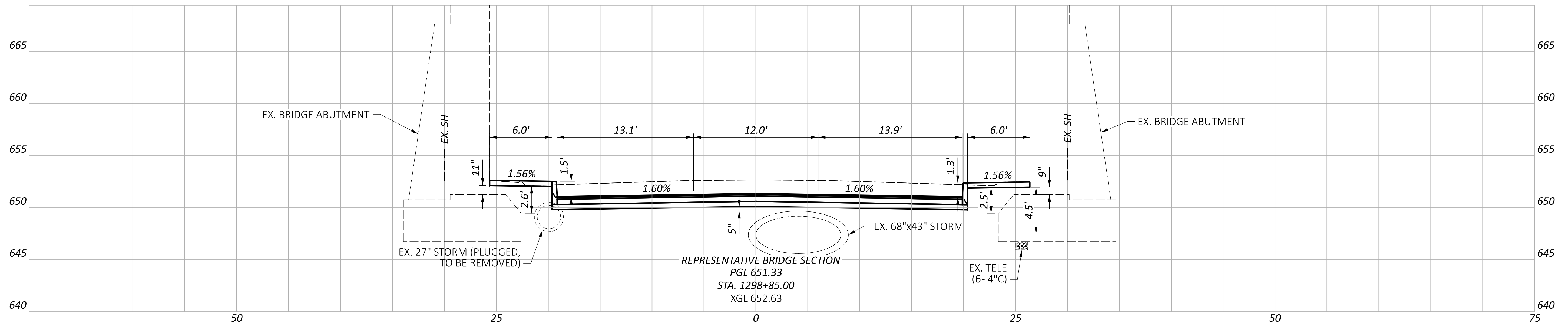
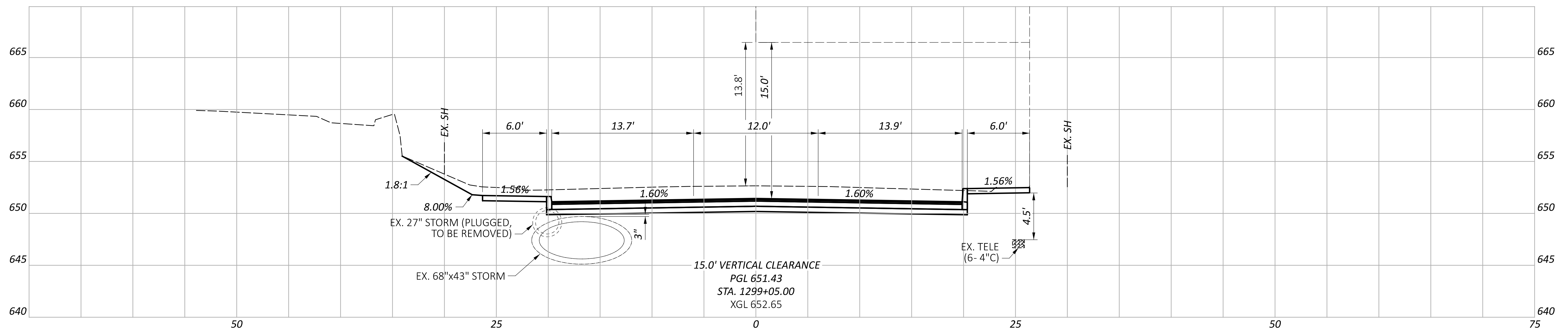

CROSS SECTIONS - SR 4 - 15.0' CLEARANCE
 STA. 1298+52.00, STA. 1298+85.00 AND STA. 1299+05.00

| | |
|-------------------------------------|--------|
| DESIGN AGENCY | |
| | |
| CHAGRIN VALLEY ENGINEERING, LTD. | |
| DESIGNER | SAF |
| REVIEWER | |
| PROJECT ID | 117275 |
| SHEET | TOTAL |
| P.1 | 3 |

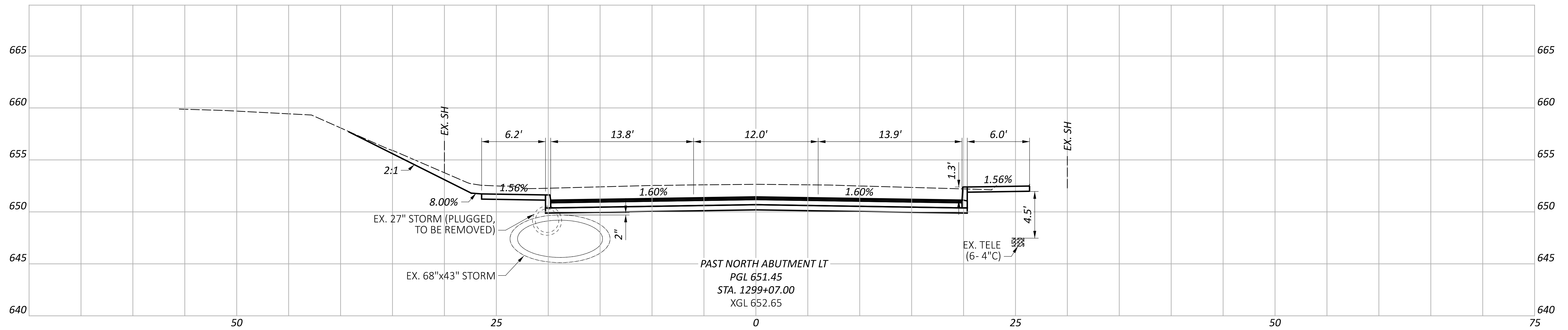
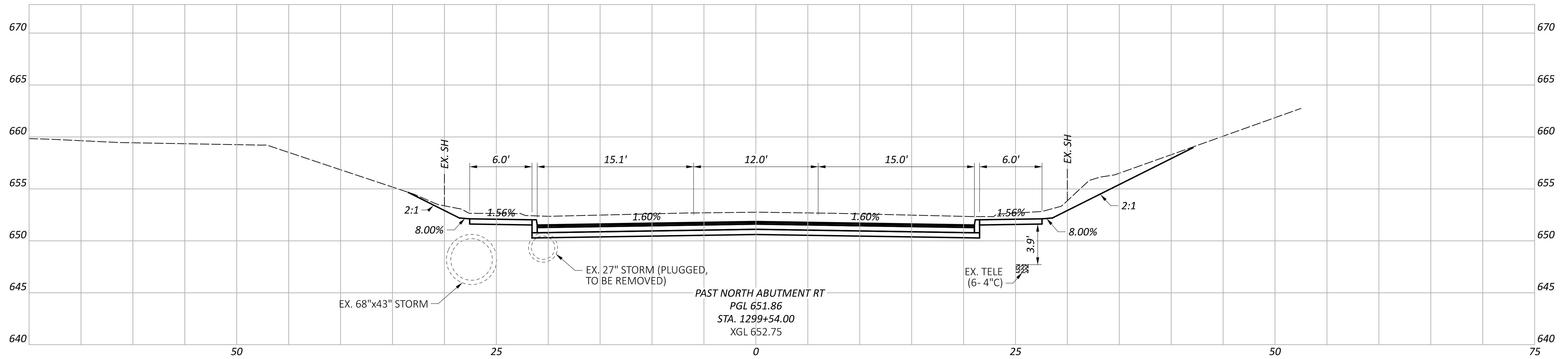

CROSS SECTIONS - SR 4 - 15.0' CLEARANCE
 STA. 1299+07.00 AND STA. 1299+54.00

DESIGN AGENCY



DESIGNER
 SAF

REVIEWER
 CWP 04-29-2024

PROJECT ID
 117275

| | |
|-------|-------|
| SHEET | TOTAL |
| P.2 | 3 |

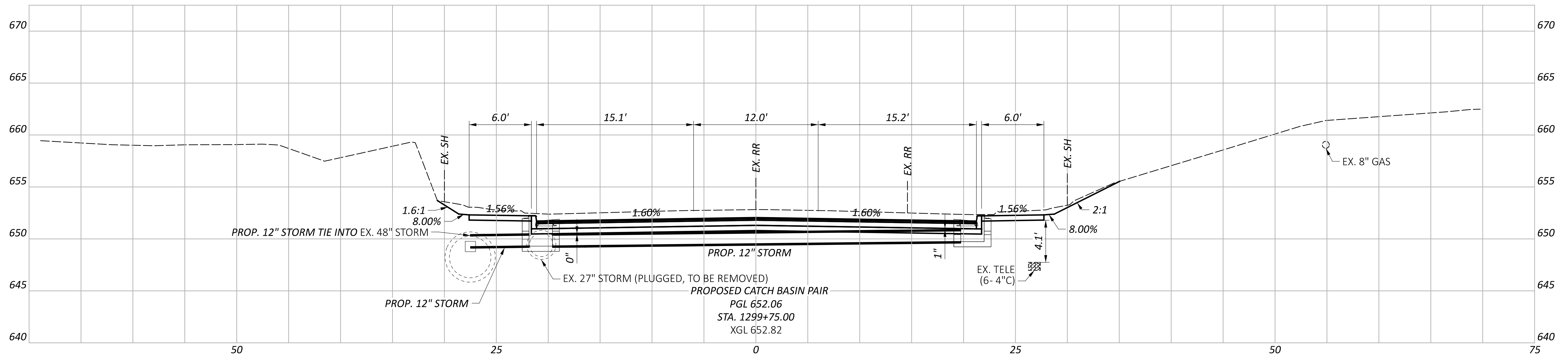

Appendix F

BUT-4 Drive Profiles

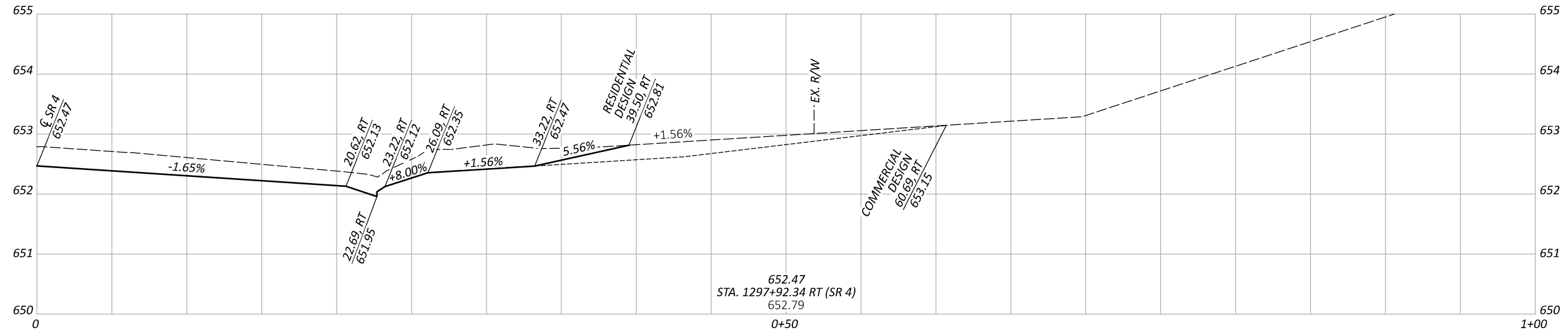

DRIVE PROFILES - SR 4
 14.0' ALTERNATIVE

DESIGN AGENCY



DESIGNER
 SAF

REVIEWER
 CWP 04-29-2024

PROJECT ID
 117275

| | |
|-------|-------|
| SHEET | TOTAL |
| P.1 | 4 |

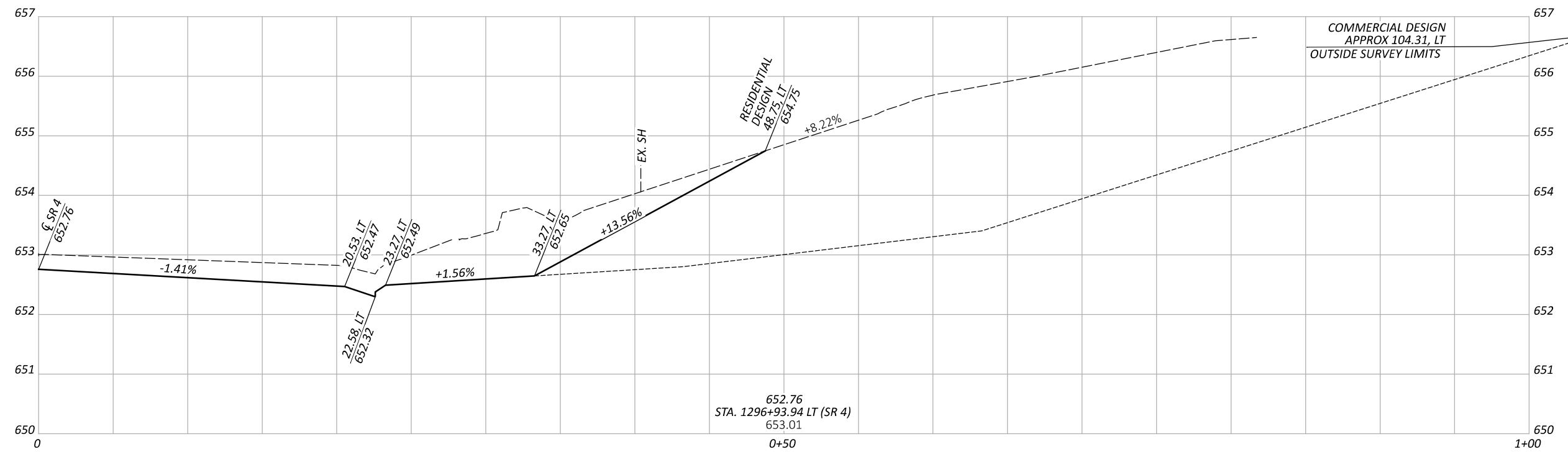
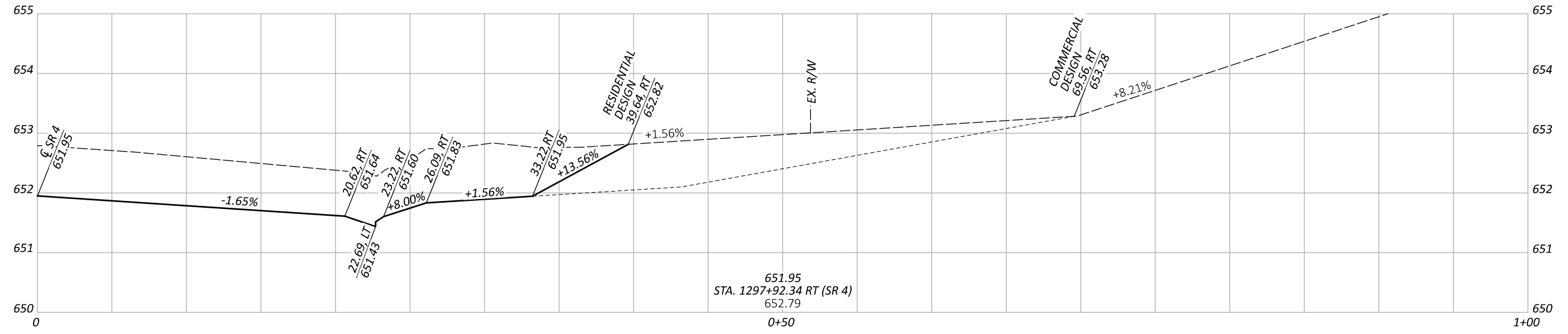

DRIVE PROFILES - SR 4
 14.5' ALTERNATIVE

DESIGN AGENCY



DESIGNER
 SAF

REVIEWER
 CWP 04-29-2024

PROJECT ID
 117275

| | |
|-------|-------|
| SHEET | TOTAL |
| P.2 | 4 |

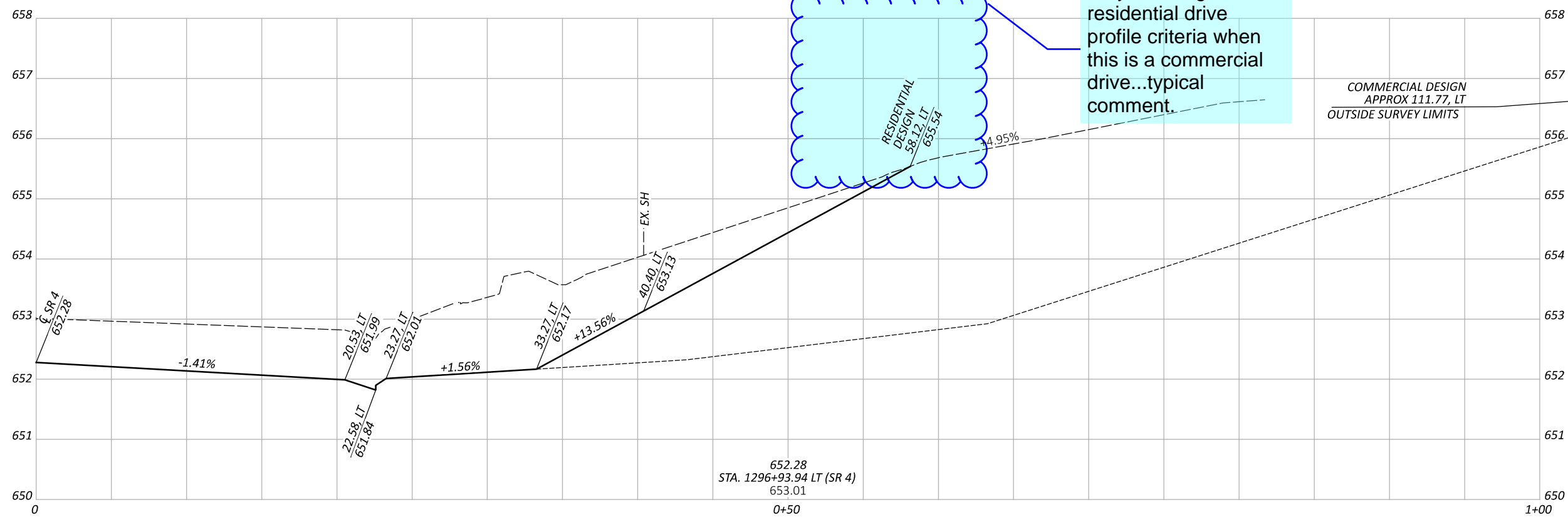
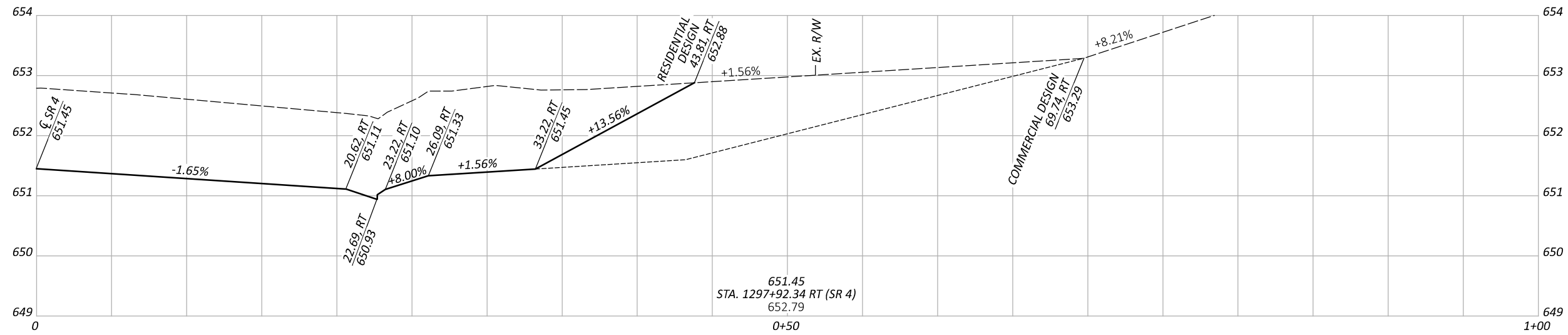

RESIDENTIAL DESIGN
 58.12 LT
 655.54

Why showing residential drive profile criteria when this is a commercial drive...typical comment.

COMMERCIAL DESIGN
 APPROX 111.77, LT
 OUTSIDE SURVEY LIMITS

BUT IR 75/VAR/5.22/VAR

MODEL: 15 [Sheet 2] PAPER SIZE: 17x11 (in.) DATE: 4/30/2024 TIME: 2:51:27 PM USER: flis
 P:\23365 - ODOT - BUT-75-5.22\117275\400-Engineering\Roadway\Sheets\117275_GD2025.dgn

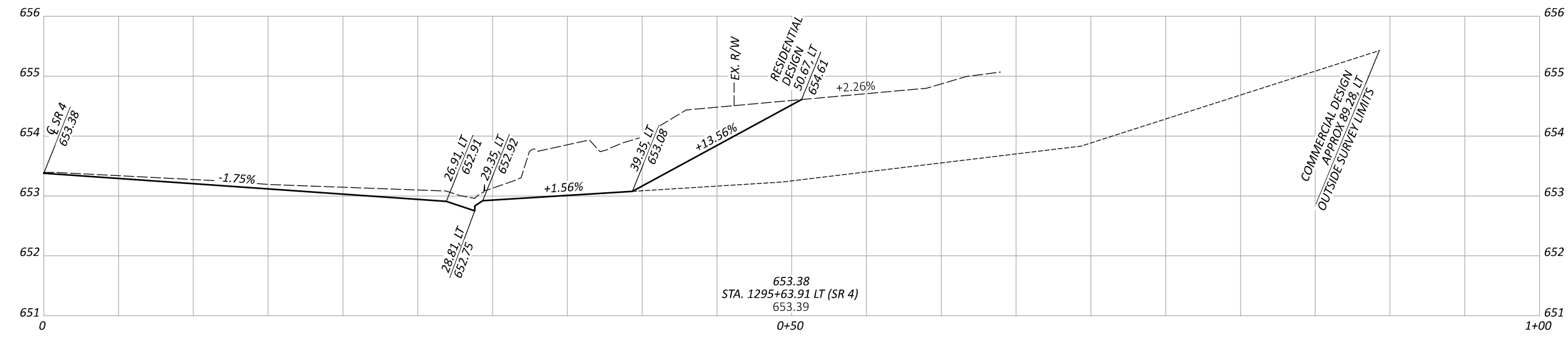
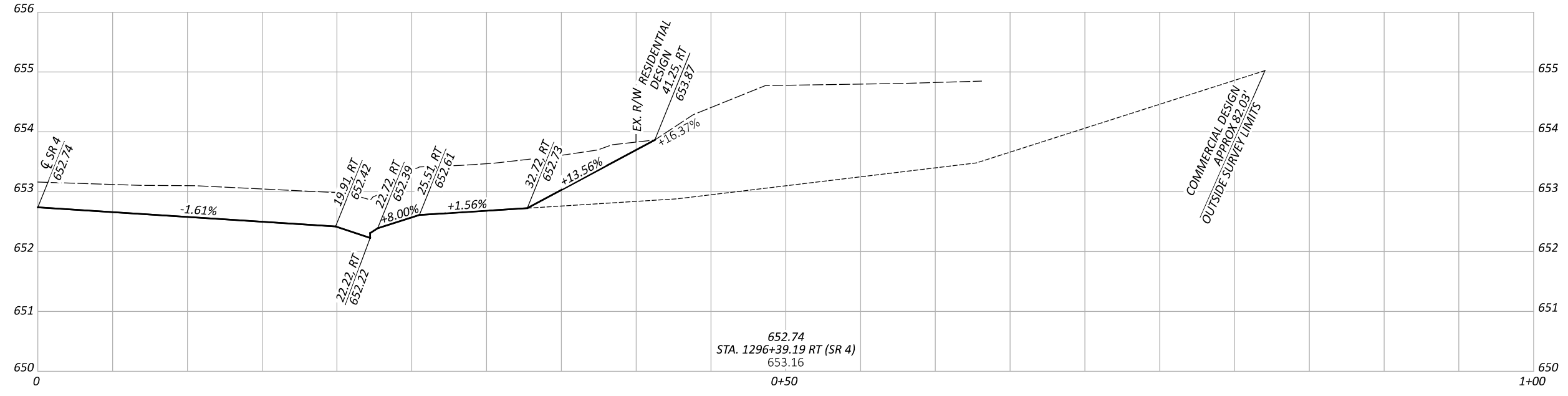

DRIVE PROFILES - SR 4
 15.0' ALTERNATIVE

DESIGN AGENCY



CHAGRIN VALLEY
 ENGINEERING, LTD.

DESIGNER
 SAF

REVIEWER
 CWP 04-29-2024





PROJECT ID
 117275





| | |
|-------|-------|
| SHEET | TOTAL |
| P.4 | 4 |

Appendix G

BUT-4 Maintenance of Traffic Schematic, Typical Sections, Detour Routes, Detour Road User Costs, Capacity Analysis, and MOT Delay & Cost Comparison

LEGEND

-  WORK ZONE
-  PAVEMENT MARKING REMOVED
-  WORK ZONE IMPACT ATTENUATOR
-  DIRECTION OF TRAFFIC
-  TYPE 3 BARRICADE WITH SIGN

-  WORK ZONE STOP LINE
-  WORK ZONE EDGE LINE, 6" (WHITE)
-  WORK ZONE DOTTED LINE, 6" (WHITE)
-  PORTABLE BARRIER, UNANCHORED

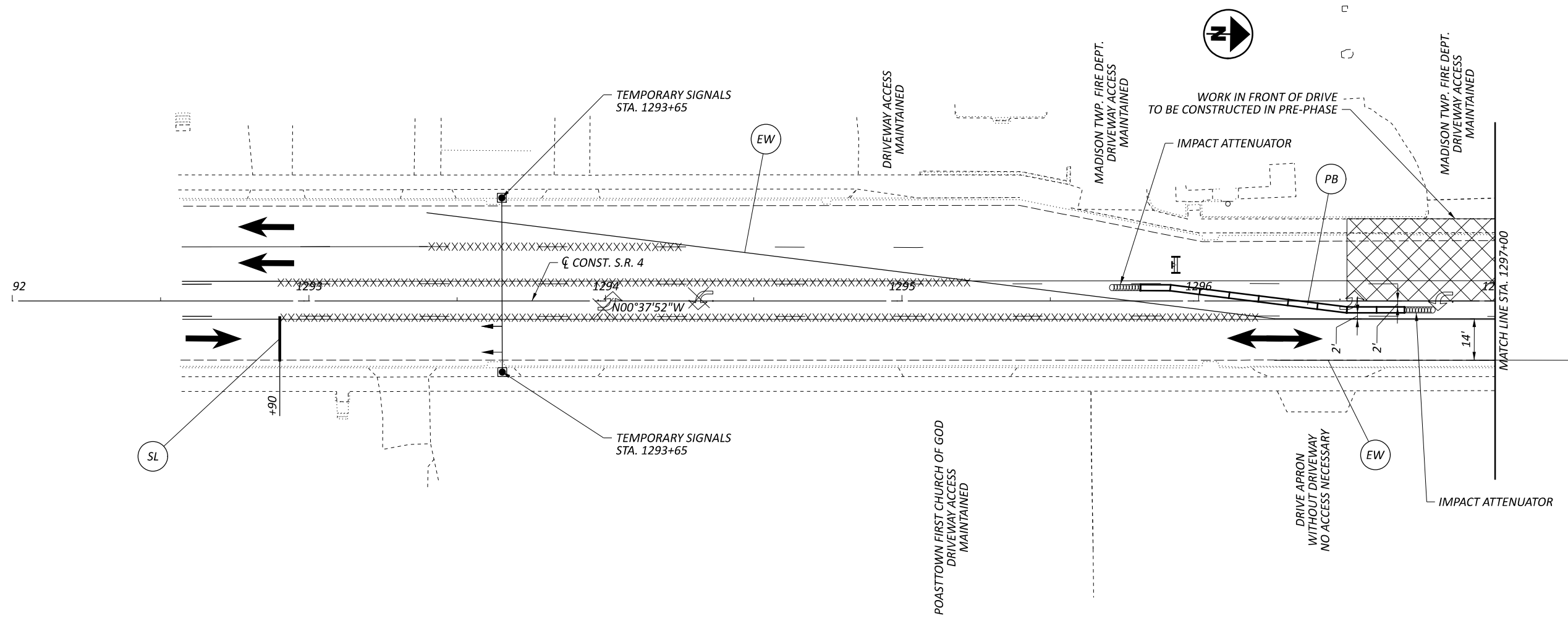

MAINTENANCE OF TRAFFIC - STAGE 1, PHASE 1 (14.5' VC OPTION)
S.R. 4 - BEGIN TO STA. 1297+00

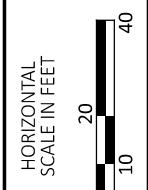

DESIGN AGENCY



DESIGNER

CJD

REVIEWER

CWP 05-01-24





PROJECT ID





117275

SHEET TOTAL

P.1 3

LEGEND

-  WORK ZONE
-  PAVEMENT MARKING REMOVED
-  WORK ZONE IMPACT ATTENUATOR
-  DIRECTION OF TRAFFIC
-  TYPE 3 BARRICADE WITH SIGN

-  SL WORK ZONE STOP LINE
-  EW WORK ZONE EDGE LINE, 6" (WHITE)
-  DW WORK ZONE DOTTED LINE, 6" (WHITE)
-  PB PORTABLE BARRIER, UNANCHORED

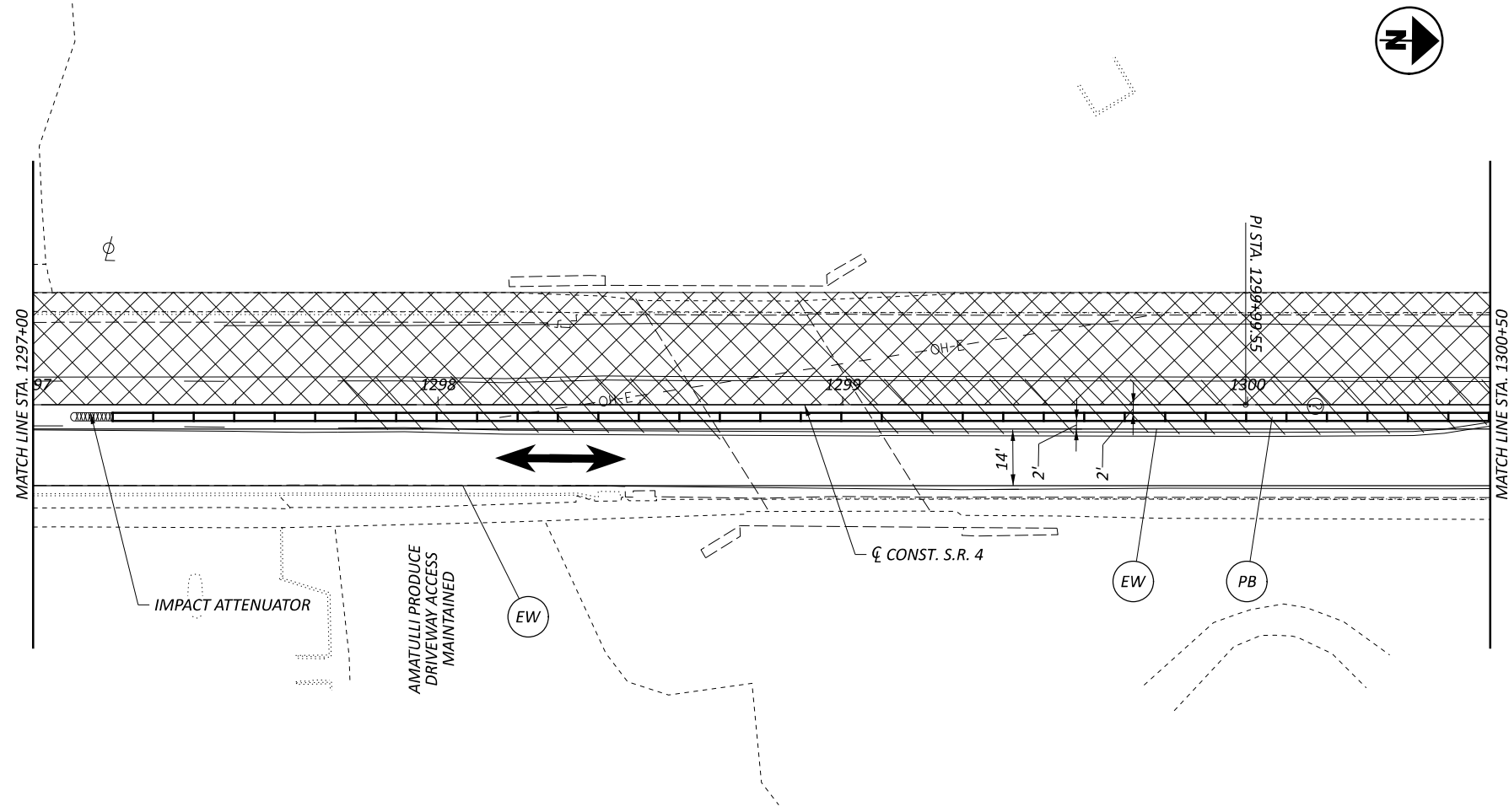

MAINTENANCE OF TRAFFIC - STAGE 1, PHASE 1 (14.5' VC OPTION)
S.R. 4 - STA. 1297+00 TO STA. 1300+50

DESIGN AGENCY



DESIGNER

CJD

REVIEWER

CWP 05-01-24

PROJECT ID

117275

SHEET TOTAL

P.2 3

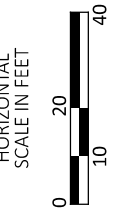

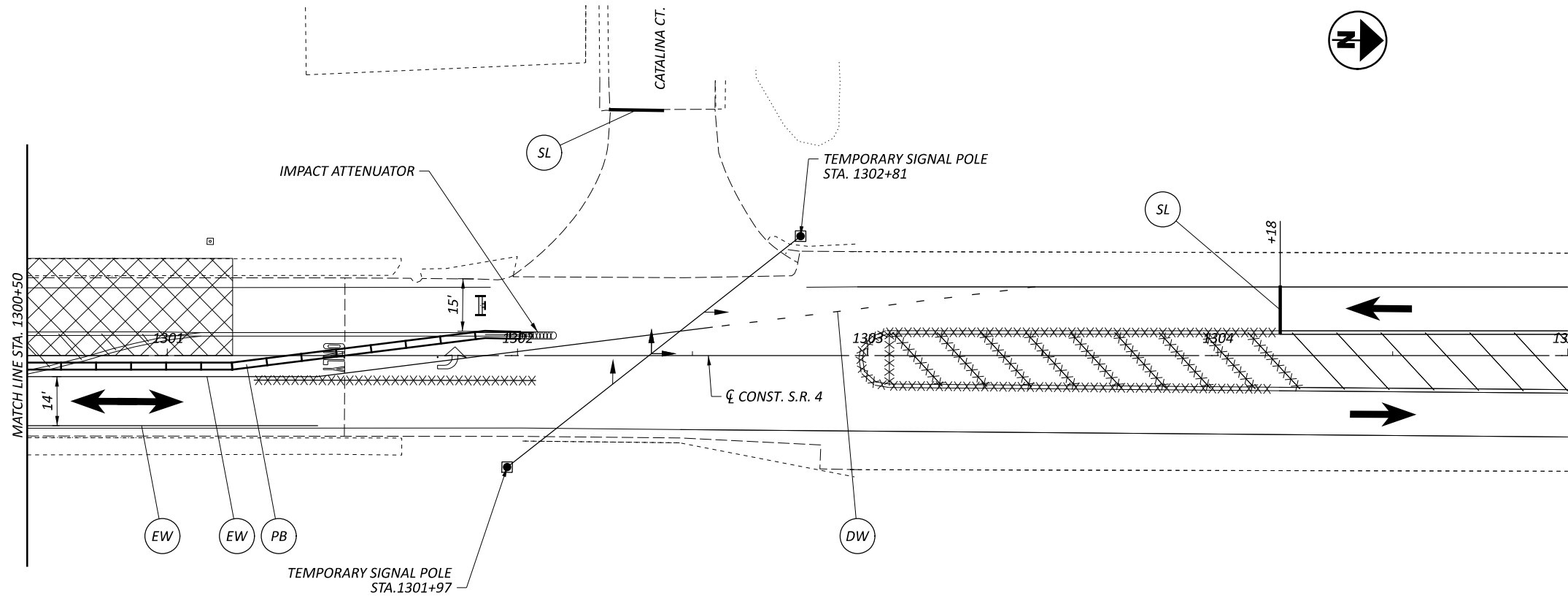

LEGEND

- WORK ZONE
- PAVEMENT MARKING REMOVED
- WORK ZONE IMPACT ATTENUATOR
- DIRECTION OF TRAFFIC
- TYPE 3 BARRICADE WITH SIGN
- WORK ZONE STOP LINE
- WORK ZONE EDGE LINE, 6" (WHITE)
- WORK ZONE DOTTED LINE, 6" (WHITE)
- PORTABLE BARRIER, UNANCHORED

MAINTENANCE OF TRAFFIC - STAGE 1, PHASE 1 (14.5' VC OPTION)
S.R. 4 - STA. 1300+50 TO END



DESIGN AGENCY







DESIGNER
 CJD







REVIEWER
 CWP 05-01-24

PROJECT ID
 117275

| | |
|-------|-------|
| SHEET | TOTAL |
| P.3 | 3 |

LEGEND

-  WORK ZONE
-  PAVEMENT MARKING REMOVED
-  WORK ZONE IMPACT ATTENUATOR
-  DIRECTION OF TRAFFIC
-  TYPE 3 BARRICADE WITH SIGN

-  SL WORK ZONE STOP LINE
-  EW WORK ZONE EDGE LINE, 6" (WHITE)
-  DW WORK ZONE DOTTED LINE, 6" (WHITE)
-  PB PORTABLE BARRIER, UNANCHORED
-  DB WORK ZONE CENTER LINE (BROKEN, SOLID)
-  LL WORK ZONE LANE LINE

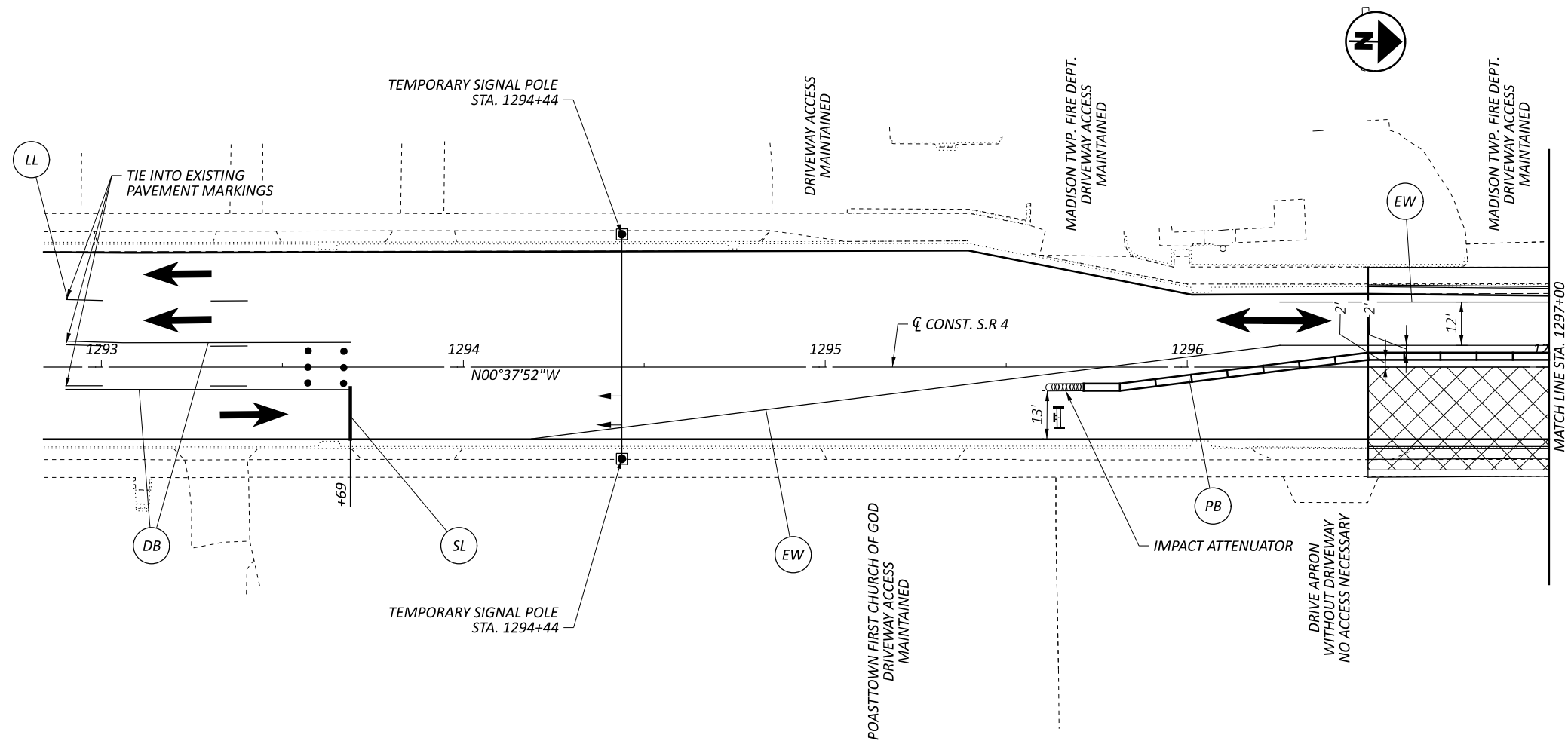

MAINTENANCE OF TRAFFIC - STAGE 1, PHASE 2 (14.5' VC OPTION)
S.R. 4 - BEGIN TO STA. 1297+00

DESIGN AGENCY



DESIGNER
CJD





REVIEWER
CWP 05-01-24







PROJECT ID
117275

SHEET TOTAL
P.1 3



LEGEND

-  WORK ZONE
-  PAVEMENT MARKING REMOVED
-  WORK ZONE IMPACT ATTENUATOR
-  DIRECTION OF TRAFFIC
-  TYPE 3 BARRICADE WITH SIGN

-  SL WORK ZONE STOP LINE
-  EW WORK ZONE EDGE LINE, 6" (WHITE)
-  DW WORK ZONE DOTTED LINE, 6" (WHITE)
-  PB PORTABLE BARRIER, UNANCHORED
-  DB WORK ZONE CENTER LINE (BROKEN, SOLID)
-  LL WORK ZONE LANE LINE

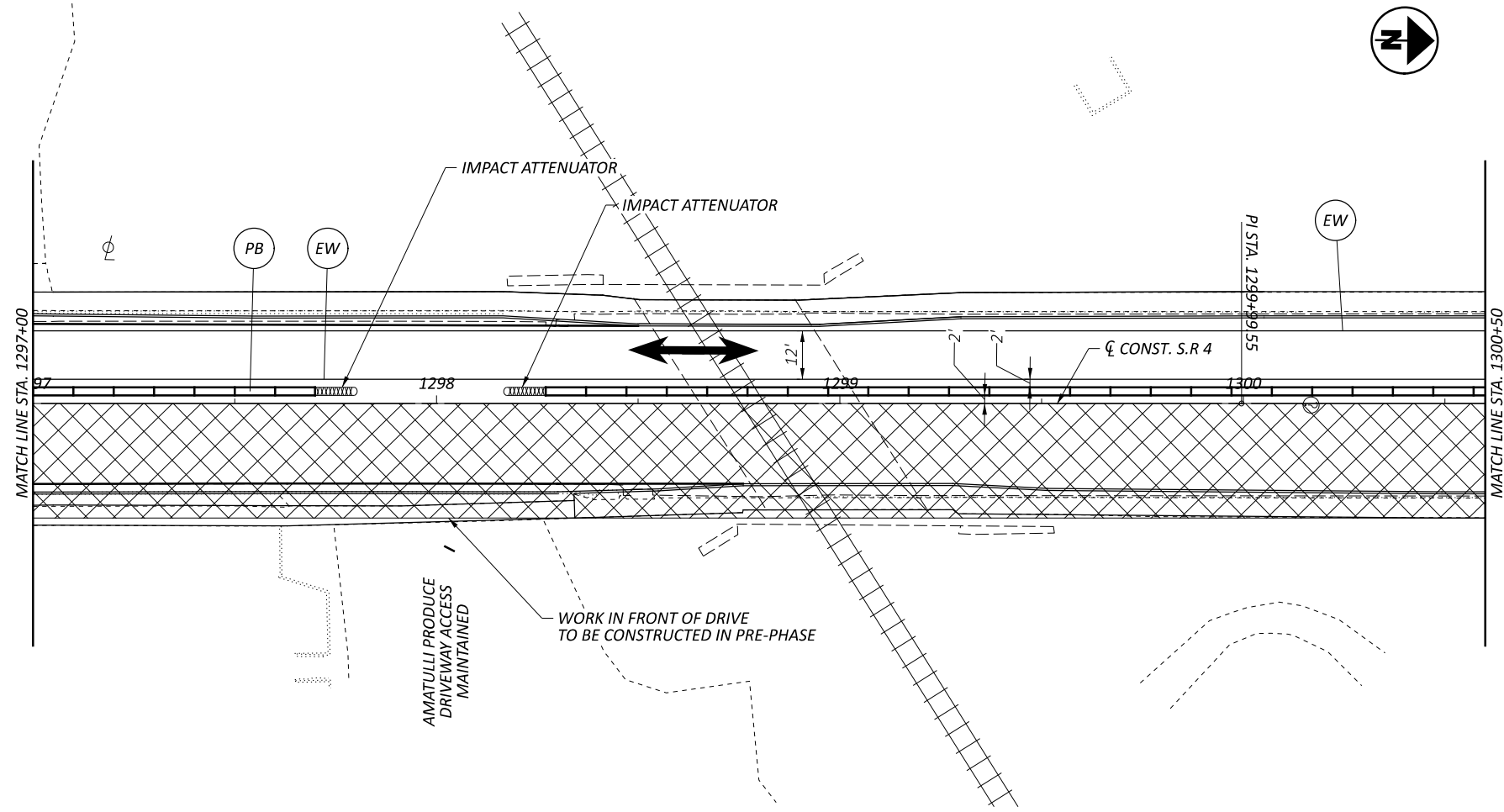

MAINTENANCE OF TRAFFIC - STAGE 1, PHASE 2 (14.5' VC OPTION)
S.R. 4 - STA. 1297+00 TO STA. 1300+50

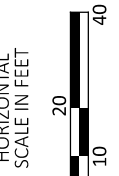

DESIGN AGENCY



DESIGNER
CJD

REVIEWER
CWP 05-01-24

PROJECT ID
117275

| | |
|-------|-------|
| SHEET | TOTAL |
| P.2 | 3 |

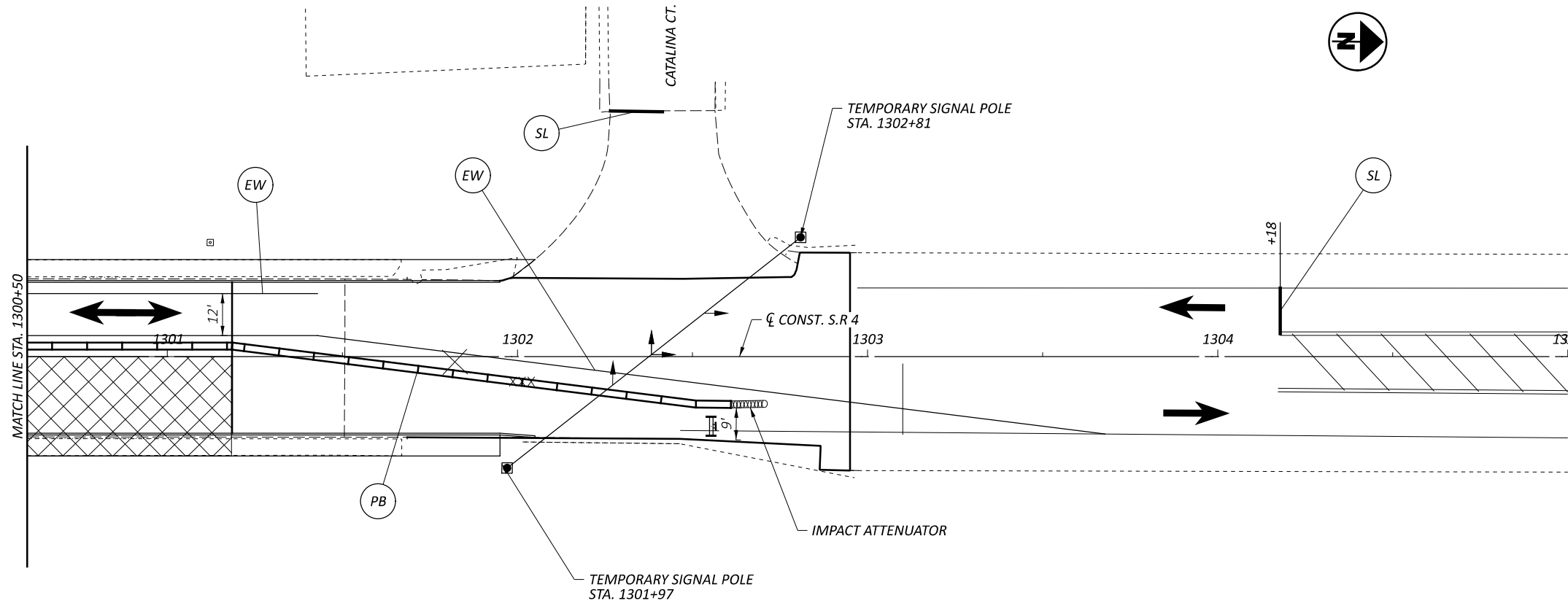

LEGEND

- WORK ZONE
- PAVEMENT MARKING REMOVED
- WORK ZONE IMPACT ATTENUATOR
- DIRECTION OF TRAFFIC
- TYPE 3 BARRICADE WITH SIGN
- SL WORK ZONE STOP LINE
- EW WORK ZONE EDGE LINE, 6" (WHITE)
- DW WORK ZONE DOTTED LINE, 6" (WHITE)
- PB PORTABLE BARRIER, UNANCHORED
- DB WORK ZONE CENTER LINE (BROKEN, SOLID)
- LL WORK ZONE LANE LINE

**MAINTENANCE OF TRAFFIC - STAGE 1, PHASE 2 (14.5' VC OPTION)
 S.R. 4 - STA. 1300+50 TO END**



DESIGN AGENCY



DESIGNER
 CJD

REVIEWER
 CWP 05-01-24

PROJECT ID
 117275

| | |
|-------|-------|
| SHEET | TOTAL |
| P.3 | 3 |

LEGEND

▨ - WORK AREA

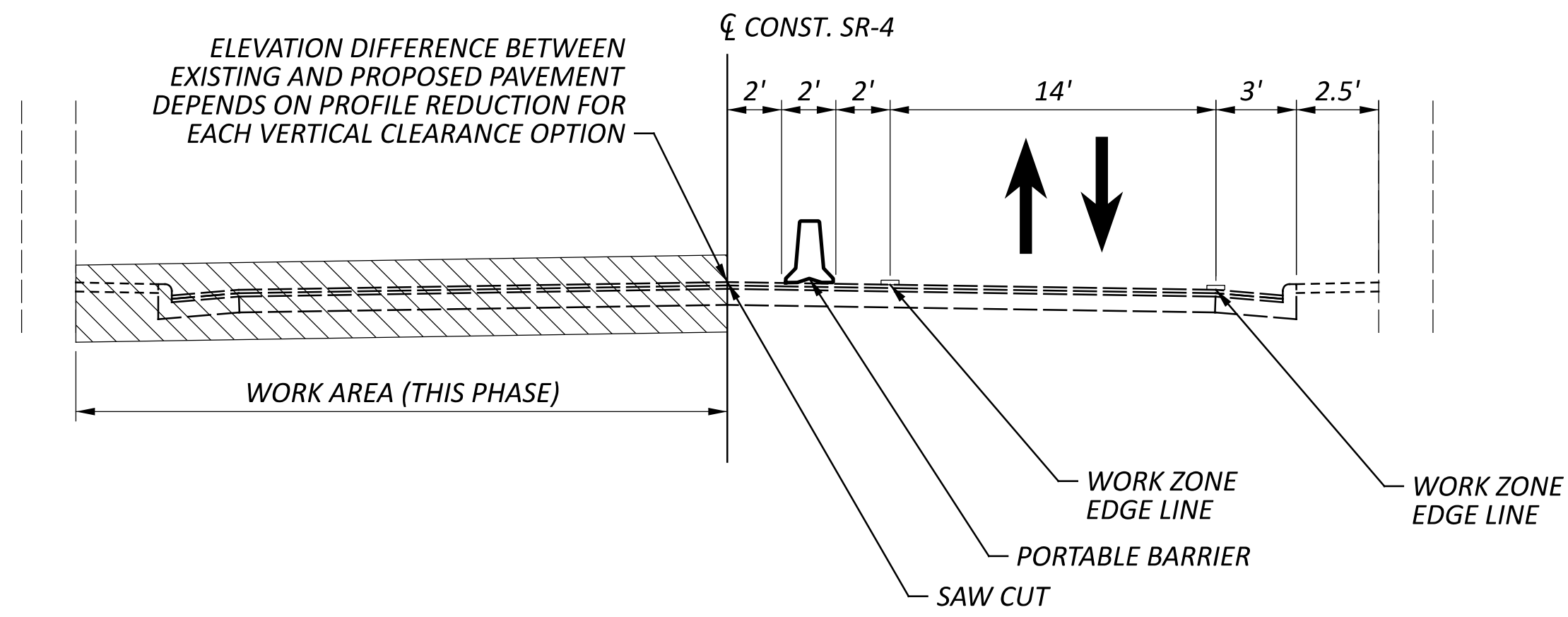

STAGE 1, PHASE 1 - SR-4
SECTION UNDER BRIDGE

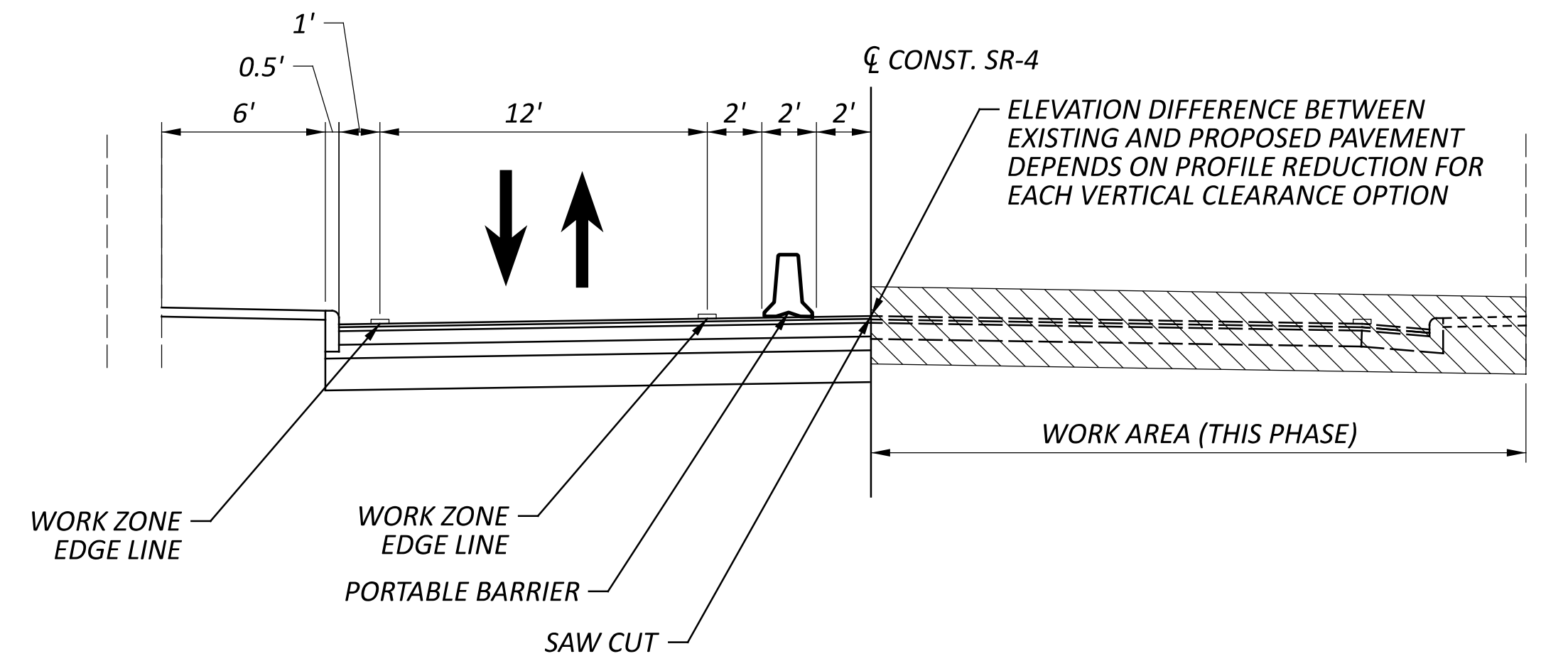

STAGE 1, PHASE 2 - SR-4
SECTION UNDER BRIDGE

MAINTENANCE OF TRAFFIC - TYPICAL SECTIONS
SR 4 - ALL VERTICAL CLEARANCE OPTIONS

DESIGN AGENCY



CHAGRIN VALLEY
ENGINEERING, LTD.

DESIGNER

CJD

REVIEWER

CWP 05-01-24

PROJECT ID

117275

SHEET

P.1

TOTAL

1



2411 N Verity Pkwy, Middletown, OH 45042 to 123 Carlisle Pike, Germantown, OH 45327

Drive 6.3 miles, 8 min

BUT-004-23.90-Normal Route-NB-TYP

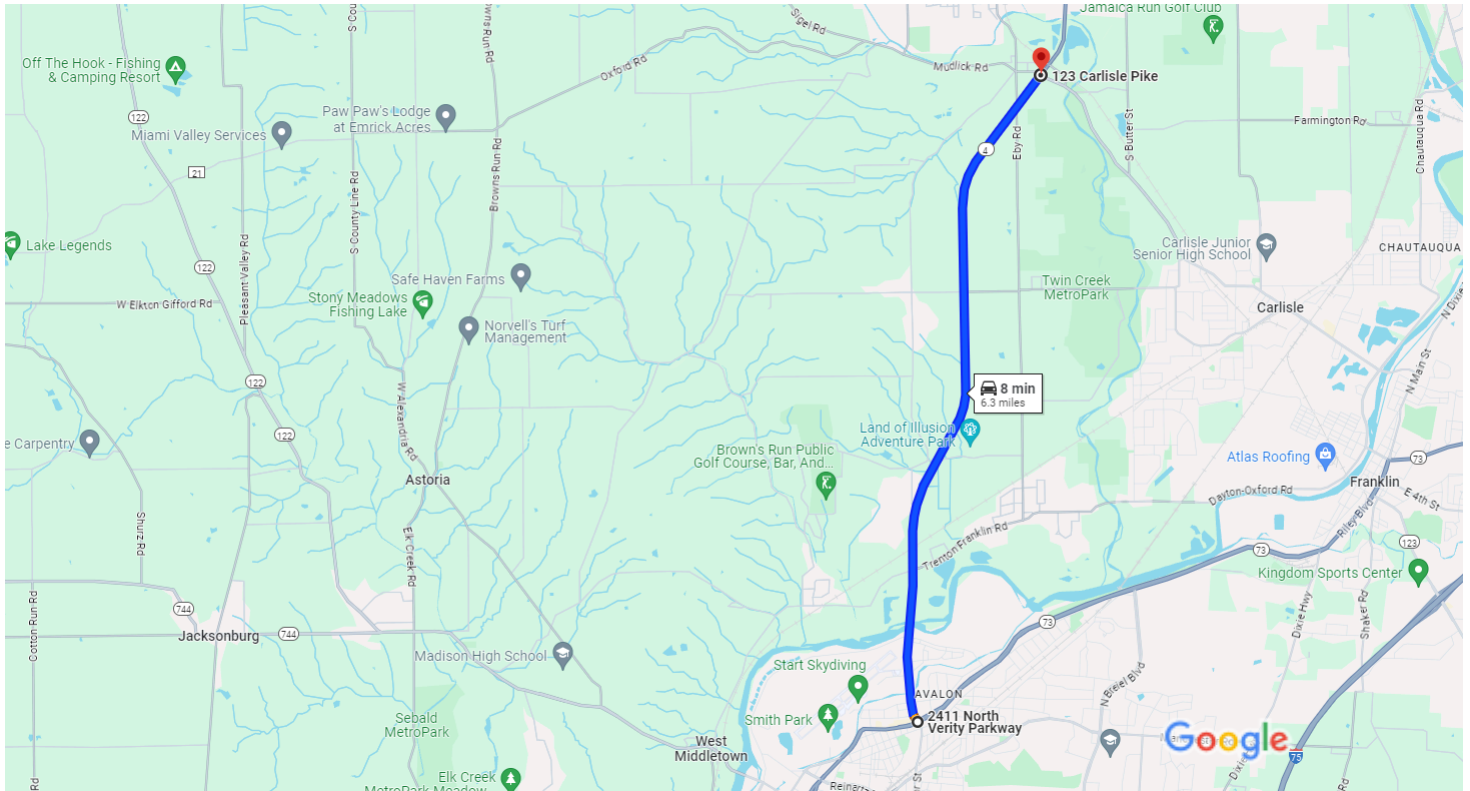

Map data ©2024 1 mi

2411 N Verity Pkwy
Middletown, OH 45042

- ↑ 1. Head northwest on OH-4 N/Germantown Rd toward Avalon Dr

i Continue to follow OH-4 N

6.3 mi

123 Carlisle Pike
Germantown, OH 45327



Middletown, Ohio 45042 to 123 Carlisle Pike,
Germantown, OH 45327

Drive 6.3 miles, 7–9 min

BUT-004-23.90-Normal Route-NB-AM

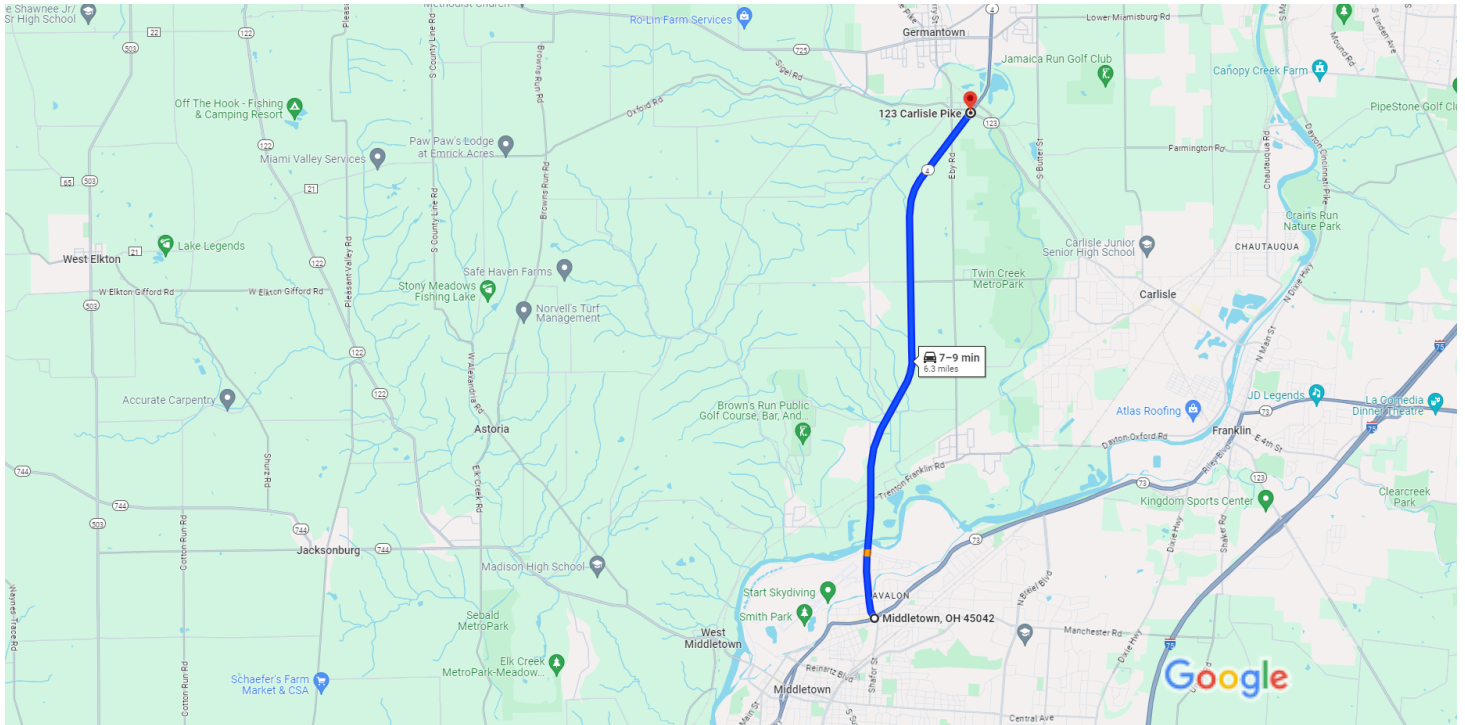

Map data ©2024 1 mi

Middletown
Ohio 45042

- ↑ 1. Head northwest on OH-4 N/Germantown Rd toward OH-73 W

i Continue to follow OH-4 N

6.3 mi

123 Carlisle Pike
Germantown, OH 45327



Middletown, Ohio 45042 to 123 Carlisle Pike,
Germantown, OH 45327

Drive 6.3 miles, 7–12 min

BUT-004-23.90-Normal Route-NB-PM

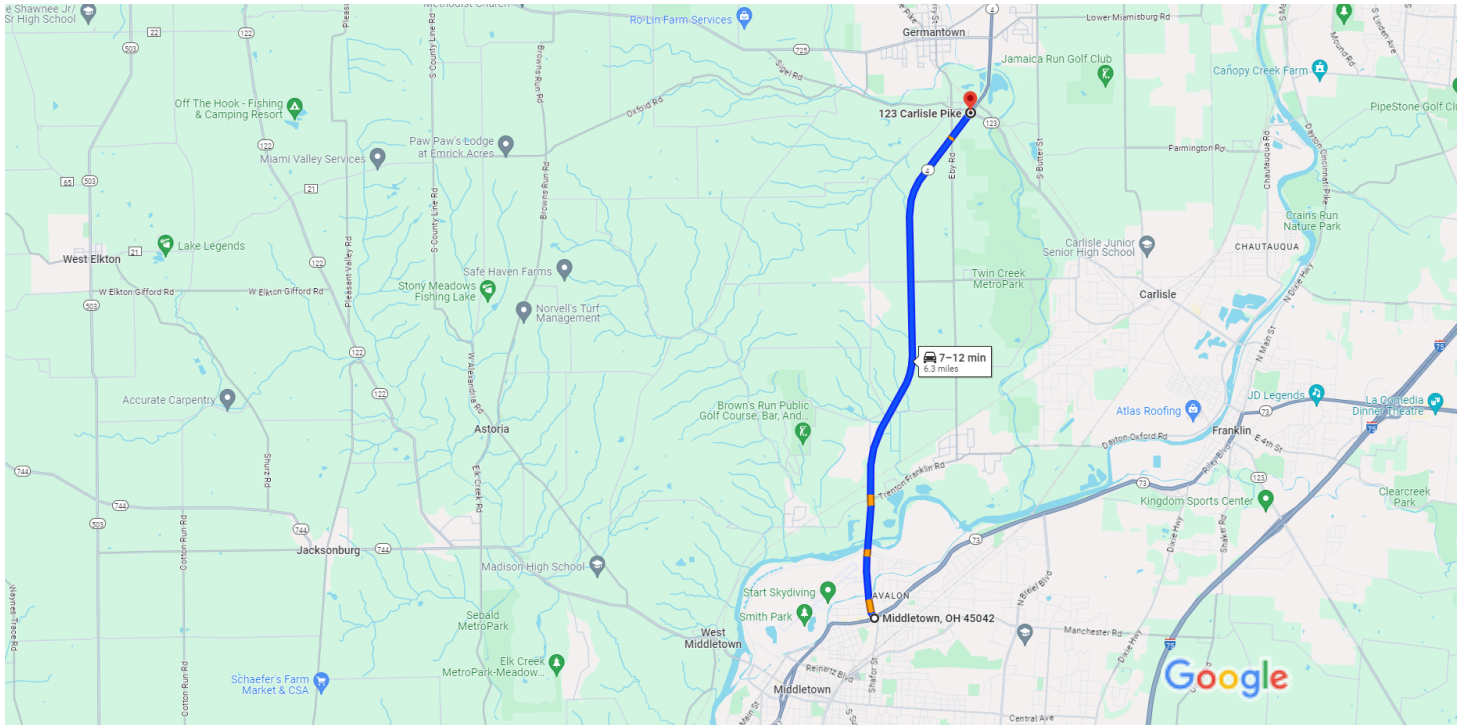

Map data ©2024 1 mi

Middletown
Ohio 45042

- ↑ 1. Head northwest on OH-4 N/Germantown Rd toward OH-73 W

i Continue to follow OH-4 N

6.3 mi

123 Carlisle Pike
Germantown, OH 45327

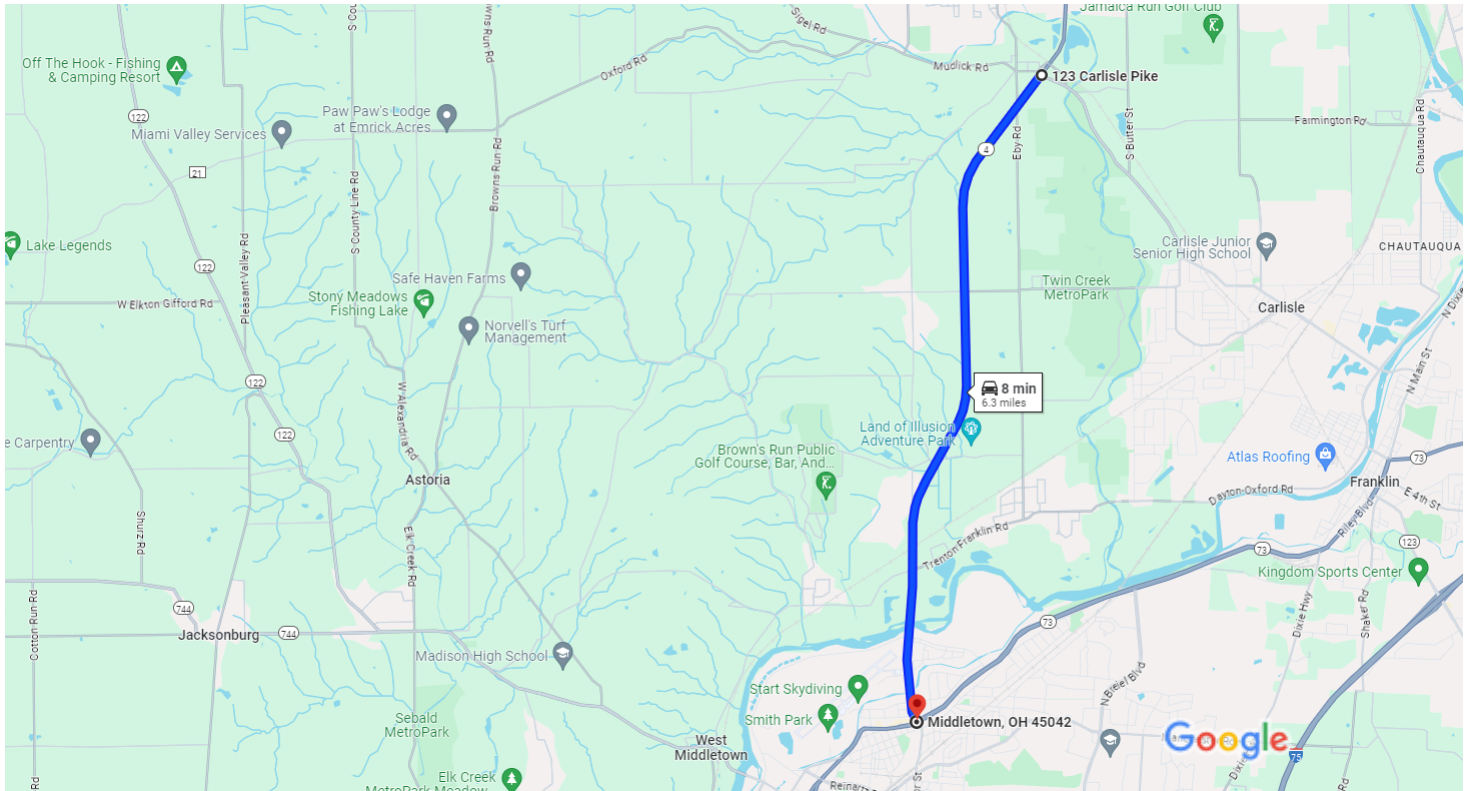

Map data ©2024 1 mi

123 Carlisle Pike
Germantown, OH 45327

- ↑ 1. Head southwest on OH-4 S toward OH-123 S
-
- 6.3 mi

Middletown
Ohio 45042



123 Carlisle Pike, Germantown, OH 45327 to
Middletown, Ohio 45042

Drive 6.3 miles, 7–12 min

BUT-004-23.90-Normal Route-SB-AM

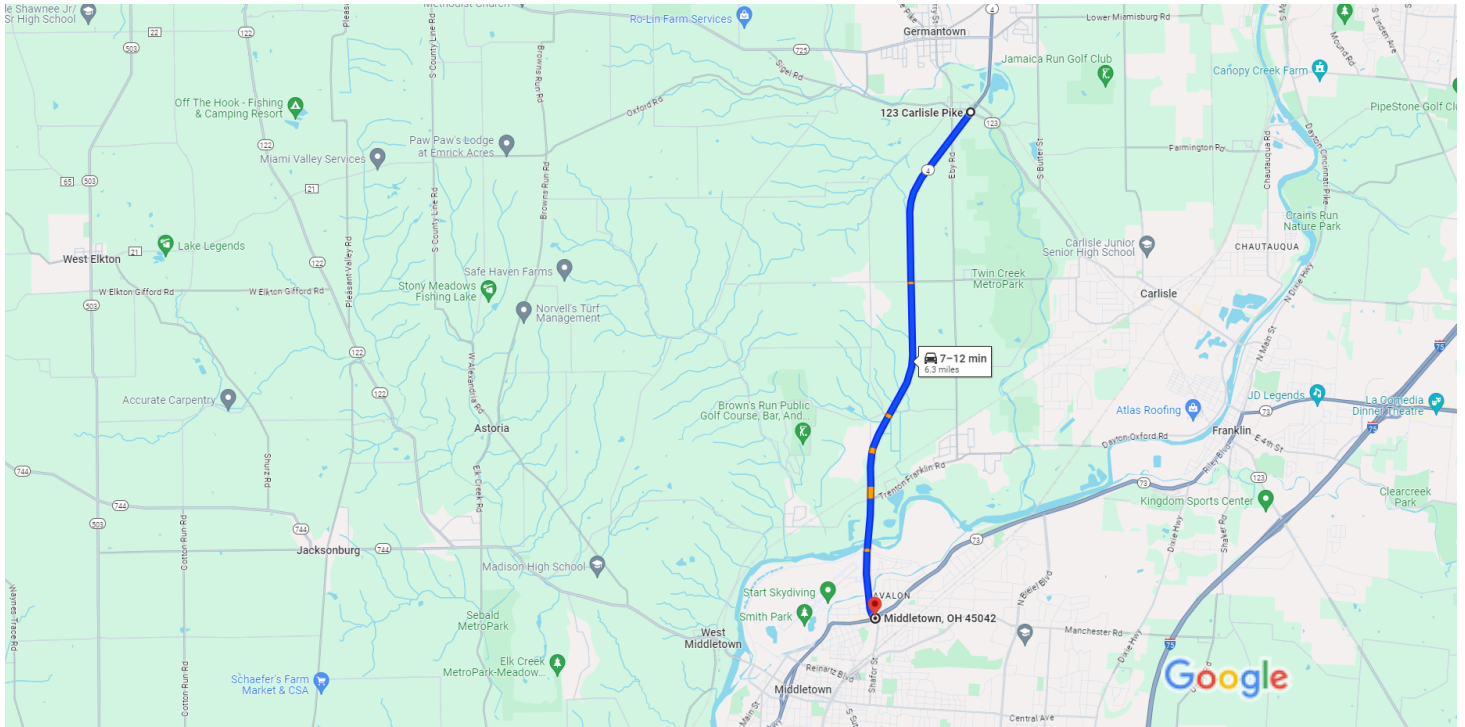

Map data ©2024 1 mi

123 Carlisle Pike
Germantown, OH 45327

↑ 1. Head southwest on OH-4 S toward Eby Rd

6.3 mi

Middletown
Ohio 45042



123 Carlisle Pike, Germantown, OH 45327 to
Middletown, Ohio 45042

Drive 6.3 miles, 7–12 min

BUT-004-23.90-Normal Route-SB-PM

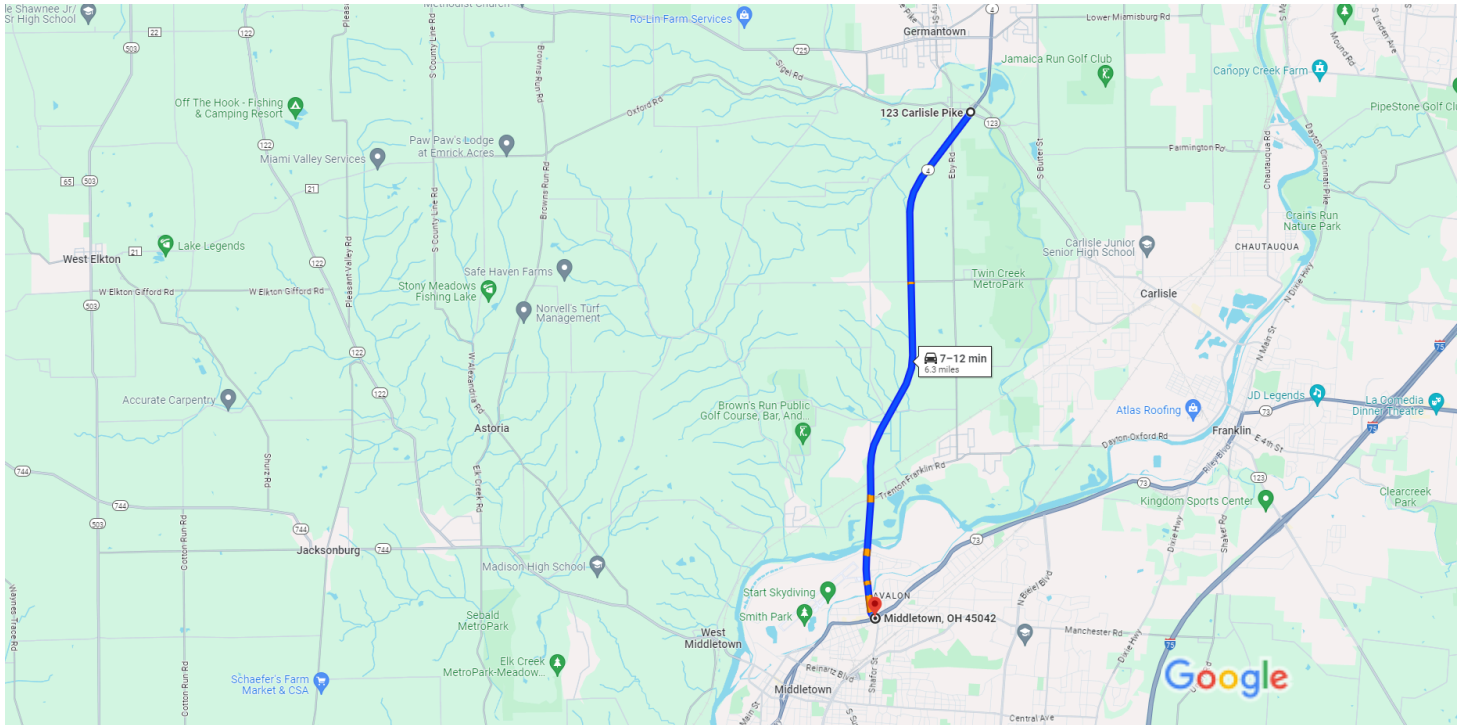

Map data ©2024 1 mi

123 Carlisle Pike
Germantown, OH 45327

↑ 1. Head southwest on OH-4 S toward Eby Rd

6.3 mi

Middletown
Ohio 45042

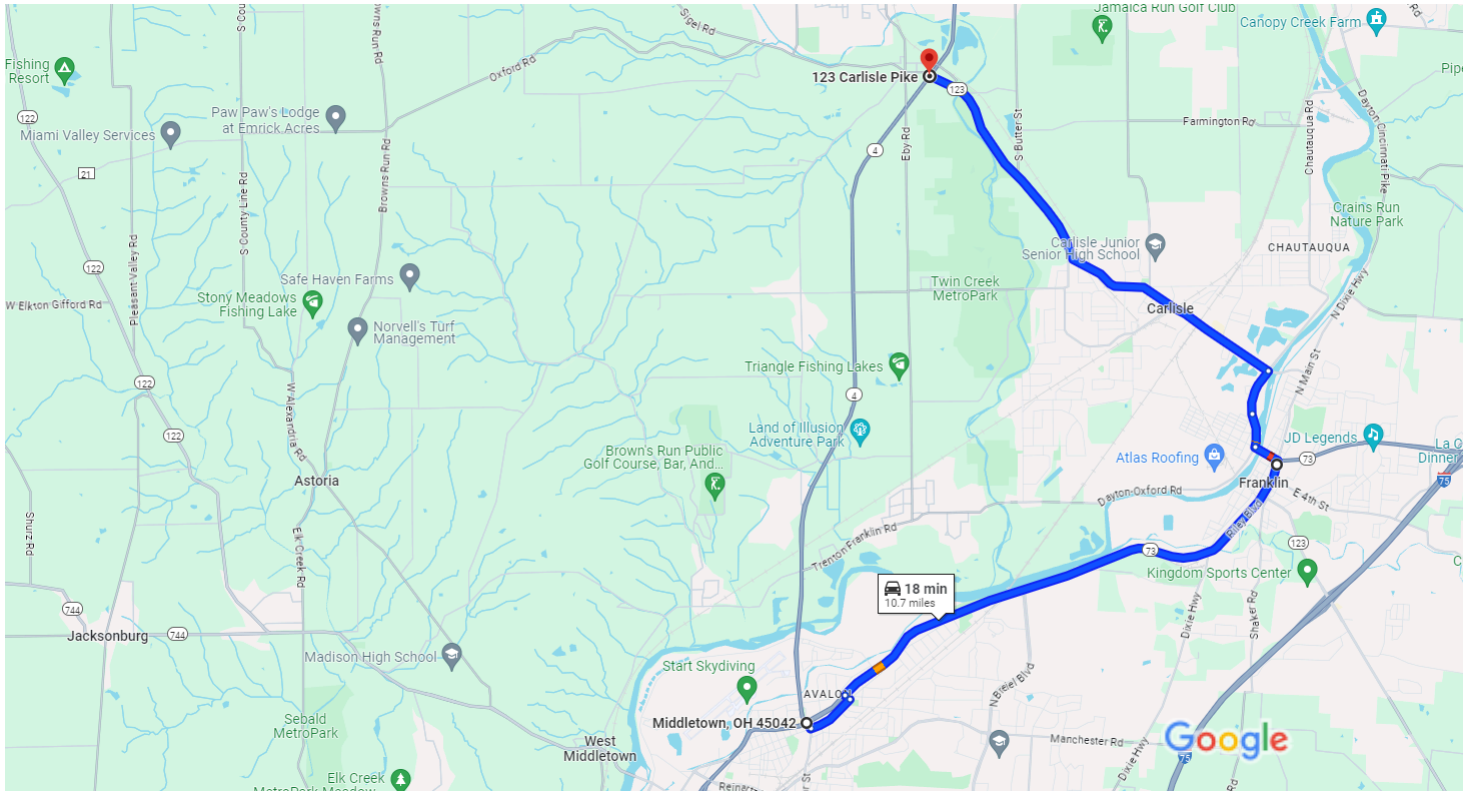

Map data ©2024 1 mi

Middletown Ohio 45042

- ↑ 1. Head south on Germantown Rd toward Germantown Rd
404 ft
- ↶ 2. Turn left onto Tytus Ave
0.5 mi
- ↶ 3. Turn left onto Eldora Dr
325 ft
- ↷ 4. Turn right onto OH-73 E/N Verity Pkwy
[Continue to follow OH-73 E](#)
4.8 mi
- ↶ 5. Turn left onto E 2nd St
0.2 mi
- ↷ 6. Turn right onto Miami Ave
0.3 mi
- ↑ 7. Continue onto Dayton-Oxford Rd
0.4 mi

← 8. Turn left onto OH-123 N/Central Ave

 Continue to follow OH-123 N

4.3 mi

123 Carlisle Pike

Germantown, OH 45327

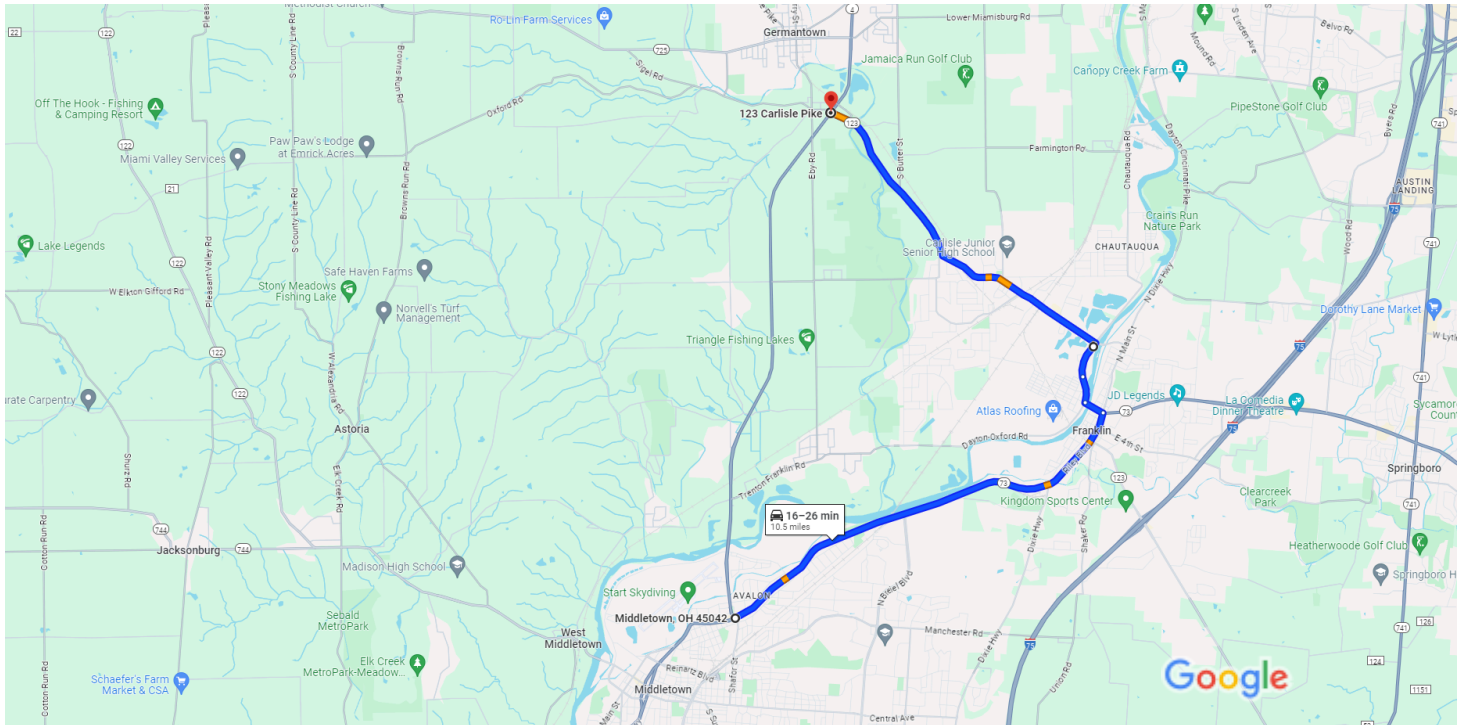

Map data ©2024 1 mi

Middletown Ohio 45042

- ↑ 1. Head northeast on OH-73 E/N Verity Pkwy toward Winona Dr
 ⓘ Continue to follow OH-73 E
 5.2 mi
- ↶ 2. Turn left onto E 2nd St
 0.2 mi
- ↷ 3. Turn right onto Miami Ave
 0.3 mi
- ↑ 4. Continue onto Dayton-Oxford Rd
 0.4 mi
- ↶ 5. Turn left onto OH-123 N/Central Ave
 ⓘ Continue to follow OH-123 N
 4.3 mi

123 Carlisle Pike
Germantown, OH 45327

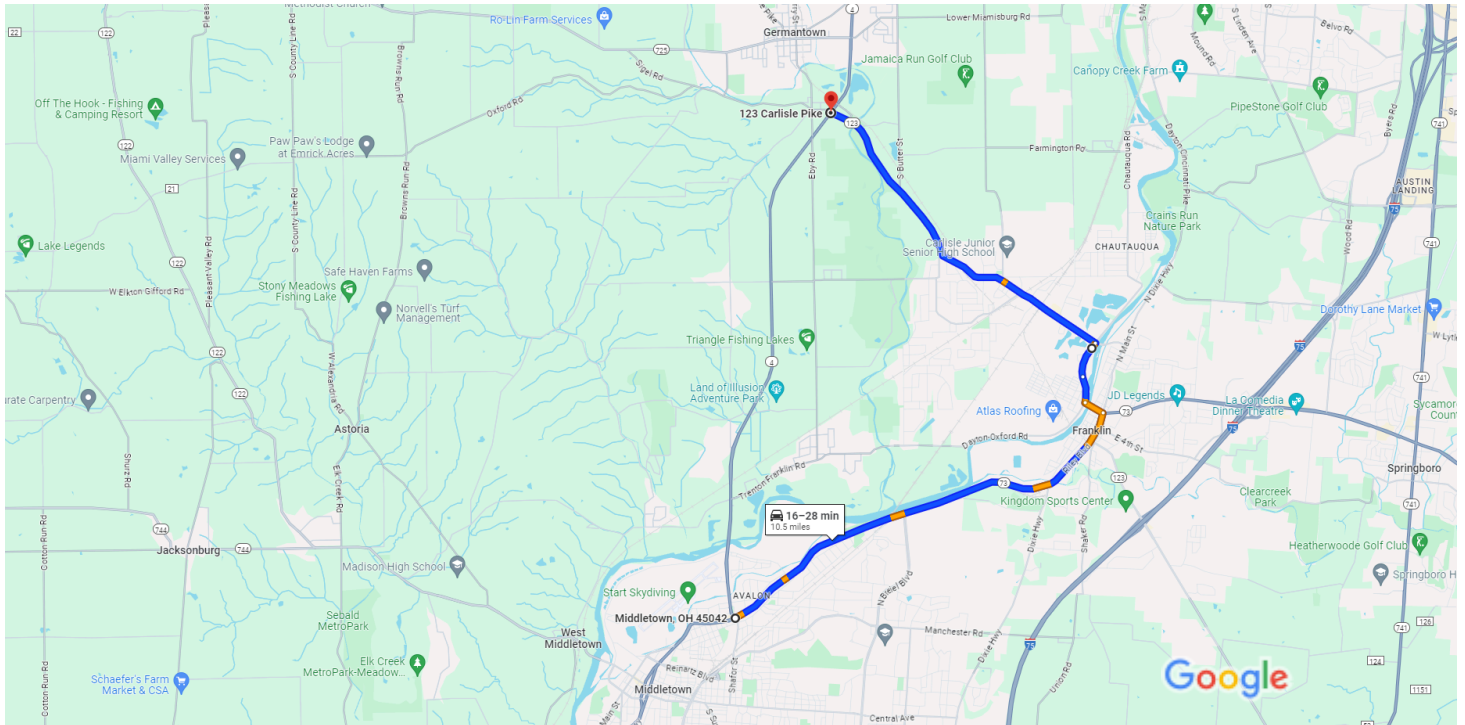

Map data ©2024 1 mi

Middletown Ohio 45042

- ↑ 1. Head northeast on OH-73 E/N Verity Pkwy toward Winona Dr
 ⓘ Continue to follow OH-73 E
 5.2 mi
- ↶ 2. Turn left onto E 2nd St
 0.2 mi
- ↷ 3. Turn right onto Miami Ave
 0.3 mi
- ↑ 4. Continue onto Dayton-Oxford Rd
 0.4 mi
- ↶ 5. Turn left onto OH-123 N/Central Ave
 ⓘ Continue to follow OH-123 N
 4.3 mi

123 Carlisle Pike Germantown, OH 45327

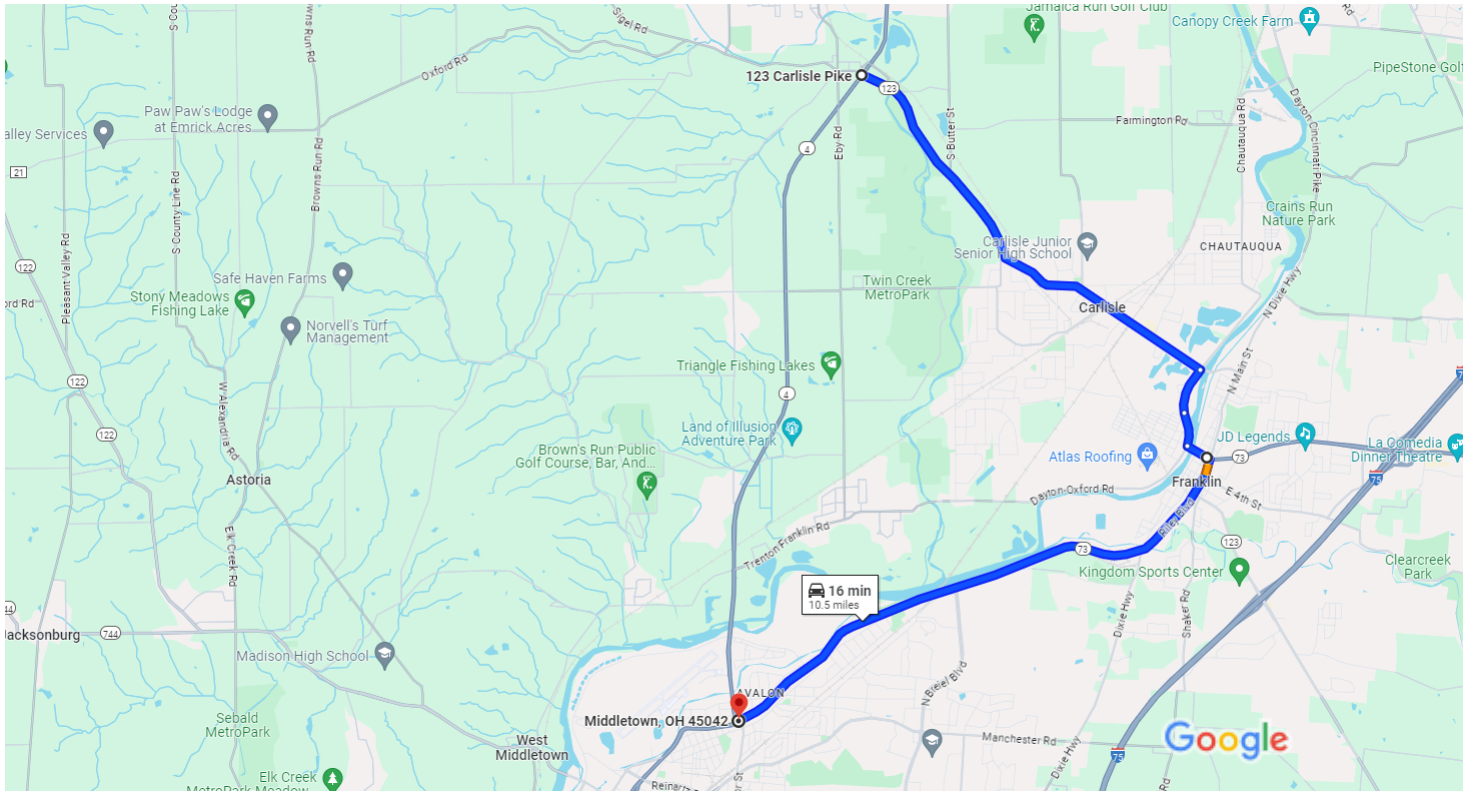

Map data ©2024 1 mi

123 Carlisle Pike
Germantown, OH 45327

- ↑ 1. Head southeast on OH-123 S toward Sugar St
4.3 mi
- ↘ 2. Turn right onto Dayton-Oxford Rd
0.4 mi
- ↑ 3. Continue onto Miami Ave
0.3 mi
- ↙ 4. Turn left onto W 2nd St
 - 📍 Pass by Subway (on the left)
0.2 mi
- ↘ 5. Turn right onto OH-73 W/Riley Blvd
 - 📍 Continue to follow OH-73 W
5.2 mi

Middletown
Ohio 45042

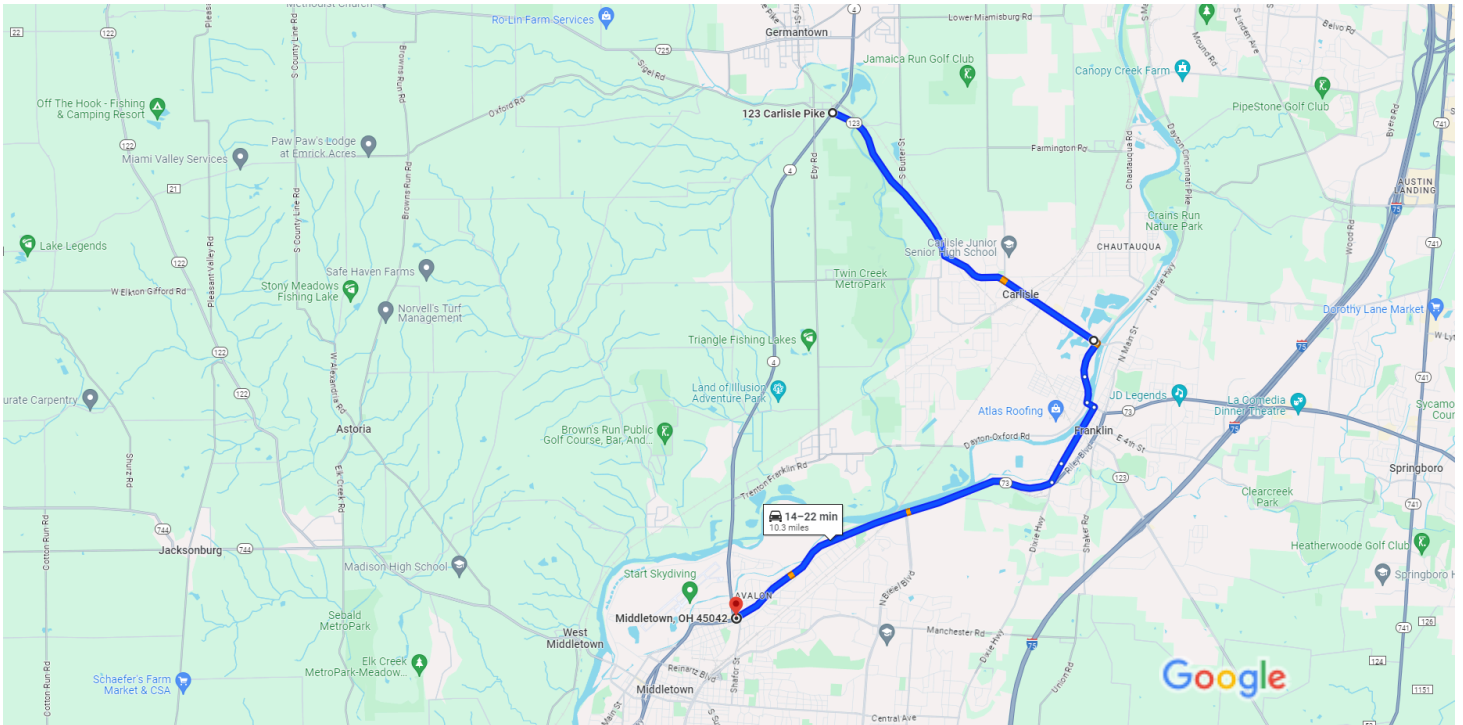

Map data ©2024 1 mi

123 Carlisle Pike
Germantown, OH 45327

- ↑ 1. Head southeast on OH-123 S toward Sugar St
4.3 mi
- ↪ 2. Turn right onto Dayton-Oxford Rd
0.4 mi
- ↑ 3. Continue onto Miami Ave
0.3 mi
- ↶ 4. Turn left onto W 2nd St
0.1 mi
- ↪ 5. Turn right onto S River St
0.8 mi
- ↑ 6. Continue onto S Main St
0.2 mi
- ↪ 7. Turn right onto OH-73 W
4.2 mi

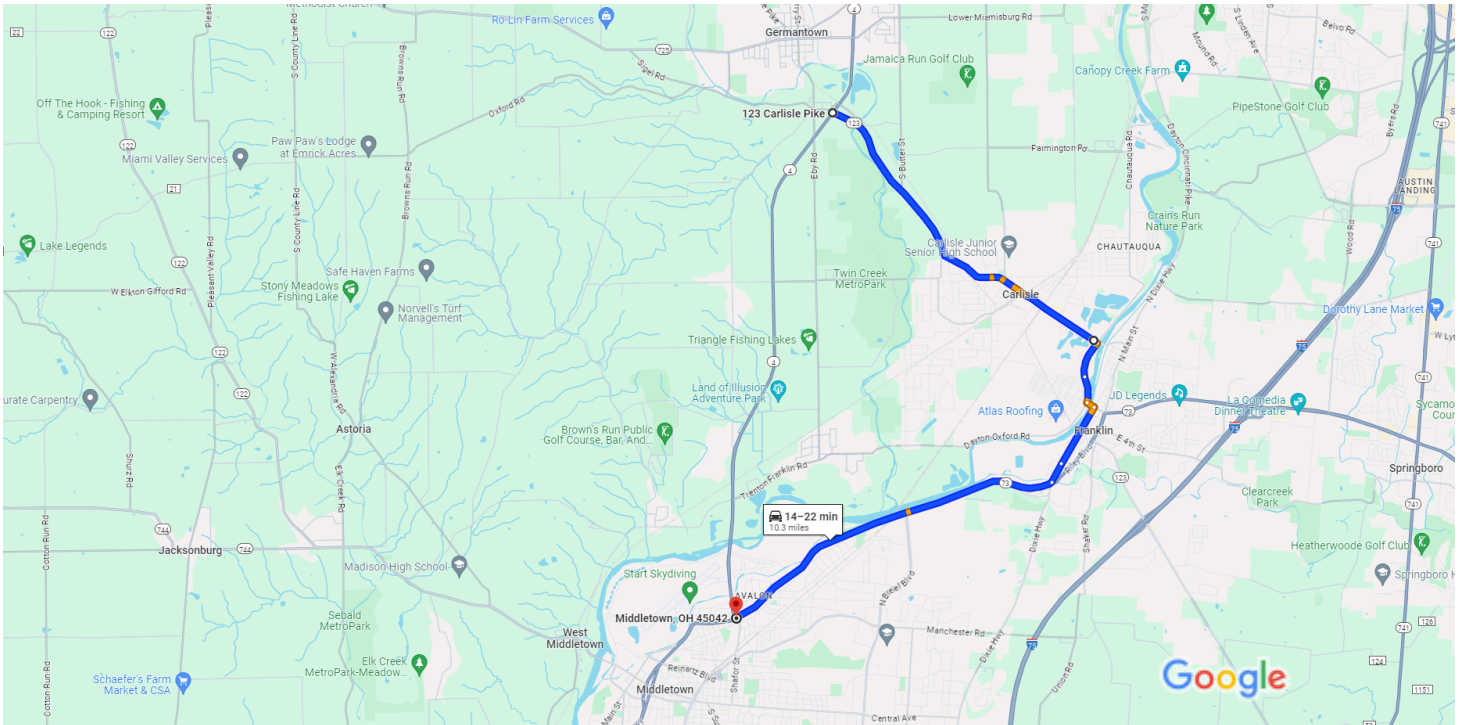

Map data ©2024 1 mi

123 Carlisle Pike
Germantown, OH 45327

- ↑ 1. Head southeast on OH-123 S toward Sugar St
4.3 mi
- ↪ 2. Turn right onto Dayton-Oxford Rd
0.4 mi
- ↑ 3. Continue onto Miami Ave
0.3 mi
- ↶ 4. Turn left onto W 2nd St
0.1 mi
- ↪ 5. Turn right onto S River St
0.8 mi
- ↑ 6. Continue onto S Main St
0.2 mi
- ↪ 7. Turn right onto OH-73 W
4.2 mi

| Work Zone User Cost Calculations | | |
|---|--------------------------------|------------------|
| Detour (Using Actual Drive Time) | | |
| Project ID: | 117275 | |
| County-Route-Section: | BUT-004-23.90-D1-NB-Typ | |
| User Input: | | |
| Construction Calendar Year: | 2023 | |
| | Car | B/C Truck |
| ADT of Detoured Section: | 5,690 | 237 |
| Time to Drive Normal Route (Min): | 8 | 8 |
| Time to Drive Detour Route (Min): | 18 | 18 |
| Duration of Closure (Days): | 60 | |
| Calculated Values: | | |
| User Cost per Vehicle per Hour: | \$26.13 | \$70.52 |
| Delay (Min): | 10 | 10 |
| Delay (Hours): | 0.167 | 0.167 |
| Delay Cost per Vehicle: | \$4.35 | \$11.75 |
| Delay Cost per Day: | \$24,775.38 | \$2,785.50 |
| Delay Cost for Closure Duration: | \$1,486,523 | \$167,130 |
| Total Delay Cost for Closure Duration: | \$1,653,653 | |
| Average Delay Cost per Day: | \$27,561 | |

| Notes (description, detour route, project phase reference, etc, as applicable) : |
|---|
| ***TIP: Alt+Enter for a line break in the box below.*** |
| Detour 1 - Northbound - Typical Hour - State Route 1 |
| ADT volumes from ODOT AADT with ODOT seasonal adjustment factors applied |

Form Version Date: 2/27/2024

Fill in all highlighted cells.

The Average Delay Cost per Day is the MAXIMUM that may be used as incentive / disincentive.

Date Calculated: 5/1/2024

| Work Zone User Cost Calculations | | |
|---|--------------------------------|------------------|
| Detour (Using Actual Drive Time) | | |
| Project ID: | 117275 | |
| County-Route-Section: | BUT-004-23.90-D1-SB-Typ | |
| User Input: | | |
| Construction Calendar Year: | 2023 | |
| | Car | B/C Truck |
| ADT of Detoured Section: | 5,541 | 238 |
| Time to Drive Normal Route (Min): | 8 | 8 |
| Time to Drive Detour Route (Min): | 16 | 16 |
| Duration of Closure (Days): | 60 | |
| Calculated Values: | | |
| User Cost per Vehicle per Hour: | \$26.13 | \$70.52 |
| Delay (Min): | 8 | 8 |
| Delay (Hours): | 0.133 | 0.133 |
| Delay Cost per Vehicle: | \$3.48 | \$9.40 |
| Delay Cost per Day: | \$19,301.28 | \$2,237.80 |
| Delay Cost for Closure Duration: | \$1,158,077 | \$134,268 |
| Total Delay Cost for Closure Duration: | \$1,292,345 | |
| Average Delay Cost per Day: | \$21,539 | |

| Notes (description, detour route, project phase reference, etc, as applicable): |
|--|
| ***TIP: Alt+Enter for a line break in the box below.*** |
| Detour 1 - Southbound - Typical Hour - State Route 1 |
| ADT volumes from ODOT AADT with ODOT seasonal adjustment factors applied |

Form Version Date: 2/27/2024

Fill in all highlighted cells.

The Average Delay Cost per Day is the MAXIMUM that may be used as incentive / disincentive.

Date Calculated: 2024-05-01

HCS Signalized Intersection Results Summary

| General Information | | | | Intersection Information | | | |
|---------------------|------------------------------|---------------|------------------------------|--------------------------|----------|--|--|
| Agency | CVE | | | Duration, h | 0.250 | | |
| Analyst | ALM | Analysis Date | Apr 26, 2024 | Area Type | Other | | |
| Jurisdiction | ODOT | Time Period | AM Peak | PHF | 0.91 | | |
| Urban Street | BUT-4 | Analysis Year | 2024 | Analysis Period | 1 > 7:00 | | |
| Intersection | Catalina & BUT-4 | File Name | 117275-BUT-4-23.90-WZ-AM.xus | | | | |
| Project Description | BUT-004-23.90 Feasibility AM | | | | | | |

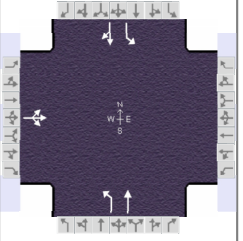

| Demand Information | EB | | | WB | | | NB | | | SB | | |
|-----------------------|----|---|----|----|---|---|----|-----|---|----|-----|----|
| | L | T | R | L | T | R | L | T | R | L | T | R |
| Approach Movement | | | | | | | | | | | | |
| Demand (v), veh/h | 12 | 0 | 11 | | | | 1 | 361 | | 0 | 310 | 10 |

| Signal Information | | | | | | | | | | | | | | | |
|--------------------|-------|-----------------|-----|--------|------|------|------|-----|-----|-----|--|--|--|--|--|
| Cycle, s | 150.0 | Reference Phase | 2 | | | | | | | | | | | | |
| Offset, s | 0 | Reference Point | End | Green | 34.0 | 31.0 | 10.0 | 0.0 | 0.0 | 0.0 | | | | | |
| Uncoordinated | Yes | Simult. Gap E/W | Off | Yellow | 4.0 | 4.0 | 4.0 | 0.0 | 0.0 | 0.0 | | | | | |
| Force Mode | Fixed | Simult. Gap N/S | Off | Red | 22.0 | 22.0 | 19.0 | 0.0 | 0.0 | 0.0 | | | | | |

| Timer Results | EBL | EBT | WBL | WBT | NBL | NBT | SBL | SBT |
|-----------------------------------|-----|------|-----|-----|------|------|------|------|
| Assigned Phase | | 4 | | | 1 | 6 | 5 | 2 |
| Case Number | | 12.0 | | | 2.0 | 4.0 | 2.0 | 4.0 |
| Phase Duration, s | | 33.0 | | | 60.0 | 60.0 | 57.0 | 57.0 |
| Change Period, ($Y+R_c$), s | | 23.0 | | | 26.0 | 26.0 | 26.0 | 26.0 |
| Max Allow Headway (MAH), s | | 2.9 | | | 2.8 | 2.7 | 0.0 | 2.7 |
| Queue Clearance Time (g_s), s | | 4.3 | | | 2.1 | 36.0 | | 33.0 |
| Green Extension Time (g_e), s | | 0.0 | | | 0.0 | 0.0 | 0.0 | 0.0 |
| Phase Call Probability | | 1.00 | | | 1.00 | 1.00 | | 1.00 |
| Max Out Probability | | 0.00 | | | 0.00 | 1.00 | | 1.00 |

| Movement Group Results | EB | | | WB | | | NB | | | SB | | |
|---|------|-------|-------|-----|---|---|-------|-------|---|-------|-------|----|
| | L | T | R | L | T | R | L | T | R | L | T | R |
| Approach Movement | | | | | | | | | | | | |
| Assigned Movement | 7 | 4 | 14 | | | | 1 | 6 | | 5 | 2 | 12 |
| Adjusted Flow Rate (v), veh/h | | 25 | | | | | 1 | 397 | | 0 | 352 | |
| Adjusted Saturation Flow Rate (s), veh/h/ln | | 1573 | | | | | 1667 | 1702 | | 1667 | 1693 | |
| Queue Service Time (g_s), s | | 2.3 | | | | | 0.1 | 34.0 | | 0.0 | 31.0 | |
| Cycle Queue Clearance Time (g_c), s | | 2.3 | | | | | 0.1 | 34.0 | | 0.0 | 31.0 | |
| Green Ratio (g/C) | | 0.07 | | | | | 0.23 | 0.23 | | 0.21 | 0.21 | |
| Capacity (c), veh/h | | 105 | | | | | 378 | 386 | | 344 | 350 | |
| Volume-to-Capacity Ratio (X) | | 0.241 | | | | | 0.003 | 1.028 | | 0.000 | 1.005 | |
| Back of Queue (Q), ft/ln (95 th percentile) | | 42 | | | | | 2 | 722 | | 0 | 644 | |
| Back of Queue (Q), veh/ln (95 th percentile) | | 1.7 | | | | | 0.1 | 28.2 | | 0.0 | 25.1 | |
| Queue Storage Ratio (RQ) (95 th percentile) | | 0.04 | | | | | 0.00 | 0.72 | | 0.00 | 0.64 | |
| Uniform Delay (d_1), s/veh | | 66.4 | | | | | 44.9 | 58.0 | | 0.0 | 59.5 | |
| Incremental Delay (d_2), s/veh | | 0.4 | | | | | 0.0 | 53.2 | | 0.0 | 49.4 | |
| Initial Queue Delay (d_3), s/veh | | 0.0 | | | | | 0.0 | 0.0 | | 0.0 | 0.0 | |
| Control Delay (d), s/veh | | 66.8 | | | | | 44.9 | 111.2 | | 0.0 | 108.9 | |
| Level of Service (LOS) | | E | | | | | D | F | | | F | |
| Approach Delay, s/veh / LOS | 66.8 | E | | 0.0 | | | 111.0 | F | | 108.9 | F | |
| Intersection Delay, s/veh / LOS | | | 108.6 | | | | | | F | | | |

| Multimodal Results | EB | | WB | | NB | | SB | |
|----------------------------|------|---|------|---|------|---|------|---|
| Pedestrian LOS Score / LOS | 1.97 | B | 1.97 | B | 1.44 | A | 1.73 | B |
| Bicycle LOS Score / LOS | 0.53 | A | | | 1.14 | A | 1.07 | A |

HCS Signalized Intersection Results Summary

| General Information | | | | Intersection Information | | | |
|---------------------|------------------------------|---------------|--------------|------------------------------|----------|--|--|
| Agency | CVE | | | Duration, h | 0.250 | | |
| Analyst | ALM | Analysis Date | Apr 26, 2024 | Area Type | Other | | |
| Jurisdiction | ODOT | Time Period | PM Peak | PHF | 0.92 | | |
| Urban Street | BUT-4 | Analysis Year | 2024 | Analysis Period | 1 > 7:00 | | |
| Intersection | Catalina & BUT-4 | | File Name | 117275-BUT-4-23.90-WZ-PM.xus | | | |
| Project Description | BUT-004-23.90 Feasibility PM | | | | | | |

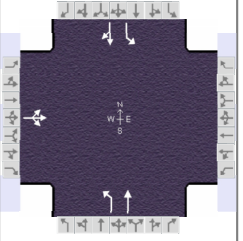

| Demand Information | EB | | | WB | | | NB | | | SB | | |
|-----------------------|----|---|----|----|---|---|----|-----|---|----|-----|----|
| | L | T | R | L | T | R | L | T | R | L | T | R |
| Approach Movement | | | | | | | | | | | | |
| Demand (v), veh/h | 13 | 0 | 14 | | | | 1 | 521 | | 0 | 570 | 17 |

| Signal Information | | | | | | | | | | | | | | | |
|--------------------|-------|-----------------|-----|--------|------|------|------|-----|-----|-----|--|--|--|--|--|
| Cycle, s | 150.0 | Reference Phase | 2 | | | | | | | | | | | | |
| Offset, s | 0 | Reference Point | End | | | | | | | | | | | | |
| Uncoordinated | Yes | Simult. Gap E/W | Off | Green | 30.5 | 34.5 | 10.0 | 0.0 | 0.0 | 0.0 | | | | | |
| Force Mode | Fixed | Simult. Gap N/S | Off | Yellow | 4.0 | 4.0 | 4.0 | 0.0 | 0.0 | 0.0 | | | | | |
| | | | | Red | 22.0 | 22.0 | 19.0 | 0.0 | 0.0 | 0.0 | | | | | |

| Timer Results | EBL | EBT | WBL | WBT | NBL | NBT | SBL | SBT |
|-----------------------------------|-----|------|-----|-----|------|------|------|------|
| Assigned Phase | | 4 | | | 1 | 6 | 5 | 2 |
| Case Number | | 12.0 | | | 2.0 | 4.0 | 2.0 | 4.0 |
| Phase Duration, s | | 33.0 | | | 56.5 | 56.5 | 60.5 | 60.5 |
| Change Period, ($Y+R_c$), s | | 23.0 | | | 26.0 | 26.0 | 26.0 | 26.0 |
| Max Allow Headway (MAH), s | | 2.9 | | | 2.8 | 2.7 | 0.0 | 2.7 |
| Queue Clearance Time (g_s), s | | 4.7 | | | 2.1 | 32.5 | | 36.5 |
| Green Extension Time (g_e), s | | 0.0 | | | 0.0 | 0.0 | 0.0 | 0.0 |
| Phase Call Probability | | 1.00 | | | 1.00 | 1.00 | | 1.00 |
| Max Out Probability | | 0.01 | | | 0.00 | 1.00 | | 1.00 |

| Movement Group Results | EB | | | WB | | | NB | | | SB | | |
|---|-------|---|----|-----|---|---|-------|-------|-------|-------|-------|------|
| | L | T | R | L | T | R | L | T | R | L | T | R |
| Assigned Movement | 7 | 4 | 14 | | | | 1 | 6 | | 5 | 2 | 12 |
| Adjusted Flow Rate (v), veh/h | 29 | | | | | | 1 | 566 | 0 | | | 638 |
| Adjusted Saturation Flow Rate (s), veh/h/ln | 1566 | | | | | | 1667 | 1716 | 1667 | | | 1707 |
| Queue Service Time (g_s), s | 2.7 | | | | | | 0.1 | 30.5 | 0.0 | | | 34.5 |
| Cycle Queue Clearance Time (g_c), s | 2.7 | | | | | | 0.1 | 30.5 | 0.0 | | | 34.5 |
| Green Ratio (g/C) | 0.07 | | | | | | 0.20 | 0.20 | 0.23 | | 0.23 | |
| Capacity (c), veh/h | 104 | | | | | | 339 | 349 | 383 | | 393 | |
| Volume-to-Capacity Ratio (X) | 0.281 | | | | | | 0.003 | 1.623 | 0.000 | | 1.625 | |
| Back of Queue (Q), ft/ln (95 th percentile) | 49 | | | | | | 2 | 1629 | 0 | | 1827 | |
| Back of Queue (Q), veh/ln (95 th percentile) | 2.0 | | | | | | 0.1 | 64.1 | 0.0 | | 71.9 | |
| Queue Storage Ratio (RQ) (95 th percentile) | 0.05 | | | | | | 0.00 | 1.63 | 0.00 | | 1.83 | |
| Uniform Delay (d_1), s/veh | 66.6 | | | | | | 47.6 | 59.8 | 0.0 | | 57.8 | |
| Incremental Delay (d_2), s/veh | 0.5 | | | | | | 0.0 | 293.3 | 0.0 | | 292.8 | |
| Initial Queue Delay (d_3), s/veh | 0.0 | | | | | | 0.0 | 0.0 | 0.0 | | 0.0 | |
| Control Delay (d), s/veh | 67.1 | | | | | | 47.6 | 353.0 | 0.0 | | 350.5 | |
| Level of Service (LOS) | E | | | | | | D | F | | | F | |
| Approach Delay, s/veh / LOS | 67.1 | E | | 0.0 | | | 352.5 | F | | 350.5 | F | |
| Intersection Delay, s/veh / LOS | 344.7 | | | | | | F | | | | | |

| Multimodal Results | EB | | WB | | NB | | SB | |
|----------------------------|------|---|------|---|------|---|------|---|
| Pedestrian LOS Score / LOS | 1.97 | B | 1.97 | B | 1.43 | A | 1.72 | B |
| Bicycle LOS Score / LOS | 0.54 | A | | | 1.42 | A | 1.54 | B |

Standard Delay Calculation
BUT-4-23.90

Urban Principal Arterial Other

HCS values

| Hour | Total | % Volume | % Heavy | NB Delay | NB Volume | NB Vol Adj | Delay Cost | SB Delay | SB Volume | SB Vol Adj | Delay Cost |
|-------------|-----------|----------|---------|----------|-----------|------------|-----------------|----------|-----------|-----------------|------------------------------|
| | 0 | 381539 | 0.4% | 6.3% | 11.0 | 21 | 21 \$ 1.89 | 10.9 | 22 | 21 \$ 1.81 | |
| | 1 | 209414 | 0.2% | 10.0% | 6.0 | 11 | 12 \$ 0.60 | 6.0 | 12 | 11 \$ 0.58 | |
| | 2 | 205634 | 0.2% | 10.9% | 5.9 | 11 | 12 \$ 0.59 | 5.9 | 12 | 11 \$ 0.56 | |
| | 3 | 305070 | 0.3% | 10.4% | 8.8 | 17 | 17 \$ 1.29 | 8.7 | 17 | 17 \$ 1.23 | |
| | 4 | 752663 | 0.7% | 6.8% | 21.7 | 41 | 42 \$ 7.42 | 21.5 | 42 | 41 \$ 7.09 | |
| | 5 | 2169597 | 2.0% | 4.1% | 62.6 | 119 | 122 \$ 59.15 | 62.0 | 122 | 117 \$ 56.53 | SAF 0.975 (U03 Mon, June) |
| | 6 | 4532997 | 4.3% | 3.0% | 130.9 | 249 | 254 \$ 253.75 | 129.5 | 256 | 245 \$ 242.51 | |
| 7:15 - 8:15 | 7 | 6961304 | 6.6% | 2.7% | 111.2 | 361 | 361 \$ 304.56 | 108.9 | 320 | 320 \$ 264.39 | |
| | 8 | 6735787 | 6.3% | 3.1% | 194.5 | 370 | 378 \$ 561.31 | 192.5 | 380 | 365 \$ 536.46 | |
| | 9 | 5835601 | 5.5% | 3.8% | 168.5 | 320 | 327 \$ 425.88 | 166.7 | 329 | 316 \$ 407.03 | |
| | 10 | 5695212 | 5.4% | 4.0% | 164.4 | 312 | 319 \$ 406.77 | 162.7 | 321 | 308 \$ 388.76 | |
| | 11 | 6280389 | 5.9% | 3.6% | 181.3 | 345 | 352 \$ 491.35 | 179.5 | 354 | 340 \$ 469.59 | |
| | 12 | 6720306 | 6.3% | 3.2% | 194.0 | 369 | 377 \$ 559.70 | 192.0 | 379 | 364 \$ 534.92 | |
| | 13 | 6761167 | 6.4% | 3.2% | 195.2 | 371 | 379 \$ 565.67 | 193.2 | 381 | 366 \$ 540.63 | |
| | 14 | 7552831 | 7.1% | 2.7% | 218.1 | 414 | 423 \$ 701.08 | 215.8 | 426 | 409 \$ 670.04 | |
| | 15 | 8566672 | 8.1% | 2.2% | 247.3 | 470 | 480 \$ 893.90 | 244.8 | 483 | 464 \$ 854.32 | |
| 4:30 - 5:30 | 16 | 9116646 | 8.6% | 1.6% | 353 | 521 | 521 \$ 1,370.09 | 350.5 | 587 | 587 \$ 1,532.72 | |
| | 17 | 8767295 | 8.3% | 1.4% | 253.1 | 481 | 491 \$ 924.33 | 250.5 | 495 | 475 \$ 883.40 | |
| | 18 | 6213536 | 5.9% | 1.5% | 179.4 | 341 | 348 \$ 464.98 | 177.5 | 351 | 336 \$ 444.39 | |
| | 19 | 4371985 | 4.1% | 1.6% | 126.2 | 240 | 245 \$ 230.68 | 124.9 | 247 | 237 \$ 220.47 | |
| | 20 | 3244956 | 3.1% | 1.8% | 93.7 | 178 | 182 \$ 127.36 | 92.7 | 183 | 176 \$ 121.72 | |
| | 21 | 2289937 | 2.2% | 2.1% | 66.1 | 126 | 128 \$ 63.77 | 65.4 | 129 | 124 \$ 60.94 | |
| | 22 | 1490170 | 1.4% | 2.7% | 43.0 | 82 | 84 \$ 27.27 | 42.6 | 84 | 81 \$ 26.06 | |
| | 23 | 932973 | 0.9% | 3.3% | 26.9 | 51 | 52 \$ 10.80 | 26.7 | 53 | 50 \$ 10.32 | |
| | 106093681 | 1.00 | | | 128 | 5820 | 5927 \$ 8,454 | 126 | 5985 | 5779 \$ 8,276 | |

| | | | | |
|-----|----|------|----|------|
| ADT | NB | 5779 | SB | 5635 |
| ADT | | 5927 | | 5779 |

| | | |
|--------------|---------|----------|
| NB veh / day | Catc | 5820.060 |
| | MS2 ADT | 5927 |
| SB veh / day | Catc | 5985.027 |
| | MS2 ADT | 5779 |

| | | | | |
|--------------|----|-----|----|-----|
| | NB | 96% | SB | 96% |
| MS2 % Cars | | | | |
| MS2 % Trucks | | 4% | | 4% |

ODOT RUC per Vehicle per hour

| | |
|--------|----------|
| Cars | \$ 26.13 |
| Trucks | \$ 70.52 |

| NB | | | | | | SB | | | | | |
|----------------------------------|-------|--------|---------------------------|-----------|-------------|----------------------------------|-------|--------|---------------------------|-----------|-------------|
| adjusted total delay per vehicle | | | Total delay (per day) | | | adjusted total delay per vehicle | | | Total delay (per day) | | |
| (s) | (min) | (hr) | (s) | (min) | (hr) | (s) | (min) | (hr) | (s) | (min) | (hr) |
| 184 | 3.067 | 0.051 | 1,090,671 | 18,178 | 302.96 | 184 | 3.074 | 0.051 | 1,065,714 | 17,762 | 296.03 |
| Vehicles by type (per day) | | | Total User Cost (per day) | | | Vehicles by type (per day) | | | Total User Cost (per day) | | |
| Total | Cars | Trucks | Cars | Trucks | Total | Total | Cars | Trucks | Cars | Trucks | Total |
| 5927 | 5690 | 237 | \$ 7,599.90 | \$ 854.31 | \$ 8,454.22 | 5779 | 5541 | 238 | \$ 7,416.74 | \$ 859.75 | \$ 8,276.49 |

Appendix H

BUT-4 Preliminary Cost Estimate

BUT-4-23.90; PID 117275
Preliminary Estimate of Probable Costs For Feasibility Study

| Items | Unit | Unit Cost \$ (2023) | Quantity | Total \$ |
|--|-------|---------------------|----------|--------------------|
| Construction Costs - BUT-4-23.90 - Alternate 1 (13.8' Vertical Clearance) | | | | |
| Roadway | | | | |
| Clearing and Grubbing | Lump | \$10,000 | 1 | \$10,000 |
| Walk Removed | Sq Ft | \$4 | 3986 | \$15,944 |
| Curb Removed | Ft | \$7.25 | 899 | \$6,518 |
| Curb and Gutter Removed | Ft | \$11.50 | 261 | \$3,002 |
| Excavation | Cu Yd | \$18 | 131 | \$2,358 |
| Excavation, As Per Plan (Retention Pond) | Cu Yd | \$25 | 433 | \$10,825 |
| Subgrade Compaction | Sq Yd | \$3 | 899 | \$2,697 |
| Proof Rolling | Hour | \$325 | 1 | \$325 |
| Geogrid | Sq Yd | \$2.50 | 899 | \$2,248 |
| 4" Concrete Walk | Sq Ft | \$8.50 | 5160 | \$43,860 |
| Curb Ramp | Sq Ft | \$18.50 | 144 | \$2,664 |
| Erosion Control | | | | |
| Seeding and Mulching | Sq Yd | \$2 | 318 | \$636 |
| Erosion Control | Each | \$1 | 27457 | \$27,457 |
| Drainage | | | | |
| Special - Fill and Plug Existing Conduit | Ft | \$30 | 16 | \$480 |
| Pipe Removed, 24" and Under | Ft | \$22 | 0 | \$0 |
| Pipe Removed, Over 24" | Ft | \$35 | 41 | \$1,435 |
| Catch Basin Removed | Each | \$425 | 5 | \$2,125 |
| Special - Pipe Cleanout, 24" and Under | Ft | \$22 | 304 | \$6,688 |
| Special - Pipe Cleanout, 27" to 48" | Ft | \$34 | 257 | \$8,738 |
| Special - Pipe Cleanout, Over 48" | Ft | \$33 | 321 | \$10,593 |
| 6" Shallow Pipe Underdrains with Geotextile Fabric | Ft | \$12 | 726 | \$8,712 |
| 6" Conduit, Type F for Underdrain Outlets | Ft | \$25 | 40 | \$1,000 |
| 12" Conduit, Type B | Ft | \$110 | 238 | \$26,180 |
| Catch Basin, No. 3 | Each | \$4,500 | 15 | \$67,500 |
| Manhole, No. 3 | Each | \$5,500 | 1 | \$5,500 |
| Manhole Adjusted to Grade | Each | \$900 | 13 | \$11,700 |
| Flap Gate | Lump | \$45,000 | 1 | \$45,000 |
| Drainage Misc. | Lump | \$40,000 | 1 | \$40,000 |
| Pavement | | | | |
| Pavement Removed | Sq Yd | \$12 | 899 | \$10,788 |
| Full Depth Pavement Sawing | Ft | \$3.50 | 683 | \$2,391 |
| Pavement Planing, Asphalt Concrete | Sq Yd | \$2 | 21920 | \$43,840 |
| Asphalt Concrete Base, PG64-22, (449) | Cu Yd | \$200 | 131 | \$26,200 |
| Aggregate Base | Cu Yd | \$70 | 131 | \$9,170 |
| 1.25" Asphalt Concrete Surface Course, Type 1, (448), PG64-22 | Cu Yd | \$210 | 802 | \$168,420 |
| 1.75" Asphalt Concrete Intermediate Course, Type 2, (448) | Cu Yd | \$255 | 1120 | \$285,600 |
| Non-Tracking Tack Coat | Gal | \$4 | 1416 | \$5,664 |
| Tack Coat, 702.13 | Gal | \$4 | 1460 | \$5,840 |
| Combination Curb and Gutter, Type 2 | Ft | \$30 | 287 | \$8,610 |
| Curb, Type 6 | Ft | \$28 | 674 | \$18,872 |
| Traffic Control | | | | |
| RPM | Each | \$40 | 55 | \$2,200 |
| Edge Line, 6" | Mile | \$4,200 | 1.79 | \$7,518 |
| Lane Line, 6" | Mile | \$3,400 | 0.99 | \$3,366 |
| Center Line | Mile | \$5,000 | 0.65 | \$3,250 |
| Channelizing Line, 8" | Ft | \$3 | 569 | \$1,707 |
| Stop Line | Ft | \$14 | 74 | \$1,036 |
| Transverse/Diagonal Line | Ft | \$11 | 636 | \$6,996 |
| Island Marking | Sf | \$8 | 170 | \$1,360 |
| Lane Arrow | Each | \$200 | 17 | \$3,400 |
| Signing Misc. | Lump | \$2,000 | 1 | \$2,000 |
| Traffic Signals | | | | |
| Detector Loop | Each | \$1,850 | 4 | \$7,400 |
| Maintenance of Traffic | | | | |
| Law Enforcement Officer with Patrol Car for Assistance | Hour | \$82 | 32 | \$2,624 |
| Special - Work Zone Traffic Signal | Each | \$25,000 | 1 | \$25,000 |
| Increased Barrier Delineation | Ft | \$2 | 621 | \$1,242 |
| Work Zone Impact Attenuator, 24" Wide Hazards, (Bidirectional) | Each | \$2,300 | 8 | \$18,400 |
| Detour Signing | Lump | \$15,000 | 1 | \$15,000 |
| Work Zone Lighting System | Each | \$13,000 | 1 | \$13,000 |
| Barrier Reflector, Type 1, Bidirectional | Each | \$12 | 17 | \$204 |
| Object Marker, Two Way | Each | \$19 | 17 | \$323 |
| Work Zone Lane Line, Class I, 642 Paint | Mile | \$700 | 0.01 | \$10 |
| Work Zone Center Line, Class I, 642 Paint | Mile | \$1,500 | 0.03 | \$45 |
| Work Zone Edge Line, Class I, 6", 642 Paint | Mile | \$1,000 | 0.27 | \$273 |
| Work Zone Edge Line, Class I, 6", 740.06, Type I | Mile | \$10,300 | 0.07 | \$687 |
| Work Zone Dotted Line, Class I, 6", 642 Paint | Ft | \$1 | 93 | \$93 |
| Work Zone Stop Line, Class I, 740.06, Type I | Ft | \$20 | 56 | \$1,120 |
| Portable Barrier, Unanchored | Ft | \$15 | 621 | \$9,315 |
| Removal of Pavement Marking | Ft | \$2 | 1121 | \$2,242 |
| Removal of Pavement Marking | Each | \$225 | 2 | \$450 |
| Primary Cost Drivers Subtotal | | | | \$1,079,839 |
| Incidentals | | | | |
| Railroad Insurance | Lump | | 1 | \$12,500 |
| Maintenance of Traffic (MOT) | Lump | | 1 | \$32,395 |
| Construction Layout Stakes | Lump | | 1 | \$8,099 |
| Field Office, Type B | Month | \$2,200 | 8 | \$17,600 |
| Mobilization | Lump | | 1 | \$21,597 |
| Contingencies for items not included (30%) | Lump | | 1 | \$323,952 |
| R/W | | | | |
| CSX Railroad Construction Agreement | Lump | | | \$10,000 |
| Summary of Probable Construction Costs 2024 | | | | \$1,506,000 |
| Probable Construction Costs Including 17.1% for 2027 | | | | \$1,770,000 |
| Right-of-Way Acquisition Costs | | | | \$0 |
| TOTAL ESTIMATED PROJECT COST | | | | \$1,770,000 |

BUT-4-23.90; PID 117275
Preliminary Estimate of Probable Costs For Feasibility Study

| Items | Unit | Unit Cost \$ (2023) | Quantity | Total \$ |
|--|-------|---------------------|----------|--------------------|
| Construction Costs - BUT-4-23.90 - Alternate 2 (14.0' Vertical Clearance) | | | | |
| Roadway | | | | |
| Clearing and Grubbing | Lump | \$15,000 | 1 | \$15,000 |
| Walk Removed | Sq Ft | \$4 | 3986 | \$15,944 |
| Curb Removed | Ft | \$7.25 | 612 | \$4,437 |
| Curb and Gutter Removed | Ft | \$11.50 | 316 | \$3,634 |
| Excavation | Cu Yd | \$18 | 285 | \$5,130 |
| Excavation, As Per Plan (Retention Pond) | Cu Yd | \$25 | 517 | \$12,925 |
| Subgrade Compaction | Sq Yd | \$3 | 1682 | \$5,046 |
| Proof Rolling | Hour | \$325 | 1 | \$325 |
| Geogrid | Sq Yd | \$2.50 | 1682 | \$4,205 |
| 4" Concrete Walk | Sq Ft | \$8.50 | 5160 | \$43,860 |
| Curb Ramp | Sq Ft | \$18.50 | 144 | \$2,664 |
| Erosion Control | | | | |
| Seeding and Mulching | Sq Yd | \$2 | 530 | \$1,060 |
| Erosion Control | Each | \$1 | 27932 | \$27,932 |
| Drainage | | | | |
| Special - Fill and Plug Existing Conduit | Ft | \$30 | 16 | \$480 |
| Pipe Removed, 24" and Under | Ft | \$22 | 0 | \$0 |
| Pipe Removed, Over 24" | Ft | \$35 | 41 | \$1,435 |
| Catch Basin Removed | Each | \$425 | 5 | \$2,125 |
| Special - Pipe Cleanout, 24" and Under | Ft | \$22 | 304 | \$6,688 |
| Special - Pipe Cleanout, 27" to 48" | Ft | \$34 | 257 | \$8,738 |
| Special - Pipe Cleanout, Over 48" | Ft | \$33 | 321 | \$10,593 |
| 6" Shallow Pipe Underdrains with Geotextile Fabric | Ft | \$12 | 720 | \$8,640 |
| 6" Conduit, Type F for Underdrain Outlets | Ft | \$25 | 40 | \$1,000 |
| 12" Conduit, Type B | Ft | \$110 | 238 | \$26,180 |
| Catch Basin, No. 3 | Each | \$4,500 | 15 | \$67,500 |
| Manhole, No. 3 | Each | \$5,500 | 1 | \$5,500 |
| Manhole Adjusted to Grade | Each | \$900 | 13 | \$11,700 |
| Flap Gate | Lump | \$45,000 | 1 | \$45,000 |
| Drainage Misc. | Lump | \$40,000 | 1 | \$40,000 |
| Pavement | | | | |
| Pavement Removed | Sq Yd | \$12 | 1629 | \$19,548 |
| Full Depth Pavement Sawing | Ft | \$3.50 | 90 | \$315 |
| Pavement Planing, Asphalt Concrete | Sq Yd | \$2 | 21662 | \$43,324 |
| Asphalt Concrete Base, PG64-22, (449) | Cu Yd | \$200 | 273 | \$54,600 |
| Aggregate Base | Cu Yd | \$70 | 273 | \$19,110 |
| 1.25" Asphalt Concrete Surface Course, Type 1, (448), PG64-22 | Cu Yd | \$210 | 816 | \$171,360 |
| 1.75" Asphalt Concrete Intermediate Course, Type 2, (448) | Cu Yd | \$255 | 1141 | \$290,955 |
| Non-Tracking Tack Coat | Gal | \$4 | 1591 | \$6,364 |
| Tack Coat, 702.13 | Gal | \$4 | 1430 | \$5,720 |
| Combination Curb and Gutter, Type 2 | Ft | \$30 | 316 | \$9,480 |
| Curb, Type 6 | Ft | \$28 | 674 | \$18,872 |
| 8" Non-Reinforced Concrete Pavement, Class QC MS (Drives) | Sq Yd | \$100 | 72 | \$7,200 |
| Traffic Control | | | | |
| RPM | Each | \$40 | 55 | \$2,200 |
| Edge Line, 6" | Mile | \$4,200 | 1.82 | \$7,644 |
| Lane Line, 6" | Mile | \$3,400 | 0.99 | \$3,366 |
| Center Line | Mile | \$5,000 | 0.69 | \$3,450 |
| Channelizing Line, 8" | Ft | \$3 | 569 | \$1,707 |
| Stop Line | Ft | \$14 | 74 | \$1,036 |
| Transverse/Diagonal Line | Ft | \$11 | 724 | \$7,964 |
| Island Marking | Sf | \$8 | 255 | \$2,040 |
| Lane Arrow | Each | \$200 | 17 | \$3,400 |
| Signing Misc. | Lump | \$2,000 | 1 | \$2,000 |
| Traffic Signals | | | | |
| Detector Loop | Each | \$1,850 | 4 | \$7,400 |
| Maintenance of Traffic | | | | |
| Law Enforcement Officer with Patrol Car for Assistance | Hour | \$82 | 32 | \$2,624 |
| Special - Work Zone Traffic Signal | Each | \$25,000 | 1 | \$25,000 |
| Increased Barrier Delineation | Ft | \$2 | 989 | \$1,978 |
| Work Zone Impact Attenuator, 24" Wide Hazards, (Bidirectional) | Each | \$2,300 | 8 | \$18,400 |
| Detour Signing | Lump | \$15,000 | 1 | \$15,000 |
| Work Zone Lighting System | Each | \$13,000 | 1 | \$13,000 |
| Barrier Reflector, Type 1, Bidirectional | Each | \$12 | 24 | \$288 |
| Object Marker, Two Way | Each | \$19 | 24 | \$456 |
| Work Zone Lane Line, Class I, 642 Paint | Mile | \$700 | 0.01 | \$10 |
| Work Zone Center Line, Class I, 642 Paint | Mile | \$1,500 | 0.03 | \$45 |
| Work Zone Edge Line, Class I, 6", 642 Paint | Mile | \$1,000 | 0.34 | \$343 |
| Work Zone Edge Line, Class I, 6", 740.06, Type I | Mile | \$10,300 | 0.14 | \$1,405 |
| Work Zone Dotted Line, Class I, 6", 642 Paint | Ft | \$1 | 93 | \$93 |
| Work Zone Stop Line, Class I, 740.06, Type I | Ft | \$20 | 56 | \$1,120 |
| Portable Barrier, Unanchored | Ft | \$15 | 989 | \$14,835 |
| Removal of Pavement Marking | Ft | \$2 | 1121 | \$2,242 |
| Removal of Pavement Marking | Each | \$225 | 2 | \$450 |
| Primary Cost Drivers Subtotal | | | | \$1,164,085 |
| Incidentals | | | | |
| Railroad Insurance | Lump | | 1 | \$12,500 |
| Maintenance of Traffic (MOT) | Lump | | 1 | \$34,923 |
| Construction Layout Stakes | Lump | | 1 | \$8,731 |
| Field Office, Type B | Month | \$2,200 | 8 | \$17,600 |
| Mobilization | Lump | | 1 | \$23,282 |
| Contingencies for items not included (30%) | Lump | | 1 | \$349,226 |
| R/W | | | | |
| CSX Railroad Construction Agreement | Lump | | | \$10,000 |
| Summary of Probable Construction Costs 2024 | | | | \$1,621,000 |
| Probable Construction Costs Including 17.1% for 2027 | | | | \$1,900,000 |
| Right-of-Way Acquisition Costs | | | | \$0 |
| TOTAL ESTIMATED PROJECT COST | | | | \$1,900,000 |

BUT-4-23.90; PID 117275
Preliminary Estimate of Probable Costs For Feasibility Study

| Items | Unit | Unit Cost \$ (2023) | Quantity | Total \$ |
|--|-------|---------------------|----------|--------------------|
| Construction Costs - BUT-4-23.90 - Alternate 3 (14.5' Vertical Clearance) | | | | |
| Roadway | | | | |
| Clearing and Grubbing | Lump | \$25,000 | 1 | \$25,000 |
| Walk Removed | Sq Ft | \$4 | 3986 | \$15,944 |
| Curb Removed | Ft | \$7.25 | 612 | \$4,437 |
| Curb and Gutter Removed | Ft | \$11.50 | 316 | \$3,634 |
| Excavation | Cu Yd | \$18 | 367 | \$6,606 |
| Excavation, As Per Plan (Retention Pond) | Cu Yd | \$25 | 782 | \$19,550 |
| Subgrade Compaction | Sq Yd | \$3 | 2243 | \$6,729 |
| Proof Rolling | Hour | \$325 | 2 | \$650 |
| Geogrid | Sq Yd | \$2.50 | 2243 | \$5,608 |
| 4" Concrete Walk | Sq Ft | \$8.50 | 5160 | \$43,860 |
| Curb Ramp | Sq Ft | \$18.50 | 144 | \$2,664 |
| Railing, Aluminum | Ft | \$235 | 156 | \$36,660 |
| Erosion Control | | | | |
| Seeding and Mulching | Sq Yd | \$2 | 800 | \$1,600 |
| Erosion Control | Each | \$1 | 28299 | \$28,299 |
| Drainage | | | | |
| Special - Fill and Plug Existing Conduit | Ft | \$30 | 0 | \$0 |
| Pipe Removed, 24" and Under | Ft | \$22 | 0 | \$0 |
| Pipe Removed, Over 24" | Ft | \$35 | 322 | \$11,270 |
| Catch Basin Removed | Each | \$425 | 5 | \$2,125 |
| Special - Pipe Cleanout, 24" and Under | Ft | \$22 | 304 | \$6,688 |
| Special - Pipe Cleanout, 27" to 48" | Ft | \$34 | 257 | \$8,738 |
| Special - Pipe Cleanout, Over 48" | Ft | \$33 | 321 | \$10,593 |
| 6" Shallow Pipe Underdrains with Geotextile Fabric | Ft | \$12 | 938 | \$11,256 |
| 6" Conduit, Type F for Underdrain Outlets | Ft | \$25 | 40 | \$1,000 |
| 12" Conduit, Type B | Ft | \$110 | 238 | \$26,180 |
| Catch Basin, No. 3 | Each | \$4,500 | 15 | \$67,500 |
| Manhole, No. 3 | Each | \$5,500 | 1 | \$5,500 |
| Manhole Adjusted to Grade | Each | \$900 | 13 | \$11,700 |
| Flap Gate | Lump | \$45,000 | 1 | \$45,000 |
| Drainage Misc. | Lump | \$40,000 | 1 | \$40,000 |
| Pavement | | | | |
| Pavement Removed | Sq Yd | \$12 | 2190 | \$26,280 |
| Full Depth Pavement Sawing | Ft | \$3.50 | 90 | \$315 |
| Pavement Planing, Asphalt Concrete | Sq Yd | \$2 | 21502 | \$43,004 |
| Asphalt Concrete Base, PG64-22, (449) | Cu Yd | \$200 | 364 | \$72,800 |
| Aggregate Base | Cu Yd | \$70 | 355 | \$24,850 |
| 1.25" Asphalt Concrete Surface Course, Type 1, (448), PG64-22 | Cu Yd | \$210 | 829 | \$174,090 |
| 1.75" Asphalt Concrete Intermediate Course, Type 2, (448) | Cu Yd | \$255 | 1160 | \$295,800 |
| Non-Tracking Tack Coat | Gal | \$4 | 1634 | \$6,536 |
| Tack Coat, 702.13 | Gal | \$4 | 1449 | \$5,796 |
| Combination Curb and Gutter, Type 2 | Ft | \$30 | 316 | \$9,480 |
| Curb, Type 6 | Ft | \$28 | 518 | \$14,504 |
| 8" Non-Reinforced Concrete Pavement, Class QC MS (Drives) | Sq Yd | \$100 | 72 | \$7,200 |
| Traffic Control | | | | |
| RPM | Each | \$40 | 55 | \$2,200 |
| Edge Line, 6" | Mile | \$4,200 | 1.84 | \$7,728 |
| Lane Line, 6" | Mile | \$3,400 | 0.99 | \$3,366 |
| Center Line | Mile | \$5,000 | 0.70 | \$3,500 |
| Channelizing Line, 8" | Ft | \$3 | 569 | \$1,707 |
| Stop Line | Ft | \$14 | 74 | \$1,036 |
| Transverse/Diagonal Line | Ft | \$11 | 834 | \$9,174 |
| Island Marking | Sf | \$8 | 255 | \$2,040 |
| Lane Arrow | Each | \$200 | 17 | \$3,400 |
| Signing Misc. | Lump | \$2,000 | 1 | \$2,000 |
| Traffic Signals | | | | |
| Detector Loop | Each | \$1,850 | 4 | \$7,400 |
| Retaining Walls | | | | |
| Retaining Walls | Sq Ft | \$50 | 615 | \$30,750 |
| Maintenance of Traffic | | | | |
| Law Enforcement Officer with Patrol Car for Assistance | Hour | \$82 | 32 | \$2,624 |
| Special - Work Zone Traffic Signal | Each | \$25,000 | 1 | \$25,000 |
| Increased Barrier Delineation | Ft | \$2 | 1207 | \$2,414 |
| Work Zone Impact Attenuator, 24" Wide Hazards, (Bidirectional) | Each | \$2,300 | 8 | \$18,400 |
| Detour Signing | Lump | \$15,000 | 1 | \$15,000 |
| Work Zone Lighting System | Each | \$13,000 | 1 | \$13,000 |
| Barrier Reflector, Type 1, Bidirectional | Each | \$12 | 29 | \$348 |
| Object Marker, Two Way | Each | \$19 | 29 | \$551 |
| Work Zone Lane Line, Class I, 642 Paint | Mile | \$700 | 0.01 | \$10 |
| Work Zone Center Line, Class I, 642 Paint | Mile | \$1,500 | 0.03 | \$45 |
| Work Zone Edge Line, Class I, 6", 642 Paint | Mile | \$1,000 | 0.38 | \$384 |
| Work Zone Edge Line, Class I, 6", 740.06, Type I | Mile | \$10,300 | 0.18 | \$1,830 |
| Work Zone Dotted Line, Class I, 6", 642 Paint | Ft | \$1 | 93 | \$93 |
| Work Zone Stop Line, Class I, 740.06, Type I | Ft | \$20 | 56 | \$1,120 |
| Portable Barrier, Unanchored | Ft | \$15 | 1207 | \$18,105 |
| Removal of Pavement Marking | Ft | \$2 | 1121 | \$2,242 |
| Removal of Pavement Marking | Each | \$225 | 2 | \$450 |
| Primary Cost Drivers Subtotal | | | | \$1,305,362 |
| Incidentals | | | | |
| Railroad Insurance | Lump | | 1 | \$12,500 |
| Maintenance of Traffic (MOT) | Lump | | 1 | \$39,161 |
| Construction Layout Stakes | Lump | | 1 | \$9,790 |
| Field Office, Type B | Month | \$2,200 | 8 | \$17,600 |
| Mobilization | Lump | | 1 | \$26,107 |
| Contingencies for items not included (30%) | Lump | | 1 | \$391,609 |
| R/W | | | | |
| CSX Railroad Construction Agreement | Lump | | | \$10,000 |
| Summary of Probable Construction Costs 2024 | | | | \$1,813,000 |
| Probable Construction Costs Including 17.1% for 2027 | | | | \$2,130,000 |
| Right-of-Way Acquisition Costs | | | | \$0 |
| TOTAL ESTIMATED PROJECT COST | | | | \$2,130,000 |

BUT-4-23.90; PID 117275
Preliminary Estimate of Probable Costs For Feasibility Study

| Items | Unit | Unit Cost \$ (2023) | Quantity | Total \$ |
|--|-------|---------------------|----------|--------------------|
| Construction Costs - BUT-4-23.90 - Alternate 4 (15.0' Vertical Clearance) | | | | |
| Roadway | | | | |
| Clearing and Grubbing | Lump | \$30,000 | 1 | \$30,000 |
| Walk Removed | Sq Ft | \$4 | 3986 | \$15,944 |
| Curb Removed | Ft | \$7.25 | 612 | \$4,437 |
| Curb and Gutter Removed | Ft | \$11.50 | 316 | \$3,634 |
| Excavation | Cu Yd | \$18 | 435 | \$7,830 |
| Excavation, As Per Plan (Retention Pond) | Cu Yd | \$25 | 1111 | \$27,775 |
| Subgrade Compaction | Sq Yd | \$3 | 2712 | \$8,136 |
| Proof Rolling | Hour | \$325 | 2 | \$650 |
| Geogrid | Sq Yd | \$2.50 | 2712 | \$6,780 |
| 4" Concrete Walk | Sq Ft | \$8.50 | 5160 | \$43,860 |
| Curb Ramp | Sq Ft | \$18.50 | 144 | \$2,664 |
| Railing, Aluminum | Ft | \$235 | 156 | \$36,660 |
| Erosion Control | | | | |
| Seeding and Mulching | Sq Yd | \$2 | 925 | \$1,850 |
| Erosion Control | Each | \$1 | 83311 | \$83,311 |
| Drainage | | | | |
| Special - Fill and Plug Existing Conduit | Ft | \$30 | 0 | \$0 |
| Pipe Removed, 24" and Under | Ft | \$22 | 0 | \$0 |
| Pipe Removed, Over 24" | Ft | \$35 | 322 | \$11,270 |
| Catch Basin Removed | Each | \$425 | 5 | \$2,125 |
| Special - Pipe Cleanout, 24" and Under | Ft | \$22 | 304 | \$6,688 |
| Special - Pipe Cleanout, 27" to 48" | Ft | \$34 | 257 | \$8,738 |
| Special - Pipe Cleanout, Over 48" | Ft | \$33 | 321 | \$10,593 |
| 6" Shallow Pipe Underdrains with Geotextile Fabric | Ft | \$12 | 1036 | \$12,432 |
| 6" Conduit, Type F for Underdrain Outlets | Ft | \$25 | 40 | \$1,000 |
| 12" Conduit, Type B | Ft | \$110 | 238 | \$26,180 |
| Catch Basin, No. 3 | Each | \$4,500 | 15 | \$67,500 |
| Catch Basin Adjusted to Grade | Each | \$1,050 | 2 | \$2,100 |
| Manhole, No. 3 | Each | \$5,500 | 1 | \$5,500 |
| Manhole Adjusted to Grade | Each | \$900 | 14 | \$12,600 |
| Flap Gate | Lump | \$45,000 | 1 | \$45,000 |
| Drainage Misc. | Lump | \$40,000 | 1 | \$40,000 |
| Pavement | | | | |
| Pavement Removed | Sq Yd | \$12 | 2659 | \$31,908 |
| Full Depth Pavement Sawing | Ft | \$3.50 | 94 | \$329 |
| Pavement Planing, Asphalt Concrete | Sq Yd | \$2 | 21084 | \$42,168 |
| Asphalt Concrete Base, PG64-22, (449) | Cu Yd | \$200 | 443 | \$88,600 |
| Aggregate Base | Cu Yd | \$70 | 423 | \$29,610 |
| 1.25" Asphalt Concrete Surface Course, Type 1, (448), PG64-22 | Cu Yd | \$210 | 828 | \$173,880 |
| 1.75" Asphalt Concrete Intermediate Course, Type 2, (448) | Cu Yd | \$255 | 1159 | \$295,545 |
| Non-Tracking Tack Coat | Gal | \$4 | 1714 | \$6,856 |
| Tack Coat, 702.13 | Gal | \$4 | 1447 | \$5,788 |
| Combination Curb and Gutter, Type 2 | Ft | \$30 | 316 | \$9,480 |
| Curb, Type 6 | Ft | \$28 | 518 | \$14,504 |
| 8" Non-Reinforced Concrete Pavement, Class QC MS (Drives) | Sq Yd | \$100 | 72 | \$7,200 |
| Traffic Control | | | | |
| RPM | Each | \$40 | 55 | \$2,200 |
| Edge Line, 6" | Mile | \$4,200 | 1.84 | \$7,728 |
| Lane Line, 6" | Mile | \$3,400 | 0.99 | \$3,366 |
| Center Line | Mile | \$5,000 | 0.70 | \$3,500 |
| Channelizing Line, 8" | Ft | \$3 | 569 | \$1,707 |
| Stop Line | Ft | \$14 | 74 | \$1,036 |
| Transverse/Diagonal Line | Ft | \$11 | 834 | \$9,174 |
| Island Marking | Sf | \$8 | 255 | \$2,040 |
| Lane Arrow | Each | \$200 | 17 | \$3,400 |
| Signing Misc. | Lump | \$2,000 | 1 | \$2,000 |
| Traffic Signals | | | | |
| Detector Loop | Each | \$1,850 | 4 | \$7,400 |
| Retaining Walls | | | | |
| Retaining Walls | Sq Ft | \$50 | 615 | \$30,750 |
| Maintenance of Traffic | | | | |
| Law Enforcement Officer with Patrol Car for Assistance | Hour | \$82 | 32 | \$2,624 |
| Special - Work Zone Traffic Signal | Each | \$25,000 | 1 | \$25,000 |
| Increased Barrier Delineation | Ft | \$2 | 1387 | \$2,774 |
| Work Zone Impact Attenuator, 24" Wide Hazards, (Bidirectional) | Each | \$2,300 | 8 | \$18,400 |
| Detour Signing | Lump | \$15,000 | 1 | \$15,000 |
| Work Zone Lighting System | Each | \$13,000 | 1 | \$13,000 |
| Barrier Reflector, Type 1, Bidirectional | Each | \$12 | 32 | \$384 |
| Object Marker, Two Way | Each | \$19 | 32 | \$608 |
| Work Zone Lane Line, Class I, 642 Paint | Mile | \$700 | 0.01 | \$10 |
| Work Zone Center Line, Class I, 642 Paint | Mile | \$1,500 | 0.03 | \$45 |
| Work Zone Edge Line, Class I, 6", 642 Paint | Mile | \$1,000 | 0.42 | \$418 |
| Work Zone Edge Line, Class I, 6", 740.06, Type I | Mile | \$10,300 | 0.21 | \$2,181 |
| Work Zone Dotted Line, Class I, 6", 642 Paint | Ft | \$1 | 93 | \$93 |
| Work Zone Stop Line, Class I, 740.06, Type I | Ft | \$20 | 56 | \$1,120 |
| Portable Barrier, Unanchored | Ft | \$15 | 1387 | \$20,805 |
| Removal of Pavement Marking | Ft | \$2 | 1121 | \$2,242 |
| Removal of Pavement Marking | Each | \$225 | 2 | \$450 |
| Primary Cost Drivers Subtotal | | | | \$1,410,580 |
| Incidentals | | | | |
| Railroad Insurance | Lump | | 1 | \$12,500 |
| Maintenance of Traffic (MOT) | Lump | | 1 | \$42,317 |
| Construction Layout Stakes | Lump | | 1 | \$10,579 |
| Field Office, Type B | Month | \$2,200 | 8 | \$17,600 |
| Mobilization | Lump | | 1 | \$28,212 |
| Contingencies for items not included (30%) | Lump | | 1 | \$423,174 |
| R/W | | | | |
| CSX Railroad Construction Agreement | Lump | | | \$10,000 |
| Temporary R/W Acquisition (PPN E2250091000004) | Acre | \$42,200 | 0.003 | \$127 |
| Summary of Probable Construction Costs 2024 | | | | \$1,956,000 |
| Probable Construction Costs Including 17.1% for 2027 | | | | \$2,300,000 |
| Right-of-Way Acquisition Costs | | | | \$14,765 |
| TOTAL ESTIMATED PROJECT COST | | | | \$2,320,000 |

Appendix I

BUT-27 Drainage Area Map, Conduit Inventory and Calculations



INLET SPACING DESIGN

PID : 117275 Date : 04/24/2024 Project : BUT IR 75/VAR/5.22/VAR Location : US-27

Description : Pavement Spread at Right Sag - STA 8+28.23

Designer : SDK

Rainfall Area: C

Storm Frequency (yr.) : 5

Total Allow. Spread (ft.) : 4.00*

Allowable Depth (ft.) 0.42

| STATION | C.B. Type | GUTTER LENGTH (ft.) | RUNOFF COEF | AREA (acres) | CONC. TIME (min.) | GUTTER TIME (min.) | TIME USED (min.) | LONG. SLOPE (ft./ft.) | GUTT. SLOPE (ft./ft.) | PAVT. SLOPE (ft./ft.) | GUTT. WIDTH (ft.) | LOCAL DEPRESS. (ft.) | RAIN FALL (in./hrs.) | INTERCPTD FLOW (cfs.) | BYPASS FLOW (cfs.) | TOTAL FLOW (cfs.) | DEPTH FLOW (ft.) | PAVT. SPREAD (ft.) |
|---------|-----------|---------------------|-------------|--------------|-------------------|--------------------|------------------|-----------------------|-----------------------|-----------------------|-------------------|----------------------|----------------------|-----------------------|--------------------|-------------------|------------------|-----------------------------|
| 11+91 | Begin | | | | | | | | | | | | | | | | | |
| 9+45 | CB-3A | 218.31 | 0.67 | 0.12 | 10.00 | 1.96 | 11.96 | 0.0131 | 0.0833 | 0.0160 | 2.00 | 0.0000 | 4.46 | 0.36 | 0.00 | 0.36 | 0.155 | 1.87 *5.38' SHOULDER |
| 8+28 | CB-3 | 116.39 | 0.90 | 0.06 | 10.00 | 2.21 | 12.22 | 0.0025 | 0.0833 | 0.0160 | 2.00 | 0.0000 | 4.42 | ***** | ***** | 0.24 | 0.182 | 2.94 Sag *7.50' SHOULDER |
| 8+22 | Begin | | | | | | | | | | | | | | | | | |
| 8+28 | CB-3 | 292.02 | 0.90 | 0.01 | 10.00 | 8.94 | 18.94 | 0.0025 | 0.0833 | 0.0160 | 2.00 | 0.0000 | 3.54 | ***** | ***** | 0.03 | 0.086 | 1.03 End *7.50' SHOULDER |

SUMP DATA

Total Flow (cfs) : 0.27

Ponded Depth (ft.) : 0.008

Spread on Pavement (ft.) : 1.50

* 4.0' spread allowed in through lane, add gutter and/or varying shoulder widths through limits.



INLET SPACING DESIGN

PID : 117275 Date : 04/24/2024 Project : BUT IR 75/VAR/5.22/VAR Location : US-27

Description : Pavement Spread at Left Sag - STA 8+28.23

Designer : SDK

Rainfall Area: C

Storm Frequency (yr.) : 5

Total Allow. Spread (ft.) : 4.00*

Allowable Depth (ft.) 0.42

| STATION | C.B. Type | GUTTER LENGTH (ft.) | RUNOFF COEF | AREA (acres) | CONC. TIME (min.) | GUTTER TIME (min.) | TIME USED (min.) | LONG. SLOPE (ft./ft.) | GUTT. SLOPE (ft./ft.) | PAVT. SLOPE (ft./ft.) | GUTT. WIDTH (ft.) | LOCAL DEPRESS. (ft.) | RAIN FALL (in./hrs.) | INTERCPTD FLOW (cfs.) | BYPASS FLOW (cfs.) | TOTAL FLOW (cfs.) | DEPTH FLOW (ft.) | PAVT. SPREAD (ft.) |
|---------|-----------|---------------------|-------------|--------------|-------------------|--------------------|------------------|-----------------------|-----------------------|-----------------------|-------------------|----------------------|----------------------|-----------------------|--------------------|-------------------|------------------|-----------------------------|
| 22+50 | Begin** | | | | | | | | | | | | | | | | | |
| 20+96 | CB-3 | 154.04 | 0.78 | 0.13 | 10.00 | 2.19 | 12.19 | 0.0100 | 0.0160 | 0.0160 | 0.00 | 0.0420 | 4.42 | 0.39 | 0.06 | 0.45 | 0.096 | 5.99*** |
| 17+78 | CB-3 | 317.58 | 0.79 | 0.26 | 10.00 | 2.83 | 12.83 | 0.0210 | 0.0160 | 0.0160 | 0.00 | 0.0420 | 4.32 | 0.67 | 0.28 | 0.95 | 0.110 | 6.89**** |
| 15+25 | CB-3 | 253.72 | 0.82 | 0.41 | 10.00 | 1.38 | 11.38 | 0.0340 | 0.0291 | 0.0291 | 0.00 | 0.0420 | 4.56 | 1.34 | 0.47 | 1.81 | 0.161 | 5.53*** |
| 13+50 | CB-3 | 173.39 | 0.68 | 0.39 | 10.00 | 0.65 | 10.66 | 0.0514 | 0.0833 | 0.0460 | 2.00 | 0.0000 | 4.69 | 1.66 | 0.05 | 1.71 | 0.215 | 3.06 |
| 11+17 | CB-6 | 230.63 | 0.79 | 0.49 | 10.00 | 1.23 | 11.23 | 0.0232 | 0.0833 | 0.0328 | 2.00 | 0.0000 | 4.59 | 1.69 | 0.14 | 1.83 | 0.250 | 4.54 *4.28' SHOULDER |
| 9+89 | CB-6 | 128.01 | 0.87 | 0.16 | 10.00 | 0.91 | 10.93 | 0.0176 | 0.0833 | 0.0160 | 2.00 | 0.0000 | 4.64 | ***** | ***** | 0.79 | 0.196 | 3.81 End *4.58' SHOULDER |

*4.0' spread allowed in through lane, add gutter and/or varying shoulder widths through limits.

**Not true high point, beginning of CDSS analysis is 2 upstream structures outside of survey limits to account for Bypass Flow onto project limits.

***2 ft was added to spread limit since a 14' lane is proposed.

****Note that the allowable spread is exceeded however this catch basins falls outside of the project limits.



STORM SEWER SYSTEM

PID : 117275 Date : 04/24/2024 Project : BUT IR 75/VAR/5.22/VAR Location : US-27

Description :US-27 Drainage Network

Designer : SDK

Rainfall Area: C

Just Full Capacity Frequency (yrs.) : 10

Hydraulic Gradient Frequency (yrs.) : 25

Minimum Pipe Size : 12.00

Tailwater Elevation (ft.): 0.00

| JUNCTION | STATION | ΔAREA | ΔCA | BEGIN | RAINFALL | DISCHARGE | | | | PIPE | | | F/L PIPE | MEAN | JUST FULL | FRICT | HYGR EL. | COVER | COVER | COVER | INLET TYPE | |
|----------|---------|---------|------|--------|-----------|-----------|-----------|-----------|-----------|-----------|-----------|--------|----------|----------|-----------|----------|----------|----------|----------|-------|------------|-----------|
| From | To | Σ AREA | Σ CA | TIME | INTENSITY | (cfs.) | (10 yrs.) | (25 yrs.) | (10 yrs.) | (25 yrs.) | DIAM. | LENGTH | SLOPE | IN / OUT | VEL | CAPACITY | SLOPE | IN / OUT | IN / OUT | MINUS | MINUS | MANNING'S |
| | | (acres) | | (min.) | (10 yrs.) | (25 yrs.) | (10 yrs.) | (25 yrs.) | (in.) | (ft.) | (ft./ft.) | (ft.) | (fps.) | (cfs.) | (ft./ft.) | (ft.) | (ft.) | (ft.) | (ft.) | HY GR | CROWN | 'n' |
| BC28 | BC27 | 17+75 | 5.04 | 3.73 | 35.00 | 2.78 | 3.22 | 10.4 | 12.0 | 21 | 39.9 | 0.0133 | 906.41 | 7.01 | 17.02 | 0.0077 | 907.71 | 908.16 | 0.45 | 0.00 | MH 3 | |
| | begin | 16+48 | 5.04 | 3.73 | | | | | | | | | 905.88 | | | | 907.40 | 907.63 | | | 0.015 | |
| D224 | BC27 | 16+47 | 0.49 | 0.32 | 15.00 | 4.47 | 5.07 | 1.4 | 1.6 | 12 | 70.9 | 0.0490 | 909.72 | 6.85 | 7.35 | 0.0027 | 910.05 | 911.91 | 1.86 | 1.19 | CB 2-2B | |
| | begin | 16+48 | 5.53 | 4.05 | | | | | | | | | 906.25 | | | | 907.02 | 907.25 | | | 0.015 | |
| BC27 | D222 | 16+48 | 0.00 | 0.00 | 35.09 | 2.78 | 3.21 | 11.2 | 13.0 | 21 | 123.0 | 0.0226 | 905.88 | 8.77 | 22.21 | 0.0089 | 906.89 | 907.63 | 0.74 | 0.00 | MH BC | |
| | | 15+23 | 5.53 | 4.05 | | | | | | | | | 903.10 | | | | 904.65 | 912.15 | | | 0.015 | |
| D223 | D222 | 15+24 | 0.41 | 0.34 | 10.00 | 5.32 | 5.98 | 1.8 | 2.0 | 12 | 46.4 | 0.0192 | 907.00 | 5.20 | 4.60 | 0.0043 | 907.48 | 911.08 | 3.60 | 3.08 | CB 3 | |
| | begin | 15+23 | 5.94 | 4.39 | | | | | | | | | 906.11 | | | | 906.91 | 912.15 | | | 0.015 | |
| D222 | BC26 | 15+23 | 0.00 | 0.00 | 35.33 | 2.76 | 3.19 | 12.1 | 14.0 | 21 | 171.9 | 0.0255 | 903.25 | 9.35 | 23.58 | 0.0104 | 904.27 | 912.15 | 7.88 | 7.15 | MH 3 | |
| | | 13+54 | 5.94 | 4.39 | | | | | | | | | 898.87 | | | | 900.44 | 900.62 | | | 0.015 | |
| D221 | BC26 | 13+50 | 0.39 | 0.27 | 10.00 | 5.32 | 5.95 | 1.4 | 1.6 | 12 | 53.7 | 0.0071 | 899.62 | 3.38 | 2.79 | 0.0026 | 900.19 | 903.91 | 3.72 | 3.29 | CB 3 | |
| | begin | 13+54 | 6.33 | 4.65 | | | | | | | | | 899.24 | | | | 900.01 | 900.24 | | | 0.015 | |
| BC26 | D218 | 13+54 | 0.00 | 0.00 | 35.64 | 2.75 | 3.19 | 12.8 | 14.8 | 21 | 54.4 | 0.0335 | 898.87 | 10.49 | 27.02 | 0.0116 | 899.84 | 900.62 | 0.78 | 0.00 | MH BC | |
| | | 13+00 | 6.33 | 4.65 | | | | | | | | | 897.05 | | | | 898.64 | 903.03 | | | 0.015 | |
| D220 | D219 | 300+30 | 1.15 | 0.79 | 25.00 | 3.42 | 3.92 | 2.7 | 3.1 | 12 | 82.8 | 0.0164 | 899.10 | 5.43 | 4.26 | 0.0100 | 899.77 | 902.67 | 2.90 | 2.57 | CB 2-2B | |
| | begin | 13+00 | 7.48 | 5.44 | | | | | | | | | 897.74 | | | | 898.62 | 900.43 | | | 0.015 | |

BC = BLIND CONNECTION



STORM SEWER SYSTEM

| JUNCTION | | STATION From To | ΔAREA ΣAREA (acres) | ΔCA ΣCA | BEGIN TIME (min.) | RAINFALL INTENSITY | | DISCHARGE (cfs.) | | PIPE | | | F/L PIPE IN / OUT (ft.) | MEAN VEL (fps.) | JUST FULL CAPACITY (cfs.) | FRICT SLOPE (ft./ft.) | HYGR EL. IN / OUT (ft.) | COVER IN / OUT (ft.) | COVER MINUS HY GR | COVER MINUS CROWN | INLET TYPE MANNING'S 'n' |
|----------|------|--------------------------|---------------------------|--------------|-------------------------|-----------------------|-----------|---------------------|-----------|-------|-------|-----------|-------------------------------|-----------------------|---------------------------------|-----------------------------|-------------------------------|----------------------------|-------------------------|-------------------------|--------------------------------|
| From | To | | | | | (10 yrs.) | (25 yrs.) | (10 yrs.) | (25 yrs.) | (in.) | (ft.) | (ft./ft.) | | | | | | | | | |
| D219 | D218 | 200+40 13+00 | 0.69 8.17 | 0.37 5.82 | 25.25 | 3.40 | 3.91 | 4.0 | 4.6 | 18 | 11.7 | 0.0264 | 897.28 896.97 | 7.09 | 15.91 | 0.0025 | 898.16 898.13 | 900.43 903.03 | 2.27 | 1.65 | CB 2-2B 0.015 |
| D218 | D216 | 13+00 12+00 | 0.00 8.17 | 0.00 5.82 | 35.72 | 2.75 | 3.18 | 16.0 | 18.5 | 24 | 102.4 | 0.0325 | 896.97 893.64 | 10.97 | 38.03 | 0.0089 | 898.00 895.41 | 903.03 897.76 | 5.03 | 4.06 | MH 3 0.015 |
| D217 | D216 | 200+84 begin 12+00 | 0.20 8.37 | 0.16 5.98 | 15.00 | 4.47 | 5.08 | 0.7 | 0.8 | 12 | 32.4 | 0.0782 | 897.12 894.59 | 6.74 | 9.29 | 0.0007 | 897.33 895.28 | 899.16 897.76 | 1.83 | 1.04 | CB 2-2B 0.015 |
| D216 | D214 | 12+00 11+43 | 0.16 8.53 | 0.09 6.07 | 35.88 | 2.74 | 3.17 | 16.6 | 19.2 | 24 | 80.5 | 0.0309 | 893.50 891.01 | 10.89 | 37.10 | 0.0096 | 894.57 892.80 | 897.76 895.72 | 3.19 | 2.26 | CB 2-2B 0.015 |
| D215 | D214 | 11+44 begin 11+43 | 0.48 9.01 | 0.28 6.34 | 15.00 | 4.47 | 5.09 | 1.2 | 1.4 | 12 | 29.2 | 0.2904 | 900.29 891.82 | 12.39 | 17.90 | 0.0021 | 900.49 892.57 | 903.38 895.72 | 2.89 | 2.09 | CB 2-2B 0.015 |
| D214 | BC25 | 11+43 11+17 | 0.00 9.01 | 0.00 6.34 | 36.00 | 2.73 | 3.17 | 17.3 | 20.1 | 24 | 26.1 | 0.0283 | 890.72 889.98 | 10.62 | 35.50 | 0.0105 | 892.06 891.79 | 895.72 891.98 | 3.66 | 3.00 | MH 3 0.015 |
| D213 | BC25 | 11+17 begin 11+17 | 0.49 9.50 | 0.39 6.73 | 10.00 | 5.32 | 3.16 | 2.1 | 1.2 | 12 | 3.3 | 0.1958 | 890.63 889.98 | 12.57 | 14.70 | 0.0016 | 891.71 891.71 | 894.71 890.98 | 3.00 | 3.08 | CB 3 0.015 |
| BC25 | BC24 | 11+17 10+76 | 0.00 9.50 | 0.00 6.73 | 36.04 | 2.73 | 3.16 | 18.4 | 21.3 | 24 | 40.8 | 0.0142 | 889.98 889.40 | 8.24 | 25.14 | 0.0118 | 891.71 891.23 | 891.98 891.40 | 0.27 | 0.00 | MH BC 0.015 |
| D212 | BC24 | 10+76 begin 10+76 | 0.08 9.58 | 0.06 6.80 | 15.00 | 4.47 | 5.06 | 0.3 | 0.3 | 12 | 41.8 | 0.0217 | 890.93 890.02 | 3.22 | 4.90 | 0.0001 | 891.11 890.64 | 894.39 891.02 | 3.28 | 2.46 | CB 2-2B 0.015 |
| BC24 | BC23 | 10+76 9+89 | 0.00 9.58 | 0.00 6.80 | 36.12 | 2.73 | 3.09 | 18.5 | 21.0 | 24 | 87.2 | 0.0350 | 889.40 886.35 | 11.69 | 39.45 | 0.0114 | 890.48 888.26 | 891.40 888.35 | 0.92 | 0.00 | MH BC 0.015 |
| D211 | BC23 | 9+89 begin 9+89 | 0.16 9.74 | 0.14 6.94 | 10.00 | 5.32 | 3.09 | 0.7 | 0.4 | 12 | 2.5 | 0.4675 | 887.50 886.35 | 12.71 | 22.71 | 0.0002 | 888.26 888.26 | 891.45 887.35 | 3.19 | 2.95 | CB 6 0.015 |

BC = BLIND CONNECTION



STORM SEWER SYSTEM

| JUNCTION | | STATION | ΔAREA | ΔCA | BEGIN | RAINFALL | | DISCHARGE | | PIPE | | | F/L PIPE | MEAN | JUST FULL | FRICT | HYGR EL. | COVER | COVER | COVER | INLET TYPE |
|----------|------|-----------------------|----------------|---------------|-------------|-----------|-----------|-----------|-----------|-------------|--------------|-----------------|------------------|------------|-----------------|-----------------|------------------|------------------|-------------|-------------|---------------------|
| From | To | From To | Σ AREA (acres) | Σ CA | TIME (min.) | (10 yrs.) | (25 yrs.) | (10 yrs.) | (25 yrs.) | DIAM. (in.) | LENGTH (ft.) | SLOPE (ft./ft.) | IN / OUT (ft.) | VEL (fps.) | CAPACITY (cfs.) | SLOPE (ft./ft.) | IN / OUT (ft.) | IN / OUT (ft.) | MINUS HY GR | MINUS CROWN | MANNING'S 'n' |
| BC23 | D210 | 9+89 9+54 | 0.00 9.74 | 0.00 6.94 | 36.25 | 2.72 | 3.09 | 18.9 | 21.4 | 24 | 34.9 | 0.0284 | 886.35 885.36 | 10.86 | 35.55 | 0.0119 | 888.26 887.85 | 888.35 890.94 | 0.09 | 0.00 | MH BC 0.015 |
| D209 | D210 | 9+45 begin 9+54 | 0.12 9.86 | 0.08 7.02 | 10.00 | 5.32 | 3.09 | 0.4 | 0.2 | 12 | 38.5 | 0.0457 | 887.94 886.18 | 4.69 | 7.10 | 0.0001 | 888.07 887.85 | 890.79 890.94 | 2.72 | 1.85 | CB 6 0.015 |
| D210 | BC22 | 9+54 9+18 | 0.00 9.86 | 0.00 7.02 | 36.30 | 2.72 | 3.09 | 19.1 | 21.6 | 36 | 35.9 | 0.0014 | 884.81 884.76 | 3.45 | 23.22 | 0.0014 | 887.85 887.80 | 890.94 887.76 | 3.09 | 3.13 | MH 3 0.015 |
| D208 | BC22 | 9+19 begin 9+18 | 0.90 10.76 | 0.54 7.55 | 20.00 | 3.87 | 3.09 | 2.1 | 1.7 | 12 | 9.9 | 0.0031 | 884.78 884.75 | 2.65 | 1.86 | 0.0029 | 887.82 887.80 | 888.87 885.75 | 1.05 | 3.09 | CB 2-2B 0.015 |
| BC22 | D207 | 9+18 8+28 | 0.00 10.76 | 0.00 7.55 | 36.48 | 2.71 | 3.09 | 20.5 | 23.3 | 36 | 90.1 | 0.0014 | 884.75 884.63 | 3.43 | 22.88 | 0.0016 | 887.80 887.65 | 887.75 889.25 | -0.05** | 0.00 | MH BC 0.015 |
| D205 | D207 | 8+28 begin 8+28 | 0.07 10.83 | 0.06 7.62 | 10.00 | 5.32 | 3.09 | 0.3 | 0.2 | 12 | 49.4 | 0.0150 | 885.37 884.63 | 2.95 | 4.06 | 0.0000 | 887.65 887.65 | 889.79 889.25 | 2.14 | 3.42 | CB 3 0.015 |
| D207 | BC21 | 8+28 7+32 | 0.00 10.83 | 0.00 7.62 | 36.91 | 2.69 | 3.09 | 20.5 | 23.5 | 36 | 96.5 | 0.0014 | 884.63 884.49 | 3.49 | 23.34 | 0.0017 | 887.65 887.49 | 889.25 887.49 | 1.60 | 1.62 | MH 3 0.015 |
| D204 | BC21 | 7+32 begin 7+32 | 0.77 11.60 | 0.45 8.06 | 20.00 | 3.87 | 3.09 | 1.7 | 1.4 | 12 | 4.4 | 0.2603 | 885.63 884.49 | 13.14 | 16.95 | 0.0020 | 887.50 887.49 | 888.87 885.49 | 1.37 | 2.24 | CB 2-2B 0.015 |
| BC21 | D203 | 7+32 6+82 | 0.00 11.60 | 0.00 8.06 | 37.37 | 2.67 | 3.09 | 21.5 | 24.9 | 36 | 49.7 | 0.0014 | 884.49 884.42 | 3.50 | 23.34 | 0.0018 | 887.49 886.72 | 887.49 889.53 | 0.00 | 0.00 | MH BC 0.015 |
| D201 | D202 | 6+82 begin 6+84 | 3.41 15.01 | 1.93 9.99 | 30.00 | 3.06 | 3.54 | 5.9 | 6.8 | 39*** | 62.2 | 0.0257 | 886.11 884.51 | 7.28 | 123.45 | 0.0001 | 886.65 886.54 | 889.11 889.39 | 2.46 | -0.25 | HW Half He 0.015 |
| D202 | D203 | 6+84 6+82 | 0.61 15.62 | 0.43 10.42 | 30.14 | 3.06 | 3.53 | 7.2 | 8.3 | 36 | 3.2 | 0.0444 | 884.51 884.37 | 9.43 | 131.09 | 0.0002 | 886.33 886.33 | 889.39 889.53 | 3.06 | 1.88 | CB 2-4 0.015 |

BC = BLIND CONNECTION

CDSS 1.0.0.3.

BUT-27 Drainage Network.xml

3

* EXISTING PIPE CANNOT HANDLE 10 YEAR JUST FULL CAPACITY, BUT DOES NOT DISCHARGE OUT THE CASTING.

** HY GR IS ABOVE PIPE BUT BELOW GROUND.

*** PIPE IS 3X3 CULVERT, A 39" DIAMETER PIPE IS AN EQUIVALENT DIAMETER FOR FLUID FLOW.

**** WARNING MESSAGE BECAUSE 36" CONTINUES FROM 39" (3X3 CULVERT). THESE ARE EXISTING CONDITIONS AND CAN BE IGNORED.



STORM SEWER SYSTEM

| JUNCTION | | STATION | ΔAREA | ΔCA | BEGIN | RAINFALL | | DISCHARGE | | PIPE | | | F/L PIPE | MEAN | JUST FULL | FRICT | HYGR EL. | COVER | COVER | COVER | INLET TYPE |
|----------|-------|---------|---------|-------|--------|-----------|-----------|-----------|-----------|-------|--------|-----------|----------|--------|-----------|-----------|----------|----------|-------|-------|------------|
| From | To | From | Σ AREA | Σ CA | TIME | INTENSITY | (cfs.) | (cfs.) | (cfs.) | DIAM. | LENGTH | SLOPE | IN / OUT | VEL | CAPACITY | SLOPE | IN / OUT | IN / OUT | MINUS | MINUS | MANNING'S |
| | | To | (acres) | | (min.) | (10 yrs.) | (25 yrs.) | (10 yrs.) | (25 yrs.) | (in.) | (ft.) | (ft./ft.) | (ft.) | (fps.) | (cfs.) | (ft./ft.) | (ft.) | (ft.) | HY GR | CROWN | 'n' |
| D203 | OUT | 6+82 | 0.00 | 0.00 | 37.61 | 2.65 | 3.08 | 27.7 | 32.1 | 36 | 79.6 | 0.0139 | 884.42 | 9.15 | 73.44 | 0.0031 | 885.97 | 889.53 | 3.56 | 2.11 | MH 3 |
| | final | 0+00 | 15.62 | 10.42 | | | | | | | | | 883.31 | | | | 885.73 | 886.31 | | | 0.015 |

BC = BLIND CONNECTION

| CRS | CFN | Inlet Station | Inlet Offset | Outlet Station | Outlet Offset | Side | Inlet Structure | Inlet Survey Point # | Outlet Structure | Outlet Survey Point # | Size | Length | Pipe Material | GA | Inventory Comments | Inspection Comments | ODOT Scope Disposition | Profile Work |
|---------------|---------|---------------|--------------|----------------|---------------|------|--------------------------------|----------------------|------------------|-----------------------|-------|--------|-----------------------------|----|--|---|------------------------|---|
| BUT-27-10.536 | 1833530 | 16+46.86 | 45.33' LT | | | Both | Catch Basin | SV5272 | Other | N/A | 12 | 72 | PVC | 7 | yard drain c/b - 20' north of hussy rd. | culvert has minor joint seperation and culvert misalignment. Slight deflection throughout culvert.culvert tee' into 24" mainline. | No work | No work |
| BUT-27-10.514 | 1832925 | 15+24.55 | 19.45' LT | 15+23.33 | 27.26' RT | Both | Catch Basin | SV5158 | Manhole | SV1673 | 12 | 46 | PVC | 8 | c/b to m/h | Null | No work | No work |
| BUT-27-10.474 | 1832924 | 13+49.68 | 20.26' LT | | | Both | Catch Basin | SV1632 | Other | N/A | 12 | 54 | PVC | 7 | pipe tee's into 24" mainline on rt. side behind curb | Minor misalignment, pipe Ts into a ditch pipe | No work | Adjust catch basin to grade |
| BUT-27-10.437 | 1832923 | 11+99.78 | 40.07' RT | 11+43.29 | 16.97' LT | Both | Catch Basin | SV1172 | Manhole | SV1057 | 24 | 78 | Corrugated Steel Spiral Rib | 7 | m/h in sb lane south of sr. 130 north of railway | Minor rust along invert | No work | Adjust manhole to grade |
| BUT-27-10.424 | 1832922 | 10+75.56 | 23.70' RT | | | Both | Catch Basin | SV5307 | Other | N/A | 12 | 45 | PVC | 7 | north of the railway. c/b behind gr | this culvert was not on our inventory. c/b is behind gr on rt. at the end of fwd. abut. | No work | Adjust catch basin to grade |
| BUT-27-10.404 | 1832921 | 9+44.61 | 20.84' RT | 9+53.96 | 19.39' LT | Both | Catch Basin | SV924 | Manhole | SV940 | 12 | 39 | PVC | 7 | south of the railway | Null | No work | Adjust catch basin and manhole to grade |
| BUT-27-10.354 | 1821668 | 6+82.00 | 30.48' RT | 6+84.00 | 30.55' LT | Both | Third Height Concrete Headwall | SV5288 | Catch Basin | SV540 | 3'x3' | 63 | Concrete | 7 | box is 47' to c/b.16' of 36" concrete pipe | Leakage at joints with stalactites, abutments have some honeycomb from construction, | No work | No work |

Appendix J

BUT-27 Preliminary Plan and Profile Sheets

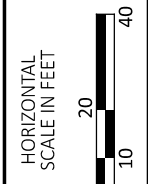
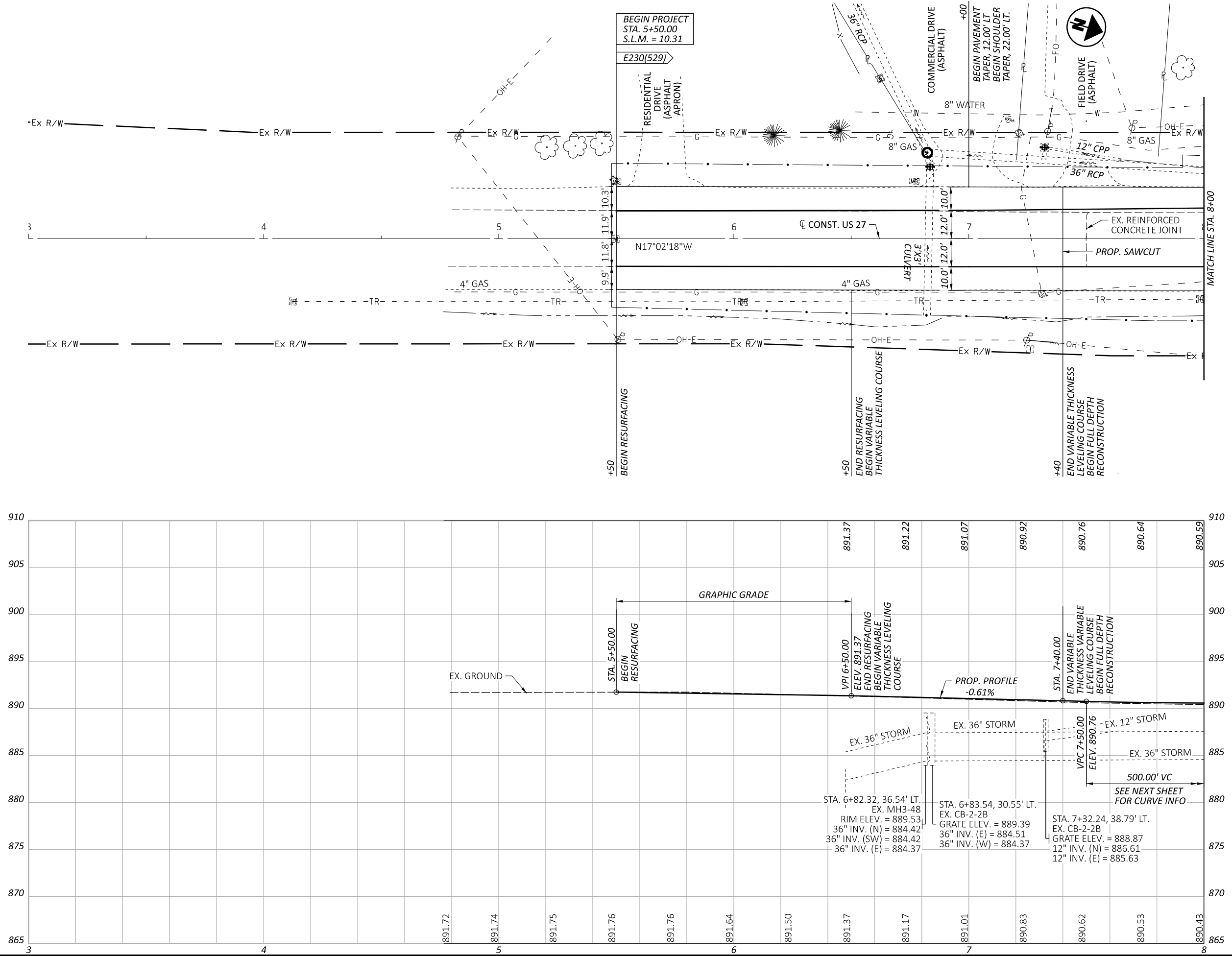

**PLAN AND PROFILE - 14.0' VERTICAL CLEARANCE
US-27 - BEGIN TO STA. 8+00**

DESIGN AGENCY



| | |
|------------|--------------|
| DESIGNER | SHT |
| REVIEWER | CWP 04-29-24 |
| PROJECT ID | 117275 |
| SHEET | P.1 |
| TOTAL | 3 |

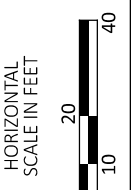
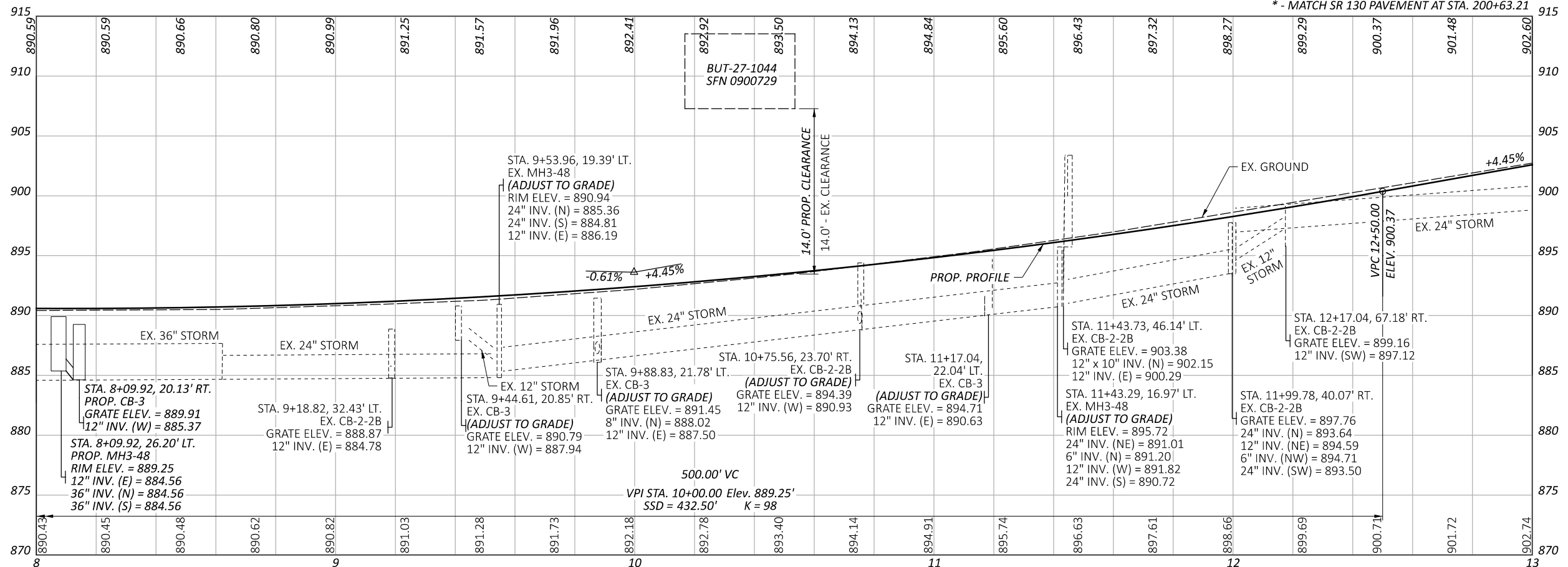
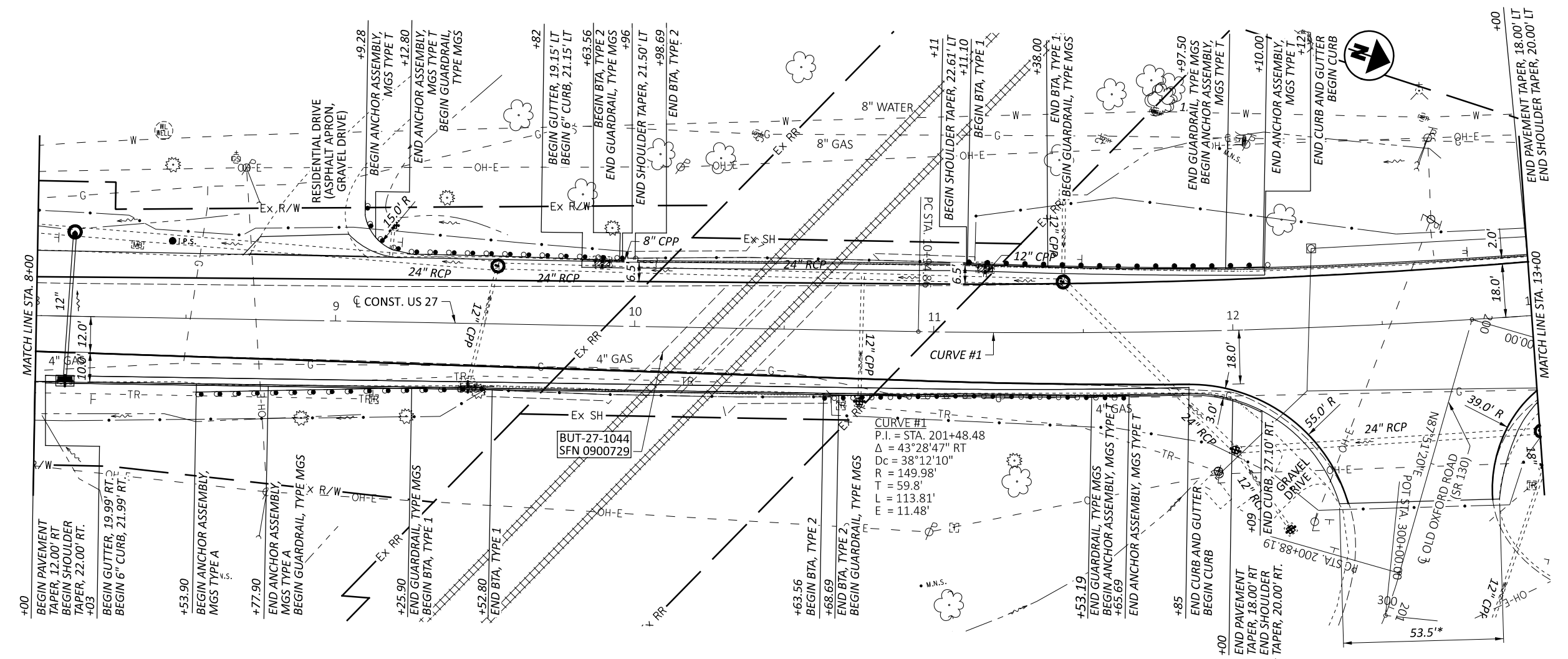

**PLAN AND PROFILE - 14.0' VERTICAL CLEARANCE
 US-27 - STA. 8+00 TO STA. 13+00**

DESIGN AGENCY



| | |
|------------|--------------|
| DESIGNER | SHT |
| REVIEWER | CWP 04-29-24 |
| PROJECT ID | 117275 |
| SHEET | P.2 |
| TOTAL | 3 |

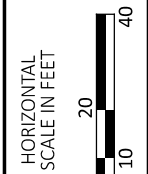
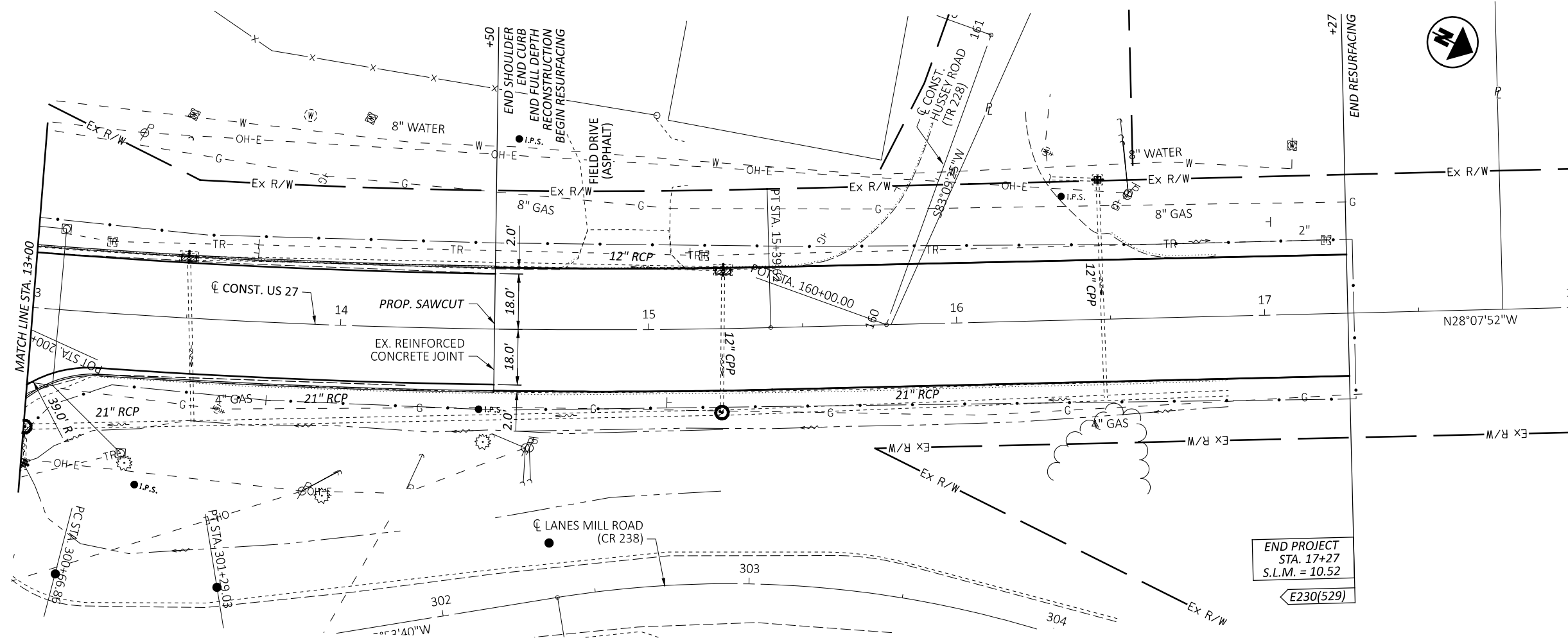
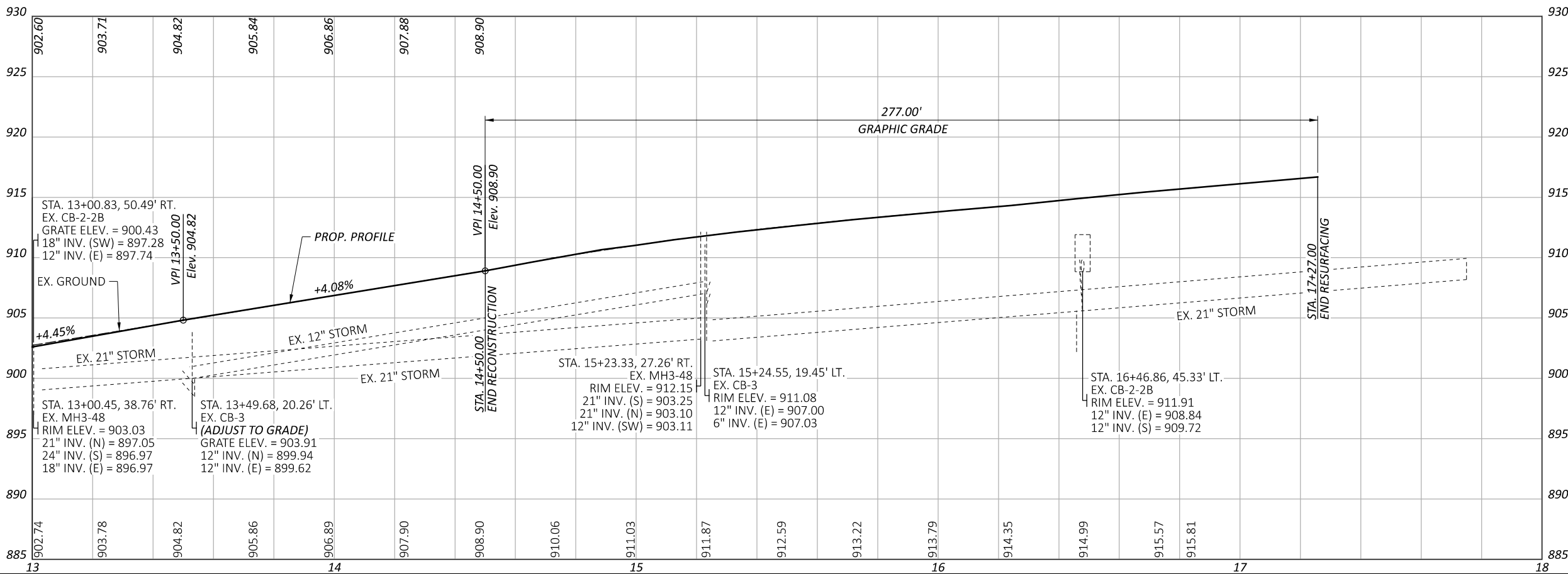

PLAN AND PROFILE - 14.0' VERTICAL CLEARANCE
US-27 - STA. 8+00 TO END

DESIGN AGENCY



DESIGNER

SHT

REVIEWER

CWP 04-29-24

PROJECT ID

117275

SHEET TOTAL

P.3 3

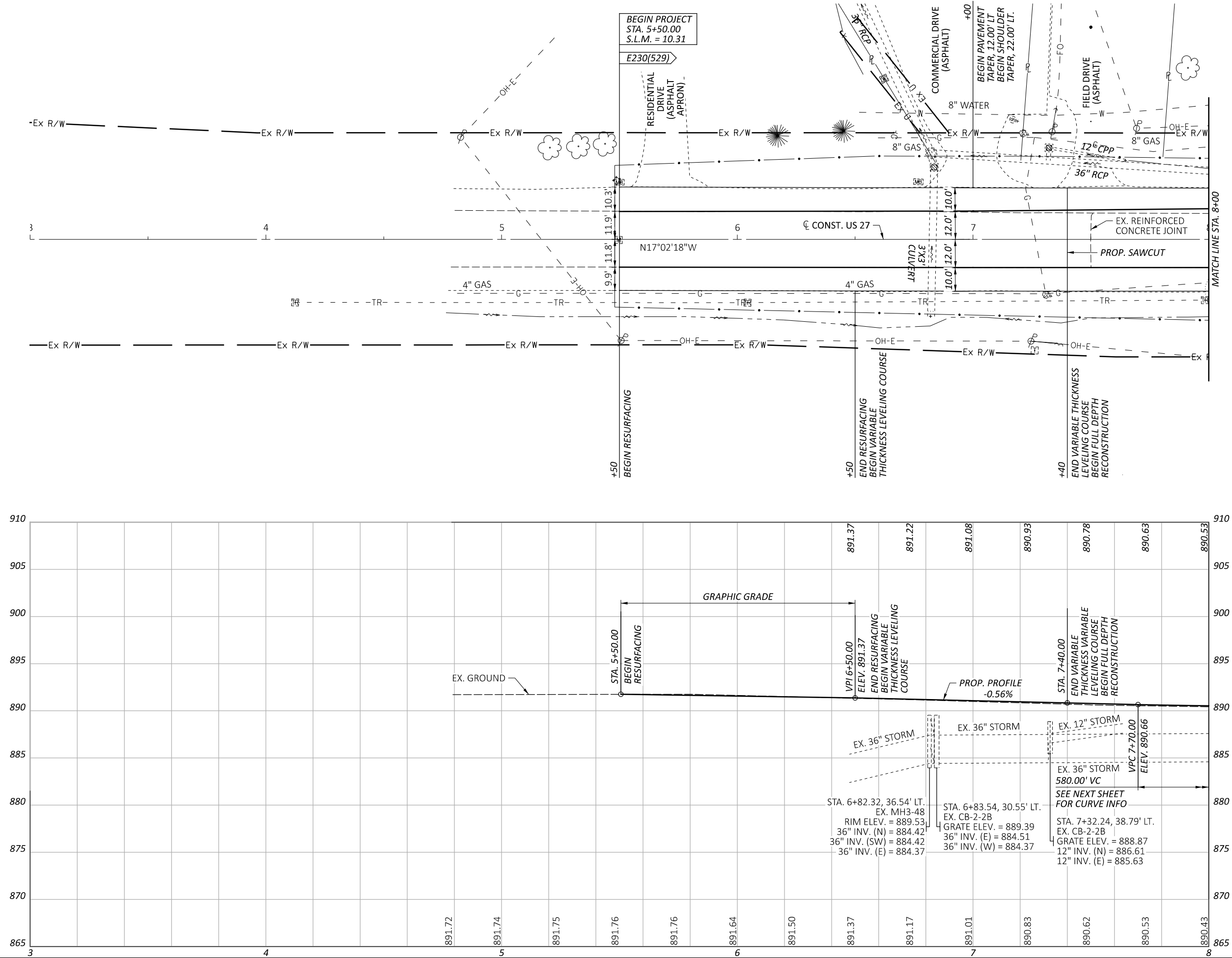

PLAN AND PROFILE - 14.5' VERTICAL CLEARANCE
US-27 - BEGIN TO STA. 8+00

DESIGN AGENCY



| | |
|------------|--------------|
| DESIGNER | SHT |
| REVIEWER | CWP 04-29-24 |
| PROJECT ID | 117275 |
| SHEET | P.1 |
| TOTAL | 3 |

BUT IR 75/VAR/5.22/VAR

MODEL: CLK_3 - Plan 2 [Sheet] PAPER SIZE: 17x11 (in.) DATE: 5/6/2024 TIME: 2:48:25 PM USER: thomas
 P:\23365 - ODOT - BUT-75-5.22\117275\400-Engineering\Roadway\Sheets\117275_GP101.dgn

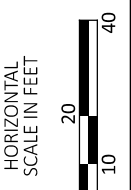
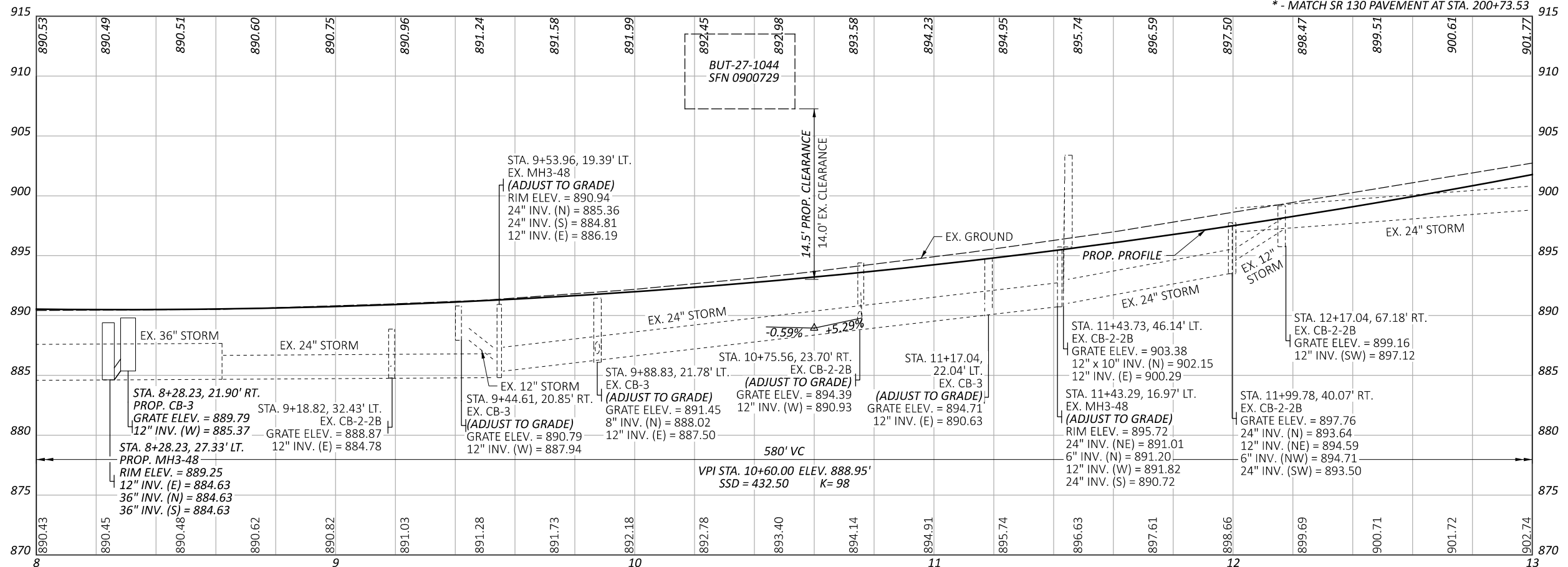
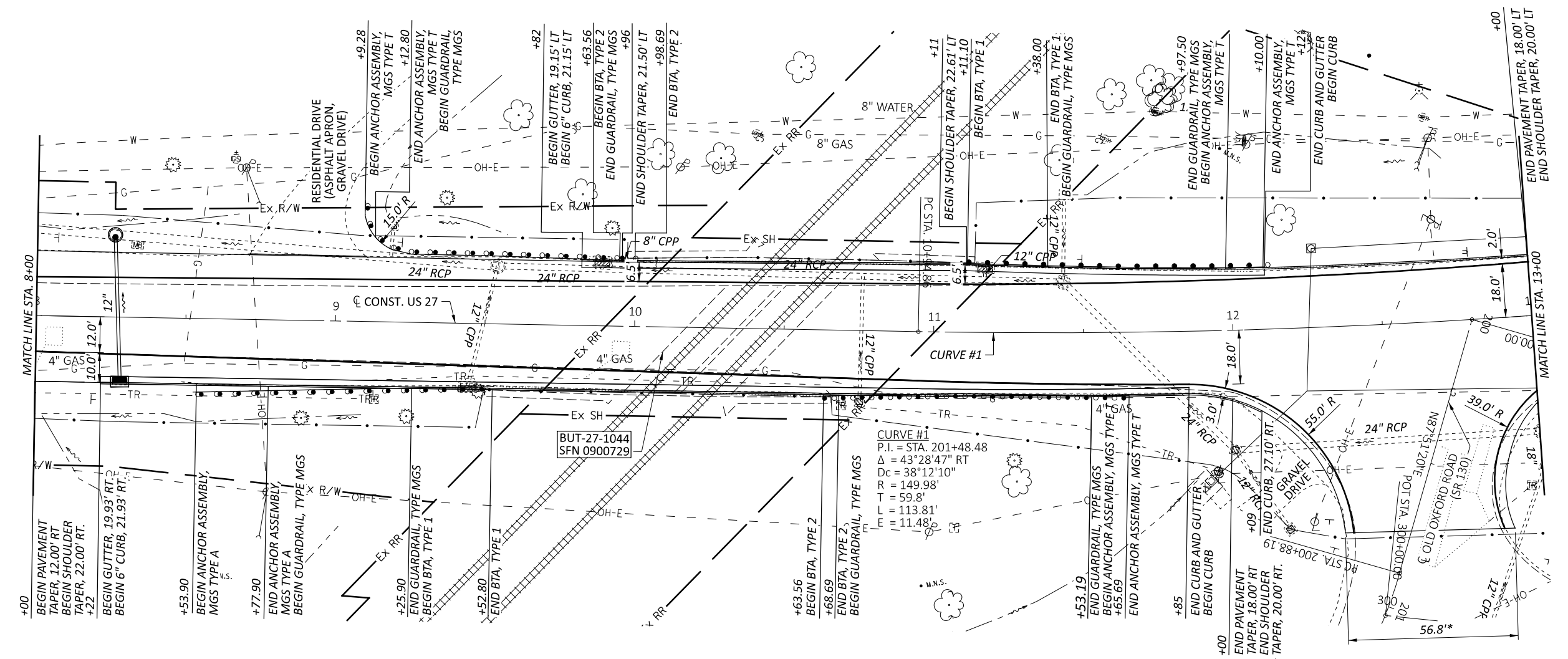

**PLAN AND PROFILE - 14.5' VERTICAL CLEARANCE
 US-27 - STA. 8+00 TO STA. 13+00**

DESIGN AGENCY



DESIGNER

REVIEWER

CWP 04-29-24

PROJECT ID

117275

SHEET TOTAL

P.2 3

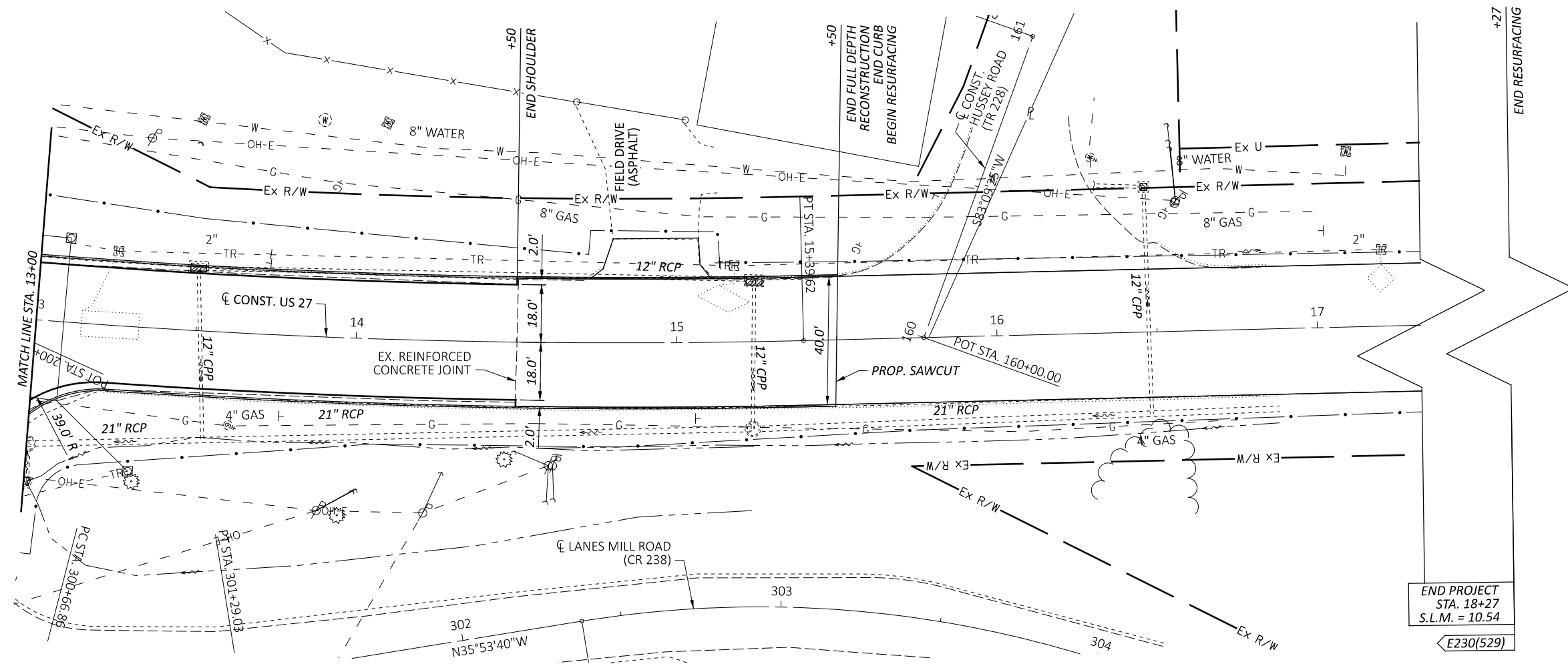
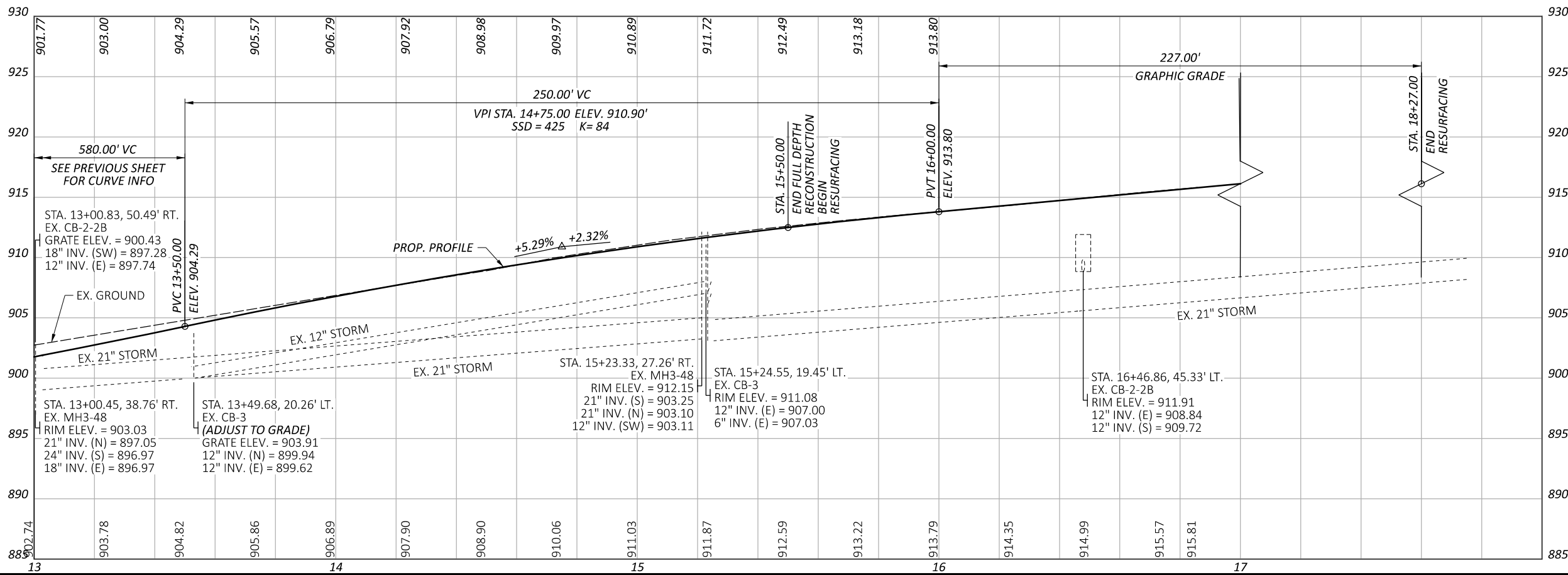

PLAN AND PROFILE - 14.5' VERTICAL CLEARANCE
US-27 - STA. 8+00 TO END

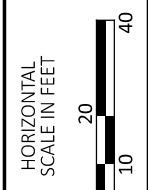

| | |
|---------------|--------------|
| DESIGN AGENCY | CVE |
| DESIGNER | SHT |
| REVIEWER | CWP 04-29-24 |
| PROJECT ID | 117275 |
| SHEET | P.3 |
| TOTAL | 3 |

Appendix K

BUT-27 Representative Typical Sections

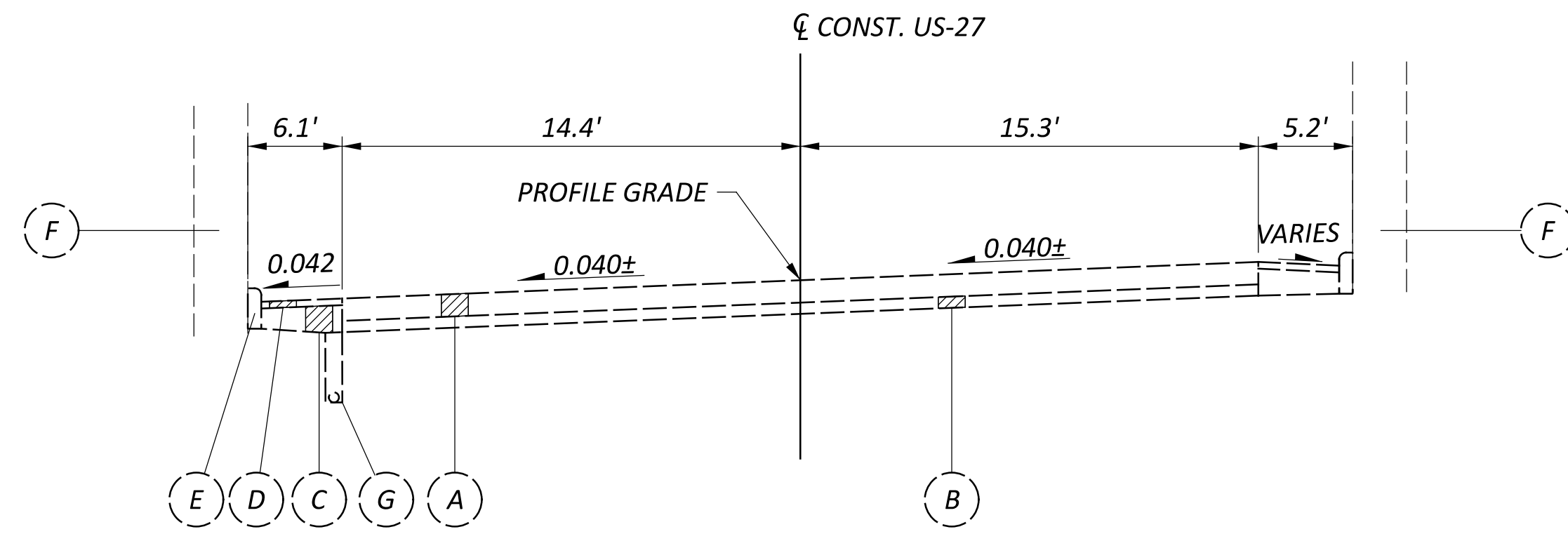

EXISTING REPRESENTATIVE (SUPERELEVATED) SECTION: US-27
STA. 10+45.37 (UNDER RAILROAD BRIDGE)

EXISTING LEGEND

- (A) 10" REINFORCED CONCRETE PAVEMENT
- (B) 5" BITUMINOUS AGGREGATE BASE, AC-20
- (C) AGGREGATE BASE, VARIABLE DEPTH
- (D) 3" ASPHALT CONCRETE
- (E) CURB, TYPE 6
- (F) EX. BRIDGE ABUTMENT
- (G) EX. 6" SHALLOW PIPE UNDERDRAIN

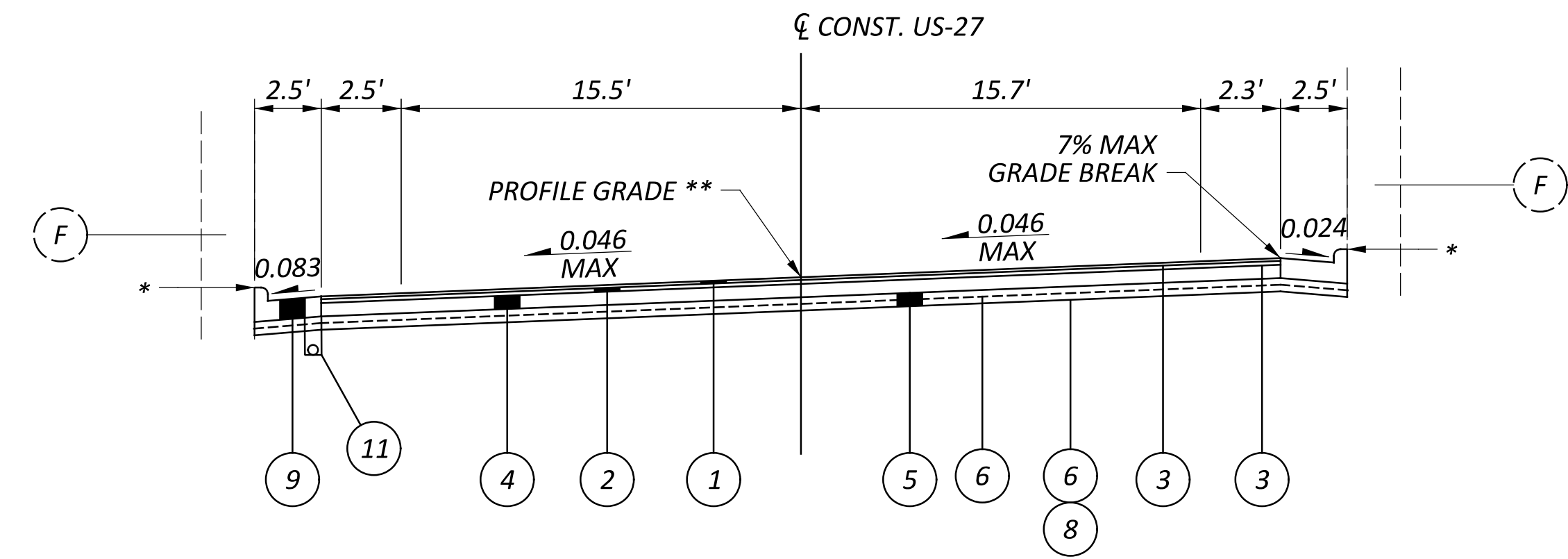

PROPOSED REPRESENTATIVE (SUPERELEVATED) SECTION: US-27
STA. 10+45.37 (UNDER RAILROAD BRIDGE)

PROPOSED LEGEND

- (1) ITEM 441 - 1.25" ASPHALT CONCRETE SURFACE COURSE, TYPE 1 (448), PG64-22
- (2) ITEM 441 - 1.75" ASPHALT CONCRETE INTERMEDIATE COURSE, TYPE 2, (448)
- (3) ITEM 407 - NON-TRACKING TACK COAT (0.055 GAL/SY)
- (4) ITEM 301 - 6" ASPHALT CONCRETE BASE, PG64-22 (449)
- (5) ITEM 304 - 6" AGGREGATE BASE
- (6) ITEM 204 - GEOGRID
- (7) ITEM 609 - COMBINATION CURB AND GUTTER, TYPE 2
- (8) ITEM 204 - PROOF ROLLING
- (9) ITEM 605 - 6" SHALLOW PIPE UNDERDRAINS WITH GEOTEXTILE FABRIC
- * MATCH EXISTING TOP OF CURB ELEVATION
- ** PROPOSED IS 0.1' HIGHER THAN EXISTING IN 14.0' OPTION AND 0.4' LOWER THAN EXISTING IN 14.5' OPTION

DESIGN AGENCY



DESIGNER

CJD

REVIEWER

CWP 05-01-24

PROJECT ID

117275

SHEET TOTAL

P.1 1

Appendix L

BUT-27 Critical Cross Sections

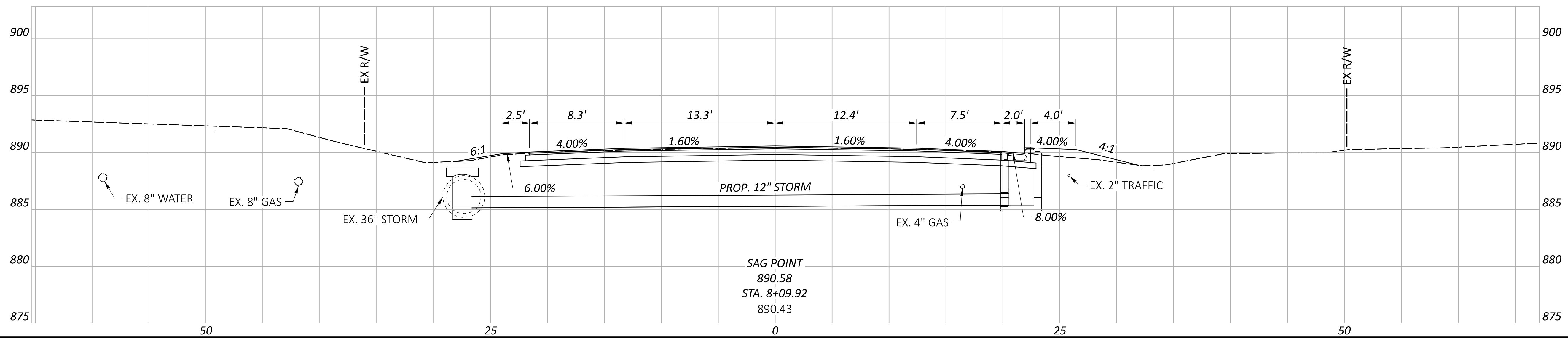
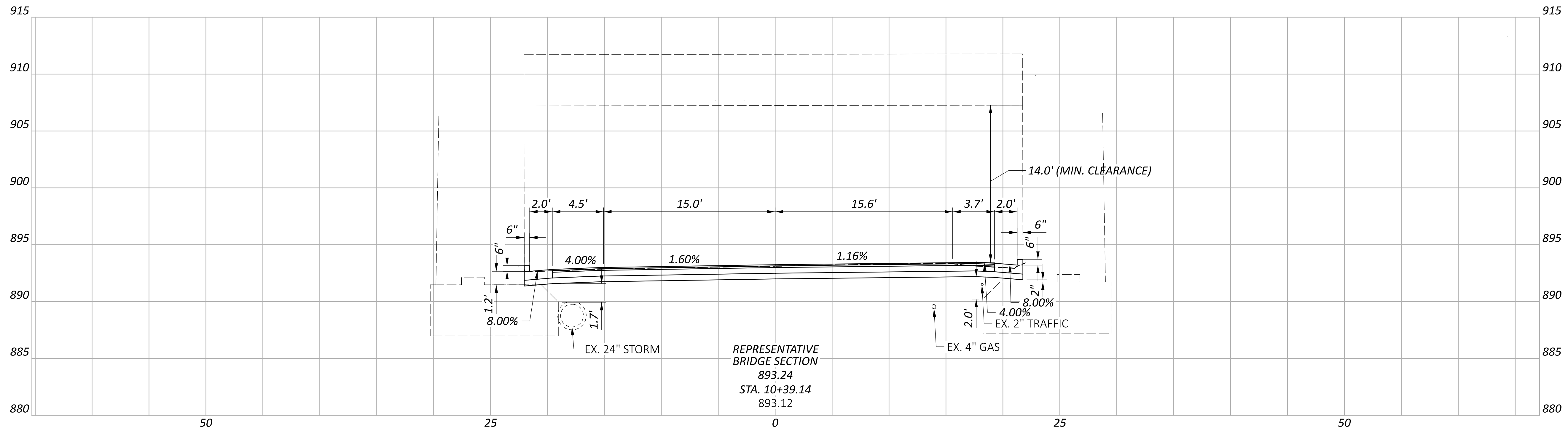
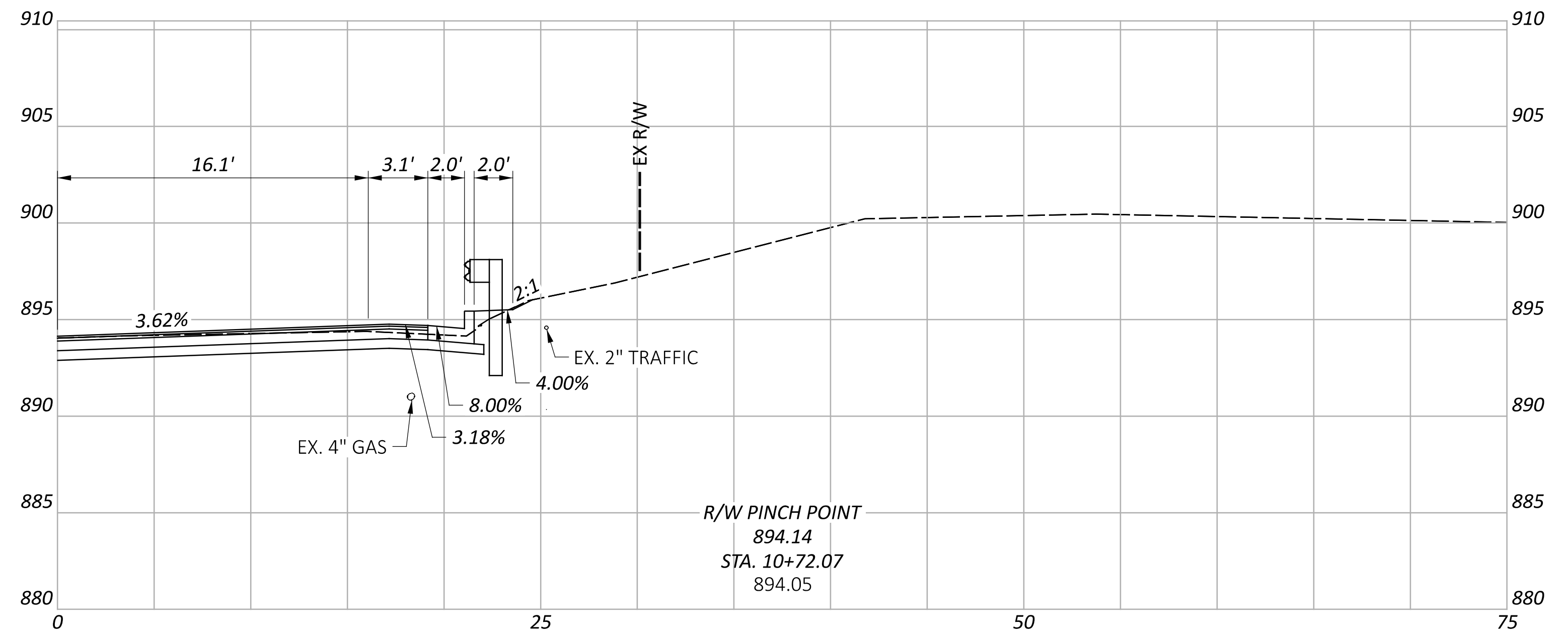

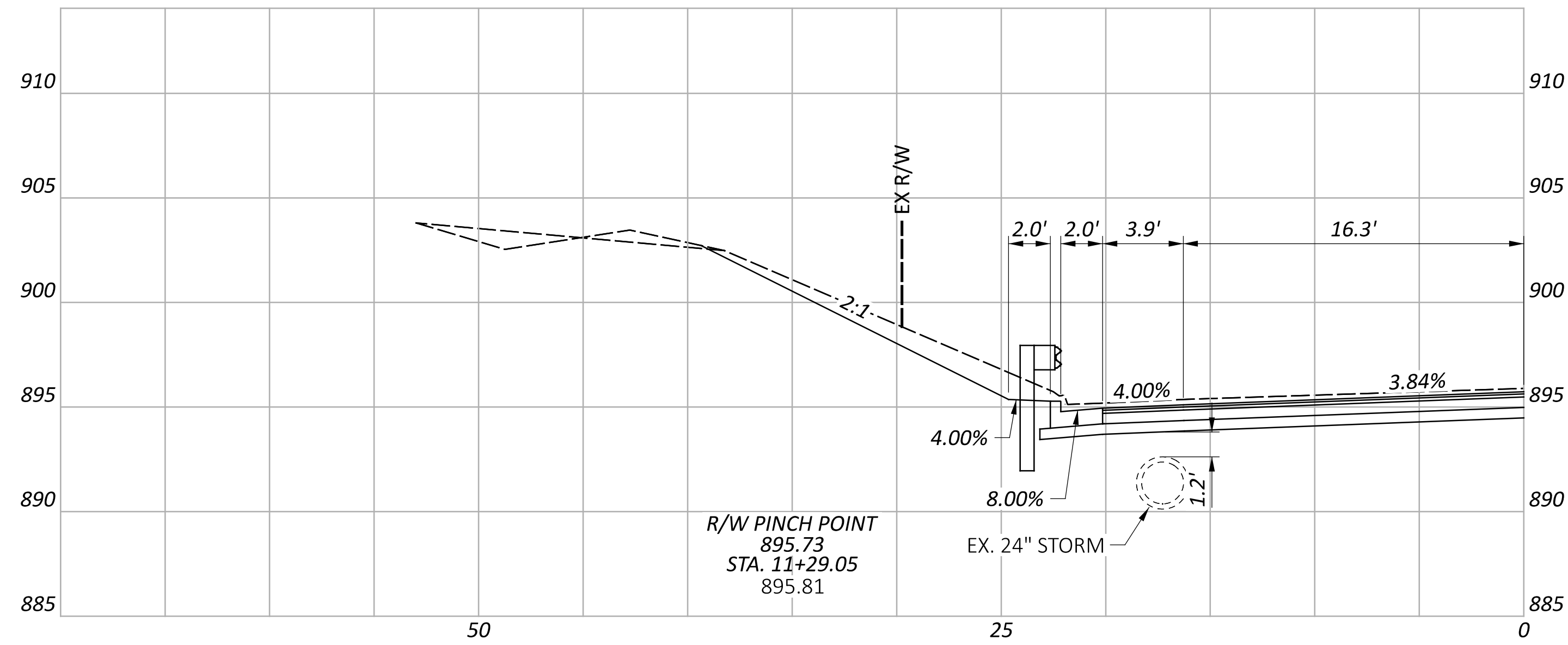

R/W PINCH POINT
 895.73
 STA. 11+29.05
 895.81

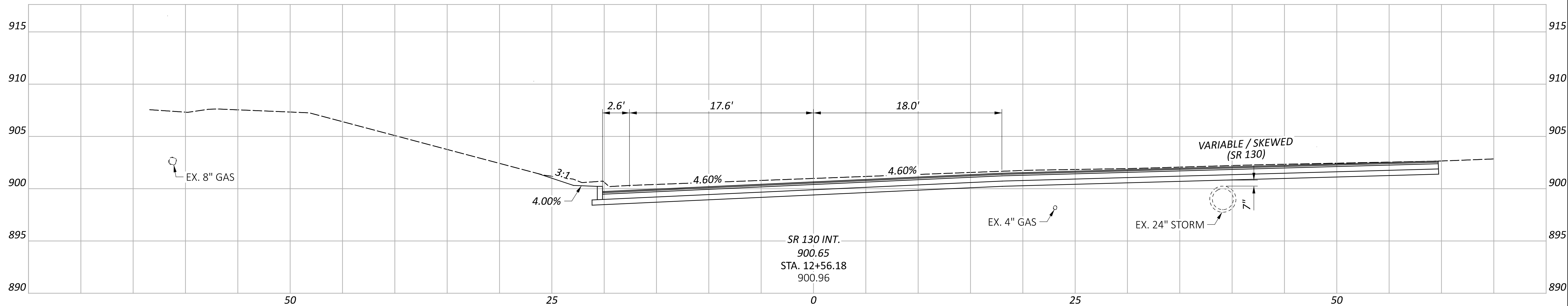

SR 130 INT.
 900.65
 STA. 12+56.18
 900.96

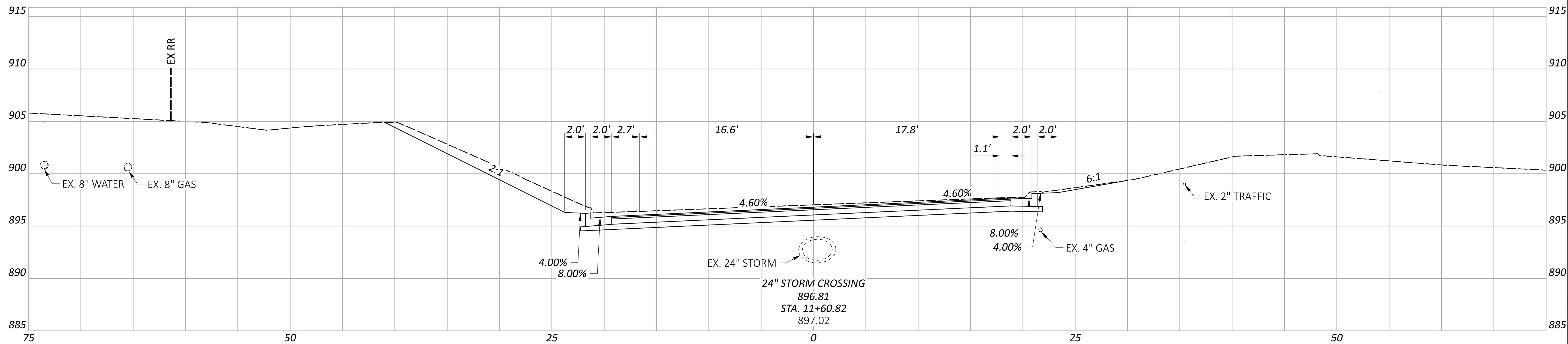

24\"/>

CROSS SECTIONS - BUT-27 - 14.0' CLEARANCE
 STA. 11+29.05 TO STA. 12+56.18

| | | |
|---------------|--------|---------|
| DESIGN AGENCY | CWE | |
| DESIGNER | SHT | |
| REVIEWER | CW | |
| PROJECT ID | 117275 | |
| SHEET | P.2 | TOTAL 2 |

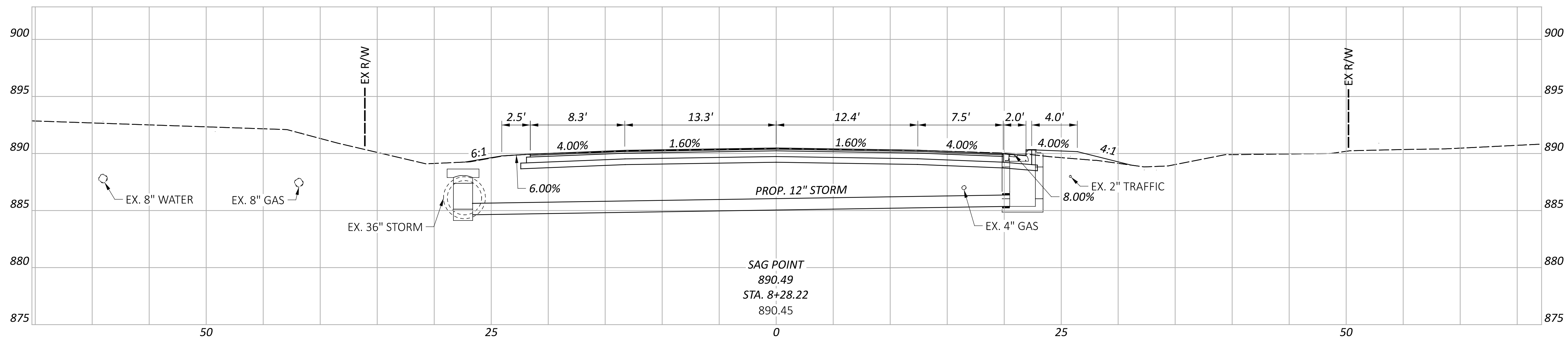
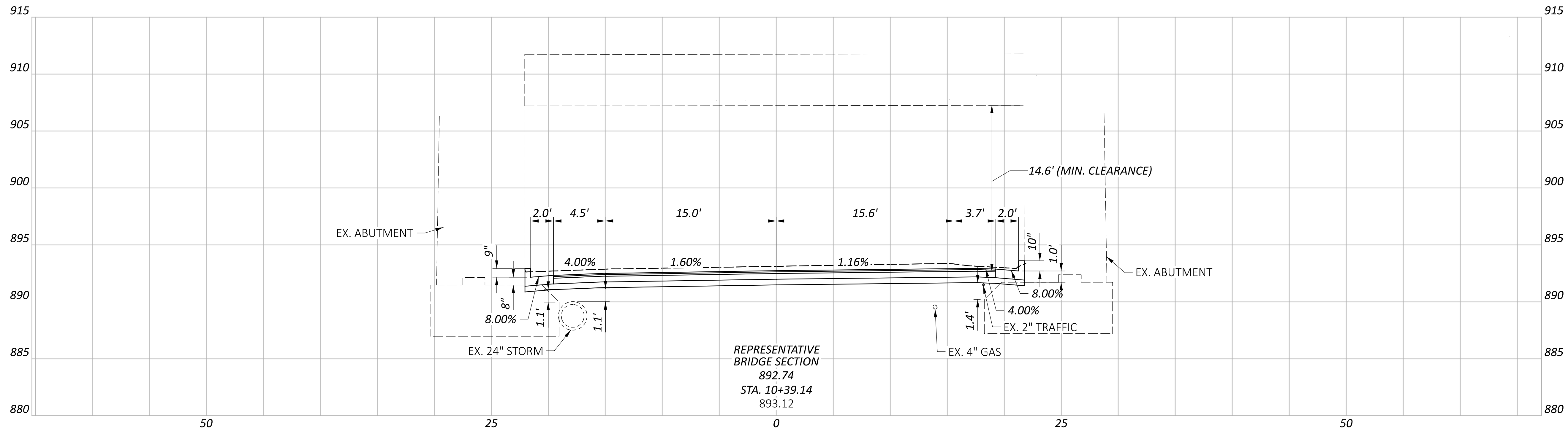
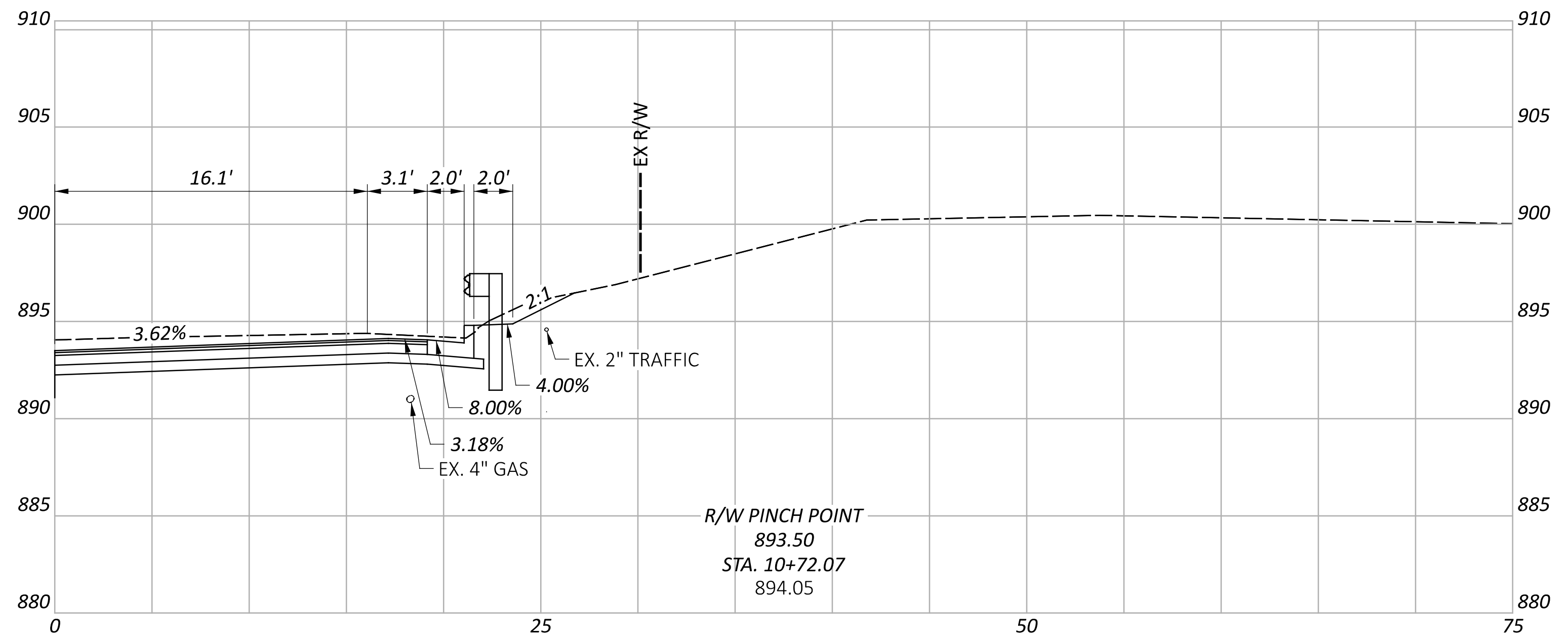

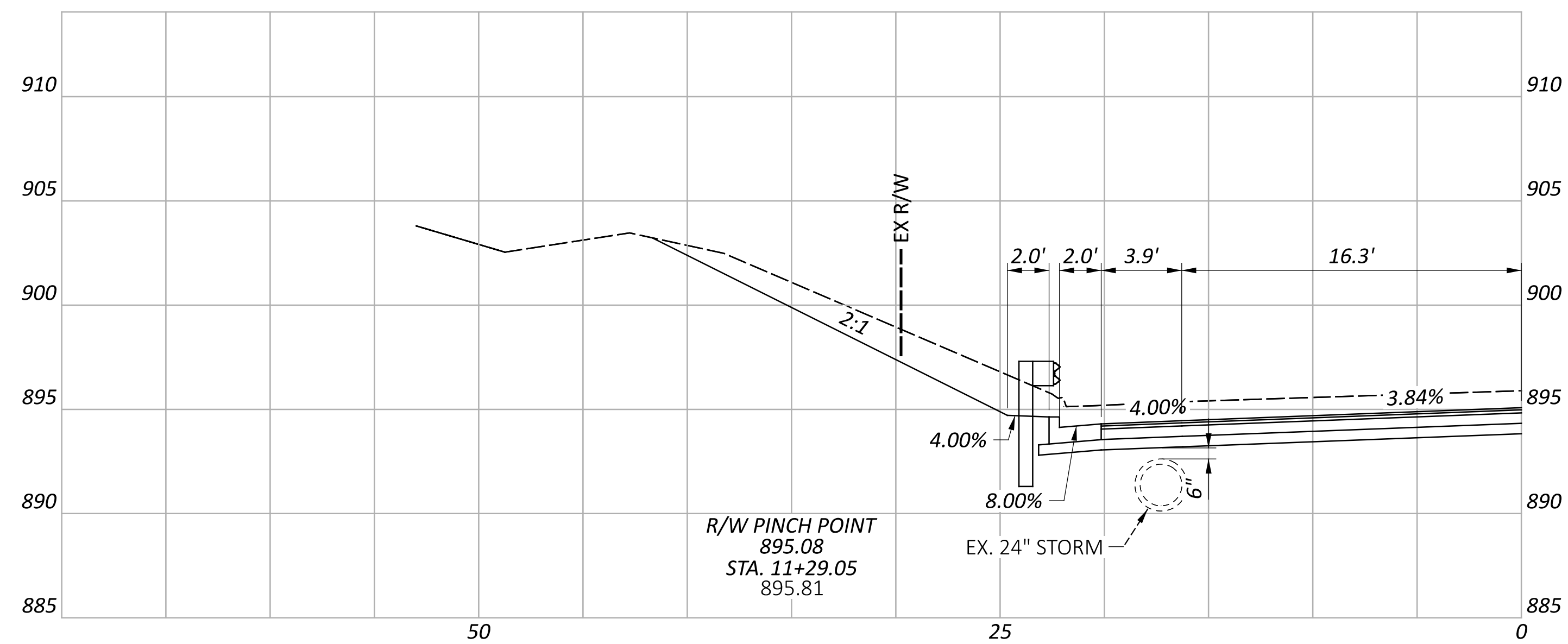
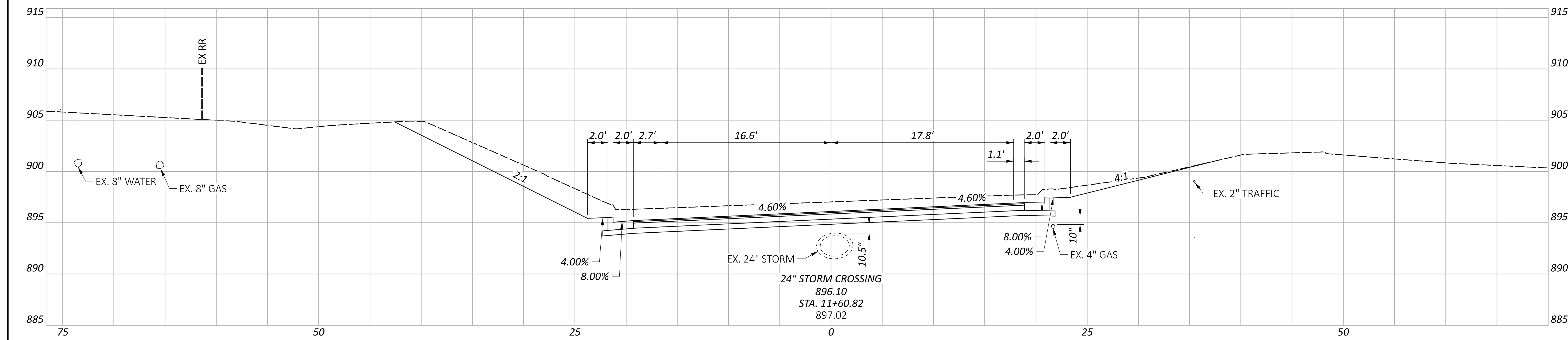
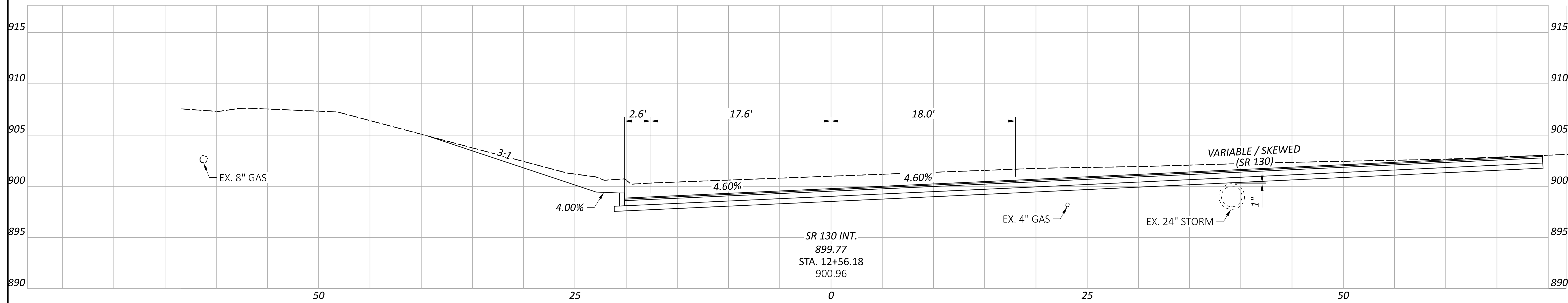

CROSS SECTIONS - BUT 27 - 14.5' CLEARANCE
 STA. 11+29.05 TO STA. 12+56.18

DESIGN AGENCY



DESIGNER

SHT

REVIEWER

CWP 4-26-24

PROJECT ID

117275

SHEET

P.2

TOTAL

2

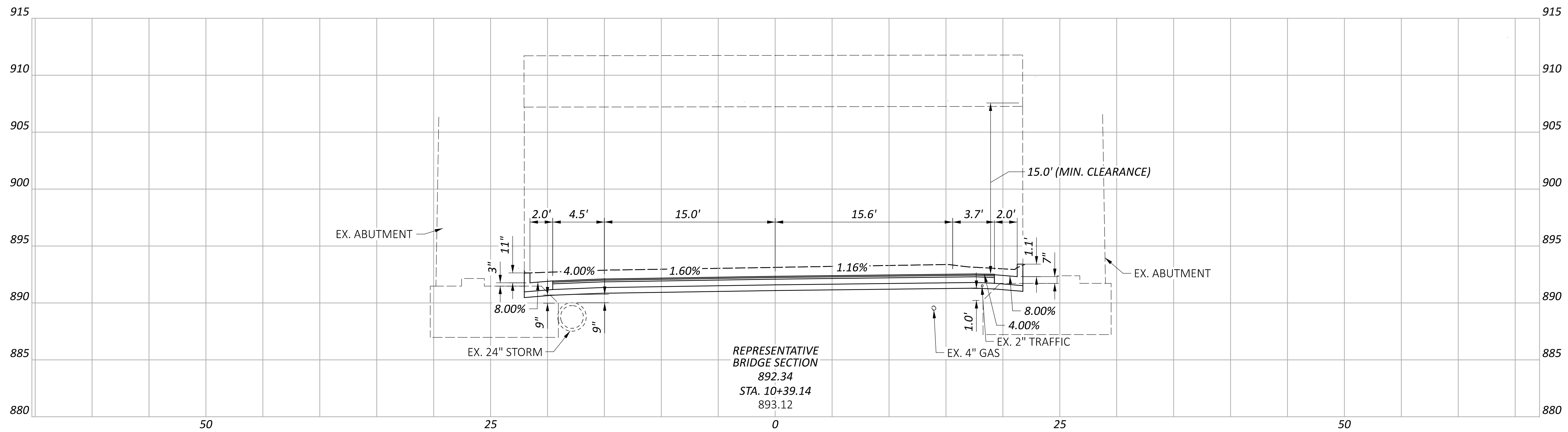

CROSS SECTIONS - BUT 27 - 15.0' CLEARANCE
STA. 8+28.22 TO STA. 10+72.07

DESIGN AGENCY



DESIGNER
SHT

REVIEWER
CWP 04-26-24

PROJECT ID
117275

SHEET TOTAL
P.1 1

Appendix M

BUT-27 Drive Profiles

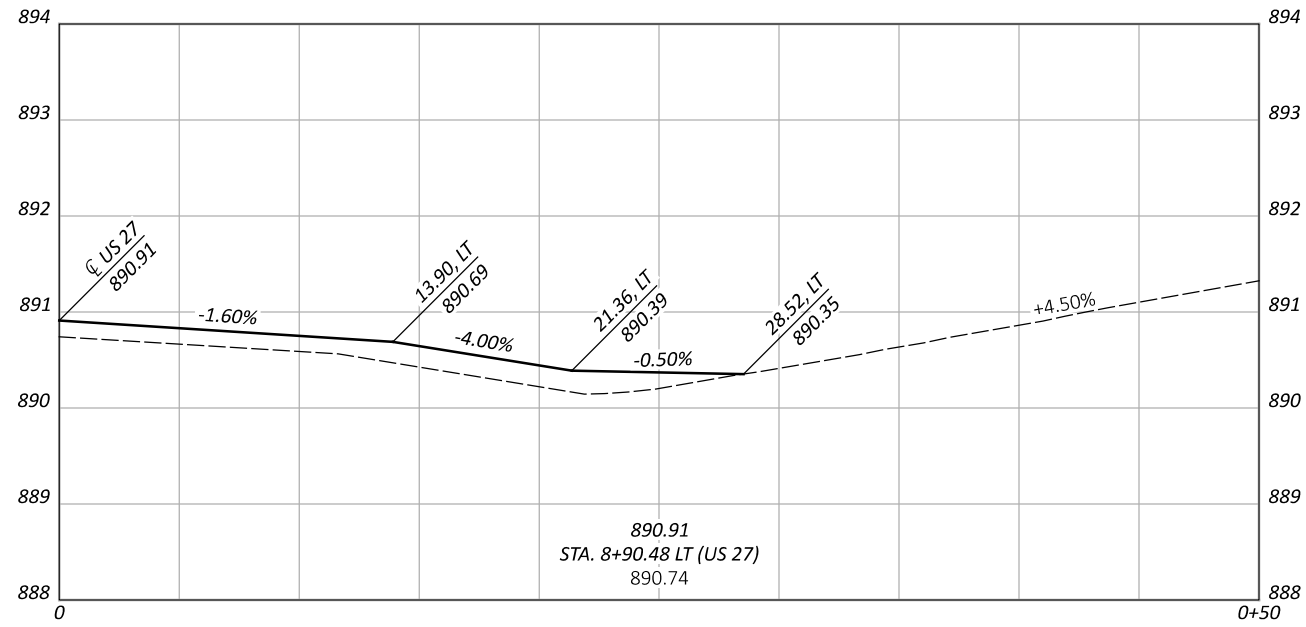

DESIGN AGENCY



DESIGNER
SHT

REVIEWER
CWP 04-29-24

PROJECT ID
117275

| SHEET | TOTAL |
|-------|-------|
| P.1 | 1 |

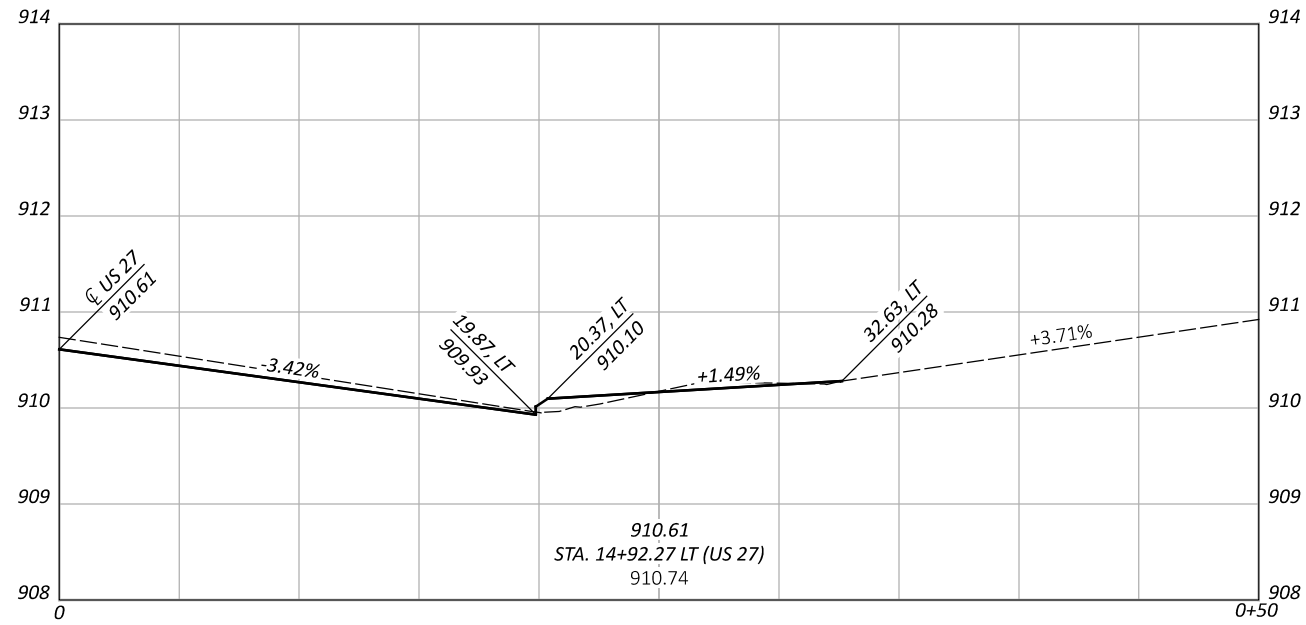

DESIGN AGENCY



DESIGNER

SHT

REVIEWER

CWP 04-29-24

PROJECT ID

117275





SHEET TOTAL





P.1 | 1

Appendix N

BUT-27 Maintenance of Traffic Schematic, Typical Sections, Capacity Analysis, Detour Routes, Detour Road User Costs and MOT Delay & Cost Comparison

LEGEND

-  WORK ZONE
-  PAVEMENT MARKING REMOVED
-  WORK ZONE IMPACT ATTENUATOR
-  DIRECTION OF TRAFFIC
-  TYPE 3 BARRICADE WITH SIGN

-  WORK ZONE STOP LINE
-  WORK ZONE EDGE LINE, 6" (WHITE)
-  WORK ZONE DOTTED LINE, 6" (WHITE)
-  PORTABLE BARRIER, UNANCHORED

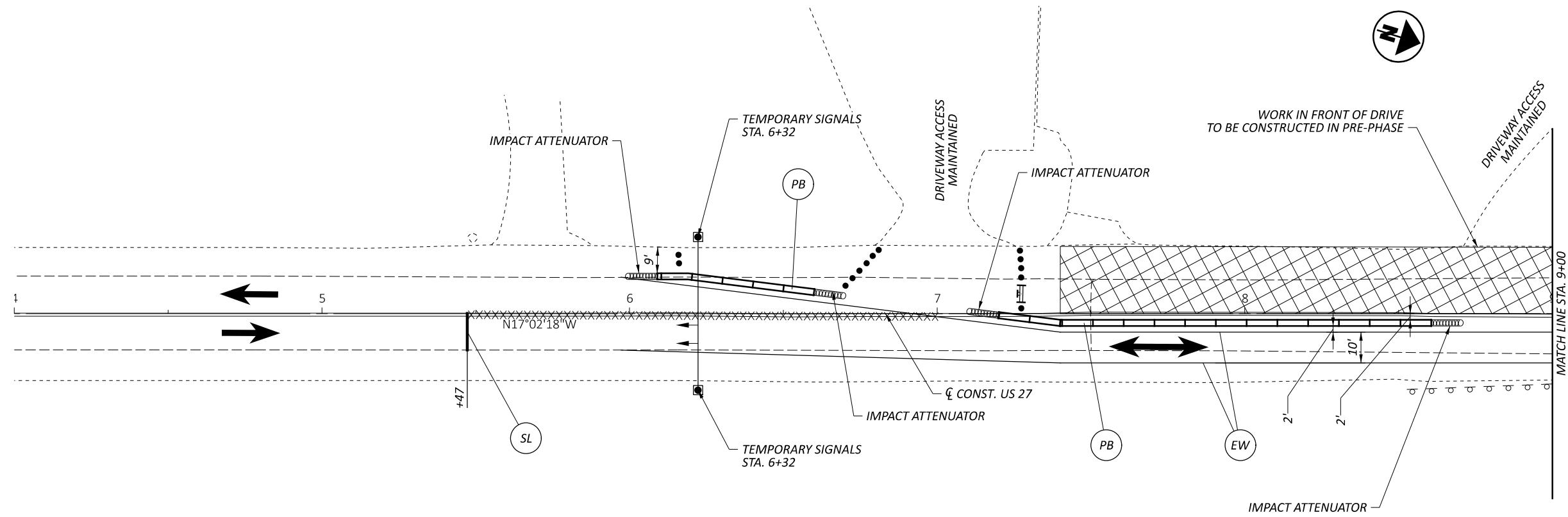

MAINTENANCE OF TRAFFIC - PHASE 1 (14.5' VC OPTION)
US-27 - BEGIN TO STA. 9+00











DESIGN AGENCY



| | |
|------------|--------|
| DESIGNER | CJD |
| REVIEWER | CWP |
| PROJECT ID | 117275 |
| SHEET | TOTAL |
| P.1 | 3 |

LEGEND

-  WORK ZONE
-  PAVEMENT MARKING REMOVED
-  WORK ZONE IMPACT ATTENUATOR
-  DIRECTION OF TRAFFIC
-  TYPE 3 BARRICADE WITH SIGN

-  SL WORK ZONE STOP LINE
-  EW WORK ZONE EDGE LINE, 6" (WHITE)
-  DW WORK ZONE DOTTED LINE, 6" (WHITE)
-  PB PORTABLE BARRIER, UNANCHORED

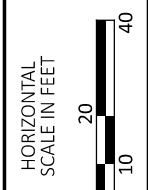
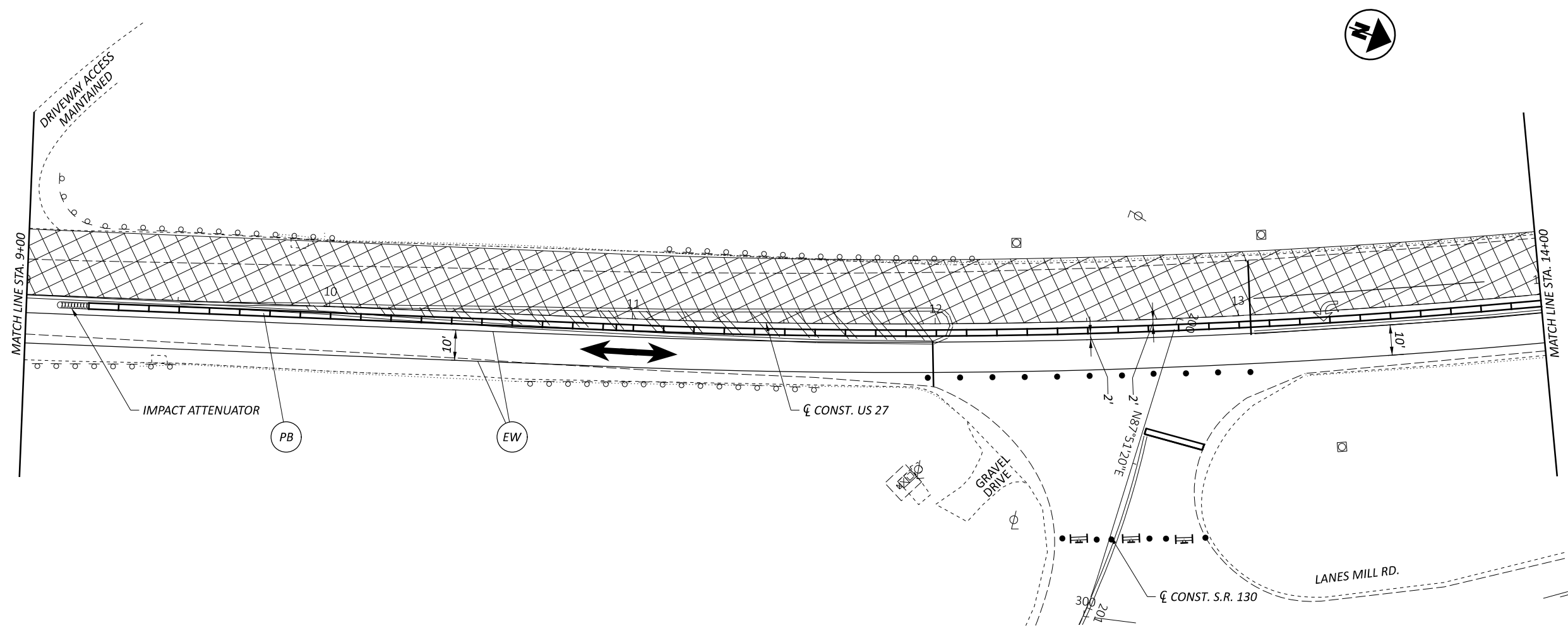

MAINTENANCE OF TRAFFIC - PHASE 1 (14.5' VC OPTION)
US-27 - STA. 9+00 TO STA. 14+00

DESIGN AGENCY



DESIGNER

CJD

REVIEWER

CWP 05-01-24

PROJECT ID

117275





SHEET





P.2

TOTAL

3

LEGEND

-  WORK ZONE
-  PAVEMENT MARKING REMOVED
-  WORK ZONE IMPACT ATTENUATOR
-  DIRECTION OF TRAFFIC
-  TYPE 3 BARRICADE WITH SIGN

-  WORK ZONE STOP LINE
-  WORK ZONE EDGE LINE, 6" (WHITE)
-  WORK ZONE DOTTED LINE, 6" (WHITE)
-  PORTABLE BARRIER, UNANCHORED

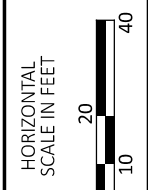
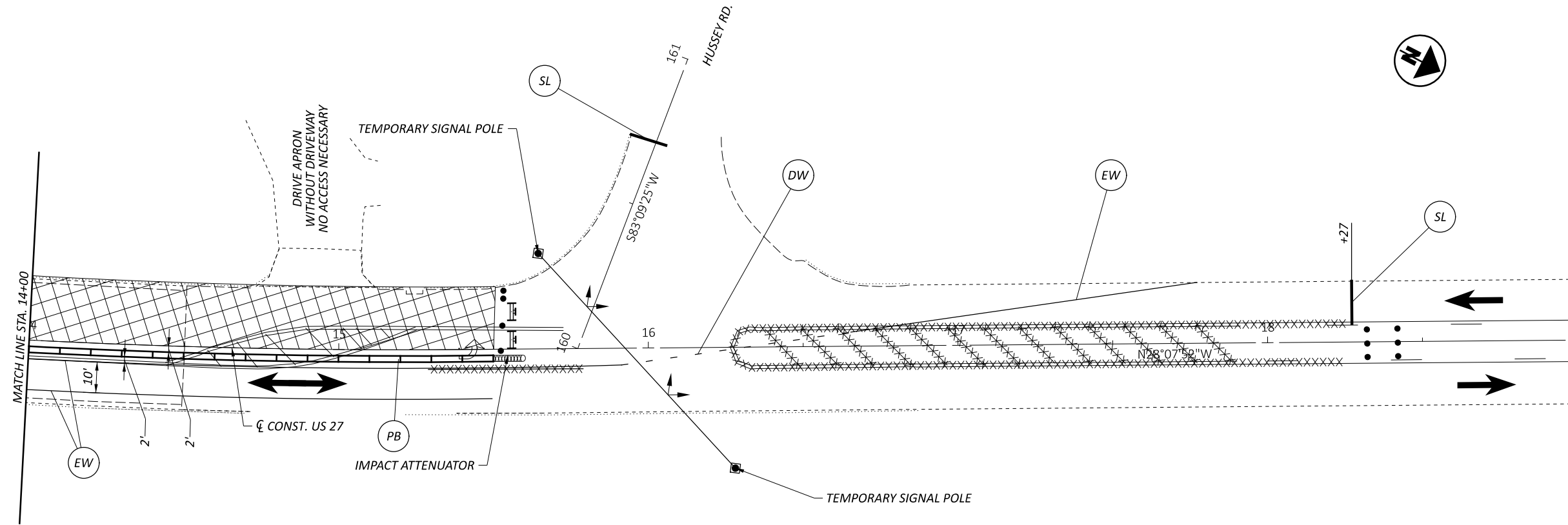

MAINTENANCE OF TRAFFIC - PHASE 1 (14.5' VC OPTION)
 US-27 - STA. 14+00 TO END

DESIGN AGENCY



DESIGNER

CJD

REVIEWER

CWP 05-01-24





PROJECT ID





117275

SHEET TOTAL

P.3 3

LEGEND

-  WORK ZONE
-  PAVEMENT MARKING REMOVED
-  WORK ZONE IMPACT ATTENUATOR
-  DIRECTION OF TRAFFIC
-  TYPE 3 BARRICADE WITH SIGN

-  SL WORK ZONE STOP LINE
-  EW WORK ZONE EDGE LINE, 6" (WHITE)
-  DW WORK ZONE DOTTED LINE, 6" (WHITE)
-  PB PORTABLE BARRIER, UNANCHORED

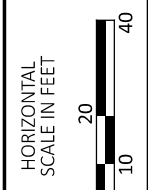
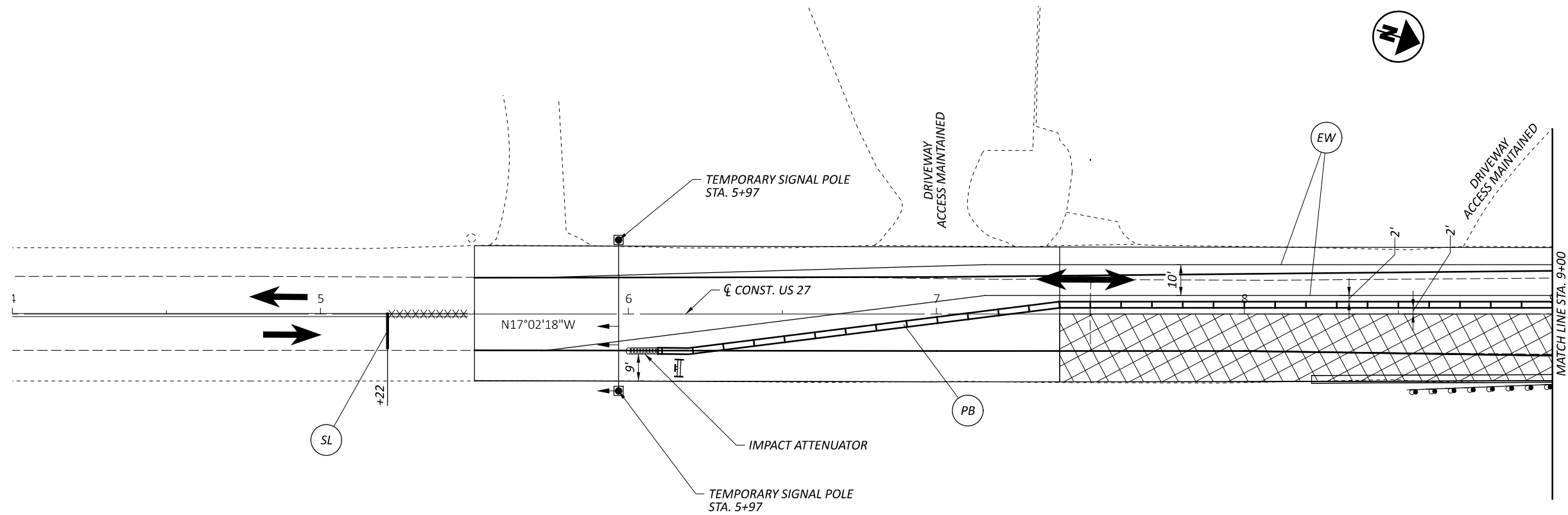

MAINTENANCE OF TRAFFIC - PHASE 2 (14.5' VC OPTION)
US-27 - BEGIN TO STA. 9+00

DESIGN AGENCY



DESIGNER

CJD

REVIEWER

CWP 05-01-24





PROJECT ID





117275

SHEET TOTAL

P.1 3

LEGEND

-  WORK ZONE
-  PAVEMENT MARKING REMOVED
-  WORK ZONE IMPACT ATTENUATOR
-  DIRECTION OF TRAFFIC
-  TYPE 3 BARRICADE WITH SIGN

-  SL WORK ZONE STOP LINE
-  EW WORK ZONE EDGE LINE, 6" (WHITE)
-  DW WORK ZONE DOTTED LINE, 6" (WHITE)
-  PB PORTABLE BARRIER, UNANCHORED

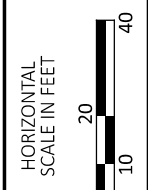
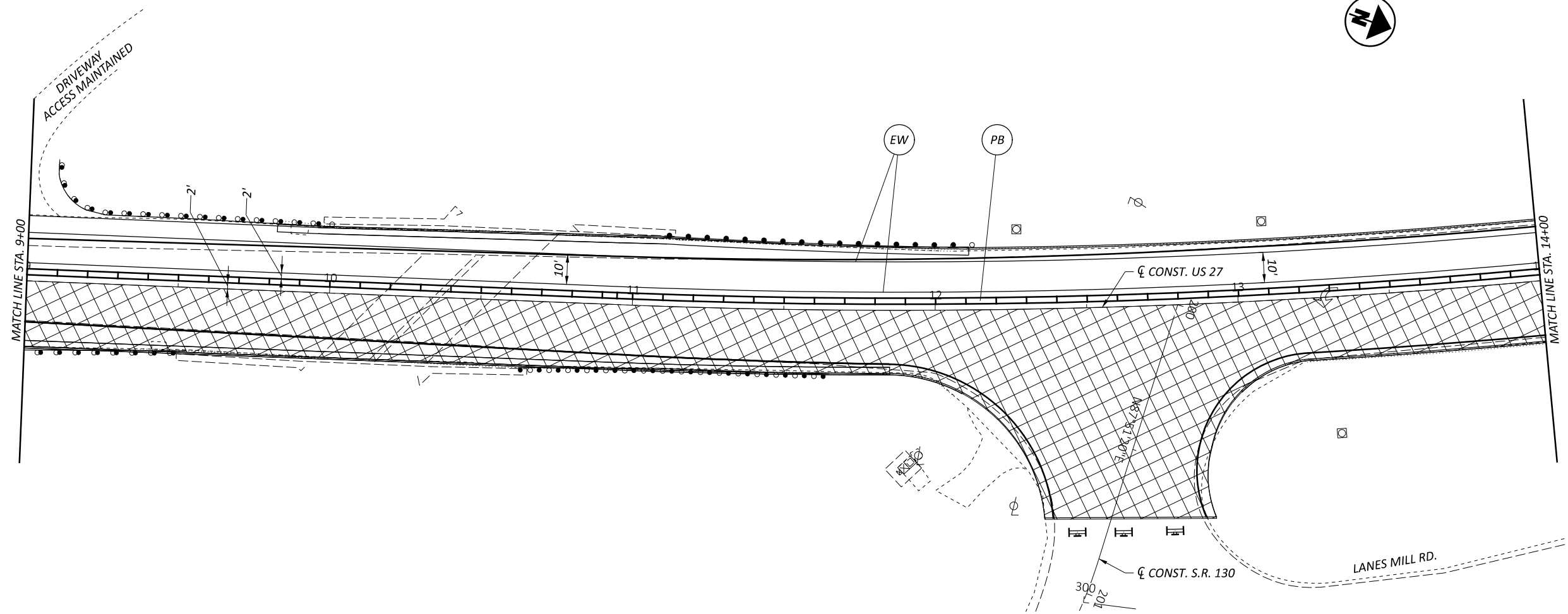





MAINTENANCE OF TRAFFIC - PHASE 2 (14.5' VC OPTION)
US-27 - STA. 9+00 TO STA. 14.00





DESIGN AGENCY



| | |
|------------|----------|
| DESIGNER | CJD |
| REVIEWER | |
| CWP | 05-01-24 |
| PROJECT ID | 117275 |
| SHEET | TOTAL |
| P.2 | 3 |

LEGEND

-  WORK ZONE
-  PAVEMENT MARKING REMOVED
-  WORK ZONE IMPACT ATTENUATOR
-  DIRECTION OF TRAFFIC
-  TYPE 3 BARRICADE WITH SIGN

-  WORK ZONE STOP LINE
-  WORK ZONE EDGE LINE, 6" (WHITE)
-  WORK ZONE DOTTED LINE, 6" (WHITE)
-  PORTABLE BARRIER, UNANCHORED

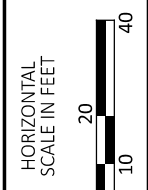
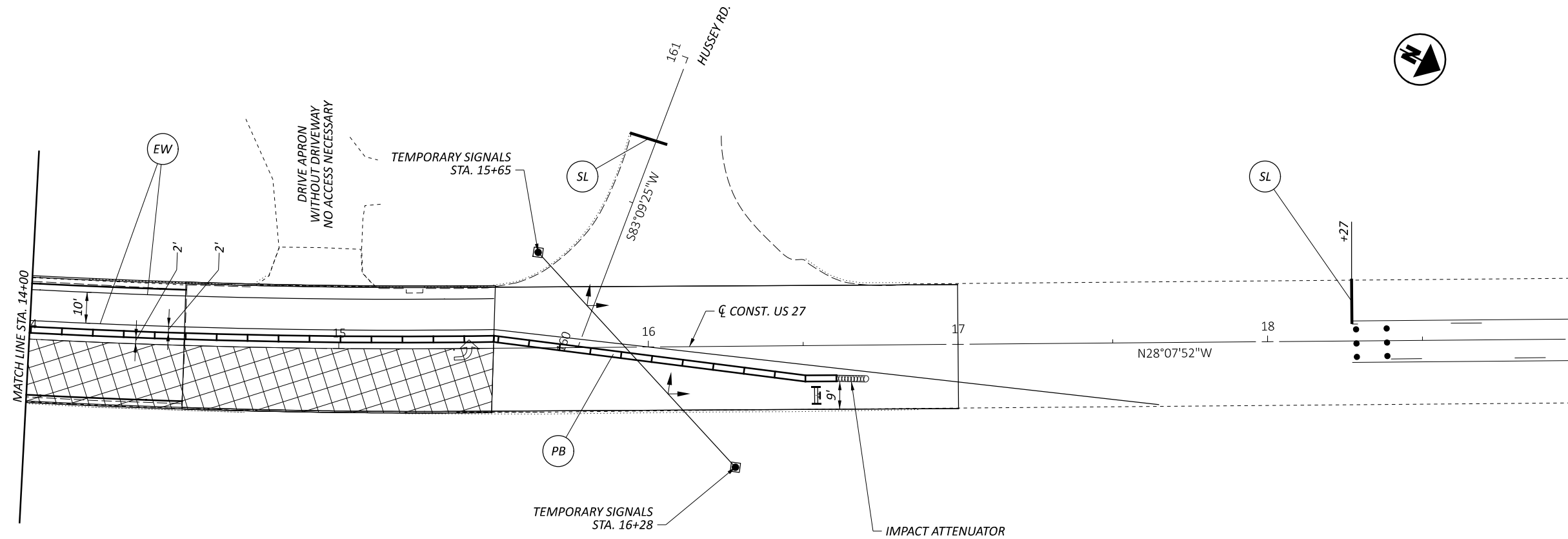

MAINTENANCE OF TRAFFIC - PHASE 2 (14.5' VC OPTION)
US-27 - STA. 14+00 TO END

DESIGN AGENCY



DESIGNER

CJD

REVIEWER

CWP 05-01-24

PROJECT ID

117275

SHEET TOTAL

P.3 3

LEGEND

 - WORK AREA

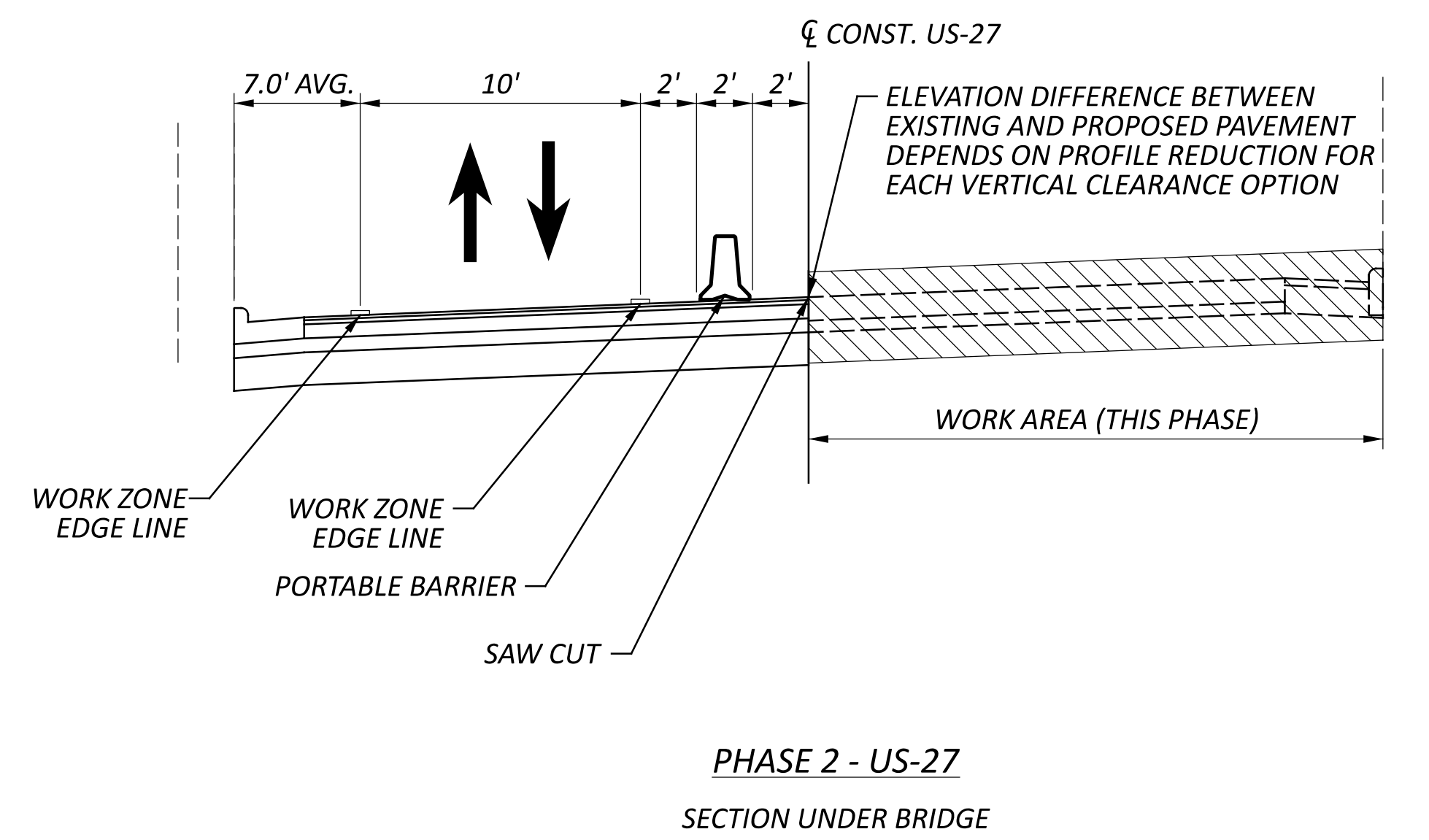
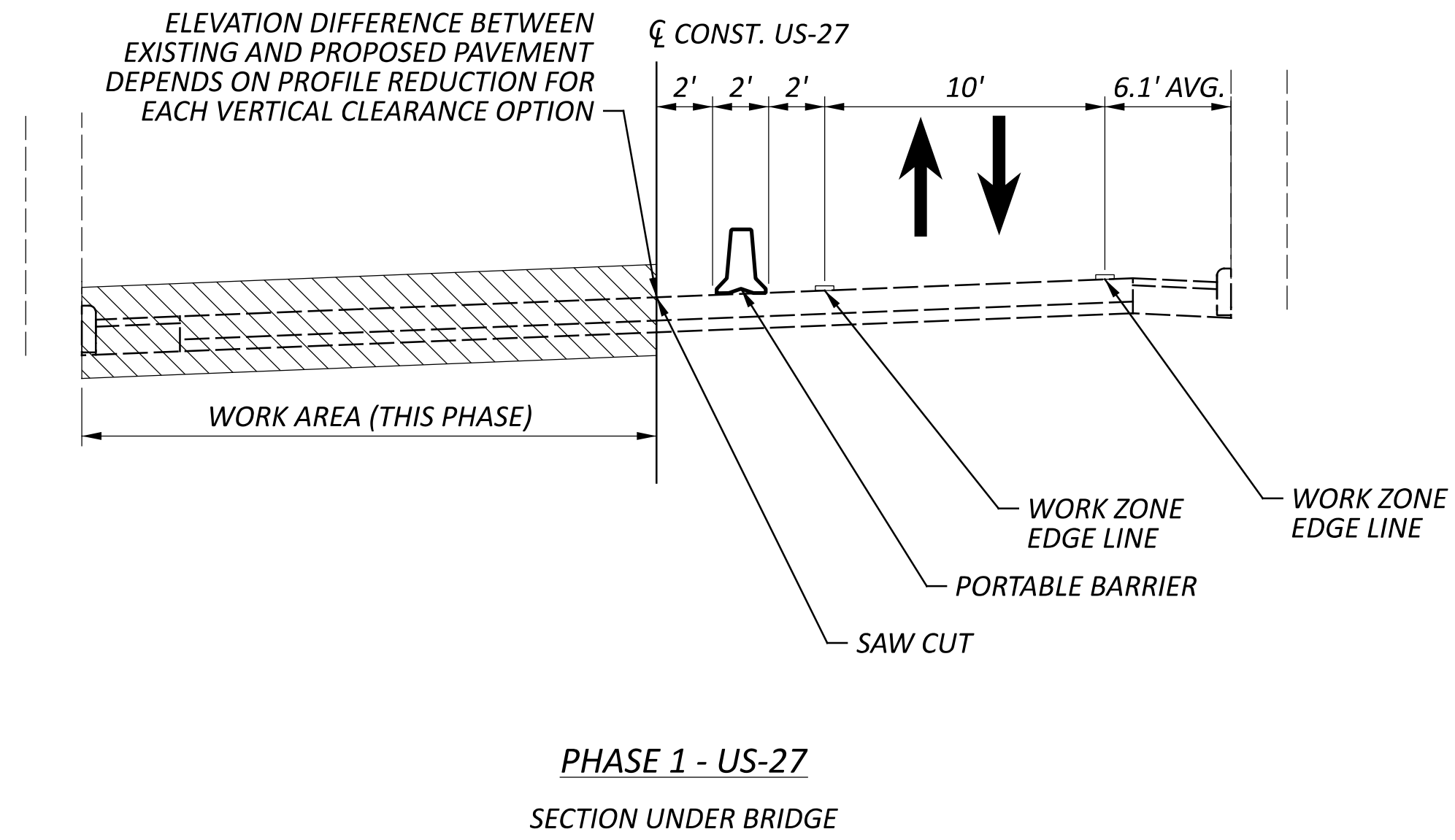

MAINTENANCE OF TRAFFIC - TYPICAL SECTIONS
US 27 - ALL VERTICAL CLEARANCE OPTIONS

DESIGN AGENCY



DESIGNER

CJD

REVIEWER

CWP 05-01-24

PROJECT ID

117275

SHEET

P.1

TOTAL

1

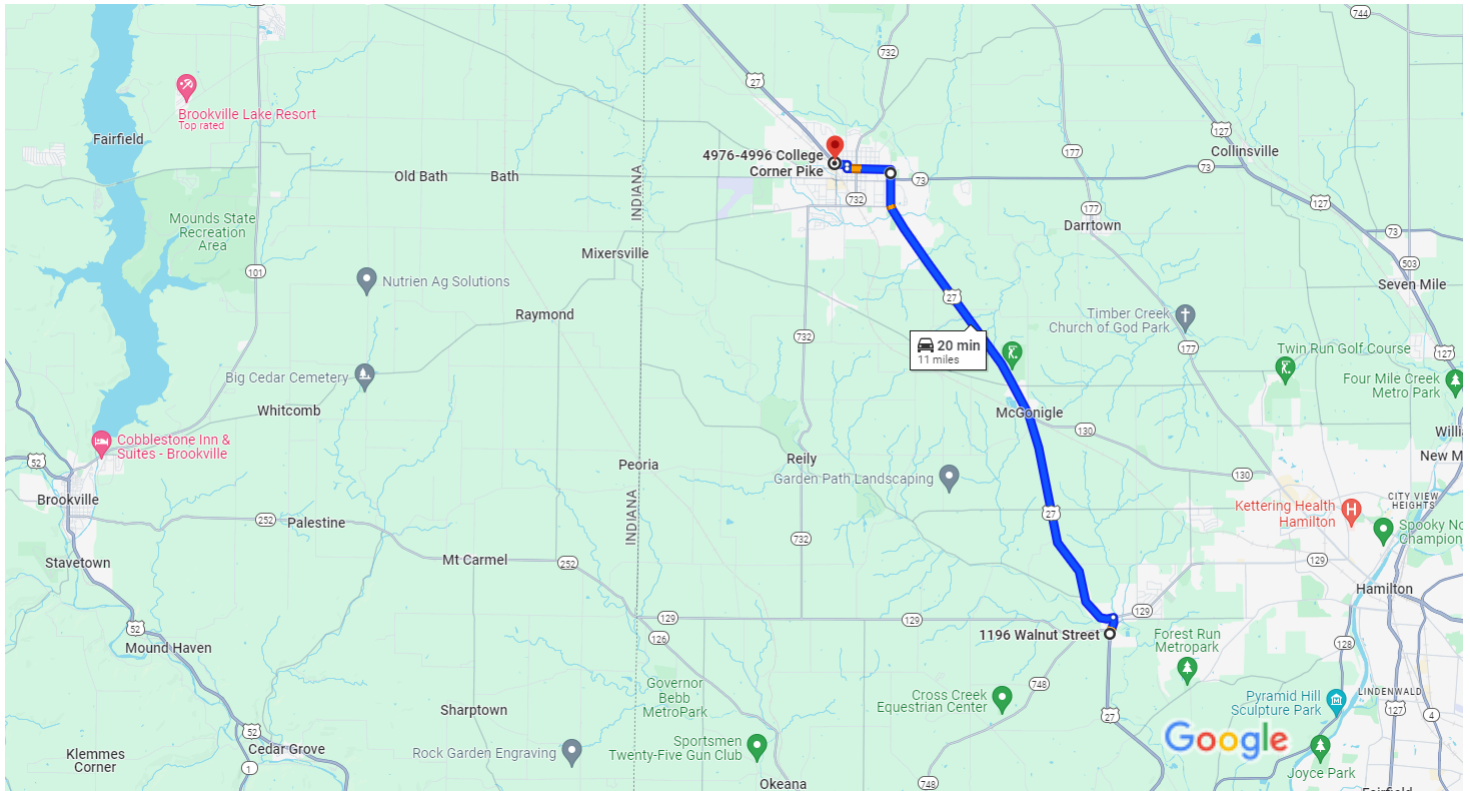

Map data ©2024 Google 2 mi

1196 Walnut St
Hamilton, OH 45013

- ↑ 1. Head north on Walnut St toward High St
0.3 mi
- ↶ 2. Turn left onto Millville Oxford Rd/US Hwy 27 N
Continue to follow US Hwy 27 N
9.5 mi
- ↶ 3. Turn left onto E High St
0.8 mi
- ↷ 4. Turn right onto N College Ave
381 ft
- ↶ 5. Turn left at the 1st cross street onto W Church St
0.2 mi
- ↑ 6. Continue onto College Corner Pike
246 ft

4976-4996 College Corner Pike

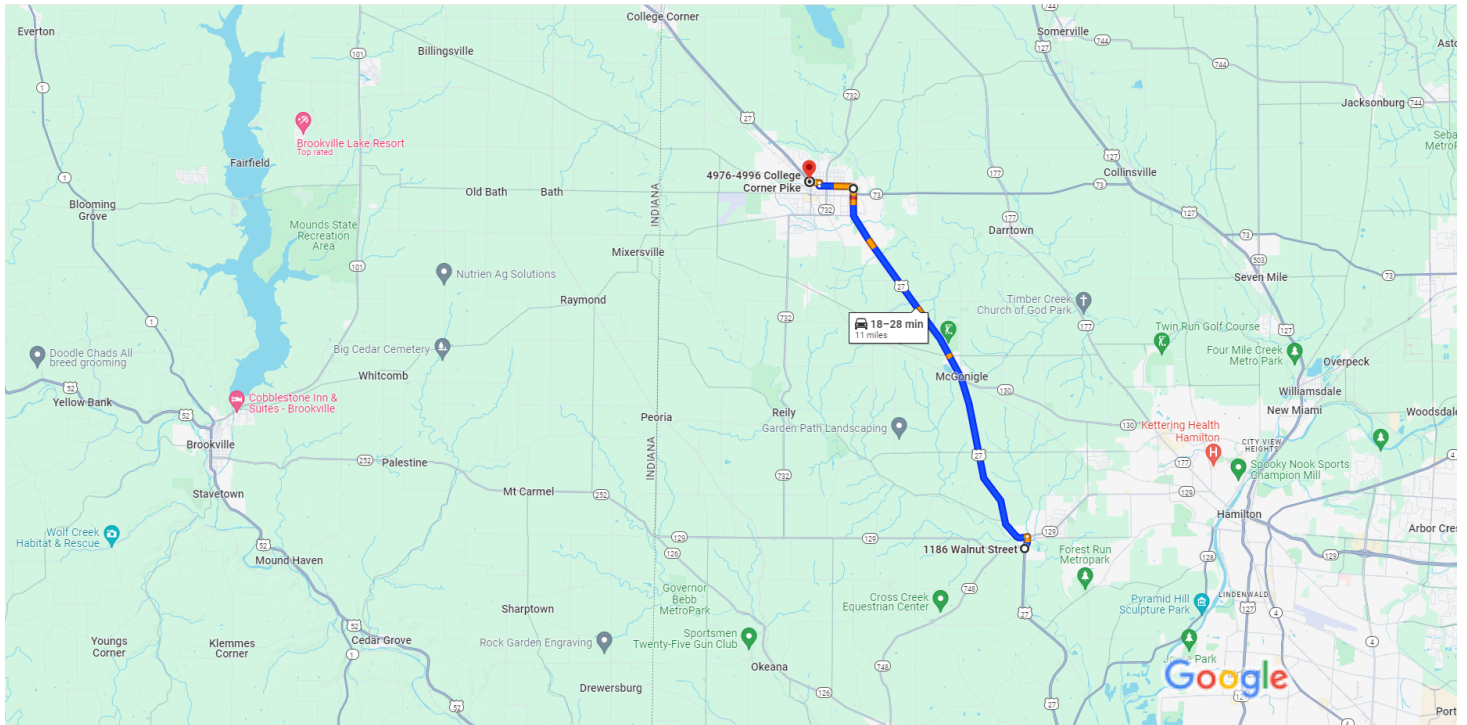

Map data ©2024 Google 2 mi

1186 Walnut St
Hamilton, OH 45013

- ↑ 1. Head north on Walnut St toward High St
_____ 0.3 mi
- ↶ 2. Turn left onto Millville Oxford Rd/US Hwy 27 N
📍 Continue to follow US Hwy 27 N
_____ 9.5 mi
- ↶ 3. Turn left onto E High St
_____ 0.8 mi
- ↷ 4. Turn right onto N College Ave
_____ 381 ft
- ↶ 5. Turn left at the 1st cross street onto W Church St
_____ 0.2 mi
- ↑ 6. Continue onto College Corner Pike
_____ 246 ft

4976-4996 College Corner Pike
Oxford, OH 45056

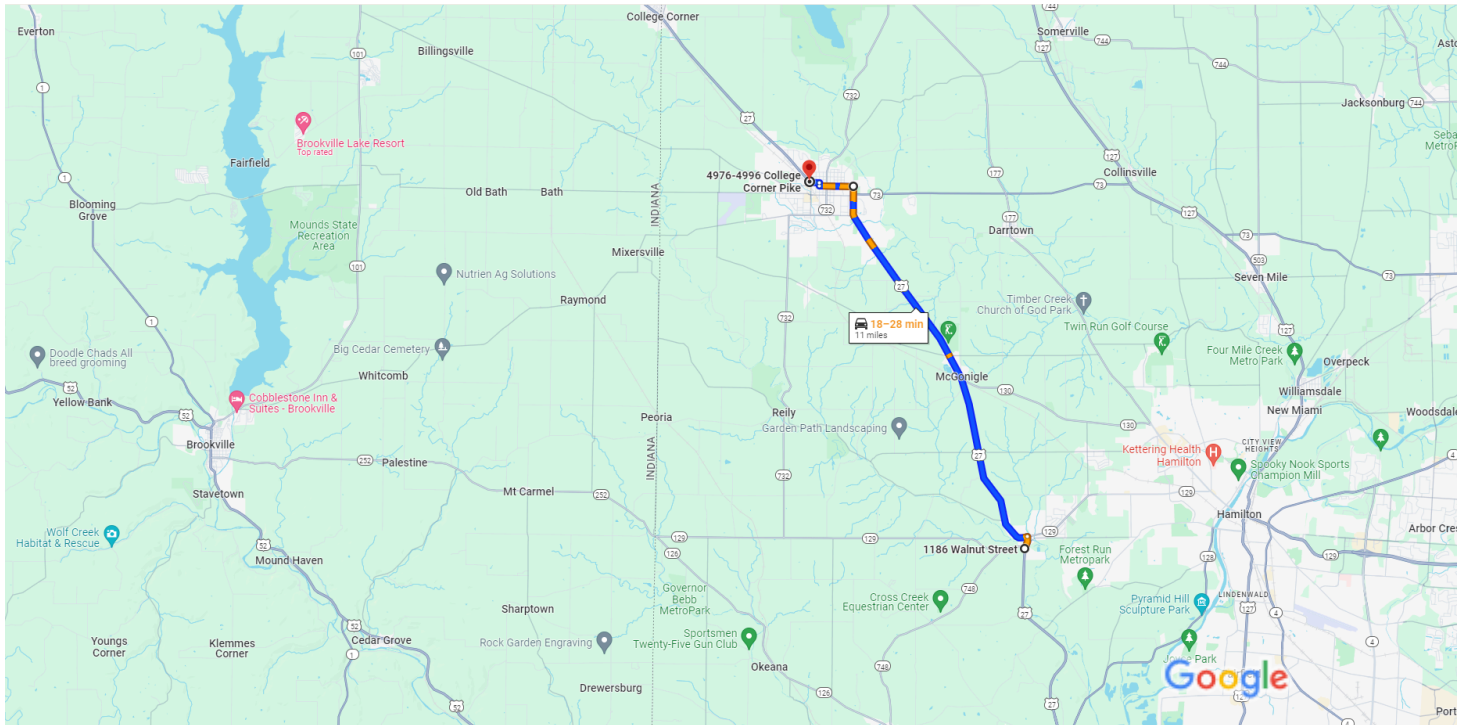

Map data ©2024 Google 2 mi

1186 Walnut St
Hamilton, OH 45013

- ↑ 1. Head north on Walnut St toward High St
_____ 0.3 mi
- ↶ 2. Turn left onto Millville Oxford Rd/US Hwy 27 N
📍 Continue to follow US Hwy 27 N
_____ 9.5 mi
- ↶ 3. Turn left onto E High St
_____ 0.8 mi
- ↷ 4. Turn right onto N College Ave
_____ 381 ft
- ↶ 5. Turn left at the 1st cross street onto W Church St
_____ 0.2 mi
- ↑ 6. Continue onto College Corner Pike
_____ 246 ft

4976-4996 College Corner Pike
Oxford, OH 45056

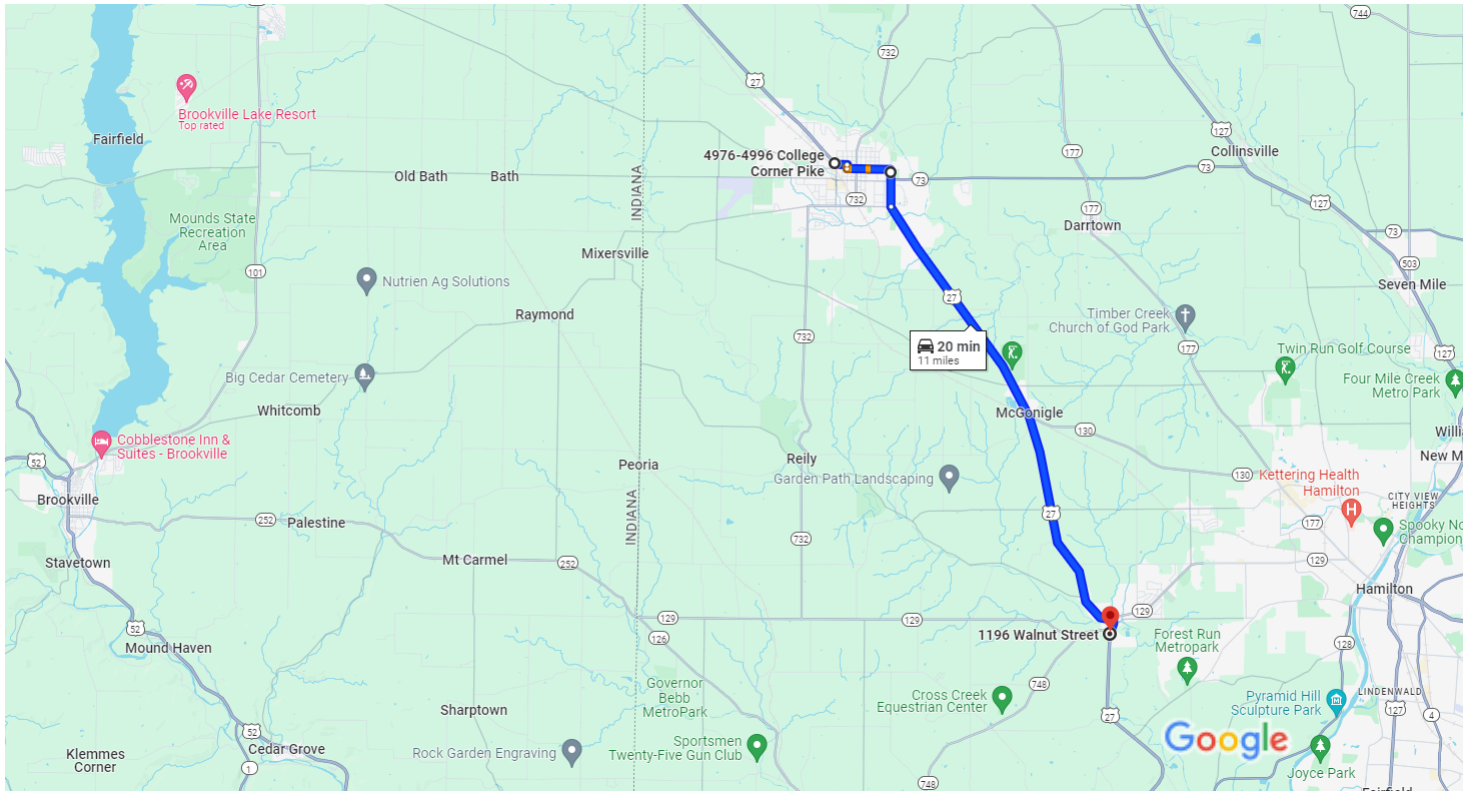

Map data ©2024 Google 2 mi

4976-4996 College Corner Pike
Oxford, OH 45056

- ↑ 1. Head southeast on College Corner Pike
_____ 246 ft
- ↑ 2. Continue onto W Church St
_____ 0.2 mi
- ↘ 3. Turn right onto N College Ave
_____ 381 ft
- ↙ 4. Turn left at the 1st cross street onto W High St
_____ 0.8 mi
- ↘ 5. Turn right onto S Patterson Ave
_____ 0.7 mi
- ↑ 6. Continue onto Millville Oxford Rd/Oxford Millville Rd/US Hwy 27 S
Continue to follow Millville Oxford Rd/US Hwy 27 S
_____ 8.9 mi
- ↘ 7. Turn right onto Walnut St
_____ 0.3 mi

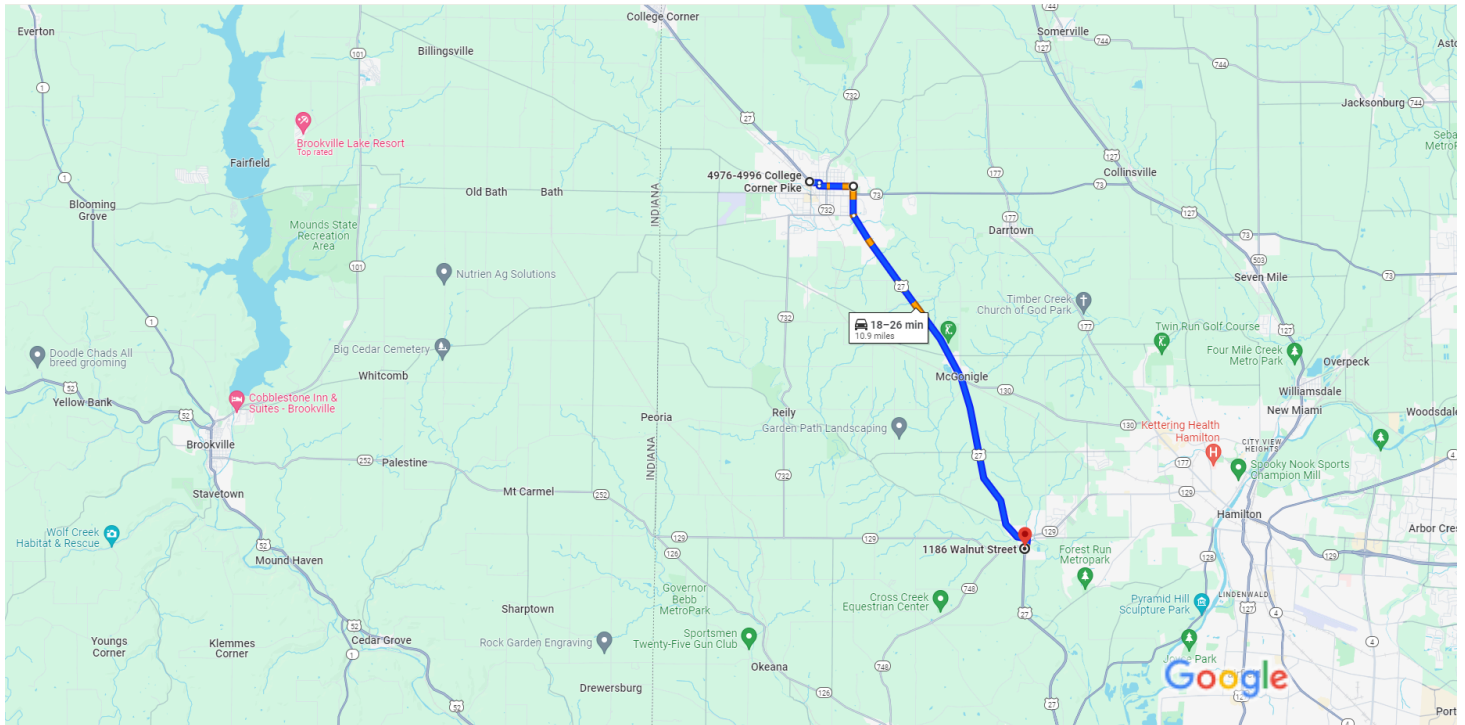

Map data ©2024 Google 2 mi

4976-4996 College Corner Pike
Oxford, OH 45056

- ↑ 1. Head southeast on College Corner Pike
246 ft
- ↑ 2. Continue onto W Church St
0.2 mi
- ↪ 3. Turn right onto N College Ave
381 ft
- ↶ 4. Turn left at the 1st cross street onto W High St
0.8 mi
- ↪ 5. Turn right onto S Patterson Ave
0.7 mi
- ↑ 6. Continue onto Millville Oxford Rd/Oxford Millville Rd/US Hwy 27 S
8.9 mi
- ↪ 7. Turn right onto Walnut St
0.3 mi

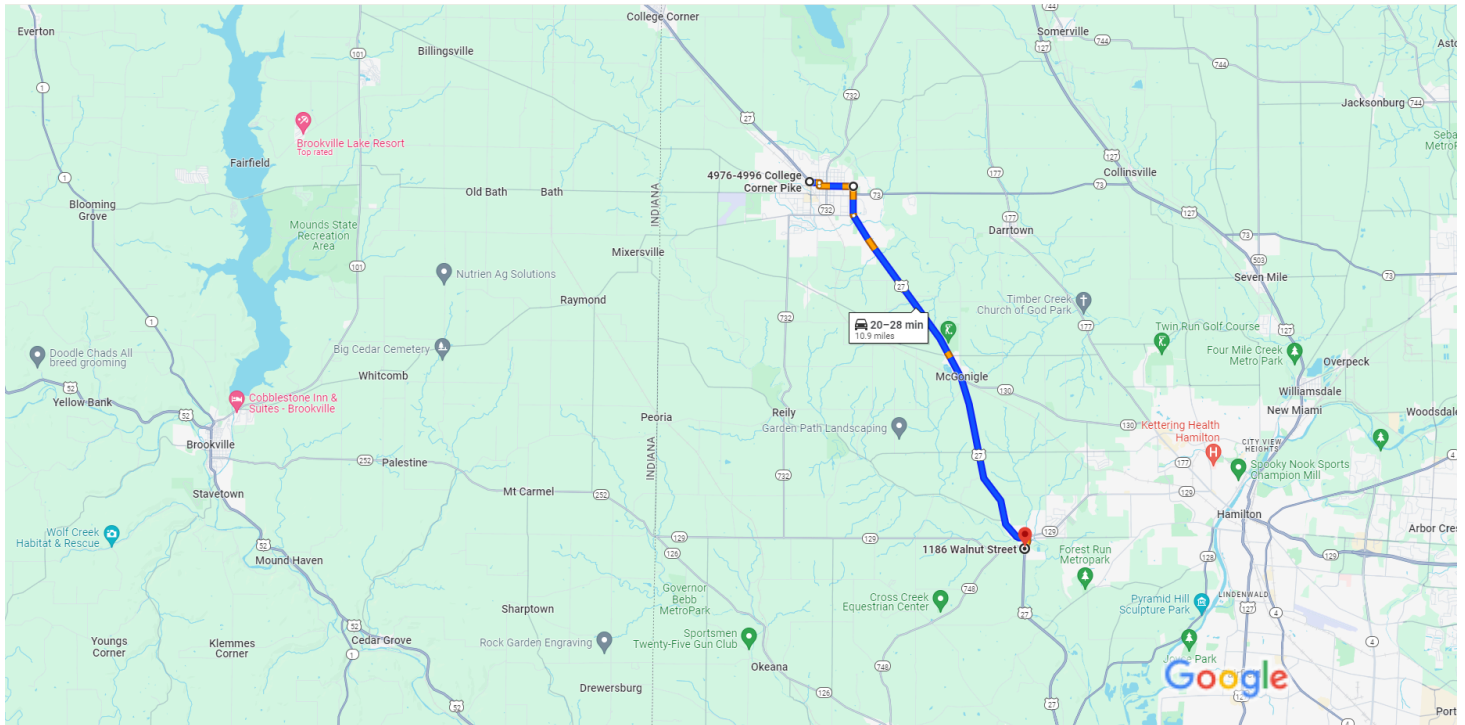

Map data ©2024 Google 2 mi

4976-4996 College Corner Pike
Oxford, OH 45056

- ↑ 1. Head southeast on College Corner Pike
246 ft
- ↑ 2. Continue onto W Church St
0.2 mi
- ↪ 3. Turn right onto N College Ave
381 ft
- ↶ 4. Turn left at the 1st cross street onto W High St
0.8 mi
- ↪ 5. Turn right onto S Patterson Ave
0.7 mi
- ↑ 6. Continue onto Millville Oxford Rd/Oxford Millville Rd/US Hwy 27 S
8.9 mi
- ↪ 7. Turn right onto Walnut St
0.3 mi

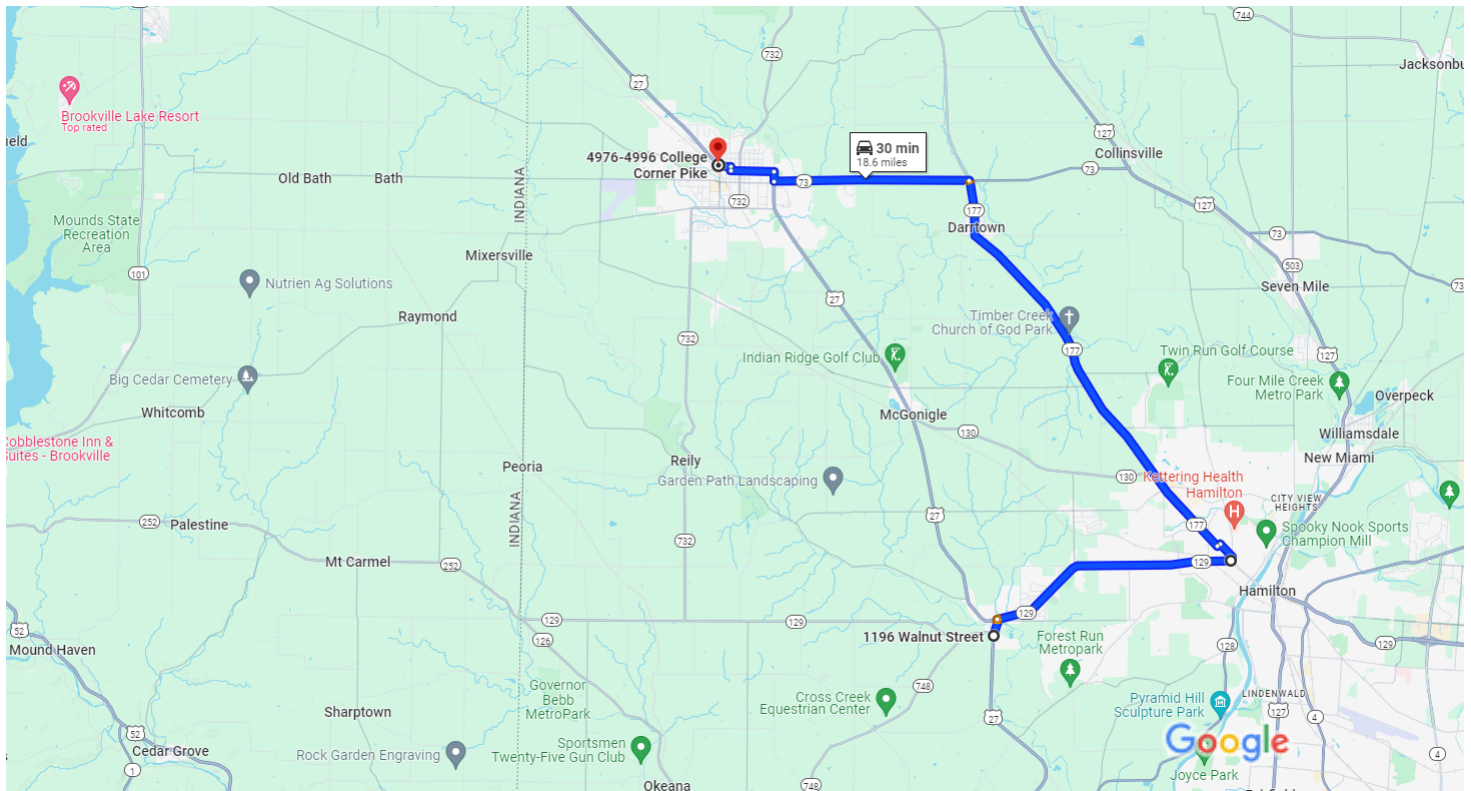

Map data ©2024 Google 2 mi

1196 Walnut St
Hamilton, OH 45013

- ↑ 1. Head north on Walnut St toward High St
0.3 mi
 - ↪ 2. Turn right onto OH-129 E/Millville Ave
4.6 mi
 - ↑ 3. Continue straight onto Eaton Ave
449 ft
 - ↶ 4. Turn left onto Park Ave
0.3 mi
 - ↶ 5. Turn left onto Beal Ave
367 ft
 - ↪ 6. Turn right onto OH-177 N/Hamilton Richmond Rd/Main St
8.3 mi
- ⓘ Continue to follow OH-177 N/Hamilton Richmond Rd
 ⓘ Pass by KeyBank (on the right in 1.4 mi)

- ↶ 7. Turn left onto OH-73 W/Trenton Oxford Rd
----- 3.6 mi
- ↷ 8. Turn right onto S Patterson Ave
----- 0.2 mi
- ↶ 9. Turn left onto E High St
----- 0.8 mi
- ↷ 10. Turn right onto N College Ave
----- 381 ft
- ↶ 11. Turn left at the 1st cross street onto W Church St
----- 0.2 mi
- ↑ 12. Continue onto College Corner Pike
----- 246 ft

4976-4996 College Corner Pike
Oxford, OH 45056

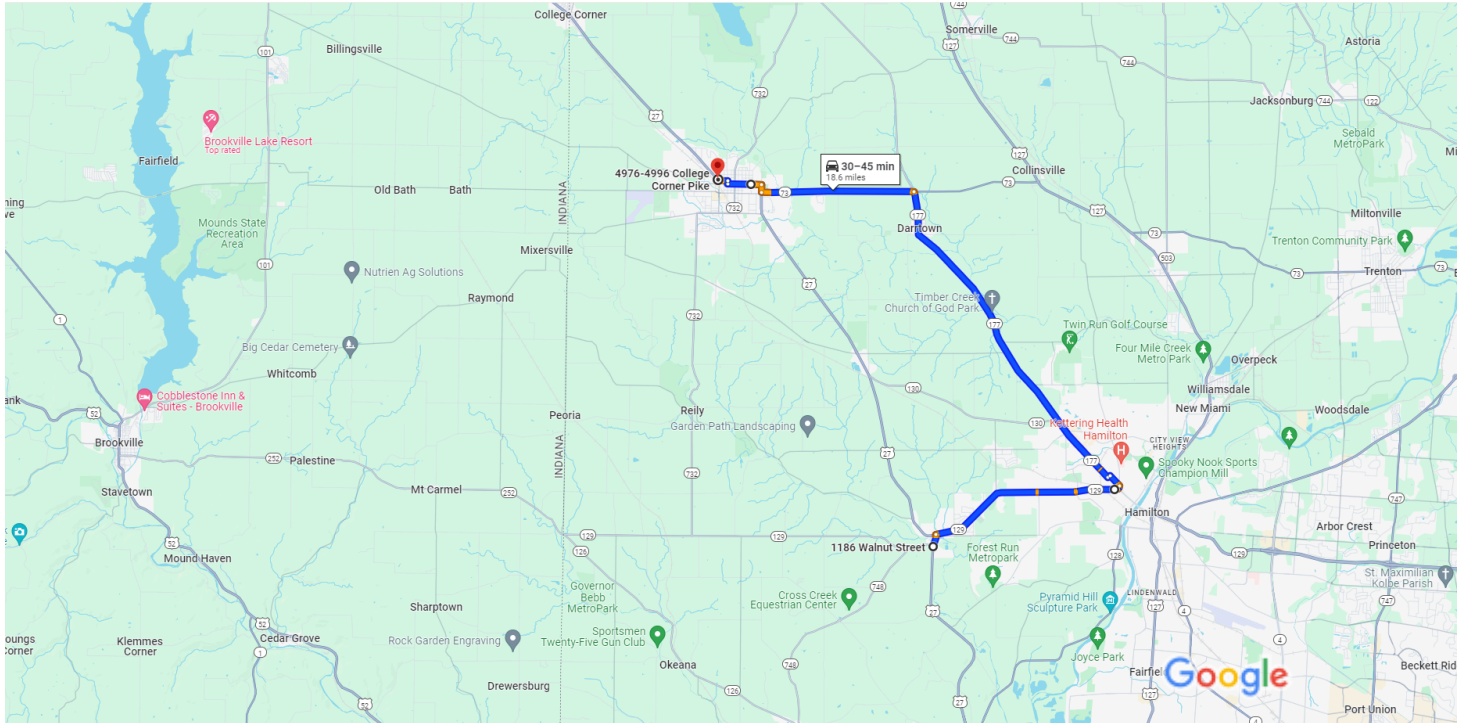

Map data ©2024 Google 2 mi

1186 Walnut St
Hamilton, OH 45013

- ↑ 1. Head north on Walnut St toward High St
0.3 mi
 - ↘ 2. Turn right onto OH-129 E/Millville Ave
4.6 mi
 - ↑ 3. Continue straight onto Eaton Ave
449 ft
 - ↙ 4. Turn left onto Park Ave
0.3 mi
 - ↙ 5. Turn left onto Beal Ave
367 ft
 - ↘ 6. Turn right onto OH-177 N/Hamilton Richmond Rd/Main St
8.3 mi
- 📍 Continue to follow OH-177 N/Hamilton Richmond Rd
 - 📍 Pass by KeyBank (on the right in 1.4 mi)

- ↶ 7. Turn left onto OH-73 W/Trenton Oxford Rd
----- 3.6 mi
- ↷ 8. Turn right onto S Patterson Ave
----- 0.2 mi
- ↶ 9. Turn left onto E High St
----- 0.8 mi
- ↷ 10. Turn right onto N College Ave
----- 381 ft
- ↶ 11. Turn left at the 1st cross street onto W Church St
----- 0.2 mi
- ↑ 12. Continue onto College Corner Pike
----- 246 ft

4976-4996 College Corner Pike

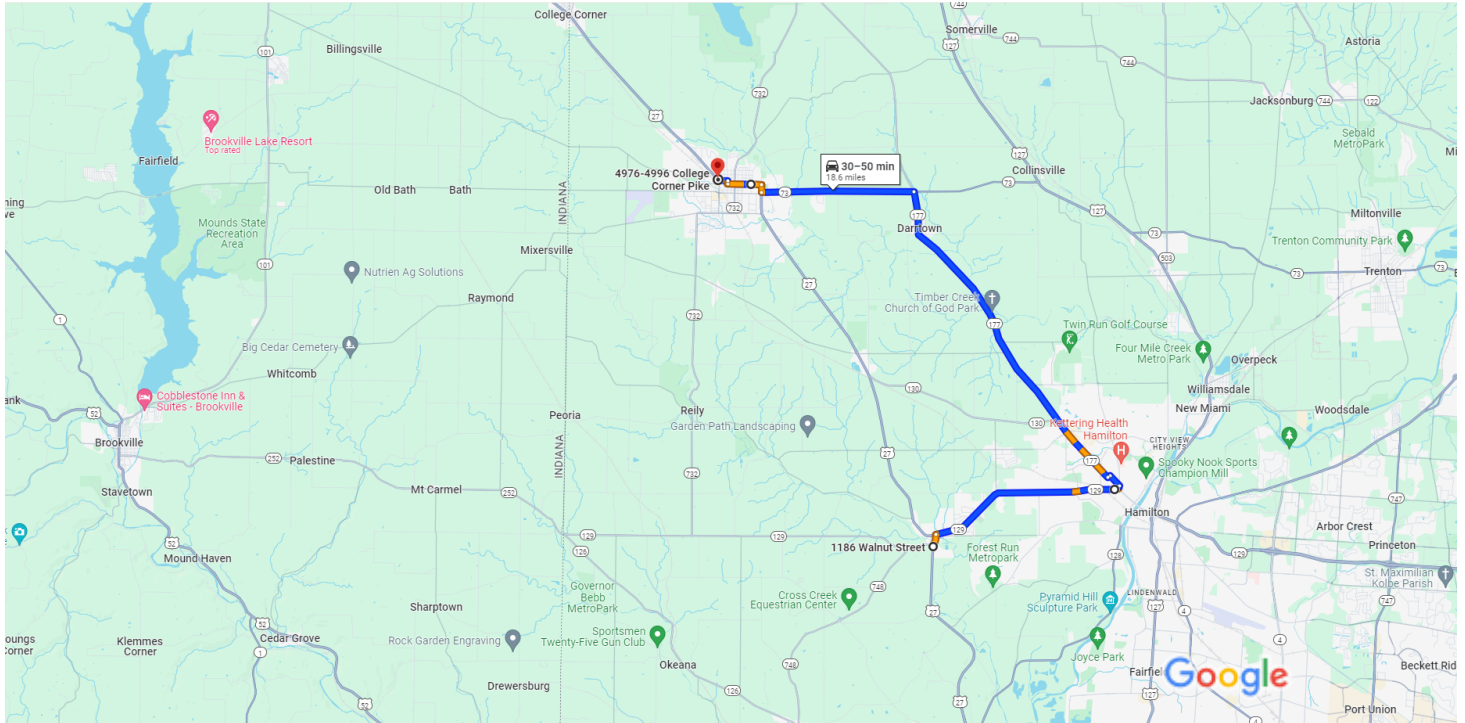

Map data ©2024 Google 2 mi

1186 Walnut St
Hamilton, OH 45013

- ↑ 1. Head north on Walnut St toward High St
0.3 mi
 - ↪ 2. Turn right onto OH-129 E/Millville Ave
4.6 mi
 - ↑ 3. Continue straight onto Eaton Ave
449 ft
 - ↶ 4. Turn left onto Park Ave
0.3 mi
 - ↶ 5. Turn left onto Beal Ave
367 ft
 - ↪ 6. Turn right onto OH-177 N/Hamilton Richmond Rd/Main St
8.3 mi
- ⓘ Continue to follow OH-177 N/Hamilton Richmond Rd
 ⓘ Pass by KeyBank (on the right in 1.4 mi)

- ↶ 7. Turn left onto OH-73 W/Trenton Oxford Rd
----- 3.6 mi
- ↷ 8. Turn right onto S Patterson Ave
----- 0.2 mi
- ↶ 9. Turn left onto E High St
----- 0.8 mi
- ↷ 10. Turn right onto N College Ave
----- 381 ft
- ↶ 11. Turn left at the 1st cross street onto W Church St
----- 0.2 mi
- ↑ 12. Continue onto College Corner Pike
----- 246 ft

4976-4996 College Corner Pike

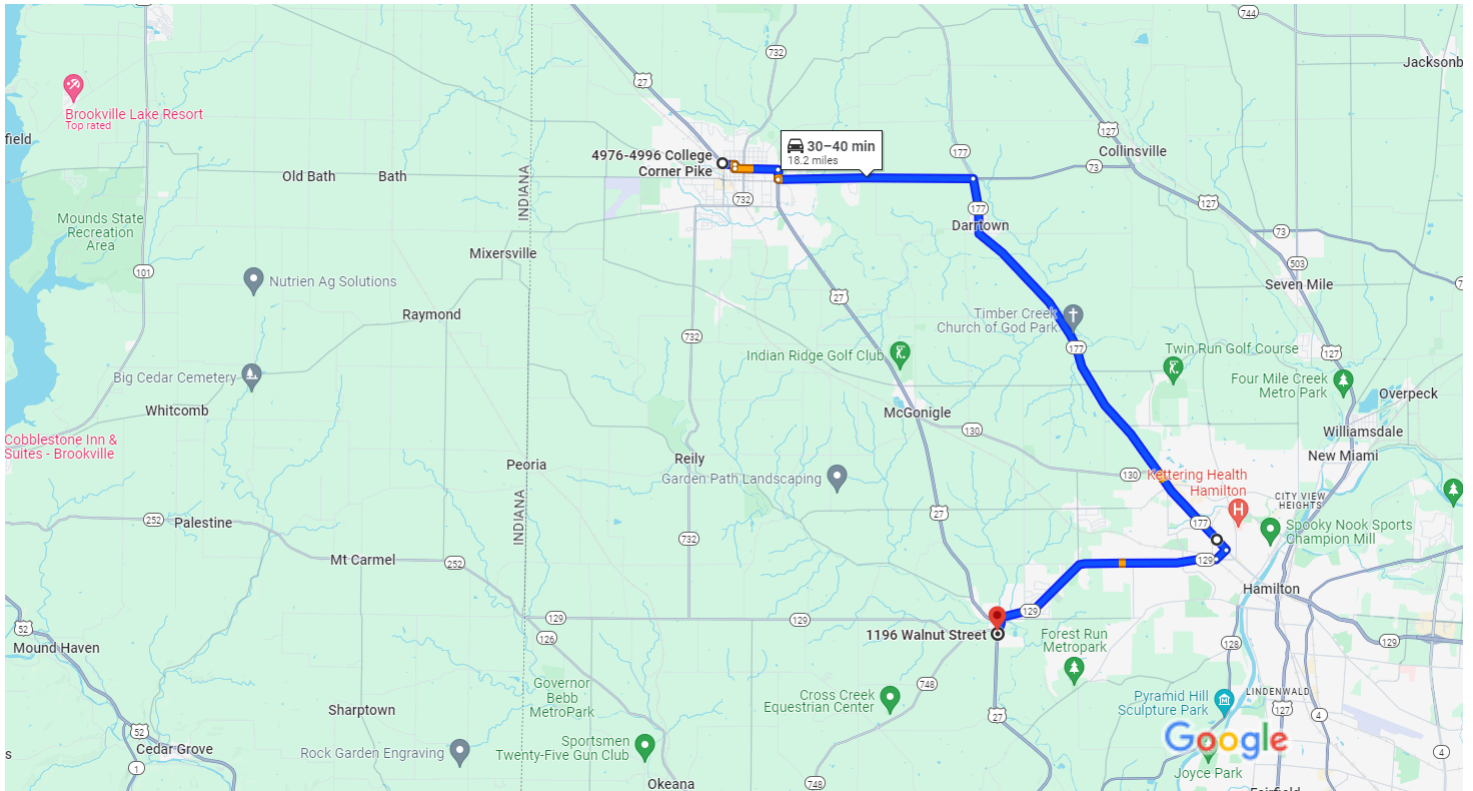

Map data ©2024 Google 2 mi

4976-4996 College Corner Pike
Oxford, OH 45056

- ↑ 1. Head southeast on College Corner Pike
246 ft
 - ↑ 2. Continue onto W Church St
0.2 mi
 - ↷ 3. Turn right onto N College Ave
381 ft
 - ↶ 4. Turn left at the 1st cross street onto W High St
0.8 mi
 - ↷ 5. Turn right onto S Patterson Ave
0.2 mi
 - ↶ 6. Turn left onto OH-73 E/Trenton Oxford Rd
3.6 mi
 - ↷ 7. Turn right onto OH-177 S/Hamilton Richmond Rd
8.4 mi
- i** Pass by Burger King (on the left in 7 mi)

- ↪ 8. Turn right onto S Edgewood Ave
0.3 mi
- ↪ 9. Turn right onto OH-129 W/Millville Ave
[Pass by McDonald's \(on the right in 1.6 mi\)](#)
4.3 mi
- ↶ 10. Turn left onto Walnut St
0.3 mi

1196 Walnut St
Hamilton, OH 45013

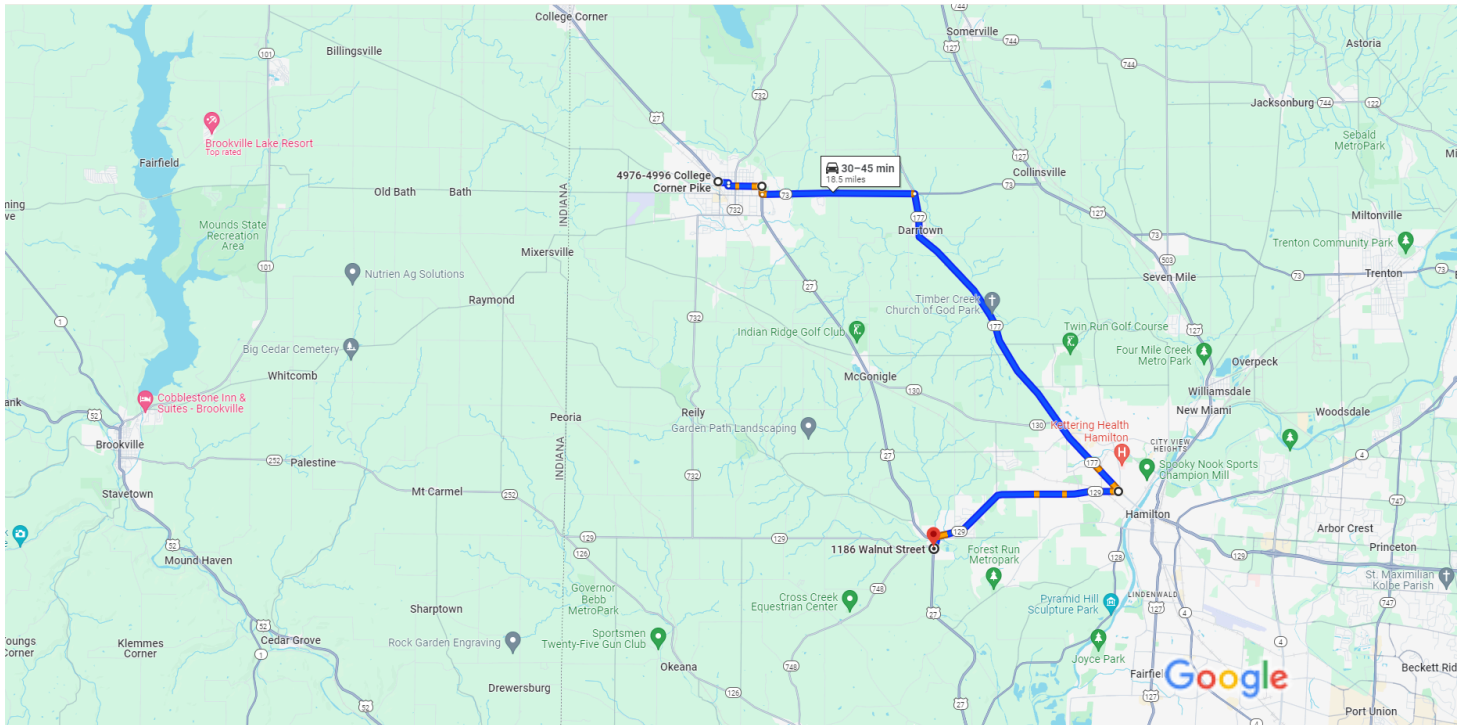

Map data ©2024 Google 2 mi

4976-4996 College Corner Pike
Oxford, OH 45056

Take OH-73 E/Trenton Oxford Rd to OH-177 S/Hamilton
Richmond Rd in Milford Township

- _____ 11 min (4.9 mi)
- ↑ 1. Head southeast on College Corner Pike
- _____ 246 ft
- ↑ 2. Continue onto W Church St
- _____ 0.2 mi
- ↪ 3. Turn right onto N College Ave
- _____ 381 ft
- ↶ 4. Turn left at the 1st cross street onto W High St
- _____ 0.8 mi
- ↪ 5. Turn right onto S Patterson Ave
- _____ 0.2 mi
- ↶ 6. Turn left onto OH-73 E/Trenton Oxford Rd
- _____ 3.6 mi

Continue on OH-177 S/Hamilton Richmond Rd to Millville

_____ 23 min (13.3 mi)

- ↪ 7. Turn right onto OH-177 S/Hamilton Richmond Rd
 ⓘ Pass by Burger King (on the left in 7 mi)
————— 8.7 mi
- ↪ 8. Turn right onto OH-129 W/Millville Ave
 ⓘ Pass by McDonald's (on the right in 1.9 mi)
————— 4.6 mi
- ↶ 9. Turn left onto Walnut St
————— 51 sec (0.3 mi)

1186 Walnut St
Hamilton, OH 45013

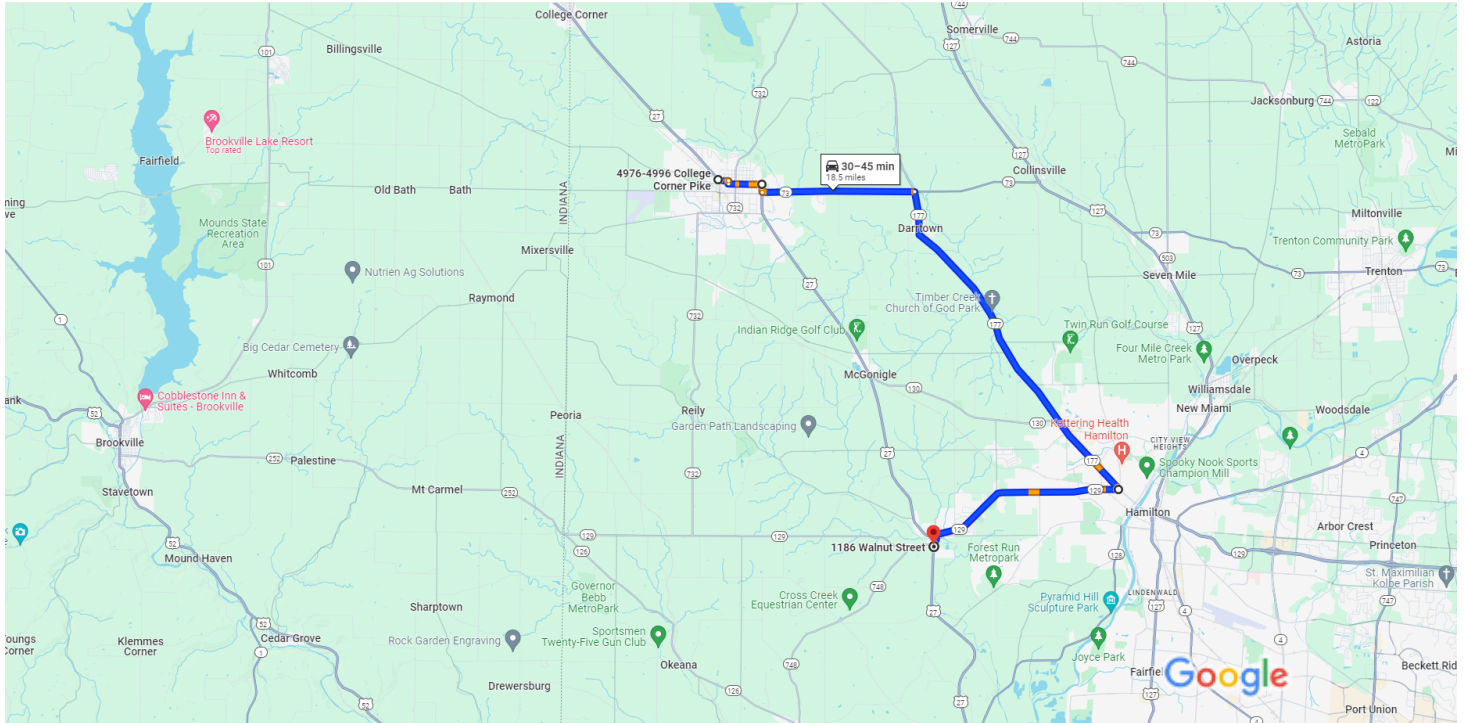

Map data ©2024 Google 2 mi

4976-4996 College Corner Pike
Oxford, OH 45056

Take OH-73 E/Trenton Oxford Rd to OH-177 S/Hamilton
Richmond Rd in Milford Township

- 11 min (4.9 mi)
- ↑ 1. Head southeast on College Corner Pike
- 246 ft
- ↑ 2. Continue onto W Church St
- 0.2 mi
- ↪ 3. Turn right onto N College Ave
- 381 ft
- ↶ 4. Turn left at the 1st cross street onto W High St
- 0.8 mi
- ↪ 5. Turn right onto S Patterson Ave
- 0.2 mi
- ↶ 6. Turn left onto OH-73 E/Trenton Oxford Rd
- 3.6 mi

Continue on OH-177 S/Hamilton Richmond Rd to Millville

23 min (13.3 mi)

- 7. Turn right onto OH-177 S/Hamilton Richmond Rd
 i Pass by Burger King (on the left in 7 mi)
_____ 8.7 mi
- 8. Turn right onto OH-129 W/Millville Ave
 i Pass by McDonald's (on the right in 1.9 mi)
_____ 4.6 mi
- ↶ 9. Turn left onto Walnut St
_____ 51 sec (0.3 mi)

1186 Walnut St
Hamilton, OH 45013

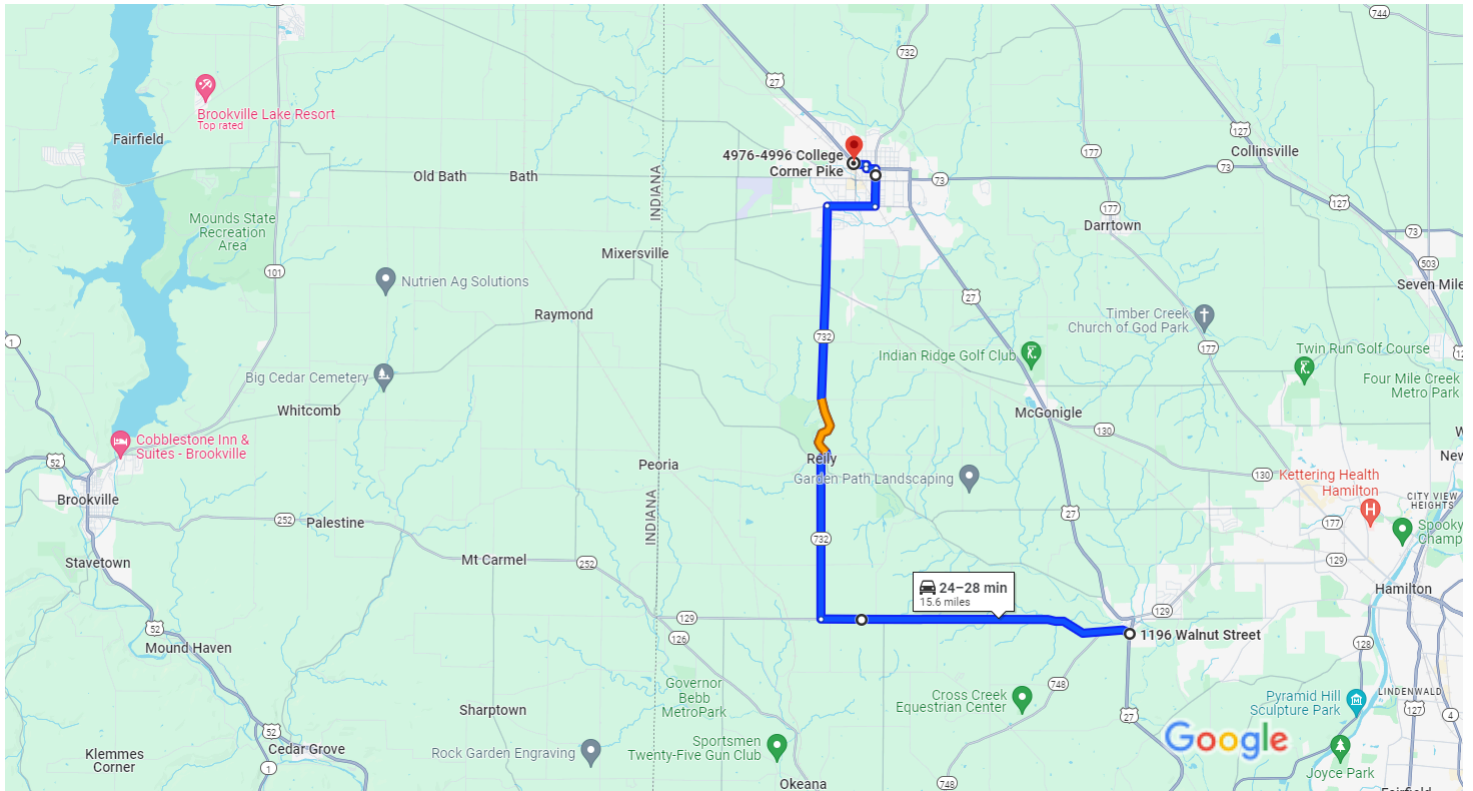

Map data ©2024 Google 2 mi

1196 Walnut St
Hamilton, OH 45013

↑ 1. Head north on Walnut St toward High St
 _____ 2 sec (52 ft)

Continue on OH-129 W. Take OH-732 N to W High St in Oxford
 _____ 22 min (15.1 mi)

← 2. Turn left onto OH-129 W/High St
 ⓘ Continue to follow OH-129 W
 _____ 5.7 mi

↘ 3. Turn right onto OH-732 N
 _____ 7.8 mi

↘ 4. Turn right onto W Chestnut St
 _____ 0.9 mi

← 5. Turn left onto S Main St
 _____ 0.7 mi

Continue on W High St. Take W Church St to College Corner Pike

-
- 3 min (0.5 mi)
- ↶ 6. Turn left onto W High St
-
- 0.2 mi
- ↷ 7. Turn right onto N College Ave
-
- 381 ft
- ↶ 8. Turn left at the 1st cross street onto W Church St
-
- 0.2 mi
- ↑ 9. Continue onto College Corner Pike
-
- 246 ft

4976-4996 College Corner Pike
Oxford, OH 45056

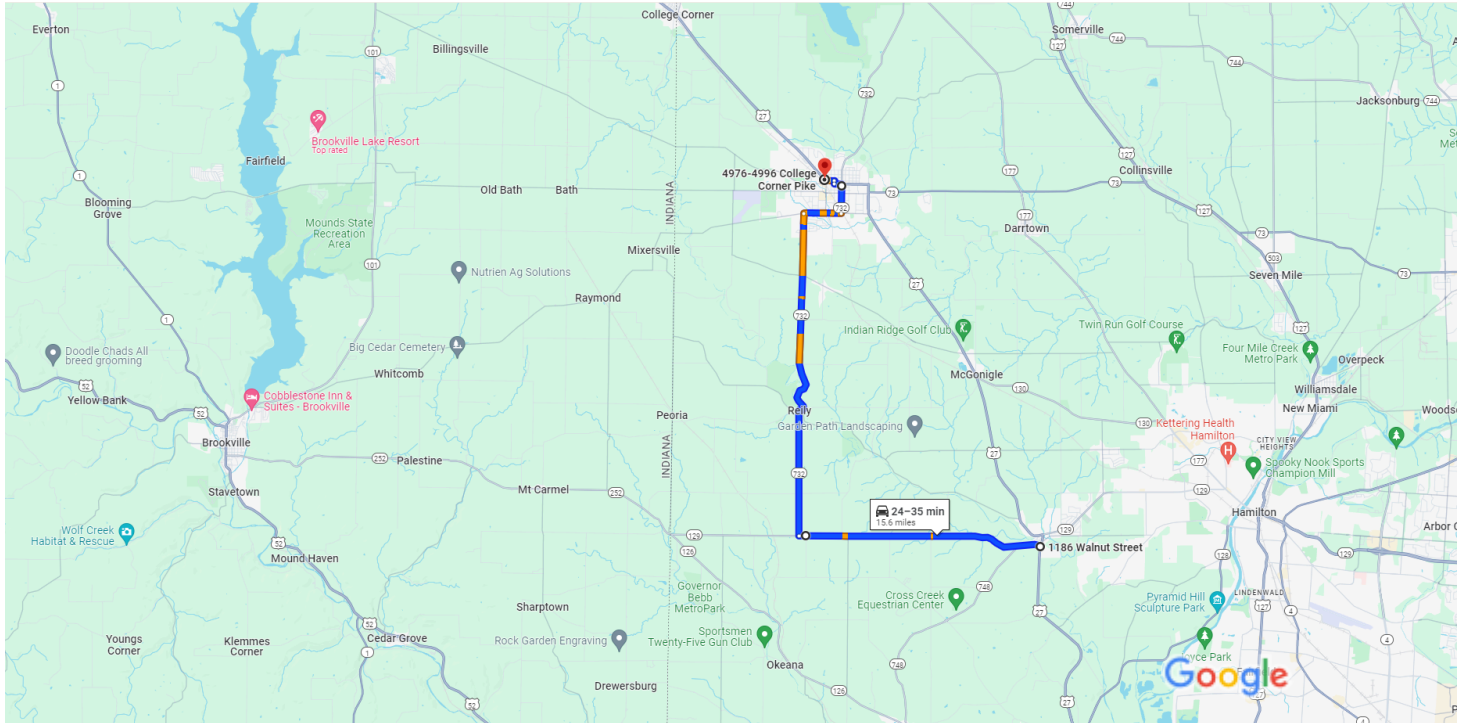

Map data ©2024 Google 2 mi

1186 Walnut St
Hamilton, OH 45013

↑ 1. Head north on Walnut St toward High St
1 sec (20 ft)

Continue on OH-129 W. Take OH-732 N to W High St in Oxford
22 min (15.1 mi)

↶ 2. Turn left onto OH-129 W/High St
Continue to follow OH-129 W
5.7 mi

↷ 3. Turn right onto OH-732 N
7.8 mi

↷ 4. Turn right onto W Chestnut St
0.9 mi

↶ 5. Turn left onto S Main St
0.7 mi

Continue on W High St. Take W Church St to College Corner Pike

-
- ↶ 6. Turn left onto W High St 3 min (0.5 mi)
-
- ↷ 7. Turn right onto N College Ave 0.2 mi
-
- ↶ 8. Turn left at the 1st cross street onto W Church St 381 ft
-
- ↑ 9. Continue onto College Corner Pike 0.2 mi
-
- 246 ft

4976-4996 College Corner Pike
Oxford, OH 45056

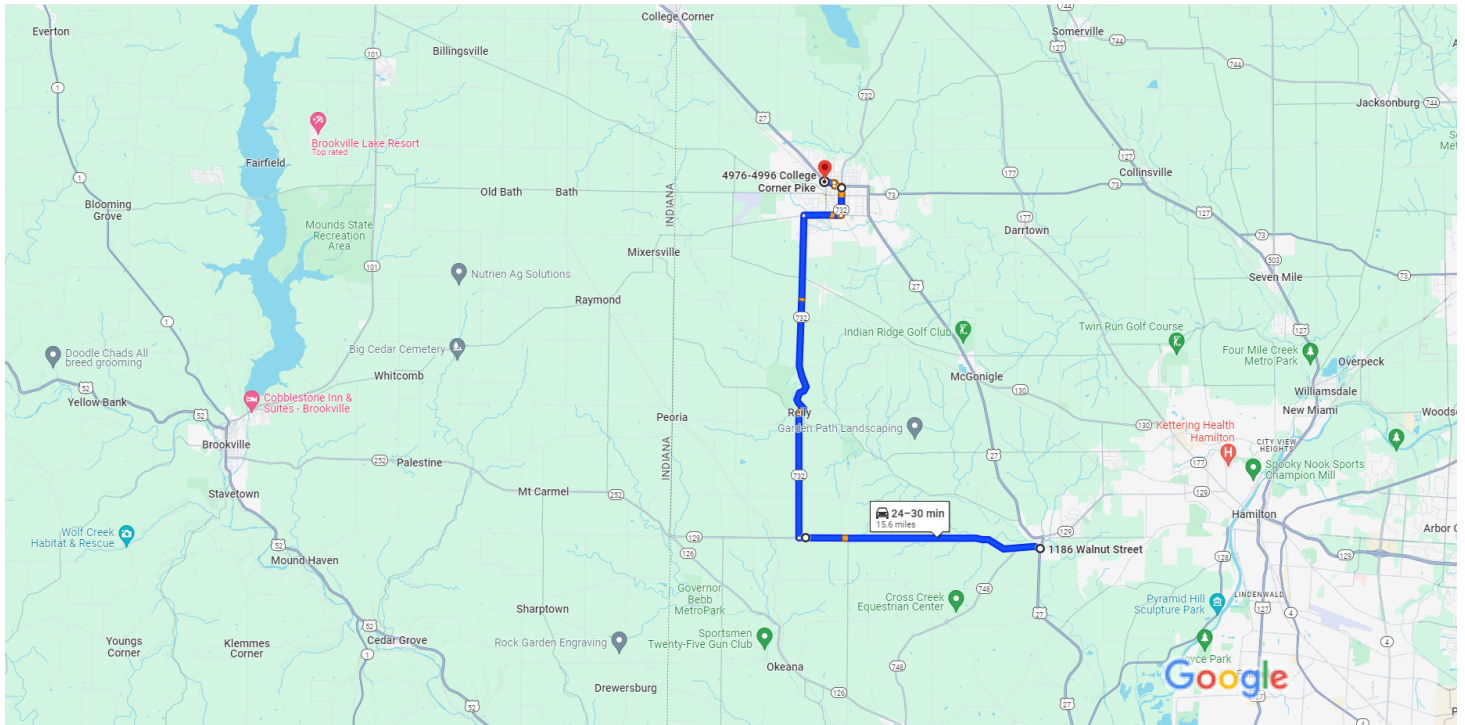

Map data ©2024 Google 2 mi

1186 Walnut St
Hamilton, OH 45013

↑ 1. Head north on Walnut St toward High St
1 sec (20 ft)

Continue on OH-129 W. Take OH-732 N to W High St in Oxford
22 min (15.1 mi)

↶ 2. Turn left onto OH-129 W/High St
Continue to follow OH-129 W
5.7 mi

↷ 3. Turn right onto OH-732 N
7.8 mi

↷ 4. Turn right onto W Chestnut St
0.9 mi

↶ 5. Turn left onto S Main St
0.7 mi

Continue on W High St. Take W Church St to College Corner Pike

-
- ↶ 6. Turn left onto W High St 3 min (0.5 mi)
-
- ↷ 7. Turn right onto N College Ave 0.2 mi
-
- ↶ 8. Turn left at the 1st cross street onto W Church St 381 ft
-
- ↑ 9. Continue onto College Corner Pike 0.2 mi
-
- 246 ft

4976-4996 College Corner Pike
Oxford, OH 45056

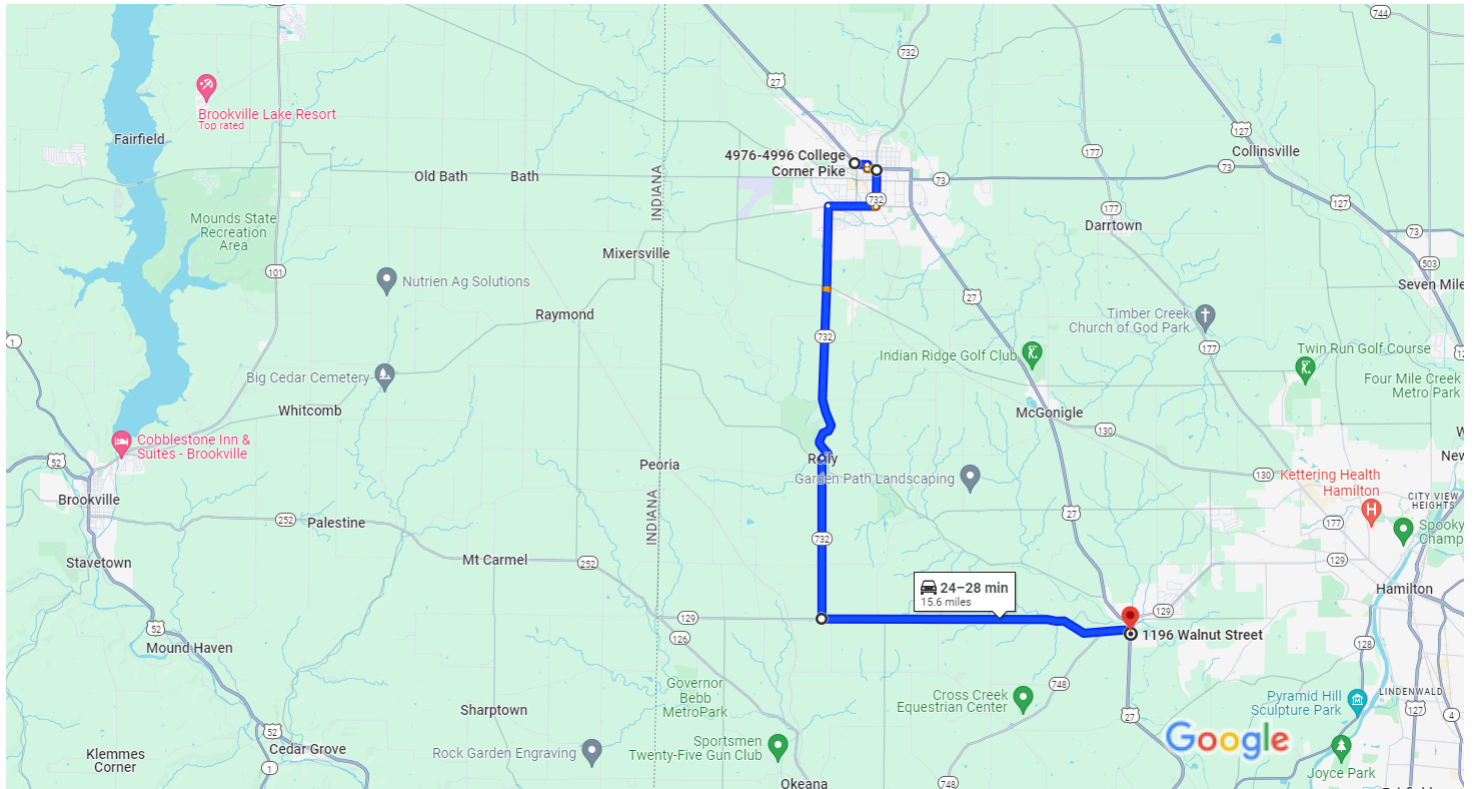

Map data ©2024 Google 2 mi

4976-4996 College Corner Pike
Oxford, OH 45056

Take W Church St and W High St to S Main St

- 3 min (0.5 mi)
- ↑ 1. Head southeast on College Corner Pike
- 246 ft
- ↑ 2. Continue onto W Church St
- 0.2 mi
- ↪ 3. Turn right onto N College Ave
- 381 ft
- ↶ 4. Turn left at the 1st cross street onto W High St
- 0.2 mi

Take OH-732 S and OH-129 E to Walnut St in Millville

- 23 min (15.1 mi)
- ↪ 5. Turn right onto S Main St
- 0.7 mi

- ↪ 6. Turn right onto W Chestnut St
0.9 mi
- ↶ 7. Turn left onto OH-732 S/Oxford Reily Rd
[Continue to follow OH-732 S](#)
4.9 mi
- ↶ 8. Turn left to stay on OH-732 S
2.9 mi
- ↶ 9. Turn left onto OH-129 E
5.7 mi
- ↪ 10. Turn right onto Walnut St
4 sec (52 ft)

1196 Walnut St
Hamilton, OH 45013

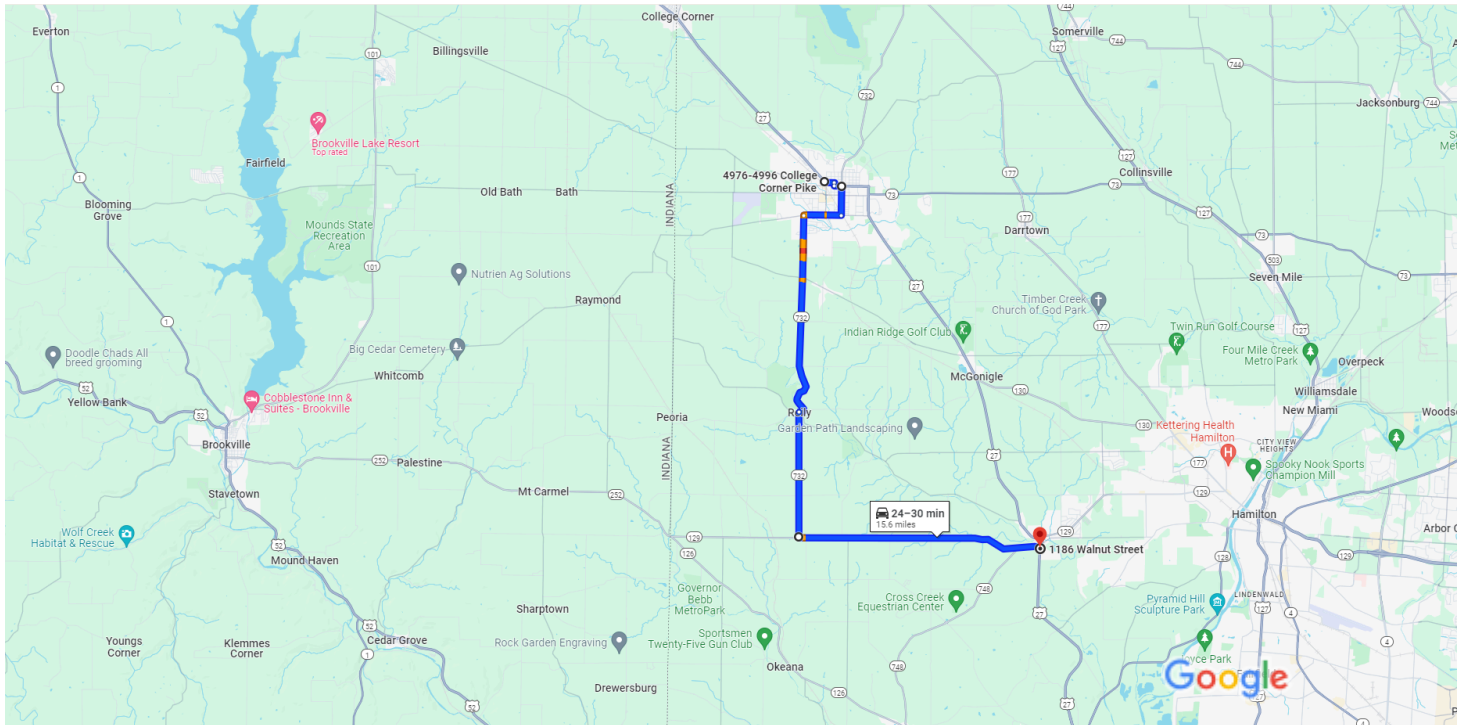

Map data ©2024 Google 2 mi

4976-4996 College Corner Pike
Oxford, OH 45056

Take W Church St and W High St to S Main St

- _____ 3 min (0.5 mi)
- ↑ 1. Head southeast on College Corner Pike
- _____ 246 ft
- ↑ 2. Continue onto W Church St
- _____ 0.2 mi
- ↘ 3. Turn right onto N College Ave
- _____ 381 ft
- ← 4. Turn left at the 1st cross street onto W High St
- _____ 0.2 mi

Take OH-732 S and OH-129 E to Walnut St in Millville

- _____ 24 min (15.1 mi)
- ↘ 5. Turn right onto S Main St
- _____ 0.7 mi
- ↘ 6. Turn right onto W Chestnut St
- _____ 0.9 mi

- ↶ 7. Turn left onto OH-732 S/Oxford Reily Rd
 - i Continue to follow OH-732 S

 - 4.9 mi
- ↶ 8. Turn left to stay on OH-732 S

- 2.9 mi
- ↶ 9. Turn left onto OH-129 E

- 5.7 mi
- ↷ 10. Turn right onto Walnut St

- 3 sec (20 ft)

1186 Walnut St
Hamilton, OH 45013

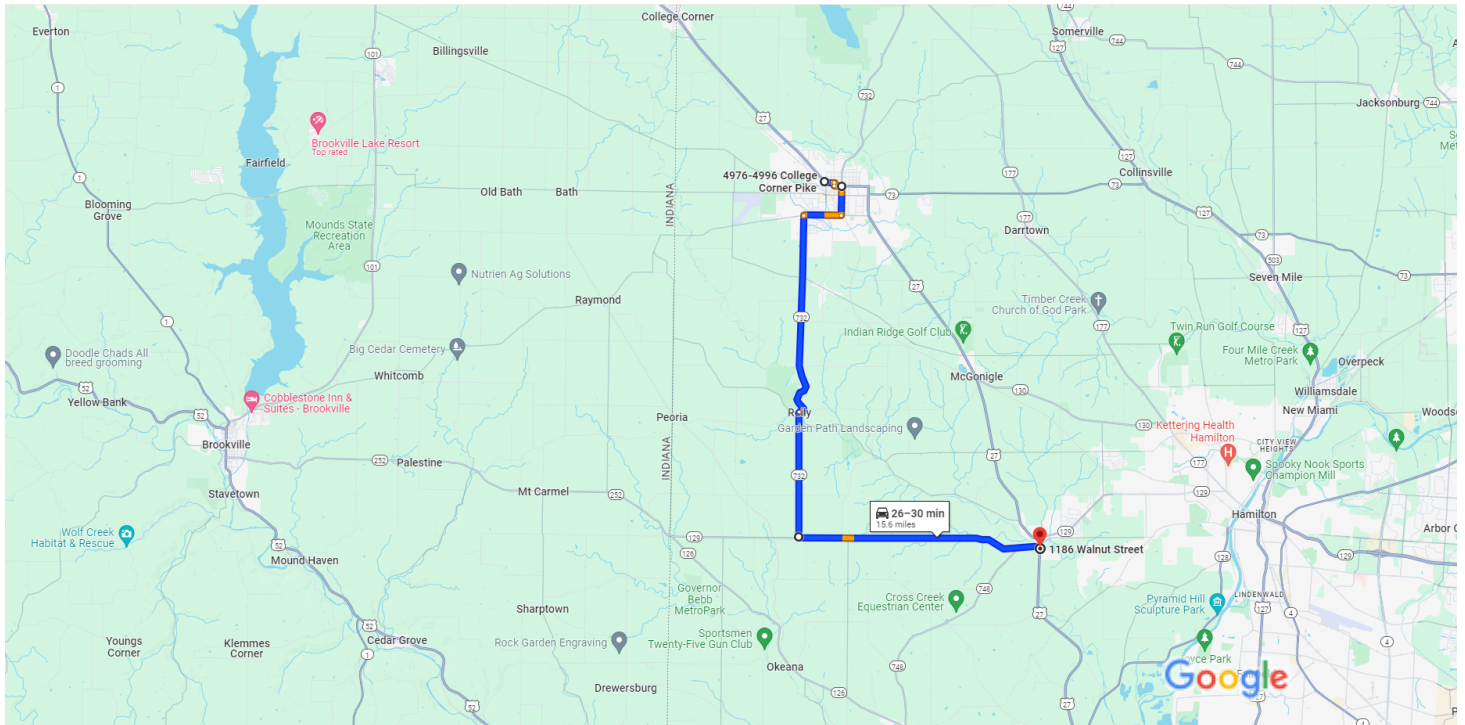

Map data ©2024 Google 2 mi

4976-4996 College Corner Pike
Oxford, OH 45056

Take W Church St and W High St to S Main St

- _____ 3 min (0.5 mi)
- ↑ 1. Head southeast on College Corner Pike
- _____ 246 ft
- ↑ 2. Continue onto W Church St
- _____ 0.2 mi
- ↘ 3. Turn right onto N College Ave
- _____ 381 ft
- ↶ 4. Turn left at the 1st cross street onto W High St
- _____ 0.2 mi

Take OH-732 S and OH-129 E to Walnut St in Millville

- _____ 24 min (15.1 mi)
- ↘ 5. Turn right onto S Main St
- _____ 0.7 mi
- ↘ 6. Turn right onto W Chestnut St
- _____ 0.9 mi

- ↶ 7. Turn left onto OH-732 S/Oxford Reily Rd
 ⓘ Continue to follow OH-732 S
————— 4.9 mi
- ↶ 8. Turn left to stay on OH-732 S
————— 2.9 mi
- ↶ 9. Turn left onto OH-129 E
————— 5.7 mi
- ↷ 10. Turn right onto Walnut St
————— 3 sec (20 ft)

1186 Walnut St
Hamilton, OH 45013

| Work Zone User Cost Calculations | | |
|---|--------------------------------|------------------|
| Detour (Using Actual Drive Time) | | |
| Project ID: | 117275 | |
| County-Route-Section: | BUT-027-10.83-D1-NB-Typ | |
| User Input: | | |
| Construction Calendar Year: | 2023 | |
| | Car | B/C Truck |
| ADT of Detoured Section: | 3,680 | 228 |
| Time to Drive Normal Route (Min): | 20 | 20 |
| Time to Drive Detour Route (Min): | 30 | 30 |
| Duration of Closure (Days): | 60 | |
| Calculated Values: | | |
| User Cost per Vehicle per Hour: | \$26.13 | \$70.52 |
| Delay (Min): | 10 | 10 |
| Delay (Hours): | 0.167 | 0.167 |
| Delay Cost per Vehicle: | \$4.35 | \$11.75 |
| Delay Cost per Day: | \$16,023.44 | \$2,679.72 |
| Delay Cost for Closure Duration: | \$961,407 | \$160,783 |
| Total Delay Cost for Closure Duration: | \$1,122,190 | |
| Average Delay Cost per Day: | \$18,703 | |

| Notes (description, detour route, project phase reference, etc, as applicable): |
|--|
| ***TIP: Alt+Enter for a line break in the box below.*** |
| Detour 1 - Northbound - Typical Hour - State Route 1 |
| ADT volumes from ODOT AADT with ODOT seasonal adjustment factors applied |

Form Version Date: 2/27/2024

Fill in all highlighted cells.

The Average Delay Cost per Day is the MAXIMUM that may be used as incentive / disincentive.

Date Calculated: 2024-05-01

| Work Zone User Cost Calculations | | |
|---|--------------------------------|------------------|
| Detour (Using Actual Drive Time) | | |
| Project ID: | 117275 | |
| County-Route-Section: | BUT-027-10.83-D1-SB-Typ | |
| User Input: | | |
| Construction Calendar Year: | 2023 | |
| | Car | B/C Truck |
| ADT of Detoured Section: | 3,888 | 196 |
| Time to Drive Normal Route (Min): | 20 | 20 |
| Time to Drive Detour Route (Min): | 35 | 35 |
| Duration of Closure (Days): | 60 | |
| Calculated Values: | | |
| User Cost per Vehicle per Hour: | \$26.13 | \$70.52 |
| Delay (Min): | 15 | 15 |
| Delay (Hours): | 0.250 | 0.250 |
| Delay Cost per Vehicle: | \$6.53 | \$17.63 |
| Delay Cost per Day: | \$25,393.67 | \$3,455.43 |
| Delay Cost for Closure Duration: | \$1,523,620 | \$207,326 |
| Total Delay Cost for Closure Duration: | \$1,730,946 | |
| Average Delay Cost per Day: | \$28,849 | |

| Notes (description, detour route, project phase reference, etc, as applicable): |
|--|
| ***TIP: Alt+Enter for a line break in the box below.*** |
| Detour 1 - Southbound - Typical Hour - State Route 1 |
| ADT volumes from ODOT AADT with ODOT seasonal adjustment factors applied |

Form Version Date: 2/27/2024

Fill in all highlighted cells.

The Average Delay Cost per Day is the MAXIMUM that may be used as incentive / disincentive.

Date Calculated: 2024-05-01

| Work Zone User Cost Calculations | | |
|---|--------------------------------|------------------|
| Detour (Using Actual Drive Time) | | |
| Project ID: | 117275 | |
| County-Route-Section: | BUT-027-10.83-D2-NB-Typ | |
| User Input: | | |
| Construction Calendar Year: | 2023 | |
| | Car | B/C Truck |
| ADT of Detoured Section: | 3,680 | 228 |
| Time to Drive Normal Route (Min): | 20 | 20 |
| Time to Drive Detour Route (Min): | 26 | 26 |
| Duration of Closure (Days): | 60 | |
| Calculated Values: | | |
| User Cost per Vehicle per Hour: | \$26.13 | \$70.52 |
| Delay (Min): | 6 | 6 |
| Delay (Hours): | 0.100 | 0.100 |
| Delay Cost per Vehicle: | \$2.61 | \$7.05 |
| Delay Cost per Day: | \$9,614.07 | \$1,607.83 |
| Delay Cost for Closure Duration: | \$576,844 | \$96,470 |
| Total Delay Cost for Closure Duration: | \$673,314 | |
| Average Delay Cost per Day: | \$11,222 | |

| Notes <i>(description, detour route, project phase reference, etc, as applicable):</i> ***TIP: Alt+Enter for a line break in the box below.*** |
|--|
| Detour 2 - Northbound - Typical Hour - State Route 2 ADT volumes from ODOT AADT with ODOT seasonal adjustment factors applied |

Form Version Date: 2/27/2024

Fill in all highlighted cells.

The Average Delay Cost per Day is the MAXIMUM that may be used as incentive / disincentive.

Date Calculated: 2024-05-01

| Work Zone User Cost Calculations | | |
|---|--------------------------------|------------------|
| Detour (Using Actual Drive Time) | | |
| Project ID: | 117275 | |
| County-Route-Section: | BUT-027-10.83-D2-SB-Typ | |
| User Input: | | |
| Construction Calendar Year: | 2023 | |
| | Car | B/C Truck |
| ADT of Detoured Section: | 3,888 | 196 |
| Time to Drive Normal Route (Min): | 20 | 20 |
| Time to Drive Detour Route (Min): | 26 | 26 |
| Duration of Closure (Days): | 60 | |
| Calculated Values: | | |
| User Cost per Vehicle per Hour: | \$26.13 | \$70.52 |
| Delay (Min): | 6 | 6 |
| Delay (Hours): | 0.100 | 0.100 |
| Delay Cost per Vehicle: | \$2.61 | \$7.05 |
| Delay Cost per Day: | \$10,157.47 | \$1,382.17 |
| Delay Cost for Closure Duration: | \$609,448 | \$82,930 |
| Total Delay Cost for Closure Duration: | \$692,378 | |
| Average Delay Cost per Day: | \$11,540 | |

| Notes (description, detour route, project phase reference, etc, as applicable): ***TIP: Alt+Enter for a line break in the box below.*** |
|---|
| Detour 2 - Southbound - Typical Hour - State Route 2 ADT volumes from ODOT AADT with ODOT seasonal adjustment factors applied |

Form Version Date: 2/27/2024

Fill in all highlighted cells.

The Average Delay Cost per Day is the MAXIMUM that may be used as incentive / disincentive.

Date Calculated: 2024-05-01

HCS Signalized Intersection Results Summary

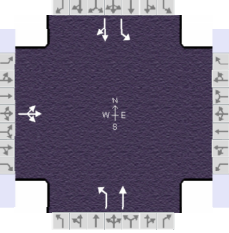
| General Information | | | | Intersection Information | |  |
|---------------------|------------------------------|---------------|-------------------------------|--------------------------|----------|---|
| Agency | CVE | | | Duration, h | 0.250 | |
| Analyst | ALM | Analysis Date | Apr 26, 2024 | Area Type | Other | |
| Jurisdiction | ODOT | Time Period | AM Peak | PHF | 0.98 | |
| Urban Street | BUT-27 | Analysis Year | 2024 | Analysis Period | 1 > 7:00 | |
| Intersection | Hussey & BUT-27 | File Name | 117275-BUT-27-10.83-WZ-AM.xus | | | |
| Project Description | BUT-027-10.83 Feasibility AM | | | | | |

| Demand Information | EB | | | WB | | | NB | | | SB | | |
|-----------------------|----|---|----|----|---|---|----|-----|---|----|-----|----|
| Approach Movement | L | T | R | L | T | R | L | T | R | L | T | R |
| Demand (v), veh/h | 10 | 0 | 13 | | | | 1 | 243 | | 0 | 297 | 12 |

| Signal Information | | | | | | | | | | | | | |
|--------------------|-------|-----------------|-----|--------|------|------|------|-----|-----|-----|--|--|--|
| Cycle, s | 150.0 | Reference Phase | 2 | | | | | | | | | | |
| Offset, s | 0 | Reference Point | End | Green | 27.5 | 33.0 | 10.0 | 0.0 | 0.0 | 0.0 | | | |
| Uncoordinated | Yes | Simult. Gap E/W | Off | Yellow | 4.0 | 4.0 | 4.0 | 0.0 | 0.0 | 0.0 | | | |
| Force Mode | Fixed | Simult. Gap N/S | Off | Red | 23.5 | 23.5 | 20.5 | 0.0 | 0.0 | 0.0 | | | |

| Timer Results | EBL | EBT | WBL | WBT | NBL | NBT | SBL | SBT |
|-----------------------------------|-----|------|-----|-----|------|------|------|------|
| Assigned Phase | | 4 | | | 1 | 6 | 5 | 2 |
| Case Number | | 12.0 | | | 2.0 | 4.0 | 2.0 | 4.0 |
| Phase Duration, s | | 34.5 | | | 55.0 | 55.0 | 60.5 | 60.5 |
| Change Period, ($Y+R_c$), s | | 24.5 | | | 27.5 | 27.5 | 27.5 | 27.5 |
| Max Allow Headway (MAH), s | | 3.0 | | | 2.8 | 2.7 | 0.0 | 2.7 |
| Queue Clearance Time (g_s), s | | 4.1 | | | 2.1 | 23.1 | | 28.8 |
| Green Extension Time (g_e), s | | 0.0 | | | 0.0 | 0.1 | 0.0 | 0.2 |
| Phase Call Probability | | 1.00 | | | 1.00 | 1.00 | | 1.00 |
| Max Out Probability | | 0.00 | | | 0.00 | 0.16 | | 0.25 |

| Movement Group Results | EB | | | WB | | | NB | | | SB | | |
|---|-------|---|----|-----|---|---|-------|-------|-------|------|---|-------|
| Approach Movement | L | T | R | L | T | R | L | T | R | L | T | R |
| Assigned Movement | 7 | 4 | 14 | | | | 1 | 6 | | 5 | 2 | 12 |
| Adjusted Flow Rate (v), veh/h | 23 | | | | | | 1 | 248 | 0 | | | 315 |
| Adjusted Saturation Flow Rate (s), veh/h/ln | 1558 | | | | | | 1667 | 1689 | 1667 | | | 1690 |
| Queue Service Time (g_s), s | 2.1 | | | | | | 0.1 | 21.1 | 0.0 | | | 26.8 |
| Cycle Queue Clearance Time (g_c), s | 2.1 | | | | | | 0.1 | 21.1 | 0.0 | | | 26.8 |
| Green Ratio (g/C) | 0.07 | | | | | | 0.18 | 0.18 | 0.22 | | | 0.22 |
| Capacity (c), veh/h | 104 | | | | | | 306 | 310 | 367 | | | 372 |
| Volume-to-Capacity Ratio (X) | 0.226 | | | | | | 0.003 | 0.801 | 0.000 | | | 0.848 |
| Back of Queue (Q), ft/ln (95 th percentile) | 39 | | | | | | 2 | 397 | 0 | | | 487 |
| Back of Queue (Q), veh/ln (95 th percentile) | 1.6 | | | | | | 0.1 | 15.4 | 0.0 | | | 19.0 |
| Queue Storage Ratio (RQ) (95 th percentile) | 0.04 | | | | | | 0.00 | 0.40 | 0.00 | | | 0.49 |
| Uniform Delay (d_1), s/veh | 66.3 | | | | | | 50.1 | 58.6 | 0.0 | | | 56.1 |
| Incremental Delay (d_2), s/veh | 0.4 | | | | | | 0.0 | 13.0 | 0.0 | | | 15.8 |
| Initial Queue Delay (d_3), s/veh | 0.0 | | | | | | 0.0 | 0.0 | 0.0 | | | 0.0 |
| Control Delay (d), s/veh | 66.7 | | | | | | 50.1 | 71.6 | 0.0 | | | 71.9 |
| Level of Service (LOS) | E | | | | | | D | E | | | | E |
| Approach Delay, s/veh / LOS | 66.7 | E | | 0.0 | | | 71.5 | E | | 71.9 | E | |
| Intersection Delay, s/veh / LOS | 71.5 | | | | | | E | | | | | |

| Multimodal Results | EB | | WB | | NB | | SB | |
|----------------------------|------|---|------|---|------|---|------|---|
| Pedestrian LOS Score / LOS | 1.97 | B | 1.97 | B | 1.43 | A | 1.73 | B |
| Bicycle LOS Score / LOS | 0.53 | A | | | 0.90 | A | 1.01 | A |

HCS Signalized Intersection Results Summary

| General Information | | | | Intersection Information | | | |
|---------------------|------------------------------|---------------|--------------|-------------------------------|----------|--|--|
| Agency | CVE | | | Duration, h | 0.250 | | |
| Analyst | ALM | Analysis Date | Apr 26, 2024 | Area Type | Other | | |
| Jurisdiction | ODOT | Time Period | PM Peak | PHF | 0.93 | | |
| Urban Street | BUT-27 | Analysis Year | 2024 | Analysis Period | 1 > 7:00 | | |
| Intersection | Hussey & BUT-27 | | File Name | 117275-BUT-27-10.83-WZ-PM.xus | | | |
| Project Description | BUT-027-10.83 Feasibility PM | | | | | | |

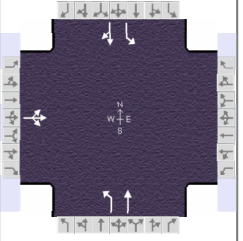

| Demand Information | EB | | | WB | | | NB | | | SB | | |
|-----------------------|----|---|----|----|---|---|----|-----|---|----|-----|----|
| | L | T | R | L | T | R | L | T | R | L | T | R |
| Approach Movement | | | | | | | | | | | | |
| Demand (v), veh/h | 15 | 0 | 12 | | | | 1 | 404 | | 0 | 304 | 14 |

| Signal Information | | | | | | | | | | | | | | | |
|--------------------|-------|-----------------|-----|--------|------|------|------|-----|-----|-----|--|--|--|--|--|
| Cycle, s | 150.0 | Reference Phase | 2 | | | | | | | | | | | | |
| Offset, s | 0 | Reference Point | End | | | | | | | | | | | | |
| Uncoordinated | Yes | Simult. Gap E/W | Off | Green | 33.5 | 27.0 | 10.0 | 0.0 | 0.0 | 0.0 | | | | | |
| Force Mode | Fixed | Simult. Gap N/S | Off | Yellow | 4.0 | 4.0 | 4.0 | 0.0 | 0.0 | 0.0 | | | | | |
| | | | | Red | 23.5 | 23.5 | 20.5 | 0.0 | 0.0 | 0.0 | | | | | |

| Timer Results | EBL | EBT | WBL | WBT | NBL | NBT | SBL | SBT |
|-----------------------------------|-----|------|-----|-----|------|------|------|------|
| Assigned Phase | | 4 | | | 1 | 6 | 5 | 2 |
| Case Number | | 12.0 | | | 2.0 | 4.0 | 2.0 | 4.0 |
| Phase Duration, s | | 34.5 | | | 61.0 | 61.0 | 54.5 | 54.5 |
| Change Period, ($Y+R_c$), s | | 24.5 | | | 27.5 | 27.5 | 27.5 | 27.5 |
| Max Allow Headway (MAH), s | | 2.9 | | | 2.8 | 2.7 | 0.0 | 2.7 |
| Queue Clearance Time (g_s), s | | 4.6 | | | 2.1 | 35.5 | | 29.0 |
| Green Extension Time (g_e), s | | 0.0 | | | 0.0 | 0.0 | 0.0 | 0.0 |
| Phase Call Probability | | 1.00 | | | 1.00 | 1.00 | | 1.00 |
| Max Out Probability | | 0.01 | | | 0.00 | 1.00 | | 1.00 |

| Movement Group Results | EB | | | WB | | | NB | | | SB | | |
|---|-------|---|----|-----|---|---|-------|-------|-------|-------|-------|------|
| | L | T | R | L | T | R | L | T | R | L | T | R |
| Assigned Movement | 7 | 4 | 14 | | | | 1 | 6 | | 5 | 2 | 12 |
| Adjusted Flow Rate (v), veh/h | 29 | | | | | | 1 | 434 | 0 | | | 342 |
| Adjusted Saturation Flow Rate (s), veh/h/ln | 1580 | | | | | | 1667 | 1702 | 1667 | | | 1702 |
| Queue Service Time (g_s), s | 2.6 | | | | | | 0.1 | 33.5 | 0.0 | | | 27.0 |
| Cycle Queue Clearance Time (g_c), s | 2.6 | | | | | | 0.1 | 33.5 | 0.0 | | | 27.0 |
| Green Ratio (g/C) | 0.07 | | | | | | 0.22 | 0.22 | 0.18 | | 0.18 | |
| Capacity (c), veh/h | 105 | | | | | | 372 | 380 | 300 | | 306 | |
| Volume-to-Capacity Ratio (X) | 0.276 | | | | | | 0.003 | 1.143 | 0.000 | | 1.116 | |
| Back of Queue (Q), ft/ln (95 th percentile) | 49 | | | | | | 2 | 884 | 0 | | 704 | |
| Back of Queue (Q), veh/ln (95 th percentile) | 1.9 | | | | | | 0.1 | 34.5 | 0.0 | | 27.7 | |
| Queue Storage Ratio (RQ) (95 th percentile) | 0.05 | | | | | | 0.00 | 0.88 | 0.00 | | 0.70 | |
| Uniform Delay (d_1), s/veh | 66.6 | | | | | | 45.3 | 58.3 | 0.0 | | 61.5 | |
| Incremental Delay (d_2), s/veh | 0.5 | | | | | | 0.0 | 91.0 | 0.0 | | 86.3 | |
| Initial Queue Delay (d_3), s/veh | 0.0 | | | | | | 0.0 | 0.0 | 0.0 | | 0.0 | |
| Control Delay (d), s/veh | 67.1 | | | | | | 45.3 | 149.2 | 0.0 | | 147.8 | |
| Level of Service (LOS) | E | | | | | | D | F | | | F | |
| Approach Delay, s/veh / LOS | 67.1 | E | | 0.0 | | | 149.0 | F | | 147.8 | F | |
| Intersection Delay, s/veh / LOS | 145.5 | | | | | | F | | | | | |

| Multimodal Results | EB | | WB | | NB | | SB | |
|----------------------------|------|---|------|---|------|---|------|---|
| Pedestrian LOS Score / LOS | 1.97 | B | 1.97 | B | 1.44 | A | 1.73 | B |
| Bicycle LOS Score / LOS | 0.54 | A | | | 1.21 | A | 1.05 | A |

HCS Signalized Intersection Results Summary

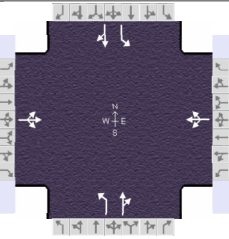
| General Information | | | | | Intersection Information | | |  | | |
|---------------------|------------------------------|---------------|--------------|--------------------------------------|--------------------------|----------|--|---|--|--|
| Agency | CVE | | | | Duration, h | 0.250 | | | | |
| Analyst | ALM | Analysis Date | Apr 26, 2024 | | Area Type | Other | | | | |
| Jurisdiction | ODOT | Time Period | AM Peak | | PHF | 0.98 | | | | |
| Urban Street | BUT-27 | Analysis Year | 2024 | | Analysis Period | 1 > 7:00 | | | | |
| Intersection | Hussey/SR-130 & BUT-27 | | File Name | 117275-BUT-27-10.83-SR-130-WZ-AM.xus | | | | | | |
| Project Description | BUT-027-10.83 Feasibility AM | | | | | | | | | |

| Demand Information | EB | | | WB | | | NB | | | SB | | |
|-----------------------|----|---|----|----|---|----|----|-----|----|----|-----|----|
| | L | T | R | L | T | R | L | T | R | L | T | R |
| Approach Movement | | | | | | | | | | | | |
| Demand (v), veh/h | 10 | 0 | 13 | 43 | 0 | 34 | 1 | 200 | 43 | 0 | 297 | 12 |

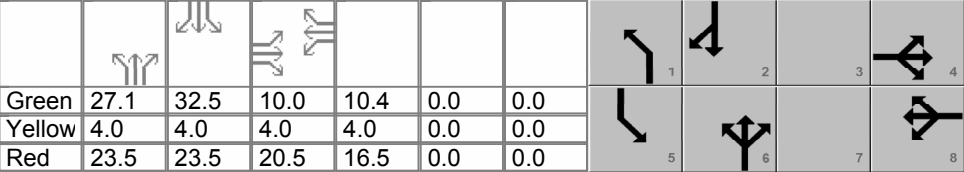
| Signal Information | | | |  | | | | | | | |
|--------------------|-------|-----------------|-----|--|--|--|--|--|--|--|--|
| Cycle, s | 180.0 | Reference Phase | 2 | | | | | | | | |
| Offset, s | 0 | Reference Point | End | | | | | | | | |
| Uncoordinated | Yes | Simult. Gap E/W | Off | | | | | | | | |
| Force Mode | Fixed | Simult. Gap N/S | Off | | | | | | | | |

| Timer Results | EBL | EBT | WBL | WBT | NBL | NBT | SBL | SBT |
|-----------------------------------|-----|------|-----|------|------|------|------|------|
| Assigned Phase | | 4 | | 8 | 1 | 6 | 5 | 2 |
| Case Number | | 12.0 | | 12.0 | 1.2 | 4.0 | 2.0 | 4.0 |
| Phase Duration, s | | 34.5 | | 30.9 | 54.6 | 54.6 | 60.0 | 60.0 |
| Change Period, ($Y+R_c$), s | | 24.5 | | 20.5 | 27.5 | 27.5 | 27.5 | 27.5 |
| Max Allow Headway (MAH), s | | 3.0 | | 2.9 | 2.8 | 2.8 | 0.0 | 2.7 |
| Queue Clearance Time (g_s), s | | 4.6 | | 10.9 | 2.1 | 29.1 | | 34.5 |
| Green Extension Time (g_e), s | | 0.0 | | 0.0 | 0.0 | 0.0 | 0.0 | 0.0 |
| Phase Call Probability | | 1.00 | | 1.00 | 1.00 | 1.00 | | 1.00 |
| Max Out Probability | | 0.01 | | 1.00 | 0.00 | 1.00 | | 1.00 |

| Movement Group Results | EB | | | WB | | | NB | | | SB | | |
|---|-------|---|----|-------|---|----|-------|-------|----|-------|-------|----|
| | L | T | R | L | T | R | L | T | R | L | T | R |
| Approach Movement | | | | | | | | | | | | |
| Assigned Movement | 7 | 4 | 14 | 3 | 8 | 18 | 1 | 6 | 16 | 5 | 2 | 12 |
| Adjusted Flow Rate (v), veh/h | 23 | | | 79 | | | 1 | 248 | | 0 | 315 | |
| Adjusted Saturation Flow Rate (s), veh/h/ln | 1558 | | | 1580 | | | 1667 | 1636 | | 1667 | 1690 | |
| Queue Service Time (g_s), s | 2.6 | | | 8.9 | | | 0.1 | 27.1 | | 0.0 | 32.5 | |
| Cycle Queue Clearance Time (g_c), s | 2.6 | | | 8.9 | | | 0.1 | 27.1 | | 0.0 | 32.5 | |
| Green Ratio (g/C) | 0.06 | | | 0.06 | | | 0.15 | 0.15 | | 0.18 | 0.18 | |
| Capacity (c), veh/h | 87 | | | 91 | | | 291 | 246 | | 301 | 305 | |
| Volume-to-Capacity Ratio (X) | 0.271 | | | 0.861 | | | 0.004 | 1.006 | | 0.000 | 1.033 | |
| Back of Queue (Q), ft/ln (95 th percentile) | 48 | | | 214 | | | 2 | 569 | | 0 | 691 | |
| Back of Queue (Q), veh/ln (95 th percentile) | 1.9 | | | 8.6 | | | 0.1 | 22.1 | | 0.0 | 27.0 | |
| Queue Storage Ratio (RQ) (95 th percentile) | 0.05 | | | 0.00 | | | 0.00 | 0.57 | | 0.00 | 0.69 | |
| Uniform Delay (d_1), s/veh | 81.5 | | | 84.1 | | | 64.9 | 76.5 | | 0.0 | 73.8 | |
| Incremental Delay (d_2), s/veh | 0.6 | | | 50.2 | | | 0.0 | 59.0 | | 0.0 | 60.3 | |
| Initial Queue Delay (d_3), s/veh | 0.0 | | | 0.0 | | | 0.0 | 0.0 | | 0.0 | 0.0 | |
| Control Delay (d), s/veh | 82.1 | | | 134.3 | | | 64.9 | 135.4 | | 0.0 | 134.1 | |
| Level of Service (LOS) | F | | | F | | | E | F | | | F | |
| Approach Delay, s/veh / LOS | 82.1 | | F | 134.3 | | F | 135.1 | | F | 134.1 | | F |
| Intersection Delay, s/veh / LOS | 132.7 | | | | | | F | | | | | |

| Multimodal Results | EB | | WB | | NB | | SB | |
|----------------------------|------|---|------|---|------|---|------|---|
| Pedestrian LOS Score / LOS | 1.98 | B | 1.98 | B | 1.74 | B | 1.74 | B |
| Bicycle LOS Score / LOS | 0.53 | A | 0.62 | A | 0.90 | A | 1.01 | A |

HCS Signalized Intersection Results Summary

| General Information | | | | Intersection Information | | | |
|---------------------|------------------------------|---------------|--------------------------------------|--------------------------|----------|--|--|
| Agency | CVE | | | Duration, h | 0.250 | | |
| Analyst | ALM | Analysis Date | Apr 26, 2024 | Area Type | Other | | |
| Jurisdiction | ODOT | Time Period | PM Peak | PHF | 0.93 | | |
| Urban Street | BUT-27 | Analysis Year | 2024 | Analysis Period | 1 > 7:00 | | |
| Intersection | Hussey/SR-130 & BUT-27 | File Name | 117275-BUT-27-10.83-SR-130-WZ-PM.xus | | | | |
| Project Description | BUT-027-10.83 Feasibility PM | | | | | | |

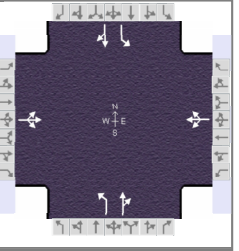

| Demand Information | EB | | | WB | | | NB | | | SB | | |
|---------------------|----|---|----|----|---|----|----|-----|----|----|-----|----|
| | L | T | R | L | T | R | L | T | R | L | T | R |
| Approach Movement | | | | | | | | | | | | |
| Demand (v), veh/h | 15 | 0 | 12 | 68 | 0 | 87 | 1 | 336 | 68 | 0 | 304 | 14 |

| Signal Information | | | | | | | | | | | | | |
|--------------------|-------|-----------------|-----|--------|------|------|------|------|-----|-----|--|--|--|
| Cycle, s | 180.0 | Reference Phase | 2 | | | | | | | | | | |
| Offset, s | 0 | Reference Point | End | | | | | | | | | | |
| Uncoordinated | Yes | Simult. Gap E/W | Off | Green | 31.5 | 25.0 | 10.0 | 13.5 | 0.0 | 0.0 | | | |
| Force Mode | Fixed | Simult. Gap N/S | Off | Yellow | 4.0 | 4.0 | 4.0 | 4.0 | 0.0 | 0.0 | | | |
| | | | | Red | 23.5 | 23.5 | 20.5 | 16.5 | 0.0 | 0.0 | | | |

| Timer Results | EBL | EBT | WBL | WBT | NBL | NBT | SBL | SBT |
|--|-----|------|-----|------|------|------|------|------|
| Assigned Phase | | 4 | | 8 | 1 | 6 | 5 | 2 |
| Case Number | | 12.0 | | 12.0 | 1.2 | 4.0 | 2.0 | 4.0 |
| Phase Duration, s | | 34.5 | | 34.0 | 59.0 | 59.0 | 52.5 | 52.5 |
| Change Period, (Y+R _c), s | | 24.5 | | 20.5 | 27.5 | 27.5 | 27.5 | 27.5 |
| Max Allow Headway (MAH), s | | 2.9 | | 3.0 | 2.8 | 2.8 | 0.0 | 2.7 |
| Queue Clearance Time (g _s), s | | 5.2 | | 15.5 | 2.1 | 33.5 | | 27.0 |
| Green Extension Time (g _e), s | | 0.0 | | 0.0 | 0.0 | 0.0 | 0.0 | 0.0 |
| Phase Call Probability | | 1.00 | | 1.00 | 1.00 | 1.00 | | 1.00 |
| Max Out Probability | | 0.02 | | 1.00 | 0.00 | 1.00 | | 1.00 |

| Movement Group Results | EB | | | WB | | | NB | | | SB | | |
|--|------|-------|----|-------|-------|----|-------|-------|----|-------|-------|----|
| | L | T | R | L | T | R | L | T | R | L | T | R |
| Approach Movement | | | | | | | | | | | | |
| Assigned Movement | 7 | 4 | 14 | 3 | 8 | 18 | 1 | 6 | 16 | 5 | 2 | 12 |
| Adjusted Flow Rate (v), veh/h | | 29 | | | 167 | | 1 | 434 | | 0 | 342 | |
| Adjusted Saturation Flow Rate (s), veh/h/ln | | 1580 | | | 1558 | | 1667 | 1652 | | 1667 | 1702 | |
| Queue Service Time (g _s), s | | 3.2 | | | 13.5 | | 0.1 | 31.5 | | 0.0 | 25.0 | |
| Cycle Queue Clearance Time (g _c), s | | 3.2 | | | 13.5 | | 0.1 | 31.5 | | 0.0 | 25.0 | |
| Green Ratio (g/C) | | 0.06 | | | 0.08 | | 0.18 | 0.18 | | 0.14 | 0.14 | |
| Capacity (c), veh/h | | 88 | | | 117 | | 332 | 289 | | 231 | 236 | |
| Volume-to-Capacity Ratio (X) | | 0.331 | | | 1.426 | | 0.003 | 1.502 | | 0.000 | 1.446 | |
| Back of Queue (Q), ft/ln (95 th percentile) | | 60 | | | 529 | | 2 | 1289 | | 0 | 999 | |
| Back of Queue (Q), veh/ln (95 th percentile) | | 2.4 | | | 21.2 | | 0.1 | 50.4 | | 0.0 | 39.3 | |
| Queue Storage Ratio (RQ) (95 th percentile) | | 0.06 | | | 0.00 | | 0.00 | 1.29 | | 0.00 | 1.00 | |
| Uniform Delay (d ₁), s/veh | | 81.8 | | | 83.3 | | 61.2 | 74.3 | | 0.0 | 77.5 | |
| Incremental Delay (d ₂), s/veh | | 0.8 | | | 233.9 | | 0.0 | 243.4 | | 0.0 | 223.0 | |
| Initial Queue Delay (d ₃), s/veh | | 0.0 | | | 0.0 | | 0.0 | 0.0 | | 0.0 | 0.0 | |
| Control Delay (d), s/veh | | 82.6 | | | 317.2 | | 61.2 | 317.6 | | 0.0 | 300.5 | |
| Level of Service (LOS) | | F | | | F | | E | F | | | F | |
| Approach Delay, s/veh / LOS | 82.6 | F | | 317.2 | F | | 317.0 | F | | 300.5 | F | |
| Intersection Delay, s/veh / LOS | | | | 304.2 | | | | | | F | | |

| Multimodal Results | EB | | WB | | NB | | SB | |
|----------------------------|------|---|------|---|------|---|------|---|
| Pedestrian LOS Score / LOS | 1.97 | B | 1.98 | B | 1.74 | B | 1.74 | B |
| Bicycle LOS Score / LOS | 0.54 | A | 0.76 | A | 1.21 | A | 1.05 | A |

Standard Delay Calculation - OH 130 Closed

BUT-27-10.83

Rural Principal Arterial Other

| Hour | Total | % Volume | % Heavy | | Delay (sec) per vehicle | | | | | | | | |
|-------------|-------|----------|---------|-------|-------------------------|-----------|------------|------------|-------------|-----------|------------|------------|-------------|
| | | | NB | SB | NB Delay | NB Volume | NB Vol Adj | Delay Cost | SB Delay | SB Volume | SB Vol Adj | Delay Cost | |
| | 0 | 294875 | 0.6% | 11.2% | 9.3% | 8.7 | 25 | 22 | \$ 1.61 | 8.6 | 25 | 23 | \$ 1.66 |
| | 1 | 215170 | 0.4% | 13.8% | 11.5% | 6.3 | 19 | 16 | \$ 0.89 | 6.3 | 18 | 17 | \$ 0.91 |
| | 2 | 200896 | 0.4% | 14.9% | 12.4% | 5.9 | 17 | 15 | \$ 0.79 | 5.9 | 17 | 16 | \$ 0.80 |
| | 3 | 281407 | 0.5% | 13.6% | 11.3% | 8.3 | 24 | 21 | \$ 1.52 | 8.2 | 24 | 22 | \$ 1.55 |
| | 4 | 644231 | 1.2% | 8.6% | 7.1% | 19.0 | 56 | 47 | \$ 7.41 | 18.9 | 54 | 50 | \$ 7.65 |
| | 5 | 1517013 | 2.9% | 4.9% | 4.1% | 44.7 | 131 | 111 | \$ 38.89 | 44.4 | 127 | 117 | \$ 40.50 |
| | 6 | 2639080 | 5.1% | 3.8% | 3.1% | 77.7 | 228 | 193 | \$ 115.53 | 77.3 | 221 | 204 | \$ 120.64 |
| 7:15 - 8:15 | 7 | 3242804 | 6.2% | 3.7% | 3.1% | 71.6 | 243 | 243 | \$ 134.17 | 71.9 | 309 | 309 | \$ 169.65 |
| | 8 | 2935280 | 5.6% | 4.5% | 3.8% | 86.4 | 253 | 214 | \$ 144.64 | 86.0 | 245 | 227 | \$ 150.76 |
| | 9 | 2863084 | 5.5% | 5.1% | 4.2% | 84.3 | 247 | 209 | \$ 138.86 | 83.9 | 239 | 222 | \$ 144.53 |
| | 10 | 2941020 | 5.6% | 5.2% | 4.3% | 86.6 | 254 | 215 | \$ 146.70 | 86.1 | 246 | 228 | \$ 152.67 |
| | 11 | 3051448 | 5.8% | 5.1% | 4.2% | 89.8 | 263 | 223 | \$ 157.66 | 89.4 | 255 | 236 | \$ 164.11 |
| | 12 | 3185569 | 6.1% | 4.8% | 4.0% | 93.8 | 275 | 232 | \$ 171.09 | 93.3 | 266 | 246 | \$ 178.21 |
| | 13 | 3304284 | 6.3% | 4.6% | 3.8% | 97.3 | 285 | 241 | \$ 183.47 | 96.8 | 276 | 256 | \$ 191.21 |
| | 14 | 3589343 | 6.9% | 4.1% | 3.4% | 105.7 | 310 | 262 | \$ 214.72 | 105.1 | 300 | 278 | \$ 224.06 |
| | 15 | 4056399 | 7.8% | 3.3% | 2.7% | 119.4 | 350 | 296 | \$ 270.87 | 118.8 | 339 | 314 | \$ 283.21 |
| 4:00 - 5:00 | 16 | 4258351 | 8.2% | 2.8% | 2.3% | 149.2 | 404 | 404 | \$ 458.08 | 147.8 | 318 | 318 | \$ 354.51 |
| | 17 | 3952528 | 7.6% | 2.6% | 2.1% | 116.3 | 341 | 288 | \$ 254.25 | 115.8 | 330 | 306 | \$ 266.32 |
| | 18 | 2819406 | 5.4% | 3.0% | 2.5% | 83.0 | 243 | 206 | \$ 130.37 | 82.6 | 236 | 218 | \$ 136.39 |
| | 19 | 2031364 | 3.9% | 3.4% | 2.9% | 59.8 | 175 | 148 | \$ 68.10 | 59.5 | 170 | 157 | \$ 71.17 |
| | 20 | 1591746 | 3.1% | 3.8% | 3.2% | 46.9 | 137 | 116 | \$ 42.06 | 46.6 | 133 | 123 | \$ 43.92 |
| | 21 | 1194084 | 2.3% | 4.4% | 3.7% | 35.1 | 103 | 87 | \$ 23.91 | 35.0 | 100 | 92 | \$ 24.92 |
| | 22 | 821520 | 1.6% | 5.8% | 4.8% | 24.2 | 71 | 60 | \$ 11.56 | 24.1 | 69 | 64 | \$ 12.01 |
| | 23 | 552526 | 1.1% | 7.3% | 6.1% | 16.3 | 48 | 40 | \$ 5.35 | 16.2 | 46 | 43 | \$ 5.54 |
| | | 52183428 | 1.00 | | | 64 | 4501 | 3908 | \$ 2,722.51 | 64 | 4362 | 4084 | \$ 2,746.89 |

HCS values

SAF 0.925
(R03 Tues/Wed, June)

NB SB
AADT 3615 3778
ADT 3908 4084

| | | |
|--------------|---------|------|
| NB veh / day | Calc | 4501 |
| | MS2 ADT | 3908 |
| SB veh / day | Calc | 4362 |
| | MS2 ADT | 4084 |

NB SB
MS2 % Cars 94% 95%
MS2 % Trucks 6% 5%

ODOT RUC per Vehicle per hour
Cars \$ 26.13
Trucks \$ 70.52

| NB BUT-27 | | | | | |
|----------------------------------|-------|--------|---------------------------|-----------|-------------|
| adjusted total delay per vehicle | | | Total delay (per day) | | |
| (s) | (min) | (hr) | (s) | (min) | (hr) |
| 87 | 1.5 | 0.024 | 341,264 | 5,688 | 94.80 |
| Vehicles by type (per day) | | | Total User Cost (per day) | | |
| Total | Cars | Trucks | Cars | Trucks | Total |
| 3908 | 3680 | 228 | \$ 2,332.49 | \$ 390.01 | \$ 2,722.51 |

| SB BUT-27 | | | | | |
|----------------------------------|-------|--------|---------------------------|-----------|-------------|
| adjusted total delay per vehicle | | | Total delay (per day) | | |
| (s) | (min) | (hr) | (s) | (min) | (hr) |
| 86 | 1.4 | 0.024 | 349,918 | 5,832 | 97.20 |
| Vehicles by type (per day) | | | Total User Cost (per day) | | |
| Total | Cars | Trucks | Cars | Trucks | Total |
| 4084 | 3888 | 196 | \$ 2,417.93 | \$ 328.96 | \$ 2,746.89 |

Standard Delay Calculation - OH 130 Open

BUT-27-10.83

Rural Principal Arterial Other

HCS values

| Hour | Total | % Volume | % Heavy | | Delay (sec) per vehicle | | | | | | | | |
|-------------|-------|----------|---------|-------|-------------------------|-----------|------------|------------|-------------|-----------|------------|------------|-------------|
| | | | NB | SB | NB Delay | NB Volume | NB Vol Adj | Delay Cost | SB Delay | SB Volume | SB Vol Adj | Delay Cost | |
| | 0 | 294875 | 0.6% | 11.2% | 9.3% | 17.8 | 25 | 22 | \$ 3.31 | 17.1 | 25 | 23 | \$ 3.28 |
| | 1 | 215170 | 0.4% | 13.8% | 11.5% | 13.0 | 19 | 16 | \$ 1.83 | 12.5 | 18 | 17 | \$ 1.80 |
| | 2 | 200896 | 0.4% | 14.9% | 12.4% | 12.1 | 17 | 15 | \$ 1.62 | 11.6 | 17 | 16 | \$ 1.59 |
| | 3 | 281407 | 0.5% | 13.6% | 11.3% | 17.0 | 24 | 21 | \$ 3.12 | 16.3 | 24 | 22 | \$ 3.07 |
| | 4 | 644231 | 1.2% | 8.6% | 7.1% | 38.9 | 56 | 47 | \$ 15.21 | 37.3 | 54 | 50 | \$ 15.14 |
| | 5 | 1517013 | 2.9% | 4.9% | 4.1% | 91.6 | 131 | 111 | \$ 79.79 | 87.9 | 127 | 117 | \$ 80.11 |
| | 6 | 2639080 | 5.1% | 3.8% | 3.1% | 159.4 | 228 | 193 | \$ 237.02 | 152.9 | 221 | 204 | \$ 238.65 |
| 7:15 - 8:15 | 7 | 3242804 | 6.2% | 3.7% | 3.1% | 135.4 | 243 | 243 | \$ 253.72 | 134.1 | 309 | 309 | \$ 316.40 |
| | 8 | 2935280 | 5.6% | 4.5% | 3.8% | 177.3 | 253 | 214 | \$ 296.74 | 170.1 | 245 | 227 | \$ 298.22 |
| | 9 | 2863084 | 5.5% | 5.1% | 4.2% | 172.9 | 247 | 209 | \$ 284.89 | 165.9 | 239 | 222 | \$ 285.91 |
| | 10 | 2941020 | 5.6% | 5.2% | 4.3% | 177.6 | 254 | 215 | \$ 300.98 | 170.4 | 246 | 228 | \$ 301.99 |
| | 11 | 3051448 | 5.8% | 5.1% | 4.2% | 184.3 | 263 | 223 | \$ 323.46 | 176.8 | 255 | 236 | \$ 324.64 |
| | 12 | 3185569 | 6.1% | 4.8% | 4.0% | 192.4 | 275 | 232 | \$ 351.01 | 184.6 | 266 | 246 | \$ 352.52 |
| | 13 | 3304284 | 6.3% | 4.6% | 3.8% | 199.5 | 285 | 241 | \$ 376.42 | 191.4 | 276 | 256 | \$ 378.24 |
| | 14 | 3589343 | 6.9% | 4.1% | 3.4% | 216.8 | 310 | 262 | \$ 440.54 | 208.0 | 300 | 278 | \$ 443.23 |
| | 15 | 4056399 | 7.8% | 3.3% | 2.7% | 245.0 | 350 | 296 | \$ 555.73 | 235.0 | 339 | 314 | \$ 560.23 |
| 4:00 - 5:00 | 16 | 4258351 | 8.2% | 2.8% | 2.3% | 317.6 | 404 | 404 | \$ 975.11 | 300.5 | 318 | 318 | \$ 720.77 |
| | 17 | 3952528 | 7.6% | 2.6% | 2.1% | 238.7 | 341 | 288 | \$ 521.63 | 229.0 | 330 | 306 | \$ 526.82 |
| | 18 | 2819406 | 5.4% | 3.0% | 2.5% | 170.3 | 243 | 206 | \$ 267.47 | 163.4 | 236 | 218 | \$ 269.79 |
| | 19 | 2031364 | 3.9% | 3.4% | 2.9% | 122.7 | 175 | 148 | \$ 139.71 | 117.7 | 170 | 157 | \$ 140.79 |
| | 20 | 1591746 | 3.1% | 3.8% | 3.2% | 96.1 | 137 | 116 | \$ 86.29 | 92.2 | 133 | 123 | \$ 86.87 |
| | 21 | 1194084 | 2.3% | 4.4% | 3.7% | 72.1 | 103 | 87 | \$ 49.05 | 69.2 | 100 | 92 | \$ 49.30 |
| | 22 | 821520 | 1.6% | 5.8% | 4.8% | 49.6 | 71 | 60 | \$ 23.71 | 47.6 | 69 | 64 | \$ 23.75 |
| | 23 | 552526 | 1.1% | 7.3% | 6.1% | 33.4 | 48 | 40 | \$ 10.98 | 32.0 | 46 | 43 | \$ 10.96 |
| | | 52183428 | 1.00 | | | 131 | 4501 | 3908 | \$ 5,599.33 | 126 | 4362 | 4084 | \$ 5,434.09 |

SAF 0.925
(R03 Tues/Wed, June)

NB SB
AADT 3615 3778
ADT 3908 4084

| | | |
|--------------|---------|------|
| NB veh / day | Calc | 4501 |
| | MS2 ADT | 3908 |
| SB veh / day | Calc | 4362 |
| | MS2 ADT | 4084 |

NB SB
MS2 % Cars 94% 95%
MS2 % Trucks 6% 5%

ODOT RUC per Vehicle per hour
Cars \$ 26.13
Trucks \$ 70.52

| NB BUT-27 | | | | | |
|----------------------------------|-------|--------|---------------------------|-----------|-------------|
| adjusted total delay per vehicle | | | Total delay (per day) | | |
| (s) | (min) | (hr) | (s) | (min) | (hr) |
| 180 | 3.0 | 0.050 | 701,871 | 11,698 | 194.96 |
| Vehicles by type (per day) | | | Total User Cost (per day) | | |
| Total | Cars | Trucks | Cars | Trucks | Total |
| 3908 | 3680 | 228 | \$ 4,797.20 | \$ 802.13 | \$ 5,599.33 |

| SB BUT-27 | | | | | |
|----------------------------------|-------|--------|---------------------------|-----------|-------------|
| adjusted total delay per vehicle | | | Total delay (per day) | | |
| (s) | (min) | (hr) | (s) | (min) | (hr) |
| 169 | 2.8 | 0.047 | 692,231 | 11,537 | 192.29 |
| Vehicles by type (per day) | | | Total User Cost (per day) | | |
| Total | Cars | Trucks | Cars | Trucks | Total |
| 4084 | 3888 | 196 | \$ 4,783.31 | \$ 650.78 | \$ 5,434.09 |

Appendix O

BUT-27 Preliminary Cost Estimate

BUT-27-10.38; PID 117275
Preliminary Estimate of Probable Costs For Feasibility Study

| Items | Unit | Unit Cost \$ (2023) | Quantity | Total \$ |
|---|-------|---------------------|----------|--------------------|
| Construction Costs - BUT-27-10.38 - Alternate 1 (14.0' Vertical Clearance) | | | | |
| Roadway | | | | |
| Clearing and Grubbing | Lump | \$20,000 | 1 | \$20,000 |
| Curb Removed | Ft | \$7.25 | 1057 | \$7,663 |
| Guardrail Removed | Ft | \$3 | 325 | \$975 |
| Anchor Assembly Removed | Each | \$150 | 4 | \$600 |
| Bridge Terminal Assembly Removed | Each | \$800 | 4 | \$3,200 |
| Excavation | Cu Yd | \$18 | 1340 | \$24,120 |
| Subgrade Compaction | Sq Yd | \$3 | 3924 | \$11,772 |
| Proof Rolling | Hour | \$325 | 2 | \$650 |
| Geogrid | Sq Yd | \$2.50 | 7522 | \$18,805 |
| Guardrail, Type MGS | Ft | \$19 | 325 | \$6,175 |
| Flared End Section | Each | \$75 | 1 | \$75 |
| Anchor Assembly, MGS Type A | Each | \$1,300 | 3 | \$3,900 |
| Anchor Assembly, MGS Type T | Each | \$1,300 | 1 | \$1,300 |
| MGS Bridge Terminal Assembly, Type 1 | Each | \$2,500 | 4 | \$10,000 |
| Monument Box Adjusted to Grade | Each | \$800 | 1 | \$800 |
| Erosion Control | | | | |
| Seeding and Mulching | Sq Yd | \$2 | 1650 | \$3,300 |
| Erosion Control | Each | \$1 | 31560 | \$31,560 |
| Drainage | | | | |
| 6" Shallow Pipe Underdrains with Geotextile Fabric | Ft | \$12 | 1030 | \$12,360 |
| 6" Conduit, Type F for Underdrain Outlets | Ft | \$25 | 70 | \$1,750 |
| 12" Conduit, Type B | Ft | \$110 | 44 | \$4,840 |
| Catch Basin, No. 3 | Each | \$4,500 | 1 | \$4,500 |
| Catch Basin Adjusted to Grade | Each | \$1,050 | 4 | \$4,200 |
| Manhole, No. 3 | Each | \$5,500 | 1 | \$5,500 |
| Manhole Adjusted to Grade | Each | \$900 | 3 | \$2,700 |
| Drainage Misc. | Lump | \$20,000 | 1 | \$20,000 |
| Pavement | | | | |
| Pavement Removed | Sq Yd | \$12 | 3942 | \$47,304 |
| Full Depth Pavement Sawing | Ft | \$3.50 | 133 | \$466 |
| Pavement Planing, Asphalt Concrete | Sq Yd | \$2 | 2161 | \$4,322 |
| Asphalt Concrete Base, PG64-22, (449) | Cu Yd | \$200 | 634 | \$126,800 |
| Asphalt Concrete Base, PG64-22, (449), Driveways | Cu Yd | \$335 | 3 | \$1,005 |
| Aggregate Base | Cu Yd | \$70 | 654 | \$45,780 |
| 1.25" Asphalt Concrete Surface Course, Type 1, (448), PG64-22 | Cu Yd | \$210 | 126 | \$26,460 |
| 1.75" Asphalt Concrete Intermediate Course, Type 2, (448) | Cu Yd | \$255 | 293 | \$74,715 |
| 1.25" Asphalt Concrete Surface Course, Type 1, (449), Driveways | Cu Yd | \$500 | 1 | \$500 |
| Non-Tracking Tack Coat | Gal | \$4 | 334 | \$1,336 |
| Tack Coat, 702.13 | Gal | \$4 | 421 | \$1,684 |
| Combination Curb and Gutter, Type 2 | Ft | \$30 | 585 | \$17,550 |
| Curb, Type 6 | Ft | \$28 | 590 | \$16,520 |
| Traffic Control | | | | |
| RPM | Each | \$40 | 38 | \$1,520 |
| Edge Line, 6" | Mile | \$4,200 | 0.38 | \$1,596 |
| Center Line | Mile | \$5,000 | 0.32 | \$1,600 |
| Channelizing Line, 8" | Ft | \$3 | 195 | \$585 |
| Stop Line | Ft | \$14 | 58 | \$812 |
| Transverse/Diagonal Line | Ft | \$11 | 360 | \$3,960 |
| Island Marking | Sf | \$8 | 114 | \$912 |
| Lane Arrow | Each | \$200 | 4 | \$800 |
| Signing Misc. | Lump | \$2,000 | 1 | \$2,000 |
| Traffic Signals | | | | |
| Detector Loop | Each | \$1,850 | 6 | \$11,100 |
| Maintenance of Traffic | | | | |
| Law Enforcement Officer with Patrol Car for Assistance | Hour | \$82 | 32 | \$2,624 |
| Special - Work Zone Traffic Signal | Each | \$25,000 | 1 | \$25,000 |
| Increased Barrier Delineation | Ft | \$2 | 1876 | \$3,752 |
| Work Zone Impact Attenuator, 24" Wide Hazards, (Bidirectional) | Each | \$2,300 | 8 | \$18,400 |
| Detour Signing | Lump | \$15,000 | 1 | \$15,000 |
| Work Zone Lighting System | Each | \$13,000 | 1 | \$13,000 |
| Barrier Reflector, Type 1, Bidirectional | Each | \$12 | 42 | \$504 |
| Object Marker, Two Way | Each | \$19 | 42 | \$798 |
| Work Zone Edge Line, Class I, 6", 642 Paint | Mile | \$1,000 | 0.50 | \$496 |
| Work Zone Edge Line, Class I, 6", 740.06, Type I | Mile | \$10,300 | 0.31 | \$3,152 |
| Work Zone Dotted Line, Class I, 6", 642 Paint | Ft | \$1 | 75 | \$75 |
| Work Zone Stop Line, Class I, 740.06, Type I | Ft | \$20 | 50 | \$1,000 |
| Portable Barrier, Unanchored | Ft | \$15 | 1876 | \$28,140 |
| Removal of Pavement Marking | Ft | \$2 | 821 | \$1,642 |
| Primary Cost Drivers Subtotal | | | | \$703,655 |
| Incidentals | | | | |
| Railroad Insurance | Lump | | 1 | \$12,500 |
| Maintenance of Traffic (MOT) | Lump | | 1 | \$7,037 |
| Construction Layout Stakes | Lump | | 1 | \$7,037 |
| Field Office, Type B | Month | \$2,200 | 8 | \$17,600 |
| Mobilization | Lump | | 1 | \$14,073 |
| Contingencies for items not included (30%) | Lump | | 1 | \$211,096 |
| R/W | | | | |
| CSX Railroad Construction Agreement | Lump | | | \$10,000 |
| Summary of Probable Construction Costs 2024 | | | | \$983,000 |
| Probable Construction Costs Including 17.1% for 2027 | | | | \$1,160,000 |
| Right-of-Way Acquisition Costs | | | | \$14,765 |
| TOTAL ESTIMATED PROJECT COST | | | | \$1,180,000 |

BUT-27-10.38; PID 117275
Preliminary Estimate of Probable Costs For Feasibility Study

| Items | Unit | Unit Cost \$ (2023) | Quantity | Total \$ |
|---|-------|---------------------|----------|--------------------|
| Construction Costs - BUT-27-10.38 - Alternate 2 (14.5' Vertical Clearance) | | | | |
| Roadway | | | | |
| Clearing and Grubbing | Lump | \$30,000 | 1 | \$30,000 |
| Curb Removed | Ft | \$7.25 | 1057 | \$7,663 |
| Guardrail Removed | Ft | \$3 | 325 | \$975 |
| Anchor Assembly Removed | Each | \$150 | 4 | \$600 |
| Bridge Terminal Assembly Removed | Each | \$800 | 4 | \$3,200 |
| Excavation | Cu Yd | \$18 | 1580 | \$28,440 |
| Subgrade Compaction | Sq Yd | \$3 | 4224 | \$12,672 |
| Proof Rolling | Hour | \$325 | 3 | \$975 |
| Geogrid | Sq Yd | \$2.50 | 8092 | \$20,230 |
| Guardrail, Type MGS | Ft | \$19 | 325 | \$6,175 |
| Flared End Section | Each | \$75 | 1 | \$75 |
| Anchor Assembly, MGS Type A | Each | \$1,300 | 3 | \$3,900 |
| Anchor Assembly, MGS Type T | Each | \$1,300 | 1 | \$1,300 |
| MGS Bridge Terminal Assembly, Type 1 | Each | \$2,500 | 4 | \$10,000 |
| Monument Box Adjusted to Grade | Each | \$800 | 1 | \$800 |
| Erosion Control | | | | |
| Seeding and Mulching | Sq Yd | \$2 | 2500 | \$5,000 |
| Erosion Control | Each | \$1 | 31560 | \$31,560 |
| Drainage | | | | |
| 6" Shallow Pipe Underdrains with Geotextile Fabric | Ft | \$12 | 1105 | \$13,260 |
| 6" Conduit, Type F for Underdrain Outlets | Ft | \$25 | 70 | \$1,750 |
| 12" Conduit, Type B | Ft | \$110 | 44 | \$4,840 |
| Catch Basin, No. 3 | Each | \$4,500 | 1 | \$4,500 |
| Catch Basin Adjusted to Grade | Each | \$1,050 | 5 | \$5,250 |
| Manhole, No. 3 | Each | \$5,500 | 1 | \$5,500 |
| Manhole Adjusted to Grade | Each | \$900 | 3 | \$2,700 |
| Drainage Misc. | Lump | \$20,000 | 1 | \$20,000 |
| Pavement | | | | |
| Pavement Removed | Sq Yd | \$12 | 4242 | \$50,904 |
| Full Depth Pavement Sawing | Ft | \$3.50 | 133 | \$466 |
| Pavement Planing, Asphalt Concrete | Sq Yd | \$2 | 2161 | \$4,322 |
| Asphalt Concrete Base, PG64-22, (449) | Cu Yd | \$200 | 679 | \$135,800 |
| Aggregate Base | Cu Yd | \$70 | 702 | \$49,140 |
| 1.25" Asphalt Concrete Surface Course, Type 1, (448), PG64-22 | Cu Yd | \$210 | 129 | \$27,090 |
| 1.75" Asphalt Concrete Intermediate Course, Type 2, (448) | Cu Yd | \$255 | 306 | \$78,030 |
| Non-Tracking Tack Coat | Gal | \$4 | 348 | \$1,392 |
| Tack Coat, 702.13 | Gal | \$4 | 441 | \$1,764 |
| Combination Curb and Gutter, Type 2 | Ft | \$30 | 585 | \$17,550 |
| Curb, Type 6 | Ft | \$28 | 590 | \$16,520 |
| 8" Non-Reinforced Concrete Pavement, Class QC MS (Drives) | Sq Yd | \$100 | 43 | \$4,300 |
| Traffic Control | | | | |
| RPM | Each | \$40 | 41 | \$1,640 |
| Edge Line, 6" | Mile | \$4,200 | 0.38 | \$1,596 |
| Center Line | Mile | \$5,000 | 0.36 | \$1,800 |
| Channelizing Line, 8" | Ft | \$3 | 195 | \$585 |
| Stop Line | Ft | \$14 | 58 | \$812 |
| Transverse/Diagonal Line | Ft | \$11 | 435 | \$4,785 |
| Island Marking | Sf | \$8 | 114 | \$912 |
| Lane Arrow | Each | \$200 | 4 | \$800 |
| Signing Misc. | Lump | \$2,000 | 1 | \$2,000 |
| Traffic Signals | | | | |
| Detector Loop | Each | \$1,850 | 6 | \$11,100 |
| Maintenance of Traffic | | | | |
| Law Enforcement Officer with Patrol Car for Assistance | Hour | \$82 | 32 | \$2,624 |
| Special - Work Zone Traffic Signal | Each | \$25,000 | 1 | \$25,000 |
| Increased Barrier Delineation | Ft | \$2 | 1876 | \$3,752 |
| Work Zone Impact Attenuator, 24" Wide Hazards, (Bidirectional) | Each | \$2,300 | 8 | \$18,400 |
| Detour Signing | Lump | \$15,000 | 1 | \$15,000 |
| Work Zone Lighting System | Each | \$13,000 | 1 | \$13,000 |
| Barrier Reflector, Type 1, Bidirectional | Each | \$12 | 42 | \$504 |
| Object Marker, Two Way | Each | \$19 | 42 | \$798 |
| Work Zone Edge Line, Class I, 6", 642 Paint | Mile | \$1,000 | 0.50 | \$496 |
| Work Zone Edge Line, Class I, 6", 740.06, Type I | Mile | \$10,300 | 0.31 | \$3,152 |
| Work Zone Dotted Line, Class I, 6", 642 Paint | Ft | \$1 | 75 | \$75 |
| Work Zone Stop Line, Class I, 740.06, Type I | Ft | \$20 | 50 | \$1,000 |
| Portable Barrier, Unanchored | Ft | \$15 | 1876 | \$28,140 |
| Removal of Pavement Marking | Ft | \$2 | 821 | \$1,642 |
| Primary Cost Drivers Subtotal | | | | \$748,256 |
| Incidentals | | | | |
| Railroad Insurance | Lump | | 1 | \$12,500 |
| Maintenance of Traffic (MOT) | Lump | | 1 | \$7,483 |
| Construction Layout Stakes | Lump | | 1 | \$7,483 |
| Field Office, Type B | Month | \$2,200 | 8 | \$17,600 |
| Mobilization | Lump | | 1 | \$14,965 |
| Contingencies for items not included (30%) | Lump | | 1 | \$224,477 |
| R/W | | | | |
| CSX Railroad Construction Agreement | Lump | | | \$10,000 |
| Summary of Probable Construction Costs 2024 | | | | \$1,043,000 |
| Probable Construction Costs Including 17.1% for 2027 | | | | \$1,230,000 |
| Right-of-Way Acquisition Costs | | | | \$14,765 |
| TOTAL ESTIMATED PROJECT COST | | | | \$1,250,000 |

Appendix P

Business Plan Inflation Calculator

FY 2025-2029 Business Plan Inflation Calculator:

[Not sure if you have the latest calculator? Click here.](#)

Last Modified: 7/23/2024

Today's Date:
August 1, 2024

Please Enter Values in the Yellow Areas Only:

Estimation Start Date:

Less than or Equal to Today's Date
(mm/dd/yyyy)

8/1/2024

Start Date:

Enter Construction Mid-Point Date:

(cannot exceed 08/01/2049)
(mm/dd/yyyy)

8/1/2027

Construction Mid-Point Date:

Present-Day Estimated Cost:

\$1,000.00

Estimated Dollar Amount:

Estimate Start Date to Construction Mid-Point Date:

36

Months

Inflation - Start to Mid-Point of Construction:

?

(compounded growth rate)

Inflated Dollar Amount:

Business Plan

17.1%

\$1,170.87

Estimator's Name:

County - Route - Section:

BUT-75/VAR 5.22/VAR

PID:

117275

Estimator's Notes:

begin construction - May 1, 2027, end construction - November 1, 2027
midpoint construction - August 1, 2027

Appendix Q

BUT-27 Justification for 15' Vertical Clearance

Chris Preto

From: Katherine.DeStefano@dot.ohio.gov
Sent: Wednesday, September 4, 2024 9:57 AM
To: Chris Preto
Cc: Brandon.Collett@dot.ohio.gov; brianne.hetzel@dot.ohio.gov
Subject: RE: [External] BUT IR 75/VAR 5.22/VAR, PID# 117275

Chris:

Just to add some additional information, provided by Brandon Collett, that helps to further justify the design approach cited below:

- Documented bridge strikes that District 08 has on file include:
 - 4-21-87: Fatality: Impact to bridge caused head on collision.
 - 12-15-08: Gouges and scrapes. Unknown vehicle.
 - 10-1-14: Fatality: Track hoe hit bridge causing it to hit oncoming traffic.
 - There have been at least two other over-height impacts in the last 6 years that were minor enough that damages were not recorded.

These accidents are directly related to the vertical clearance and not to the roadway shoulder width.

- This bridge is heavily skewed. When an over-height vehicle strikes this bridge, it is directed into oncoming traffic. Both fatalities listed above, resulted due to the insufficient vertical clearance.
- This bridge is a fracture critical bridge in that it only has two main members. A severe fracture in one bottom flange is likely to cause a bridge collapse.
- A collapsed , or even a sagging rail has a high potential to cause a train accident/derailment.
- If the bridge were constructed as a new structure today, the vertical clearance criteria for an NHS arterial route would be 15.5 (inclusive of the 1' reduction for Footnote "I", which would be 16.5' without it).

Anything that can be done to reduce risk at this location would be worthwhile and warranted.

This email correspondence may be used in the FS. Again, if you have any questions, let me know.

Thanks,
Katie

Katherine S. DeStefano, P.E.
Senior Transportation Engineer
505 South State Route 741
Lebanon, Ohio 45036
D: 513.933.6583
katherine.destefano@dot.ohio.gov



**Department of
Transportation**

From: Destefano, Katherine
Sent: Friday, August 30, 2024 9:21 AM
To: Chris Preto <preto@cvelimited.com>
Cc: Collett, Brandon <Brandon.Collett@dot.ohio.gov>; Hetzel, Brianne <brianne.hetzel@dot.ohio.gov>
Subject: RE: [External] BUT IR 75/VAR 5.22/VAR, PID# 117275

Chris:

Apologize for the lengthy response but just want to make sure all our bases are covered.

Understanding why the design criteria, listed in appendix A, was used as a starting point, it's now clear that in order to meet the minimum 15' vertical clearance constraint, some adjustments are required. In doing so, the designer must evaluate solutions that would best address all of the site conditions versus just one. However, using the minimum, or even sub-standard, design criteria must still be justifiable and defensible. So, digging a little deeper, here is what we can use and why.

Speeds:

There was a recent safety study developed for this section of US27 and the results provided the following:

Legal Speed = 40 mph north of SR130 (also posted speed)

Legal Speed = 45 mph south of SR 130 (also posted speed)

So, most of the project is located within the 45 mph legal speed zone.

In discussion with Safety staff, it could be justified to drop the legal speed to 40 mph within this project's limits given the tightened space within the horizontal and vertical curves, as well as the vertical clearance. However, this would have to be formally studied and approved which could take a few months. So, for this project we will use a

legal speed of 45 mph.

Per L&D, Vol.1, Section 104.2 – *“For facilities with a legal speed of 40 or 45 mph the design speed shall either match the legal speed, or be 5 mph greater than the legal speed, depending on the context of the area.”* The **design speed will be 45 mph**. This makes the project location a “low speed” corridor.

Functional Classification (Rural versus Urban):

TIMS TRANSPORTATION INFORMATION MAPPING SYSTEM

Project Search Create a Map Data Download Standard PDF Maps Map Viewers Data Glossary

Roadway Information 0

Safety 0

Boundaries 4

| | |
|--------------------|---------------------|
| Place | ODOT Districts |
| County | Township |
| Rural Island | Cities and Villa... |
| Adjusted Urban ... | Rural Planning ... |
| Metropolitan Pl... | US House District |
| Ohio Senate Di... | Ohio House Dis... |
| PUCO Electric ... | PUCO Telepho... |
| MS4 Urbanized... | School Districts |
| Census Urban ... | Sections Lots T... |





According to TIMS, the project falls outside of mapped urban boundaries. However, the project corridor encompasses urban design characteristics, including curb, signalized intersection, multiple curb cuts (more so north of the bridge, along US27), high ADT volumes and a lower speed limit of 40 mph within the northern project limits. This specific spot location falls within a quasi-urban/rural area located along a heavily traveled corridor connecting two urban areas. Due to these conditions, urban design criteria may be applied to this location.

Design Approach:

Within the project limits, as well as the US27 corridor north of the bridge, the existing shoulders do not currently meet the 8' minimum treated shoulder width for rural shoulder design per L&D, Vol.1, Section 300, Fig. 301-3. So, the urban shoulder criteria has already been successfully applied to this area under previous corridor improvements. In the past, a design exception for shoulder width would be warranted at this location and the same justification process would have to be compiled. Since design exceptions are no longer required for shoulder width on facilities such as this one, we are permitted to consider a Performance Based Project Development (PBPB) approach to this location, and justify the chosen design criteria via the following points:

Per the L&D Manual, Vol. 1, Section 1000: the basic tenants of PBPB will be:

- Safety will not be compromised;
 - Between 2021-23, four accidents have been documented within the project limits. Those include:
 - 1 SB US27 rear end near SR130
 - 2 NB US27 rear end near SR 130
 - 1 run off the road crash on SR 130
 - 1 left turn crash at US27/SR130
 - None of these crashes were related to the shoulder design along US27.
- In many cases, the minimum standard will be the existing condition;
 - Design Speed = 45 mph
 - Legal Speed = 45 mph
 - Urban shoulder width criteria – due to urban corridor characteristics.
- A project Purpose & Need should be focused to address specific problems supported by data;
 - The main point of the purpose and need of this project is to improve safety by avoiding future bridge strikes and removing the risk for a catastrophic event. Increasing the vertical clearance to the minimum 15 foot requirement meets the purpose and need.

- Design solutions should focus on adherence to the project Purpose & Need;
 - New “scrapes and gouges” are regularly showing up on the underside of the structure. These property damage type accidents go unreported, but the evidence is clearly visible. While many of these impacts are minor, due to the high number of strikes, the risk of a catastrophic event is also very high. This bridge structure is non-redundant, and a serious strike could result in structural failure. Railroads often transport harmful chemicals. A collision of this sort would be a disaster for the area. (East Palestine) Again, Increasing the vertical clearance to the minimum 15 foot requirement meets the purpose and need.
- Solutions should be an optimized combination of mobility, operations and other modes;
 - Meeting the critical design component (vertical clearance) with some minor geometric shoulder design tradeoffs improves overall safety for both vehicle and rail travel.
- Designs should be consistent with the context of the corridor;
 - Again, as previously listed, the project limits encompass multiple urban design characteristics, creating an urban feel corridor, so applying urban criteria to this spot location is justifiable.
- Designs should strive to maximize benefit/cost.
 - Although we would be further narrowing the existing shoulder widths, the alternatives would be to;
 1. impact the bridge structure foundation which would require significant structural re-work making the project cost prohibitive or
 2. compromise, and not meet the minimum the vertical clearance, which would not meet the purpose and need of the project.

Conclusion: Drawing upon the information provided herein, develop a design solution for the BUT-27 RR bridge location, that meets the 15’ minimum vertical clearance without negatively impacting the RR bridge structure.

Note that the barrier will have to be carried under the bridge. The 5’ deflection requirement for MGS GR cannot be met, so I recommend concrete barrier Type D, per standard RM-4.5 & RM-4.6. This roadway component will reinforce abutment stability, which the RR should not have an issue with. Drainage inlet design will have to be adjusted and incorporated into the barrier design as well.

Let me know if you have any questions or concerns regarding this approach. We can discuss further if needed.

Thanks,
Katie

Katherine S. DeStefano, P.E.
Senior Transportation Engineer
 505 South State Route 741
 Lebanon, Ohio 45036
 D: 513.933.6583
katherine.destefano@dot.ohio.gov



**Department of
Transportation**