

ODOT District 8
2024 Pre-Inspection Report

Draft April 2024

Bridge No. HAM-50-0376L
SFN: 3102521



Prepared for:



ODOT District 8
505 South SR 741
Lebanon, Ohio 45036

PID No. 105475

Prepared by:

TRANSYSTEMS

1100 Superior Avenue, Suite 1000
Cleveland, OH 44114

Project Number P402220026

Table of Contents

- INTRODUCTION 2
 - LOCATION MAP..... 2
- INSPECTION DETAILS..... 3
- NONREDUNDANT STEEL TENSION MEMBER INSPECTION REQUIREMENTS 3
- BRIDGE INFORMATION 4
- NONREDUNDANT STEEL TENSION MEMBER LOCATIONS 4
- FATIGUE PRONE DETAILS..... 4
- INSPECTION METHOD AND PLAN 4
 - FIELD COORDINATION..... 5
 - PERMITTING AND COORDINATION 5
 - TRAFFIC CONTROL 6
- FOLLOW-UP PROCEDURES 6
- QUALITY CONTROL/QUALITY ASSURANCE..... 6
- SPECIAL CONSIDERATIONS 6

INTRODUCTION

LOCATION MAP

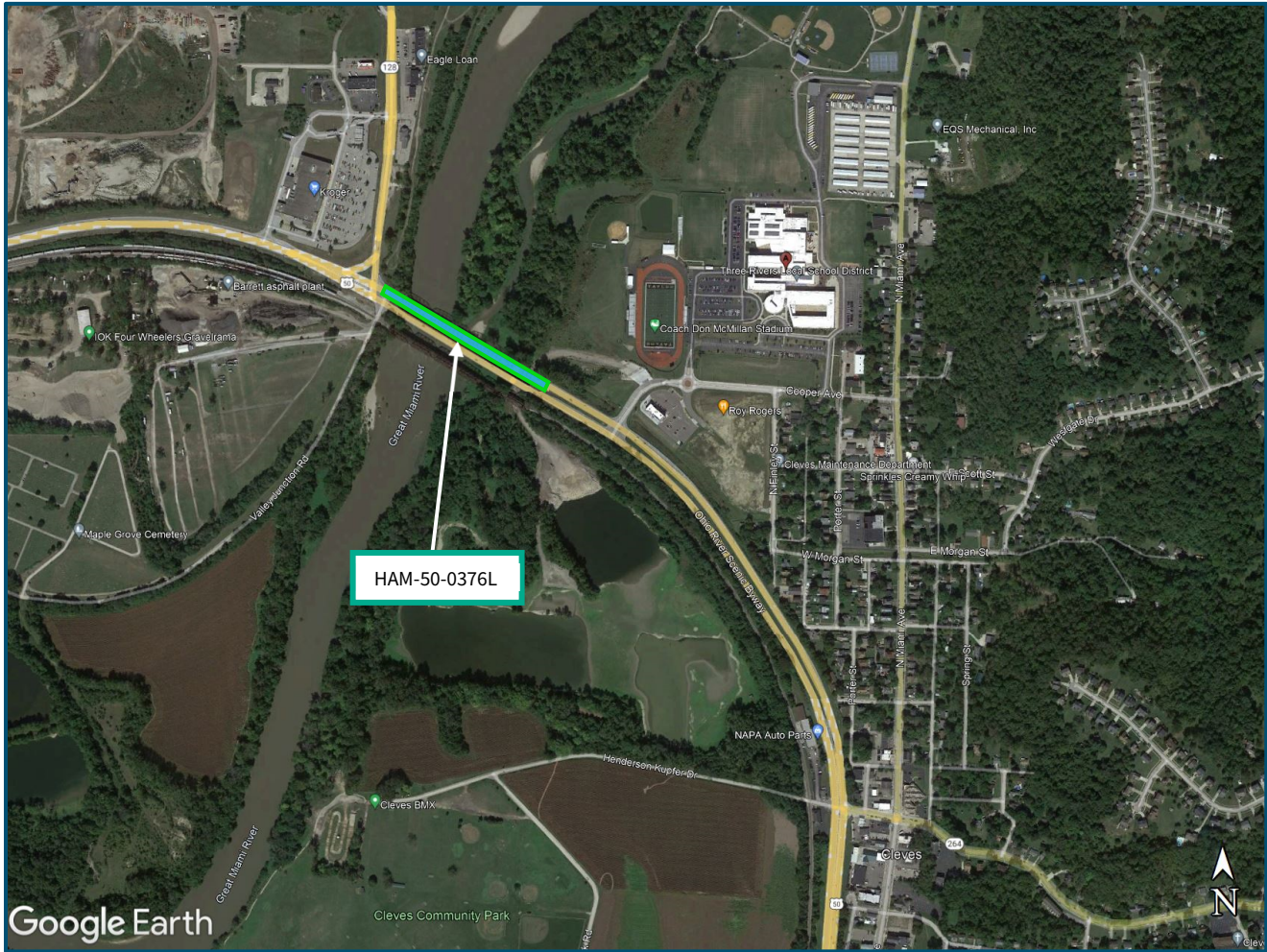

**Figure 1 - US Route 50 (Westbound) over the Great Miami River, Village of Cleves, Ohio
Location Map**

SFN: 3102521
US 50 Westbound over the Great Miami River
PID No. 105475

INSPECTION DETAILS

Bridge No.: HAM-50-0376L --- SFN 3102521

Features Intersected: US Route 50 Westbound over the Great Miami River

Locations to Inspect: In-Depth Element Level, Nonredundant Steel Tension Members (NSTM)

Number of Inspection Days: Estimated 5 days

Inspection Dates: July 8 – July 12, 2024

Inspection Hours: 7:00 AM to 5:00 PM

Inspection Equipment: 40' Manlift (above deck), 62' snooper (below deck), rope access techniques

NONREDUNDANT STEEL TENSION MEMBER INSPECTION REQUIREMENTS

The inspection will consist of an In-Depth “Arms-Reach” inspection, performed in accordance with the guidelines of the current FHWA National Bridge Inspection Standards for Nonredundant Steel Tension Members (NSTMs).

To perform an effective NSTM Inspection, the following tasks must be performed:

1. Determine Resource Requirements
(Identify qualified inspection staff, use appropriate inspection access and inspection equipment).
2. Identify the Nonredundant Steel Tension Members
(Contained in this document)
3. Develop the Inspection Procedure
(Contained in this document)
4. Prepare Follow-up Procedure
(Recommendations will be made as part of this current project)
5. Provide Quality Control/Quality Assurance for the Inspection and Report
(Procedures outlined in this document)
6. Develop a Periodic Inspection Plan
(Already in place with the Ohio Department of Transportation, District 8)

BRIDGE INFORMATION

HAM-50-0376L is a four-span structure that carries two lanes of US Route 50 westbound vehicular traffic over the Great Miami River in Cleves, Ohio. Eastbound traffic is carried by an adjacent bridge. The overall bridge length is 895'-8" and was opened to traffic in 1959. The bridge was rehabilitated in 1992 and 2017-2018.

The structure consists of four simply supported modified Pratt Truss spans, with interior spans (Spans 2 & 3) measuring 250'-0" and end spans (Spans 1 & 4) measuring 191'-4". Interior spans and end spans consist of 10 panels at 25'-0" and 8 panels at 23'-11" respectively. The truss upper and lower chord members consist of channels, angles, plates, and lacing bars with rivet and bolt connections. The truss verticals and diagonals are rolled wide flange sections. Sway bracing and upper lateral bracing are riveted to gusset plates and truss members at panel points. No lower lateral bracing exists on the structure. The floor system consists of five stringers spaced at 7'-0" with nine floorbeams spaced at panel points in end spans, and eleven floorbeams spaced at panel points in interior spans. The Piers and rear abutment are wall type substructures, but the forward abutment is a stub type substructure.

The nomenclature for this bridge follows a west to east stationing with trusses labeled as north and south. Floorbeams are labeled as 0 to 8 (Spans 1 and 4) and 0 to 10 (Spans 2 and 3) from the west to the east. The stringers are labeled as 1 to 5 from the north to the south (left to right looking forward). Abutments are labeled as Rear Abutment (west) and Forward Abutment (east). Piers are labeled as 2 to 4 (west to east).

NONREDUNDANT STEEL TENSION MEMBER LOCATIONS

Nonredundant steel tension members are shown in **Appendix B**.

FATIGUE PRONE DETAILS

The stringers are welded to floorbeam webs via a connection plate on both sides of the stringer web, as well as along the stringer bottom flange. This creates susceptible locations for fatigue cracking in floorbeams. The welded plate connection of the stringer web to the floorbeam web, and the stringer bottom flange weld, are both Category E details.

Tack welds are typical between chord members and fill plates, lower chord web plates and internal diaphragms, lower chord web plates and gusset plates, lateral bracing connection angles and upper chord splice plates, and lateral brace connection plates to upper chord cover plate.

INSPECTION METHOD AND PLAN

TranSystems Corporation and TRC Engineers Inc. will perform a nonredundant steel tension member and in-depth inspection on HAM-50-0376L. Access to the bridge members below the bridge deck will be gained by an Aspen A-62 snooper provided by the N.E. Bridge Contractors Inc. and with rope access techniques performed by SPRAT certified personnel. The truss members above the bridge deck will be inspected with the aid of a 40' manlift and rope access

SFN: 3102521
US 50 Westbound over the Great Miami River
PID No. 105475

techniques. All manlift operators will be qualified to meet the current ANSI A-92 requirement. Traffic control will be provided by A&A Safety according to ODOT's Standard Drawing MT-95.30.

FIELD COORDINATION

The following personnel are anticipated to be involved with the coordination and/or field work associated with the inspection of these structures.

TranSystems:

Project Manager/ Team Leader	Steven Hammerschmidt, PE sfhammerschmidt@transystems.com	(785) 623-6704
---------------------------------	---	----------------

Team Leader	Jake Adamrovich, EI jaadamrovich@transystems.com	(724) 787-2250
-------------	---	----------------

TRC Engineers, Inc:

Team Leader	Craig Jacob, PE CJacob@trccompanies.com	(513) 222-0344
-------------	--	----------------

PERMITTING AND COORDINATION

The following entities will be involved in the permitting and coordination of all work associated with the inspection of this structure. Copies of permits from all entities will be kept on site at all times.

ODOT – A right of entry permit is necessary through ODOT District 8 and will be secured via the ODOT Right of Way E-Permitting System. The following ODOT personnel will be contacts:

Project Manager	Brandon Collett Brandon.Collett@dot.state.oh.us	(513) 933-6643
-----------------	--	----------------

District Work Zone Traffic Manager	Scott Kraus Scott.Kraus@dot.state.oh.us	(513) 933-6519
---------------------------------------	--	----------------

Right-of-Way Use Permits	Chris Bass Chris.Bass@dot.state.oh.us	(513) 933-6577
-----------------------------	--	----------------

SFN: 3102521

US 50 Westbound over the Great Miami River

PID No. 105475

Right-of- Permit
Coordinator

Kimberly Giffin
Kim.Giffin@dot.ohio.gov

(513) 933-6580

TRAFFIC CONTROL

TranSystems has contracted A&A Safety, Inc. to provide the necessary traffic control for this inspection. They will be responsible for all signs and devices which shall be placed in accordance with the latest Ohio Manual for Uniform Traffic Control Devices.

The inspection crew plans to utilize single lane closures of US-50 WB in order to access the structure with an Aspen A-62 snoopers and a 40' manlift. The single lane closures will follow ODOT's Standard Drawing MT-95.30.

FOLLOW-UP PROCEDURES

Critical inspection findings will be reported to the District within 24 hours and details/ photographs will be provided via email. These along with other findings will be documented in the final inspection report.

QUALITY CONTROL/QUALITY ASSURANCE

TranSystems' Quality Assurance/Quality Control Plan will be followed. The team leaders were chosen to ensure that inspector qualifications are met. The team leaders have completed the course FHWA-NHI-130078, "Fracture Critical Inspection Techniques for Steel Bridges."

SPECIAL CONSIDERATIONS

HAM-50-0376L is programmed to be painted in 2026. In addition to painting, the project may include additional details found during this inspection. TranSystems will thoroughly document and photograph the location of any item that might be prudent to add to the 2026 project scope, such as deteriorated concrete, missing bolts/rivets, severely deteriorated members/lattice that should be replaced or plated over, etc. Detailed measurements of the gusset plates will be taken at locations of new/active section loss or additional out-of-plane bending. A dive inspection of the channel is scheduled for 2024 under a separate contract, however, TranSystems will document any significant findings related to scour from a high-level perspective.

SFN: 3102521
US 50 Westbound over the Great Miami River
PID No. 105475

APPENDIX A

ODOT RIGHT OF ENTRY PERMIT

MR 509
Permit No. 24-12527

Office Use Only

State of Ohio
Department of Transportation
Permit

County or Jurisdiction HAM
Rte SR128
Log Pt 0-0.19
Acc Cat

[1] Subject to all terms, conditions, and restrictions printed, written below and on the reverse side hereof, or attached,

Name: TranSystems Corporation
Address: 1100 Superior Avenue Cleveland OH 44114
Company Phone: 724 787-2250

is hereby granted a permit under Section 5515.01 and 5515.02 of Ohio Revised Code, and permission to perform work necessary in the manner described and at the location indicated in the following or attached to this permit.

Lane Closure - (see attached sheets)

Description of Work: ##DescOfWork##

[2] This permit shall be in the possession of employees /agents of permittee on site at all times who are in charge of the work and shall be shown, upon request, to any employee of the Department of Transportation.

Contact ODOT Representative 3 days before work begins, also contact ODOT Representative when work is completed for final inspection.

Failure to notify the ODOT Representative could result in work stoppage!

[3] No work authorized by this permit shall begin until the permittee has contacted and received instructions from

ODOT Representative DUSTIN WILLIAMS
Phone 513-615-4033
Email Address: DUSTIN.WILLIAMS@DOT.OHIO.GOV
(Authorized ODOT Employee)

NOTE: Any work performed by the permittee may be stopped if this requirement is not met.

[4] Prior to any excavation in the highway right-of-way, the Ohio811, <https://www.oups.org/excavators>, must be contacted in accordance with ORC Section 3781.25 to 3781.32. Ohio811 can be reached at 1-800-362-2764 or 811.

[5] If your utility is above ground in any way, you must mark your utility with a fluorescent colored marker that corresponds with the universal OUPS color code. The marker must be no shorter than six feet in height and you must maintain the marker. Guide wires must be marked a fluorescent yellow. Failure to mark as described, will result in the Department of Transportation being held harmless and no reimbursement for damage to your property.

[6] All work requiring persons or vehicles within ODOT right of way shall comply with all applicable requirements of the Ohio Manual of Uniform Traffic Control Devices and Item 614 (Maintaining Traffic) of the Construction and Material Specifications, latest editions. Failure to comply with these requirements will be cause for immediate revocation or suspension of the permit until the proper traffic control devices have been provided.

[7] The permittee accepts the conditions, terms, and requirements printed, written on, or attached to this permit and understands that failure to comply fully with those conditions, terms, and requirements or any change in the use of the permit inconsistent with its terms and conditions will be considered a violation and cause for suspension, revocation, or annulment of the permit thereby rendering the permit illegal and subject to appropriate Department action, up to an including removal of the installation at the permittee's expense.

[8] Performance Bond Required? Yes No Company _____
Effective Date _____ Expiration Date _____ Amount \$ _____

[9] This permit shall be void if the work described herein does not comply with the conditions, terms, and requirements applicable to this permit, and if the work is not completed by 10/16/2024

Dated 04/15/2024

Rev 5/6/2021

(the remainder of this page is left blank intentionally)

**General Provisions Applicable to All Permits
(Sections 5515.01 and 5515.02 of O.R.C.)**

- [1] This permit is not a substitute for satisfying the rights or obligations of any other party who may have an interest in the underlying fee interest.
- [2] The granting of this permit does not convey to the permittee or to the property served any rights, title, or interest in state highway rights of way or in the design or operation of the state highway; or in any way abridge the right of the Director of the Department of Transportation in his jurisdiction over state highways. If, in the process of any future work or for the benefit of the traveling public, it becomes necessary, in the opinion of the Director of Transportation to order the removal, reconstruction, relocation, or repair of any of the fixtures, or work performed under this permit, said removal, reconstruction, relocation, or repair shall be wholly at the expense of the owners thereof or the permittee and be made as directed by the Director of Transportation and within the time determined by the Director. Such changes in the state highway design or operation, necessary for improved safety and operation or for the benefit of the traveling public, shall not require a permit modification since the permit confers no private rights to the permittee over the control of the state highway.
- [3] The District Deputy Director acts for and on behalf of the Director in issuing and carrying out the provisions of all permits. The District Deputy Director has full authority to ensure that all provisions of the permit are met and to reject any materials, design, and workmanship that do not meet applicable Department standards. The District Deputy Director, at his/her discretion, may require a performance bond or certified check as a prerequisite to the issuance of a permit.
- [4] Failure on the part of the permittee to comply fully with the provisions and conditions of the permit will be cause for suspension, revocation, or annulment of the permit thereby rendering the permit illegal and subject to appropriate Departmental action. By accepting the permit, the permittee agrees to comply with all conditions, terms, and restrictions printed or written on or attached to the permit. If the permittee or its agent performs any work contrary to the conditions of the permit or to the instructions of the District Deputy Director and, after due notice, fails to correct the problem, the Department of Transportation may, with or without notice, correct or remove such work and the permittee shall reimburse the Department for the costs and shall hold the Department harmless for all results of such work.
- [5] The permittee shall indemnify and hold harmless the State of Ohio, Department of Transportation, its officers, representatives and assigns, from any and all loss, liability, damages, litigation costs, and claims for injury or death to any person, property, or business caused by or resulting from any act, omission, event, consequence, or occurrence, negligent or otherwise of the permittee, its employees, agents, or assigns as a result of the issuance of this permit.
- [6] All work authorized under the permit shall be performed to the Department's satisfaction, and the entire expense shall be borne by the permittee. No work shall be performed until the permittee has contacted the Department's appointed representative named on the permit and received instructions. The Department's representative may inspect all work covered by the permit, or the Department reserves the right, during the time any or all of the work is being performed, to appoint an inspector over the work who shall represent the interest of the State on the work and any compensation arranged for shall be paid wholly by the permit holder. Work not in compliance shall be halted and the District Deputy Director shall be notified of the cause. The permittee shall be notified of the Department's determination and given an opportunity to correct the problem. If the problem is not corrected timely or to the satisfaction of the Department, this permit will be revoked.
- [7] Failure to complete all work within the time specified on the permit shall void the permit, thereby making the permit illegal and subject to appropriate Departmental action. The permittee may request an extension in writing from the District Office, explaining why the extension is necessary and when the work is expected to be completed.
- [8] All work infringing on the pavement or shoulders shall comply with applicable standards and requirements regarding traffic control devices. Failure to comply will be cause for revocation or suspension of the permit. Any closure of lanes or shoulders shall be described in terms of location, duration, time of day, etc. Such work shall not begin until all traffic control devices are in place.

[9] If any grading, sidewalk, or other work allowed by a permit interferes with the drainage of the highway in any way, such catch basins and outlets as necessary shall be constructed to take proper care of said drainage and any materials such as pipes and tiles damaged during any installation or repair by the permittee or its employees or agents shall be repaired immediately at the sole cost of the permittee. Permittee shall timely notify the Department of any such damage and repairs thereto. Failure of the permittee to immediately repair the damage after it is discovered shall result in the Department performing the repair and the permittee shall reimburse the Department for the costs and shall hold the Department harmless for all the results of such work which may include removal of the permittee's facilities.

[10] Any damage to ODOT or another's property caused by the work shall be repaired by the permittee or permittee's agent or contractor in a timely manner and at the sole cost of permittee. If any emergency repairs to ODOT property are needed that cannot be performed by the permittee or permittee's agent or contractor, ODOT shall cause the repairs to be performed at the sole cost of permittee.

[11] Upon completion of the work, the permittee shall leave the highway clean of all rubbish, excess materials, temporary structures and equipment, and all parts of the highway shall be left in a condition acceptable to the Department. Upon satisfactory completion of the work authorized by the permit, the Department's appointed representative shall complete the Permit Inspection Certificate, Form No. MR 678 certifying that the permittee has complied with the terms of the permit.

[12] Except as herein authorized, no excavation shall be made or obstacle placed within the limits of the highway so as to interfere with the travel over the road.

[13] All pole lines are to be built in accordance with Rule 4901:3-1-08 of Ohio Administrative Code promulgated and enforced by the Public Utilities Commission of Ohio.

[14] All underground utilities shall be installed at a depth and horizontal distance from the road surface and any appurtenances in accordance with state and national safety standards and as pre-approved by the Department. After installation, the exact location of the utility shall be provided to the Department. The Department shall be held harmless for any damage to utilities due to insufficient or inaccurate installation or identification and all repairs shall be at the sole cost of the permittee.

[15] The permittee shall comply with the Air Pollution requirements of Rule 3745-17-08 of the Ohio Administrative Code promulgated and enforced by the Ohio Environmental Protection Agency.

[16] The permittee certifies that he or she is fully authorized to sign this permit. This permit shall apply to and be binding upon the permittee and any successors in interest. No change in ownership of the underlying property or of the facility owned by permittee shall in any way alter the permittee's obligations under this permit.

[17] The permittee(s) for herself/himself/themselves/itself, her/his/their/its personal representatives, and her/his/their/its successors in interest and assigns, as a part of the consideration hereof, do/does hereby covenant and agree that:

(1) No person on the grounds of race, color, or national origin, shall be excluded from participation in, be denied the benefits of, or be otherwise subjected to discrimination in the use of the utility/facilities/ services of the permittee.

(2) In the construction of any improvements on, over, or under the above described property and the furnishing of services thereon, no person on the grounds of race, color, national origin, sex, age, or disability shall be excluded from the participation in, be denied the benefits of, or be otherwise subjected to discrimination.

(3) The above described property shall be used in a manner that at all times is in compliance with all other requirements imposed by or pursuant to Title 49, Code of Federal Regulations, U.S. DOT, Subtitle A, Office of the Secretary, Part 21, Non-discrimination in Federally-assisted programs of the U.S. DOT — Effectuation of Title VI of the Civil Rights Act of 1964, and as said Regulations may be amended.

(4) In the event that this instrument grants a lease, license, or permit and any of the above non-discrimination covenants is breached, then the State of Ohio, Department of Transportation, shall have the unfettered right to terminate the lease, license or permit and to re-enter and repossess the above-described property and hold the same as if said lease, license or permit had never been made or issued.

This permit is granted subject to the following attached conditions:

PERMITTED LANE CLOSURE ARE FROM 9AM TO 3PM. NO EQUIPMENT OR MATERIAL WILL BE PERMITTED TO BE LEFT IN THE ODOT RIGHT OF WAY OR WITHIN THE CLEAR ZONE. ALL SIGNS WILL BE REQUIRED TO BE TURNED OR REMOVED EACH DAY.

(the remainder of this page is left blank intentionally)

APPENDIX B

NONREDUNDANT STEEL TENSION MEMBER LOCATIONS

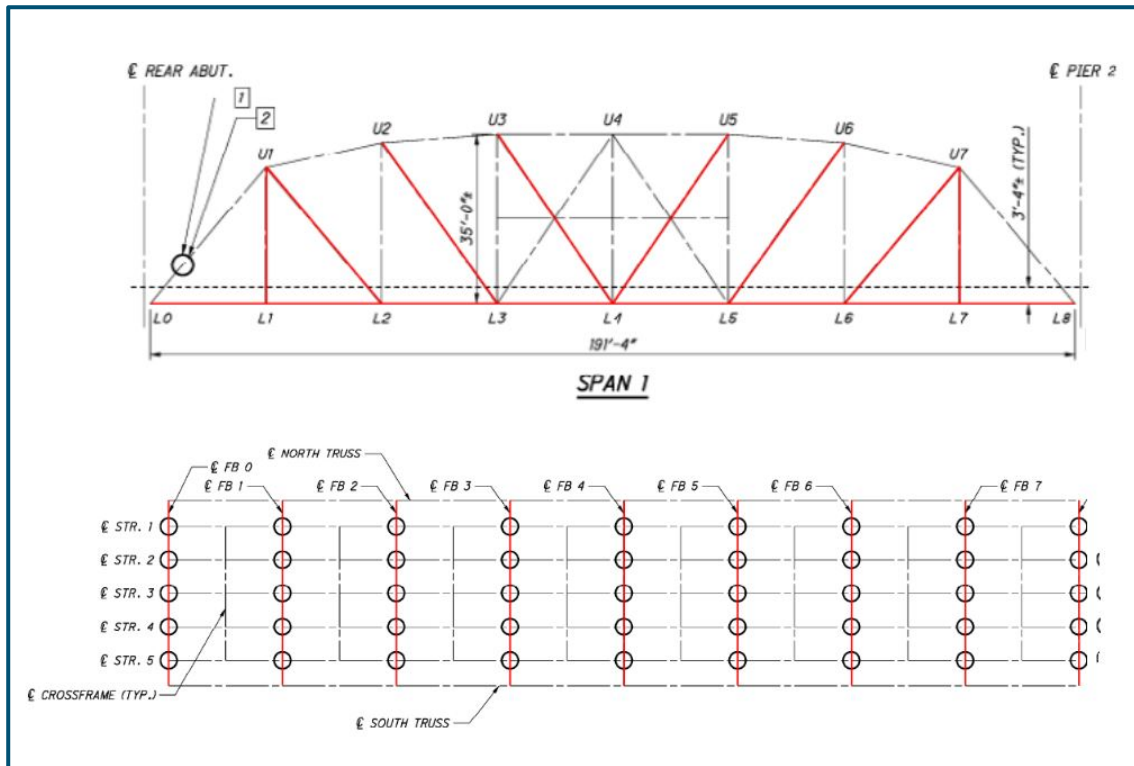

Figure 1 - Nonredundant Steel Tension Members in Span 1

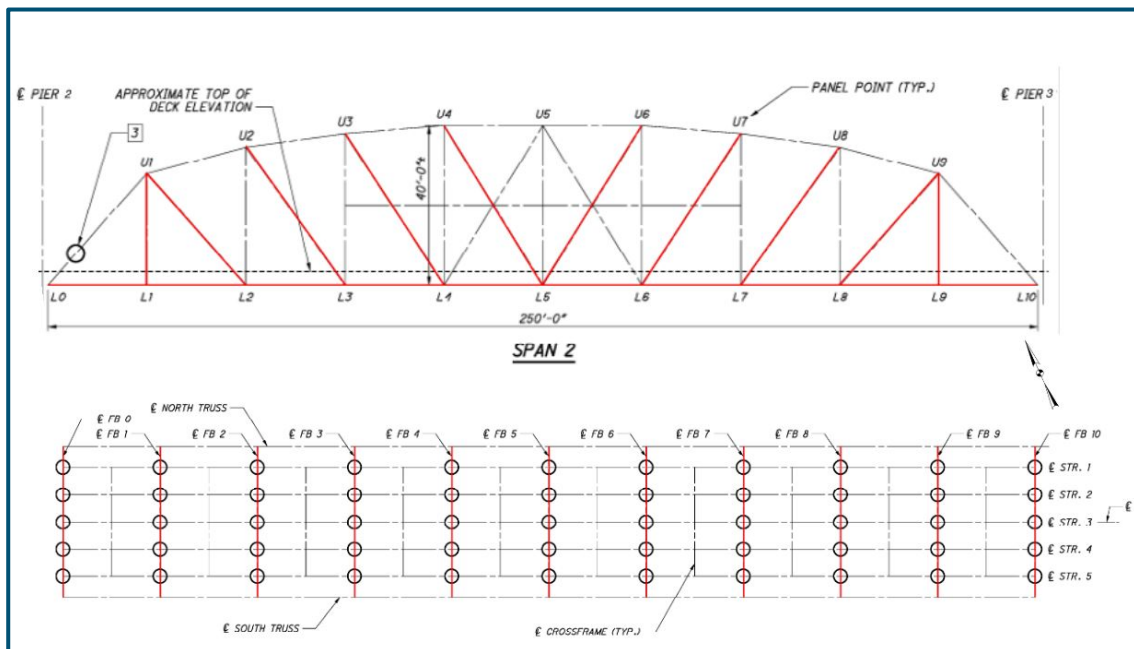

Figure 2 - Nonredundant Steel Tension Members in Span 2

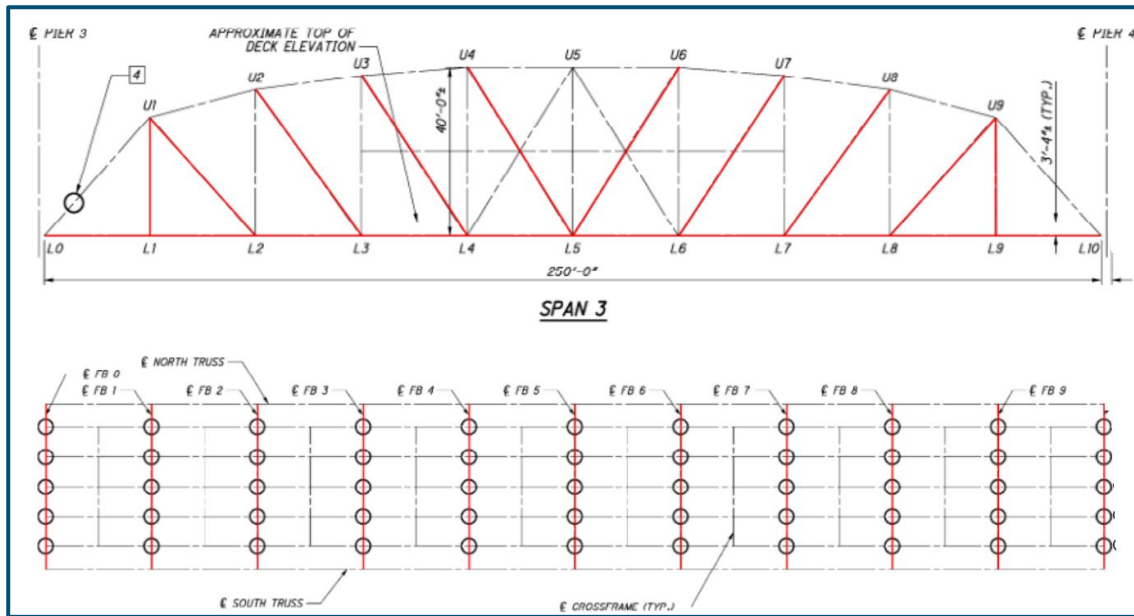

Figure 3 - Nonredundant Steel Tension Members in Span 3

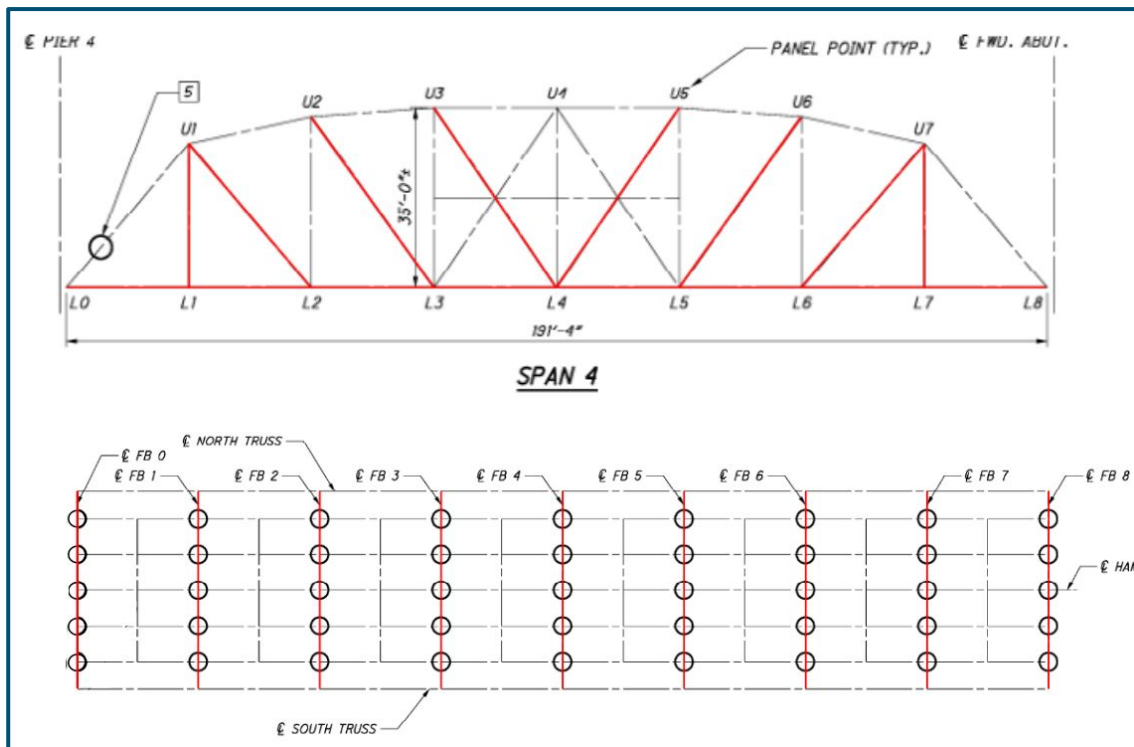

Figure 4 - Nonredundant Steel Tension Members in Span 4

SFN: 3102521
US 50 Westbound over the Great Miami River
PID No. 105475

APPENDIX C

TRAFFIC CONTROL DETAILS

OVERALL LOCATION MAP

GREATER CINCINNATI AREA

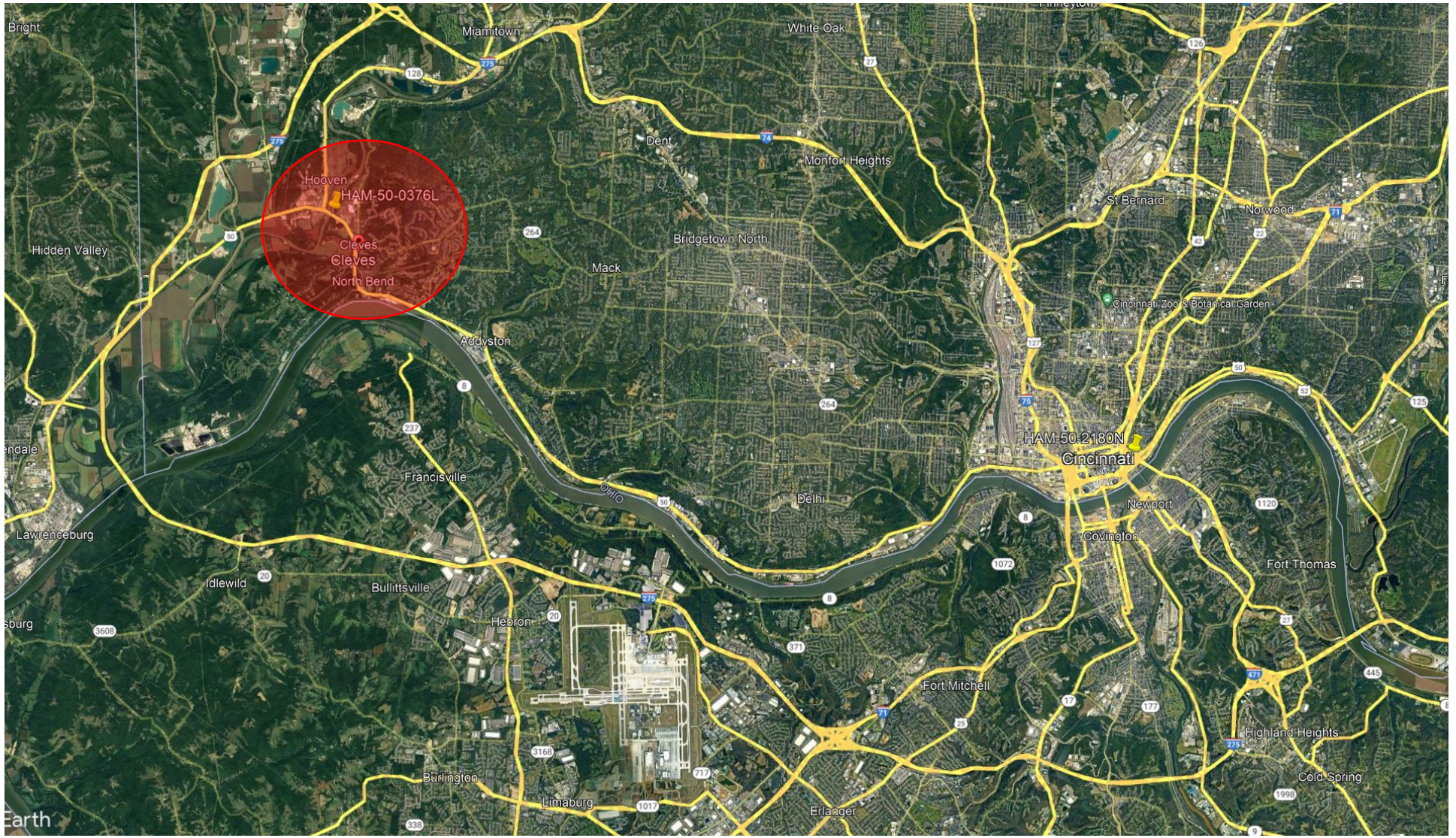

HAM-50-0376L – July 8-12, 2024

US-50 over Great Miami River (near Cleves, OH)

39.169947°, -84.758115°

Day time closure – single left closure of US-50 WB

Day time closure – single right closure of US-50 WB



Inspection
work zone ≈
0.17 mi



SFN: 3102521
US 50 Westbound over the Great Miami River
PID No. 105475

APPENDIX D
EXISTING PLANS



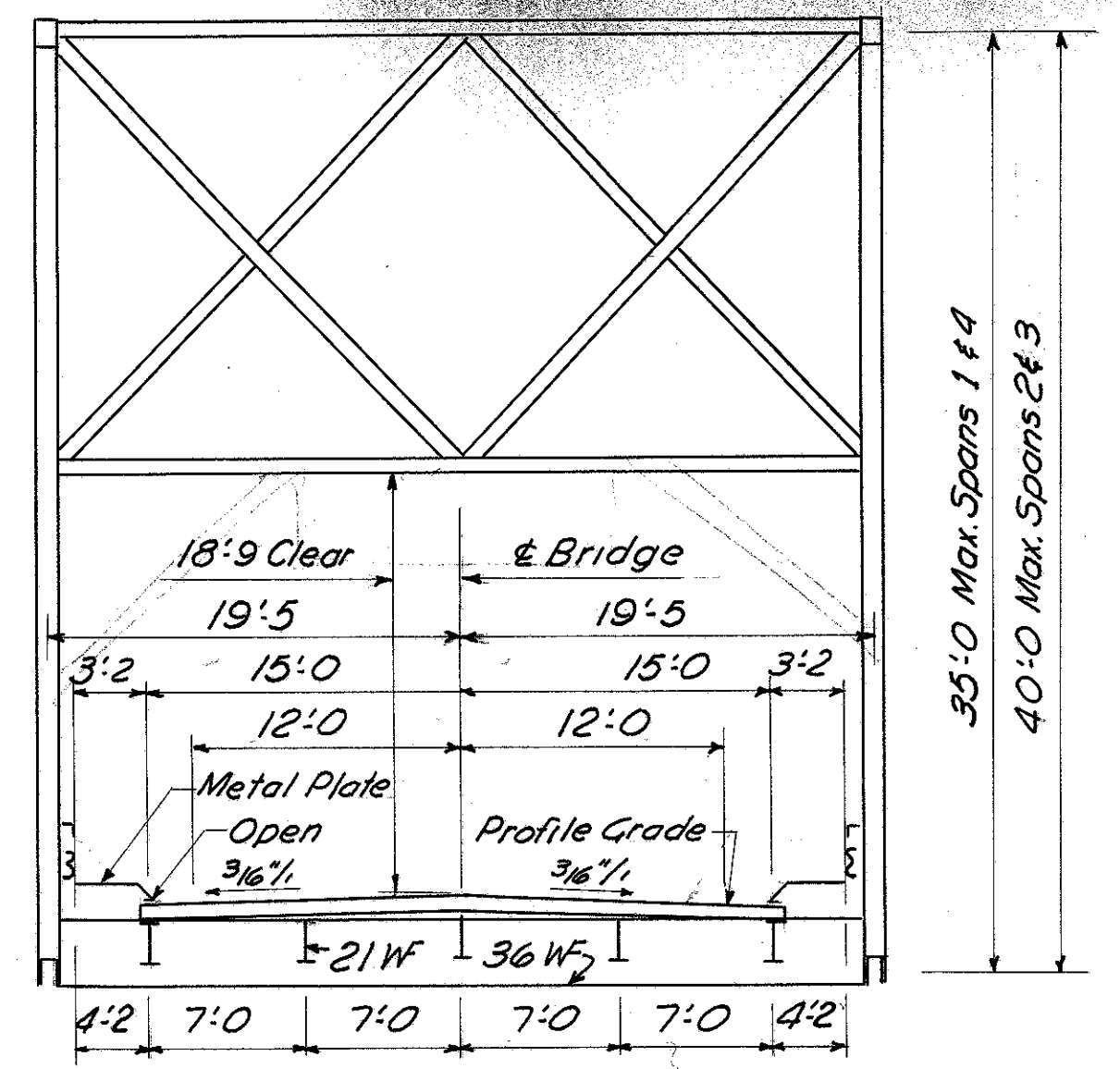
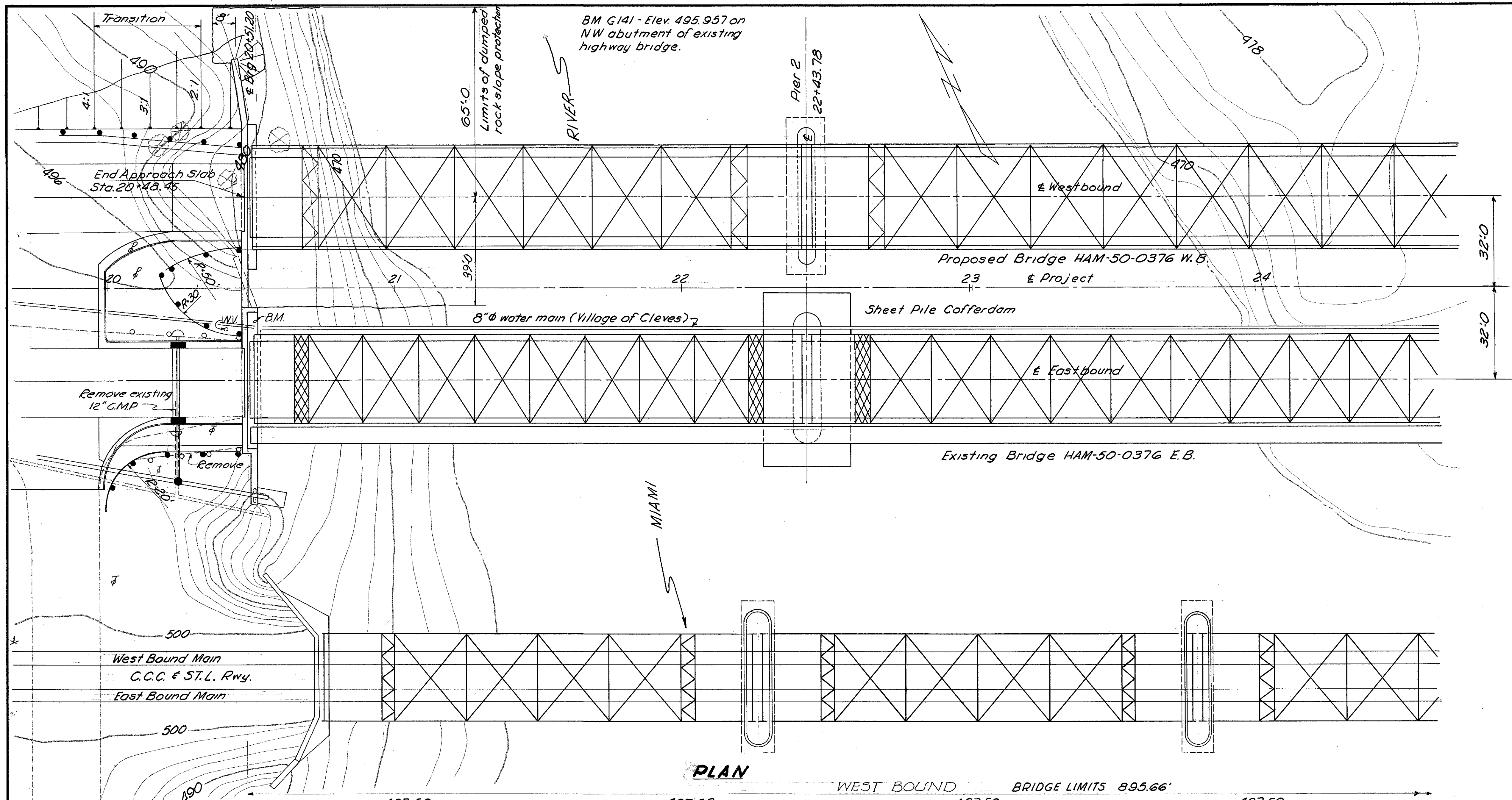

EXISTING BRIDGE DATA

GREAT MIAMI RIVER BRIDGE HAM-50-0376 E.B.
 TYPE - High Truss - Conc. Deck & Substruct.
 SPANS - 190'-10", 250'-0", 250'-0", 190'-10"
 ROADWAY - 26'-11" with 5'-9" sidewalk S. side
 WEARING SURFACE - Mono. Concrete
 LOADING - H-15
 SKEW - None
 DATE BUILT - 1914
 CONDITION - See Sheets 268, 269, 270 & 271
 C.C.C. & ST. L. RAILWAY BRIDGE No. 132
 TYPE - Thru Truss - Masonry Substruct.
 SPANS - 6 @ 150' c/c Piers
 ROADWAY - Double track main line
 WEARING SURFACE - 139' rail
 LOADING -
 SKEW - None
 DATE BUILT - 1913
 CONDITION - Good

DRAINAGE AREA = 3,950 Sq. Mi.

PROPOSED STRUCTURE

TYPE - High Truss, Concrete Deck & Substructure
 SPANS - 191'-4", 250'-0", 250'-0", 191'-4"
 ROADWAY - 30'-0" Curb to Curb
 SIDEWALKS - 3'-0" Safety Walk each Side
 LIVE LOAD - CF 2000 (57), Adequate for AASHTO alternate loading.
 SKEW - None
 ALIGNMENT - Tangent
 APPROACH SLABS - 25' long, 24' wide
 WEARING SURFACE - 1" Monolithic

Foundation design and foundation quantities are based on a study of rod soundings and soil sampling soundings made at the site. This sounding information may be inspected in the office of the Bureau of Bridges in Columbus, or in an abridged form in the Division office, but the State assumes no responsibility for the accuracy thereof.

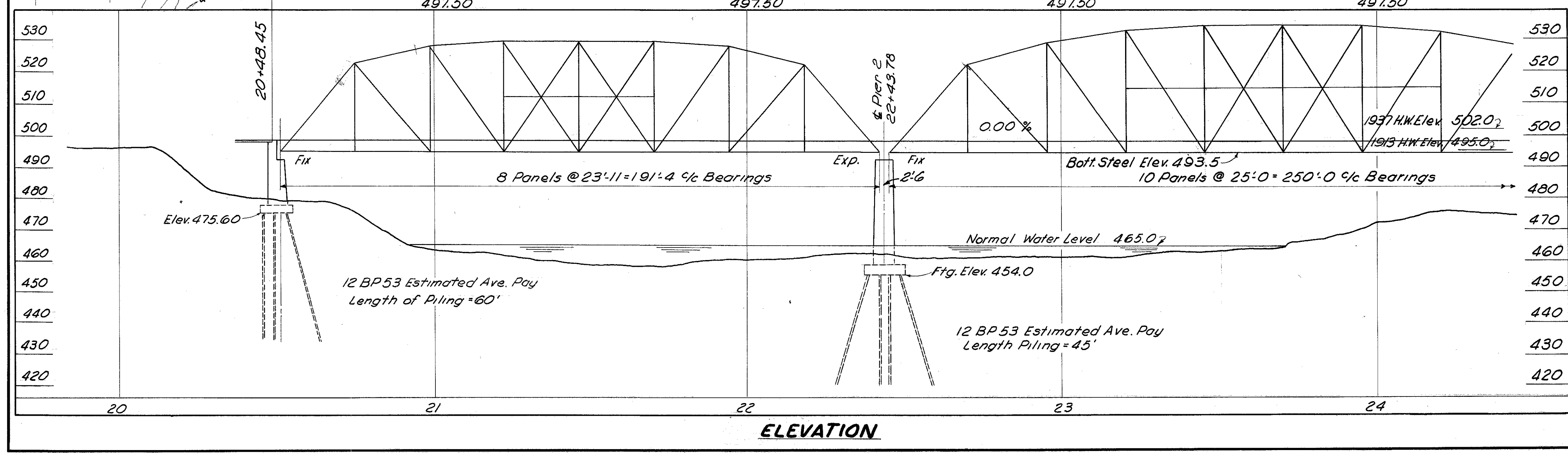

HARRY BACHE ENGINEERS
 2300 VICTORY PARKWAY
 CINCINNATI 6, O.

SITE PLAN

BRIDGE HAM-50-0376 E.B. & W.B.
 EXISTING & PROPOSED U.S. ROUTE 50
 OVER GREAT MIAMI RIVER

HAMILTON CO.
 SEC. 3, 72 STA. 21 + 96.28

DESIGNED	DRAWN	TRACED	CHECKED	REVIEWED	DATE	REVISED
RAK	RAK	D.S.	R.C.B.	A.C.A.	2/27/58	

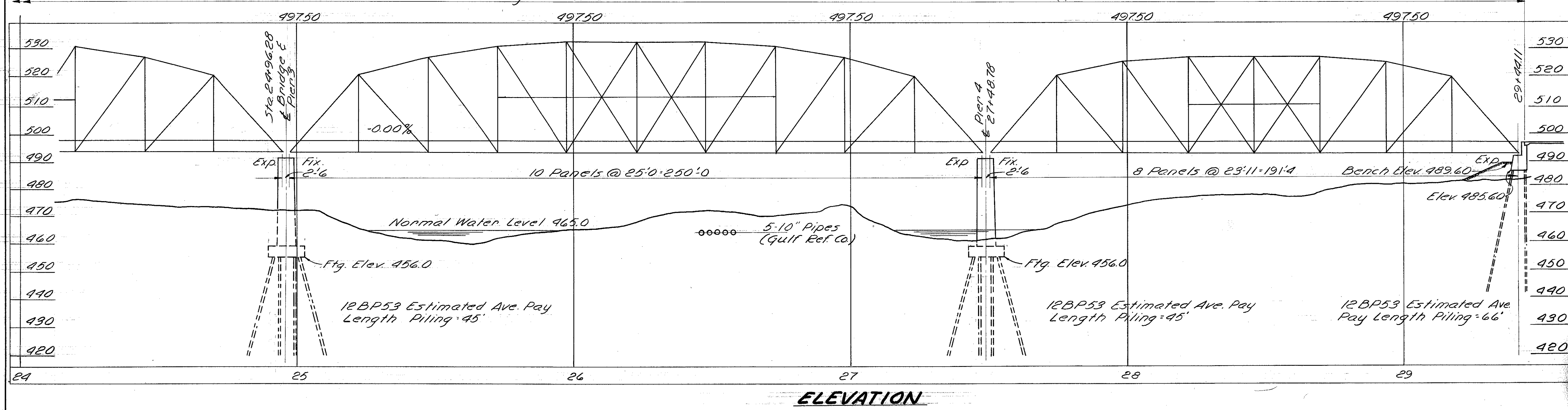
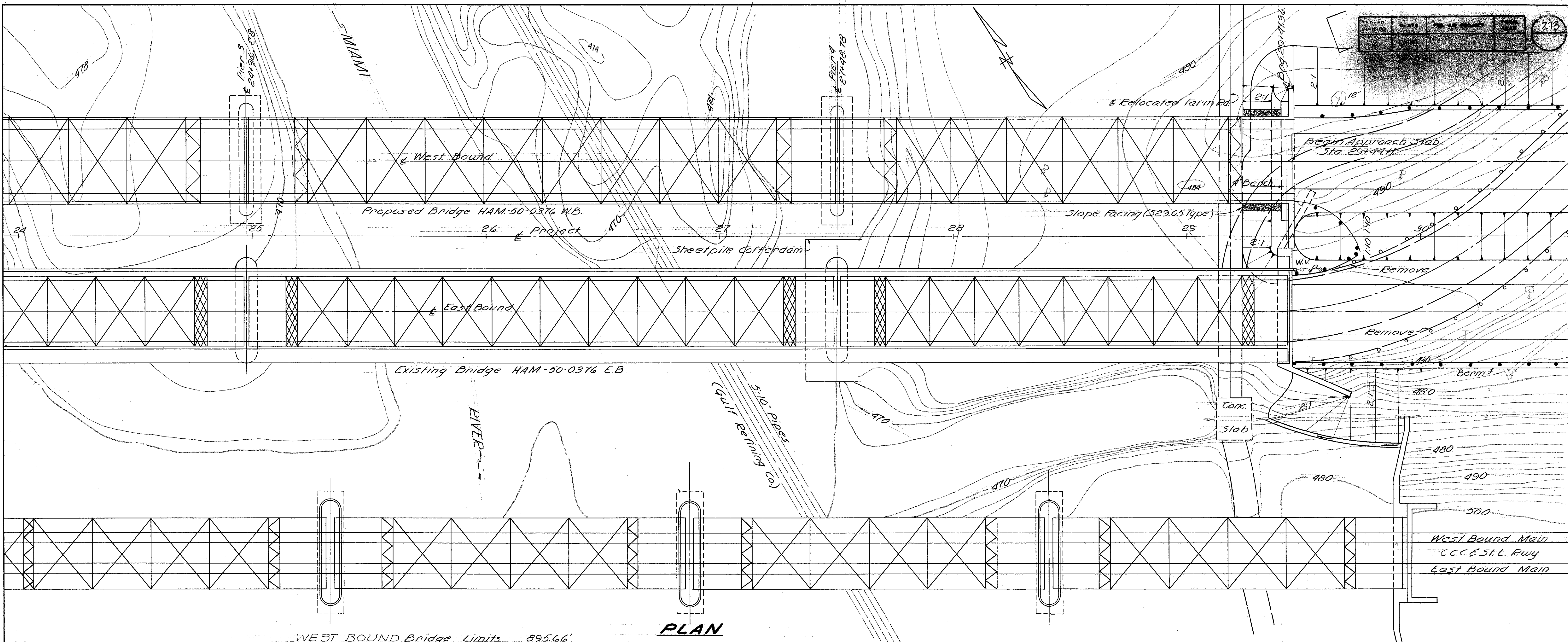

HARRY BALKE ENGINEERS
 2330 VICTORY PARKWAY
 CINCINNATI 6, O.

SITE PLAN

BRIDGE HAM-50-0376 EB&WB
 EXISTING & PROPOSED U.S. ROUTE 50
 OVER GREAT MIAMI RIVER

HAMILTON CO.
 SEC. 3, T2

STA. 24+10.11

DESIGNED	DRAWN	TRACED	CHECKED	REVIEWED	DATE
RAK.	RAK.	DG	RCB.	ACA	2/27/58

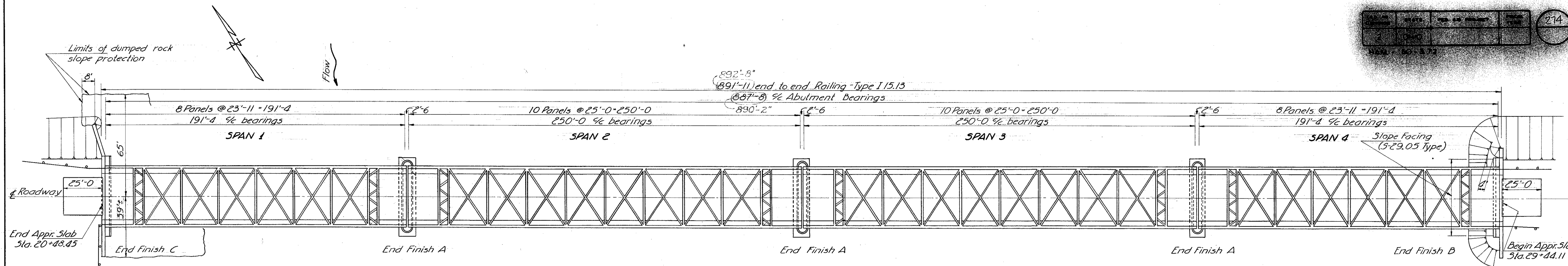

GENERAL PLAN

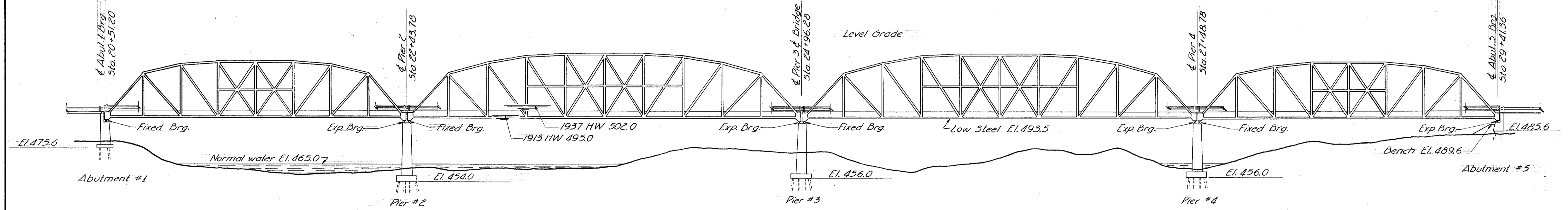

ELEVATION

ESTIMATED QUANTITIES

ITEM	TOTAL	UNIT	DESCRIPTION	Abut. 1	Pier 2	Pier 3	Pier 4	Abut. 5	Superstr.	General
E-2	lump sum	lump sum	Cofferdams, cribs & sheeting							lump sum
E-2	1,372	cu. yds.	Unclassified excavation	227	264	561	186	134		
5-1	744.2	cu. yds.	Class "C" concrete, superstructure						744.2	
5-1	321.1	cu. yds.	Class "E" concrete, abutments	222.5				98.6		
5-1	378.6	cu. yds.	Class "E" concrete, footings	83.4	98.4	98.4	98.4			
5-1	933.8	cu. yds.	Class "E" concrete, piers above footings		327.6	303.1	303.1			
5-2	125	sq. ft.	Patching concrete		93			32		
5-3	14	lin. ft.	Waterproofing, 1/2" premolded sealing strip (12" wide)		16					
5-4	265,971	lbs.	Reinforcing steel	12,764	7,476	74,222	74,222	7,293	223,594	
5-7	222,680	lbs.	Structural steel						222,680	
5-8	222,680	lbs.	Field painting of structural steel						222,680	
5-9	95	sq. ft.	1 in. Preformed expansion joint filler (Type M-10.02)	73				22		
5-14	4,783.83	lin. ft.	Railing (Type I-15.13 steel, 4x3x3/8 handrail, 6W-20 Posts)						1725.33	4783.83
5-16	lump sum	lump sum	First test pile							lump sum
5-18	11,185	lin. ft.	Steel piles (12 BP53)	2,160	2,700	2,700	2,700	925		
5-22	lump sum	lump sum	Removal of portions of existing structure							lump sum
5-29	115	cu. yds.	Porous backfill	76				39		
5-29	34	cu. yds.	Slope facing (S-29.05 Type)					34		
I-10	414	cu. yds.	Dumped rock fill	414						

GENERAL NOTES

REFERENCE shall be made to Standard Drawing A5-1-54 dated December 1, 1954.
DESIGN SPECIFICATIONS: This structure conforms to the requirements of "Design Specifications for Highway Structures" of the State of Ohio, Department of Highways, dated Sept. 1, 1957.
PILING shall be driven to a minimum bearing capacity of 50 tons.
WELDING shall be class "A" unless otherwise shown. Any weld shown as a field weld may be made in the shop at the option of the contractor.
SLOPE FACING (S-29.05, TYPE) shall be provided under the structure at Abutment 5. The slope facing material shall be 12 inches thick and shall extend from the face of the abutment down to Elev. 484.0 and transversely to 3 ft. outside the edge of the superstructure.
DUMPED ROCK FILL 2 ft. thick shall be provided under the bridge at Abutment 1. The dumped rock fill shall be constructed above Elevation 463 and to the limits shown on the plans.
CONCRETE DECK PLACING: The slab may be placed in sections, between transverse construction joints which are normal to the centerline of the bridge and are located near the center of any span.
COFFERDAMS: Before construction is started on the Piers, three sets of prints showing details of the cofferdams at each pier shall be submitted to the Director for approval by the Department of Highways.

HARRY BALKE ENGINEERS
 2200 VICTORY ST. CLEVELAND, OHIO
GENERAL PLAN & ELEVATION NOTES & ESTIMATED QUANTITIES
 BRIDGE HAM-50-0376WB
 PROPOSED U.S. ROUTE 50
 OVER GREAT MIAMI RIVER
 HAMILTON CO. OHIO
 EMB. LLT LP CHL RCB A.C.A. 8/27/50

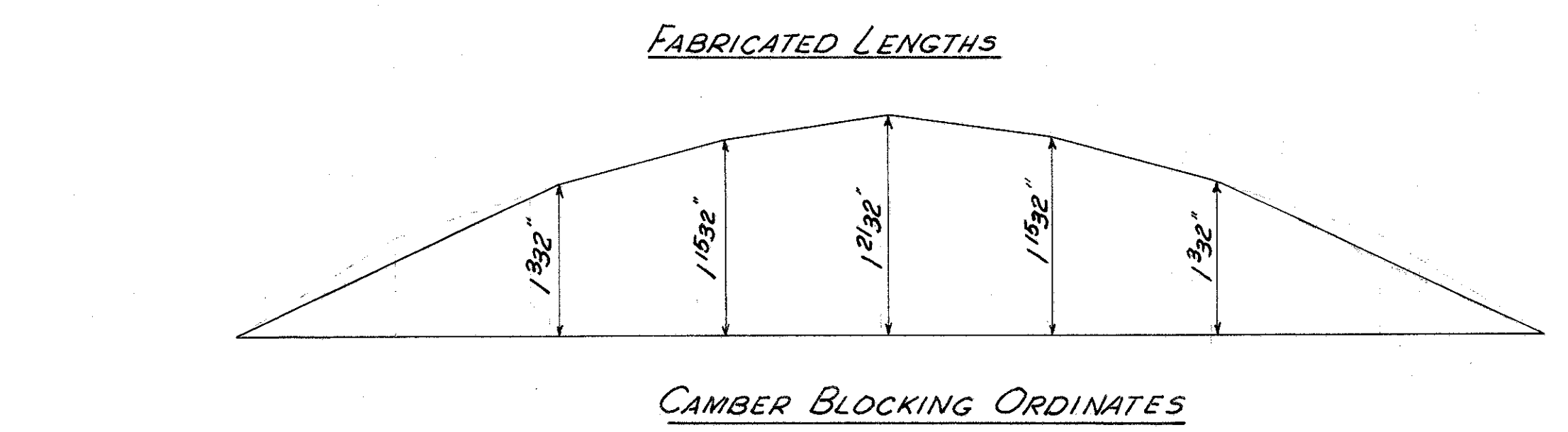
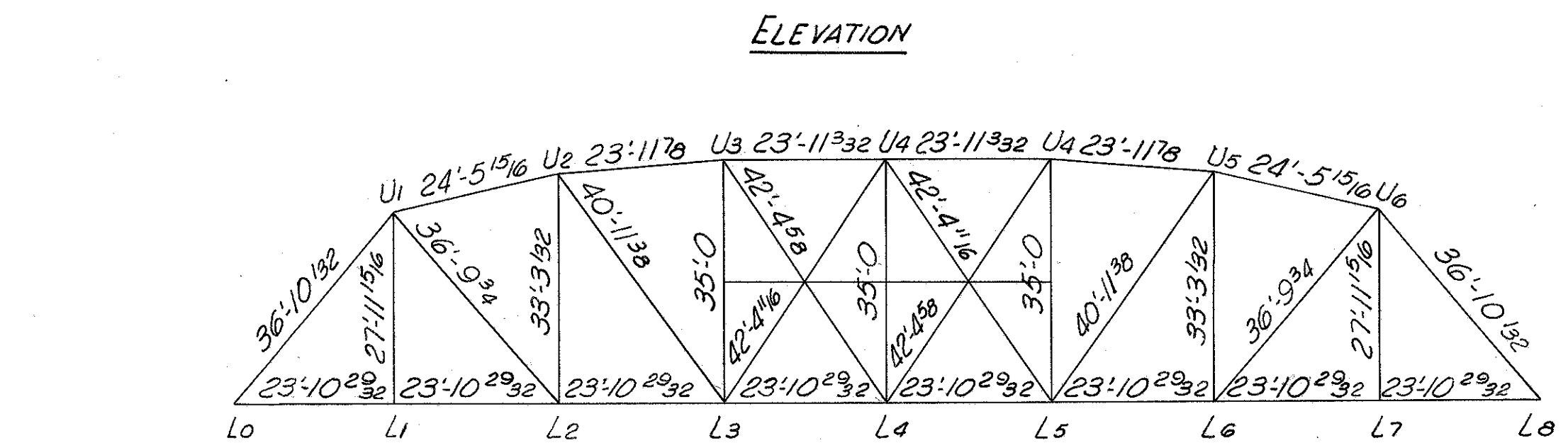
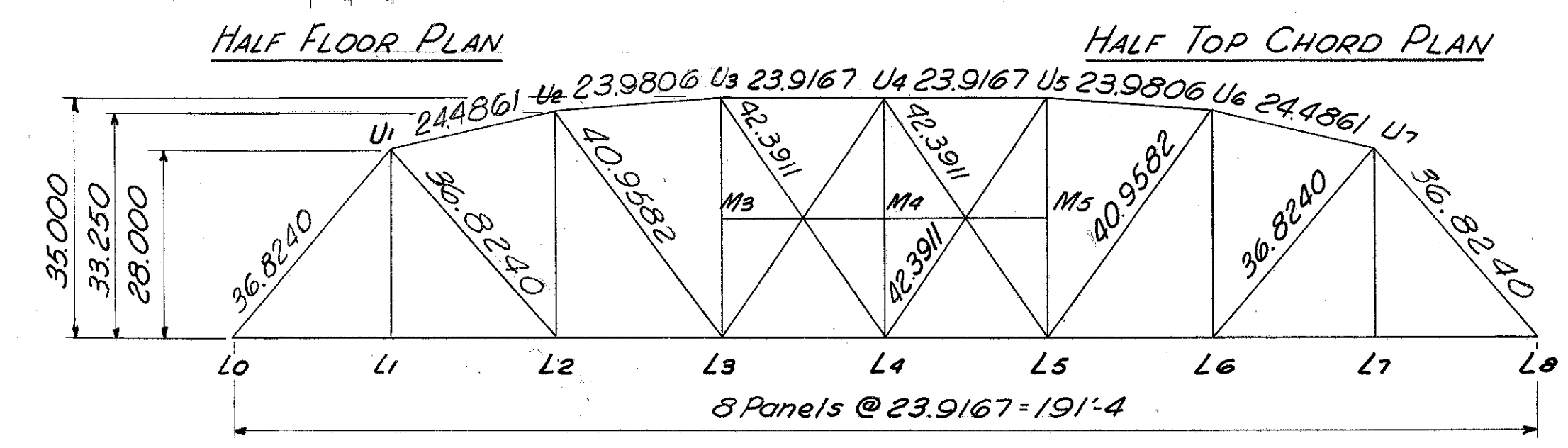
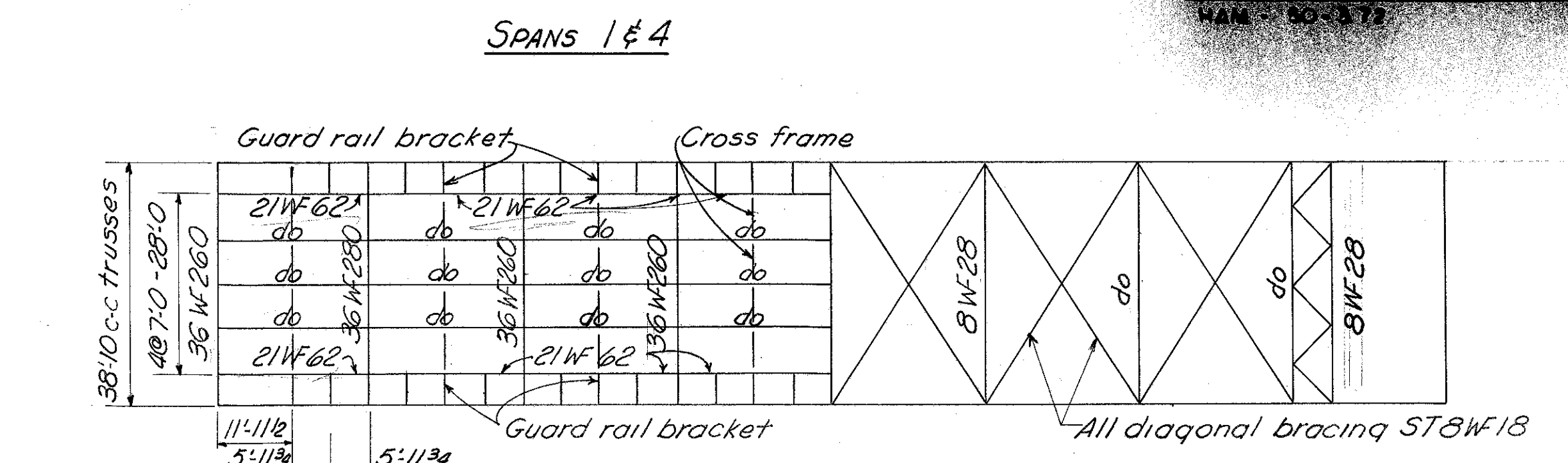
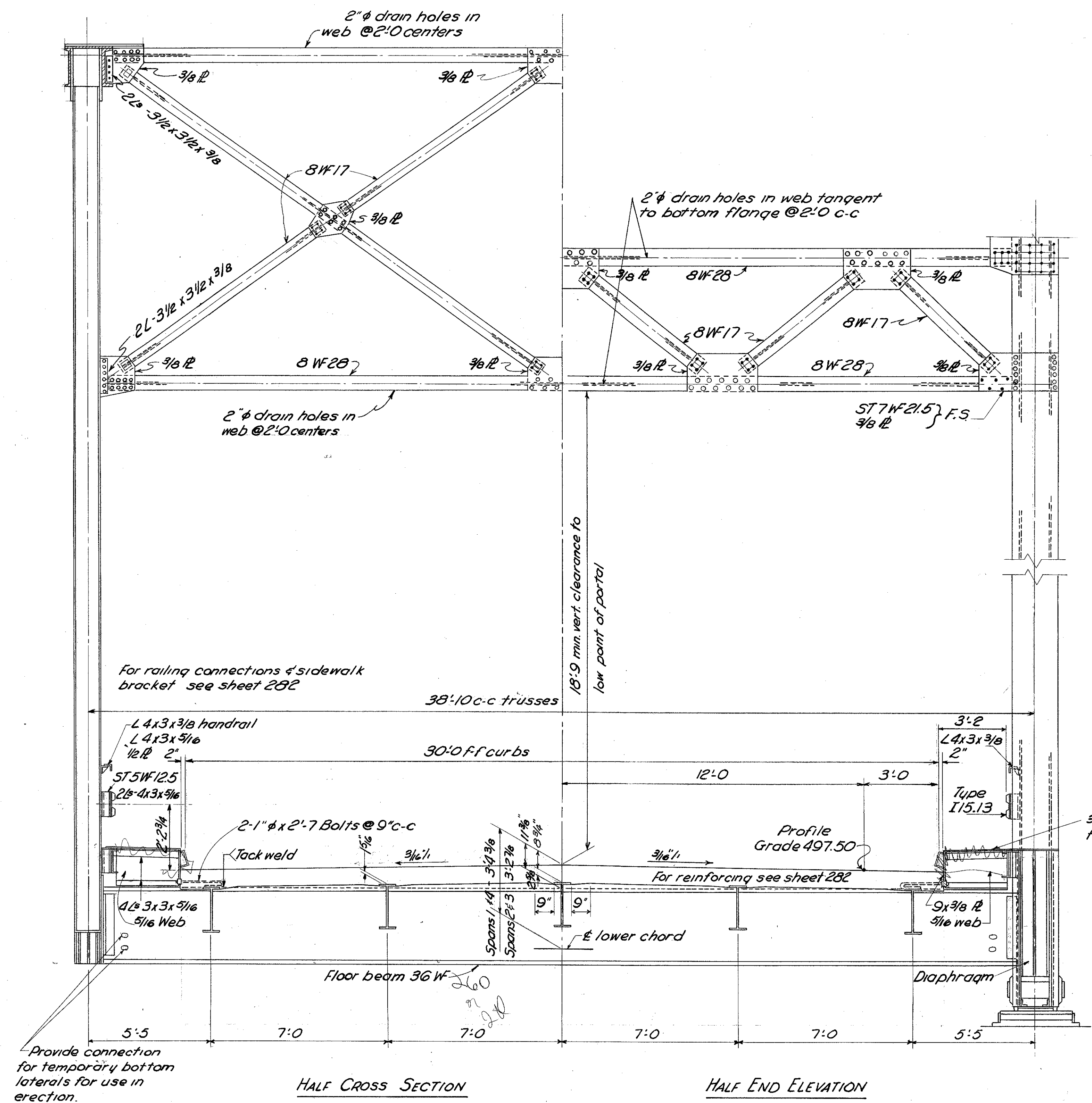

TABLE OF MODIFIED STRESSES (SPANS 1 & 4)

Member	Modified Stresses in Kips			Section	
	DL	LL & I	Total		
LoU1	-284	-200	-484	2-15x50	1-R 21x9/16
U1U2	-275	-179	-454	2-15x40	1-R 21x12
U2U3	-319	-210	-529	2-15x40	1-R 21x11/16
U3U4	-340	-224	-564	2-15x50	1-R 21x9/16
LoL2	+185	+121	+306	2-R 15x34	6 holes out
L2L3	+268	+177	+445	2-R 15x11/16	2-R 15x38
L3L4	+319	+207	+526	2-R 15x11/16	2-R 15x9/16
U1L2	+129	+109	+238	12WF58	4 holes out
U2L3	+88	+96	+184	12WF53	do
U3L4	+39	+79	+118	12WF36	do
U1L1	+59	+108	+167	12WF40	do
U2L2	-36	-62	-98	12WF65	do
U3L3	-9	-63	-72	12WF36	do
Substruts				12WF36	do
Floor beam reactions	56.6	86.4	143		

All Rivets 7/8" unless noted

191'-4" TROSS

HARRY BALKE ENGINEERS
2830 VICTORY PARKWAY
CINCINNATI 8, O.

SUPERSTRUCTURE DETAILS

BRIDGE HAM-50-0376WB
PROPOSED US ROUTE 50
OVER GREAT MIAMI RIVER
HAMILTON CO.
SEC. 3.72 STA. 24+96.29

DATE: 2/27/58

Note: Stresses modified according to sec. 76 of the 1957 Design Specification

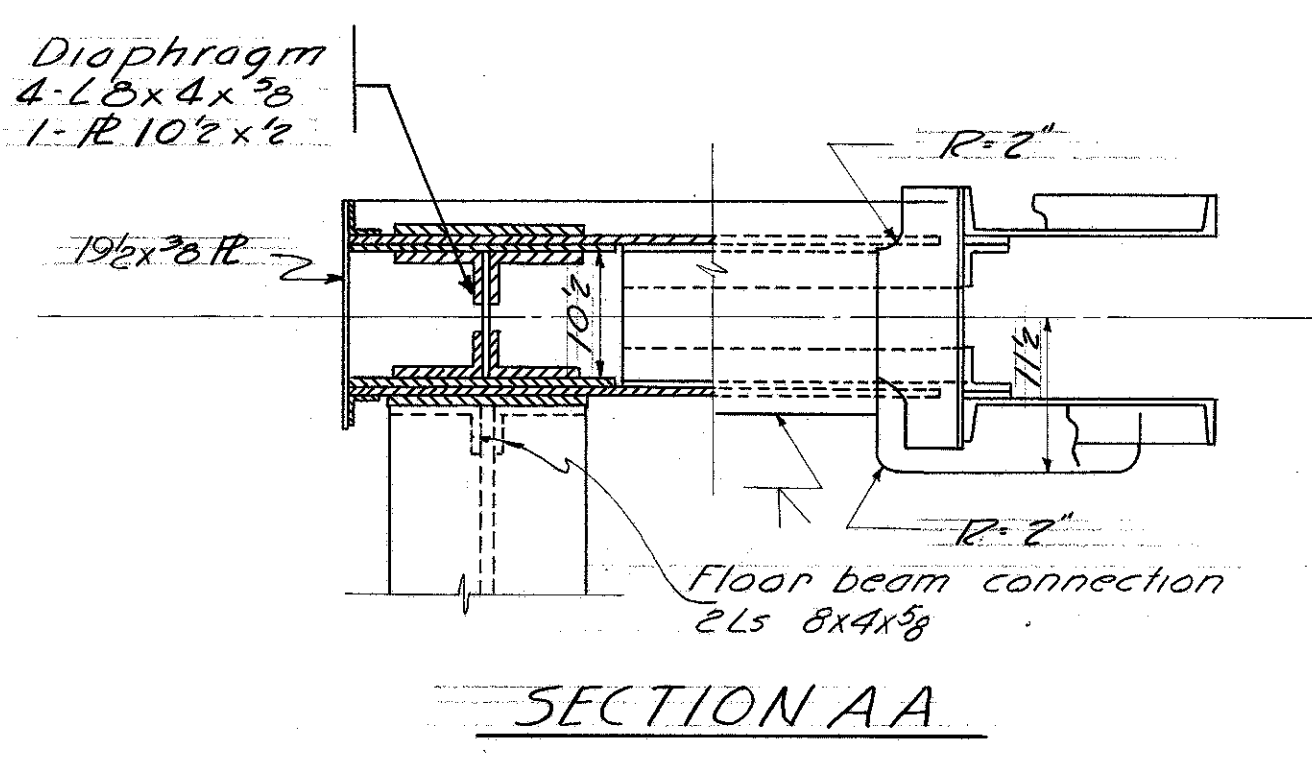

Diaphragm at all Top
Chord Panel Points
4 L 3 1/2 x 3 1/2 x 3/8
2" R

Abut. 1-N & S rail, use center
splice & continue rail on
roadway.

Abut. 1-N rail-use std splice &
continue rail on roadway.
S rail-use std end flare
Abut. 2-lap 4". Do not bolt.

Post @ Abut. 2 only

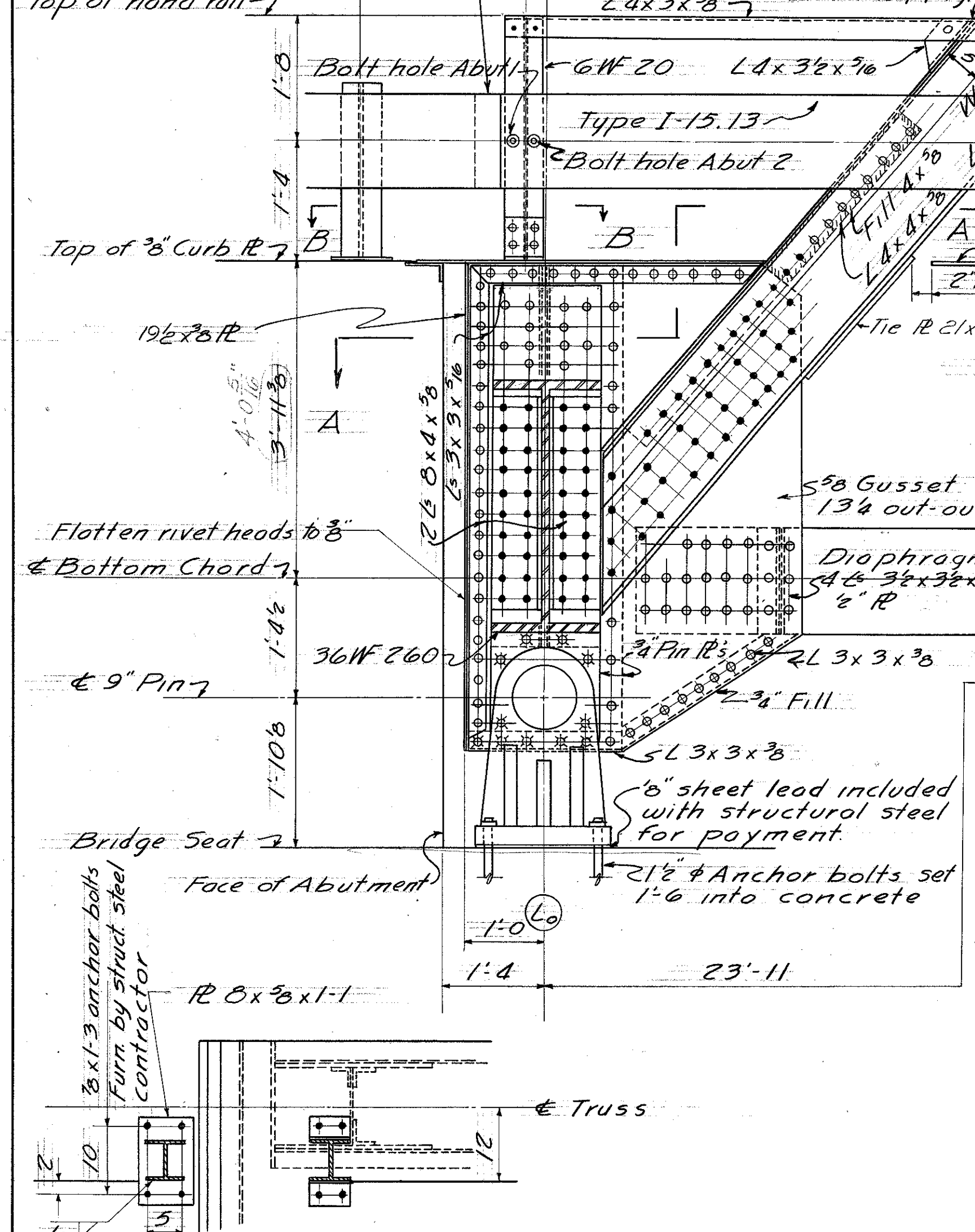

Note:
All rivets 3/8" unless noted

Diaphragm at Splice
4 L 3 1/2 x 3 1/2 x 3/8
2" R

Diaphragm of Panel Points
4 L 3 1/2 x 3 1/2 x 3/8
2" R

HARRY BALKE ENGINEERS
2340 VICTORY PARKWAY
CINCINNATI 9, O.

SUPERSTRUCTURE DETAILS

BRIDGE HAM-50-0376WB
PROPOSED U.S. ROUTE 50
OVER GREAT MIAMI RIVER

HAMILTON CO.
SEC. 3.72 STA. 21+96.28

DESIGNED	DRAWN	TRACED	CHECKED	REVIEWED	DATE
EWS	EWS	HS	RGB	ACA	2/27/58

