

The Great Lakes Construction Co.

TRANSMITTAL
No. 177

925 Laidlaw Ave.
Cincinnati, Ohio 45237

PROJECT: ODOT 150085 HAM 71-1.34 **DATE:** December 5, 2017

TO: ODOT District 8
505 South SR 741
Lebanon, OH 45036 **REF:** Enclosed Motor Controllers
Line Item: #318.00

ATTN: Marvin Lennon

WE ARE SENDING		SUBMITTED FOR:		ACTION TAKEN:	
	Shop Drawings		Approval		Approved as Submitted
	Letter	X	Your Use		Approved as Needed
	Prints		As Requested		Returned after Loan
	Change Order		Review and Comment		Resubmit
	Plans			X	Submit
	Samples		SENT VIA:		Returned
	Specifications	X	Attached		Returned for Correction
X	Other: Soft Start O&M		Separate Cover:		Due Date:

<u>SUBMITTAL</u>	<u>COPIES</u>	<u>DATE</u>	<u>DESCRIPTION</u>
TR85.15-177	1 pdf	12/5/2017	Enclosed Motor Controller O&M, per sheet 457/555, Section 1.7.A

REMARKS

CC: Joe Smithson, ODOT D8

Signed:



Jacob D. Elmore.

Altistart® 48

Y-Range Soft Start Controllers

Instruction Bulletin

S1A37491

01/2010

For use in the United States of America



TABLE OF CONTENTS

	Hazard Categories and Special Symbols	5
	Product Support	5
SECTION 1: QUICK START PROCEDURE		7
SECTION 2: RECEIVING AND HANDLING		11
	Introduction	11
	Terminology	11
	Receiving and Preliminary Inspection	11
	Storing and Shipping	12
	Handling the Controller	12
SECTION 3: TECHNICAL DATA		13
	Technical Characteristics	13
	Specifications	14
	Dimensions and Weights	17
	Serial and Model Numbers	18
SECTION 4: MOUNTING		19
	Mounting Precautions	19
	Mounting in a General Purpose Metal Enclosure	20
	Soft Starter Ventilation	20
	Mounting in a Dust and Damp-Proof Metal Enclosure	20
	Thermal Considerations for Sizing Enclosures	21
	Remote Keypad Display (if used)	22
SECTION 5: WIRING		25
	Installation Precautions	25
	System Grounding	28
	General Wiring Practices	29
	Adaptation to Line Input	29
	Power Connections	30
	Control Connections	34
	Layout of Control Terminals	35
SECTION 6: APPLICATION AND MOTOR PROTECTION		37
	Soft Starter Applications	37
	Standard Duty Applications	37
	Severe Duty Applications	37
	Reduced Torque	37
	INTELE™ Braking	38
	Motor Protection and Diagnostics	39
	Thermal Overload Protection	39
	Motor Thermal Protection with PTC Thermistor Probes	41
	Preventive Maintenance	42
SECTION 7: PROGRAMMING		43
	Programming and Setup	43
	Preliminary Recommendations	43
	Display Unit and Programming	44
	Display Principle	44
	Menus	45



SECTION 8: DETECTED FAULT AND OPERATING CONDITION MANAGEMENT	69
Soft Starter Does Not Start, No Error Code Displayed	69
Conditions Requiring a Power Reset	69
Conditions Requiring a Run Command Reset	70
Auto-Reset Conditions (Customer Configurable)	70
Conditions Requiring Reset by a Repeated (2 times) Run Command Input	71
Controller Reset Using a Logic Input	72
Troubleshooting Procedure	73
Product Support	73
Factory Settings	75
APPENDIX A: RECOMMENDED WIRING DIAGRAMS	79
APPENDIX B: RECOMMENDED COMPONENT LISTS	83
APPENDIX C: OPTIONS AND ACCESSORIES	85
INDEX:	87

Hazard Categories and Special Symbols

The following symbols and special messages may appear in this manual or on the equipment to warn of potential hazards or to call attention to information that clarifies or simplifies a procedure.

A lightning bolt or ANSI man symbol in a “Danger” or “Warning” safety label on the equipment indicates an electrical hazard which, as indicated below, can or will result in personal injury if the instructions are not followed.

The exclamation point symbol in a safety message in a manual indicates potential personal injury hazards. Obey all safety messages introduced by this symbol to avoid possible injury or death.

Symbol	Name
	Lightning Bolt
	ANSI Man
	Exclamation Point

⚠ DANGER
DANGER indicates an imminently hazardous situation which, if not avoided, will result in death or serious injury.

⚠ WARNING
WARNING indicates a potentially hazardous situation which, if not avoided, can result in death or serious injury.

⚠ CAUTION
CAUTION indicates a potentially hazardous situation which, if not avoided, can result in minor or moderate injury.

CAUTION
CAUTION , used without the safety alert symbol, indicates a potentially hazardous situation which, if not avoided, can result in property damage.

Product Support

For support and assistance, contact the Product Support Group. The Product Support Group is staffed from 8:00 am until 6:00 pm Eastern time Monday through Friday to assist with product selection, start-up, and diagnosis of product or application problems. Emergency phone support is available 24 hours a day, 365 days a year.

Toll free: 888-SquareD (888-778-2733)
E-Mail: drive.products.support@us.schneider-electric.com
Fax: 919-217-6508

Section 1—Quick Start Procedure

WARNING

DAMAGED SOFT STARTER EQUIPMENT

Do not operate or install any soft starter that appears damaged.

Failure to follow these instructions can result in death, serious injury, or additional equipment damage.

1. Before installing or storing the Altistart® 48 (ATS48) soft starter, thoroughly inspect it according to the instructions in “Receiving and Preliminary Inspection” on page 11.
 - a. Verify that the soft starter catalog number printed on the label is the same as that on the packing slip and corresponding purchase order.
 - b. Remove the ATS48 soft starter from its packaging and check that it has not been damaged during transit. If any damage is found, notify the carrier and your Schneider Electric representative.
2. Install the ATS48 soft starter in accordance with the mounting, ventilation, and environmental requirements specified under “Mounting” on page 19.

DANGER

HAZARD OF ELECTRIC SHOCK, EXPLOSION, OR ARC FLASH

- Read and understand this manual before installing or operating the Altistart 48 (ATS48) soft starter. Installation, adjustment, repair, and maintenance must be performed by qualified personnel.
- The user is responsible for compliance with all international and national electrical code requirements with respect to grounding of all equipment.
- Many parts of this soft starter, including the printed circuit boards, operate at the line voltage. **DO NOT TOUCH.** Use only electrically insulated tools.
- **DO NOT** touch unshielded components or terminal strip screw connections with voltage present.
- Before servicing the soft starter:
 - Disconnect all power, including external control power that may be present.
 - Place a “DO NOT TURN ON” label on all power disconnects.
 - Lock all power disconnects in the open position.
- Install and close all covers before applying power or starting and stopping the soft starter.

Failure to follow these instructions will result in death or serious injury.

NOTE: In this document, the terms soft starter, soft start controller, and ATS48 controller are used interchangeably to refer to the same Altistart 48 Y-Range device.

3. With the power removed, make the following connections to the ATS48 soft starter:
 - a. Connect the 115 V or 230 Vac control supply to CL1 and CL2.
 - b. Connect the power supply to 1/L1, 3/L2, and 5/L3.
 - c. Connect the motor to 2/T1, 4/T2, and 6/T3.

NOTE: If a shorting/bypass contactor is used, connect it between L1, L2, and L3 on the line side supply terminals and A2, B2, and C2 of the ATS48 soft starter. Refer to Figure 1 and to the wiring diagrams in Appendix A beginning on page 79.

Figure 1: Power Block Diagram

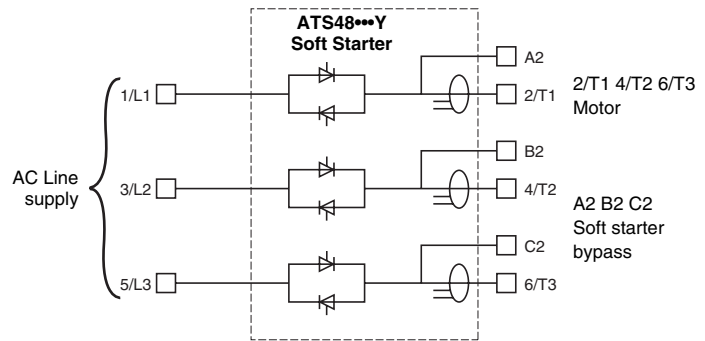
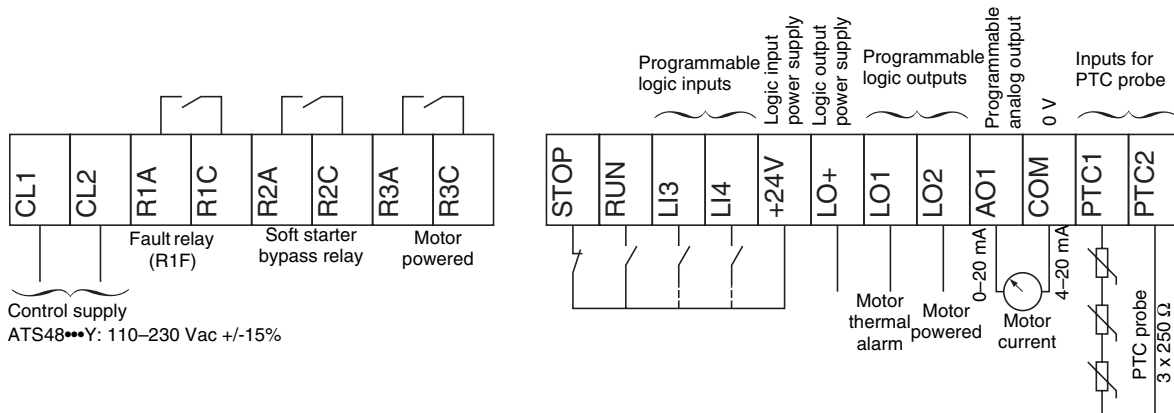

Figure 2: Control Circuit Terminal Configuration



NOTE: Wire the fault relay in the line contactor power supply sequence in order to open the electrical circuit in the event of a fault or trip condition.

4. Set parameter I_N (in the SEt menu, see page 47) to the motor nameplate current.
5. Apply power to the control terminals (CL1 and CL2). **Do not** apply power to the power terminals yet, and do not give a run command. The soft starter displays nLP to indicate that it is not powered up.
6. The ATS48 soft starter is factory configured for most standard duty applications. See Table 1 on page 10 for the factory preset values. If the factory configuration is not suitable for your application, refer to “Programming” on page 43 for information on changing the parameter settings.
7. Apply power to terminals 1/L1, 3/L2, and 5/L3. The soft starter will display rdY indicating that it is powered up.
8. Connect +24 V to the RUN and STOP control terminals to start the system in 2-wire control.

▲ WARNING

LOSS OF CONTROL—COMMUNICATION INTERRUPTION

- The designer of any control scheme must consider the potential failure modes of control paths and, for certain critical control functions, provide a means to achieve a safe state during and after a path failure. Examples of critical control functions are emergency stop and overtravel stop.
- Separate or redundant control paths must be provided for critical control functions.
- System control paths may include communication links. Consideration must be given to the implications of unanticipated transmission delays or failures of the link.¹
- Each implementation of an ATS48 soft starter must be individually and thoroughly tested for proper operation before being placed into service.

Failure to follow these instructions can result in death, serious injury, or equipment damage.

¹ For additional information, refer to NEMA ICS 1.1 (latest edition), “Safety Guidelines for the Application, Installation, and Maintenance of Solid State Control” and to NEMA ICS 7.1 (latest edition), “Safety Standards for Construction and Guide for Selection, Installation and Operation of Adjustable-Speed Drive Systems.”

Table 1: Factory Configuration

Nominal motor current (I_N)	Preset to correspond to 460 V rated motor current based on NFPA 70/NEC Table 430.150 ratings
Current limit (ILt)	400% of the motor current I_N
Acceleration ramp (ACC)	15 seconds
Initial torque on starting (tq0)	20% of the nominal torque
Stop (StY)	Freewheel stop (-F-)
Motor thermal protection (tHP)	Class 10 thermal overload protection curve
Display	rdY (soft starter ready) when power and control voltage are present and the motor is not operating nLP when power is not supplied
Logic inputs	<ul style="list-style-type: none"> • LI1 • LI2 • LI3 • LI4 <ul style="list-style-type: none"> • STOP • RUN • Forced freewheel stop (LIA) • Forced local mode (LIL)
Logic outputs	<ul style="list-style-type: none"> • LO1 • LO2 <ul style="list-style-type: none"> • Motor thermal alarm (tA1) • Motor powered (mI)
Relay outputs	<ul style="list-style-type: none"> • R1 • R2 • R3 <ul style="list-style-type: none"> • Fault relay (r1F) • Bypass relay at the end of starting • Motor powered (mI)
Analog output (AO)	Motor current (OCr, 0–20 mA)
Communication parameters	<ul style="list-style-type: none"> • When connected via the serial link, the soft starter has a logic address (Add) of 0 • Transmission speed (tbr): 19200 bits per second • Communication format (FOr): 8 bits, no parity, 1 stop bit (8n1)

Section 2—Receiving and Handling

Introduction

The Altistart® 48 (ATS48) soft starter offers state-of-the-art acceleration and deceleration control of standard three-phase asynchronous induction (squirrel cage) motors. The ATS48 controller uses a patented technology to control the motor performance based on the motor torque rather than simple voltage or current based control. Advanced control algorithms are incorporated to help ensure smooth rotation throughout the starting ramp without mechanical instability at the end of starting.

A microprocessor monitors the motor and controller performance for added protection of the controller, motor, and driven machinery. A variety of starting and stopping modes are standard. A digital keypad display is provided for controller setup and motor performance display.

The ATS48 controller is available in twenty-one current ratings from 17 to 1200 A. All models use a common control interface for consistent and simple set up. ATS48 controllers are rated for use with 208 to 690 V motors, and are self-adjusting for a 50 or 60 Hz supply frequency.

This instruction bulletin covers the technical characteristics, specifications, installation, wiring, programming, and troubleshooting of all ATS48 controllers.

Many option kits are available for the ATS48 controllers. Refer to Appendix C beginning on page 85.

Terminology

Some of the terms and acronyms used in this manual are defined in Table 2.

Table 2: Definition of Terms

Term	Definition
FLA	Full load amperes: the current rating of an induction motor at rated speed and load. This value may be found on the motor nameplate.
I_{CL}	Nominal current rating of the ATS48 controller. This value may be found on the controller nameplate.
I_N	User defined motor current rating. Same as FLA.
OCPD	Overcurrent protective device
T_N	Nominal motor torque as calculated by the ATS48 controller.
V_N	Nominal voltage of supply power (mains supply). This should correspond to the motor rated voltage on the motor nameplate.

Receiving and Preliminary Inspection

Before installing the ATS48 controller, read this manual and follow all precautions.

Before removing the ATS48 controller from its packing material, verify that the packing carton is not damaged from shipping. Damage to the packing carton usually indicates improper handling. If any damage is found, notify the carrier and your Schneider Electric representative.

After removing the ATS48 controller from its packaging, inspect it for damage. If any shipping damage is found, notify the carrier and your sales representative. Verify that the ATS48 controller nameplate and label conform to the packing slip and corresponding purchase order.

⚠ WARNING

DAMAGED SOFT STARTER EQUIPMENT

Do not operate or install any soft starter that appears damaged.

Failure to follow these instructions can result in death, serious injury, or additional equipment damage.

Storing and Shipping

If the ATS48 controller is not being immediately installed, store it in a clean, dry area where the ambient temperature is between -13 and +158 °F (-25 and +70 °C). If the ATS48 controller must be shipped to another location, use the original shipping material and carton to protect it.

Handling the Controller

Do not remove the ATS48 controller from the carton until it is at the final installation site. The carton provides protection and helps prevent damage to the controller's exterior. Handle the controller carefully after removing it from the carton to avoid damage to the internal components, frame, or exterior. Once removed from the carton, the controller can be handled:

Figure 3: Hoisting the ATS48 Controller

- With a hoist. When hoisting the controller, attach a spreader bar to the two lifting holes on top of the controller as shown in Figure 3.
- In a horizontal position, with the back of the controller resting on a pallet.

The ATS48 range comprises 6 sizes, with various weights and dimensions. Small controllers can be removed from their packaging and installed without a handling device. A handling device must be used with large controllers; for this reason they are supplied with lifting holes.

NOTE: Do not rest the unit directly on the bus bar connectors.

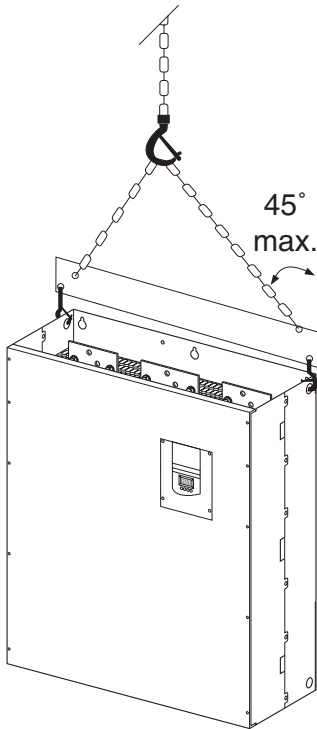

⚠ WARNING

HANDLING AND LIFTING HAZARD

Keep the area below any equipment being lifted clear of all personnel and property. Use the lifting method shown in Figure 3.

Failure to follow these instructions can result in death or serious injury.

Section 3—Technical Data

Technical Characteristics

Tables 3 and 4 (page 14) describe the technical characteristics of the ATS48 controller. The information is based on operation at a maximum ambient temperature of 40 °C without a shorting/bypass contactor and at 50 °C with a shorting/bypass contactor.

The ATS48 controller can be used in an ambient temperature of up to 60 °C as long as the maximum current rating for Class 10 thermal overload protection is derated by 2% for each degree above 40 °C without a shorting/bypass contactor or by 2% for each degree above 50 °C with a shorting/bypass contactor. The nominal motor current I_N must not exceed the maximum current rating for Class 10 thermal overload protection.

Table 3: Standard Duty Application, 208 to 690 V Supply (+10% to –15%, 50 or 60 Hz)

hp @ 208 V	hp @ 230 V	kW @ 440 V	hp @ 460 V	kW @ 500 V	hp @ 575 V	kW @ 690 V	Max. Current Rating for Class 10 Thermal Overload Protection	I _{CL} Rating	Catalog Number
3	5	7.5	10	9	15	15	17	17	ATS48D17Y
5	7.5	11	15	11	20	18.5	22	22	ATS48D22Y
7.5	10	15	20	18.5	25	22	32	32	ATS48D32Y
10	—	18.5	25	22	30	30	38	38	ATS48D38Y
—	15	22	30	30	40	37	47	47	ATS48D47Y
15	20	30	40	37	50	45	62	62	ATS48D62Y
20	25	37	50	45	60	55	75	75	ATS48D75Y
25	30	45	60	55	75	75	88	88	ATS48D88Y
30	40	55	75	75	100	90	110	110	ATS48C11Y
40	50	75	100	90	125	110	140	140	ATS48C14Y
50	60	90	125	110	150	160	170	170	ATS48C17Y
60	75	110	150	132	200	200	210	210	ATS48C21Y
75	100	132	200	160	250	250	250	250	ATS48C25Y
100	125	160	250	220	300	315	320	320	ATS48C32Y
125	150	220	300	250	350	400	410	410	ATS48C41Y
150	—	250	350	315	400	500	480	480	ATS48C48Y
—	200	355	400	400	500	560	590	590	ATS48C59Y
200	250	400	500	—	600	630	660	660	ATS48C66Y
250	300	500	600	500	800	710	790	790	ATS48C79Y
350	350	630	800	630	1000	900	1000	1000	ATS48M10Y
400	450	710	1000	800	1200	—	1200	1200	ATS48M12Y

Table 4: Severe Duty Application, 208 to 690 V Supply (+10% to –15%, 50 or 60 Hz)

hp @ 208 V	hp @ 230 V	kW @ 440 V	hp @ 460 V	kW @ 500 V	hp @ 575 V	kW @ 690 V	Max. Current Rating for Class 10 Thermal Overload Protection	I _{CL} Rating	Catalog Number
2	3	5.5	7.5	7.5	10	11	12	17	ATS48D17Y
3	5	7.5	10	9	15	15	17	22	ATS48D22Y
5	7.5	11	15	11	20	18.5	22	32	ATS48D32Y
7.5	10	15	20	18.5	25	22	32	38	ATS48D38Y
10	—	18.5	25	22	30	30	38	47	ATS48D47Y
—	15	22	30	30	40	37	47	62	ATS48D62Y
15	20	30	40	37	50	45	62	75	ATS48D75Y
20	25	37	50	45	60	55	75	88	ATS48D88Y
25	30	45	60	55	75	75	88	110	ATS48C11Y
30	40	55	75	75	100	90	110	140	ATS48C14Y
40	50	75	100	90	125	110	140	170	ATS48C17Y
50	60	90	125	110	150	160	170	210	ATS48C21Y
60	75	110	150	132	200	200	210	250	ATS48C25Y
75	100	132	200	160	250	250	250	320	ATS48C32Y
100	125	160	250	220	300	315	320	410	ATS48C41Y
125	150	220	300	250	350	400	410	480	ATS48C48Y
150	—	250	350	315	400	500	480	590	ATS48C59Y
—	200	355	400	400	500	560	590	660	ATS48C66Y
200	250	400	500	—	600	630	660	790	ATS48C79Y
250	300	500	600	500	800	710	790	1000	ATS48M10Y
350	350	630	800	630	1000	900	1000	1200	ATS48M12Y

Specifications

Table 5: Environmental Characteristics

Degree of protection	<ul style="list-style-type: none"> • IP20 for ATS48D17Y to C11Y • IP00 for ATS48C14Y to M12Y
Shock resistance	Conforms to IEC 60068-2-27: <ul style="list-style-type: none"> • 15 g, 11 ms
Vibration resistance	Conforms to IEC 60068-2-6, NCF 20706 and BV1: <ul style="list-style-type: none"> • 15 mm peak from 2 to 13 Hz • 1 gn from 13 to 200 Hz
Soft starter audible noise level	Audible noise measurements taken from 3 ft (1 m) away. The noise levels may change depending on the fan characteristics: <ul style="list-style-type: none"> • ATS48D17Y to D47Y: 52 dBA • ATS48D62Y to C11Y: 58 dBA • ATS48C14Y to C17Y: 50 dBA • ATS48C21Y to C32Y: 54 dBA • ATS48C41Y to C66Y: 55 dBA • ATS48C79Y to M12Y: 60 dBA
Resistance to electrostatic discharges	Conforms to IEC 61000-4-2, Level 3
Immunity to radio-electric interference	Conforms to IEC 61000-4-3, Level 3
Immunity to rapid electrical transients	Conforms to IEC 61000-4-4, Level 4

Table 5: Environmental Characteristics (continued)

Ambient air temperature	<p>Storage:</p> <ul style="list-style-type: none"> -13 to +158 °F (-25 to +70 °C) <p>Operation:</p> <ul style="list-style-type: none"> 14 to +104 °F (-10 °C to +40 °C) without derating. Up to +140 °F (+60 °C), derate the current by 2% for each °C above 40 °C. 14 to 122 °F (-10 °C to +50 °C) with user provided shorting/bypass contactor.
Maximum relative humidity	95% without condensation or dripping water conforming to IEC 60068-2-3
Maximum ambient pollution	Conforms to IEC 60664-1, Pollution Degree 3
Maximum operating altitude	3300 ft (1000 m) without derating. Above this, derate the nominal current by 2.2% for each additional 330 ft (100 m) to a maximum of 6600 ft (2000 m).
Operating position	Maximum vertical inclination ±10° with respect to the normal mounting position.

Table 6: Electrical Characteristics

Operating category	Conforms to IEC 60947-4-2, AC-53a
Three-phase supply voltage	208 Vac -15% to 690 Vac +10%, 50/60 Hz
Frequency	<p>Automatic sensing (preset), ±5%:</p> <ul style="list-style-type: none"> 60 Hz: 56.6 to 63.8 Hz 50 Hz: 47.6 to 52.6 Hz <p>Manual selection, ±20%:</p> <ul style="list-style-type: none"> 50 Hz: 40 to 60 Hz 60 Hz: 48 to 72 Hz
Rated current (I_{CL})	21 device ratings, 17 to 1200 A
Silicon control rectifiers (SCRs)	1800 V peak inverse voltage (PIV) rating
Motor power	3 to 1200 hp
Motor voltage	208 / 230 / 380 / 460 / 575 / 690 Vac
Soft starter control circuit supply voltage	110 Vac -15% to 230 +15% Vac, 50/60 Hz
Maximum control circuit consumption (with fans operating)	<ul style="list-style-type: none"> ATS48D17Y to C17Y: 30 W ATS48C21Y to C32Y: 50 W ATS48C41Y to M12Y: 80 W
Protection	<ul style="list-style-type: none"> Integrated thermal I²t protection for motor (Class 2, 10, 10A, 15, 20, 25, 30 or no protection) and/or thermal protection with positive temperature coefficient (PTC) probes. Motor underload settings Current overload settings Phase reversal Phase loss Automatic restart

The ATS48 controllers conform to IEC 60947-4-2 (EMC). In steady state, they emit a level of interference below the allowable levels defined in the standard.

Table 7: Electromagnetic Compatibility (EMC)

	Standards	Test Levels	Examples (sources of interference)
Immunity tests	IEC 61000-4-2, Level 3 Electrostatic discharge: • through contact • through air	6 kV 8 kV	Contact with an electrically charged person
	IEC 61000-4-3, Level 3 Radiated electromagnetic fields	10 V/m	Equipment transmitting radio frequencies
	IEC 61000-4-5, Level 4 Rapid electrical transients: • Power supply cables • Control supply cables	4 kV 2 kV	Opening/closing of a contactor
	IEC 61000-4-5, Level 3 Shock wave: • Phase-to-Phase • Phase-to-Ground	1 kV 2 kV	—
	IEC 61000-4-12, Level 3 Damped oscillating waves	1 kV – 1 MHz	Oscillating circuit on the line supply
Radiated and conducted emissions	IEC 60947-4-2, Class A		
	IEC 60947-4-2, Class B on soft starters up to 170 A (ATS48D17Y to C17Y) shorting/bypass contactors must be used.		

Fuse selections in Table 8 are based upon 150% of nominal motor current. Ferraz-Shawmut fuses are recommended for the overcurrent protective device (OCPD).

Table 8: Short Circuit Protection Device (Type 1 Coordination)

Catalog Number	Fuse Class (Time Delay)	Short Circuit Current Rating @ 575 V (A)	Recommended OCPD Rating (A) @			
			208 V	230 V	460 V	575 V
ATS48D17Y	J	5000	15	20	20	25
ATS48D22Y	J	5,000	25	30	30	30
ATS48D32Y	J	5,000	35	40	40	40
ATS48D38Y	J	5,000	45	—	50	45
ATS48D47Y	J	5,000	—	60	60	60
ATS48D62Y	J	5,000	70	80	80	80
ATS48D75Y	J	10,000	90	100	100	90
ATS48D88Y	J	10,000	110	125	110	110
ATS48C11Y	J	10,000	125	150	150	150
ATS48C14Y	J	10,000	175	200	175	175
ATS48C17Y	J	10,000	200	225	225	225
ATS48C21Y	J	10,000	250	300	250	300
ATS48C25Y	J	18,000	300	350	350	350
ATS48C32Y	J	18,000	400	450	450	400
ATS48C41Y	J	18,000	500	500	600	500
ATS48C48Y	J (600 A) or L (650 A)	18,000	600	—	650	600
ATS48C59Y	L	30,000	—	700	700	700
ATS48C66Y	L	30,000	750	900	800	800
ATS48C79Y	L	42,000	1000	1000	1000	1100
ATS48M10Y	L	85,000	1350	1200	1400	1400
ATS48M12Y	L	85,000	1500	1600	1600	1600

Dimensions and Weights

Figure 4: ATS48D17Y–C66Y

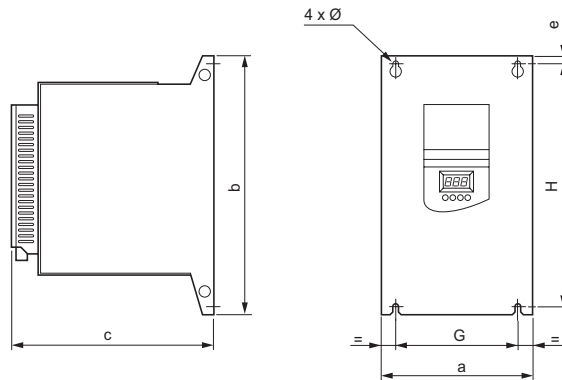

Table 9: ATS48D17Y–C66Y Dimensions

ATS48****	a in (mm)	b in (mm)	c in (mm)	e in (mm)	G in (mm)	H in (mm)	Ø in (mm)	Weight lb (kg)
D17Y, D22Y, D32Y, D38Y, D47Y	6.30 (160)	10.83 (275)	7.48 (190)	0.26 (6.6)	3.94 (100)	10.24 (260)	0.28 (7)	10.8 (4.9)
D62Y, D75Y, D88Y, C11Y	7.48 (190)	11.42 (290)	9.25 (235)	0.39 (10)	5.91 (150)	10.63 (270)	0.28 (7)	18.3 (8.3)
C14Y, C17Y	7.87 (200)	13.39 (340)	10.43 (265)	0.39 (10)	6.30 (160)	12.60 (320)	0.28 (7)	27.3 (12.4)
C21Y, C25Y, C32Y	12.60 (320)	14.96 (380)	10.43 (265)	0.59 (15)	9.84 (250)	13.78 (350)	0.35 (9)	40.1(18.2)
C41Y, C48Y, C59Y, C66Y	15.75 (400)	26.38 (670)	11.81 (300)	0.79 (20)	11.81 (300)	24.02 (610)	0.35 (9)	113.3 (51.4)

Figure 5: ATS48C79Y–M12Y

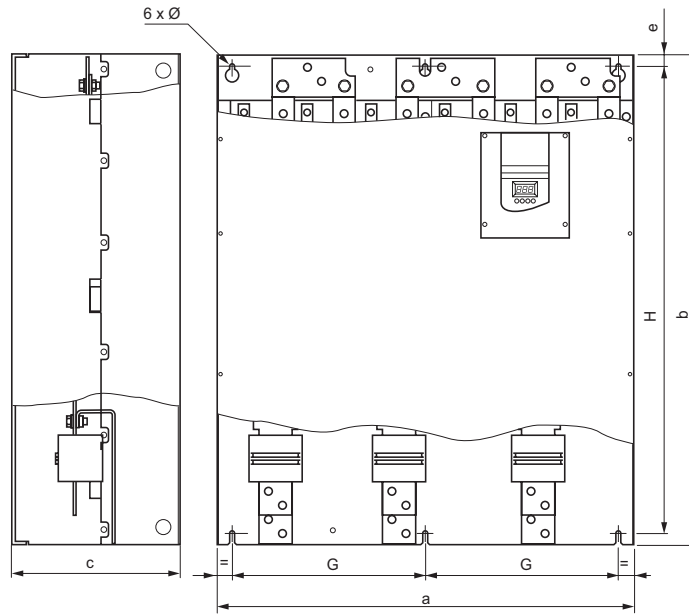

Table 10: ATS48C79Y–M12Y Dimensions

ATS48****	a in (mm)	b in (mm)	c in (mm)	e in (mm)	G in (mm)	H in (mm)	Ø in (mm)	Weight lb (kg)
C79Y, M10Y, M12Y	30.31 (770)	35.04 (890)	12.40 (315)	0.79 (20)	13.78 (350)	33.46 (850)	0.43 (11)	253.6 (115)

Serial and Model Numbers

The serial and model numbers of the ATS48 controller are on the bar code sticker located on the front right hand side of the device.

Figure 6: Serial Number and Model Numbers

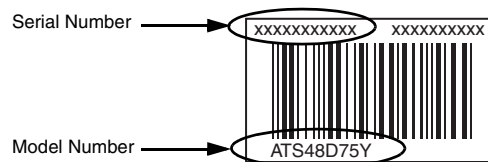

Section 4—Mounting

Mounting Precautions

Follow these precautions when mounting the ATS48 controller:

- Controllers are open devices and must be installed in suitable enclosures or controlled access areas. The environment around the controller must meet Pollution Degree 3 requirements as defined in NEMA ICS1-1 or IEC 60664-1.

⚠ DANGER

HAZARD OF ELECTRIC, SHOCK, EXPLOSION, OR ARC FLASH

ATS48 controllers are open devices and must be mounted in a suitable enclosure.

Failure to follow these instructions will result in death or serious injury.

- When the installation surface is not even, put a spacer behind the controller mounting pads to eliminate gaps. Fastening the controller exterior to an uneven surface may damage the controller.
- When installing the controller in an enclosure, cover the device to prevent metallic debris from falling into the controller.
- The ATS48 controller generates heat and must be properly ventilated. Refer to “Thermal Considerations for Sizing Enclosures” on page 21 to determine power dissipated.
- When several controllers are installed in a control panel, arrange them in a row. Do not stack controllers. Heat generated from the bottom controller can adversely affect the ambient temperature around the top controller.

⚠ CAUTION

CONTROLLER OVERHEATING HAZARD

- Mount the ATS48 controller within $\pm 10^\circ$ of vertical.
- Do not locate the controller near heat radiating elements.
- Electrical current through the controller will result in heat losses that must be dissipated into the ambient air immediately surrounding the controller. To help prevent a thermal fault or equipment damage, provide sufficient enclosure cooling and/or ventilation to limit the ambient temperature around the controller.

Failure to follow these instructions can result in injury or equipment damage.

Mounting in a General Purpose Metal Enclosure

Follow the instructions in this section in order to meet NEMA Type 1 (IP23) degree of protection. To help ensure adequate air flow inside the controller, follow these guidelines:

- Leave sufficient space around the controller (see Figure 7).
- Ensure sufficient ventilation. If necessary, install a cooling fan with filters.

Figure 7: Ventilation and Clearances

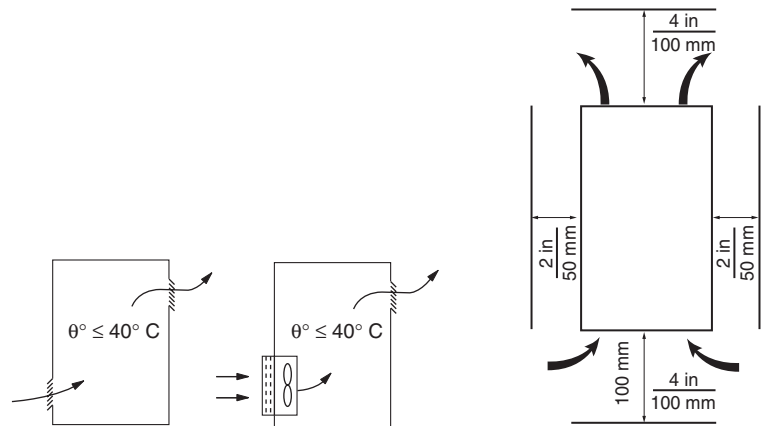

Soft Starter Ventilation

On soft starters with a factory-installed cooling fan, the fan switches on automatically as soon as the heatsink temperature reaches 50 °C. It is switched off when the temperature drops to 40 °C.

Table 11: Fan Flow Rates

Part Number	CFM	m ³ /hour
ATS48D32Y and D38Y	24	14
ATS48D47Y	48	28
ATS48D62Y to C11Y	146	86
ATS48C14Y and C17Y	235	138
ATS48C21Y to C32Y	476	280
ATS48C41Y to C66Y	1020	600
ATS48C79Y to M12Y	2040	1200

Mounting in a Dust and Damp-Proof Metal Enclosure

Figure 8: Ventilation for Dust and Damp-Proof Enclosure

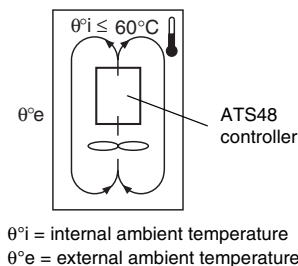

Follow the instructions in this section in order to meet NEMA Type 12 (IP54) degree of protection.

Maintain clearances as shown in Figure 7.

Do not use insulated or non-metallic enclosures as they have poor thermal conduction. Provide a stirring fan to circulate air inside the enclosure and to help prevent hot spots in the controller, as shown in Figure 8. This allows operation of the soft starter in an enclosure with a maximum internal temperature of 140 °F (60 °C). Ensure that the ambient temperature around the soft starters does not exceed this limit.

To reduce temperature rise within the enclosure, use a shorting/bypass contactor (duty cycle not to exceed 2 starts per hour) or a heat exchanger. Derate the soft starter current I_N by 2% per °C for temperatures above 40 °C if a shorting/bypass contactor is not used.

Thermal Considerations for Sizing Enclosures

When mounting the ATS48 soft starter in an enclosure, use the enclosure manufacturers' recommendations for proper sizing based on thermal considerations. For this, it is necessary to sum the power dissipated by each device in the enclosure. Table 12 lists the steady state power dissipation for the ATS48 soft starter, operating at rated current, with and without a shorting/bypass contactor.

Table 12: Watts Loss Information

Catalog Number	Power Dissipation in Watts		Catalog Number	Power Dissipation in Watts	
	with Shorting/Bypass Contactor	without Shorting/Bypass Contactor		with Shorting/Bypass Contactor	without Shorting/Bypass Contactor
ATS48D17Y	15 W	59 W	ATS48C21Y	50 W	580 W
ATS48D22Y	15 W	74 W	ATS48C25Y	50 W	695 W
ATS48D32Y	25 W	104 W	ATS48C32Y	50 W	902 W
ATS48D38Y	25 W	116 W	ATS48C41Y	80 W	1339 W
ATS48D47Y	25 W	142 W	ATS48C48Y	80 W	1386 W
ATS48D62Y	25 W	201 W	ATS48C59Y	80 W	1731 W
ATS48D75Y	25 W	245 W	ATS48C66Y	80 W	1958 W
ATS48D88Y	25 W	290 W	ATS48C79Y	80 W	2537 W
ATS48C11Y	25 W	322 W	ATS48M10Y	80 W	2865 W
ATS48C14Y	25 W	391 W	ATS48M12Y	80 W	3497 W
ATS48C17Y	25 W	479 W			

The total dissipated Watts loss is provided strictly for sizing the environmental HVAC cooling requirements based upon nominal current operating conditions. **The control power circuit consumption is 25 W.**

Remote Keypad Display (if used)

⚠ WARNING

LOSS OF CONTROL

- The designer of any control scheme must consider the potential failure modes of control paths and, for certain critical control functions, provide a means to achieve a safe state during and after a path failure. Examples of critical control functions are emergency stop and overtravel stop.
- Separate or redundant control paths must be provided for critical control functions.
- System control paths may include communication links. Consideration must be given to the implications of unanticipated transmission delays or failures of the link.¹
- Each implementation of an ATS48 soft starter must be individually and thoroughly tested for proper operation before being placed into service.

Failure to follow these instructions can result in death, serious injury, or equipment damage.

¹ For additional information, refer to NEMA ICS 1.1 (latest edition), "Safety Guidelines for the Application, Installation, and Maintenance of Solid State Control" and to NEMA ICS 7.1 (latest edition), "Safety Standards for Construction and Guide for Selection, Installation and Operation of Adjustable-Speed Drive Systems."



The VW3G48101 remote keypad display can be mounted on the door of a wall-mounted or floor-standing enclosure. The remote keypad display kit includes a seal for IP65 protection and a 9.82 ft (3 m) cable with connectors.

Communication is via the RJ-45/Modbus® connection on the starter (see Figure 10). The remote keypad display has the same signaling display and configuration buttons as the controller's integral keypad display. A switch to lock access to the parameters is located at the rear of the keypad display.

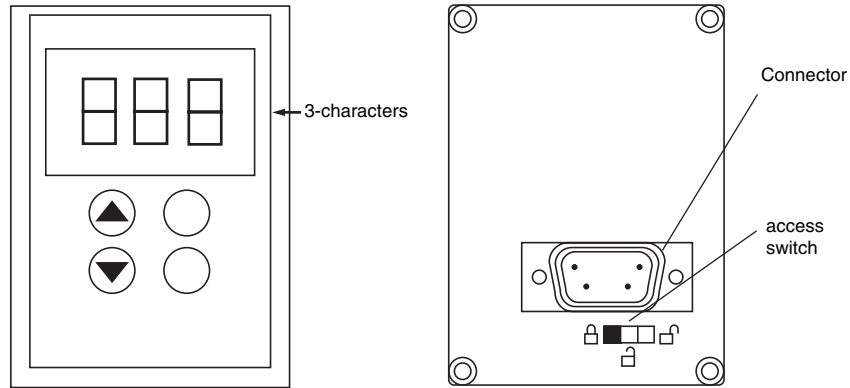
Figure 9: Remote Keypad Display, Front and Rear Views



The access switch on the remote keypad display is used as follows:

- Locked Position : Only monitoring parameters can be accessed. When the starter is running, it is not possible to select a different parameter to be displayed.
- Partial Locked Position : Limited access to the SEt, PrO, and SUP menu parameters.
- Unlocked Position : All parameters are accessible.

Any display restrictions to the starter by the access switch will still be in force once the remote keypad display has been disconnected from the controller, even if power to the controller is cycled.

Figure 10: Remote Keypad Display Cable Assembly and Connectors

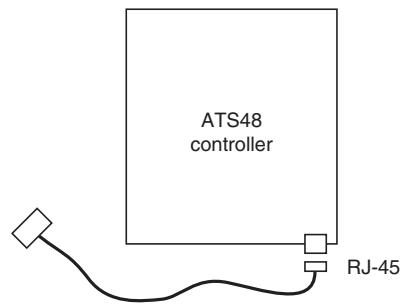

Section 5—Wiring

Good wiring practice requires the separation of control circuit wiring from all power (line and load) wiring. Power wiring to the motor must have the maximum possible separation from all other power wiring. **Do not run them in the same conduit.** This separation reduces the possibility of coupling electrical noise between circuits.

Installation Precautions

Follow these precautions when installing the ATS48 controller:

⚠ DANGER
HAZARD OF ELECTRIC SHOCK, EXPLOSION, OR ARC FLASH
<ul style="list-style-type: none">• Read and understand this manual before installing or operating the Altistart 48 (ATS48) controller. Installation, adjustment, repair, and maintenance must be performed by qualified personnel.• The user is responsible for compliance with all international and national electrical code requirements with respect to grounding of all equipment.• Many parts of this drive controller, including the printed circuit boards, operate at the line voltage. DO NOT TOUCH. Use only electrically insulated tools.• DO NOT touch unshielded components or terminal strip screw connections with voltage present.• Before servicing the controller:<ul style="list-style-type: none">— Disconnect all power, including external control power that may be present.— Place a “DO NOT TURN ON” label on all power disconnects.— Lock all power disconnects in the open position.• Install and close all covers before applying power or starting and stopping the drive controller.
Failure to follow these instructions will result in death or serious injury.

- Voltage and frequency specifications for the input line must match the controller configuration.
- A disconnect switch must be installed between the input line and the controller.

⚠ DANGER

HAZARD OF ELECTRIC SHOCK, EXPLOSION, OR ARC FLASH

- The solid state switches of the ATS48 controller's power circuit do not provide complete isolation from the AC line. Due to leakage currents through the solid-state switches, hazardous voltages can be present on the controller load-side power circuit whenever power is applied to the line side of the controller.
- Disconnect all power before servicing the controller or motor.

Failure to follow these instructions will result in death or serious injury.

- When using an isolation contactor, the contactor must close before or at the same time as the application of the controller run command. If line power is not detected at the L1, L2, and L3 terminals of the controller within 500 ms of this run command, a Phase Failure fault will occur.
- External overcurrent protection devices (OCPD), either fuses or a circuit breaker, must be installed on the line-side connections of the ATS48 controller. The maximum recommended OCPD rating, along with the associated controller short circuit withstand rating, is listed in Table 8 on page 16.

⚠ WARNING

LOSS OF CONTROL—COMMUNICATION INTERRUPTION

- The designer of any control scheme must consider the potential failure modes of control paths and, for certain critical control functions, provide a means to achieve a safe state during and after a path failure. Examples of critical control functions are emergency stop and overtravel stop.
- Separate or redundant control paths must be provided for critical control functions.
- System control paths may include communication links. Consideration must be given to the implications of unanticipated transmission delays or failures of the link.¹
- Each implementation of an ATS48 soft starter must be individually and thoroughly tested for proper operation before being placed into service.

Failure to follow these instructions can result in death, serious injury, or equipment damage.

¹ For additional information, refer to NEMA ICS 1.1 (latest edition), "Safety Guidelines for the Application, Installation, and Maintenance of Solid State Control" and to NEMA ICS 7.1 (latest edition), "Safety Standards for Construction and Guide for Selection, Installation and Operation of Adjustable-Speed Drive Systems."

⚠ WARNING

INADEQUATE OVERCURRENT PROTECTION

- An overcurrent protective device must be installed on the line-side of the ATS48 controller to achieve published short-circuit withstand ratings.
- Do not exceed the maximum overcurrent protective device ratings shown in Table 8 on page 16.
- Do not connect the controller to a power feeder whose short circuit capacity exceeds the controller short circuit withstand rating shown in Table 8 on page 16.

Failure to follow these instructions can result in death or serious injury.

- Power factor correction capacitors should not be connected to a motor controlled by an ATS48 controller. If power factor correction is required, the capacitors must be located on the line-side of the controller. A separate contactor should be used to switch the capacitors off when the motor is off, or during acceleration and deceleration. Refer to bulletin 8638PD9603.

⚠ CAUTION

IMPROPER WIRING HAZARD

Do not connect power factor correction capacitors to the load-side power circuit of the ATS48 controller.

Failure to follow these instructions can result in injury or equipment damage.

- The ATS48 controller uses solid-state power switches to control motor power. When checking the condition of conductor or motor insulation, do not connect the high potential dielectric test equipment or insulation resistance tester to the controller since the test voltages used may damage the controller. Always disconnect the controller from the conductors or motor before performing such tests.

⚠ CAUTION

ATS48 CONTROLLER EQUIPMENT DAMAGE HAZARD

- Do not perform high potential dielectric tests on circuits while the circuits are connected to the ATS48 controller.
- Any circuit requiring high potential dielectric tests must be disconnected from the controller prior to performing the test.

Failure to follow these instructions can result in injury or equipment damage.

- The ATS48 controller contains electronic protection to detect and signal when the solid-state switches have become inoperable.
- Since the solid-state switches may be incapable of completely blocking the motor power should the controller detect a fault, auxiliary isolation on the line side of the controller is required. Use either a circuit breaker equipped with a shunt trip coil or an electromagnetic contactor. Connect the isolation device to the fault relay of the controller so that it opens the

controller power circuit in the event of a controller detected fault. The isolation device must be capable of interrupting motor locked rotor current.

Refer to Appendix A beginning on page 79 for typical circuit diagrams that display the logic controlling the isolation device via the fault relay.

⚠ CAUTION

MOTOR OVERHEATING HAZARD

If the solid-state switches on the ATS48 controller become inoperable, single-phase operation of the motor can result.

- Use an isolation device consisting of either a circuit breaker equipped with a shunt trip coil or an electromagnetic contactor to open the line-side of the controller.
- The isolation device must be capable of interrupting the motor locked rotor current.
- Connect the fault relay of the controller to open the isolation device in the event of a controller detected fault.

Failure to follow these instructions can result in injury or equipment damage.

⚠ WARNING

INADEQUATE SYSTEM GROUNDING—BRANCH CIRCUIT CONDUCTOR HAZARD

If system grounding is not adequate for ground fault levels, use properly coordinated external ground fault protection. Possible solutions include:

- Time delay fuses coordinated to 125% of motor FLA
- A properly coordinated external overload relay

Failure to follow these instructions can result in death, serious injury, or equipment damage.

System Grounding

If system grounding is not adequate to handle ground fault levels which can exceed 1300% of motor full load amps (FLA), then this device may not protect the branch circuit conductors. In this case, external ground fault protection must be properly coordinated. Recommended solutions include:

- Time delay fuses coordinated to 125% of motor FLA. The fuses listed in Appendix B beginning on page 83 are sized to ensure proper coordination and may be used for applications that do not require start times longer than 50 seconds at 300% current limit or 20 seconds at 500% current limit.
- External overload relay. For multi-motor applications, applications in which motor does not match the controller size, or applications that use a full voltage bypass scheme, an external overload relay can be coordinated to protect conductors from a high-impedance ground fault.

General Wiring Practices

When wiring ATS48 controllers, follow the wiring practices required by national and local electrical codes. In addition, follow these guidelines:

- Use metallic conduit for all controller wiring. Do not run control and power wiring in the same conduit.
- Separate metallic conduits carrying power wiring or low-level control wiring by at least 3 in (80 mm).
- Separate non-metallic conduits or cable trays used to carry power wiring from metallic conduit carrying low-level control wiring by at least 12 in (305 mm).
- Always cross power and control wiring at right angles.

Adaptation to Line Input

The control circuit is completely independent of the power circuit. To apply control voltage, follow the instructions on the label located on the controller terminal strip. Remove the terminal cover label and connect single phase voltage of 110 to 230 +/-15% Vac supply to terminals CL1 and CL2.

The power circuit adapts automatically to the input line voltage and frequency over a range of 208 to 690 V (+10% to -15%) for standard controllers.

Power Connections

Table 13: Wire Size and Tightening Torque

Terminals		ATS48D17Y–D47Y	ATS48D62Y–C11Y	ATS48C14Y–C17Y	ATS48C21Y–C32Y	ATS48C41Y–C66Y	ATS48C79Y–M12Y
Power Input, Power Output, Bypass/Shorting Contactor							
L1 / L2 / L3 T1 / T2 / T3 A2 / B2 / C2	Max. Wire Size¹ AWG (mm²)	6 AWG (16 mm ²)	2/0 AWG (50 mm ²)	Bus Bar (240 mm ²)	Bus Bar (240 mm ²)	Bus Bar (2x240 mm ²)	Bus Bar (4x240 mm ²)
	Tightening Torque lb-in (N•m)	26 lb-in (3 N•m)	88 lb-in (10 N•m)	300 lb-in (34 N•m)	300 lb-in (34 N•m)	500 lb-in (57 N•m)	500 lb-in (57 N•m)
Ground Connections							
GND	Max. Wire Size AWG (mm²)	8 AWG (10 mm ²)	4 AWG (16 mm ²)	Bus Bar (120 mm ²)	Bus Bar (120 mm ²)	Bus Bar (240 mm ²)	Bus Bar (2x240 mm ²)
	Tightening Torque² lb-in (N•m)	15 lb-in (1.7 N•m)	26 lb-in (3 N•m)	238 lb-in (27 N•m)	238 lb-in 27 N•m	238 lb-in 27 N•m	238 lb-in (27 N•m)

¹ Power terminals are suitable for use with 75 °C rated conductors; copper only.

² Requires user supplied lug.

Figure 11: Power Connections ATS48D17Y to C11Y

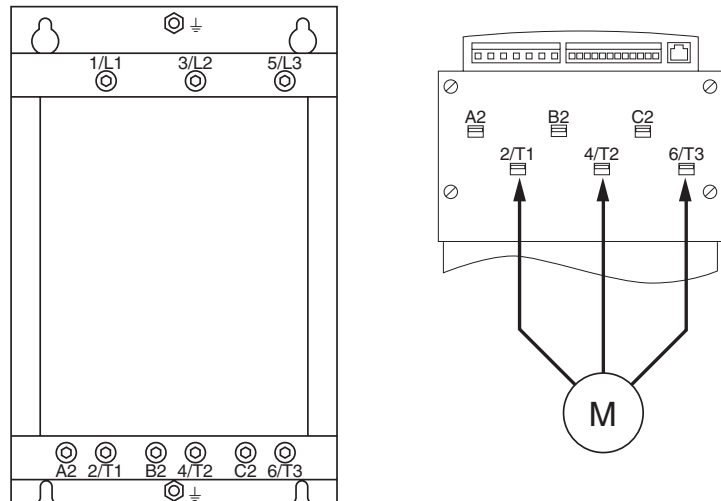

Figure 12: Power Connections ATS48C14Y to C17Y

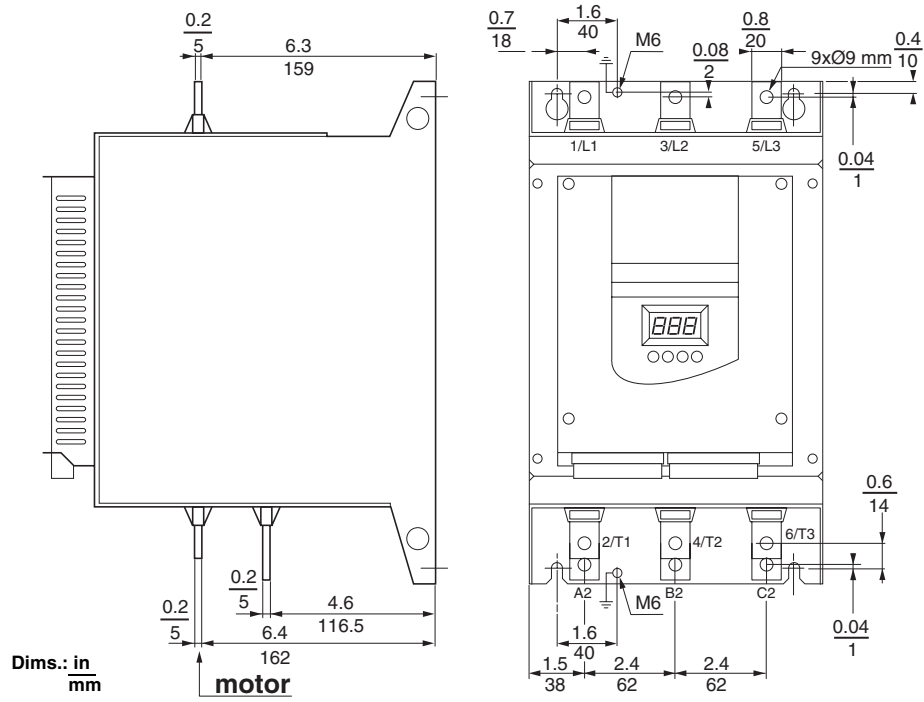
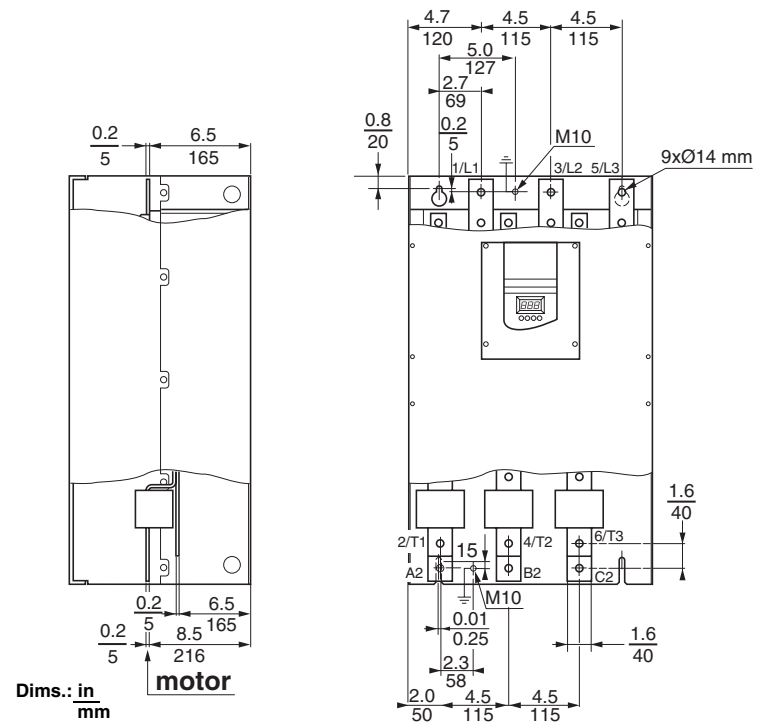

Figure 14: Power Connections ATS48C41Y to C66Y



Layout of Control Terminals

Figure 16: Control Terminals

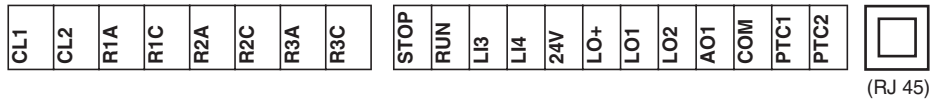

Table 14: Control Terminal Blocks

Terminal	Function	Characteristics
CL1, CL2	Control power supply	90 to 270 Vac, 50/60 Hz <ul style="list-style-type: none"> Switch mode power supply with 25 VA consumption
R1A, R1C	R1 Relay: N.O. programmable contact	Minimum switching capacity: 10 mA for 6 Vdc Maximum switching capacity on inductive load <ul style="list-style-type: none"> 1.8 A for 230 Vac and 30 Vdc Maximum voltage 400 Vac.
R2A, R2C	R2 Relay: N.O. starting relay contact	
R3A, R3C	R3 Relay: N.O. programmable contact	
STOP RUN	Stop controller Run controller	4 logic inputs with 4.3 kΩ impedance Voltage (V): 30 V max., Current (I): 8 mA max. <ul style="list-style-type: none"> State 1: V > 11 V, I > 5 mA State 0: V < 5 V, I < 2 mA
LI3, LI4	Programmable inputs	
24V	Logic input power supply	+24 V ±25% isolated and protected against short circuits and overloads, maximum current of 200 mA.
LO+	Logic output power supply	Connect to 24 V or an external supply source
LO1 LO2	Programmable logic outputs	2 open collector outputs, compatible with Level 1 [PLC], IEC 60065A-68 standard. <ul style="list-style-type: none"> Power supply +24 V (12 V min., 30 V max.) Maximum current 200 mA per output with an external source
AO1	Programmable analog output	Output can be configured as 0–20 mA or 4–20 mA <ul style="list-style-type: none"> Accuracy ±5% of the maximum value, maximum impedance 500 Ω
COM	I/O common	0 V
PTC1, PTC2	Input for PTC probes	Total resistance of probe circuit: 750 Ω at 25 °C <ul style="list-style-type: none"> For example, three 250 Ω probes in series
RJ-45	Connector for <ul style="list-style-type: none"> Remote keypad display PowerSuite Communication bus 	RS-485 Modbus

Section 6—Application and Motor Protection

Soft Starter Applications

The ATS48 soft starter must be selected for the nominal power of the motor and for the type of application, standard or severe duty. Standard and severe define the limiting values of the current and the duty cycle characteristics. The ATS48 controller is factory preset to start the motor in standard duty applications.

Standard Duty Applications

In standard duty applications, the ATS48 soft starter is designed to provide:

- Starting at 400% of I_N ¹ for 23 seconds, or 300% of I_N for 46 seconds, from a cold state
- Starting at 400% of I_N for 12 seconds, or 300% of I_N for 23 seconds, with a load factor of 50% and 10 starts per hour or an equivalent thermal cycling
- The motor thermal protection conforms to Class 10 overload protection.

Severe Duty Applications

In severe duty applications, the ATS48 soft starter is designed to provide:

- Starting at 400% of I_N for 48 seconds, or 300% of I_N for 90 seconds, from a cold state
- Starting at 400% of I_N for 25 seconds with a load factor of 50% and 5 starts per hour or an equivalent thermal cycling
- The motor thermal protection conforms to Class 20 thermal overload protection.

Reduced Torque

The key to applying a soft start successfully is matching the load to the motor capability while starting with reduced voltage applied. The asynchronous motor associated with the ATS48 soft starter must be able to accelerate the driven load when supplied with reduced voltage and current. When reduced voltage is applied to a motor during acceleration, the current the motor draws is reduced by the ratio of the voltage applied. The torque produced by the motor varies with the square of the voltage at a fixed frequency. Figure 17 on page 38 shows the speed/torque characteristics as a function of the supply voltage.

¹ I_N is the user-defined motor current rating. It is the same as full load amperes (FLA).

Figure 17: Torque as a Function of Applied Voltage

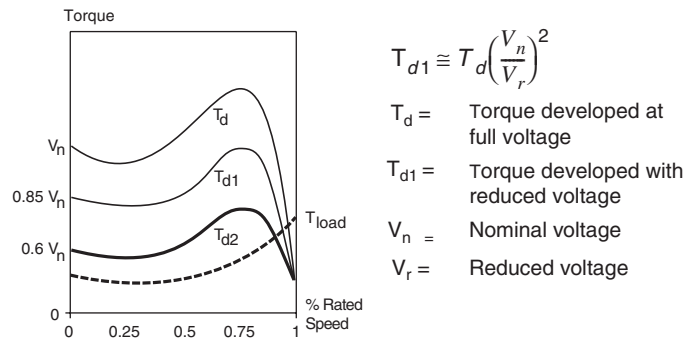
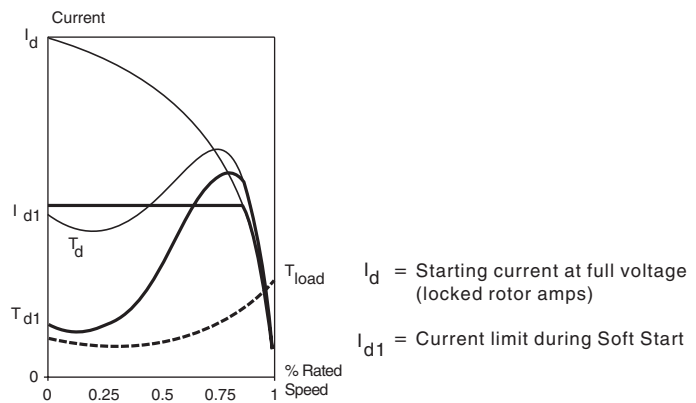

Figure 18: Torque as a Function of Starting Current



A soft start progressively increases voltage to the motor. By ramping the voltage, the ATS48 soft starter limits the amount of current the motor can draw during starting to a user-defined setting. Figure 18 shows the speed/torque characteristics of a motor as a function of starting current. The ATS48 soft starter provides optimal acceleration by ramping the acceleration torque within the envelope of curve T_{d1} .

INTELE™ Braking

When using INTELE braking, the stop time (t_3) is less than the freewheel stopping time (t_1). INTELE braking is a two-part braking process which does not require external components. It produces less motor heat than traditional DC injection braking.

INTELE braking is best used when all of the criteria below are met:

- 4-pole or 6-pole motors only
- motor slip is less than or equal to 3%

$$t \text{ (sec)} = \frac{WK^2 \times \Delta \text{rpm}}{308 \times (T_{FLT} \times 0.40)}$$

where:

$t \text{ (sec)}$ = Calculated value must be equal to or less than 40

WK^2 = Connected motor load inertia (lb-ft²)

Δrpm = Change in rpm or synchronous speed

T_{FLT} = Full Load Torque (lb-ft)

Motor Protection and Diagnostics

On all controllers, the motor protection features are available even if a shorting/bypass contactor is used to bypass the SCRs after the motor is up to speed. To assist with troubleshooting, the 3-digit LCD displays status codes. The controller memory registers and maintains the previous 5 status codes, even following power loss.

Thermal Overload Protection

The ATS48 controller is a UL Listed motor controller with integrated motor and controller thermal protection. The motor and controller temperature are continuously calculated based on the controller nominal current and the current that is actually drawn. An electronic circuit, which stores the thermal state of the motor even if the supply power is disconnected, simulates the cooling curve.

Overload of any kind over any duration can cause the motor temperature to rise. As Figure 19 shows, the ATS48 controller creates a digital model of the motor temperature based on two thermal images. The first (T1) represents the level of temperature rise corresponding to iron (motor frame). The second (T2) represents the temperature rise of copper (stator, windings). For each thermal image, two levels of alarm are detected.

An overload pre-alarm is signaled by logic output LO1 when the motor has exceeded its nominal temperature rise threshold. A pre-alarm is signaled when the thermal state exceeds 105% for T1 and/or 130% for T2.

A thermal fault signal stops the motor when the temperature rise exceeds the critical threshold. A thermal fault is signaled by relay R1 when the motor thermal state exceeds 110% for T1 and 140% for T2.

Figure 19: Thermal Trip Curves

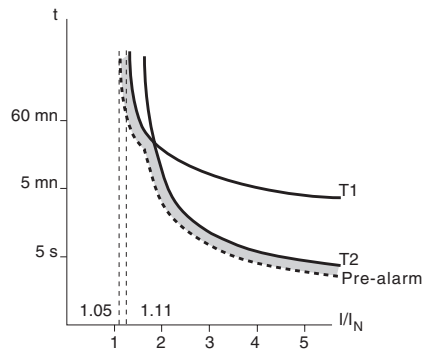

The ATS48 controller is preset to provide Class 10 thermal overload protection for standard duty applications. The ATS48 controller can be adjusted to provide Class 2, 10A, 10, 15, 20, 25, or 30 thermal overload protection, as necessary. Class 2 protection is available for applications such as submersible pumps, where very tight control of motor temperature is required. Class 30 protection is available for applications such as high inertia loading, where a longer than normal starting time is required to accelerate the load to full speed. In addition, the internal overload protection may be disabled if motor protection is provided externally.

The various thermal overload protection classes are defined to meet the standards of IEC 60947-4-2 for starting from both cold and hot states. A cold state is defined as the stabilized motor thermal state when the motor is off. Figure 20 shows the approximate trip times for starting from a cold state.

Figure 20: Cold Start Curves

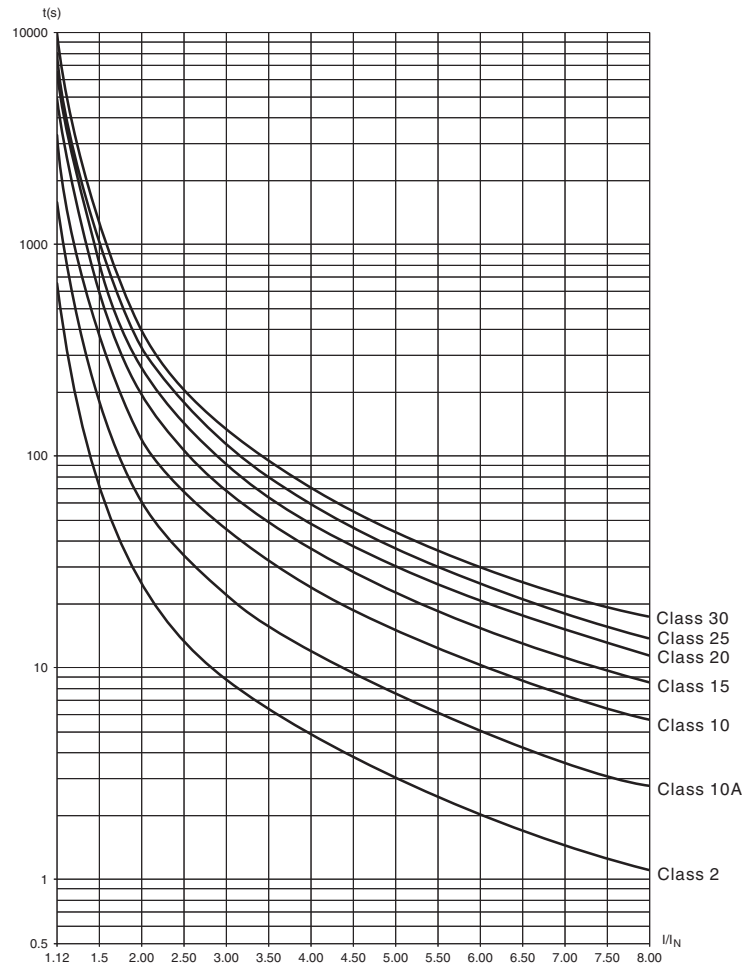

Table 15: Cold Start Trip Time

Standard Application (Class 10 Thermal Overload Protection)		Severe Application (Class 20 Thermal Overload Protection)	
$3 I_N$	$5 I_N$	$3.5 I_N$	$5 I_N$
46 s	15 s	63 s	29 s

Hot state is defined as the stabilized motor thermal state when the motor has been running at full load capacity. Figure 21 shows the approximate trip times for starting from a hot state.

Figure 21: Hot Start Curves

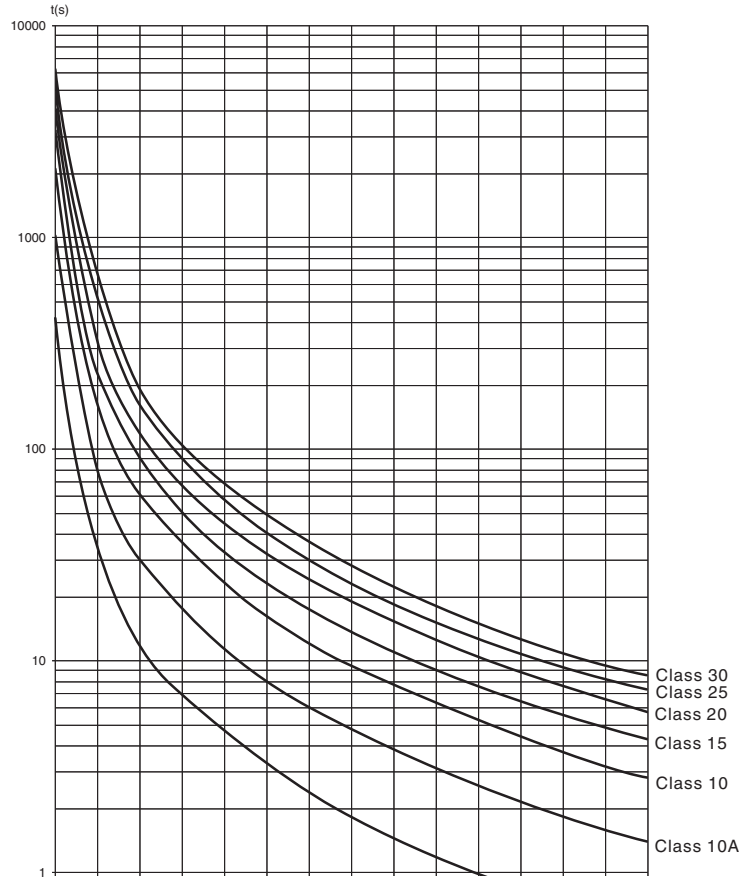

Table 16: Hot Start Trip Time

Standard Application (Class 10 Thermal Overload Protection)		Severe Application (Class 20 Thermal Overload Protection)	
$3 I_N$	$5 I_N$	$3.5 I_N$	$5 I_N$
23 s	7.5 s	32 s	15 s

Motor Thermal Protection with PTC Thermistor Probes

PTC thermistor probes integrated in the motor to measure the motor temperature can be connected to the control card terminals. This analog value is managed by the controller.

The PTC probe thermal overshoot value can be processed and used in two ways:

- To stop the machine in the event of a detected thermal trip condition, if the signal is active.
- To activate an alarm if the signal is active. This alarm can be displayed in a controller status word (serial link) or on a configurable logic output.

NOTE: PTC probe protection does not deactivate the motor thermal protection provided by the calculation. Both types of protection can operate in parallel.

Preventive Maintenance

The following steps should be done at regular intervals:

1. Check the condition and tightness of the connections.
2. Make sure ventilation is effective and the temperature around the controller remains at an acceptable level.
3. Remove any dust and debris from the controller, if necessary.

Section 7—Programming

Programming and Setup

Preliminary Recommendations

▲ WARNING

LOSS OF CONTROL—COMMUNICATION INTERRUPTION

- The designer of any control scheme must consider the potential failure modes of control paths and, for certain critical control functions, provide a means to achieve a safe state during and after a path failure. Examples of critical control functions are emergency stop and overtravel stop.
- Separate or redundant control paths must be provided for critical control functions.
- System control paths may include communication links. Consideration must be given to the implications of unanticipated transmission delays or failures of the link.¹
- Each implementation of an ATS48 soft starter must be individually and thoroughly tested for proper operation before being placed into service.

Failure to follow these instructions can result in death, serious injury, or equipment damage.

¹ For additional information, refer to NEMA ICS 1.1 (latest edition), "Safety Guidelines for the Application, Installation, and Maintenance of Solid State Control" and to NEMA ICS 7.1 (latest edition), "Safety Standards for Construction and Guide for Selection, Installation and Operation of Adjustable-Speed Drive Systems."

If starting the soft starter from line power, limit operations to the duty cycle ratings described on page 37. Use inputs LI1 to LI4 to control the soft starter.

When changing the factory configuration, record your parameter settings in the Factory Settings table beginning on page 75.

When first commissioning an ATS48 controller on a 60 Hz system, perform a factory parameter reset (see FCS on page 56).

Programming the ATS48 controller is simplified by internal sequence selections and interlocks. For ease of setup, access the menus in the following order.

1. IO—Assignment of the inputs/outputs
2. drC—Advanced settings
3. SEt—Settings

Some steps may not be necessary.

Copy and use the Factory Settings table on pages 75–78 to record your settings.

Display Unit and Programming

Figure 22: Display Functions

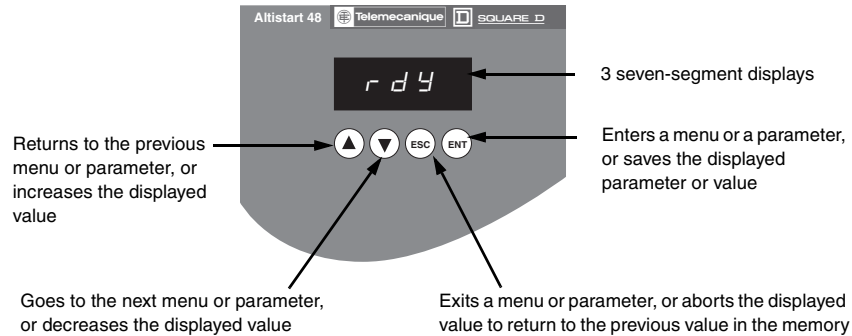

NOTE: Pressing or does not store the choices. To store the displayed choice, press . The display flashes when a value is stored.

Display Principle

The display principle for numbers differs depending on the maximum scale of the parameter and its value, see Table 17 for examples.

Table 17: How to Read Displayed Numbers

Range	Example	
	Display	Value
Max. scale 9990		
0.1 to 99.9	05.5	5.5
	55.0	55
	55.5	55.5
100 to 999	555	555
1000 to 9990	5.55	5550
Max. scale 99900		
1 to 999	005	5
	055	55
	550	550
1000 to 9990	5.55	5550
10000 to 99900	55.5	55500

Menus

Menus are accessible in the order shown in Figure 23.

Figure 23: Accessing Menus

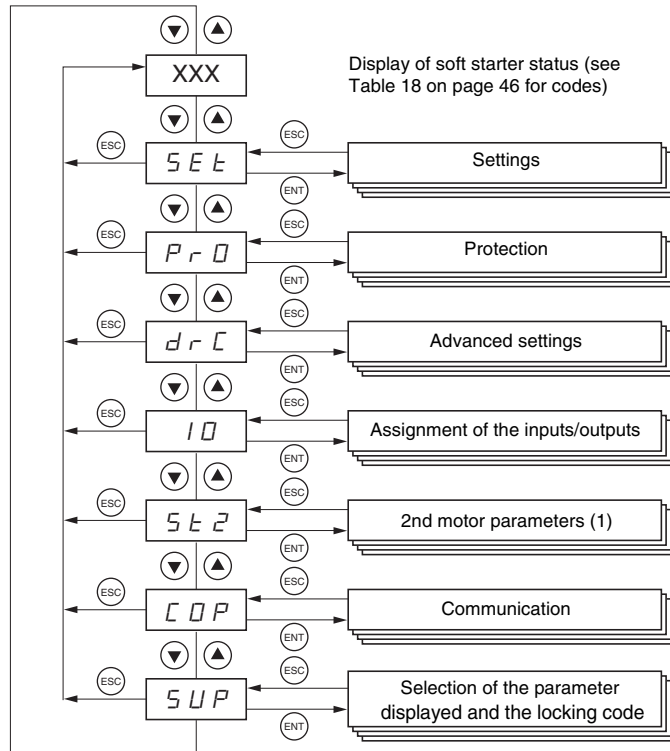

(1) Menu St2. is only available if the second set of motor parameters function is configured. See the I/O menu on page 57.

To store the displayed choice, press ENT. The display flashes when a value is stored. Navigate through the menus, depending upon the button pressed, as shown in Figure 24.

Figure 24: Accessing Parameters

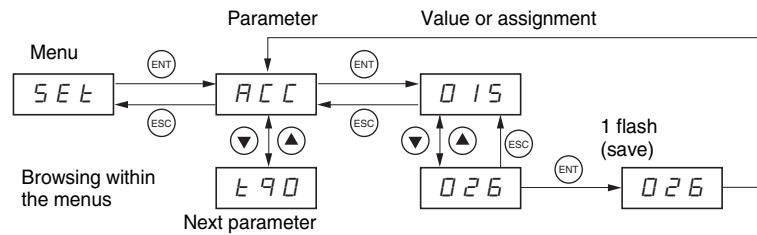

Refer to Table 18 for soft starter status codes after power up.

Table 18: Soft Starter Display Status Codes After Power Up (Non-Programming Conditions)

Status Code	Condition
Error code (see pages 69–72)	Inoperative soft starter
nLP rdY	Soft starter without run command and: • Power not supplied • Power supplied
tbS	Starting time delay not elapsed
HEA	Motor heating in progress
Monitoring parameter selected by the user (SUP menu). Factory setting: motor current. See page 64.	Soft starter with run command
brL	Soft starter braking
Stb	Waiting for a command (RUN or STOP) in cascade mode

NOTE: Shaded rows indicate typically locked out features.

Figure 25: Settings Menu

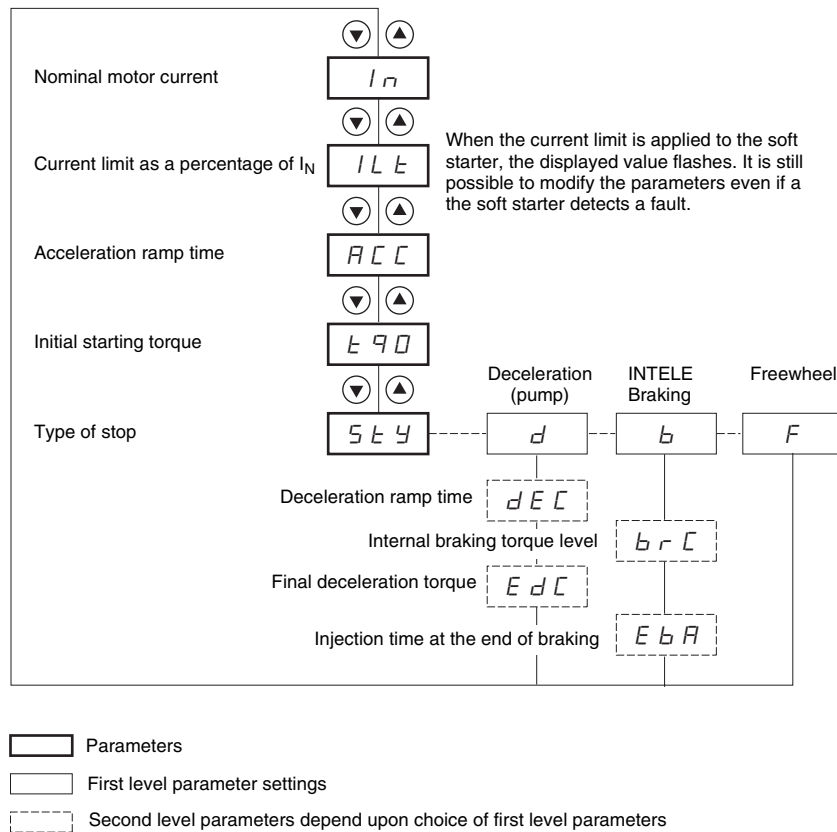

To access the parameters, see Figure 24 on page 45.

Table 19: Settings Menu (SEt) Parameters

Code	Description	Setting Range	Factory Setting
<i>I_n</i>	Nominal motor current	0.4 to 1.3 I _{CL}	*
	Adjust the value to the nominal motor current indicated on the motor nameplate. Ensure that the current is between 0.4 and 1.3 I _{CL} (I _{CL} : soft starter rating). * The factory setting corresponds to the usual value of a 460 V standardized motor in accordance with NEC and with Class 10 thermal overload protection.		
<i>I_{Lt}</i>	Current limit	150 to 700% of I _N , limited to 500% of I _{CL}	400% of I _N
	The current limit ILt is expressed as a percentage of I _N . It is limited to 500% of I _{CL} (soft starter rating, see Tables 3 and 4 on pages 13 and 14). Current limit = ILt x I _N . Example 1: I _N = 22 A, ILt = 300%, Current limit = 300% x 22 A = 66 A Example 2: ATS48C21Y, with I _{CL} = 210 A I _N = 195 A, ILt = 700%; Current limit = 700% x 195 = 1365, limited to 500% x 210 = 1050 A		
<i>ACC</i>	Acceleration ramp time	1 to 60 s	15 s
	This is the rise time of the soft starter torque between 0 and the nominal torque T _N (i.e., the gradient of the torque ramp on acceleration). 		
<i>EqD</i>	Initial starting torque	0 to 100% of T _N	20%
	Initial torque setting during the starting phases, varies from 0 to 100% of the nominal torque. 		
<i>SEY</i>	Type of stop	d-b-F	-F-
	Three types of stop are possible: <ul style="list-style-type: none"> -d-: Soft stopping by control of motor torque. The soft starter applies torque to the motor in order to decelerate progressively on the ramp, avoiding a rapid stop. This type of stop reduces the risk of water hammer on a pump. -b-: INTELE braking stop: The soft starter generates braking torque in the motor which will slow the motor down if there is considerable inertia. (See page 38.) -F-: Freewheel stop: The soft starter applies no torque to the motor. 		

Table 19: Settings Menu (SEt) Parameters (continued)

Code	Description	Setting Range	Factory Setting
dEC	<p>Deceleration ramp time</p> <p>This parameter can only be accessed if StY is set to -d-. Selects the time (1 to 60 s) the soft starter will take to reduce the estimated torque to zero during a type -d- stop. This setting determines the gradient of the torque ramp on deceleration. This feature is useful in pumping applications to help prevent hydraulic shock which may occur if the motor decelerates too quickly.</p> 	1 to 60 s	15 s
EdC	<p>Final deceleration torque</p> <p>This parameter can only be accessed if StY is set to -d- and if the CLP parameter in the drive menu (drC) is still set to On (the factory setting). Selects the final torque level (0 and 100% of estimated torque) during a type -d- stop. This is the threshold at which the controlled stop ends and the freewheel portion of the stop begins. If the estimated torque at the start of deceleration is below 20, (i.e., 20% of the nominal torque) controlled deceleration is not activated, and the motor changes to freewheel mode.</p> 	0 to 100%	20%

Table 19: Settings Menu (SEt) Parameters (continued)

Code	Description	Setting Range	Factory Setting
	Internal braking torque level		0 to 100%
	<p>This parameter can only be accessed if StY is set to -b-. Selects the braking torque level for stop type -b-. Braking is active up to 20% of the nominal speed. The total stop ramp depends on the setting of this parameter and also dependent on the motor loading. See EbA below.</p>		
<i>brC</i>	<p>The graph shows 'Motor speed' on the vertical axis and time on the horizontal axis. Three curves originate from 100% speed: the steepest is labeled 'brC = 100', the middle is 'brC = 100', and the shallowest is 'brC = 0'. A horizontal dashed line at 20% speed is shown. For the 'brC = 100' curve, the time to reach 20% speed is labeled 'T1' and 'INTELE braking time'. For the 'brC = 0' curve, the time from 20% speed to 0% is labeled 'T2' and 'Adjustment of motor stop by EbA'. The 'brC = 100' curve shows a sharp drop at 20% speed, while the 'brC = 0' curve shows a gradual decay.</p> <p>Impulse brake injection time: $T2 = T1 \times EbA$</p> <p>NOTE: Time T1 is not determined by brC. T1 is the time required in seconds for the motor to fall from 100% of the nominal speed to 20% (depends on the motor and application characteristics).</p>		
	Injection time at the end of braking	20 to 100%	20%
<i>EbA</i>	<p>This parameter can only be accessed if StY is set to -b-. Selects adjustment of the current injection time at the end of braking for stop type -b-. Can be set at 20 to 100% of the INTELE braking time (T1). Example: INTELE braking = 10 s (T1) The stopping time can vary from 2 to 10 s (T2) EbA = 20 Corresponds to an injection time of 2 s EbA = 100 Corresponds to an injection time of 10 s Factory setting: 20</p>		

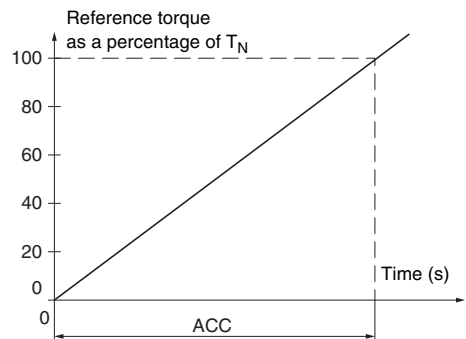
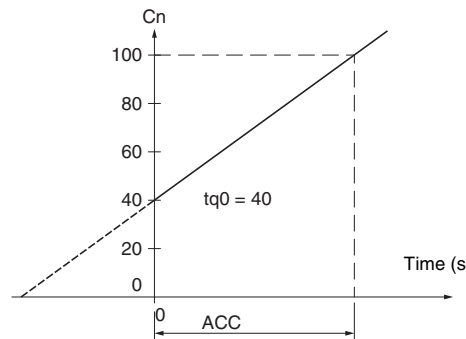
Figure 26: Motor Protection Menu (PrO)

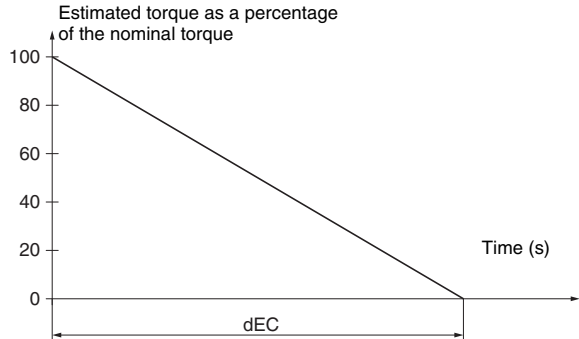
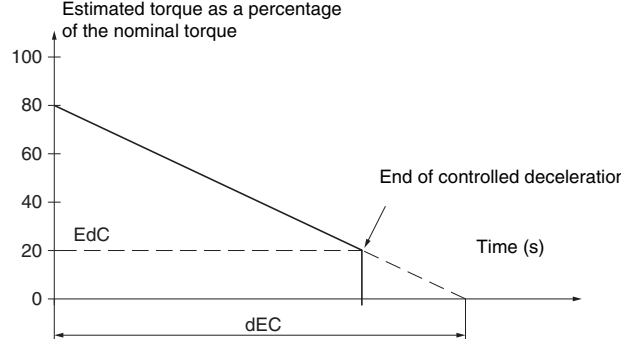
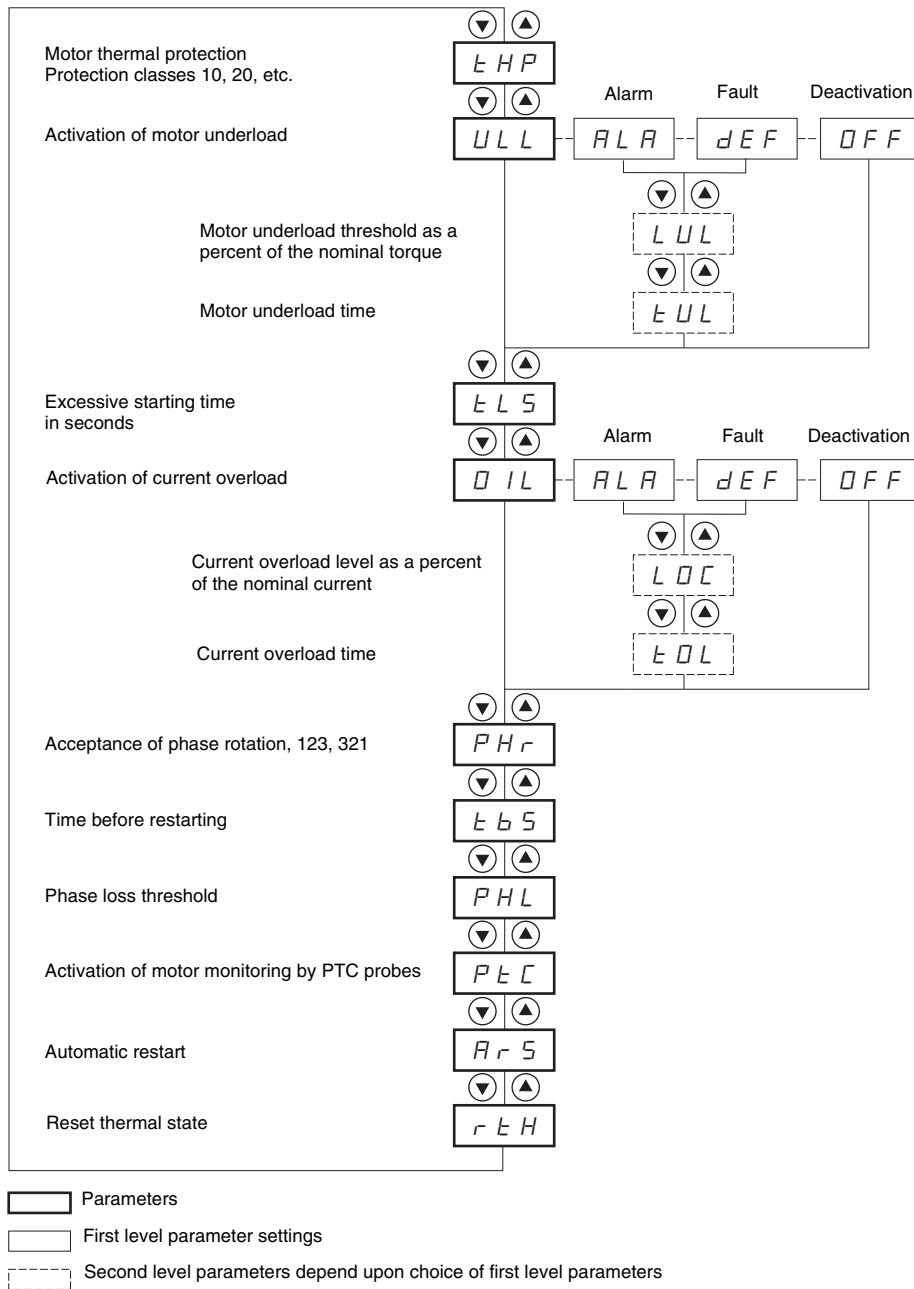

To access the parameters, see Figure 24 on page 45.

The protection parameters can only be modified when the motor is stopped.

⚠ DANGER

UNINTENDED EQUIPMENT OPERATION

- The factory configuration of a monitoring alarm (ALA) indicates the presence of a detected fault, but will not directly protect the installation.
- When using automatic restart parameter ArS (see Table 20), ensure that an accidental start will not endanger personnel or equipment in any way.

Failure to follow these instructions will result in death or serious injury.

Table 20: Motor Protection Menu (PrO) Parameters

Code	Description	Setting Range	Factory Setting
	Motor thermal protection	—	10
<i>EHP</i>	<p>See "Thermal Overload Protection" on page 39.</p> <ul style="list-style-type: none"> • 30: Class 30 • 25: Class 25 • 20: Class 20 (severe application) • 15: Class 15 • 10: Class 10 (standard application) • 10A: Class 10A • 2: Sub-class 2 • OFF: no protection 		
	Activation of motor underload	—	OFF
<i>ULL</i>	<p>If the motor torque is less than threshold setting of parameter LUL for longer than the time parameter tUL is set for, one of the following occurs:</p> <ul style="list-style-type: none"> • ALA: an alarm activates (internal bit and configurable logic output) • dEF: the soft starter will not run and the ULF error code displays • OFF: no protection 		
<i>LUL</i>	Motor underload threshold	20% to 100% of T_N	60%
	This parameter is not available if ULL is set to OFF. LUL can be set from 20% to 100% of the nominal motor torque.		
<i>EUL</i>	Motor underload time	1 to 60 s	60 s
	This parameter is not available if ULL is set to OFF. Time delay tUL activates as soon as the motor torque falls below threshold LUL. It resets to zero if the torque rises above this LUL threshold by + 10% (hysteresis).		
<i>ELS</i>	Excessive starting time	10 to 999 s or OFF	OFF
	If the starting time exceeds the value of tLS, the soft starter will not run and displays the StF error code. The conditions for the end of starting are: line voltage applied to the motor (min. firing angle) and motor current less than 1.3 I_N .		
	<ul style="list-style-type: none"> • OFF: no protection 		

Table 20: Motor Protection Menu (PrO) Parameters (continued)

Code	Description	Setting Range	Factory Setting
	Activation of current overload	—	OFF
	<p>This function is only active in steady state. If the motor current exceeds the threshold setting of parameter LOC for longer than the time parameter tOL is set for, one of the following occurs:</p> <ul style="list-style-type: none"> • ALA: an alarm activates (internal bit and configurable logic output) • dEF: the soft starter will not run and the OLC error code displays • OFF: no protection 		
<i>O I L</i>			
	Current overload threshold	50% to 300% of I_N	80%
<i>L O C</i>	<p>This parameter is not available if OIL is set to OFF. LOC can be set from 50% to 300% of the nominal motor current.</p>		
	Current overload time	0.1 to 60 s	10 s
<i>t O L</i>	<p>This parameter is not available if OIL is set to OFF. Time delay tOL activates when the motor current rises above threshold LOC. It resets to zero if the current falls below this LOC threshold again by at least 10% (hysteresis).</p>		
	Protection against line phase inversion	321, 123, or no	no
<i>P H r</i>	<p>If the line phases are not in the order configured, the soft starter locks and displays the PIF error code. This parameter tells the soft starter the line phase order.</p> <ul style="list-style-type: none"> • 321: reverse (L3 - L2 - L1) • 123: forward (L1 - L2 - L3) • no: not monitoring 		
	Time before starting	0 to 999 s	2 s
<i>t b S</i>	<p>This parameter avoids starts in quick succession which may overheat the motor. The time delay starts when the motor changes to freewheel mode. In 2-wire control, the motor is restarted after the time delay if the RUN command input is still activated. In 3-wire control, the motor is restarted after the time delay if a new RUN command is sent (rising edge). The soft starter displays <i>t b S</i> during the time delay.</p>		
	Phase loss threshold	5 to 10%	10%
<i>P H L</i>	<p>If the motor current falls below this threshold in one phase for 0.5 s or in all three phases for 0.2 s, the soft starter will not run and displays the PHF error code. Can be set at between 5 and 10% of the I_{CL} soft starter rating.</p>		
	Activation of motor monitoring by PTC probes	—	OFF
<i>P t C</i>	<p>The PTC probes on the motor must be connected to the correct analog input. This protection is independent of the calculated thermal protection (tHP parameter). Both types of protection can be used simultaneously.</p> <ul style="list-style-type: none"> • ALA: an alarm is activated (internal bit and assignable logic output) • dEF: the soft starter will not run and the OtF error code is displayed • OFF: no protection 		

Table 20: Motor Protection Menu (PrO) Parameters *(continued)*

Code	Description	Setting Range	Factory Setting
Pr5	Automatic restart	On - OFF	OFF
	<p>If this function is active and the soft starter locks on a detected fault, the soft starter automatically restarts if the detected fault is cleared and the other operating conditions permit the restart.</p> <p>A series of automatic attempts are made to restart the soft starter at intervals of 60 s. If a restart has not been possible after 6 attempts, the procedure is abandoned and the soft starter will not run until it is switched off then switched on again or reset manually (see "Detected Fault and Operating Condition Management" on page 69).</p> <p>The following error codes permit this function: PHF, FrF, CLF, USF.</p> <p>The soft starter fault relay remains activated if this function is active. The run command must be maintained.</p> <p>This function can only be used in 2-wire control.</p> <ul style="list-style-type: none"> • OFF: Function inactive • On: Function active 		
rEH	Reset motor thermal state calculated by the soft starter	no - YES	no
	<ul style="list-style-type: none"> • no: Function inactive • YES: Function active 		

Figure 27: Advanced Setting Menu (drC)

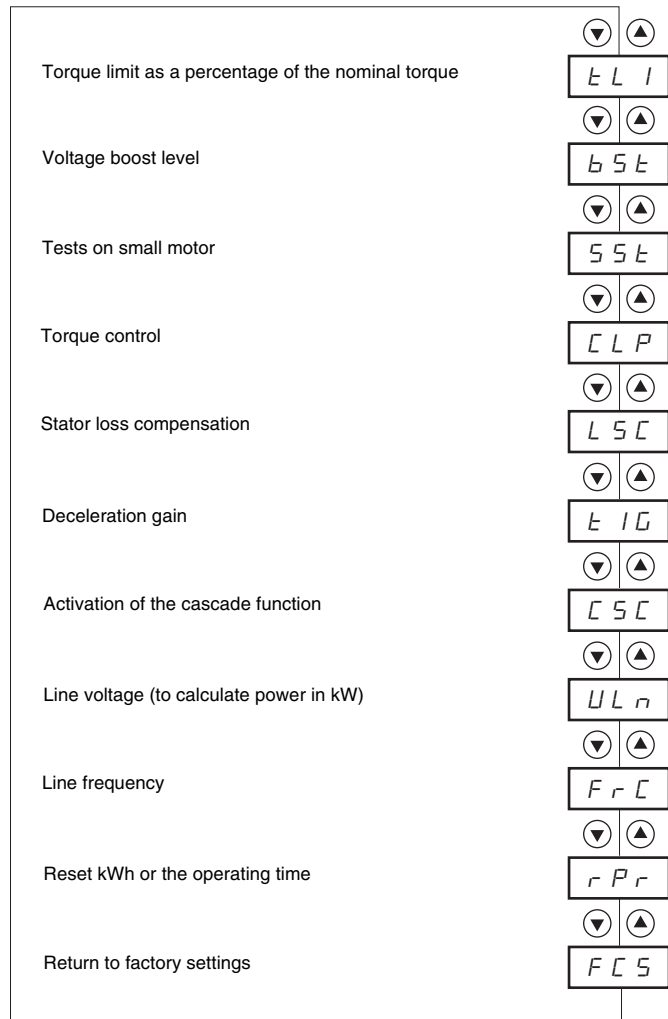

 Parameters in menu

The Advanced setting parameters can only be modified when the motor is stopped.

⚠ CAUTION

NO BRAKING

With parameter dLt, only freewheel type stopping is possible. Ensure that freewheel stopping is appropriate for the application:

- Cascading is not possible
- Preheating is not possible

Failure to follow these instructions can result in injury.

Table 21: Advanced Setting Menu (drC) Parameters

Code	Description	Setting Range	Factory Setting
	Torque limit	10 to 200% or OFF	OFF
t L l	Use this parameter to limit the torque reference to avoid regenerative behavior in applications with high inertia. It can be used for constant torque starting if tq0 = tLl. <ul style="list-style-type: none"> • OFF: no limit • 10 to 200: limit set as a percentage of the nominal torque 		
	Voltage boost level	50 to 100% or OFF	OFF
b 5 t	If active, this parameter applies a user-set voltage when a run command is present for 100 ms. Once this time has elapsed, the soft starter follows a standard acceleration ramp starting at the initial torque value set (tq0). This function can be used to avoid any starting torque (phenomenon caused by friction on stopping or by mechanical play). <ul style="list-style-type: none"> • OFF: Function inactive • 50 to 100: setting as a percentage of the nominal motor voltage <div style="text-align: center;"> <p>The graph plots voltage (U) and torque (T) against time (t). The voltage curve shows a step function: it rises to 100% of nominal voltage (Un) and remains constant for a duration of 100 ms. After this period, it drops to 50% of Un. The torque curve starts at an initial value tq0. During the 100 ms voltage boost period, the torque is constant at Ts. After the voltage drops, the torque ramps up linearly, labeled as 'Torque ramp'.</p> </div>		
	Tests on small motor	On - OFF	OFF
s 5 t	Use this parameter to check the soft starter in a testing or maintenance environment, on a motor whose power is very much lower than the soft starter rating (in particular for high power soft starters). It automatically deactivates the torque control parameter, CLP. <ul style="list-style-type: none"> • OFF: function inactive • On: function active <p>SSt returns to the OFF state as soon as the control voltage is disconnected. On the next power up, the PHF error code and the CLP parameter return to their initial configuration.</p>		
	Torque control (type of control)	On-OFF	On
c L P	<ul style="list-style-type: none"> • OFF: function inactive • On: function active <p>In the On position, starting and deceleration follow the torque ramp. In the OFF position, starting and deceleration are controlled by voltage variation. Voltage control is recommended for applications which use motors in parallel on one soft starter or a motor whose power is very low in relation to the soft starter rating. When tests on smaller motor, SSt, is active CLP is set to OFF.</p>		

Table 21: Advanced Setting Menu (drC) Parameters *(continued)*

Code	Description	Setting Range	Factory Setting
L 5 C	Stator loss compensation	0 to 90%	50%
	Parameter active in acceleration phases (and deceleration phases if StY is set to -d-). In the event of torque oscillations, reduce this parameter gradually until the device is functioning correctly. Oscillations are most common if the soft starter is connected in motors with excessive slip.		
E 1 C	Deceleration gain (for torque control)	10 to 50%	40%
	This parameter can only be accessed if CLP is set to On and if the StY parameter (SET Settings menu) is set to -d-. It can be used to eliminate instability during deceleration. Adjust the parameter in accordance with the oscillations.		
C 5 C	Activation of the cascade function	On-OFF	OFF
	<ul style="list-style-type: none"> • OFF: function inactive • On: function active This parameter can only be accessed if relay R1 has previously been assigned to the isolation relay function and if the forced freewheel stop and motor preheating functions are not configured in parameters LI3 or LI4 (IO menu). Assign an input LI = LIC. 255 motors max.		
U L n	Line voltage	180 to 790 V	460 V
	This parameter is used to calculate the power displayed (LPr and LAP parameters from the SUP menu). The display will only be accurate if this parameter has been set correctly.		
F r C	Line frequency	50-60- AUt	AUt
	<ul style="list-style-type: none"> • 50: 50 Hz (monitoring tolerance of frequency error code FrF = ± 20%). • 60: 60 Hz (monitoring tolerance of frequency error code FrF = ± 20%). • AUt: automatic recognition of the line frequency by the soft starter, with monitoring tolerance of frequency error code FrF = ± 5%. Selections 50 and 60 are recommended if the power supply is provided by a generating set, given their high tolerance.		
r P r	Reset kWh or the operating time	no-APH- trE	no
	<ul style="list-style-type: none"> • no: function inactive • APH: kWh reset to zero¹ • trE: operating time reset to zero The reset command must be confirmed with ENT. APH and trE take effect immediately. The parameter then automatically returns to no.		
F C S	Return to factory settings	no-YES	no
	This is used to reset all parameters to their factory settings. <ul style="list-style-type: none"> • no: function inactive • YES: function active, must be pressed and held down (for approx. 2 s) in order to be accepted. The display flashes to confirm. The FCS parameter then automatically resets to no when you press ESC. This parameter cannot be modified via the remote keypad display.		

¹ This information « kWh consumed » is only visible with the PowerSuite software workshop or online with Modbus (address W4074).

Figure 28: I/O Menu (IO)

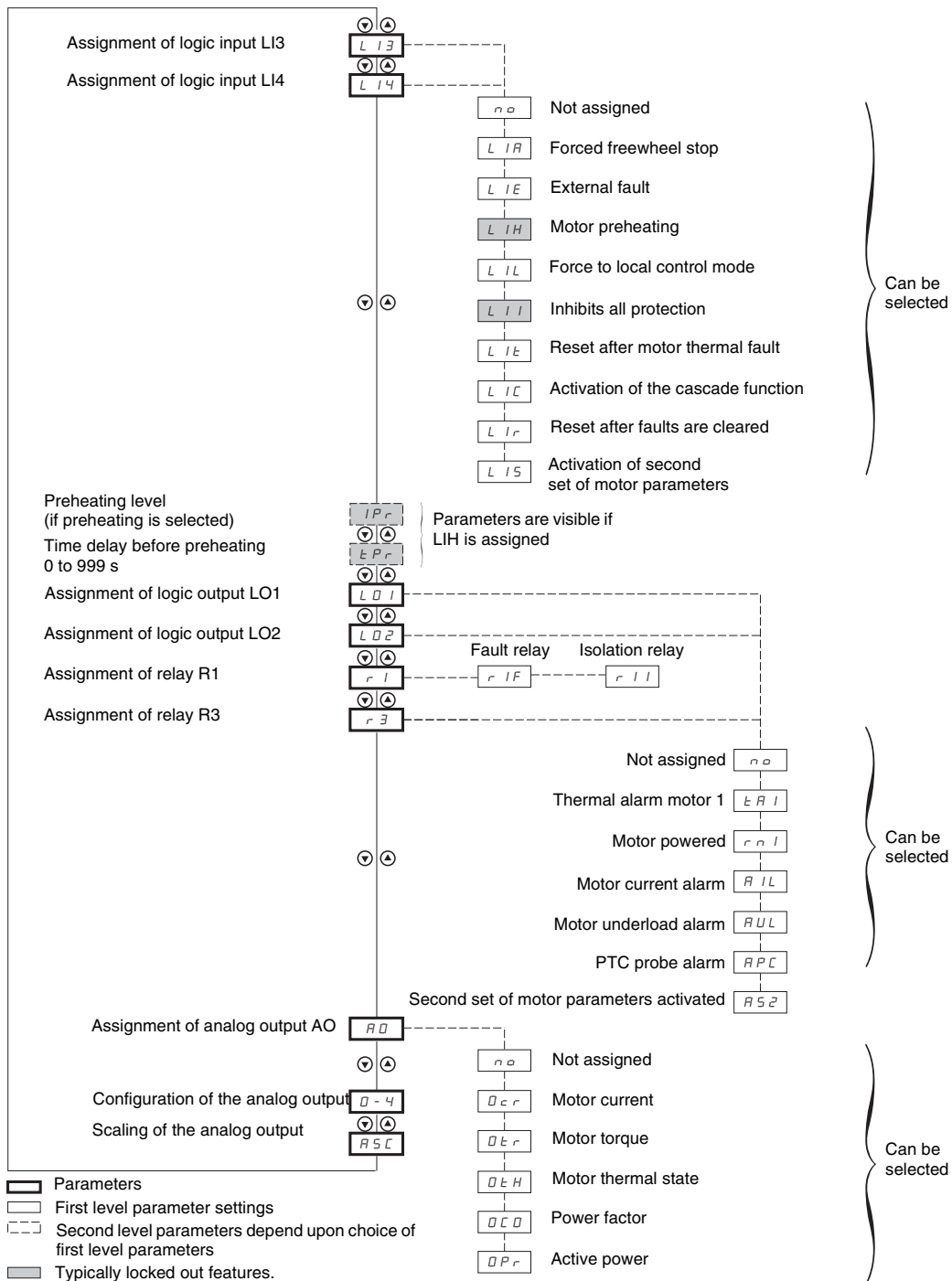

To access the parameters, see Figure 24 on page 45.

NOTE: Logic input RUN, logic input STOP, and soft starter shorting/bypass contactor control (R2) cannot be assigned.

The I/O parameters can only be modified when the motor is stopped.

Table 22: I/O Menu (IO) Parameters

Code	Description	Setting Range	Factory Setting
	Logic inputs	—	LIA LIL
	<p>The selected function is active if the input is powered up.</p> <ul style="list-style-type: none"> no: not assigned. LIA: forced freewheel stop It forces the configuration of a freewheel type stop, but does not control the stop, as soon as a STOP command is received. This selection does not appear if the CSC parameter in the drC menu is set to On. LIE: external fault This enables the soft starter to detect a user-defined, external fault, such as level and pressure. The motor comes to a freewheel stop and the soft starter displays EtF. LIL: force to local control mode If a serial link is used and this function is set, the soft starter changes from link mode (control via serial link) to local mode (control via keypad displays). LI: reset after motor thermal fault LIC: activation of the cascade function. This function disables motor thermal protection and requires that relay R1 be configured as an isolating relay. It can be used to start and decelerate several identical motors one after the other with a single soft starter. Llr: controller reset after faults are cleared LIS: activation of second set of motor parameters. This function allows start and deceleration of two different motors, one after the other, or one motor with two different configurations using a single soft starter. LIH: motor preheating This selection does not appear if the CSC parameter in the drC menu is set to On. It is used to prevent the motor from freezing or to prevent temperature deviations which may cause condensation. If the input is active, once the motor has stopped an adjustable current IPr flows through motor after an adjustable time delay tPr. This current heats the motor without causing it to rotate. IPr and tPr must be adjusted (see below). 		
L I 3			
L I 4			
	<p>Speed</p> <p>RUN</p> <p>LI</p> <p>IPr current</p> <p>tbS</p> <p>tPr</p> <p>When the input activates and the motor has stopped and after time delays tPr and tbS (PrO menu) have elapsed, preheating starts. Preheating stops if the input deactivates, if a run command is sent, or if the STOP input activates.</p> <ul style="list-style-type: none"> LII: inhibits all protection <p>NOTE: Use of this function invalidates the soft starter warranty.</p> <p>This is meant to be used to override the soft starter in the event of an emergency (smoke extraction system for example).</p>		
	Preheating level	0 to 100%	0%
	<p>This parameter appears after LI3 or LI4 have been assigned to function LIH (motor preheating). It is used to set the preheating current. Use a true value current reading ammeter to set the motor current level. Parameter I_N has no effect on the IPr current.</p>		
I P r	CAUTION		
	<p>RISK OF DAMAGE TO THE MOTOR</p> <p>If the line frequency fluctuates, you must use an external device to monitor the frequency and deactivate the preheating function in case of line frequency fluctuations.</p> <p>Failure to follow these instructions can result in equipment damage.</p>		

NOTE: Shading indicates a typically locked function. To unlock the function see LI3, LI4 Logic inputs. In order for functions LIH and LII to take effect, ENT must be pressed for 10 s (confirmed by flashing display). **These parameters cannot be modified via the remote keypad display.**

Table 22: I/O Menu (IO) Parameters (continued)

Code	Description	Setting Range	Factory Setting
L P r	Time delay before preheating	0 to 999 mn	5 mn
	This parameter appears after LI3 or LI4 have been assigned to function LIH (motor preheating). Preheating starts when the input activates, after time delays tPr and tbS (PrO menu) have elapsed.		
L O 1 L O 2	Logic outputs	—	tAl rnI
	<ul style="list-style-type: none"> no: not assigned. tAl: motor thermal alarm, see page 39. rnI: motor powered. AIL: motor current alarm (threshold OIL and time tOL of PrO menu exceeded). See page 52. AUL: motor underload alarm (threshold LUL and time tUL of PrO menu exceeded). See page 51. APC: motor PTC probe alarm. See PtC on page 52. AS2: second set of motor parameters activated. See LIS on page 58. 		
r 1	Relay R1	—	r1F
	<ul style="list-style-type: none"> r1F: fault relay. In this mode, relay R1 activates when the soft starter is powered up (minimum CL1/CL2 control). Relay R1 deactivates when a fault is detected, and the motor switches to freewheel mode. See the special case when the automatic restart function is activated and “Detected Fault and Operating Condition Management” on page 69. r1I: isolation relay. Relay R1 is designed to control the line contactor on the basis of the RUN and STOP commands and to indicate detected faults. In this mode, relay R1 activates by a RUN command (or a preheating command). It deactivates at the end of braking or deceleration or when the motor switches to freewheel mode after a STOP command. It also deactivates when a fault is detected. The motor switches to freewheel mode at this point. 		
r 2	End of Starting Relay R2	—	—
	<p>The end of starting relay R2 is activated when the soft starter is powered up, no faults are detected, and the motor has completed the start-up phase. It is deactivated in the event of a stop request or a detected fault. It has one normally open contact (N/O).</p> <p>It can be used to bypass the ATS48 soft starter at the end of the starting phase.</p> <p>This is not a programmable feature.</p>		
r 3	Relay R3	—	rnI
	<ul style="list-style-type: none"> no: not assigned. tAl: motor thermal alarm. See page 39. rnI: motor powered. AIL: motor current alarm (threshold OIL and time tOL of PrO menu exceeded). See page 52. AUL: motor underload alarm (threshold LUL and time tUL of PrO menu exceeded). See page 51. APC: motor PTC probe alarm. See PtC on page 52. AS2: second set of motor parameters activated. See LIS on page 58. 		
A O	Analog output	—	OCr
	<ul style="list-style-type: none"> no: not assigned OCr: motor current Otr: motor torque OTH: motor thermal state OCO: power factor OPr: active power 		
O 4	Configuration of the analog output AO	020–420	020
	<ul style="list-style-type: none"> 020: 0–20 mA signal 420: 4–20 mA signal 		
A 5 C	Scaling of the analog output	50 to 500%	200
	This parameter allows you to scale the analog output as a percentage of the nominal value of the parameter configured or, if the parameter is power factor, of 1 for the power factor.		

Figure 29: Second Motor Parameters Menu (St2)

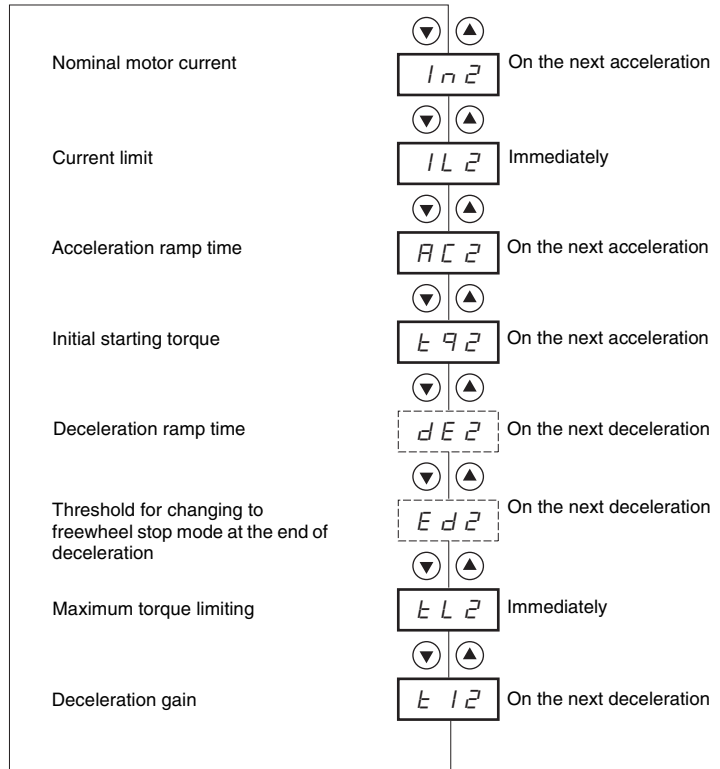

- Parameters
- Parameter availability is dependent on the StY setting in the SET menu.

This menu is only visible if a logic input is assigned to the function for activating a second set of motor parameters (LIS) in the I/O menu.

Table 23: Second Motor Parameters Menu (St2) Parameters

Code	Description	Setting Range	Factory Setting
<i>In2</i>	Nominal motor current	0.4 to 1.3 I_{CL}	See note.
	Adjust the value of the nominal motor current indicated on the motor nameplate. Ensure that the current is between 0.4 and 1.3 I_{CL} (soft starter rating). See Tables 3 and 4 on pages 13 and 14. NOTE: The factory setting of In2 corresponds with the usual value of a 460 V standardized motor in accordance with NEC and with Class 10 thermal overload protection.		
<i>IL2</i>	Current limit	150 to 700% of I_N , limited to 500% of I_{CL}	400% of I_N
	The Current limit IL2 is expressed as a percentage of In2. It is limited to 500% of I_{CL} (see Tables 3 and 4 on pages 13 and 14). Current limit = $IL2 \times In2$ Example 1: $In2 = 21$ A, $IL2 = 300\%$, Current limit = $300\% \times 21$ A = 66 A Example 2: ATS48C21Y, with $I_{CL} = 210$ A $In2 = 195$ A, $IL2 = 700\%$, Current limit = $700\% \times 195 = 1365$, limited to $500\% \times 210 = 1050$ A		
<i>AC2</i>	Acceleration ramp time	1 to 60 s	15 s
	This is the rise time of the soft starter torque between 0 and the nominal torque T_N (i.e., the gradient of the torque ramp on acceleration). 		
<i>L92</i>	Initial starting torque	0 to 100% of T_N	20%
	Initial torque setting during the starting phases, varies from 0 to 100% of the nominal torque. 		

Table 23: Second Motor Parameters Menu (St2) Parameters
(continued)

Code	Description	Setting Range	Factory Setting
	Deceleration ramp time	1 to 60 s	15 s
	<p>This parameter can only be accessed if StY is set to -d-.</p> <p>It sets a time, from 1 to 60 s, to switch from the estimated torque to zero torque (gradient of the torque ramp on deceleration when a -d- stop is applied). This modifies the progression of the deceleration and helps avoid hydraulic shocks in pump applications by modifying the gradient of the torque reference.</p> 		
	Final deceleration torque	0 to 100%	20%
	<p>This parameter can only be accessed if StY is set to -d- and if the CLP parameter in the drive menu (drC) is still set to the factory setting (On).</p> <p>It sets the final torque level from 0 and 100% of the torque estimated at the beginning of deceleration. In pump applications, deceleration control is not necessarily below a load level set by Ed2.</p> <p>If the estimated torque at the start of deceleration is below 20, (i.e., 20% of the nominal torque) controlled deceleration does not activate and the motor changes to freewheel mode.</p> 		
	Maximum torque limit	10 to 200% or OFF	OFF
	<p>This limits the torque reference to avoid regenerative behavior in applications with high inertia. It can be used for constant torque starting if tq2 = tLI.</p> <ul style="list-style-type: none"> • OFF: no limit • 10 to 200: limit set as a percentage of the nominal torque 		
	Deceleration gain (for torque control)	10 to 50%	40%
	<p>This parameter can only be accessed if CLP is set to On and if the StY parameter (SET Settings menu) is set to -d-.</p> <p>It is used to eliminate instability during deceleration. Adjust the parameter in accordance with the oscillations.</p>		

Figure 30: Communication Menu (COP)

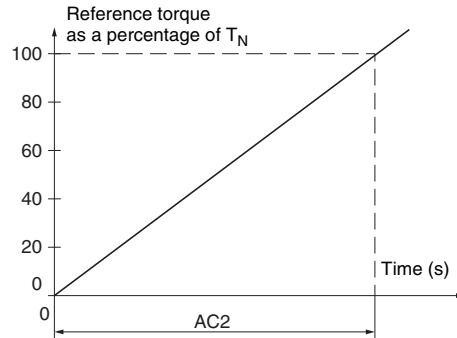
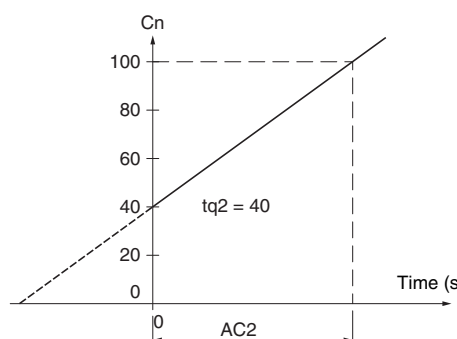

The communication menu parameters can only be modified when the motor is stopped. The internal protocol used is Modbus.

⚠ WARNING

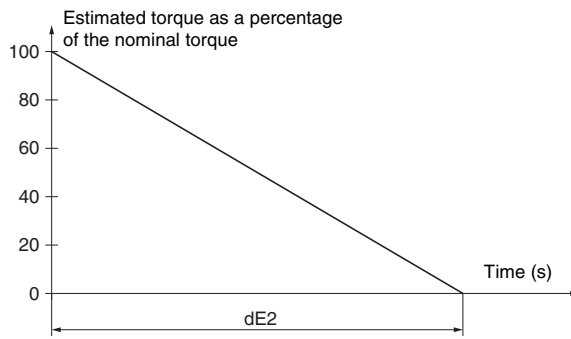
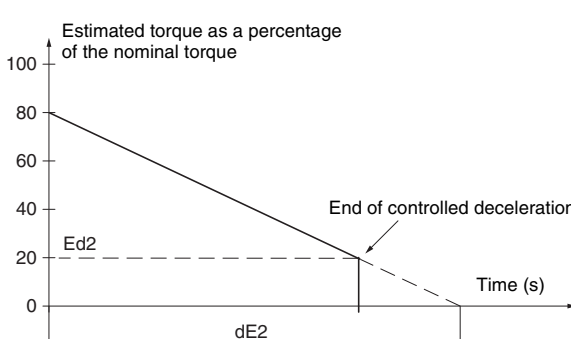
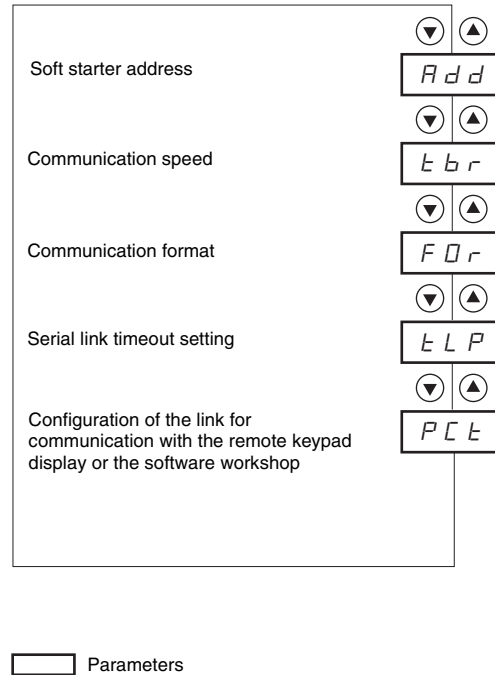
LOSS OF COMMUNICATION CAN CAUSE LOSS OF PROTECTION

When using serial link timeout setting parameter tLP, ensure that the time set will not interfere with the safe operation of the machine.

Failure to follow these instructions can result in death or serious injury.

Table 24: Communication Menu (COP) Parameters

Code	Description	Setting Range	Factory Setting
<i>Add</i>	Soft starter address by the RS-485 serial link	0 to 31	0
<i>tbr</i>	Communication speed in kbps.	4.8 - 9.6 - 19.2	19.2
<i>FDr</i>	Communication format <ul style="list-style-type: none"> • 8o1: 8 data bits, odd parity, 1 stop bit • 8E1: 8 data bits, even parity, 1 stop bit • 8n1: 8 data bits, no parity, 1 stop bit • 8n2: 8 data bits, no parity, 2 stop bits 	—	8n1

Table 24: Communication Menu (COP) Parameters *(continued)*

Code	Description	Setting Range	Factory Setting
ELP	Serial link timeout setting	0.1 to 60 s	5 s
PCt	<p>Configuration of the serial link for communication with the remote keypad display</p> <ul style="list-style-type: none"> On: function active. Temporarily configures the soft starter (tbr and FOt) for communication with the remote keypad display. OFF: function inactive <p>PCt returns to the OFF state when the control voltage is disconnected. On the next power up, the tbr and FOt parameters return to their initial configuration.</p>	—	OFF

Figure 31: Parameter Displayed Menu (SUP)

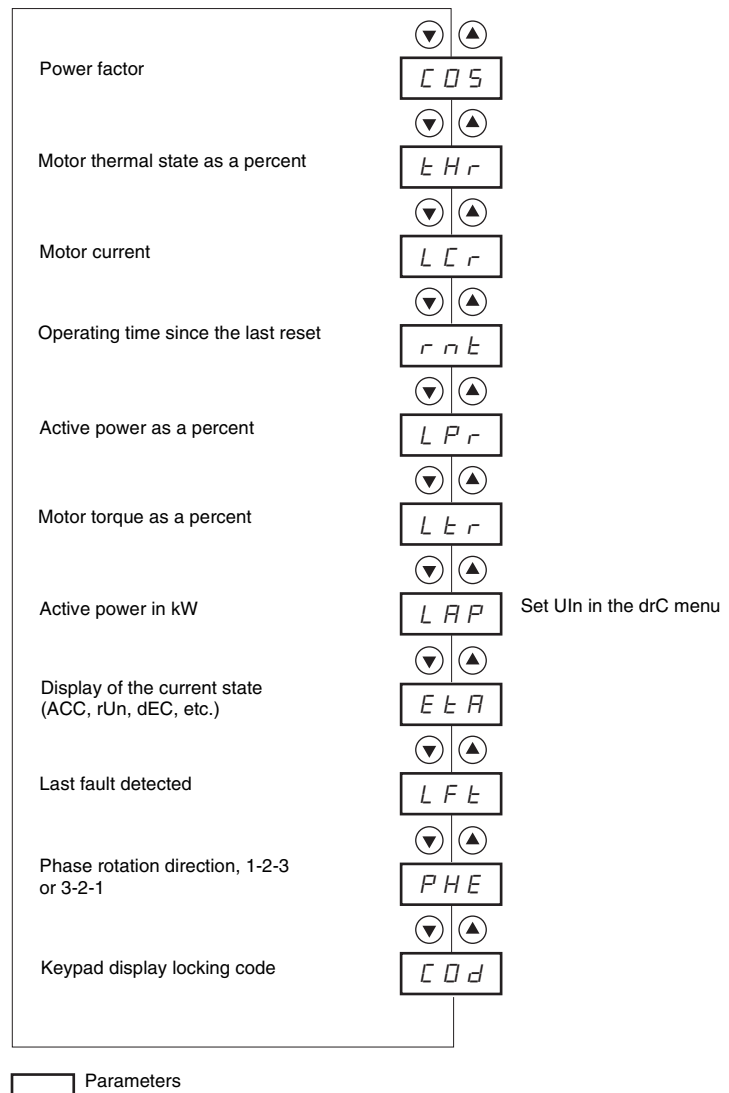

The parameters in the SUP menu below can be modified with the motor stopped or running.

The factory setting displays the motor current (parameter LCr).

To save the chosen display:

- Press the ENT key once: the choice is temporary, it will be cleared at the next power up.
- Press the ENT key again for 2 seconds: the display flashes, the choice is permanent and cannot be modified.

Table 25: Parameter Displayed Menu (SUP) Parameters

Code	Parameter	Unit
CD5	Power Factor	0.01
tHr	Motor thermal state varies from 0 to 125%. 100% corresponds to the nominal thermal state for the current I_N set.	%
LCr	Motor current In amperes up to 999 A (examples: 01.5 is 1.5 A, 15.0 is 15 A, 150 is 150 A) In kiloamperes starting at 1000 A (examples: 1.50 is 1500 A, 1.15 is 1150 A)	A or kA
rnE	Operating time in hours since the last reset. In hours up to 999 hrs (examples: 001 is 1 hr and 111 is 111 hrs) In kilo-hours from 1000 to 65535 (examples: 1.11 is 1110 hrs and 11.1 is 11100 hrs) Above 65535 hrs (65.5) the display resets to zero. Operating time is counted when the motor is not stopped, i.e. when the thyristors are fired (heating, acceleration, steady state, deceleration, braking) and in continuous bypass operation. The hour counter can be reset in the link mode using the control word or via the keypad display with the motor stopped. When the power is removed from the 115 Vac control power supply the hour counter is saved in the EEPROM.	h or kh
LP r	Active power varies from 0 to 255%. 100% corresponds to the power at nominal current and at full voltage.	%
Lt r	Motor torque varies from 0 to 255%. 100% corresponds to the nominal torque.	%
LAP	Active power in kW This parameter requires configuration of the exact value of the line voltage ULn in the drC menu.	kW
E t A	Display of the current state <ul style="list-style-type: none"> • nLP: soft starter without run command and power not supplied • rdY: soft starter without run command and power supplied • tbS: starting time delay not elapsed • ACC: acceleration in progress • dEC: deceleration in progress • rUn: steady state operation • brL: braking in progress • CLl: soft starter in current limiting mode • nSt: force to freewheel stop by a logic input or the serial link 	—
L F E	Error code for last detected fault (see page 69). If no error codes have been saved, the display shows n D F. If faults have been inhibited, the display shows i n h.	—

Table 25: Parameter Displayed Menu (SUP) Parameters *(continued)*

Code	Parameter	Unit
PHE	<p>Phase rotation direction as viewed from the soft starter</p> <ul style="list-style-type: none"> • 123: forward (L1 - L2 - L3) • 321: reverse (L3 - L2 - L1) 	—
CDd	<p>Keypad display locking code enables the soft starter configuration to be protected using an access code (password).</p> <p>OFF: no access locking codes</p> <ul style="list-style-type: none"> • To lock access, enter a code (2 to 999). The number displayed can be increased using the ▲ key. Now press ENT. On appears on the screen to indicate that the parameters have been locked. • On: a code is locking access (2 to 999) • To unlock access, enter the code (increasing the number displayed using the ▲ key) and press ENT. The code remains on the display and access is unlocked until the next power down. Parameter access will be locked again on the next power-up. • If an incorrect code is entered, On appears on the display and the parameters remain locked. <p>XXX: parameter access is unlocked (the code remains on the screen).</p> <ul style="list-style-type: none"> • To reactivate locking with the same code when the parameters have been unlocked, return to On using the ▼ button and then press ENT. On appears on the screen to indicate that the parameters have been locked. • To lock access with a new code when the parameters have been unlocked, enter a new code (change the number displayed using the ▲ or ▼ keys) and press ENT. On appears on the screen to indicate that the parameters have been locked. • To clear locking when the parameters have been unlocked, return to OFF using the ▼ button and press ENT. OFF remains on the screen. The parameters are unlocked and will remain unlocked until the next restart. <p>Remember to document your access code (password). Failure to do so could prevent use of the keypad in programming and configuration modes.</p>	—

When access is locked using a code, only the monitoring parameters can be accessed, and with only a temporary choice of parameter displayed.

The choice of application functions can be limited by the incompatibility between certain functions. The functions that are not listed in this table are not incompatible with any other functions.

Figure 32: Compatibility

Functions	Soft stop	INTELE braking stop	Force freewheel stop	Thermal protection	Loss of a motor phase	Test on small motor	Cascade	Preheating (3)
Soft stop								
INTELE braking stop								
Force freewheel stop								
Thermal protection								(2)
Loss of a motor phase								(1)
Test on small motor								
Cascade								
Preheating (3)				(2)	(1)			

	Compatible functions
	Incompatible functions
	Not significant

- (1) Motor phase loss not detected
- (2) While the motor is preheating, the thermal protection is disabled. Set the preheating current IP_r.
- (3) In order for this feature to take effect, press ENT for 10 s (confirmed by flashing display). This parameter cannot be modified via the remote keypad display.

Section 8—Detected Fault and Operating Condition Management

As a general rule, if a problem arises when the soft starter is started, it is advisable to restore the factory settings and reprogram your settings one by one. If this does not fix the problem follow the instructions below.

Soft Starter Does Not Start, No Error Code Displayed

Determine whether or not the status code displayed corresponds to the normal state of the soft starter (see Table 18 on page 46).

If no error code is displayed and the soft starter does not start:

- Check that the line supply is present on the control supply CL1/CL2 (see page 35).
- Check for the presence of the RUN/STOP commands (see Appendix A on page 79).

Conditions Requiring a Power Reset

When a condition requiring a power reset is detected, the soft starter locks and the motor switches to freewheel mode.

The following are signals that a condition requiring a power reset has been detected:

- Relay R2 opens.
- After the soft starter locks, Relay R1 opens.
- An error code flashes on the display.
- The last 5 error codes are stored and viewable with the PowerSuite software workshop.

Before restarting the soft starter:

- Remove the cause of the error, see Table 26.
- Disconnect and reconnect the control supply

Table 26: Conditions Requiring a Power Reset

Error Code Displayed	Probable Cause	Corrective Action
<i>I n F</i>	Internal analysis needed	Disconnect and reconnect the control supply. If the condition persists, contact Schneider Electric product support.
<i>D C F</i>	Overcurrent: <ul style="list-style-type: none"> • impeding short-circuit on soft starter output • internal short-circuit • bypass contactor stuck • soft starter is overloaded 	Disconnect power to the soft starter, then: <ul style="list-style-type: none"> • Check the connecting cables and the motor isolation. • Check the thyristors. • Check the bypass contactor for a stuck contact. • Check the parameter value bSt in the menu drC (page 55).
<i>P I F</i>	Phase inversion The line phase inversion does not conform to the PHr, parameter setting in the Protection menu.	Invert two line phases or set PHr to no.
<i>E E F</i>	Internal memory analysis needed	Disconnect and reconnect the control supply. If the condition persists, contact the Product Support Group. See page 73 for contact information.

Conditions Requiring a Run Command Reset

When a condition requiring a run command reset is detected, the soft starter locks and the motor switches to freewheel mode.

The following are signals that a condition requiring a run command reset has been detected:

- Relay R2 opens.
- If relay R1 is configured as an isolating relay, it opens.
- The error code flashes on the display as long as the error is present.
- The last 5 error codes are stored and viewable with the PowerSuite software workshop.

Do the following before restarting the soft starter:

- Rectify the cause of the error, see Table 27.
- In 2-wire control, maintain the run command on the RUN input.
- In 3-wire control, initiate a new run command (rising edge) on the RUN input.

Table 27: Conditions Requiring a Run Command Reset

Error Code Displayed	Probable Cause	Corrective Action
CF F	Invalid configuration on power-up	<ul style="list-style-type: none"> • Revert to the factory setting in the drive menu drC. • Reconfigure the soft starter.
CF I	<p>Invalid configuration</p> <p>The configuration loaded in the soft starter via the serial link is incompatible.</p>	<ul style="list-style-type: none"> • Check the initial configuration. • Load a compatible configuration.

Auto-Reset Conditions (Customer Configurable)

When an auto-reset condition is detected, the soft starter locks and the motor switches to freewheel mode. The soft starter will automatically restart when the fault has cleared.

The following are signals that an auto-reset condition has been detected:

- Relay R2 opens.
- If relay R1 is configured as an isolating relay, it opens. R1 remains closed if it is configured as a fault relay, see page 59.
- The error code flashes on the display as long as the fault is present.
- The last 5 error codes are stored and viewable with the PowerSuite software workshop.

Perform the following steps for any of the error codes listed in Table 28 before restarting the soft starter:

- Rectify the cause of the fault.
- In 2-wire control, maintain the run command on the RUN input.

NOTE: The soft starter attempts to restart six times at 60 second intervals. If the fault is still present at the 6th attempt it trips, requiring a manual reset (see “Conditions Requiring Reset by a Repeated (2 times) Run Command Input” on page 71). If relay R1 is configured as a fault relay it opens.

Table 28: Auto-Reset Condition Correction

Error Code Displayed	Probable Cause	Corrective Action
<i>P H F</i>	Loss of a line phase	Check the line, the connection to the soft starter, and any isolating devices located between the line and the soft starter (such as contactors, fuses, and circuit-breakers).
	Loss of a motor phase If the motor current falls below an adjustable threshold PHL for 0.5 s (single phase) or for 0.2 s (3-phase). This fault can be configured in the Protection menu PrO, parameter PHL.	<ul style="list-style-type: none"> • Check the motor connection and any isolating devices located between the soft starter and the motor (such as contactors, fuses, and circuit-breakers). • Check the motor state. • Ensure that parameter PHL is compatible with the motor.
<i>F r F</i>	Line frequency is out of tolerance. The tolerance settings related to this error code can be configured in the Advanced settings menu parameter FrC (see page 56).	<ul style="list-style-type: none"> • Check the line. • Ensure that parameter FrC is configured properly for the line used (generating set for example).
<i>U S F</i>	Power supply error on a run command	Check the power supply circuit and voltage.
<i>C L F</i>	Control line interruption	Loss of CL1/CL2 for more than 200 ms

If the automatic restart function is not selected, see “Conditions Requiring Reset by a Repeated (2 times) Run Command Input” below for the indication of these faults and the restart instructions.

Conditions Requiring Reset by a Repeated (2 times) Run Command Input

When a condition that requires reset by a repeated (2 times) run command input is detected, the soft starter locks and the motor switches to freewheel mode.

The following are signals that the controller has detected a condition requiring reset by a repeated (2 times) run command input:

- Relay R2 opens.
- Relay R1 opens.
- The error code flashes on the display as long as the fault is present.
- The last 5 error codes are stored and viewable with the PowerSuite software workshop.

Perform the following steps before restarting the soft starter:

- Rectify cause of the fault.
- In 2-wire and 3-wire control, initiate a new run command (rising edge) on the RUN input to reset the controller.
NOTE: A reset will not take place on a run command if LI is assigned to the fault reset (LIr) function.
- In 2-wire and 3-wire control, initiate another new run command (rising edge) on the RUN input to reset the controller.

Table 29: Correcting Conditions That Require Reset by a Repeated (Two Times) Run Command Input

Error Code Displayed	Probable Cause	Corrective Action
<i>S L F</i>	Serial link fault	Check the RS-485 connection.
<i>E E F</i>	External fault	<ul style="list-style-type: none"> • Check the customer-designated fault for this error code. • Check the mechanism for wear, mechanical play, lubrication, and blockages. • Check the value of the tLs setting in the PrO menu, page 51. • Make sure the soft starter and motor are sized properly for the load and application.
<i>O L C</i>	Current overload	<ul style="list-style-type: none"> • Check the mechanism for wear, mechanical play, lubrication, and blockages. • Check the value of parameters LOC and tOL in the PrO menu, page 52.
<i>O L F</i>	Motor thermal fault	<ul style="list-style-type: none"> • Check the mechanism for wear, mechanical play, lubrication, and blockages. • Make sure the soft starter and motor are sized properly for the load and application. • Check the value of parameter tHP in the PrO menu (page 51) and that of parameter I_N in the SEt menu, page 47. • Check the electrical isolation of the motor. • Wait for the motor to cool before restarting.
<i>O E F</i>	Motor thermal fault detected by the PTC probes	<ul style="list-style-type: none"> • Check the mechanism for wear, mechanical play, lubrication, and blockages. • Make sure the soft starter and motor are sized properly for the load and application. • Check the value of the PTC setting in the PrO menu, page 52. • Wait for the motor to cool before restarting.
<i>U L F</i>	Motor underload	<ul style="list-style-type: none"> • Check the hydraulic circuit. • Check the value of parameters LUL and tUL in the PrO menu, page 51.
<i>L r F</i>	Locked rotor in steady state This fault is only active in steady state with soft starter bypass contactor. It is detected if the current in a phase is greater than or equal to 5 I _N for more than 0.2 s.	Check the mechanism for wear, mechanical play, lubrication, and blockages.
<i>O H F</i>	Starter thermal fault	<ul style="list-style-type: none"> • Check the mechanism for wear, mechanical play, lubrication, and blockages. • Make sure the soft starter and motor are sized properly for the load and application. • If the soft starter has a fan, check its operation. Ensure that the air passages are not obstructed and that the heatsink is clean. • Observe the mounting recommendations beginning on page 19. • Allow the soft starter to cool before restarting it.
<i>S E F</i>	Excessive starting time fault	<ul style="list-style-type: none"> • Check the mechanism for wear, mechanical play, lubrication, and blockages. • Check the value of the tLs setting in the PrO menu, page 50. • Make sure the soft starter and motor are sized properly for the load and application.

Controller Reset Using a Logic Input

If a logic input LI is configured to reset upon a motor thermal fault (LI_t, see pages 57 and 58) or any other condition requiring a run command reset (LI_r, see pages 57 and 58), then for the motor to restart, the following conditions must be met:

- The soft starter must send a pulse on logic input LI.
- In 2-wire control, the run command must be maintained on the RUN input.
- In 3-wire control, a new run command (rising edge) must be initiated on the RUN input.

See Table 2 on page 9 for wiring the logic inputs.

Troubleshooting Procedure

When troubleshooting the soft starter, discuss the symptoms of the reported problem with the operating personnel. Ask the operator to describe the problem and to identify when and where it first occurred. Then directly observe the controller and process. Copy the Troubleshooting Sheet on page 74 and use it to record the controller, motor, and peripheral equipment nameplate data.

Product Support

For support and assistance, contact the Product Support Group. The Product Support Group is staffed from 8:00 am until 6:00 pm Eastern time Monday through Friday to assist with product selection, start-up, and diagnosis of product or application problems. Emergency phone support is available 24 hours a day, 365 days a year.

Toll free: 888-SquareD (888-778-2733)

E-Mail: drive.products.support@us.schneider-electric.com

Fax: 919-217-6508

ALTISTART 48 TROUBLESHOOTING SHEET

When requesting after-sales service, it is important to disclose all conditions under which the Schneider Electric equipment currently operates. This will help in diagnosing the system quickly. **FAX to: Product Support @ 919-217-6508**

DATE:
CONTACT NAME:
COMPANY:
ADDRESS:
CITY:
STATE:
PHONE:
FAX:

SOFT START CONFIGURATION

PART NUMBER: AT S48- SERIAL NUMBER: 6W-
 APPLICATION/EQUIPMENT DESIGNATION: _____

MOTOR NAMEPLATE DATA

HORSEPOWER: _____ VOLTAGE (3 PHASE): _____ FREQUENCY: _____ POLES: _____ FLA: _____
 SERVICE FACTOR: _____ MOTOR TYPE/DESIGN: NEMA A NEMA B NEMA C NEMA D
 MOTOR CABLE TYPE: _____ APPROXIMATE CABLE LENGTH (IN FEET): _____

POWER SOURCE AND ENVIRONMENT

VOLTAGE BETWEEN L1 AND L2: _____ VOLTAGE BETWEEN L2 AND L3: _____ VOLTAGE BETWEEN L3 AND L1: _____
 SERVICE TRANSFORMER RATING: _____ KVA, _____ % Z FREQUENCY: 60HZ OR 50 HZ
 AMBIENT TEMPERATURES: _____ MIN °C (°F) _____ MAX °C (°F) HUMIDITY: _____
 ALTITUDE IF GREATER THAN 3300 FEET ABOVE SEA LEVEL, SPECIFY: _____ FT

SOFT START ERROR CODES

REFER TO TABLES 28 THROUGH 33 FOR POSSIBLE CAUSES & CORRECTIVE ACTION

NON-RESET FAULTS	AUTO-RESET FAULTS (CUSTOMER CONFIGURABLE)	MANUAL RESET FAULTS	<input type="checkbox"/> OLF – MOTOR THERMAL FAULT
<input type="checkbox"/> InF – ANALYSIS NEEDED	<input type="checkbox"/> PHF – LOSS OF PHASE OR LOSS OF MOTOR PHASE	<input type="checkbox"/> SLF – SERIAL LINK INTERRUPTION	<input type="checkbox"/> OHF – STARTER THERMAL FAULT
<input type="checkbox"/> OCF - OVERCURRENT	<input type="checkbox"/> Fr F – LINE FREQUENCY (OUT OF TOLERANCE)	<input type="checkbox"/> Et F – EXTERNAL FAULT	<input type="checkbox"/> Ot F – MOTOR THERMAL FAULT VIA PTC PROBES
<input type="checkbox"/> PIF – PHASE INVERSION	<input type="checkbox"/> USF – POWER SUPPLY	<input type="checkbox"/> St F – EXCESSIVE STARTING TIME	<input type="checkbox"/> ULF – MOTOR UNDERLOAD
<input type="checkbox"/> EEF – INTERNAL MEMORY	<input type="checkbox"/> CLF – CONTROL LINE FAILURE (CL1/CL2)	<input type="checkbox"/> OLC – CURRENT OVERLOAD	<input type="checkbox"/> Lr F – LOCKED ROTOR (IN STEADY STATE)

CONTROLLER RESET WHEN FAULT IS CLEARED	<input type="checkbox"/> CFF – INVALID CONFIGURATION (POWER UP)	<input type="checkbox"/> CFI – INVALID CONFIGURATION (COMM)
--	--	--

DETAILED DESCRIPTION OF PROBLEM (ATTACH WIRING DIAGRAM/SCHEMATICS IF APPLICABLE):

Factory Settings

	Code	Designation	Factory Setting	Customer Setting	Parameter Range and Units
SEt Menu Settings	<i>I_n</i>	Current setting	Depends upon starter rating.		0.5 to 1.3 I _{CL} (A)
	<i>I L L</i>	Current limit	400		150 to 500% of I _n
	<i>R C C</i>	Acceleration ramp time	15		1 to 60 s
	<i>S D</i>	Initial starting torque	20		0 to 100% of T _N
	<i>S E Y</i>	Type of stop	-F- (free wheel)		-d- deceleration -b- braked -F- free wheel
	<i>d E C</i> <i>E d C</i>	Deceleration ramp time Final deceleration torque	15 20		1 to 60 s 0 to 100% of estimated torque
	<i>b r C</i> <i>E b A</i>	Internal braking torque level Injection time at the end of braking	50 20		0 to 100 20 to 100
	PRO Menu Protection	<i>t H P</i>	Motor thermal protection	10	
<i>U L L</i>		Activation of motor underload	OFF		OFF dEF: treated as fault ALA: treated as alarm
<i>L U L</i> <i>t U L</i>		Motor underload threshold Motor underload time	60 60		20 to 100% of I _N 1 to 60 s
<i>t L S</i>		Excessive starting time	OFF		OFF - 10 to 999 s
<i>D I L</i>		Activation of current overload	OFF		ALA: treated as alarm dEF: treated as fault OFF: no protection
<i>L O C</i> <i>t O L</i>		Current overload threshold Current overload time	80 10		50 to 300% of I _N 0.1 to 600 s
<i>P H r</i>		Protection against line phase inversion	no		321: reverse (L3-L2-L1) 123: forward (L1-L2-L3) no: no monitoring
<i>t b S</i>		Time before starting	2		0 to 999 s
<i>P H L</i>		Phase loss threshold	10		5 to 10%
<i>P E C</i>		Activation of motor monitoring by PTC probes	OFF		OFF dEF: treated as fault ALA: treated as alarm
<i>R r S</i>		Automatic restart	OFF		OFF - On
<i>r t H</i>		Reset motor thermal state	No		No - YES

Factory Settings *(continued)*

	Code	Designation	Factory Setting	Customer Setting	Parameter Range and Units
drC Menu Advanced Settings	<i>t L l</i>	Torque limit	OFF		OFF - 10 to 200% of T _N
	<i>b S t</i>	Voltage boost level	OFF		50 to 100% of mains voltage
	<i>S S t</i>	Tests on a small motor	OFF		On - OFF
	<i>C L P</i>	Torque control (type of control)	On		On - OFF
	<i>L S C</i>	Stator loss compensation	50		0 to 90%
	<i>t I G</i>	Deceleration gain (for torque control)	40		10 to 50%
	<i>C S C</i>	Activation of cascade function	OFF		On - OFF
	<i>U L n</i>	Line voltage	690		180 to 790 V
	<i>F r C</i>	Line frequency	AUt		50 - 60 - AUt
	<i>r P r</i>	Reset kWh or the operating time	No		No - APH - trE
	<i>F C S</i>	Return to factory settings	No		No - YES

Factory Settings *(continued)*

	Code	Designation	Factory Setting	Customer Setting	Parameter Range and Units
IO Menu (Management of Inputs / Outputs)	L 13 L 14	Logic inputs	LIA LIL		No: not assigned LIA: forced free wheel LIE: external fault LIH: not implemented LIL: force to local control mode LII: inhibition of faults LIt: reset motor thermal fault LIC: activate cascade function LIR: fault reset LIM: second configuration
	IPr	Preheating level	0%		0 to 100%
	tPr	Time delay before preheating	5 mn		0 to 999 minutes
	L 01 L 02	Logic outputs	tAl rnl		No: not assigned tAl: motor thermal alarm rnl: motor powered AlL: motor current alarm AUL: motor underload alarm APC: motor PTC sensor alarm AS2: second configuration active
	□ 1	Relay R1	r1F		R1F: fault R1I: isolation relay
	□ 3	Relay R3	rnl		No: not assigned tAl: motor thermal alarm rnl: motor powered AlL: motor current alarm AUL: motor underload alarm APC: motor PTC sensor alarm AS2: second configuration active
	AO	Analog output	OCr		No: not assigned OCr: motor current Otr: motor torque OtH: motor thermal state OC0: power factor OPr: active power
	0 4	Configuration of the analog output AO	020		020: 0 to 20 mA 420: 4 to 20 mA
ASC	Scaling of the analog output	200		50 to 500%	

Factory Settings *(continued)*

	Code	Designation	Factory Setting	Customer Setting	Parameter Range and Units
St2 Menu 2 nd Motor Parameters	<i>I n 2</i>	Nominal motor current	Depends upon starter rating.		0.5 to 1.3 I _{CL} (A)
	<i>I L 2</i>	Current limit	400		150 to 700% of I _n , limited to 500% of I _{CL}
	<i>A C 2</i>	Acceleration ramp time	15		1 to 60 s
	<i>t 9 2</i>	Initial starting torque	20		0 to 100% of T _N
	<i>d E 2</i>	Deceleration ramp time	15		1 to 60 s
	<i>E d 2</i>	Threshold for changing to freewheel stop mode at end of deceleration	20		0 to 100% of estimated torque
	<i>t L 2</i>	Maximum torque limit	OFF		10 to 200%
	<i>t I 2</i>	Deceleration gain (for torque control)	40		10 to 50%
COP Menu Communication	<i>A d d</i>	Starter address	0		0 to 31
	<i>t b r</i>	Communication speed	19.2		4.8 – 9.6 – 19.2
	<i>F D r</i>	Communication format	8n1		8o1: 8 bits, odd, 1 stop bit 8E1: 8 bits, even, 1 stop bit 8n1: 8 bits, no parity, 1 stop bit 8n2: 8 bits, no parity, 2 stop bit
	<i>t L P</i>	Serial link timeout setting	5		0.1 to 60 s
	<i>P C t</i>	Configuration of serial link for communications with remote keypad display	OFF		On – OFF

Appendix A—Recommended Wiring Diagrams

Figures 33–35 (pages 80–82) illustrate circuit diagrams for typical non-reversing and reversing applications in 2-wire and 3-wire control. The recommended circuit diagrams include SCR fault isolation for optimal protection of the motor, driven machinery, and operating personnel.

Table 30: Description of Logic for Recommended Wiring Diagrams

Item	Name	Description
IC1 IC1A	Isolation Contactor (Fwd)	The isolation contactor logic closes IC1 upon a start command and opens IC1 after the stop is complete. The RCR (or RFR and RRR for reversing) are timed contacts that must have a time delay greater than the deceleration ramp time or the INTELE braking time. When a coast stop is selected, the time delay must be set for a time that will allow complete decay of the motor residual voltage. The isolation contactor opens immediately upon a detected fault. The pilot relay (IC1A) is required when the IC1 contactor coil exceeds the relay rating.
IC2 IC2A	Isolation Contactor (Rev)	Used for reversing applications only, the IC2 must be mechanically interlocked to IC1. A reversing contactor may be used for the combination of IC1 and IC2. In general, the operation of IC2 is identical to IC1. The pilot relay (IC1A) is required when the IC1 contactor coil exceeds the relay rating.
SC SCA	Shorting Contactor and Pilot Relay	The shorting contactor is used to reduce the heat dissipated by the controller when the motor is operating at full speed and voltage. The controller provides proper sequencing of this contactor by the “end-start-up” relay. When the start is completed, the shorting contactor will be commanded to close. The controller will continue to monitor the motor thermal state and provide motor overload protection. Upon a stop command, the SC contactor will open, transferring the motor current to the SCRs to allow for controlled deceleration if desired. The pilot relay (SCA) is required when the SC contactor coil exceeds the relay rating.
TS	Transient Suppressors	Transient suppression of all relay and contactor coils (except ST) is recommended to minimize the possibility of electrical interference with the controller electronics and to increase relay contact life.
RCR	Run Command Relay	Used in all non-reversing logic (optional in shunt trip) for proper sequencing of contactor logic. When energized, RCR initiates the start sequence. When de-energized, stopping is initiated. Operator controls can be either on/off selector switch, HOA selector switch or start/stop push buttons. RCR remains energized during a fault condition. Once the fault condition has been cleared, RCR must be de-energized by a “stop” command then re-energized to restart the controller.
RFR	Run Forward Relay	Used for reversing applications only, this coil duplicates the functionality of RCR for the forward direction and is interlocked with the RFR relay.
RRR	Run Reverse Relay	Used for reversing applications only, this coil duplicates the functionality of RCR for the reverse direction and is interlocked with the RRR relay.
ST	Shunt Trip Coil	This coil is attached to the shunt trip coil on the disconnect and will energize 2 seconds after a controller detected fault by the TR timer contact. The time delay is to prevent nuisance tripping of the circuit breaker during controller power-up or during line undervoltage conditions.
TR	Trip Relay	Used in shunt trip circuit breaker logic only; coil energized upon a controller detected fault.
FR	Fault Relay	Used with logic diagrams that use an isolation contactor. The fault relay is energized during normal operation and deenergizes if the controller detected fault contacts open or if the motor thermal switch (if supplied) opens. FR also provides additional contacts for the controller detected fault output.

To select control operators (push buttons, pilot lamps, and selector switches), control power transformers, and wire management devices (control and power terminal strips, wire terminations) indicated on the recommended wiring diagram configurations, refer to the latest editions of Schneider Electric’s full line product catalogs.

Figure 33: Nonreversing with Shunt Trip Fault Isolation

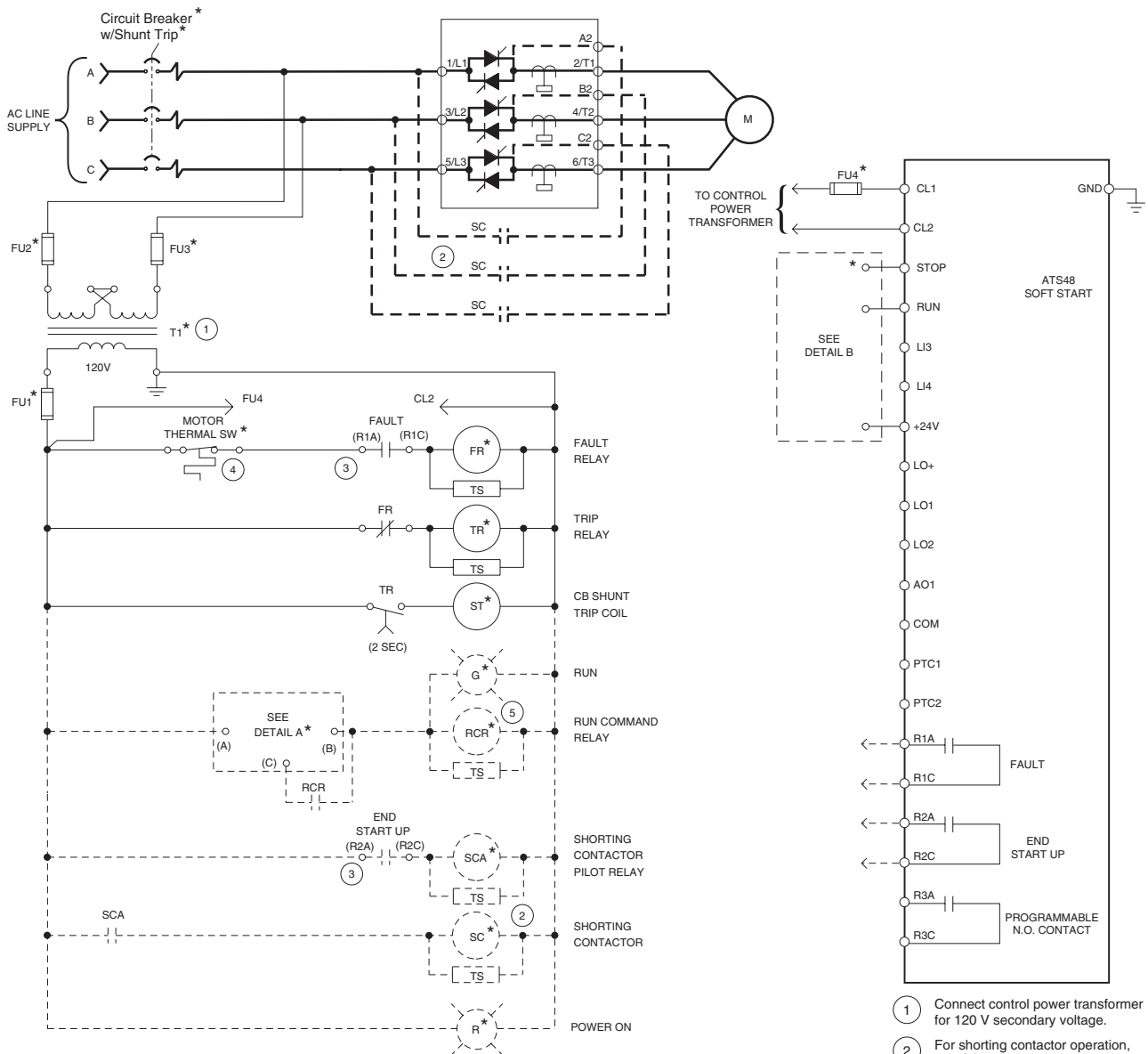

- 1 Connect control power transformer for 120 V secondary voltage.
- 2 For shorting contactor operation, add SC with associated control circuit.
- 3 Relay contact located on ATS48 controller.
- 4 Located at motor. Jumper if switch not present.
- 5 Use RCR relay logic for 120 V control of the ATS48. For 24 Vdc control, omit the RCR relay logic and wire controls directly to the ATS48 (see DETAIL B).

* = User supplied

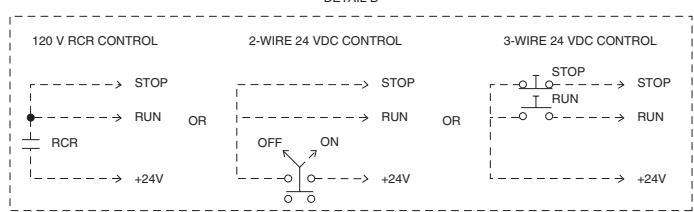
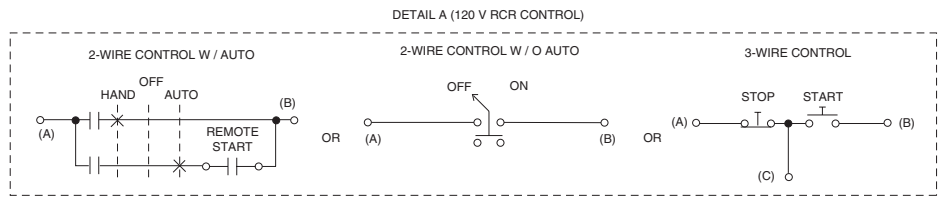
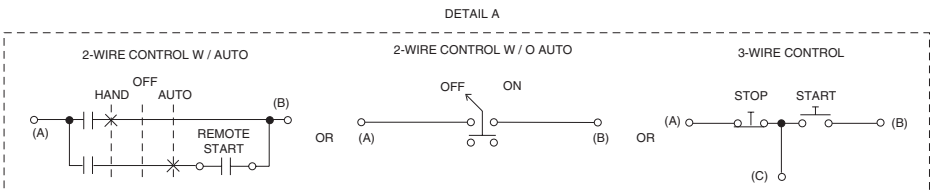
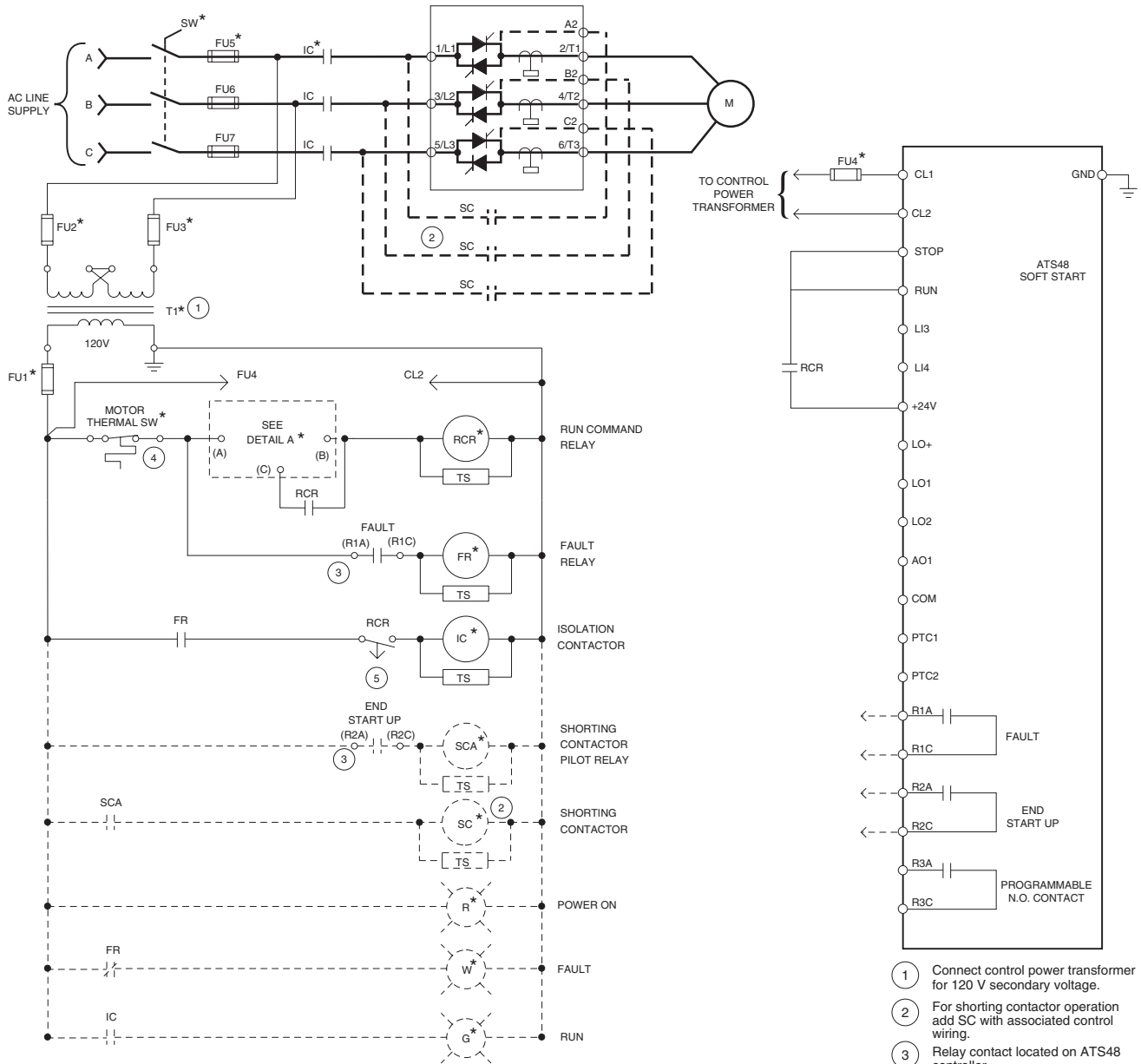

Figure 34: Nonreversing with Isolation Contactor



- 1 Connect control power transformer for 120 V secondary voltage.
- 2 For shorting contactor operation add SC with associated control wiring.
- 3 Relay contact located on ATS48 controller.
- 4 Located at motor. Jumper if switch not present.
- 5 Set RCR time slightly longer than expected deceleration time from rated speed to zero speed.

* = User supplied

Figure 35: Reversing with Isolation Contactors

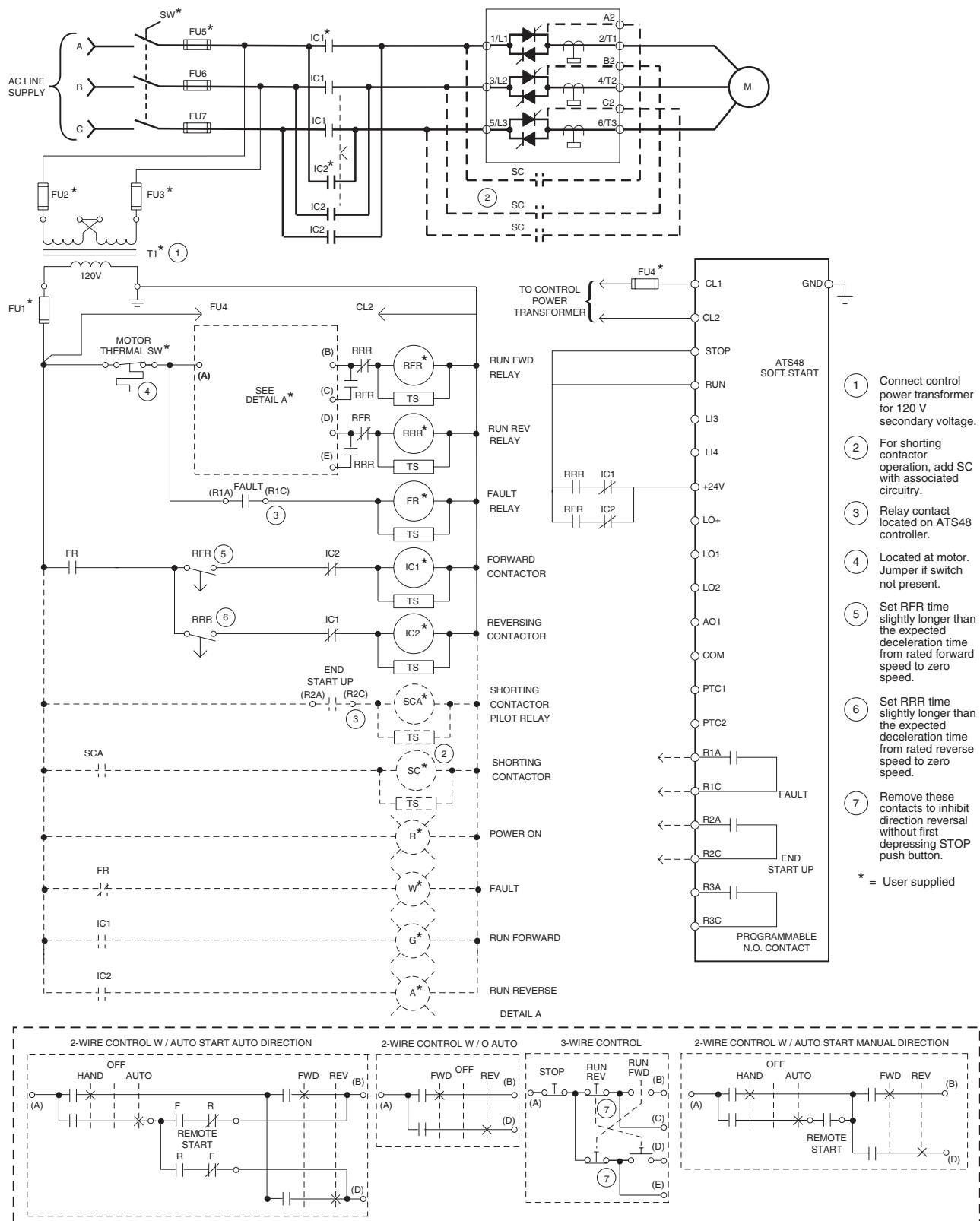

Appendix B—Recommended Component Lists

To select control operators (push buttons, pilot lamps, and selector switches), control power transformers, and wire management devices (control and power terminal strips, wire terminations) indicated on the recommended wiring diagram configurations, refer to the latest editions of Schneider Electric's full line product catalogs.

Table 31: Suggested Components for Standard Duty Applications

Induction Motor (M)				ATS48 Soft Start		FU4	
Rated hp ¹				Catalog No.	Device Rated Current	ATS Control	Class CC 600 V Time Delay
208 V	230 V	460 V	575 V		@ 40 °C (104 °F) ²	Power Burden (W)	@ 115 V
3	5	10	15	ATS48D17Y	17	25	0.5 A
5	7.5	15	20	ATS48D22Y	22	25	0.5 A
7.5	10	20	25	ATS48D32Y	32	30	0.6 A
10	—	25	30	ATS48D38Y	38	30	0.6 A
—	15	30	40	ATS48D47Y	47	30	0.6 A
15	20	40	50	ATS48D62Y	62	30	0.6 A
20	25	50	60	ATS48D75Y	75	30	0.6 A
25	30	60	75	ATS48D88Y	88	30	0.6 A
30	40	75	100	ATS48C11Y	110	30	0.6 A
40	50	100	125	ATS48C14Y	145	30	0.6 A
50	60	125	150	ATS48C17Y	170	30	0.6 A
60	75	150	200	ATS48C21Y	210	50	1 A
75	100	200	250	ATS48C25Y	250	50	1 A
100	125	250	300	ATS48C32Y	320	50	1 A
125	150	300	350	ATS48C41Y	410	80	1.5 A
150	—	350	400	ATS48C48Y	480	80	1.5 A
—	200	400	500	ATS48C59Y	590	80	1.5 A
200	250	500	600	ATS48C66Y	660	80	1.5 A
250	300	600	800	ATS48C79Y	790	80	1.5 A
350	350	800	1000	ATS48M10Y	1000	80	1.5 A
400	450	1000	1200	ATS48M12Y	1200	80	1.5 A

¹ Motor full load currents through 500 hp @ 460/575 V, 250 hp @ 230 V, and 200 hp @ 208 V are taken from the National Electric Code (NFPA 70-2002, Table 430.150). Above these ratings, motor full load currents are calculated based upon 1.2 A/hp for 460 V and 2.4 A/hp for 230 V. Motors listed are for standard duty applications. For severe duty applications, select the next larger soft start size.

² The ambient temperature indicated in the table represents the temperature of the air surrounding the ATS48 soft start. Any additional temperature factors associated with the enclosure system or actual installation ambient temperature must be considered when determining the actual rated current (I_{CL}) of the soft start. For operating ambient above 40 °C (104 °F) without a shorting/bypass contactor and 50 °C (122 °F) with a shorting/bypass contactor but not exceeding 60 °C (140 °F), the rated current (I_{CL}) of the soft start must be de-rated by 2% per °C.

Table 32: Additional Suggested Components for Standard Duty Applications¹

ATS48 Controller Model	IC1 ^{2, 3, 4, 5}			IC2 ^{2, 3, 4, 5}		SC ^{2, 3, 4, 5}		Fusible Disconnect ⁶			Thermal- Magnetic Circuit Breaker 6, 7, 10
	Isolation Contactor (AC1)	Reversing Contactor (AC1) ⁸	Mechanical Interlock	Shorting Contactor (AC1)	Power Fuses Class/Rating	Fuse Block ⁹	Molded Case Switch ¹⁰				
D17Y	LC1D09	LC1D09	¹¹	LC1D09	J / 25	60308J	HGL3600S15	HDL36030			
D22Y	LC1D18	LC1D18	¹¹	LC1D18	J / 30	60308J	HGL3600S15	HDL36040			
D32Y	LC1D25	LC1D25	¹¹	LC1D25	J / 40	60608J	HGL3600S15	HDL36050			
D38Y	LC1D32	LC1D32	¹¹	LC1D32	J / 50	60608J	HGL3600S15	HDL36060			
D47Y	LC1D40A	LC1D40A	¹¹	LC1D40A	J / 60	60608J	HGL3600S15	HDL36080			
D62Y	LC1D50A	LC1D50A	¹¹	LC1D50A	J / 80	61038J	HGL3600S15	HDL36090			
D75Y	LC1D80	LC1D80	¹¹	LC1D80	J / 100	61038J	HGL3600S15	HDL36100			
D88Y	LC1D80	LC1D80	¹¹	LC1D80	J / 120	62003J	JGL3600S25	HGL36110			
C11Y	LC1D115	LC1D115	¹¹	LC1D115	J / 150	62003J	JGL3600S25	HGL36150			
C14Y	LC1D115	LC1D115	¹¹	LC1D115	J / 200	62003J	JGL3600S25	JGL36200			
C17Y	LC1F150	LC1F150	LA9FF970	LC1F150	J / 225	64033J	LHL3600M	LAL36225			
C21Y	LC1F185	LC1F185	LA9FG970	LC1F185	J / 300	64033J	LHL3600M	LAL36250			
C25Y	LC1F225	LC1F225	LA9FJ970	LC1F225	J / 350	64033J	LHL3600M	LAL36350			
C32Y	LC1F330	LC1F330	LA9FJ970	LC1F330	J / 400	64033J	LHL3600M	LAL36400			
C41Y	LC1F400	LC1F400	LA9FJ970	LC1F400	J / 500	6633J	PJL3600S60	MGL36500			
C48Y	LC1F500	LC1F500	LA9FJ970	LC1F500	J / 600	6633J	PJL3600S60	MGL36600			
C59Y	LC1F500	LC1F500	LA9FJ970	LC1F500	L / 700	⁹	PJL3600S80	MGL36800			
C66Y	LC1F630	LC1F630	LA9FJ970	LC1F630	L / 900	⁹	PJL3600S80	MAL36900			
C79Y	LC1F630	LC1F630	LA9FL970	LC1F630	L / 1100	⁹	PJL3600S10	¹²			
M10Y	LC1F780	LC1F780	LA9FL970	LC1F780	L / 1350	⁹	PJL3600S10	¹²			
M12Y	LC1F780	LC1F780	LA9FX970	LC1F780	L / 1600	⁹	PJL3600S12	¹²			

¹ For more UL508A combinations, go to www.schneider-electric.us.
² All coils are selected for 120 V, 60 Hz operation. Refer to the *Digest* for additional coil voltages or auxiliary contact configurations. One block may be added to each contactor.
³ Power terminals are not included with LC1-F contactors. Refer to the latest editions of Schneider Electric's full line product catalogs for additional ordering information.
⁴ The use of transient suppressors across all contactor coils is recommended. Refer to the latest editions of Schneider Electric's full line product catalogs for selection of transient suppressors.
⁵ Recommended contactors are sized for a utilization category AC1 rating and must not make or break motor current. Sequencing of these contactors must be as shown on the recommended wiring diagrams in Appendix A. See pages 80 to 82.
⁶ According to the National Electrical Code, branch circuit overcurrent protection must be provided for each controller. Short circuit protective devices recommended in this table are within NEC requirements for Type 1 coordination.
⁷ For 480 V or lower only.
⁸ Reversing contactors for C11 through M12 controllers must be assembled from components. Refer to the latest editions of Schneider Electric's full line product catalogs for power connector link and terminal kits. Reversing contactor interlock units used for the C79 through M12 controllers are designed for vertical interlocking of the individual contactors. Horizontally interlocked contactors are used for D17 through C59 controllers.
⁹ Fuse holder part number references are for Class J fuses only based on Ferraz Shawmut spring reinforced with box type connectors acceptable for Al/Cu wiring. Class L fuses require bolt-on connections to user-supplied power bus work.
¹⁰ The molded case switches and circuit breakers selected require the addition of operator mechanisms to allow operation from the exterior of an enclosure. Refer to the latest editions of Schneider Electric's full line product catalogs for operator mechanism information. When using a shunt trip relay for SCR fault isolation, order a disconnect switch with suffix -1021 for addition of shunt trip coil.
¹¹ The D-Line contactor is available as a reversing configuration. For these applications, change the IC1 part number prefix from LC1- to LC2- to order the IC1 and IC2 combination complete with mechanical interlocks.
¹² Devices rated above 660 A have not been coordinated with circuit breakers. You must use a Class L fuse for overcurrent protection with ATS48 controller models C79, M10, and M12.

Appendix C—Options and Accessories

Tables 33–37 show the accessories available for ATS48 soft start controllers.

Table 33: Documentation

VVDED302023	Modbus® Protocol User's Manual (multilingual)
DCICD398111	Communications: Ethernet, FIPIO, DeviceNet, Profibus DP User's Manual (CD-ROM version only)
30072-451-28	Altistart® 48 Soft Starts Maintenance and Repair Guide

Table 34: Remote Keypad Display

VW3G48101	<p>Remote mounting kit for keypad display (IP54).</p> <ul style="list-style-type: none"> • 7-segment remote keypad display • Mounting kit containing cover, screws, and an IP54 seal on the front panel. • 9.8 ft (3 m) cable with a 9-way SUB-D connector for keypad display and an RJ-45 connector for connecting to an ATS48 controller.
-----------	--

Table 35: Protective Covers for Power Terminals

LA9F702	Set of six protective covers for ATS48C14Y to ATS48C17Y to meet international touch-safe requirements for power terminals.
LA9F703	Set of six protective covers for ATS48C21Y, ATS48C25Y, and ATS48C32Y to meet international touch-safe requirements for power terminals.

Table 36: Control Board

VX4G481	Control board
---------	---------------

NOTE: The ATS48 controller has 9 unprotected power terminals.

PowerSuite Solutions

PowerSuite solutions are compatible with software version 1.30, build 5.

Table 37: PowerSuite Software for Personal Computers

VW3A8104	PowerSuite Test and Commissioning Software on CD for use with Microsoft® Windows 95, 98, and NT™ and Windows CE v3.0 for Pocket PCs/PDA.
VW3A8106	<p>Cable connection kit for the Personal Computer to an ATS48 controller.</p> <ul style="list-style-type: none"> • two connection cables, 9.8 ft (3 m) each with two RJ-45 connectors. • one RJ-45/9-way SUB-D adaptor. • one converter marked "RS-232/RS-485 PPC" with one 9-way male SUB-D connector and one RJ-45 connector.

Factory repaired ATS48 controllers are available within 24 hours from a factory exchange pool, or your ATS48 controller can be factory repaired and returned. Contact your local Schneider Electric Distributor or the Schneider Electric Customer Service Representative at 1-888-SQUARED (1-888-778-2733) for availability.

INDEX

A

AC2 61
ACC 47
Add 63
AIL 59
AO 59
APC 59
ArS 53
AS2 59
ASC 59
AUL 59

B

brC 49
bSt 55

C

CFF 70
CFI 70
circuit breaker 84
CLF 71
CLP 55
COd 66
contactor
 isolation 84
 reversing 84
 shorting 84
COS 65
CSC 56

D

DCF 69
dE2 62
dEC 48

E

EbA 49
Ed2 62
EdC 48
EEF 69
EtA 65
EtF 72

F

factory settings 75
faults
 auto-reset 71
 manual-reset 72
 non-reset 69
 resettable 70
FCS 56
FOr 63
FrC 56
freewheel stop 47
FrF 71
fuses 16, 84

I

IL2 61
ILt 47

In 47
In2 61
InF 69
INTELE braking stop 38, 47
IPr 58
isolation contactor 28, 84

L

LAP 65
LCr 65
LFt 65
LI3 58
LI4 58
LIA 58
LIC 58
LIE 58
LIH 58
LII 58
LIL 58
Llr 58
LIS 58
Lit 58
LO1 59
LO2 59
LOC 52
LPr 65
LrF 72
LSC 56
Ltr 65
LUL 51

M

menus
 access to 45
 advanced setting (drC) 54
 communication (COP) 63
 I/O (IO) 57
 parameter displayed (SUP) 64
 protection (PrO) 50
 second motor parameters (St2) 60
 settings (SEt) 46

N

nLP 10, 46

O

O 4 59
OCO 59
OCr 59
OHF 72
OIL 52
OLC 72
OLF 72
OPr 59
OtF 72
OtH 59
Otr 59

P

parameter access 45
PCt 64
PHE 66
PHF 71
PHL 52
PHr 52
PIF 69
PtC 52

R

r1 59
r1F 59
r1I 59
r3 59
rdY 10, 46
reversing contactor 84
rnl 59
mt 65
rPr 56
rtH 53

S

setting
 factory 75
shorting contactor 84
shunt trip coil 27, 79
SLF 72
soft stopping 47
SSt 55
starter status 46
StF 72
stop
 freewheel 47
 INTELE braking 38, 47
 soft 47
StY 47

T

tAl 59
tbr 63
tbS 52
tHP 51
tHr 65
tl2 62
tIG 56
tL2 62
tLI 55
tLP 64
tLS 51
tOL 52
tPr 59
tq0 47
tq2 61
tUL 51

U

ULF 72
ULn 56
USF 71

Altistart® 48 Y-Range Soft Start Controllers
Instruction Bulletin



S1A3749101

Schneider Electric
8001 Knightdale Blvd.
Knightdale, NC 27545 USA
1-888-SquareD
(1-888-778-2733)
www.schneider-electric.us

Altistart® is a registered trademark of Schneider Electric. Other trademarks used herein are the property of their respective owners.

Electrical equipment should be installed, operated, serviced, and maintained only by qualified personnel. No responsibility is assumed by Schneider Electric for any consequences arising out of the use of this material.

S1A37491 01/2010
Replaces 30072-450-61B 05/2008
© 2002–2010 Schneider Electric All Rights Reserved