



**CUY-90-14.90**

**PID 77332/85531**

---

**APPENDIX GE-04**

---

**West Slope Stability Report  
(Reference Document)**

State of Ohio  
Department of Transportation  
Jolene M. Molitoris, Director

**Innerbelt Bridge  
Construction Contract Group 1 (CCG1)**

**the Challenge.**

Finding the right  
firm to handle  
your projects  
from inception to  
completion.

**STATE OF OHIO  
DEPARTMENT OF TRANSPORTATION**



**Central Viaduct Project**  
Cuyahoga County, Ohio

**CUY-90-14.92**  
**PID 77332**

**SLOPE STABILITY  
EVALUATION  
REPORT**

**the Choice.**

**E.L.ROBINSON**

*the Challenge. the Choice.*

**Engineering**  
**Architecture**  
**Landscape**  
**Architecture**  
**Construction**  
**Administration**  
**Surveying**  
**Planning**

**Prepared for**

**Baker**

Cleveland, Ohio

**Prepared by**

**E.L.ROBINSON**

*the Challenge. the Choice.*

1801 Watermark Drive, Suite 310, Columbus, OH 43215

**November, 2009**

11/25/2009

Mr. Jeff Broadwater, PE  
**Michael Baker Jr., Inc.**  
The Halle Building  
1228 Euclid Avenue, Suite 1050  
Cleveland, OH 44115

**Reference: CUY-90-14.92**  
**Stability Evaluation of the Slope to the west of the Cuyahoga River**

Attn. Mr. Broadwater;

Please find enclosed a copy of our *final report* addressing the stability of the CUY-90-14.92 west bank slope. As a member of the Team for this project, EL Robinson Engineering (ELR) is tasked with the assignment to review the history of the existing project, review the instrumentation monitoring data, prepare recommended grading plans for improving the stability of the west slope, and propose a future monitoring plans.

If you have any questions regarding the status of this report please contact us at 614-586-0642.

Respectfully,



Jamal Nusairat, PE, Ph.D.  
Project Manager



Rick Engel, PE  
Vice President

# CUY-90-14.92

## SLOPE STABILITY EVALUATION REPORT

### TABLE OF CONTENTS

| <b>Chapter</b> | <b>Title</b>   | <b>Page</b> |
|----------------|--|-------------|
| <b>1</b>       | <b>INTRODUCTION</b>  | <b>1-1</b>  |
| 1.1            | Statement of the Problem and Objectives of the Report                      | 1-1         |
| 1.2            | Outline of the Report  | 1-2         |
| <b>2</b>       | <b>SCOPE OF WORK AND OBJECTIVES</b>  | <b>2-1</b>  |
| <b>3</b>       | <b>DESIGN REQUIREMENTS AND CONSTRAINTS</b>                                 | <b>3-1</b>  |
| 3.1            | Introduction   | 3-1         |
| 3.2            | History of Slope Movements   | 3-1         |
| 3.3            | Existing Slope at the Westbound Bridge                                     | 3-2         |
| 3.4            | Soil Strength Parameters   | 3-3         |
| 3.5            | Pore Pressures   | 3-3         |
| 3.6            | Slope Creep  | 3-3         |
| 3.7            | Perched Water Table near the Railroad                                      | 3-4         |
| 3.8            | Cold Storage Building  | 3-4         |
| 3.9            | Bike Path  | 3-4         |
| 3.10           | Bulkhead   | 3-4         |
| 3.11           | Proposed Pier Location   | 3-5         |
| 3.12           | Utilities  | 3-5         |
| 3.13           | Lightweight Fill Material  | 3-5         |
| 3.14           | Slope Instrumentation  | 3-6         |
| 3.15           | Slope Stability Analyses for the Eastbound Bridge                          | 3-6         |
| 3.16           | Top of Graded Slope just North of Abbey Avenue                             | 3-6         |
| 3.17           | Slope Drainage   | 3-6         |
| 3.18           | Describe the shallow and deep slip plane                                   | 3-7         |
| 3.19           | Grading the Slope under the Existing Bridge                                | 3-7         |
| 3.20           | Existing Bridge Stability  | 3-7         |
| 3.21           | Gateway Animal Clinic Parking Lot  | 3-7         |
| 3.22           | Slope Drainage Design  | 3-7         |
| 3.23           | Grading Plan for Future Eastbound Bridge (Replacement for Existing Bridge) | 3-8         |
| 3.24           | Quality Control and Quality Assurance                                      | 3-8         |

|          |  |            |
|----------|--|------------|
| <b>4</b> | <b>SUMMARY OF GEOLOGIC CONDITIONS</b>  | <b>4-1</b> |
| 4.1      | Geology of the Site  | 4-1        |
| 4.2      | Subsurface Investigations  | 4-2        |
| 4.3      | Cone Penetration Soundings or Probes   | 4-3        |
| 4.4      | Laboratory Testing   | 4-4        |
| 4.4.1    | Laboratory Testing Performed in 2006   | 4-4        |
| 4.4.2    | Laboratory Testing Performed in 2009   | 4-5        |
| 4.4.3    | Conclusions from Laboratories Testing Results  | 4-5        |
| 4.5      | Recommended Strength Values for Slope Design   | 4-7        |
| 4.6      | Slope Stability Analyses Performed   | 4-7        |
| <br>     |  |            |
| <b>5</b> | <b>REVIEW OF EXISTING WEST SLOPE AND BRIDGE STABILIZATION SYSTEM INSTRUMENTATION AND MONITORING FINDINGS</b> |            |
| 5.1      | Introduction   | 5-1        |
| 5.2      | West Slope and Pier 1 Stabilization System Instrumentation Plan  | 5-1        |
| 5.3      | QA/QC Review of Instrumentation Monitoring Results   | 5-1        |
| 5.3.1    | Slope Movement Measurements  | 5-2        |
| 5.3.2    | Drilled Shafts Stress Condition Assessment   | 5-3        |
| 5.3.3    | Tie Beams  | 5-4        |
| 5.3.4    | Rock Anchors   | 5-4        |
| 5.3.5    | Piles  | 5-5        |
| 5.3.6    | Inclinometers Installed in the Drilled Shafts  | 5-5        |
| <br>     |  |            |
| <b>6</b> | <b>SLOPE STABILITY MODEL DEVELOPMENT</b>   | <b>6-1</b> |
| 6.1      | Geometry, Boundary Loads, and Stratigraphy   | 6-1        |
| 6.2      | Soil Parameters and Ground Water   | 6-2        |
| 6.2.1    | Soil Strength Parameters   | 6-2        |
| 6.2.2    | Ground Water Elevation   | 6-2        |
| 6.3      | Studied Sections   | 6-2        |
| <br>     |  |            |
| <b>7</b> | <b>EVALUATION OF EXISTING SLOPE AND SLOPE IMPROVEMENT</b>  | <b>7-1</b> |
| 7.1      | Stability Analyses of the Existing Slope   | 7-3        |
| 7.1.1    | Sections A-A, CL-CL and D-D  | 7-4        |
| 7.1.2    | Analyses for Improving Stability   | 7-7        |
| 7.1.3    | Slope Stability Issues   | 7-8        |
| 7.2      | Stability Analysis of the Existing and Graded Slopes   | 7-9        |
| 7.2.1    | Stability of the Existing Slope  | 7-9        |
| 7.2.2    | Stability Analyses of the Slope Grading Alternatives   | 7-11       |

|           |  |             |
|-----------|--|-------------|
| <b>8</b>  | <b>HORIZONTAL GRAVITY DRAINS AND VERTICAL PRESSURE RELIEF DUCTS</b>        | <b>8-1</b>  |
| 8.1       | Introduction   | 8-2         |
| 8.2       | Maintenance  | 8-3         |
| 8.3       | Cost   | 8-3         |
| 8.3       | Design   | 8-5         |
| <br>      |  |             |
| <b>9</b>  | <b>DESIGN AND CONSTRUCTION OF SUBSTRUCTURES IN THE WEST BANK SLOPE</b>     | <b>9-1</b>  |
| 9.1       | Introduction   | 9-1         |
| 9.2       | Pier Construction in The Slope Between The Cuyahoga River and Abbey Avenue | 9-2         |
| 9.2.1     | Existing and Proposed Profile of the West End Slope                        | 9-2         |
| 9.2.2     | Horizontal Drains  | 9-2         |
| 9.2.3     | Vertical Pressure Relief Ducts   | 9-3         |
| 9.2.4     | Future Grading for the Companion Structure                                 | 9-3         |
| 9.2.5     | Pier Foundations   | 9-4         |
| 9.2.6     | Contractual Requirement  | 9-4         |
| 9.3       | Sequence of Construction   | 9-4         |
| 9.4       | Instrumentation of new Piers within the Slope                              | 9-5         |
| 9.5       | Bearings for Proposed Piers within the Slope                               | 9-5         |
| 9.6       | Pier Load Transferred to the Slope   | 9-5         |
| 9.7       | Foundations located South of Abbey Avenue                                  | 9-6         |
| <br>      |  |             |
| <b>10</b> | <b>CONCLUSIONS</b>   | <b>10-1</b> |

# CHAPTER 1

## INTRODUCTION

### 1.1 Statement of the Problem and Objectives of the Report

The Central Viaduct, or "Innerbelt Bridge", is a vital link to downtown Cleveland. In March, 2009, ODOT announced plans to construct a new westbound Innerbelt Bridge, utilizing federal transportation stimulus funds made available through the *American Recovery and Reinvestment Act*. This project provides for the phased replacement of the existing Central Viaduct through construction of a new westbound bridge to the north of the existing bridge, followed by the construction of a new eastbound bridge on essentially the same alignment as the existing bridge.

The Innerbelt Bridge project will be designed and constructed using the design-build process. Design plans for the construction of the graded slope to the south of the Cuyahoga River are a component of the Innerbelt Bridge construction contract documents. This report addresses pertinent design and construction considerations and requirements for building the proposed westbound structure in the vicinity of the west bank slope. Refer to Appendix GE-05 for a copy of the 2006 Baker report titled "Slope Stability Evaluation Report of the West Bank".

The 5080 foot long Central Viaduct Bridge was constructed and opened to traffic in 1959. Due to excessive movements within the west bank slope during its operation, a slope stabilization system was proposed, designed and constructed during the period from 1997 to 1999. The stabilization system is composed of drilled shafts, driven piles, tie beams, and rock anchors. Richland Engineering Limited (REL) has prepared numerous detailed reports documenting the historical performance of the structure (see Appendix GE-06, CUY 90 Field Monitoring Reports).

ELR has evaluated the stability of the west end slope, both before and after a designed grading plan is implemented, and subsequently prepared a specific grading plan that will permit the design of bridge piers that do not include resistance to slope induced lateral loads. As part of

their quality assurance plan, ELR performed an independent evaluation of the instrumentation monitoring data collected from all the instruments from their installation until July 2009. Dr. W. Allen Marr of Geocomp Corporation performed an overall independent assessment of the integrity of the west end slope area and an evaluation of the instrumentation data. He also has performed independent slope stability analyses.

## **1.2 Outline of the Report**

The report's chapters and appendices are arranged in a logical and sequential manner to track the process of investigation, analysis, and design. The objective of the report is to document the basis for all assumptions, calculations, and recommendations such that ODOT and members of the design-build team can use its content to the fullest advantage. A brief description of each chapter follows:

In Chapter 1 the existing slope problem is briefly described to illustrate the slope's critical importance to the overall project. In Chapter 2 the scope of work and project objectives are described and summarized. Chapter 3 outlines the design requirements and constraints which influenced the analysis conducted and the design recommendations. A summary of geologic conditions is presented within Chapter 4 including all the borings and laboratory testing data.

A review of existing west end slope and bridge stabilization system instrumentation and monitoring findings are presented in Chapter 5. Chapter 6 presents the slope stability model development and the recommended soil strength parameters. In Chapter 7 a detailed evaluation of the existing slope and slope movements is presented, including the slope stability analysis for the graded slope area. The horizontal gravity drains and the vertical pressure relief ducts are discussed in Chapter 8. Chapter 9 provides the background and logic that form the basis of the design and construction guidance provided for the substructures in the west end slope. Finally, Chapter 10 presents the conclusions of this complex and unique problem study.



## **CHAPTER 2**

### **SCOPE OF WORK**

This work is to be performed by E.L. Robinson Engineering of Ohio Co. (ELR) working as a subconsultant to Michael Baker Jr. Inc. (Baker) for work through bidding of the Design-Build (DB) Contract for the CUY-90-15.24 - Innerbelt Bridge Construction Contract Group 1. Dr. W. Allen Marr of Geocomp Corporation will be assisting ELR in performing slope stability and risk assessment work for this project. Jerry DiMaggio will be performing a peer review of the slope stability related tasks as the project design progresses. The goal of all the involved consulting firms is to have continuous interaction between the Baker Team and ODOT so that the direction of this study and design work is discussed and focused at numerous concurrence points. Project tasks include:

1. Compile and analyze the historic subsurface information, engineering studies, and slope stability analyses including all data/measurements related to the ongoing, extensive instrumentation program.
2. Study the extent and cause of past slope movements, determine the locations of soil layers that are weak or have been weakened due to slope movements, and establish the shear strength parameters for the soil profile.
3. Plan a supplementary subsurface exploration program. Recommend any additional soil borings and testing necessary to support the analysis work.
4. Incorporate all previously completed subsurface explorations throughout the history of the project limits (including the existing bridge) into reports and documents that can be included in the Design Build Request for Proposals (RFP).
5. Study the overall stability of the existing slopes located below the existing structure on the west bank slope. Explain the relationship between the grading of

11. The slope stability evaluation will address the concerns for preparing a grading plan that ensures the desired overall stability within the limits of the proposed design-build corridor for the proposed bridge as well as the stability related to the grading that may be necessary in the area of the existing bridge. Ten proposed cross sections at appropriate locations and bearings within the influence of the proposed corridor will be developed. The design team will make modifications to the ten proposed cross sections based on ODOT's recommendations.
12. ELR will perform all GEOPAK work necessary to develop the existing and proposed cross sections.
13. Present to ODOT preliminary slope stability results in a meeting with the purpose of obtaining direction and concurrence and to promote a more efficient analysis schedule.
14. Based on the recommendations provided by ODOT, ELR will perform a sensitivity study by varying the pertinent slope stability strength parameters for the subsurface material within each cross section. The soil property and pore pressure information used for these analyses will be based on information obtained from previous subsurface investigations and from recent measurements in the vicinity of the proposed alignments. The existing ground surface geometry used for stability analyses will be taken directly from the topographic information obtained from the project survey/GEOPAK tin data.
15. ELR will evaluate all slope stability-related issues with regard to their influence on the west bank slope, analyze the stability of portions of the existing slope, and evaluate the effects of all stability-related parameters on the slope's performance to better understand what specifically is driving the slope movements. Additional analyses will examine slope stabilization measures if they are required to obtain a safe configuration.
16. Dr. Marr will review the stability analyses and independently perform stability and deformation analyses with the finite element program, PLAXIS. This

the slopes for the new structure and the related influence of this work on the overall stability of the slope below the existing structure.

6. Provide a discussion on the probability of slope failures as it relates to the west bank after excavating to the designed final grading plan.
7. Prepare a report summarizing the interpretation of the past performance of the existing slope with respect to the planned future bridges. Based on prior project work for the Far North Alignment Alternative, the existing west end slope was determined to present geotechnical challenges for the foundation design and construction of the proposed new westbound I-90 Innerbelt Bridge. It was determined that the factors of safety for slope stability/movement are not sufficient for standard bridge foundations without some remediation work performed to address the stability of the existing slope. The previously proposed concept of slope stability mitigation included 1) slope unloading by demolition of the abandoned Cold Storage warehouse building and 2) excavation to a flatter slope. The unloading scheme for the proposed alignment may pose additional challenges potentially affecting the stability of the existing bridge and/or limiting the degree of excavation. The previously proposed concept also included design of a foundation isolation system, which would take into account any probable movement of the slope.
8. Investigate the impact of the demolition of the cold storage building on the stability of the west end slope.
9. University Avenue to the west of the existing I-90 bridge alignment will not need to remain open to traffic.
10. The Baker Team will evaluate if a pier isolation system would be necessary with the proposed slope stability work and present to ODOT the conclusions with supporting documentation for review and comments before finalizing the design of the slope remediation work.

- program will indicate the magnitude and pattern of displacements that may develop in the slope for various geometries and loading conditions. It will also be very useful for evaluating the effectiveness of any stabilization schemes.
17. Prepare a complete slope stability solution for the entire west slope. Deliverables include plan details and estimated quantities for use in preparing the proposed grading cost estimate.
  18. The Baker Team will meet with ODOT Geotechnical staff to discuss the west end slope stability concerns and impacts on the DB project and existing Central Viaduct Bridge. The goal of this meeting(s) will be to discuss the scope of work for additional slope stability explorations (if any) and mitigation requirements.
  19. Evaluate design concerns for the bulkhead dock wall replacement efforts and incorporation into the slope stability solution.
  20. Assist in preparing bulkhead dock wall coordination documents for the Army Corps of Engineers and US Coast Guard for implementation of applicable design standards.
  21. Survey the bulkhead wall along the west bank of the Cuyahoga River under the proposed Westbound Bridge.
  22. The grading plan near the existing bridge is assumed to require two retaining walls, if-authorized hours have been provided to perform two retaining wall justification studies.
  23. Participate in risk management meetings on engineering issues.
  24. Coordinate with Dr. Marr of Geocomp Corporation for slope design work and risk management work.
  25. Coordinate slope stability efforts with ODOT. ODOT will be performing a peer review of the work.

26. Provide a discussion offering an explanation of the origin of the gas pressures and explain how the gas pressures influence the performance of the slope.
27. Discuss the long term predicted effects of creep movements.
28. Evaluate how the overall site drainage will be controlled. Include a discussion on the use of horizontal drains.
29. ELR, in conjunction with Geocomp, will develop a slope monitoring plan to be installed by the DB contractor. The Baker Team will work with ODOT to determine ODOT's requirements for long-term monitoring and maintenance of the monitoring system so the appropriate devices and data collection equipment can be defined. ELR will also develop the instrumentation specifications to follow for procuring and installing the instrumentation and demonstrating to ODOT that it is functioning properly for turnover to others for long-term monitoring.
30. Crosby, Schlessinger, Smallridge (CSS) will provide excavations and geometry associated with desired landscaping / land-use design considerations that are to be accommodated by the design of the slope. ELR will perform additional Slope Stability Analyses iterations to evaluate the potential Context Sensitive Design. After selection of the most technically advantageous alternatives, ELR will provide Baker and CSS with a preliminary grading plan. CSS will evaluate potential landscaping / land-use issues of the proposed regarding as it fits in with a planned Towpath Trail and neighborhood reuse alternatives.
31. Upon review and approval by ODOT of revised grading plans (by CSS), ELR will perform the pertinent slope stability analyses for each excavation rehabilitation geometry configuration. ELR will evaluate the differences between the original (technically-based excavation solution) and revised grading plans (landscaping/land-use considerations) and provide written comparison of the suitability of the alternatives as it relates to slope stability (if authorized).

32. Evaluate risks; this task will serve to define the severity, probability and timeframe of the risk to the project. This will help to guide the team on prioritizing the development of a risk mitigation strategy.
33. Develop risk mitigation strategy; this task will serve to define how risks will be mitigated. General categories of mitigation strategies include acceptance, avoidance, protection, research, reserves, and transfer. These strategies will likely include additional requirements in the DB specifications or actions by other outside of the DB contract. As part of the if-authorized work, ELR's contributions to the Risk Assessment efforts will be led by Dr. Marr of Geocomp.
34. All recommendations provided in the Baker report titled **Slope Stability Evaluation Report of the West Bank** dated September 18, 2006, will be discussed and addressed in this report.

## **CHAPTER 3**

### **DESIGN REQUIREMENTS AND CONSTRAINTS**

#### **3.1 Introduction**

Relatively long term field measurements at the location of the existing Central Viaduct have indicated unacceptably large movements of the west slope along the bank of the Cuyahoga River. Pier Number 1 has moved approximately 9 inches which has required span 1 of the bridge superstructure to be lifted and jacked westward on 2 occasions, once in 1999 and again in 2009.

The proposed Westbound Central Viaduct structure is to be constructed to the north of the existing Central Viaduct structure. The slope at the location of the new Westbound Central Viaduct structure must be designed and appropriately graded to ensure that when the new Westbound Central Viaduct structure is constructed, unacceptable movements will not occur in the slope. The Design Team was tasked with: 1) establishing a list of specific stability concerns at this site based on the existing constraints and the in-situ soil engineering properties and 2) providing a slope design that will be stable over the life of the bridge that uses proven engineering solutions.

The slope design and subsequent grading plan must specifically address the overall project goals, requirements, and constraints while minimizing risks. Issues considered in an effort to provide a satisfactory final design are as follows:

#### **3.2 History of Slope Movements**

The observed displacements of the existing slope beneath the existing Central Viaduct have been evaluated and we have concluded from the long-term instrumentation measurements (see inclinometer B-110 plots in Appendix 5A) that the current rate of movement is 0.08 inch/year along a shallow slip plane located 25-30 feet below the surface. This shallow slip plane movement is related to the failure of the sheet pile retaining wall. The long-term instrumentation

measurements indicate that the rate of movement along a deep slip plane located approximately 120 feet below ground, is 0.01 inch/year. The measured movement of the existing slope along Profile A-A (sheet 5 of 34) can be estimated from measurements at inclinometers B-110 and B-107. From the evaluation of the plots of instrumentation readings in Chapter 5, minimal movement has occurred along this section (a rate of  $\leq 0.01$  inch/year). Based on the inclinometer data collected since 1994, the limit of the slope displacements, (excluding construction related displacement) is located to the south of the area for new bridge construction where inclinometer B-108 is located. The data collected from inclinometer B-110 at the deep slip plane located approximately 120 feet below ground surface reveals that the movement is less than 0.03 inches in 5 years, which is a very low rate of movement. The piezometers installed at the project site indicated that the pore pressures in the slope are relatively constant with no rapid changes occurring during the monitoring period from 1994 to 2009.

### **3.3 Existing Slope at the Proposed Westbound Central Viaduct**

The existing slope at the proposed Westbound Central Viaduct location has been stable during recent geologic time with no surface indications of prior significant movements, except at the location of the dock wall at the toe of the slope where the shallow slope failure occurred. The conceptual plans for the limits of the replacement of the dock wall can be found in Appendix G-14. Chapter 6 addresses the evidence of significant shear movements within the clay layers in the slope. These movements likely occurred in the geologic past and resulted in the plastic clay layers reaching a state of residual shear strength. The calculated factor of safety for a representative section through the existing slope, including the influence of existing pore water pressure conditions, is approximately 1.15. This stability condition provides a sufficient degree of safety to maintain the slope intact without large displacements. However, any increase of pore pressure within the slope of a few feet or loss of soil support at the toe of the slope, would significantly lower the factor of safety. A reduced factor of safety would cause down-slope movement of the slope mass and could cause significant lateral forces that would influence the performance of the proposed Westbound Central Viaduct.



The available project background information indicates that some of the subsurface layers exhibit peak drained strength displacement behavior followed by a substantial reduction in strength with continued displacement. This behavior complicates the slope design for long-term stability. Visual inspections and measurements of groundwater levels and pressures have documented the presence of elevated pore pressures within the slope, in some cases the total pressure heads are above the ground surface elevation.

### **3.4 Soil Strength Parameters**

The shear strength parameters for the soils comprising the slope are of great importance to the slope design. Due to the nature of the soils and their strength behavior, the appropriate design strengths could only be determined through a high quality and comprehensive soil sampling and laboratory testing program. Two certified laboratories were utilized to test materials and provide the required design information. The testing program results are documented in Chapter 6 for the measured shear strength parameters and stress/deformation behavior of the material. The laboratory testing results confirmed that the determined design parameters have been reasonably established and are characteristic of soil behavior for over-consolidated materials.

### **3.5 Pore Pressures**

The fact that soil shear strength is reduced by increasing pore pressure and that the factor of safety of the slope is directly related to internal pore pressure is fundamentally recognized. There is significant evidence that a high groundwater level exists in the slope at the project site. Artesian pressures (water level higher than the ground surface) exist at some locations within the slope. These artesian conditions are thought to be caused by gas pressures within portions of the lower stratum above bedrock. The gas is believed to be percolating from the uppermost stratum of bedrock which is composed of Devonian Ohio Shale, which contains natural gas and organic matter. These gas pressures may vary with location and time which makes the potential changes of pore pressure in the existing slope difficult to predict. With such uncertainty, the best risk management approach is to include measures in the final design that limit and control pore

pressure in the slope. Vertical pressure relief ducts have been proposed for installation near the bulkhead wall. Vertical pressure relief ducts will be used as a remediation alternative to minimize the uncertainty related to the gas pressures present at this site. Appendix GE-01 (West Bank Grading Plans) includes a plan for the proposed vertical pressure relief ducts.

### **3.6 Slope Creep**

Slope creep (time-related movement) occurs in slopes with factors of safety below approximately 1.5. Slope creep is expressed by the slow, downward movement of entire slope which occurs when the global factor of safety decreases to low values. This movement of the soil mass takes place in soils at shear stresses sufficient to produce permanent deformation, but too small to cause discrete shear failure.

Slope creep typically occurs as a result of one or more of three common processes: 1) a seasonal soil creep process related to an increase of the load as a result of rain and localized increase in pore pressure from rain infiltration or the melting of frozen ground; 2) the slope softening process related to the reduction in the soil strength as a result of an increase in moisture content over time; and 3) creep at constant moisture content which is related to an inherent soil behavior for certain types of soils, usually highly plastic clays.

The most common form of creep is seasonal soil creep. This process usually influences the top ten to twenty feet of a slope. The introduction of water during heavy rains increases the driving force and the pore pressure which induces creep movements for cases where the factor of safety drops below 1.1 to 1.2. For slopes with a factor of safety greater than 1.5, creep by this mechanism is insignificant to none.

The slope softening creep process occurs without significant volume change and without necessarily involving massive or shallow failure. Slope softening tends to be of most concern in compacted fill areas. After construction, when additional moisture is introduced into the fill through irrigation, rainfall, groundwater, and/or other sources, the fill mass increases in weight. More importantly, pore pressure increase which reduces the effective stress, creates small strains and lowers the soil's shear strength.

The creep process can also occur under constant moisture content. This process occurs in slopes of sufficient height and steepness that contain a weak clay soil at constant moisture, usually at or near saturation. These slopes can be prone to movement analogous to the flow of a viscous fluid.

According to Kuhn and Mitchell (1992) this type of creep only occurs at high stresses (low factors of safety).

The field subsurface conditions for this project are not pertinent to either the seasonal expansive soil creep because the average factor of safety of the slope is approximately 1.6, or the soil softening creep process since the slope is mainly an excavation profile. Also, the creep under constant moisture process is not of concern since most soils in the slope area are characterized as stiff to very stiff soils and since the factor of safety of the slope is approximately 1.6. The proposed construction operation includes the introduction of vertical gas relief ducts that will eliminate the chance for pore water pressure buildup so that the minimum factor of safety should never be less than 1.5.

### **3.7 Perched Water Table near the Railroad**

Subsurface investigations found a perched water table located near the railroad. Borings B-037-2-09 and B-038-1-09 were drilled near the railroad tracks. These borings disclosed the presence of a soft soil layer as well as a perched water table. As a result, the stability evaluation program was expanded to take in consideration this information.

### **3.8 Cold Storage Building**

The removal of the Cold Storage Building near the top of the slope has the potential to improve the stability of the slope. ELR suggested a sequence of construction for the graded slope including the removal of the Cold Storage Building, which is documented in Chapter 9 of this report. ELR evaluated the concerns related to methods used to demolish the cold storage building. For example, blasting methods will not be permitted for demolition of the Cold Storage Building. Analyses indicate that removal of the building will in fact increase the slope's existing factor of safety from 1.15 to about 1.25. Analyses also indicate that removing additional soil near the top of the slope would increase the factor of safety to greater than 1.5.

### **3.9 Bike Path**

A proposed bike path (bench) has been located at approximately mid-height of the 2.5:1 portion of the designed graded slope. The bike path design requires that a 16-foot wide bench be placed in the proposed slope. A drainage ditch is provided on the uphill side of the bench along most of the bike path alignment. The drainage ditch must be lined in a manner that allows the ditch to permanently contain the drainage runoff that enters the ditch. In the area where the proposed access road is located, drainage pipes may need to be installed to allow the surface drainage to pass beneath the access road.

### **3.10 Bulkhead**

A sheet pile bulkhead wall exists at the toe of the west slope. The bulkhead wall is required by the US Army Corps of Engineers to maintain a navigable water way and the wall must be considered in all future design plans. The existing wall consists of 65 feet long sheet piles. Horizontal steel tieback rods spaced at 8 foot intervals extend from the sheeting to deadman anchors located approximately 40 feet behind the sheeting. These deadman anchors failed over time with the consequence that soil and water pressures acting on the back of the sheeting caused outward sheeting displacements of several feet. As part of the design-build contract, the bulkhead wall is to be replaced; therefore it has been included in the appropriate slope stability analyses profile sections. Design limits for the new bulkhead wall are given in Appendix ST-03 (Bulkhead Conceptual Plans).

### **3.11 Proposed Pier Locations**

ELR is providing specific guidance to ODOT addressing constraints on the design of the proposed bridge foundations that the Design-Build Team desires to place within the limits of the graded slope. The proposed excavation and grading will result in an increase in the factor of safety to approximately 1.7; and therefore there are no concerns for locating piers anywhere in the proposed slope. By removing soil from portions of the existing west bank slope, the slope can be made sufficiently stable to the extent that new piers can be built anywhere within the slope. The proposed piers can be constructed at any location in the Westbound Central Viaduct slope

and the piers can be constructed without the use of an isolation foundation system. The foundations are to be located below the defined future excavation line in Section P-P (2) on sheet 30 of 34 in the grading plans attached in Appendix GE-01.

In an effort to evaluate a worst case condition, an assumed spread footing load was applied to the area just south of Abbey Avenue and included in a slope stability analysis. The resulting factor of safety changed from 1.73 to 1.72 with the addition of a spread footing load of 4 ksf, therefore, a pier can be constructed just south of Abbey Avenue.

### **3.12 Utilities**

Utilities are present in the area of the proposed cut for the grading of the slope. The proposed removal of soil material from the slope will require many of the existing utilities to be relocated. Several committees are studying the proposed utility relocation details. The future conceptual grading plan must also be referred to when considerations are given to the locations where the proposed future utilities can be positioned.

### **3.13 Lightweight Fill Material**

A lightweight material such as EPS (expanded polystyrene) could be placed as fill near the top of the slope to reduce the driving forces that decrease the factor of safety. However, the proposed grading plan is sufficiently stable such that the use of a lightweight fill is not justified.

### **3.14 Slope Instrumentation**

A performance monitoring system is recommended as part of the long-term design to identify any undesirable developments in the slope. Plans for a suggested future monitoring program are included in the grading plans in Appendix GE-01 (West Bank Grading Plans).

### **3.15 Slope Stability Analyses for the Future Eastbound Central Viaduct**

Slope excavations planned for the future Eastbound Central Viaduct will encroach upon the slope under the existing Central Viaduct bridge. The effects of this future work on the stability of the slopes for the Westbound Central Viaduct bridge will have to be considered during the design of that future Eastbound Central Viaduct bridge; however we don't expect any significant negative stability effects when conventional construction practices are used.

### **3.16 Top of Graded Slope just North of Abbey Avenue**

A desire for the public to have access to a level area at the top of the slope required the construction of a strip approximately 13 feet wide by 153 feet long be provided on the north side of Abbey Avenue. Also, a triangular area of about 7600 square feet is provided next to the Gateway Animal Clinic. Stability analyses were prepared which included these features and the change in factor of safety to the slope when these features are added was found to be inconsequential (a difference of 0.04 in factor of safety).

### **3.17 Slope Drainage**

Horizontal drains will be used as a remediation measure to minimize the uncertainty related to the future development of perched water tables within the new slopes. A lined ditch will be provided adjacent to the bench.

### **3.18 Construction Considerations**

To reduce the chance for shallow slope failures during construction, the grading contractor is required to cut the excavations "fat"; that is, excavate in stages to allow the slope to drain/dry out prior to reaching the final proposed grade.

### **3.19 Grading the Slope under the Existing Bridge**

An attempt was made to extend the grading and excavation work to the maximum limits possible within the limits of the project right-of-way, the Cuyahoga River and Abbey Avenue. The

ultimate goal is to reduce the driving forces from the west end slope. An attempt was made to cut the slopes under the existing bridge but, the location of the proposed bike path, the removal of the concrete paved slope and the desire to maintain a substantial cover over the existing slope retention system contributed to the decision to avoid any excavation under the existing bridge.

### **3.20 Existing Central Viaduct Bridge Stability**

The slope stability sections developed for the optimization of the grading plan included five sections out of fourteen major sections passing under the existing Central Viaduct bridge. The proposed grading will not affect the down-slope factor of safety for the existing bridge. The proposed grading for the new bridge will create side slopes where the potential sliding planes will be orthogonal to the existing critical sliding planes. The final design considered was established to provide a minimum factor of safety of at least 1.5 for these slopes as well. The contractor should not be permitted to remove or add any materials beneath the existing bridge other than what is shown on the grading plans in Appendix G-14.

### **3.21 Gateway Animal Clinic Parking Lot**

ELR provided a drawing and a cost estimate for constructing a parking lot in the area of the proposed excavated slope that is adjacent to the Gateway Animal Clinic building (sheet 5 of 34 in the grading plans). This construction includes a retaining wall which is to be constructed adjacent to the Gateway Animal Clinic parking lot. Stability analyses have been performed to include the proposed retaining wall and the results indicate that the factor of safety changes from 2.36 to 2.12 when the retaining wall is added. Appendix LD-03 provides a copy of the retaining wall justification study. Final design of this retaining wall will be the responsibility of the Design-Build team.

### **3.22 Slope Drainage Design**

Surface runoff, bridge drainage, and horizontal drain outlets will need to be appropriately addressed by the Design-Build team.

### **3.23 Grading Plan for Future Eastbound Central Viaduct (Replacement for Existing Viaduct)**

ELR has considered how the grading plan for this project will need to be modified to blend in with the grading plan to be designed for the Future Eastbound Central Viaduct. The eastbound structure will be built to replace the existing Central Viaduct structure. The conceptual future grading plan is presented in Appendix G-14 and was developed to serve as a guide for evaluating pier foundation and utility location constraints that must be addressed under the Westbound Central Viaduct contract.

### **3.24 Quality Control and Quality Assurance**

The westbound bridge slope was evaluated by E.L. Robinson Engineering and Geocomp. The firms worked independently, in the context that the work was performed in two offices with different methods of analysis. The independent project management approaches were supplemented with collaboration of the team members on the important parameters and issues that were anticipated to influence slope stability evaluation. The results of these independent studies were discussed, including discrepancies between various studies, conclusions, and recommendations. This collaborative approach was established to provide quality control and quality assurance to the analysis process through independent review and external peer review.



## CHAPTER 4

### SUMMARY OF GEOLOGIC CONDITIONS

#### 4.1 Geology of the Site

Interstate-90 crosses the Cuyahoga River Valley at approximately one mile from the shore of Lake Erie. The surficial deposits along the shore line of Lake Erie are mostly lake plain deposits of glacial origin and extend from 2 to 10 miles from the lake southward into the city. The lake plain deposits are predominately sand and gravel deposits that are interbedded with till above the shale bedrock. According to Hansen (1999); Szabo et al. (2003); and BBC&M (2006), this shale contains organic matters and natural gas, which is believed to become trapped in pockets within the overlying sediments. According to BBC&M (2006), after the completion of a Cone Penetration Test (CPT), a vertical water/gas fountain formed to a height of approximately 10 feet above the ground surface, also a 3 foot high vertical fountain formed for about two hours near the CPT hole located adjacent to a 30 foot pre-drilled boring (BBC&M, 2006).

The lake plain is delineated at the location of the Rocky River, Cuyahoga River and Euclid Creek. The Cuyahoga River Valley is deeply cut into the bedrock that underlies the plain, is 2.5 to 4.0 miles wide across the top and has a relief of over 400 feet. Bedrock elevations range from 600 feet at the west side of the valley to 0 feet at the east side of the valley, which indicates that the preglacial bedrock valley is located east of the present surficial river valley. The existing valley is a relatively minor depression in the ground surface compared to a much more impressive depressed valley in the bedrock surface. Much of the bedrock valley is filled with deposits of clay till and glacial lacustrine clay or silty clay. These deposits extend upward to about Elevation 560 and are overlain by sand and silty sand.

Changing lake levels over long periods of time led to the alternating erosion events and deposition of delta materials at the mouth of the river. The deposited materials were mostly silty and sometimes organic. The soil deposits at the bridge are expected to be horizontally stratified, variable in thickness and overlying deep shale bedrock which continues to dip to the east well beyond the immediate location of the bridge structure. The stability analyses

conducted for this project took into account weak and possibly thin layers of material which may exist and govern the overall stability of the slope.

## **4.2 Subsurface Investigations**

To date, a total of fifty (50) borings and six (6) CPT probes were performed in the area of interest since 1954. The locations of drilled borings are indicated on the plan of borings shown on page 2 of Appendix 4A. The identification reference for all of the borings drilled before 2009 were renumbered to reflect the year of drilling, relative location and serial number of the borings. The original boring numbers for some of the borings are shown in page 1 of Appendix 4A and the new boring references are shown on page 2 of Appendix 4A. The borings and probes are described as follow:

- 1954 Investigations: Four (4) borings were obtained by ODOT in the area of the West End Pier and Pier No. 1 during the original subsurface investigation in 1954. These borings (numbered Borings B-001-0-54 through B-004-0-54) were used to obtain standard penetration testing data and the classification distinction between surficial granular materials and underlying clays.
- 1955 Investigations: In 1955, Seven (7) borings (Borings B-001-0-55, B-002-0-55, B-001-W-55, B-002-W-55, and B-003-W-55 were drilled by HNTB; and Borings B-001-1-55, B-002-1-55 were drilled by NYC&STLRR).
- 1990 and 1992 Investigations: In 1990, nine (9) borings (Borings B-001-0-90 thru B-009-0-90) were obtained by ODOT while installing inclinometers. In 1992, an additional boring was obtained (B-010-0-92) by ODOT.
- 1994 Investigations: In 1994, fourteen (14) borings (Borings B-001-0-94 through B-004-0-94, and B-101-0-94 through B-110-0-94) were drilled by BBC&M in the slope in the vicinity of Pier 1 and the West End Pier (BBC&M, 1994 and 2006). Slope inclinometers were installed at boring locations B-101-0-94 through B-110-0-94. These instruments have been monitored from the time of installation in 1994.

- 1996 and 2000 Investigations: In 1996 three (3) borings, Borings B-201-0-96 through B-203-0-96; (previously labeled B-201 through B-203) were drilled. In 2000, two additional borings (Borings B-003-0-00 and B-004-0-00) were completed. These borings were used to install replacement inclinometers in the proximity of previously installed inclinometers which had exceeded their movement range.
- 2006 Investigations: In 2006 BBC&M conducted an additional subsurface investigation for the purpose of evaluating the stability of the existing west slope and to provide recommendations on the placement of substructures for the proposed West Bound Central Viaduct. The subsurface investigation program included fifteen (15) borings and nine (9) CPT probes. The borings were labeled Borings B-001-0-06 thru B-004-0-06, B-105-A-06, B-108-A-06, B-011-0-06 through B-016-0-06, and V-002-0-06 and V-003-0-06. The 2006 CPT probes were numbered as C-001-0-06 thru C-004-0-06 and C-011-0-06 thru C-015-0-06. Inclinometers were also installed in the 2006-drilled boring locations.
- 2009 Borings: In 2009, Ten (10) borings (Borings B-035-0-09 through B-040-0-09, B-037-1-09, B-037-2-09 and B-038-1-09) were drilled within the project limits

The locations of all drilled borings at the west bank of the Cuyahoga River within the area of interest are shown in Appendix 4A. Boring logs are provided in Appendix 4B. Subsurface profiles produced from the subsurface investigation data were prepared by BBC&M and are presented in Appendix 4C of the report.

### **4.3 Cone Penetration Soundings or Probes**

The subsurface investigation performed by BBC&M in 2006 included six (6) Cone Penetration Tests (CPT) with pore pressure measurements at the locations identified as C-001-0-06 thru C-004-0-06, C-011-0-06, and C-012-0-06. The CPT soundings were performed by Ohio University to depths ranging from 116.5 to 193.2 feet, and are documented in BBC&M Report (dated May 2006) and are contained in Appendix 4E of this report. The tests were terminated prior to reaching the equilibrium static pore pressure values. Based on the time –pore pressure

dissipation curves, the time required for reaching a static pore pressure is anticipated to be between two (2) to eight (8) hours for the majority of the CPT locations. The dissipation tests revealed high initial excess pore pressures at the cone tip, and a relatively slow dissipation rate. Immediately following the tests, the estimated excess pore pressures ranged from 50 to 200 psi, which is equivalent to a 115.0 to 460.0 feet column height of free water.

#### **4.4 Laboratory Testing**

As part of the subsurface investigations mentioned above, representative samples were obtained and tested in several laboratories. Of particular significance is the laboratory test results performed on samples obtained from the 2006 and 2009 investigations. These results are provided in Appendix 4D and are also described and summarized in the following Sections:

##### **4.4.1 Laboratory Testing Performed in 2006**

As part of the 2006 investigation, BBC&M obtained undisturbed samples using Shelby thin wall tubes for laboratory testing to determine the engineering and shear strengths characteristics of the subsurface soils. BBC&M performed the following mechanical properties tests on some samples:

| <u>Test</u>                              | <u>No.of tests</u> |
|--|--------------------|
| Direct shear with residual strength      | 4                  |
| Direct simple shear strength             | 4                  |
| Torsional residual shear strength        | 4                  |
| Consolidated undrained triaxial strength | 3                  |

Results of these tests are provided in BBC&M Report (2006) and are provided in Appendix 4D of this report.

E.L. Robinson, as part of its QC/QA responsibilities, obtained verification samples from BBC&M and forward them to be tested by GeoTesting Express, Inc. (GTX). Results of the GTX tests are provided in Appendix 4F. GTX completed the following tests:

| <u>TEST</u>                | <u>No. of tests</u> |
|----------------------------|---------------------|
| Residual Shear test points | 10                  |
| Direct Simple Shear tests  | 3                   |
| CIU Triaxial tests         | 2                   |

|  |   |
|--|---|
| Incremental Consolidation tests            | 2 |
| Constant Rate of Strain Consolidation test | 1 |
| Gradations                                 | 5 |
| Atterberg Limits                           | 5 |
| Specific Gravity                           | 2 |
| Moisture Content                           | 2 |
| USCS Soil Classification                   | 2 |

#### 4.4.2 Laboratory Testing Performed in 2009

As part of the 2009 subsurface investigation, representative undisturbed samples were tested by BBC&M and GTX. The laboratory tests results by BBC&M and GTX are presented in Appendices 4G and 4H, respectively. GTX performed reverse shear testing on samples collected from Boring B-037-1-09 (S-037-1) between the approximate depths from 66.0 to 74.0 feet. A summary of tests results is provided below:

| Sample | Depth (ft) | Peak Values |        | Residual Values |        |
|--------|------------|-------------|--------|-----------------|--------|
|        |            | C (psf)     | $\phi$ | C(psf)          | $\phi$ |
| S-21   | 64-66      | 854.2       | 14.7   | 0               | 17.9   |
| S-22   | 66-68      | 199.8       | 25.2   | 0               | 19.4   |
| S-24   | 70-72      | 11.5        | 24.5   | 0               | 16.2   |
| S-25   | 72-74      | 600         | 22.8   | 0               | 16.3   |

These results are generally in conformance with the 2006 testing results.

#### 4.4.3 Conclusions from Laboratories Testing Results

Based on the laboratory test results, the following conclusions are made:

1. Results of the consolidation tests and the behavior of the undrained triaxial tests indicate that cohesive soils present in the slope are heavily overconsolidated. One consolidation test indicates an effective pre-consolidation stress greater than 20 tsf. This indicates that strains and displacements preceding an unloading slope failure will be relatively small.
2. Results of the consolidated undrained triaxial tests indicate that negative excess pore pressures develop during undrained shear. These negative pore pressures increase the short-term strength until enough time passes for water to flow into the pores and return

pore pressures to steady state values. Therefore, the critical strength for design in this slope is the drained strength. This conclusion is supported by the fact that peak strengths measured in the undrained triaxial tests (short term conditions )are higher than the peak strengths computed with effective stress strength parameters (long term conditions)for the same effective consolidation stress.

3. Shear strength parameters that were measured on shear planes inclined well above horizontal indicate  $c_p' = 0$  and  $\phi_p' = 32^\circ - 33^\circ$  except for one sample taken directly from the lower shear zone which indicated a secant friction angle of  $26^\circ$ .
4. Shear strength parameters measured on horizontal planes are less than those measured on inclined planes and vary with their position in the slope. Secant friction angles determined from the effective stress path plots indicate friction angles varying from  $33^\circ$  to  $17^\circ$ . Tests that provided lower values appear to coincide with samples taken from zones where inclinometer measurements showed the largest shear displacements within the slope.
5. The residual strength measured in repeated direct shear testing provided residual friction angles of  $30^\circ$  to  $13.6^\circ$ . The lowest value was measured on a specimen taken directly from the lower shear zone where GTX personnel observed indications of pre-existing shear planes in the specimen prior to lab testing. The residual friction angle is a direct function of plasticity of the soil. Soils with higher plasticity exhibit lower residual friction angles. The test data and other subsurface project knowledge suggest that the soils in the west slope have thin seams of more plastic materials that give rise to the lower residual friction values of  $13^\circ$  to  $17^\circ$ . These seams are sufficiently thin and sandwiched between layers of silty material, such that their presence is not readily apparent. Soil index classification tests will not clearly show the presence of plastic seams in a sample because these tests are performed on remolded samples and the more plastic seam material is thoroughly blended with the surrounding silty soil.
6. Test results obtained by BBC&M and those obtained by GTX generally agree when examined in a total context perspective.

#### **4.5 Recommended Strength Values for Slope Design**

The test results indicate that all designs for slope stability and foundation loading in the slope soils should use drained strength parameters with realistic “worst-case” pore pressures. The following strength parameters are recommended for the weak layer described in Chapter 6:

- a. For horizontal and near-horizontal slip surfaces use  $c' = 0$  and  $\phi' = 15^\circ$
- b. For failure surfaces inclined more than  $25^\circ$ , use  $c' = 0$  and  $\phi' = 32^\circ$

#### **4.6 Slope Stability Analyses Performed**

Chapter 6 of this report discusses the proposed soil profiles and the soil parameters used in the slope stability analysis. Detailed slope stability analyses were performed to optimize the grading and check the stability of the proposed grading slopes. The details of the analyses are presented in Chapter 7.

The Geocomp Corporation performed independent slope stability analyses as part of the quality control and their analyses are also presented in Chapter 7.

**CHAPTER 4**

**APPENDICES**



**APPENDIX 4A**

**PLAN OF BORINGS**

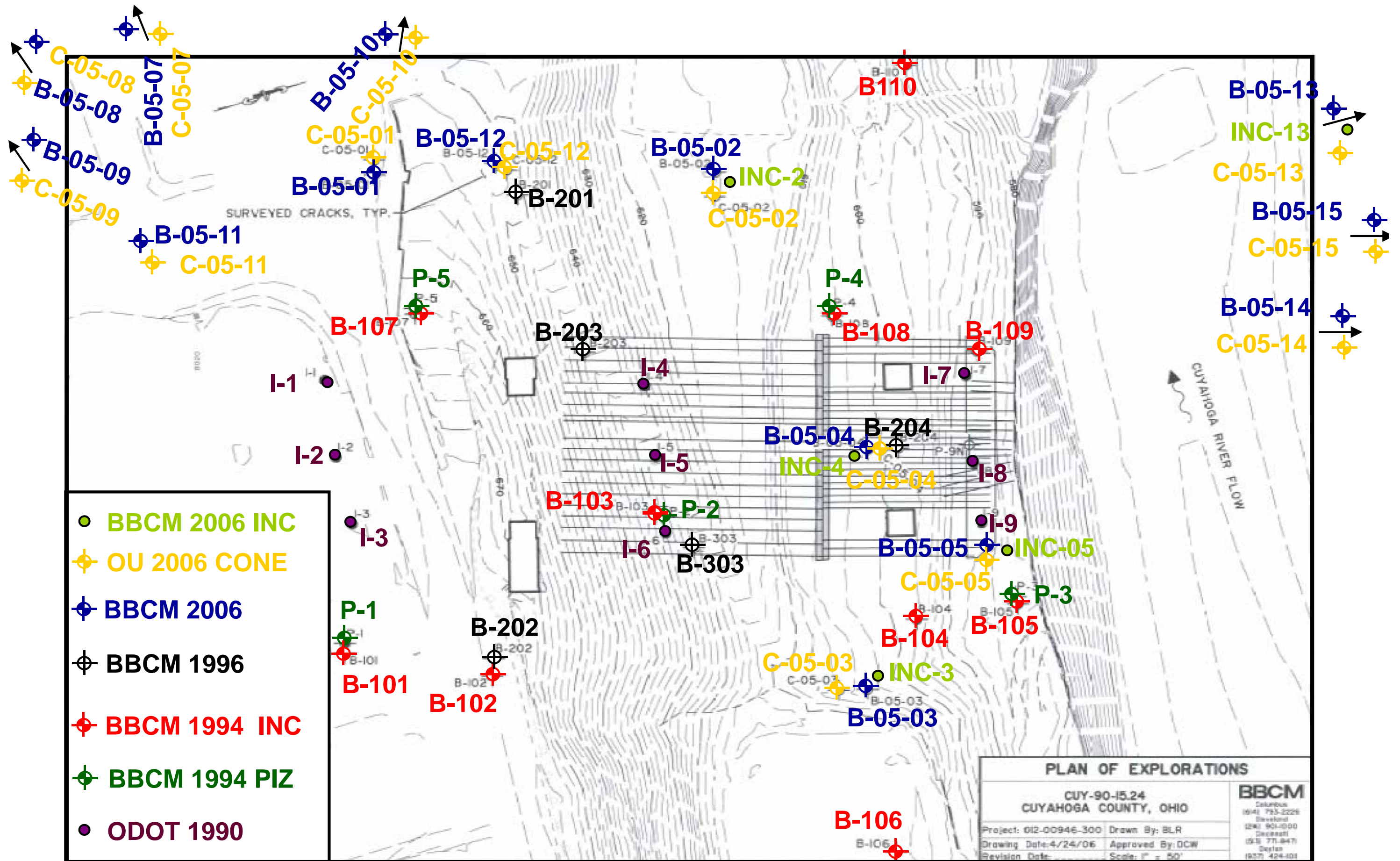

PLATE 2

Original Borings Numbering-before 2009. 2009 boring numbering next page

1- SOIL PROFILE OF BORING NOT INCLUDED ON ANY PROFILES OR CROSS SECTIONS IN THIS SUBMISSION. BORING LOG OR SOIL PROFILE IS AVAILABLE IN THE BORING LOG BINDER SUBMITTED UNDER A SEPERATE COVER.

BORING PROFILE LOCATION REFERENCE  
STA. 128+50 TO STA. 142+50

| BORING ID  | PROFILE/SECTION (SEE SHEET) | BORING ID  | PROFILE/SECTION (SEE SHEET) | BORING ID  | PROFILE/SECTION (SEE SHEET) |
|------------|-----------------------------|------------|-----------------------------|------------|-----------------------------|
| B-035-0-09 | 57, 88                      | B-102-0-94 | N/A                         | B-003-W-55 | N/A                         |
| B-036-0-09 | 115                         | B-103-0-94 | N/A                         | B-001-0-54 | N/A                         |
| B-037-0-09 | 115                         | B-104-0-94 | N/A                         | B-002-0-54 | N/A                         |
| B-037-1-09 | 57, 90                      | B-105-0-94 | N/A                         | B-003-0-54 | N/A                         |
| B-037-2-09 | 116                         | B-106-0-94 | N/A                         | B-004-0-54 | N/A                         |
| B-038-0-09 | 115                         | B-107-0-94 | 113                         | B-005-0-54 | N/A                         |
| B-038-1-09 | 116                         | B-108-0-94 | N/A                         | B-006-0-54 | N/A                         |
| B-039-0-09 | 57                          | B-109-0-94 | 92, 113                     | B-007-0-54 | N/A                         |
| B-040-0-09 | 57                          | B-110-0-94 | 92                          | B-008-0-54 | N/A                         |
| B-001-0-06 | 57                          | B-010-0-92 | N/A                         | C-001-0-06 | N/A                         |
| B-002-0-06 | 113                         | B-001-0-90 | N/A                         | C-002-0-06 | N/A                         |
| B-003-0-06 | 107                         | B-002-0-90 | 111                         | C-003-0-06 | N/A                         |
| B-004-0-06 | 111                         | B-003-0-90 | 109                         | C-004-0-06 | N/A                         |
| B-011-0-06 | 88                          | B-004-0-90 | N/A                         | C-011-0-06 | N/A                         |
| B-012-0-06 | 90                          | B-005-0-90 | N/A                         | C-012-0-06 | N/A                         |
| B-013-0-06 | 94                          | B-006-0-90 | N/A                         | C-013-0-06 | N/A                         |
| B-014-0-06 | 94                          | B-007-0-90 | N/A                         | C-014-0-06 | N/A                         |
| B-015-0-06 | 57, 96                      | B-008-0-90 | 92, 111                     | C-015-0-06 | N/A                         |
| B-016-0-06 | 57                          | B-009-0-90 | N/A                         | P-001-0-94 | N/A                         |
| B-105-A-06 | 92, 109                     | B-001-0-55 | 115                         | P-002-0-94 | 109                         |
| B-108-A-06 | 113                         | B-002-0-55 | 92, 113                     | P-003-0-94 | N/A                         |
| B-003-0-00 | 96                          | B-003-0-55 | 94                          | P-004-0-94 | N/A                         |
| B-004-0-00 | 94                          | B-004-0-55 | N/A                         | P-005-0-09 | N/A                         |
| B-201-0-96 | N/A                         | B-001-1-55 | N/A                         | V-002-0-06 | 96                          |
| B-202-0-96 | 107                         | B-002-1-55 | N/A                         | V-003-0-06 | N/A                         |
| B-203-0-96 | N/A                         | B-001-W-55 | N/A                         |            |                             |
| B-101-0-94 | 107                         | B-002-W-55 | 109                         |            |                             |

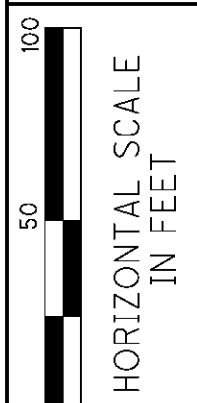
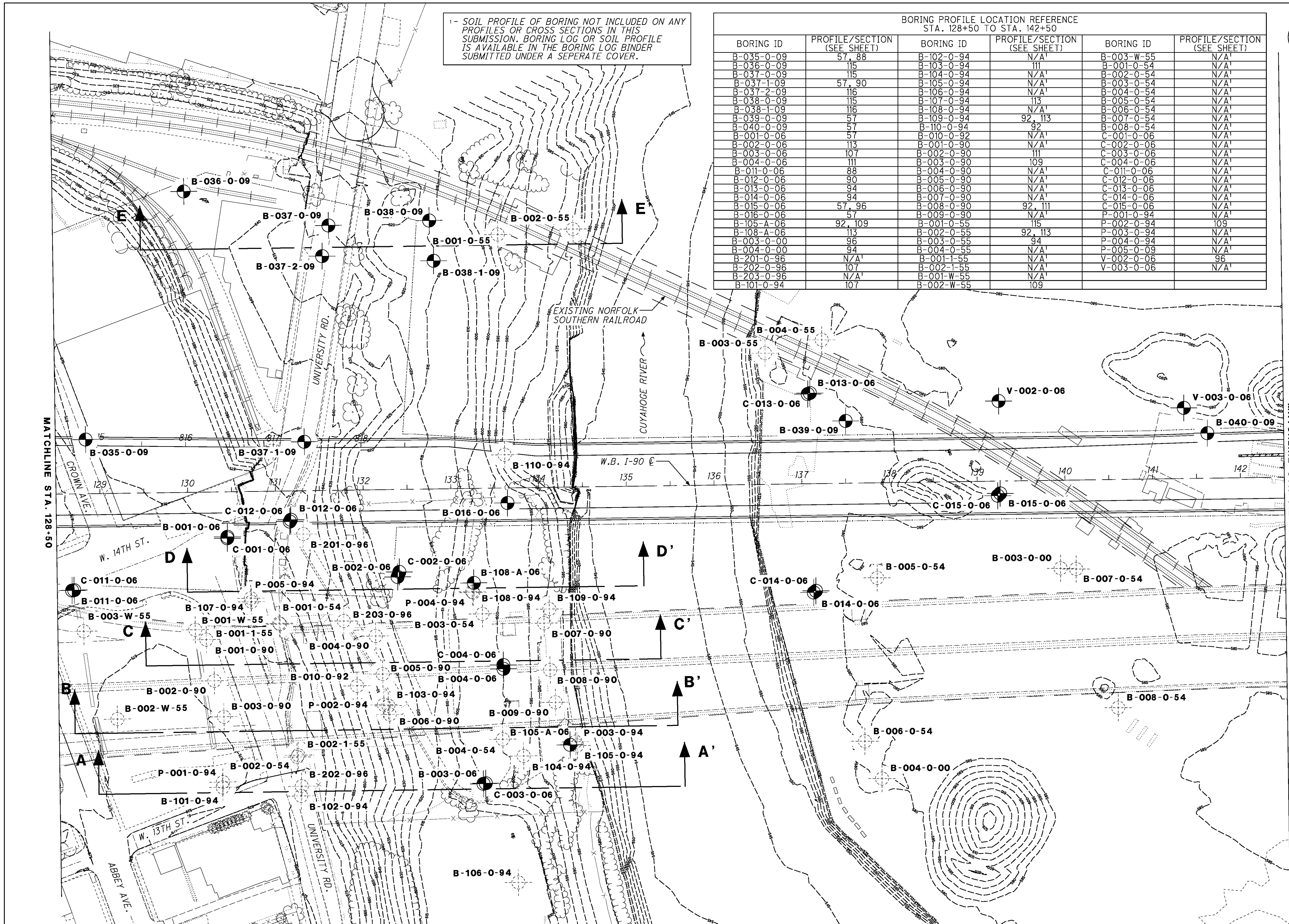

SOIL PROFILE - W.B. I-90  
STA. 128+50 TO STA. 142+50

CUY-90-14.52

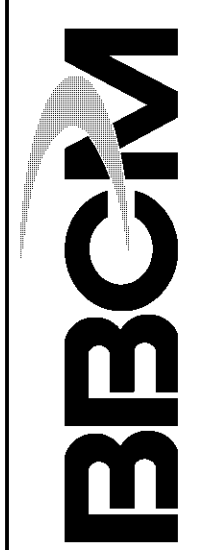
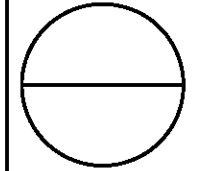

Division  
Testing Laboratory

LOG OF BORING

Date Started 5/30/90 Sampler Type SS Dia. 1 3/8" Water Elev. 639.6'  
 Date Completed 6/14/90 Casing Length Dia. \_\_\_\_\_  
 Project Identification: CUYAHOGA  
 CUY-90-15.24  
 STABILITY ANALYSIS  
 SUBSURFACE INVESTIGATION

Boring No. B-1 Renamed: B-001-0-90 Surface Elev. 675.6'

| Elev. | Depth | Std. Pen. (N) | Reg. Loss ft. | Description               | Field No. | Lab. Nos. Sa | Physical Characteristics |        |        |       |        |      | SHTL Class |        |        |
|-------|-------|---------------|---------------|---------------------------|-----------|--------------|--------------------------|--------|--------|-------|--------|------|------------|--------|--------|
|       |       |               |               |                           |           |              | % Ag                     | % C.S. | % F.S. | % Sil | % Clay | L.I. |            | P.I.   | W.C.   |
| 675.6 | 0     |               |               | GRAVELLY SANDY TOPSOIL    |           |              |                          |        |        |       |        |      |            | VISUAL |        |
|       | 2     | AUGERED       |               |                           |           |              |                          |        |        |       |        |      |            |        |        |
|       | 4     | AUGERED       |               | BROWN GRAVELLY SAND       |           |              |                          |        |        |       |        |      |            |        | VISUAL |
| 668.1 | 6     |               |               |                           |           |              |                          |        |        |       |        |      |            |        |        |
| 665.6 | 8     | AUGERED       |               | BROWN GRAVELLY SAND       |           |              |                          |        |        |       |        |      |            |        | VISUAL |
| 663.1 | 10    |               |               |                           |           |              |                          |        |        |       |        |      |            |        |        |
|       | 12    |               |               |                           |           |              |                          |        |        |       |        |      |            |        |        |
|       | 14    | 3/5/5         |               | BROWN SILTY GRAVELLY SAND | 1         | 63050        | 25                       | 35     | 22     | 12    | 6      | NP   | NP         | 6      | A-1-B  |
|       | 16    |               |               |                           |           |              |                          |        |        |       |        |      |            |        |        |
|       | 18    |               |               |                           |           |              |                          |        |        |       |        |      |            |        |        |
|       | 20    |               |               |                           |           |              |                          |        |        |       |        |      |            |        |        |
|       | 22    |               |               |                           |           |              |                          |        |        |       |        |      |            |        |        |
| 653.1 | 24    | 9/16/24       |               | BROWN SILTY SAND          | 2         | 63051        | 8                        | 42     | 30     | 14    | 6      | NP   | NP         | 4      | A-1-B  |
|       | 26    |               |               |                           |           |              |                          |        |        |       |        |      |            |        |        |
|       | 28    |               |               |                           |           |              |                          |        |        |       |        |      |            |        |        |
|       | 30    |               |               |                           |           |              |                          |        |        |       |        |      |            |        |        |
|       | 32    |               |               |                           |           |              |                          |        |        |       |        |      |            |        |        |
| 643.1 | 34    | 9/15/12       |               | BROWN SILTY SAND          | 3         | 63052        | 0                        | 3      | 72     | 19    | 6      | NP   | NP         | 16     | A-3A   |
|       | 36    |               |               |                           |           |              |                          |        |        |       |        |      |            |        |        |

Particle Sizes: Agg > 2.00 mm, Coarse Sand = 2.00 - 0.42 mm, Fine Sand = 0.42 - 0.074 mm, Silt = 0.074 - 0.005 mm, Clay < 0.005 mm















CUY-90-15.24

Surface Elev. 675.1' Project:

B-2 Renamed: B-002-0-90

| Boring No. | Elev. | Depth | Std. Pen. (N) | Rec. Los. ft. | Description        | Field No. | Lab. Nos. So. | Physical Characteristics |        |        |        |    |    | SHTL Class |      |      |
|------------|-------|-------|---------------|---------------|--------------------|-----------|---------------|--------------------------|--------|--------|--------|----|----|------------|------|------|
|            |       |       |               |               |                    |           |               | % Add. C.S.              | % F.S. | % Silt | % Clay | LL | PL |            | W.C. |      |
| 550.1      |       | 126   | 4/6/12        |               | GRAY CLAYEY SILT   | 13        | 63019         | 0                        | 1      | 2      | 52     | 45 | 28 | 8          | 22   | A-4B |
| 540.1      |       | 128   |               |               |                    |           |               |                          |        |        |        |    |    |            |      |      |
|            |       | 130   |               |               |                    |           |               |                          |        |        |        |    |    |            |      |      |
|            |       | 132   |               |               |                    |           |               |                          |        |        |        |    |    |            |      |      |
|            |       | 134   |               |               |                    |           |               |                          |        |        |        |    |    |            |      |      |
| 538.6      |       | 136   | 10/18/35      |               | GRAY SILT AND CLAY | 14        | 63020         | 0                        | 0      | 1      | 51     | 48 | 34 | 15         | 22   | A-6A |
|            |       | 138   |               |               |                    |           |               |                          |        |        |        |    |    |            |      |      |
|            |       | 140   |               |               |                    |           |               |                          |        |        |        |    |    |            |      |      |
|            |       | 142   |               |               |                    |           |               |                          |        |        |        |    |    |            |      |      |
|            |       | 144   |               |               |                    |           |               |                          |        |        |        |    |    |            |      |      |
|            |       | 146   |               |               |                    |           |               |                          |        |        |        |    |    |            |      |      |
|            |       | 148   |               |               |                    |           |               |                          |        |        |        |    |    |            |      |      |
|            |       | 150   |               |               |                    |           |               |                          |        |        |        |    |    |            |      |      |
|            |       | 152   |               |               |                    |           |               |                          |        |        |        |    |    |            |      |      |
|            |       | 154   |               |               |                    |           |               |                          |        |        |        |    |    |            |      |      |
|            |       | 156   |               |               |                    |           |               |                          |        |        |        |    |    |            |      |      |
|            |       | 158   |               |               |                    |           |               |                          |        |        |        |    |    |            |      |      |
|            |       | 160   |               |               |                    |           |               |                          |        |        |        |    |    |            |      |      |
|            |       | 162   |               |               |                    |           |               |                          |        |        |        |    |    |            |      |      |
|            |       | 164   |               |               |                    |           |               |                          |        |        |        |    |    |            |      |      |
|            |       | 166   |               |               |                    |           |               |                          |        |        |        |    |    |            |      |      |

— BOTTOM OF BORING

NOTE: SLOPE INDICATOR PIPE INSTALLED AT 138.0'







12  
34

Boring No. B-3 Renamed: B-003-0-90

Surface Elev. 675.1' Project: CUY-90-15.24

| Elev.          | Depth                    | Std. Pen. (N) | Rec. ft. | Los. ft. | Description      | Field No. | Lab. Nos. So. | Physical Characteristics |        |        |        |        |    | SHTL Class |    |      |
|----------------|--------------------------|---------------|----------|----------|------------------|-----------|---------------|--------------------------|--------|--------|--------|--------|----|------------|----|------|
|                |                          |               |          |          |                  |           |               | % Agg.                   | % C.S. | % F.S. | % Silt | % Clay | LL |            | PL | W.C. |
| 545.1          | 126<br>128<br>130<br>132 | 6/12/20       |          |          | GRAY CLAYEY SILT | 13        | 63005         | 0                        | 0      | 1      | 59     | 40     | 27 | 7          | 22 | A-4B |
| 535.1<br>533.6 | 140<br>142               | 13/18/25      |          |          | GRAY CLAY        | 14        | 63006         | 9                        | 3      | 6      | 33     | 49     | 40 | 21         | 20 | A-6B |

← BOTTOM OF BORING

NOTE: SLOPE INDICATOR PIPE INSTALLED AT 142.0'





Boring No. Renamed: B-004-0-90

Surface Elev. 616.5' Project: CUY-90-15.24

| Elev. | Depth | Std. Pen. (N) | Rec. ft. | Loss ft. | Description      | Field No. | Lab. Nos. So. | Physical Characteristics |        |        |        |      |      |      | SHTL Class |       |
|-------|-------|---------------|----------|----------|------------------|-----------|---------------|--------------------------|--------|--------|--------|------|------|------|------------|-------|
|       |       |               |          |          |                  |           |               | % Agg. C.S.              | % F.S. | % Silt | % Clay | L.L. | P.I. | W.C. |            |       |
| 576.5 | 38    |               |          |          | GRAY CLAYEY SILT | 4         | 62953         | 0                        | 0      | 1      | 55     | 44   | 31   | 10   | 19         | A-4B  |
|       | 40    |               |          |          |                  |           |               |                          |        |        |        |      |      |      |            |       |
|       | 42    | 5/9/16'       |          |          |                  |           |               |                          |        |        |        |      |      |      |            |       |
|       | 44    |               |          |          |                  |           |               |                          |        |        |        |      |      |      |            |       |
|       | 46    |               |          |          |                  |           |               |                          |        |        |        |      |      |      |            |       |
|       | 48    |               |          |          |                  |           |               |                          |        |        |        |      |      |      |            |       |
| 566.5 | 50    |               |          |          | GRAY CLAY        | 5         | 62954         | 0                        | 1      | 2      | 35     | 62   | 30   | 80   | 22         | A-7-6 |
|       | 52    | 6/6/8         |          |          |                  |           |               |                          |        |        |        |      |      |      |            |       |
|       | 54    |               |          |          |                  |           |               |                          |        |        |        |      |      |      |            |       |
|       | 56    |               |          |          |                  |           |               |                          |        |        |        |      |      |      |            |       |
|       | 58    |               |          |          |                  |           |               |                          |        |        |        |      |      |      |            |       |
| 556.5 | 60    |               |          |          | GRAY SILTY CLAY  | 6         | 62955         | 0                        | 0      | 2      | 56     | 42   | 36   | 17   | 23         | A-6B  |
|       | 62    | 7/14/17'      |          |          |                  |           |               |                          |        |        |        |      |      |      |            |       |
|       | 64    |               |          |          |                  |           |               |                          |        |        |        |      |      |      |            |       |
|       | 66    |               |          |          |                  |           |               |                          |        |        |        |      |      |      |            |       |
|       | 68    |               |          |          |                  |           |               |                          |        |        |        |      |      |      |            |       |
| 546.5 | 70    |               |          |          | GRAY CLAYEY SILT | 7         | 62956         | 0                        | 0      | 1      | 56     | 43   | 29   | 10   | 21         | A-4B  |
|       | 72    | 4/7/10        |          |          |                  |           |               |                          |        |        |        |      |      |      |            |       |
|       | 74    |               |          |          |                  |           |               |                          |        |        |        |      |      |      |            |       |
|       | 76    |               |          |          |                  |           |               |                          |        |        |        |      |      |      |            |       |
|       | 78    |               |          |          |                  |           |               |                          |        |        |        |      |      |      |            |       |



Boring No. B-4 Renamed: B-004-0-90

Surface Elev. 616.5' Project: CUY-90-15.24

| Elev. | Depth | Std. Pen. (N) | Rec. ft. | Loss ft. | Description        | Field No. | Lab. Nos. So. | Physical Characteristics |        |        |        |        | SHTL Class |      |      |      |    |    |  |      |
|-------|-------|---------------|----------|----------|--------------------|-----------|---------------|--------------------------|--------|--------|--------|--------|------------|------|------|------|----|----|--|------|
|       |       |               |          |          |                    |           |               | % Agg.                   | % C.S. | % F.S. | % Silt | % Clay |            | L.L. | P.I. | W.C. |    |    |  |      |
| 486.5 | 126   |               |          |          | GRAY SILTY SAND    | 13        | 62962         |                          |        |        |        |        |            |      |      |      |    |    |  |      |
|       | 128   |               |          |          |                    |           |               |                          |        |        |        |        |            |      |      |      |    |    |  |      |
|       | 130   | *             |          |          |                    |           |               |                          |        |        |        |        |            |      |      |      |    |    |  |      |
|       | 132   | 0/0/0         |          |          |                    |           |               |                          |        |        | 0      | 30     | 52         | 15   | 3    | NP   | NP | 19 |  | A-3A |
|       | 134   |               |          |          |                    |           |               |                          |        |        |        |        |            |      |      |      |    |    |  |      |
|       | 136   |               |          |          |                    |           |               |                          |        |        |        |        |            |      |      |      |    |    |  |      |
|       | 138   |               |          |          |                    |           |               |                          |        |        |        |        |            |      |      |      |    |    |  |      |
| 476.5 | 140   |               |          |          | GRAY SILT AND CLAY | 14        | 62963         |                          |        |        |        |        |            |      |      |      |    |    |  |      |
|       | 142   |               |          |          |                    |           |               |                          |        |        | 0      | 4      | 9          | 34   | 53   | 33   | 13 | 16 |  | A-6A |
|       | 144   |               |          |          |                    |           |               |                          |        |        |        |        |            |      |      |      |    |    |  |      |
| 471.5 | 146   |               |          |          | GRAY SANDY SILT    | 15        | 62964         |                          |        |        |        |        |            |      |      |      |    |    |  |      |
| 470.0 | 148   |               |          |          |                    |           |               |                          |        |        | 11     | 5      | 8          | 29   | 47   | 33   | 14 | 15 |  | A-6A |
|       | 150   |               |          |          |                    |           |               |                          |        |        |        |        |            |      |      |      |    |    |  |      |
|       | 152   |               |          |          |                    |           |               |                          |        |        |        |        |            |      |      |      |    |    |  |      |
|       | 154   |               |          |          |                    |           |               |                          |        |        |        |        |            |      |      |      |    |    |  |      |
|       | 156   |               |          |          |                    |           |               |                          |        |        |        |        |            |      |      |      |    |    |  |      |
|       | 158   |               |          |          |                    |           |               |                          |        |        |        |        |            |      |      |      |    |    |  |      |
|       | 160   |               |          |          |                    |           |               |                          |        |        |        |        |            |      |      |      |    |    |  |      |
|       | 162   |               |          |          |                    |           |               |                          |        |        |        |        |            |      |      |      |    |    |  |      |
|       | 164   |               |          |          |                    |           |               |                          |        |        |        |        |            |      |      |      |    |    |  |      |
|       | 166   |               |          |          |                    |           |               |                          |        |        |        |        |            |      |      |      |    |    |  |      |

← BOTTOM OF BORING

\* ROD WENT DOWN 1.5' FROM WEIGHT OF ITSELF  
 NOTE: SLOPE INDICATOR PIPE INSTALLED AT 140.0'  
 WATER HEAVED 8' ABOVE GROUND SURFACE DURING  
 INSTALLATION OF SLOPE INCLINOMETER PIPE.

163



Boring No. B-5 Renamed: B-005-0-90

Surface Elev. 617.41 Project: CUY-90-15.24

| Elev. | Depth | Std. Pen. (N) | Rec. ft. | Loss ft. | Description        | Field No. | Lab. Nos. So. | Physical Characteristics |        |        |        |    |    |      |    |
|-------|-------|---------------|----------|----------|--------------------|-----------|---------------|--------------------------|--------|--------|--------|----|----|------|----|
|       |       |               |          |          |                    |           |               | % Agg. S.S.              | % F.S. | % Silt | % Clay | LL | PI | W.C. |    |
| 572.4 | 38    |               |          |          | GRAY SILT AND CLAY | 5         | 62969         | 0                        | 1      | 2      | 38     | 59 | 36 | 15   | 30 |
|       | 40    |               |          |          |                    |           |               |                          |        |        |        |    |    |      |    |
|       | 42    |               |          |          |                    |           |               |                          |        |        |        |    |    |      |    |
|       | 44    |               |          |          |                    |           |               |                          |        |        |        |    |    |      |    |
|       | 46    | 2/4/9         |          |          |                    |           |               |                          |        |        |        |    |    |      |    |
|       | 48    |               |          |          |                    |           |               |                          |        |        |        |    |    |      |    |
|       | 50    |               |          |          |                    |           |               |                          |        |        |        |    |    |      |    |
|       | 52    |               |          |          |                    |           |               |                          |        |        |        |    |    |      |    |
| 562.4 | 54    |               |          |          | GRAY SILTY CLAY    | 6         | 62970         | 0                        | 1      | .1     | 32     | 66 | 40 | 16   | 29 |
|       | 56    | 7/11/10       |          |          |                    |           |               |                          |        |        |        |    |    |      |    |
|       | 58    |               |          |          |                    |           |               |                          |        |        |        |    |    |      |    |
|       | 60    |               |          |          |                    |           |               |                          |        |        |        |    |    |      |    |
|       | 62    |               |          |          |                    |           |               |                          |        |        |        |    |    |      |    |
|       | 64    |               |          |          |                    |           |               |                          |        |        |        |    |    |      |    |
|       | 66    |               |          |          |                    |           |               |                          |        |        |        |    |    |      |    |
|       | 68    |               |          |          |                    |           |               |                          |        |        |        |    |    |      |    |
| 552.4 | 70    |               |          |          | GRAY CLAYEY SILT   | 7         | 62971         | 0                        | 0      | 2      | 53     | 45 | 30 | 10   | 22 |
|       | 72    |               |          |          |                    |           |               |                          |        |        |        |    |    |      |    |
|       | 74    |               |          |          |                    |           |               |                          |        |        |        |    |    |      |    |
|       | 76    | 15/19/21      |          |          |                    |           |               |                          |        |        |        |    |    |      |    |
|       | 78    |               |          |          |                    |           |               |                          |        |        |        |    |    |      |    |
|       | 80    |               |          |          |                    |           |               |                          |        |        |        |    |    |      |    |
|       | 82    |               |          |          |                    |           |               |                          |        |        |        |    |    |      |    |
|       | 84    |               |          |          |                    |           |               |                          |        |        |        |    |    |      |    |
| 542.4 | 86    |               |          |          | GRAY CLAYEY SILT   | 8         | 62972         | 0                        | 1      | 2      | 54     | 43 | 30 | 10   | 22 |
|       | 88    | 12/22/20      |          |          |                    |           |               |                          |        |        |        |    |    |      |    |



CUY-90-15.24

Project: 617.41

Surface Elev. 617.41

Spring No. B-5 Renamed: B-005-0-90

| Elev  | Depth | Std. Dep. (N) | Rec. ft | Loss ft | Description      | Field No. | Lab. Nos. Se. | Physical Characteristics |        |        |        |    | SF |    |    |   |
|-------|-------|---------------|---------|---------|------------------|-----------|---------------|--------------------------|--------|--------|--------|----|----|----|----|---|
|       |       |               |         |         |                  |           |               | % Agg.                   | % F.S. | % Silt | % Clay | LL |    | PL | WC |   |
| 492.4 | 126   | 8/15/22       |         |         | GRAY SILTY CLAY  | 13        | 62977         | 0                        | 0      | 1      | 29     | 70 | 41 | 16 | 28 | A |
|       | 128   |               |         |         | BOTTOM OF BORING |           |               |                          |        |        |        |    |    |    |    |   |
|       | 130   |               |         |         |                  |           |               |                          |        |        |        |    |    |    |    |   |
|       | 132   |               |         |         |                  |           |               |                          |        |        |        |    |    |    |    |   |
|       | 134   |               |         |         |                  |           |               |                          |        |        |        |    |    |    |    |   |
|       | 136   |               |         |         |                  |           |               |                          |        |        |        |    |    |    |    |   |
|       | 138   |               |         |         |                  |           |               |                          |        |        |        |    |    |    |    |   |
|       | 140   |               |         |         |                  |           |               |                          |        |        |        |    |    |    |    |   |
|       | 142   |               |         |         |                  |           |               |                          |        |        |        |    |    |    |    |   |
|       | 144   |               |         |         |                  |           |               |                          |        |        |        |    |    |    |    |   |
|       | 146   |               |         |         |                  |           |               |                          |        |        |        |    |    |    |    |   |
|       | 148   |               |         |         |                  |           |               |                          |        |        |        |    |    |    |    |   |
|       | 150   |               |         |         |                  |           |               |                          |        |        |        |    |    |    |    |   |
|       | 152   |               |         |         |                  |           |               |                          |        |        |        |    |    |    |    |   |
|       | 154   |               |         |         |                  |           |               |                          |        |        |        |    |    |    |    |   |
|       | 156   |               |         |         |                  |           |               |                          |        |        |        |    |    |    |    |   |
|       | 158   |               |         |         |                  |           |               |                          |        |        |        |    |    |    |    |   |
|       | 160   |               |         |         |                  |           |               |                          |        |        |        |    |    |    |    |   |
|       | 162   |               |         |         |                  |           |               |                          |        |        |        |    |    |    |    |   |
|       | 164   |               |         |         |                  |           |               |                          |        |        |        |    |    |    |    |   |
|       | 166   |               |         |         |                  |           |               |                          |        |        |        |    |    |    |    |   |

NOTE: SLOPE INDICATOR PIPE INSTALLED AT 125.0'





Project: CUY-90-15.24

Boring No. B-6 Renamed: B-006-0-90

Surface Elev. 617.5'

| Elev. | Depth | Srd. Pen. (N) | Rec. Loss ft. | Description      | Field No. | Lab. Nos. So. | Physical Characteristics |        |        |        |      |      |      |    |
|-------|-------|---------------|---------------|------------------|-----------|---------------|--------------------------|--------|--------|--------|------|------|------|----|
|       |       |               |               |                  |           |               | % Agg. C.S.              | % F.S. | % Silt | % Clay | L.L. | P.I. | W.C. |    |
| 575.0 | 38    |               |               | GRAY CLAYEY SILT | 4         | 63066         | 0                        | 2      | 4      | 42     | 52   | 34   | 10   | 18 |
|       | 40    |               |               |                  |           |               |                          |        |        |        |      |      |      |    |
|       | 42    |               |               |                  |           |               |                          |        |        |        |      |      |      |    |
|       | 44    | 7/8/12        |               |                  |           |               |                          |        |        |        |      |      |      |    |
|       | 46    |               |               |                  |           |               |                          |        |        |        |      |      |      |    |
|       | 48    |               |               |                  |           |               |                          |        |        |        |      |      |      |    |
|       | 50    |               |               |                  |           |               |                          |        |        |        |      |      |      |    |
|       | 52    |               |               |                  |           |               |                          |        |        |        |      |      |      |    |
|       | 54    | 5/6/12        |               |                  |           |               |                          |        |        |        |      |      |      |    |
|       | 56    |               |               |                  |           |               |                          |        |        |        |      |      |      |    |
| 565.0 | 58    |               |               | GRAY CLAYEY SILT | 5         | 63067         | 0                        | 1      | 1      | 37     | 61   | 34   | 8    | 29 |
|       | 60    |               |               |                  |           |               |                          |        |        |        |      |      |      |    |
|       | 62    |               |               |                  |           |               |                          |        |        |        |      |      |      |    |
|       | 64    | 10/17/21      |               |                  |           |               |                          |        |        |        |      |      |      |    |
|       | 66    |               |               |                  |           |               |                          |        |        |        |      |      |      |    |
|       | 68    |               |               |                  |           |               |                          |        |        |        |      |      |      |    |
|       | 70    |               |               |                  |           |               |                          |        |        |        |      |      |      |    |
|       | 72    |               |               |                  |           |               |                          |        |        |        |      |      |      |    |
| 545.0 | 74    | 11/17/23      |               | GRAY CLAYEY SILT | 7         | 63069         | 0                        | 0      | 1      | 60     | 39   | 30   | 9    | 20 |
|       | 76    |               |               |                  |           |               |                          |        |        |        |      |      |      |    |
|       | 78    |               |               |                  |           |               |                          |        |        |        |      |      |      |    |
|       | 80    |               |               |                  |           |               |                          |        |        |        |      |      |      |    |
|       | 82    |               |               |                  |           |               |                          |        |        |        |      |      |      |    |
|       | 84    |               |               |                  |           |               |                          |        |        |        |      |      |      |    |

CUY-90-15.24

Project: 617.5' Surface Elev.

Boring No. B-6 Renamed: B-006-0-90

| Elev. | Depth | Std. Pen. (N) | Rec. Loss ft. | Description        | Field No. | Lab. Nos. | Physical Characteristics |        |        |        |    |    | SHTL Class |      |      |
|-------|-------|---------------|---------------|--------------------|-----------|-----------|--------------------------|--------|--------|--------|----|----|------------|------|------|
|       |       |               |               |                    |           |           | % Agg. C.S.              | % F.S. | % Silt | % Clay | LL | PL |            | W.C. |      |
| 535.0 | 82    |               |               | GRAY SILT          | 8         | 63070     | 0                        | 4      | 9      | 49     | 38 | 25 | 6          | 13   | A-4A |
|       | 84    | 8/20/25       |               |                    |           |           |                          |        |        |        |    |    |            |      |      |
|       | 86    |               |               |                    |           |           |                          |        |        |        |    |    |            |      |      |
|       | 88    |               |               |                    |           |           |                          |        |        |        |    |    |            |      |      |
|       | 90    |               |               |                    |           |           |                          |        |        |        |    |    |            |      |      |
|       | 92    |               |               |                    |           |           |                          |        |        |        |    |    |            |      |      |
|       | 94    | 17/24/34      |               |                    |           |           |                          |        |        |        |    |    |            |      |      |
|       | 96    |               |               |                    |           |           |                          |        |        |        |    |    |            |      |      |
|       | 98    |               |               |                    |           |           |                          |        |        |        |    |    |            |      |      |
|       | 100   |               |               |                    |           |           |                          |        |        |        |    |    |            |      |      |
| 515.0 | 102   |               |               | GRAY CLAYEY SILT   | 9         | 63071     | 0                        | 2      | 4      | 37     | 57 | 25 | 2          | 21   | A-4A |
|       | 104   | 8/15/19       |               |                    |           |           |                          |        |        |        |    |    |            |      |      |
|       | 106   |               |               |                    |           |           |                          |        |        |        |    |    |            |      |      |
|       | 108   |               |               |                    |           |           |                          |        |        |        |    |    |            |      |      |
|       | 110   |               |               |                    |           |           |                          |        |        |        |    |    |            |      |      |
|       | 112   |               |               |                    |           |           |                          |        |        |        |    |    |            |      |      |
|       | 114   | 13/16/19      |               |                    |           |           |                          |        |        |        |    |    |            |      |      |
|       | 116   |               |               |                    |           |           |                          |        |        |        |    |    |            |      |      |
|       | 118   |               |               |                    |           |           |                          |        |        |        |    |    |            |      |      |
|       | 120   |               |               |                    |           |           |                          |        |        |        |    |    |            |      |      |
| 505.0 | 122   |               |               | GRAY SILT AND CLAY | 10        | 63072     | 0                        | 1      | 3      | 38     | 58 | 34 | 10         | 23   | A-4A |
|       | 112   |               |               |                    |           |           |                          |        |        |        |    |    |            |      |      |
|       | 114   | 13/16/19      |               |                    |           |           |                          |        |        |        |    |    |            |      |      |
|       | 116   |               |               |                    |           |           |                          |        |        |        |    |    |            |      |      |
|       | 118   |               |               |                    |           |           |                          |        |        |        |    |    |            |      |      |
|       | 120   |               |               |                    |           |           |                          |        |        |        |    |    |            |      |      |
|       | 122   |               |               |                    |           |           |                          |        |        |        |    |    |            |      |      |
|       | 124   |               |               |                    |           |           |                          |        |        |        |    |    |            |      |      |
|       | 126   |               |               |                    |           |           |                          |        |        |        |    |    |            |      |      |
|       | 128   |               |               |                    |           |           |                          |        |        |        |    |    |            |      |      |
| 495.0 | 130   |               |               | GRAY SILT AND CLAY | 11        | 63073     | 0                        | 2      | 3      | 38     | 57 | 35 | 12         | 18   | A-6A |
|       | 132   |               |               |                    |           |           |                          |        |        |        |    |    |            |      |      |
|       | 134   |               |               |                    |           |           |                          |        |        |        |    |    |            |      |      |
|       | 136   |               |               |                    |           |           |                          |        |        |        |    |    |            |      |      |
|       | 138   |               |               |                    |           |           |                          |        |        |        |    |    |            |      |      |
|       | 140   |               |               |                    |           |           |                          |        |        |        |    |    |            |      |      |
|       | 142   |               |               |                    |           |           |                          |        |        |        |    |    |            |      |      |
|       | 144   |               |               |                    |           |           |                          |        |        |        |    |    |            |      |      |
|       | 146   |               |               |                    |           |           |                          |        |        |        |    |    |            |      |      |
|       | 148   |               |               |                    |           |           |                          |        |        |        |    |    |            |      |      |
|       | 150   |               |               |                    |           |           |                          |        |        |        |    |    |            |      |      |
|       | 152   |               |               |                    |           |           |                          |        |        |        |    |    |            |      |      |
|       | 154   |               |               |                    |           |           |                          |        |        |        |    |    |            |      |      |
|       | 156   |               |               |                    |           |           |                          |        |        |        |    |    |            |      |      |
|       | 158   |               |               |                    |           |           |                          |        |        |        |    |    |            |      |      |
|       | 160   |               |               |                    |           |           |                          |        |        |        |    |    |            |      |      |
|       | 162   |               |               |                    |           |           |                          |        |        |        |    |    |            |      |      |
|       | 164   |               |               |                    |           |           |                          |        |        |        |    |    |            |      |      |
|       | 166   |               |               |                    |           |           |                          |        |        |        |    |    |            |      |      |
|       | 168   |               |               |                    |           |           |                          |        |        |        |    |    |            |      |      |
|       | 170   |               |               |                    |           |           |                          |        |        |        |    |    |            |      |      |
|       | 172   |               |               |                    |           |           |                          |        |        |        |    |    |            |      |      |
|       | 174   |               |               |                    |           |           |                          |        |        |        |    |    |            |      |      |
|       | 176   |               |               |                    |           |           |                          |        |        |        |    |    |            |      |      |
|       | 178   |               |               |                    |           |           |                          |        |        |        |    |    |            |      |      |
|       | 180   |               |               |                    |           |           |                          |        |        |        |    |    |            |      |      |
|       | 182   |               |               |                    |           |           |                          |        |        |        |    |    |            |      |      |
|       | 184   |               |               |                    |           |           |                          |        |        |        |    |    |            |      |      |
|       | 186   |               |               |                    |           |           |                          |        |        |        |    |    |            |      |      |
|       | 188   |               |               |                    |           |           |                          |        |        |        |    |    |            |      |      |
|       | 190   |               |               |                    |           |           |                          |        |        |        |    |    |            |      |      |
|       | 192   |               |               |                    |           |           |                          |        |        |        |    |    |            |      |      |
|       | 194   |               |               |                    |           |           |                          |        |        |        |    |    |            |      |      |
|       | 196   |               |               |                    |           |           |                          |        |        |        |    |    |            |      |      |
|       | 198   |               |               |                    |           |           |                          |        |        |        |    |    |            |      |      |
|       | 200   |               |               |                    |           |           |                          |        |        |        |    |    |            |      |      |
|       | 202   |               |               |                    |           |           |                          |        |        |        |    |    |            |      |      |
|       | 204   |               |               |                    |           |           |                          |        |        |        |    |    |            |      |      |
|       | 206   |               |               |                    |           |           |                          |        |        |        |    |    |            |      |      |
|       | 208   |               |               |                    |           |           |                          |        |        |        |    |    |            |      |      |
|       | 210   |               |               |                    |           |           |                          |        |        |        |    |    |            |      |      |
|       | 212   |               |               |                    |           |           |                          |        |        |        |    |    |            |      |      |
|       | 214   |               |               |                    |           |           |                          |        |        |        |    |    |            |      |      |
|       | 216   |               |               |                    |           |           |                          |        |        |        |    |    |            |      |      |
|       | 218   |               |               |                    |           |           |                          |        |        |        |    |    |            |      |      |
|       | 220   |               |               |                    |           |           |                          |        |        |        |    |    |            |      |      |
|       | 222   |               |               |                    |           |           |                          |        |        |        |    |    |            |      |      |
|       | 224   |               |               |                    |           |           |                          |        |        |        |    |    |            |      |      |
|       | 226   |               |               |                    |           |           |                          |        |        |        |    |    |            |      |      |
|       | 228   |               |               |                    |           |           |                          |        |        |        |    |    |            |      |      |
|       | 230   |               |               |                    |           |           |                          |        |        |        |    |    |            |      |      |
|       | 232   |               |               |                    |           |           |                          |        |        |        |    |    |            |      |      |
|       | 234   |               |               |                    |           |           |                          |        |        |        |    |    |            |      |      |
|       | 236   |               |               |                    |           |           |                          |        |        |        |    |    |            |      |      |
|       | 238   |               |               |                    |           |           |                          |        |        |        |    |    |            |      |      |
|       | 240   |               |               |                    |           |           |                          |        |        |        |    |    |            |      |      |
|       | 242   |               |               |                    |           |           |                          |        |        |        |    |    |            |      |      |
|       | 244   |               |               |                    |           |           |                          |        |        |        |    |    |            |      |      |
|       | 246   |               |               |                    |           |           |                          |        |        |        |    |    |            |      |      |
|       | 248   |               |               |                    |           |           |                          |        |        |        |    |    |            |      |      |
|       | 250   |               |               |                    |           |           |                          |        |        |        |    |    |            |      |      |
|       | 252   |               |               |                    |           |           |                          |        |        |        |    |    |            |      |      |
|       | 254   |               |               |                    |           |           |                          |        |        |        |    |    |            |      |      |
|       | 256   |               |               |                    |           |           |                          |        |        |        |    |    |            |      |      |
|       | 258   |               |               |                    |           |           |                          |        |        |        |    |    |            |      |      |
|       | 260   |               |               |                    |           |           |                          |        |        |        |    |    |            |      |      |
|       | 262   |               |               |                    |           |           |                          |        |        |        |    |    |            |      |      |
|       | 264   |               |               |                    |           |           |                          |        |        |        |    |    |            |      |      |
|       | 266   |               |               |                    |           |           |                          |        |        |        |    |    |            |      |      |
|       | 268   |               |               |                    |           |           |                          |        |        |        |    |    |            |      |      |
|       | 270   |               |               |                    |           |           |                          |        |        |        |    |    |            |      |      |
|       | 272   |               |               |                    |           |           |                          |        |        |        |    |    |            |      |      |
|       | 274   |               |               |                    |           |           |                          |        |        |        |    |    |            |      |      |
|       | 276   |               |               |                    |           |           |                          |        |        |        |    |    |            |      |      |
|       | 278   |               |               |                    |           |           |                          |        |        |        |    |    |            |      |      |
|       | 280   |               |               |                    |           |           |                          |        |        |        |    |    |            |      |      |
|       | 282   |               |               |                    |           |           |                          |        |        |        |    |    |            |      |      |
|       | 284   |               |               |                    |           |           |                          |        |        |        |    |    |            |      |      |
|       | 286   |               |               |                    |           |           |                          |        |        |        |    |    |            |      |      |
|       | 288   |               |               |                    |           |           |                          |        |        |        |    |    |            |      |      |
|       | 290   |               |               |                    |           |           |                          |        |        |        |    |    |            |      |      |
|       | 292   |               |               |                    |           |           |                          |        |        |        |    |    |            |      |      |
|       | 294   |               |               |                    |           |           |                          |        |        |        |    |    |            |      |      |
|       | 296   |               |               |                    |           |           |                          |        |        |        |    |    |            |      |      |
|       | 298   |               |               |                    |           |           |                          |        |        |        |    |    |            |      |      |
|       | 300   |               |               |                    |           |           |                          |        |        |        |    |    |            |      |      |
|       | 302   |               |               |                    |           |           |                          |        |        |        |    |    |            |      |      |
|       | 304   |               |               |                    |           |           |                          |        |        |        |    |    |            |      |      |
|       | 306   |               |               |                    |           |           |                          |        |        |        |    |    |            |      |      |
|       | 308   |               |               |                    |           |           |                          |        |        |        |    |    |            |      |      |
|       | 310   |               |               |                    |           |           |                          |        |        |        |    |    |            |      |      |
|       | 312   |               |               |                    |           |           |                          |        |        |        |    |    |            |      |      |
|       | 314   |               |               |                    |           |           |                          |        |        |        |    |    |            |      |      |
|       | 316   |               |               |                    |           |           |                          |        |        |        |    |    |            |      |      |
|       | 318   |               |               |                    |           |           |                          |        |        |        |    |    |            |      |      |
|       | 320   |               |               |                    |           |           |                          |        |        |        |    |    |            |      |      |
|       | 322   |               |               |                    |           |           |                          |        |        |        |    |    |            |      |      |
|       | 324   |               |               |                    |           |           |                          |        |        |        |    |    |            |      |      |
|       | 326   |               |               |                    |           |           |                          |        |        |        |    |    |            |      |      |
|       | 328   |               |               |                    |           |           |                          |        |        |        |    |    |            |      |      |
|       | 330   |               |               |                    |           |           |                          |        |        |        |    |    |            |      |      |
|       | 332   |               |               |                    |           |           |                          |        |        |        |    |    |            |      |      |
|       | 334   |               |               |                    |           |           |                          |        |        |        |    |    |            |      |      |
|       | 336   |               |               |                    |           |           |                          |        |        |        |    |    |            |      |      |
|       | 338   |               |               |                    |           |           |                          |        |        |        |    |    |            |      |      |
|       | 340   |               |               |                    |           |           |                          |        |        |        |    |    |            |      |      |
|       | 342   |               |               |                    |           |           |                          |        |        |        |    |    |            |      |      |
|       | 344   |               |               |                    |           |           |                          |        |        |        |    |    |            |      |      |
|       | 346   |               |               |                    |           |           |                          |        |        |        |    |    |            |      |      |
|       | 348   |               |               |                    |           |           |                          |        |        |        |    |    |            |      |      |
|       | 350   |               |               |                    |           |           |                          |        |        |        |    |    |            |      |      |
|       | 352   |               |               |                    |           |           |                          |        |        |        |    |    |            |      |      |
|       | 354   |               |               |                    |           |           |                          |        |        |        |    |    |            |      |      |
|       | 356   |               |               |                    |           |           |                          |        |        |        |    |    |            |      |      |
|       | 358   |               |               |                    |           |           |                          |        |        |        |    |    |            |      |      |
|       | 360   |               |               |                    |           |           |                          |        |        |        |    |    |            |      |      |
|       | 362   |               |               |                    |           |           |                          |        |        |        |    |    |            |      |      |
|       | 364   |               |               |                    |           |           |                          |        |        |        |    |    |            |      |      |
|       | 366   |               |               |                    |           |           |                          |        |        |        |    |    |            |      |      |
|       | 368   |               |               |                    |           |           |                          |        |        |        |    |    |            |      |      |
|       | 370   |               |               |                    |           |           |                          |        |        |        |    |    |            |      |      |
|       | 372   |               |               |                    |           |           |                          |        |        |        |    |    |            |      |      |
|       | 374   |               |               |                    |           |           |                          |        |        |        |    |    |            |      |      |
|       | 376   |               |               |                    |           |           |                          |        |        |        |    |    |            |      |      |
|       | 378   |               |               |                    |           |           |                          |        |        |        |    |    |            |      |      |
|       | 380   |               |               |                    |           |           |                          |        |        |        |    |    |            |      |      |
|       | 382   |               |               |                    |           |           |                          |        |        |        |    |    |            |      |      |
|       | 384   |               |               |                    |           |           |                          |        |        |        |    |    |            |      |      |
|       | 386   |               |               |                    |           |           |                          |        |        |        |    |    |            |      |      |
|       | 388   |               |               |                    |           |           |                          |        |        |        |    |    |            |      |      |
|       | 390   |               |               |                    |           |           |                          |        |        |        |    |    |            |      |      |
|       | 392   |               |               |                    |           |           |                          |        |        |        |    |    |            |      |      |
|       | 394   |               |               |                    |           |           |                          |        |        |        |    |    |            |      |      |
|       | 396   |               |               |                    |           |           |                          |        |        |        |    |    |            |      |      |
|       | 398   |               |               |                    |           |           |                          |        |        |        |    |    |            |      |      |
|       | 400   |               |               |                    |           |           |                          |        |        |        |    |    |            |      |      |
|       | 402   |               |               |                    |           |           |                          |        |        |        |    |    |            |      |      |
|       | 404   |               |               |                    |           |           |                          |        |        |        |    |    |            |      |      |
|       | 406   |               |               |                    |           |           |                          |        |        |        |    |    |            |      |      |
|       | 408   |               |               |                    |           |           |                          |        |        |        |    |    |            |      |      |
|       | 410   |               |               |                    |           |           |                          |        |        |        |    |    |            |      |      |
|       | 412   |               |               |                    |           |           |                          |        |        |        |    |    |            |      |      |
|       | 414   |               |               |                    |           |           |                          |        |        |        |    |    |            |      |      |
|       | 416   |               |               |                    |           |           |                          |        |        |        |    |    |            |      |      |
|       | 418   |               |               |                    |           |           |                          |        |        |        |    |    |            |      |      |
|       | 420   |               |               |                    |           |           |                          |        |        |        |    |    |            |      |      |
|       | 422   |               |               |                    |           |           |                          |        |        |        |    |    |            |      |      |
|       | 424   |               |               |                    |           |           |                          |        |        |        |    |    |            |      |      |
|       | 426   |               |               |                    |           |           |                          |        |        |        |    |    |            |      |      |
|       | 428   |               |               |                    |           |           |                          |        |        |        |    |    |            |      |      |
|       | 430   |               |               |                    |           |           |                          |        |        |        |    |    |            |      |      |
|       | 432   |               |               |                    |           |           |                          |        |        |        |    |    |            |      |      |
|       | 434   |               |               |                    |           |           |                          |        |        |        |    |    |            |      |      |
|       | 436   |               |               |                    |           |           |                          |        |        |        |    |    |            |      |      |
|       | 438   |               |               |                    |           |           |                          |        |        |        |    |    |            |      |      |
|       | 440   |               |               |                    |           |           |                          |        |        |        |    |    |            |      |      |
|       | 442   |               |               |                    |           |           |                          |        |        |        |    |    |            |      |      |
|       | 444   |               |               |                    |           |           |                          |        |        |        |    |    |            |      |      |
|       | 446   |               |               |                    |           |           |                          |        |        |        |    |    |            |      |      |
|       | 448   |               |               |                    |           |           |                          |        |        |        |    |    |            |      |      |
|       | 450   |               |               |                    |           |           |                          |        |        |        |    |    |            |      |      |
|       | 452   |               |               |                    |           |           |                          |        |        |        |    |    |            |      |      |
|       | 454   |               |               |                    |           |           |                          |        |        |        |    |    |            |      |      |
|       | 456   |               |               |                    |           |           |                          |        |        |        |    |    |            |      |      |
|       | 458   |               |               |                    |           |           |                          |        |        |        |    |    |            |      |      |
|       | 460   |               |               |                    |           |           |                          |        |        |        |    |    |            |      |      |
|       | 462   |               |               |                    |           |           |                          |        |        |        |    |    |            |      |      |
|       | 464   |               |               |                    |           |           |                          |        |        |        |    |    |            |      |      |
|       | 466   |               |               |                    |           |           |                          |        |        |        |    |    |            |      |      |
|       | 468   |               |               |                    |           |           |                          |        |        |        |    |    |            |      |      |
|       | 470   |               |               |                    |           |           |                          |        |        |        |    |    |            |      |      |
|       | 472   |               |               |                    |           |           |                          |        |        |        |    |    |            |      |      |
|       | 474   |               |               |                    |           |           |                          |        |        |        |    |    |            |      |      |
|       | 476   |               |               |                    |           |           |                          |        |        |        |    |    |            |      |      |
|       | 478   |               |               |                    |           |           |                          |        |        |        |    |    |            |      |      |
|       | 480   |               |               |                    |           |           |                          |        |        |        |    |    |            |      |      |
|       | 482   |               |               |                    |           |           |                          |        |        |        |    |    |            |      |      |
|       | 484   |               |               |                    |           |           |                          |        |        |        |    |    |            |      |      |
|       | 486   |               |               |                    |           |           |                          |        |        |        |    |    |            |      |      |
|       | 488   |               |               |                    |           |           |                          |        |        |        |    |    |            |      |      |
|       | 490   |               |               |                    |           |           |                          |        |        |        |    |    |            |      |      |
|       | 492   |               |               |                    |           |           |                          |        |        |        |    |    |            |      |      |
|       | 494   |               |               |                    |           |           |                          |        |        |        |    |    |            |      |      |
|       | 496   |               |               |                    |           |           |                          |        |        |        |    |    |            |      |      |
|       | 498   |               |               |                    |           |           |                          |        |        |        |    |    |            |      |      |
|       | 500   |               |               |                    |           |           |                          |        |        |        |    |    |            |      |      |
|       | 502   |               |               |                    |           |           |                          |        |        |        |    |    |            |      |      |
|       | 504   |               |               |                    |           |           |                          |        |        |        |    |    |            |      |      |
|       | 506   |               |               |                    |           |           |                          |        |        |        |    |    |            |      |      |
|       | 508   |               |               |                    |           |           |                          |        |        |        |    |    |            |      |      |
|       | 510   |               |               |                    |           |           |                          |        |        |        |    |    |            |      |      |
|       | 512   |               |               |                    |           |           |                          |        |        |        |    |    |            |      |      |
|       | 514   |               |               |                    |           |           |                          |        |        |        |    |    |            |      |      |
|       | 516   |               |               |                    |           |           |                          |        |        |        |    |    |            |      |      |
|       | 518   |               |               |                    |           |           |                          |        |        |        |    |    |            |      |      |
|       | 520   |               |               |                    |           |           |                          |        |        |        |    |    |            |      |      |
|       | 522   |               |               |                    |           |           |                          |        |        |        |    |    |            |      |      |
|       | 524   |               |               |                    |           |           |                          |        |        |        |    |    |            |      |      |
|       | 526   |               |               |                    |           |           |                          |        |        |        |    |    |            |      |      |
|       | 528   |               |               |                    |           |           |                          |        |        |        |    |    |            |      |      |
|       | 530   |               |               |                    |           |           |                          |        |        |        |    |    |            |      |      |
|       | 532   |               |               |                    |           |           |                          |        |        |        |    |    |            |      |      |
|       | 534   |               |               |                    |           |           |                          |        |        |        |    |    |            |      |      |
|       | 536   |               |               |                    |           |           |                          |        |        |        |    |    |            |      |      |
|       | 538   |               |               |                    |           |           |                          |        |        |        |    |    |            |      |      |
|       | 540   |               |               |                    |           |           |                          |        |        |        |    |    |            |      |      |
|       | 542   |               |               |                    |           |           |                          |        |        |        |    |    |            |      |      |
|       | 544   |               |               |                    |           |           |                          |        |        |        |    |    |            |      |      |
|       | 546   |               |               |                    |           |           |                          |        |        |        |    |    |            |      |      |
|       | 548   |               |               |                    |           |           |                          |        |        |        |    |    |            |      |      |
|       | 550   |               |               |                    |           |           |                          |        |        |        |    |    |            |      |      |
|       | 552   |               |               |                    |           |           |                          |        |        |        |    |    |            |      |      |
|       | 554   |               |               |                    |           |           |                          |        |        |        |    |    |            |      |      |
|       | 556   |               |               |                    |           |           |                          |        |        |        |    |    |            |      |      |
|       | 558   |               |               |                    |           |           |                          |        |        |        |    |    |            |      |      |
|       | 560   |               |               |                    |           |           |                          |        |        |        |    |    |            |      |      |
|       | 562   |               |               |                    |           |           |                          |        |        |        |    |    |            |      |      |
|       | 564   |               |               |                    |           |           |                          |        |        |        |    |    |            |      |      |
|       | 566   |               |               |                    |           |           |                          |        |        |        |    |    |            |      |      |
|       | 568   |               |               |                    |           |           |                          |        |        |        |    |    |            |      |      |
|       | 570   |               |               |                    |           |           |                          |        |        |        |    |    |            |      |      |
|       | 572   |               |               |                    |           |           |                          |        |        |        |    |    |            |      |      |
|       | 574   |               |               |                    |           |           |                          |        |        |        |    |    |            |      |      |
|       | 576   |               |               |                    |           |           |                          |        |        |        |    |    |            |      |      |
|       | 578   |               |               |                    |           |           |                          |        |        |        |    |    |            |      |      |
|       | 580   |               |               |                    |           |           |                          |        |        |        |    |    |            |      |      |
|       | 582   |               |               |                    |           |           |                          |        |        |        |    |    |            |      |      |
|       | 584   |               |               |                    |           |           |                          |        |        |        |    |    |            |      |      |
|       | 586   |               |               |                    |           |           |                          |        |        |        |    |    |            |      |      |
|       | 588   |               |               |                    |           |           |                          |        |        |        |    |    |            |      |      |
|       | 590   |               |               |                    |           |           |                          |        |        |        |    |    |            |      |      |
|       | 592   |               |               |                    |           |           |                          |        |        |        |    |    |            |      |      |
|       | 594   |               |               |                    |           |           |                          |        |        |        |    |    |            |      |      |
|       | 596   |               |               |                    |           |           |                          |        |        |        |    |    |            |      |      |
|       | 598   |               |               |                    |           |           |                          |        |        |        |    |    |            |      |      |
|       | 600   |               |               |                    |           |           |                          |        |        |        |    |    |            |      |      |
|       | 602   |               |               |                    |           |           |                          |        |        |        |    |    |            |      |      |
|       | 604   |               |               |                    |           |           |                          |        |        |        |    |    |            |      |      |
|       | 606   |               |               |                    |           |           |                          |        |        |        |    |    |            |      |      |
|       | 608   |               |               |                    |           |           |                          |        |        |        |    |    |            |      |      |
|       | 610   |               |               |                    |           |           |                          |        |        |        |    |    |            |      |      |
|       | 612   |               |               |                    |           |           |                          |        |        |        |    |    |            |      |      |
|       | 614   |               |               |                    |           |           |                          |        |        |        |    |    |            |      |      |
|       | 616   |               |               |                    |           |           |                          |        |        |        |    |    |            |      |      |
|       | 618   |               |               |                    |           |           |                          |        |        |        |    |    |            |      |      |
|       | 620   |               |               |                    |           |           |                          |        |        |        |    |    |            |      |      |
|       | 622   |               |               |                    |           |           |                          |        |        |        |    |    |            |      |      |
|       | 624   |               |               |                    |           |           |                          |        |        |        |    |    |            |      |      |
|       | 626   |               |               |                    |           |           |                          |        |        |        |    |    |            |      |      |
|       | 628   |               |               |                    |           |           |                          |        |        |        |    |    |            |      |      |
|       | 630   |               |               |                    |           |           |                          |        |        |        |    |    |            |      |      |
|       | 632   |               |               |                    |           |           |                          |        |        |        |    |    |            |      |      |
|       | 634   |               |               |                    |           |           |                          |        |        |        |    |    |            |      |      |
|       | 636   |               |               |                    |           |           |                          |        |        |        |    |    |            |      |      |
|       | 638   |               |               |                    |           |           |                          |        |        |        |    |    |            |      |      |
|       | 640   |               |               |                    |           |           |                          |        |        |        |    |    |            |      |      |
|       | 642   |               |               |                    |           |           |                          |        |        |        |    |    |            |      |      |
|       | 644   |               |               |                    |           |           |                          |        |        |        |    |    |            |      |      |
|       | 646   |               |               |                    |           |           |                          |        |        |        |    |    |            |      |      |
|       | 648   |               |               |                    |           |           |                          |        |        |        |    |    |            |      |      |
|       | 650   |               |               |                    |           |           |                          |        |        |        |    |    |            |      |      |
|       | 652   |               |               |                    |           |           |                          |        |        |        |    |    |            |      |      |
|       | 654   |               |               |                    |           |           |                          |        |        |        |    |    |            |      |      |
|       | 656   |               |               |                    |           |           |                          |        |        |        |    |    |            |      |      |
|       | 658   |               |               |                    |           |           |                          |        |        |        |    |    |            |      |      |
|       | 660   |               |               |                    |           |           |                          |        |        |        |    |    |            |      |      |
|       | 662   |               |               |                    |           |           |                          |        |        |        |    |    |            |      |      |
|       | 664   |               |               |                    |           |           |                          |        |        |        |    |    |            |      |      |
|       | 666   |               |               |                    |           |           |                          |        |        |        |    |    |            |      |      |
|       | 668   |               |               |                    |           |           |                          |        |        |        |    |    |            |      |      |
|       | 670   |               |               |                    |           |           |                          |        |        |        |    |    |            |      |      |
|       | 672   |               |               |                    |           |           |                          |        |        |        |    |    |            |      |      |
|       | 674   |               |               |                    |           |           |                          |        |        |        |    |    |            |      |      |
|       | 676   |               |               |                    |           |           |                          |        |        |        |    |    |            |      |      |
|       | 678   |               |               |                    |           |           |                          |        |        |        |    |    |            |      |      |
|       | 680   |               |               |                    |           |           |                          |        |        |        |    |    |            |      |      |
|       | 682   |               |               |                    |           |           |                          |        |        |        |    |    |            |      |      |
|       | 684   |               |               |                    |           |           |                          |        |        |        |    |    |            |      |      |
|       | 686   |               |               |                    |           |           |                          |        |        |        |    |    |            |      |      |
|       | 688   |               |               |                    |           |           |                          |        |        |        |    |    |            |      |      |
|       | 690   |               |               |                    |           |           |                          |        |        |        |    |    |            |      |      |
|       | 692   |               |               |                    |           |           |                          |        |        |        |    |    |            |      |      |
|       | 694   |               |               |                    |           |           |                          |        |        |        |    |    |            |      |      |
|       | 696   |               |               |                    |           |           |                          |        |        |        |    |    |            |      |      |
|       | 698   |               |               |                    |           |           |                          |        |        |        |    |    |            |      |      |
|       | 700   |               |               |                    |           |           |                          |        |        |        |    |    |            |      |      |
|       | 702   |               |               |                    |           |           |                          |        |        |        |    |    |            |      |      |
|       | 704   |               |               |                    |           |           |                          |        |        |        |    |    |            |      |      |
|       | 706   |               |               |                    |           |           |                          |        |        |        |    |    |            |      |      |
|       | 708   |               |               |                    |           |           |                          |        |        |        |    |    |            |      |      |
|       | 710   |               |               |                    |           |           |                          |        |        |        |    |    |            |      |      |
|       | 712   |               |               |                    |           |           |                          |        |        |        |    |    |            |      |      |
|       | 714   |               |               |                    |           |           |                          |        |        |        |    |    |            |      |      |
|       | 716   |               |               |                    |           |           |                          |        |        |        |    |    |            |      |      |
|       | 718   |               |               |                    |           |           |                          |        |        |        |    |    |            |      |      |
|       | 720   |               |               |                    |           |           |                          |        |        |        |    |    |            |      |      |
|       | 722   |               |               |                    |           |           |                          |        |        |        |    |    |            |      |      |
|       | 724   |               |               |                    |           |           |                          |        |        |        |    |    |            |      |      |
|       | 726   |               |               |                    |           |           |                          |        |        |        |    |    |            |      |      |
|       | 728   |               |               |                    |           |           |                          |        |        |        |    |    |            |      |      |
|       | 730   |               |               |                    |           |           |                          |        |        |        |    |    |            |      |      |
|       | 732   |               |               |                    |           |           |                          |        |        |        |    |    |            |      |      |
|       | 734   |               |               |                    |           |           |                          |        |        |        |    |    |            |      |      |
|       | 736   |               |               |                    |           |           |                          |        |        |        |    |    |            |      |      |
|       | 738   |               |               |                    |           |           |                          |        |        |        |    |    |            |      |      |
|       | 740   |               |               |                    |           |           |                          |        |        |        |    |    |            |      |      |
|       | 742   |               |               |                    |           |           |                          |        |        |        |    |    |            |      |      |
|       | 744   |               |               |                    |           |           |                          |        |        |        |    |    |            |      |      |
|       | 746   |               |               |                    |           |           |                          |        |        |        |    |    |            |      |      |
|       | 748   |               |               |                    |           |           |                          |        |        |        |    |    |            |      |      |
|       | 750   |               |               |                    |           |           |                          |        |        |        |    |    |            |      |      |
|       | 752   |               |               |                    |           |           |                          |        |        |        |    |    |            |      |      |
|       | 754   |               |               |                    |           |           |                          |        |        |        |    |    |            |      |      |
|       | 756   |               |               |                    |           |           |                          |        |        |        |    |    |            |      |      |
|       | 758   |               |               |                    |           |           |                          |        |        |        |    |    |            |      |      |
|       | 760   |               |               |                    |           |           |                          |        |        |        |    |    |            |      |      |
|       | 762   |               |               |                    |           |           |                          |        |        |        |    |    |            |      |      |
|       | 764   |               |               |                    |           |           |                          |        |        |        |    |    |            |      |      |
|       | 766   |               |               |                    |           |           |                          |        |        |        |    |    |            |      |      |
|       | 768   |               |               |                    |           |           |                          |        |        |        |    |    |            |      |      |
|       | 770   |               |               |                    |           |           |                          |        |        |        |    |    |            |      |      |
|       | 772   |               |               |                    |           |           |                          |        |        |        |    |    |            |      |      |
|       | 774   |               |               |                    |           |           |                          |        |        |        |    |    |            |      |      |
|       | 776   |               |               |                    |           |           |                          |        |        |        |    |    |            |      |      |
|       | 778   |               |               |                    |           |           |                          |        |        |        |    |    |            |      |      |
|       | 780   |               |               |                    |           |           |                          |        |        |        |    |    |            |      |      |
|       | 782   |               |               |                    |           |           |                          |        |        |        |    |    |            |      |      |
|       | 784   |               |               |                    |           |           |                          |        |        |        |    |    |            |      |      |
|       | 786   |               |               |                    |           |           |                          |        |        |        |    |    |            |      |      |
|       | 788   |               |               |                    |           |           |                          |        |        |        |    |    |            |      |      |
|       | 790   |               |               |                    |           |           |                          |        |        |        |    |    |            |      |      |
|       | 792   |               |               |                    |           |           |                          |        |        |        |    |    |            |      |      |
|       | 794   |               |               |                    |           |           |                          |        |        |        |    |    |            |      |      |
|       | 796   |               |               |                    |           |           |                          |        |        |        |    |    |            |      |      |
|       | 798   |               |               |                    |           |           |                          |        |        |        |    |    |            |      |      |
|       | 800   |               |               |                    |           |           |                          |        |        |        |    |    |            |      |      |
|       | 802   |               |               |                    |           |           |                          |        |        |        |    |    |            |      |      |
|       | 804   |               |               |                    |           |           |                          |        |        |        |    |    |            |      |      |
|       | 806   |               |               |                    |           |           |                          |        |        |        |    |    |            |      |      |
|       |       |               |               |                    |           |           |                          |        |        |        |    |    |            |      |      |

LOG OF BORING

A LARGE AMOUNT AT  
Water Elev. 588.5' AT  
SEE NOTE ON BOTTOM  
OF LOG

Project Identification: CUYAHOGA  
CUY-90-15-24

STABILITY ANALYSIS  
SUBSURFACE INVESTIGATION

Date Started 5/23/90  
Date Completed 5/23/90  
Sampler Type SS Dia. 1 3/8"  
Casing Length Dia.

Surface Elev. 588.5'

Boring No. B-7 Stationed at  
Renamed: B-007-0-90

| Elev. | Depth | Std Pen. | Rec. Loss | Description   | Field No. | Lab. Nos. | Physical Characteristics |      |        |        |        |    |    |    |  |  |  |  |
|-------|-------|----------|-----------|---|-----------|-----------|--------------------------|------|--------|--------|--------|----|----|----|--|--|--|--|
|       |       |          |           |   |           |           | % Ag.                    | % S. | % F.S. | % Silt | % Clay | LL | PL | WC |  |  |  |  |
| 588.5 | 0     |          |           |   |           |           |                          |      |        |        |        |    |    |    |  |  |  |  |
| 576.0 | 12    | 3/3/4    |           | BLACK SANDY SILT WITH CINDERS AND ASHES                 | 14        | 63034     | 26                       | 24   | 26     | 20     | 4      | NP | NP | 19 |  |  |  |  |
|       | 14    |          |           | BLACK SILTY GRAVELLY SAND WITH CINDERS AND ASHES        |           |           |                          |      |        |        |        |    |    |    |  |  |  |  |
|       | 16    |          |           | SLAG BOULDERS (19.5 - 20.5')                            |           |           |                          |      |        |        |        |    |    |    |  |  |  |  |
| 566.0 | 22    | 12/7/20  |           | GRAY GRAVELLY SILT WITH SLAG AND COBBLES                | 15        | 63035     | 43                       | 1    | 2      | 33     | 21     | -  | -  | 23 |  |  |  |  |
| 556.0 | 34    | 4/5/14   |           | GRAY SILTY CLAY W/BRICK FRAGMENTS AND WOOD (TIMBER PIE) | 16        | 63036     | 50                       | 2    | 2      | 44     | 52     | 36 | 15 | 23 |  |  |  |  |





Department of Transportation  
Division of Highways  
Testing Laboratory

LOG OF BORING

Date Started 5/22/90 Sampler: Type SS Dia. 1 3/8" Water Elev. 501.3'  
 Date Completed 5/22/90 Casing: Length      Dia.       
 Project Identification: CUYAHOGA  
CUY-90-15.24  
 STABILITY ANALYSIS  
 SUBSURFACE INVESTIGATION

| Boring No. | Depth | Sig. Pen. (lb) | Rac. Loss (lb) | Description                    | Field No. | Lab. Nos. So. | Physical Characteristics |        |        |        |        |      | SHTL Class |      |      |  |  |       |
|------------|-------|----------------|----------------|--------------------------------|-----------|---------------|--------------------------|--------|--------|--------|--------|------|------------|------|------|--|--|-------|
|            |       |                |                |                                |           |               | % Agg.                   | % C.S. | % F.S. | % Silt | % Clay | L.L. |            | P.I. | W.C. |  |  |       |
| 591.3      | 0     |                |                |                                |           |               |                          |        |        |        |        |      |            |      |      |  |  |       |
| 581.3      | 2     |                |                | DARK BROWN SILTY GRAVELLY SAND | 1         | 63021         | 22                       | 32     | 22     | 24     | 0      | NP   | NP         | 20   |      |  |  | A-1-B |
| 571.3      | 10    | 1/2/2          |                |                                |           |               |                          |        |        |        |        |      |            |      |      |  |  |       |
|            | 12    |                |                |                                |           |               |                          |        |        |        |        |      |            |      |      |  |  |       |
|            | 14    |                |                |                                |           |               |                          |        |        |        |        |      |            |      |      |  |  |       |
|            | 16    |                |                |                                |           |               |                          |        |        |        |        |      |            |      |      |  |  |       |
|            | 18    |                |                |                                |           |               |                          |        |        |        |        |      |            |      |      |  |  |       |
|            | 20    |                |                |                                |           |               |                          |        |        |        |        |      |            |      |      |  |  |       |
|            | 22    | 4/6/9          |                | GRAY SILTY CLAY                | 2         | 63022         | 0                        | 1      | 1      | 52     | 46     | 38   | 17         | 20   |      |  |  | A-6B  |
|            | 24    |                |                |                                |           |               |                          |        |        |        |        |      |            |      |      |  |  |       |
|            | 26    |                |                |                                |           |               |                          |        |        |        |        |      |            |      |      |  |  |       |
|            | 28    |                |                |                                |           |               |                          |        |        |        |        |      |            |      |      |  |  |       |
|            | 30    |                |                |                                |           |               |                          |        |        |        |        |      |            |      |      |  |  |       |
|            | 32    | 2/2/4          |                | GRAY SILT                      | 3         | 63023         | 0                        | 1      | 1      | 34     | 64     | 28   | 6          | 26   |      |  |  | A-4A  |
|            | 34    |                |                |                                |           |               |                          |        |        |        |        |      |            |      |      |  |  |       |
|            | 36    |                |                |                                |           |               |                          |        |        |        |        |      |            |      |      |  |  |       |

Surface Elev. 591.3'      Silt = 0.074 - 0.005 mm.      Clay < 0.005 mm

Renamed: B-008-0-90  
 Surface Elev. 591.3' Project: CUY-90-15.24

| Boring No. | Elev. | Depth | Std. Pen. (N) | Rec. Loss ft. | Description        | Field No. | Lab. Nos. So. | Physical Characteristics |          |        |        |    |    |      |    |
|------------|-------|-------|---------------|---------------|--------------------|-----------|---------------|--------------------------|----------|--------|--------|----|----|------|----|
|            |       |       |               |               |                    |           |               | % Agg.                   | % C.S.F. | % Silt | % Clay | LL | PI | W.C. |    |
| 551.3      |       | 38    |               |               | GRAY SILTY CLAY    | 4         | 63024         | 0                        | 0        | 1      | 50     | 49 | 36 | 16   | 22 |
|            |       | 40    | 6/9/12        |               |                    |           |               |                          |          |        |        |    |    |      |    |
|            |       | 42    |               |               |                    |           |               |                          |          |        |        |    |    |      |    |
|            |       | 44    |               |               |                    |           |               |                          |          |        |        |    |    |      |    |
|            |       | 46    |               |               |                    |           |               |                          |          |        |        |    |    |      |    |
|            |       | 48    |               |               |                    |           |               |                          |          |        |        |    |    |      |    |
| 541.3      |       | 50    |               |               | GRAY SILTY CLAY    | 5         | 63025         | 0                        | 0        | 1      | 61     | 38 | 37 | 17   | 22 |
|            |       | 52    | 8/12/16       |               |                    |           |               |                          |          |        |        |    |    |      |    |
|            |       | 54    |               |               |                    |           |               |                          |          |        |        |    |    |      |    |
|            |       | 56    |               |               |                    |           |               |                          |          |        |        |    |    |      |    |
|            |       | 58    |               |               |                    |           |               |                          |          |        |        |    |    |      |    |
|            |       | 60    |               |               |                    |           |               |                          |          |        |        |    |    |      |    |
| 531.3      |       | 62    |               |               | GRAY SANDY CLAY    | 6         | 63026         | 0                        | 9        | 15     | 43     | 33 | 28 | 11   | 13 |
|            |       | 64    | 14/25/32      |               |                    |           |               |                          |          |        |        |    |    |      |    |
|            |       | 66    |               |               |                    |           |               |                          |          |        |        |    |    |      |    |
|            |       | 68    |               |               |                    |           |               |                          |          |        |        |    |    |      |    |
|            |       | 70    |               |               |                    |           |               |                          |          |        |        |    |    |      |    |
|            |       | 72    |               |               |                    |           |               |                          |          |        |        |    |    |      |    |
| 521.3      |       | 72    |               |               | GRAY SILT AND CLAY | 7         | 63027         | 0                        | 2        | 3      | 37     | 58 | 36 | 15   | 21 |
|            |       | 74    | 6/11/15       |               |                    |           |               |                          |          |        |        |    |    |      |    |
|            |       | 76    |               |               |                    |           |               |                          |          |        |        |    |    |      |    |
|            |       | 78    |               |               |                    |           |               |                          |          |        |        |    |    |      |    |





Boring No. B-8 Renamed: B-008-0-90  
 Surface Elev. 591.3' Project: CUY-90-15.24

| Elev. | Depth | Std. Pen. (N) | Rec. Los. ft. | Description        | Field No. | Lab. Nos. So | Physical Characteristics |        |        |        |        |      | SH | CI |      |
|-------|-------|---------------|---------------|--------------------|-----------|--------------|--------------------------|--------|--------|--------|--------|------|----|----|------|
|       |       |               |               |                    |           |              | % Agg.                   | % C.S. | % F.S. | % Silt | % Clay | L.L. |    |    | P.I. |
| 461.3 | 126   |               |               |                    | 13        | 63033        | 13                       | 4      | 6      | 29     | 48     | NP   | NP | 16 | A    |
| 459.8 | 128   |               |               |                    |           |              |                          |        |        |        |        |      |    |    |      |
|       | 130   |               |               | GRAY GRAVELLY SILT |           |              |                          |        |        |        |        |      |    |    |      |
|       | 132   |               |               |                    |           |              |                          |        |        |        |        |      |    |    |      |
|       | 134   |               |               |                    |           |              |                          |        |        |        |        |      |    |    |      |
|       | 136   |               |               |                    |           |              |                          |        |        |        |        |      |    |    |      |
|       | 138   |               |               |                    |           |              |                          |        |        |        |        |      |    |    |      |
|       | 140   |               |               |                    |           |              |                          |        |        |        |        |      |    |    |      |
|       | 142   |               |               |                    |           |              |                          |        |        |        |        |      |    |    |      |
|       | 144   |               |               |                    |           |              |                          |        |        |        |        |      |    |    |      |
|       | 146   |               |               |                    |           |              |                          |        |        |        |        |      |    |    |      |
|       | 148   |               |               |                    |           |              |                          |        |        |        |        |      |    |    |      |
|       | 150   |               |               |                    |           |              |                          |        |        |        |        |      |    |    |      |
|       | 152   |               |               |                    |           |              |                          |        |        |        |        |      |    |    |      |
|       | 154   |               |               |                    |           |              |                          |        |        |        |        |      |    |    |      |
|       | 156   |               |               |                    |           |              |                          |        |        |        |        |      |    |    |      |
|       | 158   |               |               |                    |           |              |                          |        |        |        |        |      |    |    |      |
|       | 160   |               |               |                    |           |              |                          |        |        |        |        |      |    |    |      |
|       | 162   |               |               |                    |           |              |                          |        |        |        |        |      |    |    |      |
|       | 164   |               |               |                    |           |              |                          |        |        |        |        |      |    |    |      |
|       | 166   |               |               |                    |           |              |                          |        |        |        |        |      |    |    |      |

— BOTTOM OF BORING

NOTE: SLOPE INDICATOR PIPE INSTALLED AT 130.0'

State of Ohio  
Department of Transportation  
Division of Highways  
Testing Laboratory

LOG OF BORING

Project Identification: CUYAHOGA  
CUY-90-15.24

Water Elev. 461.2'

Date Started 5/17/90  
Date Completed 5/19/90  
Sampler Type SS  
Casing Length Dka

STABILITY ANALYSIS  
SUBSURFACE INVESTIGATION

Surface Elev. 586.2'

Boring No. B-9 Renamed: B-009-0-90

| Elev. | Depth | Std. Pen. | Rqc. Loss | Description | Field No. | Lab. Nos. | Physical Characteristics |      |        |              |    | SHTL Class |    |      |  |  |  |  |  |  |  |  |  |  |
|-------|-------|-----------|-----------|-------------|-----------|-----------|--------------------------|------|--------|--------------|----|------------|----|------|--|--|--|--|--|--|--|--|--|--|
|       |       |           |           |             |           |           | % Agg.                   | % S. | % F.S. | % Silty Clay | LL |            | PI | W.C. |  |  |  |  |  |  |  |  |  |  |
| 586.2 | 0     |           |           |             |           |           |                          |      |        |              |    |            |    |      |  |  |  |  |  |  |  |  |  |  |
| 581.2 | 2     |           |           |             |           |           |                          |      |        |              |    |            |    |      |  |  |  |  |  |  |  |  |  |  |
|       | 4     |           |           |             |           |           |                          |      |        |              |    |            |    |      |  |  |  |  |  |  |  |  |  |  |
|       | 6     |           |           |             |           |           |                          |      |        |              |    |            |    |      |  |  |  |  |  |  |  |  |  |  |
|       | 8     |           |           |             |           |           |                          |      |        |              |    |            |    |      |  |  |  |  |  |  |  |  |  |  |
|       | 10    |           |           |             |           |           |                          |      |        |              |    |            |    |      |  |  |  |  |  |  |  |  |  |  |
|       | 12    |           |           |             |           |           |                          |      |        |              |    |            |    |      |  |  |  |  |  |  |  |  |  |  |
|       | 14    |           |           |             |           |           |                          |      |        |              |    |            |    |      |  |  |  |  |  |  |  |  |  |  |
| 571.2 | 16    |           |           |             |           |           |                          |      |        |              |    |            |    |      |  |  |  |  |  |  |  |  |  |  |
|       | 18    |           |           |             |           |           |                          |      |        |              |    |            |    |      |  |  |  |  |  |  |  |  |  |  |
|       | 20    |           |           |             |           |           |                          |      |        |              |    |            |    |      |  |  |  |  |  |  |  |  |  |  |
|       | 22    |           |           |             |           |           |                          |      |        |              |    |            |    |      |  |  |  |  |  |  |  |  |  |  |
|       | 24    |           |           |             |           |           |                          |      |        |              |    |            |    |      |  |  |  |  |  |  |  |  |  |  |
| 561.2 | 26    |           |           |             |           |           |                          |      |        |              |    |            |    |      |  |  |  |  |  |  |  |  |  |  |
|       | 28    |           |           |             |           |           |                          |      |        |              |    |            |    |      |  |  |  |  |  |  |  |  |  |  |
|       | 30    |           |           |             |           |           |                          |      |        |              |    |            |    |      |  |  |  |  |  |  |  |  |  |  |
|       | 32    |           |           |             |           |           |                          |      |        |              |    |            |    |      |  |  |  |  |  |  |  |  |  |  |
|       | 34    |           |           |             |           |           |                          |      |        |              |    |            |    |      |  |  |  |  |  |  |  |  |  |  |
| 551.2 | 36    |           |           |             |           |           |                          |      |        |              |    |            |    |      |  |  |  |  |  |  |  |  |  |  |

7/11/13

Surface Elev. 586.2' Project: CUY-90-15.24

Boring No. B-9 Renamed: B-009-0-90

| Elev. | Depth | Std. Pen. (N) | Rec. ft. | Loss ft. | Description        | Field No. | Lab. Nos. | Physical Characteristics |        |        |        |    |    |      |    |
|-------|-------|---------------|----------|----------|--------------------|-----------|-----------|--------------------------|--------|--------|--------|----|----|------|----|
|       |       |               |          |          |                    |           |           | % Agg.                   | % S.S. | % Silt | % Clay | LL | PL | W.C. |    |
| 541.2 | 38    |               |          |          | GRAY CLAYEY SILT   | 18        | 62982     | 0                        | 0      | 1      | 63     | 36 | 26 | 7    | 21 |
|       | 40    |               |          |          |                    |           |           |                          |        |        |        |    |    |      |    |
|       | 42    |               |          |          |                    |           |           |                          |        |        |        |    |    |      |    |
|       | 44    |               |          |          |                    |           |           |                          |        |        |        |    |    |      |    |
|       | 46    | 7/18/20       |          |          |                    |           |           |                          |        |        |        |    |    |      |    |
|       | 48    |               |          |          |                    |           |           |                          |        |        |        |    |    |      |    |
|       | 50    |               |          |          |                    |           |           |                          |        |        |        |    |    |      |    |
|       | 52    |               |          |          |                    |           |           |                          |        |        |        |    |    |      |    |
|       | 54    |               |          |          |                    |           |           |                          |        |        |        |    |    |      |    |
|       | 56    | 7/16/14       |          |          |                    |           |           |                          |        |        |        |    |    |      |    |
| 531.2 | 58    |               |          |          | GRAY CLAYEY SILT   | 19        | 62983     | 0                        | 0      | 1      | 55     | 44 | 29 | 9    | 22 |
|       | 60    |               |          |          |                    |           |           |                          |        |        |        |    |    |      |    |
|       | 62    |               |          |          |                    |           |           |                          |        |        |        |    |    |      |    |
|       | 64    |               |          |          |                    |           |           |                          |        |        |        |    |    |      |    |
|       | 66    | 9/15/17       |          |          |                    |           |           |                          |        |        |        |    |    |      |    |
|       | 68    |               |          |          |                    |           |           |                          |        |        |        |    |    |      |    |
|       | 70    |               |          |          |                    |           |           |                          |        |        |        |    |    |      |    |
|       | 72    |               |          |          |                    |           |           |                          |        |        |        |    |    |      |    |
|       | 74    |               |          |          |                    |           |           |                          |        |        |        |    |    |      |    |
|       | 76    | 11/12/16      |          |          |                    |           |           |                          |        |        |        |    |    |      |    |
| 521.2 | 78    |               |          |          | GRAY SILT AND CLAY | 20        | 62984     | 0                        | 1      | 2      | 51     | 46 | 29 | 9    | 21 |
|       | 80    |               |          |          |                    |           |           |                          |        |        |        |    |    |      |    |
|       |       |               |          |          |                    |           |           |                          |        |        |        |    |    |      |    |
|       |       |               |          |          |                    |           |           |                          |        |        |        |    |    |      |    |
| 511.2 |       |               |          |          |                    | 21        | 62985     | 0                        | 2      | 3      | 40     | 55 | 35 | 13   | 22 |
|       |       |               |          |          |                    |           |           |                          |        |        |        |    |    |      |    |



Boring No. B-9 Renamed: B-009-0-90

Surface Elev. 586.2' Project: CUY-90-15.2A

| Elev. | Depth | Std. Pen. (N) | Rec. ft. | Los. ft. | Description      | Field No. | Lab. Nos. So. | Physical Characteristics |        |        |        |        |    |    |      |
|-------|-------|---------------|----------|----------|------------------|-----------|---------------|--------------------------|--------|--------|--------|--------|----|----|------|
|       |       |               |          |          |                  |           |               | % Agg.                   | % C.S. | % F.S. | % Silt | % Clay | LL | PL | W.C. |
| 461.2 | 126   | 22/32/45      |          |          | GRAY SILTY CLAY  | 26        | 62990         | 0                        | 2      | 7      | 32     | 59     | 38 | 16 | 17   |
| 456.2 | 128   |               |          |          |                  |           |               |                          |        |        |        |        |    |    |      |
| 454.7 | 130   |               |          |          |                  |           |               |                          |        |        |        |        |    |    |      |
|       | 132   | 17/21/27      |          |          | GRAY CLAYEY SILT | 27        | 62991         | 0                        | 1      | 1      | 29     | 69     | 35 | 10 | 23   |
|       | 134   |               |          |          |                  |           |               |                          |        |        |        |        |    |    |      |
|       | 136   |               |          |          |                  |           |               |                          |        |        |        |        |    |    |      |
|       | 138   |               |          |          |                  |           |               |                          |        |        |        |        |    |    |      |
|       | 140   |               |          |          |                  |           |               |                          |        |        |        |        |    |    |      |
|       | 142   |               |          |          |                  |           |               |                          |        |        |        |        |    |    |      |
|       | 144   |               |          |          |                  |           |               |                          |        |        |        |        |    |    |      |
|       | 146   |               |          |          |                  |           |               |                          |        |        |        |        |    |    |      |
|       | 148   |               |          |          |                  |           |               |                          |        |        |        |        |    |    |      |
|       | 150   |               |          |          |                  |           |               |                          |        |        |        |        |    |    |      |
|       | 152   |               |          |          |                  |           |               |                          |        |        |        |        |    |    |      |
|       | 154   |               |          |          |                  |           |               |                          |        |        |        |        |    |    |      |
|       | 156   |               |          |          |                  |           |               |                          |        |        |        |        |    |    |      |
|       | 158   |               |          |          |                  |           |               |                          |        |        |        |        |    |    |      |
|       | 160   |               |          |          |                  |           |               |                          |        |        |        |        |    |    |      |
|       | 162   |               |          |          |                  |           |               |                          |        |        |        |        |    |    |      |
|       | 164   |               |          |          |                  |           |               |                          |        |        |        |        |    |    |      |
|       | 166   |               |          |          |                  |           |               |                          |        |        |        |        |    |    |      |

BOTTOM OF BORING

NOTE: SLOPE INDICATOR PIPE INSTALLED AT 130.0'

**APPENDIX 4B -2**  
**BBCM BORINGS 1994**

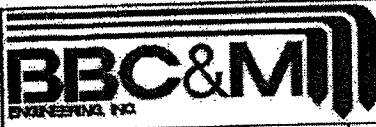

TYPE: 2" O.D. Split-barrel Sampler LOCATION: Sta. 15+06.50  
3" O.D. Shelby Tube 120.7' Rt. of  
NXM Rock-core Barrel Centerline

COMPLETION DEPTH: 230.1' ELEVATION: 676.6 DATE: 8/23/94 8/25/94

| DEP. FEET | SAMPLE NO. | SAMPLES SAMPLING EFFORT | HAND PENE-TROMETER | MOISTURE CONTENT | LIQUID LIMIT | PLASTIC LIMIT | AGG. C. S. F. S. SILT:CLAY |    |    |   | DESCRIPTION  |
|-----------|------------|-------------------------|--------------------|------------------|--------------|---------------|----------------------------|----|----|---|--|
|           |            |                         |                    |                  |              |               | tsf                        | %  | %  | % |  |
| 0         |            |                         |                    |                  |              |               |                            |    |    |   | FILL: Loose brown fine to coarse sand, trace to little fine to coarse gravel, interbedded with fine to medium sand, trace coarse sand, trace fine gravel.  |
| 5         | 1          | 3/3/3                   |                    |                  |              |               |                            |    |    |   | Est. A-2-4   |
| 10        | 2A<br>2B   | 3/3/4                   |                    |                  |              |               |                            |    |    |   | Loose brown and gray fine to medium sand, trace coarse sand, trace fine gravel.<br>- From 10.4' to 12.0': Seam of clayey silt.   |
| 15        | 3          | 6/10/10                 |                    |                  |              | 36            | 43                         | 14 | 7  |   | Est. A-1-b   |
| 20        | 4          | 5/7/8                   |                    |                  |              |               |                            |    |    |   | A-1-b(0)   |
| 25        | 5          | 8/11/12                 |                    |                  |              | 10            | 54                         | 26 | 10 |   | Medium-dense brown fine to medium sand, trace to little silt, trace coarse sand, trace fine gravel, contains seams (1 to 6 inches) of silt, fine sand, and silty clay.<br><br>- Sample 5: Medium-dense fine to coarse sand, trace fine gravel, trace silt, A-1-b(0). |
| 30        | 6A<br>6B   | 5/9/14                  |                    |                  |              |               |                            |    |    |   |  |
| 35        | 7A<br>7B   | 10/12/15                |                    |                  |              |               |                            |    |    |   |  |
| 40        | 8          | 3/6/11                  |                    |                  |              | 0             | 2                          | 84 | 14 |   | A-3a(0)  |
| 45        | 9          | 6/7/15                  |                    |                  |              | 0             | 0                          | 21 | 71 | 8 | Medium-dense gray silt, little fine sand, trace clay.  |
|           |            |                         |                    |                  |              |               |                            |    |    |   | A-4b(8)  |

DESCRIPTION ON NEXT PAGE

50 WATER LEVEL:                                
 WATER NOTE:                                
 DATE:



Renamed: B-101-0-94

**LOG OF BORING NO. B-101**  
**CUY-90-15.24**  
**CLEVELAND, OHIO**

| DEPTH FEET | SAMPLE NO. | SAMPLES | SAMPLING EFFORT | HAND PENE-TROMETER | MOISTURE CONTENT | LIQUID LIMIT | PLASTIC LIMIT | TYPE: <u>2" O.D. Split-barrel Sampler</u> |   |    | LOCATION: <u>Sta. 15+06.50</u>           |    |  |                              |  |  |
|------------|------------|---------|-----------------|--------------------|------------------|--------------|---------------|---|---|----|--|----|--|------------------------------|--|--|
|            |            |         |                 |                    |                  |              |               | TYPE: <u>3" O.D. Shelby Tube</u>          |   |    | LOCATION: <u>120.7 Rt. of Centerline</u> |    |  |                              |  |  |
|            |            |         |                 |                    |                  |              |               | COMPLETION DEPTH: <u>230.1'</u>           |   |    | ELEVATION: <u>676.6</u>                  |    |  | DATE: <u>8/23/94 8/25/94</u> |  |  |
|            |            |         |                 |                    |                  |              |               |   |   |    | DESCRIPTION - CONTINUED                  |    |  |                              |  |  |
| tsf        | %          | %       | %               | AGG.               | C.S.             | F.S.         | SILT          | CLAY                                      |   |    |  |    |  |                              |  |  |
| 50-10      | 10         | 3       | 15/7            | 1.5-2.0            | 21               | 24           | 17            | 0   | 0 | 10 | 66                                       | 24 | Medium-dense to dense gray silt interbedded with silty clay, trace fine to medium sand.  |                              |  |  |
| 55-11      | 11         | P       |                 |                    | 19               | 25           | 18            | 0   | 0 | 3  | 80                                       | 17 | A-4b(8)<br>Dense gray silt, little to "and" fine sand, trace clay interbedded with dense gray fine sand, little to "and" silt, trace clay. |                              |  |  |
| 60-12      | 12         | 15      | 22/32           |                    |                  |              |               |   |   |    |  |    |  |                              |  |  |
| 60-13      | 13         | 21      | 32/49           |                    | 15               |              |               | 0   | 0 | 38 | 54                                       | 8  |  |                              |  |  |
| 65-14      | 14         | 29      | 46/48           |                    |                  |              |               |   |   |    |  |    | A-4b(5)<br>Stiff to hard gray silt clay, trace fine to medium sand, few lenses of silt, horizontal structure.                              |                              |  |  |
| 70-15      | 15         | 3       | 16/19           | 1.5-2.2            | 22               | 32           | 16            | 0   | 0 | 1  | 57                                       | 42 | - From 73.4' to 87.0': Hard in consistency.  |                              |  |  |
| 75-16      | 16         | 9       | 15/21           | 4.5+               |                  |              |               |   |   |    |  |    | - From 80.0' to 92.0': Contains seams of silt.   |                              |  |  |
| 80-17      | 17         | 7       | 14/19           | 4.0-4.5+           |                  |              |               |   |   |    |  |    |  |                              |  |  |
| 85-18      | 18         | 7       | 12/15           | 4.5+               |                  |              |               |   |   |    |  |    |  |                              |  |  |
| 90-19      | 19         | 5       | 8/12            | 2.0-4.0            | 22               | 33           | 17            | 0   | 0 | 0  | 56                                       | 44 |  |                              |  |  |
| 95-20      | 20         | 4       | 14/15           | 1.0-1.5            |                  |              |               |   |   |    |  |    | A-6b(10)   |                              |  |  |
|            |            |         |                 |                    |                  |              |               |   |   |    | DESCRIPTION ON NEXT PAGE                 |    |  |                              |  |  |

100 WATER LEVEL:      WATER NOTE:      DATE:     

-CONTINUED-





Renamed: B-101-0-94

LOG OF BORING NO. B-101  
 CUY-90-15.24  
 CLEVELAND, OHIO

TYPE: 2" O.D. Split-barrel Sampler LOCATION: Sta. 15+06.50  
3" O.D. Shelby Tube 120.7' Rt. of  
NXM Rock-core Barrel Centerline  
 COMPLETION DEPTH: 230.1' ELEVATION: 676.6 DATE: 8/23/94 8/25/94

| DEPT FEET | SAMPLE NO. | SAMPLES SAMPLING EFFORT | HAND PENE-TROMETER | MOISTURE CONTENT | LIQUID LIMIT | PLASTIC LIMIT | DESCRIPTION - CONTINUED |   |   |    |      |  |
|-----------|------------|-------------------------|--------------------|------------------|--------------|---------------|-------------------------|---|---|----|------|--|
|           |            |                         |                    |                  |              |               | tsf                     | % | % | %  | AGG. | C.S.   |
| 100       | 21         | S/H 3/3                 | 0.5                | 28               | 37           | 21            | 1                       | 1 | 3 | 33 | 62   | Medium-stiff to stiff gray silty clay, trace fine to coarse sand, trace fine gravel, few lenses of silt.<br><br><br><br><br><br><br><br><br><br><br>A-6b(10,11)<br><br>Stiff to very-stiff gray silty clay, trace fine to medium sand, contains thin seams of clayey silt and silt.<br><br><br><br><br><br><br><br><br><br><br>- From 142.0' to 143.5': Very-stiff to hard.<br><br><br><br><br><br><br><br><br><br><br>A-6b(10,12) |
| 105       | 22         | P                       | 1.0                |                  |              |               | 0                       | 1 | 1 | 22 | 76   |  |
|           | 23         | 2/3/5                   | 0.5-0.8            |                  |              |               |                         |   |   |    |      |  |
| 110       | 24         | 3/4/5                   | 0.8-1.0            |                  |              |               |                         |   |   |    |      |  |
| 115       | 25         | 2/4/5                   | 0.8-1.1            | 25               | 39           | 21            | 1                       | 1 | 2 | 36 | 60   |  |
| 120       | 26         | P                       | 1.7                |                  |              |               |                         |   |   |    |      |  |
|           | 27         | 4/7/10                  | 1.3-1.6            |                  |              |               |                         |   |   |    |      |  |
| 125       | 28         | 6/11/18                 | 2.5-3.5            |                  |              |               |                         |   |   |    |      |  |
| 130       | 29         | P                       | 2.5-3.0            |                  |              |               |                         |   |   |    |      |  |
|           | 30         | 6/10/15                 | 1.8-2.2            |                  |              |               |                         |   |   |    |      |  |
| 135       | 31         | 4/8/12                  | 1.3-2.5            | 24               | 35           | 19            | 0                       | 0 | 1 | 47 | 52   |  |
| 140       | 32         | P                       | 2.2-2.5            |                  | 22           | 37            | 18                      | 1 | 0 | 0  | 47   | 52   |
|           | 33         | 8/15/20                 | 3.2-4.5+           |                  |              |               |                         |   |   |    |      |  |
| 145       | 34         | 6/12/19                 | 2.3-3.2            |                  |              |               |                         |   |   |    |      |  |

150 WATER LEVEL:                                
 WATER NOTE:                                
 DATE:



Renamed: B-101-0-94

**LOG OF BORING NO. B-101**  
**CUY-90-15.24**  
**CLEVELAND, OHIO**

TYPE: 2' O.D. Split-barrel Sampler LOCATION: Sta. 15+06.50  
3' O.D. Shelby Tube 120.7 Rt. of  
NXM Rock-core Barrel Centerline

COMPLETION DEPTH: 230.1' ELEVATION: 676.6 DATE: 8/23/94 8/25/94

| DEPT<br>FEET | SAMPLE NO. | SAMPLES<br>SAMPLING<br>EFFORT | HAND<br>PENE-<br>TROMETER | MOISTURE<br>CONTENT | LIQUID<br>LIMIT | PLASTIC<br>LIMIT | AGG. | C.S. | F.S. | SILT | CLAY | DESCRIPTION - CONTINUED   |   |
|--------------|------------|-------------------------------|---------------------------|---------------------|-----------------|------------------|------|------|------|------|------|---|---|
|              |            |                               |                           |                     |                 |                  |      |      |      |      |      | tsf   | % |
| 150          | 35         | 8 1/2 / 18                    | 2.0-2.5                   |                     |                 |                  |      |      |      |      |      | DESCRIPTION ON PREVIOUS PAGE  |   |
| 155          | 36         | 7 1/5 / 21                    | 3.0-3.3                   | 20                  | 36              | 19               | 1    | 2    | 3    | 32   | 62   | Very-stiff gray silty clay, trace fine to coarse sand, trace fine to coarse gravel, some horizontal structures.                 |   |
| 160          | 37         | 10 1/16 / 24                  | 2.5-3.5                   |                     |                 |                  |      |      |      |      |      |   |   |
| 165          | 38         | 9 1/17 / 26                   | 3.4-3.7                   |                     |                 |                  |      |      |      |      |      |   |   |
| 170          | 39         | 9 1/14 / 21                   | 2.3-3.8                   | 21                  | 34              | 20               | 1    | 1    | 2    | 35   | 61   | A-6a, A-6b(10,11)   |   |
| 175          | 40         | 7 1/13 / 18                   | 2.5-3.0                   |                     |                 |                  |      |      |      |      |      | Stiff to very-stiff gray silty clay, trace fine to medium sand, horizontal structure, contains streaks of silt and clayey silt. |   |
| 180          | 41         | 6 1/10 / 16                   | 2.2-3.0                   |                     |                 |                  |      |      |      |      |      | - From 179.5' to 180.2': Diorite boulder.   |   |
| 185          | 42         | 4 1/7 / 7                     | 1.0-1.7                   | 27                  | 39              | 22               | 0    | 0    | 1    | 28   | 71   | A-6b(11)  |   |
| 190          | 43         | 9 1/15 / 26                   |                           | 20                  | 20              | 14               | 2    | 2    | 16   | 61   | 19   | Dense gray silt, little fine sand, trace medium to coarse sand interbedded with silty clay.                                     |   |
| 195          | 44         | 29 / 90-1'R                   |                           |                     |                 |                  |      |      |      |      |      | A-4b(8)   |   |
|              |            |                               |                           |                     |                 |                  |      |      |      |      |      | Dense gray fine to coarse sand, little fine gravel, some silty clay.  |   |
|              |            |                               |                           |                     |                 |                  |      |      |      |      |      | - From 195.5' to 196.3': Granite boulder. Est. A-1-b  |   |
|              |            |                               |                           |                     |                 |                  |      |      |      |      |      | DESCRIPTION ON NEXT PAGE  |   |

200 WATER LEVEL:                                
 WATER NOTE:                                
 DATE:



Renamed: B-101-0-94

CUY-90-15.24  
CLEVELAND, OHIO

TYPE: 2" O.D. Split-barrel Sampler  
3" O.D. Shelby Tube  
NXM Rock-core Barrel

LOCATION: Sta. 15+06.50  
120.7' Rt. of  
Centerline

COMPLETION DEPTH: 230.1' ELEVATION: 676.6 DATE: 8/23/94 8/25/94

| DEP. FEET | SAMPLE NO. | SAMPLES SAMPLING EFFORT | HAND PENE-TROMETER | MOISTURE CONTENT | LIQUID LIMIT | PLASTIC LIMIT | DESCRIPTION - CONTINUED |   |   |    |      |       |       |      |      |  |  |  |  |   |
|-----------|------------|-------------------------|--------------------|------------------|--------------|---------------|-------------------------|---|---|----|------|-------|-------|------|------|--|--|--|--|---|
|           |            |                         |                    |                  |              |               | tsf                     | % | % | %  | AGG. | C. S. | F. S. | SILT | CLAY |  |  |  |  |   |
| 200       | 45         | 36/60                   | 4.5+               |                  |              |               |                         |   |   |    |      |       |       |      |      |  |  |  |  | Very-stiff to hard gray silty clay, trace to little fine to coarse sand, trace fine to coarse gravel, few lenses of silt.     |
| 205       | 46         | 28/47/67                | 4.5+               |                  |              |               |                         |   |   |    |      |       |       |      |      |  |  |  |  | - From 210.0; to 211.5': Contains slickenside planes.   |
| 210       | 47         | 27/32/32                | 2.5-4.5            |                  |              |               |                         |   |   |    |      |       |       |      |      |  |  |  |  | - From 217.2' to 217.4': Cobble or cobble gravel.   |
| 215       | 48         | 9/13/18                 | 2.5-3.5            |                  |              |               |                         |   |   |    |      |       |       |      |      |  |  |  |  |   |
| 220       | 49         | 11/14/18                | 2.2-2.8            | 19               | 29           | 17            | 1                       | 5 | 9 | 33 | 52   |       |       |      |      |  |  |  |  | A-6a(9)   |
| 225       | 50         | 77-1"R<br>NXM<br>REC    | RQD                |                  |              |               |                         |   |   |    |      |       |       |      |      |  |  |  |  | Soft to medium-hard gray and dark-gray shale, nearly horizontally bedded, fissile, 1/4" to 13" core pieces.                   |
| 230       | 51         | 98%                     | 76%                |                  |              |               |                         |   |   |    |      |       |       |      |      |  |  |  |  | - Encountered water at 36.0'.   |
| 235       |            |                         |                    |                  |              |               |                         |   |   |    |      |       |       |      |      |  |  |  |  | - From 0.0' to 55.0': 3-1/4" I.D. Hollow-stem Auger with plug, replaced with 4" I.D. Flush-coupled casing from 0.0' to 60.0'. |
| 240       |            |                         |                    |                  |              |               |                         |   |   |    |      |       |       |      |      |  |  |  |  | - From 55.0' to 225.0': 3-7/8" Tricone Bit.   |
| 245       |            |                         |                    |                  |              |               |                         |   |   |    |      |       |       |      |      |  |  |  |  | - From 58.3' to 230.1': Recirculated water used for drilling fluid.   |

WATER LEVEL:  WATER NOTE: \_\_\_\_\_ DATE: \_\_\_\_\_



Renamed: B-102-0-94

LOG OF BORING NO. B-102

CUY-90-15.24  
CLEVELAND, OHIO

TYPE: 2" O.D. Split-barrel Sampler LOCATION: Sta. 15+95.34  
3" O.D. Shelby Tube 134.7' Rt. of  
NXM Rock-core Barrel Centerline

COMPLETION DEPTH: 232.0' ELEVATION: 675.7 DATE: 9/9/94 9/14/94

| DEPT. FEET | SAMPLE NO. | SAMPLES | SAMPLING EFFORT | HAND PENE-TROMETER | MOISTURE CONTENT | LIQUID LIMIT | PLASTIC LIMIT | COMPLETION DEPTH: 232.0' ELEVATION: 675.7 DATE: 9/9/94 9/14/94 |   |   |   | DESCRIPTION   |
|------------|------------|---------|-----------------|--------------------|------------------|--------------|---------------|--|---|---|---|---|
|            |            |         |                 |                    |                  |              |               | tst  | % | % | % |   |
| 0          |            |         |                 |                    |                  |              |               |  |   |   |   | FILL: Loose gray coarse gravel.<br>Est. A-1-a   |
| 5          | 1          | 3       | 14/6            |                    |                  |              |               |  |   |   |   | FILL: Medium-dense to dense black fine to medium sand, trace coarse sand, trace fine to coarse gravel.<br>Est. A-3a |
| 10         | 2          | 2       | 13/2            |                    |                  |              |               |  |   |   |   | Medium-dense brown fine to coarse sand, trace to little fine gravel, trace silt.                                    |
| 15         | 3          | 4       | 18/10           |                    |                  |              |               |  |   |   |   |   |
| 20         | 4          | 9       | 13/15           |                    |                  |              |               |  |   |   |   |   |
| 25         | 5          | 6       | 11/13           |                    |                  |              |               |  |   |   |   |   |
| 30         | 6          | 7       | 10/14           |                    |                  |              |               |  |   |   |   | - At 32.1': Contains seams of fine sand, some to "and" silt.  |
| 35         | 7          | 6       | 9/10            |                    |                  |              |               |  |   |   |   | Est. A-3a   |
| 40         | 8          | 17      | 18/22           |                    |                  |              |               |  |   |   |   | Dense brown fine sand, trace to little silt, trace medium to coarse sand, trace fine gravel.                        |
| 45         | 9A<br>9B   | 20      | 25/30           |                    |                  |              |               |  |   |   |   | Est. A-3a   |

DESCRIPTION ON NEXT PAGE

50 WATER LEVEL:                                
WATER NOTE:                                
DATE:



Renamed: B-102-0-94

**LOG OF BORING NO. B-102**  
**CUY-90-15,24**  
**CLEVELAND, OHIO**

TYPE: 2" O.D. Split-barrel Sampler LOCATION: Sta. 15+95.34  
3" O.D. Shelby Tube 134.7' Rt. of  
NXM Rock-core Barrel Centerline

COMPLETION DEPTH: 232.0' ELEVATION: 675.7 DATE: 9/9/94 9/14/94

| DEPTH FEET | SAMPLE NO. | SAMPLES SAMPLING EFFORT | HAND PENE-TROMETER | MOISTURE CONTENT | LIQUID LIMIT | PLASTIC LIMIT | COMPLETION DEPTH |   |    |    | ELEVATION |      | DATE   | DESCRIPTION - CONTINUED |
|------------|------------|-------------------------|--------------------|------------------|--------------|---------------|------------------|---|----|----|-----------|------|--|-------------------------|
|            |            |                         |                    |                  |              |               | tsf              | % | %  | %  | AGG.      | C.S. |  |                         |
| 50         | 10         | 4 / 10 / 11             | 2.8-3.5            | 18               | 23           | 18            | 0                | 0 | 10 | 65 | 25        |      | Very-stiff gray clayey silt interbedded with silt, trace fine to medium sand.<br>A-4b(8)                               |                         |
| 55         | 11         | 16 / 24 / 22            |                    |                  |              |               |                  |   |    |    |           |      | Medium-dense to dense gray silt, little to "and" fine sand.  |                         |
| 60         | 12         | 12 / 12 / 14            |                    |                  |              |               | 0                | 0 | 5  | 79 | 16        |      | A-4b(8)  |                         |
| 65         | 13         | 2 / 3 / 2               | 0.5-0.7            |                  |              |               |                  |   |    |    |           |      | Interbedded medium-stiff gray silty clay and very-loose to loose silt, some fine sand, horizontal laminated structure. |                         |
| 70         | 14         | P                       | 0.8-1.0            |                  |              |               |                  |   |    |    |           |      | Est. A-6a  |                         |
| 75         | 15         | 5 / 9 / 12              | 1.5-4.5+           |                  |              |               |                  |   |    |    |           |      | Stiff to hard gray silty clay, trace fine to medium sand, contains seams of silt, horizontal structure.                |                         |
| 80         | 16         | P                       | 4.5+               |                  |              |               |                  |   |    |    |           |      |  |                         |
| 85         | 17         | 5 / 7 / 13              | 1.5-2.5            |                  |              |               |                  |   |    |    |           |      |  |                         |
| 90         | 18         | P                       | 1.0                |                  |              |               |                  |   |    |    |           |      | Est. A-6b  |                         |
| 95         | 19         | 2 / 2 / 2               | 0.5-1.0            |                  |              |               |                  |   |    |    |           |      | Medium-stiff to stiff gray silty clay, trace fine to coarse sand, trace fine gravel, few seams of silt.                |                         |

A-6a, A-6b(9,11)

100 WATER LEVEL:                                
 WATER NOTE:                                
 DATE:                              

-CONTINUED-



Renamed: B-102-0-94

LOG OF BORING NO. B-102  
 CUY-90-15.24  
 CLEVELAND, OHIO

TYPE: 2" O.D. Split-barrel Sampler LOCATION: Sta. 15+95.34  
3" O.D. Shelby Tube 134.7' Rt. of  
NXM Rock-core Barrel Centerline  
 COMPLETION DEPTH: 232.0' ELEVATION: 675.7 DATE: 9/9/94 9/14/94

| DEPT. FEET | SAMPLE NO. | SAMPLES SAMPLING EFFORT | HAND PENE-TROMETER | MOISTURE CONTENT | LIQUID LIMIT | PLASTIC LIMIT | COMPLETION DEPTH: 232.0' ELEVATION: 675.7 |   |   |    | DATE: 9/9/94 9/14/94 | DESCRIPTION - CONTINUED   |
|------------|------------|-------------------------|--------------------|------------------|--------------|---------------|---|---|---|----|----------------------|---|
|            |            |                         |                    |                  |              |               | tsf                                       | % | % | %  |                      |   |
| 100        | 20         |                         | 0.8-1.2            |                  |              |               |   |   |   |    |                      | Medium-stiff to stiff gray silty clay, trace fine to coarse sand, trace fine gravel, few seams of silt.   |
| 105        | 21         | S/H-12"<br>4            | 0.5-0.8            | 33               | 41           | 22            | 1   | 1 | 1 | 10 | 87                   | - Sample 21: Medium-stiff gray silty clay, trace fine to coarse sand, A-7-6(12).  |
| 110        | 22         | P<br>S/H-8"<br>9        | 0.5                |                  |              |               |   |   |   |    |                      |   |
| 115        | 23         | P                       | 1.0-1.5            | 30               | 38           | 20            | 1   | 1 | 1 | 31 | 66                   |   |
| 120        | 24         | S/H-12"<br>7.5          | 0.6-0.8            |                  |              |               |   |   |   |    |                      |   |
| 125        | 25         | P                       | 1.5-2.0            | 24               | 29           | 17            | 0   | 0 | 1 | 53 | 46                   |   |
| 130        | 26         | S/H-12"<br>7            | 0.5-1.0            | 24               | 30           | 18            | 0   | 0 | 1 | 49 | 50                   |   |
| 135        | 27         | S/H-18"                 | 0.7-1.0            |                  |              |               |   |   |   |    |                      |   |
| 140        | 28         | S/H-18"<br>23           | 2.5-3.5            |                  |              |               |   |   |   |    |                      | A-6a, A-6b(9,11)<br>Stiff to very-stiff gray silty clay, trace fine to coarse sand, trace fine gravel, horizontal structure, contains thin seams of clayey silt and silt. |
| 145        | 29         | S/H-18"<br>26           | 3.2-3.5            |                  |              |               |   |   |   |    |                      |   |

150 WATER LEVEL:                                
 WATER NOTE:                                
 DATE:



Renamed: B-102-0-94

LOG OF BORING NO. B-102  
 CUY-90-15.24  
 CLEVELAND, OHIO

TYPE: 2' O.D. Split-barrel Sampler LOCATION: Sta. 15+95.34  
3' O.D. Shelby Tube 134.7' Rt. of  
NXM Rock-core Barrel Centerline  
 COMPLETION DEPTH: 232.0' ELEVATION: 675.7 DATE: 9/9/94 9/14/94

| DEP<br>FEET | SAMPLE NO. | SAMPLES<br>SAMPLING<br>EFFORT | HAND<br>PENE-<br>TRONETER | MOISTURE<br>CONTENT | LIQUID<br>LIMIT | PLASTIC<br>LIMIT | AGG. C. S. F. S. SILT/CLAY |   |   |    | DESCRIPTION - CONTINUED |   |
|-------------|------------|-------------------------------|---------------------------|---------------------|-----------------|------------------|----------------------------|---|---|----|-------------------------|---|
|             |            |                               |                           |                     |                 |                  | tsf                        | % | % | %  |                         |   |
| 150         | 30         | 8 /17/24                      | 3.0-3.5                   |                     |                 |                  |                            |   |   |    |                         | Stiff to very-stiff gray silty clay, trace fine to coarse sand, trace fine gravel, horizontal structure, contains thin seams of clayey silt and silt. |
| 155         | 31         | 10 /16/20                     | 2.0-3.0                   |                     |                 |                  |                            |   |   |    |                         |   |
| 160         | 32         | 6 /11/16                      | 1.8-2.4                   |                     |                 |                  |                            |   |   |    |                         |   |
| 165         | 33         | 8 /13/18                      | 2.0-2.5                   |                     |                 |                  |                            |   |   |    |                         |   |
| 170         | 34         | 12 /17/20                     | 1.5-2.0                   | 28                  | 35              | 19               | 0                          | 2 | 2 | 27 | 69                      |   |
| 175         | 35         | 7 /13/18                      | 2.5-3.0                   |                     |                 |                  |                            |   |   |    |                         |   |
| 180         | 36         | 7 /11/14                      | 2.4-3.0                   |                     |                 |                  |                            |   |   |    |                         |   |
| 185         | 37         | P                             | 1.0-1.5                   |                     |                 |                  |                            |   |   |    |                         |   |
| 190         | 38         | P                             | 1.5                       |                     |                 |                  |                            |   |   |    |                         |   |
| 195         | 39         | P                             | 2.5-3.0                   |                     |                 |                  |                            |   |   |    |                         |   |

A-6b(10)

DESCRIPTION ON NEXT PAGE

200  
 WATER LEVEL:       
 WATER NOTE:       
 DATE:

LOG OF BORING NO. B-102  
 CUY-90-15.24  
 CLEVELAND, OHIO



Renamed: B-102-0-94

TYPE: 2" O.D. Split-barrel Sampler LOCATION: Sta. 15+95.34  
3" O.D. Shelby Tube 134.7 Rt. of  
NXM Rock-core Barrel Centerline  
 COMPLETION DEPTH: 232.0' ELEVATION: 675.7 DATE: 9/9/94 9/14/94

| DEP. FEET | SAMPLE NO. | SAMPLES | SAMPLING EFFORT | HAND PENE-TROMETER | MOISTURE CONTENT | LIQUID LIMIT | PLASTIC LIMIT | DESCRIPTION - CONTINUED |   |   |   |      |       |       |      |      |  |  |  |  |   |
|-----------|------------|---------|-----------------|--------------------|------------------|--------------|---------------|-------------------------|---|---|---|------|-------|-------|------|------|--|--|--|--|---|
|           |            |         |                 |                    |                  |              |               | tsf                     | % | % | % | AGG. | C. S. | F. S. | SILT | CLAY |  |  |  |  |   |
| 200       | 40         | 19      | 132/44          | 4.5+               |                  |              |               |                         |   |   |   |      |       |       |      |      |  |  |  |  | Very-stiff gray silty clay, trace fine to coarse sand, trace fine gravel, few lenses of silt.<br><br>- From 198.4' to 200.0': Few seams of fine to coarse gravel.<br>- From 200.1' to 200.4': Cobble. |
| 205       | 41         | 11      | 21/25           | 4.3-4.5+           |                  |              |               |                         |   |   |   |      |       |       |      |      |  |  |  |  |   |
| 210       | 42         | 13      | 19/23           | 3.0-3.8            |                  |              |               |                         |   |   |   |      |       |       |      |      |  |  |  |  |   |
| 215       | 43         | 8       | 14/17           | 2.0-3.0            |                  |              |               |                         |   |   |   |      |       |       |      |      |  |  |  |  |   |
| 220       | 44         | 6       | 12/14           | 2.0-2.5            |                  |              |               |                         |   |   |   |      |       |       |      |      |  |  |  |  |   |
| 225       |            |         | NXM REC         | ROD                |                  |              |               |                         |   |   |   |      |       |       |      |      |  |  |  |  |   |
| 230       | 45         |         | 100%            | 50%                |                  |              |               |                         |   |   |   |      |       |       |      |      |  |  |  |  |   |
| 235       |            |         |                 |                    |                  |              |               |                         |   |   |   |      |       |       |      |      |  |  |  |  |   |
| 240       |            |         |                 |                    |                  |              |               |                         |   |   |   |      |       |       |      |      |  |  |  |  |   |
| 245       |            |         |                 |                    |                  |              |               |                         |   |   |   |      |       |       |      |      |  |  |  |  |   |

Est. A-6b

Dense gray fine to coarse gravel, sand and silty clay, some fine to coarse sand.

Est. A-1-b

Medium-hard gray shale, nearly horizontally bedded, slightly fissile.  
 - From 230.7' to 231.2': Several vertical fractures.  
 - From 231.8' to 232.0': Few diagonal fractures.

- Encountered water at 39.5'.

- From 0.0' to 64.0': 3-1/4" I.D. Hollow-stem Anger with plug, replaced with 4" I.D. Flush-coupled casing from 0.0' to 64.0'.

- From 65.0' to 225.5': 3-7/8" Tricone Bit.

- From 65.0' to 232.0': Recirculated water used for drilling fluid.

250 WATER LEVEL:                    
 WATER NOTE:                    
 DATE:





Renamed: B-103-0-94

LOG OF BORING NO. B-103  
 CUY-90-15.24  
 CLEVELAND, OHIO

TYPE: 2" O.D. Split-barrel Sampler LOCATION: Sta. 16+93.83  
 3" O.D. Shelby Tube 34.49' Rt. of  
 NXM Rock-core Barrel Centerline  
 COMPLETION DEPTH: 175.0' ELEVATION: 616.2 DATE: 8/15/94 8/17/94

| DEPT<br>FEET | SAMPLE NO.    | SAMPLES        | SAMPLING EFFORT | HAND PENE-TROMETER | MOISTURE CONTENT | LIQUID LIMIT | PLASTIC LIMIT | DESCRIPTION |   |    |    |      |      |      |      |      |  |  |
|--------------|---------------|----------------|-----------------|--------------------|------------------|--------------|---------------|-------------|---|----|----|------|------|------|------|------|--|--|
|              |               |                |                 |                    |                  |              |               | tsf         | % | %  | %  | AGG. | C.S. | F.S. | SILT | CLAY |  |  |
| 0            |               |                |                 |                    |                  |              |               |             |   |    |    |      |      |      |      |      |  | FILL: Loose light-gray fine gravel (crushed stone).  |
| 5            | 1             | 1/1/3          |                 |                    |                  |              |               |             |   |    |    |      |      |      |      |      |  | FILL: Medium-dense black fine to coarse gravel, some fine to coarse sand, little silt.<br>Est. A-1-b                   |
| 10           | 2A<br>2B      | 4/7/8          |                 |                    |                  |              |               |             |   |    |    |      |      |      |      |      |  | FILL: Very-loose to loose brown and black fine to medium sand, trace silt, few fragments of decayed wood.<br>Est. A-3  |
| 15           | 3             | 5/10/13        |                 |                    | 17               | 24           | 18            | 0           | 0 | 12 | 66 | 22   |      |      |      |      |  | Medium-dense gray silt, little fine sand, little clay, contains thin seams of fine and fine to medium sand.            |
| 20           | 4<br>5A<br>5B | P/R<br>9/12/14 |                 | 4.2-4.5+           | 20               | 37           | 20            | 0           | 0 | 1  | 57 | 42   |      |      |      |      |  | Very-stiff to hard gray silty clay, trace fine to medium sand, contains seams of silt.<br>A-4b(8)                      |
| 25           | 6             | P              |                 | 4.5+               | 20               | 29           | 20            | 0           | 0 | 0  | 57 | 43   |      |      |      |      |  |  |
| 30           | 7             | 4/7/12         |                 | 3.5-4.5+           |                  |              |               |             |   |    |    |      |      |      |      |      |  |  |
| 35           | 8             | 5/9/15         |                 | 2.5-3.3            |                  |              |               |             |   |    |    |      |      |      |      |      |  |  |
| 40           | 9             | 2/4/5          |                 | 0.8-1.8            |                  |              |               |             |   |    |    |      |      |      |      |      |  | Medium-stiff to stiff gray silty clay, trace fine to coarse sand, trace fine gravel, horizontal structure.<br>A-6b(11) |
| 45           | 10            | 2/4/4          |                 | 0.8-2.0            | 30               | 39           | 21            | 0           | 1 | 2  | 20 | 77   |      |      |      |      |  |  |

50 WATER LEVEL:  \_\_\_\_\_  \_\_\_\_\_  \_\_\_\_\_  \_\_\_\_\_  \_\_\_\_\_  \_\_\_\_\_  
 WATER NOTE: \_\_\_\_\_  
 DATE: \_\_\_\_\_



Renamed: B-103-0-94

LOG OF BORING NO. B-103  
 CUY-90-15.24  
 CLEVELAND, OHIO

TYPE: 2" O.D. Split-barrel Sampler  
3" O.D. Shelby Tube  
NXM Rock-core Barrel

LOCATION: Sta. 16+93.83  
34.49' Rt. of  
Centerline

COMPLETION DEPTH: 175.0' ELEVATION: 616.2 DATE: 8/15/94 8/17/94

| DEP. FEET | SAMPLE NO. | SAMPLES | SAMPLING EFFORT | HAND PENE-TROMETER | MOISTURE CONTENT | LIQUID LIMIT | PLASTIC LIMIT | DESCRIPTION - CONTINUED |   |   |    |      |      |      |           |  |  |          |
|-----------|------------|---------|-----------------|--------------------|------------------|--------------|---------------|-------------------------|---|---|----|------|------|------|-----------|--|--|----------|
|           |            |         |                 |                    |                  |              |               | tsf                     | % | % | %  | AGG. | C.S. | F.S. | SILT:CLAY |  |  |          |
| 50        | 11         | 2       | 1/4/5           | 0.9-1.3            |                  |              |               |                         |   |   |    |      |      |      |           |  | Medium-stiff to stiff gray silty clay, trace fine to coarse sand, trace fine gravel, horizontal structure.                 | A-6b(11) |
| 55        | 12         | 3       | 1/6/10          | 1.6-2.5            |                  |              |               |                         |   |   |    |      |      |      |           |  | Stiff to very-stiff gray silty clay, trace fine to coarse sand, trace fine gravel, contains seams of clayey silt and silt. |          |
| 60        | 13         | 5       | 1/8/11          | 2.0-3.3            | 22               | 30           | 20            | 0                       | 0 | 2 | 66 | 32   |      |      |           |  | - Sample 13: Very-stiff brown-gray clayey silt, trace fine to medium sand, A-4b(8).  |          |
| 65        | 14         | 5       | 1/8/12          | 2.5-3.5            | 21               | 32           | 17            | 0                       | 0 | 2 | 61 | 37   |      |      |           |  |  |          |
| 70        | 15         | 5       | 1/9/12          | 3.3-4.0            |                  |              |               |                         |   |   |    |      |      |      |           |  |  |          |
| 75        | 16         | 4       | 1/9/11          | 2.0-3.0            |                  |              |               |                         |   |   |    |      |      |      |           |  |  |          |
| 80        | 17         | 7       | 1/11/15         | 2.5-3.0            |                  |              |               |                         |   |   |    |      |      |      |           |  |  |          |
| 85        | 18         | 7       | 1/12/16         | 2.3-2.9            |                  |              |               |                         |   |   |    |      |      |      |           |  |  |          |
| 90        | 19         | 5       | 1/11/14         | 2.0-2.5            |                  |              |               |                         |   |   |    |      |      |      |           |  |  |          |
| 95        | 20         | 5       | 1/9/15          | 1.5-2.0            | 21               | 31           | 17            | 2                       | 2 | 6 | 41 | 49   |      |      |           |  |  |          |

A-6a(10)

100 WATER LEVEL:                                
 WATER NOTE:                                
 DATE:



Renamed: B-103-0-94

LOG OF BORING NO. B-103  
 CUY-90-15.24  
 CLEVELAND, OHIO

TYPE: 2" O.D. Split-barrel Sampler  
3" O.D. Shelby Tube  
NXM Rock-core Barrel

LOCATION: Sta. 16+93.83  
34.49' Rt. of  
Centerline

COMPLETION DEPTH: 175.0' ELEVATION: 616.2 DATE: 8/15/94 8/17/94

| DEPT<br>FEET | SAMPLE NO. | SAMPLES<br>SAMPLING<br>EFFORT | HAND<br>PENE-<br>TROMETER | MOISTURE<br>CONTENT | LIQUID<br>LIMIT | PLASTIC<br>LIMIT | COMPLETION DEPTH: 175.0' |    |    |    | ELEVATION: 616.2 |      | DATE: 8/15/94 8/17/94 | DESCRIPTION - CONTINUED   |
|--------------|------------|-------------------------------|---------------------------|---------------------|-----------------|------------------|--------------------------|----|----|----|------------------|------|-----------------------|---|
|              |            |                               |                           |                     |                 |                  | tsf                      | %  | %  | %  | AGG.             | C.S. |                       |   |
| 100          | 21         | 5/9/12                        | 1.5-2.0                   |                     |                 |                  |                          |    |    |    |                  |      |                       | Stiff to very-stiff gray silty clay, trace fine to coarse sand, trace fine gravel, contains seams of clayey silt and silt.                      |
| 105          | 22         | 5/9/13                        | 1.5-2.3                   | 20                  | 34              | 19               | 6                        | 2  | 3  | 38 | 51               |      |                       |   |
| 110          | 23         | 6/11/17                       | 2.5                       |                     |                 |                  |                          |    |    |    |                  |      |                       | A-6a(10)  |
| 115          | 24         | 6/13/17                       | 2.5-3.2                   |                     |                 |                  |                          |    |    |    |                  |      |                       | Stiff to very-stiff gray silty clay, trace fine to coarse sand, trace fine gravel, horizontal structure, few lenses of silt.                    |
| 120          | 25         | P                             | 2.5                       |                     |                 |                  |                          |    |    |    |                  |      |                       |   |
|              | 26         | 7/10/12                       | 1.0-1.7                   | 26                  | 41              | 21               | 0                        | 1  | 1  | 29 | 69               |      |                       | - Sample 26: Stiff to very-stiff gray silty clay, A-7-6(12).  |
| 125          | 27         | P                             | 1.8-2.0                   | 29                  | 40              | 20               | 0                        | 0  | 1  | 23 | 76               |      |                       |   |
|              | 28         | 4/6/8                         | 1.0-1.5                   | 26                  | 36              | 21               | 1                        | 1  | 1  | 19 | 78               |      |                       | A-6a, A-6b(10)  |
| 130          | 29A        | P                             | 1.0                       | 21                  | NP              | NP               | 0                        | 0  | 1  | 82 | 17               |      |                       | Interbedded: Medium-stiff to stiff gray clayey silt, silty clay, medium-dense silt, and dense fine sand, some silt, 1/2" to 6"+ each soil type. |
|              | 29B        |                               |                           |                     |                 |                  |                          |    |    |    |                  |      |                       | A-4b(8)   |
|              | 29C        |                               |                           |                     |                 |                  |                          |    |    |    |                  |      |                       |   |
| 135          | 30         | 7/20/28                       |                           |                     |                 |                  | 35                       | 41 | 12 |    | 12               |      |                       | Dense gray fine to coarse sand, little fine gravel, little clayey silt.   |
|              |            |                               |                           |                     |                 |                  |                          |    |    |    |                  |      |                       | A-1-b(0)  |
| 140          | 31         | 24/50/77                      | 4.5+                      |                     |                 |                  |                          |    |    |    |                  |      |                       | Very-hard gray silty clay, little to some fine to coarse sand, trace fine to coarse gravel.   |
|              |            |                               |                           |                     |                 |                  |                          |    |    |    |                  |      |                       | - From 142.1' tp 142.5': Cobbles or boulders.   |
|              |            |                               |                           |                     |                 |                  |                          |    |    |    |                  |      |                       | - At 146.0': Slickensided plane.  |
| 145          | 32         | 18/41/64                      | 4.5+                      |                     |                 |                  |                          |    |    |    |                  |      |                       | - From 150.0' to 151.5': Contains slickensided planes.  |
|              |            |                               |                           |                     |                 |                  |                          |    |    |    |                  |      |                       | Est. A-6a   |

150 WATER LEVEL:                              

WATER NOTE:                              

DATE:



Renamed: B-103-0-94

LOG OF BORING NO. B-103  
 CUY-90-15.24  
 CLEVELAND, OHIO

TYPE: 2" O.D. Split-barrel Sampler LOCATION: Sta. 16+93.83  
3" O.D. Shelby Tube 34.49' Rt. of  
NXM Rock-core Barrel Centerline

COMPLETION DEPTH: 175.0' ELEVATION: 616.2 DATE: 8/15/94 8/17/94

| DEPT. FEET | SAMPLE NO. | SAMPLES     | SAMPLING EFFORT | HAND PENE-TROMETER | MOISTURE CONTENT | LIQUID LIMIT | PLASTIC LIMIT | DESCRIPTION - CONTINUED |    |    |    |      |       |       |           |  |  |  |  |
|------------|------------|-------------|-----------------|--------------------|------------------|--------------|---------------|-------------------------|----|----|----|------|-------|-------|-----------|--|--|--|--|
|            |            |             |                 |                    |                  |              |               | tsf                     | %  | %  | %  | AGG. | C. S. | F. S. | SILT/CLAY |  |  |  |  |
| 150        | 33         | 18          | 33/47           | 4.5+               |                  |              |               |                         |    |    |    |      |       |       |           |  |  |  |  |
| 155        | 34         | 7           | 10/14           | 1.8-2.5            | 24               | 32           | 20            | 0                       | 0  | 1  | 43 | 56   |       |       |           |  |  |  |  |
| 160        | 35         | 6           | 13/15           | 2.2-2.5            |                  |              |               |                         |    |    |    |      |       |       |           |  |  |  |  |
| 165        | 36         | 23          | 44/60           | 4.5+               |                  |              |               | 21                      | 25 | 19 | 35 |      |       |       |           |  |  |  |  |
| 170        | 37         | NXM REC 96% |                 | ROD 60%            |                  |              |               |                         |    |    |    |      |       |       |           |  |  |  |  |

DESCRIPTION ON PREVIOUS PAGE  
 Est. A-6a

Stiff to very-stiff gray silty clay, trace fine to medium sand, horizontal structure.

A-6a(9)  
 Dense gray fine to coarse gravel (mostly shale fragments) "and" silty clay, some fine to coarse sand, contains seams of fine to medium sand, some silt.

A-2-4(0)  
 Very-soft to soft gray shale, partly similar to soil.  
 Soft to medium-hard gray shale, nearly horizontally bedded, fissile 1/4" to 7" core layers.  
 - From 169.6' to 174.1': Very-soft shale seam similar to hard soil.

---

- Encountered water at 27.5'.

- From 0.0' to 27.5': 3-1/4" I.D. Hollow-stem Auger with plug, replaced with 4" I.D. Flush-coupled casing from 0.0' to 30.0'.

- From 27.5' to 170.0': 3-7/8" Tricone Bit.

- From 27.5' to 175.0': Recirculated water used for drilling fluid.

200 WATER LEVEL:  \_\_\_\_\_  \_\_\_\_\_  \_\_\_\_\_  \_\_\_\_\_  \_\_\_\_\_  \_\_\_\_\_

WATER NOTE: \_\_\_\_\_

DATE: \_\_\_\_\_



Renamed: B-104-0-94

**LOG OF BORING NO. B-104**  
**CUY-90-15.24**  
**CLEVELAND, OHIO**

TYPE: 2" O.D. Split-barrel Sampler LOCATION: Sta. 18+50.53  
3" O.D. Shelby Tube 100.2' Rt. of  
NXM Rock-core Barrel Centerline

COMPLETION DEPTH: 165.5' ELEVATION: 601.8 DATE: 9/13/94 9/15/94

| DEPTH FEET | SAMPLE NO. | SAMPLES SAMPLING EFFORT | HAND PENE-TROMETER | MOISTURE CONTENT | LIQUID LIMIT | PLASTIC LIMIT | AGG. |   |   |    | SILT:CLAY |    | DESCRIPTION   |
|------------|------------|-------------------------|--------------------|------------------|--------------|---------------|------|---|---|----|-----------|----|---|
|            |            |                         |                    |                  |              |               | tsf  | % | % | %  | C.        | S. |   |
| 0          |            |                         |                    |                  |              |               |      |   |   |    |           |    | FILL: (Estimated) Medium-dense to dense brown and gray fine to coarse gravel, little fine to coarse sand.<br>Est. A-1-a                             |
| 5          | 1          | 5 / 5 / 7               |                    |                  |              |               |      |   |   |    |           |    | FILL: Medium-dense to dense black fine to coarse sand, some fine to coarse gravel, trace clayey silt, (cinders), and shale fragments.<br>Est. A-1-b |
| 10         | 2A<br>2B   | 2 / 3 / 4               |                    |                  |              |               |      |   |   |    |           |    | Loose brown fine to medium sand, trace coarse sand, trace silt.<br>Est. A-3a  |
| 15         | 3A<br>3B   | 3 / 2 / 2               |                    |                  |              |               |      |   |   |    |           |    | Gray silt, little fine sand.<br>Est. A-4b   |
| 20         | 4A<br>4B   | P                       |                    |                  |              |               |      |   |   |    |           |    | Very-stiff to hard gray silty clay, trace fine sand, few lenses of silt.<br>Est. A-6b   |
| 25         | 5          | 3 / 4 / 7               | 3.7-4.3            |                  |              |               |      |   |   |    |           |    | Stiff gray silty clay, trace fine to coarse sand, trace fine gravel, few seams and lenses of silt.<br>A-7-6(12)                                     |
| 30         | 6          | P                       | 1.1-1.2            |                  |              |               |      |   |   |    |           |    | Very-stiff gray silty clay, trace fine sand, many seams and lenses of silt, horizontal structure.<br>A-4b(8)  |
| 35         | 7          | 2 / 3 / 4               | 1.2-1.3            | 30               | 42           | 24            | 1    | 1 | 1 | 22 | 75        |    |   |
| 40         | 8          | P                       | 2.3-2.7            | 24               | 30           | 20            | 0    | 0 | 0 | 50 | 50        |    |   |
| 45         | 9          | 4 / 4 / 5               | 2.2-2.6            |                  |              |               |      |   |   |    |           |    |   |

50 WATER LEVEL:                                     
WATER NOTE:                                     
DATE:



Renamed: B-104-0-94

**LOG OF BORING NO. B-104**  
**CUY-90-15.24**  
**CLEVELAND, OHIO**

TYPE: 2" O.D. Split-barrel Sampler  
3" O.D. Shelby Tube  
NXM Rock-core Barrel

LOCATION: Sta. 18+50.53  
100.2' Rt. of  
Centerline

COMPLETION DEPTH: 165.5' ELEVATION: 601.8 DATE: 9/13/94 9/15/94

| DEPTH<br>FEET | SAMPLE NO. | SAMPLES<br>SAMPLING<br>EFFORT | HAND<br>PENE-<br>TROMETER | MOISTURE<br>CONTENT | LIQUID<br>LIMIT | PLASTIC<br>LIMIT | AGG. C.S.F.S. |   |   |    | SILT:CLAY |  | DESCRIPTION - CONTINUED |   |
|---------------|------------|-------------------------------|---------------------------|---------------------|-----------------|------------------|---------------|---|---|----|-----------|--|-------------------------|---|
|               |            |                               |                           |                     |                 |                  | tsf           | % | % | %  |           |  |                         |   |
| 50            | 10         | P                             |                           |                     |                 |                  |               |   |   |    |           |  |                         | Very-stiff to hard gray silty clay, trace fine sand, many seams and lenses of silt, horizontal structure.                         |
| 55            | 11         | 4 / 4 / 7                     | 2.4-2.7                   |                     |                 |                  |               |   |   |    |           |  |                         |   |
| 60            | 12         | P                             |                           |                     |                 |                  |               |   |   |    |           |  |                         | Stiff to hard gray silty clay, trace fine to coarse sand, trace fine gravel, many seams and lenses of silt, horizontal structure. |
| 65            | 13         | 5 / 7 / 10                    | 2.5-3.2                   |                     |                 |                  |               |   |   |    |           |  |                         |   |
| 70            | 14         | 4 / 5 / 9                     | 2.4-2.7                   |                     |                 |                  |               |   |   |    |           |  |                         |   |
| 75            | 15         | 3 / 4 / 3                     | 1.4-1.8                   | 24                  | 29              | 19               | 0             | 0 | 1 | 60 | 39        |  |                         | A-4b(8)   |
| 80            | 16         | 4 / 6 / 8                     | 1.8-2.2                   |                     |                 |                  |               |   |   |    |           |  |                         |   |
| 85            | 17         | 4 / 7 / 8                     | 2.1-2.3                   |                     |                 |                  |               |   |   |    |           |  |                         |   |
| 90            | 18         | 4 / 7 / 9                     | 2.4-2.7                   |                     |                 |                  |               |   |   |    |           |  |                         |   |
| 95            | 19         | 4 / 7 / 9                     | 2.0-2.7                   |                     |                 |                  |               |   |   |    |           |  |                         |   |

100 WATER LEVEL:                              

WATER NOTE:                              

DATE:



Renamed: B-104-0-94

LOG OF BORING NO. B-104  
 CUY-90-15.24  
 CLEVELAND, OHIO

TYPE: 2' O.D. Split-barrel Sampler LOCATION: Sta. 18+50.53  
3' O.D. Shelby Tube 100.2' Rt. of  
NXM Rock-core Barrel Centerline  
 COMPLETION DEPTH: 165.5' ELEVATION: 601.8 DATE: 9/13/94 9/15/94

| DEPT. FEET | SAMPLE NO. | SAMPLES | SAMPLING EFFORT | HAND PENE-TROMETER | MOISTURE CONTENT | LIQUID LIMIT | PLASTIC LIMIT | DESCRIPTION - CONTINUED |    |    |    |      |      |      |           |  |   |
|------------|------------|---------|-----------------|--------------------|------------------|--------------|---------------|-------------------------|----|----|----|------|------|------|-----------|--|---|
|            |            |         |                 |                    |                  |              |               | tsf                     | %  | %  | %  | AGG. | C.S. | F.S. | SILT:CLAY |  |   |
| 100        | 20         | 7/13    | 20              | 4.2-4.4            |                  |              |               |                         |    |    |    |      |      |      |           |  | Stiff to hard gray silty clay, trace fine to coarse sand, trace fine gravel, many seams and lenses of silt, horizontal structure. |
| 105        | 21         | 6/10    | 17              | 3.1-3.7            | 22               | 35           | 20            | 0                       | 0  | 1  | 36 | 63   |      |      |           |  |   |
| 110        | 22         | 6/17    | 10              | 2.3-2.5            |                  |              |               |                         |    |    |    |      |      |      |           |  | A-6a(10)  |
| 115        | 23         | 5/7     | 9               | 1.5                |                  |              |               |                         |    |    |    |      |      |      |           |  | Stiff gray silty clay, some fine to coarse sand, trace fine gravel.   |
| 120        | 24         | P       |                 |                    |                  |              |               |                         |    |    |    |      |      |      |           |  | Est. A-6a   |
| 125        | 25         | 19/23   | 24              |                    |                  |              |               | 40                      | 32 | 15 | 13 |      |      |      |           |  | Dense gray fine to coarse sand, little fine gravel, little silty clay.  |
| 130        | 26         | 11/21   | 24              | 4.5+               |                  |              |               |                         |    |    |    |      |      |      |           |  | A-1-b(0)  |
| 135        | 27         | 8/15    | 16              | 3.2-4.5+           |                  |              |               |                         |    |    |    |      |      |      |           |  | Very-stiff to hard gray silty clay, trace fine to coarse sand, seams and lenses of silt.  |
| 140        | 28         | P       |                 | 2.0-2.2            | 22               | 39           | 22            | 0                       | 0  | 0  | 27 | 73   |      |      |           |  |   |
| 145        | 29A<br>29B | 6/11    | 21              | 2.5-3.2<br>4.5+    |                  |              |               |                         |    |    |    |      |      |      |           |  | Hard gray silty clay interbedded with silt and clayey silt, some fine to coarse sand, little fine to coarse gravel.               |
| 150        |            |         |                 |                    |                  |              |               |                         |    |    |    |      |      |      |           |  | Est. A-6a   |

WATER LEVEL:    WATER NOTE:    DATE:     
 -CONTINUED- 3 - 2 - 18



Renamed: B-104-0-94

LOG OF BORING NO. B-104  
 CUY-90-15.24  
 CLEVELAND, OHIO

TYPE: 2" O.D. Split-barrel Sampler  
3" O.D. Shelby Tube  
NXM Rock-core Barrel

LOCATION: Sta. 18+50.53  
100.2' Rt. of  
Centerline

COMPLETION DEPTH: 165.5' ELEVATION: 601.8 DATE: 9/13/94 9/15/94

DEPT. FEET  
 150  
 155  
 160  
 165  
 170  
 175  
 180  
 185  
 190  
 195  
 200

SAMPLE NO.  
 30  
 31  
 32

SAMPLES  
 P  
 29/27/83  
 NXM REC 89%

SAMPLING EFFORT

HAND PENE-TROMETER

MOISTURE CONTENT

LIQUID LIMIT

PLASTIC LIMIT

tsf

%

%

%

AGG.

C. S.

F. S.

SILT/CLAY

40

29

11

20

DESCRIPTION - CONTINUED

Dense gray fine to coarse sand, some fine to coarse gravel, trace silt.

A-1-b(0)

Hard gray silty clay, some fine to coarse sand, little fine gravel (shale fragments). Est. A-6a

Medium-hard gray shale, nearly horizontally bedded.  
 - From 163.1' to 163.8': Contains zones of clay.

- Encountered water from 25.0' to 165.5'.

- From 0.0' to 29.0': 3-1/4" I.D. Hollow-stem Auger with plug, replaced with 4" I.D. Flush-coupled casing from 0.0' to 29.0'.

- From 29.0' to 159.5': 3-7/8" Tricone Bit.

- From 29.0' to 165.5': Recirculated water used for drilling fluid.

WATER LEVEL:                              

WATER NOTE:                              

DATE:







Renamed: B-105-0-94

LOG OF BORING NO. B-105  
 CUY-90-15.24  
 CLEVELAND, OHIO

TYPE: 2" O.D. Split-barrel Sampler LOCATION: Sta. 19+11.38  
3" O.D. Shelby Tube  
NXM Rock-core Barrel  
90.9' Rt. of Centerline

COMPLETION DEPTH: 149.5' ELEVATION: 585.4 DATE: 8/17/94 8/18/94

| DEP. FEET | SAMPLE NO. | SAMPLES | SAMPLING EFFORT | HAND PENE-TROMETER | MOISTURE CONTENT | LIQUID LIMIT | PLASTIC LIMIT | AGG. C.S.F.S. |   |   |    | SILT:CLAY |  | DESCRIPTION - CONTINUED |  |
|-----------|------------|---------|-----------------|--------------------|------------------|--------------|---------------|---------------|---|---|----|-----------|--|-------------------------|--|
|           |            |         |                 |                    |                  |              |               | tsf           | % | % | %  |           |  |                         |  |
| 50        | 12         |         | 4 1/6 / 7       | 1.3-2.5            |                  |              |               |               |   |   |    |           |  |                         | Stiff to very-stiff gray silty clay, trace fine to coarse sand, trace fine gravel, few lenses of silt. |
| 55        | 13         |         | P               |                    |                  |              |               |               |   |   |    |           |  |                         |  |
|           | 14A        |         | 4 1/6 / 10      | 1.6-2.2            |                  |              |               |               |   |   |    |           |  |                         |  |
|           | 14B        |         |                 | 1.3-1.8            |                  |              |               |               |   |   |    |           |  |                         |  |
| 60        | 15         |         | 5 1/6 / 9       | 1.2-1.7            | 21               | 32           | 18            | 0             | 0 | 2 | 21 | 77        |  |                         |  |
| 65        | 16         |         | P               | 1.8-1.9            |                  |              |               |               |   |   |    |           |  |                         |  |
|           | 17         |         | 5 1/8 / 12      | 1.4-1.7            |                  |              |               |               |   |   |    |           |  |                         |  |
| 70        | 18         |         | 7 1/8 / 10      | 1.3-1.9            |                  |              |               |               |   |   |    |           |  |                         |  |
| 75        | 19         |         | 4 1/7 / 11      | 1.6-2.0            | 22               | 32           | 18            | 1             | 2 | 4 | 43 | 50        |  |                         |  |
| 80        | 20         |         | 4 1/8 / 11      | 1.5-2.2            |                  |              |               |               |   |   |    |           |  |                         |  |
| 85        | 21         |         | P               | 1.3-1.5            |                  |              |               |               |   |   |    |           |  |                         |  |
|           | 22         |         | 4 1/7 / 9       | 1.2-2.0            | 27               | 40           | 22            | 0             | 1 | 1 | 24 | 74        |  |                         |  |
| 90        | 23         |         | 5 1/8 / 11      | 1.2-2.0            |                  |              |               |               |   |   |    |           |  |                         |  |
|           | 24         |         | P               | 1.0-2.0            | 30               | 42           | 23            | 0             | 1 | 1 | 13 | 85        |  |                         |  |
|           | 25         |         | 3 1/4 / 6       | 0.5-0.6            |                  |              |               |               |   |   |    |           |  |                         |  |

- Below 77.5': Few seams of 1/8" silt.

A-6a, A-6b(10,11)

Medium-stiff to stiff gray silty clay, trace fine to coarse sand, few seams of silt, horizontal structure.

A-6a(10)

100 WATER LEVEL: 11.0

WATER NOTE: \_\_\_\_\_

DATE: 08/17/94





LOG OF BORING NO. B-105  
 CUY-90-15.24  
 CLEVELAND, OHIO

Renamed: B-105-0-94

TYPE: 2" O.D. Split-barrel Sampler LOCATION: Sta. 19+11.38  
3" O.D. Shelby Tube 90.9' Rt. of  
NXM Rock-core Barrel Centerline

COMPLETION DEPTH: 149.5' ELEVATION: 585.4 DATE: 8/17/94 8/18/94

| DEP. FEET | SAMPLE NO. | SAMPLES | SAMPLING EFFORT | HAND PENE-TROMETER | MOISTURE CONTENT | LIQUID LIMIT | PLASTIC LIMIT | AGG. C. S. F. S. SILT:CLAY |   |   |   | DESCRIPTION - CONTINUED   |
|-----------|------------|---------|-----------------|--------------------|------------------|--------------|---------------|----------------------------|---|---|---|---|
|           |            |         |                 |                    |                  |              |               | tsf                        | % | % | % |   |
| 150       |            |         |                 |                    |                  |              |               |                            |   |   |   | <ul style="list-style-type: none"> <li>- Encountered slight seepage at 9.3' to 12.0'.</li> <li>- Encountered water at 12.0' to 24.9'.</li> <li>- Encountered seepage at 110.0' to 113.5'.</li> <li>- From 0.0' to 30.2': 3-1/4" I.D. Hollow-stem Auger with plug, replaced with 4" I.D. Flush-coupled casing from 0.0' to 30.2'.</li> <li>- From 30.2' to 144.5': 3-7/8" Tricone Bit.</li> <li>- From 30.2' to 149.5': Recirculated water used for drilling fluid.</li> </ul> |
| 155       |            |         |                 |                    |                  |              |               |                            |   |   |   |   |
| 160       |            |         |                 |                    |                  |              |               |                            |   |   |   |   |
| 165       |            |         |                 |                    |                  |              |               |                            |   |   |   |   |
| 170       |            |         |                 |                    |                  |              |               |                            |   |   |   |   |
| 175       |            |         |                 |                    |                  |              |               |                            |   |   |   |   |
| 180       |            |         |                 |                    |                  |              |               |                            |   |   |   |   |
| 185       |            |         |                 |                    |                  |              |               |                            |   |   |   |   |
| 190       |            |         |                 |                    |                  |              |               |                            |   |   |   |   |
| 195       |            |         |                 |                    |                  |              |               |                            |   |   |   |   |

200 WATER LEVEL: ✓ 11.0 ✓ ✓ ✓ ✓ ✓  
 WATER NOTE: \_\_\_\_\_  
 DATE: 08/17/94





Renamed: B-106-0-94

LOG OF BORING NO. B-106  
 CUY-90-15.24  
 CLEVELAND, OHIO

TYPE: 2" O.D. Split-barrel Sampler  
 3" O.D. Shelby Tube  
 NXM Rock-core Barrel

LOCATION: Sta. 18+38.12  
 243.9' Rt. of  
 Centerline

COMPLETION DEPTH: 174.2' ELEVATION: 612.3 DATE: 9/8/94 9/12/94

| DEP. FEET | SAMPLE NO. | SAMPLES SAMPLING EFFORT | HAND PENE-TROMETER | MOISTURE CONTENT | LIQUID LIMIT | PLASTIC LIMIT | AGG. C.S.F.S. |   |   |    | SILT/CLAY |  | DESCRIPTION - CONTINUED   |
|-----------|------------|-------------------------|--------------------|------------------|--------------|---------------|---------------|---|---|----|-----------|--|---|
|           |            |                         |                    |                  |              |               | tsf           | % | % | %  |           |  |   |
| 50        | 10         | 4 / 4 / 6               | 1.9-2.1            |                  |              |               |               |   |   |    |           |  | Stiff to hard gray silty clay, trace fine to coarse sand, few seams and lenses of silt, horizontal structure.   |
| 55        | 11         | 4 / 4 / 5               | 1.7-1.9            | 23               | 33           | 19            | 0             | 0 | 2 | 52 | 46        |  | A-6a(10)  |
| 60        | 12         | 3 / 5 / 8               | 2.2-2.8            |                  |              |               |               |   |   |    |           |  | Very-stiff to hard gray silty clay, trace fine to medium sand, trace fine gravel, few seams and lenses of silt. |
| 65        | 13         | 4 / 6 / 6               | 2.0-2.1            |                  |              |               |               |   |   |    |           |  |   |
| 70        | 14         | 4 / 8 / 10              | 2.5-3.4            |                  |              |               |               |   |   |    |           |  |   |
| 75        | 15         | 5 / 8 / 12              | 3.6-4.5+           |                  |              |               |               |   |   |    |           |  |   |
| 80        | 16         | 5 / 11 / 13             | 2.7-3.4            |                  |              |               |               |   |   |    |           |  |   |
| 85        | 17         | 9 / 11 / 16             | 4.2-4.5+           |                  |              |               |               |   |   |    |           |  |   |
| 90        | 18         | 5 / 9 / 11              | 2.0-2.3            | 21               | 35           | 19            | 1             | 2 | 3 | 34 | 60        |  |   |
| 95        | 19         | 5 / 8 / 10              | 2.1-2.3            |                  |              |               |               |   |   |    |           |  |   |

100 WATER LEVEL:  WATER NOTE: \_\_\_\_\_ DATE: \_\_\_\_\_





Renamed: B-106-0-94

LOG OF BORING NO. B-106  
 CUY-90-15.24  
 CLEVELAND, OHIO

TYPE: 2" O.D. Split-barrel Sampler LOCATION: Sta. 18+38.12  
3" O.D. Shelby Tube 243.9' Rt. of  
NXM Rock-core Barrel Centerline  
 COMPLETION DEPTH: 174.2' ELEVATION: 612.3 DATE: 9/8/94 9/12/94

| DEPT. FEET | SAMPLE NO. | SAMPLES SAMPLING EFFORT | HAND PENE-TROMETER | MOISTURE CONTENT | LIQUID LIMIT | PLASTIC LIMIT | COMPLETION DEPTH: 174.2' ELEVATION: 612.3 DATE: 9/8/94 9/12/94 |    |    |    | DESCRIPTION - CONTINUED |   |
|------------|------------|-------------------------|--------------------|------------------|--------------|---------------|--|----|----|----|-------------------------|---|
|            |            |                         |                    |                  |              |               | tsf  | %  | %  | %  |                         | AGG.  |
| 150        | 29         | 7/19/11                 | 2.7-3.2            |                  |              |               |  |    |    |    |                         | Very-stiff to hard gray silty clay, trace fine to coarse sand, trace fine gravel, few lenses of silt.<br>Est. A-6b            |
| 155        | 30         | 25/30/30                |                    |                  |              |               |  |    |    |    |                         | Dense gray fine to coarse sand, little to some silty clay, little fine gravel.  |
| 160        | 31         | 57/38/30                |                    | 13               |              |               | 35   | 15 | 27 | 19 | 4                       |   |
| 165        | 32         | 28/22/24                |                    |                  |              |               |  |    |    |    |                         |   |
| 170        | 33         | 50-2"R<br>NXM<br>REC    | RQD<br>67%         |                  |              |               |  |    |    |    |                         | Soft gray shale, nearly horizontally bedded.<br>A-1-b(0)  |
|            | 34         | 77%                     |                    |                  |              |               |  |    |    |    |                         |   |
|            | 35         | 85%                     | 0%                 |                  |              |               |  |    |    |    |                         |   |
| 175        |            |                         |                    |                  |              |               |  |    |    |    |                         | - Encountered seepage at 18.0'.   |
| 180        |            |                         |                    |                  |              |               |  |    |    |    |                         | - From 0.0' to 30.8': 3-1/4" I.D. Hollow-stem Auger with plug, replaced with 4" I.D. Flush-coupled casing from 0.0' to 30.8'. |
| 185        |            |                         |                    |                  |              |               |  |    |    |    |                         | - From 30.8' to 169.2': 3-7/8" Tricone Bit.   |
| 190        |            |                         |                    |                  |              |               |  |    |    |    |                         | - From 30.8' to 147.2': Recirculated water used for drilling fluid.   |
| 195        |            |                         |                    |                  |              |               |  |    |    |    |                         |   |

200 WATER LEVEL:                    
 WATER NOTE:                    
 DATE:





Renamed: B-107-0-94

**LOG OF BORING NO. B-107**  
**CUY-90-15.24**  
**CLEVELAND, OHIO**

| DEPT<br>FEET | SAMPLE NO. | SAMPLES<br>SAMPLING<br>EFFORT | HAND<br>PENE-<br>TROMETER | MOISTURE<br>CONTENT | LIQUID<br>LIMIT | PLASTIC<br>LIMIT | TYPE: 2" O.D. Split-barrel Sampler<br>3" O.D. Shelby Tube<br>NXM Rock-core Barrel |   |    |    | LOCATION: Sta. 15+49.05<br>89.6' Lt. of<br>Centerline |      |  |
|--------------|------------|-------------------------------|---------------------------|---------------------|-----------------|------------------|---|---|----|----|---|------|--|
|              |            |                               |                           |                     |                 |                  | tsf   | % | %  | %  | AGG.  | C.S. | F.S.   |
| 0            |            |                               |                           |                     |                 |                  |   |   |    |    |   |      | ASPHALT - 13 INCHES  |
|              |            |                               |                           |                     |                 |                  |   |   |    |    |   |      | FILL: Loose brown fine to coarse sand, some fine to coarse gravel.<br>Est. A-1-b                     |
| 5            | 1          | 3/4/4                         |                           |                     |                 |                  |   |   |    |    |   |      | Loose brown fine to medium sand, little coarse sand, trace silt.<br>Est. A-3a                        |
|              |            |                               |                           |                     |                 |                  |   |   |    |    |   |      | Loose brown silt, little fine sand.<br>Est. A-4a   |
| 10           | 2A<br>2B   | 4/7/7                         |                           |                     |                 |                  |   |   |    |    |   |      | Medium-dense brown fine sand, trace medium to coarse sand, trace silt.                               |
| 15           | 3          | P                             |                           |                     |                 |                  |   |   |    |    |   |      |  |
| 20           | 4          | 6/7/8                         |                           |                     |                 |                  |   |   |    |    |   |      | Loose brown fine sand, some silt, trace medium to coarse sand.<br>Est. A-3a                          |
| 25           | 5          | 2/3/3                         |                           | 25                  |                 |                  | 0   | 0 | 70 | 30 |   |      |  |
| 30           | 6          | 7/10/4                        |                           |                     |                 |                  |   |   |    |    |   |      | Very-stiff gray silty clay, little fine to coarse sand, many seams and lenses of silt.<br>A-3a(0)    |
| 35           | 7          | 5/6/9                         |                           | 19                  |                 |                  | 0   | 0 | 11 | 63 | 26  |      | Dense gray fine sand, trace medium to coarse sand, little silt.<br>Est. A-4b                         |
| 40           | 8          | 16/28/40                      |                           |                     |                 |                  |   |   |    |    |   |      | Medium-dense to dense gray silt interbedded with silty clay, trace fine to medium sand.<br>Est. A-3a |
| 45           | 9          | 12/10/19                      |                           |                     |                 |                  | 0   | 0 | 2  | 79 | 19  |      | Medium-dense to dense gray silt interbedded with silty clay, trace fine to medium sand.<br>Est. A-4b |
| 50           |            |                               |                           |                     |                 |                  |   |   |    |    |   |      |  |

WATER LEVEL:  \_\_\_\_\_  \_\_\_\_\_  \_\_\_\_\_  \_\_\_\_\_  \_\_\_\_\_  \_\_\_\_\_  
 WATER NOTE: \_\_\_\_\_  
 DATE: \_\_\_\_\_



Renamed: B-107-0-94

LOG OF BORING NO. B-107  
 CUY-90-15.24  
 CLEVELAND, OHIO

TYPE: 2" O.D. Split-barrel Sampler  
3" O.D. Shelby Tube  
NXM Rock-core Barrel

LOCATION: Sta. 15+49.05  
89.6' Lt. of  
Centerline

COMPLETION DEPTH: 215.0' ELEVATION: 662.7 DATE: 9/19/94 9/22/94

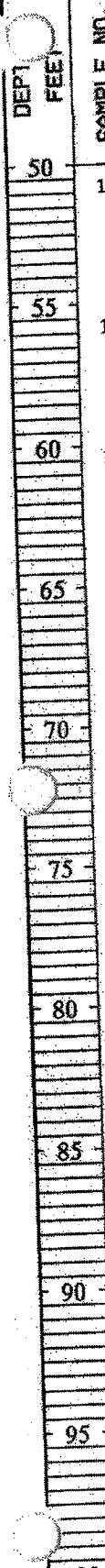

| SAMPLE NO. | SAMPLES SAMPLING EFFORT | HAND PENE-TROMETER | MOISTURE CONTENT | LIQUID LIMIT | PLASTIC LIMIT | AGG. | C. | S. | F. | S. | SILT | CLAY | DESCRIPTION - CONTINUED   |
|------------|-------------------------|--------------------|------------------|--------------|---------------|------|----|----|----|----|------|------|---|
|            |                         |                    |                  |              |               |      |    |    |    |    |      |      |   |
| 10         | 7/6/8                   | 2.7-3.4            |                  |              |               |      |    |    |    |    |      |      | Stiff to very-stiff gray silty clay, trace fine to medium sand, few to many seams and lenses of silt, horizontal structure.<br><br>- From 64.0' to 65.5': Very-stiff to hard. |
| 11         | 3/5/5                   | 1.7-2.2            |                  |              |               |      |    |    |    |    |      |      |   |
| 12         | P                       | 3.2-3.3            |                  |              |               |      |    |    |    |    |      |      |   |
| 13         | 4/11/15                 | 3.4-4.5+           |                  |              |               |      |    |    |    |    |      |      |   |
| 14         | P                       | 2.2-2.6            |                  |              |               |      |    |    |    |    |      |      |   |
| 15         | 5/9/14                  | 2.8-3.6            |                  |              |               |      |    |    |    |    |      |      |   |
| 16         | P                       | 1.7-2.1            |                  |              |               |      |    |    |    |    |      |      |   |
| 17         | 3/3/4                   | 1.3-1.8            | 31               | 38           | 20            | 0    | 1  | 1  | 18 | 80 |      |      |   |
| 18         | 5/7/8                   | 2.2-2.8            |                  |              |               |      |    |    |    |    |      |      |   |
| 19         | 4/6/8                   | 1.9-2.7            |                  |              |               |      |    |    |    |    |      |      |   |

DESCRIPTION - CONTINUED

Stiff to very-stiff gray silty clay, trace fine to medium sand, few to many seams and lenses of silt, horizontal structure.

- From 64.0' to 65.5': Very-stiff to hard.

A-6b(11)

100  
 WATER LEVEL:       
 WATER NOTE:       
 DATE:



Renamed: B-107-0-94

LOG OF BORING NO. B-107  
 CUY-90-15.24  
 CLEVELAND, OHIO

TYPE: 2" O.D. Split-barrel Sampler  
 3" O.D. Shelby Tube  
 NXM Rock-core Barrel

LOCATION: Sta. 15+49.05  
 89.6' Lt. of  
 Centerline

COMPLETION DEPTH: 215.0' ELEVATION: 662.7 DATE: 9/19/94 9/22/94

| DEPTH<br>FEET | SAMPLE NO. | SAMPLES<br>SAMPLING<br>EFFORT | HAND<br>PENE-<br>TROMETER | MOISTURE<br>CONTENT | LIQUID<br>LIMIT | PLASTIC<br>LIMIT | DESCRIPTION - CONTINUED |   |   |    |      |      |      |      |      |  |  |   |
|---------------|------------|-------------------------------|---------------------------|---------------------|-----------------|------------------|-------------------------|---|---|----|------|------|------|------|------|--|--|---|
|               |            |                               |                           |                     |                 |                  | tsf                     | % | % | %  | AGG. | C.S. | F.S. | SILT | CLAY |  |  |   |
| 100           | 20         | 5 / 6 / 8                     | 1.3-1.8                   |                     |                 |                  |                         |   |   |    |      |      |      |      |      |  |  | Stiff to very-stiff gray silty clay, trace fine to medium sand, few to many seams and lenses of silt, horizontal structure.<br>A-6b(11) |
| 105           | 21         | 6 / 10 / 15                   | 3.3-4.5+                  |                     |                 |                  |                         |   |   |    |      |      |      |      |      |  |  | Very-stiff to hard gray silty clay, trace fine to medium sand, few to many seams and lenses of silt, horizontal structure.              |
| 110           | 22         | 8 / 12 / 16                   | 2.7-4.5+                  |                     |                 |                  |                         |   |   |    |      |      |      |      |      |  |  |   |
| 115           | 23         | 7 / 12 / 19                   | 2.9-3.7                   |                     |                 |                  |                         |   |   |    |      |      |      |      |      |  |  | Est. A-6b   |
| 120           | 24         | P                             | 1.7-2.0                   |                     |                 |                  |                         |   |   |    |      |      |      |      |      |  |  |   |
| 125           | 25         | 3 / 6 / 12                    | 1.8-2.8                   | 23                  | 31              | 19               | 0                       | 1 | 1 | 52 | 46   |      |      |      |      |  |  |   |
| 130           | 26         | P                             | 3.2-3.3                   |                     |                 |                  |                         |   |   |    |      |      |      |      |      |  |  |   |
| 135           |            | 9 / 15 / 21                   |                           |                     |                 |                  |                         |   |   |    |      |      |      |      |      |  |  |   |
| 140           | 27         | P                             | 2.0-2.3                   |                     |                 |                  |                         |   |   |    |      |      |      |      |      |  |  |   |
| 145           | 28         | 6 / 10 / 14                   | 2.2-2.7                   |                     |                 |                  |                         |   |   |    |      |      |      |      |      |  |  |   |

A-6a(9)

150 WATER LEVEL:  \_\_\_\_\_  
 WATER NOTE: \_\_\_\_\_  
 DATE: \_\_\_\_\_

-CONTINUED-



Renamed: B-107-0-94

CUY-90-15.24  
CLEVELAND, OHIO

TYPE: 2" O.D. Split-barrel Sampler  
3" O.D. Shelby Tube  
NXM Rock-core Barrel

LOCATION: Sta. 15+49.05  
89.6' Lt. of  
Centerline

COMPLETION DEPTH: 215.0' ELEVATION: 662.7 DATE: 9/19/94 9/22/94

| DEP. FEET | SAMPLE NO. | SAMPLES      | SAMPLING EFFORT | HAND PENE-TROMETER | MOISTURE CONTENT | LIQUID LIMIT | PLASTIC LIMIT | DESCRIPTION - CONTINUED |   |   |    |      |       |       |           |  |  |   |
|-----------|------------|--------------|-----------------|--------------------|------------------|--------------|---------------|-------------------------|---|---|----|------|-------|-------|-----------|--|--|---|
|           |            |              |                 |                    |                  |              |               | tsf                     | % | % | %  | AGG. | C. S. | F. S. | SILT/CLAY |  |  |   |
| 150       | 29         | 6/10/15      |                 | 1.8-2.1            |                  |              |               |                         |   |   |    |      |       |       |           |  |  | Stiff to very-stiff gray silty clay, trace fine to coarse sand, few lenses of silt.<br>A-6a(9)            |
| 155       | 30         | S/H-18/23    |                 | 2.1-2.4            |                  |              |               |                         |   |   |    |      |       |       |           |  |  | Very-stiff to hard gray silty clay, trace fine to coarse sand, trace fine gravel.                         |
| 160       | 31         | 7/13/18      |                 | 3.2-3.3            |                  |              |               |                         |   |   |    |      |       |       |           |  |  |   |
| 165       | 32         | 7/12/17      |                 | 3.0-3.4            |                  |              |               |                         |   |   |    |      |       |       |           |  |  |   |
| 170       | 33         | 7/11/15      |                 | 2.7-4.2            |                  |              |               |                         |   |   |    |      |       |       |           |  |  | Est. A-6a   |
| 175       | 34         | 5/8/10       |                 | 1.7-2.8            | 26               | 32           | 18            | 0                       | 0 | 1 | 38 | 61   |       |       |           |  |  | Stiff to very-stiff gray silty clay, trace fine to coarse sand, few seams and lenses of silt.<br>A-6a(10) |
| 180       | 35         | 16/27/38     |                 |                    |                  |              |               |                         |   |   |    |      |       |       |           |  |  | Dense gray fine to medium sand, little silt, trace coarse sand.<br>Est. A-3a                              |
| 185       | 36         | 16/43/50-4 R |                 | 4.5+               |                  |              |               |                         |   |   |    |      |       |       |           |  |  | Hard gray silty clay, trace to little fine to coarse sand, trace fine gravel, few lenses of silt.         |
| 190       | 37         | 18/38/50-5 R |                 | 4.5+               |                  |              |               |                         |   |   |    |      |       |       |           |  |  |   |
| 195       | 38         | 11/22/30     |                 | 4.5+               |                  |              |               |                         |   |   |    |      |       |       |           |  |  |   |
| 200       |            |              |                 |                    |                  |              |               |                         |   |   |    |      |       |       |           |  |  | Est. A-6  |

WATER LEVEL:                                
 WATER NOTE:                                
 DATE:



Renamed: B-107-0-94

LOG OF BORING NO. B-107  
 CUY-90-15.24  
 CLEVELAND, OHIO

Page 2 of 2

TYPE: 2" O.D. Split-barrel Sampler  
3" O.D. Shelby Tube  
NXM Rock-core Barrel

LOCATION: Sta. 15+49.05  
89.6' Lt. of  
Centerline

COMPLETION DEPTH: 215.0' ELEVATION: 662.7 DATE: 9/19/94 9/22/94

| DEPTH | SAMPLE NO. | SAMPLES | HAND PENE-TROMETER EFFORT | MOISTURE CONTENT | LIQUID LIMIT | PLASTIC LIMIT | AGG. | C.S. | F.S. | SILT | CLAY | DESCRIPTION - CONTINUED  |
|-------|------------|---------|---------------------------|------------------|--------------|---------------|------|------|------|------|------|--|
|       |            |         |                           |                  |              |               |      |      |      |      |      |  |
| 200   | 39         | 8       | 12/14                     | 2.3-3.5          |              |               |      |      |      |      |      | Hard gray silty clay, trace to little fine to coarse sand, trace fine gravel, few lenses of silt.<br><br>Est. A-6b<br>Very-soft to soft gray shale, nearly horizontally bedded, contains few horizontal to diagonal fractures.   |
| 205   | 40A        | 11      | 20/30                     | 2.4-3.5          |              |               |      |      |      |      |      |  |
|       | 40B        |         |                           | 3.4-4.5+         |              |               |      |      |      |      |      |  |
| 210   | 41         | 25      | 50-2" R NXM RBC           | 4.2-4.5+         |              |               |      |      |      |      |      |  |
|       | 42         |         | 100%                      | 83%              |              |               |      |      |      |      |      |  |
| 215   |            |         |                           |                  |              |               |      |      |      |      |      | - Encountered water from 0.0' to 215.0'.<br><br>- From 0.0' to 59.4': 3-1/4" I.D. Hollow-stem Auger with plug, replaced with 4" I.D. Flush-coupled casing from 0.0' to 59.4'.<br><br>- From 59.4' to 210.0': 3-7/8" Tricone Bit.<br><br>- From 0.0' to 215.0': Recirculated water used for drilling fluid. |
| 220   |            |         |                           |                  |              |               |      |      |      |      |      |  |
| 225   |            |         |                           |                  |              |               |      |      |      |      |      |  |
| 230   |            |         |                           |                  |              |               |      |      |      |      |      |  |
| 235   |            |         |                           |                  |              |               |      |      |      |      |      |  |
| 240   |            |         |                           |                  |              |               |      |      |      |      |      |  |
| 245   |            |         |                           |                  |              |               |      |      |      |      |      |  |
| 250   |            |         |                           |                  |              |               |      |      |      |      |      |  |

WATER LEVEL:                              

WATER NOTE:                              

DATE:                              

JOB: 4500





Renamed: B-108-0-94

LOG OF BORING NO. B-108  
 CUY-90-15.24  
 CLEVELAND, OHIO

TYPE: 2" O.D. Split-barrel Sampler LOCATION: Sta. 18+00.15  
3" O.D. Shelby Tube 87.8' Lt. of  
NXM Rock-core Barrel Centerline  
 COMPLETION DEPTH: 170.2' ELEVATION: 610.4 DATE: 8/8/94 8/10/94

| DEPT<br>FEET | SAMPLE NO. | SAMPLES<br>SAMPLING<br>EFFORT | HAND<br>PENE-<br>TROMETER | MOISTURE<br>CONTENT |    |    |   | AGG. | C.S. | F.S. | SILT | CLAY | DESCRIPTION - CONTINUED   |
|--------------|------------|-------------------------------|---------------------------|---------------------|----|----|---|------|------|------|------|------|---|
|              |            |                               |                           | tsf                 | %  | %  | % |      |      |      |      |      |   |
| 50           | 14         | 3/6/7                         | 1.5-1.8                   |                     |    |    |   |      |      |      |      |      | Stiff to very-stiff gray silty clay, trace to little fine to medium sand, contains many seams and lenses of silt. |
| 55           | 15         | 3/6/6                         | 1.3-1.8                   | 23                  | 30 | 17 | 0 | 0    | 1    | 56   | 43   |      |   |
| 60           | 16         | 3/7/8                         | 2.0-3.0*                  |                     |    |    |   |      |      |      |      |      |   |
| 65           | 17         | 5/8/10                        | 2.0-4.0*                  | 22                  | 29 | 18 | 1 | 1    | 2    | 62   | 34   |      |   |
| 70           | 18         | 2/5/5                         | 1.0-1.5                   |                     |    |    |   |      |      |      |      |      | A-6a(8,9)   |
| 75           | 19         | 5/8/11                        | 1.5-1.7                   | 22                  | 33 | 18 | 1 | 2    | 6    | 31   | 60   |      | Stiff to very-stiff gray silty clay, trace to little fine to coarse sand, trace fine gravel, few lenses of silt.  |
| 80           | 20         | 4/7/11                        | 1.5-2.0                   |                     |    |    |   |      |      |      |      |      |   |
| 85           | 21         | 6/11/16                       | 2.0-2.3                   |                     |    |    |   |      |      |      |      |      |   |
| 90           | 22         | 5/11/15                       | 2.0-2.3                   | 21                  | 33 | 18 | 2 | 3    | 4    | 33   | 58   |      |   |
| 95           | 23         | 6/11/14                       | 2.0-2.3                   |                     |    |    |   |      |      |      |      |      |   |

A-6a, A-6b(10,11)

100 WATER LEVEL: None to 48.5'  
 WATER NOTE: \_\_\_\_\_  
 DATE: 08/10/94



Renamed: B-108-0-94

LOG OF BORING NO. B-108  
 CUY-90-15.24  
 CLEVELAND, OHIO

TYPE: 2" O.D. Split-barrel Sampler LOCATION: Sta. 18+00.15  
3" O.D. Shelby Tube  
NXM Rock-core Barrel 87.8' Lt. of Centerline

COMPLETION DEPTH: 170.2' ELEVATION: 610.4 DATE: 8/8/94 8/10/94

| DEPT. FEET | SAMPLE NO. | SAMPLES SAMPLING EFFORT | HAND PENE-TROMETER | MOISTURE CONTENT | LIQUID LIMIT | PLASTIC LIMIT | TYPE |   |   |    | SILT:CLAY |   | DESCRIPTION - CONTINUED |
|------------|------------|-------------------------|--------------------|------------------|--------------|---------------|------|---|---|----|-----------|---|-------------------------|
|            |            |                         |                    |                  |              |               | tsf  | % | % | %  | AGG.      | C.S.  |                         |
| 100        | 24         | 5/9/12                  | 1.6-1.9            | 22               | 33           | 20            | 4    | 3 | 3 | 30 | 60        | Stiff to very-stiff gray silty clay, trace to little fine to coarse sand, trace fine gravel, few lenses of silt.              |                         |
| 105        | 25         | 5/9/13                  | 1.9-2.3            |                  |              |               |      |   |   |    |           |   |                         |
| 110        | 26         | 5/9/13                  | 2.0-2.5            | 23               | 34           | 19            | 0    | 0 | 1 | 37 | 62        |   |                         |
| 115        | 27         | 5/7/11                  | 1.7-2.3            |                  |              |               |      |   |   |    |           |   |                         |
| 120        | 28A<br>28B | 3/6/9                   | 1.0-1.3<br>2.0-2.5 | 29               | 38           | 20            | 0    | 1 | 3 | 22 | 74        | A-6a, A-6b(10,11)<br>Interbedded: Medium-dense gray silt, stiff gray silty clay, and fine sand.                               |                         |
| 125        | 29A<br>29B | 4/6/5                   | 1.0                |                  |              |               |      |   |   |    |           | Est. A-4b<br>Very-stiff to hard gray silty clay, trace to little fine to coarse sand, trace fine gravel.                      |                         |
| 130        | 30         | 15/20/27                |                    |                  |              |               |      |   |   |    |           | - From 129.8' to 131.8': Seam of dense gray fine to coarse sand, "and" fine gravel, little silt.                              |                         |
| 135        | 31         | 18/40/58                | 4.5+               | 16               | 32           | 18            | 5    | 3 | 6 | 29 | 57        | - From 135.0' to 135.7': Contains many slickensided partings.   |                         |
| 140        | 32         | 16/31/58                | 3.5-4.5+           |                  |              |               |      |   |   |    |           | A-6a(10)<br>Stiff to very-stiff gray silty clay, trace fine to coarse sand, trace fine to coarse gravel, many lenses of silt. |                         |
| 145        | 33         | 7/10/13                 | 2.0-2.6            | 25               | 32           | 20            | 0    | 0 | 0 | 95 | 5         | A-6a(8,9)   |                         |

150 WATER LEVEL: None to 48.5'  
 WATER NOTE: \_\_\_\_\_  
 DATE: 08/10/94





Renamed: B-108-0-94

**LOG OF BORING NO. B-108**  
**CUY-90-15.24**  
**CLEVELAND, OHIO**

| DEPTH<br>FEET | SAMPLE NO. | SAMPLES<br>SAMPLING<br>EFFORT | HAND<br>PENE-<br>TRONETER | MOISTURE<br>CONTENT | LIQUID<br>LIMIT | PLASTIC<br>LIMIT | TYPE: <u>2" O.D. Split-barrel Sampler</u> LOCATION: <u>Sta. 18+00.15</u>            |      |      |                     |      | DESCRIPTION - CONTINUED   |
|---------------|------------|-------------------------------|---------------------------|---------------------|-----------------|------------------|---|------|------|---------------------|------|---|
|               |            |                               |                           |                     |                 |                  | COMPLETION DEPTH: <u>170.2'</u> ELEVATION: <u>610.4</u> DATE: <u>8/8/94 8/10/94</u> |      |      | 3" O.D. Shelby Tube |      |   |
|               |            |                               |                           |                     |                 |                  | AGG.  | C.S. | F.S. | SILT                | CLAY |   |
| 150           | 34         | SH-12"<br>46                  | 1.0-2.0                   | 23                  | 31              | 20               | 13  | 0    | 1    | 33                  | 53   | Stiff to very-stiff gray silty clay, trace fine to coarse sand, trace fine to coarse gravel, many lenses of silt.   |
| 155           | 35         | 7<br>10, 15                   | 2.0-2.5                   |                     |                 |                  |   |      |      |                     |      | A-6a(8,9)   |
| 160           | 36         | P/R                           | 4.5+                      |                     |                 |                  | 43  | 11   | 4    |                     | 42   | Hard gray silty clay, little to some fine to coarse sand, trace to little fine to coarse gravel. Est. A-6a  |
|               | 37         | 20, 28, 52                    | 4.5+                      |                     |                 |                  |   |      |      |                     |      | Dense gray fine to coarse gravel, some fine to coarse sand, "and" clayey silt. A-4a(1)  |
| 165           | 38         | 100-2" R<br>NXM<br>REC        | RQD                       |                     |                 |                  |   |      |      |                     |      | Soft to medium-hard black and gray shale.<br>Very-soft to soft gray shale, nearly horizontally bedded, partly similar to hard soil.   |
|               | 39         | 100%                          | 64%                       |                     |                 |                  |   |      |      |                     |      | Soft to medium-hard black and gray shale, nearly horizontally bedded, fissile.<br>- From 165.9' to 166.2': Iron carbonate seams.<br>- From 169.5' to 170.2': Near-vertical fracture, filled with broken shale fragments and soft clay.              |
| 170           |            |                               |                           |                     |                 |                  |   |      |      |                     |      | - From 0.0' to 45.0': 3-1/4" I.D. Hollow-stem Auger with plug, replaced with 4" I.D. Flush-coupled casing from 0.0' to 45.0'.<br>- From 45.0' to 165.2': 3-7/8" Tricone Bit.<br>- From 45.0' to 170.2': Recirculated water used for drilling fluid. |
| 175           |            |                               |                           |                     |                 |                  |   |      |      |                     |      |   |
| 180           |            |                               |                           |                     |                 |                  |   |      |      |                     |      |   |
| 185           |            |                               |                           |                     |                 |                  |   |      |      |                     |      |   |
| 190           |            |                               |                           |                     |                 |                  |   |      |      |                     |      |   |
| 195           |            |                               |                           |                     |                 |                  |   |      |      |                     |      |   |

200  
 WATER LEVEL: ∇  
 WATER NOTE: None to 48.5'  
 DATE: 08/10/94



Renamed: B-109-0-94

LOG OF BORING NO. B-109  
 CUY-90-15.24  
 CLEVELAND, OHIO

TYPE: 2" O.D. Split-barrel Sampler  
3" O.D. Shelby Tube  
NXM Rock-core Barrel

LOCATION: Sta. 18+86.96  
65.6' Lt. of  
Centerline

COMPLETION DEPTH: 163.2' ELEVATION: 593.3 DATE: 8/25/94

| DEPT<br>FEET | SAMPLE NO. | SAMPLES | SAMPLING EFFORT | HAND | PENE-<br>TRMETER | MOISTURE<br>CONTENT | LIQUID<br>LIMIT | PLASTIC<br>LIMIT | AGG. | C.S. | F.S. | SILT | CLAY | DESCRIPTION   |
|--------------|------------|---------|-----------------|------|------------------|---------------------|-----------------|------------------|------|------|------|------|------|---|
|              |            |         |                 |      |                  |                     |                 |                  |      |      |      |      |      |   |
| 0            |            |         |                 |      |                  |                     |                 |                  |      |      |      |      |      | FILL: Dense black fine to coarse sand, little fine to coarse gravel, trace silt, (cinders, slag, and foundry sand). |
| 5            | 1          | 24/34   | 31              |      |                  |                     |                 |                  |      |      |      |      |      |   |
| 10           | 2          | 5/6     | 4               |      |                  |                     |                 |                  |      |      |      |      |      |   |
| 15           | 3          | 2/1     | 1               |      |                  |                     |                 |                  |      |      |      |      |      |   |
| 20           | 4          | 3/2     | 2               |      |                  |                     |                 |                  |      |      |      |      |      |   |
| 25           | 5          | 2/3     | 5               |      | 1.5-3.5          | 21                  | 34              | 19               | 0    | 0    | 1    | 66   | 33   | Stiff to very-stiff gray silty clay, trace fine to medium sand, horizontal structure.<br>Est. A-1-b<br>A-6a(10)     |
| 30           | 6          | 2/3     | 5               |      | 0.3-0.5          |                     |                 |                  |      |      |      |      |      | Medium-stiff to stiff gray silty clay, trace fine to medium sand, trace fine gravel, few lenses of silt.            |
| 35           | 7          | 1/3     | 6               |      | 0.5-1.5          | 24                  | 32              | 19               | 0    | 1    | 1    | 64   | 34   | A-6a(9)   |
|              | 8          | P       |                 |      |                  | 25                  | 32              | 18               | 0    | 1    | 1    | 55   | 43   | Stiff to very-stiff gray silty clay, trace fine to coarse sand, few seams and lenses of silt.                       |
| 45           | 9          | P       |                 |      | 3.0-3.5          |                     |                 |                  |      |      |      |      |      |   |

50 WATER LEVEL:                                
 WATER NOTE:                                
 DATE:

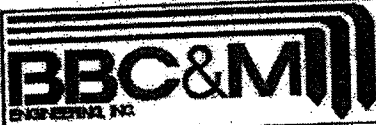

Renamed: B-109-0-94

LOG OF BORING NO. B-109  
 CUY-90-15.24  
 CLEVELAND, OHIO

TYPE: 2" O.D. Split-barrel Sampler LOCATION: Sta. 18+86.96  
3" O.D. Shelby Tube 65.6' Lt. of  
NXM Rock-core Barrel Centerline

COMPLETION DEPTH: 163.2' ELEVATION: 593.3 DATE: 8/25/94

| DEPT. FEET | SAMPLE NO. | SAMPLES SAMPLING EFFORT | HAND PENE-TROMETER | MOISTURE CONTENT |    |    | AGG. | C.S. | F.S. | SILT:CLAY |    | DESCRIPTION - CONTINUED   |
|------------|------------|-------------------------|--------------------|------------------|----|----|------|------|------|-----------|----|---|
|            |            |                         |                    | %                | %  | %  |      |      |      |           |    |   |
| 50         | 10         | 5/5/6                   | 2.0-3.0            | 23               | 31 | 19 | 0    | 1    | 4    | 44        | 51 | Stiff to very-stiff gray silty clay, trace fine to coarse sand, few seams and lenses of silt. |
| 55         | 11         | P                       |                    |                  |    |    |      |      |      |           |    |   |
| 60         | 12         | P                       | 3.0-4.5+           |                  |    |    |      |      |      |           |    | - At 60.0': Very-stiff to hard.   |
| 65         |            | P                       |                    |                  |    |    |      |      |      |           |    |   |
| 70         | 13         | P                       | 1.5-2.0            |                  |    |    | 37   | 21   | 2    | 1         | 2  | 32 63   |
| 75         | 14         | 4/6/9                   | 1.5-2.5            |                  |    |    |      |      |      |           |    |   |
| 80         | 15         | 4/7/8                   | 1.0-2.0            | 23               | 35 | 19 | 1    | 2    | 4    | 36        | 57 |   |
| 85         | 16         | 5/7/11                  | 1.5-2.5            |                  |    |    |      |      |      |           |    |   |
| 90         | 17         | 6/8/11                  | 1.5-2.0            |                  |    |    |      |      |      |           |    |   |
| 95         | 18         | 5/8/11                  |                    |                  |    |    |      |      |      |           |    |   |

A-6a, A-6b(9,10)

100 WATER LEVEL:                                
 WATER NOTE:                                
 DATE:               

-CONTINUED-

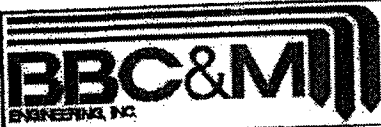

Renamed: B-109-0-94

LOG OF BORING NO. B-109  
 CUY-90-15.24  
 CLEVELAND, OHIO

TYPE: 2" O.D. Split-barrel Sampler LOCATION: Sta. 18+86.96  
3" O.D. Shelby Tube 65.6' Lt. of  
NXM Rock-core Barrel Centerline

COMPLETION DEPTH: 163.2' ELEVATION: 593.3 DATE: 8/25/94

| DEP. FEET | SAMPLE NO. | SAMPLES   | SAMPLING EFFORT | HAND PENE-TROMETER | MOISTURE CONTENT | LIQUID LIMIT | PLASTIC LIMIT | AGG. C. S. F. S. |    |    |    | SILT:CLAY |    | DESCRIPTION - CONTINUED  |
|-----------|------------|-----------|-----------------|--------------------|------------------|--------------|---------------|------------------|----|----|----|-----------|----|--|
|           |            |           |                 |                    |                  |              |               | tsf              | %  | %  | %  |           |    |  |
| 100       | 19         | P         |                 | 2.0-3.0            |                  |              |               |                  |    |    |    |           |    | Stiff to very-stiff gray silty clay, trace fine to coarse sand, few seams and lenses of silt.                                |
| 105       | 20         | P         |                 | 2.0-2.5            |                  |              |               |                  |    |    |    |           |    | - From 110.0' to 113.0': Very-stiff to hard.   |
| 110       | 21         | P         |                 | 2.5                |                  |              |               |                  |    |    |    |           |    | A-6a, A-6b(9,10)   |
| 115       | 22A<br>22B | 10/14, 19 |                 | 2.5-4.5+           |                  |              |               | 9                | 9  | 33 | 49 |           |    | (Estimated) Medium-dense fine to medium sand intermixed with clayey silt, trace coarse sand, trace fine gravel.<br>Est. A-4a |
| 120       | 23         | 15/21, 27 |                 | 4.5+               |                  |              |               |                  |    |    |    |           |    |  |
| 125       | 24         | P         |                 | 4.5+               |                  |              | 37            | 21               | 1  | 1  | 2  | 33        | 64 |  |
| 130       |            | P         |                 |                    |                  |              |               |                  |    |    |    |           |    | Est. A-6b  |
| 135       | 25         | 19/19, 27 |                 |                    | 2                |              |               | 16               | 35 | 31 | 15 | 3         |    | Dense gray fine to coarse sand, little clayey silt, trace coarse sand, trace fine gravel.                                    |
| 140       | 26         | 15/19, 20 |                 |                    |                  |              |               |                  |    |    |    |           |    | A-1-b(0)   |
| 145       | 27         | 23/34, 38 |                 |                    |                  |              |               |                  |    |    |    |           |    | Dense gray fine to coarse gravel, some fine to coarse sand, trace clayey silt.   |
| 150       | 28         | 52        |                 | 4.5+               |                  |              |               |                  |    |    |    |           |    | Est. A-1-a   |

DESCRIPTION ON NEXT PAGE

WATER LEVEL:                                
 WATER NOTE:                                
 DATE:



|   |   |                                |
|---|---|--------------------------------|
|   | TYPE: <u>2" O.D. Split-barrel Sampler</u> | LOCATION: <u>Sta. 18+86.96</u> |
|   | <u>3" O.D. Shelby Tube</u>                | <u>65.6' Lt. of</u>            |
|   | <u>NXM Rock-core Barrel</u>               | <u>Centerline</u>              |
| COMPLETION DEPTH: <u>163.2'</u> ELEVATION: <u>593.3</u> |   | DATE: <u>8/25/94</u>           |

| DEPTH FEET | SAMPLE NO. | SAMPLES SAMPLING EFFORT | HAND PENE-TROMETER | MOISTURE CONTENT | LIQUID LIMIT | PLASTIC LIMIT | AGG. C. S. F. S. |   |   | SILT:CLAY | DESCRIPTION - CONTINUED   |
|------------|------------|-------------------------|--------------------|------------------|--------------|---------------|------------------|---|---|-----------|---|
|            |            |                         |                    |                  |              |               | tsf              | % | % |           |   |
| 150        |            |                         |                    |                  |              |               |                  |   |   |           | Very-soft to soft gray shale, nearly horizontally bedded, partly similar to hard soil.  |
| 155        | 29         | 36<br>50-1"R            | 4.5+               |                  |              |               |                  |   |   |           |   |
| 160        | 30         | 100-2"R<br>NXM<br>REC   | RQD                |                  |              |               |                  |   |   |           |   |
| 165        | 31         | 84%                     | 27%                |                  |              |               |                  |   |   |           | - From 161.5' to 162.1': Diagonal fractures, partly clay filled.<br><br>- Encountered slight seepage at 19.7'.<br><br>- From 0.0' to 35.0': 3-1/4" I.D. Hollow-stem Auger with plug, replaced with 4" I.D. Flush-coupled casing from 0.0' to 35.0'.<br><br>- From 35.0' to 158.7': 3-7/8" Tricone Bit.<br><br>- From 35.0' to 163.2': Recirculated water used for drilling fluid. |
| 170        |            |                         |                    |                  |              |               |                  |   |   |           |   |
| 175        |            |                         |                    |                  |              |               |                  |   |   |           |   |
| 180        |            |                         |                    |                  |              |               |                  |   |   |           |   |
| 185        |            |                         |                    |                  |              |               |                  |   |   |           |   |
| 190        |            |                         |                    |                  |              |               |                  |   |   |           |   |
| 195        |            |                         |                    |                  |              |               |                  |   |   |           |   |
| 200        |            |                         |                    |                  |              |               |                  |   |   |           |   |

|  |   |   |  |  |  |
|--|---|---|--|--|--|
| WATER LEVEL: <input checked="" type="checkbox"/> | WATER NOTE: <input checked="" type="checkbox"/> | DATE: <input checked="" type="checkbox"/> |  |  |  |
|--|---|---|--|--|--|



Renamed: B-110-0-94

LOG OF BORING NO. B-110  
 CUY-90-15.24  
 CLEVELAND, OHIO

TYPE: 2" O.D. Split-barrel Sampler LOCATION: Sta. 18+43.85  
3" O.D. Shelby Tube 243.9' Lt. of  
NXM Rock-core Barrel Centerline  
 COMPLETION DEPTH: 155.0' ELEVATION: 596.7 DATE: 8/31/94 9/8/94

| DEP. FEET | SAMPLE NO. | SAMPLES SAMPLING EFFORT | HAND PENE-TROMETER | MOISTURE CONTENT | LIQUID LIMIT | PLASTIC LIMIT | TYPE |   |    |    | DESCRIPTION |       |  |
|-----------|------------|-------------------------|--------------------|------------------|--------------|---------------|------|---|----|----|-------------|-------|--|
|           |            |                         |                    |                  |              |               | tsf  | % | %  | %  | AGG.        | C. S. | F. S.  |
| 0         |            |                         |                    |                  |              |               |      |   |    |    |             |       | FILL: Loose brown and black fine to coarse gravel, some to "and" fine to coarse sand, trace to little clayey silt, (cinders and slag). |
| 5         | 1          | 3/3/3                   |                    |                  |              |               |      |   |    |    |             |       | Est. A-1-b   |
| 10        | 2          | 2/1/2                   |                    |                  |              |               |      |   |    |    |             |       | Very-loose brown and gray silt, "and" fine sand, trace medium to coarse sand.  |
| 15        | 3A<br>3B   | 1/3/2                   |                    |                  |              |               | 0    | 1 | 43 |    | 56          |       | Est. A-4a  |
| 20        | 4          | 1/3/5                   | 0.8-2.0            | 22               | 31           | 19            | 0    | 0 | 1  | 57 | 42          |       | Medium-stiff to stiff gray silty clay, trace fine to medium sand, few lenses of silt.  |
| 25        | 5          | 3/4/5                   | 0.8-1.8            |                  |              |               |      |   |    |    |             |       | A-6a(9)  |
| 30        | 6          | P                       | 2.0                |                  |              |               |      |   |    |    |             |       | Stiff to very-stiff gray silty clay, trace fine to medium sand, many lenses of silt and fine sand.                                     |
| 35        | 7          | 3/6/8                   | 1.3-2.0            | 24               | 31           | 18            | 0    | 0 | 2  | 52 | 46          |       | A-6a(9)  |
| 40        | 8          | P                       | 2.0-3.0            |                  |              |               |      |   |    |    |             |       | Stiff to hard gray silty clay interbedded with silt, trace fine to medium sand, horizontal structure.                                  |
| 45        | 9          | 5/9/13                  | 3.5-4.5            |                  |              |               |      |   |    |    |             |       | A-6a(8)  |

50 WATER LEVEL:                                
 WATER NOTE:                                
 DATE:



Renamed: B-110-0-94

LOG OF BORING NO. B-110  
 CUY-90-15.24  
 CLEVELAND, OHIO

Page 2 of 7

TYPE: 2" O.D. Split-barrel Sampler LOCATION: Sta. 18+43.85  
3" O.D. Shelby Tube 243.9' Lt. of  
NXM Rock-core Barrel Centerline  
 COMPLETION DEPTH: 155.0' ELEVATION: 596.7 DATE: 8/31/94 9/8/94

| DEPTH<br>FEET | SAMPLE NO. | SAMPLES<br>SAMPLING<br>EFFORT | HAND<br>PENE-<br>TRMETER | MOISTURE<br>CONTENT | LIQUID<br>LIMIT | PLASTIC<br>LIMIT | AGG. C. S. F. S. |   |   |    | SILT: CLAY |  | DESCRIPTION - CONTINUED   |
|---------------|------------|-------------------------------|--------------------------|---------------------|-----------------|------------------|------------------|---|---|----|------------|--|---|
|               |            |                               |                          |                     |                 |                  | tsf              | % | % | %  |            |  |   |
| 50            | 10         | P                             | 2.0-2.5                  |                     |                 |                  |                  |   |   |    |            |  | Stiff to hard gray silty clay interbedded with silt, trace fine to medium sand, horizontal structure. |
| 55            | 11         | 4/5/7                         | 1.0-1.5                  | 25                  | 29              | 18               | 0                | 0 | 1 | 55 | 44         |  | A-6a(8)   |
| 60            | 12         | P                             | 1.5-1.8                  |                     |                 |                  |                  |   |   |    |            |  | Stiff to very-stiff gray silty clay, trace fine to coarse sand, trace fine gravel.                    |
| 65            | 13         | 5/8/13                        | 2.0-2.4                  |                     |                 |                  |                  |   |   |    |            |  |   |
| 70            | 14         | 4/8/12                        | 1.5-2.3                  | 21                  | 33              | 19               | 7                | 3 | 5 | 29 | 56         |  |   |
| 75            | 15         | 4/7/12                        | 1.8-2.4                  |                     |                 |                  |                  |   |   |    |            |  |   |
| 80            | 16         | 4/10/11                       | 1.2-1.5                  | 24                  | 34              | 20               | 1                | 2 | 2 | 32 | 63         |  |   |
| 85            | 17         | 4/8/12                        | 1.5-2.0                  |                     |                 |                  |                  |   |   |    |            |  |   |
| 90            | 18         | 5/8/13                        | 1.5-1.8                  | 23                  | 34              | 20               | 2                | 2 | 2 | 32 | 62         |  |   |
| 95            | 19         | 5/9/13                        | 1.8-2.0                  |                     |                 |                  |                  |   |   |    |            |  |   |

A-6a, A-6b(10)

100 WATER LEVEL:                                
 WATER NOTE:                                
 DATE:



Renamed: B-110-0-94

**LOG OF BORING NO. B-110**  
**CUY-90-15.24**  
**CLEVELAND, OHIO**

TYPE: 2" O.D. Split-barrel Sampler LOCATION: Sta. 18+43.85  
3" O.D. Shelby Tube 243.9' Lt. of  
NXM Rock-core Barrel Centerline

COMPLETION DEPTH: 155.0' ELEVATION: 596.7 DATE: 8/31/94 9/8/94

| DEPT. FEET | SAMPLE NO. | SAMPLES | SAMPLING EFFORT | HAND PENE-TROMETER | MOISTURE CONTENT | LIQUID LIMIT | PLASTIC LIMIT | AGG. |    | F. S. |    | SILT/CLAY |  | DESCRIPTION - CONTINUED |
|------------|------------|---------|-----------------|--------------------|------------------|--------------|---------------|------|----|-------|----|-----------|--|-------------------------|
|            |            |         |                 |                    |                  |              |               | tsf  | %  | %     | %  | %         | %  |                         |
| 100        | 20         | 5/8     | 41              | 1.5-2.0            | 25               | 37           | 21            | 0    | 1  | 1     | 29 | 69        | Stiff to very-stiff gray silty clay, trace fine to coarse sand, trace fine gravel.   |                         |
| 105        | 21         | 5/9     | 41              | 1.0-2.0            |                  |              |               |      |    |       |    |           |  |                         |
| 110        | 22         | P       |                 |                    |                  |              |               |      |    |       |    |           | A-6a, A-6b(10)<br>Medium-dense gray silt, little to some fine sand.<br>Est. A-4b   |                         |
| 115        | 23         | 11/14   | 49              |                    |                  |              |               | 13   | 28 | 39    | 20 |           | Dense gray fine to coarse sand, trace silt, trace fine gravel.<br>- From 119.6' to 119.9': Seam of fine to coarse gravel.<br>A-3a(0) |                         |
| 120        | 24A<br>24B | 15/37   | 58              | 4.5+               |                  |              |               |      |    |       |    |           | Hard gray silty clay, trace to little fine to coarse sand, trace fine gravel, contains slickensided surfaces.                        |                         |
| 125        | 25         | 14/36   | 52              | 4.5+               | 18               | 35           | 18            | 2    | 3  | 5     | 27 | 63        | A-6b(11)<br>Medium-stiff to stiff gray silty clay, trace fine to coarse sand, trace fine to coarse gravel.                           |                         |
| 130        | 26         | 7/12    | 14              | 1.3-2.0            |                  |              |               |      |    |       |    |           |  |                         |
| 135        | 27         | P-R     |                 | 0.8-1.0            |                  |              |               |      |    |       |    |           | - From 140.1' to 140.8': fine sandstone boulder.<br>Est. A-6a  |                         |
| 140        | 28         | 80-4"   | R               | 2.0                |                  |              |               |      |    |       |    |           | Hard gray silty clay, some fine to coarse gravel (shale fragments).  |                         |
| 145        | 29         | 20/41   | 67              | 4.5+               |                  |              |               |      |    |       |    |           | Est. A-6a  |                         |

DESCRIPTION ON NEXT PAGE

150 WATER LEVEL:                                
 WATER NOTE:                                
 DATE:





Renamed: B-110-0-94

**LOG OF BORING NO. B-110**  
**CUY-90-15.24**  
**CLEVELAND, OHIO**

TYPE: 2' O.D. Split-barrel Sampler LOCATION: Sta. 18+43.85  
3' O.D. Shelby Tube 243.9' Lt. of  
NXM Rock-core Barrel Centerline

COMPLETION DEPTH: 155.0' ELEVATION: 596.7 DATE: 8/31/94 9/8/94

| DEPTH FEET | SAMPLE NO. | SAMPLES SAMPLING EFFORT | HAND PENE-TROMETER | MOISTURE CONTENT | LIQUID LIMIT | PLASTIC LIMIT | COMPLETION DEPTH: 155.0' ELEVATION: 596.7 |    |    |    | DATE: 8/31/94 9/8/94 |  | DESCRIPTION - CONTINUED |
|------------|------------|-------------------------|--------------------|------------------|--------------|---------------|---|----|----|----|----------------------|--|-------------------------|
|            |            |                         |                    |                  |              |               | tsf                                       | %  | %  | %  | AGG.                 | C. S.  |                         |
| 100        | 20         | 5/8/11                  | 1.5-2.0            | 25               | 37           | 21            | 0   | 1  | 1  | 29 | 69                   | Stiff to very-stiff gray silty clay, trace fine to coarse sand, trace fine gravel.   |                         |
| 105        | 21         | 5/9/11                  | 1.0-2.0            |                  |              |               |   |    |    |    |                      |  |                         |
| 110        | 22         | P                       |                    |                  |              |               |   |    |    |    |                      | A-6a, A-6b(10)<br>Medium-dense gray silt, little to some fine sand.<br>Est. A-4b   |                         |
| 115        | 23         | 11/14/19                |                    |                  |              |               | 13  | 28 | 39 | 20 |                      | Dense gray fine to coarse sand, trace silt, trace fine gravel.<br>- From 119.6' to 119.9': Seam of fine to coarse gravel.<br>A-3a(0) |                         |
| 120        | 24A<br>24B | 15/37/58                | 4.5+               |                  |              |               |   |    |    |    |                      | Hard gray silty clay, trace to little fine to coarse sand, trace fine gravel, contains slickensided surfaces.                        |                         |
| 125        | 25         | 14/36/52                | 4.5+               | 18               | 35           | 18            | 2   | 3  | 5  | 27 | 63                   | A-6b(11)<br>Medium-stiff to stiff gray silty clay, trace fine to coarse sand, trace fine to coarse gravel.                           |                         |
| 130        | 26         | 7/12/44                 | 1.3-2.0            |                  |              |               |   |    |    |    |                      |  |                         |
| 135        | 27         | P-R                     | 0.8-1.0            |                  |              |               |   |    |    |    |                      | - From 140.1' to 140.8': fine sandstone boulder.<br>Est. A-6a  |                         |
| 140        | 28         | 80-4" R                 | 2.0                |                  |              |               |   |    |    |    |                      | Hard gray silty clay, some fine to coarse gravel (shale fragments).<br>Est. A-6a   |                         |
| 145        | 29         | 20/41/67                | 4.5+               |                  |              |               |   |    |    |    |                      | DESCRIPTION ON NEXT PAGE   |                         |

150 WATER LEVEL:                                
 WATER NOTE:                                
 DATE:



Renamed: B-110-0-94

LOG OF BORING NO. B-110

CUY-90-15.24

CLEVELAND, OHIO

TYPE: 2" O.D. Split-barrel Sampler  
3" O.D. Shelby Tube  
NXM Rock-core Barrel

LOCATION: Sta. 18+43.85  
243.9' Lt. of  
Centerline

COMPLETION DEPTH: 155.0' ELEVATION: 596.7 DATE: 8/31/94 9/8/94

| DEP. FEET | SAMPLE NO. | SAMPLES | SAMPLING EFFORT | HAND PENE-TROMETER | MOISTURE CONTENT | LIQUID LIMIT | PLASTIC LIMIT | DESCRIPTION - CONTINUED |   |   |   |      |       |       |      |      |  |  |  |  |
|-----------|------------|---------|-----------------|--------------------|------------------|--------------|---------------|-------------------------|---|---|---|------|-------|-------|------|------|--|--|--|--|
|           |            |         |                 |                    |                  |              |               | tsf                     | % | % | % | AGG. | C. S. | F. S. | SILT | CLAY |  |  |  |  |
| 150       | 30         |         | NXM REC 100%    | RQD 92%            |                  |              |               |                         |   |   |   |      |       |       |      |      |  |  |  | Soft to medium-hard dark-gray to light-gray shale, nearly horizontally bedded, 2" to 9" core pieces, few cemented vertical fractures, contains few thin seams of hard siltstone. |
| 155       |            |         |                 |                    |                  |              |               |                         |   |   |   |      |       |       |      |      |  |  |  | - Encountered water at 11.0'.  |
| 160       |            |         |                 |                    |                  |              |               |                         |   |   |   |      |       |       |      |      |  |  |  | - From 0.0' to 29.5': 3-1/4" I.D. Hollow-stem Auger with plug, replaced with 4" I.D. Flush-coupled casing from 0.0' to 34.0'.  |
| 165       |            |         |                 |                    |                  |              |               |                         |   |   |   |      |       |       |      |      |  |  |  | - From 29.5' to 150.0': 3-7/8" Tricone Bit.  |
| 170       |            |         |                 |                    |                  |              |               |                         |   |   |   |      |       |       |      |      |  |  |  | - From 29.5' to 120.0': Circulated water used for drilling fluid.  |
| 175       |            |         |                 |                    |                  |              |               |                         |   |   |   |      |       |       |      |      |  |  |  | - From 120.0' to 155.0': Bentonite drilling mud used.  |
| 180       |            |         |                 |                    |                  |              |               |                         |   |   |   |      |       |       |      |      |  |  |  |  |
| 185       |            |         |                 |                    |                  |              |               |                         |   |   |   |      |       |       |      |      |  |  |  |  |
| 190       |            |         |                 |                    |                  |              |               |                         |   |   |   |      |       |       |      |      |  |  |  |  |
| 195       |            |         |                 |                    |                  |              |               |                         |   |   |   |      |       |       |      |      |  |  |  |  |

200 WATER LEVEL:  \_\_\_\_\_  \_\_\_\_\_  \_\_\_\_\_  \_\_\_\_\_  \_\_\_\_\_  \_\_\_\_\_

WATER NOTE: \_\_\_\_\_

DATE: \_\_\_\_\_



Renamed: P-001-0-94

**LOG OF BORING NO. P-1**  
**CUY-90-15.24**  
**CLEVELAND, OHIO**

TYPE: 2" O.D. Split-barrel Sampler LOCATION: Sta. 15+06.89  
3" O.D. Shelby Tube 114.5' Rt. of  
NXM Rock-core Barrel Centerline  
 COMPLETION DEPTH: 158.5' ELEVATION: 676.6 DATE: 9/1/94 9/2/94

| DEPTH<br>FEET | SAMPLE NO. | SAMPLES<br>SAMPLING<br>EFFORT | HAND<br>PENE-<br>TROMETER | MOISTURE<br>CONTENT | LIQUID<br>LIMIT | PLASTIC<br>LIMIT | COMPLETION DEPTH: 158.5' ELEVATION: 676.6 DATE: 9/1/94 9/2/94 |   |    |    | DESCRIPTION |   |
|---------------|------------|-------------------------------|---------------------------|---------------------|-----------------|------------------|---|---|----|----|-------------|---|
|               |            |                               |                           |                     |                 |                  | tsf   | % | %  | %  |             | AGG.  |
| 0             |            |                               |                           |                     |                 |                  |   |   |    |    |             | FILL: Loose black and brown fine to coarse sand and cinders, little to some fine to coarse gravel.<br>- At 4.5': Brick fragments.<br>Est. A-1-b   |
| 5             |            |                               |                           |                     |                 |                  |   |   |    |    |             | Medium-dense brown fine to medium sand, trace coarse sand, trace to little fine to coarse gravel, contains occasional thin seam of silt or clayey silt.<br>Est. A-1-b                         |
| 10            | 1          | 6 / 8 / 10                    |                           |                     |                 |                  |   |   |    |    |             |   |
| 15            | 2          | 5 / 5 / 6                     |                           |                     |                 |                  |   |   |    |    |             | Medium-dense brown fine to coarse sand, little fine to coarse gravel, trace silt.<br>Est. A-1-b   |
| 20            | 3          | 11 / 12 / 14                  |                           |                     |                 |                  |   |   |    |    |             |   |
| 25            | 4          | 4 / 9 / 12                    |                           |                     |                 |                  | 1   | 9 | 59 | 31 |             | Medium-dense to dense brown fine to medium sand, trace to little silt, trace coarse sand, trace fine gravel, contains seams (1 to 6 inches) of silt, fine sand, and silty clay.<br>Est. A-1-b |
| 30            | 5          | 6 / 9 / 7                     |                           |                     |                 |                  |   |   |    |    |             |   |
| 35            | 6A<br>6B   | 5 / 8 / 12                    |                           |                     |                 |                  |   |   |    |    |             |   |
| 40            | 7A<br>7B   | 3 / 6 / 8                     |                           |                     |                 |                  |   |   |    |    |             |   |
| 45            | 8          | 4 / 15 / 28                   |                           |                     |                 |                  | 8   | 9 | 69 | 14 |             | Dense gray silt, little fine sand, trace clay.<br>A-3a (0)  |
| 50            | 9          | 15 / 14 / 19                  |                           |                     |                 |                  |   |   |    |    |             | Est. A-4b   |

DESCRIPTION ON NEXT PAGE

50 WATER LEVEL:                    
 WATER NOTE:                    
 DATE:



Renamed: P-001-0-94

**LOG OF BORING NO. P-1**  
**CUY-90-15.24**  
**CLEVELAND, OHIO**

TYPE: 2" O.D. Split-barrel Sampler LOCATION: Sta. 15+06.89  
3" O.D. Shelby Tube 114.5' Rt. of  
NXM Rock-core Barrel Centerline  
 COMPLETION DEPTH: 158.5' ELEVATION: 676.6 DATE: 9/1/94 9/2/94

| DEPT<br>FEET | SAMPLE NO. | SAMPLES<br>SAMPLING<br>EFFORT | HAND<br>PENE-<br>TRMETER | MOISTURE<br>CONTENT | LIQUID<br>LIMIT | PLASTIC<br>LIMIT | TYPE |   |    |    | DESCRIPTION - CONTINUED |      |  |
|--------------|------------|-------------------------------|--------------------------|---------------------|-----------------|------------------|------|---|----|----|-------------------------|------|--|
|              |            |                               |                          |                     |                 |                  | tsf  | % | %  | %  | AGG.                    | C.S. | F.S.   |
| 50           |            |                               |                          |                     |                 |                  |      |   |    |    |                         |      | Medium-dense gray silt interbedded with silty clay, trace fine to medium sand.                           |
| 10           |            | 3 / 7 / 9                     | 2.0-2.7                  |                     |                 |                  |      |   |    |    |                         |      | Est. A-4b  |
| 55           |            |                               |                          |                     |                 |                  |      |   |    |    |                         |      | Dense gray silt, little to "and" fine sand, little clay, interbedded with fine sand, some to "and" silt. |
| 11           |            | 20 / 28 / 33                  |                          |                     |                 |                  | 0    | 0 | 10 | 78 | 12                      |      |  |
| 60           |            |                               |                          |                     |                 |                  |      |   |    |    |                         |      |  |
| 12           |            | 26 / 37 / 50                  |                          |                     |                 |                  |      |   |    |    |                         |      | A-4b(8)  |
| 65           |            |                               |                          |                     |                 |                  |      |   |    |    |                         |      | Medium-stiff gray silty clay interbedded with silt, trace fine to medium sand.                           |
| 13           |            | 4 / 5 / 5                     | 0.5-0.7                  | 26                  | 30              | 19               | 0    | 0 | 1  | 62 | 37                      |      | A-6a(8)  |
| 70           |            | P                             | 1.5-2.5                  |                     |                 |                  |      |   |    |    |                         |      | Stiff to hard gray silty clay, trace fine sand, few thin seams of clayey silt and silt.                  |
| 75           |            |                               |                          |                     |                 |                  |      |   |    |    |                         |      |  |
| 15           |            | 6 / 13 / 19                   | 4.5+                     |                     |                 |                  |      |   |    |    |                         |      |  |
| 80           |            |                               |                          |                     |                 |                  |      |   |    |    |                         |      |  |
| 16           |            | 6 / 10 / 18                   | 2.5-3.5                  | 21                  | 32              | 19               | 0    | 0 | 0  | 51 | 49                      |      |  |
| 85           |            |                               |                          |                     |                 |                  |      |   |    |    |                         |      |  |
| 17           |            | 5 / 10 / 15                   | 2.7-4.3                  |                     |                 |                  |      |   |    |    |                         |      |  |
| 90           |            |                               |                          |                     |                 |                  |      |   |    |    |                         |      |  |
| 18           |            | 3 / 5 / 8                     | 1.0-2.0                  |                     |                 |                  |      |   |    |    |                         |      |  |
| 95           |            |                               |                          |                     |                 |                  |      |   |    |    |                         |      |  |
| 19           |            | P                             | 0.8-1.0                  |                     |                 |                  |      |   |    |    |                         |      | A-6a(9)  |

DESCRIPTION ON NEXT PAGE

100 WATER LEVEL: ✓ ✓ ✓ ✓ ✓ ✓  
 WATER NOTE: \_\_\_\_\_  
 DATE: \_\_\_\_\_



Renamed: P-001-0-94

**LOG OF BORING NO. P-1**  
**CUY-90-15.24**  
**CLEVELAND, OHIO**

TYPE: 2" O.D. Split-barrel Sampler LOCATION: Sta. 15+06.89  
3" O.D. Shelby Tube 114.5' Rt. of  
NXM Rock-core Barrel Centerline

COMPLETION DEPTH: 158.5' ELEVATION: 676.6 DATE: 9/1/94 9/2/94

| DEPT<br>FEET | SAMPLE NO. | SAMPLES<br>SAMPLING<br>EFFORT | HAND<br>PENE-<br>TROMETER | MOISTURE<br>CONTENT | LIQUID<br>LIMIT | PLASTIC<br>LIMIT | DESCRIPTION - CONTINUED |   |   |    |      |  |
|--------------|------------|-------------------------------|---------------------------|---------------------|-----------------|------------------|-------------------------|---|---|----|------|--|
|              |            |                               |                           |                     |                 |                  | tsf                     | % | % | %  | AGG. | C. S.  |
| 100          | 20         | 2 / 3/4                       | 0.5-0.8                   | 31                  | 43              | 22               | 0                       | 1 | 1 | 20 | 78   | Medium-stiff to stiff gray silty clay, trace fine to coarse sand, trace fine gravel, few lenses of silt.                                       |
| 105          | 21         | P                             | 1.5                       |                     |                 |                  |                         |   |   |    |      |  |
| 110          | 22         | 3 / 5/8                       | 1.2-1.8                   |                     |                 |                  |                         |   |   |    |      |  |
| 115          | 23         | P                             | 1.5-1.8                   |                     |                 |                  |                         |   |   |    |      | A-7-6(13)  |
| 120          | 24         | 4 / 1 1/16                    | 1.5-3.0                   | 21                  | 31              | 19               | 0                       | 0 | 1 | 52 | 47   |  |
| 125          | 25         | P                             | 3.0-4.0                   |                     |                 |                  |                         |   |   |    |      |  |
| 130          | 26         | 5 / 10/14                     | 2.2-2.5                   |                     |                 |                  |                         |   |   |    |      | Stiff to very-stiff gray silty clay, trace fine to medium sand, contains thin seams of silt and clayey silt, mostly with horizontal structure. |
| 135          | 27         | P                             | 2.0-3.0                   |                     |                 |                  |                         |   |   |    |      |  |
| 140          | 28         | 6 / 12/16                     | 1.5-2.5                   | 24                  | 34              | 21               | 0                       | 0 | 0 | 43 | 57   |  |
| 145          | 29         | 5 / 13/20                     | 2.5-3.0                   |                     |                 |                  |                         |   |   |    |      | A-6a(9)  |
| 150          |            |                               |                           |                     |                 |                  |                         |   |   |    |      |  |

WATER LEVEL:                                
 WATER NOTE:                                
 DATE:



Renamed: P-001-0-94

**LOG OF BORING NO. P-1**  
**CUY-90-15.24**  
**CLEVELAND, OHIO**

| DEPTH<br>FEET | SAMPLE NO. | SAMPLES<br>SAMPLING<br>EFFORT | HAND<br>PENE-<br>TROMETER | MOISTURE<br>CONTENT | LIQUID<br>LIMIT | PLASTIC<br>LIMIT | TYPE: <u>2" O.D. Split-barrel Sampler</u>  |   |   |   | LOCATION: <u>Sta. 15+06.89</u>  |      |      |      |      |                         |   |  |
|---------------|------------|-------------------------------|---------------------------|---------------------|-----------------|------------------|--|---|---|---|---------------------------------|------|------|------|------|-------------------------|---|--|
|               |            |                               |                           |                     |                 |                  | COMPLETION DEPTH: <u>158.5'</u> ELEVATION: <u>676.6</u> DATE: <u>9/1/94 9/2/94</u> |   |   |   | <u>114.5' Rt. of Centerline</u> |      |      |      |      |                         |   |  |
|               |            |                               |                           |                     |                 |                  | tsf  | % | % | % | AGG.                            | C.S. | F.S. | SILT | CLAY | DESCRIPTION - CONTINUED |   |  |
| 150           |            |                               |                           |                     |                 |                  |  |   |   |   |                                 |      |      |      |      |                         | DESCRIPTION ON PREVIOUS PAGE  |  |
| 30            |            | 8 1/16, 22                    | 2.0-3.8                   |                     |                 |                  |  |   |   |   |                                 |      |      |      |      |                         | Very-stiff gray silty clay, trace fine to coarse sand, trace fine to coarse gravel, horizontal structure.                     |  |
| 155           |            |                               |                           |                     |                 |                  |  |   |   |   |                                 |      |      |      |      |                         | Est. A-6b   |  |
| 31            |            | 9 1/16, 24                    | 2.5-3.0                   |                     |                 |                  |  |   |   |   |                                 |      |      |      |      |                         | - Encountered water at 36.0'.   |  |
| 160           |            |                               |                           |                     |                 |                  |  |   |   |   |                                 |      |      |      |      |                         | - From 0.0' to 52.5': 3-1/4" I.D. Hollow-stem Auger with plug, replaced with 4" I.D. Flush-coupled casing from 0.0' to 54.0'. |  |
| 165           |            |                               |                           |                     |                 |                  |  |   |   |   |                                 |      |      |      |      |                         | - From 52.5' to 158.5': 3-7/8" Tricone Bit.   |  |
| 170           |            |                               |                           |                     |                 |                  |  |   |   |   |                                 |      |      |      |      |                         | - From 52.5' to 158.5': Recirculated water used for drilling fluid.   |  |
| 175           |            |                               |                           |                     |                 |                  |  |   |   |   |                                 |      |      |      |      |                         |   |  |
| 180           |            |                               |                           |                     |                 |                  |  |   |   |   |                                 |      |      |      |      |                         |   |  |
| 185           |            |                               |                           |                     |                 |                  |  |   |   |   |                                 |      |      |      |      |                         |   |  |
| 190           |            |                               |                           |                     |                 |                  |  |   |   |   |                                 |      |      |      |      |                         |   |  |
| 195           |            |                               |                           |                     |                 |                  |  |   |   |   |                                 |      |      |      |      |                         |   |  |

200 WATER LEVEL:      WATER NOTE:      DATE:





Renamed: P-002-0-94

LOG OF BORING NO. P-2  
 CUY-90-15.24  
 CLEVELAND, OHIO

TYPE: 2" O.D. Split-barrel Sampler  
 3" O.D. Shelby Tube  
 NXM Rock-core Barrel

LOCATION: Sta. 16+98.90  
 36.2' Rt. of  
 Centerline

COMPLETION DEPTH: 168.1' ELEVATION: 616.3 DATE: 8/18/94 8/19/94

| DEPTH FEET | SAMPLE NO. | SAMPLES SAMPLING EFFORT | HAND PENE-TROMETER | MOISTURE CONTENT | LIQUID LIMIT | PLASTIC LIMIT | DESCRIPTION - CONTINUED |   |   |    |      |  |
|------------|------------|-------------------------|--------------------|------------------|--------------|---------------|-------------------------|---|---|----|------|--|
|            |            |                         |                    |                  |              |               | tsf                     | % | % | %  | AGG. | C.S.   |
| 50         | 12         | 3/4/6                   | 1.0                | 30               | 40           | 21            | 0                       | 1 | 1 | 32 | 66   | Medium-stiff to stiff gray silty clay, trace to little fine to coarse sand, trace fine gravel, horizontal structure.<br><br>A-6b(12) |
|            | 13         | 2/5/6                   | 1.0                |                  |              |               |                         |   |   |    |      |  |
| 55         |            |                         |                    |                  |              |               |                         |   |   |    |      | Stiff to very-stiff gray silty clay, trace fine to coarse sand, trace fine gravel, contains seams of clayey silt and silt.           |
|            | 14         | 5/8/12                  | 1.7-3.0            |                  |              |               |                         |   |   |    |      |  |
| 60         |            |                         |                    |                  |              |               |                         |   |   |    |      | - Sample 15: Contains seam of silt, A-4b(8).   |
|            | 15         | 5/10/13                 | 1.5-3.0            | 23               | 28           | 18            | 0                       | 0 | 2 | 64 | 34   |  |
| 65         |            |                         |                    |                  |              |               |                         |   |   |    |      |  |
|            | 16         | 6/10/15                 | 2.0-2.5            |                  |              |               |                         |   |   |    |      |  |
| 70         |            |                         |                    |                  |              |               |                         |   |   |    |      |  |
|            | 17         | 7/19/13                 | 2.7-4.0            |                  |              |               |                         |   |   |    |      |  |
| 75         |            |                         |                    |                  |              |               |                         |   |   |    |      |  |
|            | 18         | 4/8/13                  | 2.0-3.0            |                  |              |               |                         |   |   |    |      |  |
| 80         |            |                         |                    |                  |              |               |                         |   |   |    |      |  |
|            | 19         | 6/10/17                 | 1.8-2.5            |                  |              |               |                         |   |   |    |      |  |
| 85         |            |                         |                    |                  |              |               |                         |   |   |    |      |  |
|            | 20         | 6/10/14                 | 2.0-2.5            |                  |              |               |                         |   |   |    |      |  |
| 90         |            |                         |                    |                  |              |               |                         |   |   |    |      |  |
|            | 21         | 5/10/15                 | 2.0-2.2            |                  |              |               |                         |   |   |    |      |  |
| 95         |            |                         |                    |                  |              |               |                         |   |   |    |      |  |
|            | 22         | 5/19/13                 | 1.5-2.0            | 21               | 33           | 18            | 2                       | 2 | 2 | 42 | 52   |  |

A-6a, A-6b(10)

100 WATER LEVEL:  WATER NOTE: \_\_\_\_\_ DATE: \_\_\_\_\_



TYPE: 2" O.D. Split-barrel Sampler LOCATION: Sta. 16+98.90  
3" O.D. Shelby Tube  
NXM Rock-core Barrel  
36.2' Rt. of Centerline

COMPLETION DEPTH: 168.1' ELEVATION: 616.3 DATE: 8/18/94 8/19/94

| FEET | SAMPLE NO. | SAMPLES SAMPLING EFFORT | HAND PENE-TROMETER | MOISTURE CONTENT | LIQUID LIMIT | PLASTIC LIMIT | AGG. |    |    |    | SILT |    | CLAY   | DESCRIPTION - CONTINUED  |
|------|------------|-------------------------|--------------------|------------------|--------------|---------------|------|----|----|----|------|----|--|--|
|      |            |                         |                    |                  |              |               | tsf  | %  | %  | %  | C.   | F. |  |  |
| 100  | 23         | 4 / 9 / 13              | 1.5-1.7            |                  |              |               |      |    |    |    |      |    |  | Stiff to very-stiff gray silty clay, trace fine to coarse sand, trace fine gravel, contains seams of clayey silt and silt. |
| 105  | 24         | 5 / 10 / 14             | 1.7-2.1            |                  |              |               |      |    |    |    |      |    |  |  |
| 110  | 25         | 6 / 10 / 16             | 1.8-2.4            | 22               | 34           | 18            | 6    | 1  | 1  | 41 | 51   |    |  |  |
| 115  | 26         | 8 / 13 / 17             | 1.9-2.2            |                  |              |               |      |    |    |    |      |    |  |  |
| 120  | 27         | P                       | 1.0-1.5            |                  |              |               |      |    |    |    |      |    |  |  |
| 125  | 28         | P                       |                    |                  |              |               |      |    |    |    |      |    |  |  |
| 130  | 29A<br>29B | 5 / 8 / 9               | 1.0-2.0            | 26               | 26           | 19            | 0    | 0  | 0  | 75 | 25   |    | A-6a, A-6b(10)<br>Interbedded: Stiff gray silty clay, and medium-dense gray silt, 1/4" to 8"+ layers of each soil type.<br>A-4b(8) |  |
| 135  | 30<br>31   | P-R<br>10 / 24 / 23     |                    | 12               |              |               | 35   | 39 | 12 |    | 14   |    | Dense gray fine to coarse sand, little to some fine to coarse gravel, trace to little silt.<br>A-1-b(0)                            |  |
| 140  | 32A<br>32B | 18 / 22 / 22            | 4.5+               |                  |              |               |      |    |    |    |      |    | Hard gray silty clay, little to some fine to coarse sand, trace fine to coarse gravel, contains slickensided planes.               |  |
| 145  | 33         | 35 / 60<br>20 / 40 / 62 | 4.5+               | 15               | 31           | 17            | 3    | 5  | 8  | 32 | 52   |    | A-6a(10)   |  |

150 WATER LEVEL:                                
 WATER NOTE:                                
 DATE:



Renamed: P-002-0-94

**LOG OF BORING NO. P-2**  
**CUY-90-15.24**  
**CLEVELAND, OHIO**

TYPE: 2" O.D. Split-barrel Sampler  
3" O.D. Shelby Tube  
NXM Rock-core Barrel

LOCATION: Sta. 16+98.90  
36.2' Rt. of  
Centerline

COMPLETION DEPTH: 168.1' ELEVATION: 616.3 DATE: 8/18/94 8/19/94

| DEPT. FEET | SAMPLE NO. | SAMPLES SAMPLING EFFORT | HAND PENE-TROMETER | MOISTURE CONTENT | LIQUID LIMIT | PLASTIC LIMIT | DESCRIPTION - CONTINUED |   |   |    |      |      |      |  |
|------------|------------|-------------------------|--------------------|------------------|--------------|---------------|-------------------------|---|---|----|------|------|------|--|
|            |            |                         |                    |                  |              |               | tsf                     | % | % | %  | AGG. | C.S. | F.S. | SILT   |
| 150        | 34         | 12 21/27                | 4.5+               |                  |              |               |                         |   |   |    |      |      |      | Hard gray silty clay, little to some fine to coarse sand, trace fine to coarse gravel, contains slickensided planes.<br>A-6a(10)           |
| 155        | 35         | 4 9/10                  | 1.5-2.5            | 13               | 33           | 20            | 0                       | 0 | 0 | 43 | 57   |      |      | Stiff to very-stiff gray silty clay, trace fine to coarse sand, trace fine to coarse gravel, few seams of fine to medium sand.<br>A-6a(10) |
| 160        | 36         | 10 13/17                | 1.2-2.0            | 23               | 30           | 20            | 22                      | 0 | 0 | 37 | 41   |      |      | Stiff gray clayey silt, trace fine to coarse sand, trace fine to coarse gravel.<br>A-4a(8)   |
| 165        | 37A<br>37B | 44<br>50-1"R            | 1.5-2.0            |                  |              |               |                         |   |   |    |      |      |      | Dense gray fine to coarse gravel, some silty clay, some fine to coarse sand.<br>Est. A-2-4'  |
| 170        |            |                         |                    |                  |              |               |                         |   |   |    |      |      |      | - Encountered water at 19.0'.  |
| 175        |            |                         |                    |                  |              |               |                         |   |   |    |      |      |      | - From 0.0' to 27.5': 3-1/4" I.D. Hollow-stem Auger with plug, replaced with 4" I.D. Flush-coupled casing from 0.0' to 30.0'.              |
| 180        |            |                         |                    |                  |              |               |                         |   |   |    |      |      |      | - From 27.5' to 140.0': 3-7/8" Tricone Bit.  |
| 185        |            |                         |                    |                  |              |               |                         |   |   |    |      |      |      | - From 27.5' to 175': Recirculated water used for drilling fluid.  |
| 190        |            |                         |                    |                  |              |               |                         |   |   |    |      |      |      |  |
| 195        |            |                         |                    |                  |              |               |                         |   |   |    |      |      |      |  |

200 WATER LEVEL:                    
 WATER NOTE:                    
 DATE:











Renamed: P-004-0-94

LOG OF BORING NO. P-4  
 CUY-90-15.24  
 CLEVELAND, OHIO

TYPE: 2" O.D. Split-barrel Sampler LOCATION: Sta. 18+00.08  
3" O.D. Shelby Tube 89.7' Lt. of  
NXM Rock-core Barrel Centerline  
 COMPLETION DEPTH: 200.0' ELEVATION: 610.1 DATE: 8/11/94 8/12/94

| DEPT. FEET | SAMPLE NO. | SAMPLES SAMPLING EFFORT | HAND PENE-TROMETER | MOISTURE CONTENT | LIQUID LIMIT | PLASTIC LIMIT | DESCRIPTION - CONTINUED |   |   |    |      |      |      |           |  |  |  |   |
|------------|------------|-------------------------|--------------------|------------------|--------------|---------------|-------------------------|---|---|----|------|------|------|-----------|--|--|--|---|
|            |            |                         |                    |                  |              |               | tsf                     | % | % | %  | AGG. | C.S. | F.S. | SILT/CLAY |  |  |  |   |
| 50         | 13         | 4/6/8                   | 1.2-2.0            |                  |              |               |                         |   |   |    |      |      |      |           |  |  |  | Stiff to very-stiff gray silty clay, trace to little fine to medium sand, contains many seams and lenses of silt. |
|            | 14         | 4/8/9                   | 1.0-2.0            | 17               | 29           | 17            | 0                       | 0 | 1 | 57 | 42   |      |      |           |  |  |  |   |
| 55         |            |                         |                    |                  |              |               |                         |   |   |    |      |      |      |           |  |  |  |   |
|            | 15         | 4/6/10                  | 1.2-1.9            |                  |              |               |                         |   |   |    |      |      |      |           |  |  |  |   |
| 60         |            |                         |                    |                  |              |               |                         |   |   |    |      |      |      |           |  |  |  |   |
|            | 16         | 4/7/10                  | 1.8-3.0            |                  |              |               |                         |   |   |    |      |      |      |           |  |  |  |   |
| 65         |            |                         |                    |                  |              |               |                         |   |   |    |      |      |      |           |  |  |  |   |
|            | 17         | 4/6/9                   | 1.9-2.5            |                  |              |               |                         |   |   |    |      |      |      |           |  |  |  | - From 69.0' to 75.0': With horizontal structure.   |
| 70         |            |                         |                    |                  |              |               |                         |   |   |    |      |      |      |           |  |  |  |   |
|            | 18         | 2/2/4                   | 0.8-1.2            | 26               | 31           | 18            | 0                       | 0 | 0 | 50 | 50   |      |      |           |  |  |  | - From 72.5' to 74.0': Medium-stiff to stiff.   |
| 75         |            |                         |                    |                  |              |               |                         |   |   |    |      |      |      |           |  |  |  | A-6a(9)   |
|            | 19         | P                       | 1.3-1.8            |                  |              |               |                         |   |   |    |      |      |      |           |  |  |  | Stiff to very-stiff gray silty clay, trace to little fine to coarse sand, trace fine gravel, few lenses of silt.  |
| 80         | 20         | 5/8/14                  | 1.5-2.2            |                  |              |               |                         |   |   |    |      |      |      |           |  |  |  |   |
|            | 21         | 8/9/13                  | 1.7-2.0            | 22               | 33           | 17            | 0                       | 2 | 4 | 32 | 62   |      |      |           |  |  |  |   |
| 85         |            |                         |                    |                  |              |               |                         |   |   |    |      |      |      |           |  |  |  |   |
|            | 22         | 7/11/15                 | 1.8-2.1            |                  |              |               |                         |   |   |    |      |      |      |           |  |  |  |   |
| 90         |            |                         |                    |                  |              |               |                         |   |   |    |      |      |      |           |  |  |  |   |
|            | 23         | 6/11/17                 | 2.2-2.8            | 22               | 33           | 19            | 1                       | 2 | 3 | 30 | 64   |      |      |           |  |  |  |   |
| 95         |            |                         |                    |                  |              |               |                         |   |   |    |      |      |      |           |  |  |  |   |
|            | 24         | 6/10/14                 | 1.8-2.2            | 22               | 33           | 18            | 1                       | 2 | 3 | 34 | 60   |      |      |           |  |  |  | A-6a, A-6b(10)  |

100 WATER LEVEL:                                
 WATER NOTE:                                
 DATE:



Renamed: P-004-0-94

LOG OF BORING NO. P-4  
 CUY-90-15.24  
 CLEVELAND, OHIO

TYPE: 2" O.D. Split-barrel Sampler LOCATION: Sta. 18+00.08  
3" O.D. Shelby Tube  
NXM Rock-core Barrel  
89.7 Lt. of Centerline

COMPLETION DEPTH: 200.0' ELEVATION: 610.1 DATE: 8/11/94 8/12/94

| DEPTH FEET | SAMPLE NO. | SAMPLES SAMPLING EFFORT | HAND PENE-TROMETER | MOISTURE CONTENT | LIQUID LIMIT | PLASTIC LIMIT | AGG. |    |    |    | SILT-CLAY |      |  |
|------------|------------|-------------------------|--------------------|------------------|--------------|---------------|------|----|----|----|-----------|------|--|
|            |            |                         |                    |                  |              |               | tsf  | %  | %  | %  | C.S.      | F.S. | SILT   |
| 100        |            |                         |                    |                  |              |               |      |    |    |    |           |      |  |
| 25         |            | 5 / 9 1/4               | 1.7-2.0            |                  |              |               |      |    |    |    |           |      |  |
| 105        |            |                         |                    |                  |              |               |      |    |    |    |           |      |  |
| 26         |            | 6 / 11 1/5              | 1.8-2.2            | 23               | 34           | 20            | 1    | 1  | 1  | 31 | 66        |      |  |
| 110        |            |                         |                    |                  |              |               |      |    |    |    |           |      |  |
| 27         |            | 7 / 10 1/4              | 1.8-2.5            |                  |              |               |      |    |    |    |           |      |  |
| 115        |            |                         |                    |                  |              |               |      |    |    |    |           |      |  |
| 28         |            | 5 / 8 1/4               | 1.5-1.8            | 26               | 36           | 21            | 0    | 2  | 2  | 21 | 75        |      |  |
| 120        |            |                         |                    |                  |              |               |      |    |    |    |           |      |  |
| 29         |            |                         | 1.1-1.2            |                  |              |               |      |    |    |    |           |      |  |
| 125        | 30A        | 5 / 17 1/7              | 1.0-1.5            | 27               | 30           | 21            | 0    | 0  | 4  | 37 | 59        |      | A-6a, A-6b(10)   |
|            | 30B        |                         |                    | 27               | 25           | 18            | 0    | 0  | 1  | 83 | 16        |      | Medium-dense gray silt, with seams of stiff gray silty clay<br>A-4b(8)   |
|            | 31A        | 5 / 20 1/20             | 1.5                |                  |              |               | 39   | 17 | 21 | 23 |           |      | Dense gray fine to coarse sand, some fine to coarse gravel, some clayey silt.<br>A-1-b(0)  |
| 130        | 31B        |                         |                    |                  |              |               |      |    |    |    |           |      |  |
| 135        |            |                         |                    |                  |              |               |      |    |    |    |           |      |  |
| 32         |            | 20 / 50 1/19            | 4.5+               | 15               | 31           | 18            | 0    | 4  | 7  | 31 | 58        |      | Hard gray silty clay, trace to little fine to coarse sand, trace fine gravel.<br>- Sample at 132.5' contains slicken-sided partings. |
| 140        |            |                         |                    |                  |              |               |      |    |    |    |           |      |  |
| 33         |            | 15 / 32 1/47            | 4.5+               |                  |              |               |      |    |    |    |           |      | - From 139.0' to 141.0': Gradually becomes less hard.<br>A-6a(9)   |
| 145        |            |                         |                    |                  |              |               |      |    |    |    |           |      |  |
| 34         |            | 5 / 9 1/12              | 1.2-1.5            | 24               | 34           | 19            | 0    | 0  | 1  | 27 | 72        |      | Stiff to very-stiff gray silty clay, trace fine to coarse sand, trace fine to coarse gravel, many lenses of silt.<br>A-6a(10)        |
| 150        |            |                         |                    |                  |              |               |      |    |    |    |           |      |  |
| 35         |            | 5 / 9 1/12              | 1.9-2.5            |                  |              |               |      |    |    |    |           |      |  |

DESCRIPTION - CONTINUED

Stiff to very-stiff gray silty clay, trace to little fine to coarse sand, trace fine gravel, few lenses of silt.

- From 0.0' to 27.5': 3-1/4" I.D. Hollow-stem Auger with plug, replaced with 4" I.D. Flush-coupled casing from 0.0' to 31.5'.  
 - From 27.5' to 149.0': 3-7/8" Tricone Bit.  
 - From 45.0' to 170.2': Recirculated water used for drilling fluid.

- From 123.0' to 124.8': Contains seams of clayey silt and silt.  
 A-6a, A-6b(10)

Medium-dense gray silt, with seams of stiff gray silty clay  
 A-4b(8)

Dense gray fine to coarse sand, some fine to coarse gravel, some clayey silt.  
 A-1-b(0)

Hard gray silty clay, trace to little fine to coarse sand, trace fine gravel.  
 - Sample at 132.5' contains slicken-sided partings.

- From 139.0' to 141.0': Gradually becomes less hard.  
 A-6a(9)

Stiff to very-stiff gray silty clay, trace fine to coarse sand, trace fine to coarse gravel, many lenses of silt.  
 A-6a(10)

150 WATER LEVEL:                                
 WATER NOTE:                                
 DATE:



Renamed: P-005-0-94

CUY-90-15.24

CLEVELAND, OHIO



| DEPTH<br>FEET | SAMPLE NO. | SAMPLES<br>SAMPLING<br>EFFORT | HAND<br>PENE-<br>TROMETER | MOISTURE<br>CONTENT | LIQUID<br>LIMIT | PLASTIC<br>LIMIT | TYPE: 2" O.D. Split-barrel Sampler  |      |      |           | LOCATION: Sta. 15+48.44  |                            |
|---------------|------------|-------------------------------|---------------------------|---------------------|-----------------|------------------|---|------|------|-----------|--|----------------------------|
|               |            |                               |                           |                     |                 |                  | AGG.  | C.S. | F.S. | SILT/CLAY | 3" O.D. Shelby Tube  | 93.1' Lt. of<br>Centerline |
|               |            |                               |                           |                     |                 |                  | COMPLETION DEPTH: 173.0'  |      |      |           | ELEVATION: 662.3   |                            |
|               |            |                               |                           |                     |                 |                  |   |      |      |           | DATE: 9/26/94 9/28/94  |                            |
|               |            |                               |                           |                     |                 |                  | DESCRIPTION   |      |      |           |  |                            |
|               |            |                               |                           |                     |                 |                  | ASPHALT - 10 INCHES   |      |      |           |  |                            |
|               |            |                               |                           |                     |                 |                  | Granite paver blocks.   |      |      |           |  |                            |
|               |            |                               |                           |                     |                 |                  | FILL: Loose brown fine to coarse sand, some fine to coarse gravel, trace silt.                          |      |      |           |  | Est. A-1-b                 |
|               |            |                               |                           |                     |                 |                  | FILL: Stiff brown silty clay, little fine to coarse sand, trace fine gravel.                            |      |      |           |  | Est. A-6b                  |
|               |            |                               |                           |                     |                 |                  | Loose to medium-dense brown fine to medium sand, trace coarse sand, trace silt.                         |      |      |           |  |                            |
|               |            |                               |                           |                     |                 |                  |   |      |      |           |  |                            |
|               |            |                               |                           |                     |                 |                  |   |      |      |           |  | Est. A-3a                  |
|               | 5A<br>5B   | 3/4/7                         |                           |                     |                 |                  | 0   | 0    | 10   | 90        | Medium-dense brown silt, little fine to coarse sand, trace clay. |                            |
|               |            |                               |                           |                     |                 |                  |   |      |      |           |  | Est. A-4a                  |
|               |            |                               |                           |                     |                 |                  | Dense brown fine sand, "and" silt, trace medium sand.   |      |      |           |  |                            |
|               |            |                               |                           |                     |                 |                  |   |      |      |           |  | Est. A-4a                  |
|               |            |                               |                           |                     |                 |                  | Very-stiff to hard gray silty clay interbedded with silt, trace fine to medium sand.                    |      |      |           |  |                            |
|               |            |                               |                           |                     |                 |                  |   |      |      |           |  | Est. A-6a                  |
|               |            |                               |                           |                     |                 |                  | Dense gray fine to medium sand, little silt.  |      |      |           |  |                            |
|               |            |                               |                           |                     |                 |                  |   |      |      |           |  | Est. A-3a                  |
|               | 8A<br>8B   | 20/25/23                      |                           |                     |                 |                  | Dense gray silt interbedded with silty clay, trace fine to medium sand.                                 |      |      |           |  |                            |
|               |            |                               |                           |                     |                 |                  |   |      |      |           |  | Est. A-4a                  |
|               |            |                               |                           |                     |                 |                  | Stiff to very-stiff gray silty clay, trace to little fine to medium sand, few seams and lenses of silt. |      |      |           |  |                            |
|               |            |                               |                           |                     |                 |                  |   |      |      |           |  | A-6a(9)                    |
| 50            |            |                               |                           |                     |                 |                  |   |      |      |           |  |                            |
| WATER LEVEL:  |            | ▽                             |                           |                     |                 |                  |   |      |      |           |  |                            |
| WATER NOTE:   |            |                               |                           |                     |                 |                  |   |      |      |           |  |                            |
| DATE:         |            |                               |                           |                     |                 |                  |   |      |      |           |  |                            |





Renamed: P-005-0-94

LOG OF BORING NO. P-5  
 CUY-90-15.24  
 CLEVELAND, OHIO

TYPE: 2" O.D. Split-barrel Sampler LOCATION: Sta. 15+48.44  
3" O.D. Shelby Tube 93.1' Lt. of  
NXM Rock-core Barrel Centerline

COMPLETION DEPTH: 173.0' ELEVATION: 662.3 DATE: 9/26/94 9/28/94

| DEP. FEET | SAMPLE NO. | SAMPLES | SAMPLING EFFORT | HAND PENE-TROMETER | MOISTURE CONTENT | LIQUID LIMIT | PLASTIC LIMIT | AGG. C.S. F.S. SILT/CLAY |   |   |   | DESCRIPTION - CONTINUED  |
|-----------|------------|---------|-----------------|--------------------|------------------|--------------|---------------|--------------------------|---|---|---|--|
|           |            |         |                 |                    |                  |              |               | tsf                      | % | % | % |  |
| 100       | 20         | 7       | 13/18           | 1.6-4.3            |                  |              |               |                          |   |   |   | Stiff to very-stiff gray silty clay, trace fine to medium sand, few to many seams and lenses of silt.<br><br>A-6a(9)       |
| 105       | 21         | 6       | 10/14           | 2.4-3.3            |                  |              |               |                          |   |   |   | Very-stiff to hard gray silty clay, trace fine to medium sand, few to many seams and lenses of silt, horizontal structure. |
| 110       | 22         | 8       | 15/20           | 4.1-4.5+           |                  |              |               |                          |   |   |   |  |
| 115       | 23         | 5       | 10/11           | 2.1-3.4            |                  |              |               |                          |   |   |   |  |
| 120       | 24         | 2       | 5/7             | 1.5-2.7            |                  |              |               |                          |   |   |   | - From 121.5' to 123.0': Stiff to very-stiff.  |
| 125       | 25         | P       |                 | 4.5+               |                  |              |               |                          |   |   |   | Est. A-6a  |
| 130       | 26         | 8       | 18/26           | 4.3-4.5+           |                  |              |               |                          |   |   |   | Very-stiff to hard gray silty clay, trace to little fine to coarse sand, trace fine gravel.                                |
| 135       | 27         | P       |                 | 2.1-2.3            |                  |              |               |                          |   |   |   |  |
| 140       | 28         | 5       | 10/12           | 2.2-2.3            |                  |              |               |                          |   |   |   |  |
| 145       | 29         | P       |                 | 2.0-2.1            |                  |              |               |                          |   |   |   | A-6a(9)  |

150 WATER LEVEL:                                
 WATER NOTE:                                
 DATE:



TYPE: 2" O.D. Split-barrel Sampler LOCATION: Sta. 15+48.44  
3" O.D. Shelby Tube 93.1' Lt. of  
NXM Rock-core Barrel Centerline

COMPLETION DEPTH: 173.0' ELEVATION: 662.3 DATE: 9/26/94 9/28/94

| DEPT. FEET | SAMPLE NO. | SAMPLES SAMPLING EFFORT | HAND PENE-TROMETER | MOISTURE CONTENT | LIQUID LIMIT | PLASTIC LIMIT | COMPLETION DEPTH: 173.0' ELEVATION: 662.3 |   |   |    | AGG. | C. | S. | F. | S. | SILT | CLAY | DESCRIPTION - CONTINUED   |
|------------|------------|-------------------------|--------------------|------------------|--------------|---------------|---|---|---|----|------|----|----|----|----|------|------|---|
|            |            |                         |                    |                  |              |               | tsf                                       | % | % | %  |      |    |    |    |    |      |      |   |
| 150        | 30         | 5 / 11 / 13             | 2.4-2.7            | 23               | 33           | 20            | 1   | 2 | 2 | 35 | 60   |    |    |    |    |      |      | Very-stiff to hard gray silty clay, trace to little fine to coarse sand, trace fine gravel. |
| 155        | 31         | 7 / 13 / 18             | 2.7-3.0            |                  |              |               |   |   |   |    |      |    |    |    |    |      |      |   |
| 160        | 32         | 8 / 14 / 20             | 2.0-2.2            |                  |              |               |   |   |   |    |      |    |    |    |    |      |      |   |
| 165        | 33         | 10 / 12 / 17            | 2.3-2.7            |                  |              |               |   |   |   |    |      |    |    |    |    |      |      |   |
| 170        | 34         | 8 / 14 / 16             | 2.5-2.7            |                  |              |               |   |   |   |    |      |    |    |    |    |      |      |   |

A-6a(9)

- Encountered water at 27.5'.

- From 0.0' to 54.0': 3-1/4" I.D. Hollow-stem Auger with plug, replaced with 4" I.D. Flush-coupled casing from 0.0' to 54.0'.

- From 54.0' to 173.0': 3-7/8" Tricone Bit.

- From 54.0' to 173.0': Recirculated water used for drilling fluid.

200  
 WATER LEVEL:                    
 WATER NOTE:                    
 DATE:

**APPENDIX 4B -3**  
**BBCM BORINGS 2006**



**LOG OF BORING NO. B-05-01**  
**CUY-90-15.24 West Abutment**  
**CUYAHOGA COUNTY, OHIO**

Renamed: B-001-0-06

BBC&M JOB 012-00936.300

TYPE: 3-1/4" I.D. Hollow-stem Auger 3-7/8" Tricone Roller Bit  
2" O.D. Split-barrel Sampler 3" O.D. Shelby Tube Sampler  
NX Rock Core Barrel

LOCATION: Proposed I-90 Central Viaduct  
Sta. 130+41.92  
91.59' Rt. of Centerline

COMPLETION DEPTH: 233.7'  
ELEVATION: 675.4  
DATE: 4/3/06 - 4/10/06

| Elev (feet) | Depth (feet) | Samp. | Std. Pen. / RQD | Hand Pen. (tsf) | Rec./Loss (feet) | CLASSIFICATION: DESCRIPTION   | Samp. No | Physical Characteristics |        |        |        |        |    |    | ODOT Class |    |           |
|-------------|--------------|-------|-----------------|-----------------|------------------|---|----------|--------------------------|--------|--------|--------|--------|----|----|------------|----|-----------|
|             |              |       |                 |                 |                  |   |          | % AGG.                   | % C.S. | % F.S. | % SILT | % CLAY | LL | PI |            | WC |           |
| 675.7       | 0            |       |                 |                 |                  | 0.3 ASPHALT - 4 INCHES  |          |                          |        |        |        |        |    |    |            |    |           |
| 674.3       |              |       | 3/5/4           |                 |                  | 0.1 CONCRETE - 9 INCHES   | 1        |                          |        |        |        |        |    |    |            |    | Est. A-3a |
|             | 5            |       | 3/2/2           |                 |                  | COARSE AND FINE SAND (FILL): Very-loose to loose brown fine to coarse sand, some fine to coarse gravel, trace silt, trace clay, contains few clayey silt pockets. | 2        |                          |        |        |        |        |    |    |            |    | Est. A-3a |
|             | 10           |       | 2/2/2           |                 |                  |   | 3        |                          |        |        |        |        |    |    |            |    | Est. A-3a |
|             | 15           |       | 2/3/3           |                 |                  |   | 4        | 21                       | 37     | 29     | 7      | 6      |    |    | 9          |    | Est. A-3a |
|             | 20           |       | 2/3/5           |                 |                  |   | 5        |                          |        |        |        |        |    |    |            |    | Est. A-3a |
| 653.4       |              |       |                 |                 |                  | 22.0  |          |                          |        |        |        |        |    |    |            |    |           |
|             | 25           |       | 4/6/7           | 3.0-4.5+        |                  | SILT: Very-stiff to hard brown silt, some clay, trace fine to coarse sand.  | 6        | 0                        | 1      | 3      | 72     | 24     | 27 | 7  | 20         |    | A-4b(8)   |
| 648.4       |              |       |                 |                 |                  | 27.0  |          |                          |        |        |        |        |    |    |            |    |           |
|             | 30           |       | 4/4/6           |                 |                  | FINE SAND: Loose to medium-dense gray fine sand, trace coarse sand, trace silt, trace clay.   | 7        |                          |        |        |        |        |    |    |            |    | Est. A-3  |
|             | 35           |       | 5/8/9           |                 |                  |   | 8        | 0                        | 8      | 83     | 4      | 5      | NP | NP | 7          |    | A-3(0)    |
| 638.4       |              |       |                 |                 |                  | 37.0  |          |                          |        |        |        |        |    |    |            |    |           |
|             | 40           |       | 3/3/4           |                 |                  | SILT: Loose to medium-dense brown and gray silt, some fine sand, trace to little clay, contains few fine sand lenses.   | 9        |                          |        |        |        |        |    |    |            |    | Est. A-4b |
|             | 45           |       | 11/13/15        |                 |                  |   | 10       |                          |        |        |        |        |    |    |            |    | Est. A-4b |
| 628.4       |              |       |                 |                 |                  | 47.0  |          |                          |        |        |        |        |    |    |            |    |           |
|             | 50           |       | 3/5/9           | 1.25-4.25       |                  | SILT: Medium-stiff to stiff gray silt, some to "and" clay, trace fine sand, contains few very-stiff to hard zones.  | 11       |                          |        |        |        |        |    |    |            |    | Est. A-4b |

PLATE 1

WATER LEVEL: ▽ 38.5 ▽ 21.0 ▽ 25.5 ▽  
WATER NOTE: Encountered After HSA Removed - Prior to Washbore Inside Casing - Prior to Washbore  
DATE: 4/3/06 4/3/06 4/4/06

-CONTINUED-



**LOG OF BORING NO. B-05-01**  
**CUY-90-15.24 West Abutment**  
**CUYAHOGA COUNTY, OHIO**

Renamed: B-001-0-06

BBC&M JOB 012-00946.300

TYPE: 3-1/4" I.D. Hollow-stem Auger    3-7/8" Tricone Roller Bit    LOCATION: Proposed I-90 Central Viaduct    COMPLETION DEPTH: 233.7'  
2" O.D. Split-barrel Sampler    3" O.D. Shelby Tube Sampler    Sta. 130+41.92    ELEVATION: 675.4  
NX Rock Core Barrel    91.59' Rt. of Centerline    DATE: 4/3/06 - 4/10/06

| Elev. (feet) | Depth (feet) | Samp.   | Std. Pen. / RQD | Hand Pen. (tsf) | Rec./Loss (feet) | CLASSIFICATION: DESCRIPTION  | Samp. No. | Physical Characteristics |        |        |        |        |    |    | ODOT Class |    |  |           |
|--------------|--------------|---------|-----------------|-----------------|------------------|--|-----------|--------------------------|--------|--------|--------|--------|----|----|------------|----|--|-----------|
|              |              |         |                 |                 |                  |  |           | % AGG.                   | % C.S. | % F.S. | % SILT | % CLAY | LL | PI |            | WC |  |           |
|              | 50           |         |                 |                 |                  | SILT: Medium-stiff to stiff gray silt, some to "and" clay, trace fine sand, contains few very-stiff to hard zones. |           |                          |        |        |        |        |    |    |            |    |  |           |
|              | 55           | 6/4/6   |                 | 0.75-2.0        |                  |  | 12        |                          |        |        |        |        |    |    |            |    |  | Est. A-4b |
|              |              | P       |                 | 1.5-2.5         |                  |  | 13        | 0                        | 0      | 2      | 67     | 31     | 28 | 8  | 22         |    |  | A-4b(8)   |
|              |              | P       |                 | 1.25-1.5        |                  |  | 14        |                          |        |        |        |        |    |    |            |    |  | Est. A-4b |
|              | 60           | 2/4/5   |                 | 0.75-2.0        |                  |  | 15        |                          |        |        |        |        |    |    |            |    |  | Est. A-4b |
|              |              |         |                 |                 |                  |  | 16        |                          |        |        |        |        |    |    |            |    |  | Est. A-4b |
|              | 65           | 3/6/5   |                 | 1.0-2.5         |                  |  | 17        |                          |        |        |        |        |    |    |            |    |  | Est. A-4b |
|              |              | 2/3/4   |                 | 1.0-1.75        |                  |  | 18        | 0                        | 0      | 3      | 57     | 40     | 29 | 8  | 24         |    |  | A-4b(8)   |
|              |              | 2/2/4   |                 | 0.75-1.25       |                  |  | 19        |                          |        |        |        |        |    |    |            |    |  | Est. A-4b |
| 605.9        |              | 3/6/7   |                 | 1.5-2.5         |                  |  | 20        |                          |        |        |        |        |    |    |            |    |  | Est. A-6a |
|              | 70           | 6/9/13  |                 | 2.75-4.5+       |                  | SILT AND CLAY: Very-stiff to hard gray clay, "and" silt, contains many interbedded silt seams.                     | 21        |                          |        |        |        |        |    |    |            |    |  | Est. A-6a |
|              |              | 4/7/13  |                 | 4.0-4.5+        |                  |  | 22        |                          |        |        |        |        |    |    |            |    |  | Est. A-6a |
|              |              | 7/10/14 |                 | 4.0-4.5+        |                  |  | 23        |                          |        |        |        |        |    |    |            |    |  | Est. A-6a |
|              | 75           | 6/12/18 |                 | 4.5+            |                  |  |           |                          |        |        |        |        |    |    |            |    |  |           |
|              |              |         |                 |                 |                  |  | 24        |                          |        |        |        |        |    |    |            |    |  | Est. A-6a |
|              | 80           | 8/11/14 |                 | 2.25-4.5+       |                  |  |           |                          |        |        |        |        |    |    |            |    |  |           |
|              |              |         |                 |                 |                  |  | 25        | 0                        | 0      | 0      | 48     | 52     | 32 | 11 | 21         |    |  | A-6a(8)   |
|              | 85           | 4/8/11  |                 | 2.0-3.0         |                  |  |           |                          |        |        |        |        |    |    |            |    |  |           |
|              |              |         |                 |                 |                  |  | 26        |                          |        |        |        |        |    |    |            |    |  | Est. A-6a |
| 584.4        | 90           | 9/10/14 |                 | 2.0-3.25        |                  |  |           |                          |        |        |        |        |    |    |            |    |  |           |
|              |              |         |                 |                 |                  |  | 27        |                          |        |        |        |        |    |    |            |    |  | Est. A-6a |
|              |              | P       |                 | 1.25-1.5        |                  |  | 28        |                          |        |        |        |        |    |    |            |    |  | Est. A-6a |
|              | 95           | P       |                 | 1.25            |                  |  |           |                          |        |        |        |        |    |    |            |    |  |           |
|              |              |         |                 |                 |                  |  | 29        | 1                        | 0      | 1      | 28     | 70     | 38 | 14 | 28         |    |  | A-6a(10)  |
|              | 100          | 3/4/6   |                 | 0.5-1.25        |                  |  |           |                          |        |        |        |        |    |    |            |    |  |           |

PLATE 2

WATER LEVEL: ▽ 38.5    ▽ 21.0    ▽ 25.5    ▽  
WATER NOTE: Encountered    After HSA Removed - Prior to Washbore    Inside Casing - Prior to Washbore  
DATE: 4/3/06    4/3/06    4/4/06

-CONTINUED-



**LOG OF BORING NO. B-05-01**  
**CUY-90-15.24 West Abutment**  
**CUYAHOGA COUNTY, OHIO**

Renamed: B-001-0-06

BBC&M JOB: 012-00946.300

TYPE: 3-1/4" I.D. Hollow-stem Auger    3-7/8" Tricone Roller Bit    LOCATION: Proposed I-90 Central Viaduct    COMPLETION DEPTH: 233.7'  
2" O.D. Split-barrel Sampler    3" O.D. Shelby Tube Sampler    Sta. 130+41.92    ELEVATION: 675.4  
NX Rock Core Barrel    91.59' Rt. of Centerline    DATE: 4/3/06 - 4/10/06

| Elev. (feet) | Depth (feet) | Samp. | Std. Pen. / RQD | Hand Pen. (tsf) | Rec./Loss (feet) | CLASSIFICATION, DESCRIPTION   | Samp. No. | Physical Characteristics |        |        |        |        |    |    | ODOT Class |    |           |           |
|--------------|--------------|-------|-----------------|-----------------|------------------|---|-----------|--------------------------|--------|--------|--------|--------|----|----|------------|----|-----------|-----------|
|              |              |       |                 |                 |                  |   |           | % AGG.                   | % C.S. | % F.S. | % SILT | % CLAY | LL | PI |            | WC |           |           |
|              | 100          |       |                 |                 |                  | SILT AND CLAY: Stiff to very-stiff gray clay, some silt, trace fine to coarse sand, trace fine gravel, contains few to many fine sand and silt seams, and few medium-stiff zones. |           |                          |        |        |        |        |    |    |            |    |           |           |
|              | 105          |       | 4/6/8           | 1.75-2.5        |                  |   | 30        |                          |        |        |        |        |    |    |            |    |           | Est. A-6a |
|              | 110          |       | 6/9/13          | 2.0-2.75        |                  |   | 31        |                          |        |        |        |        |    |    |            |    |           | Est. A-6a |
|              | 115          |       | 6/8/9           | 2.25-3.0        |                  |   | 32        |                          |        |        |        |        |    |    |            |    | Est. A-6a |           |
| 558.4        |              |       |                 |                 |                  |   |           |                          |        |        |        |        |    |    |            |    |           |           |
|              | 120          |       | 5/8/12          | 1.25-2.5        |                  | SILT: Stiff to very-stiff gray silt, "and" clay, trace fine to coarse sand, trace fine gravel.  | 33        | 0                        | 0      | 1      | 53     | 46     | 29 | 9  | 23         |    | A-4b(8)   |           |
|              | 125          |       | 8/11/12         | 1.75-3.75       |                  |   | 34        |                          |        |        |        |        |    |    |            |    | Est. A-4b |           |
|              | 130          |       | 11/13/17        | 2.25-3.75       |                  |   | 35        |                          |        |        |        |        |    |    |            |    | Est. A-4b |           |
|              | 135          |       | 5/8/10          | 1.75-3.0        |                  |   | 36        | 1                        | 1      | 2      | 54     | 42     | 28 | 9  | 23         |    | A-4b(8)   |           |
| 538.4        |              |       |                 |                 |                  |   |           |                          |        |        |        |        |    |    |            |    |           |           |
|              | 140          |       | 8/13/21         | 3.0-3.5         |                  | SILT AND CLAY: Stiff to very-stiff gray clay, some silt, trace fine to coarse sand, trace fine gravel, contains few silt seams, pockets and lenses, and few medium-stiff zones.   | 37        |                          |        |        |        |        |    |    |            |    | Est. A-6a |           |
|              | 145          |       | 7/11/16         | 2.5-3.75        |                  |   | 38        |                          |        |        |        |        |    |    |            |    | Est. A-6a |           |
|              | 150          |       | 8/12/16         | 2.0-3.5         |                  |   | 39        | 1                        | 2      | 4      | 33     | 60     | 34 | 13 | 21         |    | A-6a(9)   |           |

WATER LEVEL: ▽ 38.5    ▽ 21.0    ▽ 25.5    ▽  
WATER NOTE: Encountered    After HSA Removed - Prior to Washbore    Inside Casing - Prior to Washbore  
DATE: 4/3/06    4/3/06    4/4/06

-CONTINUED-

PLATE 3





**LOG OF BORING NO. B-05-01**  
**CUY-90-15.24 West Abutment**  
**CUYAHOGA COUNTY, OHIO**

Renamed: B-001-0-06

BBC&M JOB: 012-00946.300

TYPE: 3-1/4" I.D. Hollow-stem Auger    3-7/8" Tricone Roller Bit    LOCATION: Proposed I-90 Central Viaduct    COMPLETION DEPTH: 233.7'  
2" O.D. Split-barrel Sampler    3" O.D. Shelby Tube Sampler    Sta. 130+41.92    ELEVATION: 675.4  
NX Rock Core Barrel    91.59' Rt. of Centerline    DATE: 4/3/06 - 4/10/06

| Elev. (feet) | Depth (feet) | Samp.    | Std. Pen. / RQD | Hand Pen. (tsf) | Rec./Loss (feet) | CLASSIFICATION: DESCRIPTION   | Samp. No.   | Physical Characteristics |        |        |        |        |    |    | ODOT Class |    |  |           |           |
|--------------|--------------|----------|-----------------|-----------------|------------------|---|---|--------------------------|--------|--------|--------|--------|----|----|------------|----|--|-----------|-----------|
|              |              |          |                 |                 |                  |   |   | % AGG.                   | % C.S. | % F.S. | % SILT | % CLAY | LL | PI |            | WC |  |           |           |
| 483.4        | -150         |          |                 |                 |                  | SILT AND CLAY: Stiff to very-stiff gray clay, some silt, trace fine to coarse sand, trace fine gravel, contains few silt seams, pockets and lenses, and few medium-stiff zones. |   |                          |        |        |        |        |    |    |            |    |  |           |           |
|              | -155         | 6/9/12   | 1.75-2.75       |                 |                  |   | 40  |                          |        |        |        |        |    |    |            |    |  |           | Est. A-6a |
|              | -160         | 6/8/11   | 1.75-2.5        |                 |                  |   | 41  |                          |        |        |        |        |    |    |            |    |  |           | Est. A-6a |
|              | -165         | 7/9/12   | 0.75-2.5        |                 |                  |   | 42  | 1                        | 2      | 3      | 33     | 61     | 32 | 13 | 22         |    |  |           | A-6a(9)   |
|              | -170         | 8/9/13   | 1.75-2.5        |                 |                  |   | 43  |                          |        |        |        |        |    |    |            |    |  |           | Est. A-6a |
|              | -175         | 7/11/15  | 2.0-3.75        |                 |                  |   | 44  |                          |        |        |        |        |    |    |            |    |  |           | Est. A-6a |
|              | -180         | 5/9/12   | 1.75-2.75       |                 |                  |   | 45  | 0                        | 0      | 1      | 31     | 68     | 37 | 15 | 24         |    |  |           | A-6a(10)  |
|              | -185         | 4/7/8    | 0.5-1.75        |                 |                  |   | 46  |                          |        |        |        |        |    |    |            |    |  |           | Est. A-6a |
|              | -190         | 5/6/7    | 0.5-1.75        |                 |                  |   | 47  |                          |        |        |        |        |    |    |            |    |  |           | Est. A-6a |
| 478.4        | -195         | 15/16/17 |                 |                 |                  |   | COARSE AND FINE SAND: Dense gray fine to coarse sand, some fine gravel, little silt, little clay. | 48                       | 22     | 31     | 14     | 20     | 13 |    |            |    |  | 13        | Est. A-3a |
|              | -200         | 15/28/45 | 2.0-4.25        |                 |                  |   | 49  |                          |        |        |        |        |    |    |            |    |  | Est. A-4a |           |

PLATE 4

WATER LEVEL: ▽ 38.5    ▽ 21.0    ▽ 25.5    ▽  
WATER NOTE: Encountered    After HSA Removed - Prior to Washbore    Inside Casing - Prior to Washbore  
DATE: 4/3/06    4/3/06    4/4/06

-CONTINUED-

TYPE: 3-1/4" I.D. Hollow-stem Auger    3-7/8" Tricone Roller Bit    LOCATION: Proposed I-90 Central Viaduct    COMPLETION DEPTH: 233.7'  
2" O.D. Split-barrel Sampler    3" O.D. Shelby Tube Sampler    Sta. 130+41.92    ELEVATION: 675.4  
NX Rock Core Barrel    91.59' Rt. of Centerline    DATE: 4/3/06 - 4/10/06

| Elev. (feet) | Depth (feet) | Samp. | Std. Pen. / RQD | Hand Pen. (tsf) | Rec./Loss (feet) | CLASSIFICATION: DESCRIPTION  | Samp. No. | Physical Characteristics |        |        |        |        |    |    | ODOT Class |           |
|--------------|--------------|-------|-----------------|-----------------|------------------|--|-----------|--------------------------|--------|--------|--------|--------|----|----|------------|-----------|
|              |              |       |                 |                 |                  |  |           | % AGG.                   | % C.S. | % F.S. | % SILT | % CLAY | LL | PI |            | WC        |
| 468.4        | 200-205      |       | 11/17/20        | 2.75-4.5+       |                  | SANDY SILT: Very-stiff to hard gray clay, "and" silt, trace fine to coarse sand, contains few silt pockets and shale fragments.  | 50        | 0                        | 1      | 2      | 34     | 63     | 32 | 10 | 26         | A-4a(8)   |
|              | 210          |       | 5/7/9           | 0.75-2.25       |                  | SILT AND CLAY: Stiff to very-stiff gray clay, some silt, trace fine to coarse sand, trace fine gravel, contains many silt lenses, and few medium-stiff zones.  | 51        | 1                        | 1      | 2      | 21     | 75     | 35 | 11 | 25         | A-6a(8)   |
| 458.9        | 215          |       | 7/10/25         | 1.5-2.5         |                  |  | 52        |                          |        |        |        |        |    |    |            | Est. A-6a |
| 455.4        | 220          |       | 23/38/50-5"R    | 4.5+            |                  | SANDY SILT: Hard gray silt, some clay, little fine to coarse sand, little fine to coarse gravel, contains shale fragments.   | 53        | 19                       | 12     | 8      | 33     | 28     | 25 | 7  | 10         | A-4a(5)   |
| 451.7        | 225          |       | 50-1.5"R        |                 |                  | SHALE: Very-soft gray shale, fragmented.   | 54        |                          |        |        |        |        |    |    |            | Visual    |
|              | 230          |       | 63%             |                 | 5.0/0.0          | SHALE: Soft to medium-hard dark gray and gray shale, nearly horizontally bedded, few horizontal fractures from 223.7' to 228.7', many horizontal and few vertical fractures from 229.3' to 230.7', contains diagonal fractures from 224.7' to 225.2' with a fracture angle of ranging between 20 and 25 degrees, and at 227.0' with a fracture angle of ranging between 15 and 20 degrees, contains few silty clay seams at 226.7' and 230.2', arenaceous. | 55        |                          |        |        |        |        |    |    |            | Visual    |
| 441.7        | 235          |       | 67%             |                 | 4.7/0.3          |  | 56        |                          |        |        |        |        |    |    |            | Visual    |

- Qu=1477 psi at 229.0'.

**NOTES:**

- Encountered water at 38.5'.
- Water added to borehole at 40.0' to facilitate drilling.
- Switched to washbore at 57.0'.
- Base of inclinometer installed at an approximate depth of 231'.
- Two vibrating wire piezometers installed in an offset hole between 5/23/06 and 5/26/06. Transducers were installed at approximate depths of 65' and 95'. The piezometer offset hole was backfilled with grout.

WATER LEVEL: 38.5    21.0    25.5  
WATER NOTE: Encountered    After HSA Removed - Prior to Washbore    Inside Casing - Prior to Washbore  
DATE: 4/3/06    4/3/06    4/4/06

PLATES



TYPE: 3-1/4" I.D. Hollow-stem Auger    3-1/8" Tricone Roller Bit  
2" O.D. Split-barrel Sampler    3" O.D. Shelby Tube Sampler  
NX Rock Core Barrel

LOCATION: Proposed I-90 Central Viaduct  
Sta. 132+38.69  
132.15' Rt. of Centerline

COMPLETION DEPTH: 178.5'  
ELEVATION: 617.9  
DATE: 4/10/06 - 4/13/06

| Elev. (feet) | Depth (feet) | Samp. | Std. Pen. / RQD | Hand Pen. (tst) | Rec./Loss (feet) | CLASSIFICATION: DESCRIPTION   | Samp. No. | Physical Characteristics |        |        |        |        |    |    | ODOT Class |    |           |  |
|--------------|--------------|-------|-----------------|-----------------|------------------|---|-----------|--------------------------|--------|--------|--------|--------|----|----|------------|----|-----------|--|
|              |              |       |                 |                 |                  |   |           | % AGG.                   | % C.S. | % F.S. | % SILT | % CLAY | LL | PI |            | WC |           |  |
|              | 50           |       |                 |                 |                  |   |           |                          |        |        |        |        |    |    |            |    |           |  |
|              | 55           |       | 3/5/5           | 1.25-2.25       |                  | SILT: Stiff to very-stiff becoming very-stiff to hard gray silt, "and" clay, trace fine sand, contains many interbedded silty clay seams, lenses and pockets. | 17        | 0                        | 0      | 2      | 51     | 47     | 30 | 10 | 24         |    | A-4b(8)   |  |
|              | 60           |       | 4/7/8           | 1.25-3.0        |                  |   | 18        |                          |        |        |        |        |    |    |            |    | Est. A-4b |  |
|              | 65           |       | 6/9/10          | 2.5-4.25        |                  |   | 19        | 0                        | 0      | 3      | 56     | 41     | 28 | 9  | 22         |    | A-4b(8)   |  |
|              | 70           |       | 6/11/14         | 3.0-4.5+        |                  |   | 20        |                          |        |        |        |        |    |    |            |    | Est. A-4b |  |
| 545.4        | 75           |       | 6/9/10          | 2.5-4.0         |                  | SANDY SILT: Stiff to very-stiff gray clay, "and" silt, trace fine sand, contains few to many interbedded silt seams, contains few medium-stiff zones.         | 21        |                          |        |        |        |        |    |    |            |    | Est. A-4a |  |
|              | 80           |       | 4/7/9           | 0.5-2.5         |                  |   | 22        | 0                        | 0      | 2      | 47     | 51     | 29 | 10 | 24         |    | A-4a(8)   |  |
|              | 85           |       | 5/8/11          | 1.5-3.75        |                  |   | 23        |                          |        |        |        |        |    |    |            |    | Est. A-4a |  |
| 530.9        | 90           |       | 4/8/11          | 1.0-2.0         |                  | SILT AND CLAY: Medium-stiff to stiff gray clay, "and" silt, trace fine to coarse sand, trace fine gravel, contains few silt pockets.                          | 24        |                          |        |        |        |        |    |    |            |    | Est. A-6a |  |
|              | 95           |       | 5/7/9           | 1.25-2.0        |                  |   | 25        | 1                        | 2      | 3      | 35     | 59     | 34 | 12 | 22         |    | A-6a(9)   |  |
|              | 100          |       | 5/8/9           | 0.75-2.0        |                  |   | 26        |                          |        |        |        |        |    |    |            |    | Est. A-6a |  |

WATER LEVEL: ▽ "Dry"    ▽    ▽    ▽  
WATER NOTE: Inside HSA - Prior to Washbore  
DATE: 4/10/06



**LOG OF BORING NO. B-05-02**  
**CUY-90-15.24 West Abutment**  
**CUYAHOGA COUNTY, OHIO**

Renamed: B-002-0-06

BBC&M JOB 012-00946.300

TYPE 3-1/4" I.D. Hollow-stem Auger 3-1/8" Tricone Roller Bit  
2" O.D. Split-barrel Sampler 3" O.D. Shelby Tube Sampler  
NX Rock Core Barrel

LOCATION: Proposed I-90 Central Viaduct  
Sta. 132+38.69  
132.15' Rt. of Centerline

COMPLETION DEPTH: 178.5'  
ELEVATION: 617.9  
DATE: 4/10/06 - 4/13/06

| Elev. (feet) | Depth (feet) | Samp. | Std. Pen. / RQD | Hand Pen. (tsf) | Rec./Loss (feet) | CLASSIFICATION: DESCRIPTION   | Samp. No.  | Physical Characteristics |        |        |        |        |    |    | ODOT Class |    |                        |
|--------------|--------------|-------|-----------------|-----------------|------------------|---|------------|--------------------------|--------|--------|--------|--------|----|----|------------|----|------------------------|
|              |              |       |                 |                 |                  |   |            | % AGG.                   | % C.S. | % F.S. | % SILT | % CLAY | LL | PI |            | WC |                        |
| 510.4        | 100-105      |       | 5/9/10          | 1.0-2.0         |                  | SILT AND CLAY: Medium-stiff to stiff gray clay, "and" silt, trace fine to coarse sand, trace fine gravel, contains few silt pockets.            | 27         |                          |        |        |        |        |    |    |            |    | Est. A-6a              |
|              | 105-110      |       | 5/8/10          | 1.5-2.25        |                  | SILT AND CLAY: Stiff to very-stiff gray clay, "and" silt, trace fine to coarse sand, trace fine gravel.   | 28         |                          |        |        |        |        |    |    |            |    | Est. A-6a              |
|              | 110-115      |       | 5/8/11          | 1.0-2.5         |                  |   | 29         | 1                        | 2      | 3      | 34     | 60     | 33 | 13 | 22         |    | A-6a(9)                |
|              | 115-120      |       | 7/8/12          | 2.0-2.5         |                  |   | 30         |                          |        |        |        |        |    |    |            |    | Est. A-6a              |
|              | 120-125      |       | 6/9/10          | 1.0-2.5         |                  |   | 31         |                          |        |        |        |        | 30 | 11 |            |    | Est. A-6a              |
|              | 125-130      |       | P               | 1.5-2.0         |                  |   | 32         |                          |        |        |        |        |    |    |            |    | Est. A-6a              |
|              | 130-135      |       | P               | 2.0-2.5         |                  |   | 33         |                          |        |        |        |        |    |    |            |    | Est. A-6a              |
| 489.9        | 135-140      |       | 6/9/14          | 1.75-3.25       |                  |   | 34         |                          |        |        |        |        |    |    |            |    | Est. A-6a              |
|              | 140-145      |       | 7/9/8           |                 |                  | SILT: Medium-dense gray silt, trace fine sand, contains few fine sand seams and lenses.   | 35         |                          |        |        |        |        | NP | NP |            |    | Est. A-4b              |
| 485.4        | 145-150      |       | 14/14/14        |                 |                  | COARSE AND FINE SAND: Medium-dense gray coarse sand, little fine gravel, trace fine sand, trace silt, trace clay, boulder encountered at 137.5' | 36         | 12                       | 64     | 5      | 9      | 10     |    |    | 16         |    | Est. A-3a              |
| 478.9        | 150-155      |       | 30/18/22        | 2.75-4.5+       |                  | SILTY CLAY: Very-stiff to hard gray silty clay, trace fine to coarse sand, trace fine gravel, contains few silt pockets.                        | 37A<br>37B |                          |        |        |        |        |    |    |            |    | Est. A-3a<br>Est. A-6b |
| 470.9        | 155-160      |       | 18/34/40        | 4.5+            |                  |   | 38         | 2                        | 3      | 5      | 32     | 58     | 34 | 16 | 17         |    | A-6b(10)               |
|              | 160-165      |       | 9/11/14         | 2.5-3.25        |                  |   | 39         |                          |        |        |        |        |    |    |            |    | Est. A-6a              |

PLATE 8

WATER LEVEL:  "Dry"      
WATER NOTE: Inside HSA - Prior to Washbore  
DATE: 4/10/06

-CONTINUED-

TYPE: 3-1/4" I.D. Hollow-stem Auger    3-1/8" Tricone Roller Bit  
2" O.D. Split-barrel Sampler    3" O.D. Shelby Tube Sampler  
NX Rock Core Barrel

LOCATION: Proposed I-90 Central Viaduct  
Sta. 132+38.69  
132.15' Rt. of Centerline

COMPLETION DEPTH: 178.5'  
ELEVATION: 617.9  
DATE: 4/10/06 - 4/13/06

| Elev. (feet) | Depth (feet) | Samp.     | Std. Pen. / RQD | Hand Pen. (tsf) | Rec./Loss (feet) | CLASSIFICATION: DESCRIPTION   | Samp. No.  | Physical Characteristics |        |        |        |        |    |    | ODOT Class |    |          |                     |
|--------------|--------------|-----------|-----------------|-----------------|------------------|---|------------|--------------------------|--------|--------|--------|--------|----|----|------------|----|----------|---------------------|
|              |              |           |                 |                 |                  |   |            | % AGG.                   | % C.S. | % F.S. | % SILT | % CLAY | LL | PI |            | WC |          |                     |
|              | -150         |           |                 |                 |                  | SILT AND CLAY: Stiff to very-stiff gray clay, "and" silt, trace fine to coarse sand, trace fine gravel, contains few silt pockets, seams and lenses.  |            |                          |        |        |        |        |    |    |            |    |          |                     |
|              | -155         | 8/12/13   |                 | 2.0-3.5         |                  |   | 40         |                          |        |        |        |        |    |    |            |    |          | Est. A-6a           |
|              | -160         | 7/9/11    |                 | 1.25-2.5        |                  | SHALE: Very-soft gray shale, fragmented.  | 41         | 2                        | 1      | 2      | 27     | 68     | 36 | 14 | 25         |    | A-6a(10) |                     |
| 453.9        | -165         | 10/50-4"R |                 | 1.25-2.0        | 164.0            |   | 42A<br>42B |                          |        |        |        |        |    |    |            |    |          | Est. A-6a<br>Visual |
| 449.4        | -170         |           | 0%              |                 | 4.7/0.3          | SHALE: Very-soft to soft gray shale, nearly horizontally bedded, many horizontal and few vertical fractures, contains many interbedded silty clay and few arenaceous siltstone layers.  | 43         |                          |        |        |        |        | 27 | 8  |            |    | Visual   |                     |
|              | -175         |           | 0%              |                 | 4.5/0.5          |   | 44         |                          |        |        |        |        |    |    |            |    |          | Visual              |
| 439.4        | -178.5       |           |                 |                 |                  |   |            |                          |        |        |        |        |    |    |            |    |          |                     |
|              | -180         |           |                 |                 |                  | <b>NOTES:</b><br>- Encountered seepage at 20.0'<br>- Encountered a boulder at 37.5' and 137.5'<br>- Switched to washbore at 41.5'<br>- Base of inclinometer installed at an approximate depth of 176'.<br>- Two vibrating wire piezometers installed in an offset hole between 5/18/06 and 5/22/06. Transducers were installed at approximate depths of 46' and 122'. The piezometer offset hole was backfilled with grout.<br>- Constant 2' to 3' eruption of water/gas above the ground surface at the CPT location for approximately 2 hours have occasional 10' to 15' spurts. In addition, a constant spurting of water/gas occurred from a nearby 30' open boring cased with 2.25" hollow stem auger. |            |                          |        |        |        |        |    |    |            |    |          |                     |
|              | -185         |           |                 |                 |                  |   |            |                          |        |        |        |        |    |    |            |    |          |                     |
|              | -190         |           |                 |                 |                  |   |            |                          |        |        |        |        |    |    |            |    |          |                     |
|              | -195         |           |                 |                 |                  |   |            |                          |        |        |        |        |    |    |            |    |          |                     |
|              | -200         |           |                 |                 |                  |   |            |                          |        |        |        |        |    |    |            |    |          |                     |

PLATE 9

WATER LEVEL: ∇ "Dry"    ∇    ∇    ∇  
WATER NOTE: Inside HSA - Prior to Washbore  
DATE: 4/10/06



**LOG OF BORING NO. B-05-03**  
**CUY-90-15.24 West Abutment**  
**CUYAHOGA COUNTY, OHIO**

Renamed: B-003-0-06

BBC&M JOB 012-00946.300

TYPE: 3-1/4" I.D. Hollow-stem Auger 3-7/8" Tricone Roller Bit  
2" O.D. Split-barrel Sampler 3" O.D. Shelby Tube Sampler  
NX Rock Core Barrel

LOCATION: Proposed I-90 Central Viaduct  
Sta. 133+30.45  
380.00' Rt. of Centerline

COMPLETION DEPTH: 172.0'  
ELEVATION: 605.1  
DATE: 4/3/06 - 4/7/06

| Elev. (feet) | Depth (feet) | Samp. | Std. Pen. / RQD | Hand Pen. (tsf) | Rec./Loss (feet) | CLASSIFICATION: DESCRIPTION  | Samp. No. | Physical Characteristics |        |        |        |        |    |    | ODOT Class |    |  |            |
|--------------|--------------|-------|-----------------|-----------------|------------------|--|-----------|--------------------------|--------|--------|--------|--------|----|----|------------|----|--|------------|
|              |              |       |                 |                 |                  |  |           | % AGG.                   | % C.S. | % F.S. | % SILT | % CLAY | LL | PI |            | WC |  |            |
| 604.9        | 0            |       |                 |                 |                  | 0.3 TOPSOIL - 4 INCHES   |           |                          |        |        |        |        |    |    |            |    |  |            |
|              | 5            |       | 7/7/6           |                 |                  | GRAVEL WITH SAND (FILL): Loose to medium-dense dark brown and black fine to coarse sand, some to "and" fine to coarse gravel, little silt, trace to little clay, contains few coal and concrete fragments. | 1         |                          |        |        |        |        |    |    |            |    |  | Est. A-1-b |
|              | 5            |       | 2/2/3           |                 |                  |  | 2         |                          |        |        |        |        |    |    |            |    |  |            |
| 597.1        | 10           |       | 1/1/1           |                 |                  | 8.0 COARSE AND FINE SAND: Very-loose to loose brown fine sand, little coarse sand, some silt, little clay.   | 3         |                          |        |        |        |        |    |    |            |    |  | Est. A-3   |
| 591.2        | 15           |       | 2/2/4           |                 |                  | 13.9 SILT: Loose gray silt, "and" fine sand, little clay, contains few silty clay lenses.  | 4A        |                          |        |        |        |        |    |    |            |    |  | Est. A-3   |
| 587.6        | 20           |       | 2/2/4           | 1.0-1.75        |                  | 17.5 SILT AND CLAY: Medium-stiff to stiff gray silt, "and" clay, trace fine to coarse sand, trace fine gravel, contains few interbedded silt seams.  | 4B        |                          |        |        |        |        |    |    |            |    |  | Est. A-4b  |
| 582.6        | 25           |       | 2/2/4           | 1.0-1.75        |                  | 22.5 SILT: Very-soft to soft gray silt, "and" clay, trace fine sand, contains few silt pockets and seams, and few medium-stiff to stiff zones.   | 5         | 0                        | 0      | 1      | 53     | 46     | 30 | 11 | 23         |    |  | A-6a(8)    |
| 574.1        | 30           |       | 1-18" 2         | 0.0-1.75        |                  | 31.0 SILT: Very-soft to soft gray silt, "and" clay, trace fine sand, contains few silt pockets and seams, and few medium-stiff to stiff zones.   | 6         | 1                        | 1      | 1      | 56     | 41     | 27 | 7  | 22         |    |  | A-4b(8)    |
|              | 35           |       | SD              | 0.0-0.5         |                  | 36.0 SILTY CLAY: Very-soft to soft gray silty clay, trace fine to coarse sand, contains few silt seams.  | 7         |                          |        |        |        |        | 24 | 7  |            |    |  | Est. A-4b  |
| 569.1        | 40           |       | P               | 0.0-0.5         |                  | 38.0 SILTY CLAY: Very-soft to soft gray silty clay, trace fine to coarse sand, contains few silt seams.  | 8         |                          |        |        |        |        |    | 35 | 16         |    |  | Est. A-6b  |
| 567.1        | 45           |       | P               | 0.0-0.5         |                  | 36.0 SILTY CLAY: Very-soft to soft gray silty clay, trace fine to coarse sand, contains few silt seams.  | 9         |                          |        |        |        |        |    |    |            |    |  | Est. A-6b  |
|              | 50           |       | 4/4/5           | 0.75-1.75       |                  | 38.0 SILT AND CLAY: Medium-stiff to stiff gray clay, some silt, trace fine sand, contains few silt seams.  | 10        | 0                        | 0      | 2      | 24     | 74     | 39 | 15 | 28         |    |  | A-6a(10)   |
| 562.6        | 50           |       | 3/3/3           | 0.5-0.75        |                  | 42.5 SILTY CLAY: Soft to medium-stiff gray silty clay, trace fine to coarse sand, contains few silt seams.   | 11        | 0                        | 1      | 1      | 25     | 73     | 40 | 16 | 29         |    |  | A-6b(10)   |
|              | 50           |       | 4/6/9           | 2.25-3.75       |                  | SILT AND CLAY: Stiff to very-stiff gray clay, "and" silt, trace fine sand, contains few silt seams and lenses.   | 12        |                          |        |        |        |        |    |    |            |    |  | Est. A-6a  |
|              | 50           |       | 4/4/6           | 1.25-2.25       |                  |  | 13        |                          |        |        |        |        |    |    |            |    |  | Est. A-6a  |

WATER LEVEL: 13.0  
WATER NOTE: Encountered  
DATE: 4/4/06

-CONTINUED-

PLATE 10



**LOG OF BORING NO. B-05-03**  
**CUY-90-15.24 West Abutment**  
**CUYAHOGA COUNTY, OHIO**

Renamed: B-003-0-06

BBC&M JOB 012-00946.300

TYPE: 3-1/4" I.D. Hollow-stem Auger 3-7/8" Tricone Roller Bit  
2" O.D. Split-barrel Sampler 3" O.D. Shelby Tube Sampler  
NX Rock Core Barrel

LOCATION: Proposed I-90 Central Viaduct  
Sta. 133+30.45  
380.00' Rt. of Centerline

COMPLETION DEPTH: 172.0'  
ELEVATION: 605.1  
DATE: 4/3/06 - 4/7/06

| Elev. (feet) | Depth (feet) | Samp. | Std. Pen. / RQD | Hand Pen. (tsf) | Rec./Loss (feet) | CLASSIFICATION: DESCRIPTION   | Samp. No. | Physical Characteristics |        |        |        |        |    |    | ODOT Class |           |
|--------------|--------------|-------|-----------------|-----------------|------------------|---|-----------|--------------------------|--------|--------|--------|--------|----|----|------------|-----------|
|              |              |       |                 |                 |                  |   |           | % AGG.                   | % C.S. | % F.S. | % SILT | % CLAY | LL | PI |            | WC        |
| 549.1        | 50-55        |       | 4/6/6           | 1.5-2.25        |                  | SILT AND CLAY: Stiff to very-stiff gray clay, "and" silt, trace fine sand, contains few silt seams and lenses.  | 14        | 0                        | 0      | 1      | 48     | 51     | 32 | 12 | 23         | A-6a(9)   |
|              | 56.0         |       |                 |                 |                  |   |           |                          |        |        |        |        |    |    |            |           |
|              | 60           |       | 5/8/10          | 2.0-4.5+        |                  | SANDY SILT: Stiff to hard gray clay, "and" silt, trace fine sand, contains few silt seams and pockets.  | 15        |                          |        |        |        |        |    |    |            | Est. A-4a |
|              | 65           |       | 5/9/11          | 2.0-3.5         |                  |   | 16        |                          |        |        |        |        |    |    |            | Est. A-4a |
|              | 70           |       | 4/4/6           | 1.5-2.75        |                  |   | 17        | 0                        | 0      | 1      | 42     | 57     | 30 | 9  | 25         | A-4a(8)   |
| 532.6        | 75           |       | 5/9/14          | 2.5-4.5+        |                  | SANDY SILT: Very-stiff to hard gray mottled with red silt, "and" clay, little fine to coarse sand, trace fine gravel, contains few silt seams and lenses. | 18        | 3                        | 7      | 12     | 41     | 37     | 23 | 7  | 15         | A-4a(8)   |
| 527.6        | 80           |       | 5/7/9           | 2.0-2.5         |                  | SILT AND CLAY: Stiff to very-stiff gray clay, little silt, trace fine to coarse sand, contains few silt seams.  | 19        |                          |        |        |        |        |    |    |            | Est. A-6a |
|              | 85           |       | 4/6/10          | 1.25-2.25       |                  |   | 20        |                          |        |        |        |        |    |    |            | Est. A-6a |
|              | 90           |       | 4/6/9           | 1.25-2.75       |                  |   | 21        | 0                        | 1      | 1      | 20     | 78     | 39 | 15 | 27         | A-6a(10)  |
|              | 95           |       | 7/9/11          | 2.0-3.25        |                  |   | 22        |                          |        |        |        |        |    |    |            | Est. A-6a |
|              | 100          |       | 6/7/9           | 1.75-3.0        |                  |   | 23        |                          |        |        |        |        |    |    |            | Est. A-6a |

PLATE 11

WATER LEVEL: 13.0  
WATER NOTE: Encountered  
DATE: 4/4/06

-CONTINUED-





**LOG OF BORING NO. B-05-03**  
**CUY-90-15.24 West Abutment**  
**CUYAHOGA COUNTY, OHIO**

Renamed: B-003-0-06

BBC&M JOB: 012-00946-300

TYPE: 3-1/4" I.D. Hollow-stem Auger    3-7/8" Tricone Roller Bit    LOCATION: Proposed I-90 Central Viaduct    COMPLETION DEPTH: 172.0'  
2" O.D. Split-barrel Sampler    3" O.D. Shelby Tube Sampler    Sta. 133+30.45    ELEVATION: 605.1  
NX Rock Core Barrel    380.00' Rt. of Centerline    DATE: 4/3/06 - 4/7/06

| Elev. (feet) | Depth (feet) | Samp. | Std. Pen. / RQD | Hand Pen. (tsf) | Rec./Loss (feet) | CLASSIFICATION: DESCRIPTION   | Samp. No. | Physical Characteristics |        |        |        |        |    |    | ODOT Class |    |         |            |
|--------------|--------------|-------|-----------------|-----------------|------------------|---|-----------|--------------------------|--------|--------|--------|--------|----|----|------------|----|---------|------------|
|              |              |       |                 |                 |                  |   |           | % AGG.                   | % C.S. | % F.S. | % SILT | % CLAY | LL | PI |            | WC |         |            |
| 502.6        |              |       |                 |                 |                  | 102.5   |           |                          |        |        |        |        |    |    |            |    |         |            |
|              | -105         |       | 8/11/13         | 2.0-2.25        |                  | SILT AND CLAY: Stiff to very-stiff gray clay, some silt, trace fine to coarse sand, trace fine gravel.                | 24        |                          |        |        |        |        |    |    |            |    |         | Est. A-6a  |
|              | -110         |       | 6/9/11          | 2.0-3.75        |                  |   | 25        | 2                        | 1      | 2      | 34     | 61     | 36 | 13 | 24         |    | A-6a(9) |            |
|              | -115         |       | 5/6/8           | 1.5-2.5         |                  |   | 26        |                          |        |        |        |        |    |    |            |    |         | Est. A-6a  |
| 490.1        |              |       | 5/5/7           | 1.25-2.25       |                  |   | 27        |                          |        |        |        |        |    |    |            |    |         | Est. A-6a  |
|              | -120         |       | 5/5/6           | 0.75-1.5        |                  | SILT AND CLAY: Medium-stiff to stiff gray clay, little silt, trace fine to coarse sand, contains few very-soft zones. | 28        | 0                        | 1      | 2      | 17     | 80     | 39 | 15 | 29         |    |         | A-6a(10)   |
|              | -125         |       | P               | 1.5-2.0         |                  |   | 29        |                          |        |        |        |        |    |    |            |    |         | Est. A-6a  |
|              | -130         |       | P               | 1.25-1.5        |                  |   | 30        |                          |        |        |        |        |    |    |            |    |         | Est. A-6a  |
| 481.3        |              |       |                 | 0.0-1.25        |                  |   | 31A       |                          |        |        |        |        |    |    |            |    |         | Est. A-6a  |
| 480.6        | -125         |       | 5/9/14          |                 |                  | SILT: Medium-dense gray silt, trace fine sand, contains many silty clay seams.  | 31B       |                          |        |        |        |        | NP | NP |            |    |         | Est. A-4b  |
|              | -135         |       |                 |                 |                  | COARSE AND FINE SAND: Medium-dense gray fine to coarse sand, little silt, little clay, trace fine gravel.             | 31C       |                          |        |        |        |        |    |    |            |    |         | Est. A-3a  |
|              | -140         |       | 9/11/12         |                 |                  |   | 32        | 6                        | 35     | 34     | 11     | 14     |    |    | 16         |    |         | Est. A-3a  |
| 472.6        |              |       |                 |                 |                  |   | 33        | 0                        | 0      | 0      | 35     | 65     | 31 | 9  | 23         |    |         | A-4a(8)    |
|              | -135         |       | 8/11/14         | 2.5-4.0         |                  | SANDY SILT: Very-stiff to hard gray clay, some silt, contains few interbedded silt seams.                             |           |                          |        |        |        |        |    |    |            |    |         |            |
| 467.6        |              |       |                 |                 |                  |   | 34        |                          |        |        |        |        |    |    |            |    |         | Est. A-3a  |
|              | -140         |       | 14/16/15        |                 |                  | COARSE AND FINE SAND: Medium-dense to dense gray fine to coarse sand, little silt, little clay, trace fine gravel.    |           |                          |        |        |        |        |    |    |            |    |         |            |
|              | -145         |       | 11/15/15        |                 |                  |   | 35        | 4                        | 36     | 37     | 12     | 11     |    |    | 19         |    |         | Est. A-3a  |
| 457.6        |              |       |                 |                 |                  |   | 36        | 26                       | 41     | 14     | 10     | 9      |    |    | 14         |    |         | Est. A-1-b |
|              | -150         |       | 14/16/17        |                 |                  | GRAVEL WITH SAND: Dense gray fine to coarse sand, some fine gravel, trace silt, trace clay.                           |           |                          |        |        |        |        |    |    |            |    |         |            |

PLATE 12

WATER LEVEL: 13.0  
 WATER NOTE: Encountered  
 DATE: 4/4/06

-CONTINUED-



**LOG OF BORING NO. B-05-03**  
**CUY-90-15.24 West Abutment**  
**CUYAHOGA COUNTY, OHIO**

Renamed: B-003-0-06

BBC&M JOB: 012-00946.300

TYPE: 3-1/4" I.D. Hollow-stem Auger    3-7/8" Tricone Roller Bit  
2" O.D. Split-barrel Sampler    3" O.D. Shelby Tube Sampler  
NX Rock Core Barrel

LOCATION: Proposed I-90 Central Viaduct  
Sta. 133+30.45  
380.00' Rt. of Centerline

COMPLETION DEPTH: 172.0'  
ELEVATION: 605.1  
DATE: 4/3/06 - 4/7/06

| Elev. (feet) | Depth (feet) | Samp. | Std. Pen. / RQD | Hand Pen. (tsf) | Rec./Loss (feet) | CLASSIFICATION: DESCRIPTION  | Samp. No.  | Physical Characteristics |        |        |        |        |    |    | ODOT Class |    |                     |  |
|--------------|--------------|-------|-----------------|-----------------|------------------|--|------------|--------------------------|--------|--------|--------|--------|----|----|------------|----|---------------------|--|
|              |              |       |                 |                 |                  |  |            | % AGG.                   | % C.S. | % F.S. | % SILT | % CLAY | LL | PI |            | WC |                     |  |
| 448.1        | -155         |       | 12/14/19        |                 |                  | GRAVEL WITH SAND: Dense gray fine to coarse sand, some fine gravel, trace silt, trace clay.  | 37         |                          |        |        |        |        |    |    |            |    | Est. A-1-b          |  |
| 446.2        | -160         |       | 28/50-3"R       | 4.5+            |                  | SILT AND CLAY: Hard gray silt, "and" clay, some fine to coarse sand, some fine gravel, contains many siltstone and shale fragments.  | 38A<br>38B |                          |        |        |        |        |    |    |            |    | Est. A-6a<br>Visual |  |
| 443.1        | -165         |       |                 |                 | 4.8/0.2          | SHALE: Very-soft gray shale, similar to hard silty clay.   | 39         |                          |        |        |        |        |    |    |            |    | Visual              |  |
| 433.1        | -170         |       | 35%             |                 | 4.4/0.6          | SHALE: Very-soft to soft gray and dark gray shale, nearly horizontally bedded, many horizontal and few vertical fractures, contains many interbedded silty clay seams from 162.7' to 163.0' and from 168.1' to 168.3'.<br><br>- Qu=1311 psi at 165.5'.   | 40         |                          |        |        |        |        |    |    |            |    | Visual              |  |
|              | -175         |       |                 |                 |                  | <b>NOTES:</b><br>- Encountered seepage at 8.0'.<br>- Encountered water at 13.0'.<br>- Switched to washbore at 37.0'.<br>- Base of inclinometer installed to an approximate depth of 170'.<br>- Two vibrating wire piezometers installed in an offset hole between 5/12/06 and 5/16/06. Transducers were installed at approximate depths of 32' and 112'. The piezometer offset hole was backfilled with grout. |            |                          |        |        |        |        |    |    |            |    |                     |  |
|              | -180         |       |                 |                 |                  |  |            |                          |        |        |        |        |    |    |            |    |                     |  |
|              | -185         |       |                 |                 |                  |  |            |                          |        |        |        |        |    |    |            |    |                     |  |
|              | -190         |       |                 |                 |                  |  |            |                          |        |        |        |        |    |    |            |    |                     |  |
|              | -195         |       |                 |                 |                  |  |            |                          |        |        |        |        |    |    |            |    |                     |  |

WATER LEVEL: 13.0    13.0    13.0    13.0  
WATER NOTE: Encountered  
DATE: 4/4/06

PLATE 13



**LOG OF BORING NO. B-05-04**  
**CUY-90-15.24 West Abutment**  
**CUYAHOGA COUNTY, OHIO**

Renamed: B-004-0-06

BBC&M JOB: 012-00946.300

TYPE: 3-1/4" I.D. Hollow-stem Auger 3-7/8" Tricone Roller Bit  
2" O.D. Split-barrel Sampler 3" O.D. Shelby Tube Sampler  
NX Rock Core Barrel

LOCATION: Proposed I-90 Central Viaduct  
Sta. 133+51.67  
242.09' Rt. of Centerline

COMPLETION DEPTH: 174.0'  
ELEVATION: 600.8  
DATE: 3/24/06 - 3/30/06

| Elev. (feet) | Depth (feet) | Samp. | Std. Pen. / RQD | Hand Pen. (tsf) | Rec./Loss (feet) | CLASSIFICATION: DESCRIPTION  | Samp. No. | Physical Characteristics |        |        |        |        |    |    | ODOT Class |           |           |
|--------------|--------------|-------|-----------------|-----------------|------------------|--|-----------|--------------------------|--------|--------|--------|--------|----|----|------------|-----------|-----------|
|              |              |       |                 |                 |                  |  |           | % AGG.                   | % C.S. | % F.S. | % SILT | % CLAY | LL | PI |            | WC        |           |
|              | 0            |       | 4/5/4           |                 |                  | COARSE AND FINE SAND (FILL): Loose to medium-dense brown fine to coarse sand, little fine gravel, some silt, little clay, contains few slag fragments. | 1         |                          |        |        |        |        |    |    |            |           | Est. A-3a |
|              | 5            |       | 4/6/5           |                 |                  |  | 2         |                          |        |        |        |        |    |    |            |           | Est. A-3a |
|              |              |       | 6/9/8           |                 |                  |  | 3         |                          |        |        |        |        |    |    |            |           | Est. A-3a |
|              | 10           |       | 6/9/11          |                 |                  |  | 4         | 16                       | 23     | 27     | 22     | 12     | NP | NP | 12         |           | A-3a(0)   |
| 587.3        |              |       | 6/8/10          |                 |                  |  | 5         |                          |        |        |        |        |    |    |            |           | Est. A-3a |
|              | 15           |       | 3/3/4           |                 |                  | 13.5   | 6         |                          |        |        |        |        |    |    |            | Est. A-3a |           |
| 584.3        |              |       | 5/5/4           |                 |                  | 16.5   | 7A        |                          |        |        |        |        |    |    |            | Est. A-3a |           |
| 582.8        |              |       | 2/3/2           |                 |                  | 18.0   | 7B        |                          |        |        |        |        |    |    |            | Est. A-3a |           |
|              | 20           |       | 3/3/3           |                 |                  | 18.0   | 8         | 1                        | 8      | 34     | 45     | 12     |    | 23 |            | Est. A-4b |           |
| 577.8        |              |       | 2/2/3           | 1.0-2.0         |                  | 23.0   | 9         |                          |        |        |        |        |    |    |            | Est. A-4b |           |
|              | 25           |       | 3/4/5           | 1.0-1.75        |                  | 23.0   | 10        |                          |        |        |        |        |    |    |            | Est. A-6b |           |
| 572.8        |              |       | 2/3/3           | 0.25-1.0        |                  | 28.0   | 11        | 1                        | 1      | 4      | 25     | 69     | 40 | 18 | 25         | A-6b(11)  |           |
|              | 30           |       | 1/2/3           | 0.25-1.0        |                  | 28.0   | 12        |                          |        |        |        |        |    |    |            | Est. A-6a |           |
|              |              |       | 1/2/2           | 0.5-1.0         |                  | 35.5   | 13        |                          |        |        |        |        |    |    |            | Est. A-6a |           |
| 565.3        | 35           |       | 2/3/4           | 0.5-1.25        |                  | 35.5   | 14        | 0                        | 1      | 1      | 23     | 75     | 40 | 15 | 30         | A-6a(10)  |           |
|              | 40           |       | 2/3/4           | 1.5-2.5         |                  | 35.5   | 15        | 0                        | 0      | 2      | 46     | 52     | 31 | 10 | 24         | A-4a(8)   |           |
|              |              |       | 5/5/6           | 1.5-2.75        |                  | 35.5   | 16        |                          |        |        |        |        |    |    |            | Est. A-4a |           |
|              | 45           |       | 3/3/5           | 1.5-3.0         |                  | 35.5   | 17        |                          |        |        |        |        |    |    |            | Est. A-4a |           |
|              |              |       | 3/4/6           | 1.5-3.0         |                  | 35.5   | 18        |                          |        |        |        |        |    |    |            | Est. A-4a |           |
|              | 50           |       | P               |                 |                  | 35.5   | 19        | 0                        | 0      | 2      | 47     | 51     | 30 | 10 | 23         | A-4a(8)   |           |
|              |              |       |                 |                 |                  | 35.5   | 20        |                          |        |        |        |        |    |    |            | Est. A-4a |           |

PLATE 14

WATER LEVEL: ▽ 18.5      ▽ "Dry"      ▽  
WATER NOTE: Encountered      Inside HSA - Prior to Washbore  
DATE: 3/27/06      3/24/06

-CONTINUED-



**LOG OF BORING NO. B-05-04**  
**CUY-90-15.24 West Abutment**  
**CUYAHOGA COUNTY, OHIO**

Renamed: B-004-0-06

BBC&M JOB: 012-00946.300

TYPE: 3-1/4" I.D. Hollow-stem Auger    3-7/8" Tricone Roller Bit  
2" O.D. Split-barrel Sampler    3" O.D. Shelby Tube Sampler  
NX Rock Core Barrel

LOCATION: Proposed I-90 Central Viaduct  
Sta. 133+51.67  
242.09' Rt. of Centerline

COMPLETION DEPTH: 174.0'  
ELEVATION: 600.8  
DATE: 3/24/06 - 3/30/06

| Elev (feet) | Depth (feet) | Samp. | Std. Pen. / RQD | Hand Pen. (tsf) | Rec./Loss (feet) | CLASSIFICATION: DESCRIPTION  | Samp. No. | Physical Characteristics |        |        |        |        |    |    | ODOT Class |    |           |
|-------------|--------------|-------|-----------------|-----------------|------------------|--|-----------|--------------------------|--------|--------|--------|--------|----|----|------------|----|-----------|
|             |              |       |                 |                 |                  |  |           | % AGG.                   | % C.S. | % F.S. | % SILT | % CLAY | LL | PI |            | WC |           |
| 547.8       | 50           |       | P               | 2.0             |                  |  | 21        |                          |        |        |        |        |    |    |            |    | Est. A-4a |
|             | 55           |       | 3/4/5           | 1.75-3.5        |                  | SILT: Stiff to very-stiff gray silt, "and" clay, trace fine sand.  | 22        |                          |        |        |        |        |    |    |            |    | Est. A-4b |
|             | 60           |       | 4/4/4           | 1.25-3.0        |                  |  | 23        | 0                        | 0      | 2      | 61     | 37     | 28 | 8  | 25         |    | A-4b(8)   |
|             | 65           |       | 4/5/6           | 1.25-2.5        |                  |  | 24        |                          |        |        |        |        |    |    |            |    | Est. A-4b |
| 533.8       | 67.0         |       |                 |                 |                  |  |           |                          |        |        |        |        |    |    |            |    |           |
|             | 70           |       | P               | 1.75-2.0        |                  | SILT AND CLAY: Stiff to very-stiff gray clay, some silt, trace fine to coarse sand, trace fine gravel.                   | 25        | 2                        | 4      | 6      | 33     | 55     | 31 | 12 | 20         |    | A-6a(9)   |
|             |              |       | P               | 1.5-1.75        |                  |  | 26        |                          |        |        |        |        |    |    |            |    | Est. A-6a |
|             |              |       | P               | 1.75-2.0        |                  |  | 27        |                          |        |        |        |        |    |    |            |    | Est. A-6a |
| 523.8       | 75           |       | P               | 1.5-2.0         |                  |  | 28        |                          |        |        |        |        |    |    |            |    | Est. A-6a |
|             | 80           |       | 4/6/8           | 1.25-2.0        |                  | SILTY CLAY: Stiff to very-stiff gray silty clay, trace fine to coarse sand, trace fine gravel, contains few silt lenses. | 29        |                          |        |        |        |        |    |    |            |    | Est. A-6b |
|             | 85           |       | 4/6/7           | 1.5-1.75        |                  |  | 30        | 2                        | 1      | 3      | 31     | 63     | 35 | 16 | 22         |    | A-6b(10)  |
|             | 90           |       | 5/6/8           | 1.25-2.25       |                  |  | 31        |                          |        |        |        |        |    |    |            |    | Est. A-6b |
|             | 95           |       | 6/9/12          | 1.5-3.5         |                  |  | 32        |                          |        |        |        |        |    |    |            |    | Est. A-6b |
| 503.3       | 97.5         |       |                 |                 |                  |  |           |                          |        |        |        |        |    |    |            |    |           |
|             | 100          |       | 5/8/10          | 1.5-2.5         |                  |  | 33        |                          |        |        |        |        |    |    |            |    | Est. A-6a |

PLATE 15

WATER LEVEL: ▽ 18.5    ▽ "Dry"    ▽  
WATER NOTE: Encountered    Inside HSA - Prior to Washbore  
DATE: 3/27/06    3/24/06

-CONTINUED-



**LOG OF BORING NO. B-05-04**  
**CUY-90-15.24 West Abutment**  
**CUYAHOGA COUNTY, OHIO**

Renamed: B-004-0-06

BBC&M JOB 012-00946 300

TYPE: 3-1/4" I.D. Hollow-stem Auger    3-7/8" Tricone Roller Bit    LOCATION: Proposed I-90 Central Viaduct    COMPLETION DEPTH: 174.0'  
2" O.D. Split-barrel Sampler    3" O.D. Shelby Tube Sampler    Sta. 133+51.67    ELEVATION: 600.8  
NX Rock Core Barrel    242.09' Rt. of Centerline    DATE: 3/24/06 - 3/30/06

| Elev. (feet) | Depth (feet) | Samp. | Std. Pen. / RQD | Hand Pen. (tsf) | Rec./Loss (feet) | CLASSIFICATION DESCRIPTION   | Samp. No. | Physical Characteristics |        |        |        |        |    |    | ODOT Class |    |            |          |
|--------------|--------------|-------|-----------------|-----------------|------------------|--|-----------|--------------------------|--------|--------|--------|--------|----|----|------------|----|------------|----------|
|              |              |       |                 |                 |                  |  |           | % AGG.                   | % C.S. | % F.S. | % SILT | % CLAY | LL | PI |            | WC |            |          |
|              | -100         |       |                 |                 |                  | SILT AND CLAY: Very-stiff becoming medium-stiff gray clay, little silt, trace fine to coarse sand, contains few silt pockets.                                    |           |                          |        |        |        |        |    |    |            |    | Est. A-6a  |          |
|              | -105         |       | 5/7/9           | 1.25-2.25       |                  |  |           | 34                       |        |        |        |        |    |    |            |    |            |          |
|              | -110         |       | 3/4/5           | 0.5-1.25        |                  |  |           | 35                       | 0      | 1      | 1      | 19     | 79 | 38 | 15         | 31 |            | A-6a(10) |
|              | -115         |       | 4/5/6           | 0.5-1.25        |                  |  | 36        |                          |        |        |        |        |    |    |            |    | Est. A-6a  |          |
| 483.8        |              |       |                 |                 |                  | 117.0  |           |                          |        |        |        |        |    |    |            |    |            |          |
| 481.8        |              |       | P               |                 |                  | 119.0  |           |                          |        |        |        |        | 22 | 3  | 25         |    | Est. A-4b  |          |
|              | -120         |       | 11/11/13        |                 |                  | GRAVEL WITH SAND: Medium-dense to dense gray fine to coarse sand, "and" fine to coarse gravel, trace silt, trace clay, contains silt seam from 120.3' to 120.5'. | 38        |                          |        |        |        |        |    |    |            |    | Est. A-1-b |          |
|              | -125         |       | 16/16/21        |                 |                  |  | 39        |                          |        |        |        |        |    |    |            |    | Est. A-1-b |          |
| 473.3        |              |       |                 |                 |                  |  | 40        | 42                       | 31     | 11     | 7      | 9      | 20 | 4  | 11         |    | A-1-b(0)   |          |
|              | -130         |       | 10/20/30        | 3.75-4.5+       |                  | 127.5  |           |                          |        |        |        |        |    |    |            |    |            |          |
| 468.3        |              |       |                 |                 |                  | 132.5  |           |                          |        |        |        |        |    |    |            |    |            |          |
|              | -135         |       | 14/13/18        |                 |                  | GRAVEL WITH SAND: Dense gray fine to coarse sand, little fine to coarse gravel, trace silt, trace clay.  | 41        | 3                        | 3      | 5      | 24     | 65     | 33 | 12 | 19         |    | A-6a(9)    |          |
|              | -140         |       | 14/17/20        |                 |                  |  | 42        |                          |        |        |        |        |    |    |            |    | Est. A-1-b |          |
|              | -145         |       | 12/14/18        |                 |                  |  | 43        |                          |        |        |        |        |    |    |            |    | Est. A-1-b |          |
|              | -150         |       | 22/18/18        |                 |                  |  | 44        | 15                       | 45     | 22     | 8      | 10     | NP | NP | 16         |    | A-1-b(0)   |          |
|              |              |       |                 |                 |                  |  | 45        |                          |        |        |        |        |    |    |            |    | Est. A-1-b |          |

PLATE 16

WATER LEVEL: 18.5    "Dry"    18.5  
WATER NOTE: Encountered    Inside HSA - Prior to Washbore  
DATE: 3/27/06    3/24/06

-CONTINUED-



**LOG OF BORING NO. B-05-04**  
**CUY-90-15.24 West Abutment**  
**CUYAHOGA COUNTY, OHIO**

Renamed: B-004-0-06

BBC&M JOB: 012-00946.300

TYPE: 3-1/4" I.D. Hollow-stem Auger    3-7/8" Tricone Roller Bit  
2" O.D. Split-barrel Sampler    3" O.D. Shelby Tube Sampler  
NX Rock Core Barrel

LOCATION: Proposed I-90 Central Viaduct  
Sta. 133+51.67  
242.09' Rt. of Centerline

COMPLETION DEPTH: 174.0'  
ELEVATION: 600.8  
DATE: 3/24/06 - 3/30/06

| Elev. (feet) | Depth (feet) | Samp. | Std. Pen. / RQD | Hand Pen. (tst) | Rec./Loss (feet) | CLASSIFICATION: DESCRIPTION | Samp. No. | Physical Characteristics |        |        |        |        |    |    | ODOT Class |    |  |            |
|--------------|--------------|-------|-----------------|-----------------|------------------|-----------------------------|-----------|--------------------------|--------|--------|--------|--------|----|----|------------|----|--|------------|
|              |              |       |                 |                 |                  |                             |           | % AGG.                   | % C.S. | % F.S. | % SILT | % CLAY | LL | PI |            | WC |  |            |
| 448.8        |              |       |                 |                 |                  | 152.0                       |           |                          |        |        |        |        |    |    |            |    |  |            |
| 446.9        |              |       | 24/34/50        |                 |                  | 153.9                       | 46A       |                          |        |        |        |        |    |    |            |    |  | Est. A-4b  |
|              | -155         |       |                 |                 |                  |                             | 46B       |                          |        |        |        |        |    |    |            |    |  | Est. A-1-b |
| 443.3        |              |       |                 |                 |                  | 157.5                       |           |                          |        |        |        |        |    |    |            |    |  |            |
|              |              |       | 50-4"R          |                 |                  |                             | 47        |                          |        |        |        |        |    |    |            |    |  | Visual     |
|              | -160         |       |                 |                 |                  |                             |           |                          |        |        |        |        |    |    |            |    |  |            |
| 436.8        |              |       | 50-4"R          |                 |                  | 164.0                       | 48        |                          |        |        |        |        |    |    |            |    |  | Visual     |
| 435.7        | -165         |       | 100%            |                 | 1.1/0.0          | 165.1                       | 49        |                          |        |        |        |        |    |    |            |    |  | Visual     |
|              |              |       | 64%             |                 | 3.8/0.1          |                             | 50        |                          |        |        |        |        |    |    |            |    |  |            |
|              |              |       | 50%             |                 | 5.0/0.0          |                             |           |                          |        |        |        |        |    |    |            |    |  | Visual     |
| 426.8        |              |       |                 |                 |                  | 174.0                       |           |                          |        |        |        |        |    |    |            |    |  |            |
|              | -175         |       |                 |                 |                  |                             |           |                          |        |        |        |        |    |    |            |    |  |            |
|              |              |       |                 |                 |                  |                             |           |                          |        |        |        |        |    |    |            |    |  |            |
|              | -180         |       |                 |                 |                  |                             |           |                          |        |        |        |        |    |    |            |    |  |            |
|              |              |       |                 |                 |                  |                             |           |                          |        |        |        |        |    |    |            |    |  |            |
|              | -185         |       |                 |                 |                  |                             |           |                          |        |        |        |        |    |    |            |    |  |            |
|              |              |       |                 |                 |                  |                             |           |                          |        |        |        |        |    |    |            |    |  |            |
|              | -190         |       |                 |                 |                  |                             |           |                          |        |        |        |        |    |    |            |    |  |            |
|              |              |       |                 |                 |                  |                             |           |                          |        |        |        |        |    |    |            |    |  |            |
|              | -195         |       |                 |                 |                  |                             |           |                          |        |        |        |        |    |    |            |    |  |            |
|              |              |       |                 |                 |                  |                             |           |                          |        |        |        |        |    |    |            |    |  |            |
|              | -200         |       |                 |                 |                  |                             |           |                          |        |        |        |        |    |    |            |    |  |            |

NOTES:  
- Encountered seepage at 12.0' and 16.5'.  
- Encountered water at 18.5'.  
- Switched to washbore at 41.0'.  
- Base of inclinometer installed at an approximate depth of 172'.  
- Two vibrating wire piezometers installed in an offset hole between 5/16/06 and 5/17/06. Transducers were installed at approximate depths of 59' and 119'. The piezometer offset hole was backfilled with grout.

WATER LEVEL: 18.5    "Dry"    174.0  
WATER NOTE: Encountered    Inside HSA - Prior to Washbore  
DATE: 3/27/06    3/24/06

PLATE 17



**LOG OF BORING NO. B-05-07**  
**CUY-90-15.24 West Abutment**  
**CUYAHOGA COUNTY, OHIO**

Renamed: B-007-0-06

BBC&M JOB: 012-09946 300

TYPE: 3-1/4" I.D. Hollow-stem Auger    3-7/8" Tricone Roller Bit  
2/2.5" O.D. Split-barrel Sampler    3" O.D. Shelby Tube Sampler  
NQ Rock Core Barrel

LOCATION: Proposed I-90 Central Viaduct  
Sta. 127+43.46  
206.83' Lt. of Centerline

COMPLETION DEPTH: 229.0'  
ELEVATION: 678.9  
DATE: 4/18/06 - 4/24/06

| Elev. (feet) | Depth (feet) | Samp. | Std. Pen. / RQD | Hand Pen. (tsf) | Rec./Loss (feet) | CLASSIFICATION: DESCRIPTION   | Samp No. | Physical Characteristics |        |        |        |        |    |    | ODOT Class |            |
|--------------|--------------|-------|-----------------|-----------------|------------------|---|----------|--------------------------|--------|--------|--------|--------|----|----|------------|------------|
|              |              |       |                 |                 |                  |   |          | AGG. %                   | C.S. % | F.S. % | SILT % | CLAY % | LL | PI |            | WC         |
| 678.4        | 0            |       | 4/4/4           |                 |                  | 0.5 GRANULAR BASE - 6 INCHES  | 1        |                          |        |        |        |        |    |    |            | Est. A-3a  |
| 675.4        | 3            |       | 3/3/2           |                 |                  | 3.5 COARSE AND FINE SAND (FILL): Loose brown fine to coarse sand, little silt, little clay, contains few clayey silt seams.   | 2        |                          |        |        |        |        |    |    |            | Est. A-1-b |
|              | 5            |       | 5/3/3           |                 |                  | GRAVEL WITH SAND (FILL): Very-loose becoming medium-dense brown fine to coarse sand, some fine to coarse gravel, trace silt, trace clay, contains few slag and brick fragments. | 3        |                          |        |        |        |        |    |    |            | Est. A-1-b |
|              | 10           |       | 2/2/2           |                 |                  |   | 4        | 34                       | 36     | 21     | 9      |        |    | 7  |            | Est. A-1-b |
|              | 15           |       | 6/8/9           |                 |                  |   | 5        |                          |        |        |        |        |    |    |            | Est. A-1-b |
| 656.9        | 20           |       | 5/7/8           |                 |                  | 22.0 FINE SAND: Medium-dense brown fine sand, little coarse sand, trace fine gravel, trace silt, trace clay.  | 6        | 1                        | 16     | 77     | 6      |        |    | 4  |            | Est. A-3   |
|              | 25           |       | 7/10/12         |                 |                  |   | 7        | 0                        | 17     | 75     | 3      | 5      | NP | NP | 4          | A-3(0)     |
|              | 30           |       | 8/9/11          |                 |                  |   | 8        |                          |        |        |        |        |    |    |            | Est. A-3   |
| 641.9        | 35           |       | 4/4/5           |                 |                  | 37.0 COARSE AND FINE SAND: Loose becoming very-dense brown and gray fine sand, trace silt, trace clay.  | 9        | 0                        | 0      | 83     | 10     | 7      | NP | NP | 25         | A-3a(0)    |
|              | 40           |       | 8/10/8          |                 |                  |   | 10       |                          |        |        |        |        |    |    | 21         | Est. A-3a  |
|              | 45           |       | 16/31/25        |                 |                  |   | 11       |                          |        |        |        |        |    |    |            | Est. A-3a  |
|              | 50           |       |                 |                 |                  |   |          |                          |        |        |        |        |    |    |            |            |

WATER LEVEL: ∇ 38.5    ∇    ∇    ∇

WATER NOTE: Encountered

DATE: 4/18/06

-CONTINUED-

PLATE 18



**LOG OF BORING NO. B-05-07**  
**CUY-90-15.24 West Abutment**  
**CUYAHOGA COUNTY, OHIO**

Renamed: B-007-0-06

BBC&M JOB 012-00946 300

TYPE: 3-1/4" I.D. Hollow-stem Auger 3-7/8" Tricone Roller Bit  
2/2.5" O.D. Split-barrel Sampler 3" O.D. Shelby Tube Sampler  
NQ Rock Core Barrel

LOCATION: Proposed I-90 Central Viaduct  
Sta. 127+43.46  
206.83' Lt. of Centerline

COMPLETION DEPTH: 229.0'  
ELEVATION: 678.9  
DATE: 4/18/06 - 4/24/06

| Elev. (feet) | Depth (feet) | Samp. | Std. Pen. / RQD | Hand Pen. (tsf) | Rec./Loss (feet) | CLASSIFICATION: DESCRIPTION   | Samp. No. | Physical Characteristics |        |        |        |        |    |    | ODOT Class |    |         |           |
|--------------|--------------|-------|-----------------|-----------------|------------------|---|-----------|--------------------------|--------|--------|--------|--------|----|----|------------|----|---------|-----------|
|              |              |       |                 |                 |                  |   |           | % AGG.                   | % C.S. | % F.S. | % SILT | % CLAY | LL | PI |            | WC |         |           |
| 626.9        | 50           |       |                 |                 |                  | 52.0  |           |                          |        |        |        |        |    |    |            |    |         |           |
|              |              |       | 8/14/24         |                 |                  | SANDY SILT: Dense brown and gray fine sand, "and" silt, trace coarse sand, trace clay, contains few silty clay seams.                         | 12        | 0                        | 1      | 54     | 38     | 7      | NP | NP | 23         |    | A-4a(0) |           |
| 621.9        | 55           |       |                 |                 |                  | 57.0  |           |                          |        |        |        |        |    |    |            |    |         |           |
|              |              |       | 8/12/17         |                 |                  | SILT: Medium-dense gray silt, little clay, trace fine to coarse sand, trace fine gravel, contains few silty clay lenses.                      | 13        | 1                        | 1      | 1      | 83     | 14     | NP | NP | 20         |    | A-4b(0) |           |
| 616.9        | 60           |       |                 |                 |                  | 62.0  |           |                          |        |        |        |        |    |    |            |    |         |           |
|              |              |       | 5/8/8           | 1.5-2.5         |                  | SILT: Stiff to very-stiff gray mottled with red silt, "and" clay, trace fine to coarse sand, contains few silty clay seams.                   | 14        |                          |        |        |        |        |    |    |            |    |         | Est. A-4b |
|              | 65           |       |                 |                 |                  |   |           |                          |        |        |        |        |    |    |            |    |         |           |
|              |              |       | 4/8/9           | 1.5-2.5         |                  |   | 15        | 0                        | 1      | 3      | 55     | 41     | 28 | 9  | 17         |    | A-4b(8) |           |
| 606.9        | 70           |       |                 |                 |                  | 72.0  |           |                          |        |        |        |        |    |    |            |    |         |           |
|              |              |       | 6/10/14         | 2.25-3.0        |                  | SILT: Very-stiff becoming medium-stiff to stiff gray silt, "and" clay, trace fine to coarse sand, contains many silty clay seams.             | 16        |                          |        |        |        |        |    |    |            |    |         | Est. A-4b |
|              | 75           |       |                 |                 |                  |   |           |                          |        |        |        |        |    |    |            |    |         |           |
|              |              |       | 7/12/15         | 2.0-4.0         |                  |   | 17        | 0                        | 1      | 1      | 50     | 48     | 30 | 10 | 27         |    | A-4b(8) |           |
|              | 80           |       |                 |                 |                  |   |           |                          |        |        |        |        |    |    |            |    |         |           |
|              |              |       | 4/6/8           | 0.75-1.5        |                  |   | 18        |                          |        |        |        |        |    |    |            |    |         | Est. A-4b |
|              | 85           |       |                 |                 |                  |   |           |                          |        |        |        |        |    |    |            |    |         |           |
|              |              |       | 3/5/6           | 0.5-1.0         |                  |   | 19        |                          |        |        |        |        |    |    |            |    |         | Est. A-4b |
|              | 90           |       |                 |                 |                  |   |           |                          |        |        |        |        |    |    |            |    |         |           |
| 586.9        | 95           |       |                 |                 |                  | 92.0  |           |                          |        |        |        |        |    |    |            |    |         |           |
|              |              |       | 4/6/7           | 0.5-1.25        |                  | SANDY SILT: Medium-stiff to stiff gray clay, some silt, trace fine to coarse sand, trace fine to coarse gravel, contains few shale fragments. | 20        | 7                        | 1      | 5      | 35     | 52     | 30 | 10 | 24         |    | A-4a(8) |           |
| 581.9        |              |       |                 |                 |                  | 97.0  |           |                          |        |        |        |        |    |    |            |    |         |           |
|              |              |       | 5/4/7           | 0.25-0.75       |                  | SILTY CLAY: Soft to medium-stiff gray silty clay, trace fine sand.  | 21        |                          |        |        |        |        |    |    |            |    |         | Est. A-6b |
|              | 100          |       |                 |                 |                  |   |           |                          |        |        |        |        |    |    |            |    |         |           |

PLATE 19

WATER LEVEL: ▽ 38.5 ▽ ▽ ▽

WATER NOTE: Encountered

DATE: 4/18/06

-CONTINUED-





**LOG OF BORING NO. B-05-07**  
**CUY-90-15.24 West Abutment**  
**CUYAHOGA COUNTY, OHIO**

Renamed: B-007-0-06

BBC&M JOB: 012-00946.300

TYPE: 3-1/4" I.D. Hollow-stem Auger    3-7/8" Tricone Roller Bit  
2/2.5" O.D. Split-barrel Sampler    3" O.D. Shelby Tube Sampler  
NQ Rock Core Barrel

LOCATION: Proposed I-90 Central Viaduct  
Sta. 127+43.46  
206.83' Lt. of Centerline

COMPLETION DEPTH: 229.0'  
ELEVATION: 678.9  
DATE: 4/18/06 - 4/24/06

| Elev. (feet) | Depth (feet) | Samp. | Std. Pen. / RQD | Hand Pen. (tsf) | Rec./Loss (feet) | CLASSIFICATION: DESCRIPTION   | Samp. No. | Physical Characteristics |        |        |        |        |    |    | ODOT Class |           |
|--------------|--------------|-------|-----------------|-----------------|------------------|---|-----------|--------------------------|--------|--------|--------|--------|----|----|------------|-----------|
|              |              |       |                 |                 |                  |   |           | % AGG.                   | % C.S. | % F.S. | % SILT | % CLAY | LL | PI |            | WC        |
| 571.9        | -105         |       | P               | 0.25-0.5        |                  | SILTY CLAY: Soft to medium-stiff gray silty clay, trace fine sand.  | 22        |                          |        |        |        |        | 40 | 17 |            | Est. A-6b |
|              | -110         |       | 3/5/7           | 0.25-0.75       |                  | SILT AND CLAY: Soft to medium-stiff gray clay, "and" silt, trace fine to coarse sand, contains few stiff zones.                                     | 23        | 0                        | 1      | 2      | 37     | 60     | 35 | 15 | 26         | A-6a(10)  |
| 561.9        | -115         |       | 4/5/7           | 0.25-1.25       |                  |   | 24        |                          |        |        |        |        |    |    |            | Est. A-6a |
|              | -120         |       | 4/6/9           | 0.25-0.75       |                  | SANDY SILT: Soft to medium-stiff gray clay, "and" silt, trace fine to coarse sand, trace fine gravel, contains few silt seams, and few stiff zones. | 25        |                          |        |        |        |        |    |    |            | Est. A-4a |
| 551.9        | -125         |       | 5/6/9           | 0.25-1.25       |                  |   | 26        | 1                        | 1      | 1      | 42     | 55     | 30 | 10 | 24         | A-4a(8)   |
|              | -130         |       | 6/8/10          | 2.0-2.75        |                  | SANDY SILT: Very-stiff to hard gray clay, "and" silt, trace fine to coarse sand, contains many silt seams, lenses and pockets.                      | 27        |                          |        |        |        |        |    |    |            | Est. A-4a |
|              | -135         |       | 6/12/15         | 2.5-4.5+        |                  |   | 28        |                          |        |        |        |        |    |    |            | Est. A-4a |
| 537.9        | -140         |       | 9/12/15         | 2.75-3.75       |                  |   | 29        | 0                        | 1      | 1      | 46     | 52     | 28 | 9  | 22         | A-4a(8)   |
|              | -145         |       | P               | 4.5+            |                  | SILT AND CLAY: Stiff to very-stiff gray clay, some silt, trace fine to coarse sand, trace fine gravel, contains few hard zones.                     | 30        |                          |        |        |        |        |    |    |            | Est. A-6a |
|              |              |       | P               | 2.5-3.25        |                  |   | 31        |                          |        |        |        |        |    |    |            | Est. A-6a |
|              | -150         |       | 8/15/20         | 2.75-4.25       |                  |   | 32        | 2                        | 3      | 5      | 32     | 58     | 33 | 12 | 20         | A-6a(9)   |

PLATE 20

WATER LEVEL: ∇    38.5    ∇    ∇    ∇  
WATER NOTE: Encountered  
DATE: 4/18/06

-CONTINUED-



**LOG OF BORING NO. B-05-07**  
**CUY-90-15.24 West Abutment**  
**CUYAHOGA COUNTY, OHIO**

Renamed: B-007-0-06

BBC&M JOB: 012-00946.300

TYPE: **3-1/4" I.D. Hollow-stem Auger**    **3-7/8" Tricone Roller Bit**  
**2/2.5" O.D. Split-barrel Sampler**    **3" O.D. Shelby Tube Sampler**  
**NQ Rock Core Barrel**

LOCATION: **Proposed I-90 Central Viaduct**  
**Sta. 127+43.46**  
**206.83' Lt. of Centerline**

COMPLETION DEPTH: **229.0'**  
ELEVATION: **678.9**  
DATE: **4/18/06 - 4/24/06**

| Elev. (feet) | Depth (feet) | Samp. | Std. Pen. / RQD   | Hand Pen. (tsf) | Rec./Loss (feet) | CLASSIFICATION: DESCRIPTION   | Samp No. | Physical Characteristics |        |        |        |        |    |    | ODOT Class |    |  |           |
|--------------|--------------|-------|-------------------|-----------------|------------------|---|----------|--------------------------|--------|--------|--------|--------|----|----|------------|----|--|-----------|
|              |              |       |                   |                 |                  |   |          | % AGG.                   | % C.S. | % F.S. | % SILT | % CLAY | LL | PI |            | WC |  |           |
|              | -150         |       |                   |                 |                  | SILT AND CLAY: Stiff to very-stiff gray clay, some silt, trace fine to coarse sand, trace fine gravel, contains few hard zones.       |          |                          |        |        |        |        |    |    |            |    |  |           |
|              | -155         | 2S    | 7/13/18<br>50-5"R | 2.0-3.25        |                  |   | 33       |                          |        |        |        |        |    |    |            |    |  | Est. A-6a |
|              | -160         |       | 7/10/17           | 2.25-3.25       |                  |   | 34       |                          |        |        |        |        |    |    |            |    |  | Est. A-6a |
|              | -165         |       | 7/11/15           | 2.25-2.75       |                  |   | 35       |                          |        |        |        |        |    |    |            |    |  | Est. A-6a |
|              | -170         |       | 6/9/13            | 1.75-2.25       |                  |   | 36       | 5                        | 3      | 4      | 33     | 55     | 33 | 13 | 21         |    |  | A-6a(9)   |
|              | -175         |       | 6/9/14            | 2.0-2.25        |                  |   | 37       |                          |        |        |        |        |    |    |            |    |  | Est. A-6a |
|              | -180         | 2S    | 6/9/12<br>38      | 1.75-2.75       |                  |   | 38       | 0                        | 0      | 1      | 32     | 67     | 33 | 12 | 23         |    |  | A-6a(9)   |
|              | -185         |       | 6/9/13            | 2.0-2.75        |                  |   | 39       |                          |        |        |        |        |    |    |            |    |  | Est. A-6a |
| 491.9        |              |       |                   |                 |                  | 187.0   |          |                          |        |        |        |        |    |    |            |    |  |           |
| 490.1        |              |       | 19/46/63          |                 |                  | 188.8   | 40A      |                          |        |        |        |        |    |    |            |    |  | Est. A-4b |
| 486.9        |              |       |                   |                 |                  | 192.0   | 40B      |                          |        |        |        |        |    |    |            |    |  | Est. A-3a |
|              | -195         |       | 50-4"R            | 4.5+            |                  | SILT AND CLAY: Very-stiff to hard gray clay, some silt, little fine to coarse sand, trace fine gravel, boulder encountered at 193.6'. | 41       |                          |        |        |        |        |    |    |            |    |  | Est. A-6a |
|              | 200          |       | 16/36/47          | 4.5+            |                  |   | 42       | 3                        | 6      | 8      | 24     | 59     | 30 | 11 | 16         |    |  | A-6a(8)   |

WATER LEVEL:  $\nabla$  **38.5**     $\nabla$      $\nabla$      $\nabla$

WATER NOTE: **Encountered**

DATE: **4/18/06**

-CONTINUED-

PLATE 21



**LOG OF BORING NO. B-05-07**  
**CUY-90-15.24 West Abutment**  
**CUYAHOGA COUNTY, OHIO**

Renamed: B-007-0-06

BBC&M JOB 012-00946.300

TYPE: 3-1/4" I.D. Hollow-stem Auger    3-7/8" Tricone Roller Bit    LOCATION: Proposed I-90 Central Viaduct    COMPLETION DEPTH: 229.0'  
2/2.5" O.D. Split-barrel Sampler    3" O.D. Shelby Tube Sampler    Sta. 127+43.46    ELEVATION: 678.9  
NQ Rock Core Barrel    206.83' Lt. of Centerline    DATE: 4/18/06 - 4/24/06

| Elev. (feet) | Depth (feet) | Samp.     | Std. Pen. / RQD | Hand Pen. (tsf) | Rec./Loss (feet) | CLASSIFICATION: DESCRIPTION  | Samp. No. | Physical Characteristics |        |        |        |        |    |    | ODOT Class |    |  |           |
|--------------|--------------|-----------|-----------------|-----------------|------------------|--|-----------|--------------------------|--------|--------|--------|--------|----|----|------------|----|--|-----------|
|              |              |           |                 |                 |                  |  |           | % AGG.                   | % C.S. | % F.S. | % SILT | % CLAY | LL | PI |            | WC |  |           |
|              | 200          |           |                 |                 |                  | SILT AND CLAY: Very-stiff to hard gray clay, some silt, little fine to coarse sand, trace fine gravel, boulder encountered at 193.6'.  |           |                          |        |        |        |        |    |    |            |    |  |           |
|              | 205          | 16/32/44  |                 | 4.5+            |                  |  | 43        |                          |        |        |        |        |    |    |            |    |  | Est. A-6a |
|              | 210          | 10/13/19  |                 | 3.0-4.5+        |                  | SANDY SILT: Hard gray silt, some clay, little fine to coarse sand, trace fine gravel, contains many shale fragments, similar to very-soft shale.   |           |                          |        |        |        |        |    |    |            |    |  |           |
| 467.9        | 210          |           |                 |                 |                  |  | 211.0     | 44                       |        |        |        |        |    |    |            |    |  | Est. A-6a |
|              | 215          | 25/50-5"R |                 | 4.5+            |                  | SHALE: Very-soft gray shale.   |           |                          |        |        |        |        |    |    |            |    |  |           |
| 461.9        | 215          |           |                 |                 |                  |  | 217.0     | 45                       |        |        |        |        |    |    |            |    |  | Est. A-4a |
|              | 220          | 50-1.5"R  |                 |                 |                  | SHALE: Soft dark gray and gray shale interbedded with siltstone, nearly horizontally bedded, many horizontal and few vertical and diagonal fractures, contains few silty clay seams, contain iron oxide stains throughout.<br><br>- Qu=1113 psi at 224.0'.   |           |                          |        |        |        |        |    |    |            |    |  |           |
| 459.9        | 220          |           | 48%             |                 | 5.0/0.0          |  | 219.0     | 46                       |        |        |        |        |    |    |            |    |  | Visual    |
|              | 225          |           |                 |                 |                  |  |           | 47                       |        |        |        |        |    |    |            |    |  | Visual    |
|              | 230          |           | 18%             |                 | 5.0/0.0          |  | 48        |                          |        |        |        |        |    |    |            |    |  | Visual    |
| 449.9        | 230          |           |                 |                 |                  |  |           |                          |        |        |        |        |    |    |            |    |  |           |
|              | 235          |           |                 |                 |                  | <b>NOTES:</b><br>- Encountered water at 38.5'.<br>- Water added to borehole at 40.0' to prevent heave and facilitate drilling.<br>- Switched to washbore at 60.0'.<br>- Encountered a boulder at 193.6'.<br>- Base of inclinometer installed at an approximate depth of 228'.<br>- Two vibrating wire piezometers installed in an offset hole between 5/30/06 and 6/7/06. Transducers were installed at approximate depths of 102' and 220'. The piezometer offset hole was backfilled with grout.<br>- Encountered a gas pocket at approximately 219.0'. Water erupted approximately 10' above the ground surface for approximately one minute. |           |                          |        |        |        |        |    |    |            |    |  |           |
|              | 240          |           |                 |                 |                  |  |           |                          |        |        |        |        |    |    |            |    |  |           |
|              | 245          |           |                 |                 |                  |  |           |                          |        |        |        |        |    |    |            |    |  |           |
|              | 250          |           |                 |                 |                  |  |           |                          |        |        |        |        |    |    |            |    |  |           |
|              | 250          |           |                 |                 |                  |  |           |                          |        |        |        |        |    |    |            |    |  |           |

WATER LEVEL: 38.5  
 WATER NOTE: Encountered  
 DATE: 4/18/06

PLATE 22



**LOG OF BORING NO. B-05-08**  
**CUY-90-15.24 West Abutment**  
**CUYAHOGA COUNTY, OHIO**

Renamed: B-008-0-06

BBC&M JOB 012-00946.300

TYPE: **3-1/4" I.D. Hollow-stem Auger** **3-7/8" Tricone Roller Bit**  
**2/2.5" O.D. Split-barrel Sampler** **3" O.D. Shelby Tube Sampler**  
**NQ Rock Core Barrel**

LOCATION: **Proposed I-90 Central Viaduct**  
**Sta. 126+26.08**  
**28.31' Lt. of Centerline**

COMPLETION DEPTH: **229.0'**  
ELEVATION: **679.9**  
DATE: **4/27/06 - 5/3/06**

| Elev. (feet) | Depth (feet) | Samp. | Std. Pen. / RQD | Hand Pen. (tsf) | Rec./Loss (feet) | CLASSIFICATION: DESCRIPTION  | Samp. No. | Physical Characteristics |        |        |        |        |    |    | ODOT Class |    |            |
|--------------|--------------|-------|-----------------|-----------------|------------------|--|-----------|--------------------------|--------|--------|--------|--------|----|----|------------|----|------------|
|              |              |       |                 |                 |                  |  |           | % AGG.                   | % C.S. | % F.S. | % SILT | % CLAY | LL | PI |            | WC |            |
| 679.2        | 0            |       |                 |                 |                  | 0.7 TOPSOIL - 8 INCHES   |           |                          |        |        |        |        |    |    |            |    |            |
|              | 5            |       | 4/8/8           |                 |                  | COARSE AND FINE SAND (FILL): Loose to medium-dense brown and dark brown fine to coarse sand, trace fine gravel, trace silt, trace clay, contains few roots.    | 1         |                          |        |        |        |        |    |    |            |    | Est. A-3a  |
|              |              |       | 5/3/4           |                 |                  |  | 2         |                          |        |        |        |        |    |    |            |    | Est. A-3a  |
| 672.4        |              |       | 5/8/7           |                 |                  | 7.5 GRAVEL WITH SAND (POSSIBLE FILL): Medium-dense becoming very-loose brown and gray fine to coarse sand, some fine to coarse gravel, trace silt, trace clay. | 3         | 35                       | 32     | 25     | 4      | 4      | NP | NP | 5          |    | A-1-b(0)   |
|              | 10           |       | 3/2/2           |                 |                  |  | 4         |                          |        |        |        |        |    |    |            |    | Est. A-1-b |
| 662.9        |              |       | 8/11/10         |                 |                  | 17.0 FINE SAND: Loose to medium-dense brown fine to coarse sand, trace fine gravel, trace silt, trace clay.  | 5         |                          |        |        |        |        |    |    |            |    | Est. A-3   |
|              | 20           |       | 6/7/11          |                 |                  |  | 6         |                          |        |        |        |        |    |    |            |    | Est. A-3   |
|              | 25           |       | 6/8/9           |                 |                  |  | 7         | 1                        | 41     | 49     | 4      | 5      | NP | NP | 5          |    | A-3(0)     |
|              | 30           |       | 6/7/5           |                 |                  |  | 8         |                          |        |        |        |        |    |    |            |    | Est. A-3   |
| 640.6        |              |       | 3/4/5           |                 |                  | 39.3 SILT: Loose becoming dense gray silt, trace clay, trace fine sand.  | 9A        |                          |        |        |        |        |    |    |            |    | Est. A-3   |
|              | 40           |       | 10/19/17        |                 |                  |  | 9B        |                          |        |        |        |        |    |    |            |    | Est. A-4b  |
|              | 45           |       |                 |                 |                  |  | 10        |                          |        |        |        |        |    |    |            |    | Est. A-4b  |

WATER LEVEL:  $\nabla$  **38.0**  $\nabla$   $\nabla$   $\nabla$   $\nabla$   $\nabla$

WATER NOTE: **Encountered**

DATE: **4/27/06**

-CONTINUED-

PLATE 23



**LOG OF BORING NO. B-05-08**  
**CUY-90-15.24 West Abutment**  
**CUYAHOGA COUNTY, OHIO**

Renamed: B-008-0-06

BBC&M JOB: 012-00946.300

TYPE: 3-1/4" I.D. Hollow-stem Auger 3-7/8" Tricone Roller Bit  
2/2.5" O.D. Split-barrel Sampler 3" O.D. Shelby Tube Sampler  
NQ Rock Core Barrel

LOCATION: Proposed I-90 Central Viaduct  
Sta. 126+26.08  
28.31' Lt. of Centerline

COMPLETION DEPTH: 229.0'  
ELEVATION: 679.9  
DATE: 4/27/06 - 5/3/06

| Elev. (feet) | Depth (feet) | Samp.    | Std. Pen. / RQD | Hand Pen. (tsf) | Rec./Loss (feet) | CLASSIFICATION: DESCRIPTION   | Samp. No. | Physical Characteristics |        |      |        |        |    |    | ODOT Class |    |         |           |
|--------------|--------------|----------|-----------------|-----------------|------------------|---|-----------|--------------------------|--------|------|--------|--------|----|----|------------|----|---------|-----------|
|              |              |          |                 |                 |                  |   |           | % AGG.                   | % C.S. | F.S. | % SILT | % CLAY | LL | PI |            | WC |         |           |
| 632.9        | 45           |          |                 |                 |                  | 47.0  |           |                          |        |      |        |        |    |    |            |    |         |           |
|              | 50           | 19/26/30 |                 |                 |                  | SANDY SILT: Very-dense gray fine sand, "and" silt, little clay.   | 11        | 0                        | 0      | 49   | 37     | 14     | NP | NP | 20         |    | A-4a(0) |           |
| 627.9        | 52.0         |          |                 |                 |                  | 52.0  |           |                          |        |      |        |        |    |    |            |    |         |           |
|              | 55           | 13/14/18 |                 |                 |                  | SILT: Medium-dense to dense gray silt, trace clay, trace fine sand.   | 12        |                          |        |      |        |        |    |    |            |    |         | Est. A-4b |
|              | 60           | 10/12/14 |                 |                 |                  |   | 13        | 0                        | 0      | 2    | 93     | 5      | 26 | 6  | 20         |    | A-4b(8) |           |
| 617.9        | 62.0         |          |                 |                 |                  | 62.0  |           |                          |        |      |        |        |    |    |            |    |         |           |
|              | 65           | 6/4/7    | 0.75-1.5        |                 |                  | SILT AND CLAY: Soft to medium-stiff gray silt, "and" clay, trace fine to coarse sand, contains many interbedded gray and black silt lenses and seams, and many stiff zones. | 14        | 0                        | 1      | 2    | 53     | 44     | 32 | 12 | 33         |    | A-6a(9) |           |
|              | 70           | 3/4/5    | 0.25-1.25       |                 |                  |   | 15        |                          |        |      |        |        |    |    |            |    |         | Est. A-6a |
|              |              | P        | 0.25-0.5        |                 |                  |   | 16        |                          |        |      |        |        |    |    |            |    |         | Est. A-6a |
| 606.9        | 73.0         |          |                 |                 |                  | 73.0  |           |                          |        |      |        |        |    |    |            |    |         |           |
|              | 75           | 5/8/11   |                 |                 |                  | SILT: Medium-dense gray silt, trace fine sand, contains many interbedded silty clay seams.  | 17        |                          |        |      |        |        |    |    |            |    |         | Est. A-4b |
| 602.9        | 77.0         |          |                 |                 |                  | 77.0  |           |                          |        |      |        |        |    |    |            |    |         |           |
|              | 80           | 5/11/16  | 1.75-2.75       |                 |                  | SILT: Stiff to very-stiff gray silt, "and" clay, contains many interbedded silt lenses, and few hard zones.   | 18        |                          |        |      |        |        |    |    |            |    |         | Est. A-4b |
|              | 85           | 8/12/16  | 1.75-4.5+       |                 |                  |   | 19        | 0                        | 0      | 0    | 50     | 50     | 29 | 10 | 20         |    | A-4b(8) |           |
|              | 90           | 6/9/14   | 2.0-3.5         |                 |                  |   | 20        |                          |        |      |        |        |    |    |            |    |         | Est. A-4b |

WATER LEVEL: 38.0  
WATER NOTE: Encountered  
DATE: 4/27/06

-CONTINUED-

PLATE 24



**LOG OF BORING NO. B-05-08**  
**CUY-90-15.24 West Abutment**  
**CUYAHOGA COUNTY, OHIO**

Renamed: B-008-0-06

BBC&M JOB 012-00936 300

TYPE: **3-1/4" I.D. Hollow-stem Auger** **3-7/8" Tricone Roller Bit**  
**2/2.5" O.D. Split-barrel Sampler** **3" O.D. Shelby Tube Sampler**  
**NQ Rock Core Barrel**

LOCATION: **Proposed I-90 Central Viaduct**  
**Sta. 126+26.08**  
**28.31' Lt. of Centerline**

COMPLETION DEPTH: **229.0'**  
ELEVATION: **679.9**  
DATE: **4/27/06 - 5/3/06**

| Elev. (feet) | Depth (feet) | Samp. | Std Pen / RQD | Hand Pen. (tsf) | Rec./Loss (feet) | CLASSIFICATION, DESCRIPTION   | Samp. No. | Physical Characteristics |        |        |        |        |    |    | ODOT Class |    |  |           |
|--------------|--------------|-------|---------------|-----------------|------------------|---|-----------|--------------------------|--------|--------|--------|--------|----|----|------------|----|--|-----------|
|              |              |       |               |                 |                  |   |           | % AGG.                   | % C.S. | % F.S. | % SILT | % CLAY | LL | PI |            | WC |  |           |
| 587.9        | 90           |       |               |                 |                  | 92.0  |           |                          |        |        |        |        |    |    |            |    |  |           |
|              | -95          |       | 4/5/7         | 0.5-1.0         |                  | SILT AND CLAY: Very-soft to medium-stiff gray clay, some silt, trace fine sand. | 21        |                          |        |        |        |        |    |    |            |    |  | Est. A-6a |
|              | -100         |       | 3/5/8         | 0.25-0.75       |                  |   | 22        | 0                        | 0      | 1      | 25     | 74     | 36 | 15 | 29         |    |  | A-6a(10)  |
|              | -105         |       | SH/4/5        | 0.0-0.5         |                  |   | 23        |                          |        |        |        |        |    |    |            |    |  | Est. A-6a |
|              | -110         |       | 2/4/4         | 0.25-0.5        |                  |   | 24        |                          |        |        |        |        |    |    |            |    |  | Est. A-6a |
|              | -115         |       | P             | 0.25-0.5        |                  |   | 25        |                          |        |        |        |        |    |    |            |    |  | Est. A-6a |
|              | -115         |       | 3/5/6         | 0.25-0.75       |                  |   | 26        |                          |        |        |        |        |    |    |            |    |  | Est. A-6a |
| 561.9        | -120         |       | P             | 0.25-0.5        |                  |   | 27        |                          |        |        |        |        |    |    |            |    |  | Est. A-6a |
|              | -120         |       | 6/10/15       | 0.75-3.75       |                  | 118.0   | 28        |                          |        |        |        |        |    |    |            |    |  | Est. A-6a |
| 557.9        | -125         |       | 9/13/16       | 2.25-3.25       |                  | 122.0   | 29        |                          |        |        |        |        |    |    |            |    |  | Est. A-4b |
|              | -130         |       | 8/11/18       | 1.75-2.25       |                  |   | 30        | 0                        | 0      | 1      | 60     | 39     | 27 | 8  | 23         |    |  | A-4b(8)   |
|              | -135         |       | 7/9/13        | 1.5-2.75        |                  |   | 31        |                          |        |        |        |        |    |    |            |    |  | Est. A-4b |

WATER LEVEL:  $\nabla$  **38.0**  $\nabla$   $\nabla$   $\nabla$   $\nabla$   $\nabla$   
WATER NOTE: **Encountered**  
DATE: **4/27/06**

-CONTINUED-

PLATE 25

TYPE: **3-1/4" I.D. Hollow-stem Auger**    **3-7/8" Tricone Roller Bit**  
**2/2.5" O.D. Split-barrel Sampler**    **3" O.D. Shelby Tube Sampler**  
**NQ Rock Core Barrel**

LOCATION: **Proposed I-90 Central Viaduct**  
**Sta. 126+26.08**  
**28.31' Lt. of Centerline**

COMPLETION DEPTH: 229.0'  
ELEVATION: 679.9  
DATE: 4/27/06 - 5/3/06

| Elev. (feet) | Depth (feet) | Samp.   | Std. Pen. / RQD | Hand Pen. (tst) | Rec./Loss (feet) | CLASSIFICATION: DESCRIPTION  | Samp. No. | Physical Characteristics |        |        |        |        |    |    | ODOT Class |    |           |
|--------------|--------------|---------|-----------------|-----------------|------------------|--|-----------|--------------------------|--------|--------|--------|--------|----|----|------------|----|-----------|
|              |              |         |                 |                 |                  |  |           | % AGG.                   | % C.S. | % F.S. | % SILT | % CLAY | LL | PI |            | WC |           |
| 537.9        | -140         | 7/11/16 | 1.5-2.75        |                 |                  | SILT: Stiff to very-stiff gray silt, "and" clay, trace fine sand, contains many interbedded silty clay seams and pockets.              | 32        |                          |        |        |        |        |    |    |            |    | Est. A-4b |
|              | -142.0       |         |                 |                 |                  |  |           |                          |        |        |        |        |    |    |            |    |           |
|              | -145         | 7/13/19 | 2.25-3.75       |                 |                  | SANDY SILT: Stiff to very-stiff gray silt, "and" clay, little fine to coarse sand, trace fine gravel, contains many silty clay lenses. | 33        | 4                        | 8      | 11     | 39     | 38     | 25 | 7  | 16         |    | A-4a(8)   |
| 527.9        | -150         | 6/9/13  | 1.5-1.75        |                 |                  |  | 34        |                          |        |        |        |        |    |    |            |    | Est. A-4a |
|              | -152.0       |         |                 |                 |                  |  |           |                          |        |        |        |        |    |    |            |    |           |
|              | -155         | 6/11/13 | 1.25-2.0        |                 |                  | SILT AND CLAY: Medium-stiff to stiff gray clay, some silt, trace fine to coarse sand, trace fine gravel.                               | 35        | 2                        | 2      | 3      | 33     | 60     | 32 | 11 | 23         |    | A-6a(8)   |
|              | -160         | 5/9/12  | 1.25-2.0        |                 |                  |  | 36        |                          |        |        |        |        |    |    |            |    | Est. A-6a |
|              | -165         | 6/10/16 | 1.0-1.5         |                 |                  |  | 37        |                          |        |        |        |        |    |    |            |    | Est. A-6a |
|              | -170         | 7/11/16 | 0.5-1.25        |                 |                  |  | 38        | 2                        | 2      | 3      | 32     | 61     | 33 | 12 | 23         |    | A-6a(9)   |
|              | -175         | 6/8/12  | 0.5-1.75        |                 |                  |  | 39        |                          |        |        |        |        |    |    |            |    | Est. A-6a |
|              | -180         | 6/11/13 | 1.0-1.75        |                 |                  |  | 40        | 8                        | 1      | 1      | 22     | 68     | 35 | 15 | 23         |    | A-6a(10)  |

WATER LEVEL: 38.0  
WATER NOTE: Encountered  
DATE: 4/27/06

-CONTINUED-

PLATE 26

TYPE: 3-1/4" I.D. Hollow-stem Auger    3-7/8" Tricone Roller Bit  
2/2.5" O.D. Split-barrel Sampler    3" O.D. Shelby Tube Sampler  
NQ Rock Core Barrel

LOCATION: Proposed I-90 Central Viaduct  
Sta. 126+26.08  
28.31' Lt. of Centerline

COMPLETION DEPTH: 229.0'  
ELEVATION: 679.9  
DATE: 4/27/06 - 5/3/06

| Elev. (feet) | Depth (feet) | Samp.        | Std. Pen. / RQD | Hand Pen. (tsf) | Rec./Loss (feet) | CLASSIFICATION: DESCRIPTION  | Samp. No.  | Physical Characteristics |        |        |        |        |    |    | ODOT Class |    |                     |
|--------------|--------------|--------------|-----------------|-----------------|------------------|--|------------|--------------------------|--------|--------|--------|--------|----|----|------------|----|---------------------|
|              |              |              |                 |                 |                  |  |            | % AGG.                   | % C.S. | % F.S. | % SILT | % CLAY | LL | PI |            | WC |                     |
| 492.9        | 180-185      | 8/12/15      | 1.25-2.0        |                 |                  | SILT AND CLAY: Medium-stiff to stiff gray clay, some silt, trace fine to coarse sand, trace fine gravel.   | 41         |                          |        |        |        |        |    |    |            |    | Est. A-6a           |
| 487.9        | 185-190      | 11/17/29     | 1.5-3.25        |                 |                  | SILT: Stiff to very-stiff gray silt, "and" clay, trace fine to coarse sand, trace fine gravel.   | 42         | 7                        | 1      | 1      | 49     | 42     | 25 | 6  | 22         |    | A-4a(8)             |
| 477.9        | 190-195      | 22/36/50-5"R | 4.5+            |                 |                  | SILT AND CLAY: Hard gray clay, "and" silt, little to some fine to coarse sand, trace fine gravel, contains few cobbles.  | 43         |                          |        |        |        |        |    |    |            |    | Est. A-6a           |
| 477.9        | 195-200      | 21/42/50-5"R | 4.5+            |                 |                  |  | 44         |                          |        |        |        |        |    |    |            |    | Est. A-6a           |
| 465.7        | 200-205      | 15/26/32     | 2.5-3.75        |                 |                  | SANDY SILT: Stiff to very-stiff gray clay, some silt, trace fine to coarse sand, contains few to many silt lenses, pockets and shale fragments, and few hard zones.  | 45         | 0                        | 1      | 2      | 21     | 76     | 33 | 10 | 24         |    | A-4a(8)             |
| 465.7        | 205-210      | 9/14/15      | 1.5-3.25        |                 |                  |  | 46         |                          |        |        |        |        |    |    |            |    | Est. A-4a           |
| 460.9        | 210-215      | 26/37/50-5"R | 1.75-4.5+       |                 |                  | SHALE: Very-soft gray shale.   | 47A<br>47B |                          |        |        |        |        |    |    |            |    | Est. A-4a<br>Visual |
| 460.9        | 215-220      | 50-2"R       |                 |                 |                  |  | 48         |                          |        |        |        |        |    |    |            |    | Visual              |
|              | 220-225      | 45%          |                 |                 | 5.0/0.0          | SHALE: Soft dark gray and gray shale, nearly horizontally bedded, many horizontal, few vertical and diagonal fractures, contains a significant diagonal fracture of 70 degrees from 222.1' to 222.3' and few interbedded silty clay seams. | 49         |                          |        |        |        |        |    |    |            |    | Visual              |

WATER LEVEL: 38.0  
WATER NOTE: Encountered  
DATE: 4/27/06



TYPE: 3-1/4" I.D. Hollow-stem Auger    3-7/8" Tricone Roller Bit  
2/2.5" O.D. Split-barrel Sampler    3" O.D. Shelby Tube Sampler  
NQ Rock Core Barrel

LOCATION: Proposed I-90 Central Viaduct  
Sta. 126+26.08  
28.31' Lt. of Centerline

COMPLETION DEPTH: 229.0'  
ELEVATION: 679.9  
DATE: 4/27/06 - 5/3/06

| Elev. (feet) | Depth (feet) | Samp. | Std. Pen. / RQD | Hand Pen. (tsf) | Rec./Loss (feet) | CLASSIFICATION: DESCRIPTION | Samp. No. | Physical Characteristics |      |      |      |      |    |    | ODOT Class |    |        |
|--------------|--------------|-------|-----------------|-----------------|------------------|-----------------------------|-----------|--------------------------|------|------|------|------|----|----|------------|----|--------|
|              |              |       |                 |                 |                  |                             |           | AGG.                     | C.S. | F.S. | SILT | CLAY | LL | PI |            | WC |        |
| 450.9        | 225          |       | 45%             |                 | 5.0/0.0          | 229.0                       | 50        |                          |      |      |      |      |    |    |            |    | Visual |
|              | 230          |       |                 |                 |                  |                             |           |                          |      |      |      |      |    |    |            |    |        |
|              | 235          |       |                 |                 |                  |                             |           |                          |      |      |      |      |    |    |            |    |        |
|              | 240          |       |                 |                 |                  |                             |           |                          |      |      |      |      |    |    |            |    |        |
|              | 245          |       |                 |                 |                  |                             |           |                          |      |      |      |      |    |    |            |    |        |
|              | 250          |       |                 |                 |                  |                             |           |                          |      |      |      |      |    |    |            |    |        |
|              | 255          |       |                 |                 |                  |                             |           |                          |      |      |      |      |    |    |            |    |        |
|              | 260          |       |                 |                 |                  |                             |           |                          |      |      |      |      |    |    |            |    |        |
|              | 265          |       |                 |                 |                  |                             |           |                          |      |      |      |      |    |    |            |    |        |
|              | 270          |       |                 |                 |                  |                             |           |                          |      |      |      |      |    |    |            |    |        |

**NOTES:**

- Encountered water at 38.0'.
- Switched to washbore at 60.0'.
- Cobbles encountered at 194.5' and 199.5'.
- Base of inclinometer installed at an approximate depth of 228'.
- Two vibrating wire piezometers installed in an offset hole between 5/24/06 and 5/30/06. Transducers were installed at approximate depths of 65.5' and 110.5'. The piezometer offset hole was backfilled with grout.

WATER LEVEL:  38.0    WATER NC:  Encountered    DATE: 4/27/06

PLATE 28

TYPE: 3-1/4" I.D. Hollow-stem Auger    3-7/8" Tricone Roller Bit  
2" O.D. Split-barrel Sampler    3" O.D. Shelby Tube Sampler  
NQ Rock Core Barrel

LOCATION: Proposed I-90 Central Viaduct  
Sta. 128+63.03  
147.49' Rt. of Centerline

COMPLETION DEPTH: 230.0'  
ELEVATION: 675.1  
DATE: 4/11/06 - 4/17/06

| Elev. (feet) | Depth (feet) | Samp. | Std. Pen. / RQD | Hand Pen. (tsf) | Rec./Loss (feet) | CLASSIFICATION: DESCRIPTION   | Samp. No. | Physical Characteristics |        |        |        |        |    |    | ODOT Class |    |    |            |            |
|--------------|--------------|-------|-----------------|-----------------|------------------|---|-----------|--------------------------|--------|--------|--------|--------|----|----|------------|----|----|------------|------------|
|              |              |       |                 |                 |                  |   |           | AGG. %                   | C.S. % | F.S. % | SILT % | CLAY % | LL | PI |            | WC |    |            |            |
| 674.6        | 0            |       |                 |                 |                  | ASPHALT - 6 INCHES  |           |                          |        |        |        |        |    |    |            |    |    |            |            |
| 673.8        | 0.8          |       |                 |                 |                  | CONCRETE - 9 INCHES   |           |                          |        |        |        |        |    |    |            |    |    |            |            |
|              | 5            |       | 4/6/7           |                 |                  | GRAVEL WITH SAND (FILL): Loose to medium-dense brown fine to coarse sand, little fine to coarse gravel, trace silt, trace clay. | 1         |                          |        |        |        |        |    |    |            |    |    | Est. A-1-b |            |
|              | 10           |       | 6/5/4           |                 |                  |   | 2         |                          |        |        |        |        |    |    |            |    |    |            | Est. A-1-b |
|              | 15           |       | 3/4/4           |                 |                  |   | 3         | 19                       | 47     | 24     | 4      | 6      |    |    |            |    | 5  |            | Est. A-1-b |
|              | 20           |       | 3/5/4           |                 |                  |   | 4         |                          |        |        |        |        |    |    |            |    |    |            | Est. A-1-b |
| 658.1        | 25           |       | 7/11/14         |                 |                  | COARSE AND FINE SAND: Medium-dense brown fine sand, little silt, trace clay, trace coarse sand, contains few iron oxide stains. | 5         |                          |        |        |        |        |    |    |            |    |    |            | Est. A-3a  |
|              | 30           |       | 6/8/9           |                 |                  | SANDY SILT: Medium-dense to dense brown and gray fine sand, "and" silt, little clay.  | 6         | 0                        | 2      | 79     | 13     | 6      | NP | NP |            | 8  |    |            | A-3a(0)    |
|              | 35           |       | 9/9/9           |                 |                  |   | 7         |                          |        |        |        |        |    |    |            |    |    |            | Est. A-3a  |
|              | 40           |       | 6/7/8           |                 |                  |   | 8         | 0                        | 2      | 77     | 12     | 9      |    |    |            |    | 24 |            | Est. A-3a  |
| 638.1        | 45           |       | 9/9/9           |                 |                  |   | 9         |                          |        |        |        |        |    |    |            |    |    |            | Est. A-4a  |
|              | 50           |       | 9/15/18         |                 |                  |   | 10        | 0                        | 0      | 46     | 42     | 12     | NP | NP |            | 22 |    |            | A-4a(0)    |
| 628.1        | 50           |       | 3/5/8           |                 |                  |   | 11        | 0                        | 0      | 14     | 62     | 24     | NP | NP |            | 18 |    |            | A-4b(0)    |

PLATE 29

WATER LEVEL:                               
WATER NOTE:                               
DATE:

TYPE: 3-1/4" I.D. Hollow-stem Auger 3-7/8" Tricone Roller Bit  
2" O.D. Split-barrel Sampler 3" O.D. Shelby Tube Sampler  
NQ Rock Core Barrel

LOCATION: Proposed I-90 Central Viaduct  
Sta. 128+63.03  
147.49' Rt. of Centerline

COMPLETION DEPTH: 230.0'  
 ELEVATION: 675.1  
 DATE: 4/11/06 - 4/17/06

| Elev. (feet) | Depth (feet) | Samp. | Std. Pen. / RQD | Hand Pen. (tsf) | Rec./Loss (feet) | CLASSIFICATION: DESCRIPTION  | Samp. No.  | Physical Characteristics |        |        |        |        |    |    | ODOT Class |    |  |                      |
|--------------|--------------|-------|-----------------|-----------------|------------------|--|------------|--------------------------|--------|--------|--------|--------|----|----|------------|----|--|----------------------|
|              |              |       |                 |                 |                  |  |            | % AGG.                   | % C.S. | % F.S. | % SILT | % CLAY | LL | PI |            | WC |  |                      |
|              | 50           |       |                 |                 |                  | SILT: Medium-dense becoming very-dense gray silt, little to some clay, little fine sand, trace coarse sand, contains few silty clay seams.                       |            |                          |        |        |        |        |    |    |            |    |  |                      |
|              | 55           |       | 10/16/20        |                 |                  |  | 12         |                          |        |        |        |        |    |    |            |    |  | Est. A-4b            |
| 615.6        | 60           |       | 24/29/40        |                 |                  | COARSE AND FINE SAND: Very-dense becoming medium-dense gray fine to coarse sand, trace to little silt, trace to little clay, contains few silty clay seams.      | 13A<br>13B | 0                        | 1      | 11     | 70     | 18     | NP | NP | 15         |    |  | A-4b(0)<br>Est. A-3a |
| 610.1        | 65           |       | 14/18/12        |                 |                  |  | 14         |                          |        |        |        |        |    |    |            |    |  | Est. A-3a            |
|              |              |       | 3/5/6           | 0.75-1.5        |                  | SANDY SILT: Medium-stiff to stiff becoming stiff to very-stiff brown and gray clay, "and" silt, trace fine to coarse sand, contains many interbedded silt seams. | 15         |                          |        |        |        |        |    |    |            |    |  | Est. A-4a            |
|              |              |       | 4/6/9           | 0.5-2.0         |                  |  | 16         |                          |        |        |        |        |    |    |            |    |  | Est. A-4a            |
|              |              |       | 5/10/11         | 2.0-3.75        |                  |  | 17         |                          |        |        |        |        |    |    |            |    |  | Est. A-4a            |
|              | 70           |       | 5/6/7           | 1.5-2.5         |                  |  | 18         | 0                        | 1      | 1      | 47     | 51     | 32 | 10 | 26         |    |  | A-4a(8)              |
| 601.6        |              |       |                 |                 |                  |  |            |                          |        |        |        |        |    |    |            |    |  |                      |
|              | 75           |       | 5/8/9           | 1.5-3.0         |                  | SILT: Medium-stiff to stiff brown and gray silt, "and" clay, contains many silty clay seams and pockets, and few very-stiff zones.                               | 19         |                          |        |        |        |        |    |    |            |    |  | Est. A-4b            |
|              | 80           |       | 3/6/6           | 1.0-2.75        |                  |  | 20         |                          |        |        |        |        |    |    |            |    |  | Est. A-4b            |
|              |              |       | 3/5/6           | 0.5-1.25        |                  |  | 21         | 0                        | 0      | 0      | 54     | 46     | 30 | 9  | 26         |    |  | A-4b(8)              |
|              | 85           |       | 6/8/11          | 0.5-2.0         |                  |  | 22         |                          |        |        |        |        |    |    |            |    |  | Est. A-4b            |
|              |              |       | 4/6/9           | 0.75-1.25       |                  |  | 23         |                          |        |        |        |        |    |    |            |    |  | Est. A-4b            |
| 585.6        |              |       |                 |                 |                  |  |            |                          |        |        |        |        |    |    |            |    |  |                      |
|              | 90           |       | 2/3/3           | 0.75            |                  | SILT AND CLAY: Medium-stiff gray silt, "and" clay, contains many silty clay seams and pockets.   | 24         |                          |        |        |        |        | 35 | 13 |            |    |  | Est. A-6a            |
|              | 95           |       | P               | 0.75            |                  |  | 25         |                          |        |        |        |        |    |    |            |    |  | Est. A-6a            |
|              |              |       | P               | 0.75            |                  |  | 26         |                          |        |        |        |        |    |    |            |    |  | Est. A-6a            |
|              | 100          |       |                 |                 |                  |  |            |                          |        |        |        |        |    |    |            |    |  |                      |

WATER LEVEL: ▽  
 WATER NC ▽  
 DA ▽

TYPE: 3-1/4" I.D. Hollow-stem Auger    3-7/8" Tricone Roller Bit  
2" O.D. Split-barrel Sampler    3" O.D. Shelby Tube Sampler  
NQ Rock Core Barrel

LOCATION: Proposed I-90 Central Viaduct  
Sta. 128+63.03  
147.49' Rt. of Centerline

COMPLETION DEPTH: 230.0'  
ELEVATION: 675.1  
DATE: 4/11/06 - 4/17/06

| Elev. (feet) | Depth (feet) | Samp. | Std. Pen. / RQD | Hand Pen. (tsf) | Rec./Loss (feet) | CLASSIFICATION: DESCRIPTION   | Samp. No. | Physical Characteristics |        |        |        |        |    |    | ODOT Class |    |           |  |
|--------------|--------------|-------|-----------------|-----------------|------------------|---|-----------|--------------------------|--------|--------|--------|--------|----|----|------------|----|-----------|--|
|              |              |       |                 |                 |                  |   |           | % AGG.                   | % C.S. | % F.S. | % SILT | % CLAY | LL | PI |            | WG |           |  |
| 573.1        | 100          |       |                 |                 |                  | 102.0   |           |                          |        |        |        |        |    |    |            |    |           |  |
|              | 105          |       | 5/7/8           | 1.5-2.25        |                  | SILT: Very-stiff to hard gray silt, "and" clay, trace fine sand, contains many fine sand and silt pockets, and few stiff zones.   | 27        |                          |        |        |        |        |    |    |            |    | Est. A-4b |  |
|              |              |       | 8/10/15         | 3.0-4.25        |                  |   | 28        | 0                        | 0      | 2      | 61     | 37     | 27 | 7  | 21         |    | A-4b(8)   |  |
|              | 110          |       | 5/6/11          | 3.0-4.25        |                  |   | 29        |                          |        |        |        |        |    |    |            |    | Est. A-4b |  |
|              |              |       | 6/12/14         | 3.5-4.5         |                  |   | 30        |                          |        |        |        |        |    |    |            |    | Est. A-4b |  |
|              |              |       | 7/11/14         | 1.75-3.75       |                  |   | 31        |                          |        |        |        |        |    |    |            |    | Est. A-4b |  |
|              | 115          |       |                 |                 |                  |   |           |                          |        |        |        |        |    |    |            |    |           |  |
|              | 120          |       | 8/13/18         | 3.25-4.5+       |                  |   | 32        | 0                        | 0      | 2      | 59     | 39     | 29 | 9  | 20         |    | A-4b(8)   |  |
|              | 125          |       | 8/13/18         | 4.0-4.5+        |                  |   | 33        |                          |        |        |        |        |    |    |            |    | Est. A-4b |  |
|              | 130          |       | 6/11/15         | 2.5-4.0         |                  |   | 34        |                          |        |        |        |        |    |    |            |    | Est. A-4b |  |
| 543.1        | 132.0        |       |                 |                 |                  |   | 132.0     |                          |        |        |        |        |    |    |            |    |           |  |
|              | 135          |       | 7/11/15         | 2.0-3.25        |                  | SILT AND CLAY: Stiff to very-stiff gray clay, some silt, trace fine to coarse sand, trace fine gravel, contains few interbedded silt seams and pockets, and few medium-stiff zones. | 35        |                          |        |        |        |        |    |    |            |    | Est. A-6a |  |
|              | 140          |       | 6/10/15         | 1.75-3.25       |                  |   | 36        |                          |        |        |        |        |    |    |            |    | Est. A-6a |  |
|              | 145          |       | 5/10/17         | 2.0-2.75        |                  |   | 37        | 2                        | 3      | 7      | 29     | 59     | 32 | 11 | 21         |    | A-6a(8)   |  |
|              |              |       | 8/11/17         | 2.0-3.5         |                  |   | 38        |                          |        |        |        |        |    |    |            |    | Est. A-6a |  |
|              | 150          |       |                 |                 |                  |   |           |                          |        |        |        |        |    |    |            |    |           |  |

WATER LEVEL:                       
WATER NOTE: \_\_\_\_\_  
DATE: \_\_\_\_\_

PLATE 31

TYPE: **3-1/4" I.D. Hollow-stem Auger**    **3-7/8" Tricone Roller Bit**  
**2" O.D. Split-barrel Sampler**    **3" O.D. Shelby Tube Sampler**  
**NQ Rock Core Barrel**

LOCATION: **Proposed I-90 Central Viaduct**  
**Sta. 128+63.03**  
**147.49' Rt. of Centerline**

COMPLETION DEPTH: **230.0'**  
ELEVATION: **675.1**  
DATE: **4/11/06 - 4/17/06**

| Elev. (feet) | Depth (feet) | Samp. | Std. Pen. / RQD | Hand Pen. (tsf) | Rec./Loss (feet) | CLASSIFICATION: DESCRIPTION   | Samp. No. | Physical Characteristics |      |      |      |      |    | ODOT Class |           |           |
|--------------|--------------|-------|-----------------|-----------------|------------------|---|-----------|--------------------------|------|------|------|------|----|------------|-----------|-----------|
|              |              |       |                 |                 |                  |   |           | AGG.                     | C.S. | F.S. | SILT | CLAY | LL |            | PI        | WC        |
| 498.1        | 150          |       |                 |                 |                  | SILT AND CLAY: Stiff to very-stiff gray clay, some silt, trace fine to coarse sand, trace fine gravel, contains few interbedded silt seams and pockets, and few medium-stiff zones. |           |                          |      |      |      |      |    |            |           |           |
|              | 155          |       | 7/12/13         | 0.5-1.5         |                  |   | 39        | 2                        | 2    | 3    | 32   | 61   | 33 | 12         | 24        | A-6a(9)   |
|              | 160          |       | 7/10/13         | 1.5-1.75        |                  |   | 40        |                          |      |      |      |      |    |            |           | Est. A-6a |
|              | 165          |       | 7/10/14         | 1.5-2.25        |                  |   | 41        |                          |      |      |      |      |    |            |           | Est. A-6a |
|              | 170          |       | 7/11/16         | 1.75-3.0        |                  |   | 42        |                          |      |      |      |      |    |            |           | Est. A-6a |
|              | 175          |       | 6/10/14         | 1.75-2.75       |                  |   | 43        | 4                        | 0    | 1    | 32   | 63   | 35 | 14         | 22        | A-6a(10)  |
|              | 180          |       | 6/9/12          | 1.5-2.5         |                  |   | 44        |                          |      |      |      |      |    |            |           | Est. A-4a |
|              | 185          |       | 6/7/7           | 0.5-2.25        |                  |   | 45        |                          |      |      |      |      |    |            |           | Est. A-4a |
|              | 190          |       | 6/6/9           | 0.5-1.25        |                  |   | 46        | 1                        | 1    | 2    | 39   | 57   | 30 | 9          | 26        | A-4a(8)   |
|              | 195          |       | 10/19/32        | 3.0-4.5+        |                  |   | 47        |                          |      |      |      |      |    |            |           | Est. A-4a |
|              | 200          |       | 12/22/36        | 4.5+            |                  | 48  |           |                          |      |      |      |      |    |            | Est. A-4a |           |

WATER LEVEL:  $\nabla$  \_\_\_\_\_  $\nabla$  \_\_\_\_\_  $\nabla$  \_\_\_\_\_  $\nabla$  \_\_\_\_\_  
WATER NO. \_\_\_\_\_  
DATE: \_\_\_\_\_

PLATE 32

TYPE: 3-1/4" I.D. Hollow-stem Auger    3-7/8" Tricone Roller Bit  
2" O.D. Split-barrel Sampler    3" O.D. Shelby Tube Sampler  
NQ Rock Core Barrel

LOCATION: Proposed I-90 Central Viaduct  
Sta. 128+63.03  
147.49' Rt. of Centerline

COMPLETION DEPTH: 230.0'  
ELEVATION: 675.1  
DATE: 4/11/06 - 4/17/06

| Elev. (feet) | Depth (feet) | Samp. | Std. Pen. / RQD | Hand Pen. (tsf) | Rec./Loss (feet) | CLASSIFICATION: DESCRIPTION  | Samp. No. | Physical Characteristics |        |        |        |        |    |    | ODOT Class |    |           |  |
|--------------|--------------|-------|-----------------|-----------------|------------------|--|-----------|--------------------------|--------|--------|--------|--------|----|----|------------|----|-----------|--|
|              |              |       |                 |                 |                  |  |           | % AGG.                   | % C.S. | % F.S. | % SILT | % CLAY | LL | PI |            | WC |           |  |
|              | 200          |       |                 |                 |                  |  |           |                          |        |        |        |        |    |    |            |    |           |  |
|              | 205          |       | 11/16/21        | 1.75-4.0        |                  | SANDY SILT: Medium-stiff to stiff gray clay, some to "and" silt, trace fine to coarse sand, trace fine gravel, contains few interbedded silt seams and pockets, and many very-stiff to hard zones. | 49        | 1                        | 1      | 0      | 34     | 64     | 31 | 8  | 23         |    | A-4a(8)   |  |
|              | 210          |       | 7/10/14         | 1.0-1.75        |                  |  | 50        |                          |        |        |        |        |    |    |            |    | Est. A-4a |  |
| 463.1        |              |       |                 |                 |                  |  |           |                          |        |        |        |        |    |    |            |    |           |  |
|              | 215          |       | 18/28/33        | 4.5+            |                  | SANDY SILT: Hard gray silt, little clay, some fine to coarse sand, some fine to coarse gravel, contains many shale fragments, similar to very-soft shale.  | 51        | 23                       | 12     | 10     | 35     | 20     | 24 | 6  | 12         |    | A-4a(4)   |  |
| 458.1        |              |       |                 |                 |                  |  |           |                          |        |        |        |        |    |    |            |    |           |  |
|              | 220          |       | 50-3"R          |                 |                  | SHALE: Very-soft gray shale, fragmented.   | 52        |                          |        |        |        |        |    |    |            |    | Visual    |  |
| 455.1        |              |       |                 |                 |                  |  |           |                          |        |        |        |        |    |    |            |    |           |  |
|              | 225          |       | 18%             |                 | 5.0/0.0          | SHALE: Soft gray shale, nearly horizontally bedded, many horizontal and few vertical fractures, contains few interbedded silty clay seams, possible slickenside at 229.0', arenaceous.             | 53        |                          |        |        |        |        |    |    |            |    | Visual    |  |
|              | 230          |       | 37%             |                 | 4.8/0.2          | - Qu=209 psi at 225.0'.  | 54        |                          |        |        |        |        |    |    |            |    | Visual    |  |
| 445.1        |              |       |                 |                 |                  |  |           |                          |        |        |        |        |    |    |            |    |           |  |
|              | 235          |       |                 |                 |                  |  |           |                          |        |        |        |        |    |    |            |    |           |  |
|              | 240          |       |                 |                 |                  |  |           |                          |        |        |        |        |    |    |            |    |           |  |
|              | 245          |       |                 |                 |                  |  |           |                          |        |        |        |        |    |    |            |    |           |  |
|              | 250          |       |                 |                 |                  |  |           |                          |        |        |        |        |    |    |            |    |           |  |

**NOTES:**

- Encountered seepage at 33.5'.
- Water added to borehole at 35.0' to facilitate drilling.
- Switched to washbore at 55.0'.
- Base of inclinometer installed at an approximate depth of 229'.
- Two vibrating wire piezometers installed in an offset hole between 6/7/06 and 6/9/06. Transducers were installed at approximate depths of 95' and 130'. The piezometer offset hole was backfilled with grout.
- Possible gas pocket encountered at 218.0'. Water bubbled to surface of drilling fluid.

WATER LEVEL:     
WATER NOTE:     
DATE:

TYPE: 3-1/4" I.D. Hollow-stem Auger    3-7/8" Tricone Roller Bit    LOCATION: Proposed I-90 Central Viaduct    COMPLETION DEPTH: 213.5'  
2" O.D. Split-barrel Sampler    3" O.D. Shelby Tube Sampler    Sta. 131+14.70    ELEVATION: 652.7  
NX Rock Core Barrel    74.16' Rt. of Centerline    DATE: 4/17/06 - 4/21/06

| Elev. (feet) | Depth (feet) | Samp. | Std. Pen. / RQD | Hand Pen. (tsf) | Rec./Loss (feet) | CLASSIFICATION: DESCRIPTION   | Samp. No. | Physical Characteristics |        |        |        |        |    |    | ODOT Class |    |  |            |
|--------------|--------------|-------|-----------------|-----------------|------------------|---|-----------|--------------------------|--------|--------|--------|--------|----|----|------------|----|--|------------|
|              |              |       |                 |                 |                  |   |           | % AGG.                   | % C.S. | % F.S. | % SILT | % CLAY | LL | PI |            | WC |  |            |
| 651.8        | 0            |       |                 |                 |                  | 0.9 CONCRETE - 10 1/2 INCHES  |           |                          |        |        |        |        |    |    |            |    |  |            |
| 651.7        | 1.0          |       |                 |                 |                  | 1.0 GRANULAR BASE - 1 1/2 INCHES  |           |                          |        |        |        |        |    |    |            |    |  |            |
|              | 5            |       | 5/6/5           |                 |                  | GRAVEL WITH SAND (FILL): Loose to medium-dense dark brown and brown fine to coarse sand, little fine to coarse gravel, trace silt, trace clay, contains few slag fragments. | 1         |                          |        |        |        |        |    |    |            |    |  | Est. A-1-b |
|              | 10           |       | 3/2/3           |                 |                  |   | 2         |                          |        |        |        |        |    |    |            |    |  | Est. A-1-b |
| 640.7        | 12.0         |       |                 |                 |                  | 12.0 COARSE AND FINE SAND: Loose brown and gray fine sand, trace coarse sand, little silt, trace clay, contains many iron oxide stains.                                     | 3         | 0                        | 2      | 80     | 15     | 3      | NP | NP | 13         |    |  | A-3a(0)    |
|              | 15           |       | 2/2/3           |                 |                  |   | 4         |                          |        |        |        |        |    |    |            |    |  | Est. A-3a  |
|              | 20           |       | 2/3/3           |                 |                  |   | 5         |                          |        |        |        |        |    |    |            |    |  | Est. A-3a  |
|              | 25           |       | 2/3/2           |                 |                  |   | 6         |                          |        |        |        |        |    |    |            |    |  | Est. A-3a  |
| 625.2        | 27.5         |       |                 |                 |                  | 27.5 SILT: Medium-dense gray silt, little clay, trace fine to coarse sand.  | 6         |                          |        |        |        |        |    |    |            |    |  | Est. A-4b  |
|              | 30           |       | 6/8/8           |                 |                  |   | 7         |                          |        |        |        |        |    |    |            |    |  | Est. A-4b  |
|              | 35           |       | 8/9/11          |                 |                  |   | 8         | 0                        | 1      | 4      | 76     | 19     | NP | NP | 17         |    |  | A-4b(0)    |
|              | 38.0         |       | 10/13/13        |                 |                  |   | 9         |                          |        |        |        |        |    |    |            |    |  | Est. A-4b  |
| 614.7        | 38.0         |       |                 |                 |                  | 38.0 SILT AND CLAY: Stiff to very-stiff gray silt, "and" clay, trace fine to coarse sand, contains few hard zones.  | 10        |                          |        |        |        |        |    |    |            |    |  | Est. A-6a  |
|              | 40           |       | 2/4/5           | 3.0-4.25        |                  |   | 11        |                          |        |        |        |        |    |    |            |    |  | Est. A-6a  |
|              |              |       | P               | 1.5-1.75        |                  |   | 12        |                          |        |        |        |        |    |    |            |    |  | Est. A-6a  |
|              |              |       | P               | 3.0-4.0         |                  |   | 13        |                          |        |        |        |        |    |    |            |    |  | Est. A-6a  |
|              | 45           |       | 4/5/7           | 1.5-2.0         |                  |   | 14        | 0                        | 1      | 1      | 53     | 45     | 31 | 12 | 23         |    |  | A-6a(9)    |
|              |              |       | 6/7/10          | 3.0-4.0         |                  |   | 15        |                          |        |        |        |        |    |    |            |    |  | Est. A-6a  |
|              | 50           |       | 5/7/9           | 3.0-4.5         |                  |   |           |                          |        |        |        |        |    |    |            |    |  |            |

WATER LEVEL: ∇    23.0    ∇    "Dry"    ∇    ∇

WATER NO.    Encountered    Inside Casing - Prior to Washb

DATE    4/17/06    4/17/06

PLATE 34



**LOG OF BORING NO. B-05-12** Renamed: B-012-0-06  
**CUY-90-15.24 West Abutment**  
**CUYAHOGA COUNTY, OHIO**

BBC&M JOB: 012-00946.300

TYPE: 3-1/4" I.D. Hollow-stem Auger 3-7/8" Tricone Roller Bit  
2" O.D. Split-barrel Sampler 3" O.D. Shelby Tube Sampler  
NX Rock Core Barrel

LOCATION: Proposed I-90 Central Viaduct  
Sta. 131+14.70  
74.16' Rt. of Centerline

COMPLETION DEPTH: 213.5'  
ELEVATION: 652.7  
DATE: 4/17/06 - 4/21/06

| Elev. (feet) | Depth (feet) | Samp. | Std. Pen. / RQD | Hand Pen. (tsf) | Rec./Loss (feet) | CLASSIFICATION: DESCRIPTION   | Samp. No.  | Physical Characteristics |        |        |        |        |    |    | ODOT Class |           |
|--------------|--------------|-------|-----------------|-----------------|------------------|---|--|--------------------------|--------|--------|--------|--------|----|----|------------|-----------|
|              |              |       |                 |                 |                  |   |  | % AGG.                   | % C.S. | % F.S. | % SILT | % CLAY | LL | PI |            | WC        |
|              | 50           |       | 5/9/11          | 3.0-4.5         |                  | SILT AND CLAY: Stiff to very-stiff gray silt, "and" clay, trace fine to coarse sand, contains few hard zones.   | 16   |                          |        |        |        |        |    |    |            | Est. A-6a |
|              | 55           |       | 6/8/10          | 2.0-3.0         |                  |   | 17   | 0                        | 1      | 1      | 53     | 45     | 32 | 12 | 23         | A-6a(9)   |
|              | 60           |       | 5/6/11          | 2.0-3.0         |                  |   | 18   |                          |        |        |        |        |    |    |            | Est. A-6a |
| 588.7        |              |       | 6/6/10          | 1.75-3.0        |                  | 64.0  | 19   |                          |        |        |        |        |    |    |            | Est. A-6a |
|              | 65           |       | 4/5/7           | 1.0-2.0         |                  | SILT: Stiff to very-stiff gray mottled with red silt, "and" clay, trace fine to coarse sand, trace fine gravel, contains many interbedded silty clay seams. | 20   | 2                        | 1      | 2      | 52     | 43     | 30 | 10 | 23         | A-4b(8)   |
|              |              |       | 3/4/7           | 1.75-2.5        |                  |   | 21   |                          |        |        |        |        |    |    |            | Est. A-4b |
|              |              |       | 4/6/7           | 1.25-2.0        |                  |   | 22   |                          |        |        |        |        |    |    |            | Est. A-4b |
| 582.2        | 70           |       | 3/6/7           | 1.0-1.25        |                  |   | 70.5   | 23                       |        |        |        |        |    |    |            | Est. A-4b |
|              |              |       | 3/5/7           | 0.75-1.25       |                  | SANDY SILT: Medium-stiff to stiff gray clay, "and" silt, trace fine to coarse sand, contains few silt seams and lenses.                                     | 24   | 0                        | 1      | 1      | 42     | 56     | 28 | 8  | 26         | A-4a(8)   |
|              | 75           |       | 3/4/3           | 0.5-0.75        |                  |   | 25   |                          |        |        |        |        |    |    |            | Est. A-4a |
|              |              |       | 4/5/7           | 1.0-1.5         |                  |   | 26   |                          |        |        |        |        |    |    |            | Est. A-4a |
| 573.2        |              |       | P               | 1.5-2.0         |                  |   | 79.5   | 27                       |        |        |        |        |    |    |            | Est. A-4a |
|              | 80           |       | 4/5/8           | 1.25-1.75       |                  |   | SILT: Stiff to very-stiff gray silt, "and" clay, trace fine sand, contains many interbedded silty clay seams, few cobbles. | 28                       |        |        |        |        |    |    |            |           |
|              |              |       | 4/7/9           | 2.0-2.25        |                  | 29  |  | 0                        | 0      | 2      | 53     | 45     | 29 | 10 | 22         | A-4b(8)   |
|              |              |       | 5/7/11          | 2.25-3.0        |                  | 30  |  |                          |        |        |        |        |    |    |            | Est. A-4b |
|              | 85           |       | 5/8/13          | 2.5-3.0         |                  | 31  |  |                          |        |        |        |        |    |    |            | Est. A-4b |
|              |              |       | 5/10/12         | 3.0-3.75        |                  | 32  |  |                          |        |        |        |        |    |    |            | Est. A-4b |
|              | 90           |       | 5/7/10          | 2.0-3.5         |                  | 33  |  |                          |        |        |        |        |    |    |            | Est. A-4b |
|              | 95           |       | 5/8/11          | 1.5-2.0         |                  | 34  |  | 0                        | 0      | 2      | 55     | 43     | 30 | 10 | 23         | A-4b(8)   |
|              | 100          |       | 6/10/13         | 1.5-2.25        |                  | 35  |  |                          |        |        |        |        |    |    |            | Est. A-4b |

WATER LEVEL: 23.0 "Dry"  
WATER NOTE: Encountered Inside Casing - Prior to Washbore  
DATE: 4/17/06 4/17/06

PLATE 35



TYPE: 3-1/4" I.D. Hollow-stem Auger    3-7/8" Tricone Roller Bit    LOCATION: Proposed I-90 Central Viaduct    COMPLETION DEPTH: 213.5'  
2" O.D. Split-barrel Sampler    3" O.D. Shelby Tube Sampler    Sta. 131+14.70    ELEVATION: 652.7  
NX Rock Core Barrel    74.16' Rt. of Centerline    DATE: 4/17/06 - 4/21/06

| Elev. (feet) | Depth (feet) | Samp.   | Std. Pen. / RQD | Hand Pen. (tsf) | Rec./Loss (feet) | CLASSIFICATION DESCRIPTION   | Samp. No. | Physical Characteristics |      |      |      |      |    |    | ODOT Class |    |           |
|--------------|--------------|---------|-----------------|-----------------|------------------|--|-----------|--------------------------|------|------|------|------|----|----|------------|----|-----------|
|              |              |         |                 |                 |                  |  |           | AGG                      | C.S. | F.S. | SILT | CLAY | LL | PI |            | WC |           |
|              | 100          |         |                 |                 |                  | SILT: Stiff to very-stiff gray silt, "and" clay, trace fine sand, contains many interbedded silty clay seams, few cobbles. |           |                          |      |      |      |      |    |    |            |    |           |
|              | 105          | 6/10/14 |                 | 2.75-3.0        |                  |  | 36        |                          |      |      |      |      |    |    |            |    |           |
|              | 110          | 7/12/14 |                 | 2.25-3.0        |                  | SANDY SILT: Very-stiff to hard gray silt, "and" clay, little fine to coarse sand, trace fine gravel.                       |           |                          |      |      |      |      |    |    |            |    |           |
| 540.2        | 112.5        |         |                 |                 |                  |  | 37        |                          |      |      |      |      |    |    |            |    |           |
|              | 115          | 8/14/18 |                 | 3.0-4.0         |                  | SILT AND CLAY: Stiff to very-stiff gray clay, "and" silt, trace fine to coarse sand, trace fine gravel.                    |           |                          |      |      |      |      |    |    |            |    |           |
|              | 120          | 7/10/14 |                 | 2.5-3.25        |                  |  | 38        | 2                        | 3    | 8    | 44   | 43   | 28 | 10 | 20         |    | A-4a(8)   |
|              | 125          | 7/11/14 |                 | 2.5-2.75        |                  | SILT AND CLAY: Stiff to very-stiff gray clay, "and" silt, trace fine to coarse sand, trace fine gravel.                    |           |                          |      |      |      |      |    |    |            |    |           |
| 525.2        | 127.5        |         |                 |                 |                  |  | 39        |                          |      |      |      |      |    |    |            |    |           |
|              | 130          | 7/10/13 |                 | 2.0-2.5         |                  | SILT AND CLAY: Stiff to very-stiff gray clay, "and" silt, trace fine to coarse sand, trace fine gravel.                    |           |                          |      |      |      |      |    |    |            |    |           |
|              | 135          | 6/8/11  |                 | 1.75-2.0        |                  |  | 40        |                          |      |      |      |      |    |    |            |    |           |
|              | 140          | 5/7/10  |                 | 1.5-1.75        |                  | SILT AND CLAY: Stiff to very-stiff gray clay, "and" silt, trace fine to coarse sand, trace fine gravel.                    |           |                          |      |      |      |      |    |    |            |    |           |
|              | 145          | 5/9/11  |                 | 1.5-1.75        |                  |  | 41        |                          |      |      |      |      |    |    |            |    |           |
| 505.7        | 147.0        |         |                 |                 |                  | SILT AND CLAY: Stiff to very-stiff gray clay, "and" silt, trace fine to coarse sand, trace fine gravel.                    |           |                          |      |      |      |      |    |    |            |    |           |
|              | 150          | 5/8/11  |                 | 1.75-2.25       |                  |  | 42        | 2                        | 1    | 4    | 39   | 54   | 33 | 13 | 23         |    | A-6a(9)   |
|              |              |         |                 |                 |                  | SILTY CLAY: Stiff to very-stiff gray silty clay, trace fine sand.  |           |                          |      |      |      |      |    |    |            |    |           |
|              |              |         |                 |                 |                  |  | 44        |                          |      |      |      |      |    |    |            |    | Est. A-6a |
|              |              |         |                 |                 |                  |  | 45        |                          |      |      |      |      |    |    |            |    | Est. A-6b |

PLATE 36

WATER LEVEL: ∇ 23.0    ∇ "Dry"    ∇    ∇  
WATER NC Encountered    Inside Casing - Prior to Washbo  
DA 4/17/06    4/17/06

TYPE: 3-1/4" I.D. Hollow-stem Auger 3-7/8" Tricone Roller Bit  
2" O.D. Split-barrel Sampler 3" O.D. Shelby Tube Sampler  
NX Rock Core Barrel

LOCATION: Proposed I-90 Central Viaduct  
Sta. 131+14.70  
74.16' Rt. of Centerline

COMPLETION DEPTH: 213.5'  
 ELEVATION: 652.7  
 DATE: 4/17/06 - 4/21/06

| Elev. (feet) | Depth (feet) | Samp. | Std. Pen. / RQD | Hand Pen. (tsf) | Rec./Loss (feet) | CLASSIFICATION: DESCRIPTION   | Samp. No. | Physical Characteristics |        |        |        |        |    |    | ODOT Class |    |           |  |
|--------------|--------------|-------|-----------------|-----------------|------------------|---|-----------|--------------------------|--------|--------|--------|--------|----|----|------------|----|-----------|--|
|              |              |       |                 |                 |                  |   |           | % AGG.                   | % C.S. | % F.S. | % SILT | % CLAY | LL | PI |            | WC |           |  |
|              | 150          |       |                 |                 |                  | SILTY CLAY: Stiff to very-stiff gray silty clay, trace fine sand.   |           |                          |        |        |        |        |    |    |            |    |           |  |
|              | 155          |       | 7/11/13         | 2.0-2.75        |                  |   | 46        | 0                        | 0      | 1      | 33     | 66     | 36 | 16 | 24         |    | A-6b(10)  |  |
|              | 160          |       | 5/8/11          | 1.75-2.25       |                  |   | 47        |                          |        |        |        |        |    |    |            |    | Est. A-6b |  |
| 490.2        |              |       |                 |                 |                  | 162.5   |           |                          |        |        |        |        |    |    |            |    |           |  |
|              | 165          |       | SD-9"4/5        | 0.5-0.75        |                  | SILT AND CLAY: Soft to medium-stiff gray clay, some silt, trace fine sand.  | 48        | 0                        | 0      | 1      | 25     | 74     | 35 | 13 | 29         |    | A-6a(9)   |  |
| 485.2        |              |       |                 |                 |                  | 167.5   |           |                          |        |        |        |        |    |    |            |    |           |  |
| 483.2        |              |       | 5/5/5           | 1.0-1.5         |                  | SILT: Medium-stiff to stiff gray silt, "and" clay.  | 49A       | 0                        | 0      | 0      | 61     | 39     | 25 | 6  | 28         |    | A-4b(8)   |  |
|              | 170          |       |                 | 0.75            |                  | SILT AND CLAY: Medium-stiff gray clay, some silt, trace fine sand, contains few silt lenses.  | 49B       |                          |        |        |        |        |    |    |            |    | Est. A-6a |  |
| 480.2        |              |       |                 |                 |                  | 172.5   |           |                          |        |        |        |        |    |    |            |    |           |  |
| 478.3        |              |       | 13/18/20        | 4.5+            |                  | SANDY SILT: Dense gray fine sand, some silt, little clay, little coarse sand, trace fine gravel.  | 50A       | 5                        | 11     | 40     | 29     | 15     |    |    | 17         |    | Est. A-4a |  |
|              | 175          |       |                 |                 |                  | SANDY SILT: Very-stiff to hard gray clay, some silt, little fine to coarse sand, trace fine gravel, contains few silt seams, few cobbles. | 50B       |                          |        |        |        |        |    |    |            |    | Est. A-4a |  |
|              | 180          |       | 18/21/42        | 4.5+            |                  |   | 51        | 3                        | 5      | 8      | 29     | 55     | 28 | 10 | 16         |    | A-4a(8)   |  |
|              | 185          |       |                 |                 |                  |   | 52        |                          |        |        |        |        |    |    |            |    | Est. A-4a |  |
| 465.2        |              |       |                 |                 |                  | 187.5   |           |                          |        |        |        |        |    |    |            |    |           |  |
|              | 190          |       | 7/9/11          | 2.0-2.5         |                  | SILT AND CLAY: Stiff to very-stiff gray clay, "and" silt, contains few to many silt seams and lenses.                                     | 53        | 0                        | 0      | 0      | 46     | 54     | 31 | 11 | 25         |    | A-6a(8)   |  |
|              | 195          |       | 8/11/15         | 2.5-3.25        |                  |   | 54        |                          |        |        |        |        |    |    |            |    | Est. A-6a |  |
| 455.0        |              |       |                 |                 |                  | 197.7   |           |                          |        |        |        |        |    |    |            |    |           |  |
|              | 200          |       | 26/50-5"R       |                 |                  | SHALE: Very-soft gray shale, fragmented.  | 55        |                          |        |        |        |        |    |    |            |    | Visual    |  |

PLATE 37

WATER LEVEL: ∇ 23.0 ∇ "Dry" ∇  
 WATER NOTE: Encountered Inside Casing - Prior to Washbore  
 DATE: 4/17/06 4/17/06





**LOG OF BORING NO. B-05-13**  
**CUY-90-15.24 West Abutment**  
**CUYAHOGA COUNTY, OHIO**

Renamed: B-013-0-06

BBC&M JOB: 012-00946.300

TYPE: 3-1/4" I.D. Hollow-stem Auger 3-7/8" Tricone Roller Bit  
2/2.5" O.D. Split-barrel Sampler 3" O.D. Shelby Tube Sampler  
NQ Rock Core Barrel

LOCATION: Proposed I-90 Central Viaduct  
Sta. 137+07.46  
53.17' Rt. of Centerline

COMPLETION DEPTH: 189.0'  
 ELEVATION: 580.0  
 DATE: 5/4/06 - 5/10/06

| Elev. (feet) | Depth (feet) | Samp. | Std. Pen. / RQD | Hand Pen. (tsf) | Rec./Loss (feet) | CLASSIFICATION: DESCRIPTION   | Samp. No. | Physical Characteristics |        |        |        |        |    |    | ODOT Class |    |                        |
|--------------|--------------|-------|-----------------|-----------------|------------------|---|-----------|--------------------------|--------|--------|--------|--------|----|----|------------|----|------------------------|
|              |              |       |                 |                 |                  |   |           | % AGG.                   | % C.S. | % F.S. | % SILT | % CLAY | LL | PI |            | WC |                        |
| 579.0        | 0            |       |                 |                 |                  | 1.0 GRANULAR BASE - 12 INCHES   | 1         |                          |        |        |        |        |    |    |            |    | Est. A-3a              |
| 575.0        | 5            |       | 12/5/5          |                 |                  | COARSE AND FINE SAND (FILL): Very-loose to loose black and brown fine to coarse sand, little fine gravel, little silt, little clay, contains few asphalt fragments, slightly organic. | 2A<br>2B  |                          |        |        |        |        |    |    |            |    | Est. A-3a<br>Est. A-6a |
| 572.5        |              |       | 2/2/1           | 0.0             |                  | 7.5 SILT AND CLAY: Very-soft black and gray silt, "and" clay, contains a hydrocarbon odor.  |           |                          |        |        |        |        |    |    |            |    |                        |
| 568.0        | 10           |       | 1/1-12"         |                 |                  | 12.0 SANDY SILT: Very-loose gray and brown silt, some clay, some fine sand, trace coarse sand, trace fine gravel.   | 3         | 1                        | 1      | 26     | 47     | 25     | 20 | 2  | 27         |    | A-4a(7)                |
| 563.0        | 15           |       | 1/1/3           |                 |                  | 17.0 SANDY SILT: Very-loose brown and gray fine sand, "and" silt, little clay.  | 4         | 0                        | 0      | 41     | 41     | 18     | NP | NP | 47         |    | A-4a(0)                |
|              | 20           |       | 2/7/5           |                 |                  | 32.0 GRAVEL WITH SAND: Loose to medium-dense brown and gray fine to coarse sand, trace fine gravel, trace silt, trace clay.   | 5         |                          |        |        |        |        |    |    |            |    | Est. A-1-b             |
|              | 25           |       | 3/4/7           |                 |                  |   | 6         | 3                        | 47     | 39     | 5      | 6      | NP | NP | 18         |    | A-1-b(0)               |
|              | 30           |       | 8/5/4           |                 |                  |   | 7         |                          |        |        |        |        |    |    |            |    | Est. A-1-b             |
| 548.0        | 35           |       | 4/5/7           | 1.25-2.5        |                  | SILT: Medium-stiff to stiff gray silt, "and" clay, trace fine sand, contains many silty clay lenses and pockets, and few very-stiff zones.  | 8         |                          |        |        |        |        |    |    |            |    | Est. A-4b              |
|              | 40           |       | 3/4/5           | 0.75-2.25       |                  |   | 9         | 0                        | 0      | 1      | 50     | 49     | 30 | 10 | 26         |    | A-4b(8)                |
|              | 45           |       | P               | 1.25-1.5        |                  |   | 10        |                          |        |        |        |        |    |    |            |    | Est. A-4b              |
|              |              |       | 3/4/6           | 0.5-1.25        |                  |   | 11        |                          |        |        |        |        |    |    |            |    | Est. A-4b              |

PLATE 39

WATER LEVEL: 13.5  
 WATER NOTE: Encountered

TYPE: 3-1/4" I.D. Hollow-stem Auger    3-7/8" Tricone Roller Bit    LOCATION: Proposed I-90 Central Viaduct    COMPLETION DEPTH: 189.0'  
2/2.5" O.D. Split-barrel Sampler    3" O.D. Shelby Tube Sampler    Sta. 137+07.46    ELEVATION: 580.0  
NQ Rock Core Barrel    53.17' Rt. of Centerline    DATE: 5/4/06 - 5/10/06

| Elev. (feet) | Depth (feet) | Samp. | Std. Pen. / RQD  | Hand Pen. (tsf)       | Rec./Loss (feet) | CLASSIFICATION: DESCRIPTION   | Samp. No. | Physical Characteristics |        |        |          |          |          |          | ODOT Class |    |                      |  |  |
|--------------|--------------|-------|------------------|-----------------------|------------------|---|-----------|--------------------------|--------|--------|----------|----------|----------|----------|------------|----|----------------------|--|--|
|              |              |       |                  |                       |                  |   |           | % AGG.                   | % C.S. | % F.S. | % SILT   | % CLAY   | LL       | PI       |            | WC |                      |  |  |
| 532.5        | 45           |       |                  |                       |                  | +++<br>+++<br>+++<br>47.5   |           |                          |        |        |          |          |          |          |            |    |                      |  |  |
|              | 50           | 2S    | 5/8/9<br>20<br>P | 1.25-2.0<br>1.25-1.5  |                  | SANDY SILT: Stiff to very-stiff gray silt, "and" clay, little fine to coarse sand, trace fine gravel.   | 12<br>13  | 3                        | 8      | 12     | 40       | 37       | 24       | 7        | 16         |    | A-4a(8)<br>Est. A-4a |  |  |
| 527.0        | 55           |       | 3/5/7            | 0.75-1.5              |                  | SILT AND CLAY: Medium-stiff to stiff gray silt, trace clay, trace fine to coarse sand, trace fine gravel.   | 14        |                          |        |        |          |          |          |          |            |    | Est. A-6a            |  |  |
|              | 60           |       | 5/6/9            | 1.0-1.5               |                  |   | 15        | 2                        | 3      | 4      | 81       | 10       | 32       | 12       | 22         |    | A-6a(9)              |  |  |
| 518.0        | 65           |       | 7/9/12           | 1.5-2.25              |                  | SILT AND CLAY: Stiff to very-stiff gray clay, some silt, trace fine to coarse sand, trace fine gravel, contains few silt seams, lenses and pockets, and few soft zones. | 16        |                          |        |        |          |          |          |          |            |    | Est. A-6a            |  |  |
|              | 70           |       | 5/7/11<br>P      | 1.25-1.75<br>0.5-1.25 |                  |   | 17<br>18  | 1<br>4                   | 2<br>3 | 4<br>5 | 31<br>35 | 62<br>53 | 33<br>30 | 13<br>13 | 23<br>22   |    | A-6a(9)<br>A-6a(9)   |  |  |
|              | 75           |       | 4/7/11           | 1.25-1.5              |                  |   | 19        |                          |        |        |          |          |          |          |            |    | Est. A-6a            |  |  |
|              | 80           |       | 5/8/12           | 1.25-2.25             |                  |   | 20        | 1                        | 1      | 2      | 30       | 66       | 35       | 15       | 24         |    | A-6a(10)             |  |  |
|              | 85           |       | 4/7/9            | 1.0-2.0               |                  |   | 21        |                          |        |        |          |          |          |          |            |    | Est. A-6a            |  |  |
|              | 90           |       | 4/6/9            | 1.0-2.25              |                  |   | 22        | 1                        | 1      | 1      | 29       | 68       | 34       | 12       | 27         |    | A-6a(9)              |  |  |

WATER LEVEL: 13.5    WATER N°: Encountered    DA: 5/4/06

PLATE 40



TYPE: 3-1/4" I.D. Hollow-stem Auger    3-7/8" Tricone Roller Bit    LOCATION: Proposed I-90 Central Viaduct    COMPLETION DEPTH: 189.0'  
2/2.5" O.D. Split-barrel Sampler    3" O.D. Shelby Tube Sampler    Sta. 137+07.46    ELEVATION: 580.0  
NQ Rock Core Barrel    53.17' Rt. of Centerline    DATE: 5/4/06 - 5/10/06

| Elev. (feet) | Depth (feet) | Samp. | Std. Pen. / RQD | Hand Pen. (tsf) | Rec./Loss (feet) | CLASSIFICATION: DESCRIPTION  | Samp. No. | Physical Characteristics |      |      |      |      |    |    | ODOT Class |    |          |  |
|--------------|--------------|-------|-----------------|-----------------|------------------|--|-----------|--------------------------|------|------|------|------|----|----|------------|----|----------|--|
|              |              |       |                 |                 |                  |  |           | AGG.                     | C.S. | F.S. | SILT | CLAY | LL | PI |            | WC |          |  |
| 443.0        | 135          |       |                 |                 |                  | 137.0  |           |                          |      |      |      |      |    |    |            |    |          |  |
|              |              |       | 20/41/48        |                 |                  | GRAVEL WITH SAND AND SILT: Very-dense gray fine to coarse gravel, some fine to coarse sand, some clay, little silt, contains many siltstone fragments and a silty clay seam from 138.8' to 139.8'.                   | 32        | 37                       | 18   | 10   | 13   | 22   | 25 | 8  | 25         |    | A-2-4(0) |  |
| 436.2        | 140          |       |                 |                 |                  | 143.8  |           |                          |      |      |      |      |    |    |            |    |          |  |
|              |              |       | 45/50-4"R       |                 |                  | SHALE: Very-soft gray shale.   | 33        |                          |      |      |      |      |    |    |            |    | Visual   |  |
| 431.0        | 145          |       |                 |                 |                  | 149.0  |           |                          |      |      |      |      |    |    |            |    |          |  |
|              |              |       | 50-2"R          |                 |                  | SHALE: Soft to medium-hard dark gray and gray shale, nearly horizontally bedded, few horizontal fractures, contains nodules, and many silty clay pockets, seams and nodules, highly fractured from 149.4' to 149.8'. | 34        |                          |      |      |      |      |    |    |            |    | Visual   |  |
|              | 150          |       |                 |                 | 5.0/0.0          |  | 35        |                          |      |      |      |      |    |    |            |    | Visual   |  |
|              | 155          |       |                 |                 | 4.9/0.1          | - Qu=1553 psi at 152.5'.   | 36        |                          |      |      |      |      |    |    |            |    | Visual   |  |
| 421.0        | 160          |       |                 |                 |                  | 159.0  |           |                          |      |      |      |      |    |    |            |    |          |  |
|              |              |       | 42%             |                 | 4.5/0.5          | SHALE: Medium-hard dark gray and gray shale interbedded with siltstone, nearly horizontally bedded, many horizontal and few diagonal fractures, nodules, contains many silty lenses and pockets.                     | 37        |                          |      |      |      |      |    |    |            |    | Visual   |  |
|              | 165          |       |                 |                 | 2.8/2.2          | - Qu=2955 psi at 160.5'.<br>- μ=0.39 at 160.5'.  | 38        |                          |      |      |      |      |    |    |            |    | Visual   |  |
|              | 170          |       |                 |                 | 2.1/2.9          |  | 39        |                          |      |      |      |      |    |    |            |    | Visual   |  |
| 406.0        | 175          |       |                 |                 |                  | 174.0  |           |                          |      |      |      |      |    |    |            |    |          |  |
|              |              |       | 88%             |                 | 5.0/0.0          |  | 40        |                          |      |      |      |      |    |    |            |    | Visual   |  |

WATER LEVEL: ∇    13.5    ∇    ∇    ∇  
WATER NC    Encountered  
DA:    5/4/06

PLATE #2

TYPE: 3-1/4" LD. Hollow-stem Auger 3-7/8" Tritone Roller Bit  
2/2.5" O.D. Split-barrel Sampler 3" O.D. Shelby Tube Sampler  
NQ Rock Core Barrel

LOCATION: Proposed I-90 Central Viaduct  
Sta. 137+07.46  
53.17' Rt. of Centerline

COMPLETION DEPTH: 189.0'  
 ELEVATION: 580.0  
 DATE: 5/4/06 - 5/10/06

| Elev. (feet) | Depth (feet) | Samp. | Std. Pen. / RQD | Hand Pen. (tsf) | Rec./Loss (feet) | CLASSIFICATION DESCRIPTION  | Samp. No. | Physical Characteristics |        |        |        |        |    |    | ODOT Class |        |
|--------------|--------------|-------|-----------------|-----------------|------------------|---|-----------|--------------------------|--------|--------|--------|--------|----|----|------------|--------|
|              |              |       |                 |                 |                  |   |           | % AGG.                   | % C.S. | % F.S. | % SILT | % CLAY | LL | PI |            | WC     |
|              | 180          |       | 63%             |                 | 5.0/0.0          | SHALE: Medium-hard dark gray and gray shale, nearly horizontally bedded, few horizontal and few diagonal fractures at 177.8', 180.2' and 181.0', contains many silty clay seams and nodules.<br><br>- Qu=348 psi at 178.5'  | 41        |                          |        |        |        |        |    |    |            | Visual |
|              | 185          |       | 87%             |                 | 4.7/0.3          |   | 42        |                          |        |        |        |        |    |    |            |        |
| 391.0        | 189.0        |       |                 |                 |                  |   |           |                          |        |        |        |        |    |    |            |        |
|              | 190          |       |                 |                 |                  | <b>NOTES:</b><br>- Encountered seepage at 5.0'.<br>- Encountered water at 13.5'.<br>- Pressure Tests were performed by EL Robinson on 5/5/06 between the depths of 31.0' to 33.0', 41.0' to 43.0', and 52.5' to 54.5'.<br>- Switched to washbore at 40.0'.<br>- Encountered a gas pocket during rock coring. Water bubbled to surface of drilling fluid.<br>- Base of inclinometer installed at an approximate depth of 141'.<br>- Two vibrating wire piezometers installed in an offset hole between 6/8/06 and 6/12/06. Transducers were installed at approximate depths of 60' and 135'. The piezometer offset hole was backfilled with grout. |           |                          |        |        |        |        |    |    |            |        |
|              | 195          |       |                 |                 |                  |   |           |                          |        |        |        |        |    |    |            |        |
|              | 200          |       |                 |                 |                  |   |           |                          |        |        |        |        |    |    |            |        |
|              | 205          |       |                 |                 |                  |   |           |                          |        |        |        |        |    |    |            |        |
|              | 210          |       |                 |                 |                  |   |           |                          |        |        |        |        |    |    |            |        |
|              | 215          |       |                 |                 |                  |   |           |                          |        |        |        |        |    |    |            |        |
|              | 220          |       |                 |                 |                  |   |           |                          |        |        |        |        |    |    |            |        |
|              | 225          |       |                 |                 |                  |   |           |                          |        |        |        |        |    |    |            |        |

WATER LEVEL: 13.5  
 WATER NOTE: Encountered  
 DATE: 5/4/06





**LOG OF BORING NO. B-05-14** Renamed: B-014-0-06  
**CUY-90-15.24 West Abutment**  
**CUYAHOGA COUNTY, OHIO**

BBC&M JOB: 012-00946-300

TYPE: 3-1/4" I.D. Hollow-stem Auger 3-7/8" Tricone Roller Bit LOCATION: Proposed I-90 Central Viaduct COMPLETION DEPTH: 199.0'  
2/2.5" O.D. Split-barrel Sampler 3" O.D. Shelby Tube Sampler Sta. 137+07.98 ELEVATION: 579.7  
NQ Rock Core Barrel 172.70' Rt. of Centerline DATE: 5/11/06 - 5/18/06

| Elev. (feet) | Depth (feet) | Samp. | Std. Pen. / RQD | Hand Pen. (tsf) | Rec./Loss (feet) | CLASSIFICATION: DESCRIPTION | Samp. No. | Physical Characteristics |      |      |      |      |    |    | ODOT Class |    |  |            |
|--------------|--------------|-------|-----------------|-----------------|------------------|-----------------------------|-----------|--------------------------|------|------|------|------|----|----|------------|----|--|------------|
|              |              |       |                 |                 |                  |                             |           | AGG                      | C.S. | F.S. | SILT | CLAY | LL | PI |            | WC |  |            |
| 579.2        | 0            |       |                 |                 |                  | 0.5                         |           |                          |      |      |      |      |    |    |            |    |  |            |
|              |              |       | 7/21/13         |                 |                  |                             |           |                          |      |      |      |      |    |    |            |    |  | Est. A-1-b |
|              | -5-          |       | 28/21/28        |                 |                  | 7.5                         | 1         | 41                       | 27   | 21   | 3    | 8    | NP | NP | 35         |    |  | A-1-b(0)   |
| 572.2        |              |       |                 |                 |                  |                             |           |                          |      |      |      |      |    |    |            |    |  |            |
|              | -10-         |       | 5/3/2           | 0.5-1.5         |                  |                             | 2         |                          |      |      |      |      |    |    |            |    |  | Est. A-4a  |
| 567.7        |              |       |                 |                 |                  | 12.0                        | 3         |                          |      |      |      |      |    |    |            |    |  |            |
|              | -15-         |       | 2/3/3           |                 |                  |                             | 4         | 0                        | 3    | 79   | 9    | 9    | NP | NP | 25         |    |  | A-3a(0)    |
|              | -20-         |       | 1/1/3           |                 |                  |                             | 5         |                          |      |      |      |      |    |    |            |    |  | Est. A-3a  |
| 557.7        |              |       |                 |                 |                  | 22.0                        |           |                          |      |      |      |      |    |    |            |    |  |            |
|              | -25-         |       | 5/4/4           |                 |                  |                             | 6         | 11                       | 25   | 52   | 5    | 7    | NP | NP | 18         |    |  | A-3a(0)    |
|              | -30-         |       | 3/2/2           |                 |                  |                             | 7         | 8                        | 31   | 35   | 13   | 13   | NP | NP | 36         |    |  | A-3a(0)    |
| 545.8        |              |       |                 |                 |                  | 33.9                        | 8A        |                          |      |      |      |      |    |    |            |    |  | Est. A-3a  |
| 545.2        | -35-         |       | 10/11/7         | 1.0-1.75        |                  | 34.5                        | 8B        | 0                        | 0    | 20   | 64   | 16   | NP | NP | 20         |    |  | A-4b(0)    |
|              |              |       |                 |                 |                  |                             | 8C        |                          |      |      |      |      |    |    |            |    |  | Est. A-6b  |
|              | -40-         |       | 4/5/8           | 1.0-2.0         |                  |                             | 9         |                          |      |      |      |      |    |    |            |    |  | Est. A-6b  |
|              | -45-         |       | 4/4/5           | 0.25-1.0        |                  |                             | 10        | 0                        | 1    | 1    | 29   | 69   | 34 | 16 | 28         |    |  | A-6b(10)   |

WATER LEVEL: 10.0  
 WATER NO. Encountered  
 DATE: 5/11/06

PLATE 44

TYPE: 3-1/4" I.D. Hollow-stem Auger 3-7/8" Tricone Roller Bit LOCATION: Proposed I-90 Central Viaduct COMPLETION DEPTH: 199.0'  
2/2.5" O.D. Split-barrel Sampler 3" O.D. Shelby Tube Sampler Sta. 137+07.98 ELEVATION: 579.7  
NQ Rock Core Barrel 172.70' Rt. of Centerline DATE: 5/11/06 - 5/18/06

| Elev. (feet) | Depth (feet) | Samp. | Std. Pen. / RQD | Hand Pen. (tsf) | Rec./Loss (feet) | CLASSIFICATION: DESCRIPTION  | Samp. No. | Physical Characteristics |        |        |        |        |    |    | ODOT Class |    |  |           |
|--------------|--------------|-------|-----------------|-----------------|------------------|--|-----------|--------------------------|--------|--------|--------|--------|----|----|------------|----|--|-----------|
|              |              |       |                 |                 |                  |  |           | % AGG.                   | % C.S. | % F.S. | % SILT | % CLAY | LL | PI |            | WC |  |           |
|              | 45           |       |                 |                 |                  | SILTY CLAY: Medium-stiff to stiff gray silty clay, trace fine sand, contains few soft zones.   |           |                          |        |        |        |        |    |    |            |    |  |           |
|              | 50           |       | 4/7/8           | 0.5-1.0         |                  |  | 11        |                          |        |        |        |        |    |    |            |    |  | Est. A-6b |
| 527.7        | 52.0         |       |                 |                 |                  |  |           |                          |        |        |        |        |    |    |            |    |  |           |
|              | 55           |       | 6/9/9<br>21     | 0.25-0.75       |                  | SILT AND CLAY: Medium-stiff to stiff gray clay, some silt, trace fine to coarse sand, trace fine gravel, contains many silt seams and shale fragments, and few soft zones. | 12        | 4                        | 4      | 4      | 27     | 61     | 32 | 12 | 26         |    |  | A-6a(9)   |
|              | 60           |       | 3/6/9           | 0.5-1.75        |                  |  | 13        |                          |        |        |        |        |    |    |            |    |  | Est. A-6a |
|              | 65           |       | P<br>4/8/10     | 0.5             |                  |  | 14        |                          |        |        |        |        |    |    |            |    |  | Est. A-6a |
|              | 65           |       | 4/8/10          | 0.5-1.5         |                  |  | 15        | 1                        | 1      | 3      | 32     | 63     | 34 | 13 | 24         |    |  | A-6a(9)   |
|              | 70           |       | 4/7/9           | 0.75-1.5        |                  |  | 16        |                          |        |        |        |        |    |    |            |    |  | Est. A-6a |
|              | 75           |       | 5/8/12          | 1.0-1.5         |                  |  | 17        |                          |        |        |        |        |    |    |            |    |  | Est. A-6a |
|              | 80           |       | 6/9/14          | 1.25-2.0        |                  |  | 18        | 1                        | 1      | 2      | 33     | 63     | 34 | 14 | 23         |    |  | A-6a(10)  |
| 497.7        | 82.0         |       |                 |                 |                  |  |           |                          |        |        |        |        |    |    |            |    |  |           |
|              | 85           |       | 7/9/12          | 1.0-2.0         |                  | SILT AND CLAY: Medium-stiff to stiff gray clay, "and" silt, trace fine to coarse sand, trace fine gravel, contains many silt seams.  | 19        |                          |        |        |        |        |    |    |            |    |  | Est. A-6a |
|              | 90           |       | 5/6/6           | 0.5-0.75        |                  |  | 20        |                          |        |        |        |        |    |    |            |    |  | Est. A-6a |

PLATE 45

WATER LEVEL: 10.0  
 WATER NOTE: Encountered  
 DATE: 5/11/06



**LOG OF BORING NO. B-05-14**  
**CUY-90-15.24 West Abutment**  
**CUYAHOGA COUNTY, OHIO**

Renamed: B-014-0-06

BBC&M JOB: 013-00946.300

TYPE: 3-1/4" I.D. Hollow-stem Auger 3-7/8" Tricone Roller Bit  
2/2.5" O.D. Split-barrel Sampler 3" O.D. Shelby Tube Sampler  
NQ Rock Core Barrel

LOCATION: Proposed I-90 Central Viaduct  
Sta. 137+07.98  
172.70' Rt. of Centerline

COMPLETION DEPTH: 199.0'  
ELEVATION: 579.7  
DATE: 5/11/06 - 5/18/06

| Elev. (feet) | Depth (feet) | Samp. | Std. Pen. / RQD | Hand Pen. (tsf)   | Rec./Loss. (feet) | CLASSIFICATION: DESCRIPTION   | Samp. No. | Physical Characteristics |        |        |        |        |    |    | ODOT Class |                      |
|--------------|--------------|-------|-----------------|-------------------|-------------------|---|-----------|--------------------------|--------|--------|--------|--------|----|----|------------|----------------------|
|              |              |       |                 |                   |                   |   |           | % AGG.                   | % C.S. | % F.S. | % SILT | % CLAY | LL | PI |            | WC                   |
| 482.7        | 90-95        |       | 3/5/5           | 0.5-0.75          |                   | SILT AND CLAY: Medium-stiff to stiff gray clay, "and" silt, trace fine to coarse sand, trace fine gravel, contains many silt seams.                                     | 21        | 1                        | 1      | 1      | 41     | 56     | 31 | 11 | 27         | A-6a(8)              |
|              | 97.0         |       | P               | 4.5+              |                   | SILT AND CLAY: Very-stiff to hard gray clay, some silt, little fine to coarse sand, trace fine gravel, contains many shale fragments, few cobbles and fine sand lenses. | 22        |                          |        |        |        |        |    |    |            | Est. A-6a            |
|              | 100-105      |       | 19/48/50-5"R    | 4.5+              |                   |   | 23        |                          |        |        |        |        |    |    |            | Est. A-6a            |
| 467.7        | 110-115      | 2S    | 21/27/38 50-4"R | 3.0-3.5           |                   |   | 24        | 3                        | 5      | 8      | 29     | 55     | 33 | 14 | 18         | A-6a(10)             |
|              | 112.0        |       | 13/13/13        | 0.75-1.75         |                   | SILT AND CLAY: Medium-stiff to stiff gray clay, some silt, trace fine to coarse sand, trace fine gravel, contains few fine to coarse sand and silt seams.               | 25        |                          |        |        |        |        |    |    |            | Est. A-6a            |
|              | 120          |       | 7/10/12         | 0.75-1.5          |                   |   | 26        |                          |        |        |        |        |    |    |            | Est. A-6a            |
| 455.1        | 125          |       | 6/13/26         | 0.75-1.25<br>0.75 |                   |   | 27A       | 4                        | 3      | 4      | 30     | 59     | 32 | 11 | 25         | A-6a(8)<br>Est. A-4a |
|              | 124.6        |       |                 |                   |                   | SANDY SILT: Medium-stiff becoming hard silt, some clay, "and" fine to coarse sand, little fine to coarse gravel, contains few cobbles.                                  | 27B       |                          |        |        |        |        |    |    |            |                      |
|              | 130          |       | 30/50-5"R       | 3.5-4.5+          |                   |   | 28        |                          |        |        |        |        |    |    |            | Est. A-4a            |
| 447.7        | 132.0        |       |                 |                   |                   |   |           |                          |        |        |        |        |    |    |            |                      |
|              | 135          |       | 33/48/38        | 3.5-4.25          |                   |   | 29        | 2                        | 3      | 5      | 47     | 43     | 27 | 9  | 16         | A-4a(8)              |

WATER LEVEL: 10.0  
WATER NC: Encountered  
DATE: 5/11/06

PLATE 46

TYPE: 3-1/4" I.D. Hollow-stem Auger 3-7/8" Tricone Roller Bit  
2/2.5" O.D. Split-barrel Sampler 3" O.D. Shelby Tube Sampler  
NQ Rock Core Barrel

LOCATION: Proposed I-90 Central Viaduct  
Sta. 137+07.98  
172.70' Rt. of Centerline

COMPLETION DEPTH: 199.0'  
 ELEVATION: 579.7  
 DATE: 5/11/06 - 5/18/06

| Elev. (feet) | Depth (feet) | Samp. | Std. Pen. / RQD  | Hand Pen. (tsf)     | Rec./Loss (feet) | CLASSIFICATION: DESCRIPTION   | Samp. No.  | Physical Characteristics |        |        |        |        |    |    | ODOT Class |    |  |                      |
|--------------|--------------|-------|------------------|---------------------|------------------|---|------------|--------------------------|--------|--------|--------|--------|----|----|------------|----|--|----------------------|
|              |              |       |                  |                     |                  |   |            | % AGG.                   | % C.S. | % F.S. | % SILT | % CLAY | LL | PI |            | WC |  |                      |
|              | 135          |       |                  |                     |                  |   |            |                          |        |        |        |        |    |    |            |    |  |                      |
|              | 140          |       | 26/30/<br>50-3"R | 2.75-4.5+           |                  | SANDY SILT: Very-stiff to hard gray silt, "and" clay, trace fine to coarse sand, trace fine gravel, contains many silt lenses, and few stiff zones.   | 30         |                          |        |        |        |        |    |    |            |    |  | Est. A-4a            |
| 435.9        | 145          |       | 38/28/42         | 1.5-4.5+<br>0.5-1.5 |                  | SILT AND CLAY: Medium-stiff to stiff gray clay, some silt, little fine to coarse sand, little fine gravel, contains many shale fragments.   | 31A<br>31B | 16                       | 8      | 3      | 31     | 42     | 31 | 11 | 18         |    |  | Est. A-4a<br>A-6a(8) |
| 432.7        | 150          |       | 50/50-3"R        |                     |                  | SANDY SILT: Very-dense gray fine to coarse sand, trace fine gravel, little silt, little clay.   | 32         |                          |        |        |        |        |    |    |            |    |  | Est. A-4a            |
|              | 155          |       | 37/50-5"R        |                     |                  |   | 33         |                          |        |        |        |        |    |    |            |    |  | Est. A-4a            |
| 422.7        | 157.0        |       |                  |                     |                  |   |            |                          |        |        |        |        |    |    |            |    |  |                      |
| 420.7        | 159.0        |       | 50-3"R           |                     |                  | SHALE: Very-soft gray shale.  | 34         |                          |        |        |        |        |    |    |            |    |  | Visual               |
|              | 160          |       | 77%              |                     | 5.0/0.0          | SHALE: Soft dark gray and gray shale, nearly horizontally bedded, few horizontal, diagonal, and vertical fractures, contains many interbedded siltstone layers, nodules.  | 35         |                          |        |        |        |        |    |    |            |    |  | Visual               |
| 413.1        | 165          |       | 53%              |                     | 2.6/0.0          |   |            |                          |        |        |        |        |    |    |            |    |  |                      |
|              | 170          |       | 54%              |                     | 6.1/0.0          | SHALE: Soft dark gray and gray shale, nearly horizontally bedded, many horizontal, and diagonal fractures, contains few interbedded silty clay layers, highly fractured from 171.5' to 171.7' and 172.4' to 172.8'. | 36         |                          |        |        |        |        |    |    |            |    |  | Visual               |
| 407.0        | 172.7        |       | 64%              |                     | 1.3/0.0          | - Qu=1313 psi at 168.5'.  |            |                          |        |        |        |        |    |    |            |    |  |                      |
|              | 175          |       | 79%              |                     | 10.0/0.0         |   | 37         |                          |        |        |        |        |    |    |            |    |  | Visual               |
|              | 180          |       |                  |                     |                  |   |            |                          |        |        |        |        |    |    |            |    |  |                      |

PLATE 47

WATER LEVEL: 10.0  
 WATER NOTE: Encountered  
 DATE: 5/11/06

TYPE: 3-1/4" I.D. Hollow-stem Auger 3-7/8" Tricone Roller Bit  
2/2.5" O.D. Split-barrel Sampler 3" O.D. Shelby Tube Sampler  
NQ Rock Core Barrel

LOCATION: Proposed I-90 Central Viaduct  
Sta. 137+07.98  
172.70' Rt. of Centerline

COMPLETION DEPTH: 199.0'  
ELEVATION: 579.7  
DATE: 5/11/06 - 5/18/06

| Elev. (feet) | Depth (feet) | Samp. | Std. Pen. / RQD | Hand Pen. (tsf) | Rec./Loss (feet) | CLASSIFICATION: DESCRIPTION  | Samp. No. | Physical Characteristics |      |      |      |      |    |    | ODOT Class |        |        |
|--------------|--------------|-------|-----------------|-----------------|------------------|--|-----------|--------------------------|------|------|------|------|----|----|------------|--------|--------|
|              |              |       |                 |                 |                  |  |           | AGG.                     | C.S. | F.S. | SILT | CLAY | LL | PI |            | WC     |        |
| 180          |              |       |                 |                 |                  | <b>SHALE:</b> Soft dark gray and gray shale, nearly horizontally bedded, few horizontal, diagonal, and vertical fractures, contains many interbedded siltstone layers, nodules.<br><br>- Qu=1198 psi at 180.0'.<br>- Qu=3228 psi at 190.5'.<br>- $\mu=0.13$ at 190.5'.   | 38        |                          |      |      |      |      |    |    |            | Visual |        |
| 185          |              |       | 75%             |                 | 5.0/0.0          |  | 39        |                          |      |      |      |      |    |    |            |        | Visual |
| 190          |              |       |                 |                 |                  |  |           |                          |      |      |      |      |    |    |            |        |        |
| 195          |              |       | 14%             |                 | 2.5/7.5          |  |           |                          |      |      |      |      |    |    |            |        |        |
| 199.0        |              |       |                 |                 |                  |  |           |                          |      |      |      |      |    |    |            |        |        |
| 200          |              |       |                 |                 |                  | <b>NOTES:</b><br>- Encountered water at 10.0'.<br>- Added water at 15.0' to prevent heave.<br>- Switched to washbore at 35.0'.<br>- Pressure Tests were performed by EL Robinson on 5/5/06 between the depths of 40.0' to 42.0', 62.0' to 64.0', and 71.0' to 73.0'.<br>- Encountered cobbles at 104.5', 110.0', and 129.0'.<br>- Encountered a gas pocket at approximately 161.0'. Gas vapor visible during rock coring.<br>- Rock-core barrel may have become plugged leading to poor recovery in Sample S-39. |           |                          |      |      |      |      |    |    |            |        |        |
| 205          |              |       |                 |                 |                  |  |           |                          |      |      |      |      |    |    |            |        |        |
| 210          |              |       |                 |                 |                  |  |           |                          |      |      |      |      |    |    |            |        |        |
| 215          |              |       |                 |                 |                  |  |           |                          |      |      |      |      |    |    |            |        |        |
| 220          |              |       |                 |                 |                  |  |           |                          |      |      |      |      |    |    |            |        |        |
| 225          |              |       |                 |                 |                  |  |           |                          |      |      |      |      |    |    |            |        |        |
| 380.7        |              |       |                 |                 |                  |  |           |                          |      |      |      |      |    |    |            |        |        |

WATER LEVEL: 10.0  
 WATER NC: Encountered  
 DATE: 5/11/06

PLATE 48



**LOG OF BORING NO. B-05-15** Renamed: B-015-0-06  
**CUY-90-15.24 West Abutment**  
**CUYAHOGA COUNTY, OHIO**

BBC&M JOB: 012-00946.300

TYPE: 3-1/4" I.D. Hollow-stem Auger 3-7/8" Tricone Roller Bit  
2 7/8" O.D. Split-barrel Sampler 3" O.D. Shelby Tube Sampler  
NQ Rock Core Barrel

LOCATION: Proposed I-90 Central Viaduct  
Sta. 139+23.33  
65.91' Rt. of Centerline

COMPLETION DEPTH: 214.0'  
 ELEVATION: 581.1  
 DATE: 5/18/06 - 5/24/06

| Elev. (feet) | Depth (feet) | Samp. | Std. Pen. / RQD | Hand Pen. (tsf) | Rec./Loss (feet) | CLASSIFICATION: DESCRIPTION   | Samp. No. | Physical Characteristics |      |      |      |      |    |    | ODOT Class |    |           |
|--------------|--------------|-------|-----------------|-----------------|------------------|---|-----------|--------------------------|------|------|------|------|----|----|------------|----|-----------|
|              |              |       |                 |                 |                  |   |           | AGG.                     | C.S. | F.S. | SILT | CLAY | LL | PI |            | WC |           |
| 579.8        | 0            |       | 20/14/7         |                 |                  | 1.3 GRANULAR BASE - 16 INCHES   | 1A        |                          |      |      |      |      |    |    |            |    | Visual    |
|              |              |       |                 |                 |                  | COARSE AND FINE SAND (FILL): Loose to medium-dense black intermixed with brown fine to coarse sand, little fine to coarse gravel, trace silt, trace clay. | 1B        |                          |      |      |      |      |    |    |            |    | Est. A-3a |
| 576.4        | 5            |       | 3/3/5           | 2.0-4.5+        |                  | 4.7 SILT AND CLAY (FILL): Very-stiff to hard brown intermixed with black clay, "and" silt, some fine to coarse sand, little fine to coarse gravel.        | 2A        |                          |      |      |      |      |    |    |            |    | Est. A-3a |
| 573.6        |              |       |                 |                 |                  | 7.5 SANDY SILT: Very-loose brown and gray silt, some clay, some fine sand, contains many silty clay pockets and seams.                                    | 2B        |                          |      |      |      |      |    |    |            |    | Est. A-6a |
|              | 10           |       | 1/1/1           |                 |                  | 12.0 COARSE AND FINE SAND: Very-loose gray fine sand, some silt, little clay, trace coarse sand.  | 3         | 0                        | 0    | 35   | 41   | 24   | NP | NP | 25         |    | A-4a(0)   |
| 569.1        |              |       |                 |                 |                  | 17.0 COARSE AND FINE SAND: Loose gray fine to coarse sand, trace fine gravel, trace silt, trace clay.   | 4         | 0                        | 1    | 66   | 22   | 11   | NP | NP | 30         |    | A-3a(0)   |
| 564.1        | 15           |       | 2/2/2           |                 |                  | 24.0 COARSE AND FINE SAND: Loose gray fine to coarse sand, trace fine gravel, trace silt, trace clay.   | 5         | 1                        | 22   | 61   | 9    | 7    | NP | NP | 23         |    | A-3a(0)   |
|              | 20           |       | 2/3/3           |                 |                  | 32.0 SILT AND CLAY: Stiff to very-stiff becoming soft to medium-stiff gray clay, "and" silt, trace fine sand, contains few silt seams.                    | 6A        |                          |      |      |      |      |    |    |            |    | Est. A-3a |
| 557.1        | 25           |       | 2/3/3           |                 |                  |   | 6B        |                          |      |      |      |      |    |    |            |    | Est. A-3a |
|              | 30           |       | 5/5/5           |                 |                  |   | 7         |                          |      |      |      |      |    |    |            |    | Est. A-3a |
| 549.1        | 35           |       | P               | 2.25-3.75       |                  |   | 8         |                          |      |      |      |      |    |    |            |    | Est. A-6a |
|              |              |       | 5/8/12          | 1.25-2.75       |                  |   | 9         |                          |      |      |      |      |    |    |            |    | Est. A-6a |
|              | 40           |       | 4/6/9           | 1.75-2.5        |                  |   | 10        | 0                        | 0    | 2    | 49   | 49   | 34 | 13 | 27         |    | A-6a(9)   |
|              | 45           |       | 2/3/5           | 0.5-1.0         |                  |   | 11        |                          |      |      |      |      |    |    |            |    | Est. A-6a |
|              |              |       | P               | 0.25-0.5        |                  |   | 12        |                          |      |      |      |      |    |    |            |    | Est. A-6a |
| 533.1        | 50           |       | 4/7/11          | 0.75-3.0        |                  |   | 13        | 6                        | 8    | 11   | 35   | 40   | 26 | 8  | 18         |    | A-4a(8)   |

PLATE 49

WATER LEVEL: 8.0 0.5 4.0 4.0  
 WATER NOTE: Encountered After HSA Removed - Prior to Washbore Augers Pulled - Prior to Washbore  
 DATE: 5/18/06 5/18/06 5/19/06

TYPE: 3-1/4" I.D. Hollow-stem Auger 3-7/8" Tricone Roller Bit  
2 1/2" O.D. Split-barrel Sampler 3" O.D. Shelby Tube Sampler  
NQ Rock Core Barrel

LOCATION: Proposed I-90 Central Viaduct  
Sta. 139+23.33  
65.91' Rt. of Centerline

COMPLETION DEPTH: 214.0'  
 ELEVATION: 581.1  
 DATE: 5/18/06 - 5/24/06

| Elev. (feet) | Depth (feet) | Samp. | Std. Pen. / RQD | Hand Pen. (tsf) | Rec./Loss (feet) | CLASSIFICATION: DESCRIPTION   | Samp. No. | Physical Characteristics |        |        |        |        |    |    | ODOT Class |    |  |           |           |
|--------------|--------------|-------|-----------------|-----------------|------------------|---|-----------|--------------------------|--------|--------|--------|--------|----|----|------------|----|--|-----------|-----------|
|              |              |       |                 |                 |                  |   |           | AGG. %                   | C.S. % | F.S. % | SILT % | CLAY % | LL | PI |            | WC |  |           |           |
| 514.1        | 50           |       |                 |                 |                  | SANDY SILT: Medium-stiff to stiff gray clay, some silt, little fine to coarse sand, trace fine gravel, contains few very-stiff zones. |           |                          |        |        |        |        |    |    |            |    |  |           |           |
|              | 55           |       | 4/8/11          | 1.0-1.75        |                  |   | 14        |                          |        |        |        |        |    |    |            |    |  |           | Est. A-4a |
|              | 60           |       | 5/9/12          | 1.25-2.0        |                  |   | 15        |                          |        |        |        |        |    |    |            |    |  |           | Est. A-4a |
|              | 65           |       | 5/9/13          | 0.75-1.75       |                  |   | 16        |                          |        |        |        |        |    |    |            |    |  |           | Est. A-4a |
|              |              | P     |                 |                 |                  |   |           |                          |        |        |        |        |    |    |            |    |  |           |           |
|              |              | P     |                 | 1.25-1.5        |                  |   |           |                          |        |        |        |        |    |    |            |    |  |           |           |
|              | 70           |       | 5/8/10          | 1.25-1.5        |                  |   | 17        |                          |        |        |        |        |    |    |            |    |  |           | Est. A-6a |
|              |              |       |                 |                 |                  |   | 18        | 2                        | 2      | 3      | 33     | 60     | 35 | 14 | 25         |    |  |           | A-6a(10)  |
|              | 75           |       | 5/9/12          | 1.0-1.5         |                  |   | 19        |                          |        |        |        |        |    |    |            |    |  |           | Est. A-6a |
|              |              | P     |                 | 1.25-1.75       |                  |   | 20        |                          |        |        |        |        |    |    |            |    |  |           | Est. A-6a |
|              | 80           |       | 7/10/16         |                 |                  |   | 21        |                          |        |        |        |        |    |    |            |    |  |           | Est. A-6a |
| 498.6        |              | 25    | 27              | 1.5-1.75        |                  |   |           |                          |        |        |        |        |    |    |            |    |  |           |           |
|              | 85           |       | 7/10/13         | 1.75-2.25       |                  |   | 22        | 1                        | 1      | 1      | 33     | 64     | 38 | 16 | 25         |    |  |           | A-6b(10)  |
| 494.1        |              |       |                 |                 |                  |   |           |                          |        |        |        |        |    |    |            |    |  |           |           |
|              | 90           |       | 6/9/12          | 1.25-2.0        |                  | 23  |           |                          |        |        |        |        |    |    |            |    |  | Est. A-6a |           |
|              | 95           |       | 3/4/6           | 0.5-1.25        |                  | 24  | 1         | 1                        | 1      | 29     | 68     | 37     | 15 | 30 |            |    |  | A-6a(10)  |           |
|              |              | P     |                 | 1.0-1.5         |                  | 25  |           |                          |        |        |        |        |    |    |            |    |  | Est. A-6a |           |
|              | 100          |       | 5/6/10          | 0.25-1.25       |                  | 26  |           |                          |        |        |        |        |    |    |            |    |  | Est. A-6a |           |

PLATE 50

WATER LEVEL: 8.0 0.5 4.0  
 WATER NC Encountered After HSA Removed - Prior to Was' Augers Pulled - Prior to Washbore  
 DA 5/18/06 5/18/06 5/19/06

TYPE: 3-1/4" I.D. Hollow-stem Auger 3-7/8" Tricone Roller Bit  
2/2.5" O.D. Split-barrel Sampler 3" O.D. Shelby Tube Sampler  
NQ Rock Core Barrel

LOCATION: Proposed I-90 Central Viaduct  
Sta. 139+23.33  
65.91' Rt. of Centerline

COMPLETION DEPTH: 214.0'  
ELEVATION: 581.1  
DATE: 5/18/06 - 5/24/06

| Elev. (feet) | Depth (feet) | Samp. | Std. Pen. / RQD  | Hand Pen. (tsf) | Rec./Loss (feet) | CLASSIFICATION: DESCRIPTION   | Samp. No. | Physical Characteristics |        |        |        |        |    |    | ODOT Class |    |          |           |
|--------------|--------------|-------|------------------|-----------------|------------------|---|-----------|--------------------------|--------|--------|--------|--------|----|----|------------|----|----------|-----------|
|              |              |       |                  |                 |                  |   |           | AGG. %                   | C.S. % | F.S. % | SILT % | CLAY % | LL | PI |            | WC |          |           |
| 479.1        | 100          |       |                  |                 |                  | 102.0   |           |                          |        |        |        |        |    |    |            |    |          |           |
|              |              |       | 13/31/44         | 4.5+            |                  | SANDY SILT: Hard gray clay, some silt, some fine to coarse sand.  | 27        | 9                        | 12     | 15     | 31     | 33     | 22 | 7  | 11         |    | A-4a(6)  |           |
| 474.1        | 105          |       |                  |                 |                  | 107.0   |           |                          |        |        |        |        |    |    |            |    |          |           |
|              |              |       | 15/29/44         | 4.0-4.5+        |                  | SILT AND CLAY: Very-stiff to hard gray clay, some silt, trace fine to coarse sand, trace fine gravel, contains few silt lenses. | 28        |                          |        |        |        |        |    |    |            |    |          | Est. A-6a |
|              | 110          |       |                  |                 |                  |   |           |                          |        |        |        |        |    |    |            |    |          |           |
|              |              |       | 13/28/39         | 3.75-4.5+       |                  |   | 29        | 2                        | 3      | 3      | 29     | 63     | 36 | 14 | 19         |    | A-6a(10) |           |
|              | 115          |       |                  |                 |                  |   |           |                          |        |        |        |        |    |    |            |    |          |           |
|              |              |       | 9/16/21          | 2.5-4.0         |                  |   | 30        |                          |        |        |        |        |    |    |            |    |          | Est. A-6a |
| 459.1        | 120          |       |                  |                 |                  | 122.0   |           |                          |        |        |        |        |    |    |            |    |          |           |
|              |              |       | 9/11/11          | 1.25-1.5        |                  | SILTY CLAY: Stiff gray silty clay, contains few silt lenses.  | 31        | 0                        | 0      | 0      | 27     | 73     | 39 | 16 | 29         |    | A-6b(10) |           |
| 454.1        | 125          |       |                  |                 |                  | 127.0   |           |                          |        |        |        |        |    |    |            |    |          |           |
|              |              |       | 31/25/33         |                 |                  | SANDY SILT: Very-dense gray fine to coarse sand, some silt, little clay, little fine gravel.                                    | 32        |                          |        |        |        |        |    |    |            |    |          | Est. A-4a |
| 449.1        | 130          |       |                  |                 |                  | 132.0   |           |                          |        |        |        |        |    |    |            |    |          |           |
|              |              |       | 22/44/<br>50-5"R | 4.5+            |                  | SILTY CLAY: Hard gray silty clay, trace fine to coarse sand, contains few shale fragments.                                      | 33        |                          |        |        |        |        |    |    |            |    |          | Est. A-6b |
|              | 135          |       |                  |                 |                  |   |           |                          |        |        |        |        |    |    |            |    |          |           |
|              |              |       | 17/39/33         | 4.5+            |                  |   | 34        | 0                        | 1      | 2      | 26     | 71     | 39 | 16 | 22         |    | A-6b(10) |           |
| 439.1        | 140          |       |                  |                 |                  | 142.0   |           |                          |        |        |        |        |    |    |            |    |          |           |
|              |              |       | 14/27/35         | 4.0-4.25        |                  | SILT AND CLAY: Hard gray clay, "and" silt, trace fine to coarse sand, trace fine gravel, contains few silt lenses.              | 35        |                          |        |        |        |        |    |    |            |    |          | Est. A-6a |
|              | 145          |       |                  |                 |                  |   |           |                          |        |        |        |        |    |    |            |    |          |           |
|              |              |       | 17/31/39         | 4.5+            |                  |   | 36        |                          |        |        |        |        |    |    |            |    |          | Est. A-6a |
|              | 150          |       |                  |                 |                  |   |           |                          |        |        |        |        |    |    |            |    |          |           |

WATER LEVEL: 8.0      0.5      4.0  
WATER NOTE: Encountered      After HSA Removed - Prior to Washbore      Augers Pulled - Prior to Washbore  
DATE: 5/18/06      5/18/06      5/19/06

PLATE 51



TYPE: 3-1/4" I.D. Hollow-stem Auger 3-7/8" Tricone Roller Bit  
2/2.5" O.D. Split-barrel Sampler 3" O.D. Shelby Tube Sampler  
NQ Rock Core Barrel

LOCATION: Proposed I-90 Central Viaduct  
Sta. 139+23.33  
65.91' Rt. of Centerline

COMPLETION DEPTH: 214.0'  
 ELEVATION: 581.1  
 DATE: 5/18/06 - 5/24/06

| Elev. (feet) | Depth (feet) | Samp. | Std. Pen. / RQD | Hand Pen. (tsf) | Rec./Loss (feet) | CLASSIFICATION: DESCRIPTION   | Samp. No. | Physical Characteristics |        |        |        |        |    |    | ODOT Class |    |           |        |
|--------------|--------------|-------|-----------------|-----------------|------------------|---|-----------|--------------------------|--------|--------|--------|--------|----|----|------------|----|-----------|--------|
|              |              |       |                 |                 |                  |   |           | % AGG.                   | % C.S. | % F.S. | % SILT | % CLAY | LL | PI |            | WC |           |        |
|              | 150          |       |                 |                 |                  |   |           |                          |        |        |        |        |    |    |            |    |           |        |
|              | 155          |       | 19/33/45        | 4.5+            |                  | SILT AND CLAY: Hard gray clay, "and" silt, trace fine to coarse sand, trace fine gravel, contains few silt lenses.  | 37        | 1                        | 1      | 1      | 41     | 56     | 34 | 12 | 20         |    | A-6a(9)   |        |
|              | 160          |       | 23/33/39        | 4.5+            |                  |   | 38        |                          |        |        |        |        |    |    |            |    | Est. A-6a |        |
| 419.1        |              |       |                 |                 |                  |   |           |                          |        |        |        |        |    |    |            |    |           |        |
|              | 165          |       | 18/33/43        | 4.5+            |                  | SANDY SILT: Hard gray silt, "and" clay, trace fine to coarse sand, trace fine gravel, contains few shale fragments.   | 39        | 4                        | 5      | 5      | 45     | 41     | 27 | 9  | 15         |    | A-4a(8)   |        |
| 414.1        |              |       |                 |                 |                  |   |           |                          |        |        |        |        |    |    |            |    |           |        |
|              | 170          |       | 50-5"R          |                 |                  | SHALE: Very-soft gray shale, contains few silty clay seams.   | 40        |                          |        |        |        |        |    |    |            |    |           | Visual |
| 407.1        |              |       | 50-1"R          |                 |                  |   | 41        |                          |        |        |        |        |    |    |            |    |           | Visual |
|              | 175          |       | 35%             |                 | 5.0/0.0          | SHALE: Soft dark gray to gray shale, nearly horizontally bedded, many horizontal and few vertical fractures, contains few interbedded siltstone and silty clay layers, vertical fracture from 183.4' to 184.0'. | 42        |                          |        |        |        |        |    |    |            |    |           | Visual |
|              | 180          |       | 47%             |                 | 4.8/0.2          |   | 43        |                          |        |        |        |        |    |    |            |    |           | Visual |
| 397.1        |              |       |                 |                 |                  |   |           |                          |        |        |        |        |    |    |            |    |           |        |
|              | 185          |       | 0%              |                 | 5.0/0.0          | SHALE: Very-soft to soft dark gray and gray shale, nearly horizontally bedded, many horizontal fractures, contains many interbedded silty clay and few siltstone layers.  | 44        |                          |        |        |        |        |    |    |            |    |           | Visual |
| 392.1        |              |       |                 |                 |                  |   |           |                          |        |        |        |        |    |    |            |    |           |        |
|              | 190          |       | 68%             |                 | 5.0/0.0          |   | 45        |                          |        |        |        |        |    |    |            |    |           | Visual |
|              | 195          |       | 68%             |                 | 5.0/0.0          |   | 46        |                          |        |        |        |        |    |    |            |    |           | Visual |
|              | 200          |       |                 |                 |                  |   |           |                          |        |        |        |        |    |    |            |    |           |        |

WATER LEVEL: 8.0      0.5      4.0  
 WATER NC: Encountered      After HSA Removed - Prior to Wash      Angers Pulled - Prior to Washbore  
 DA: 5/18/06      5/18/06      5/19/06

PLATE 52



**LOG OF BORING NO. B-05-15** Renamed: B-015-0-06  
**CUY-90-15.24 West Abutment**  
**CUYAHOGA COUNTY, OHIO**

BBC&M JOB: 012-00946.300

TYPE: 3-1/4" I.D. Hollow-stem Auger 3-7/8" Tricone Roller Bit LOCATION: Proposed I-90 Central Viaduct COMPLETION DEPTH: 214.0'  
2/2.5" O.D. Split-barrel Sampler 3" O.D. Shelby Tube Sampler Sta. 139+23.33 ELEVATION: 581.1  
NQ Rock Core Barrel 65.91' Rt. of Centerline DATE: 5/18/06 - 5/24/06

| Elev. (feet) | Depth (feet) | Samp. | Std. Pen. / RQD | Hand Pen. (tsf) | Rec./Loss (feet) | CLASSIFICATION: DESCRIPTION  | Samp. No. | Physical Characteristics |      |      |      |      |    |    | ODOT Class |        |        |
|--------------|--------------|-------|-----------------|-----------------|------------------|--|-----------|--------------------------|------|------|------|------|----|----|------------|--------|--------|
|              |              |       |                 |                 |                  |  |           | AGG.                     | C.S. | F.S. | SILT | CLAY | LL | PI |            | WC     |        |
| 367.1        | 200          |       | 52%             |                 | 5.0/0.0          | SHALE: Soft gray and dark gray shale, nearly horizontally bedded, few to many horizontal and few diagonal fractures, major diagonal fractures located at 196.1', 197.2', 199.3', and 199.7'.<br>- Qu=2057 psi at 202.5'.<br>- Qu=2916 psi at 208.5'.<br>- Qu=2322 psi at 213.5'.<br>- μ=0.40 at 213.5'.  | 47        |                          |      |      |      |      |    |    |            | Visual |        |
|              | 205          |       | 52%             |                 | 4.2/0.8          |  | 48        |                          |      |      |      |      |    |    |            |        | Visual |
|              | 210          |       | 73%             |                 | 5.0/0.0          |  | 49        |                          |      |      |      |      |    |    |            |        | Visual |
|              | 214.0        |       |                 |                 |                  |  |           |                          |      |      |      |      |    |    |            |        |        |
|              | 215          |       |                 |                 |                  | <b>NOTES</b><br>- Encountered water at 8'.<br>- Water added at 15.0' to prevent heave.<br>- Switched to washbore at 35.0'.<br>- Constant 8' to 10' eruption of water/gas above casing for 10 minutes during first core run. Water/gas also erupted during core barrel removal. Water escaped from top of core barrel, which was lifted up approximately 15 feet above ground surface. Water/gas/debris also escaped horizontally from the top of the core barrel connection and sprayed approximately 40' horizontally from drill rig. |           |                          |      |      |      |      |    |    |            |        |        |
|              | 220          |       |                 |                 |                  |  |           |                          |      |      |      |      |    |    |            |        |        |
|              | 225          |       |                 |                 |                  |  |           |                          |      |      |      |      |    |    |            |        |        |
|              | 230          |       |                 |                 |                  |  |           |                          |      |      |      |      |    |    |            |        |        |
|              | 235          |       |                 |                 |                  |  |           |                          |      |      |      |      |    |    |            |        |        |
|              | 240          |       |                 |                 |                  |  |           |                          |      |      |      |      |    |    |            |        |        |
|              | 245          |       |                 |                 |                  |  |           |                          |      |      |      |      |    |    |            |        |        |
|              | 250          |       |                 |                 |                  |  |           |                          |      |      |      |      |    |    |            |        |        |

WATER LEVEL: ∇ 8.0 ∇ 0.5 ∇ 4.0 ∇  
 WATER NOTE: Encountered After HSA Removed - Prior to Washbore Augers Pulled - Prior to Washbore  
 DATE: 5/18/06 5/18/06 5/19/06

PLATE 53

TYPE: 3-1/4" I.D. Hollow-stem Auger 3-7/8" Tricone Roller Bit  
2" O.D. Split-barrel Sampler 3" O.D. Shelby Tube Sampler  
NX Rock Core Barrel

LOCATION: Proposed I-90 Central Viaduct  
Sta. 133+62.01  
61.67' Rt. of Centerline

COMPLETION DEPTH: 164.0'  
 ELEVATION: 598.5  
 DATE: 6/8/06 - 6/14/06

| Elev. (feet) | Depth (feet) | Samp. | Std. Pen. / RQD | Hand Pen. (tsf) | Rec./Loss (feet) | CLASSIFICATION: DESCRIPTION   | Samp. No. | Physical Characteristics |        |        |        |        |    |    | ODOT Class |    |            |
|--------------|--------------|-------|-----------------|-----------------|------------------|---|-----------|--------------------------|--------|--------|--------|--------|----|----|------------|----|------------|
|              |              |       |                 |                 |                  |   |           | % AGG.                   | % C.S. | % F.S. | % SILT | % CLAY | LL | PI |            | WC |            |
| 598.5        | 0            |       |                 |                 |                  | 0.2 TOPSOIL/ROOTMAT - 2 1/2 INCHES  |           |                          |        |        |        |        |    |    |            |    |            |
| 595.0        | 3.5          |       | 5/6/12          |                 |                  | GRAVEL WITH SAND (FILL): Medium-dense dark brown and black fine to coarse sand, little fine to coarse gravel, trace silt, contains few slag fragments.                        | 1         |                          |        |        |        |        |    |    |            |    | Est. A-1-b |
|              | 5            |       | 3/2/3           |                 |                  | GRAVEL WITH SAND (FILL): Very-loose to loose brown and black fine to coarse sand, "and" fine to coarse gravel, trace silt, trace clay, contains many slag and coal fragments. | 2         |                          |        |        |        |        |    |    |            |    | Est. A-1-b |
|              | 10           |       | 3/2/1           |                 |                  |   | 3         |                          |        |        |        |        |    |    |            |    | Est. A-1-b |
| 586.0        | 12.5         |       |                 |                 |                  | COARSE AND FINE SAND: Very-loose brown fine to coarse sand, trace fine gravel, trace silt, trace clay.  | 4         | 9                        | 27     | 46     | 9      | 9      | NP | NP | 13         |    | A-3a(0)    |
| 580.0        | 18.5         |       | 1/1/1           |                 |                  |   | 5         |                          |        |        |        |        |    |    |            |    | Est. A-3a  |
| 578.5        | 20.0         |       | 1/2/1           |                 |                  | COARSE AND FINE SAND: Very-loose black and brown fine to coarse sand, trace fine gravel, little silt, trace clay, contains few coal fragments, slightly organic.              | 6A        |                          |        |        |        |        |    |    |            |    | Est. A-4b  |
| 576.0        | 22.5         |       | P               | 0.5-1.25        |                  | SILT: Very-loose brown silt, "and" fine sand, trace coarse sand.  | 6B        | 1                        | 1      | 3      | 57     | 38     | 25 | 7  | 26         |    | A-4b(8)    |
| 575.5        | 23.0         |       | 2/2/1           | 1.5-2.0         |                  | SILT: Medium-stiff to stiff gray silt, "and" clay, trace fine to coarse sand, trace fine gravel, contains many silty clay lenses and seams.                                   | 7         | 1                        | 1      | 1      | 49     | 48     | 36 | 16 | 26         |    | A-6b(10)   |
|              | 30           |       | 1/2/3           | 0.5-1.5         |                  | SILTY CLAY: Medium-stiff gray silty clay, trace fine to coarse sand, trace fine gravel, contains few silt lenses.   | 8         | 1                        | 1      | 1      | 33     | 64     | 35 | 16 | 28         |    | A-6b(10)   |
| 566.5        | 32.0         |       |                 |                 |                  |   | 9         |                          |        |        |        |        |    |    |            |    | Est. A-6a  |
|              | 35           |       | 3/4/3           | 1.0-1.75        |                  | SILT AND CLAY: Stiff to very-stiff gray silt, "and" clay, trace fine gravel, contains many silt pockets and lenses, and few hard zones.                                       |           |                          |        |        |        |        |    |    |            |    |            |
|              | 40           |       | 3/4/6           | 1.75-3.5        |                  |   | 10        |                          |        |        |        |        |    |    |            |    | Est. A-6a  |
|              | 45           |       | 5/8/11          | 2.75-4.25       |                  |   | 11        | 0                        | 0      | 3      | 51     | 45     | 28 | 11 | 22         |    | A-6a(8)    |

WATER LEVEL: 21.0  
 WATER NC Encountered  
 DA. 6/8/06

PLATE 54

TYPE: 3-1/4" I.D. Hollow-stem Auger    3-7/8" Tricone Roller Bit    LOCATION: Proposed I-90 Central Viaduct    COMPLETION DEPTH: 164.0'  
2" O.D. Split-barrel Sampler    3" O.D. Shelby Tube Sampler    Sta. 133+62.01    ELEVATION: 598.5  
NX Rock Core Barrel    61.67' Rt. of Centerline    DATE: 6/8/06 - 6/14/06

| Elev. (feet) | Depth (feet) | Samp. | Std. Pen. / RQD | Hand Pen. (tsf) | Rec./Loss (feet) | CLASSIFICATION: DESCRIPTION   | Samp. No. | Physical Characteristics |      |      |      |      |    |    | ODOT Class |    |  |           |
|--------------|--------------|-------|-----------------|-----------------|------------------|---|-----------|--------------------------|------|------|------|------|----|----|------------|----|--|-----------|
|              |              |       |                 |                 |                  |   |           | AGG.                     | C.S. | F.S. | SILT | CLAY | LL | PI |            | WC |  |           |
| 551.0        | 45           |       |                 |                 |                  | 47.5  |           |                          |      |      |      |      |    |    |            |    |  |           |
|              | 50           |       | 6/8/11          | 4.25            |                  | SILT: Stiff to very-stiff gray silt, "and" clay, trace fine sand, contains many silty clay seams, and few hard zones. | 12        |                          |      |      |      |      |    |    |            |    |  | Est. A-4b |
|              | 55           |       | 4/6/9           | 1.75-2.25       |                  |   | 13        |                          |      |      |      |      |    |    |            |    |  | Est. A-4b |
|              | 60           |       | 4/7/7           | 1.75-2.25       |                  |   | 14        | 0                        | 0    | 1    | 53   | 46   | 27 | 10 | 26         |    |  | A-4b(8)   |
| 536.0        | 65           |       | 4/7/7           | 1.25-2.5        |                  | 62.5  | 15        |                          |      |      |      |      |    |    |            |    |  | Est. A-6a |
|              | 70           |       | 4/6/7           | 0.75-1.5        |                  |   | 16        | 1                        | 2    | 6    | 27   | 64   | 32 | 13 | 26         |    |  | A-6a(9)   |
|              | 75           |       | 5/7/10          | 1.25-1.75       |                  |   | 17        |                          |      |      |      |      |    |    |            |    |  | Est. A-6a |
|              | 80           |       | 5/6/8           | 1.25-1.75       |                  |   | 18        |                          |      |      |      |      |    |    |            |    |  | Est. A-6a |
|              | 85           |       | 4/7/10          | 1.0-1.75        |                  |   | 19        | 1                        | 2    | 3    | 28   | 66   | 31 | 12 | 24         |    |  | A-6a(9)   |
|              | 90           |       | 5/5/9           | 1.25-1.75       |                  |   | 20        |                          |      |      |      |      |    |    |            |    |  | Est. A-6a |

WATER LEVEL: 21.0    WATER NOTE: Encountered    DATE: 6/8/06

TYPE: 3-1/4" I.D. Hollow-stem Auger    3-7/8" Tricone Roller Bit    LOCATION: Proposed I-90 Central Viaduct    COMPLETION DEPTH: 164.0'  
2" O.D. Split-barrel Sampler    3" O.D. Shelby Tube Sampler    Sta. 133+62.01    ELEVATION: 598.5  
NX Rock Core Barrel    61.67' Rt. of Centerline    DATE: 6/8/06 - 6/14/06

| Elev. (feet) | Depth (feet) | Samp. | Std. Pen. / RQD | Hand Pen. (tsf) | Rec./Loss (feet) | CLASSIFICATION: DESCRIPTION   | Samp. No. | Physical Characteristics |        |        |        |        |    |    | ODOT Class |    |           |
|--------------|--------------|-------|-----------------|-----------------|------------------|---|-----------|--------------------------|--------|--------|--------|--------|----|----|------------|----|-----------|
|              |              |       |                 |                 |                  |   |           | % AGG.                   | % C.S. | % F.S. | % SILT | % CLAY | LL | PI |            | WC |           |
|              | 90           |       |                 |                 |                  |   |           |                          |        |        |        |        |    |    |            |    |           |
|              | 95           |       | 7/10/13         | 1.5-2.5         |                  | SILT AND CLAY: Stiff to very-stiff gray clay, some silt, trace fine to coarse sand, trace fine gravel, contains few medium-stiff zones, and a fine to coarse sand seam from 69.5' to 69.6'. | 21        |                          |        |        |        |        |    |    |            |    | Est. A-6a |
|              | 100          |       | 5/9/11          | 1.75-2.25       |                  |   | 22        | 0                        | 0      | 1      | 33     | 66     | 33 | 13 | 24         |    | A-6a(9)   |
|              | 105          |       | 5/7/10          | 1.5-2.5         |                  |   | 23        |                          |        |        |        |        |    |    |            |    | Est. A-6a |
| 488.0        | 110          |       | 5/7/8           | 1.5-2.25        |                  |   | 24        |                          |        |        |        |        |    |    |            |    | Est. A-6a |
| 485.5        |              |       | P               | 1.5-1.75        |                  | SILT: Stiff gray silt, "and" clay, trace fine sand, contains many silty clay seams.   | 25        | 0                        | 0      | 1      | 52     | 47     | 27 | 7  | 30         |    | A-4b(8)   |
|              | 115          |       | P               |                 |                  | SILT: Loose (estimated) gray silt, trace clay, trace fine to coarse sand, trace fine gravel.  | 26        | 1                        | 1      | 5      | 84     | 9      | NP | NP | 25         |    | A-4b(0)   |
| 481.5        |              |       |                 |                 |                  |   |           |                          |        |        |        |        |    |    |            |    |           |
|              | 120          |       | 12/24/44        | 4.5+            |                  | SILT AND CLAY: Hard gray clay, some silt, trace fine to coarse sand.  | 27        |                          |        |        |        |        |    |    |            |    | Est. A-6a |
|              | 125          |       | 12/24/31        | 4.5+            |                  |   | 28        |                          |        |        |        |        |    |    |            |    | Est. A-6a |
| 471.0        |              |       |                 |                 |                  |   |           |                          |        |        |        |        |    |    |            |    |           |
|              | 130          |       | 5/9/11          | 1.0-2.25        |                  | SILT AND CLAY: Stiff to very-stiff gray clay, some silt, trace fine sand.   | 29        | 0                        | 0      | 1      | 25     | 74     | 37 | 14 | 30         |    | A-6a(10)  |
|              | 135          |       | 5/7/8           | 1.0-1.75        |                  |   | 30        |                          |        |        |        |        |    |    |            |    | Est. A-6a |

WATER LEVEL: 21.0    WATER NO: Encountered    DATE: 6/8/06

PLATE 56

TYPE: 3-1/4" I.D. Hollow-stem Auger    3-7/8" Tricone Roller Bit  
2" O.D. Split-barrel Sampler    3" O.D. Shelby Tube Sampler  
NX Rock Core Barrel

LOCATION: Proposed I-90 Central Viaduct  
Sta. 133+62.01  
61.67' Rt. of Centerline

COMPLETION DEPTH: 164.0'  
ELEVATION: 598.5  
DATE: 6/8/06 - 6/14/06

| Elev. (feet) | Depth (feet) | Samp. | Std. Pen. / RQD | Hand Pen. (tsf) | Rec./Loss (feet) | CLASSIFICATION: DESCRIPTION   | Samp. No. | Physical Characteristics |        |        |        |        |    |    | ODOT Class |    |           |
|--------------|--------------|-------|-----------------|-----------------|------------------|---|-----------|--------------------------|--------|--------|--------|--------|----|----|------------|----|-----------|
|              |              |       |                 |                 |                  |   |           | % AGG.                   | % C.S. | % F.S. | % SILT | % CLAY | LL | PI |            | WC |           |
| 456.0        | 135-140      |       | 7/9/11          | 1.0-2.0         |                  | SILT AND CLAY: Stiff to very-stiff gray clay, some silt, trace fine sand.   | 31        |                          |        |        |        |        |    |    |            |    | Est. A-6a |
| 451.4        | 143-145      |       | 6/11/15         | 1.75-2.25       |                  | SILT AND CLAY: Stiff to very-stiff gray clay, some silt, little fine to coarse sand, trace fine gravel.   | 32        | 2                        | 4      | 8      | 26     | 60     | 30 | 11 | 22         |    | A-6a(8)   |
| 446.5        | 150-150      |       | 16/30/50-5"R    | 4.0-4.5+        |                  | SANDY SILT: Hard gray silt, "and" clay, little fine to coarse sand, little fine gravel.   | 33        |                          |        |        |        |        |    |    |            |    | Est. A-4a |
| 444.5        | 155-155      |       | 50-2"R          |                 |                  | SHALE: Very-soft gray shale.  | 34        |                          |        |        |        |        |    |    |            |    | Visual    |
| 434.5        | 160-160      |       | 18%             |                 | 3.6/1.4          | SHALE: Soft gray and dark gray shale, nearly horizontally bedded, many horizontal and few diagonal and vertical fractures, contains few to many silty clay seams.                         | 35        |                          |        |        |        |        |    |    |            |    | Visual    |
| 434.5        | 165-165      |       | 33%             |                 | 4.8/0.2          | - Qu=2295 psi at 163.5'.  | 36        |                          |        |        |        |        |    |    |            |    | Visual    |
|              | 170-170      |       |                 |                 |                  | <b>NOTES:</b><br>- Encountered seepage at 8.5'.<br>- Encountered water at 21.0'.<br>- Switched to washbore at 42.5'.<br>- Base of inclinometer installed at an approximate depth of 163'. |           |                          |        |        |        |        |    |    |            |    |           |
|              | 175-175      |       |                 |                 |                  |   |           |                          |        |        |        |        |    |    |            |    |           |
|              | 180-180      |       |                 |                 |                  |   |           |                          |        |        |        |        |    |    |            |    |           |

WATER LEVEL: 21.0  
WATER NOTE: Encountered  
DATE: 6/8/06

TYPE: 3-1/4" I.D. Hollow-stem Auger    3-7/8" Tricone Roller Bit    LOCATION: Proposed I-90 Central Viaduct    COMPLETION DEPTH: 156.0'  
2/2.5" O.D. Split-barrel Sampler    3" O.D. Shelby Tube Sampler    Sta. 134+26.02    ELEVATION: 585.7  
NX Rock Core Barrel    338.66' Rt. of Centerline    DATE: 5/5/06 - 5/10/06

| Elev. (feet) | Depth (feet) | Samp. | Std. Pen. / RQD | Hand Pen. (tsf) | Rec./Loss (feet) | CLASSIFICATION: DESCRIPTION  | Samp. No. | Physical Characteristics |        |        |        |        |    |    | ODOT Class |    |                          |
|--------------|--------------|-------|-----------------|-----------------|------------------|--|-----------|--------------------------|--------|--------|--------|--------|----|----|------------|----|--------------------------|
|              |              |       |                 |                 |                  |  |           | % AGG.                   | % C.S. | % F.S. | % SILT | % CLAY | LL | PI |            | WC |                          |
| 585.7        | 0            |       | 4/7/8           |                 |                  | 0.2' TOPSOIL/ROOTMAT - 2 INCHES  | 1         |                          |        |        |        |        |    |    |            |    | Est. A-1-b               |
|              | 5            |       | 3/2/3           |                 |                  | GRAVEL WITH SAND (FILL): Medium-dense becoming very-loose dark brown, black and brown fine gravel, "and" fine to coarse sand, trace silt, trace clay, contains many slag and asphalt fragments.        | 2         | 46                       | 28     | 15     | 7      | 4      | NP | NP | 18         |    | A-1-b(0)                 |
| 576.6        | 10           |       | 1/1/2           |                 |                  | 9.1 GRAVEL WITH SAND AND SILT (FILL): Very-loose to loose dark brown, black and brown fine to coarse sand, some fine gravel, little silt, trace clay, contains few to many asphalt and slag fragments. | 3A<br>3B  |                          |        |        |        |        |    |    |            |    | Est. A-1-b<br>Est. A-2-4 |
|              | 15           |       | 1/1/1           |                 |                  |  | 4         |                          |        |        |        |        |    |    |            |    | Est. A-2-4               |
| 566.0        | 20           |       | 4/4/3           |                 |                  | 19.7   | 5A<br>5B  | 30                       | 19     | 22     | 20     | 9      | NP | NP | 32         |    | A-2-4(0)<br>Est. A-3a    |
| 563.2        | 25           |       | 2/4/4           | 0.75-2.5        |                  | 22.5 COARSE AND FINE SAND: Loose brown, black and gray fine to coarse sand, little silt, trace clay.   | 6         | 1                        | 3      | 4      | 39     | 53     | 33 | 13 | 23         |    | A-6a(9)                  |
|              | 30           |       | 2/3/3           | 0.75-2.0        |                  | SILT AND CLAY: Medium-stiff to stiff gray clay, "and" silt, trace fine to coarse sand, trace fine gravel, contains few silt pockets and fine to coarse sand seams, and few very-stiff zones.           | 7         |                          |        |        |        |        |    |    |            |    | Est. A-6a                |
| 553.2        | 35           |       | 4/6/7           | 1.25-3.0        |                  | 32.5 SILT: Stiff to very-stiff gray silt, "and" clay, trace fine sand, contains many silt lenses, few pockets and seams.   | 8         | 0                        | 0      | 1      | 51     | 48     | 29 | 9  | 22         |    | A-4b(8)                  |
|              | 40           |       | 4/7/8           | 1.25-3.5        |                  |  | 9         |                          |        |        |        |        |    |    |            |    | Est. A-4b                |
|              | 45           |       | 4/5/6           | 1.5-2.5         |                  |  | 10        |                          |        |        |        |        |    |    |            |    | Est. A-4b                |
|              | 50           |       | 4/5/7           | 1.5-3.5         |                  |  | 11        | 0                        | 0      | 1      | 52     | 47     | 29 | 10 | 24         |    | A-4b(8)                  |

PLATES 8

WATER LEVEL: 13.5    12.6    12.6    12.6  
WATER NO: Encountered    After HSA Removed - Prior to Wash  
DATE: 5/5/06    5/5/06





TYPE: 3-1/4" I.D. Hollow-stem Auger    3-7/8" Tricone Roller Bit  
272.5" O.D. Split-barrel Sampler    3" O.D. Shelby Tube Sampler  
NX Rock Core Barrel

LOCATION: Proposed I-90 Central Viaduct  
Sta. 134+26.02  
338.66' Rt. of Centerline

COMPLETION DEPTH: 156.0'  
ELEVATION: 585.7  
DATE: 5/5/06 - 5/10/06

| Elev. (feet) | Depth (feet) | Samp. | Std. Pen. / RQD | Hand Pen. (tsf) | Rec./Loss (feet) | CLASSIFICATION: DESCRIPTION  | Samp. No. | Physical Characteristics |      |      |      |      |    | ODOT Class |    |    |  |           |
|--------------|--------------|-------|-----------------|-----------------|------------------|--|-----------|--------------------------|------|------|------|------|----|------------|----|----|--|-----------|
|              |              |       |                 |                 |                  |  |           | AGG.                     | C.S. | F.S. | SILT | CLAY | LL |            | PI | WC |  |           |
|              | 100          |       |                 |                 |                  |  |           |                          |      |      |      |      |    |            |    |    |  |           |
| 480.7        | 105          |       | P               | 0.75-1.25       |                  | SILTY CLAY: Medium-stiff to stiff gray silty clay, trace fine to coarse sand, contains few soft zones,   | 23        | 0                        | 1    | 1    | 37   | 61   | 34 | 16         | 28 |    |  | A-6b(10)  |
| 478.7        |              |       | P               | 0.5-1.25        |                  | CLAY: Medium-stiff to stiff gray clay, "and" silt, trace fine sand.  | 24        | 0                        | 0    | 1    | 49   | 50   | 45 | 21         | 34 |    |  | A-7-6(13) |
|              |              |       | P               | 1.0-1.75        |                  | SILT AND CLAY: Stiff gray clay, some silt, trace fine to coarse sand, trace fine gravel.   | 25        | 1                        | 1    | 1    | 22   | 75   | 29 | 11         | 28 |    |  | A-6a(8)   |
| 474.7        | 110          |       |                 |                 |                  |  |           |                          |      |      |      |      |    |            |    |    |  |           |
|              | 115          |       | 14/28/36        | 4.0-4.5+        |                  | SILT AND CLAY: Very-stiff to hard gray clay, some silt, little fine to coarse sand, trace fine gravel.   | 26        | 4                        | 7    | 8    | 27   | 54   | 30 | 12         | 16 |    |  | A-6a(9)   |
|              | 120          |       | 9/13/14         | 2.0-4.5+        |                  |  | 27        |                          |      |      |      |      |    |            |    |    |  | Est. A-6a |
| 463.7        | 125          |       | 6/10/10         | 1.0-3.25        |                  | SILT AND CLAY: Stiff to very-stiff gray clay, some silt, trace fine to coarse sand, trace fine gravel, contains many silt lenses and pockets.  | 28        |                          |      |      |      |      |    |            |    |    |  | Est. A-6a |
|              | 130          |       | 7/8/10          | 1.25-2.75       |                  |  | 29        | 1                        | 1    | 1    | 29   | 68   | 36 | 13         | 28 |    |  | A-6a(9)   |
| 449.2        | 135          | 2S    | 5/8/11<br>30    | 1.25-2.0        |                  |  | 30        |                          |      |      |      |      |    |            |    |    |  | Est. A-6a |
| 444.7        | 140          |       | 11/11/22        |                 |                  | SANDY SILT: Dense gray fine to coarse sand, some silt, little clay, some fine to coarse gravel.  | 31        |                          |      |      |      |      |    |            |    |    |  | Est. A-4a |
|              | 145          |       | 50/50-1"R       |                 |                  | SHALE: Very-soft to soft dark gray and gray shale, nearly horizontally bedded, many horizontal and few vertical and diagonal fractures, contains many silty clay layers from 148' to 152', diagonal joints at 146.6' and 153.0'. | 32        |                          |      |      |      |      |    |            |    |    |  | Visual    |
|              | 150          |       | 8.0%            |                 | 5.0/0.0          | - Qu=828 psi at 155.0'.  | 33        |                          |      |      |      |      |    |            |    |    |  | Visual    |

WATER LEV: 13.5    12.6  
WATER NC: Encountered    After HSA Removed - Prior to Wa  
DA: 5/5/06    5/5/06

PLATE 60

TYPE: 3-1/4" I.D. Hollow-stem Auger 3-7/8" Tricone Roller Bit  
2/2.5" O.D. Split-barrel Sampler 3" O.D. Shelby Tube Sampler  
NX Rock Core Barrel

LOCATION: Proposed I-90 Central Viaduct  
Sta. 134+26.02  
338.66' Rt. of Centerline

COMPLETION DEPTH: 156.0'  
ELEVATION: 585.7  
DATE: 5/5/06 - 5/10/06

| Elev.<br>(feet) | Depth<br>(feet) | Samp. | Std. Pen. /<br>RQD | Hand Pen.<br>(tsf) | Rec./Loss<br>(feet) | CLASSIFICATION: DESCRIPTION  | Samp.<br>No. | Physical Characteristics |           |           |           |           |    |    | ODOT<br>Class |        |
|-----------------|-----------------|-------|--------------------|--------------------|---------------------|--|--------------|--------------------------|-----------|-----------|-----------|-----------|----|----|---------------|--------|
|                 |                 |       |                    |                    |                     |  |              | %<br>AGG.                | %<br>C.S. | %<br>F.S. | %<br>SILT | %<br>CLAY | LL | PI |               | WC     |
| 429.7           | 150             |       | 32%                |                    | 5.0/0.0             | <br>156.0<br><hr/> NOTES:<br>- Encountered water at 13.5'.<br>- Switched to washbore at 37.5'.<br>- Base of inclinometer installed at an approximate depth of 155'. | 34           |                          |           |           |           |           |    |    |               | Visual |

WATER LEVEL:  $\nabla$  13.5       $\nabla$  12.6       $\nabla$  \_\_\_\_\_       $\nabla$  \_\_\_\_\_  
 WATER NOTE: Encountered      After HSA Removed - Prior to Washbore      \_\_\_\_\_      \_\_\_\_\_  
 DATE: 5/5/06      5/5/06      \_\_\_\_\_      \_\_\_\_\_



**LOG OF BORING NO. B-108A**  
**CUY-90-15.24 West Abutment**  
**CUYAHOGA COUNTY, OHIO**

Renamed: B-108-A-06

BBC&M JOB: 012-00946.300

TYPE: 3-1/4" I.D. Hollow-stem Auger    3-7/8" Tricone Roller Bit  
2 1/2" O.D. Split-barrel Sampler    3" O.D. Shelby Tube Sampler  
NX Rock Core Barrel

LOCATION: Proposed I-90 Central Viaduct  
Sta. 133+21.32  
151.63' Rt. of Centerline

COMPLETION DEPTH: 168.7'  
ELEVATION: 603.0  
DATE: 4/28/06 - 5/3/06

| Elev. (feet) | Depth (feet) | Samp. | Std. Pen. / RQD | Hand Pen. (tsf) | Rec./Loss (feet) | CLASSIFICATION: DESCRIPTION   | Samp. No. | Physical Characteristics |        |        |        |        |    |    | ODOT Class |    |  |            |
|--------------|--------------|-------|-----------------|-----------------|------------------|---|-----------|--------------------------|--------|--------|--------|--------|----|----|------------|----|--|------------|
|              |              |       |                 |                 |                  |   |           | % AGG.                   | % C.S. | % F.S. | % SILT | % CLAY | LL | PI |            | WC |  |            |
| 602.7        | 0            |       |                 |                 |                  | 0.5 TOPSOIL - 3 INCHES  |           |                          |        |        |        |        |    |    |            |    |  |            |
| 600.0        |              |       | 4/3/3           |                 |                  | 3.0 COARSE AND FINE SAND (FILL): Loose dark brown fine to coarse sand, trace silt, trace clay, trace fine to coarse gravel, contains few concrete fragments.                    | 1         |                          |        |        |        |        |    |    |            |    |  | Est. A-3a  |
|              | 5            |       | 2/5/6           |                 |                  | SANDY SILT (FILL): Loose to medium-dense dark brown and brown fine to coarse sand, some silt, little clay, little fine to coarse gravel, contains many slag and coal fragments. | 2         |                          |        |        |        |        |    |    |            |    |  | Est. A-4a  |
|              | 10           |       | 3/5/5           |                 |                  |   | 3         | 14                       | 18     | 23     | 27     | 18     | 22 | 4  | 14         |    |  | A-4a(2)    |
| 590.5        |              |       | 3/4/3           |                 |                  | 12.5 COARSE AND FINE SAND (POSSIBLE FILL): Loose dark brown fine to coarse sand, little fine gravel, little silt, trace clay, contains many coal fragments.                     | 4         | 19                       | 26     | 26     | 19     | 10     | NP | NP | 16         |    |  | A-3a(0)    |
| 585.5        | 15           |       |                 |                 |                  | 17.5 GRAVEL WITH SAND: Loose light gray fine to coarse sand, some fine to coarse gravel, trace silt.  | 5         |                          |        |        |        |        |    |    |            |    |  | Est. A-1-b |
| 582.0        | 20           |       | 4/4/4           |                 |                  | 21.0 CLAY: Stiff to very-stiff gray clay, little to some silt, trace fine to coarse sand, trace fine gravel.  | 6         | 1                        | 1      | 1      | 24     | 73     | 42 | 19 | 28         |    |  | A-7-6(12)  |
|              | 25           |       | 3/4/6           | 1.5-2.25        |                  |   | 7         |                          |        |        |        |        |    |    |            |    |  | Est. A-7-6 |
|              | 30           |       | 2/3/4           | 1.5-2.5         |                  |   | 8         | 0                        | 1      | 1      | 20     | 78     | 42 | 19 | 31         |    |  | A-7-6(12)  |
| 565.5        | 35           |       | 2/2/3           | 1.0-1.25        |                  |   | 9         |                          |        |        |        |        |    |    |            |    |  | Est. A-4b  |
|              | 40           |       | 3/5/6           | 2.0-4.5+        |                  | 37.5 SANDY SILT: Stiff to very-stiff gray silt, "and" clay, contains many silt pockets and lenses, and few hard zones.  | 10        |                          |        |        |        |        |    |    |            |    |  | Est. A-4b  |
|              | 45           |       | 4/5/7           | 2.0-3.5         |                  |   | 11        | 0                        | 0      | 0      | 53     | 47     | 29 | 10 | 23         |    |  | A-4b(8)    |
|              | 50           |       | 4/5/7           | 1.75-3.0        |                  |   |           |                          |        |        |        |        |    |    |            |    |  |            |

WATER LEVEL:  "Dry"     "Dry"     "Dry"     "Dry"

WATER NO: Inside HSA - Prior to Washbore    Inside HSA - Prior to Washbor    Inside HSA - Prior to Washbor    Inside HSA - Prior to Washbor

DA: 4/28/06    5/1/06

PLATE 62



**LOG OF BORING NO. B-108A**  
**CUY-90-15.24 West Abutment**  
**CUYAHOGA COUNTY, OHIO**

Renamed: B-108-A-06

BBC&MJOB: 012-00946.300

TYPE: 3-1/4" I.D. Hollow-stem Auger 3-7/8" Tricone Roller Bit  
2/2.5" O.D. Split-barrel Sampler 3" O.D. Shelby Tube Sampler  
NX Rock Core Barrel

LOCATION: Proposed I-90 Central Viaduct  
Sta. 133+21.32  
151.63' Rt. of Centerline

COMPLETION DEPTH: 168.7'  
ELEVATION: 603.0  
DATE: 4/28/06 - 5/3/06

| Elev. (feet) | Depth (feet) | Samp. | Std. Pen. / RQD | Hand Pen. (tsf) | Rec./Loss (feet) | CLASSIFICATION: DESCRIPTION   | Samp. No.  | Physical Characteristics |        |        |        |        |    |    | ODOT Class |    |  |           |           |
|--------------|--------------|-------|-----------------|-----------------|------------------|---|--|--------------------------|--------|--------|--------|--------|----|----|------------|----|--|-----------|-----------|
|              |              |       |                 |                 |                  |   |  | % AGG.                   | % C.S. | % F.S. | % SILT | % CLAY | LL | PI |            | WC |  |           |           |
|              | 50           |       |                 |                 |                  | SANDY SILT: Stiff to very-stiff gray silt, "and" clay, contains many silt pockets and lenses, and few hard zones. |  |                          |        |        |        |        |    |    |            |    |  |           |           |
|              | 55           |       | 4/5/8           | 1.5-3.5         |                  |   | 12   |                          |        |        |        |        |    |    |            |    |  |           | Est. A-4b |
|              | 60           |       | 5/7/8           | 2.0-4.0         |                  |   | 13   |                          |        |        |        |        |    |    |            |    |  |           | Est. A-4b |
|              | 65           |       | P               | 1.25-1.5        |                  |   | 14   |                          |        |        |        |        |    |    |            |    |  |           | Est. A-4b |
|              | 70           |       | 4/4/5           | 1.5-2.0         |                  |   | 15   |                          |        |        |        |        |    |    |            |    |  |           | Est. A-4b |
| 530.5        | 72.5         |       |                 |                 |                  |   |  |                          |        |        |        |        |    |    |            |    |  |           |           |
|              | 75           |       | 5/8/10          | 2.0-3.0         |                  |   | SILT AND CLAY: Stiff to very-stiff gray clay, some silt, trace to little fine to coarse sand, trace fine gravel. | 16                       |        |        |        |        |    |    |            |    |  |           | Est. A-6a |
|              | 80           | 2S    | 8/11/13<br>24   | 1.5-3.0         |                  |   |  | 17                       | 3      | 5      | 7      | 30     | 55 | 30 | 12         | 19 |  |           | A-6a(9)   |
|              | 85           |       | 5/7/10          | 2.25-2.5        |                  |   |  | 18                       |        |        |        |        |    |    |            |    |  |           | Est. A-6a |
|              | 90           |       | 4/6/10          | 1.75-2.5        |                  |   |  | 19                       |        |        |        |        |    |    |            |    |  |           | Est. A-6a |
|              | 95           |       | 5/8/9           | 1.25-2.5        |                  |   | 20   | 1                        | 2      | 3      | 29     | 65     | 33 | 13 | 23         |    |  | A-6a(9)   |           |
|              | 100          |       | 4/7/10          | 1.25-2.5        |                  |   | 21   |                          |        |        |        |        |    |    |            |    |  | Est. A-6a |           |

PLATE 63

WATER LEVEL: ∇ "Dry" ∇ "Dry" ∇ ∇  
WATER NOTE: Inside HSA - Prior to Washbore Inside HSA - Prior to Washbore  
DATE: 4/28/06 5/1/06



**LOG OF BORING NO. B-108A**  
**CUY-90-15.24 West Abutment**  
**CUYAHOGA COUNTY, OHIO**

Renamed: B-108-A-06

BBC&M JOB: 012-00946.300

TYPE: 3-1/4" I.D. Hollow-stem Auger 3-7/8" Tricone Roller Bit  
2/2.5" O.D. Split-barrel Sampler 3" O.D. Shelby Tube Sampler  
NX Rock Core Barrel

LOCATION: Proposed I-90 Central Viaduct  
Sta. 133+21.32  
151.63' Rt. of Centerline

COMPLETION DEPTH: 168.7'  
ELEVATION: 603.0  
DATE: 4/28/06 - 5/3/06

| Elev. (feet) | Depth (feet) | Samp. | Std. Pen. / RQD | Hand Pen. (tsf) | Rec./Loss (feet) | CLASSIFICATION: DESCRIPTION  | Samp. No. | Physical Characteristics |      |      |        |        |    |    | ODOT Class |    |           |
|--------------|--------------|-------|-----------------|-----------------|------------------|--|-----------|--------------------------|------|------|--------|--------|----|----|------------|----|-----------|
|              |              |       |                 |                 |                  |  |           | AGG.                     | C.S. | F.S. | % SILT | % CLAY | LL | PI |            | WC |           |
|              | 100          |       |                 |                 |                  | SILT AND CLAY: Stiff to very-stiff gray clay, some silt, trace to little fine to coarse sand, trace fine gravel. |           |                          |      |      |        |        |    |    |            |    |           |
|              | 105          |       | 5/7/11          | 1.25-2.5        |                  |  | 22        |                          |      |      |        |        |    |    |            |    | Est. A-6a |
|              | 110          |       | 4/6/8           | 1.25-2.25       |                  |  | 23        |                          |      |      |        |        |    |    |            |    | Est. A-6a |
| 488.0        | 115          |       | P               | 1.25-1.5        |                  | 115.0  | 24        | 0                        | 0    | 2    | 22     | 76     | 36 | 13 | 29         |    | A-6a(9)   |
| 486.0        |              |       | P               | 0.75-1.75       |                  | 117.0  | 25        | 0                        | 0    | 0    | 42     | 58     | 30 | 9  | 26         |    | A-4a(8)   |
| 484.0        |              |       | P               |                 |                  | 119.0  | 26A       | 0                        | 0    | 0    | 69     | 31     | 24 | 3  | 27         |    | A-4b(8)   |
|              | 120          |       |                 |                 |                  |  | 26B       | 0                        | 0    | 0    | 74     | 26     | NP | NP | 26         |    | A-4b(0)   |
|              |              |       |                 |                 |                  | GRAVEL WITH SAND: Dense gray fine to coarse sand, "and" fine to coarse gravel, trace silt, trace clay.           |           |                          |      |      |        |        |    |    |            |    |           |
| 478.9        | 125          |       | 20/18/23        | 4.5+            |                  | 124.1  | 27A       | 38                       | 36   | 11   | 5      | 10     | 19 | 4  | 12         |    | A-1-b(0)  |
|              |              |       |                 |                 |                  | SILT AND CLAY: Hard gray clay, some silt, little fine to coarse sand, trace fine gravel.                         | 27B       |                          |      |      |        |        |    |    |            |    | Est. A-6a |
|              | 130          |       | 14/30/43        | 4.5+            |                  |  | 28        | 2                        | 4    | 7    | 28     | 59     | 31 | 14 | 18         |    | A-6a(10)  |
| 470.5        | 135          |       | 6/8/10          | 1.5-3.5         |                  | 132.5  | 29        |                          |      |      |        |        |    |    |            |    | Est. A-6a |
|              |              |       |                 |                 |                  | SILT AND CLAY: Stiff to very-stiff gray clay, "and" silt, trace fine sand, contains many silt seams and lenses.  |           |                          |      |      |        |        |    |    |            |    |           |
|              | 140          |       | 7/12/15         | 1.5-3.0         |                  |  | 30        |                          |      |      |        |        |    |    |            |    | Est. A-6a |
|              | 145          |       | 6/10/12         | 1.25-3.0        |                  |  | 31        | 0                        | 0    | 1    | 24     | 75     | 34 | 12 | 26         |    | A-6a(9)   |
|              | 150          |       | 7/10/15         | 1.25-3.0        |                  |  | 32        |                          |      |      |        |        |    |    |            |    | Est. A-6a |

WATER LEV: ∇ "Dry" ∇ "Dry" ∇ ∇  
WATER NO: Inside HSA - Prior to Washbore Inside HSA - Prior to Washbore  
DATE: 4/28/06 5/1/06

PLATE 64



**APPENDIX 4B -4**  
**BBCM BORINGS 2009**











C-R-S: CUY-90-14.52  
 PID No.: 77332  
 Bridge No.:

LOG OF BORING NO. B-035-0-09  
 CUY-90-14.52 WEST ABUTMENT  
 CLEVELAND, OHIO



TYPE: 3-1/4" I.D. Hollow-stem Auger; 3-7/8" Spade Bit  
 2" O.D. Split-barrel Sampler, NQ Rock Core Barrel  
 3" O.D. Shelby Tube Sampler

LOCATION: Sta. 128+85  
 62.3' Lt of Proposed W.B. I-90 Centerline  
 COORDINATES: N 663456.3; E 2190021.9

COMPLETION DEPTH: 252.0'  
 ELEVATION: 674.6  
 DATE: 7/2/09 - 7/13/09

| Elev.<br>(feet) | Depth Samp.<br>(feet) | Std. Pen. /<br>RQD-% | N <sub>60</sub> | Hand Pen.<br>(tsf) | Sample<br>Rec-% | Description  | Samp.<br>No. | Physical Characteristics |      |      |        |        | ODOT<br>Class |    |    |    |             |
|-----------------|-----------------------|----------------------|-----------------|--------------------|-----------------|--|--------------|--------------------------|------|------|--------|--------|---------------|----|----|----|-------------|
|                 |                       |                      |                 |                    |                 |  |              | % Agg.                   | % CS | % FS | % Silt | % Clay |               | LL | PL | PI | WC          |
| 483.6           | 180-185               | 6/9/11               | 28              | 1.5-2.5            | 87              | Stiff to very-stiff gray SILT AND CLAY, trace fine sand, trace fine gravel, contains few silt lenses, damp.  | 47           | 6                        | 6    | 8    | 30     | 50     | 29            | 18 | 11 | 25 | A-6a (Vis.) |
| 483.6           | 190                   | 6/12/12              | 34              | 1.0-3.5            | 80              | 191.0<br>Hard gray SILT AND CLAY, little fine to coarse sand, trace fine gravel, contains many silt lenses, damp.  | 48           | 6                        | 6    | 8    | 30     | 50     | 29            | 18 | 11 | 26 | A-6a (Vis.) |
| 472.6           | 195-200               | 15/30/47             | 109             | 4.5+               | 87              | 202.0<br>Very-stiff to hard gray SILT AND CLAY, trace fine sand, contains many silt lenses, damp.  | 49           | 6                        | 0    | 1    | 31     | 68     | 33            | 22 | 11 | 23 | A-6a(8)     |
| 472.6           | 205-210               | 9/13/17              | 43              | 2.0-3.8            | 93              | 212.0<br>Hard gray SANDY SILT, some fine to coarse sand, little fine gravel, contains many shale fragments, damp.  | 50           | 6                        | 0    | 1    | 31     | 68     | 33            | 22 | 11 | 23 | A-6a(8)     |
| 462.6           | 215                   | 16/23/27             | 71              | 4.5+               | 73              | SHALE, gray, moderately to severely weathered, very weak to slightly strong, ROD = 0%, Core Loss = 100% (no recovery due to a plugged rock core barrel). | 51           | 19                       | 17   | 10   | 34     | 20     | 24            | 19 | 5  | 13 | A-4a(4)     |
| 455.7           | 220-225               | 31/50-4"R            |                 | 4.0-4.5+           | 50              |  | 52           | 19                       | 17   | 10   | 34     | 20     | 24            | 19 | 5  | 13 | A-4a(4)     |
|                 |                       |                      |                 |                    |                 |  | 53           | 19                       | 17   | 10   | 34     | 20     | 24            | 19 | 5  | 13 | A-4a(4)     |
|                 |                       |                      |                 |                    |                 |  | 54           | 19                       | 17   | 10   | 34     | 20     | 24            | 19 | 5  | 13 | A-4a(4)     |

WATER LEVEL:   
 WATER NOTE:   
 DATE: 7/2/09

33.5  
 Encountered  
 7/2/09

Drill Rod Energy Ratio : 0.85  
 Last Calibration Date : 09/13/07  
 Drill Rig Number : OTB-ATV D50



C-R-S : CUY-90-14.52  
 PID No. : 77332  
 Bridge No. :

LOG OF BORING NO. B-035-0-09  
 CUY-90-14.52 WEST ABUTMENT  
 CLEVELAND, OHIO



TYPE: 3-1/4" I.D. Hollow-stem Auger; 3-7/8" Spade Bit  
 2" O.D. Split-barrel Sampler, NQ Rock Core Barrel  
 3" O.D. Shelby Tube Sampler

LOCATION: Sta. 128+85  
 62.3' Lt of Proposed W.B. I-90 Centerline  
 COORDINATES : N 663456.3; E 2190021.9

COMPLETION DEPTH: 252.0'  
 ELEVATION: 674.6  
 DATE: 7/2/09 - 7/13/09

| Elev. (feet) | Depth (feet) | Samp. | Std. Pen. / RQD-% | N <sub>60</sub> | Hand Pen. (tsf) | Sample Rec-% | Description   | Samp. No. | Physical Characteristics |      |      |        |        |    |    | ODOT Class |    |    |  |  |  |
|--------------|--------------|-------|-------------------|-----------------|-----------------|--------------|---|-----------|--------------------------|------|------|--------|--------|----|----|------------|----|----|--|--|--|
|              |              |       |                   |                 |                 |              |   |           | % Agg.                   | % CS | % FS | % Silt | % Clay | LL | PL |            | PI | WC |  |  |  |
| 270          |              |       |                   |                 |                 |              | <p><u>NOTES:</u></p> <ul style="list-style-type: none"> <li>- Encountered water at 33.5' during drilling.</li> <li>- Used 3-1/4" I.D. Hollow-stem augers from 0.0' to 55.0'.</li> <li>- At 55.0', augers were removed and 4" O.D. casing was placed down to 55.0'.</li> <li>- From 55.0' to 219.3', used 3-1/8" Tricone Roller Bit with water (washbore).</li> <li>- No sample recovery from Shelby tube attempts at 105' to 107', 107' to 109' and 109.5' to 111.5'. SPT samples (Samples 30 through 32) were obtained after the unsuccessful Shelby tube attempts; therefore, the blowcounts for Samples 30 through 32 may not be accurate due to sample disturbance, and are thereby not shown.</li> <li>- Rock core barrel became plugged upon the start of coring operations. Problem not discovered until reaching a depth of 225' and solution not ascertained until reaching a depth of 227'. No rock core samples were recovered from 220' to 227'.</li> <li>- Vibrating wire piezometers set at depths of 220' and 100'.</li> </ul> <p><u>ROCK CORE TEST RESULTS</u></p> <ul style="list-style-type: none"> <li>- Q<sub>u</sub> = 2120 psi at 230.0'</li> <li>- Q<sub>u</sub> = 1140 psi at 235.55'</li> <li>- Q<sub>u</sub> = 2260 psi at 246.55'</li> <li>- SDI (I<sub>42</sub>) from Sample 55 (water) = 90.3%, Type II</li> <li>- SDI (I<sub>42</sub>) from Sample 55 (mineral) = 90.1%, Type II</li> <li>- SDI (I<sub>42</sub>) from Sample 55 (polymer) = 93.1%, Type II</li> <li>- SDI (I<sub>42</sub>) from Sample 56 (water) = 85.2%, Type II</li> <li>- SDI (I<sub>42</sub>) from Sample 56 (mineral) = 87.7%, Type II</li> <li>- SDI (I<sub>42</sub>) from Sample 56 (polymer) = 92.0%, Type II</li> <li>- SDI (I<sub>42</sub>) from Sample 57 (water) = 85.3%, Type II</li> <li>- SDI (I<sub>42</sub>) from Sample 57 (mineral) = 80.9%, Type II</li> <li>- SDI (I<sub>42</sub>) from Sample 57 (polymer) = 86.4%, Type II</li> </ul> |           |                          |      |      |        |        |    |    |            |    |    |  |  |  |
| 275          |              |       |                   |                 |                 |              |   |           |                          |      |      |        |        |    |    |            |    |    |  |  |  |
| 280          |              |       |                   |                 |                 |              |   |           |                          |      |      |        |        |    |    |            |    |    |  |  |  |
| 285          |              |       |                   |                 |                 |              |   |           |                          |      |      |        |        |    |    |            |    |    |  |  |  |
| 290          |              |       |                   |                 |                 |              |   |           |                          |      |      |        |        |    |    |            |    |    |  |  |  |
| 295          |              |       |                   |                 |                 |              |   |           |                          |      |      |        |        |    |    |            |    |    |  |  |  |
| 300          |              |       |                   |                 |                 |              |   |           |                          |      |      |        |        |    |    |            |    |    |  |  |  |
| 305          |              |       |                   |                 |                 |              |   |           |                          |      |      |        |        |    |    |            |    |    |  |  |  |
| 310          |              |       |                   |                 |                 |              |   |           |                          |      |      |        |        |    |    |            |    |    |  |  |  |
| 315          |              |       |                   |                 |                 |              |   |           |                          |      |      |        |        |    |    |            |    |    |  |  |  |

WATER LEVEL:  33.5 Encountered 7/2/09

WATER NOTE: \_\_\_\_\_

DATE: \_\_\_\_\_

Drill Rod Energy Ratio : 0.85

Last Calibration Date : 09/13/07

Drill Rig Number : OTB-ATV D50

C-R-S: CUY-90-14.52  
 PID No.: 77332  
 Bridge No.:

LOG OF BORING NO. B-036-0-09  
 CUY-90-14.52 WEST ABUTMENT  
 CLEVELAND, OHIO



TYPE: 3-1/4" I.D. Hollow-stem Auger; 3-1/8" Tricone Roller Bit  
 2" O.D. Split-barrel Sampler

LOCATION: Sta. 130+00  
 342.6' Lt of Proposed W.B. I-90 Centerline  
 COORDINATES: N 663656.8; E 2189794.4

COMPLETION DEPTH: 90.0'  
 ELEVATION: 642.7  
 DATE: 7/1/09 - 7/2/09

| Elev. (feet) | Depth Samp. (feet) | Std. Pen. / RQD-% | N <sub>60</sub> | Hand Pen. (tsf) | Sample Rec-% | Description   | Samp. No. | Physical Characteristics |      |      |        |        | ODOT Class |    |    |             |             |
|--------------|--------------------|-------------------|-----------------|-----------------|--------------|---|-----------|--------------------------|------|------|--------|--------|------------|----|----|-------------|-------------|
|              |                    |                   |                 |                 |              |   |           | % Agg.                   | % CS | % FS | % Silt | % Clay |            | LL | PL | PI          | WC          |
| 634.7        | 0                  | 3/3/4             | 10              |                 | 60           | FILL: Very-loose to loose dark brown COARSE AND FINE SAND, trace to little silt, trace clay, trace fine gravel, contains many cinders, and few brick and glass fragments, damp. | 1         |                          |      |      |        |        |            |    | 16 | A-3a (Vis.) |             |
|              | 5                  | 2/2/1             | 4               |                 | 60           |   | 2         |                          |      |      |        |        |            |    |    | 13          | A-3a (Vis.) |
|              |                    | 5/5/2             | 10              |                 | 80           |   | 3         |                          |      |      |        |        |            |    |    | 12          | A-3a (Vis.) |
|              | 10                 | 2/2/3             | 7               |                 | 93           | POSSIBLE FILL: Loose brown FINE SAND, some coarse sand, trace fine gravel, trace silt, trace clay, damp.  | 4         |                          |      |      |        |        |            |    |    | 9           | A-3 (Vis.)  |
| 629.7        |                    | 3/3/2             | 7               |                 | 100          |   | 5         |                          |      |      |        |        |            |    |    | 5           | A-3 (Vis.)  |
|              | 15                 | 1/2/1             | 4               |                 | 93           | Very-loose to loose brown COARSE AND FINE SAND, little to some silt, trace clay, moist to wet.  | 6         |                          |      |      |        |        |            |    |    | 23          | A-3a (Vis.) |
| 626.2        |                    | 1/2/5             | 10              |                 | 100          |   | 7A        |                          |      |      |        |        |            |    |    | 29          | A-3a (Vis.) |
|              |                    |                   |                 |                 | 100          |   | 7B        |                          |      |      |        |        |            |    |    | 24          | A-4b (Vis.) |
|              | 20                 | 2/3/5             | 11              |                 | 80           | Loose to medium-dense gray SILT, little clay, little fine sand, slightly organic, moist.  | 8         |                          | 0    | 17   | 66     | 17     | NP         | NP | 24 | 24          | A-4b(8)     |
| 619.7        |                    | 2/4/4             | 11              |                 | 80           |   | 9         |                          |      |      |        |        |            |    |    | 20          | A-4b (Vis.) |
|              | 25                 | 4/6/10            | 23              |                 | 60           | Medium-dense gray SILT, little clay, trace fine sand.   | 10        |                          |      |      |        |        |            |    |    | 17          | A-4b (Vis.) |
|              |                    | 3/6/10            | 23              |                 | 53           |   | 11        |                          | 0    | 6    | 76     | 18     | NP         | NP | 17 | 17          | A-4b(8)     |
|              | 30                 | 6/8/9             | 24              |                 | 80           |   | 12        |                          |      |      |        |        |            |    |    | 19          | A-4b (Vis.) |
| 610.7        |                    | 2/3/4             | 10              | 2.5-3.8         | 100          | Very-stiff to hard gray SILT, "and" clay, trace fine sand, contains few stiff zones, damp.  | 13        |                          |      |      |        |        |            |    |    | 22          | A-4b (Vis.) |

WATER LEVEL:  32.0  
 WATER NOTE: In Augers Prior to Washbore  
 DATE: 7/1/09

Drill Rod Energy Ratio: 0.85  
 Last Calibration Date: 09/13/07  
 Drill Rig Number: OTB-ATV D50

C-R-S: CUY-90-14.52  
 PID No.: 77332  
 Bridge No.:

LOG OF BORING NO. B-036-0-09  
 CUY-90-14.52 WEST ABUTMENT  
 CLEVELAND, OHIO



TYPE: 3-1/4" I.D. Hollow-stem Auger; 3-1/8" Tricone Roller Bit  
 2" O.D. Split-barrel Sampler

LOCATION: Sta. 130+00  
 342.6' Lt of Proposed W.B. I-90 Centerline  
 COORDINATES: N 663656.8; E 2189794.4

COMPLETION DEPTH: 90.0'  
 ELEVATION: 642.7  
 DATE: 7/1/09 - 7/2/09

| Elev. (feet) | Depth Samp. (feet) | Std. Pen. / RQD-% | N <sub>60</sub> | Hand Pen. (tsf) | Sample Rec-% | Description  | Samp. No.   | Physical Characteristics   |      |      |        |        |    |    | ODOT Class |    |         |             |             |
|--------------|--------------------|-------------------|-----------------|-----------------|--------------|--|---|--|------|------|--------|--------|----|----|------------|----|---------|-------------|-------------|
|              |                    |                   |                 |                 |              |  |   | % Agg.   | % CS | % FS | % Silt | % Clay | LL | PL |            | PI | WC      |             |             |
| 590.7        | 35                 |                   |                 |                 |              | Very-stiff to hard gray SILT, "and" clay, trace fine sand, contains few stiff zones, damp. | 14  | 0  | 0    | 1    | 60     | 39     | 27 | 19 | 8          | 28 | A-4b(8) |             |             |
|              | 40                 | 2/1/3             | 6               | 1.0-1.8         | 87           |  |   |  |      |      |        |        |    |    |            |    |         |             |             |
|              | 45                 | 5/8/14            | 31              | 4.0-4.5+        | 73           |  |   | 15   |      |      |        |        |    |    |            |    | 20      | A-4b (Vis.) |             |
|              | 50                 | 5/8/11            | 27              | 3.5-4.5+        | 93           |  |   | 16   | 0    | 0    | 0      | 50     | 50 | 30 | 21         | 9  | 20      | A-4b(8)     |             |
|              | 55                 | 3/4/5             | 13              | 2.3-2.8         | 87           |  | Very-stiff gray SILT AND CLAY, trace fine sand, contains many silt lenses, damp to moist. | 17   | 0    | 0    | 1      | 47     | 52 | 32 | 21         | 11 | 23      | A-6a(8)     |             |
|              | 60                 | 5/8/12            | 28              | 2.0-3.0         | 100          |  |   |  | 18   |      |        |        |    |    |            |    |         | 15          | A-6a (Vis.) |
| 580.7        | 65                 | 3/4/6             | 14              | 1.0-1.5         | 80           |  |   | Medium-stiff to stiff gray SILTY CLAY, trace fine to coarse sand, contains few silt lenses, moist. | 19   |      |        |        |    |    |            |    |         | 27          | A-6b (Vis.) |
|              | 70                 | 3/3/4             | 10              | 0.5-1.0         | 100          |  |   |  | 20   | 0    | 1      | 2      | 26 | 71 | 37         | 19 | 18      | 28          | A-6b(11)    |

WATER LEVEL:  32.0  
 WATER NOTE: In Augers Prior to Washbore  
 DATE: 7/1/09

Drill Rod Energy Ratio: 0.85  
 Last Calibration Date: 09/13/07  
 Drill Rig Number: OTB-ATV D50







C-R-S: CUY-90-14.52  
 PID No.: 77332  
 Bridge No.:

LOG OF BORING NO. B-037-0-09  
 CUY-90-14.52 WEST ABUTMENT  
 CLEVELAND, OHIO



TYPE: 3-1/4" I.D. Hollow-stem Auger; 3-1/8" Tricone Roller Bit  
 2" O.D. Split-barrel Sampler

LOCATION: Sta. 131+65  
 301.7' Lt of Proposed W.B. I-90 Centerline  
 COORDINATES: N 663799; E 2189886.5

COMPLETION DEPTH: 90.0'  
 ELEVATION: 629.3  
 DATE: 6/29/09

| Elev. (feet) | Depth Samp. (feet) | Std. Pen. / RQD-% | N <sub>60</sub> | Hand Pen. (tsf) | Sample Rec-% | Description  | Samp. No. | Physical Characteristics |      |      |        |        |    |    | ODOT Class |    |    |             |
|--------------|--------------------|-------------------|-----------------|-----------------|--------------|--|-----------|--------------------------|------|------|--------|--------|----|----|------------|----|----|-------------|
|              |                    |                   |                 |                 |              |  |           | % Agg.                   | % CS | % FS | % Silt | % Clay | LL | PL |            | PI | WC |             |
| 587.3        | 35                 | 4/6/8             | 20              | 2.5-4.0         | 100          | Very-stiff gray SILT, "and" clay, trace fine sand, moist.  | 14        |                          |      |      |        |        |    |    |            |    | 23 | A-4b (Vis.) |
|              | 40                 |                   |                 |                 |              |  |           |                          |      |      |        |        |    |    |            |    |    |             |
|              | 45                 | 3/3/6             | 13              | 1.0-2.3         | 87           | Stiff to very-stiff gray SILT AND CLAY, trace fine to coarse sand, trace fine gravel, contains few silt lenses, moist. | 15        | 1                        | 0    | 2    | 41     | 56     | 32 | 21 | 11         |    | 26 | A-6a(8)     |
|              | 50                 |                   |                 |                 |              |  | 16        |                          |      |      |        |        |    |    |            |    | 21 | A-6a (Vis.) |
|              | 55                 | 3/4/6             | 14              | 1.0-2.5         | 100          | Medium-stiff gray SILT AND CLAY, trace fine to coarse sand, moist.   | 17        | 1                        | 1    | 1    | 24     | 73     | 38 | 23 | 15         |    | 29 | A-6a(10)    |
|              | 60                 | 2/3/5             | 11              | 0.5-0.8         | 100          |  |           |                          |      |      |        |        |    |    |            |    |    |             |
|              | 65                 | 3/3/6             | 13              | 0.7-1.0         | 100          |  | 19        | 0                        | 1    | 2    | 42     | 55     | 33 | 20 | 13         |    | 25 | A-6a(9)     |
|              | 70                 | 3/5/7             | 17              | 0.7-1.0         | 100          |  |           |                          |      |      |        |        |    |    |            |    |    |             |

WATER LEVEL:   
 WATER NOTE:   
 DATE: 6/29/09

14.0  
 In Augers Prior to Washbore  
 6/29/09

Drill Rod Energy Ratio: 0.85  
 Last Calibration Date: 09/13/07  
 Drill Rig Number: OTB-ATV D50

C-R-S: CUY-90-14.52  
 PID No.: 77332  
 Bridge No.:

LOG OF BORING NO. B-037-0-09  
 CUY-90-14.52 WEST ABUTMENT  
 CLEVELAND, OHIO



TYPE: 3-1/4" I.D. Hollow-stem Auger; 3-1/8" Tricone Roller Bit  
 2" O.D. Split-barrel Sampler

LOCATION: Sta. 131+65  
 301.7' Lt of Proposed W.B. I-90 Centerline  
 COORDINATES: N 663799; E 2189886.5

COMPLETION DEPTH: 90.0'  
 ELEVATION: 629.3  
 DATE: 6/29/09

| Elev. (feet) | Depth Samp. (feet) | Std. Pen. / RQD-% | N <sub>60</sub> | Hand Pen. (tsf) | Sample Rec-% | Description   | Samp. No. | Physical Characteristics |      |      |        |        |    | ODOT Class |    |    |    |  |  |    |             |
|--------------|--------------------|-------------------|-----------------|-----------------|--------------|---|-----------|--------------------------|------|------|--------|--------|----|------------|----|----|----|--|--|----|-------------|
|              |                    |                   |                 |                 |              |   |           | % Agg.                   | % CS | % FS | % Silt | % Clay | LL |            | PL | PI | WC |  |  |    |             |
| 557.3        | 70                 |                   |                 |                 |              |   |           |                          |      |      |        |        |    |            |    |    |    |  |  |    |             |
|              | 75                 | 7/9/12            | 30              | 3.3-4.5+        | 80           | Very-stiff to hard gray SIL.T, "and" clay, damp to moist. | 21        | 0                        | 0    | 0    | 53     | 47     | 29 | 20         | 9  | 21 |    |  |  | 23 | A-4b (Vis.) |
|              | 80                 | 6/11/13           | 34              | 3.5-4.5+        | 100          |   | 22        | 0                        | 0    | 0    | 53     | 47     | 29 | 20         | 9  | 21 |    |  |  | 21 | A-4b (Vis.) |
|              | 85                 | 8/12/13           | 35              | 3.8-4.0         | 73           |   | 23        |                          |      |      |        |        |    |            |    |    |    |  |  | 21 | A-4b (Vis.) |
| 539.3        | 90                 | 5/6/8             | 20              | 2.0-3.5         | 100          |   | 24        |                          |      |      |        |        |    |            |    |    |    |  |  | 23 | A-4b (Vis.) |

NOTES:  
 - Encountered water at 11.2' during drilling.  
 - Used 3-1/4" I.D. Hollow-stem Augers from 0.0' to 30.0'.  
 - From 30.0' to 90.0', used 3-1/8" Tricone Roller Bit with water (washbore), with augers left in hole to act as casing.

WATER LEVEL: 11.2  
 WATER NOTE: Encountered  
 DATE: 6/29/09

In Augers Prior to Washbore: 14.0  
 DATE: 6/29/09

Drill Rod Energy Ratio: 0.85  
 Last Calibration Date: 09/13/07  
 Drill Rig Number: OTB ATV D50





C-R-S: CUY-90-14.52  
 PID No.: 77332  
 Bridge No.:

LOG OF BORING NO. B-037-1-09  
 CUY-90-14.52 WEST ABUTMENT  
 CLEVELAND, OHIO



TYPE: 3-1/4" I.D. Hollow-stem Auger; 3-1/8 Tricone Roller Bit  
 2" O.D. Split-barrel Sampler, 3" O.D. Shelby Tube Sampler

LOCATION: Sta. 131+34

55.5' Lt of Proposed W.B. I-90 Centerline

COMPLETION DEPTH: 215.5'

ELEVATION: 645.5

DATE: 7/14/09

COORDINATES: N 663689.7; E 2190109.4

| Elev. (feet) | Depth (feet) | Samp. | Std. Pen. / RQD-% | N <sub>60</sub> | Hand Pen. (tsf) | Sample Rec-% | Description  | Samp. No. | Physical Characteristics |      |      |        |        | ODOT Class |    |    |    |             |
|--------------|--------------|-------|-------------------|-----------------|-----------------|--------------|--|-----------|--------------------------|------|------|--------|--------|------------|----|----|----|-------------|
|              |              |       |                   |                 |                 |              |  |           | % Agg.                   | % CS | % FS | % Silt | % Clay |            | LL | PL | PI | WC          |
| 543.5        | -90 to -95   | +     | 4/7/10            | 24              | 2.0-4.0         | 93           | Very-stiff gray SILT, "and" clay, trace fine sand, damp to moist.  | 29        | 0                        | 0    | 1    | 54     | 45     | 28         | 19 | 9  | 22 | A-4b(8)     |
| 538.5        | -100 to -105 | +     | 5/10/11           | 29              | 2.5-4.0         | 87           | Very-stiff gray SILT AND CLAY, trace fine to coarse sand, trace fine gravel, damp to moist.                            | 30        | 1                        | 1    | 2    | 41     | 55     | 30         | 19 | 11 | 21 | A-6a(8)     |
| 527.5        | -110 to -115 | +     | 8/13/18           | 43              | 2.5-4.5+        | 80           | Very-stiff to hard gray SANDY SILT, some clay, trace fine gravel, contains many silt lenses, damp.                     | 31        | 1                        | 1    | 2    | 41     | 55     | 30         | 19 | 11 | 21 | A-6a(8)     |
|              | -120 to -125 | +     | 4/9/13            | 31              | 2.3-3.2         | 93           | Very-stiff gray SILT AND CLAY, trace fine to coarse sand, trace fine gravel, contains many silt lenses, damp to moist. | 32        | 1                        | 2    | 3    | 31     | 63     | 33         | 19 | 14 | 21 | A-6a(10)    |
|              | -130 to -135 | +     | 4/8/11            | 27              | 2.0-2.5         | 93           | Very-stiff gray SILT AND CLAY, trace fine to coarse sand, trace fine gravel, contains many silt lenses, damp to moist. | 33        | 1                        | 2    | 3    | 31     | 63     | 33         | 19 | 14 | 21 | A-6a(10)    |
|              |              | +     | 4/7/10            | 24              | 2.0-2.3         | 100          |  | 34        | 1                        | 2    | 3    | 31     | 63     | 33         | 19 | 14 | 21 | A-6a(10)    |
|              |              | +     |                   |                 |                 |              |  | 35        |                          |      |      |        |        |            |    |    |    | A-6a (Vis.) |
|              |              | +     |                   |                 |                 |              |  | 36        |                          |      |      |        |        |            |    |    |    | A-6a (Vis.) |

WATER LEVEL:  Encountered  
 WATER NOTE:  Encountered  
 DATE: 7/14/09

Drill Rod Energy Ratio:  0.84  
 Last Calibration Date: 09/13/07  
 Drill Rig Number: OTB TRUCK 2800

C-R-S: CUY-90-14.52  
 PID No.: 77332  
 Bridge No.:

LOG OF BORING NO. B-037-1-09  
 CUY-90-14.52 WEST ABUTMENT  
 CLEVELAND, OHIO



TYPE: 3-1/4" I.D. Hollow-stem Auger; 3-1/8 Tricone Roller Bit  
 2" O.D. Split-barrel Sampler, 3" O.D. Shelby Tube Sampler

LOCATION: Sta. 131+34  
 55.5' Lt of Proposed W.B. I-90 Centerline  
 COORDINATES: N 663689.7; E 2190109.4

COMPLETION DEPTH: 215.5'  
 ELEVATION: 645.5'  
 DATE: 7/14/09

| Elev. (feet) | Depth Samp. (feet) | Std. Pen. / RQD-% | N <sub>60</sub> | Hand Pen. (tsf) | Sample Rec-% | Description  | Samp. No.  | Physical Characteristics |      |      |        |        |    | ODOT Class |    |                            |    |
|--------------|--------------------|-------------------|-----------------|-----------------|--------------|--|------------|--------------------------|------|------|--------|--------|----|------------|----|----------------------------|----|
|              |                    |                   |                 |                 |              |  |            | % Agg.                   | % CS | % FS | % Silt | % Clay | LL |            | PL | PI                         | WC |
| 498.5        | -140               | 4/8/9             | 24              | 2.0-2.3         | 100          | Very-stiff gray SILT AND CLAY, trace fine to coarse sand, trace fine gravel, contains many silt lenses, damp to moist.                         | 37         | 2                        | 2    | 3    | 30     | 63     | 19 | 13         | 23 | A-6a(9)                    |    |
|              | -145               | 3/7/9             | 22              | 2.0-2.2         | 100          |  |            |                          |      |      |        |        |    |            |    |                            |    |
| 490.5        | -150               | 6/10/11           | 29              | 0.7-1.5         | 100          | Medium-stiff to stiff gray SILT AND CLAY, trace fine to coarse sand, moist.  | 39         | 0                        | 1    | 1    | 32     | 66     | 34 | 21         | 13 | A-6a(9)                    |    |
|              | -155               | 6/11/15           | 36              | 1.5             | 20           |  |            |                          |      |      |        |        |    |            |    |                            |    |
| 485.5        | -160               | P                 |                 | 2.0-4.5+        | 90           | Very-stiff to hard gray SILT AND CLAY, trace fine sand, trace fine gravel, damp.   | 41         | 0                        | 0    | 0    | 42     | 58     | 30 | 18         | 12 | A-6a(9)                    |    |
|              | -165               | P                 |                 | 2.0-4.5+        | 90           |  |            |                          |      |      |        |        |    |            |    |                            |    |
| 481.0        | -170               | 23/26/30          | 78              | 4.5+            | 60           | Very-dense gray SANDY SILT, trace to little clay, trace fine gravel, moist.  | 42         | 1                        | 0    | 1    | 21     | 77     | 37 | 22         | 15 | A-6a(10)                   |    |
|              | -175               | 17/33/45          | 109             | 4.0-4.5+        | 87           |  |            |                          |      |      |        |        |    |            |    |                            |    |
| 469.5        | -180               | 14/41/40          | 113             | 4.0-4.5+        | 80           | Hard gray SILT AND CLAY, trace to little fine to coarse sand, trace fine to coarse gravel, contains few shale fragments and silt lenses, damp. | 43A<br>43B |                          |      |      |        |        |    |            |    | A-4a (Vis.)<br>A-6a (Vis.) |    |
|              | -175               | 8/11/15           | 36              | 2.3-4.25        | 100          |  |            |                          |      |      |        |        |    |            |    |                            |    |
|              | -180               |                   |                 |                 |              | Very-stiff to hard gray SANDY SILT, trace fine sand, trace fine to coarse gravel, contains few silt lenses, damp to moist.                     | 44         |                          |      |      |        |        |    |            |    | A-6a (Vis.)                |    |
|              | -180               |                   |                 |                 |              |  |            |                          |      |      |        |        |    |            |    |                            |    |
|              | -180               |                   |                 |                 |              |  | 45         |                          |      |      |        |        |    |            |    | A-6a (Vis.)                |    |
|              | -180               |                   |                 |                 |              |  |            |                          |      |      |        |        |    |            |    |                            |    |
|              | -180               |                   |                 |                 |              |  | 46         | 6                        | 0    | 1    | 35     | 58     | 31 | 21         | 10 | A-4a(8)                    |    |
|              | -180               |                   |                 |                 |              |  |            |                          |      |      |        |        |    |            |    |                            |    |

WATER LEVEL:  $\nabla$  23.0  
 WATER NOTE: Encountered  
 DATE: 7/14/09

Drill Rod Energy Ratio:  $\nabla$  0.84  
 Last Calibration Date: 09/13/07  
 Drill Rig Number: OTB TRUCK 2800



C-R-S: CUY-90-14.52  
 PID No.: 77332  
 Bridge No.:

LOG OF BORING NO. B-037-1-09  
 CUY-90-14.52 WEST ABUTMENT  
 CLEVELAND, OHIO



TYPE: 3-1/4" I.D. Hollow-stem Auger; 3-1/8 Tricone Roller Bit  
 2" O.D. Split-barrel Sampler, 3" O.D. Shelby Tube Sampler

LOCATION: Sta. 131+34  
 55.5' Lt of Proposed W.B. I-90 Centerline  
 COORDINATES: N 663689.7; E 2190109.4

COMPLETION DEPTH: 215.5'  
 ELEVATION: 645.5  
 DATE: 7/14/09

| Elev. (feet) | Depth (feet) | Samp. | Std. Pen. / RQD-% | N <sub>60</sub> | Hand Pen. (tsf) | Sample Rec-% | Description  | Samp. No. | Physical Characteristics |      |      |        |        |    | ODOT Class |    |    |    |         |
|--------------|--------------|-------|-------------------|-----------------|-----------------|--------------|--|-----------|--------------------------|------|------|--------|--------|----|------------|----|----|----|---------|
|              |              |       |                   |                 |                 |              |  |           | % Agg.                   | % CS | % FS | % Silt | % Clay | LL |            | PL | PI | WC |         |
| 463.5        | -180         |       |                   |                 |                 |              |  |           |                          |      |      |        |        |    |            |    |    |    |         |
|              | -185         |       | 7/11/14           | 35              | 2.0-2.3         | 67           | Very-stiff gray SILT AND CLAY, trace fine to coarse sand, trace fine gravel, contains few silt lenses, moist.  | 47        | 2                        | 1    | 1    | 29     | 67     | 33 | 20         | 13 | 24 |    | A-6a(9) |
| 458.0        | -190         |       | 16/33/36          | 97              | 4.0-4.5+        | 60           | Hard dark gray SILT AND CLAY, some fine to coarse gravel, some fine to coarse sand, contains many shale fragments, moist.  | 48        | 33                       | 17   | 8    | 17     | 25     | 29 | 18         | 11 |    |    | A-6a(2) |
| 453.3        | -195         |       | RQD 48%           |                 |                 | 90           | SHALE, gray, severely weathered, very weak to slightly strong, laminated, fissile, highly fractured, open, very to slightly rough, contains many clayey silt pockets, RQD = 0%, Core Loss = 36%.   | 50        |                          |      |      |        |        |    |            |    |    |    | Visual  |
|              |              |       | 90-3"R            |                 |                 | 100          |  | 49        |                          |      |      |        |        |    |            |    |    |    | Visual  |
| 447.9        | -200         |       | RQD 89%           |                 |                 | 100          | SHALE, gray, moderately to highly weathered, weak to slightly strong, laminated to thinly laminated, fractured, narrow to open, slightly rough, vertical fracture from 194.2' to 195.5', contains few clayey silt pockets, and few diagonal fractures, RQD = 69%, Core Loss = 0%.      | 51        |                          |      |      |        |        |    |            |    |    |    | Visual  |
|              | -205         |       |                   |                 |                 |              | SHALE, gray to dark gray with few very light gray seams, moderately to slightly weathered, weak to slightly strong, laminated to thinly laminated, fractured to moderately fractured, narrow to open, slightly rough, few brown seams (possible siltstone), RQD = 89%, Core Loss = 0%. |           |                          |      |      |        |        |    |            |    |    |    | Visual  |
| 430.0        | -210         |       | RQD 85%           |                 |                 | 100          |  |           |                          |      |      |        |        |    |            |    |    |    | Visual  |
|              | -215         |       |                   |                 |                 |              |  |           |                          |      |      |        |        |    |            |    |    |    |         |
|              | -220         |       |                   |                 |                 |              |  |           |                          |      |      |        |        |    |            |    |    |    |         |
|              | -225         |       |                   |                 |                 |              |  |           |                          |      |      |        |        |    |            |    |    |    |         |

SEE NEXT PAGE FOR NOTES

WATER LEVEL:   
 WATER NOTE:   
 DATE: 7/14/09

23.0  
 Encountered  
 7/14/09

Drill Rod Energy Ratio : 0.84  
 Last Calibration Date : 09/13/07  
 Drill Rig Number : OTB TRUCK 2800

C-R-S: CUY-90-14.52  
 PID No.: 77332  
 Bridge No.:

**LOG OF BORING NO. B-037-1-09  
 CUY-90-14.52 WEST ABUTMENT  
 CLEVELAND, OHIO**



TYPE: 3-1/4" I.D. Hollow-stem Auger; 3-1/8" Tricone Roller Bit  
 2" O.D. Split-barrel Sampler, 3" O.D. Shelby Tube Sampler

LOCATION: Sta. 131+34  
 55.5' Lt of Proposed W.B. I-90 Centerline  
 COORDINATES: N 663689.7; E 2190109.4

COMPLETION DEPTH: 215.5'  
 ELEVATION: 645.5  
 DATE: 7/14/09

| Elev.<br>(feet) | Depth<br>Samp.<br>(feet) | Std. Pen. /<br>RQD-% | N <sub>60</sub> | Hand Pen.<br>(tsf) | Sample<br>Rec-% | Description   | Samp.<br>No. | Physical Characteristics |      |      |        |        | ODOT<br>Class |    |    |
|-----------------|--------------------------|----------------------|-----------------|--------------------|-----------------|---|--------------|--------------------------|------|------|--------|--------|---------------|----|----|
|                 |                          |                      |                 |                    |                 |   |              | % Agg.                   | % CS | % FS | % Silt | % Clay |               | LL | PL |
| 225             |                          |                      |                 |                    |                 | <p><b>NOTES:</b></p> <ul style="list-style-type: none"> <li>- Encountered seepage at 21' during drilling.</li> <li>- Encountered water at 23' during drilling.</li> <li>- Used 3-1/4" I.D. Hollow-stem Augers from 0.0' to 52.0'.</li> <li>- At 52.0', removed augers and placed 4" O.D. casing to a depth of 52.0'.</li> <li>- Used 3-7/8" Tricone Roller Bit with water (washbore) from 52.0' to 193.5'.</li> <li>- No sample recovery from Shelby tube attempt at 68' to 70'. SPT sample (Sample 23) was obtained after the unsuccessful Shelby tube attempt; therefore, the blowcounts for Sample 23 may not be accurate due to sample disturbance, and are thereby not shown.</li> <li>- During installation of rock coring equipment, a cobble previously encountered near 150' to 155', knocked the rock core barrels slightly askew and the barrels were forced out of previously bored hole. Coring through soil to form a "new" hole from 165' to 190.5' (at which depth coreable rock was encountered) with rock core barrel was required.</li> <li>- Sample 49 was taken in original hole.</li> <li>- Vibrating wire piezometers were installed at depths of 70' and 185'.</li> </ul> <p><b>ROCK CORE TEST RESULTS</b></p> <ul style="list-style-type: none"> <li>- Q<sub>u</sub> = 1530 psi at 192.7'</li> <li>- Q<sub>u</sub> = 1570 psi at 203.3'</li> <li>- Q<sub>u</sub> = 1730 psi at 206.5'</li> <li>- SDI (I<sub>u2</sub>) from Sample 50 (water) = 81.0%, Type II</li> <li>- SDI (I<sub>u2</sub>) from Sample 50 (mineral) = 86.1%, Type II</li> <li>- SDI (I<sub>u2</sub>) from Sample 50 (polymer) = 87.6%, Type II</li> <li>- SDI (I<sub>u2</sub>) from Sample 51 (water) = 84.9%, Type II</li> <li>- SDI (I<sub>u2</sub>) from Sample 51 (mineral) = 85.7%, Type II</li> <li>- SDI (I<sub>u2</sub>) from Sample 51 (polymer) = 88.4%, Type II</li> <li>- SDI (I<sub>u2</sub>) from Sample 52 (water) = 85.2%, Type II</li> <li>- SDI (I<sub>u2</sub>) from Sample 52 (mineral) = 85.5%, Type II</li> <li>- SDI (I<sub>u2</sub>) from Sample 52 (polymer) = 88.0%, Type II</li> </ul> |              |                          |      |      |        |        |               |    |    |
| 230             |                          |                      |                 |                    |                 |   |              |                          |      |      |        |        |               |    |    |
| 235             |                          |                      |                 |                    |                 |   |              |                          |      |      |        |        |               |    |    |
| 240             |                          |                      |                 |                    |                 |   |              |                          |      |      |        |        |               |    |    |
| 245             |                          |                      |                 |                    |                 |   |              |                          |      |      |        |        |               |    |    |
| 250             |                          |                      |                 |                    |                 |   |              |                          |      |      |        |        |               |    |    |
| 255             |                          |                      |                 |                    |                 |   |              |                          |      |      |        |        |               |    |    |
| 260             |                          |                      |                 |                    |                 |   |              |                          |      |      |        |        |               |    |    |
| 265             |                          |                      |                 |                    |                 |   |              |                          |      |      |        |        |               |    |    |
| 270             |                          |                      |                 |                    |                 |   |              |                          |      |      |        |        |               |    |    |

WATER LEVEL:  23.0  
 WATER NOTE: Encountered  
 DATE: 7/14/09

Drill Rod Energy Ratio:  0.84  
 Last Calibration Date: 09/13/07  
 Drill Rig Number: OTB TRUCK 2800

C-R-S: CUY-90-14.52  
 PID No.: 77332  
 Bridge No.:

LOG OF BORING NO. B-038-0-09  
 CUY-90-14.52 WEST ABUTMENT  
 CLEVELAND, OHIO



TYPE: 3-1/4" I.D. Hollow-stem Auger; 3-1/8" Tricone Roller Bit  
 2" O.D. Split-barrel Sampler

LOCATION: Sta. 132+80  
 305.8' Lt of Proposed W.B. I-90 Centerline  
 COORDINATES: N 663909.1; E 2189920

COMPLETION DEPTH: 90.0'  
 ELEVATION: 614.7  
 DATE: 6/30/09

| Elev. (feet) | Depth Samp. (feet) | Std. Pen. / RQD-% | N <sub>60</sub> | Hand Pen. (tsf) | Sample Rec-% | Description   | Samp. No. | Physical Characteristics |      |      |        |        | ODOT Class |    |    |    |             |             |
|--------------|--------------------|-------------------|-----------------|-----------------|--------------|---|-----------|--------------------------|------|------|--------|--------|------------|----|----|----|-------------|-------------|
|              |                    |                   |                 |                 |              |   |           | % Agg.                   | % CS | % FS | % Silt | % Clay |            | LL | PL | PI | WC          |             |
| 610.5        | 0                  | 6/6/5             | 16              |                 | 80           | FILL: Medium-dense dark brown COARSE AND FINE SAND, trace fine gravel, trace silt, trace clay, contains many cinders, damp to moist.                                | 1         |                          |      |      |        |        |            |    |    | 14 | A-3a (Vis.) |             |
|              | 5                  | 7/7/6             | 18              |                 | 100          |   | 2A        |                          |      |      |        |        |            |    |    |    | 16          | A-3a (Vis.) |
|              |                    |                   |                 |                 | 88           |   | 2B        |                          |      |      |        |        |            |    |    |    | 11          | A-3 (Vis.)  |
|              |                    | 3/2/4             | 9               |                 | 67           | Loose to medium-dense brown FINE SAND, some coarse sand, trace fine gravel, trace silt, trace clay, damp.   | 3         |                          |      |      |        |        |            |    |    |    | 11          | A-3 (Vis.)  |
|              |                    | 3/4/3             | 10              |                 | 60           |   | 4         |                          |      |      |        |        |            |    |    |    | 9           | A-3 (Vis.)  |
| 604.2        | 10                 | 2/2/2             | 6               |                 | 73           |   | 5         |                          |      |      |        |        |            |    |    |    | 11          | A-3 (Vis.)  |
|              |                    | 2/2/3             | 7               |                 | 93           | Very-loose to loose brown FINE SAND, little coarse sand, trace fine gravel, trace silt, trace clay, contains few silt and silty clay lenses and seams, damp to wet. | 6         |                          |      |      |        |        |            |    |    |    | 11          | A-3 (Vis.)  |
|              | 15                 | 2/2/3             | 7               |                 | 100          |   | 7         |                          |      |      |        |        |            |    |    |    | 22          | A-3 (Vis.)  |
|              |                    | 2/1/1             | 3               |                 | 100          |   | 8         |                          |      |      |        |        |            |    |    |    | 31          | A-3 (Vis.)  |
| 594.2        | 20                 | SH-12"/2          |                 |                 | 67           |   | 9         |                          |      |      |        |        |            |    |    |    | 27          | A-3a (Vis.) |
|              |                    |                   |                 |                 |              | Very-loose brown COARSE AND FINE SAND, little silt, wet.  |           |                          |      |      |        |        |            |    |    |    |             |             |
| 591.7        |                    |                   |                 |                 | 80           |   | 10        |                          |      |      |        |        |            |    |    |    | 27          | A-4b(8)     |
|              |                    | 3/3/6             | 13              |                 |              | Medium-dense gray SILT, little clay, little fine sand, moist to wet.  |           |                          |      |      |        |        |            |    |    |    |             |             |
|              | 25                 |                   |                 |                 | 100          |   | 11        |                          |      |      |        |        |            |    |    |    | 27          | A-4b (Vis.) |
| 588.7        |                    | 2/2/3             | 7               | 0.7-1.3         |              | Medium-stiff to stiff gray SILT, "and" clay, trace fine sand, slightly organic, moist to wet.   |           |                          |      |      |        |        |            |    |    |    |             |             |
|              |                    | 1/2/3             | 7               | 0.5-1.3         | 100          |   | 12        |                          |      |      |        |        |            |    |    |    | 30          | A-4b(8)     |
|              | 30                 |                   |                 |                 |              |   |           |                          |      |      |        |        |            |    |    |    |             |             |
| 582.7        |                    | 2/3/5             | 11              | 1.5-2.5         | 100          | Stiff to very-stiff gray SILT AND CLAY, trace fine to coarse sand, contains few silt and fine sand lenses and black (slightly organic) pockets, damp to moist.      | 13        |                          |      |      |        |        |            |    |    |    | 25          | A-6a (Vis.) |

WATER LEVEL:  19.0  
 WATER NOTE:  In Augers Prior to Washbore  
 DATE: 6/30/09

Drill Rod Energy Ratio: 0.85  
 Last Calibration Date: 09/13/07  
 Drill Rig Number: OTB-ATV D50

C-R-S: CUY-90-14.52  
 PID No.: 77332  
 Bridge No.:

**LOG OF BORING NO. B-038-0-09**  
**CUY-90-14.52 WEST ABUTMENT**  
**CLEVELAND, OHIO**



TYPE: 3-1/4" I.D. Hollow-stem Auger; 3-1/8" Tricone Roller Bit  
 2" O.D. Split-barrel Sampler

LOCATION: Sta. 132+80  
 305.8' Lt of Proposed W.B. I-90 Centerline  
 COORDINATES: N 663909.1; E 2189920

COMPLETION DEPTH: 90.0'  
 ELEVATION: 614.7  
 DATE: 6/30/09 - 7/1/09

| Elev.<br>(feet) | Depth Samp.<br>(feet) | Std. Pen. /<br>RQD-% | N <sub>60</sub> | Hand Pen.<br>(tsf) | Sample<br>Rec-% | Description   | Samp.<br>No. | Physical Characteristics |         |         |           |           |    |    | ODOT<br>Class |    |    |  |  |  |    |             |  |
|-----------------|-----------------------|----------------------|-----------------|--------------------|-----------------|---|--------------|--------------------------|---------|---------|-----------|-----------|----|----|---------------|----|----|--|--|--|----|-------------|--|
|                 |                       |                      |                 |                    |                 |   |              | %<br>Agg.                | %<br>CS | %<br>FS | %<br>Silt | %<br>Clay | LL | PL |               | PI | WC |  |  |  |    |             |  |
| 577.7           | 35                    |                      |                 |                    |                 |   |              |                          |         |         |           |           |    |    |               |    |    |  |  |  |    |             |  |
|                 | 37.0                  | 1/3/3                | 9               | 0.5-1.5            | 100             | Medium-stiff to stiff gray SILT AND CLAY, trace fine to coarse sand, trace fine gravel, damp. | 14           |                          |         |         |           |           |    |    |               |    |    |  |  |  | 26 | A-6a (Vis.) |  |
|                 | 42.0                  | 2/2/2                | 6               | 0.0-0.5            | 100             | Very-soft to soft gray SILTY CLAY, trace fine to coarse sand, moist.                          | 15           | 0                        | 1       | 3       | 30        | 66        | 37 | 21 | 16            |    |    |  |  |  | 29 | A-6b(10)    |  |
|                 | 50                    | 2/3/3                | 9               | 0.0-0.5            | 100             |   | 16           |                          |         |         |           |           |    |    |               |    |    |  |  |  | 32 | A-6b (Vis.) |  |
|                 | 55                    | 2/3/4                | 10              | 0.2-0.5            | 100             |   | 17           |                          |         |         |           |           |    |    |               |    |    |  |  |  | 31 | A-6b (Vis.) |  |
|                 | 57.0                  | 2/3/4                | 10              | 0.5-0.8            | 100             | Medium-stiff gray SILT AND CLAY, trace fine sand, trace fine gravel, moist.                   | 18           | 1                        | 1       | 2       | 44        | 52        | 31 | 17 | 14            |    |    |  |  |  | 28 | A-6a(10)    |  |
|                 | 60                    | 2/3/4                | 10              | 0.5-1.0            | 100             |   | 19           |                          |         |         |           |           |    |    |               |    |    |  |  |  | 26 | A-6a (Vis.) |  |
|                 | 65                    | 2/2/3                | 7               | 0.0-0.5            | 87              | Very-soft to soft gray SILT AND CLAY, trace fine sand, trace fine gravel, moist.              | 20           | 1                        | 0       | 2       | 45        | 52        | 31 | 17 | 14            |    |    |  |  |  | 27 | A-6a(10)    |  |
|                 | 70                    |                      |                 |                    |                 |   |              |                          |         |         |           |           |    |    |               |    |    |  |  |  |    |             |  |

WATER LEVEL:  19.0  
 WATER NOTE:  Encountered  
 DATE: 6/30/09

"Dry"  
 In Augers Prior to Washbore  
 6/30/09

Drill Rod Energy Ratio: 0.85  
 Last Calibration Date: 09/13/07  
 Drill Rig Number: OTB-ATV D50

C-R-S: CUY-90-14.52  
 PID No.: 77332  
 Bridge No.:

LOG OF BORING NO. B-038-0-09  
 CUY-90-14.52 WEST ABUTMENT  
 CLEVELAND, OHIO



TYPE: 3-1/4" I.D. Hollow-stem Auger; 3-1/8" Tricone Roller Bit  
 2" O.D. Split-barrel Sampler

LOCATION: Sta. 132+80  
 305.8' Lt of Proposed W.B. I-90 Centerline  
 COORDINATES: N 663909.1; E 2189920

COMPLETION DEPTH: 90.0'  
 ELEVATION: 614.7  
 DATE: 6/30/09 - 7/1/09

| Elev. (feet) | Depth Samp. (feet) | Std. Pen. / RQD-% | N <sub>60</sub> | Hand Pen. (tsf) | Sample Rec-% | Description  | Samp. No. | Physical Characteristics |      |      |        |        |    |    | ODOT Class |    |    |             |             |
|--------------|--------------------|-------------------|-----------------|-----------------|--------------|--|-----------|--------------------------|------|------|--------|--------|----|----|------------|----|----|-------------|-------------|
|              |                    |                   |                 |                 |              |  |           | % Agg.                   | % CS | % FS | % Silt | % Clay | LL | PL |            | PI | WC |             |             |
| 542.7        | 70                 | 5/7/9             | 23              | 1.8-2.5         | 73           | Stiff to very-stiff gray SILT AND CLAY, trace fine sand, moist.                                    | 21        | 0                        | 0    | 1    | 49     | 50     | 32 | 19 | 13         | 22 | 23 | A-6a (Vis.) |             |
| 532.7        | 80                 | 6/7/11            | 26              | 2.0-2.8         | 87           | Very-stiff gray SILTY CLAY, trace to little fine to coarse sand, trace fine gravel, damp to moist. | 22        | 0                        | 0    | 1    | 49     | 50     | 32 | 19 | 13         | 22 | 22 | A-6a(9)     |             |
| 524.7        | 85                 | 5/7/8             | 21              | 2.0             | 87           |  | 23        | 1                        | 2    | 3    | 24     | 70     | 39 | 23 | 16         | 26 | 26 | A-6b(10)    |             |
| 524.7        | 90                 | 4/6/8             | 20              | 2.0             | 87           |  | 24        |                          |      |      |        |        |    |    |            |    |    | 22          | A-6b (Vis.) |

NOTES:

- Encountered water at 19.0' during drilling.
- Used 3-1/4" I.D. Hollow-stem Augers from 0.0' to 40.0'.
- From 40.0' to 90.0', used 3-1/8" Tricone Roller Bit with water (washbore), with augers left in hole to act as casing.

WATER LEVEL:  19.0  
 WATER NOTE: Encountered  
 DATE: 6/30/09

"Dry"  
 In Augers Prior to Washbore  
 DATE: 6/30/09

Drill Rod Energy Ratio : 0.85  
 Last Calibration Date : 09/13/07  
 Drill Rig Number : OTB ATV D50

**APPENDIX 4C**  
**SUBSURFACE PROFILES**

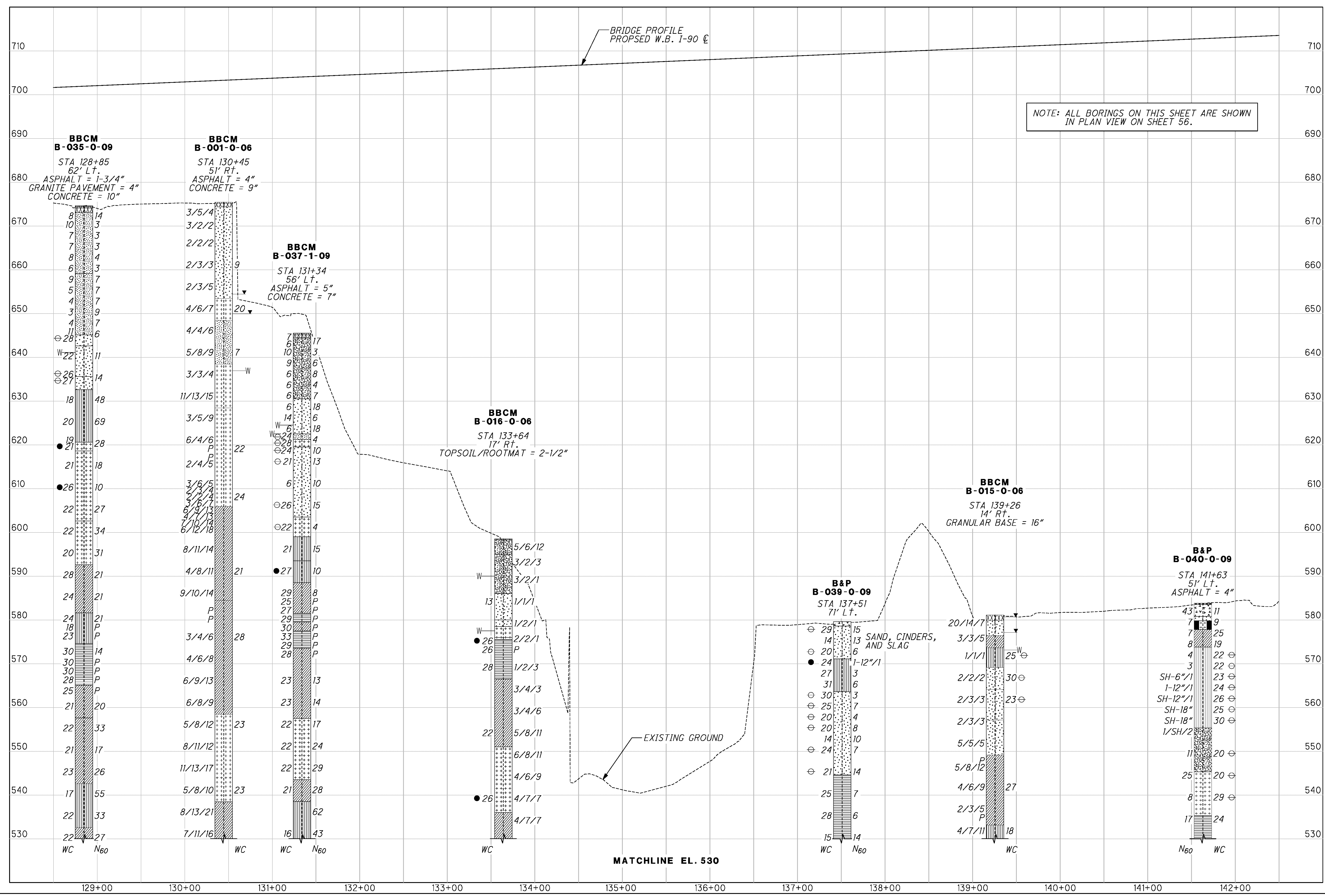

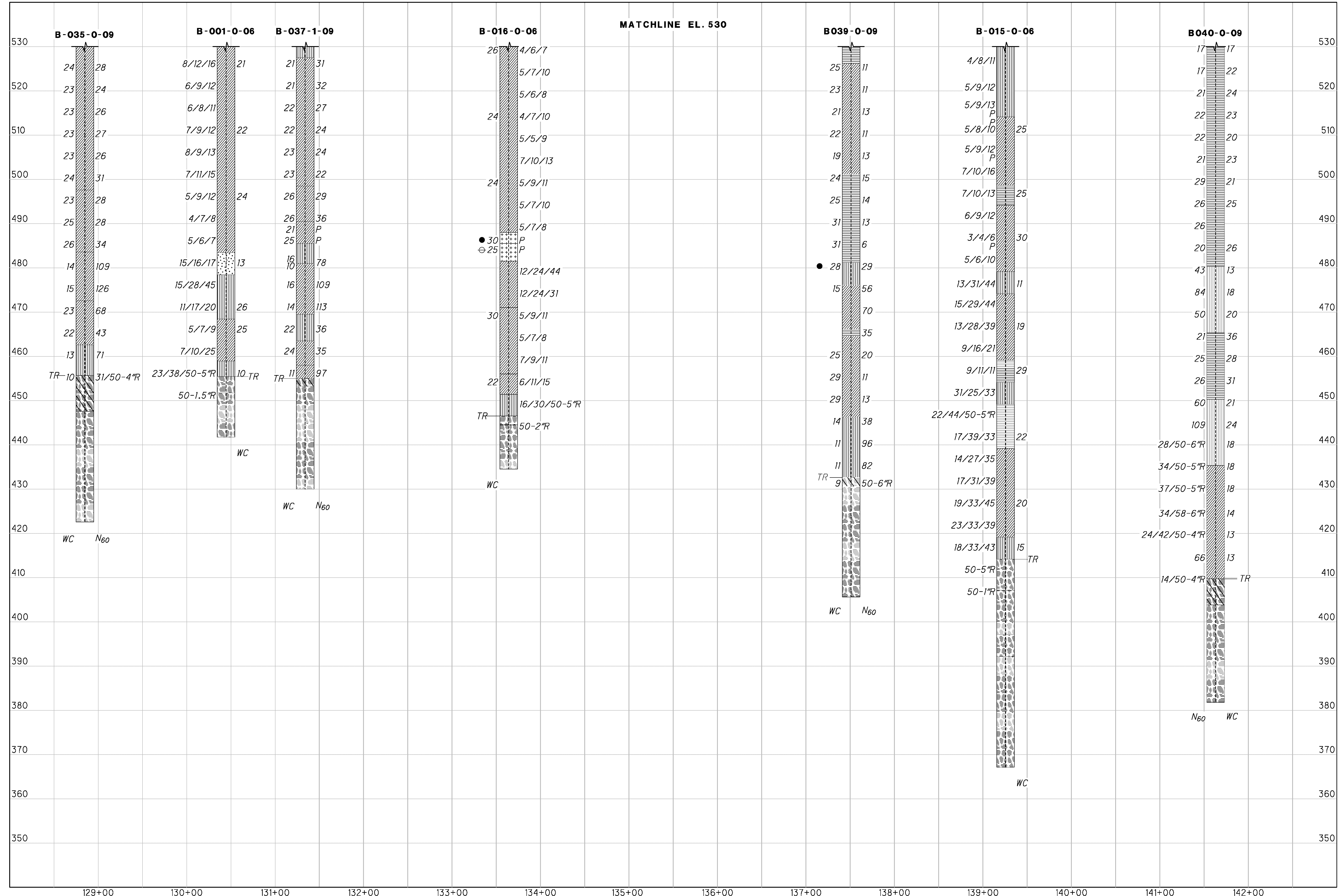
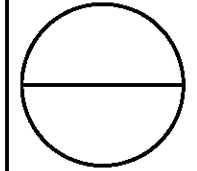



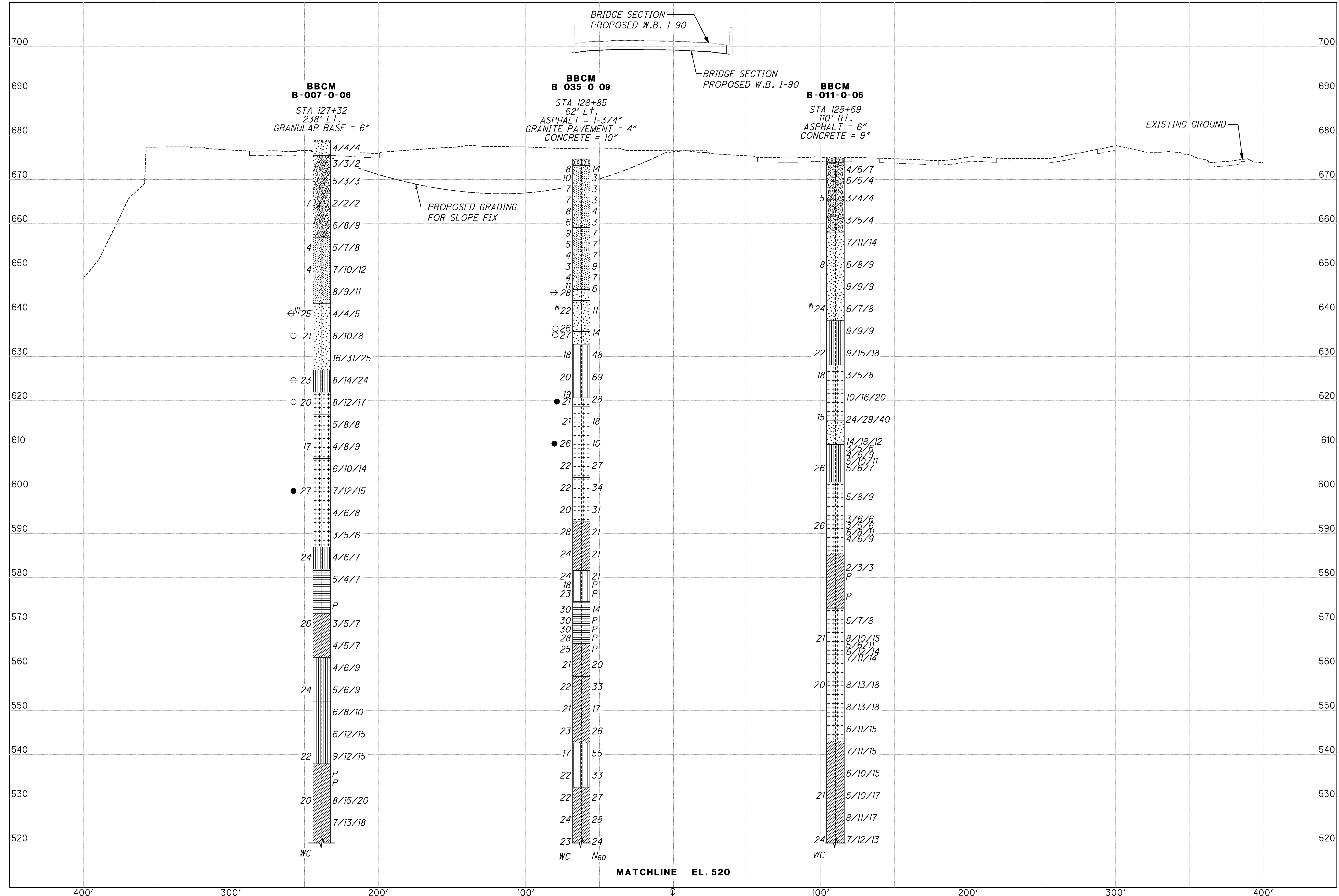
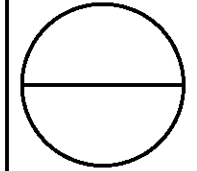

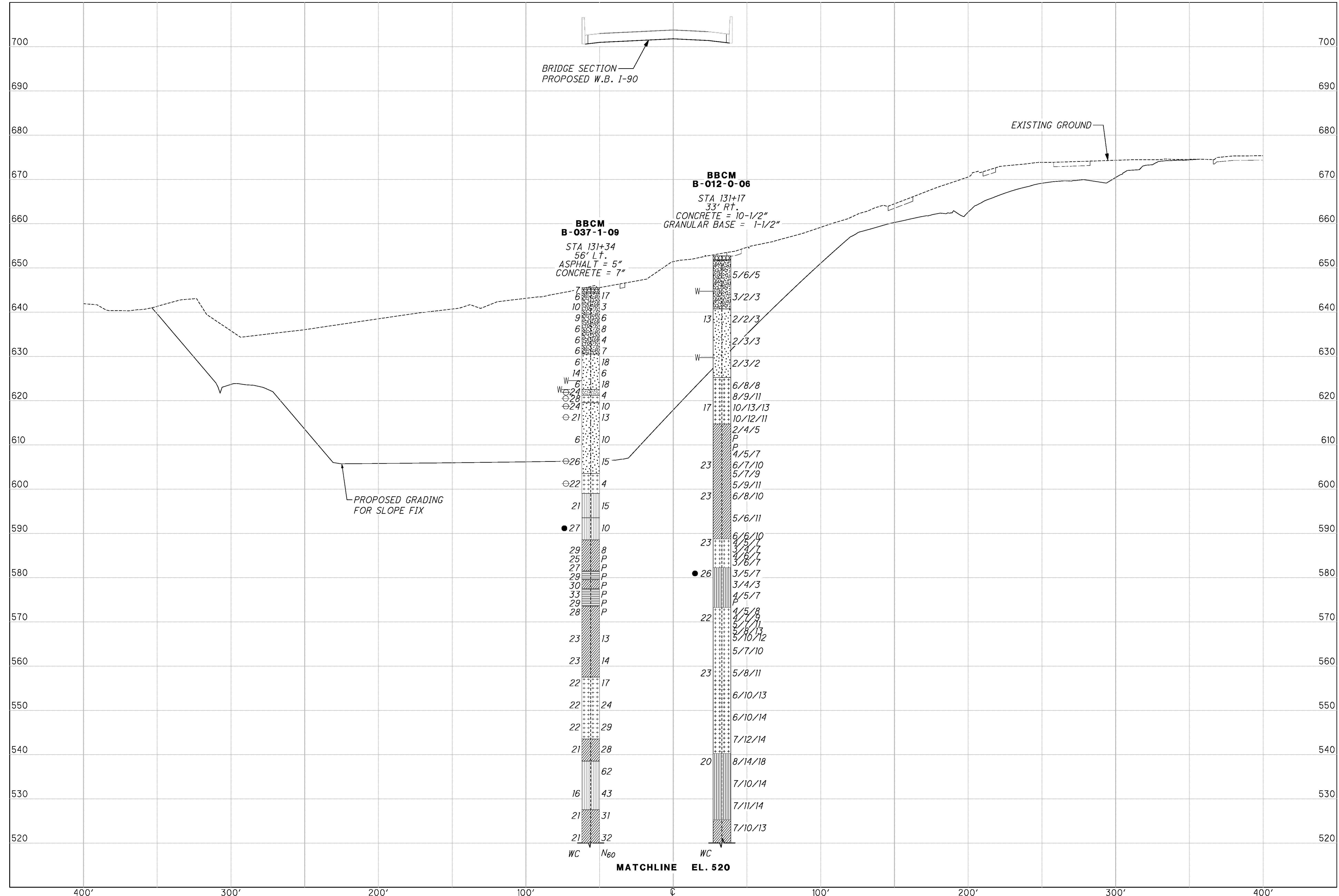
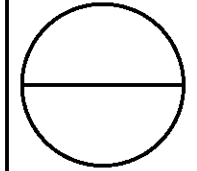

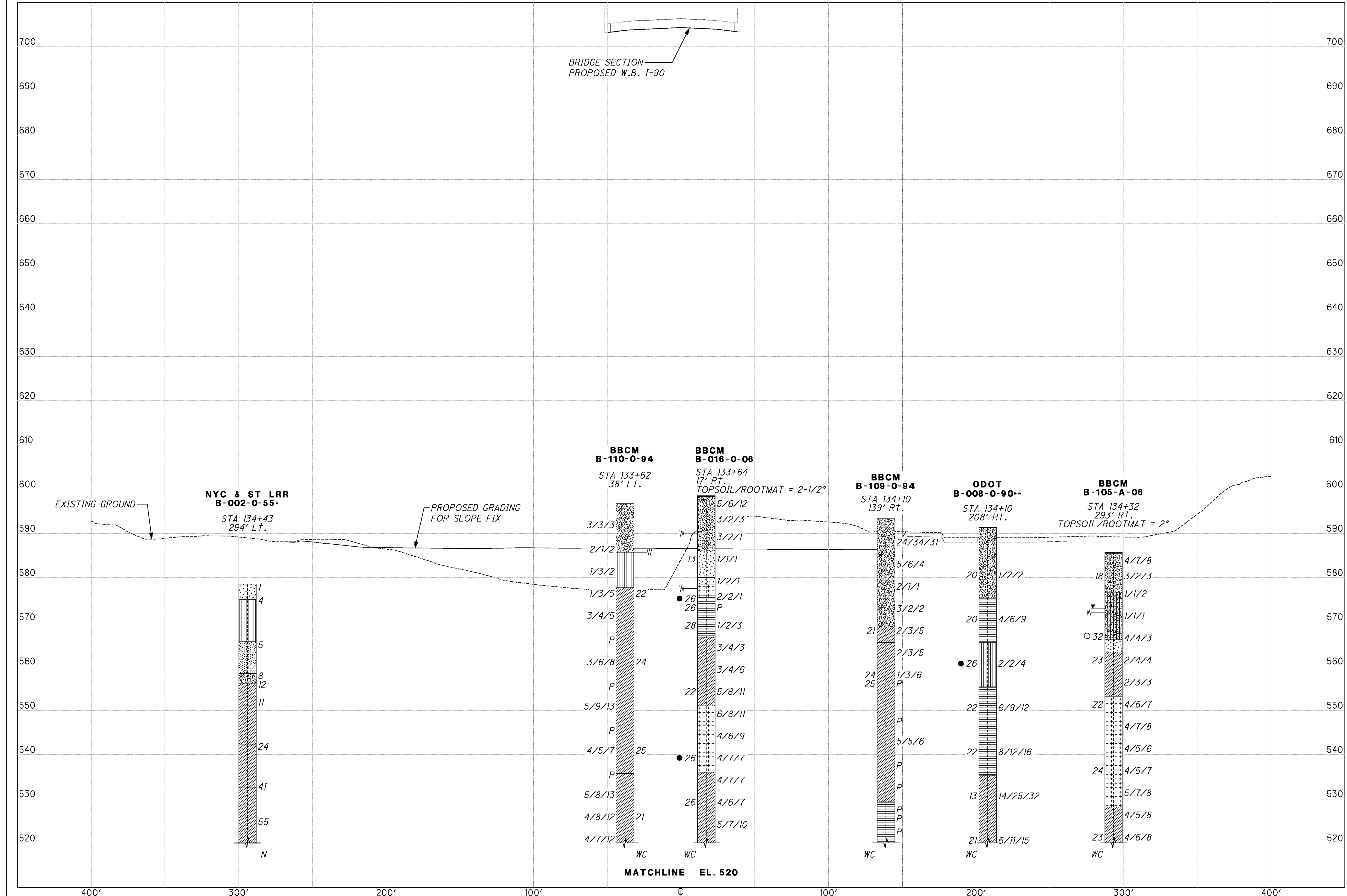

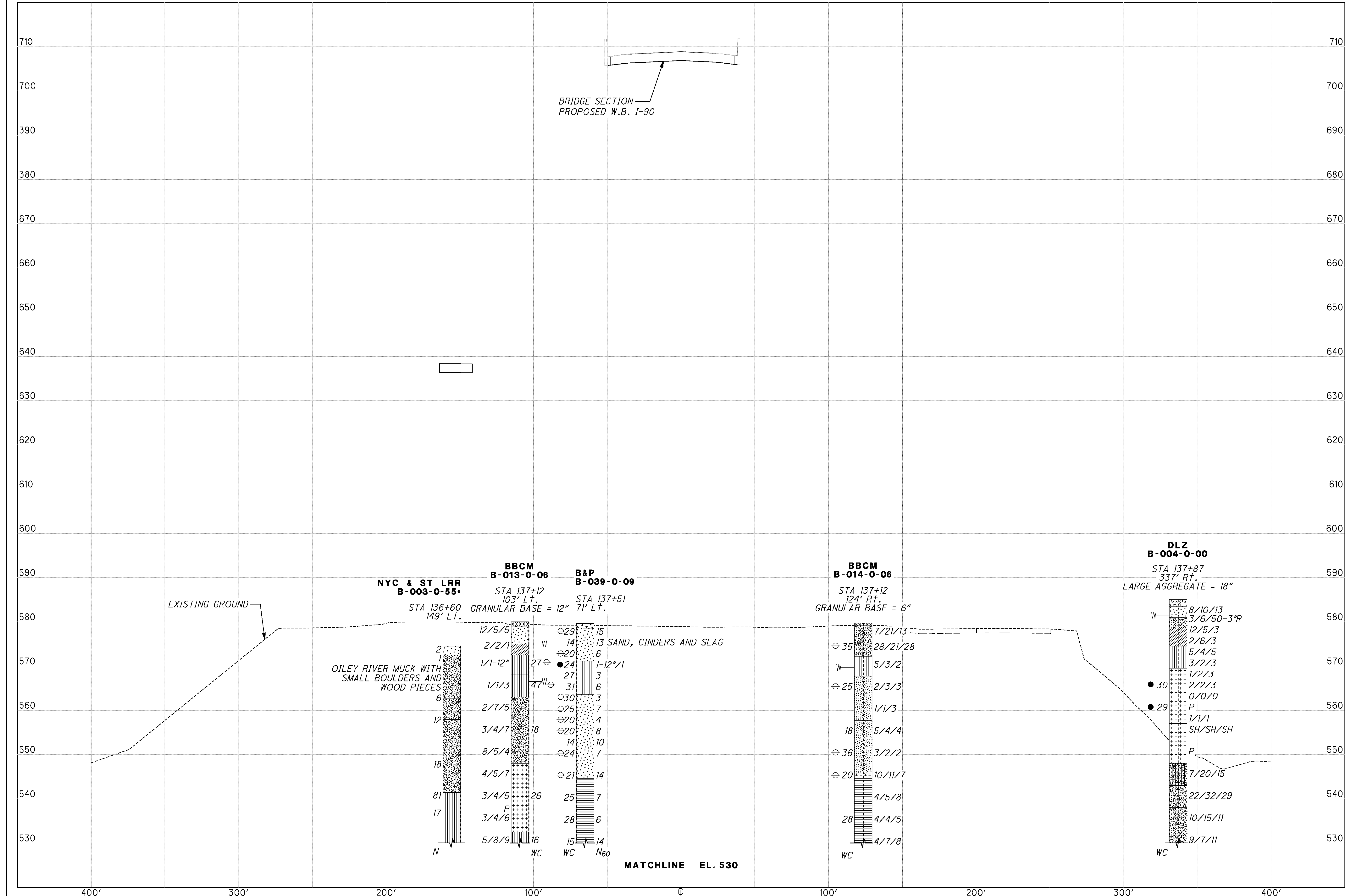

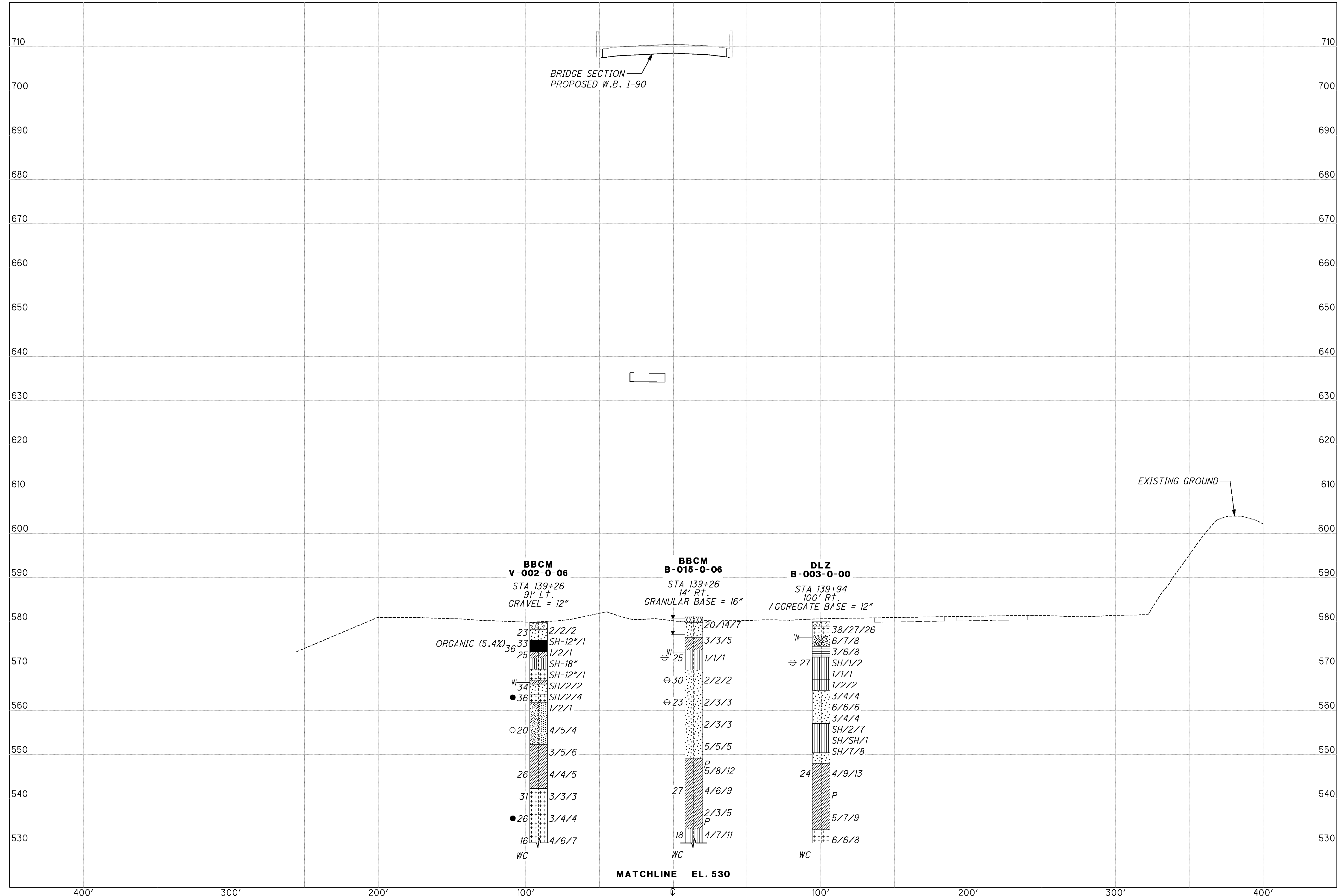
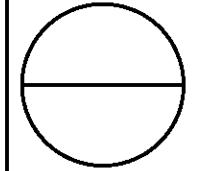

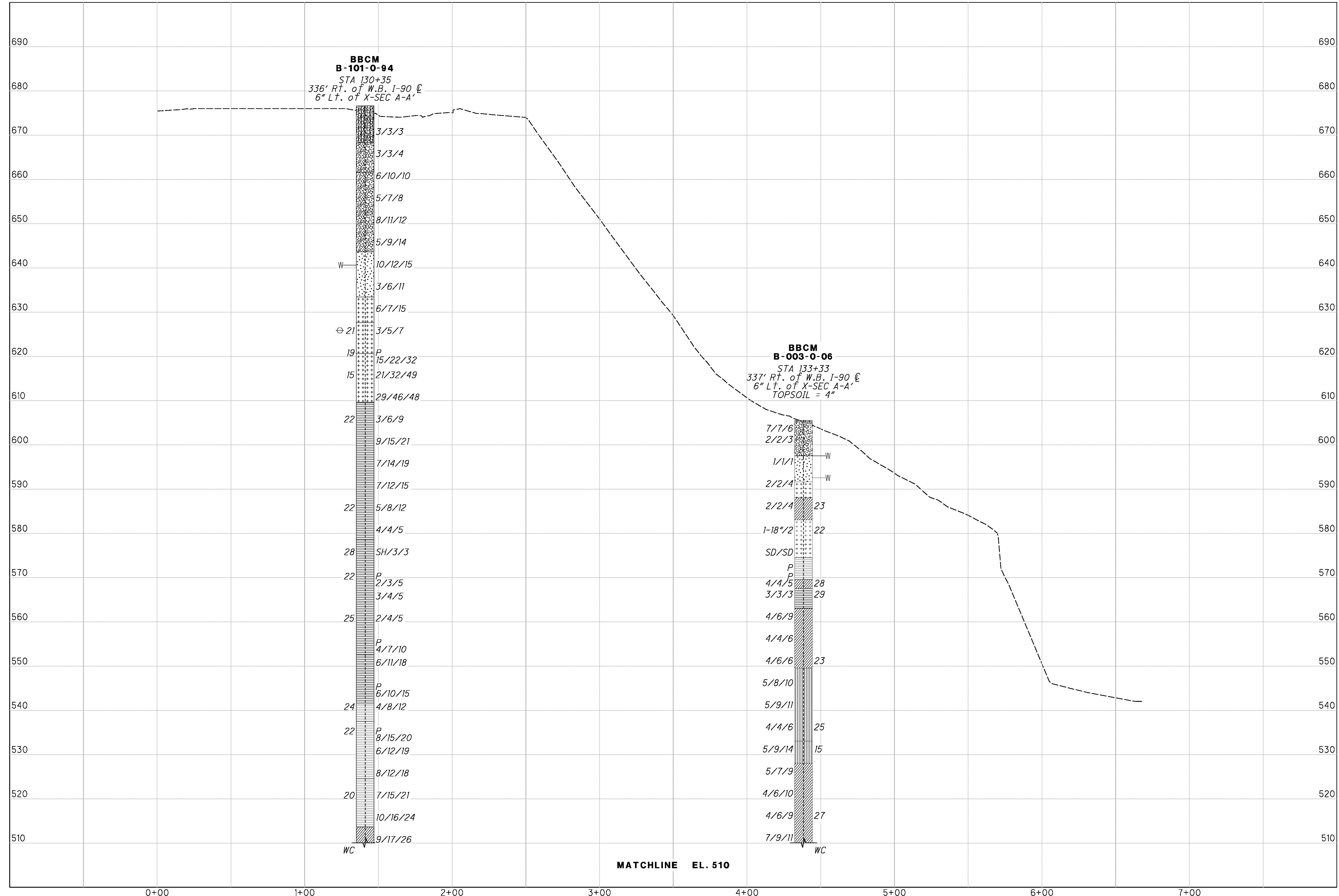
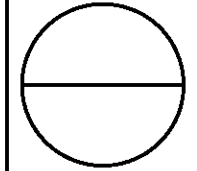

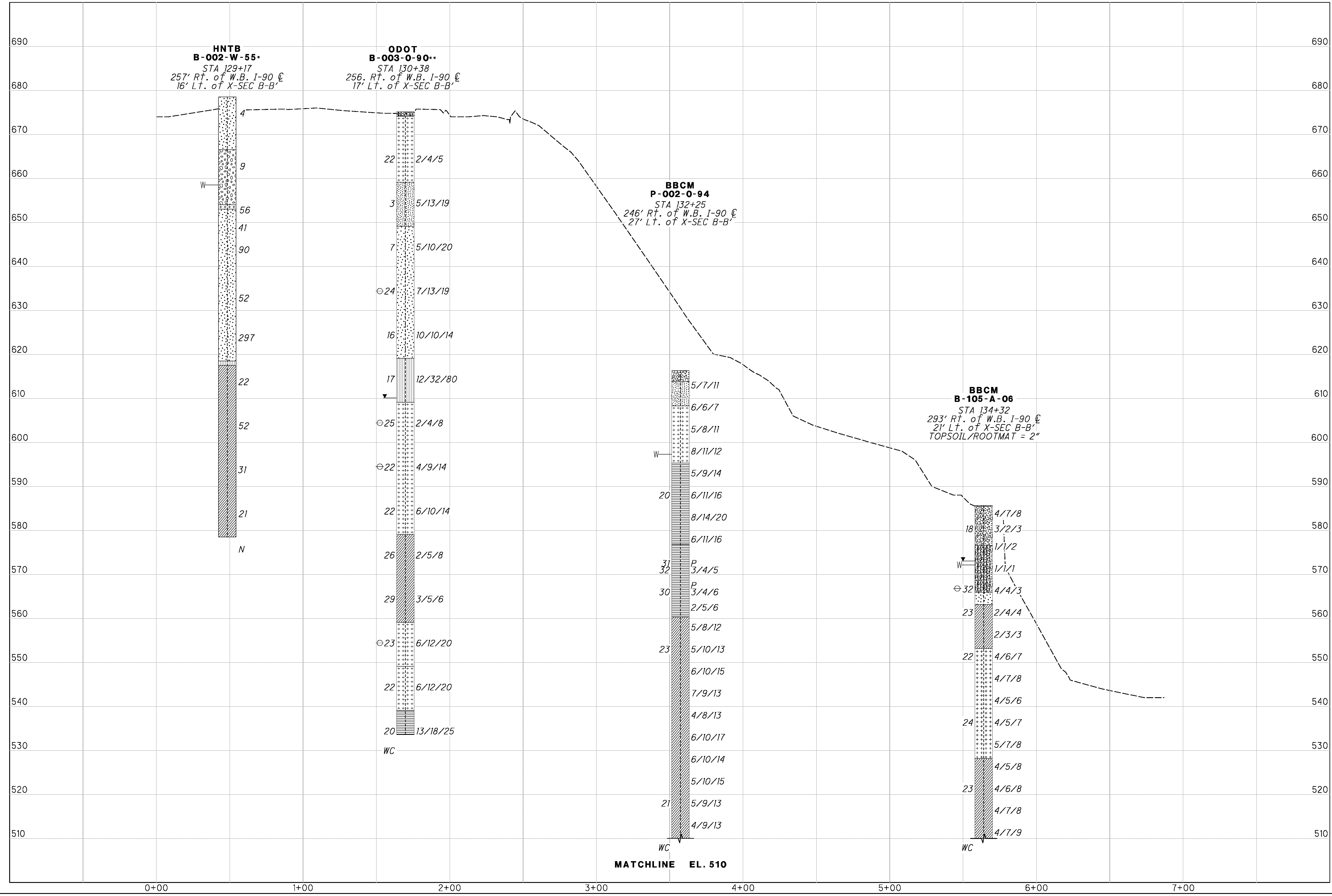

MATCHLINE EL. 510

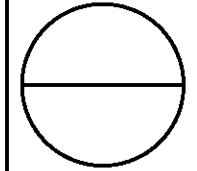
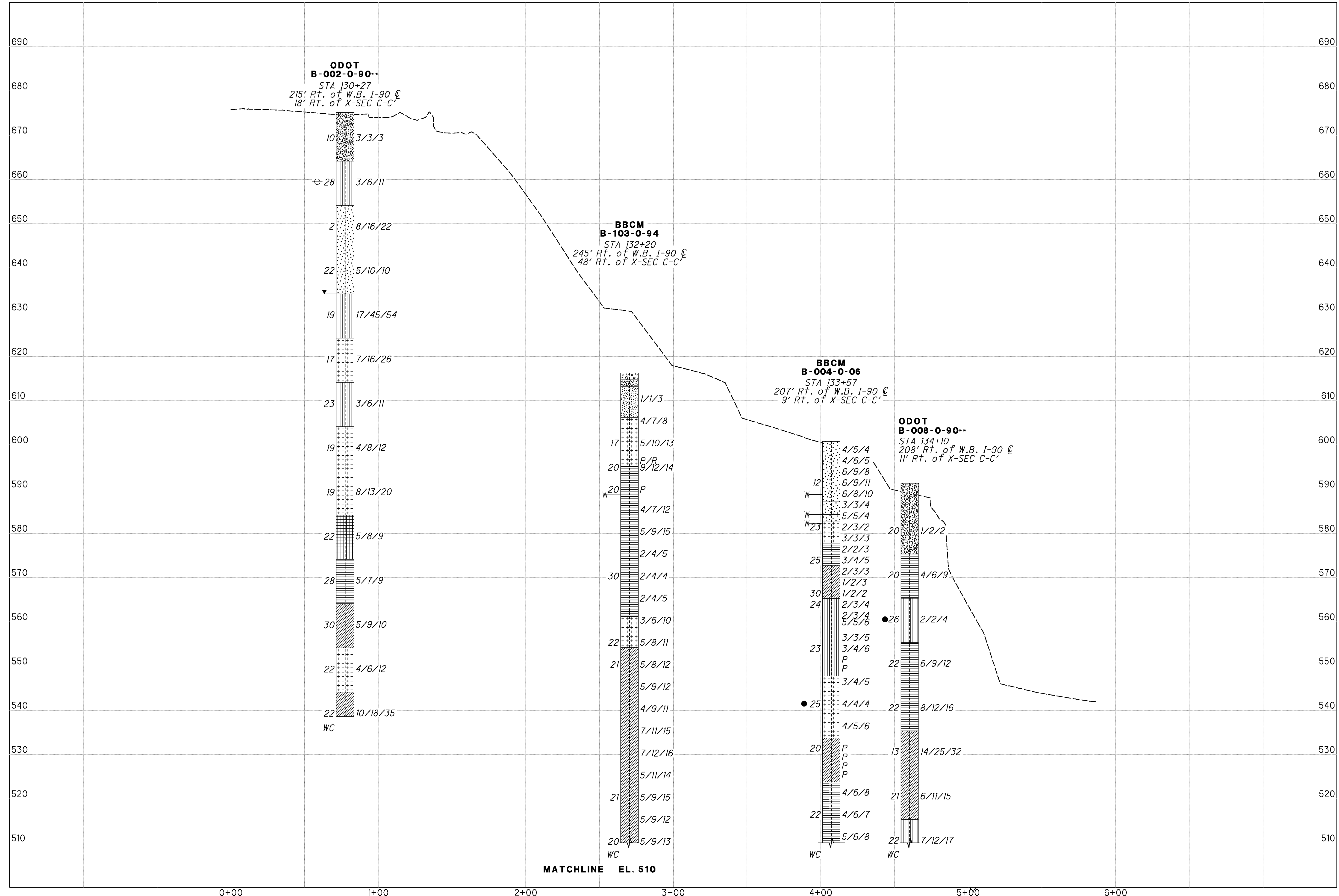







**APPENDIX 4D**  
**LABORATORY TEST RESULTS**  
**FROM 2006 AND 2009 INVESTIGATION**

**LABORATORY TEST RESULTS SUMMARY**

| Anisotropically Consolidated Triaxial Compression Tests |            |            |                      |                      |       |                  |   |
|---|------------|------------|----------------------|----------------------|-------|------------------|---|
| Boring No.  | Depth (ft) | Sample No. | $\sigma'_{vc}$ (ksf) | $\sigma'_{hc}$ (ksf) | $K_0$ | Effective Stress |   |
|   |            |            |                      |                      |       | $s_u$ (ksf)      | $c' \text{ (ksf)}$ $\phi'_{secant} (\circ)$ |
| B-05-01   | 55'-57'    | S-13 I     | 3.04                 | 2.46                 | 0.81  | 3.4              | 0 32  |
|   |            | S-13 II    | 6.83                 | 3.72                 | 0.54  | 4.6              | 0 32  |
|   |            | S-13 III   | 9.94                 | 4.99                 | 0.50  | 5.5              | 0 32  |
| Isotropically Consolidated Triaxial Compression Tests   |            |            |                      |                      |       |                  |   |
| Boring No.  | Depth (ft) | Sample No. | $\sigma'_{vc}$ (ksf) | $\sigma'_{hc}$ (ksf) | $K_0$ | Effective Stress |   |
|   |            |            |                      |                      |       | $s_u$ (ksf)      | $c' \text{ (ksf)}$ $\phi'_{secant} (\circ)$ |
| B-05-13   | 70'-71.6'  | S-18 I     | 2.82                 | 2.82                 | 1.0   | 1.8              | 0 26  |
|   |            | S-18 II    | 5.63                 | 5.63                 | 1.0   | 3.5              | 0 26  |
|   |            | S-18 III   | 11.26                | 11.26                | 1.0   | 5.6              | 0 26  |

| Direct Simple Shear Tests |            |            |                      |             |                    |
|---------------------------|------------|------------|----------------------|-------------|--------------------|
| Boring No.                | Depth (ft) | Sample No. | $\sigma'_{vc}$ (ksf) | $s_u$ (ksf) | $s_u/\sigma'_{vc}$ |
| B-05-02                   | 44'-46'    | 14         | 5.6                  | 1.5         | 0.27               |
| B-05-02                   | 122'-124'  | 32         | 10.6                 | 3.2         | 0.30               |
| B-05-03                   | 32'-33.5'  | 8          | 3.9                  | 1.16        | 0.3                |
| B-05-07                   | 104'-106'  | 22         | 10.6                 | 2.0         | 0.19               |

**LABORATORY TEST RESULTS SUMMARY (cont.)**

| Torsional Ring Shear Tests |               |            |                      |                         |
|----------------------------|---------------|------------|----------------------|-------------------------|
| Boring No.                 | Depth (ft)    | Sample No. | $\sigma'_{vc}$ (ksf) | $\phi'_{R(secant)}$ (°) |
| B-05-02                    | 128.5'-130'   | S-35       | 5.0                  | 33                      |
|                            |               |            | 11.1                 | 32                      |
|                            |               |            | 16.2                 | 32                      |
| B-05-03                    | 30'-30.5'     | S-7        | 1.0                  | 31                      |
|                            |               |            | 3.5                  | 30                      |
|                            |               |            | 6.0                  | 29                      |
| B-05-03                    | 123.8'-124.5' | S-31B      | 5.0                  | 33                      |
|                            |               |            | 9.6                  | 33                      |
|                            |               |            | 15.1                 | 33                      |
| B-05-04                    | 58.8'-59.2'   | S-23       | 3.0                  | 32                      |
|                            |               |            | 5.6                  | 32                      |
|                            |               |            | 8.0                  | 32                      |
| B-05-04                    | 113.5'-114.5' | S-36       | 9.0                  | 24                      |
|                            |               |            | 2                    | 22                      |
| B-05-11                    | 92'-93.5'     | S-24       | 4                    | 19                      |
|                            |               |            | 15.7                 | 17                      |

| Direct Shear Tests |             |            |                      |                         |
|--------------------|-------------|------------|----------------------|-------------------------|
| Boring No.         | Depth (ft)  | Sample No. | $\sigma'_{vc}$ (ksf) | $\phi'_{R(secant)}$ (°) |
| B-105A             | 103'-105'   | S-23 I     | 7.9                  | 24                      |
| B-108A             | 117'-117.5' | S-26 I     | 8.6                  | 25                      |
| B-05-16            | 24' - 26'   | S-7 I      | 2.4                  | 32                      |
| B-05-16            | 111' - 113' | S-25 I     | 7.0                  | 36                      |
| B-05-16            | 113' - 115' | S-26 III   | 7.0                  | 41                      |

**LABORATORY TEST RESULTS SUMMARY (cont.)**

| Unconfined Compression Tests |               |            |                      |                               |
|------------------------------|---------------|------------|----------------------|-------------------------------|
| Boring No.                   | Depth (ft)    | Sample No. | q <sub>u</sub> (psi) | v (tangent over linear range) |
| B-05-01                      | 228.8 - 229.3 | 56         | 1476.67              | ---                           |
| B-05-03                      | 165.2 - 165.9 | 39         | 1311.26              | ---                           |
| B-05-04                      | 169.9 - 170.4 | 50         | 1115.95              | ---                           |
| B-05-07                      | 224.0 - 224.5 | 48         | 1112.63              | ---                           |
| B-05-11                      | 225.0 - 225.5 | 55         | 209.37               | ---                           |
| B-05-12                      | 207.6 - 208.1 | 56         | 1020.94              | ---                           |
| B-05-13                      | 152.5 - 153.0 | 35         | 1553.10              | ---                           |
| B-05-13                      | 178.5 - 179.0 | 40         | 347.96               | ---                           |
| B-05-13                      | 160.1 - 160.6 | 37         | 2955.0               | 0.39                          |
| B-05-14                      | 168.4 - 169.0 | 36         | 1313.31              | ---                           |
| B-05-14                      | 180.0 - 180.4 | 37         | 1198.22              | ---                           |
| B-05-14                      | 190.5 - 191.0 | 39         | 3228.0               | 0.13                          |
| B-05-15                      | 202.4 - 203.0 | 47         | 2056.59              | ---                           |
| B-05-15                      | 208.4 - 209.0 | 48         | 2916.94              | ---                           |
| B-05-15                      | 213.1 - 213.6 | 49         | 2322.0               | 0.40                          |
| B-05-16                      | 163.5 - 163.8 | 36         | 2295.18              | ---                           |
| B-105A                       | 154.4 - 155.2 | 34         | 827.76               | ---                           |

**SUMMARY OF DIRECT SHEAR TESTS**  
**SATURATED, CONSOLIDATED, DRAINED**  
**ASTM D3080; AASHTO T-236**



**SHEAR STRESS VS NORMAL STRESS**

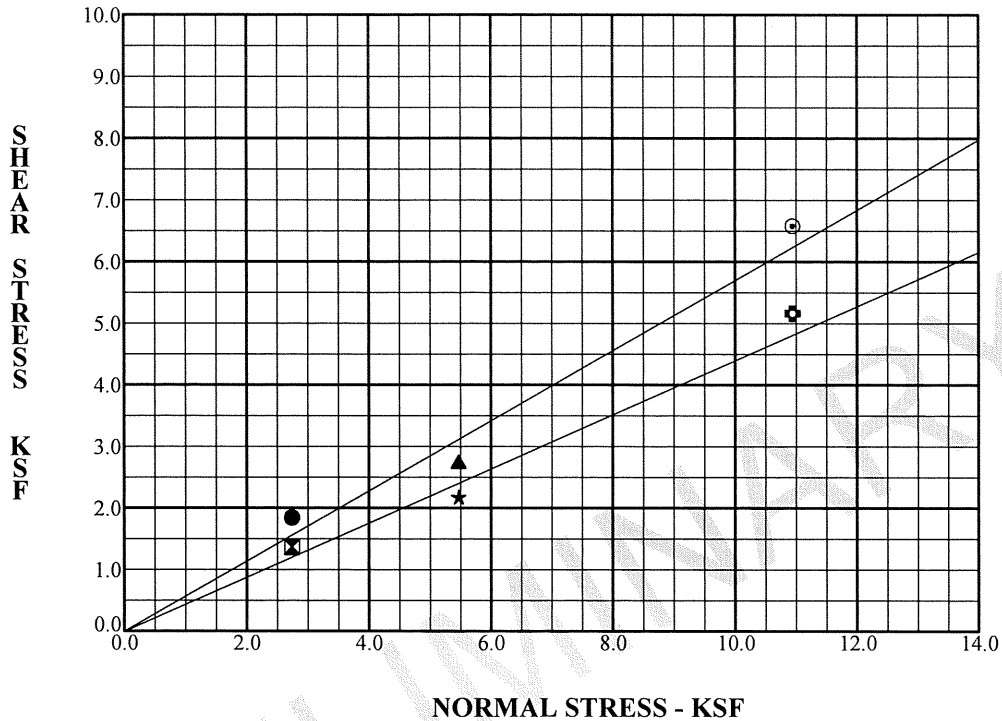

| DATA INTERPRETATION RESULTS |                        |                        |
|-----------------------------|------------------------|------------------------|
| Test Method                 | Drained Friction Angle | Drained Cohesion (ksf) |
| Peak                        | 30°                    | 0                      |
| Residual                    | 24°                    | 0                      |

| Specimen Identification          | Normal Load | Type Plot | Classification   | DD  | MC% |
|----------------------------------|-------------|-----------|--|-----|-----|
| ● B-037-1 S-22 II 66.0' to 68.0' | 2.74 ksf    | PEAK      | Soft to stiff gray SILT AND CLAY,<br>trace fine to coarse sand, trace fine<br>gravel, contains few lenses and<br>seams of silt, moist. | 96  | 28  |
| ⊠ B-037-1 S-22 II 66.0' to 68.0' | 2.74 ksf    | RESIDUAL  |  | 96  | 28  |
| ▲ B-037-1 S-22 II 66.0' to 68.0' | 5.47 ksf    | PEAK      |  | 94  | 30  |
| ★ B-037-1 S-22 II 66.0' to 68.0' | 5.47 ksf    | RESIDUAL  |  | 94  | 30  |
| ⊙ B-037-1 S-22 II 66.0' to 68.0' | 10.94 ksf   | PEAK      |  | 100 | 24  |
| ⊕ B-037-1 S-22 II 66.0' to 68.0' | 10.94 ksf   | RESIDUAL  |  | 100 | 24  |

|                 |                             |                     |
|-----------------|-----------------------------|---------------------|
| <b>PROJECT</b>  | CUY-90-14.52, West Abutment |                     |
| <b>LOCATION</b> | Cleveland, Ohio             |                     |
| <b>JOB NO.</b>  | 012.00946.307               | <b>DATE</b> 9/15/09 |

**DIRECT SHEAR TESTS**  
**SATURATED, CONSOLIDATED, DRAINED**  
**ASTM D3080; AASHTO T-236**



**SHEAR STRESS VS HORIZONTAL DISPLACEMENT**

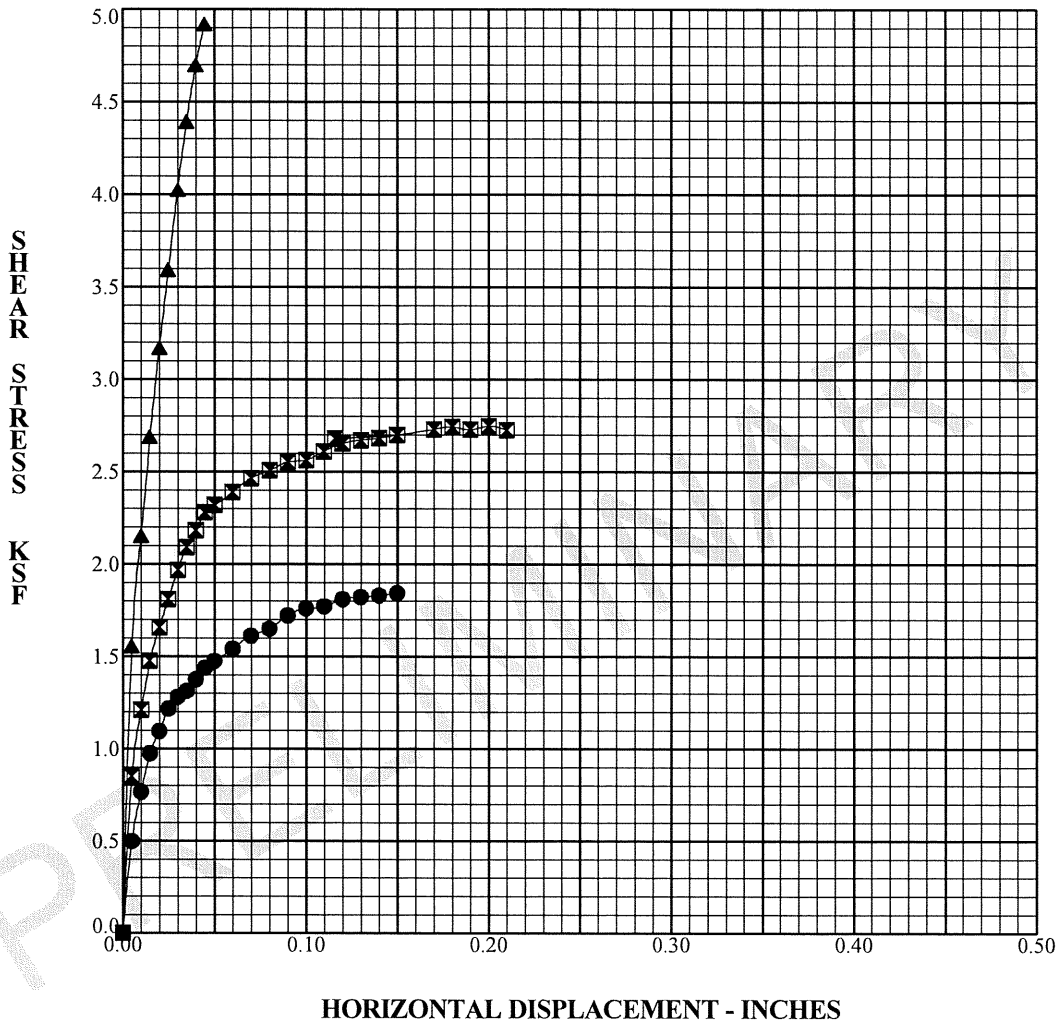

| Specimen Identification          | Normal Load | Classification  | DD   | MC%  |
|----------------------------------|-------------|---|------|------|
| ● B-037-1 S-22 II 66.0' to 68.0' | 2.74 ksf    | Soft to stiff gray SILT AND CLAY, trace fine to coarse sand, trace fine gravel, contains few lenses and seams of silt, moist. | 95.6 | 27.6 |
| ⊠ B-037-1 S-22 II 66.0' to 68.0' | 5.47 ksf    |   | 93.6 | 29.5 |
| ▲ B-037-1 S-22 II 66.0' to 68.0' | 10.94 ksf   |   | 99.8 | 24.2 |

|                 |                             |             |         |
|-----------------|-----------------------------|-------------|---------|
| <b>PROJECT</b>  | CUY-90-14.52, West Abutment |             |         |
| <b>LOCATION</b> | Cleveland, Ohio             |             |         |
| <b>JOB NO.</b>  | 012.00946.307               | <b>DATE</b> | 9/15/09 |



**DIRECT SHEAR TESTS - RESIDUAL**  
**SATURATED, CONSOLIDATED, DRAINED**  
**ASTM D3080; AASHTO T-236**



**SHEAR STRESS VS HORIZONTAL DISPLACEMENT**

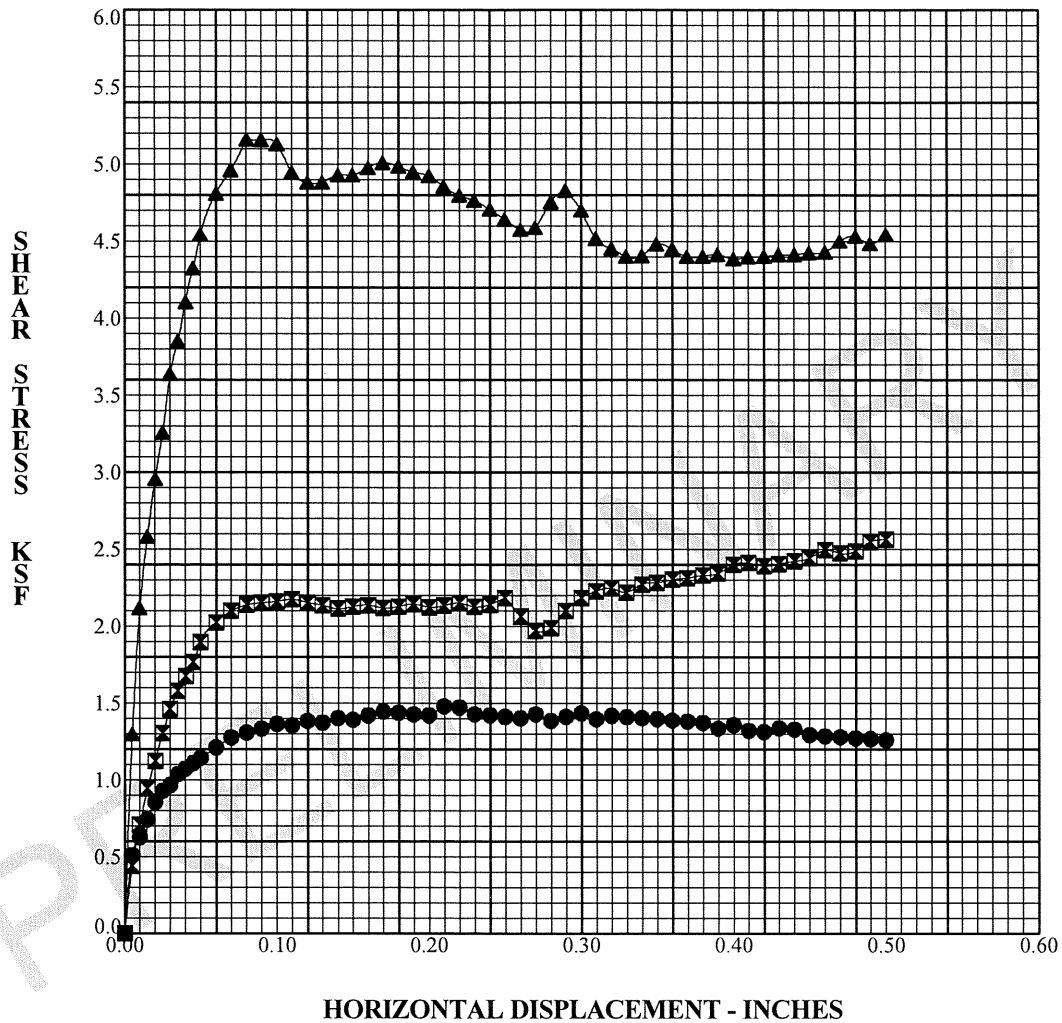

| Specimen Identification          | Normal Load | Classification  | DD   | MC%  |
|----------------------------------|-------------|---|------|------|
| ● B-037-1 S-22 II 66.0' to 68.0' | 2.74 ksf    | Soft to stiff gray SILT AND CLAY, trace fine to coarse sand, trace fine gravel, contains few lenses and seams of silt, moist. | 95.6 | 27.6 |
| ⊠ B-037-1 S-22 II 66.0' to 68.0' | 5.47 ksf    |   | 93.6 | 29.5 |
| ▲ B-037-1 S-22 II 66.0' to 68.0' | 10.94 ksf   |   | 99.8 | 24.2 |

|                 |                             |             |         |
|-----------------|-----------------------------|-------------|---------|
| <b>PROJECT</b>  | CUY-90-14.52, West Abutment |             |         |
| <b>LOCATION</b> | Cleveland, Ohio             |             |         |
| <b>JOB NO.</b>  | 012.00946.307               | <b>DATE</b> | 9/15/09 |

**SUMMARY OF DIRECT SHEAR TESTS**  
**SATURATED, CONSOLIDATED, DRAINED**  
**ASTM D3080; AASHTO T-236**



**SHEAR STRESS VS NORMAL STRESS**

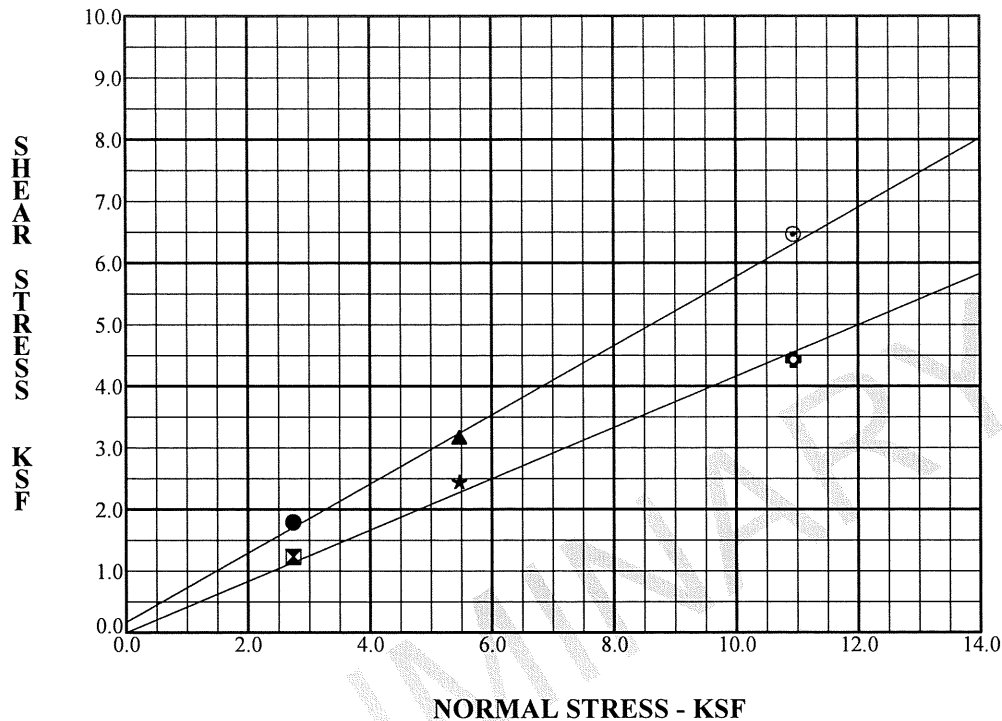

| DATA INTERPRETATION RESULTS |                        |                        |
|-----------------------------|------------------------|------------------------|
| Test Method                 | Drained Friction Angle | Drained Cohesion (ksf) |
| Peak                        | 29°                    | 0.2                    |
| Residual                    | 23°                    | 0                      |

| Specimen Identification          | Normal Load | Type Plot | Classification   | DD | MC% |
|----------------------------------|-------------|-----------|--|----|-----|
| ● B-037-1 S-24    70.0' to 72.0' | 2.74 ksf    | PEAK      | Medium-stiff gray SILTY CLAY,<br>trace fine to coarse sand, trace fine<br>gravel, contains few lenses and<br>seams of silt, moist. | 91 | 32  |
| ⊠ B-037-1 S-24    70.0' to 72.0' | 2.74 ksf    | RESIDUAL  |  | 91 | 32  |
| ▲ B-037-1 S-24    70.0' to 72.0' | 5.47 ksf    | PEAK      |  | 94 | 29  |
| ★ B-037-1 S-24    70.0' to 72.0' | 5.47 ksf    | RESIDUAL  |  | 94 | 29  |
| ⊙ B-037-1 S-24    70.0' to 72.0' | 10.94 ksf   | PEAK      |  | 98 | 28  |
| ⊕ B-037-1 S-24    70.0' to 72.0' | 10.94 ksf   | RESIDUAL  |  | 98 | 28  |

|                 |                             |                     |
|-----------------|-----------------------------|---------------------|
| <b>PROJECT</b>  | CUY-90-14.52, West Abutment |                     |
| <b>LOCATION</b> | Cleveland, Ohio             |                     |
| <b>JOB NO.</b>  | 012.00946.307               | <b>DATE</b> 9/15/09 |

**DIRECT SHEAR TESTS**  
**SATURATED, CONSOLIDATED, DRAINED**  
**ASTM D3080; AASHTO T-236**



**SHEAR STRESS VS HORIZONTAL DISPLACEMENT**

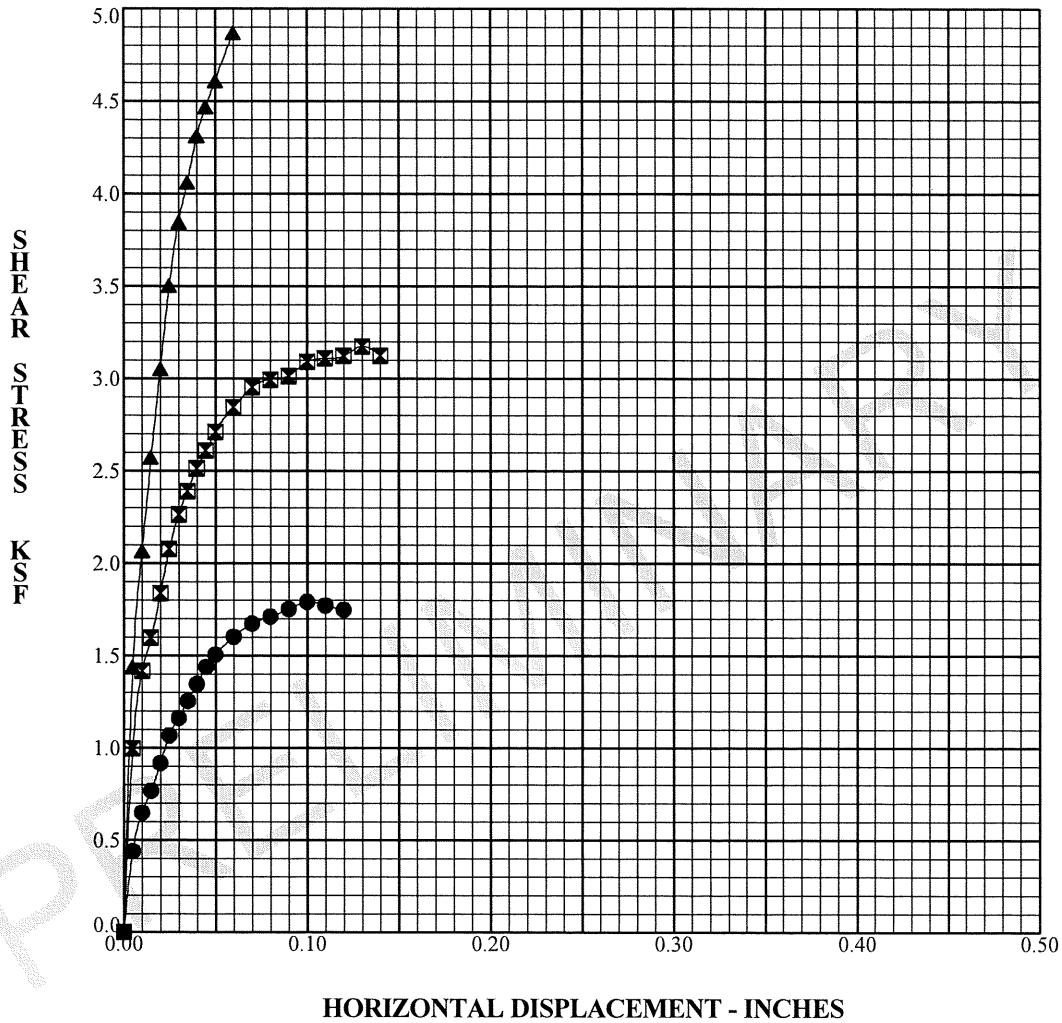

| Specimen Identification          | Normal Load | Classification  | DD   | MC%  |
|----------------------------------|-------------|---|------|------|
| ● B-037-1 S-24 II 70.0' to 72.0' | 2.74 ksf    | Medium-stiff gray SILTY CLAY, trace fine to coarse sand, trace fine gravel, contains few lenses and seams of silt, moist. | 91.1 | 31.7 |
| ⊠ B-037-1 S-24 II 70.0' to 72.0' | 5.47 ksf    |   | 91.1 | 31.7 |
| ▲ B-037-1 S-24 II 70.0' to 72.0' | 10.94 ksf   |   | 98.3 | 28.4 |

|                 |                             |             |         |
|-----------------|-----------------------------|-------------|---------|
| <b>PROJECT</b>  | CUY-90-14.52, West Abutment |             |         |
| <b>LOCATION</b> | Cleveland, Ohio             |             |         |
| <b>JOB NO.</b>  | 012.00946.307               | <b>DATE</b> | 9/15/09 |

**DIRECT SHEAR TESTS - RESIDUAL**  
**SATURATED, CONSOLIDATED, DRAINED**  
**ASTM D3080; AASHTO T-236**



**SHEAR STRESS VS HORIZONTAL DISPLACEMENT**

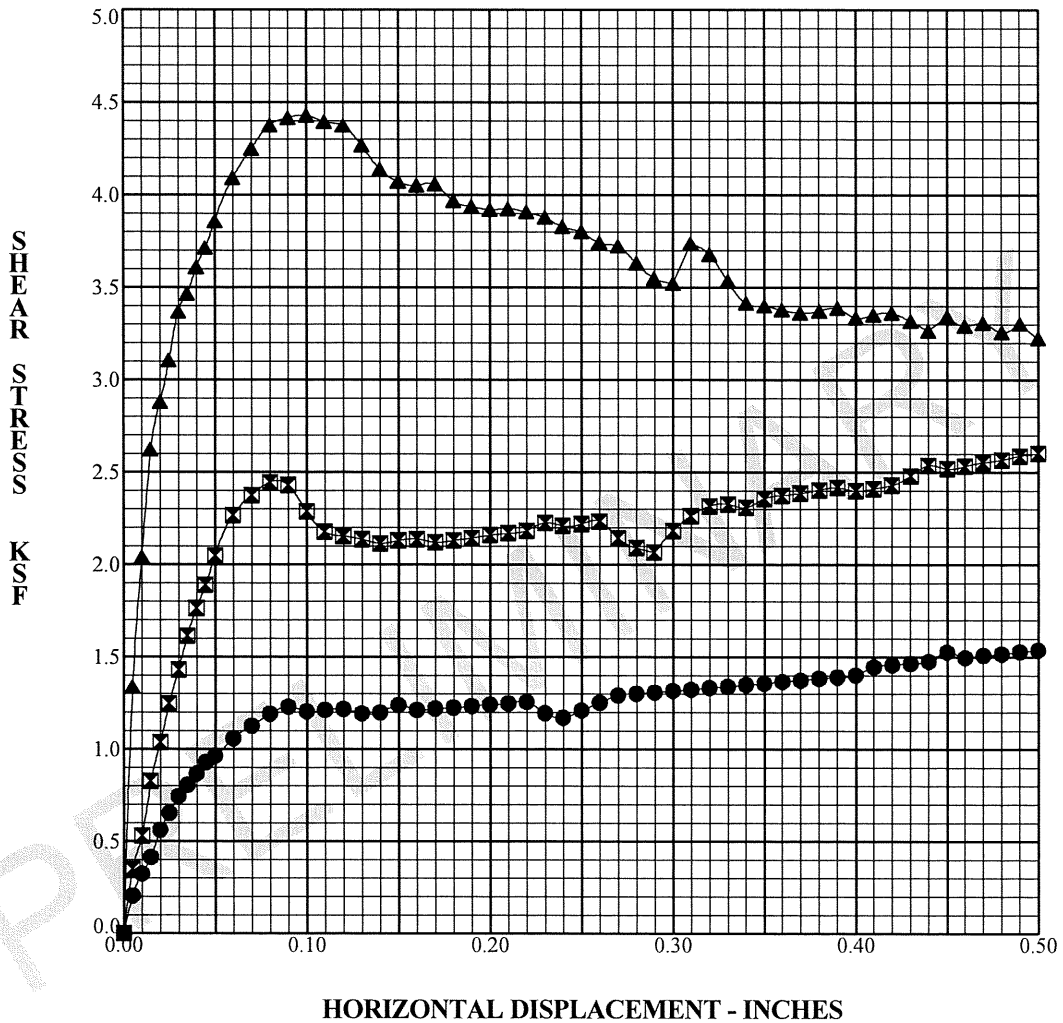

| Specimen Identification          | Normal Load | Classification  | DD   | MC%  |
|----------------------------------|-------------|---|------|------|
| ● B-037-1 S-24 II 70.0' to 72.0' | 2.74 ksf    | Medium-stiff gray SILTY CLAY, trace fine to coarse sand, trace fine gravel, contains few lenses and seams of silt, moist. | 91.1 | 31.7 |
| ☒ B-037-1 S-24 II 70.0' to 72.0' | 5.47 ksf    |   | 91.1 | 31.7 |
| ▲ B-037-1 S-24 II 70.0' to 72.0' | 10.94 ksf   |   | 98.3 | 28.4 |

|                 |                             |             |         |
|-----------------|-----------------------------|-------------|---------|
| <b>PROJECT</b>  | CUY-90-14.52, West Abutment |             |         |
| <b>LOCATION</b> | Cleveland, Ohio             |             |         |
| <b>JOB NO.</b>  | 012.00946.307               | <b>DATE</b> | 9/15/09 |

**APPENDIX 4E**  
**CONE PENETRATION TESTS**  
**(CPT)**

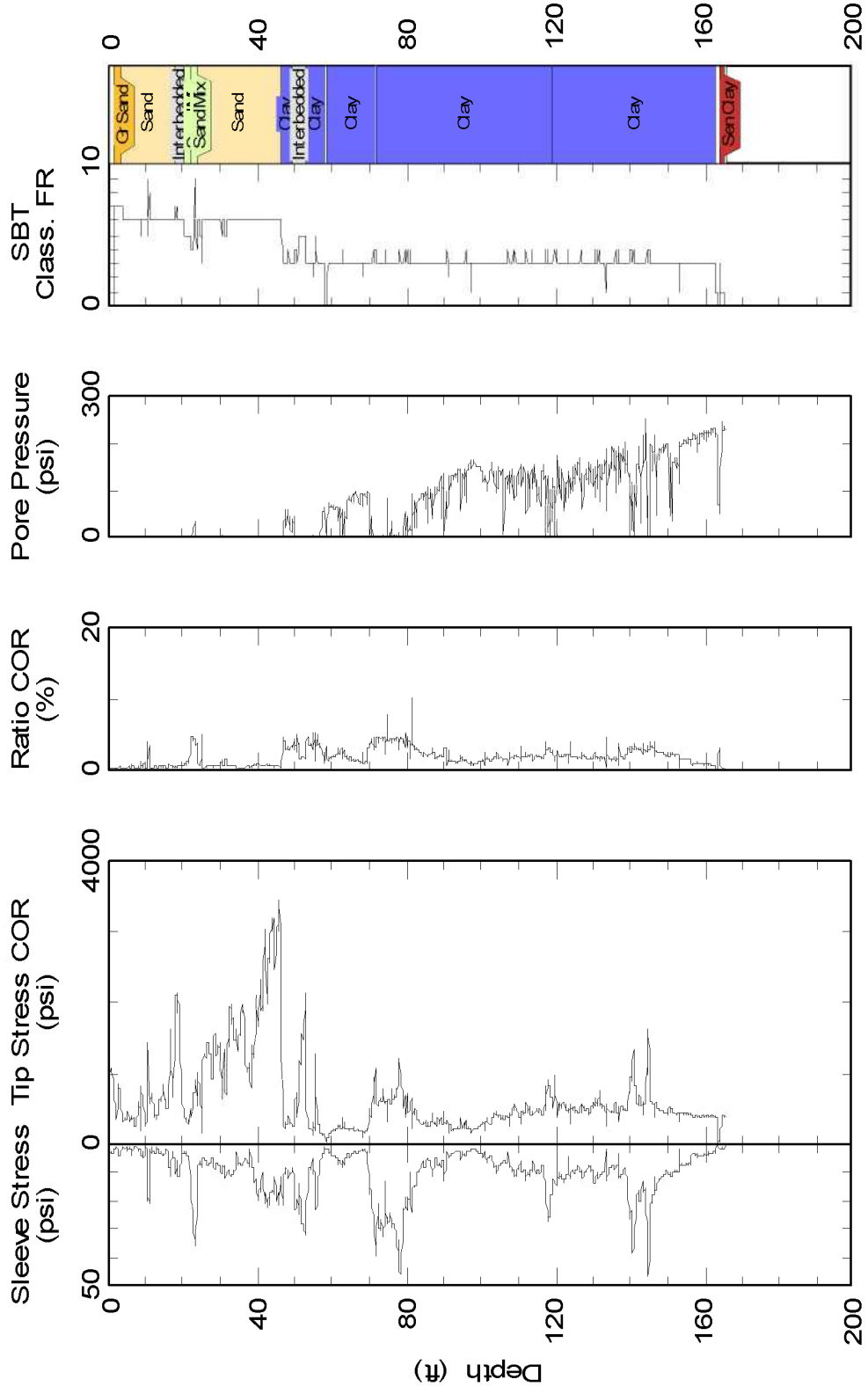

Plate 1: Cone Penetration Testing Results for C-05-01

# C-05-01

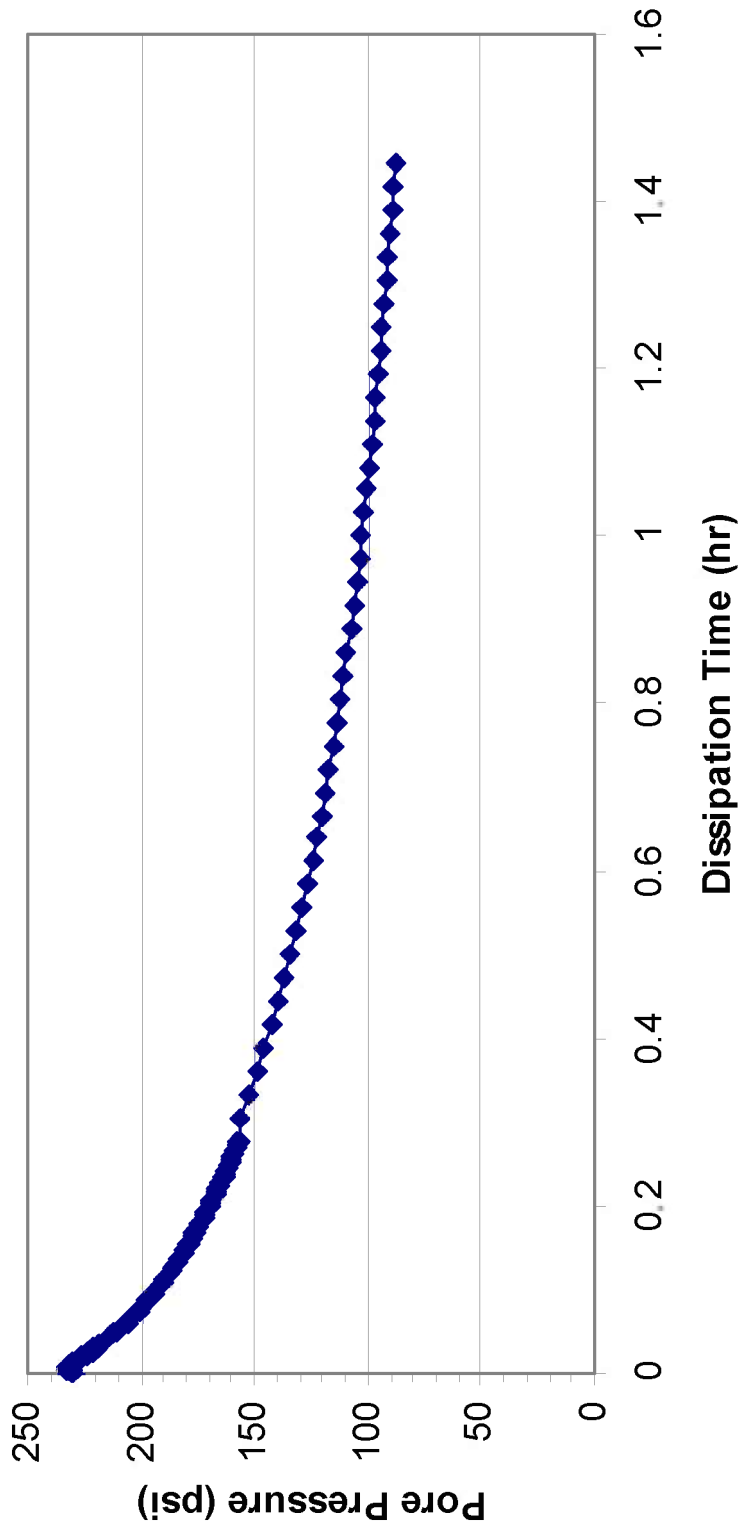

Plate 2: Pore Pressure Dissipation for C-05-01 taken at an approximate depth of 167 feet.

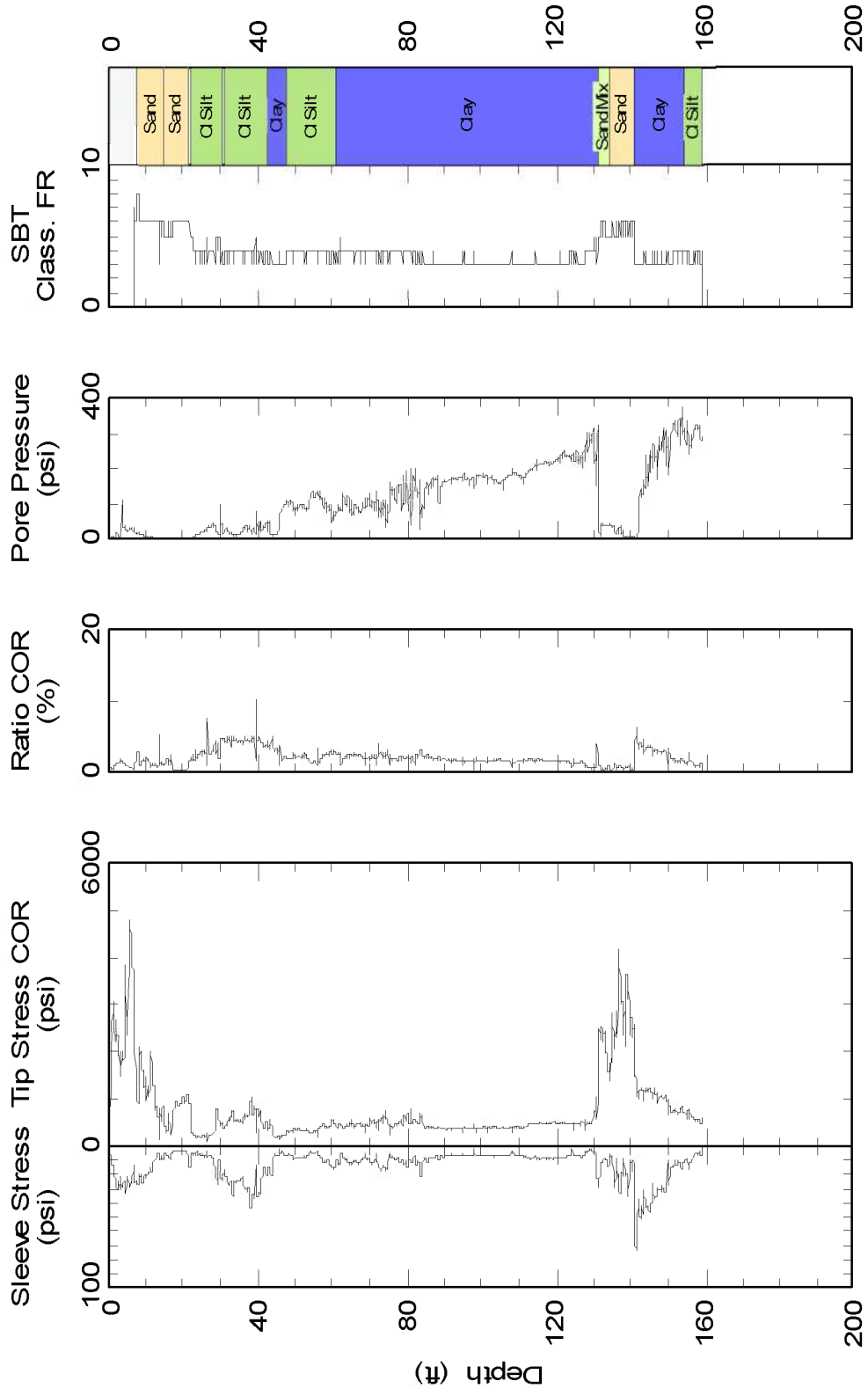

Plate 3: Cone Penetration Testing Results for C-05-02.



# C-05-02

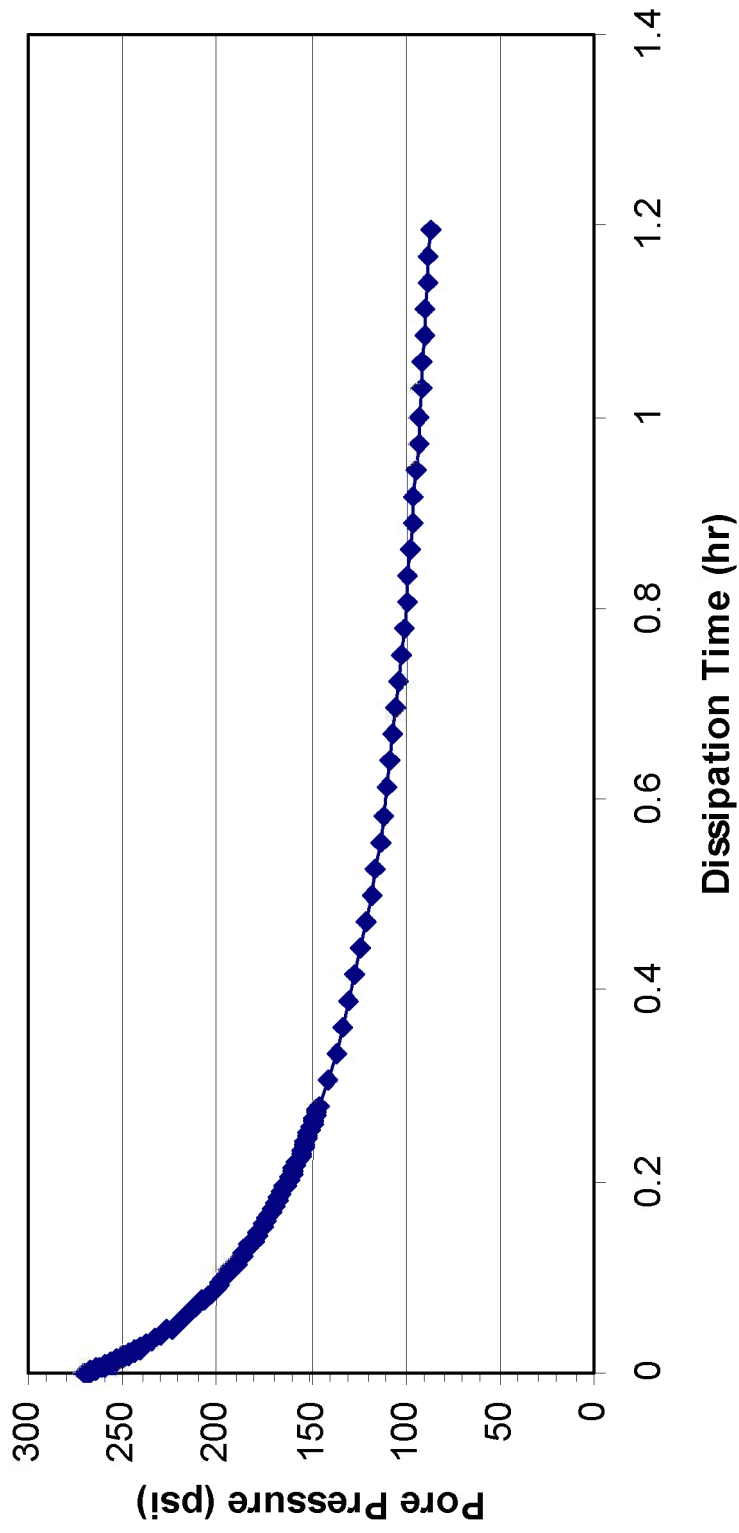

Plate 4: Pore Pressure Dissipation for C-05-02 taken at an approximate depth of 160 feet.

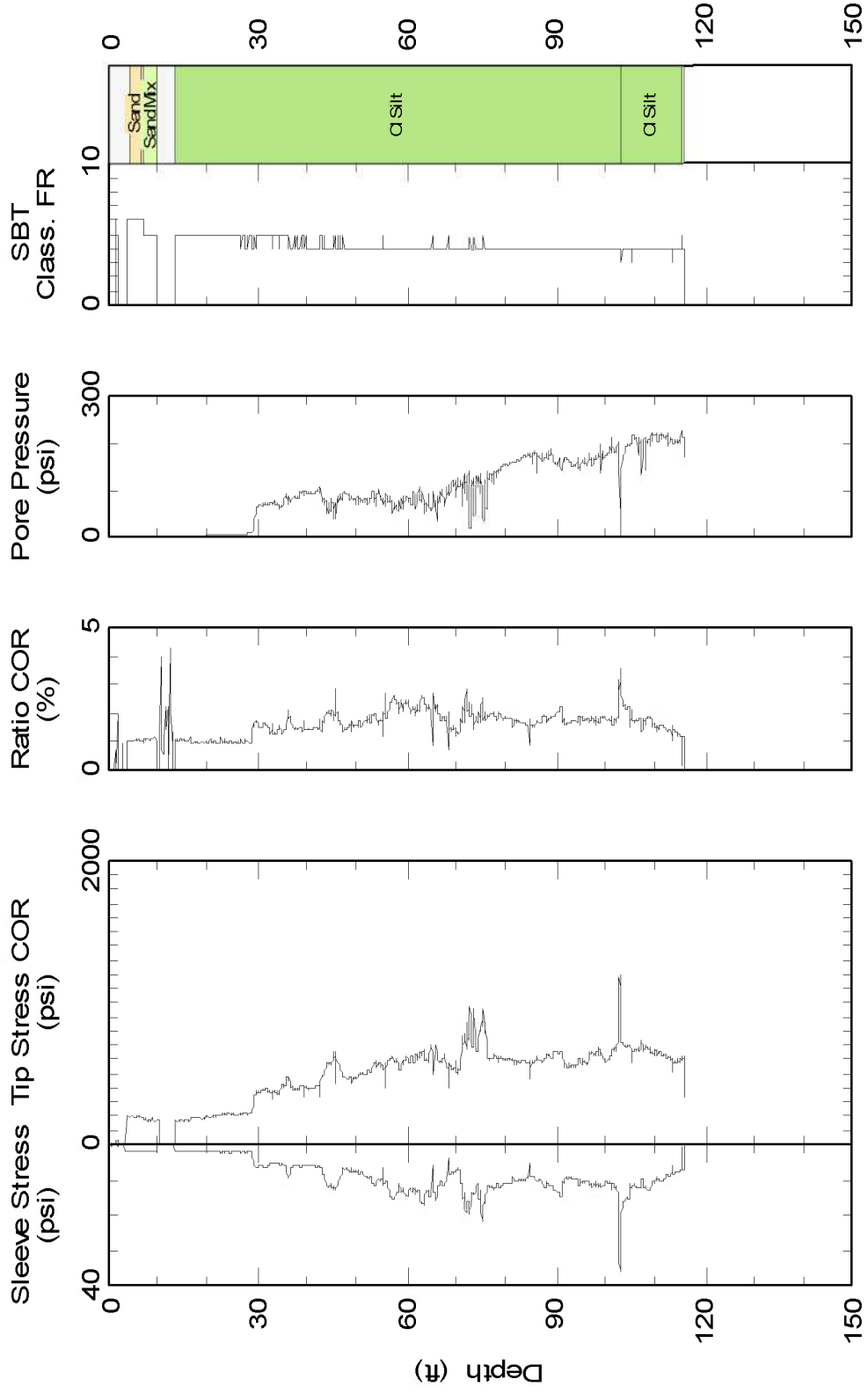

Plate 5: Cone Penetration Testing Results for C-05-03, run number 2.

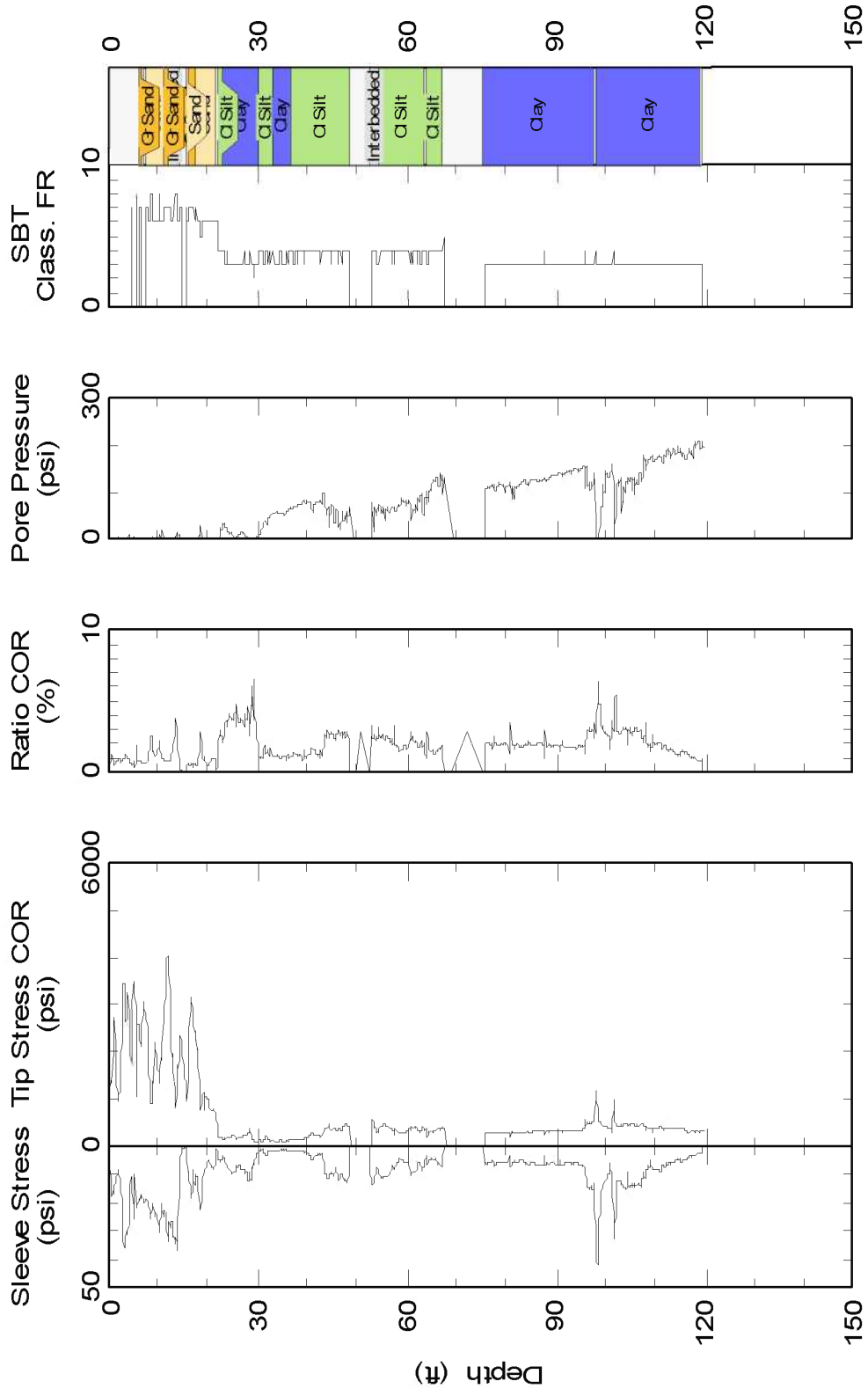

Plate 6: Cone Penetration Testing Results for C-05-04, run number 3.

# C-05-04

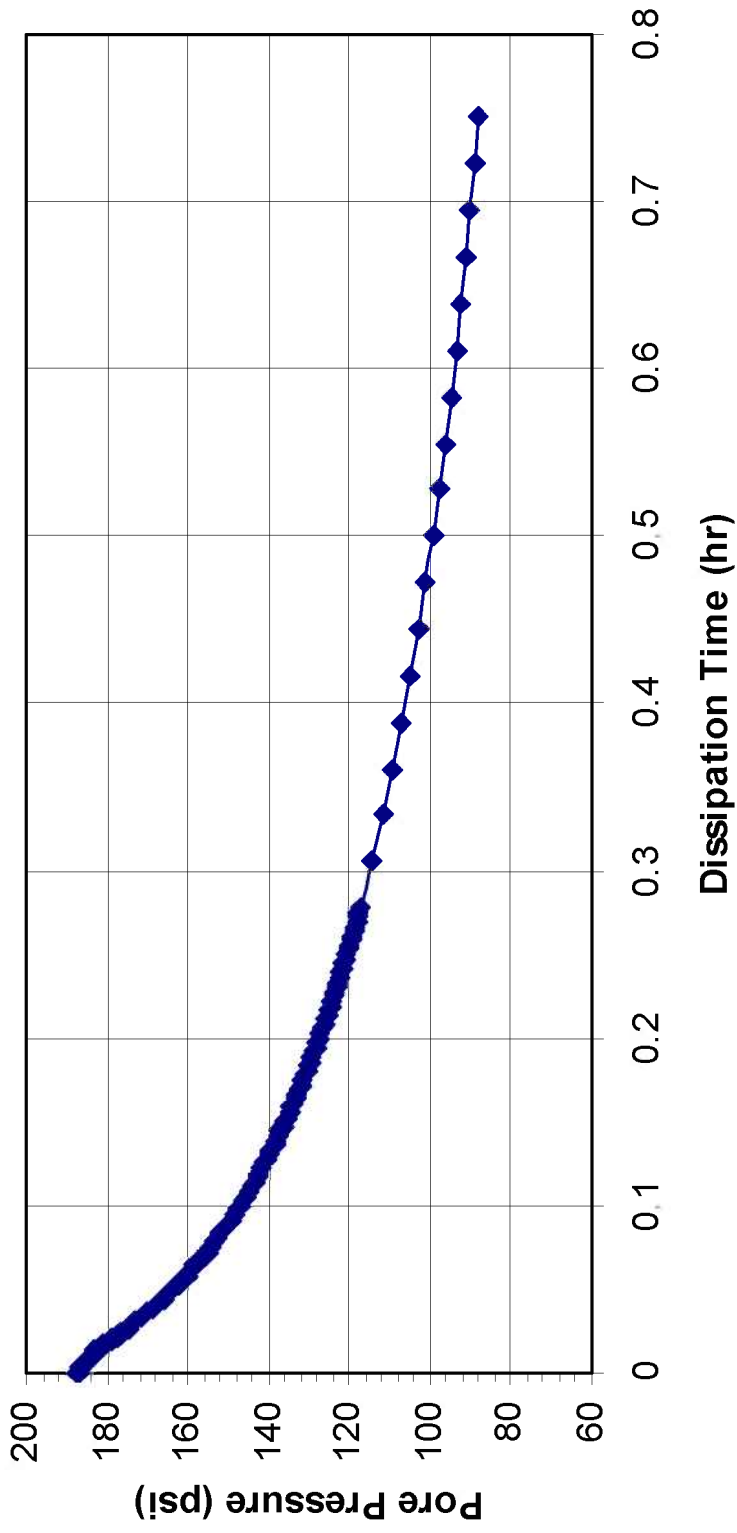

Plate 7: Pore Pressure Dissipation for C-05-04, run number 3, taken at an approximate depth of 120 feet.

Test ID: C0507A

Project: CUY901524

Date: 05/Apr/2006

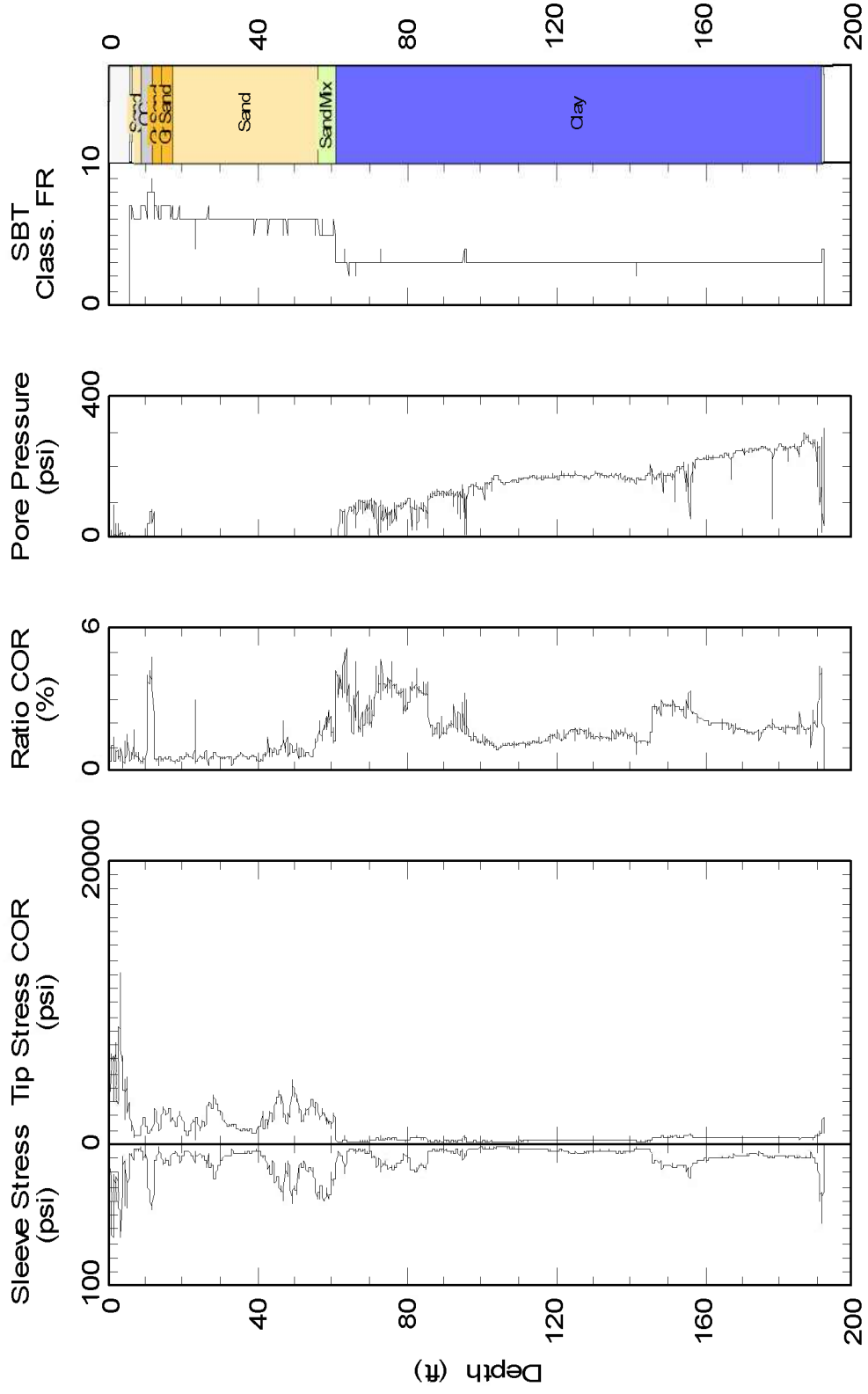

Plate 12: Cone Penetration Testing Results for C-05-07.

# C-05-07

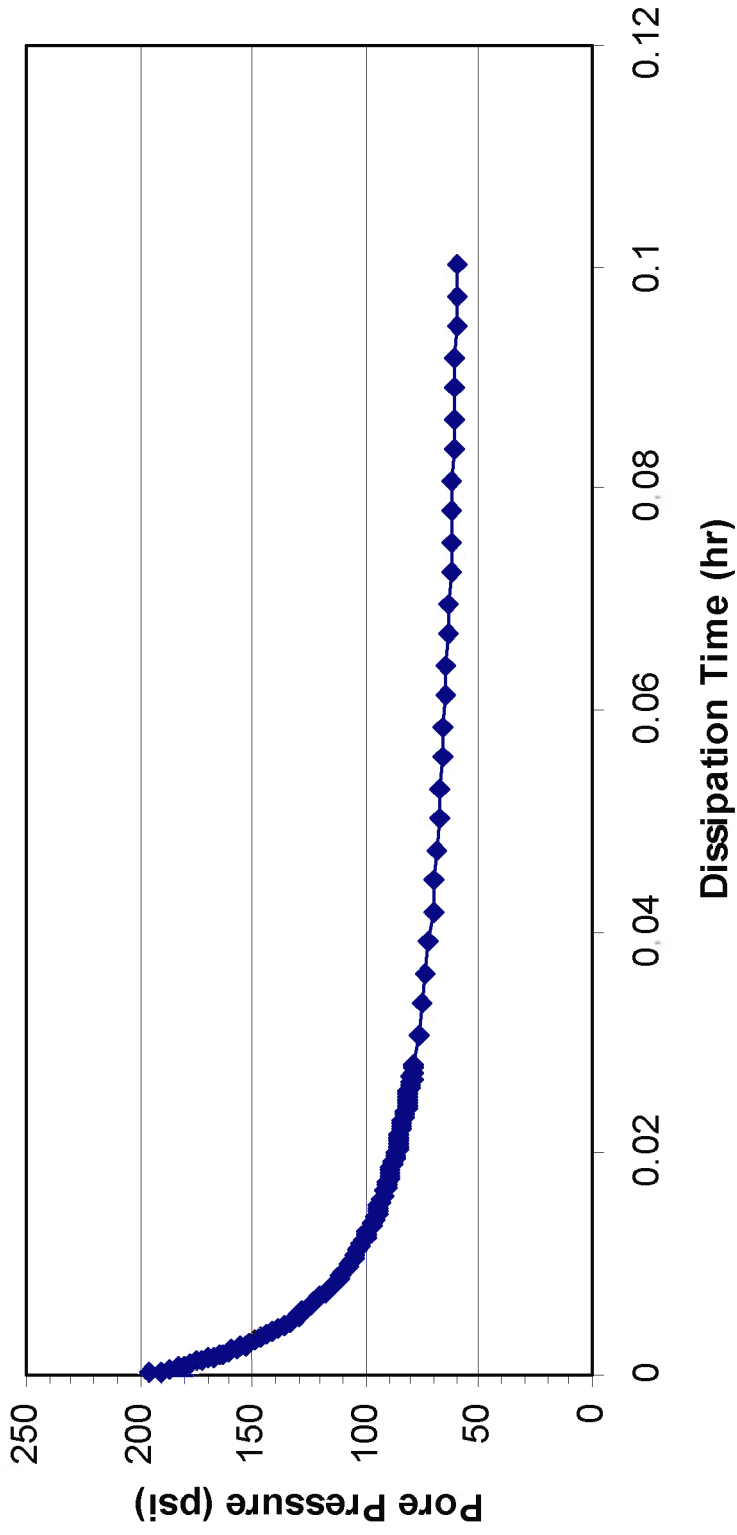

Plate 13: Pore Pressure Dissipation for C-05-07 taken at an approximate depth of 193 feet.

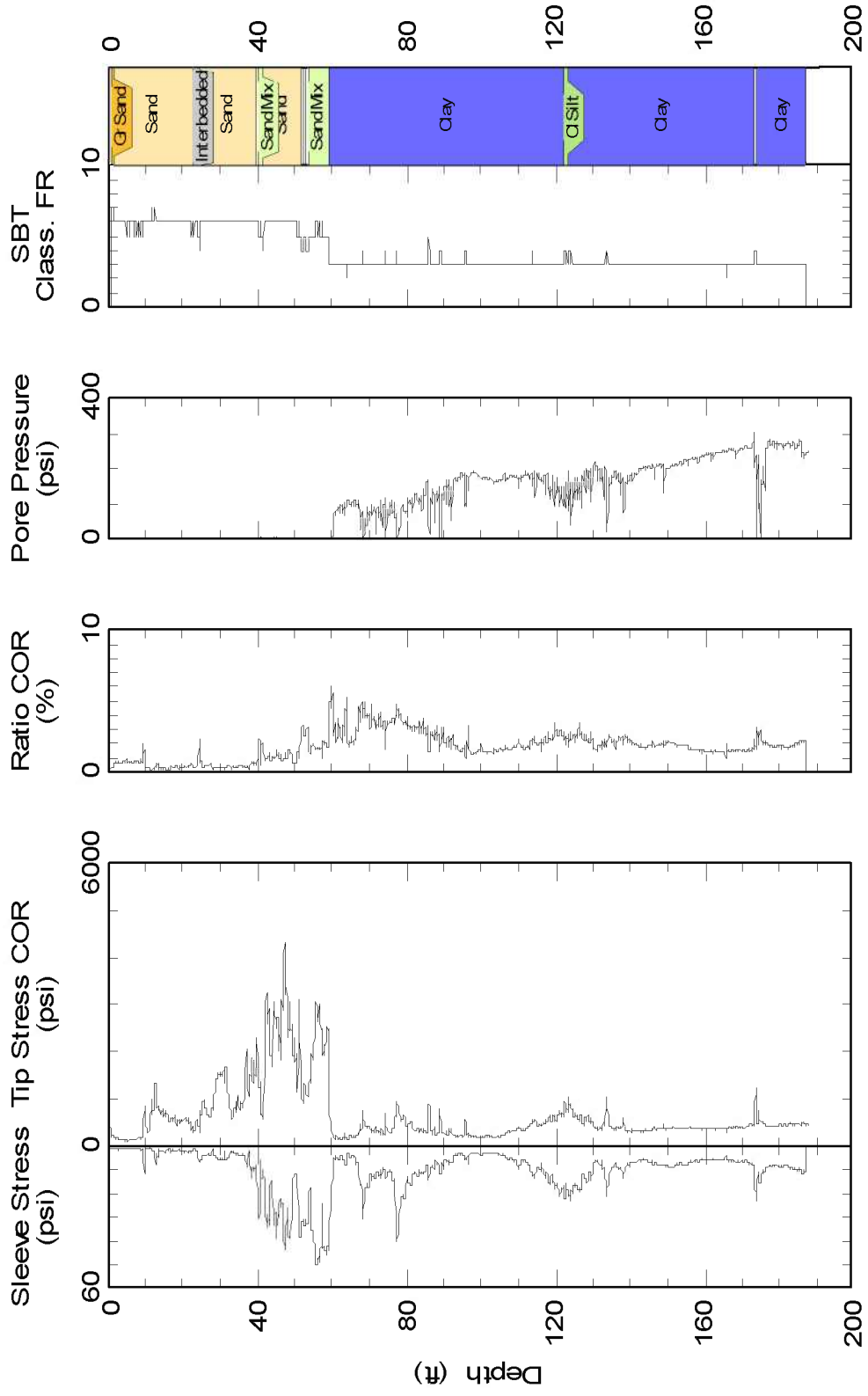

Plate 18: Cone Penetration Testing Results for C-05-10.

# C-05-10

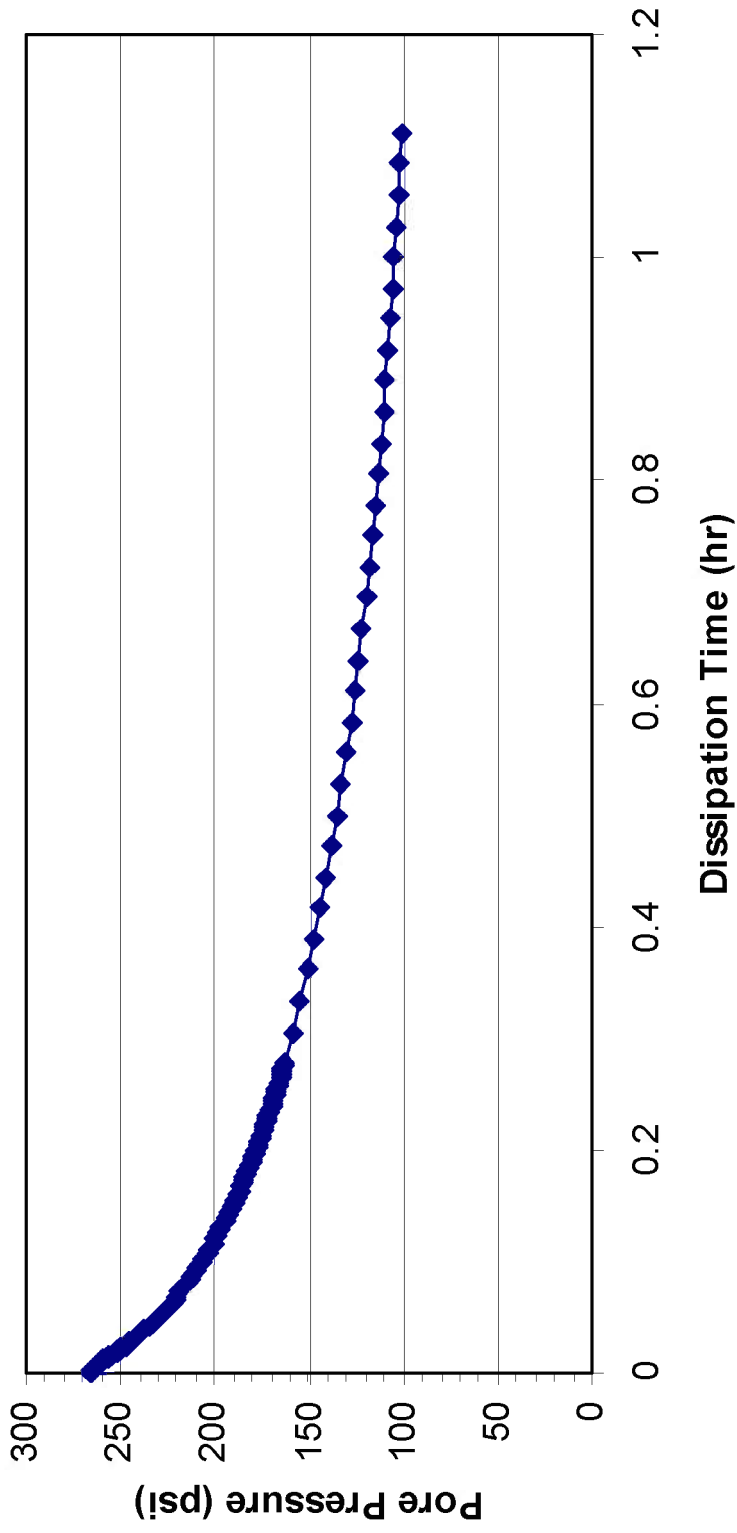

Plate 19. Pore Pressure Dissipation for C-05-10 taken at an approximate depth of 188 feet.



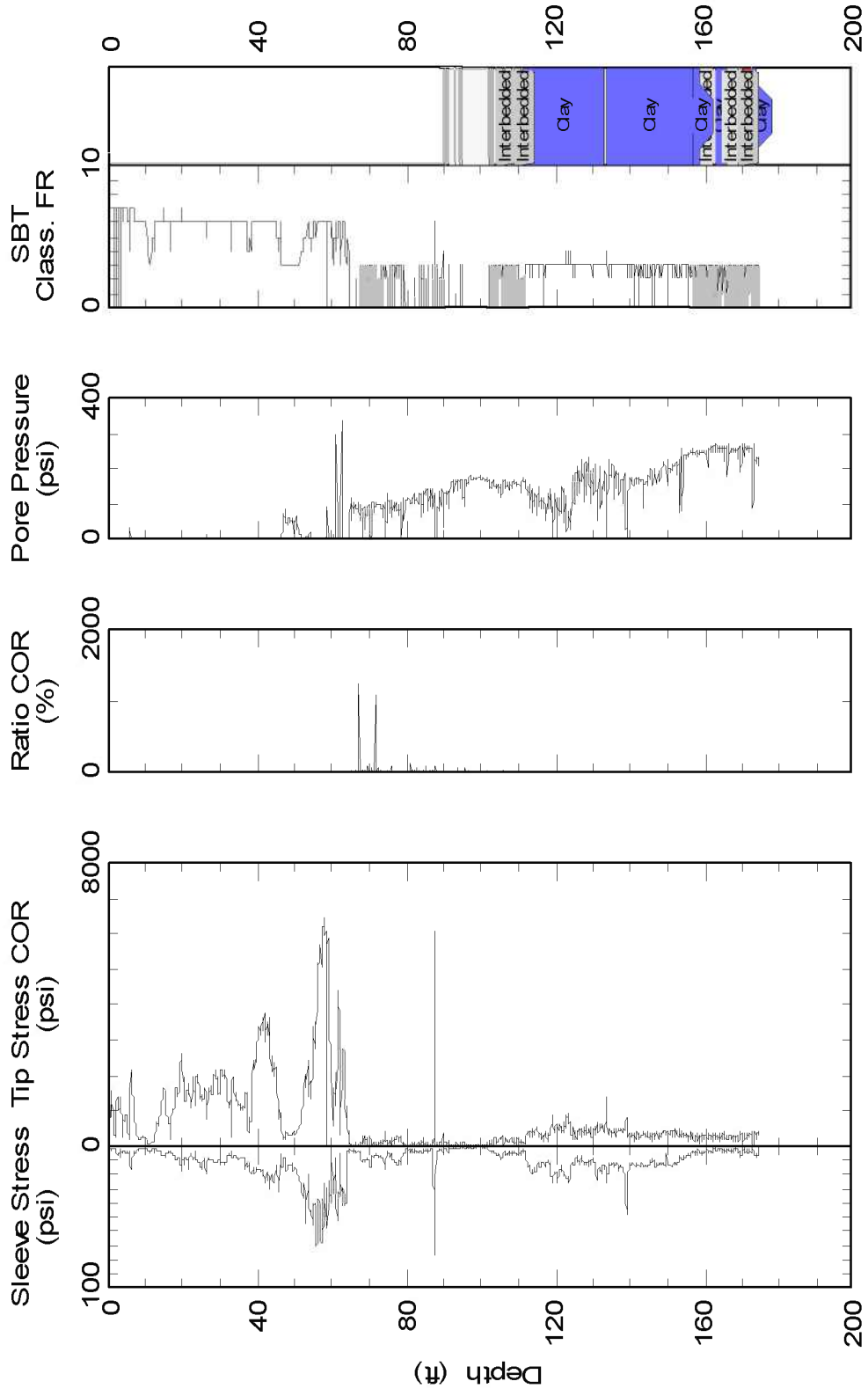

Plate 20: Cone Penetration Testing Results for C-05-11.

# C-05-11

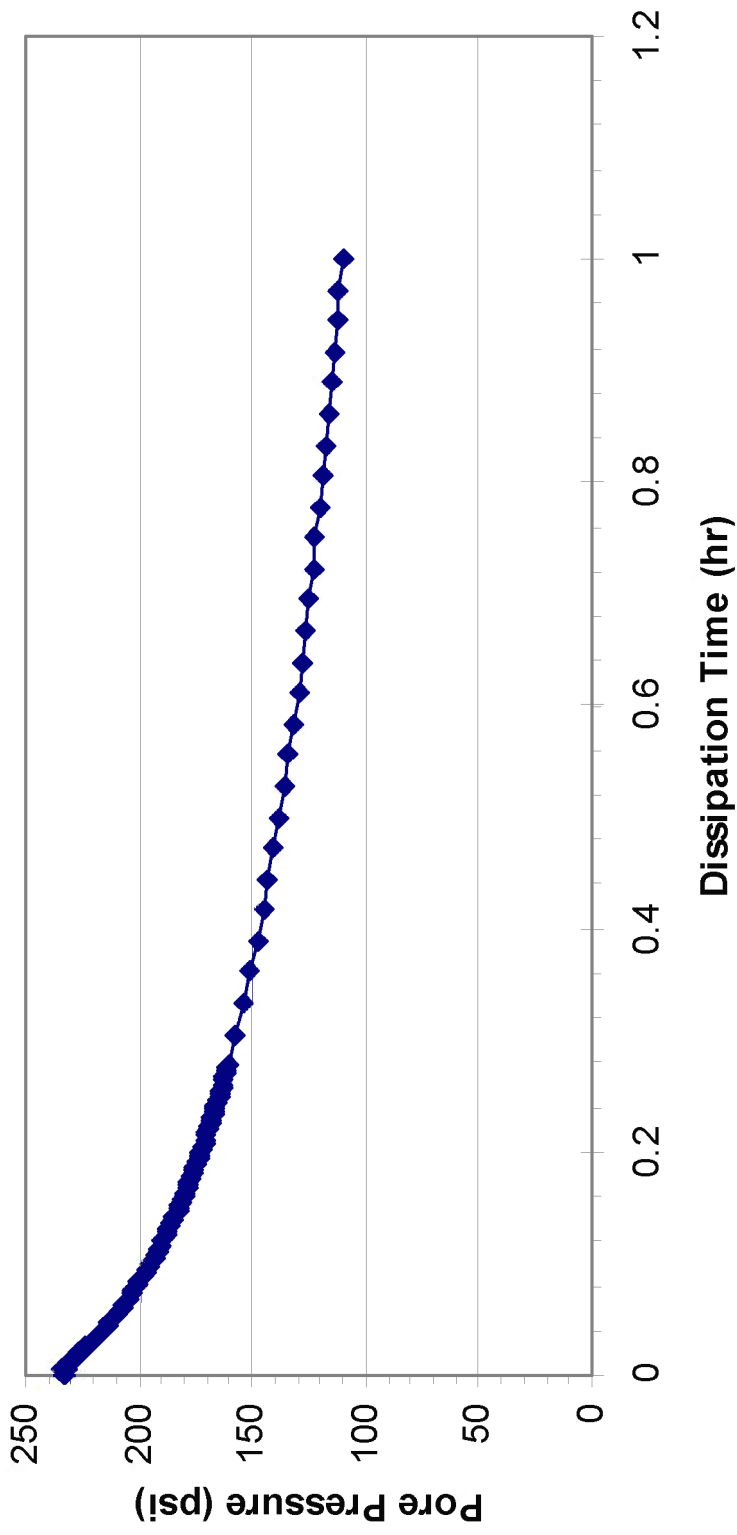

Plate 21: Pore Pressure Dissipation for C-05-11 taken at an approximate depth of 175 feet.

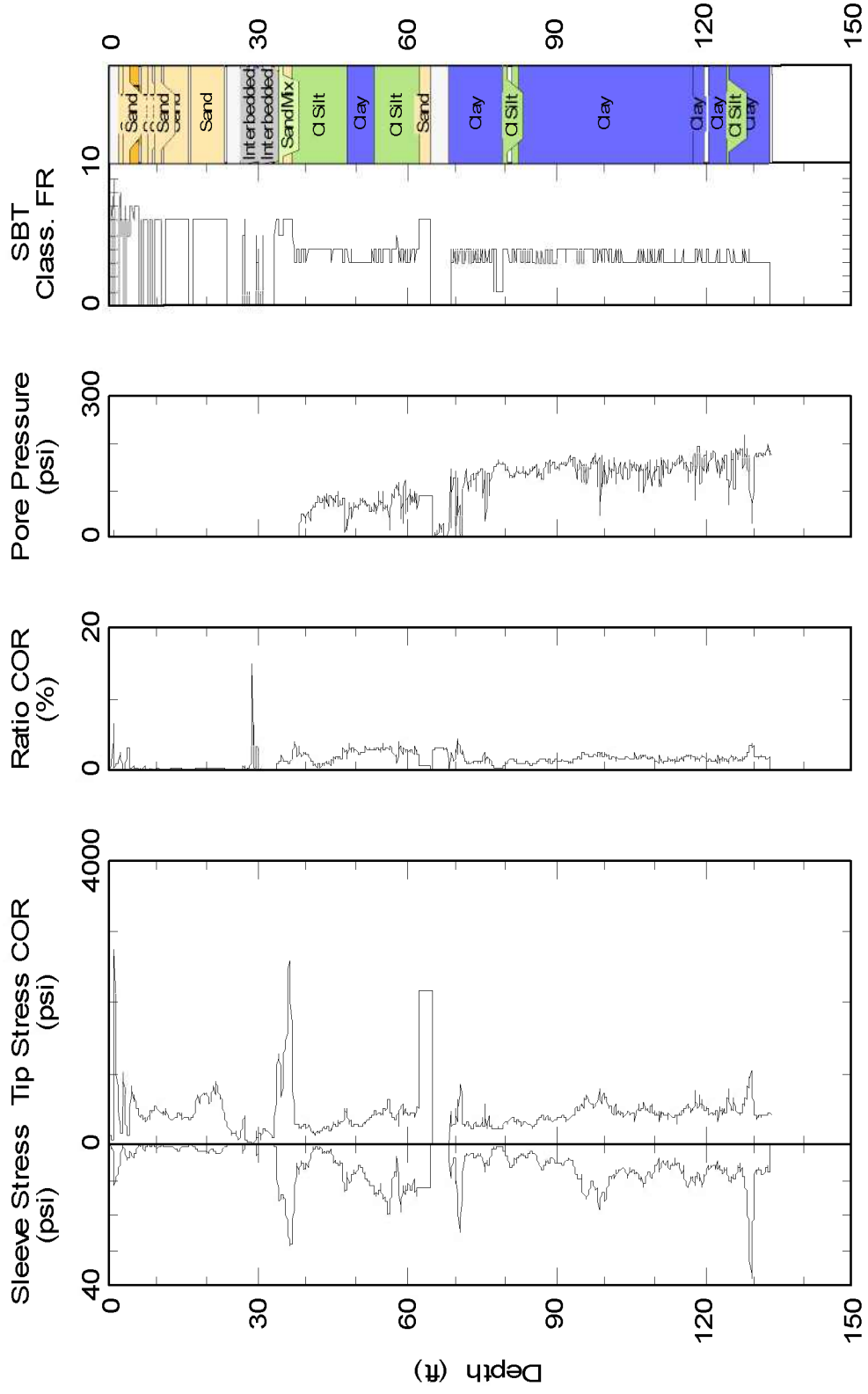

Plate 22: Cone Penetration Testing Results for C-05-12.

**APPENDIX 4F**  
**GTX 2006 LABORATORY TESTING REPORT**



a subsidiary of Geocomp Corporation

1145 Massachusetts Avenue  
Boxborough, MA 01719  
978 635 0424 Tel  
978 635 0266 Fax

---

## **Geotechnical Test Report**

---

June 14, 2006

# GTX-6678 I-90 Central Viaduct Project

Cleveland, OH

Prepared for:



## **EXECUTIVE SUMMARY**

This report documents the results of laboratory tests performed by GeoTesting Express, Inc. on undisturbed samples of soils obtained from the I-90 Central Viaduct project in Cleveland, OH. Testing was performed under the direction of W. Allen Marr. Samples were 2.87 inch diameter Shelby tube samples shipped to GeoTesting Express's laboratory in Boxborough, MA. A total of 5 samples were provided.

The samples were received in two separate shipments. The first shipment contained two samples from Boring B-05-03. The second shipment contained three samples from separate borings; B-05-08, B-105A and C-05-04. The samples were shipped to the laboratory inside specially designed and insulated soil sample tube shipping containers to minimize disturbance to the soil.

GeoTesting Express, Inc., has completed the following tests on these samples:

- 10 Residual Shear test points
- 3 Direct Simple Shear tests
- 2 CIU Triaxial tests
- 2 Incremental Consolidation tests
- 1 Constant Rate of Strain Consolidation test
- 5 Gradations
- 5 Atterberg Limits
- 2 Specific Gravity
- 2 Moisture Content
- 2 USCS Soil Classification

**Table of Contents**

Executive Summary.....1  
Table of Contents.....2  
List of Tables.....2  
Introduction.....3  
Sample Preparation.....3  
Test Methods.....4  
Test Results.....5  
Tables.....6  
Appendix A: Classification Results.....7  
Appendix B: Consolidation Results.....21  
Appendix C: Direct Simple Shear Results.....53  
Appendix D: Residual Shear Results.....64  
Appendix E: CIU Triaxial Test Results.....91  
Appendix F: Photographs.....96

**List of Tables**

Table 1      Sample Information

## **Introduction**

E.L. Robinson of Columbus, Ohio retained Geocomp Corporation to perform advanced consolidation and strength testing on undisturbed samples of soils obtained from the vicinity of the I-90 Central Viaduct in Cleveland, OH. The tests were performed by Geocomp's subsidiary laboratory, GeoTesting Express Inc. (GTX) in their Boxborough, MA facility under the direction and supervision of W. Allen Marr.

Tests were performed on specimens trimmed from 2.87-inch Shelby tube samples provided by BBC&M of Cleveland, Ohio. The samples were shipped to the laboratory inside specially designed and insulated shipping containers to minimize disturbance to the soil. Upon arrival the samples were unpacked and inspected for any damage. The tubes arrived in excellent condition. At GTX the samples were kept at 70°F in a 100% humid environment at all times except when removed to trim out test specimens.

Table 1 summarizes the samples and their depths. Figure 1 shows the locations of the borings from which these samples were obtained.

## **Specimen Preparation**

The tube samples were kept stored in humid conditions at all times except when being used to obtain test specimens. Trimming occurred under a hood with a humidifier operating inside. After a specimen was obtained the sample was returned to the humid storage container.

Specimens were trimmed to fit into the test ring, of the appropriate test being performed. The Constant Rate of Strain, Incremental Consolidation and Residual Shear devices all use a stainless steel ring with an internal diameter of 2.5 inches and a height of 1- inch. The Direct Simple Shear device uses a wire-reinforced latex membrane with an internal diameter of 2.62-inches and a height of 1-inch to hold a one-inch high sample.

The CIU Triaxial tests were performed on 2.87-inch diameter specimens approximately 6-inches tall. All trimming was performed by experienced personnel.



## Test Methods

Test methods and procedures followed the applicable ASTM and US COE test methods, utilizing the most current edition. These included the following:

|                                      |   |
|--------------------------------------|---|
| US COE EM 1110                       | Residual Shear  |
| ASTM D 6528-00                       | Standard Test Method for Consolidated Undrained Direct Simple Shear Testing of Cohesive Soil                    |
| ASTM D 4767-04                       | Standard Test Method for Consolidated Undrained Triaxial Compression Test for Cohesive Soil                     |
| ASTM D 2435-04                       | Standard Test Method for One-Dimensional Consolidation Properties of Soil Using Incremental Loading             |
| ASTM D 4186-89<br>(Re-approved 1998) | Standard Test Method for One-Dimension Consolidation Properties of Soils Using Controlled-Strain Loading        |
| ASTM D 422-63<br>(Re-approved 2002)  | Standard Test Method for Particle-Size Analysis of Soils  |
| ASTM D 4318-05                       | Standard Test Methods for Liquid Limit, Plastic Limit, and Plasticity Index of Soils                            |
| ASTM D 854-05                        | Standard Test Methods for Specific Gravity of Soil Solids By Water Pycnometer                                   |
| ASTM D 2216-05                       | Standard Test Methods for Laboratory Determination of Water (Moisture) Content of Soil and Rock by Mass         |
| ASTM D 2487-00                       | Standard Test Methods for Classification of Soils for Engineering Purposes (Unified Soil Classification System) |

## **Test Results**

Results for the tests reduced to engineering units are provided in appendices attached to this report. Appendix A contains the results of classification tests made on the samples. These include soil classification, moisture content, specific gravity, gradation and Atterberg Limit tests.

Appendix B contains the test results for the consolidation tests performed, both the incremental consolidation and the constant rate of strain consolidation.

Results of the Direct Simple Shear tests are in Appendix C. Peak strengths were corrected for membrane stiffness with the calibration curves measured on the membrane used for the test. The calibration curve is also included in Appendix C.

Residual Shear Summaries for three-3 point series and one-1 point test, as well as the individual point test curves are in Appendix D.

CIU Triaxial test results are located in Appendix E.

Prepared and submitted by:

Joseph Tomei  
Laboratory Manager  
GeoTesting Express, Inc.

Table 1:

| SAMPLE INFORMATION |              |             |
|--------------------|--------------|-------------|
| BORING ID          | SAMPLE ID    | DEPTH (ft)  |
| C-05-03            | COY-90-15.24 | 116.5-118.5 |
| C-05-03            | COY-90-15.24 | 118.5-120.3 |
| B-05-08            | S-27         | 116-118     |
| B-105A             | S-20         | 90-92       |
| C-05-04            | S-27         | 72-74       |

# **Appendix A**

## **Classification Tests**

|                            |                               |                         |                      |
|----------------------------|-------------------------------|-------------------------|----------------------|
| Client: Geocomp Consulting | Project: I-90 Central Viaduct | Location: Cleveland, OH | Project No: GTX-6678 |
| Boring ID: ---             | Sample Type: ---              | Tested By: pcs          |                      |
| Sample ID:---              | Test Date: 06/12/06           | Checked By: jdt         |                      |
| Depth : ---                | Sample Id: ---                |                         |                      |

**Moisture Content of Soil - ASTM D 2216**

| Boring ID | Sample ID | Depth       | Description           | Moisture Content,% |
|-----------|-----------|-------------|-----------------------|--------------------|
| C-05-03   | S-29      | 116.5-118.5 | Moist, dark gray clay | 27                 |
| C-05-03   | S-30      | 118.5-120.5 | Moist, dark gray clay | 26                 |

Notes: Temperature of Drying : 110° Celsius

|                            |                               |                         |                      |
|----------------------------|-------------------------------|-------------------------|----------------------|
| Client: Geocomp Consulting | Project: I-90 Central Viaduct | Location: Cleveland, OH | Project No: GTX-6678 |
| Boring ID: ---             | Sample Type: ---              | Tested By: pcs          |                      |
| Sample ID:---              | Test Date: 05/31/06           | Checked By: jdt         |                      |
| Depth : ---                | Test Id: 89806                |                         |                      |

**USCS Classification - ASTM D 2487**

| Boring ID | Sample ID | Depth       | Group Name | Group Symbol | Gravel, % | Sand, % | Fines, % |
|-----------|-----------|-------------|------------|--------------|-----------|---------|----------|
| C-05-03   | S-29      | 116.5-118.5 | lean clay  | CL           | 0.0       | 2.1     | 97.9     |
| C-05-03   | S-30      | 118.5-120.5 | lean clay  | CL           | 0.0       | 0.3     | 99.7     |

Remarks: Grain Size analysis performed by ASTM D422, results enclosed  
 Atterbeg Limits performed by ASTM 4318, results enclosed

|   |                               |                         |                      |
|---|-------------------------------|-------------------------|----------------------|
| Client: Geocomp Consulting                | Project: I-90 Central Viaduct | Location: Cleveland, OH | Project No: GTX-6678 |
| Boring ID: C-05-03                        | Sample Type: tube             | Tested By: pcs          | Sample ID: S-29      |
| Depth: 116.5-118.5                        | Test Date: 05/11/06           | Checked By: jdt         | Test ID: 89803       |
| Test Comment: ---                         |                               |                         |                      |
| Sample Description: Moist, dark gray clay |                               |                         |                      |
| Sample Comment: ---                       |                               |                         |                      |

## Particle Size Analysis - ASTM D 422

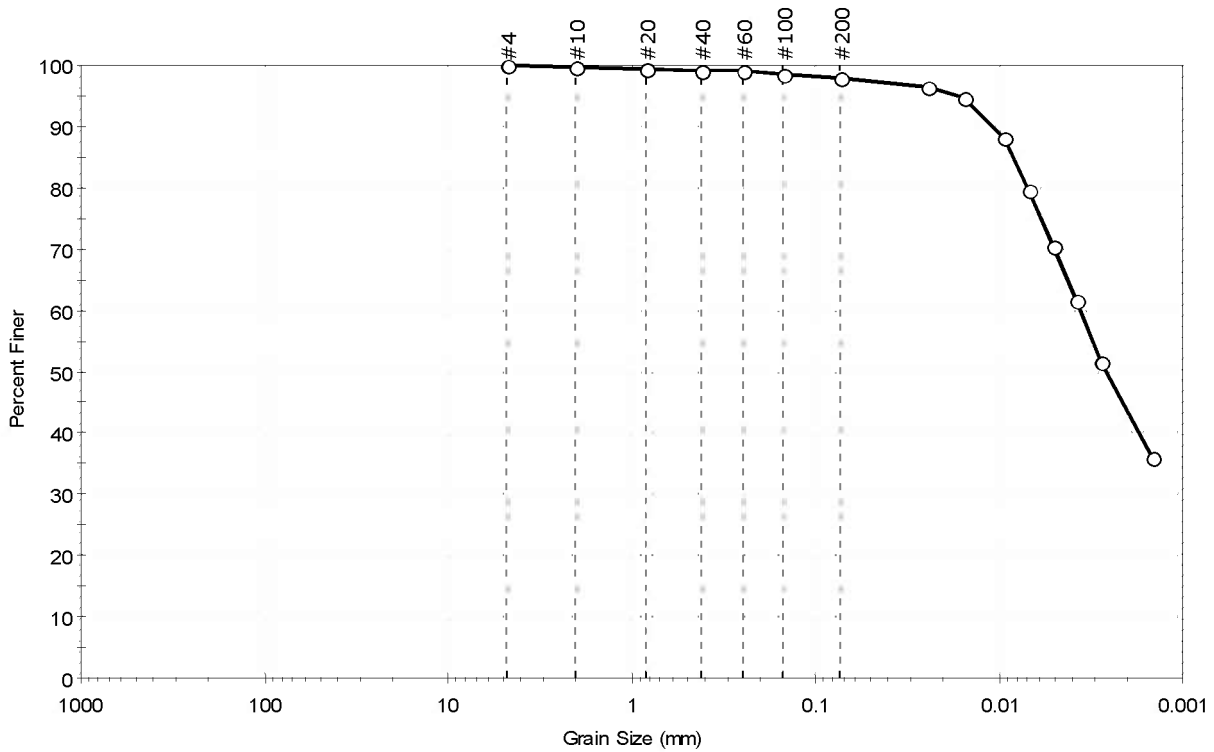

|          |          |        |                    |
|----------|----------|--------|--------------------|
| % Cobble | % Gravel | % Sand | % Silt & Clay Size |
| —        | 0.0      | 2.1    | 97.9               |

| Sieve Name | Sieve Size, mm     | Percent Finer | Spec. Percent | Complies |
|------------|--------------------|---------------|---------------|----------|
| #4         | 4.75               | 100           |               |          |
| #10        | 2.00               | 100           |               |          |
| #20        | 0.84               | 99            |               |          |
| #40        | 0.42               | 99            |               |          |
| #60        | 0.25               | 99            |               |          |
| #100       | 0.15               | 99            |               |          |
| #200       | 0.074              | 98            |               |          |
| ---        | Particle Size (mm) | Percent Finer | Spec. Percent | Complies |
| ---        | 0.0244             | 97            |               |          |
| ---        | 0.0156             | 95            |               |          |
| ---        | 0.0094             | 88            |               |          |
| ---        | 0.0069             | 80            |               |          |
| ---        | 0.0051             | 71            |               |          |
| ---        | 0.0038             | 62            |               |          |
| ---        | 0.0028             | 52            |               |          |
| ---        | 0.0015             | 36            |               |          |

| Coefficients                |                       |
|-----------------------------|-----------------------|
| D <sub>85</sub> = 0.0084 mm | D <sub>30</sub> = N/A |
| D <sub>60</sub> = 0.0036 mm | D <sub>15</sub> = N/A |
| D <sub>50</sub> = 0.0026 mm | D <sub>10</sub> = N/A |
| C <sub>u</sub> = N/A        | C <sub>c</sub> = N/A  |

| Classification |                         |
|----------------|-------------------------|
| ASTM           | lean clay (CL)          |
| AASHTO         | Clayey Soils (A-6 (18)) |

| Sample/Test Description    |       |
|----------------------------|-------|
| Sand/Gravel Particle Shape | : --- |
| Sand/Gravel Hardness       | : --- |

|   |                               |                         |                      |
|---|-------------------------------|-------------------------|----------------------|
| Client: Geocomp Consulting                | Project: I-90 Central Viaduct | Location: Cleveland, OH | Project No: GTX-6678 |
| Boring ID: C-05-03                        | Sample Type: tube             | Tested By: pcs          |                      |
| Sample ID: S-29                           | Test Date: 05/11/06           | Checked By: jdt         |                      |
| Depth: 116.5-118.5                        | Test Id: 89801                |                         |                      |
| Test Comment: ---                         |                               |                         |                      |
| Sample Description: Moist, dark gray clay |                               |                         |                      |
| Sample Comment: ---                       |                               |                         |                      |

## Atterberg Limits - ASTM D 4318

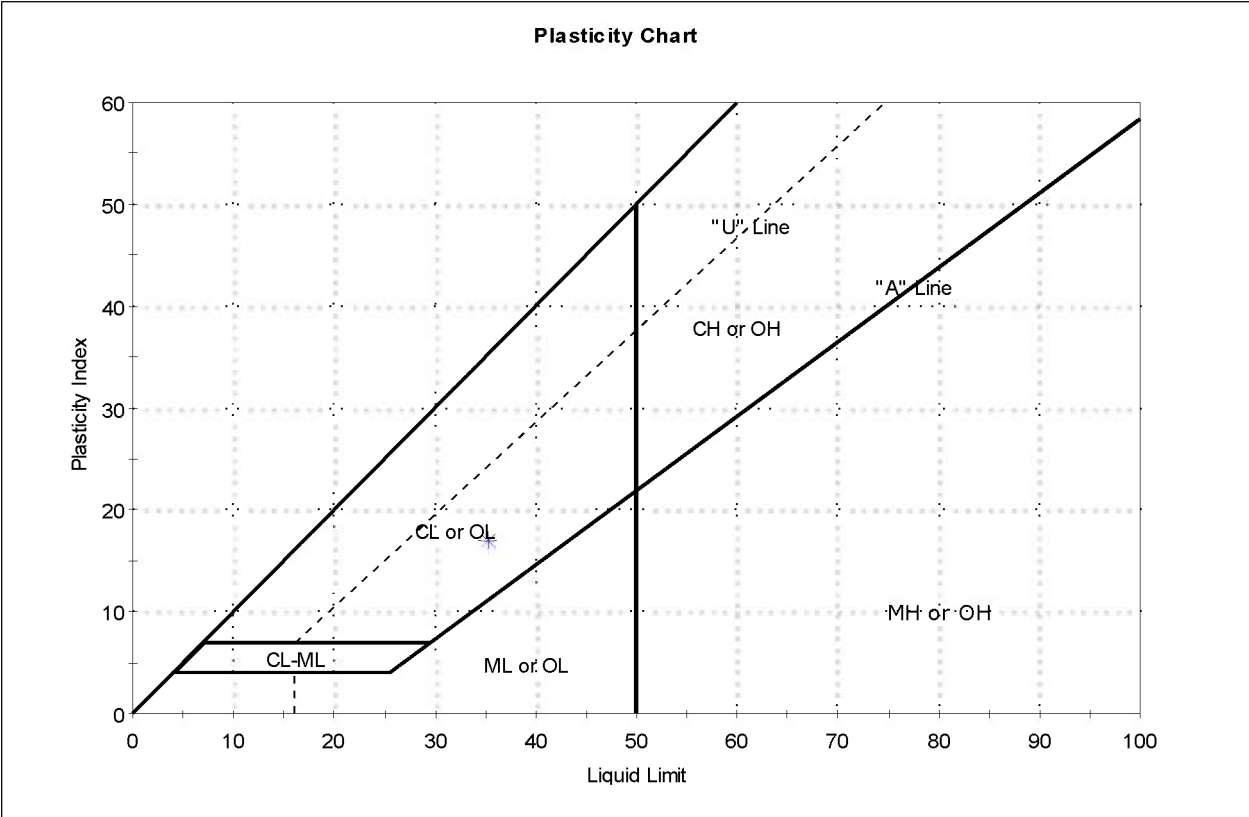

| Symbol | Sample ID | Boring  | Depth       | Natural Moisture Content, % | Liquid Limit | Plastic Limit | Plasticity Index | Liquidity Index | Soil Classification |
|--------|-----------|---------|-------------|-----------------------------|--------------|---------------|------------------|-----------------|---------------------|
| *      | S-29      | C-05-03 | 116.5-118.5 | 27                          | 35           | 18            | 17               | 0               | lean clay (CL)      |

Sample Prepared using the WET method  
 1% Retained on #40 Sieve  
 Dry Strength: HIGH  
 Dilatancy: NONE  
 Toughness: LOW



|   |                               |                         |                      |
|---|-------------------------------|-------------------------|----------------------|
| Client: Geocomp Consulting                | Project: I-90 Central Viaduct | Location: Cleveland, OH | Project No: GTX-6678 |
| Boring ID: C-05-03                        | Sample Type: tube             | Tested By: pcs          | Sample ID: S-30      |
| Depth: 118.5-120.5                        | Test Date: 05/11/06           | Checked By: jdt         | Test Id: 89804       |
| Test Comment: ---                         |                               |                         |                      |
| Sample Description: Moist, dark gray clay |                               |                         |                      |
| Sample Comment: ---                       |                               |                         |                      |

## Particle Size Analysis - ASTM D 422

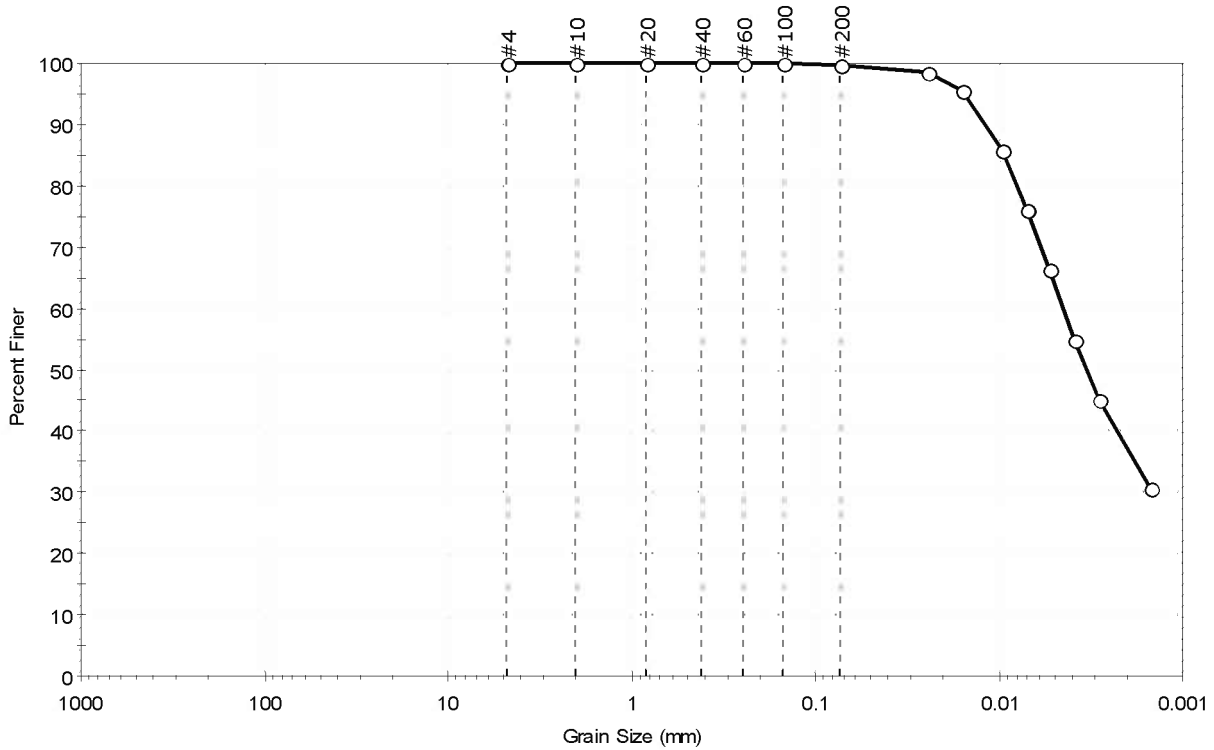

|          |          |        |                    |
|----------|----------|--------|--------------------|
| % Cobble | % Gravel | % Sand | % Silt & Clay Size |
| —        | 0.0      | 0.3    | 99.7               |

| Sieve Name | Sieve Size, mm     | Percent Finer | Spec. Percent | Complies |
|------------|--------------------|---------------|---------------|----------|
| #4         | 4.75               | 100           |               |          |
| #10        | 2.00               | 100           |               |          |
| #20        | 0.84               | 100           |               |          |
| #40        | 0.42               | 100           |               |          |
| #60        | 0.25               | 100           |               |          |
| #100       | 0.15               | 100           |               |          |
| #200       | 0.074              | 100           |               |          |
| ---        | Particle Size (mm) | Percent Finer | Spec. Percent | Complies |
| ---        | 0.0246             | 98            |               |          |
| ---        | 0.0158             | 96            |               |          |
| ---        | 0.0096             | 86            |               |          |
| ---        | 0.0071             | 76            |               |          |
| ---        | 0.0053             | 66            |               |          |
| ---        | 0.0039             | 55            |               |          |
| ---        | 0.0029             | 45            |               |          |
| ---        | 0.0015             | 31            |               |          |

| Coefficients                |                       |
|-----------------------------|-----------------------|
| D <sub>85</sub> = 0.0094 mm | D <sub>30</sub> = N/A |
| D <sub>60</sub> = 0.0045 mm | D <sub>15</sub> = N/A |
| D <sub>50</sub> = 0.0033 mm | D <sub>10</sub> = N/A |
| C <sub>u</sub> = N/A        | C <sub>c</sub> = N/A  |

| Classification |                         |
|----------------|-------------------------|
| ASTM           | lean clay (CL)          |
| AASHTO         | Clayey Soils (A-6 (16)) |

| Sample/Test Description          |
|----------------------------------|
| Sand/Gravel Particle Shape : --- |
| Sand/Gravel Hardness : ---       |

|   |                               |                         |                      |
|---|-------------------------------|-------------------------|----------------------|
| Client: Geocomp Consulting                | Project: I-90 Central Viaduct | Location: Cleveland, OH | Project No: GTX-6678 |
| Boring ID: C-05-03                        | Sample Type: tube             | Tested By: pcs          |                      |
| Sample ID: S-30                           | Test Date: 05/12/06           | Checked By: jdt         |                      |
| Depth: 118.5-120.5                        | Test Id: 89802                |                         |                      |
| Test Comment: ---                         |                               |                         |                      |
| Sample Description: Moist, dark gray clay |                               |                         |                      |
| Sample Comment: ---                       |                               |                         |                      |

## Atterberg Limits - ASTM D 4318

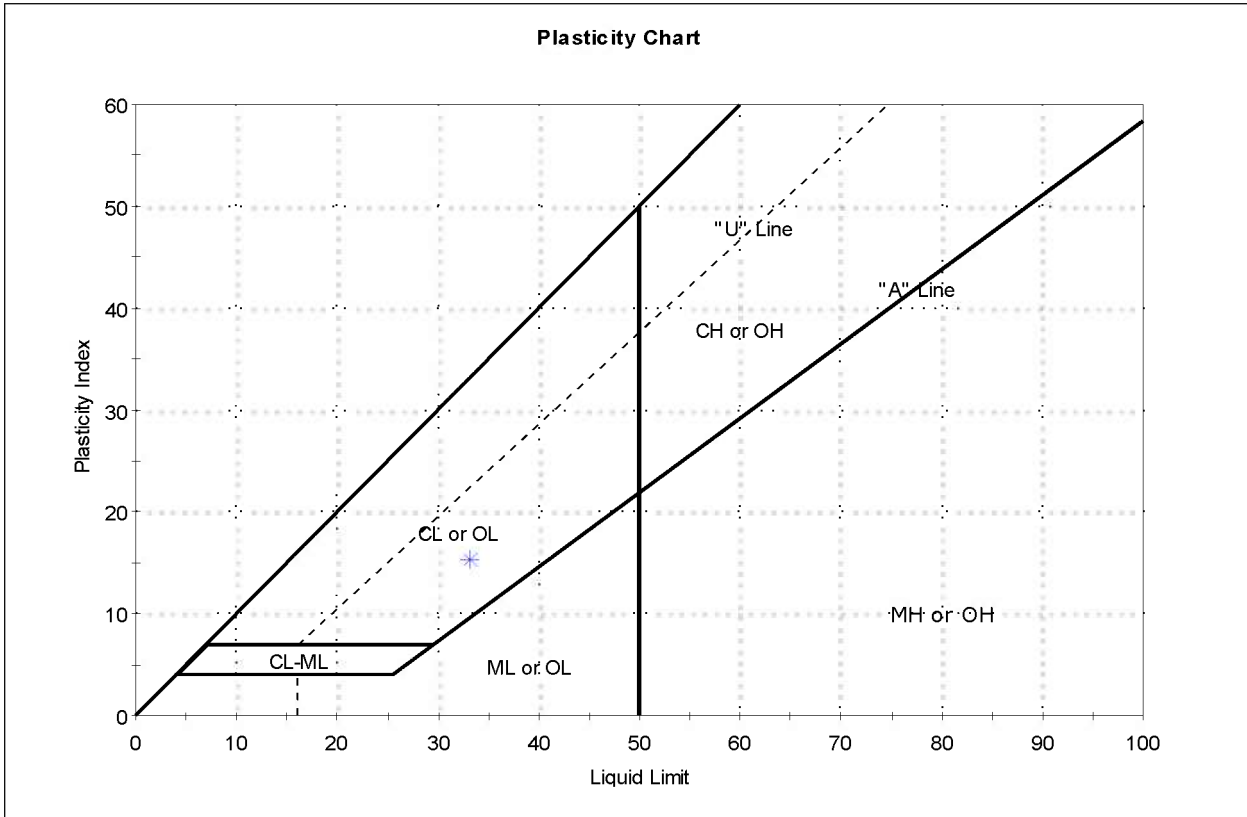

| Symbol | Sample ID | Boring  | Depth       | Natural Moisture Content, % | Liquid Limit | Plastic Limit | Plasticity Index | Liquidity Index | Soil Classification |
|--------|-----------|---------|-------------|-----------------------------|--------------|---------------|------------------|-----------------|---------------------|
| *      | S-30      | C-05-03 | 118.5-120.5 | 26                          | 33           | 18            | 15               | 1               | lean clay (CL)      |

Sample Prepared using the WET method  
 0% Retained on #40 Sieve  
 Dry Strength: HIGH  
 Dilatancy: NONE  
 Toughness: LOW

|                            |                               |                         |                      |
|----------------------------|-------------------------------|-------------------------|----------------------|
| Client: Geocomp Consulting | Project: I-90 Central Viaduct | Location: Cleveland, OH | Project No: GTX-6678 |
| Boring ID: ---             | Sample Type: ---              | Tested By: pcs          |                      |
| Sample ID:---              | Test Date: 05/11/06           | Checked By: jdt         |                      |
| Depth : ---                | Test Id: 89812                |                         |                      |

## Specific Gravity of Soils by ASTM D 854

| Boring ID | Sample ID | Depth       | Visual Description    | Specific Gravity |
|-----------|-----------|-------------|-----------------------|------------------|
| C-05-03   | S-29      | 116.5-118.5 | Moist, dark gray clay | 2.75             |
| C-05-03   | S-30      | 118.5-120.5 | Moist, dark gray clay | 2.73             |

Notes: Specific Gravity performed by using method A (oven dried specimens) of ASTM D 854  
 Moisture Content determined by ASTM D 2216.

|   |                               |                         |                      |
|---|-------------------------------|-------------------------|----------------------|
| Client: Geocomp Consulting                              | Project: I-90 Central Viaduct | Location: Cleveland, OH | Project No: GTX-6678 |
| Boring ID: C-05-04                                      | Sample Type: tube             | Tested By: pcs          | Sample ID: S-27      |
| Depth: 72-74 ft   | Test Date: 05/31/06           | Checked By: jdt         | Test Id: 90387       |
| Test Comment: ---                                       |                               |                         |                      |
| Sample Description: Moist, very dark grayish brown clay |                               |                         |                      |
| Sample Comment: ---                                     |                               |                         |                      |

## Particle Size Analysis - ASTM D 422

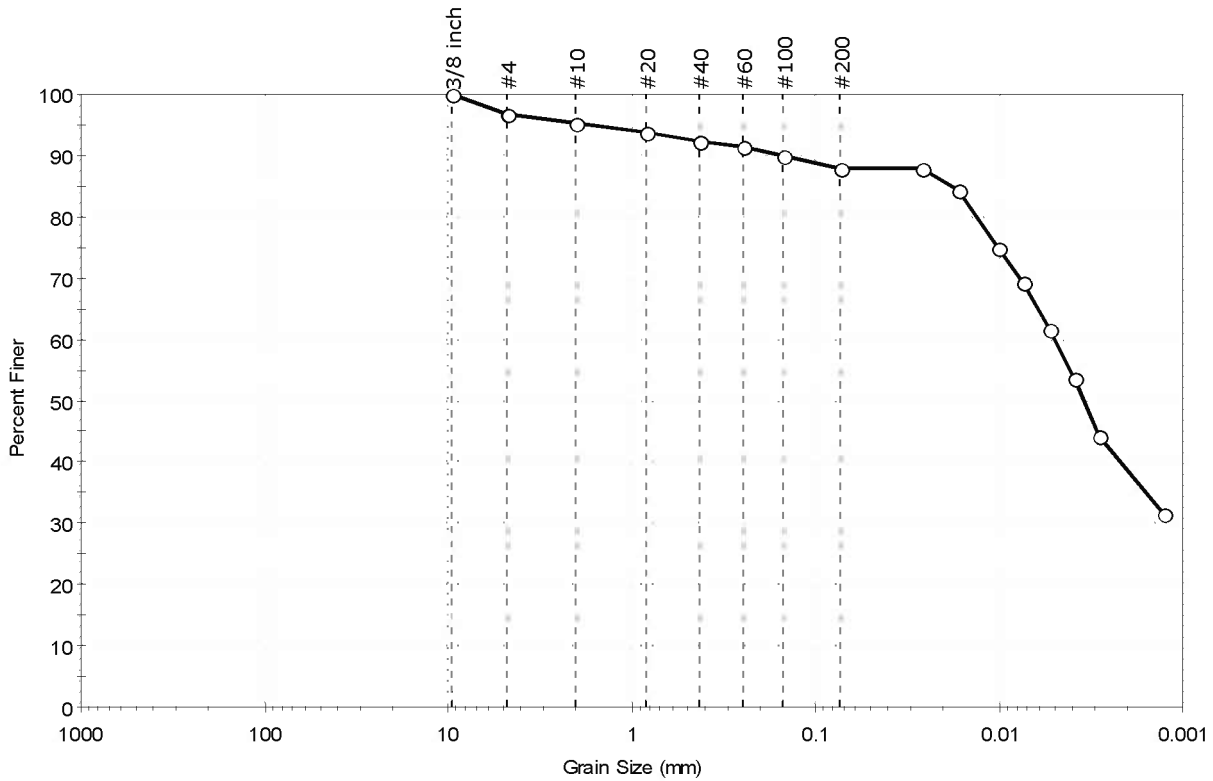

|          |          |        |                    |
|----------|----------|--------|--------------------|
| % Cobble | % Gravel | % Sand | % Silt & Clay Size |
| —        | 3.2      | 8.9    | 87.9               |

| Sieve Name | Sieve Size, mm     | Percent Finer | Spec. Percent | Complies |
|------------|--------------------|---------------|---------------|----------|
| 3/8 inch   | 9.50               | 100           |               |          |
| #4         | 4.75               | 97            |               |          |
| #10        | 2.00               | 95            |               |          |
| #20        | 0.84               | 94            |               |          |
| #40        | 0.42               | 92            |               |          |
| #60        | 0.25               | 91            |               |          |
| #100       | 0.15               | 90            |               |          |
| #200       | 0.074              | 88            |               |          |
| ---        | Particle Size (mm) | Percent Finer | Spec. Percent | Complies |
| ---        | 0.0265             | 88            |               |          |
| ---        | 0.0168             | 84            |               |          |
| ---        | 0.0101             | 75            |               |          |
| ---        | 0.0074             | 69            |               |          |
| ---        | 0.0054             | 62            |               |          |
| ---        | 0.0039             | 54            |               |          |
| ---        | 0.0029             | 44            |               |          |
| ---        | 0.0013             | 32            |               |          |

| Coefficients                |                       |
|-----------------------------|-----------------------|
| D <sub>85</sub> = 0.0184 mm | D <sub>30</sub> = N/A |
| D <sub>60</sub> = 0.0050 mm | D <sub>15</sub> = N/A |
| D <sub>50</sub> = 0.0035 mm | D <sub>10</sub> = N/A |
| C <sub>u</sub> = N/A        | C <sub>c</sub> = N/A  |

| Classification |                         |
|----------------|-------------------------|
| ASTM           | lean clay (CL)          |
| AASHTO         | Clayey Soils (A-6 (10)) |

| Sample/Test Description    |           |
|----------------------------|-----------|
| Sand/Gravel Particle Shape | : ANGULAR |
| Sand/Gravel Hardness       | : HARD    |

|   |                               |                         |                      |
|---|-------------------------------|-------------------------|----------------------|
| Client: Geocomp Consulting                              | Project: I-90 Central Viaduct | Location: Cleveland, OH | Project No: GTX-6678 |
| Boring ID: C-05-04                                      | Sample Type: tube             | Tested By: pcs          |                      |
| Sample ID: S-27   | Test Date: 05/24/06           | Checked By: jdt         |                      |
| Depth: 72-74 ft   | Test Id: 90390                |                         |                      |
| Test Comment: ---                                       |                               |                         |                      |
| Sample Description: Moist, very dark grayish brown clay |                               |                         |                      |
| Sample Comment: ---                                     |                               |                         |                      |

## Atterberg Limits - ASTM D 4318

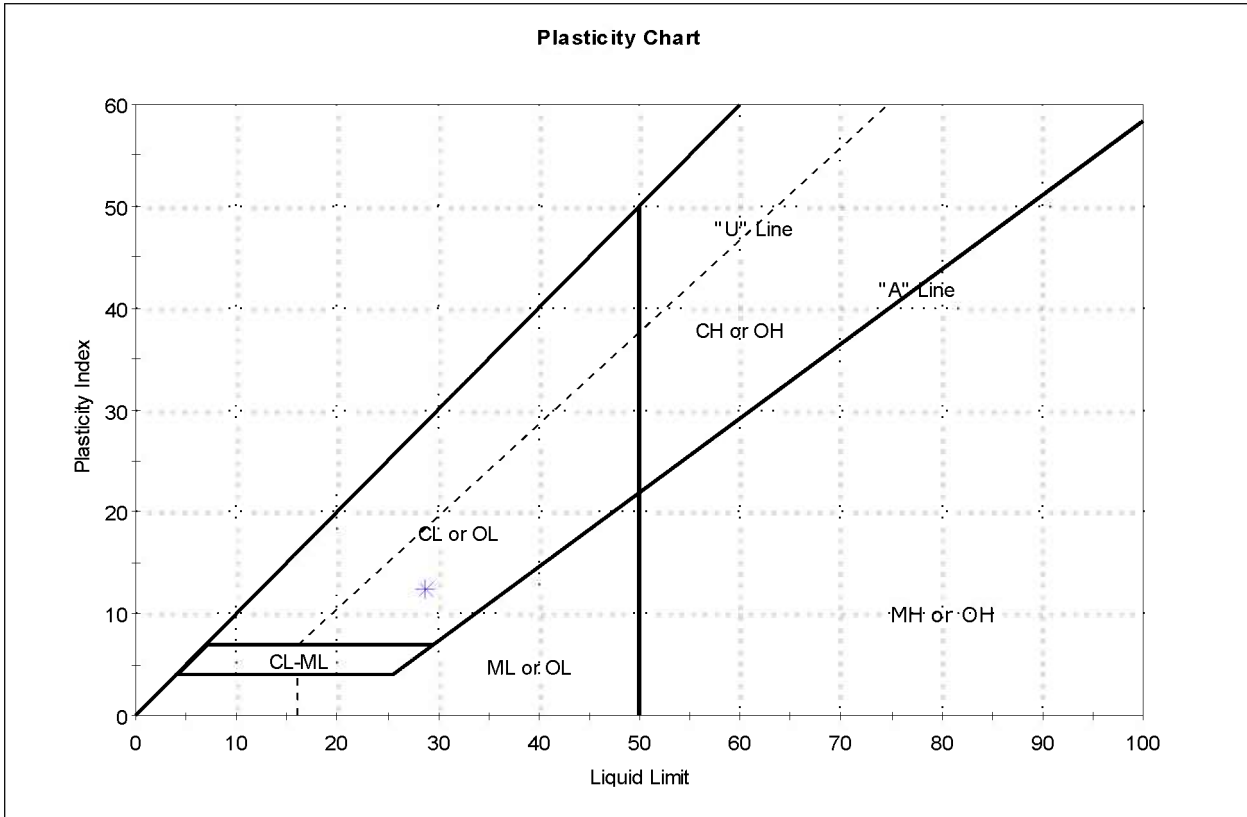

| Symbol | Sample ID | Boring  | Depth    | Natural Moisture Content, % | Liquid Limit | Plastic Limit | Plasticity Index | Liquidity Index | Soil Classification |
|--------|-----------|---------|----------|-----------------------------|--------------|---------------|------------------|-----------------|---------------------|
| *      | S-27      | C-05-04 | 72-74 ft | 21                          | 29           | 16            | 13               | 0               | lean clay (CL)      |

Sample Prepared using the WET method  
 8% Retained on #40 Sieve  
 Dry Strength: HIGH  
 Dilatancy: NONE  
 Toughness: LOW

|                            |   |                         |                      |
|----------------------------|---|-------------------------|----------------------|
| Client: Geocomp Consulting | Project: I-90 Central Viaduct                   | Location: Cleveland, OH | Project No: GTX-6678 |
| Boring ID: B-05-08         | Sample Type: tube                               | Tested By: pcs          | Checked By: jdt      |
| Sample ID: S-27            | Test Date: 06/01/06                             | Test Id: 90389          |                      |
| Depth: 116-118 ft          |   |                         |                      |
| Test Comment: ---          | Sample Description: Moist, dark olive gray clay |                         |                      |
| Sample Comment: ---        |   |                         |                      |

## Particle Size Analysis - ASTM D 422

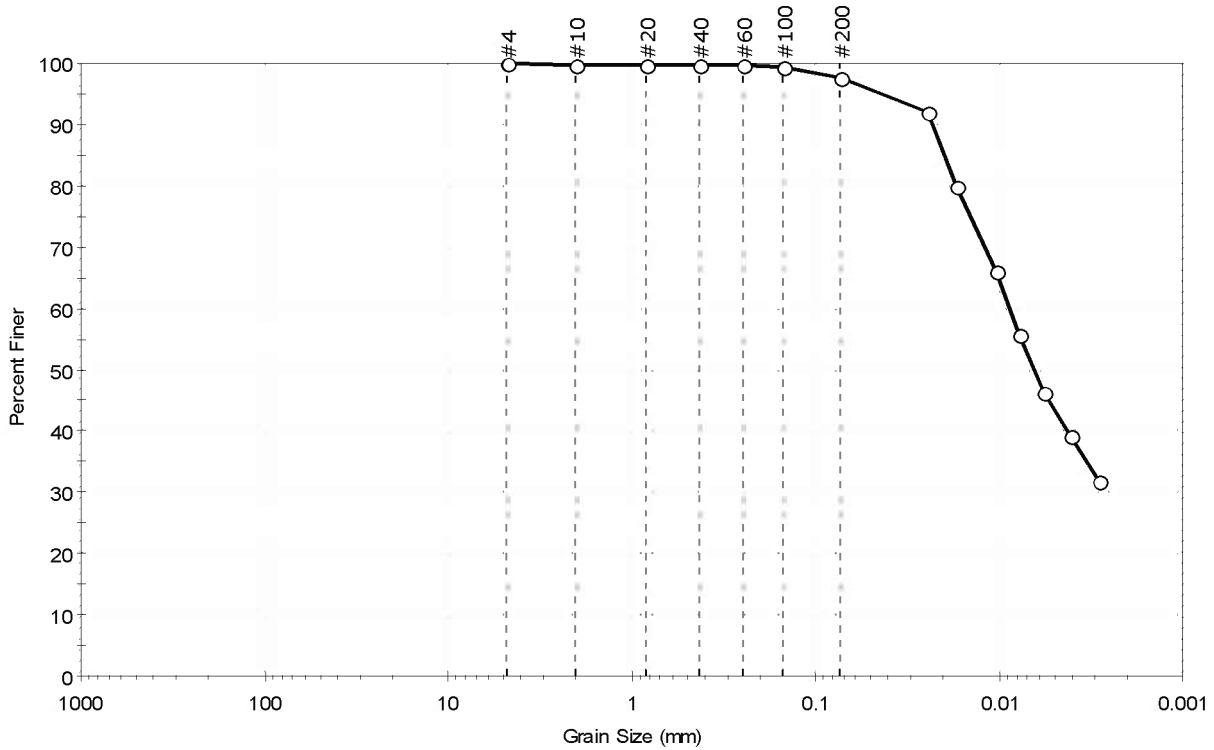

|          |          |        |                    |
|----------|----------|--------|--------------------|
| % Cobble | % Gravel | % Sand | % Silt & Clay Size |
| —        | 0.0      | 2.2    | 97.8               |

| Sieve Name | Sieve Size, mm     | Percent Finer | Spec. Percent | Complies |
|------------|--------------------|---------------|---------------|----------|
| #4         | 4.75               | 100           |               |          |
| #10        | 2.00               | 100           |               |          |
| #20        | 0.84               | 100           |               |          |
| #40        | 0.42               | 100           |               |          |
| #60        | 0.25               | 100           |               |          |
| #100       | 0.15               | 99            |               |          |
| #200       | 0.074              | 98            |               |          |
| ---        | Particle Size (mm) | Percent Finer | Spec. Percent | Complies |
| ---        | 0.0245             | 92            |               |          |
| ---        | 0.0169             | 80            |               |          |
| ---        | 0.0104             | 66            |               |          |
| ---        | 0.0077             | 56            |               |          |
| ---        | 0.0057             | 46            |               |          |
| ---        | 0.0041             | 39            |               |          |
| ---        | 0.0029             | 32            |               |          |

| Coefficients                |                       |
|-----------------------------|-----------------------|
| D <sub>85</sub> = 0.0197 mm | D <sub>30</sub> = N/A |
| D <sub>60</sub> = 0.0088 mm | D <sub>15</sub> = N/A |
| D <sub>50</sub> = 0.0064 mm | D <sub>10</sub> = N/A |
| C <sub>u</sub> = N/A        | C <sub>c</sub> = N/A  |

| Classification |                        |
|----------------|------------------------|
| ASTM           | lean clay (CL)         |
| AASHTO         | Clayey Soils (A-6 (9)) |

| Sample/Test Description    |           |
|----------------------------|-----------|
| Sand/Gravel Particle Shape | : ANGULAR |
| Sand/Gravel Hardness       | : HARD    |

|   |                               |                         |                      |
|---|-------------------------------|-------------------------|----------------------|
| Client: Geocomp Consulting                      | Project: I-90 Central Viaduct | Location: Cleveland, OH | Project No: GTX-6678 |
| Boring ID: B-05-08                              | Sample Type: tube             | Tested By: pcs          |                      |
| Sample ID: S-27                                 | Test Date: 05/31/06           | Checked By: jdt         |                      |
| Depth: 116-118 ft                               | Test Id: 90392                |                         |                      |
| Test Comment: ---                               |                               |                         |                      |
| Sample Description: Moist, dark olive gray clay |                               |                         |                      |
| Sample Comment: ---                             |                               |                         |                      |

## Atterberg Limits - ASTM D 4318

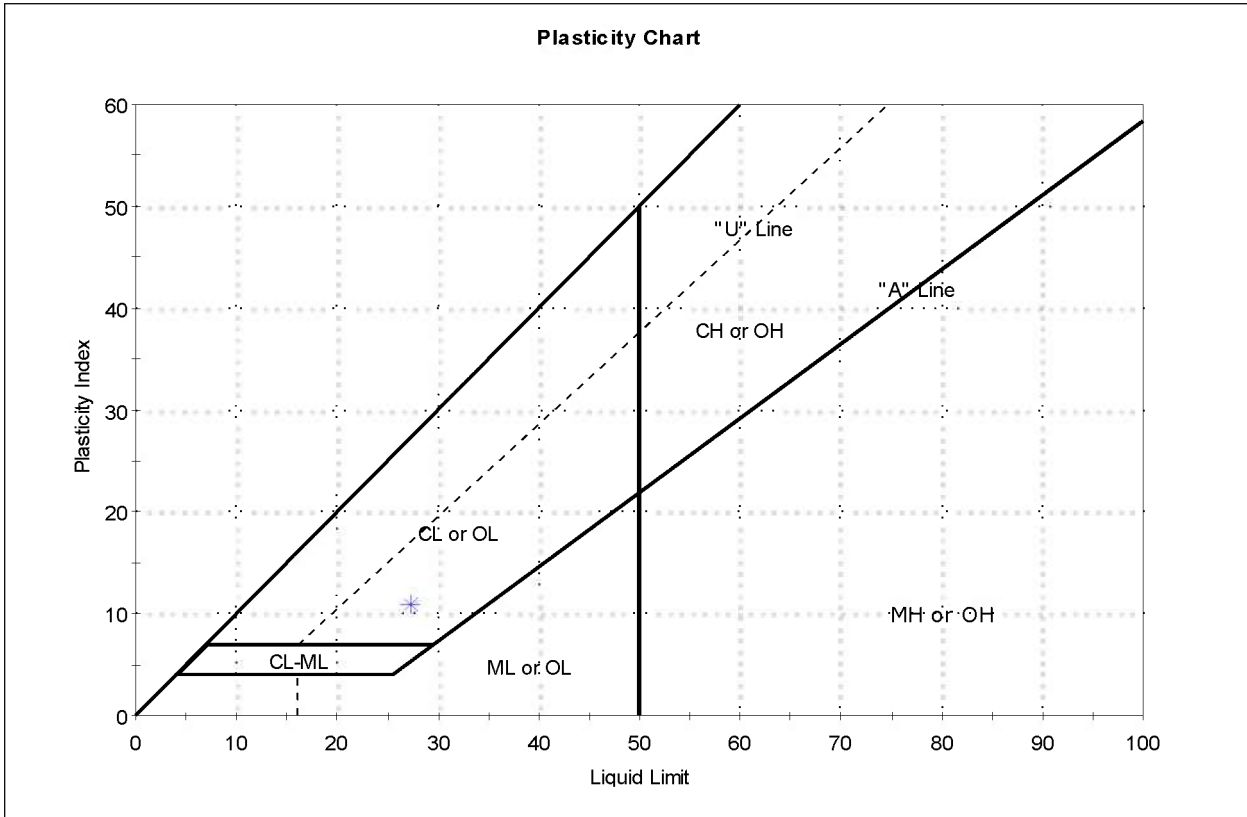

| Symbol | Sample ID | Boring  | Depth      | Natural Moisture Content, % | Liquid Limit | Plastic Limit | Plasticity Index | Liquidity Index | Soil Classification |
|--------|-----------|---------|------------|-----------------------------|--------------|---------------|------------------|-----------------|---------------------|
| *      | S-27      | B-05-08 | 116-118 ft | 22                          | 27           | 16            | 11               | 1               | lean clay (CL)      |

Sample Prepared using the WET method  
 0% Retained on #40 Sieve  
 Dry Strength: VERY HIGH  
 Dilatancy: SLOW  
 Toughness: LOW

|   |                               |                         |                      |
|---|-------------------------------|-------------------------|----------------------|
| Client: Geocomp Consulting                | Project: I-90 Central Viaduct | Location: Cleveland, OH | Project No: GTX-6678 |
| Boring ID: B-105A                         | Sample Type: tube             | Tested By: pcs          | Sample ID: S-20      |
| Test Date: 05/30/06                       | Checked By: jdt               | Depth: 90-92 ft         | Test Id: 90388       |
| Test Comment: ---                         |                               |                         |                      |
| Sample Description: Moist, dark gray clay |                               |                         |                      |
| Sample Comment: ---                       |                               |                         |                      |

## Particle Size Analysis - ASTM D 422

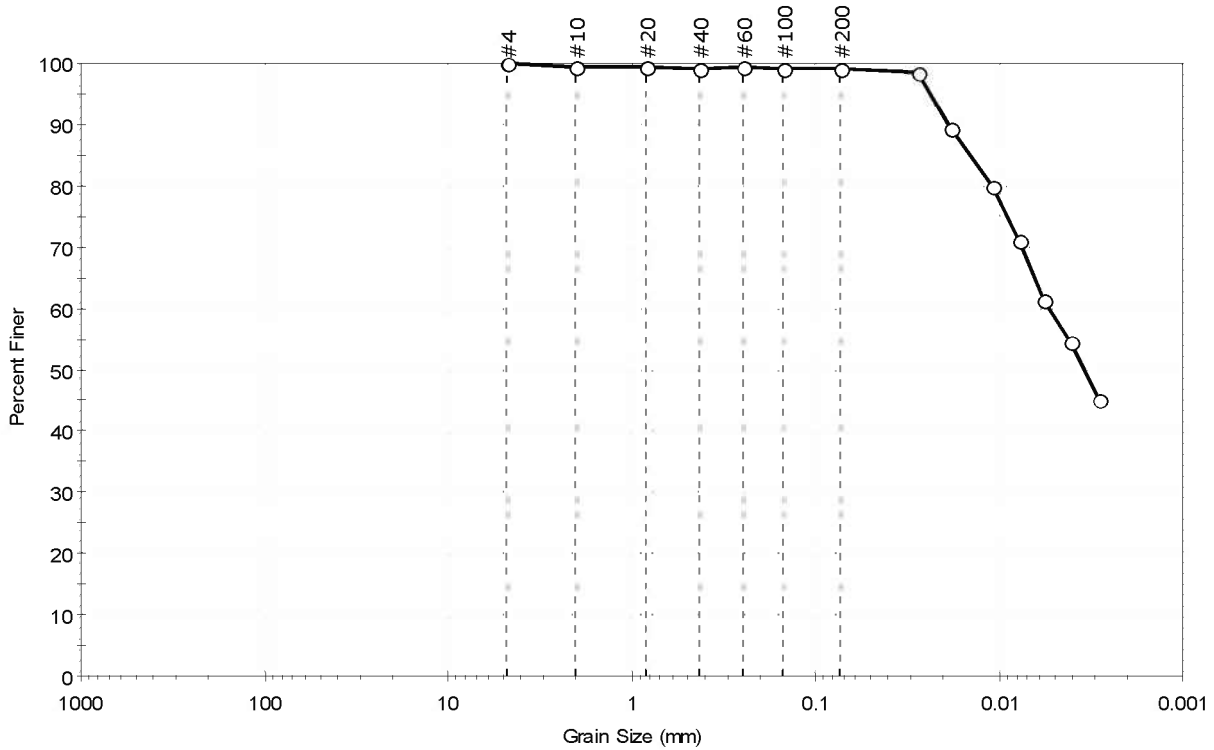

|          |          |        |                    |
|----------|----------|--------|--------------------|
| % Cobble | % Gravel | % Sand | % Silt & Clay Size |
| —        | 0.0      | 1.0    | 99.0               |

| Sieve Name | Sieve Size, mm     | Percent Finer | Spec. Percent | Complies |
|------------|--------------------|---------------|---------------|----------|
| #4         | 4.75               | 100           |               |          |
| #10        | 2.00               | 100           |               |          |
| #20        | 0.84               | 99            |               |          |
| #40        | 0.42               | 99            |               |          |
| #60        | 0.25               | 99            |               |          |
| #100       | 0.15               | 99            |               |          |
| #200       | 0.074              | 99            |               |          |
| ---        | Particle Size (mm) | Percent Finer | Spec. Percent | Complies |
| ---        | 0.0274             | 99            |               |          |
| ---        | 0.0183             | 89            |               |          |
| ---        | 0.0108             | 80            |               |          |
| ---        | 0.0078             | 71            |               |          |
| ---        | 0.0057             | 61            |               |          |
| ---        | 0.0041             | 55            |               |          |
| ---        | 0.0029             | 45            |               |          |

| Coefficients                |                       |
|-----------------------------|-----------------------|
| D <sub>85</sub> = 0.0143 mm | D <sub>30</sub> = N/A |
| D <sub>60</sub> = 0.0053 mm | D <sub>15</sub> = N/A |
| D <sub>50</sub> = 0.0034 mm | D <sub>10</sub> = N/A |
| C <sub>u</sub> = N/A        | C <sub>c</sub> = N/A  |

| Classification |                         |
|----------------|-------------------------|
| ASTM           | lean clay (CL)          |
| AASHTO         | Clayey Soils (A-6 (16)) |

| Sample/Test Description    |           |
|----------------------------|-----------|
| Sand/Gravel Particle Shape | : ANGULAR |
| Sand/Gravel Hardness       | : HARD    |



|   |                               |                         |                      |
|---|-------------------------------|-------------------------|----------------------|
| Client: Geocomp Consulting                | Project: I-90 Central Viaduct | Location: Cleveland, OH | Project No: GTX-6678 |
| Boring ID: B-105A                         | Sample Type: tube             | Tested By: pcs          |                      |
| Sample ID: S-20                           | Test Date: 06/01/06           | Checked By: jdt         |                      |
| Depth: 90-92 ft                           | Test Id: 90391                |                         |                      |
| Test Comment: ---                         |                               |                         |                      |
| Sample Description: Moist, dark gray clay |                               |                         |                      |
| Sample Comment: ---                       |                               |                         |                      |

## Atterberg Limits - ASTM D 4318

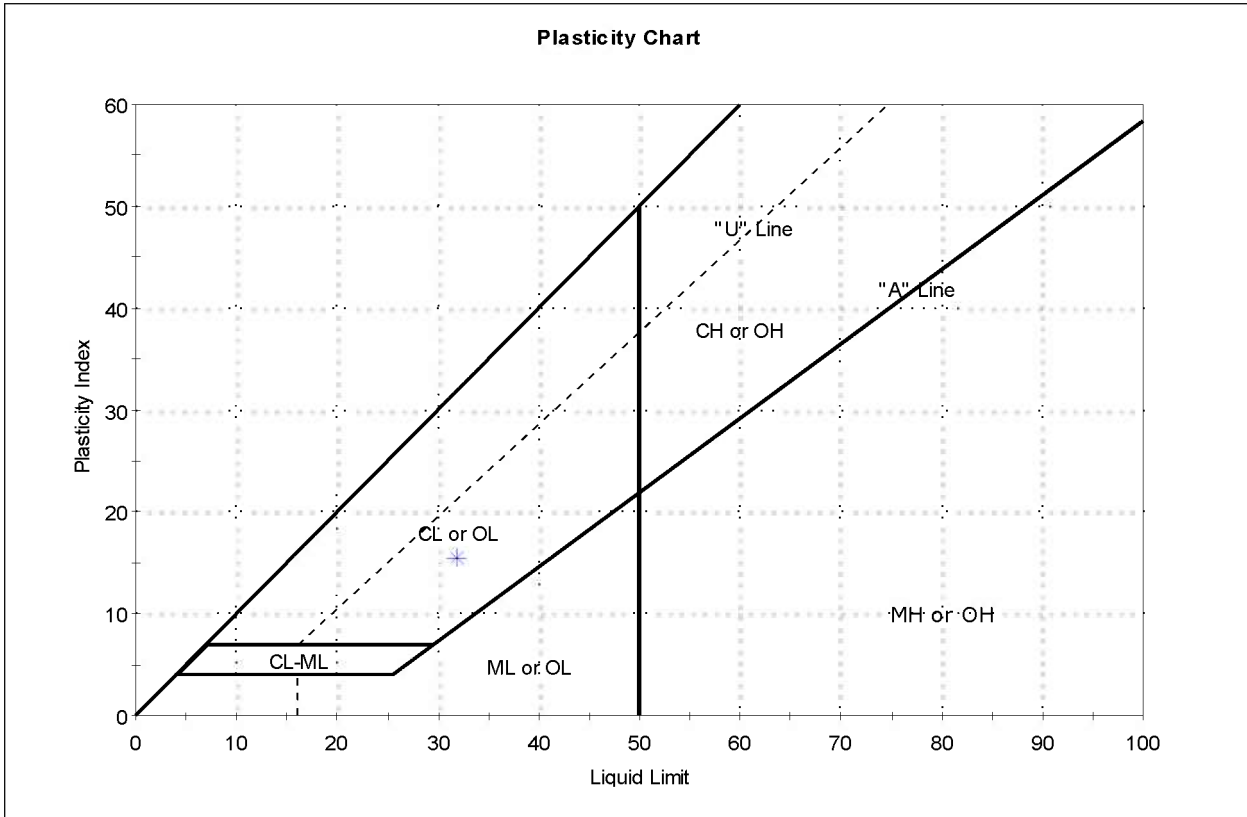

| Symbol | Sample ID | Boring | Depth    | Natural Moisture Content, % | Liquid Limit | Plastic Limit | Plasticity Index | Liquidity Index | Soil Classification |
|--------|-----------|--------|----------|-----------------------------|--------------|---------------|------------------|-----------------|---------------------|
| *      | S-20      | B-105A | 90-92 ft | 23                          | 32           | 16            | 16               | 0               | lean clay (CL)      |

Sample Prepared using the WET method  
 1% Retained on #40 Sieve  
 Dry Strength: HIGH  
 Dilatancy: SLOW  
 Toughness: LOW

# **Appendix B**

## **Consolidation Tests**

# CONSOLIDATION TEST DATA

## SUMMARY REPORT

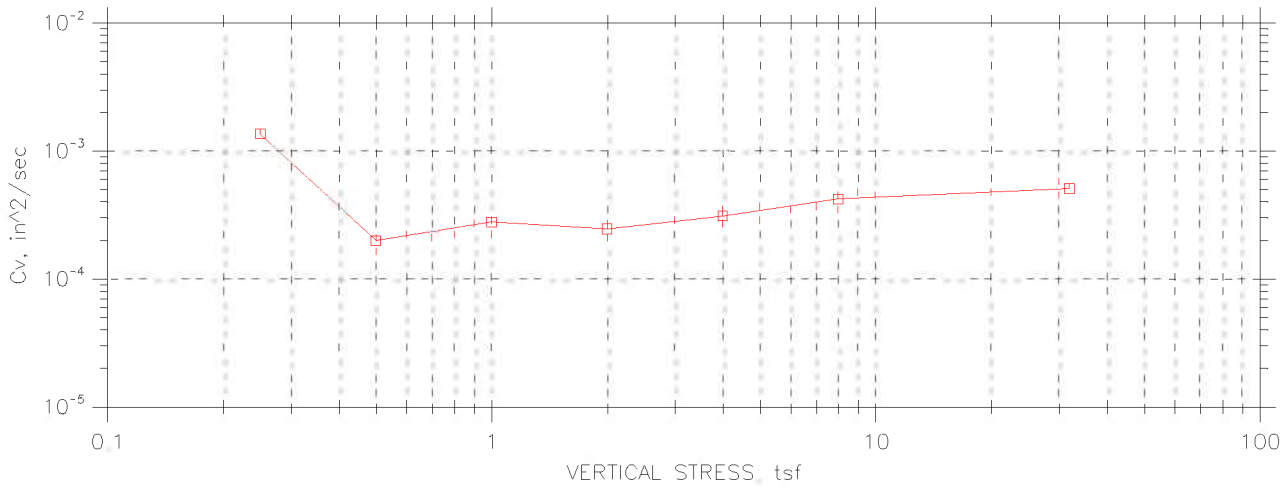
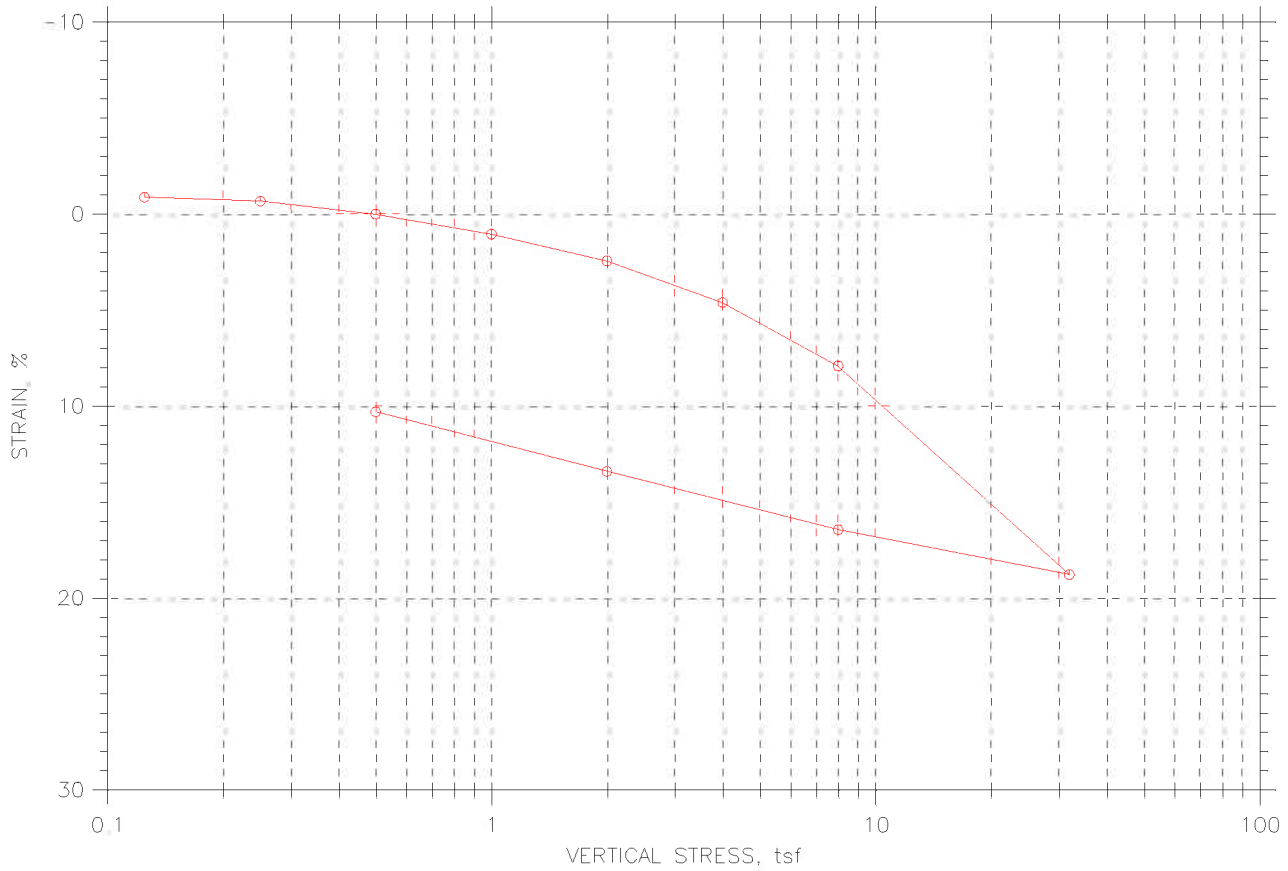

|  |                                    |                         |                       |
|--|------------------------------------|-------------------------|-----------------------|
|  | Project: I90 Central Viaduct       | Location: Cleveland, OH | Project No.: GTX-6678 |
|  | Boring No.: C-05-03                | Tested By: jdt          | Checked By: njh       |
|  | Sample No.: S-29                   | Test Date: 05/05/06     | Depth: 116.5-118.5    |
|  | Test No.: C-1                      | Sample Type: Tube       | Elevation: ---        |
|  | Description: Moist, dark gray clay |                         |                       |
|  | Remarks: ---                       |                         |                       |
|  |                                    |                         |                       |

# CONSOLIDATION TEST DATA

## SUMMARY REPORT

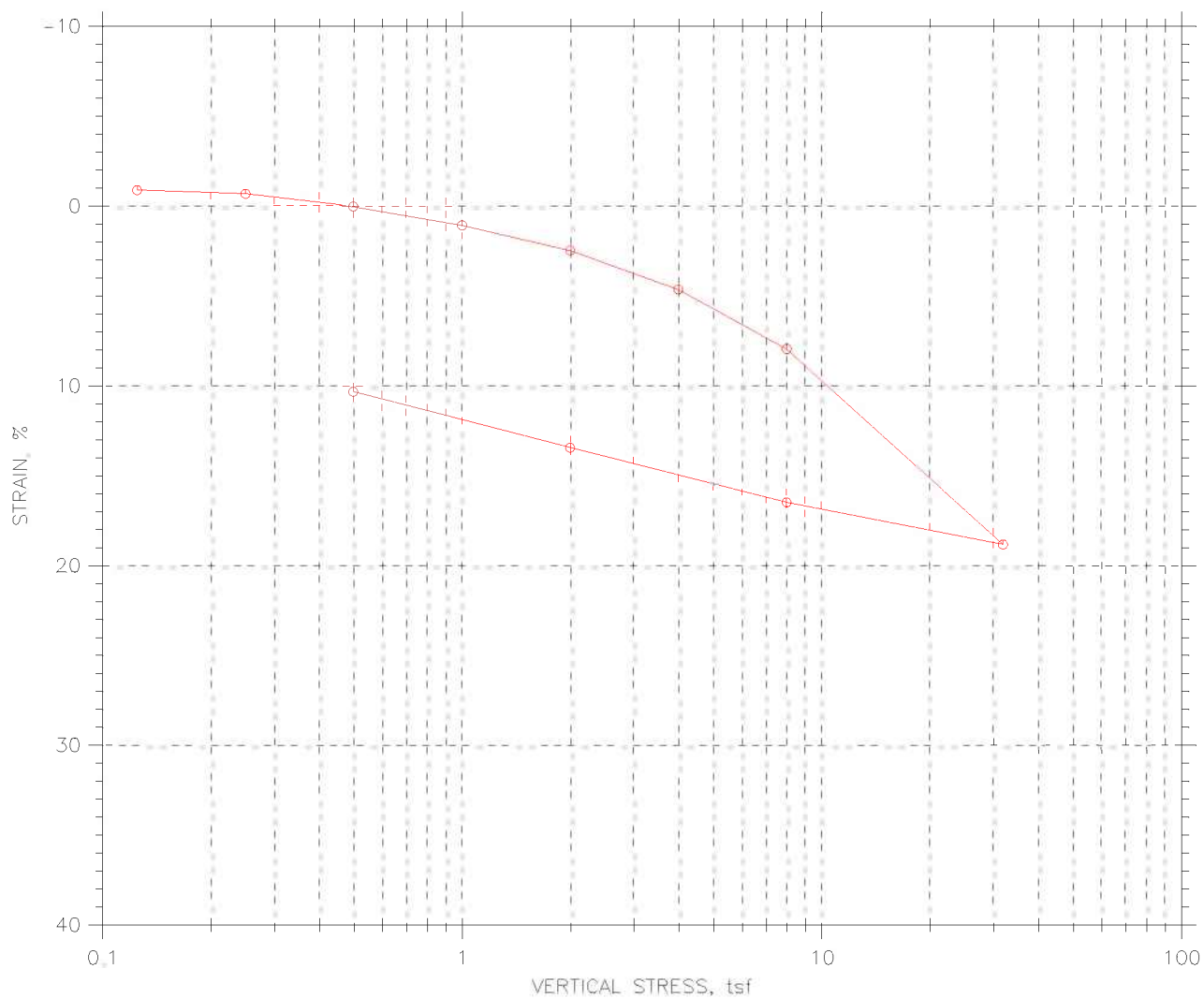

|                                 |        |              |          | Before Test          | After Test |       |
|---------------------------------|--------|--------------|----------|----------------------|------------|-------|
| Overburden Pressure: ---        |        |              |          | Water Content, %     | 28.73      | 22.08 |
| Preconsolidation Pressure: ---  |        |              |          | Dry Unit Weight, pcf | 95.81      | 106.8 |
| Compression Index: 2.54639e-313 |        |              |          | Saturation, %        | 99.78      | 99.99 |
| Diameter: 2.5 in                |        | Height: 1 in |          | Void Ratio           | 0.79       | 0.61  |
| LL: 35                          | PL: 18 | PI: 17       | GS: 2.75 |                      |            |       |

|  |                                    |                         |                       |
|--|------------------------------------|-------------------------|-----------------------|
|  | Project: I90 Central Viaduct       | Location: Cleveland, OH | Project No.: GTX-6678 |
|  | Boring No.: C-05-03                | Tested By: jdt          | Checked By: njh       |
|  | Sample No.: S-29                   | Test Date: 05/05/06     | Depth: 116.5-118.5    |
|  | Test No.: C-1                      | Sample Type: Tube       | Elevation: ---        |
|  | Description: Moist, dark gray clay |                         |                       |
|  | Remarks: ---                       |                         |                       |

# CONSOLIDATION TEST DATA

## TIME CURVES

Constant Load Step: 1 of 11

Stress: 0.125 tsf

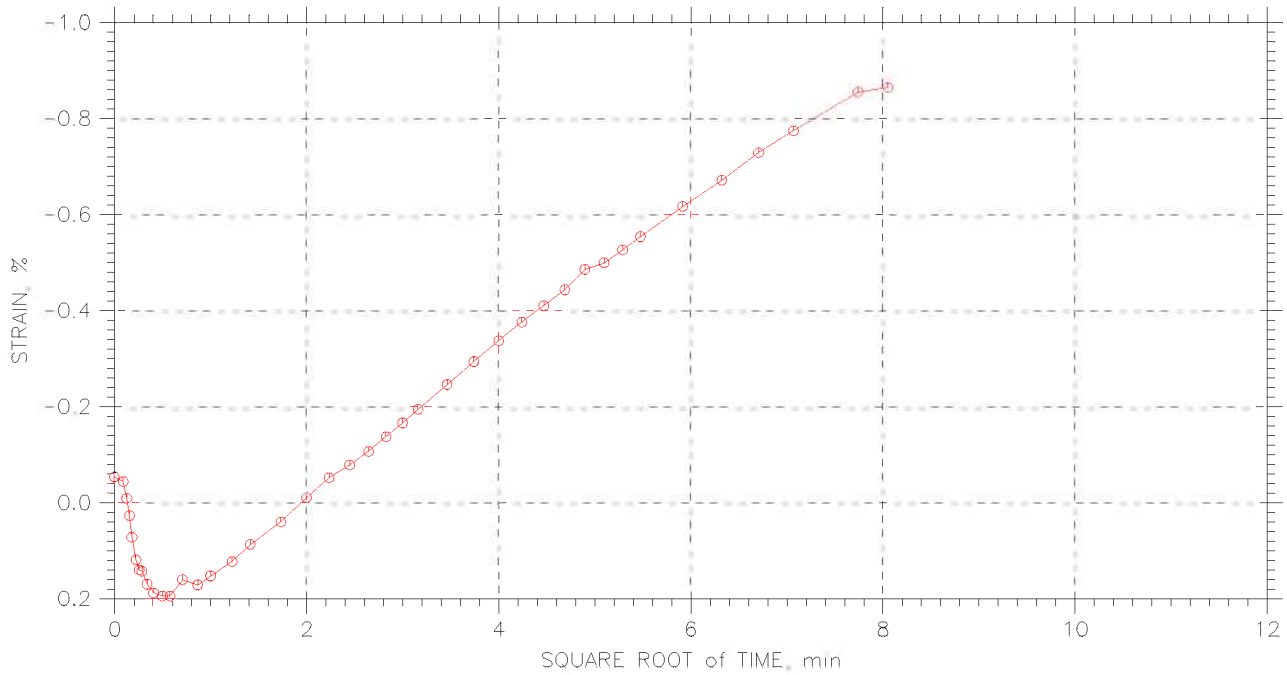
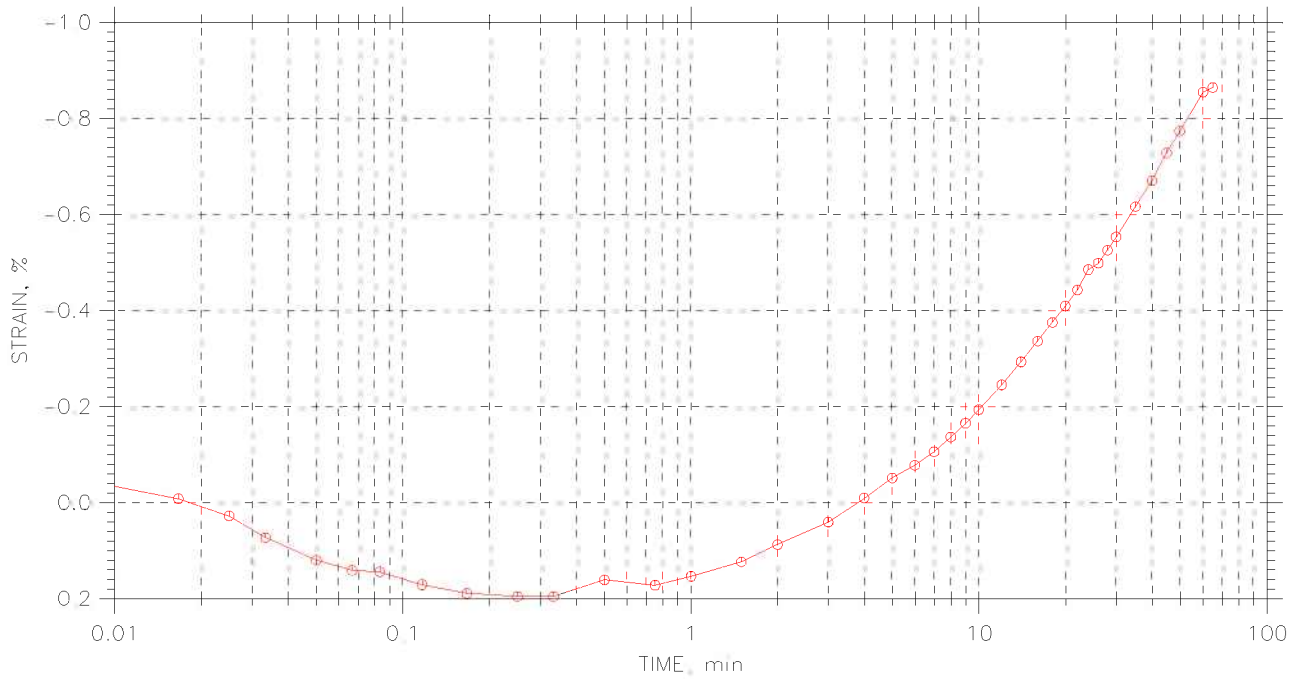

|  |                                    |                         |                       |
|--|------------------------------------|-------------------------|-----------------------|
|  | Project: I90 Central Viaduct       | Location: Cleveland, OH | Project No.: GTX-6678 |
|  | Boring No.: C-05-03                | Tested By: jdt          | Checked By: njh       |
|  | Sample No.: S-29                   | Test Date: 05/05/06     | Depth: 116.5-118.5    |
|  | Test No.: C-1                      | Sample Type: Tube       | Elevation: ---        |
|  | Description: Moist, dark gray clay |                         |                       |
|  | Remarks: ---                       |                         |                       |

# CONSOLIDATION TEST DATA

## TIME CURVES

Constant Load Step: 2 of 11

Stress: 0.25 tsf

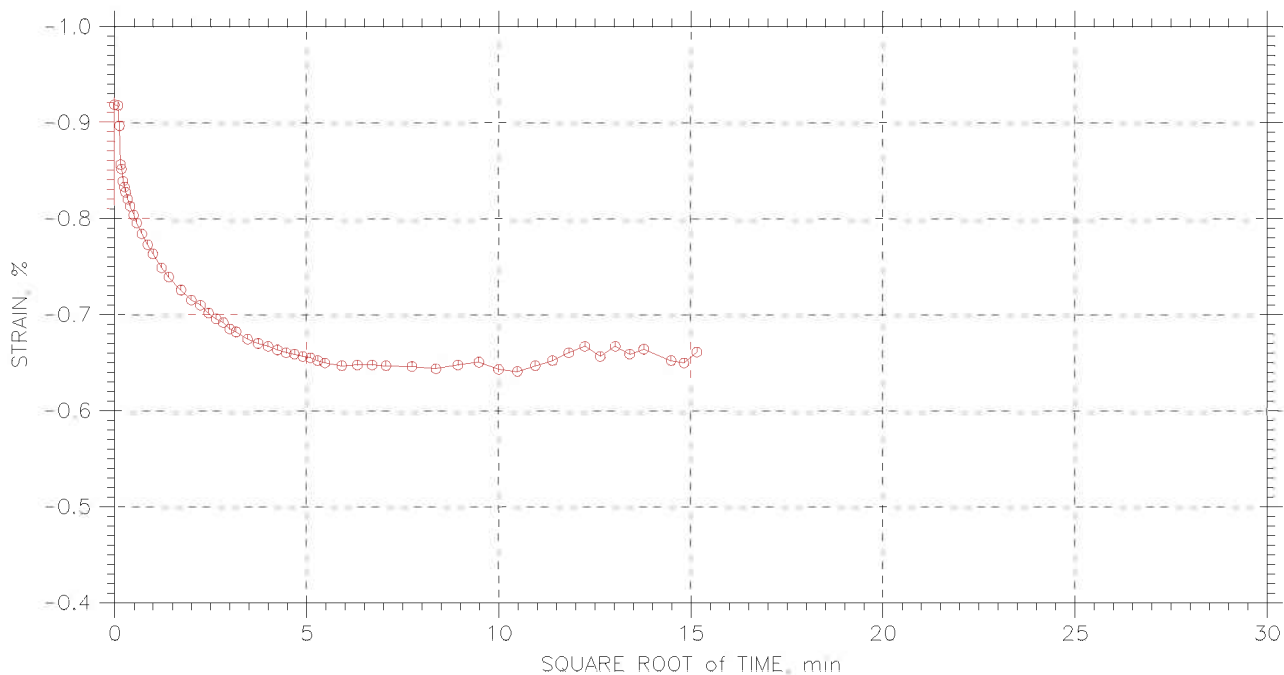
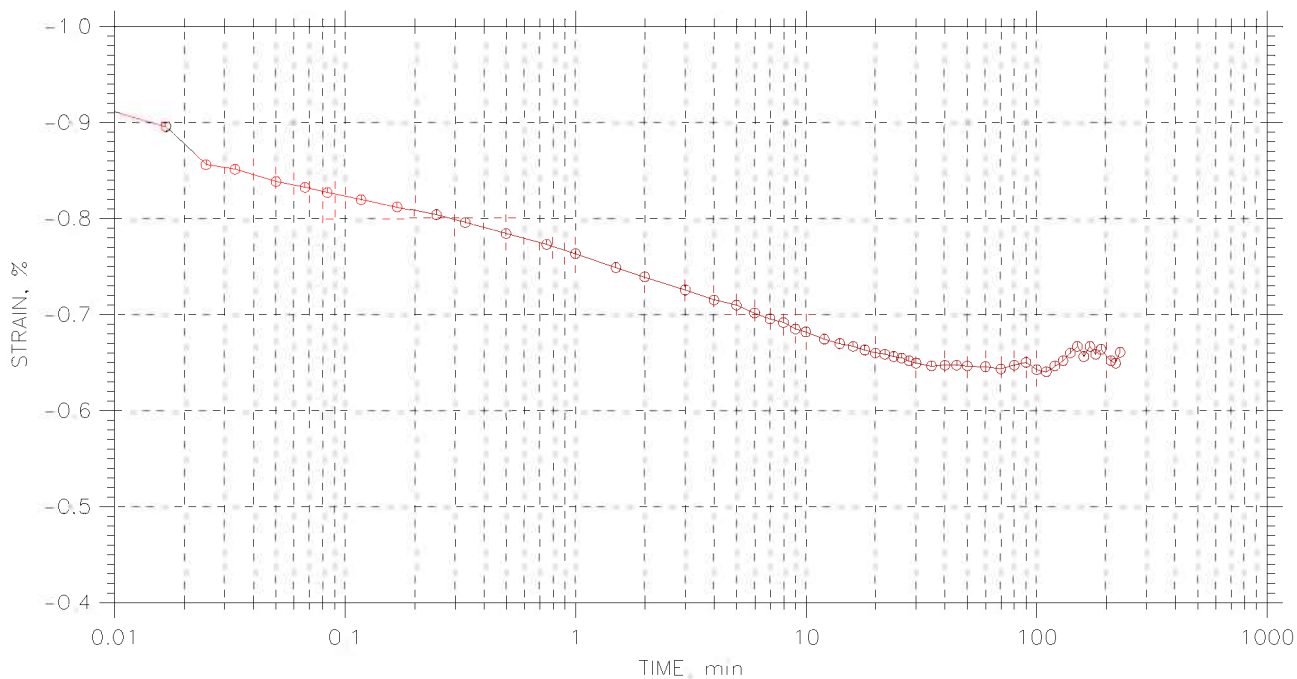

|  |                                    |                         |                       |
|--|------------------------------------|-------------------------|-----------------------|
|  | Project: I90 Central Viaduct       | Location: Cleveland, OH | Project No.: GTX-6678 |
|  | Boring No.: C-05-03                | Tested By: jdt          | Checked By: njh       |
|  | Sample No.: S-29                   | Test Date: 05/05/06     | Depth: 116.5-118.5    |
|  | Test No.: C-1                      | Sample Type: Tube       | Elevation: ---        |
|  | Description: Moist, dark gray clay |                         |                       |
|  | Remarks: ---                       |                         |                       |
|  |                                    |                         |                       |

# CONSOLIDATION TEST DATA

## TIME CURVES

Constant Load Step: 3 of 11

Stress: 0.5 tsf

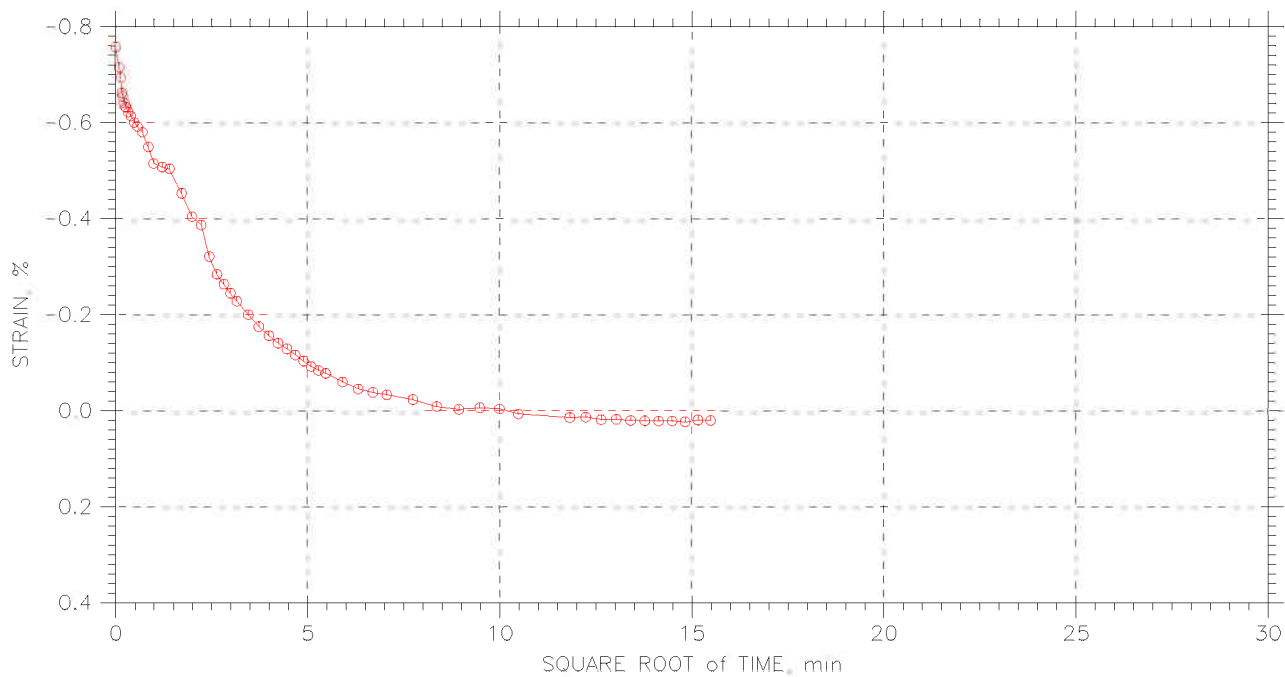
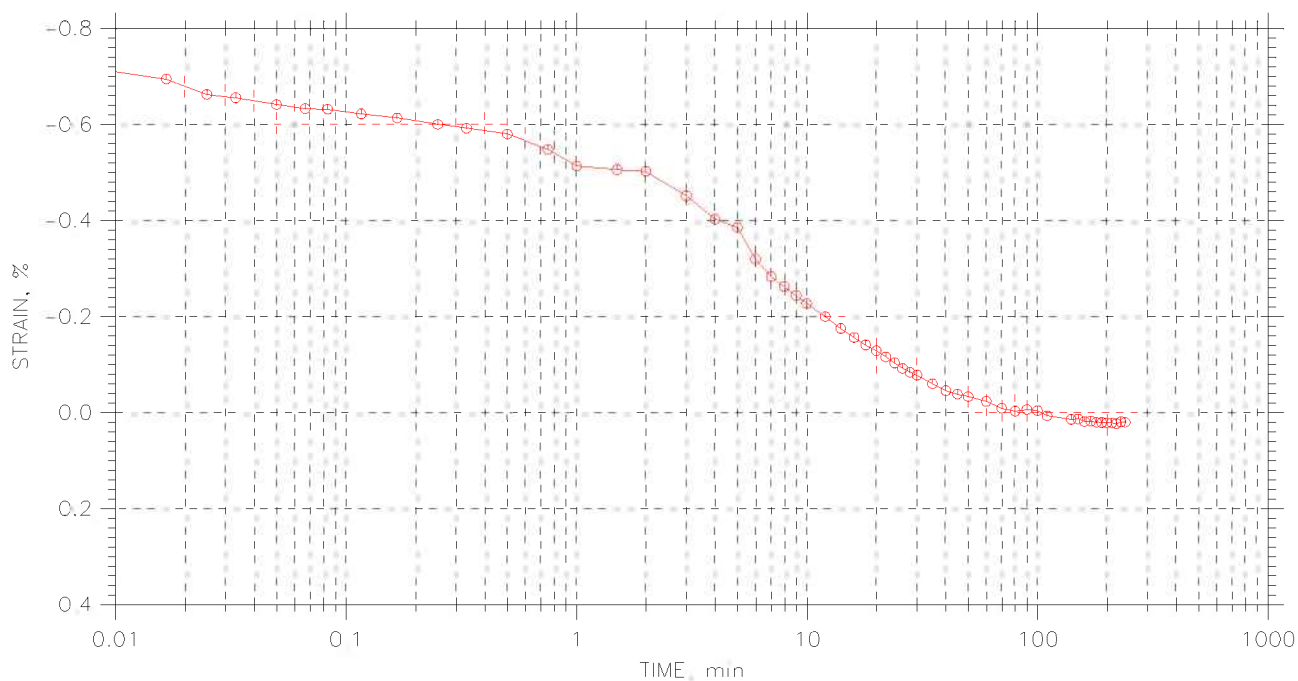

|  |                                    |                         |                       |
|--|------------------------------------|-------------------------|-----------------------|
|  | Project: I90 Central Viaduct       | Location: Cleveland, OH | Project No.: GTX-6678 |
|  | Boring No.: C-05-03                | Tested By: jdt          | Checked By: njh       |
|  | Sample No.: S-29                   | Test Date: 05/05/06     | Depth: 116.5-118.5    |
|  | Test No.: C-1                      | Sample Type: Tube       | Elevation: ---        |
|  | Description: Moist, dark gray clay |                         |                       |
|  | Remarks: ---                       |                         |                       |

# CONSOLIDATION TEST DATA

## TIME CURVES

Constant Load Step: 4 of 11

Stress: 1. tsf

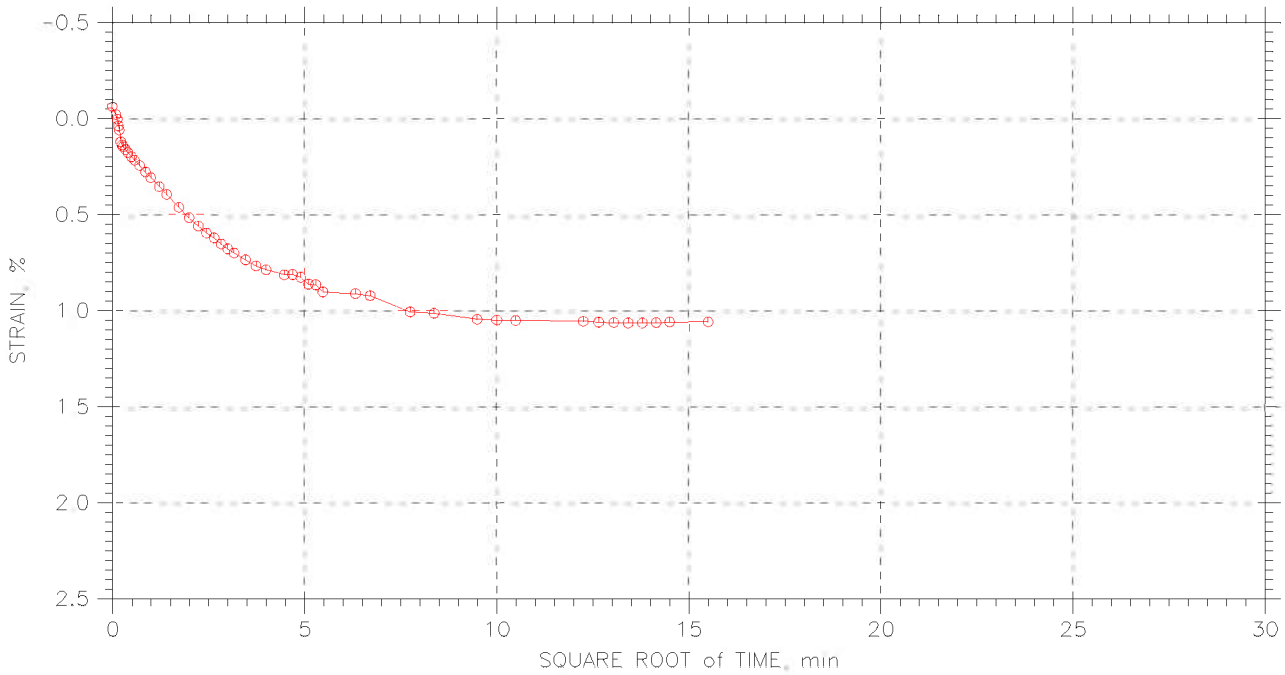
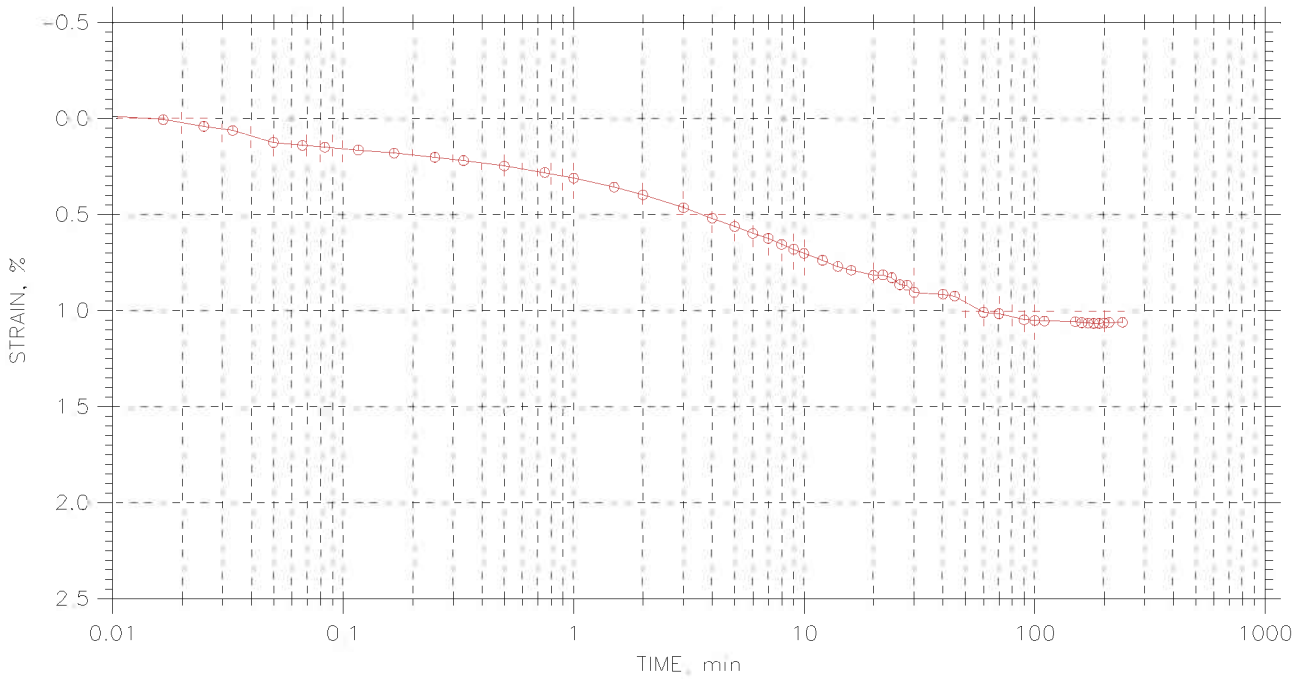

|  |                                    |                         |                       |
|--|------------------------------------|-------------------------|-----------------------|
|  | Project: I90 Central Viaduct       | Location: Cleveland, OH | Project No.: GTX-6678 |
|  | Boring No.: C-05-03                | Tested By: jdt          | Checked By: njh       |
|  | Sample No.: S-29                   | Test Date: 05/05/06     | Depth: 116.5-118.5    |
|  | Test No.: C-1                      | Sample Type: Tube       | Elevation: ---        |
|  | Description: Moist, dark gray clay |                         |                       |
|  | Remarks: ---                       |                         |                       |





# CONSOLIDATION TEST DATA

TIME CURVES

Constant Load Step: 5 of 11

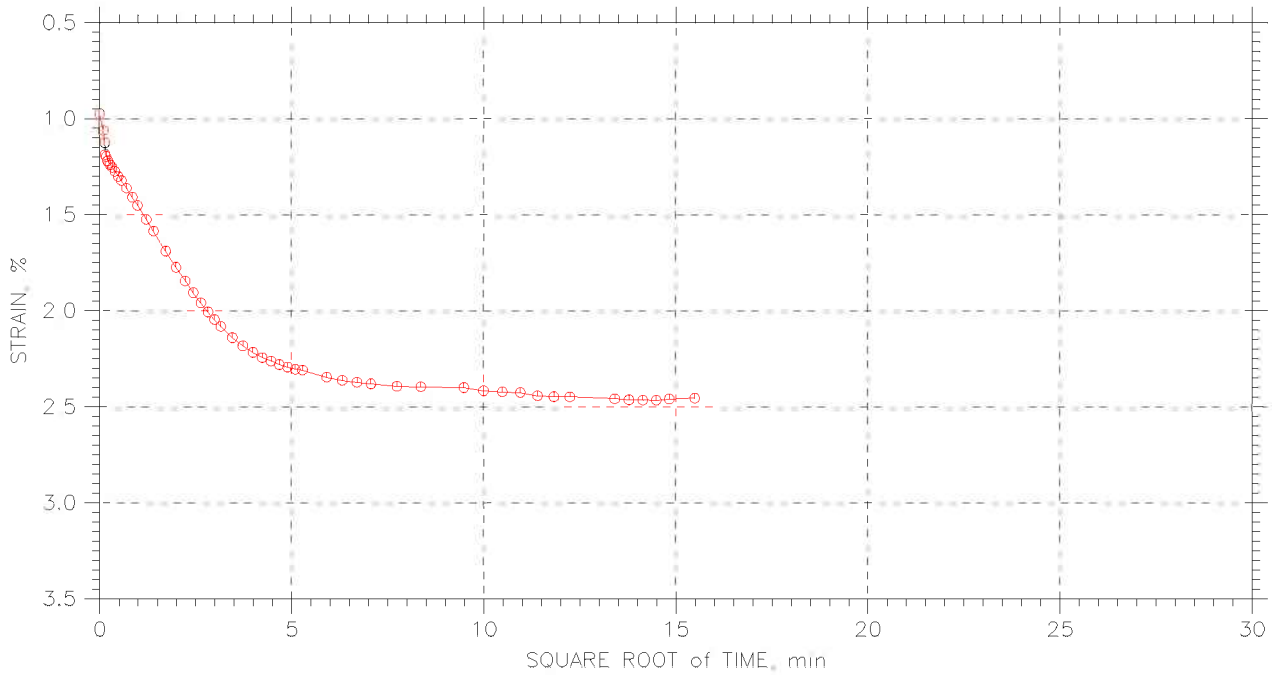
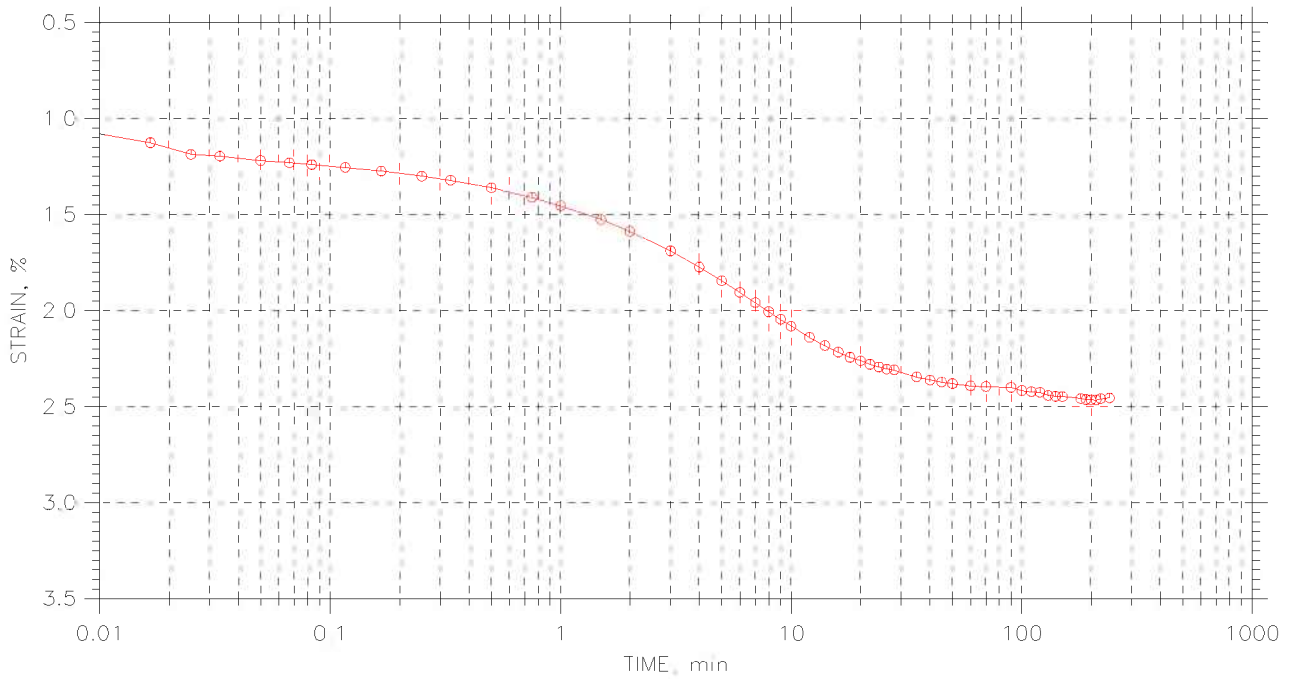
Stress: 2. tsf



|  |                                    |                         |                       |
|--|------------------------------------|-------------------------|-----------------------|
|  | Project: I90 Central Viaduct       | Location: Cleveland, OH | Project No.: GTX-6678 |
|  | Boring No.: C-05-03                | Tested By: jdt          | Checked By: njh       |
|  | Sample No.: S-29                   | Test Date: 05/05/06     | Depth: 116.5-118.5    |
|  | Test No.: C-1                      | Sample Type: Tube       | Elevation: ---        |
|  | Description: Moist, dark gray clay |                         |                       |
|  | Remarks: ---                       |                         |                       |

# CONSOLIDATION TEST DATA

## TIME CURVES

Constant Load Step: 6 of 11

Stress: 4. tsf

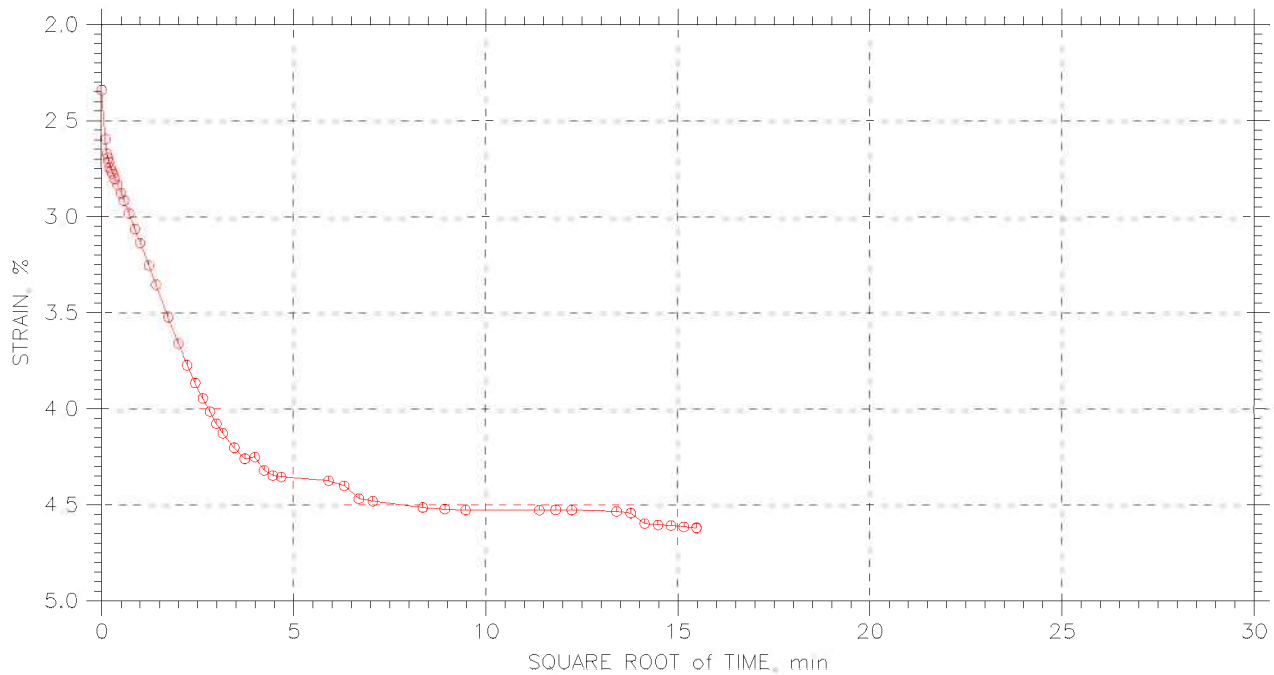
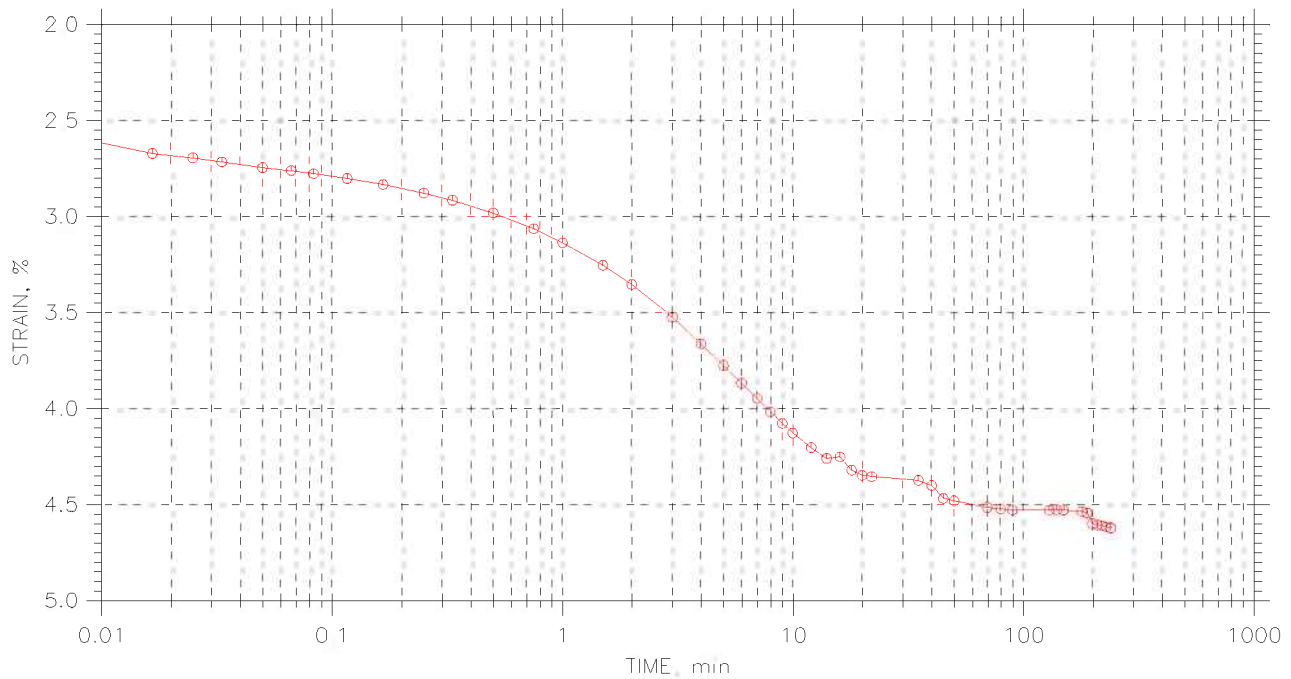

|  |                                    |                         |                       |
|--|------------------------------------|-------------------------|-----------------------|
|  | Project: I90 Central Viaduct       | Location: Cleveland, OH | Project No.: GTX-6678 |
|  | Boring No.: C-05-03                | Tested By: jdt          | Checked By: njh       |
|  | Sample No.: S-29                   | Test Date: 05/05/06     | Depth: 116.5-118.5    |
|  | Test No.: C-1                      | Sample Type: Tube       | Elevation: ---        |
|  | Description: Moist, dark gray clay |                         |                       |
|  | Remarks: ---                       |                         |                       |

# CONSOLIDATION TEST DATA

## TIME CURVES

Constant Load Step: 7 of 11

Stress: 8. tsf

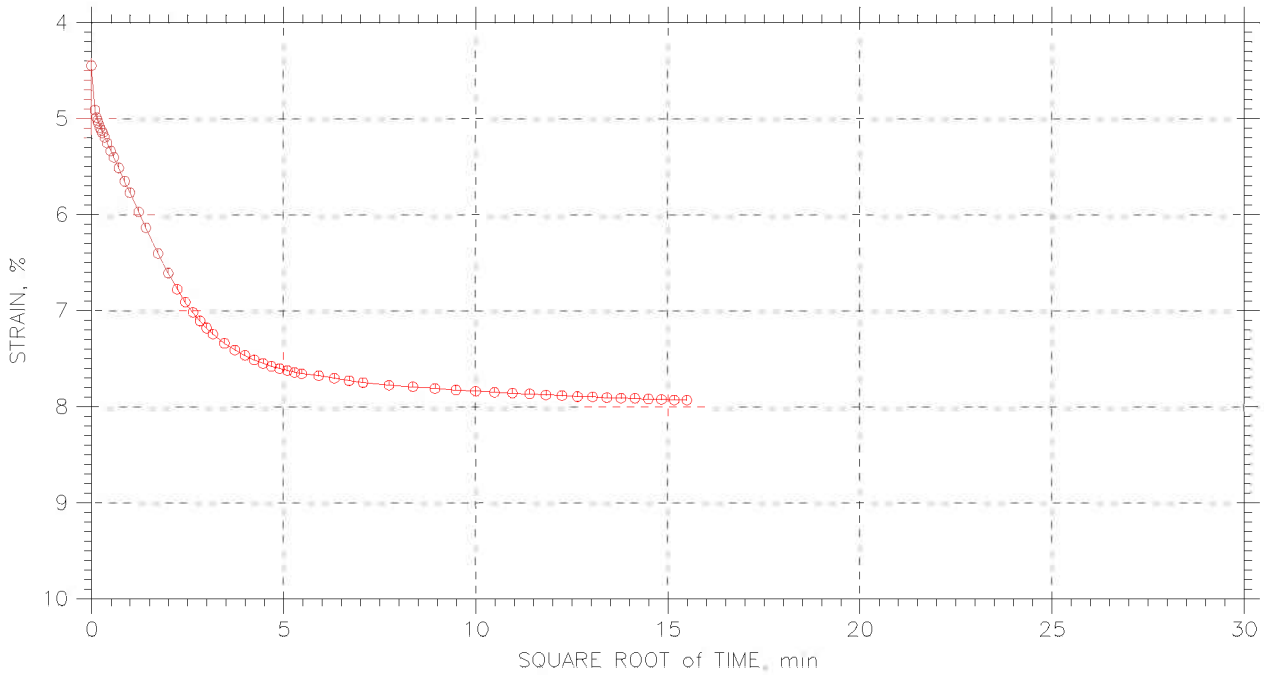
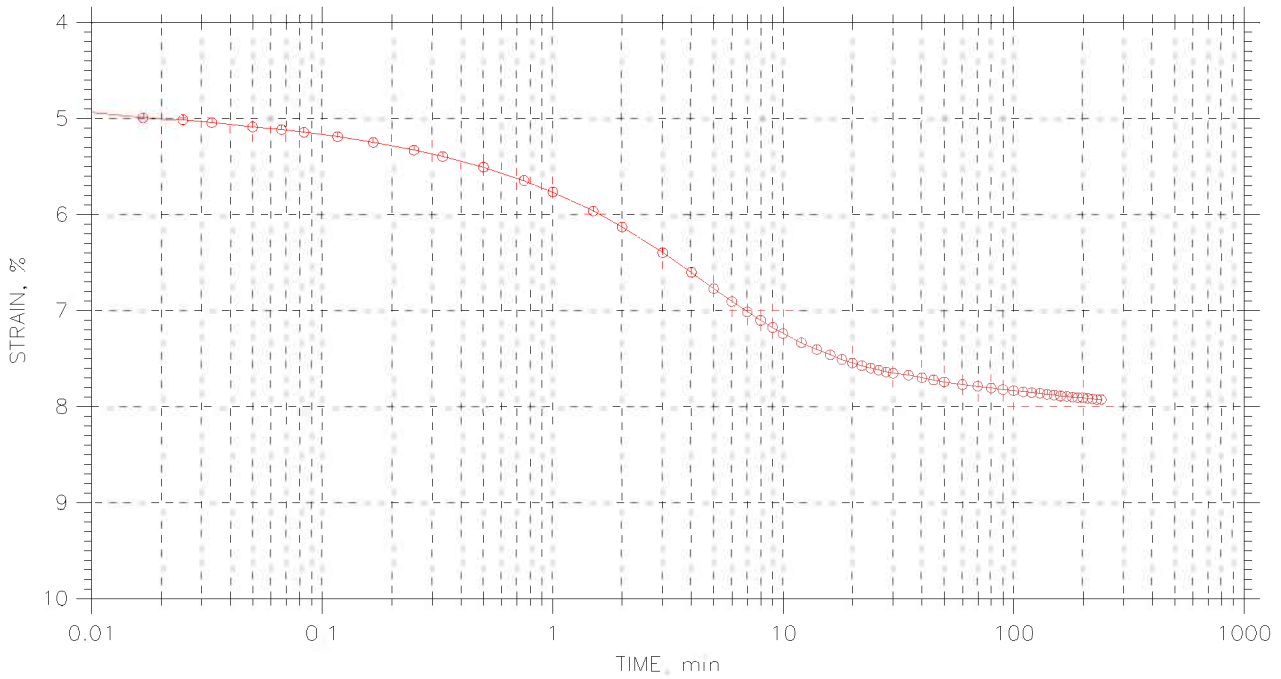

|  |                                    |                         |                       |
|--|------------------------------------|-------------------------|-----------------------|
|  | Project: I90 Central Viaduct       | Location: Cleveland, OH | Project No.: GTX-6678 |
|  | Boring No.: C-05-03                | Tested By: jdt          | Checked By: njh       |
|  | Sample No.: S-29                   | Test Date: 05/05/06     | Depth: 116.5-118.5    |
|  | Test No.: C-1                      | Sample Type: Tube       | Elevation: ---        |
|  | Description: Moist, dark gray clay |                         |                       |
|  | Remarks: ---                       |                         |                       |

# CONSOLIDATION TEST DATA

## TIME CURVES

Constant Load Step: 8 of 11

Stress: 32 tsf

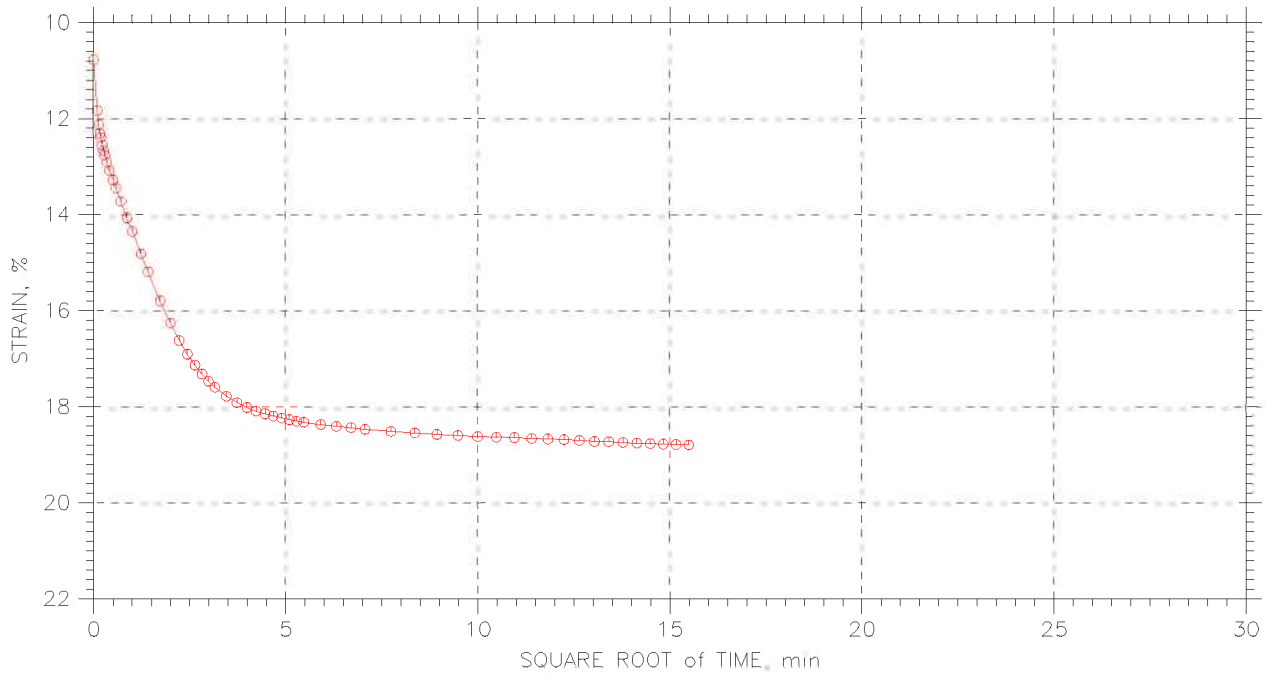
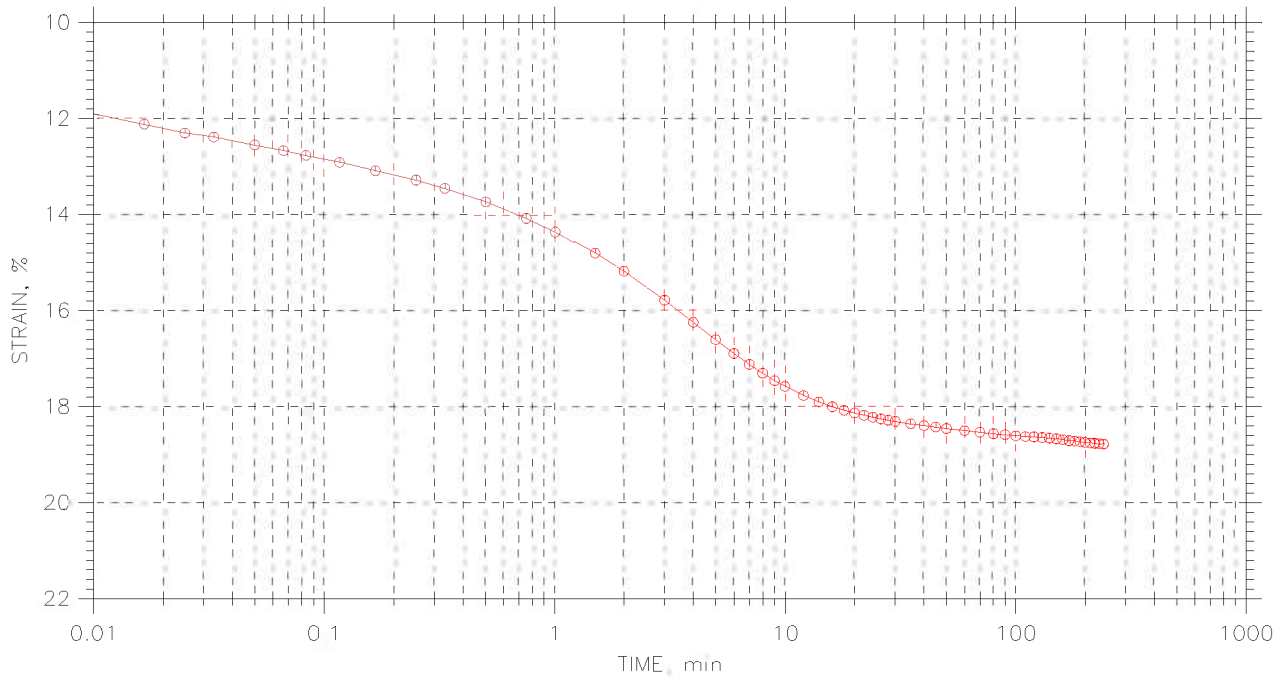

|  |                                    |                         |                       |
|--|------------------------------------|-------------------------|-----------------------|
|  | Project: I90 Central Viaduct       | Location: Cleveland, OH | Project No.: GTX-6678 |
|  | Boring No.: C-05-03                | Tested By: jdt          | Checked By: njh       |
|  | Sample No.: S-29                   | Test Date: 05/05/06     | Depth: 116.5-118.5    |
|  | Test No.: C-1                      | Sample Type: Tube       | Elevation: ---        |
|  | Description: Moist, dark gray clay |                         |                       |
|  | Remarks: ---                       |                         |                       |

# CONSOLIDATION TEST DATA

## TIME CURVES

Constant Load Step: 9 of 11

Stress: 8. tsf

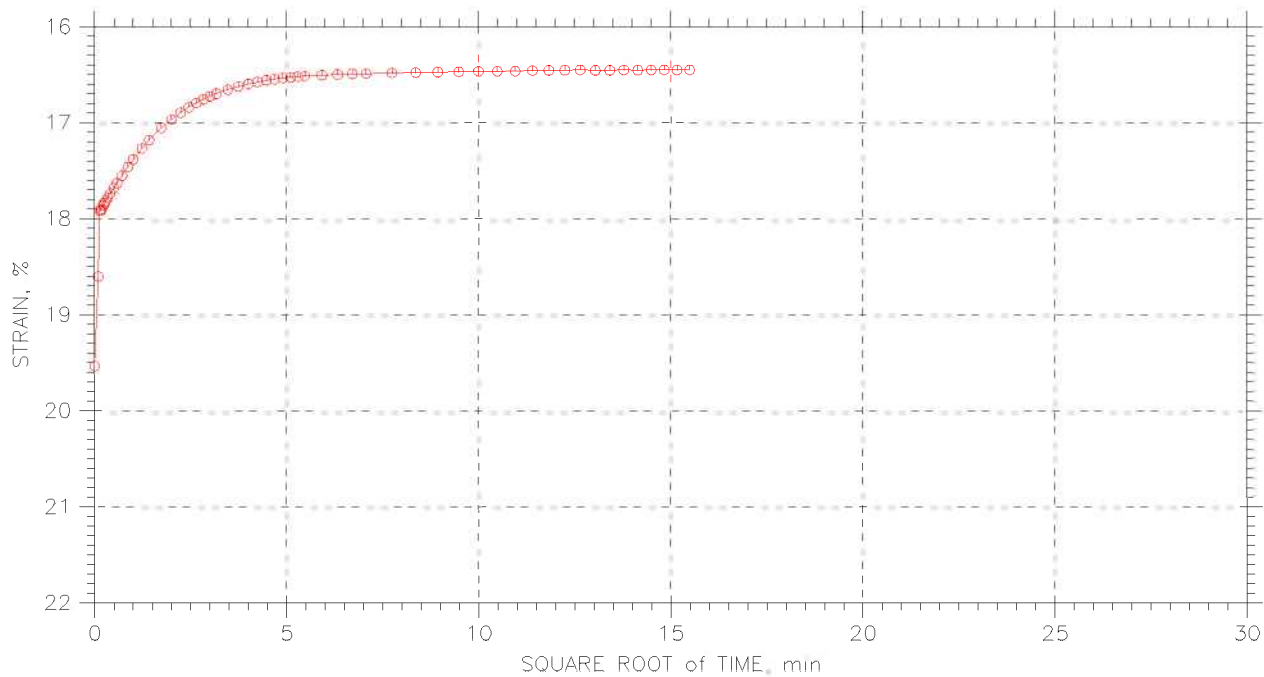
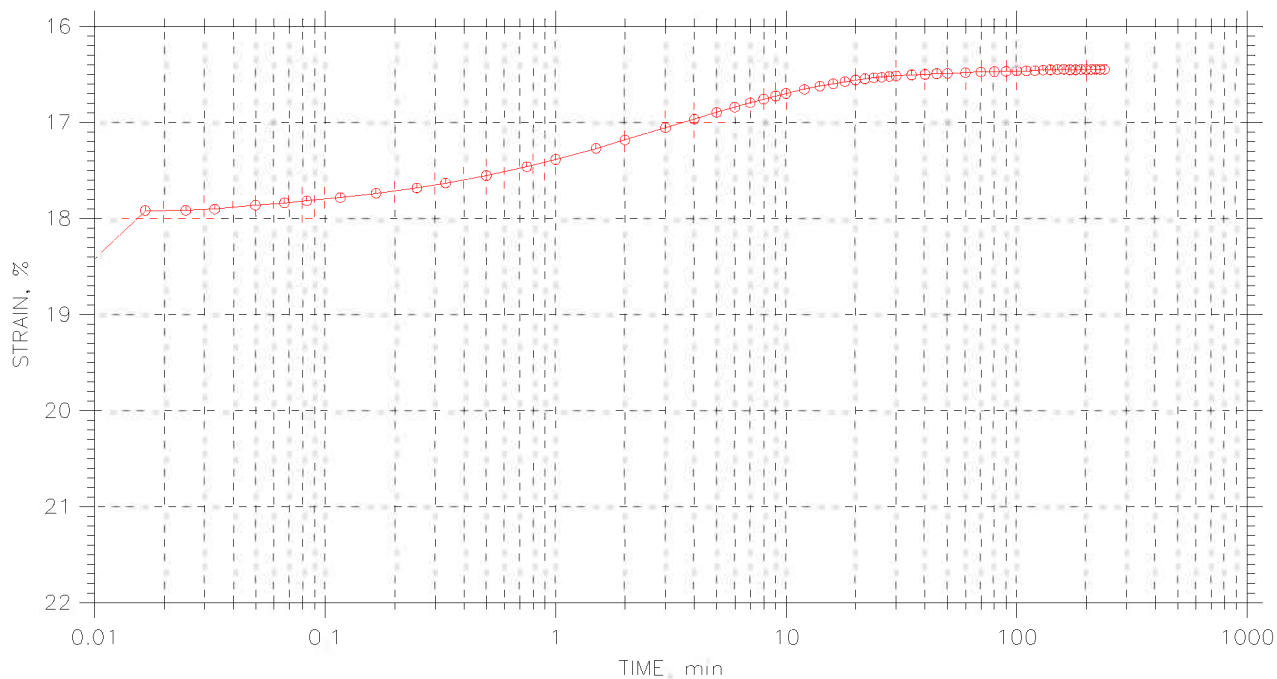

|  |                                    |                         |                       |
|--|------------------------------------|-------------------------|-----------------------|
|  | Project: I90 Central Viaduct       | Location: Cleveland, OH | Project No.: GTX-6678 |
|  | Boring No.: C-05-03                | Tested By: jdt          | Checked By: njh       |
|  | Sample No.: S-29                   | Test Date: 05/05/06     | Depth: 116.5-118.5    |
|  | Test No.: C-1                      | Sample Type: Tube       | Elevation: ---        |
|  | Description: Moist, dark gray clay |                         |                       |
|  | Remarks: ---                       |                         |                       |

# CONSOLIDATION TEST DATA

## TIME CURVES

Constant Load Step: 10 of 11

Stress: 2. tsf

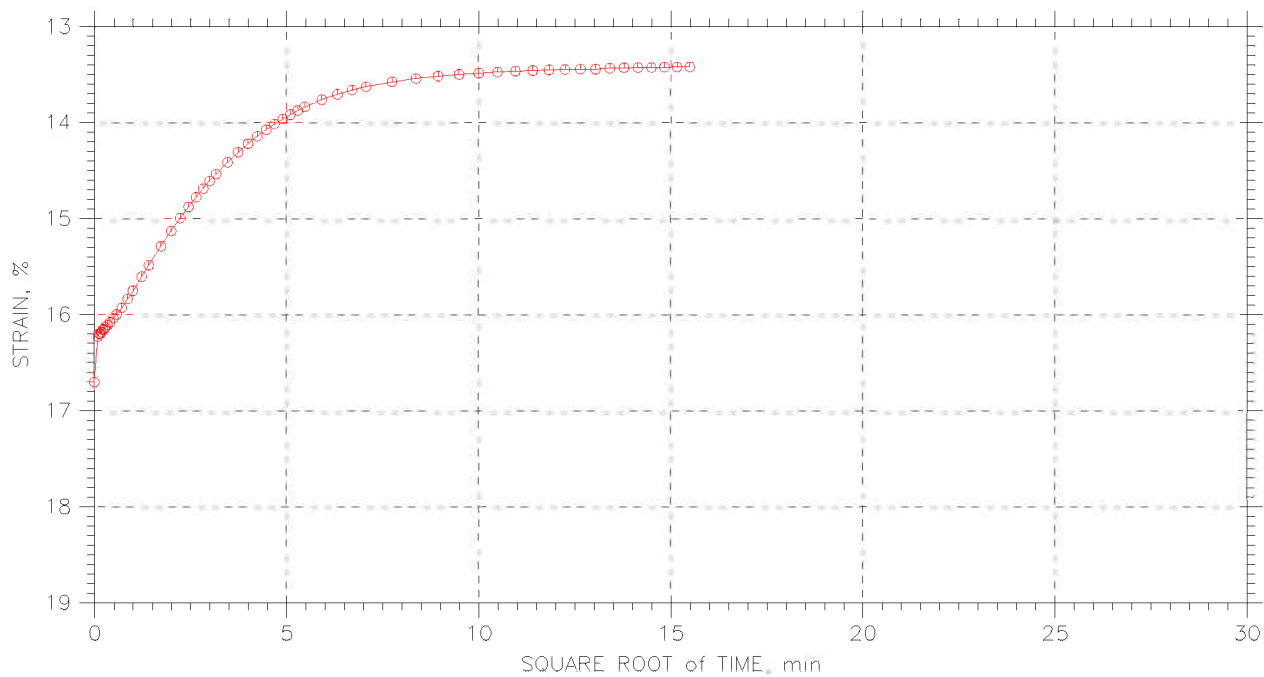
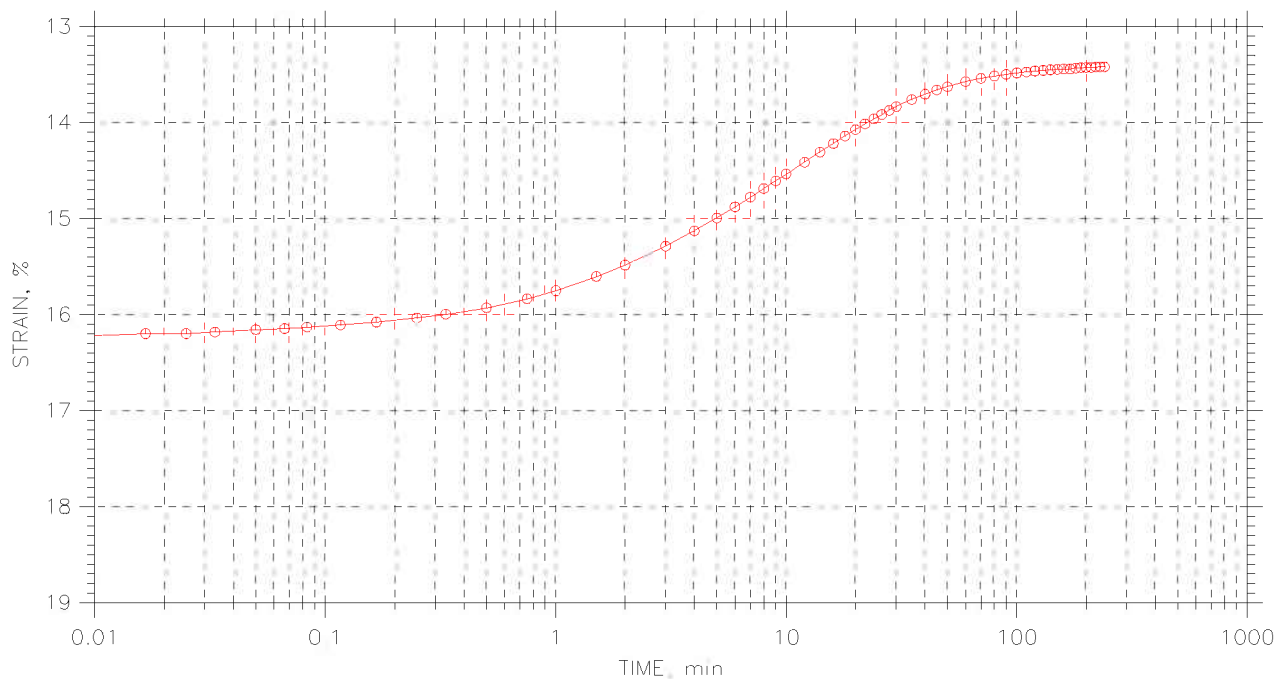

|  |                                    |                         |                       |
|--|------------------------------------|-------------------------|-----------------------|
|  | Project: I90 Central Viaduct       | Location: Cleveland, OH | Project No.: GTX-6678 |
|  | Boring No.: C-05-03                | Tested By: jdt          | Checked By: njh       |
|  | Sample No.: S-29                   | Test Date: 05/05/06     | Depth: 116.5-118.5    |
|  | Test No.: C-1                      | Sample Type: Tube       | Elevation: ---        |
|  | Description: Moist, dark gray clay |                         |                       |
|  | Remarks: ---                       |                         |                       |

# CONSOLIDATION TEST DATA

## TIME CURVES

Constant Load Step: 11 of 11

Stress: 0.5 tsf

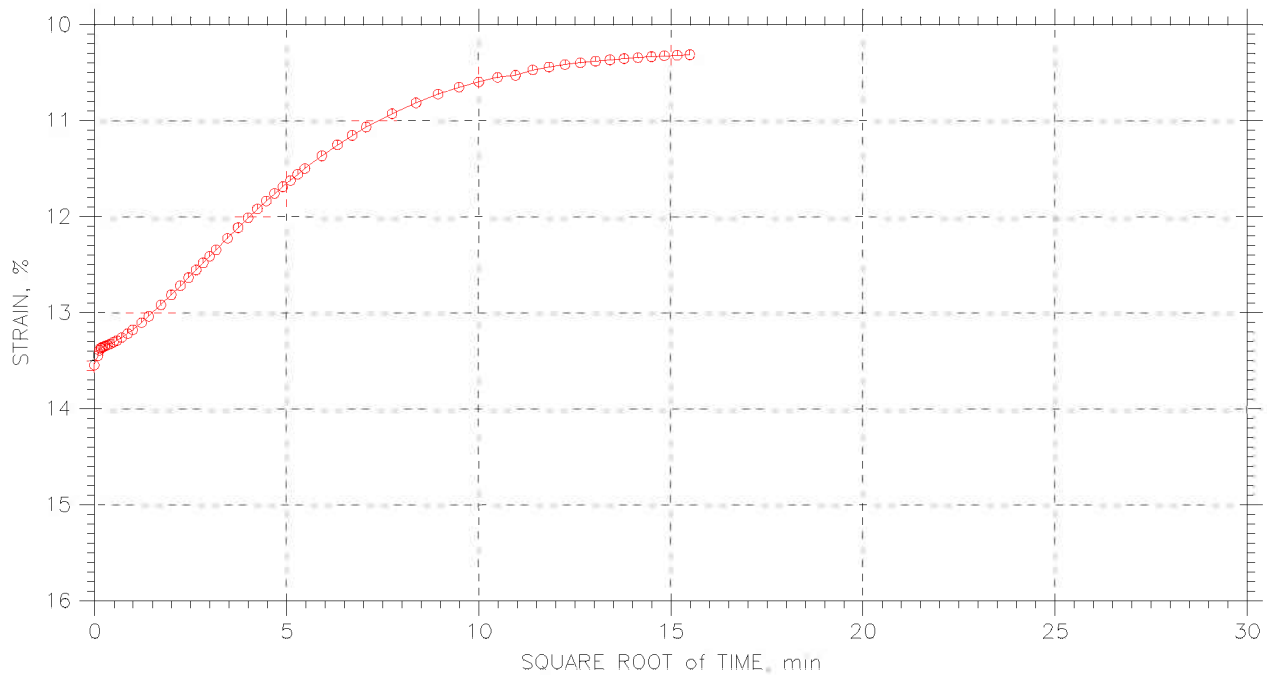
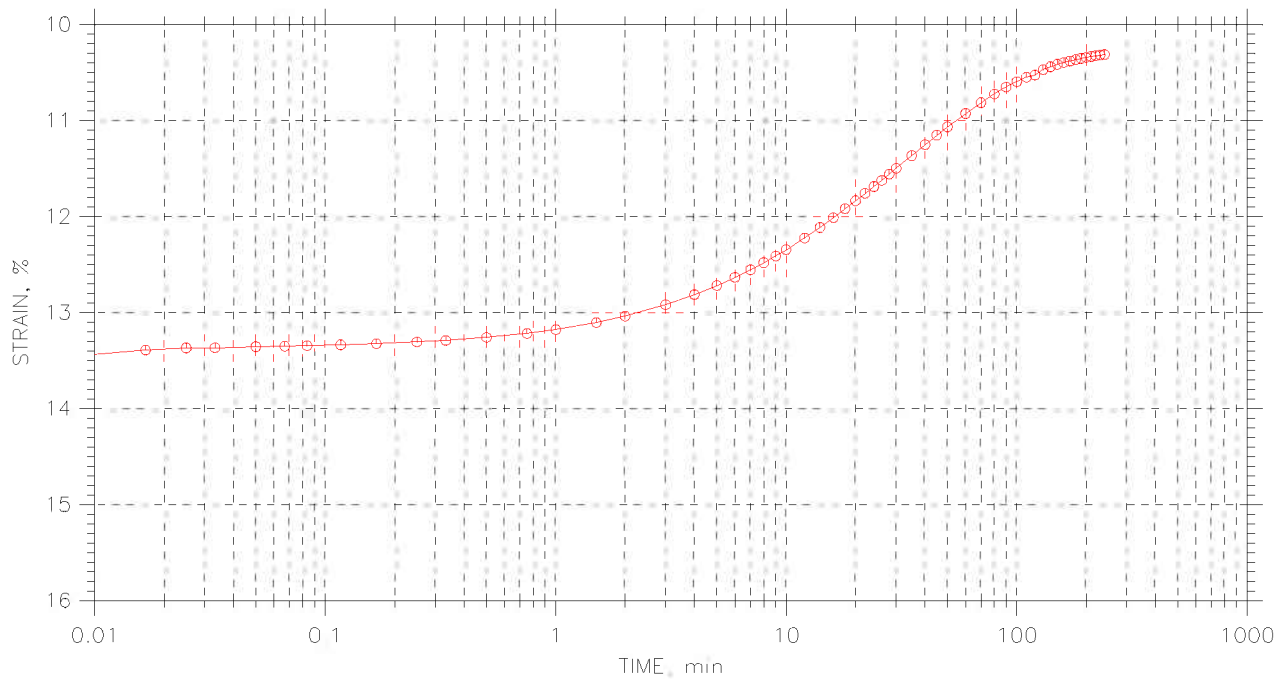

|  |                                    |                         |                       |
|--|------------------------------------|-------------------------|-----------------------|
|  | Project: I90 Central Viaduct       | Location: Cleveland, OH | Project No.: GTX-6678 |
|  | Boring No.: C-05-03                | Tested By: jdt          | Checked By: njh       |
|  | Sample No.: S-29                   | Test Date: 05/05/06     | Depth: 116.5-118.5    |
|  | Test No.: C-1                      | Sample Type: Tube       | Elevation: ---        |
|  | Description: Moist, dark gray clay |                         |                       |
|  | Remarks: ---                       |                         |                       |

CONSOLIDATION TEST DATA

Project: I90 Central Viaduct  
 Boring No.: C-05-03  
 Sample No.: S-29  
 Test No.: C-1

Location: Cleveland, OH  
 Tested By: jdt  
 Test Date: 05/05/06  
 Sample Type: Tube

Project No.: GTX-6678  
 Checked By: njh  
 Depth: 116.5-118.5  
 Elevation: ---

Soil Description: Moist, dark gray clay  
 Remarks: ---

Measured Specific Gravity: 2.75  
 Initial Void Ratio: 0.79  
 Final Void Ratio: 0.61

Liquid Limit: 35  
 Plastic Limit: 18  
 Plasticity Index: 17

Initial Height: 1.00 in  
 Specimen Diameter: 2.50 in

|                              | Before Consolidation |               | After Consolidation |           |
|------------------------------|----------------------|---------------|---------------------|-----------|
|                              | Trimmings            | Specimen+Ring | Specimen+Ring       | Trimmings |
| Container ID                 | dodge9               | RING          |                     | 30912     |
| Wt. Container + Wet Soil, gm | 93.18                | 370           | 361.78              | 157.13    |
| Wt. Container + Dry Soil, gm | 77.74                | 334.53        | 334.53              | 130.18    |
| Wt. Container, gm            | 8.27                 | 211.08        | 211.08              | 8.1       |
| Wt. Dry Soil, gm             | 69.47                | 123.45        | 123.45              | 122.08    |
| Water Content, %             | 22.23                | 28.73         | 22.08               | 22.08     |
| Void Ratio                   | ---                  | 0.79          | 0.61                | ---       |
| Degree of Saturation, %      | ---                  | 99.78         | 99.99               | ---       |
| Dry Unit Weight, pcf         | ---                  | 95.806        | 106.82              | ---       |



# CONSOLIDATION TEST DATA

## SUMMARY REPORT

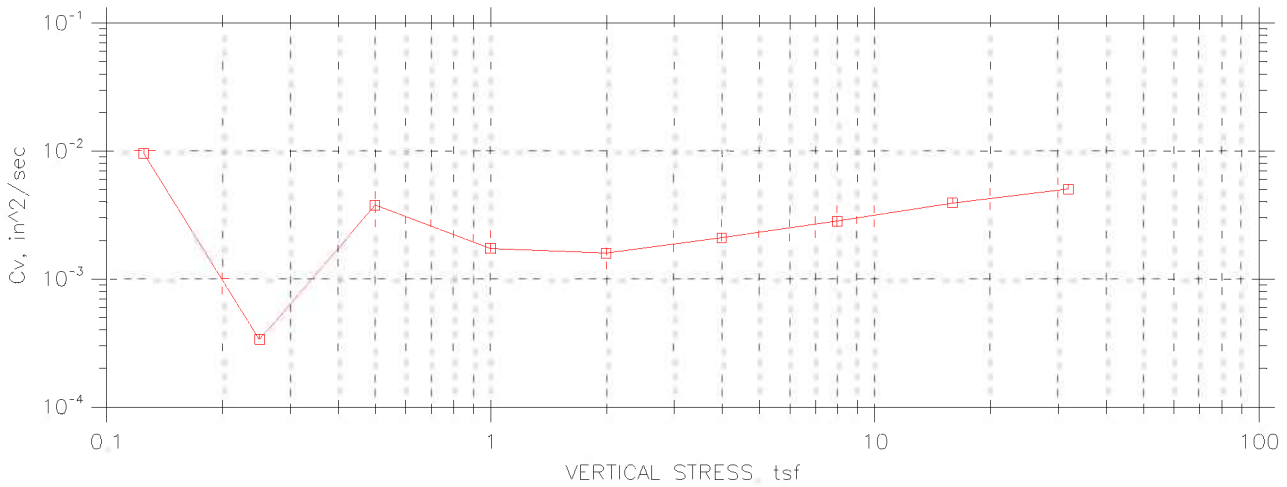
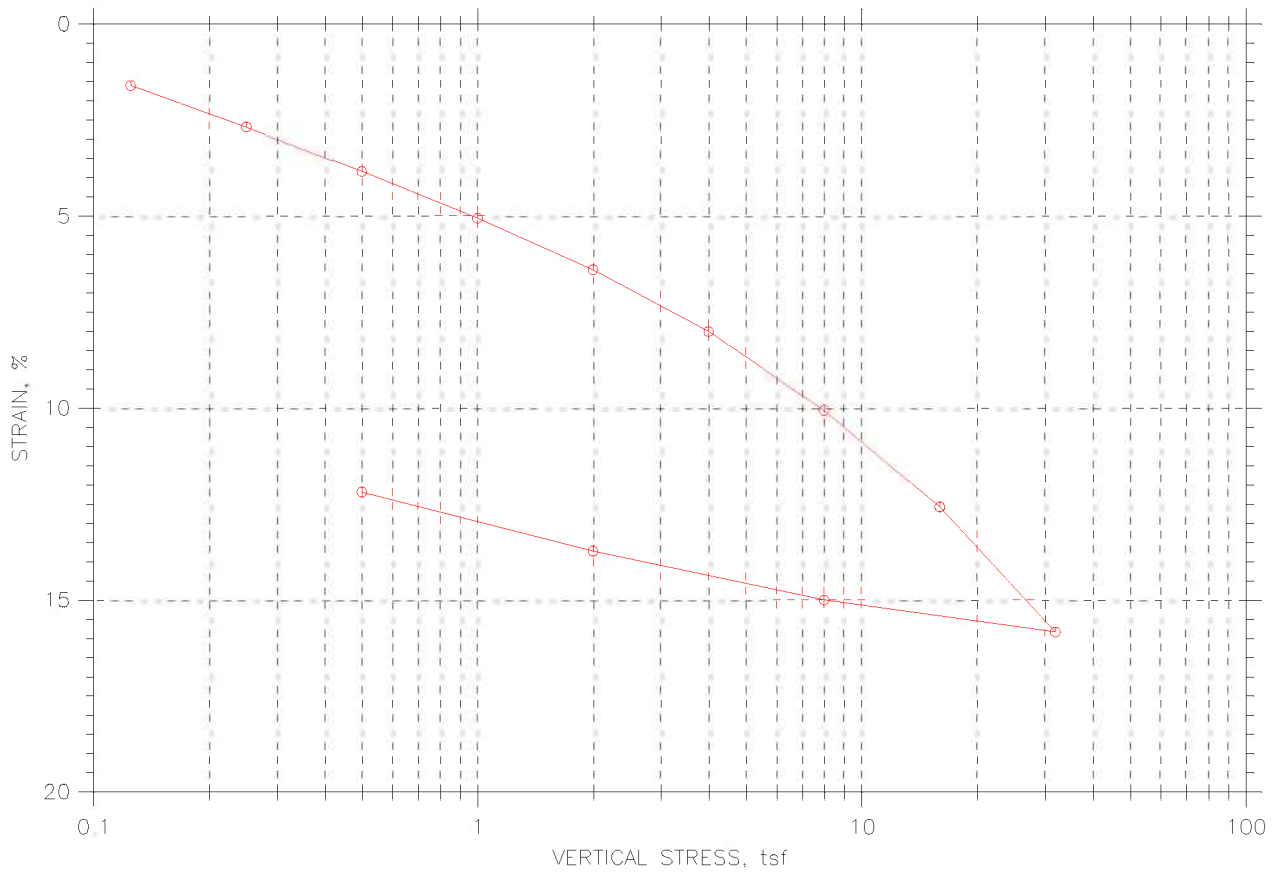

|  |                                    |                         |                       |
|--|------------------------------------|-------------------------|-----------------------|
|  | Project: I90 Central Viaduct       | Location: Cleveland, OH | Project No.: GTX-6678 |
|  | Boring No.: C-05-03                | Tested By: fy           | Checked By: jdt       |
|  | Sample No.: S-30                   | Test Date: 05/05/06     | Depth: 118.5-120.5    |
|  | Test No.: C-2                      | Sample Type: Tube       | Elevation: ---        |
|  | Description: Moist, dark gray clay |                         |                       |
|  | Remarks: ---                       |                         |                       |
|  |                                    |                         |                       |

# CONSOLIDATION TEST DATA

## SUMMARY REPORT

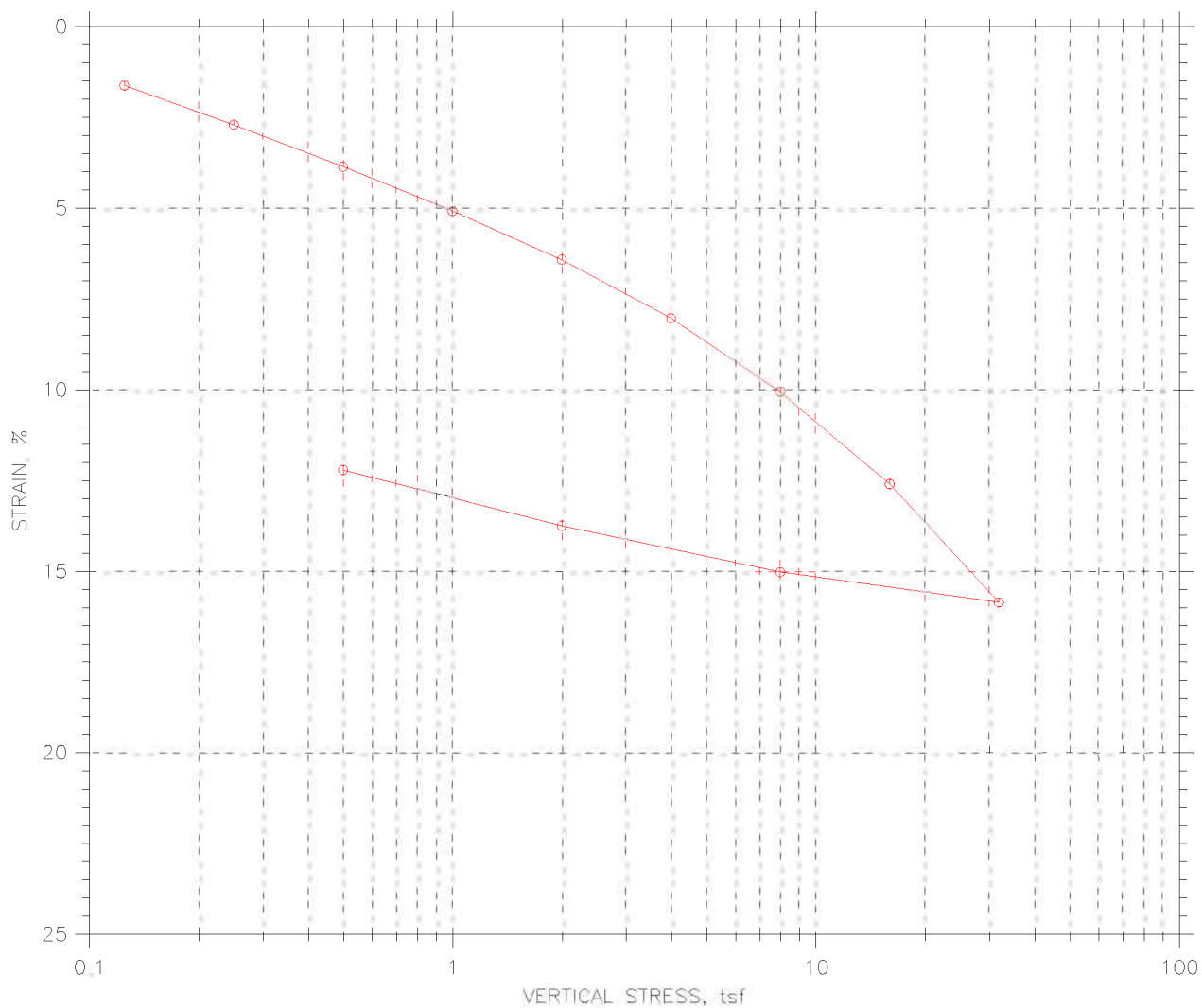

|                                  |        |                      |          | Before Test | After Test |
|----------------------------------|--------|----------------------|----------|-------------|------------|
| Overburden Pressure: 0 tsf       |        | Water Content, %     |          | 31.49       | 22.77      |
| Preconsolidation Pressure: 0 tsf |        | Dry Unit Weight, pcf |          | 91.64       | 104.4      |
| Compression Index: 2.75859e-313  |        | Saturation, %        |          | 100.00      | 98.23      |
| Diameter: 2.5 in                 |        | Height: 1 in         |          | 0.86        | 0.63       |
| LL: 33                           | PL: 18 | PI: 15               | GS: 2.73 |             |            |

|  |                                    |                         |                       |
|--|------------------------------------|-------------------------|-----------------------|
|  | Project: I90 Central Viaduct       | Location: Cleveland, OH | Project No.: GTX-6678 |
|  | Boring No.: C-05-03                | Tested By: fy           | Checked By: jdt       |
|  | Sample No.: S-30                   | Test Date: 05/05/06     | Depth: 118.5-120.5    |
|  | Test No.: C-2                      | Sample Type: Tube       | Elevation: ---        |
|  | Description: Moist, dark gray clay |                         |                       |
|  | Remarks: ---                       |                         |                       |

# CONSOLIDATION TEST DATA

## TIME CURVES

Constant Load Step: 1 of 12

Stress: 0.125 tsf

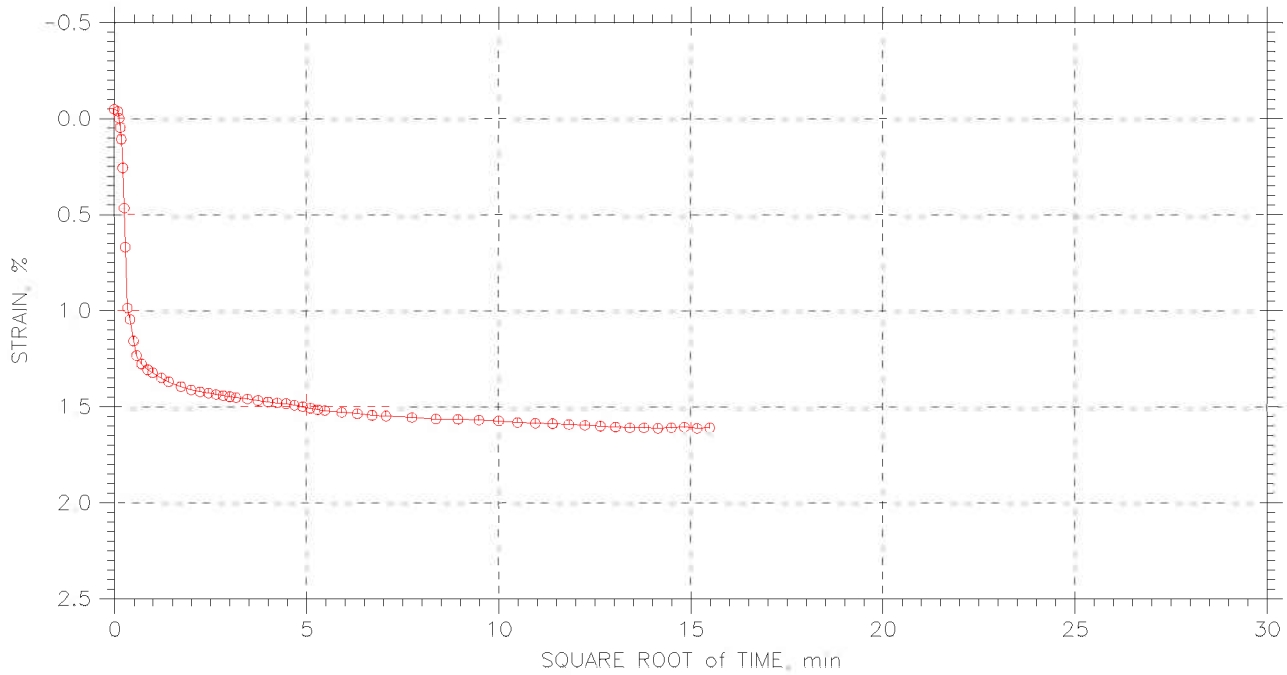
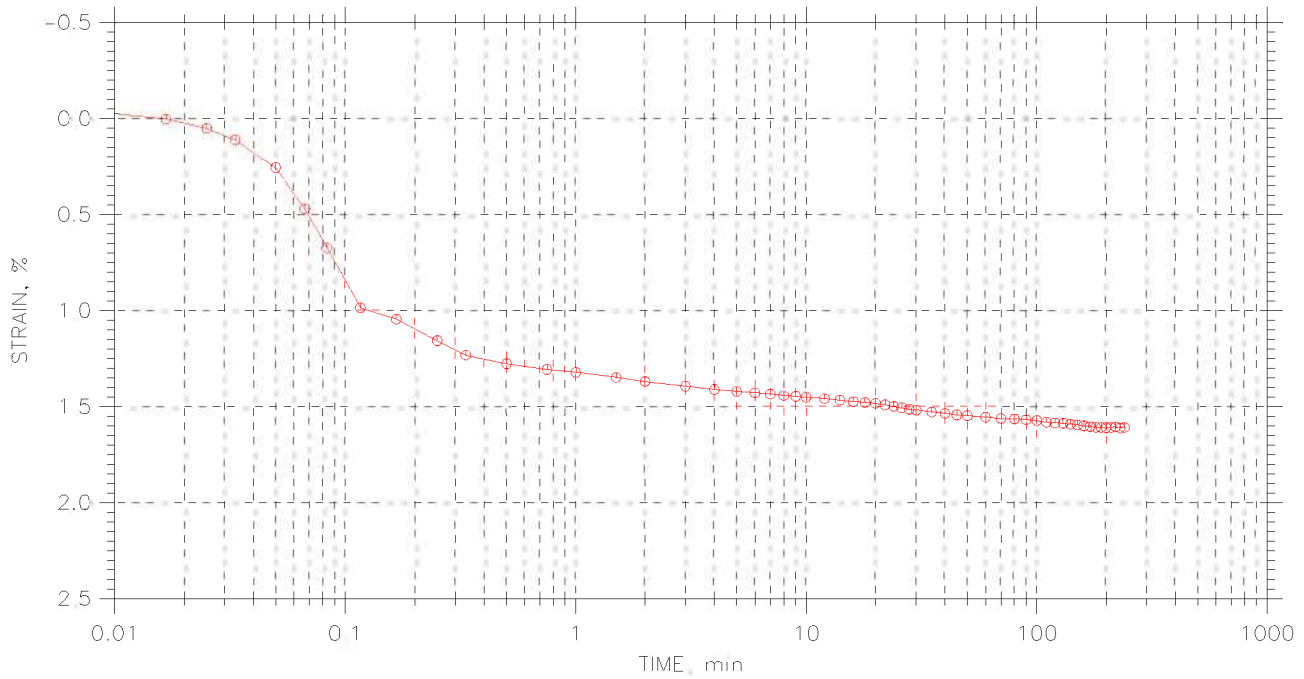

|  |                                    |                         |                       |
|--|------------------------------------|-------------------------|-----------------------|
|  | Project: I90 Central Viaduct       | Location: Cleveland, OH | Project No.: GTX-6678 |
|  | Boring No.: C-05-03                | Tested By: fy           | Checked By: jdt       |
|  | Sample No.: S-30                   | Test Date: 05/05/06     | Depth: 118.5-120.5    |
|  | Test No.: C-2                      | Sample Type: Tube       | Elevation: ---        |
|  | Description: Moist, dark gray clay |                         |                       |
|  | Remarks: ---                       |                         |                       |

# CONSOLIDATION TEST DATA

## TIME CURVES

Constant Load Step: 2 of 12

Stress: 0.25 tsf

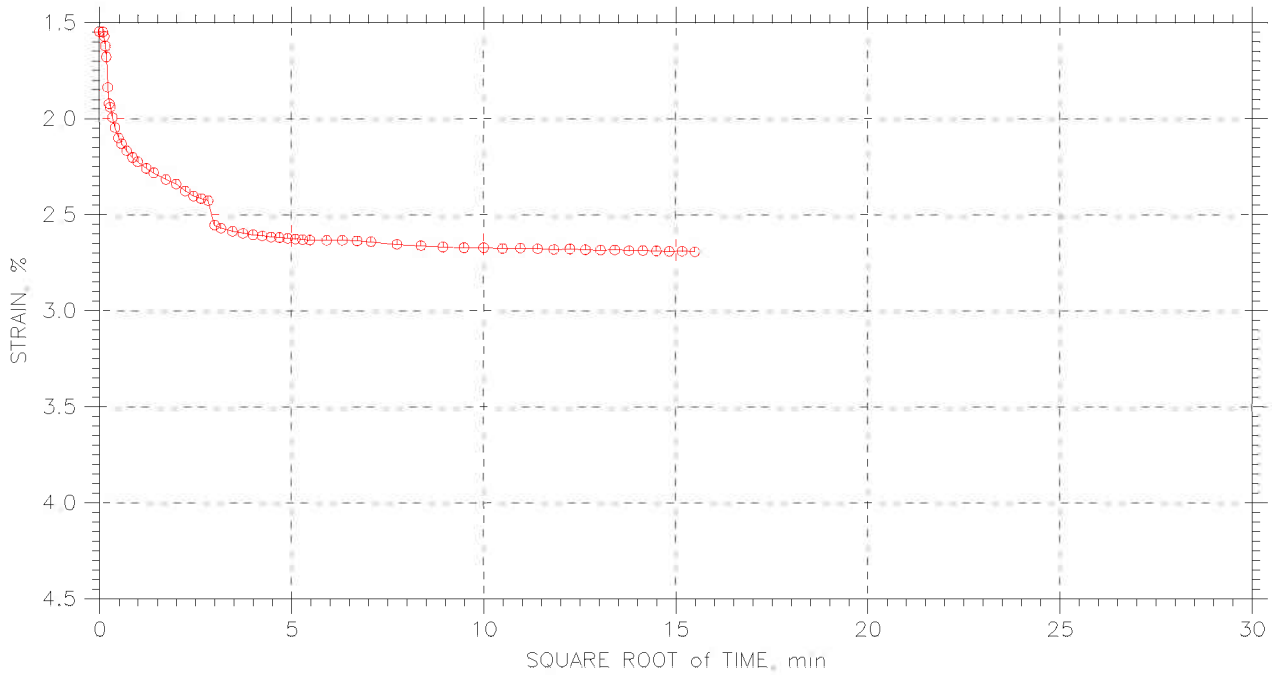
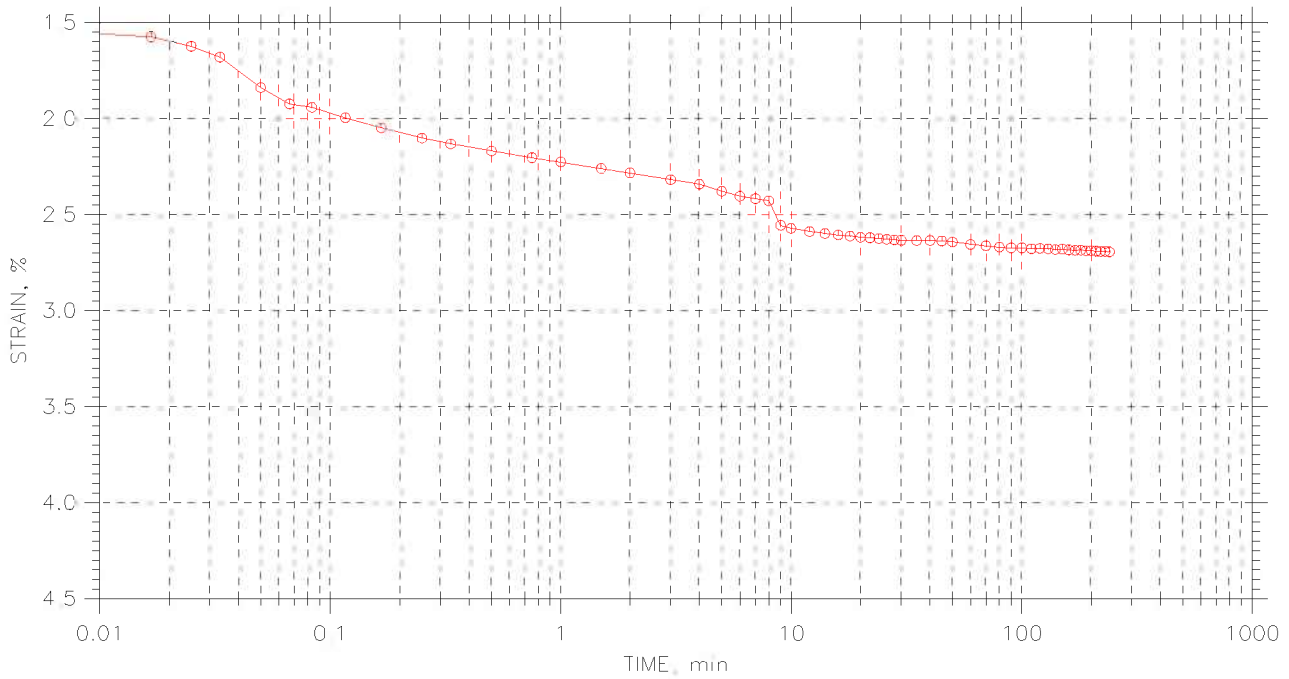

|  |                                    |                         |                       |
|--|------------------------------------|-------------------------|-----------------------|
|  | Project: I90 Central Viaduct       | Location: Cleveland, OH | Project No.: GTX-6678 |
|  | Boring No.: C-05-03                | Tested By: fy           | Checked By: jdt       |
|  | Sample No.: S-30                   | Test Date: 05/05/06     | Depth: 118.5-120.5    |
|  | Test No.: C-2                      | Sample Type: Tube       | Elevation: ---        |
|  | Description: Moist, dark gray clay |                         |                       |
|  | Remarks: ---                       |                         |                       |

# CONSOLIDATION TEST DATA

## TIME CURVES

Constant Load Step: 3 of 12

Stress: 0.5 tsf

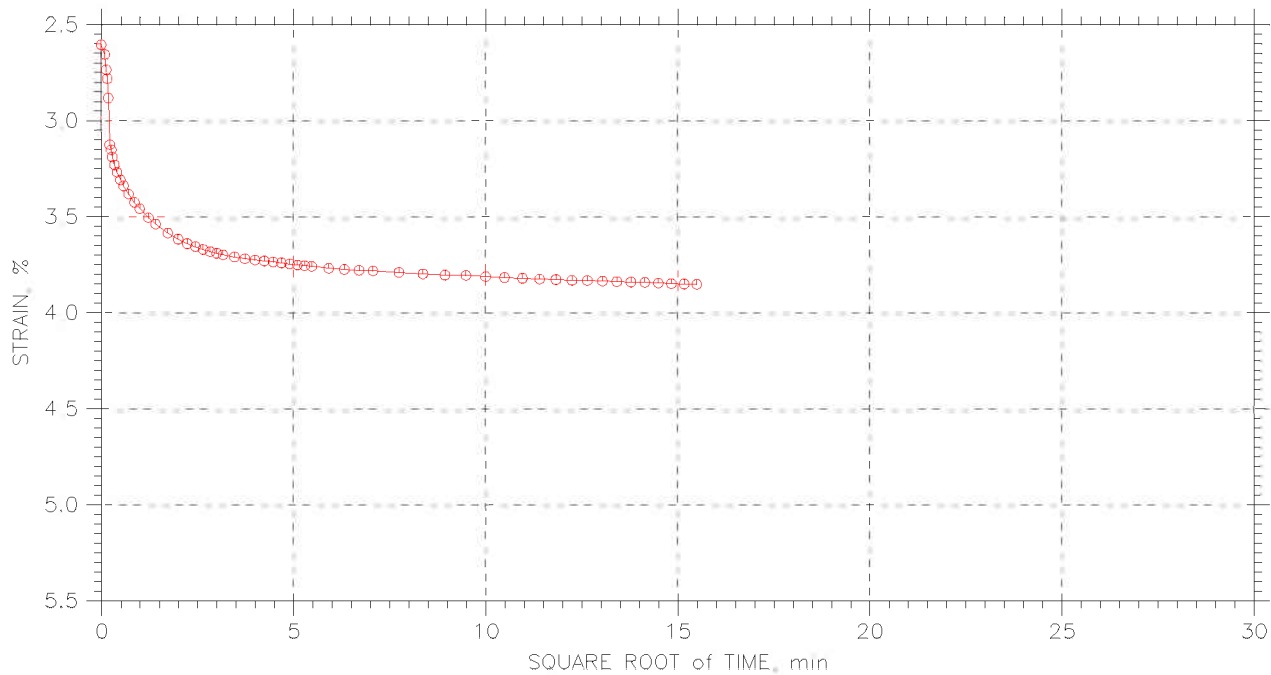
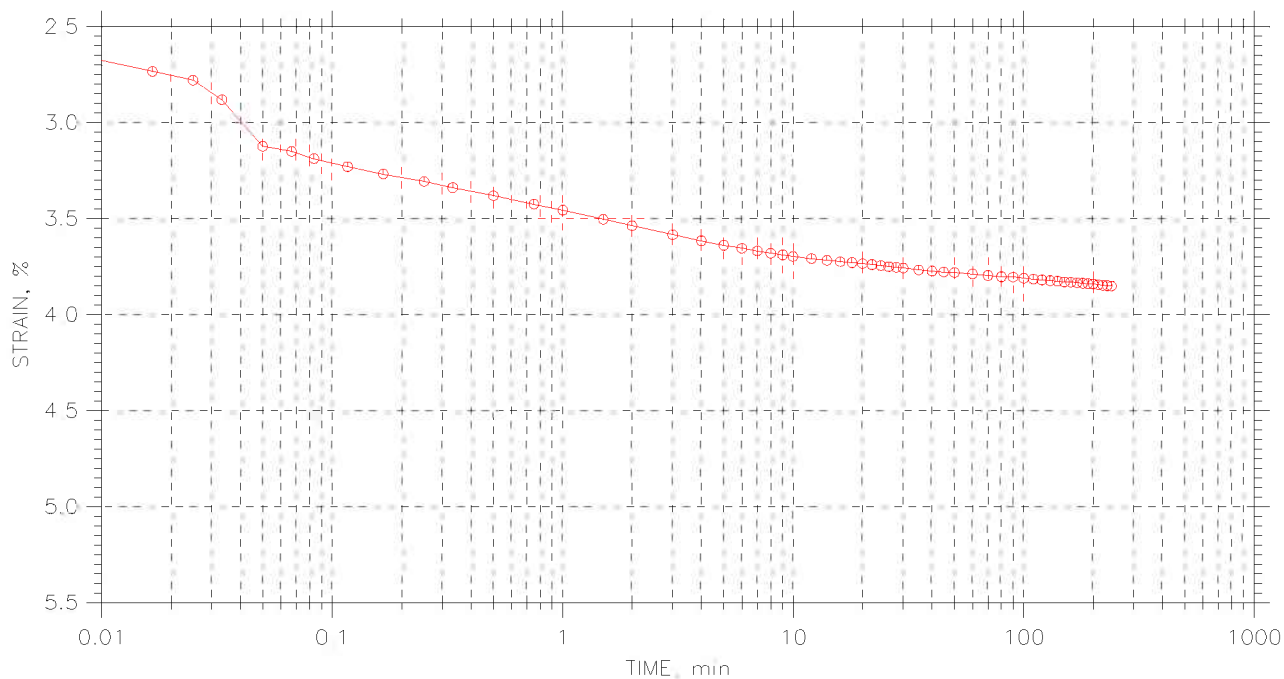

|  |                                    |                         |                       |
|--|------------------------------------|-------------------------|-----------------------|
|  | Project: I90 Central Viaduct       | Location: Cleveland, OH | Project No.: GTX-6678 |
|  | Boring No.: C-05-03                | Tested By: fy           | Checked By: jdt       |
|  | Sample No.: S-30                   | Test Date: 05/05/06     | Depth: 118.5-120.5    |
|  | Test No.: C-2                      | Sample Type: Tube       | Elevation: ---        |
|  | Description: Moist, dark gray clay |                         |                       |
|  | Remarks: ---                       |                         |                       |

# CONSOLIDATION TEST DATA

## TIME CURVES

Constant Load Step: 4 of 12

Stress: 1. tsf

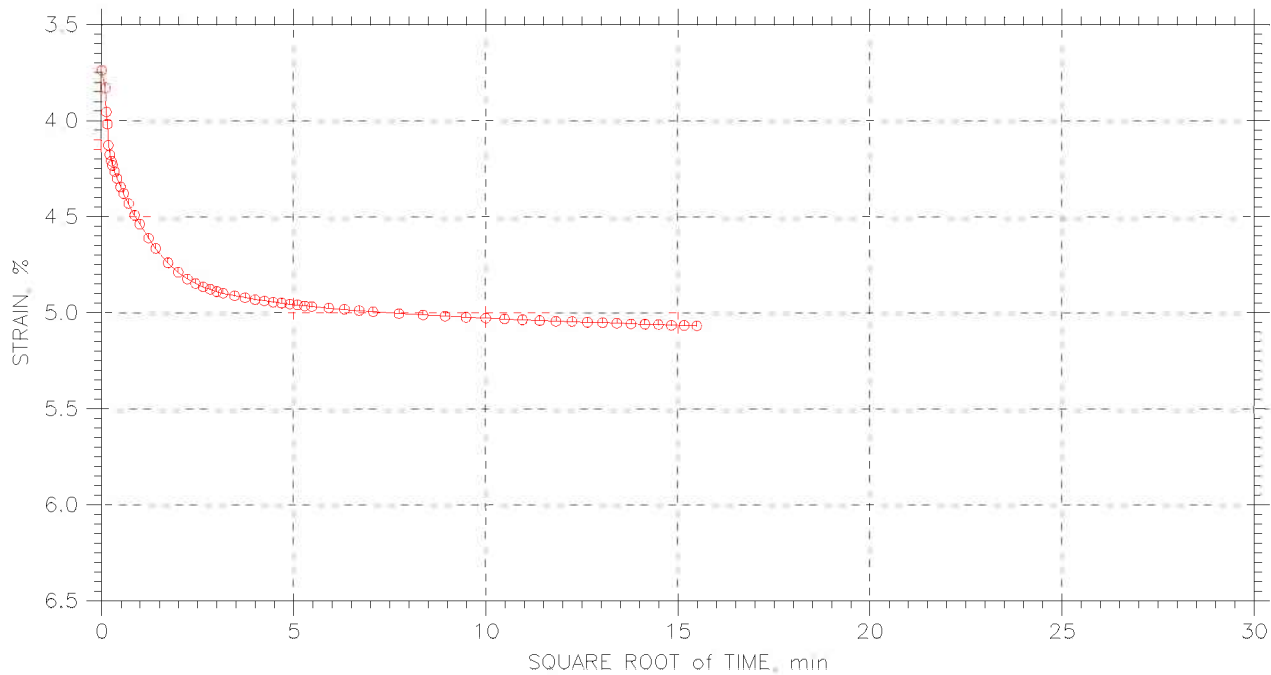
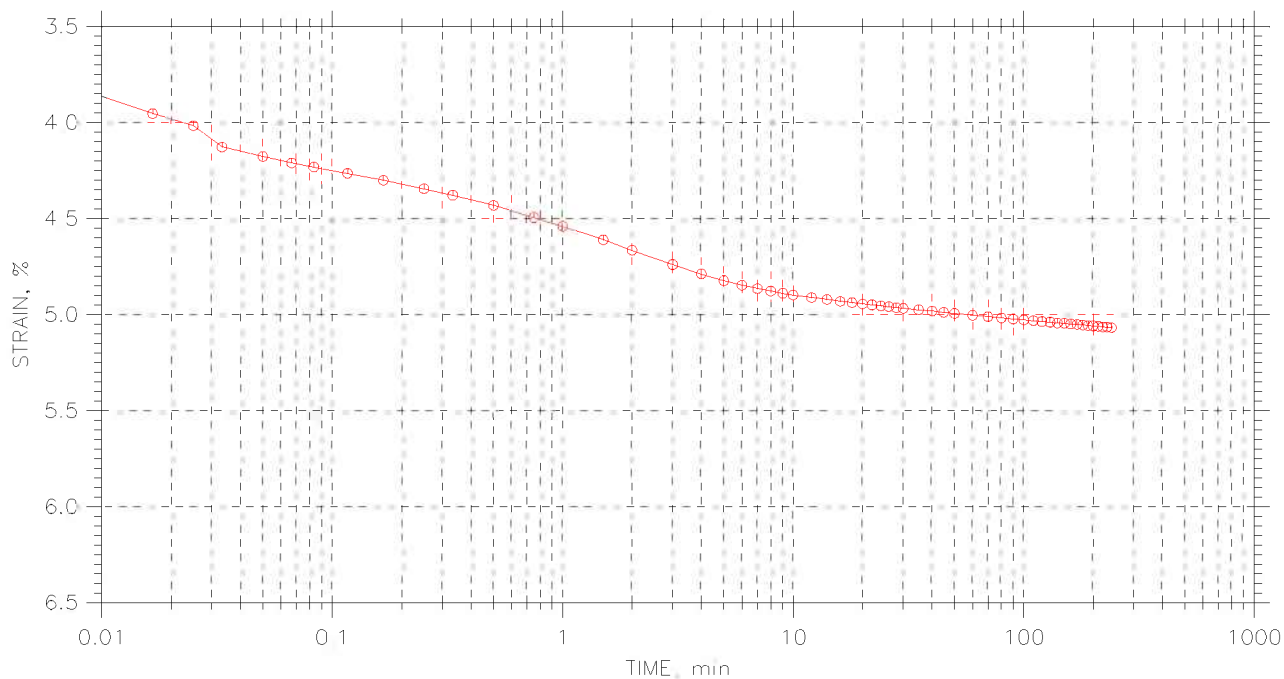

|  |                                    |                         |                       |
|--|------------------------------------|-------------------------|-----------------------|
|  | Project: I90 Central Viaduct       | Location: Cleveland, OH | Project No.: GTX-6678 |
|  | Boring No.: C-05-03                | Tested By: fy           | Checked By: jdt       |
|  | Sample No.: S-30                   | Test Date: 05/05/06     | Depth: 118.5-120.5    |
|  | Test No.: C-2                      | Sample Type: Tube       | Elevation: ---        |
|  | Description: Moist, dark gray clay |                         |                       |
|  | Remarks: ---                       |                         |                       |

# CONSOLIDATION TEST DATA

## TIME CURVES

Constant Load Step: 5 of 12

Stress: 2. tsf

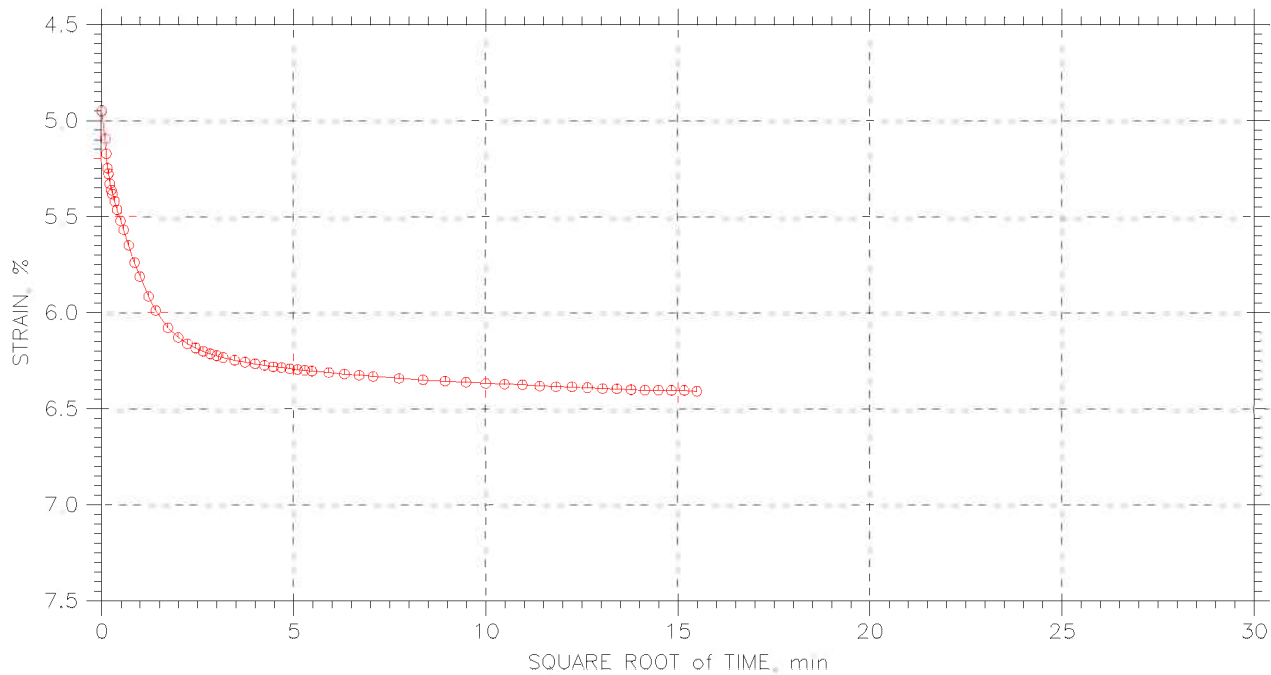
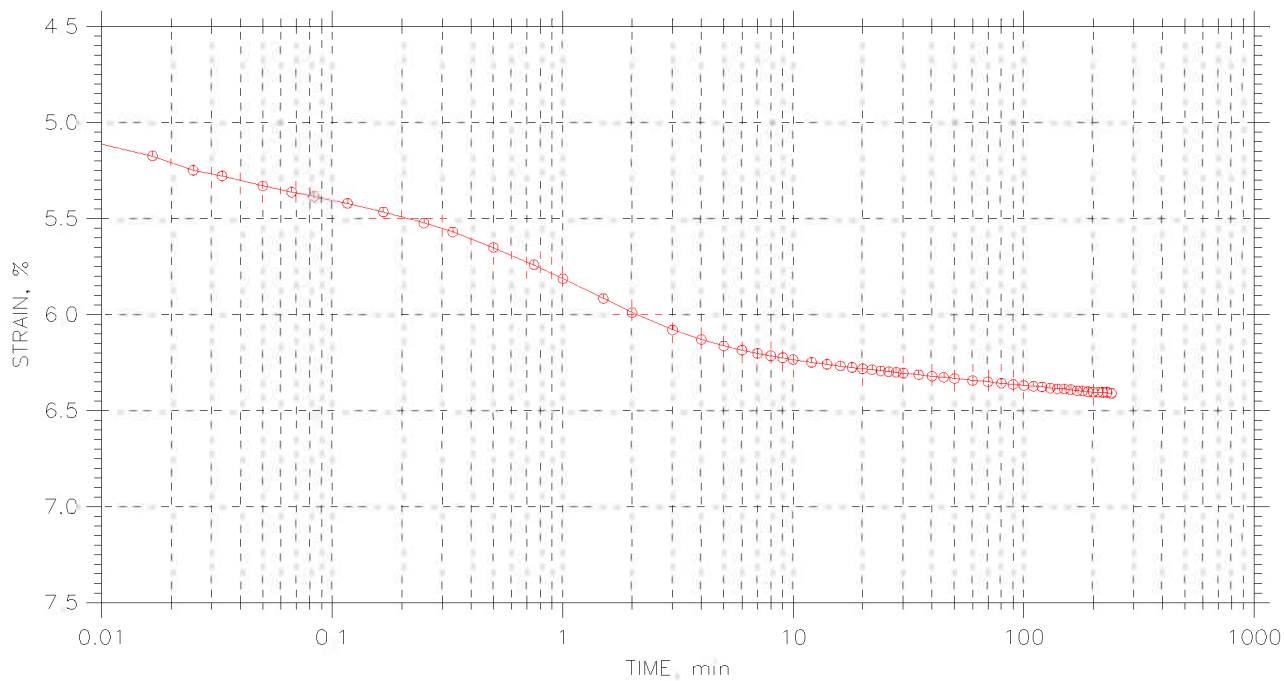

|  |                                    |                         |                       |
|--|------------------------------------|-------------------------|-----------------------|
|  | Project: I90 Central Viaduct       | Location: Cleveland, OH | Project No.: GTX-6678 |
|  | Boring No.: C-05-03                | Tested By: fy           | Checked By: jdt       |
|  | Sample No.: S-30                   | Test Date: 05/05/06     | Depth: 118.5-120.5    |
|  | Test No.: C-2                      | Sample Type: Tube       | Elevation: ---        |
|  | Description: Moist, dark gray clay |                         |                       |
|  | Remarks: ---                       |                         |                       |

# CONSOLIDATION TEST DATA

## TIME CURVES

Constant Load Step: 6 of 12

Stress: 4. tsf

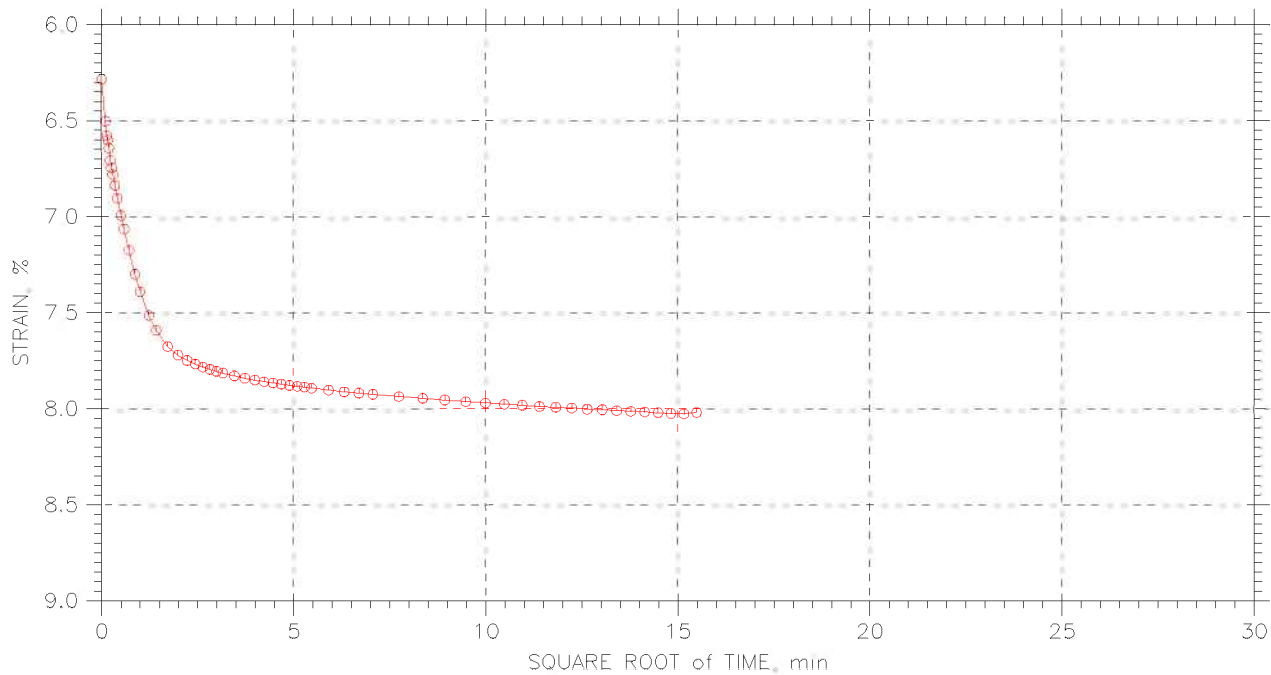
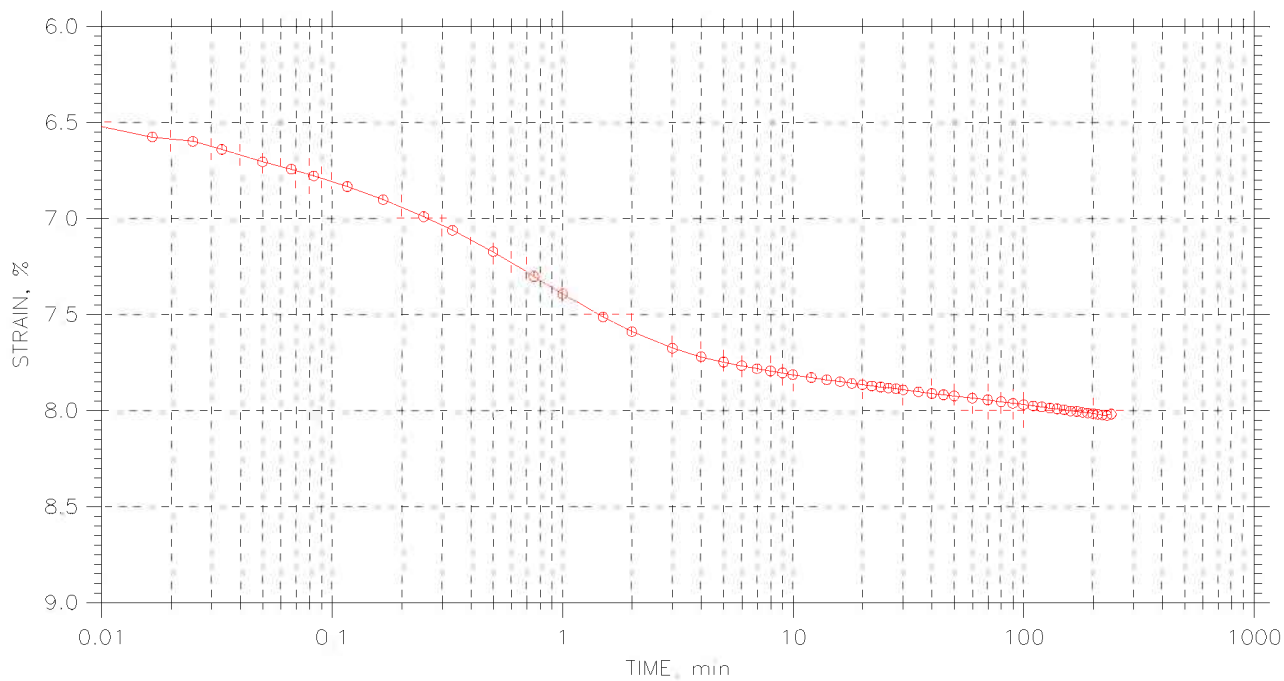

|  |                                    |                         |                       |
|--|------------------------------------|-------------------------|-----------------------|
|  | Project: I90 Central Viaduct       | Location: Cleveland, OH | Project No.: GTX-6678 |
|  | Boring No.: C-05-03                | Tested By: fy           | Checked By: jdt       |
|  | Sample No.: S-30                   | Test Date: 05/05/06     | Depth: 118.5-120.5    |
|  | Test No.: C-2                      | Sample Type: Tube       | Elevation: ---        |
|  | Description: Moist, dark gray clay |                         |                       |
|  | Remarks: ---                       |                         |                       |





# CONSOLIDATION TEST DATA

## TIME CURVES

Constant Load Step: 7 of 12

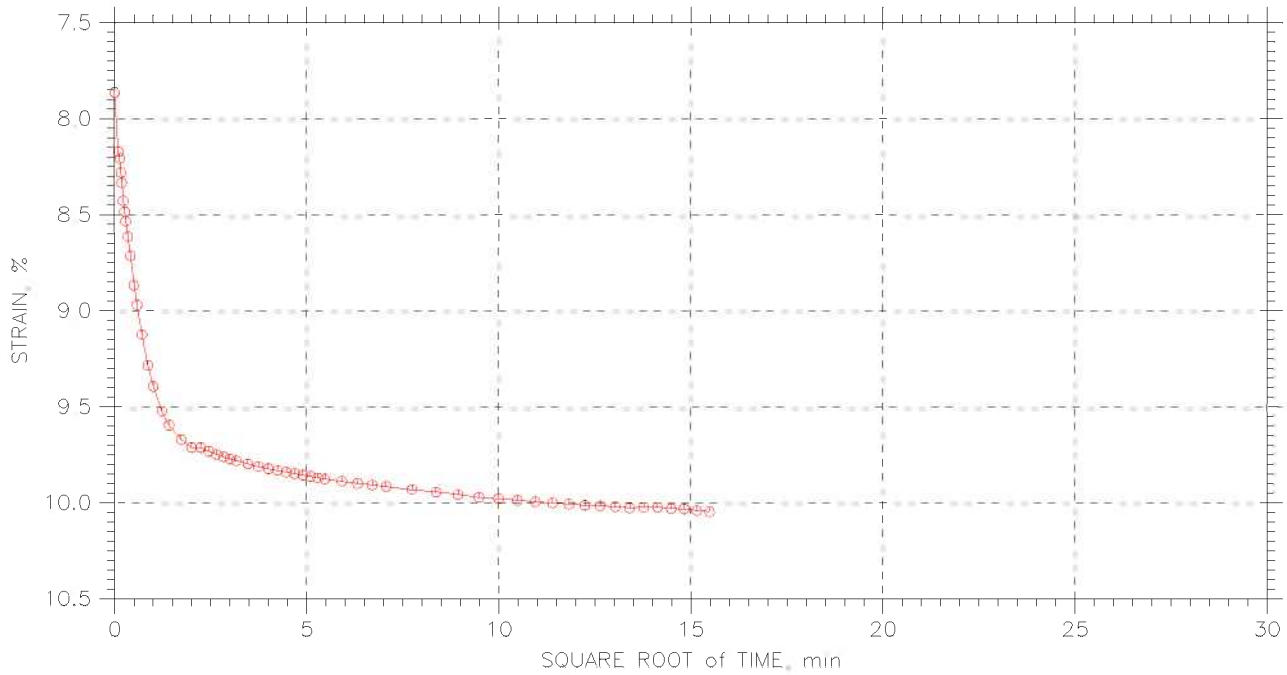
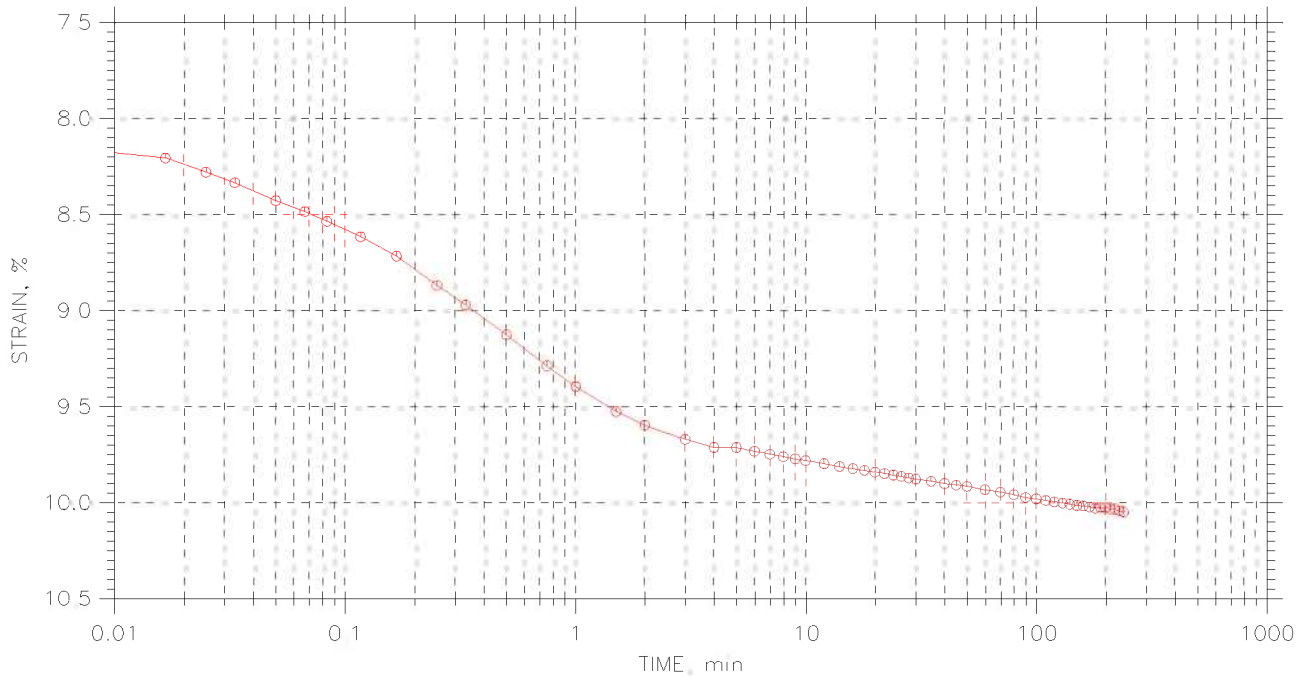
Stress: 8. tsf



|  |                                    |                         |                       |
|--|------------------------------------|-------------------------|-----------------------|
|  | Project: I90 Central Viaduct       | Location: Cleveland, OH | Project No.: GTX-6678 |
|  | Boring No.: C-05-03                | Tested By: fy           | Checked By: jdt       |
|  | Sample No.: S-30                   | Test Date: 05/05/06     | Depth: 118.5-120.5    |
|  | Test No.: C-2                      | Sample Type: Tube       | Elevation: ---        |
|  | Description: Moist, dark gray clay |                         |                       |
|  | Remarks: ---                       |                         |                       |

# CONSOLIDATION TEST DATA

## TIME CURVES

Constant Load Step: 8 of 12

Stress: 16. tsf

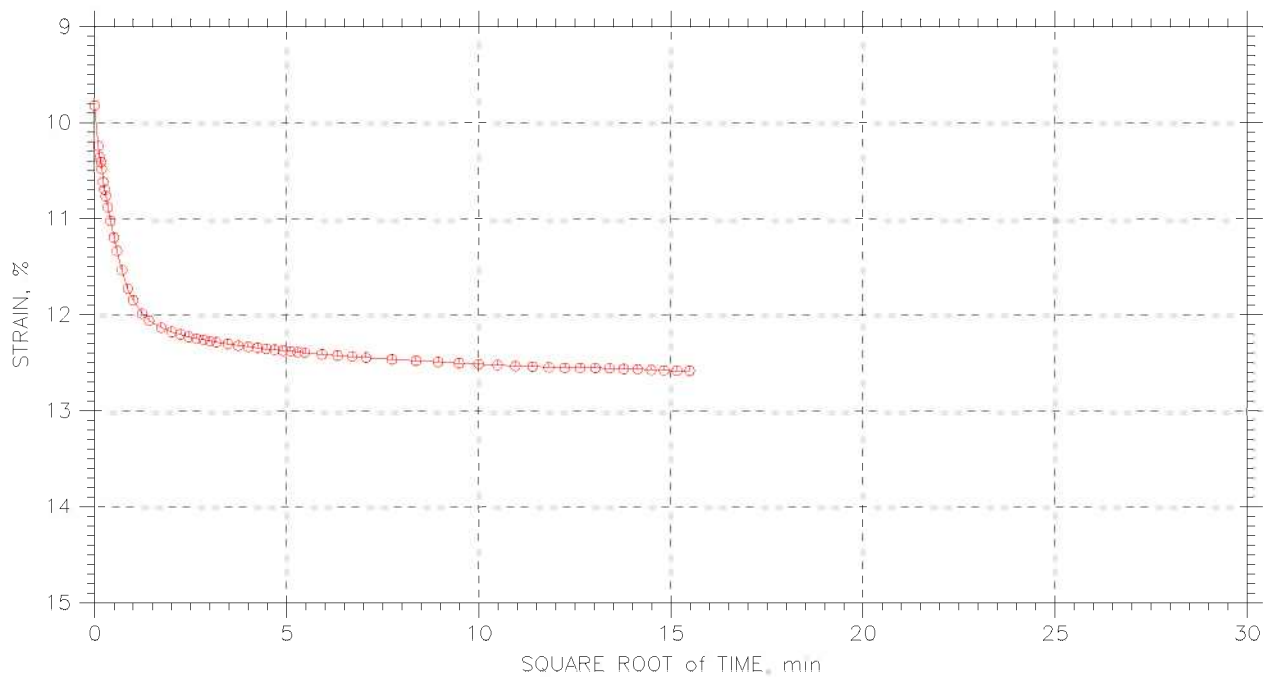
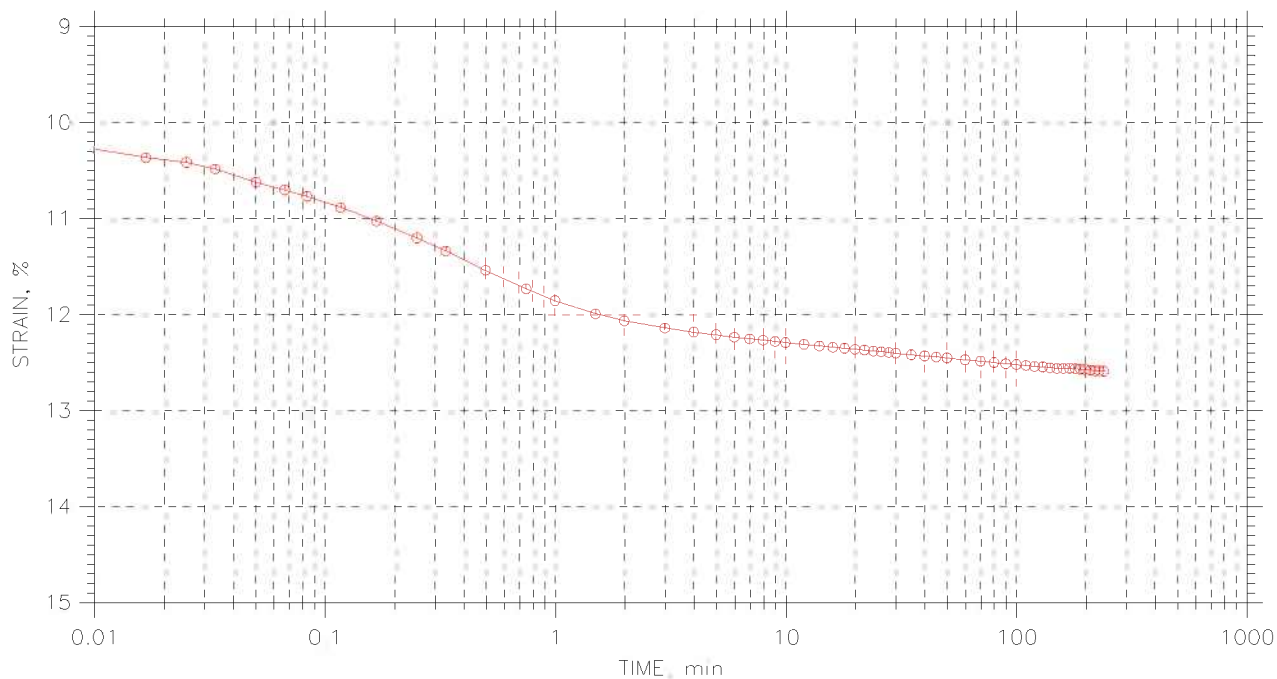

|  |                                    |                         |                       |
|--|------------------------------------|-------------------------|-----------------------|
|  | Project: I90 Central Viaduct       | Location: Cleveland, OH | Project No.: GTX-6678 |
|  | Boring No.: C-05-03                | Tested By: fy           | Checked By: jdt       |
|  | Sample No.: S-30                   | Test Date: 05/05/06     | Depth: 118.5-120.5    |
|  | Test No.: C-2                      | Sample Type: Tube       | Elevation: ---        |
|  | Description: Moist, dark gray clay |                         |                       |
|  | Remarks: ---                       |                         |                       |

# CONSOLIDATION TEST DATA

## TIME CURVES

Constant Load Step: 9 of 12

Stress: 32 tsf

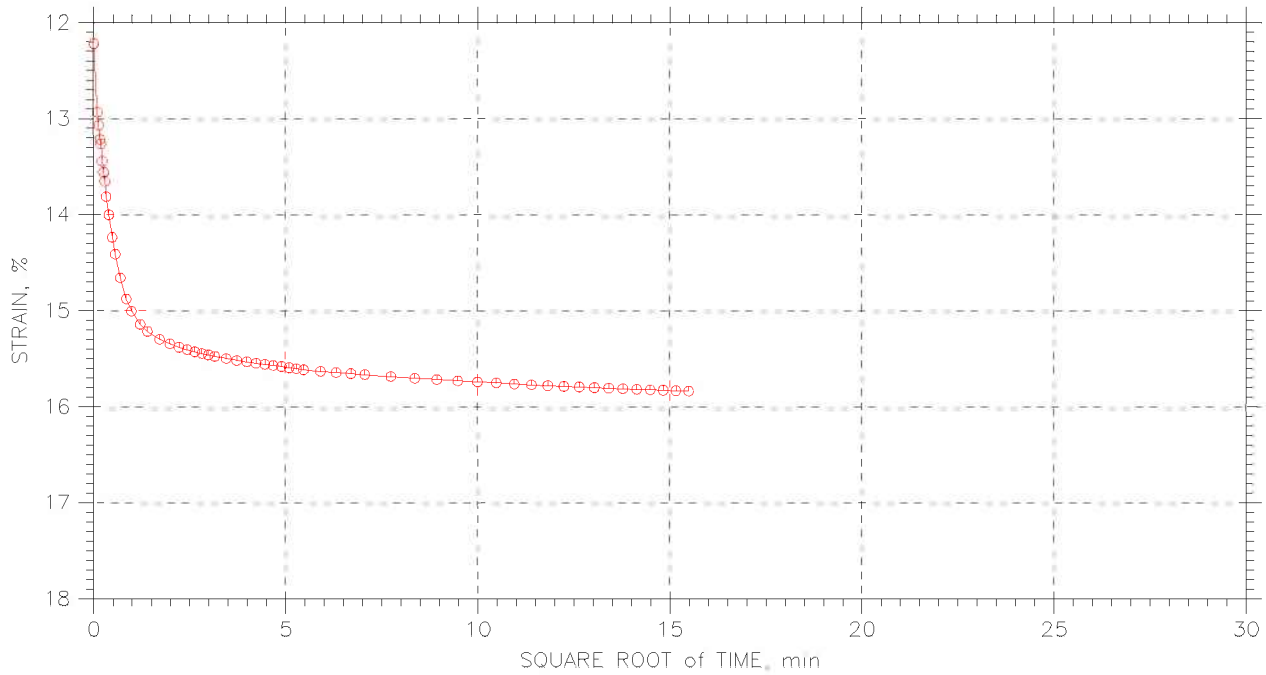
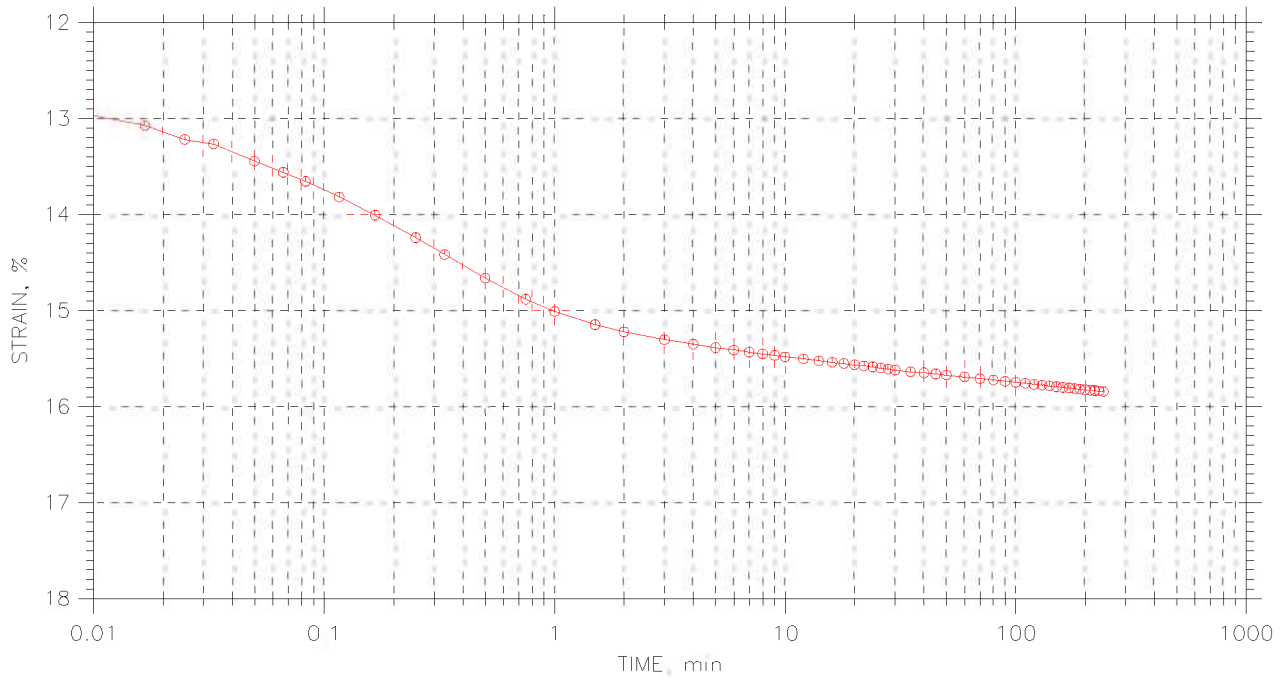

|  |                                    |                         |                       |
|--|------------------------------------|-------------------------|-----------------------|
|  | Project: I90 Central Viaduct       | Location: Cleveland, OH | Project No.: GTX-6678 |
|  | Boring No.: C-05-03                | Tested By: fy           | Checked By: jdt       |
|  | Sample No.: S-30                   | Test Date: 05/05/06     | Depth: 118.5-120.5    |
|  | Test No.: C-2                      | Sample Type: Tube       | Elevation: ---        |
|  | Description: Moist, dark gray clay |                         |                       |
|  | Remarks: ---                       |                         |                       |

# CONSOLIDATION TEST DATA

## TIME CURVES

Constant Load Step: 10 of 12

Stress: 8. tsf

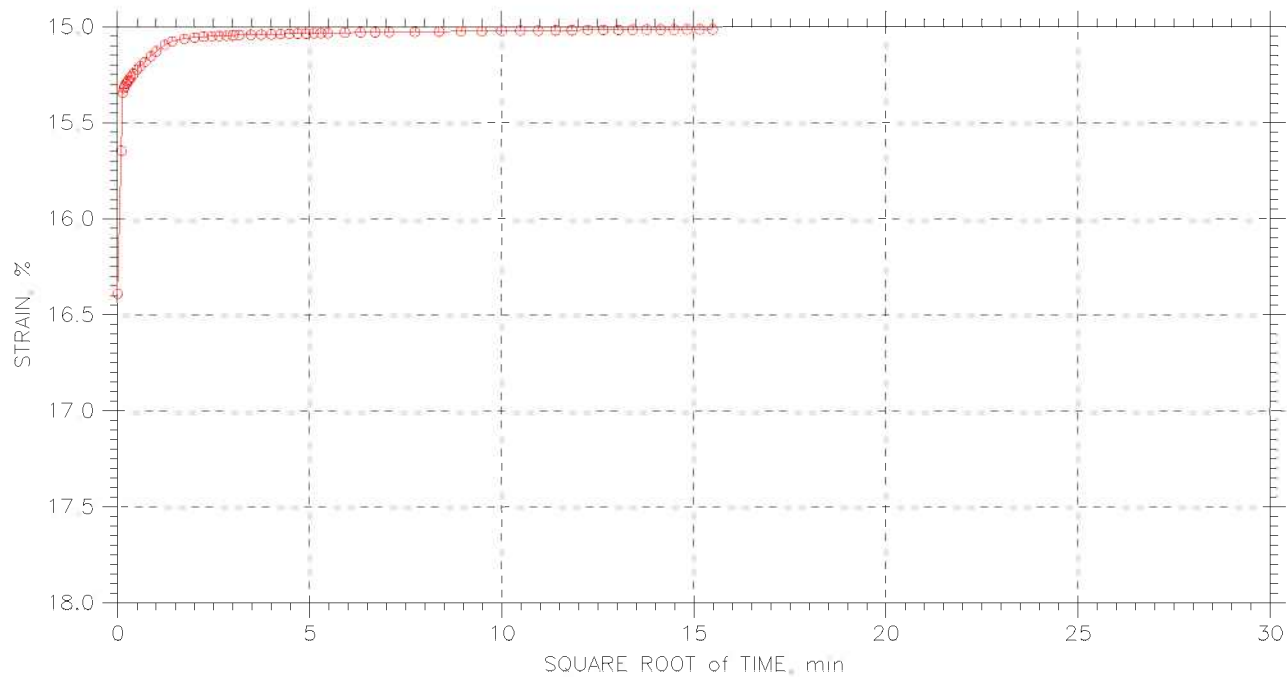
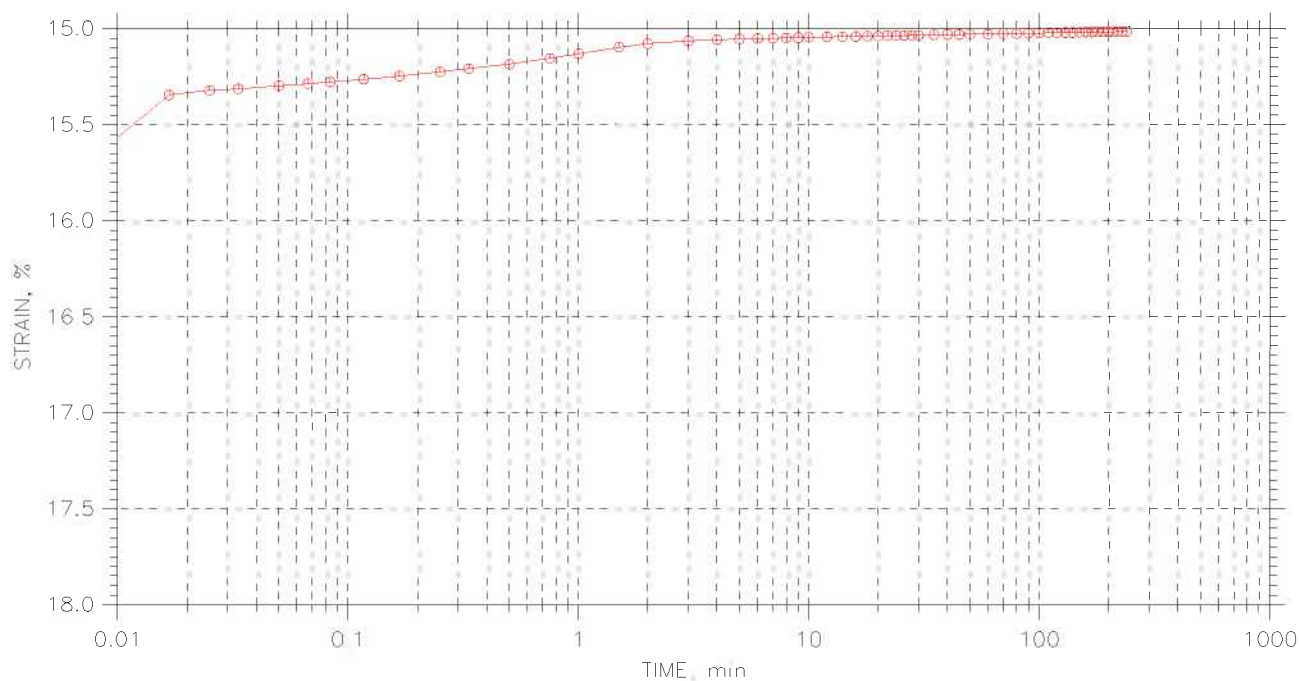

|  |                                    |                         |                       |
|--|------------------------------------|-------------------------|-----------------------|
|  | Project: I90 Central Viaduct       | Location: Cleveland, OH | Project No.: GTX-6678 |
|  | Boring No.: C-05-03                | Tested By: fy           | Checked By: jdt       |
|  | Sample No.: S-30                   | Test Date: 05/05/06     | Depth: 118.5-120.5    |
|  | Test No.: C-2                      | Sample Type: Tube       | Elevation: ---        |
|  | Description: Moist, dark gray clay |                         |                       |
|  | Remarks: ---                       |                         |                       |

# CONSOLIDATION TEST DATA

TIME CURVES

Constant Load Step: 11 of 12

Stress: 2. tsf

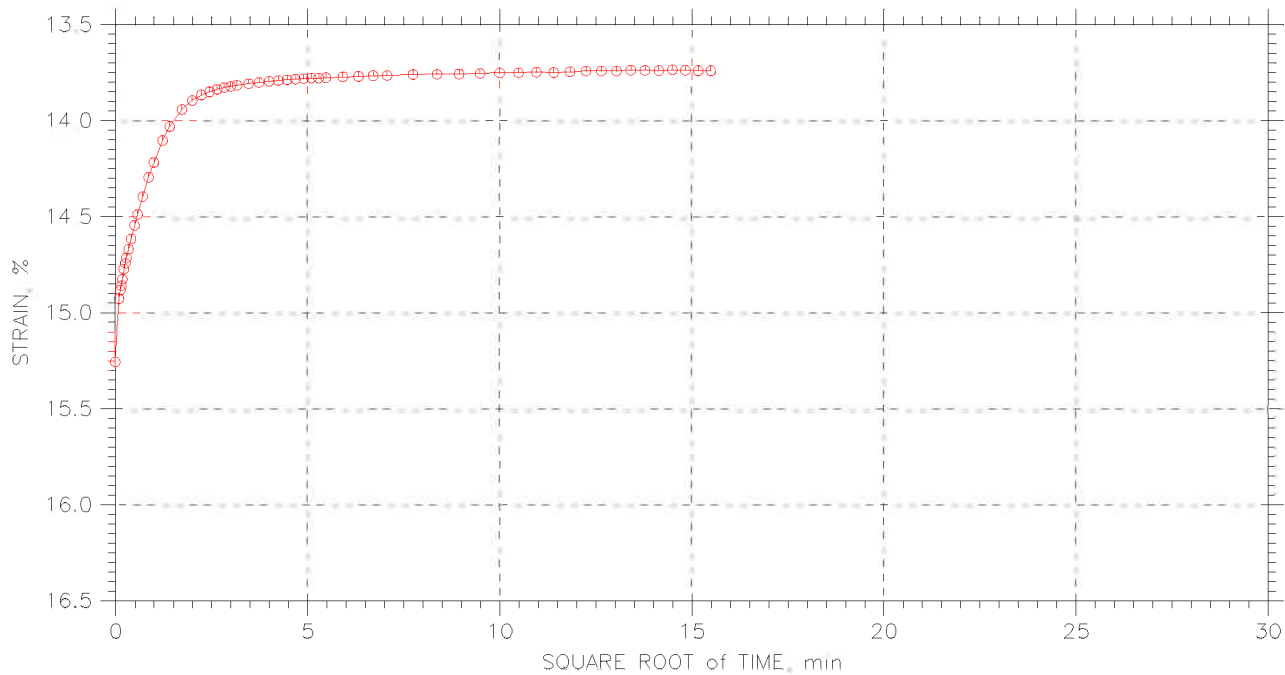
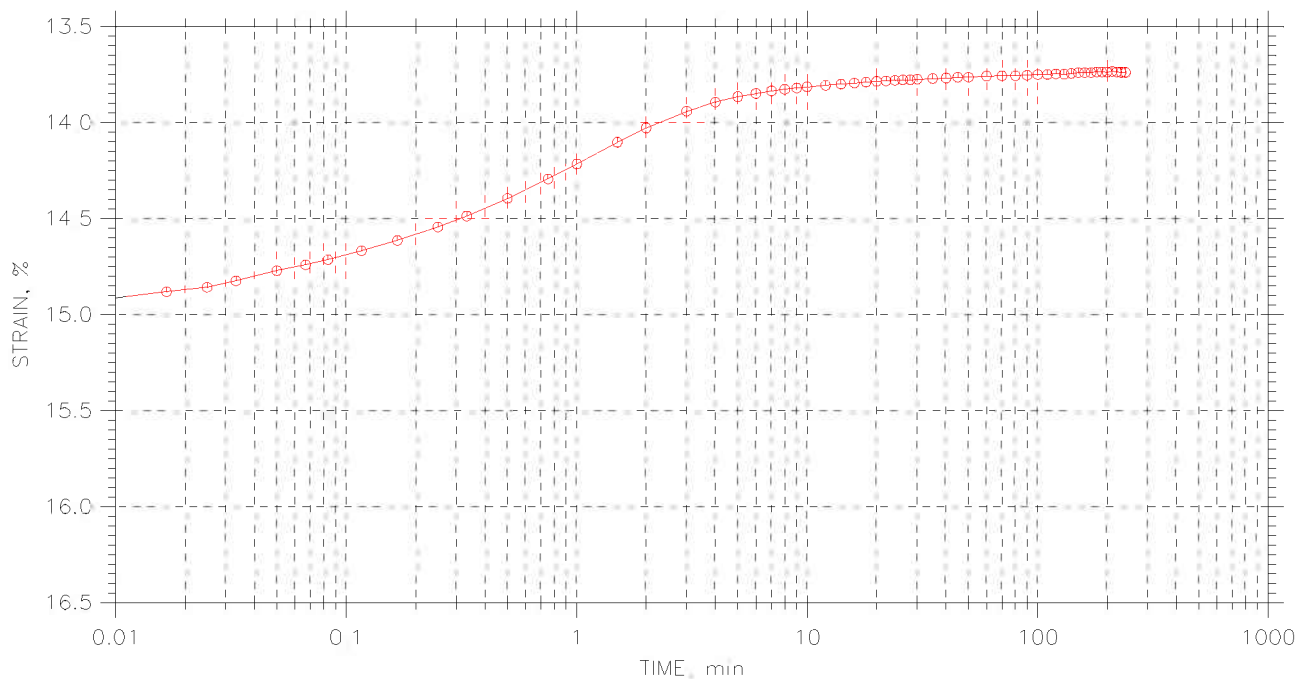

|  |                                    |                         |                       |
|--|------------------------------------|-------------------------|-----------------------|
|  | Project: I90 Central Viaduct       | Location: Cleveland, OH | Project No.: GTX-6678 |
|  | Boring No.: C-05-03                | Tested By: fy           | Checked By: jdt       |
|  | Sample No.: S-30                   | Test Date: 05/05/06     | Depth: 118.5-120.5    |
|  | Test No.: C-2                      | Sample Type: Tube       | Elevation: ---        |
|  | Description: Moist, dark gray clay |                         |                       |
|  | Remarks: ---                       |                         |                       |

# CONSOLIDATION TEST DATA

## TIME CURVES

Constant Load Step: 12 of 12

Stress: 0.5 tsf

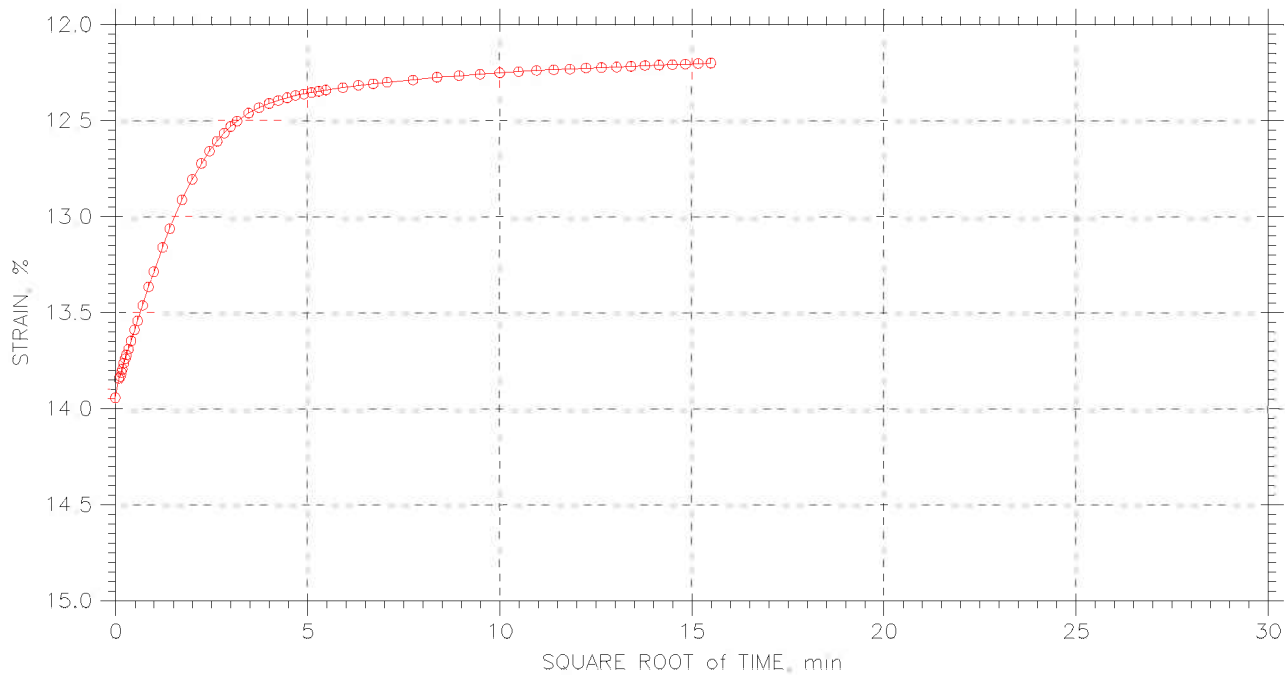
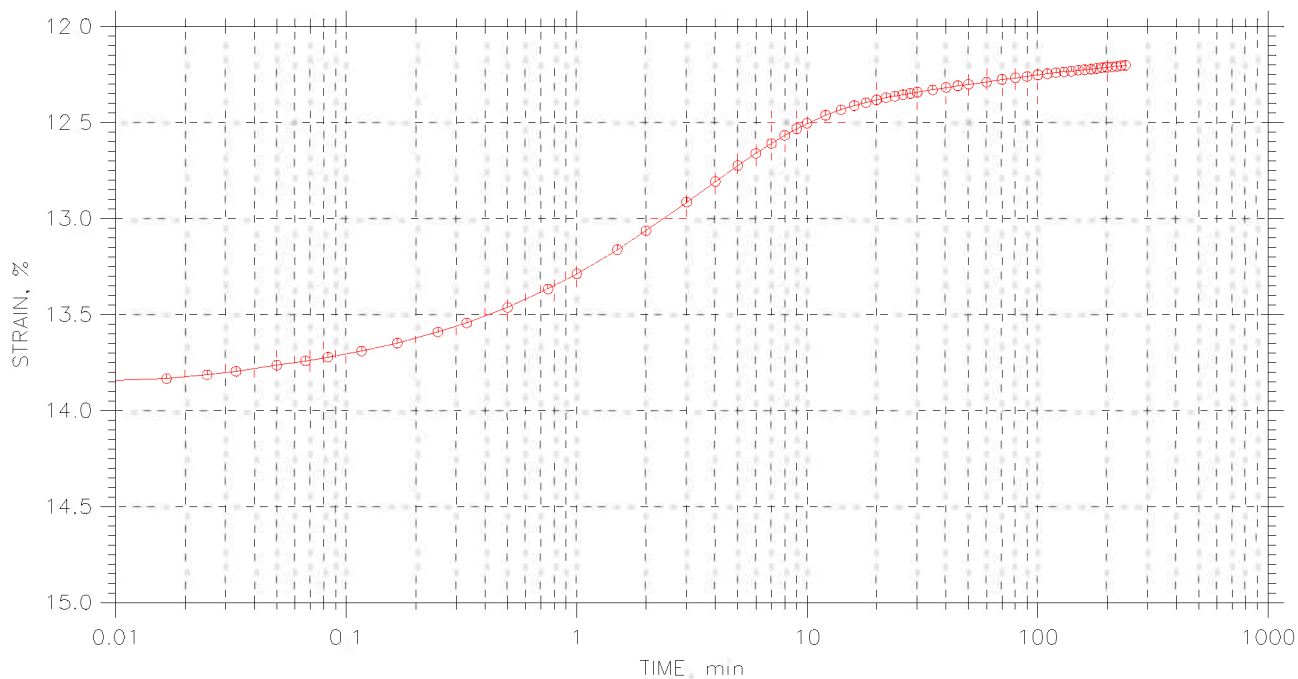

|  |                                    |                         |                       |
|--|------------------------------------|-------------------------|-----------------------|
|  | Project: I90 Central Viaduct       | Location: Cleveland, OH | Project No.: GTX-6678 |
|  | Boring No.: C-05-03                | Tested By: fy           | Checked By: jdt       |
|  | Sample No.: S-30                   | Test Date: 05/05/06     | Depth: 118.5-120.5    |
|  | Test No.: C-2                      | Sample Type: Tube       | Elevation: ---        |
|  | Description: Moist, dark gray clay |                         |                       |
|  | Remarks: ---                       |                         |                       |

CONSOLIDATION TEST DATA

Project: I90 Central Viaduct  
 Boring No.: C-05-03  
 Sample No.: S-30  
 Test No.: C-2

Location: Cleveland, OH  
 Tested By: fy  
 Test Date: 05/05/06  
 Sample Type: Tube

Project No.: GTX-6678  
 Checked By: jdt  
 Depth: 118.5-120.5  
 Elevation: ---

Soil Description: Moist, dark gray clay  
 Remarks: ---

Measured Specific Gravity: 2.73  
 Initial Void Ratio: 0.86  
 Final Void Ratio: 0.63

Liquid Limit: 33  
 Plastic Limit: 18  
 Plasticity Index: 15

Initial Height: 1.00 in  
 Specimen Diameter: 2.50 in

| Container ID                 | Before Consolidation |               | After Consolidation |           |
|------------------------------|----------------------|---------------|---------------------|-----------|
|                              | Trimmings            | Specimen+Ring | Specimen+Ring       | Trimmings |
|                              | xtw                  | RING          |                     | dodge 5   |
| Wt. Container + Wet Soil, gm | 147.11               | 371.8         | 361.5               | 157.16    |
| Wt. Container + Dry Soil, gm | 117.33               | 334.62        | 334.62              | 129.53    |
| Wt. Container, gm            | 8.26                 | 216.53        | 216.53              | 8.17      |
| Wt. Dry Soil, gm             | 109.07               | 118.09        | 118.09              | 121.36    |
| Water Content, %             | 27.30                | 31.49         | 22.77               | 22.77     |
| Void Ratio                   | ---                  | 0.86          | 0.63                | ---       |
| Degree of Saturation, %      | ---                  | 100.00        | 98.23               | ---       |
| Dry Unit Weight, pcf         | ---                  | 91.644        | 104.38              | ---       |

**Constant Rate of Consolidation**  
 Constant Strain Rate by ASTM D4186  
 Summary Report

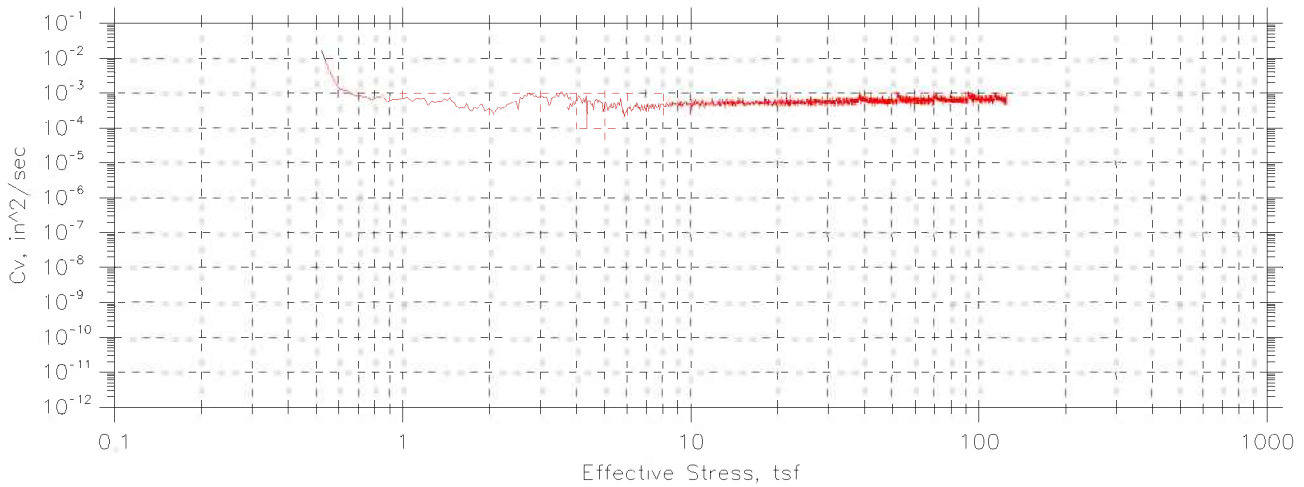
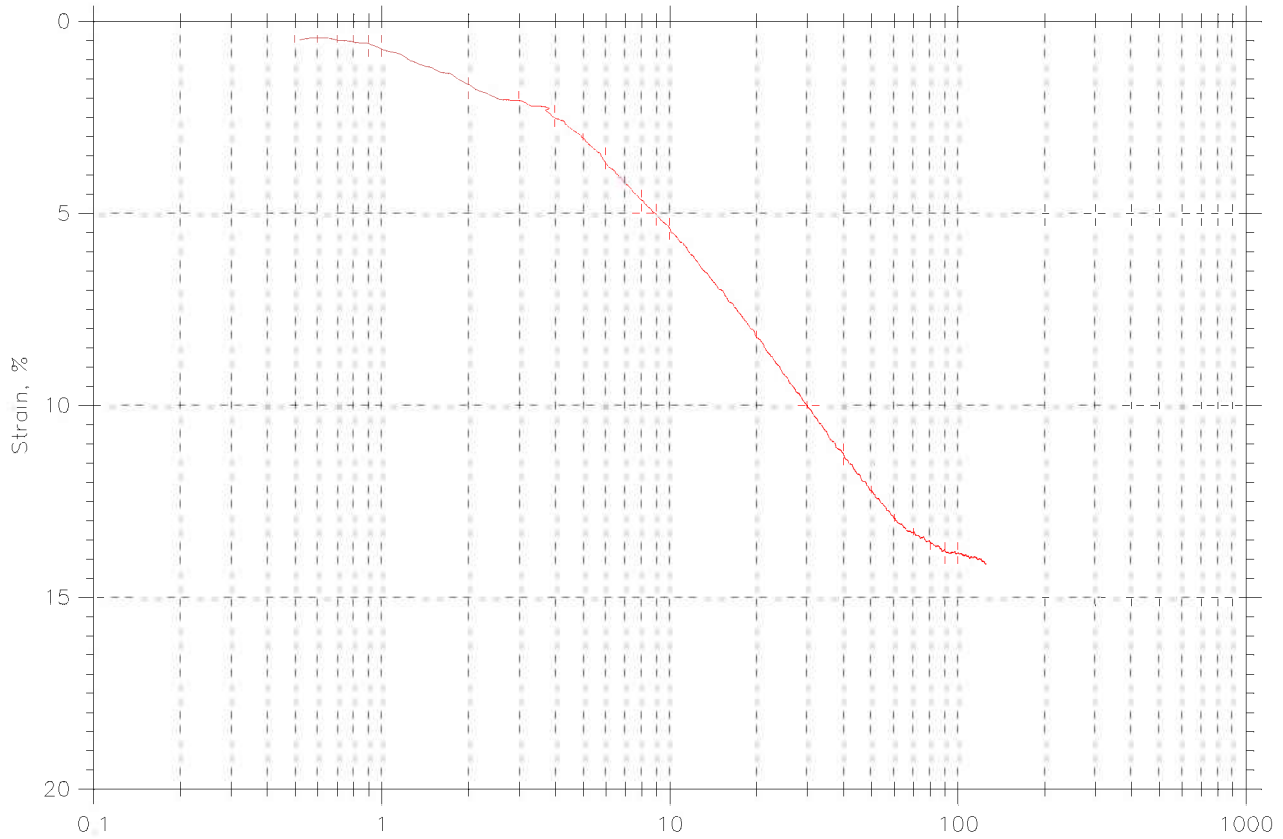

|                                    |                         |                       |
|------------------------------------|-------------------------|-----------------------|
| Project: I-90 Central Viaduct      | Location: Cleveland, OH | Project No.: GTX-6678 |
| Boring No.: C-05-03                | Tested By: njh          | Checked By: jdt       |
| Sample No.: S-29                   | Test Date: 05/15/06     | Depth: 116.5-118.5    |
| Test No.: crc-1                    | Sample Type: tube       | Elevation: ---        |
| Description: Moist, dark gray clay |                         |                       |
| Remarks:                           |                         |                       |
|                                    |                         |                       |



CRC TEST DATA

Project: I-90 Central Viaduct  
 Boring No.: C-05-03  
 Sample No.: S-29  
 Test No.: crc-1

Location: Cleveland, OH  
 Tested By: njh  
 Test Date: 05/15/06  
 Sample Type: tube

Project No.: GTX-6678  
 Checked By: jdt  
 Depth: 116.5-118.5  
 Elevation: ---

Soil Description: Moist, dark gray clay  
 Remarks:

Measured Specific Gravity: 2.75  
 Initial Void Ratio: 0.53  
 Final Void Ratio: 0.34

Liquid Limit: 35  
 Plastic Limit: 18  
 Plasticity Index: 17

Initial Height: 1.00 in  
 Specimen Diameter: 2.50 in

|                              | Before Consolidation |               | After Consolidation |           |
|------------------------------|----------------------|---------------|---------------------|-----------|
|                              | Trimmings            | Specimen+Ring | Specimen+Ring       | Trimmings |
| Container ID                 | sweet                | RING          |                     | 1355      |
| Wt. Container + Wet Soil, gm | 135.17               | 383.55        | 378.55              | 168.61    |
| Wt. Container + Dry Soil, gm | 111.25               | 360.47        | 360.47              | 150.77    |
| Wt. Container, gm            | 7.98                 | 216.07        | 216.07              | 8.32      |
| Wt. Dry Soil, gm             | 103.27               | 144.4         | 144.4               | 142.45    |
| Water Content, %             | 23.16                | 15.99         | 12.52               | 12.52     |
| Void Ratio                   | ---                  | 0.53          | 0.34                | ---       |
| Degree of Saturation, %      | ---                  | 82.64         | 100.00              | ---       |
| Dry Unit Weight, pcf         | ---                  | 112.06        | 127.7               | ---       |

# **Appendix C**

## **Direct Simple Shear Tests**

**Consolidated Undrained Direct Simple Shear Test of Cohesive Soil  
by ASTM D 6528**

Client: Geocomp Consulting GTX#: 6678  
 Project Name: I-90 Central Viaduct Test Date: 05/07/06  
 Project Location: Cleveland, OH

Boring ID: C-05-03  
 Sample ID: S-29  
 Depth, ft: 116.5-118.5 ft

Visual Description: Moist, dark gray clay

Test Equipment: Top and bottom box (circular) = 2.62 in diameter. Load cells and LVDT's connected to data acquisition system for shear force, normal load, horizontal and vertical displacement; surface area = 5.39 in<sup>2</sup>, soil height = 1 inch

Test Condition: inundated

Sample Type and Preparation: Extruded from tube, cut, trimmed and placed into apparatus at as-received density and moisture content.

| Parameter                            | Point 1 | Point 2 | Point 3 | Point 4 | Point 5 |
|--------------------------------------|---------|---------|---------|---------|---------|
| Test No.                             | DSS-1   |         |         |         |         |
| Initial Moisture Content, %          | 29      |         |         |         |         |
| Initial Dry Density, pcf             | 96.3    |         |         |         |         |
| Nominal Rate of Shear Strain, %/min  | 0.0008  |         |         |         |         |
| Vertical Consolidation Stress, psf   | 9500    |         |         |         |         |
| Final Moisture Content, %            | 28      |         |         |         |         |
| Measured Peak Shear Stress, psf      | 2240    |         |         |         |         |
| Shear Strain at Peak Shear Stress, % | 15.6    |         |         |         |         |
| Membrane Correction, psf             | 73      |         |         |         |         |
| $S / \sigma'_{vc}$                   | 0.23    |         |         |         |         |

Comments: Tested By: njh Checked By: jdt

Notes: These results apply only to the sample tested for the specific test conditions. The test procedures employed follow accepted industry practice and the indicated test method. GeoTesting Express has no specific knowledge as to conditioning, origin, sampling procedure or intended use of the material.

# DIRECT SIMPLE SHEAR TEST

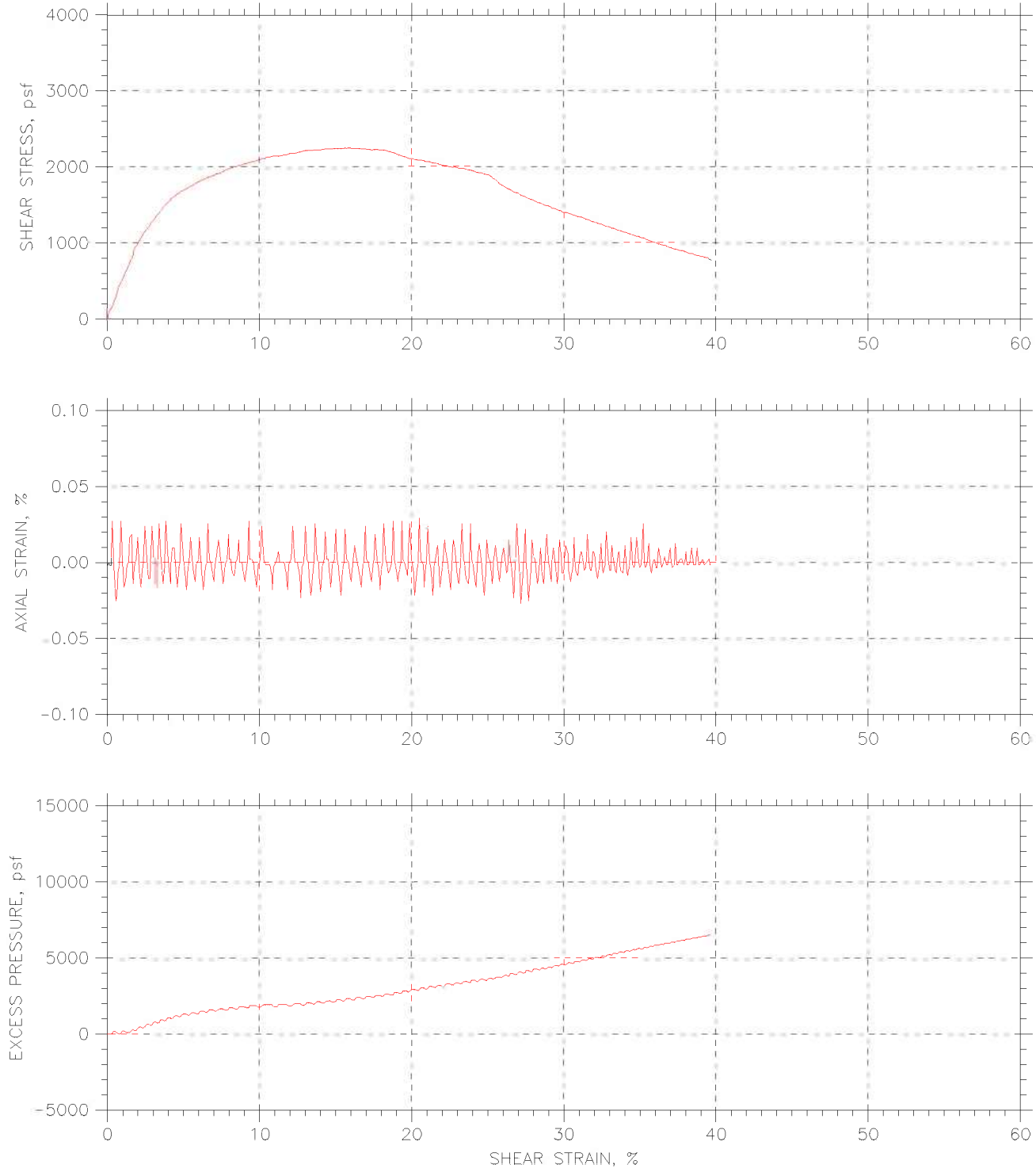

|  |                         |                       |
|--|-------------------------|-----------------------|
| Project: I-90 Central Viaduct  | Location: Cleveland, OH | Project No.: GTX-6678 |
| Boring No.: C-05-03  | Tested By: njh          | Checked By: jdt       |
| Sample No.: S-29   | Test Date: 05/05/06     | Depth: 115.5-118.5    |
| Test No.: DSS-1  | Sample Type: tube       | Elevation: ---        |
| Description: Moist, dark gray clay   |                         |                       |
| Remarks: 500 lb vertical load cell - 500 lb low profile horizontal load cell |                         | 1.5 membrane          |
| File: \\Geocomp\db1\projects\GTX6678\6678-DSS-1.dat                          |                         |                       |

# DIRECT SIMPLE SHEAR TEST

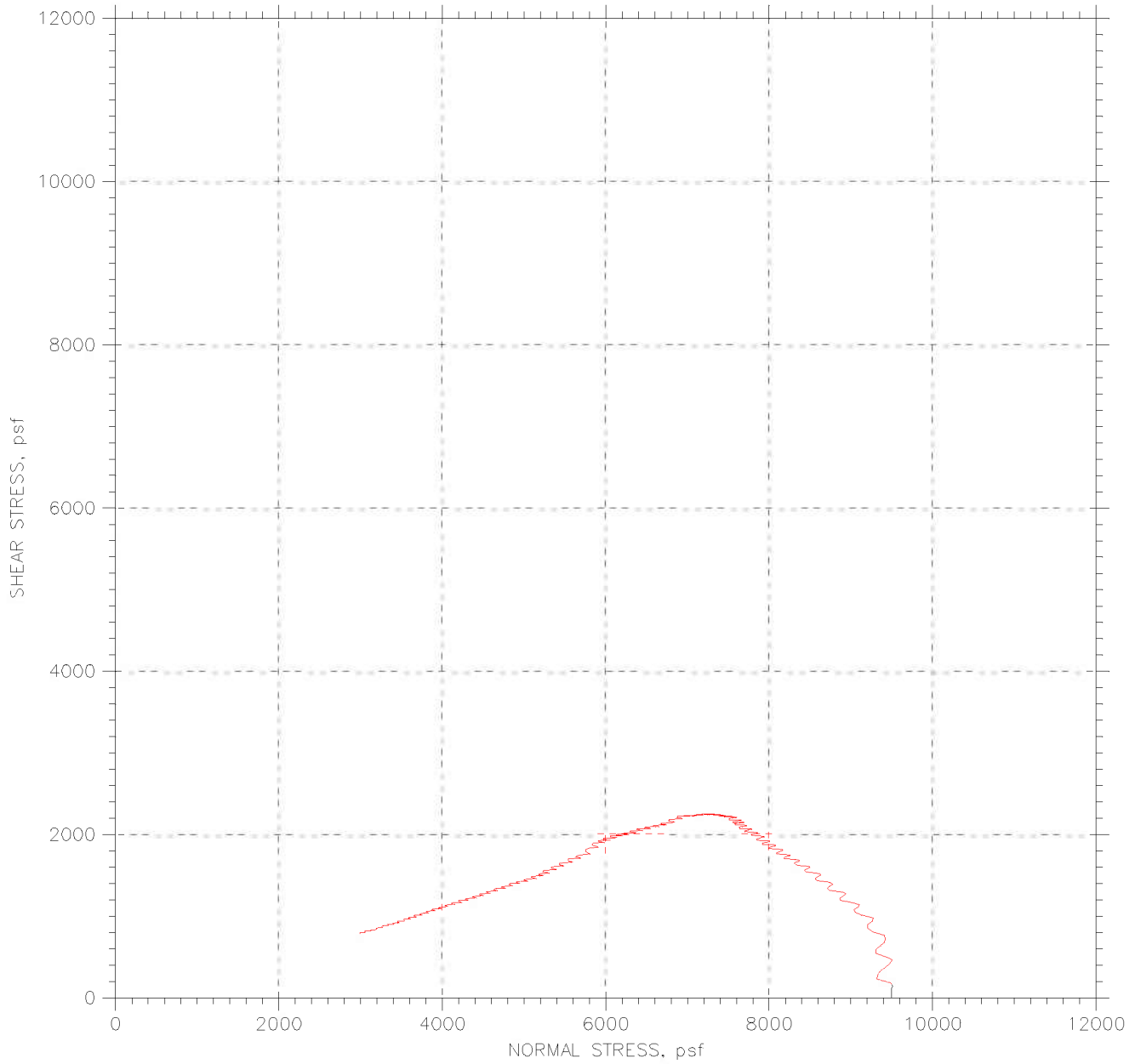

|  |                         |                       |
|--|-------------------------|-----------------------|
| Project: I-90 Central Viaduct  | Location: Cleveland, OH | Project No.: GTX-6678 |
| Boring No.: C-05-03  | Tested By: njh          | Checked By: jdt       |
| Sample No.: S-29   | Test Date: 05/05/06     | Depth: 115.5-118.5    |
| Test No.: DSS-1  | Sample Type: tube       | Elevation: ---        |
| Description: Moist, dark gray clay   |                         |                       |
| Remarks: 500 lb vertical load cell - 500 lb low profile horizontal load cell |                         | 1.5 membrane          |
| File: \\Geocompdb1\projects\GTX6678\6678-DSS-1.dat                           |                         |                       |

**Consolidated Undrained Direct Simple Shear Test of Cohesive Soil  
by ASTM D 6528**

Client: Geocomp Consulting GTX#: 6678  
 Project Name: I-90 Central Viaduct Test Date: 05/08/06  
 Project Location: Cleveland, OH

Boring ID: C-05-03  
 Sample ID: S-30  
 Depth, ft: 118.5-120.3 ft

Visual Description: Moist, dark gray clay

Test Equipment: Top and bottom box (circular) = 2.62 in diameter. Load cells and LVDT's connected to data acquisition system for shear force, normal load, horizontal and vertical displacement; surface area = 5.39 in<sup>2</sup>, soil height = 1 inch

Test Condition: inundated

Sample Type and Preparation: Extruded from tube, cut, trimmed and placed into apparatus at as-received density and moisture content.

| Parameter                            | Point 1 | Point 2 | Point 3 | Point 4 | Point 5 |
|--------------------------------------|---------|---------|---------|---------|---------|
| Test No.                             | DSS-2   |         |         |         |         |
| Initial Moisture Content, %          | 26      |         |         |         |         |
| Initial Dry Density, pcf             | 99.3    |         |         |         |         |
| Nominal Rate of Shear Strain, %/min  | 0.0008  |         |         |         |         |
| Vertical Consolidation Stress, psf   | 9500    |         |         |         |         |
| Final Moisture Content, %            | 29      |         |         |         |         |
| Measured Peak Shear Stress, psf      | 2514    |         |         |         |         |
| Shear Strain at Peak Shear Stress, % | 20.0    |         |         |         |         |
| Membrane Correction, psf             | 78      |         |         |         |         |
| $S / \sigma'_{vc}$                   | 0.26    |         |         |         |         |

Comments: Tested By: njh Checked By: jdt

Notes: These results apply only to the sample tested for the specific test conditions. The test procedures employed follow accepted industry practice and the indicated test method. GeoTesting Express has no specific knowledge as to conditioning, origin, sampling procedure or intended use of the material.

# DIRECT SIMPLE SHEAR TEST

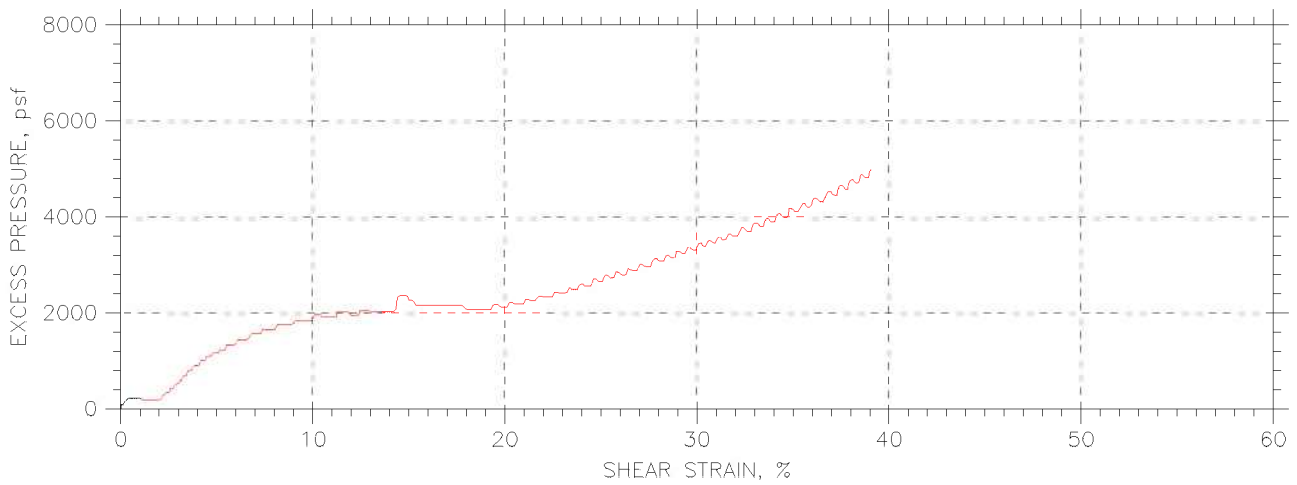
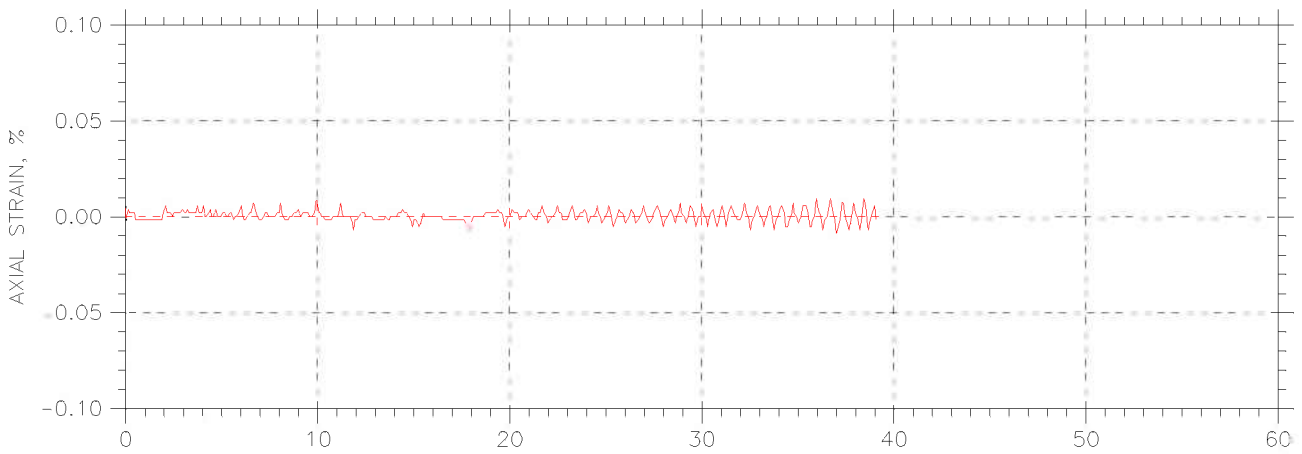
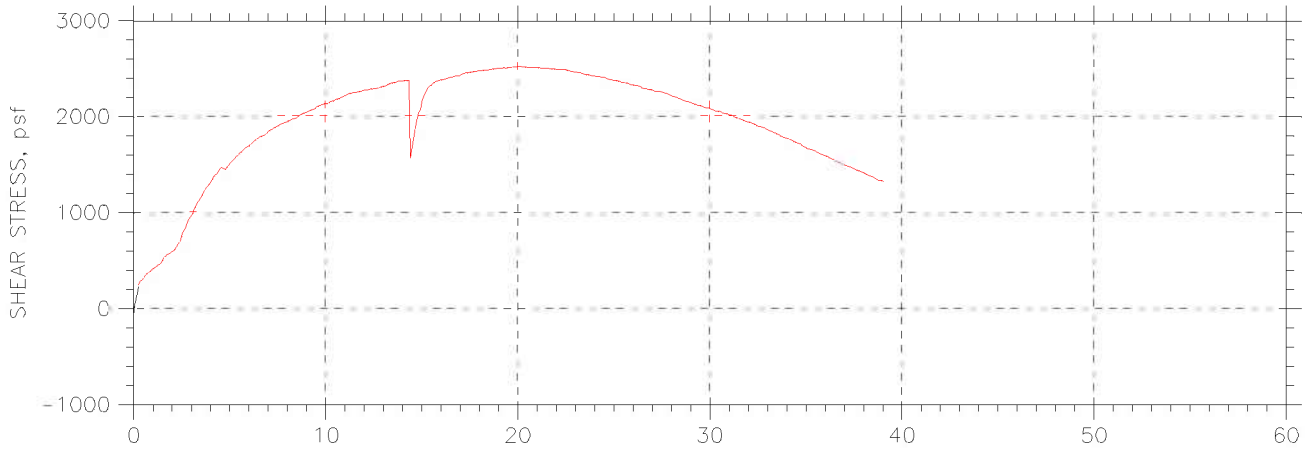

|  |                         |                       |
|--|-------------------------|-----------------------|
| Project: I-90 Central Viaduct  | Location: Cleveland, OH | Project No.: GTX-6678 |
| Boring No.: C-05-03  | Tested By: njh          | Checked By: jdt       |
| Sample No.: S-30   | Test Date: 05/06/06     | Depth: 118.5-120.3    |
| Test No.: DSS-2  | Sample Type: tube       | Elevation: ---        |
| Description: Moist, dark gray clay   |                         |                       |
| Remarks: 500 lb vertical load cell - 500 lb low profile horizontal load cell |                         | 1.5 membrane          |
| File: \\Geocomp\db1\projects\GTX6678\6678-DSS-2.dat                          |                         |                       |

# DIRECT SIMPLE SHEAR TEST

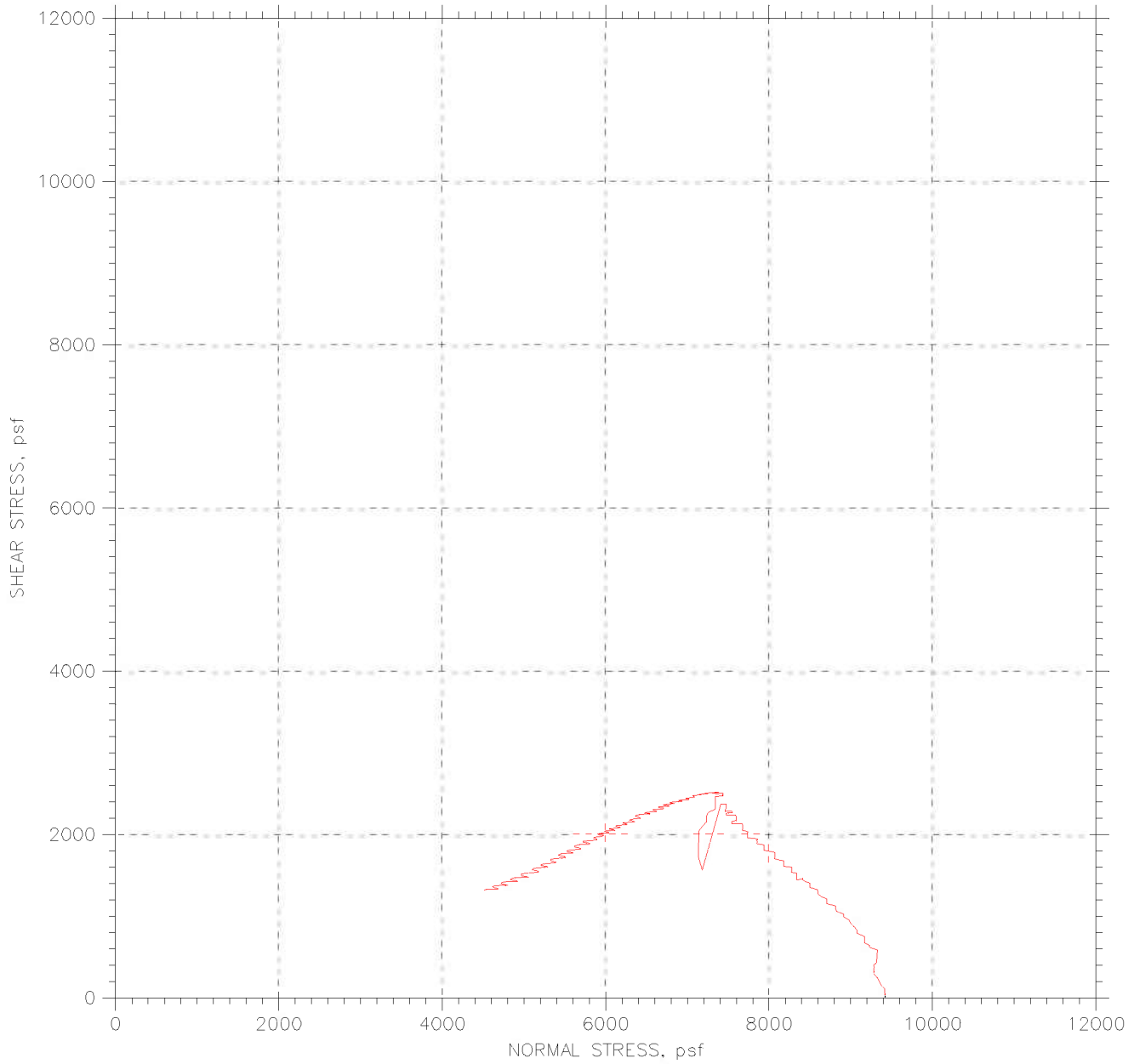

|  |                         |                       |
|--|-------------------------|-----------------------|
| Project: I-90 Central Viaduct  | Location: Cleveland, OH | Project No.: GTX-6678 |
| Boring No.: C-05-03  | Tested By: njh          | Checked By: jdt       |
| Sample No.: S-30   | Test Date: 05/06/06     | Depth: 118.5-120.3    |
| Test No.: DSS-2  | Sample Type: tube       | Elevation: ---        |
| Description: Moist, dark gray clay   |                         |                       |
| Remarks: 500 lb vertical load cell - 500 lb low profile horizontal load cell |                         | 1.5 membrane          |
| File: \\Geocomp\db1\projects\GTX6678\6678-DSS-2.dat                          |                         |                       |



## Consolidated Undrained Direct Simple Shear Test of Cohesive Soil by ASTM D 6528

Client: Geocomp Consulting GTX#: 6678  
 Project Name: I-90 Central Viaduct Test Date: 05/30/06  
 Project Location: Cleveland, OH

Boring ID: C-05-04  
 Sample ID: S-27  
 Depth, ft: 72-74 ft

Visual Description: Moist, very dark grayish brown clay

Test Equipment: Top and bottom box (circular) = 2.62 in diameter. Load cells and LVDT's connected to data acquisition system for shear force, normal load, horizontal and vertical displacement; surface area = 5.39 in<sup>2</sup>, soil height = 1 inch

Test Condition: inundated

Sample Type and Preparation: Extruded from tube, cut, trimmed and placed into apparatus at as-received density and moisture content.

| Parameter                            | Point 1 | Point 2 | Point 3 | Point 4 | Point 5 |
|--------------------------------------|---------|---------|---------|---------|---------|
| Test No.                             | DSS-3   |         |         |         |         |
| Initial Moisture Content, %          | 22      |         |         |         |         |
| Initial Dry Density, pcf             | 107     |         |         |         |         |
| Nominal Rate of Shear Strain, %/min  | 0.0008  |         |         |         |         |
| Vertical Consolidation Stress, psf   | 5506    |         |         |         |         |
| Final Moisture Content, %            | 21      |         |         |         |         |
| Measured Peak Shear Stress, psf      | 2092    |         |         |         |         |
| Shear Strain at Peak Shear Stress, % | 10.7    |         |         |         |         |
| Membrane Correction, psf             | 64      |         |         |         |         |
| $S / \sigma'_{vc}$                   | 0.37    |         |         |         |         |

Comments: Tested By: njh Checked By: jdt

Notes: These results apply only to the sample tested for the specific test conditions. The test procedures employed follow accepted industry practice and the indicated test method. GeoTesting Express has no specific knowledge as to conditioning, origin, sampling procedure or intended use of the material.

# DIRECT SIMPLE SHEAR TEST

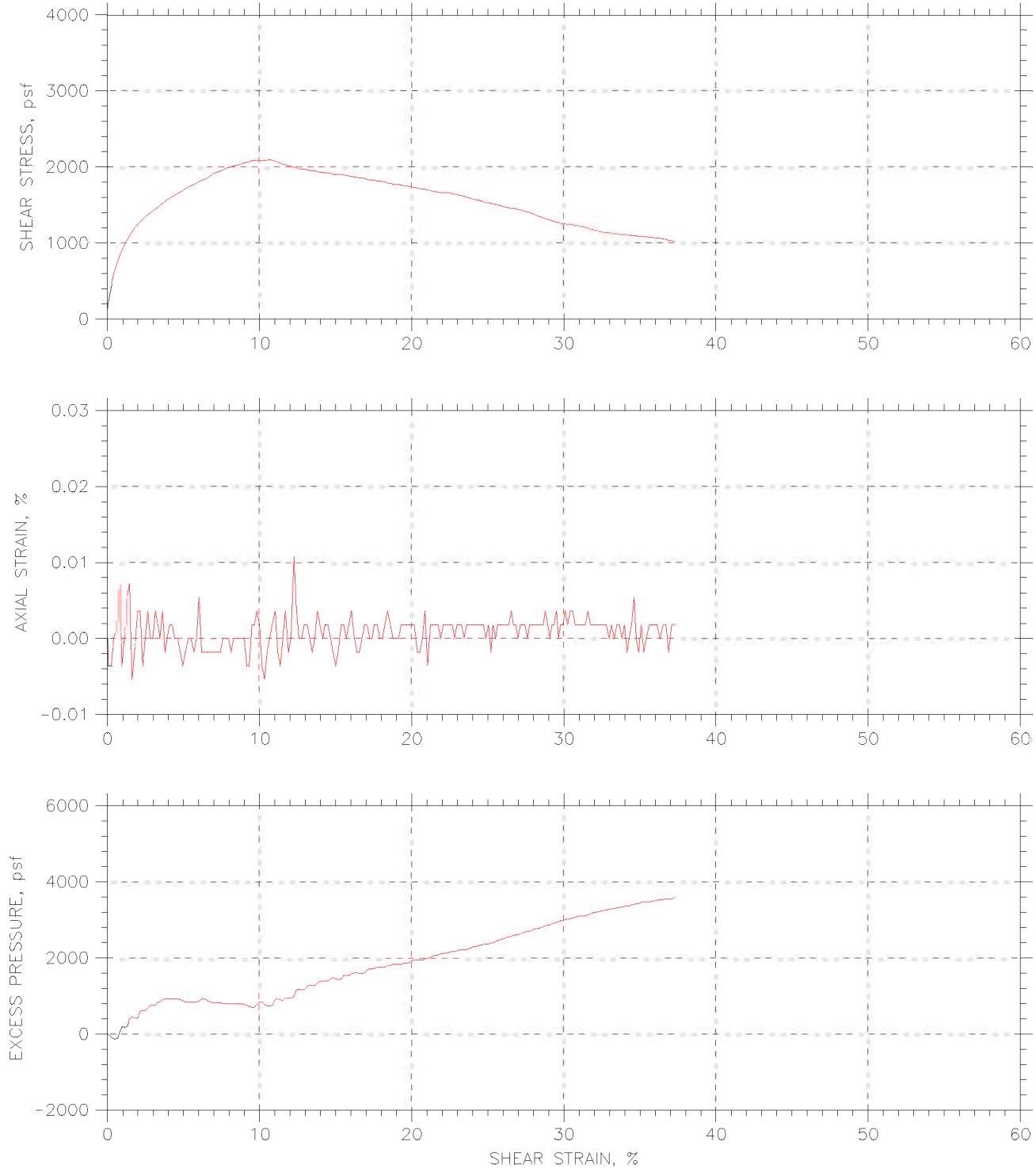

|   |                         |                       |
|---|-------------------------|-----------------------|
| Project: I-90 Central Viaduct                     | Location: Cleveland, OH | Project No.: GTX-6678 |
| Boring No.: C-05-04                               | Tested By: njh          | Checked By: jdt       |
| Sample No.: S-27                                  | Test Date: 05/30/06     | Depth: 72-74 ft       |
| Test No.: DSS-3                                   | Sample Type: ---        | Elevation: ---        |
| Description: Moist, very dark grayish brown clay  |                         |                       |
| Remarks: 1.5 membrane                             |                         |                       |
| File: \\Geocompdb1\projects\GTX6678\6678-DSS3.dat |                         |                       |

# DIRECT SIMPLE SHEAR TEST

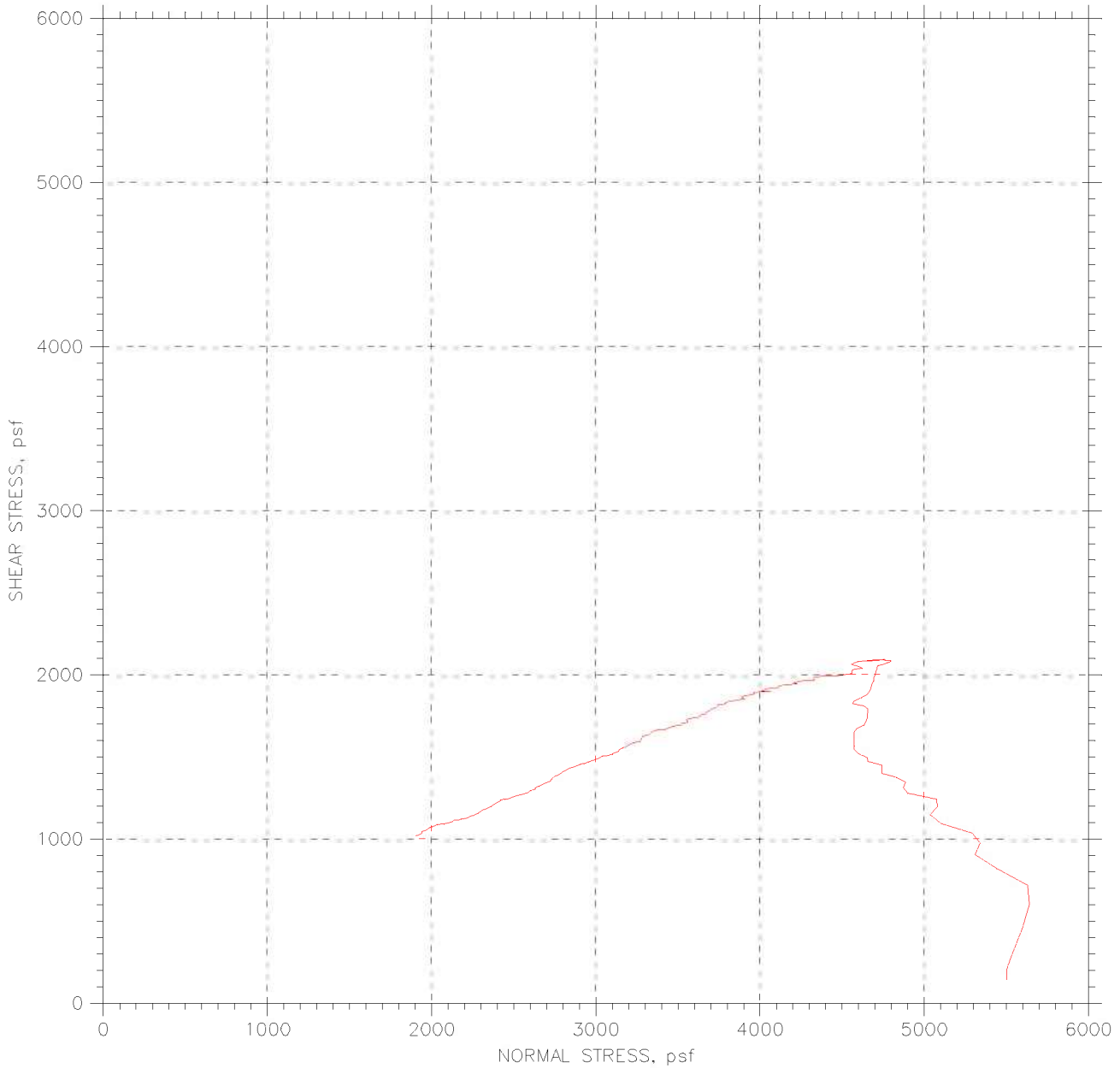

|   |                         |                       |
|---|-------------------------|-----------------------|
| Project: I-90 Central Viaduct                     | Location: Cleveland, OH | Project No.: GTX-6678 |
| Boring No.: C-05-04                               | Tested By: njh          | Checked By: jdt       |
| Sample No.: S-27                                  | Test Date: 05/30/06     | Depth: 72-74 ft       |
| Test No.: DSS-3                                   | Sample Type: ---        | Elevation: ---        |
| Description: Moist, very dark grayish brown clay  |                         |                       |
| Remarks: 1.5 membrane                             |                         |                       |
| File: \\Geocompdb1\projects\GTX6678\6678-DSS3.dat |                         |                       |

# DIRECT SIMPLE SHEAR TEST

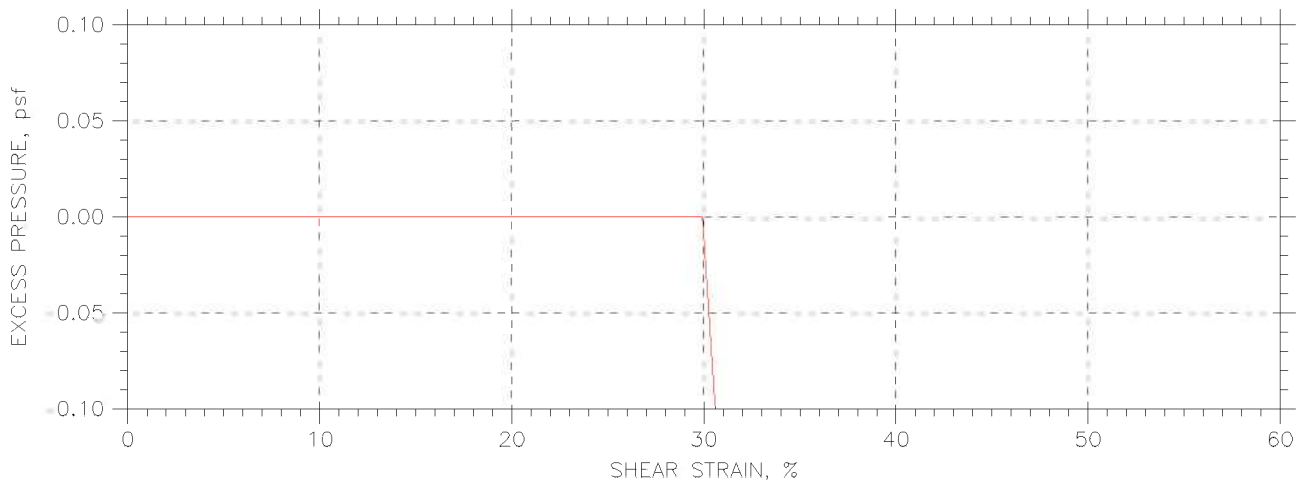
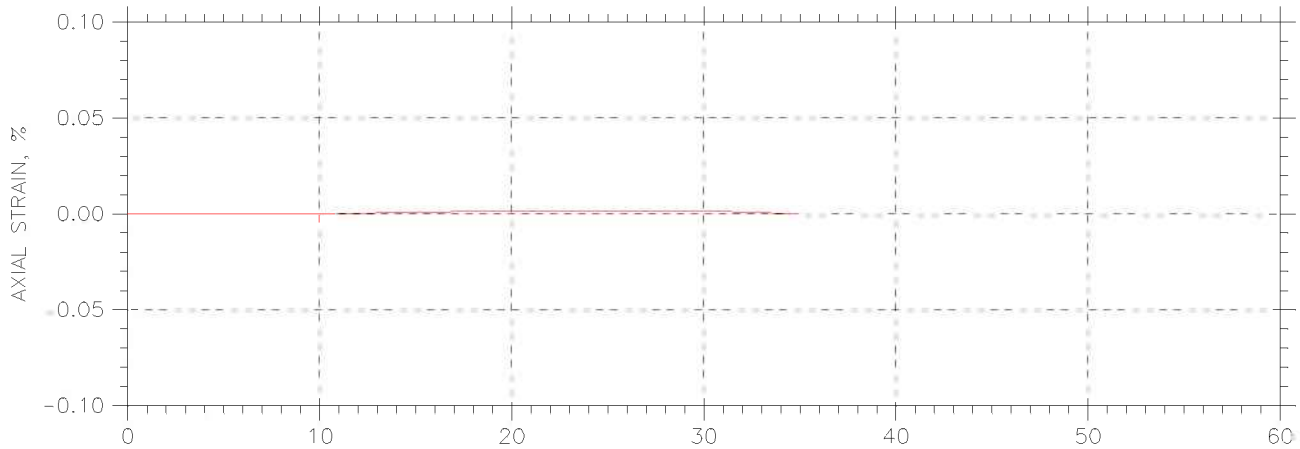
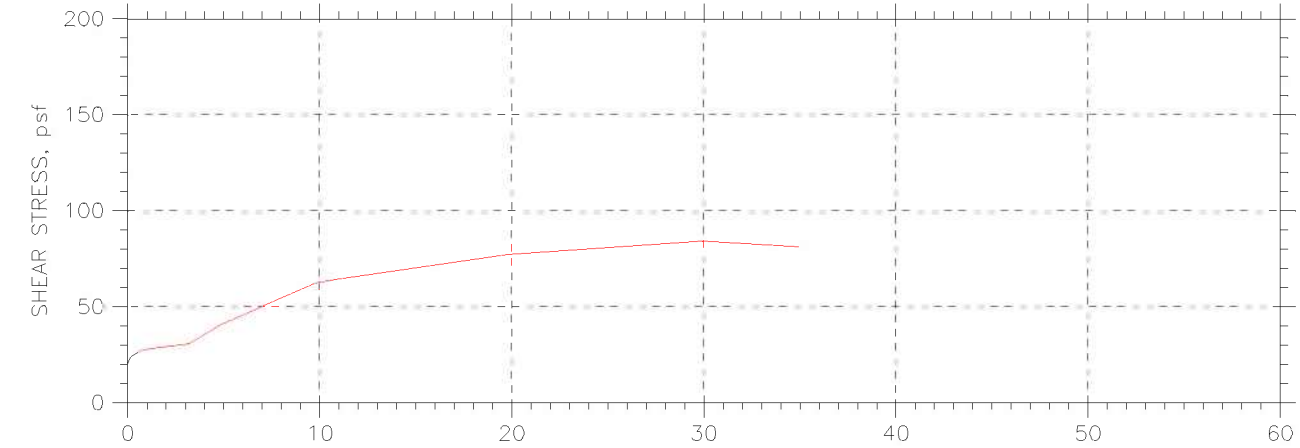

|   |                     |              |
|---|---------------------|--------------|
| Project: MEMBRANE CORRECTION  | Location:           | Project No.: |
| Boring No.:   | Tested By: md       | Checked By:  |
| Sample No.: 1.5   | Test Date: 04/04/06 | Depth:       |
| Test No.:   | Sample Type:        | Elevation:   |
| Description: Membrane Correction Curve  |                     |              |
| Remarks:  |                     |              |
| File: \\Geocomp\db1\projects\Calibration\Membrane Correction Files\Mem cal-take4(1.5).dat |                     |              |

# **Appendix D**

## **Residual Shear Tests**



|                   |   |             |        |
|-------------------|---|-------------|--------|
| Client:           | Geocomp Consulting  |             |        |
| Project Name:     | I-90 Central Viaduct  |             |        |
| Project Location: | Cleveland, OH   |             |        |
| GTX #:            | 6678  | Tested By:  | njh/md |
| Test Date:        | 05/06-05/19/06  | Checked By: | jdt    |
| Boring ID:        | C-05-03   |             |        |
| Sample ID:        | S-29  |             |        |
| Depth, ft.        | 116.5-118.5 ft  |             |        |
| Description:      | Moist, dark gray clay   |             |        |
| Preparation:      | Extruded from tube, cut and trimmed and tested at the as-received moisture and density. |             |        |

## Direct Shear and Residual Shear by ASTM D 3080

| Parameter                                | Point 1 | Point 2 | Point 3 |
|--|---------|---------|---------|
| Test No.                                 | RS5     | RS4     | RS6     |
| Initial Moisture Content, %              | 26      | 26      | 24      |
| Initial Dry Density, pcf                 | 98.2    | 97.4    | 99.1    |
| Nominal Rate of Shear Strain, inches/min | 0.003   | 0.003   | 0.001   |
| Vertical Consolidation Stress, psf       | 4748    | 9500    | 14249   |
| Peak Shear Stress, psf                   | 2519    | 3849    | 6367    |
| Post-Peak Shear Stress, psf              | 1851    | 2559    | 5611    |
| Final Moisture Content, %                | 31      | 25      | 22      |

|  |                           |      |         |
|--|---------------------------|------|---------|
| Notes: Residual values taken near the end of the final shear step. | Peak Friction Angle:      | 22.0 | degrees |
|  | Peak Cohesion:            | 398  | psf     |
|  | Post Peak Friction Angle: | 19.7 | degrees |
|  | Post Peak Cohesion:       | 0    | psf     |

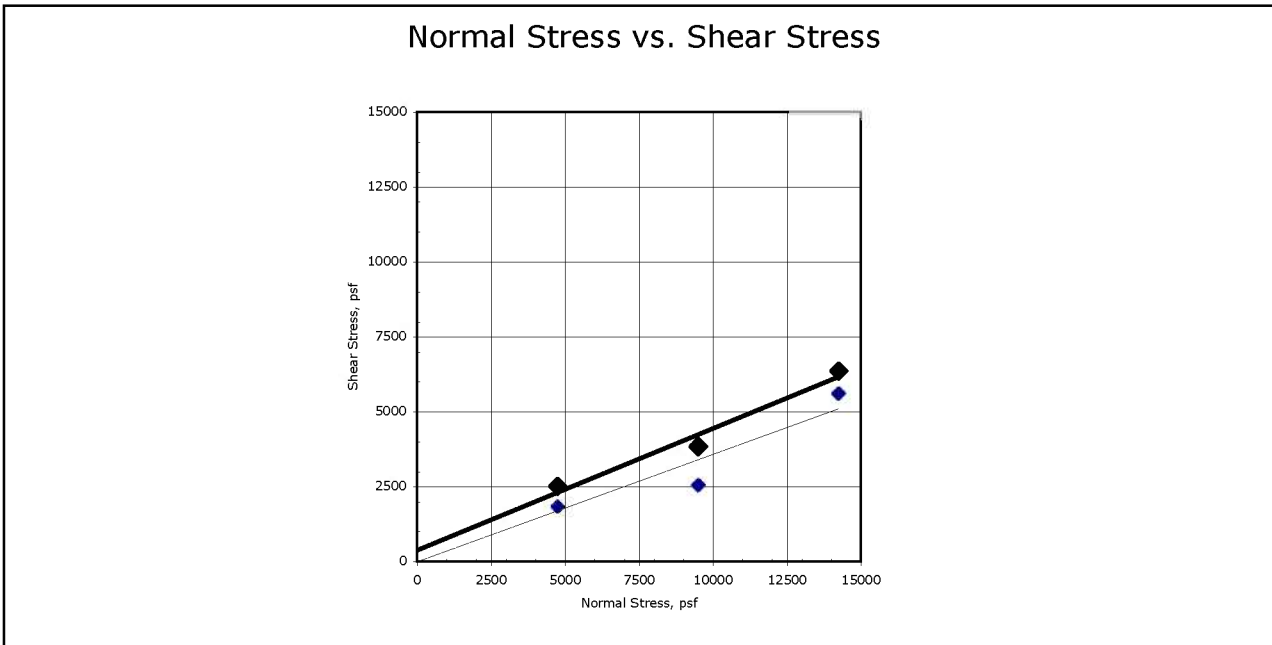

Comments: See attached plots for additional information

# RESIDUAL SHEAR TEST

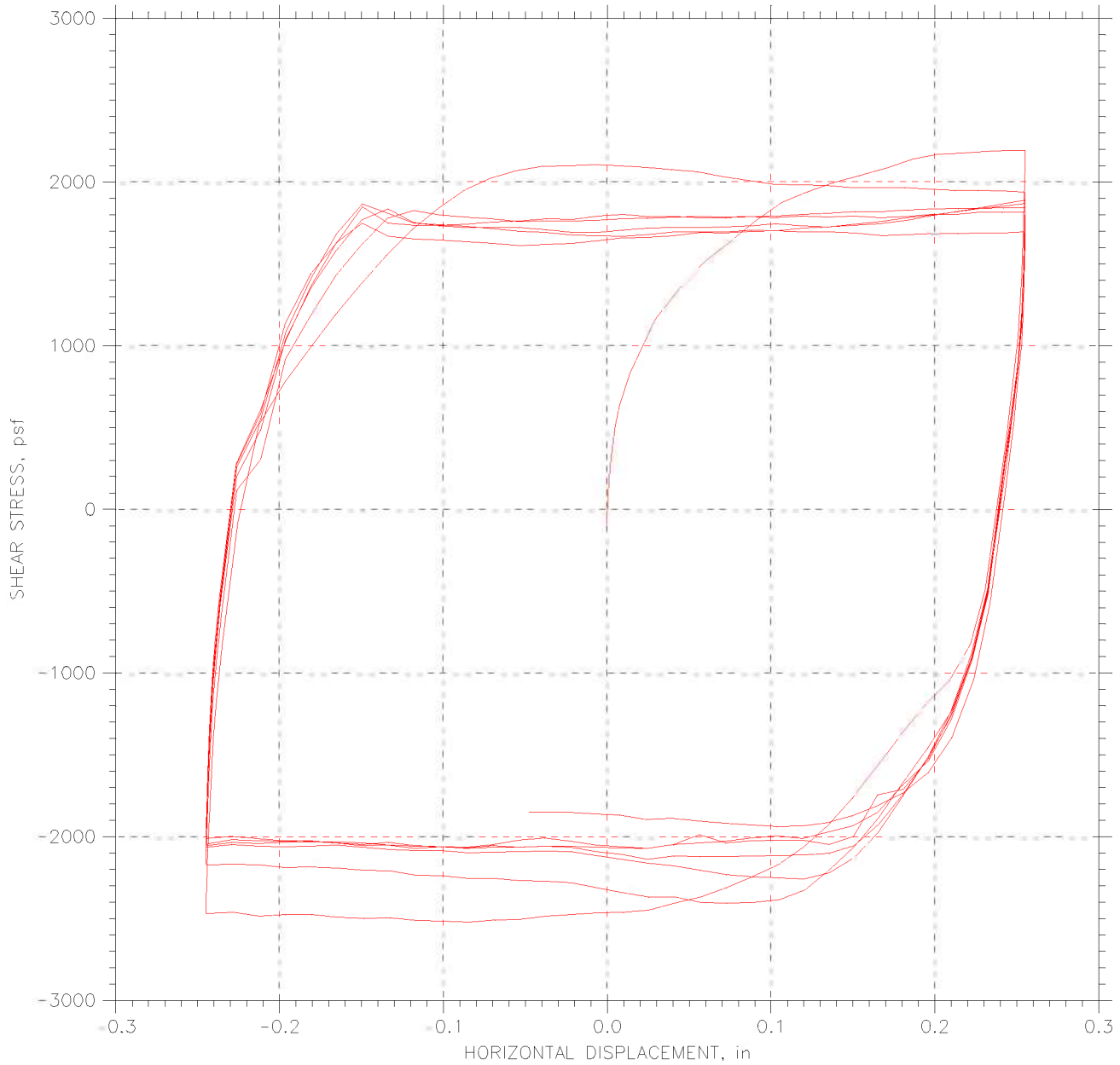

|   |                         |                       |
|---|-------------------------|-----------------------|
| Project: I-90 Central Viaduct                         | Location: Cleveland, OH | Project No.: GTX-6678 |
| Boring No.: C-05-03                                   | Tested By: njh          | Checked By: jdt       |
| Sample No.: S-29                                      | Test Date: 05/11/06     | Depth: 116.5-118.5    |
| Test No.: RS-5  | Sample Type: tube       | Elevation: ---        |
| Description: Moist, dark gray clay                    |                         |                       |
| Remarks: Shear Loop rates (in/min): All loops @ .003. |                         |                       |
| File: \\Geocomp\db1\projects\GTX6678\6678-rs5.dat     |                         |                       |

## RESIDUAL SHEAR TEST

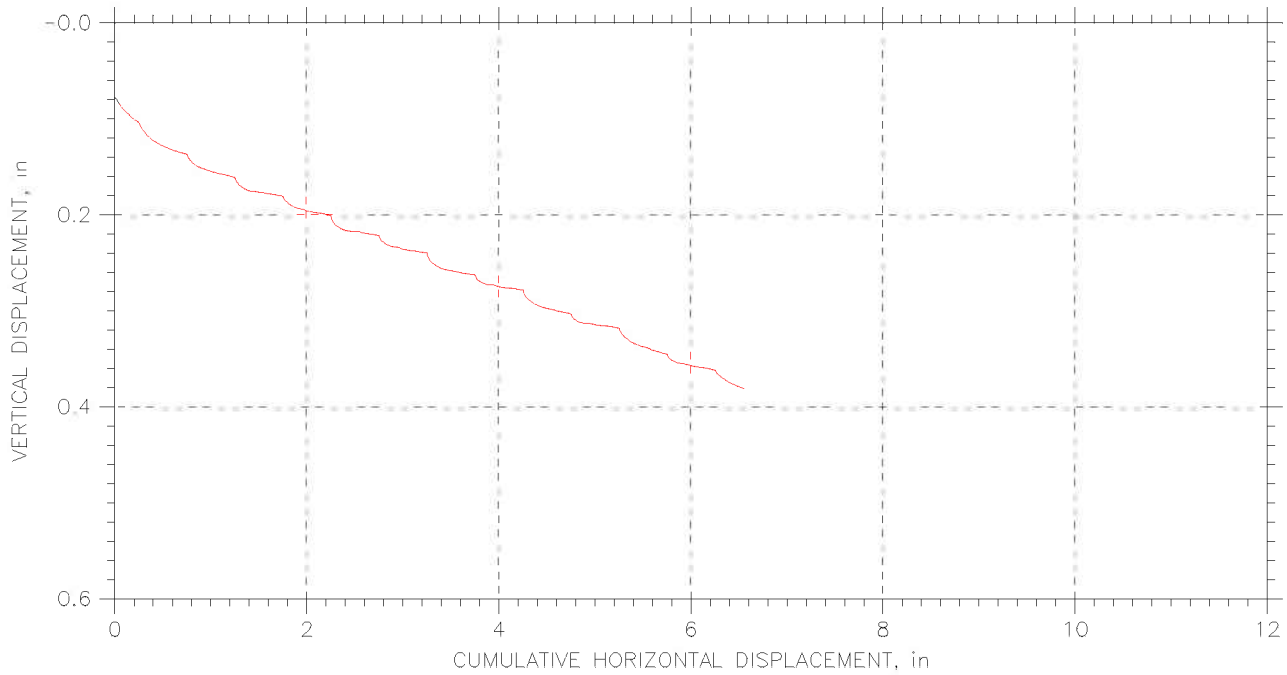
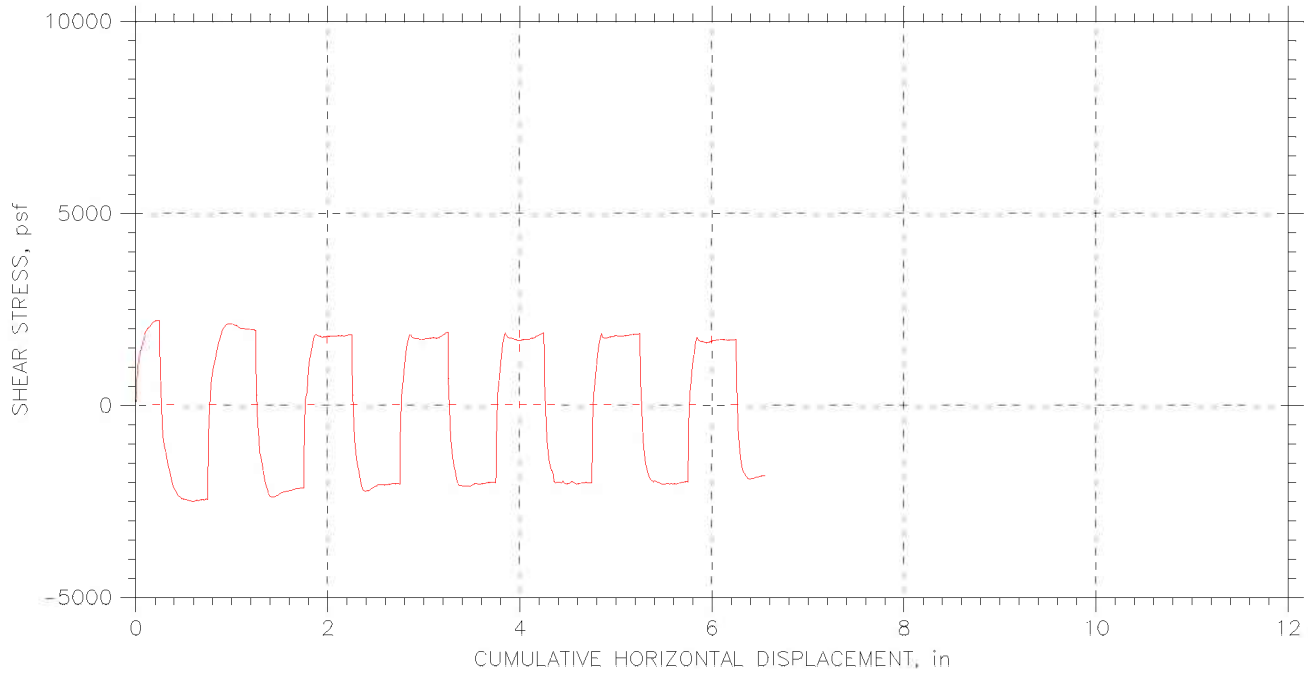

|   |                         |                       |
|---|-------------------------|-----------------------|
| Project: I-90 Central Viaduct                         | Location: Cleveland, OH | Project No.: GTX-6678 |
| Boring No.: C-05-03                                   | Tested By: njh          | Checked By: jdt       |
| Sample No.: S-29                                      | Test Date: 05/11/06     | Depth: 116.5-118.5    |
| Test No.: RS-5  | Sample Type: tube       | Elevation: ---        |
| Description: Moist, dark gray clay                    |                         |                       |
| Remarks: Shear Loop rates (in/min): All loops @ .003. |                         |                       |
| File: \\Geocompdb1\projects\GTX6678\6678-rs5.dat      |                         |                       |



## RESIDUAL SHEAR TEST

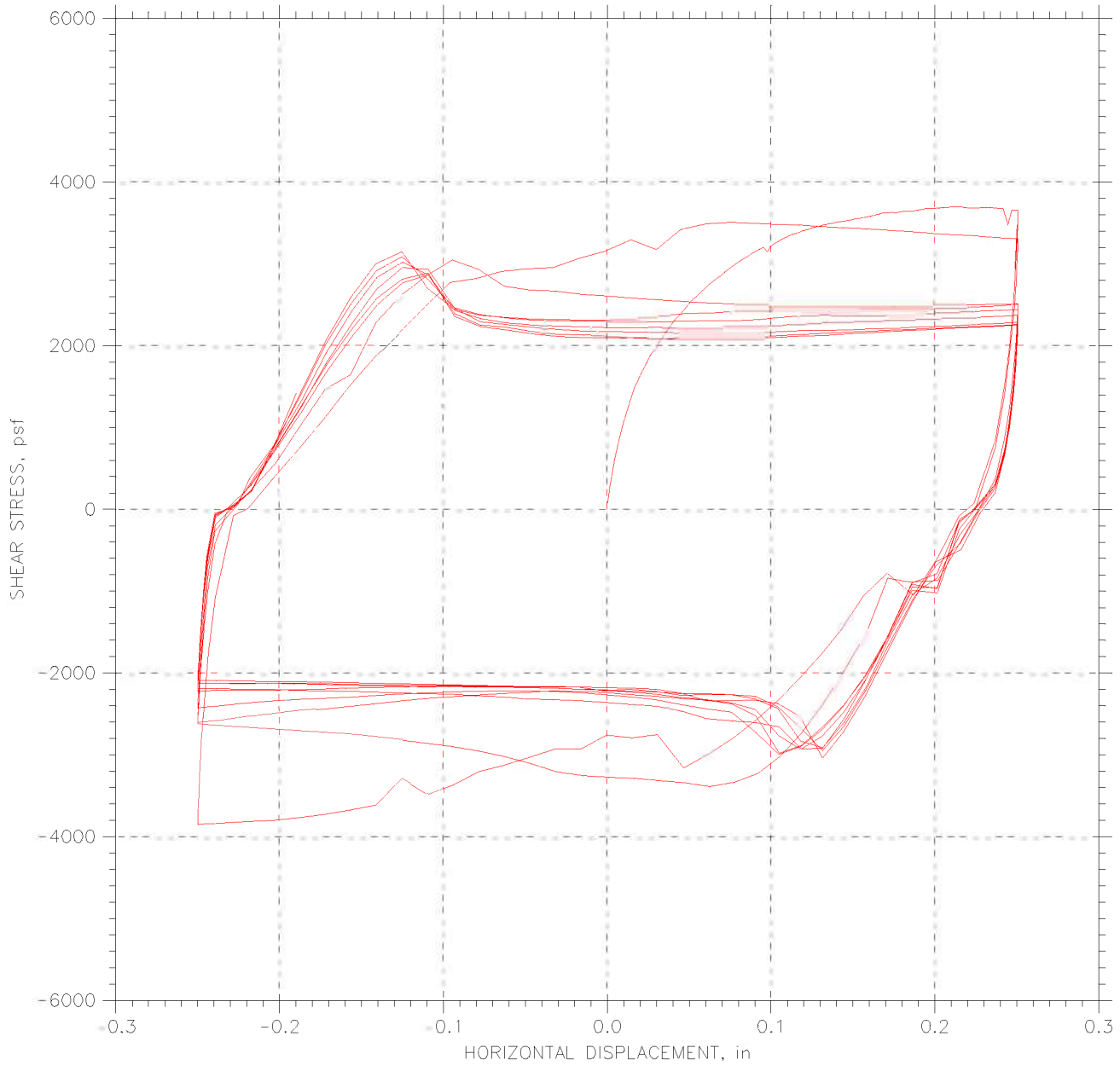

|  |                         |                       |
|--|-------------------------|-----------------------|
| Project: I-90 Central Viaduct  | Location: Cleveland, OH | Project No.: GTX-6678 |
| Boring No.: C-05-03  | Tested By: njh          | Checked By: jdt       |
| Sample No.: S-29   | Test Date: 05/05/06     | Depth: 116.5-118.5    |
| Test No.: RS-4   | Sample Type: tube       | Elevation: ---        |
| Description: Moist, dark gray clay   |                         |                       |
| Remarks: Shear Loop rates (in/min): First .25 @.0005, then 1 @ .00005, then 9 @.003. |                         |                       |
| File: \\Geocomp\db1\projects\GTX6678\6678-rs4.dat                                    |                         |                       |

# RESIDUAL SHEAR TEST

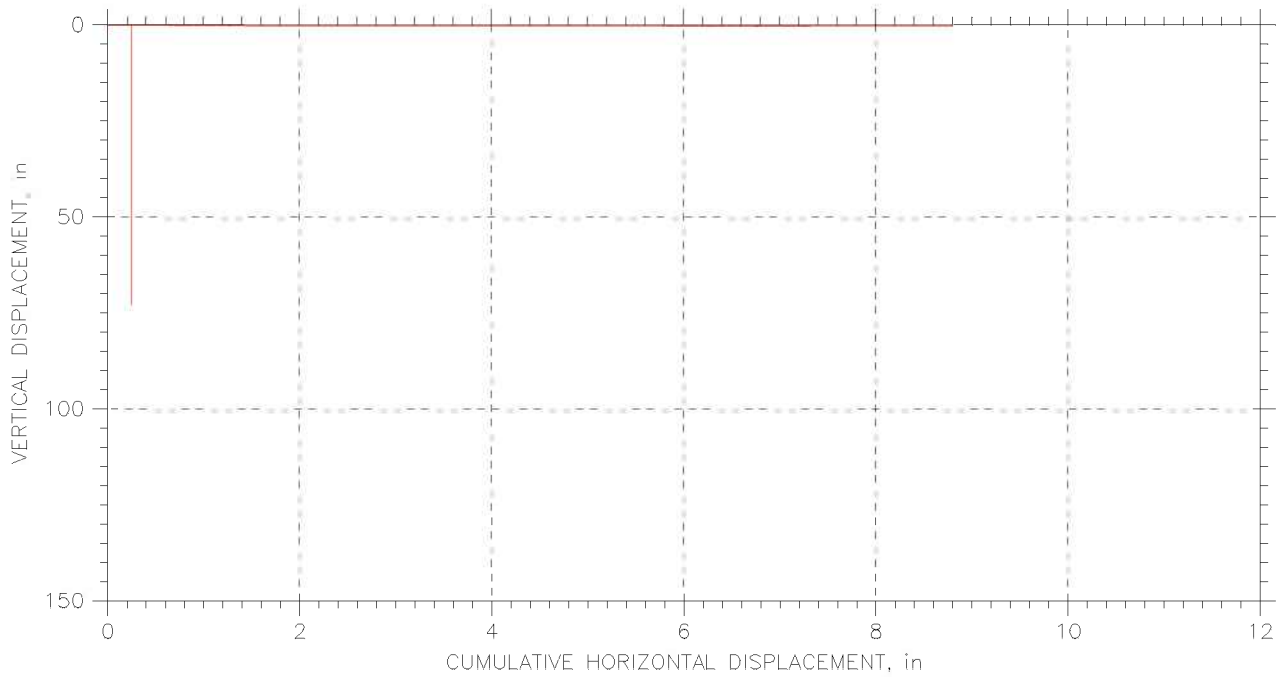
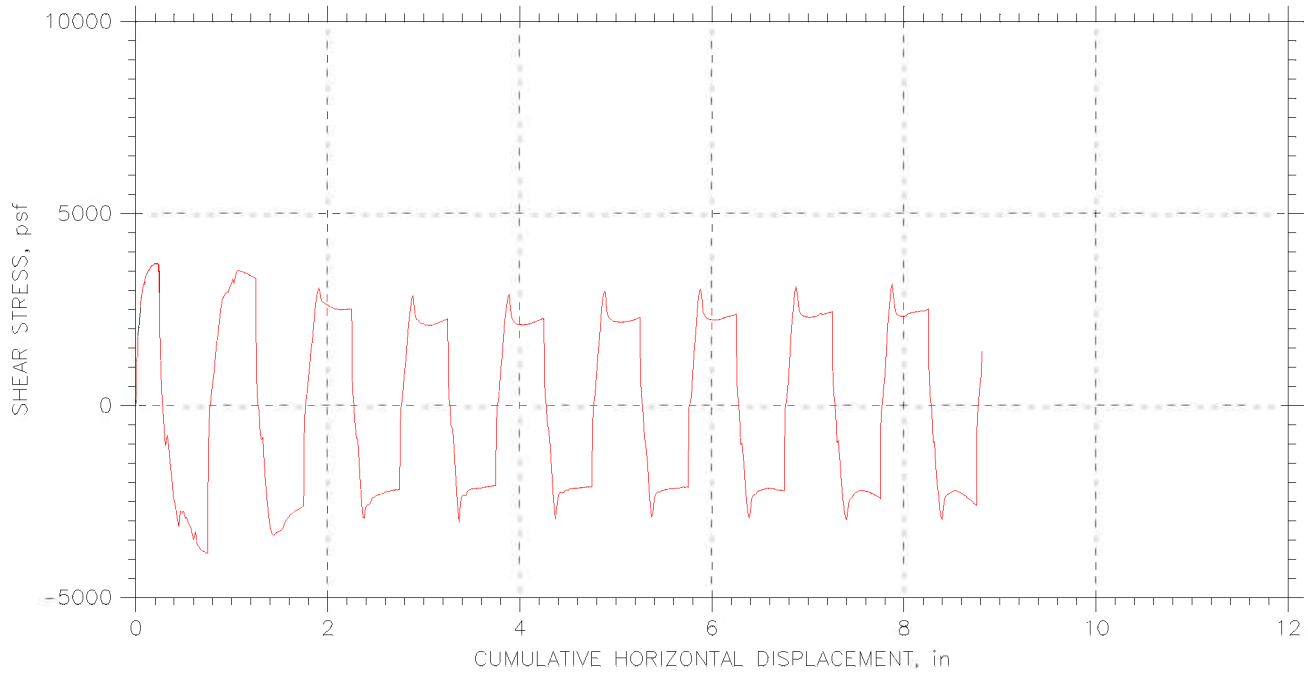

|  |                         |                       |
|--|-------------------------|-----------------------|
| Project: I-90 Central Viaduct  | Location: Cleveland, OH | Project No.: GTX-6678 |
| Boring No.: C-05-03  | Tested By: njh          | Checked By: jdt       |
| Sample No.: S-29   | Test Date: 05/05/06     | Depth: 116.5-118.5    |
| Test No.: RS-4   | Sample Type: tube       | Elevation: ---        |
| Description: Moist, dark gray clay   |                         |                       |
| Remarks: Shear Loop rates (in/min): First .25 @.0005, then 1 @ .00005, then 9 @.003. |                         |                       |
| File: \\Geocompb1\projects\GTX6678\6678-rs4.dat                                      |                         |                       |

## RESIDUAL SHEAR TEST

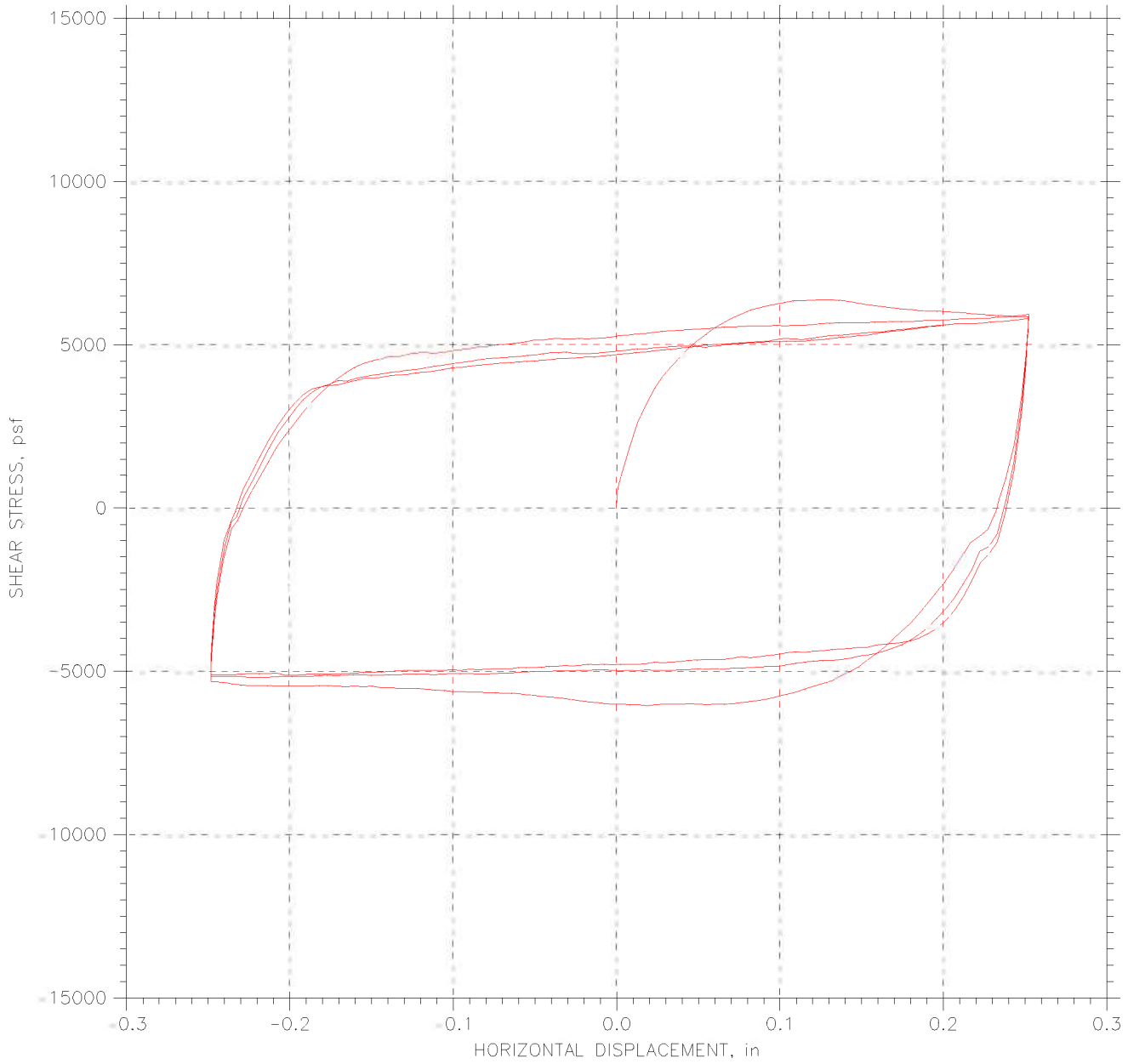

|   |                         |                       |
|---|-------------------------|-----------------------|
| Project: I-90 Central Viaduct                         | Location: Cleveland, OH | Project No.: GTX-6678 |
| Boring No.: C-05-03                                   | Tested By: md           | Checked By: jdt       |
| Sample No.: S-29                                      | Test Date: 05/15/06     | Depth: 116.5-118.5    |
| Test No.: RS-6  | Sample Type: tube       | Elevation: ---        |
| Description: Moist, dark gray clay                    |                         |                       |
| Remarks: Shear Loop rates (in/min): All loops @ .001. |                         |                       |
| File: \\Geocomp\db1\projects\GTX6678\6678-rs6.dat     |                         |                       |

## RESIDUAL SHEAR TEST

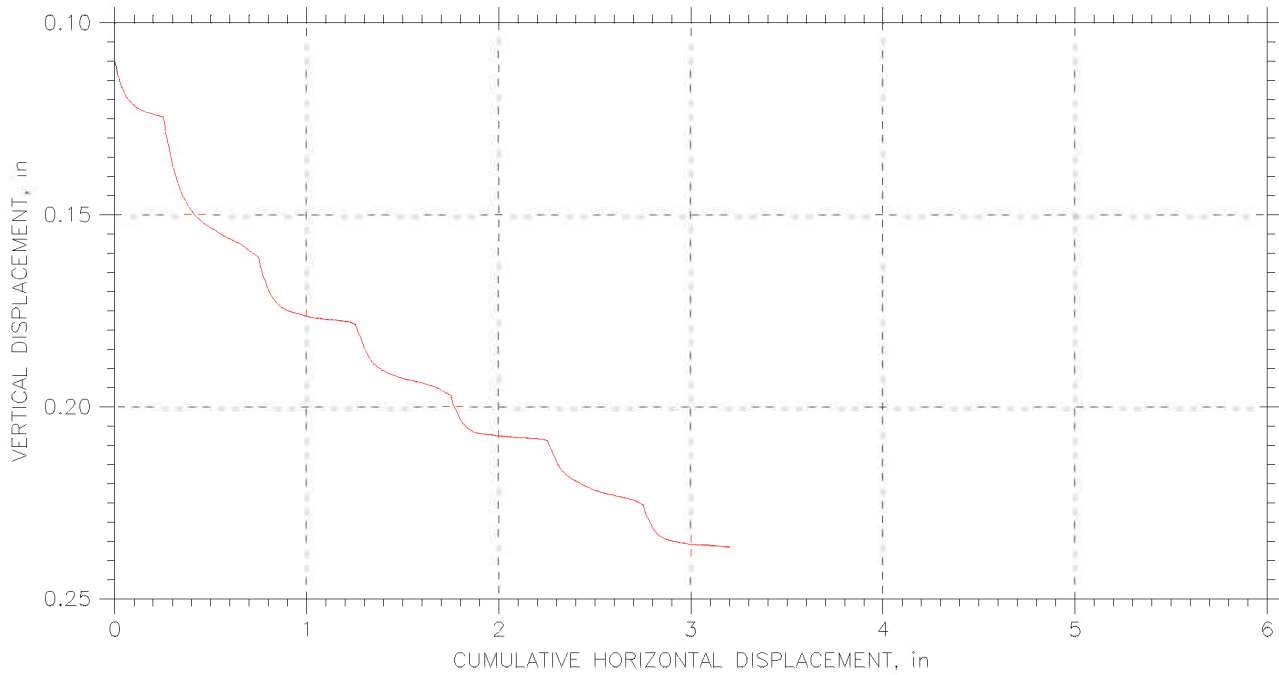
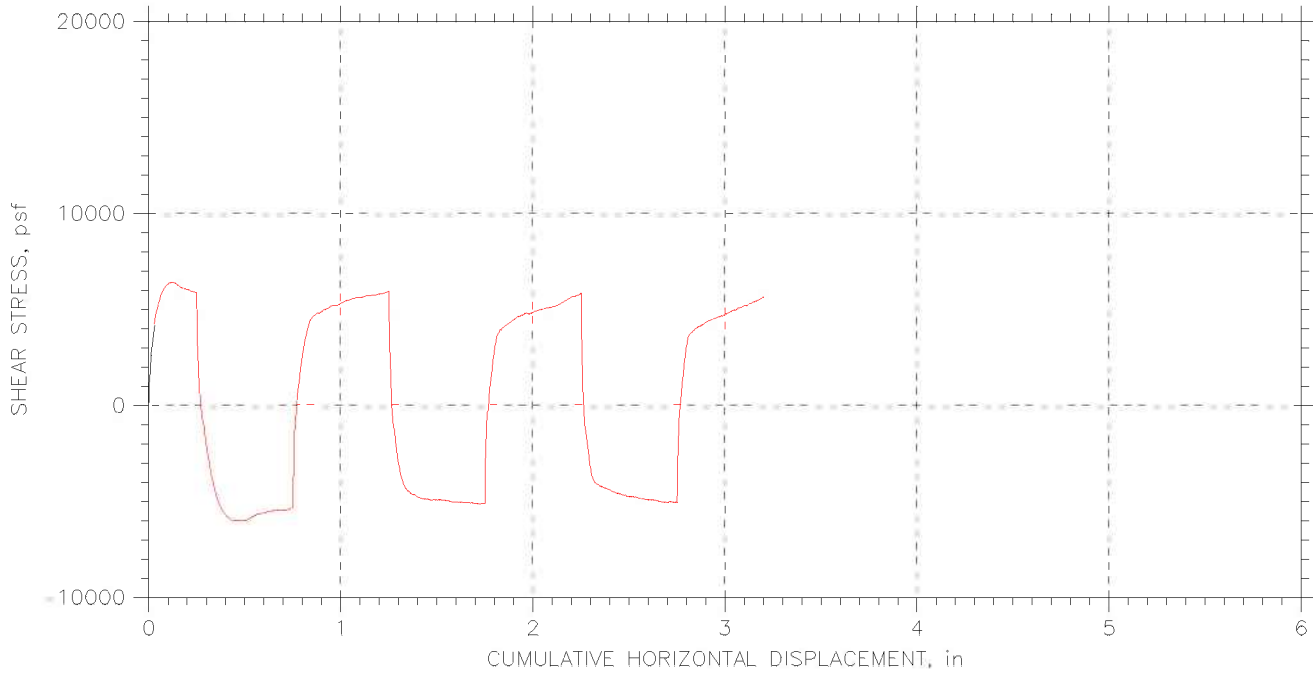

|   |                         |                       |
|---|-------------------------|-----------------------|
| Project: I-90 Central Viaduct                         | Location: Cleveland, OH | Project No.: GTX-6678 |
| Boring No.: C-05-03                                   | Tested By: md           | Checked By: jdt       |
| Sample No.: S-29                                      | Test Date: 05/15/06     | Depth: 116.5-118.5    |
| Test No.: RS-6  | Sample Type: tube       | Elevation: ---        |
| Description: Moist, dark gray clay                    |                         |                       |
| Remarks: Shear Loop rates (in/min): All loops @ .001. |                         |                       |
| File: \\Geocomp\db1\projects\GTX6678\6678-rs6.dat     |                         |                       |



|                   |   |             |        |
|-------------------|---|-------------|--------|
| Client:           | Geocomp Consulting  |             |        |
| Project Name:     | I-90 Central Viaduct  |             |        |
| Project Location: | Cleveland, OH   |             |        |
| GTX #:            | 6678  | Tested By:  | njh/md |
| Test Date:        | 05/06-05/19/06  | Checked By: | jdt    |
| Boring ID:        | C-05-03   |             |        |
| Sample ID:        | S-30  |             |        |
| Depth, ft.        | 118.5-120.3 ft  |             |        |
| Description:      | Moist, dark gray clay   |             |        |
| Preparation:      | Extruded from tube, cut and trimmed and tested at the as-received moisture and density. |             |        |

## Direct Shear and Residual Shear by ASTM D 3080

| Parameter                                | Point 1 | Point 2 | Point 3 |
|--|---------|---------|---------|
| Test No.                                 | RS1     | RS2     | RS3     |
| Initial Moisture Content, %              | 20      | 28      | 21      |
| Initial Dry Density, pcf                 | 103     | 99.0    | 94.7    |
| Nominal Rate of Shear Strain, inches/min | 0.003   | 0.003   | 0.001   |
| Vertical Consolidation Stress, psf       | 4749    | 9500    | 14249   |
| Peak Shear Stress, psf                   | 2433    | 4818    | 5111    |
| Post-Peak Shear Stress, psf              | 2400    | 3858    | 3444    |
| Final Moisture Content, %                | 23      | 24      | 22      |

|  |                           |      |         |
|--|---------------------------|------|---------|
| Notes: Residual values taken near the end of the final shear step. | Peak Friction Angle:      | 15.7 | degrees |
|  | Peak Cohesion:            | 1444 | psf     |
|  | Post Peak Friction Angle: | 6.3  | degrees |
|  | Post Peak Cohesion:       | 2190 | psf     |

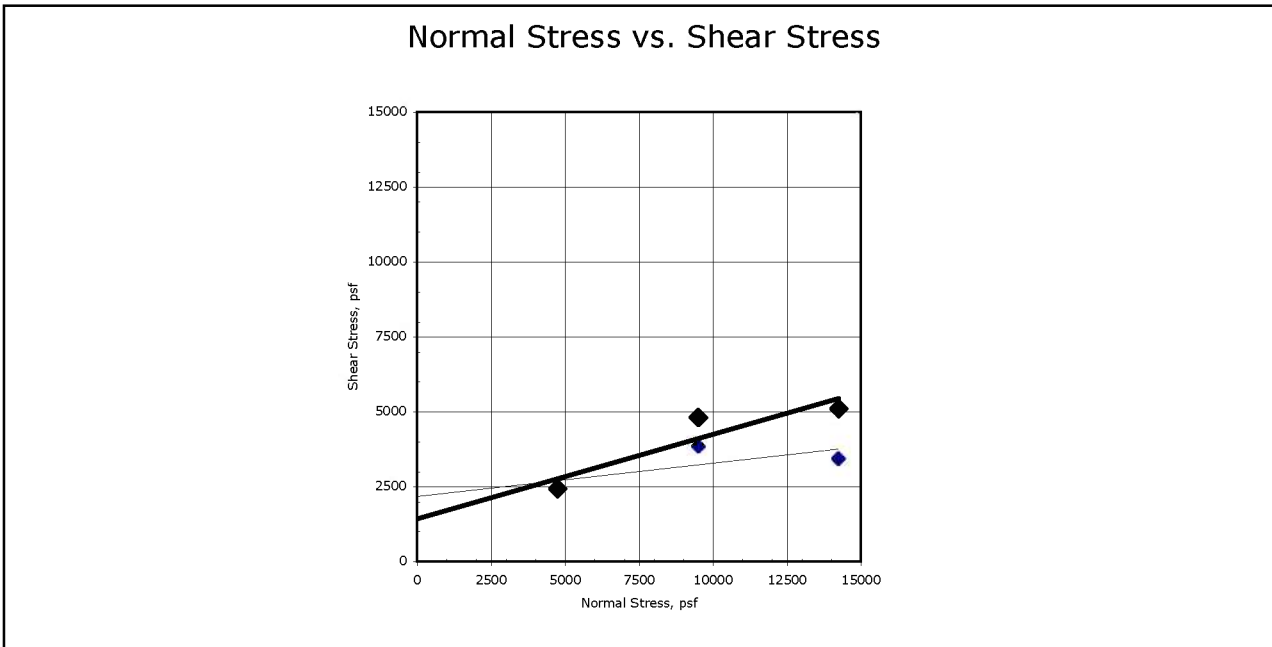

Comments: See attached plots for additional information

# RESIDUAL SHEAR TEST

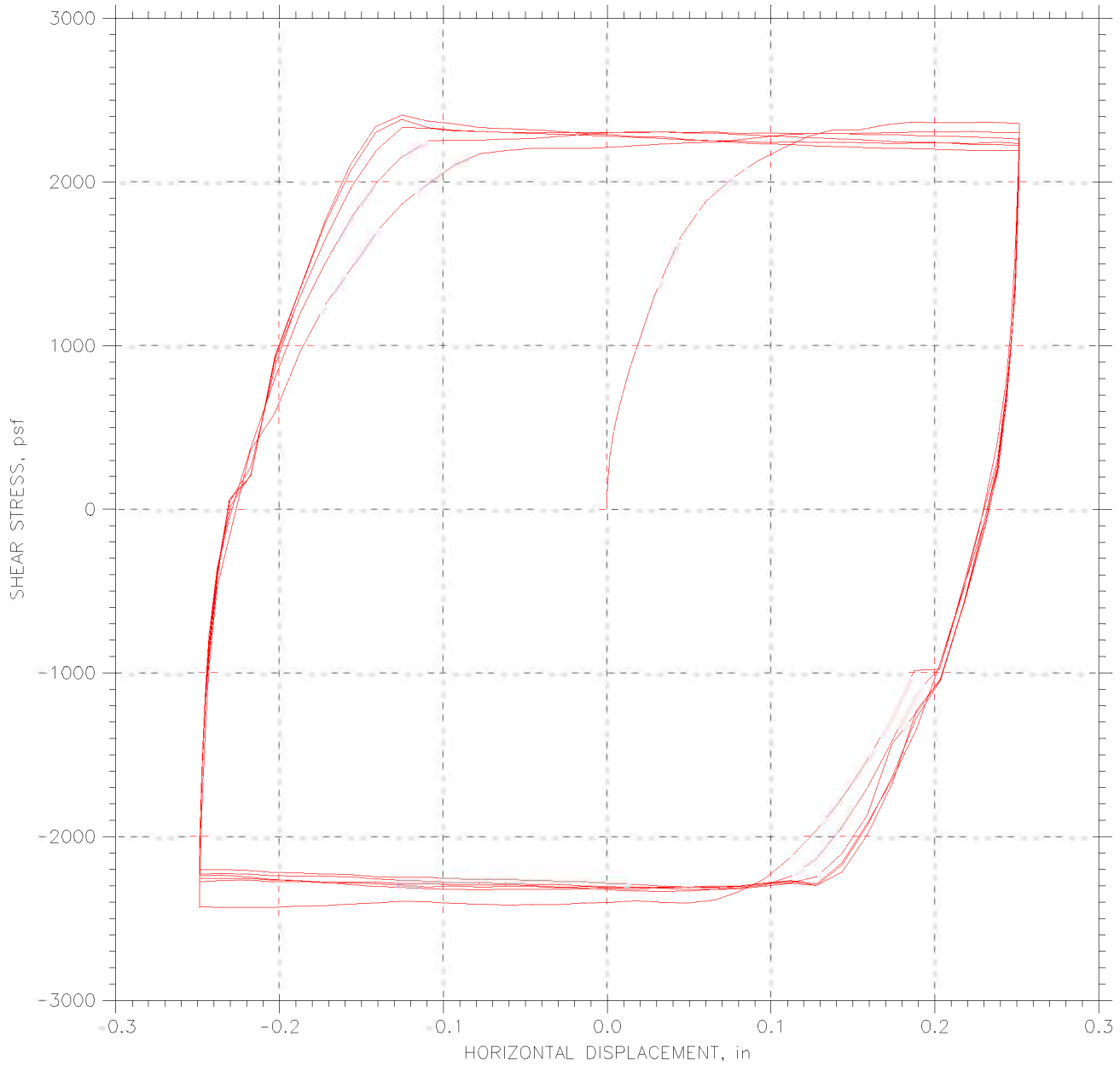

|  |                         |                       |
|--|-------------------------|-----------------------|
| Project: I-90 Central Viaduct                        | Location: Cleveland, OH | Project No.: GTX-6678 |
| Boring No.: C-05-03                                  | Tested By: njh          | Checked By: jdt       |
| Sample No.: S-30                                     | Test Date: 05/09/06     | Depth: 118.5-120.3    |
| Test No.: RS-1                                       | Sample Type: tube       | Elevation: ---        |
| Description: Moist, dark gray clay                   |                         |                       |
| Remarks: Shear Loop rates (in/min): All loops @ .003 |                         |                       |
| File: \\Geocomp\db1\projects\GTX6678\6678-rs1.dat    |                         |                       |

# RESIDUAL SHEAR TEST

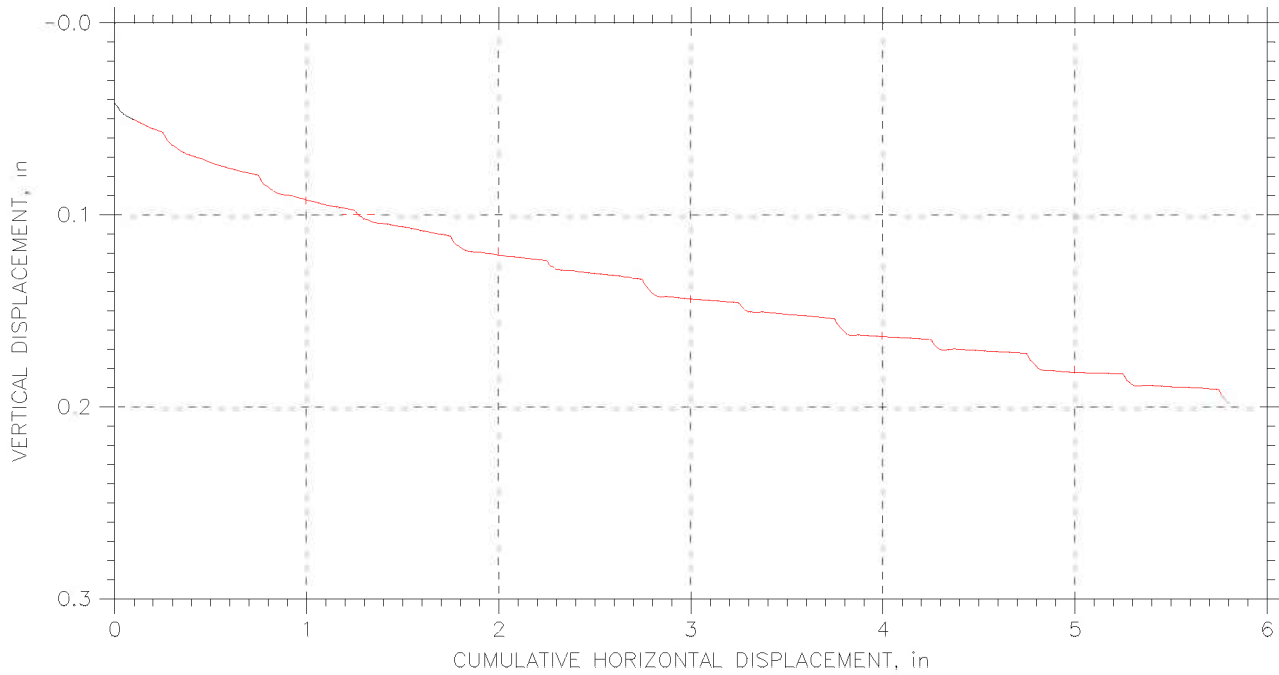
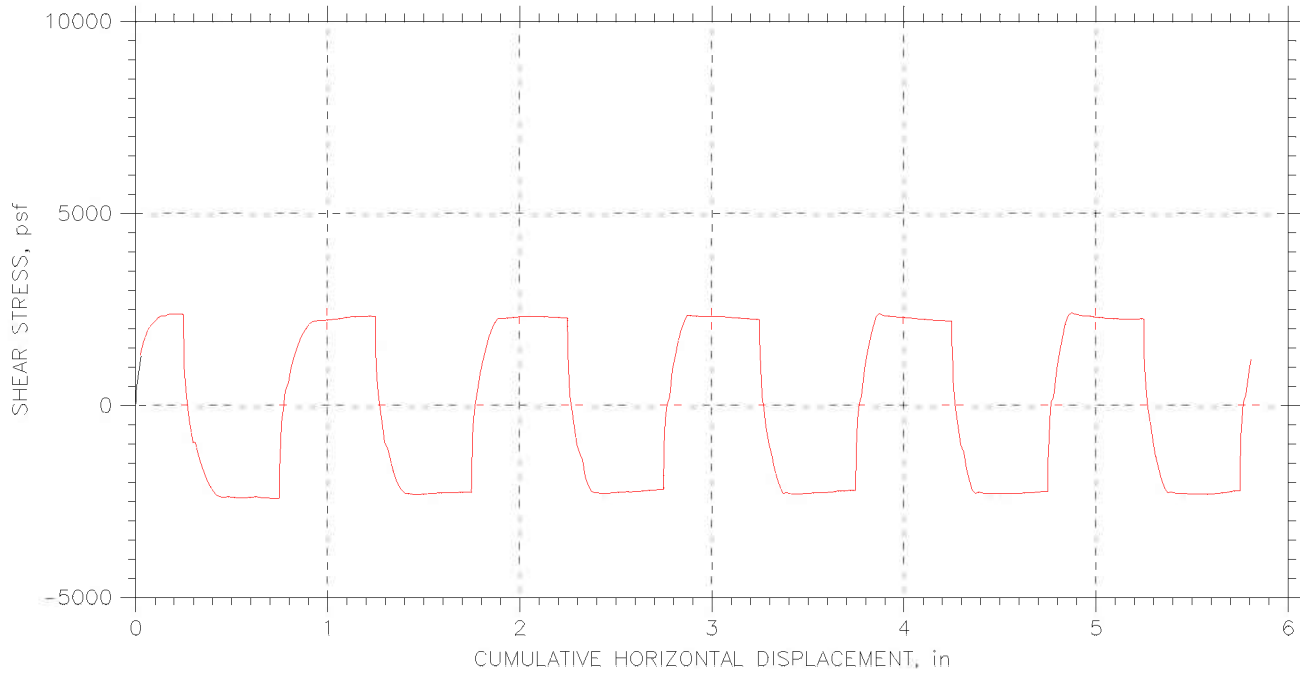

|  |                         |                       |
|--|-------------------------|-----------------------|
| Project: I-90 Central Viaduct                        | Location: Cleveland, OH | Project No.: GTX-6678 |
| Boring No.: C-05-03                                  | Tested By: njh          | Checked By: jdt       |
| Sample No.: S-30                                     | Test Date: 05/09/06     | Depth: 118.5-120.3    |
| Test No.: RS-1                                       | Sample Type: tube       | Elevation: ---        |
| Description: Moist, dark gray clay                   |                         |                       |
| Remarks: Shear Loop rates (in/min): All loops @ .003 |                         |                       |
| File: \\Geocomp\db1\projects\GTX6678\6678-rs1.dat    |                         |                       |

# RESIDUAL SHEAR TEST

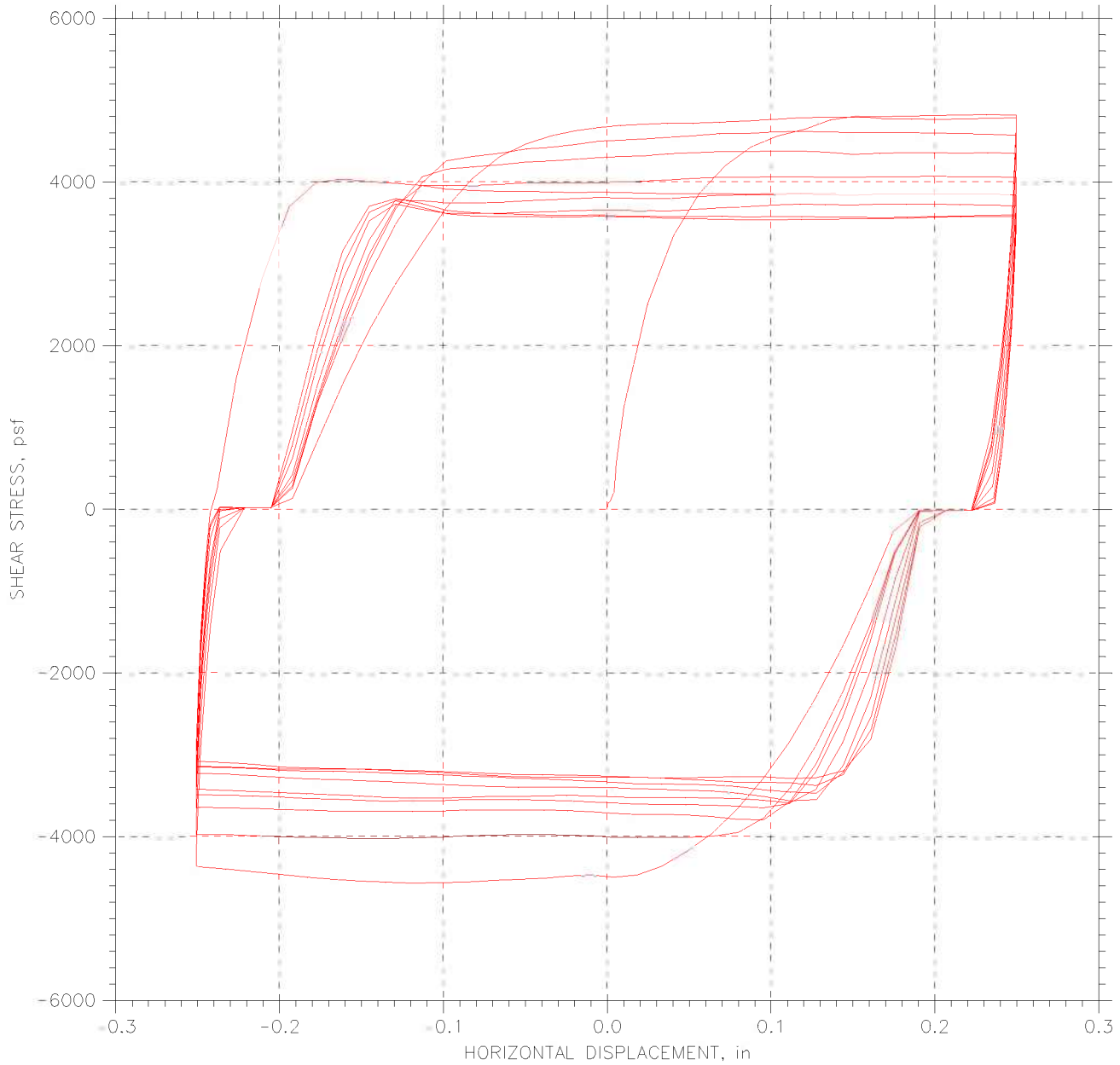

|  |                         |                       |
|--|-------------------------|-----------------------|
| Project: I-90 Central Viaduct                            | Location: Cleveland, OH | Project No.: GTX-6678 |
| Boring No.: C-05-03                                      | Tested By: njh          | Checked By: jdt       |
| Sample No.: S-30   | Test Date: 05/06/06     | Depth: 118.5-120.3    |
| Test No.: RS-2   | Sample Type: tube       | Elevation: ---        |
| Description: Moist, dark gray clay                       |                         |                       |
| Remarks: Shear Loop rates (in/min): All loops run @ .003 |                         |                       |
| File: \\Geocompdb1\projects\GTX6678\6678-rs2.dat         |                         |                       |



## RESIDUAL SHEAR TEST

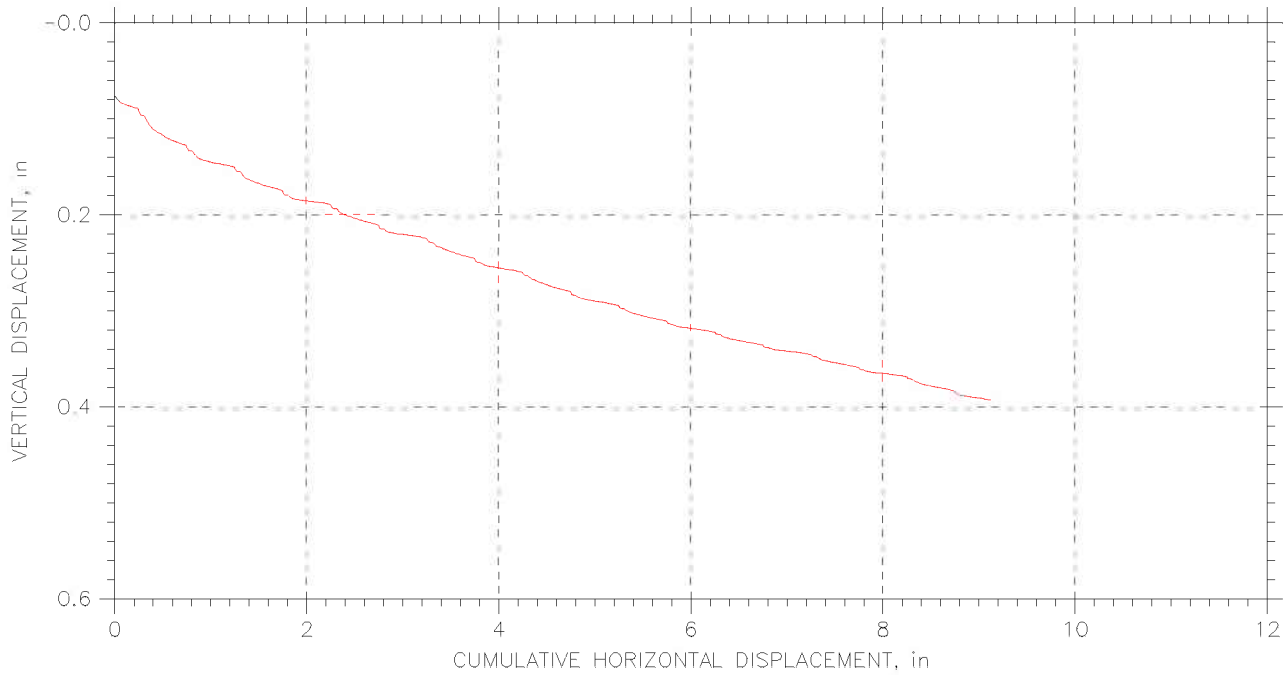
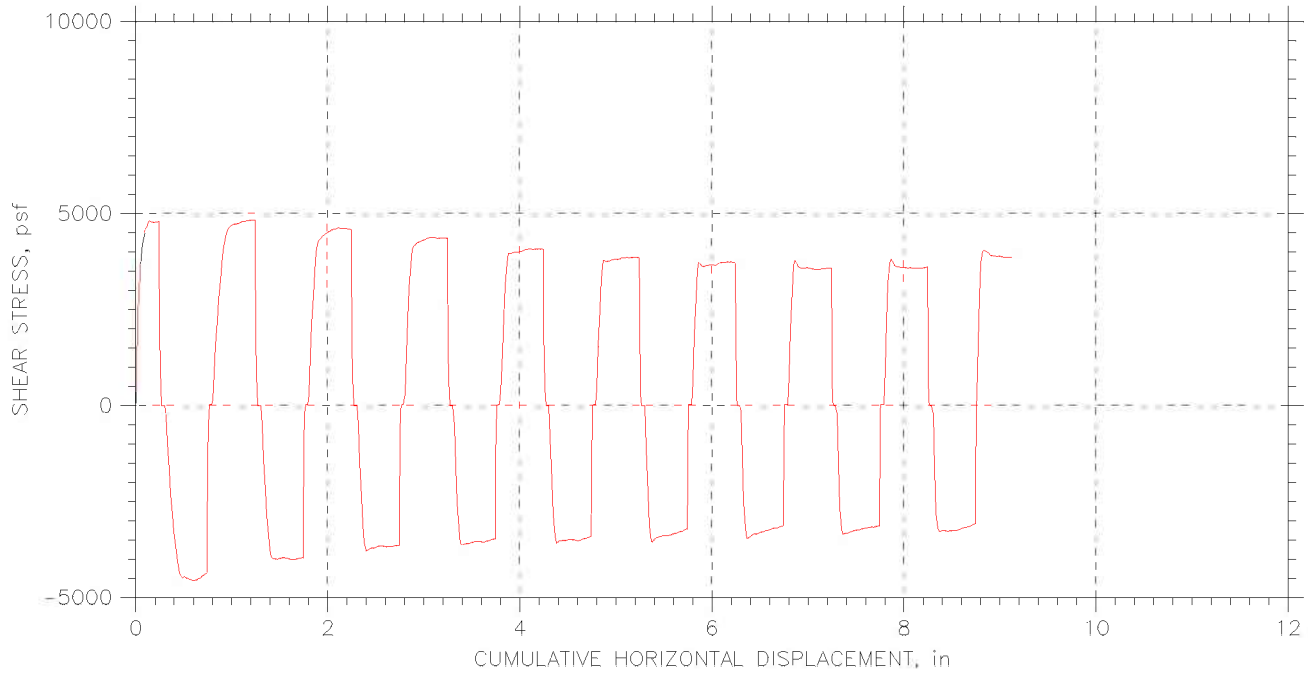

|  |                         |                       |
|--|-------------------------|-----------------------|
| Project: I-90 Central Viaduct                            | Location: Cleveland, OH | Project No.: GTX-6678 |
| Boring No.: C-05-03                                      | Tested By: njh          | Checked By: jdt       |
| Sample No.: S-30   | Test Date: 05/06/06     | Depth: 118.5-120.3    |
| Test No.: RS-2   | Sample Type: tube       | Elevation: ---        |
| Description: Moist, dark gray clay                       |                         |                       |
| Remarks: Shear Loop rates (in/min): All loops run @ .003 |                         |                       |
| File: \\Geocompdb1\projects\GTX6678\6678-rs2.dat         |                         |                       |

## RESIDUAL SHEAR TEST

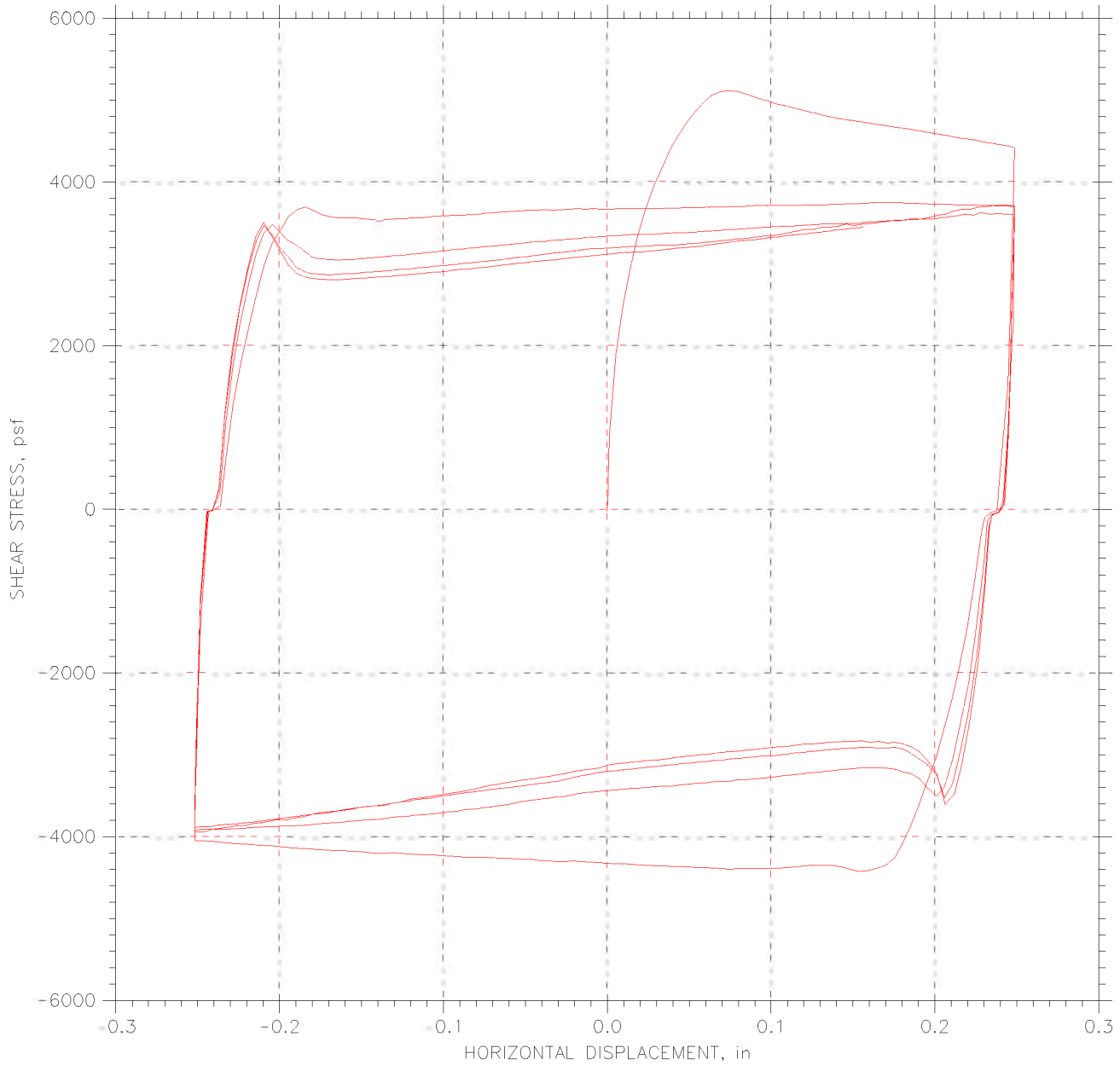

|  |                        |                       |
|--|------------------------|-----------------------|
| Project: I-90 Central Viaduct                        | Location: Cleveland OH | Project No.: Gtx-6678 |
| Boring No.: C-05-03                                  | Tested By: md          | Checked By: jdt       |
| Sample No.: S-30                                     | Test Date: 05/15/06    | Depth: 118.5-120.3    |
| Test No.: RS3  | Sample Type: tube      | Elevation: ---        |
| Description: Moist, dark gray clay                   |                        |                       |
| Remarks: Shear Loop rates (in/min): All loops @ .001 |                        |                       |
| File: \\Geocomp\db1\projects\GTX6678\6678-rs3.dat    |                        |                       |

# RESIDUAL SHEAR TEST

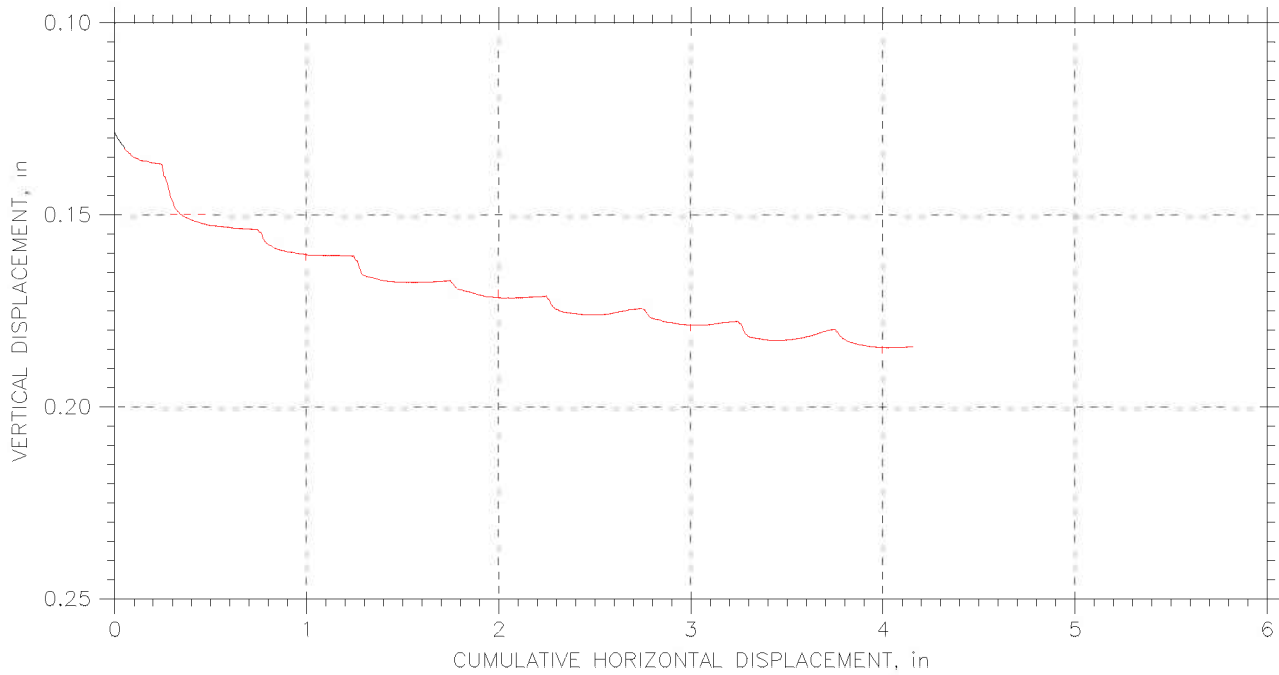
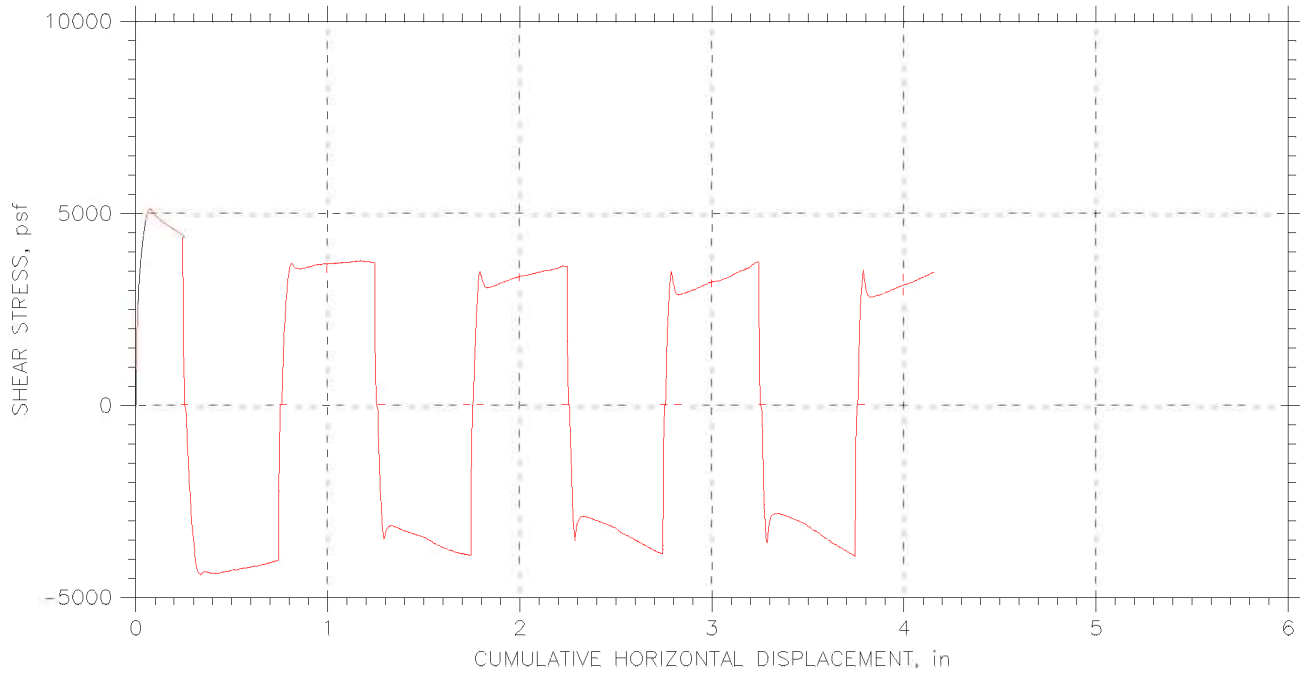

|  |                        |                       |
|--|------------------------|-----------------------|
| Project: I-90 Central Viaduct                        | Location: Cleveland OH | Project No.: Gtx-6678 |
| Boring No.: C-05-03                                  | Tested By: md          | Checked By: jdt       |
| Sample No.: S-30                                     | Test Date: 05/15/06    | Depth: 118.5-120.3    |
| Test No.: RS3  | Sample Type: tube      | Elevation: ---        |
| Description: Moist, dark gray clay                   |                        |                       |
| Remarks: Shear Loop rates (in/min): All loops @ .001 |                        |                       |
| File: \\Geocompdb1\projects\GTX6678\6678-rs3.dat     |                        |                       |



|                   |   |             |        |
|-------------------|---|-------------|--------|
| Client:           | Geocomp Consulting  |             |        |
| Project Name:     | I-90 Central Viaduct  |             |        |
| Project Location: | Cleveland, OH   |             |        |
| GTX #:            | 6678  | Tested By:  | njh/md |
| Test Date:        | 05/06-05/19/06  | Checked By: | jdt    |
| Boring ID:        | C-05-04   |             |        |
| Sample ID:        | S-27  |             |        |
| Depth, ft.        | 72-74 ft.   |             |        |
| Description:      | Moist, very dark grayish brown clay   |             |        |
| Preparation:      | Extruded from tube, cut and trimmed and tested at the as-received moisture and density. |             |        |

## Direct Shear and Residual Shear by ASTM D 3080

| Parameter                                | Point 1 | Point 2 | Point 3 |
|--|---------|---------|---------|
| Test No.                                 | RS7     | RS8     | RS9     |
| Initial Moisture Content, %              | 22      | 21      | 22      |
| Initial Dry Density, pcf                 | 107     | 107     | 107     |
| Nominal Rate of Shear Strain, inches/min | 0.0004  | 0.0004  | 0.0004  |
| Vertical Consolidation Stress, psf       | 2752    | 3519    | 8258    |
| Peak Shear Stress, psf                   | 1580    | 1891    | 4519    |
| Post-Peak Shear Stress, psf              | 1374    | 1681    | 4393    |
| Final Moisture Content, %                | 23      | 23      | 20      |

|  |                           |      |         |
|--|---------------------------|------|---------|
| Notes: Residual values taken near the end of the final shear step. | Peak Friction Angle:      | 28.4 | degrees |
|  | Peak Cohesion:            | 43   | psf     |
|  | Post Peak Friction Angle: | 27.5 | degrees |
|  | Post Peak Cohesion:       | 0    | psf     |

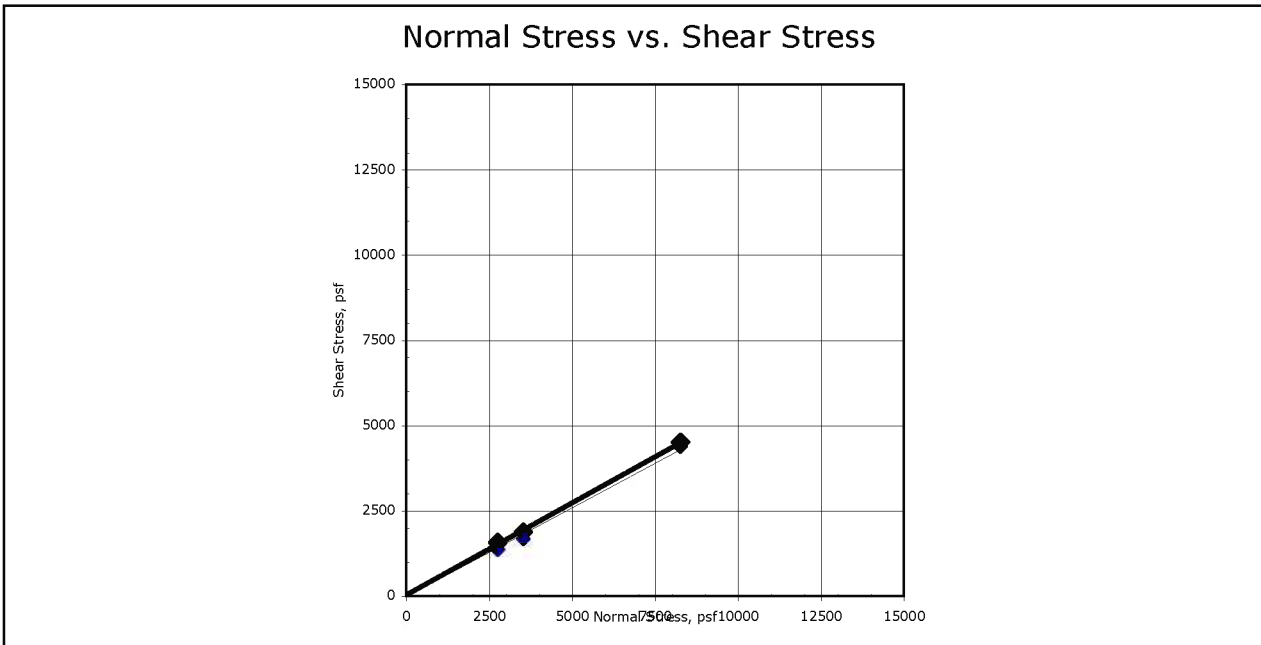

Comments: See attached plots for additional information

# RESIDUAL SHEAR TEST

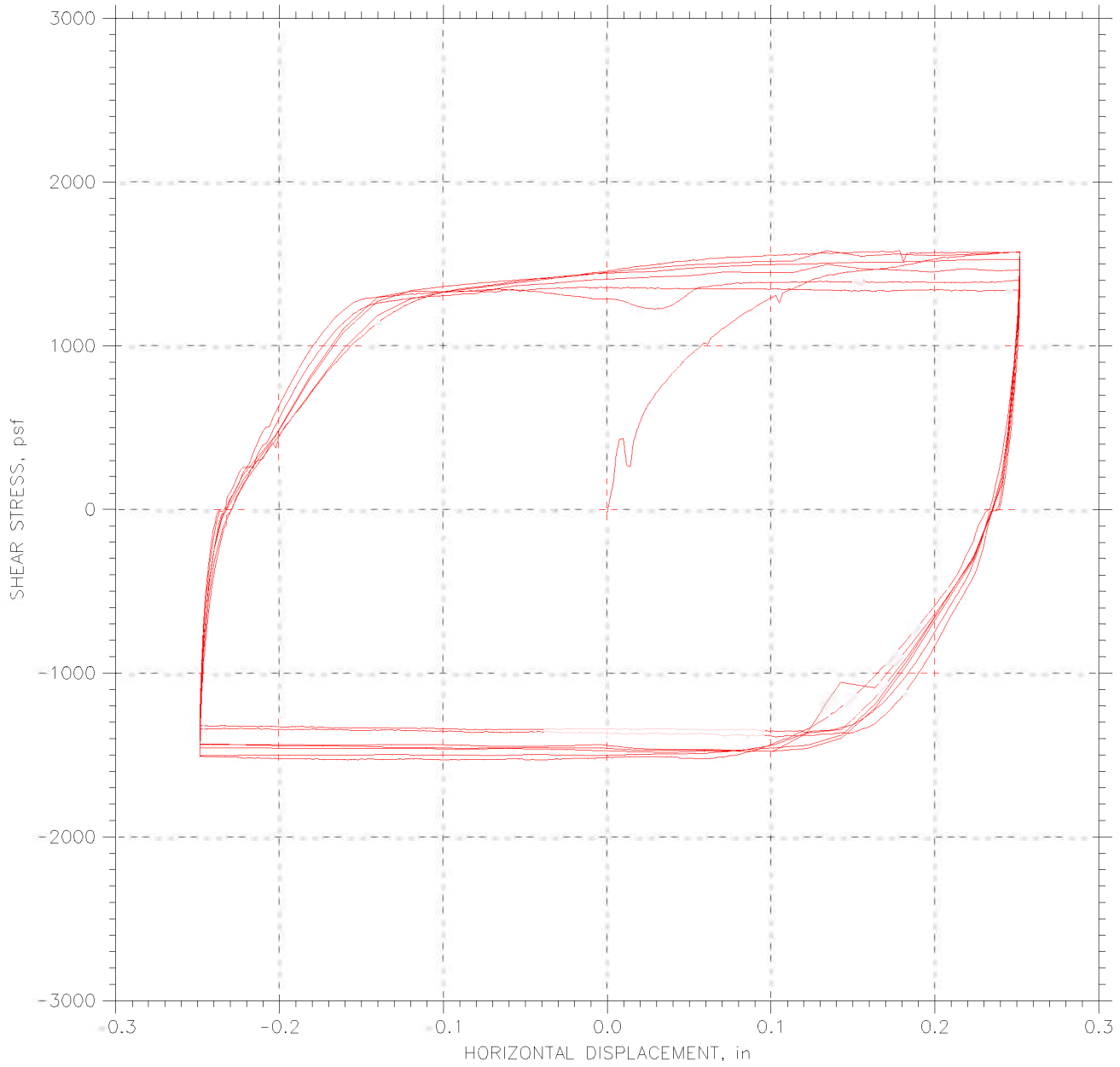

|  |                         |                       |
|--|-------------------------|-----------------------|
| Project: I-90 Central Viaduct  | Location: Cleveland, OH | Project No.: GTX-6678 |
| Boring No.: C-05-04  | Tested By: md           | Checked By: jdt       |
| Sample No.: S-27   | Test Date: 05/19/06     | Depth: 72-74 ft.      |
| Test No.: RS-7   | Sample Type: tube       | Elevation: ---        |
| Description: Moist, very dark grayish brown clay                                       |                         |                       |
| Remarks: Shear Loop rates (in/min): First 1.25 @ .0004, then 4 @ .004, then 2 @ .0004. |                         |                       |
| File: \\Geocomp\db1\projects\GTX6678\6678-rs7.dat                                      |                         |                       |

# RESIDUAL SHEAR TEST

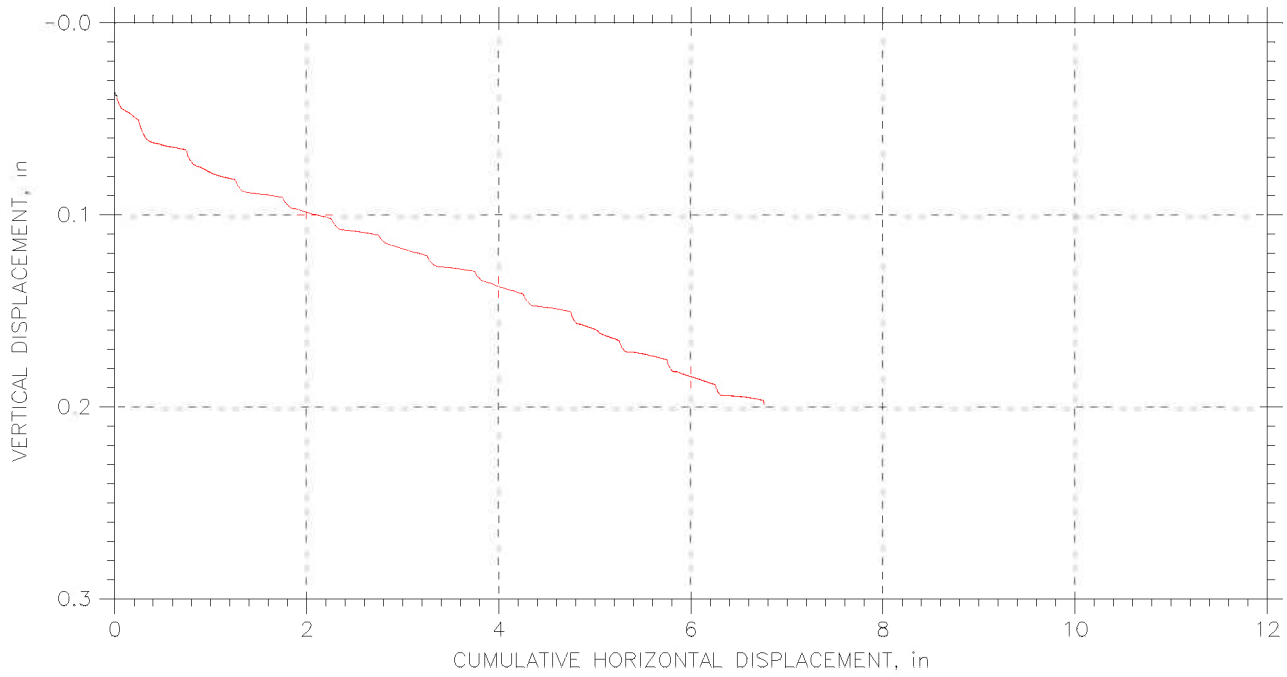
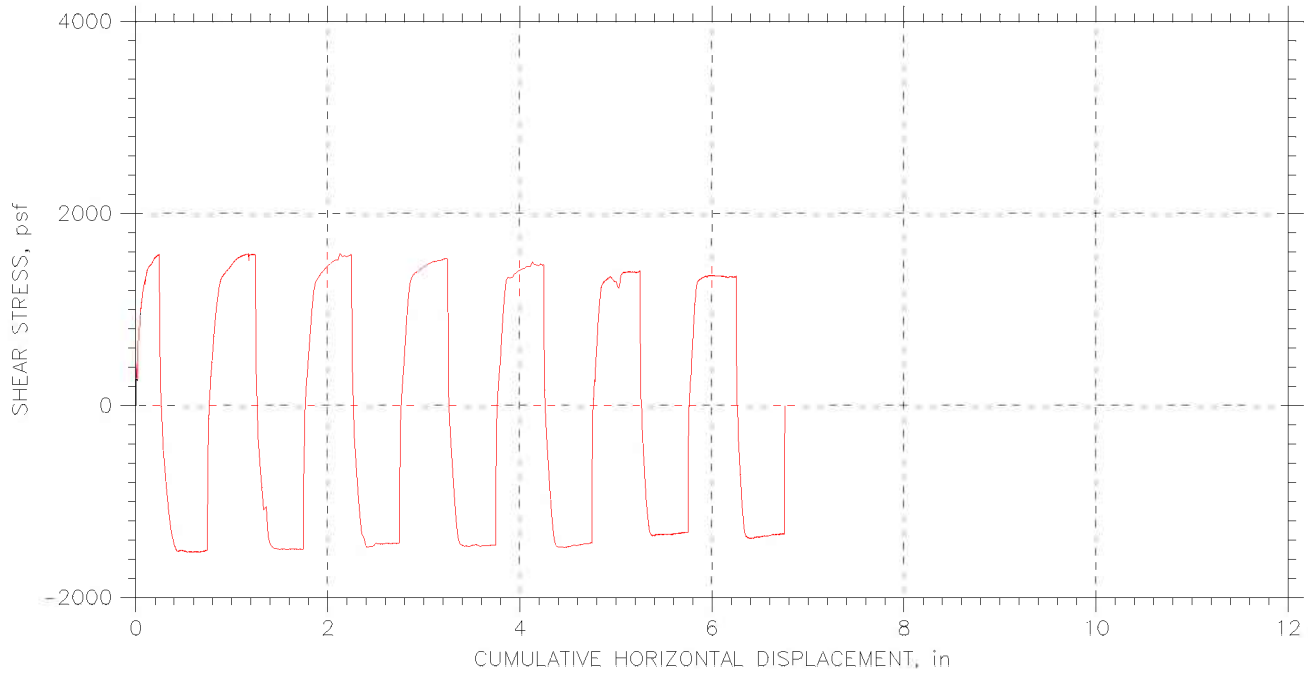

|  |                         |                       |
|--|-------------------------|-----------------------|
| Project: I-90 Central Viaduct  | Location: Cleveland, OH | Project No.: GTX-6678 |
| Boring No.: C-05-04  | Tested By: md           | Checked By: jdt       |
| Sample No.: S-27   | Test Date: 05/19/06     | Depth: 72-74 ft.      |
| Test No.: RS-7   | Sample Type: tube       | Elevation: ---        |
| Description: Moist, very dark grayish brown clay                                       |                         |                       |
| Remarks: Shear Loop rates (in/min): First 1.25 @ .0004, then 4 @ .004, then 2 @ .0004. |                         |                       |
| File: \\Geocompb1\projects\GTX6678\6678-rs7.dat  |                         |                       |

# RESIDUAL SHEAR TEST

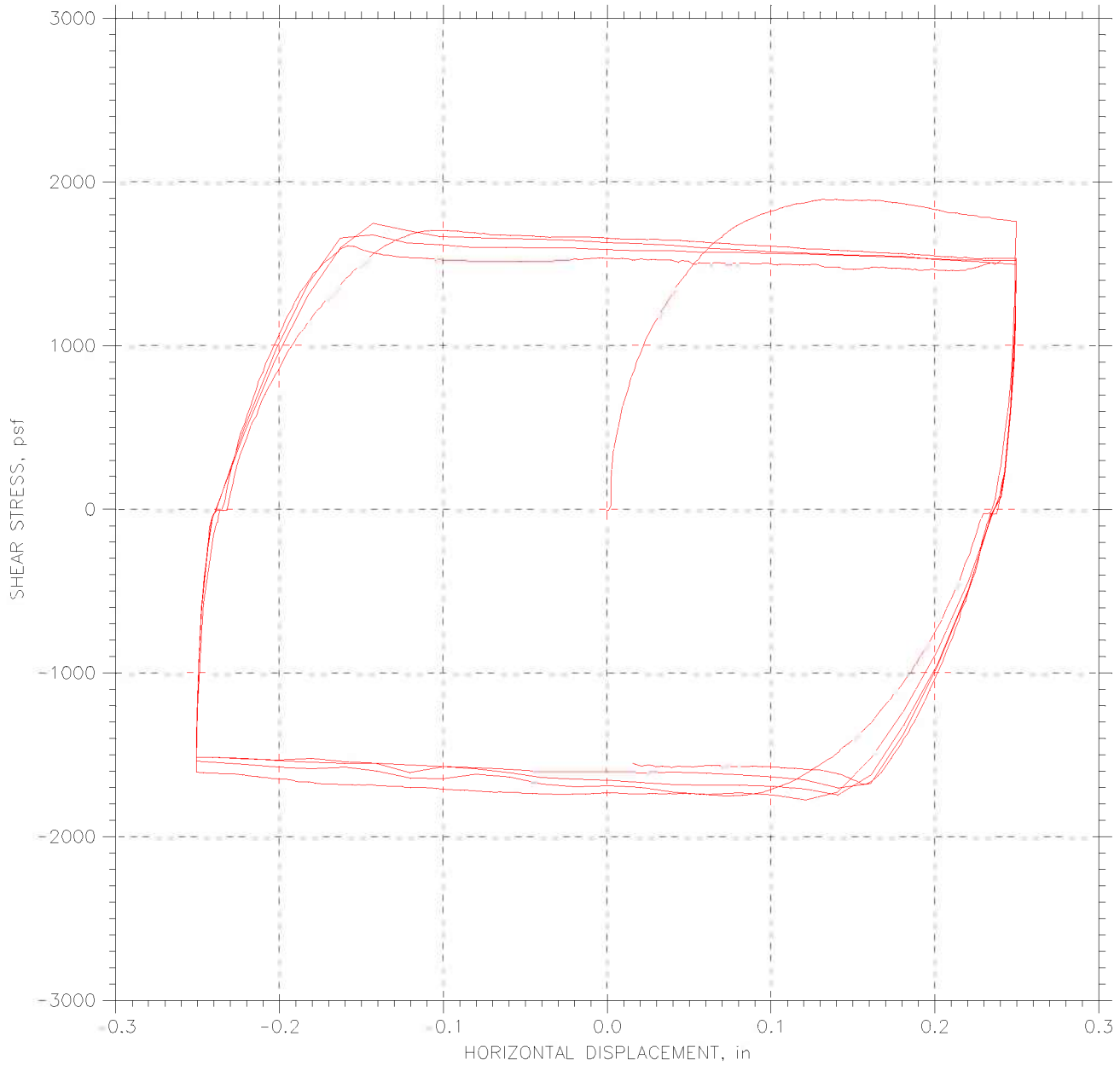

|  |                        |                       |
|--|------------------------|-----------------------|
| Project: I-90 Central Viaduct  | Location: Cleveland OH | Project No.: Gtx-6678 |
| Boring No.: C-05-04  | Tested By: md          | Checked By: jdt       |
| Sample No.: S-27   | Test Date: 05/19/06    | Depth: 72-74 ft       |
| Test No.: RS-8   | Sample Type: tube      | Elevation: ---        |
| Description: Moist, very dark grayish brown clay   |                        |                       |
| Remarks: Shear Loop rates (in/min): First 1.25 @ .0004, then 2.5 @ .004, then 1 @ .0004. |                        |                       |
| File: \\Geocompdb1\projects\GTX6678\6678-RS8njh2-final test.dat                          |                        |                       |

# RESIDUAL SHEAR TEST

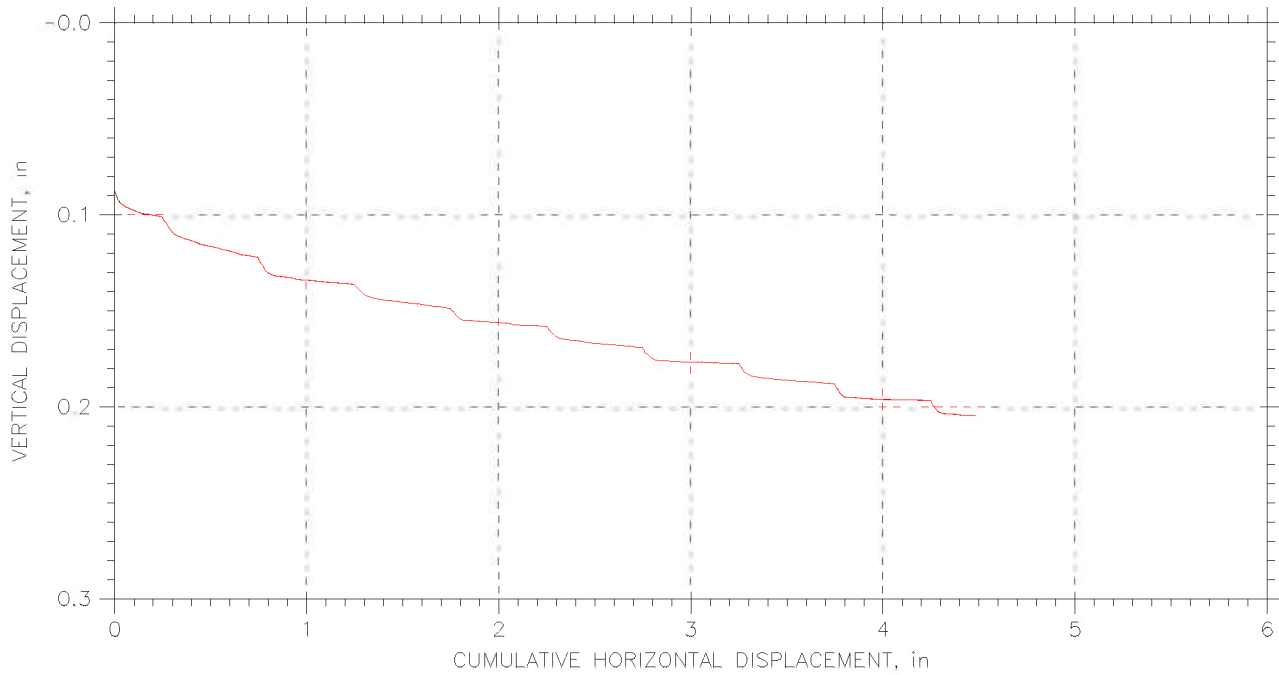
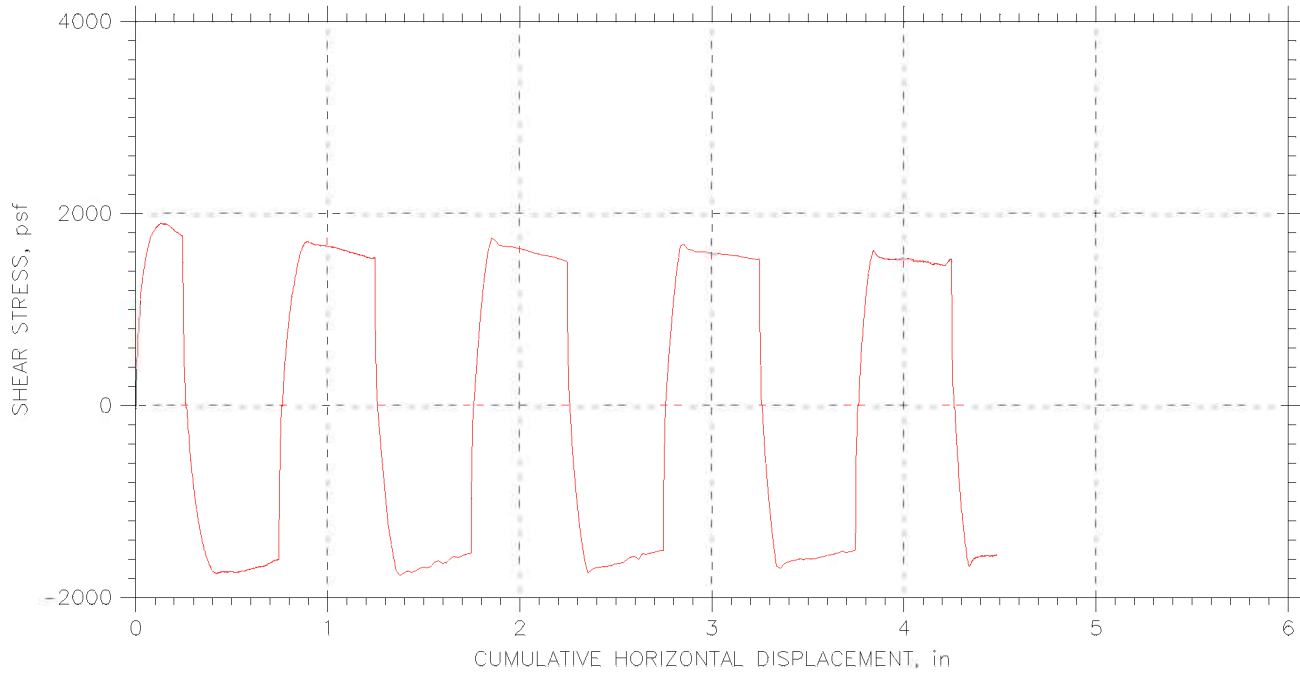

|  |                        |                       |
|--|------------------------|-----------------------|
| Project: I-90 Central Viaduct  | Location: Cleveland OH | Project No.: Gtx-6678 |
| Boring No.: C-05-04  | Tested By: md          | Checked By: jdt       |
| Sample No.: S-27   | Test Date: 05/19/06    | Depth: 72-74 ft       |
| Test No.: RS-8   | Sample Type: tube      | Elevation: ---        |
| Description: Moist, very dark grayish brown clay   |                        |                       |
| Remarks: Shear Loop rates (in/min): First 1.25 @ .0004, then 2.5 @ .004, then 1 @ .0004. |                        |                       |
| File: \\Geocomp\projects\GTX6678\6678-RS8njh2-final test.dat                             |                        |                       |



# RESIDUAL SHEAR TEST

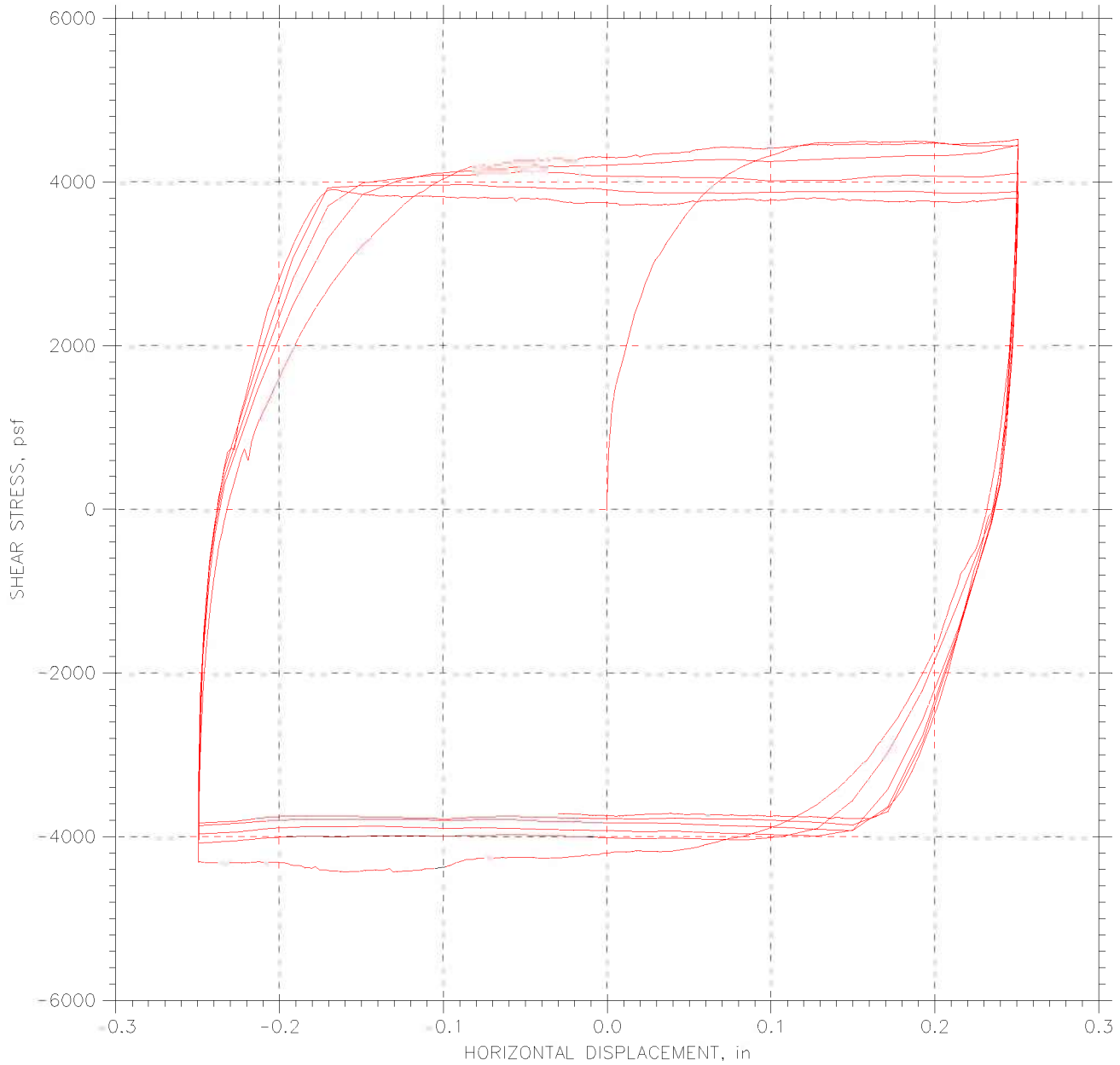

|  |                         |                       |
|--|-------------------------|-----------------------|
| Project: I-90 Central Viaduct  | Location: Cleveland, OH | Project No.: GTX-6678 |
| Boring No.: C-05-04  | Tested By: md           | Checked By: jdt       |
| Sample No.: S-27   | Test Date: 05/19/06     | Depth: 72-74 ft       |
| Test No.: RS-9   | Sample Type: tube       | Elevation: ---        |
| Description: Moist, very dark grayish brown clay   |                         |                       |
| Remarks: Shear Loop rates (in/min): First 1.25 @ .0004, then 3.5 @ .004, then 1 @ .0004. |                         |                       |
| File: \\Geocomp\db1\projects\GTX6678\6678-rs9njh1.dat                                    |                         |                       |

# RESIDUAL SHEAR TEST

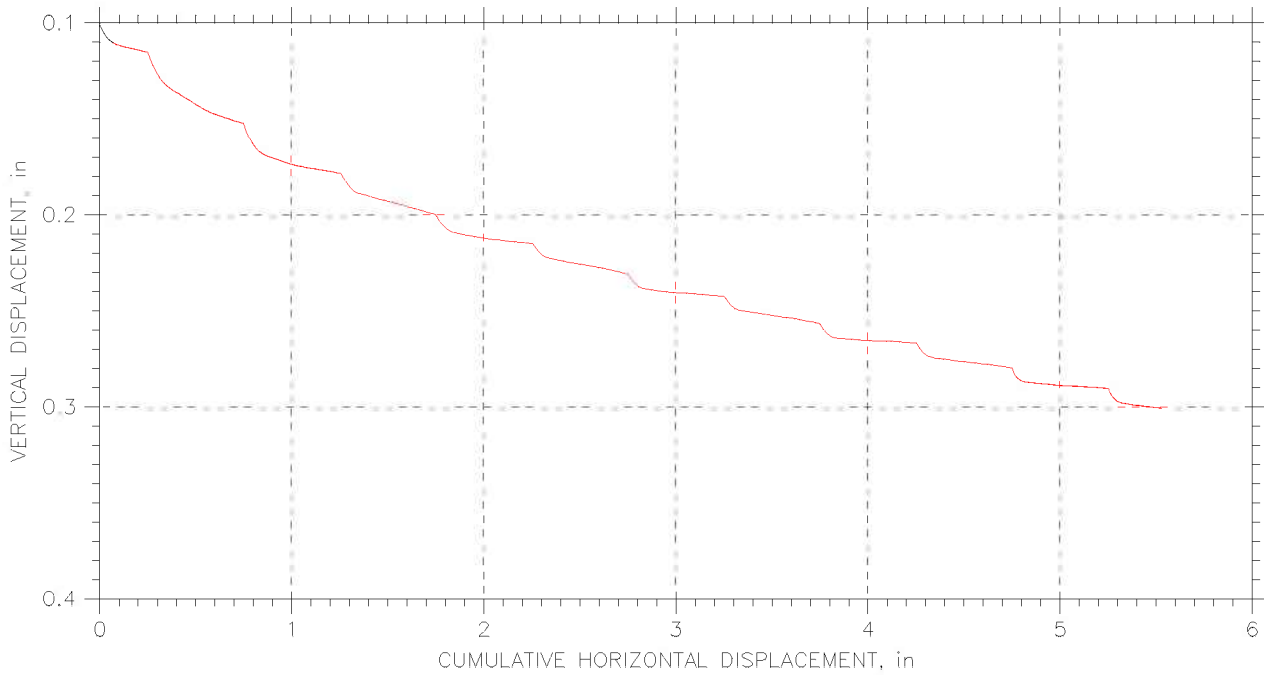
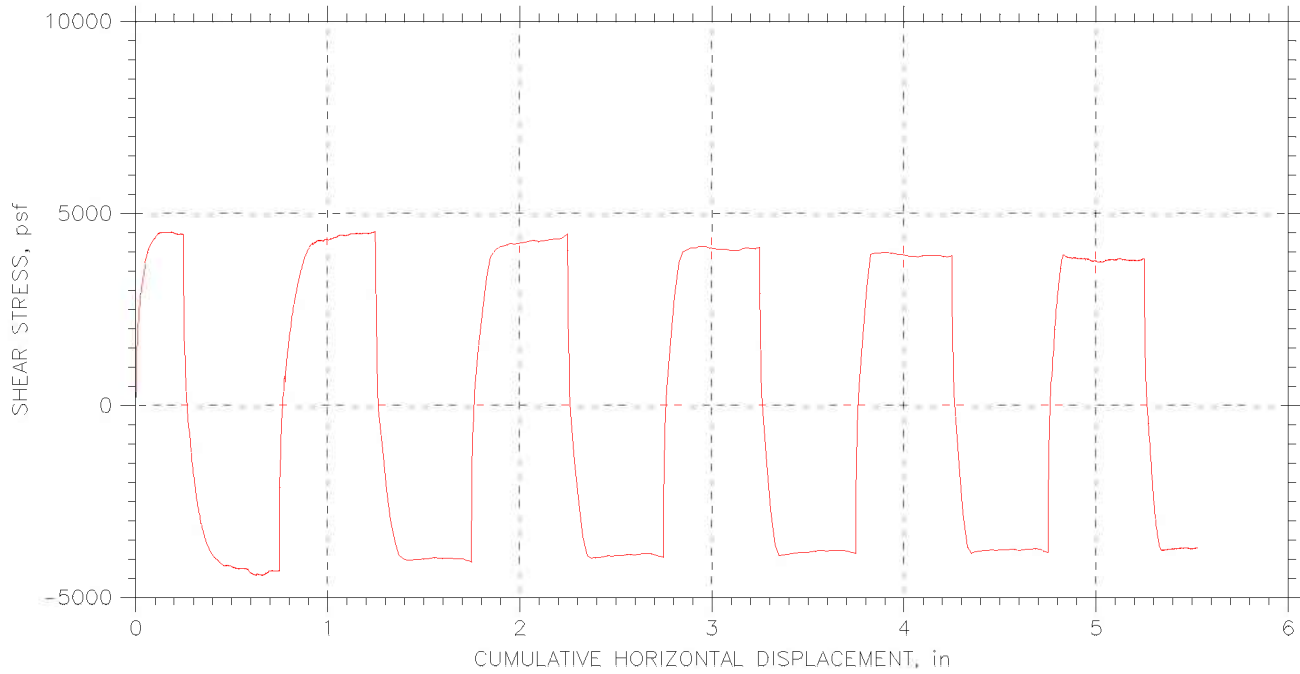

|  |                         |                       |
|--|-------------------------|-----------------------|
| Project: I-90 Central Viaduct  | Location: Cleveland, OH | Project No.: GTX-6678 |
| Boring No.: C-05-04  | Tested By: md           | Checked By: jdt       |
| Sample No.: S-27   | Test Date: 05/19/06     | Depth: 72-74 ft       |
| Test No.: RS-9   | Sample Type: tube       | Elevation: ---        |
| Description: Moist, very dark grayish brown clay   |                         |                       |
| Remarks: Shear Loop rates (in/min): First 1.25 @ .0004, then 3.5 @ .004, then 1 @ .0004. |                         |                       |
| File: \\Geocomp\db1\projects\GTX6678\6678-rs9njh1.dat                                    |                         |                       |

# RESIDUAL SHEAR TEST

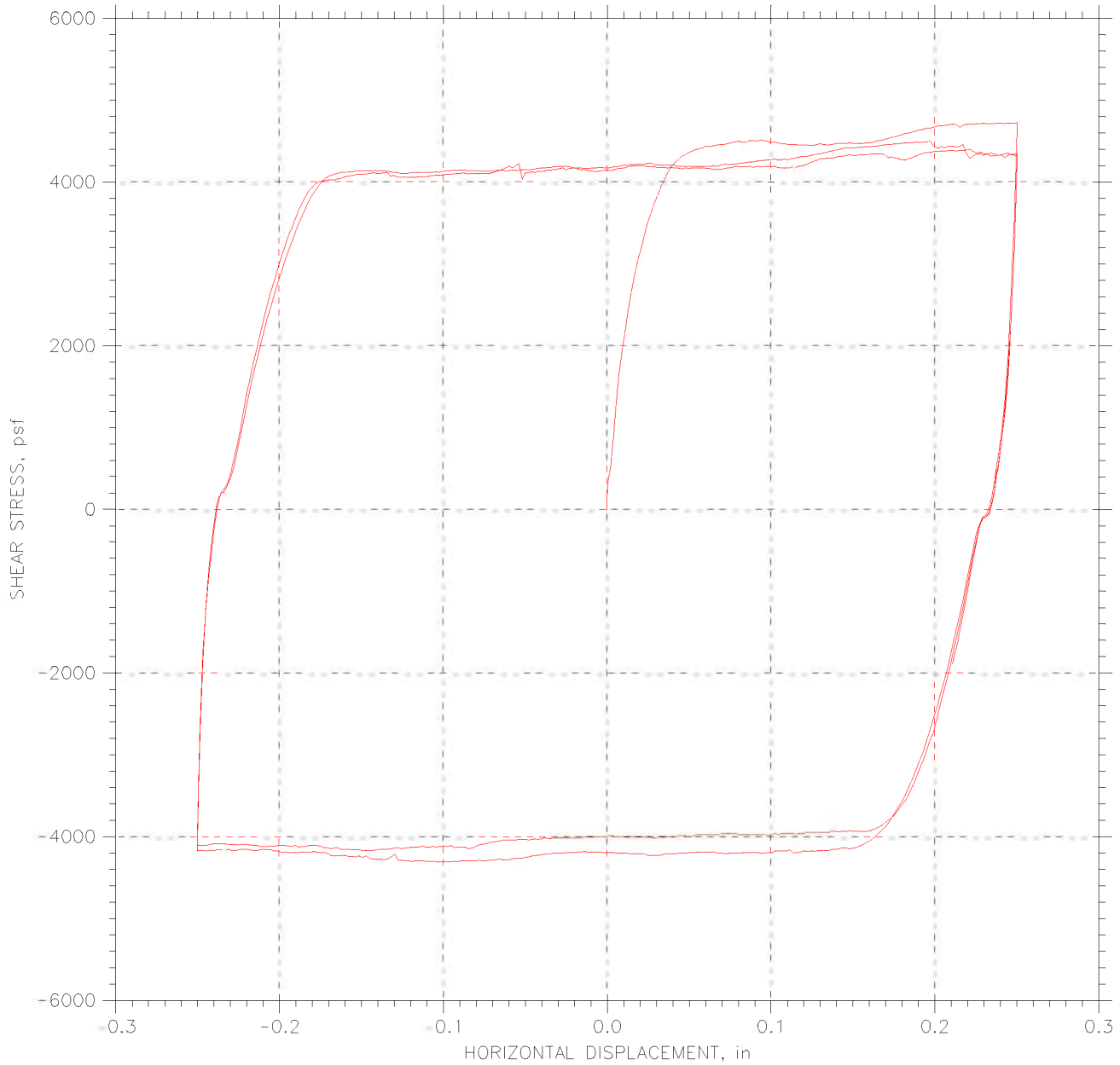

|   |                         |                       |
|---|-------------------------|-----------------------|
| Project: I-90 Central Viaduct   | Location: Cleveland, OH | Project No.: GTX-6678 |
| Boring No.: C-05-04   | Tested By: md           | Checked By: jdt       |
| Sample No.: S-27  | Test Date: 05/19/06     | Depth: 72-74 ft       |
| Test No.: RS-9  | Sample Type: tube       | Elevation: ---        |
| Description: Moist, very dark grayish brown clay  |                         |                       |
| Remarks: Shear Loop rates (in/min): All loops @ .0004. Continuation of test after normal load was lost and reapplied. |                         |                       |
| File: \\Geocomp\db1\projects\GTX6678\6678-rs9a.dat  |                         |                       |

# RESIDUAL SHEAR TEST

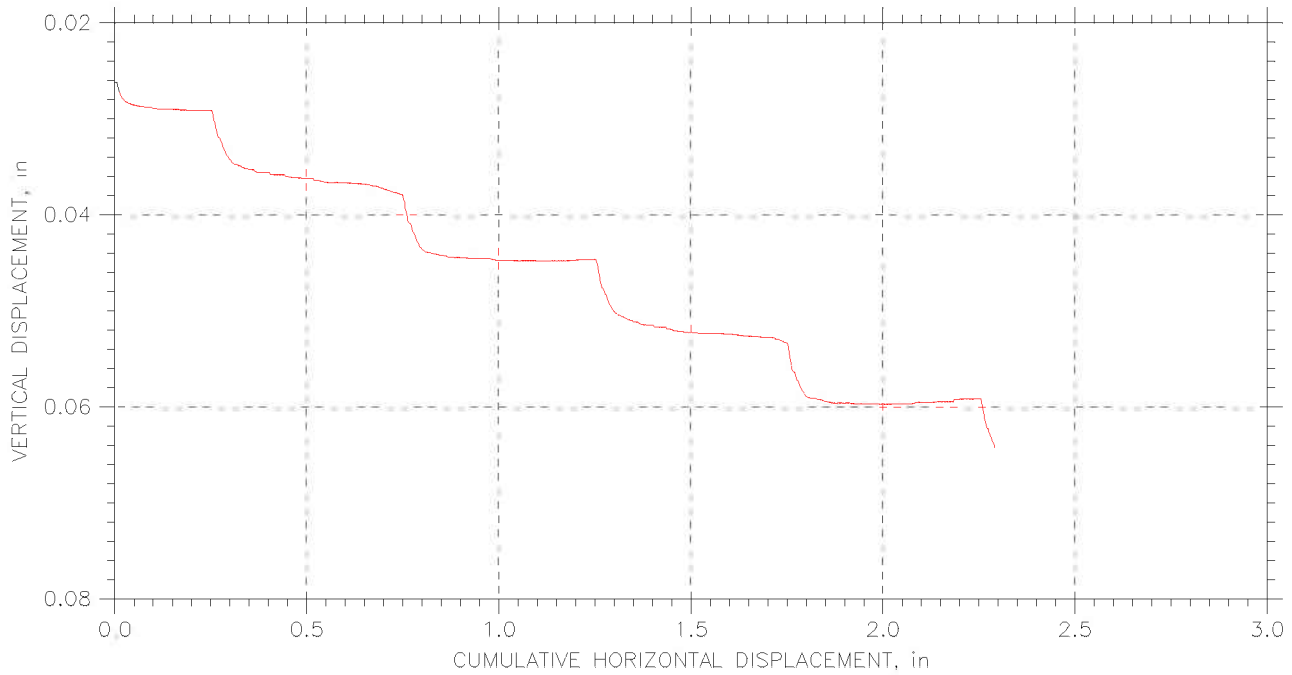
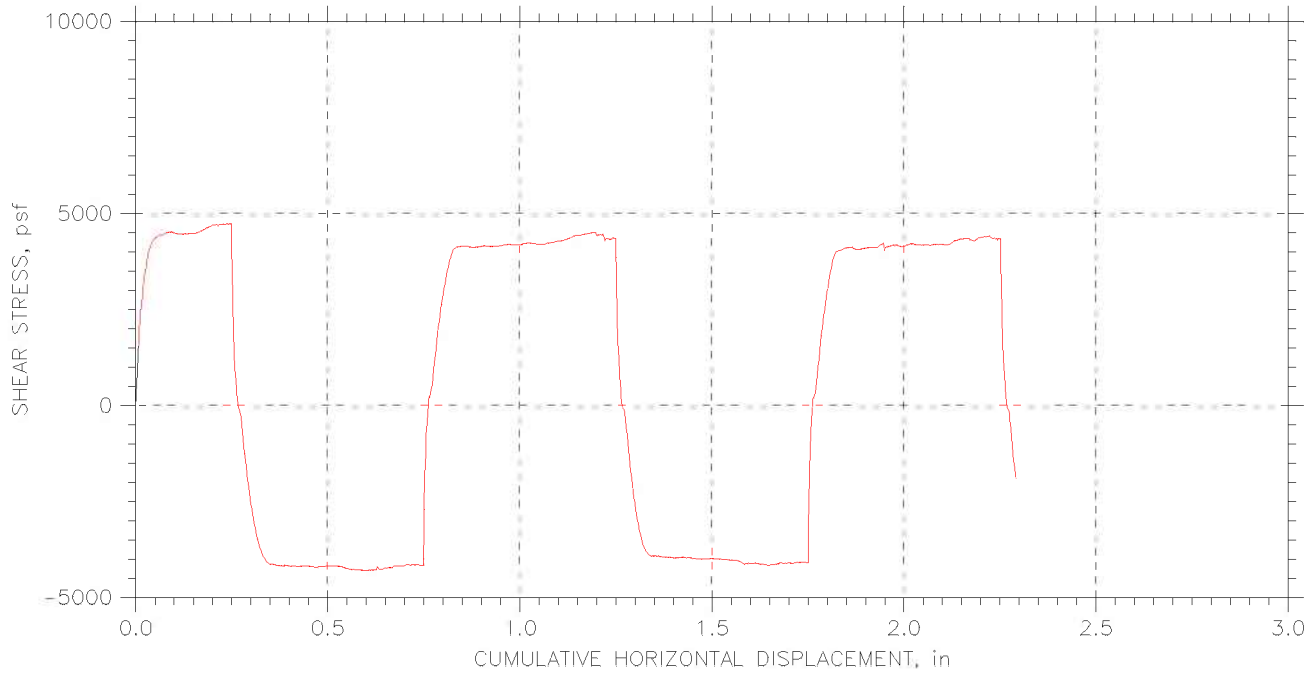

|   |                         |                       |
|---|-------------------------|-----------------------|
| Project: I-90 Central Viaduct   | Location: Cleveland, OH | Project No.: GTX-6678 |
| Boring No.: C-05-04   | Tested By: md           | Checked By: jdt       |
| Sample No.: S-27  | Test Date: 05/19/06     | Depth: 72-74 ft       |
| Test No.: RS-9  | Sample Type: tube       | Elevation: ---        |
| Description: Moist, very dark grayish brown clay  |                         |                       |
| Remarks: Shear Loop rates (in/min): All loops @ .0004. Continuation of test after normal load was lost and reapplied. |                         |                       |
| File: \\Geocomp\db1\projects\GTX6678\6678-rs9a.dat  |                         |                       |



|                   |   |             |        |
|-------------------|---|-------------|--------|
| Client:           | Geocomp Consulting  |             |        |
| Project Name:     | I-90 Central Viaduct  |             |        |
| Project Location: | Cleveland, OH   |             |        |
| GTX #:            | 6678  | Tested By:  | njh/md |
| Test Date:        | 05/30/06  | Checked By: | jdt    |
| Boring ID:        | B-05-08   |             |        |
| Sample ID:        | S-27  |             |        |
| Depth, ft.        | 116-118 ft  |             |        |
| Description:      | Moist, olive gray clay  |             |        |
| Preparation:      | Extruded from tube, cut and trimmed and tested at the as-received moisture and density. |             |        |

## Direct Shear and Residual Shear by ASTM D 3080

| Parameter                                | Point 1 | Point 2 | Point 3 |
|--|---------|---------|---------|
| Test No.                                 | RS10    |         |         |
| Initial Moisture Content, %              | 21      |         |         |
| Initial Dry Density, pcf                 | 108     |         |         |
| Nominal Rate of Shear Strain, inches/min | 0.0002  |         |         |
| Vertical Consolidation Stress, psf       | 4130    |         |         |
| Peak Shear Stress, psf                   | 2677    |         |         |
| Post-Peak Shear Stress, psf              | 2385    |         |         |
| Final Moisture Content, %                | 19      |         |         |

|  |                           |      |         |
|--|---------------------------|------|---------|
| Notes: Residual values taken near the end of the final shear step. | Peak Friction Angle:      | 33.0 | degrees |
|  | Peak Cohesion:            | 0    | psf     |
|  | Post Peak Friction Angle: | 30.0 | degrees |
|  | Post Peak Cohesion:       | 0    | psf     |

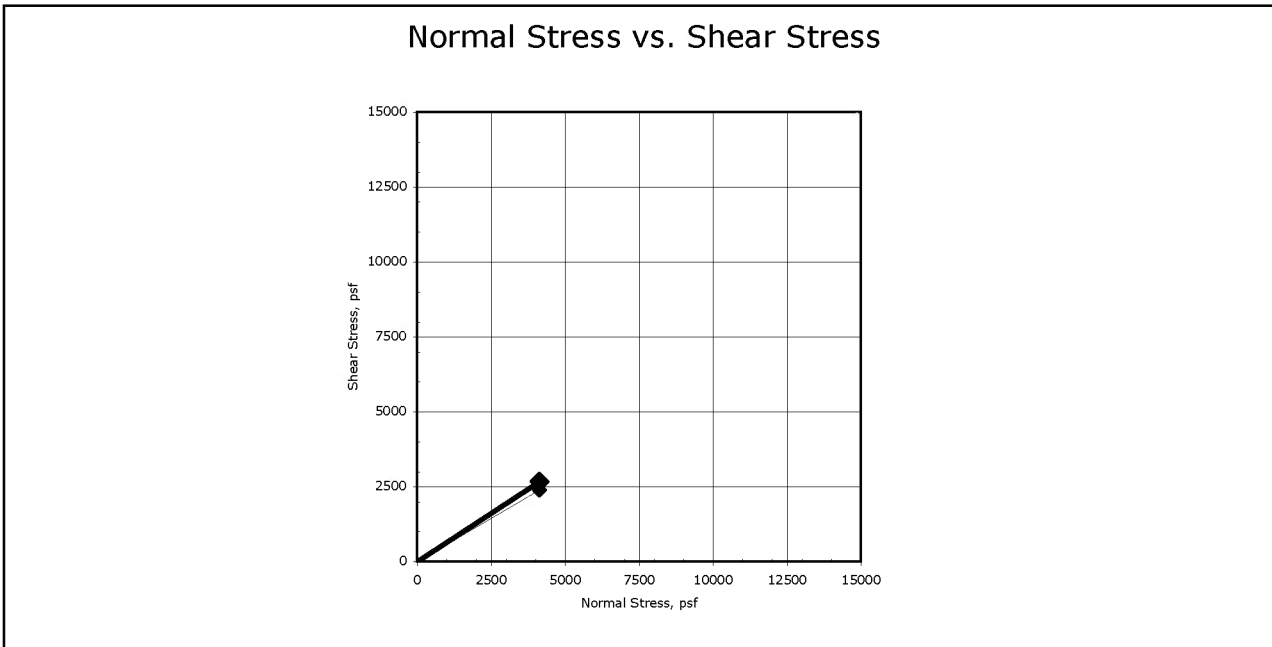

Comments: See attached plots for additional information

# RESIDUAL SHEAR TEST

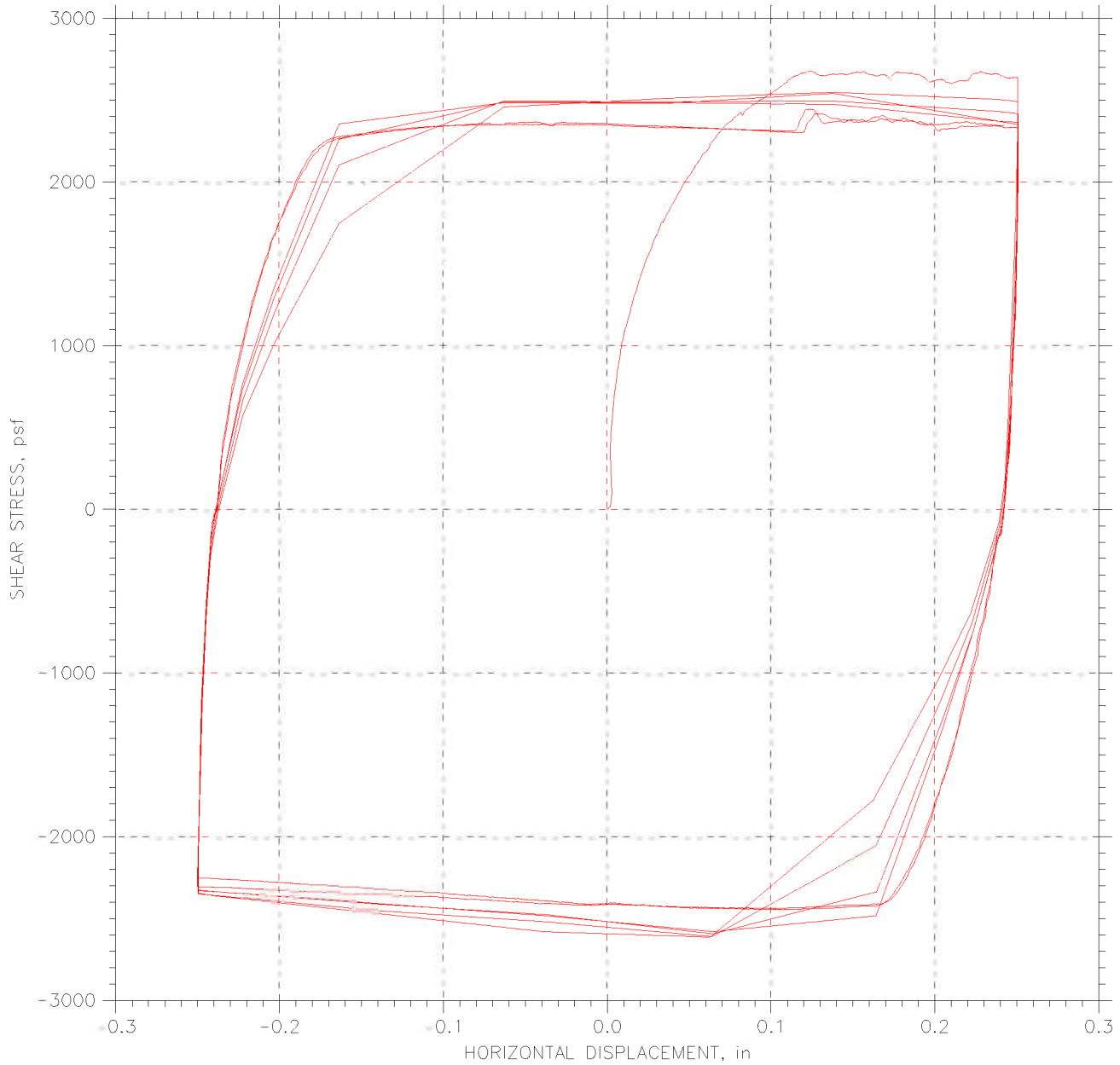

|  |                         |                       |
|--|-------------------------|-----------------------|
| Project: I-90 Central Viaduct  | Location: Cleveland, OH | Project No.: Gtx-6678 |
| Boring No.: S-27   | Tested By: md           | Checked By: jdt       |
| Sample No.: B-05-08  | Test Date: 05/30/06     | Depth: 116-118 ft     |
| Test No.: RS-10  | Sample Type: tube       | Elevation: ---        |
| Description: Moist, olive gray clay  |                         |                       |
| Remarks: Shear Loop rates (in/min): First .25 @ .0002, then 4 @ .02, then 2 @ .0002. |                         |                       |
| File: \\Geocompdb1\projects\GTX6678\6678-RS10.dat                                    |                         |                       |

## RESIDUAL SHEAR TEST

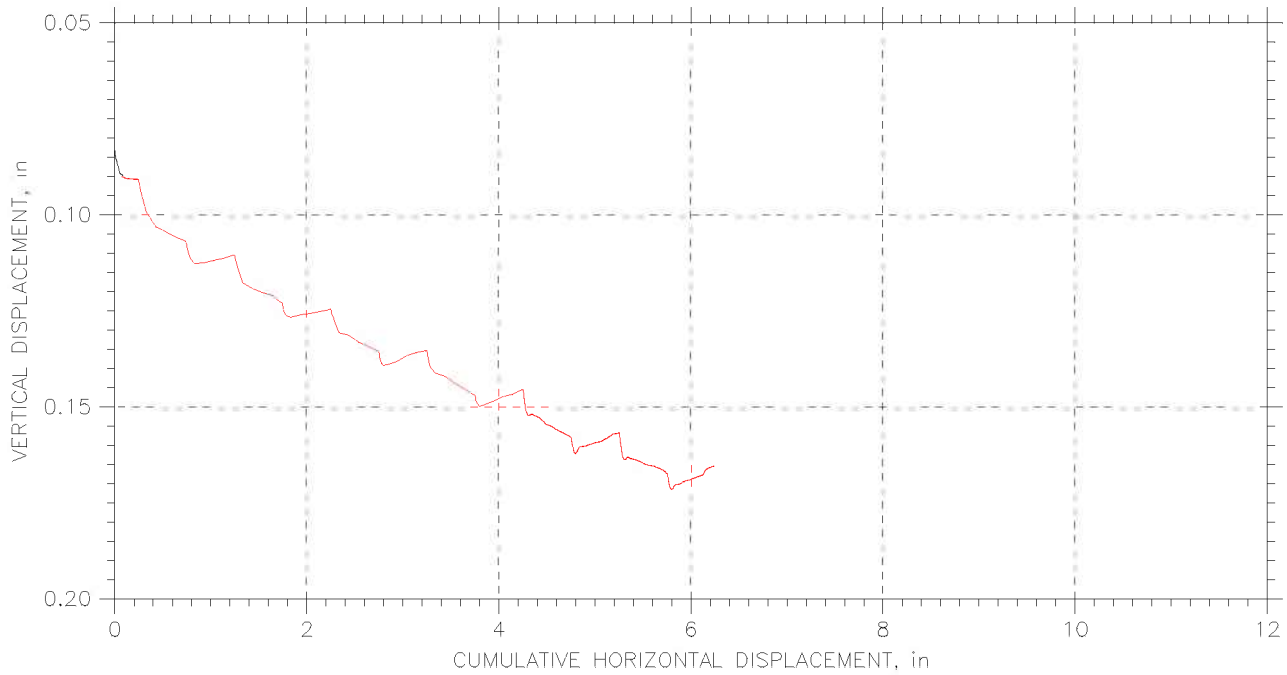
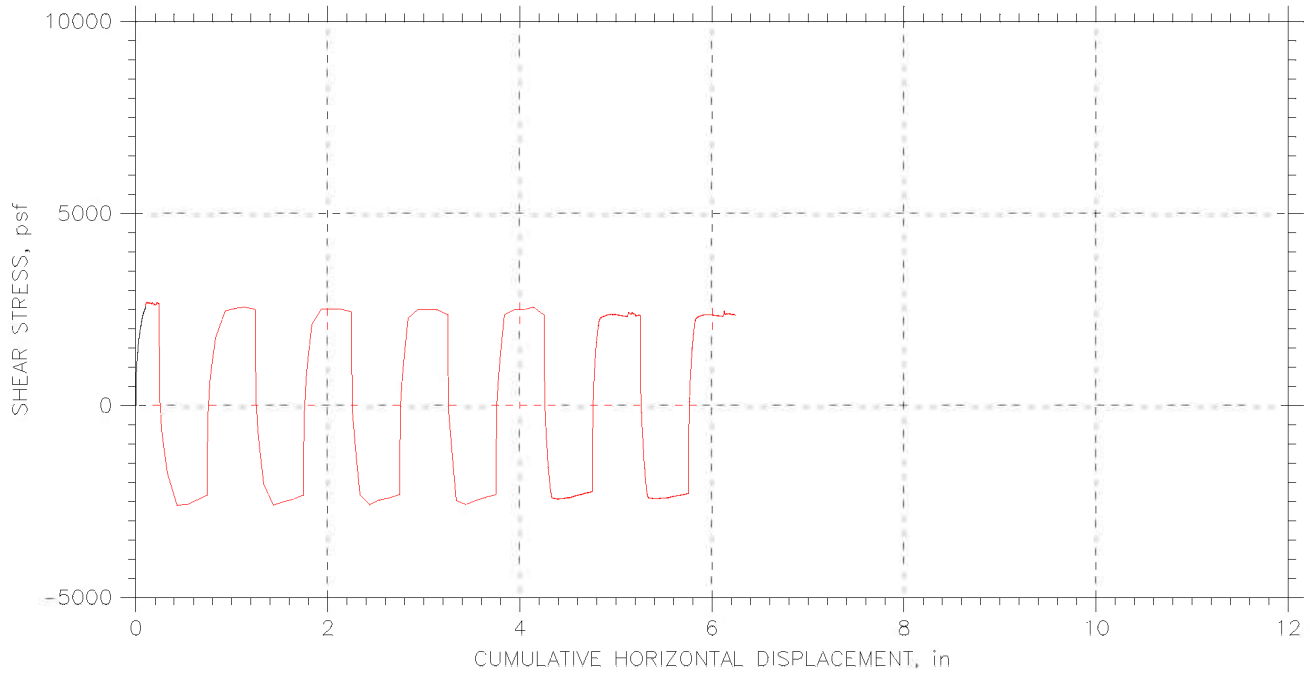

|  |                         |                       |
|--|-------------------------|-----------------------|
| Project: I-90 Central Viaduct  | Location: Cleveland, OH | Project No.: Gtx-6678 |
| Boring No.: S-27   | Tested By: md           | Checked By: jdt       |
| Sample No.: B-05-08  | Test Date: 05/30/06     | Depth: 116-118 ft     |
| Test No.: RS-10  | Sample Type: tube       | Elevation: ---        |
| Description: Moist, olive gray clay  |                         |                       |
| Remarks: Shear Loop rates (in/min): First .25 @ .0002, then 4 @ .02, then 2 @ .0002. |                         |                       |
| File: \\Geocompdb1\projects\GTX6678\6678-RS10.dat                                    |                         |                       |

# **Appendix E**

## **CIU Triaxial Tests**



# CONSOLIDATED UNDRAINED TRIAXIAL TEST by ASTM D4767

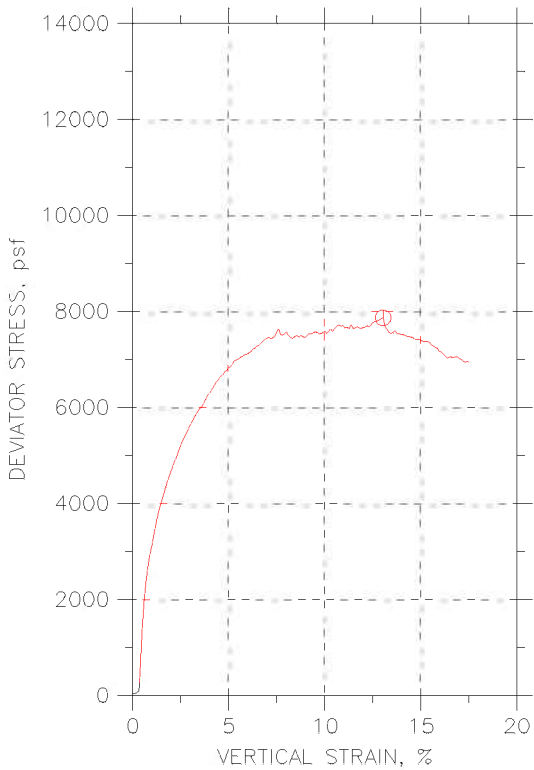
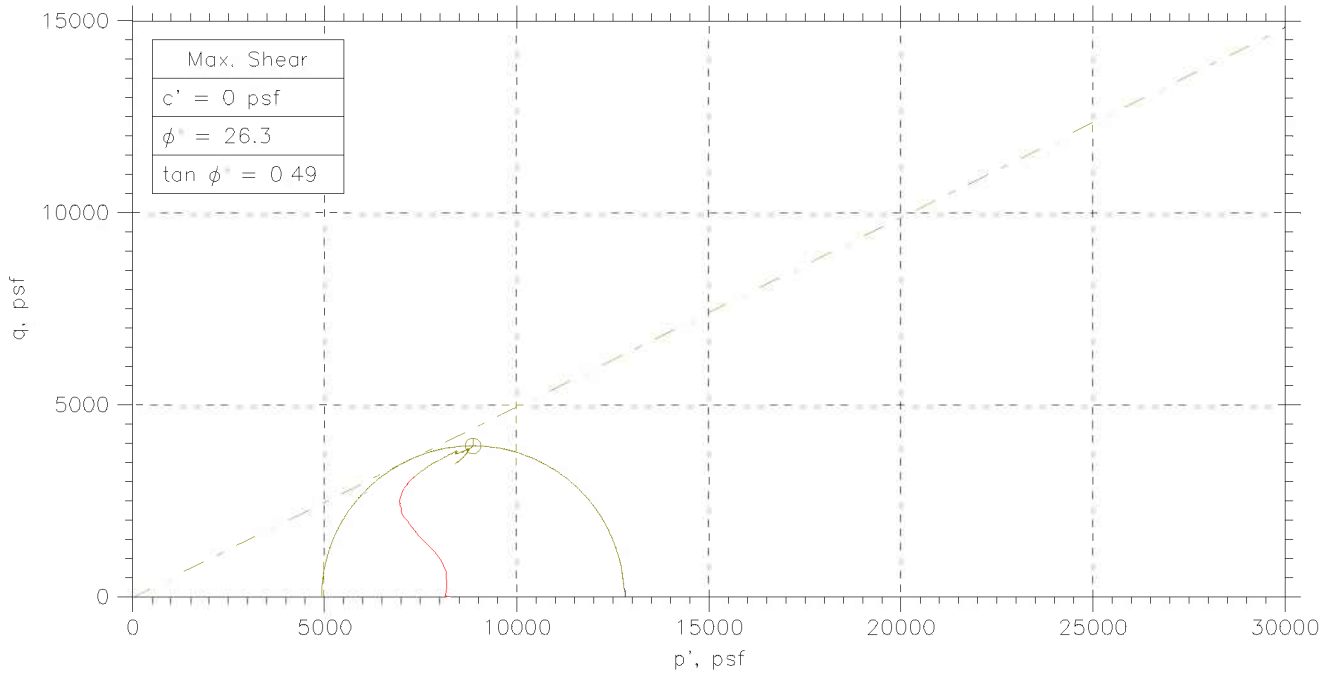

|              |                             |       |  |
|--------------|-----------------------------|-------|--|
| Symbol       | ⊙                           |       |  |
| Sample No.   | S-30                        |       |  |
| Test No.     | CU1                         |       |  |
| Depth        | 118.5-120.3                 |       |  |
| Initial      | Diameter, in                | 2.87  |  |
|              | Height, in                  | 5.96  |  |
|              | Water Content, %            | 26.7  |  |
|              | Dry Density, pcf            | 95.1  |  |
|              | Saturation, %               | 91.9  |  |
| Before Shear | Void Ratio                  | 0.792 |  |
|              | Water Content, %            | 25.2  |  |
|              | Dry Density, pcf            | 100.9 |  |
|              | Saturation*, %              | 100.0 |  |
|              | Void Ratio                  | 0.688 |  |
|              | Back Press., psf            | 14410 |  |
|              | Ver. Eff. Cons. Stress, psf | 9493  |  |
|              | Shear Strength, psf         | 3934  |  |
|              | Strain at Failure, %        | 13    |  |
|              | Strain Rate, %/min          | 0.05  |  |
|              | B-Value                     | 0.95  |  |
|              | Measured Specific Gravity   | 2.73  |  |
|              | Liquid Limit                | 33    |  |
|              | Plastic Limit               | 18    |  |

|              |                                    |  |  |  |  |
|--------------|------------------------------------|--|--|--|--|
|              | Project: I-90 Central Viaduct      |  |  |  |  |
|              | Location: Cleveland, OH            |  |  |  |  |
|              | Project No.: GTX-6678              |  |  |  |  |
|              | Boring No.: C-05-03                |  |  |  |  |
|              | Sample Type: tube                  |  |  |  |  |
|              | Description: Moist, dark gray clay |  |  |  |  |
| Remarks: --- |                                    |  |  |  |  |

# CONSOLIDATED UNDRAINED TRIAXIAL TEST by ASTM D4767

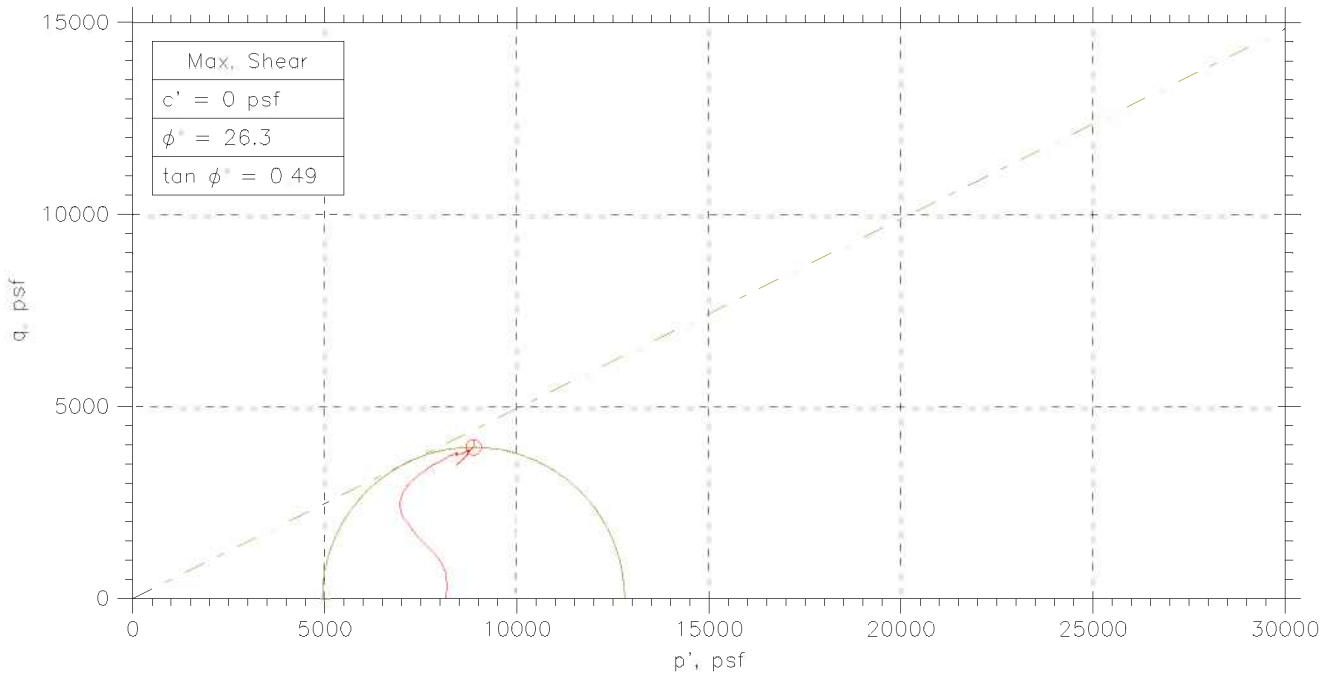
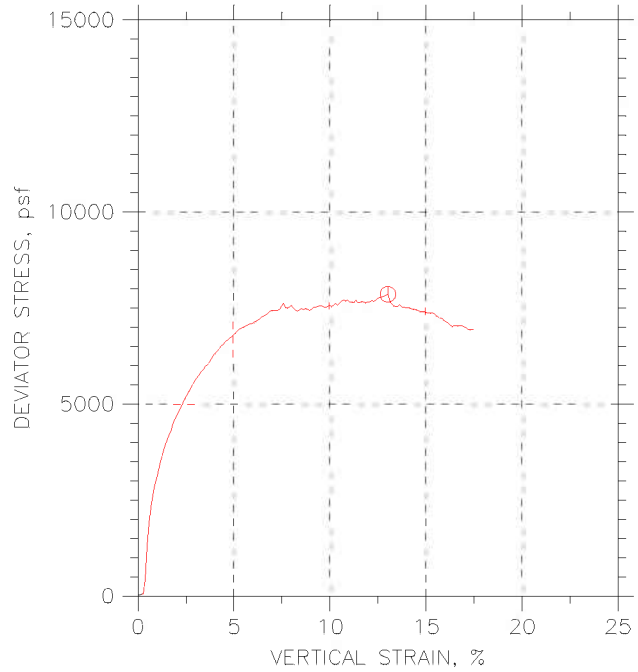
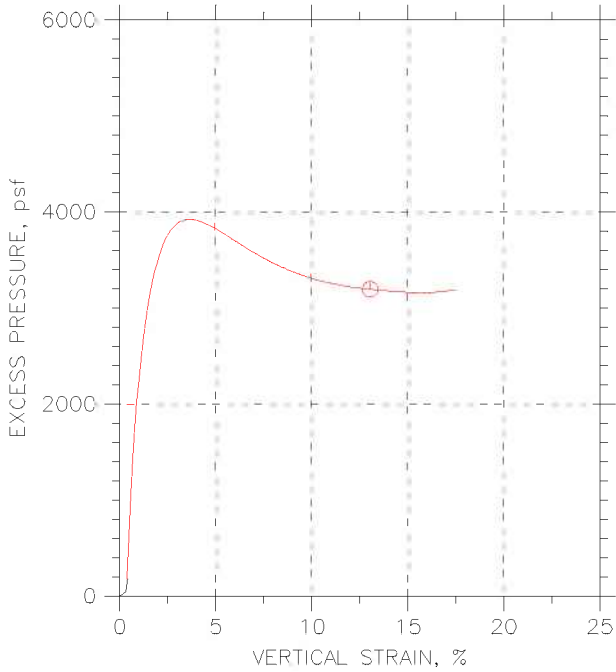

| Sample No. | Test No. | Depth           | Tested By | Test Date | Checked By | Check Date | Test File     |
|------------|----------|-----------------|-----------|-----------|------------|------------|---------------|
| ⊙ S-30     | CU1      | 118.5-120.3 njh |           | 05/31/06  | jdt        |            | 6678-cu1c.dat |
|            |          |                 |           |           |            |            |               |
|            |          |                 |           |           |            |            |               |

|  |                                    |                         |                       |
|--|------------------------------------|-------------------------|-----------------------|
|  | Project: I-90 Central Viaduct      | Location: Cleveland, OH | Project No.: GTX-6678 |
|  | Boring No.: C-05-03                | Sample Type: tube       |                       |
|  | Description: Moist, dark gray clay |                         |                       |
|  | Remarks: ---                       |                         |                       |

# CONSOLIDATED UNDRAINED TRIAXIAL TEST by ASTM D4767

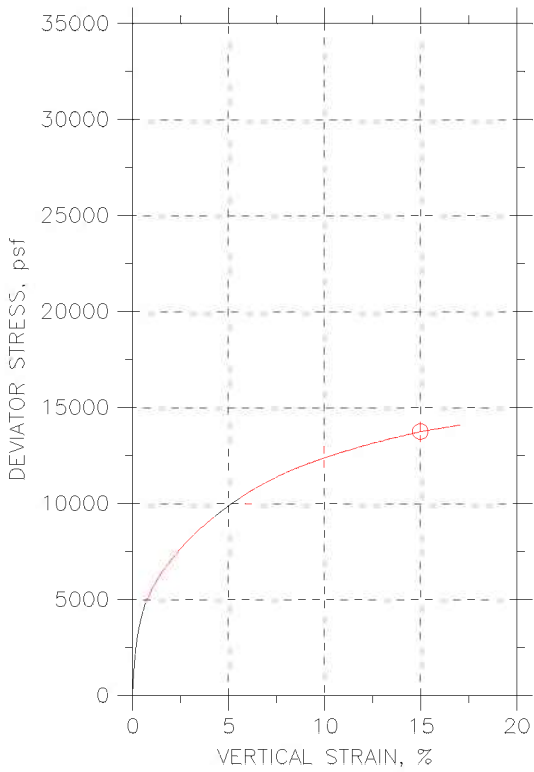
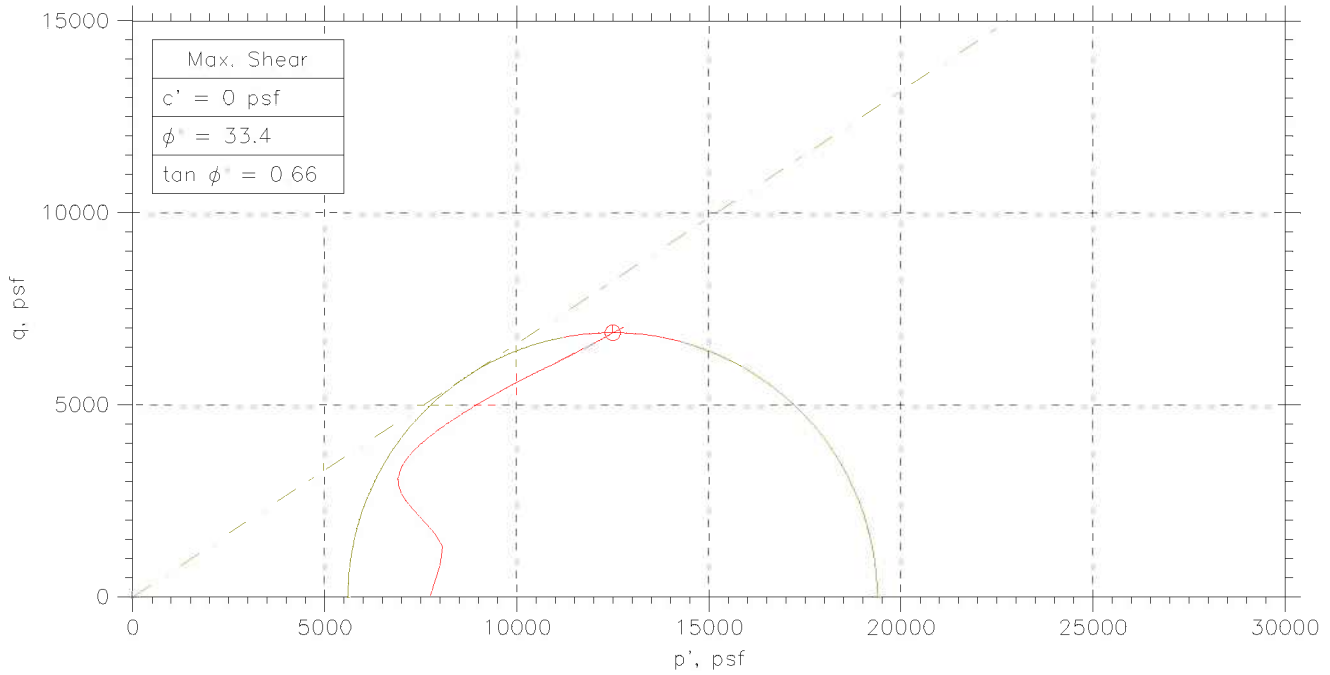

|                             |                  |       |  |
|-----------------------------|------------------|-------|--|
| Symbol                      | ⊙                |       |  |
| Sample No.                  | S-27             |       |  |
| Test No.                    | CU2              |       |  |
| Depth                       | 116-118 ft       |       |  |
| Initial                     | Diameter, in     | 2.87  |  |
|                             | Height, in       | 6.1   |  |
|                             | Water Content, % | 22.2  |  |
|                             | Dry Density, pcf | 105.1 |  |
|                             | Saturation, %    | 97.1  |  |
| Before Shear                | Water Content, % | 19.5  |  |
|                             | Dry Density, pcf | 111.4 |  |
|                             | Saturation*, %   | 100.0 |  |
|                             | Void Ratio       | 0.536 |  |
| Ver. Eff. Cons. Stress, psf | 8267             |       |  |
| Shear Strength, psf         | 6882             |       |  |
| Strain at Failure, %        | 15               |       |  |
| Strain Rate, %/min          | 0.05             |       |  |
| B-Value                     | 0.92             |       |  |
| Estimated Specific Gravity  | 2.74             |       |  |
| Liquid Limit                | 27               |       |  |
| Plastic Limit               | 16               |       |  |

|              |  |  |  |  |  |
|--------------|--|--|--|--|--|
|              | Project: I-90 Central Viaduct            |  |  |  |  |
|              | Location: Cleveland, OH                  |  |  |  |  |
|              | Project No.: GTX-6678                    |  |  |  |  |
|              | Boring No.: B-05-08                      |  |  |  |  |
|              | Sample Type: tube                        |  |  |  |  |
|              | Description: Moist, dark olive gray clay |  |  |  |  |
| Remarks: --- |  |  |  |  |  |

## CONSOLIDATED UNDRAINED TRIAXIAL TEST by ASTM D4767

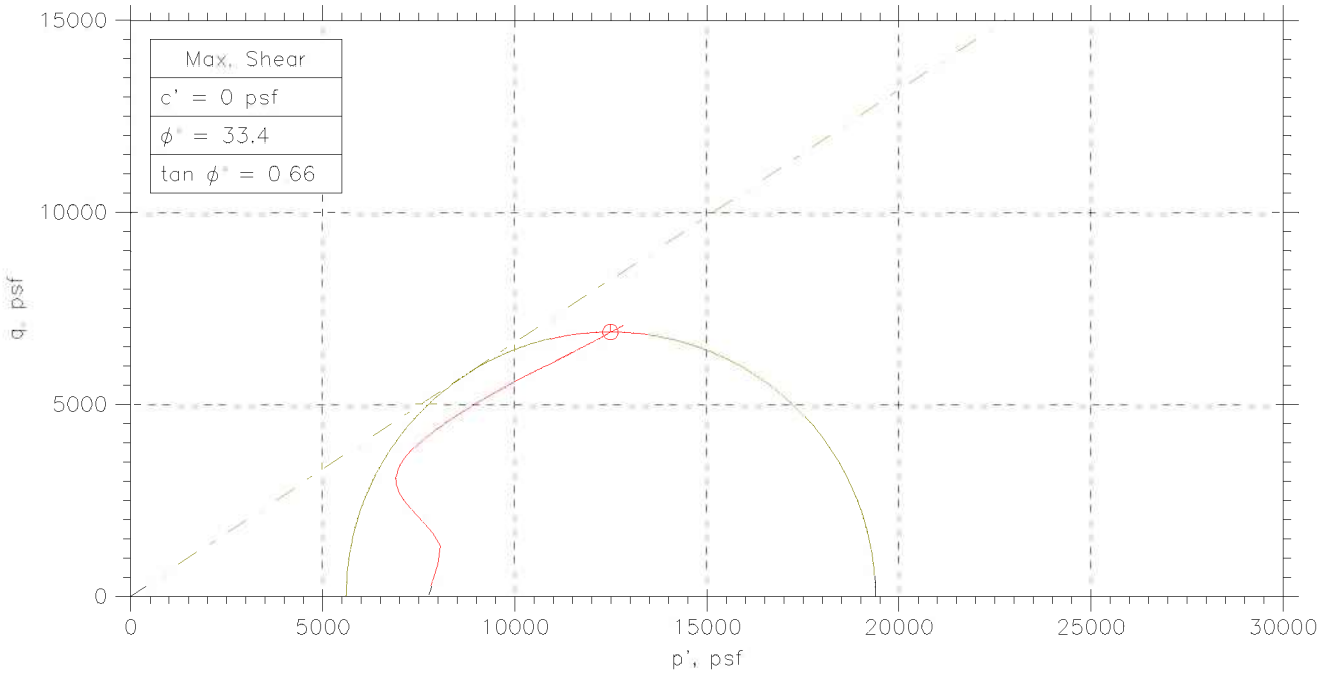
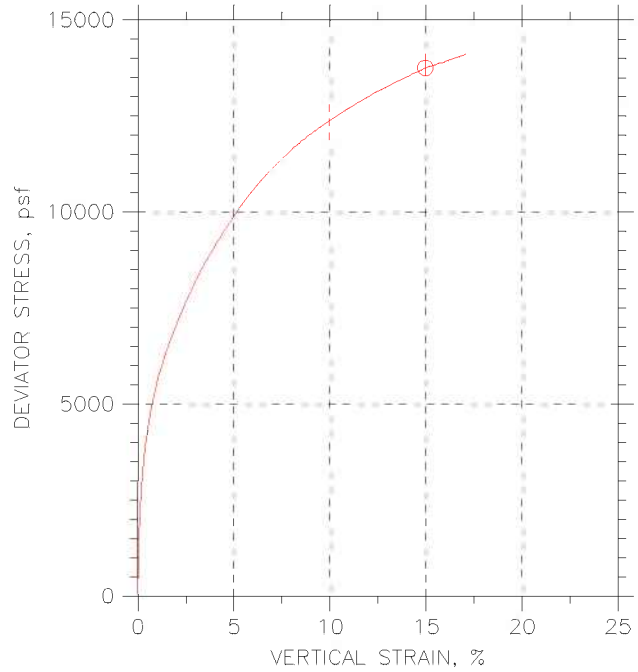
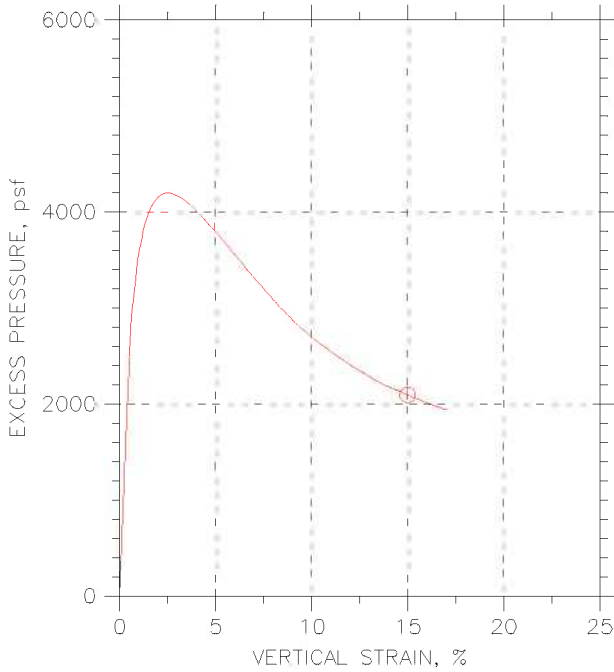

| Sample No. | Test No. | Depth      | Tested By | Test Date | Checked By | Check Date | Test File     |
|------------|----------|------------|-----------|-----------|------------|------------|---------------|
| ⊙ S-27     | CU2      | 116-118 ft | njh       | 06/01/06  | jdt        |            | 6678-cu2b.dat |
|            |          |            |           |           |            |            |               |
|            |          |            |           |           |            |            |               |

|  |  |  |                         |  |                       |  |
|--|--|--|-------------------------|--|-----------------------|--|
|  | Project: I-90 Central Viaduct            |  | Location: Cleveland, OH |  | Project No.: GTX-6678 |  |
|  | Boring No.: B-05-08                      |  | Sample Type: tube       |  |                       |  |
|  | Description: Moist, dark olive gray clay |  |                         |  |                       |  |
|  | Remarks: ---                             |  |                         |  |                       |  |

# **Appendix F**

## **Photos**

|                   |                      |
|-------------------|----------------------|
| Client:           | Geocomp Consulting   |
| Project Name:     | I-90 Central Viaduct |
| Project Location: | Cleveland, OH        |
| GTX #:            | 6678                 |
| Test Date:        | 05/06/06             |
| Tested By:        | njh                  |
| Checked By:       | jdt                  |
| Boring ID:        | C-05-03              |
| Sample ID:        | S-30                 |
| Depth, ft:        | 118.5-120.3          |



Extruded sample showing in-situ shear plane. Side view.  
Direct Simple Shear test, DSS-2 was trimmed from this piece.

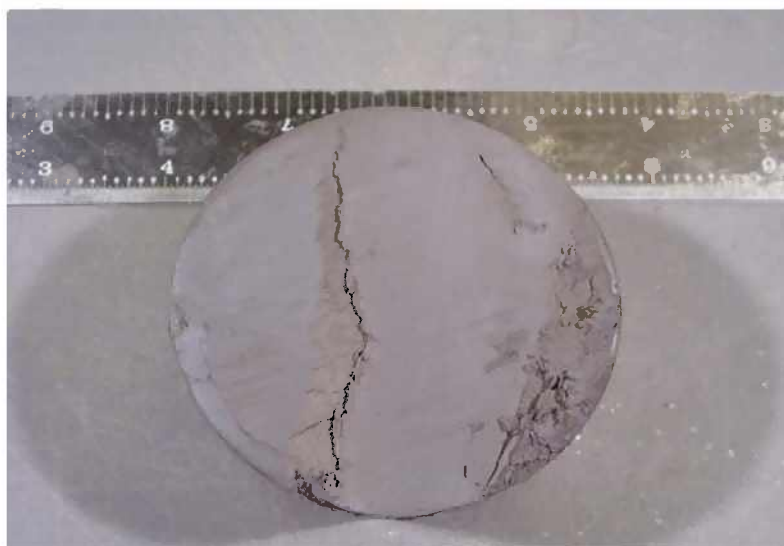

Same extruded sample showing in-situ shear plane. Top view.

|                   |                      |
|-------------------|----------------------|
| Client:           | Geocomp Consulting   |
| Project Name:     | I-90 Central Viaduct |
| Project Location: | Cleveland, OH        |
| GTX #:            | 6678                 |
| Test Date:        | 05/06/06             |
| Tested By:        | njh                  |
| Checked By:       | jdt                  |
| Boring ID:        | C-05-03              |
| Sample ID:        | S-30                 |
| Depth, ft:        | 118.5-120.3          |



Post test picture, after pulling apart and putting back together. Shows development of an angular shear plane. Direct Simple Shear (DSS-2) test sample.



Same sample, pulled apart view of the internal structure along horizontal planes. The material appeared rough. There were no visible polished surfaces.

|                   |                      |
|-------------------|----------------------|
| Client:           | Geocomp Consulting   |
| Project Name:     | I-90 Central Viaduct |
| Project Location: | Cleveland, OH        |
| GTX #:            | 6678                 |
| Test Date:        | 05/06/06             |
| Tested By:        | njh                  |
| Checked By:       | jdt                  |
| Boring ID:        | C-05-03              |
| Sample ID:        | S-30                 |
| Depth, ft:        | 118.5-120.3          |



Post test showing failure lean to the left. Slight shear plane developing angling back. Direct Simple Shear (DSS-2) test specimen.



Same sample, broken to show the cross section through the middle of specimen. Shows horizontal layers, some with an almost blocky structure at a very small scale.



|                   |                      |
|-------------------|----------------------|
| Client:           | Geocomp Consulting   |
| Project Name:     | I-90 Central Viaduct |
| Project Location: | Cleveland, OH        |
| GTX #:            | 6678                 |
| Test Date:        | 05/06/06             |
| Tested By:        | njh                  |
| Checked By:       | jdt                  |
| Boring ID:        | C-05-03              |
| Sample ID:        | S-30                 |
| Depth, ft:        | 118.5-120.3          |



Sample in trimming ring showing an in-situ shear plane in the material as received. Residual Shear test (RS-2), angled view.



Same sample, in trimming ring showing an in-situ shear plane in the material as received. Residual Shear test (RS-2), top view.

**APPENDIX 4G**  
**BBCM 2006 LABORATORY TESTING REPORT**

JOB NUMBER : 012-00946-300

PROJECT : CUY-90-15.24 West Abutment

## LABORATORY LOG OF SHELBY TUBES

| Boring : B-05-01   | Sample : 13   | Boring : B-05-13       | Sample : 18       | Boring : | Sample :   |
|--|---|------------------------|-------------------|----------|------------|
| Depth : 55.0' to 57.0'   | Recovery : 20.50"   | Depth : 70.0' to 71.6' | Recovery : 18.00" | Depth :  | Recovery : |
| <p>disturbed - discarded<br/>Gray silt inter-bedded with silty clay, trace fine sand.<br/>-@ 55.0' to 55.2' many lenses of fine to coarse sand.</p> <p>A-4b (8)</p> <p>30.50" tube</p> | <p>disturbed - discarded<br/>Stiff to very-stiff gray silty clay, trace fine to coarse sand, trace fine gravel, few lenses of silt.<br/>-@ 70.0' to 70.3' Soft</p> <p>A-6a (9)</p> <p>H=2.25<br/>H=1.3</p> <p>AL/MA on Sections I,II,III</p> <p>30.00" tube</p> |                        |                   |          |            |

**LEGEND**

- Wax
- Consolidation, Vertical
- Permeability, Vertical / Horizontal
- Unconfined Compression Test
- Triaxial Compression Test
- H - Hand Penetrometer (tsf)
- Ds - Direct Shear
- LOI - Loss on Ignition
- AL - Atterberg Limits
- MA - Mechanical Analysis
- SG - Specific Gravity
- POR - Porosity
- UDW - Unit Dry Weight
- MC - Moisture Content
- DR - Relative Density
- S - Sieve

**JL NUMBER :** 012-00946.300  
**PROJECT :** CUY-90-15.24 West Abutment

## LABORATORY LOG OF SHELBY TUBES

| Boring : B-05-04  | Sample : S-25   | Sample : S-37   | Sample :  |
|---|---|---|---|
| <b>Depth :</b> 68.0' to 70.0'<br><b>Recovery :</b> 20.50"<br> | <b>Depth :</b> 118.0' to 119.0'<br><b>Recovery :</b> 12.00"<br> | <b>Depth :</b> [Blank]<br><b>Recovery :</b> [Blank]<br> | <b>Depth :</b> [Blank]<br><b>Recovery :</b> [Blank]<br> |

- LEGEND**
- Wax
  - Consolidation, Vertical
  - Unconfined Compression Test
  - Permeability, Vertical / Horizontal
  - Triaxial Compression Test
  - H** - Hand Penetrometer (tsf)
  - Ds** - Direct Shear
  - LOI** - Loss on Ignition
  - AL** - Atterberg Limits
  - MA** - Mechanical Analysis
  - SG** - Specific Gravity
  - POR** - Porosity
  - UDW** - Unit Dry Weight
  - MC** - Moisture Content
  - Dr** - Relative Density
  - S** - Sieve

JOB NUMBER : 012-00946.300

PROJECT : CUY-90-15.24 West Abutment



LABORATORY LOG OF SHELBY TUBES

| Boring : B-05-16  | Sample : 7  | Boring : B-05-16  | Sample : 25       | Boring : B-05-16         | Sample : 26       |
|---|---|---|-------------------|--------------------------|-------------------|
| Depth : 24.0' to 26.0'  | Recovery : 18.00"   | Depth : 111.0' to 113.0'  | Recovery : 23.00" | Depth : 113.0' to 115.0' | Recovery : 21.00" |
| <p>VOID<br/>OUT<br/>AL/MA<br/>Ds<br/>SAVE<br/>SAVE</p> <p>disturbed - discarded</p> <p>Very-stiff gray silty clay, trace fine to coarse sand, trace fine gravel, many silt lenses.</p> <p>A-6b (10)</p> <p>H=2.1-2.4</p> <p>30.00" tube</p> | <p>VOID<br/>OUT<br/>AL/MA<br/>Ds<br/>SAVE<br/>SAVE<br/>SAVE</p> <p>disturbed - discarded</p> <p>Stiff to very-stiff gray silt, "and" clay, trace fine sand, contains few silty clay seams.</p> <p>A-4b (8)</p> <p>H=1.25-3.6</p> <p>30.00" tube</p> | <p>VOID<br/>OUT<br/>SAVE<br/>SAVE<br/>AL/MA<br/>Ds<br/>JAR</p> <p>disturbed - discarded</p> <p>Loose (est.) gray silt, trace clay, trace fine to coarse sand, trace fine gravel, contains few fine sand lenses.</p> <p>---Note : very moist @ 113.0' to 114.3'</p> <p>A-4b (0)</p> <p>30.00" tube</p> |                   |                          |                   |

**LEGEND**

- Wax
- Consolidation, Vertical
- Unconfined Compression Test
- Permeability, Vertical / Horizontal
- Triaxial Compression Test
- Hand Penetrometer (tsf)
- Direct Shear
- Loss on Ignition
- Atterberg Limits
- Mechanical Analysis
- Specific Gravity
- Porosity
- Unit Dry Weight
- Moisture Content
- Relative Density
- Sieve

JOB NUMBER : 012-00946-300

PROJECT : CUY-90-15.24 West Abutment

## LABORATORY LOG OF SHELBY TUBES

| Boring : B-105A          | Sample : 23       | Boring : B-105A          | Sample : 24       | Boring : B-105A          | Sample : 25       |
|--------------------------|-------------------|--------------------------|-------------------|--------------------------|-------------------|
| Depth : 103.0' to 105.0' | Recovery : 24.00" | Depth : 105.0' to 107.0' | Recovery : 25.50" | Depth : 107.0' to 109.0' | Recovery : 25.00" |
|                          |                   |                          |                   |                          |                   |

**LEGEND**

- Wax
- Consolidation, Vertical
- Unconfined Compression Test
- Permeability, Vertical / Horizontal
- Triaxial Compression Test
- H** - Hand Penetrometer (tsf)
- Ds** - Direct Shear
- LOI** - Loss on Ignition
- AL** - Atterberg Limits
- MA** - Mechanical Analysis
- SG** - Specific Gravity
- POR** - Porosity
- UDW** - Unit Dry Weight
- MC** - Moisture Content
- DR** - Relative Density
- S** - Sieve

JOB NUMBER : 012-00946.300  
 PROJECT : CUY-90-15.24 West Abutment

## LABORATORY LOG OF SHELBY TUBES

| Boring : B-108A                            | Sample : S-24                              | Boring : B-108A                            | Sample : S-25                              | Boring : B-108A                            | Sample : S-26                              |
|--|--|--|--|--|--|
| Depth : 113.0' to 115.0' Recovery : 24.00" | Depth : 113.0' to 115.0' Recovery : 24.00" | Depth : 115.0' to 117.0' Recovery : 24.00" | Depth : 115.0' to 117.0' Recovery : 24.00" | Depth : 117.0' to 119.0' Recovery : 24.00" | Depth : 117.0' to 119.0' Recovery : 24.00" |
|  |  |  |  |  |  |

**LEGEND**

- Wax
- Consolidation, Vertical
- Permeability, Vertical / Horizontal
- Unconfined Compression Test
- Triaxial Compression Test
- H** - Hand Penetrometer (tsf)
- Ds** - Direct Shear
- LOI** - Loss on Ignition
- AL** - Atterberg Limits
- MA** - Mechanical Analysis
- SG** - Specific Gravity
- POR** - Porosity
- UDW** - Unit Dry Weight
- MC** - Moisture Content
- DR** - Relative Density
- S** - Sieve





# SUMMARY OF TRIAXIAL COMPRESSION TESTS

SATURATED, CONSOLIDATED, UNDRAINED  
(RESIDUAL PLOTTED)

## SHEAR STRESS VS NORMAL STRESS

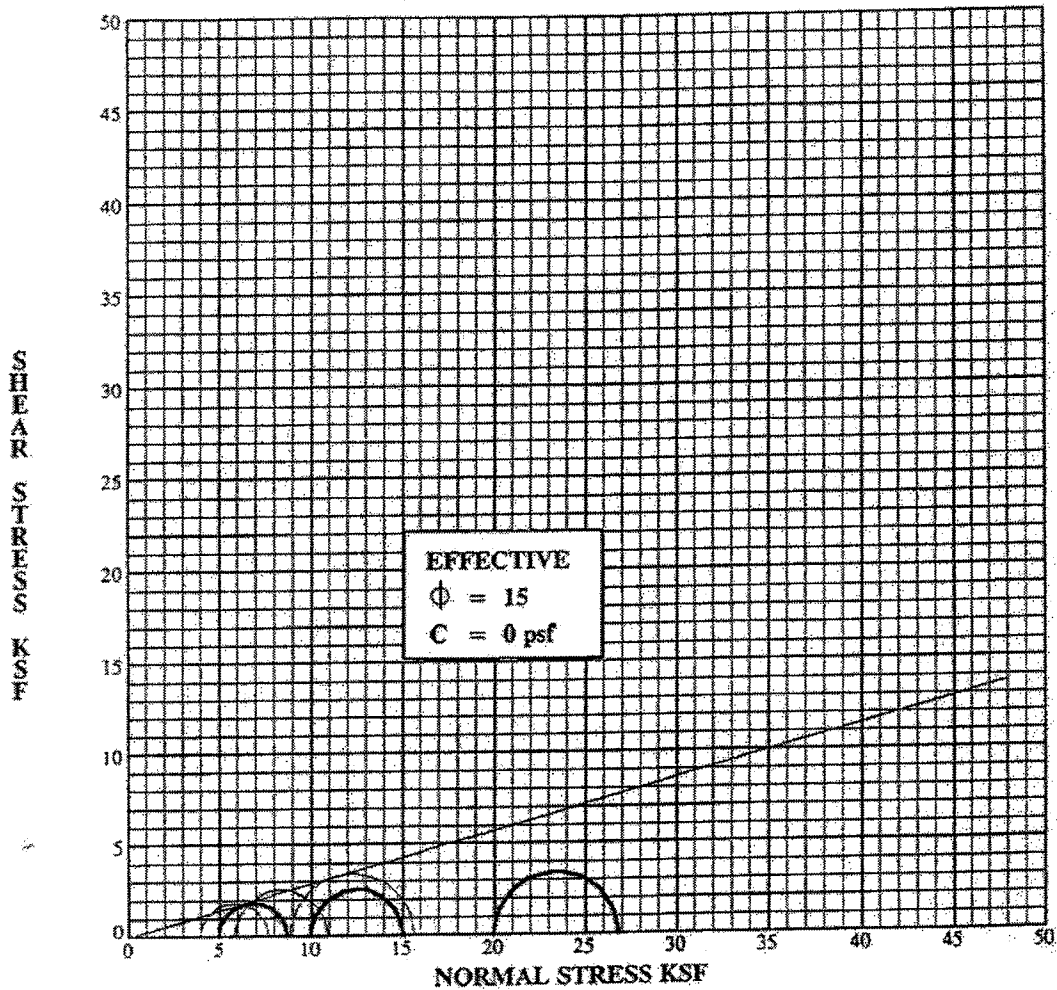

TOTAL STRESS

EFFECTIVE STRESS

| Specimen Identification      | Classification   | DD  | MC% |
|------------------------------|--|-----|-----|
| B-109 S-24 I 124.5'-126.2'   | Very-stiff gray silty clay, trace fine to coarse sand, trace fine gravel, contains few lenses of silt. A-6b (10) | 103 | 23  |
| B-109 S-24 II 124.5'-126.2'  | Very-stiff gray silty clay, trace fine to coarse sand, trace fine gravel, contains few lenses of silt. A-6b (10) | 98  | 27  |
| B-109 S-24 III 124.5'-126.2' | Very-stiff gray silty clay, trace fine to coarse sand, trace fine gravel, contains few lenses of silt. A-6b (10) | 107 | 20  |



PROJECT CUY-90-15.24  
 LOCATION CLEVELAND, OHIO  
 JOB NO. 4500 DATE 12/10/94

# SUMMARY OF DIRECT SHEAR TESTS

SATURATED, CONSOLIDATED, DRAINED

SHEAR STRESS VS NORMAL LOAD

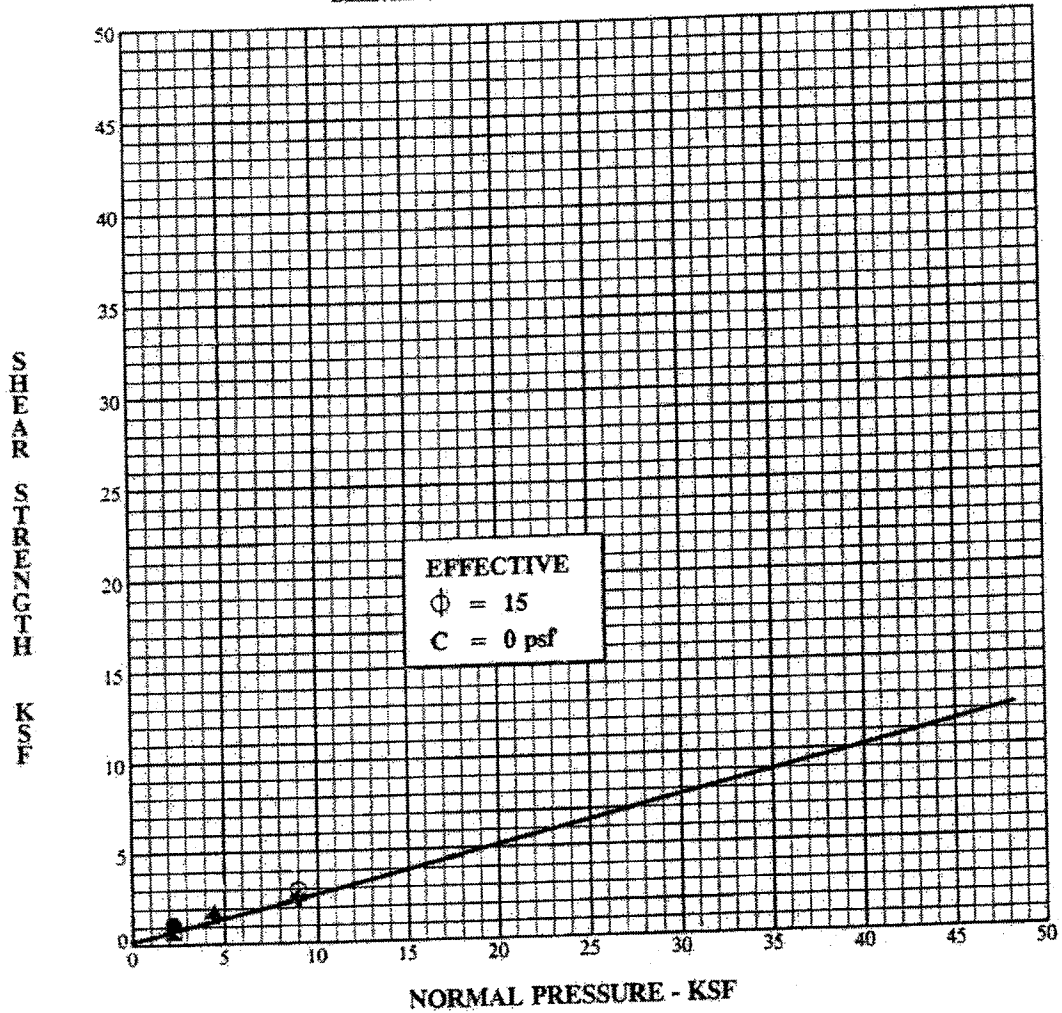

| Specimen Identification    | Normal Load | Type Plot | Classification                    | DD  | MC% |
|----------------------------|-------------|-----------|-----------------------------------|-----|-----|
| ● B-108 S-8 IV 35.0'-37.0' | 2.25 KSF    | Peak      | Stiff gray silty clay, trace fine | 101 | 26  |
| ■                          | 2.25 KSF    | RESIDUAL  | to medium sand. A-6a (10)         |     |     |
| ▲                          | 4.50 KSF    | Peak      |                                   | 100 | 26  |
| ★                          | 4.50 KSF    | RESIDUAL  |                                   |     |     |
| ○                          | 9.00 KSF    | Peak      |                                   | 95  | 28  |
| ⊗                          | 9.00 KSF    | RESIDUAL  |                                   |     |     |



PROJECT CUY-90-15.24  
 LOCATION Cleveland, Ohio  
 JOB NO. 4500 DATE 10/29/94

Figure:

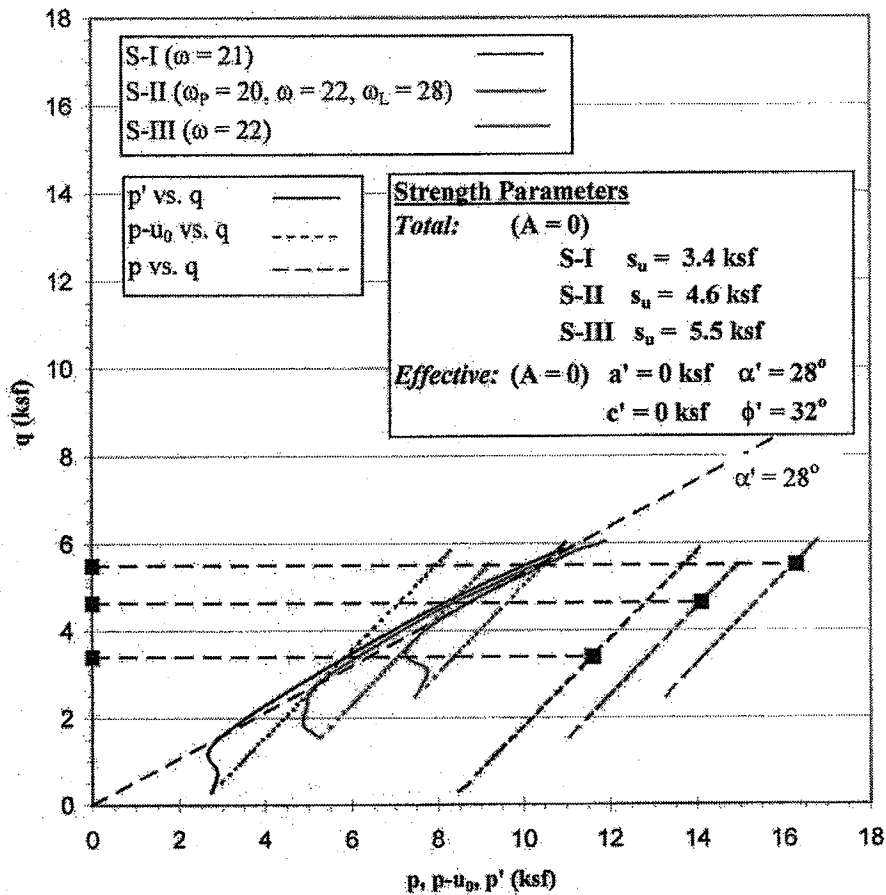

**Type of Test:** CK<sub>0</sub>UTXC with pore pressure measurements  
**Description:** SILT - Medium-stiff to very-stiff gray silt, some to "and" clay, trace fine sand.  
**Assumed Specific Gravity:** 2.75

| Sample No. |                  | I     | II    | III   |
|------------|------------------|-------|-------|-------|
| Initial    | Water Content    | 21.3  | 22.4  | 21.5  |
|            | Dry Density, pcf | 111.0 | 107.8 | 107.2 |
|            | Saturation       | 107.2 | 103.9 | 98.3  |
|            | Void Ratio       | 0.546 | 0.592 | 0.602 |
|            | Diameter, in     | 2.87  | 2.86  | 2.88  |
|            | Height, in       | 5.60  | 5.61  | 5.59  |
| At Test    | Water Content    | 18.3  | 20.1  | 19.0  |
|            | Dry Density, pcf | 115.7 | 113.3 | 112.6 |
|            | Saturation       | 103.8 | 107.3 | 99.5  |
|            | Void Ratio       | 0.484 | 0.516 | 0.525 |
|            | Diameter, in     | 2.82  | 2.82  | 2.85  |
|            | Height, in       | 5.55  | 5.48  | 5.41  |

**BBC&M ENGINEERING, INC. - Triaxial Compression Test Report**

**Boring:** B-05-01 **Project:** CUY-90.15.24 West Abutment  
**Sample:** S13, Sec I to III **Depth:** 55' to 57' **Project No:** 012 00946.300  
**Client:** Micheal Baker Jr. Inc.

Figure:

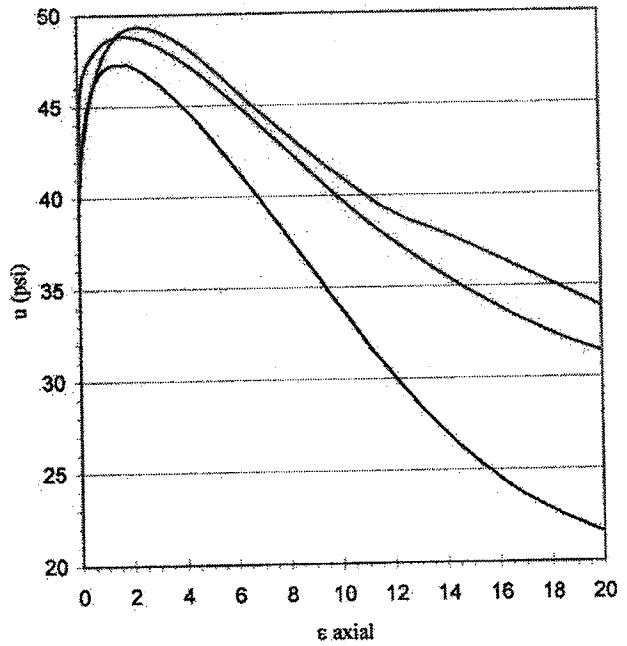
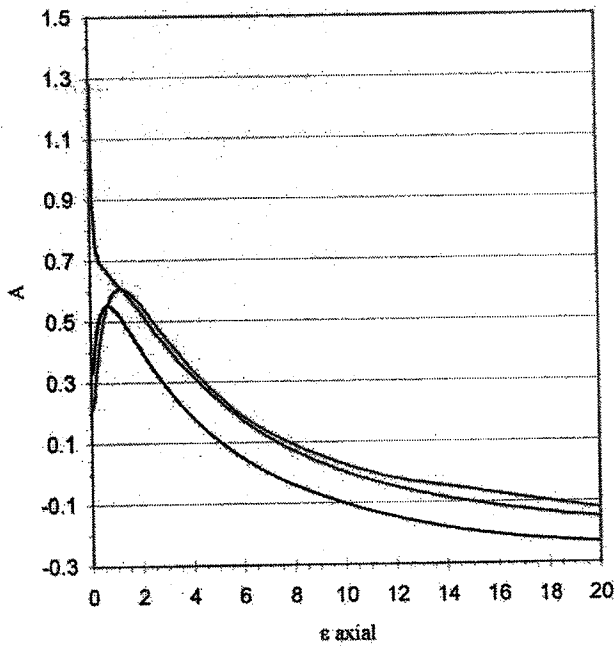
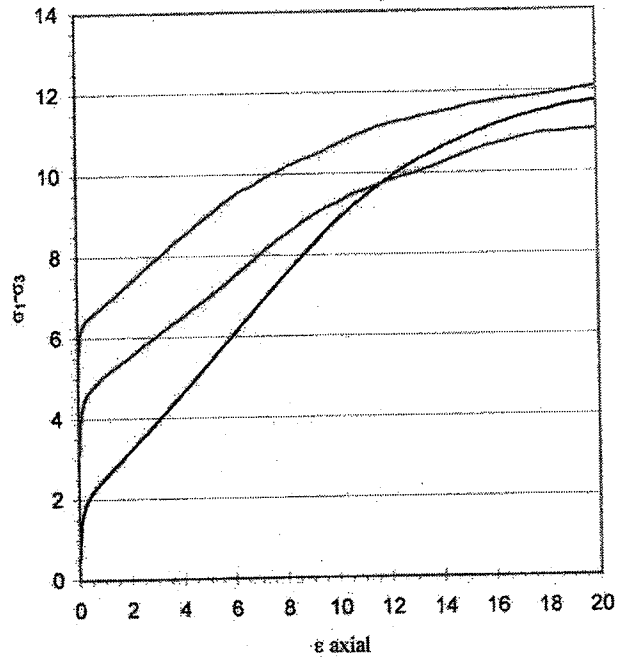
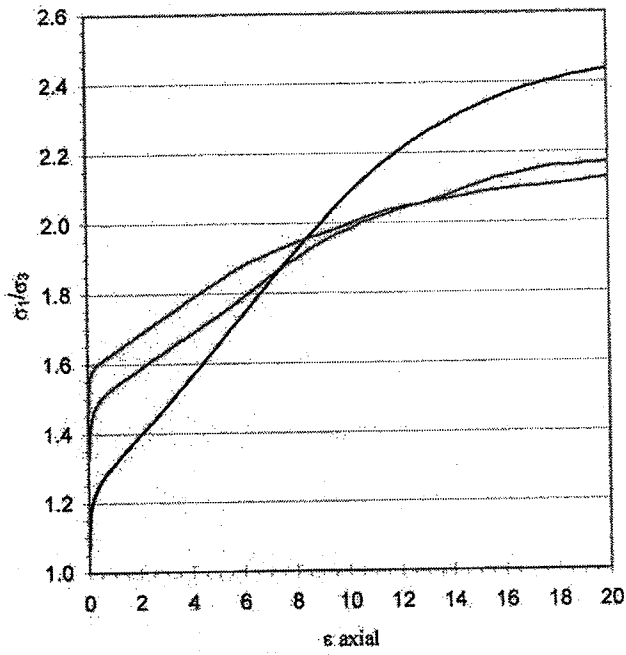

**BBC&M ENGINEERING, INC. - Triaxial Compression Test Report**

Boring: B-05-01  
Sample: S13, Sec I to III

Depth: 55' to 57'

Project: CUY-90.15.24 West Abutment  
Project No: 012 00946.300  
Client: Micheal Baker Jr. Inc.

Figure:

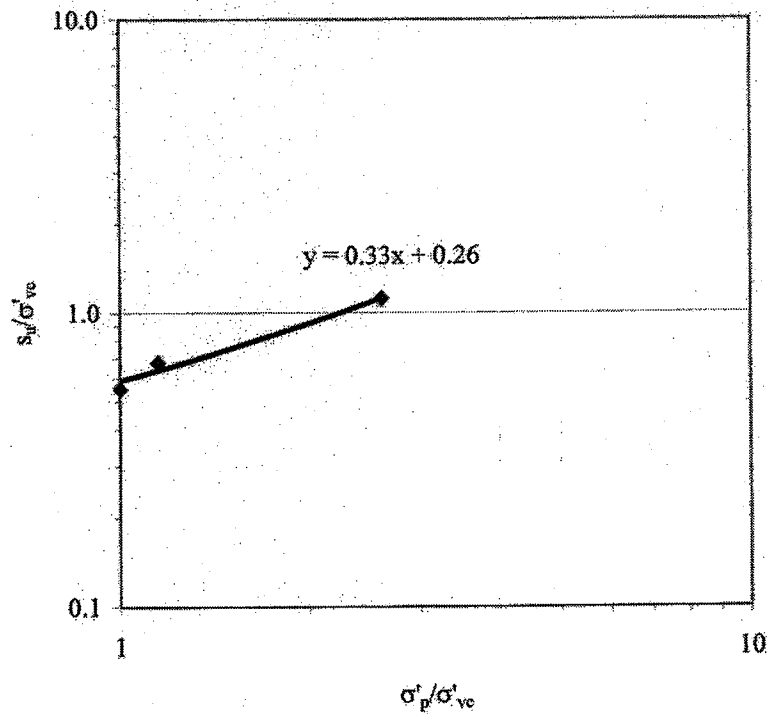
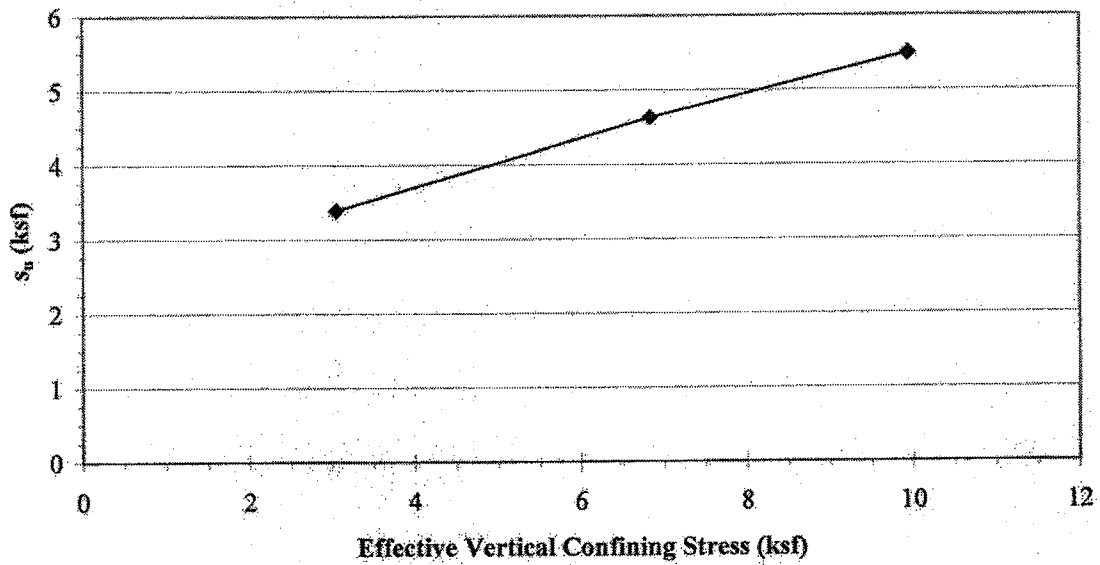

**BBC&M ENGINEERING, INC. - Triaxial Compression Test Report**

Boring: B-05-01  
Sample: S13, Sec I to III

Depth: 55' to 57'

Project: CUY-90.15.24 West Abutment  
Project No: 012 00946.300  
Client: Micheal Baker Jr. Inc.

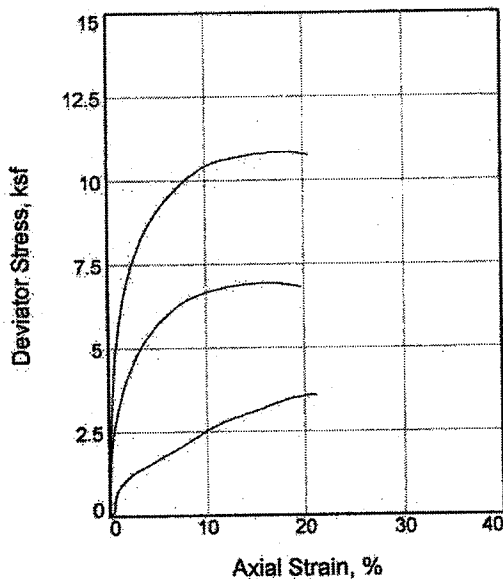
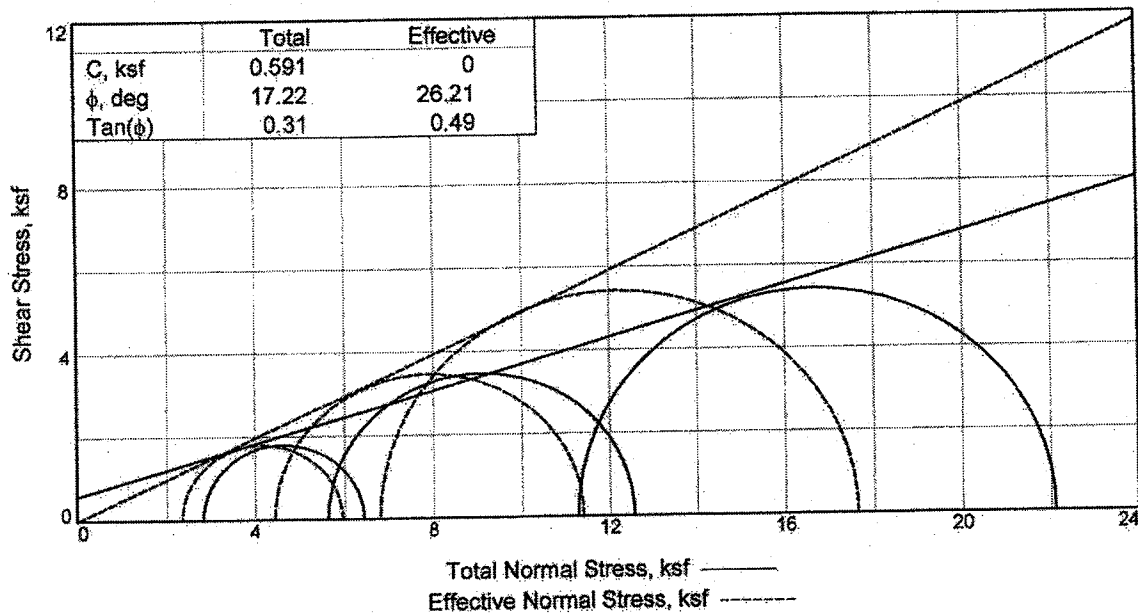

| Sample No.                    | 1      | 2      | 3      |
|-------------------------------|--------|--------|--------|
| <b>Initial</b>                |        |        |        |
| Water Content,                | 23.5   | 21.8   | 21.2   |
| Dry Density, pcf              | 98.2   | 105.5  | 107.1  |
| Saturation,                   | 86.3   | 95.7   | 96.8   |
| Void Ratio                    | 0.7488 | 0.6278 | 0.6029 |
| Diameter, in.                 | 2.878  | 2.868  | 2.866  |
| Height, in.                   | 5.590  | 5.600  | 5.590  |
| <b>At Test</b>                |        |        |        |
| Water Content,                | 21.4   | 19.9   | 18.7   |
| Dry Density, pcf              | 108.0  | 111.0  | 115.9  |
| Saturation,                   | 99.9   | 99.8   | 106.7  |
| Void Ratio                    | 0.5894 | 0.5472 | 0.4808 |
| Diameter, in.                 | 2.823  | 2.827  | 2.792  |
| Height, in.                   | 5.279  | 5.477  | 5.442  |
| <b>1</b>                      |        |        |        |
| Strain rate, in./min.         | 0.002  | 0.002  | 0.002  |
| Eff. Cell Pressure, ksf       | 2.82   | 5.63   | 11.26  |
| Fail. Stress, ksf             | 3.60   | 6.94   | 10.85  |
| Excess Pore Pr., ksf          | 0.47   | 1.18   | 4.48   |
| Strain, %                     | 20.7   | 15.9   | 17.8   |
| Ult. Stress, ksf              | 3.33   |        |        |
| Excess Pore Pr., ksf          | 0.77   |        |        |
| Strain, %                     | 17.0   |        |        |
| $\bar{\sigma}_1$ Failure, ksf | 5.95   | 11.39  | 17.63  |
| $\bar{\sigma}_3$ Failure, ksf | 2.35   | 4.45   | 6.79   |

**Type of Test:**

CU with Pore Pressures

**Sample Type:** Shelby Tube

**Description:** Stiff to very-stiff gray silty clay, little fine to coarse sand, trace fine gravel. A-6a

LL= 30 PL= 17 PI= 13

Assumed Specific Gravity= 2.75

Remarks: top 3" of Section I disturbed

**Client:**

**Project:** CUY-90-15.24 West Abutment

Cleveland, Ohio

**Location:** B-05-13

**Sample Number:** 18 Section I,II,III

Proj. No.: 012-00946-300

Date: 05/19/06

TRIAXIAL SHEAR TEST REPORT

**BBC&M Engineering, Inc.**

Report Date 05/16-19/06

Tested By: JJ

Checked By: JJ

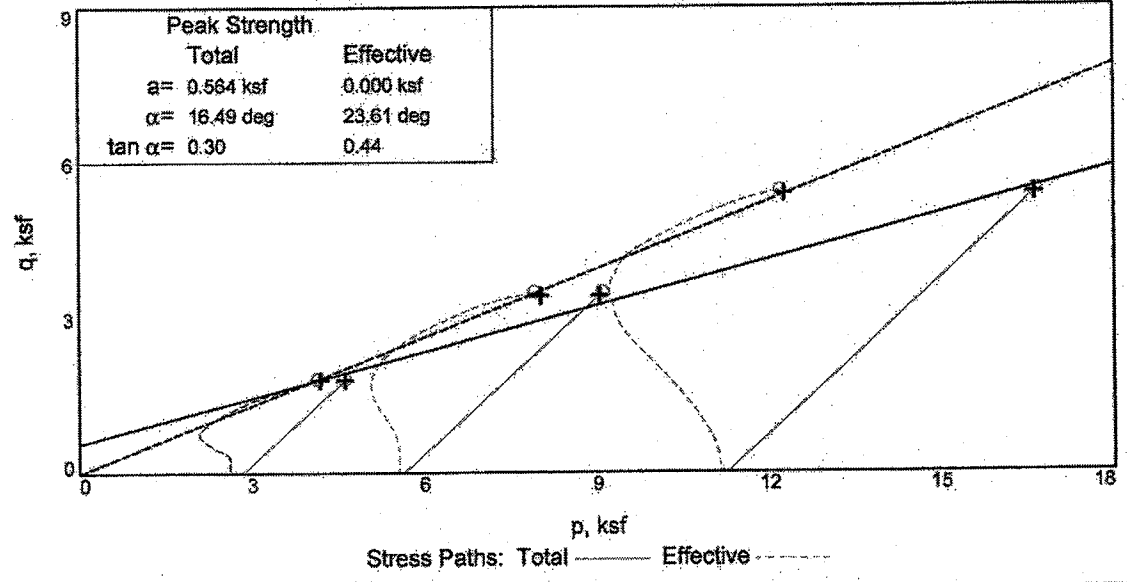
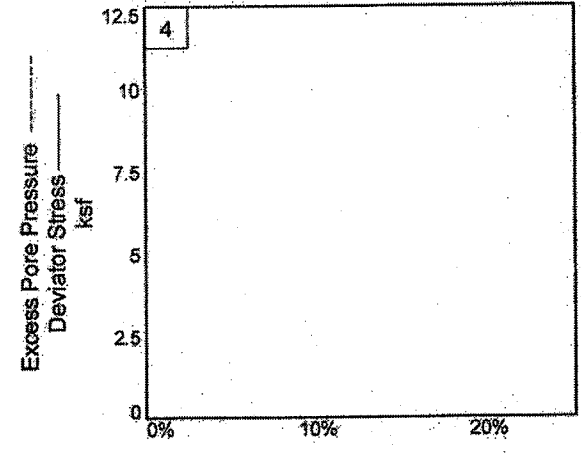
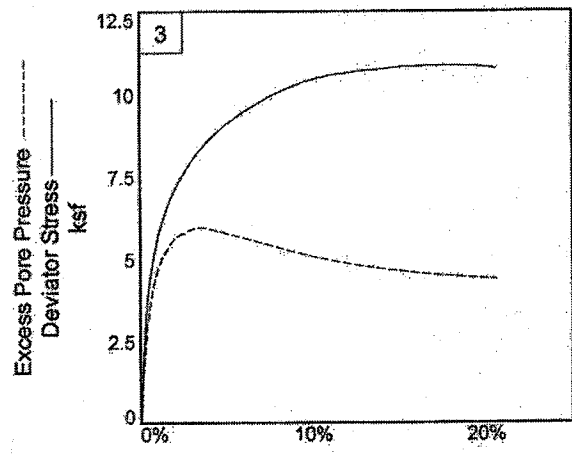
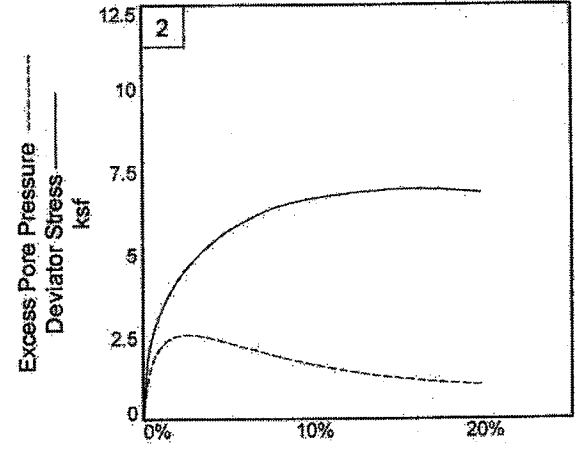
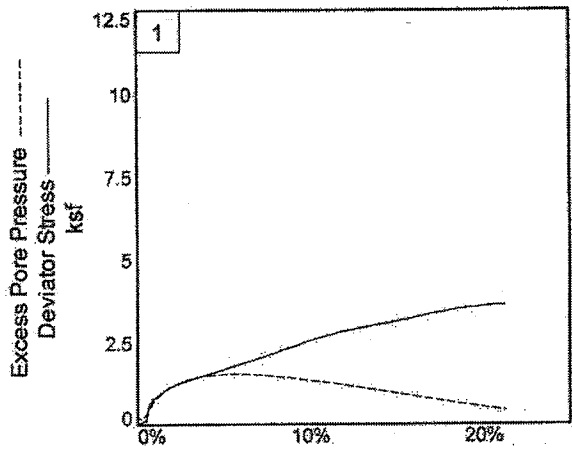

Client:  
 Project: CUY-90-15.24 West Abutment  
 Location: B-05-13      Depth: 70.0' to 71.6'      Sample Number: 18 Section I,II,III  
 Project No.: 012-00946-300      Report Date: \_\_\_\_\_      **BBC&M Engineering, Inc.**

Tested By: JJ      Checked By: JJ

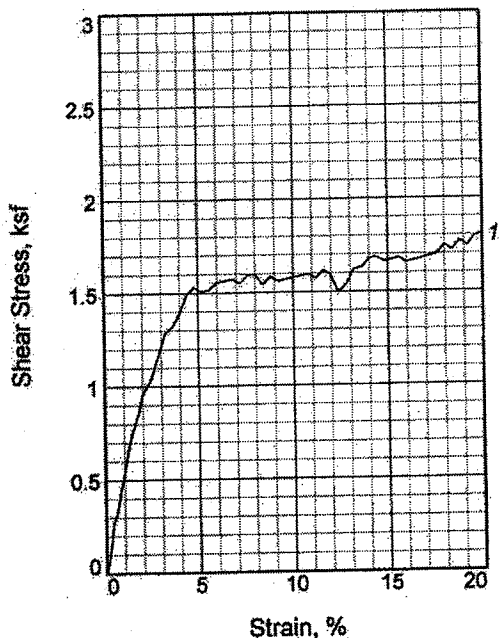
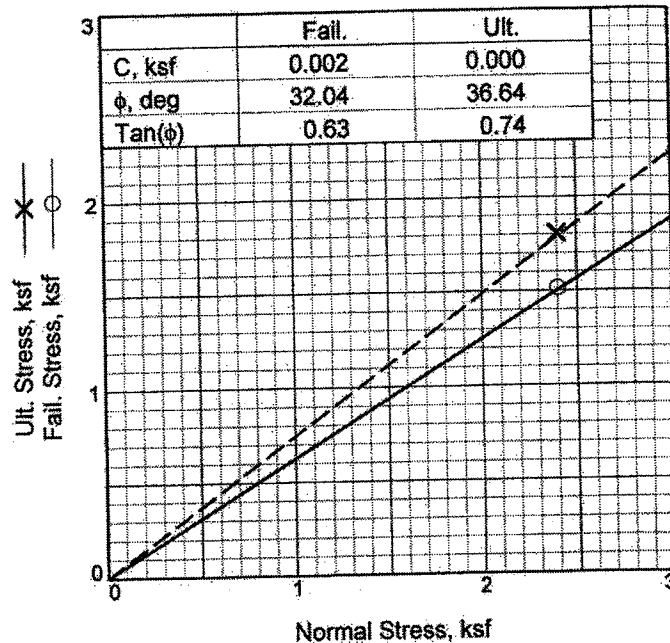
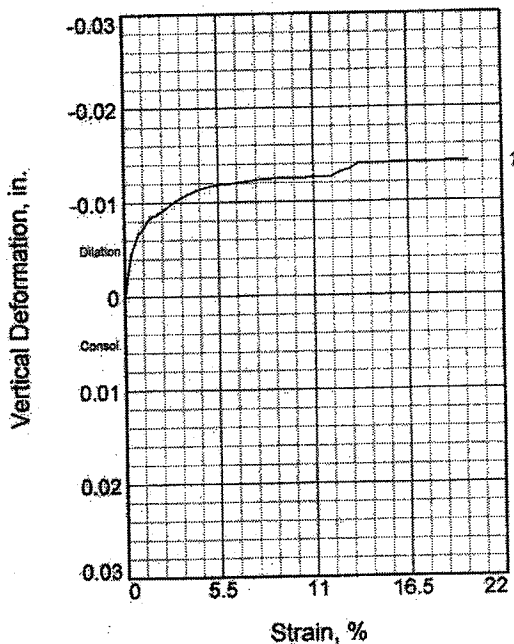

|                       |                    |        |
|-----------------------|--------------------|--------|
| Sample No.            |                    | 1      |
| Initial               | Water Content, %   | 23.6   |
|                       | Dry Density, pcf   | 104.1  |
|                       | Saturation, %      | 99.9   |
|                       | Void Ratio         | 0.6494 |
|                       | Diameter, in.      | 2.500  |
| At Test               | Height, in.        | 1.000  |
|                       | Water Content, %   | 20.9   |
|                       | Dry Density, pcf   | 109.1  |
|                       | Saturation, %      | 100.4  |
|                       | Void Ratio         | 0.5737 |
|                       | Diameter, in.      | 2.500  |
|                       | Height, in.        | 0.954  |
|                       | Normal Stress, ksf | 2.400  |
| Fail. Stress, ksf     | 1.516              |        |
| Strain, %             | 5.6                |        |
| Ult. Stress, ksf      | 1.806              |        |
| Strain, %             | 20.0               |        |
| Strain rate, in./min. | 0.002              |        |

**Sample Type:** Shelby Tube  
**Description:** Very-stiff gray silty clay, trace fine to coarse sand, trace fine gravel, many lenses of silt.  
**LL= 36      PL= 20      PI= 16**  
**Assumed Specific Gravity= 2.75**  
**Remarks:** Residual Shear  
 A-6b(10)

**Client:**  
**Project:** CUY-90-15.24 West Abutment  
 Cleveland, Ohio  
**Location:** B-05-16  
**Sample Number:** 7      **Depth:** 24.0' to 26.0'  
 Proj. No.: 012-00946-300      **Date:** 06/16-19/06

Figure 06/20/06

DIRECT SHEAR TEST REPORT  
**BBC&M Engineering, Inc.**

Tested By: SW

Checked By: JJ



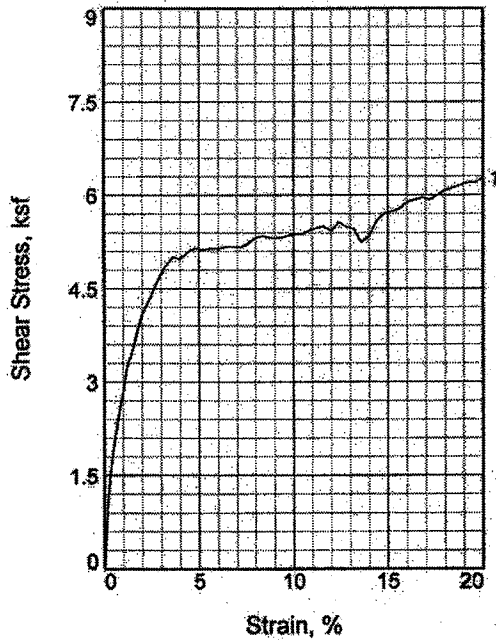
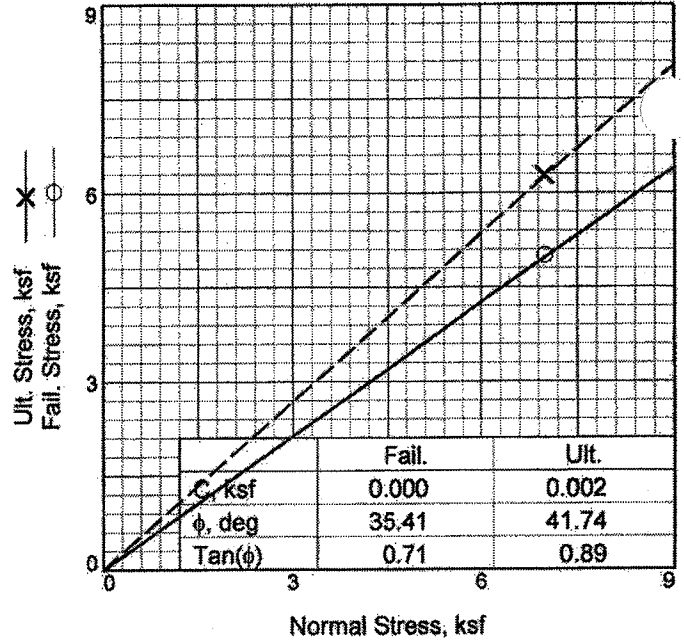
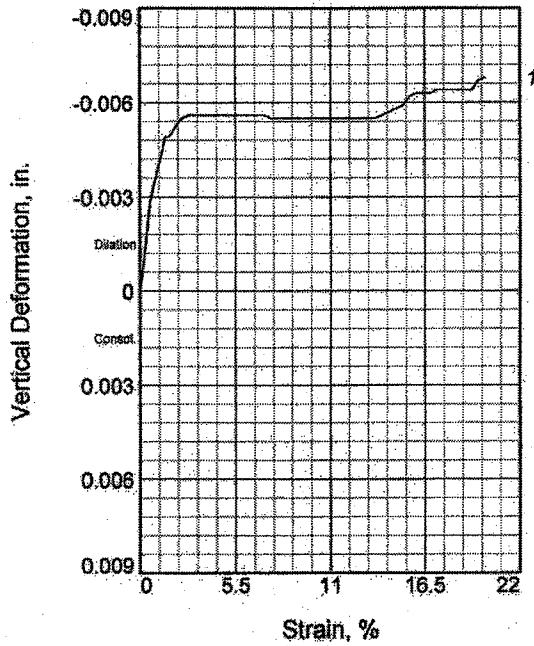

|                       |                  |        |
|-----------------------|------------------|--------|
| Sample No.            | 1                |        |
| Initial               | Water Content, % | 30.5   |
|                       | Dry Density, pcf | 98.6   |
|                       | Saturation, %    | 113.1  |
|                       | Void Ratio       | 0.7412 |
|                       | Diameter, in.    | 2.500  |
| At Test               | Water Content, % | 22.8   |
|                       | Dry Density, pcf | 103.2  |
|                       | Saturation, %    | 94.6   |
|                       | Void Ratio       | 0.6640 |
|                       | Diameter, in.    | 2.500  |
| Height, in.           | 1.000            |        |
| Normal Stress, ksf    | 7.000            |        |
| Fail. Stress, ksf     | 5.011            |        |
| Strain, %             | 3.6              |        |
| Ult. Stress, ksf      | 6.283            |        |
| Strain, %             | 20.0             |        |
| Strain rate, in./min. | 0.002            |        |

**Sample Type:** Shelby Tube  
**Description:** Stiff to very-stiff gray silty clay interbedded with silt, trace fine sand.  
**LL= 27      PL= 20      PI= 7**  
**Assumed Specific Gravity= 2.75**  
**Remarks:** Residual Shear  
 A-4b(8)

**Client:**  
**Project:** CUY-90-15.24 West Abutment  
 Cleveland, Ohio  
**Location:** B-05-16  
**Sample Number:** 25 Section I      **Depth:** 111.0' to 113.0'  
 Proj. No.: 012-00946-300      **Date:** 06/19-20/06

Figure 06/23/06

DIRECT SHEAR TEST REPORT  
**BBC&M Engineering, Inc.**

Tested By: SW

Checked By: JJ

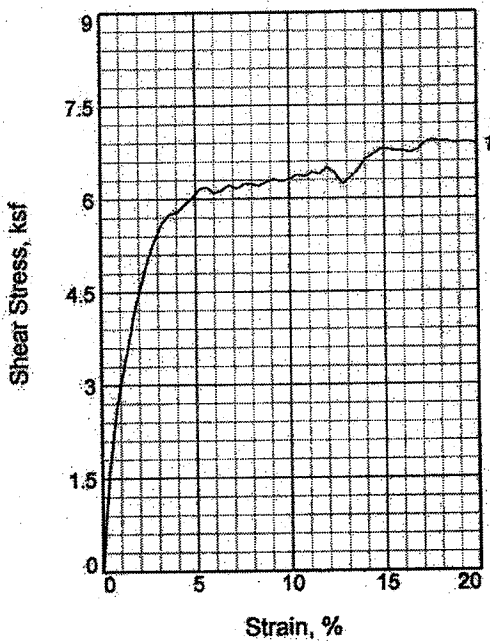
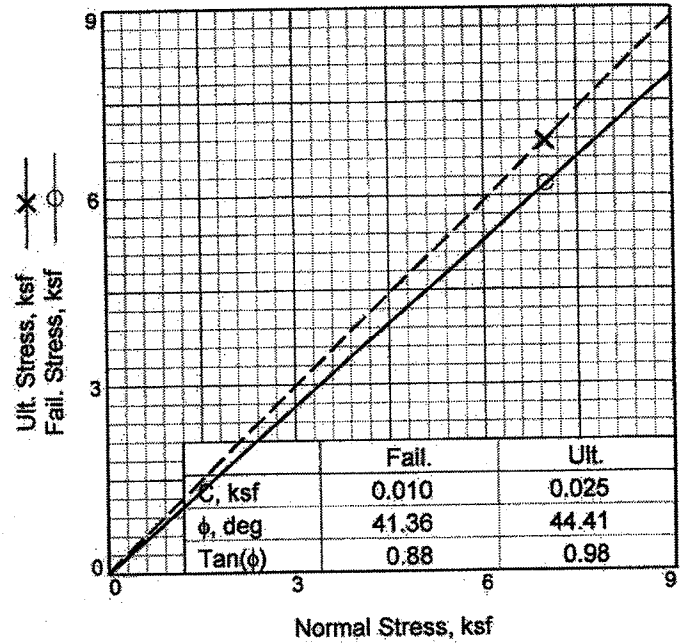
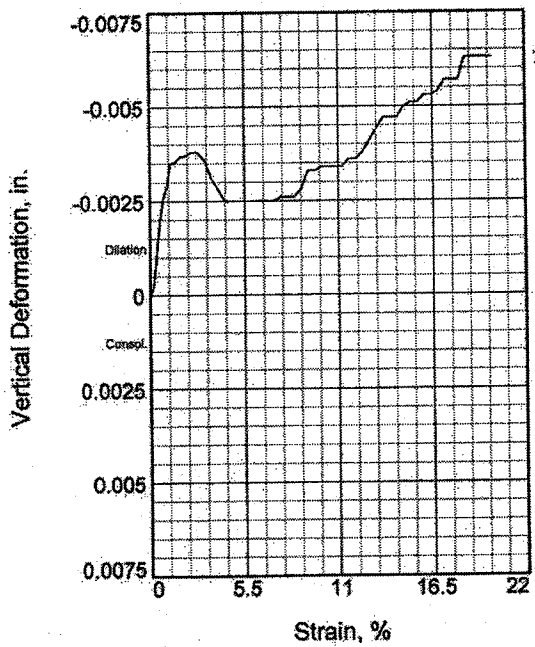

|            |                       |        |
|------------|-----------------------|--------|
| Sample No. |                       | 1      |
| Initial    | Water Content, %      | 25.2   |
|            | Dry Density, pcf      | 100.7  |
|            | Saturation, %         | 98.4   |
|            | Void Ratio            | 0.7043 |
|            | Diameter, in.         | 2.500  |
| At Test    | Height, in.           | 1.000  |
|            | Water Content, %      | 22.1   |
|            | Dry Density, pcf      | 104.9  |
|            | Saturation, %         | 95.2   |
|            | Void Ratio            | 0.6370 |
|            | Diameter, in.         | 2.500  |
|            | Height, in.           | 0.961  |
|            | Normal Stress, ksf    | 7.000  |
|            | Fail. Stress, ksf     | 6.191  |
|            | Strain, %             | 5.6    |
|            | Ult. Stress, ksf      | 6.872  |
|            | Strain, %             | 20.0   |
|            | Strain rate, in./min. | 0.002  |

**Sample Type:** Shelby Tube  
**Description:** Gray silt, trace clay, trace fine to coarse sand, trace fine gravel, few lenses of fine  
**LL= NP** **PI= NP**  
**Assumed Specific Gravity= 2.75.**  
**Remarks:** Residual Shear  
 A-4b(0)

**Client:**  
**Project:** CUY-90-15.24 West Abutment  
 Cleveland, Ohio  
**Location:** B-05-16  
**Sample Number:** 26 Sec. III **Depth:** 113.0' to 115.0'  
**Date:** 06-20-21/06  
 Proj. No.: 012-00946-300

Figure 06/22/06

DIRECT SHEAR TEST REPORT  
**BBC&M Engineering, Inc.**

Tested By: SW

Checked By: JJ

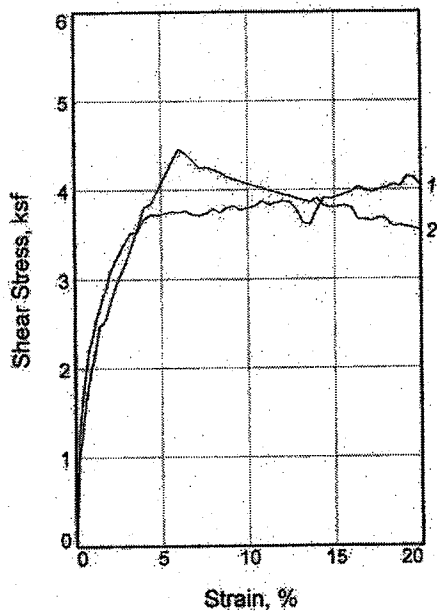
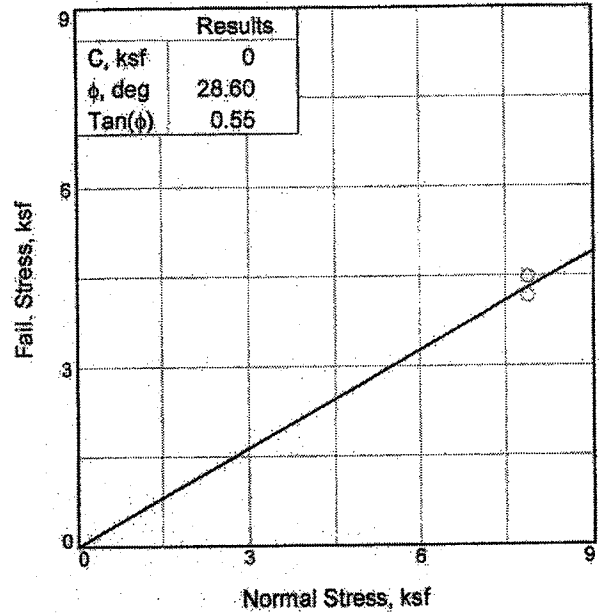
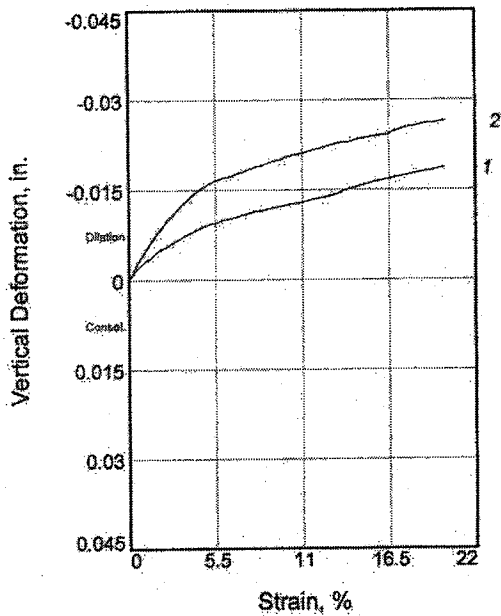

| Sample No.            | 1                | 2      |        |
|-----------------------|------------------|--------|--------|
| Initial               | Water Content, % | 27.9   | 27.9   |
|                       | Dry Density, pcf | 94.1   | 94.1   |
|                       | Saturation, %    | 93.1   | 93.1   |
|                       | Void Ratio       | 0.8238 | 0.8238 |
|                       | Diameter, in.    | 2.500  | 2.500  |
|                       | Height, in.      | 1.000  | 1.000  |
| At Test               | Water Content, % | 24.0   | 24.0   |
|                       | Dry Density, pcf | 103.5  | 103.5  |
|                       | Saturation, %    | 99.9   | 99.9   |
|                       | Void Ratio       | 0.6593 | 0.6593 |
|                       | Diameter, in.    | 2.500  | 2.500  |
|                       | Height, in.      | 0.910  | 0.910  |
| Normal Stress, ksf    | 7.900            | 7.900  |        |
| Fail. Stress, ksf     | 4.146            | 4.467  |        |
| Strain, %             | 19.2             | 6.0    |        |
| Ult. Stress, ksf      |                  |        |        |
| Strain, %             |                  |        |        |
| Strain rate, in./min. | 0.012            | 0.002  |        |

**Sample Type:** Shelby Tube  
**Description:** Medium-stiff gray silty clay, trace fine sand.  
**LL= 34      PL= 18      PI= 16**  
**Assumed Specific Gravity= 2.75**  
**Remarks:** 1= initial Shear  
                   2= Residual Shear

**Client:**  
**Project:** CUY-90-15.24 West Abutment  
 Cleveland, Ohio  
**Location:** B-105A  
**Sample Number:** 23 I      **Depth:** 103.0' to 105.0'  
 Proj. No.: 012-00946-300      **Date:** 02/24/06

Report Date 05/25/06

DIRECT SHEAR TEST REPORT

**BBC&M Engineering, Inc.**

Tested By: MA

Checked By: JJ

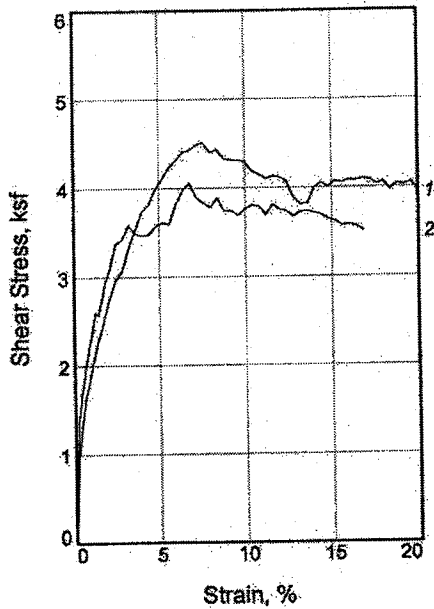
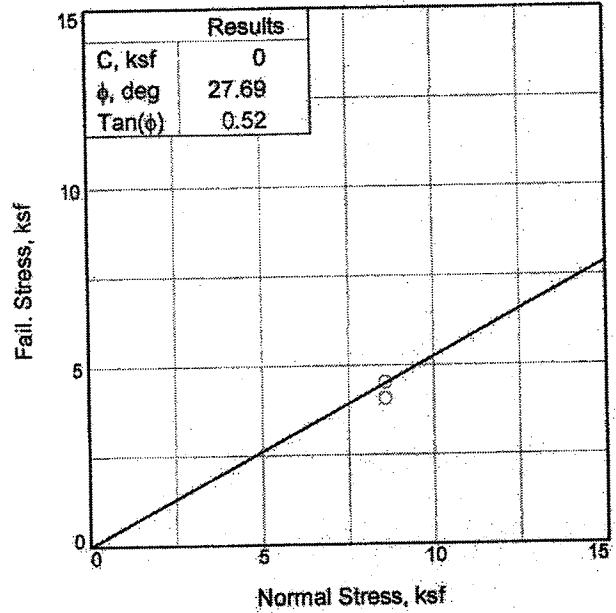
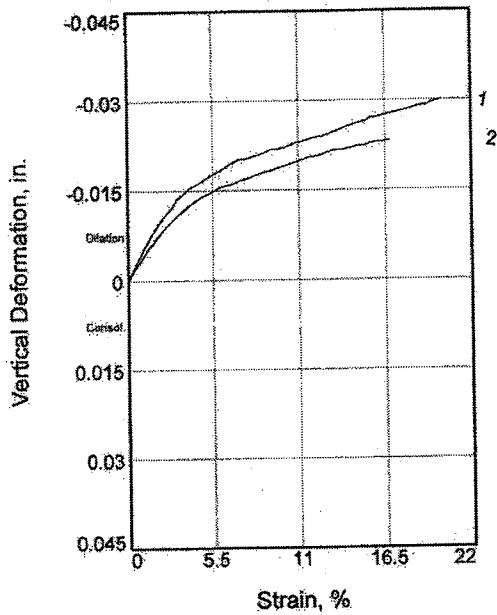

|                       | 1                | 2      |        |
|-----------------------|------------------|--------|--------|
| Sample No.            | 1                | 2      |        |
| Initial               | Water Content, % | 28.1   | 28.1   |
|                       | Dry Density, pcf | 91.9   | 91.9   |
|                       | Saturation, %    | 91.0   | 91.0   |
|                       | Void Ratio       | 0.8333 | 0.8333 |
|                       | Diameter, in.    | 2.500  | 2.500  |
| At Test               | Height, in.      | 1.000  | 1.000  |
|                       | Water Content, % | 20.9   | 20.9   |
|                       | Dry Density, pcf | 107.6  | 107.6  |
|                       | Saturation, %    | 99.8   | 99.8   |
|                       | Void Ratio       | 0.5662 | 0.5662 |
| Normal Stress, ksf    | Diameter, in.    | 2.500  | 2.500  |
|                       | Height, in.      | 0.854  | 0.854  |
| Normal Stress, ksf    | 8.600            | 8.600  |        |
| Fail. Stress, ksf     | 4.514            | 4.059  |        |
| Strain, %             | 7.6              | 6.8    |        |
| Ult. Stress, ksf      |                  |        |        |
| Strain, %             |                  |        |        |
| Strain rate, in./min. | 0.001            | 0.001  |        |

**Sample Type:** Shelby Tube  
**Description:** Soft to medium gray silty clay, trace fine sand, many lenses of silt.  
**LL= 35      PL= 20      PI= 15**  
**Assumed Specific Gravity= 2.7**  
**Remarks:**

Report Date 05/16/06

**Client:**

**Project:** CUY-90-15.24 West Abutment

Cleveland, Ohio

**Location:** B-108A

**Sample Number:** 26 Section I

**Depth:** 117.0' to 117.5'

Proj. No.: 012-00946-300

**Date:** 05/14-16/06

DIRECT SHEAR TEST REPORT

**BBC&M Engineering, Inc.**

Tested By: BR

Checked By: JJ

# LIQUID AND PLASTIC LIMITS TEST REPORT

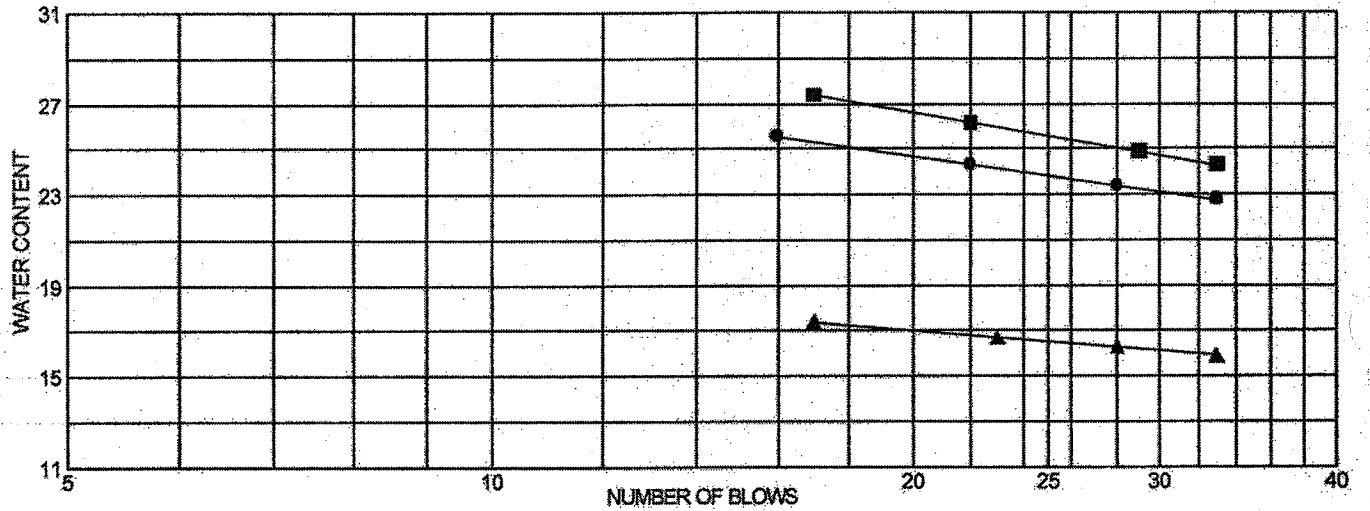
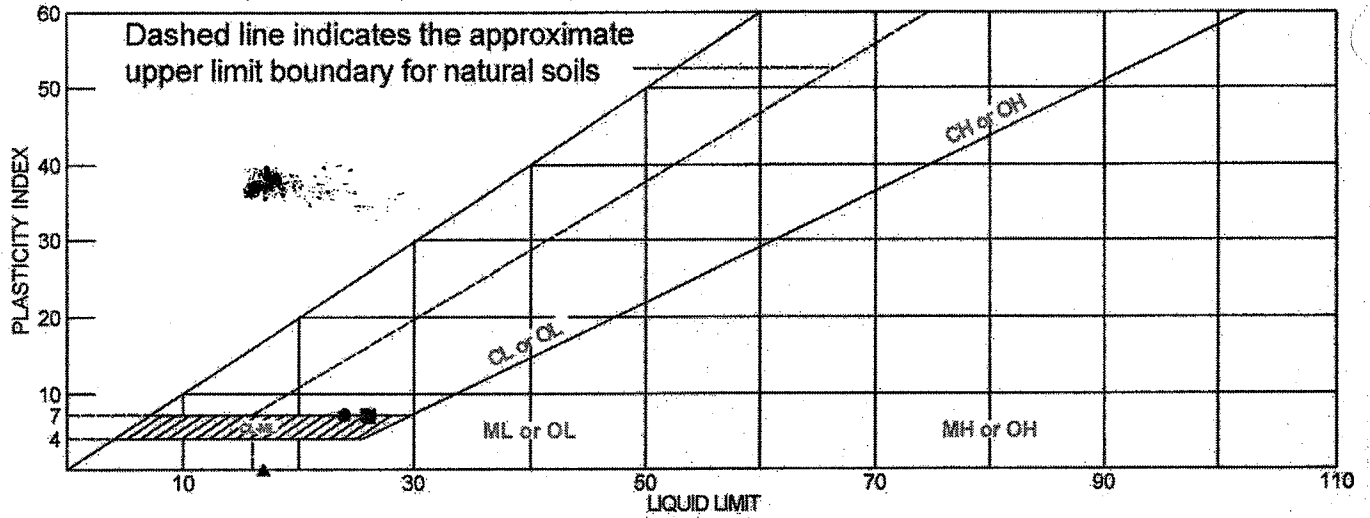

|   | MATERIAL DESCRIPTION              | LL | PL | PI | %<#40 | %<#200 | USCS |
|---|-----------------------------------|----|----|----|-------|--------|------|
| ● | Bluish Gray SILTY CLAY            | 24 | 17 | 7  |       |        |      |
| ■ | Greenish Gray SILTY CLAY w/ Sand  | 26 | 19 | 7  |       |        |      |
| ▲ | Gray SILT w/ Sand near Sandy SILT | 17 | 18 | NP |       |        |      |
|   |                                   |    |    |    |       |        |      |
|   |                                   |    |    |    |       |        |      |

Project No. 607-001 Client: BBCM Engineering

Project: CUY-90 WEST ABUTMENT - 012-00946-300

|                 |                     |                           |
|-----------------|---------------------|---------------------------|
| ● Source: S-7   | Sample No.: C-05-03 | Elev./Depth: 30-30.5'     |
| ■ Source: S-23  | Sample No.: C-05-04 | Elev./Depth: 58.8-59.2'   |
| ▲ Source: S-31b | Sample No.: C-05-03 | Elev./Depth: 123.8-124.5' |

Remarks:

●  
■  
▲

LIQUID AND PLASTIC LIMITS TEST REPORT  
**COOPER TESTING LABORATORY**

Figure

# LIQUID AND PLASTIC LIMITS TEST REPORT

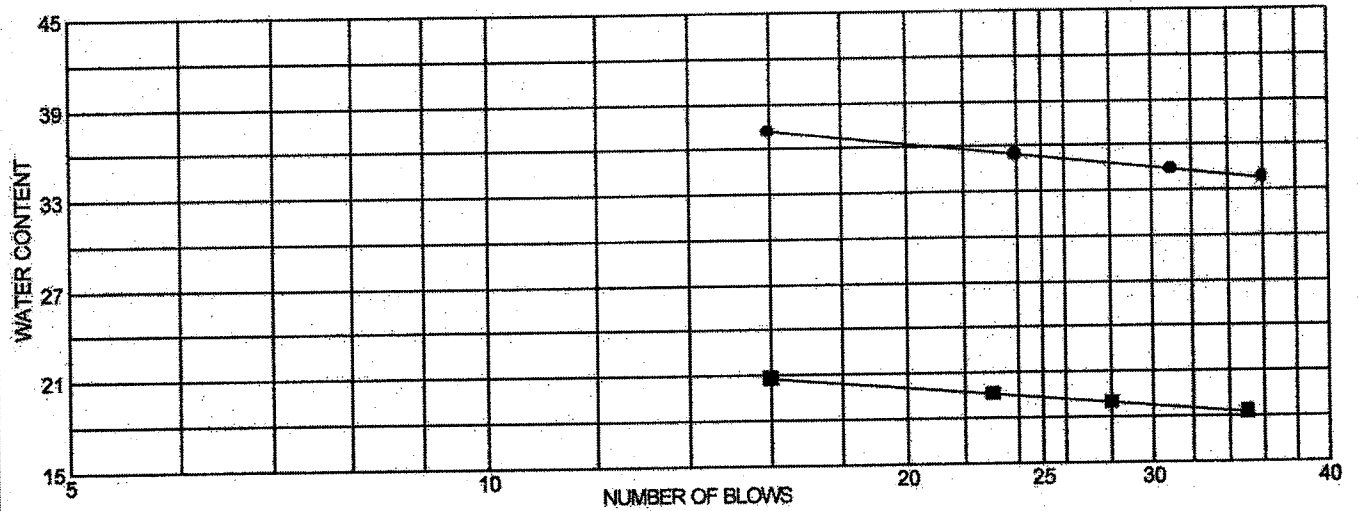
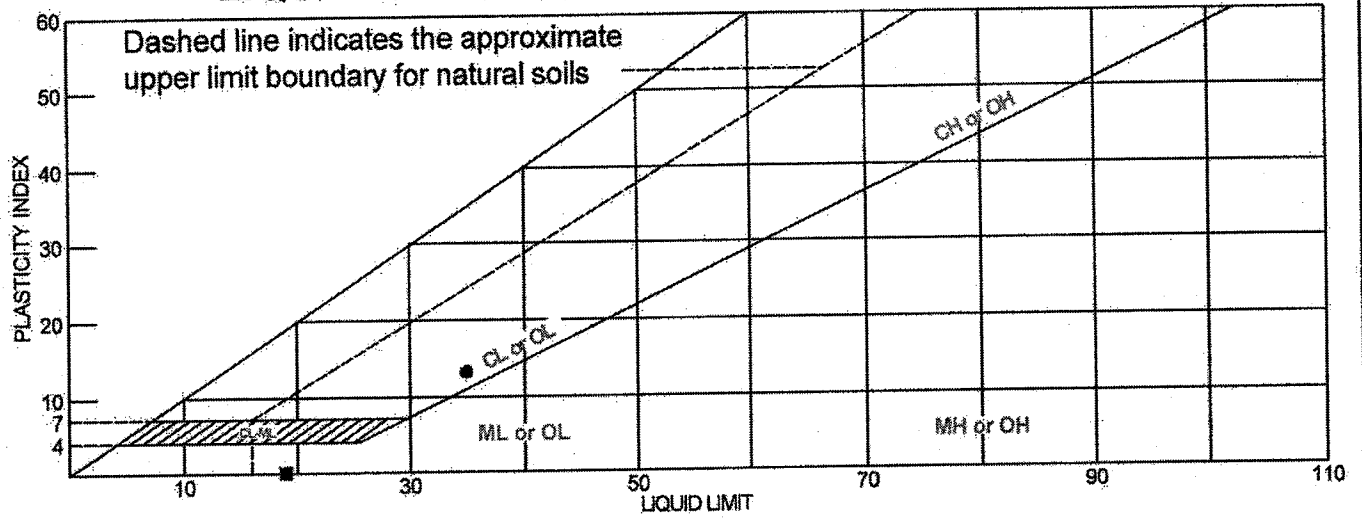

| MATERIAL DESCRIPTION | LL | PL | PI | %<#40 | %<#200 | USCS |
|----------------------|----|----|----|-------|--------|------|
| ● Gray Lean CLAY     | 35 | 22 | 13 |       |        |      |
| ■ Gray SILT          | 19 | 21 | NP |       |        |      |
|                      |    |    |    |       |        |      |
|                      |    |    |    |       |        |      |

**Project No.** 607-002      **Client:** BBC&M Engineering  
**Project:** 190 West Abutment - 012-00946.300  
  
 ● **Source:** S-24                      **Sample No.:** B-05-11      **Elev./Depth:** 92.0-93.5'  
 ■ **Source:** S-35                      **Sample No.:** B-05-02      **Elev./Depth:** 128.5-130'

**Remarks:**

●

■

Figure

# LIQUID AND PLASTIC LIMITS TEST REPORT

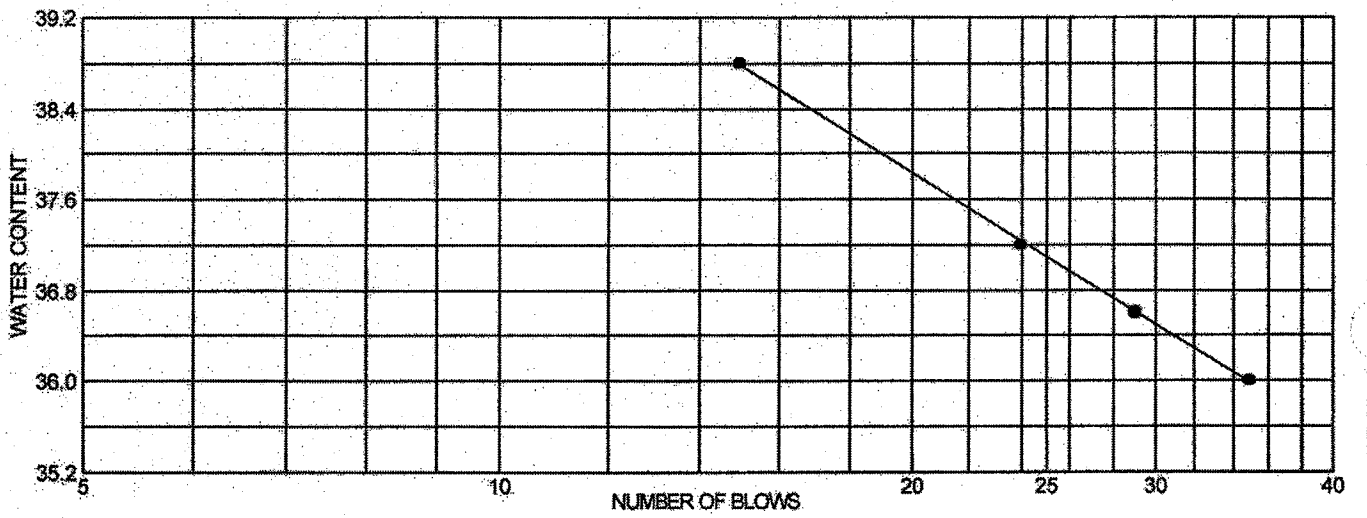
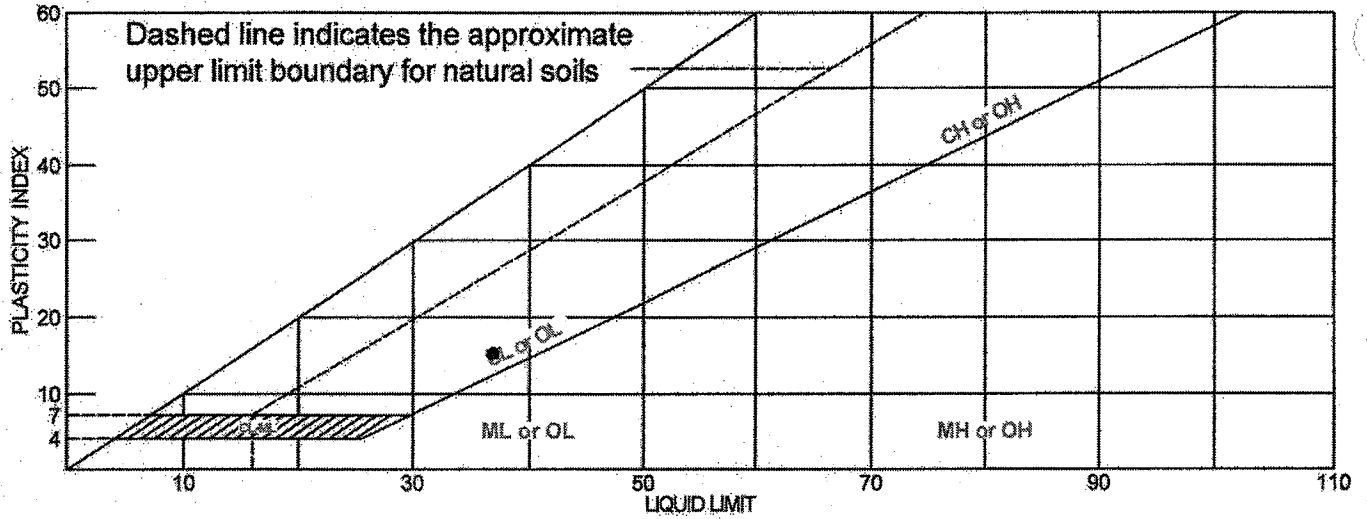

| MATERIAL DESCRIPTION         | LL | PL | PI | %<#40 | %<#200 | USCS |
|------------------------------|----|----|----|-------|--------|------|
| ● Gray Lean CLAY, trace Sand | 37 | 22 | 15 |       |        |      |
|                              |    |    |    |       |        |      |
|                              |    |    |    |       |        |      |
|                              |    |    |    |       |        |      |

**Project No.** 607-003      **Client:** BBCM  
**Project:** CUY-90 West Abutment - 012 00946.300  
**Source:** C-05-04      **Sample No.:** S-36      **Elev./Depth:** 113.5-114.5'

**Remarks:**

●



**Drained, Residual Torsional Ring Shear  
Test ASTM D 6467**

|                    |  |         |            |          |          |                 |   |
|--------------------|--|---------|------------|----------|----------|-----------------|---|
| Job No.:           | 607-002  | Boring: | B-05-02    | Date:    | 5/5/2006 | Undisturbed:    |   |
| Client:            | BBCM   | Sample: | S-35       | By:      | PJ       | Peak:           |   |
| Project:           | I90 West Abutment  | Depth:  | 128.5-130' | Checked: | DC       | Residual:       |   |
| Soil Type:         | Gray SILT  |         |            | Clay, %: |          | Fully Softened: | X |
| Remarks:           | Dropped high load to 16.2ksf to avoid exceeding equip. capacity. |         |            | LL:      | 19       | Peak:           |   |
| Normal Stress, psf | 5000   | 11100   | 16200      | PL:      | 21       | Residual:       | X |
| Secant Phi, deg.   | 33   | 32      | 32         |          |          |                 |   |

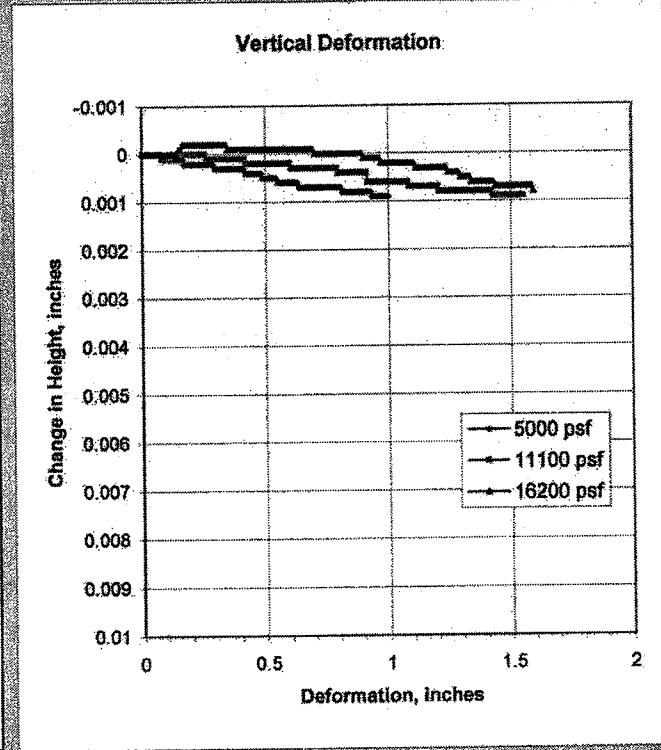
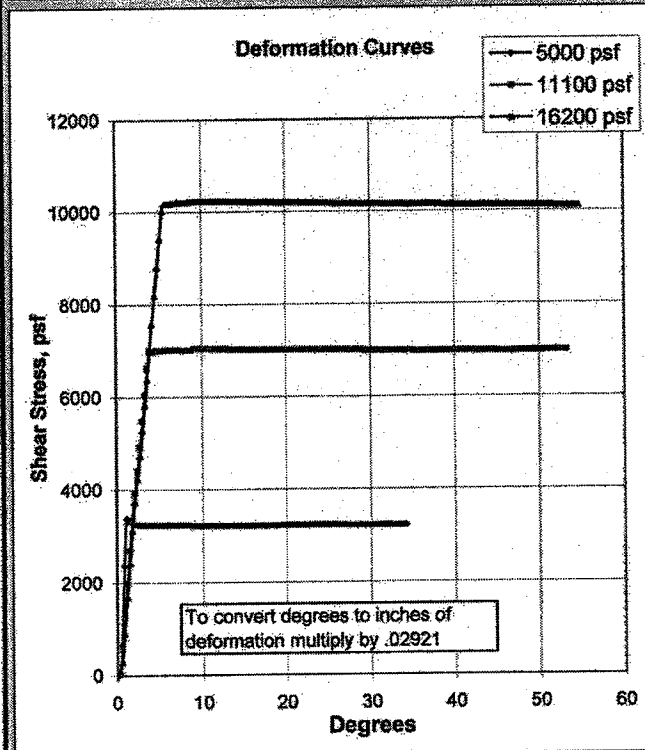
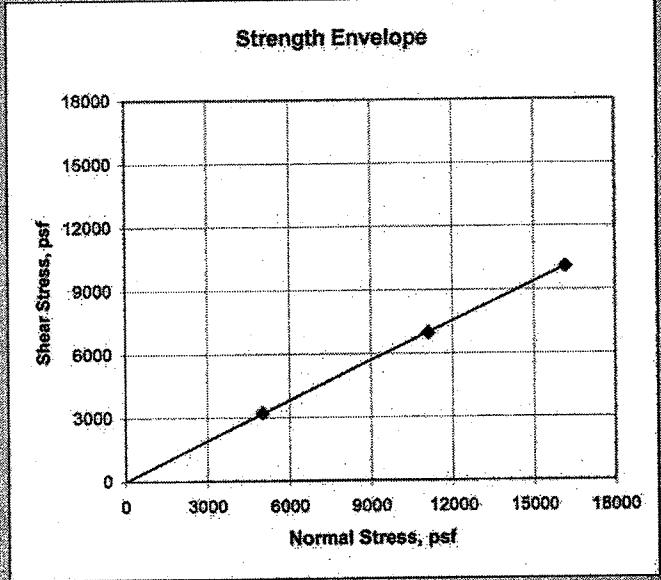
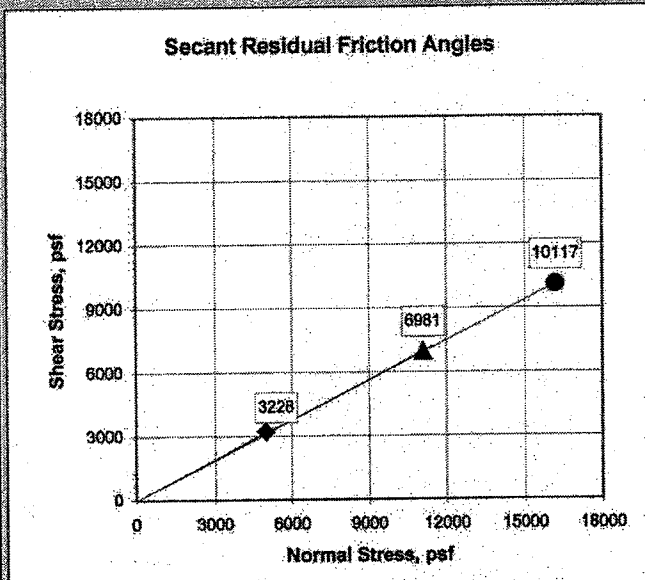





## Drained, Residual Torsional Ring Shear Test ASTM D 6467

|                    |  |         |          |          |          |                 |   |
|--------------------|--|---------|----------|----------|----------|-----------------|---|
| Job No.:           | 607-001A   | Boring: | C-05-03  | Date:    | 5/1/2006 | Undisturbed:    |   |
| Client:            | BBCM   | Sample: | S-7      | By:      | PJ       | Peak:           |   |
| Project:           | 012 00946.300                                      | Depth:  | 30-30.5' | Checked: | DC       | Residual:       |   |
| Soil Type:         | Bluish Gray CLAY (silty)                           |         |          | Clay, %: |          | Fully Softened: | X |
| Remarks:           | A small friction correction applied to each point. |         |          | LL:      | 24       | Peak:           |   |
| Normal Stress, psf | 1000   | 3500    | 6000     | PL:      | 17       | Residual:       | X |
| Secant Phi, deg.   | 31   | 30      | 29       |          |          |                 |   |

**Secant Residual Friction Angles**

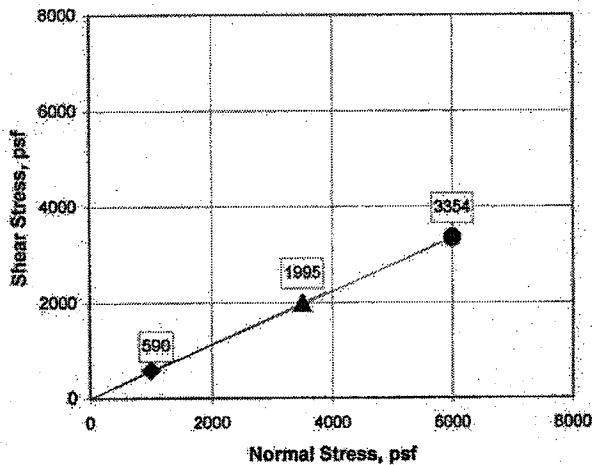

**Strength Envelope**

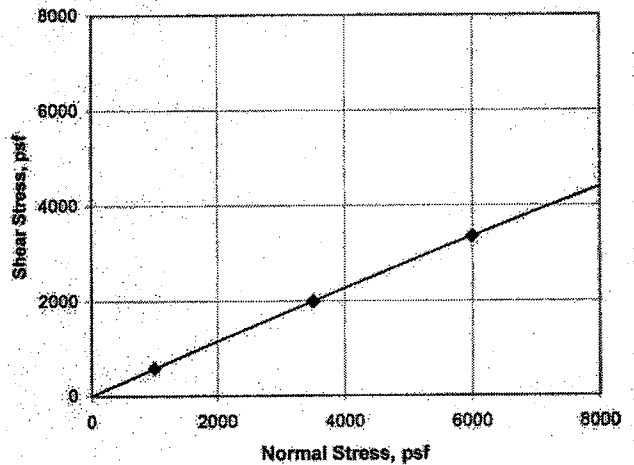

**Deformation Curves**

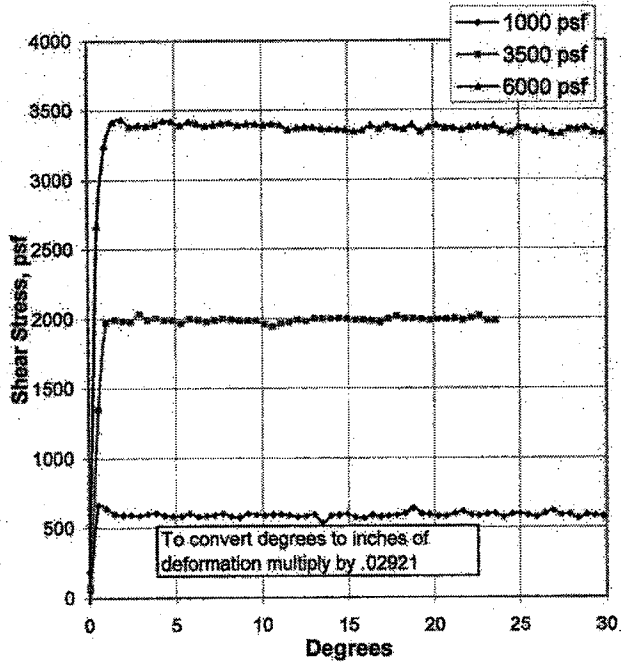

**Vertical Deformation**

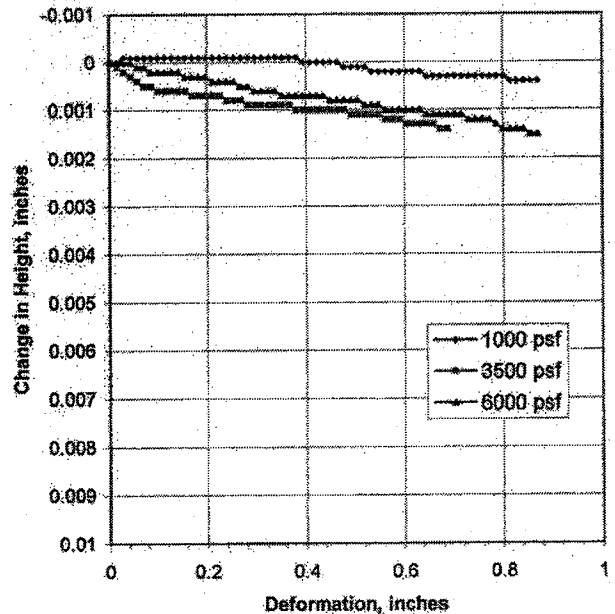



**Drained, Residual Torsional Ring Shear  
Test ASTM D 6467**

|                    |   |         |             |          |          |                 |   |
|--------------------|---|---------|-------------|----------|----------|-----------------|---|
| Job No.:           | 607-001B  | Boring: | C-05-03     | Date:    | 5/1/2006 | Undisturbed:    |   |
| Client:            | BBCM  | Sample: | S-31B       | By:      | PJ       | Peak:           |   |
| Project:           | 012 00946.300   | Depth:  | 123.8-124.5 | Checked: | DC       | Residual:       | X |
| Soil Type:         | Gray Silt w/ Sand / Sandy SILT                        |         |             | Clay, %: |          | Fully Softened: | X |
| Remarks:           | A small friction correction was applied to each point |         |             | LL:      | 17       | Peak:           |   |
| Normal Stress, psf | 5000  | 9600    | 15100       | PL:      | 18       | Residual:       | X |
| Secant Phi, deg.   | 33  | 33      | 33          |          |          |                 |   |

Secant Residual Friction Angles

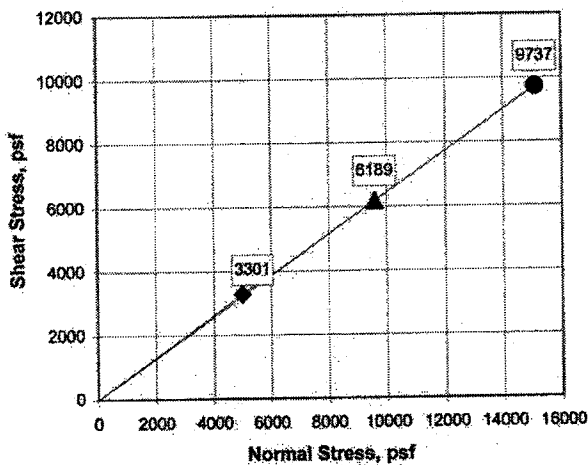

Strength Envelope

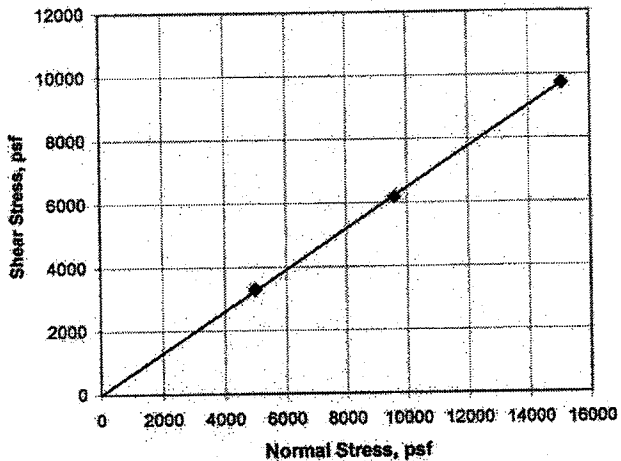

Deformation Curves

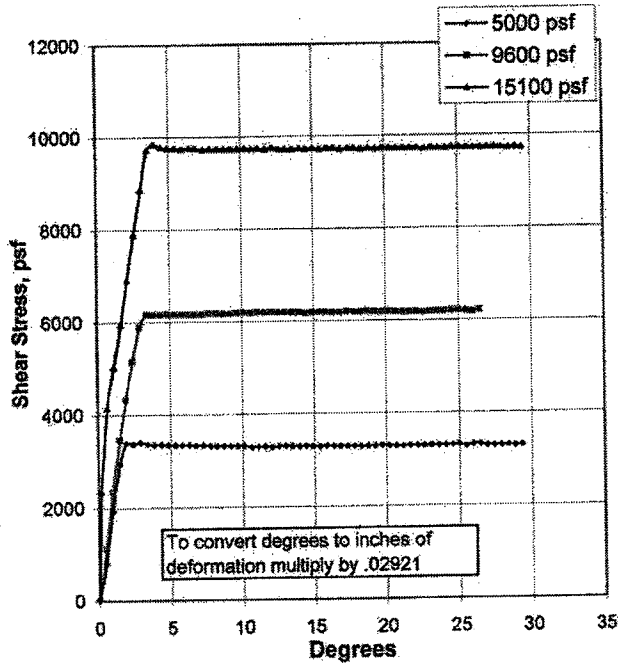

Vertical Deformation

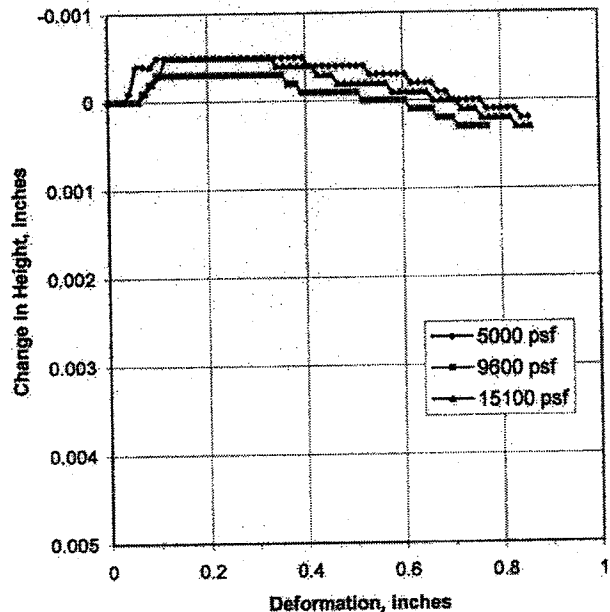



## Drained, Residual Torsional Ring Shear Test ASTM D 6467

|                    |   |         |            |          |          |                 |   |
|--------------------|---|---------|------------|----------|----------|-----------------|---|
| Job No.:           | 607-001C  | Boring: | C-05-04    | Date:    | 5/1/2006 | Undisturbed:    |   |
| Client:            | BBCM  | Sample: | S-23       | By:      | PJ       | Peak:           |   |
| Project:           | 012 00946.300   | Depth:  | 58.8-59.2' | Checked: | DC       | Residual:       |   |
| Soil Type:         | Greenish Gray SILTY CLAY w/ Sand                          |         |            | Clay, %: |          | Fully Softened: | X |
| Remarks:           | A small friction correction was applied to the 8 KSF POIN |         |            | LL:      | 26       | Peak:           |   |
| Normal Stress, psf | 3000  | 5600    | 8000       | PL:      | 19       | Residual:       | X |
| Secant Phi, deg.   | 32  | 32      | 32         |          |          |                 |   |

**Secant Residual Friction Angles**

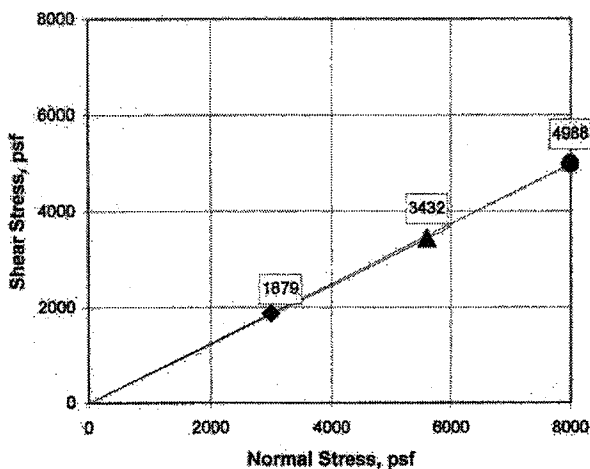

**Strength Envelope**

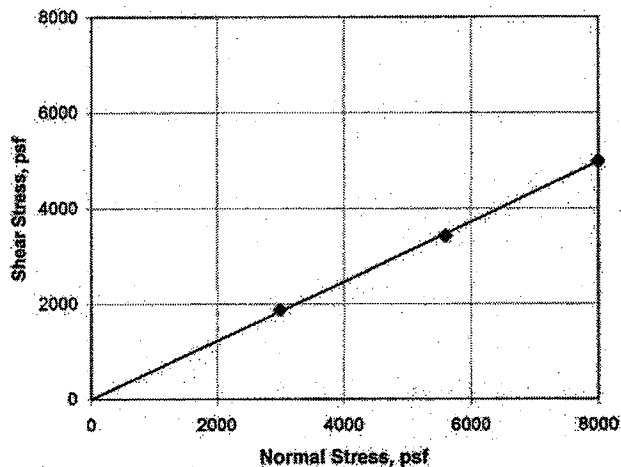

**Deformation Curves**

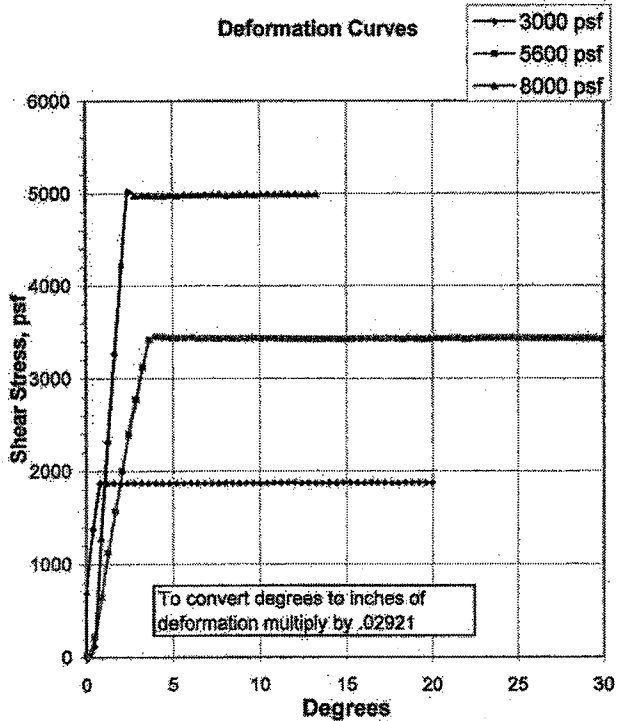

**Vertical Deformation**

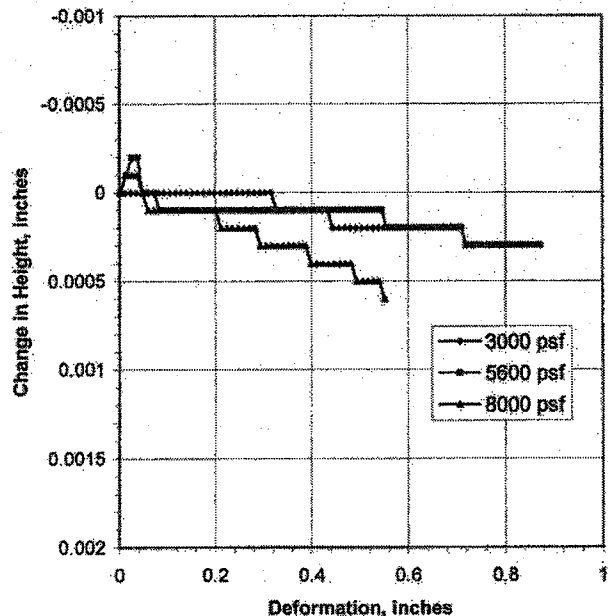



**Drained, Residual Torsional Ring Shear  
Test ASTM D 6467**

|                    |  |         |             |           |           |                 |   |
|--------------------|--|---------|-------------|-----------|-----------|-----------------|---|
| Job No.:           | 607-003  | Boring: | C-05-04     | Date:     | 5/19/2006 | Undisturbed:    |   |
| Client:            | BBCM   | Sample: | S-36        | By:       | PJ        | Peak:           |   |
| Project:           | I-90 West Abutment                                     | Depth:  | 113.5-114.5 | Checked:  | DC        | Residual:       |   |
| Soil Type:         | Gray Lean CLAY, trace Sand                             |         |             | Clay, %:  |           | Fully Softened: | X |
| Remarks:           | A small friction correction was applied to this point. |         |             | LL:       | 37        | Peak:           |   |
| Normal Stress, psf | 9000   | PL:     | 22          | Residual: |           |                 | X |
| Secant Phi, deg.   | 24   |         |             |           |           |                 |   |

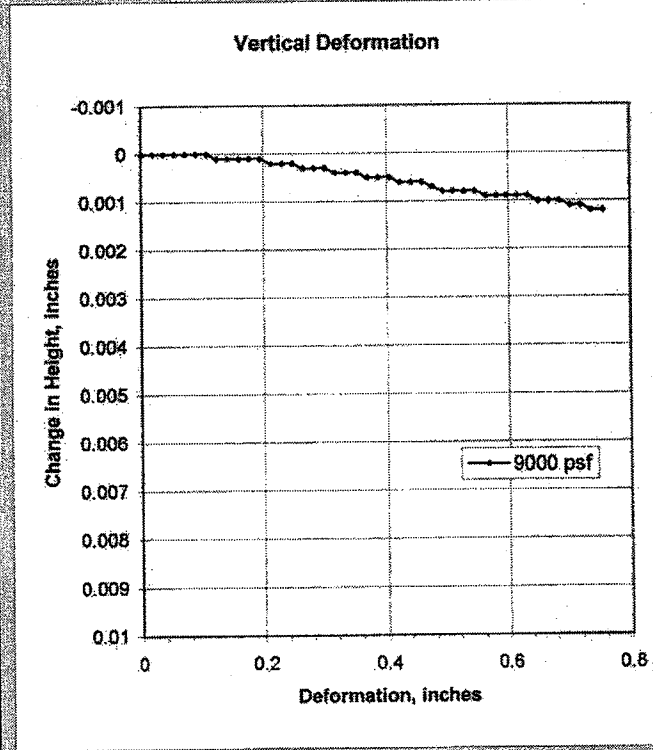
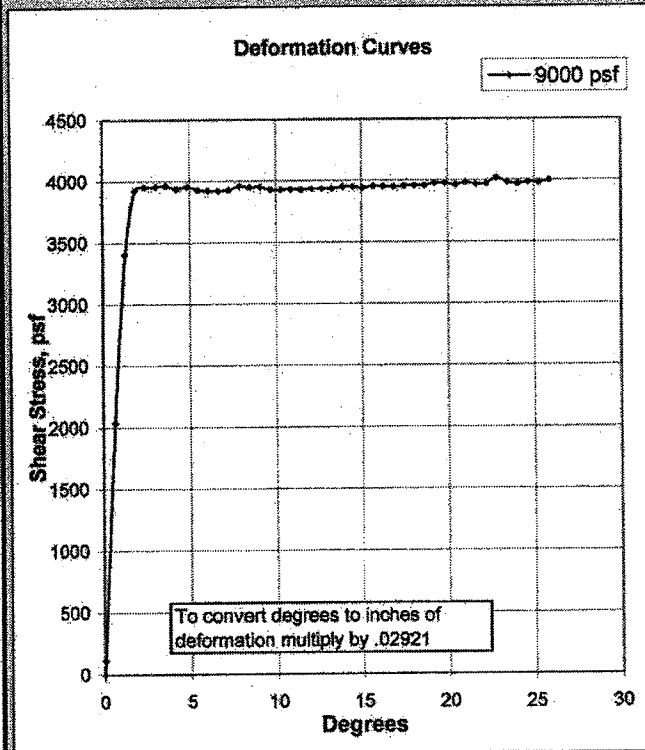
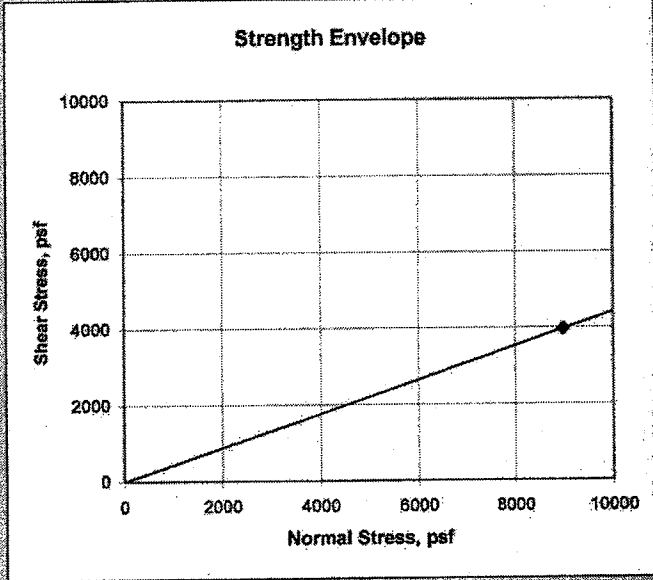
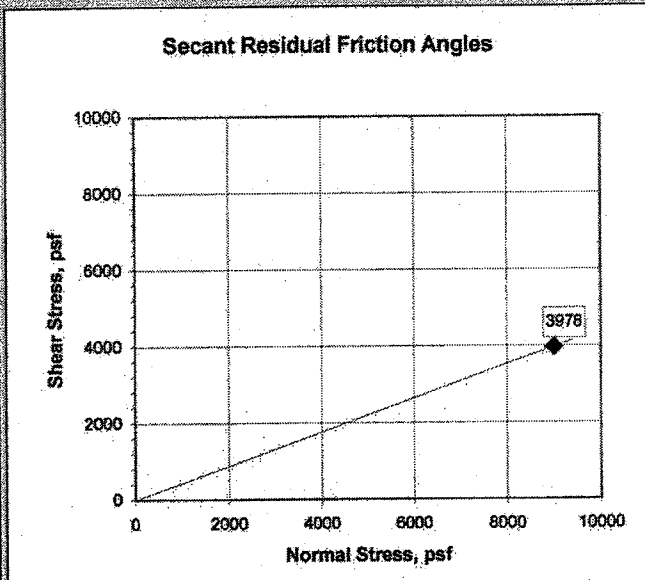



## Drained, Residual Torsional Ring Shear Test ASTM D 6467

|                    |  |         |          |          |          |                 |     |    |
|--------------------|--|---------|----------|----------|----------|-----------------|-----|----|
| Job No.:           | 607-002B   | Boring: | B-05-11  | Date:    | 5/5/2006 | Undisturbed:    |     |    |
| Client:            | BBCM   | Sample: | S-24     | By:      | PJ       | Peak:           |     |    |
| Project:           | I-90 West Abutment   | Depth:  | 92-93.5' | Checked: | DC       | Residual:       |     |    |
| Soil Type:         | Gray Lean CLAY   |         |          | Clay, %: |          | Fully Softened: | X   |    |
| Remarks:           | A small friction correction was applied to each point. This material exhibited a tendency to break down during shearing. Lower strengths may be possible with further deformation. |         |          |          |          |                 | LL: | 35 |
|                    |  |         |          |          |          | Peak:           |     |    |
| Normal Stress, psf | 4000   | 8000    | 15700    | PL:      | 22       | Residual:       | X   |    |
| Secant Phi, deg.   | 22   | 19      | 17       |          |          |                 |     |    |

**Secant Residual Friction Angles**

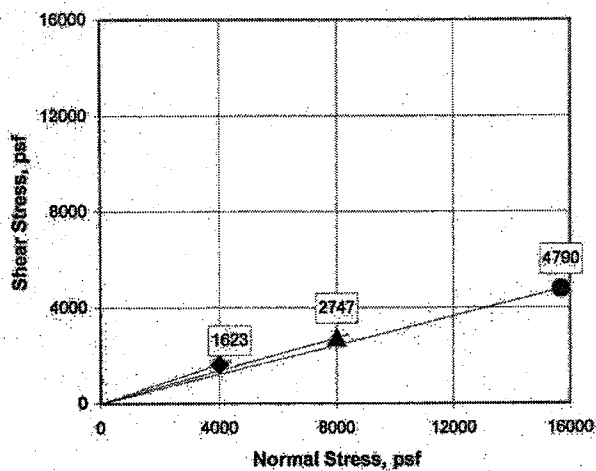

**Strength Envelope**

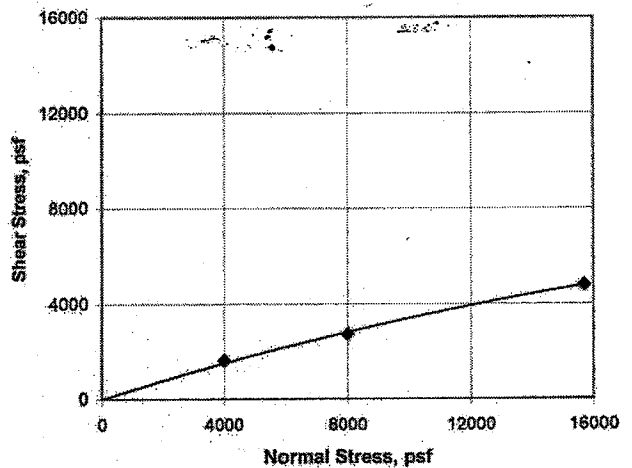

**Deformation Curves**

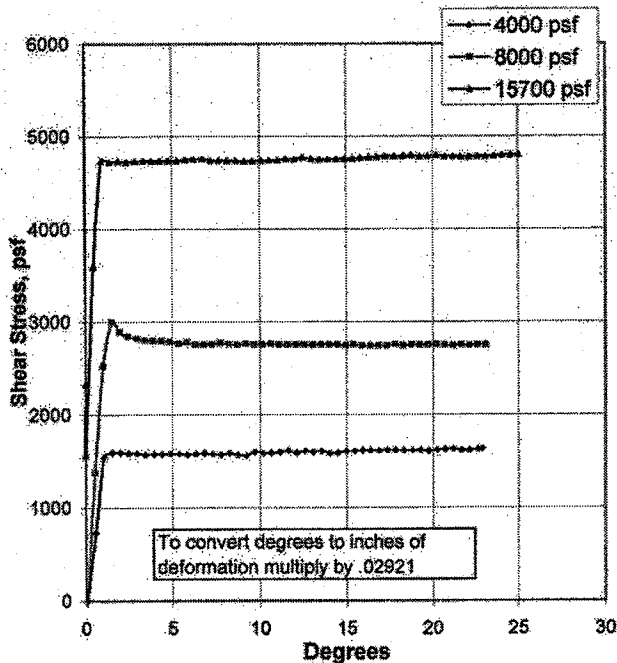

**Vertical Deformation**

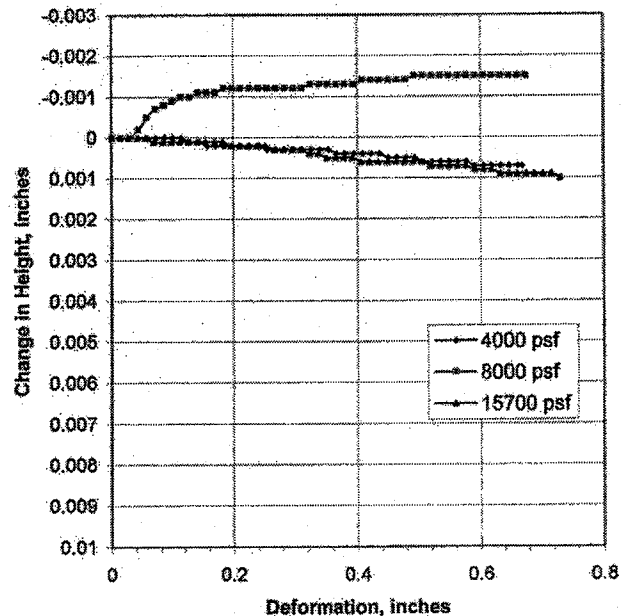

## Residual Shear Strength Test Summary

| Boring  | Sample | $\sigma'_{vc}$ (ksf) | $\sigma'_{vc}$ (kPa) | CF  | LL | TRS       | Stark Chart Values |           |
|---------|--------|----------------------|----------------------|-----|----|-----------|--------------------|-----------|
|         |        |                      |                      |     |    | $\phi'_R$ | LL                 | $\phi'_R$ |
| B-05-03 | 31B    | 15.1                 | 723                  | <20 | 17 | 33        | N/A                | 33        |
| B-05-02 | 35     | 16.2                 | 776                  | <21 | 19 | 32        | N/A                | 32        |
| B-05-03 | 7      | 6                    | 287                  | 16  | 24 | 29        | N/A                | 29        |
| B-05-04 | 23     | 8                    | 383                  | 23  | 26 | 32        | N/A                | 32        |
| B-05-11 | 24     | 15.7                 | 752                  | ~50 | 35 | 17        | 47                 | 16        |
| B-05-04 | 36     | 9                    | 431                  | <50 | 37 | 24        | N/A                | 24        |

For CF > 50%, perform Stark Chart conversion to account for ball milling used for chart

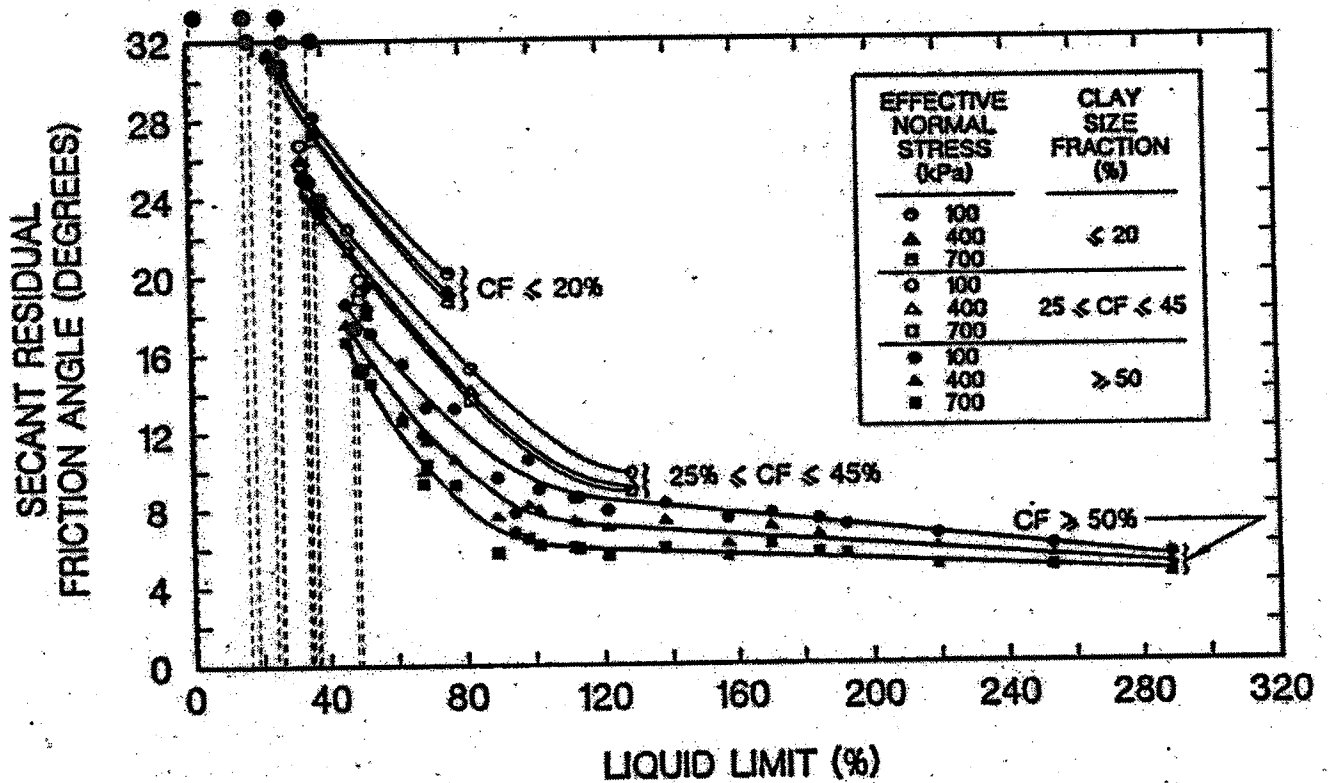

## Direct Shear Test Results Summary

| Boring  | Sample | $\sigma'_{vc}$ (ksf) | $\sigma'_{vc}$ (kPa) | CF  | LL | DS        | Stark Chart Values |           |
|---------|--------|----------------------|----------------------|-----|----|-----------|--------------------|-----------|
|         |        |                      |                      |     |    | $\phi'_R$ | LL                 | $\phi'_R$ |
| B-101   | 32     | 20                   | 958                  | <50 | 37 | 24        | N/A                | 23        |
| B-108   | 8      | 9                    | 431                  | >50 | 36 | 15        | 48                 | 16        |
| B-108A  | 26     | 8.6                  | 412                  | ~20 | 35 | 25        | N/A                | 24        |
| B-105A  | 23     | 7.9                  | 378                  | <50 | 34 | 24        | N/A                | 24        |
| B-05-16 | 7      | 2.4                  | 115                  | <25 | 36 | 32        | N/A                | 29        |
| B-05-16 | 25     | 7                    | 335                  | <25 | 27 | 36        | N/A                | >32       |
| B-05-16 | 26     | 7                    | 335                  | ~5  | 0  | 41        | N/A                | >32       |

## Sample Info For DSS Specimens

Project: **CUY-90 West Abutment** Job: **5653**  
 Client: **BBC&M Engineering, Inc.** Date: **5/9/2006**

| Test # | Boring  | Sample # | Depth (ft) | WC % | Initial Density (PCF) | Before Shear Density (PCF) | Normal Load (TSF) | Additional Testing |      |      |      |
|--------|---------|----------|------------|------|-----------------------|----------------------------|-------------------|--------------------|------|------|------|
|        |         |          |            |      |                       |                            |                   | Gs                 | LL   | PL   | PI   |
| 1      | B-05-07 | S-22     | 104-106    | 34.4 | 88.5                  | 99.0                       | 5.3 tsf           | -----              | 40.1 | 22.5 | 17.6 |
| 2      | B-05-02 | S-14     | 44-46      | 28.8 | 94.3                  | 99.9                       | 2.8 tsf           | -----              | 37.7 | 21.4 | 16.3 |
| 3      | B-05-03 | S-8      | 32-33.5    | 25.9 | 100.8                 | 107.0                      | 1.95 tsf          | -----              | 34.8 | 18.8 | 16.0 |
| 4      | B-05-02 | S-32     | 122-124    | 21.2 | 103.2                 | 110.1                      | 5.3 tsf           | -----              | 30.3 | 18.8 | 11.5 |
|        |         |          |            |      |                       |                            |                   |                    |      |      |      |
|        |         |          |            |      |                       |                            |                   |                    |      |      |      |
|        |         |          |            |      |                       |                            |                   |                    |      |      |      |
|        |         |          |            |      |                       |                            |                   |                    |      |      |      |
|        |         |          |            |      |                       |                            |                   |                    |      |      |      |
|        |         |          |            |      |                       |                            |                   |                    |      |      |      |
|        |         |          |            |      |                       |                            |                   |                    |      |      |      |

# DIRECT SIMPLE SHEAR TEST

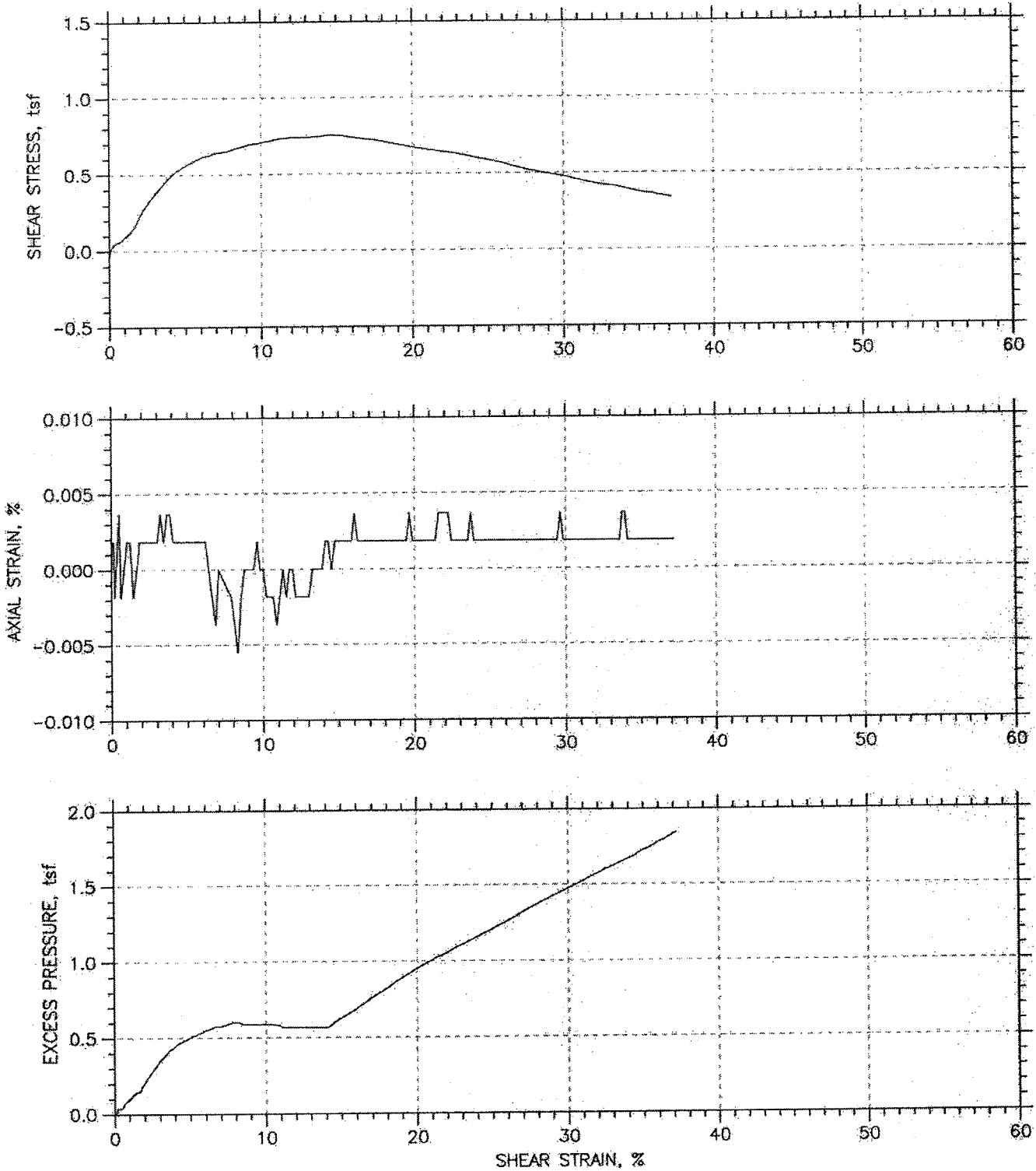

|  |                           |                   |
|--|---------------------------|-------------------|
| Project: CUY-90 West Abutment                                    | Location: 14" from Bottom | Project No.: 5653 |
| Boring No.: B-05-02  | Tested By: SO             | Checked By: JW    |
| Sample No.: S-14   | Test Date: 11-6-05        | Depth: 44-46      |
| Test No.: 2  | Sample Type: Undisturbed  | Elevation:        |
| Description: Lean Clay w/an occasional piece of coarse sand (CL) |                           |                   |
| Remarks: ASTM D 6528   |                           |                   |
| File: \\dell\GeoComp\Software\DSS\5653-s14-mod2.dat              |                           |                   |



# DIRECT SIMPLE SHEAR TEST

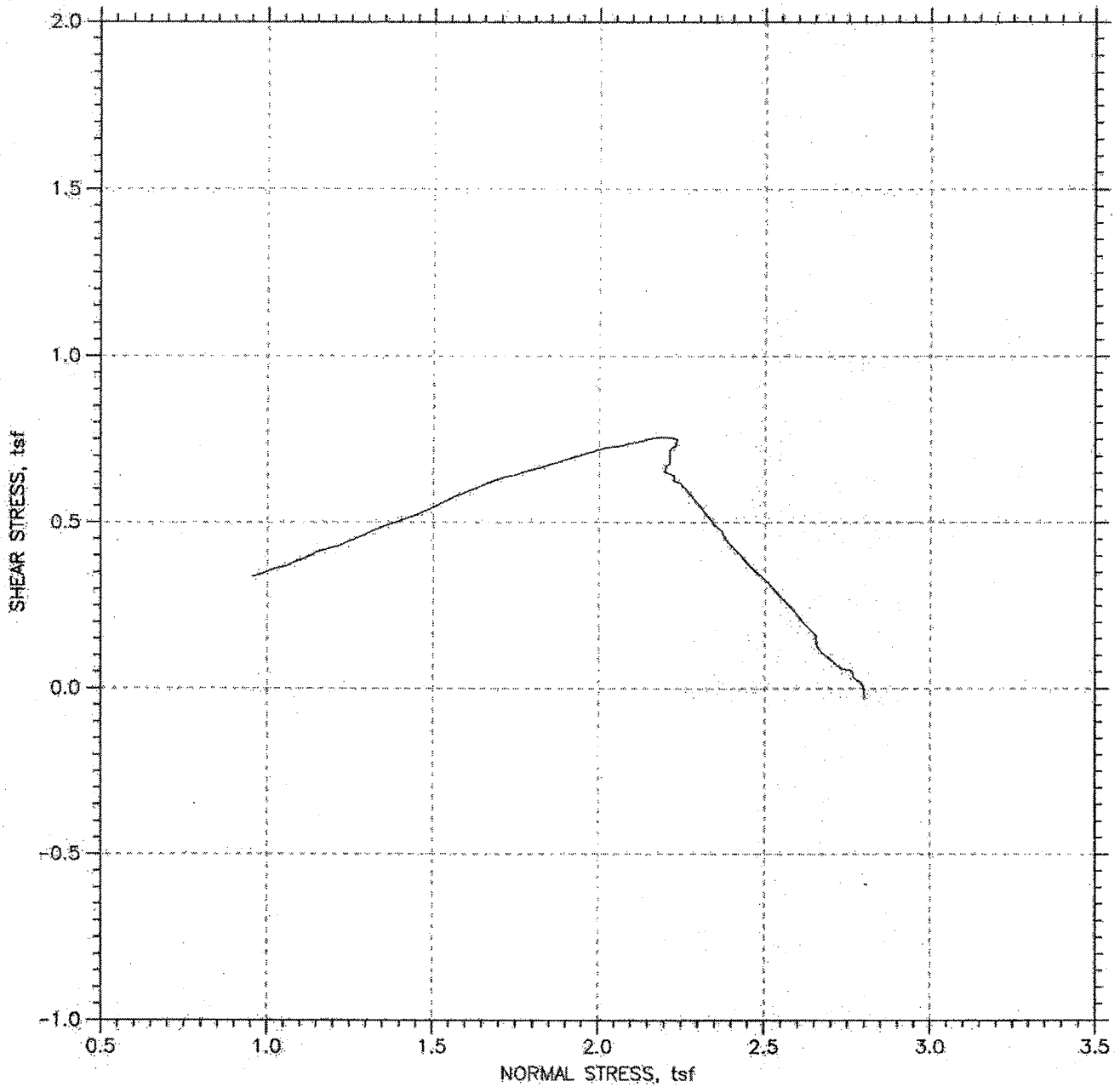

|  |                           |                   |
|--|---------------------------|-------------------|
| Project: CUY-90 West Abutment                                    | Location: 14" from Bottom | Project No.: 5653 |
| Boring No.: B-05-02  | Tested By: SO             | Checked By: JW    |
| Sample No.: S-14   | Test Date: 11-6-05        | Depth: 44-46      |
| Test No.: 2  | Sample Type: Undisturbed  | Elevation:        |
| Description: Lean Clay w/an occasional piece of coarse sand (CL) |                           |                   |
| Remarks: ASTM D 6528   |                           |                   |
| File: \\del\GeoComp\Software\DSS\5653-s14-mod2.dat               |                           |                   |

# DIRECT SIMPLE SHEAR TEST

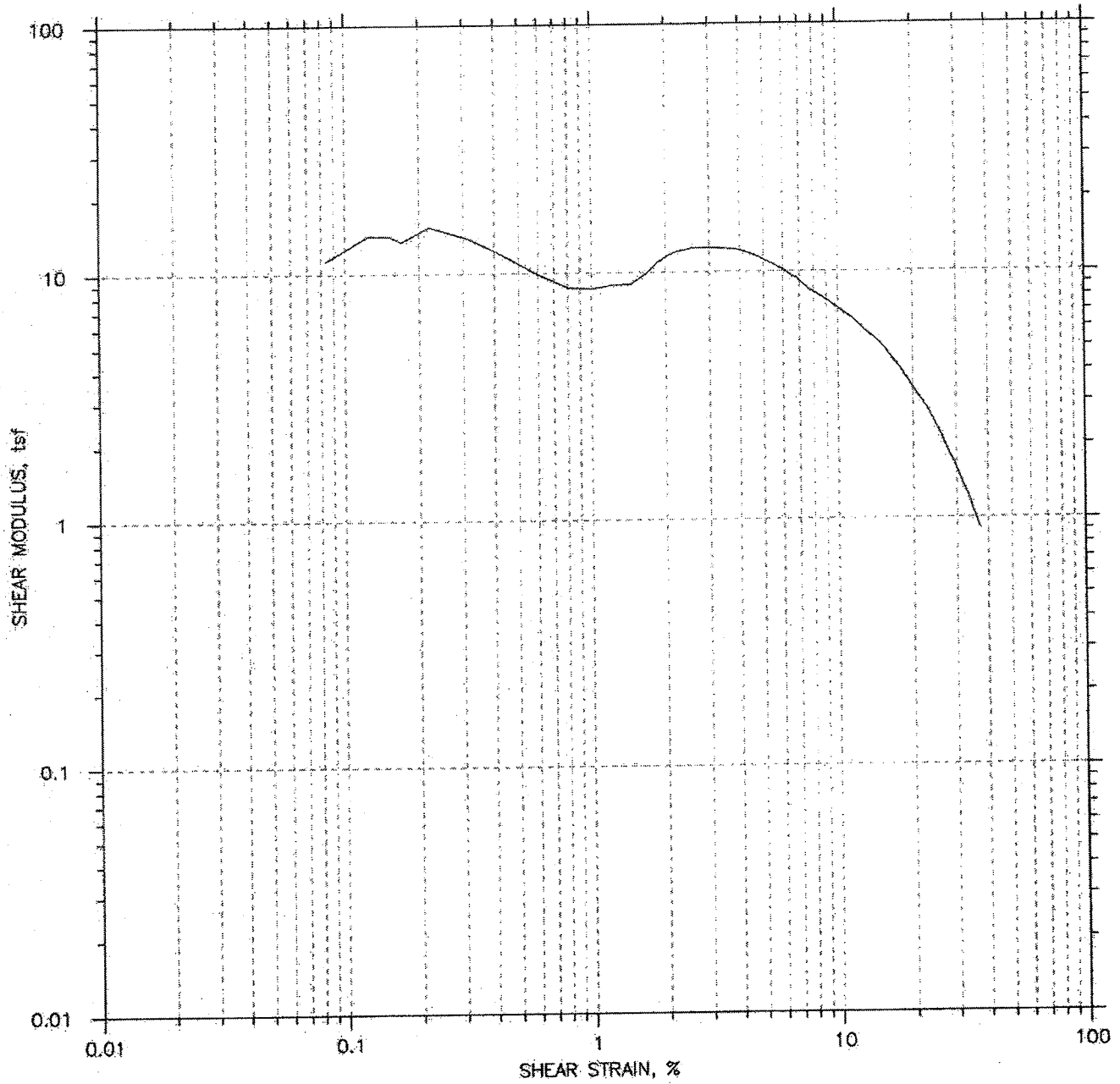

|  |                           |                   |
|--|---------------------------|-------------------|
| Project: CUY-90 West Abutment                                    | Location: 14" from Bottom | Project No.: 5653 |
| Boring No.: B-05-02  | Tested By: SO             | Checked By: JW    |
| Sample No.: S-14   | Test Date: 11-6-05        | Depth: 44-46      |
| Test No.: 2  | Sample Type: Undisturbed  | Elevation:        |
| Description: Lean Clay w/an occasional piece of coarse sand (CL) |                           |                   |
| Remarks: ASTM D 6528   |                           |                   |
| File: \\dell\GeoComp\Software\DSS\5653-s14-mod2.dat              |                           |                   |

# DIRECT SIMPLE SHEAR TEST

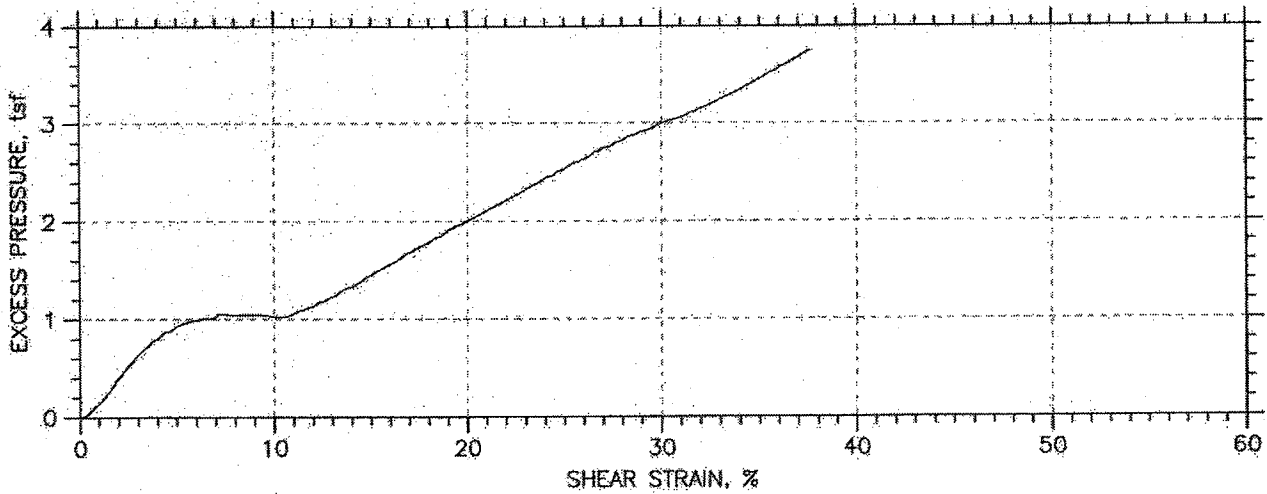
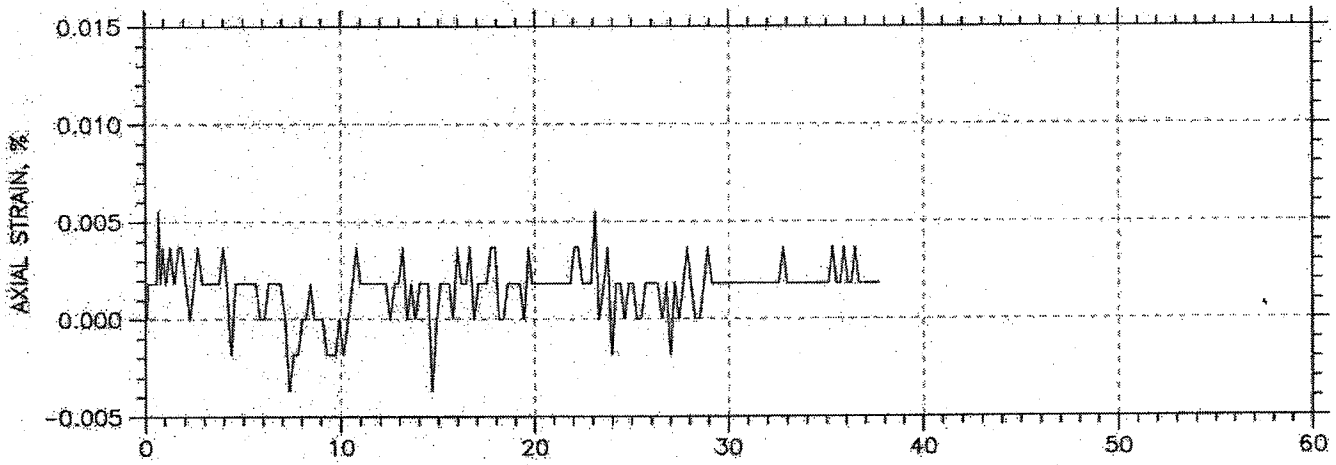
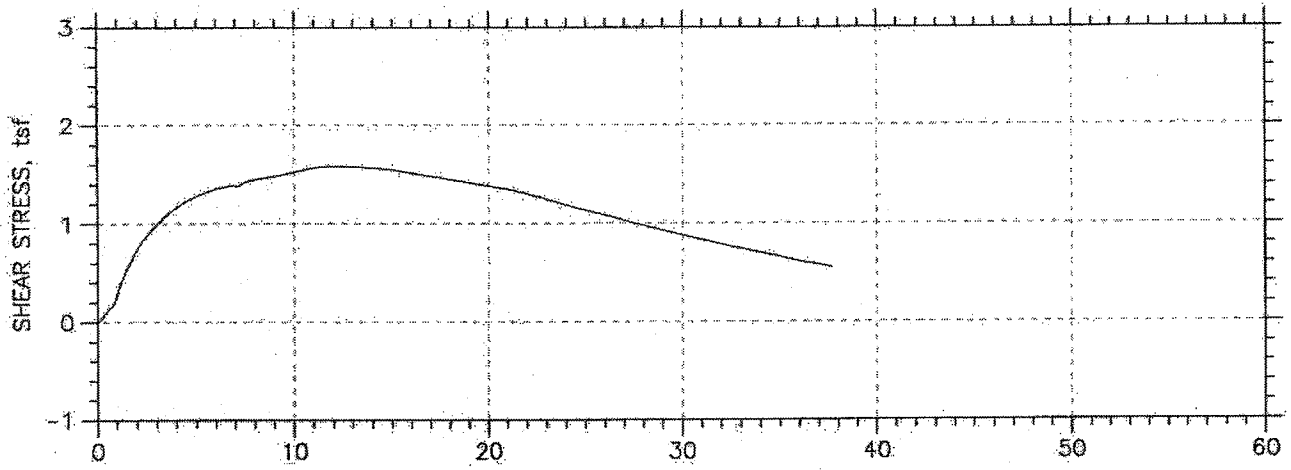

|  |                          |                   |
|--|--------------------------|-------------------|
| Project: CUY-90 West Abutment                        | Location: 8" from bottom | Project No.: 5653 |
| Boring No.: B-05-02                                  | Tested By: SO            | Checked By: JW    |
| Sample No.: S-32                                     | Test Date: 5-5-06        | Depth: 122-124    |
| Test No.: 4  | Sample Type: Undisturbed | Elevation:        |
| Description: Lean Clay mixture with silt (CL) & (ML) |                          |                   |
| Remarks: ASTM D 6528                                 |                          |                   |
| File: \\dell\GeoComp\Software\DSS\5653-s32.dot       |                          |                   |

# DIRECT SIMPLE SHEAR TEST

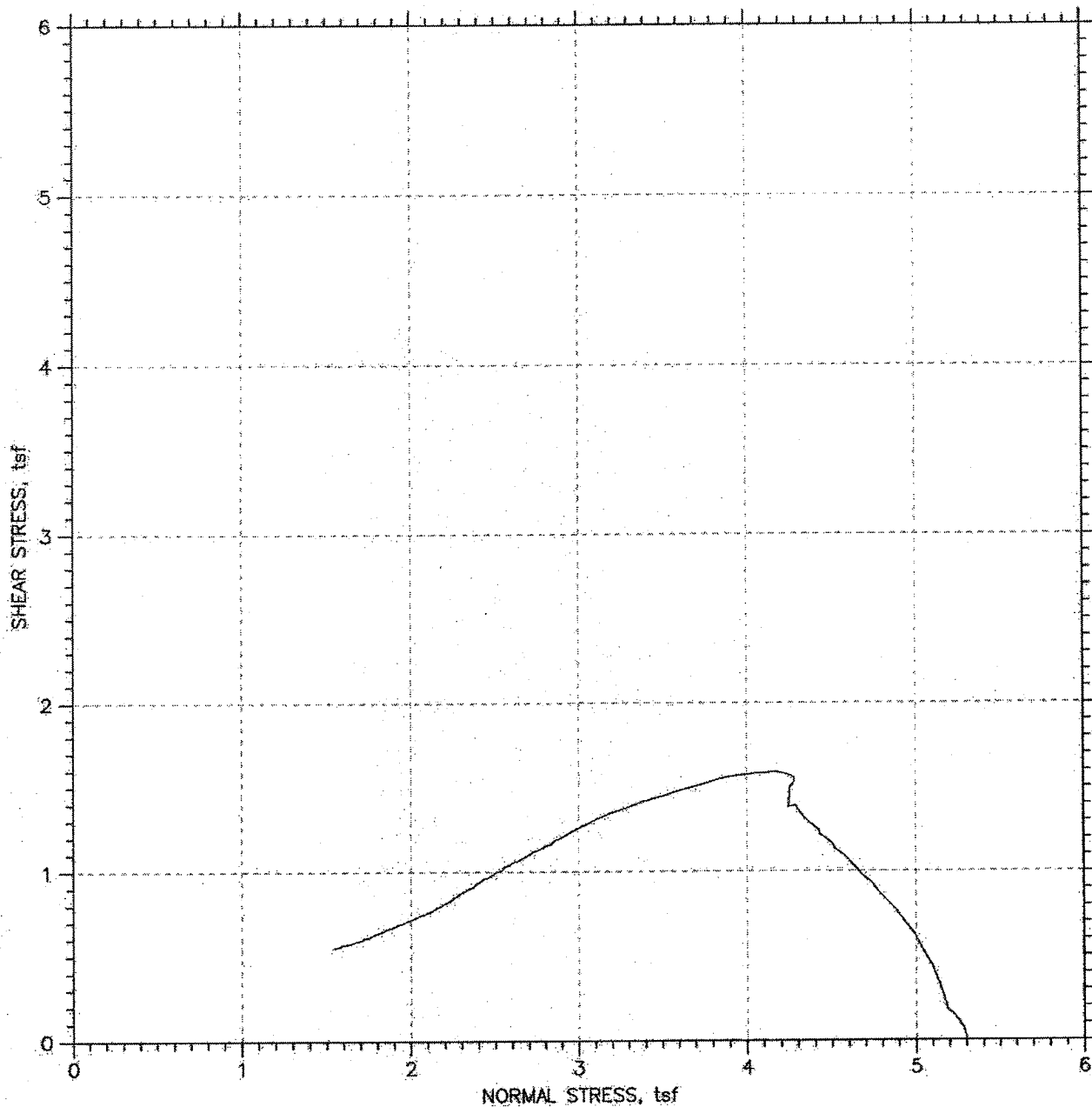

|  |                          |                   |
|--|--------------------------|-------------------|
| Project: CUY-90 West Abutment                        | Location: 8" from bottom | Project No.: 5653 |
| Boring No.: B-05-02                                  | Tested By: SO            | Checked By: JW    |
| Sample No.: S-32                                     | Test Date: 5-5-06        | Depth: 122-124    |
| Test No.: 4  | Sample Type: Undisturbed | Elevation:        |
| Description: Lean Clay mixture with silt (CL) & (ML) |                          |                   |
| Remarks: ASTM D 6528                                 |                          |                   |
| File: \\dell\GeoComp\Software\DSS\5653-s32.dat       |                          |                   |

# DIRECT SIMPLE SHEAR TEST

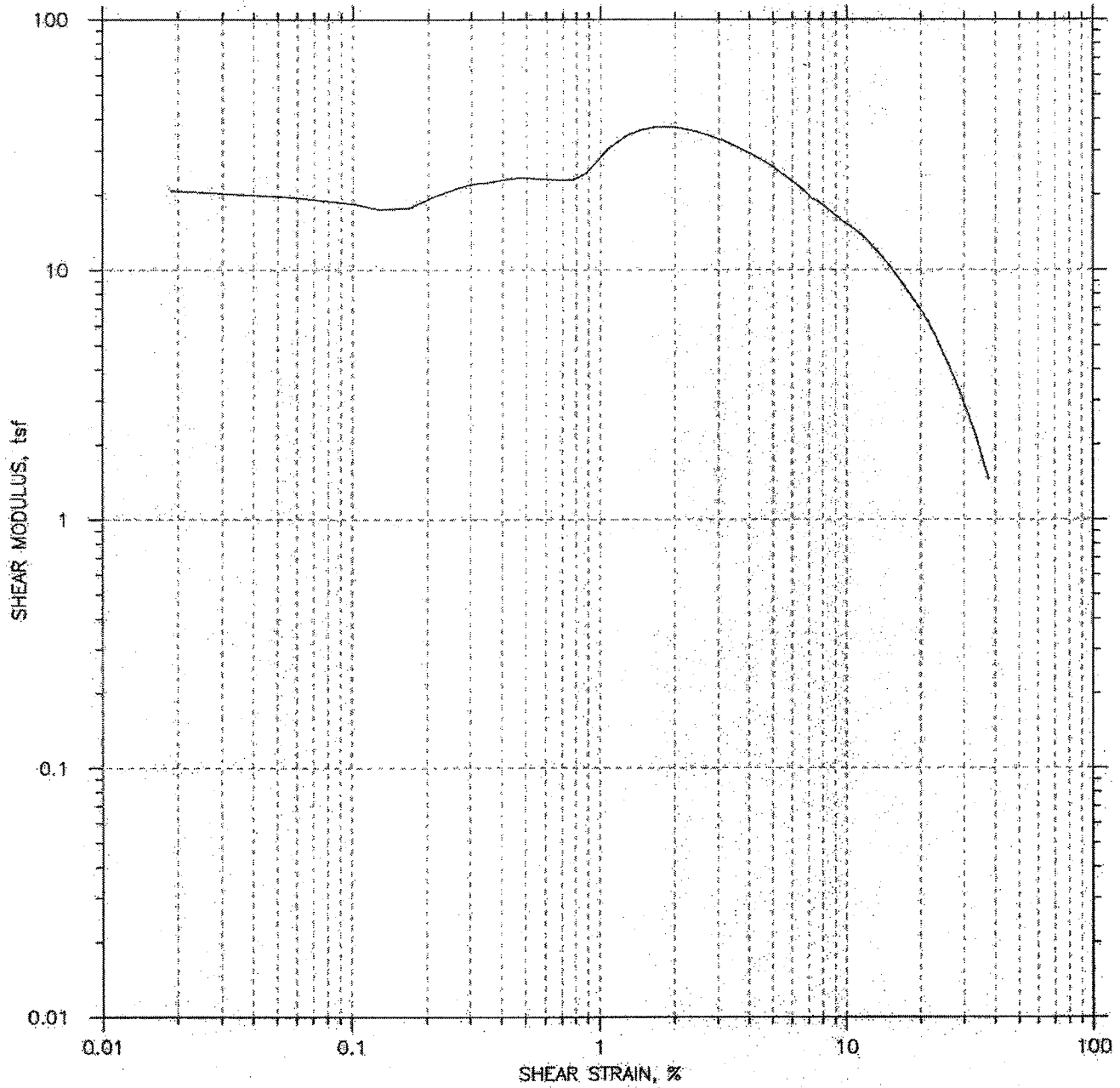

|  |                          |                   |
|--|--------------------------|-------------------|
| Project: CUY-90 West Abutment                        | Location: 8" from bottom | Project No.: 5653 |
| Boring No.: B-05-02                                  | Tested By: SO            | Checked By: JW    |
| Sample No.: S-32                                     | Test Date: 5-5-06        | Depth: 122-124    |
| Test No.: 4  | Sample Type: Undisturbed | Elevation:        |
| Description: Lean Clay mixture with silt (CL) & (ML) |                          |                   |
| Remarks: ASTM D 6528                                 |                          |                   |
| File: \\dell\GeoComp\Software\DSS\5653-s32.dat       |                          |                   |

# DIRECT SIMPLE SHEAR TEST

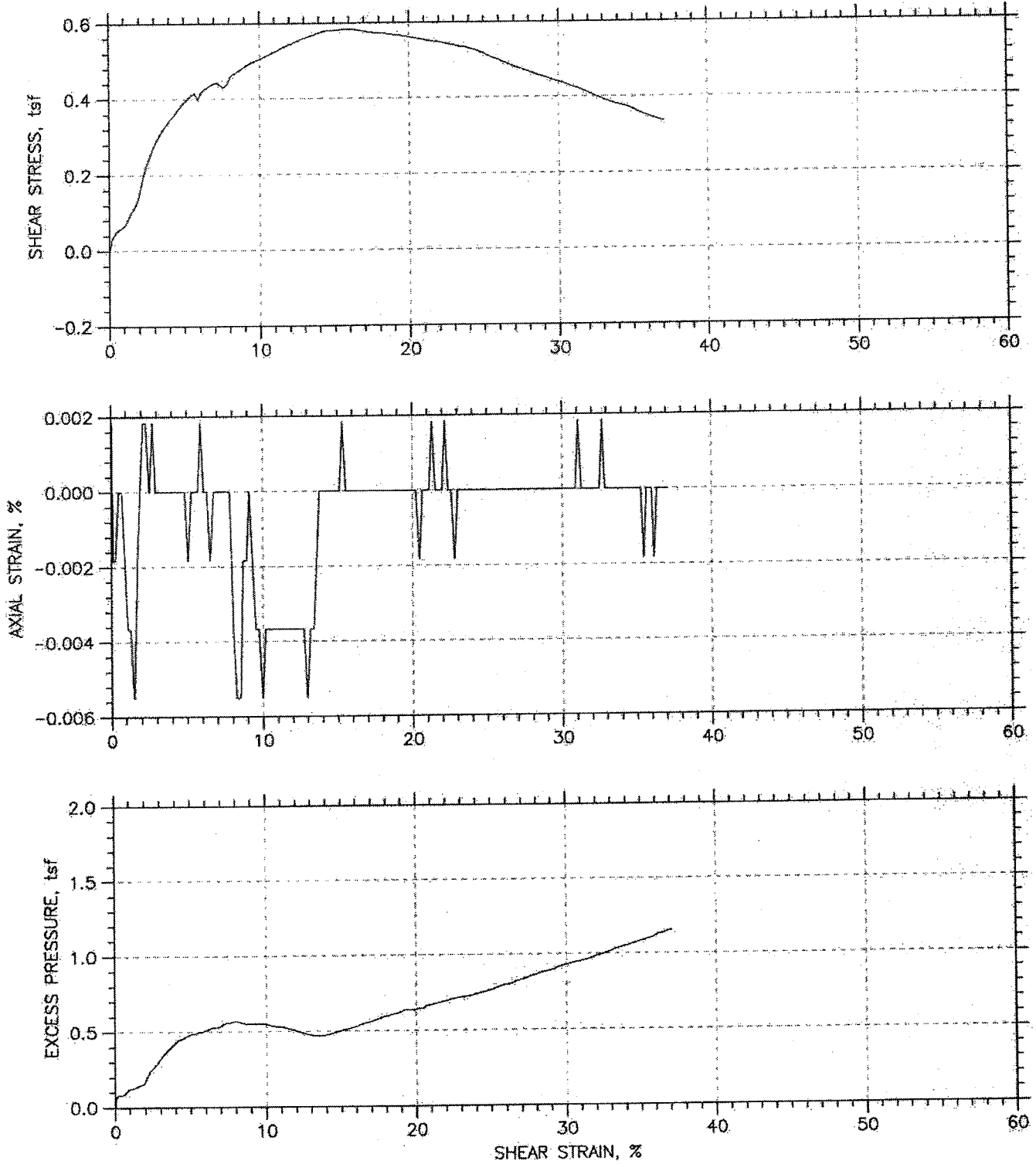

|   |                          |                   |
|---|--------------------------|-------------------|
| Project: CUY-90 West Abutment                             | Location:                | Project No.: 5653 |
| Boring No.: B-05-03                                       | Tested By: SO            | Checked By: JW    |
| Sample No.: S-8   | Test Date: 5-4-06        | Depth: 32-33.5    |
| Test No.: 3   | Sample Type: Undisturbed | Elevation:        |
| Description: Lean Clay w/an occasional piece of sand (CL) |                          |                   |
| Remarks: ASTM D 6528                                      |                          |                   |
| File: \\dell\GeoComp\Software\DSS\5653-s8.dat             |                          |                   |

# DIRECT SIMPLE SHEAR TEST

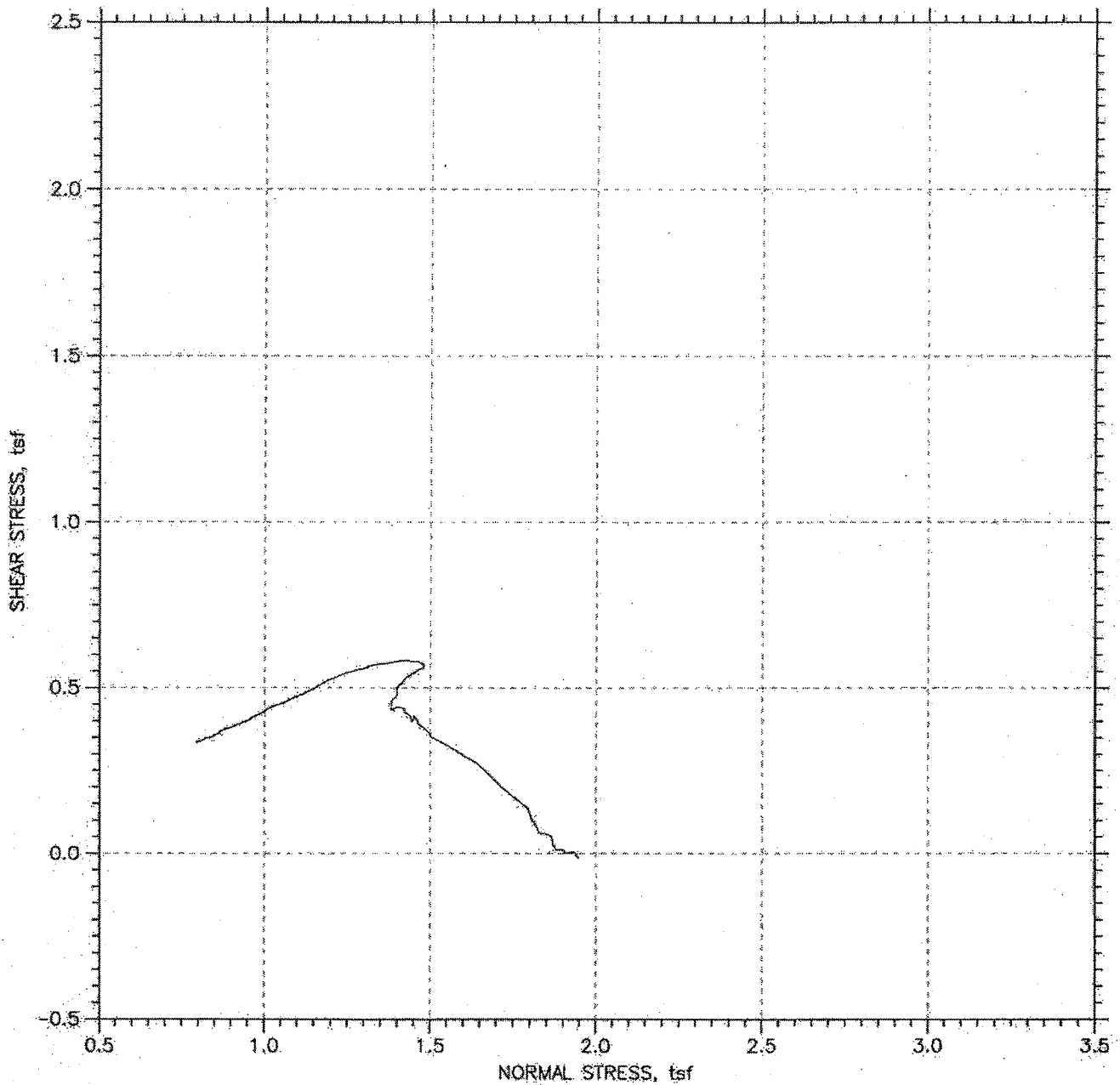

|   |                          |                   |
|---|--------------------------|-------------------|
| Project: CUY-90 West Abutment                             | Location:                | Project No.: 5653 |
| Boring No.: B-05-03                                       | Tested By: SO            | Checked By: JW    |
| Sample No.: S-8   | Test Date: 5-4-06        | Depth: 32-33.5    |
| Test No.: 3   | Sample Type: Undisturbed | Elevation:        |
| Description: Lean Clay w/an occasional piece of sand (CL) |                          |                   |
| Remarks: ASTM D 6528                                      |                          |                   |
| File: \\dell\GeoComp\Software\DSS\5653-s8.dat             |                          |                   |

# DIRECT SIMPLE SHEAR TEST

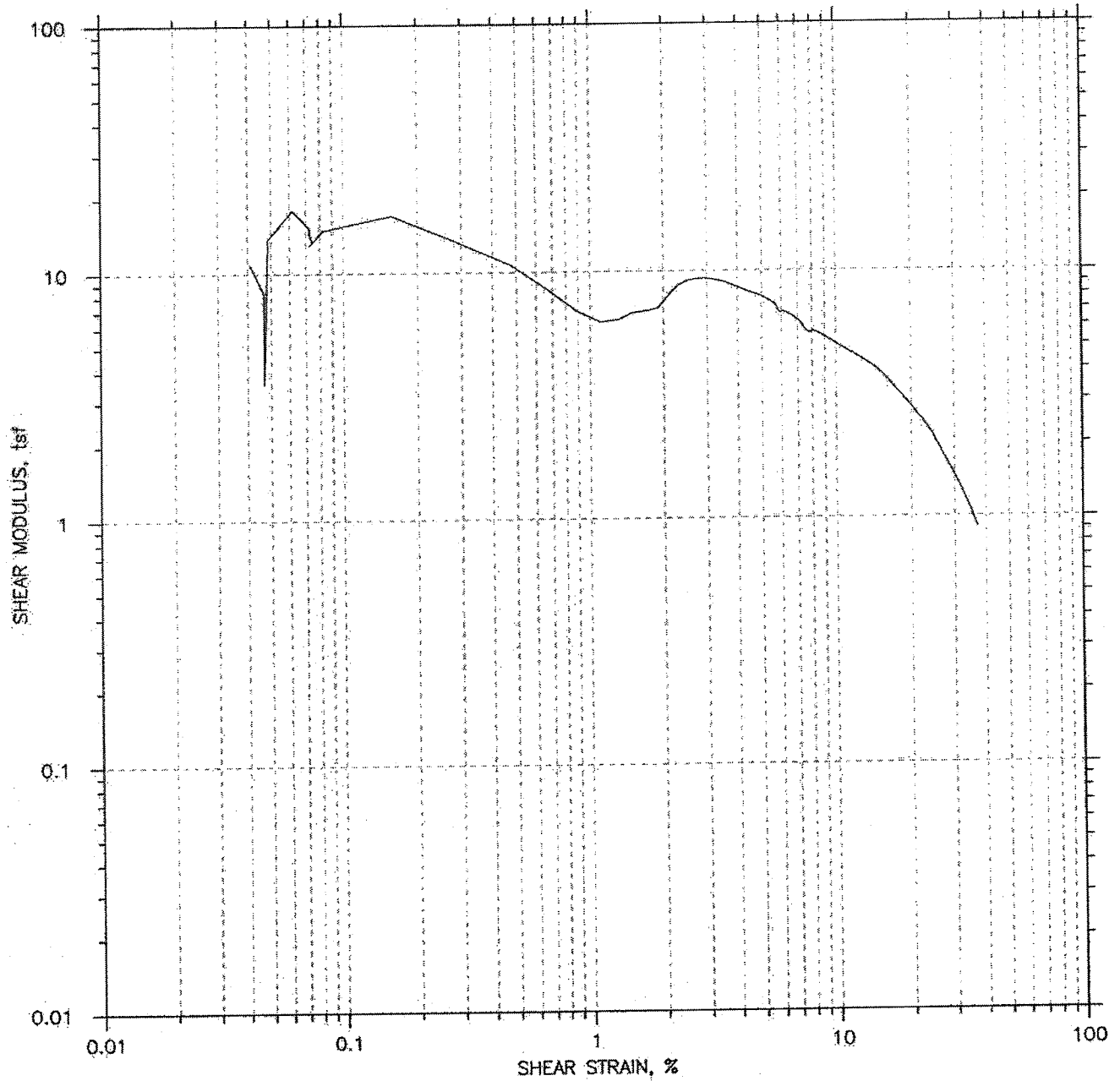

|   |                          |                   |
|---|--------------------------|-------------------|
| Project: CUY-90 West Abutment.                            | Location:                | Project No.: 5653 |
| Boring No.: B-05-03                                       | Tested By: SO            | Checked By: JW    |
| Sample No.: S-8   | Test Date: 5-4-06        | Depth: 32-33.5    |
| Test No.: 3   | Sample Type: Undisturbed | Elevation:        |
| Description: Lean Clay w/an occasional piece of sand (CL) |                          |                   |
| Remarks: ASTM D 6528                                      |                          |                   |
| File: \\del\GeoComp\Software\DSS\5653-s8.dat              |                          |                   |



# DIRECT SIMPLE SHEAR TEST

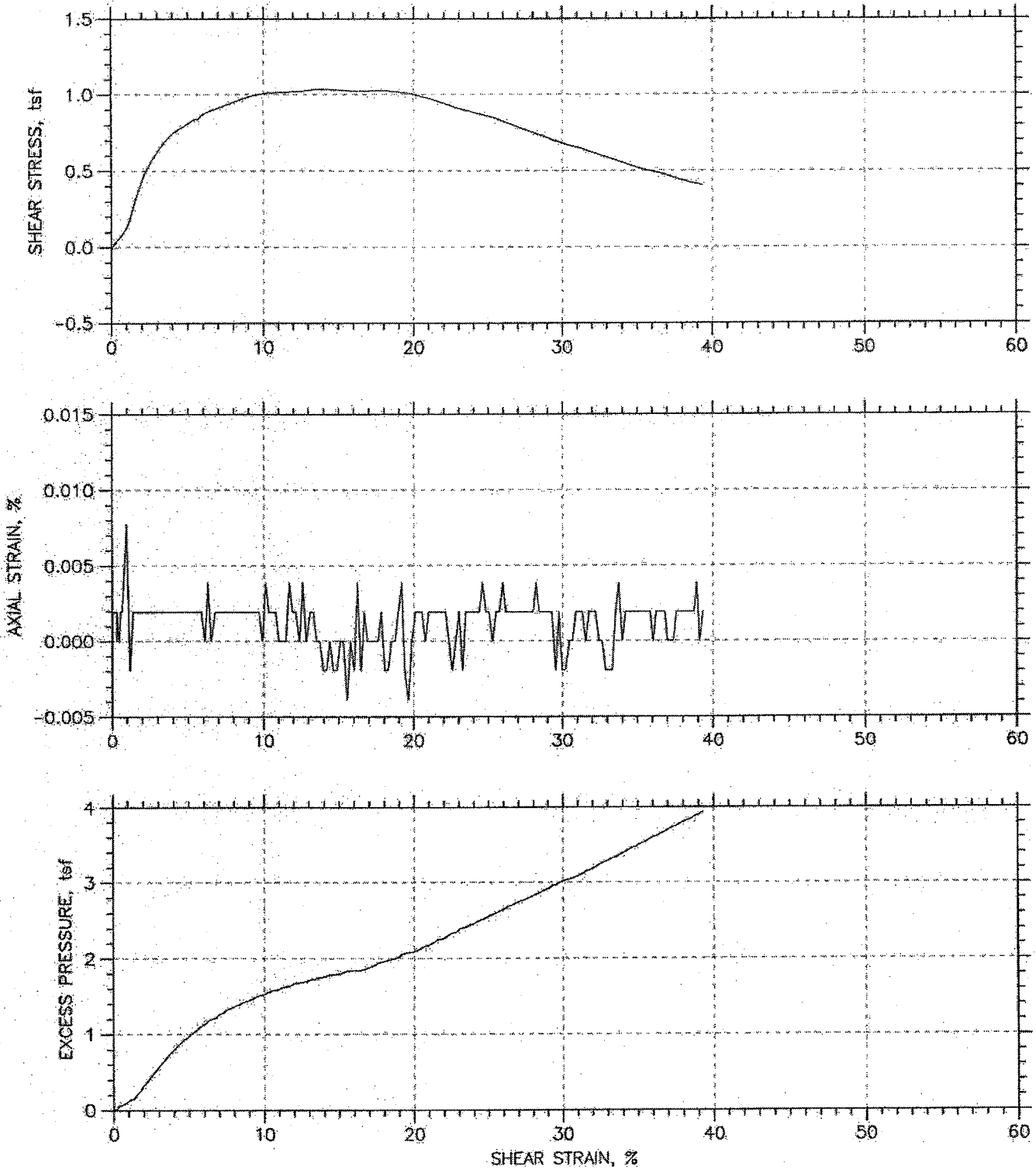

|  |                           |                   |
|--|---------------------------|-------------------|
| Project: CUY-90 West Abutment                  | Location: 14" from Bottom | Project No.: 5653 |
| Boring No.: B-05-07                            | Tested By: SO             | Checked By: JW    |
| Sample No.: S-22                               | Test Date: 5-2-06         | Depth: 104-106    |
| Test No.: 1                                    | Sample Type: Undisturbed  | Elevation:        |
| Description: Lean Clay w/pockets of silt (CL)  |                           |                   |
| Remarks: ASTM D 6528                           |                           |                   |
| File: \\dell\GeoComp\Software\DSS\5653-s22.dat |                           |                   |

# DIRECT SIMPLE SHEAR TEST

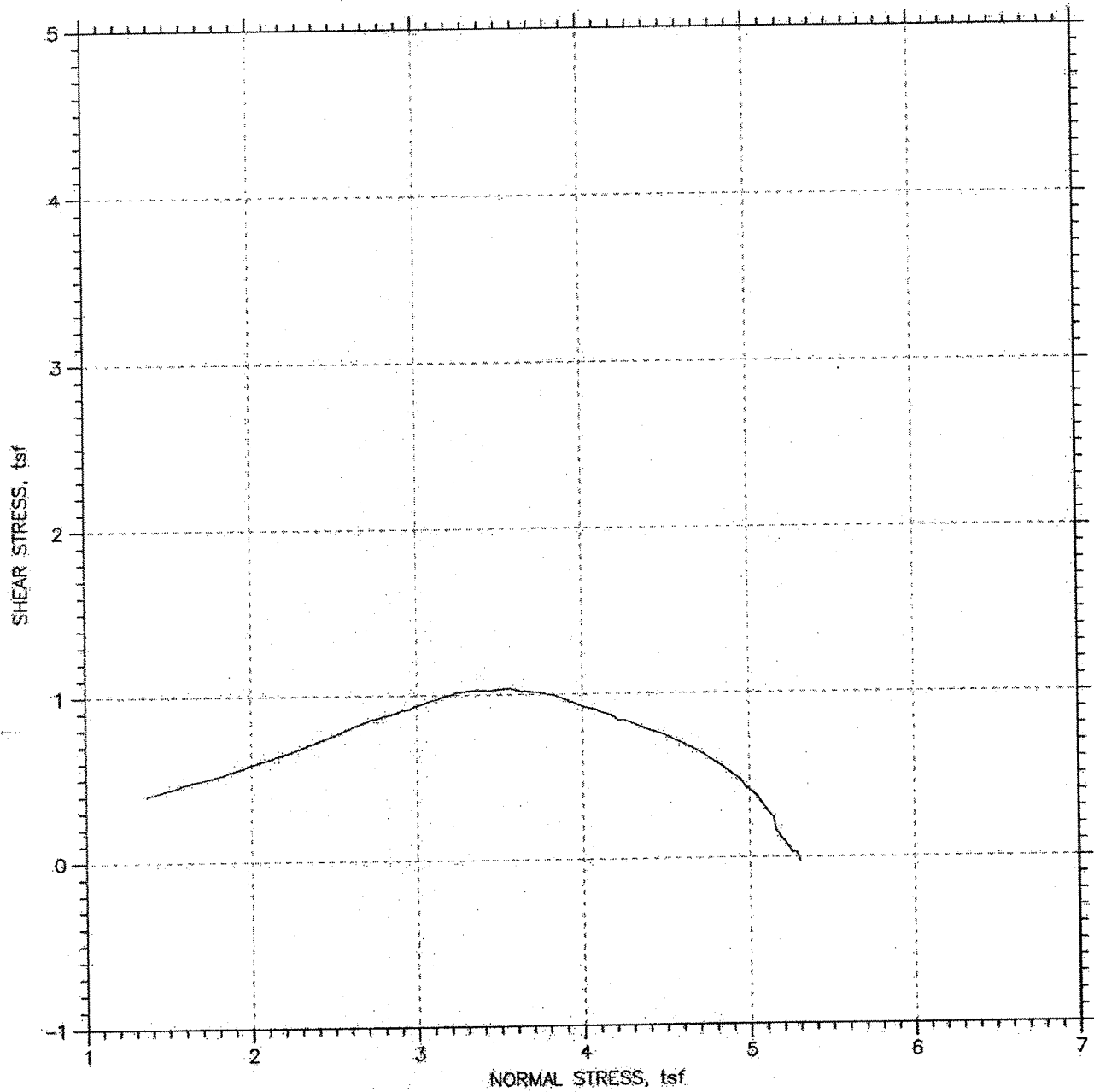

|  |                           |                   |
|--|---------------------------|-------------------|
| Project: CUY-90 West Abutment                  | Location: 14" from Bottom | Project No.: 5653 |
| Boring No.: B-05-07                            | Tested By: S0             | Checked By: JW    |
| Sample No.: S-22                               | Test Date: 5-2-06         | Depth: 104-106    |
| Test No.: 1                                    | Sample Type: Undisturbed  | Elevation:        |
| Description: León Clay w/pockets of silt (CL)  |                           |                   |
| Remarks: ASTM D 6528                           |                           |                   |
| File: \\dell\GeoComp\Software\DSS\5653-s22.dat |                           |                   |

# DIRECT SIMPLE SHEAR TEST

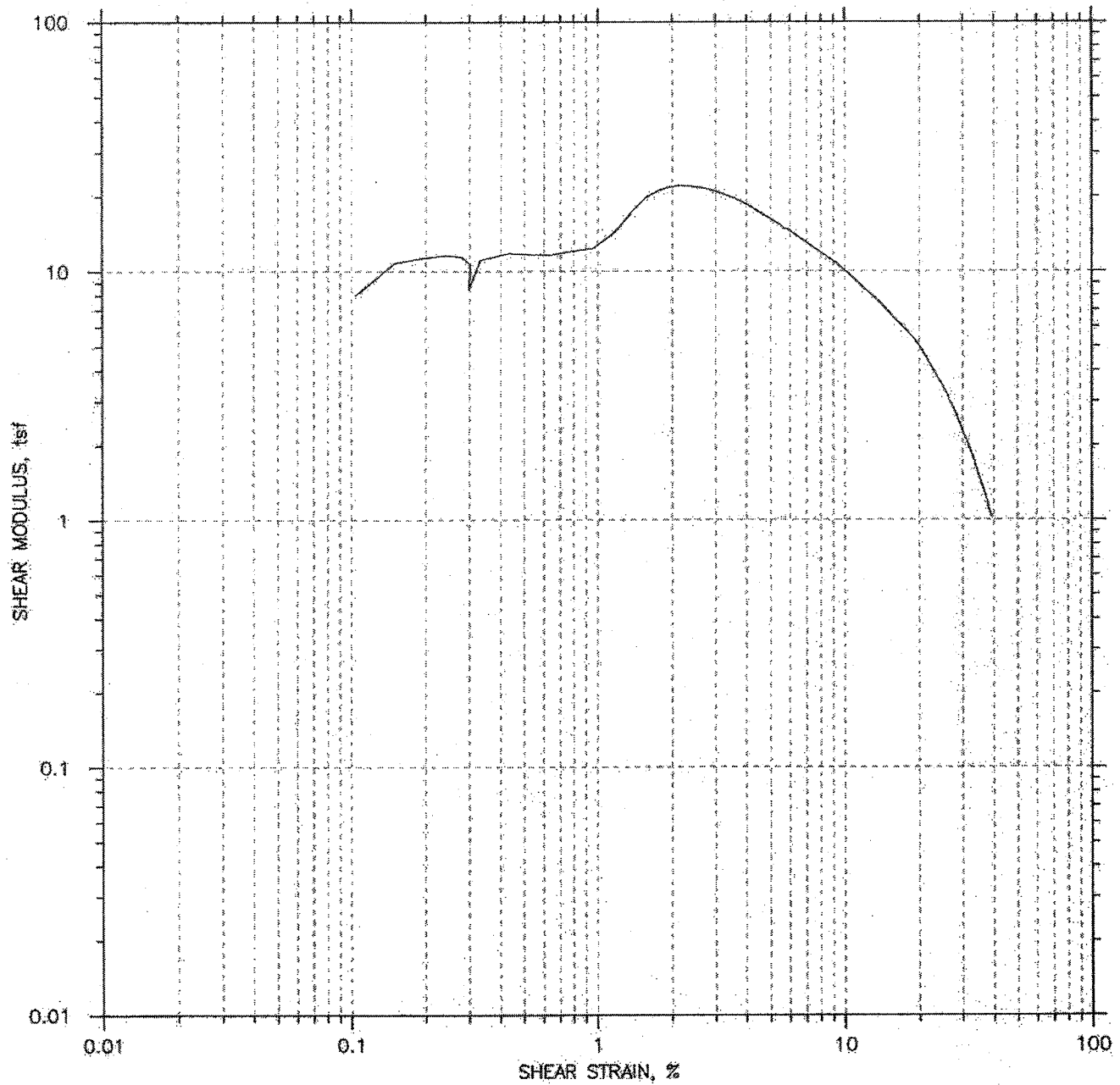

|   |                           |                   |
|---|---------------------------|-------------------|
| Project: CUY-90 West Abutment                 | Location: 14" from Bottom | Project No.: 5653 |
| Boring No.: B-05-07                           | Tested By: SO             | Checked By: JW    |
| Sample No.: S-22                              | Test Date: 5-2-06         | Depth: 104-106    |
| Test No.: 1                                   | Sample Type: Undisturbed  | Elevation:        |
| Description: Lean Clay w/pockets of silt (CL) |                           |                   |
| Remarks: ASTM D 6528                          |                           |                   |
| File: \\del\GeoComp\Software\DSS\5653-s22.dat |                           |                   |

# UNCONFINED COMPRESSION TEST

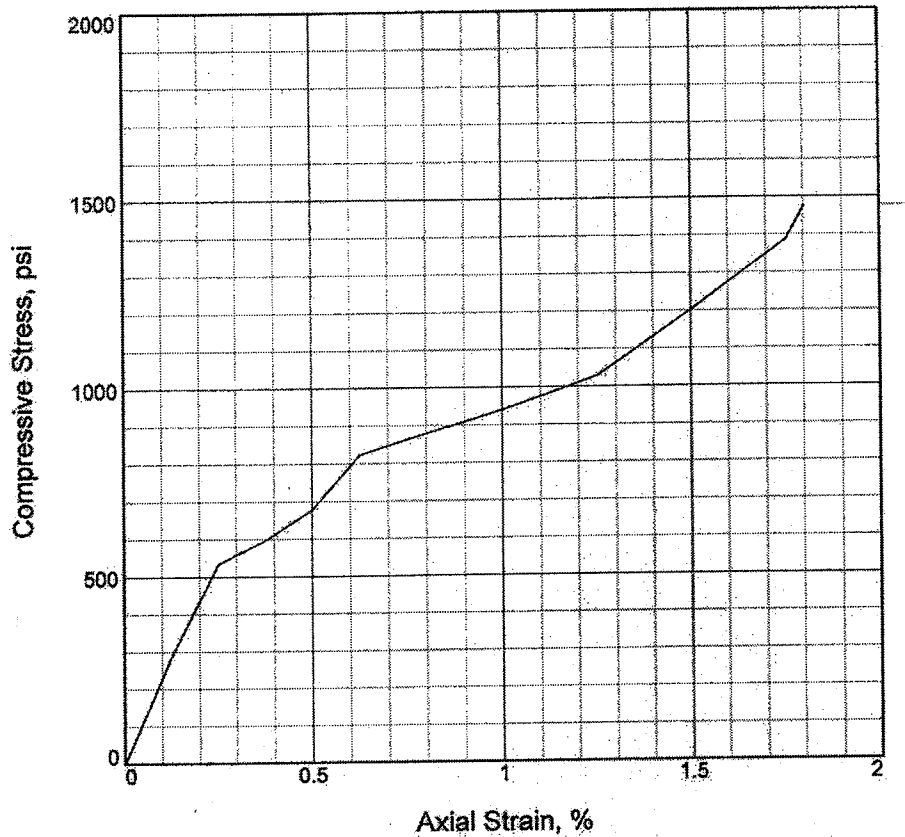

|                               |         |  |  |  |
|-------------------------------|---------|--|--|--|
| Sample No.                    | 1       |  |  |  |
| Unconfined strength, psi      | 1476.67 |  |  |  |
| Undrained shear strength, psi | 738.34  |  |  |  |
| Failure strain, %             | 1.8     |  |  |  |
| Strain rate, in./min.         | 1.00    |  |  |  |
| Water content, %              | 17.0    |  |  |  |
| Wet density, pcf              | 160.7   |  |  |  |
| Dry density, pcf              | 137.3   |  |  |  |
| Saturation, %                 | 220.5   |  |  |  |
| Void ratio                    | 0.2046  |  |  |  |
| Specimen diameter, in.        | 2.04    |  |  |  |
| Specimen height, in.          | 3.99    |  |  |  |
| Height/diameter ratio         | 1.96    |  |  |  |

**Description:** Soft dark gray shale, nearly horizontally bedded, many horizontal fractures, contains many interbedded siltstone

LL =      PL =      PI =      Assumed GS= 2.65      Type: Rock core

Project No.: 012 00946300

Date: 4/19/06

Remarks:

**Client:** Michael Baker Inc.

**Project:** Cuy-90-15.24 West Abutment

**Location:** B-05-01

**Sample Number:** S-56      **Depth:** 228.8 - 229.3

UNCONFINED COMPRESSION TEST

## BBC&M Engineering, Inc.

Figure \_\_\_\_\_

Tested By: RAK

Checked By: RAK

# UNCONFINED COMPRESSION TEST

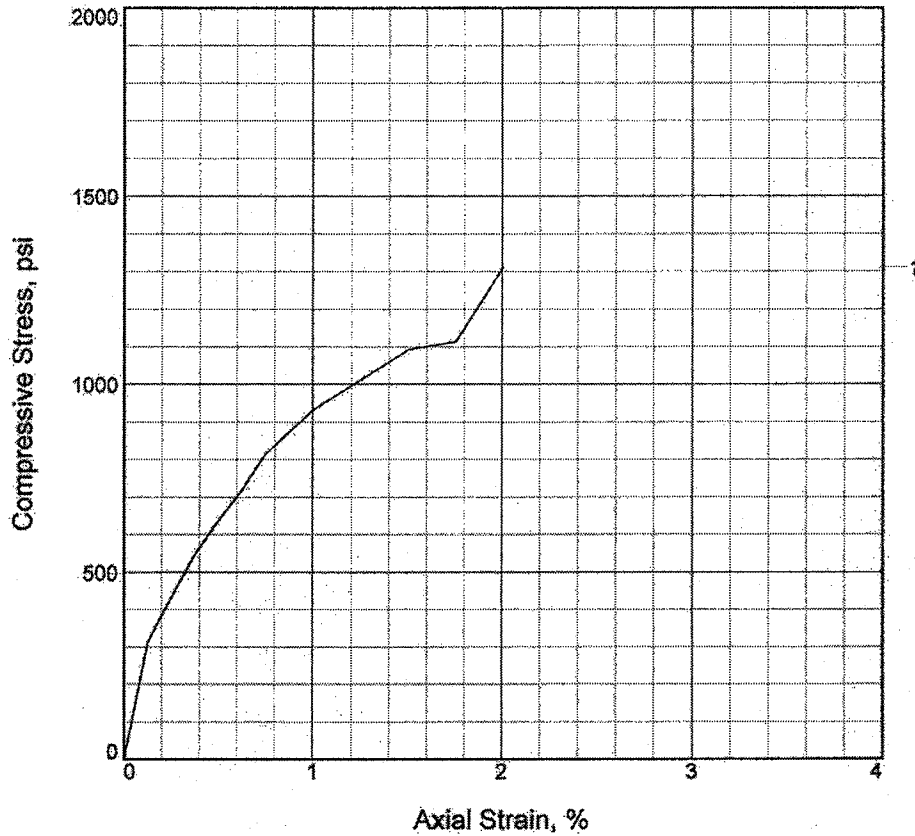

|                               |         |  |  |
|-------------------------------|---------|--|--|
| Sample No.                    | 1       |  |  |
| Unconfined strength, psi      | 1311.26 |  |  |
| Undrained shear strength, psi | 655.63  |  |  |
| Failure strain, %             | 2.0     |  |  |
| Strain rate, in./min.         | 1.00    |  |  |
| Water content, %              | 4.3     |  |  |
| Wet density, pcf              | 171.6   |  |  |
| Dry density, pcf              | 164.5   |  |  |
| Saturation, %                 | 271.3   |  |  |
| Void ratio                    | 0.0435  |  |  |
| Specimen diameter, in.        | 1.95    |  |  |
| Specimen height, in.          | 3.99    |  |  |
| Height/diameter ratio         | 2.05    |  |  |

**Description:** Soft dark gray and gray shale, nearly horizontally bedded, many horizontal and few diagonal and vertical

**LL =**      **PL =**      **PI =**      **Assumed GS= 2.75**      **Type: Rock Core**

Project No.: 012 00946.300

Date: 6/14/06

Remarks:

**Client:** Michael Baker Inc.

**Project:** Cuy-90-15.24 West Abutment

**Location:** B-05-03

**Sample Number:** S-39      **Depth:** 165.2' - 165.9'

UNCONFINED COMPRESSION TEST

## BBC&M Engineering, Inc.

Figure \_\_\_\_\_

Tested By: RAK

Checked By: RAK

# UNCONFINED COMPRESSION TEST

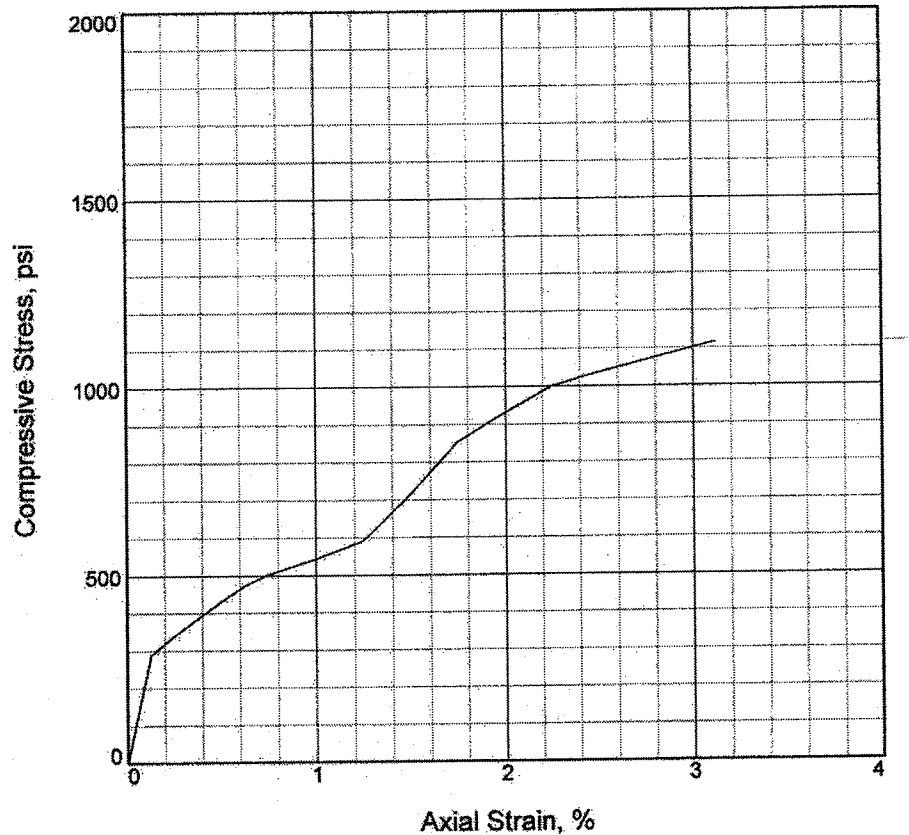

|                               |         |  |  |
|-------------------------------|---------|--|--|
| Sample No.                    | 1       |  |  |
| Unconfined strength, psi      | 1115.95 |  |  |
| Undrained shear strength, psi | 557.97  |  |  |
| Failure strain, %             | 3.1     |  |  |
| Strain rate, in./min.         | 1.00    |  |  |
| Water content, %              | 3.1     |  |  |
| Wet density, pcf              | 167.1   |  |  |
| Dry density, pcf              | 162.0   |  |  |
| Saturation, %                 | 391.3   |  |  |
| Void ratio                    | 0.0210  |  |  |
| Specimen diameter, in.        | 2.04    |  |  |
| Specimen height, in.          | 4.01    |  |  |
| Height/diameter ratio         | 1.97    |  |  |

**Description:** Soft dark gray and gray shale interbedded with siltstone, NEarly horizontally bedded, few horizontal fractures.

LL =      PL =      PI =      Assumed GS= 2.65      Type: Rock Core

Project No.: 012 00946.300

Date: 4/5/06

Remarks:

Client: Michael Baker Inc.

Project: Cuy-90-15.24 West Abutment

Location: B-05-04

Sample Number: S-50      Depth: 169.9 - 170.4

UNCONFINED COMPRESSION TEST

**BBC&M Engineering, Inc.**

Figure \_\_\_\_\_

Tested By: RAK

Checked By: RAK

# UNCONFINED COMPRESSION TEST

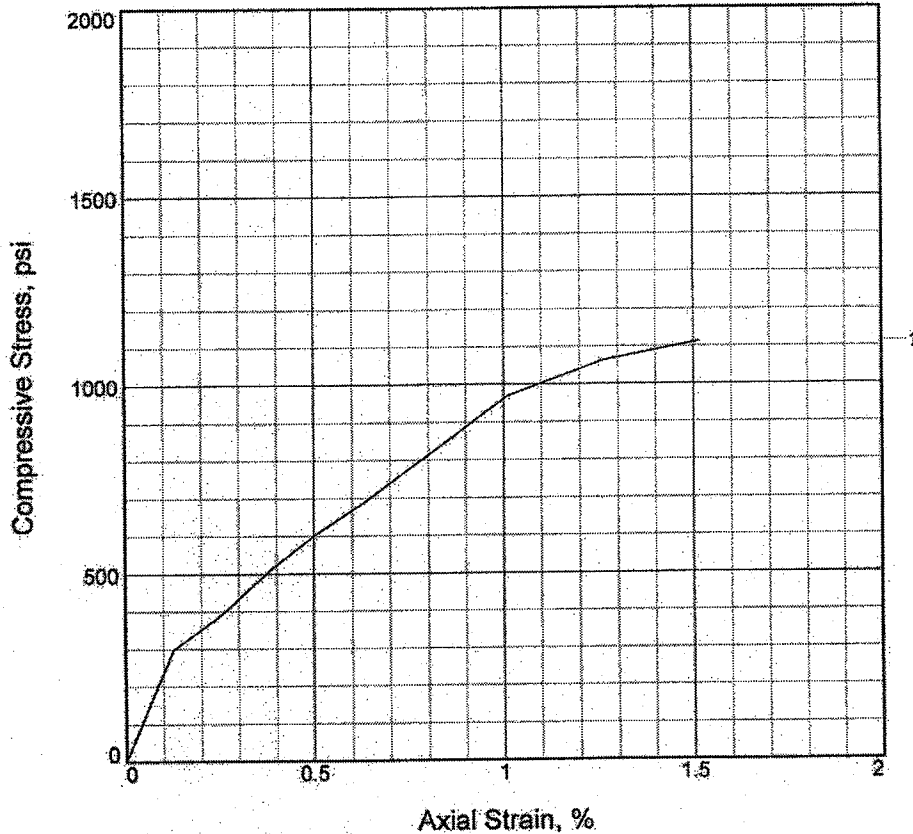

|                               |         |  |  |
|-------------------------------|---------|--|--|
| Sample No.                    | 1       |  |  |
| Unconfined strength, psi      | 1112.63 |  |  |
| Undrained shear strength, psi | 556.32  |  |  |
| Failure strain, %             | 1.5     |  |  |
| Strain rate, in./min.         | 1.00    |  |  |
| Water content, %              | 3.7     |  |  |
| Wet density, pcf              | 167.6   |  |  |
| Dry density, pcf              | 161.6   |  |  |
| Saturation, %                 | 164.0   |  |  |
| Void ratio                    | 0.0622  |  |  |
| Specimen diameter, in.        | 1.97    |  |  |
| Specimen height, in.          | 3.96    |  |  |
| Height/diameter ratio         | 2.01    |  |  |

**Description:** Soft dark gray and gray shale, nearly horizontally bedded, many horizontal and few diagonal and vertical

|      |      |      |                  |                 |
|------|------|------|------------------|-----------------|
| LL = | PL = | PI = | Assumed GS= 2.75 | Type: Rock Core |
|------|------|------|------------------|-----------------|

Project No.: 012 00946300

Date: 6/14/06

Remarks:

Client: Michael Baker Inc.

Project: Cuy-90-15.24 West Abutment

Location: B-05-07

Sample Number: S-48

Depth: 224.0' - 224.5'

UNCONFINED COMPRESSION TEST

**BBC&M Engineering, Inc.**

Figure \_\_\_\_\_

Tested By: RAK

Checked By: RAK

# UNCONFINED COMPRESSION TEST

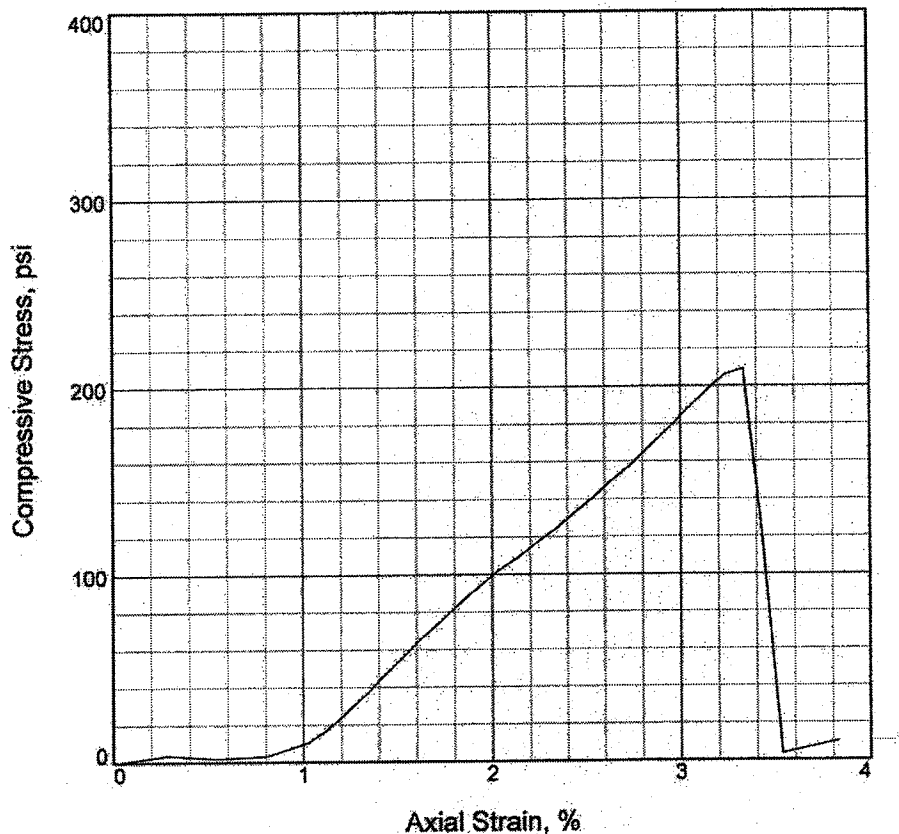

|                               |        |  |  |  |
|-------------------------------|--------|--|--|--|
| Sample No.                    | 1      |  |  |  |
| Unconfined strength, psi      | 209.37 |  |  |  |
| Undrained shear strength, psi | 104.69 |  |  |  |
| Failure strain, %             | 3.3    |  |  |  |
| Strain rate, in./min.         | 3.98   |  |  |  |
| Water content, %              | 0.0    |  |  |  |
| Wet density, pcf              | 160.3  |  |  |  |
| Dry density, pcf              | 160.3  |  |  |  |
| Saturation, %                 | 0.0    |  |  |  |
| Void ratio                    | 0.0515 |  |  |  |
| Specimen diameter, in.        | 2.05   |  |  |  |
| Specimen height, in.          | 3.95   |  |  |  |
| Height/diameter ratio         | 1.93   |  |  |  |

**Description:** Soft dark gray and gray shale, nearly horizontally bedded, many horizontal and few diagonal and vertical

|      |      |      |                 |                 |
|------|------|------|-----------------|-----------------|
| LL = | PL = | PI = | Assumed GS= 2.7 | Type: Rock core |
|------|------|------|-----------------|-----------------|

Project No.: 012 00946.300  
 Date: 5/1/06  
 Remarks:  
 Figure \_\_\_\_\_

**Client:** Michael Baker Inc.  
**Project:** Cuy-90-15.24 West Abutment  
**Location:** B-05-11  
**Sample Number:** S-55      **Depth:** 225.0' -225.5'  
 UNCONFINED COMPRESSION TEST  
**BBC&M Engineering, Inc.**

Tested By: RAK

Checked By: RAK



# UNCONFINED COMPRESSION TEST

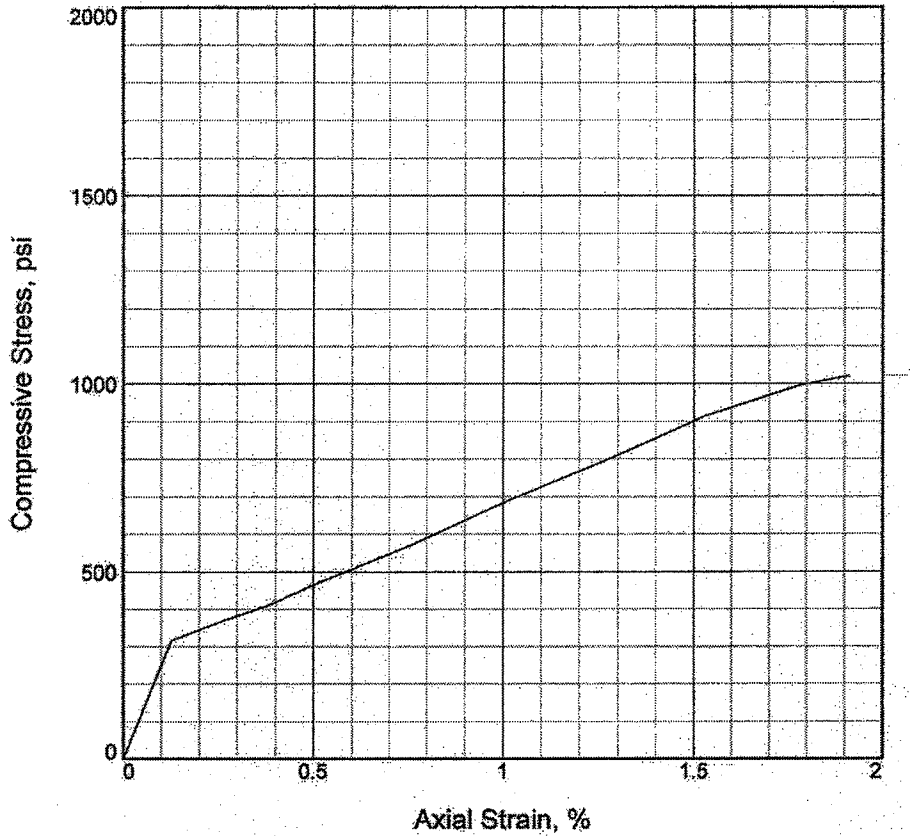

|                               |         |  |  |
|-------------------------------|---------|--|--|
| Sample No.                    | 1       |  |  |
| Unconfined strength, psi      | 1020.94 |  |  |
| Undrained shear strength, psi | 510.47  |  |  |
| Failure strain, %             | 1.9     |  |  |
| Strain rate, in./min.         | 1.00    |  |  |
| Water content, %              | 4.0     |  |  |
| Wet density, pcf              | 167.4   |  |  |
| Dry density, pcf              | 161.0   |  |  |
| Saturation, %                 | 165.6   |  |  |
| Void ratio                    | 0.0663  |  |  |
| Specimen diameter, in.        | 1.96    |  |  |
| Specimen height, in.          | 3.92    |  |  |
| Height/diameter ratio         | 2.00    |  |  |

**Description:** Soft dark gray and gray shale, nearly horizontally bedded, many horizontal and few diagonal and vertical

LL =      PL =      PI =      Assumed GS= 2.75      Type: Rock Core

Project No.: 012 00946.300

Date: 6/14/06

Remarks:

**Client:** Michael Baker Inc.

**Project:** Cuy-90-15.24 West Abutment

**Location:** B-05-12

**Sample Number:** S-56      **Depth:** 207.6' - 208.1'

UNCONFINED COMPRESSION TEST

## BBC&M Engineering, Inc.

Figure \_\_\_\_\_

Tested By: RAK

Checked By: RAK



# UNCONFINED COMPRESSION TEST

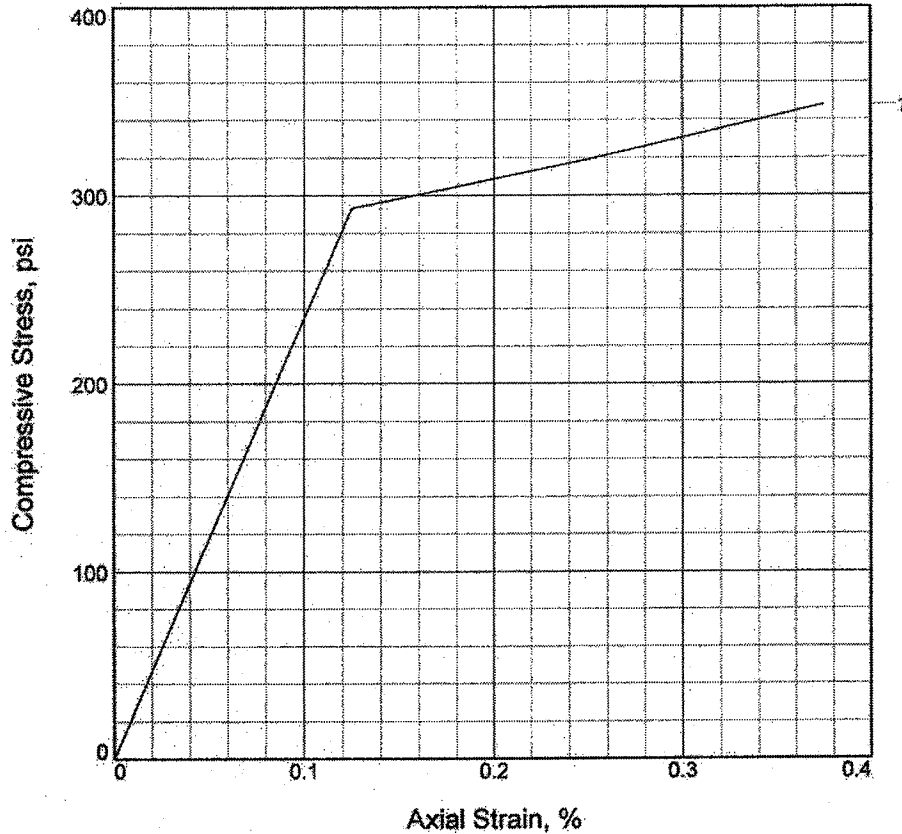

|                               |        |  |  |  |
|-------------------------------|--------|--|--|--|
| Sample No.                    | 1      |  |  |  |
| Unconfined strength, psi      | 347.96 |  |  |  |
| Undrained shear strength, psi | 173.98 |  |  |  |
| Failure strain, %             | 0.4    |  |  |  |
| Strain rate, in./min.         | 1.00   |  |  |  |
| Water content, %              | 0.0    |  |  |  |
| Wet density, pcf              | 162.6  |  |  |  |
| Dry density, pcf              | 162.6  |  |  |  |
| Saturation, %                 | 0.0    |  |  |  |
| Void ratio                    | 0.0172 |  |  |  |
| Specimen diameter, in.        | 1.98   |  |  |  |
| Specimen height, in.          | 4.01   |  |  |  |
| Height/diameter ratio         | 2.03   |  |  |  |

**Description:** Soft dark gray and gray shale, nearly horizontally bedded, many horizontal and few diagonal and vertical

|      |      |      |                  |                 |
|------|------|------|------------------|-----------------|
| LL = | PL = | PI = | Assumed GS= 2.65 | Type: Rock Core |
|------|------|------|------------------|-----------------|

Project No.: 012 00946.300

Date: 5/20/06

Remarks:

**Client:** Michael Baker Inc.

**Project:** Cuy-90-15.24 West Abutment

**Location:** B-05-13

**Sample Number:** S-40      **Depth:** 178.5' - 179.0'

UNCONFINED COMPRESSION TEST

## BBC&M Engineering, Inc.

Figure \_\_\_\_\_

Tested By: RAK

Checked By: RAK

# UNCONFINED COMPRESSION TEST

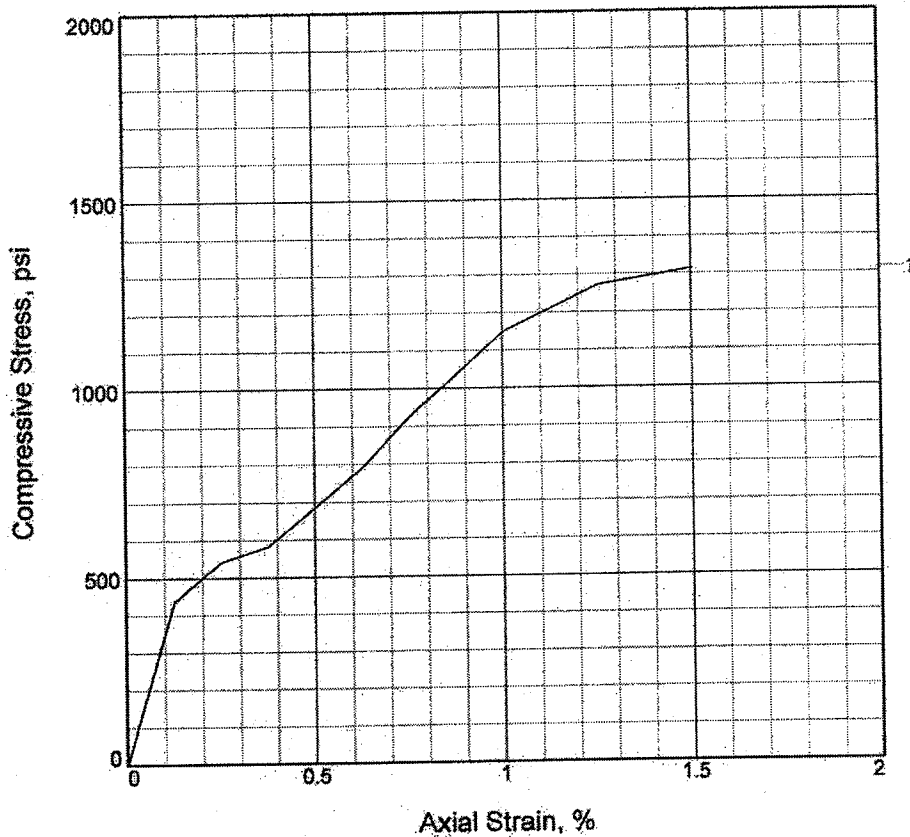

|                               |         |  |  |
|-------------------------------|---------|--|--|
| Sample No.                    | 1       |  |  |
| Unconfined strength, psi      | 1313.31 |  |  |
| Undrained shear strength, psi | 656.65  |  |  |
| Failure strain, %             | 1.5     |  |  |
| Strain rate, in./min.         | 1.00    |  |  |
| Water content, %              | 0.4     |  |  |
| Wet density, pcf              | 161.5   |  |  |
| Dry density, pcf              | 160.9   |  |  |
| Saturation, %                 | 36.2    |  |  |
| Void ratio                    | 0.0282  |  |  |
| Specimen diameter, in.        | 1.98    |  |  |
| Specimen height, in.          | 3.99    |  |  |
| Height/diameter ratio         | 2.01    |  |  |

**Description:** Soft dark gray and gray shale, nearly horizontally bedded, many horizontal and few diagonal and vertical

LL =      PL =      PI =      Assumed GS= 2.65      Type: Rock Core

Project No.: 012 00946.300

Date: 5/20/06

Remarks:

Client: Michael Baker Inc.

Project: Cuy-90-15.24 West Abutment

Location: B-05-14

Sample Number: S-36      Depth: 168.4' - 169.0'

UNCONFINED COMPRESSION TEST

## BBC&M Engineering, Inc.

Figure \_\_\_\_\_

Tested By: RAK

Checked By: RAK

# UNCONFINED COMPRESSION TEST

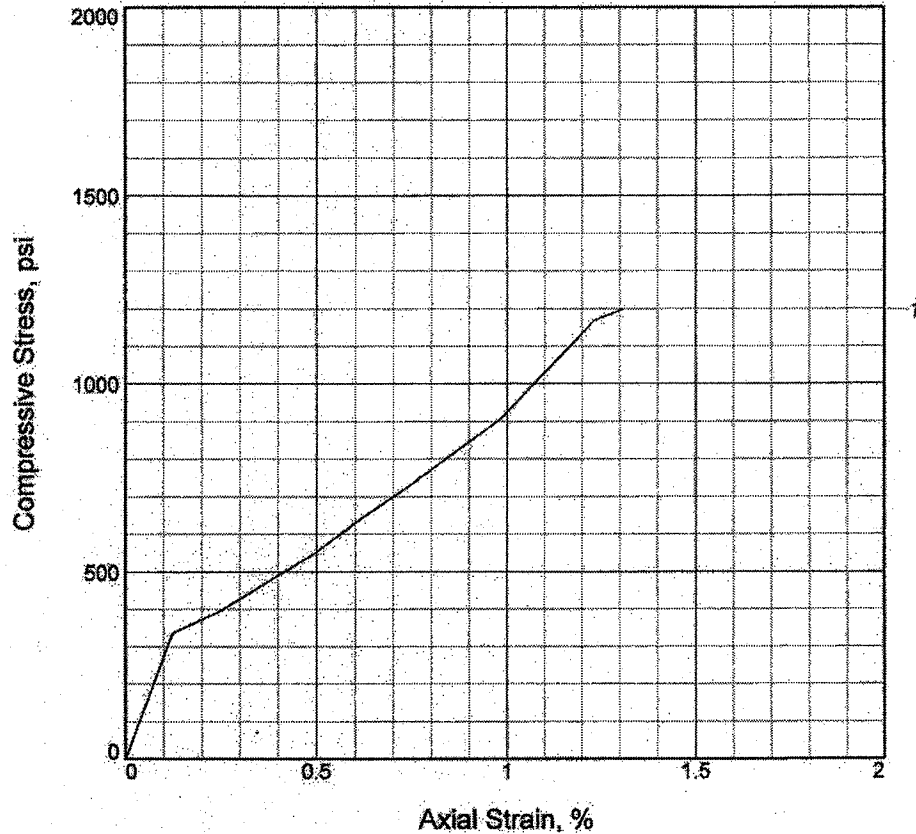

|                               |         |  |  |
|-------------------------------|---------|--|--|
| Sample No.                    | 1       |  |  |
| Unconfined strength, psi      | 1198.22 |  |  |
| Undrained shear strength, psi | 599.11  |  |  |
| Failure strain, %             | 1.3     |  |  |
| Strain rate, in./min.         | 1.00    |  |  |
| Water content, %              | 0.0     |  |  |
| Wet density, pcf              | 168.8   |  |  |
| Dry density, pcf              | 168.8   |  |  |
| Saturation, %                 | 0.0     |  |  |
| Void ratio                    | -0.0199 |  |  |
| Specimen diameter, in.        | 1.97    |  |  |
| Specimen height, in.          | 4.06    |  |  |
| Height/diameter ratio         | 2.06    |  |  |

**Description:** Soft dark gray and gray shale, nearly horizontally bedded, many horizontal and few diagonal and vertical

**LL =**      **PL =**      **PI =**      **Assumed GS= 2.65**      **Type: Rock Core**

Project No.: 012 00946.300

Date: 5/20/06

Remarks:

**Client:** Michael Baker Inc.

**Project:** Cuy-90-15.24 West Abutment

**Location:** B-05-14

**Sample Number:** S-37      **Depth:** 180.0' - 180.4'

UNCONFINED COMPRESSION TEST

**BBC&M Engineering, Inc.**

Figure \_\_\_\_\_

Tested By: RAK

Checked By: RAK

# UNCONFINED COMPRESSION TEST

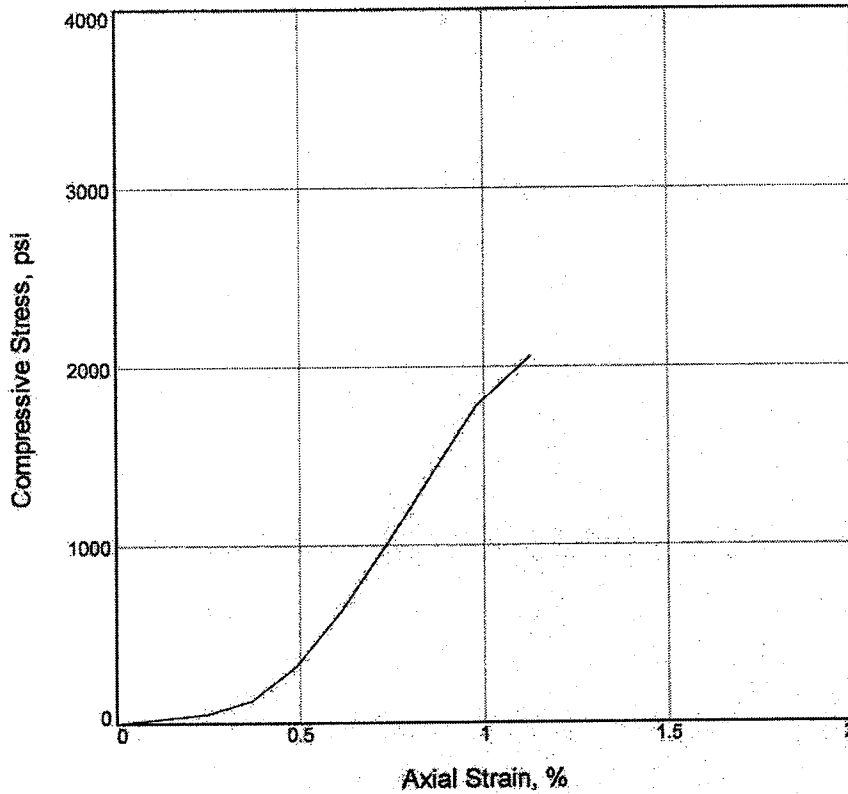

|                               |         |  |  |
|-------------------------------|---------|--|--|
| Sample No.                    | 1       |  |  |
| Unconfined strength, psi      | 2056.59 |  |  |
| Undrained shear strength, psi | 1028.29 |  |  |
| Failure strain, %             | 1.1     |  |  |
| Strain rate, in./min.         | 0.04    |  |  |
| Water content, %              | 3.0     |  |  |
| Wet density, pcf              | 158.9   |  |  |
| Dry density, pcf              | 154.3   |  |  |
| Saturation, %                 | 87.3    |  |  |
| Void ratio                    | 0.0922  |  |  |
| Specimen diameter, in.        | 1.98    |  |  |
| Specimen height, in.          | 4.08    |  |  |
| Height/diameter ratio         | 2.06    |  |  |

**Description:** Medium-hard dark gray shale.

|      |      |      |                 |                 |
|------|------|------|-----------------|-----------------|
| LL = | PL = | PI = | Assumed GS= 2.7 | Type: Rock Core |
|------|------|------|-----------------|-----------------|

Project No.: 012-00946-309

Date: 6/3/06

Remarks:

**Client:**

Project: CUY-90 WEST A

Cleveland, Ohio

Location: B-05-15

Sample Number: S-47

Depth: 202.4' to 203.0'

UNCONFINED COMPRESSION TEST

**BBC&M Engineering, Inc.**

Figure 1

Tested By: CBP

Checked By: PJW

## UNCONFINED COMPRESSION TEST

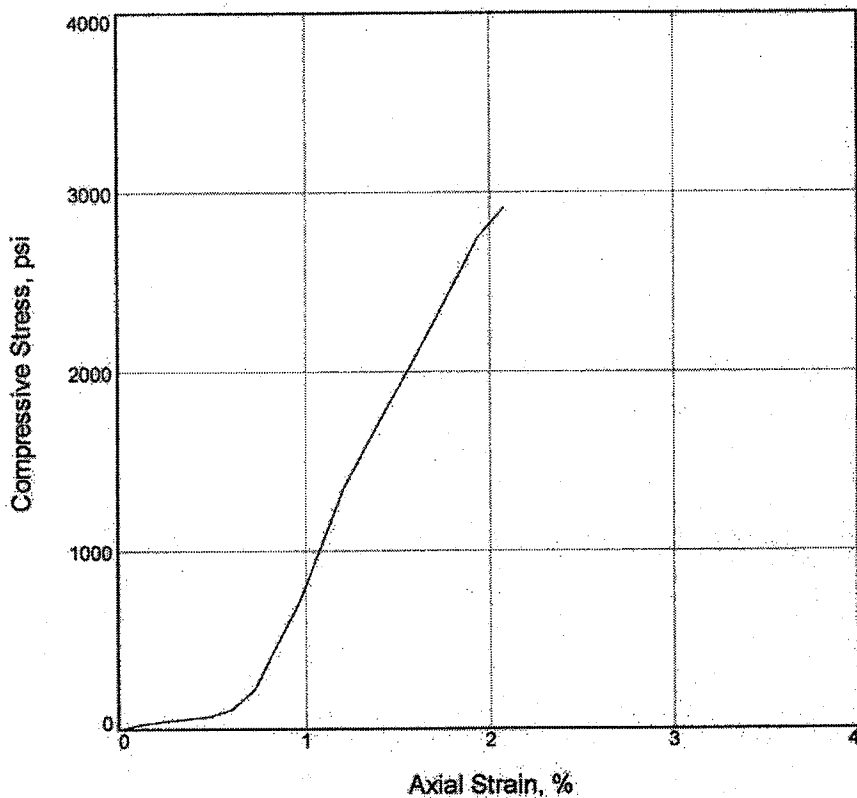

|                               |         |  |  |  |
|-------------------------------|---------|--|--|--|
| Sample No.                    | 1       |  |  |  |
| Unconfined strength, psi      | 2915.94 |  |  |  |
| Undrained shear strength, psi | 1457.97 |  |  |  |
| Failure strain, %             | 2.1     |  |  |  |
| Strain rate, in./min.         | 0.04    |  |  |  |
| Water content, %              | 3.0     |  |  |  |
| Wet density, pcf              | 163.4   |  |  |  |
| Dry density, pcf              | 158.6   |  |  |  |
| Saturation, %                 | 96.4    |  |  |  |
| Void ratio                    | 0.0862  |  |  |  |
| Specimen diameter, in.        | 1.98    |  |  |  |
| Specimen height, in.          | 4.14    |  |  |  |
| Height/diameter ratio         | 2.09    |  |  |  |

**Description:** Medium-hard dark gray shale.

|             |             |             |                         |                        |
|-------------|-------------|-------------|-------------------------|------------------------|
| <b>LL =</b> | <b>PL =</b> | <b>PI =</b> | <b>Assumed GS= 2.76</b> | <b>Type: Rock Core</b> |
|-------------|-------------|-------------|-------------------------|------------------------|

Project No.: 012-00946-300

Date: 6/3/06

Remarks:

**Client:**

**Project:** CUY-90 WEST A.  
Cleveland, Ohio

**Location:** B-05-15

**Sample Number:** S-48

**Depth:** 208.4' to 209.0'

UNCONFINED COMPRESSION TEST

**BBC&M Engineering, Inc.**

Figure 1

Tested By: CBP

Checked By: PJW

# UNCONFINED COMPRESSION TEST

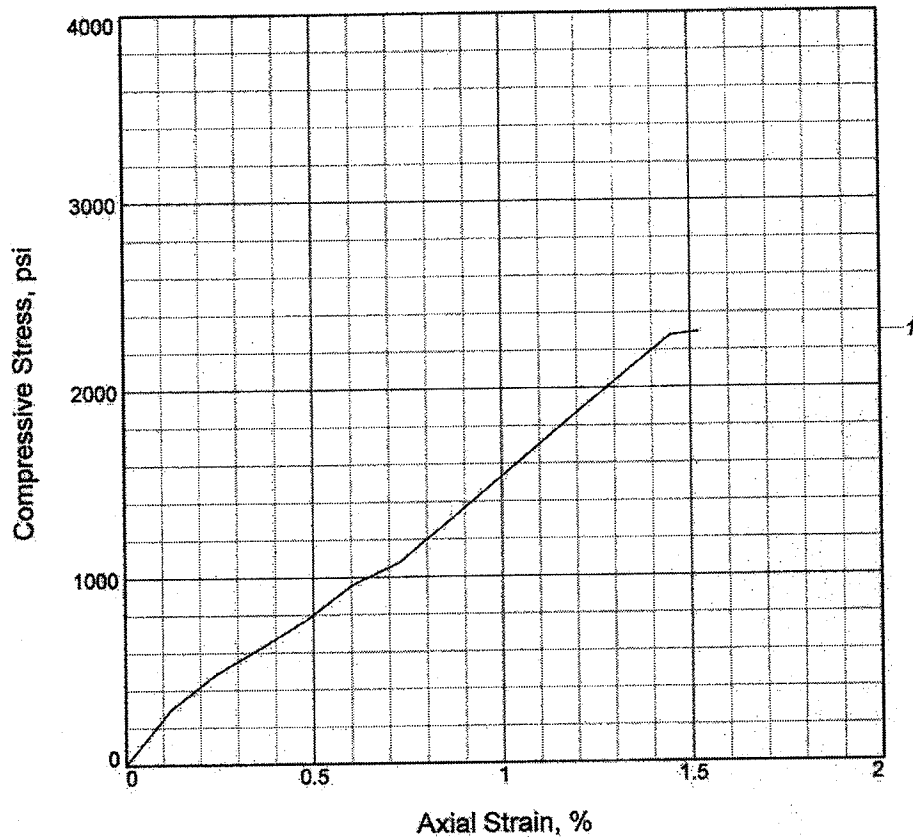

|                               |         |  |  |
|-------------------------------|---------|--|--|
| Sample No.                    | 1       |  |  |
| Unconfined strength, psi      | 2295.18 |  |  |
| Undrained shear strength, psi | 1147.59 |  |  |
| Failure strain, %             | 1.5     |  |  |
| Strain rate, in./min.         | 1.00    |  |  |
| Water content, %              | 3.1     |  |  |
| Wet density, pcf              | 163.1   |  |  |
| Dry density, pcf              | 158.3   |  |  |
| Saturation, %                 | 100.0   |  |  |
| Void ratio                    | 0.0848  |  |  |
| Specimen diameter, in.        | 1.96    |  |  |
| Specimen height, in.          | 4.14    |  |  |
| Height/diameter ratio         | 2.11    |  |  |

**Description:** Soft dark gray and gray shale, nearly horizontally bedded, many horizontal and few diagonal and vertical

LL =      PL =      PI =      Assumed GS= 2.75      Type: Rock Core

Project No.: 012 00946.300

Date: 6/14/06

Remarks:

Client: Michael Baker Inc.

Project: Cuy-90-15.24 West Abutment

Location: B-05-16

Sample Number: S-36      Depth: 163.5' - 163.8'

UNCONFINED COMPRESSION TEST

## BBC&M Engineering, Inc.

Figure \_\_\_\_\_

Tested By: RAK

Checked By: RAK



# UNCONFINED COMPRESSION TEST

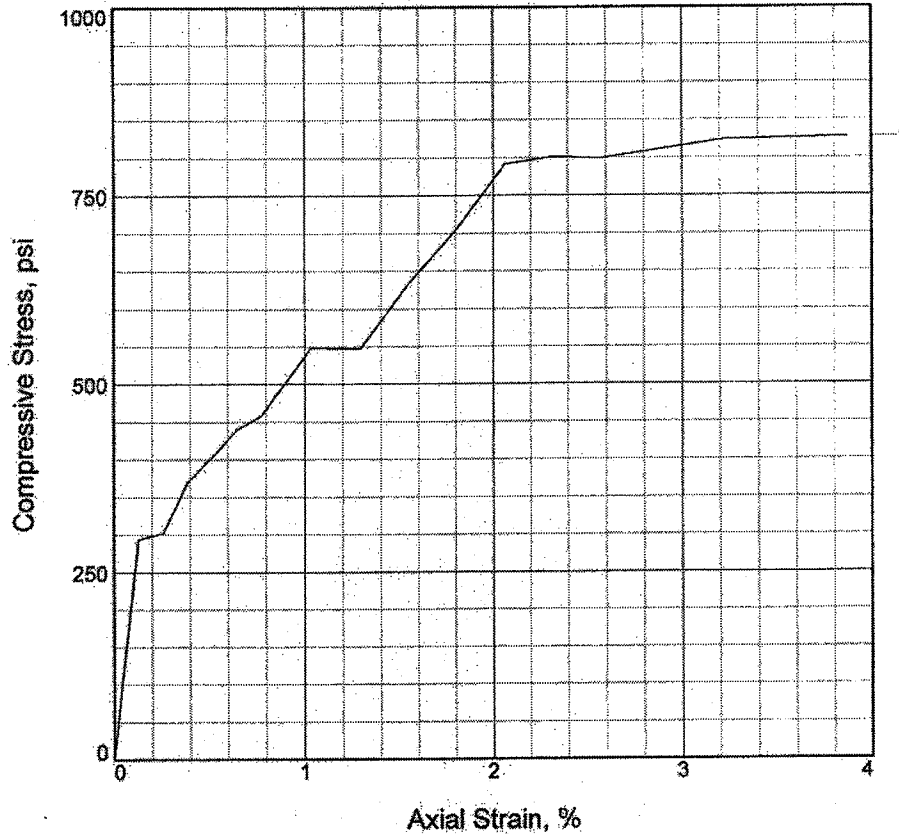

|                               |        |  |  |
|-------------------------------|--------|--|--|
| Sample No.                    | 1      |  |  |
| Unconfined strength, psi      | 827.76 |  |  |
| Undrained shear strength, psi | 413.88 |  |  |
| Failure strain, %             | 3.9    |  |  |
| Strain rate, in./min.         | 1.00   |  |  |
| Water content, %              | 0.0    |  |  |
| Wet density, pcf              | 161.8  |  |  |
| Dry density, pcf              | 161.8  |  |  |
| Saturation, %                 | 0.0    |  |  |
| Void ratio                    | 0.0223 |  |  |
| Specimen diameter, in.        | 2.03   |  |  |
| Specimen height, in.          | 3.88   |  |  |
| Height/diameter ratio         | 1.91   |  |  |

**Description:** Soft dark gray and gray shale, nearly horizontally bedded, many horizontal and few diagonal and vertical

**LL =**      **PL =**      **PI =**      **Assumed GS= 2.65**      **Type: Rock Core**

Project No.: 012 00946.300

Date: 5/20/06

Remarks:

**Client:** Michael Baker Inc.

**Project:** Cuy-90-15.24 West Abutment

**Location:** B-105A

**Sample Number:** S-34      **Depth:** 154.4' - 155.2'

UNCONFINED COMPRESSION TEST

**BBC&M Engineering, Inc.**

Figure \_\_\_\_\_

Tested By: RAK

Checked By: RAK

**Ackenheil Engineers, Inc.**  
**ASTM D3148 ROCK MODULUS TEST RESULTS**

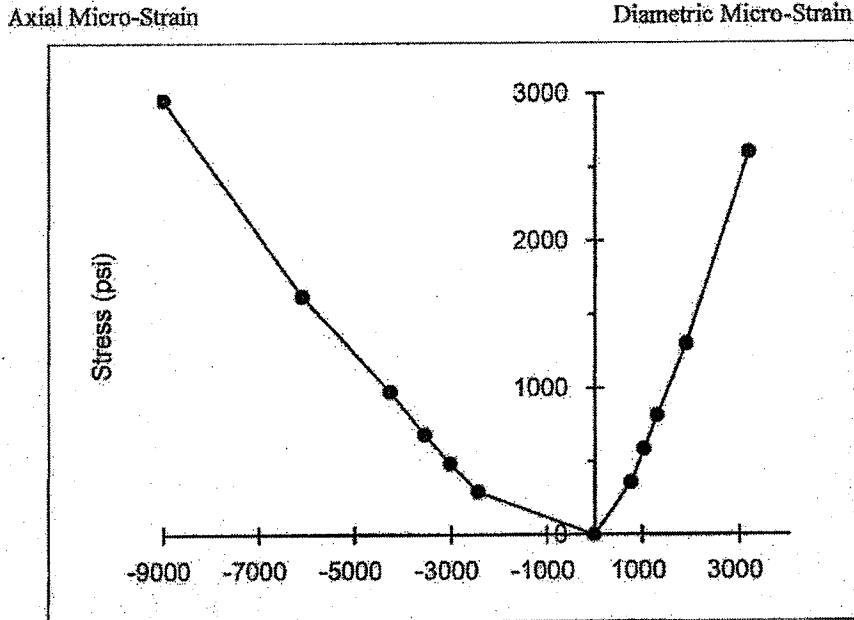

**PROJECT INFO**

CUY - 90, West Abutment

Project No. 04607

**SAMPLE AND TEST METHOD DATA**

**VALUE UNITS**

|  |                                       |
|--|---------------------------------------|
| Specimen Boring No.                            | B-05-13                               |
| Specimen Boring Inclination                    | Vertical                              |
| Specimen Depth                                 | 160.1-160.6 ft.                       |
| Specimen Description                           | SHALE, Dark Gray, Argillaceous, Silty |
| Specimen Received Date                         | 06/01/06 mo/dy/yr                     |
| Specimen Tested Date                           | 06/03/06 mo/dy/yr                     |
| Specimen Moisture (As Received, Dried ...)     | As Received                           |
| Specimen End Prep'n. Mthd. (Ground, Capped...) | Saw-cut, Capped                       |
| Diameter                                       | 1.98 in.                              |
| Height   | 4.63 in.                              |
| Aspect Ratio                                   | 2.34                                  |
| Test Duration (at failure)                     | 13.2 min.                             |
| Moist Unit Weight                              | 160 pcf                               |
| Moisture Content as Tested                     | 3.1 %                                 |

**TEST RESULTS**

|  |            |
|--|------------|
| Unconfined Compressive Strength                    | 2,955 psi  |
| Modulus of Deformation (tangent over linear range) | 26,052 tsf |
| Poisson Ratio (tangent over linear range)          | 0.39       |

**NOTES**

1) Micro-Strain is the change of length divided by the length reported as millionths inch per inch.

Ackenheil Engineers, Inc.  
ASTM D3148 ROCK MODULUS TEST RESULTS

SKETCH  
OF  
FAILURE

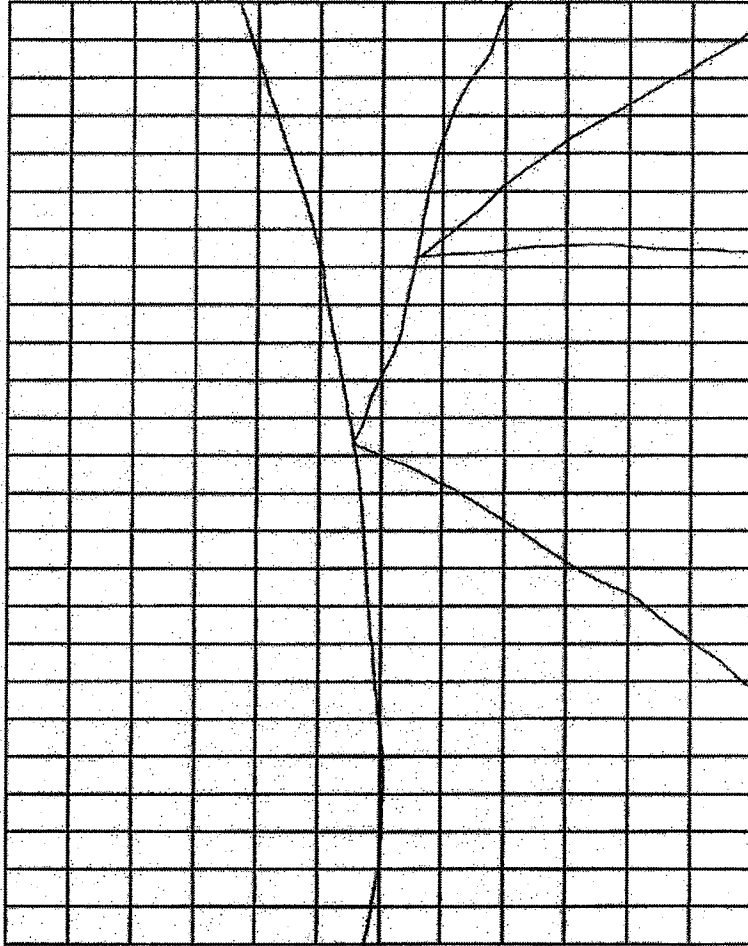

PROJECT INFO

CUY - 90, West Abutment

Project No. 04607

SAMPLE AND TEST METHOD DATA

Specimen Boring No.

Specimen Boring Inclination

Specimen Depth

Specimen Description

VALUE UNITS

B-05-13

Vertical

160.1-160.6 ft.

SHALE, Dark Gray, Argillaceous, Silty

**Ackenheil Engineers, Inc.**  
**ASTM D3148 ROCK MODULUS TEST RESULTS**

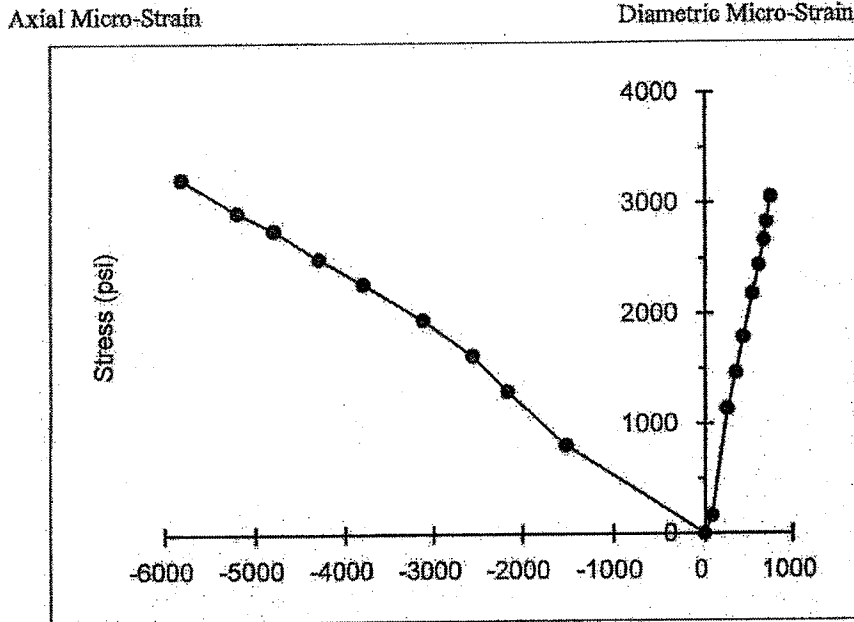

**PROJECT INFO**

CUY - 90, West Abutment

Project No. 04607

**SAMPLE AND TEST METHOD DATA**

Specimen Boring No.  
 Specimen Boring Inclination  
 Specimen Depth  
 Specimen Description

**VALUE UNITS**

B-05-14  
 Vertical  
 190.5-191.0 ft.

SHALE, Dark Gray, Argillaceous, Silty

Specimen Received Date  
 Specimen Tested Date  
 Specimen Moisture (As Received, Dried ...)  
 Specimen End Prep'n. Mthd. (Ground, Capped...)  
 Diameter  
 Height  
 Aspect Ratio  
 Test Duration (at failure)  
 Moist Unit Weight  
 Moisture Content as Tested

06/01/06 mo/dy/yr  
 06/03/06 mo/dy/yr  
 As Received  
 Saw-cut, Capped  
 1.98 in.  
 4.90 in.  
 2.47  
 15.0 min.  
 167 pcf  
 3.1 %

**TEST RESULTS**

Unconfined Compressive Strength  
 Modulus of Deformation (tangent over linear range)  
 Poisson Ratio (tangent over linear range)

3,228 psi  
 35,430 tsf  
 0.13

**NOTES**

1) Micro-Strain is the change of length divided by the length reported as millionths inch per inch.

Ackenheil Engineers, Inc.  
ASTM D3148 ROCK MODULUS TEST RESULTS

SKETCH  
OF  
FAILURE

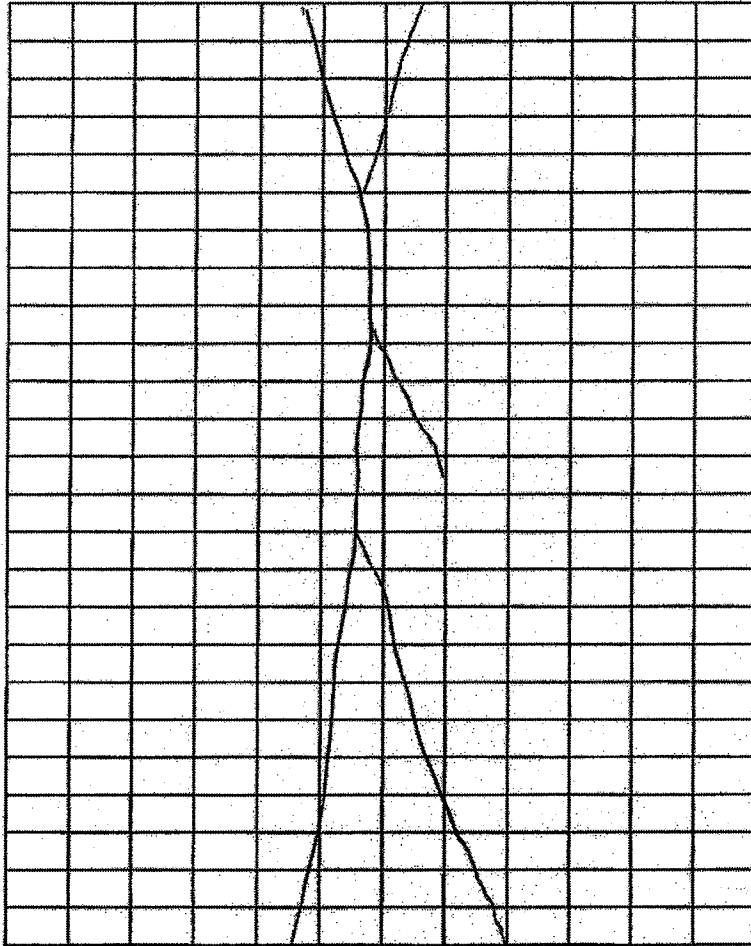

PROJECT INFO

CUY - 90, West Abutment

Project No. 04607

SAMPLE AND TEST METHOD DATA

Specimen Boring No.  
Specimen Boring Inclination  
Specimen Depth  
Specimen Description

VALUE UNITS

B-05-14  
Vertical  
190.5-191.0 ft.  
SHALE, Dark Gray, Argillaceous, Silty

**Ackenheil Engineers, Inc.**  
**ASTM D3148 ROCK MODULUS TEST RESULTS**

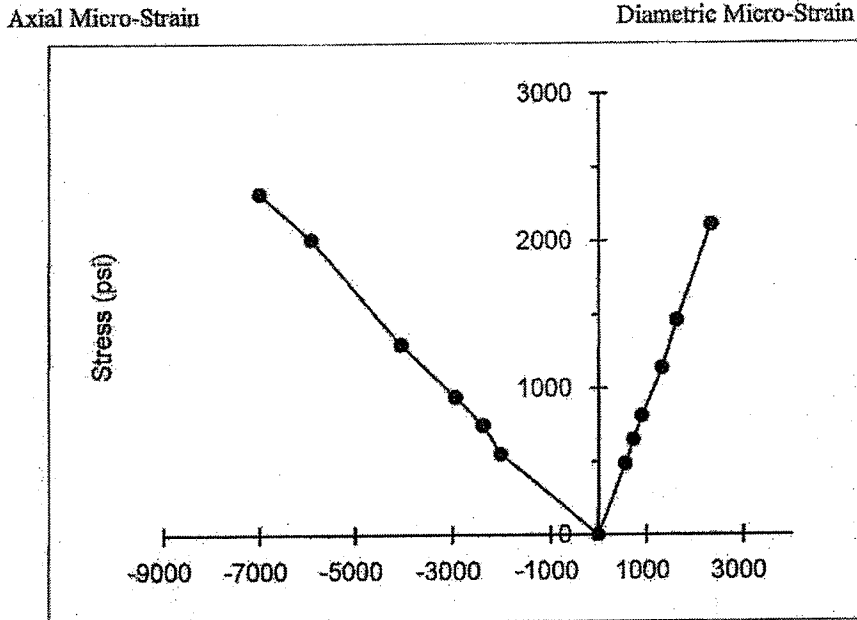

**PROJECT INFO**

CUY - 90, West Abutment

Project No. 04607

**SAMPLE AND TEST METHOD DATA**

**VALUE UNITS**

|  |                                       |
|--|---------------------------------------|
| Specimen Boring No.                            | B-05-15                               |
| Specimen Boring Inclination                    | Vertical                              |
| Specimen Depth                                 | 213.1-213.6 ft.                       |
| Specimen Description                           | SHALE, Dark Gray, Argillaceous, Silty |
| Specimen Received Date                         | 06/01/06 mo/dy/yr                     |
| Specimen Tested Date                           | 06/03/06 mo/dy/yr                     |
| Specimen Moisture (As Received, Dried ...)     | As Received                           |
| Specimen End Prep'n. Mthd. (Ground, Capped...) | Saw-cut, Capped                       |
| Diameter                                       | 1.98 in.                              |
| Height   | 4.09 in.                              |
| Aspect Ratio                                   | 2.07                                  |
| Test Duration (at failure)                     | 14.6 min.                             |
| Moist Unit Weight                              | 163 pcf                               |
| Moisture Content as Tested                     | 2.4 %                                 |

**TEST RESULTS**

|  |            |
|--|------------|
| Unconfined Compressive Strength                    | 2,322 psi  |
| Modulus of Deformation (tangent over linear range) | 26,442 tsf |
| Poisson Ratio (tangent over linear range)          | 0.40       |

**NOTES**

1) Micro-Strain is the change of length divided by the length reported as millionths inch per inch.

Ackenheil Engineers, Inc.  
ASTM D3148 ROCK MODULUS TEST RESULTS

SKETCH  
OF  
FAILURE

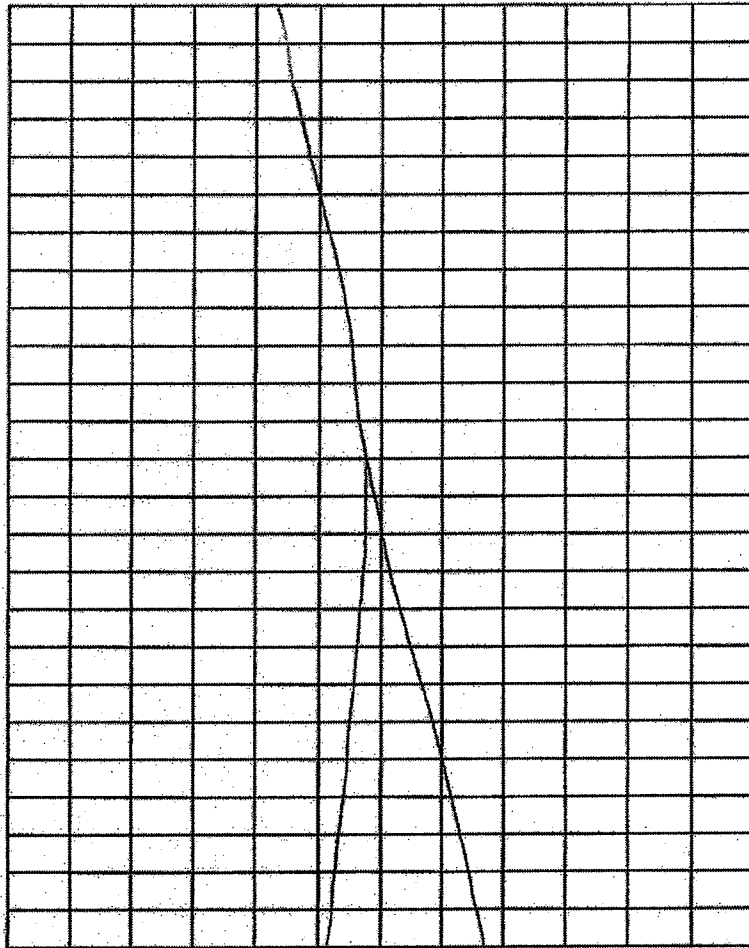

PROJECT INFO

CUY - 90, West Abutment

Project No. 04607

SAMPLE AND TEST METHOD DATA

Specimen Boring No.

Specimen Boring Inclination

Specimen Depth

Specimen Description

VALUE UNITS

B-05-15

Vertical

213.1-213.6 ft.

SHALE, Dark Gray, Argillaceous, Silty

**APPENDIX 4H**  
**GTX 2009 LABORATORY TESTING REPORT**



1145 Massachusetts Avenue  
 Boxborough, MA 01719  
 978 635 0424 Tel  
 978 635 0266 Fax

# Transmittal

TO:

Dr. W. Allen Marr

Geocomp Consulting, Inc.

1145 Massachusetts Ave

Boxborough, MA 01719

|                         |              |
|-------------------------|--------------|
| DATE: 9/16/2009         | GTX NO: 9236 |
| RE: I-90 Bridge Project |              |
|                         |              |

| COPIES | DATE      | DESCRIPTION                           |
|--------|-----------|---------------------------------------|
|        | 9/16/2009 | September 2009 Laboratory Test Report |
|        |           |                                       |
|        |           |                                       |
|        |           |                                       |

REMARKS:

---



---



---

CC:

SIGNED:

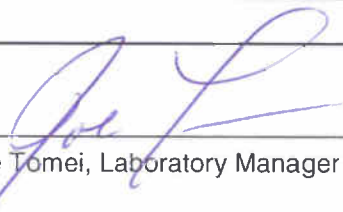
  
 Joe Tomei, Laboratory Manager

APPROVED BY:

  
 Nancy Hubbard, Project Manager

September 16, 2009

Dr. W. Allen Marr  
Geocomp Consulting Inc.  
1145 Massachusetts Ave  
Boxborough, MA 01719

RE: I-90 Bridge Project, OH (GTX-9236)

Dear Allen Marr:

Enclosed are the test results you requested for the above referenced project. GeoTesting Express, Inc. (GTX) received four samples from you on August 12, 2009. These samples were labeled as follows:

B-037-1 S-21 (64-66 ft)  
B-037-1 S-22 (66-68 ft)  
B-037-1 S-24 (70-72 ft)  
B-037-1 S-25 (72-74 ft)

GTX performed the following test on each of these samples:

US COE EM 1110 - Residual Shear (3-point test series)

The initial shear rate used for each series was determined using the consolidation data from the test point at the highest vertical consolidation stress. This rate was used for the first 0.25 inches of horizontal displacement. The following three shear loops were then run at a shear rate 10 times faster. Any subsequent shear loops were then run at the initial shear rate.

The results presented in this report apply only to the items tested. This report shall not be reproduced except in full, without written approval from GeoTesting Express. The remainder of these samples will be retained for a period of sixty (60) days and will then be discarded unless otherwise notified by you. Please call me if you have any questions or require additional information. Thank you for allowing GeoTesting Express the opportunity of providing you with testing services. We look forward to working with you again in the future.

Respectfully yours,



Joe Tomei  
Laboratory Manager



a subsidiary of Geocomp Corporation

1145 Massachusetts Avenue

Boxborough, MA 01719

978 635 0424 Tel

978 635 0266 Fax

---

## **Geotechnical Test Report**

**9/16/2009**

---

# **GTX-9236**

# **I-90 Bridge Project**

**OH**

Prepared for:

**Geocomp Consulting Inc.**

---

|                   |   |             |     |
|-------------------|---|-------------|-----|
| Client:           | Geocomp Consulting  |             |     |
| Project Name:     | I-90 Bridge   |             |     |
| Project Location: | OH  |             |     |
| GTX #:            | 9236  | Tested By:  | md  |
| Test Date:        | 08/19/09  | Checked By: | jdt |
| Boring ID:        | B-037-1   |             |     |
| Sample ID:        | S-21  |             |     |
| Depth, ft.        | 64-66   |             |     |
| Description:      | Moist, brown clay with sand lenses  |             |     |
| Preparation:      | Extruded from tube, cut and trimmed and tested at the as-received moisture and density. |             |     |

## Residual Shear by USACOE EM1110

| Parameter                                | Point 1 | Point 2 | Point 3 |
|--|---------|---------|---------|
| Test No.                                 | RS-1    | RS-2    | RS-3A   |
| Initial Moisture Content, %              | 21.3    | 28.9    | 27.1    |
| Initial Dry Density, pcf                 | 104     | 94.5    | 95.8    |
| Nominal Rate of Shear Strain, inches/min | 0.0005  | 0.0005  | 0.0005  |
| Vertical Consolidation Stress, psf       | 2346    | 4691    | 5864    |
| Peak Shear Stress, psf                   | 1441    | 2159    | 2335    |
| Post-Peak Shear Stress, psf              | 1241    | 1528    | 1696    |
| Final Moisture Content, %                | 22.9    | 28.0    | 27.1    |

|                           |       |         |
|---------------------------|-------|---------|
| Peak Friction Angle:      | 14.7  | degrees |
| Peak Cohesion:            | 854.2 | psf     |
| Post Peak Friction Angle: | 17.9  | degrees |
| Post Peak Cohesion:       | 0.0   | psi     |

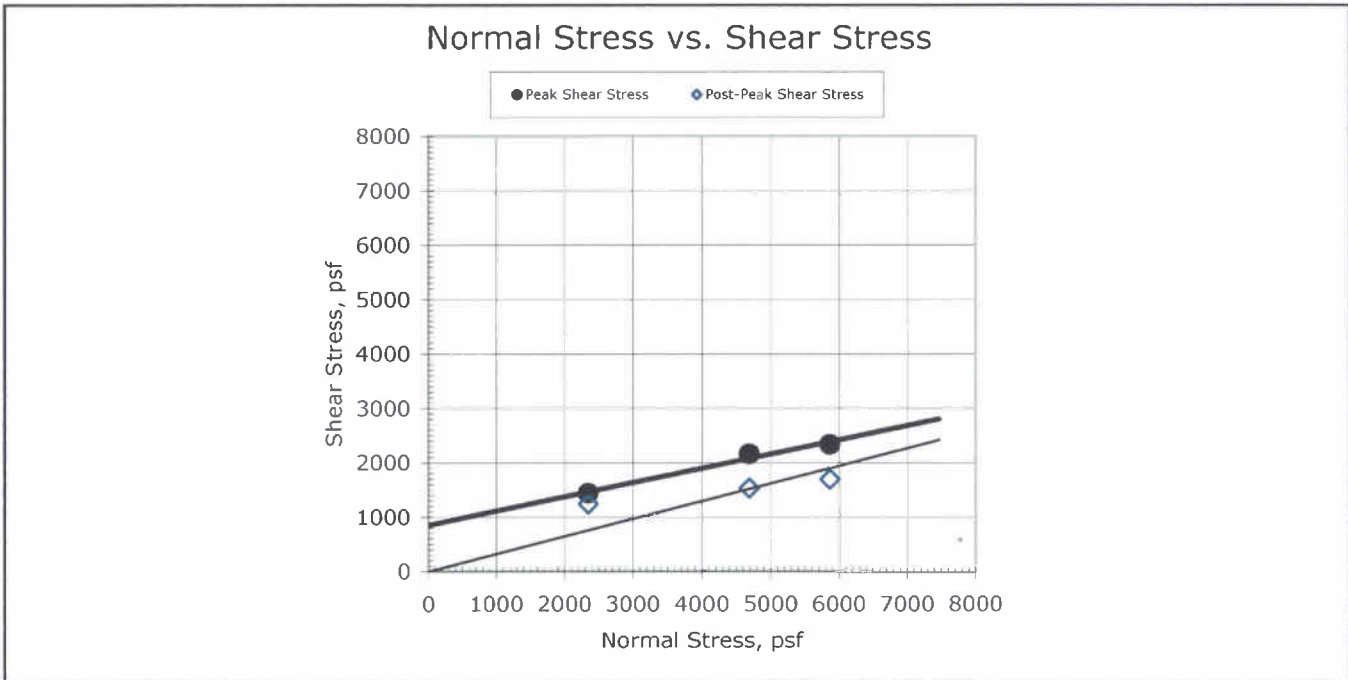

Comments: See attached plots for additional information

## RESIDUAL SHEAR TEST

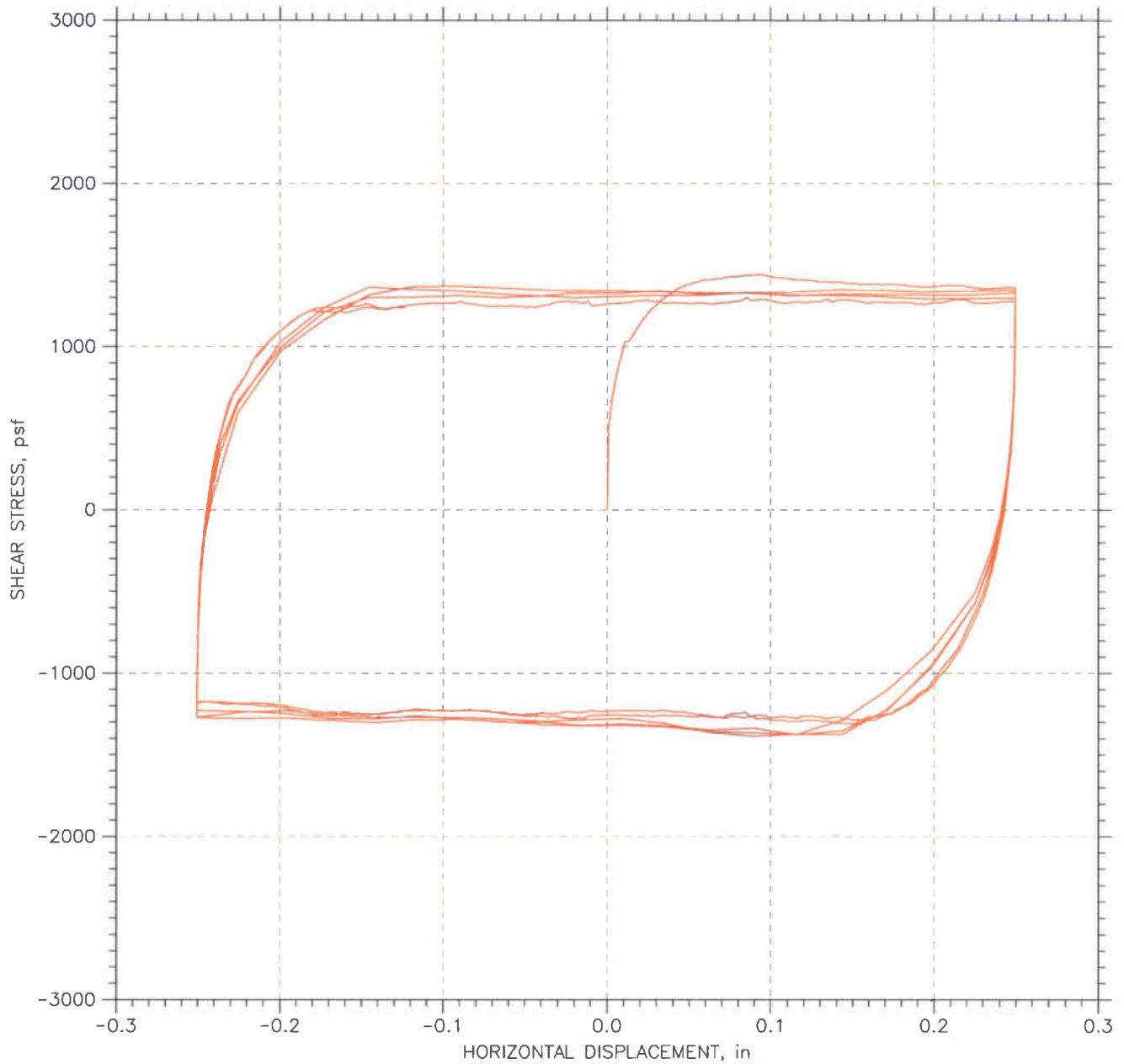

|  |                     |                       |
|--|---------------------|-----------------------|
| Project: I-90 Bridge                               | Location: OH        | Project No.: GTX-9236 |
| Boring No.: B-037-1                                | Tested By: md       | Checked By: jdt       |
| Sample No.: S-21                                   | Test Date: 08/25/09 | Depth: 64-66          |
| Test No.: RS-1                                     | Sample Type: tube   | Elevation: ---        |
| Description: Moist, brown clay with sand lenses    |                     |                       |
| Remarks: System H                                  |                     |                       |
| File: \\Geocompdb1\Projects\GTX9236\9236-RS-1n.dat |                     |                       |

## RESIDUAL SHEAR TEST

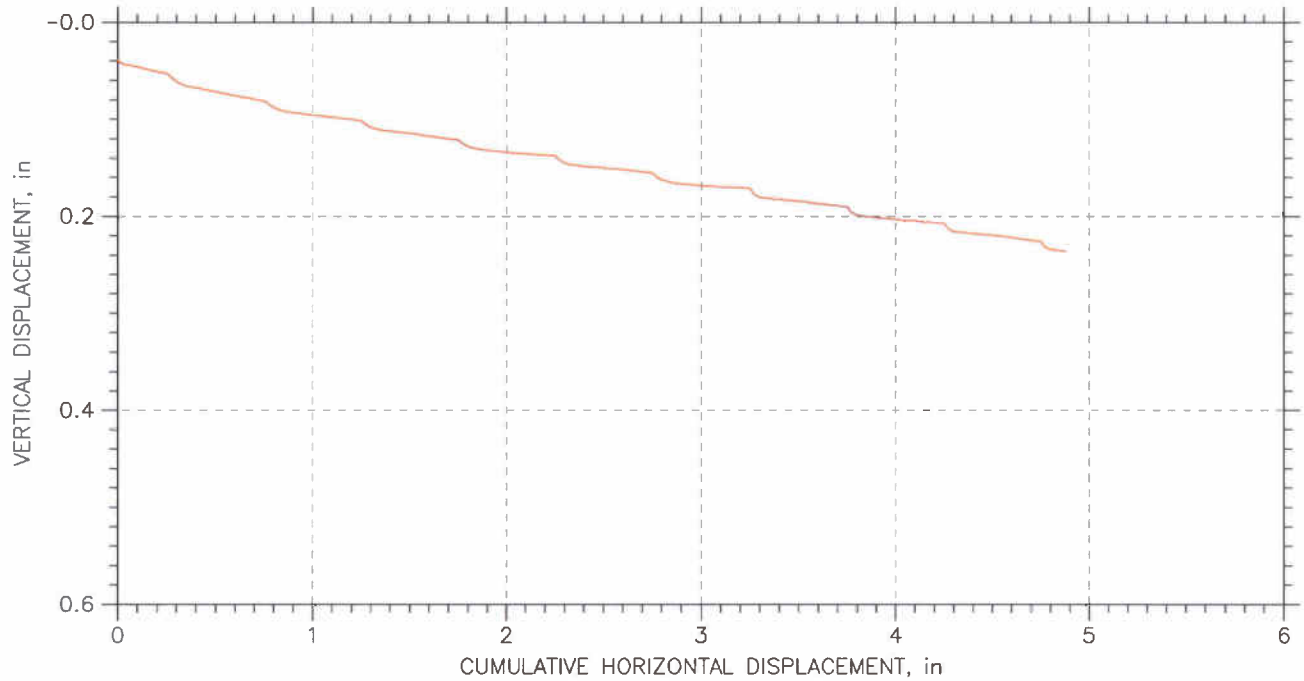
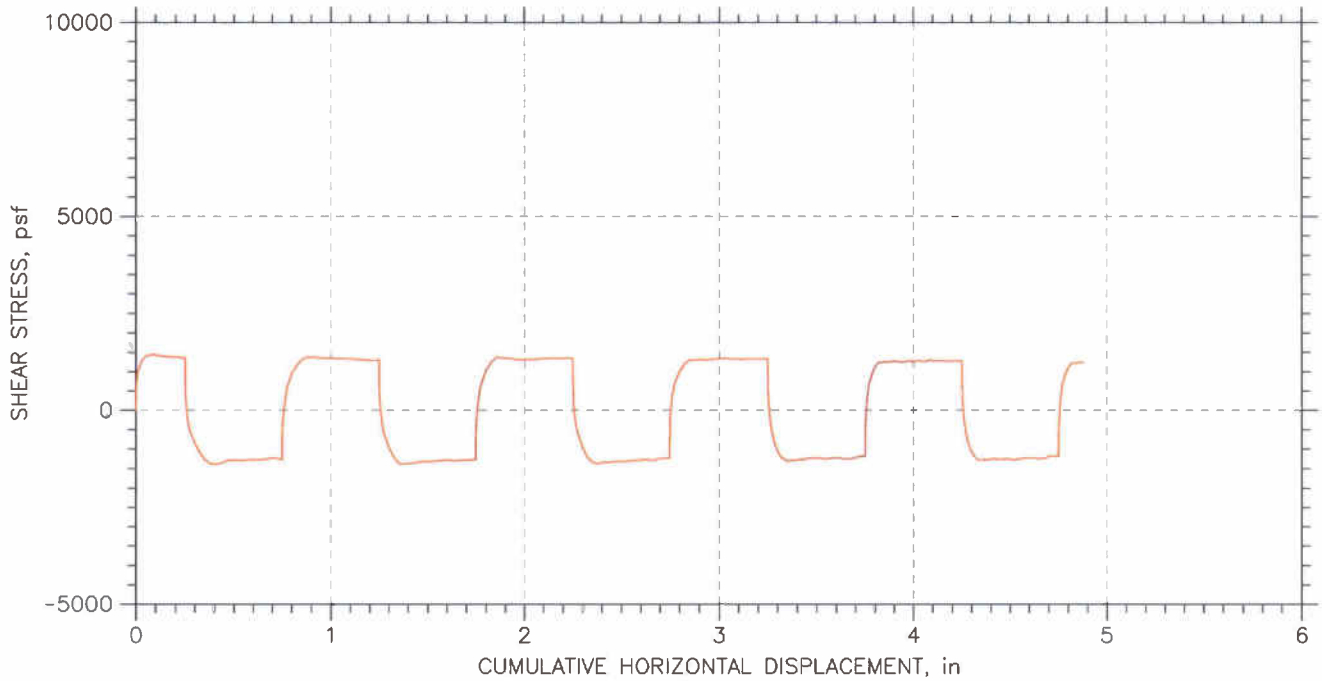

|  |                     |                       |
|--|---------------------|-----------------------|
| Project: I-90 Bridge                               | Location: OH        | Project No.: GTX-9236 |
| Boring No.: B-037-1                                | Tested By: md       | Checked By: jdt       |
| Sample No.: S-21                                   | Test Date: 08/25/09 | Depth: 64-66          |
| Test No.: RS-1                                     | Sample Type: tube   | Elevation: ---        |
| Description: Moist, brown clay with sand lenses    |                     |                       |
| Remarks: System H                                  |                     |                       |
| File: \\Geocompdb1\Projects\GTX9236\9236-RS-1n.dat |                     |                       |

## RESIDUAL SHEAR TEST

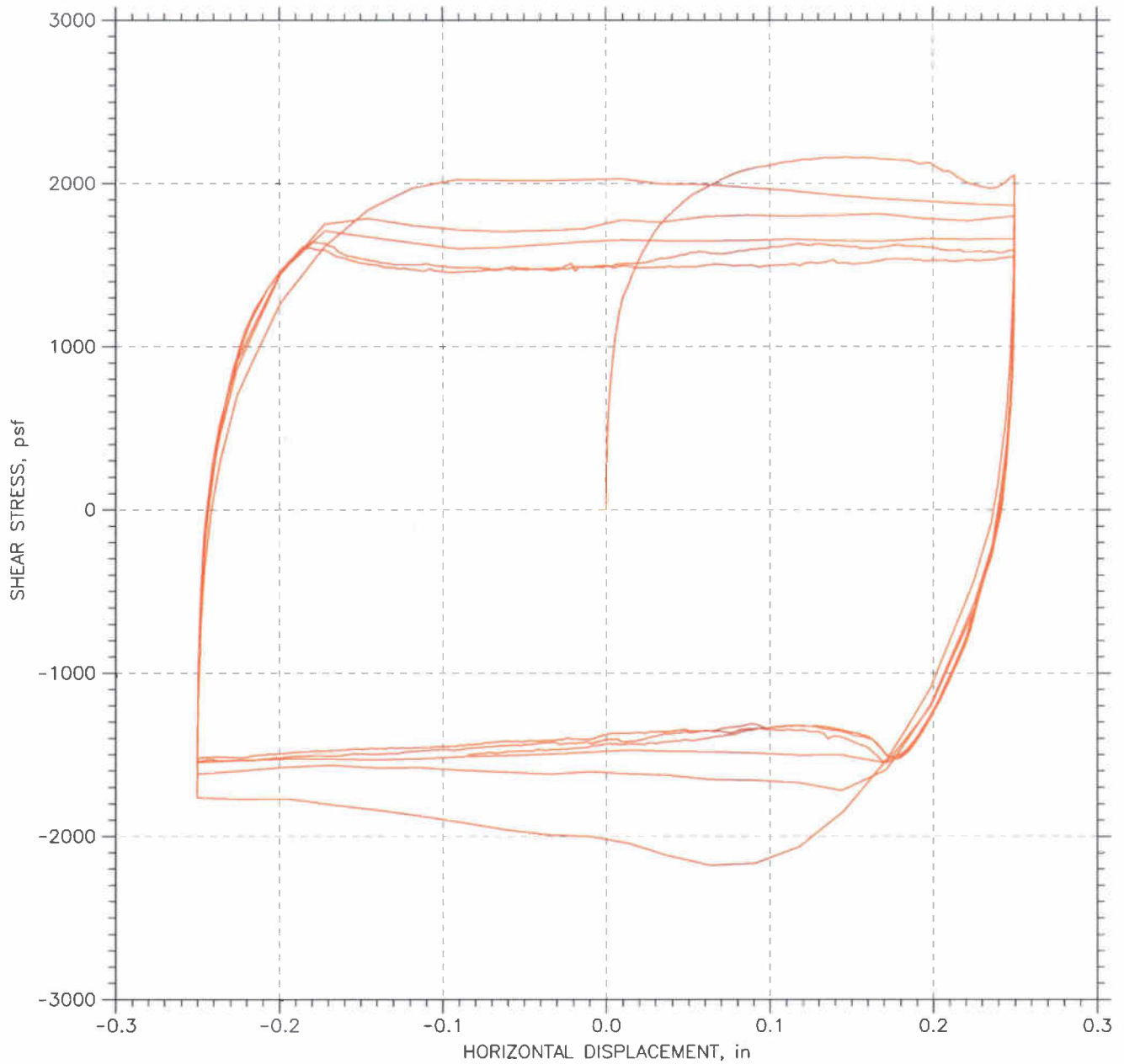

|  |                     |                       |
|--|---------------------|-----------------------|
| Project: I-90 Bridge                               | Location: OH        | Project No.: GTX-9236 |
| Boring No.: B-037-1                                | Tested By: md       | Checked By: jdt       |
| Sample No.: S-21                                   | Test Date: 08/21/09 | Depth: 64-66          |
| Test No.: RS-2                                     | Sample Type: tube   | Elevation: ---        |
| Description: Moist, brown clay with sand lenses    |                     |                       |
| Remarks: System H                                  |                     |                       |
| File: \\Geocompdb1\Projects\GTX9236\9236-RS-2n.dat |                     |                       |

## RESIDUAL SHEAR TEST

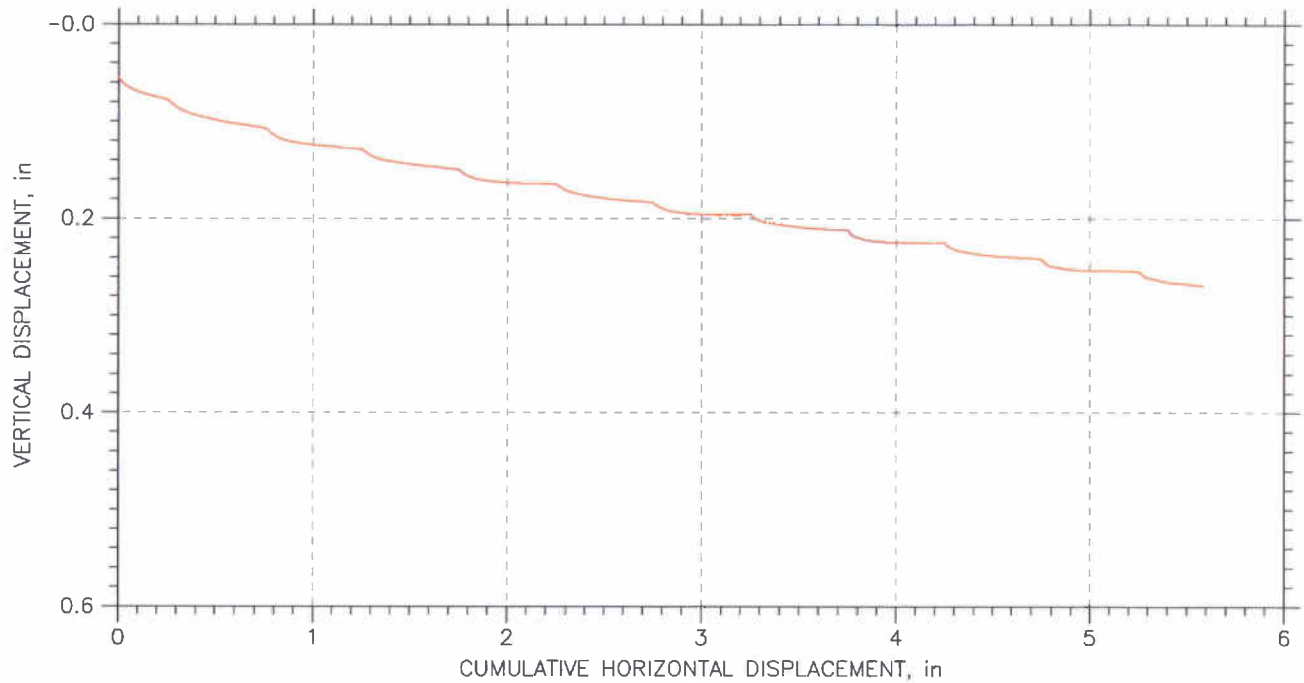
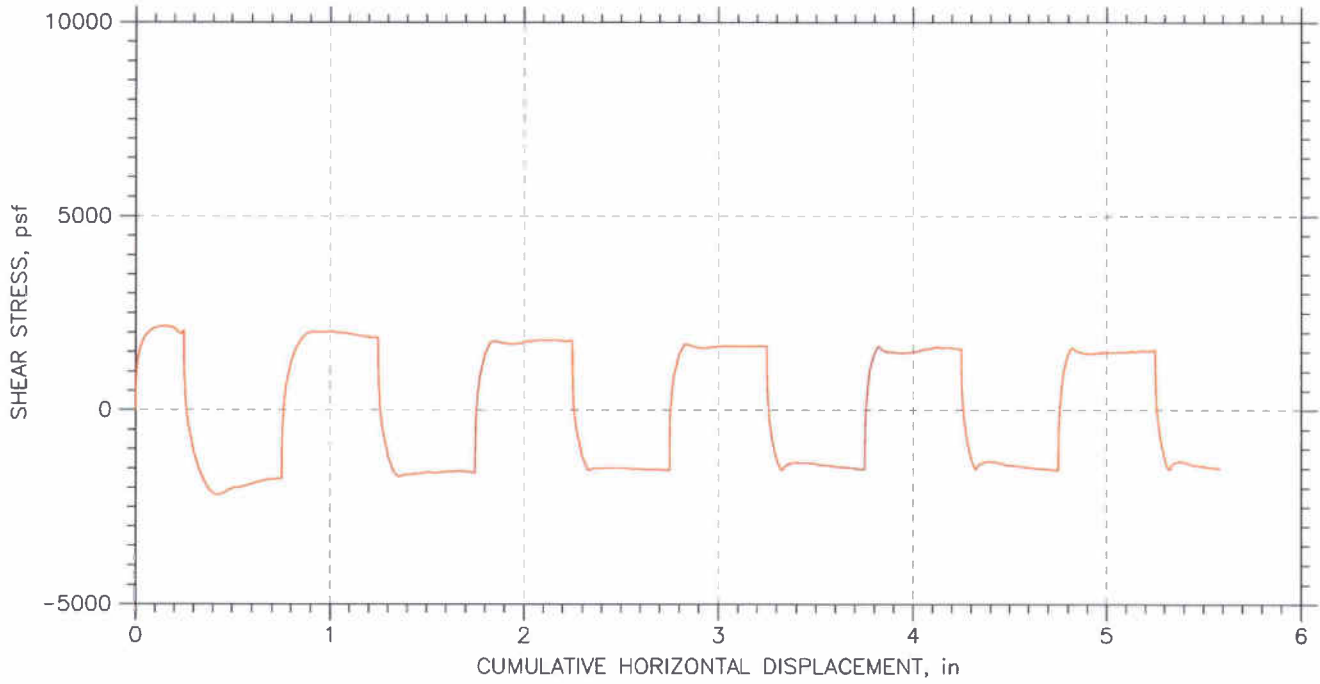

|   |                     |                       |
|---|---------------------|-----------------------|
| Project: I-90 Bridge                              | Location: OH        | Project No.: GTX-9236 |
| Boring No.: B-037-1                               | Tested By: md       | Checked By: jdt       |
| Sample No.: S-21                                  | Test Date: 08/21/09 | Depth: 64-66          |
| Test No.: RS-2                                    | Sample Type: tube   | Elevation: ---        |
| Description: Moist, brown clay with sand lenses   |                     |                       |
| Remarks: System H                                 |                     |                       |
| File: \\Geocompb1\Projects\GTX9236\9236-RS-2n.dat |                     |                       |



## RESIDUAL SHEAR TEST

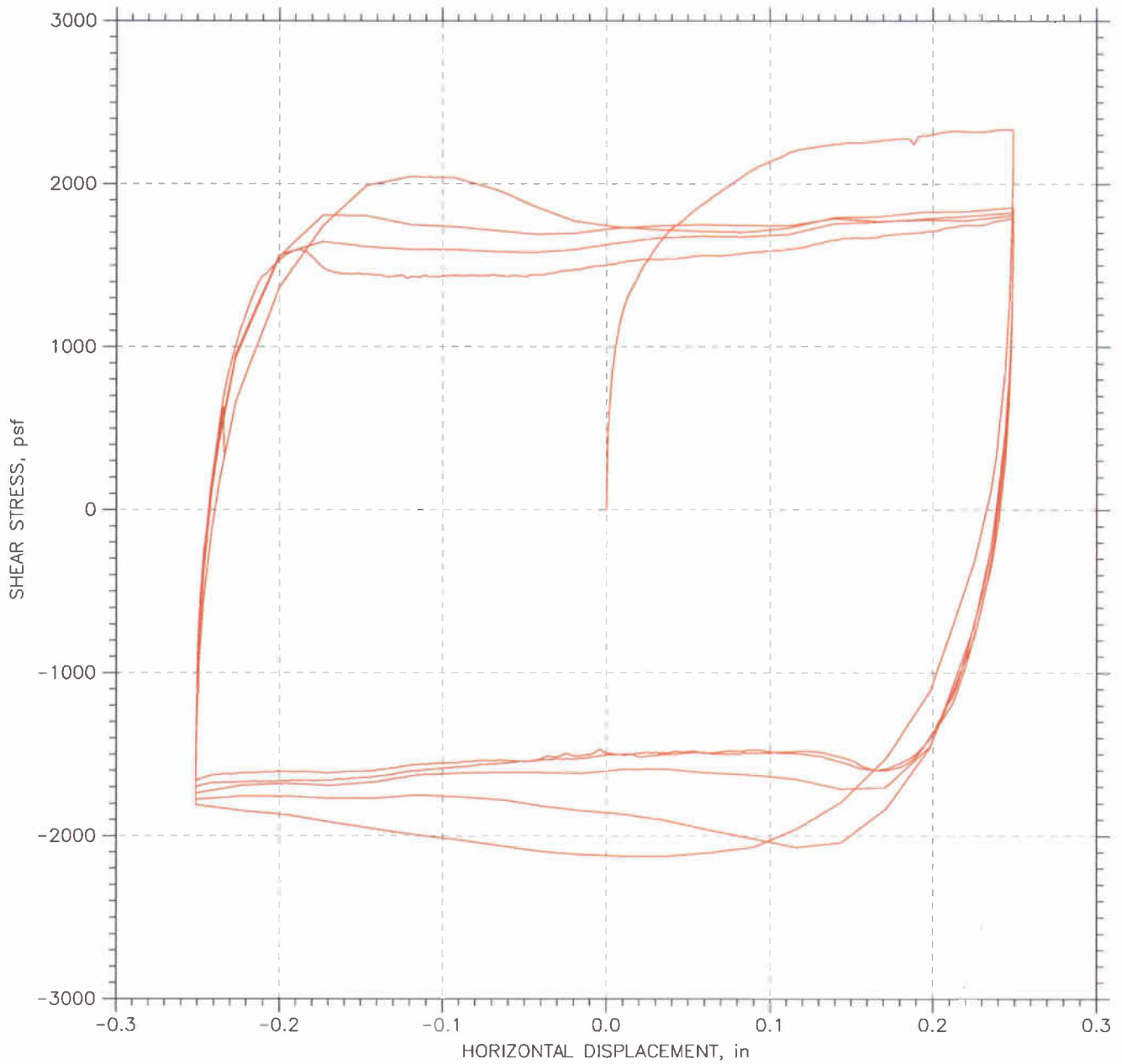

|   |                     |                       |
|---|---------------------|-----------------------|
| Project: I-90 Bridge                                | Location: OH        | Project No.: GTX-9236 |
| Boring No.: B-037-1                                 | Tested By: md       | Checked By: jdt       |
| Sample No.: S-21                                    | Test Date: 09/01/09 | Depth: 64-66 ft       |
| Test No.: RS-3A                                     | Sample Type: tube   | Elevation: ---        |
| Description: Moist, brown clay with sand lenses     |                     |                       |
| Remarks: System H                                   |                     |                       |
| File: \\Geocompdb1\Projects\GTX9236\9236-RS-3An.dat |                     |                       |

## RESIDUAL SHEAR TEST

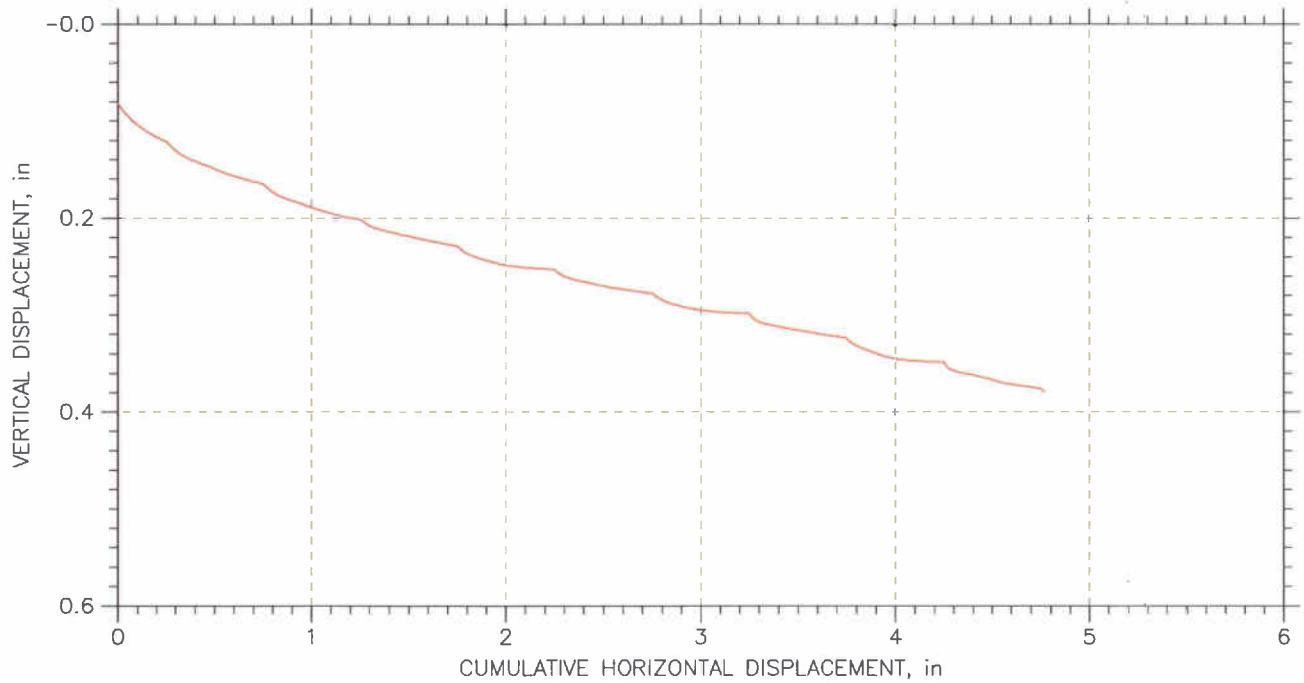
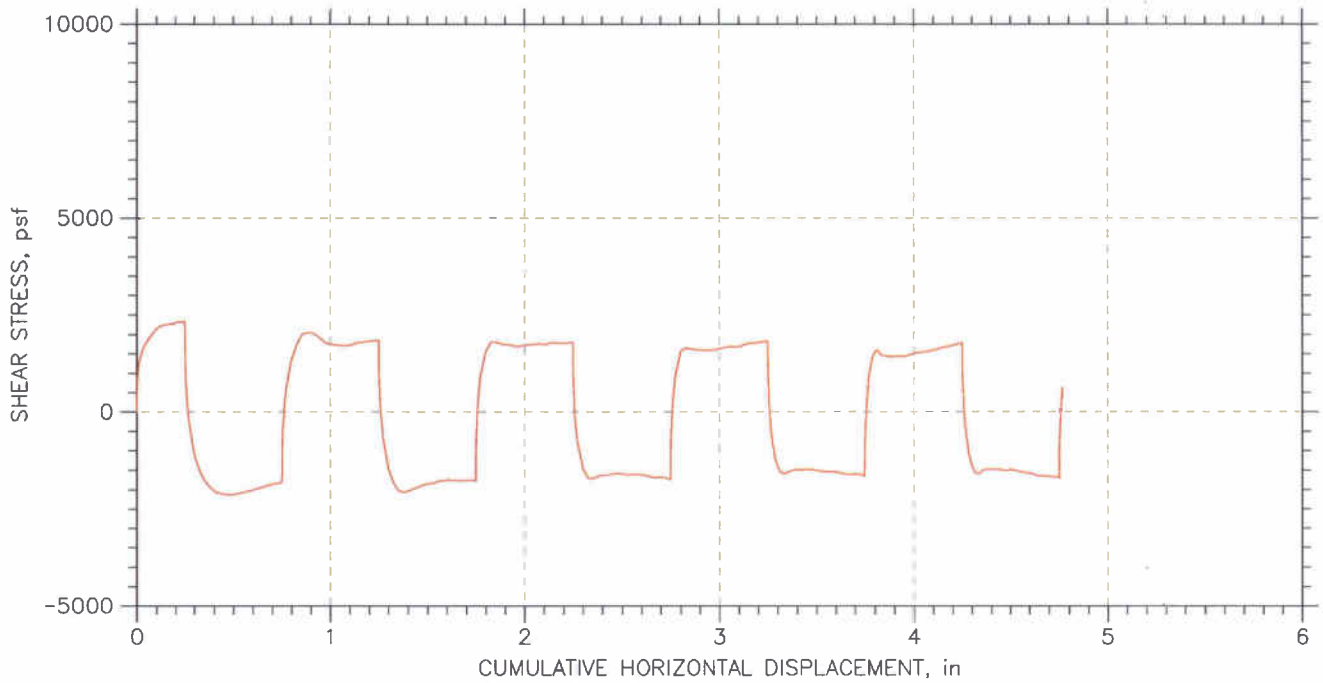

|   |                     |                       |
|---|---------------------|-----------------------|
| Project: I-90 Bridge                                | Location: OH        | Project No.: GTX-9236 |
| Boring No.: B-037-1                                 | Tested By: md       | Checked By: jdt       |
| Sample No.: S-21                                    | Test Date: 09/01/09 | Depth: 64-66 ft       |
| Test No.: RS-3A                                     | Sample Type: tube   | Elevation: ---        |
| Description: Moist, brown clay with sand lenses     |                     |                       |
| Remarks: System H                                   |                     |                       |
| File: \\Geocompdb1\Projects\GTX9236\9236-RS-3An.dat |                     |                       |

|                   |   |             |     |
|-------------------|---|-------------|-----|
| Client:           | Geocomp Consulting  |             |     |
| Project Name:     | I-90 Bridge   |             |     |
| Project Location: | OH  |             |     |
| GTX #:            | 9236  | Tested By:  | md  |
| Test Date:        | 08/19/09  | Checked By: | jdt |
| Boring ID:        | B-037-1   |             |     |
| Sample ID:        | S-22  |             |     |
| Depth, ft.        | 66-68   |             |     |
| Description:      | Moist, brown clay with sand lenses  |             |     |
| Preparation:      | Extruded from tube, cut and trimmed and tested at the as-received moisture and density. |             |     |

## Residual Shear by USACOE EM1110

| Parameter                                | Point 1 | Point 2 | Point 3 |
|--|---------|---------|---------|
| Test No.                                 | RS-4    | RS-5    | RS-6    |
| Initial Moisture Content, %              | 27.9    | 24.8    | 22.1    |
| Initial Dry Density, pcf                 | 95.8    | 100.0   | 101.0   |
| Nominal Rate of Shear Strain, inches/min | 0.0008  | 0.0008  | 0.0008  |
| Vertical Consolidation Stress, psf       | 2408    | 4816    | 6020    |
| Peak Shear Stress, psf                   | 1356    | 2399    | 3079    |
| Post-Peak Shear Stress, psf              | 960     | 1770    | 2007    |
| Final Moisture Content, %                | 30.8    | 25.5    | 25.5    |

|                           |       |         |
|---------------------------|-------|---------|
| Peak Friction Angle:      | 25.2  | degrees |
| Peak Cohesion:            | 199.8 | psf     |
| Post Peak Friction Angle: | 19.4  | degrees |
| Post Peak Cohesion:       | 0.0   | psi     |

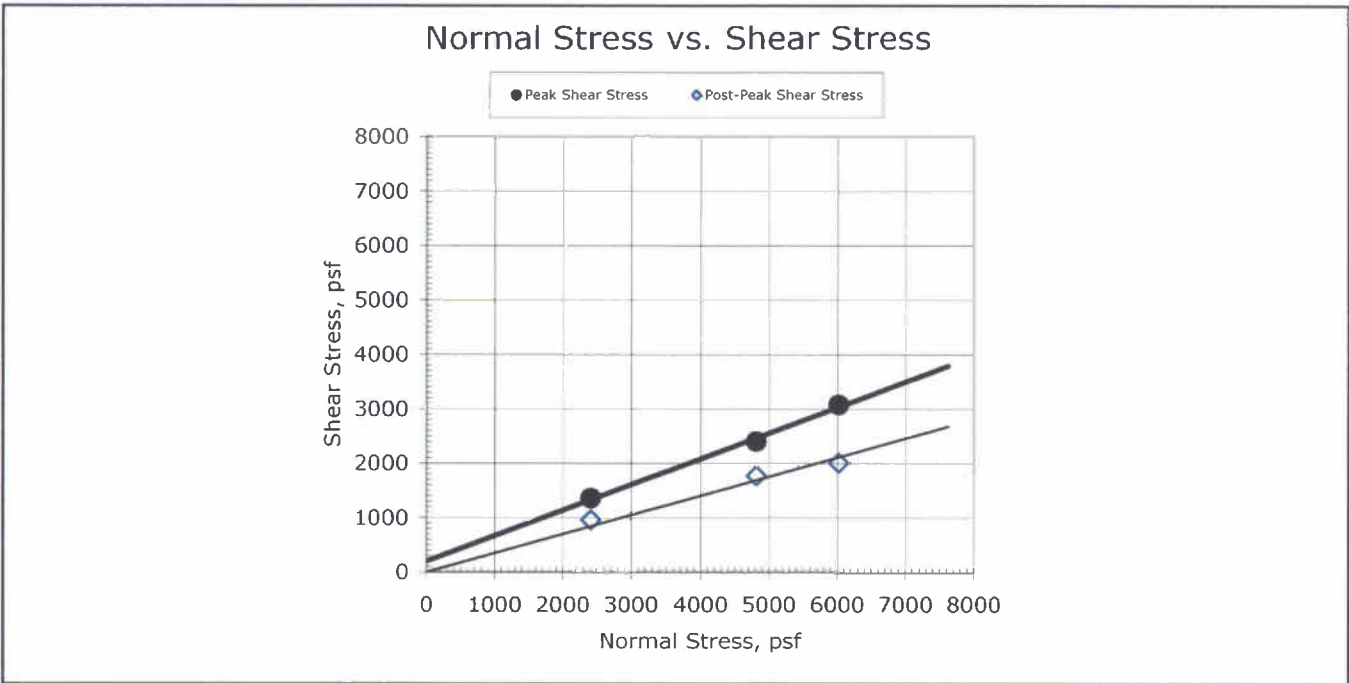

Comments: See attached plots for additional information

## RESIDUAL SHEAR TEST

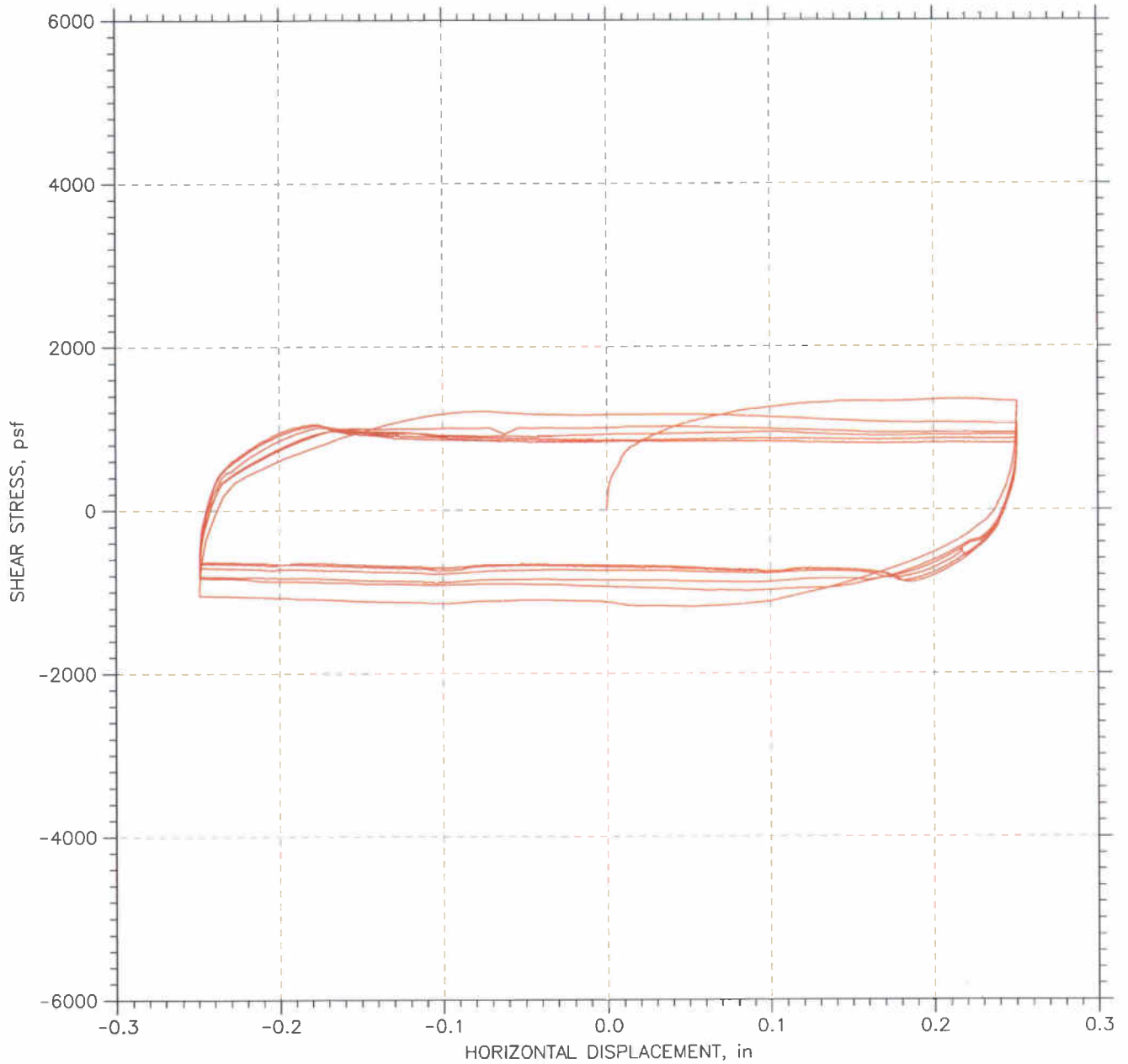

|  |                     |                       |
|--|---------------------|-----------------------|
| Project: I-90 Bridge                               | Location: OH        | Project No.: GTX-9236 |
| Boring No.: B-037-1                                | Tested By: md       | Checked By: jdt       |
| Sample No.: S-22                                   | Test Date: 08/28/09 | Depth: 66-68 ft       |
| Test No.: RS-4                                     | Sample Type: tube   | Elevation: ---        |
| Description: Moist, brown clay with sand lenses    |                     |                       |
| Remarks: System J                                  |                     |                       |
| File: \\Geocompdb1\Projects\GTX9236\9236-RS-4n.dat |                     |                       |

## RESIDUAL SHEAR TEST

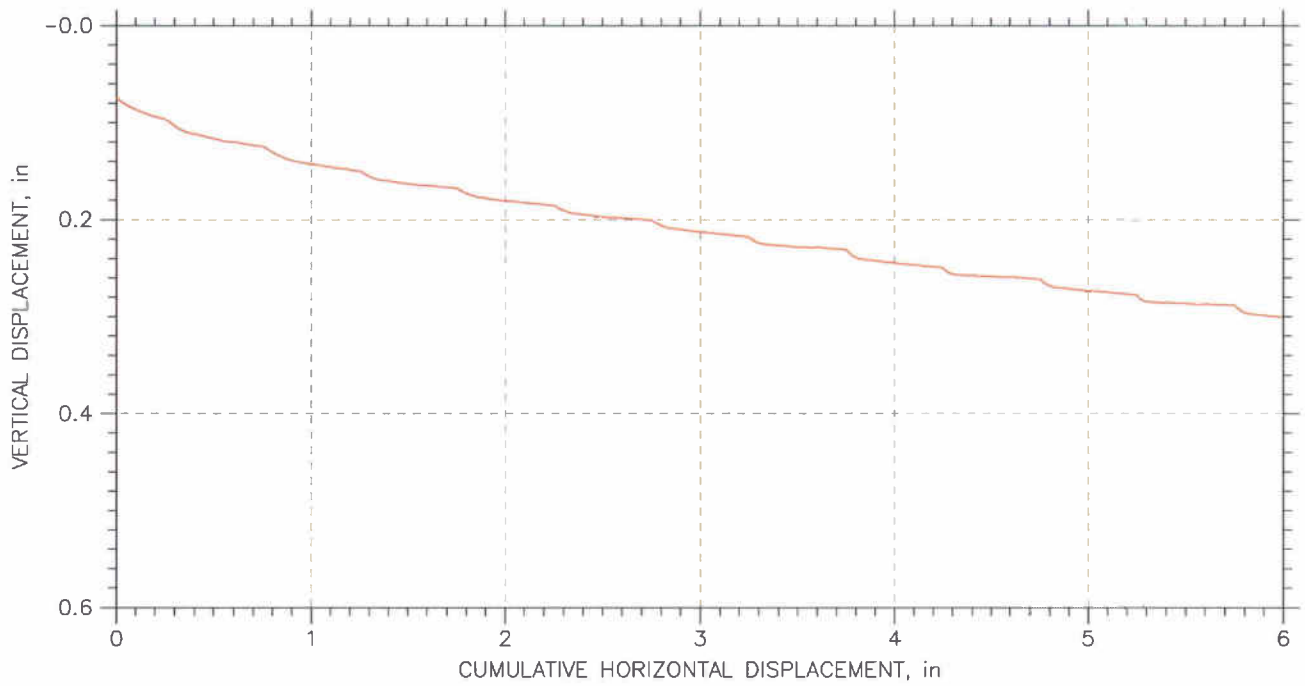
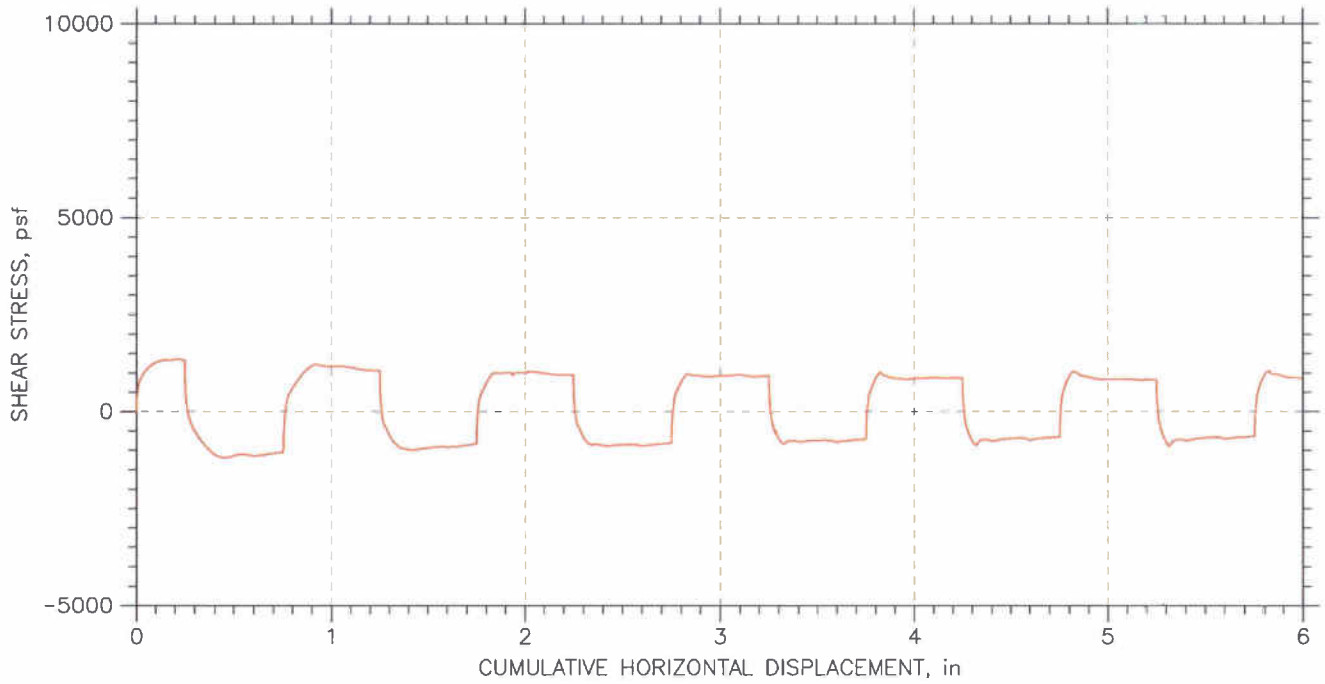

|  |                     |                       |
|--|---------------------|-----------------------|
| Project: I-90 Bridge                               | Location: OH        | Project No.: GTX-9236 |
| Boring No.: B-037-1                                | Tested By: md       | Checked By: jdt       |
| Sample No.: S-22                                   | Test Date: 08/28/09 | Depth: 66-68 ft       |
| Test No.: RS-4                                     | Sample Type: tube   | Elevation: ---        |
| Description: Moist, brown clay with sand lenses    |                     |                       |
| Remarks: System J                                  |                     |                       |
| File: \\Geocompdb1\Projects\GTX9236\9236-RS-4n.dat |                     |                       |

## RESIDUAL SHEAR TEST

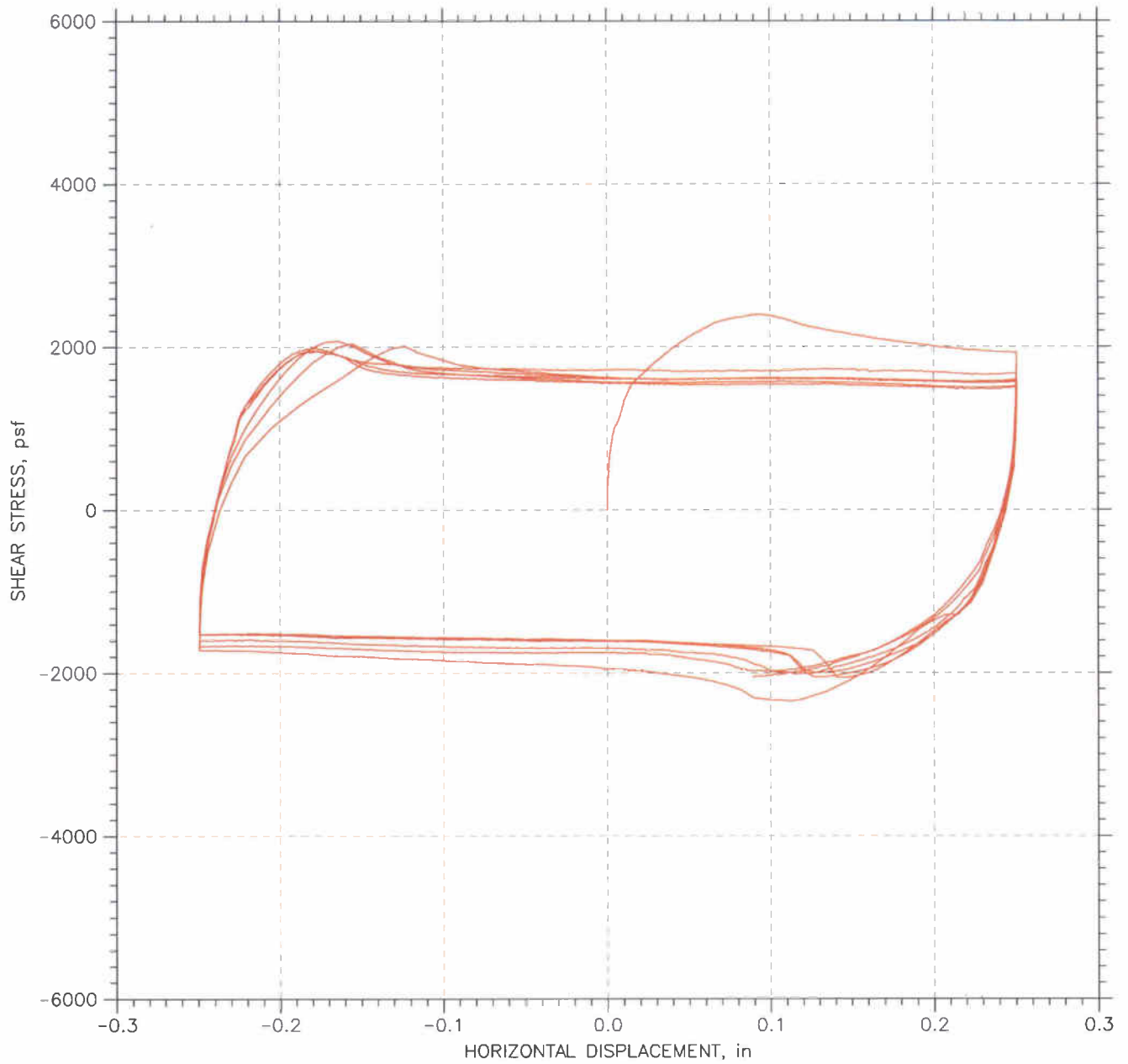

|  |                     |                       |
|--|---------------------|-----------------------|
| Project: I-90 Bridge                               | Location: OH        | Project No.: GTX-9236 |
| Boring No.: B-037-1                                | Tested By: md       | Checked By: jdt       |
| Sample No.: S-22                                   | Test Date: 08/24/09 | Depth: 66-68 ft       |
| Test No.: RS-5                                     | Sample Type: tube   | Elevation: ---        |
| Description: Moist, brown clay with sand lenses    |                     |                       |
| Remarks: System J                                  |                     |                       |
| File: \\Geocompdb1\Projects\GTX9236\9236-RS-5n.dat |                     |                       |

## RESIDUAL SHEAR TEST

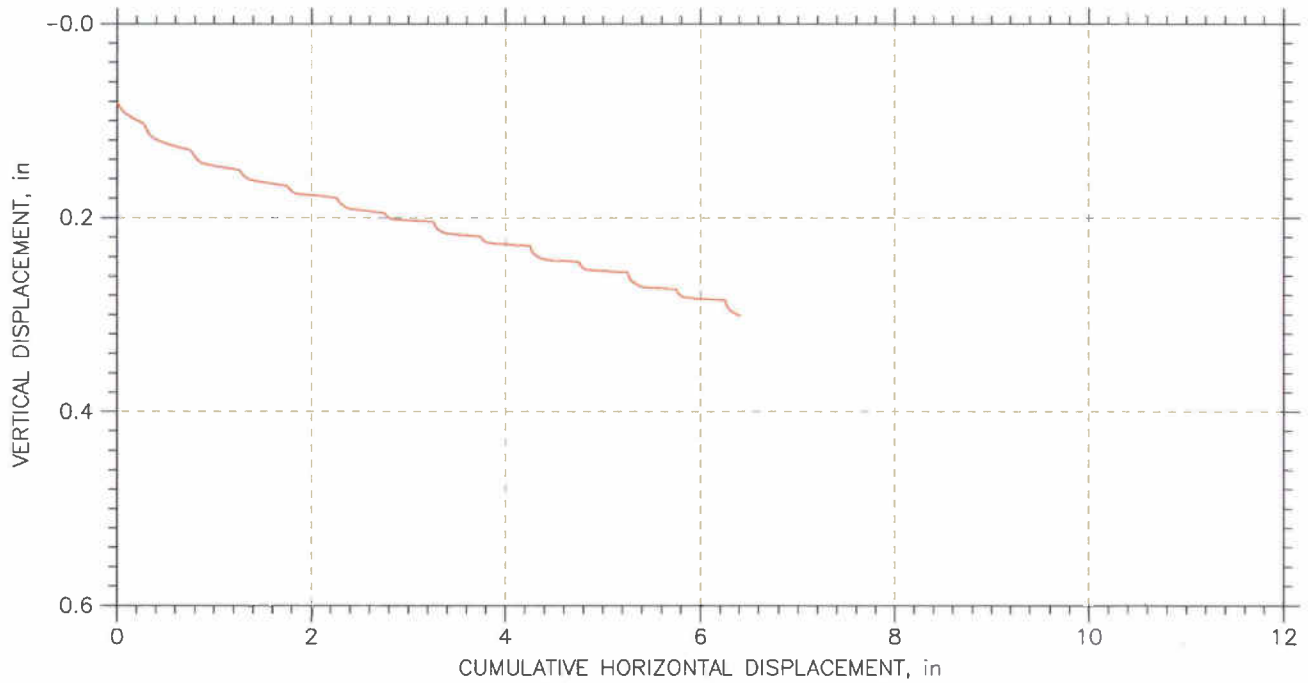
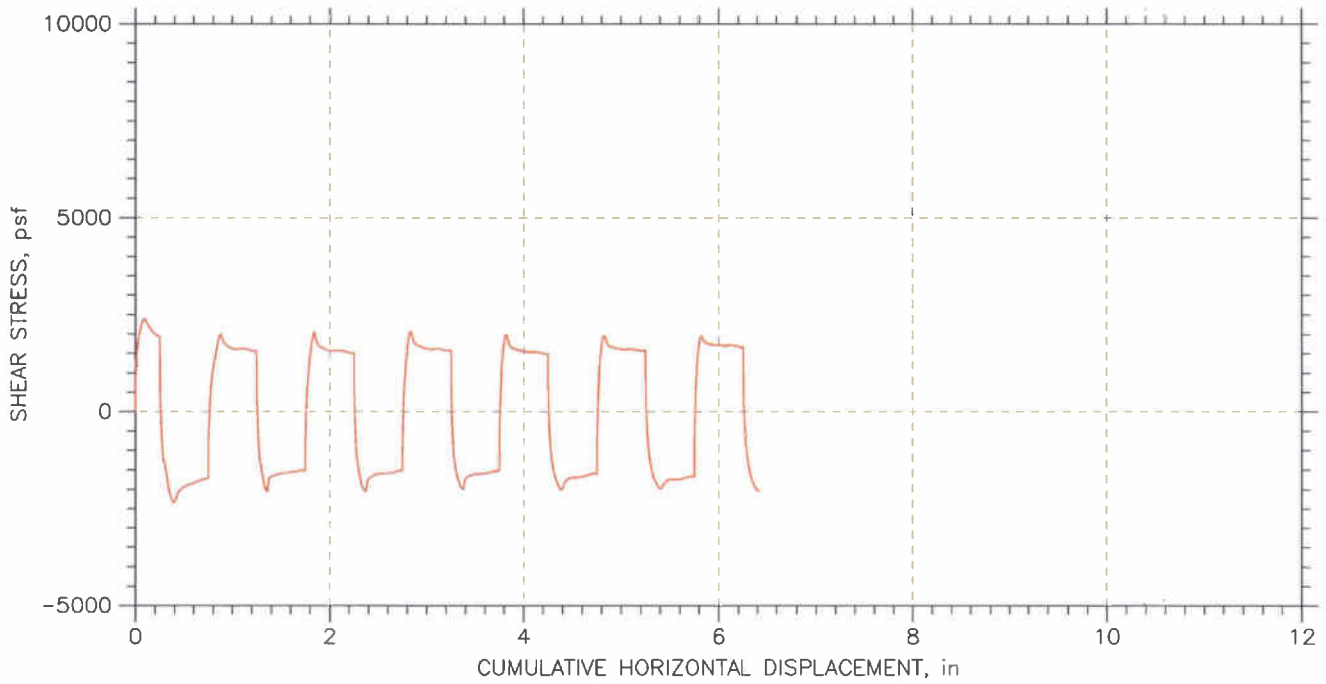

|  |                     |                       |
|--|---------------------|-----------------------|
| Project: I-90 Bridge                               | Location: OH        | Project No.: GTX-9236 |
| Boring No.: B-037-1                                | Tested By: md       | Checked By: jdt       |
| Sample No.: S-22                                   | Test Date: 08/24/09 | Depth: 66-68 ft       |
| Test No.: RS-5                                     | Sample Type: tube   | Elevation: ---        |
| Description: Moist, brown clay with sand lenses    |                     |                       |
| Remarks: System J                                  |                     |                       |
| File: \\Geocompdb1\Projects\GTX9236\9236-RS-5n.dat |                     |                       |

## RESIDUAL SHEAR TEST

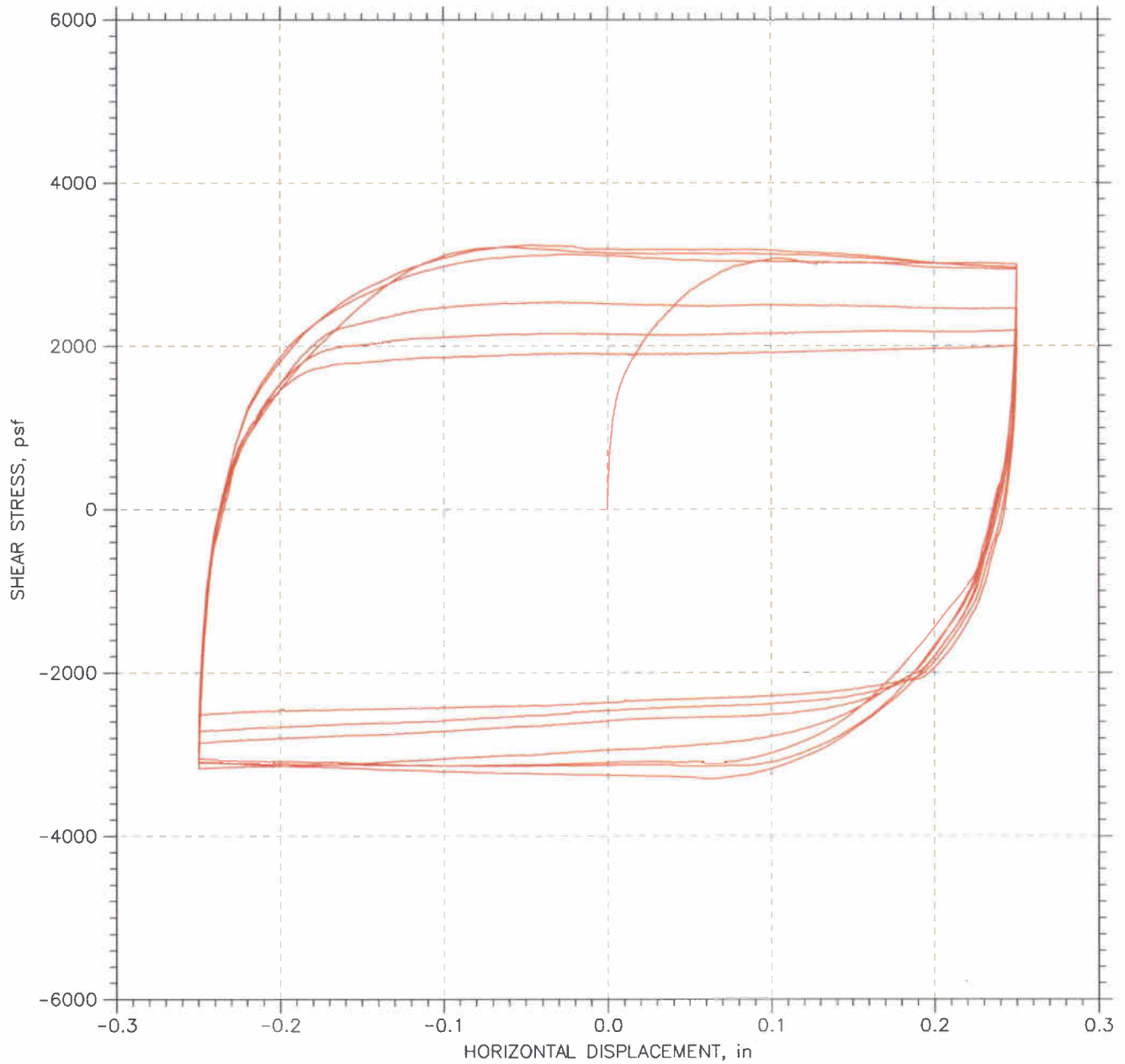

|  |                     |                       |
|--|---------------------|-----------------------|
| Project: I-90 Bridge                               | Location: OH        | Project No.: GTX-9236 |
| Boring No.: B-037-1                                | Tested By: md       | Checked By: jdt       |
| Sample No.: S-22                                   | Test Date: 08/19/09 | Depth: 66-68 ft       |
| Test No.: RS-6                                     | Sample Type: tube   | Elevation: ---        |
| Description: Moist, brown clay with sand lenses    |                     |                       |
| Remarks: System J                                  |                     |                       |
| File: \\Geocompdb1\Projects\GTX9236\9236-RS-6n.dat |                     |                       |



## RESIDUAL SHEAR TEST

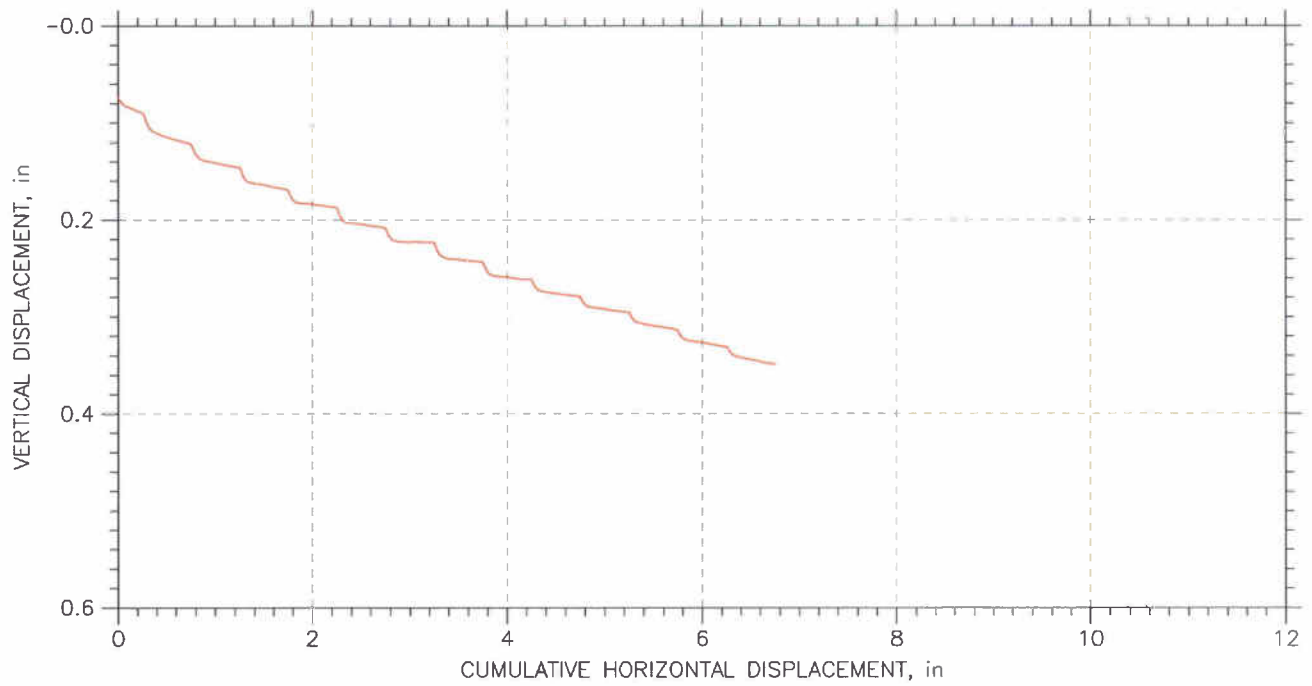
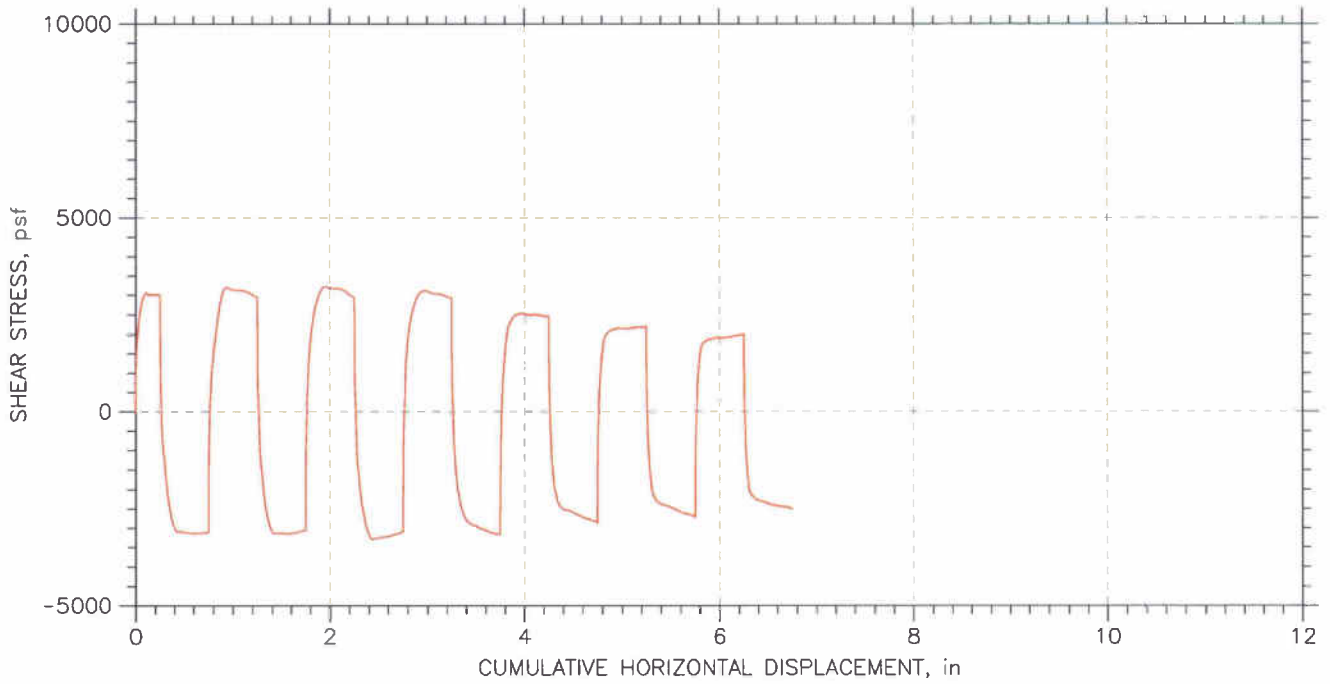

|  |                     |                       |
|--|---------------------|-----------------------|
| Project: I-90 Bridge                               | Location: OH        | Project No.: GTX-9236 |
| Boring No.: B-037-1                                | Tested By: md       | Checked By: jdt       |
| Sample No.: S-22                                   | Test Date: 08/19/09 | Depth: 66-68 ft       |
| Test No.: RS-6                                     | Sample Type: tube   | Elevation: ---        |
| Description: Moist, brown clay with sand lenses    |                     |                       |
| Remarks: System J                                  |                     |                       |
| File: \\Geocompdb1\Projects\GTX9236\9236-RS-6n.dat |                     |                       |

|                   |   |             |     |
|-------------------|---|-------------|-----|
| Client:           | Geocomp Consulting  |             |     |
| Project Name:     | I-90 Bridge   |             |     |
| Project Location: | OH  |             |     |
| GTX #:            | 9236  | Tested By:  | md  |
| Test Date:        | 08/20/09  | Checked By: | jdt |
| Boring ID:        | B-037-1   |             |     |
| Sample ID:        | S-24  |             |     |
| Depth, ft.        | 70-72   |             |     |
| Description:      | Moist, brown clay   |             |     |
| Preparation:      | Extruded from tube, cut and trimmed and tested at the as-received moisture and density. |             |     |

## Residual Shear by USACOE EM1110

| Parameter                                | Point 1 | Point 2 | Point 3 |
|--|---------|---------|---------|
| Test No.                                 | RS-7    | RS-8    | RS-9    |
| Initial Moisture Content, %              | 35.0    | 33.6    | 30.7    |
| Initial Dry Density, pcf                 | 86.7    | 87.4    | 92.0    |
| Nominal Rate of Shear Strain, inches/min | 0.0003  | 0.0003  | 0.0003  |
| Vertical Consolidation Stress, psf       | 2533    | 5067    | 6333    |
| Peak Shear Stress, psf                   | 1243    | 2018    | 3045    |
| Post-Peak Shear Stress, psf              | 775     | 1500    | 1800    |
| Final Moisture Content, %                | 33.5    | 34.7    | 28.5    |

|                           |      |         |
|---------------------------|------|---------|
| Peak Friction Angle:      | 24.2 | degrees |
| Peak Cohesion:            | 11.5 | psf     |
| Post Peak Friction Angle: | 16.2 | degrees |
| Post Peak Cohesion:       | 0.0  | psi     |

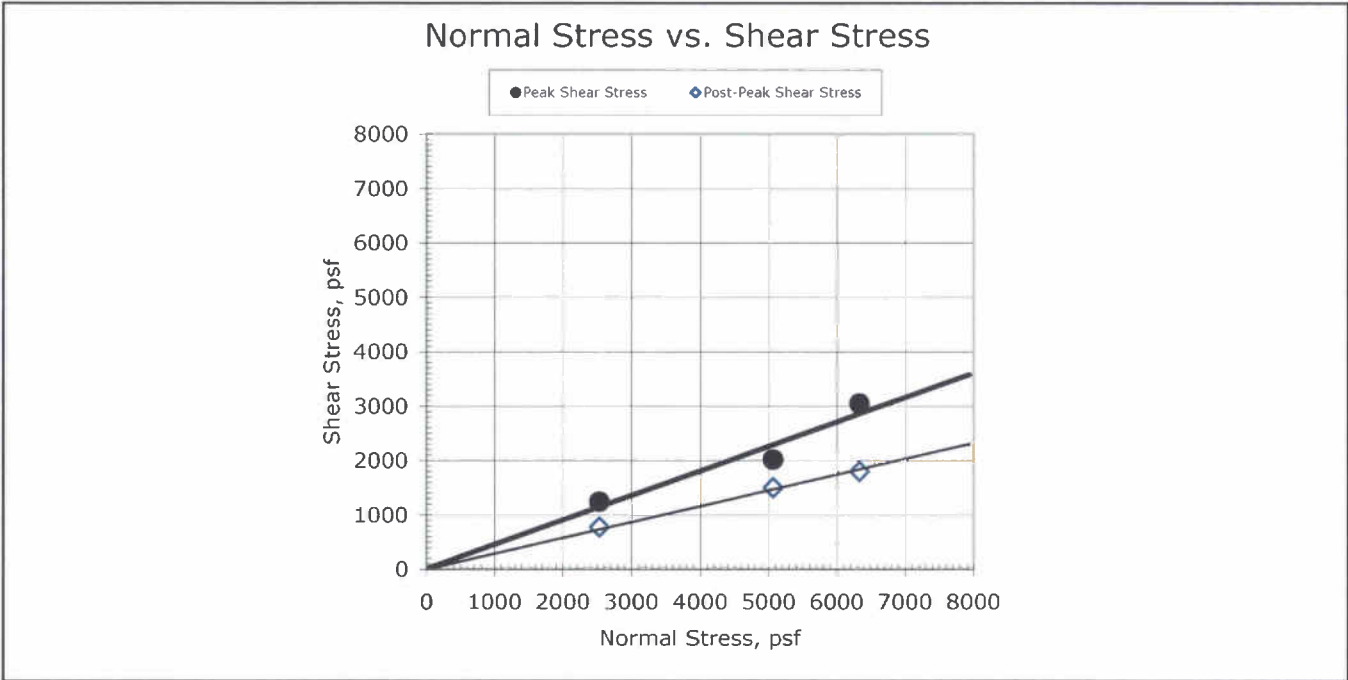

Comments: See attached plots for additional information

## RESIDUAL SHEAR TEST

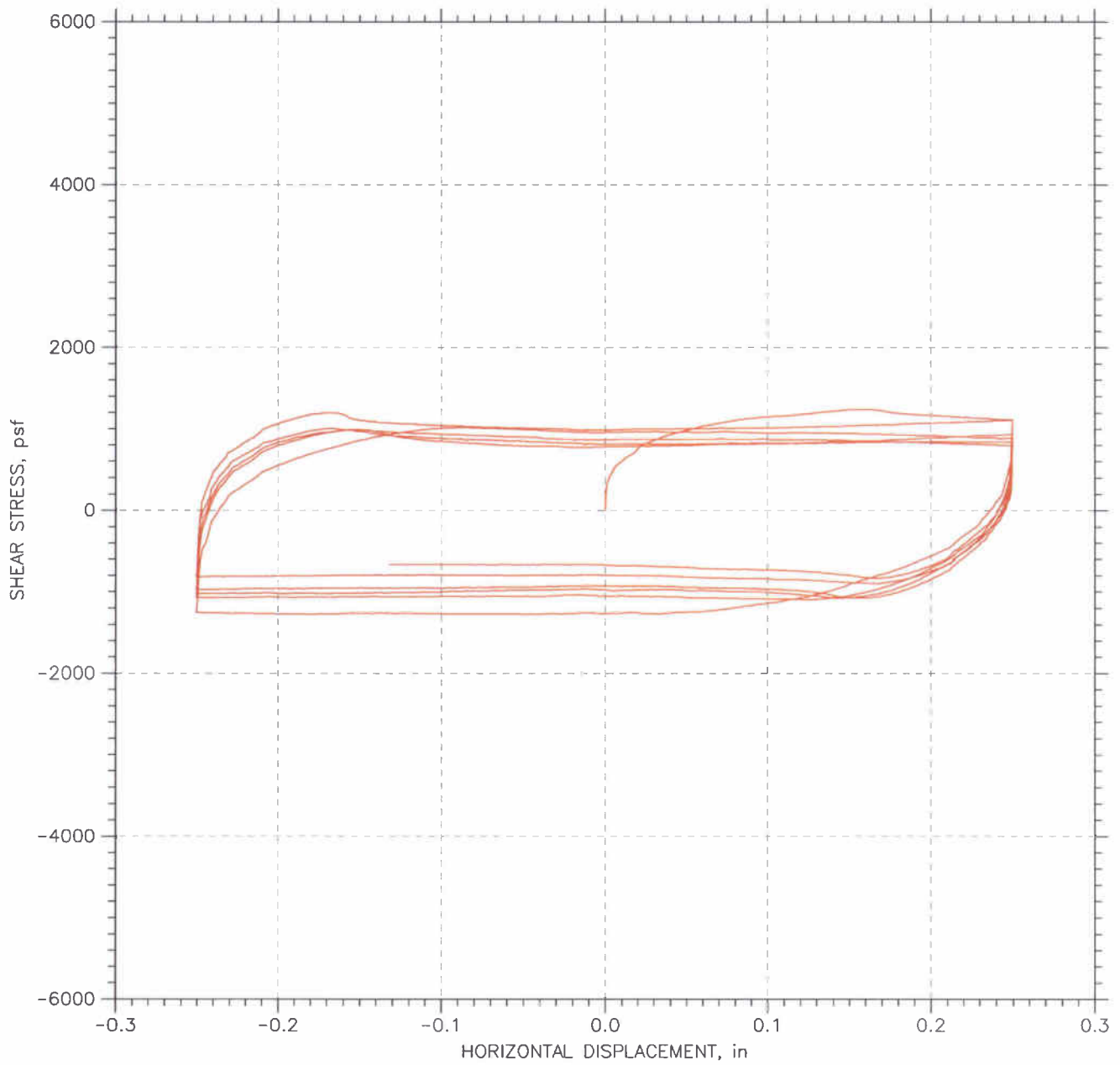

|  |                     |                       |
|--|---------------------|-----------------------|
| Project: I-90 Bridge                               | Location: OH        | Project No.: GTX-9236 |
| Boring No.: B-037-1                                | Tested By: md       | Checked By: jdt       |
| Sample No.: S-24                                   | Test Date: 08/31/09 | Depth: 70-72 ft       |
| Test No.: RS-7                                     | Sample Type: tube   | Elevation:            |
| Description: Moist, brown clay                     |                     |                       |
| Remarks: System N                                  |                     |                       |
| File: \\Geocompdb1\Projects\GTX9236\9236-RS-7n.dat |                     |                       |

## RESIDUAL SHEAR TEST

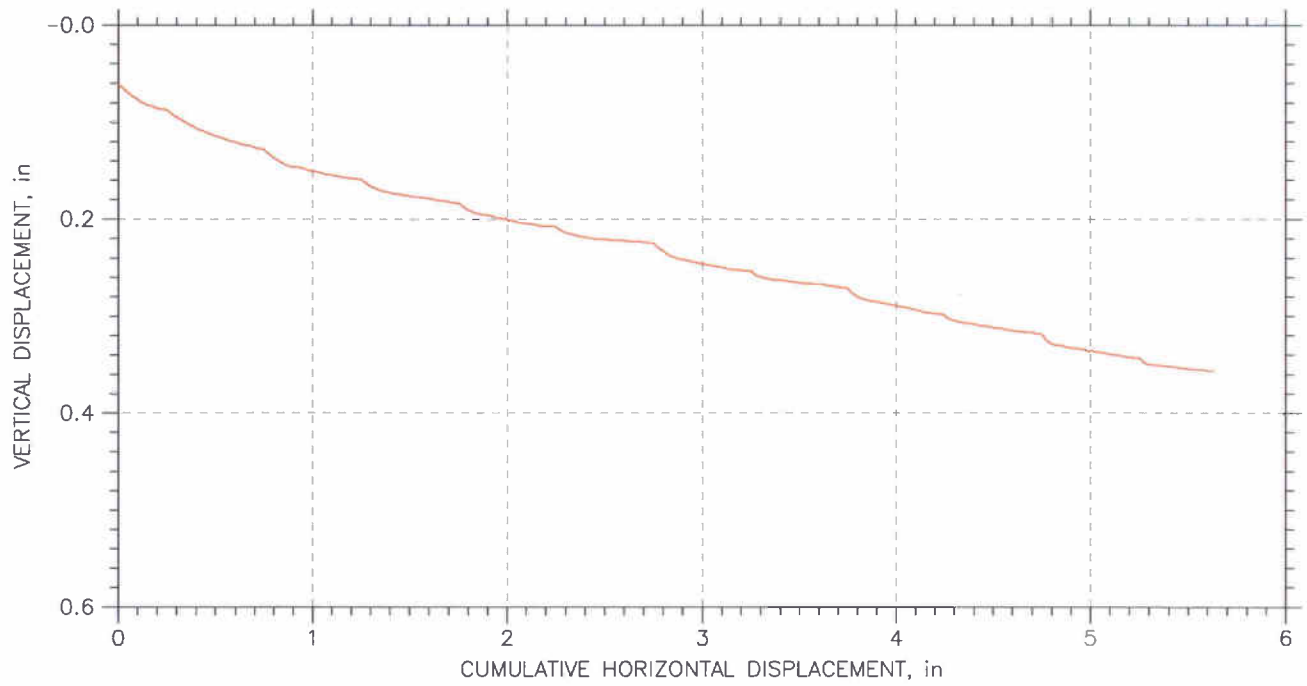
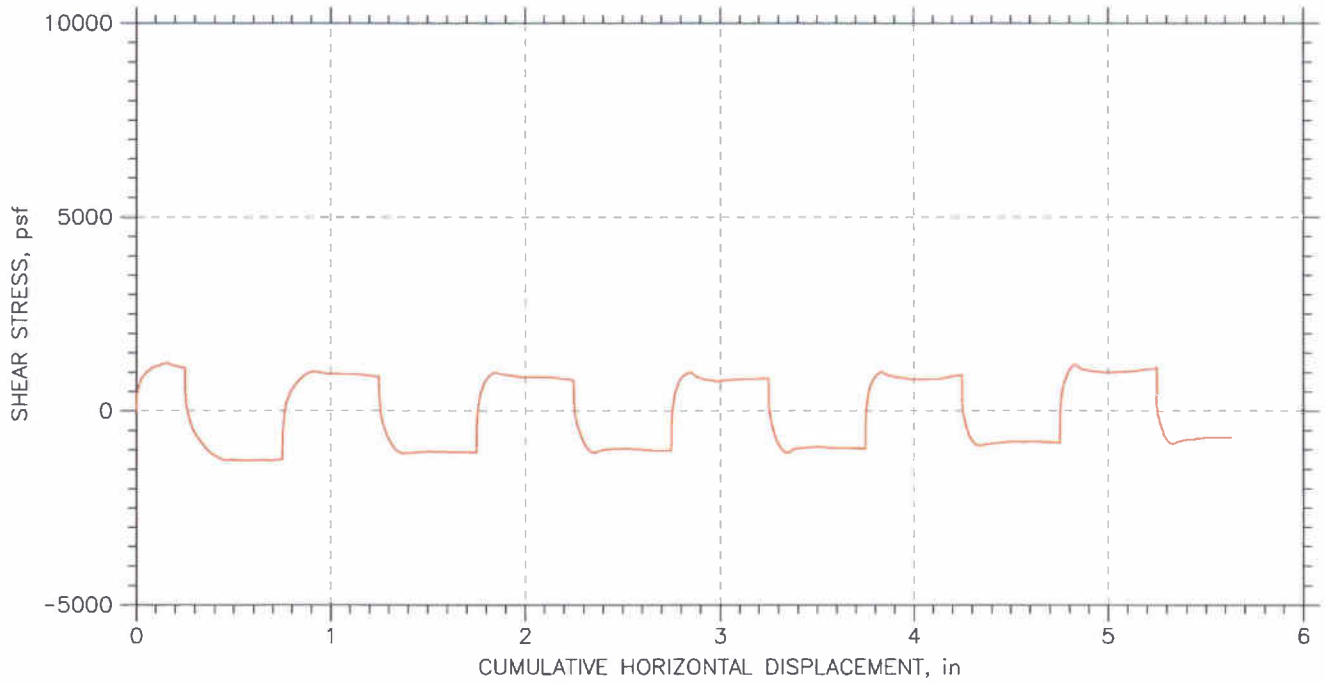

|  |                     |                       |
|--|---------------------|-----------------------|
| Project: I-90 Bridge                               | Location: OH        | Project No.: GTX-9236 |
| Boring No.: B-037-1                                | Tested By: md       | Checked By: jdt       |
| Sample No.: S-24                                   | Test Date: 08/31/09 | Depth: 70-72 ft       |
| Test No.: RS-7                                     | Sample Type: tube   | Elevation:            |
| Description: Moist, brown clay                     |                     |                       |
| Remarks: System N                                  |                     |                       |
| File: \\Geocompdb1\Projects\GTX9236\9236-RS-7n.dat |                     |                       |

## RESIDUAL SHEAR TEST

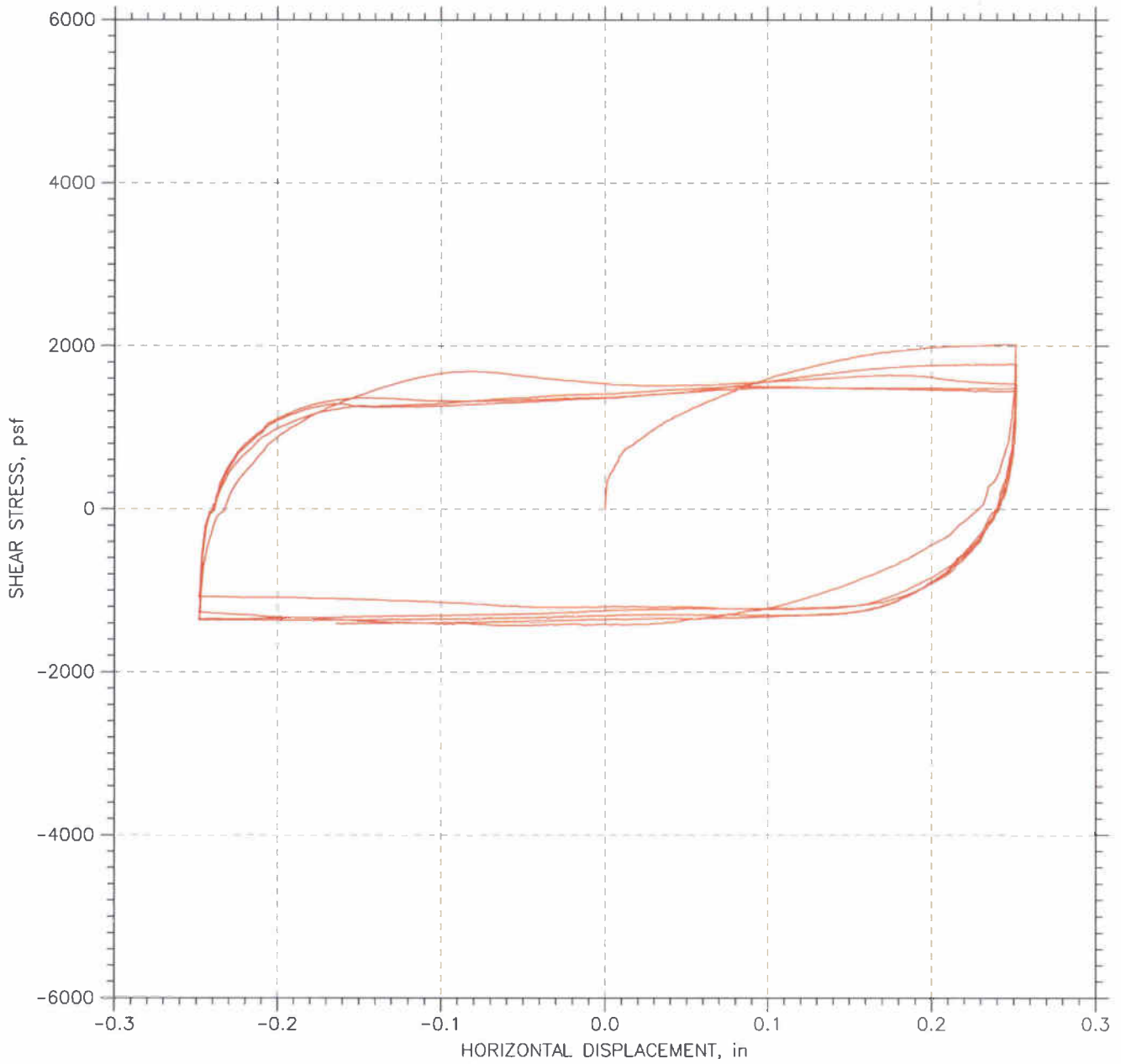

|  |                     |                       |
|--|---------------------|-----------------------|
| Project: I-90 Bridge                               | Location: OH        | Project No.: GTX-9236 |
| Boring No.: B-037-1                                | Tested By: md       | Checked By: jdt       |
| Sample No.: S-24                                   | Test Date: 08/25/09 | Depth: 70-72 ft       |
| Test No.: RS-8                                     | Sample Type: tube   | Elevation:            |
| Description: Moist, brown clay                     |                     |                       |
| Remarks: System N                                  |                     |                       |
| File: \\Geocompdb1\Projects\GTX9236\9236-RS-8n.dat |                     |                       |

## RESIDUAL SHEAR TEST

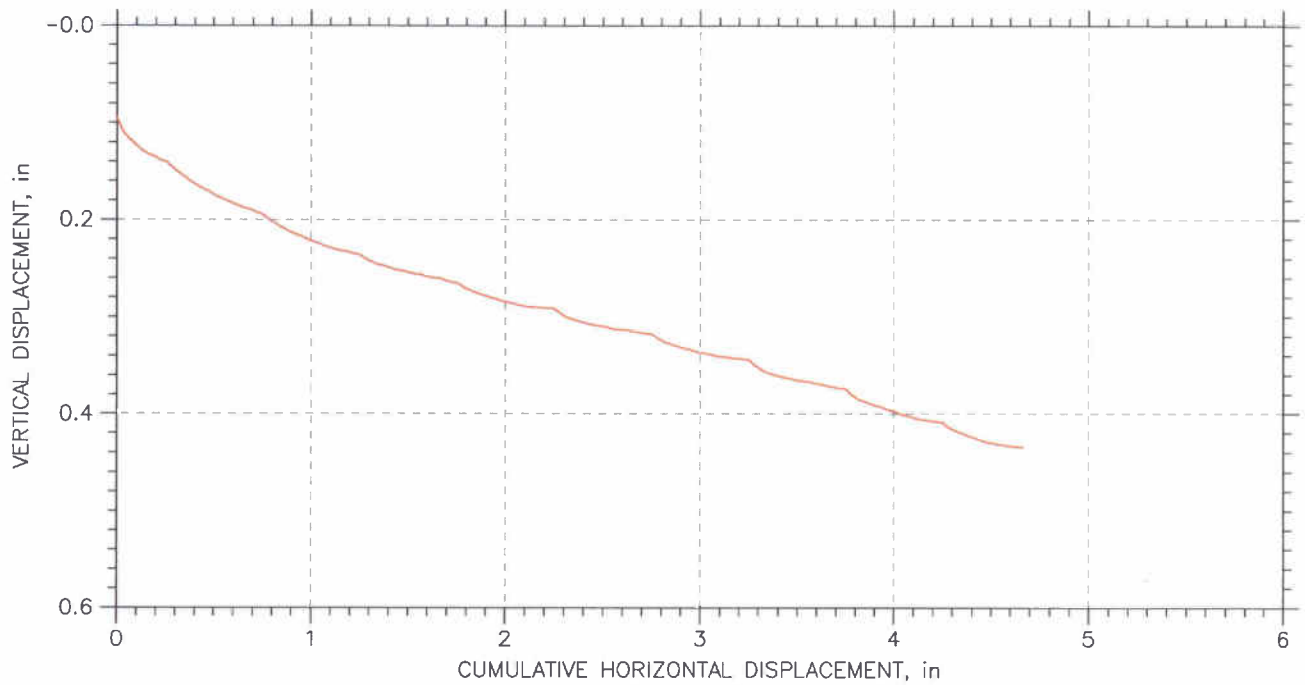
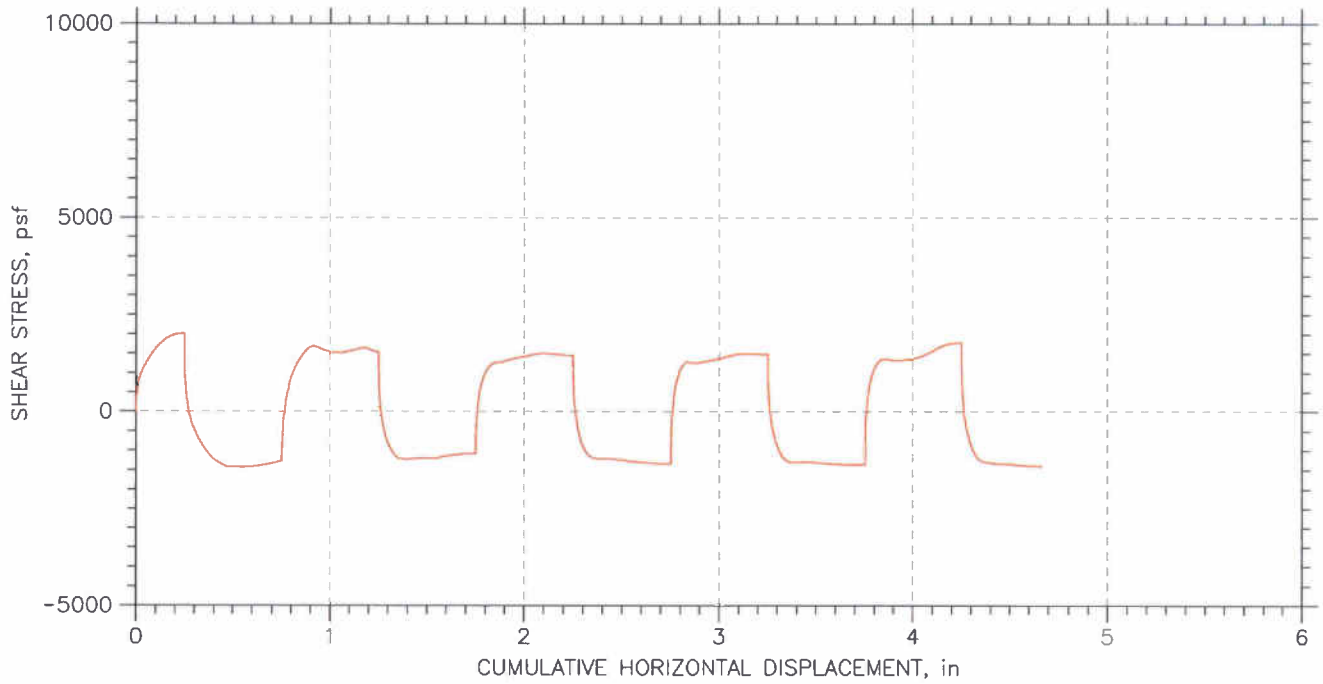

|  |                     |                       |
|--|---------------------|-----------------------|
| Project: I-90 Bridge                               | Location: OH        | Project No.: GTX-9236 |
| Boring No.: B-037-1                                | Tested By: md       | Checked By: jdt       |
| Sample No.: S-24                                   | Test Date: 08/25/09 | Depth: 70-72 ft       |
| Test No.: RS-8                                     | Sample Type: tube   | Elevation:            |
| Description: Moist, brown clay                     |                     |                       |
| Remarks: System N                                  |                     |                       |
| File: \\Geocompdb1\Projects\GTX9236\9236-RS-8n.dat |                     |                       |

## RESIDUAL SHEAR TEST

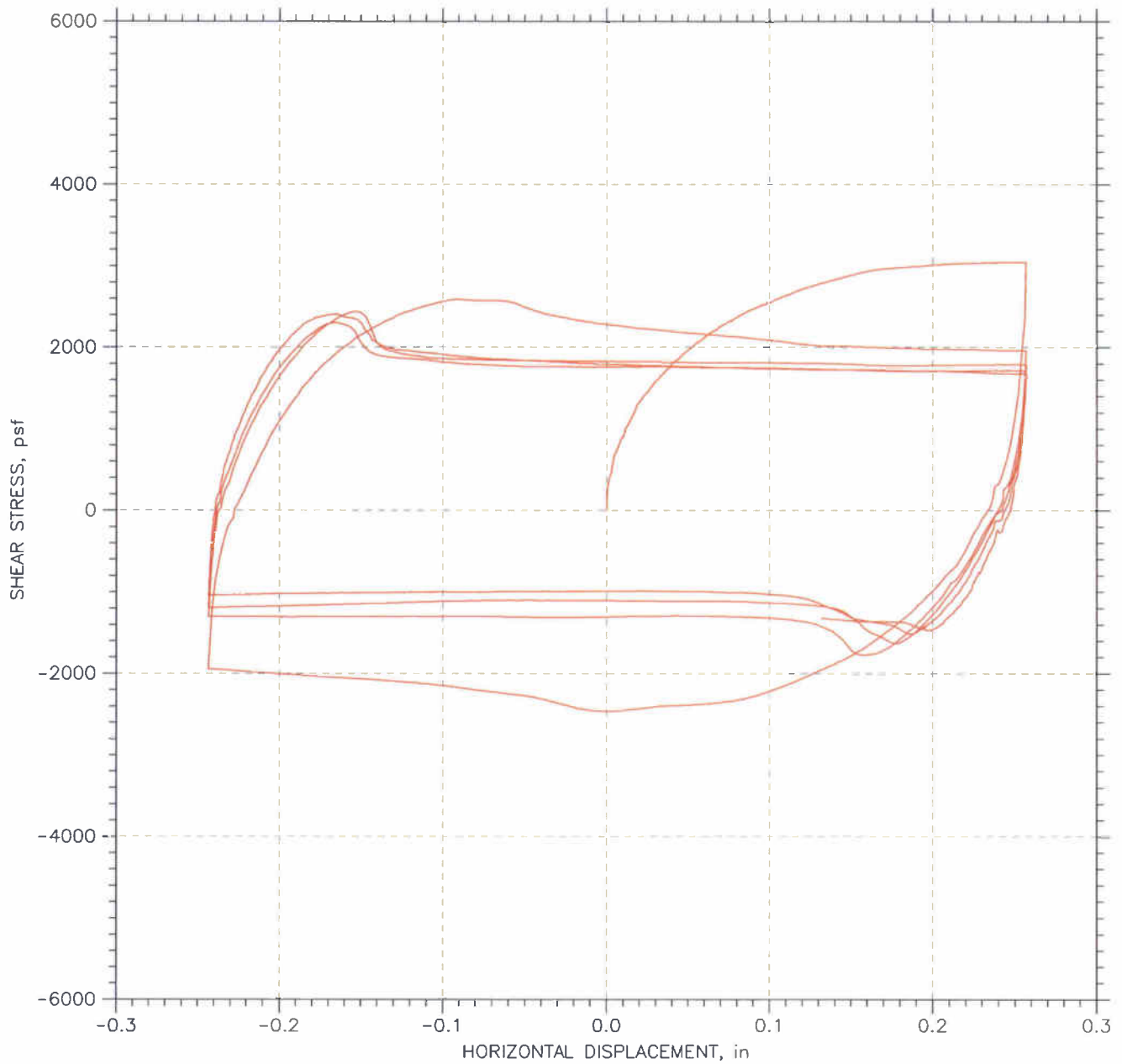

|  |                     |                       |
|--|---------------------|-----------------------|
| Project: I-90 Bridge                               | Location: OH        | Project No.: GTX-9236 |
| Boring No.: B-037-1                                | Tested By: md       | Checked By: jdt       |
| Sample No.: S-24                                   | Test Date: 08/20/09 | Depth: 70-72 ft       |
| Test No.: RS-9                                     | Sample Type: tube   | Elevation: ---        |
| Description: Moist, brown clay                     |                     |                       |
| Remarks: System N                                  |                     |                       |
| File: \\Geocompdb1\Projects\GTX9236\9236-RS-9n.dat |                     |                       |

## RESIDUAL SHEAR TEST

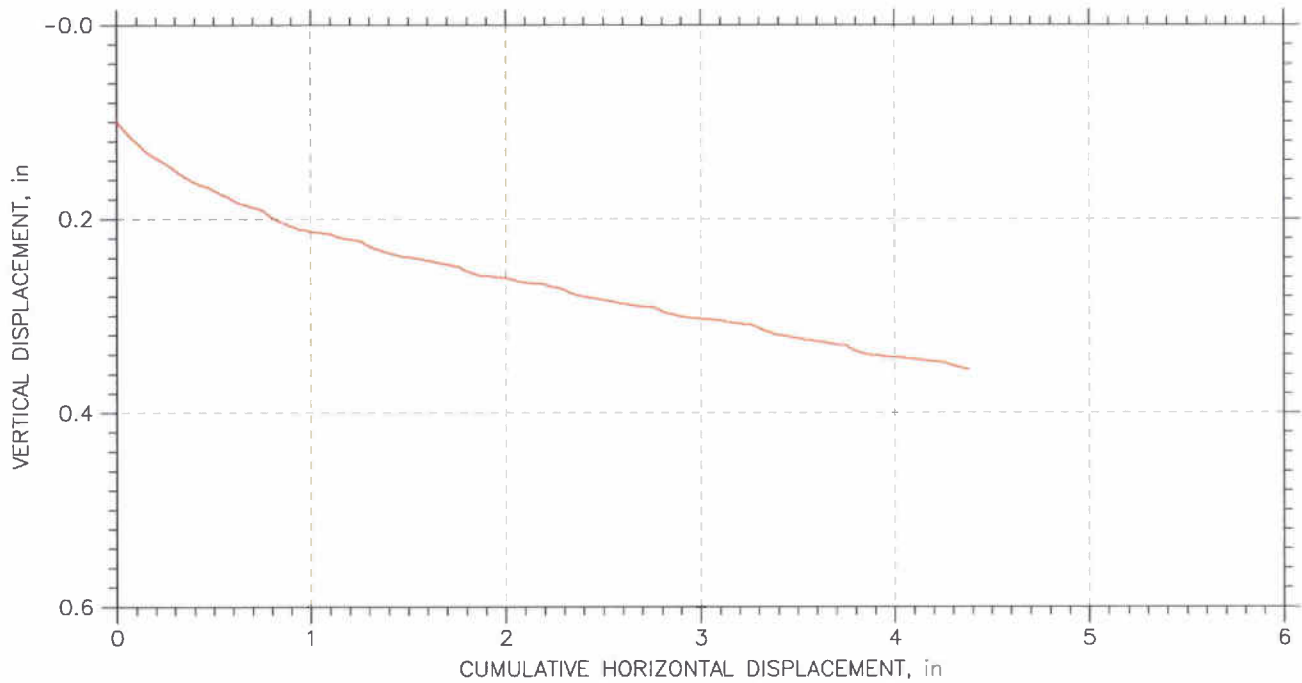
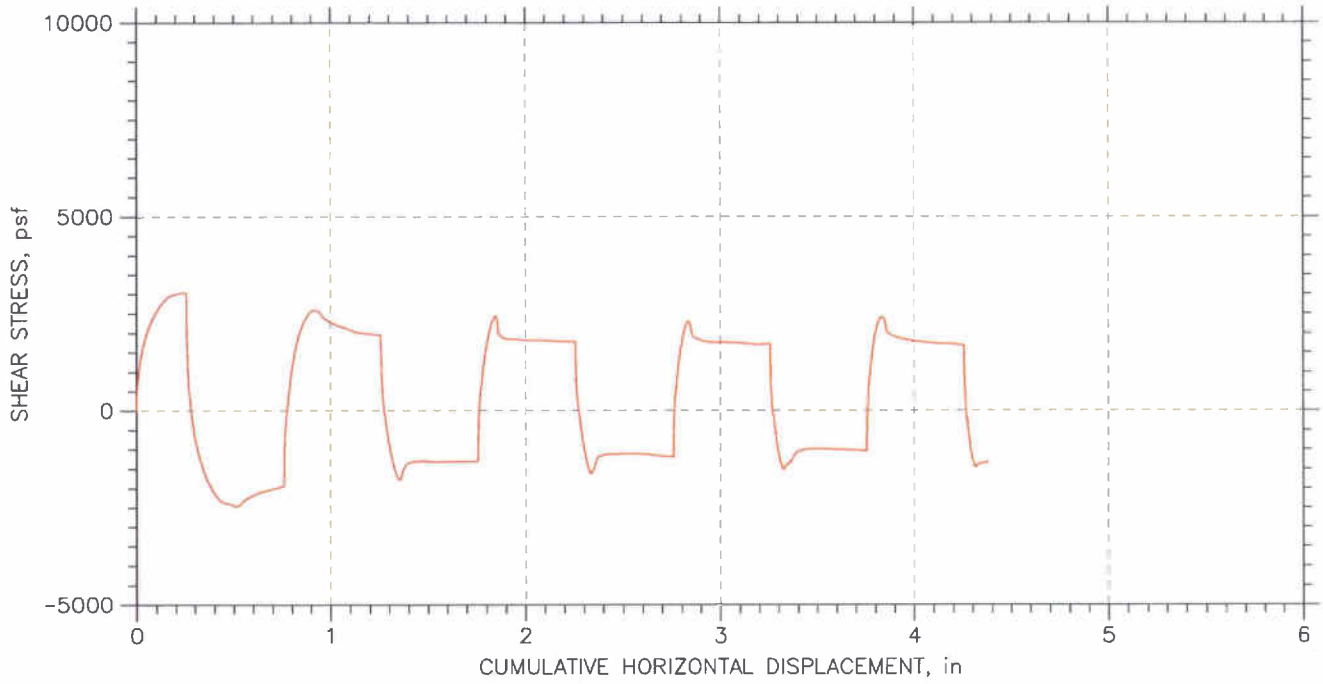

|  |                     |                       |
|--|---------------------|-----------------------|
| Project: I-90 Bridge                               | Location: OH        | Project No.: GTX-9236 |
| Boring No.: B-037-1                                | Tested By: md       | Checked By: jdt       |
| Sample No.: S-24                                   | Test Date: 08/20/09 | Depth: 70-72 ft       |
| Test No.: RS-9                                     | Sample Type: tube   | Elevation: ---        |
| Description: Moist, brown clay                     |                     |                       |
| Remarks: System N                                  |                     |                       |
| File: \\Geocompdb1\Projects\GTX9236\9236-RS-9n.dat |                     |                       |



|                   |   |             |     |
|-------------------|---|-------------|-----|
| Client:           | Geocomp Consulting  |             |     |
| Project Name:     | I-90 Bridge   |             |     |
| Project Location: | OH  |             |     |
| GTX #:            | 9236  | Tested By:  | md  |
| Test Date:        | 08/20/09  | Checked By: | jdt |
| Boring ID:        | B-037-1   |             |     |
| Sample ID:        | S-25  |             |     |
| Depth, ft.        | 72-74   |             |     |
| Description:      | Moist, brown clay   |             |     |
| Preparation:      | Extruded from tube, cut and trimmed and tested at the as-received moisture and density. |             |     |

## Residual Shear by USACOE EM1110

| Parameter                                | Point 1 | Point 2 | Point 3 |
|--|---------|---------|---------|
| Test No.                                 | RS-10   | RS-11   | RS-12   |
| Initial Moisture Content, %              | 25.5    | 24.4    | 25.8    |
| Initial Dry Density, pcf                 | 99.4    | 100.0   | 98.0    |
| Nominal Rate of Shear Strain, inches/min | 0.0002  | 0.0002  | 0.0002  |
| Vertical Consolidation Stress, psf       | 2596    | 5192    | 6490    |
| Peak Shear Stress, psf                   | 1555    | 3188    | 3056    |
| Post-Peak Shear Stress, psf              | 1300    | 2700    | 1900    |
| Final Moisture Content, %                | 24.4    | 25.4    | 24.3    |

|                           |       |         |
|---------------------------|-------|---------|
| Peak Friction Angle:      | 22.8  | degrees |
| Peak Cohesion:            | 600.0 | psf     |
| Post Peak Friction Angle: | 16.3  | degrees |
| Post Peak Cohesion:       | 0.0   | psi     |

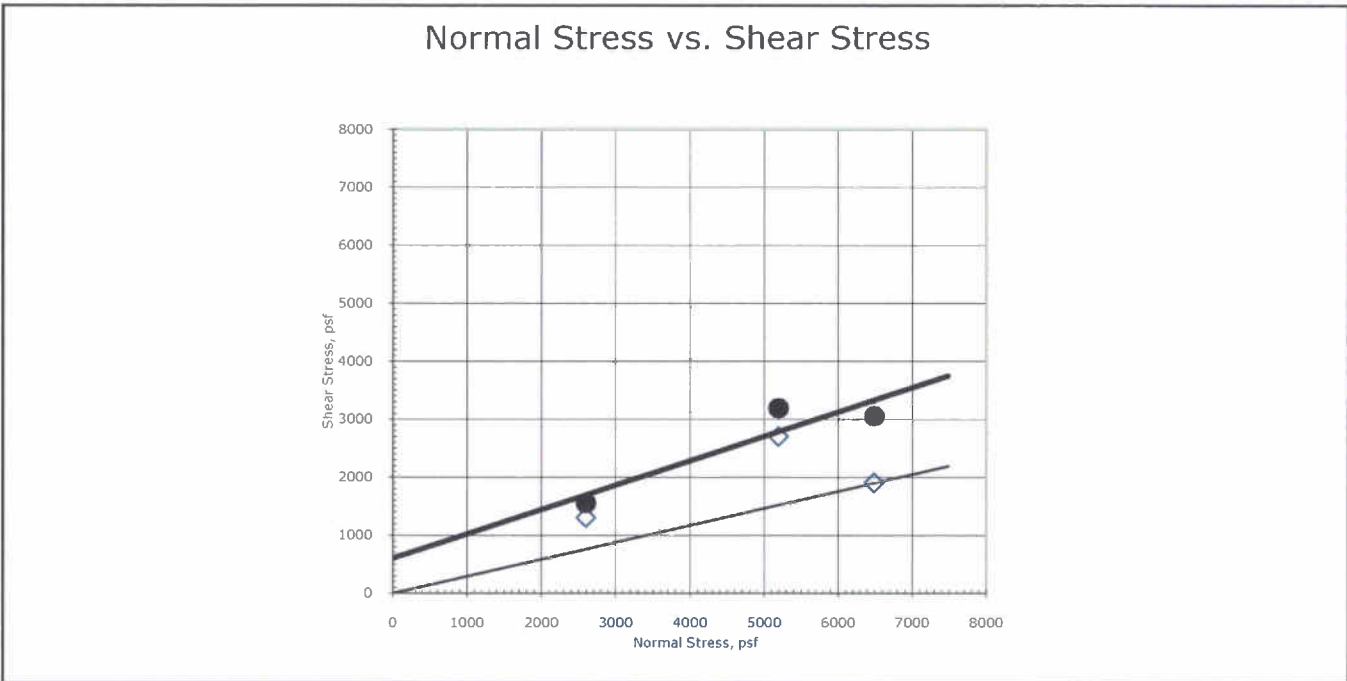

Comments: See attached plots for additional information

## RESIDUAL SHEAR TEST

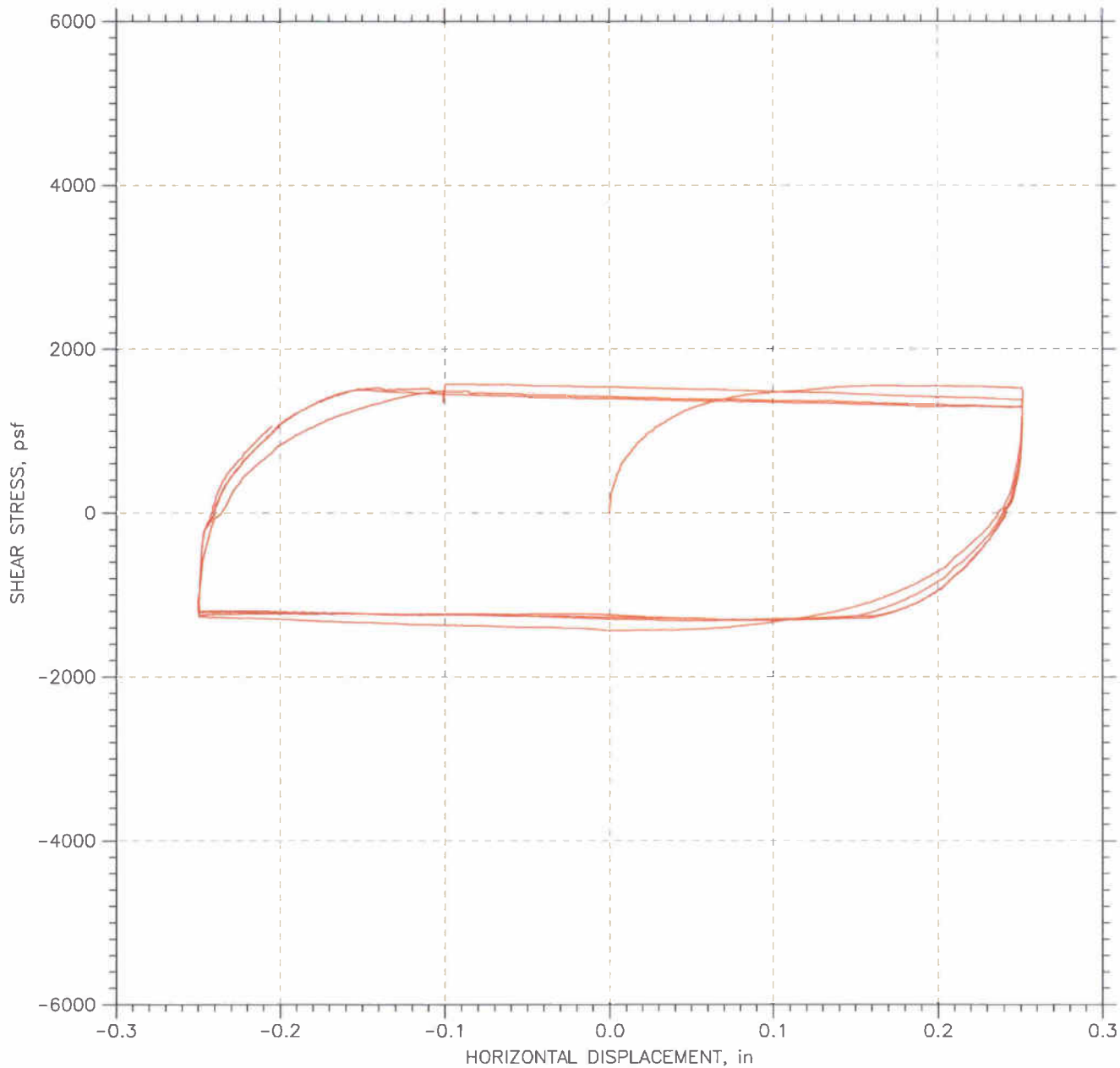

|   |                     |                       |
|---|---------------------|-----------------------|
| Project: I-90 Bridge                                | Location: OH        | Project No.: GTX-9236 |
| Boring No.: B-037-1                                 | Tested By: md       | Checked By: jdt       |
| Sample No.: S-25                                    | Test Date: 09/02/09 | Depth: 72-74 ft       |
| Test No.: RS-10                                     | Sample Type: tube   | Elevation:            |
| Description: Moist, brown clay                      |                     |                       |
| Remarks: System M                                   |                     |                       |
| File: \\Geocompdb1\Projects\GTX9236\9236-RS-10n.dat |                     |                       |

## RESIDUAL SHEAR TEST

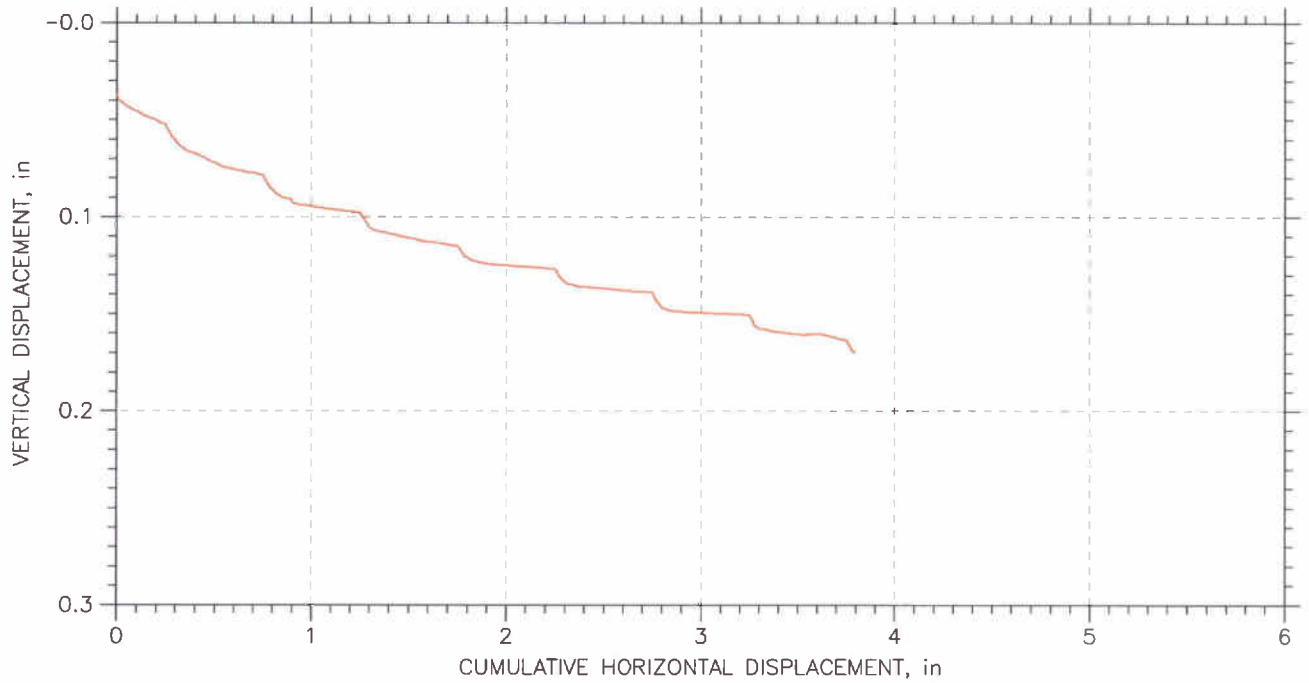
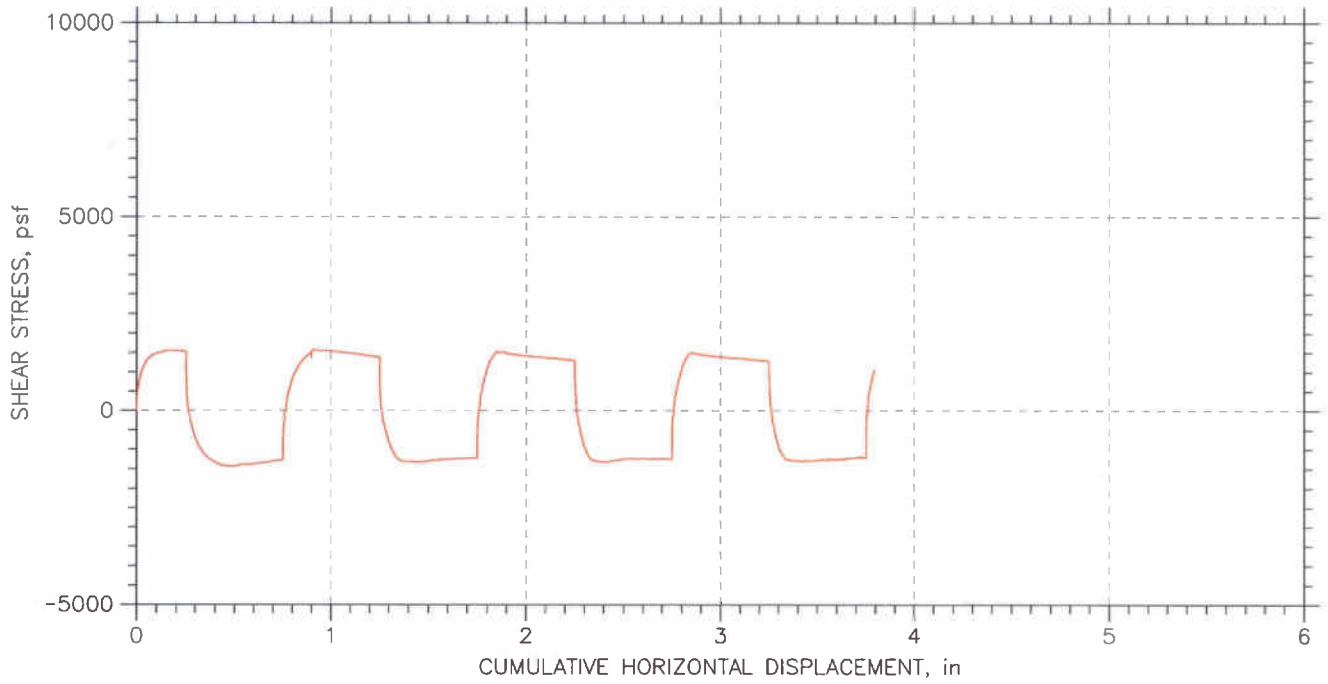

|   |                     |                       |
|---|---------------------|-----------------------|
| Project: I-90 Bridge                                | Location: OH        | Project No.: GTX-9236 |
| Boring No.: B-037-1                                 | Tested By: md       | Checked By: jdt       |
| Sample No.: S-25                                    | Test Date: 09/02/09 | Depth: 72-74 ft       |
| Test No.: RS-10                                     | Sample Type: tube   | Elevation:            |
| Description: Moist, brown clay                      |                     |                       |
| Remarks: System M                                   |                     |                       |
| File: \\Geocompdb1\Projects\GTX9236\9236-RS-10n.dat |                     |                       |

## RESIDUAL SHEAR TEST

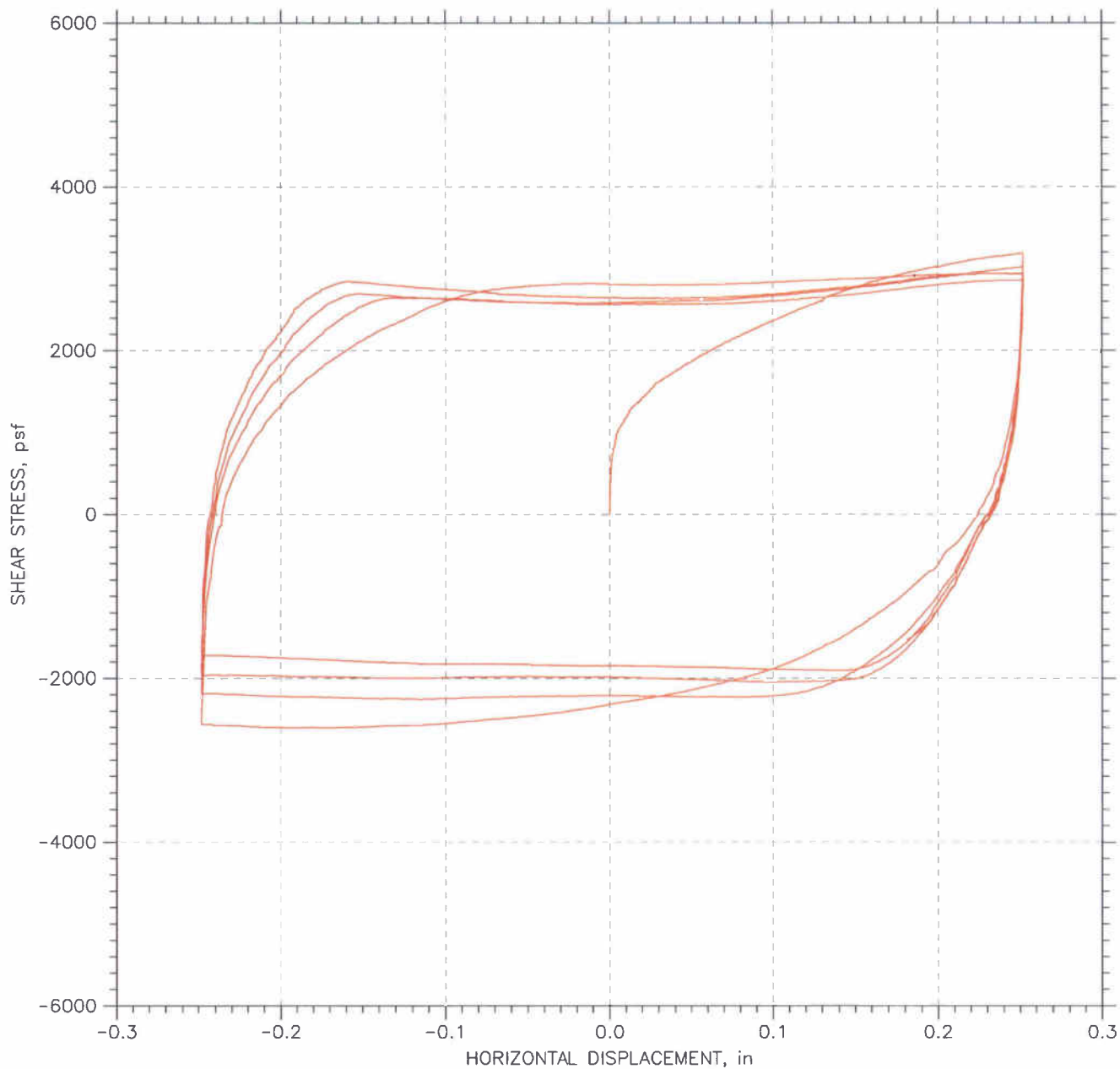

|   |                     |                       |
|---|---------------------|-----------------------|
| Project: I-90 Bridge                                | Location: OH        | Project No.: GTX-9236 |
| Boring No.: B-037-1                                 | Tested By: md       | Checked By: jdt       |
| Sample No.: S-25                                    | Test Date: 08/27/09 | Depth: 72-74 ft       |
| Test No.: RS-11                                     | Sample Type: tube   | Elevation: ---        |
| Description: Moist, brown clay                      |                     |                       |
| Remarks: System M                                   |                     |                       |
| File: \\Geocompdb1\Projects\GTX9236\9236-RS-11n.dat |                     |                       |

## RESIDUAL SHEAR TEST

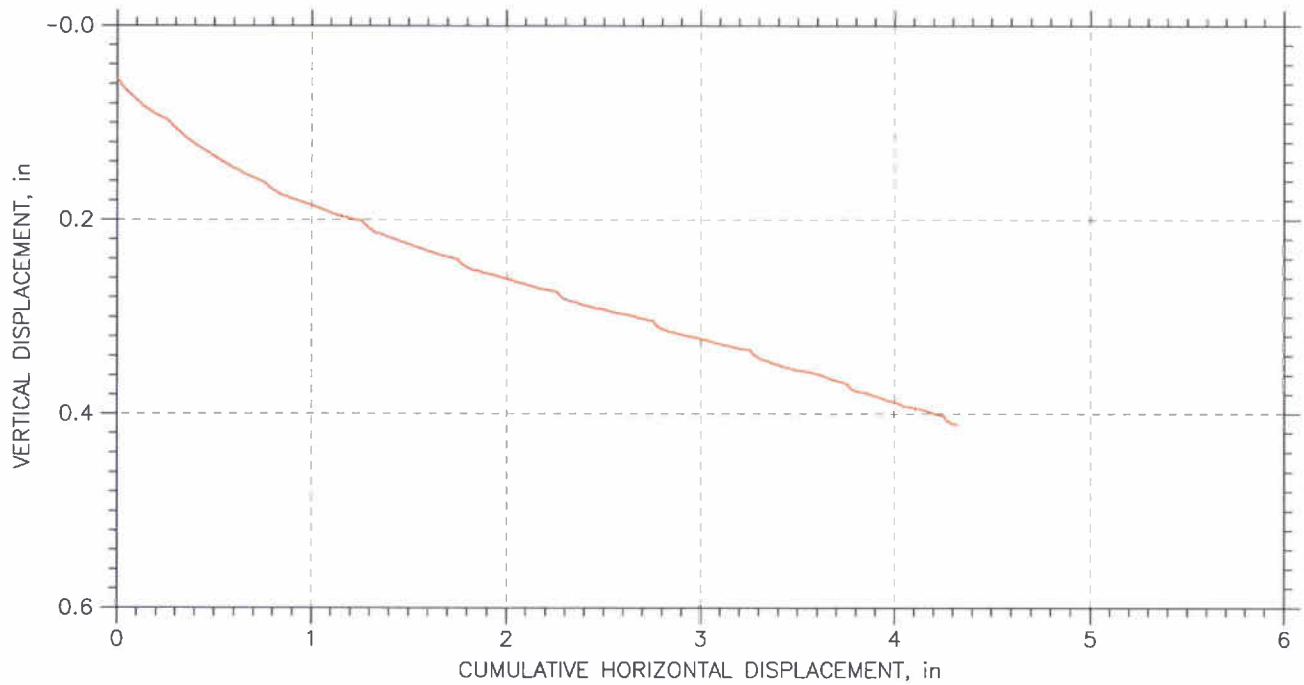
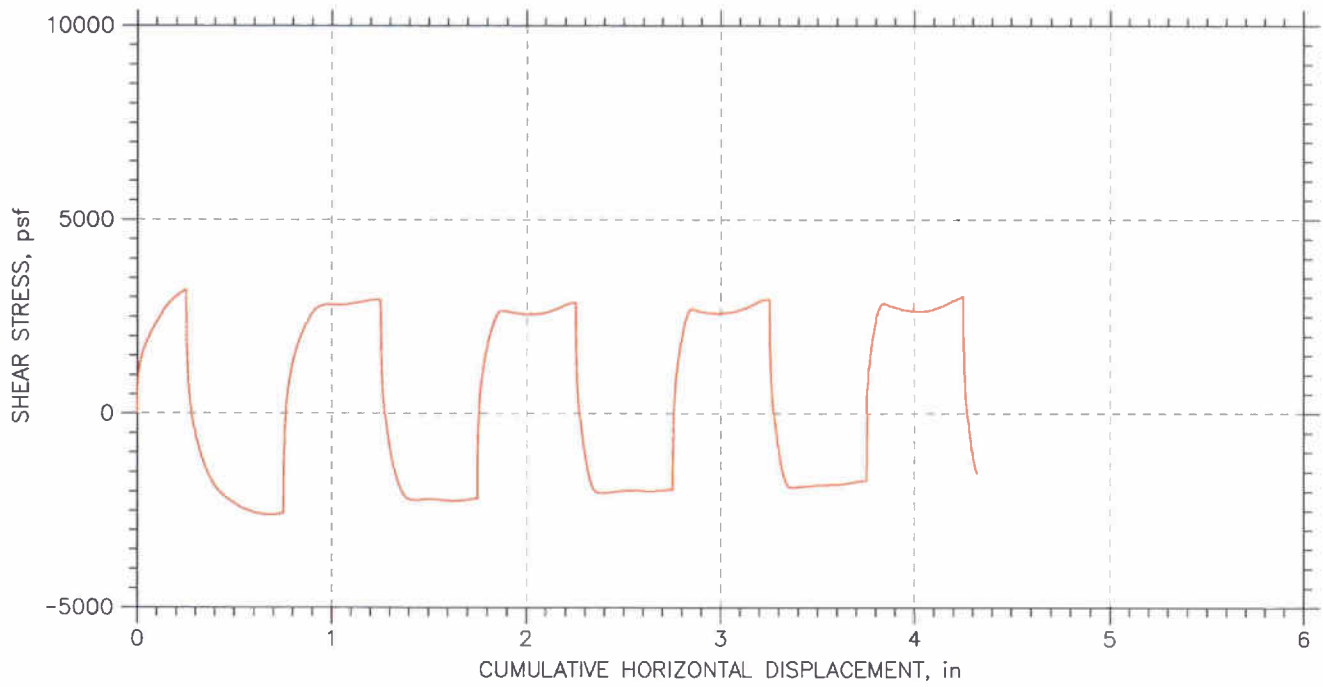

|   |                     |                       |
|---|---------------------|-----------------------|
| Project: I-90 Bridge                                | Location: OH        | Project No.: GTX-9236 |
| Boring No.: B-037-1                                 | Tested By: md       | Checked By: jdt       |
| Sample No.: S-25                                    | Test Date: 08/27/09 | Depth: 72-74 ft       |
| Test No.: RS-11                                     | Sample Type: tube   | Elevation: ---        |
| Description: Moist, brown clay                      |                     |                       |
| Remarks: System M                                   |                     |                       |
| File: \\Geocompdb1\Projects\GTX9236\9236-RS-11n.dat |                     |                       |

## RESIDUAL SHEAR TEST

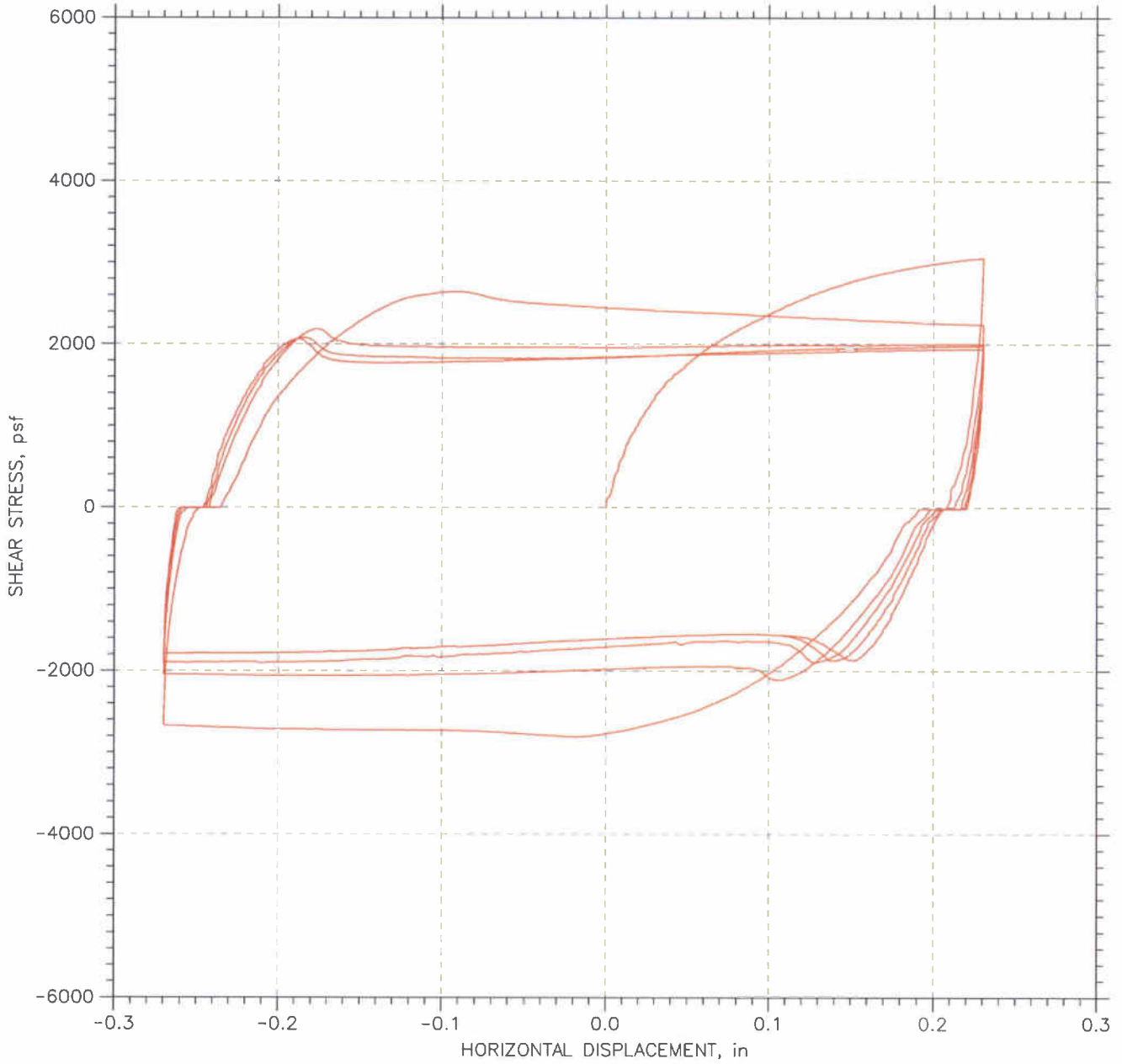

|   |                     |                       |
|---|---------------------|-----------------------|
| Project: I-90 Bridge                                | Location: OH        | Project No.: GTX-9236 |
| Boring No.: B-037-1                                 | Tested By: md       | Checked By: jdt       |
| Sample No.: S-25                                    | Test Date: 08/20/09 | Depth: 72-74 ft       |
| Test No.: RS-12                                     | Sample Type: tube   | Elevation:            |
| Description: Moist, brown clay                      |                     |                       |
| Remarks: System M                                   |                     |                       |
| File: \\Geocompdb1\Projects\GTX9236\9236-RS-12n.dat |                     |                       |

## RESIDUAL SHEAR TEST

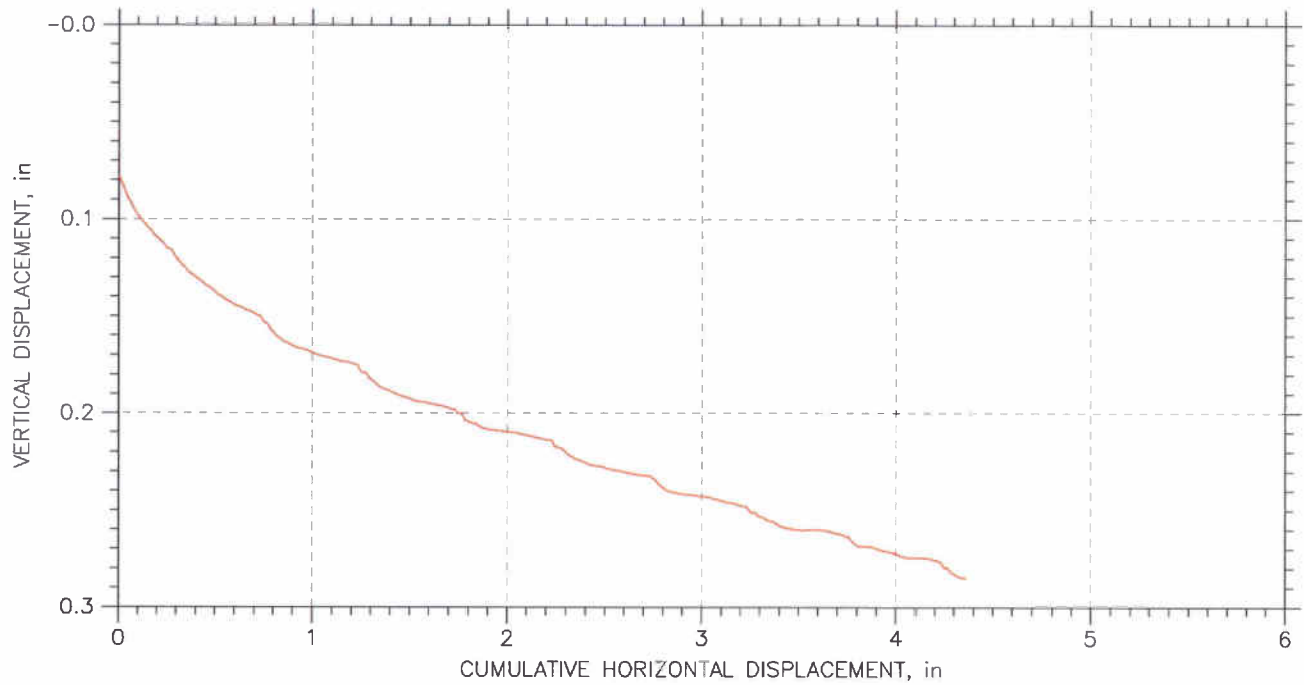
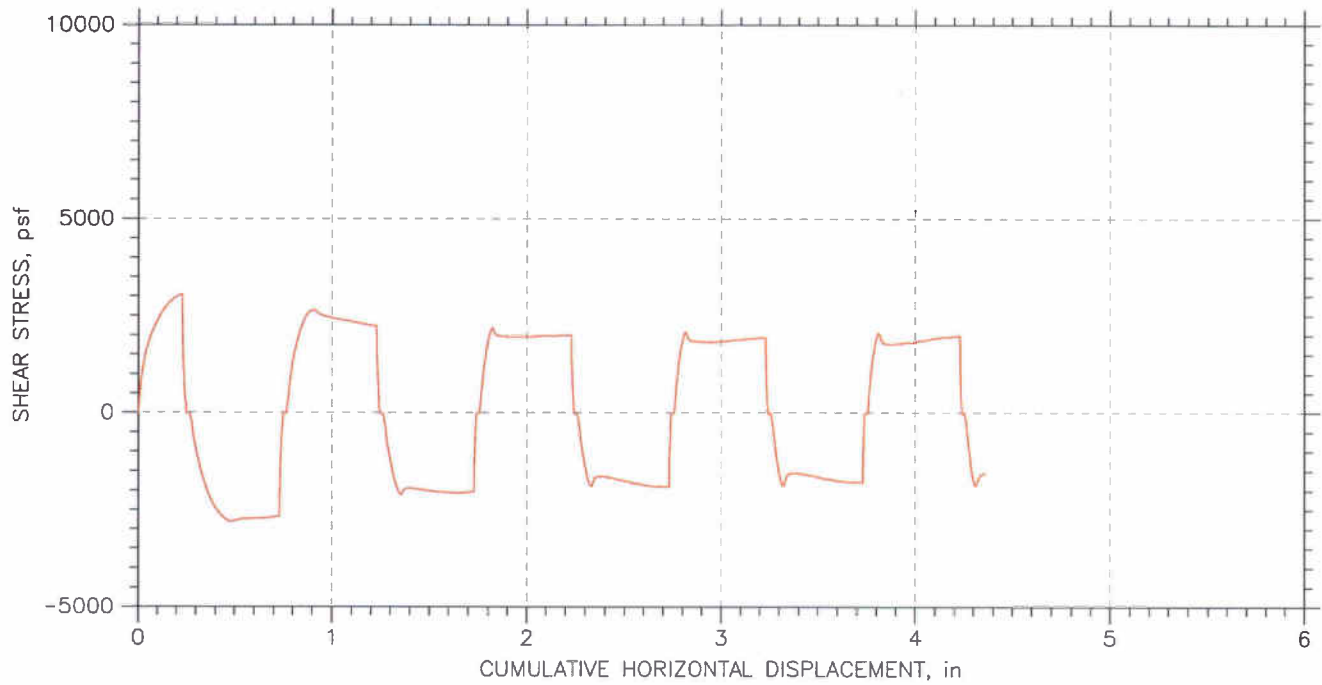

|   |                     |                       |
|---|---------------------|-----------------------|
| Project: I-90 Bridge                                | Location: OH        | Project No.: GTX-9236 |
| Boring No.: B-037-1                                 | Tested By: md       | Checked By: jdt       |
| Sample No.: S-25                                    | Test Date: 08/20/09 | Depth: 72-74 ft       |
| Test No.: RS-12                                     | Sample Type: tube   | Elevation:            |
| Description: Moist, brown clay                      |                     |                       |
| Remarks: System M                                   |                     |                       |
| File: \\Geocompdb1\Projects\GTX9236\9236-RS-12n.dat |                     |                       |

## WARRANTY and LIABILITY

GeoTesting Express (GTX) warrants that all tests it performs are run in general accordance with the specified test procedures and accepted industry practice. GTX will correct or repeat any test that does not comply with this warranty. GTX has no specific knowledge as to conditioning, origin, sampling procedure or intended use of the material.

GTX may report engineering parameters that require us to interpret the test data. Such parameters are determined using accepted engineering procedures. However, GTX does not warrant that these parameters accurately reflect the true engineering properties of the *in situ* material. Responsibility for interpretation and use of the test data and these parameters for engineering and/or construction purposes rests solely with the user and not with GTX or any of its employees.

GTX's liability will be limited to correcting or repeating a test which fails our warranty. GTX's liability for damages to the Purchaser of testing services for any cause whatsoever shall be limited to the amount GTX received for the testing services. GTX will not be liable for any damages, or for any lost benefits or other consequential damages resulting from the use of these test results, even if GTX has been advised of the possibility of such damages. GTX will not be responsible for any liability of the Purchaser to any third party.

## Commonly Used Symbols

|            |   |                          |   |
|------------|---|--------------------------|---|
| A          | pore pressure parameter for $\Delta\sigma_1 - \Delta\sigma_3$   | T                        | temperature                                     |
| B          | pore pressure parameter for $\Delta\sigma_3$                    | t                        | time  |
| CIU        | isotropically consolidated undrained triaxial shear test        | U, UC                    | unconfined compression test                     |
| CR         | compression ratio for one dimensional consolidation             | UU, Q                    | unconsolidated undrained triaxial test          |
| $C_c$      | coefficient of curvature, $(D_{30})^2 / (D_{10} \times D_{60})$ | $u_a$                    | pore gas pressure                               |
| $C_u$      | coefficient of uniformity, $D_{60}/D_{10}$                      | $u_e$                    | excess pore water pressure                      |
| $C_c$      | compression index for one dimensional consolidation             | $u_s, u_w$               | pore water pressure                             |
| $C_\alpha$ | coefficient of secondary compression                            | V                        | total volume                                    |
| $c_v$      | coefficient of consolidation                                    | $V_g$                    | volume of gas                                   |
| c          | cohesion intercept for total stresses                           | $V_s$                    | volume of solids                                |
| $c'$       | cohesion intercept for effective stresses                       | $V_v$                    | volume of voids                                 |
| D          | diameter of specimen  | $V_w$                    | volume of water                                 |
| $D_{10}$   | diameter at which 10% of soil is finer                          | $V_o$                    | initial volume                                  |
| $D_{15}$   | diameter at which 15% of soil is finer                          | v                        | velocity  |
| $D_{30}$   | diameter at which 30% of soil is finer                          | W                        | total weight                                    |
| $D_{50}$   | diameter at which 50% of soil is finer                          | $W_s$                    | weight of solids                                |
| $D_{60}$   | diameter at which 60% of soil is finer                          | $W_w$                    | weight of water                                 |
| $D_{85}$   | diameter at which 85% of soil is finer                          | w                        | water content                                   |
| $d_{50}$   | displacement for 50% consolidation                              | $w_c$                    | water content at consolidation                  |
| $d_{90}$   | displacement for 90% consolidation                              | $w_f$                    | final water content                             |
| $d_{100}$  | displacement for 100% consolidation                             | $w_l$                    | liquid limit                                    |
| E          | Young's modulus   | $w_n$                    | natural water content                           |
| e          | void ratio  | $w_p$                    | plastic limit                                   |
| $e_c$      | void ratio after consolidation                                  | $w_s$                    | shrinkage limit                                 |
| $e_o$      | initial void ratio  | $w_o, w_i$               | initial water content                           |
| G          | shear modulus   | $\alpha$                 | slope of $q_f$ versus $p_f'$                    |
| $G_s$      | specific gravity of soil particles                              | $\alpha'$                | slope of $q_f$ versus $p_f'$                    |
| H          | height of specimen  | $\gamma_t$               | total unit weight                               |
| PI         | plasticity index  | $\gamma_d$               | dry unit weight                                 |
| i          | gradient  | $\gamma_s$               | unit weight of solids                           |
| $K_o$      | lateral stress ratio for one dimensional strain                 | $\gamma_w$               | unit weight of water                            |
| k          | permeability  | $\epsilon$               | strain  |
| LI         | Liquidity Index   | $\epsilon_{vol}$         | volume strain                                   |
| $m_v$      | coefficient of volume change                                    | $\epsilon_h, \epsilon_v$ | horizontal strain, vertical strain              |
| n          | porosity  | $\mu$                    | Poisson's ratio, also viscosity                 |
| PI         | plasticity index  | $\sigma$                 | normal stress                                   |
| $P_c$      | preconsolidation pressure                                       | $\sigma'$                | effective normal stress                         |
| p          | $(\sigma_1 + \sigma_3) / 2, (\sigma_v + \sigma_h) / 2$          | $\sigma_c, \sigma'_c$    | consolidation stress in isotropic stress system |
| $p^*$      | $(\sigma'_1 + \sigma'_3) / 2, (\sigma'_v + \sigma'_h) / 2$      | $\sigma_h, \sigma'_h$    | horizontal normal stress                        |
| $p'_c$     | $p'$ at consolidation   | $\sigma_v, \sigma'_v$    | vertical normal stress                          |
| Q          | quantity of flow  | $\sigma_1$               | major principal stress                          |
| q          | $(\sigma_1 - \sigma_3) / 2$                                     | $\sigma_2$               | intermediate principal stress                   |
| $q_f$      | q at failure  | $\sigma_3$               | minor principal stress                          |
| $q_o, q_i$ | initial q   | $\tau$                   | shear stress                                    |
| $q_c$      | q at consolidation  | $\varphi$                | friction angle based on total stresses          |
| S          | degree of saturation  | $\varphi'$               | friction angle based on effective stresses      |
| SL         | shrinkage limit   | $\varphi'_r$             | residual friction angle                         |
| $s_u$      | undrained shear strength  | $\varphi_{ult}$          | $\varphi$ for ultimate strength                 |
| T          | time factor for consolidation                                   |                          |   |



## **CHAPTER 5**

### **REVIEW OF EXISTING WEST SLOPE AND BRIDGE STABILIZATION SYSTEM INSTRUMENTATION AND MONITORING FINDINGS**

#### **5.1 Introduction**

The existing data recorded by the instruments installed at the job site were collected by ODOT District 12 and transferred to EL Robinson Engineering (ELR) to be used by ELR to understand the mechanism and limits of movement in the slope.

#### **5.2 West Slope and Pier 1 Stabilization System Instrumentation Plan**

The west slope has been monitored since 1994 using inclinometers and piezometers. Due to excessive movements within the west bank slope where Pier 1 and the West End Pier are located, a slope stabilization system was proposed, designed, and constructed during the period from 1997 to 1999. The stabilization system consisted of two rows of drilled shafts with a reinforced concrete cap, tension tieback beams, driven piles with a reinforced concrete cap, and relatively long rock anchors. The drilled shaft reinforced concrete cap was tied to the pile cap with steel W 8 x 35 members. Figure 5.1 shows a plan view of the stabilization system.

Between 1999 and 2009, several additional inclinometers and piezometers were installed either as replacements for ones that had exceeded the range of their measurement or as additional instruments to monitor the area where the proposed I-90 westbound bridge is going to be constructed. The plan view of all the inclinometers and piezometers is shown in Figure 5.2.

#### **5.3 QA/QC Review of Instrumentation Monitoring Results**

As part of the QA/QC work, ELR reviewed the data collected from the instrumentation installed in the slope since 1994 and in the stabilization structure since 1999.

### 5.3.1 Slope Movement Measurements

The collected data was reviewed and updated to reflect the latest quarterly readings obtained in July of 2009. Data from the earth inclinometers installed and monitored by BBC&M was independently analyzed by ELR to provide an alternative opinion. The data were processed using the GTILT Plus software and figures showing movement versus depth and rates of movement were developed. The figures which show the magnitude of movement versus depth and the rates of movement are attached in Appendix 5A.

The rate of movement at each slip plane depth was thoroughly investigated. The data was divided into four phases:

1. Phase 1: before construction started in 1997.
2. Phase 2: from 1997 until 6/1999.
3. Phase 3: From 6/1999 until 12/2001.
4. Phase 4: long term monitoring from 1/2002-to the present.

The movements at each slip plane during each of the four phases are presented in Figures 5.3 to 5.6.

Soil profiles developed from old and new borings were used to postulate the movement along the centerline of the proposed structure (Profile A-A) and to the south of the existing structure (Profile D-D). The movements along Profile A-A are shown in Figures 5.7 through 5.10, respectively, for each of the four Phases. Figures 5.11 through 5.14 present the movements along Profile D-D for the four Phases. Table 5.1 summarizes the total movement and the rate of movement during each of the four phases.

The movement plots and plan views show that in the area of the new structure there is minimal movement along the deep slip plane. The rate of movement is estimated to be 0.01 inches per year.

The data collected from the pneumatic and vibrating wire piezometers installed in the west

slope area were analyzed and plotted. Appendix 5B contains the pressure versus time plots from all installed piezometers.

### **5.3.2 Drilled Shafts Stress Condition Assessment**

During construction of the drilled shafts for the stabilization structure, a lateral load test was conducted between shafts #1 and #3. The maximum applied lateral load was 800 kips. The deflection associated with a lateral load of 800 kips was 5 inches as shown in Figure 5.15. The maximum bending strain along the depth of shaft #1 associated with the 800 kips lateral load was 1614 micro strains as shown in Table 5.2. From long term monitoring data obtained from instrumentation installed in drilled shaft #9, measurements indicated a maximum bending strain located at a depth of 95 feet to have a magnitude equal to 151 micro strains. This value is 10% of the 1614 value measured during the lateral load test.

For shaft #17, which experienced a maximum movement of 1.7 inches, the strain equivalent to this value from the lateral load test is equal to 231 micro strains. Figure 5.16 shows the interaction diagram for the stabilization drilled shafts. The concrete strength used was 6000 psi, which was taken from the drilled shaft inspection record included in Appendix 5C.

Based on the findings from the lateral load test, the drilled shafts have the ability to move up to 5 inches elastically (which was the maximum movement reported in the lateral load test). The rate of movement in drilled shaft #17 was the highest (i.e. 0.12 inch/yr). Assuming a constant rate of 0.12 inch/yr, it will take 15 years to reach a total movement of 3.5 inches (1.7 + 1.8). Assuming a constant rate of 0.12 inch/yr, it will take 28 years to reach a total movement of 5 inches (1.7 + 3.3). This indicates that the safe life of the stabilization shafts is approximately 30 years before getting beyond the condition as tested in 1998. From the long term monitoring data, the rate of increase in the moment and axial force in shaft #9 at a depth of 95 feet appears to have decreased as shown in Figures 5.17 and 5.18. The recently collected data from the July 2009 readings show minimal increase in the strain in the shaft.

### **5.3.3 Tie Beams**

Tie beam measurements are experiencing a steady state condition with no indication of any trend to vary with time except for slight stress changes which are most likely a result of changes in temperature. Note that there is a relatively high frictional resistance from the soil around and on top of the beams. The tie beams were insulated in a 24" diameter corrugated PVC, pipe which was filled with concrete after tensioning of the anchors. Due to the corrugated pipe and the concrete filling, the tie beams are acting as a composite 24" diameter corrugated section. The steel beam inside the section is not indicating any increase in stress in response to the movement of the caps. The force transmitted through the PVC composite sections has to overcome the friction of the surrounding soil. It appears that the drilled shaft cap and the pile cap are moving similar distances laterally, which allows the tie beams to remain in a constant state of stress. Pictures in Figure 5.19 show the construction of the tie beams and the placement of substantial embankment on top of the tie beams.

### **5.3.4 Rock Anchors**

Rock anchor data was reviewed and plots were updated to reflect the collected data that was available prior to and including the April 2006 quarterly data. A trend indicating a loss of load was noticed in all anchors. The rate of loss in load was the highest in anchor #17, which is in line with drilled shaft #17, which showed the most movement. Anchor #17 showed a loss in the range of 8.5 kips per year, while anchor #1 showed a loss of 5.5 kips per year.

The variation in load loss is in agreement with the movement trend in the drilled shafts which can be explained by the rotation of the reinforced concrete pile cap.

The plots of anchor load vs. time since lock-off in 1999 until April 2006 are shown in Figures 5.20 thru 5.23 for anchors #1, 8, 9, and 17, respectively.

### **5.3.5 Piles**

The driven piles experienced an increase in the axial force after the completion of construction ranging from 40 to 150 kips. The bending moment increase was in the range of 30 ft-k to 150 ft-k in the down-slope direction (river side of the pile) and 1 to 55 ft-k in the direction 90° from down-slope. The axial force and bending moment are below the allowable values for the HP14 x 89 pile section. The mechanism of force and moment buildup can be explained as follows: the tensioning of the rock anchors caused an axial force in the piles due to the 45° downward angle of the anchors. The cap rotated several degrees by the time the 17 anchors were tensioned. The corrugated tubes around the tie beams were concreted after completion of tensioning the anchors. After the placement of concrete in the PVC pipes that were placed around the tie beams, the 25 feet of embankment was constructed on top of the tie beams and the anchor cap. This resulted in additional dead load on the pile cap from the weight of the soil carried by the cap and the tie beams. The pile cap was somewhat restrained from rotating backwards due to the force in the anchors and the framed-in 34 tie beams embedded in the opposite side. The pile cap deflected elastically downward because of the weight of the soil on the tie beams.

### **5.3.6 Inclometers Installed in the Drilled Shafts**

The movements in the inclinometers installed in shafts #1, 3, 8, 9, 10, and 17 have been monitored since 1999. The data indicates a trend for an increase in the lateral movement at shaft #17 equal to almost twice the movement observed in shaft #1.

The consolidation of the embankment caused an increase in dead load supported by the top of the tie beams.

### **Status of Monitoring as of July 2009**

The latest measurement readings collected from instrumentation in the stabilization structure for the existing bridge and in various locations in the slope indicated no change in magnitude from the April 2006 readings. The quarterly report titled “July 2006 Quarterly Report Field

Monitoring Services,” dated August 2006, was prepared by BBC&M Engineering Inc.

Our conclusion is that the slope retention structure has a 30-year remaining safe life before reaching the stress condition that existed when tested in 1998.

**Table 5.1: Horizontal Movements Measured using Inclinometers**

| Inclinometer No. | Elevation (Feet) | Date of the Measurements                |           |            |          |
|------------------|------------------|---|-----------|------------|----------|
|                  |                  | 9/23/1997                               | 6/30/1999 | 12/30/2001 | 1/1/2006 |
|                  |                  | Inclinometer Movement Horizontal (Inch) |           |            |          |
| B101             | 505              | 0.000                                   | 0.000     | 0.000      | 0.000    |
|                  | 492              | 0.000                                   | 0.000     | 0.000      | 0.060    |
| B102             | 607              | 0.000                                   | 0.000     | 0.000      | 0.000    |
| B105             | 490              | 0.000                                   | 0.210     | 0.170      | 0.100    |
|                  | 475              | 0.130                                   | 0.730     | 0.340      | 0.520    |
| B107             | 614              | 0.000                                   | 0.000     | 0.000      | 0.000    |
|                  | 515              | 0.000                                   | 0.000     | 0.000      | 0.000    |
|                  | 478              | 0.000                                   | 0.000     | 0.000      | 0.000    |
| B108             | 592              | -                                       | -         | -          | 0.000    |
|                  | 542              | -                                       | -         | -          | 0.100    |
|                  | 540              | -                                       | -         | -          | 0.100    |
| B110             | 567              | 0.000                                   | 0.000     | 0.191      | 0.230    |
|                  | 552              | 0.000                                   | 0.000     | 0.000      | 0.000    |
|                  | 479              | 0.000                                   | 0.000     | 0.000      | 0.000    |
| B203             | 599              | -                                       | 0.341     | 0.000      | 0.055    |
|                  | 579              | -                                       | 0.050     | 0.000      | 0.000    |
|                  | 561              | -                                       | 0.272     | 0.076      | 0.114    |
| B204             | 582              | -                                       | -         | -          | 0.000    |
|                  | 498              | -                                       | -         | -          | 0.000    |
|                  | 482              | -                                       | -         | -          | 0.200    |
| B303             | 573              | -                                       | 0.250     | 0.110      | 0.220    |
|                  | 566              | -                                       | 0.411     | 0.083      | 0.102    |
|                  | 525              | -                                       | 1.002     | 0.331      | 0.370    |

**Table 5.2: Strain Measurements during the Lateral Load Test on Shafts #1 and #3**

**SHAFT # 1 - SOUTH (TENSION SIDE), REDUCED STRAIN DATA**

|            | SB-12269 | SB-12229 | SB-12270 | SB-12271 | SB-12268 | SB-12274 | SB-12272 | SB-12226 | SB-12238 | SB-12257 | SB-12258 | SB-12228 | SB-12255 | SB-12273 |
|------------|----------|----------|----------|----------|----------|----------|----------|----------|----------|----------|----------|----------|----------|----------|
| Depth (ft) | 4.5      | 11       | 17.5     | 24       | 30.5     | 37       | 42.33    | 49.83    | 59.83    | 69.83    | 79.83    | 89.83    | 110      | 130      |
| Load (K)   |          |          |          |          |          |          |          |          |          |          |          |          |          |          |
| 0          | 0.00     | 0.00     | 0.00     | 0.00     | 0.00     | 0.00     | 0.00     | 0.00     | 0.00     | 0.00     | 0.00     | 0.00     | 0.00     | 0.00     |
| 50         | 1.43     | 7.71     | 8.33     | 5.60     | 3.44     | 1.04     | 0.29     | 0.04     | -0.21    | 0.00     | -0.30    | 0.14     | 0.22     | 0.11     |
| 100        | 1.46     | 8.63     | 9.14     | 6.30     | 3.89     | 1.22     | 0.40     | 0.18     | -0.28    | 0.04     | -0.41    | 0.22     | 0.18     | 0.11     |
| 200        | 8.55     | 38.36    | 51.55    | 41.17    | 28.71    | 10.41    | 3.90     | 2.43     | -0.18    | -0.29    | 0.37     | 0.76     | 0.63     | 0.25     |
| 300        | 13.90    | 64.90    | 95.05    | 82.21    | 64.78    | 24.63    | 10.00    | 8.16     | 0.32     | -0.92    | 0.04     | 1.09     | 0.89     | 0.36     |
| 400        | 19.18    | 91.43    | 131.84   | 145.49   | 97.77    | 38.39    | 16.26    | 14.17    | 2.43     | -1.40    | -0.11    | 1.66     | 1.22     | 0.50     |
| 500        | 25.91    | 120.27   | 473.54   | 379.36   | 145.12   | 57.66    | 25.52    | 23.56    | 5.59     | -1.44    | -0.33    | 2.50     | 1.81     | 0.75     |
| 600        | 35.22    | 308.53   | 574.73   | 718.38   | 231.32   | 68.64    | 30.52    | 29.72    | 8.20     | -1.21    | 0.59     | 3.37     | 2.36     | 0.93     |
| 680        | 42.81    | 457.92   | 631.01   | 1528.79  | 1352.42  | 80.42    | 38.17    | 38.03    | 13.01    | -1.40    | 0.74     | 4.16     | 2.73     | 1.18     |
| 720        | 46.94    | 569.07   | 736.89   | 1586.51  | 1406.40  | 89.75    | 43.25    | 42.88    | 14.63    | -1.29    | 0.52     | 4.70     | 3.17     | 1.32     |
| 800        | 51.19    | 622.56   | 862.69   | 1614.50  | 1461.09  | 95.15    | 47.77    | 48.68    | 16.99    | -1.62    | 0.19     | 4.99     | 3.43     | 1.42     |
| 0          | 12.58    | 136.86   | 18.01    | 321.88   | 610.18   | 67.89    | 36.08    | 45.02    | 19.21    | -3.97    | -4.82    | 0.22     | 0.52     | 0.11     |

**SHAFT # 1 - NORTH (COMPRESSION SIDE), REDUCED STRAIN DATA**

|            | SB-12266 | SB-12250 | SB-12227 | SB-12236 | SB-12256 | SB-12224 | SB-12252 | SB-12237 | SB-12251 | SB-12239 | SB-12259 | SB-12253 | SB-12225 | SB-12267 |
|------------|----------|----------|----------|----------|----------|----------|----------|----------|----------|----------|----------|----------|----------|----------|
| Depth (ft) | 4.5      | 11       | 17.5     | 24       | 30.5     | 37       | 42.33    | 49.83    | 59.83    | 69.83    | 79.83    | 89.83    | 110      | 130      |
| Load (K)   |          |          |          |          |          |          |          |          |          |          |          |          |          |          |
| 0          | 0.00     | 0.00     | 0.00     | 0.00     | 0.00     | 0.00     | 0.00     | 0.00     | 0.00     | 0.00     | 0.00     | 0.00     | 0.00     | 0.00     |
| 50         | -2.50    | -7.22    | -9.34    | -7.22    | -5.10    | -0.89    | -0.14    | -0.07    | 0.55     | 0.11     | 0.15     | 0.44     | -0.07    | 0.22     |
| 100        | -3.12    | -8.03    | -10.39   | -8.25    | -5.85    | -1.03    | -0.18    | 0.11     | 0.96     | 0.33     | 0.34     | 0.44     | -0.07    | -0.11    |
| 200        | -12.94   | -42.82   | -58.23   | -52.17   | -38.82   | -8.29    | -5.15    | -2.55    | 2.43     | 2.47     | 1.13     | 0.77     | 0.61     | 0.18     |
| 300        | -18.89   | -70.84   | -104.46  | -103.34  | -84.93   | -21.07   | -14.76   | -12.05   | 2.35     | 4.50     | 2.56     | 0.95     | 0.65     | 0.07     |
| 400        | -24.30   | -95.61   | -160.14  | -208.95  | -125.83  | -31.75   | -23.62   | -21.12   | 2.02     | 7.20     | 4.18     | 1.42     | 0.72     | 0.37     |
| 500        | -30.18   | -125.58  | -317.20  | -327.35  | -176.28  | -46.48   | -35.27   | -35.25   | -0.18    | 10.67    | 6.21     | 2.15     | 1.15     | 0.22     |
| 600        | -47.60   | -249.00  | -460.12  | -456.76  | -334.18  | -55.66   | -41.10   | -41.28   | -0.11    | 13.36    | 8.95     | 62.32    | 1.83     | -0.11    |
| 680        | -57.71   | -303.92  | -554.04  | -618.26  | -477.71  | -68.51   | -49.03   | -51.69   | -1.99    | 16.32    | 11.43    | 3.98     | 2.41     | 0.48     |
| 720        | -64.40   | -378.80  | -646.90  | -712.68  | -582.21  | -82.96   | -55.75   | -58.67   | -3.09    | 18.24    | 12.64    | 4.78     | 2.84     | 0.85     |
| 800        | -70.65   | -404.24  | -716.73  | -774.65  | -674.32  | -101.14  | -62.65   | -65.55   | -4.34    | 19.97    | 14.63    | 5.95     | 2.30     | 0.96     |
| 0          | -10.33   | -70.49   | -216.91  | -304.33  | -355.04  | -70.89   | -55.96   | -75.33   | -24.58   | 7.57     | 8.16     | 0.69     | 0.25     | 0.22     |



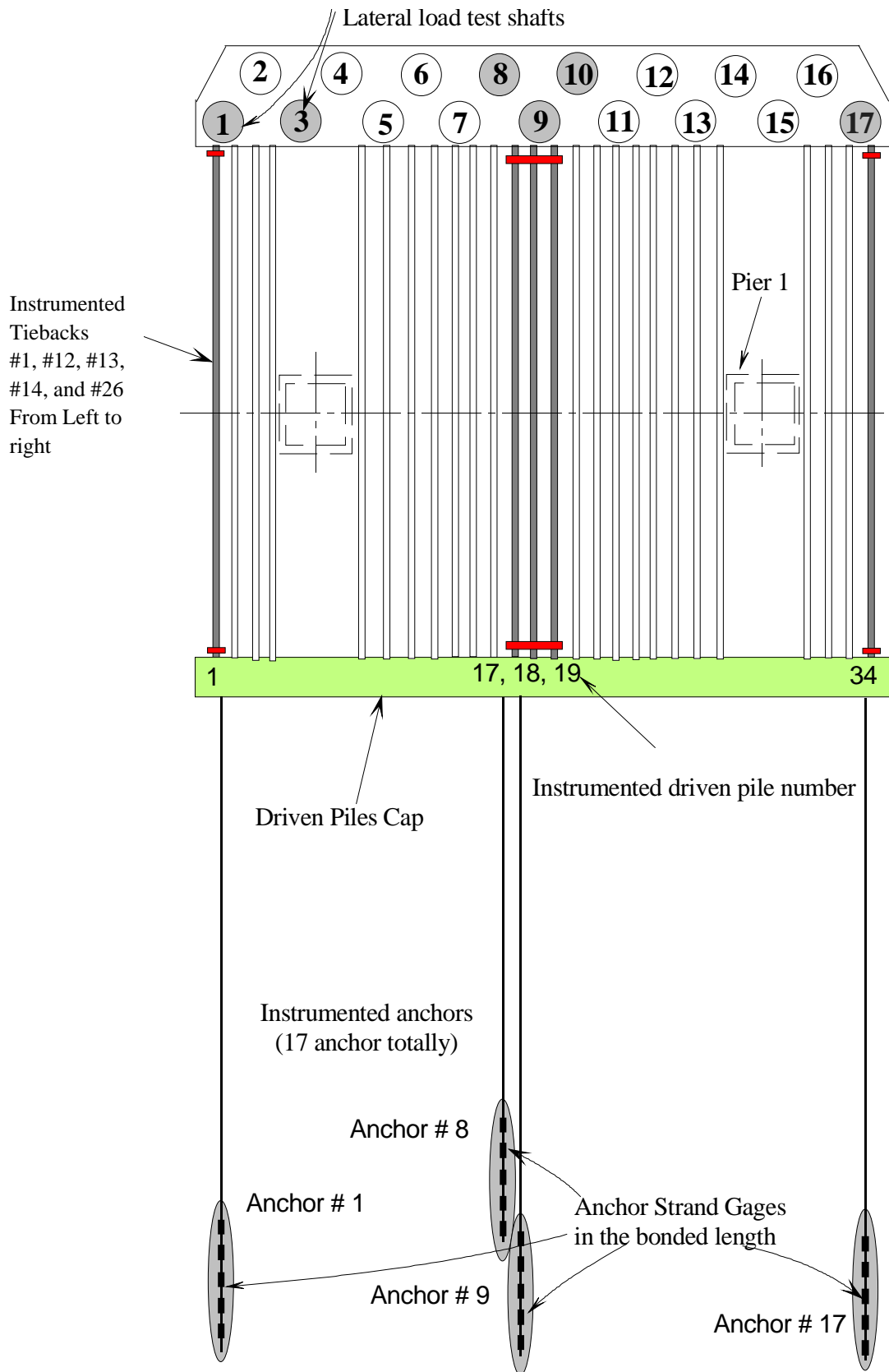

Figure 5.1: Plan view of the stabilization structure and instrumentation layout

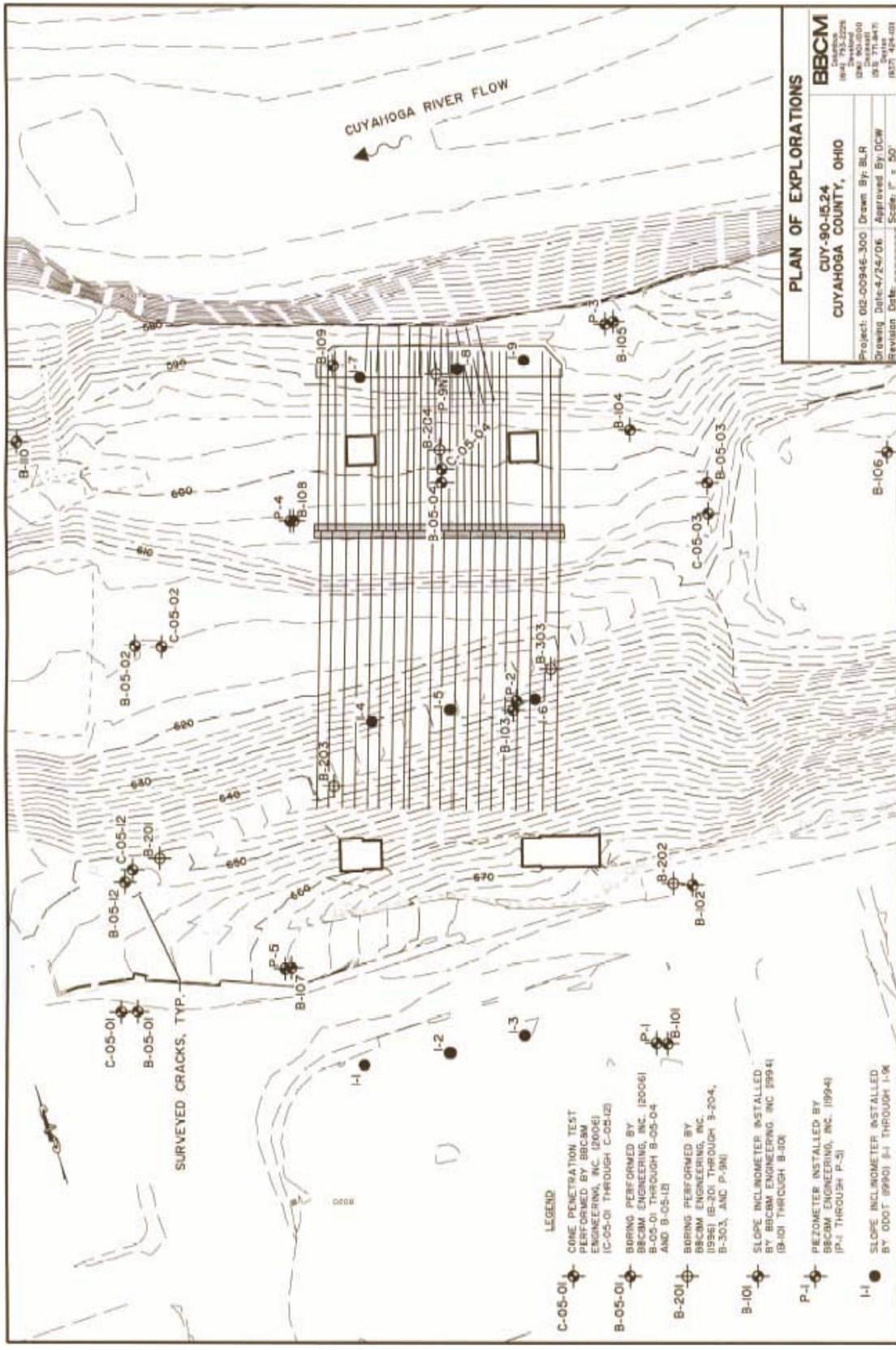

Figure 5.2 Plan view showing the location of the inclinometers in the project area



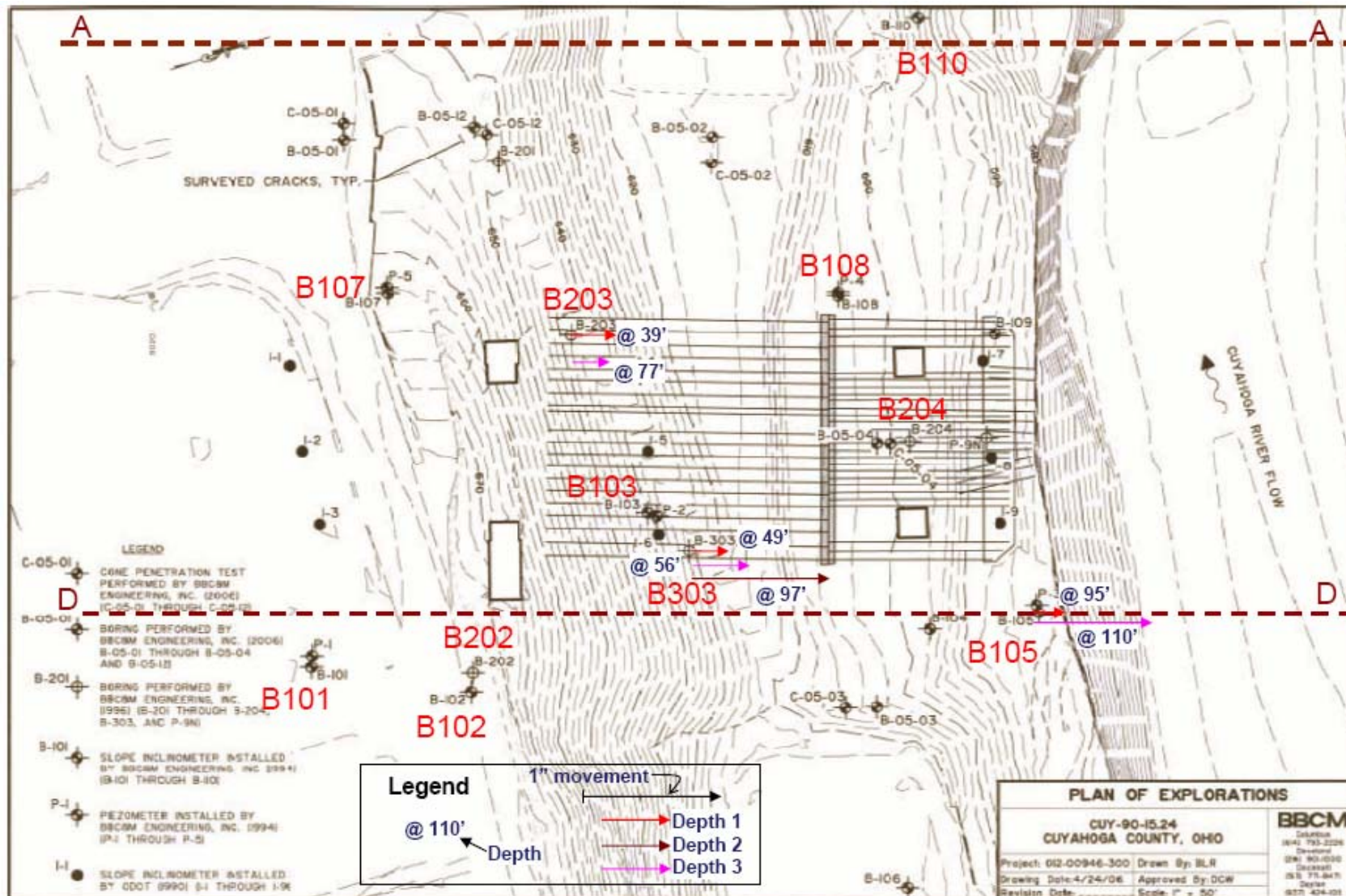

Figure 5.4 Ground movements at each slip plane during phase 2

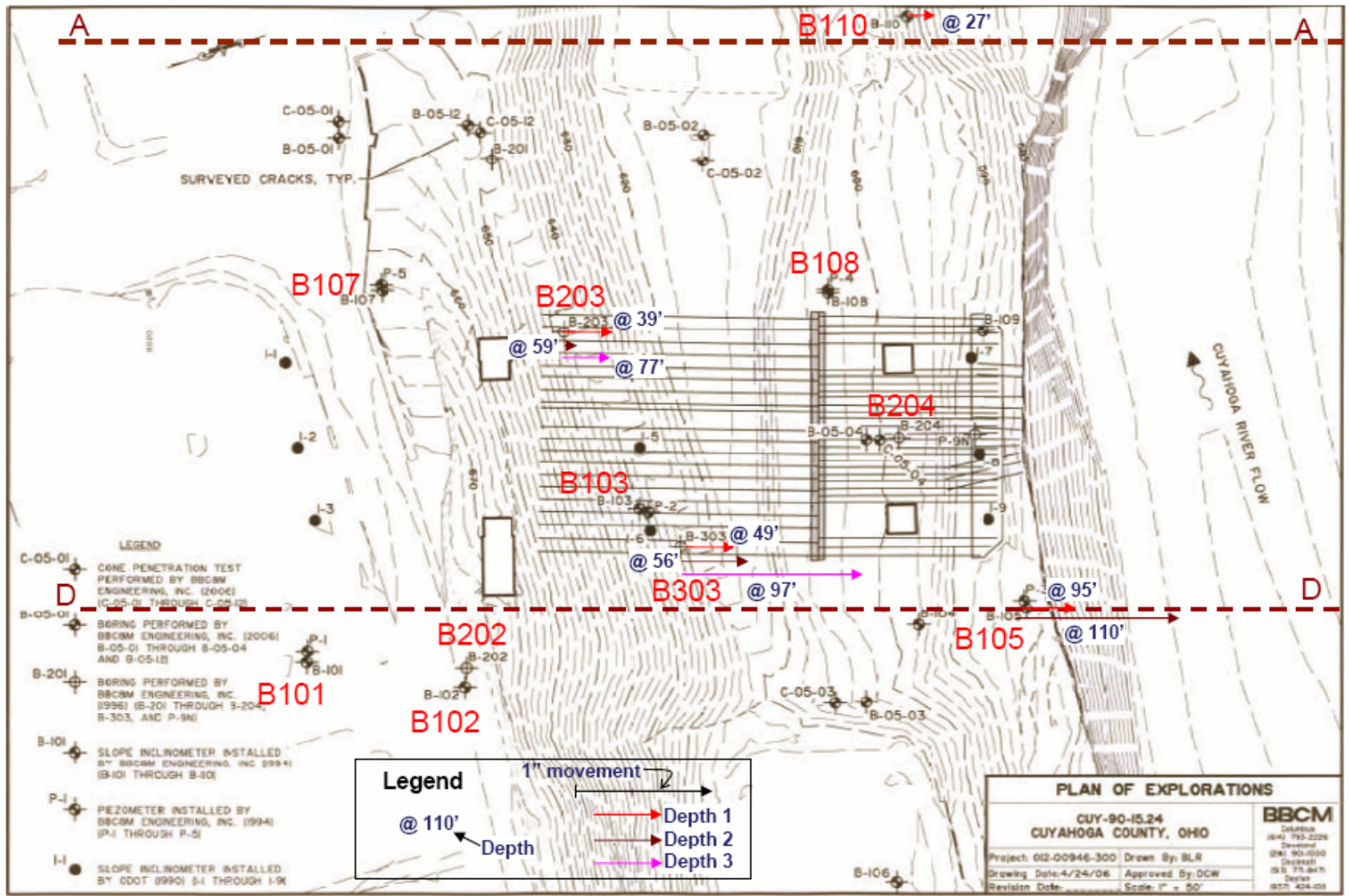

Figure 5.5 Ground movements at each slip plane during phase 3



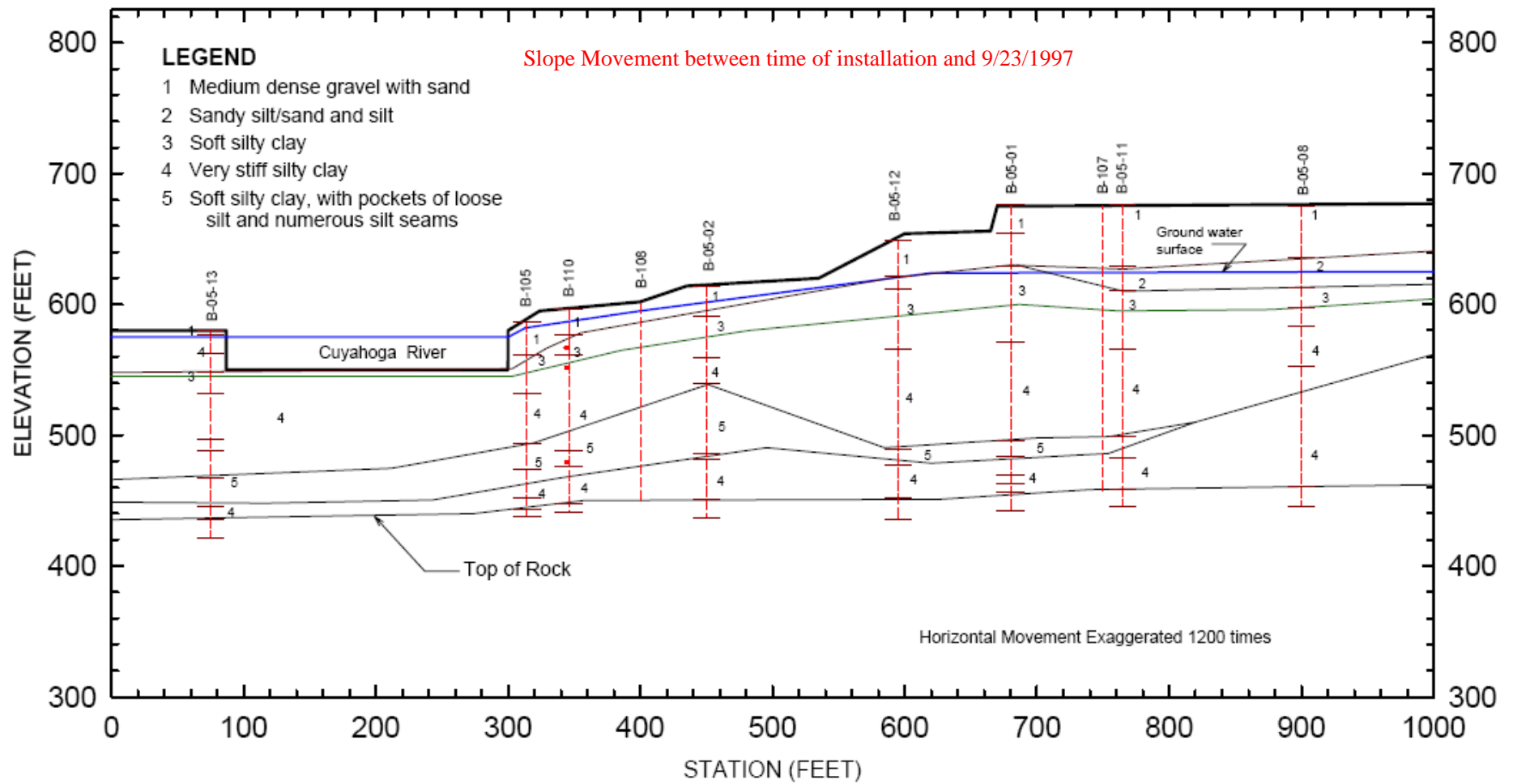

Figure 5.7 Ground movement along section A-A during phase 1

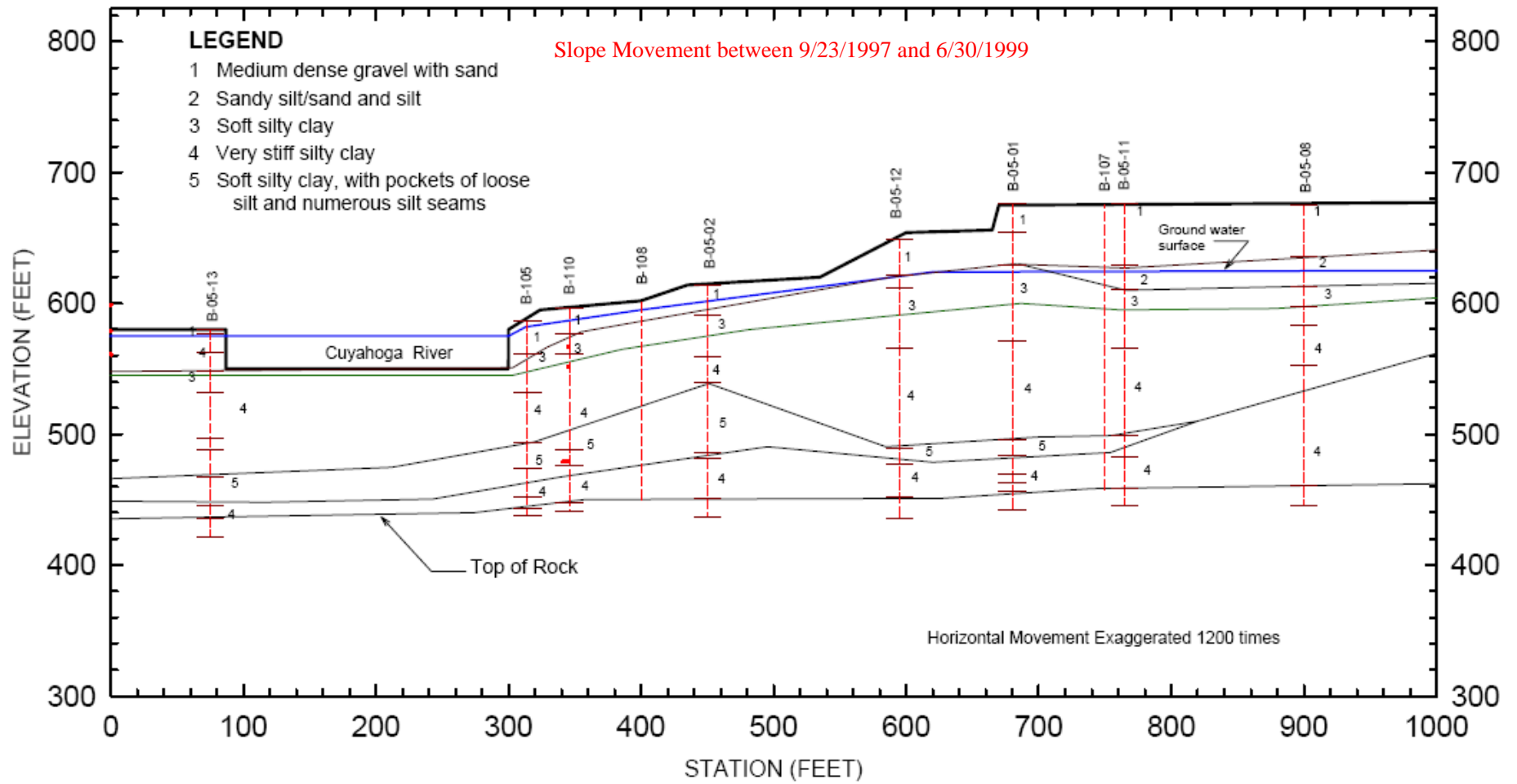

Figure 5.8 Ground movement along section A-A during phase 2



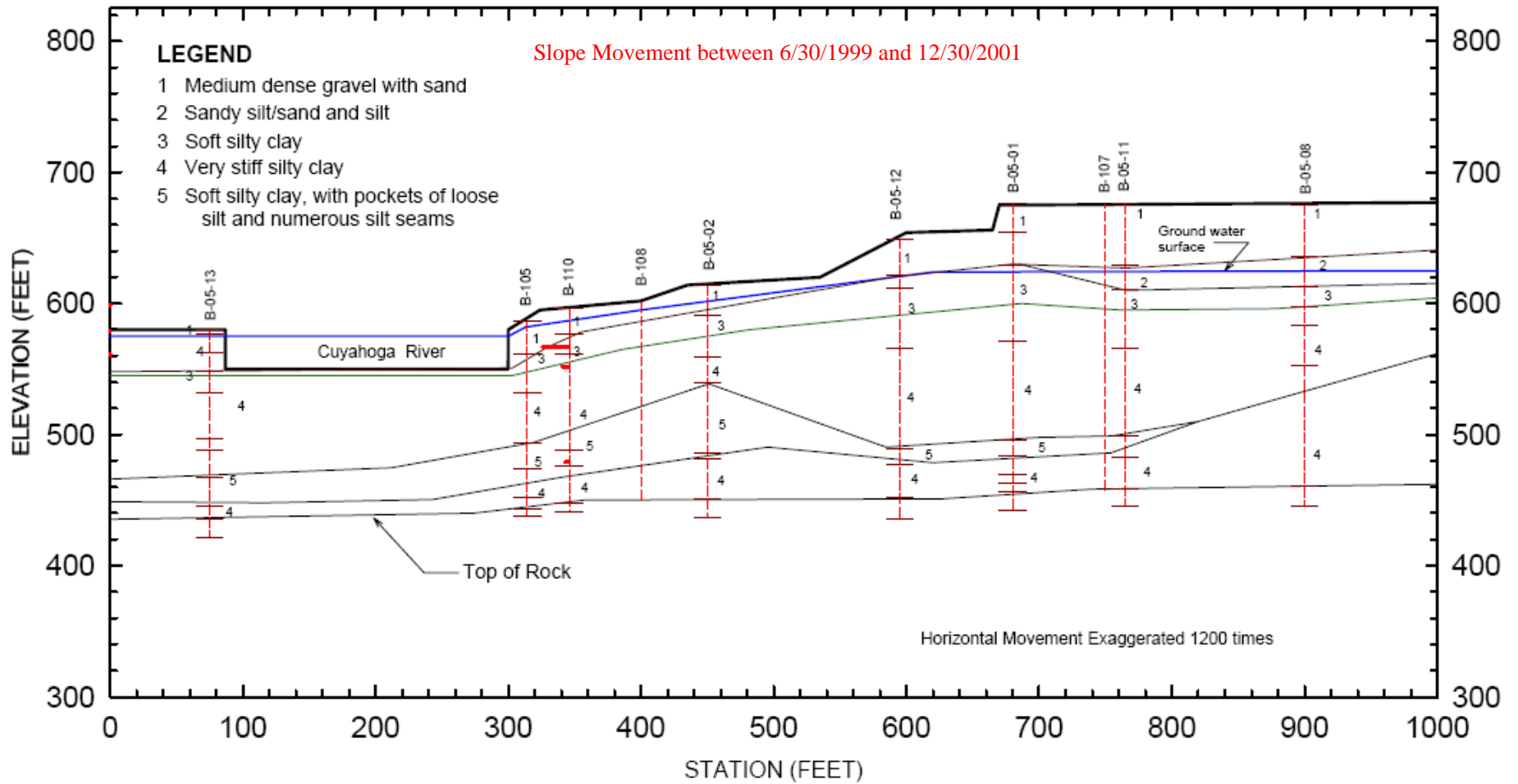

Figure 5.9 Ground movement along section A-A during phase 3

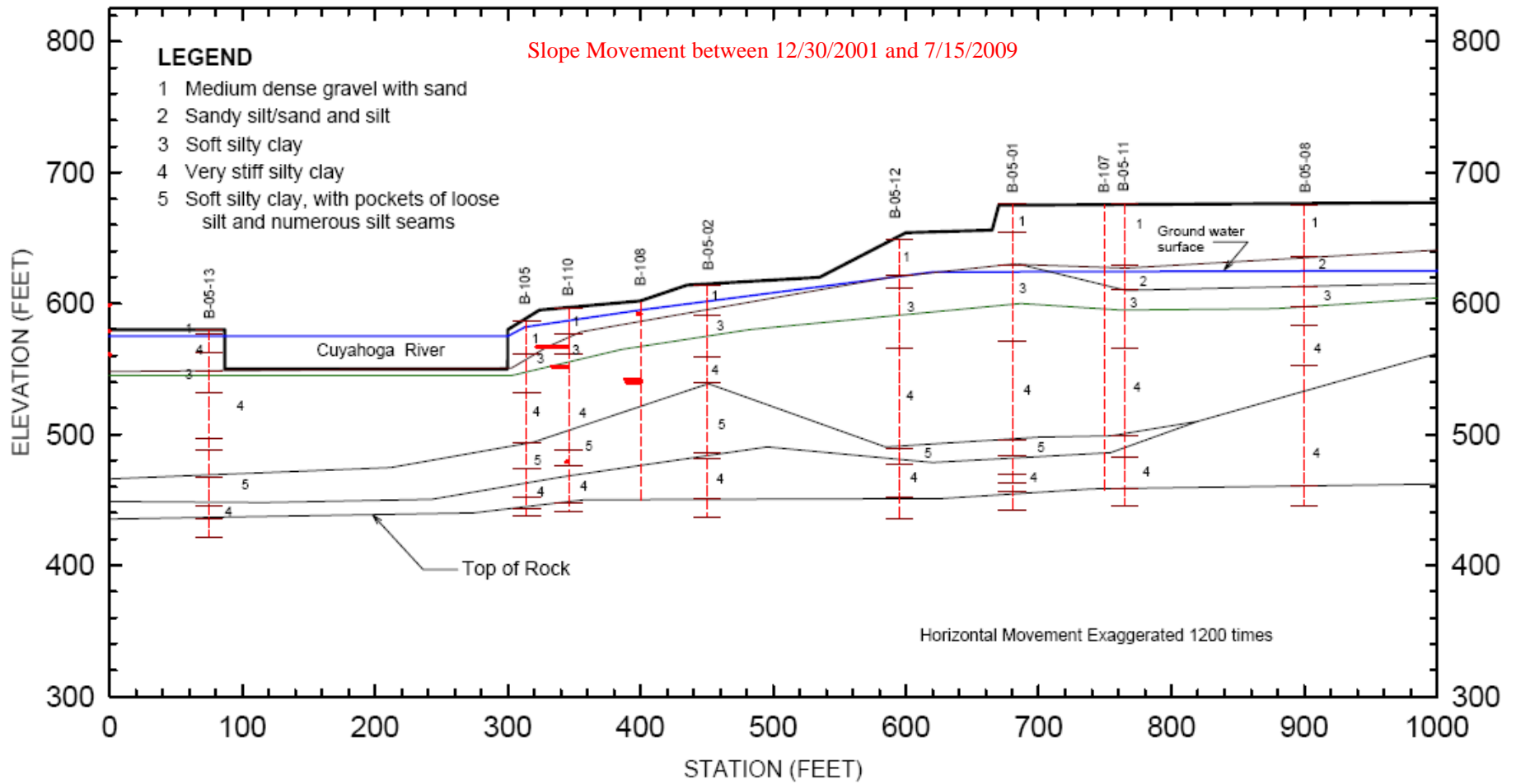

Figure 5.10 Ground movement along section A-A during phase 4

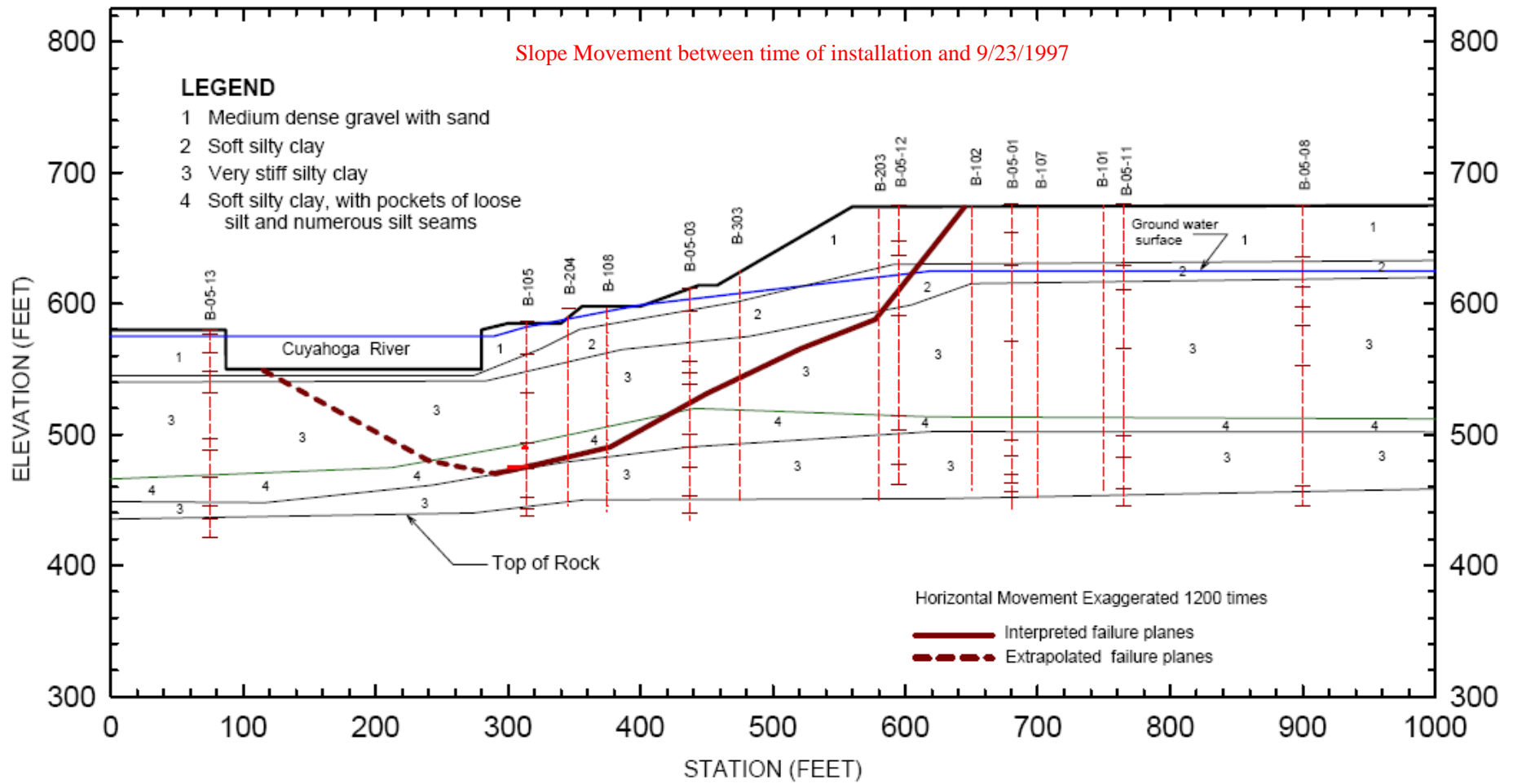

Figure 5.11 Ground movements along section D-D during phase 1

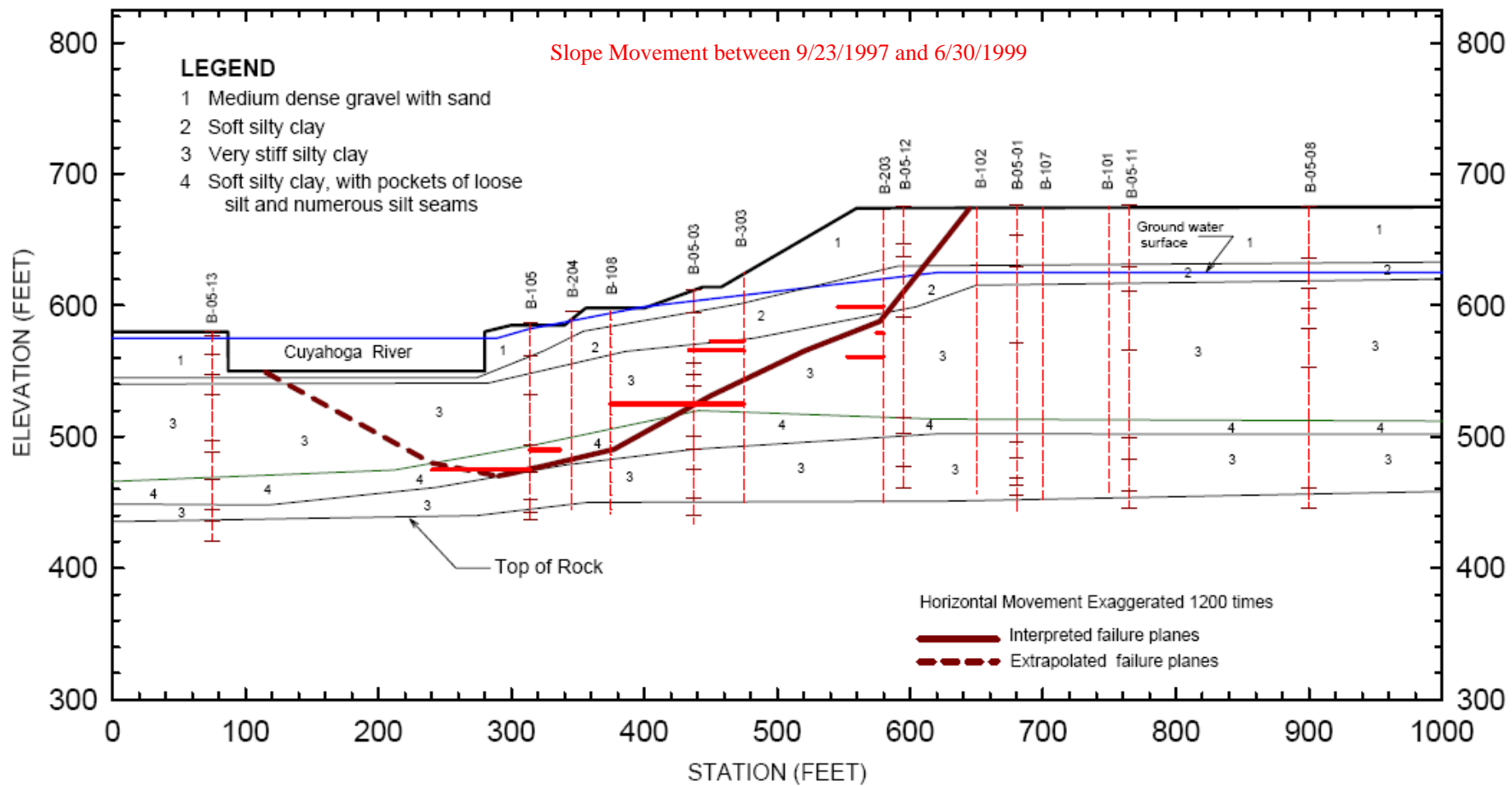
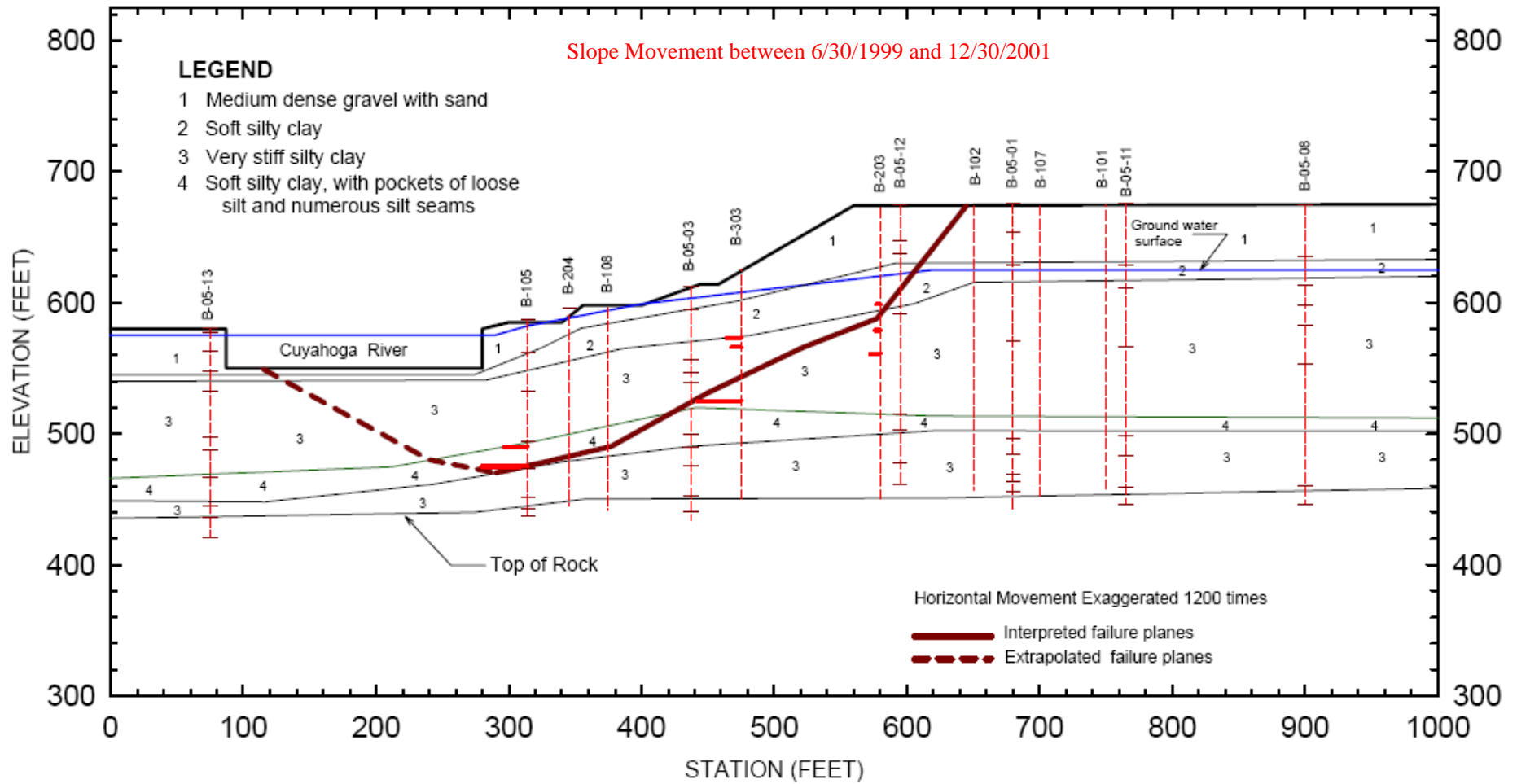
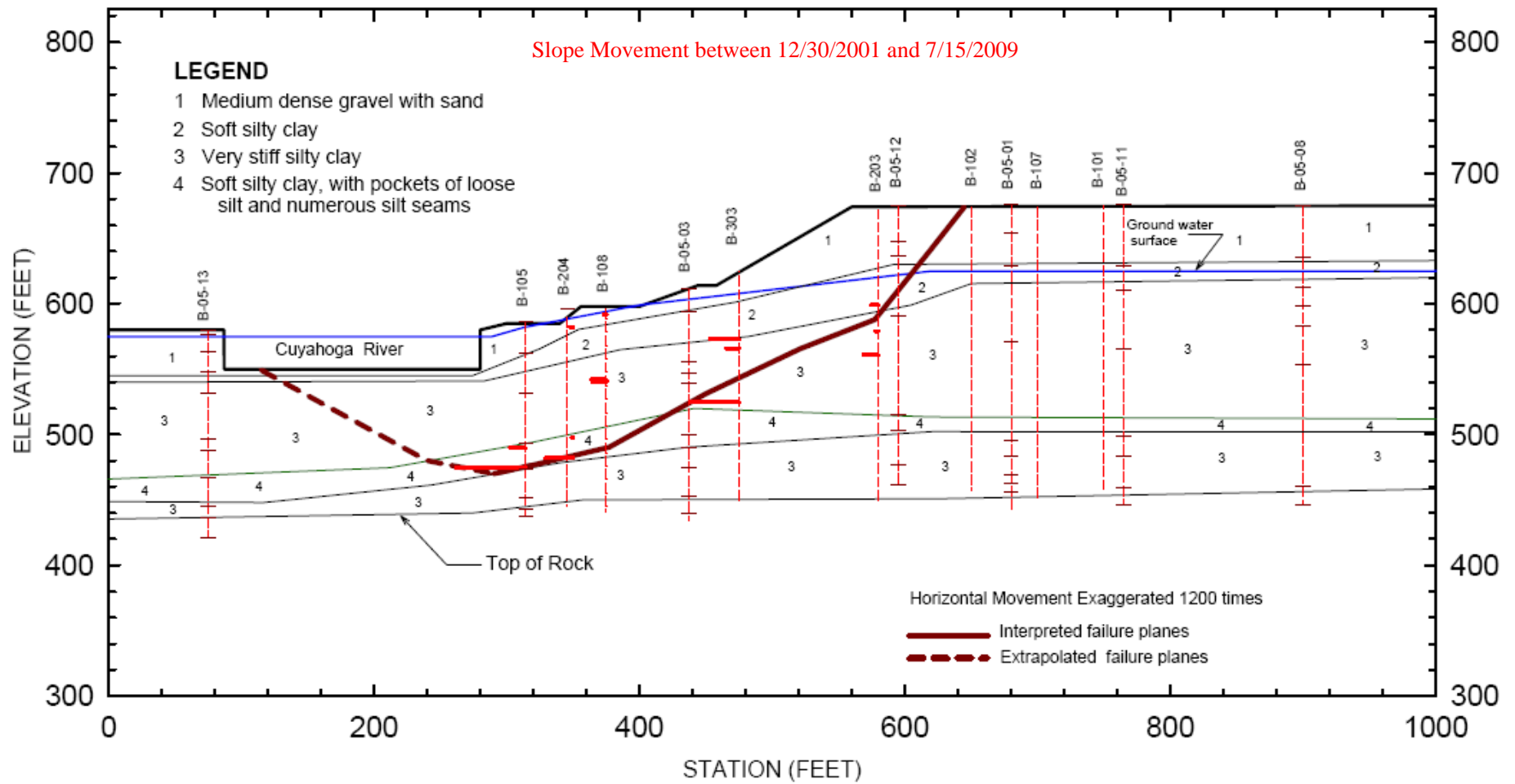

Figure 5.12 Ground movements along section D-D during phase 2





### CUY-90-15.24 Lateral load test Shaft - 1 Direction vs. depth

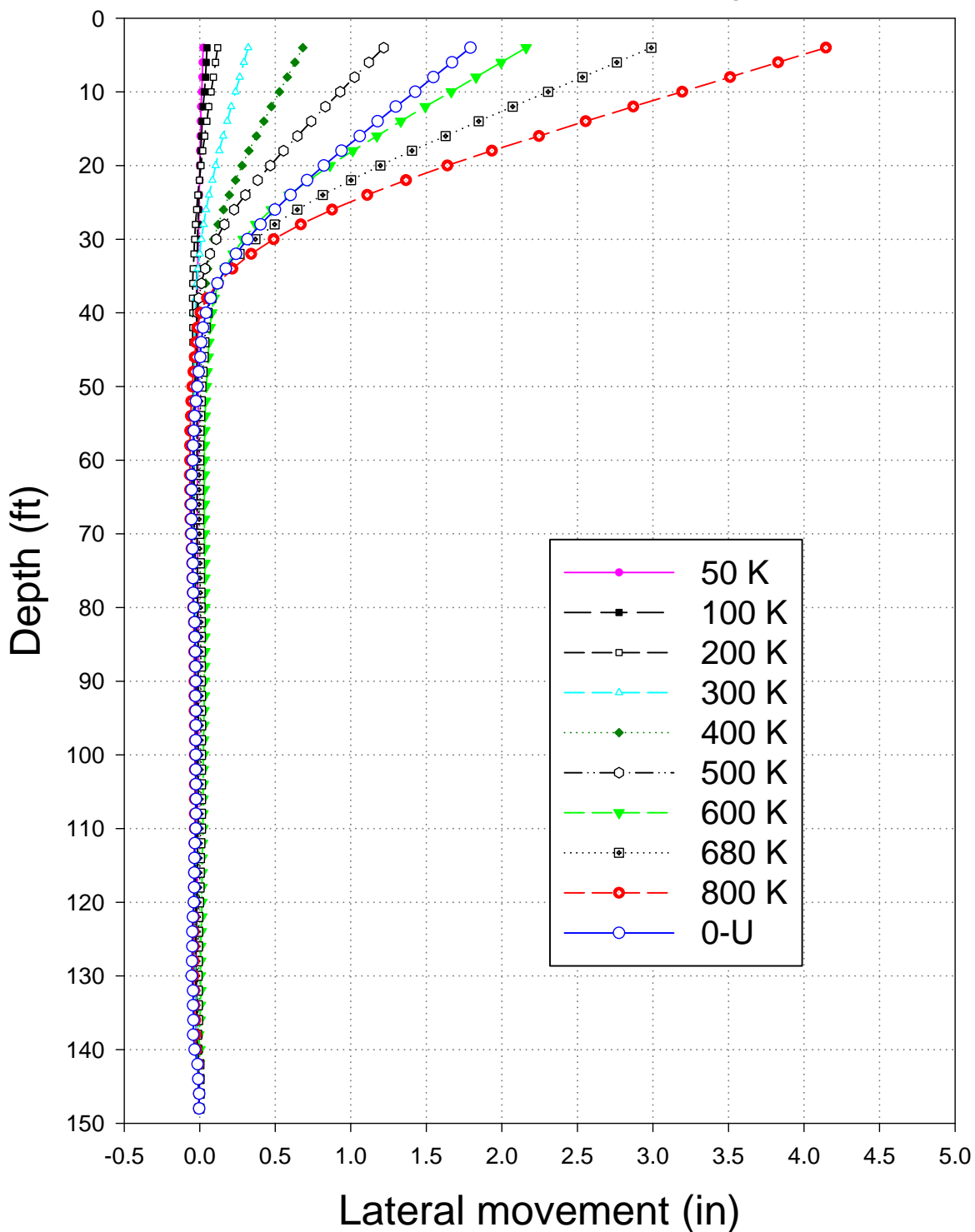

Figure 5.15 Deflection vs. Depth from Shaft #1 during the lateral load test.

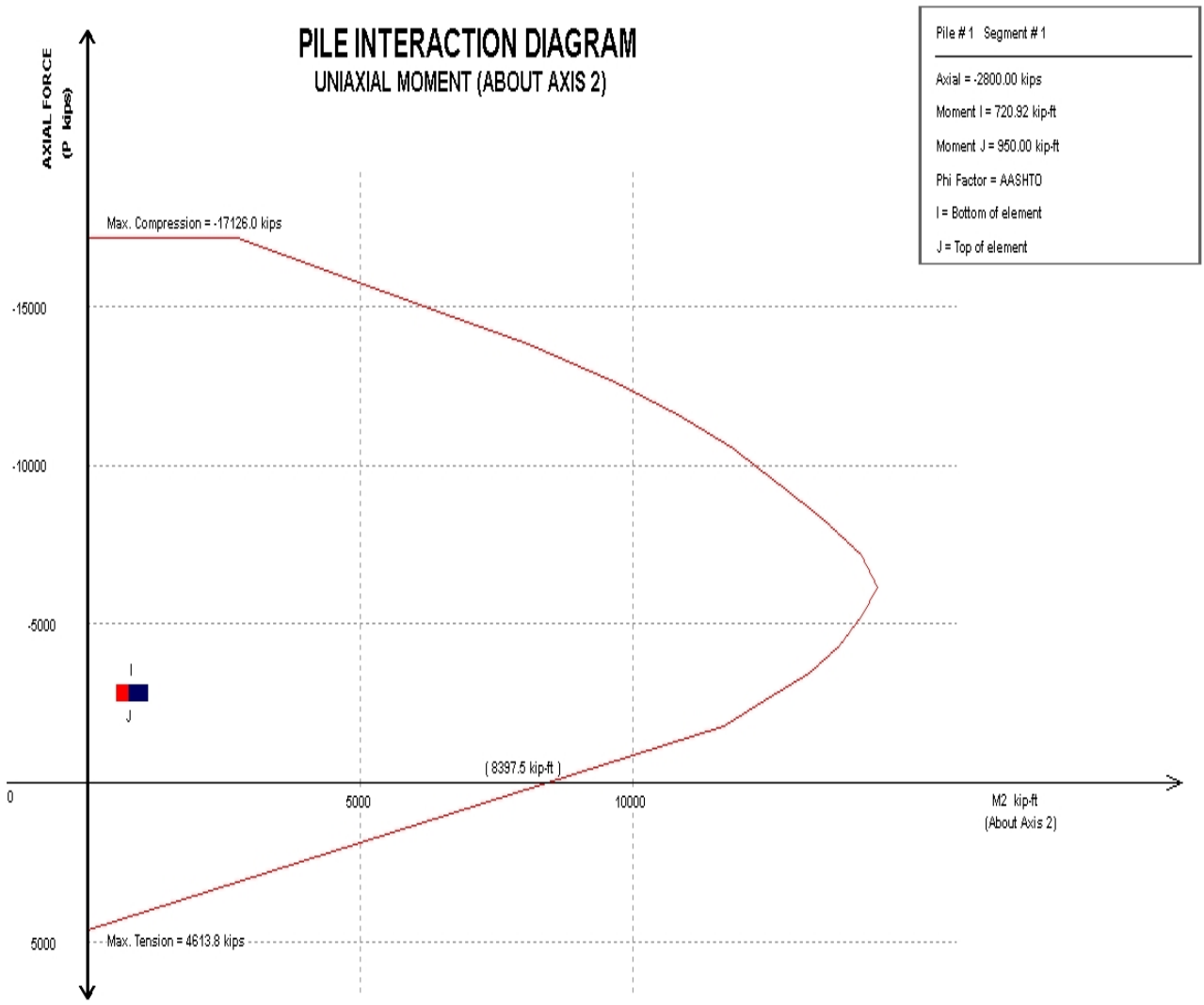
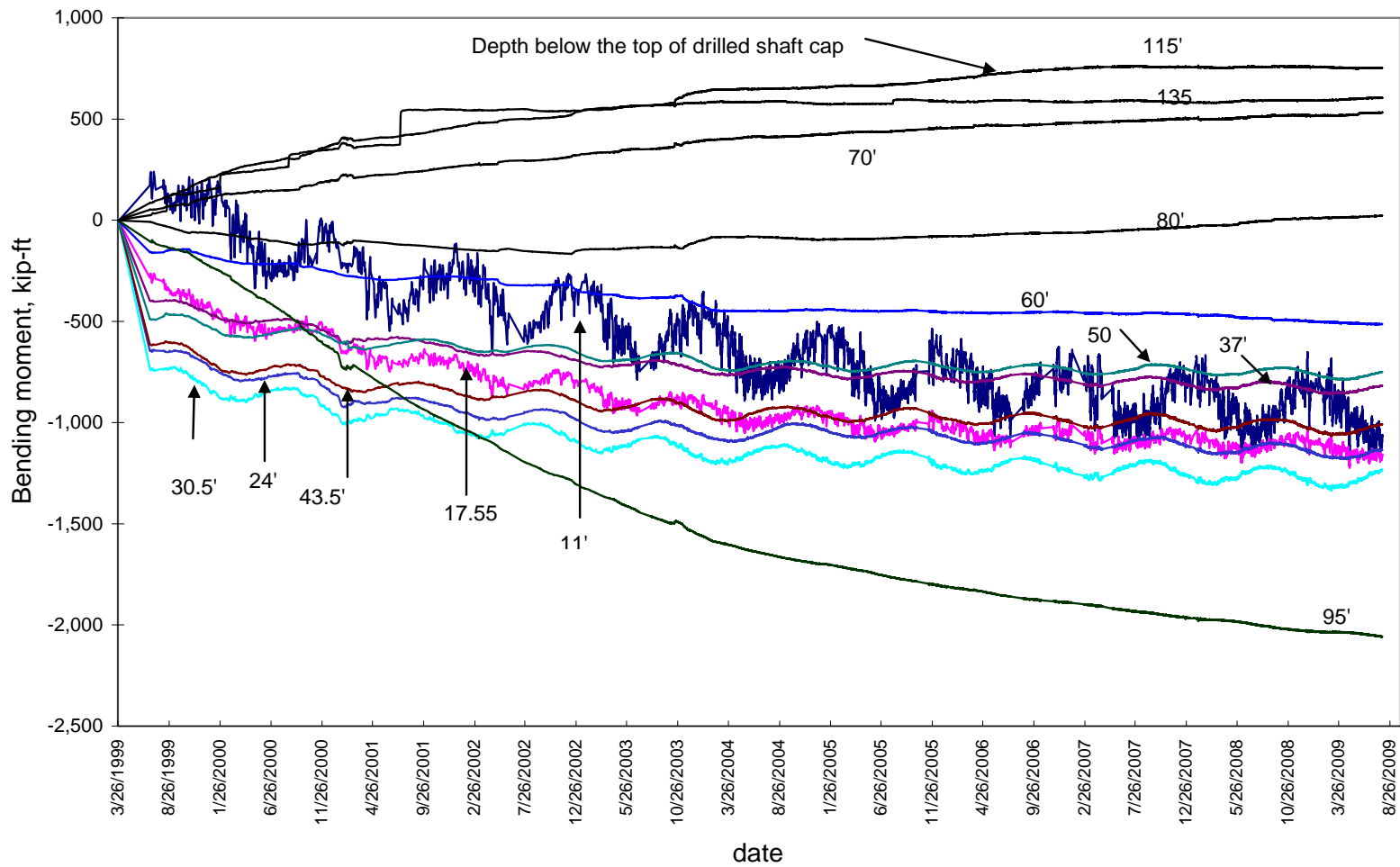

Figure 5.16 Interaction Diagram for Drilled shafts in the stabilization structure.





Shaft #9, Bending moment vs. date in different elevations below the top of cap

Figure 5.17 Rate of increase in Drilled shaft # 9 moment

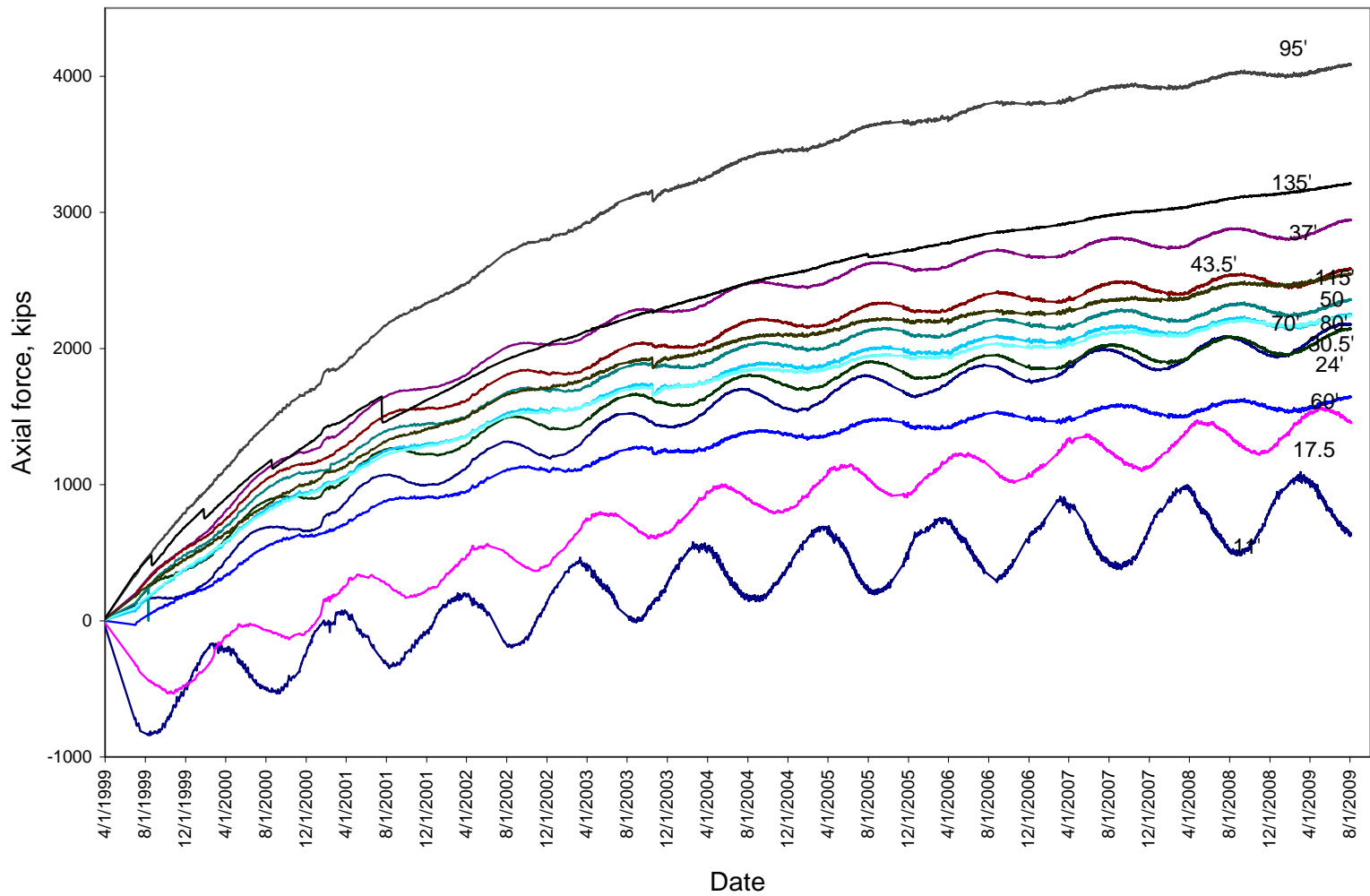

Shaft #9, Axial force vs. date in different elevations below the top of cap

Figure 5.18 Rate of increase in Drilled shaft # 9 Axial Force



Figure 5.19 Photo showing the construction of the tie beams and the buildup of fill on top

# CUY-90 Anchor 1

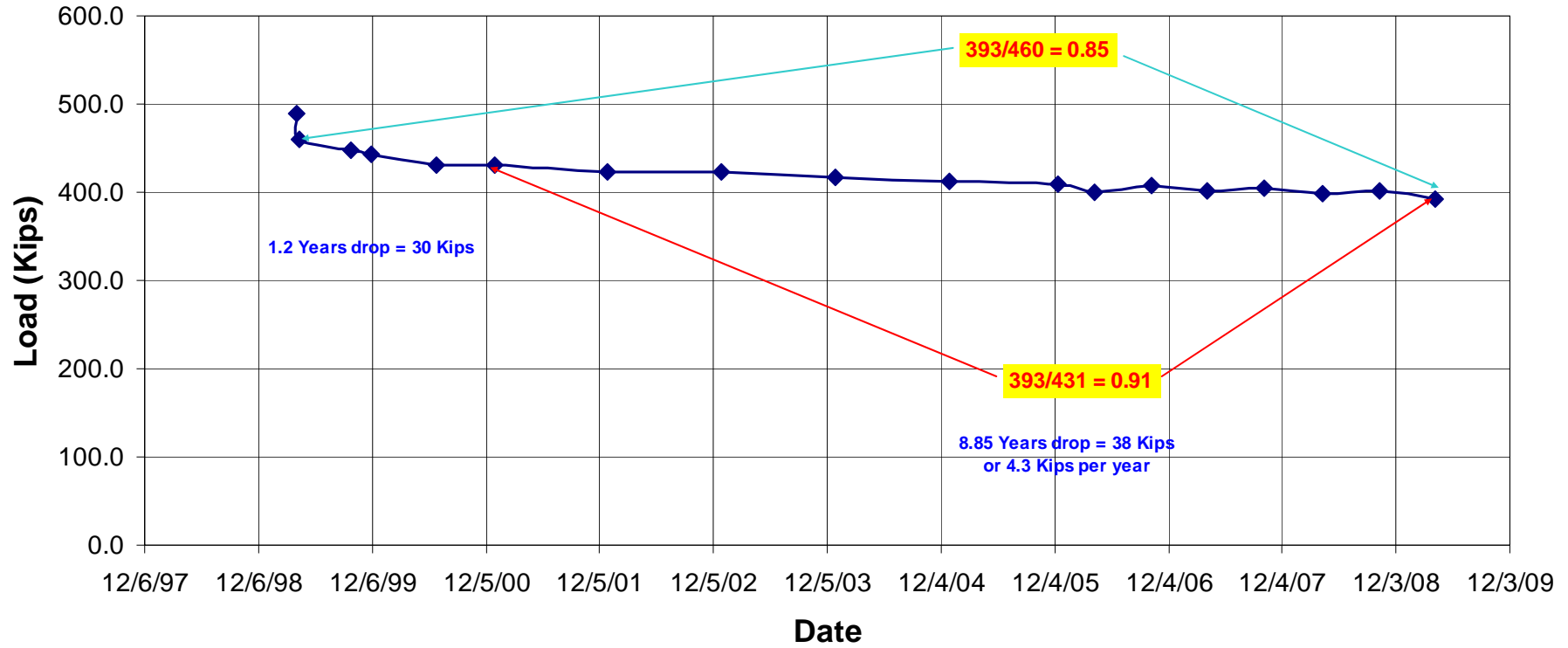

Figure 5.20 Anchor # 1: Force vs. time plot

# CUY-90 Anchor 8

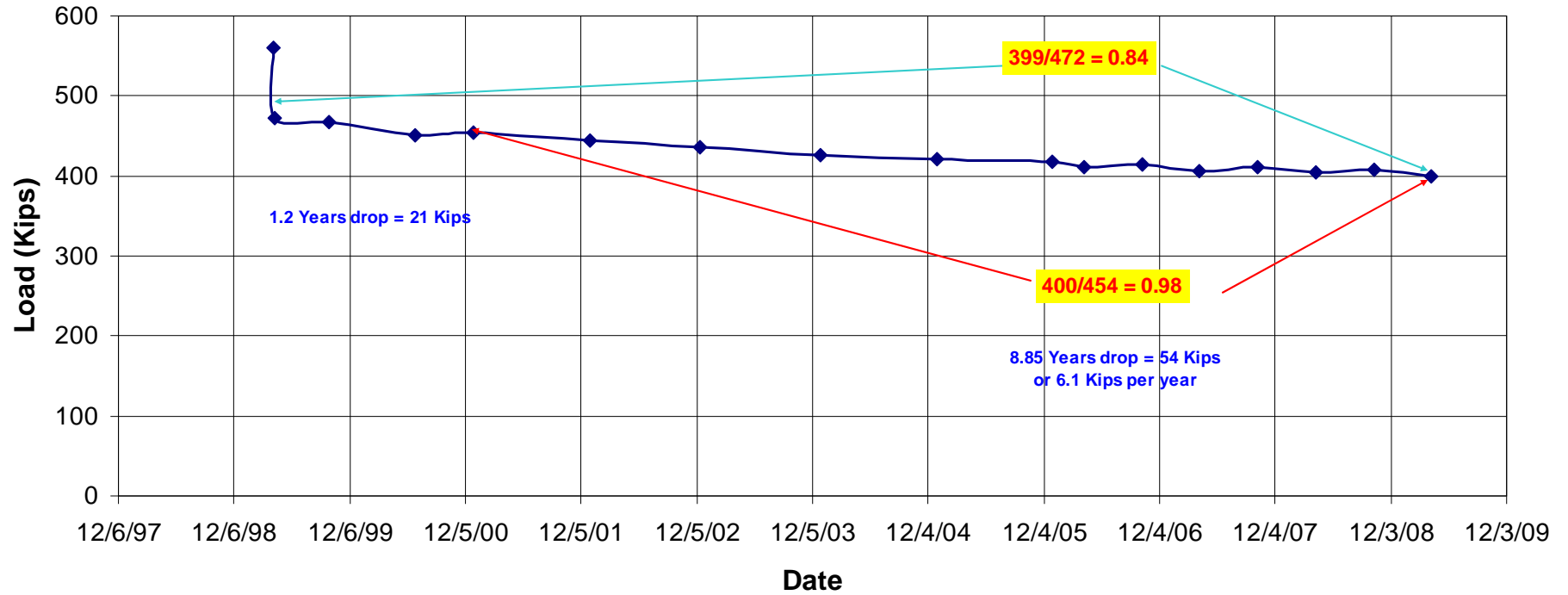

Figure 5.21 Anchor # 8: Force vs. time plot

### CUY-90 Anchor # 9

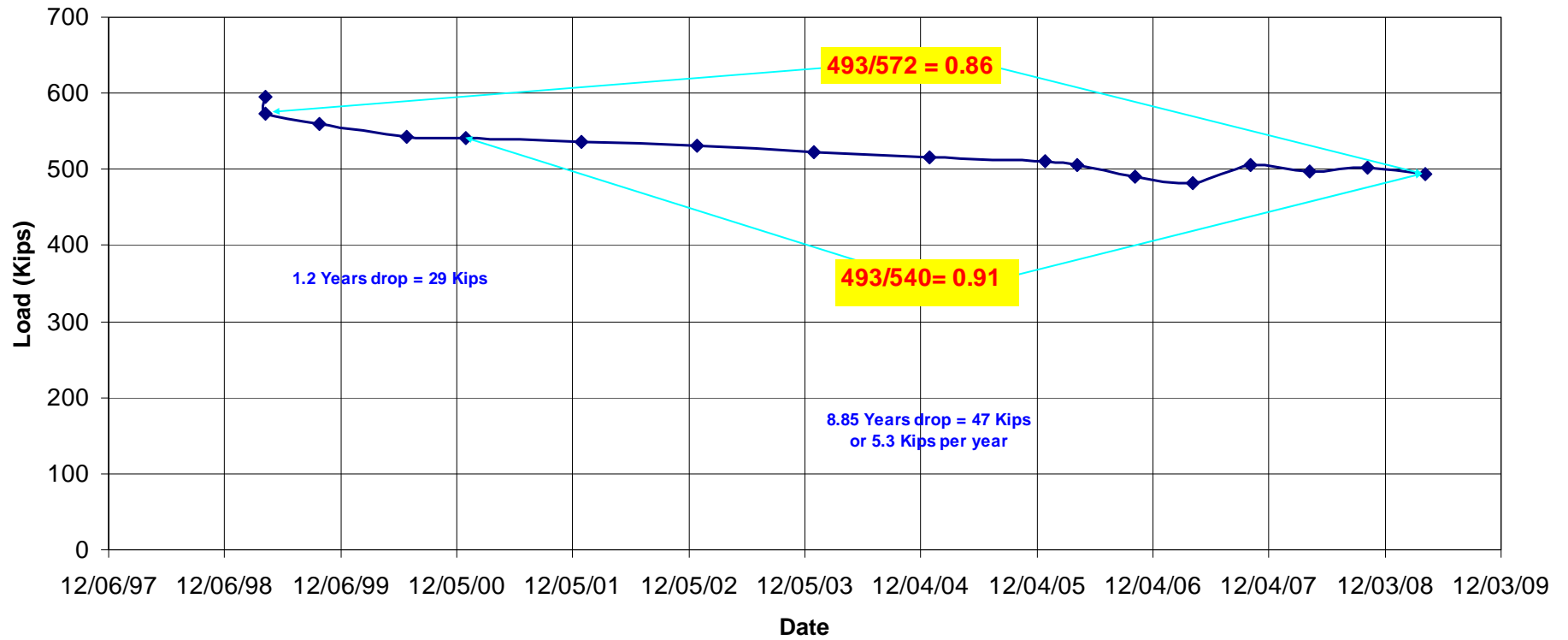

Figure 5.22 Anchor # 9: Force vs. time plot

## CUY-90 Anchor 17

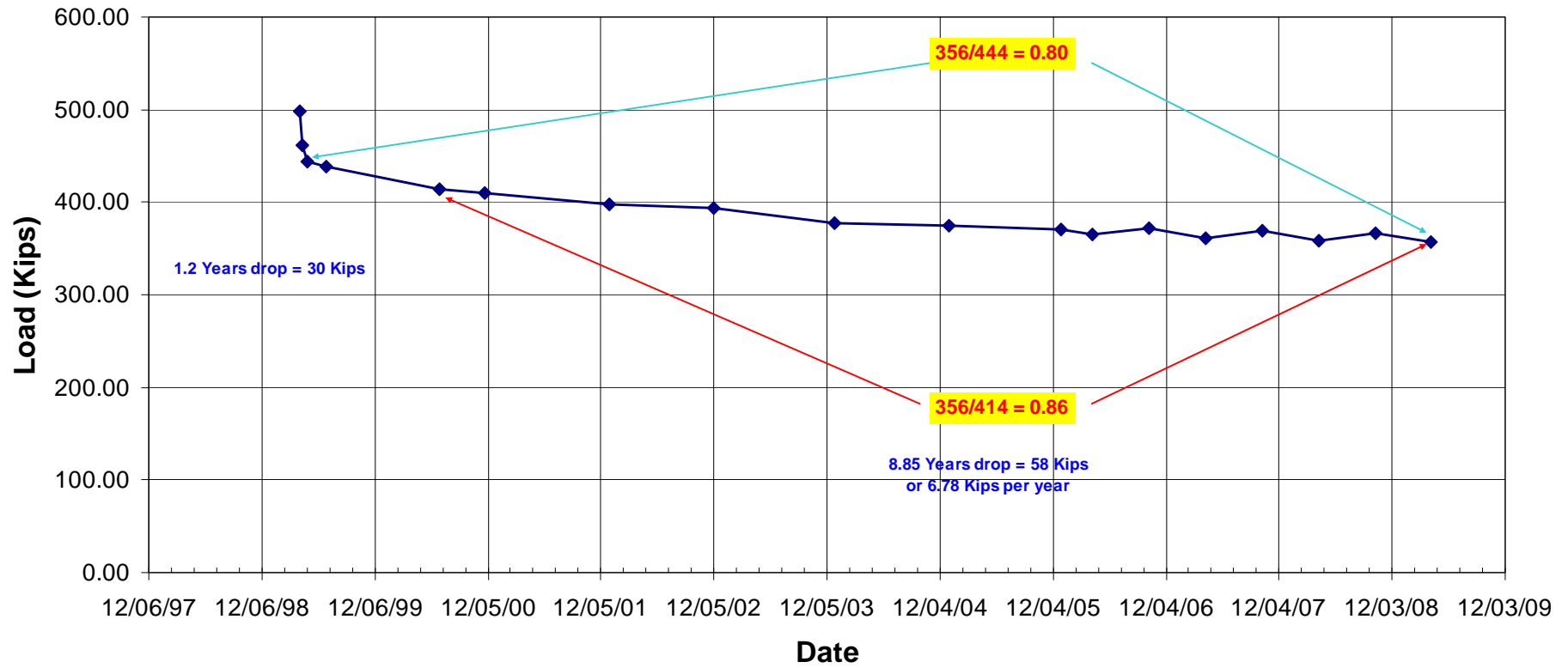

Figure 5.23 Anchor # 17: Force vs. time plot

**CHAPTER 5**

**APPENDICES**



**APPENDIX 5A**

**REDUCED INCLINOMETERS DATA**

**CUY-90-14.92 Inclinerometers**

**Updated until July 2009**

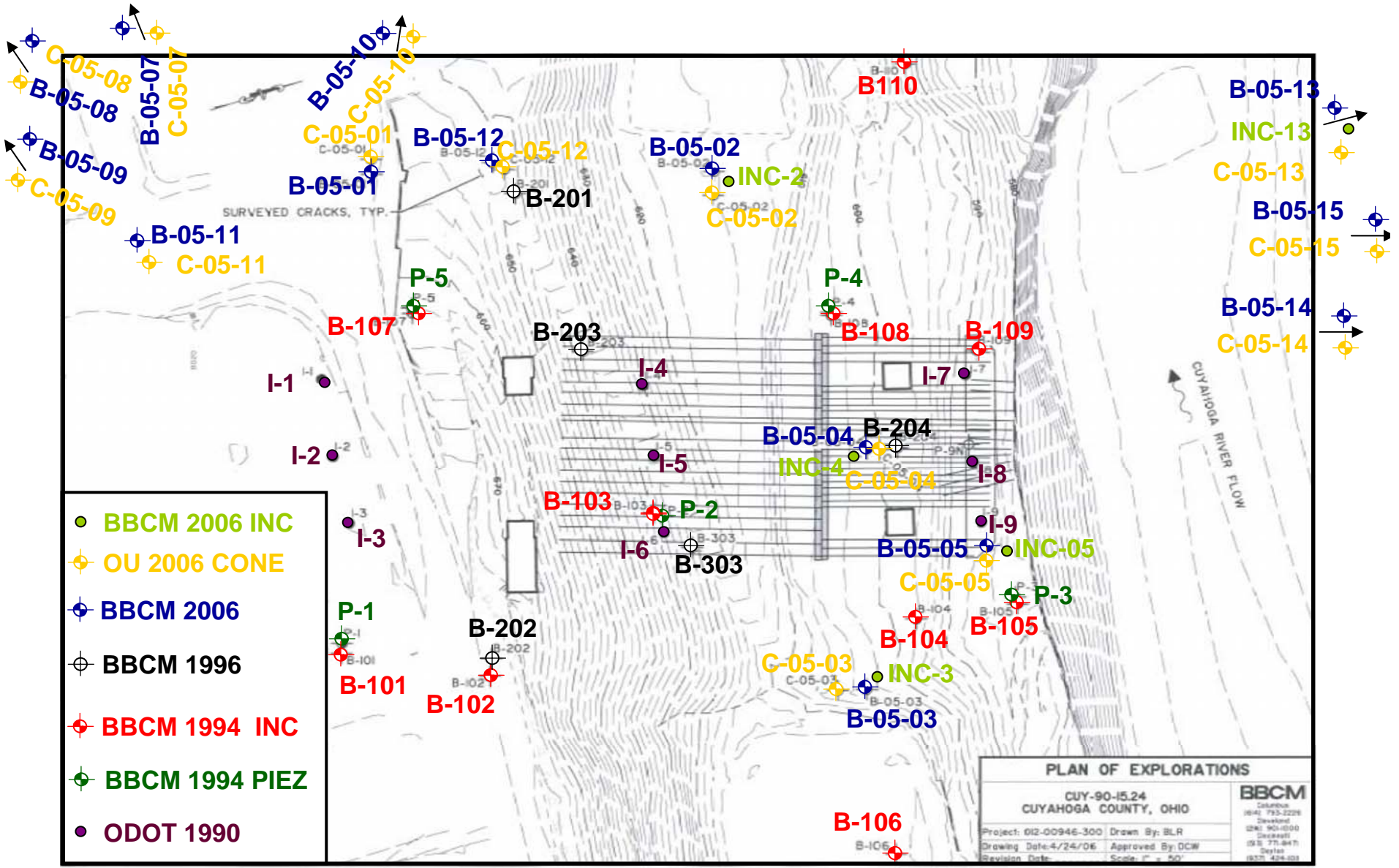

**INCLINOMETER B-101**

NO MOVEMENT

E.L. Robinson - Columbus, OH

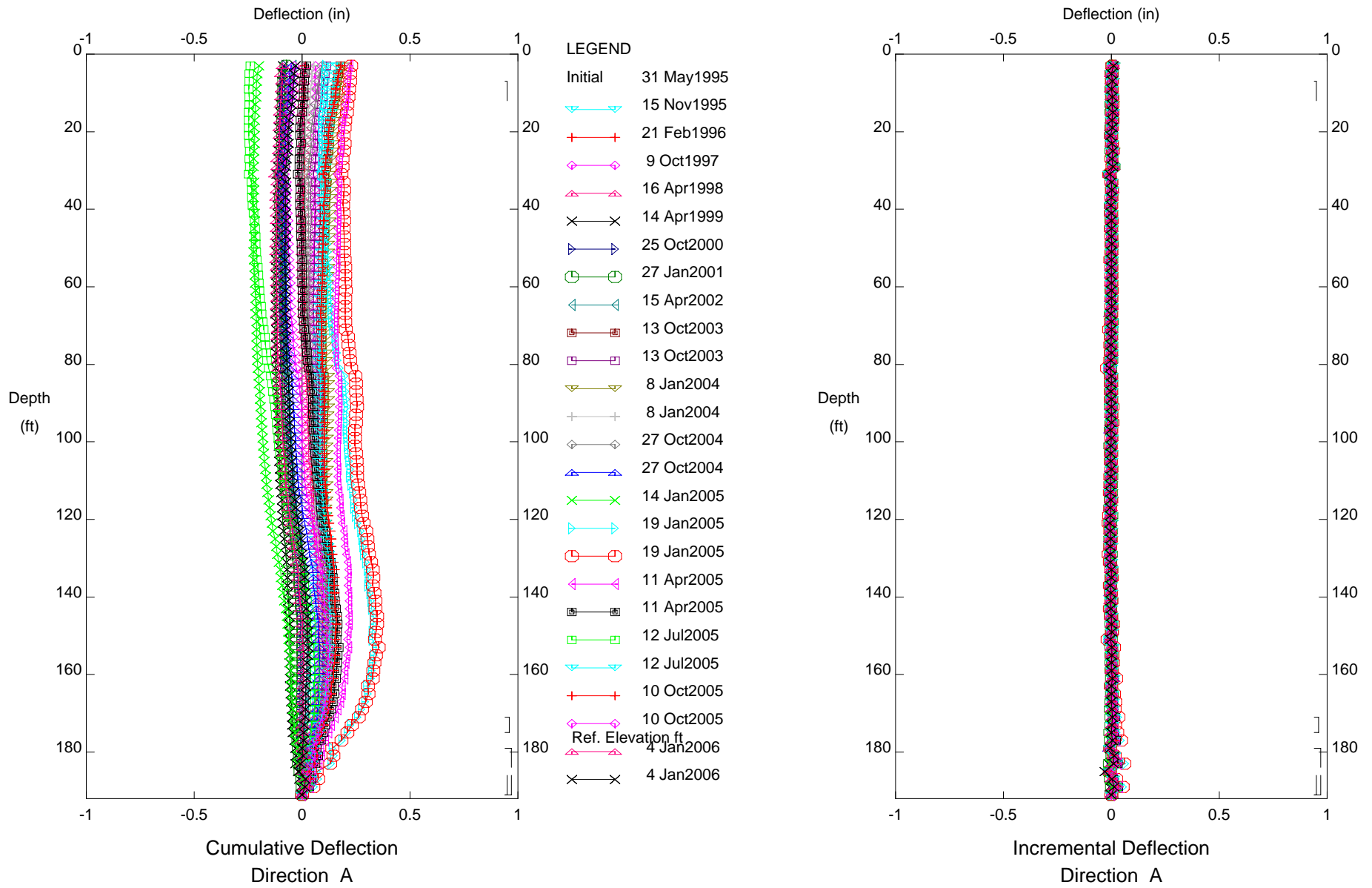

CUY-90, Inclinometer B-101

E.L. Robinson - Columbus, OH

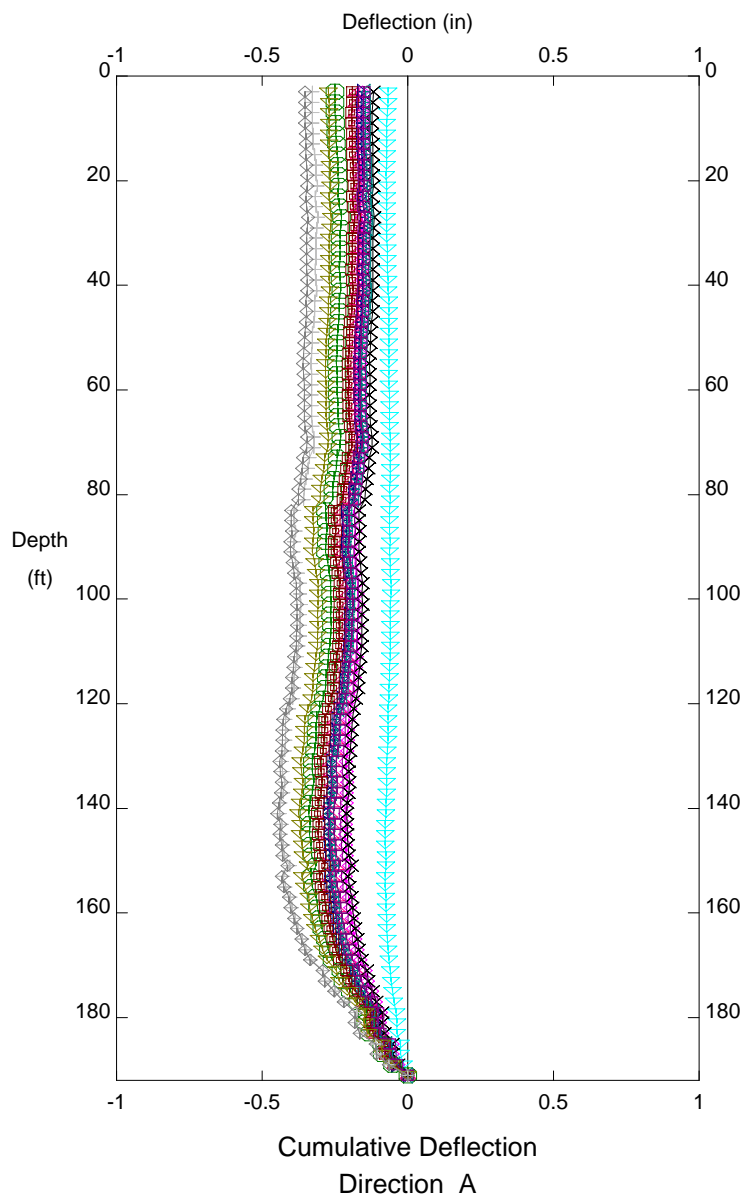

LEGEND

|         |            |
|---------|------------|
| Initial | 18 Apr2006 |
| ↔       | 11 Jul2006 |
| ◇       | 16 Jan2007 |
| △       | 16 Apr2007 |
| ×       | 9 Jul2007  |
| ▷       | 12 Oct2007 |
| ○       | 8 Jan2008  |
| ◀       | 14 Apr2008 |
| ■       | 14 Jul2008 |
| □       | 14 Oct2008 |
| ▽       | 12 Jan2009 |
| +       | 16 Apr2009 |
| ◊       | 17 Jul2009 |

Ref. Elevation ft

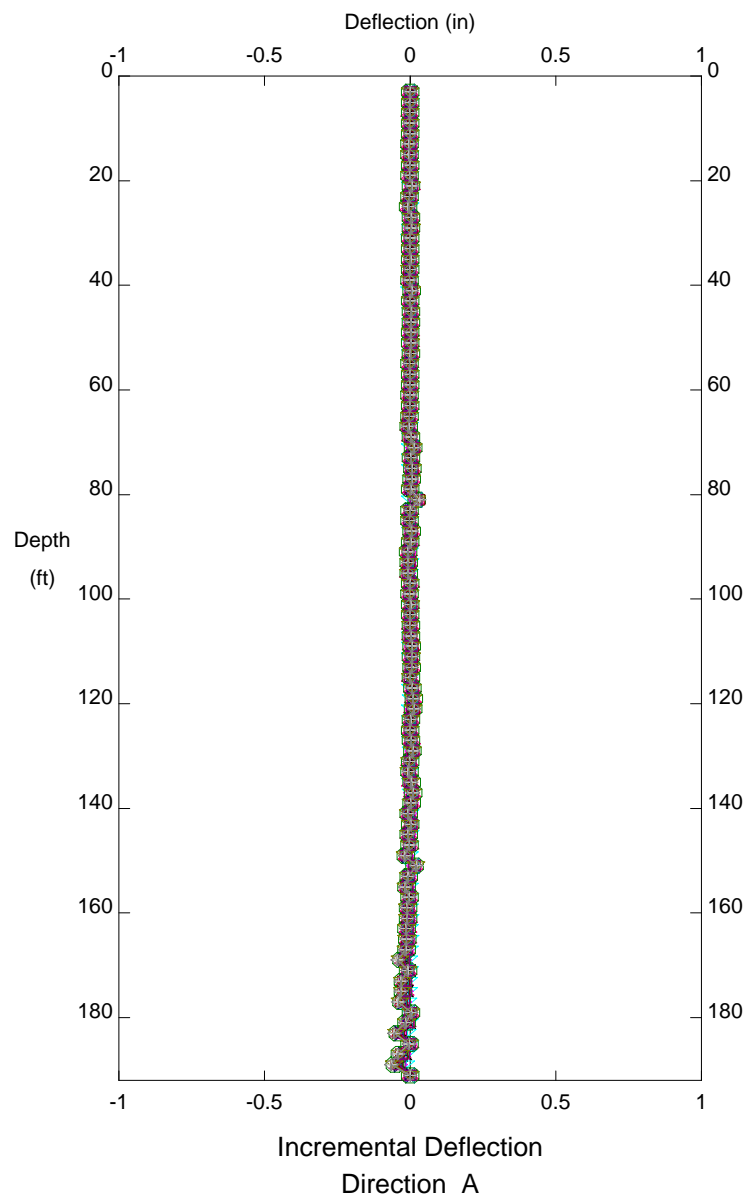

CUY-90, Inclinator B-101

E.L. Robinson - Columbus, OH

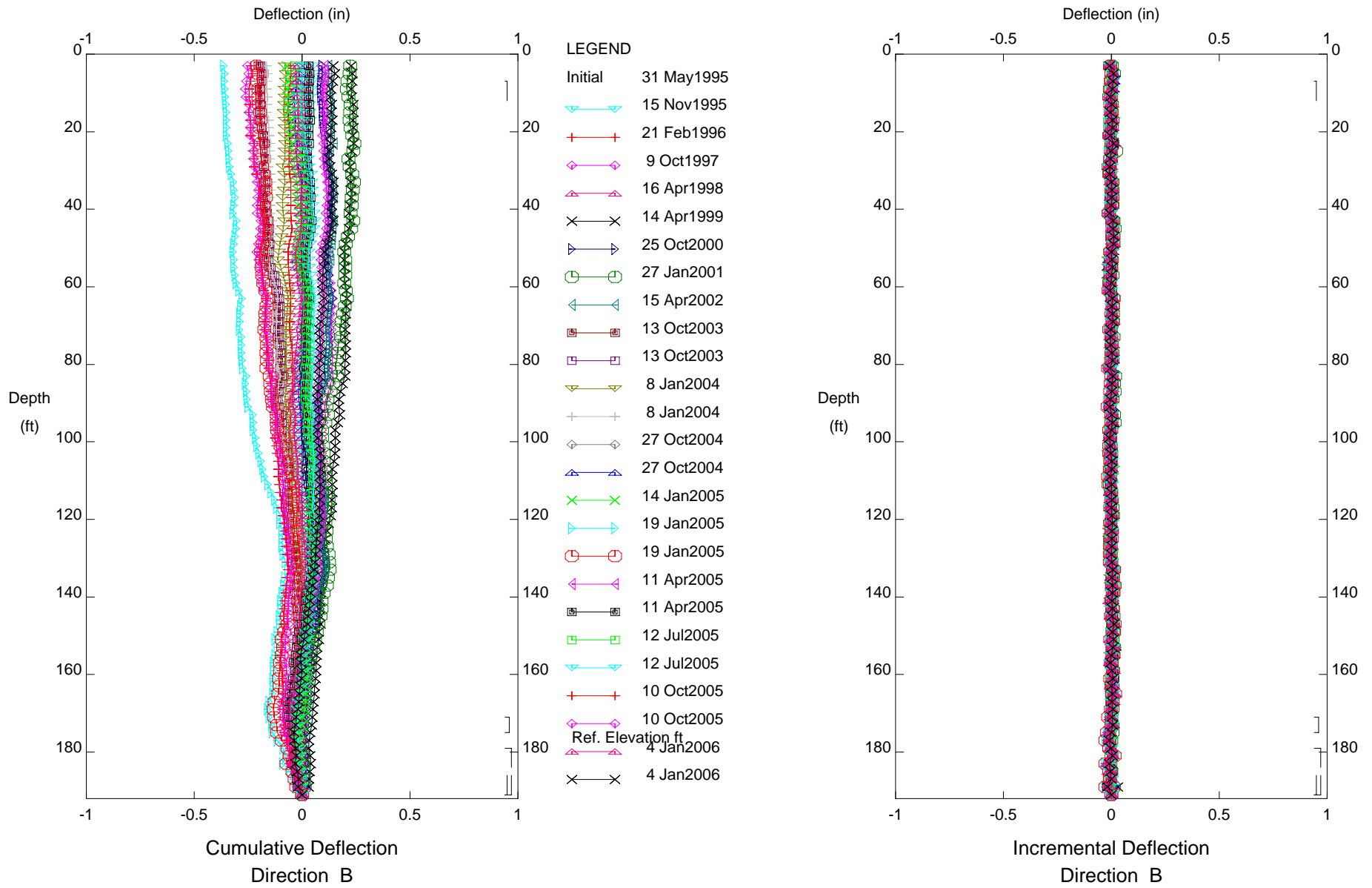

CUY-90, Inclinator B-101

E.L. Robinson - Columbus, OH

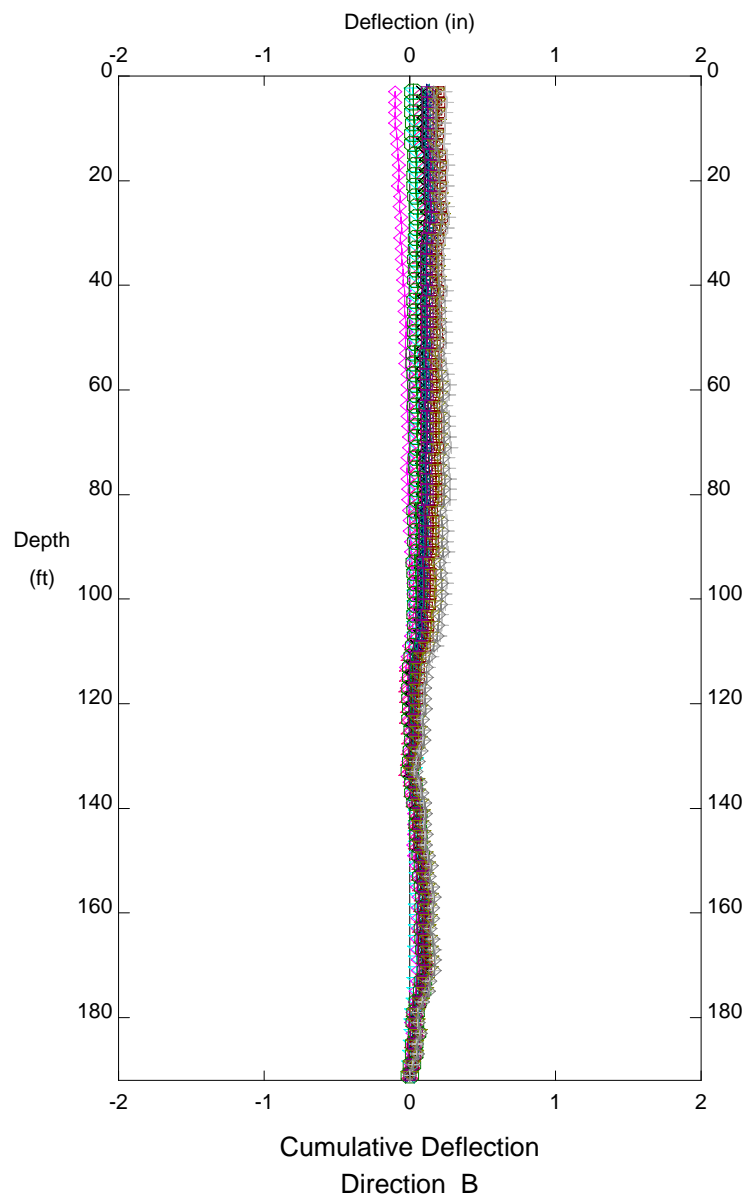

LEGEND

|         |            |
|---------|------------|
| Initial | 18 Apr2006 |
| ↔       | 11 Jul2006 |
| ◇       | 16 Jan2007 |
| △       | 16 Apr2007 |
| ×       | 9 Jul2007  |
| ▷       | 12 Oct2007 |
| ○       | 8 Jan2008  |
| ◀       | 14 Apr2008 |
| ■       | 14 Jul2008 |
| □       | 14 Oct2008 |
| ▽       | 12 Jan2009 |
| +       | 16 Apr2009 |
| ◇       | 17 Jul2009 |

Ref. Elevation ft

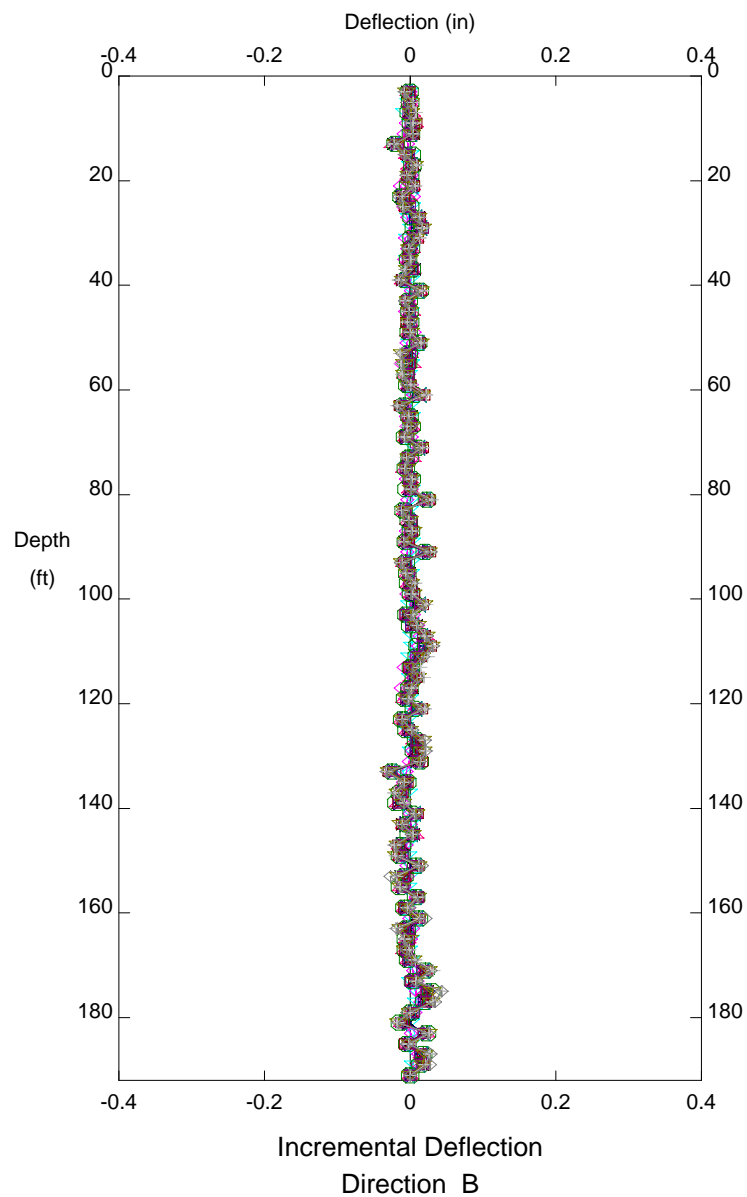

CUY-90, Inclinator B-101



**INCLINOMETER B-102**

DEPTH FROM 65'/73' RATE OF MOVEMENT = 0.01 INCH PER YEAR BETWEEN 1995 AND 2009

E.L. Robinson - Columbus, OH

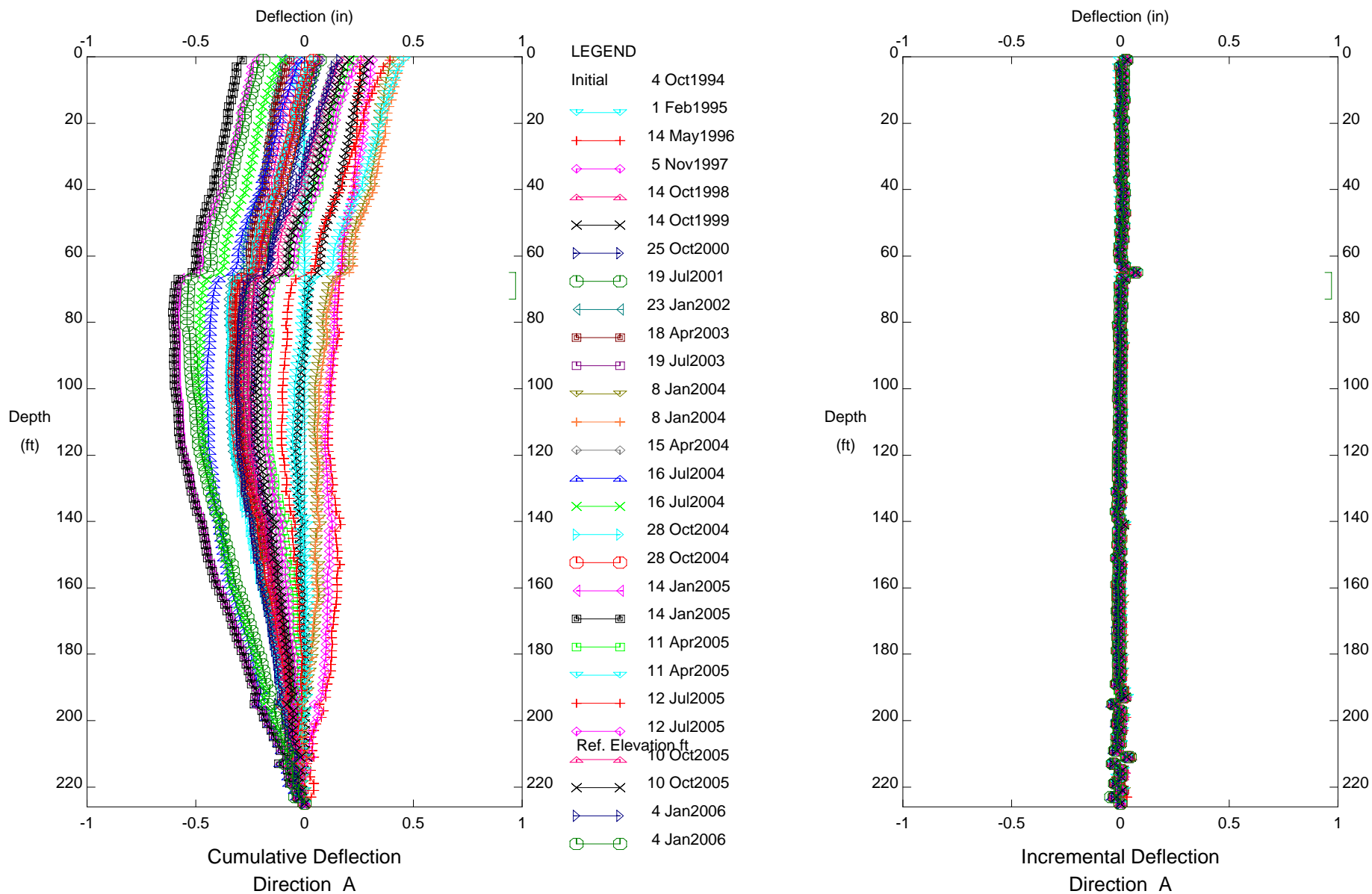

CUY-90, Inclinometer B-102

E.L. Robinson - Columbus, OH

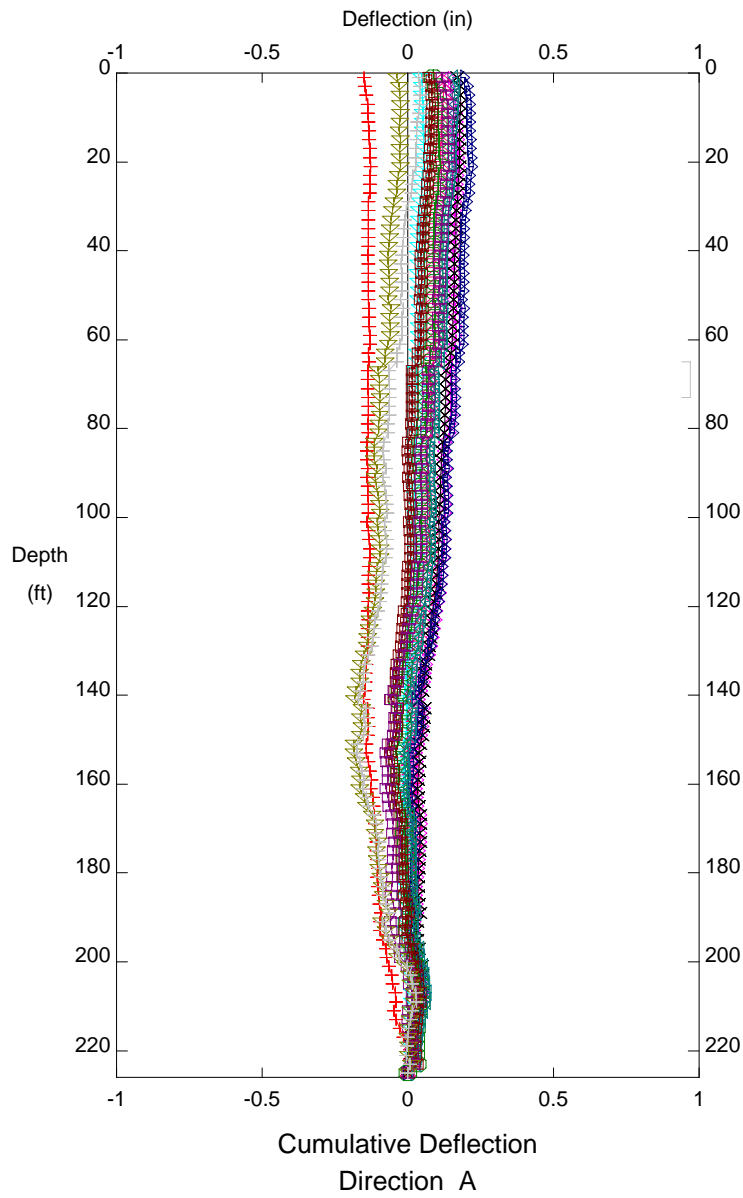

LEGEND

|         |            |
|---------|------------|
| Initial | 11 Jul2006 |
| ◁       | 12 Oct2006 |
| +       | 16 Jan2007 |
| ◇       | 16 Apr2007 |
| △       | 9 Jul2007  |
| ×       | 10 Oct2007 |
| ▷       | 8 Jan2008  |
| ○       | 16 Apr2008 |
| ◁       | 15 Jul2008 |
| ■       | 14 Oct2008 |
| □       | 12 Jan2009 |
| ▽       | 16 Apr2009 |
| +       | 17 Jul2009 |

Ref. Elevation ft

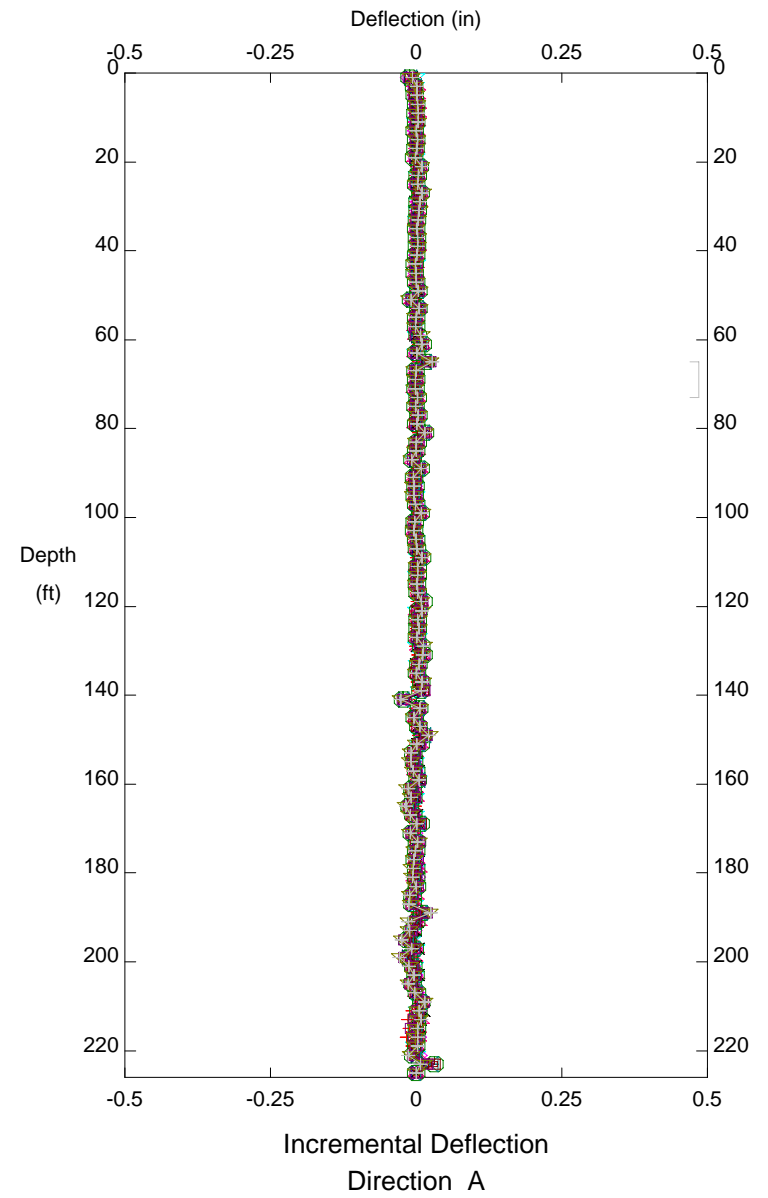

CUY-90, Inclinator B-102

E.L. Robinson - Columbus, OH

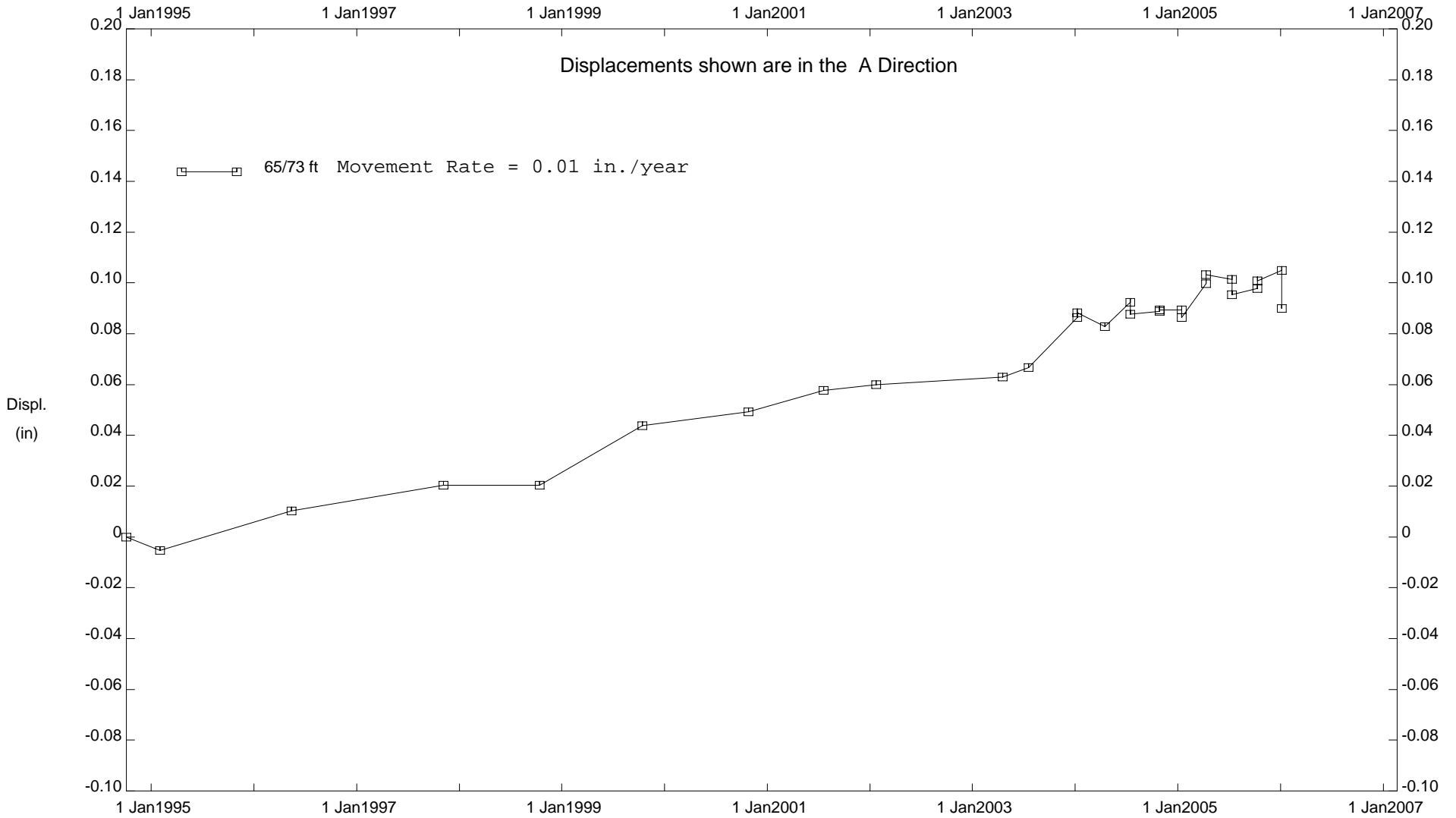

CUY-90, Inclinator B-102

E.L. Robinson - Columbus, OH

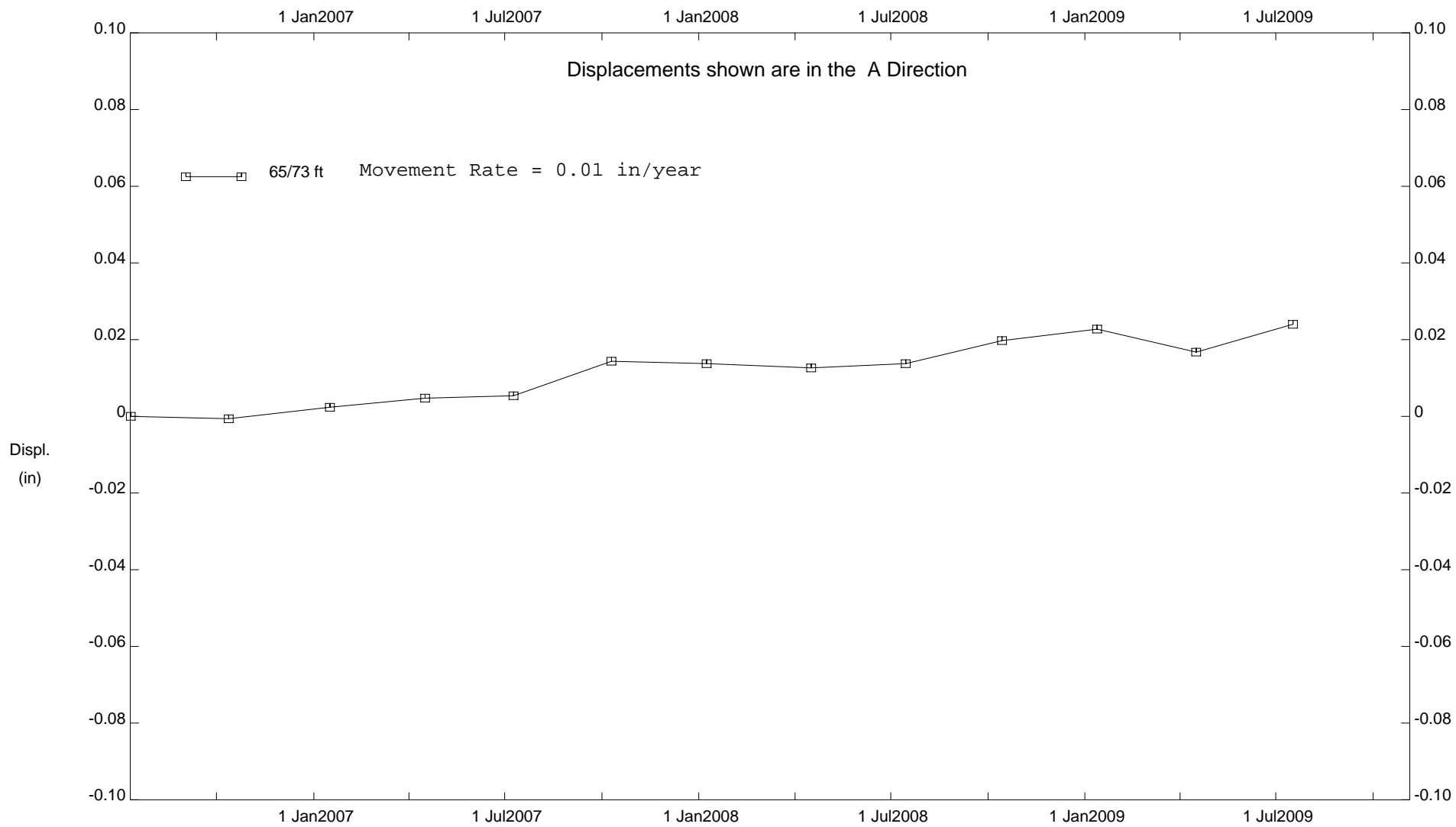

CUY-90, Inclinator B-102

E.L. Robinson - Columbus, OH

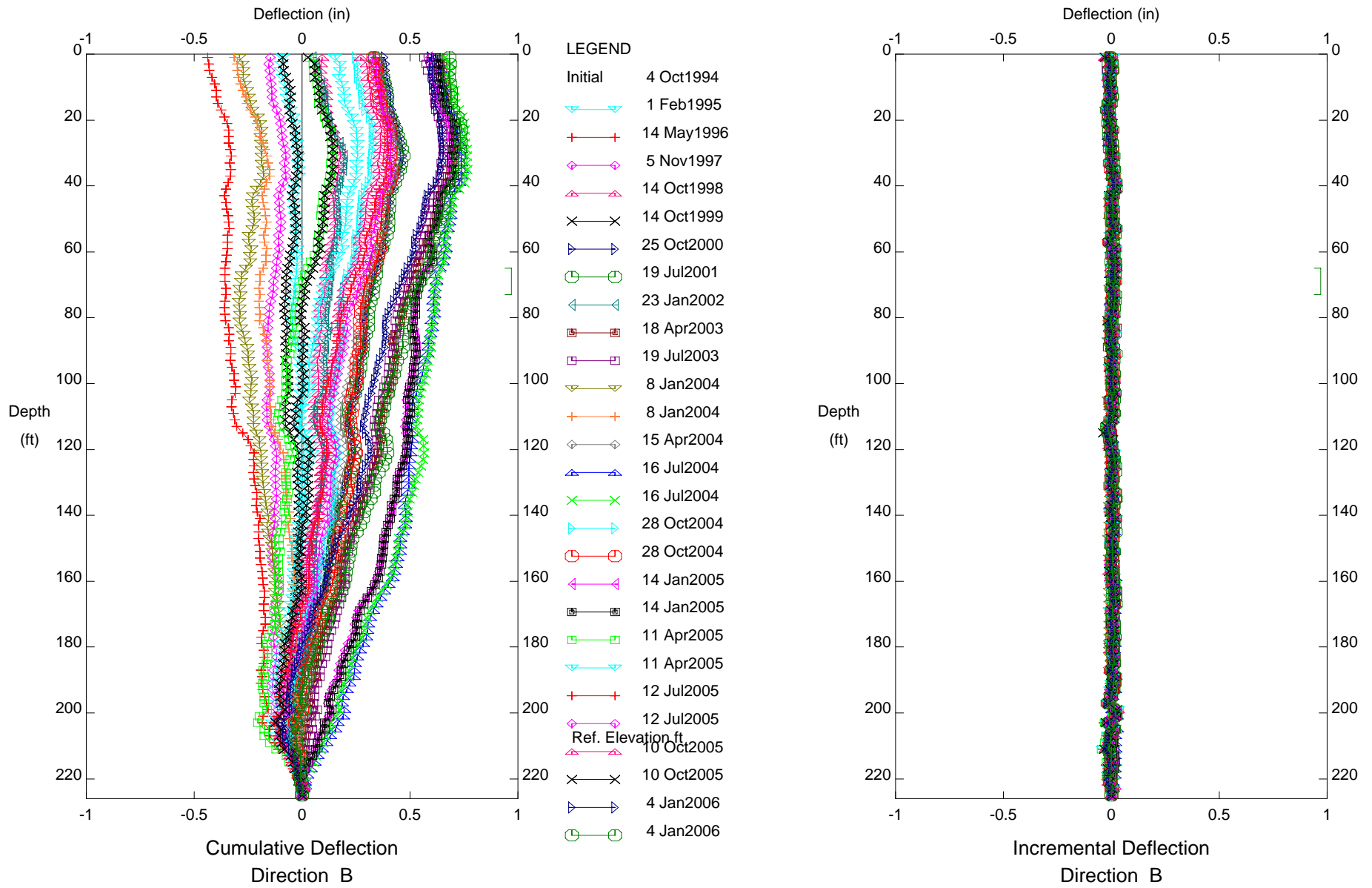

CUY-90, Inclinometer B-102

E.L. Robinson - Columbus, OH

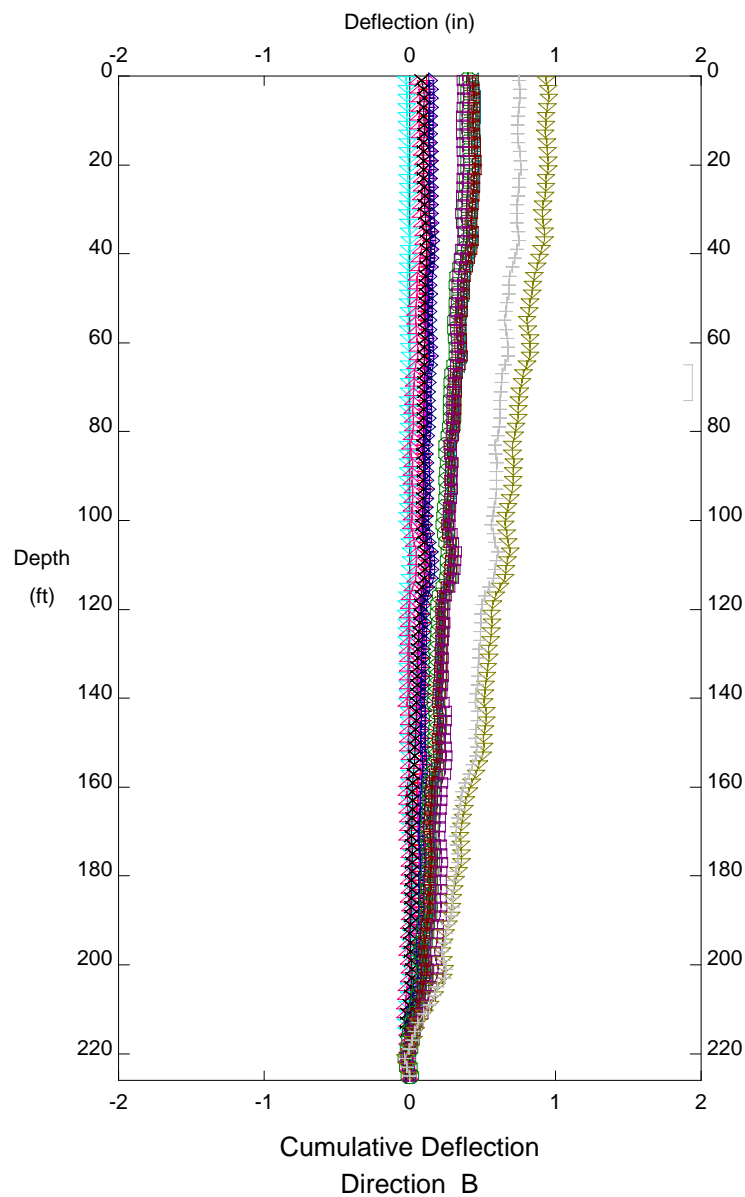

LEGEND

|         |            |
|---------|------------|
| Initial | 11 Jul2006 |
| ◁       | 12 Oct2006 |
| +       | 16 Jan2007 |
| ◇       | 16 Apr2007 |
| △       | 9 Jul2007  |
| ×       | 10 Oct2007 |
| ▷       | 8 Jan2008  |
| ○       | 16 Apr2008 |
| ◁       | 15 Jul2008 |
| ■       | 14 Oct2008 |
| □       | 12 Jan2009 |
| ▽       | 16 Apr2009 |
| +       | 17 Jul2009 |

Ref. Elevation ft

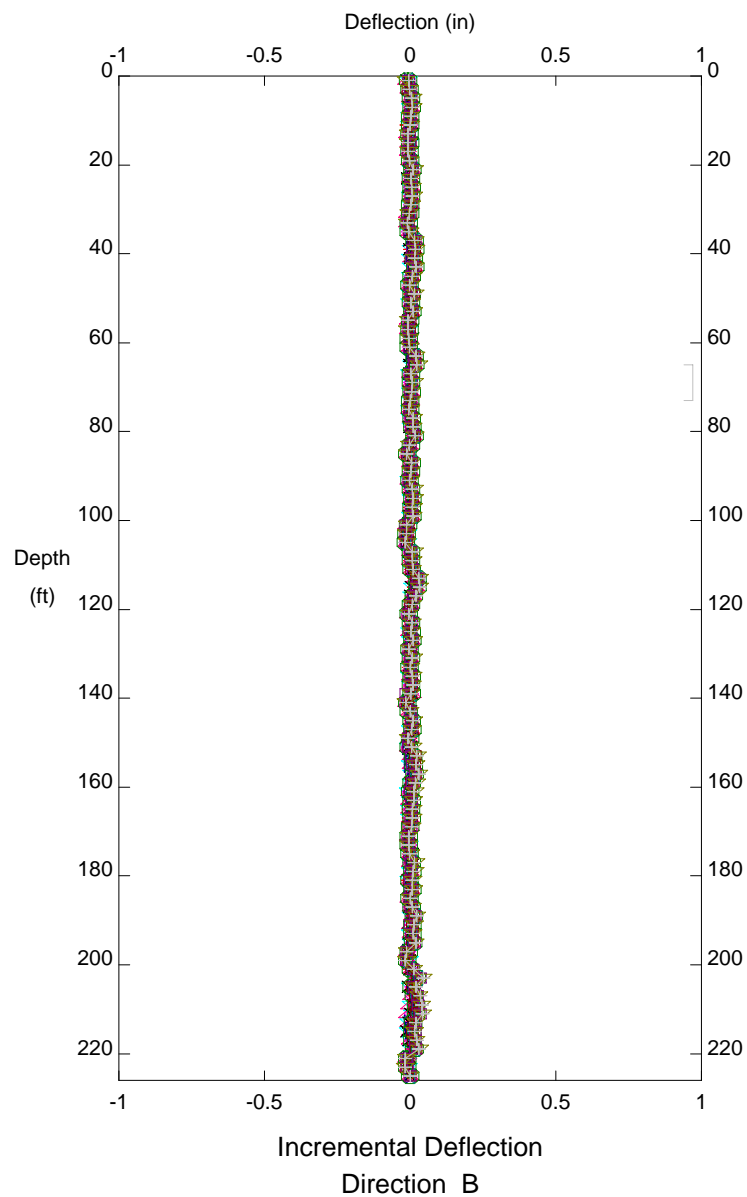

CUY-90, Inclinator B-102

E.L. Robinson - Columbus, OH

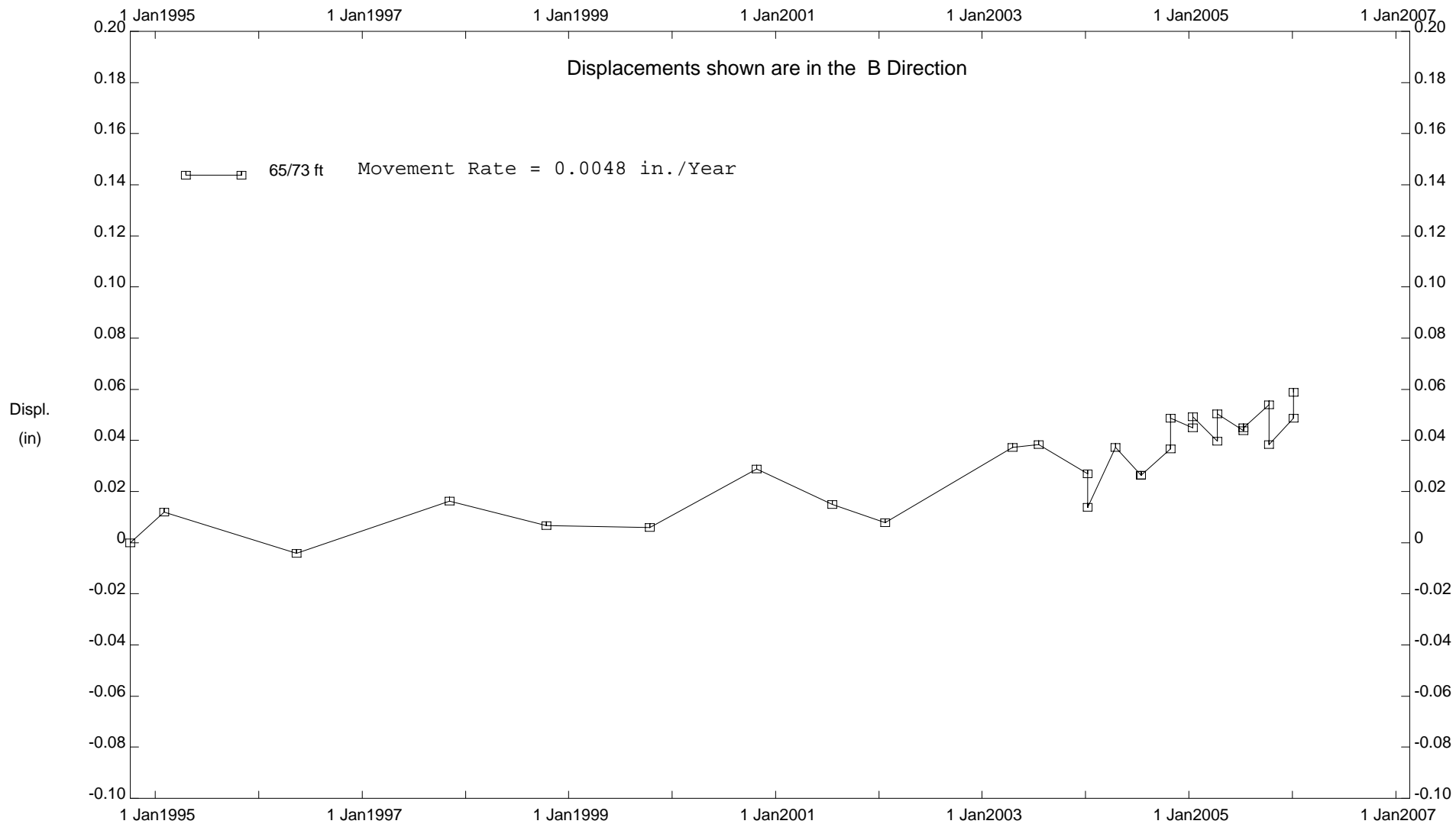

CUY-90, Inclinator B-102



E.L. Robinson - Columbus, OH

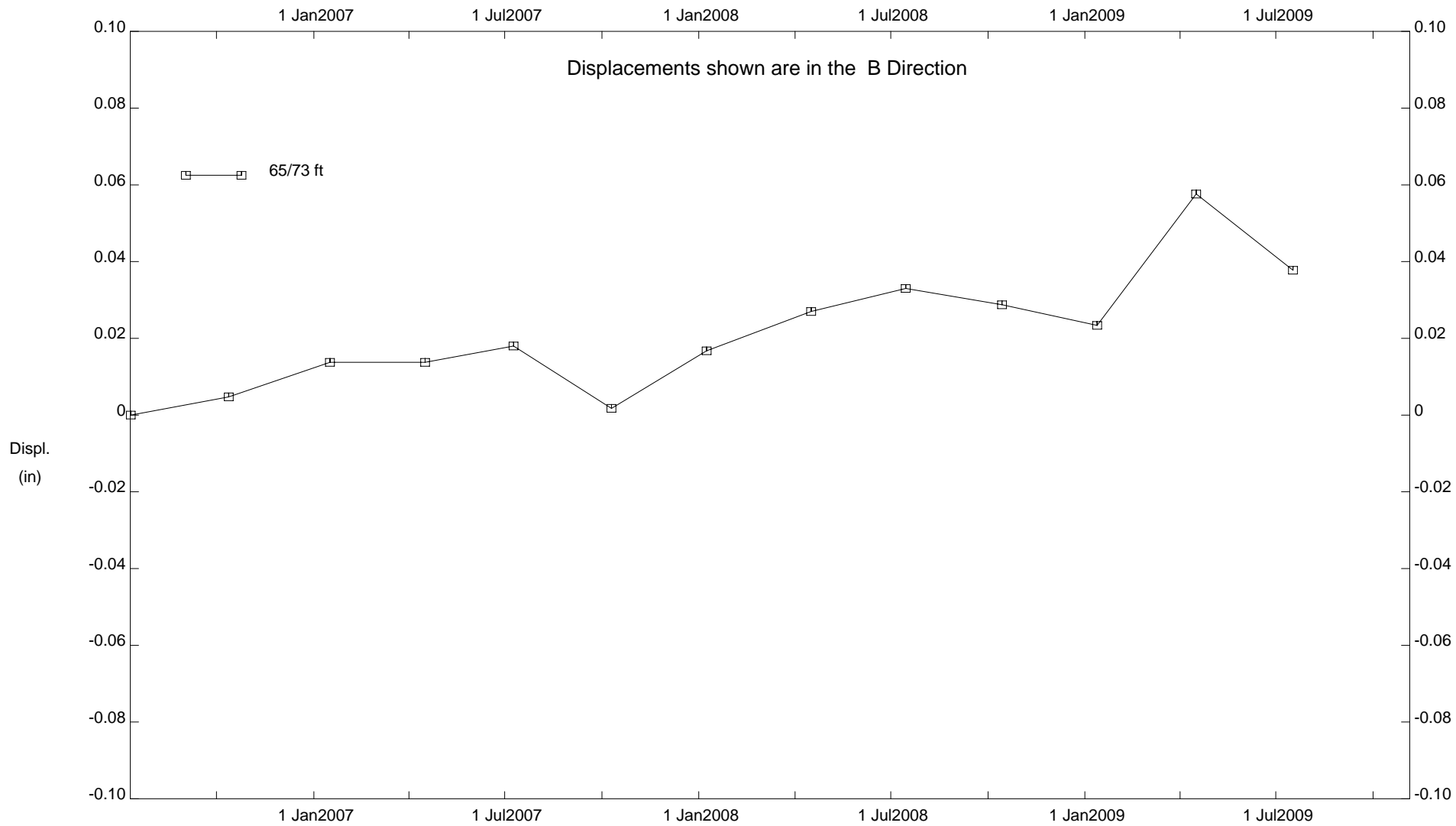

CUY-90, Inclinometer B-102

**INCLINOMETER B-105**

DEPTH FROM 93'/97' RATE OF MOVEMENT = 0.04 INCHES PER YEAR BETWEEN 2005 AND 2009

DEPTH FROM 107'/113' RATE OF MOVEMENT = 0.01 INCHES PER YEAR BETWEEN 2005 AND 2009

E.L. Robinson - Columbus, OH

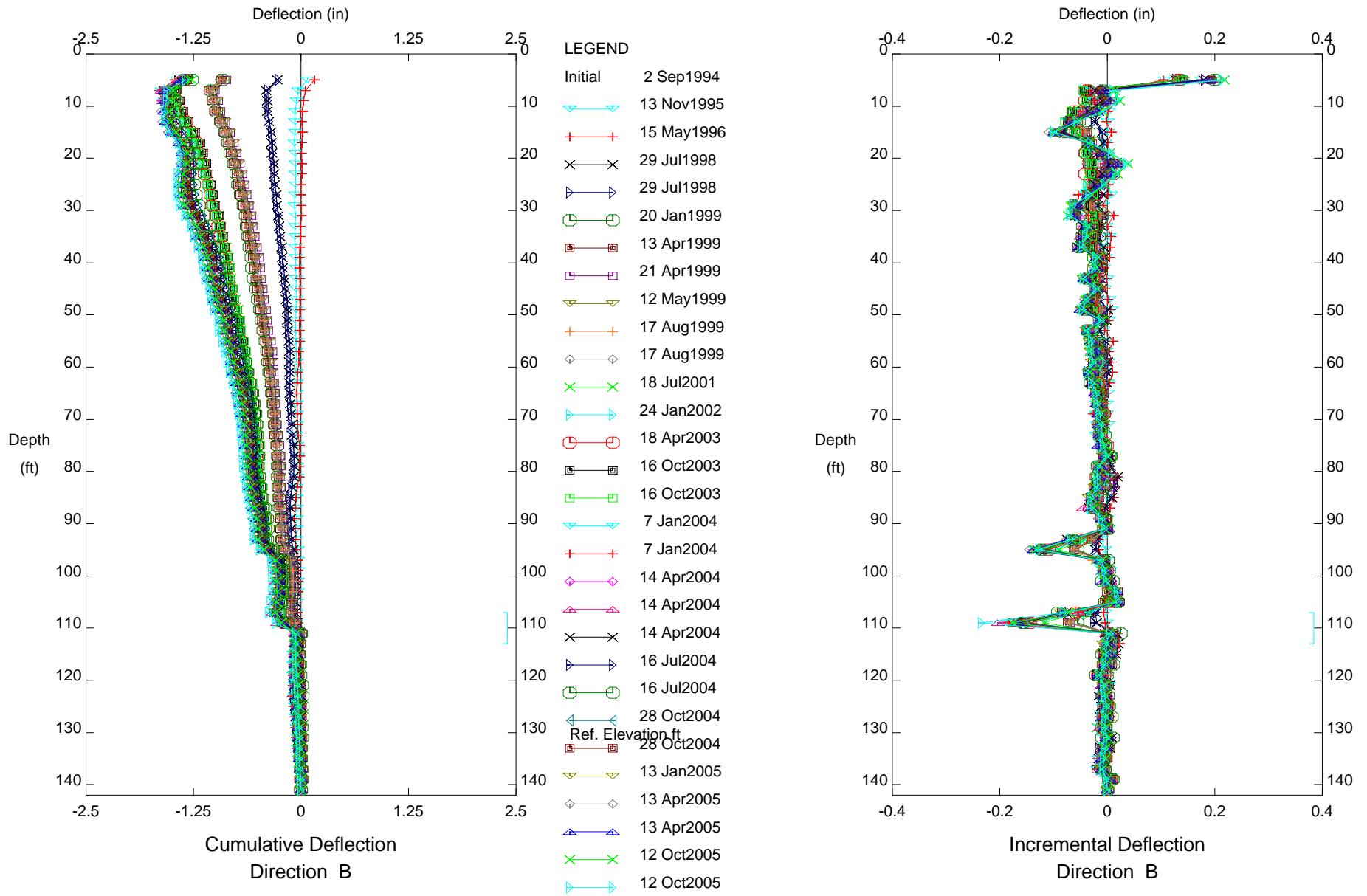

CUY-90, Inclinometer B-105

# E.L. Robinson - Columbus, OH

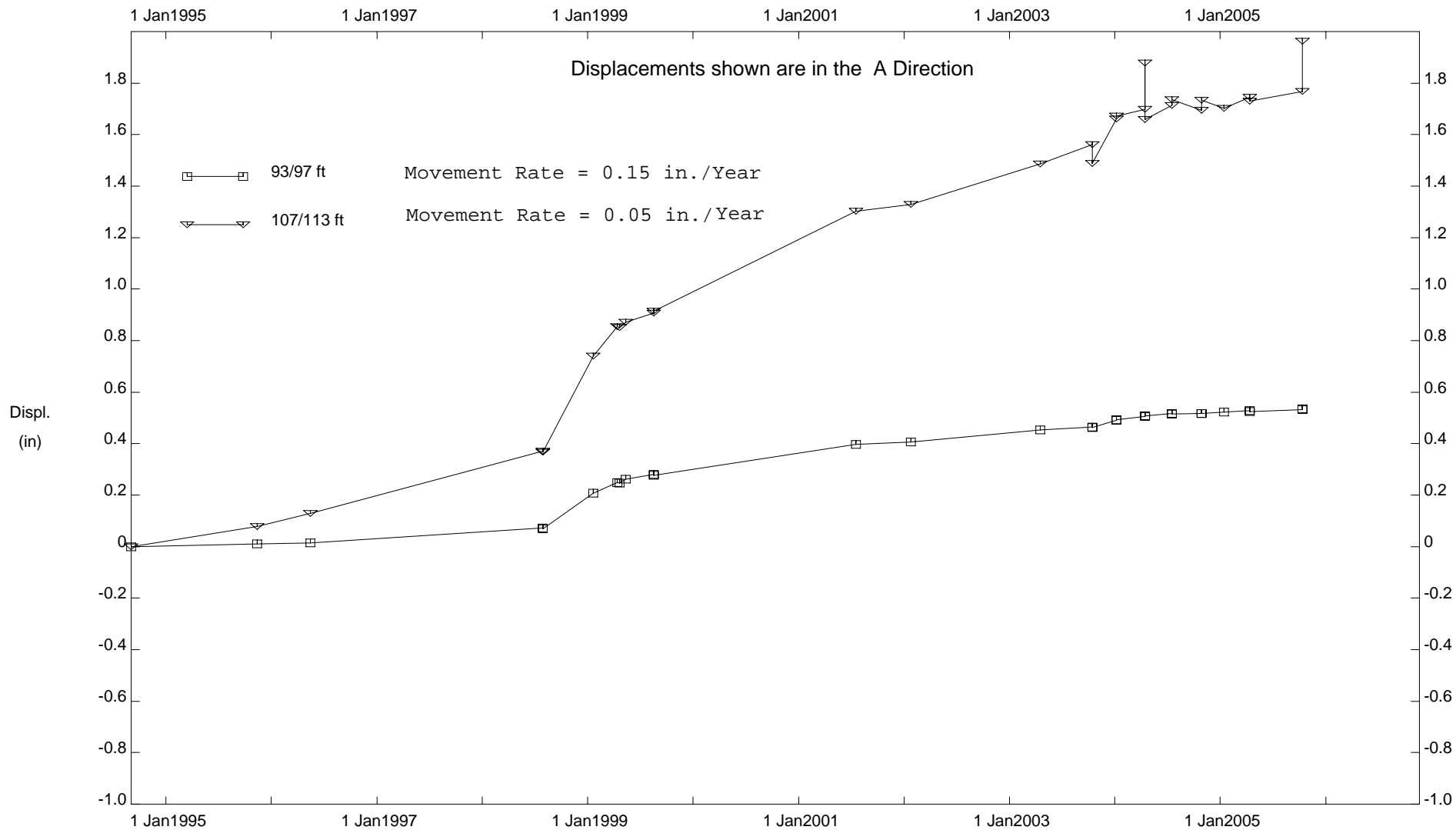

CUY-90, Inclinator B-105

E.L. Robinson - Columbus, OH

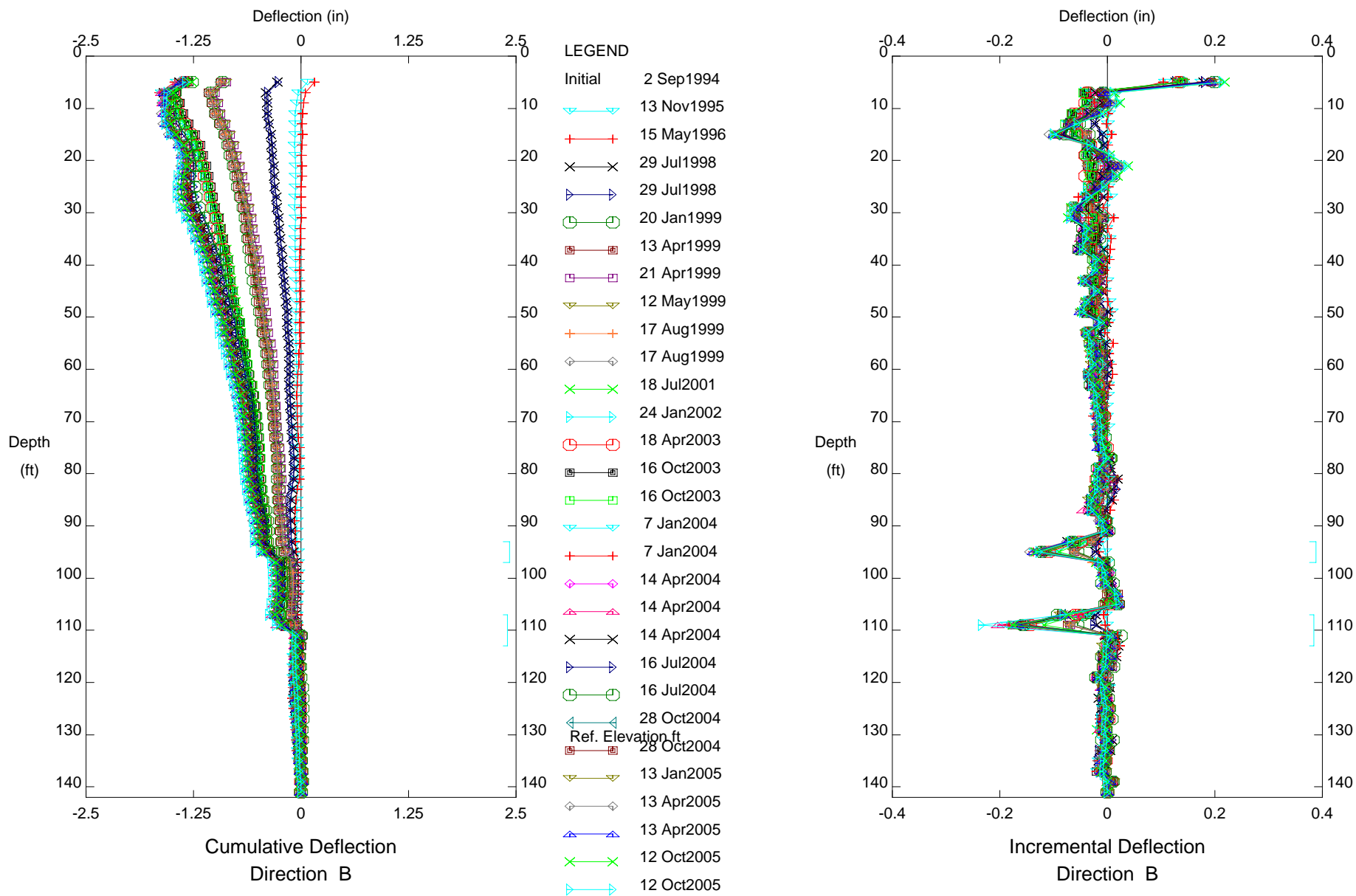

CUY-90, Inclinometer B-105

E.L. Robinson - Columbus, OH

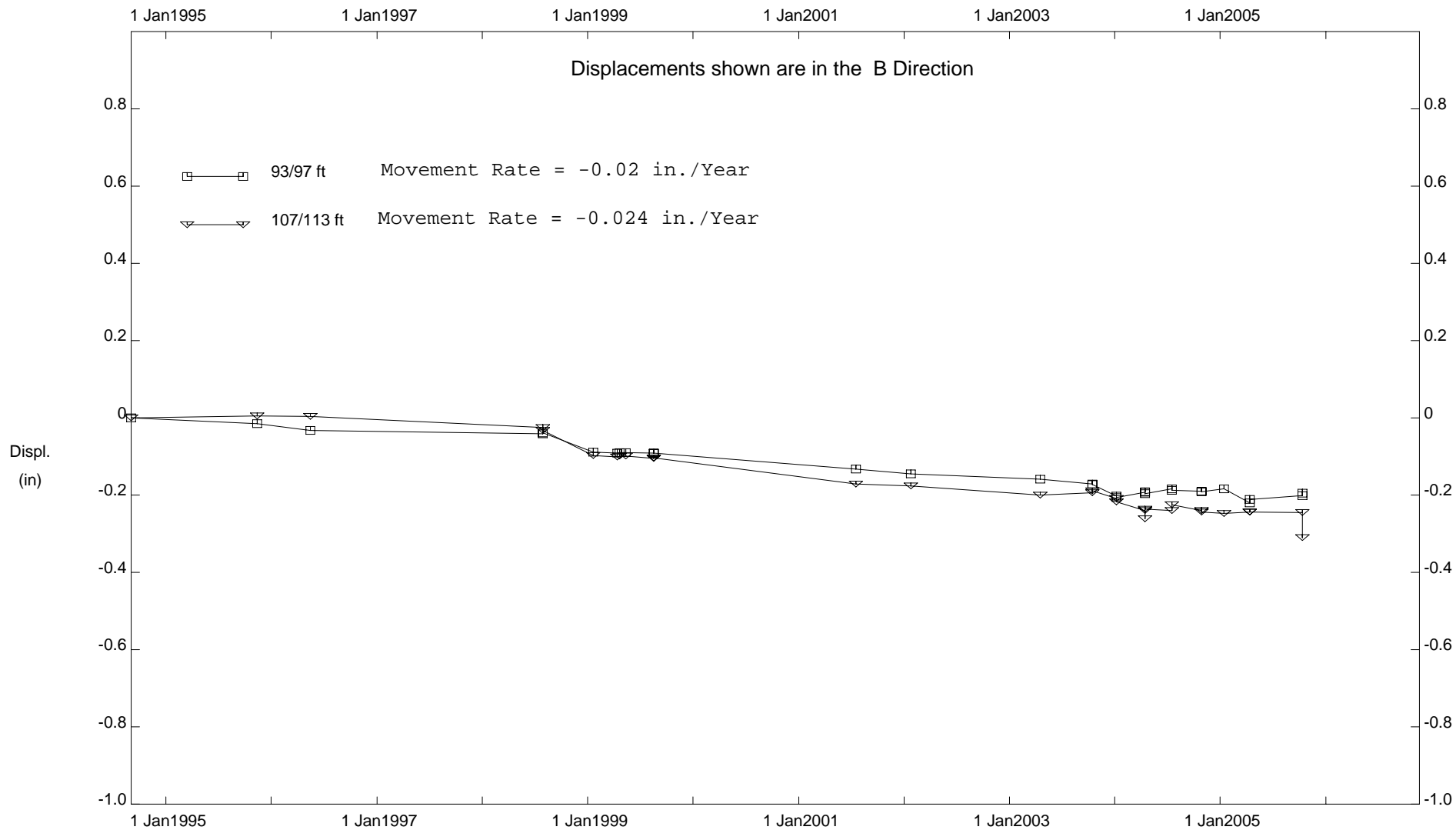

CUY-90, Inclinator B-105

**INCLINOMETER B-105A**

DEPTH FROM 93'/97' RATE OF MOVEMENT = 0.03 INCHES PER YEAR BETWEEN 2006 AND 2009

DEPTH FROM 105'/111' RATE OF MOVEMENT = 0.04 INCHES PER YEAR BETWEEN 2006 AND 2009

SHALLOW SLIP PLANE <41' DEEP MOVED 1 INCH IN 3 YEARS

E.L. Robinson - Columbus, OH

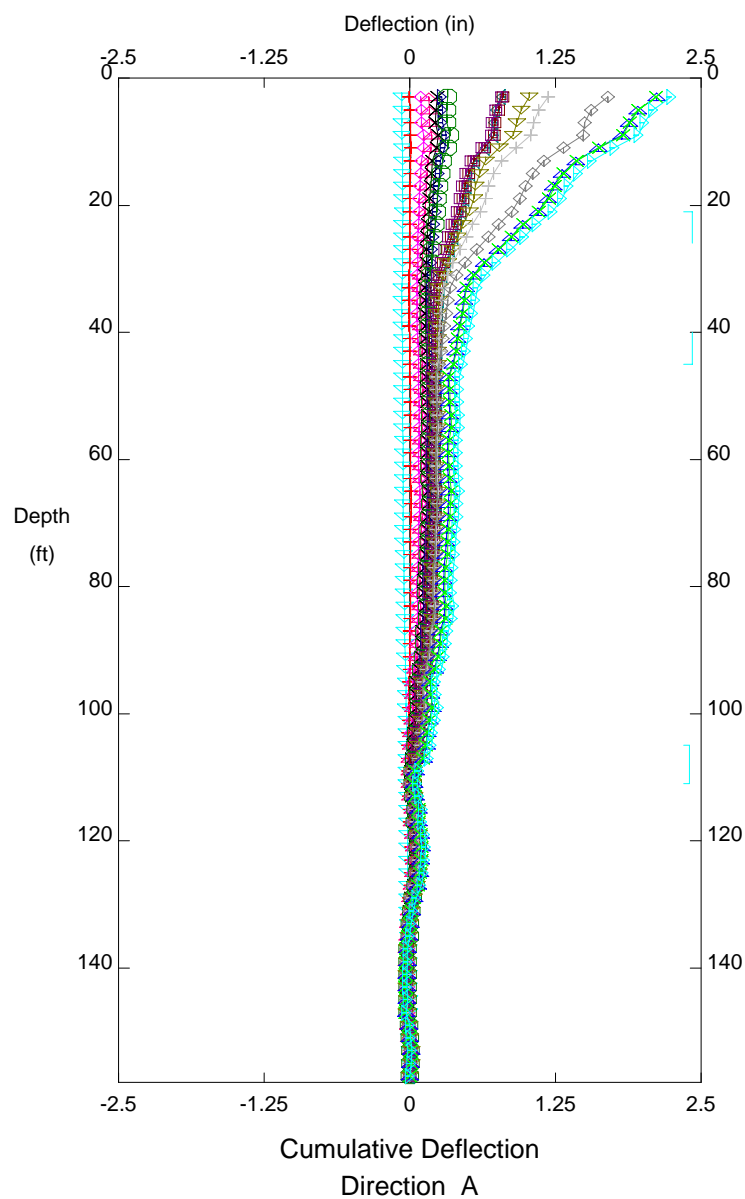

LEGEND

|         |            |
|---------|------------|
| Initial | 22 Jun2006 |
| ◀       | 22 Jun2006 |
| + +     | 13 Jul2006 |
| ◇       | 16 Oct2006 |
| △       | 17 Jan2007 |
| ×       | 17 Apr2007 |
| ▷       | 9 Jul2007  |
| ○       | 10 Oct2007 |
| ◀       | 9 Jan2008  |
| ■       | 28 Jan2008 |
| □       | 28 Jan2008 |
| ▽       | 17 Apr2008 |
| +       | 16 Jul2008 |
| ◇       | 15 Oct2008 |
| ▷       | 22 Jan2009 |
| ×       | 17 Apr2009 |
| ▶       | 21 Jul2009 |

Ref. Elevation ft

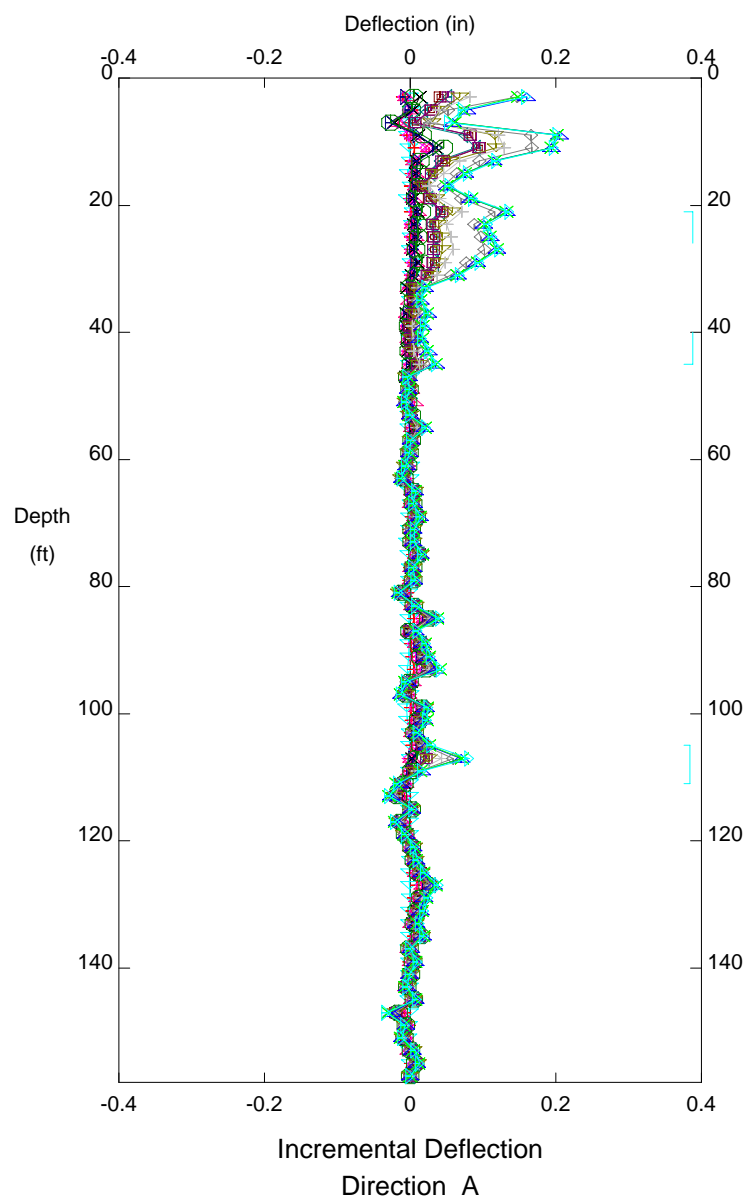

CUY-90, Inclinator B-105A



E.L. Robinson - Columbus, OH

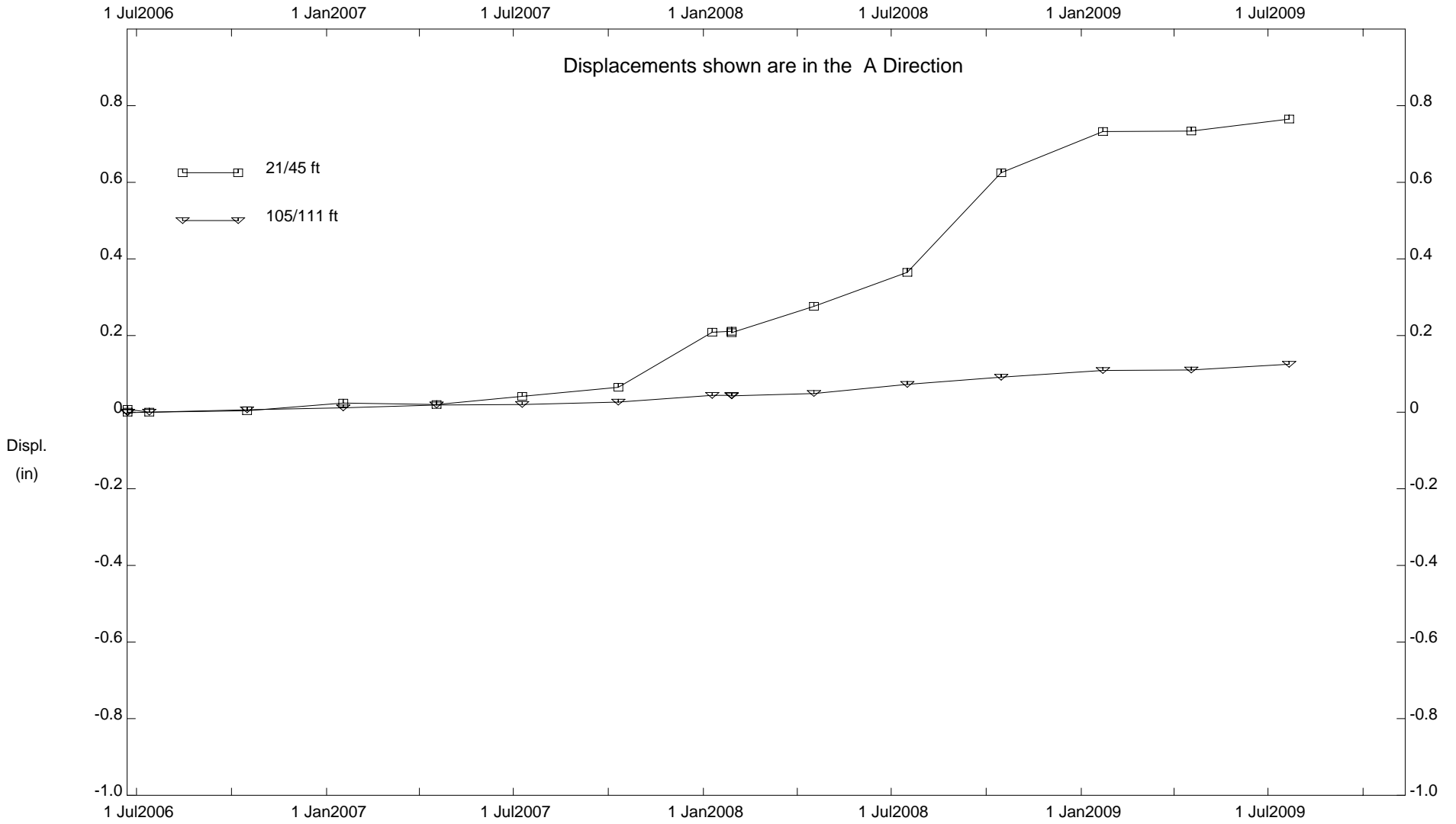

CUY-90, Inclinometer B-105A

E.L. Robinson - Columbus, OH

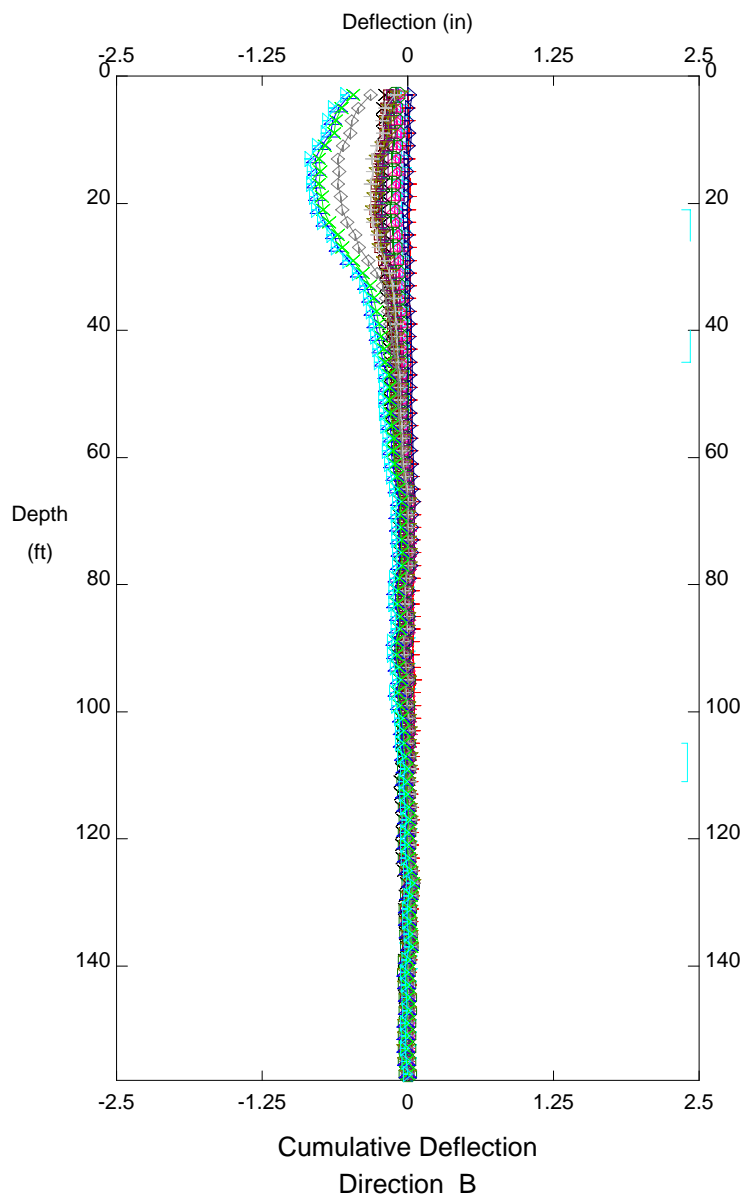

LEGEND

|         |            |
|---------|------------|
| Initial | 22 Jun2006 |
| ◁       | 22 Jun2006 |
| +       | 13 Jul2006 |
| ◇       | 16 Oct2006 |
| △       | 17 Jan2007 |
| ×       | 17 Apr2007 |
| ▷       | 9 Jul2007  |
| ⊖       | 10 Oct2007 |
| ◁       | 9 Jan2008  |
| ⊞       | 28 Jan2008 |
| ⊞       | 28 Jan2008 |
| ▷       | 17 Apr2008 |
| +       | 16 Jul2008 |
| ◇       | 15 Oct2008 |
| ▷       | 22 Jan2009 |
| ×       | 17 Apr2009 |
| ▷       | 21 Jul2009 |

Ref. Elevation ft

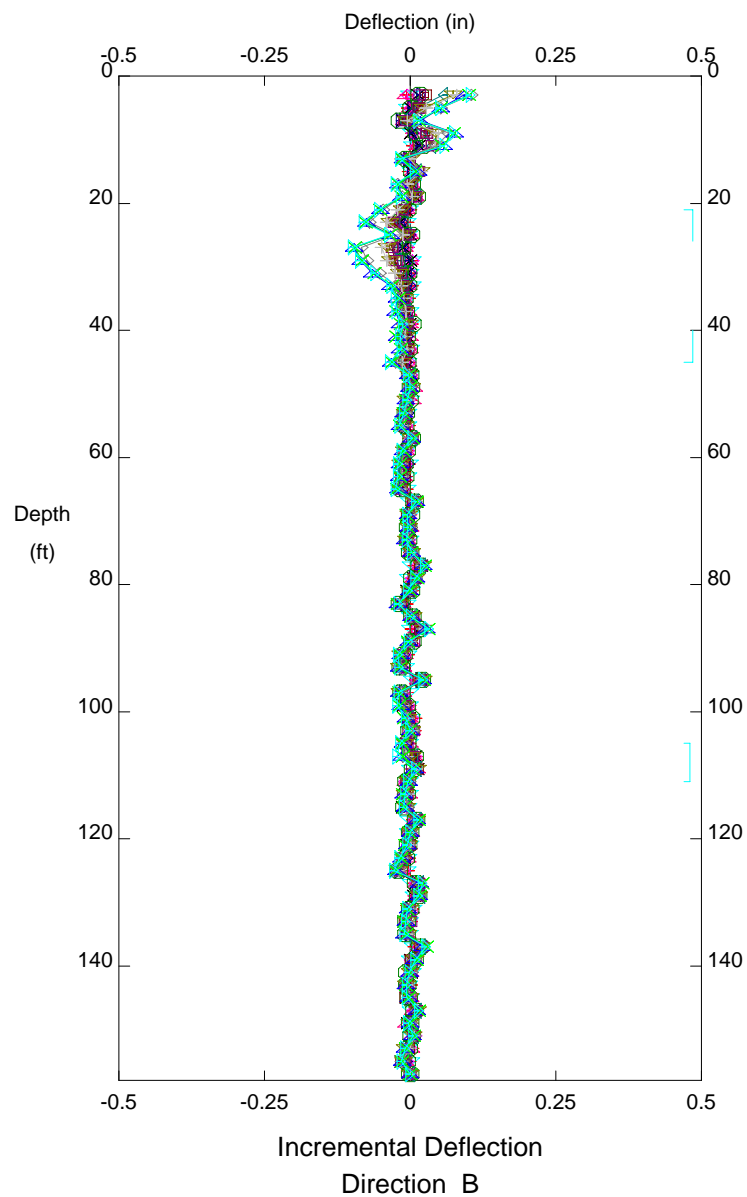

CUY-90, Inclinator B-105A

E.L. Robinson - Columbus, OH

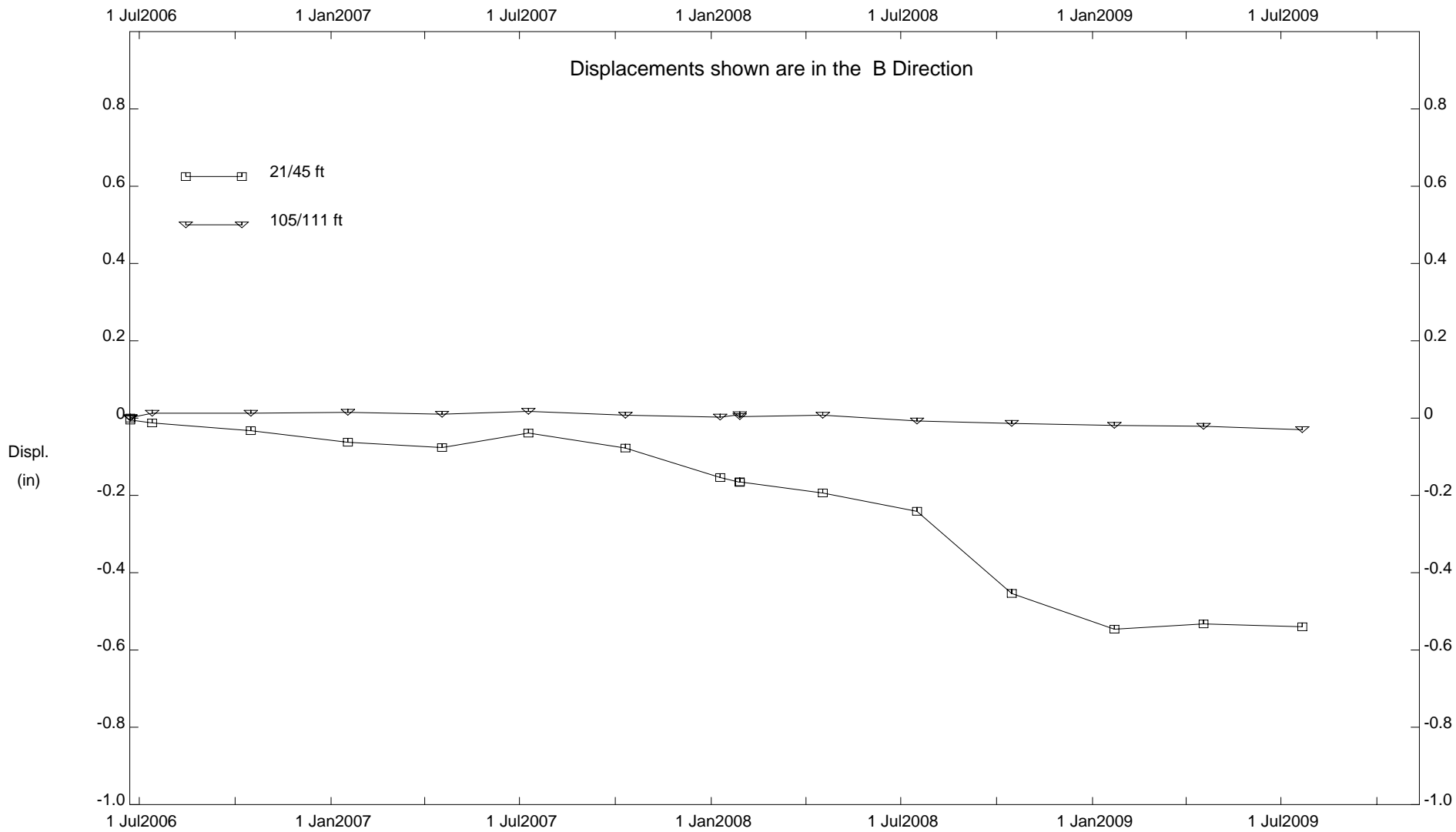

CUY-90, Inclinator B-105A

**INCLINOMETER B-107**

DEPTH FROM 45'/51' RATE OF MOVEMENT = 0.005 INCHES PER YEAR BETWEEN 1994 AND 2006

DEPTH FROM 45'/51' RATE OF MOVEMENT = 0.005 INCHES PER YEAR BETWEEN 2006 AND 2009

DEPTH FROM 181'/187' RATE OF MOVEMENT = 0.008 INCHES PER YEAR BETWEEN 2006 AND 2009

E.L. Robinson - Columbus, OH

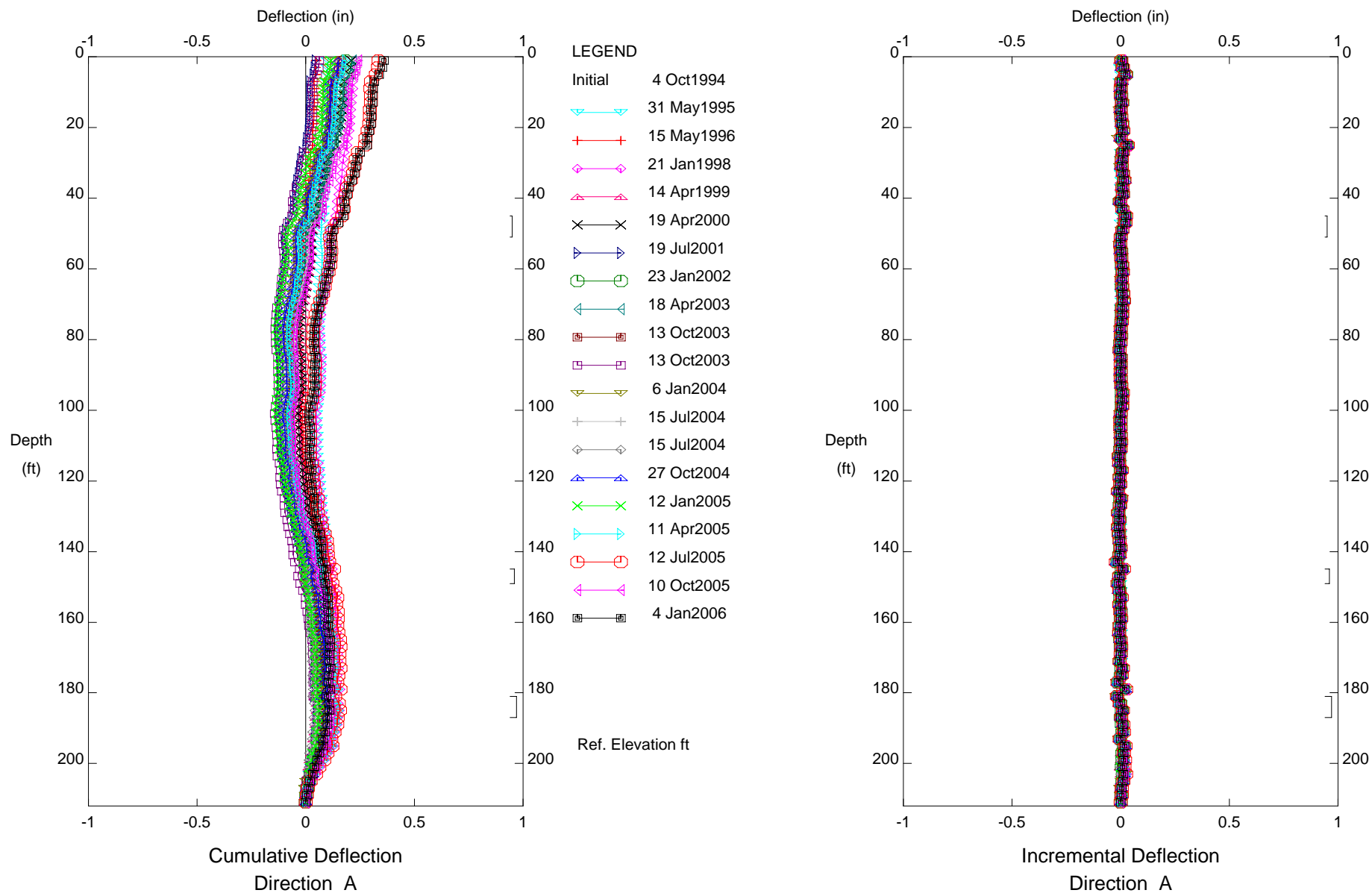

CUY-90, Inclinator B-107

# E.L. Robinson - Columbus, OH

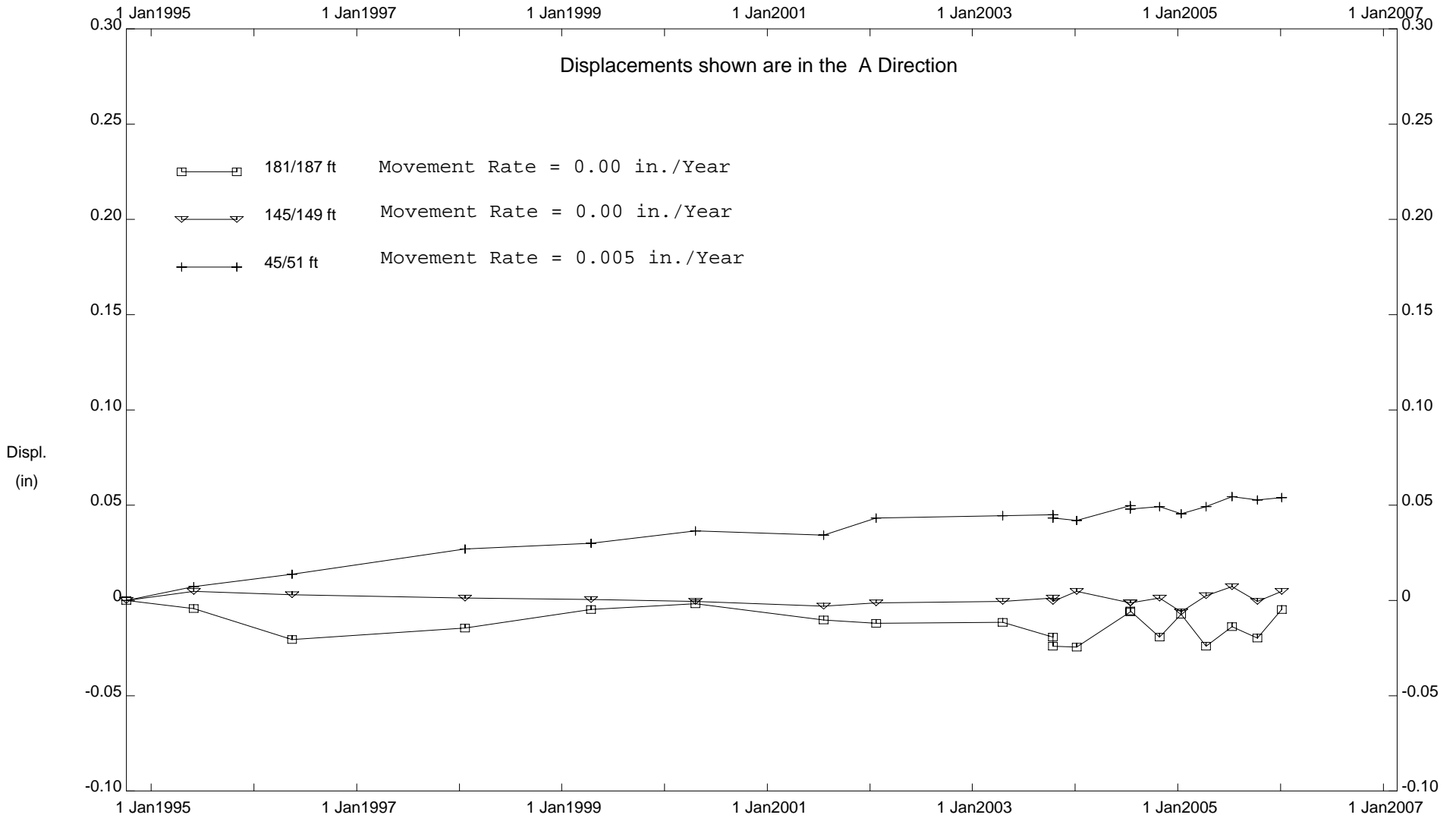

CUY-90, Inclinometer B-107

E.L. Robinson - Columbus, OH

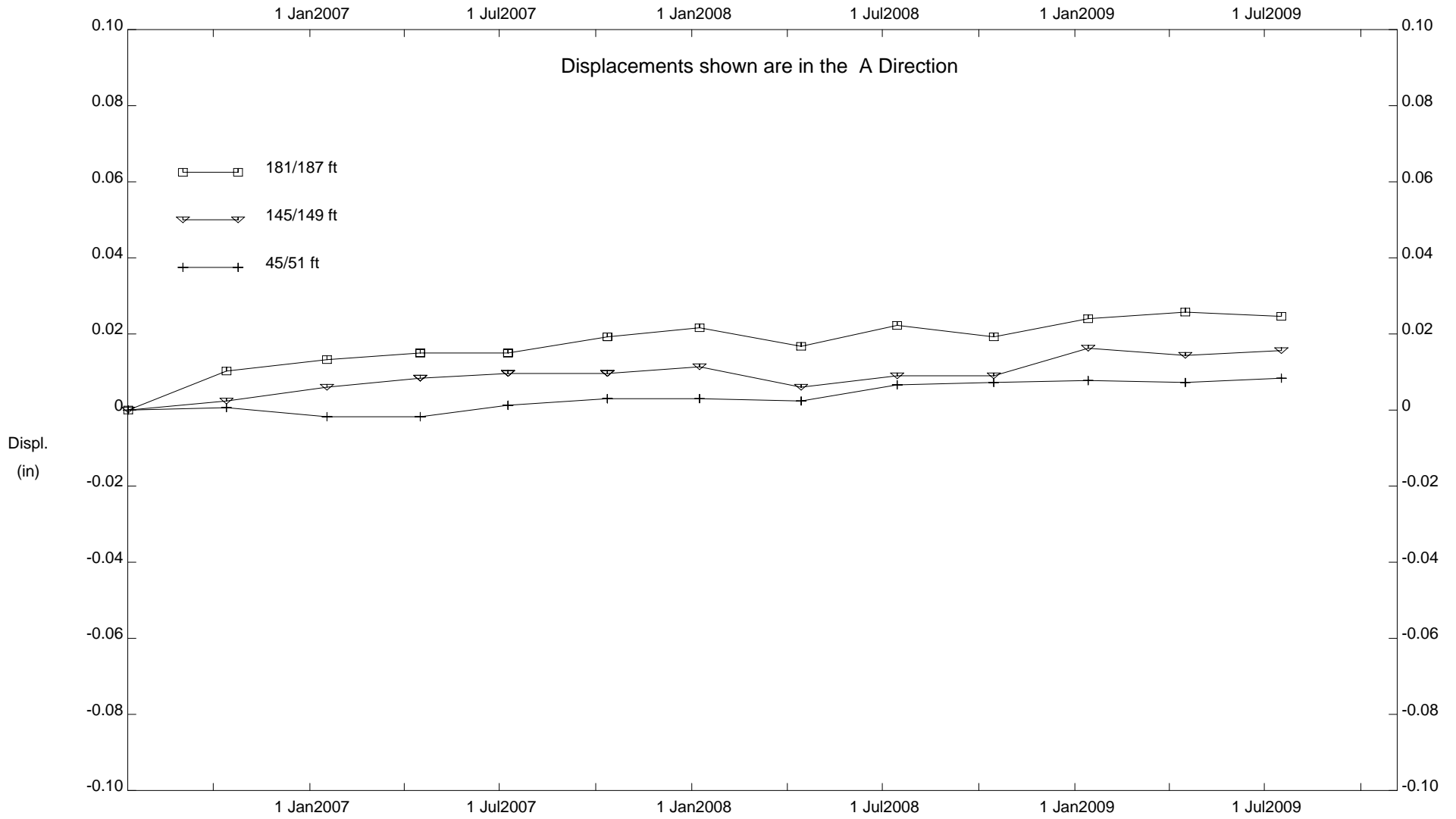

CUY-90, Inclinometer B-107

E.L. Robinson - Columbus, OH

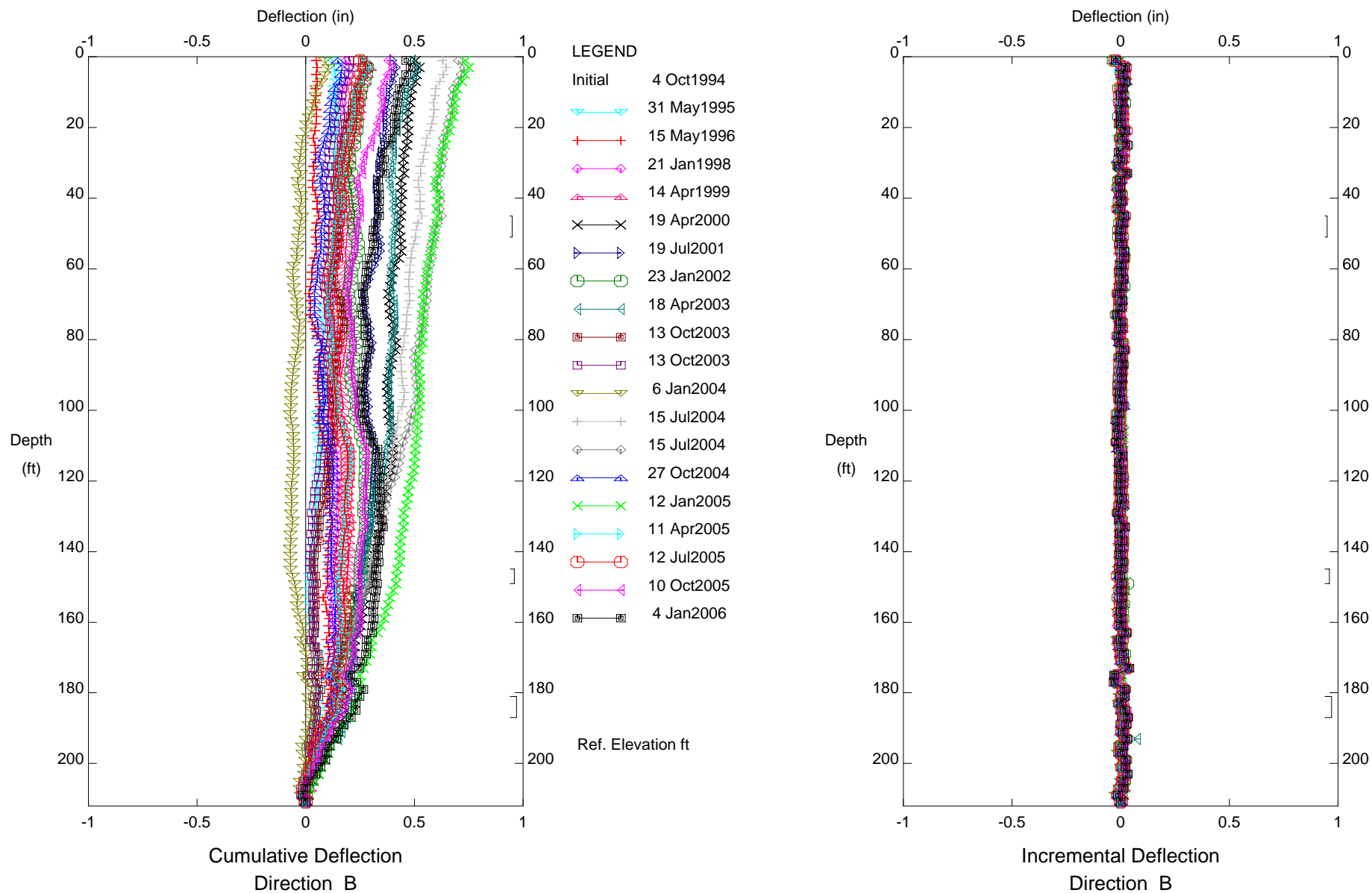

CUY-90, Inclinometer B-107



# E.L. Robinson - Columbus, OH

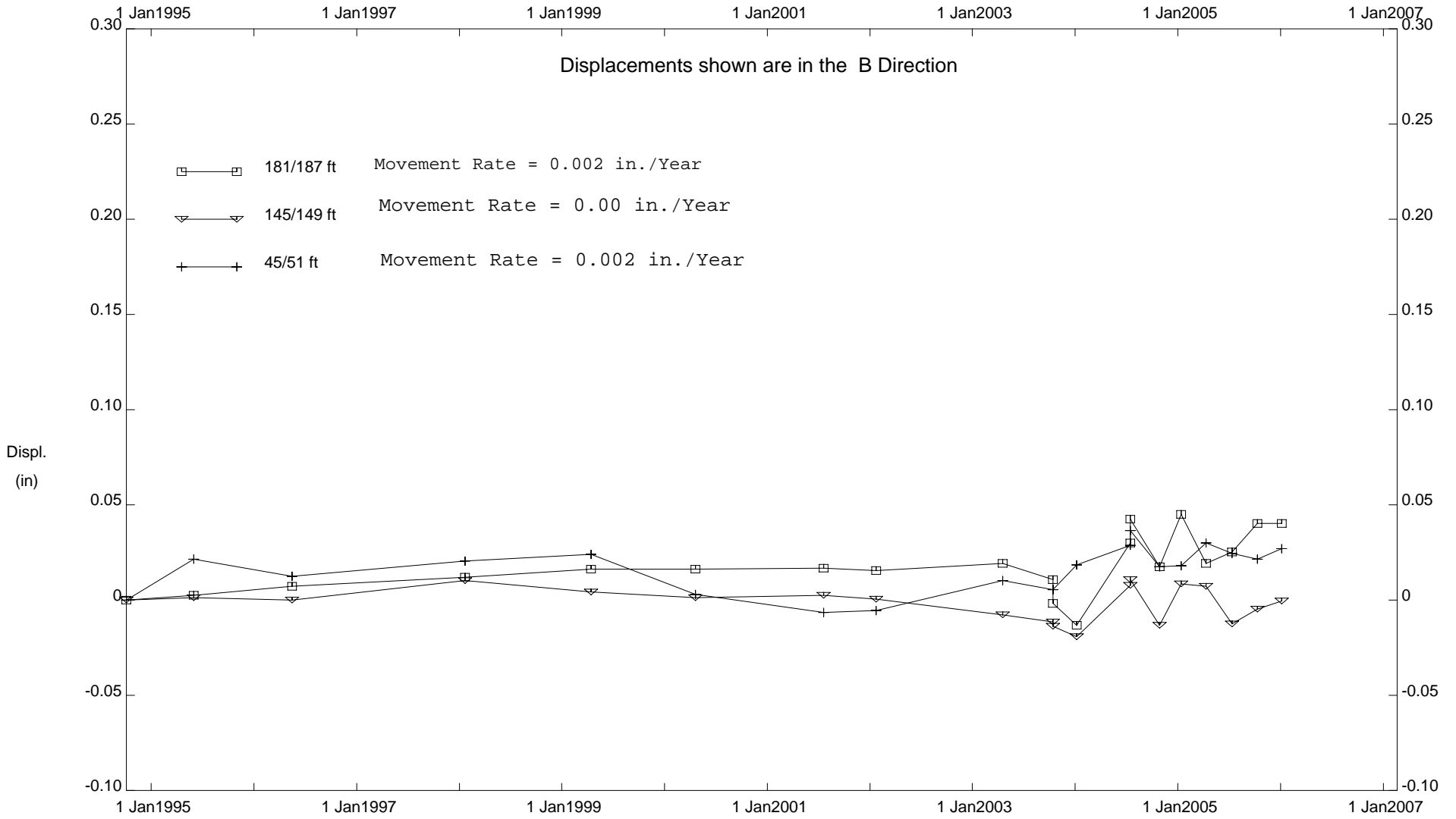

CUY-90, Inclinator B-107

E.L. Robinson - Columbus, OH

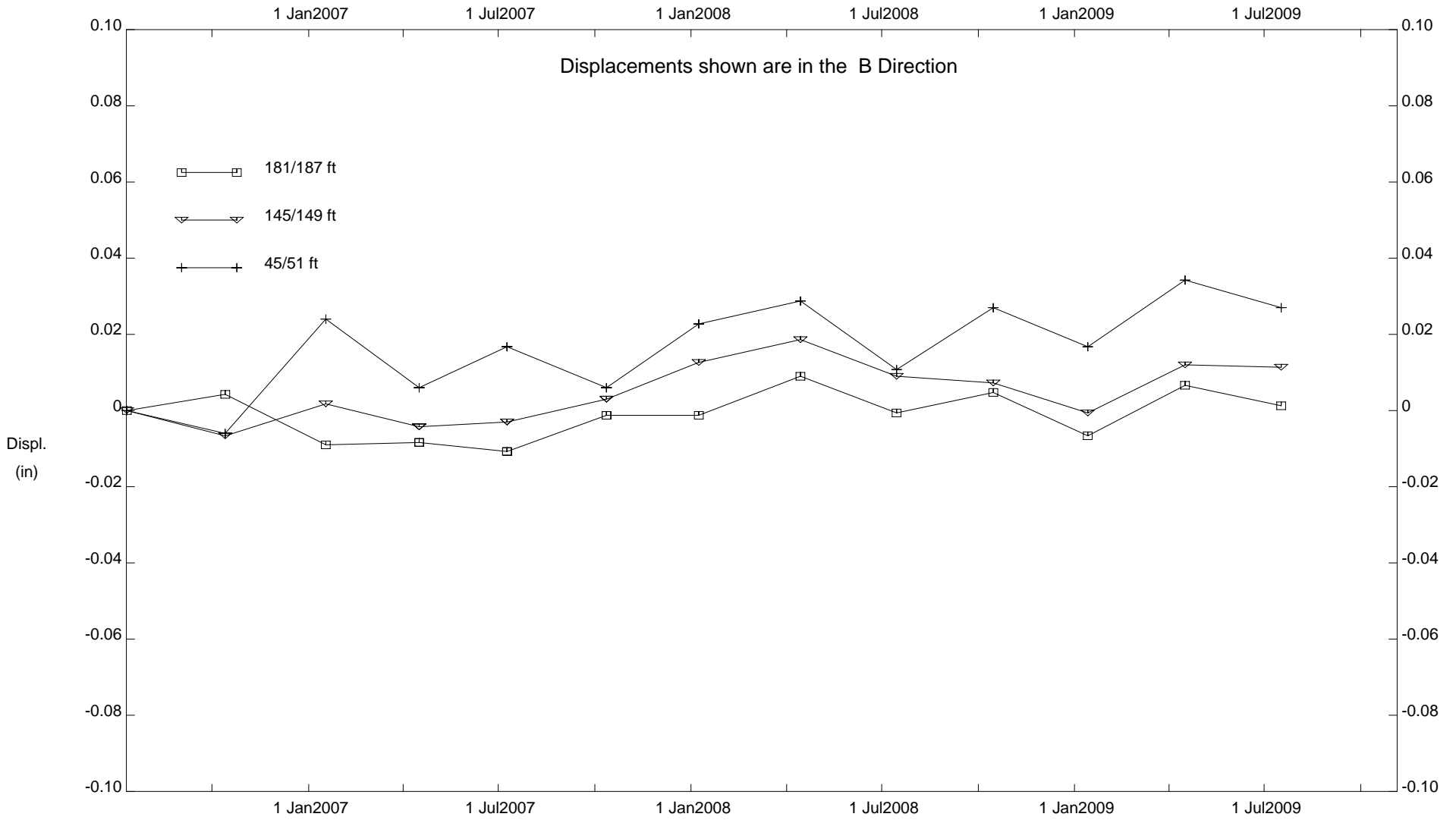

CUY-90, Inclinator B-107

E.L. Robinson - Columbus, OH

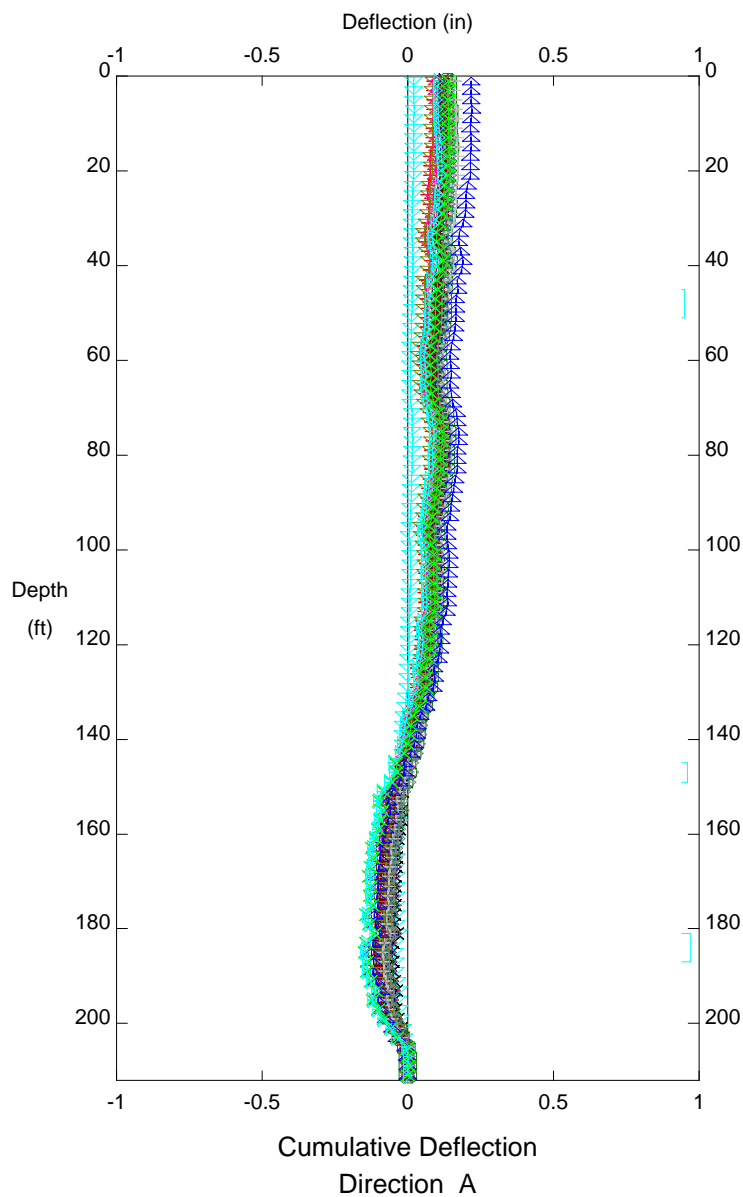

LEGEND

|         |            |
|---------|------------|
| Initial | 11 Jul2006 |
| ◁       | 13 Oct2006 |
| +       | 17 Jan2007 |
| ◇       | 16 Apr2007 |
| △       | 16 Apr2007 |
| ×       | 9 Jul2007  |
| ▷       | 9 Jul2007  |
| ⊕       | 12 Oct2007 |
| ◁       | 12 Oct2007 |
| ⊞       | 8 Jan2008  |
| ▽       | 14 Apr2008 |
| +       | 15 Jul2008 |
| ◇       | 15 Oct2008 |
| ▷       | 13 Jan2009 |
| ×       | 16 Apr2009 |
| ▷       | 17 Jul2009 |

Ref. Elevation ft

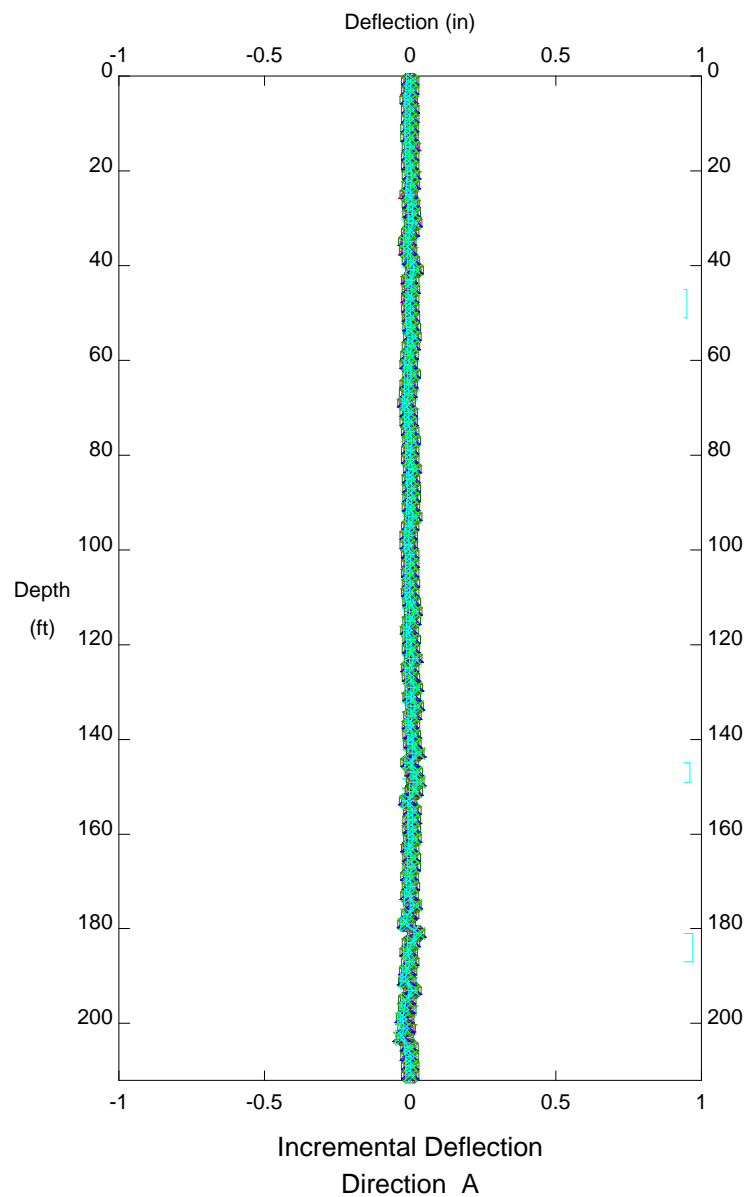

CUY-90, Inclinator B-107

E.L. Robinson - Columbus, OH

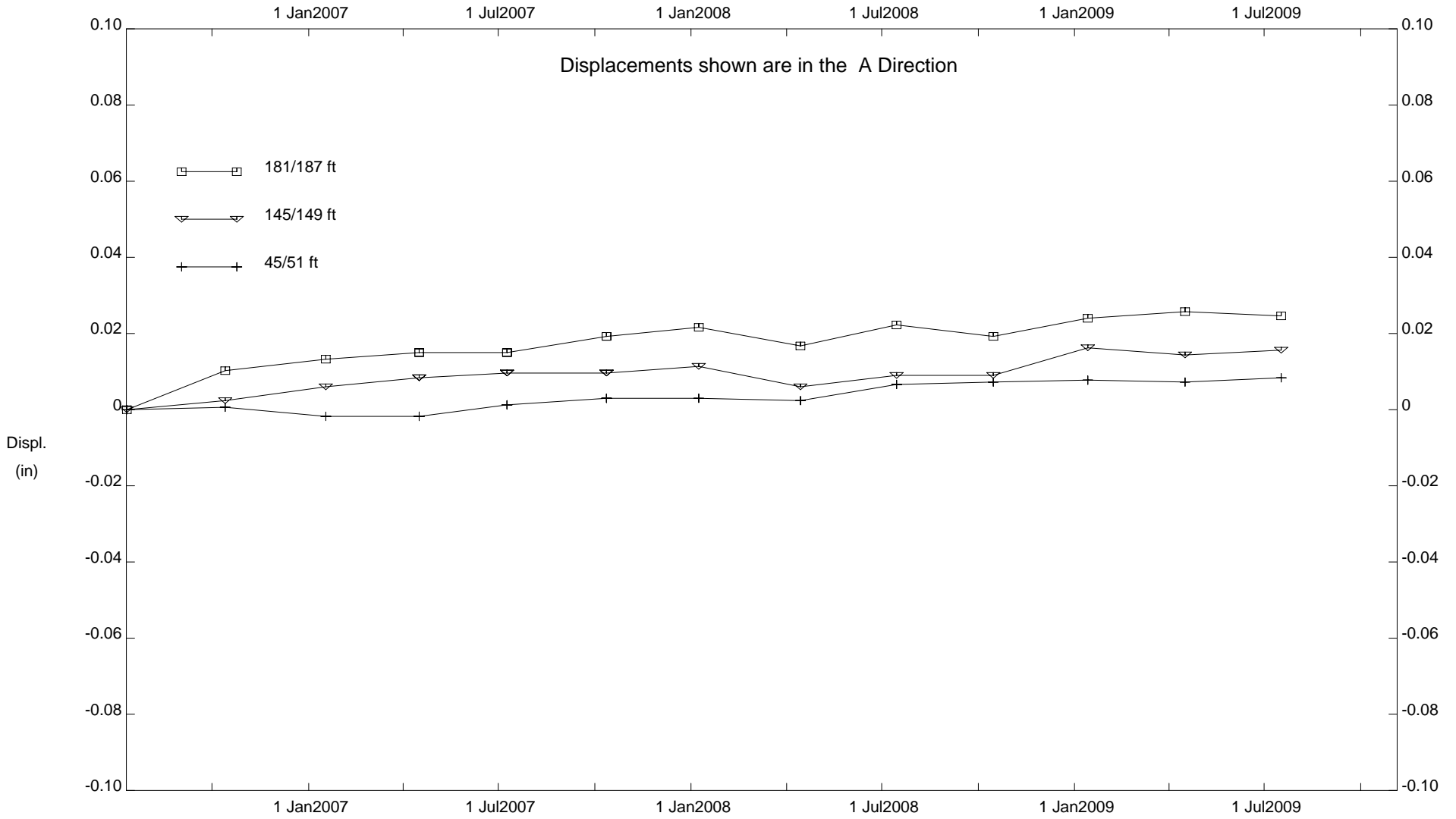

CUY-90, Inclinometer B-107

E.L. Robinson - Columbus, OH

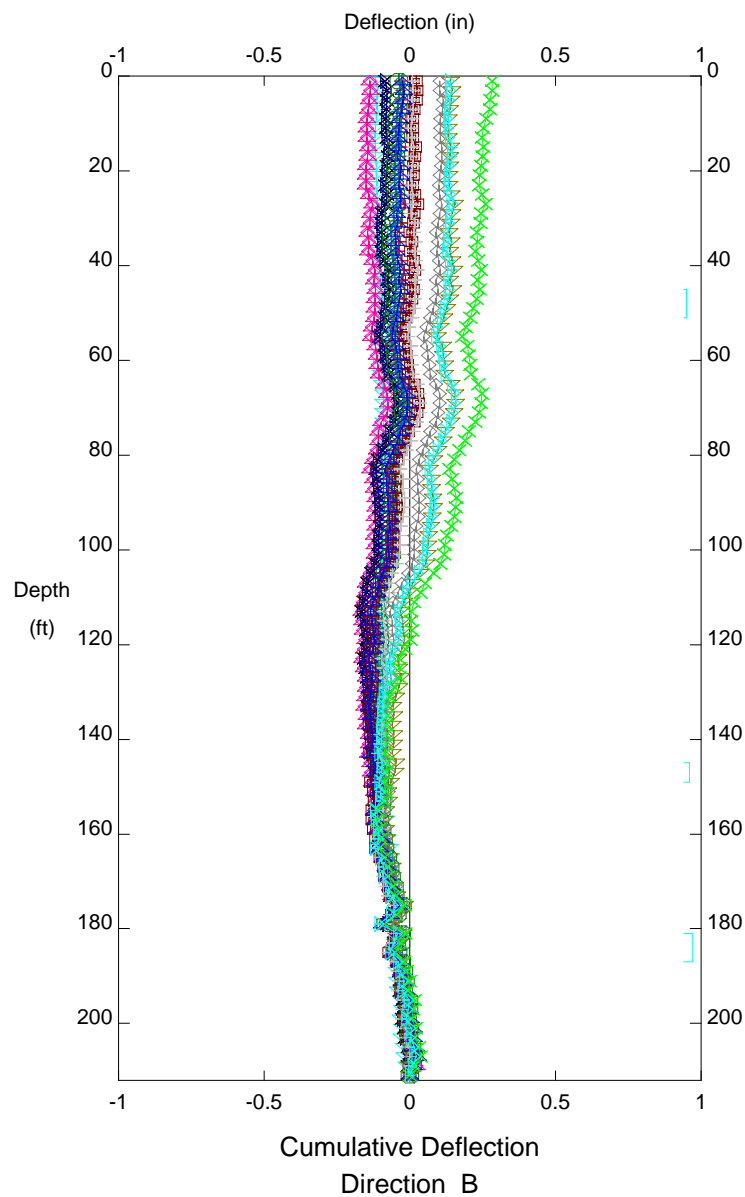

LEGEND

|         |            |
|---------|------------|
| Initial | 11 Jul2006 |
| ◁       | 13 Oct2006 |
| +       | 17 Jan2007 |
| ◇       | 16 Apr2007 |
| △       | 16 Apr2007 |
| ×       | 9 Jul2007  |
| ▷       | 9 Jul2007  |
| ⊕       | 12 Oct2007 |
| ◁       | 12 Oct2007 |
| ⊞       | 8 Jan2008  |
| ▽       | 14 Apr2008 |
| +       | 15 Jul2008 |
| ◇       | 15 Oct2008 |
| △       | 13 Jan2009 |
| ×       | 16 Apr2009 |
| ▷       | 17 Jul2009 |

Ref. Elevation ft

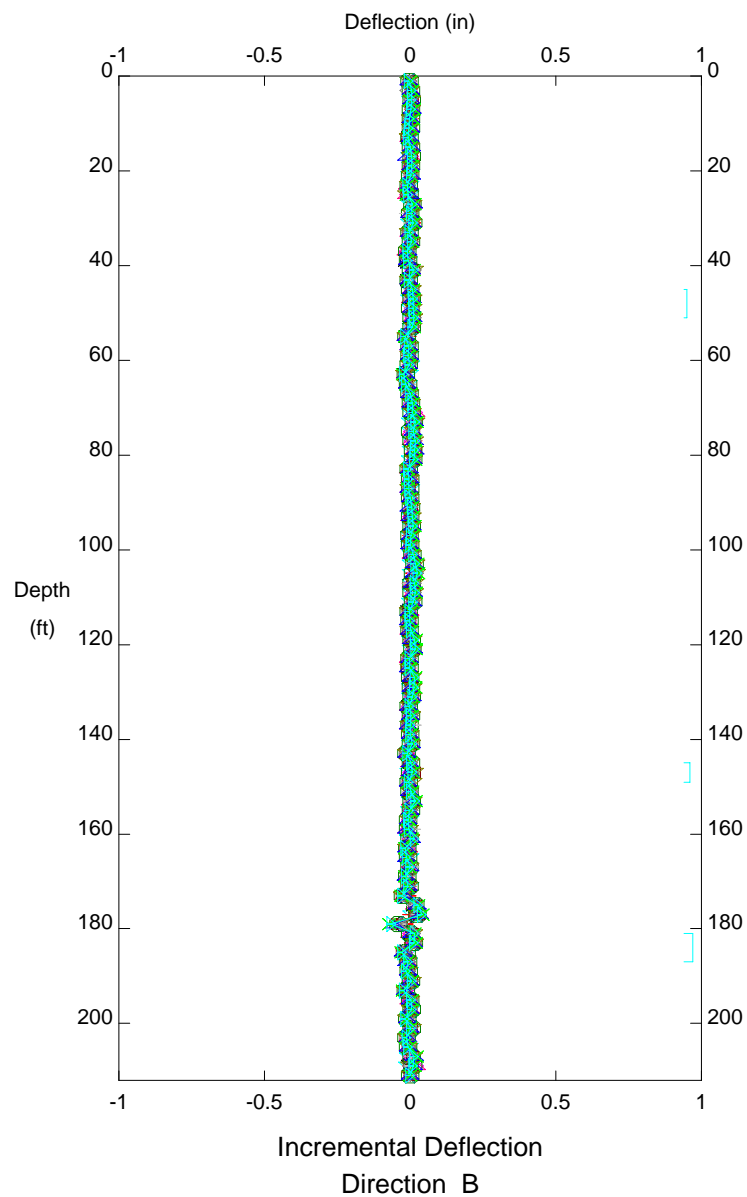

CUY-90, Inclinator B-107

E.L. Robinson - Columbus, OH

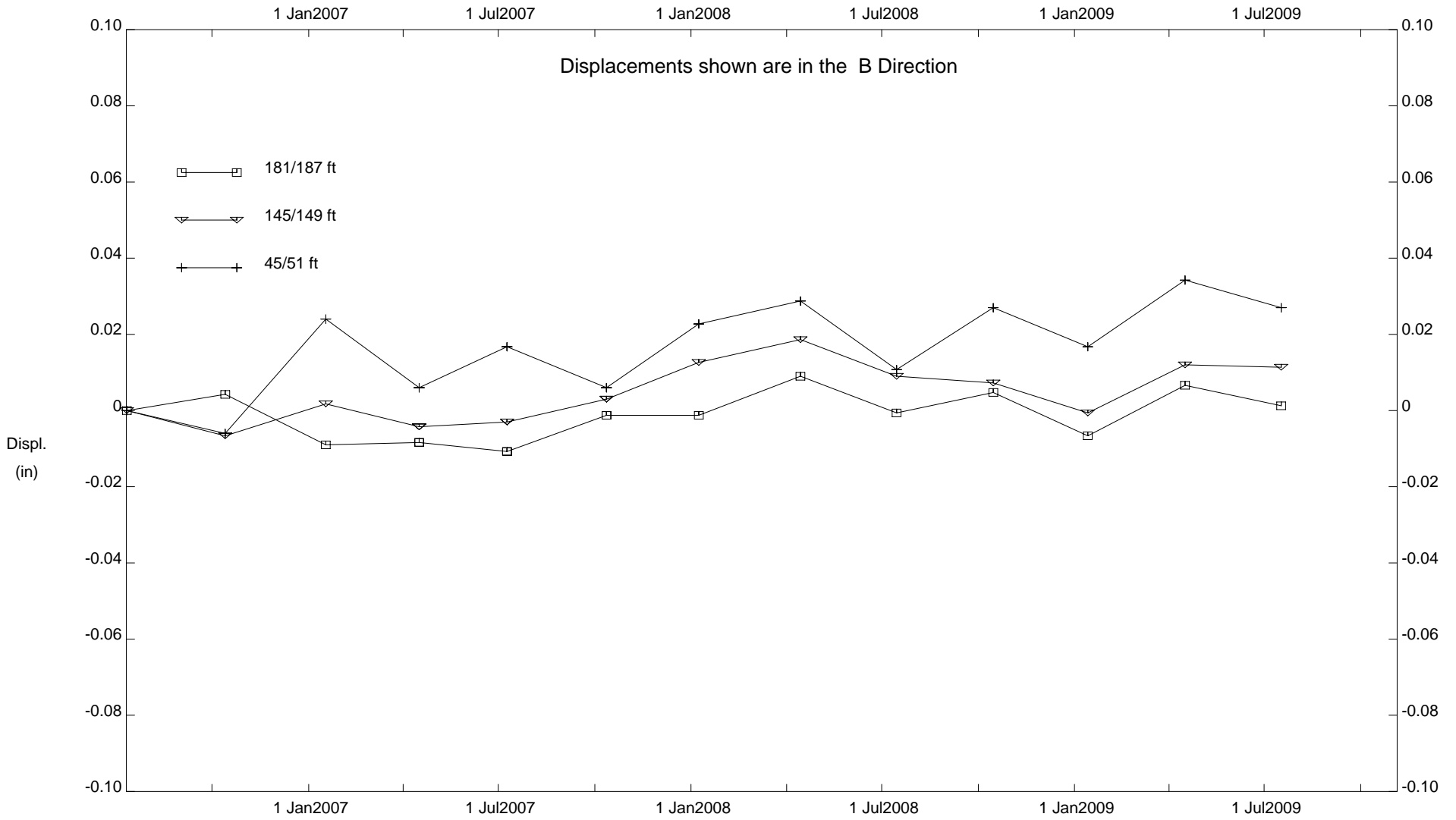

CUY-90, Inclinator B-107

**INCLINOMETER B-108**

DEPTH FROM 119'123' RATE OF MOVEMENT = 0.02 INCHES PER YEAR BETWEEN 2000 AND 2006

E.L. Robinson - Columbus, OH

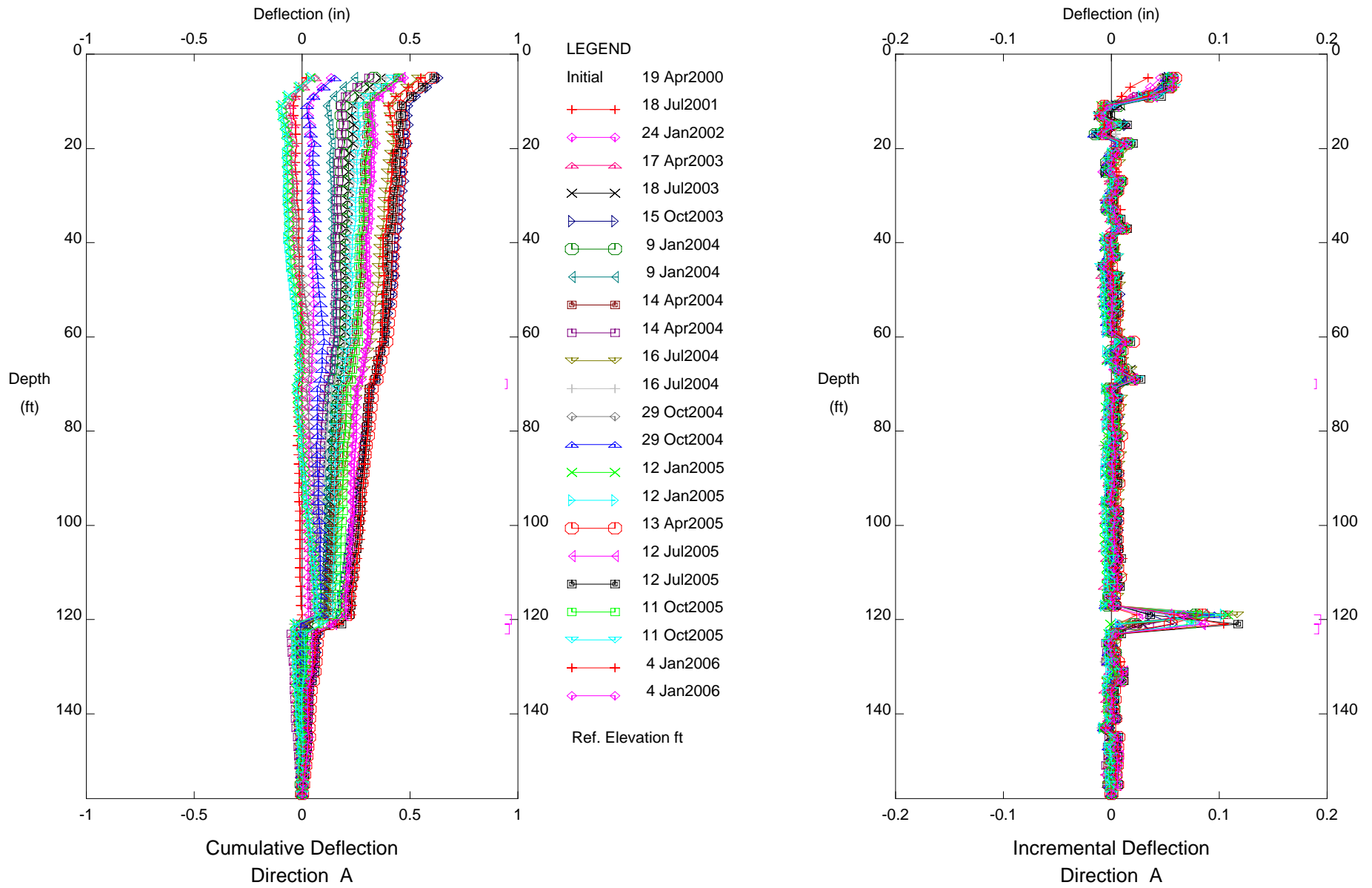

CUY-90, Inclinator B-108



E.L. Robinson - Columbus, OH

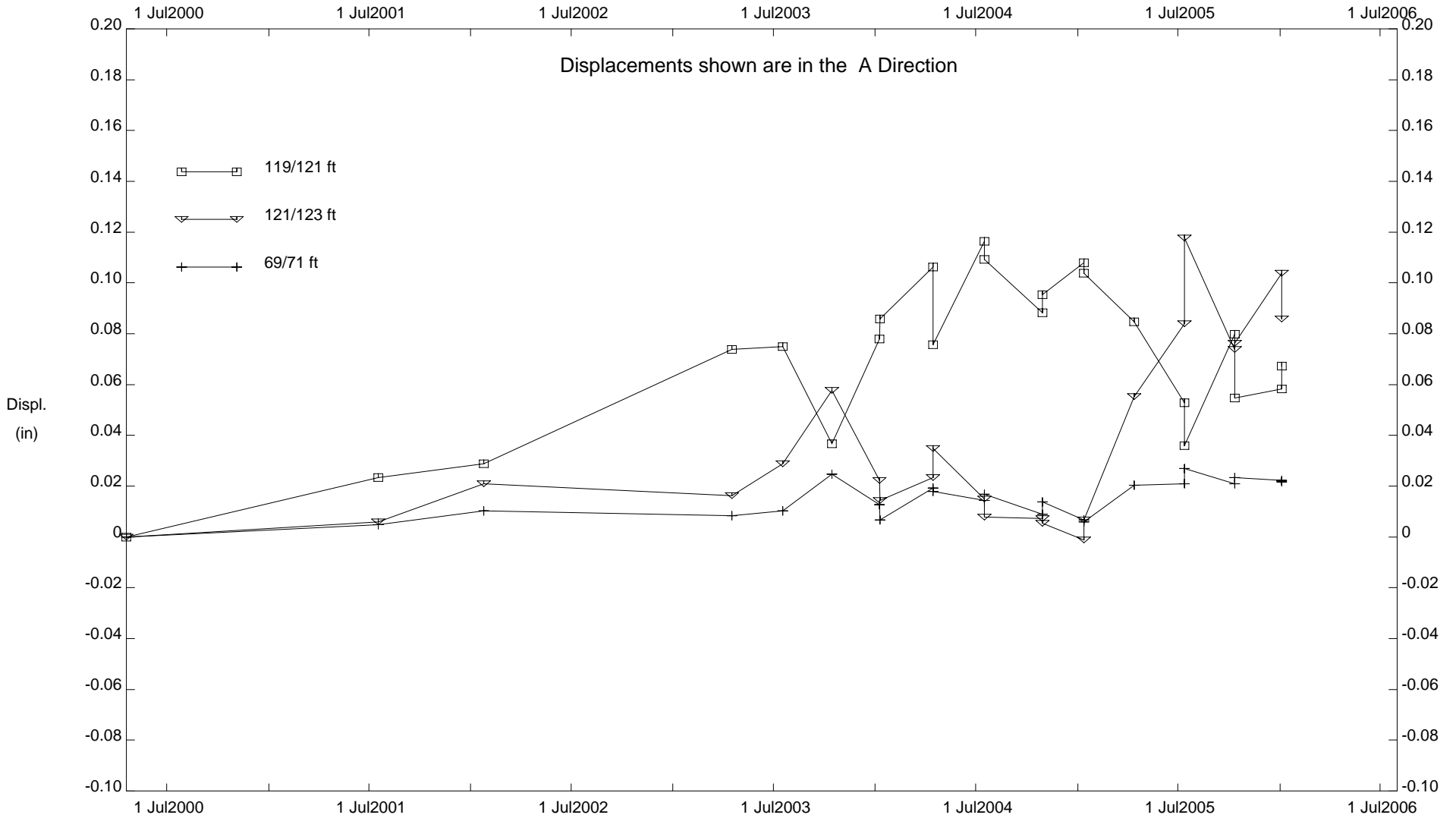

CUY-90, Inclinator B-108

E.L. Robinson - Columbus, OH

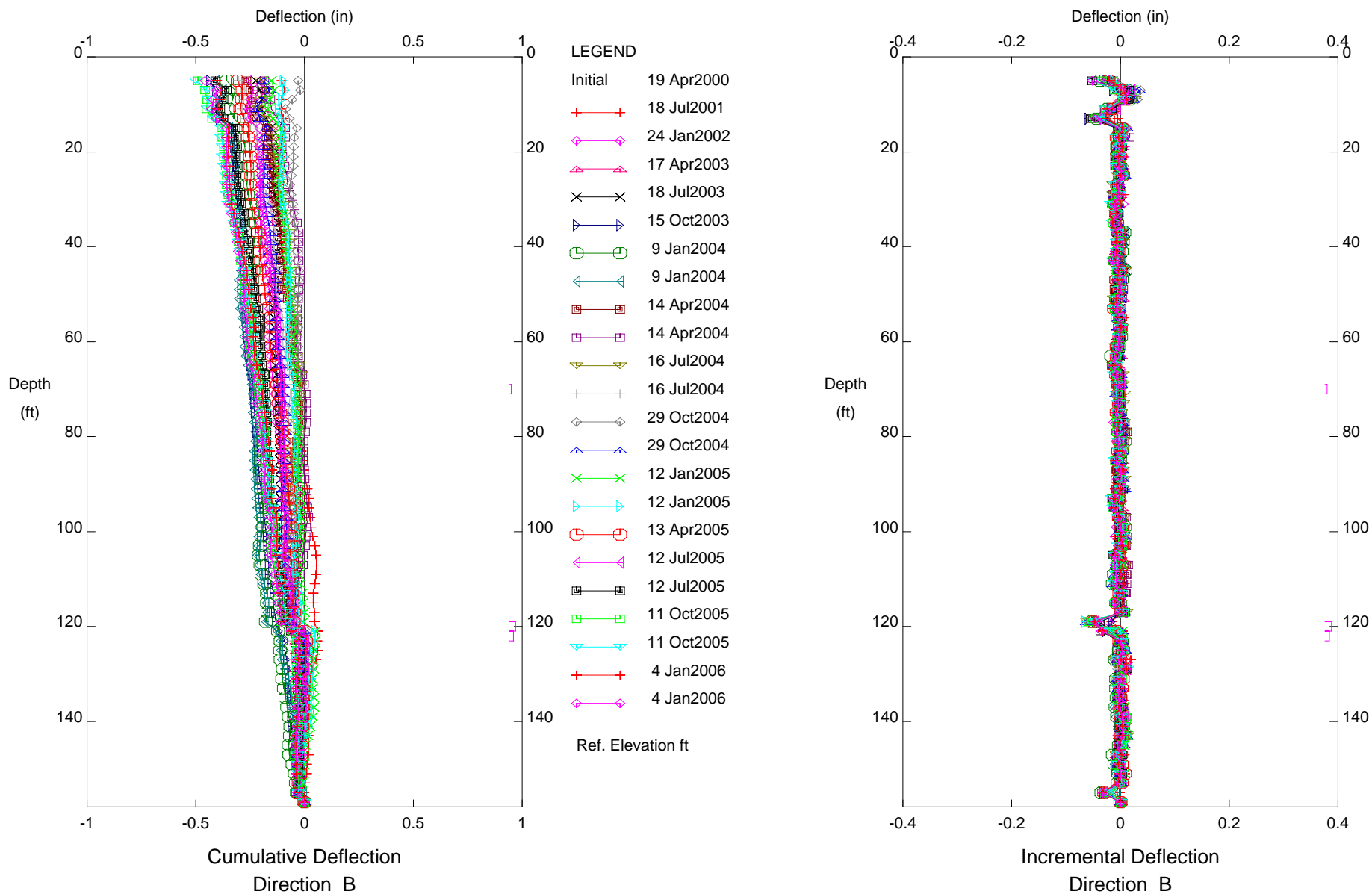

CUY-90, Inclinometer B-108

E.L. Robinson - Columbus, OH

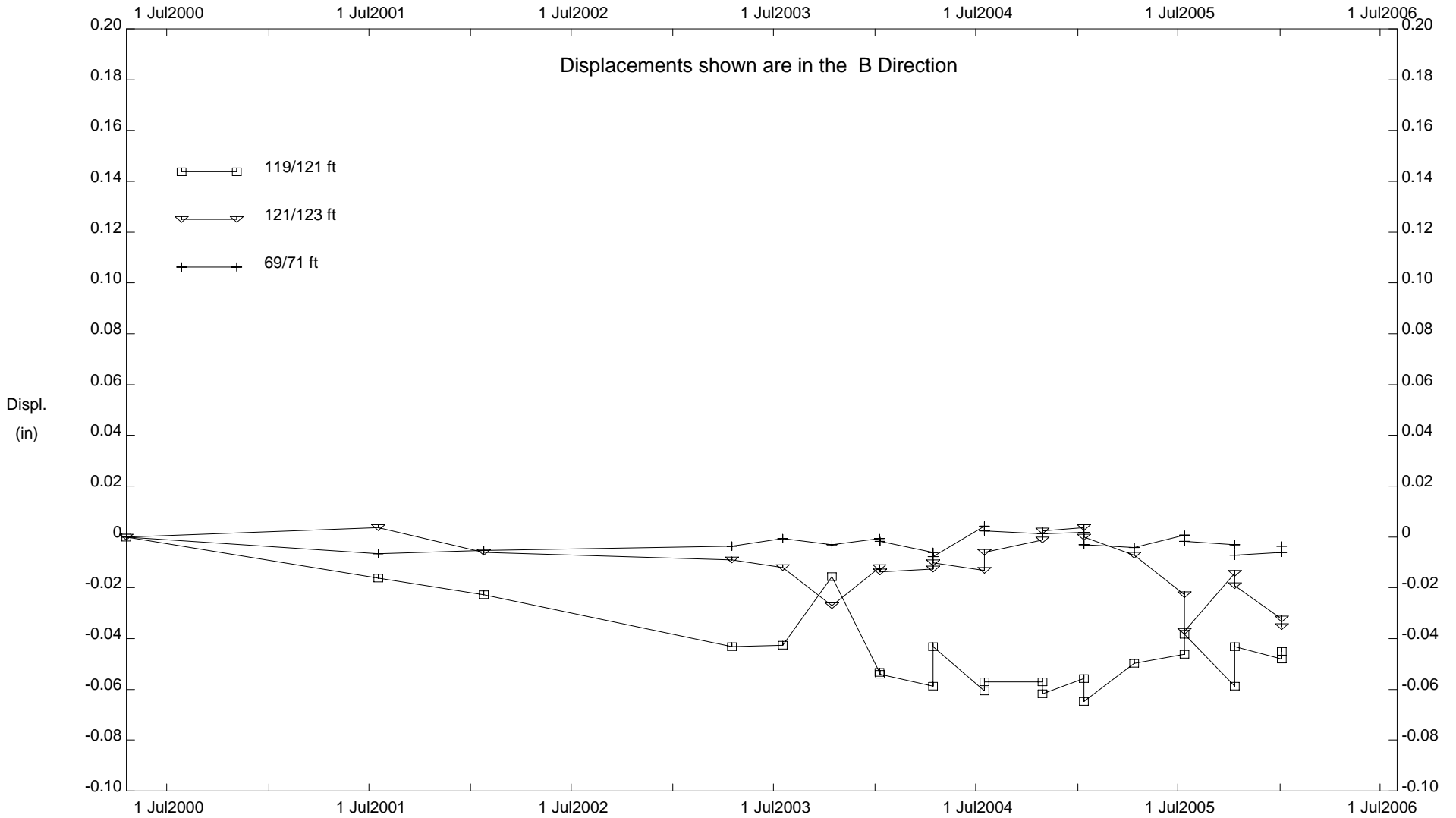

CUY-90, Inclinator B-108

**INCLINOMETER B-108A**

DEPTH FROM 119'123' RATE OF MOVEMENT = 0.02 INCHES PER YEAR BETWEEN 2006 AND 2009

E.L. Robinson - Columbus, OH

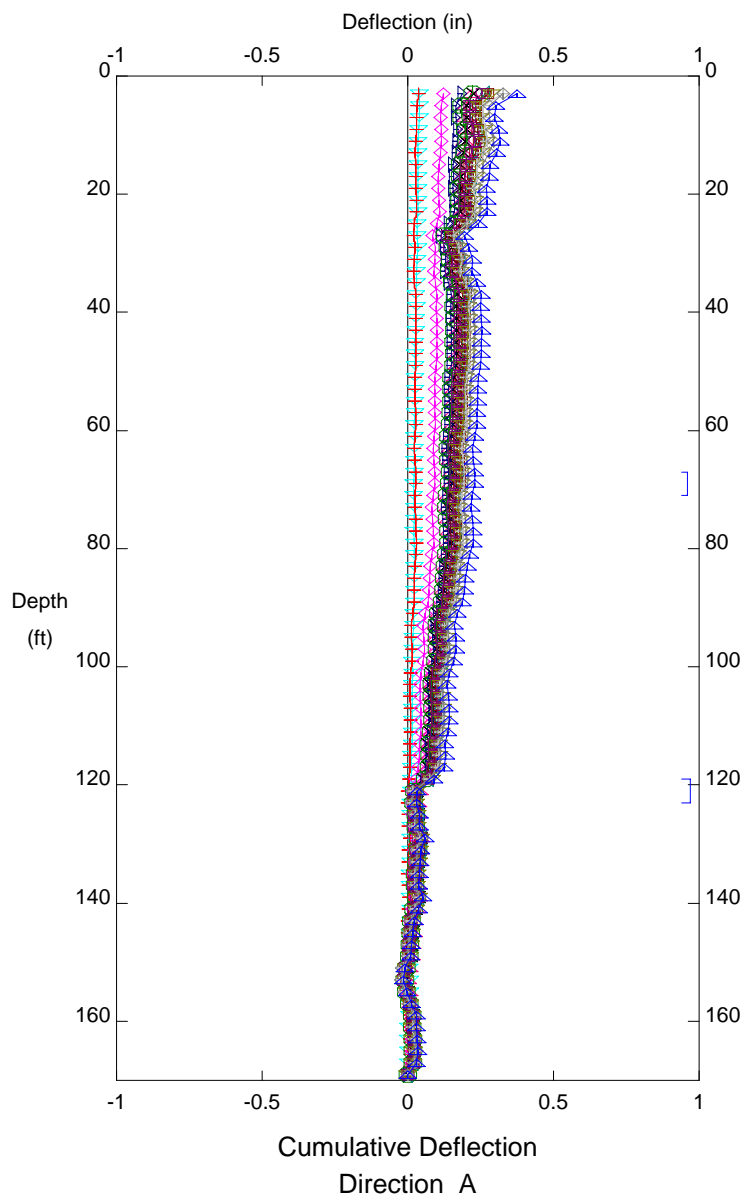

- LEGEND
- Initial 21 Jun2006
  - ◁ 21 Jun2006
  - + 12 Jul2006
  - ◇ 18 Oct2006
  - △ 17 Jan2007
  - × 17 Apr2007
  - ▷ 9 Jul2007
  - ⊕ 10 Oct2007
  - ◁ 9 Jan2008
  - ⊞ 17 Apr2008
  - ⊞ 16 Jul2008
  - ▽ 13 Oct2008
  - + 22 Jan2009
  - ◇ 21 Apr2009
  - ▷ 21 Jul2009
- Ref. Elevation ft

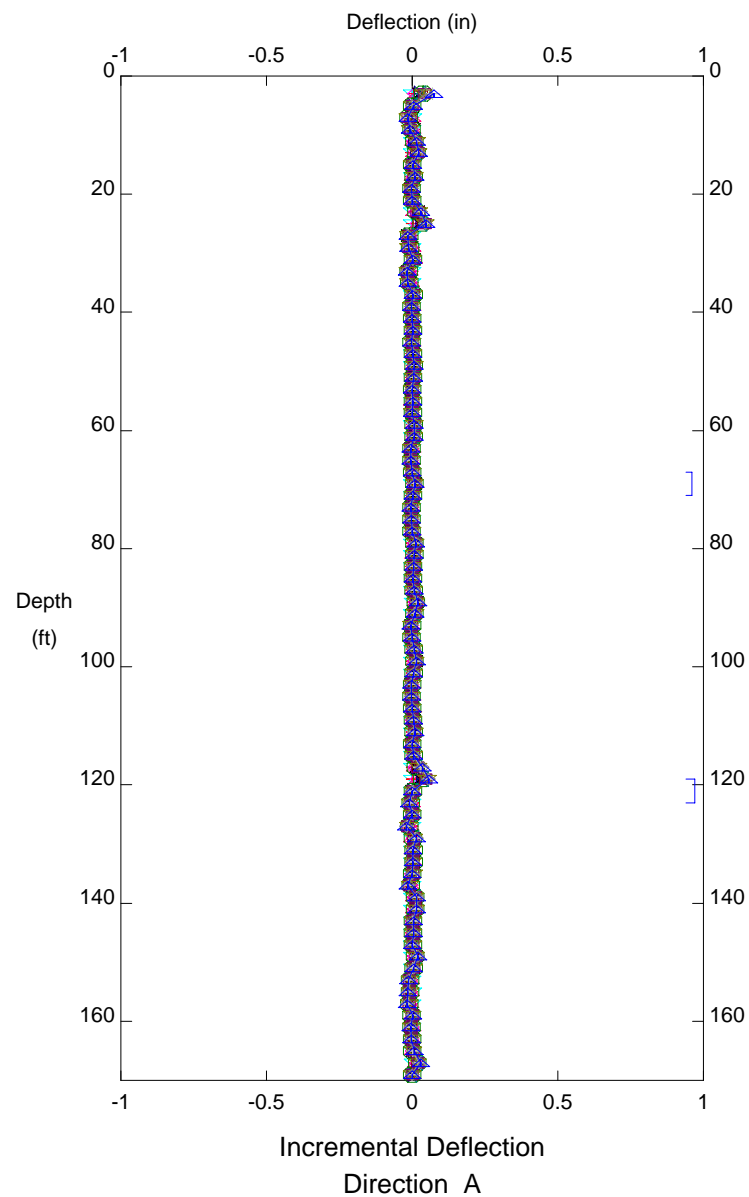

CUY-90, Inclinator B-108A

E.L. Robinson - Columbus, OH

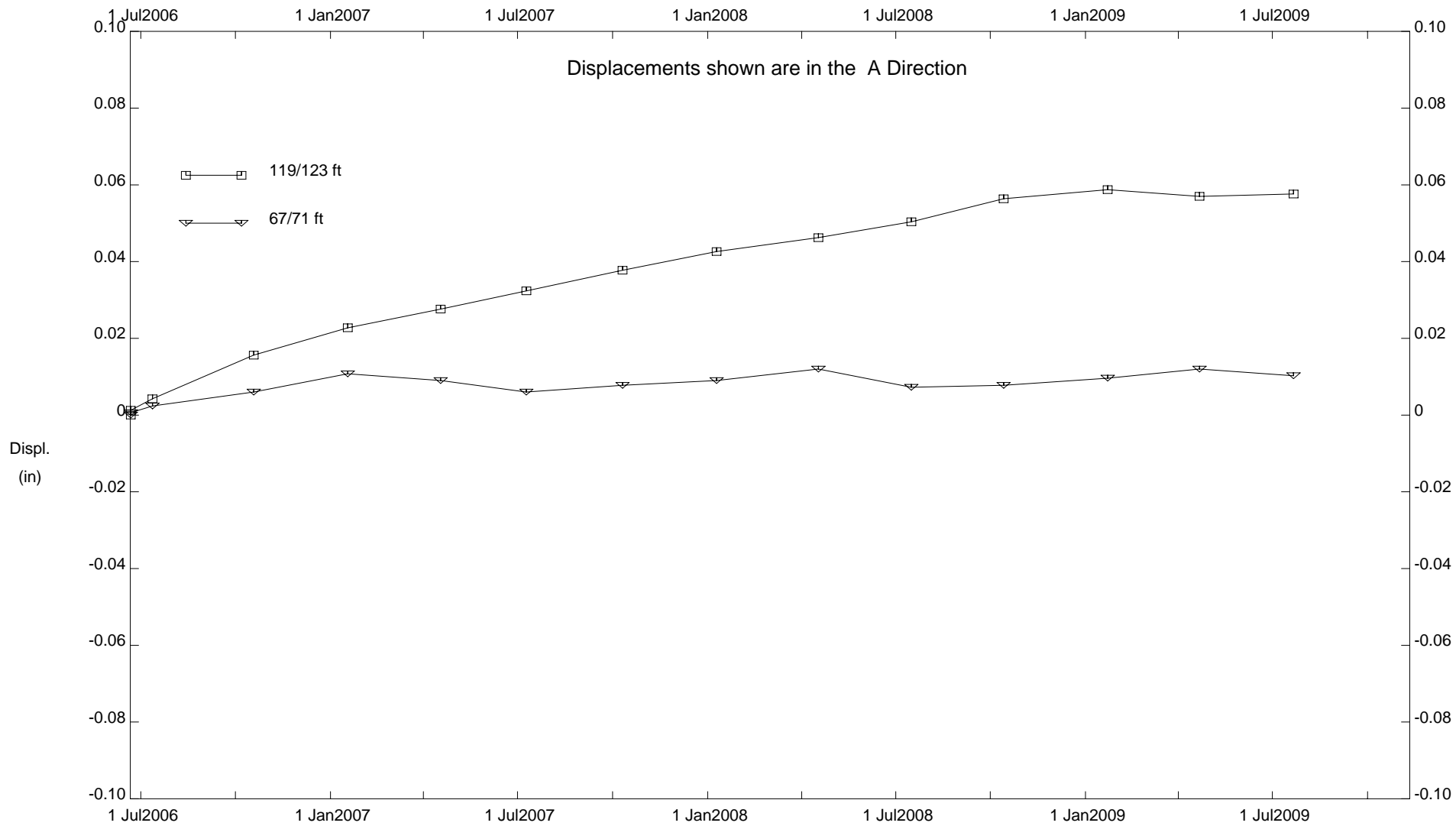

CUY-90, Inclinator B-108A

E.L. Robinson - Columbus, OH

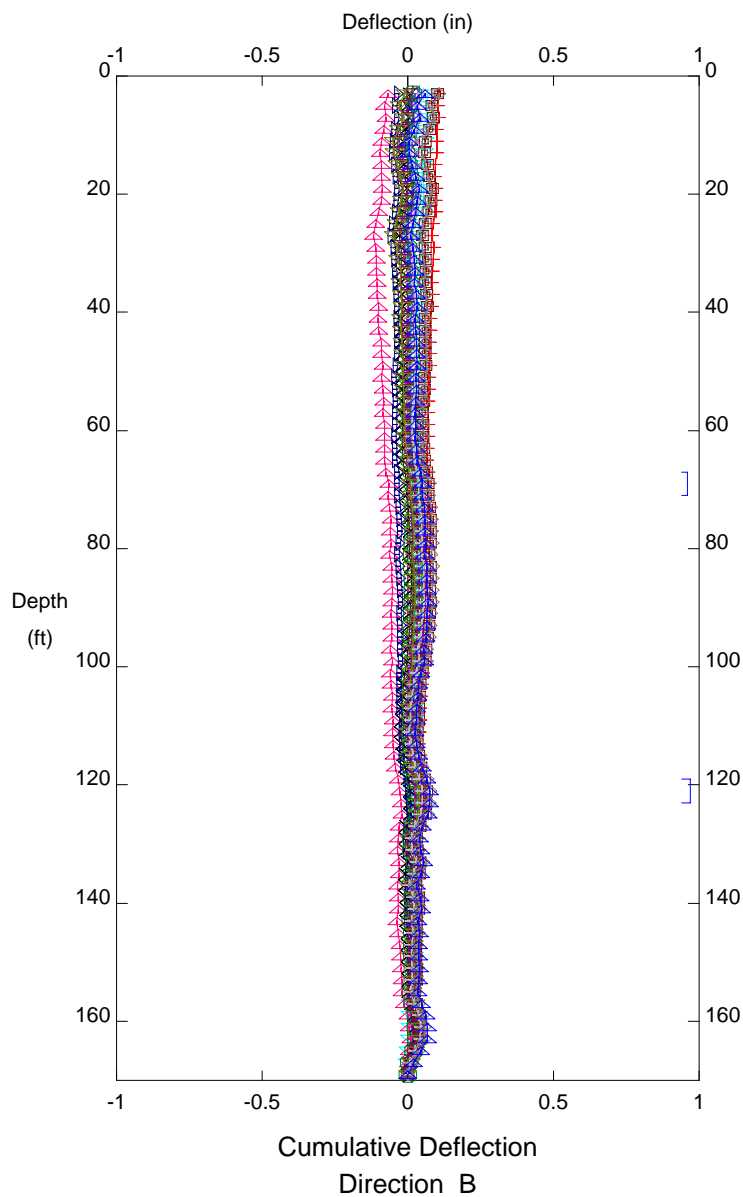

LEGEND

|         |            |
|---------|------------|
| Initial | 21 Jun2006 |
| ↔       | 21 Jun2006 |
| +—+     | 12 Jul2006 |
| ◇—◇     | 18 Oct2006 |
| △—△     | 17 Jan2007 |
| ×—×     | 17 Apr2007 |
| ▷—▷     | 9 Jul2007  |
| ⊕—⊕     | 10 Oct2007 |
| ◁—▷     | 9 Jan2008  |
| ⊞—⊞     | 17 Apr2008 |
| ◻—◻     | 16 Jul2008 |
| ▽—▽     | 13 Oct2008 |
| +—+     | 22 Jan2009 |
| ◇—◇     | 21 Apr2009 |
| ▷—▷     | 21 Jul2009 |

Ref. Elevation ft

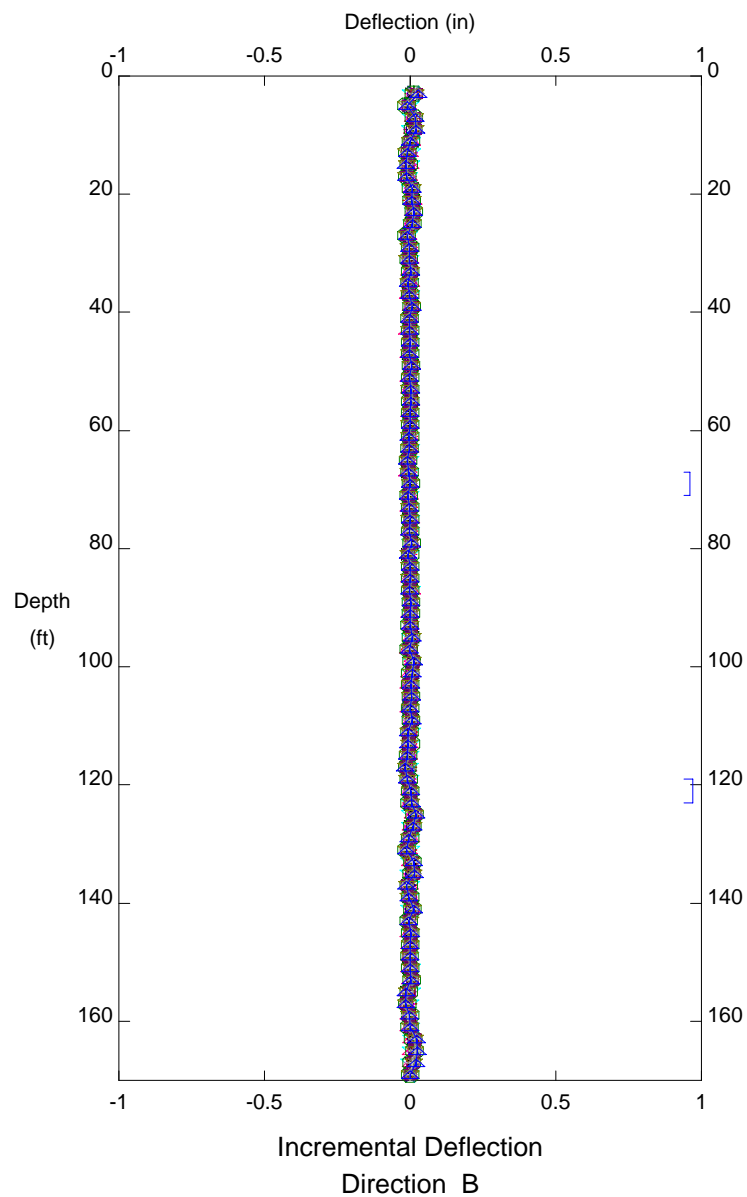

CUY-90, Inclinator B-108A

E.L. Robinson - Columbus, OH

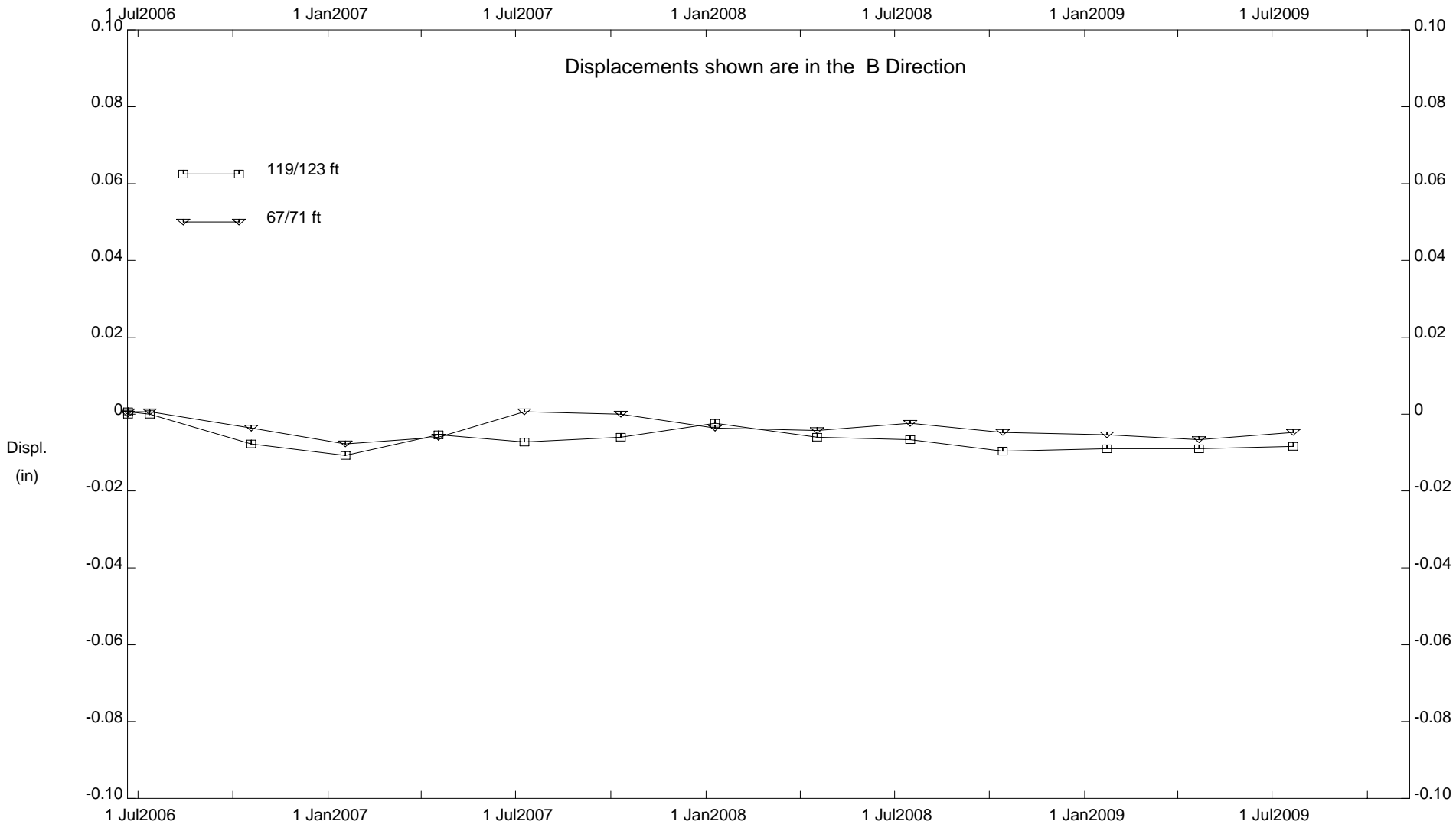

CUY-90, Inclinometer B-108A



**INCLINOMETER B-110**

DEPTH FROM 41'47' RATE OF MOVEMENT = 0.012 INCHES PER YEAR BETWEEN 1995 AND 2005

DEPTH FROM 111'119' RATE OF MOVEMENT = 0.01 INCHES PER YEAR BETWEEN 1995 AND 2005

E.L. Robinson - Columbus, OH

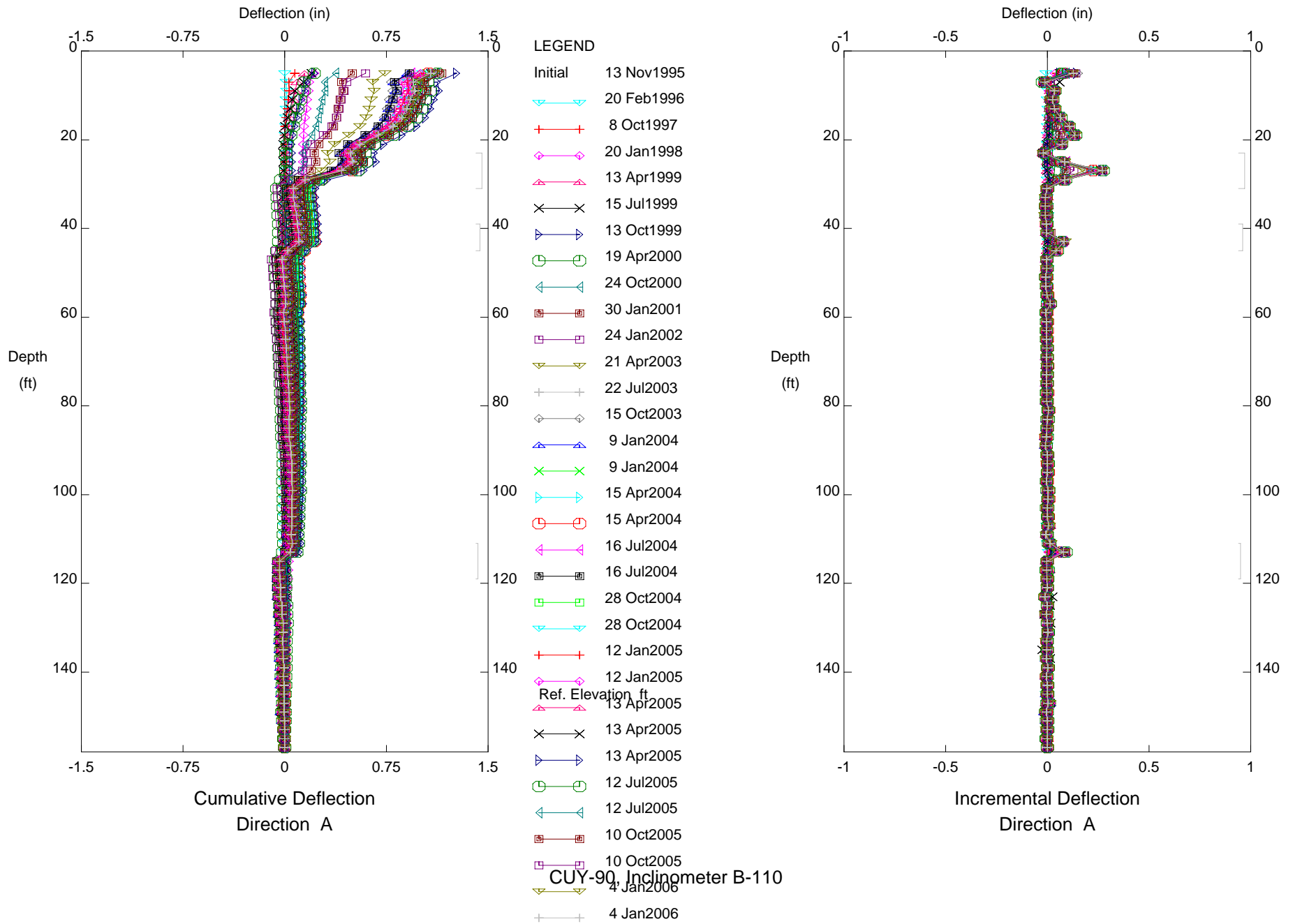

# E.L. Robinson - Columbus, OH

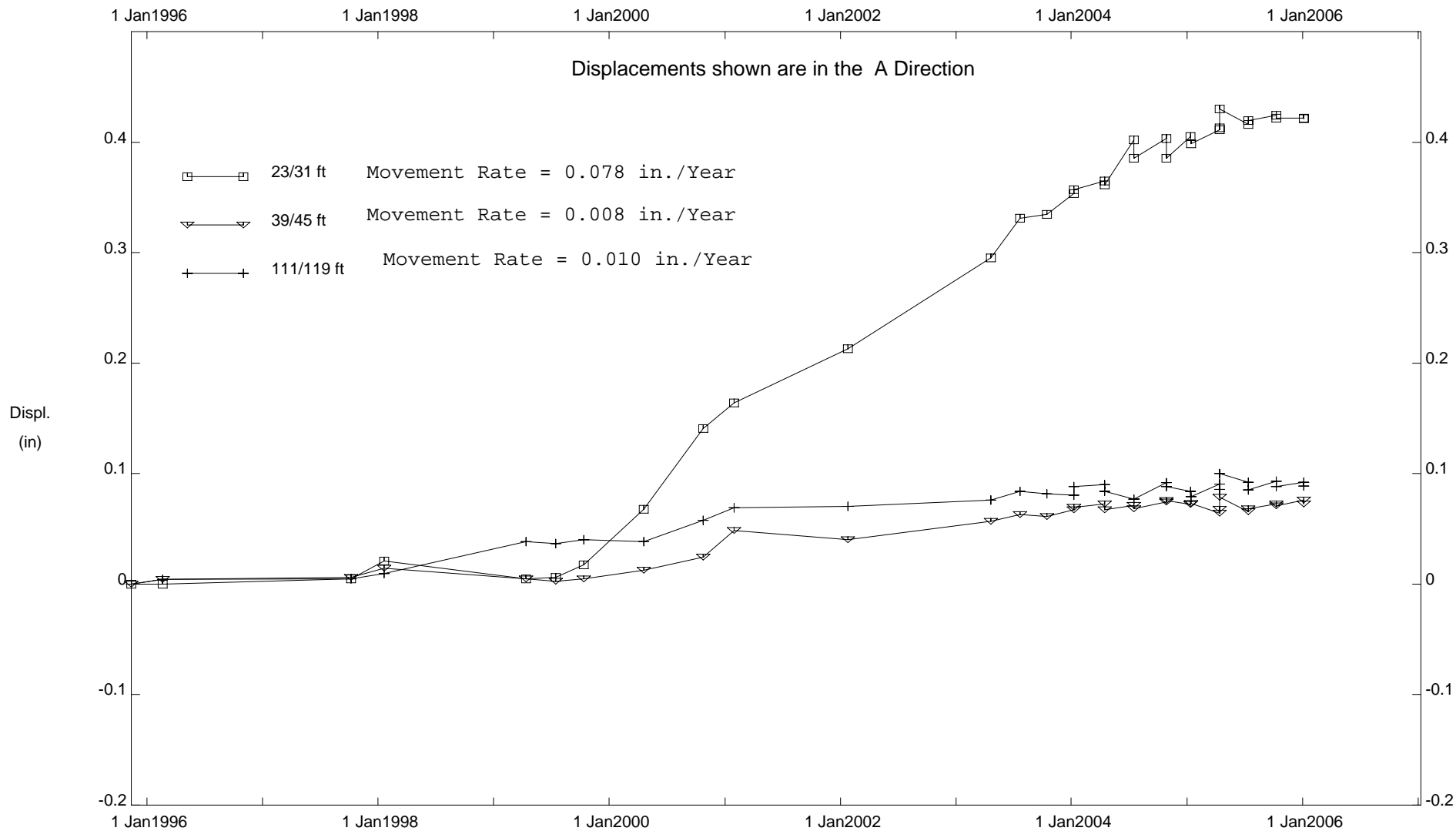

CUY-90, Inclinometer B-110

E.L. Robinson - Columbus, OH

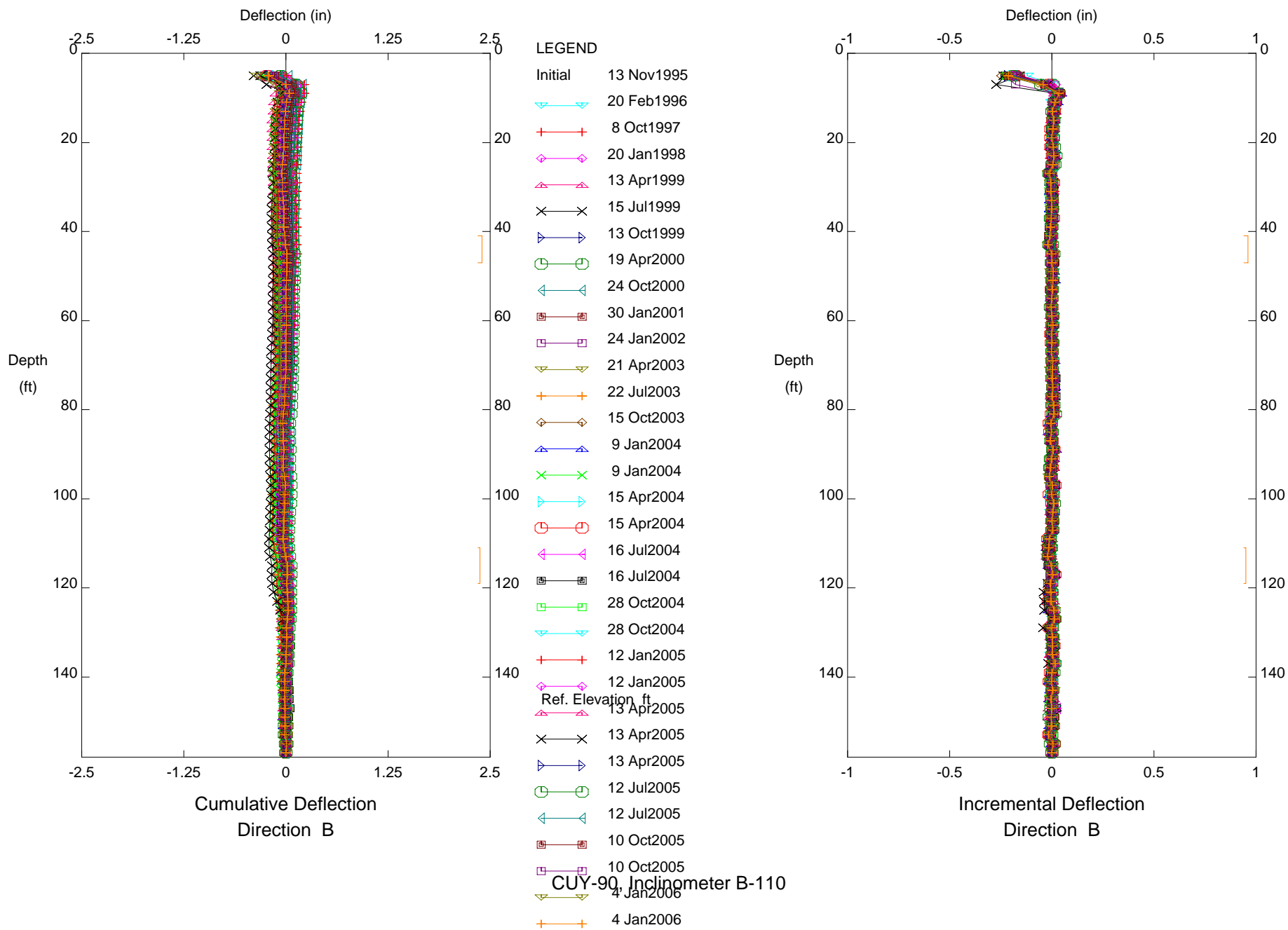

E.L. Robinson - Columbus, OH

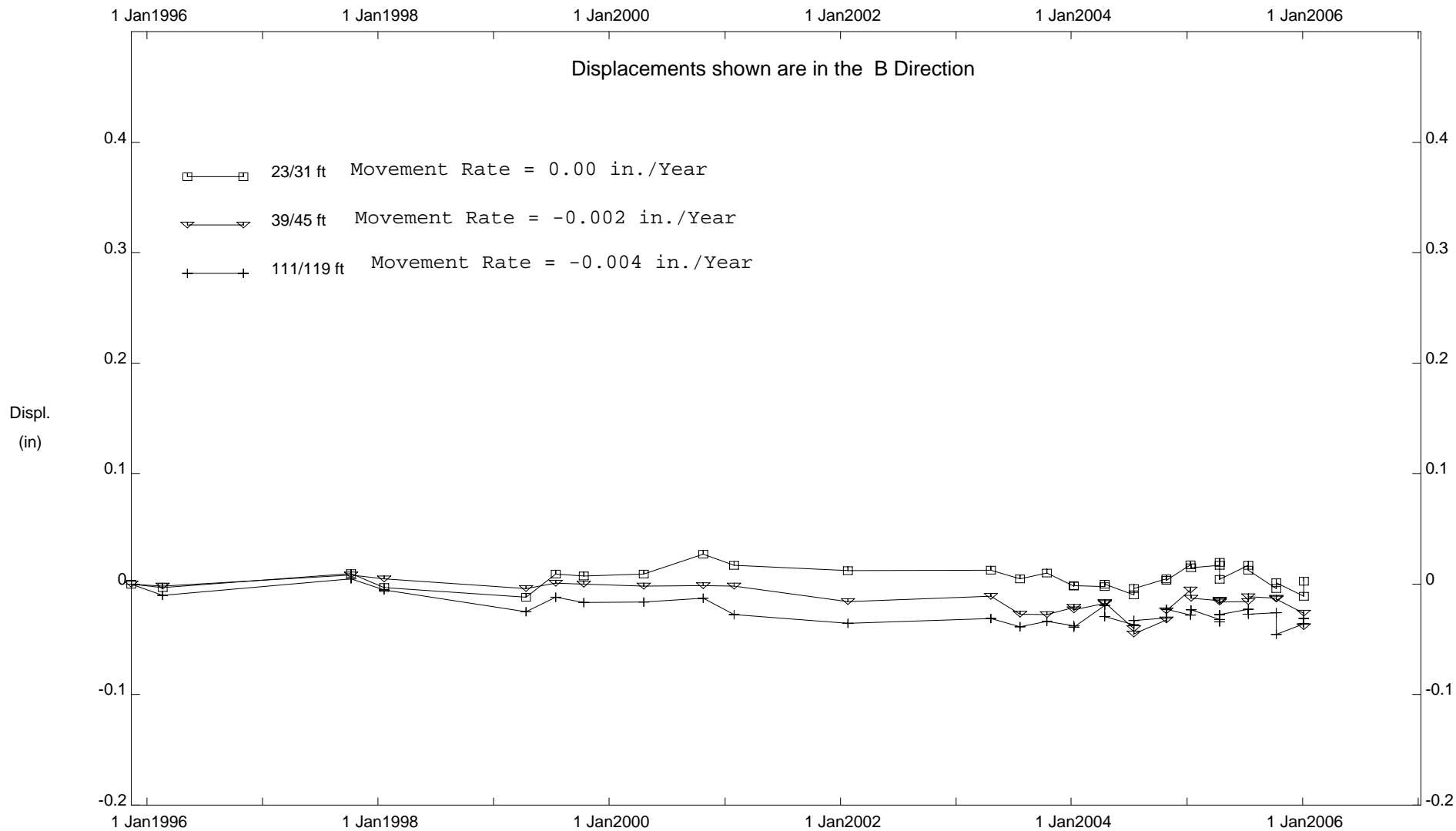

CUY-90, Inclinator B-110

**INCLINOMETER B-203**

DEPTH FROM 55'/63' RATE OF MOVEMENT = 0.02 INCHES PER YEAR BETWEEN 1998 AND 2009

DEPTH FROM 73'/83' RATE OF MOVEMENT = 0.01 INCHES PER YEAR BETWEEN 1998 AND 2009

E.L. Robinson - Columbus, OH

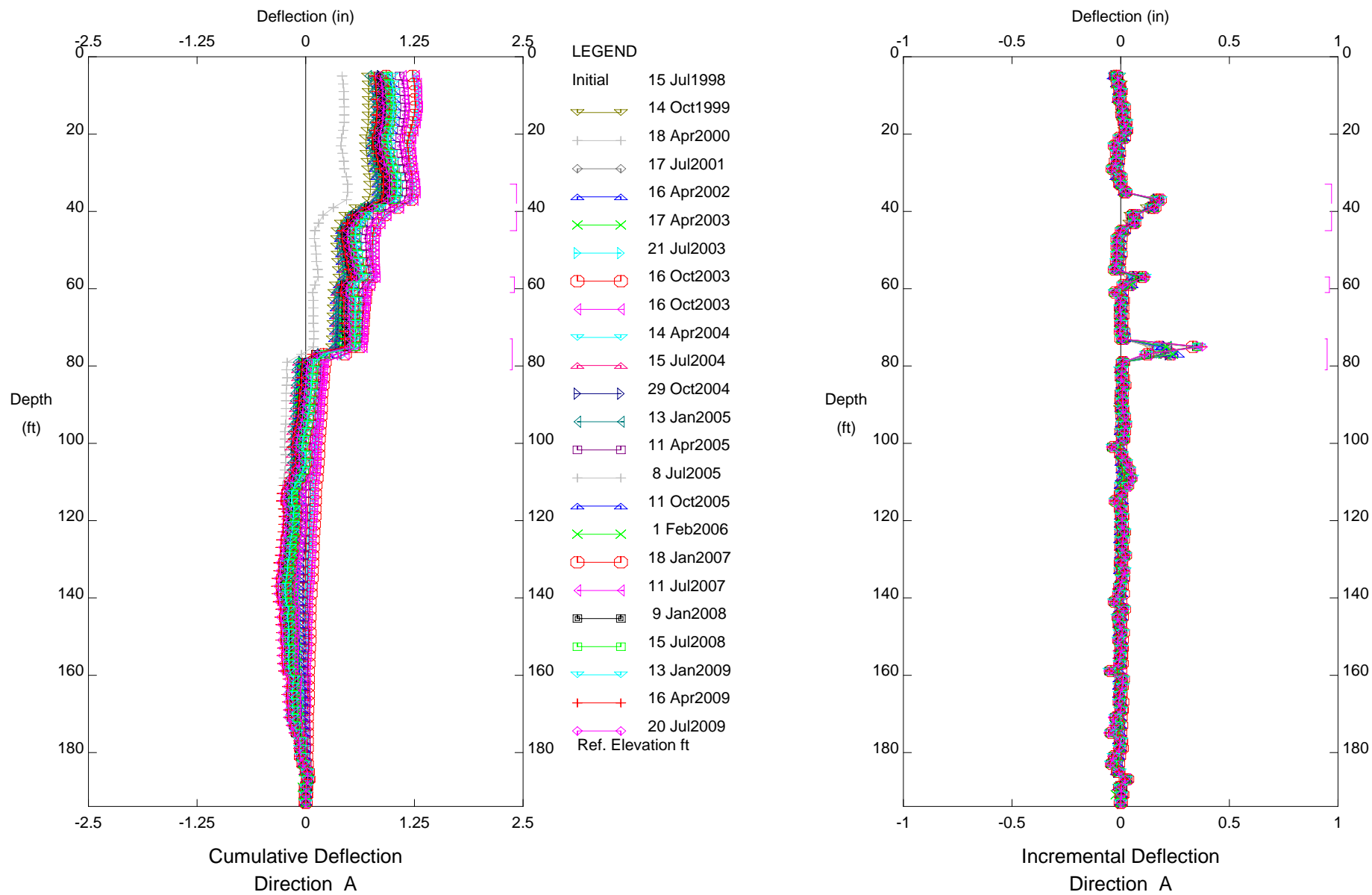

CUY-90, Inclinometer B-203

E.L. Robinson - Columbus, OH

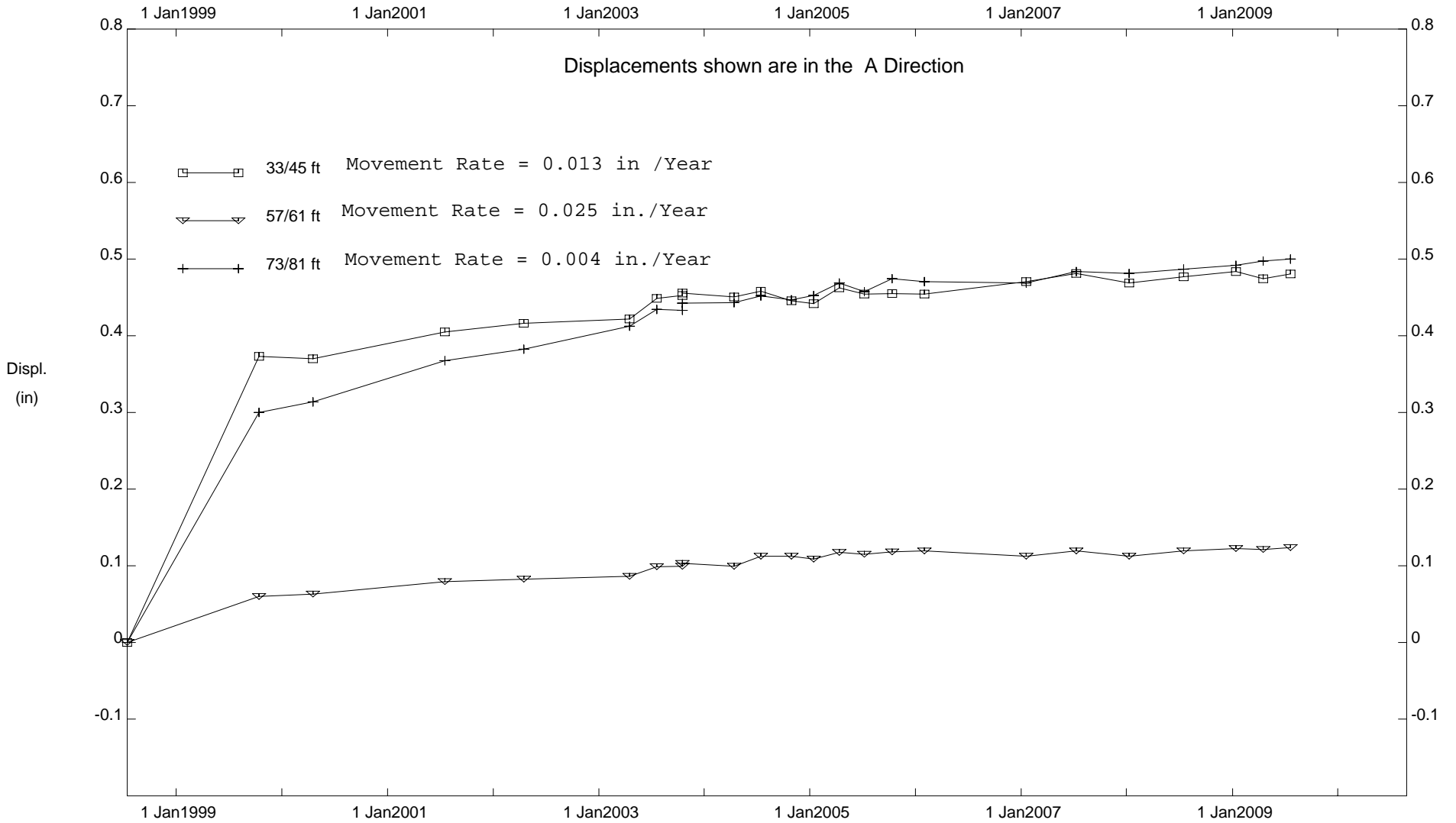

CUY-90, Inclinator B-203



E.L. Robinson - Columbus, OH

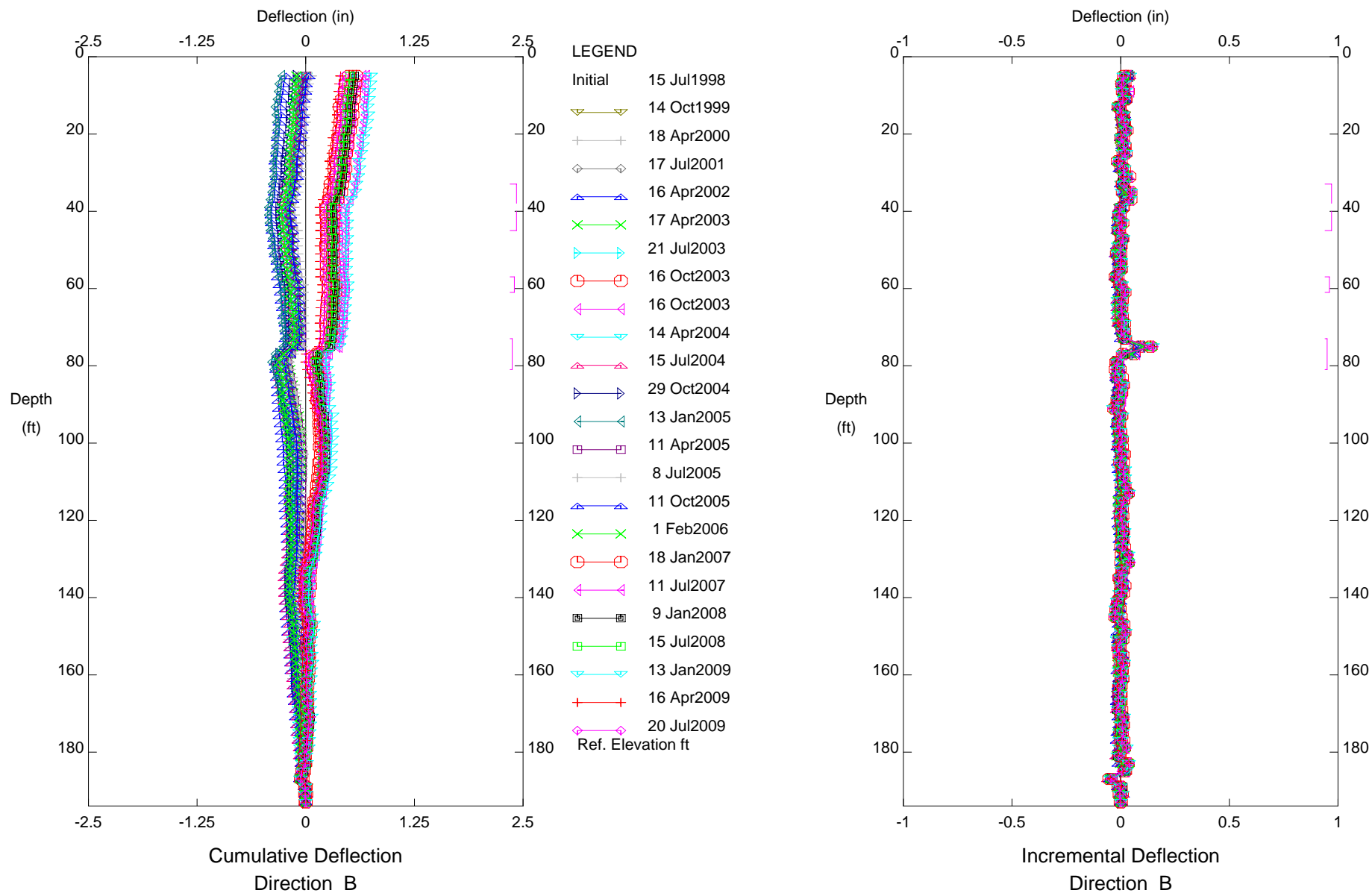

CUY-90, Inclinometer B-203

# E.L. Robinson - Columbus, OH

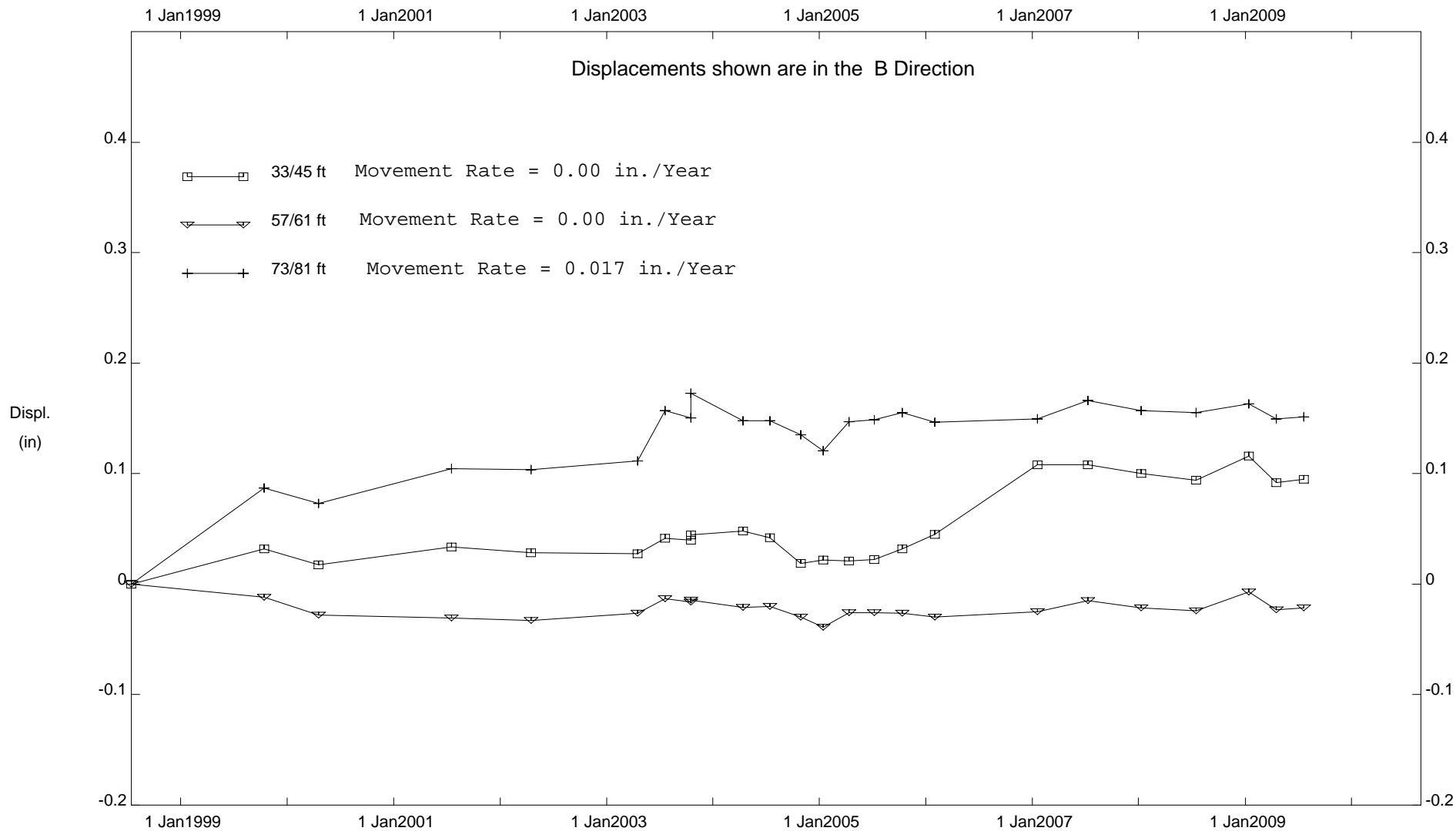

CUY-90, Inclinator B-203

**INCLINOMETER B-204**

DEPTH FROM 115'/119' RATE OF MOVEMENT = 0.04 INCHES PER YEAR BETWEEN 2001 AND 2009

E.L. Robinson - Columbus, OH

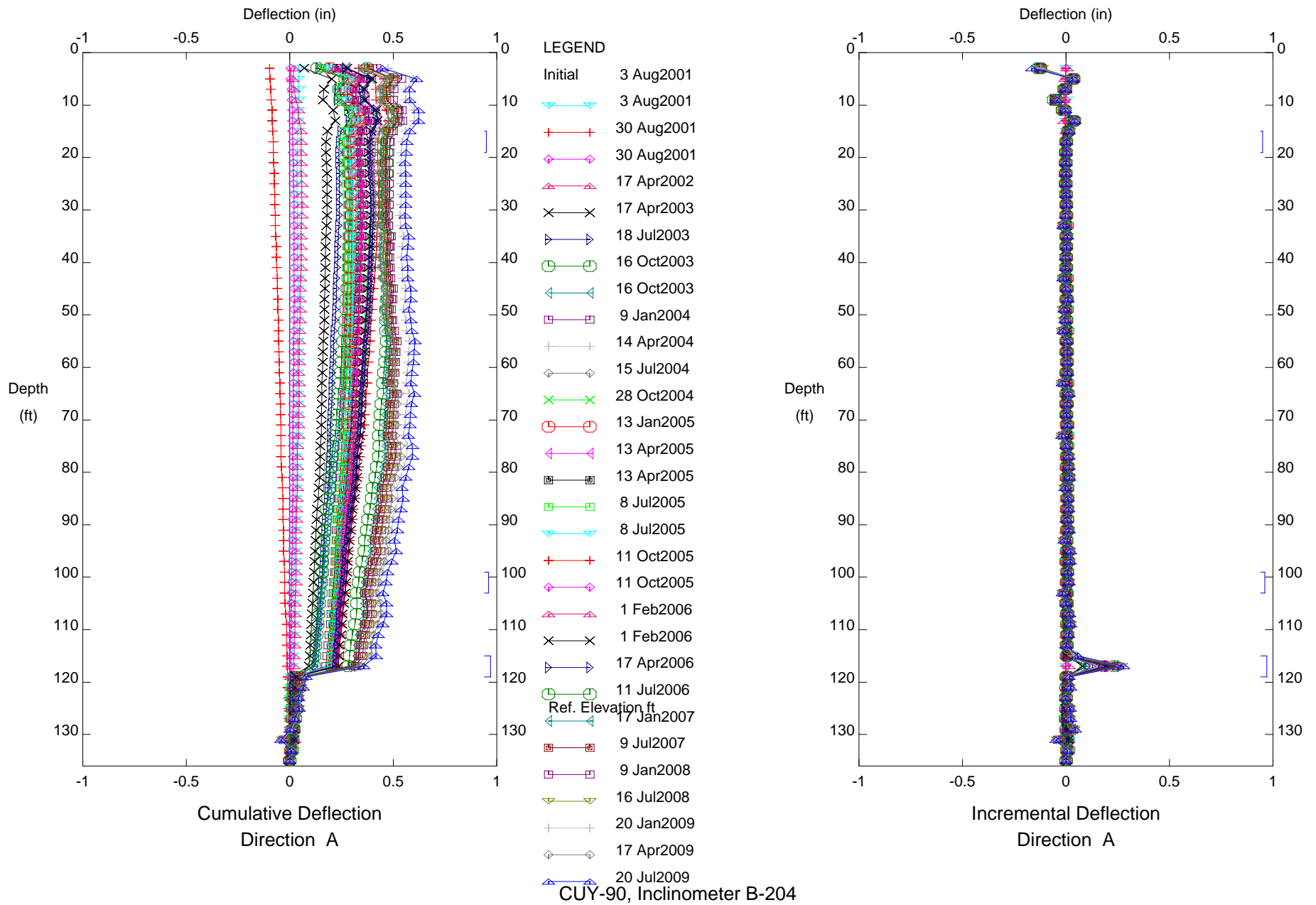

# E.L. Robinson - Columbus, OH

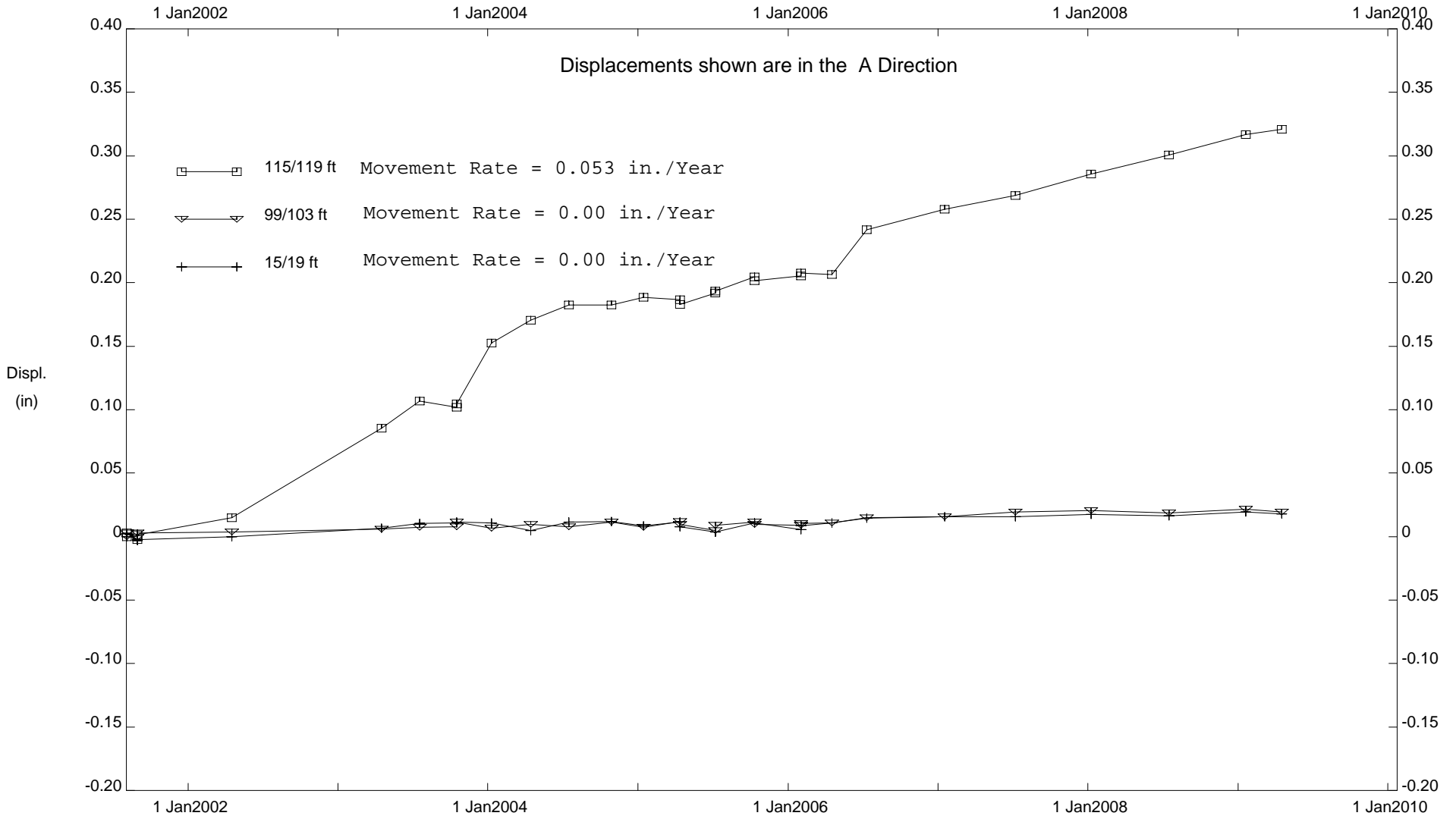

CUY-90, Inclinator B-204

E.L. Robinson - Columbus, OH

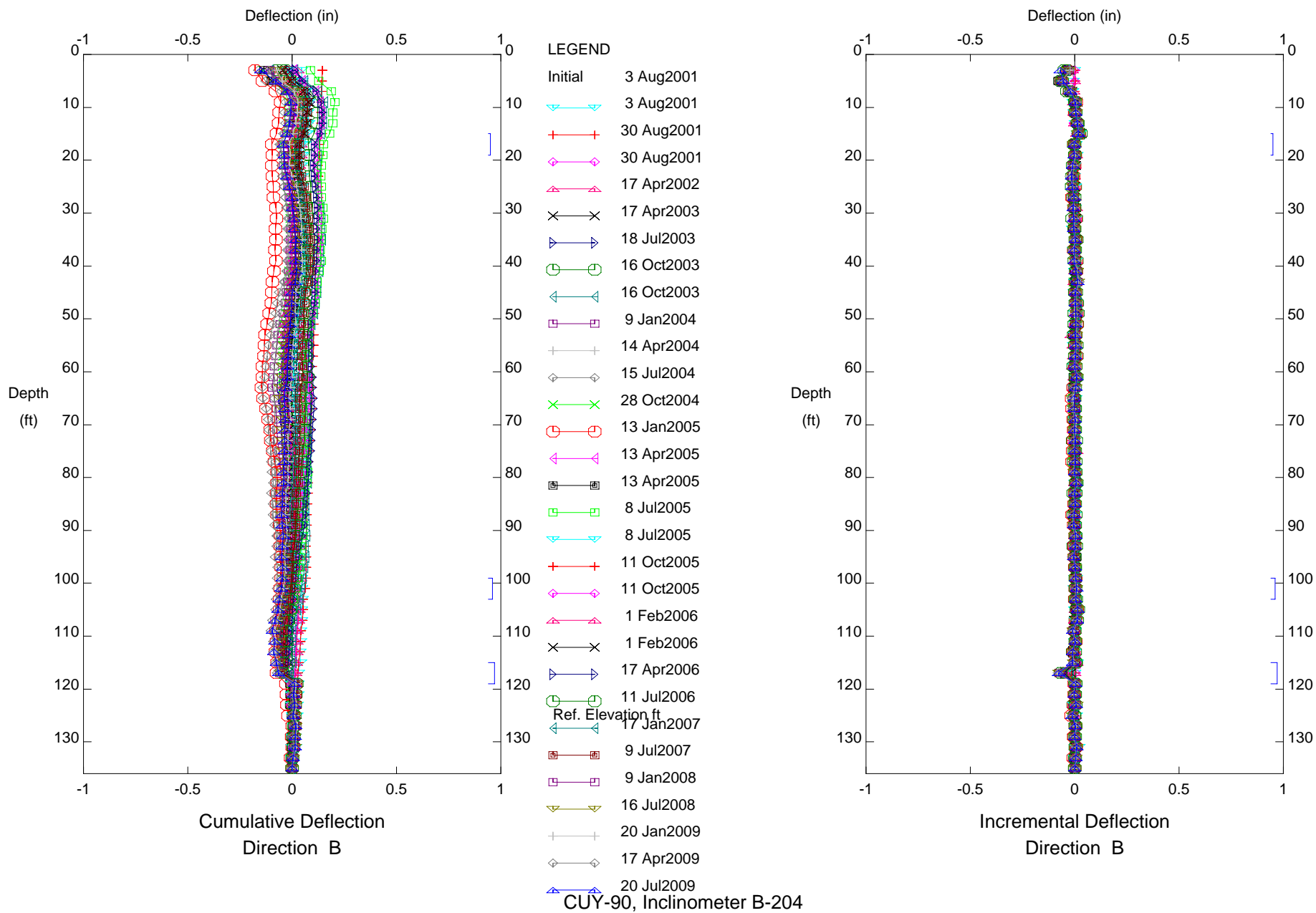

# E.L. Robinson - Columbus, OH

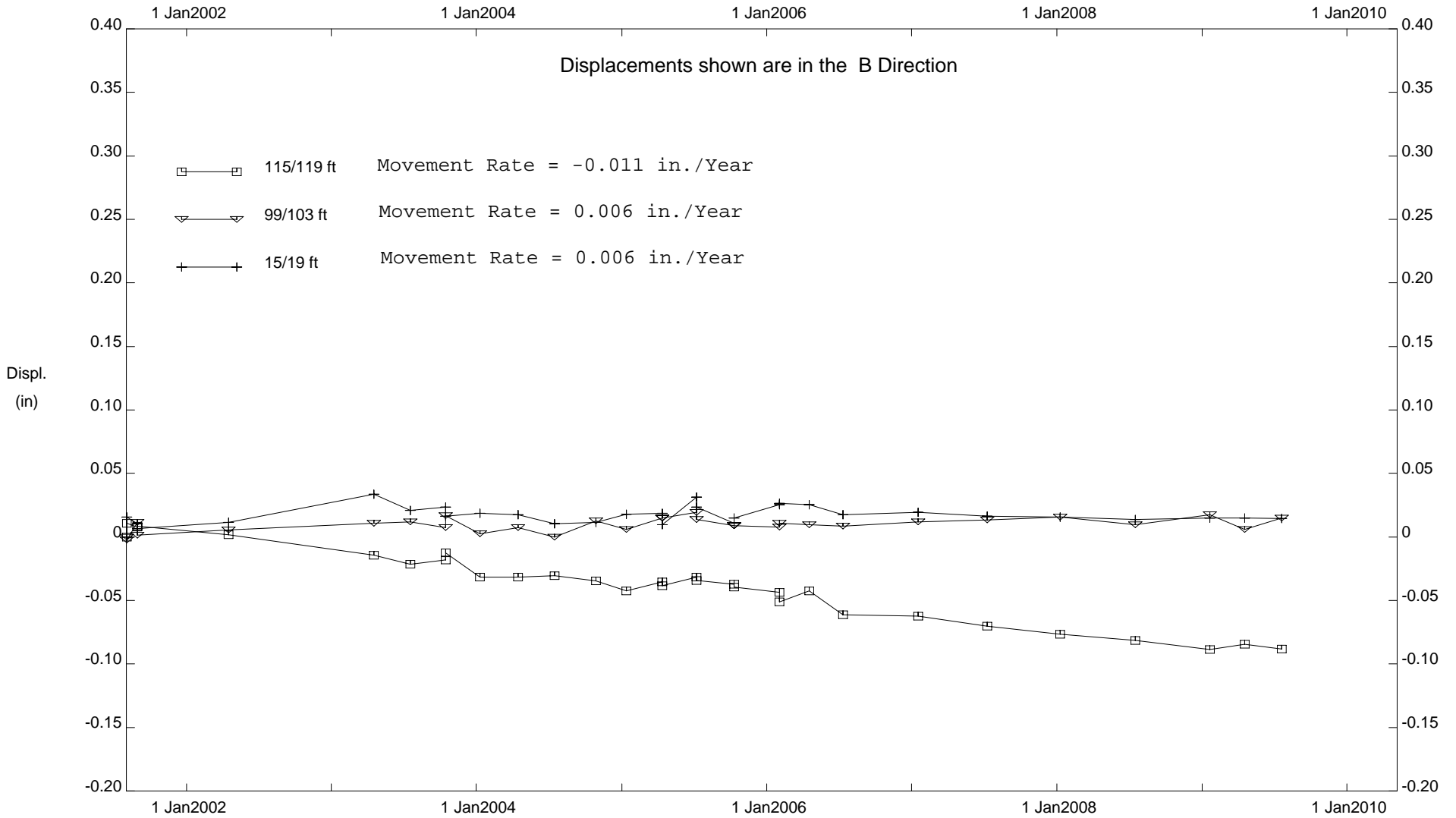

CUY-90, Inclinator B-204

**INCLINOMETER B-303**

DEPTH FROM 47'/51' RATE OF MOVEMENT = 0.04 INCHES PER YEAR BETWEEN 1998 AND 2009  
DEPTH FROM 55'/57' RATE OF MOVEMENT = 0.02 INCHES PER YEAR BETWEEN 1998 AND 2009  
DEPTH FROM 95'/99' RATE OF MOVEMENT = 0.04 INCHES PER YEAR BETWEEN 1998 AND 2009



E.L. Robinson - Columbus, OH

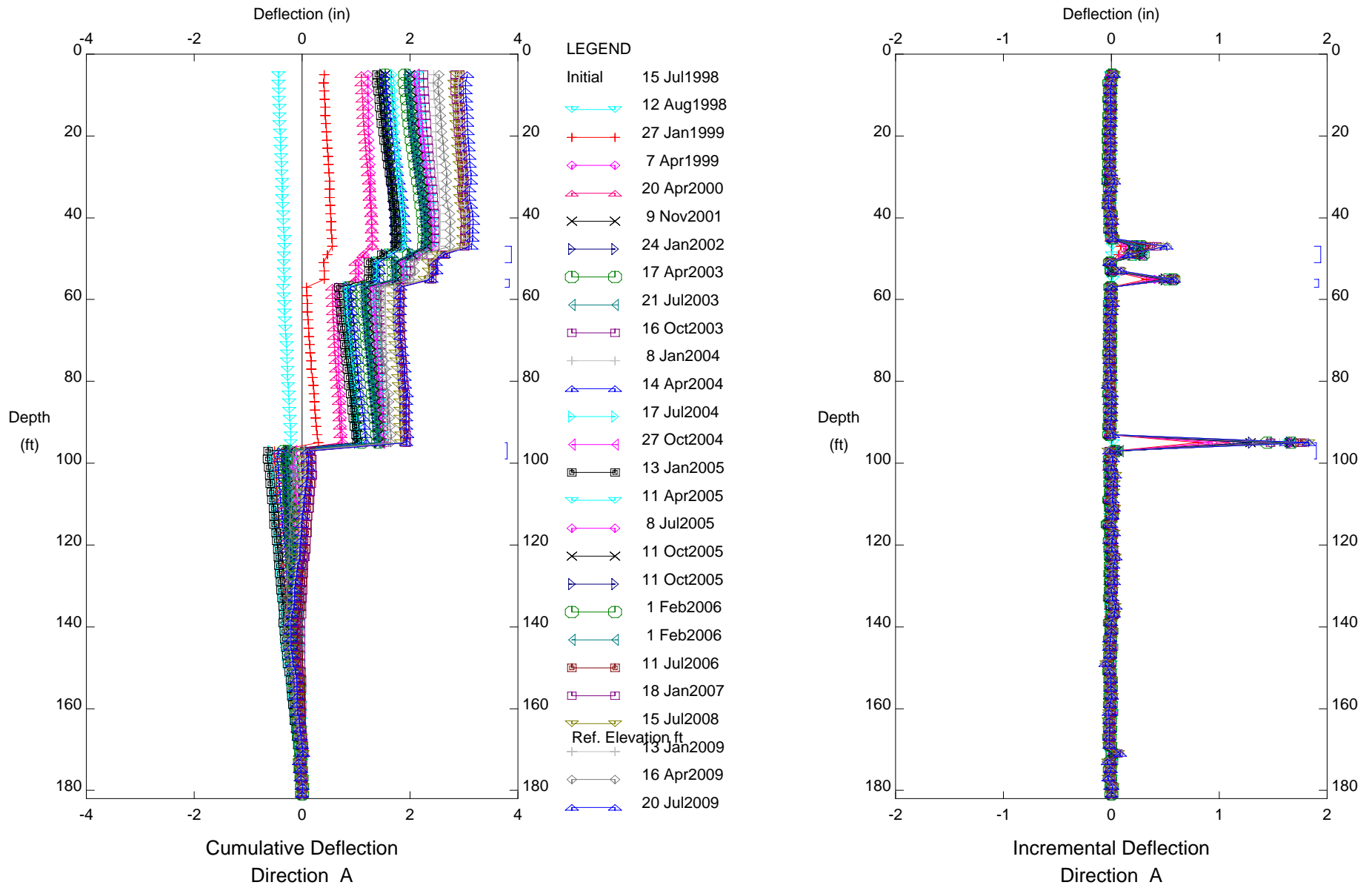

CUY-90, Inclinometer B-303

E.L. Robinson - Columbus, OH

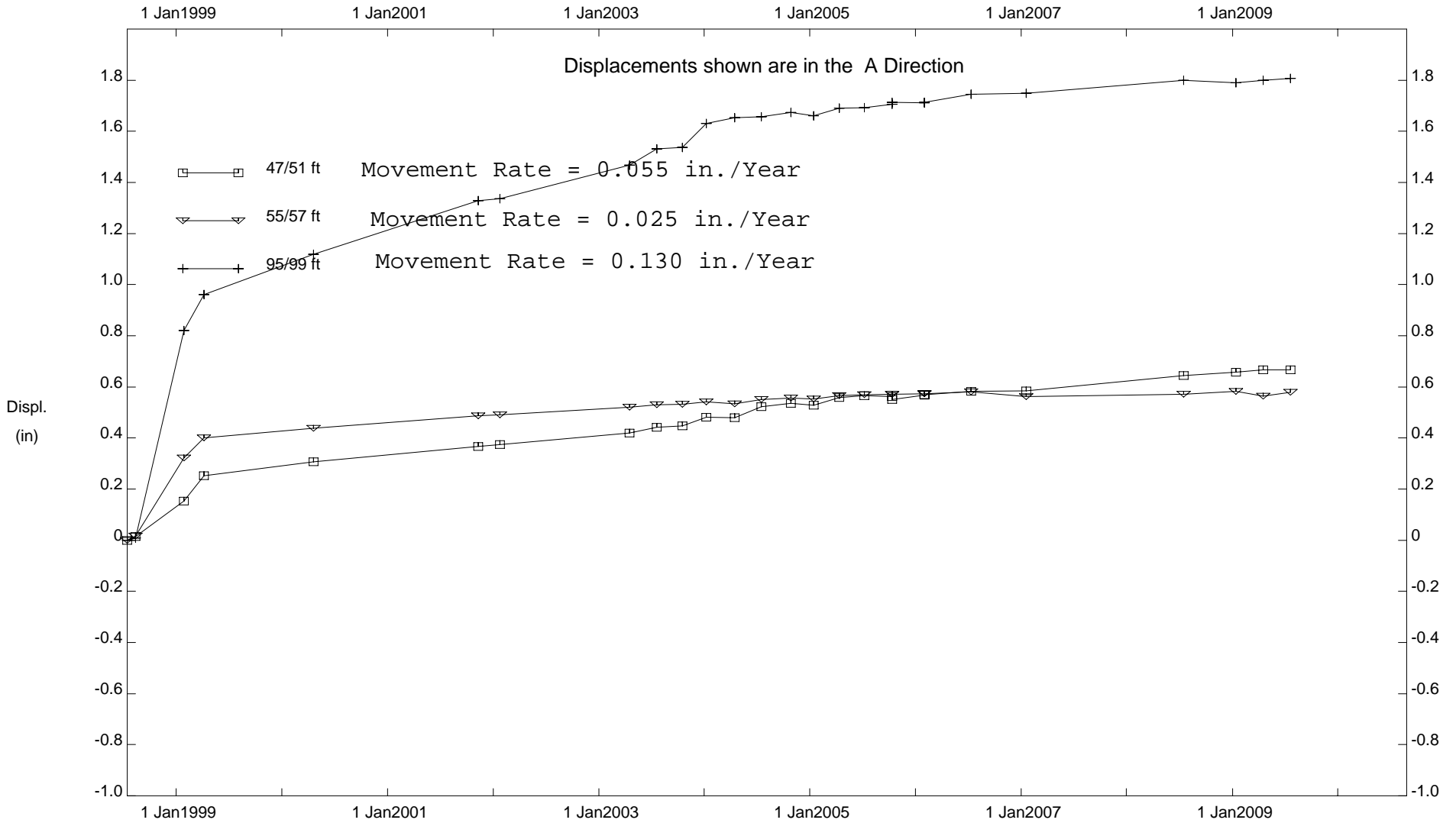

CUY-90, Inclinator B-303

E.L. Robinson - Columbus, OH

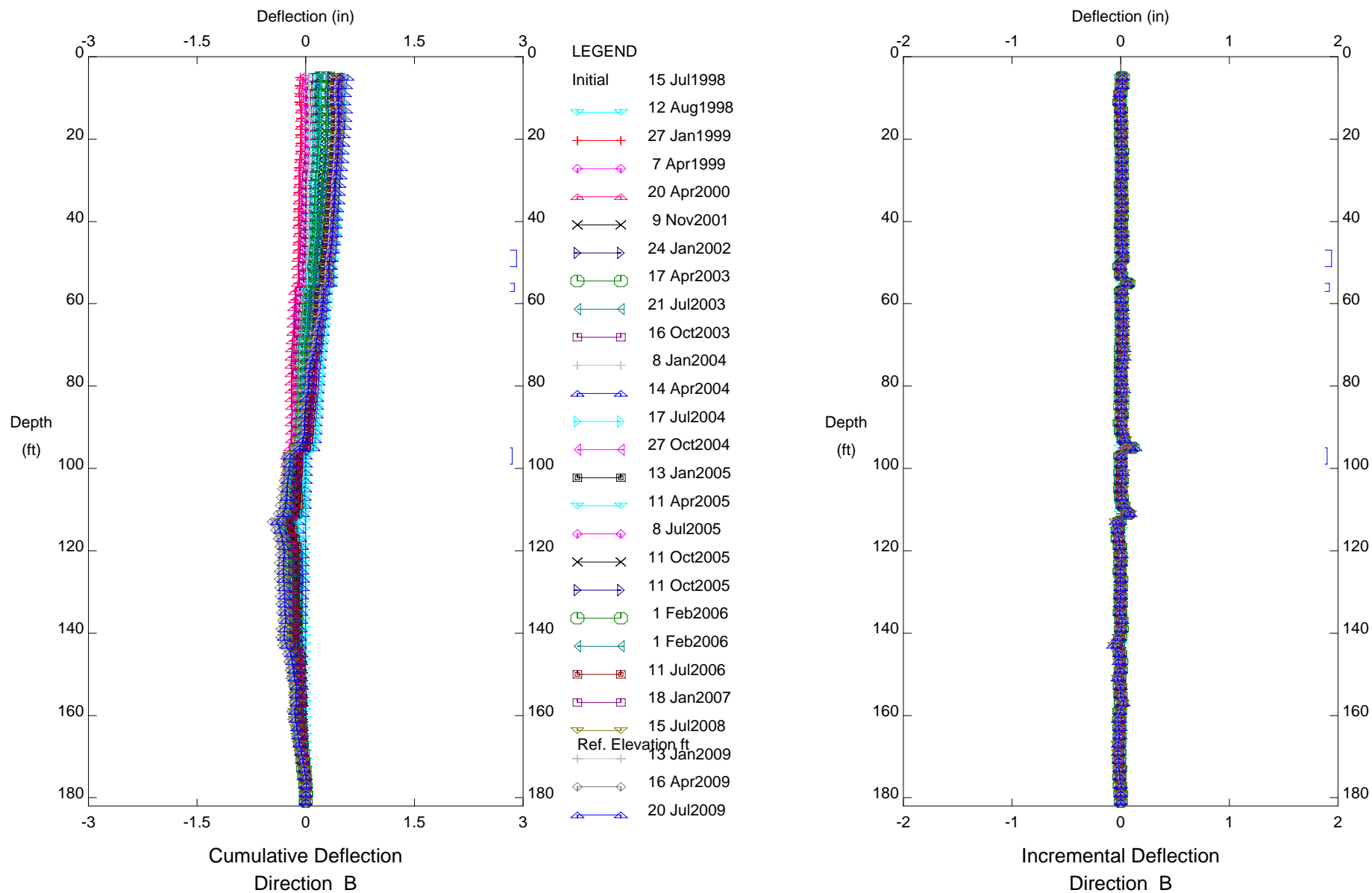

CUY-90, Inclinometer B-303

# E.L. Robinson - Columbus, OH

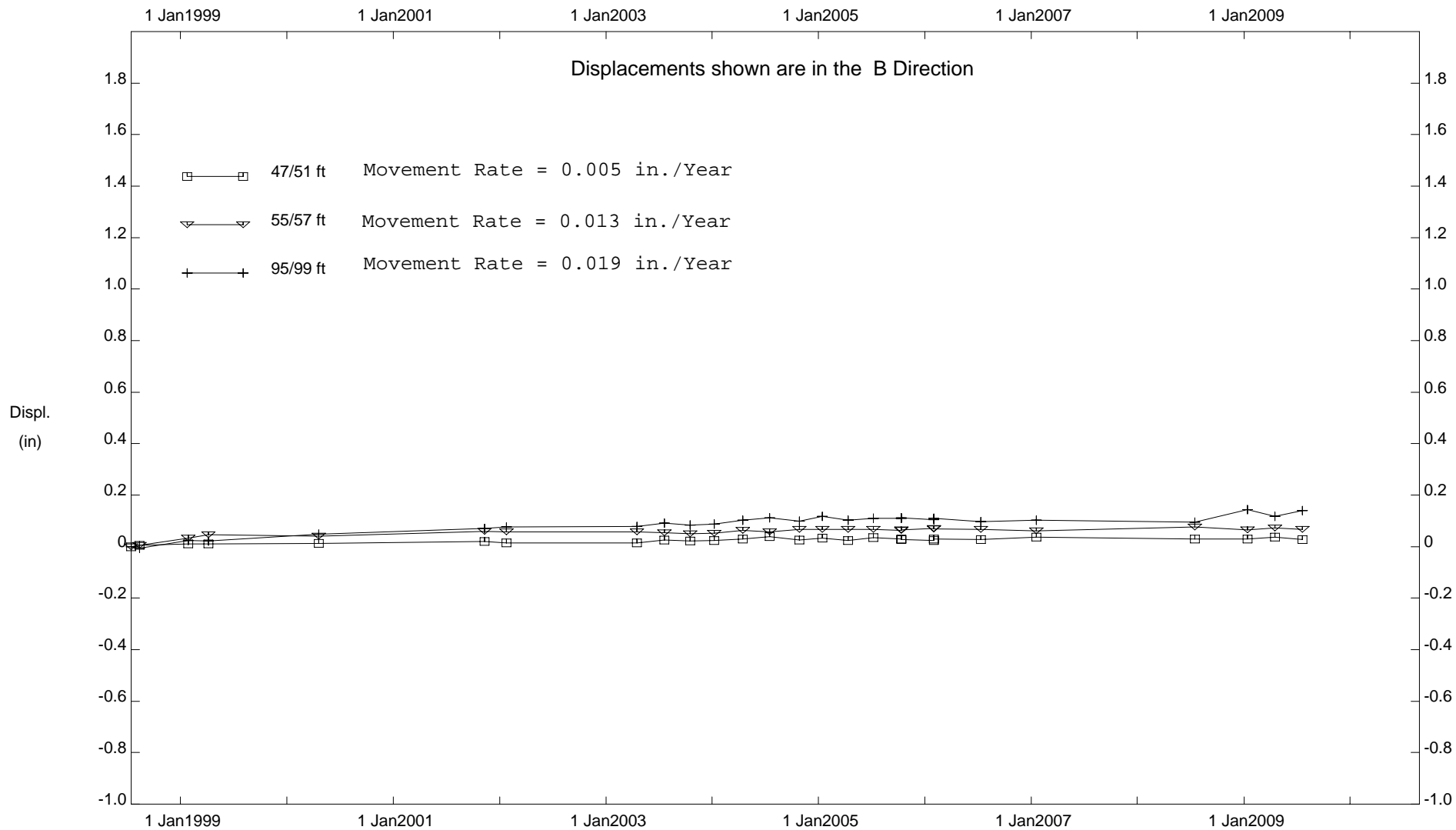

CUY-90, Inclinator B-303

**INCLINOMETER B-9N**

DEPTH FROM 5'/147' RATE OF MOVEMENT = 0.04 INCHES PER YEAR BETWEEN 1999 AND 2009

E.L. Robinson - Columbus, OH

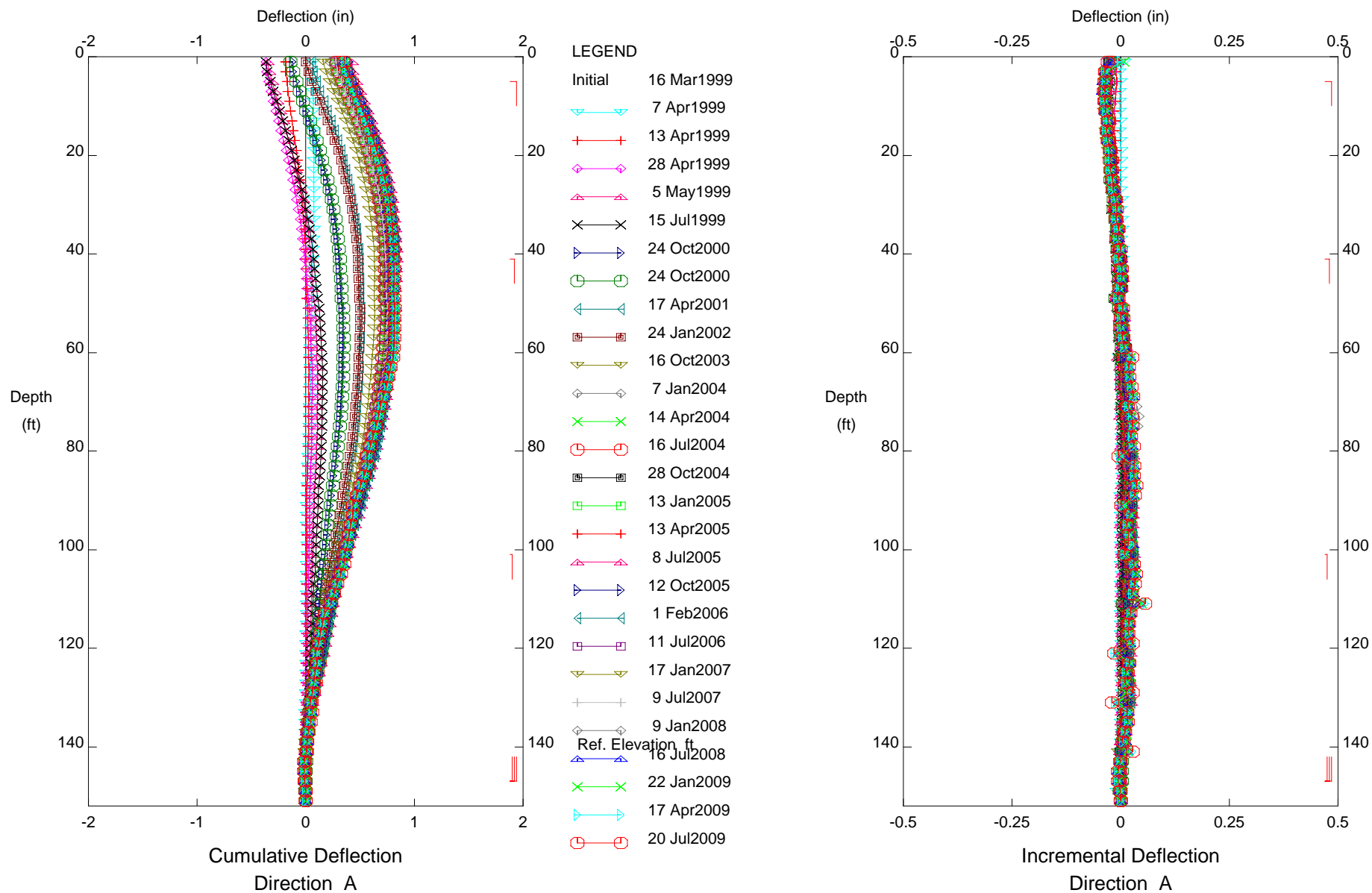

CUY-90, Inclinator P-9N

# E.L. Robinson - Columbus, OH

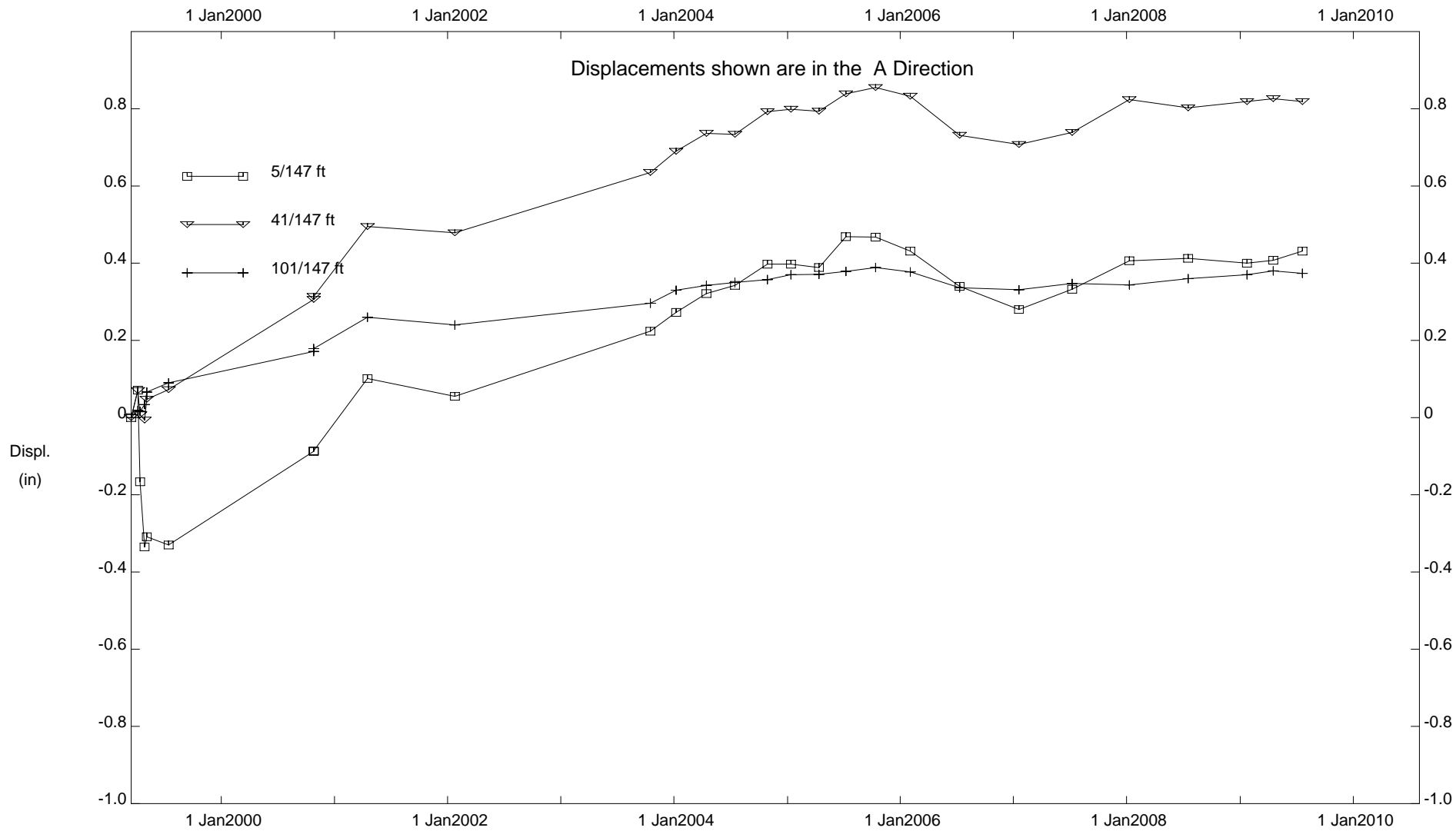

CUY-90, Inclinator P-9N

E.L. Robinson - Columbus, OH

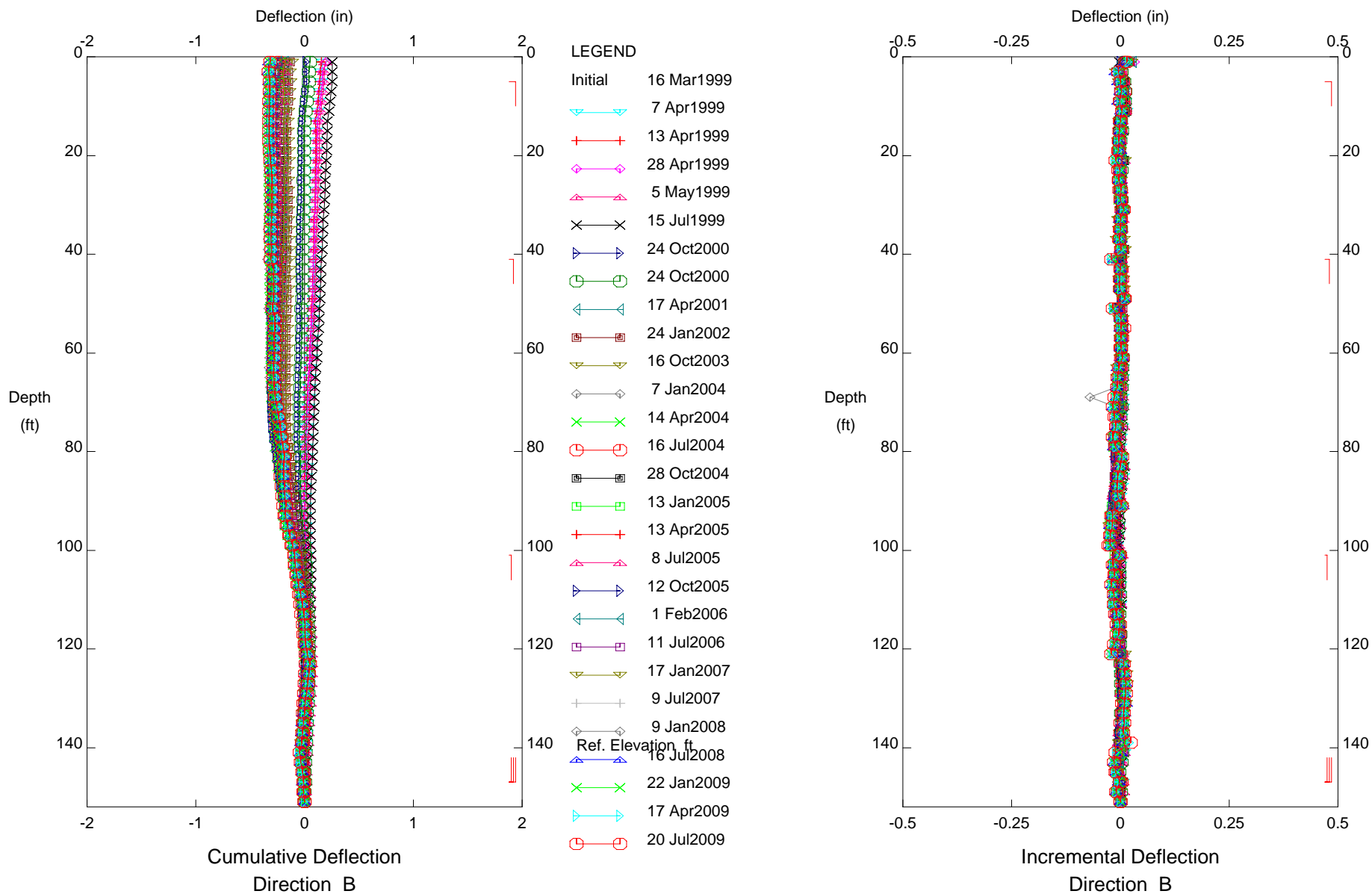

CUY-90, Inclinator P-9N



E.L. Robinson - Columbus, OH

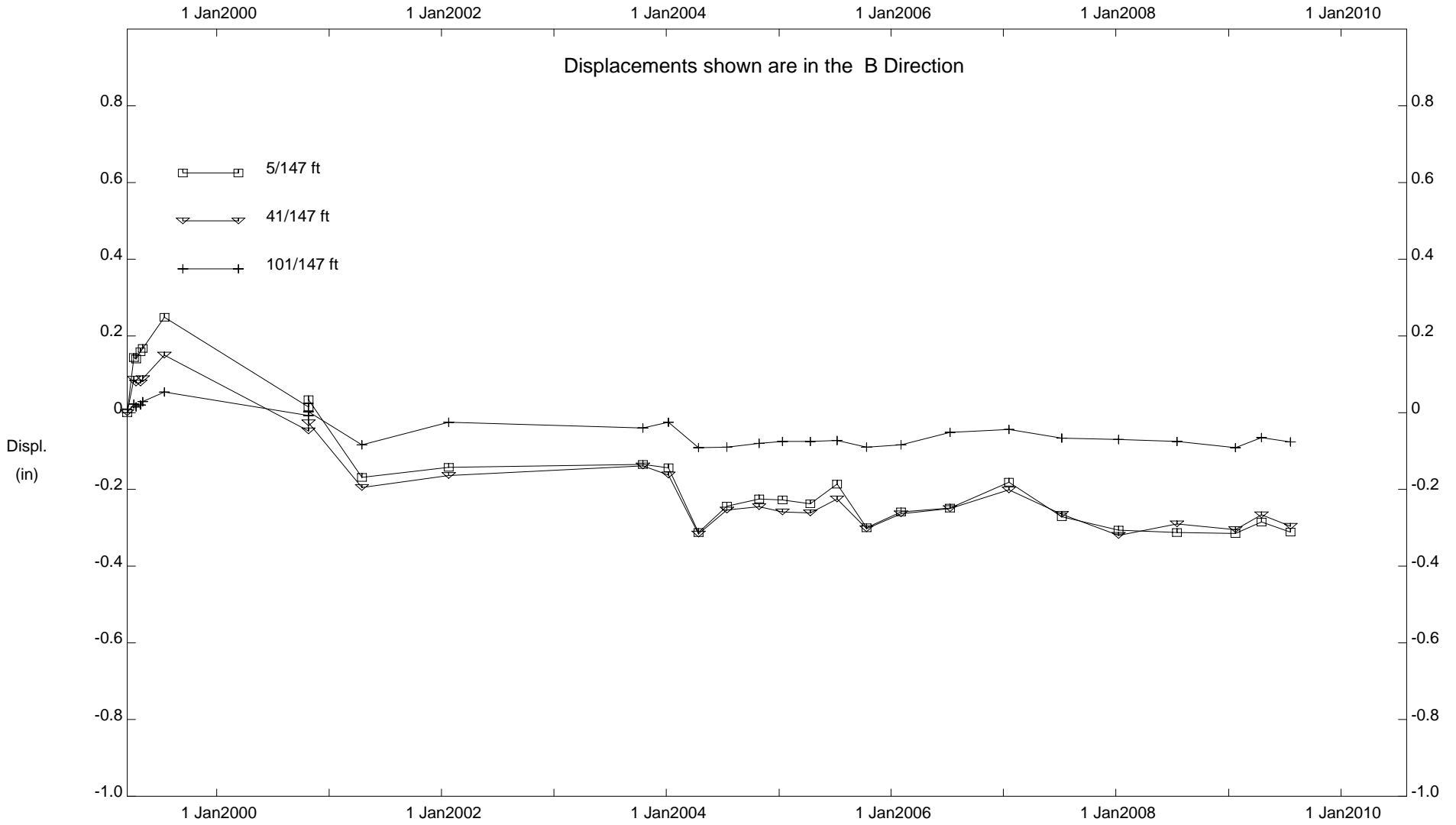

CUY-90, Inclinator P-9N

NO MOVEMENT

**INCLINOMETER B05-01**

E.L. Robinson - Columbus, OH

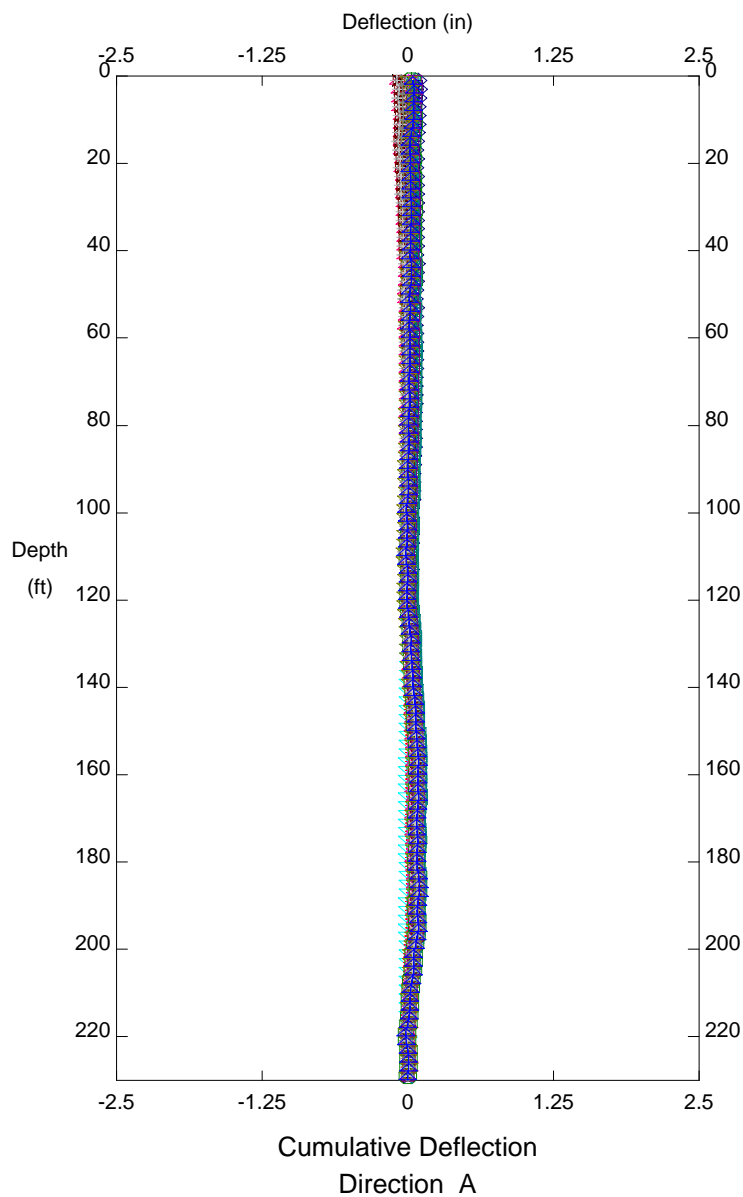

LEGEND

|         |            |
|---------|------------|
| Initial | 22 Jun2006 |
| ↔       | 22 Jun2006 |
| +—+     | 12 Jul2006 |
| ◇—◇     | 12 Oct2006 |
| △—△     | 16 Jan2007 |
| ×—×     | 16 Apr2007 |
| ▷—▷     | 11 Jul2007 |
| ⊕—⊕     | 12 Oct2007 |
| ◀—▶     | 8 Jan2008  |
| ▣—▣     | 14 Apr2008 |
| ▢—▢     | 14 Jul2008 |
| ▽—▽     | 14 Oct2008 |
| +—+     | 12 Jan2009 |
| ◊—◊     | 16 Apr2009 |
| ▷—▷     | 17 Jul2009 |

Ref. Elevation ft

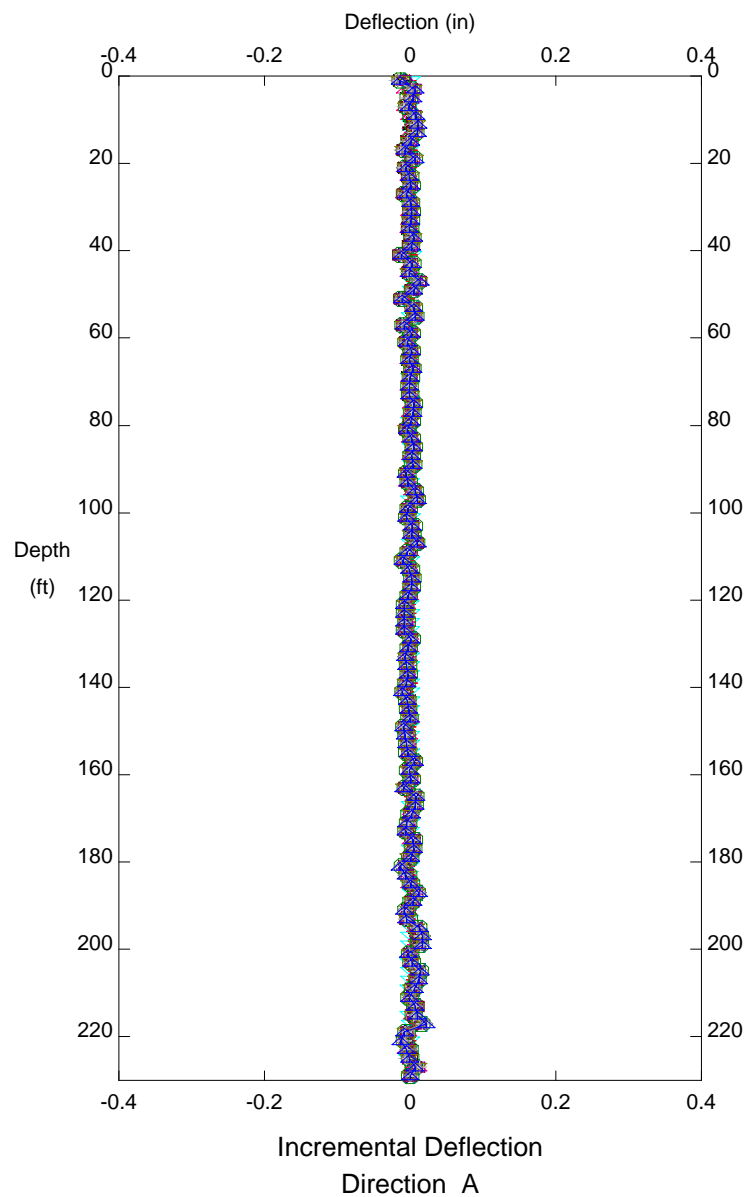

CUY-90, Inclinator B05-01

E.L. Robinson - Columbus, OH

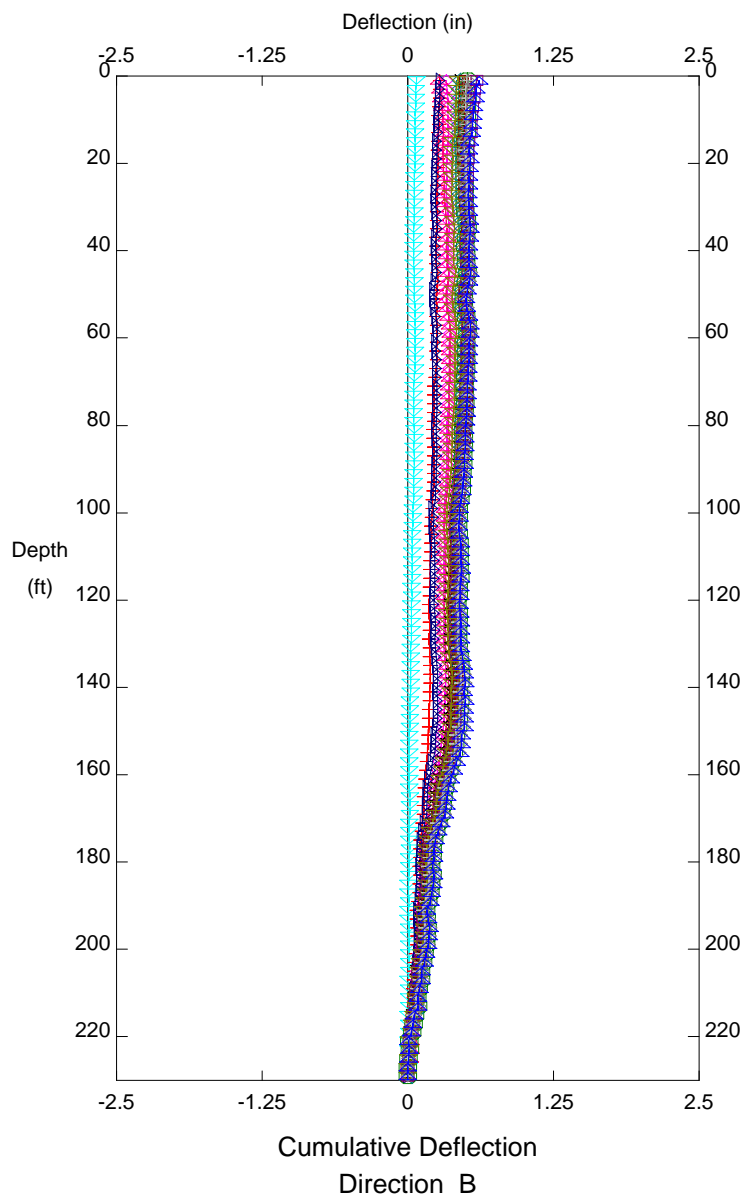

LEGEND

|         |            |
|---------|------------|
| Initial | 22 Jun2006 |
| ↔       | 22 Jun2006 |
| +—+     | 12 Jul2006 |
| ◇—◇     | 12 Oct2006 |
| △—△     | 16 Jan2007 |
| ×—×     | 16 Apr2007 |
| ▷—▷     | 11 Jul2007 |
| ⊕—⊕     | 12 Oct2007 |
| ◀—▶     | 8 Jan2008  |
| ▣—▣     | 14 Apr2008 |
| ▢—▢     | 14 Jul2008 |
| ▽—▽     | 14 Oct2008 |
| +—+     | 12 Jan2009 |
| ◊—◊     | 16 Apr2009 |
| ▷—▷     | 17 Jul2009 |

Ref. Elevation ft

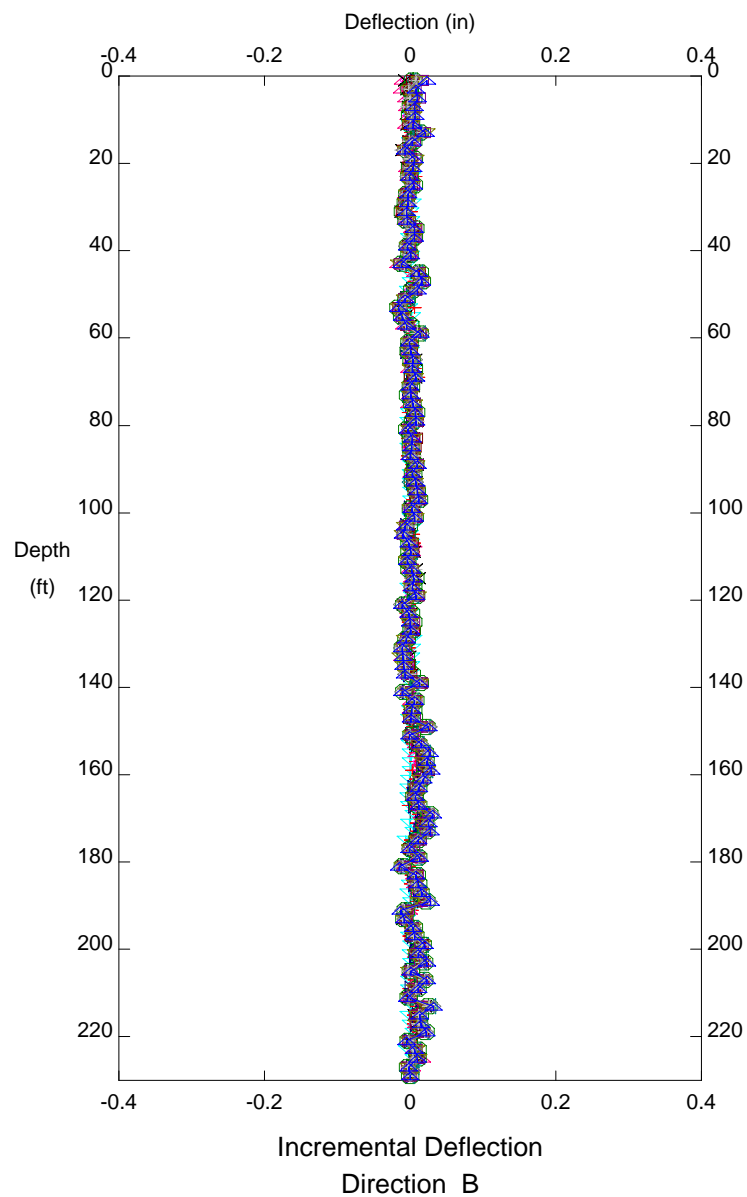

CUY-90, Inclinometer B05-01

**INCLINOMETER B05-02**

DEPTH FROM 107'/117' RATE OF MOVEMENT = 0.03 INCHES PER YEAR BETWEEN 2006 AND 2009

E.L. Robinson - Columbus, OH

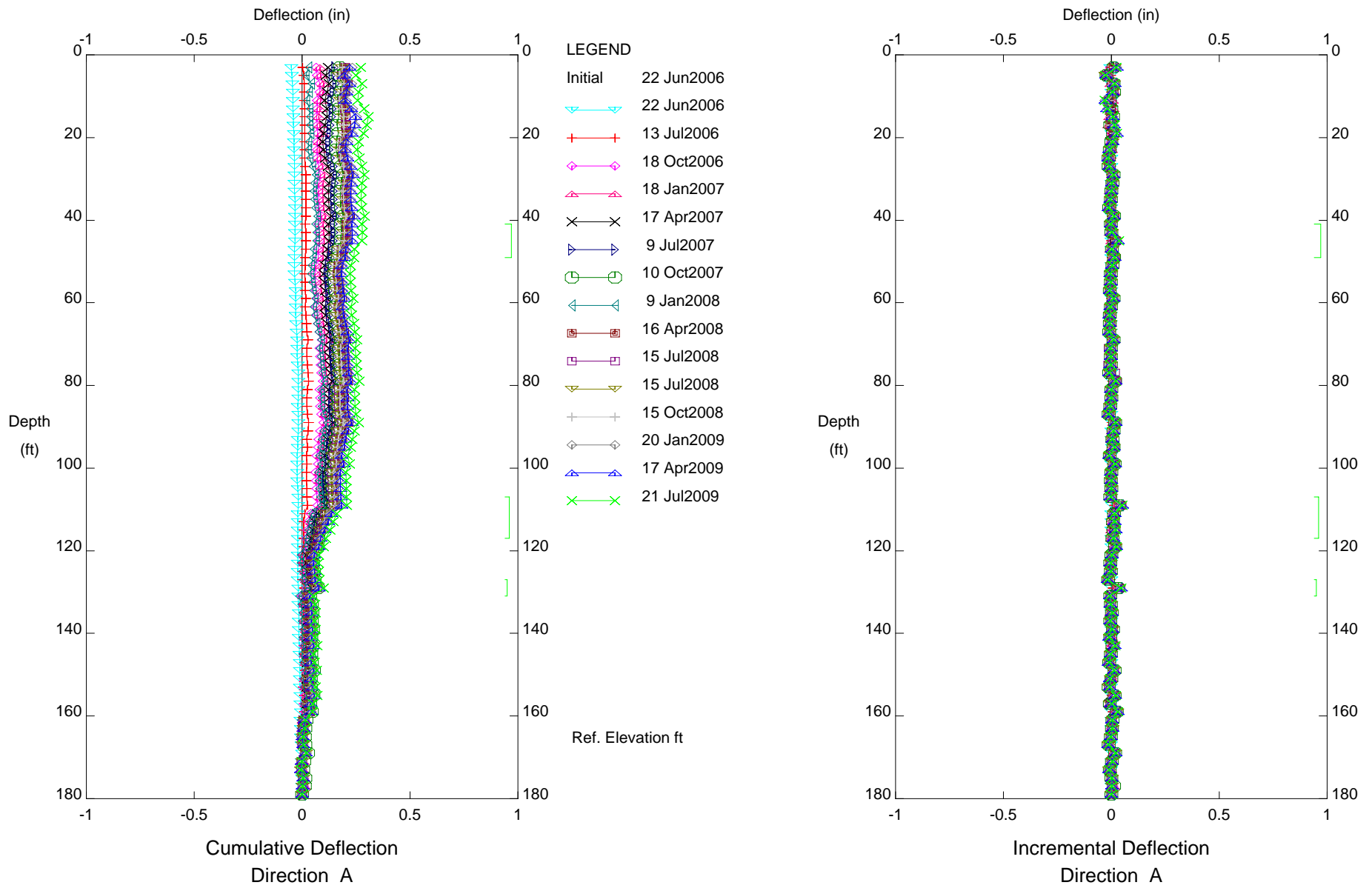

CUY-90, Inclinator B05-02

E.L. Robinson - Columbus, OH

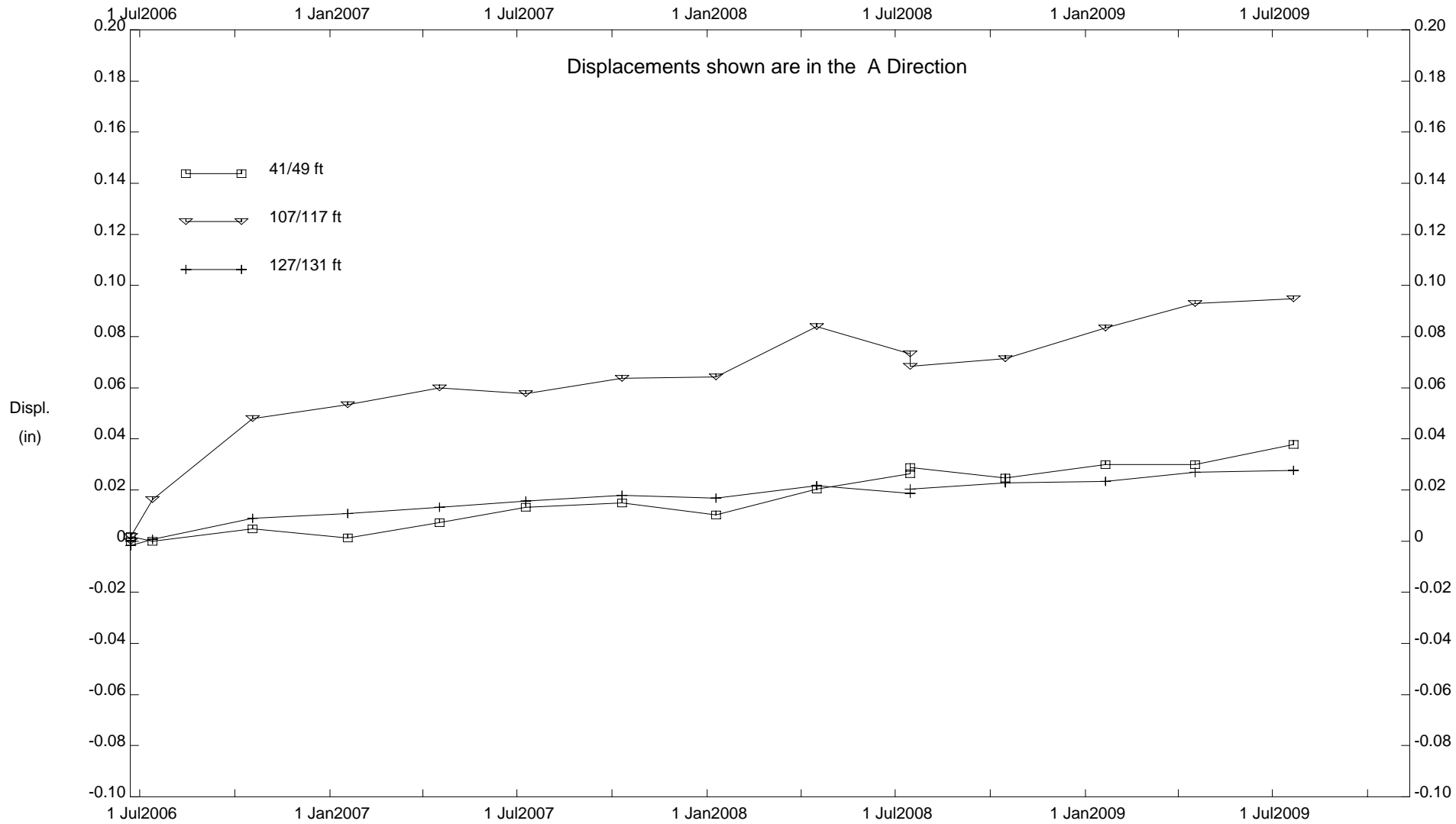

CUY-90, Inclinometer B05-02

E.L. Robinson - Columbus, OH

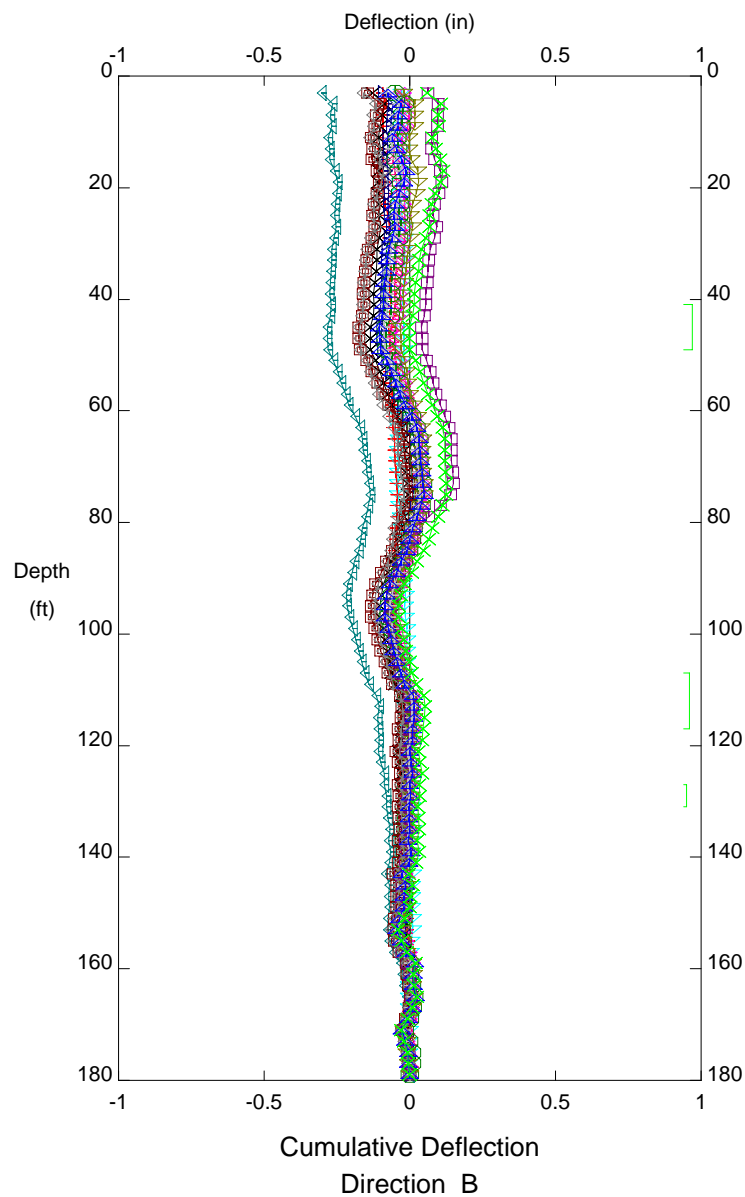

- LEGEND
- Initial 22 Jun2006
  - ◁ 22 Jun2006
  - + 13 Jul2006
  - ◇ 18 Oct2006
  - △ 18 Jan2007
  - × 17 Apr2007
  - ▷ 9 Jul2007
  - 10 Oct2007
  - ◁ 9 Jan2008
  - 16 Apr2008
  - 15 Jul2008
  - ▽ 15 Jul2008
  - + 15 Oct2008
  - ◇ 20 Jan2009
  - △ 17 Apr2009
  - × 21 Jul2009
- Ref. Elevation ft

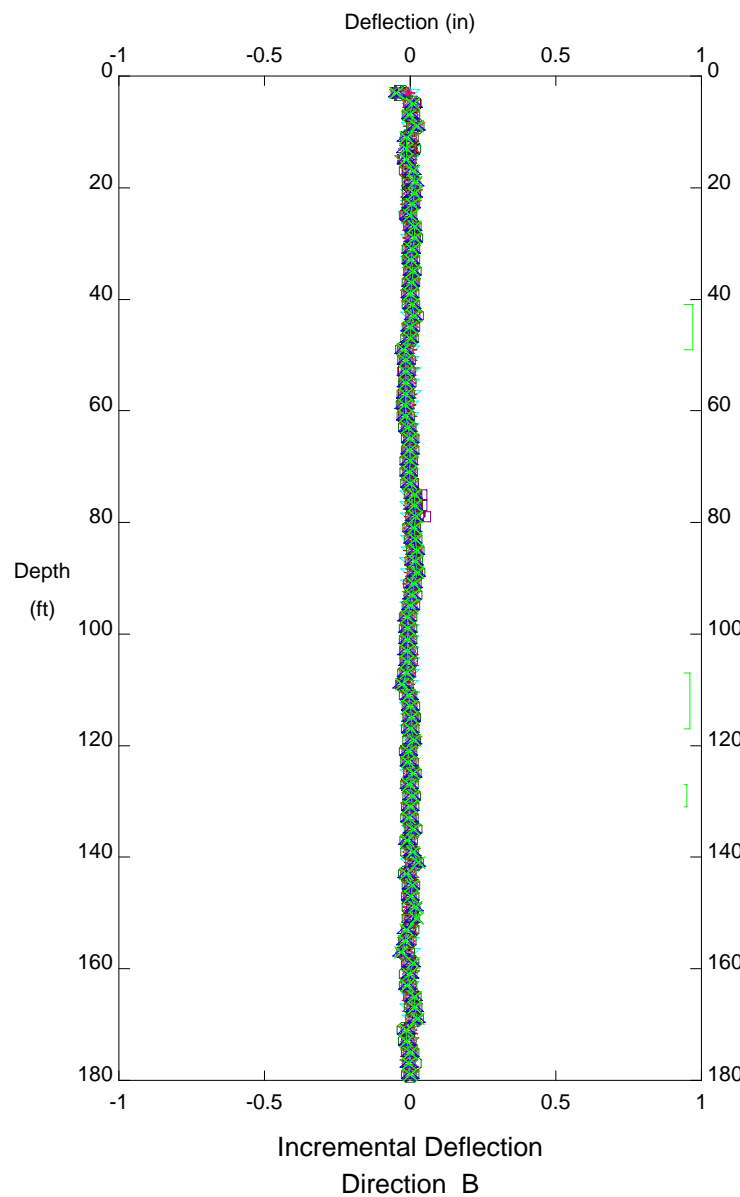

CUY-90, Inclinator B05-02



E.L. Robinson - Columbus, OH

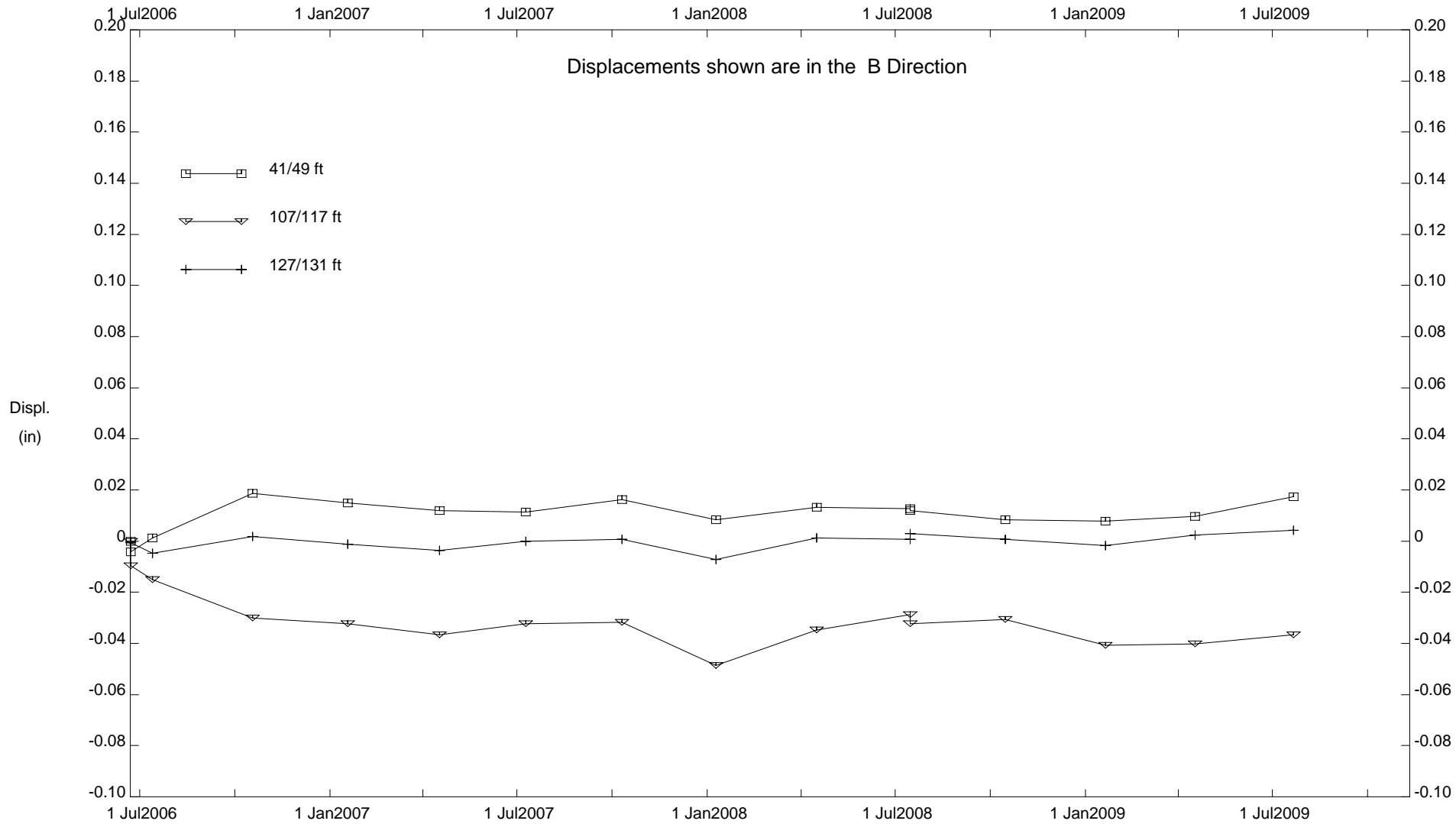

CUY-90, Inclinometer B05-02

**INCLINOMETER B05-03**

DEPTH FROM 37'/43' RATE OF MOVEMENT = 0.08 INCHES PER YEAR BETWEEN 1998 AND 2009

DEPTH FROM 121'/127' RATE OF MOVEMENT = 0.03 INCHES PER YEAR BETWEEN 1998 AND 2009

E.L. Robinson - Columbus, OH

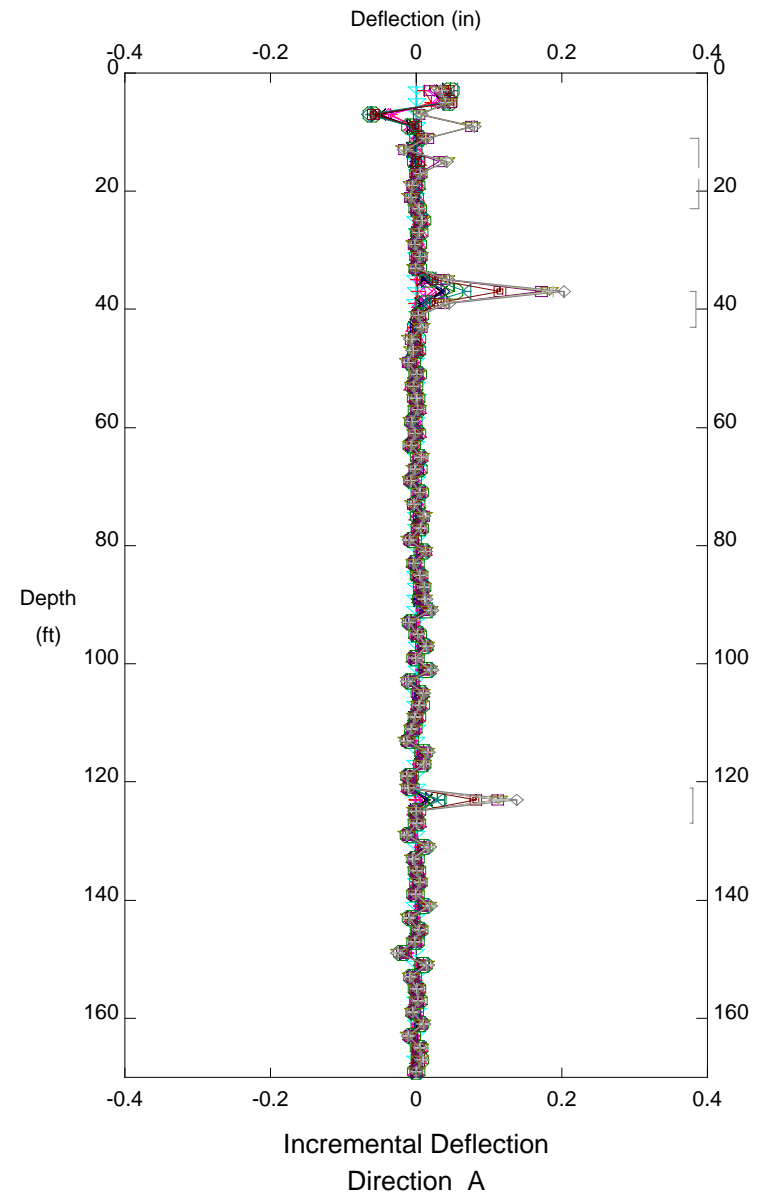
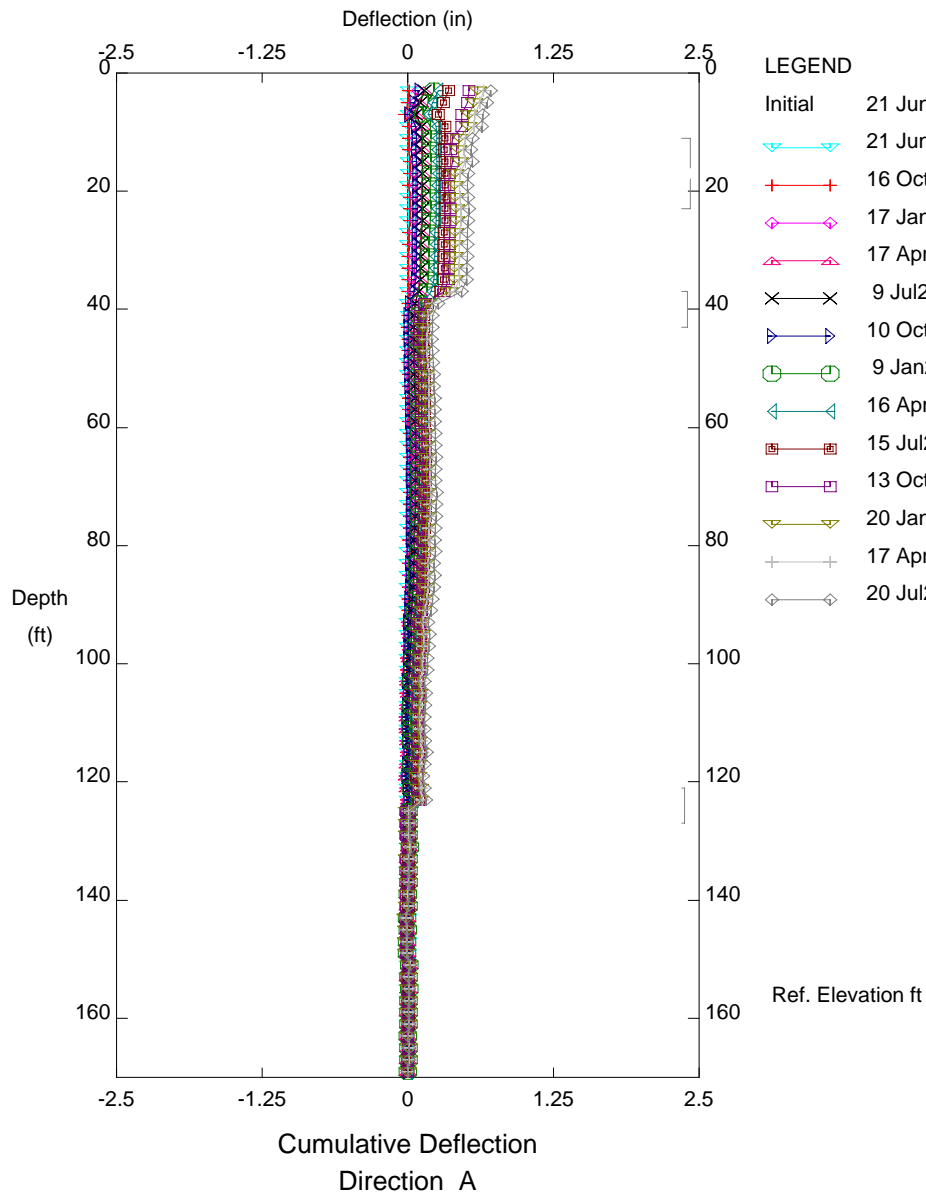

CUY-90, Inclinator B05-03

# E.L. Robinson - Columbus, OH

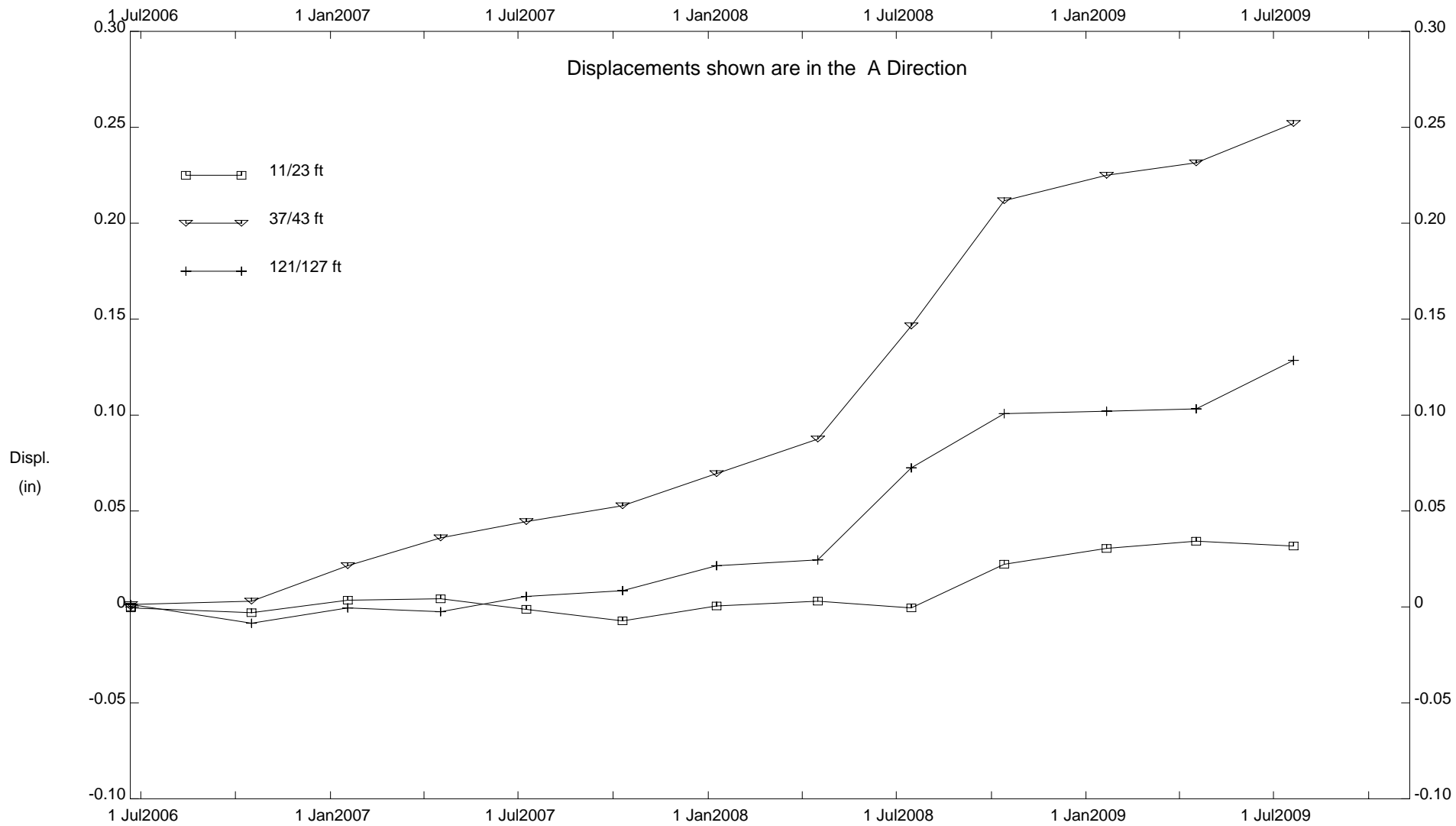

CUY-90, Inclinometer B05-03

E.L. Robinson - Columbus, OH

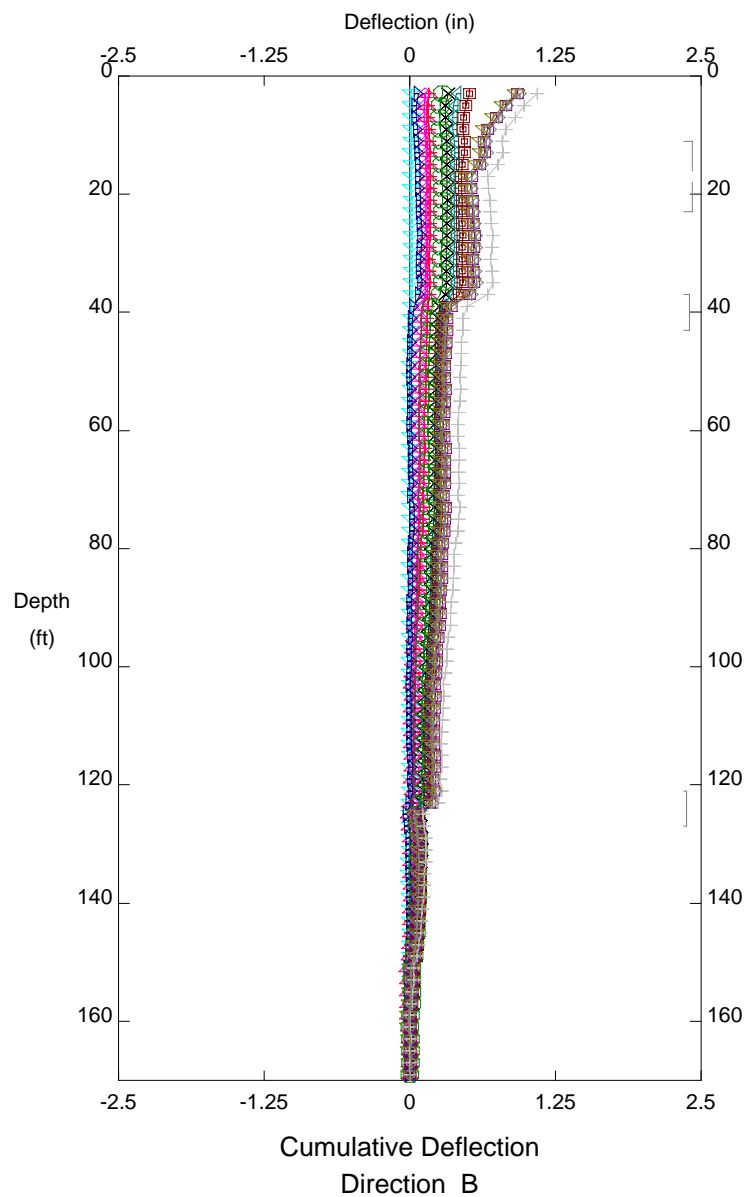

- LEGEND
- Initial 21 Jun2006
  - 21 Jun2006
  - 16 Oct2006
  - 17 Jan2007
  - 17 Apr2007
  - 9 Jul2007
  - 10 Oct2007
  - 9 Jan2008
  - 16 Apr2008
  - 15 Jul2008
  - 13 Oct2008
  - 20 Jan2009
  - 17 Apr2009
  - 20 Jul2009

Ref. Elevation ft

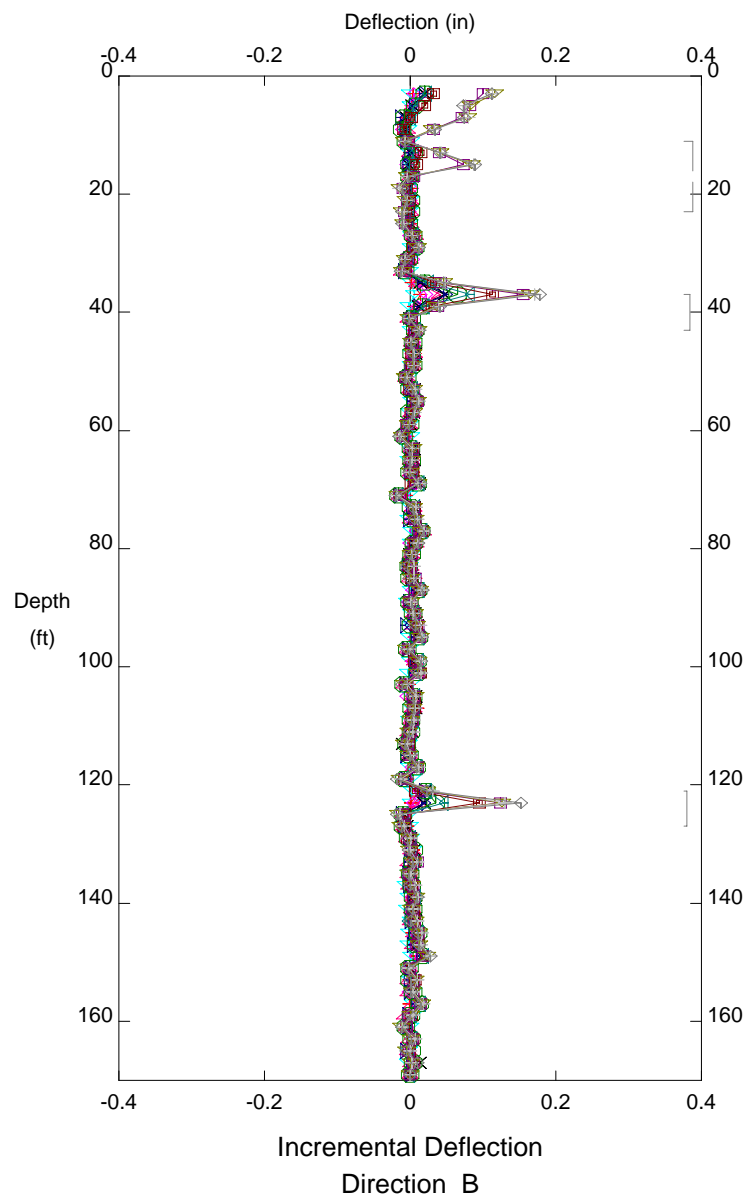

CUY-90, Inclinator B05-03

# E.L. Robinson - Columbus, OH

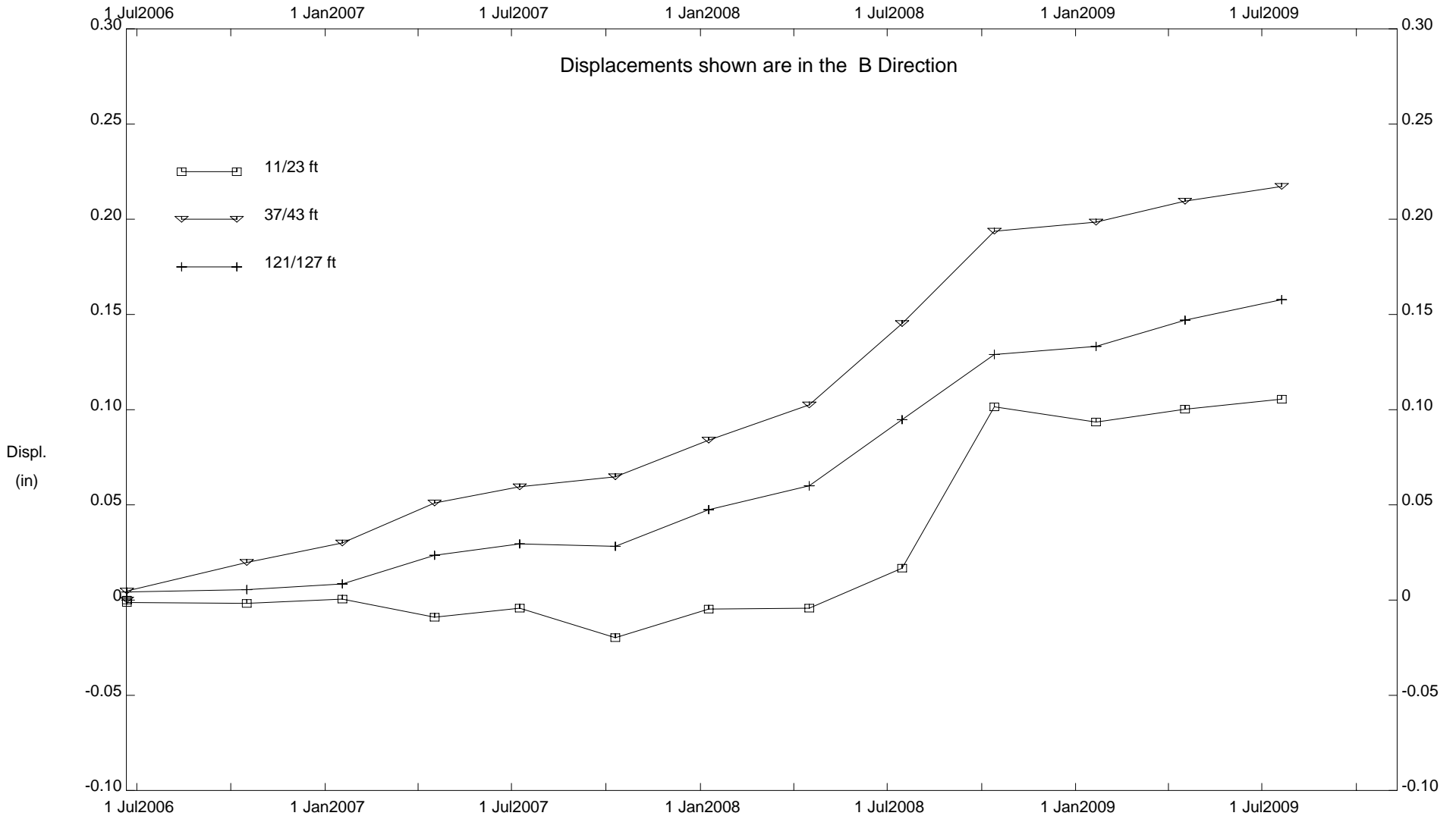

CUY-90, Inclinometer B05-03

**INCLINOMETER B05-04**

DEPTH FROM 115'/119' RATE OF MOVEMENT = 0.02 INCHES PER YEAR BETWEEN 2006 AND 2009

E.L. Robinson - Columbus, OH

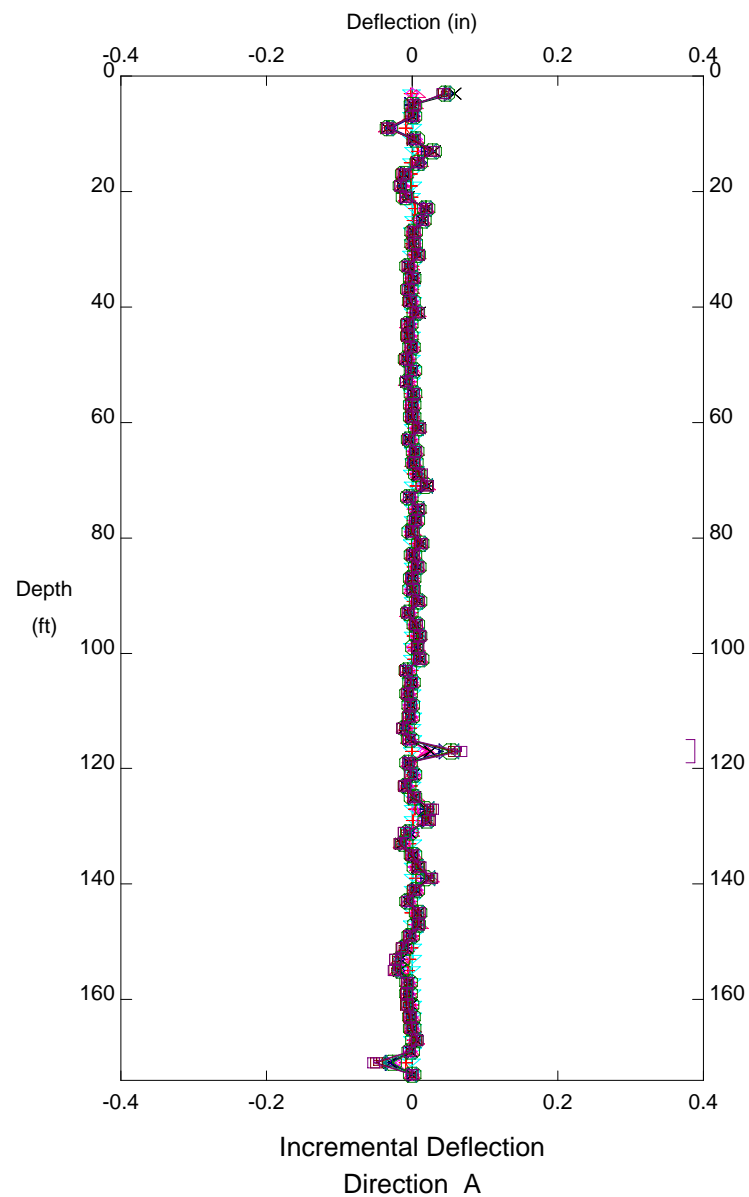
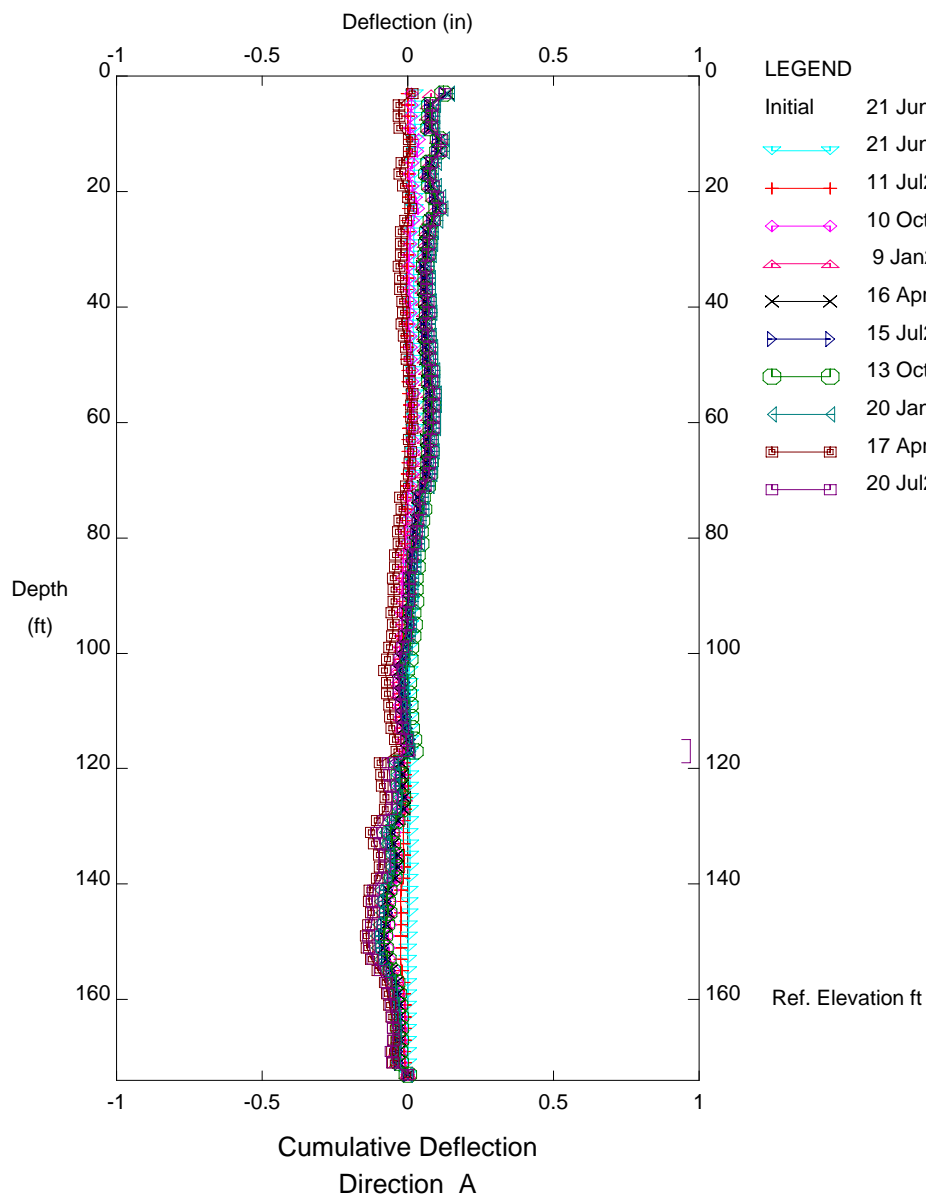

CUY-90, Inclinator B05-04



E.L. Robinson - Columbus, OH

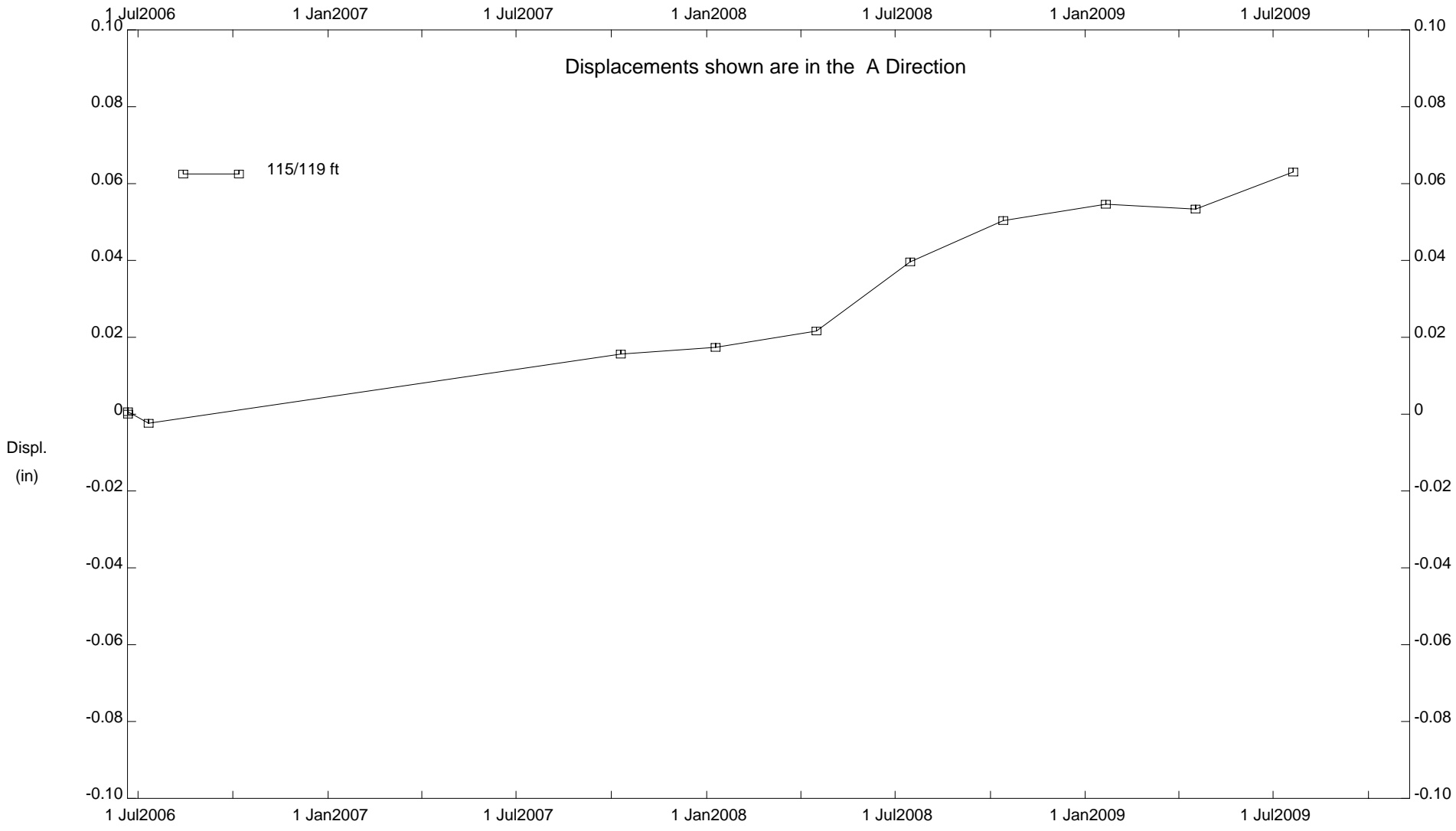

CUY-90, Inclinometer B05-04

E.L. Robinson - Columbus, OH

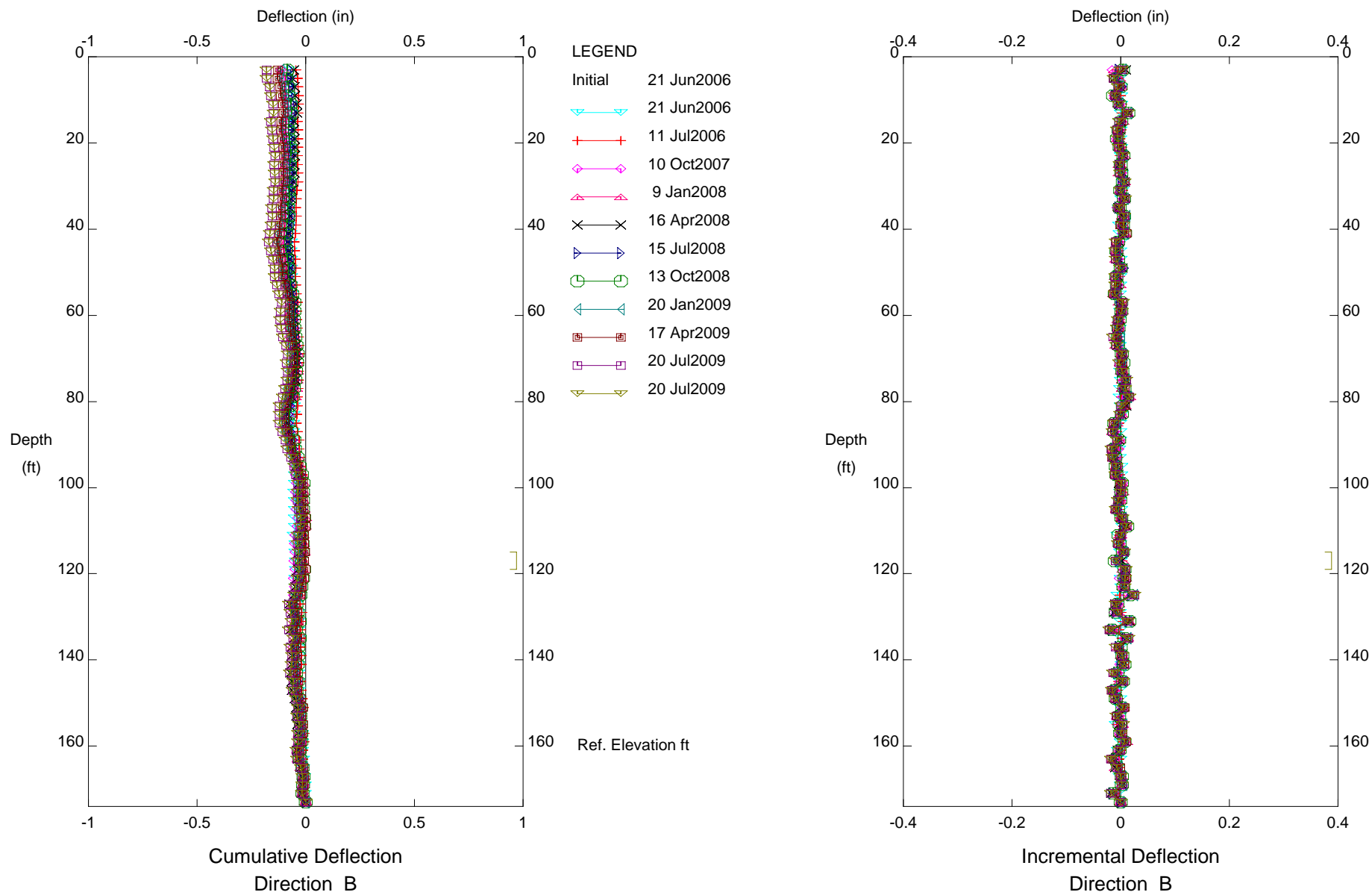

CUY-90, Inclinator B05-04

NO MOVEMENT

**INCLINOMETER B05-07**

E.L. Robinson - Columbus, OH

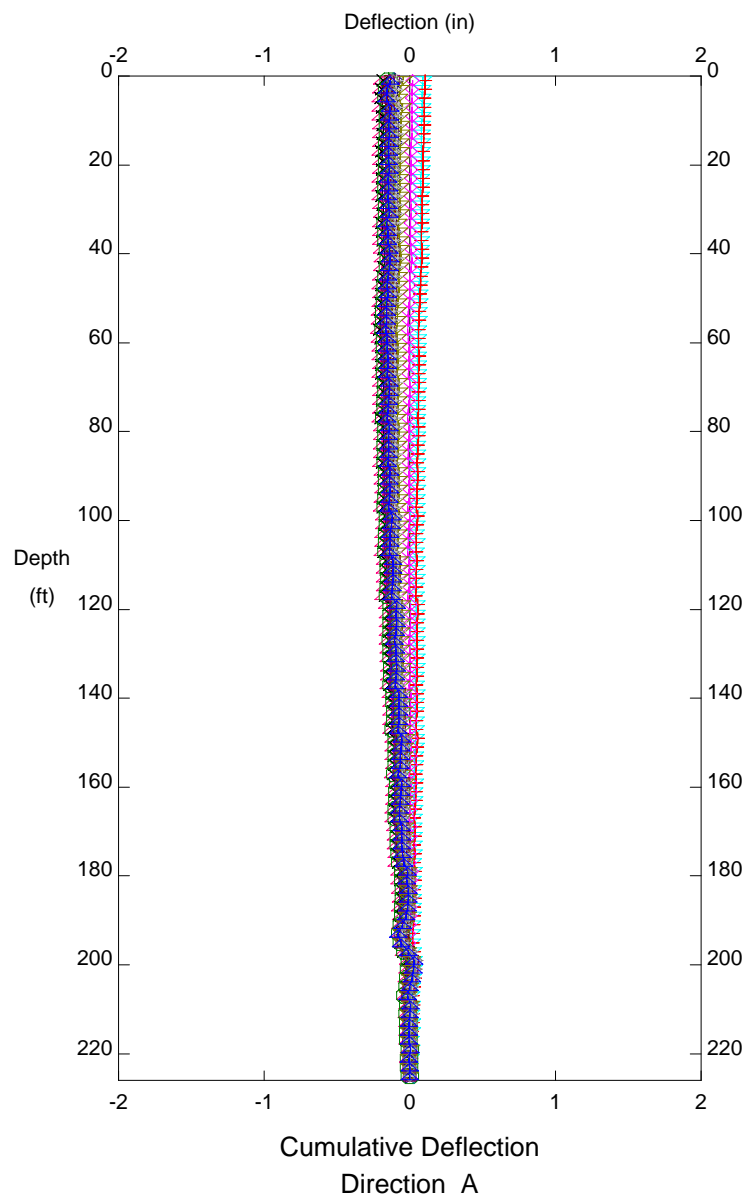

LEGEND

|         |            |
|---------|------------|
| Initial | 26 Jun2006 |
| ◁       | 30 Jun2006 |
| +       | 12 Jul2006 |
| ◇       | 12 Oct2006 |
| △       | 16 Jan2007 |
| ×       | 16 Apr2007 |
| ▷       | 11 Jul2007 |
| ○       | 16 Oct2007 |
| ◁       | 8 Jan2008  |
| ■       | 14 Apr2008 |
| □       | 14 Jul2008 |
| ▽       | 14 Oct2008 |
| +       | 23 Jan2009 |
| ◇       | 16 Apr2009 |
| ▷       | 17 Jul2009 |

Ref. Elevation ft

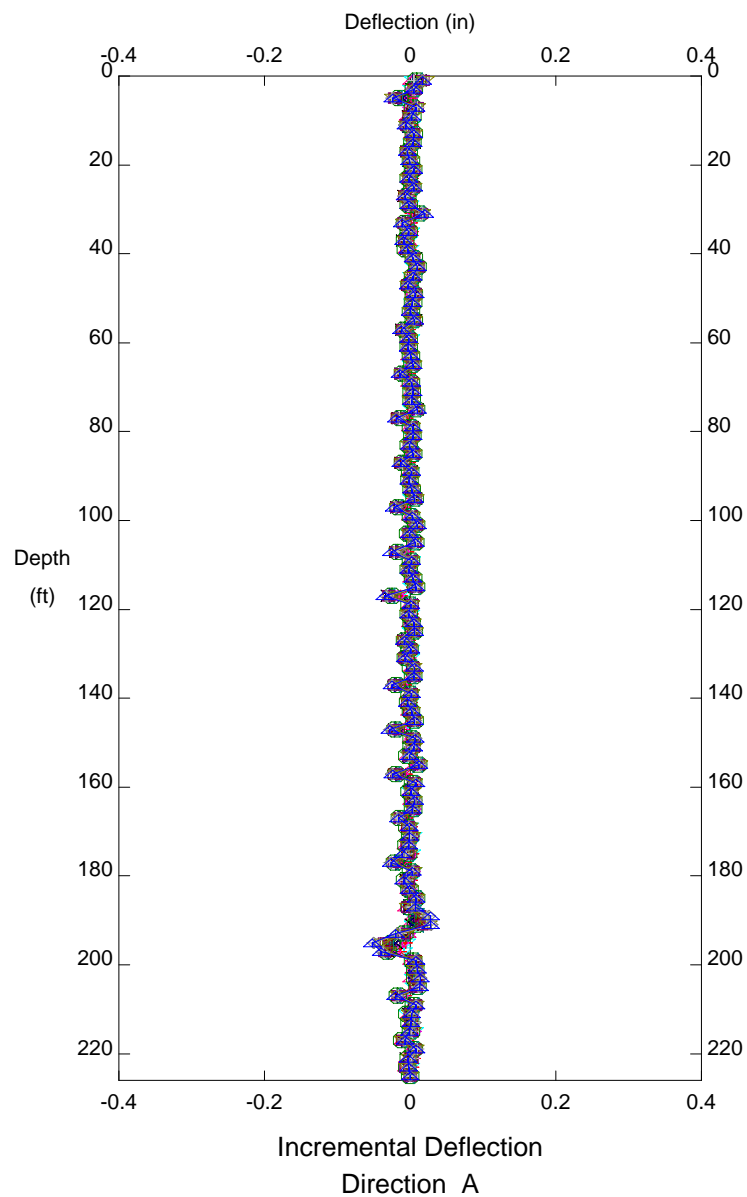

CUY-90, Inclinator B05-07

E.L. Robinson - Columbus, OH

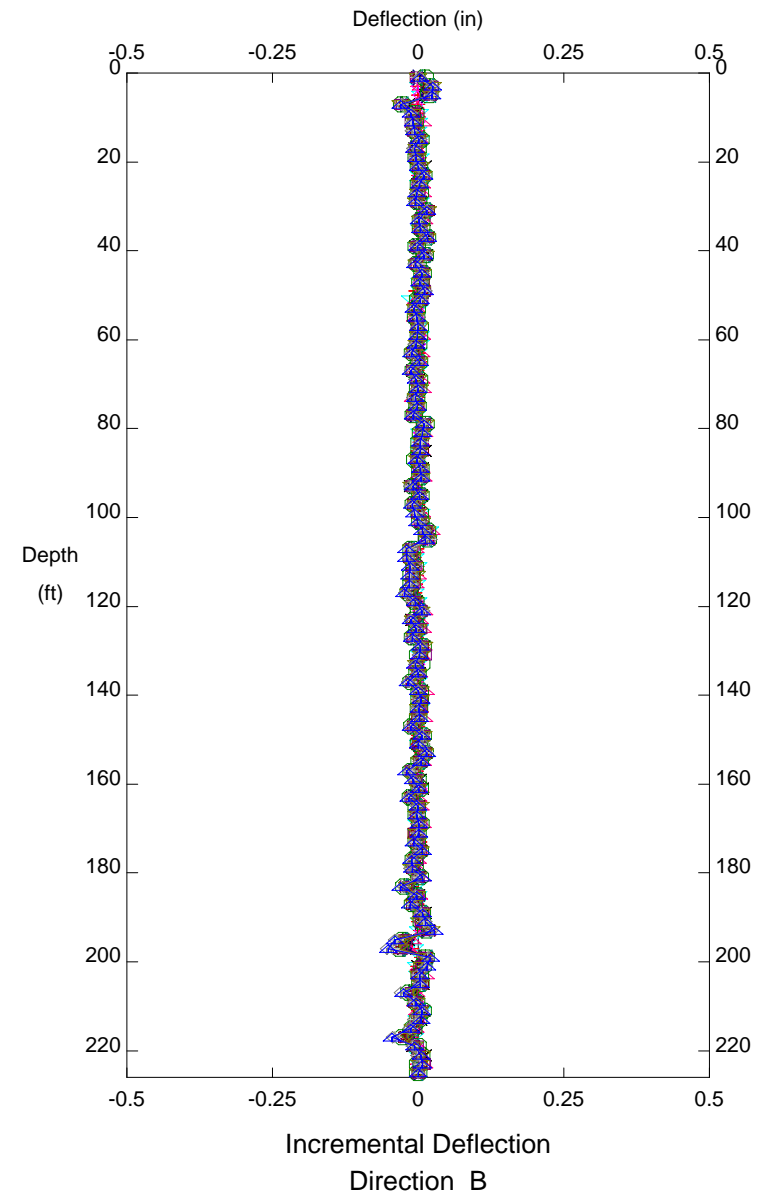
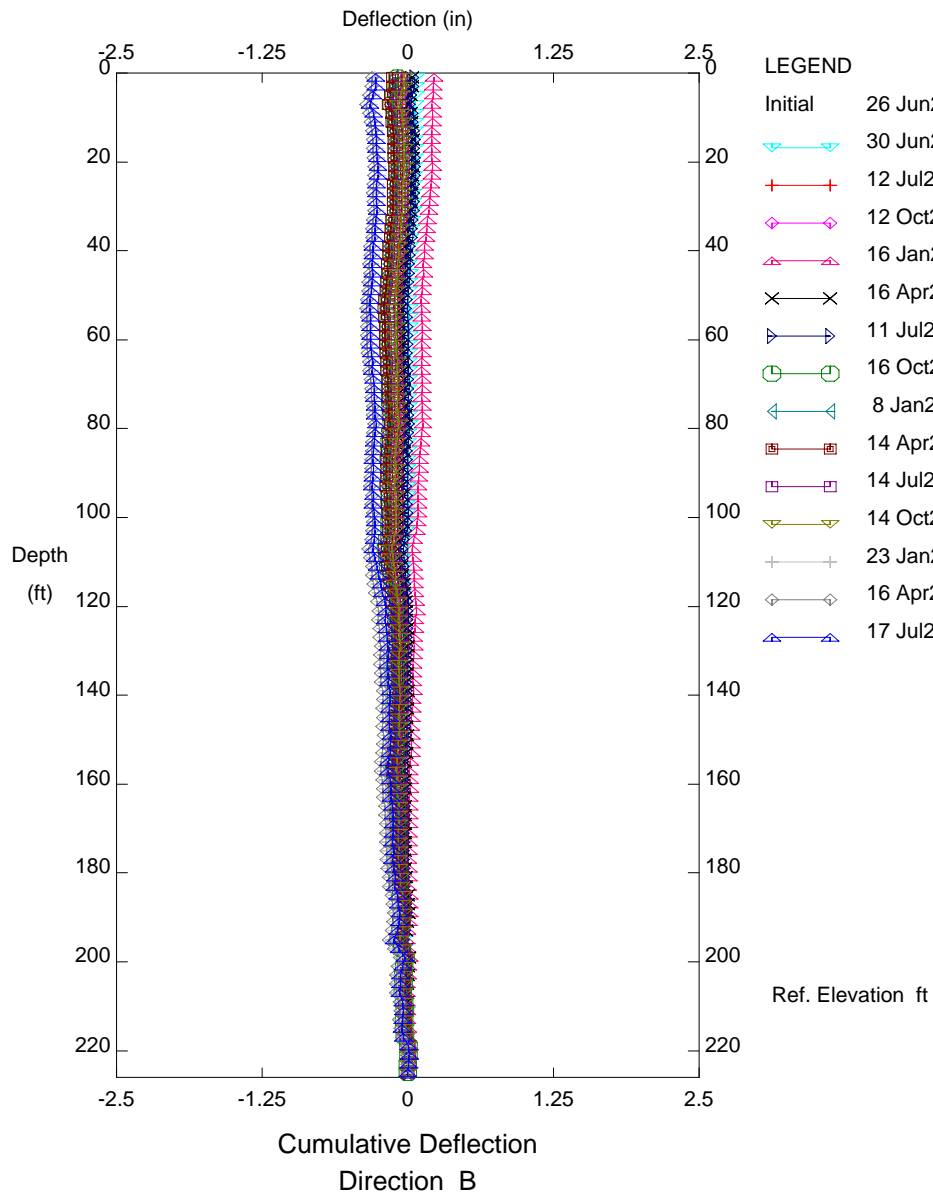

CUY-90, Inclinator B05-07

NO MOVEMENT

**INCLINOMETER B05-08**

E.L. Robinson - Columbus, OH

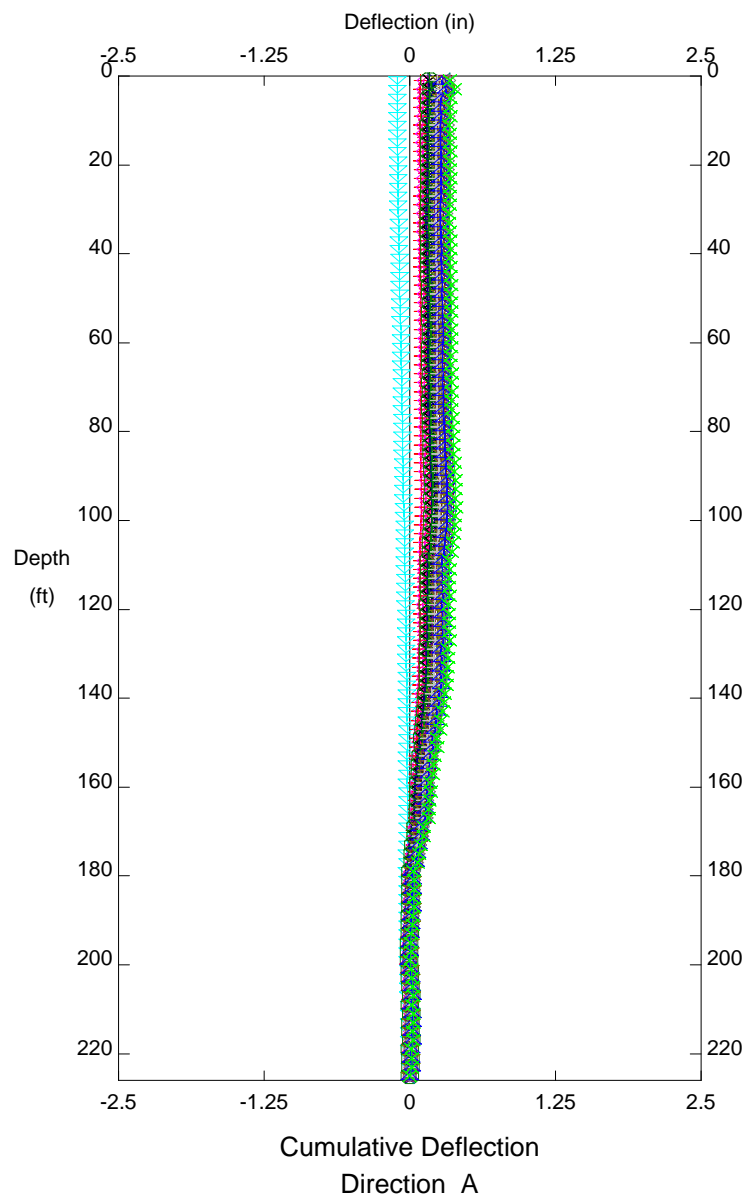

LEGEND

|         |            |
|---------|------------|
| Initial | 26 Jun2006 |
| ↔       | 26 Jun2006 |
| +—+     | 12 Jul2006 |
| ◇—◇     | 24 Jul2006 |
| △—△     | 12 Oct2006 |
| ×—×     | 16 Jan2007 |
| ▷—▷     | 16 Apr2007 |
| ⊕—⊕     | 11 Jul2007 |
| ◁—▷     | 16 Oct2007 |
| ⊞—⊞     | 8 Jan2008  |
| ⊠—⊠     | 14 Apr2008 |
| ▽—▽     | 14 Jul2008 |
| +—+     | 14 Oct2008 |
| ◁—▷     | 12 Jan2009 |
| ▷—▷     | 16 Apr2009 |
| ×—×     | 17 Jul2009 |

Ref. Elevation ft

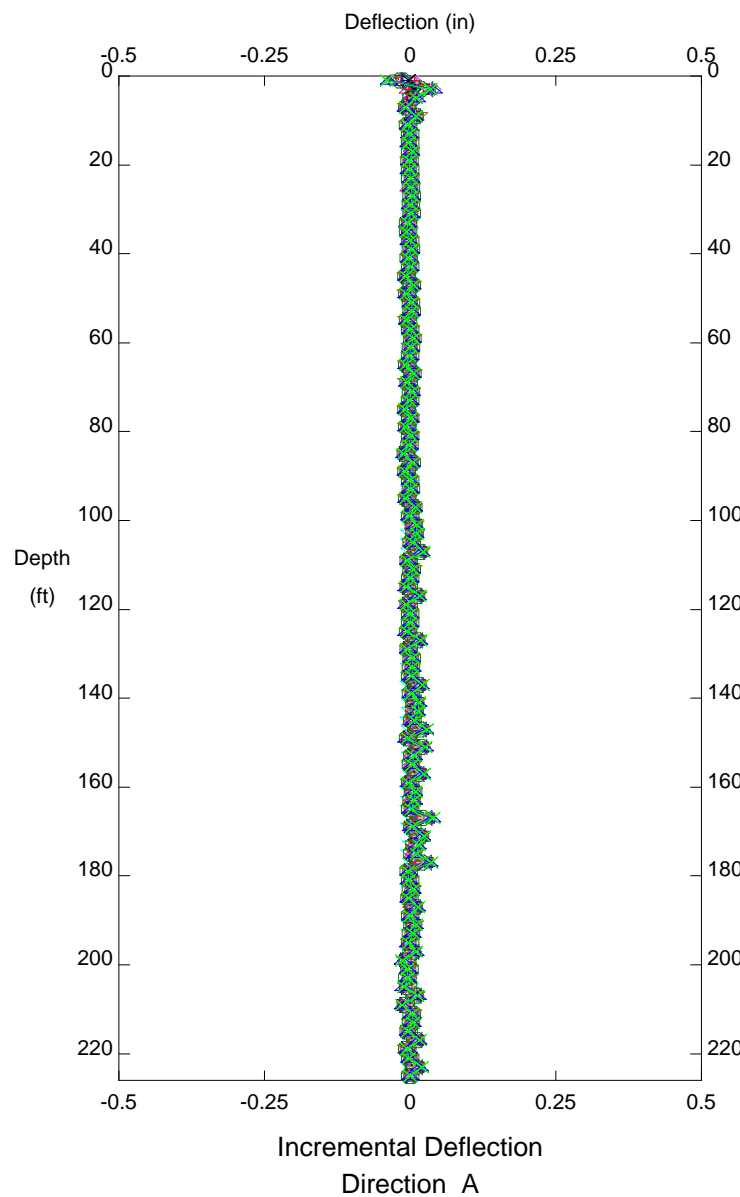

CUY-90, Inclinator B05-08

E.L. Robinson - Columbus, OH

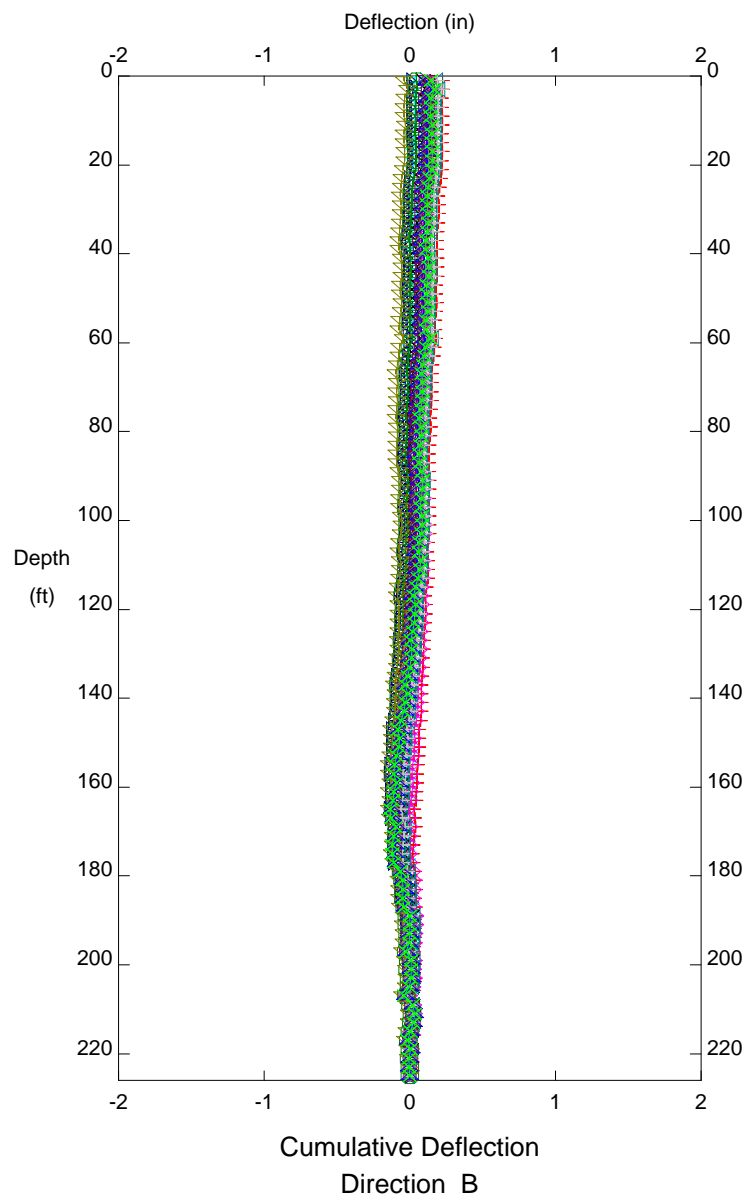

LEGEND

|         |            |
|---------|------------|
| Initial | 26 Jun2006 |
| ↔       | 26 Jun2006 |
| +—+     | 12 Jul2006 |
| ◇—◇     | 24 Jul2006 |
| △—△     | 12 Oct2006 |
| ×—×     | 16 Jan2007 |
| ▷—▷     | 16 Apr2007 |
| ⊕—⊕     | 11 Jul2007 |
| ◁—◁     | 16 Oct2007 |
| ⊠—⊠     | 8 Jan2008  |
| ◻—◻     | 14 Apr2008 |
| ▽—▽     | 14 Jul2008 |
| +—+     | 14 Oct2008 |
| ◊—◊     | 12 Jan2009 |
| ▷—▷     | 16 Apr2009 |
| ×—×     | 17 Jul2009 |

Ref. Elevation ft

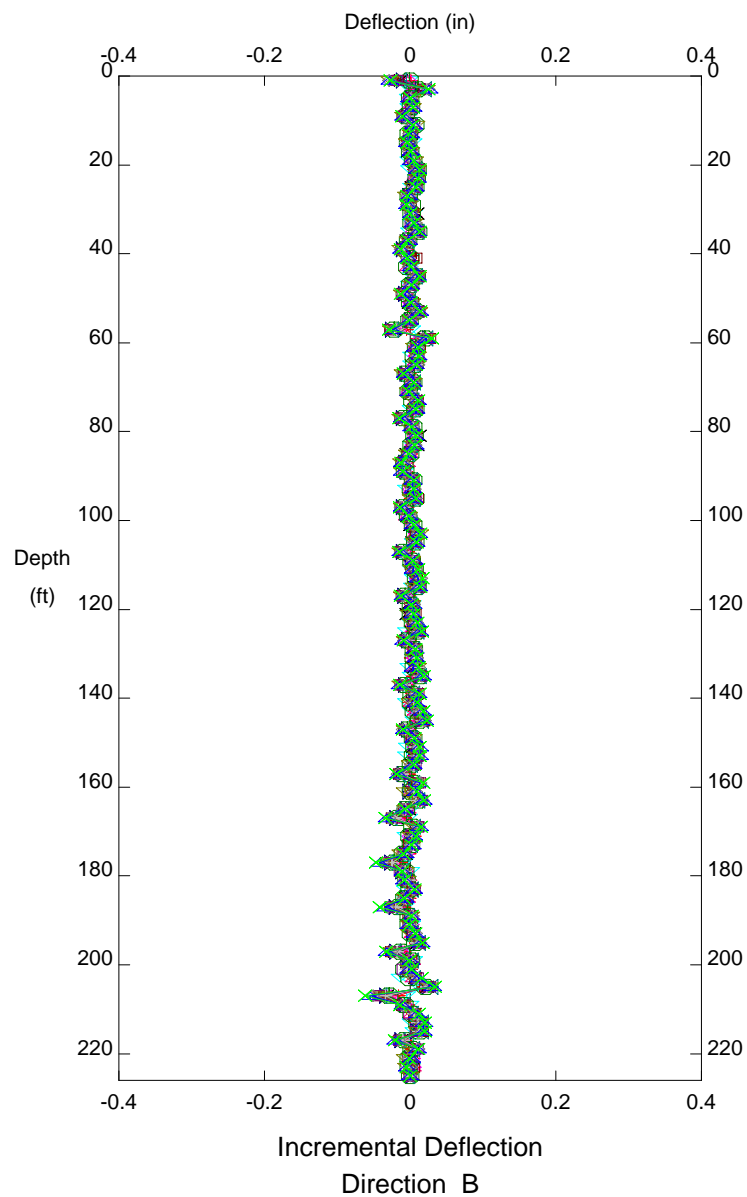

CUY-90, Inclinator B05-08



NO MOVEMENT

**INCLINOMETER B05-11**

E.L. Robinson - Columbus, OH

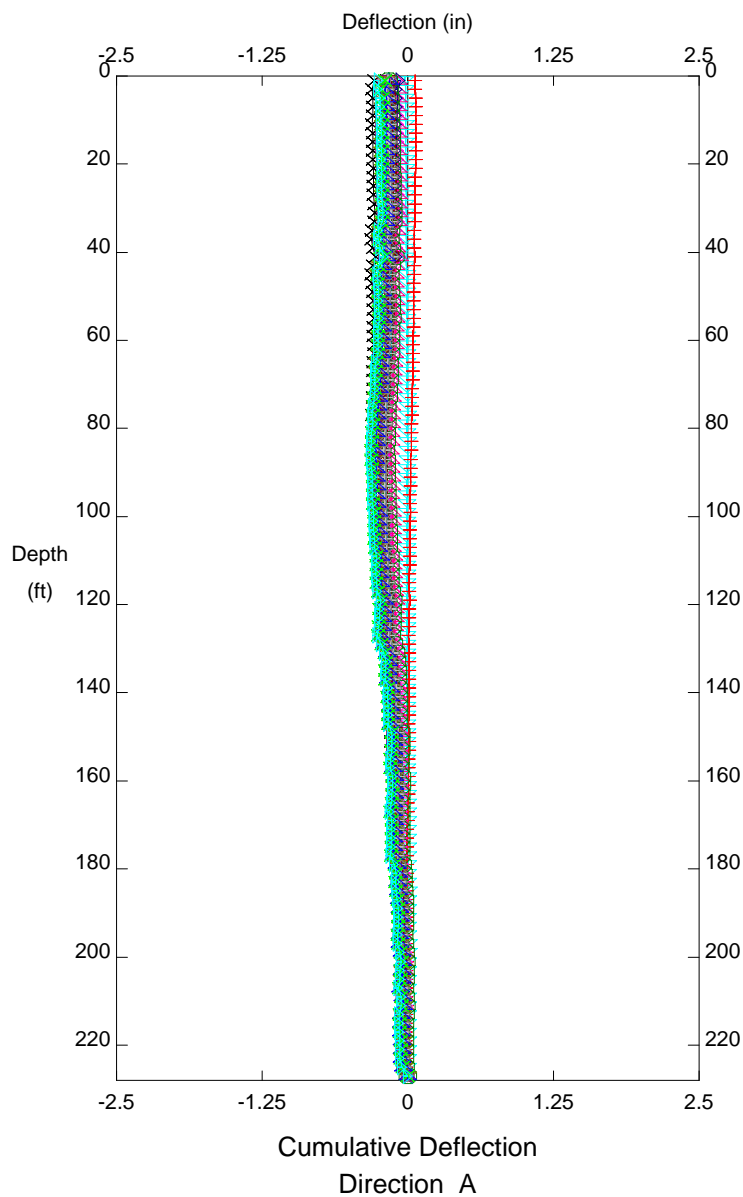

LEGEND

|         |            |
|---------|------------|
| Initial | 23 Jun2006 |
| ↔       | 23 Jun2006 |
| +—+     | 13 Jul2006 |
| ◇—◇     | 12 Oct2006 |
| △—△     | 18 Oct2006 |
| ×—×     | 16 Jan2007 |
| ▷—▷     | 16 Apr2007 |
| ⊕—⊕     | 11 Jul2007 |
| ◁—▷     | 13 Jul2007 |
| ▣—▣     | 12 Oct2007 |
| ▢—▢     | 8 Jan2008  |
| ▽—▽     | 14 Apr2008 |
| +—+     | 14 Jul2008 |
| ◁—▷     | 14 Oct2008 |
| ▷—▷     | 12 Jan2009 |
| ×—×     | 16 Apr2009 |
| ▷—▷     | 17 Jul2009 |

Ref. Elevation ft

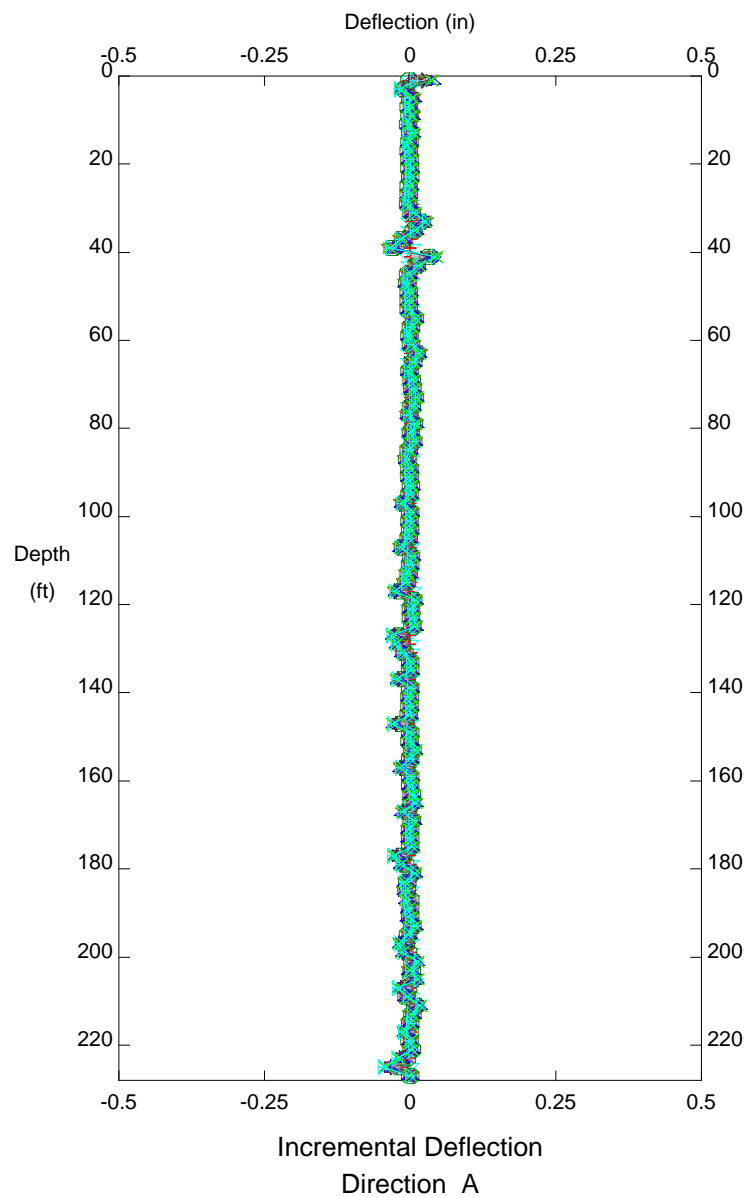

CUY-90, Inclinator B05-11

E.L. Robinson - Columbus, OH

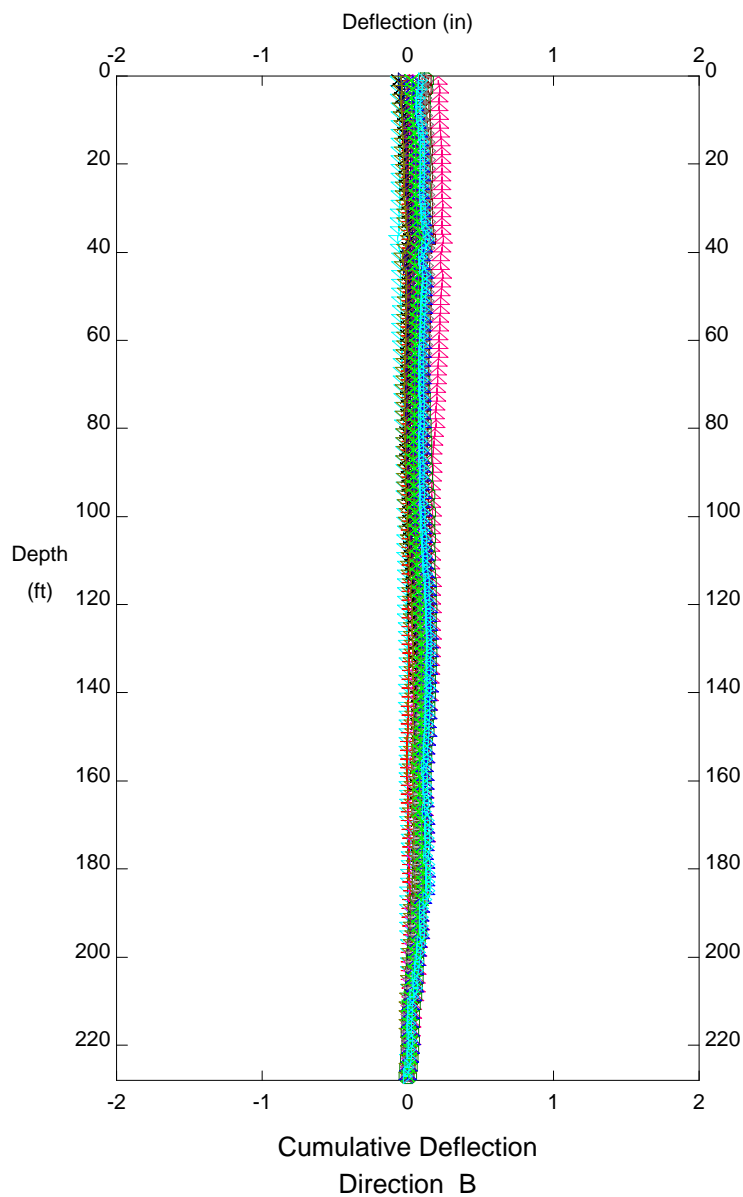

LEGEND

|         |            |
|---------|------------|
| Initial | 23 Jun2006 |
| ◁       | 23 Jun2006 |
| +       | 13 Jul2006 |
| ◇       | 12 Oct2006 |
| △       | 18 Oct2006 |
| ×       | 16 Jan2007 |
| ▷       | 16 Apr2007 |
| ○       | 11 Jul2007 |
| ◁       | 13 Jul2007 |
| ■       | 12 Oct2007 |
| □       | 8 Jan2008  |
| ▽       | 14 Apr2008 |
| +       | 14 Jul2008 |
| ◇       | 14 Oct2008 |
| △       | 12 Jan2009 |
| ×       | 16 Apr2009 |
| ▷       | 17 Jul2009 |

Ref. Elevation ft

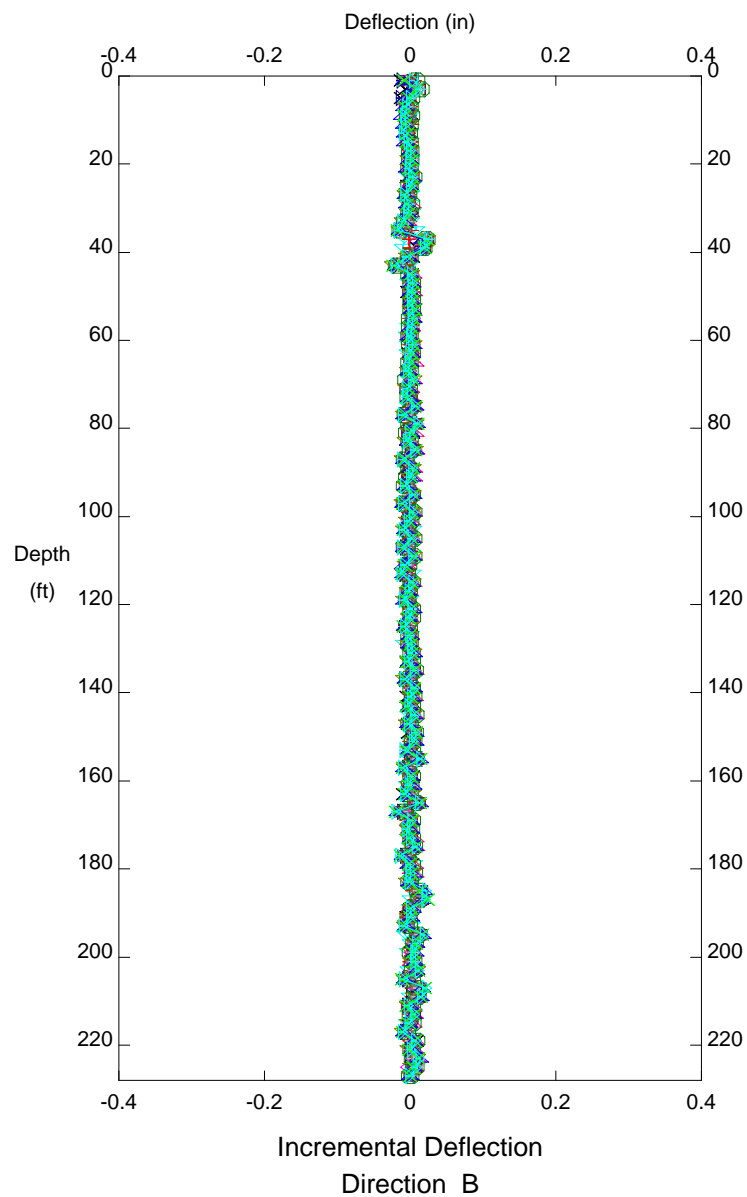

CUY-90, Inclinator B05-11

NO MOVEMENT

**INCLINOMETER B05-12**

E.L. Robinson - Columbus, OH

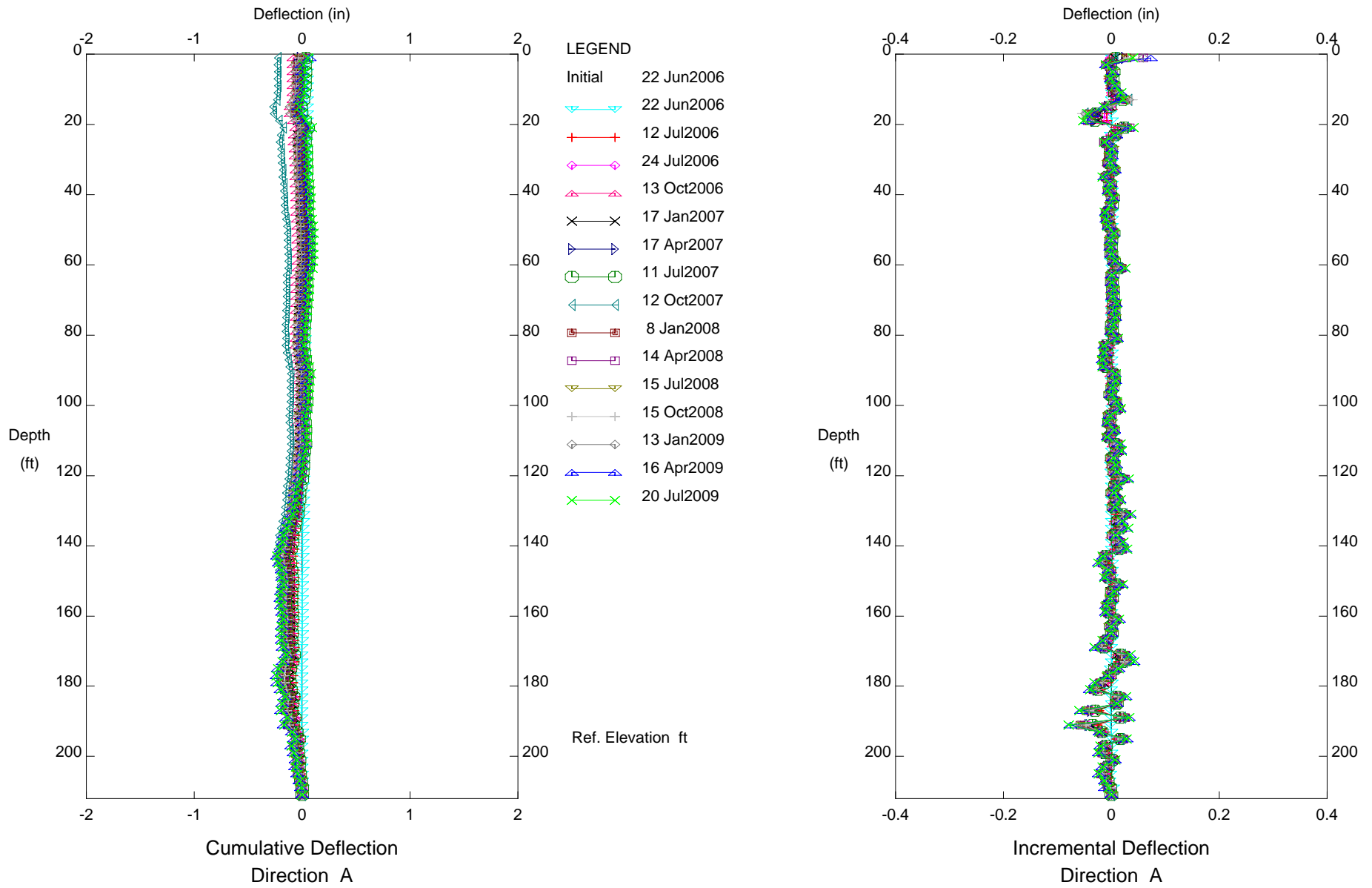

CUY-90, Inclinometer B05-12

E.L. Robinson - Columbus, OH

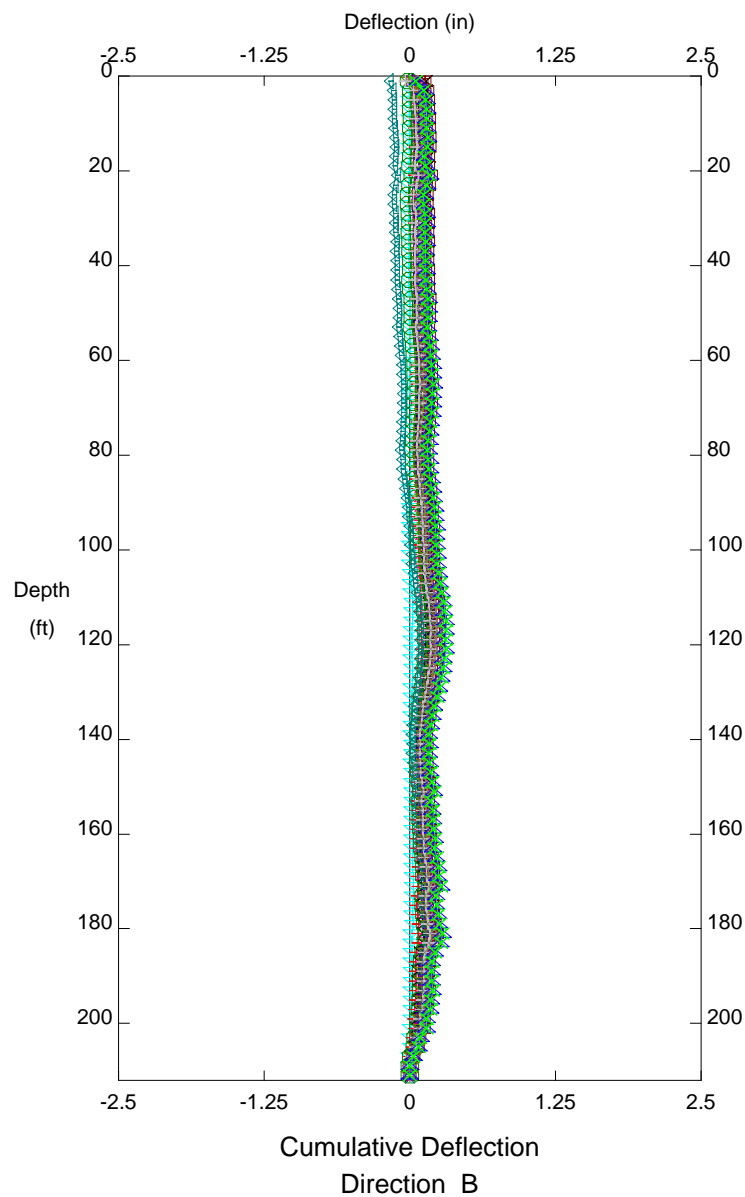

- LEGEND
- Initial 22 Jun2006
  - ◁ 22 Jun2006
  - + 12 Jul2006
  - ◇ 24 Jul2006
  - △ 13 Oct2006
  - × 17 Jan2007
  - ▷ 17 Apr2007
  - 11 Jul2007
  - ◁ 12 Oct2007
  - 8 Jan2008
  - 14 Apr2008
  - ▽ 15 Jul2008
  - + 15 Oct2008
  - ◇ 13 Jan2009
  - ▷ 16 Apr2009
  - × 20 Jul2009
- Ref. Elevation ft

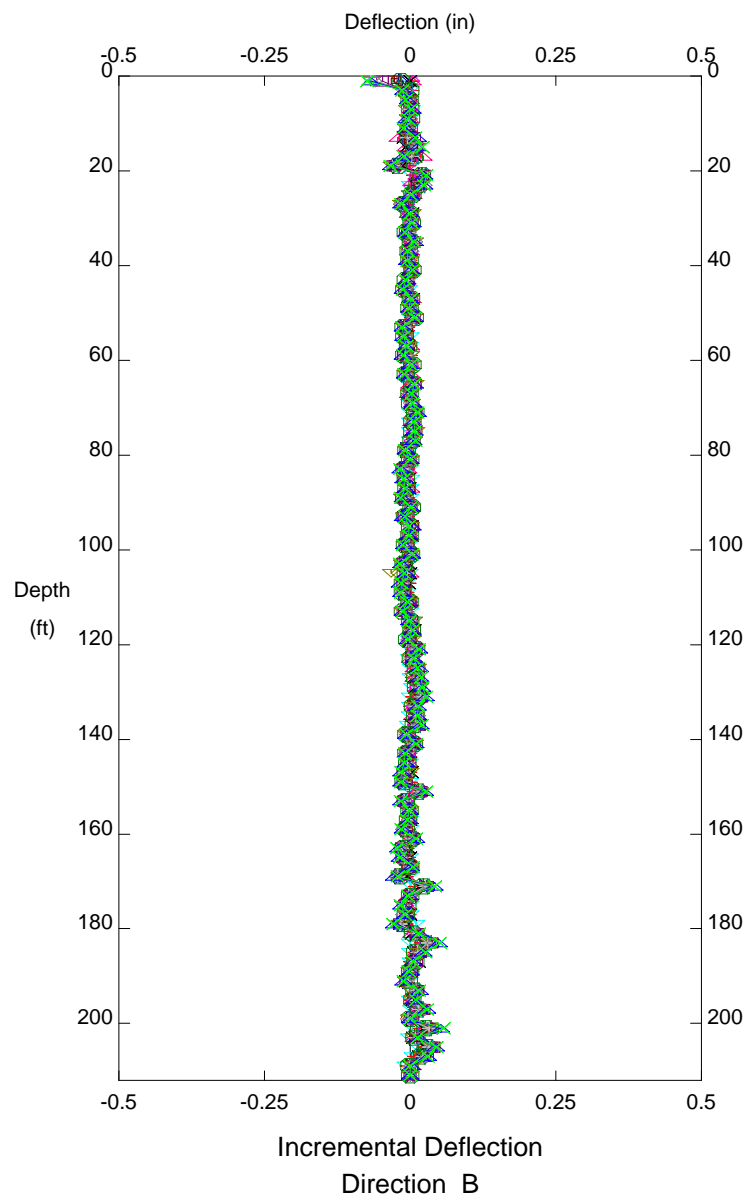

CUY-90, Inclinator B05-12

**INCLINOMETER B05-13**

NO MOVEMENT

E.L. Robinson - Columbus, OH

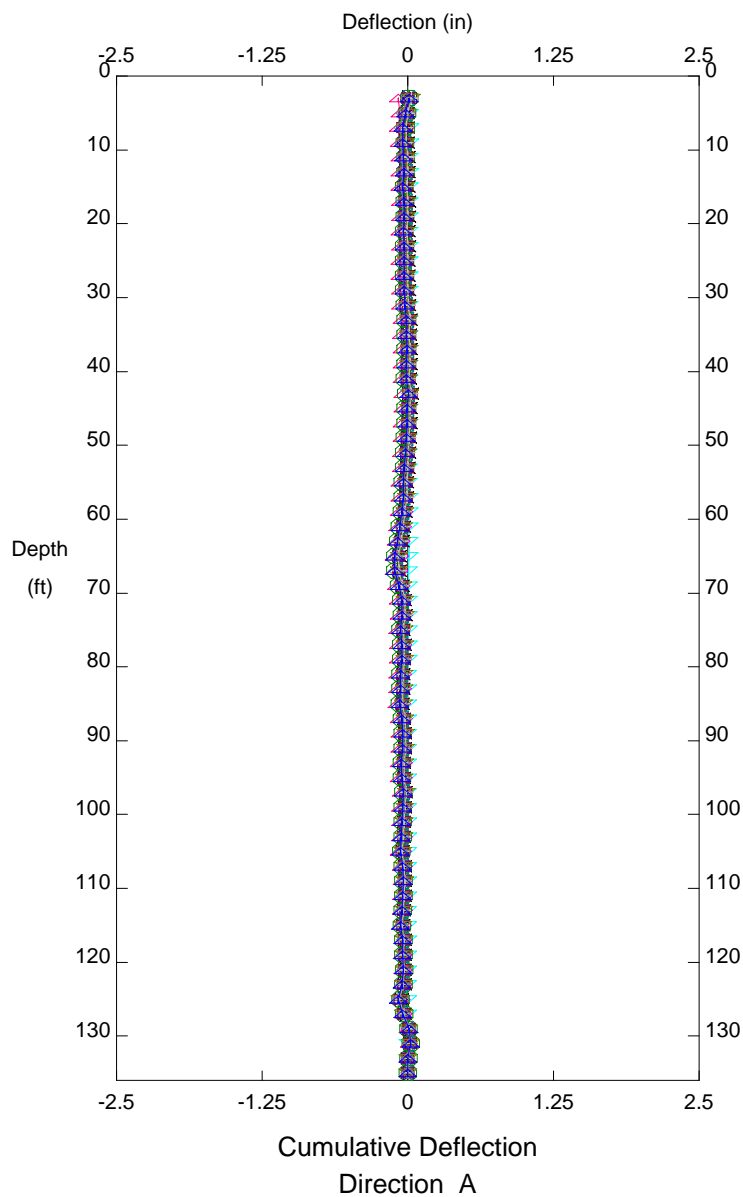

LEGEND

|         |            |
|---------|------------|
| Initial | 26 Jun2006 |
| ◁       | 26 Jun2006 |
| ▷       | 13 Jul2006 |
| ◊       | 13 Oct2006 |
| △       | 18 Jan2007 |
| ×       | 18 Apr2007 |
| ▷       | 11 Jul2007 |
| ◉       | 16 Oct2007 |
| ◁       | 8 Jan2008  |
| ◻       | 17 Apr2008 |
| ◻       | 16 Jul2008 |
| ▽       | 15 Oct2008 |
| +       | 23 Jan2009 |
| ◊       | 21 Apr2009 |
| ▷       | 21 Jul2009 |

Ref. Elevation ft

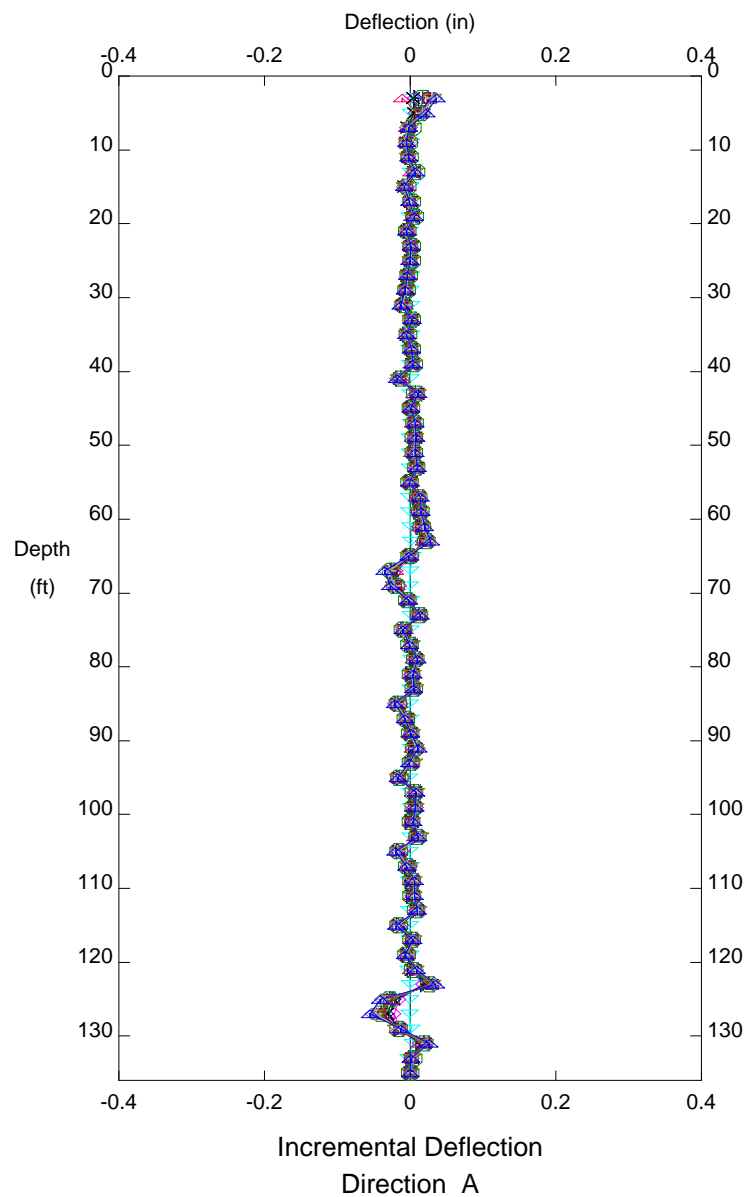

CUY-90, Inclinator B05-13



E.L. Robinson - Columbus, OH

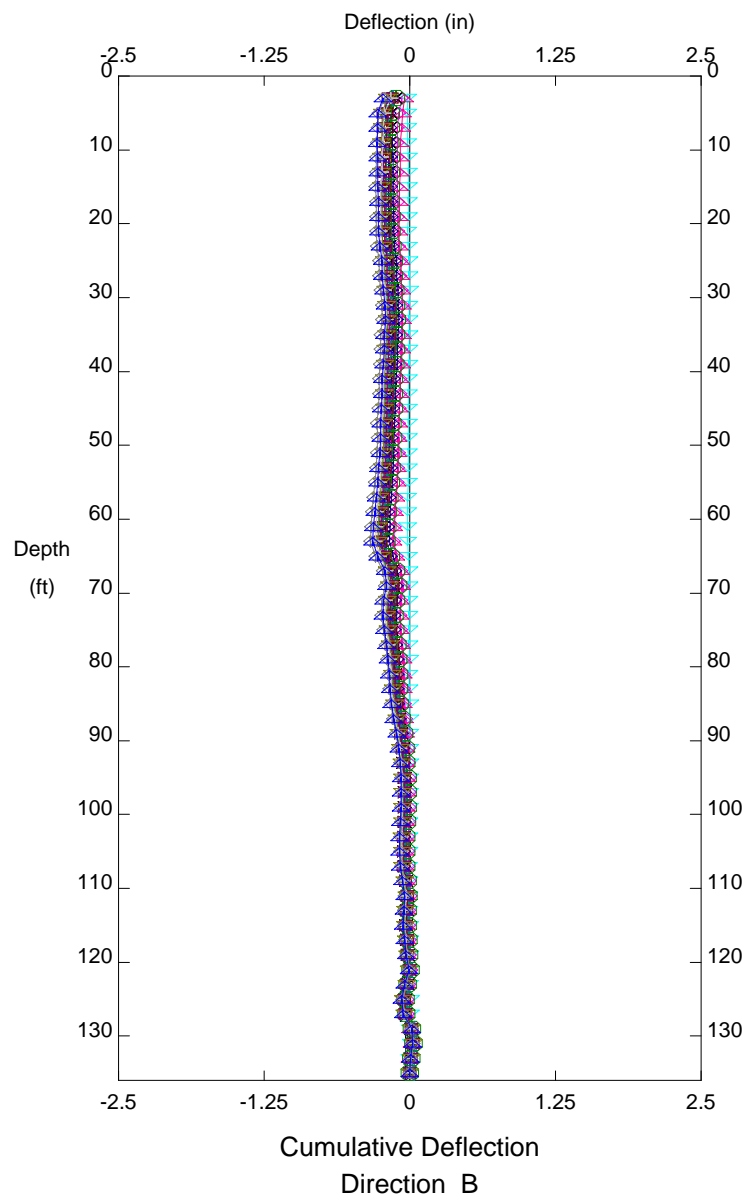

LEGEND

|         |            |
|---------|------------|
| Initial | 26 Jun2006 |
| ↔       | 26 Jun2006 |
|         | 13 Jul2006 |
| ◇       | 13 Oct2006 |
| △       | 18 Jan2007 |
| ×       | 18 Apr2007 |
| ▷       | 11 Jul2007 |
| ⊕       | 16 Oct2007 |
| ◁       | 8 Jan2008  |
| ⊞       | 17 Apr2008 |
| ⊠       | 16 Jul2008 |
| ▽       | 15 Oct2008 |
| +       | 23 Jan2009 |
| ◊       | 21 Apr2009 |
| ▷       | 21 Jul2009 |

Ref. Elevation ft

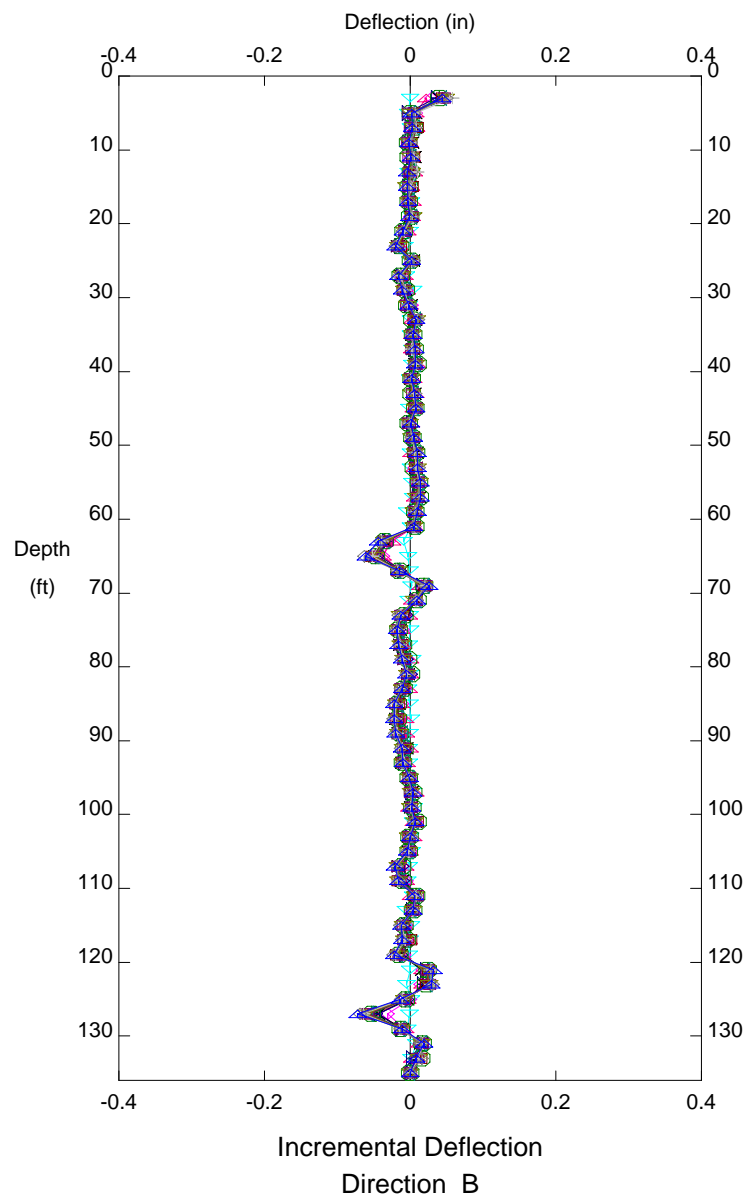

CUY-90, Inclinator B05-13

**INCLINOMETER B05-16**

CLOSE TO B-110

DEPTH FROM 27'/31' RATE OF MOVEMENT = 0.09 INCHES PER YEAR BETWEEN 2006 AND 2009

DEPTH FROM 111'/113' RATE OF MOVEMENT = 0.007 INCHES PER YEAR BETWEEN 2006 AND 2009

E.L. Robinson - Columbus, OH

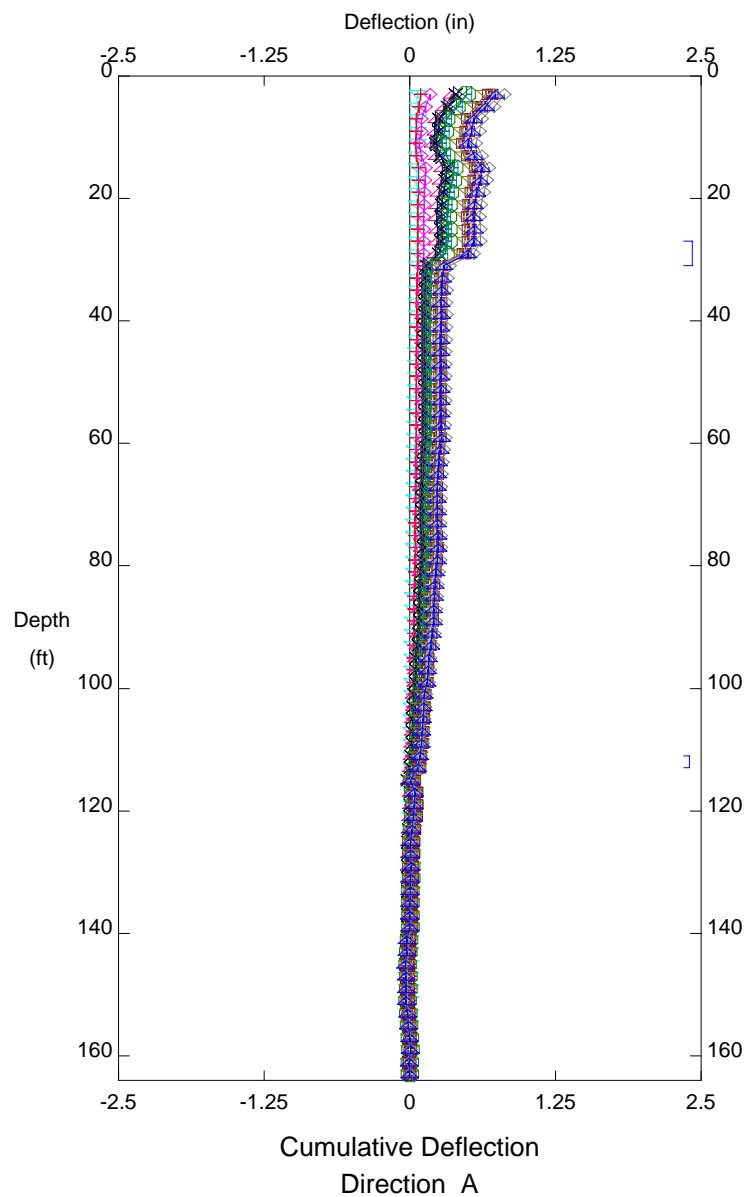

- LEGEND
- Initial 21 Jun2006
  - ◁ 21 Jun2006
  - + 12 Jul2006
  - ◇ 18 Oct2006
  - △ 17 Jan2007
  - × 17 Apr2007
  - ▷ 9 Jul2007
  - ⊕ 10 Oct2007
  - ◁ 9 Jan2008
  - ⊞ 16 Apr2008
  - ⊞ 16 Jul2008
  - ▽ 13 Oct2008
  - + 22 Jan2009
  - ◇ 21 Apr2009
  - ▷ 21 Jul2009
- Ref. Elevation ft

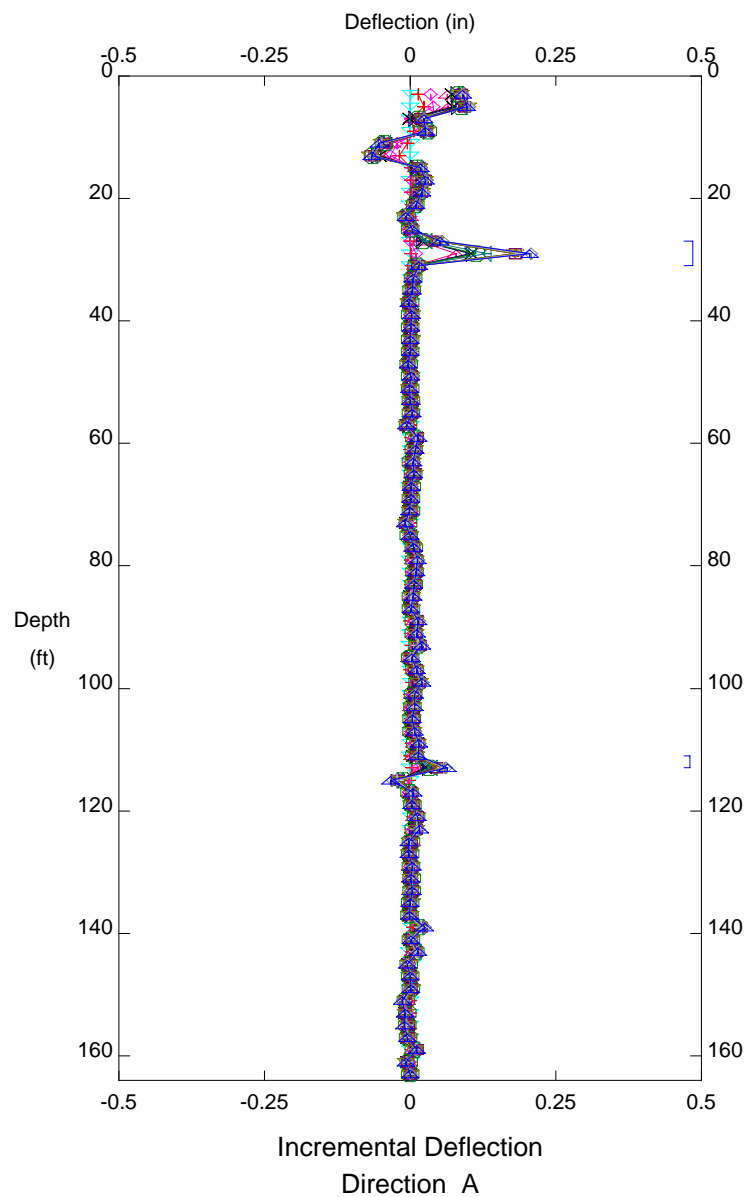

CUY-90, Inclinator B05-16

E.L. Robinson - Columbus, OH

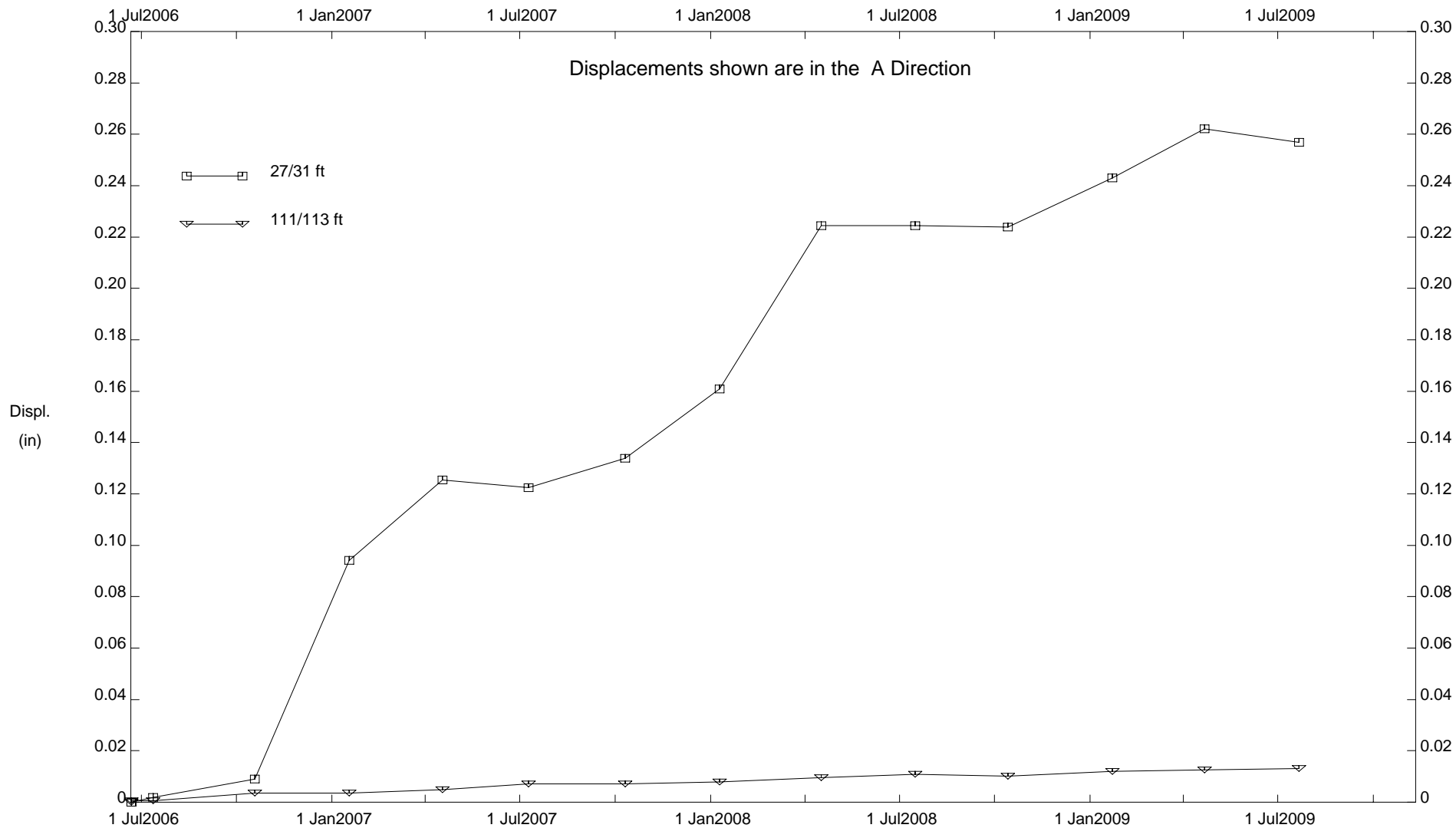

CUY-90, Inclinometer B05-16

E.L. Robinson - Columbus, OH

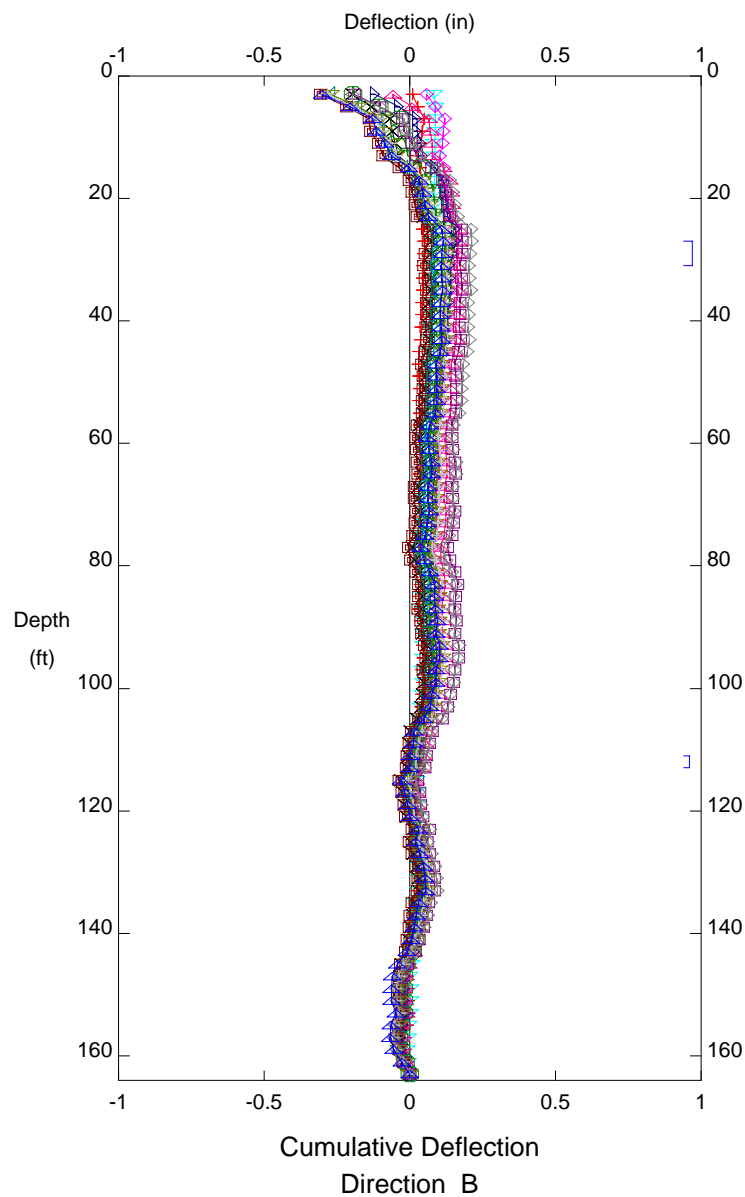

- LEGEND
- Initial 21 Jun2006
  - 21 Jun2006
  - 12 Jul2006
  - 18 Oct2006
  - 17 Jan2007
  - 17 Apr2007
  - 9 Jul2007
  - 10 Oct2007
  - 9 Jan2008
  - 16 Apr2008
  - 16 Jul2008
  - 13 Oct2008
  - 22 Jan2009
  - 21 Apr2009
  - 21 Jul2009
- Ref. Elevation ft

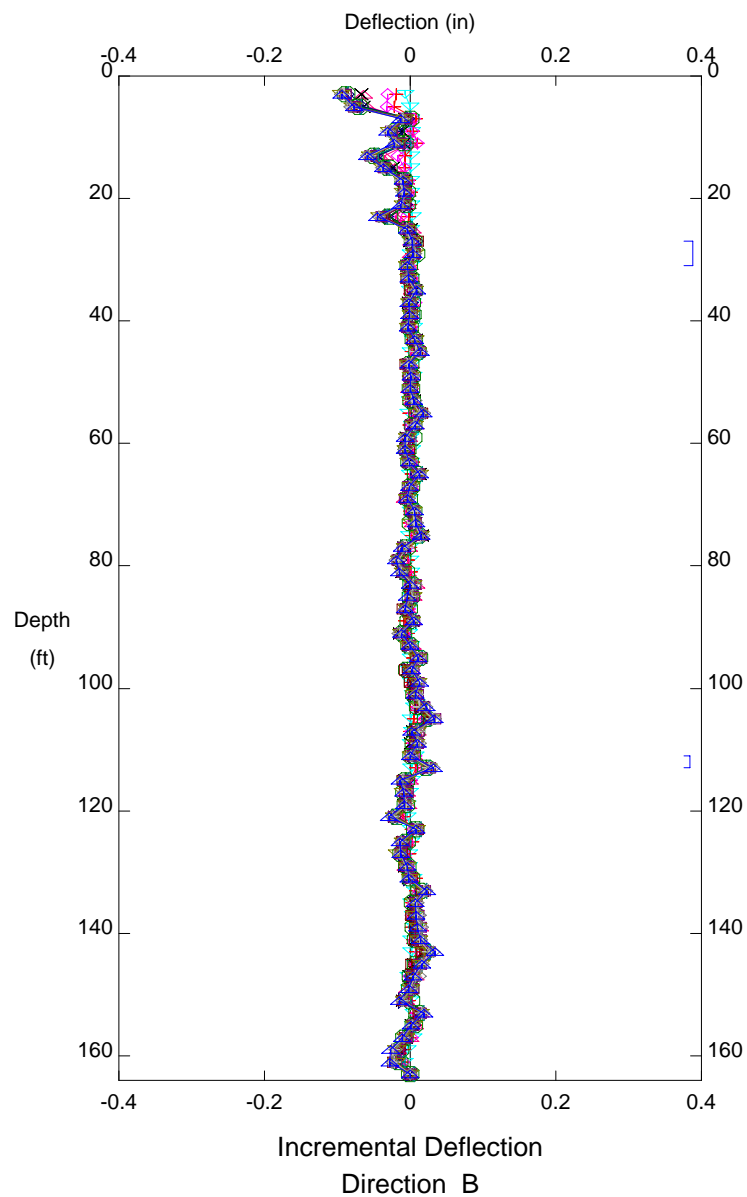

CUY-90, Inclinator B05-16

**APPENDIX 5B**

**REDUCED PIEZOMETERS DATA**

E.L. Robinson - Columbus, OH

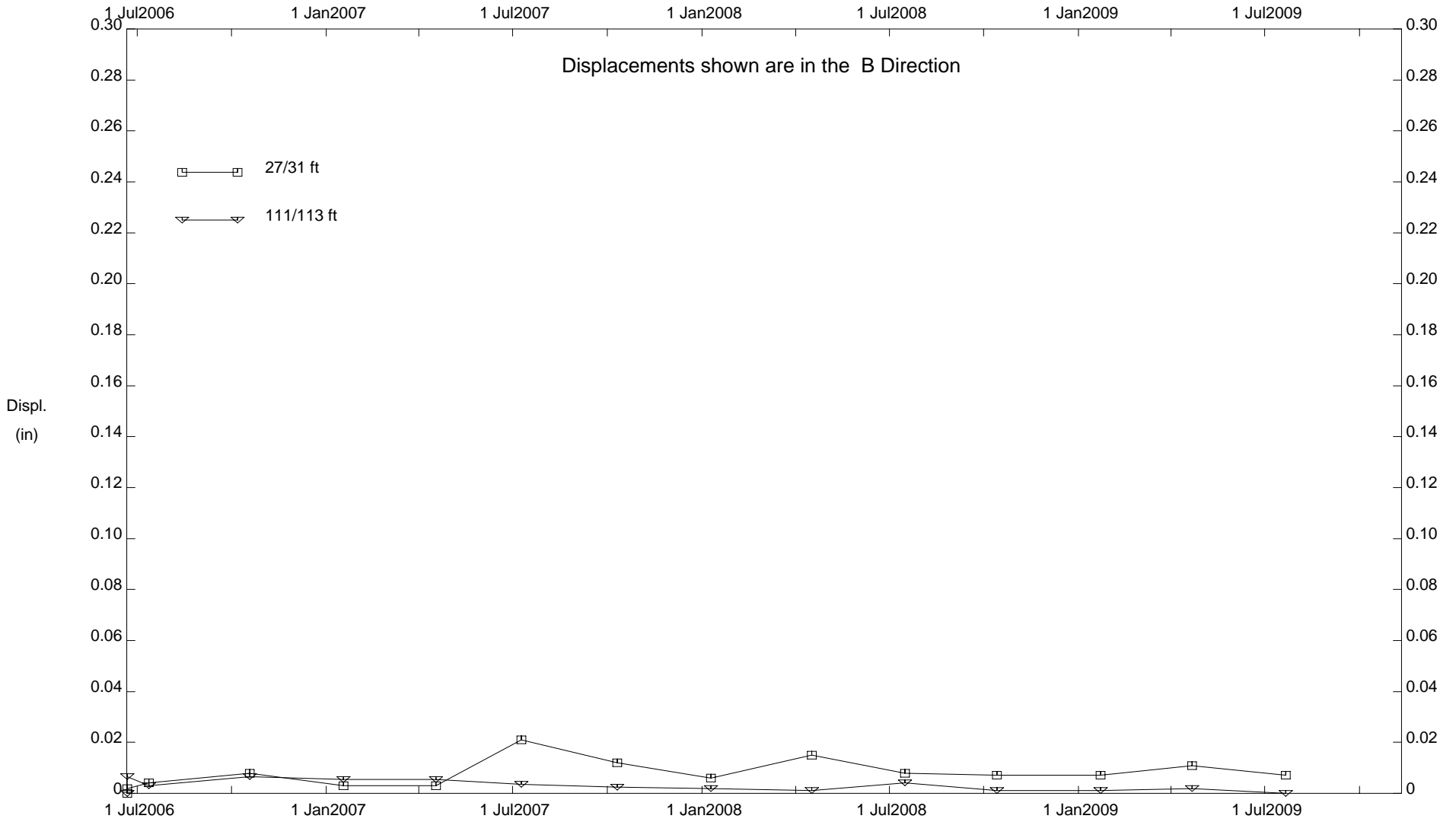

CUY-90, Inclinometer B05-16

### B-101 Pneumatic Piezometer Readings

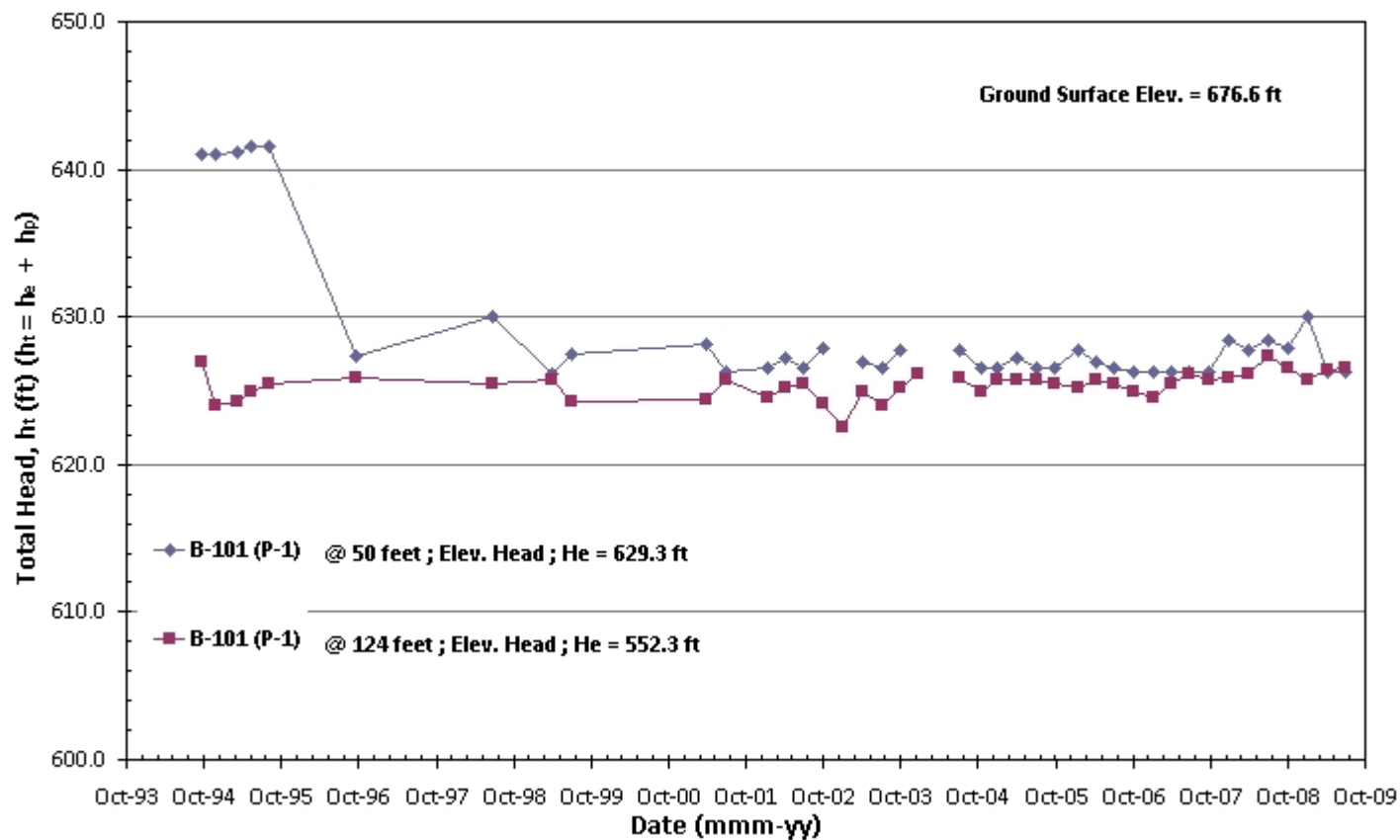



### B-105 Pneumatic Piezometer Readings

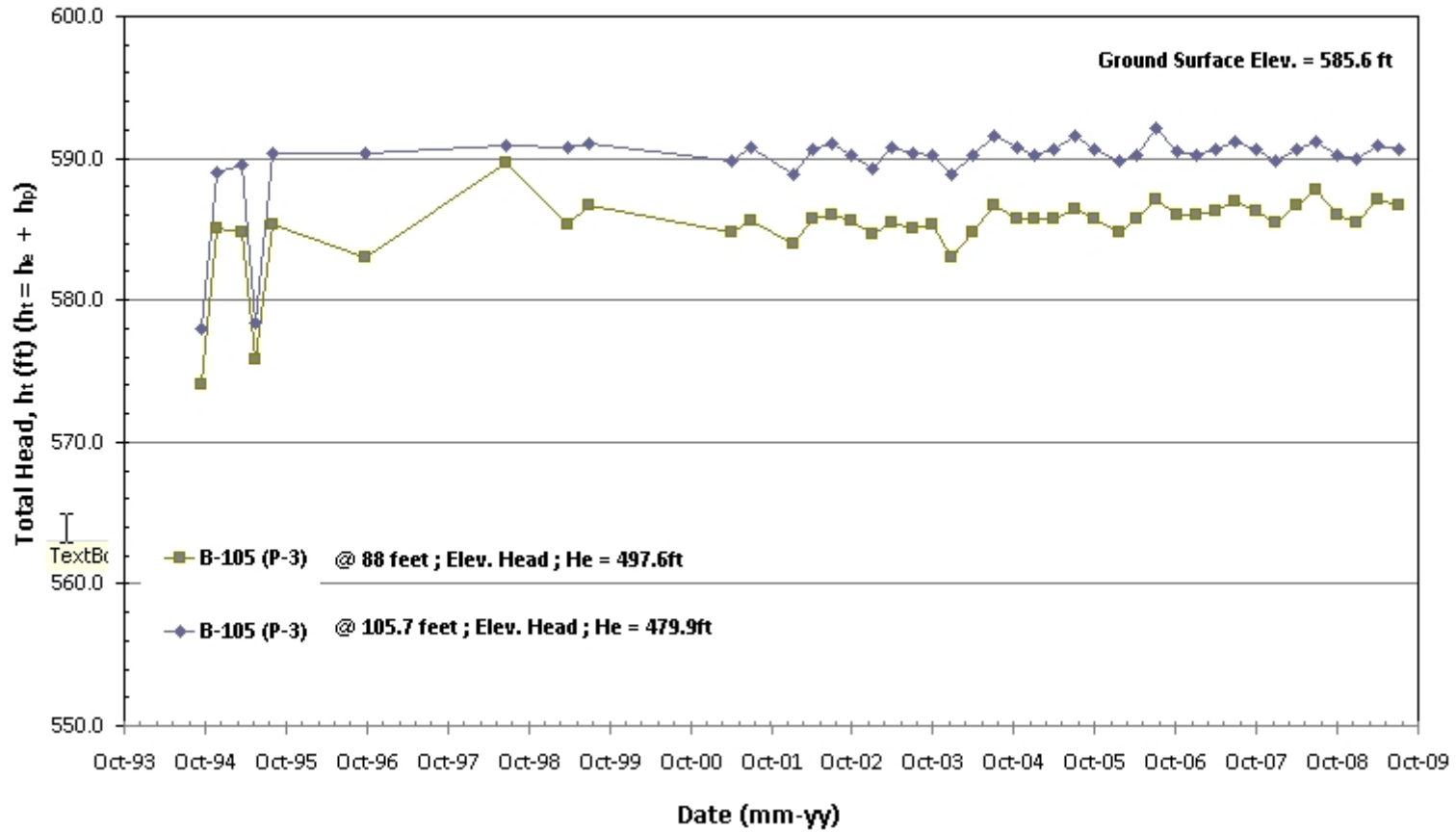

B-107 Pneumatic Piezometer Readings

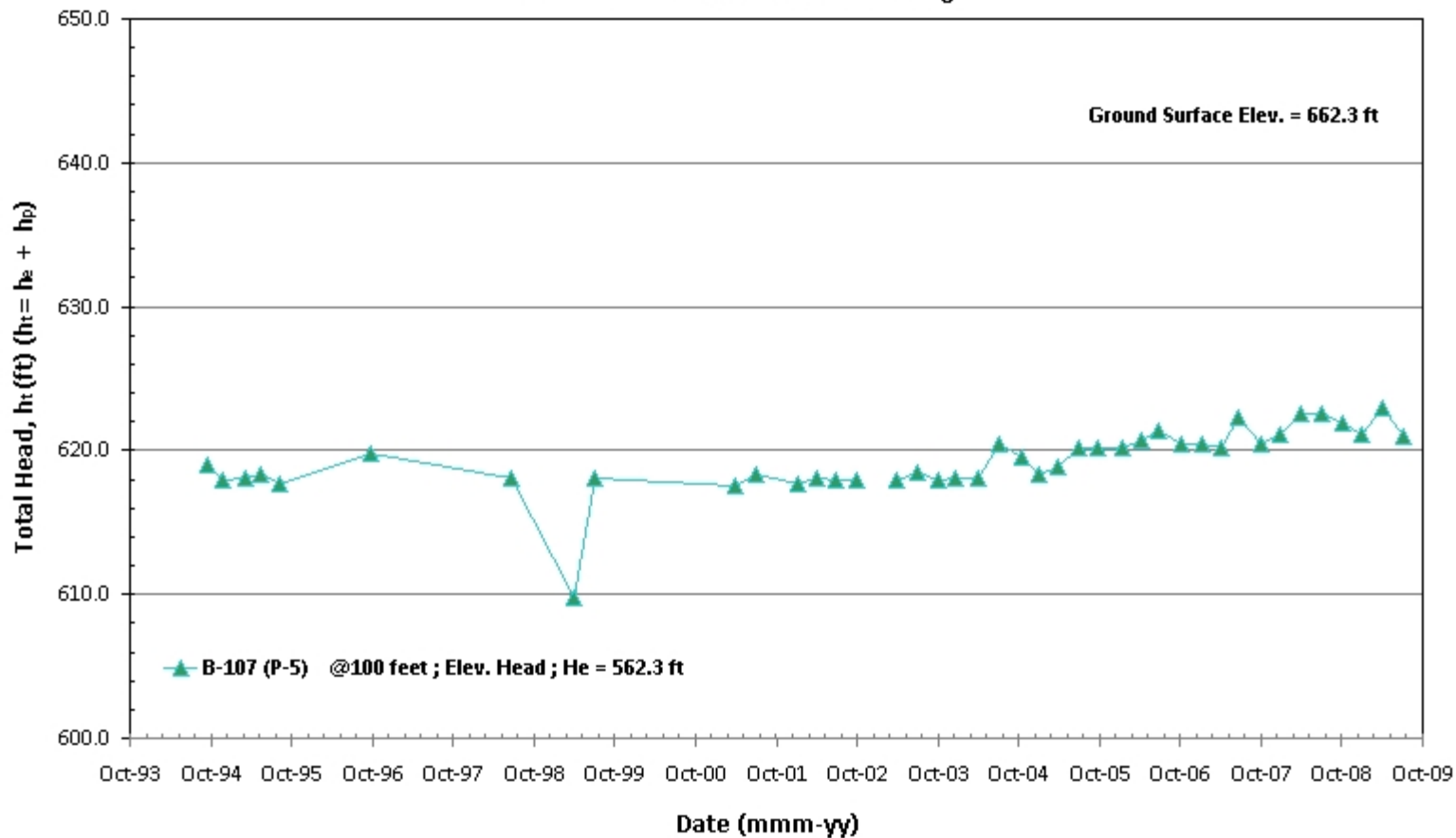

### B-303 Pneumatic Piezometer Readings

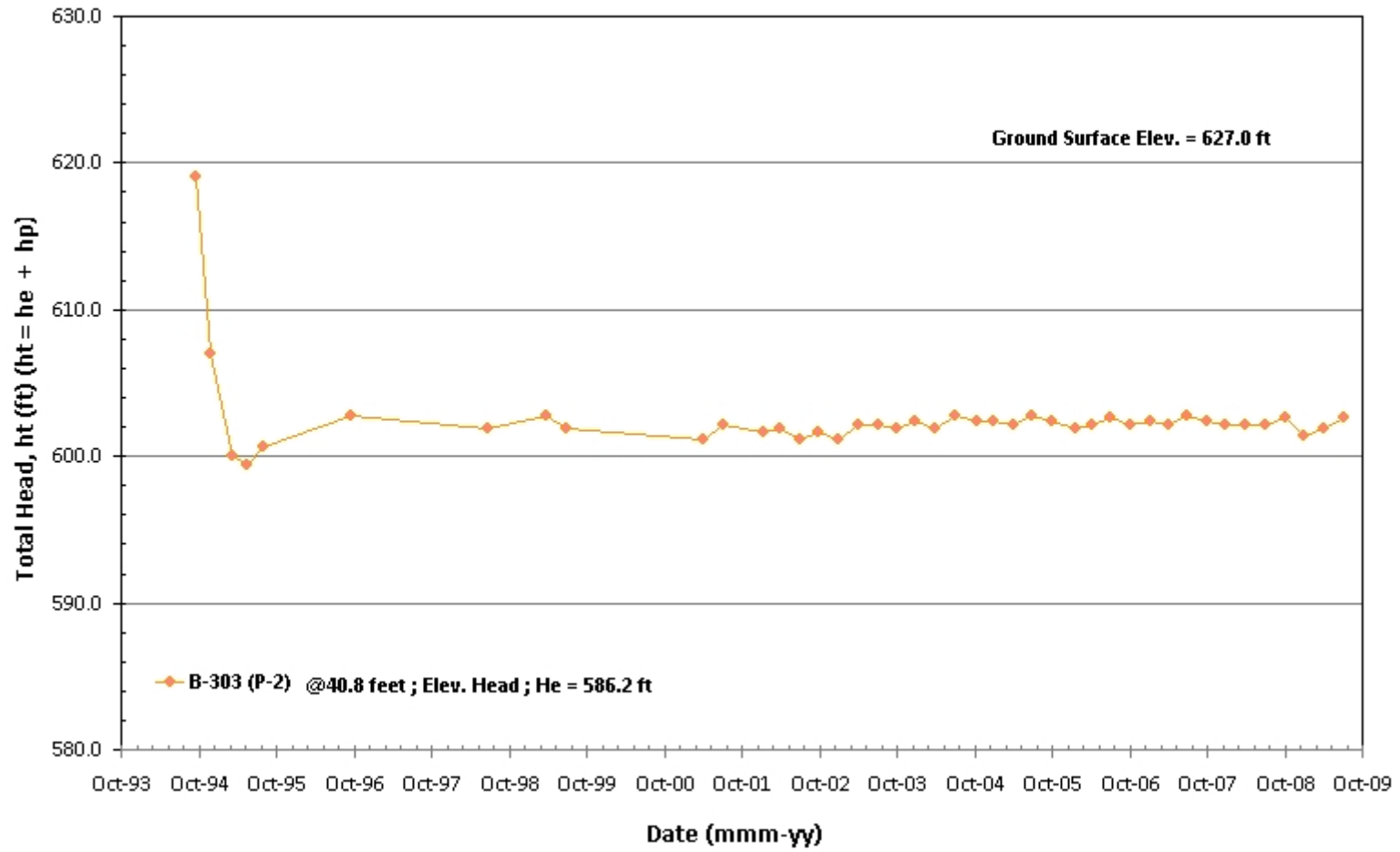

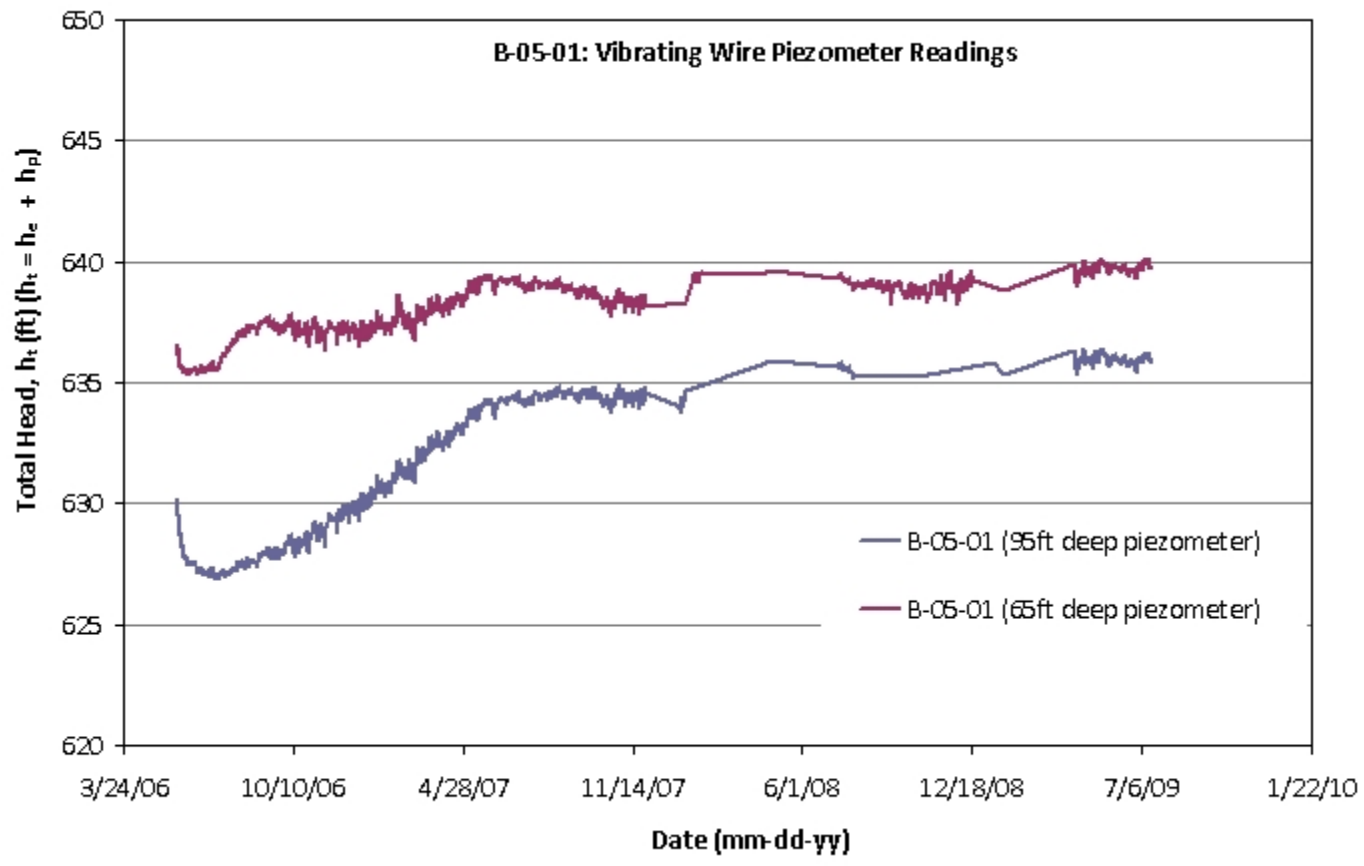

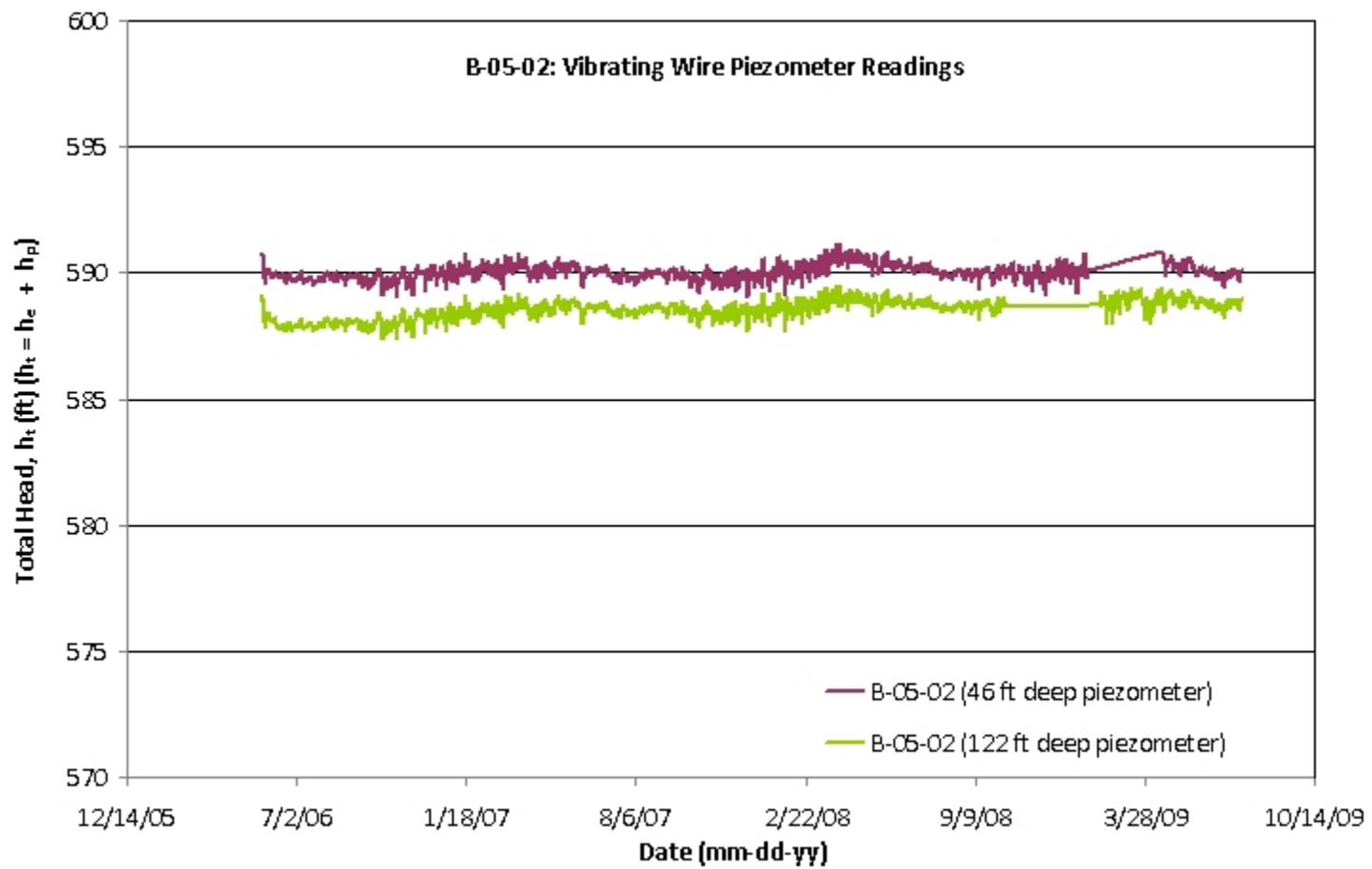

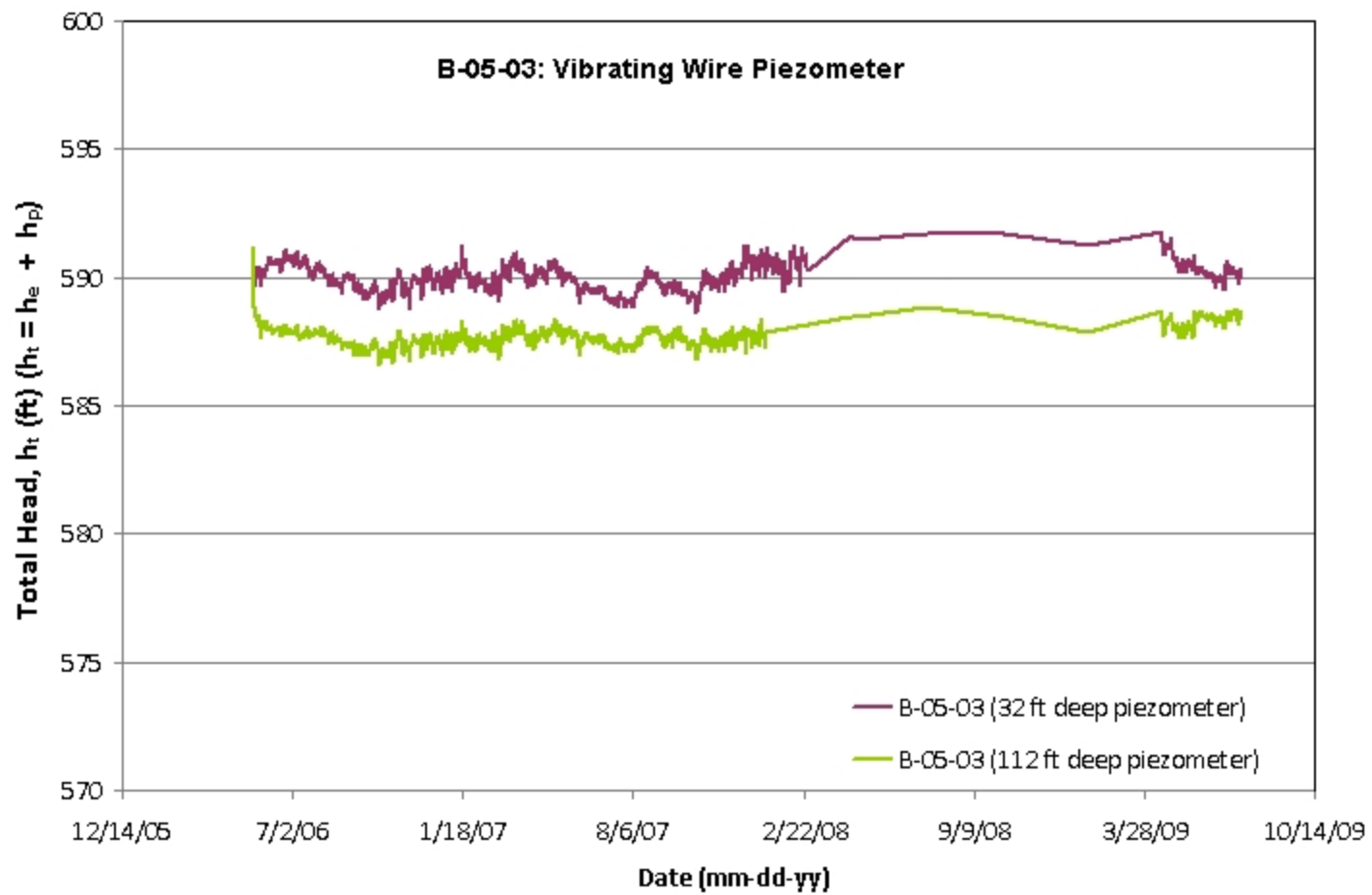

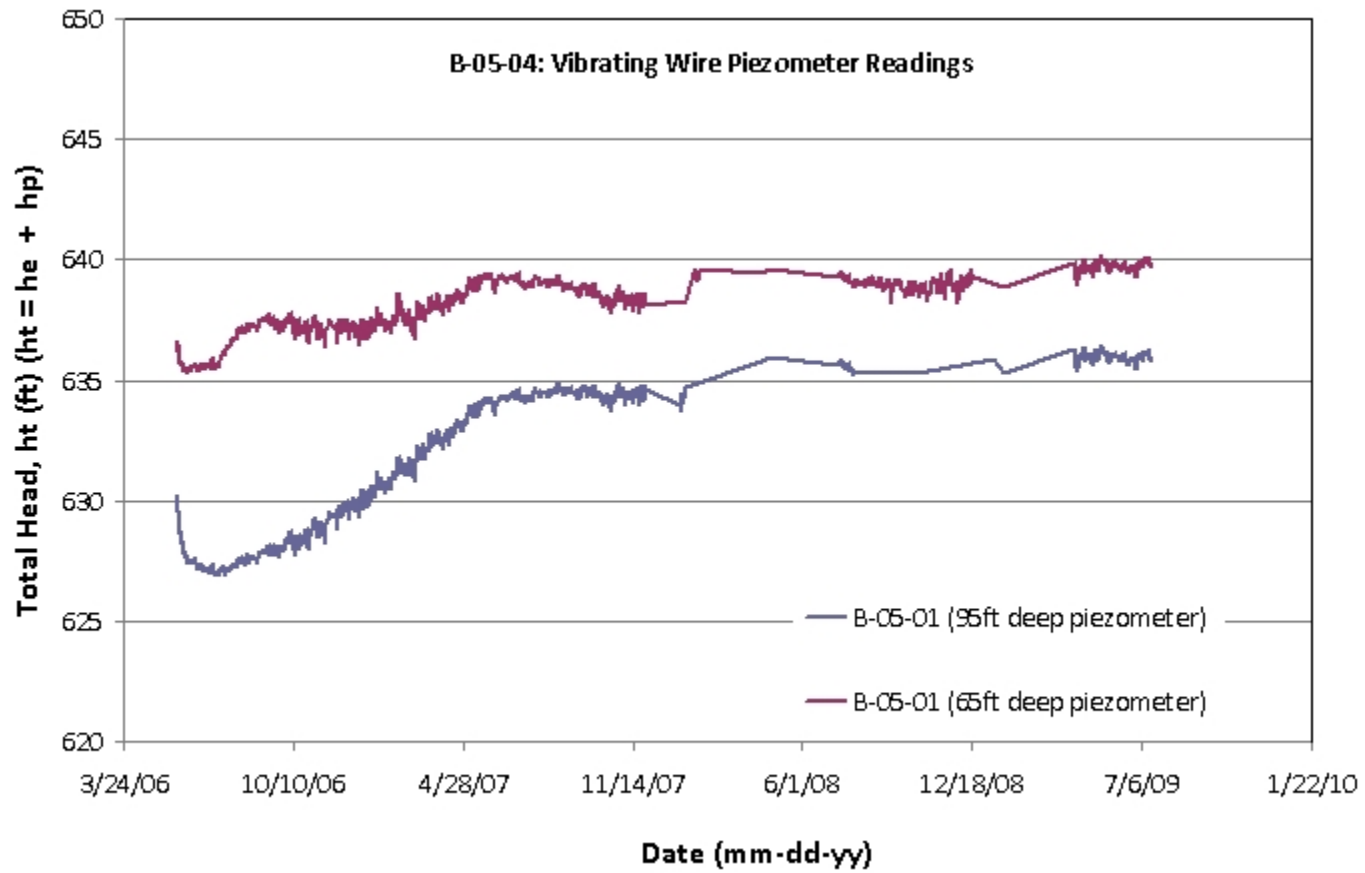

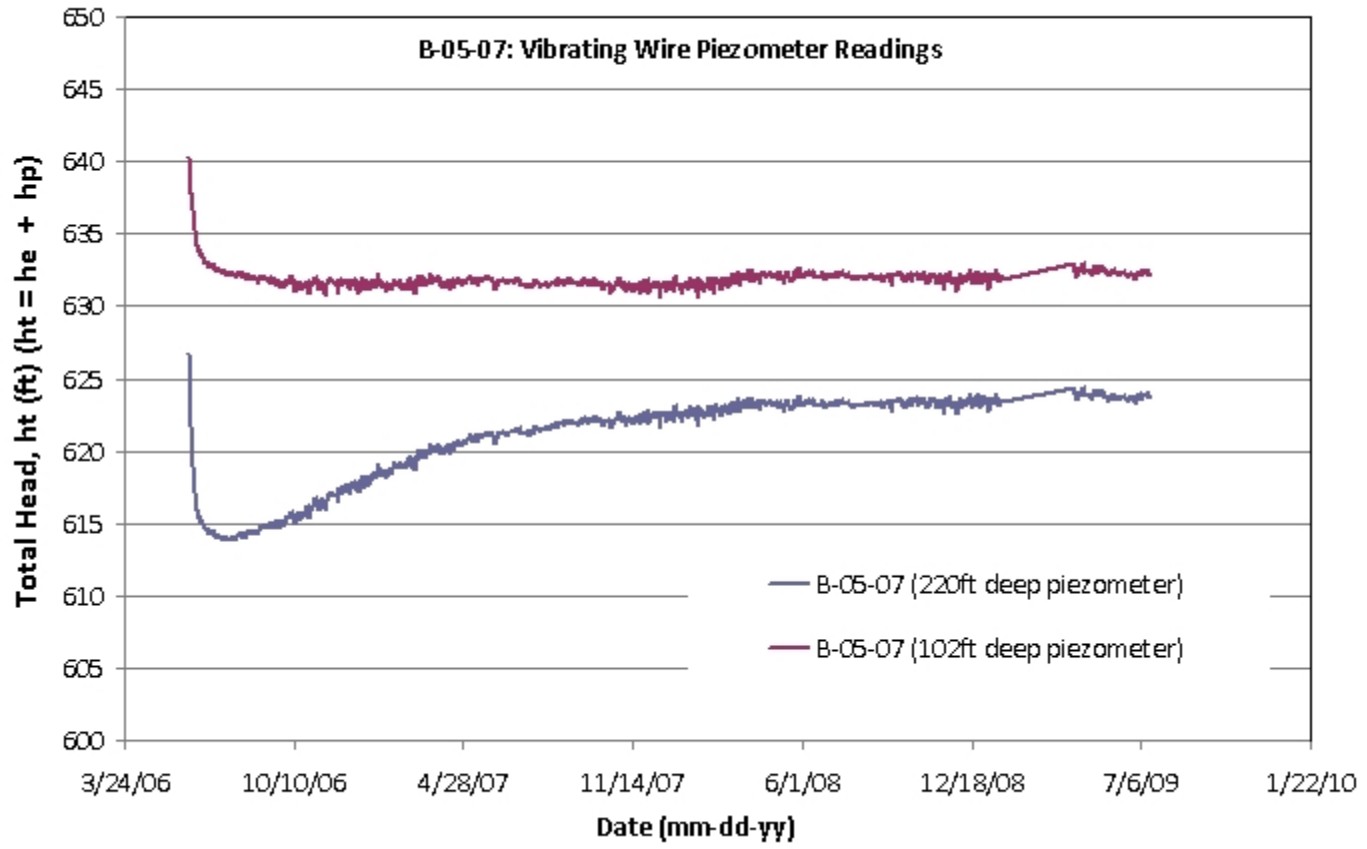



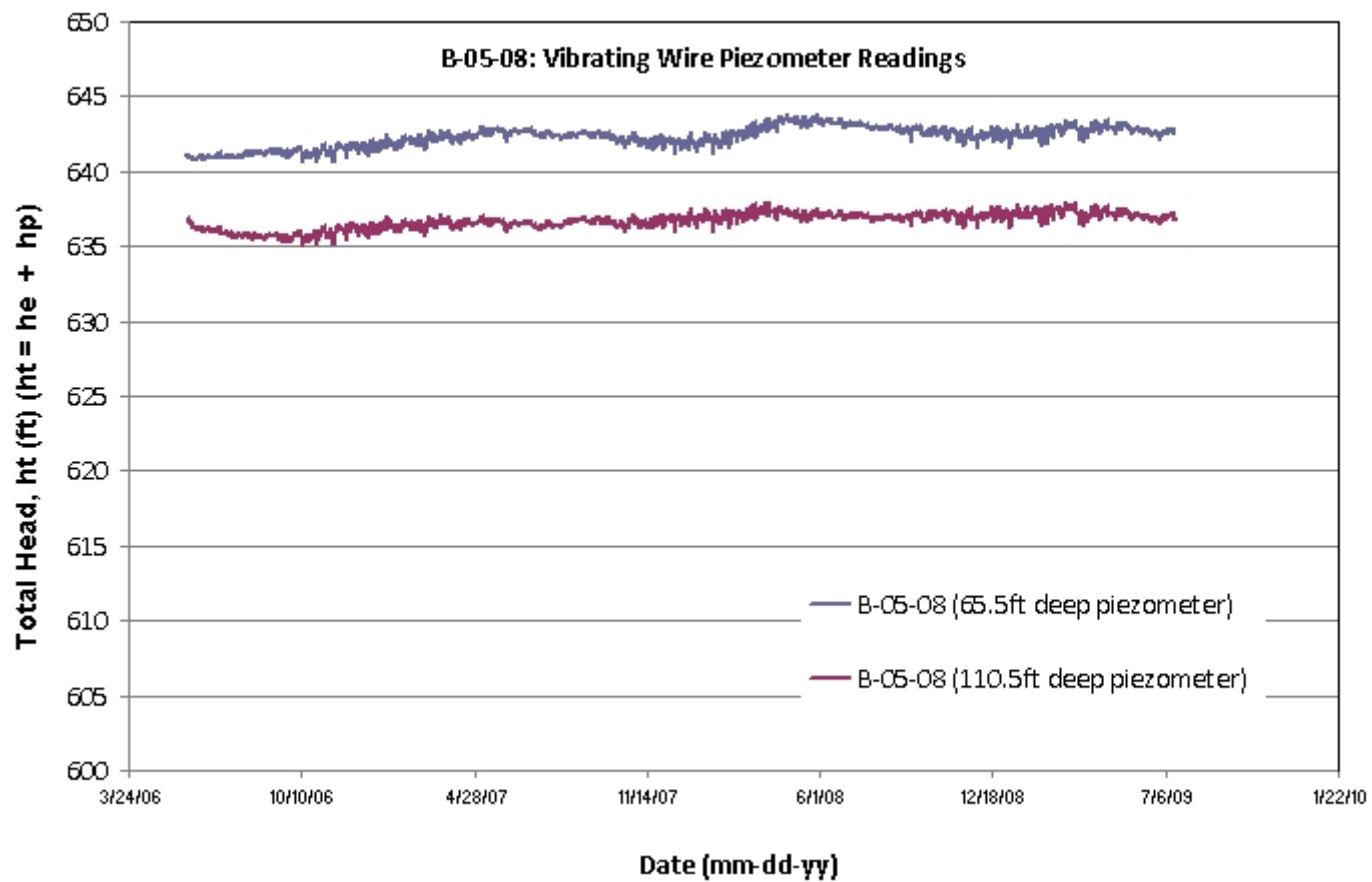

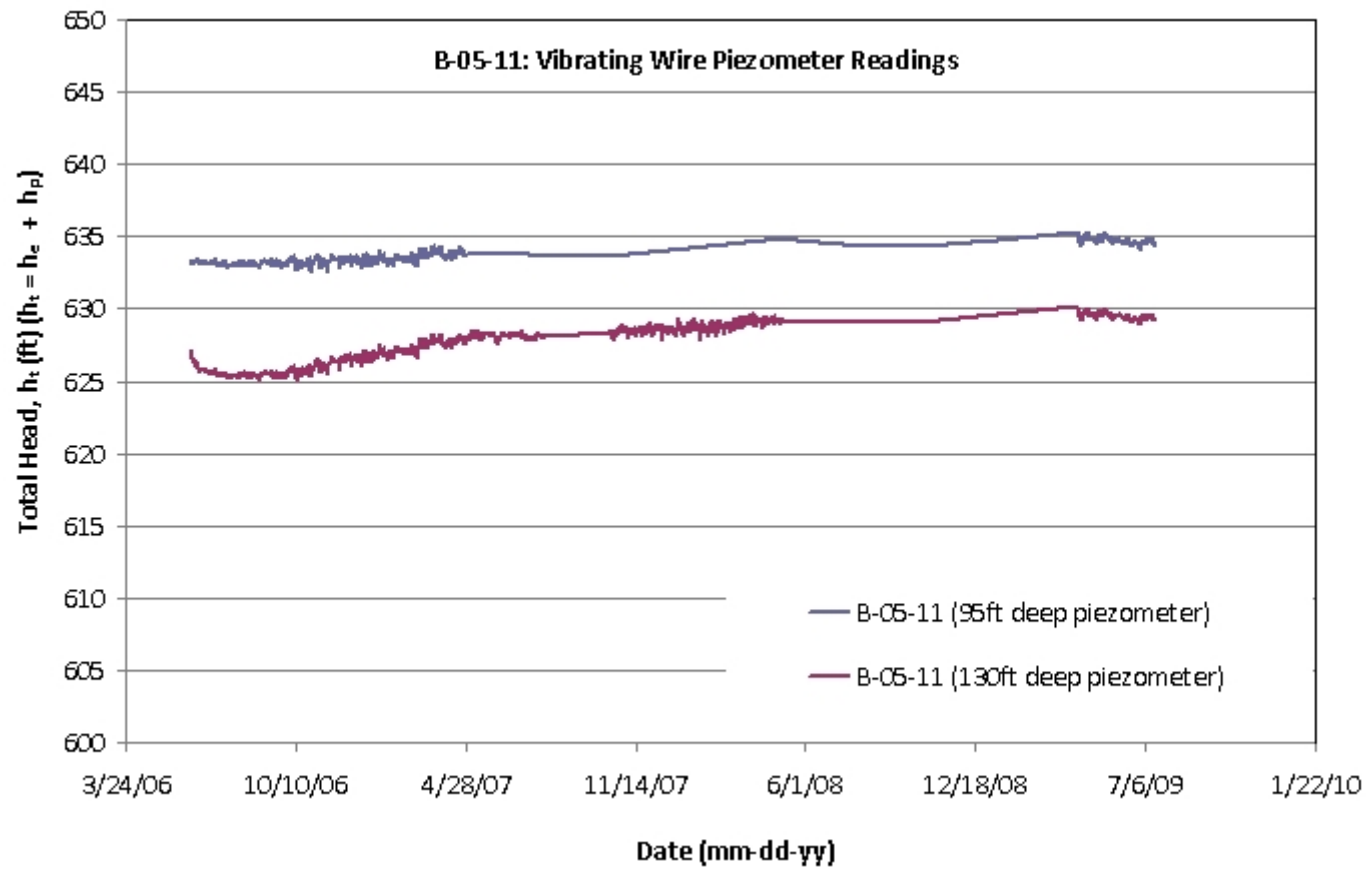

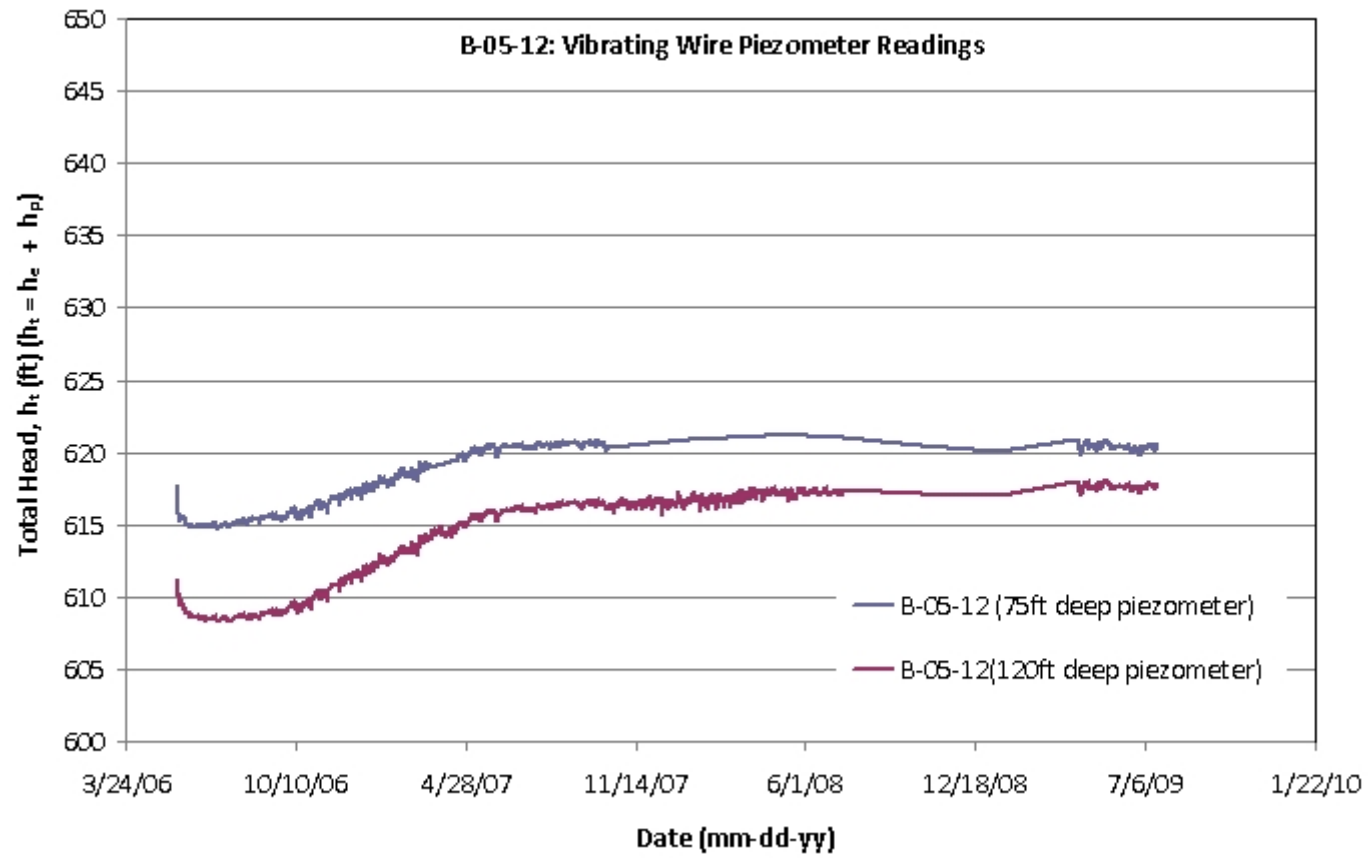

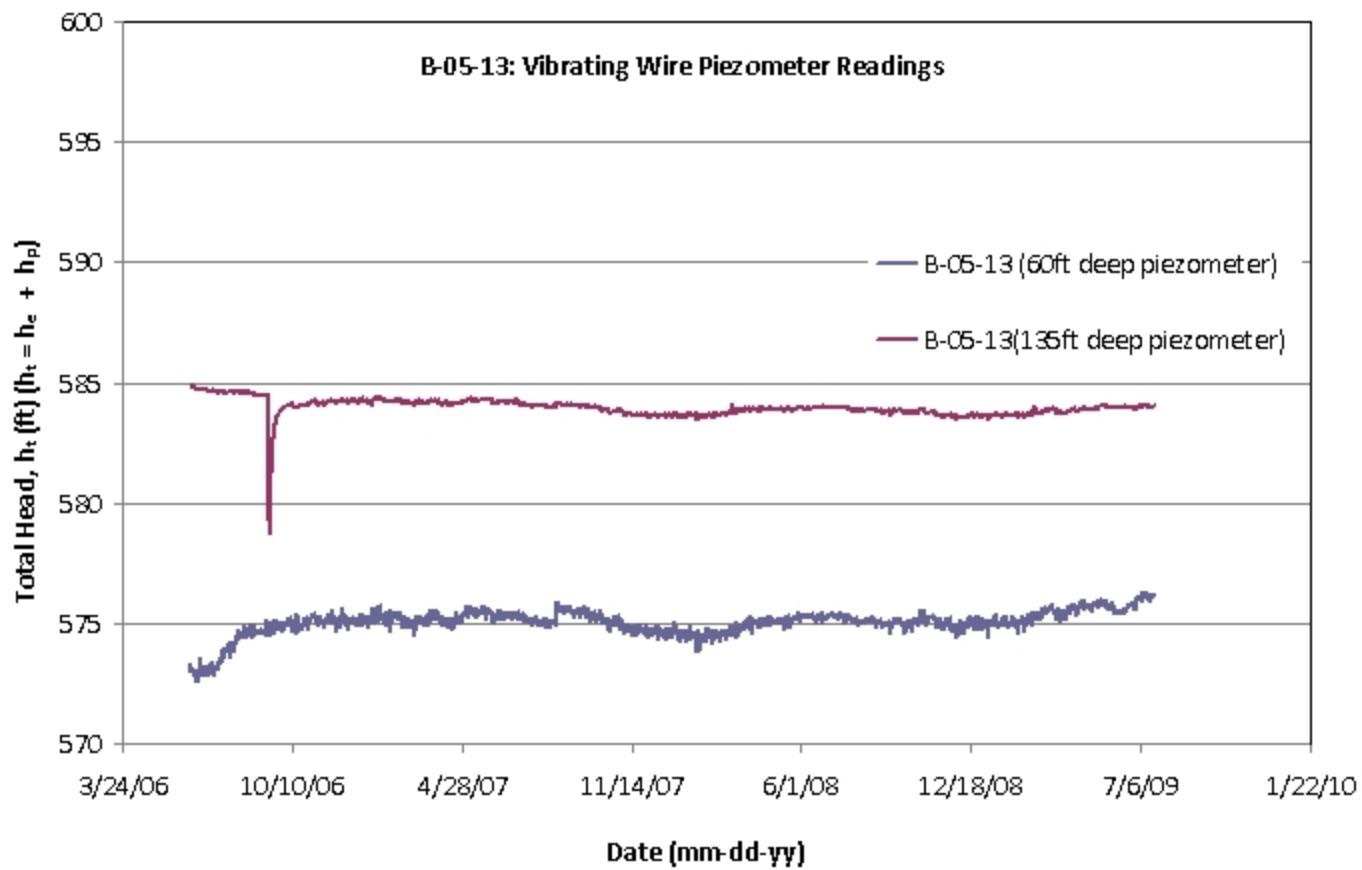

**APPENDIX 5C**

**DRILLED SHAFTS CONSTRUCTION RECORD**

## INSPECTION RECORD FOR DRILLED SHAFTS

|  |   |                 |   |  |           |           |
|--|---|-----------------|---|--|-----------|-----------|
| Project Number<br>457-97                                 | Drilling Contractor<br><br>Agra Foundations |                 | Type and Model of Drilling Machinery<br>CMV TH18-50 Crawler Hydraulic Piling Rig          | Bid Price Above Bedrock (\$/ft)<br>713               |           |           |
| Bridge Number<br>CUY-90-15.24                            |   |                 | Max. Continuous Torque (ft-lbs)<br>132,752 @ 7.4 RPM                                      | Bid Price in Bedrock Socket (\$/ft)<br>1620          |           |           |
| Structure File Number<br>1809393                         | Project Engineer<br><br>Kirk M. Gegick, PE  |                 | CROWD (max. Cont. Downward Force (lbs)<br>44,805 (Which is Equal To The Extraction Force) | Type of Slurry Used<br>KB Technologies' "Slurry Pro" |           |           |
|  |   |                 | Type of Bedrock<br>Soft to Medium Hard Shale  |  |           |           |
| DRILLED SHAFT NUMBER                                     |   |                 | 9   | 11   | 13        | 15        |
| DATE & TIME OF DRILLING                                  | STARTED                                     | DATE            | 10/30/98  | 9/23/98  | 11/4/98   | 10/22/98  |
|  |   | TIME            | 3:30 PM   | 8:30 AM  | 11:00 AM  | 1:30 PM   |
|  | FINISHED                                    | DATE            | 11/19/98  | 9/30/98  | 11/6/98   | 10/30/98  |
|  |   | TIME            | 5:30 PM   | 3:30 PM  | 11:30 AM  | 1:30 PM   |
| APPROXIMATE ELEVATION OF TOP OF OVERBURDEN               |   |                 | 586.00  | 586.00   | 586.00    | 586.00    |
| LENGTH OF DRILLED SHAFTS ABOVE THE BEDROCK SOCKET        | THROUGH AIR (FT)                            |                 | N/A   | N/A  | N/A       | N/A       |
|  | THROUGH OVERBURDEN (FT)                     |                 | 143.00  | 140.50   | 144.00    | 144.50    |
|  | PAY LENGTH (FT)                             |                 | 143.00  | 140.50   | 144.00    | 144.50    |
| OBSTRUCTIONS ENCOUNTERED                                 | NUMBER                                      |                 | 1   | 3  | 0         | 4         |
|  | SIZE (IN)                                   |                 | See Below   | See Below  | N/A       | See Below |
|  | TIME OF REMOVAL (HR)                        |                 | See Below   | See Below  | N/A       | See Below |
| LENGTH OF DRILLED SHAFTS IN BEDROCK SOCKET               | ELEV., TOP OF BEDROCK SOCKET                |                 | 443.00  | 442.50   | 442.00    | 441.50    |
|  | ELEV., BOTTOM OF BEDROCK                    |                 | 437.00  | 436.50   | 436.00    | 435.50    |
|  | LENGTH OF BEDROCK SOCKET                    |                 | 6   | 9  | 6         | 6         |
| STEEL CASING   | CASING THICKNESS (IN)                       |                 | 5/8   | 5/8  | 5/8       | 5/8       |
|  | CASING LEFT IN PLACE (FT)                   |                 | 0   | 0  | 0         | 0         |
| REINFORCING STEEL  | VERTICAL                                    | BAR SIZE-NUMBER | #11   | #11  | #11       | #11       |
|  |   | NUMBER OF REBAR | 24  | 24   | 24        | 24        |
|  | SPIRAL                                      | BAR SIZE-NUMBER | #4  | #4   | #4        | #4        |
|  |   | PITCH (IN)      | 4.5   | 4.5  | 4.5       | 4.5       |
| CONCRETE   | SLUMP (IN)                                  |                 | 7-9   | 7-9  | 7-9       | 7-9       |
|  | CYLINDER STRENGTH (PSI)                     |                 | 6790/6960   | 6530/6620  | 4970/4780 | 7880/7730 |
|  | AIR TEMPERATURE                             |                 | 50/36   | 72/45  | 51/45     | 47/36     |
|  | DATE PLACED                                 |                 | 11/23/98  | 10/2/98  | 11/10/98  | 11/3/98   |
|  | QUANTITY (CY)                               |                 | 214   | 196  | 198       | 200       |
| TOLERANCES   | LATERAL DEVIATION                           | N-S (FT)        | 0.29-N  | 0.83-N   | 0.03-N    | 0.52-N    |
|  |   | E-W (FT)        | 0.65-W  | 0.17-W   | 0.07-E    | 0.25-W    |
| PLAN SHAFT DIAMETER ABOVE/BELOW BEDROCK SOCKET (IN)      |   |                 | 72/66   | 72/66  | 72/66     | 72/66     |
| ACTUAL DIAMETER ABOVE/BELOW BEDROCK SOCKET (IN)          |   |                 | 72/72   | 72/72  | 72/72     | 72/72     |
| PROJECT ENGINEER'S COMMENTS: See Obstruction Table Below |   |                 |   |  |           |           |
| Drilled Shaft #  | Date  | Time            | Type  |  |           | Depth     |
| 9  | 11/2 - 11/19                                | 4 pm - 5:30pm   | H-Pile  |  |           | 48'       |
| 11   | 9/23  | 8:30am - 1:30pm | Timber  |  |           | 18'       |
| 11   | 9/23 - 9/24                                 | 5 pm - 2 pm     | H-Pile (Stub) #1  |  |           | 50'       |
| 11   | 9/24 - 9/25                                 | 5 pm - 10 am    | H-Pile (Stub) #2  |  |           | 55'       |
| 15   | 10/22                                       | 2 pm - 4 pm     | Timber  |  |           | 18'       |
| 15   | 10/22 - 10/27                               | 4 pm - 5pm      | H-Pile #1   |  |           | 52'       |
| 15   | 10/27 - 10/28                               | 5 pm - 2 pm     | H-Pile #2   |  |           | 60'       |
| 15   | 10/28 - 10/29                               | 2 pm - 5 pm     | H-Pile #3   |  |           | 69'       |

### INSPECTION RECORD FOR DRILLED SHAFTS

|   |   |   |  |           |           |           |
|---|---|---|--|-----------|-----------|-----------|
| Project Number<br>457-97                                  | Drilling Contractor<br>Agra Foundations | Type and Model of Drilling Machinery<br>CMV TH18-50 Crawler Hydraulic Piling Rig          | Bid Price Above Bedrock (\$/ft)<br>713               |           |           |           |
| Bridge Number<br>CUY-90-15.24                             |   | Max. Continuous Torque (ft-lbs)<br>132,752 @ 7.4 RPM                                      | Bid Price in Bedrock Socket (\$/ft)<br>1620          |           |           |           |
| Structure File Number<br>1809393                          | Project Engineer<br>Kirk M. Gegick, PE  | CROWD (max. Cont. Downward Force (lbs)<br>44,805 (Which is Equal To The Extraction Force) | Type of Slurry Used<br>KB Technologies' "Slurry Pro" |           |           |           |
|   |   | Type of Bedrock<br>Soft to Medium Hard Shale  |  |           |           |           |
| DRILLED SHAFT NUMBER                                      |   | 1   | 3  | 5         | 7         |           |
| DATE & TIME OF DRILLING                                   | STARTED                                 | DATE  | 9/9/98   | 11/9/98   | 10/30/98  | 10/19/98  |
|   |   | TIME  | 9:00 AM  | 9:30 AM   | 1:30 PM   | 3:00 PM   |
|   | FINISHED                                | DATE  | 10/13/98   | 11/12/98  | 11/4/98   | 10/22/98  |
|   |   | TIME  | 5:00 PM  | 9:00 AM   | 11:00 AM  | 1:30 PM   |
| APPROXIMATE ELEVATION OF TOP OF OVERBURDEN                |   | 586.00  | 586.00   | 586.00    | 586.00    |           |
| LENGTH OF DRILLED SHAFTS ABOVE THE BEDROCK SOCKET         | THROUGH AIR (FT)                        |   | N/A  | N/A       | N/A       | N/A       |
|   | THROUGH OVERBURDEN (FT)                 |   | 140.00   | 141.50    | 143.00    | 142.50    |
|   | PAY LENGTH (FT)                         |   | 140.00   | 141.50    | 143.00    | 142.50    |
| OBSTRUCTIONS ENCOUNTERED                                  | NUMBER                                  |   | 1  | 2         | 2         | 2         |
|   | SIZE (IN)                               |   | See Below  | See Below | See Below | See Below |
|   | TIME OF REMOVAL (HR)                    |   | See Below  | See Below | See Below | See Below |
| LENGTH OF DRILLED SHAFTS IN BEDROCK SOCKET                | ELEV., TOP OF BEDROCK SOCKET            |   | 446.00   | 444.50    | 443.00    | 443.50    |
|   | ELEV., BOTTOM OF BEDROCK                |   | 439.00   | 438.50    | 437.00    | 437.50    |
|   | LENGTH OF BEDROCK SOCKET                |   | 7  | 6         | 6         | 6         |
| STEEL CASING  | CASING THICKNESS (IN)                   |   | 5/8  | 5/8       | 5/8       | 5/8       |
|   | CASING LEFT IN PLACE (FT)               |   | 0  | 0         | 0         | 0         |
| REINFORCING STEEL   | VERTICAL                                | BAR SIZE-NUMBER   | #11  | #11       | #11       | #11       |
|   |   | NUMBER OF REBAR   | 24   | 24        | 24        | 24        |
|   | SPIRAL                                  | BAR SIZE-NUMBER   | #4   | #4        | #4        | #4        |
|   |   | PITCH (IN)  | 4.5  | 4.5       | 4.5       | 4.5       |
| CONCRETE  | SLUMP (IN)                              |   | 7-9  | 7-9       | 7-9       | 7-9       |
|   | CYLINDER STRENGTH (PSI)                 |   | 4390/5190  | 6700/6580 | 6290/6360 | 5906/5900 |
|   | AIR TEMPERATURE                         |   | 64/46  | 48/34     | 52/46     | 65/45     |
|   | DATE PLACED                             |   | 10/15/98   | 11/13/98  | 11/6/98   | 10/27/98  |
|   | QUANTITY (CY)                           |   | 205  | 189       | 202       | 187       |
| TOLERANCES  | LATERAL DEVIATION                       | N-S (FT)  | 0.50-N   | 0.02-N    | 0.42-N    | 0.24-N    |
|   |   | E-W (FT)  | 0.50-W   | 0.30-E    | 0.24-W    | 0.60-W    |
| PLAN SHAFT DIAMETER ABOVE/BELOW BEDROCK SOCKET (IN)       |   | 72/66   | 72/66  | 72/66     | 72/66     |           |
| ACTUAL DIAMETER ABOVE/BELOW BEDROCK SOCKET (IN)           |   | 72/72   | 72/72  | 72/72     | 72/72     |           |
| PROJECT ENGINEER'S COMMENTS: See Obstruction Table Below. |   |   |  |           |           |           |
| Drilled Shaft #   | Date                                    | Time  | Type   |           | Depth     |           |
| 1   | 9/9 - 10/8                              | 3 pm - 5:30pm   | H-Pile   |           | 48'       |           |
| 3   | 11/9                                    | 9:30am - 3 pm   | Timber   |           | 12'       |           |
| 3   | 11/9 - 11/11                            | 4 pm - 4:30 pm  | H-Pile   |           | 54'       |           |
| 5   | 10/30 - 11/2                            | 4 pm - 9 am   | Timber   |           | 16'       |           |
| 5   | 11/2                                    | 9 am - 4 pm   | H-Pile   |           | 54'       |           |
| 7   | 10/19 - 10/20                           | 4 pm - 11 am  | Timber   |           | 17'       |           |
| 7   | 10/20 - 10/21                           | 11 am - 11:30 am  | H-Pile x2  |           | 42'       |           |

## INSPECTION RECORD FOR DRILLED SHAFTS

|   |   |   |  |       |
|---|---|---|--|-------|
| Project Number<br>457-97                                  | Drilling Contractor<br><br>Agra Foundations | Type and Model of Drilling Machinery<br>CMV TH18-50 Crawler Hydraulic Piling Rig              | Bid Price Above Bedrock (\$/ft)<br>713               |       |
| Bridge Number<br>CUY-90-15.24                             |   | Max. Continuous Torque (ft-lbs)<br>132,752 @ 7.4 RPM  | Bid Price in Bedrock Socket (\$/ft)<br>1620          |       |
| Structure File Number<br>1809393                          | Project Engineer<br>Kirk M. Gegick, PE      | CROWD (max. Cont. Downward Force (lbs)<br><br>44,805 (Which is Equal To The Extraction Force) | Type of Shurry Used<br>KB Technologies' "Shurry Pro" |       |
|   |   |   | Type of Bedrock<br>Soft to Medium Hard Shale         |       |
| DRILLED SHAFT NUMBER                                      |   | 17  |  |       |
| DATE & TIME OF DRILLING                                   | STARTED                                     | DATE  | 11/20/98   |       |
|   |   | TIME  | 7:00 am  |       |
|   | FINISHED                                    | DATE  | 11/23/98   |       |
|   |   | TIME  | 5:30 pm  |       |
| APPROXIMATE ELEVATION OF TOP OF OVERBURDEN                |   | 586.00  |  |       |
| LENGTH OF DRILLED SHAFTS ABOVE THE BEDROCK SOCKET         | THROUGH AIR (FT)                            | N/A   |  |       |
|   | THROUGH OVERBURDEN (FT)                     | 145.00  |  |       |
|   | PAY LENGTH (FT)                             | 145.00  |  |       |
| OBSTRUCTIONS ENCOUNTERED                                  | NUMBER                                      | 2   |  |       |
|   | SIZE (IN)                                   | See Below   |  |       |
|   | TIME OF REMOVAL (HR)                        | See Below   |  |       |
| LENGTH OF DRILLED SHAFTS IN BEDROCK SOCKET                | ELEV., TOP OF BEDROCK SOCKET                | 441.00  |  |       |
|   | ELEV., BOTTOM OF BEDROCK                    | 435.00  |  |       |
|   | LENGTH OF BEDROCK SOCKET                    | 6   |  |       |
| STEEL CASING  | CASING THICKNESS (IN)                       | 5/8   |  |       |
|   | CASING LEFT IN PLACE (FT)                   | 0   |  |       |
| REINFORCING STEEL   | VERTICAL                                    | BAR SIZE-NUMBER   | #11  |       |
|   |   | NUMBER OF REBAR   | 24   |       |
|   | SPIRAL                                      | BAR SIZE-NUMBER   | #4   |       |
|   |   | PITCH (IN)  | 4.5  |       |
| CONCRETE  | SLUMP (IN)                                  | 7-9   |  |       |
|   | CYLINDER STRENGTH (PSI)                     | 5760/5790   |  |       |
|   | AIR TEMPERATURE                             | 54/40   |  |       |
|   | DATE PLACED                                 | 11/25/98  |  |       |
|   | QUANTITY (CY)                               | 186   |  |       |
| TOLERANCES  | LATERAL DEVIATION                           | N-S (FT)  | 0.7-N  |       |
|   |   | E-W (FT)  | 0.42-E   |       |
| PLAN SHAFT DIAMETER ABOVE/BELOW BEDROCK SOCKET (IN)       |   | 72/66   |  |       |
| ACTUAL DIAMETER ABOVE/BELOW BEDROCK SOCKET (IN)           |   | 72/72   |  |       |
| PROJECT ENGINEER'S COMMENTS: See Obstruction Table Below. |   |   |  |       |
| Drilled Shaft #   | Date  | Time  | Type   | Depth |
| 17  | 11/20                                       | 8 am - 1 pm   | Timber   | 6'    |
| 17  | 11/20 - 11/21                               | 1:30 pm - 9:30 am   | H-Pile   | 48'   |



## INSPECTION RECORD FOR DRILLED SHAFTS

|   |   |   |  |           |           |           |
|---|---|---|--|-----------|-----------|-----------|
| Project Number<br>457-97                                  | Drilling Contractor<br><br>Agra Foundations | Type and Model of Drilling Machinery<br>CMV TH18-50 Crawler Hydraulic Piling Rig              | Bid Price Above Bedrock (\$/ft)<br>713               |           |           |           |
| Bridge Number<br>CUY-90-15.24                             |   | Max. Continuous Torque (ft-lbs)<br>132,752 @ 7.4 RPM  | Bid Price in Bedrock Socket (\$/ft)<br>1620          |           |           |           |
| Structure File Number<br>1809393                          | Project Engineer<br>Kirk M. Gegick, PE      | CROWD (max. Cont. Downward Force (lbs)<br><br>44,805 (Which is Equal To The Extraction Force) | Type of Slurry Used<br>KB Technologies' "Slurry Pro" |           |           |           |
|   |   |   | Type of Bedrock<br>Soft to Medium Hard Shale         |           |           |           |
| DRILLED SHAFT NUMBER                                      |   |   | 2  | 4         | 6         | 8         |
| DATE & TIME OF DRILLING                                   | STARTED                                     | DATE  | 8/20/98  | 8/3/98    | 9/17/98   | 8/24/98   |
|   |   | TIME  | 10:00 AM   | 11:30 AM  | 1:30 PM   | 12:00 PM  |
|   | FINISHED                                    | DATE  | 8/27/98  | 8/13/98   | 9/22/98   | 9/8/98    |
|   |   | TIME  | 10:30 AM   | 9:00 AM   | 6:30 PM   | 5:30 PM   |
| APPROXIMATE ELEVATION OF TOP OF OVERBURDEN                |   |   | 586.00   | 586.00    | 586.00    | 586.00    |
| LENGTH OF DRILLED SHAFTS ABOVE THE BEDROCK SOCKET         | THROUGH AIR (FT)                            |   | N/A  | N/A       | N/A       | N/A       |
|   | THROUGH OVERBURDEN (FT)                     |   | 133.80   | 141.75    | 142.25    | 142.75    |
|   | PAY LENGTH (FT)                             |   | 133.80   | 141.75    | 142.25    | 142.75    |
| OBSTRUCTIONS ENCOUNTERED                                  | NUMBER                                      |   | 2  | 0         | 1         | 2         |
|   | SIZE (IN)                                   |   | See Below  | N/A       | See Below | See Below |
|   | TIME OF REMOVAL (HR)                        |   | See Below  | N/A       | See Below | See Below |
| LENGTH OF DRILLED SHAFTS IN BEDROCK SOCKET                | ELEV., TOP OF BEDROCK SOCKET                |   | 452.20   | 444.25    | 443.75    | 443.25    |
|   | ELEV., BOTTOM OF BEDROCK                    |   | 443.00   | 438.25    | 437.75    | 437.25    |
|   | LENGTH OF BEDROCK SOCKET                    |   | 9.2  | 6         | 6         | 6         |
| STEEL CASING  | CASING THICKNESS (IN)                       |   | 5/8  | 5/8       | 5/8       | 5/8       |
|   | CASING LEFT IN PLACE (FT)                   |   | 0  | 0         | 0         | 0         |
| REINFORCING STEEL   | VERTICAL                                    | BAR SIZE-NUMBER   | #11  | #11       | #11       | #11       |
|   |   | NUMBER OF REBAR   | 24   | 24        | 24        | 24        |
|   | SPIRAL                                      | BAR SIZE-NUMBER   | #4   | #4        | #4        | #4        |
|   |   | PITCH (IN)  | 4.5  | 4.5       | 4.5       | 4.5       |
| CONCRETE  | SLUMP (IN)                                  |   | 7-9  | 7-9       | 7-9       | 7-9       |
|   | CYLINDER STRENGTH (PSI)                     |   | 5060/5110  | 5740/5950 | 5090/5300 | 4210/4070 |
|   | AIR TEMPERATURE                             |   | 84/66  | 80/67     | 69/45     | 65/50     |
|   | DATE PLACED                                 |   | 8/28/98  | 8/19/98   | 9/24/98   | 9/10/98   |
|   | QUANTITY (CY)                               |   | 180  | 202       | 185       | 180       |
| TOLERANCES  | LATERAL DEVIATION                           | N-S (FT)  | 0.28-N   | 0.05-N    | 1.16-N    | 1.24-N    |
|   |   | E-W (FT)  | 0.01-E   | 0.28-E    | 0.31-W    | 0.21-E    |
| PLAN SHAFT DIAMETER ABOVE/BELOW BEDROCK SOCKET (IN)       |   |   | 72/66  | 72/66     | 72/66     | 72/66     |
| ACTUAL DIAMETER ABOVE/BELOW BEDROCK SOCKET (IN)           |   |   | 72/72  | 72/72     | 72/72     | 72/72     |
| PROJECT ENGINEER'S COMMENTS: See Obstruction Table Below. |   |   |  |           |           |           |
| Drilled Shaft #   | Date  | Time  | Type   |           |           | Depth     |
| 2   | 8/21 - 8/24                                 | 1 pm - 9am  | H-Pile (Stub)  |           |           | 75'       |
| 2   | 8/24 - 8/25                                 | 11am - 1pm  | Methane  |           |           | 117'      |
| 6   | 9/18 - 9/21                                 | 1:30pm - 3:30pm   | H-Pile (Stub)  |           |           | 74'       |
| 8   | 8/24  | 1pm - 3pm   | Timber   |           |           | 15'       |
| 8   | 8/24 - 9/3                                  | 4pm - 3pm   | H-Pile (Stub)  |           |           | 65'       |

## INSPECTION RECORD FOR DRILLED SHAFTS

|  |   |                 |   |  |           |           |
|--|---|-----------------|---|--|-----------|-----------|
| Project Number<br>457-97                                 | Drilling Contractor<br><br>Agra Foundations |                 | Type and Model of Drilling Machinery<br>CMV TH18-50 Crawler Hydraulic Piling Rig              | Bid Price Above Bedrock (\$/ft)<br><br>713           |           |           |
| Bridge Number<br>CUY-90-15.24                            |   |                 | Max. Continuous Torque (ft-lbs)<br>132,752 @ 7.4 RPM  | Bid Price in Bedrock Socket (\$/ft)<br><br>1620      |           |           |
| Structure File Number<br>1809393                         | Project Engineer<br><br>Kirk M. Gegick, PE  |                 | CROWD (max. Cont. Downward Force (lbs)<br><br>44,805 (Which is Equal To The Extraction Force) | Type of Slurry Used<br>KB Technologies' "Slurry Pro" |           |           |
|  |   |                 |   | Type of Bedrock<br>Soft to Medium Hard Shale         |           |           |
| DRILLED SHAFT NUMBER                                     |   |                 | 10  | 12   | 14        | 16        |
| DATE & TIME OF DRILLING                                  | STARTED                                     | DATE            | 8/13/98   | 8/27/98  | 10/9/98   | 11/12/98  |
|  |   | TIME            | 10:00 am  | 2:00 pm  | 3:00 pm   | 2:00 pm   |
|  | FINISHED                                    | DATE            | 8/20/98   | 9/2/98   | 10/19/98  | 11/18/98  |
|  |   | TIME            | 9:00 am   | 5:30 pm  | 3:00 pm   | 5:30 pm   |
| APPROXIMATE ELEVATION OF TOP OF OVERBURDEN               |   |                 | 586.00  | 586.00   | 586.00    | 586.00    |
| LENGTH OF DRILLED SHAFTS ABOVE THE BEDROCK SOCKET        | THROUGH AIR (FT)                            |                 | N/A   | N/A  | N/A       | N/A       |
|  | THROUGH OVERBURDEN (FT)                     |                 | 143.25  | 143.75   | 144.25    | 144.75    |
|  | PAY LENGTH (FT)                             |                 | 143.25  | 143.75   | 144.25    | 144.75    |
| OBSTRUCTIONS ENCOUNTERED                                 | NUMBER                                      |                 | 0   | 0  | 2         | 2         |
|  | SIZE (IN)                                   |                 | N/A   | N/A  | See below | See below |
|  | TIME OF REMOVAL (HR)                        |                 | N/A   | N/A  | See below | See below |
| LENGTH OF DRILLED SHAFTS IN BEDROCK SOCKET               | ELEV., TOP OF BEDROCK SOCKET                |                 | 442.75  | 442.25   | 441.75    | 441.25    |
|  | ELEV., BOTTOM OF BEDROCK                    |                 | 436.75  | 436.25   | 435.75    | 435.25    |
|  | LENGTH OF BEDROCK SOCKET                    |                 | 6   | 6  | 6         | 6         |
| STEEL CASING   | CASING THICKNESS (IN)                       |                 | 5/8   | 5/8  | 5/8       | 5/8       |
|  | CASING LEFT IN PLACE (FT)                   |                 | 0   | 0  | 0         | 0         |
| REINFORCING STEEL  | VERTICAL                                    | BAR SIZE-NUMBER | #11   | #11  | #11       | #11       |
|  |   | NUMBER OF REBAR | 24  | 24   | 24        | 24        |
|  | SPIRAL                                      | BAR SIZE-NUMBER | #4  | #4   | #4        | #4        |
|  |   | PITCH (IN)      | 4.5   | 4.5  | 4.5       | 4.5       |
| CONCRETE   | SLUMP (IN)                                  |                 | 7-9   | 7-9  | 7-9       | 7-9       |
|  | CYLINDER STRENGTH (PSI)                     |                 | 6260/6590   | 5560/5780  | 6250/6190 | 4740/4730 |
|  | AIR TEMPERATURE                             |                 | 82/62   | 76/53  | 48/36     | 58/42     |
|  | DATE PLACED                                 |                 | 8/21/98   | 9/4/98   | 10/21/98  | 11/18/98  |
|  | QUANTITY (CY)                               |                 | 195   | 186  | 180       | 190       |
| TOLERANCES   | LATERAL DEVIATION                           | N-S (FT)        | 0.07-S  | 0.99-S   | 0.60-N    | 0.47-N    |
|  |   | E-W (FT)        | 0.01-W  | 0.25-W   | 0.02-E    | 0.26-W    |
| PLAN SHAFT DIAMETER ABOVE/BELOW BEDROCK SOCKET (IN)      |   |                 | 72/66   | 72/66  | 72/66     | 72/66     |
| ACTUAL DIAMETER ABOVE/BELOW BEDROCK SOCKET (IN)          |   |                 | 72/72   | 72/72  | 72/72     | 72/72     |
| PROJECT ENGINEER'S COMMENTS: See Obstruction Table Below |   |                 |   |  |           |           |
| Drilled Shaft #  | Date  | Time            | Type  |  |           | Depth     |
| 14   | 10/9 - 10/12                                | 4 pm - 9 am     | Timber  |  |           | 19'       |
| 14   | 10/12 - 10/16                               | 5 pm - 12 pm    | H-Pile  |  |           | 34'       |
| 16   | 11/13                                       | 8 am - 4 pm     | H-Pile #1   |  |           | 35'       |
| 16   | 11/13 - 11/14                               | 4 pm - 3 pm     | H-Pile #2   |  |           | 45'       |

ODOT PROJECT 457-97

Concrete Curves For Drilled Shaft #1  
Placed 10/15/98 - 205 CY

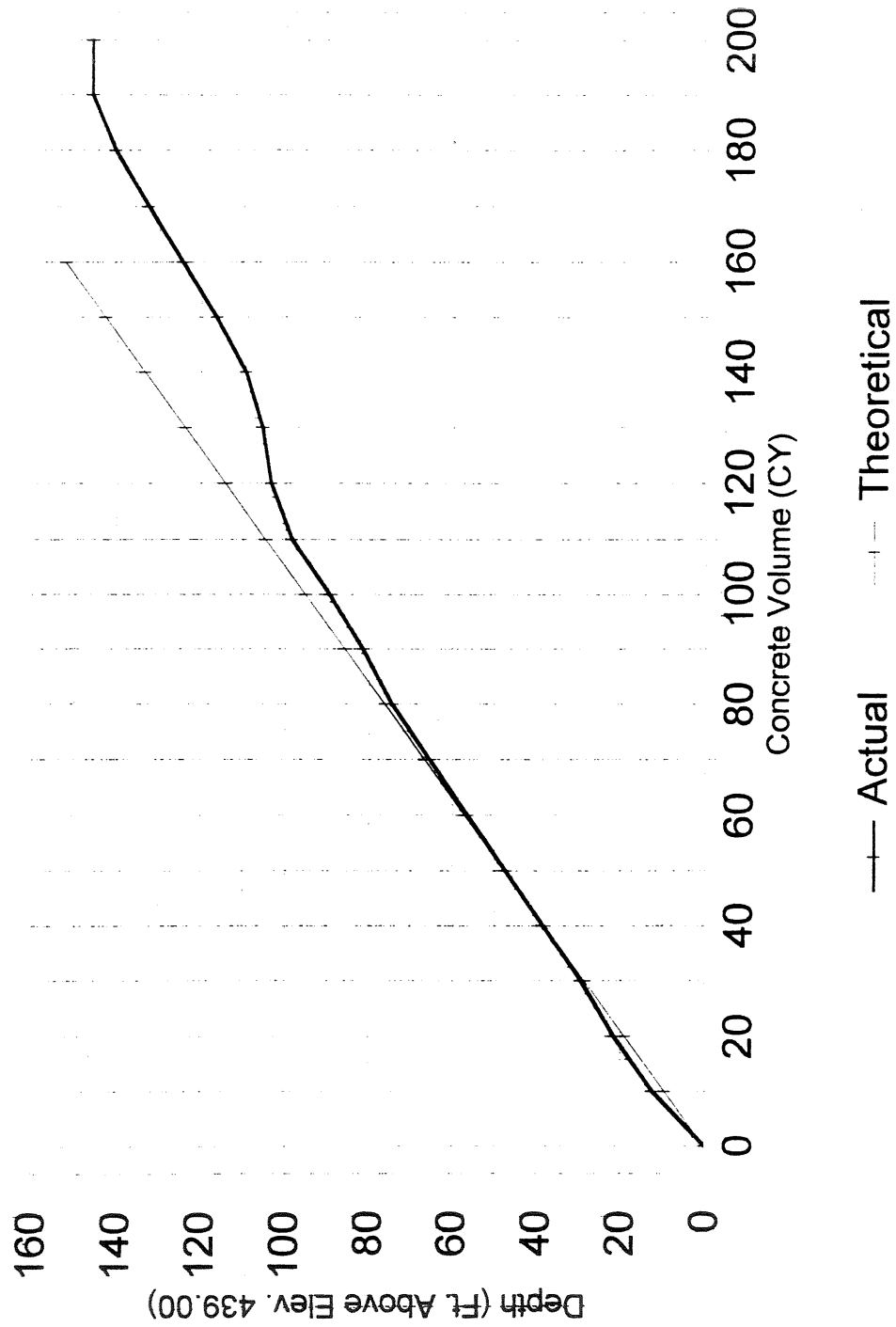

ODOT PROJECT 457-97

Concrete Curves For Drilled Shaft #2

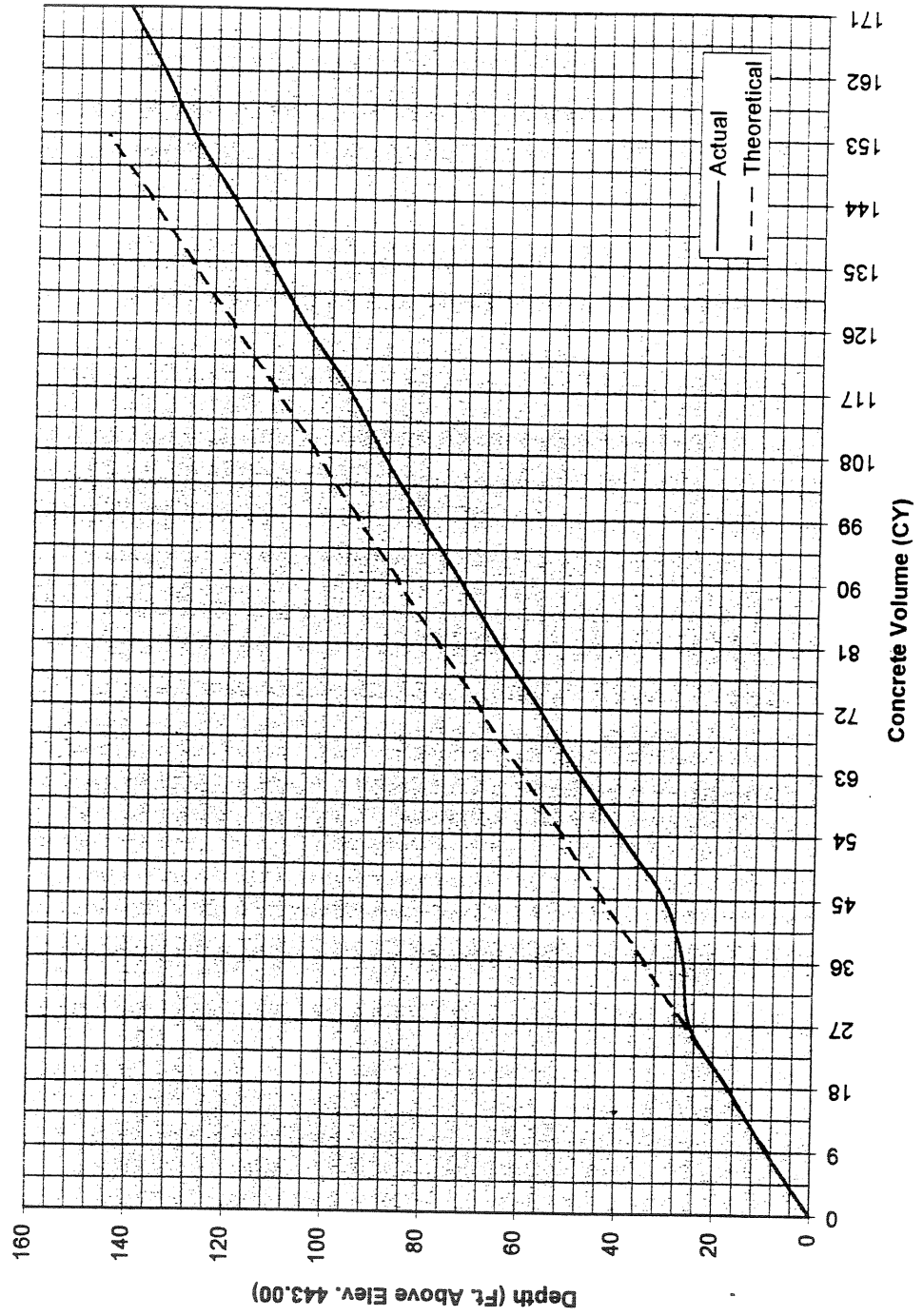

ODOT PROJECT 457-97

### Concrete Curves For Drilled Shaft #3

Placed 11/13/98 - 189 CY

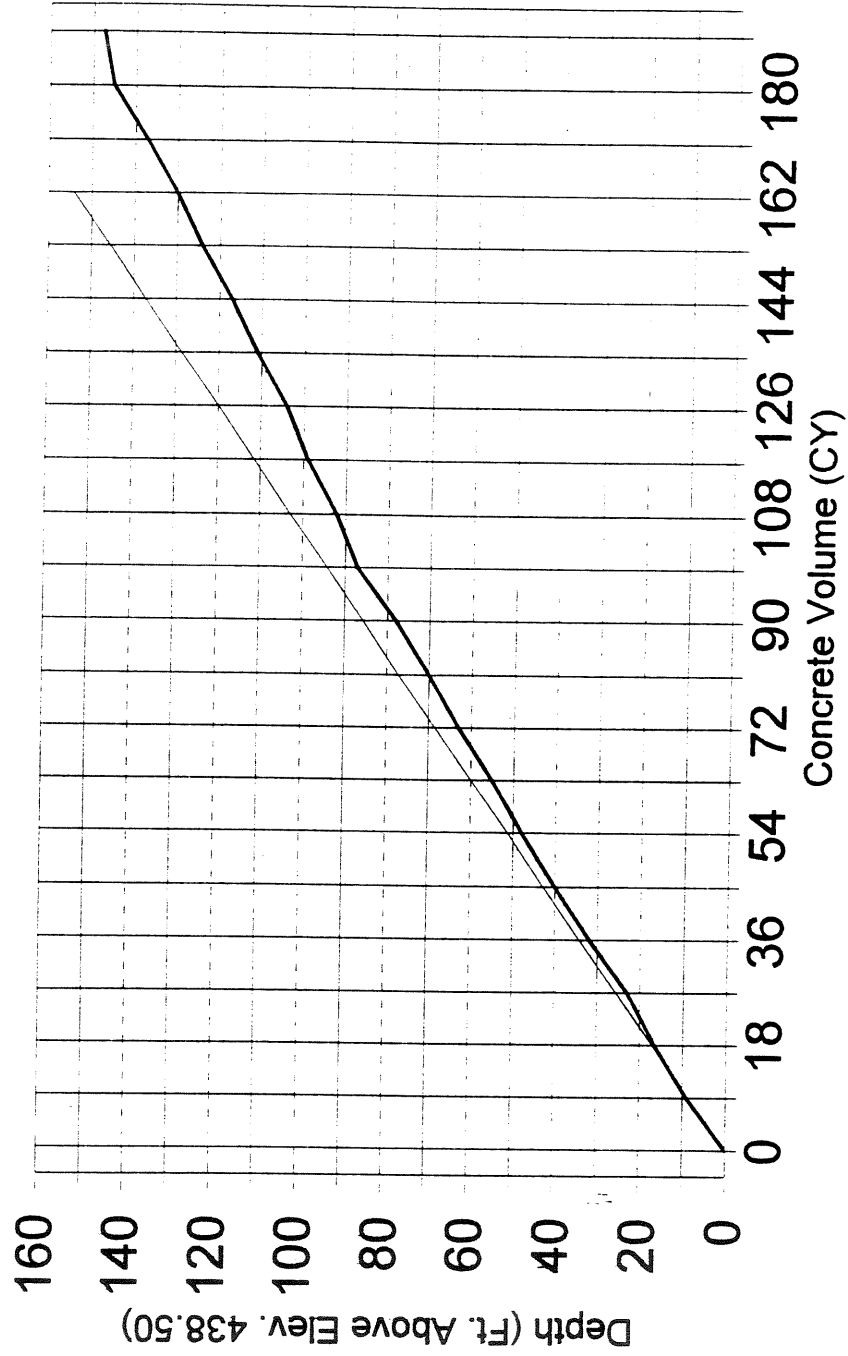

— Actual

- - - Theoretical

ODOT PROJECT 457-97

Concrete Curves For Drilled Shaft #4

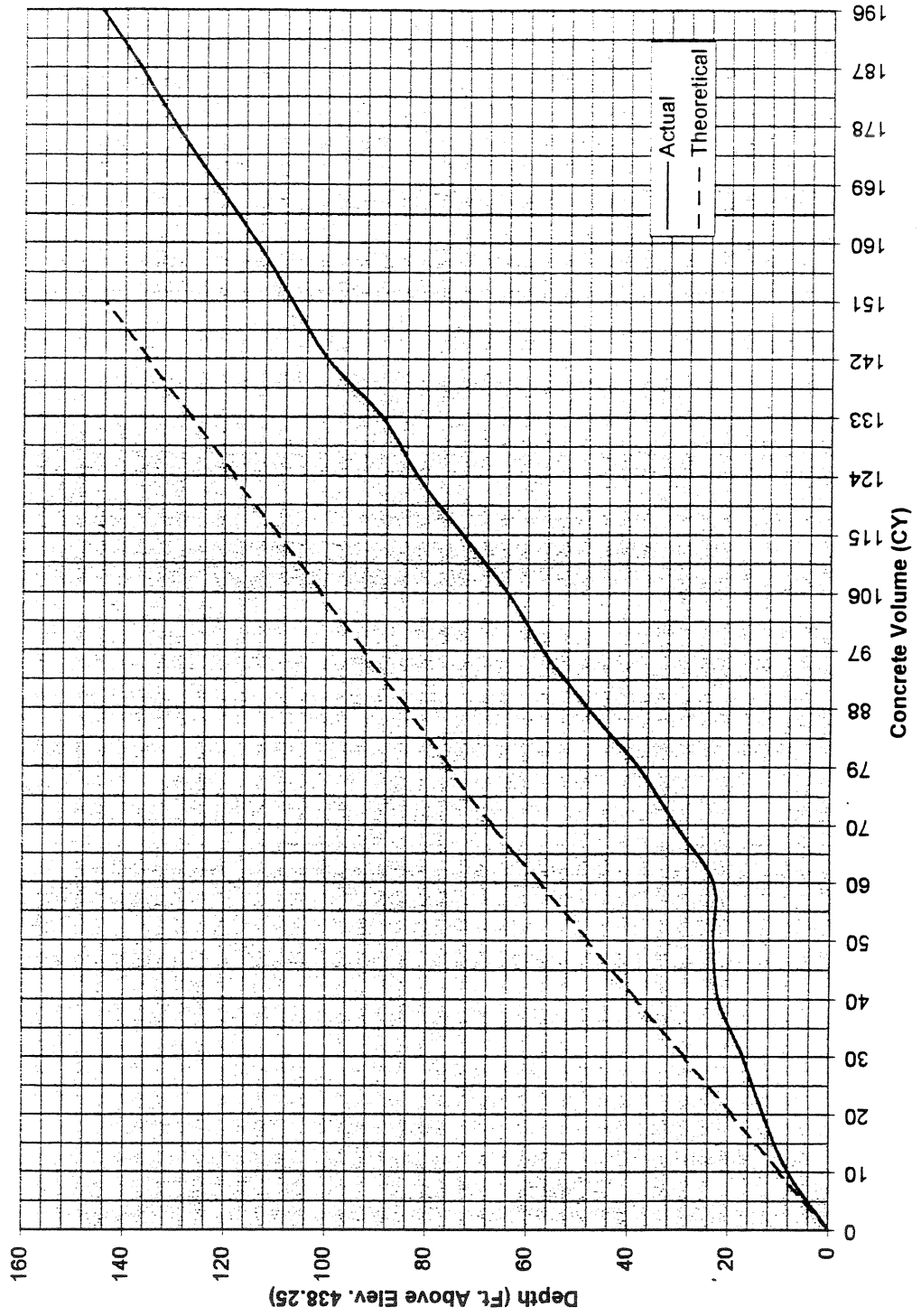

ODOT PROJECT 457-97

**Concrete Curves For Drilled Shaft #5**

Placed 11/6/98 - 202 CY

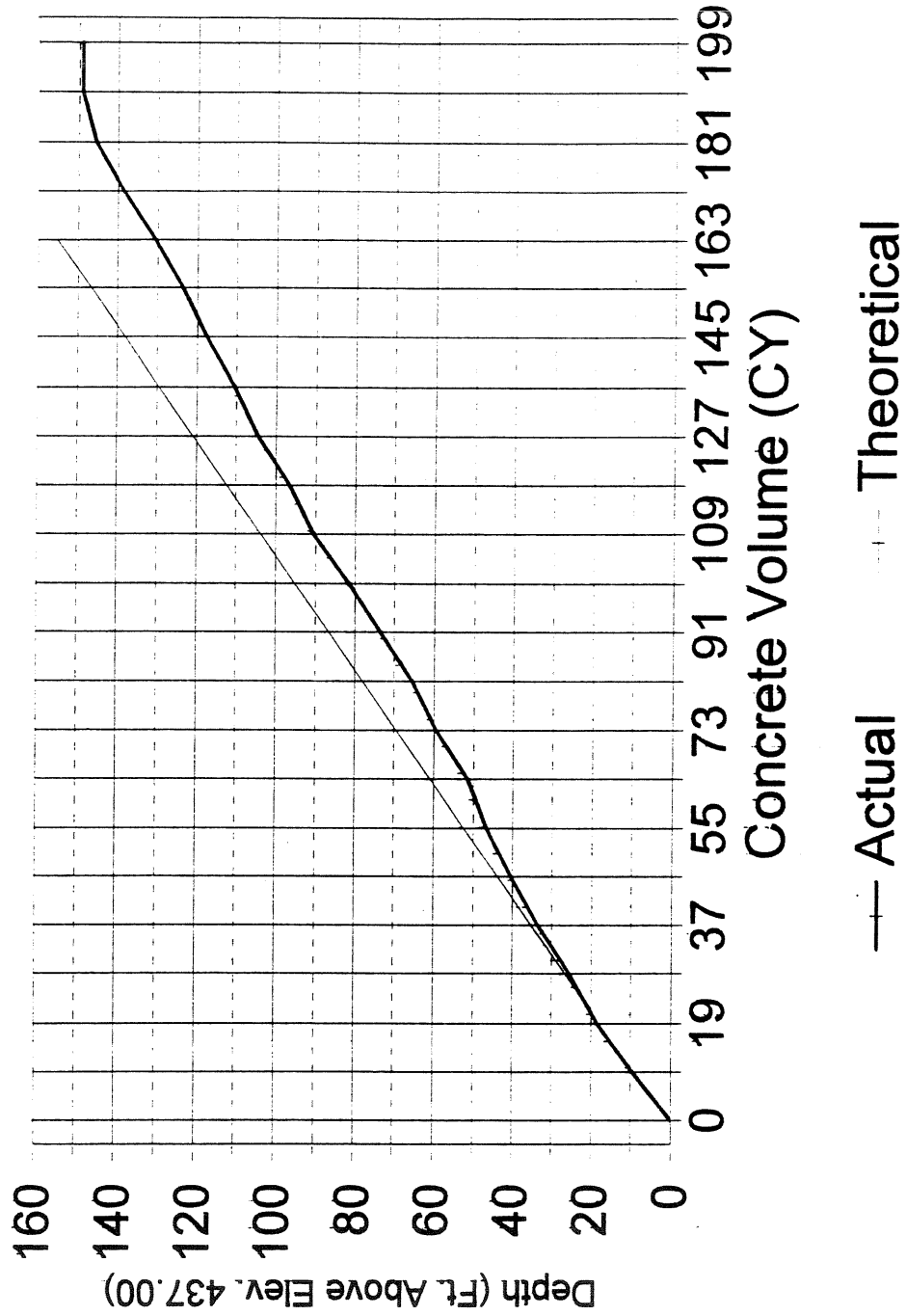

ODOT PROJECT 457-97

Concrete Curves For Drilled Shaft #6

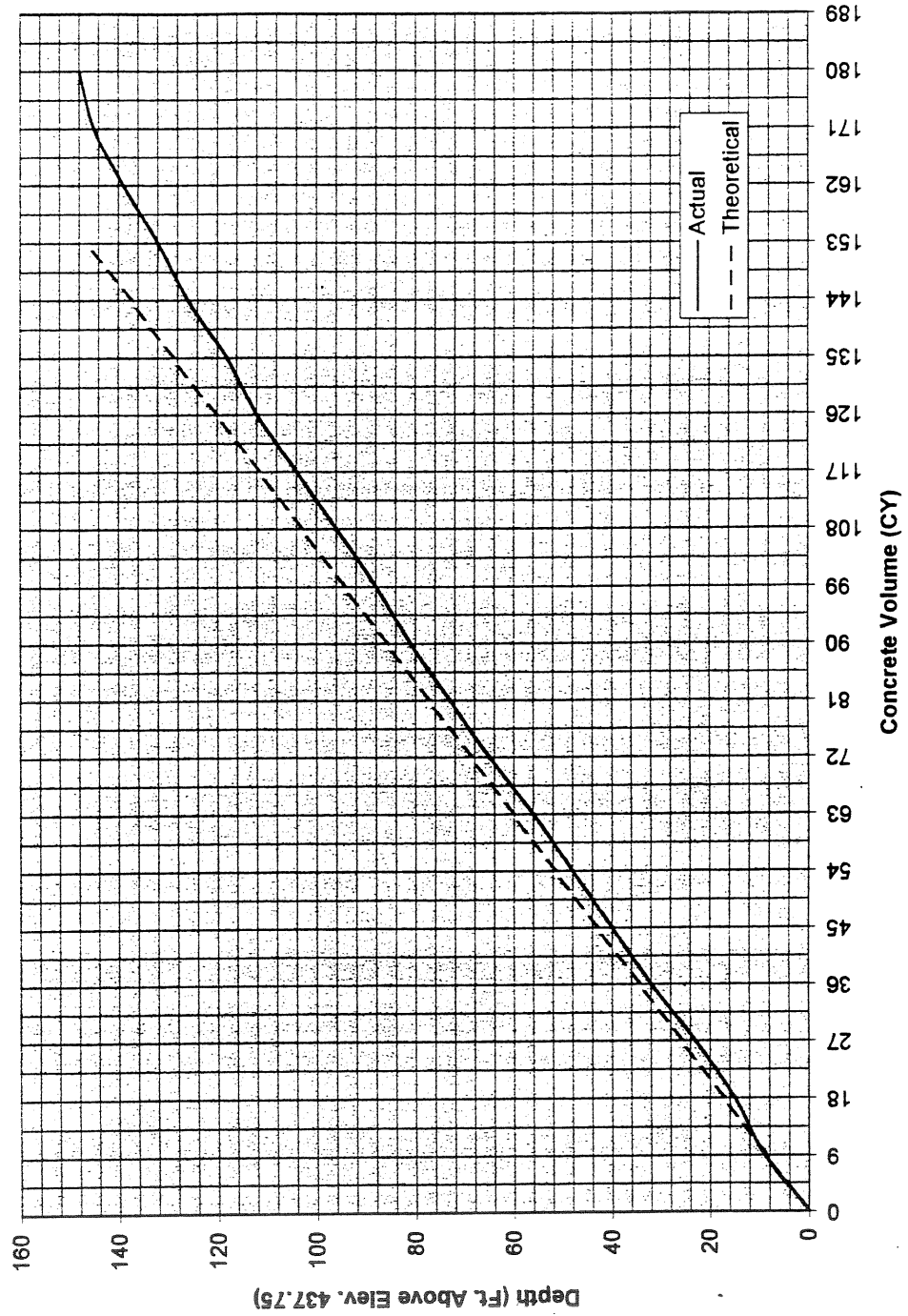



ODOT PROJECT 457-97

### Concrete Curves For Drilled Shaft #7

Placed 10/27/98 - 187 CY

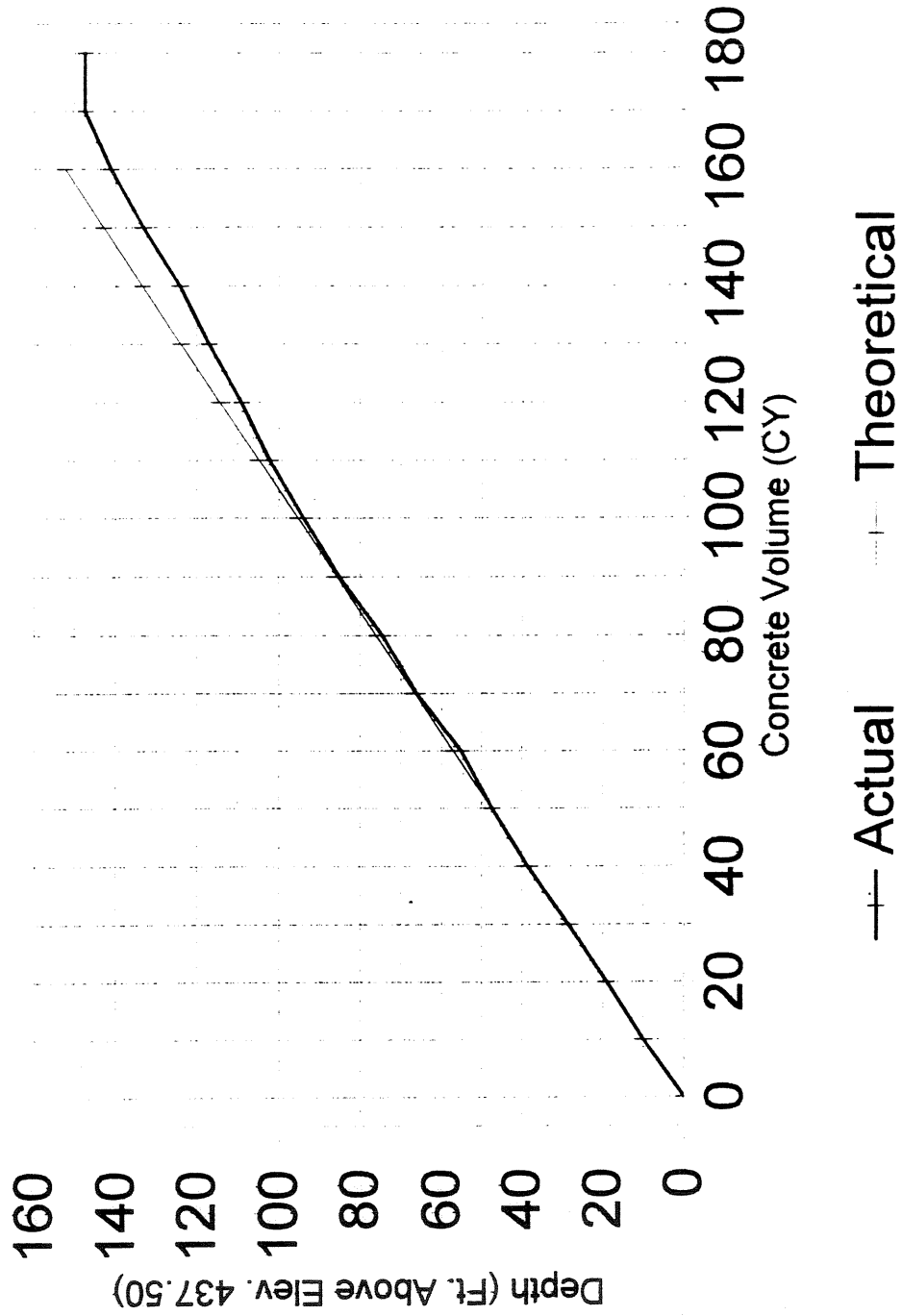

ODOT PROJECT 457-97

Concrete Curves For Drilled Shaft #8

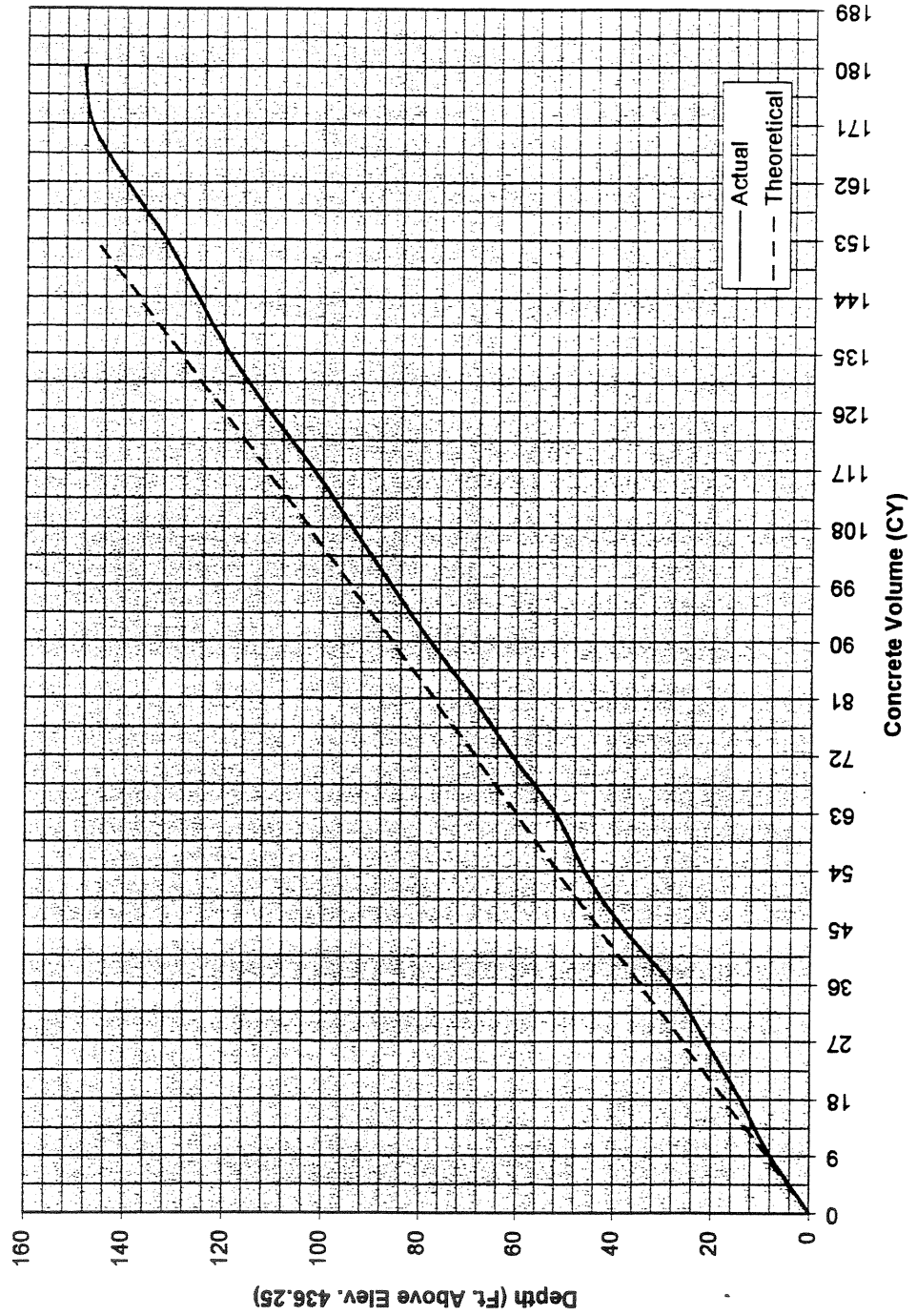

ODOT PROJECT 457-97

### Concrete Curves For Drilled Shaft #9

Placed 11/23/98 - 214 CY

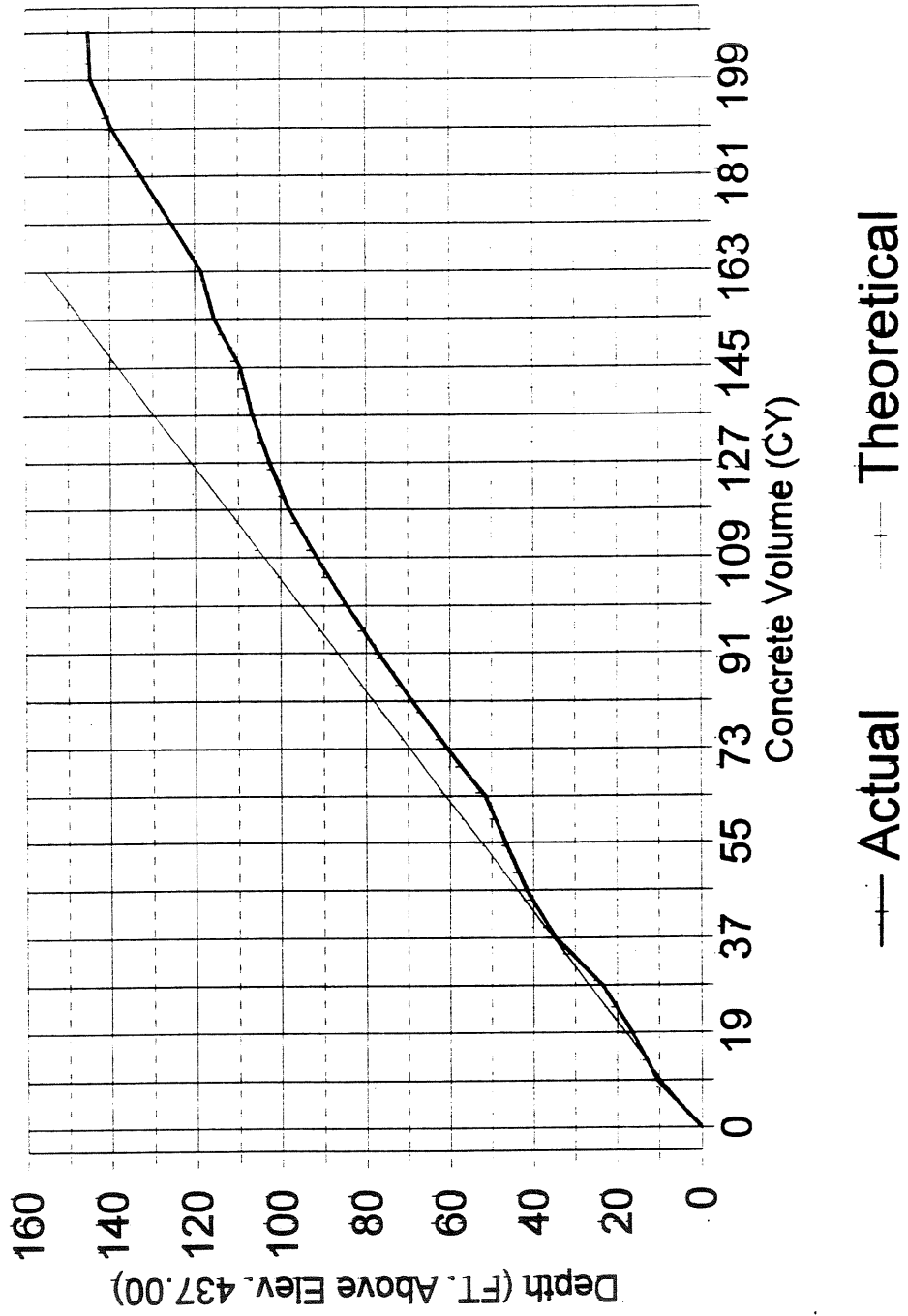

ODOT PROJECT 457-97

Concrete Curves For Drilled Shaft #10

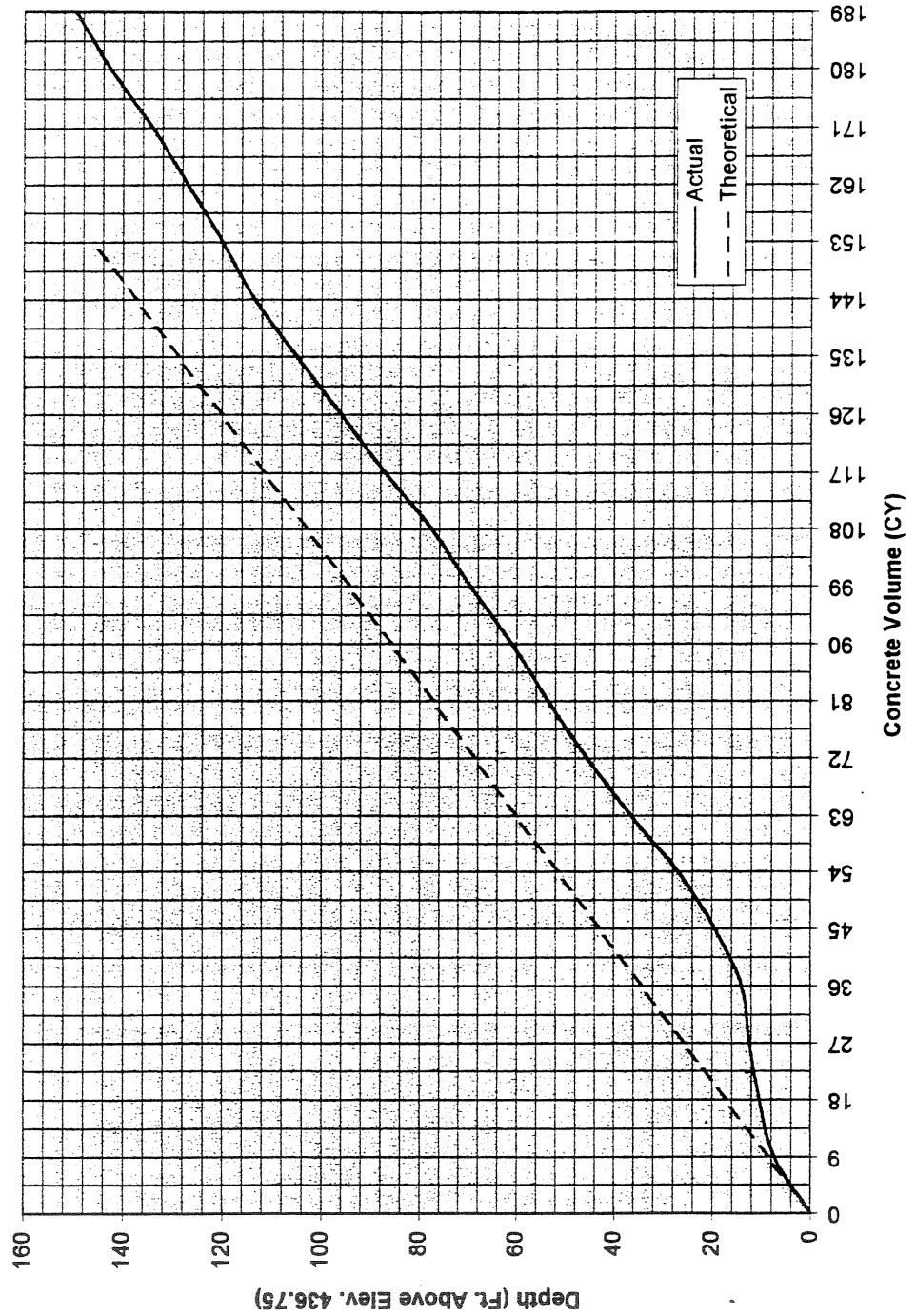

ODOT PROJECT 457-97

Concrete Curves For Drilled Shaft #11

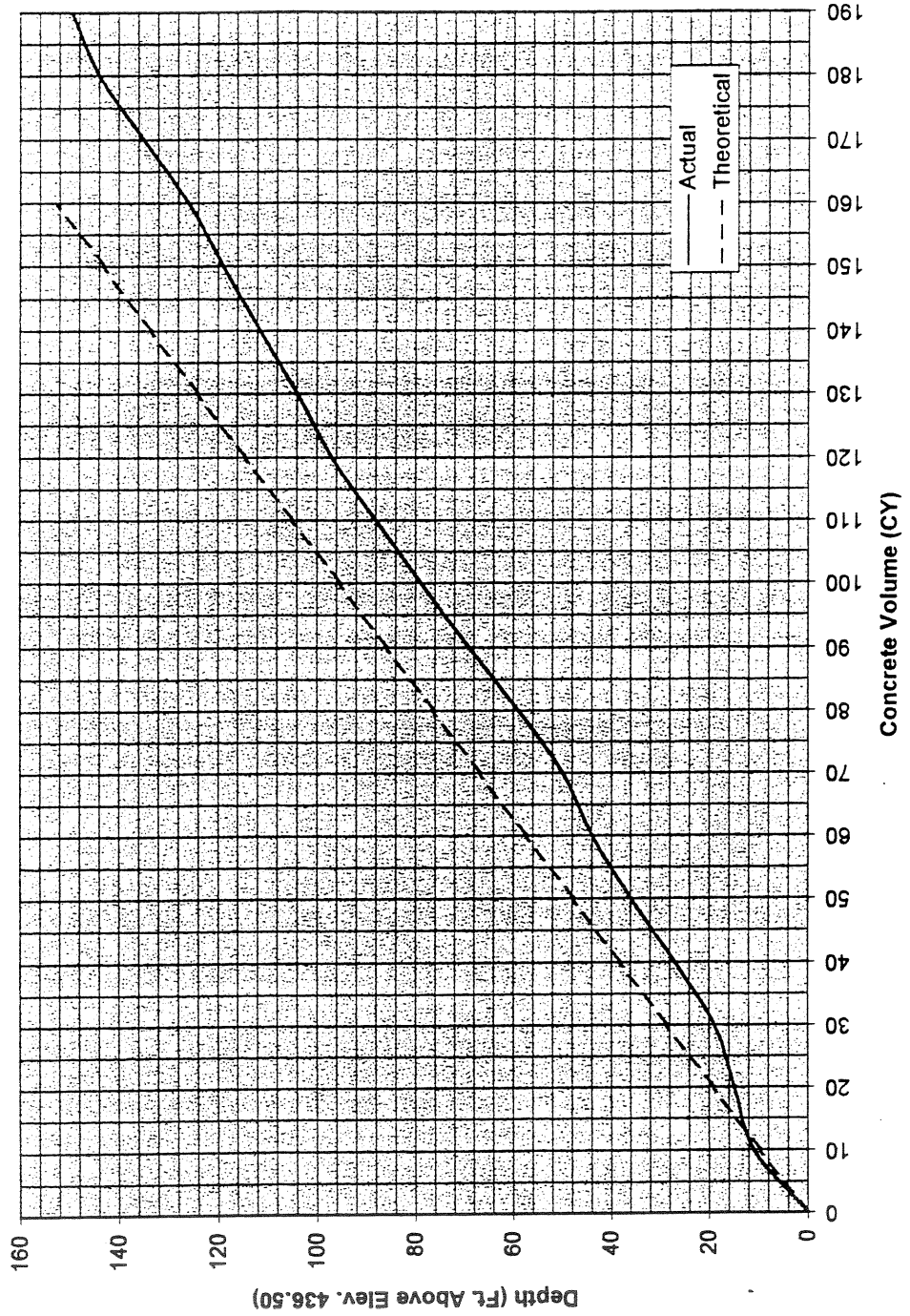

ODOT PROJECT 457-97

Concrete Curves For Drilled Shaft #12

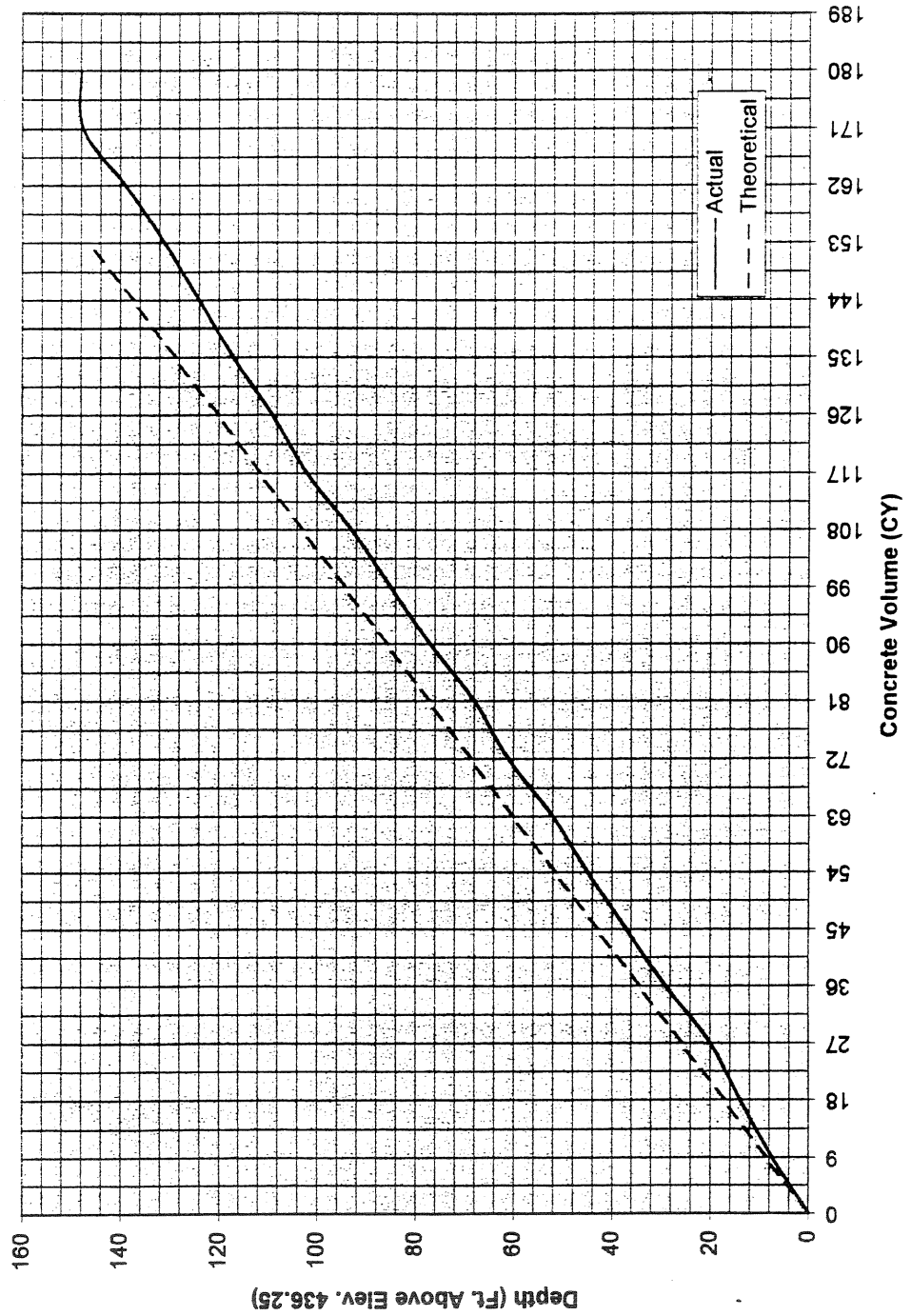

ODOT PROJECT 457-97

Concrete Curves For Drilled Shaft #13

Placed 11/10/98 - 198 CY

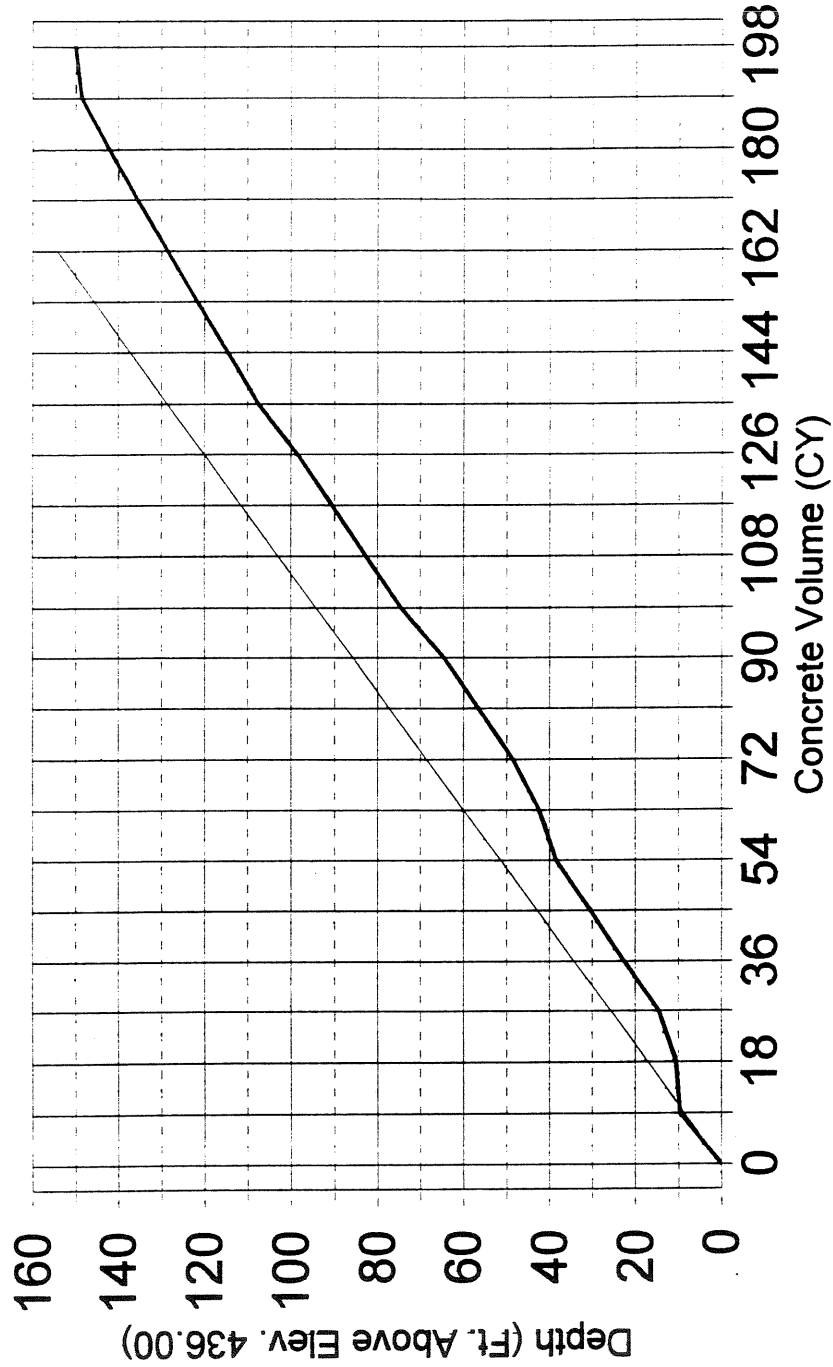

— Actual      - - - Theoretical

ODOT PROJECT 457-97

### Concrete Curves For Drilled Shaft #14

Placed 10/21/98 - 180 CY

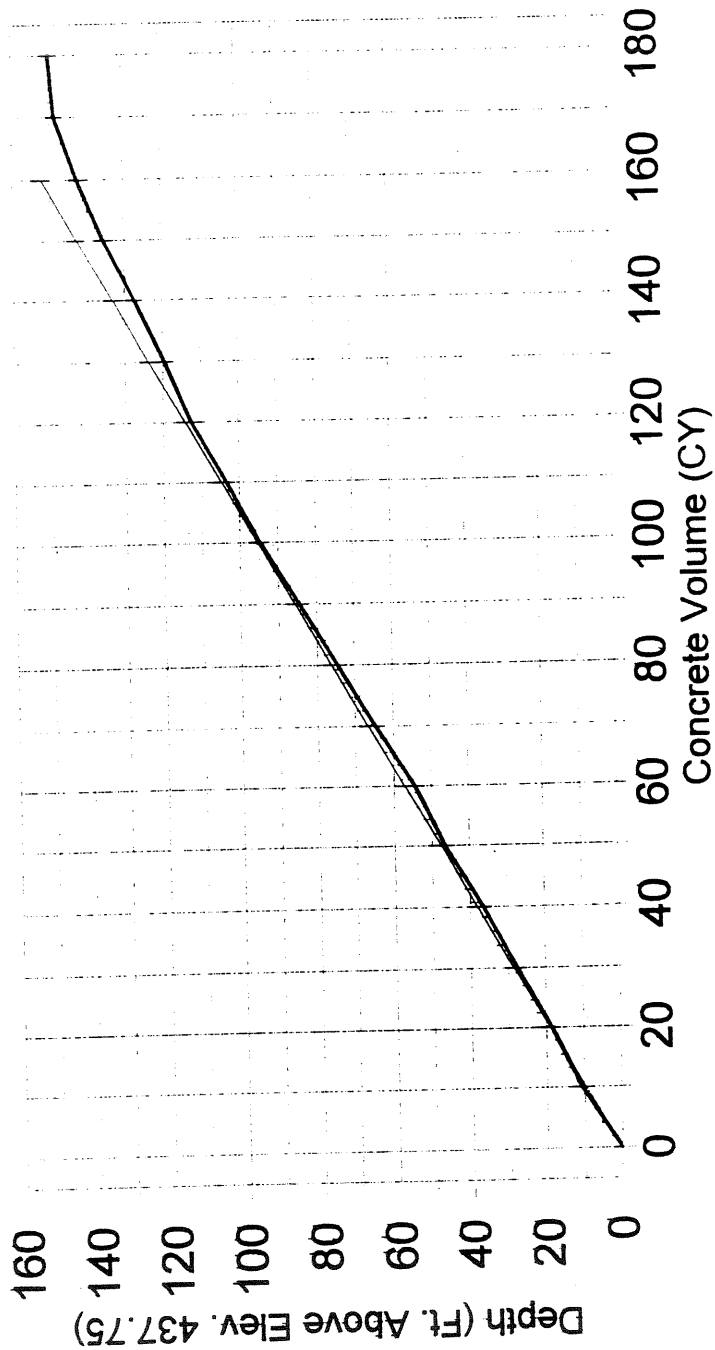

—+— Actual      —+— Theoretical



ODOT PROJECT 457-97

### Concrete Curves For Drilled Shaft #15

Placed 11/3/98 - 200 CY

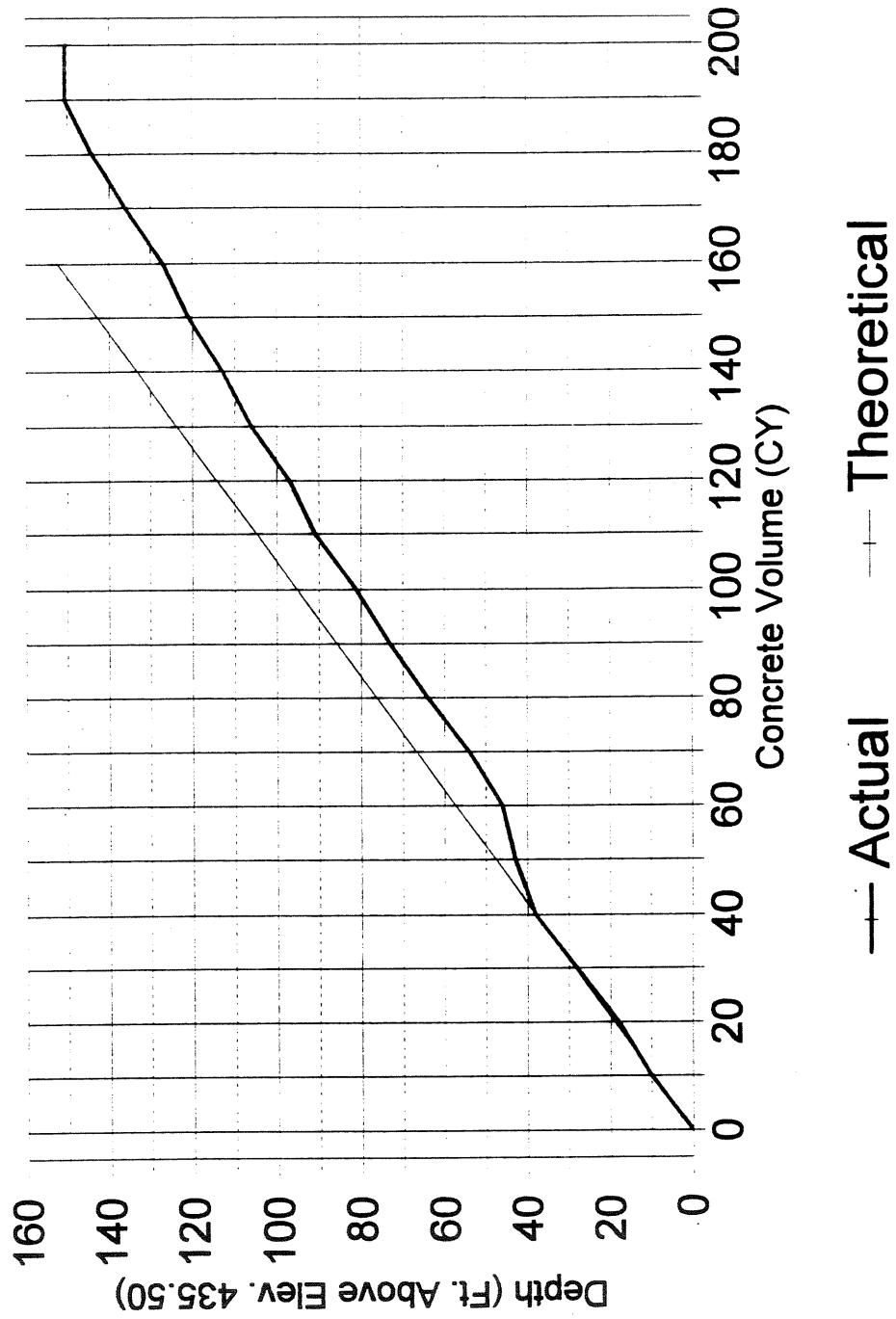

ODOT PROJECT 457-97

### Concrete Curves For Drilled Shaft #16

Placed 11/18/98 - 190 CY

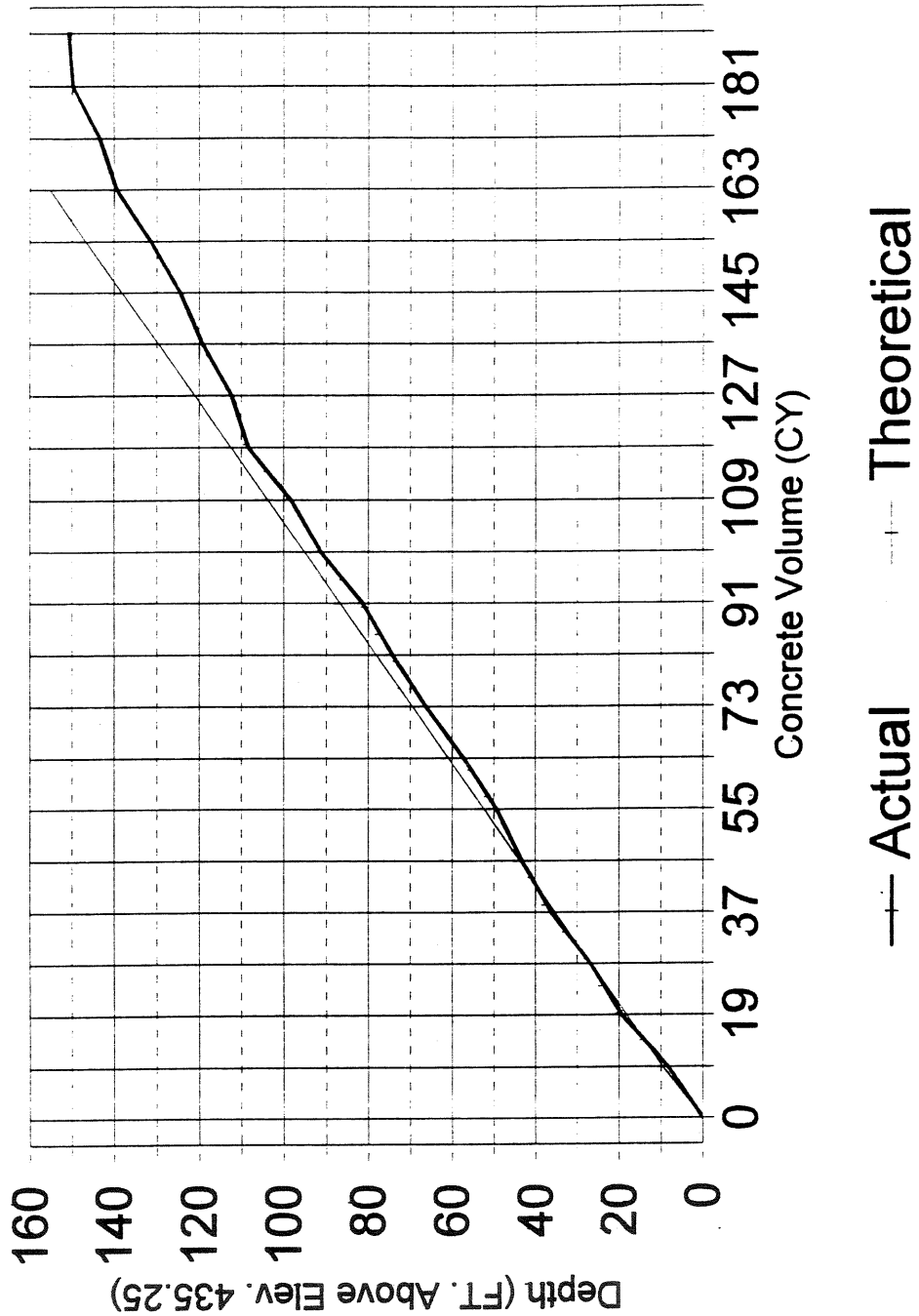

ODOT PROJECT 457-97

### Concrete Curves For Drilled Shaft #17

Placed 11/25/98 - 186 CY

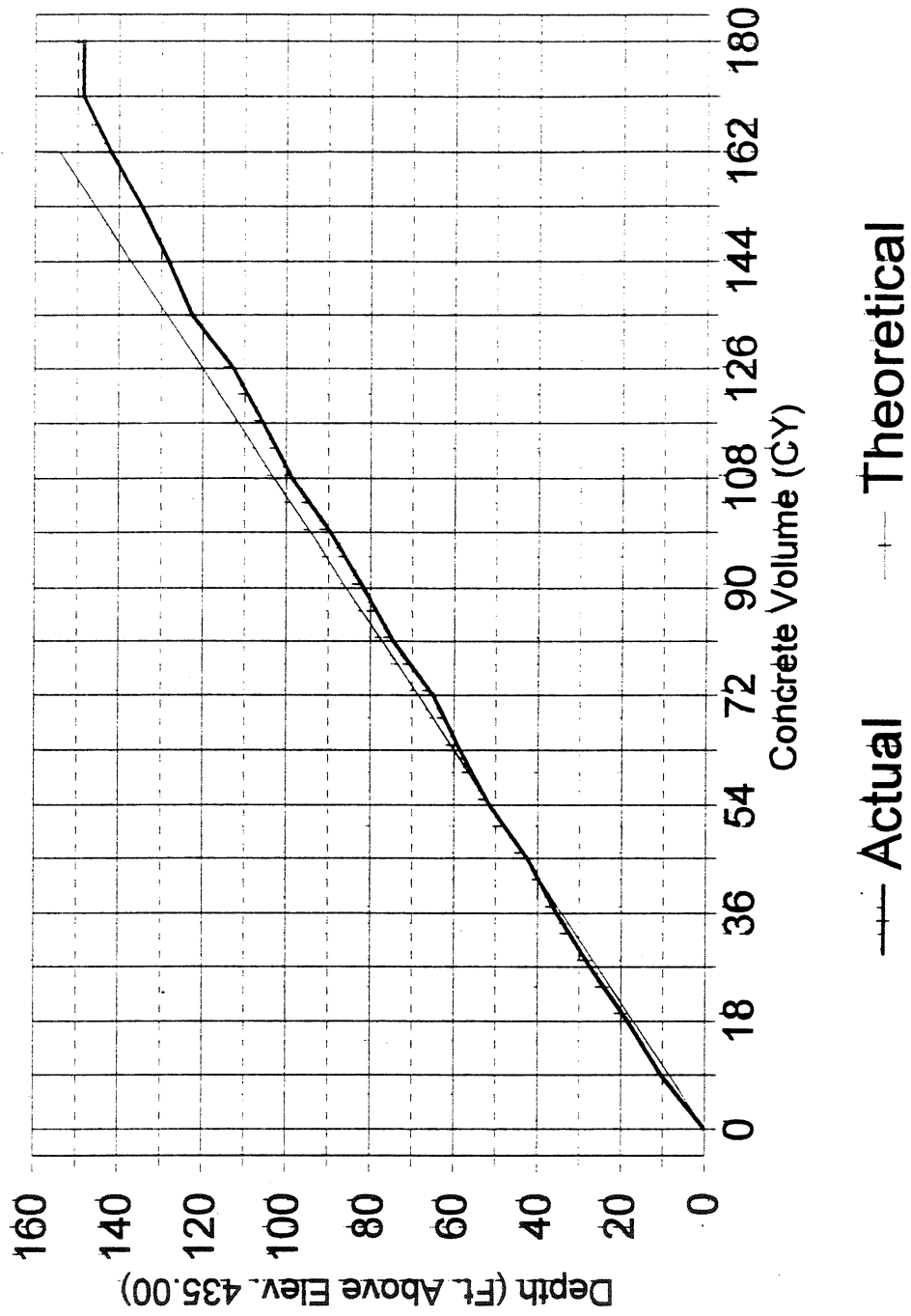

## CHAPTER 6

### SLOPE STABILITY MODEL DEVELOPMENT

#### 6.1 Geometry, Boundary Loads, and Stratigraphy

One of the first steps in evaluating the stability of a slope is to prepare the subsurface profile. Subsurface profiles for the I-90 project were meticulously prepared using all of the available topographic and exploratory information. The surface geometry of each cross-section was derived using the topographic map obtained from the survey provided by Michael Baker, Jr. and the original plans for the existing bridge slope remediation work. The subsurface profiles of the three major cross sections were used to produce the subsurface profiles for all fourteen (14) cross-sections used in the design. The three major cross sections (Sections A-A, CL-CL, and DD) were developed from the project site plan and are shown in Figure 6A-1 of Appendix 6A. The site plan showing the locations of all studied sections is presented in Figure 6A-2 of Appendix 6A. The subsurface stratigraphy profiles were developed using the 1994, 2006, and 2009 borings, the 2006 cone penetration tests results, and the up to date ground movement measurements from the earth inclinometers that have been installed since 1994. The recently completed (2009) borings are in general agreement with the previous borings (drilled on and before 2006). The step-by-step procedure used to develop the subsurface profiles at the three major sections crossing the site in the direction parallel to the existing bridge at the middle and the left and right end boundaries is as follows:

- 1) The log of each boring was refined by considering the Standard Penetration Test (SPT) blow counts ( $N_f$ ) at each sampling depth. Blow counts ( $N_f$ ) were then corrected for overburden and rod length effects, and the resulting corrected blow counts ( $N'$ ) were recorded against depth intervals of a similar soil type and  $N'$  values.

- 2) The interpreted subsurface profiles and corresponding  $N'$  values were then compared with the CPT tip resistances as presented in Appendix 6B. As shown in these Figures, the corrected blow count ( $N'$ ) trend matched reasonably well with the trend for the tip resistances and these trends indicated the presence of several relatively weak layers. The CPT tip resistances were only used to verify the reliability of using SPT- $N'$  values to determine the relative strength and/or stiffness of soil layers.
- 3) The information from inclinometer measurements was closely examined to identify the locations of the excessive incremental movements where the corresponding soil strength would have been decreased to the residual state.

The subsurface profiles were then finalized based on the SPT and CPT results and adjustments were made based on the inclinometer data for the major sections (A-A, and D-D). These profiles were then extrapolated based on interpretation to produce the subsurface profiles of the remaining sections which are presented in Appendix 6B. These profiles were used in the slope stability analyses of both the existing sections and the proposed remediation alternatives as presented in Chapter 7.

## **6.2 Soil Parameters and Ground Water**

### **6.2.1 Soil Strength Parameters:**

The shear strength parameters for the subsurface profile layers were selected based on interpretation of the laboratory test results performed by BBC&M and Cooper Testing Laboratory. The shear strength property selection process was augmented by values obtained from the interpreting of the CPT and SPT results, as well as from the inclinometers measurements. The shear strength property values for the soil layers are listed in Tables 6.1 and 6.2. The selected strength parameters of bedrock used in the analysis are also provided. The same property values are used for all of the remaining (interpreted) cross sections.

### 6.2.2 Ground Water Elevation:

For all stability analyses performed prior to August 2006, the location of the static groundwater table was estimated from the information in the existing soil borings and from the available piezometers data (1994 and 2006 investigations). This water table location was designated as w1. The recently completed borings (2009) revealed similar results; showing minimal variation from earlier measurements. Additional vibrating wire piezometers were installed (2006 and 2009) to provide additional data regarding the water table elevation. Each of these recently installed piezometers was connected to a single channel data logger and have been monitored since their respective installation dates..

### 6.3 Studied Sections

A total of fourteen (14) soil profiles (sections A-A, B-B, CL-CL, D-D, E-E, F-F, G-G, H-H, I-I, J-J, K-K, U-U, Y-Y, W-W, and Z-Z) were developed to represent the variation of the geometry and soil properties existing on the site. The locations of each cross section are depicted on the site plan enclosed in Appendix 6A, and the corresponding subsurface profiles are also presented in the remaining pages of this same Appendix..

**Table 6.1: Stratification and Soil Strength Parameters for Section A-A.**

| Layer No. | Description   | C**     | $\phi$ | C`**  | $\phi`$ |
|-----------|---|---------|--------|-------|---------|
| 1         | Medium dense gravel with sand                                       | 0.0     | 36.0   | 0.0   | 36.0    |
| 2         | Sandy silt/sand and silt  | 0.0     | 32.0   | 0.0   | 32.0    |
| 3*        | Soft silty clay   | 800.0   | 0.0    | 0.0   | 22.0    |
| 4         | Very stiff silty clay   | 3500.0  | 0.0    | 0.0   | 32.0    |
| 5*        | Soft silty clay, with pockets of loose silt and numerous silt seams | 800.0   | 0.0    | 0.0   | 15.0    |
| 6         | Bedrock-shale   | 20000.0 | 20.0   | 20000 | 20.0    |

\* Layers where low SPT blow count, low CPT tip resistance or/and excessive movements have been recorded in inclinometers.

\*\* in pounds per square foot (psf)

**Table 6.2: Stratification and Soil Strength Parameters for Section D-D and Bridge Centerline (Section CL-CL).**

| Layer No. | Description   | $C_u$   | $\phi$ | $C^{**}$ | $\phi'$ |
|-----------|---|---------|--------|----------|---------|
| 1         | Medium dense gravel with sand                                       | 0.0     | 36.0   | 0.0      | 36.0    |
| 2*        | Soft silty clay   | 800.0   | 0.0    | 0.0      | 22.0    |
| 3         | Very stiff silty clay   | 3500.0  | 0.0    | 0.0      | 32.0    |
| 4*        | Soft silty clay, with pockets of loose silt and numerous silt seams | 800.0   | 0.0    | 0.0      | 15.0    |
| 5         | Bedrock-shale   | 20000.0 | 20.0   | 20000    | 20.0    |

\* Layers where low SPT blow count, low CPT tip resistance or/and excessive movements have been recorded in inclinometers.

\*\* in pounds per square foot (psf)

**CHAPTER 6**  
**APPENDICES**



## **APPENDIX 6A**

- **SITE PLAN WITH INVESTIGATION POINTS AND LOCATIONS OF MAJOR THREE SECTIONS**
- **SITE PLAN WITH LOCATIONS OF ALL INVESTIGATED SECTIONS**
- **CROSS SECTIONS WITH SUBSURFACE PROFILES**

CUY-90-14.92 West Slope Stability  
1954 thru 2009 Borings used in the Study

**Borings**

B-004-0-54  
B-002-0-54  
B-001-0-54  
B-003-0-54  
B-001-0-55  
B-002-0-55  
B-001-0-55  
B-002-0-55  
B-001-W-55  
B-002-W-55  
B-003-W-55  
B-001-0-90  
B-002-0-90  
B-003-0-90  
B-004-0-90  
B-005-0-90  
B-006-0-90  
B-007-0-90  
B-008-0-90  
B-009-0-90  
B-010-0-92  
B-101-0-94  
B-102-0-94  
B-103-0-94  
B-104-0-94  
B-105-0-94  
B-106-0-94  
B-107-0-94  
B-108-0-94  
B-109-0-94  
B-110-0-94  
B-201-0-96  
B-202-0-96  
B-203-0-96  
B-204-0-96  
B-303-0-98  
B-001-0-06  
B-002-0-06  
B-003-0-06  
B-004-0-06  
B-007-0-06  
B-011-0-06  
B-012-0-06  
B-016-0-06  
B-105-A-06  
B-108-A-06  
B-035-0-09  
B-036-0-09  
B-037-0-09  
B-038-0-09  
B-037-1-09  
B-037-A-09  
B-038-A-09

NYC&STLRR  
NYC&STLRR  
HNTB  
HNTB

**CPT**

C-001-0-06  
C-002-0-06  
C-003-0-06  
C-004-0-06  
C-007-0-06  
C-010-0-06  
C-011-0-06  
C-012-0-06

To be drilled  
To be drilled



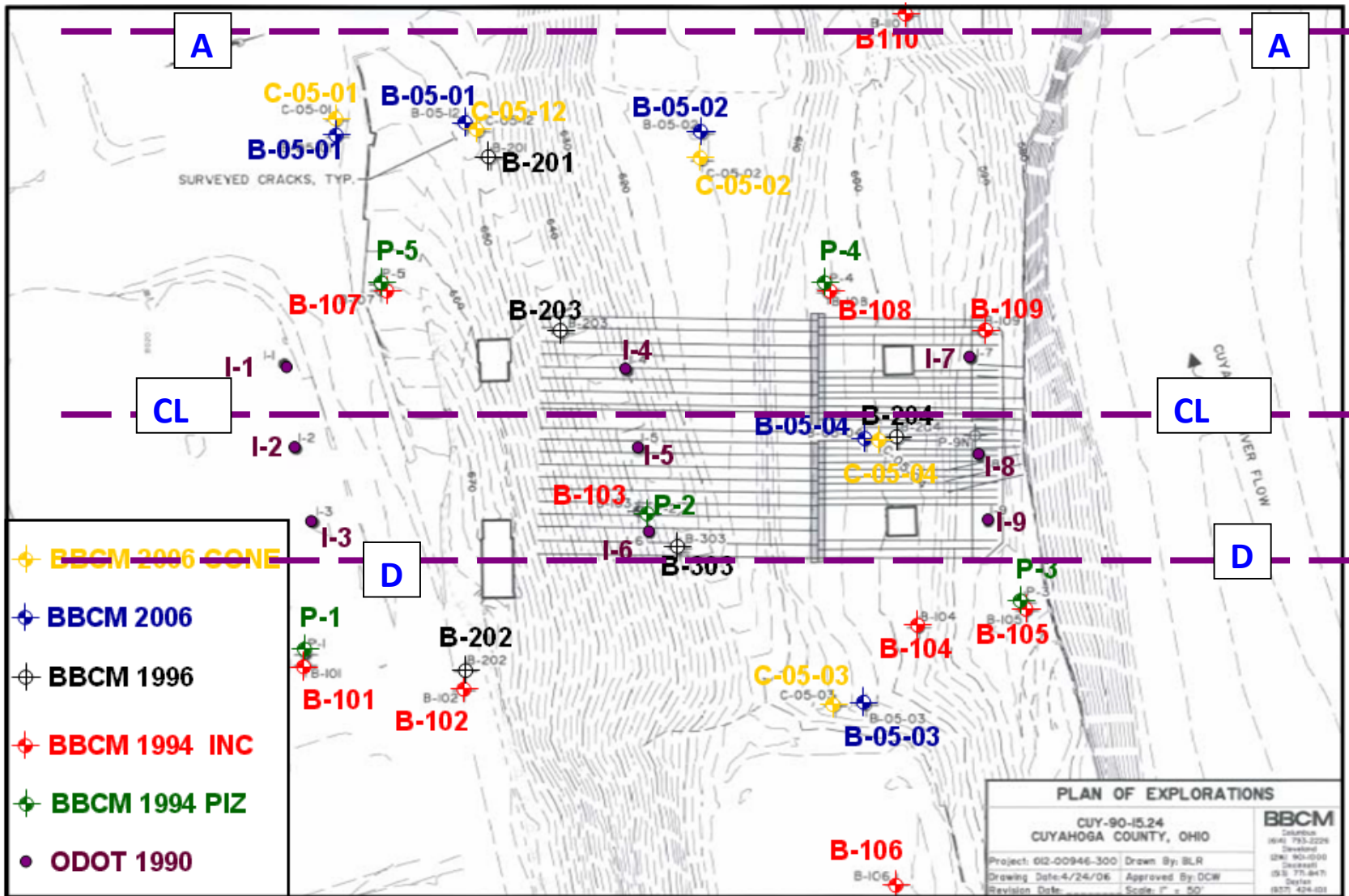

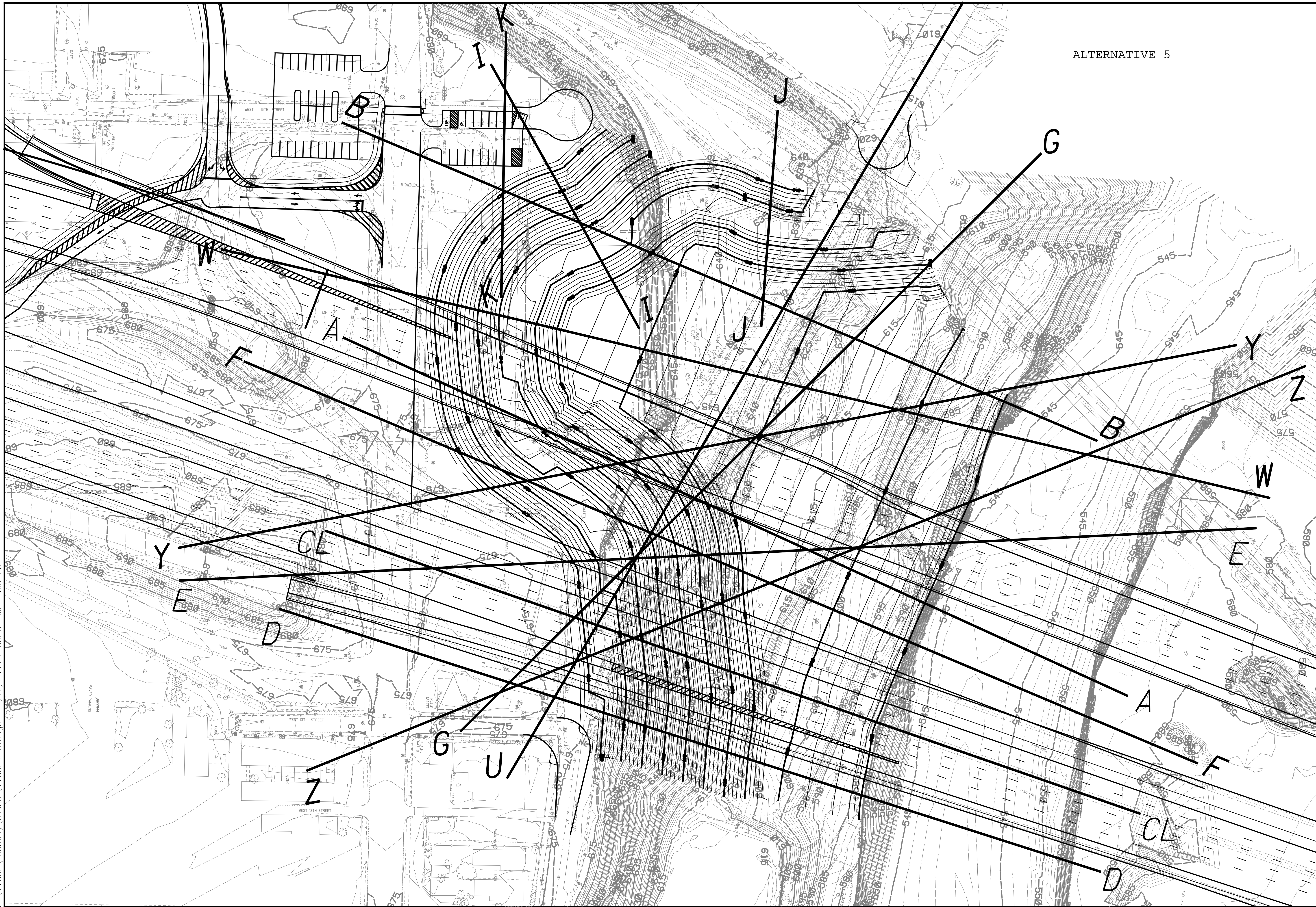

ALTERNATIVE 5

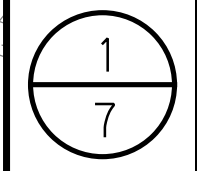



CUY-90-14.92  
PID No. 77332

ALT 5 SLOPE GRADING PLAN  
CUYAHOGA RIVER WEST BANK

|          |         |                       |      |
|----------|---------|-----------------------|------|
| DESIGNED | DRAWN   | REVIEWED              | DATE |
| CHECKED  | REVISED | STRUCTURE FILE NUMBER |      |

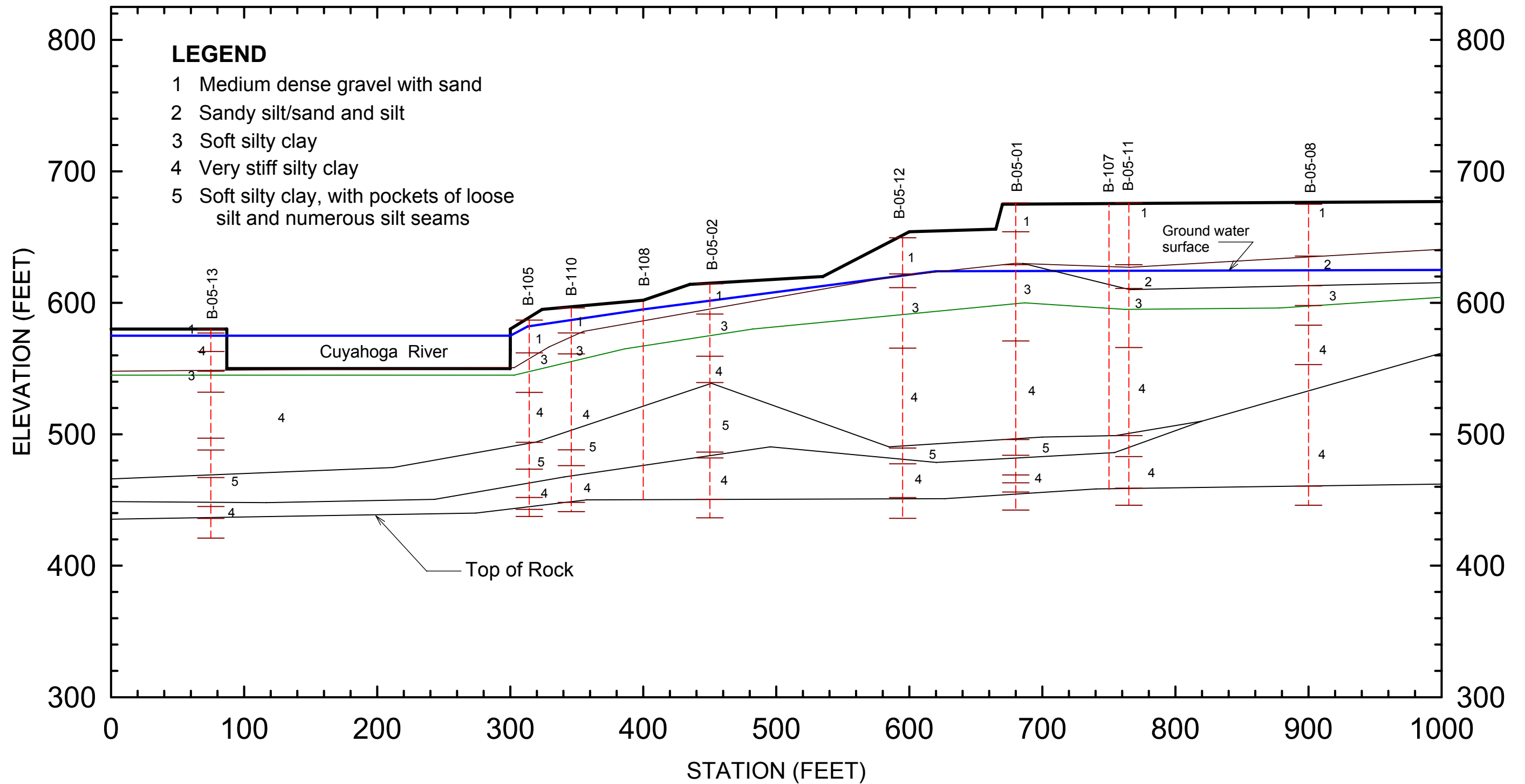
**E.L. ROBINSON**  
The Challenge, the Choice  
1801 Watermark Drive, Suite 310  
Columbus, OH 43260



|   |       |        |     |         |   |         |              |
|---|-------|--------|-----|---------|---|---------|--------------|
| CLIENT Ohio Departement of Transportation                         |       |        |     |         | TITLE SOIL PROFILE AT CROSS-SECTION A-A   |         |              |
| PROJ Slope Stability Investigation for Wet Bank of Cuyahoga River |       |        |     |         |   |         |              |
| REVISION NO   | FIRST | DES BY | JHN | 5/21/06 |  | PROJ NO | CUY-90-15.24 |
| SCALE   | NTS   | DR BY  | MAA | 5/21/06 |   | FIGURE  | 6.5          |
| FILE  |       | CHK BY | JHN | 5/21/06 |   |         |              |
|   |       |        |     |         |   |         |              |

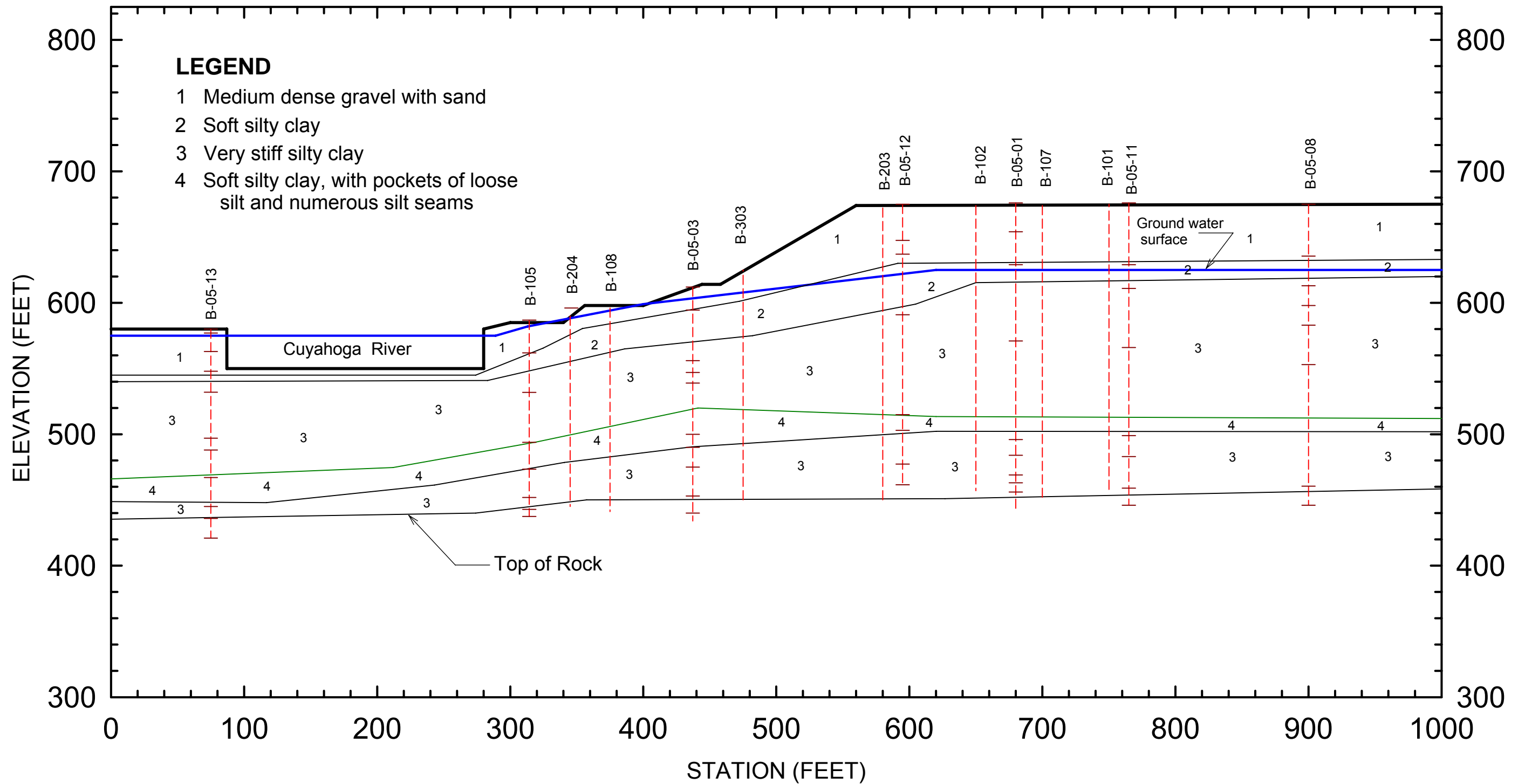

|   |       |        |     |         |   |  |  |         |              |
|---|-------|--------|-----|---------|---|--|--|---------|--------------|
| CLIENT Ohio Departement of Transportation                         |       |        |     |         | TITLE SOIL PROFILE AT CROSS-SECTION D-D   |  |  |         |              |
| PROJ Slope Stability Investigation for Wet Bank of Cuyahoga River |       |        |     |         |  |  |  |         |              |
| REVISION NO   | FIRST | DES BY | JHN | 5/21/06 |   |  |  | PROJ NO | CUY-90-15.24 |
| SCALE   | NTS   | DR BY  | MAA | 5/21/06 |   |  |  | FIGURE  | 6.6          |
| FILE  |       | CHK BY | JHN | 5/21/06 |   |  |  |         |              |
|   |       |        |     |         |   |  |  |         |              |

# CUY-90-14.40 (Sec. A-A): EXISTING GEOMETRY

E:\REPORTS\CUY-190\2009WO~1\2009-S~1\EXIST~1\AA-EX.PL0 Geometry Preview 7/22/2009 11:17 PM

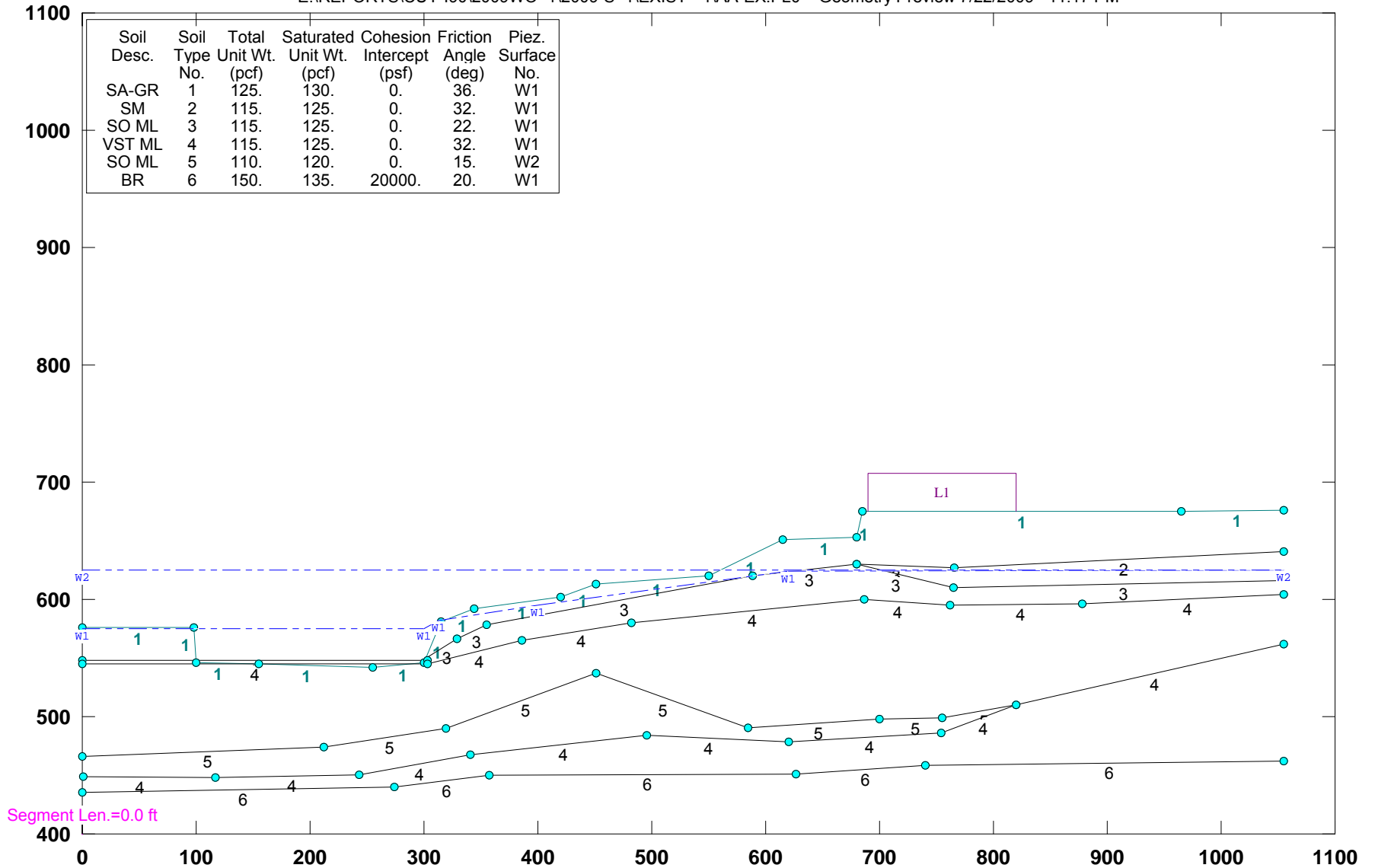



# CUY-90-14.40 (Sec. B-B): EXISTING GEOMETRY

E:\REPORTS\CUY-190\2009WO~1\2009-S~1\EXIST~1\BB-EX.PL0 Geometry Preview 7/22/2009 11:22 PM

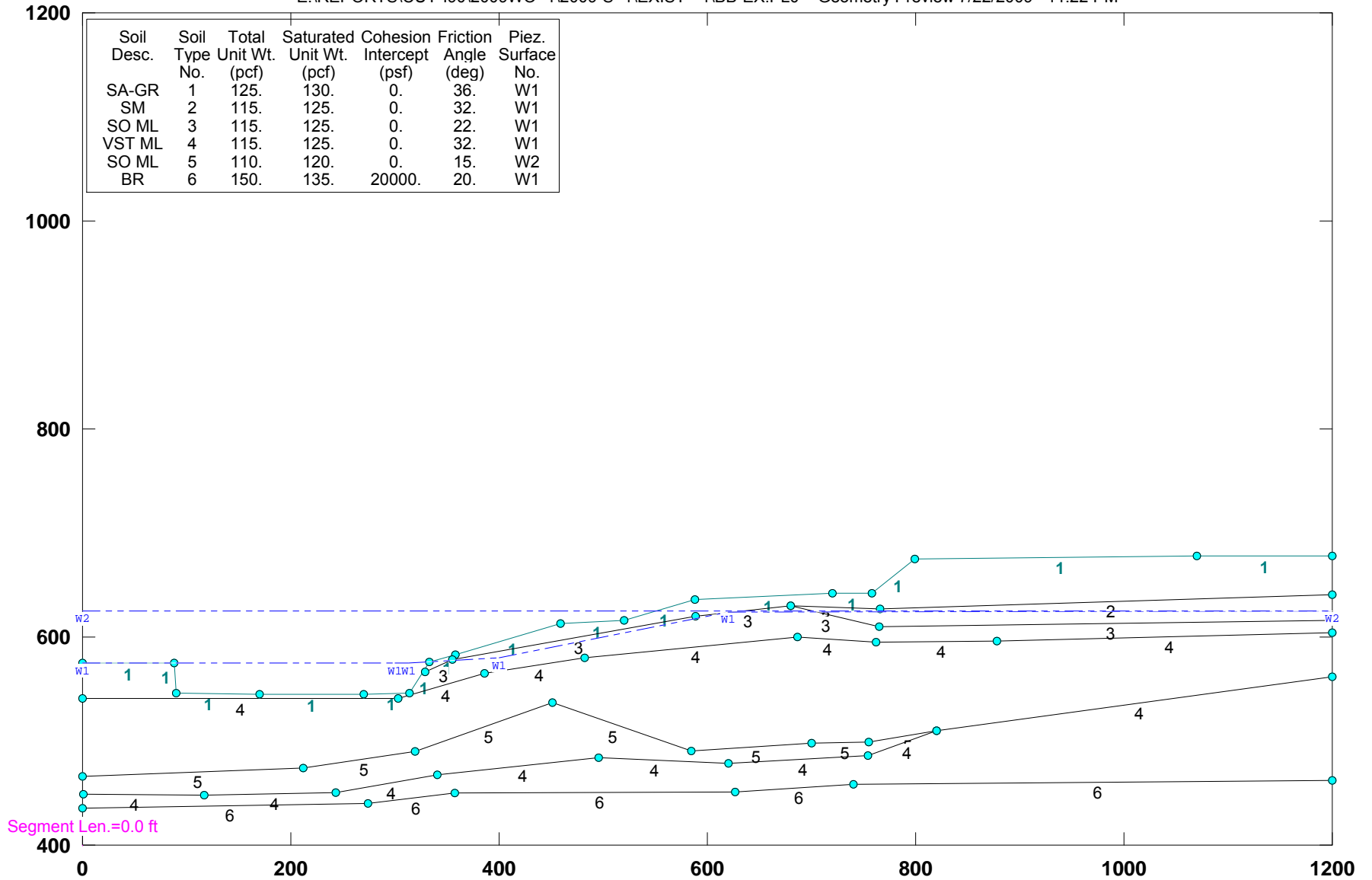

# CUY-90-14.40: CENTERLINE OF BRIDGE TOTAL STRESS ANALYSES

E:\REPORTS\CUY-190\2009WO~1\2009-S~1\EXIST--1\CL5-06.PLO Geometry Preview 7/22/2009 11:23 PM

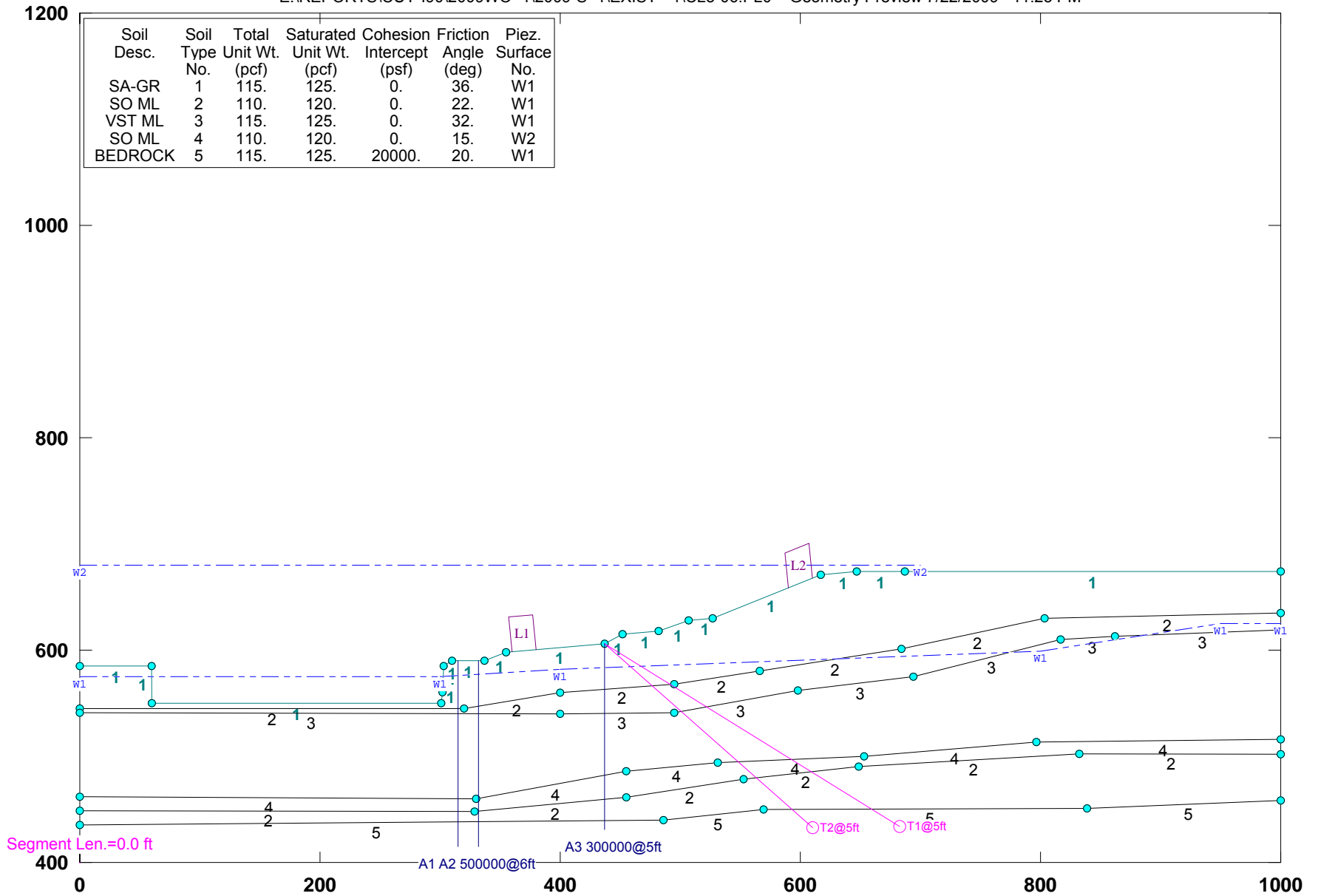

# CUY-90-14.40 (Sec. D-D): EXISTING GEOMETRY

E:\REPORTS\CUY-190\2009WO~1\2009-S~1\EXIST--1\DD-.PL0 Geometry Preview 7/22/2009 11:23 PM

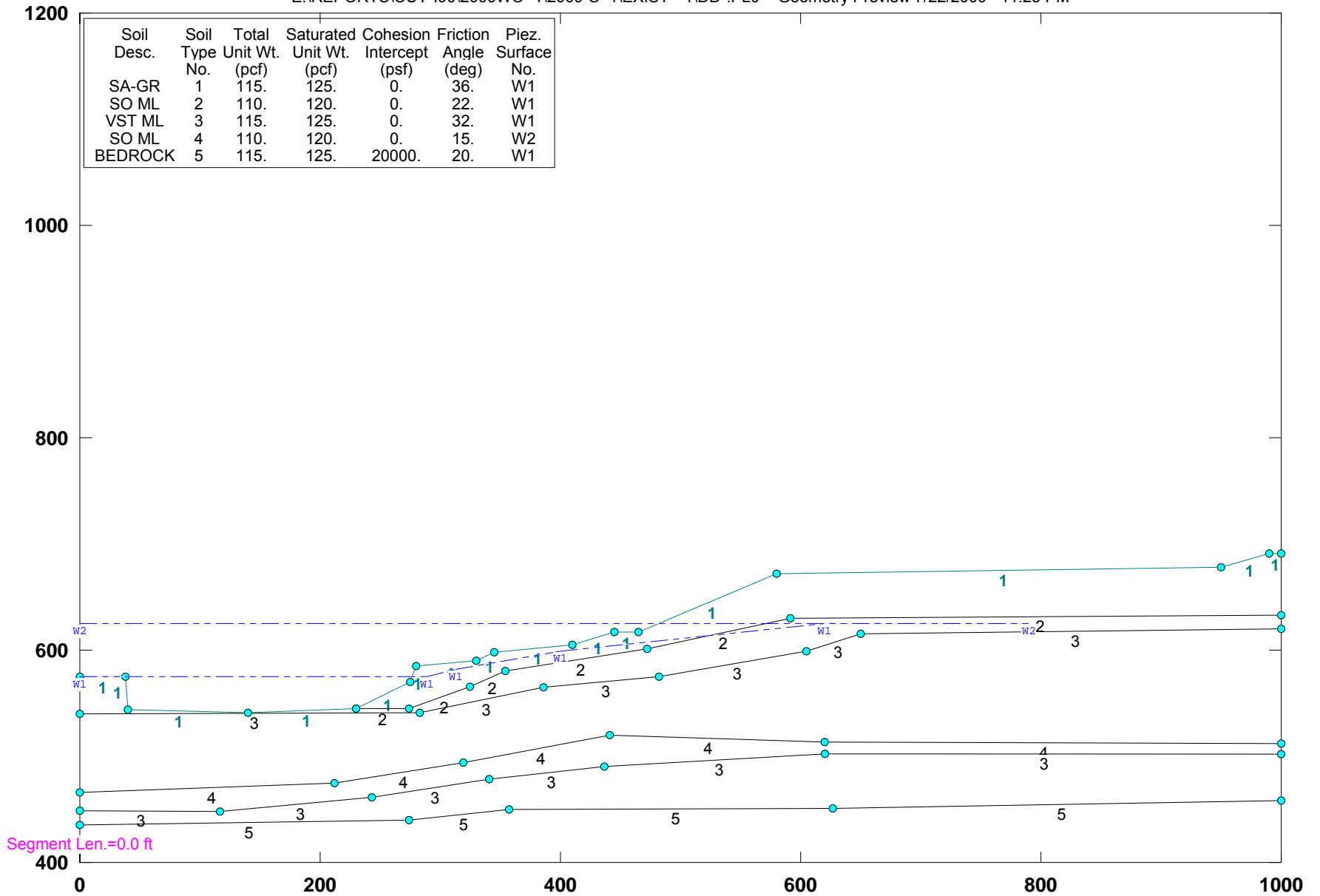

# CUY-90-14.40 (Sec. E-E): EXISTING GEOMETRY

E:\REPORTS\CUY-190\2009WO~1\2009-S~1\EXIST~1\EE-EX.PL0 Geometry Preview 7/22/2009 11:24 PM

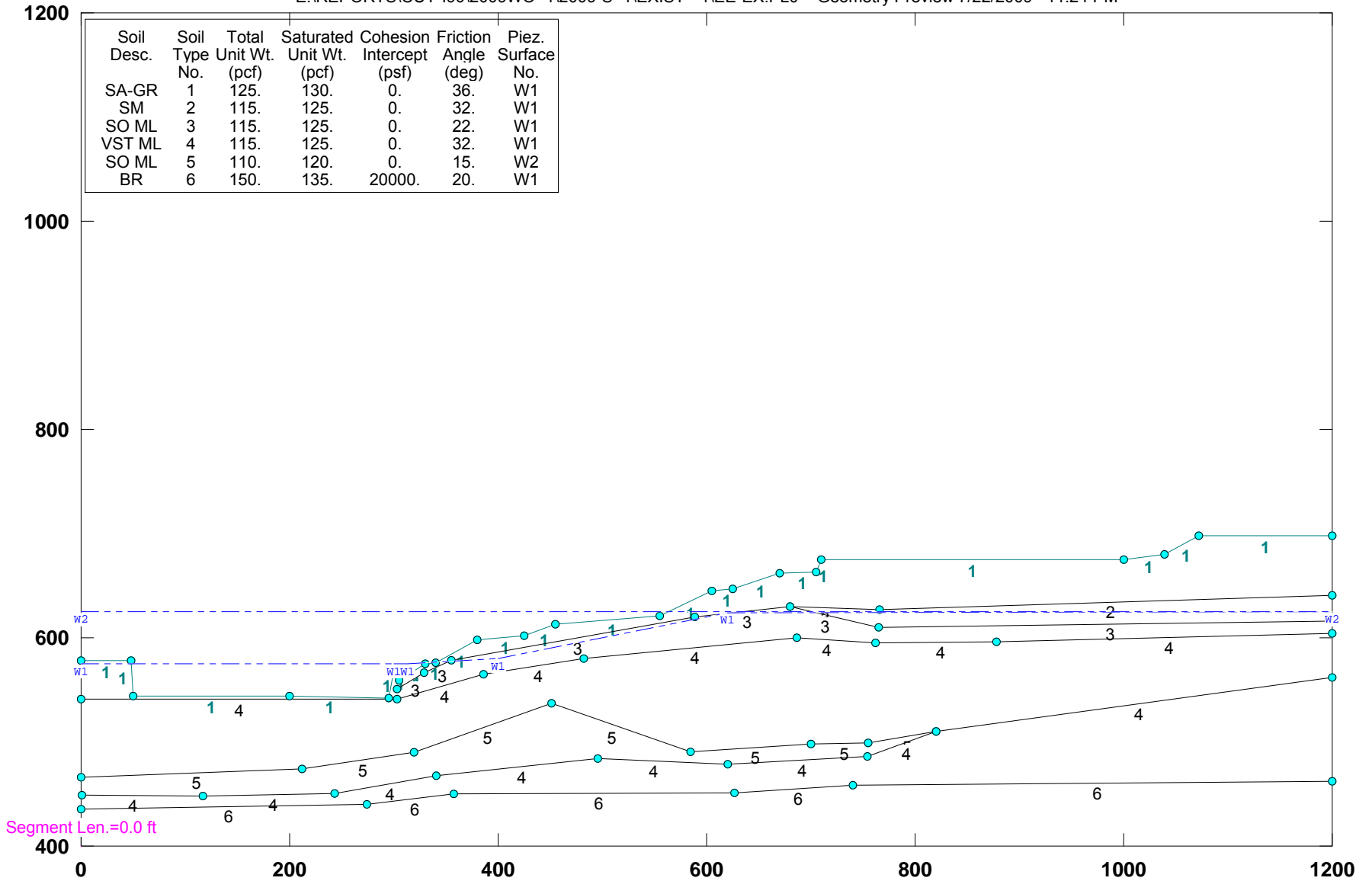

# CUY-90-14.40 (Sec. FF): EXISTING GEOMETRY

E:\REPORTS\CUY-190\2009WO~1\2009-S~1\EXIST~1\FF-EX.PL0 Geometry Preview 7/22/2009 11:25 PM

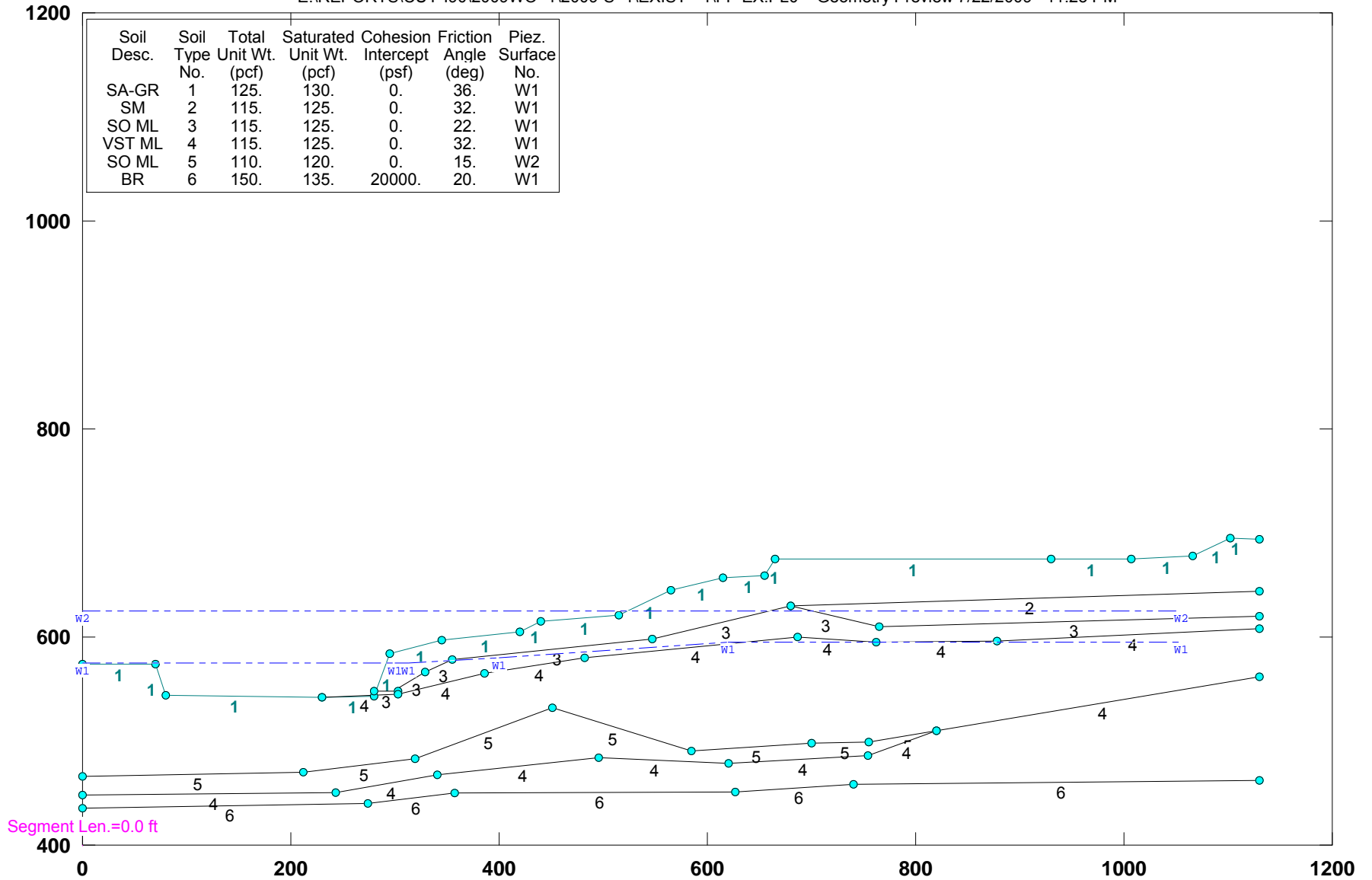

# CUY-90-14.40 (Sec. G-G): Existing Geometry

E:\REPORTS\CUY-190\2009WO~1\2009-S~1\EXIST--1\GG-EX.PL0 Geometry Preview 7/22/2009 11:26 PM

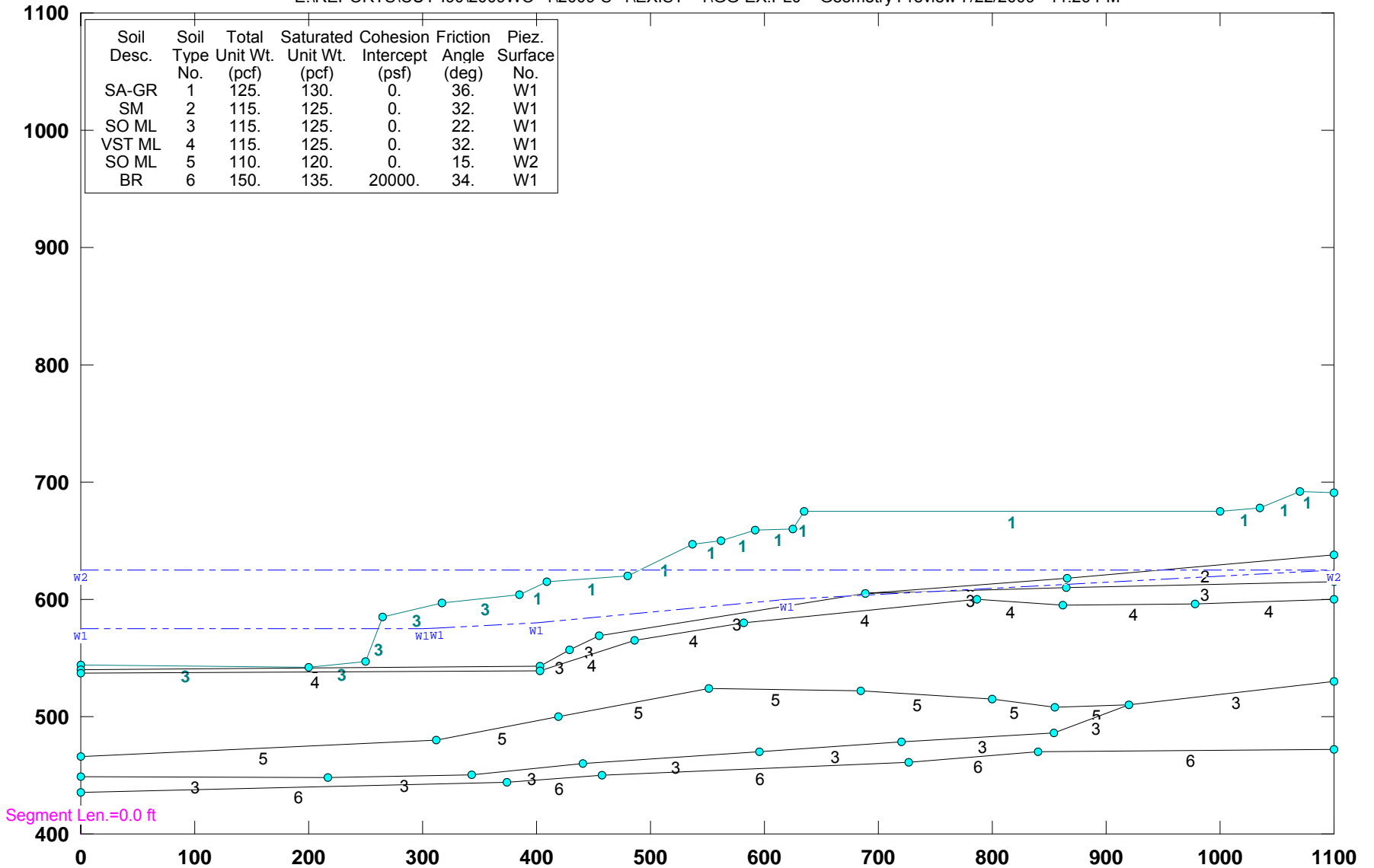

# CUY-90-14.40 (Sec. W-W): EXISTING GEOMETRY

E:\REPORTS\CUY-190\2009WO~1\2009-S~1\EXIST~1\WW-EX.PLO Geometry Preview 7/22/2009 11:27 PM

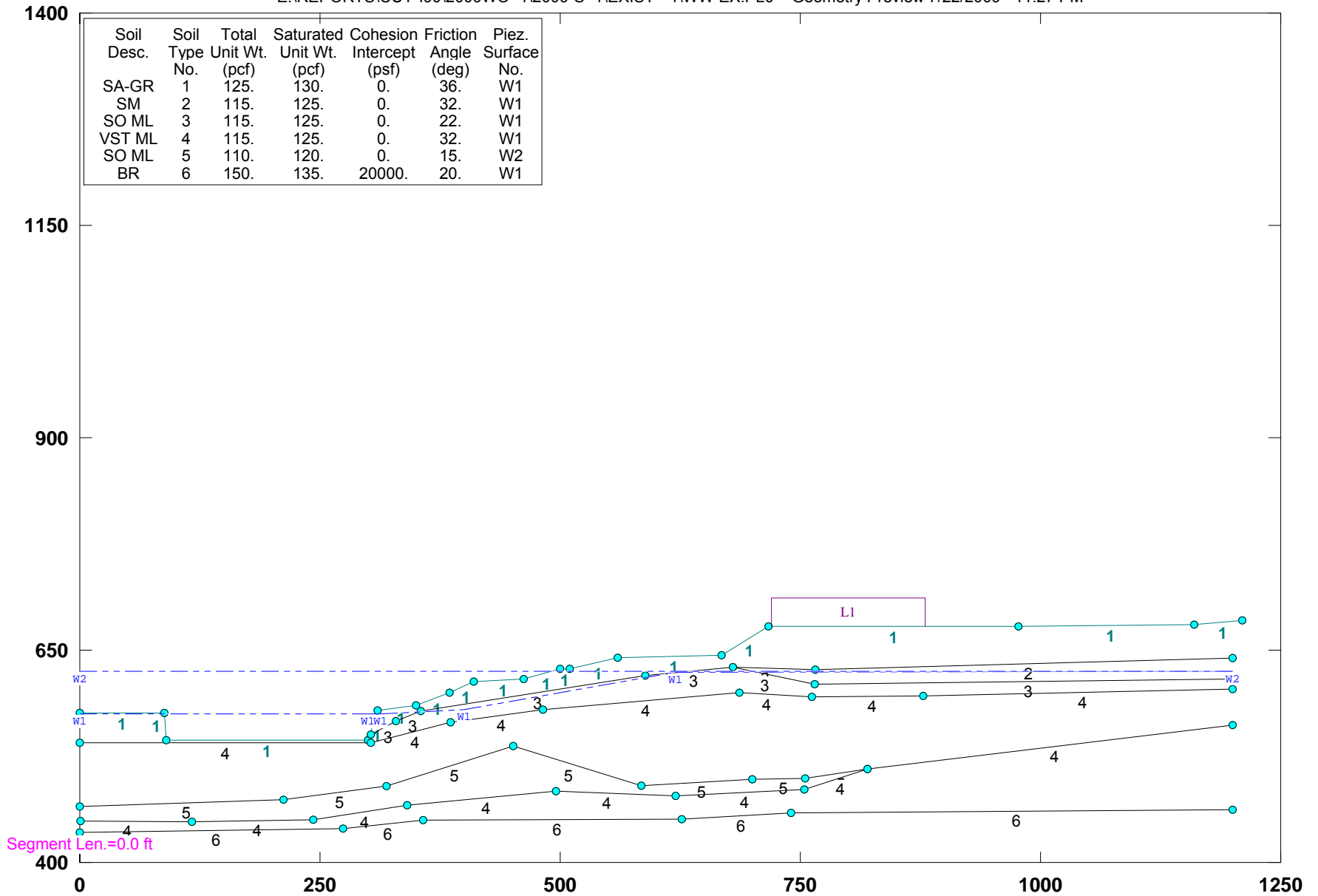

| Soil Desc. | Soil Type No. | Total Unit Wt. (pcf) | Saturated Unit Wt. (pcf) | Cohesion Intercept (psf) | Friction Angle (deg) | Piez. Surface No. |
|------------|---------------|----------------------|--------------------------|--------------------------|----------------------|-------------------|
| SA-GR      | 1             | 125.                 | 130.                     | 0.                       | 36.                  | W1                |
| SM         | 2             | 115.                 | 125.                     | 0.                       | 32.                  | W1                |
| SO ML      | 3             | 115.                 | 125.                     | 0.                       | 22.                  | W1                |
| VST ML     | 4             | 115.                 | 125.                     | 0.                       | 32.                  | W1                |
| SO ML      | 5             | 110.                 | 120.                     | 0.                       | 15.                  | W2                |
| BR         | 6             | 150.                 | 135.                     | 20000.                   | 20.                  | W1                |



# CUY-90-14.40 (Sec. Y-Y): EXISTING GEOMETRY

E:\REPORTS\CUY-190\2009WO~1\2009-S~1\EXIST~1\YY-EX.PL0 Geometry Preview 7/22/2009 11:28 PM

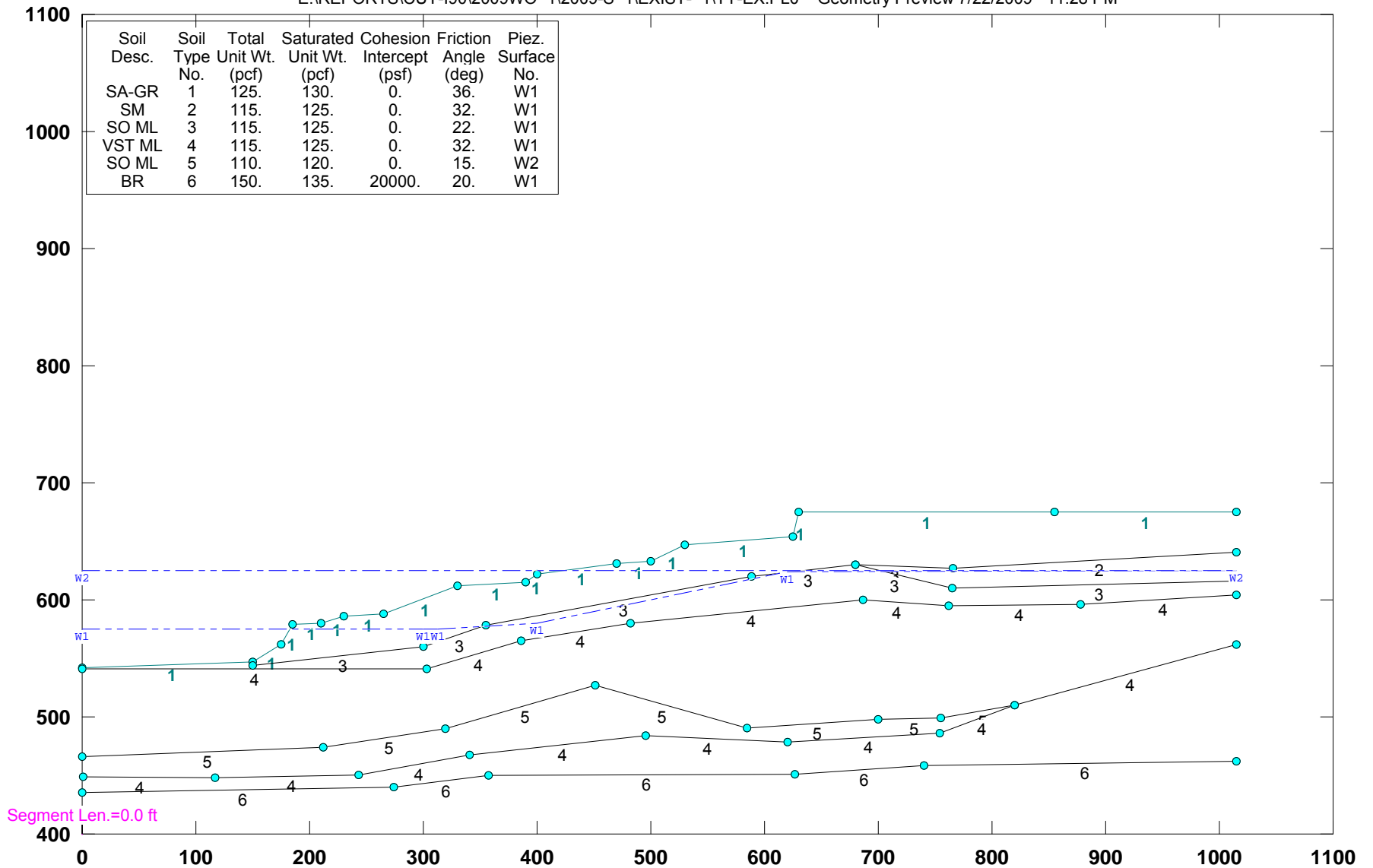



# CUY-90-14.40 (Sec. Z-Z): EXISTING GEOMETRY

E:\REPORTS\CUY-190\2009WO~1\2009-S~1\EXIST~1\ZZ-EX.PL0 Geometry Preview 7/22/2009 11:29 PM

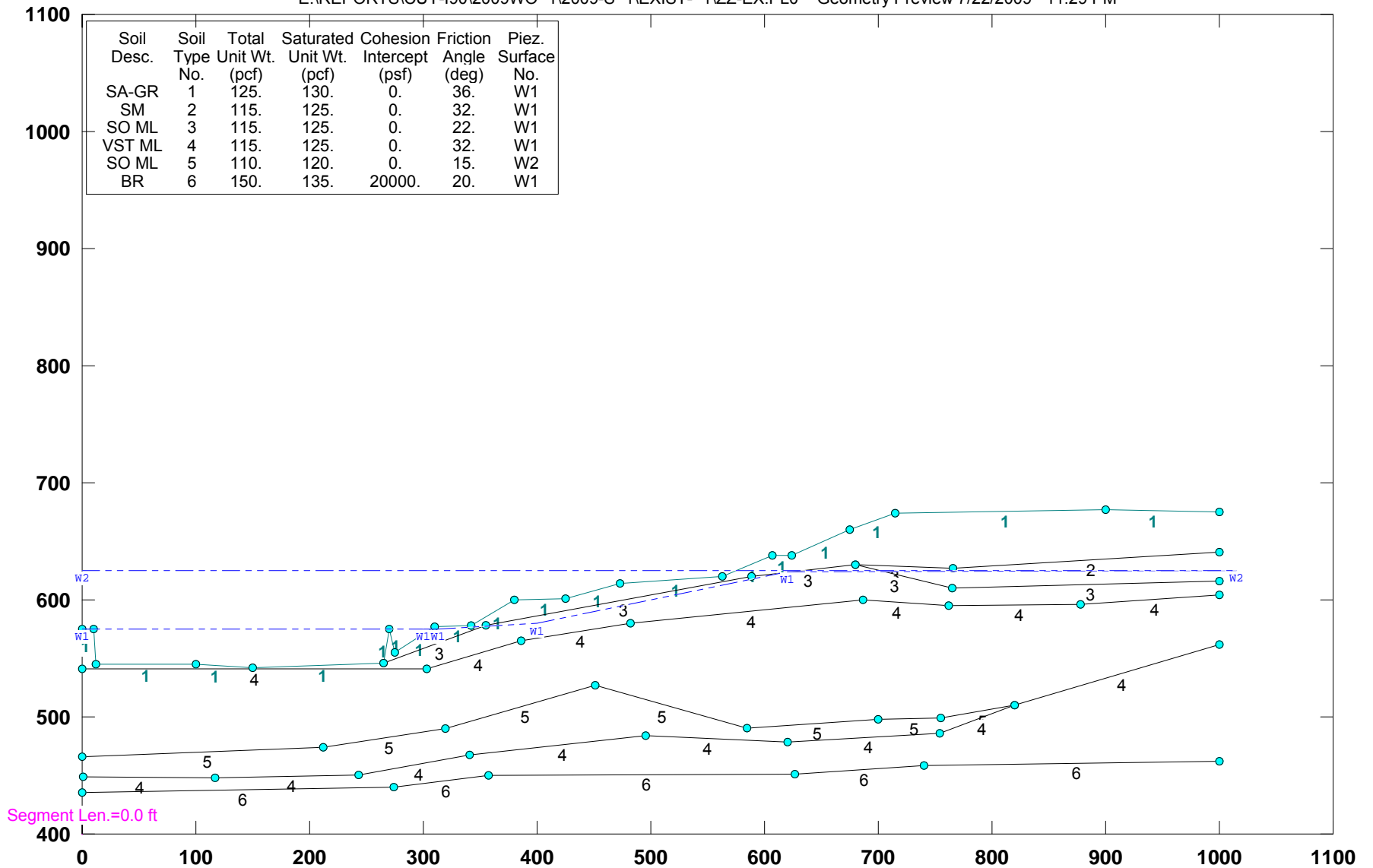

# CUY-90-14.40 (Sec. I-I): PROPOSED EXCAVATED GEOMETRY- STABILITY IF SIDE SLOPE

E:\REPORTS\CUY-190\2009WO~1\2009-S~1\ALT-2\_~1\II-PR.PLO Geometry Preview 7/22/2009 11:35 PM

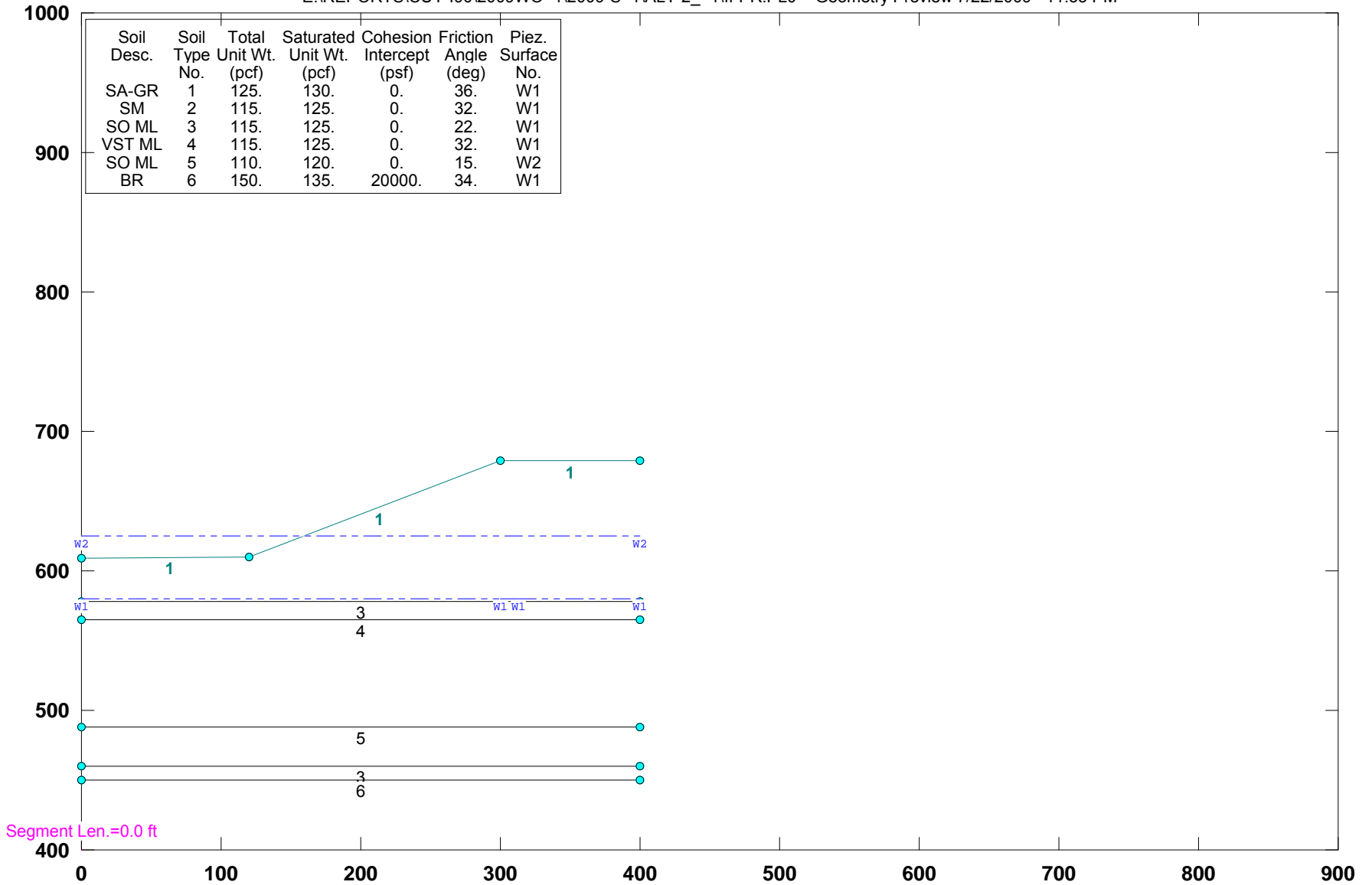

# CUY-90-14.40 (Sec. J-J): PROPOSED EXCAVATED GEOMETRY- STABILITY IF SIDE SLOPE

E:\REPORTS\CUY-190\2009WO~1\2009-S~1\ALT-2\_~1\JJ-PR.PLO Geometry Preview 7/22/2009 11:36 PM

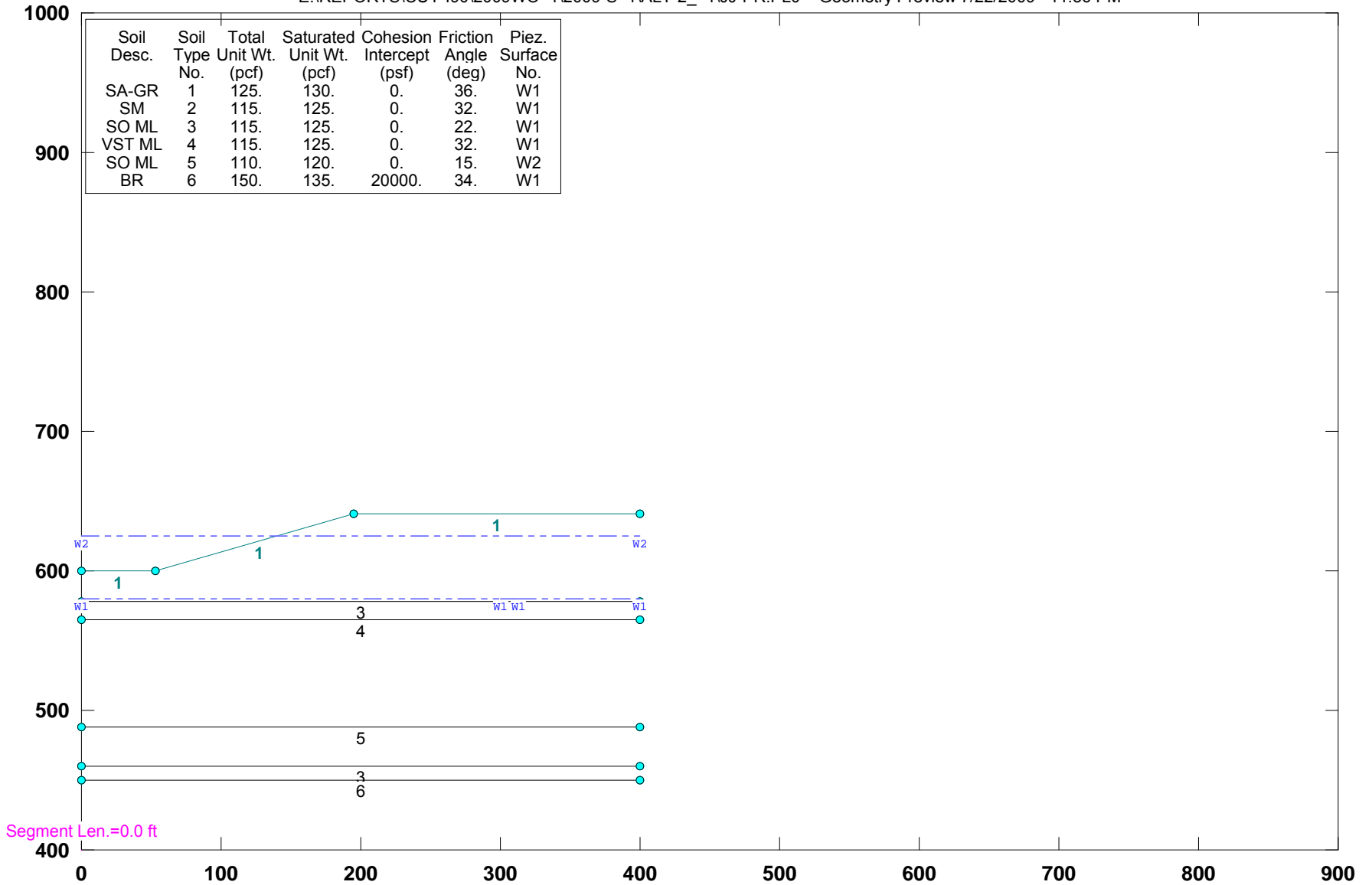

# CUY-90-14.40 (Sec. U-U): PROPOSED EXCAVATED GEOMETRY- STABILITY (Alt-1)

E:\REPORTS\CUY-190\2009WO~1\2009-S~1\ALT-2\_~1\UU-PR.PL0 Geometry Preview 7/22/2009 11:36 PM

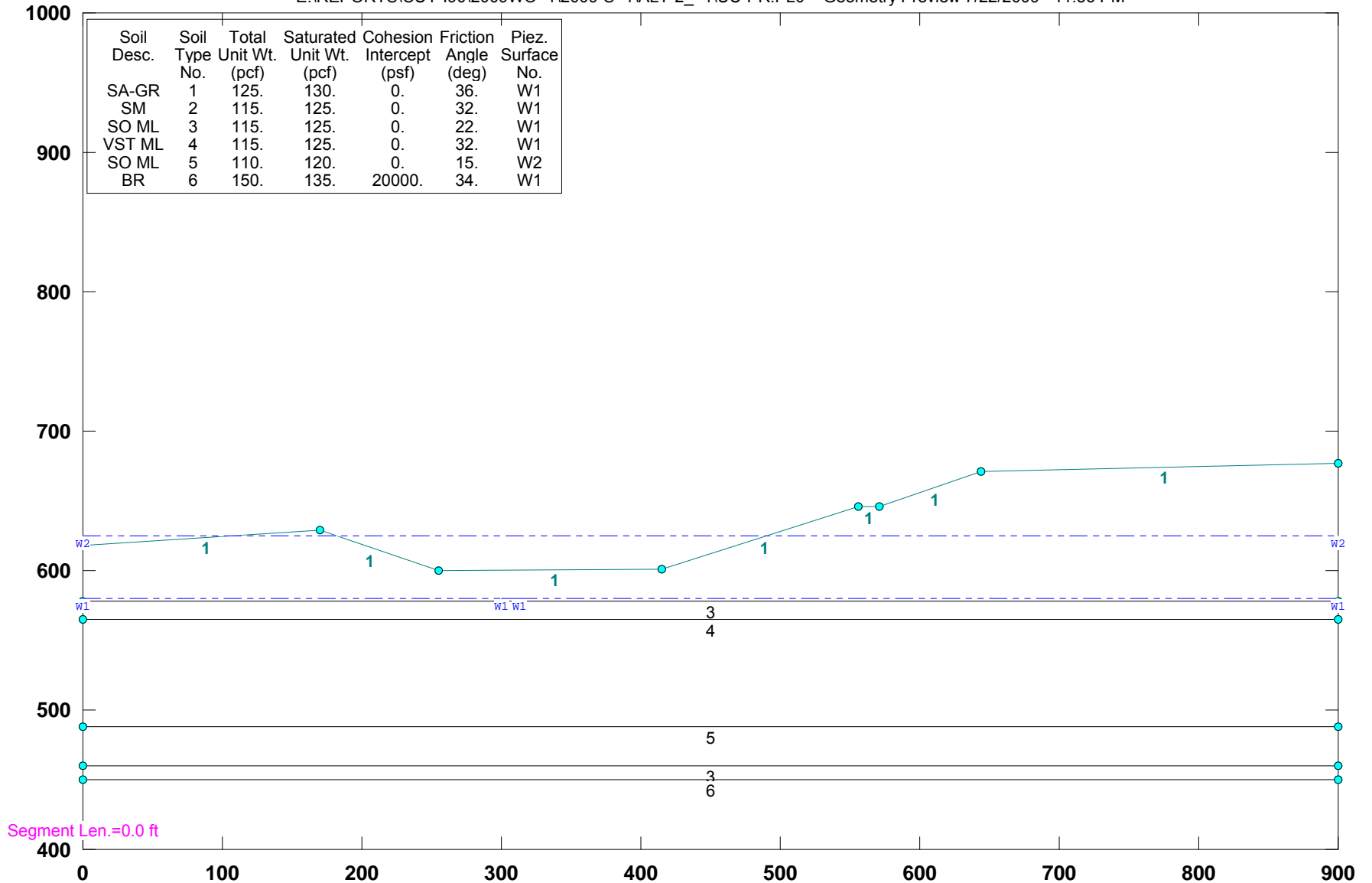

**APPENDIX 6B**

**LOGS OF CPT AND SPT MEASUREMENTS**

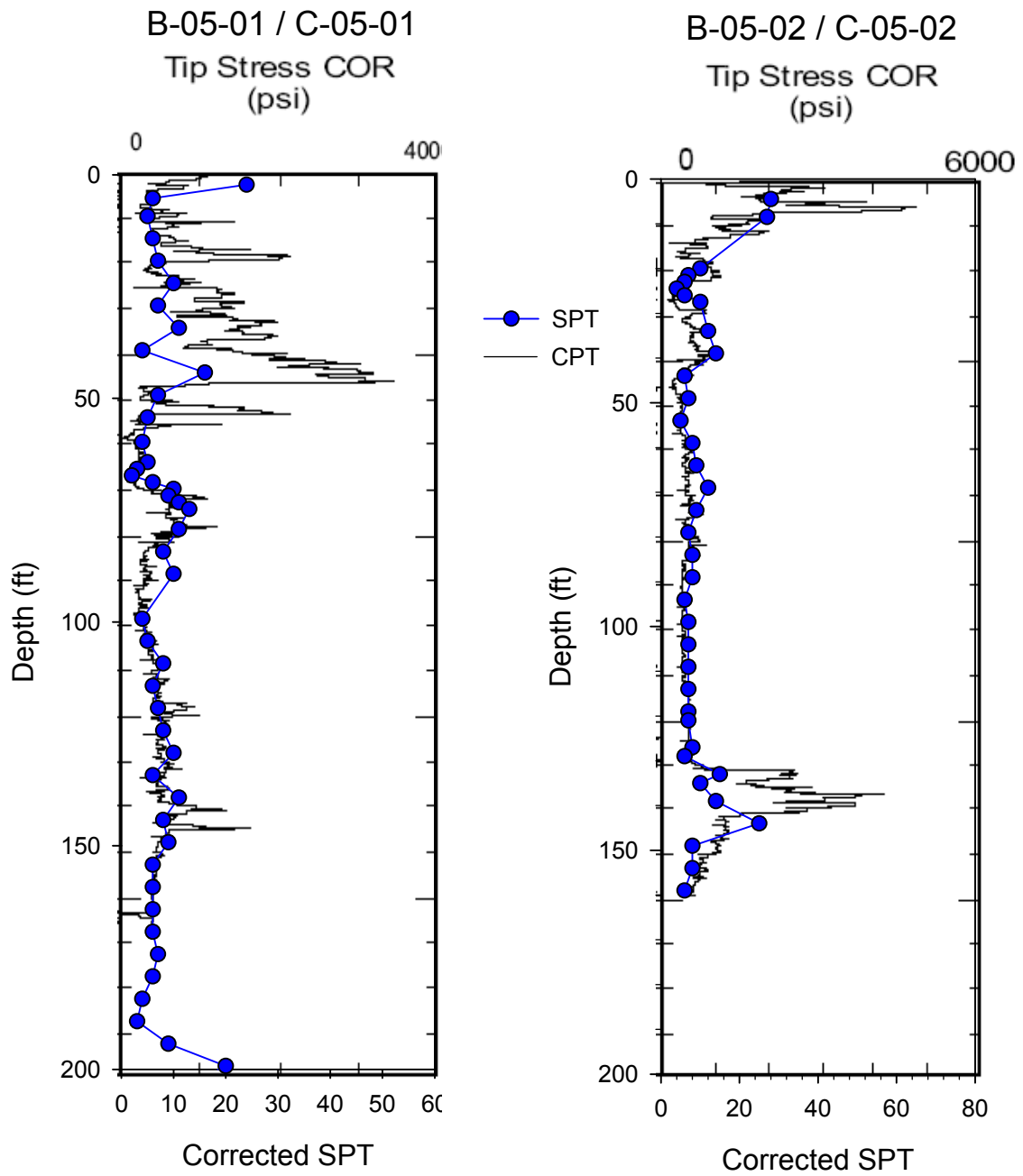

Figure 6B-1: Comparison CPT vs. Corrected SPT for:

a) B-05-01/C-05-01, b) B-05-02/C-05-02

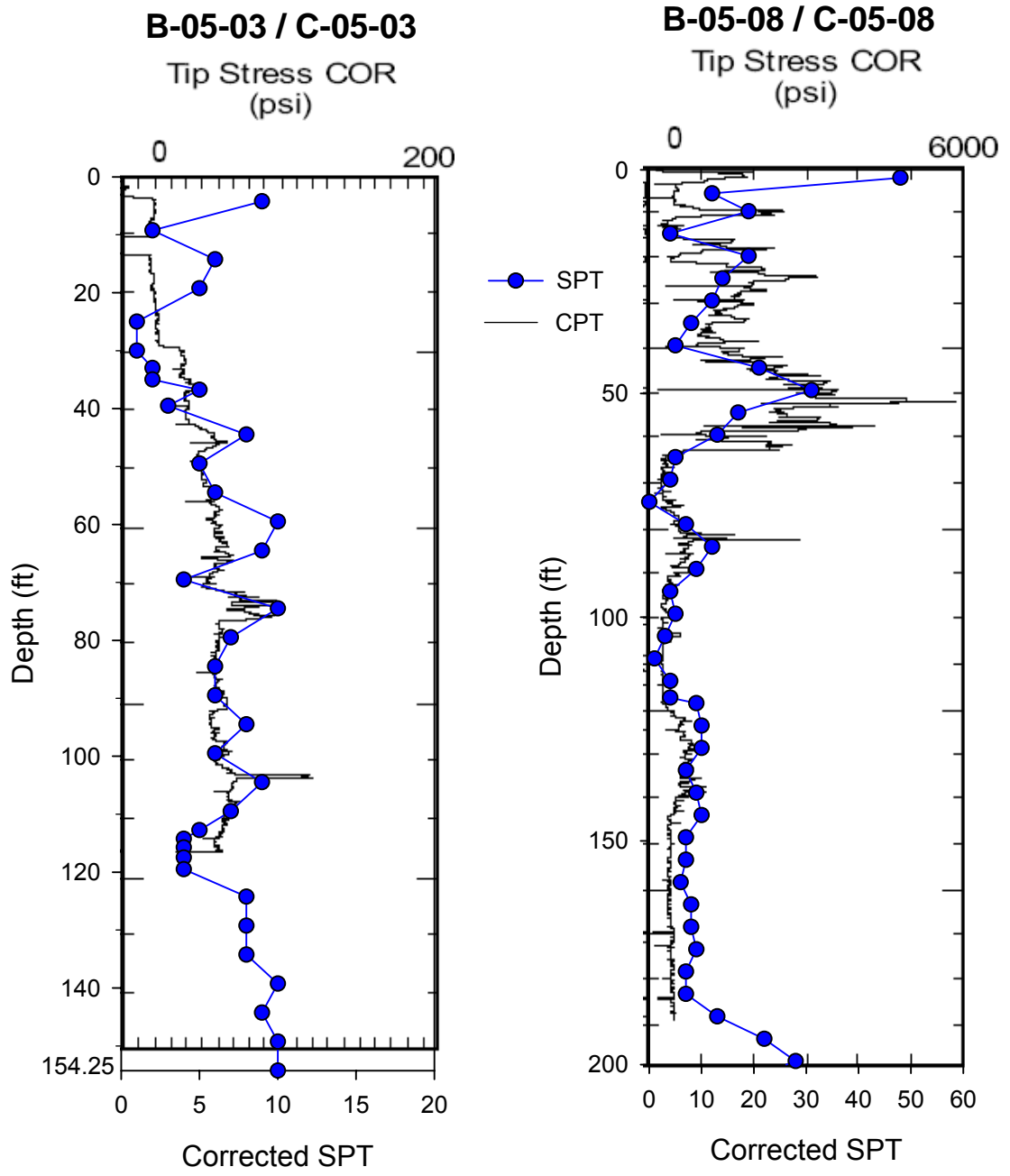

Figure 6B-2: Comparison CPT vs. Corrected SPT for:

a) B-05-03/C-05-03, b) B-05-08/C-05-08

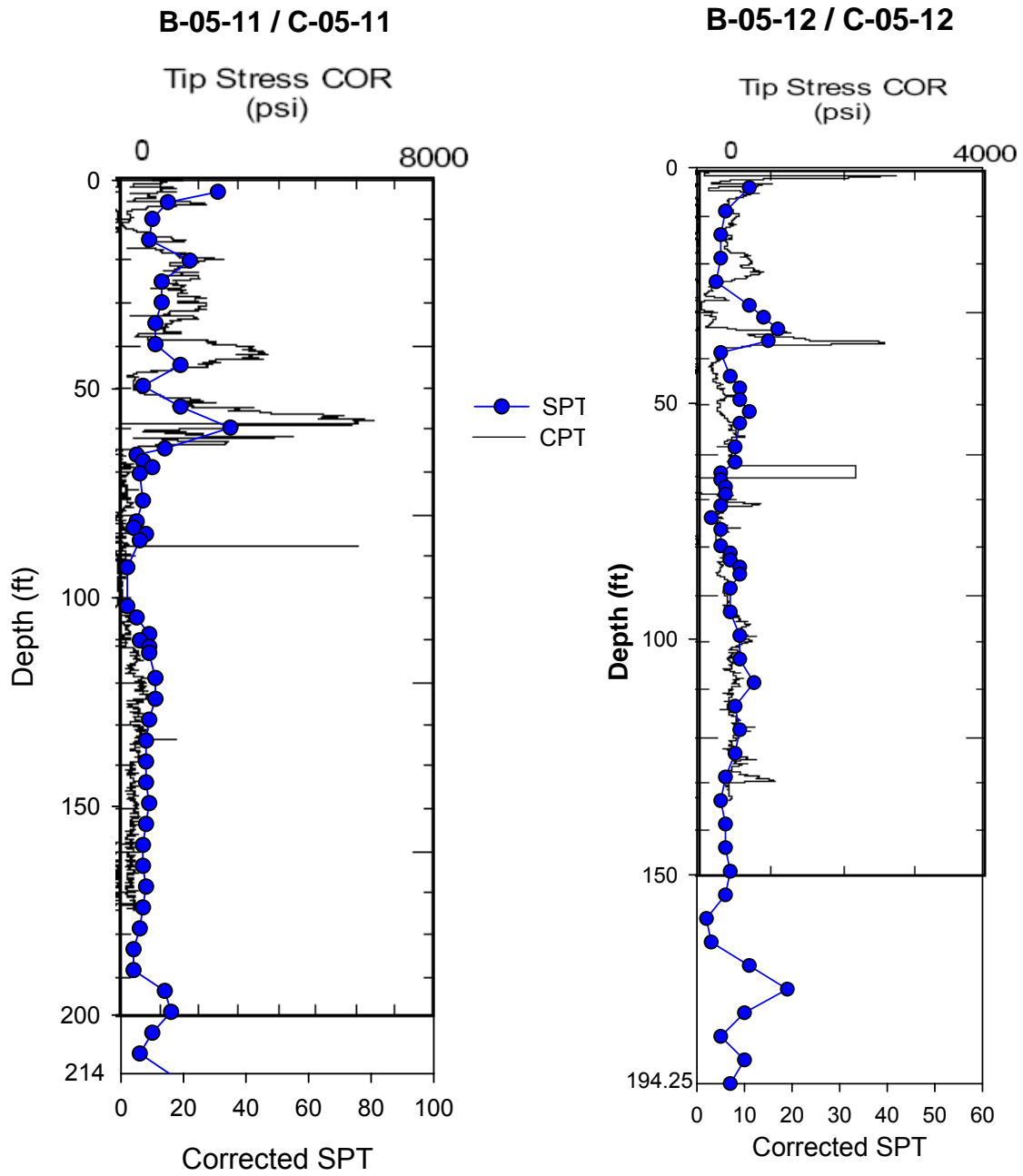

Figure 6B-3: Comparison CPT vs. Corrected SPT for:

a) B-05-11/C-05-11, b) B-05-12/C-05-12



## **CHAPTER 7**

### **EVALUATION OF EXISTING SLOPE AND SLOPE IMPROVEMENT**

Slope stability analyses were performed on fourteen sections located within the west bank of the Cuyahoga River. The selection of the sections for evaluation was discussed with ODOT engineers during numerous progress meetings. The evaluated sections were labeled as Sections A-A, B-B, CL-CL, D-D, E-E, F-F, G-G, I-I, J-J, K-K, U-U, W-W, Y-Y, and Z-Z. Engineering judgment was used to determine the appropriate specific orientation of each section. Generally information, such as, the steepness of the slope along with knowledge of the measured slope movements was used to help predict appropriate orientations for the sections to be evaluated for stability. The approximate general locations of the sections can be described as follows: (1) Section A-A, the centerline of the proposed bridge alignment, (2) Section B-B, 200 feet left of the proposed bridge alignment, (3) Section CL-CL, the centerline of the existing I-90 bridge, (4) Section D-D, just to the south of the alignment of the existing I-90 bridge, (5) Section E-E, on a 24 degree skew to the proposed bridge alignment to capture the influence of the grading on the area around the west end pier of the existing I-90 bridge, (6) Section F-F, along the proposed bridge alignment and approximately 50 feet to the right to capture the influence of grading on the stability of the area between the two bridges, (7) Section G-G, on a 70 degree skew to the proposed bridge alignment to check the influence of the proposed grading on the stability of the side slope close to University Inn and the Railroad Bridge pier on the west bank of the Cuyahoga River, (8) Section I-I, near the Gateway Animal Clinic, perpendicular to the slope grading, (9) Section J-J, near the Rail Road Bridge Abutment, (10) Section K-K, near the Gateway Animal Clinic, (11) Section U-U, on approximately a 90 degree skew to the proposed bridge alignment along University Avenue to check the influence of grading on the stability of the side slope close to existing I-90 bridge west end pier and the area to the east of the Railroad Bridge abutment, (12) Section W-W, on a 15 degree skew to the proposed bridge alignment to capture the influence of the removal of the cold storage building and grading on the area along Abbey road to the north of the proposed bridge, (13) Section Y-Y, on a 30 degree

skew to the proposed bridge alignment to capture the influence of the grading on the area north of the west end pier of the existing I-90 bridge and the area around the railroad pier to the west of the Cuyahoga River bank, and (14) Section Z-Z, on a 30 degree skew to the proposed bridge alignment to capture the influence of the grading on the area under and south of the west end pier of the existing I-90 bridge and the area under the alignment of the proposed bridge at the Cuyahoga River bank.

The subsurface profile models for the cross sections are based on all the subsurface investigation information at and around the west bank of the Cuyahoga River in the proximity of the existing I-90 bridge and along the alignment of the proposed bridge site. The subsurface profiles developed for stability analyses are presented in Chapter 6 and Appendix 6A. The stability analyses utilized all available geotechnical data that was provided through June 2009. The profiles for the studied sections were developed based on the logs of 50 soil borings, measured SPT blow counts, as well as 15 CPT test logs performed in 2006. Some of the profile sections were positioned to be aligned with the slope movements measured by the earth inclinometers. The existing geotechnical soil profiles and boundary loads (existing structures within the slope) for all sections investigated are presented in Appendix 7A and are also shown with the deduced subsurface profiles in Appendix 6A. These geometries and subsurface profiles are based on topographic mapping of the site, and are presented in graphical outputs from the computer analyses program (GSTABL7 with STEDWIN).

Stability analyses were performed mainly using the computer program GSTABL7 with STEDWIN. The analyses were focused on evaluating the effects of geometric (topography and steep slopes), gravimetric (water table and elevated pore water pressures), and environmental (existing building and construction activity) variables on the stability/instability of the existing slopes. For selected sections, additional stability evaluations were performed by Geocomp using the computer program UTEXAS-4.0 and the finite element program PLAXIS. The design recommendations for improving the stability of the slope will be based on the effects caused by these variables. The slope

stability models and evaluation results are described separately in the following sections of this chapter.

Slope stability analyses for the 14 sections were performed for each of the following cases:

- 1- Existing Subsurface Profiles: The existing subsurface profiles for the investigated sections are presented in Appendix 6A.
- 2- Proposed Grading Alternatives for Improving Slope Stability: Four grading alternatives were evaluated and are shown in Appendix 7A. Alternative No. 5 utilizes the preferred features of Alternatives 1 through 4. The Alternative 5 grading plan is also presented in Appendix 7A. For each grading alternative, the following cases were analyzed:
  - a. Circular surface search.
  - b. Circular surface search including an elevated hydrostatic table.
  - c. Block surface search method.
  - d. Block surface search method including an elevated hydrostatic table.

The results of the analyses indicated that the effective stress condition was more critical than the total stress condition. Therefore, the slope stability evaluation and analyses efforts presented in this report are based on the effective stress condition.

## **7.1 Stability Analyses of the Existing Slope**

The slope stability analyses for the existing topography and subsurface conditions at the locations of the investigated sections were performed utilizing the subsurface profile models presented in Chapter 6. The sections were selected to ensure that a comprehensive study of the stability of the west end slope was accomplished. These analyses are essential to verify the factors that are likely related to or have resulted in the existing slope instability and relatively long term slope movements. The slope stability analyses were computed using several geotechnical related variables to study all possible mechanisms that may induce additional load or reduce the shear strength of the slope material.

### 7.1.1 Sections A-A, CL-CL and D-D

These three primary sections are located approximately parallel to the proposed and existing bridge alignments. The initial group of stability analyses was performed to help identify the preferred approach for evaluating the stability of the existing and proposed slope. The preliminary analyses addressed the following slope stability design conditions:

- 1- Total stress and effective stress conditions.
- 2- Effects of existing dead loads, such as structures located within the area of influence to the stability of the slope.
- 3- Effects of the elevated pore water pressure/gas pressure condition on the stability.
- 4- Different shapes of slip surfaces including circular or non-circular (multi-linear) surfaces.
- 5- Evaluating the effects of recent construction activities such as, removal of sheet piles and regrading.

Figures 7B-1, 7B-2, and 7B-3 show three different grading plans for section A-A, which were used in the preliminary analyses. These grading plans consist of (1) the existing slope with the cold storage building, (2) the existing slope with the removal of the building, and (3) the removal of the building with a regraded slope. In the analysis of the centerline cross section (Section CL-CL), the surface inclined loads were introduced in order to represent the contributions of the ground anchors and drilled shafts. The loads shown are smaller than the actual loads to ensure a conservative model is evaluated.

Based on the analytical models in Appendix 6A, the analyses included two distinct water table profiles. Water table (w1) represents the static (long-term) water table levels as measured from the piezometers. Water table (w2) is the hypothetical elevated water table that simulates the pressurized water conditions resulting from the potential methane gas pockets produced from the shale bedrock. Water table w2 is used only to create elevated water pressure in the weak soil layer (number 5).

The results of the preliminary stability analyses of the sections with the existing soil profiles are graphically represented and shown in Appendix 7B, and are also listed in

Table 7.1 in Appendix 7B. The results of the analyses for sections A-A, W-W, B-B, Z-Z, E-E, F-F and Y-Y indicate that the factor of safety is less than 1.30. The target factor of safety is 1.5. The significant effects of water table w2 on the stability of the slopes were also verified by analyzing sections A-A and B-B with and without the elevated piezometric surface (w2). It is important to understand the variables that can reduce the stability of the slope so that the appropriate remedial measures can be specified by the designer.

Figure 7B-1 presents the geometry and material properties used in the analyses at section A-A. The analyses included two distinct water table profiles. Water table (w1) represents the static water table as measured from the piezometers. Water table (w2) is an elevated hypothetical water table to simulate the effect of the potential gas pockets. Water table w2 is used only to create elevated water pressure in the weak soil layer (number 5), described in Table 6.1.

The geometry and material properties used in the analysis of Section CL-CL along the centerline of the existing bridge are shown in Figure 7B-4. Figure 7B-5 presents the geometry and material properties for Section D-D, which is parallel to the existing bridge and located approximately 30 feet to the south of the existing structure.

Slope stability analyses were performed using the groundwater table reported in the previous subsurface investigations and long term monitoring reports. As stated in Chapter 6 of this report, the piezometers data was last collected in April 2009. The water table used in these analyses was revised to reflect the water elevation based on the April 2009 piezometers readings.

The results of the stability analyses of the existing slopes at the studied cross-sections (Section A-A, centerline-section CL-CL, and Section D-D) are graphically presented in Figures 7B-6 through 7B-15, and are also listed in Table 7B.1 in Appendix 7B. The results of the stability analyses for the various slope cross sections indicate the following:

1. The effective stress analysis is shown to be more critical than the total stress analysis. The resulting safety factor based on effective stress analysis of section A-A (Figures 7B-6 with FS=1.08 (w2)) is less than the safety factor based on the total stress analysis (Figures 7B-7 with FS=1.17 (w2)). Accordingly, effective

stress analyses were used for all sections and for examining the effects of different factors on the stability of the existing slopes.

2. The existing slope at both sides of the centerline of the existing bridge (Sections A-A and D-D) has a relatively low factor of safety, whereas the existing bridge centerline slope has a factor of safety (F.S.) that is greater than 1.50 (w2). This is attributed to the existence of the stabilization structure, which includes drilled shafts, piles and ground anchors.
3. The hypothetical pore water pressure, represented by water table w2 is shown to be the most influential factor leading to the stability/instability of the slopes. Increasing the elevation of the w2 water table to elevations 625 or 650 significantly reduced the safety factors of sections A-A, CL-CL and D-D (Figures 7B-8 to 7B-11). The effects of this elevated pore water are further investigated in the next subsection.
4. Block search with non-circular slip surface models were also used to study the stability of section A-A (Figures 7B-12 through 7B-14). In Figures 7B-12 and 7B-14 the strength parameters of the bottom layer, which is located immediately above bedrock, are based on the laboratory results and the field SPT blow counts. Whereas in Figure 7B-13, this layer was assumed to have strength equal to the soil residual strength. In Figures 7B-12 and 7B-14 this layer was also assumed to have residual strength with elevated water table (w2) conditions. The block search for all conditions resulted in higher safety factors than those obtained from the circular or semicircular surfaces.
5. The recent construction activities (removal of sheet piles and excavating a portion of the toe of the slope and placing the excavated material on the existing slope are shown to slightly reduce the safety factor of the slope (Figure 7B-15).

### **7.1.2 Analyses for Improving Stability**

The construction of the proposed bridge will require the removal of the existing relatively large abandoned cold storage building and some of the soil which is immediately beneath

the building. The stability evaluation results of section A-A after removing the building and the uppermost slope are presented in Figure 7B-16. To study the effect of the building removal, a series of analyses were performed by forcing the slip plane to terminate under the building, then removing the building and reanalyzing the slope forcing the slip plane to remain within the limits of the building footprint. With the building removed the safety factor improved from 0.99 (w2) to 1.13 (w2) as demonstrated in Figures 7B-16A and 7B-16B. All of the subsequent analyses for section A-A did assume that this building structure has been removed.

Numerous slope grading models were analyzed to evaluate the stability of the slope. The increase in stability as a result of lowering the elevations of water tables w1 and w2 was quantified. Lowering the water tables can be accomplished by using horizontal and vertical drains as follows:

1. Horizontal drains installed above the existing river pool elevation (El. 580.0 feet) can help to reduce the w1 water table elevation to approximately 580.0 feet within the west bank slope. The results of stability analyses based on these assumptions are shown in Figures 7B-17, 7B-18, and 7B-19 for sections A-A, centerline (Section CL-CL), and section D-D, respectively.
2. By installing horizontal drains and excavating the slope at section A-A, stability is significantly improved (Figure 7B-20). Slope excavations and lowering the water table are shown to increase the safety factor from 1.37 (w1) to 1.51 (w1).
3. Using the Block Search and non-circular slip surfaces, the stability of section A-A, with the bottom layer at residual strength, is also shown to significantly increase as indicated by a safety factor of 1.69 (w1,w2@600') (Figure 7B-21).
4. The advantages of horizontal drains are: (1) facilitate a rapid dissipation of pore pressures, thus reducing the elevations of w1 to approximate elevation 580 feet within the slope area, (2) improve the strength and compressibility of the weak cohesive soil layers by increasing the preconsolidation stress, at least by an amount equivalent to the excess pore pressures (estimated between 7.0 and 15.0 ksf, depending on the location within the slope and the existing pore pressures).

The results of the stability analyses, shown in Figures 7B-22 thru 7B-25, indicate that the vertical and horizontal drains provide significant improvements in the safety factors for the slopes.

Additional improvement to the stability of the slope at section A-A was also obtained by excavating the slope as shown in Figures 7B-25. The resulting safety factor was further increased to 1.66. Slope excavation (grading) without the aid of vertical or horizontal drains is shown to improve the stability of the slope and result in a safety factor of 1.53, as shown in Figures 7B-26. The recommended grading profile starting with 2.5:1 at Abbey and transitioning to 15:1 and extending to the river resulted in a safety factor of greater than 1.5 as shown in Figures in appendices 7C thru 7J. Assuming the hypothetical water surface w2 is lowered from elevation 625.0 feet to elevation 600 feet, the factor of safety will increase from 1.61 to 1.99 as shown in Figures 7B-28 and 7B-29. A summary of the results of the stability analyses is provided in Table 7B.1.

### **7.1.3 Slope Stability Issues**

Based on the slope stability analyses, the following remarks can be made:

- 1- The evaluations and verifications of slope safety should be based on effective stress (long-term) analyses.
- 2- Circular and non-circular (block search) methods should both be utilized.
- 3- Improvements to the stability of the slope (existing and planned future) will be contingent on providing the following slope improvements:
  - a. Removal of or reducing the boundary loads.
  - b. Re-grading of the slopes in such a way as to reduce the driving forces within the upper portions of the slopes.
  - c. Preventing or controlling the w2 elevated water table. This can be accomplished by pressure relief wells.
  - d. The improvement to slope stability should be based on both the resulting factors of safety and the percentage of increase (improvement) in the factors of safety from the original stability analysis, which is the stability under existing conditions.



It is essential to evaluate stability for all existing sections by first evaluating the existing slope stability condition and then the slope stability after the various grading excavation profiles have been considered. In addition the benefits of the use of horizontal gravity drains and vertical gas relief wells should be considered. For each of the five grading alternatives, the following cases were analyzed:

- a. Circular slip surfaces search.
- b. Circular slip surfaces search including w2.
- c. Block search surface method.
- d. Block search surface method including w2.

## **7.2 Stability Analysis of the Existing and Graded Slopes**

### **7.2.1 Stability of the Existing Slope**

The slope stability analyses for the existing conditions were performed utilizing the developed subsurface profile models presented in Chapter 6. The final location of the sections to be analyzed was recommended by E.L. Robinson and agreed to by ODOT and the surface elevations were provided by Baker. The sections were selected to study the stability of the slope to the west of the Cuyahoga River and the impact of the grading on the existing I-90 bridge. These analyses are essential to verify the factors that are likely related to or have resulted in the existing instabilities and slope movements. They were conducted by varying several geotechnical related conditions to address all possible mechanisms that may induce additional load or reduction in the shear strength of the slope material.

Based on the analytical models in Appendix 6A, the analyses for all existing sections considered two distinct water table profiles, w1 and w2.

The results of the stability analyses for the sections are graphically represented in Appendix 7C, and are also listed in Table 7.1. Based on these results, sections A-A, W-W, B-B, Z-Z, E-E, F-F and Y-Y are shown to be critical (not meeting the minimum required factor of safety) with factors of safety less than 1.30 (some are less than 1.0). The significant effects of the pressurized water (represented by water table w2) on the

stability of the slopes were also verified by analyzing sections A-A and B-B with and without the piezometric surface (w2). Accordingly, improvements to the stability of the area will be based on selecting the best grading plan which leads to an acceptable improvement to safety, and also verifying the improvements resulting from preventing the pore water pressure increases (i.e., w2) from occurring.

### **7.2.2 Stability Analyses of the Slope Grading Alternatives**

The results of the slope stability analyses for each of the grading alternatives 1 through 5 are presented in Appendices 7D through 7H, respectively. Alternative 5 was generated by selecting the best features of Alternatives 1 thru 4. The results are also presented in Table 7.1 for different conditions like introducing the berm in the slope, and the use of elevated water table (w2). The verification of the analysis by Geocomp Corporation using UTEXAS 4.0 and Finite Element Program PLAXIS for some of the sections and grading alternatives is presented in Appendix J. The influence of locating a substructure unit on the west side of Abbey was studied and found not to affect the stability as shown in Appendix 7I.

Based on these results, the following remarks and conclusions are made:

- 1- The use of pressure relief wells will improve the stability of the overall slope by preventing the high water table (w2) condition from developing.
- 2- The pressurized water (development of elevated w2) can be considered to be a rare event, similar to a seismic activity. The required minimum factor of safety for this unlikely condition should be taken as 1.10, provided that pressure relief wells are installed.
- 3- The advantages of relief wells are to: (1) facilitate the dissipation of pore pressures, and prevent the occurrence of excess pore pressure, (2) improve the strength and compressibility of the weak cohesive soil layers by increasing the preconsolidation stress.
- 4- The use of horizontal drains in the areas with 2.5H:1V slopes will improve the stability of the steeper portions of the graded slope.

**Table 7.1 CUY-90-14.52 WEST ABUTMENT SLOPE STABILITY ANALYSIS MATRIX (App. 7C – 7H)**

| Section | Case * | Excavation side slopes |                |        | Berm (Y/N) | Water |       | Factor of Safety |       |      |      |      | Improvement |       |      | Best Alternative   |
|---------|--------|------------------------|----------------|--------|------------|-------|-------|------------------|-------|------|------|------|-------------|-------|------|--------------------|
|         |        | Top                    | Middle         | Bottom |            | w1    | w2    | Circular         | Block | UTEX |      | PLAX | Circular    | Block | Grid |                    |
|         |        |                        |                |        |            | Circ. | Block |                  |       |      |      |      |             |       |      |                    |
| A-A     | Ex     | Flat                   | 2:1            | 6:1    |            | Y     | Y     | 0.99             | 0.91  | 1.10 | 1.08 | 1.06 | -           | -     |      | Alt. 4<br>& Alt. 5 |
|         |        |                        |                |        |            | Y     | N     | 1.13             | 1.09  |      |      |      |             |       |      |                    |
|         | A1     | 3:1                    | 13:1/<br>3.5:1 | 15:1   | N          | Y     | Y     | 1.48             | 1.38  |      |      |      | 49.5        | 50.0  |      |                    |
|         | A2     | 3:1                    | 7:1            | 15:1   | N          | Y     | Y     | 1.37             | 1.28  | 1.46 | 1.31 | 1.28 | 38.4        | 40.2  |      |                    |
|         | A3     | 3:1                    | 8:1            | 15:1   | Y          | Y     | Y     | 1.47             | 1.29  |      |      |      | 48.5        | 40.2  |      |                    |
|         |        |                        |                |        |            | Y     | N     | 1.49             | 1.30  |      |      |      | 51.5        | 41.3  |      |                    |
|         | A5     |                        |                |        | Y          | Y     | Y     | 1.51             | 1.32  | 1.64 | 1.43 | 1.51 | 51.5        | 44.6  |      |                    |
| Y       |        |                        |                |        |            | N     | 1.90  | 1.71             | 2.08  | 1.84 | 1.83 |      | 85.9        | 81.5  |      |                    |
| B-B     | Ex     | Flat                   | 1:1            | 6.5:1  |            | Y     | Y     | 1.02             | 0.98  |      |      |      | -           | -     |      | Alt. 2<br>Alt. 4   |
|         |        |                        |                |        |            | Y     | N     | 1.22             | 1.23  |      |      |      |             |       |      |                    |
|         | A1     | 6:1                    | 2.5:1          | 18:1   | N          | Y     | Y     | 1.25             | 1.21  |      |      |      | 23.5        | 24.2  |      |                    |
|         | A2     | 6:1                    | 2.5:1          | 20:1   | N          | Y     | Y     | 1.97             | 1.35  |      |      |      | 88.2        | 36.4  |      |                    |
|         | A3     | 6:1                    | 3.4:1          | 15:1   | Y          | Y     | Y     | 1.98             | 1.33  |      |      |      | 89.2        | 34.3  |      |                    |
|         |        |                        |                |        |            | Y     | Y     | 1.48             | 1.30  |      |      |      | 45.1        | 31.3  |      |                    |
|         | A4     | 2.5:1                  | 4:1            | 15:1   | Y          | Y     | N     | 1.87             | 1.85  |      |      |      | 83.3        | 75.8  |      |                    |
| Y       |        |                        |                |        |            | Y     | 1.31  | 1.19             |       |      |      | 28.4 | 20.2        |       |      |                    |
| A5      |        |                        |                | Y      | Y          | N     | 1.61  | 1.52             |       |      |      | 57.8 | 53.5        |       |      |                    |

\* Ex: existing; Ai: Alternative No. i (eg.: A1: Alternative 1)

\* Improvement:  $\Delta FS/FS_{ex}$

**Table 7.1 CUY-90-14.52 WEST ABUTMENT SLOPE STABILITY ANALYSIS MATRIX (App. 7C – 7H)**

| Section | Case* | Excavation slopes |        |        | Berm (Y/N) | Water |      | Factor of Safety |       |      |       |      | Improvement |       |      | Best Alternative |
|---------|-------|-------------------|--------|--------|------------|-------|------|------------------|-------|------|-------|------|-------------|-------|------|------------------|
|         |       | Top               | Middle | Bottom |            | w1    | w2   | Circular         | Block | UTEX |       | PLAX | Circular    | Block | Grid |                  |
|         |       |                   |        |        |            |       |      |                  |       | Circ | Block |      |             |       |      |                  |
| CL-CL   | Ex    | Flat              | 2.25:1 | 5.5:1  |            | Y     | Y    | 1.55             | 1.84  |      |       |      | -           | -     |      | Alt. 4           |
|         | A1    | 2:1               | 3:1    | 15:1   | N          | Y     | Y    | 1.47             | NA    |      |       |      | -           | -     |      |                  |
|         | A2    | 2:1               | 3:1    | 15:1   | N          | Y     | Y    | NA               | NA    |      |       |      | -           | -     |      |                  |
|         | A3    | 2:1               | 4:1    | 15:1   | Y          | Y     | Y    | NA               | NA    |      |       |      | -           | -     |      |                  |
|         | A4    | 2.5:1             | 2.5:1  | 15:1   | Y          | Y     | Y    | 1.59             | 1.55  |      |       |      | -10%        | -10%  |      |                  |
|         |       |                   |        |        |            | Y     | N    | 1.59             | 1.55  |      |       |      | -           | -     |      |                  |
| D-D     | Ex    | Flat              | 2:1    | 6:1    | -          | Y     | Y    | 0.98             | 0.94  |      |       |      | NA          | NA    |      | Alt. 4           |
|         | A1    | -                 | -      | -      | -          | Y     | Y    | NA               | NA    |      |       |      | NA          | NA    |      |                  |
|         | A2    | -                 | -      | -      | -          | Y     | Y    | NA               | NA    |      |       |      | NA          | NA    |      |                  |
|         | A3    | -                 | -      | -      | Y          | Y     | Y    | -                | -     |      |       |      | NA          | NA    |      |                  |
|         | A4    | 2.5:1             | 2.5:1  | 15:1   | Y          | Y     | Y    | 1.13/<br>1.25    | 1.01  |      |       |      | NA          | NA    |      |                  |
|         |       |                   |        |        |            | Y     | N    | 1.43             | 1.38  |      |       |      | NA          | NA    |      |                  |
|         | A5    |                   |        |        | Y          | Y     | Y    | 1.15             | 1.05  | 1.30 | 1.27  | 1.17 | NA          | NA    |      |                  |
|         |       |                   |        | Y      |            | N     | 1.31 | 1.26             | 1.35  | 1.54 | 1.30  | NA   | NA          |       |      |                  |
| E-E     | Ex    | 5:1               | 2:1    | 8:1    | -          | Y     | Y    | 1.01             | 0.99  |      |       |      | -           | -     |      | Alt. 5           |
|         | A1    | 5:1               | 2.5:1  | 15:1   | N          | Y     | Y    | 1.27             | 1.22  |      |       |      | 24.5        | 23.2  |      |                  |
|         | A2    | 5:1               | 2.4:1  | 15:1   | N          | Y     | Y    | 1.83             | 1.41  |      |       |      | 78.4        | 42.4  |      |                  |
|         | A3    | 4:1               | 3:1    | -      | Y          | Y     | Y    | 1.83             | 1.41  |      |       |      | 78.4        | 42.4  |      |                  |
|         | A4    | 2.5:1             | 2.5:1  | 15:1   | Y          | Y     | Y    | 1.55             | 1.23  |      |       |      | 50.0        | 23.2  |      |                  |
|         |       |                   |        |        |            | Y     | N    | 1.75             | 1.51  |      |       |      | 71.6        | 51.5  |      |                  |
|         | A5    |                   |        |        | Y          | Y     | Y    | 1.62             | 1.31  |      |       |      | 57.8        | 33.3  |      |                  |
|         |       |                   |        | Y      |            | N     | 1.91 | 1.74             |       |      |       | 86.3 | 33.3        |       |      |                  |

\* Ex: existing; Ai: Alternative No. i (eg.: A1: Alternative 1)

\* Improvement:  $\Delta FS/FS_{ex}$

**Table 7.1 CUY-90-14.52 WEST ABUTMENT SLOPE STABILITY ANALYSIS MATRIX (App. 7C – 7H)**

| Section    | Case* | Excavation slopes |                |               | Berm (Y/N) | Water |      | Factor of Safety |       |      |       |      | Improvement |       |      | Best Alternative        |
|------------|-------|-------------------|----------------|---------------|------------|-------|------|------------------|-------|------|-------|------|-------------|-------|------|-------------------------|
|            |       | Top               | Middle         | Bottom        |            | w1    | w2   | Circular         | Block | UTEX |       | PLAX | Circular    | Block | Grid |                         |
|            |       |                   |                |               |            |       |      |                  |       | Circ | Block |      |             |       |      |                         |
| <b>F-F</b> | Ex    | flat              | 4:1            | 7:1           | -          | Y     | Y    | 1.20             | 1.19  |      |       |      | -           | -     |      | <b>Alt. 4</b>           |
|            | A1    | 12:1              | 3:1            | 15:1          | N          | Y     | Y    | 1.22             | 1.20  |      |       |      | 0.8         | 0.8   |      |                         |
|            | A2    | 12:1              | 3:1            | 13:1          | N          | Y     | Y    | 1.44             | 1.36  |      |       |      | 41.2        | 38.4  |      |                         |
|            | A3    | 4:1/<br>20:1      | 3.5:1          | 10:1          | Y          | Y     | Y    | 1.44             | 1.38  |      |       |      | 42.2        | 39.4  |      |                         |
|            | A4    | 2.5:1             | 15:1/<br>2.5:1 | 15:1          | Y          | Y     | Y    | 1.49             | 1.40  |      |       |      | 46.1        | 41.4  |      |                         |
|            |       |                   |                |               |            | Y     | N    | 1.69             | 1.62  |      |       |      | 65.7        | 63.6  |      |                         |
| A5         |       |                   |                | Y             | Y          | Y     | 1.47 | 1.38             |       |      |       | 21.5 | 15.0        |       |      |                         |
|            |       |                   |                |               | Y          | N     | 1.65 | 1.60             |       |      |       | 36.4 | 33.3        |       |      |                         |
| <b>G-G</b> | Ex    | 10:1              | 6:1            | 12:1          | -          | Y     | Y    | 3.42             | OK    | 3.76 | --    | 3.55 | OK          | OK    |      | <b>All Alternatives</b> |
|            | A1    | 2.5:1             | 25:1           | -5:1          | N          | Y     | Y    | 2.21             | 2.32  |      |       |      | OK          | OK    |      |                         |
|            | A2    | 2.5:1             | 20:1           | -4:1          | N          | Y     | Y    | 2.63             | 2.86  | 1.86 | 1.86  | 1.75 | OK          | OK    |      |                         |
|            | A3    | 2.5:1             | 3:1            | 35:1/<br>-3:1 | Y          | Y     | Y    | 2.02             | 2.09  |      |       |      | OK          | OK    |      |                         |
|            | A4    | 2.5:1             | 2.5:1          | 15:1          | Y          | Y     | Y    | 2.27             | 2.41  |      |       |      | OK          | OK    |      |                         |
|            |       |                   |                |               |            | Y     | N    | OK               | 2.41  |      |       |      | OK          | OK    |      |                         |
| A5         |       |                   |                | Y             | Y          | Y     | 2.12 | 2.33             | 2.10  | 2.41 | 2.24  | OK   | OK          |       |      |                         |
|            |       |                   |                |               | Y          | N     | 2.12 | 2.33             |       |      |       | OK   | OK          |       |      |                         |
| <b>I-I</b> | Ex    | Flat              | Flat           | Flat          | -          | Y     | Y    | OK               | OK    |      |       |      | OK          | OK    |      | <b>All Alternatives</b> |
|            | A1    | 3:1               | 2.5:1          | 15:1          | N          | Y     | Y    | OK               | NA    |      |       |      | OK          | OK    |      |                         |
|            | A2    | 3:1               | 2.5:1          | 15:1          | N          | Y     | Y    | 1.97             | NA    |      |       |      | OK          | OK    |      |                         |
|            | A3    | 3.5:1             | 3.5:1          | 15:1          | Y          | Y     | Y    | 2.80             | NA    |      |       |      | OK          | OK    |      |                         |
|            | A4    | 2.5:1             | 2.5:1          | 15:1          | Y          | Y     | Y    | 2.25             | NA    |      |       |      | OK          | OK    |      |                         |
|            | A5    |                   |                |               | Y          | Y     | Y    | 2.06             | NA    |      |       |      | OK          | OK    |      |                         |

\* Ex: existing; Ai: Alternative No. i (eg.: A1: Alternative 1)

\* Improvement:  $\Delta FS/FS_{ex}$

**Table 7.1 CUY-90-14.52 WEST ABUTMENT SLOPE STABILITY ANALYSIS MATRIX (App. 7C – 7H)**

| Section    | Case* | Excavation slopes |        |                  | Berm<br>(Y/N) | Water |    | Factor of Safety |       |      |       |      | Improvement |       |      | Best<br>Alternative         |
|------------|-------|-------------------|--------|------------------|---------------|-------|----|------------------|-------|------|-------|------|-------------|-------|------|-----------------------------|
|            |       | Top               | Middle | Bottom           |               | w1    | w2 | Circular         | Block | UTEX |       | PLAX | Circular    | Block | Grid |                             |
|            |       |                   |        |                  |               |       |    |                  |       | Circ | Block |      |             |       |      |                             |
| <b>J-J</b> | Ex    | Flat              | Flat   | Flat             |               | Y     | Y  | OK               | OK    |      |       |      | -           | -     |      | <b>All<br/>Alternatives</b> |
|            | A1    | 3.5:1             | 15:1   | -                | N             | Y     | Y  | OK               | OK    |      |       |      | OK          | OK    |      |                             |
|            | A2    | 3:1               | 15:1   | -                | N             | Y     | Y  | 2.65             | OK    | 2.69 | --    | 2.72 | OK          | OK    |      |                             |
|            | A3    | 2.5:1             | 15:1   | -                | Y             | Y     | Y  | OK               | OK    |      |       |      | OK          | OK    |      |                             |
|            | A4    | 2.5:1             | 15:1   | -                | Y             | Y     | Y  | OK               | OK    |      |       |      | OK          | OK    |      |                             |
|            | A5    |                   |        |                  | Y             | Y     | Y  | 2.36             | NA    | 1.86 | --    | 2.32 | OK          | OK    |      |                             |
| <b>K-K</b> | Ex    |                   |        |                  |               | Y     | Y  | OK               | OK    |      |       |      | -           | -     |      | <b>All<br/>Alternatives</b> |
|            | A1    |                   |        |                  |               | Y     | Y  | OK               | OK    |      |       |      | OK          | OK    |      |                             |
|            | A2    |                   |        |                  |               | Y     | Y  | OK               | OK    |      |       |      | OK          | OK    |      |                             |
|            | A3    |                   |        |                  |               | Y     | Y  | OK               | OK    |      |       |      | OK          | OK    |      |                             |
|            | A4    |                   |        |                  |               | Y     | Y  | 1.83             | NA    |      |       |      | OK          | OK    |      |                             |
| <b>U-U</b> | Ex    | 12:1              | 12:1   | 12:1             |               | Y     | Y  | > 2.0            | OK    |      |       |      | -           | -     |      | <b>All<br/>Alternatives</b> |
|            | A1    | 3:1               | 30:1   | -3:1             | N             | Y     | Y  | 2.27             | 2.42  |      |       |      | OK          | OK    |      |                             |
|            | A2    | 3:1               | 30:1   | -3:1             | N             | Y     | Y  | 2.16             | 2.32  |      |       |      | OK          | OK    |      |                             |
|            | A3    | 3:1               | 3:1    | FLA<br>T/<br>3:1 | Y             | Y     | Y  | 2.31             | 2.52  |      |       |      | OK          | OK    |      |                             |
|            | A4    | 5:1               | 3:1    | FLA<br>T/<br>3:1 | Y             | Y     | Y  | 2.57             | 2.69  |      |       |      | OK          | OK    |      |                             |
|            | A5    |                   |        |                  | Y             | Y     | Y  | 1.75             | 2.88  |      |       |      | OK          | OK    |      |                             |

\* Ex: existing; Ai: Alternative No. i (eg.: A1: Alternative 1)

\* Improvement:  $\Delta FS/FS_{ex}$

**Table 7.1 CUY-90-14.52 WEST ABUTMENT SLOPE STABILITY ANALYSIS MATRIX (App. 7C – 7H)**

| Section | Case* | Excavation slopes |        |        | Berm (Y/N) | Water |      | Factor of Safety |       |      |       | Improvement   |          |       | Best Alternative |                |
|---------|-------|-------------------|--------|--------|------------|-------|------|------------------|-------|------|-------|---------------|----------|-------|------------------|----------------|
|         |       | Top               | Middle | Bottom |            | w1    | w2   | Circular         | Block | UTEX |       | PLAX          | Circular | Block |                  | Grid           |
|         |       |                   |        |        |            |       |      |                  |       | Circ | Block |               |          |       |                  |                |
| W-W     | Ex    | Flat              | 1.3:1  | 7:1    |            | Y     | Y    | 0.98             | 0.97  | 1.17 | 1.12  | 1.09          | OK       | OK    |                  | Alt. 5         |
|         | A1    | 3:1               | 15:1   | -      | N          | Y     | Y    | 1.62             | 1.60  |      |       |               | 65.3     | 64.9  |                  |                |
|         | A2    | 3:1               | 25:1   | 25:1   | N          | Y     | Y    | 1.65             | 1.48  | 1.83 | 1.58  | 1.55          | 106.1    | 54.6  |                  |                |
|         | A3    | 2.5:1             | 2.5:1  | 15:1   | Y          | Y     | Y    | 2.09             | 1.48  |      |       |               | 109.2    | 53.6  |                  |                |
|         | A4    | 2.5:1             | 2.5:1  | 15:1   | Y          | Y     | Y    | 1.76             | 1.44  |      |       |               | 79.6     | 48.5  |                  |                |
|         |       |                   |        |        |            | Y     | N    | 2.21             | 1.84  |      |       |               | 125.5    | 89.7  |                  |                |
|         | A5    |                   |        |        | Y          | Y     | Y    | 1.77             | 1.44  | 1.65 | 1.76  | 1.39/<br>1.62 | 80.6     | 49.5  |                  |                |
|         |       |                   |        |        |            | Y     | N    | 2.22             | 1.86  | 2.18 | 2.39  | 1.39/<br>2.10 | 141.8    | 90.7  |                  |                |
| Y-Y     | Ex    | Flat              | 2.5:1  | 7:1    |            | Y     | Y    | 1.22             | 1.23  |      |       |               | -        | -     |                  | Alt. 5         |
|         | A1    | 4:1               | 2.5:1  | 17:1   | N          | Y     | Y    | 2.01             | 1.53  |      |       |               | 64.8     | 21.8  |                  |                |
|         | A2    | 4:1               | 2.5:1  | 15:1   | N          | Y     | Y    | 2.22             | 1.53  |      |       |               | 77.9     | 20.2  |                  |                |
|         | A3    | 4:1               | 4:1    | 15:1   | Y          | Y     | Y    | 1.87             | 1.58  |      |       |               | 52.5     | 21.0  |                  |                |
|         |       |                   |        |        |            | Y     | N    | 1.57             | 1.38  |      |       |               | 27.9     | 12.1  |                  |                |
|         | A4    | 3:1               | 4:1    | 15:1   | Y          | Y     | Y    | 1.90             | 1.79  |      |       |               | 55.7     | 44.4  |                  |                |
|         |       |                   |        |        |            | Y     | N    | 2.13             | 1.49  |      |       |               | 73.0     | 20.2  |                  |                |
| A5      |       |                   |        |        |            |       | 2.44 | 1.83             |       |      |       | OK            | 47.6     |       |                  |                |
| Z-Z     | Ex    | Flat              | Flat   | 5:1    |            | Y     | Y    | 1.15             | 1.12  |      |       |               | -        | -     |                  | Alt. 4 & Alt 5 |
|         | A1    | 2:1               | 20:1   | 4:1    | N          | Y     | Y    | 1.40             | 1.23  |      |       |               | 21.7     | 8.9   |                  |                |
|         | A2    | 2:1               | 15:1   | 4:1    | N          | Y     | Y    | 1.45             | 1.21  |      |       |               | 26.1     | 7.1   |                  |                |
|         | A3    | 2:1               | 3.5:1  | 18:1   | Y          | Y     | Y    | 1.45             | 1.21  |      |       |               | 26.1     | 7.1   |                  |                |
|         | A4    | 2.75:1            | 2.75:1 | 20:1   | Y          | Y     | Y    | 1.66             | 1.19  |      |       |               | 41.7     | 5.4   |                  |                |
|         |       |                   |        |        |            | Y     | N    | 1.68             | 1.46  |      |       |               | 46.1     | 30.4  |                  |                |
|         | A5    |                   |        |        | A5         | Y     | Y    | 1.55             | 1.18  |      |       |               | 33.0     | 5.3   |                  |                |
| Y       |       |                   |        |        |            | N     | 1.60 | 1.43             |       |      |       | 39.1          | 27.7     |       |                  |                |

\* Ex: existing; Ai: Alternative No. i (eg.:A1: Alternative 1)

\* Improvement:  $\Delta FS/FS_{ex}$

**CHAPTER 7**

**APPENDICES**



## **APPENDIX 7A**

- GRADING PLAN VIEWS OF ANALYZED SECTIONS
- EXISTING GEOMETRY & PROPOSED GRADING

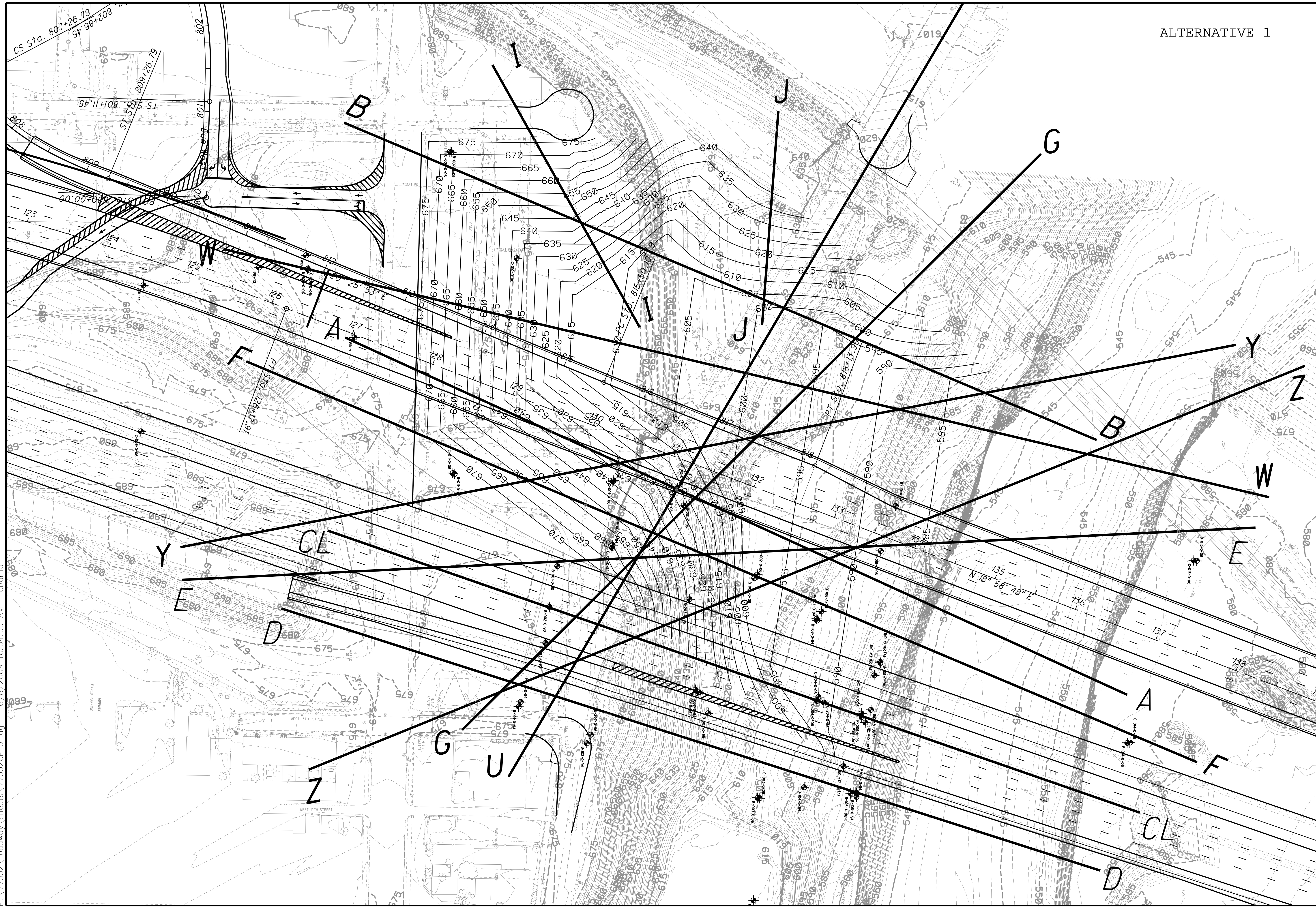

ALTERNATIVE 1

| DESIGNED | CHECKED | DRAWN | REVIEWED | DATE |
|----------|---------|-------|----------|------|
|          |         |       |          |      |

**ALT 1 SLOPE GRADING PLAN**  
 CUYAHOGA RIVER WEST BANK

**CUY-90-14.92**  
 PID No. 77332

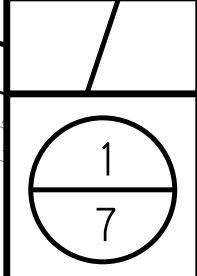

P:\77332\roadway\sheets\77332GF101.dgn 6/8/2009 10:04:52 AM dbarna

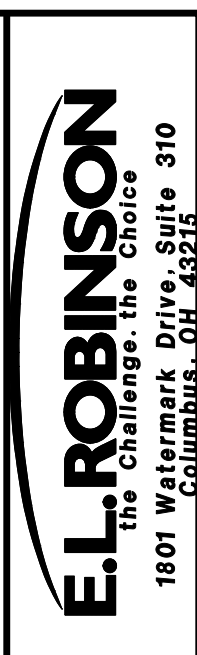
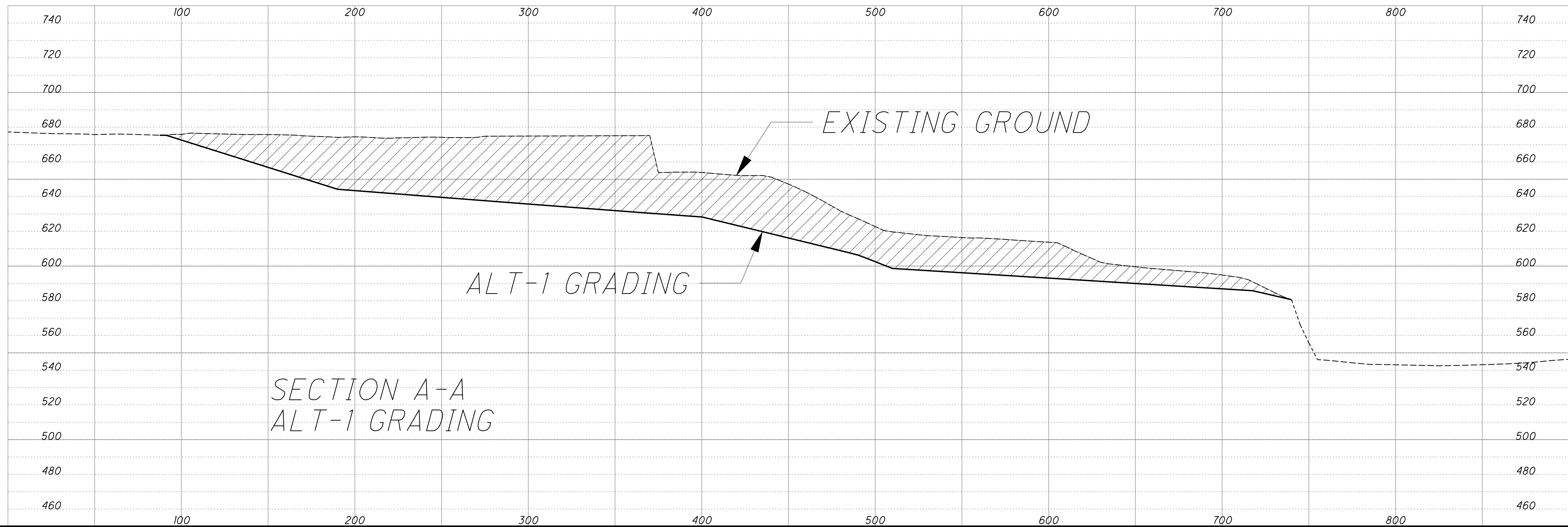
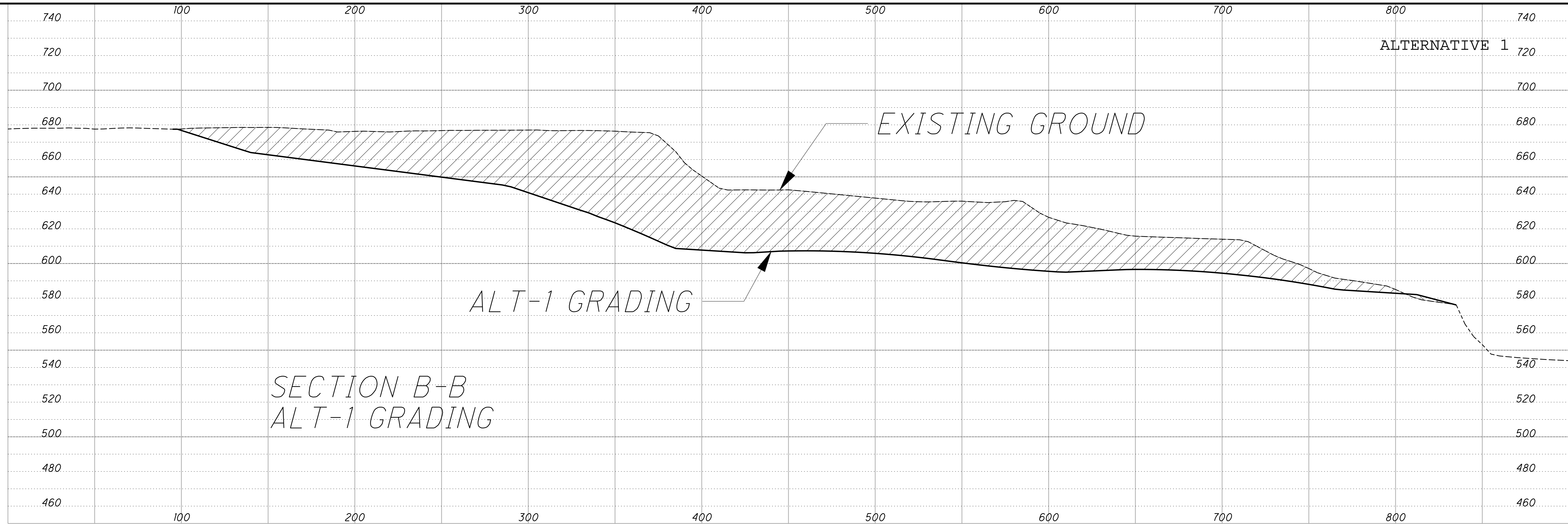

| DESIGNED | CHECKED | DRAWN | REVIEWED | DATE |
|----------|---------|-------|----------|------|
|          |         |       |          |      |

| STRUCTURE FILE NUMBER | REVISED |
|-----------------------|---------|
|                       |         |

SECTION A-A AND B-B  
CUYAHOGA RIVER WEST BANK

CUY-90-14.92  
PID No. 77332

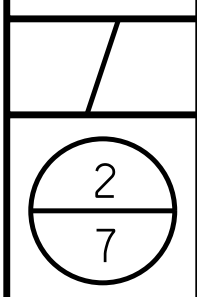

P:\77332\roadway\sheets\77332GF102.dgn 6/8/2009 10:04:56 AM dbarna

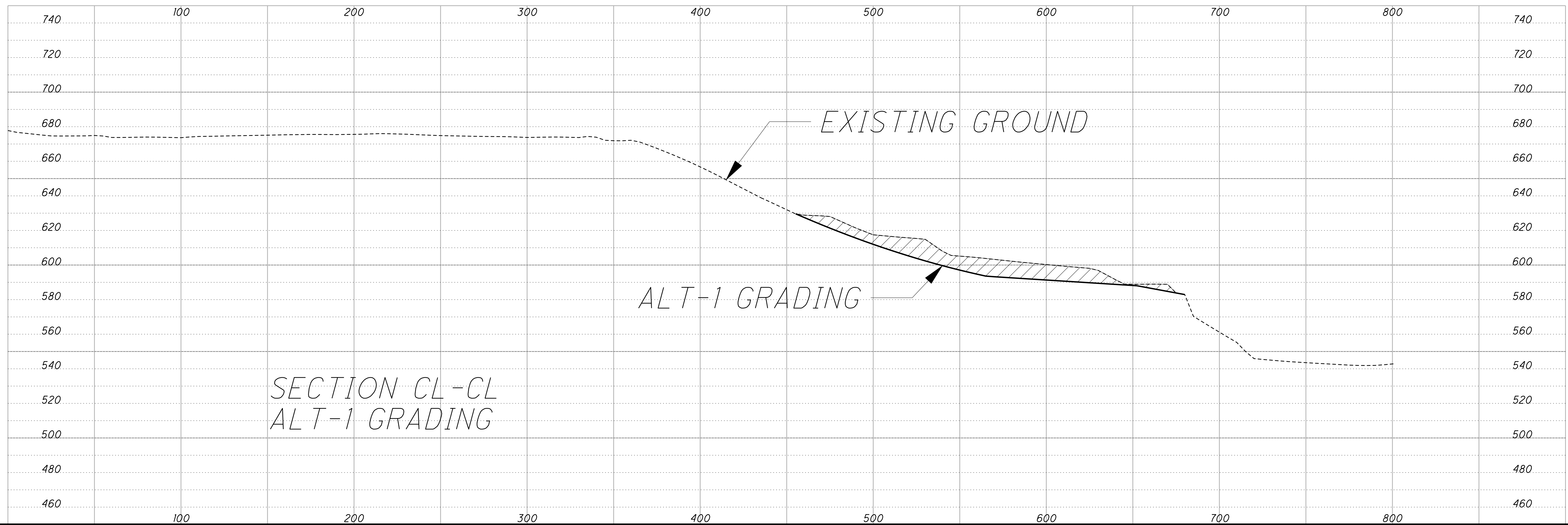
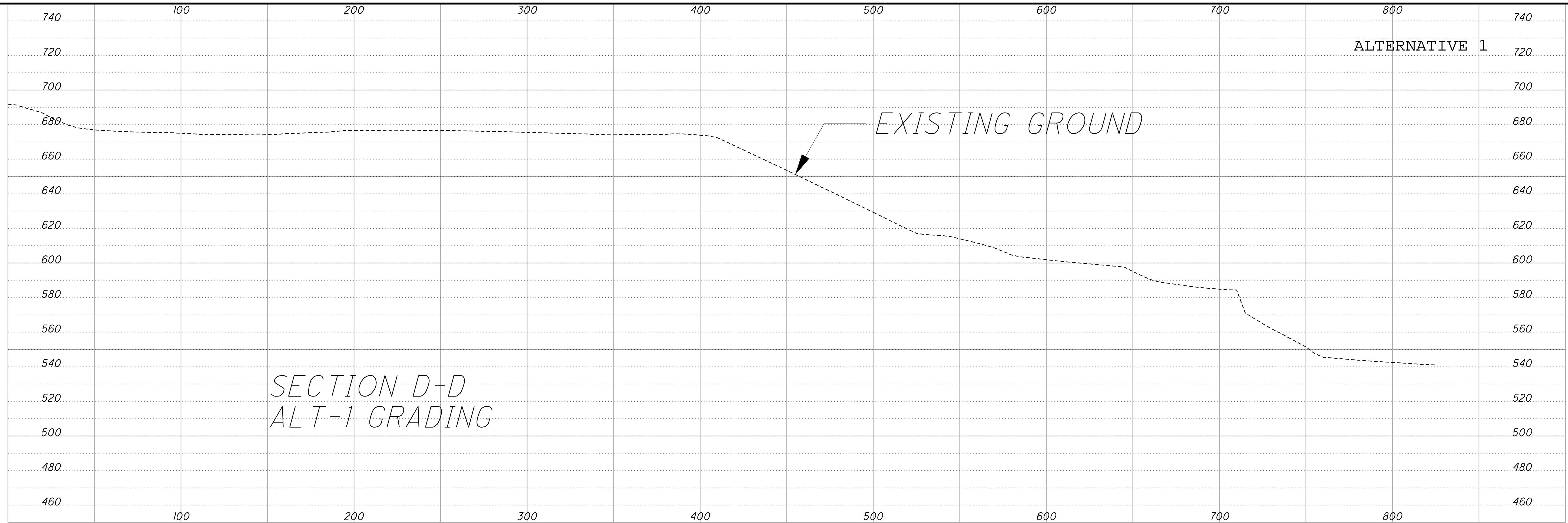

**E.L. ROBINSON**  
The Challenge. The Choice.  
1801 Watermark Drive, Suite 310  
Columbus, OH 43261

|          |         |       |          |      |
|----------|---------|-------|----------|------|
| DESIGNED | CHECKED | DRAWN | REVIEWED | DATE |
|          |         |       |          |      |

SECTION CL-CL AND D-D  
CUYAHOGA RIVER WEST BANK

CUY-90-14.92  
PID No. 77332

3  
7

P:\77332\roadway\sheets\77332GF103.dgn 6/8/2009 10:05:00 AM dbarna

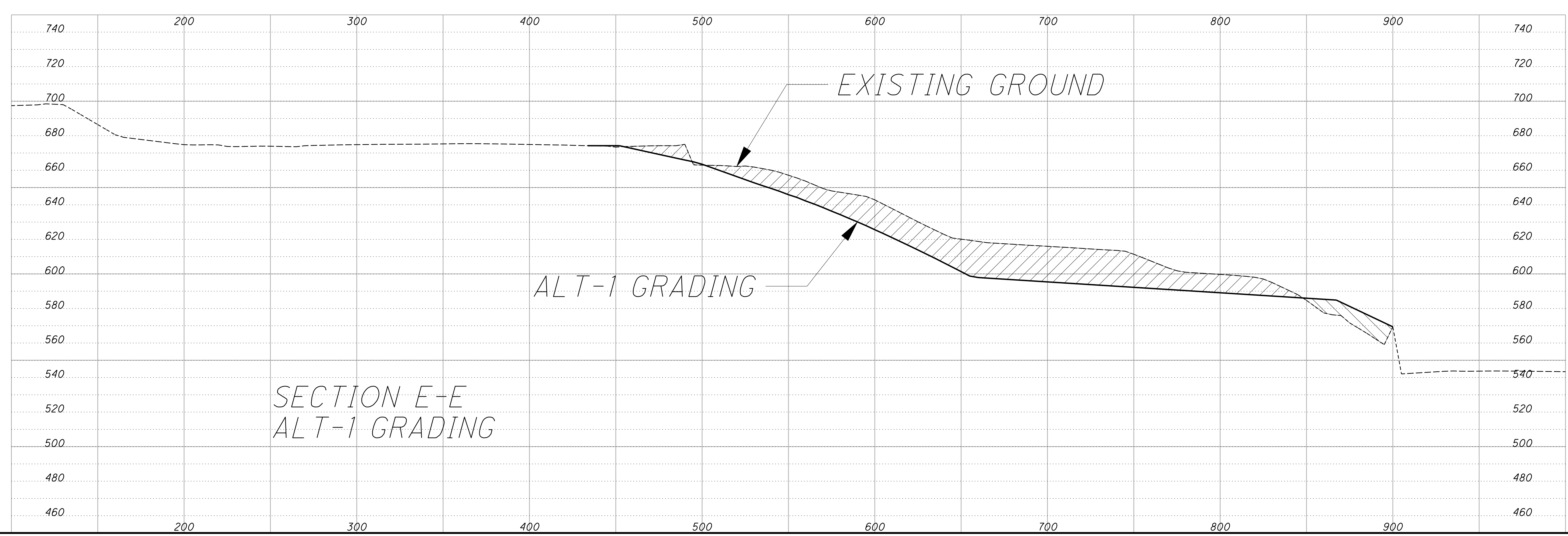
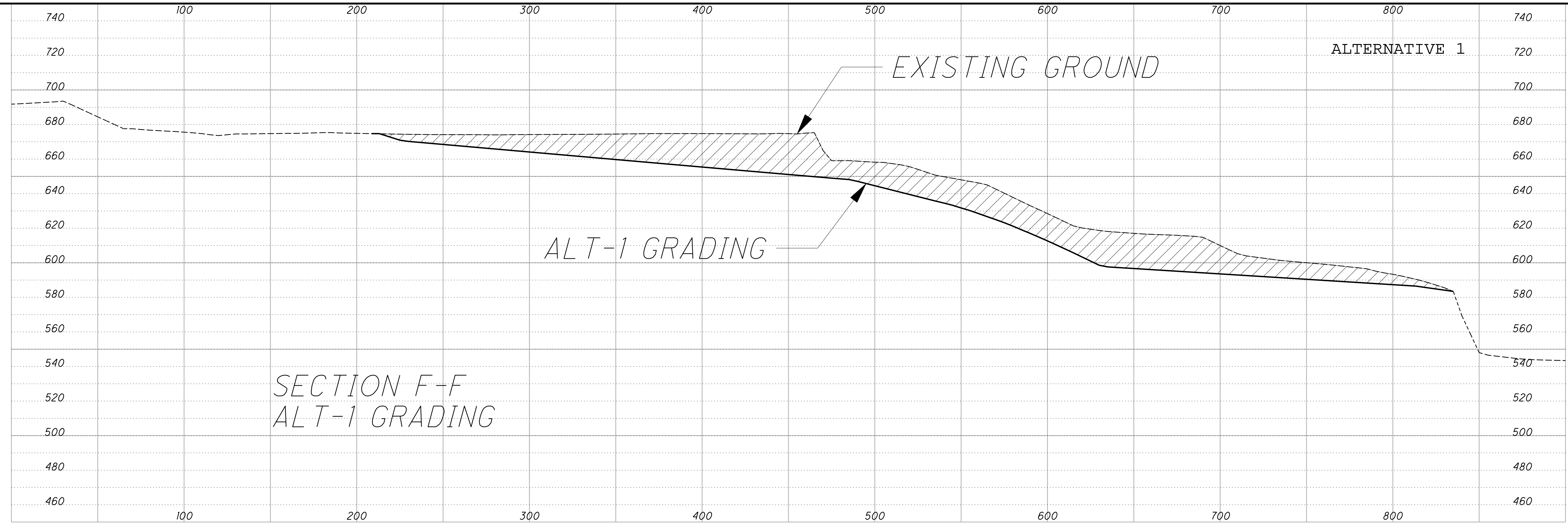

**E.L. ROBINSON**  
The Challenge. The Choice.  
1801 Watermark Drive, Suite 310  
Columbus, OH 43261

| DESIGNED | CHECKED | DRAWN | REVIEWED | DATE |
|----------|---------|-------|----------|------|
|          |         |       |          |      |

SECTION E AND F-F  
CUYAHOGA RIVER WEST BANK

CUY-90-14.92  
PID No. 77332

4  
7

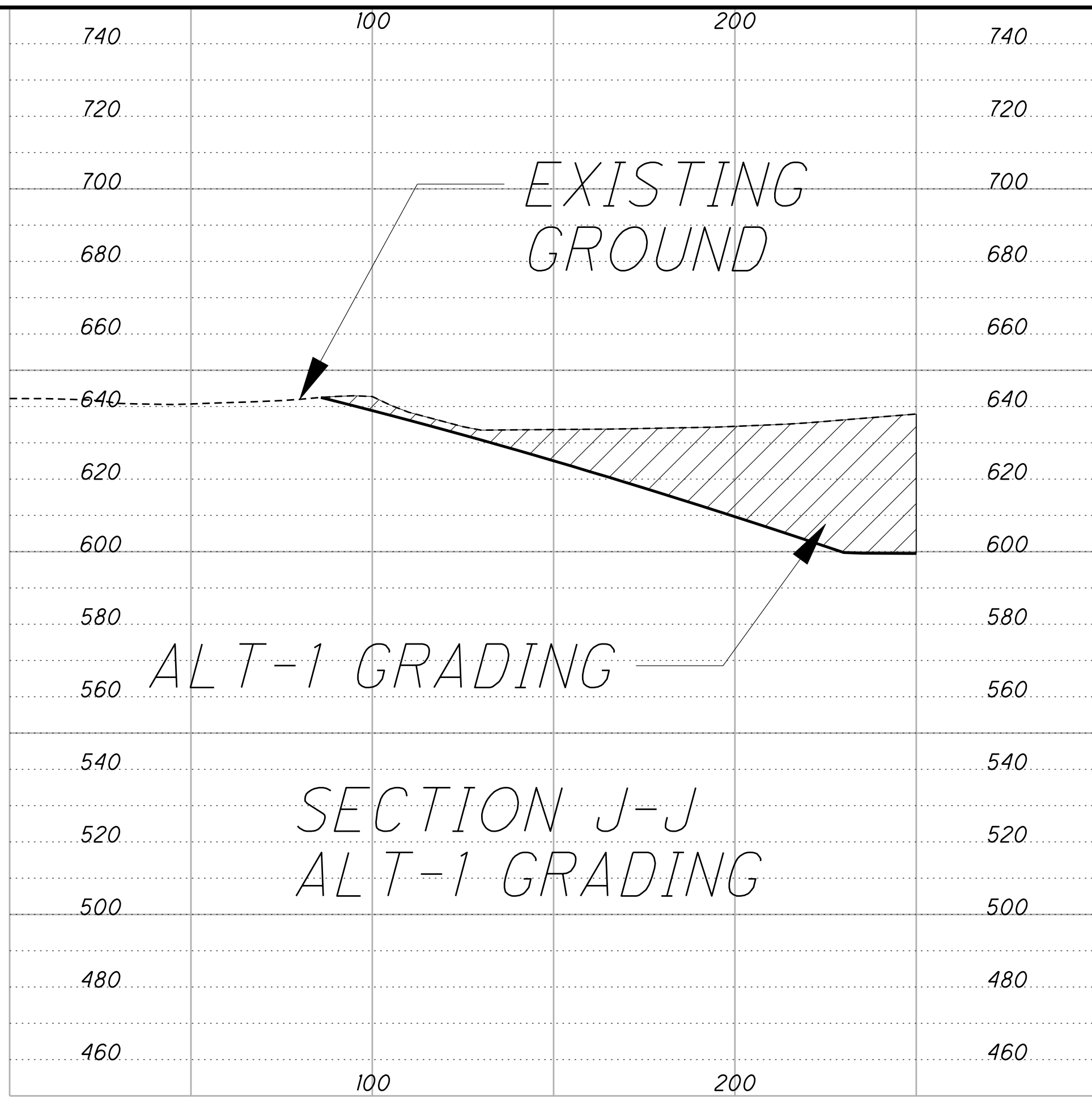
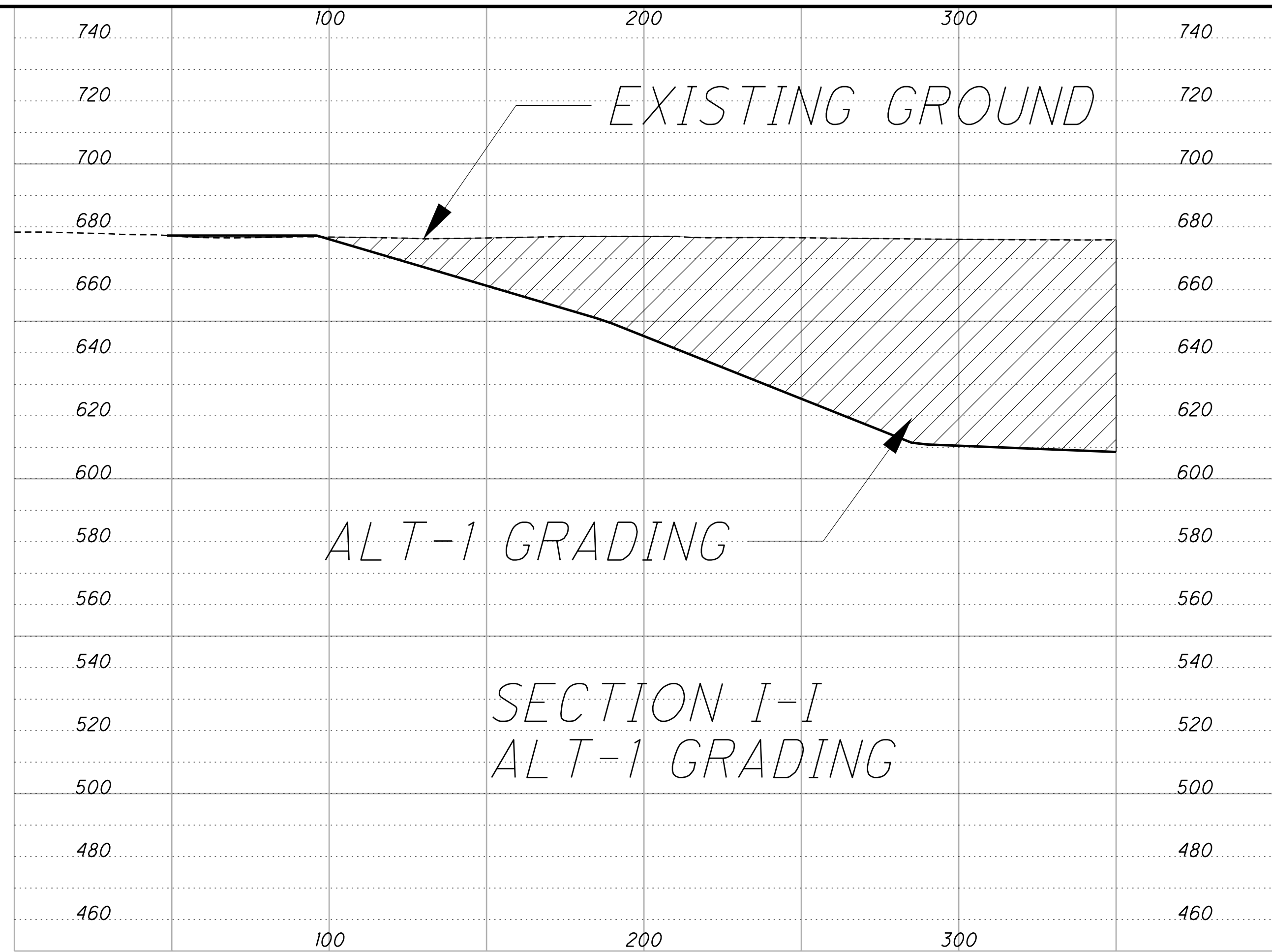

ALTERNATIVE 1

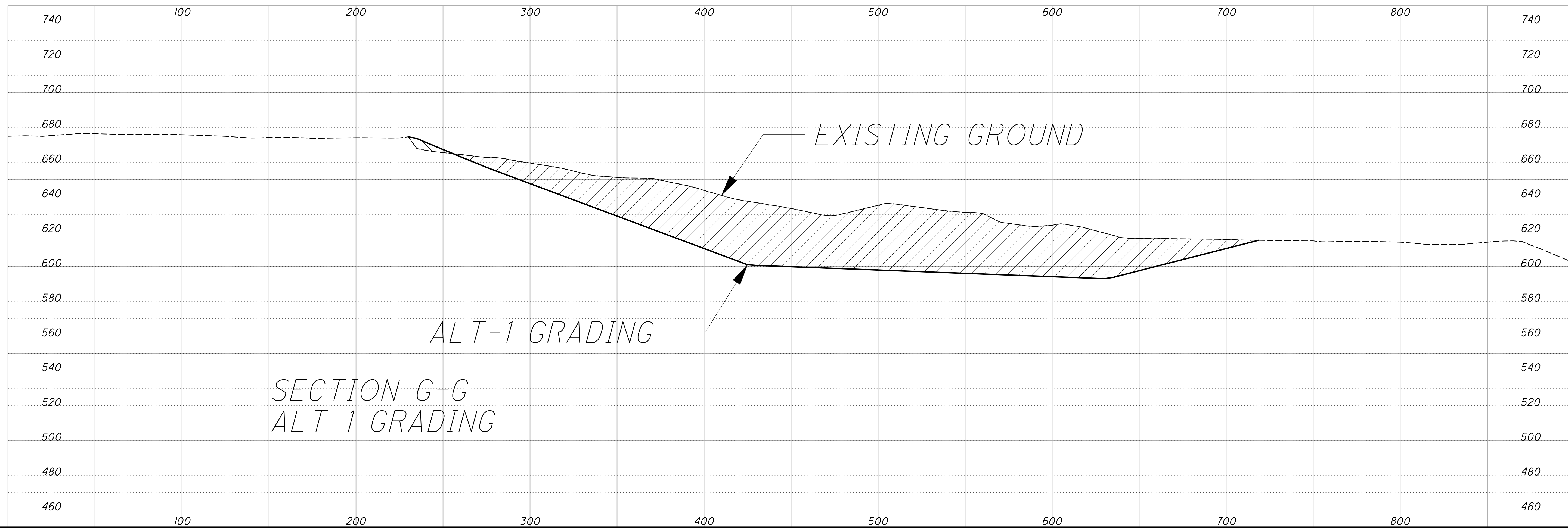

P:\77332\roadway\sheets\77332GF104.dgn 6/8/2009 10:05:04 AM dbarna

**E.L. ROBINSON**  
The Challenge. The Choice.  
1801 Watermark Drive, Suite 310  
Columbus, OH 43261

| DESIGNED | CHECKED | DRAWN | REVIEWED | DATE |
|----------|---------|-------|----------|------|
|          |         |       |          |      |

SECTION G-G, I-I, AND SECTION J-J  
CUYAHOGA RIVER WEST BANK

**CUY-90-14.92**  
PID No. 77332

5  
7

P:\77332\roadway\sheets\77332GF105.dgn 6/8/2009 10:05:08 AM dbarna

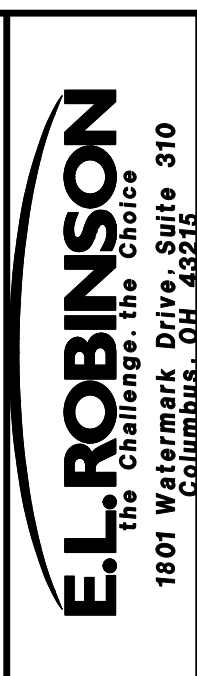
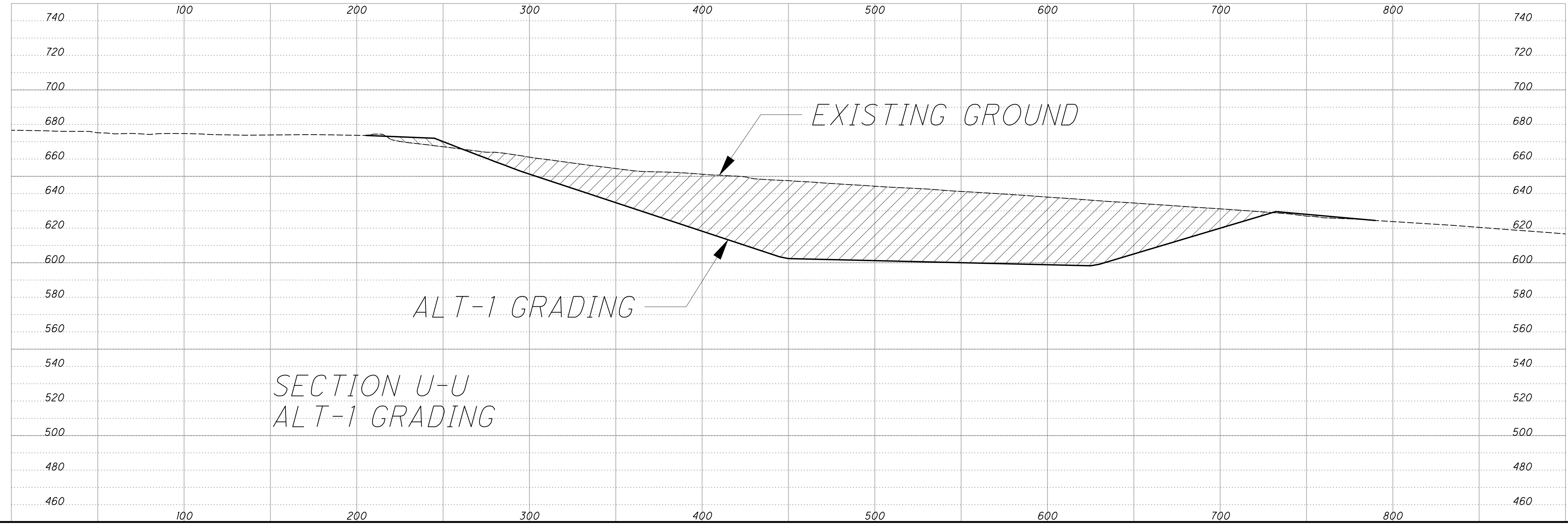
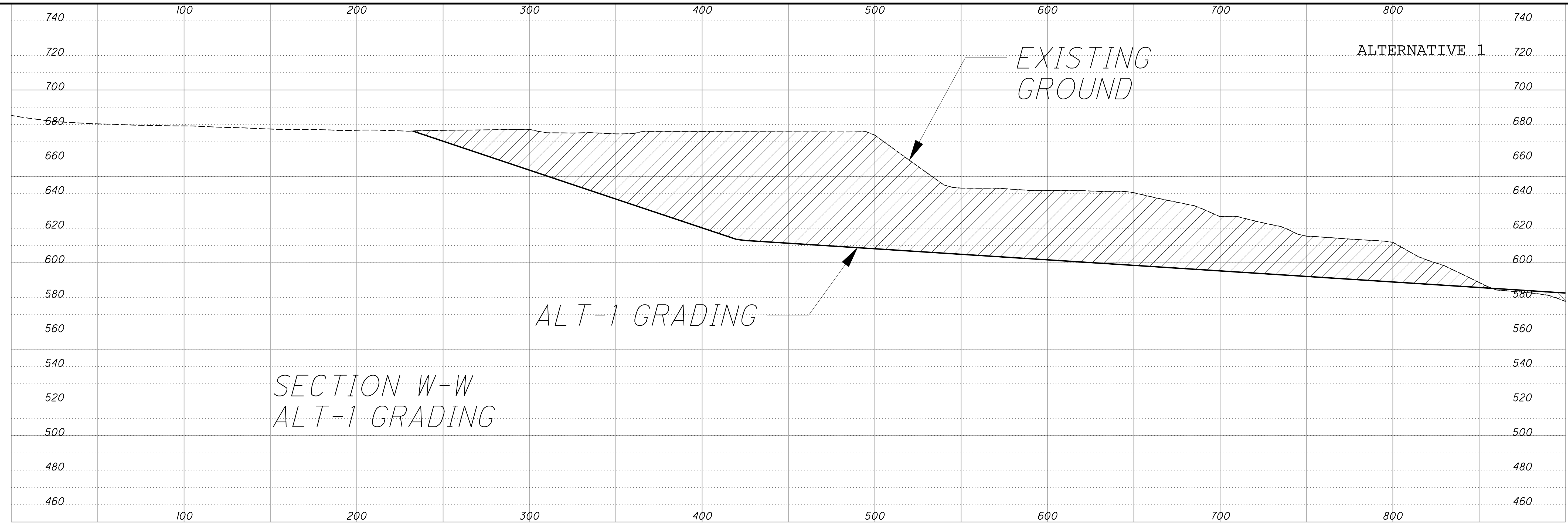

|          |                       |
|----------|-----------------------|
| DESIGNED | CHECKED               |
| DRAWN    | REVISED               |
| REVIEWED | STRUCTURE FILE NUMBER |
| DATE     |                       |

SECTION W-W AND SECTION W-W  
CUYAHOGA RIVER WEST BANK

CUY-90-14.92  
PID No. 77332

P:\77332\roadway\sheets\77332GF106.dgn 6/8/2009 10:05:12 AM dbarna

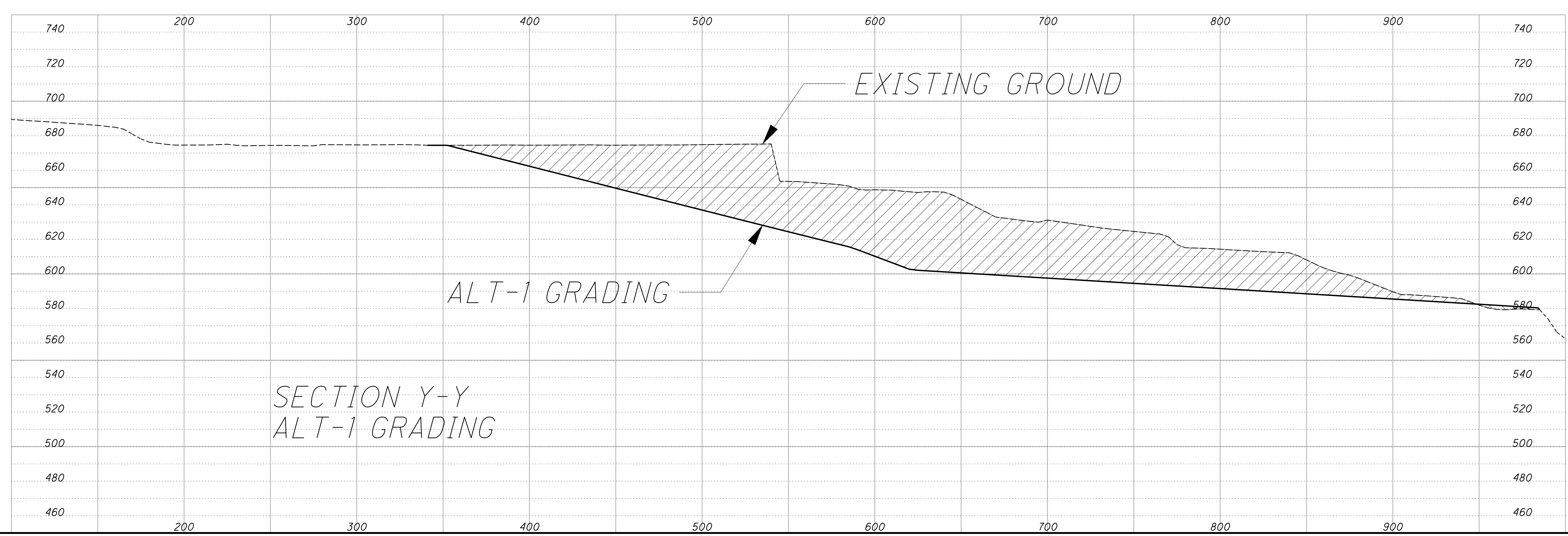
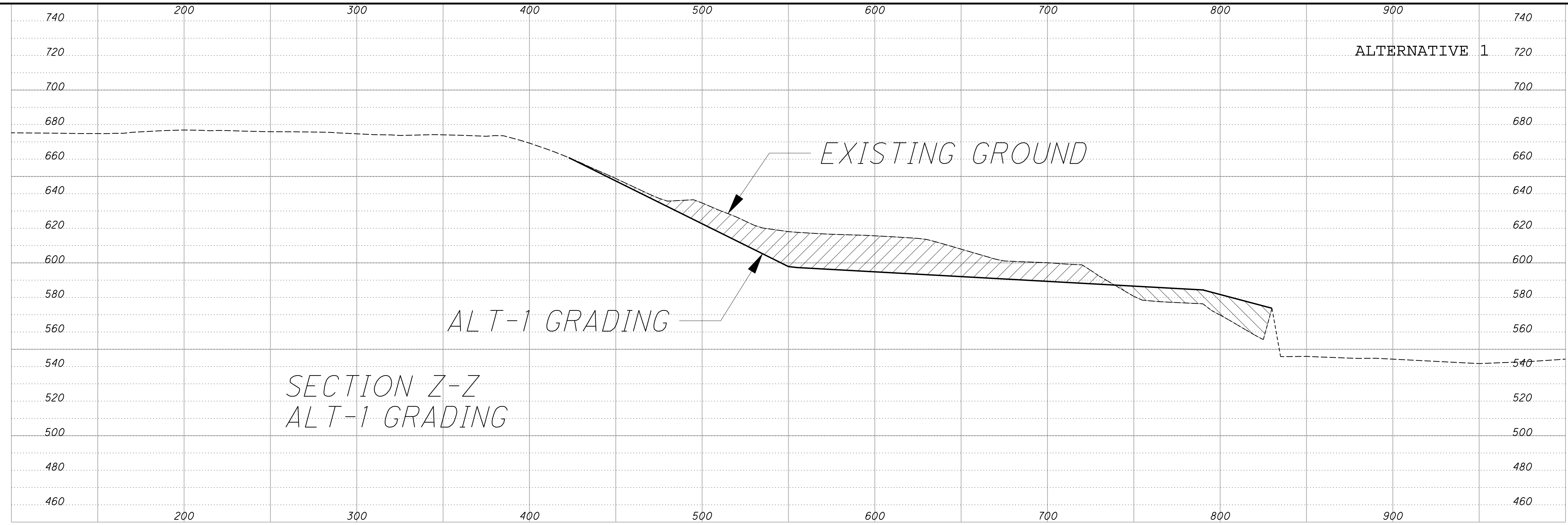

**E.L. ROBINSON**  
The Challenge. The Choice.  
1801 Watermark Drive, Suite 310  
Columbus, OH 43261

| DESIGNED | CHECKED | DRAWN | REVIEWED | DATE |
|----------|---------|-------|----------|------|
|          |         |       |          |      |

SECTION Y-Y AND Z-Z  
CUYAHOGA RIVER WEST BANK

**CUY-90-14.92**  
PID No. 77332

7  
7



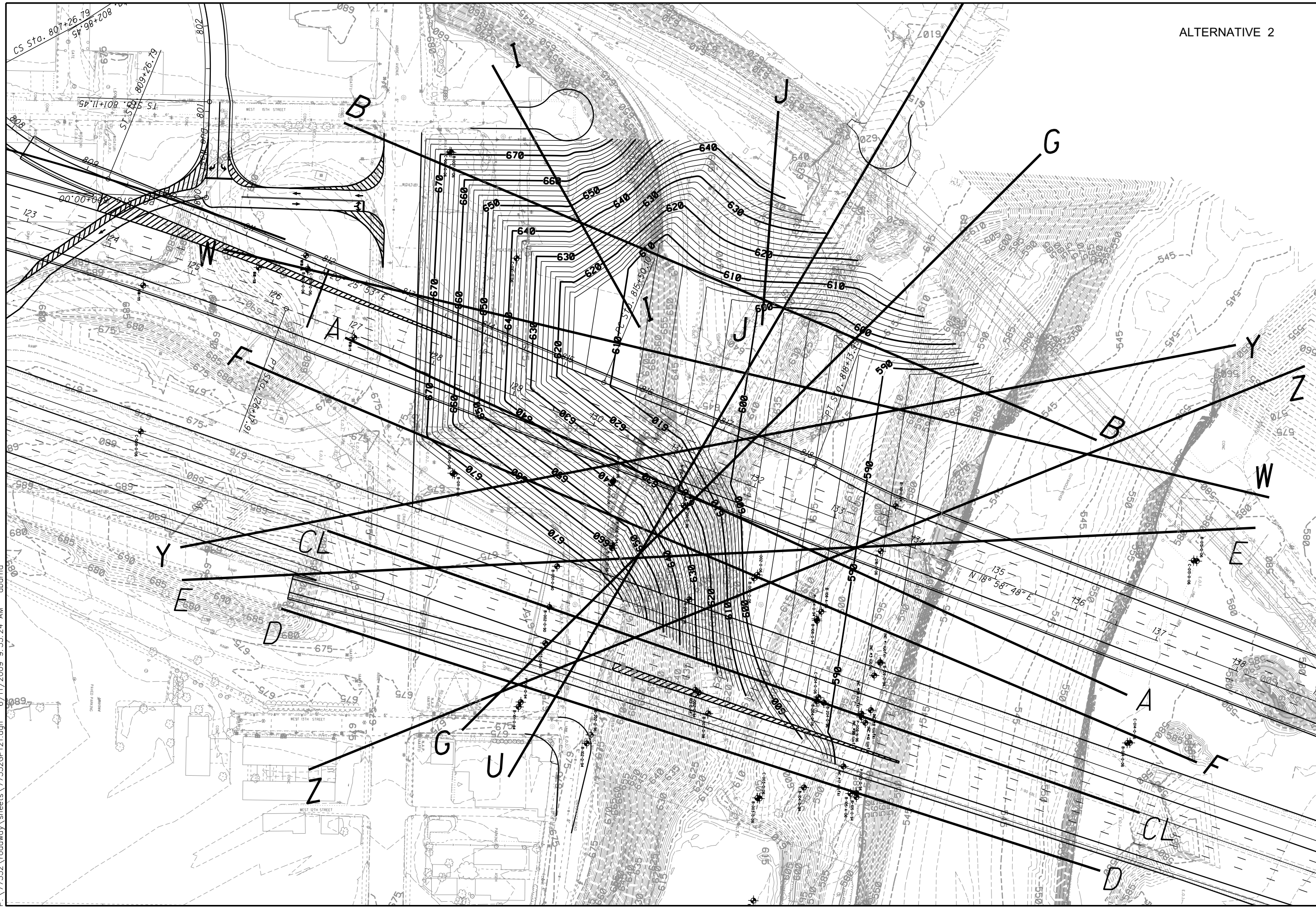

ALTERNATIVE 2

|          |         |                       |      |
|----------|---------|-----------------------|------|
| DESIGNED | DRAWN   | REVIEWED              | DATE |
| CHECKED  | REVISED | STRUCTURE FILE NUMBER |      |

ALT 2 SLOPE GRADING PLAN  
 CUYAHOGA RIVER WEST BANK

CUY-90-14.92  
 PID No. 77332

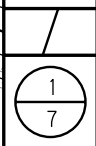

P:\77332\roadway\sheets\77332GF121.dgn 6/11/2009 9:20:50 AM dbarna

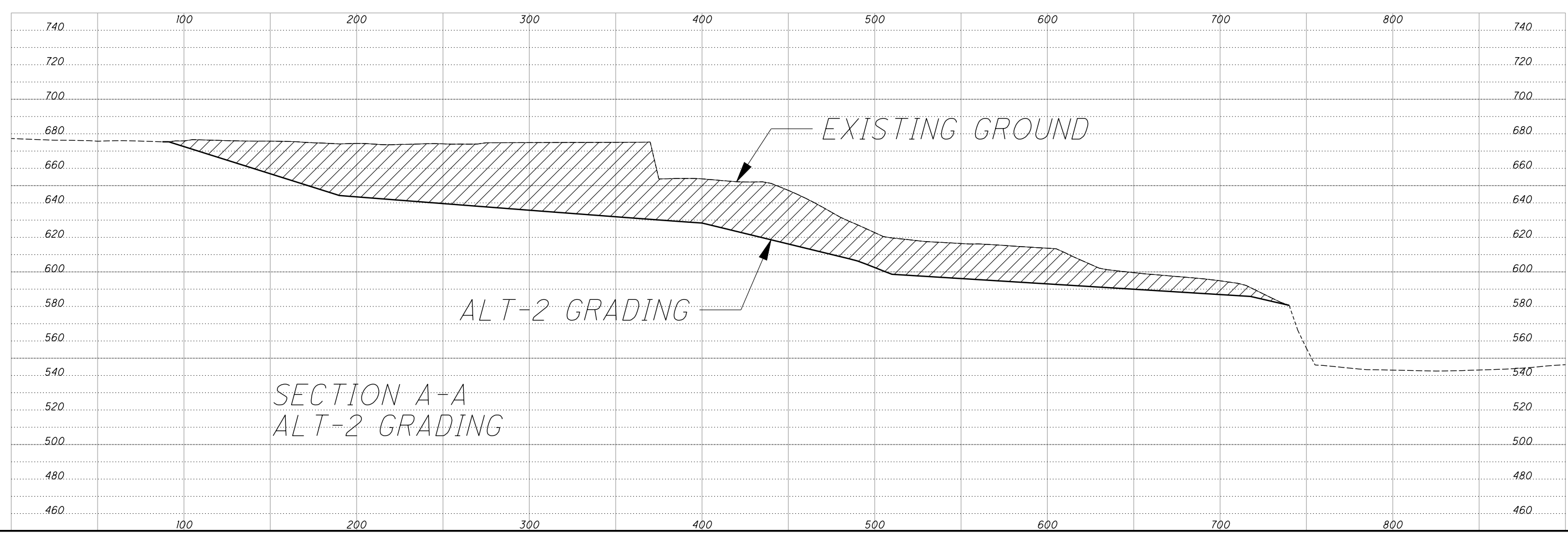
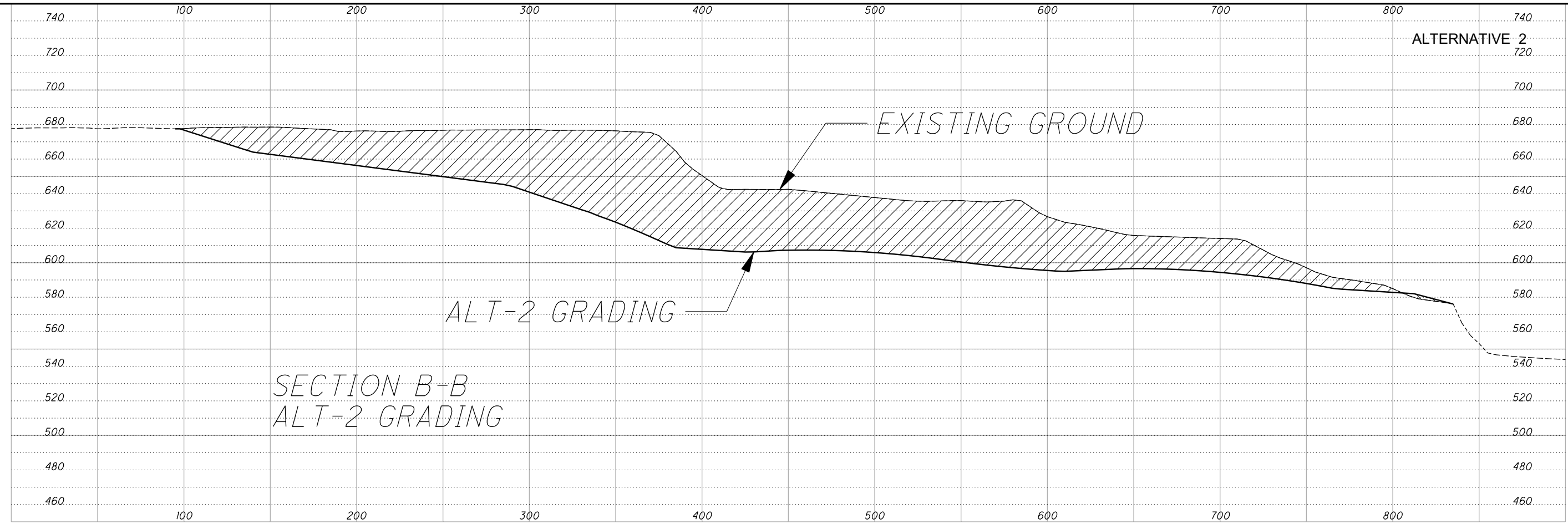

|          |                       |
|----------|-----------------------|
| DESIGNED | CHECKED               |
| DRAWN    | REVISED               |
| REVIEWED | STRUCTURE FILE NUMBER |
| DATE     |                       |

SECTION A-A AND B-B  
CUYAHOGA RIVER WEST BANK

CUY-90-14.92  
PID No. 77332

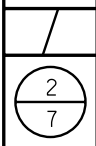

P:\77332\roadway\sheets\77332GF122.dgn 6/11/2009 9:20:54 AM dbarna

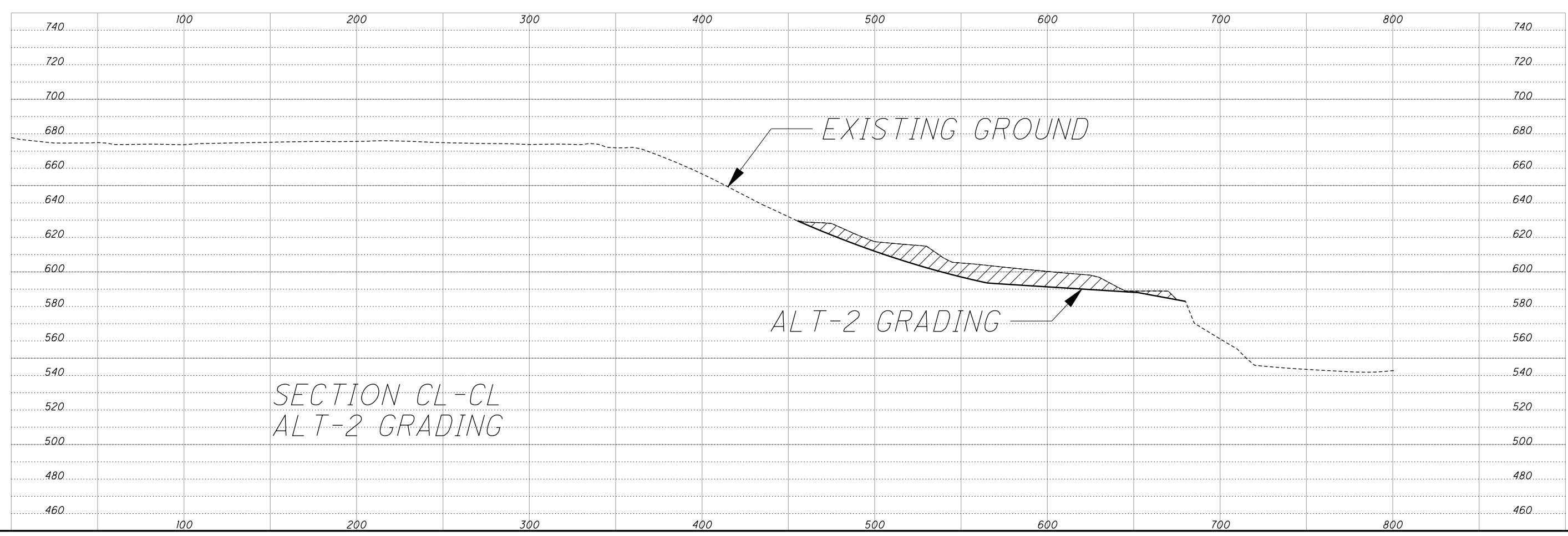
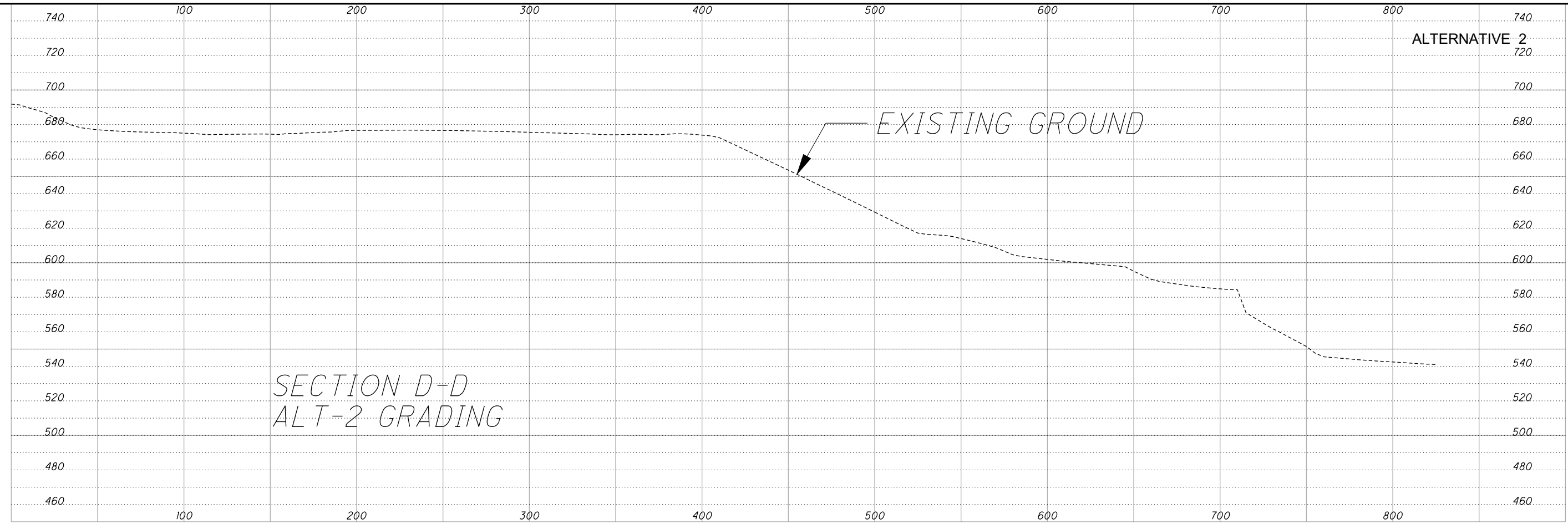

ALTERNATIVE 2



|          |                       |
|----------|-----------------------|
| DESIGNED | CHECKED               |
| DRAWN    | REVISED               |
| REVIEWED | STRUCTURE FILE NUMBER |
| DATE     |                       |

SECTION CL-CL AND D-D  
CUYAHOGA RIVER WEST BANK

CUY-90-14.92  
PID No. 77332

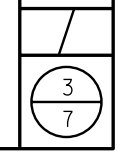

P:\77332\roadway\sheets\77332GF123.dgn 6/11/2009 9:20:57 AM dbarna

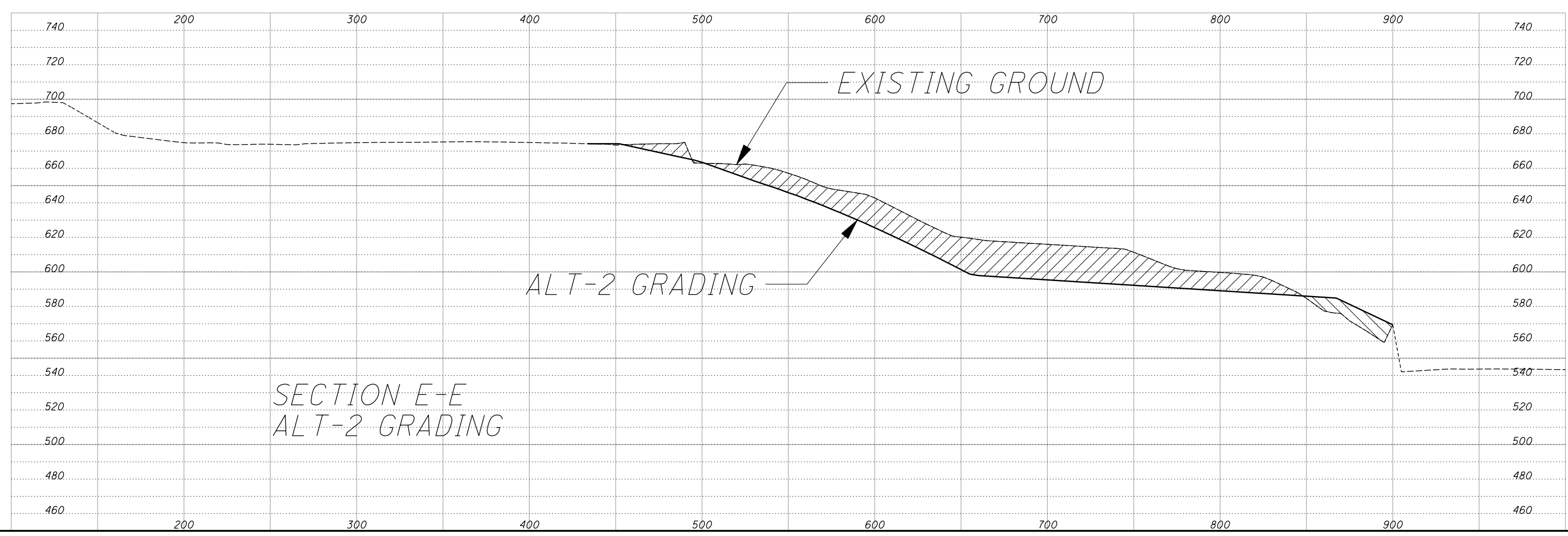
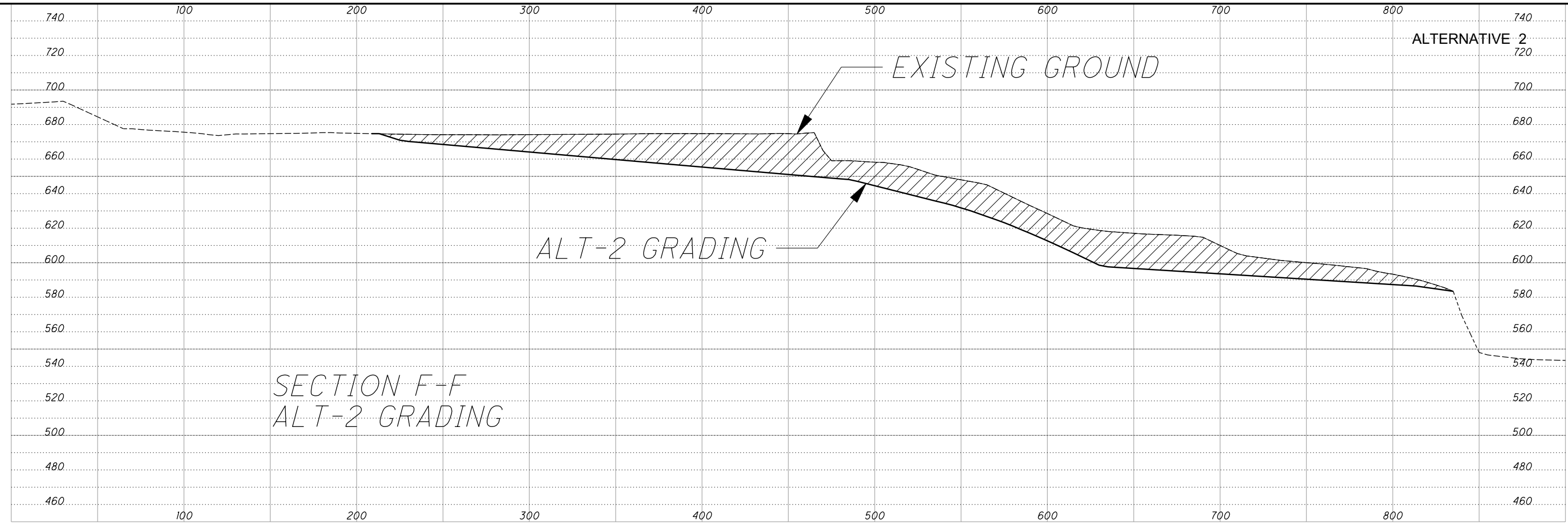

|          |                       |
|----------|-----------------------|
| DESIGNED | CHECKED               |
| DRAWN    | REVISED               |
| REVIEWED | STRUCTURE FILE NUMBER |
| DATE     |                       |

SECTION E-E AND F-F  
CUYAHOGA RIVER WEST BANK

CUY-90-14.92  
PID No. 77332

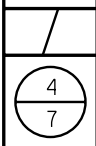

P:\77332\roadway\sheets\77332GF124.dgn 6/11/2009 9:21:00 AM dbarna

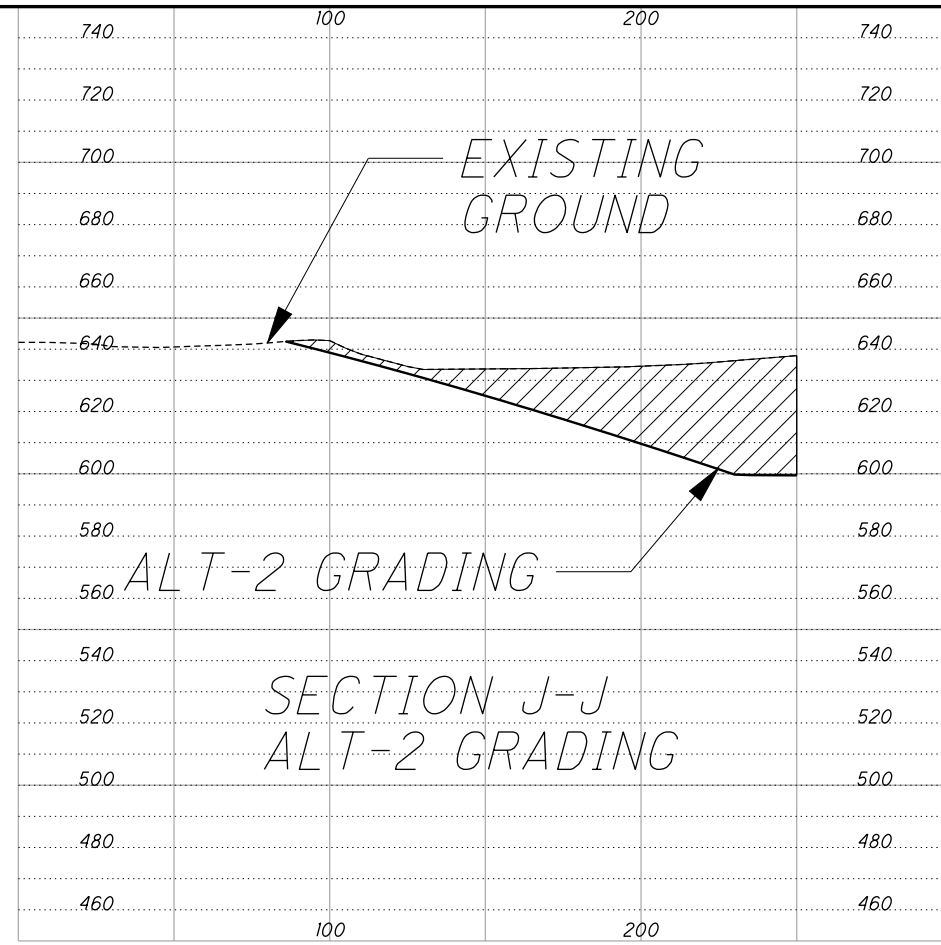
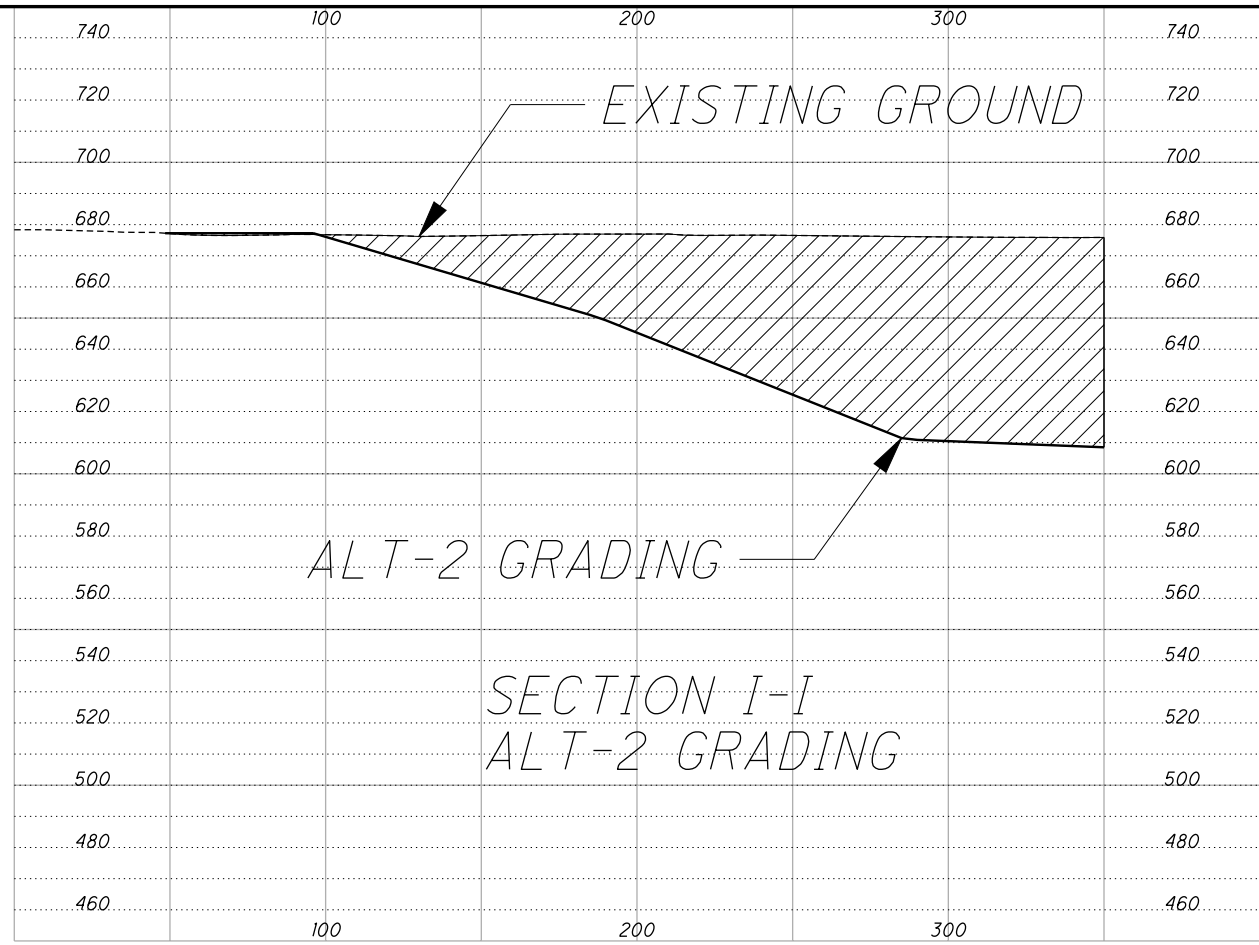

ALTERNATIVE 2

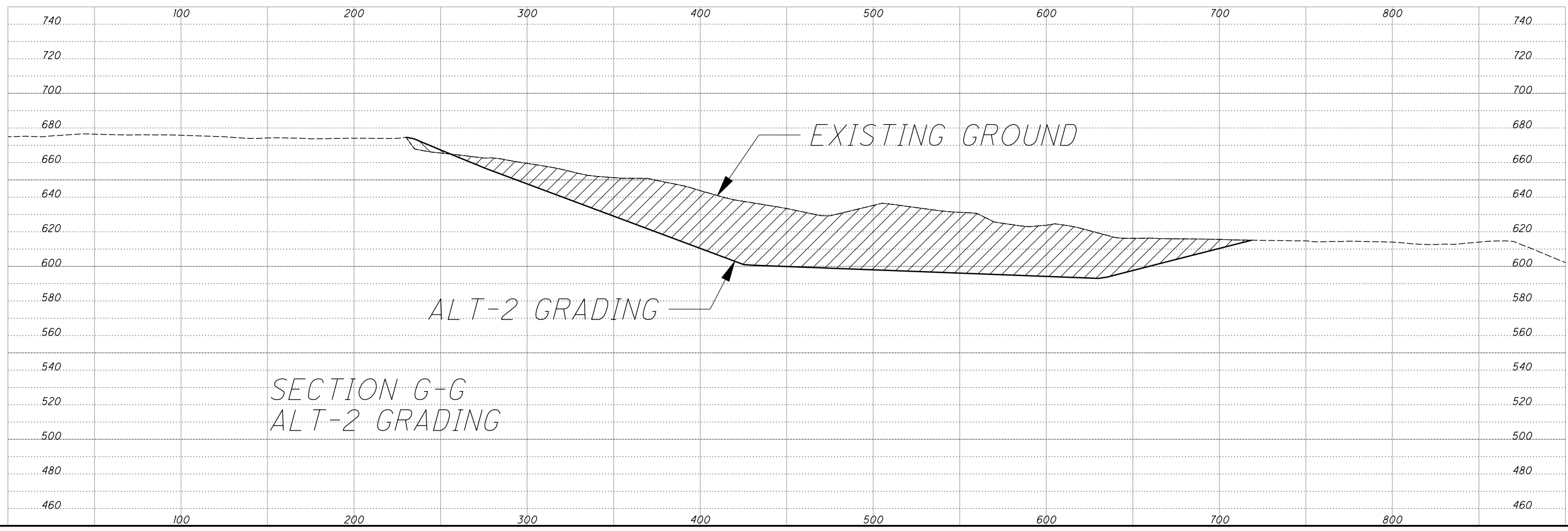

|          |                       |
|----------|-----------------------|
| DESIGNED | CHECKED               |
| DRAWN    | REVISED               |
| REVIEWED | STRUCTURE FILE NUMBER |
| DATE     |                       |

SECTION G-G, I-I, AND SECTION J-J  
CUYAHOGA RIVER WEST BANK

CUY-90-14.92  
PID No. 77332

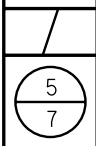

P:\77332\roadway\sheets\77332GF125.dgn 6/11/2009 9:21:04 AM dbarna

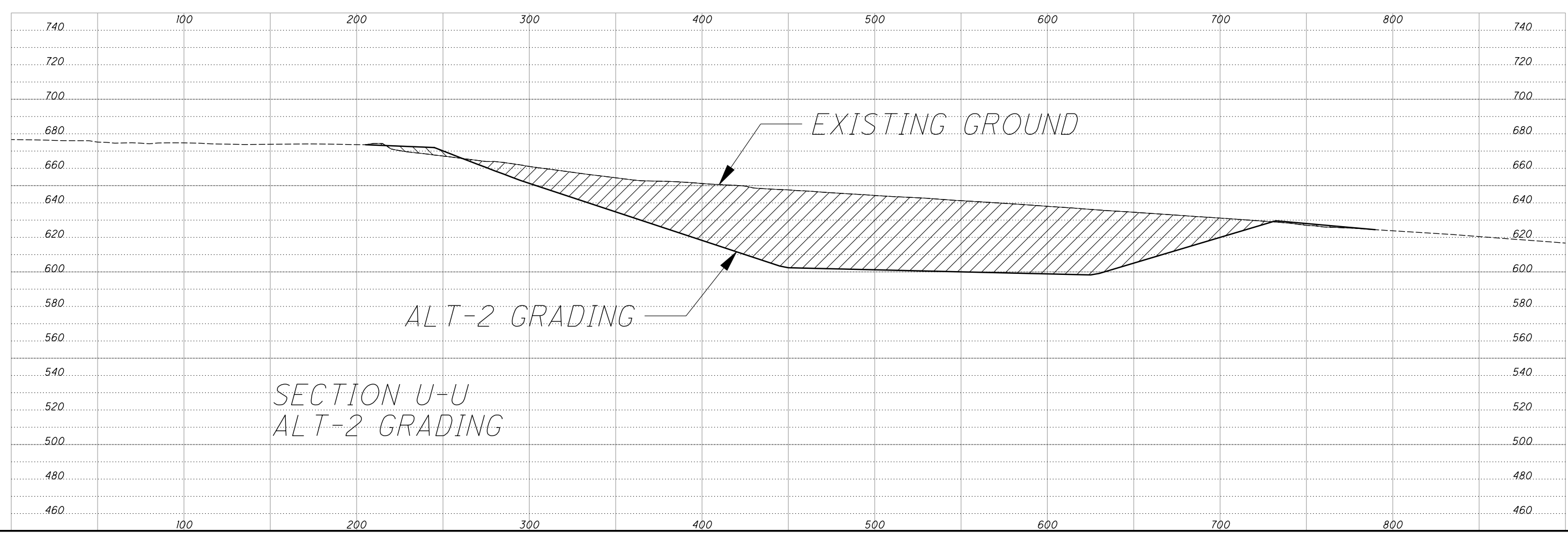
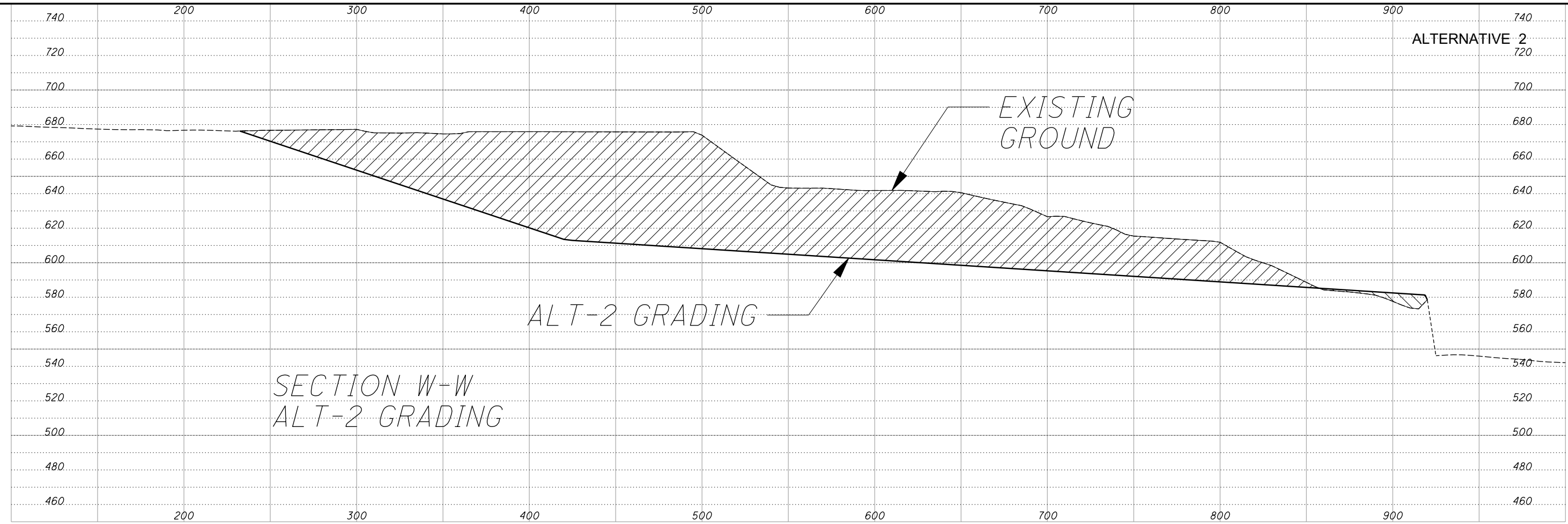

|          |                       |
|----------|-----------------------|
| DESIGNED | CHECKED               |
| DRAWN    | REVISED               |
| REVIEWED | STRUCTURE FILE NUMBER |
| DATE     |                       |

SECTION W-W AND SECTION W-W  
CUYAHOGA RIVER WEST BANK

CUY-90-14.92  
PID No. 77332

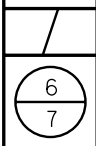

P:\77332\roadway\sheets\77332GF126.dgn 6/11/2009 9:21:07 AM dbarna

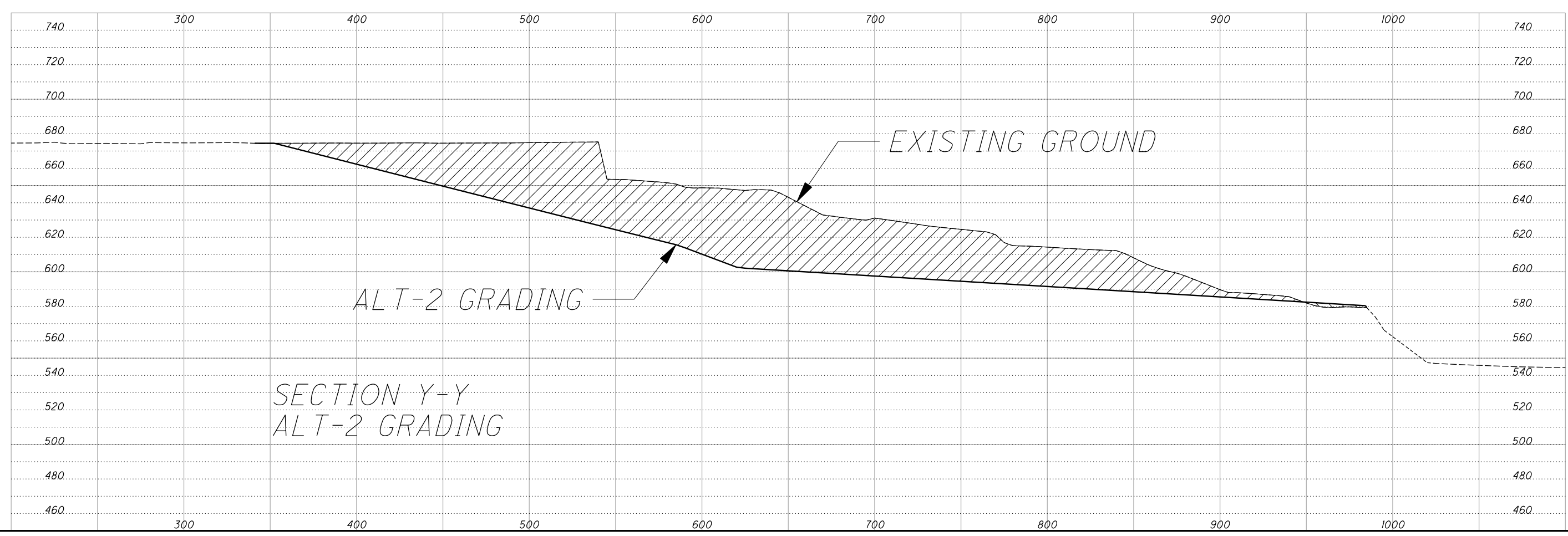
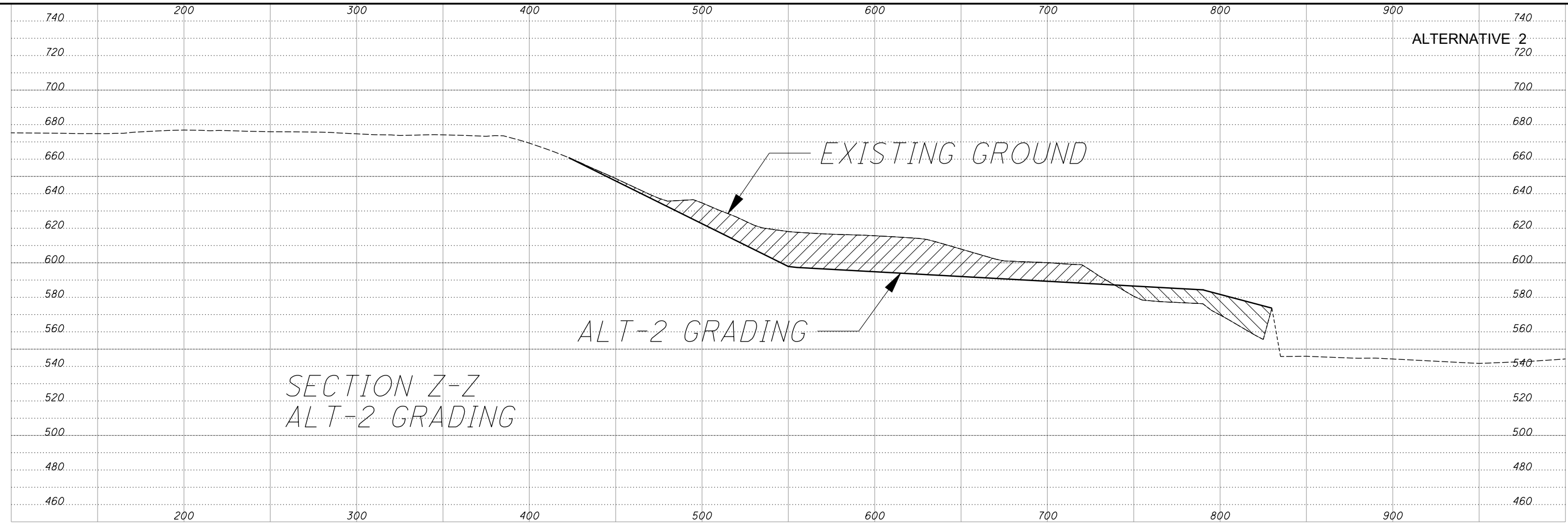

|          |                       |
|----------|-----------------------|
| DESIGNED | CHECKED               |
| DRAWN    | REVISED               |
| REVIEWED | STRUCTURE FILE NUMBER |
| DATE     |                       |

SECTION Y-Y AND Z-Z  
CUYAHOGA RIVER WEST BANK

CUY-90-14.92  
PID No. 77332

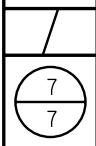

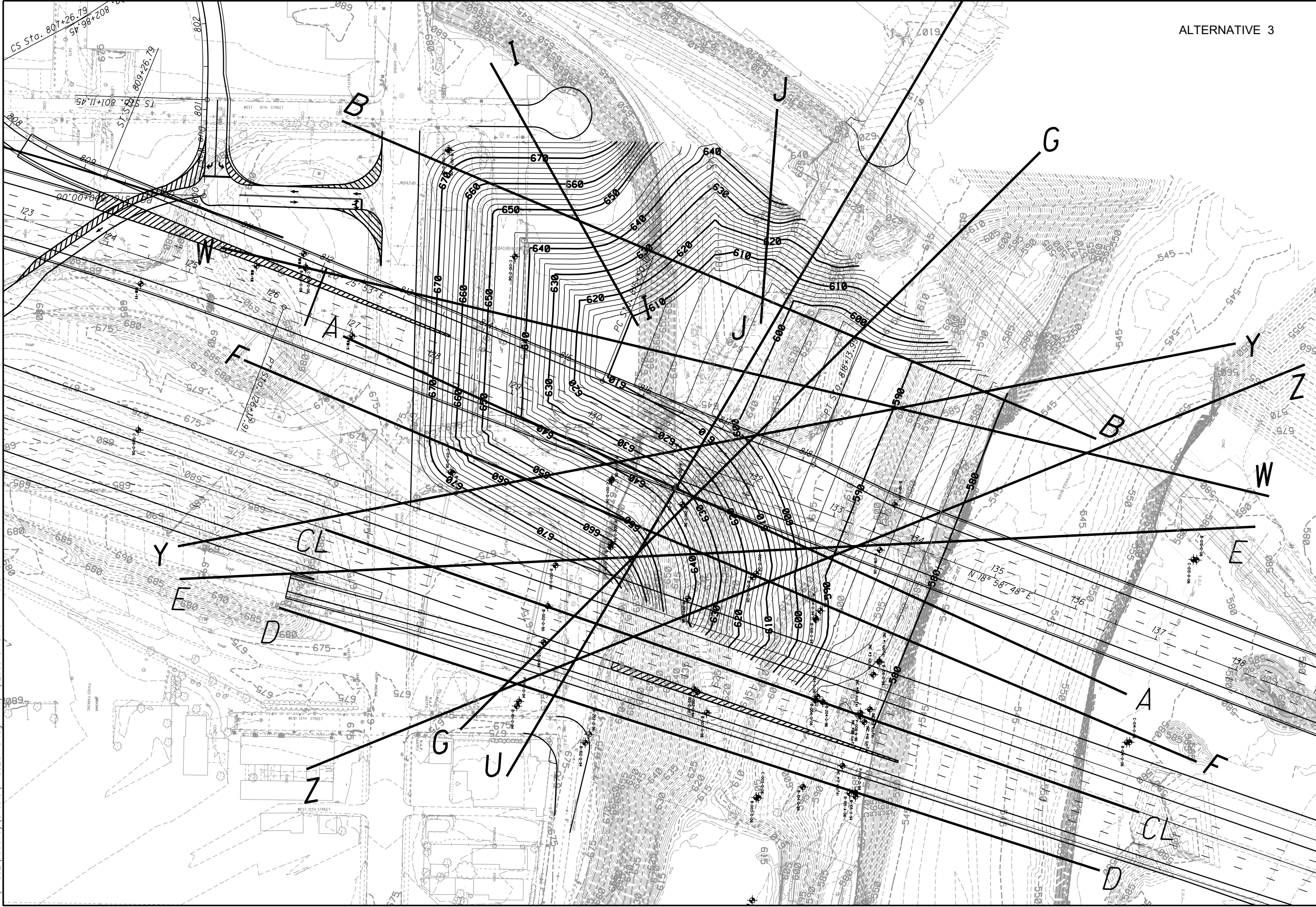

ALTERNATIVE 3



|          |         |                       |      |
|----------|---------|-----------------------|------|
| DESIGNED | DRAWN   | REVIEWED              | DATE |
| CHECKED  | REVISED | STRUCTURE FILE NUMBER |      |

ALT 3 SLOPE GRADING PLAN  
CUYAHOGA RIVER WEST BANK

CUY-90-14.92  
PID No. 77332

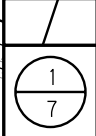



P:\77332\roadway\sheets\77332GF131.dgn 6/11/2009 8:49:02 AM dbarna

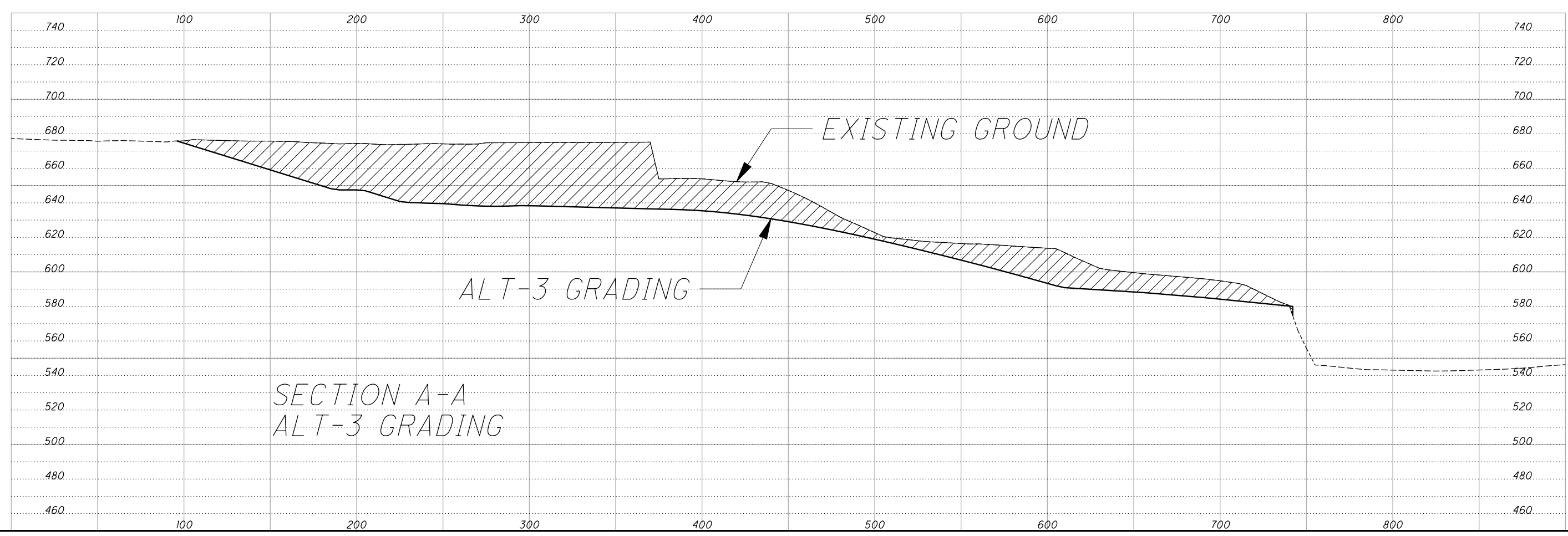
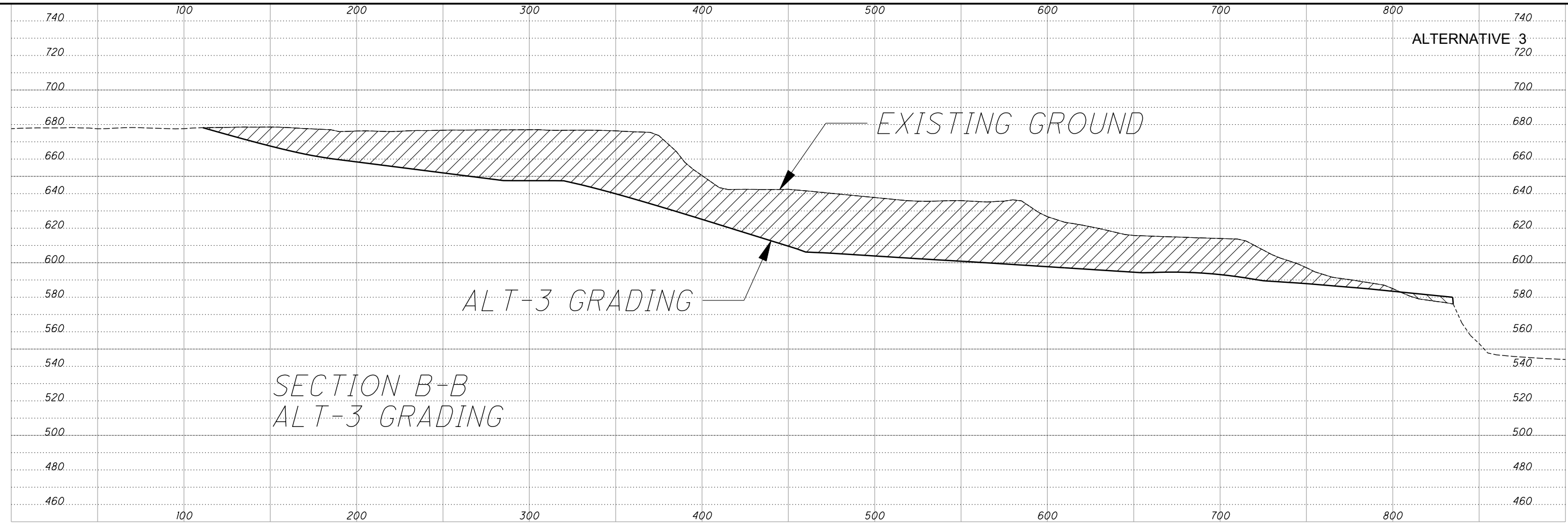

ALTERNATIVE 3



|          |                       |
|----------|-----------------------|
| DESIGNED | CHECKED               |
| DRAWN    | REVISED               |
| REVIEWED | STRUCTURE FILE NUMBER |
| DATE     |                       |

SECTION A-A AND B-B  
CUYAHOGA RIVER WEST BANK

CUY-90-14.92  
PID No. 77332

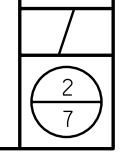

P:\77332\roadway\sheets\77332GF132.dgn 6/11/2009 8:49:06 AM dbarna

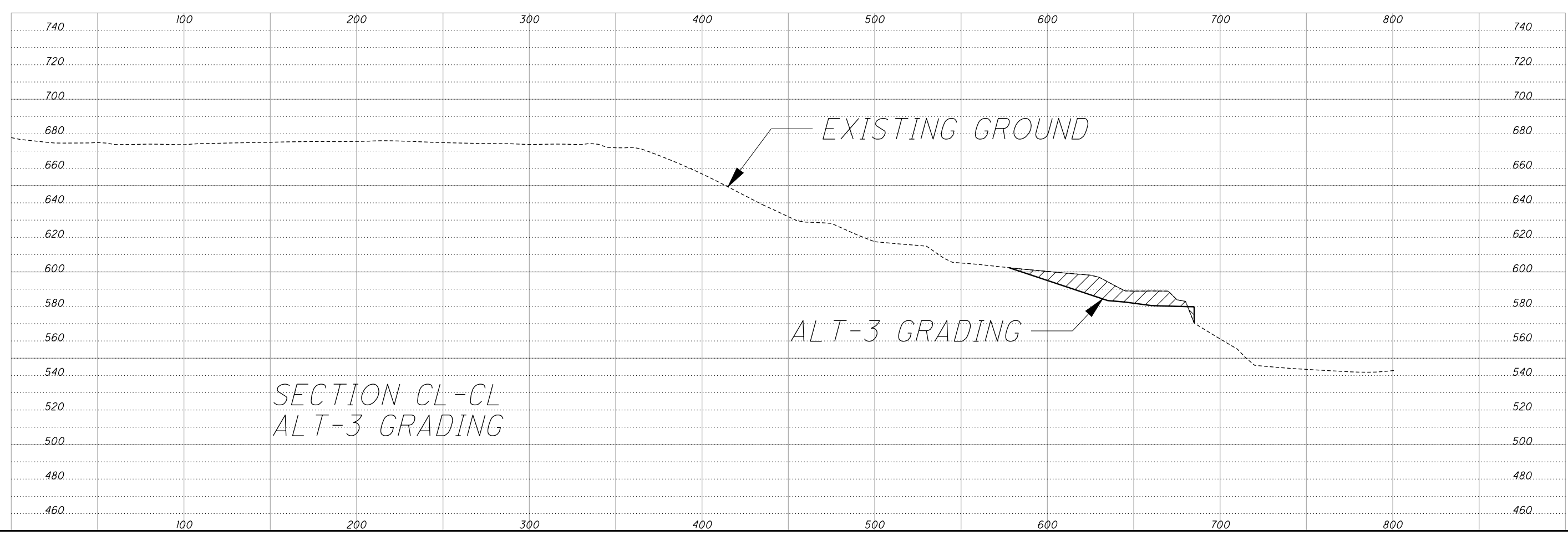
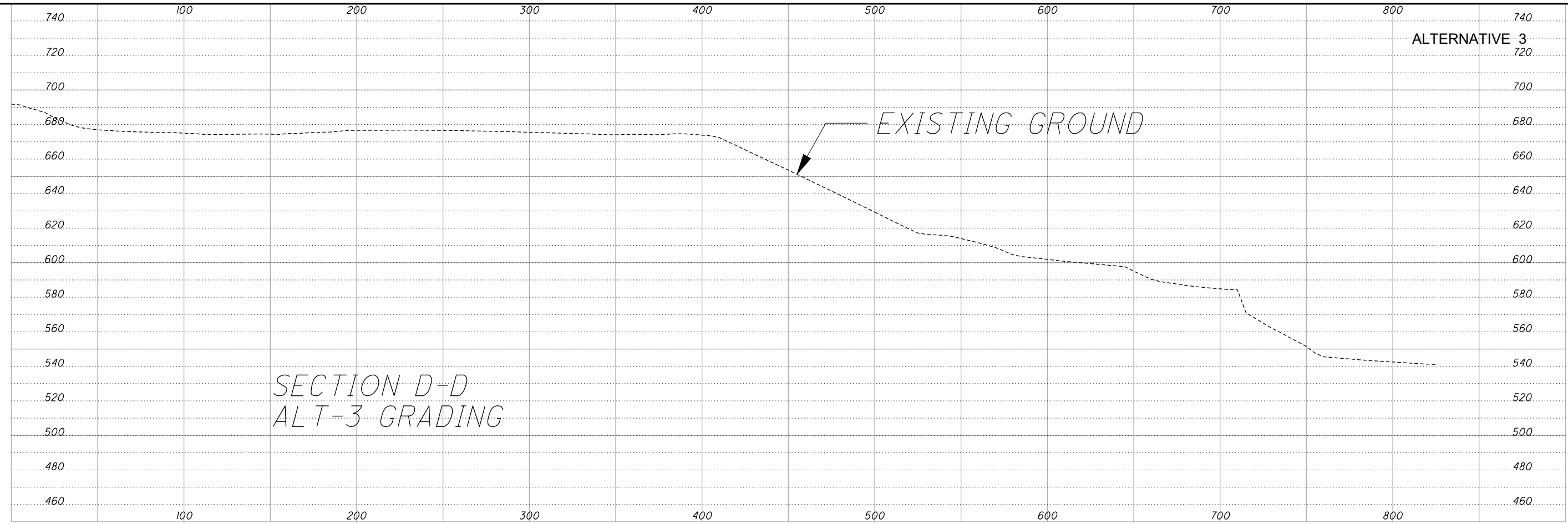

ALTERNATIVE 3



|          |                       |
|----------|-----------------------|
| DESIGNED | DATE                  |
| CHECKED  | STRUCTURE FILE NUMBER |
| DRAWN    | REVIEWED              |
| REVISED  |                       |

SECTION CL-CL AND D-D  
CUYAHOGA RIVER WEST BANK

CUY-90-14.92  
PID No. 77332

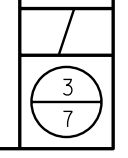

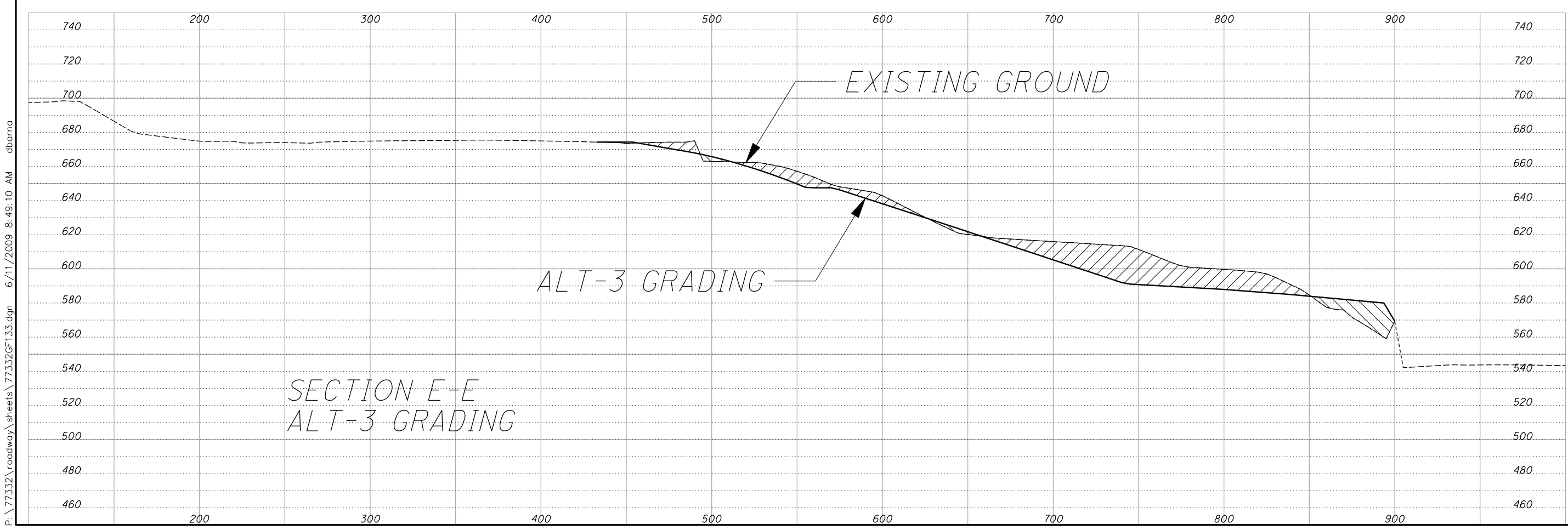
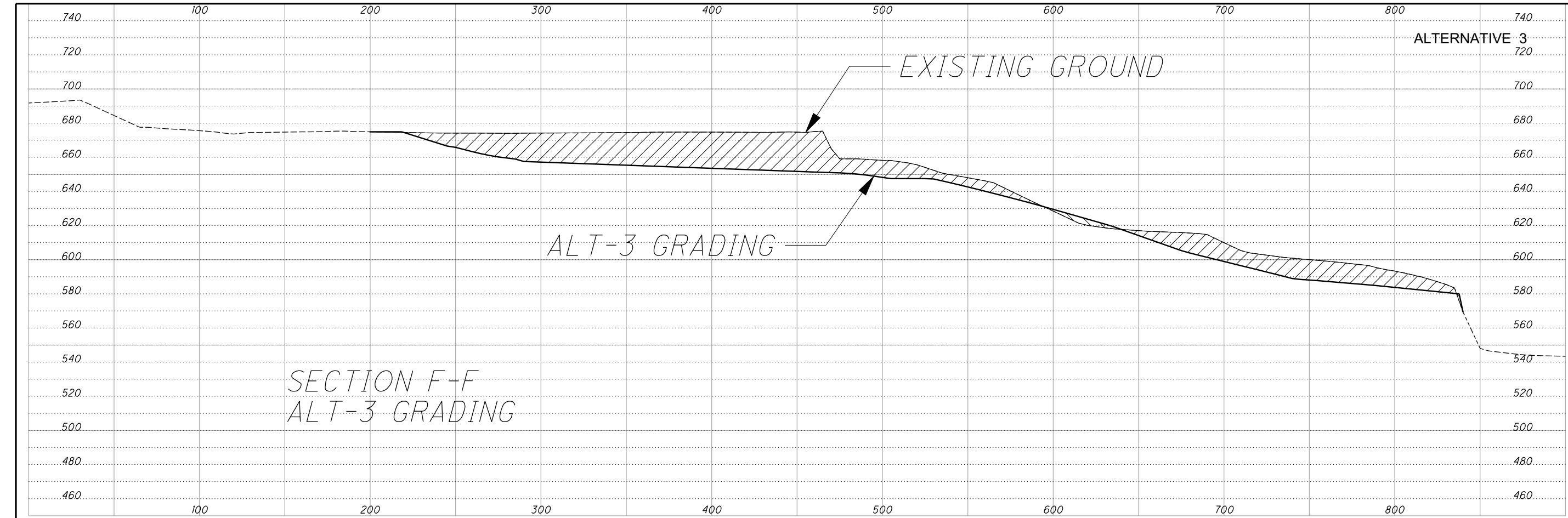

P:\77332\roadway\sheets\77332GF133.dgn 6/11/2009 8:49:10 AM dbarna



|          |                       |
|----------|-----------------------|
| DESIGNED | CHECKED               |
| DRAWN    | REVISED               |
| REVIEWED | STRUCTURE FILE NUMBER |
| DATE     |                       |

SECTION E-E AND F-F  
CUYAHOGA RIVER WEST BANK

CUY-90-14.92  
PID No. 77332

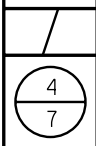

P:\77332\roadway\sheets\77332GF134.dgn 6/11/2009 8:49:14 AM dbarna

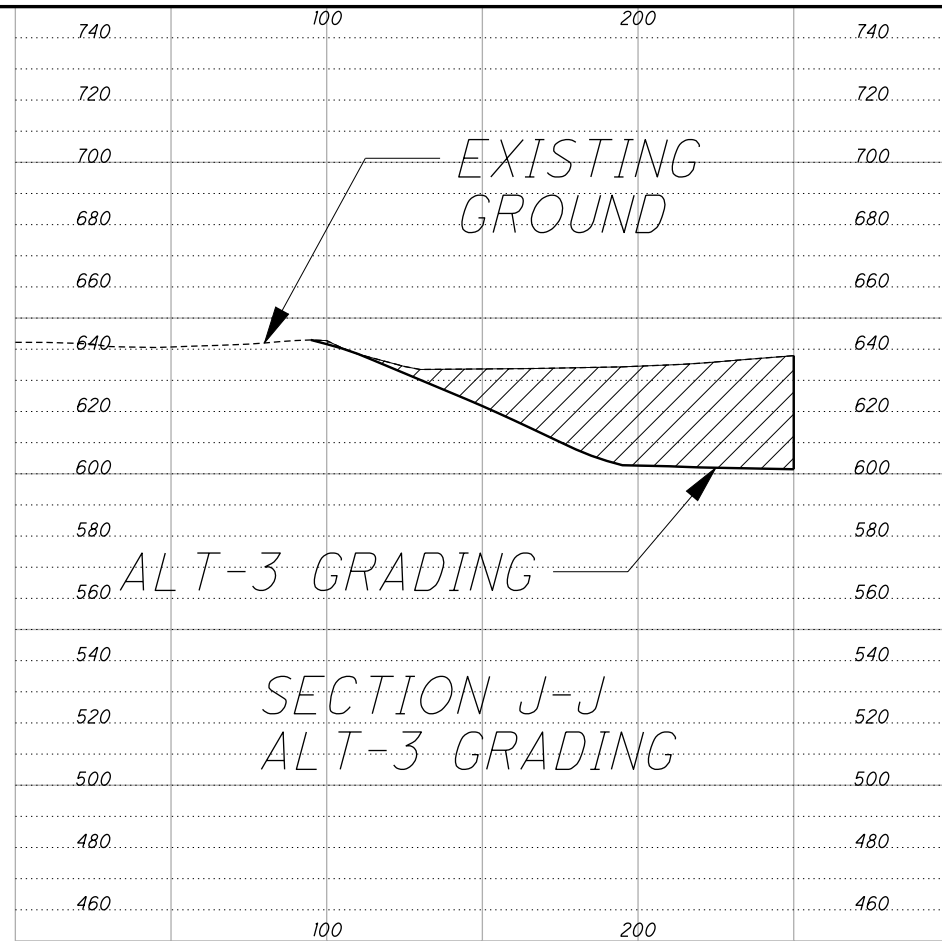
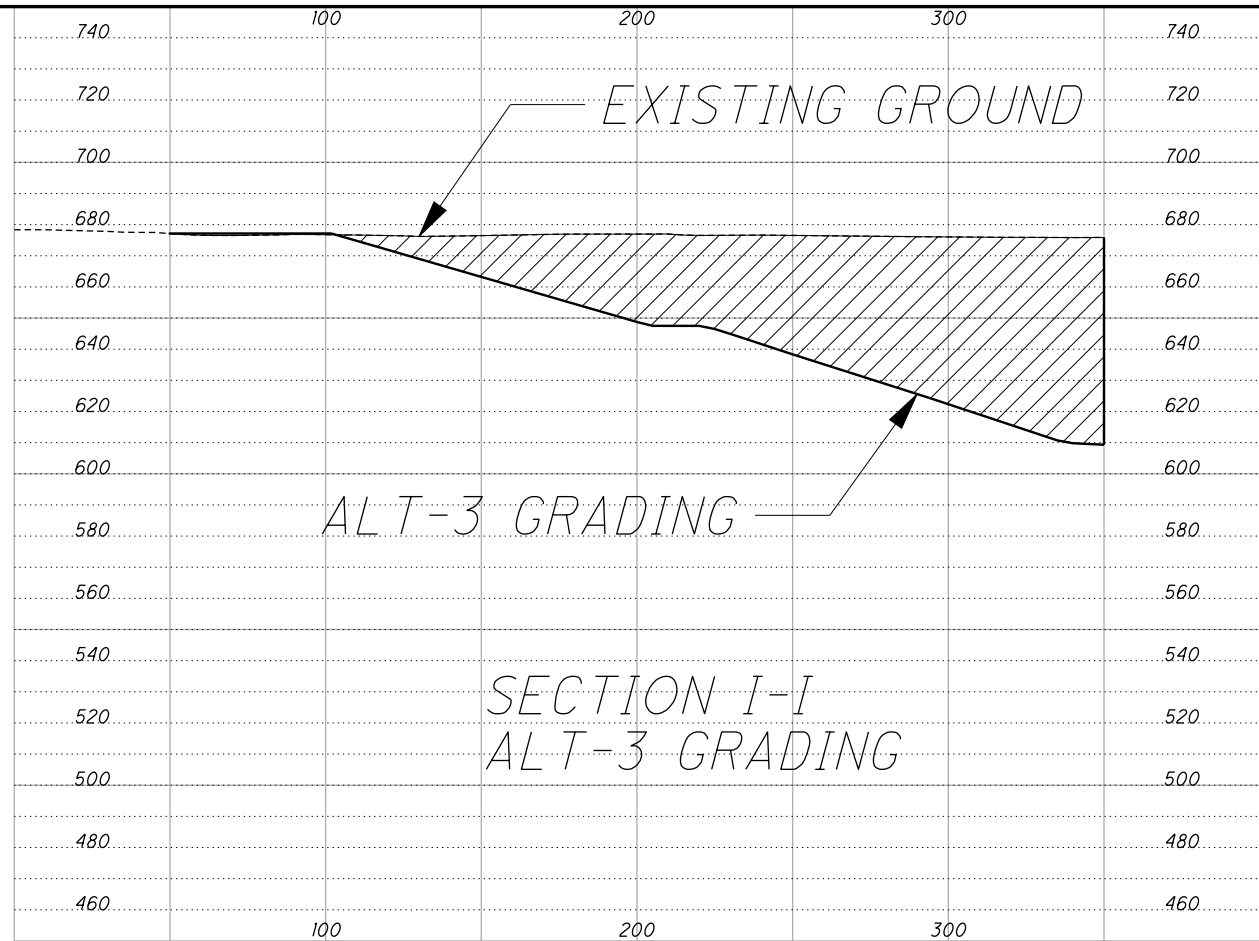

ALTERNATIVE 3

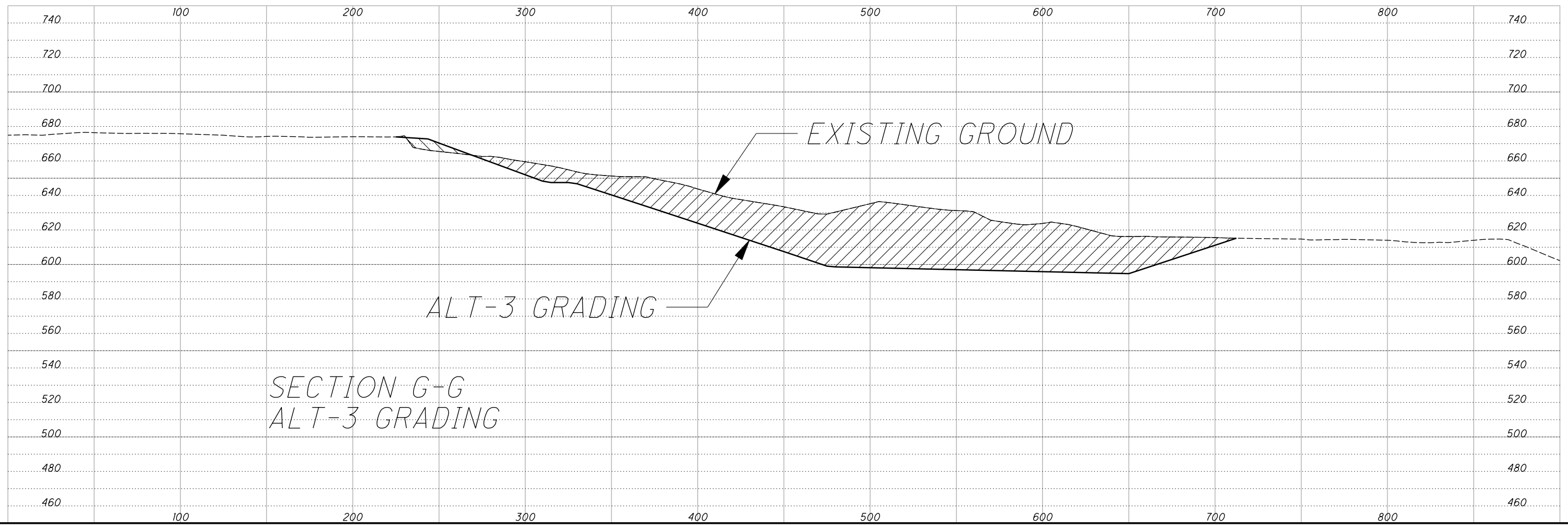

|          |                       |
|----------|-----------------------|
| DESIGNED | CHECKED               |
| DRAWN    | REVISED               |
| REVIEWED | STRUCTURE FILE NUMBER |
| DATE     |                       |

SECTION G-G, I-I, AND SECTION J-J  
CUYAHOGA RIVER WEST BANK

CUY-90-14.92  
PID No. 77332

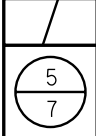

P:\77332\roadway\sheets\77332GF135.dgn 6/11/2009 8:49:19 AM dbarna

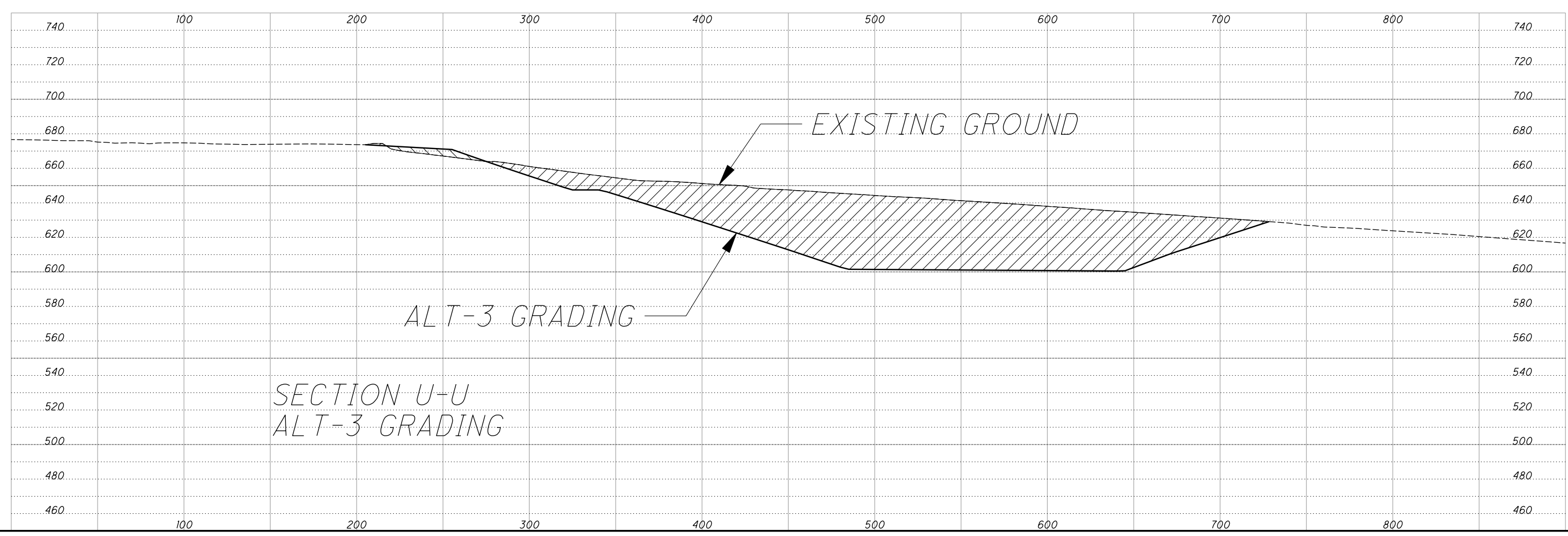
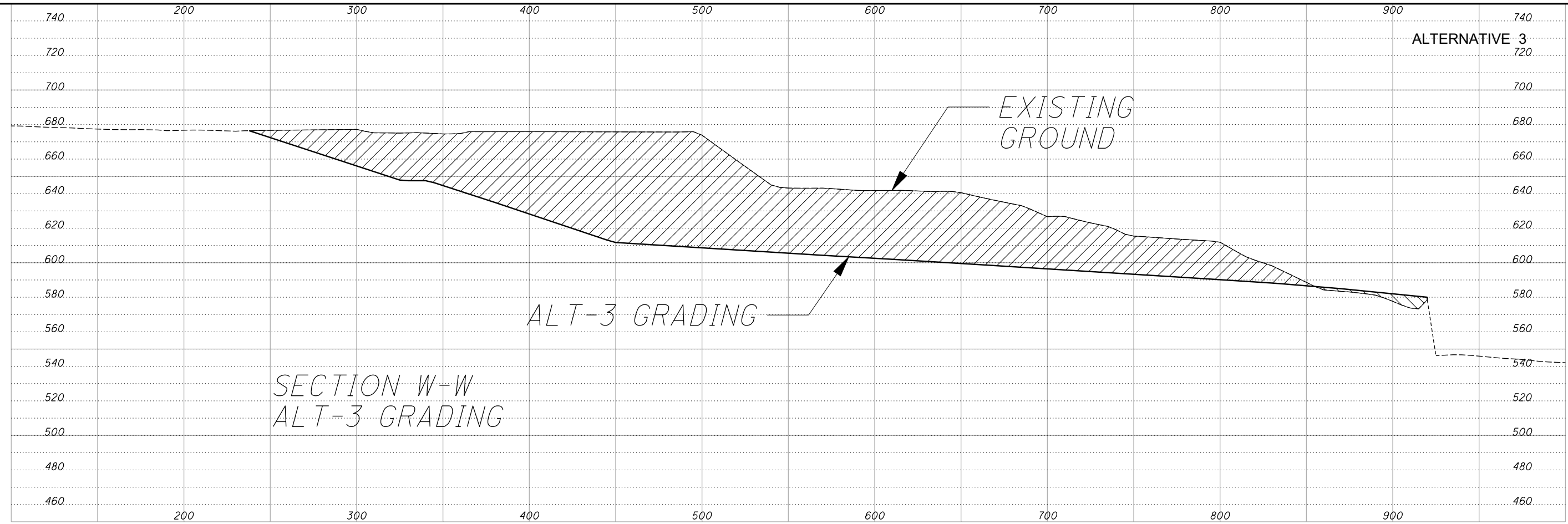

|          |                       |
|----------|-----------------------|
| DESIGNED | CHECKED               |
| DRAWN    | REVISED               |
| REVIEWED | STRUCTURE FILE NUMBER |
| DATE     |                       |

SECTION W-W AND SECTION W-W  
CUYAHOGA RIVER WEST BANK

CUY-90-14.92  
PID No. 77332

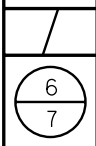

P:\77332\roadway\sheets\77332GF136.dgn 6/11/2009 8:49:23 AM dbarna

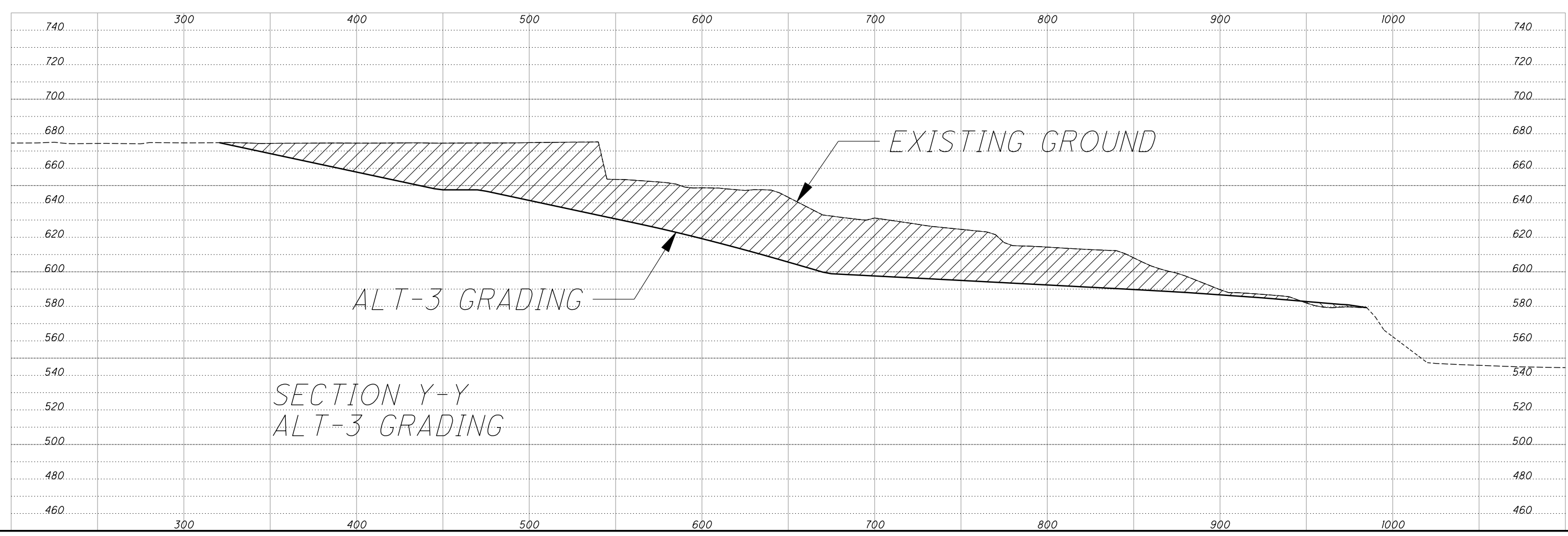
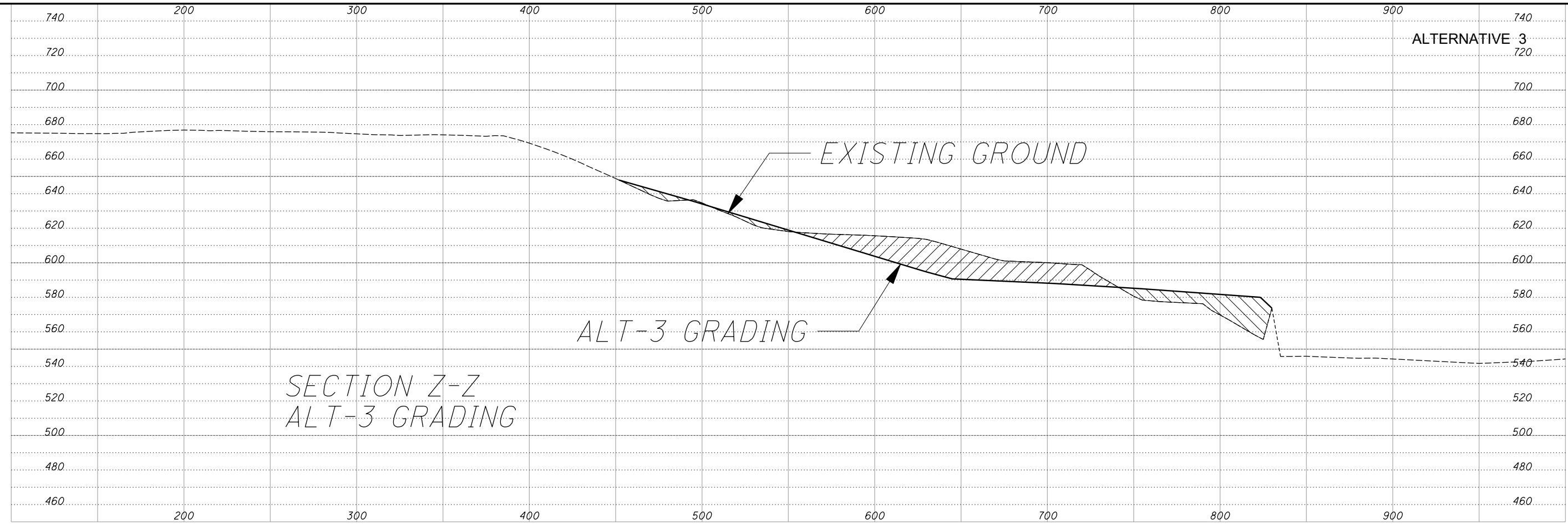

|          |                       |
|----------|-----------------------|
| DESIGNED | CHECKED               |
| DRAWN    | REVISED               |
| REVIEWED | STRUCTURE FILE NUMBER |
| DATE     |                       |

SECTION Y-Y AND Z-Z  
CUYAHOGA RIVER WEST BANK

CUY-90-14.92  
PID No. 77332

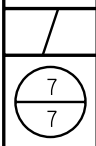

P:\77332\roadway\sheets\77332GP141.dgn 6/18/2009 11:27:14 AM dbarna

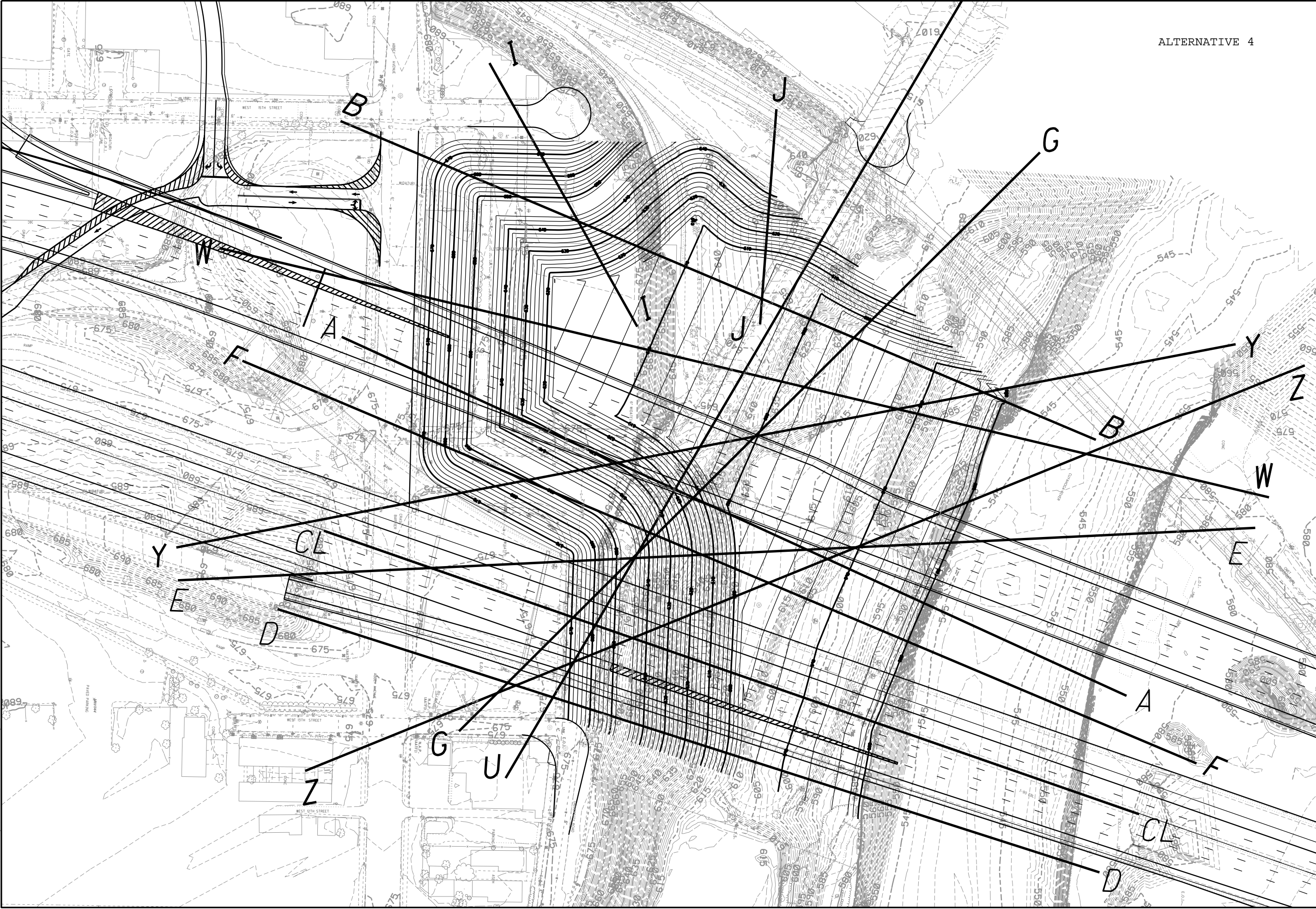

ALTERNATIVE 4



| DESIGNED | DRAWN   | REVIEWED              | DATE |
|----------|---------|-----------------------|------|
| CHECKED  | REVISED | STRUCTURE FILE NUMBER |      |

ALT 4 SLOPE GRADING PLAN  
 CUYAHOGA RIVER WEST BANK

CUY-90-14.92  
 PID No. 77332

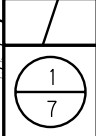

P:\77332\roadway\sheets\77332GF141.dgn 6/18/2009 11:27:26 AM dbarna

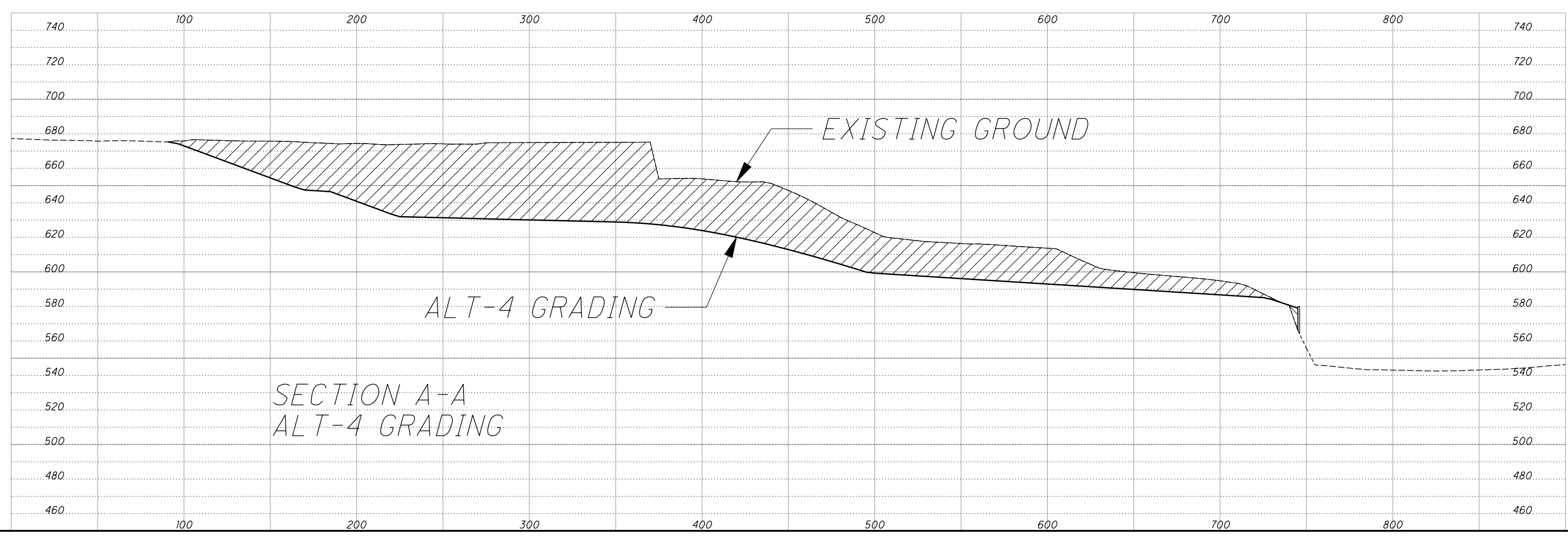
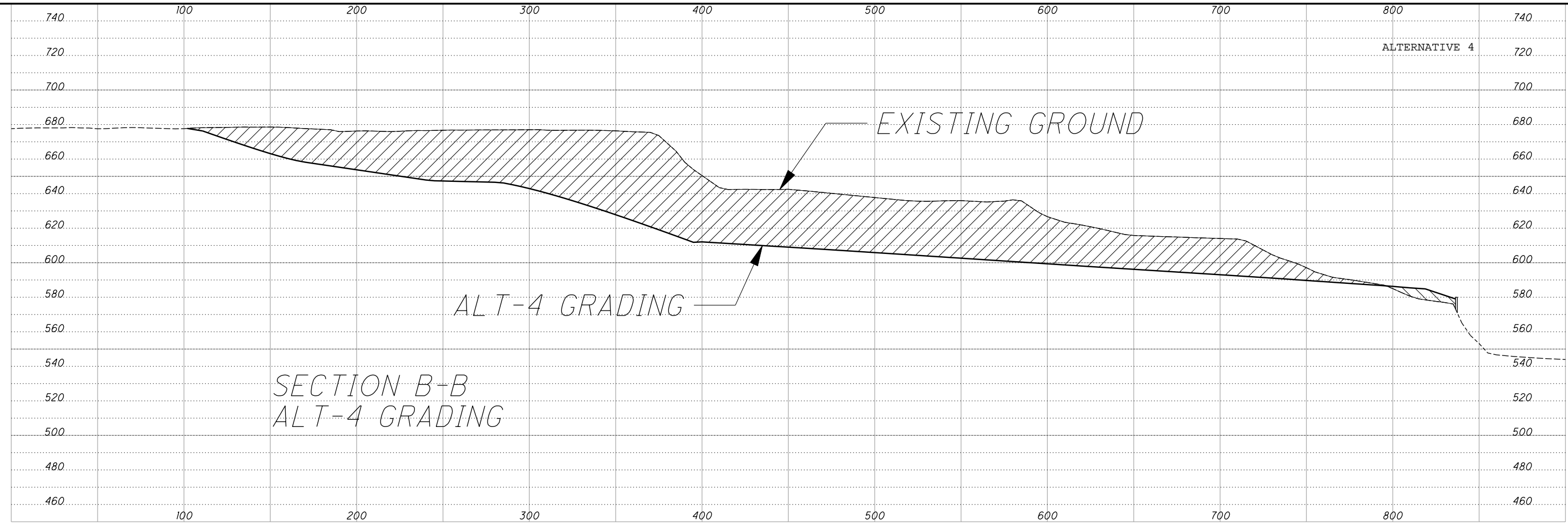

|          |                       |
|----------|-----------------------|
| DESIGNED | CHECKED               |
| DRAWN    | REVISED               |
| REVIEWED | STRUCTURE FILE NUMBER |
| DATE     |                       |

SECTION A-A AND B-B  
CUYAHOGA RIVER WEST BANK

CUY-90-14.92  
PID No. 77332

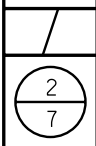



P:\77332\roadway\sheets\77332GF142.dgn 6/18/2009 11:27:30 AM dbarna

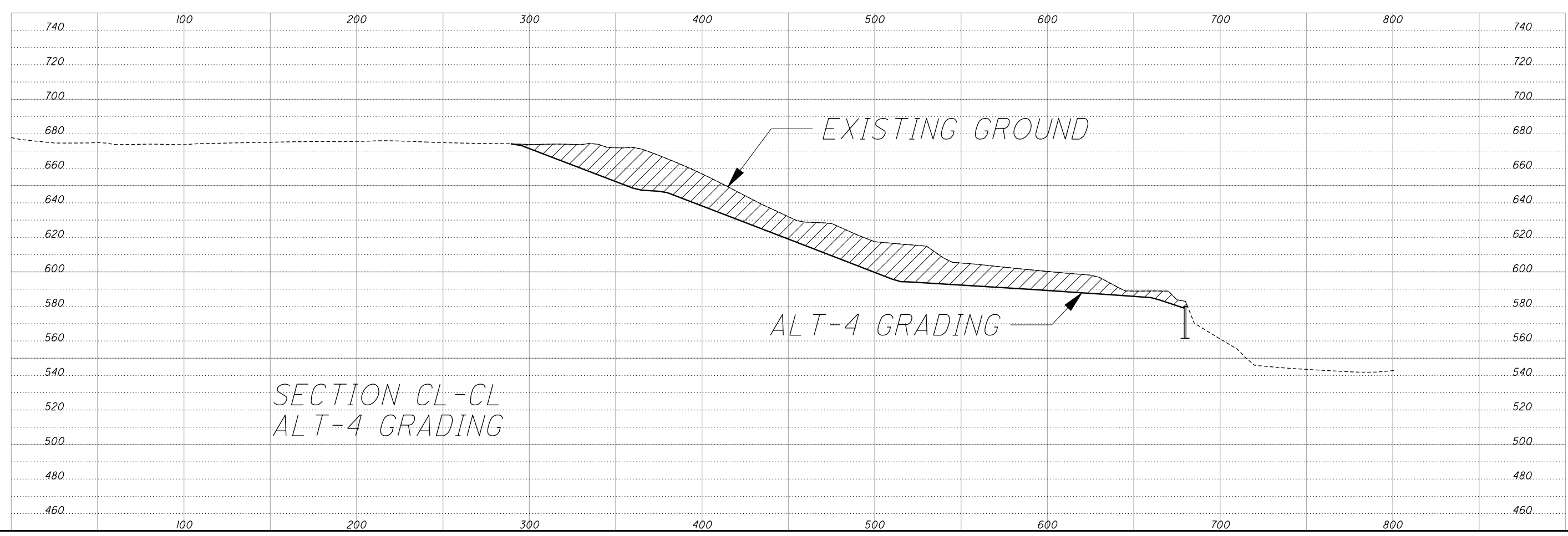
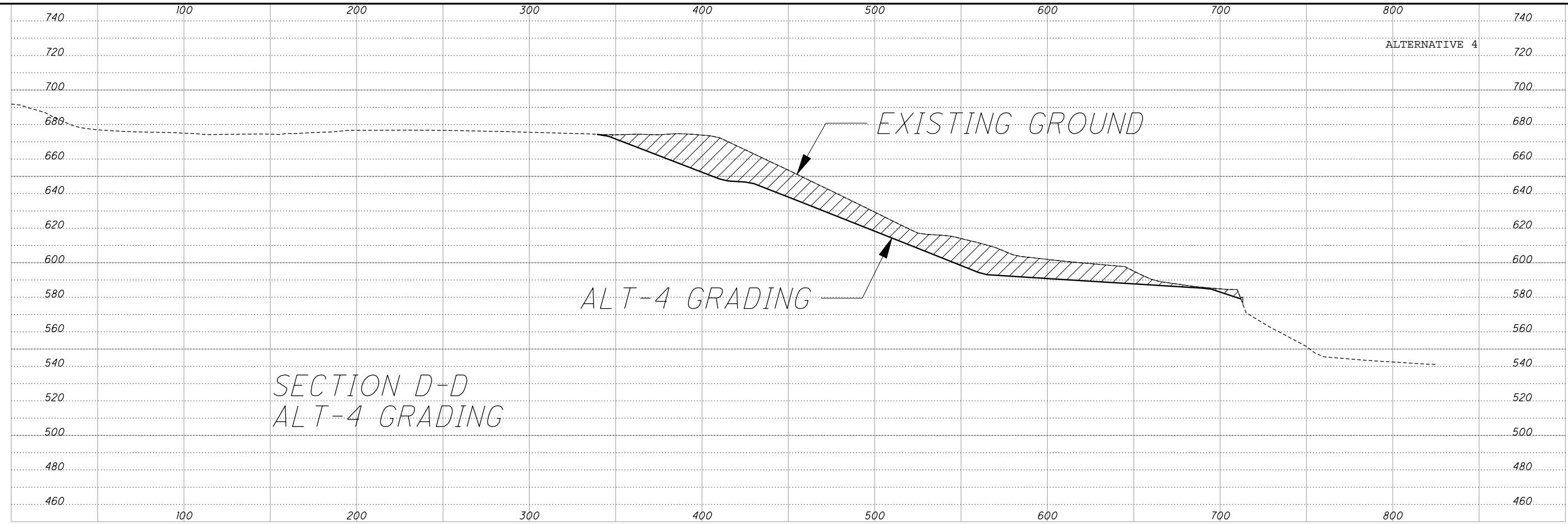

|          |                       |
|----------|-----------------------|
| DESIGNED | CHECKED               |
| DRAWN    | REVISED               |
| REVIEWED | STRUCTURE FILE NUMBER |
| DATE     |                       |

SECTION CL-CL AND D-D  
CUYAHOGA RIVER WEST BANK

CUY-90-14.92  
PID No. 77332

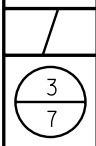

P:\77332\roadway\sheets\77332GF143.dgn 6/18/2009 11:27:34 AM dbarna

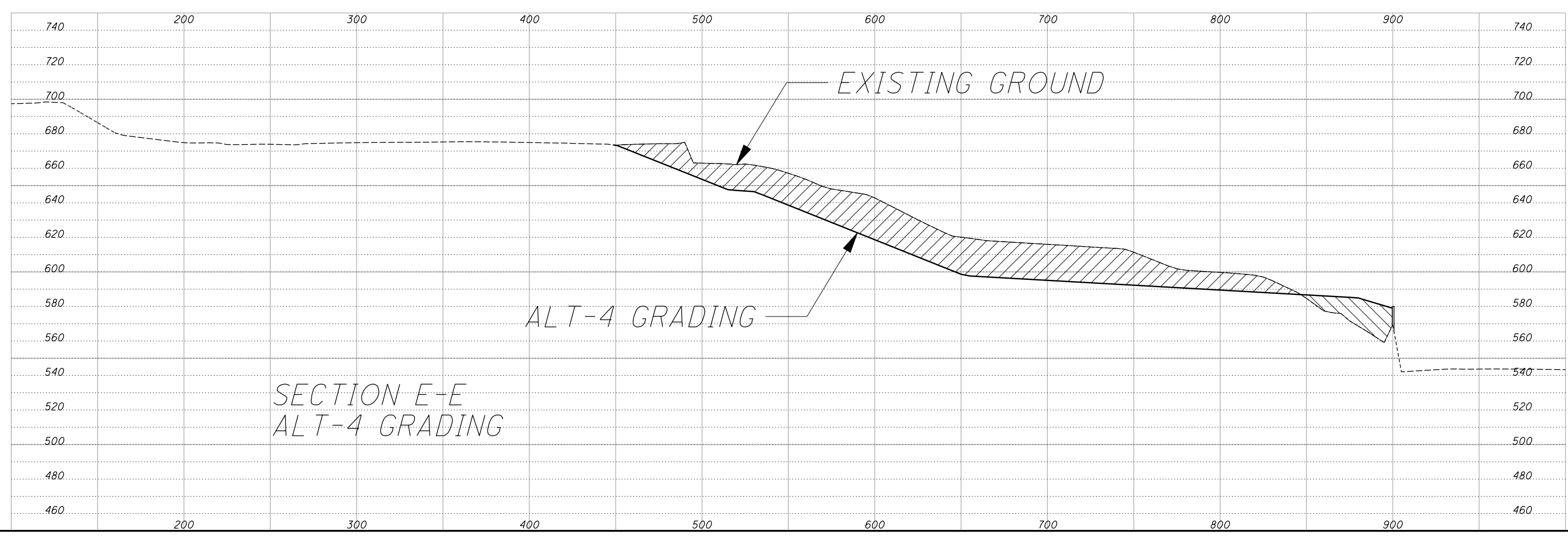
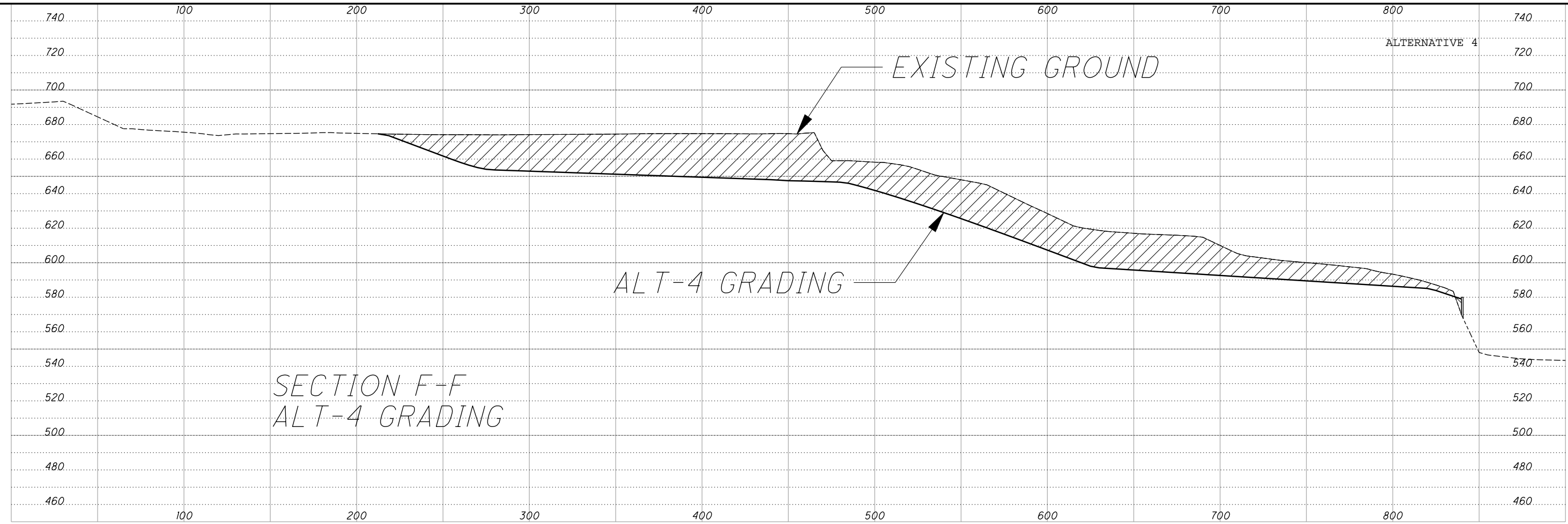

|          |                       |
|----------|-----------------------|
| DESIGNED | CHECKED               |
| DRAWN    | REVISD                |
| REVIEWED | STRUCTURE FILE NUMBER |
| DATE     |                       |

SECTION E-E AND F-F  
CUYAHOGA RIVER WEST BANK

CUY-90-14.92  
PID No. 77332

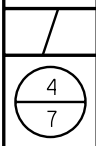

P:\77332\roadway\sheets\77332GF14.dgn 6/18/2009 11:27:38 AM dbarna

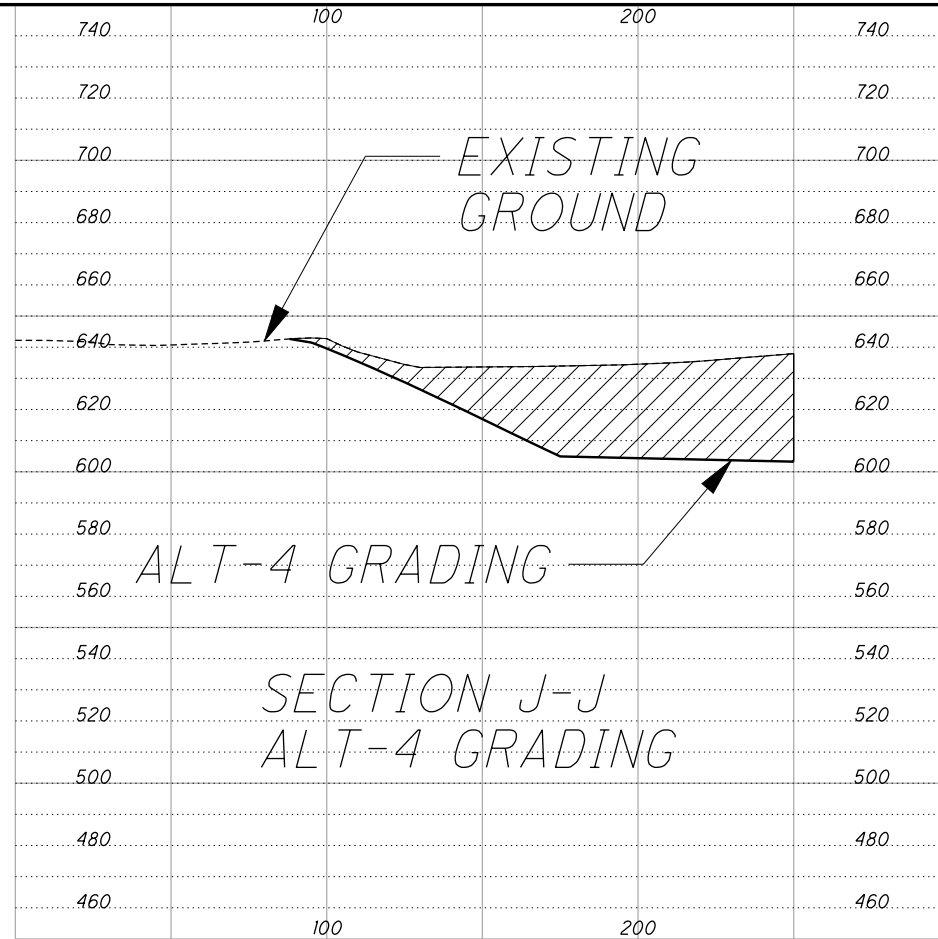
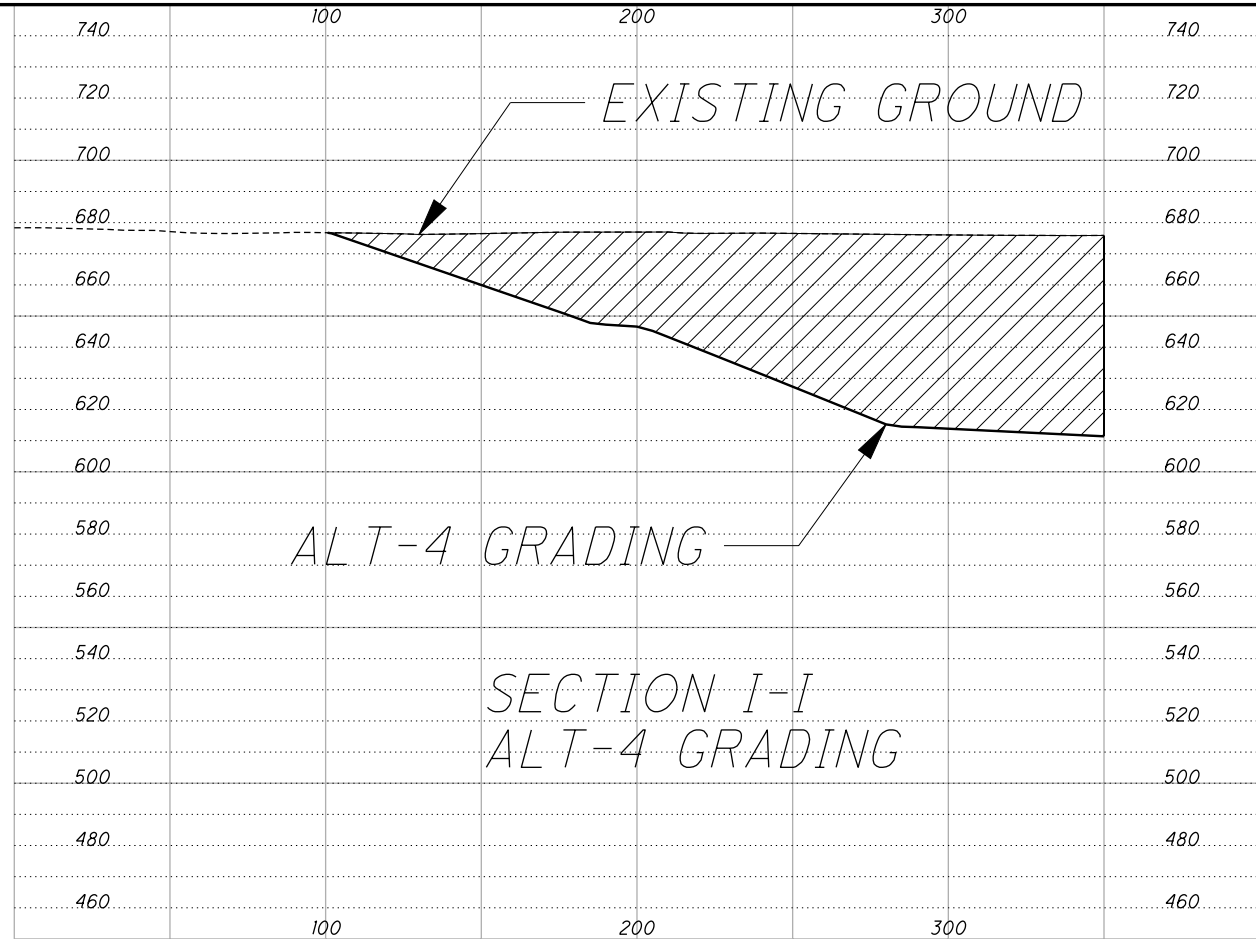

ALTERNATIVE 4

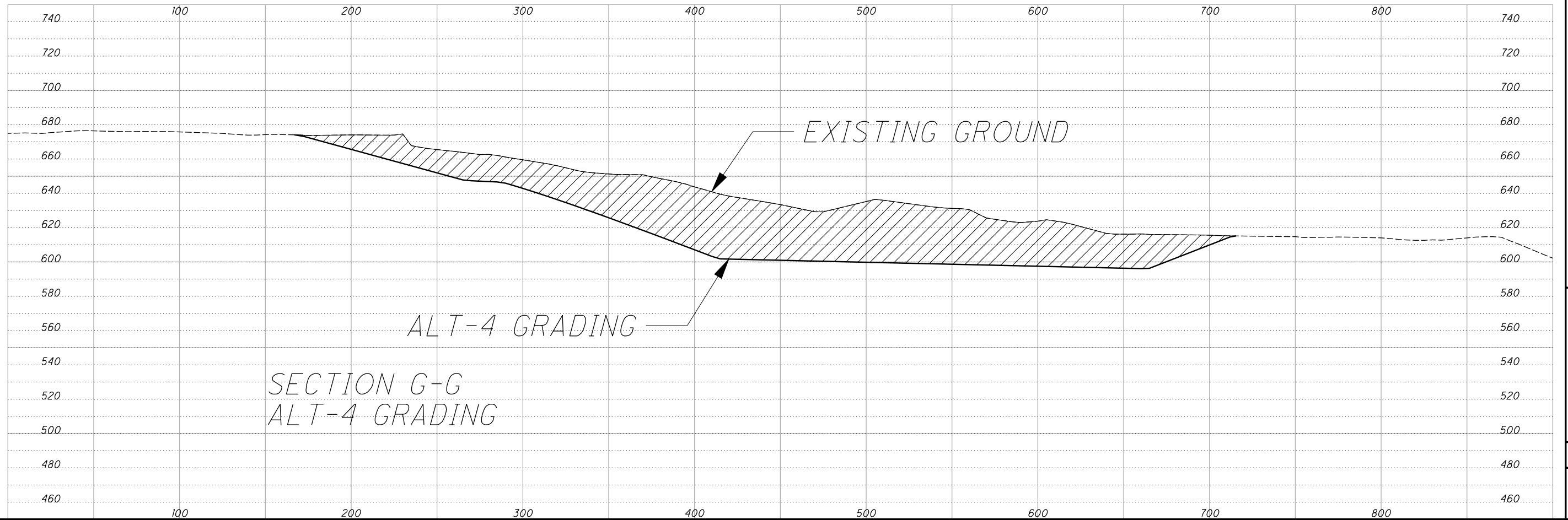

|          |                       |
|----------|-----------------------|
| DESIGNED | CHECKED               |
| DRAWN    | REVISED               |
| REVIEWED | STRUCTURE FILE NUMBER |
| DATE     |                       |

SECTION G-G, I-I, AND SECTION J-J  
CUYAHOGA RIVER WEST BANK

CUY-90-14.92  
PID No. 77332

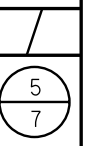

P:\77332\roadway\sheets\77332GF145.dgn 6/18/2009 11:27:42 AM dbarna

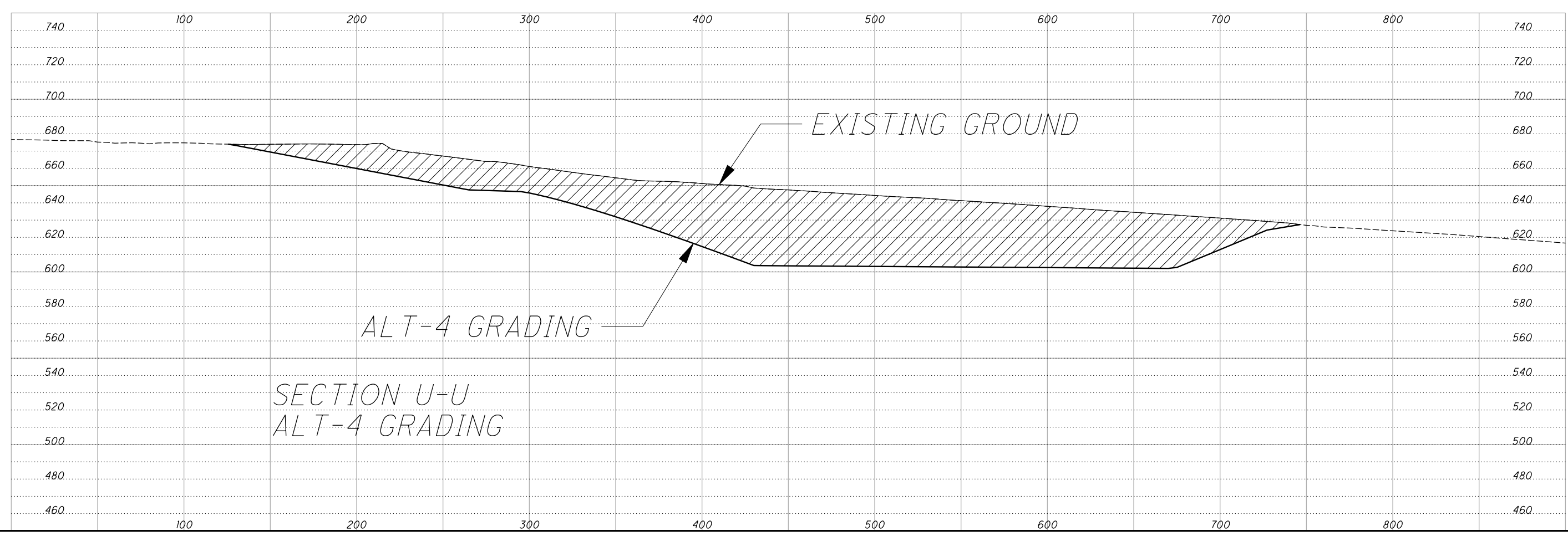
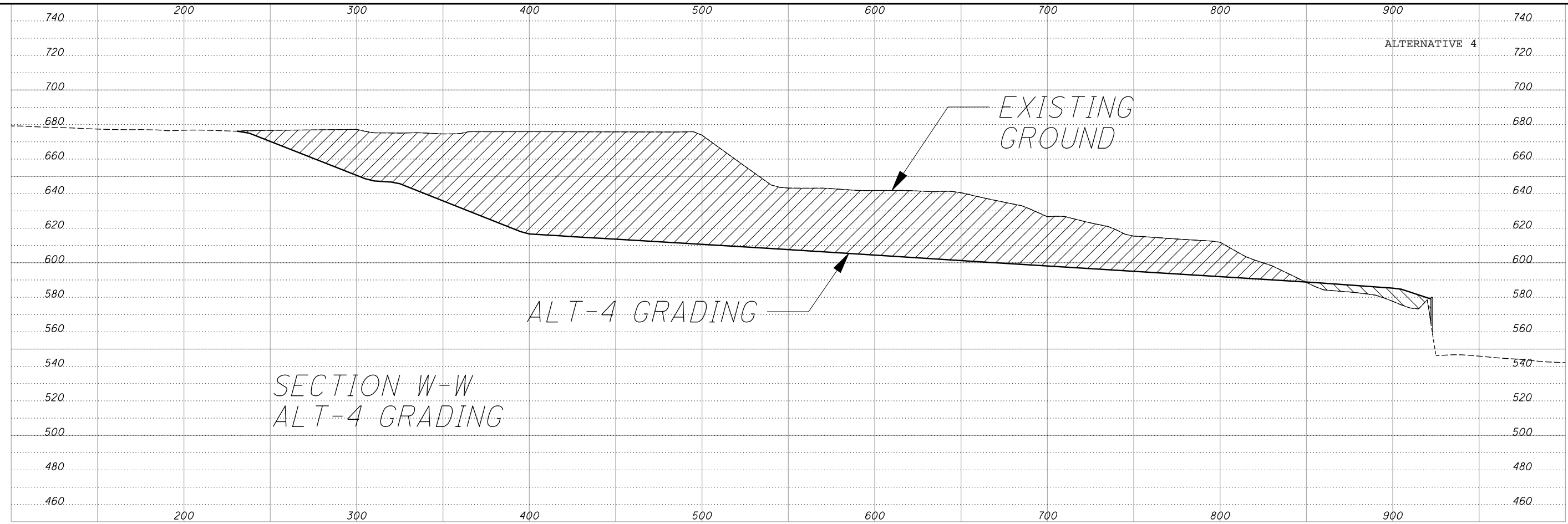

|          |                       |
|----------|-----------------------|
| DESIGNED | CHECKED               |
| DRAWN    | REVISED               |
| REVIEWED | STRUCTURE FILE NUMBER |
| DATE     |                       |

SECTION W-W AND SECTION W-W  
CUYAHOGA RIVER WEST BANK

CUY-90-14.92  
PID No. 77332

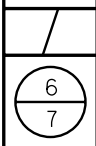

P:\77332\roadway\sheets\77332GF146.dgn 6/18/2009 11:27:46 AM dbarna

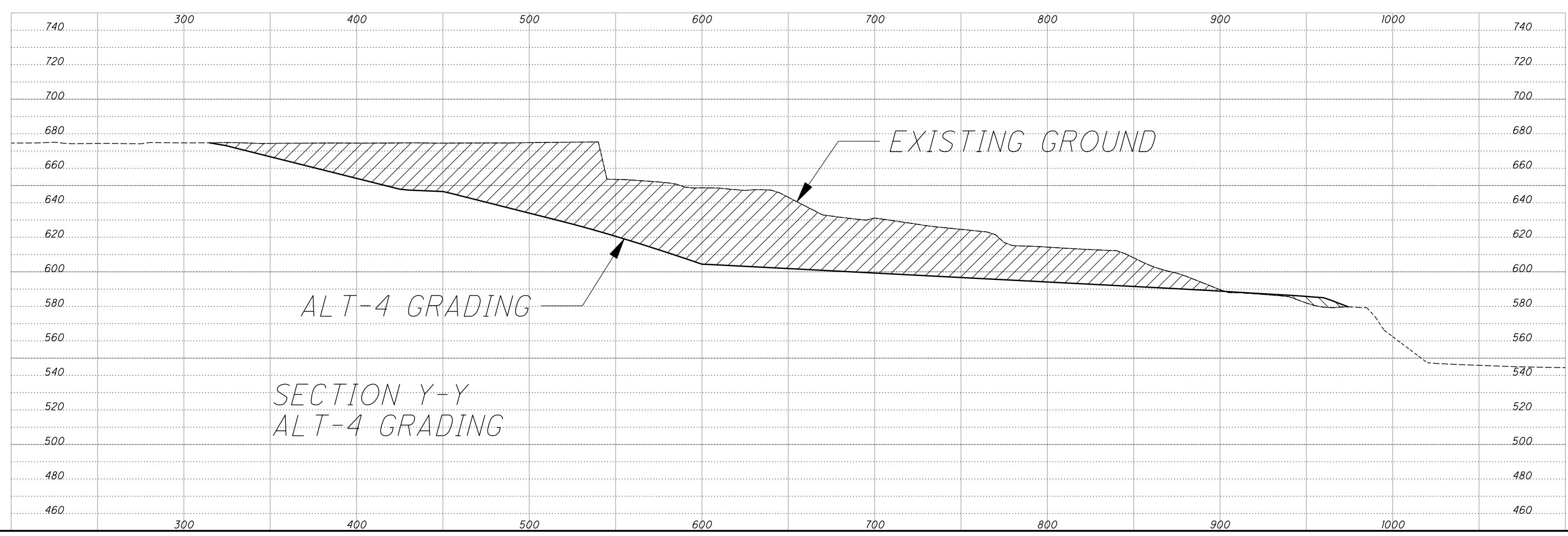
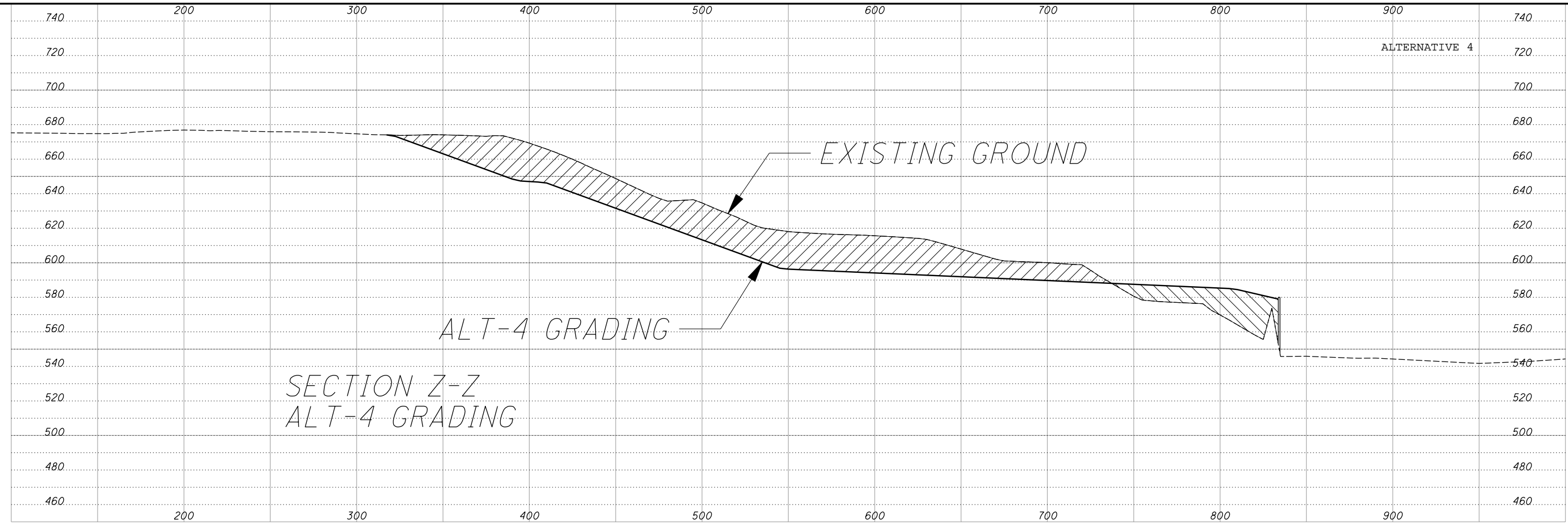

|          |                       |
|----------|-----------------------|
| DESIGNED | CHECKED               |
| DRAWN    | REVISED               |
| REVIEWED | STRUCTURE FILE NUMBER |
| DATE     |                       |

SECTION Y-Y AND Z-Z  
CUYAHOGA RIVER WEST BANK

CUY-90-14.92  
PID No. 77332

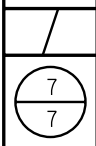

P:\77332\roadway\sheets\77332GP512.dgn 11/23/2009 1:45:56 PM csteck

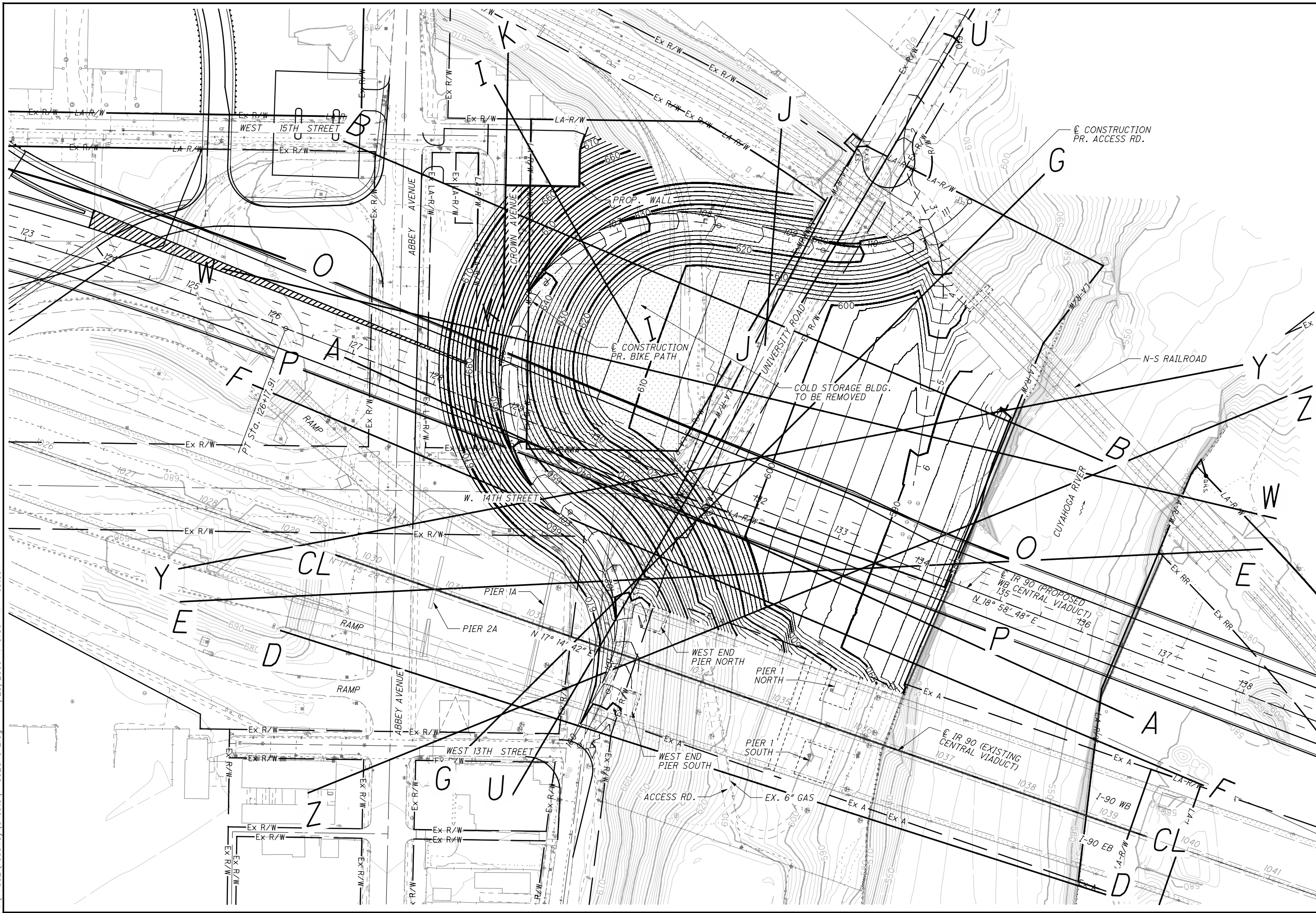

CALCULATED  
 DWB  
 CHECKED  
 R/L

**SLOPE GRADING PLAN & PROFILE LOCATIONS**  
**CUYAHOGA RIVER WEST BANK**

**CUY-90-14.92**

5  
 34

P:\77332\roadway\sheets\77332GF510.dgn 11/21/2009 9:14:01 PM csteck

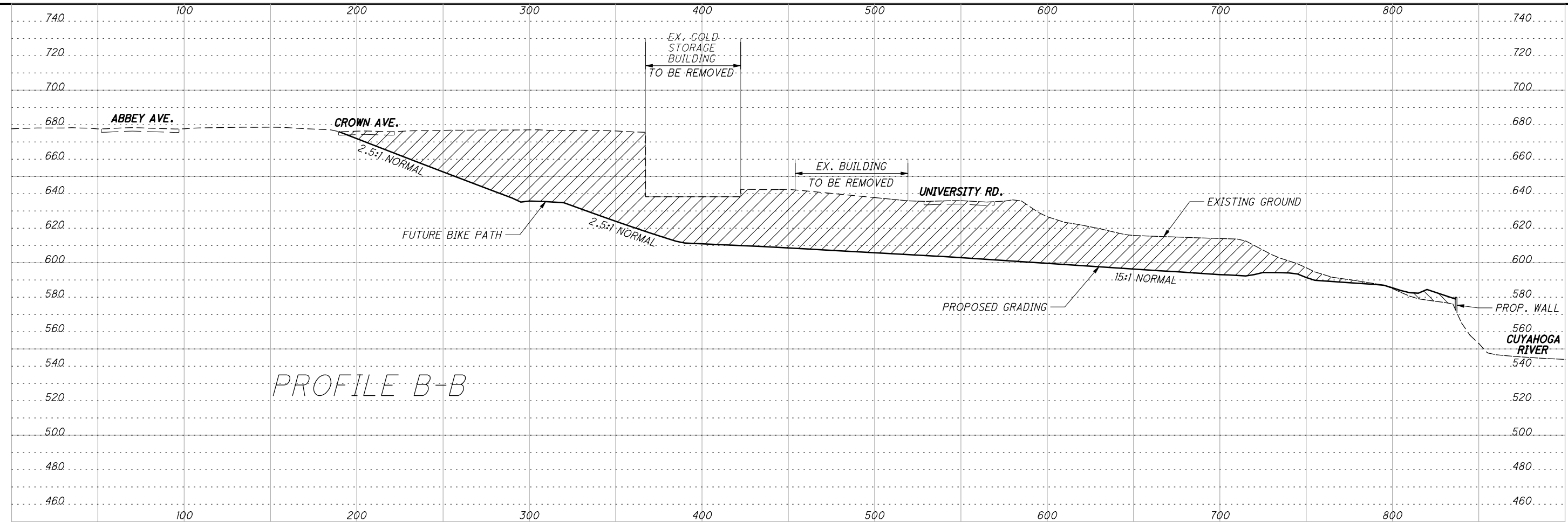

PROFILE B-B

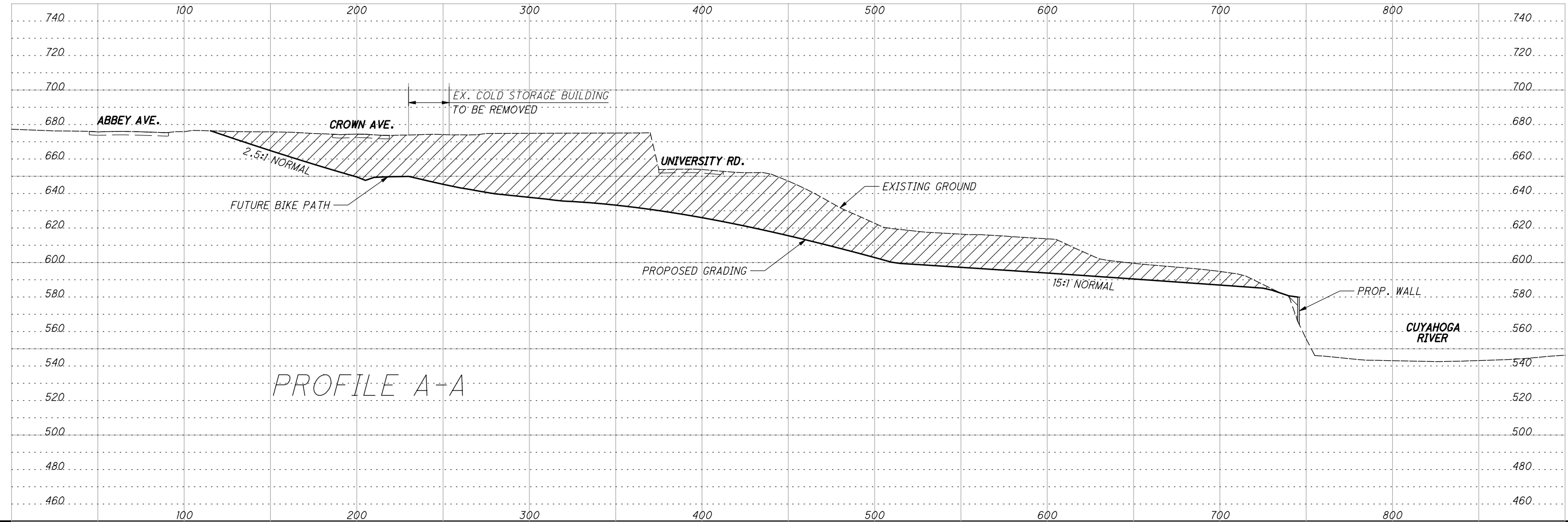

PROFILE A-A

|   |     |         |     |
|---|-----|---------|-----|
| CALCULATED                                | DWB | CHECKED | RLE |
| <b>SLOPE GRADING PROFILES A-A AND B-B</b> |     |         |     |
| <b>CUY-90-14.92</b>                       |     |         |     |
| 23  |     | 34      |     |

P:\77332\roadway\sheets\77332GF512.dgn 11/21/2009 9:14:04 PM csteck

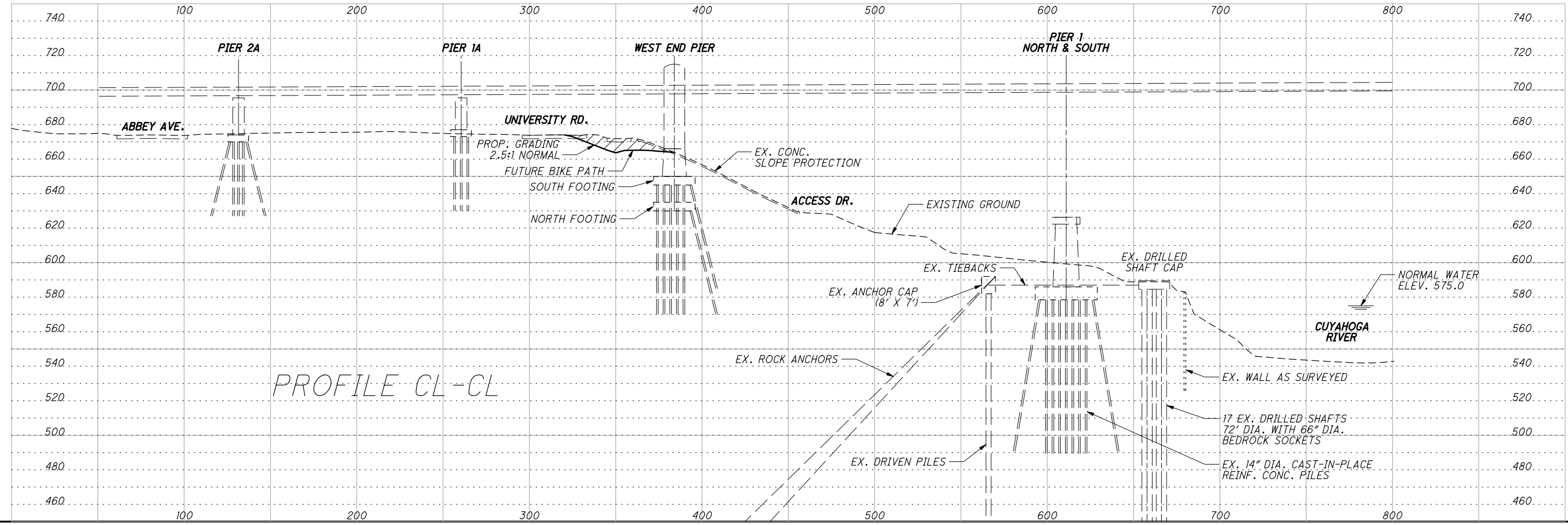
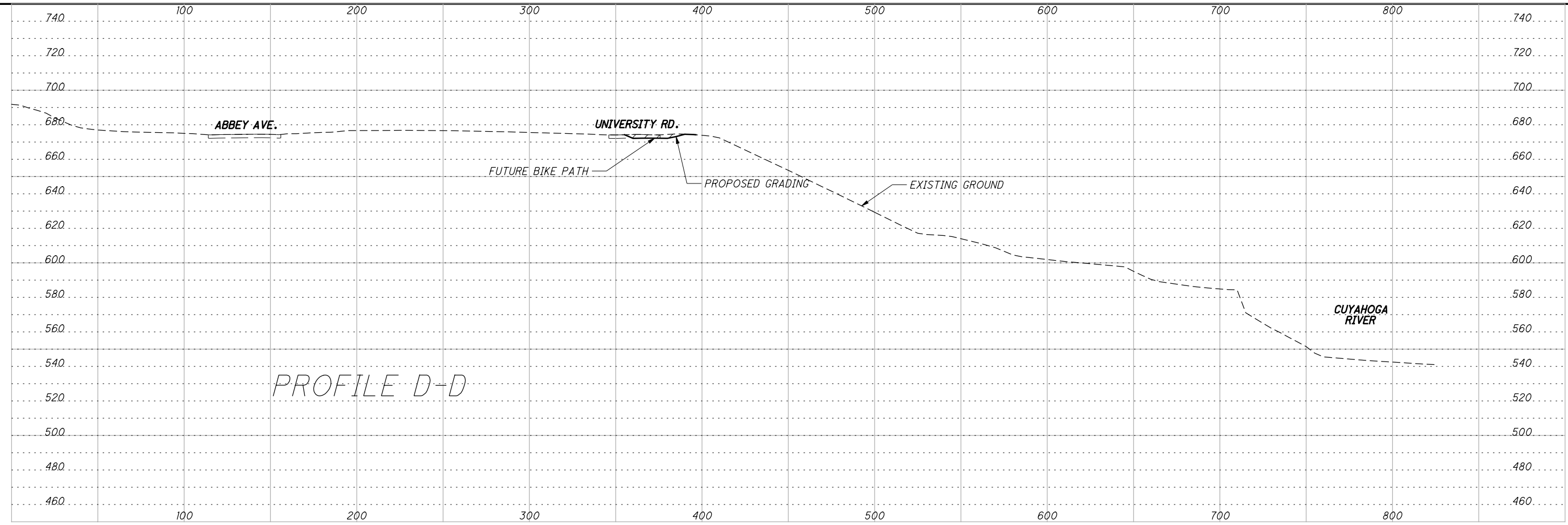

CALCULATED  
DWB  
CHECKED  
RLE

**SLOPE GRADING PROFILES CL-CL AND D-D**

**CUY-90-14.92**

24  
34



P:\77332\roadway\sheets\77332GF513.dgn 11/21/2009 9:14:07 PM csteck

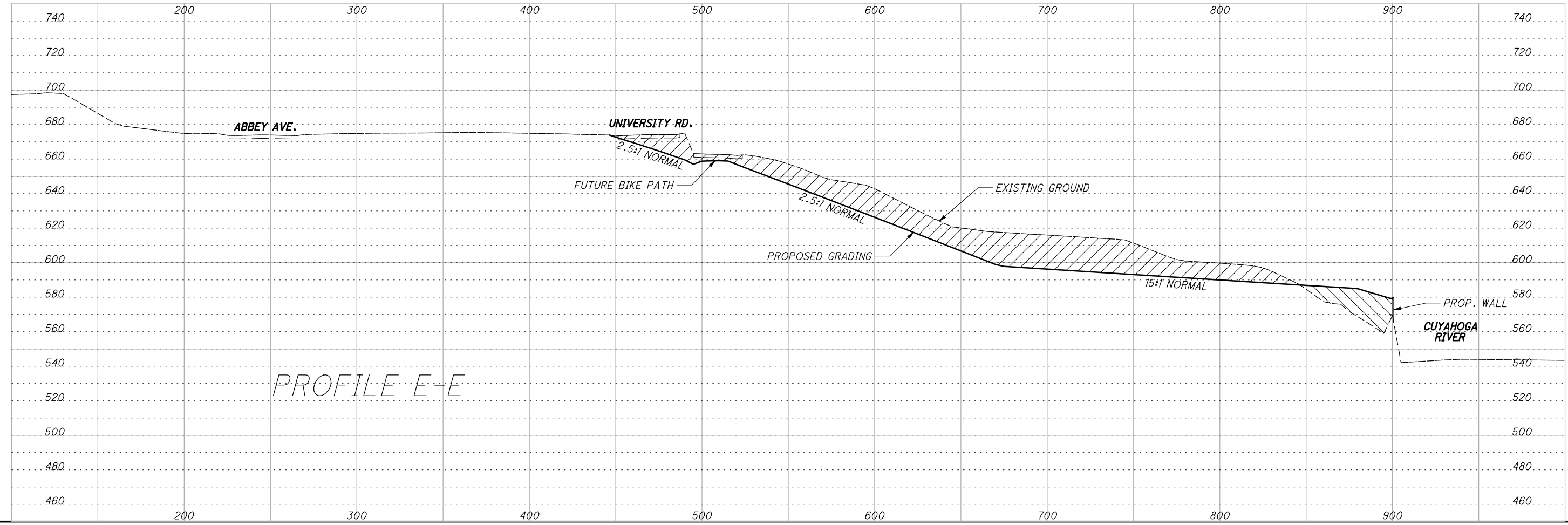
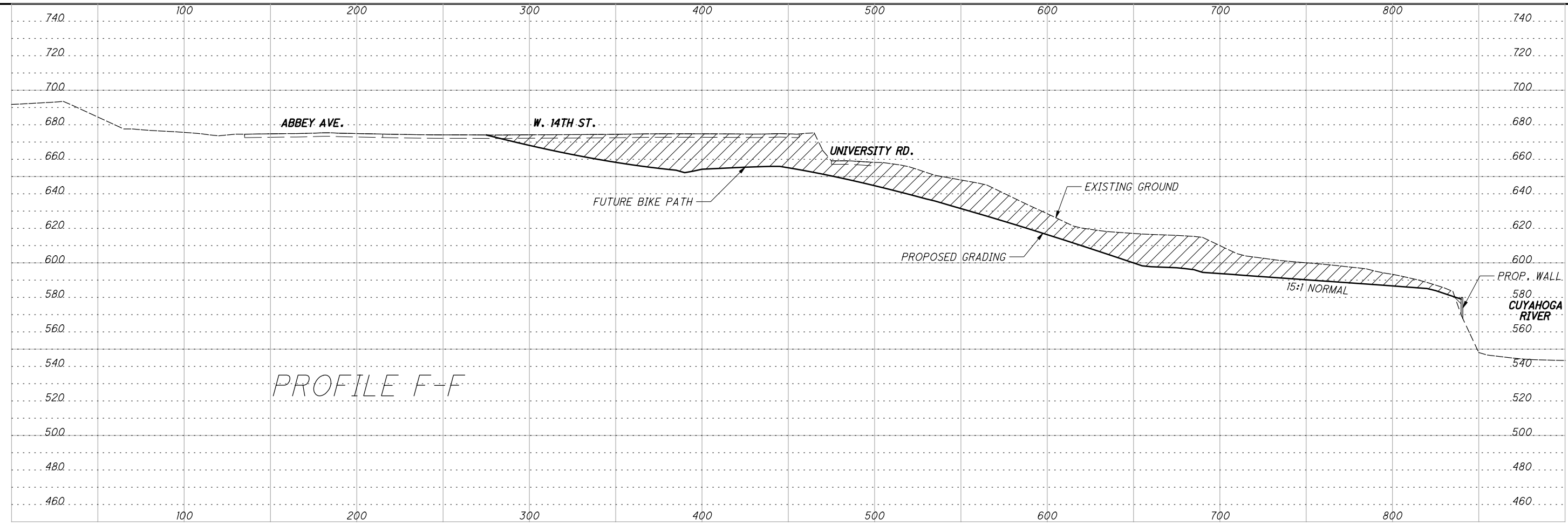

CALCULATED  
DWB  
CHECKED  
RLE

SLOPE GRADING PROFILES E-E AND F-F

CUY-90-14.92

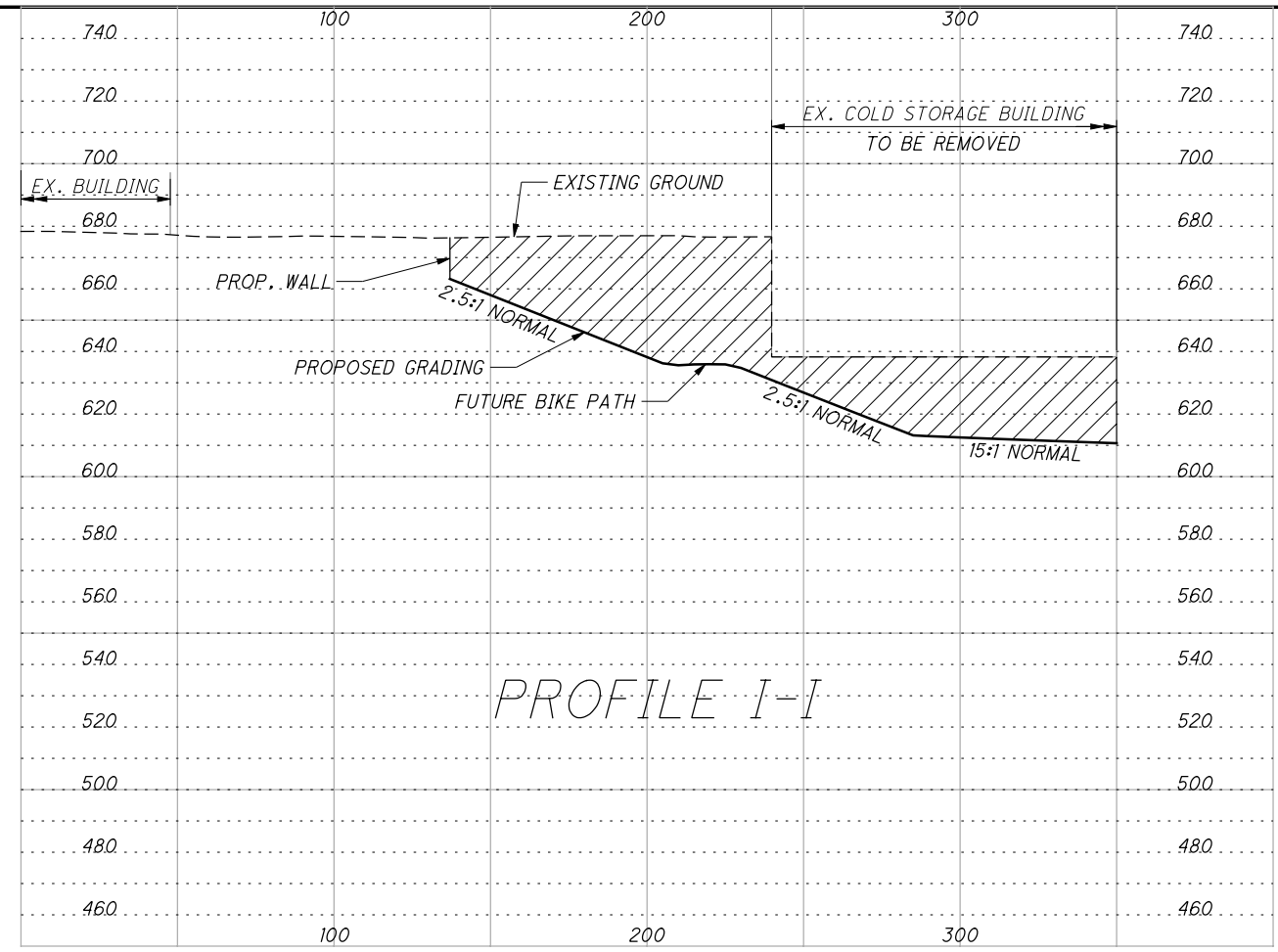

PROFILE I-I

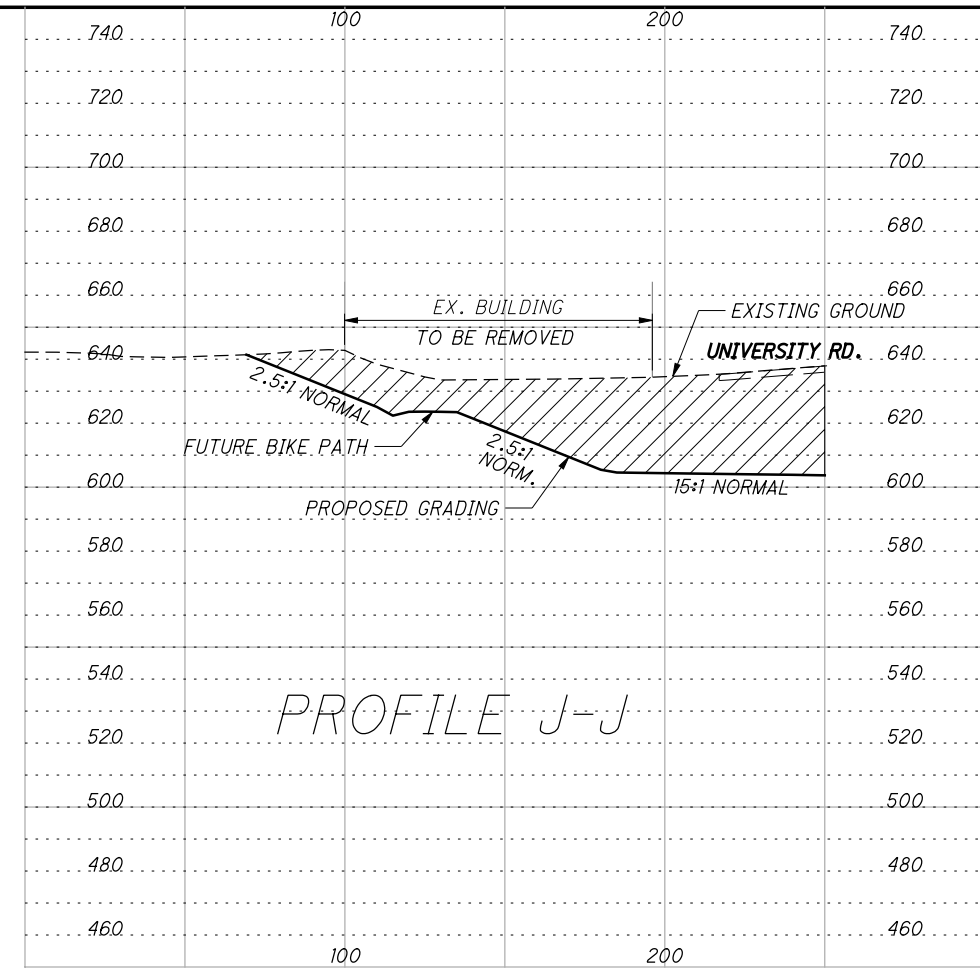

PROFILE J-J

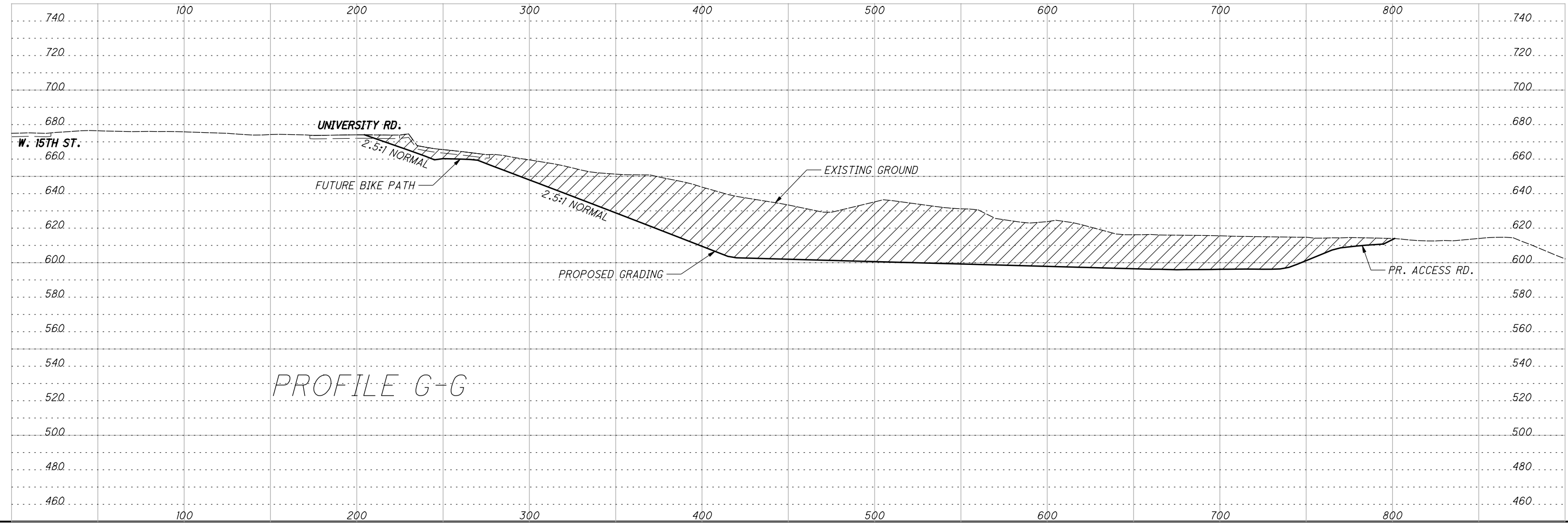

PROFILE G-G

P:\77332\roadway\sheets\77332GF514.dgn 11/21/2009 9:14:09 PM csteck

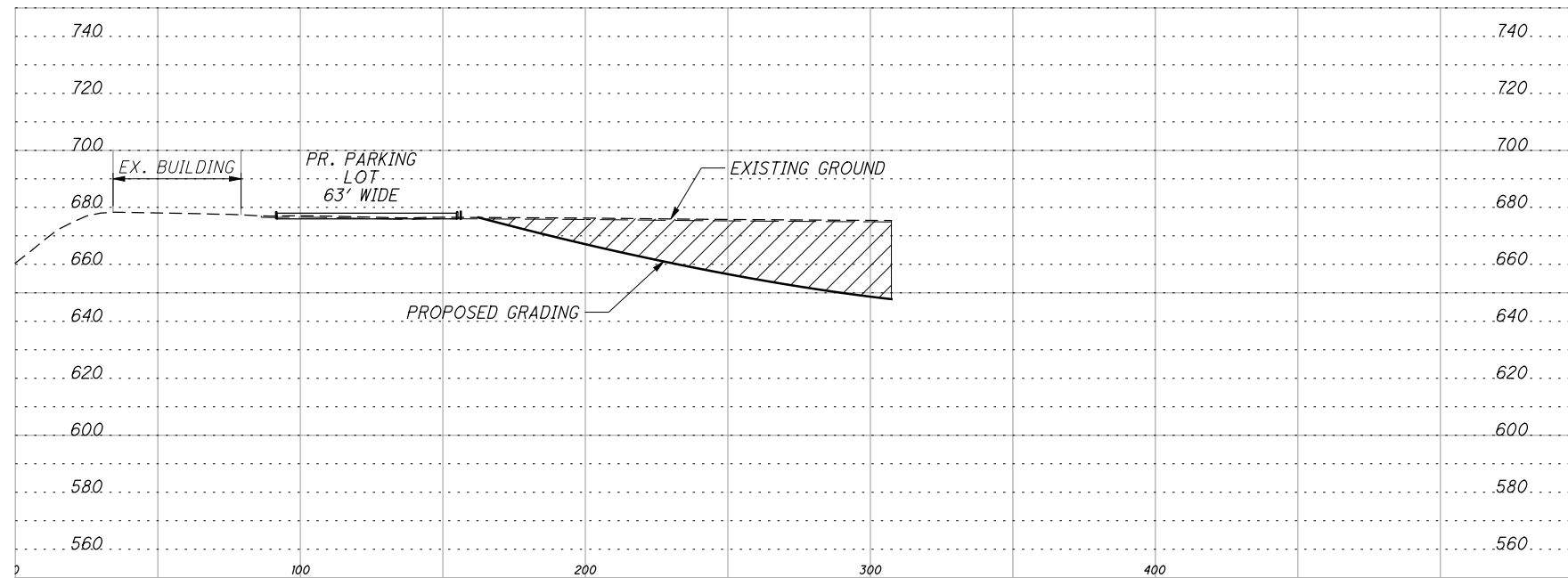

PROFILE K-K

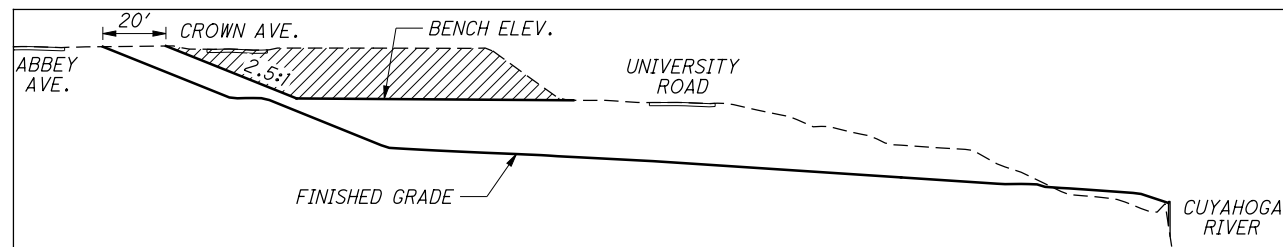

STAGE 1 EXCAVATION

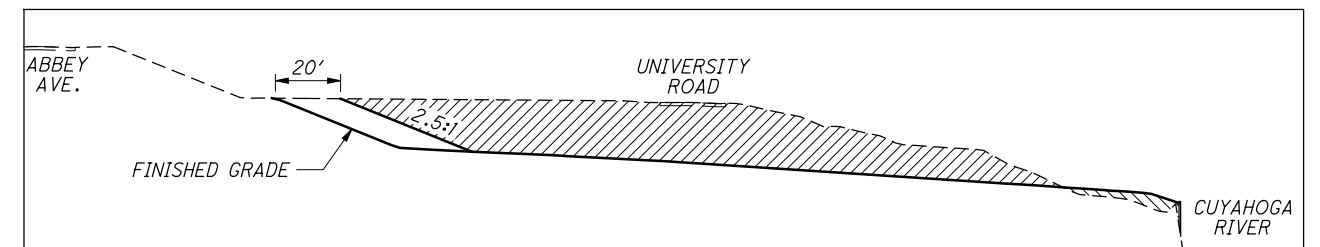

STAGE 3 EXCAVATION

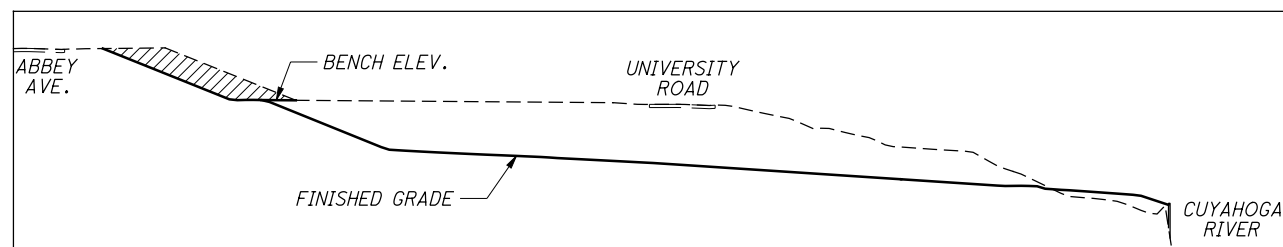

STAGE 2 EXCAVATION

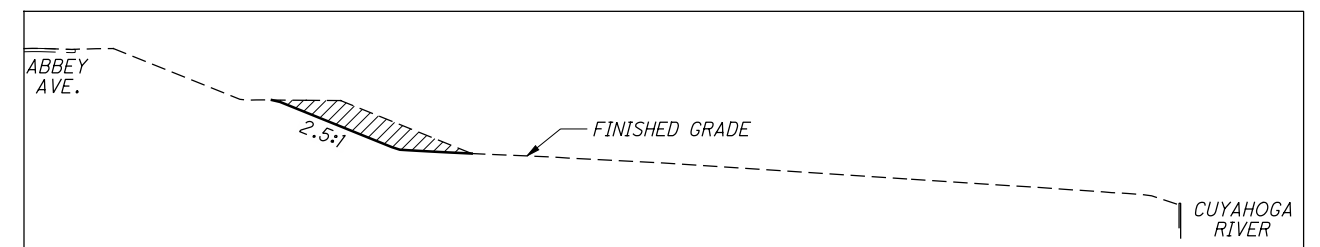

STAGE 4 EXCAVATION

TYPICAL WEST BANK EXCAVATION SEQUENCE

WORK PERFORMED IN EACH STAGE

P:\77332\roadway\sheets\77332GF518.dgn 11/21/2009 9:14:13 PM csteck

CALCULATED  
CDS  
CHECKED  
RLE

SLOPE GRADING PROFILE K-K & EXCAVATION SEQUENCE

CUY-90-14.92

CALCULATED  
DWB  
CHECKED  
RLE

**SLOPE GRADING PROFILES U-U AND W-W**

**CUY-90-14.92**

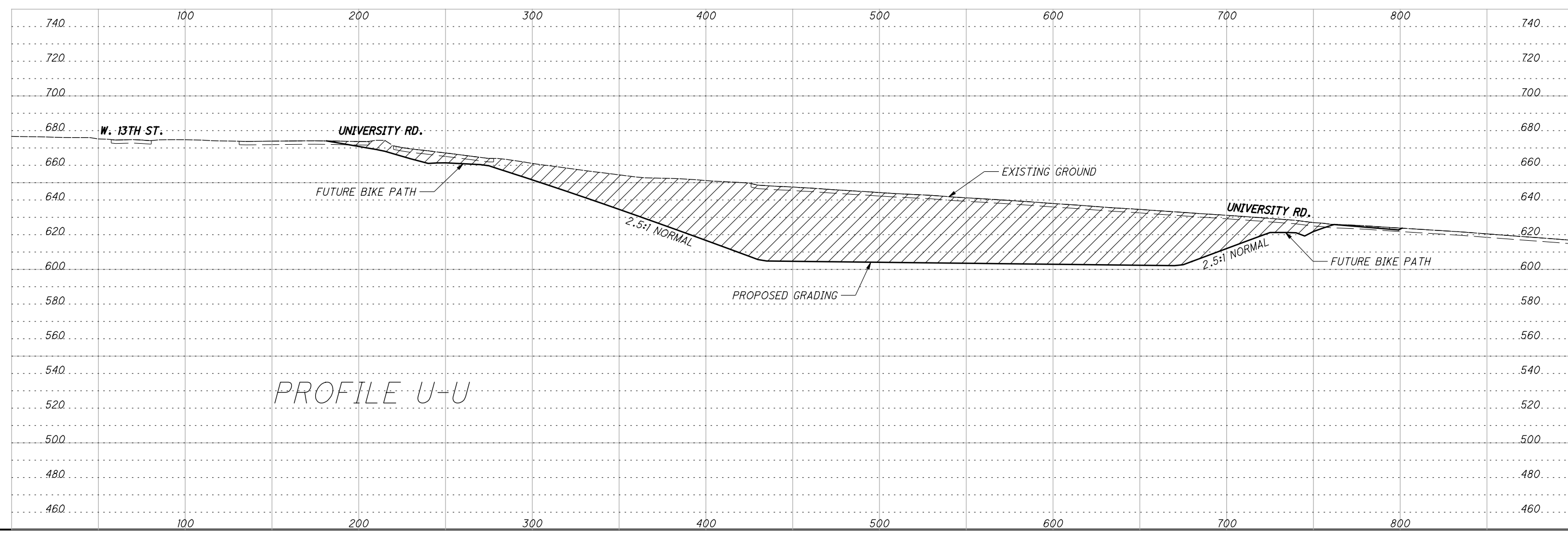
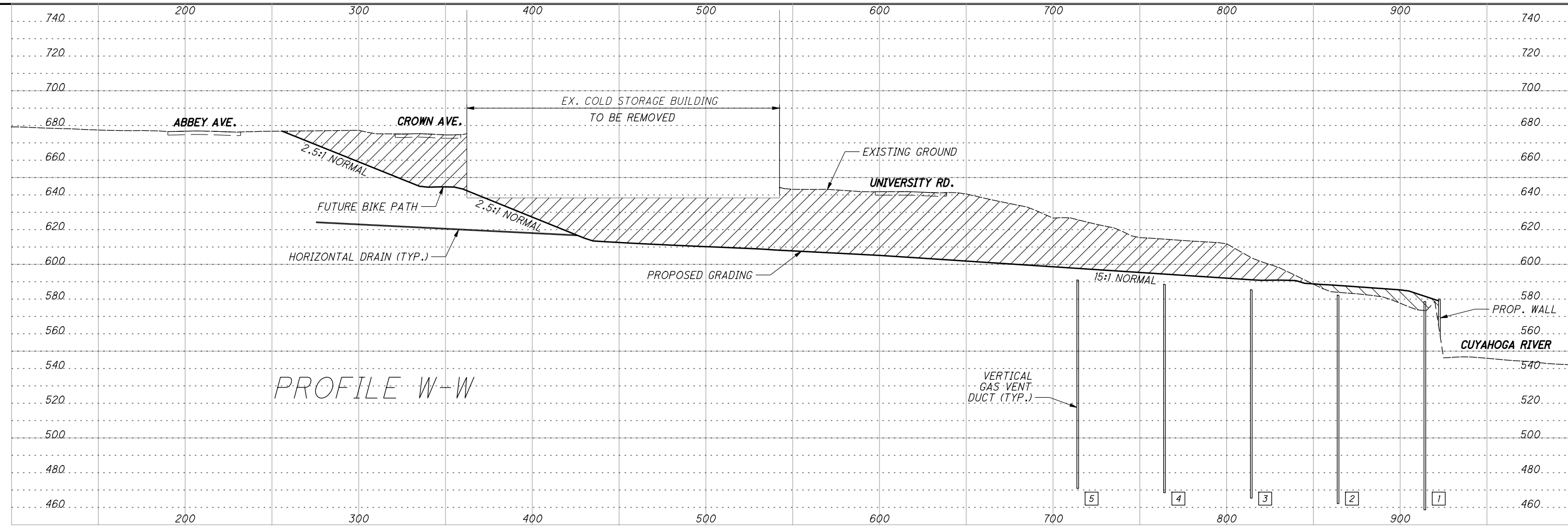

P:\77332\roadway\sheets\77332GF515.dgn 11/21/2009 9:14:15 PM csteck

P:\77332\roadway\sheets\77332GF517.dgn 11/21/2009 9:14:18 PM csteck

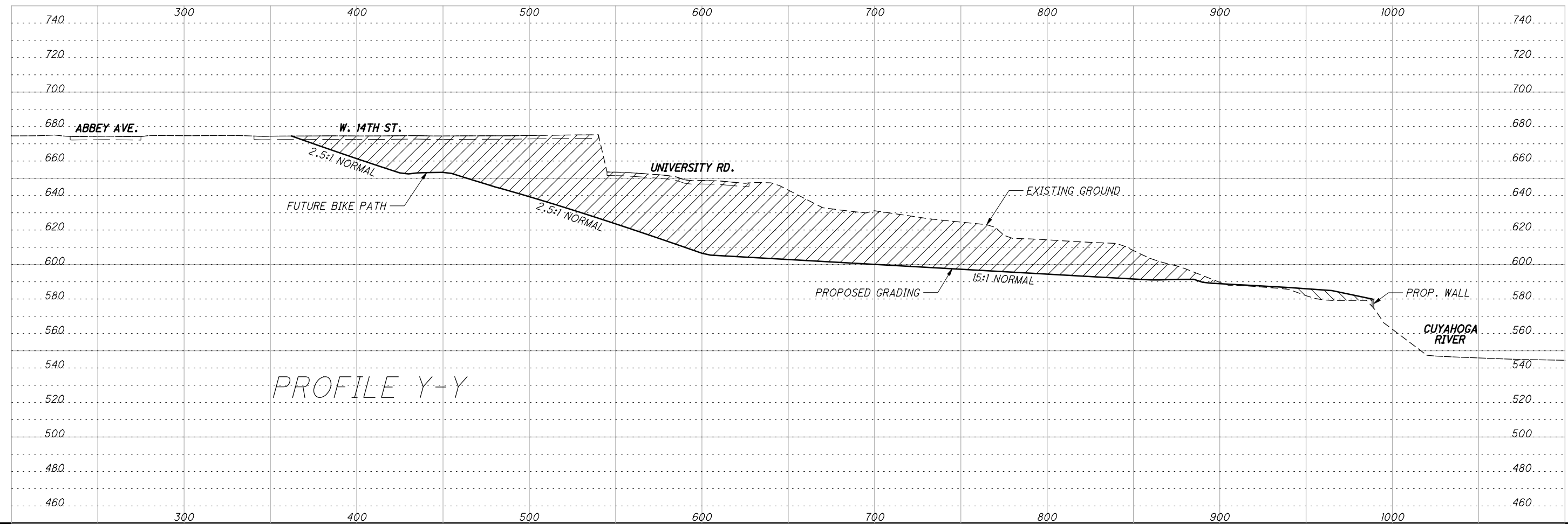
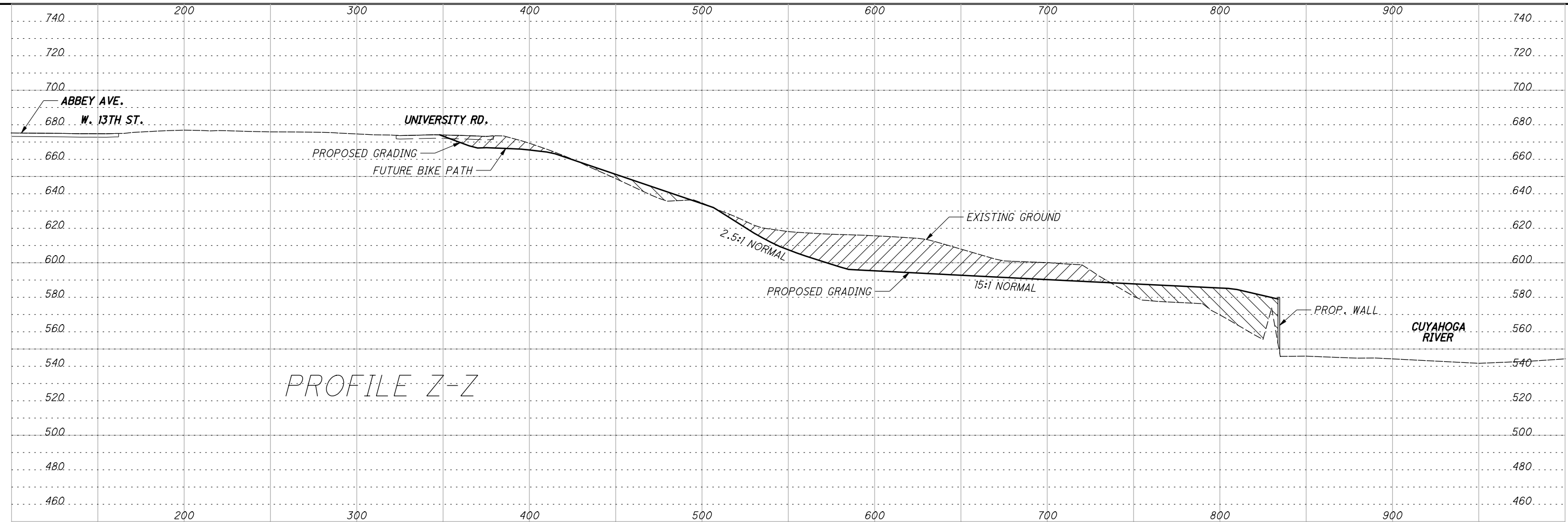

|   |     |
|---|-----|
| CALCULATED                                | DWB |
| CHECKED                                   | RLE |
| <b>SLOPE GRADING PROFILES Y-Y AND Z-Z</b> |     |
| <b>CUY-90-14.92</b>                       |     |
| 29  |     |
| 34  |     |

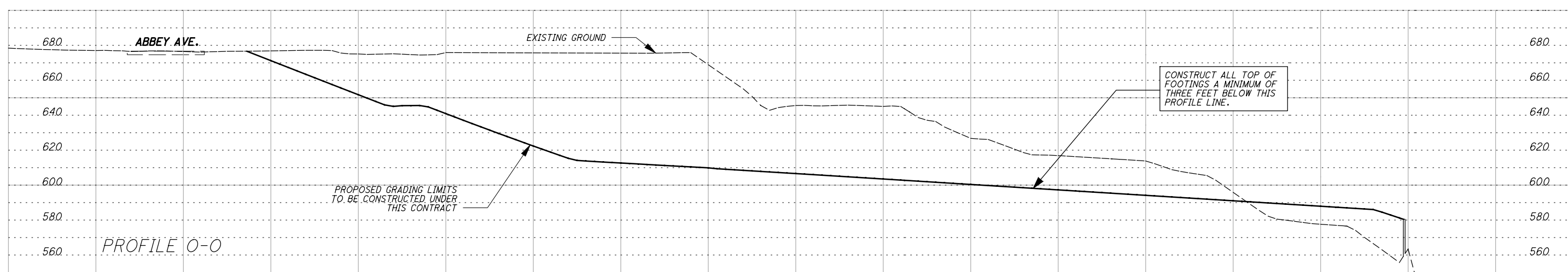
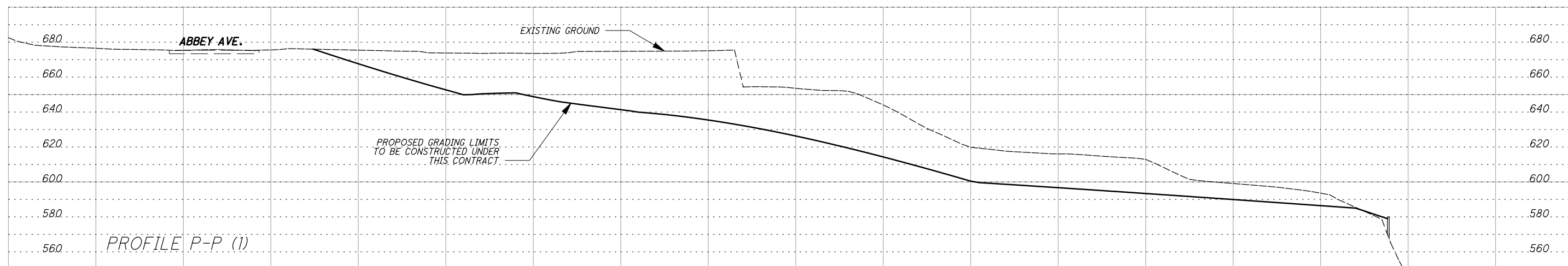
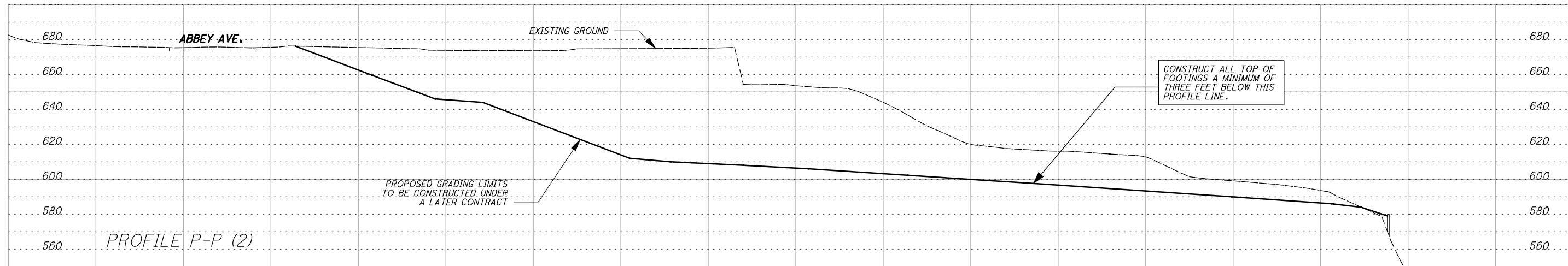

**NOTE:**  
 IF THE CONTRACTOR ELECTS TO CONSTRUCT A BRIDGE PIER FOUNDATION THAT HAS A FOOTING LOCATED WITHIN THE LIMITS OF AN EXCAVATED SLOPE SURFACE AREA BOUND BY ABBEY ROAD, PROFILE P-P (2), PROFILE O-O, AND A LINE LOCATED 10 FEET SOUTH OF THE PROPOSED SOUTH SIDE OF THE CUYAHOGA RIVER BULKHEAD WALL, THE TOP OF THE FOOTING SHALL BE DESIGNED TO HAVE A MINIMUM OF THREE FEET OF SOIL COVER AS SHOWN IN PROFILE P-P (2) AND PROFILE O-O. ALL EXCAVATIONS MADE FOR THE PURPOSE OF CONSTRUCTING THE PIER FOUNDATIONS SHALL BE BACKFILLED IN ACCORDANCE WITH CMS 203.06, 203.07, AND 503.08. PIER FOUNDATIONS PLACED WITHIN THE LIMITS DESCRIBED ABOVE SHALL BE SUPPORTED ON BEDROCK.

**SLOPE GRADING PROFILES O-O, P-P(1), & P-P(2)**

**CUY-90-14.92**

P:\77332\roadway\sheet\77332GF511.dgn 11/21/2009 9:14:21 PM csteck

## **APPENDIX 7B**

**SLOPE STABILITY ANALYSES OF SECTIONS A-A, CL-CL, D-D**

**Table 7B.1 Summary of Stability Analyses Results**

| Case Description   | Factor of Safety |             |             |
|--|------------------|-------------|-------------|
|  | AA               | CL          | DD          |
| Existing slope condition with hypothetical water table(w2) @ 625.0'  | <b>0.99</b>      | <b>1.65</b> | <b>0.97</b> |
| Existing slope condition with hypothetical water table(w2) @ 625.0'<br><b>(Undrained Analysis)</b>   | <b>1.17</b>      |             |             |
| Existing slope condition with hypothetical water table(w2) @ 625.0'<br><b>(using Block Search)</b>   | <b>0.92</b>      |             |             |
| Existing slope condition with hypothetical water table(w2) @ 625.0'<br><b>(using Block Search) - Residual Strength for Bottom Soil Layer 5</b>                   | <b>0.90</b>      |             |             |
| Existing slope condition with hypothetical water table (w2) @ 650.0'   | <b>0.98</b>      | <b>1.49</b> |             |
| Existing slope condition with hypothetical water table(w2) @ 650.0'<br><b>(using Block Search)</b>   | <b>0.81</b>      |             |             |
| Recent Construction ( <b>Removal of Sheet Pile wall and excavation</b> )<br>Effects with hypothetical water table (w2) @ 625.0'                                  | <b>0.95</b>      |             |             |
| <b>Removal of Building</b> and Upper slope with hypothetical water table<br>(w2) @ 650.0'  | <b>0.98</b>      |             |             |
| <b>Using Horizontal Drains at elev. 580</b> , with hypothetical water table<br>(w2) @ 600.0'   | <b>1.37</b>      | <b>1.99</b> | <b>1.40</b> |
| <b>Slope Flattening (12:1) Using Horizontal Drains at elev. 580'</b> , with<br>hypothetical water table (w2) @ 600.0'  | <b>1.51</b>      |             |             |
| <b>Using Horizontal Drains at elev. 580'</b> , with hypothetical water table<br>(w2) @ 600.0', <b>Block Search- Bottom Soil Layer 5 in Residual<br/>Strength</b> | <b>1.69</b>      |             |             |
| <b>Using Horizontal Drains at elev. 580'</b> , and vertical drains, <b>Bottom<br/>Soil Layer in Residual Strength</b>  | <b>1.48</b>      | <b>2.07</b> | <b>1.41</b> |
| <b>Slope Flattening (12:1) and using both Horizontal Drains at elev.<br/>580'</b> , and vertical drains  | <b>1.66</b>      |             |             |
| Design Slope Excavation (12:1 then 3:1), with hypothetical water table<br>(w2) @ 625.0'  | <b>1.53</b>      |             |             |
| Recommended Design Slope Excavation (9:1 then 5:1) with<br>hypothetical water table (w2) @ 625.0'  | <b>1.44</b>      |             |             |
| Recommended Design Slope Excavation (9:1 then 5:1) with<br>hypothetical water table (w2) @ 600.0'  | <b>1.61</b>      |             |             |
| Recommended Design Slope Excavation (9:1 then 5:1) without w2  | <b>1.99</b>      |             |             |



### CUY-90-14.92 (Sec. A-A)

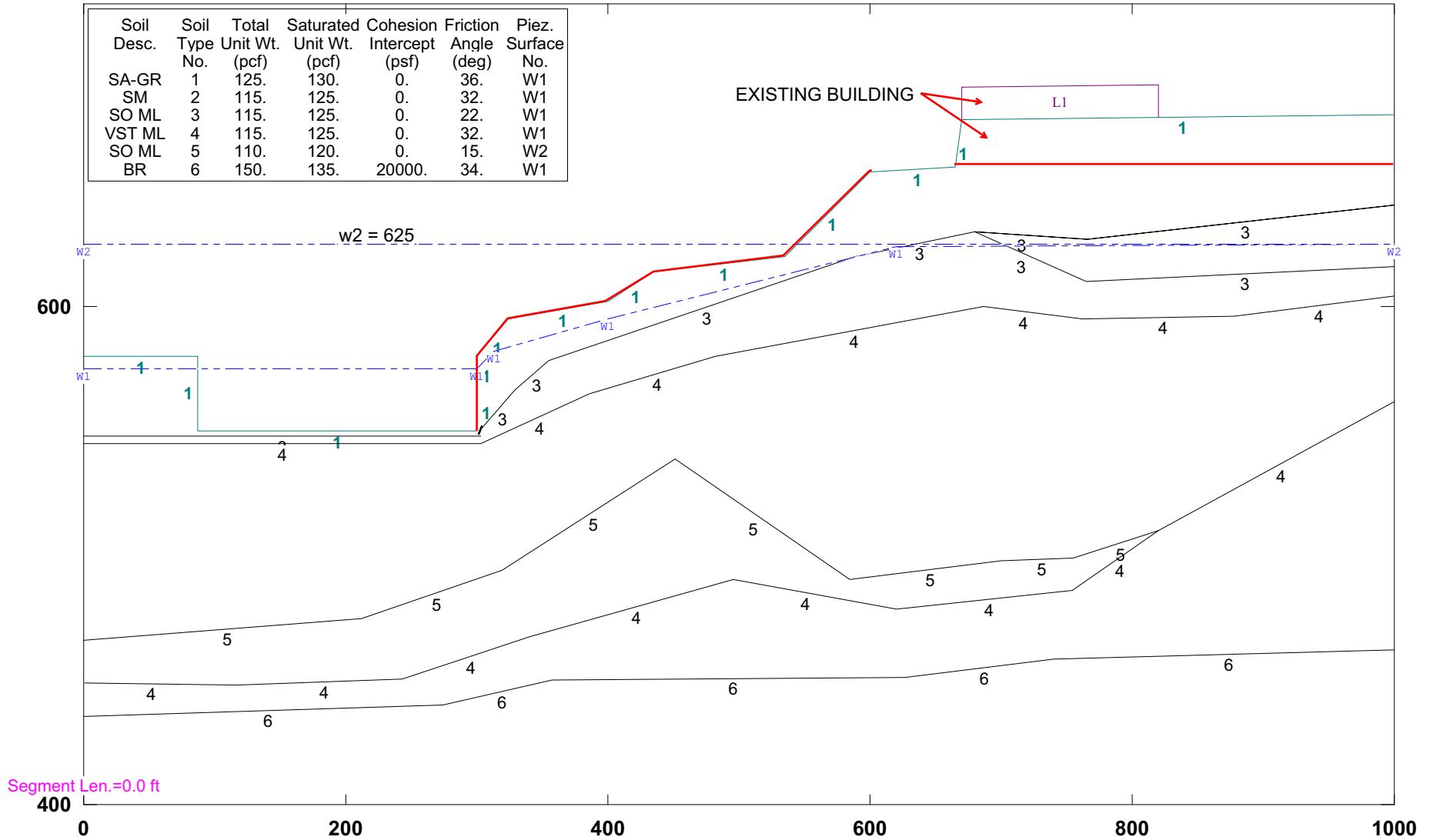

**Figure 7B.1: Geometry and Material Properties at Section A-A.**

### CUY-90-14.92 (Sec. A-A) : Removal of Building Structure

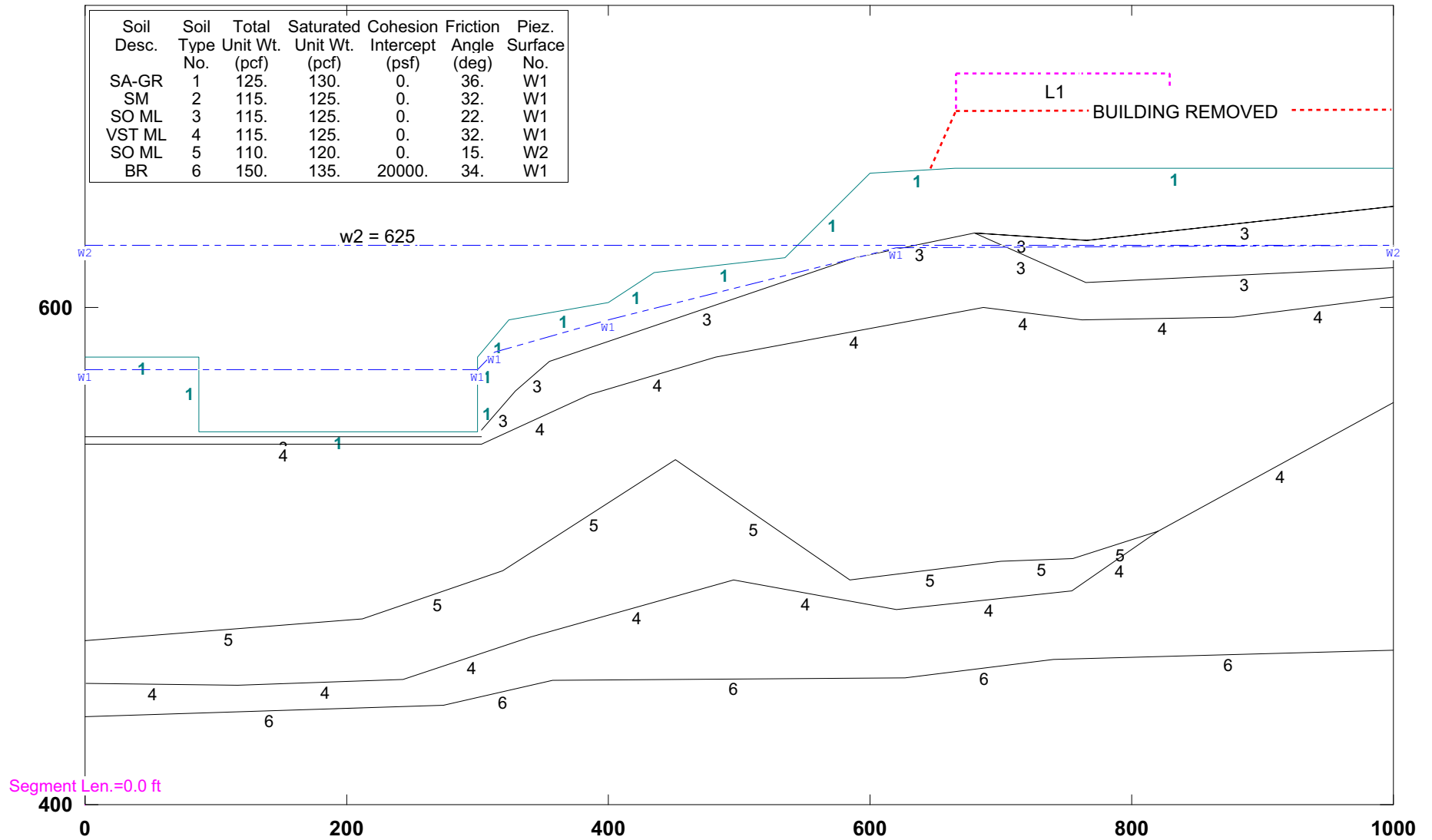

**Figure 7B.2: Geometry and Material Properties at Section A-A After Removal of Existing Building.**

### CUY-90-14.92 (Sec. A-A)

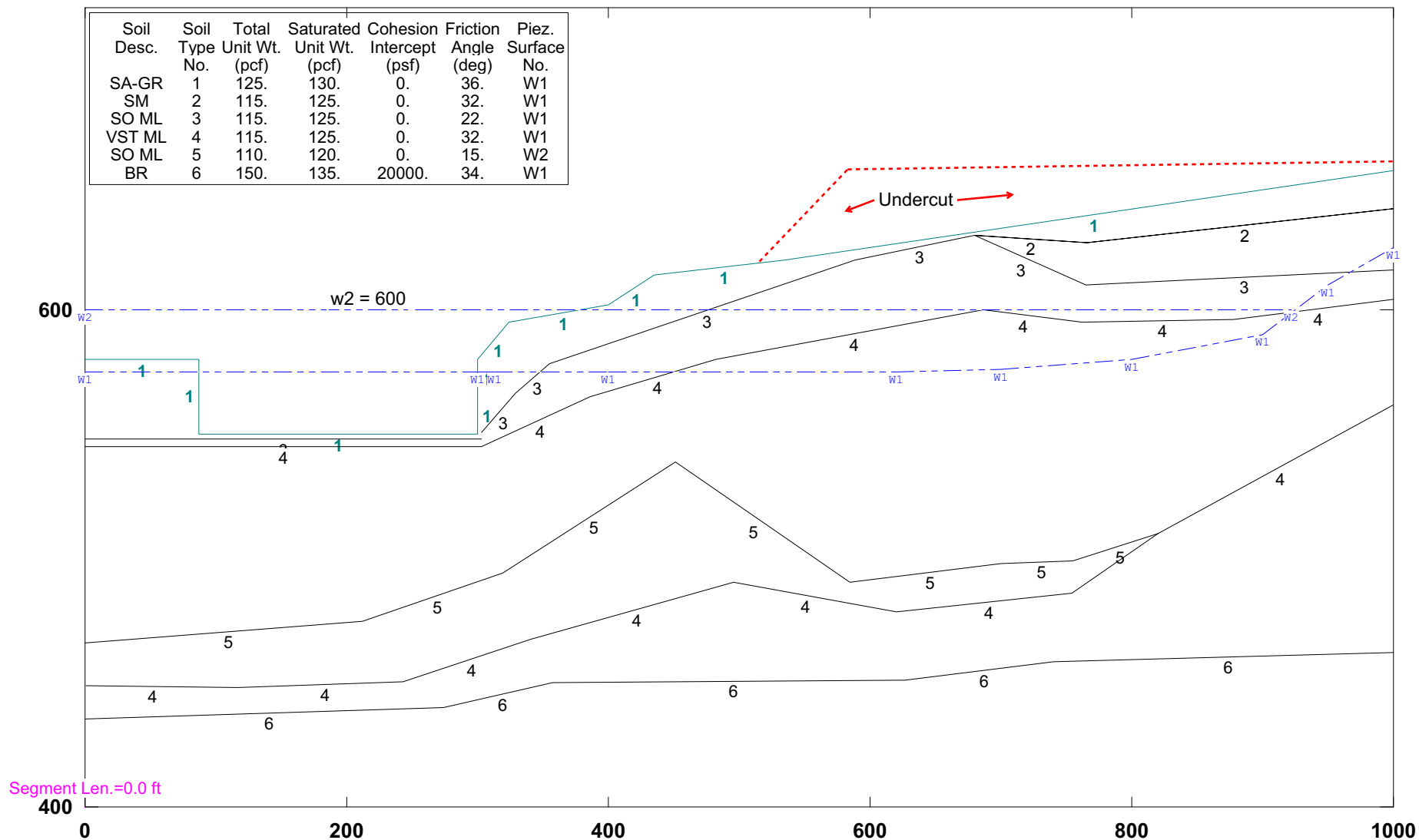

**Figure 7B.3: Geometry and Material Properties at Section A-A After Flattening of Upper Slope.**

### CUY-90-14.92 (BRIDGE CL-CL)

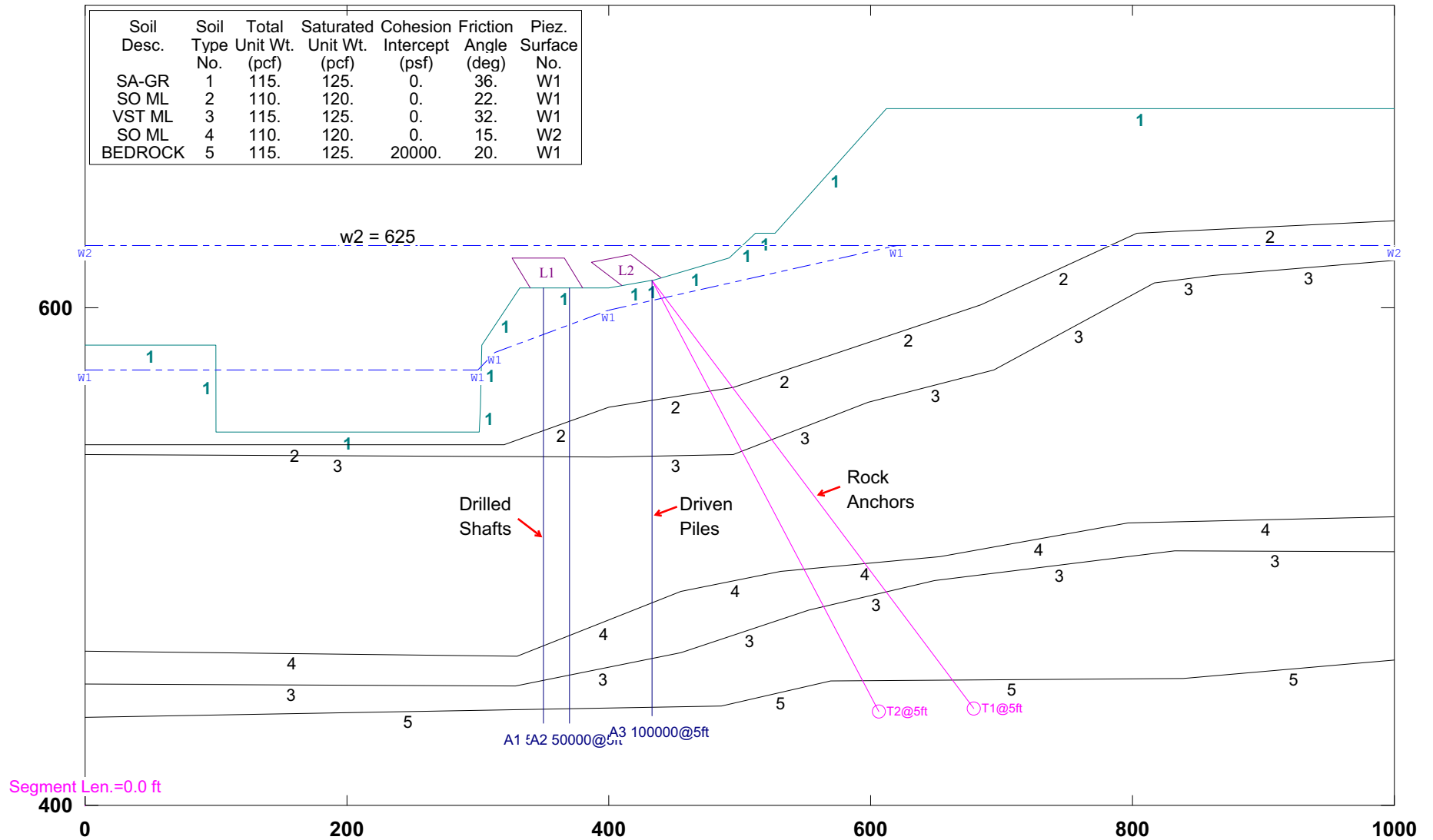

**Figure 7B.4: Geometry and Material Properties at Centerline of Existing Bridge Section CL-CL.**

### CUY-90-14.92 (Sec. D-D)

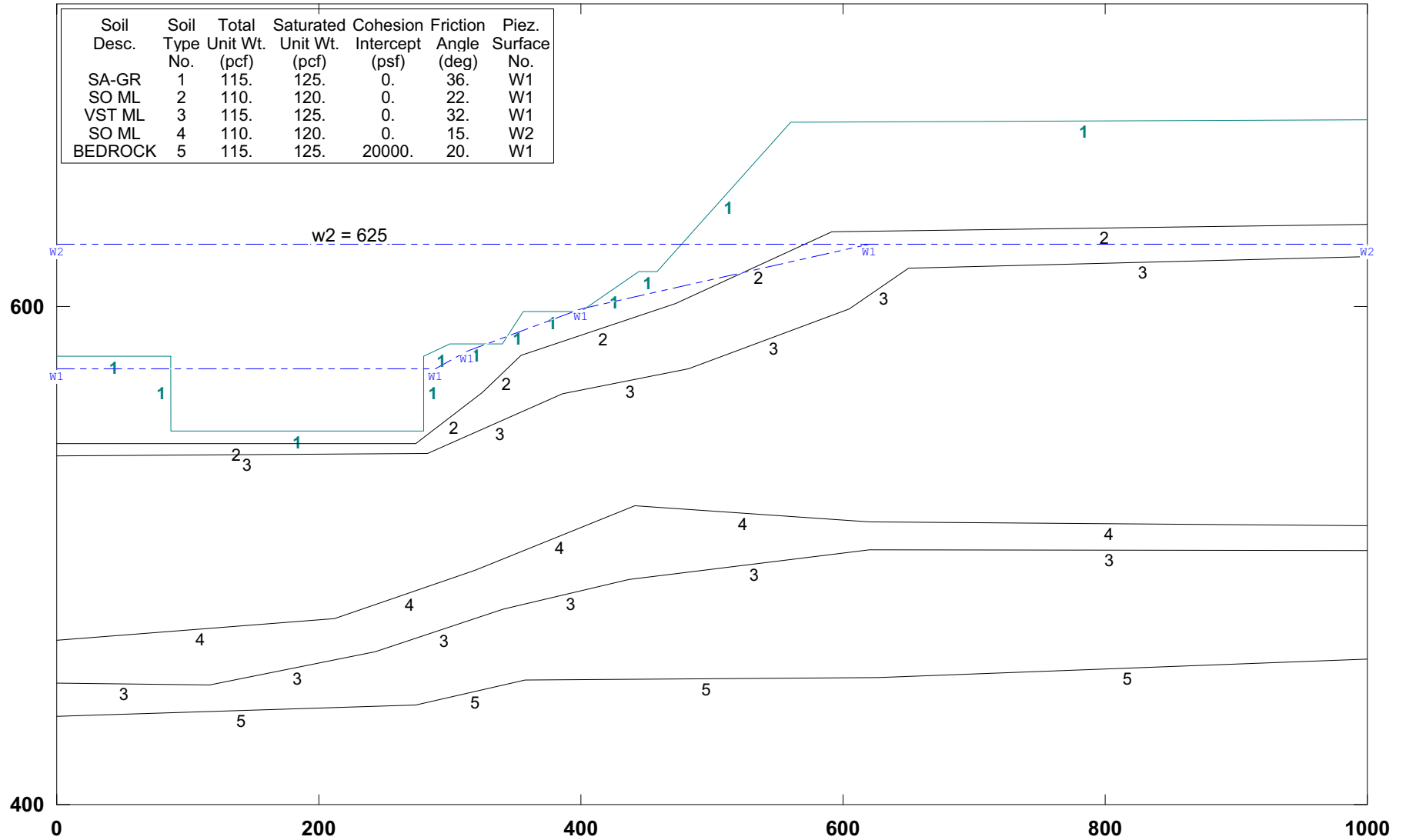

Figure 7B.5: Geometry and Material Properties at Section D-D.

### CUY-90-14.92 (Sec. A-A): Effective Stress Analyses

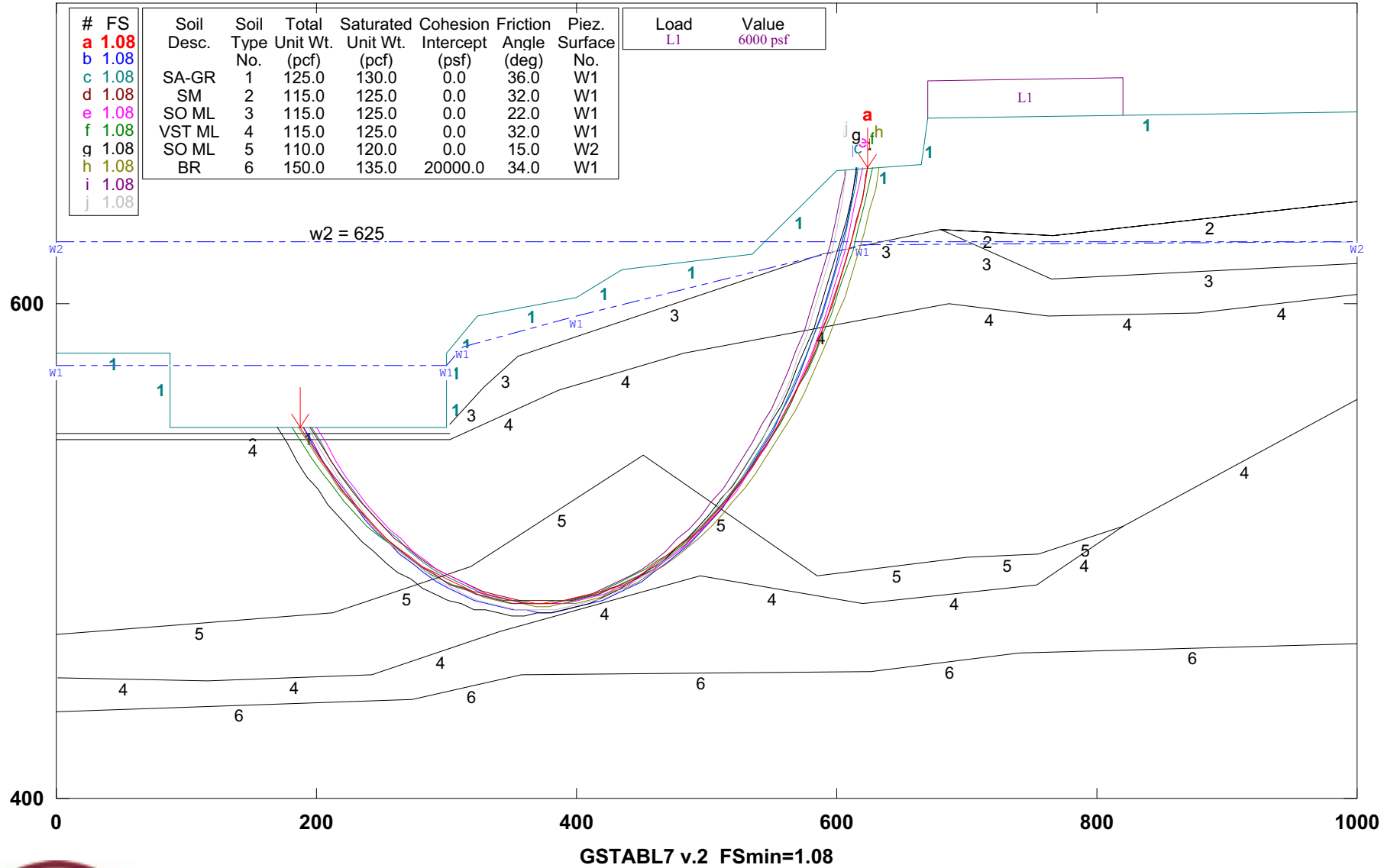
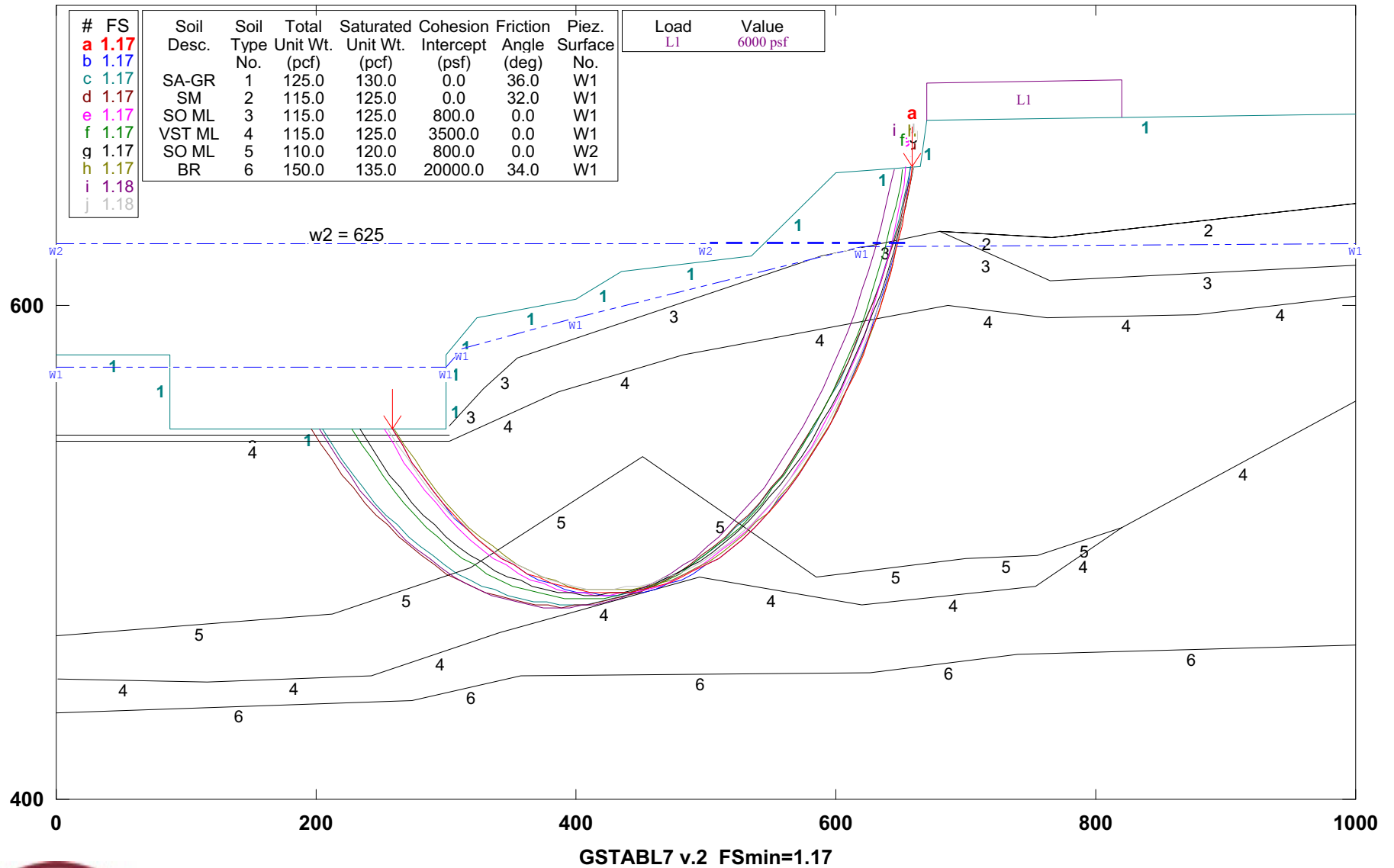

Figure 7B.6: Stability of Existing Slope at Section A-A.

### CUY-90-14.92 (Sec. A-A): Undrained Strength Analyses



**Figure 7B.7: Stability of Existing Slope at Section A-A Using Undrained Analyses.**

### CUY-90-14.92 (Sec. A-A): Effect of Elevated Pore Water Pressure

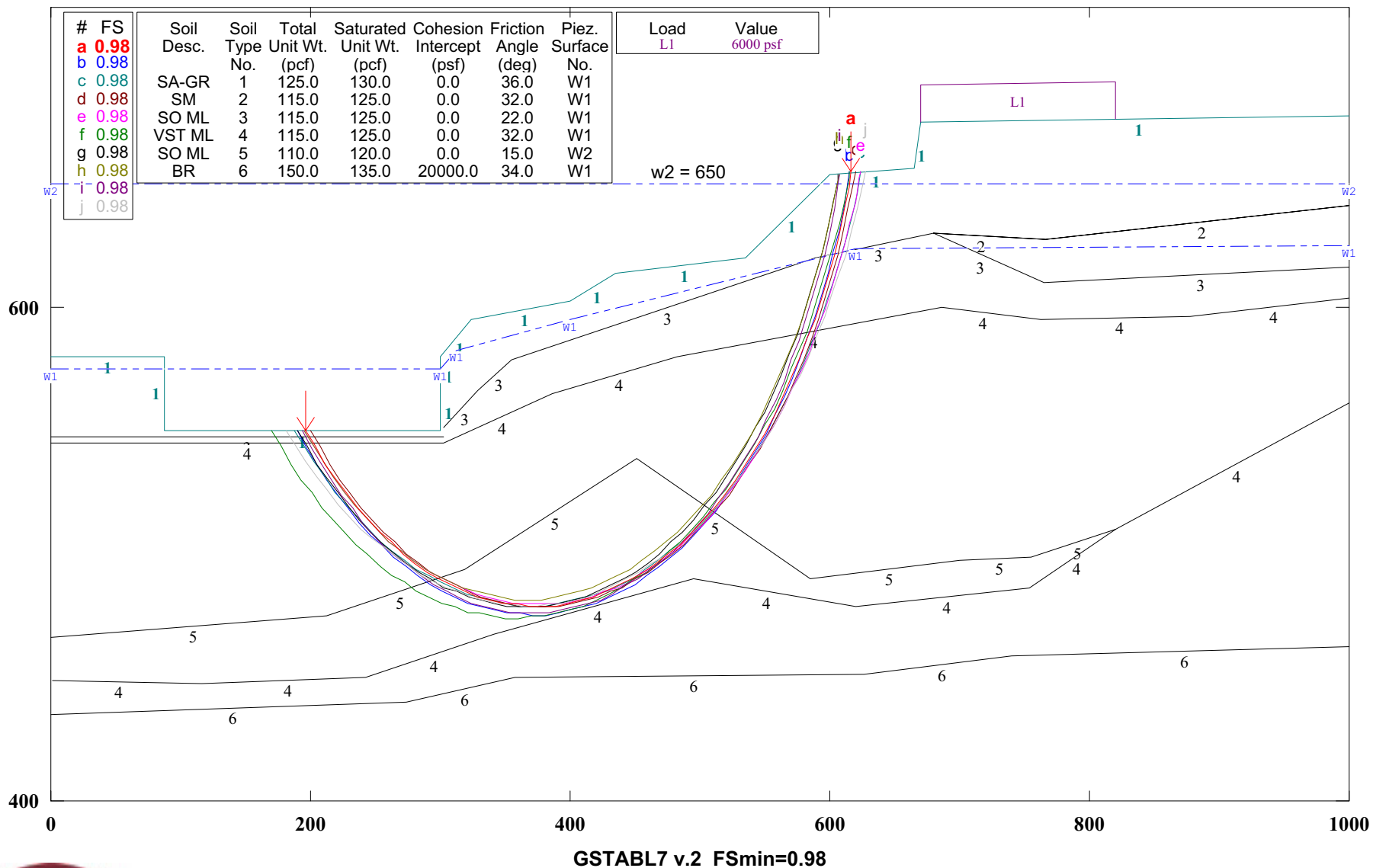

**Figure 7B.8: Stability of Existing Slope at Section A-A With Elevated Pore Pressure (w2 = 650).**



### CUY-90-14.92 (BRIDGE CL-CL)

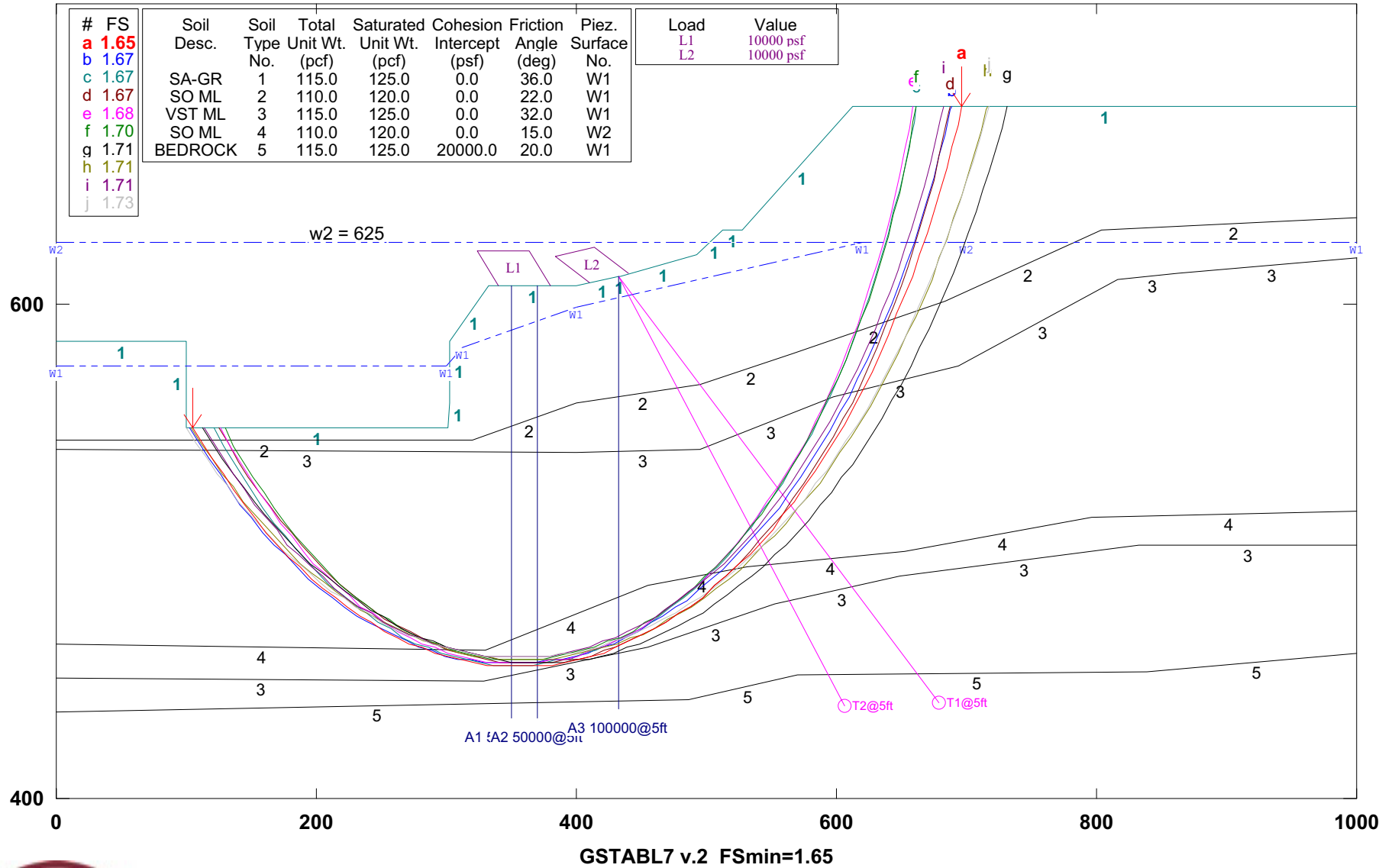

**Figure 7B.9: Stability of Existing Slope at Centerline of Existing Bridge (Section A-A).**

### CUY-90-14.92 (BRIDGE CL-CL): Effect of Elevated Pore Pressure

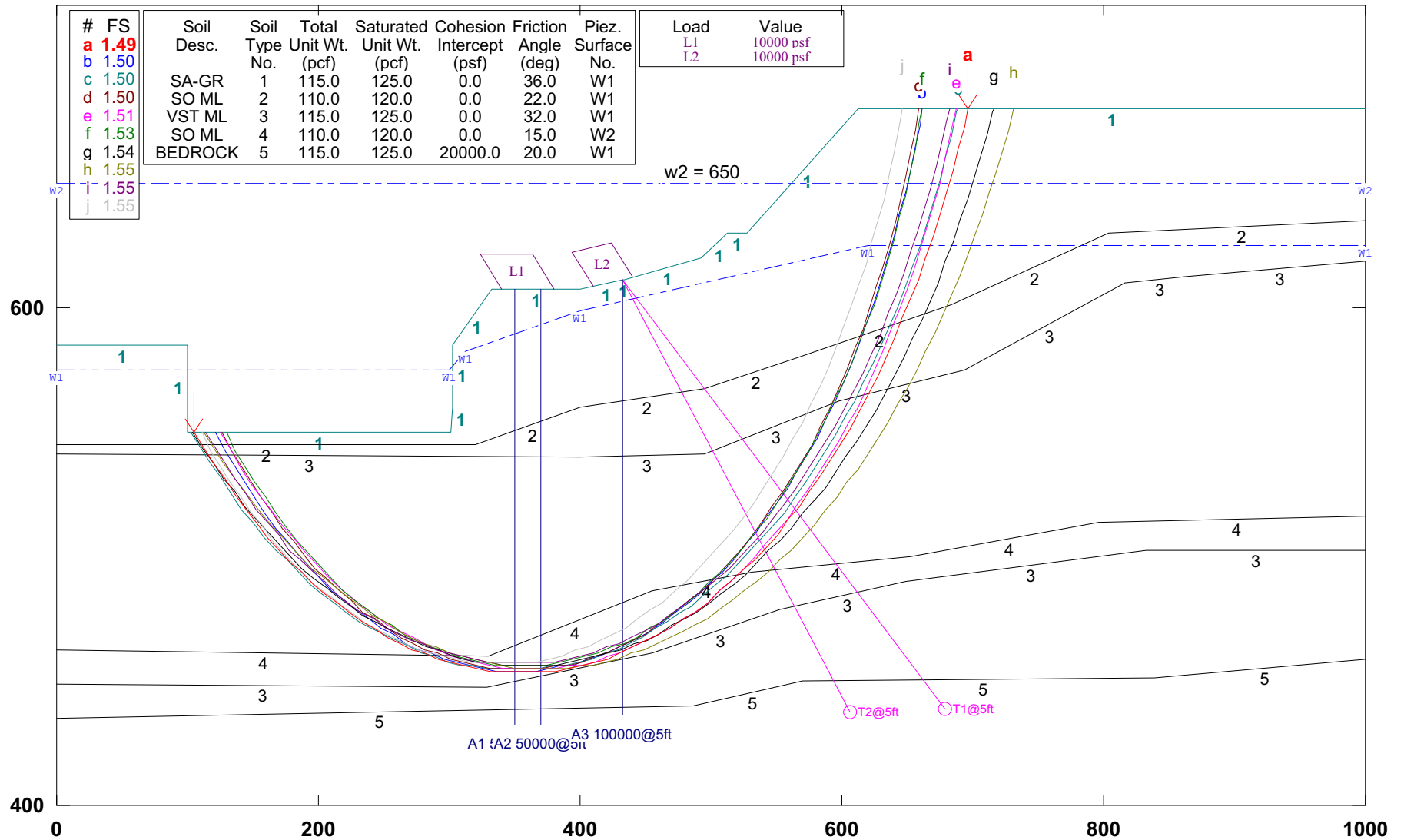

GSTABL7 v.2 FSmin=1.49

**Figure 7B.10: Stability of Existing Slope at Centerline of Existing Bridge (Section CL-CL) with Elevated Pore Water Pressure (w2 = 650).**

### CUY-90-14.92 (Sec. D-D): Effect of Elevated Pore Pressure

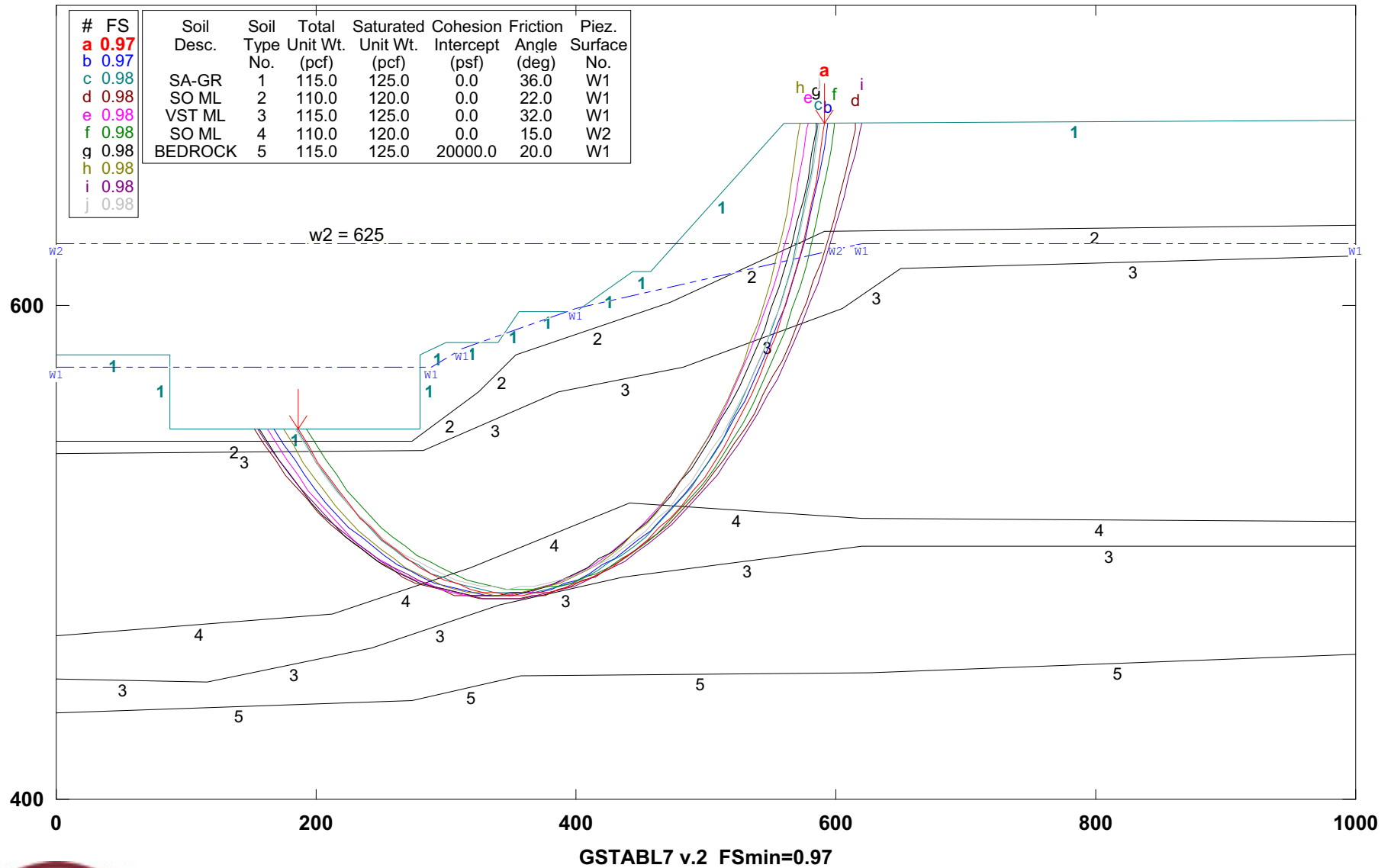
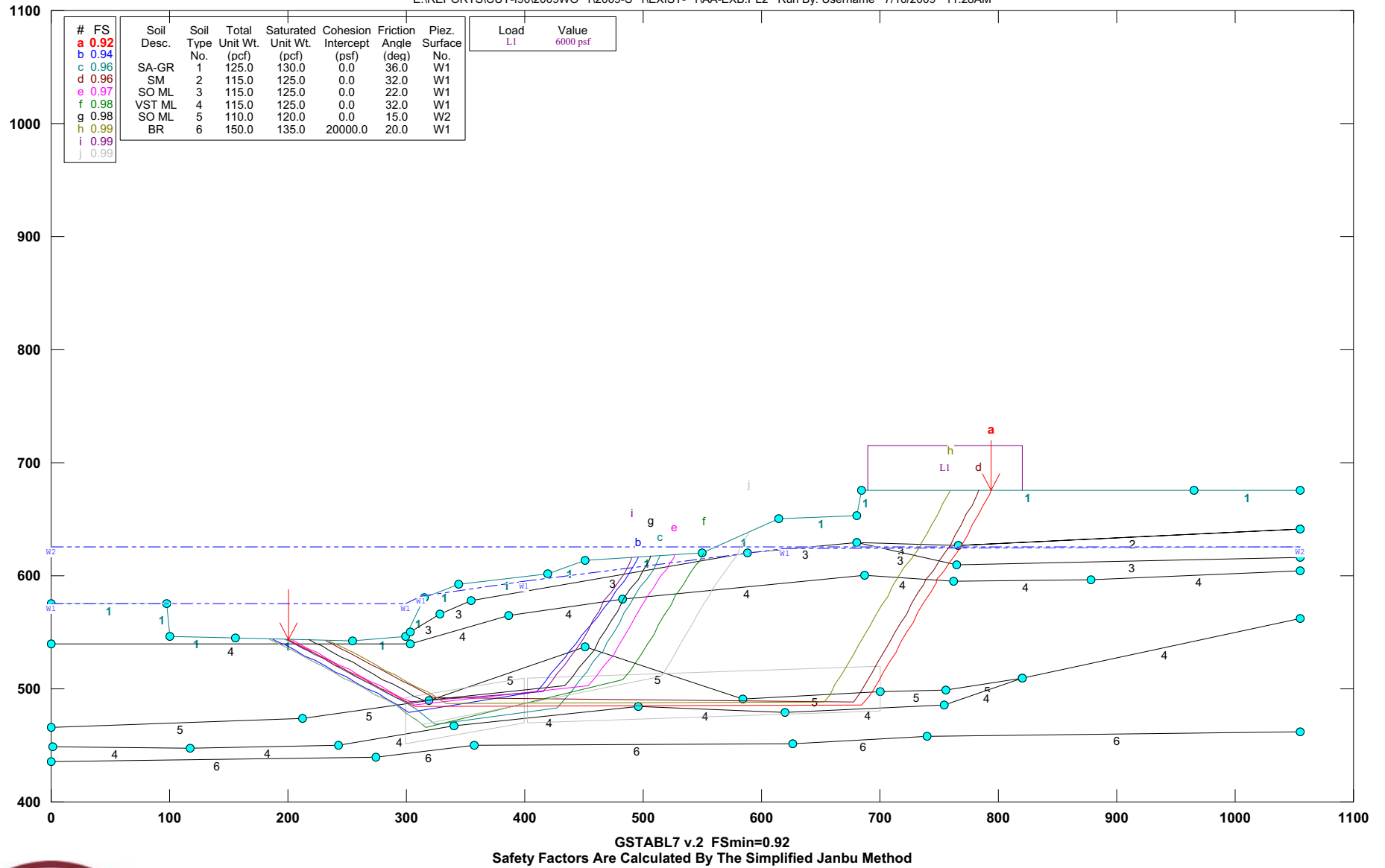

Figure 7B.11: Stability of Existing Slope at Section D-D.

# CUY-90-14.92 (Sec. A-A): EXISTING GEOMETRY-Block search

E:\REPORTS\CUY-190\2009WO-1\2009-S-1\EXIST--1\AA-EXB.PL2 Run By: Username 7/10/2009 11:28AM



**Figure 7B.12: Stability of Existing Slope at Section A-A Using Block Search.**

### CUY-90-14.92 (Sec. A-A): Bottom layer in residual strength-Block search

E:\REPORTS\CUY-190\2009WO~1\2009-S-1\EXIST--1A-EXB2.PL2 Run By: Username 8/29/2009 8:53PM

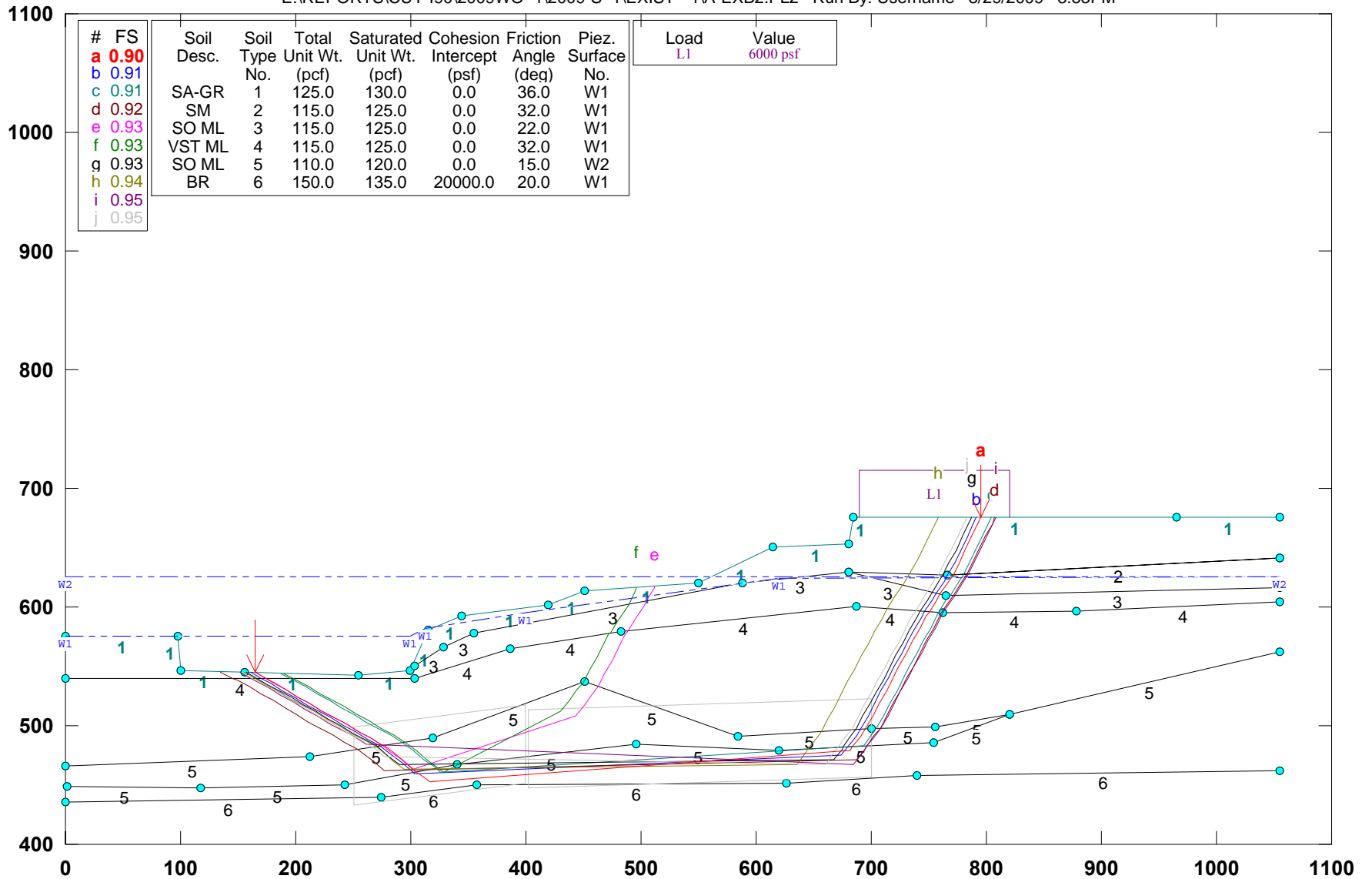

GSTABL7 v.2 FSmin=0.90

Safety Factors Are Calculated By The Simplified Janbu Method



**Figure 7B.13: Stability of Existing Slope at Section A-A Using Block Search and Residual Strength For Bottom Layer.**

### CUY-90-14.92 (Sec. A-A): EXISTING GEOMETRY-Block search

E:\REPORTS\CUY-190\2009WO~1\2009-S-1\EXIST--1\A-EXB3.PL2 Run By: Username 8/29/2009 9:02PM

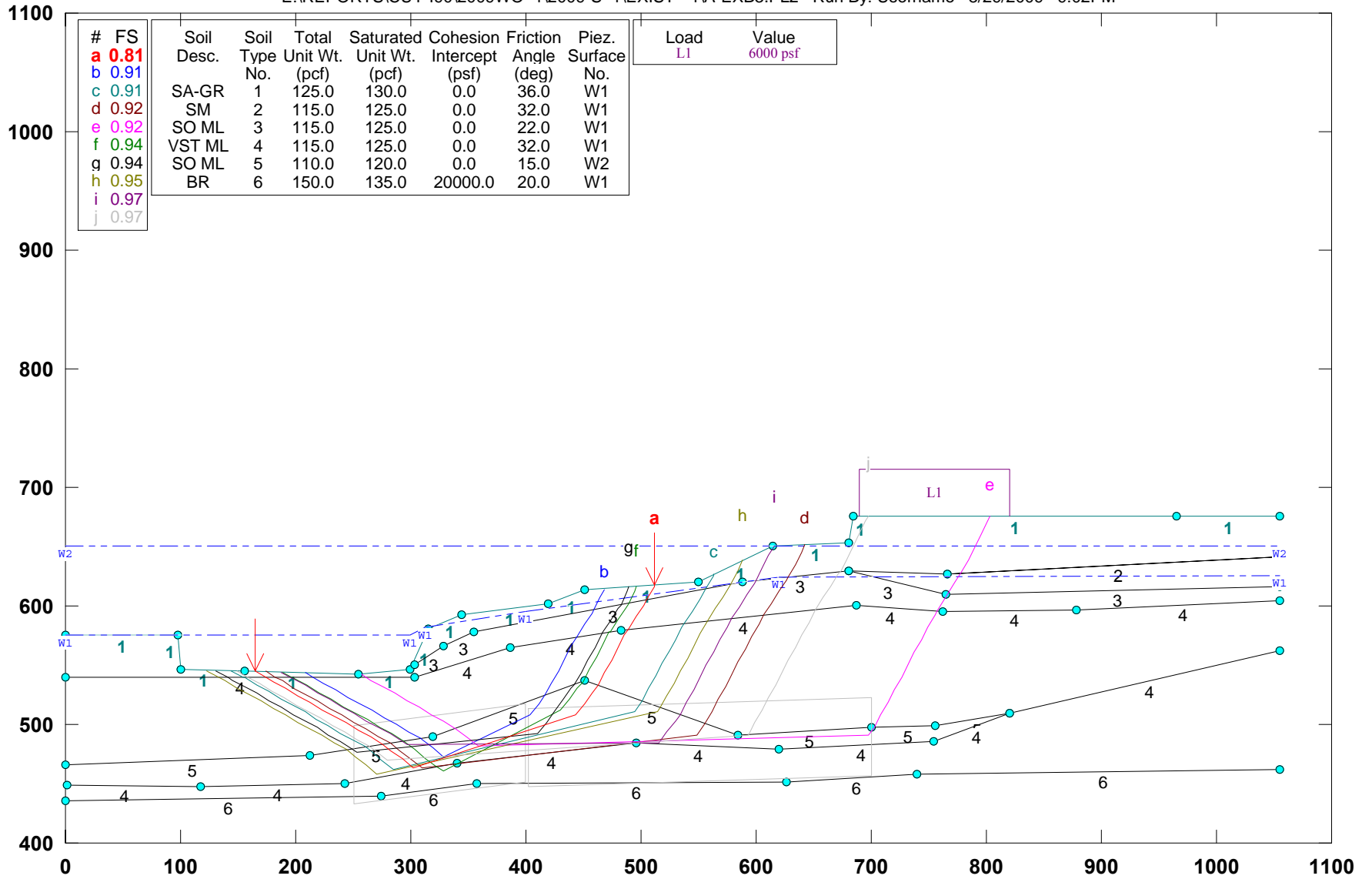

GSTABL7 v.2 FSmin=0.81

Safety Factors Are Calculated By The Simplified Janbu Method



**Figure 7B.14: Stability of Existing Slope at Section A-A with Elevated Pore Water Pressure (w2 = 650).**

### CUY-90-14.92 (Sec. A-A) : Removal of sheet pile (Existing Construction)

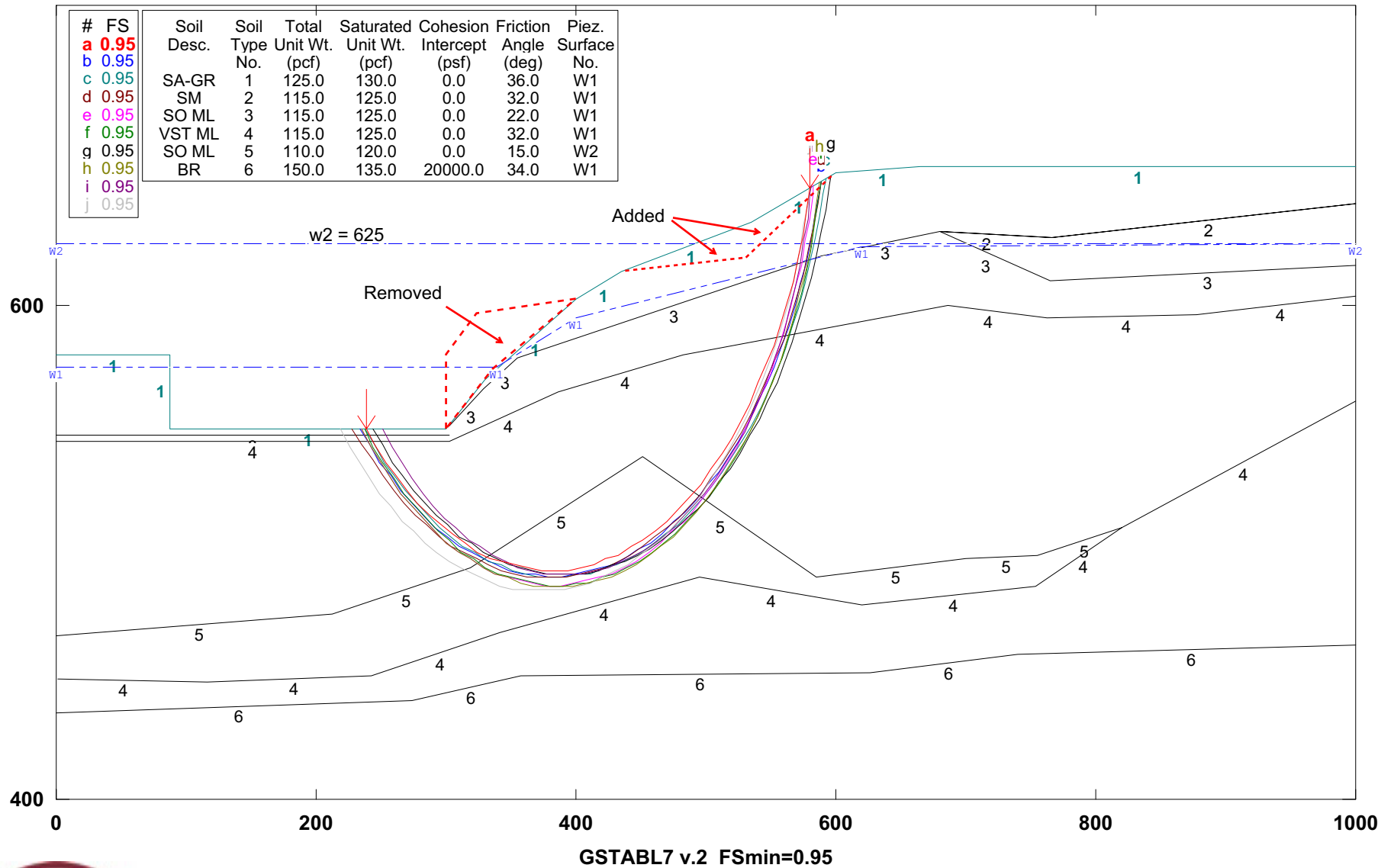

**Figure 7B.15: Effects of Recent Construction Involving Removing Sheet Piles and Flattening Slope on the Stability of Existing Section A-A.**

### CUY-90-14.92 (Sec. A-A) : Removal of Building Structure

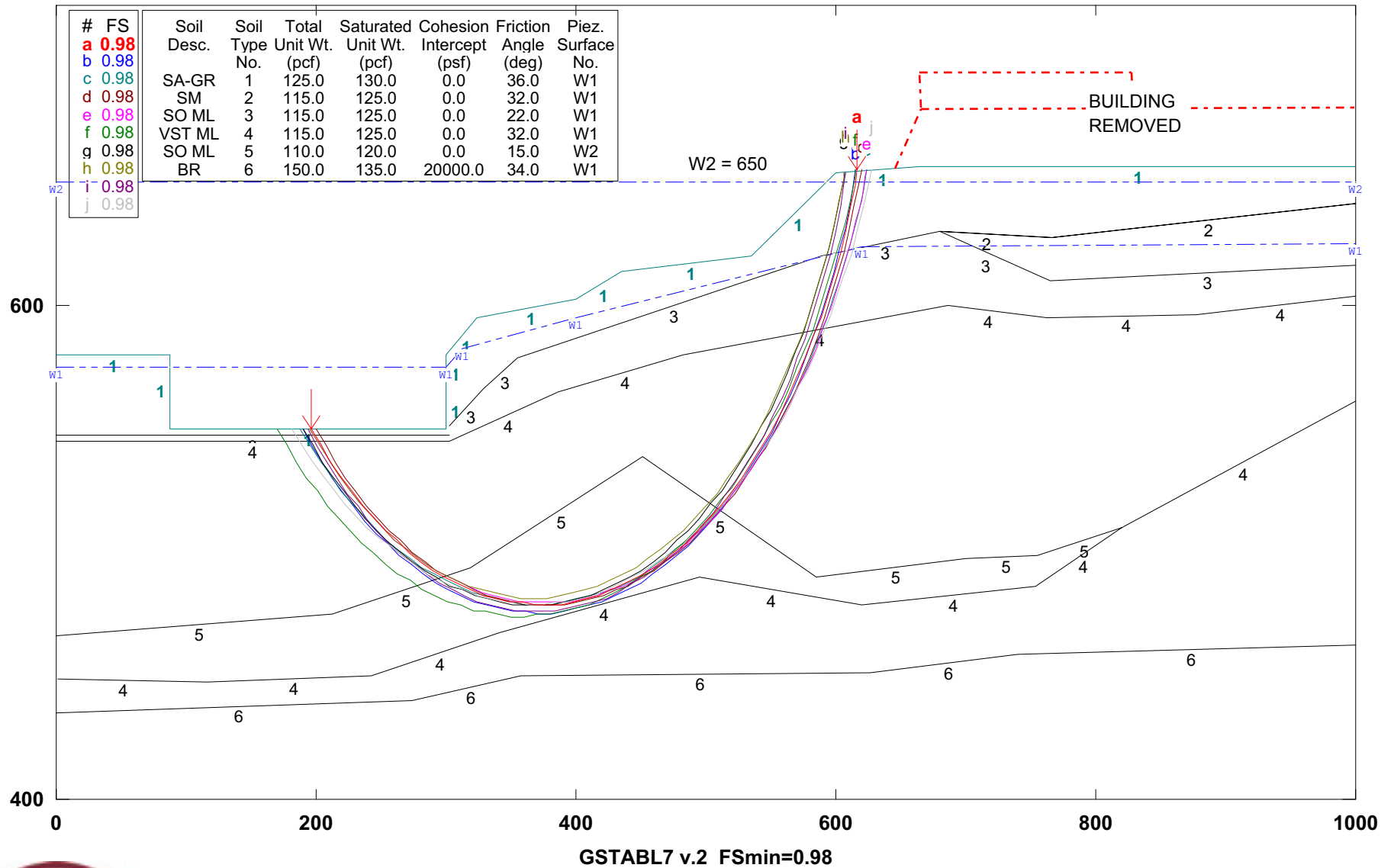
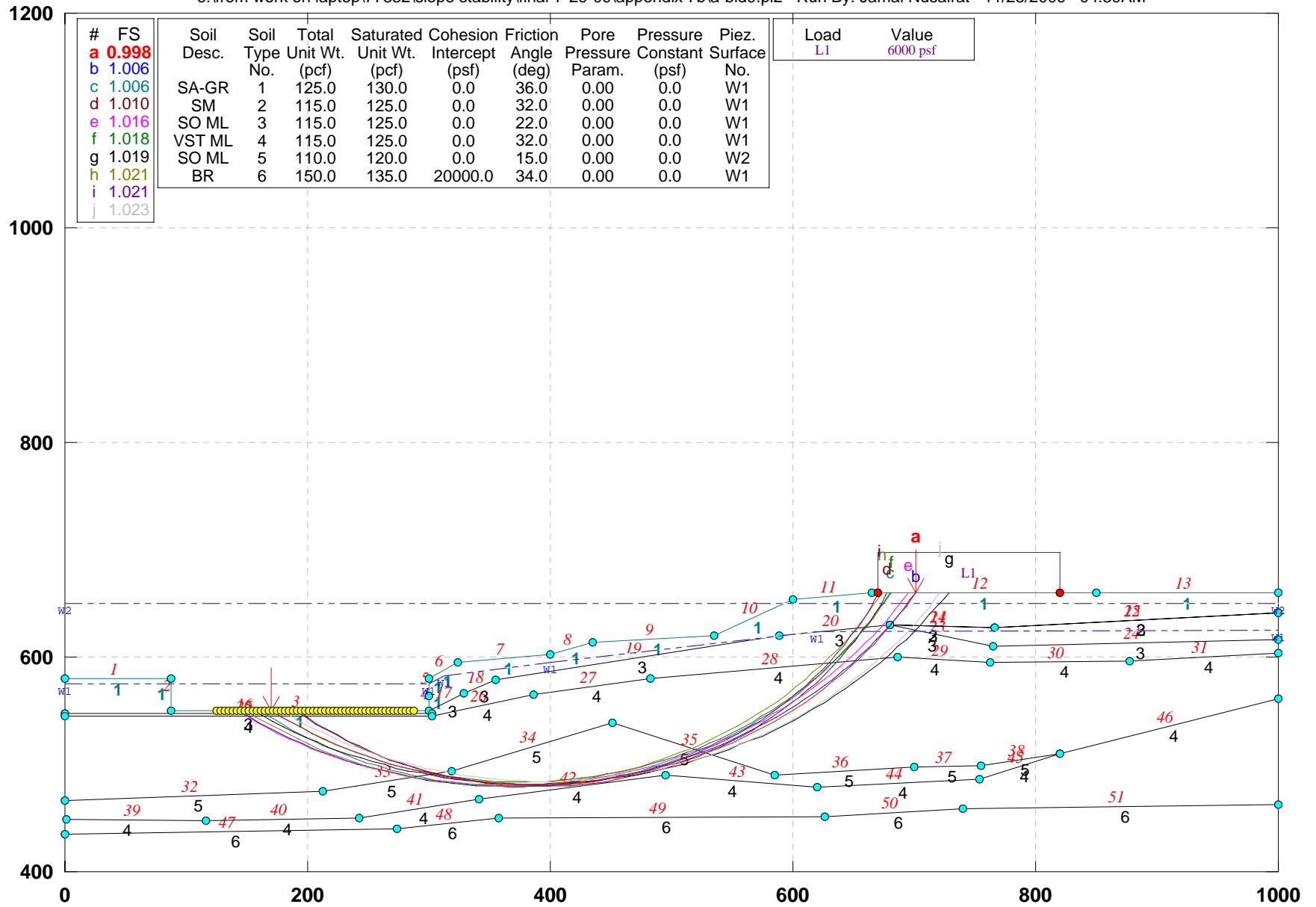

Figure 7B.16: Effects of Existing Building on Stability of Section A-A.



# CUY-90-14.92 (Sec. A-A) : Removal of Building Structure (W2 at 650.0)

e:\from work on laptop\77332\slope stability\final-7-29-09\appendix 7b\A-bld9.pl2 Run By: Jamal Nusairat 11/25/2009 04:39AM



GSTABL7 v.2 FSmin=0.998

Safety Factors Are Calculated By The Simplified Janbu Method



Figure 7B.16A: Effect of Building Load on Stability

## CUY-90-14.92 (Sec. A-A) : Removal of Building Structure (W2 at 650.0)

e:\from work on laptop\77332\slope stability\final-7-29-09\appendix 7b\A-bld9-1.pl2 Run By: Jamal Nusairat 11/25/2009 04:37AM

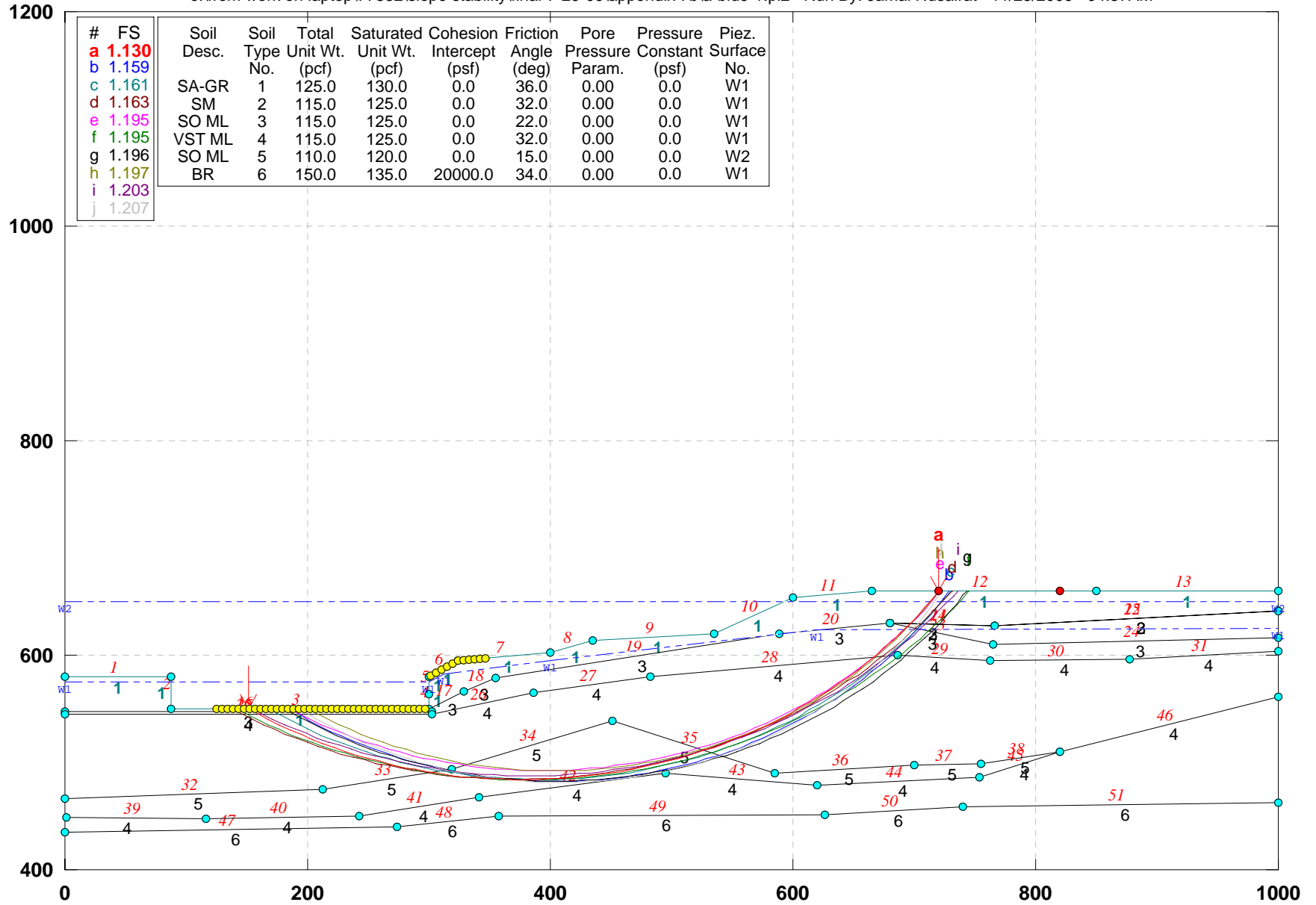

GSTABL7 v.2 FSmin=1.130

Safety Factors Are Calculated By The Simplified Janbu Method



Figure 7B.16B: Effect of Removing Building on Stability

### CUY-90-14.92 (Sec. A-A) : Effect of Horizontal Drains

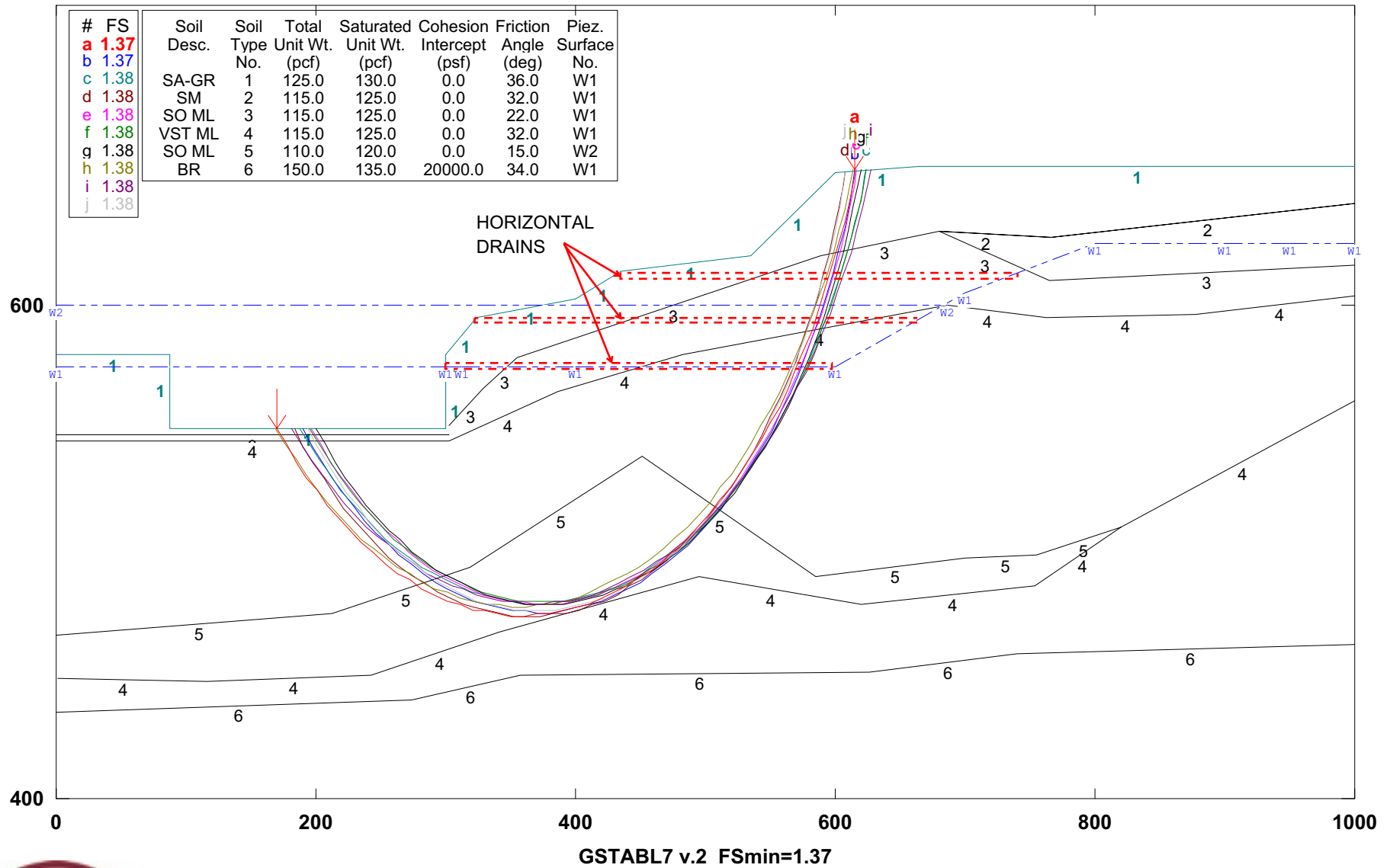

Figure7B.17: Effects of Horizontal Drains on Stability of Section A-A.

### CUY-90-14.92 (Bridge CL): Effect of Horizontal Drains

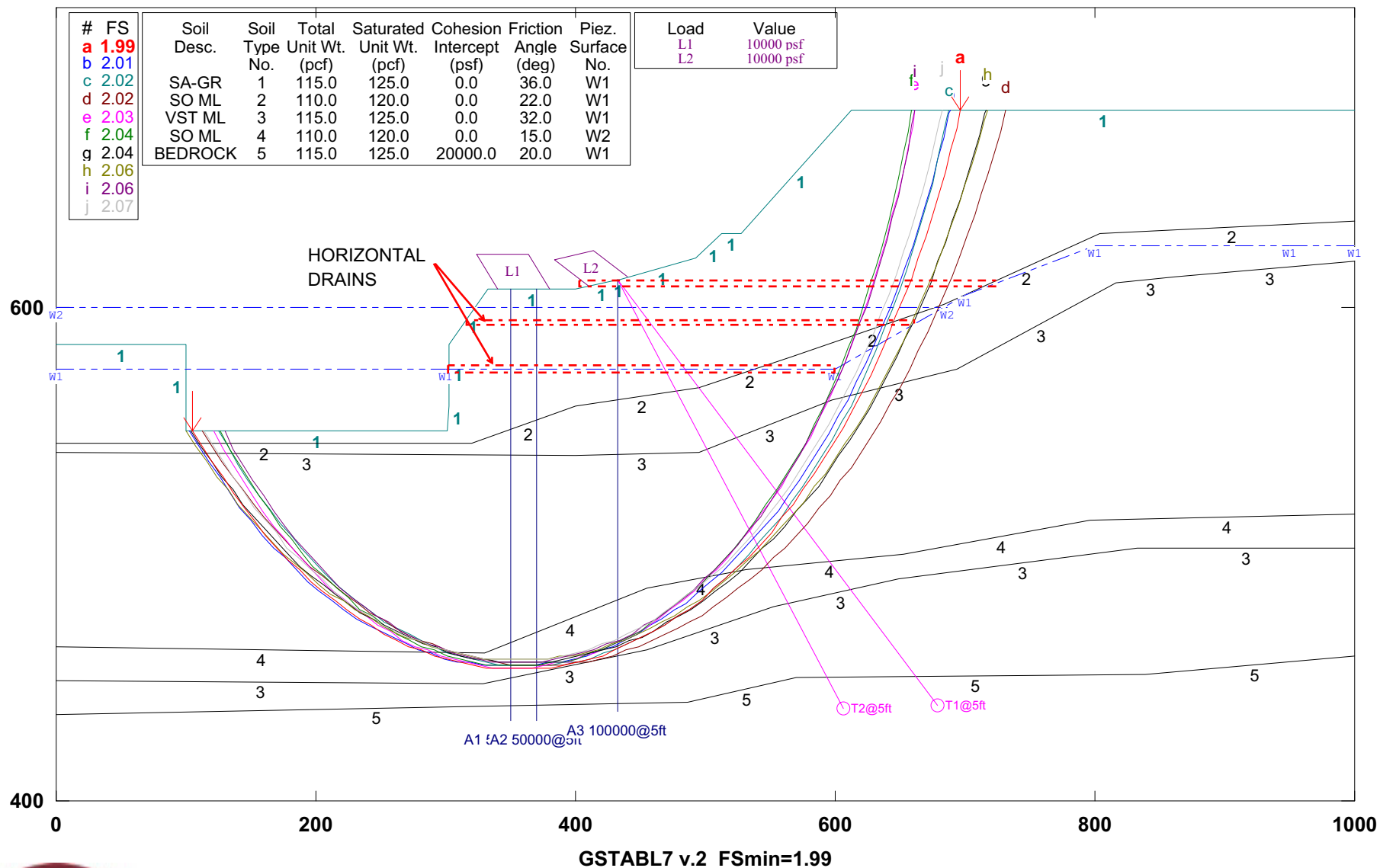

Figure 7B.18: Effects of Horizontal Drains on Stability of Centerline Section (Section CL-CL).

### CUY-90-14.92 (Section D-D): Effect of Horizontal Drains

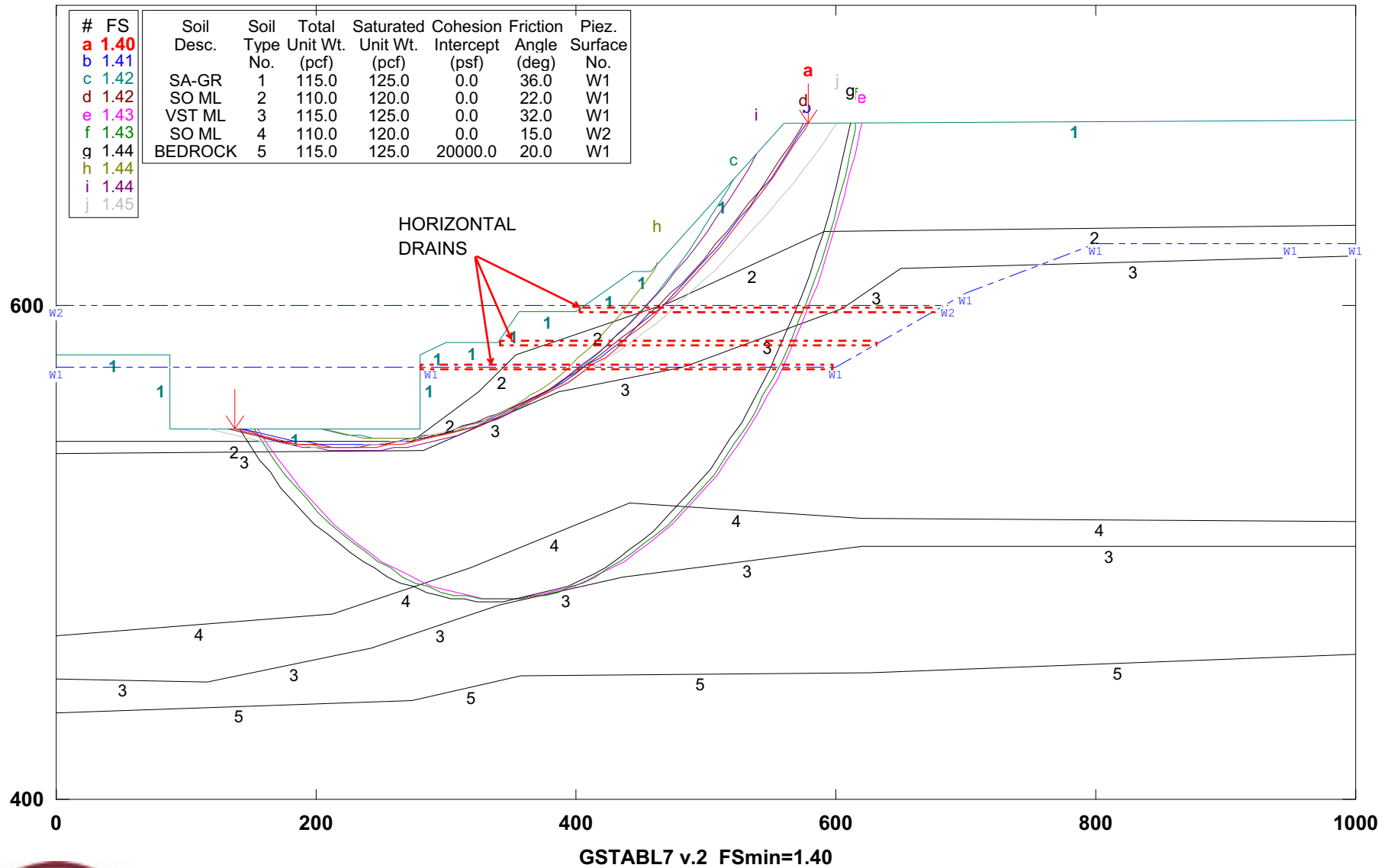

Figure7B.19: Effects of Horizontal Drains on Stability of Section D-D.

### CUY-90-14.92 (Section A-A) : Horizontal Drains & Slope Flattening

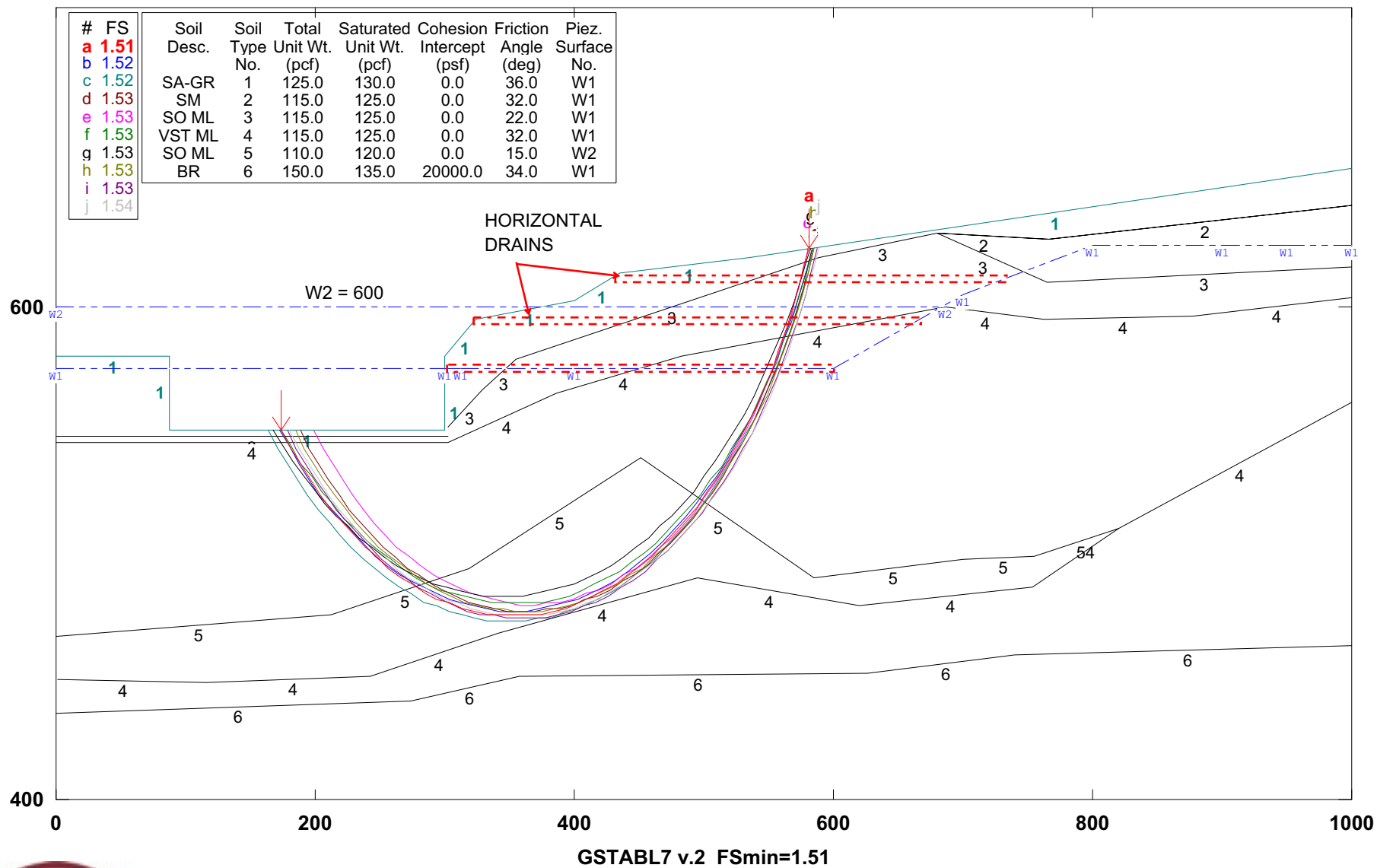

Figure 7B.20: Effects of Horizontal Drains and Slope Flattening on Stability of Section A-A.

### CUY-90-14.92 (Sec. A-A): Block Search & Bottom Layer at Residual Strength

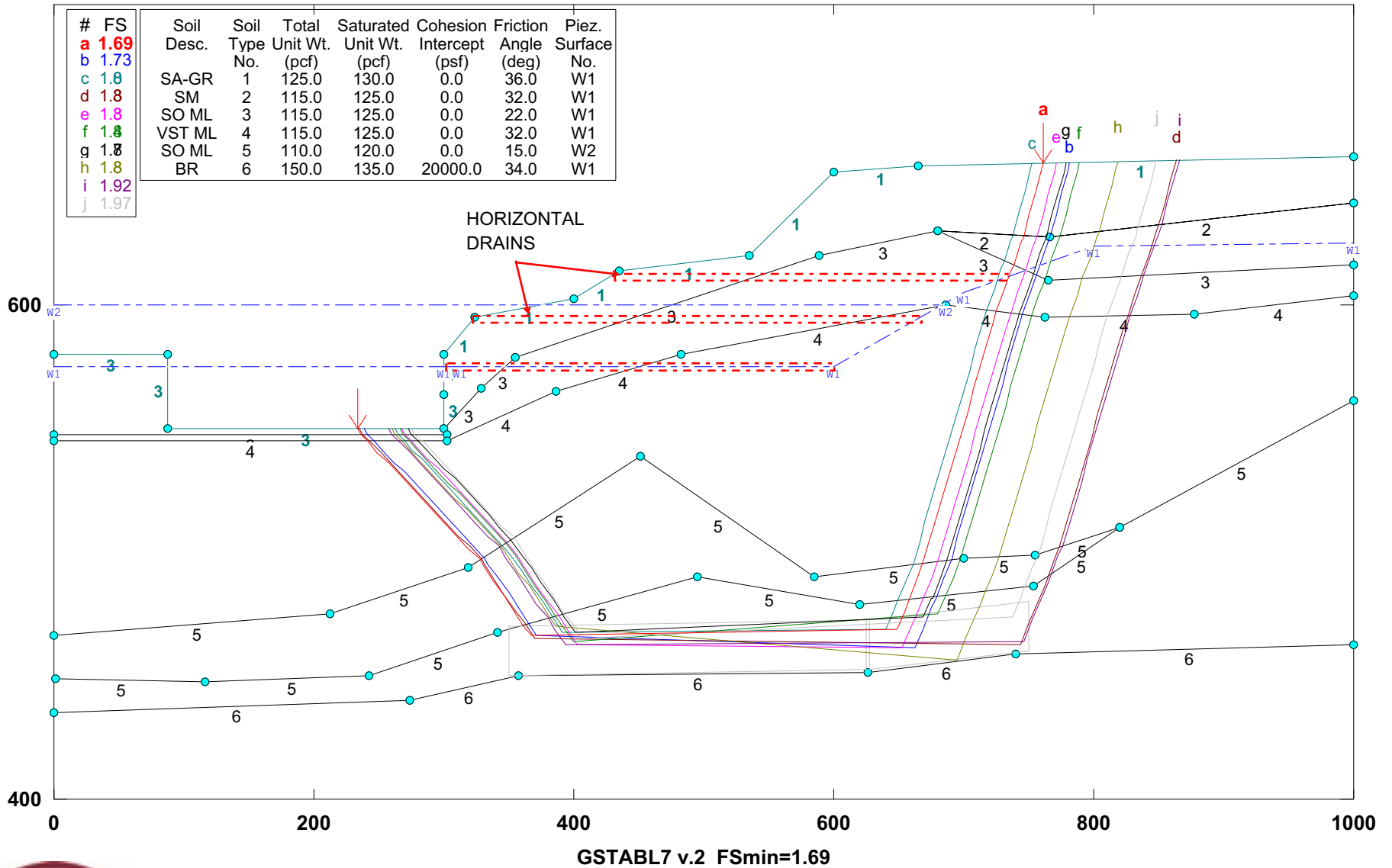

Figure 7B.21: Effects of Horizontal Drains on Stability of Section A-A (Block Search).

### CUY-90-14.92 (Section A-A) : Horizontal and Vertical Drains

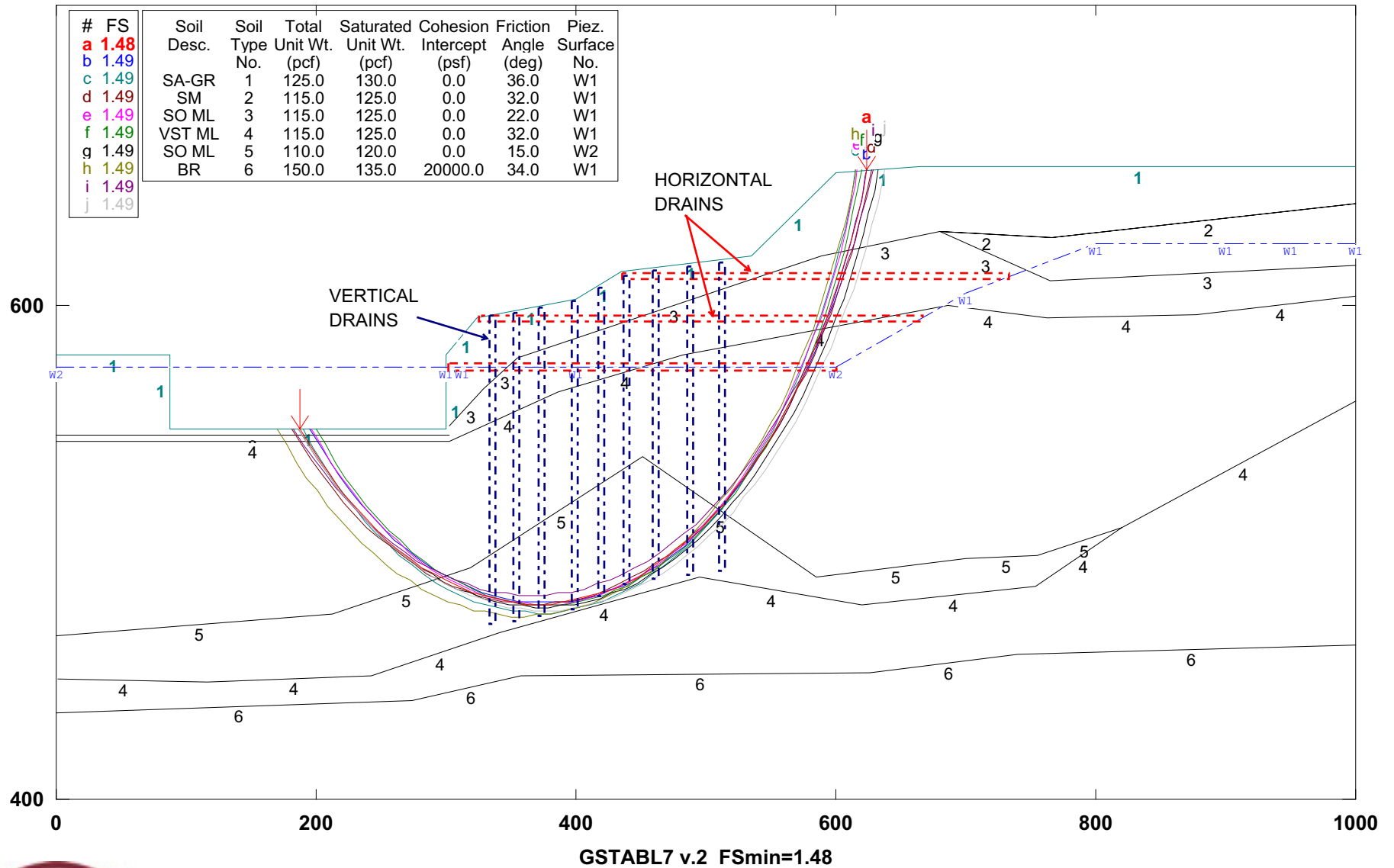

Figure B7.22: Effects of Horizontal and vertical Drains on Stability of Section A-A.



### CUY-90-14.92 (Bridge Centerline): Effects of Horizontal & Vertical Drains

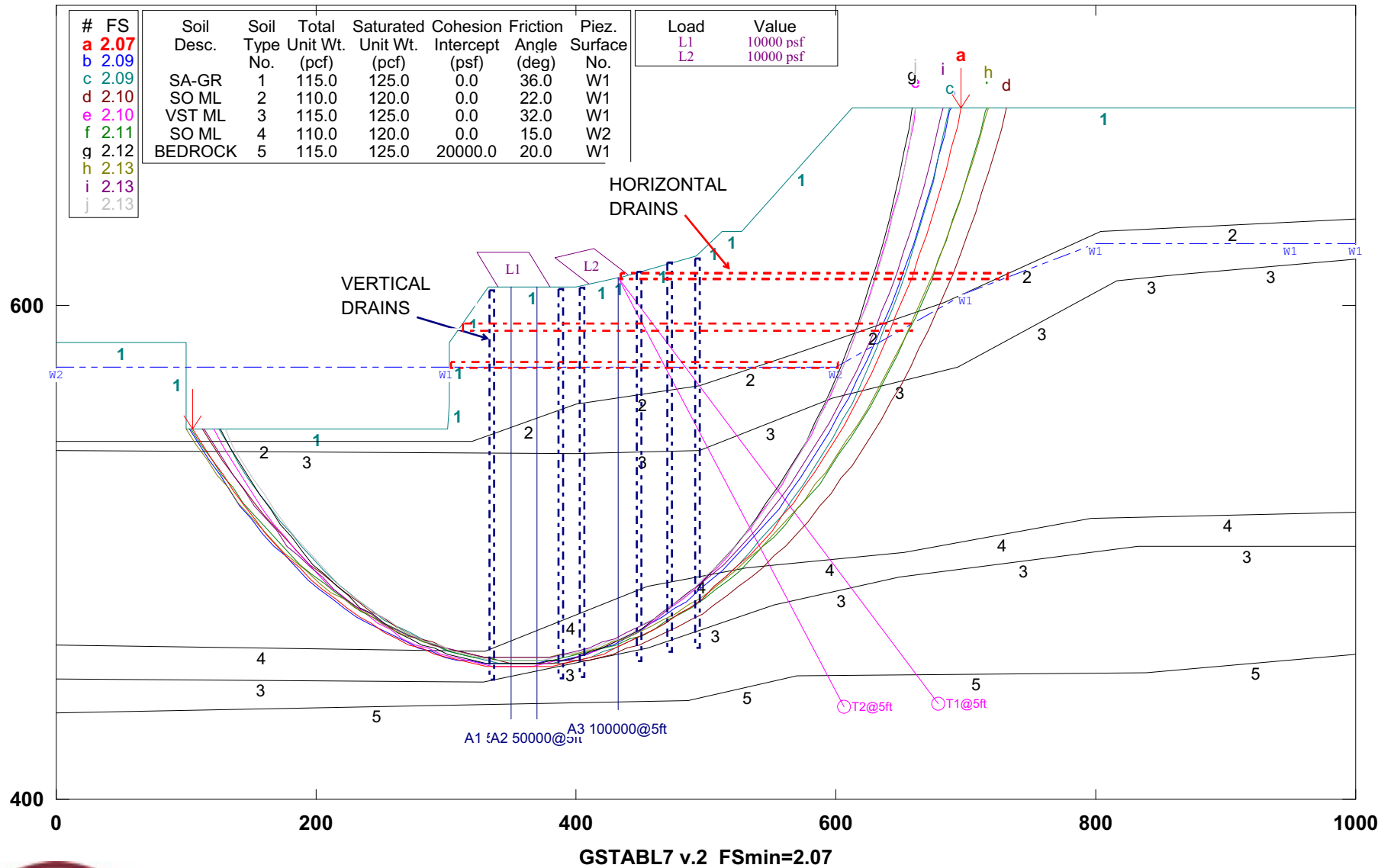

Figure 7B.23: Effects of Horizontal and vertical Drains on Stability at Centerline Section CL-CL.

### CUY-90-14.92 (Section D-D): Effects of Horizontal & Vertical Drains

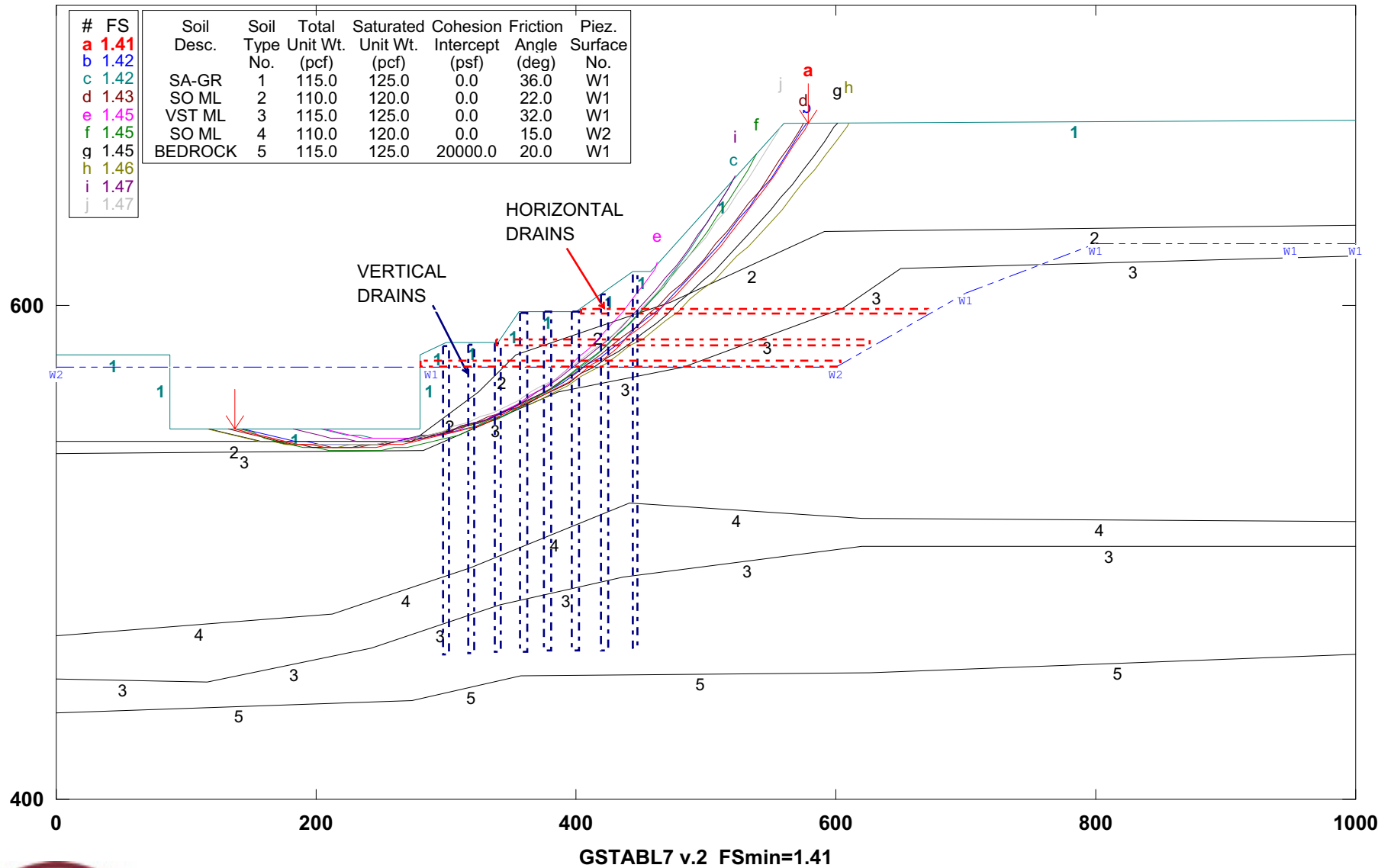

Figure 7B.24: Effects of Horizontal and Vertical Drains on Stability of Section D-D.

### CUY-90-14.92 (Section A-A) : Horizontal and Vertical Drains & Slope Flattening

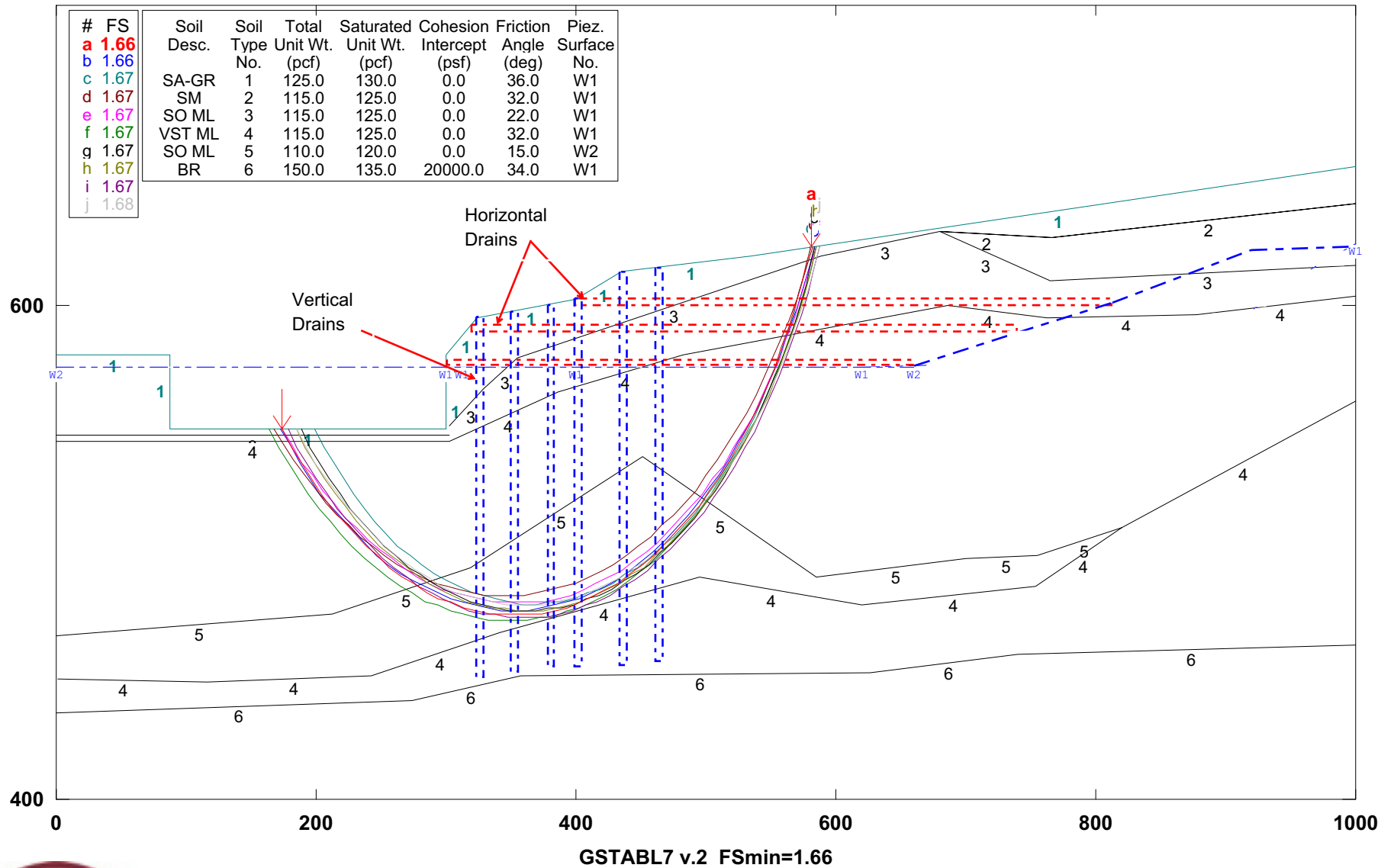

Figure 7B.25: Effects of Horizontal/vertical Drains and Slope Flattening on Stability of Section A-A.

## CUY-90-14.92 (Sec. A-A) : ALTERNATIVE 10(3:1 ABBEY & 12:1 TO RIVER)

\AA-BEST.PL2 Run By: Username 6/18/2006 5:36PM

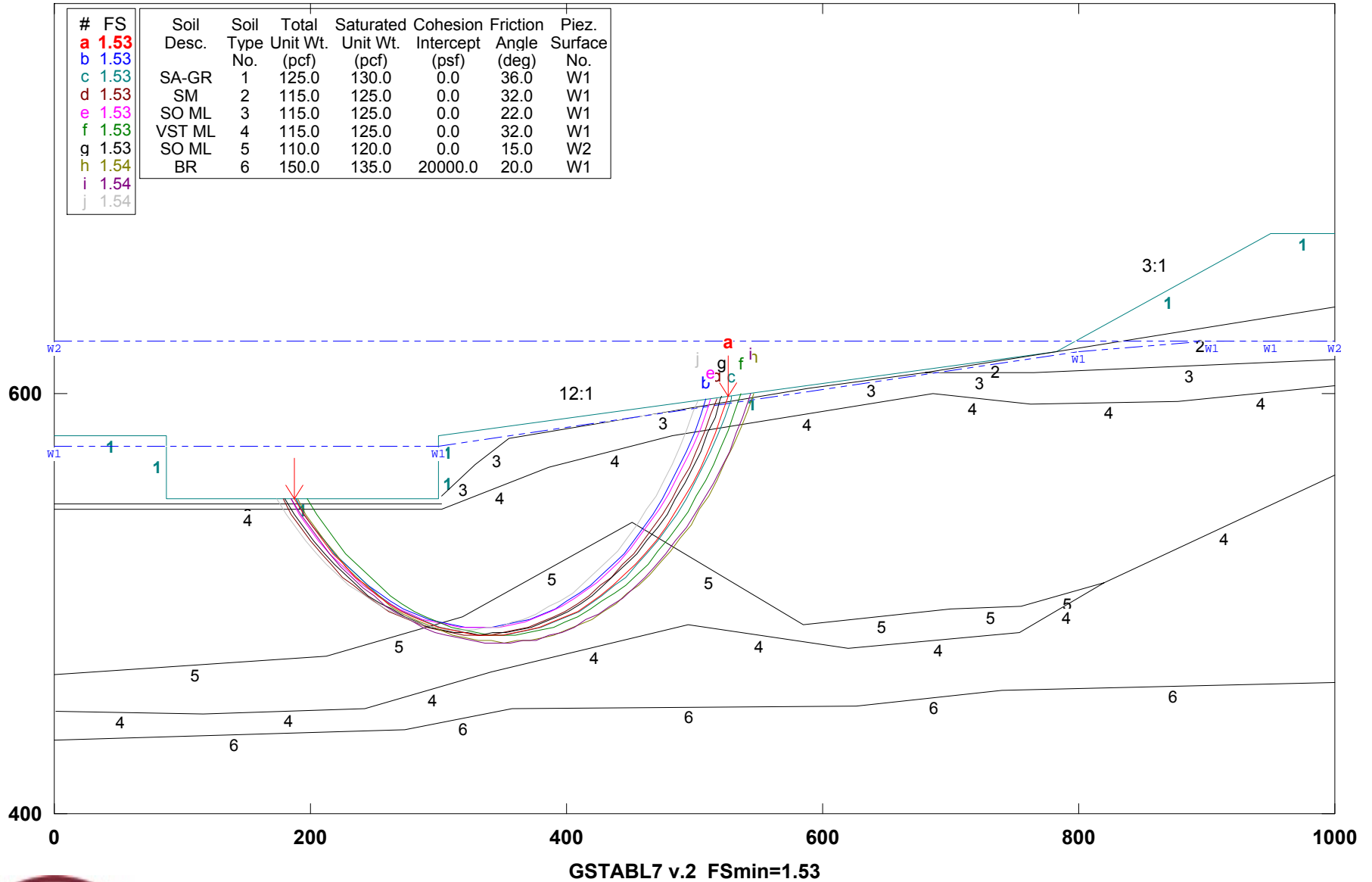

Figure 7B.26: Slope Excavation using (3:1 and 12:1 ) slopes.

## CUY-90-14.92 (Sec. A-A) : ALTERNATIVE 20(5:1 ABBEY & 9:1 TO RIVER)

VA-BEST.PL2 Run By: Username 6/18/2006 9:55PM

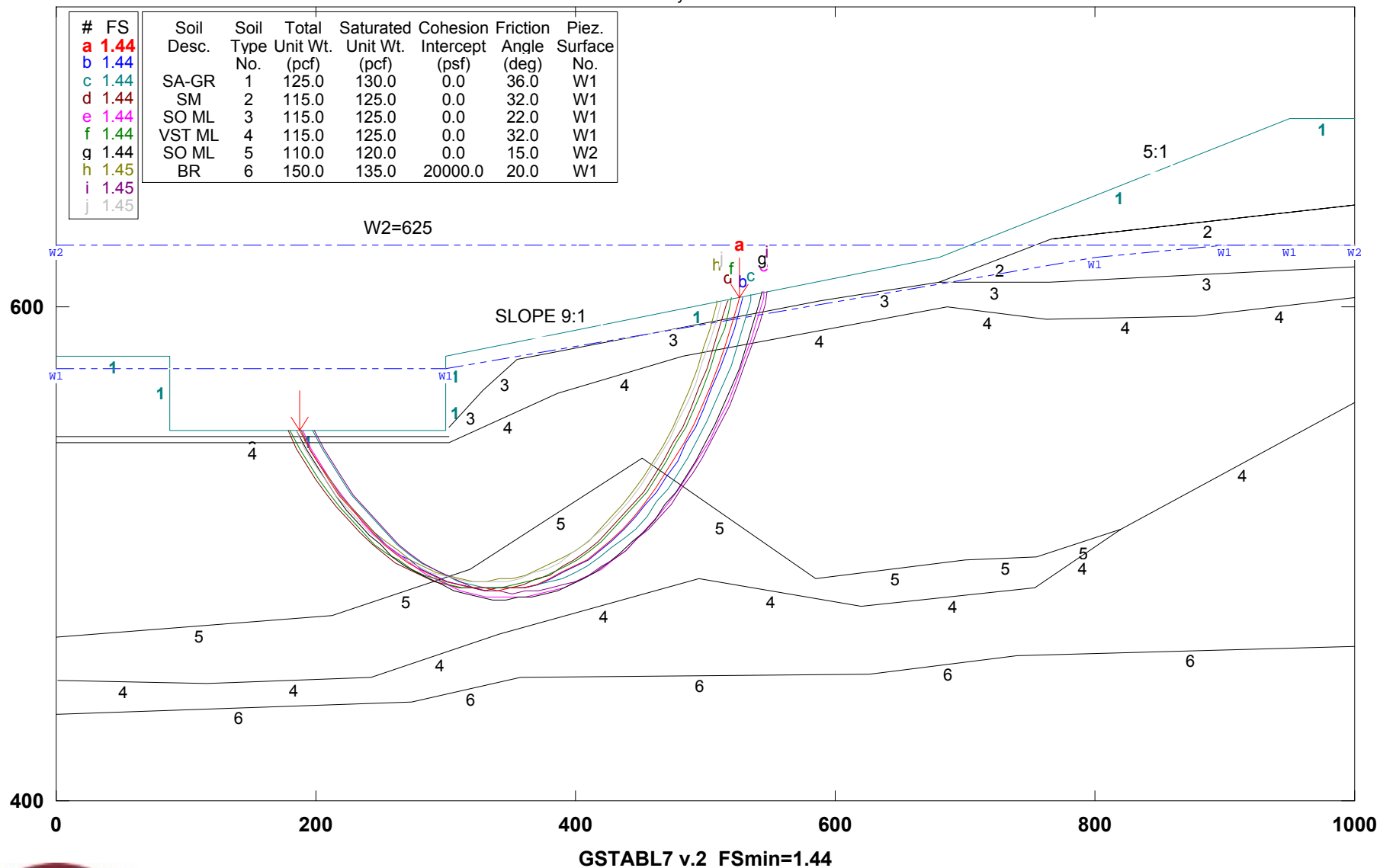

Figure 7B.27: Slope Excavation using (5:1 and 9:1 ) slopes.

### CUY-90-14.92 (Sec. A-A) : 5:1 @ ABBEY & 9:1 TO RIVER

EXCESS PORE PRESSURE (W2) IS REDUCED DUE TO REDUCED (EXCAVATED) WEIGHT

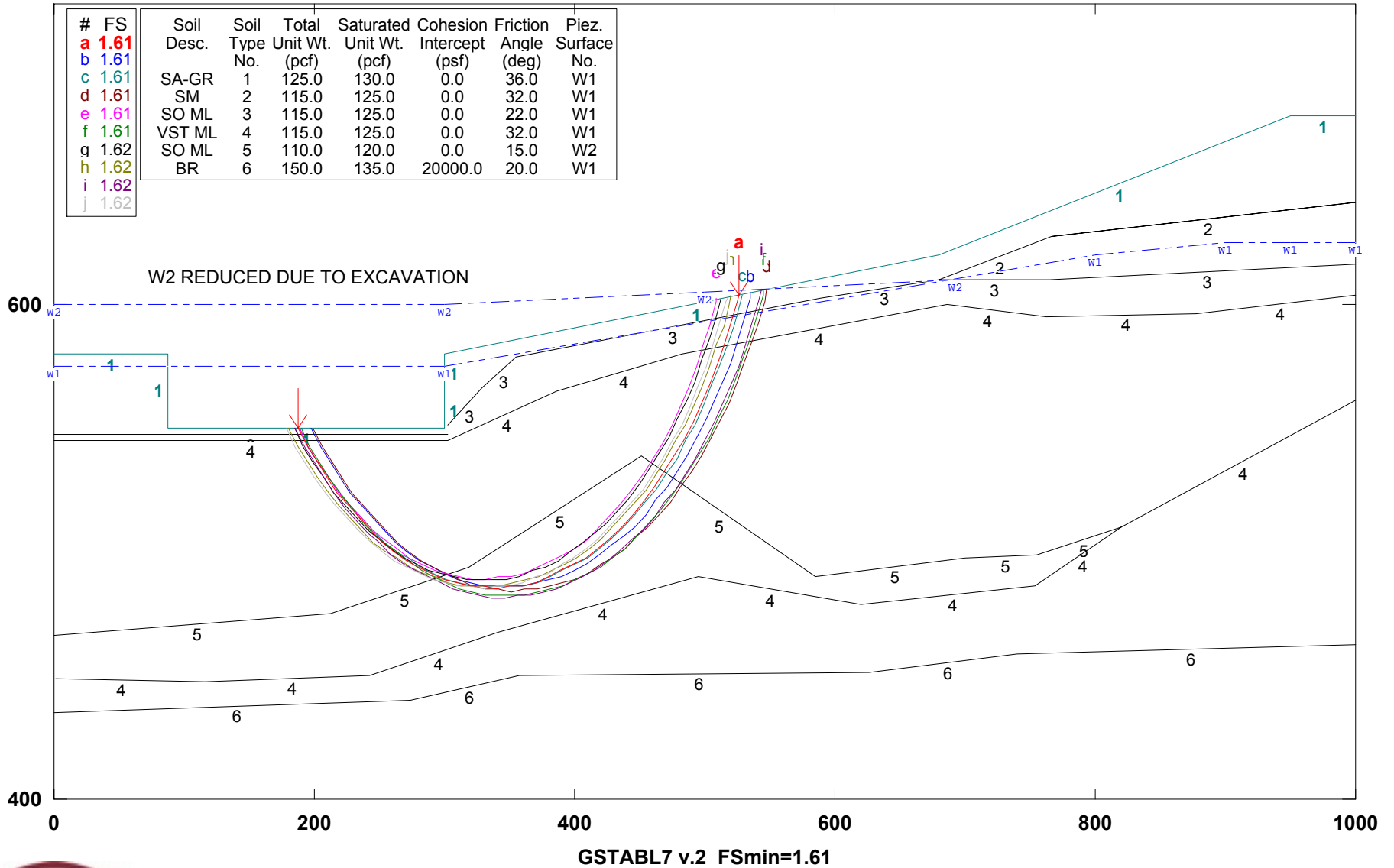

Figure 7B.28: Slope Excavation Effects (5:1 and 9:1 slopes) on stability and w2 reduction.

### CUY-90-14.92 (Sec. A-A) : ALTERNATIVE 20(5:1 ABBEY & 9:1 TO RIVER)

VA-BEST-d.PL2 Run By: Username 6/18/2006 11:03PM

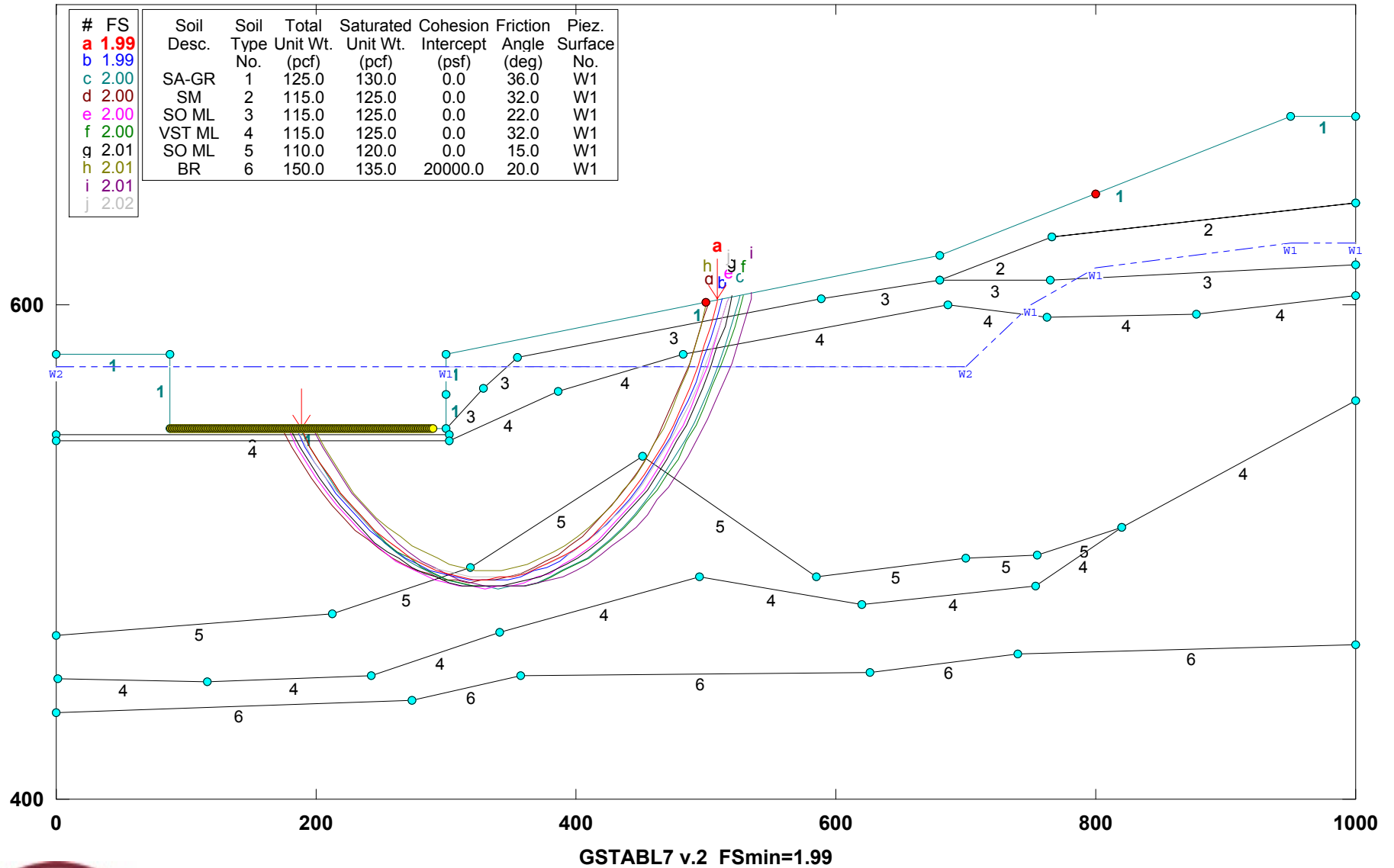

Figure 7B.29: Slope Excavation (5:1 and 9:1 slopes) and vertical and horizontal drains.



## **APPENDIX 7C**

### **SLOPE STABILITY ANALYSES BASED ON EXISTING GEOMETRY**



# CUY-90-14.92 (Sec. A-A): EXISTING GEOMETRY-Block search

e:\from work on laptop\77332\slope stability\final-7-29-09\alt-existing\aa-exb.pl2 Run By: Jamal Nusairat 11/25/2009 01:23AM

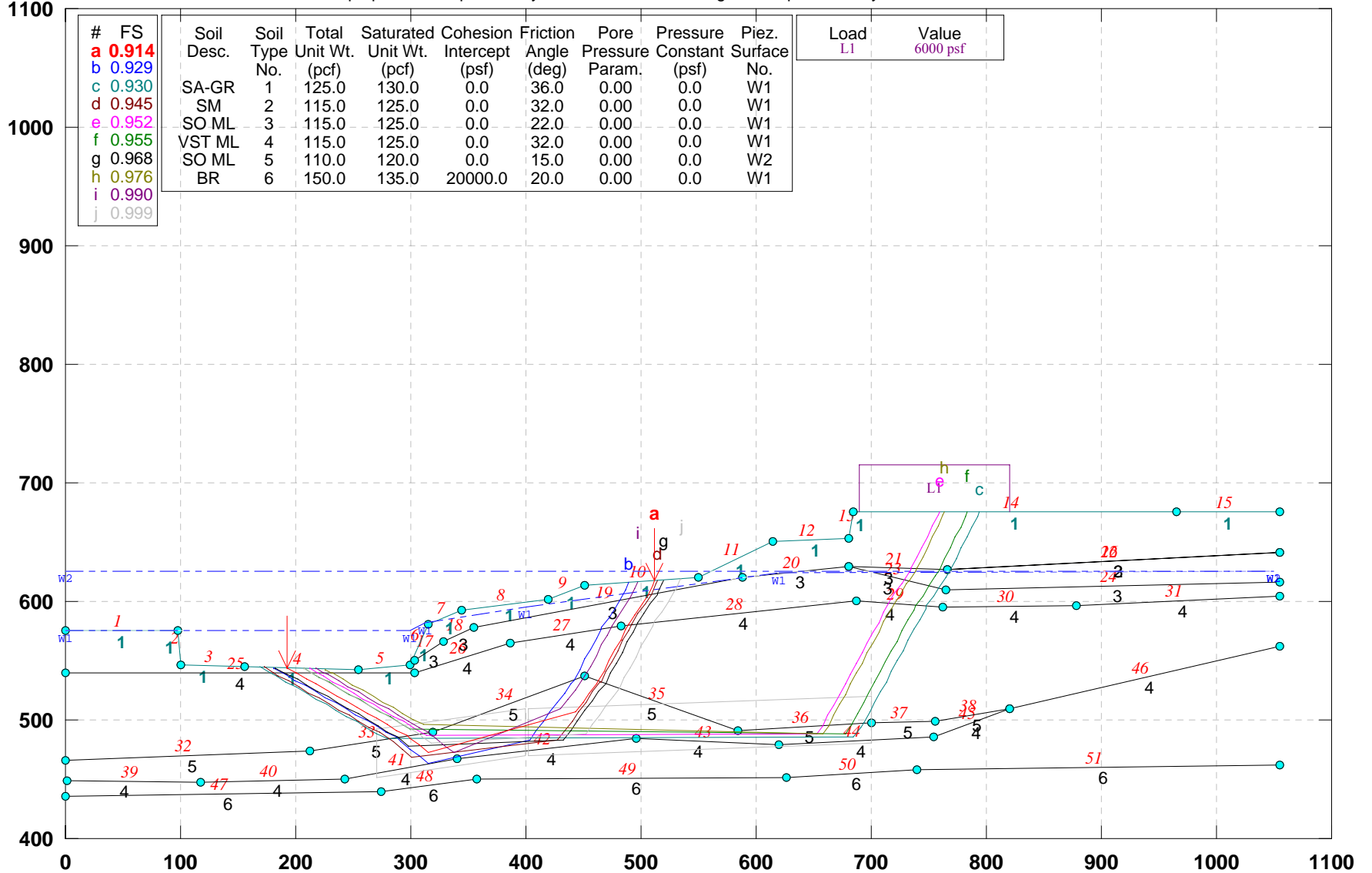

GSTABL7 v.2 FSmin=0.914

Safety Factors Are Calculated By The Simplified Janbu Method



# CUY-90-14.92 (Sec. A-A): EXISTING GEOMETRY-Block search

e:\from work on laptop\77332\slope stability\final-7-29-09\alt-existing\aa-exbw.pl2 Run By: Jamal Nusairat 11/25/2009 01:26AM

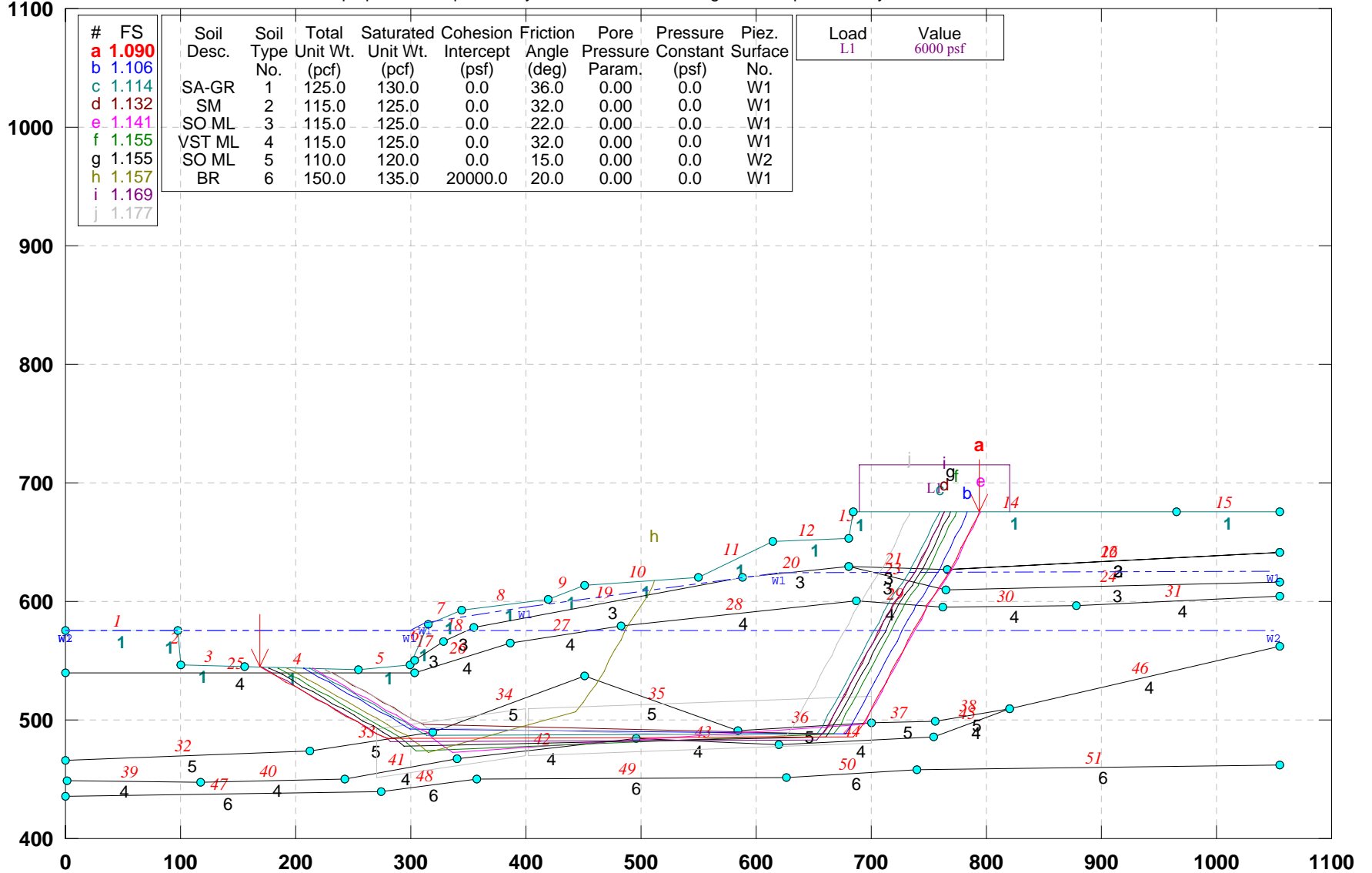

GSTABL7 v.2 FSmin=1.090

Safety Factors Are Calculated By The Simplified Janbu Method



# CUY-90-14.92 (Sec. B-B): EXISTING GEOMETRY\_Block Search

e:\from work on laptop\77332\slope stability\final-7-29-09\alt-existing\bb-exb.pl2 Run By: Jamal Nusairat 11/24/2009 02:31PM

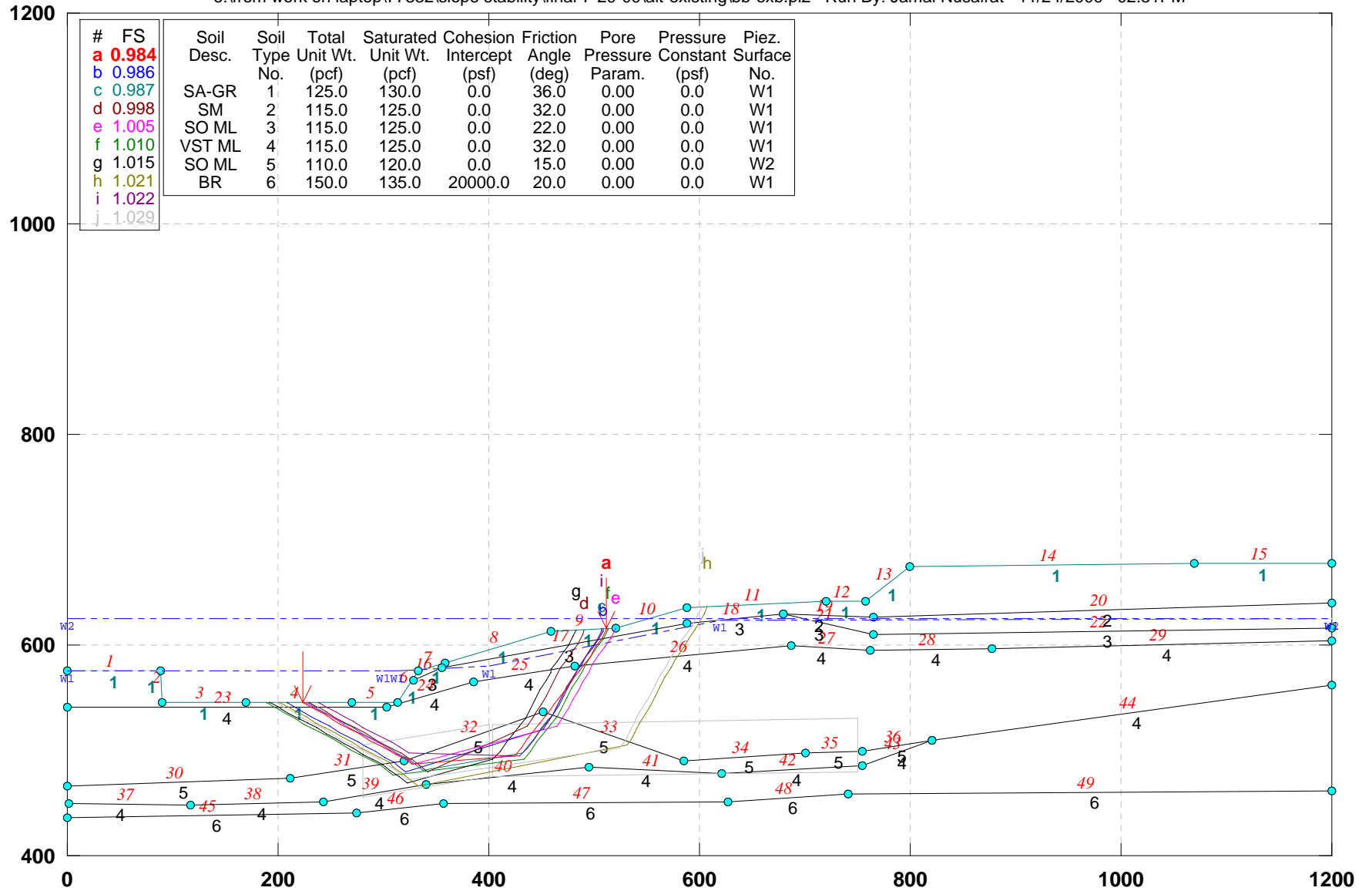

GSTABL7 v.2 FSmin=0.984

Safety Factors Are Calculated By The Simplified Janbu Method



## CUY-90-14.92 (Sec. B-B): EXISTING GEOMETRY\_Block Search

e:\from work on laptop\77332\slope stability\final-7-29-09\alt-existing\bb-exbw.pl2 Run By: Jamal Nusairat 11/25/2009 01:29AM

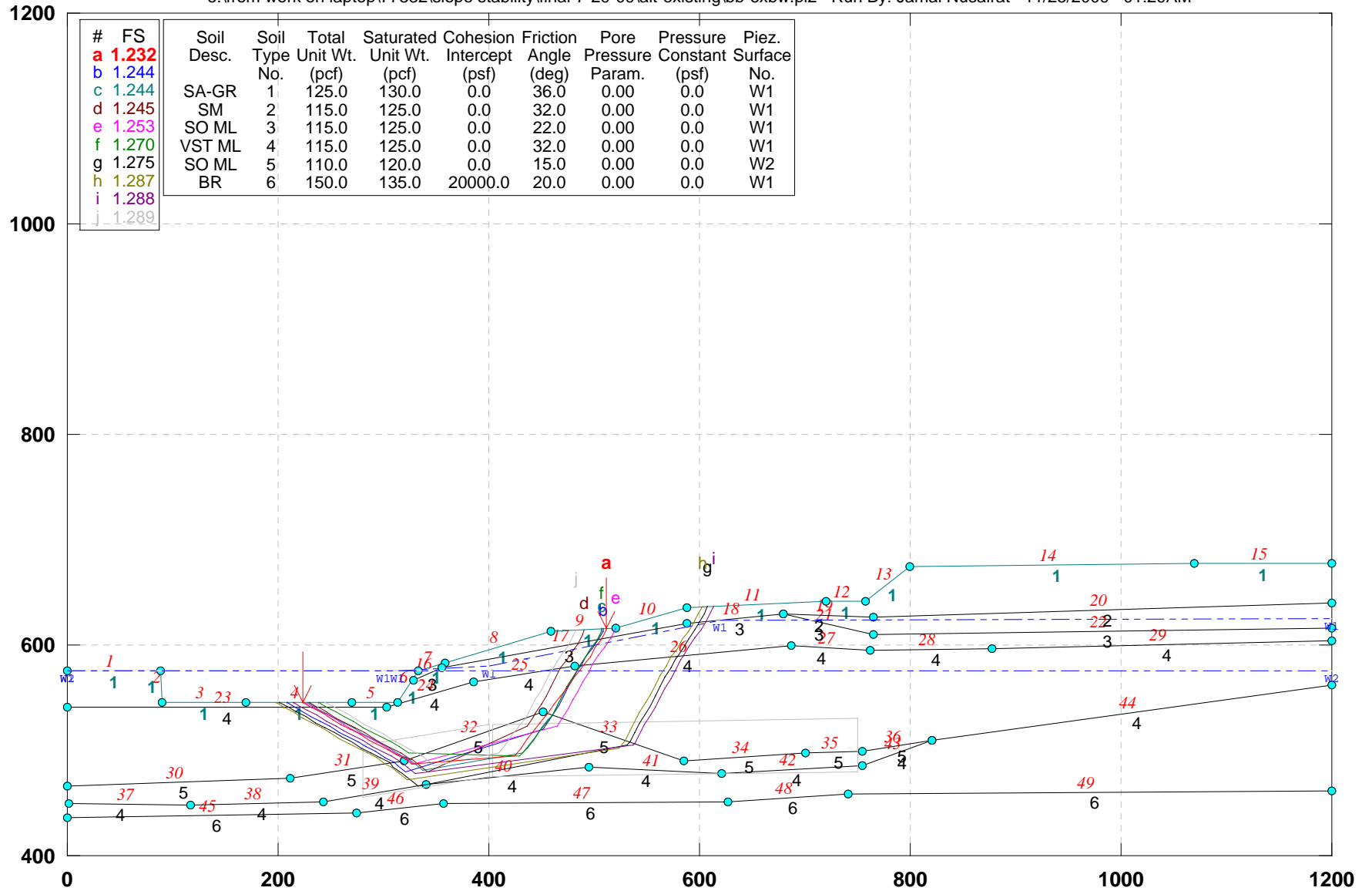

GSTABL7 v.2 FSmin=1.232

Safety Factors Are Calculated By The Simplified Janbu Method



# CUY-90-14.40: CENTERLINE OF BRIDGE\_ Block Search

e:\from work on laptop\77332\slope stability\final-7-29-09\alt-existing\cl-exb.pl2 Run By: Jamal Nusairat 11/24/2009 02:32PM

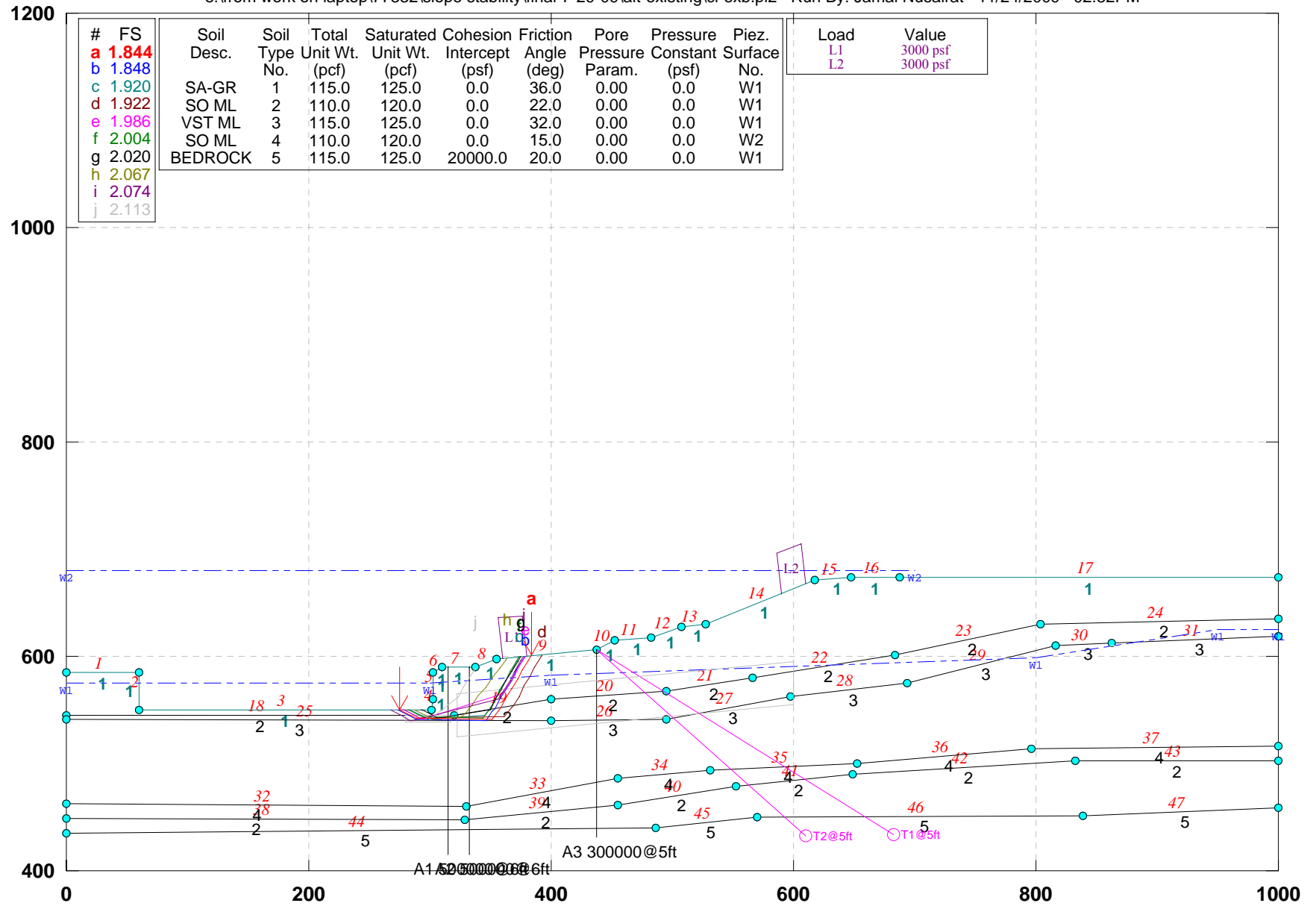

GSTABL7 v.2 FSmin=1.844

Safety Factors Are Calculated By The Simplified Janbu Method



# CUY-90-14.92 (Sec. D-D): EXISTING GEOMETRY\_Block Search

e:\from work on laptop\77332\slope stability\final-7-29-09\alt-existing\dd-b.pl2 Run By: Jamal Nusairat 11/24/2009 02:33PM

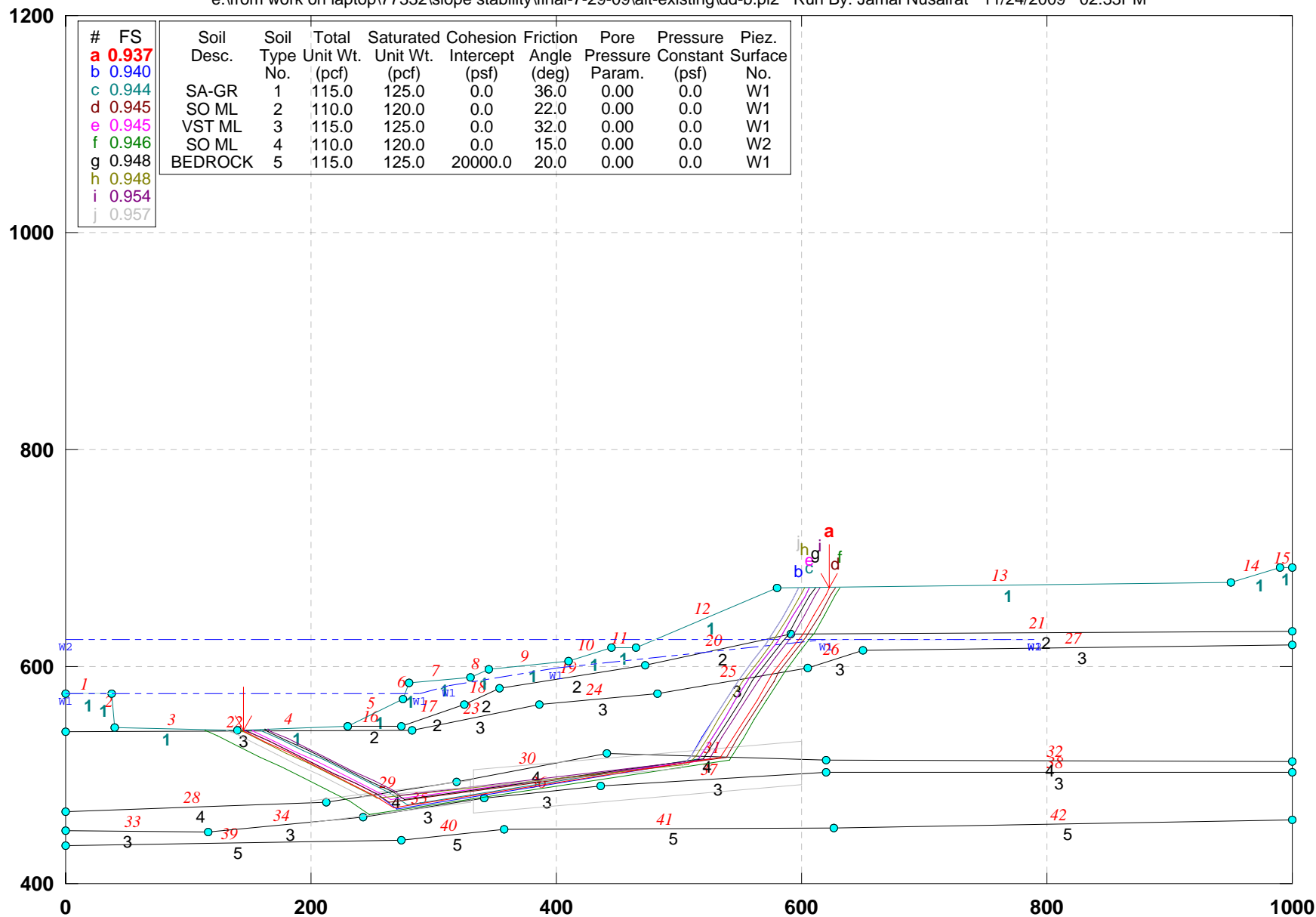

GSTABL7 v.2 FSmin=0.937

Safety Factors Are Calculated By The Simplified Janbu Method



# CUY-90-14.92 (Sec. E-E): EXISTING GEOMETRY\_Block Search

e:\from work on laptop\77332\slope stability\final-7-29-09\alt-existing\lee-exb.pl2 Run By: Jamal Nusairat 11/24/2009 02:35PM

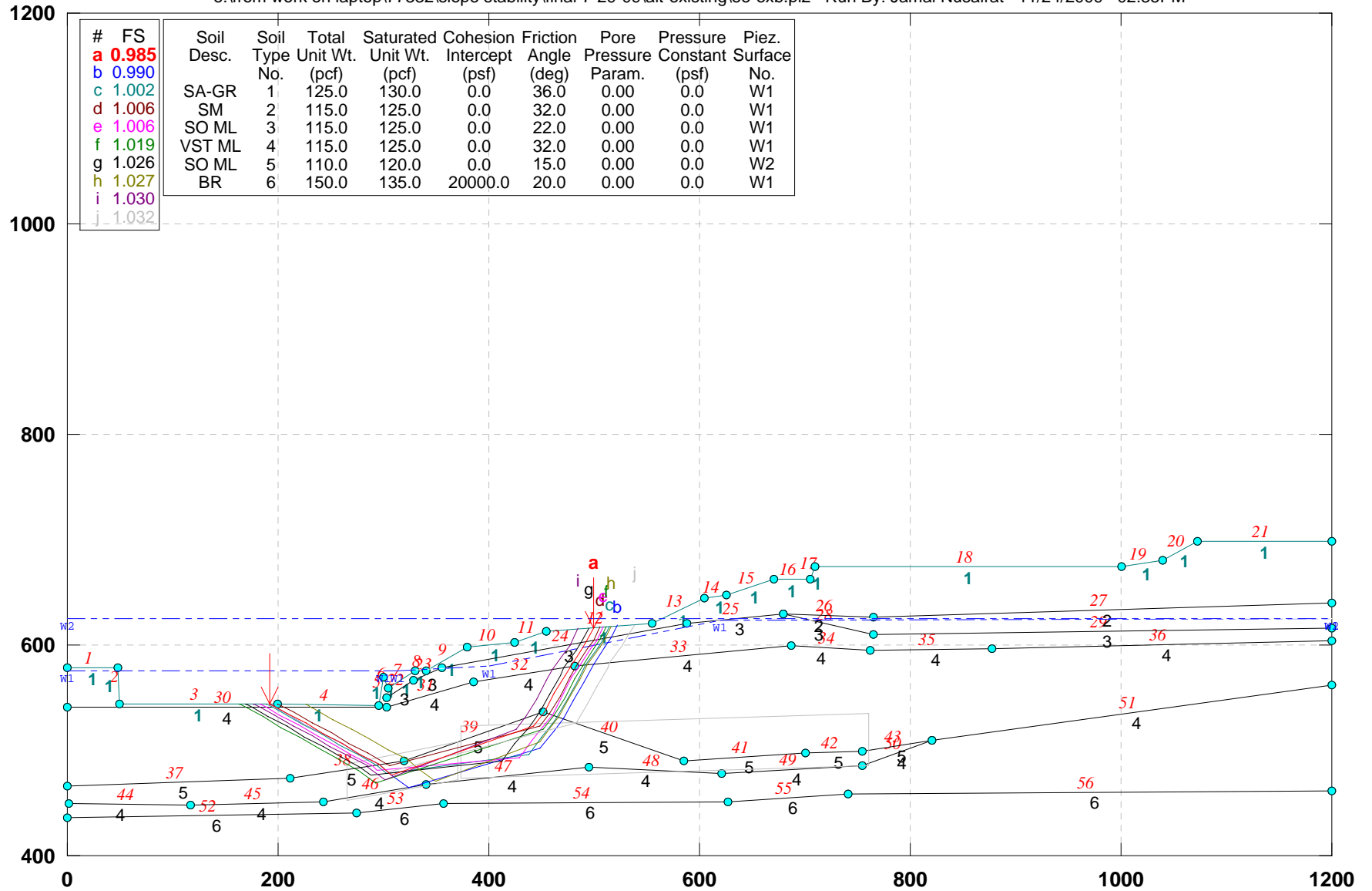

GSTABL7 v.2 FSmin=0.985

Safety Factors Are Calculated By The Simplified Janbu Method



## CUY-90-14.92 (Sec. F-F): EXISTING GEOMETRY\_Block Search

e:\from work on laptop\77332\slope stability\final-7-29-09\alt-existing\ff-exb.pl2 Run By: Jamal Nusairat 11/24/2009 02:37PM

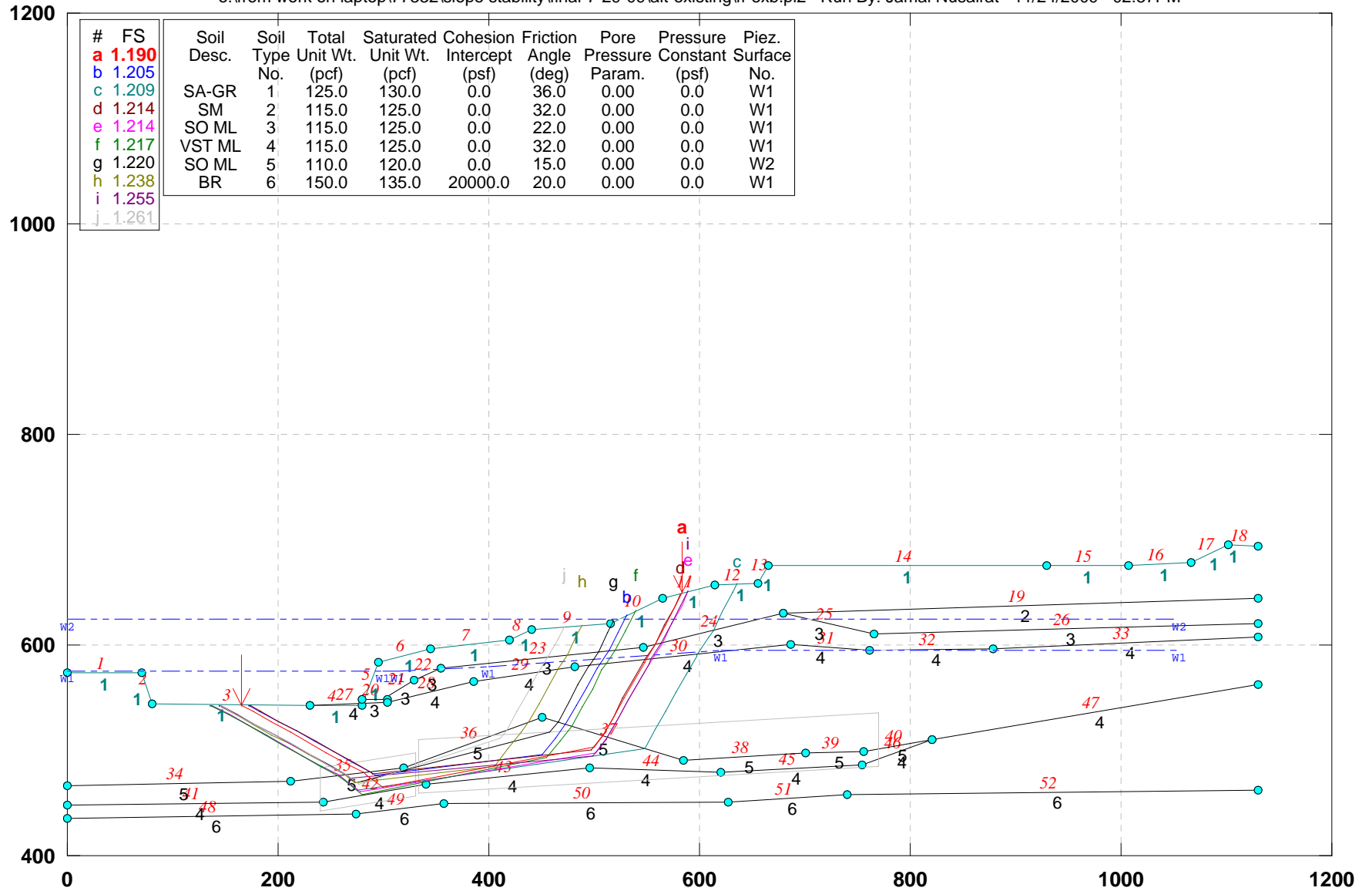

GSTABL7 v.2 FSmin=1.190

Safety Factors Are Calculated By The Simplified Janbu Method





# CUY-90-14.92 (Sec. W-W): EXISTING GEOMETRY\_Block Search

e:\from work on laptop\77332\slope stability\final-7-29-09\alt-existing\ww-exb.pl2 Run By: Jamal Nusairat 11/24/2009 02:42PM

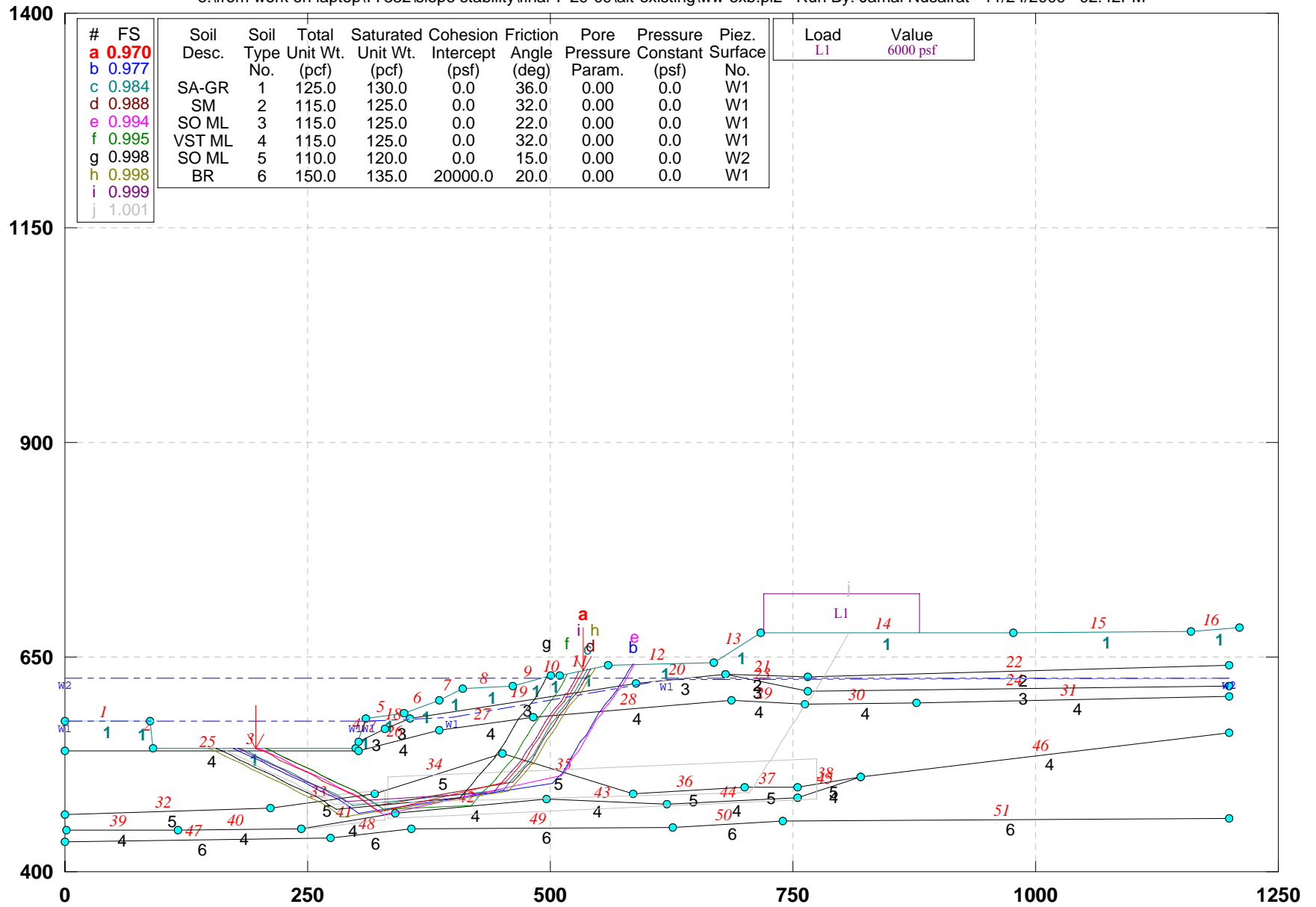

GSTABL7 v.2 FSmin=0.970

Safety Factors Are Calculated By The Simplified Janbu Method



# CUY-90-14.92 (Sec. Y-Y): EXISTING GEOMETRY\_Block Search

e:\from work on laptop\77332\slope stability\final-7-29-09\alt-existing\yy-exb.pl2 Run By: Jamal Nusairat 11/24/2009 02:44PM

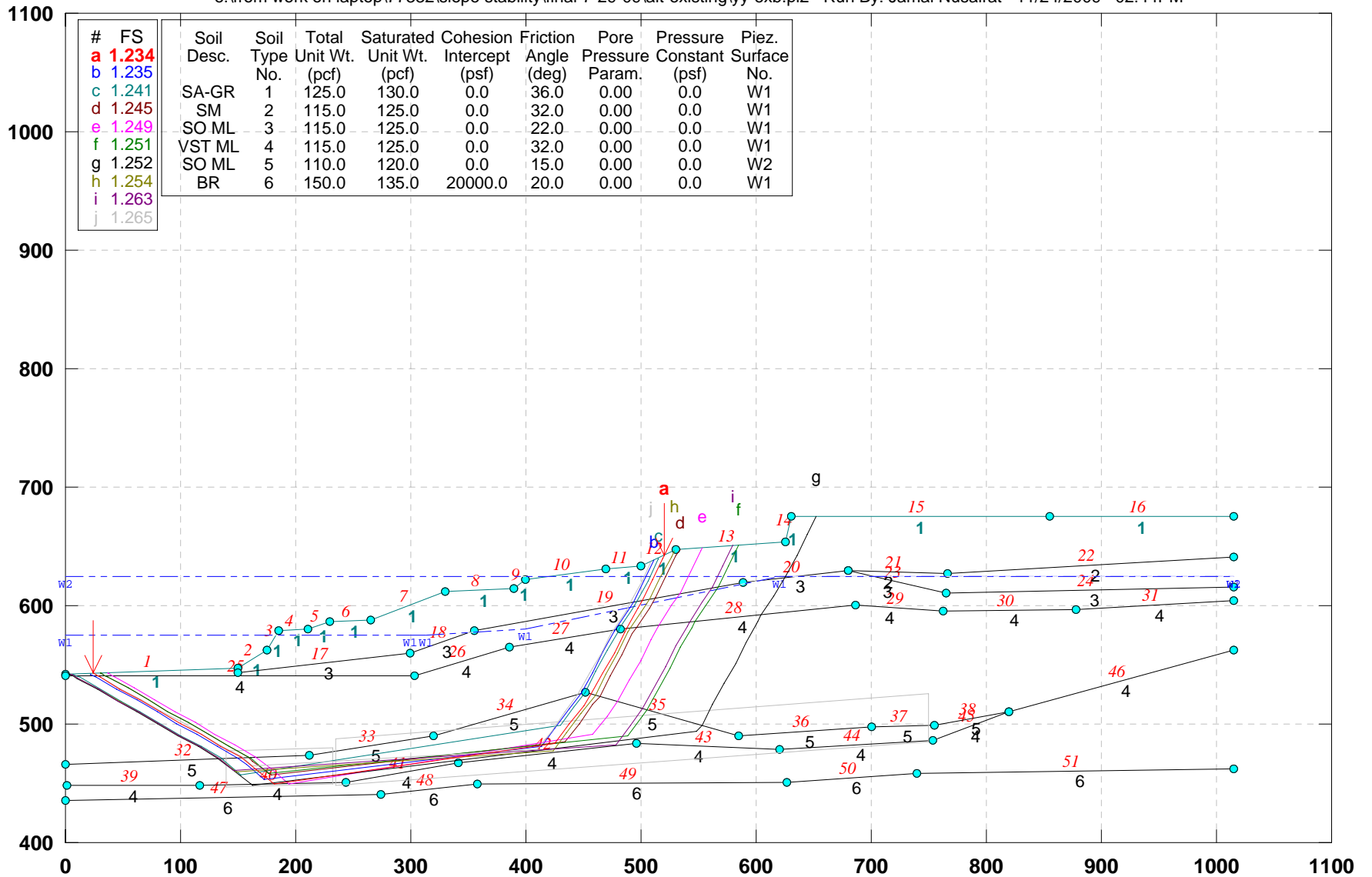

GSTABL7 v.2 FSmin=1.234

Safety Factors Are Calculated By The Simplified Janbu Method



## CUY-90-14.40 (Sec. Z-Z): EXISTING GEOMETRY\_Block Search

e:\from work on laptop\77332\slope stability\final-7-29-09\alt-existing\zz-exb.pl2 Run By: Jamal Nusairat 11/24/2009 02:45PM

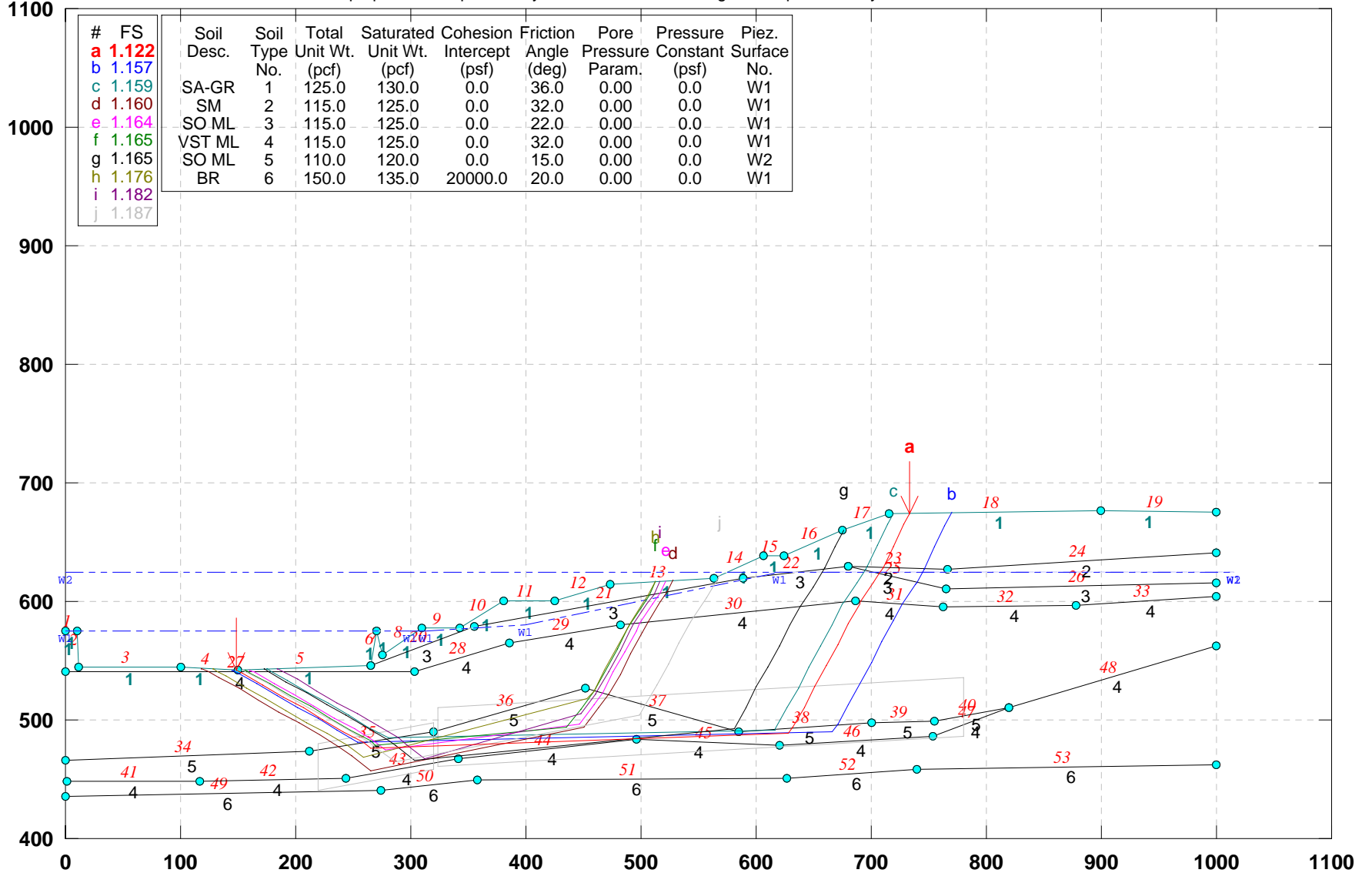

GSTABL7 v.2 FSmin=1.122

Safety Factors Are Calculated By The Simplified Janbu Method



# CUY-90-14.92 (Sec. A-A): EXISTING GEOMETRY

e:\from work on laptop\77332\slope stability\final-7-29-09\alt-existing\aa-ex0.pl2 Run By: Jamal Nusairat 11/25/2009 01:33AM

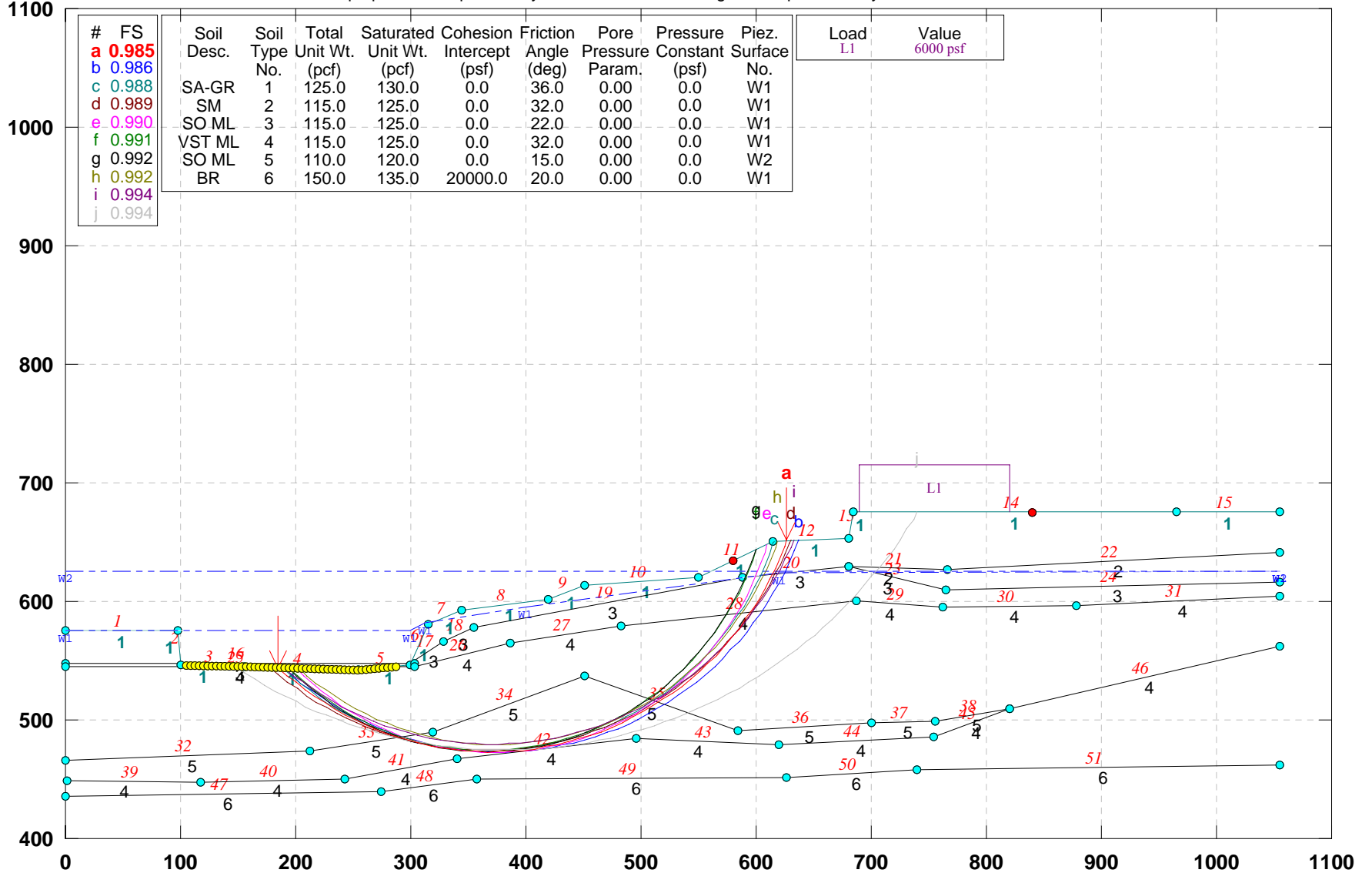

GSTABL7 v.2 FSmin=0.985

Safety Factors Are Calculated By The Simplified Janbu Method



# CUY-90-14.92 (Sec. A-A): EXISTING GEOMETRY\_ No Elev. Water

e:\from work on laptop\77332\slope stability\final-7-29-09\alt-existing\aa-ex0w.pl2 Run By: Jamal Nusairat 11/25/2009 01:34AM

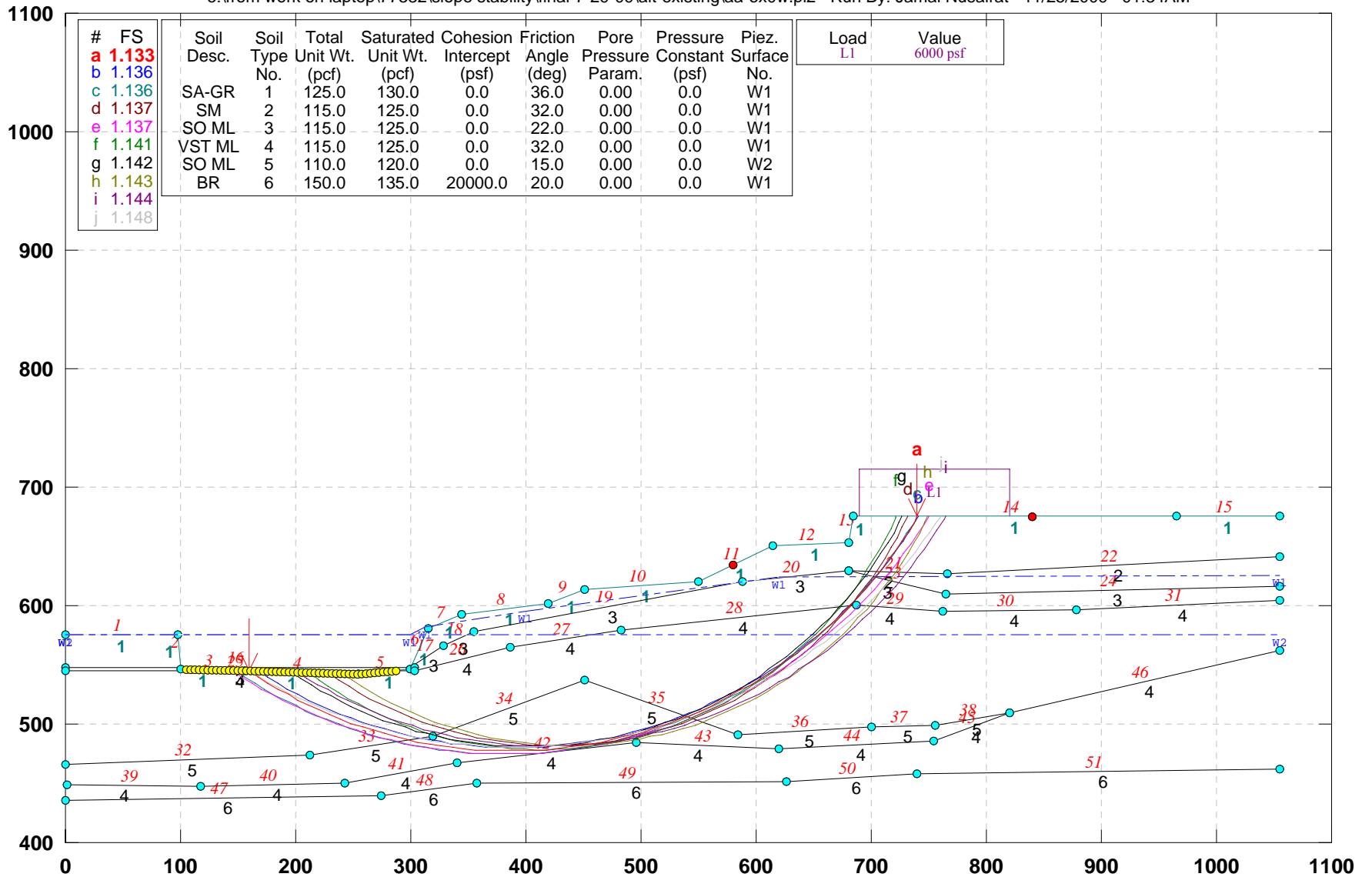

GSTABL7 v.2 FSmin=1.133

Safety Factors Are Calculated By The Simplified Janbu Method



# CUY-90-14.92 (Sec. B-B): EXISTING GEOMETRY

e:\from work on laptop\77332\slope stability\final-7-29-09\alt-existing\bb-ex.pl2 Run By: Jamal Nusairat 11/24/2009 02:50PM

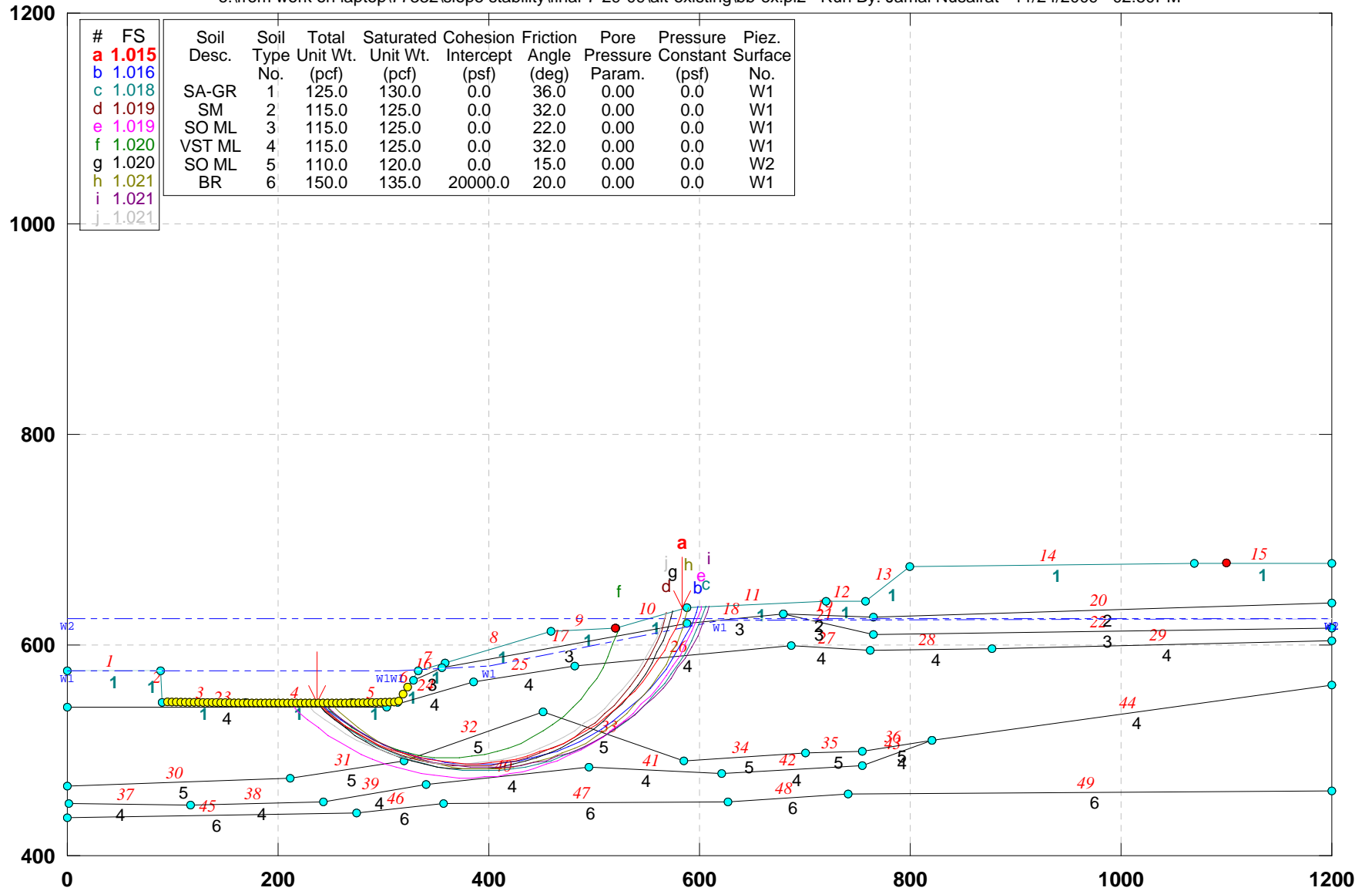

GSTABL7 v.2 FSmin=1.015

Safety Factors Are Calculated By The Simplified Janbu Method



# CUY-90-14.92 (Sec. B-B): EXISTING GEOMETRY\_ No Elev. Water

e:\from work on laptop\77332\slope stability\final-7-29-09\alt-existing\bb-exw.pl2 Run By: Jamal Nusairat 11/25/2009 01:37AM

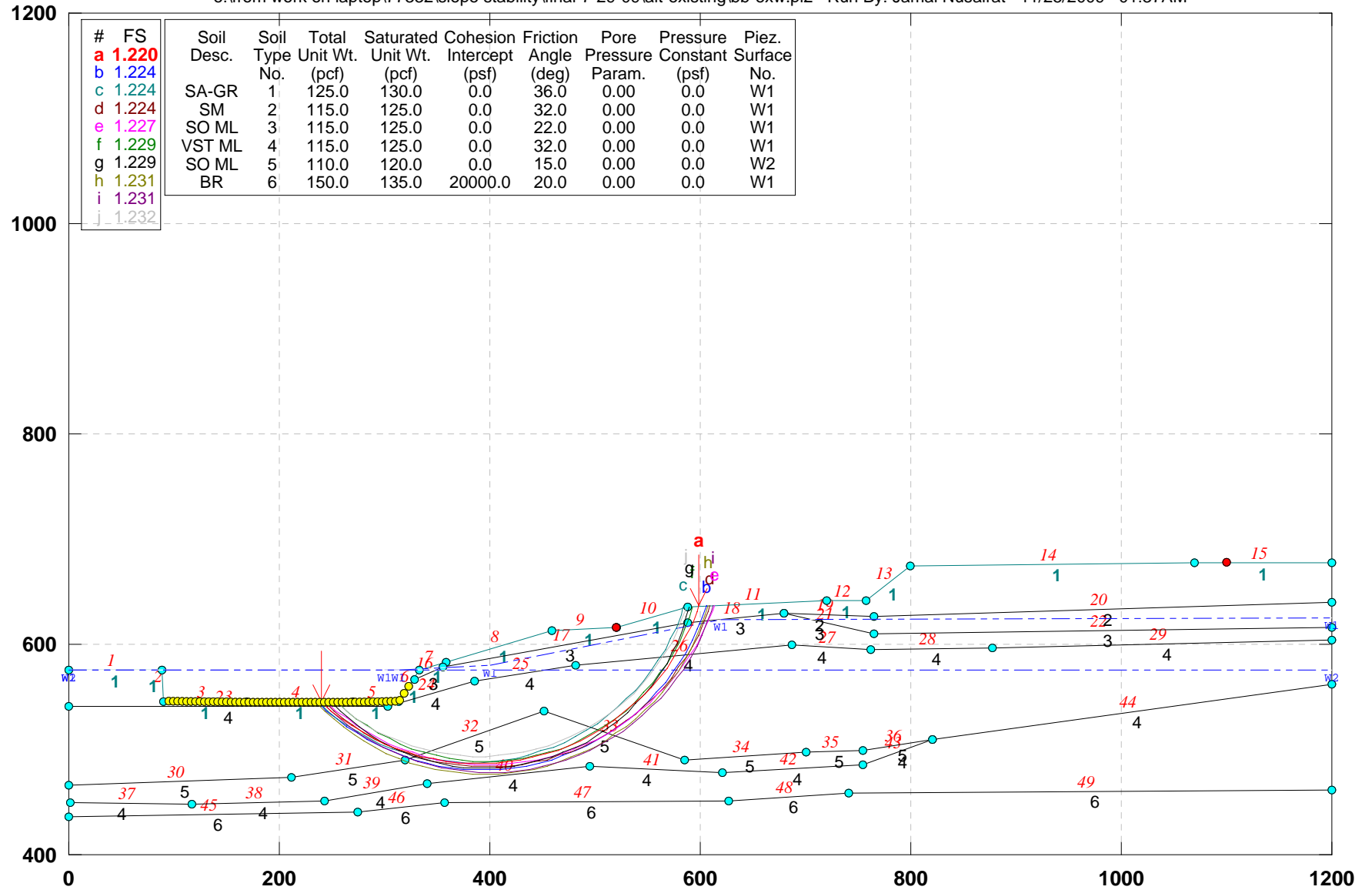

GSTABL7 v.2 FSmin=1.220

Safety Factors Are Calculated By The Simplified Janbu Method



# CUY-90-14.92: CENTERLINE OF BRIDGE TOTAL STRESS ANALYSES

e:\from work on laptop\77332\slope stability\final-7-29-09\alt-existing\cl-ex.pl2 Run By: Jamal Nusairat 11/24/2009 02:54PM

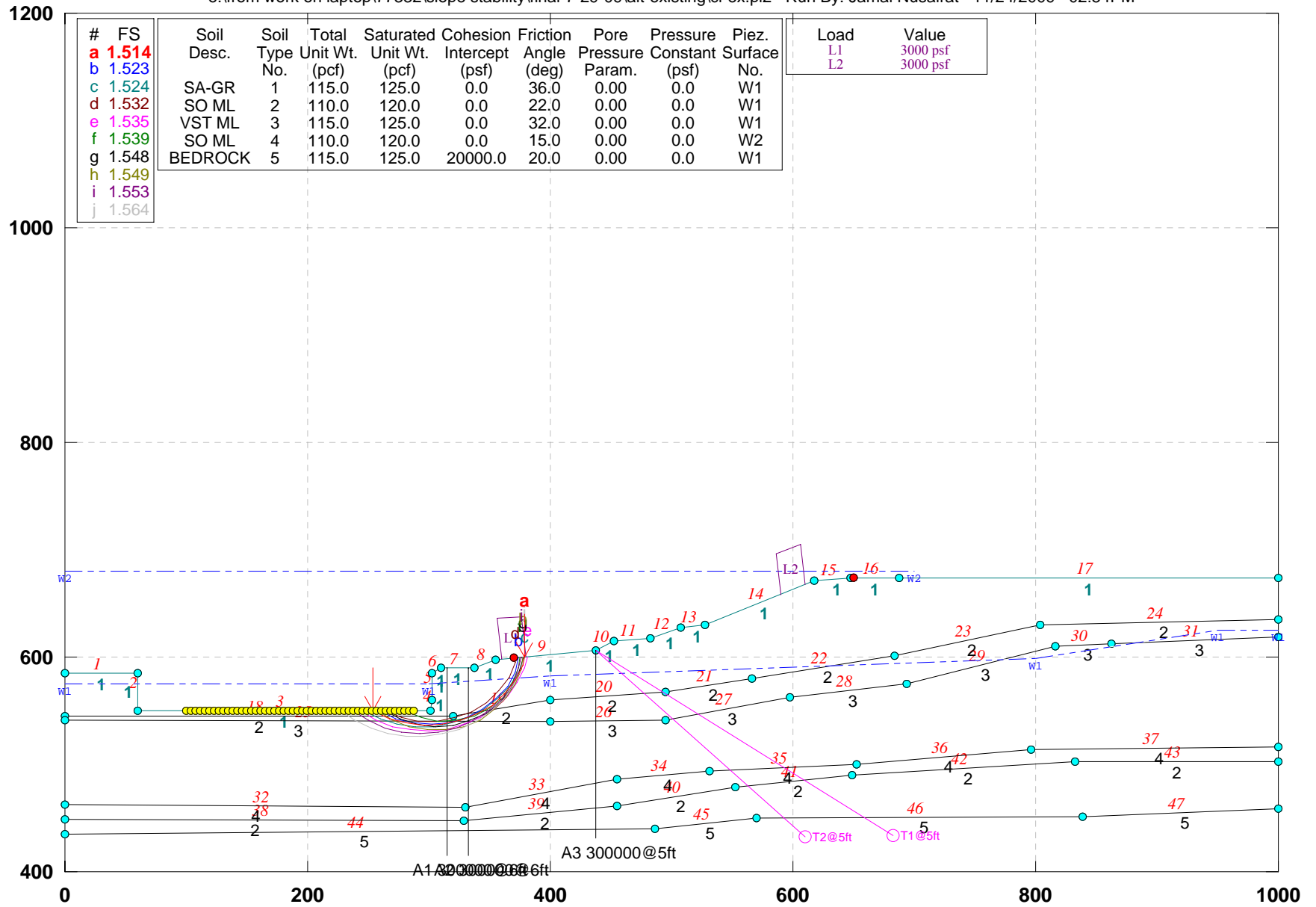

GSTABL7 v.2 FSmin=1.514

Safety Factors Are Calculated By The Simplified Janbu Method





# CUY-90-14.92 (Sec. D-D): EXISTING GEOMETRY

e:\from work on laptop\77332\slope stability\final-7-29-09\alt-existing\dd-.pl2 Run By: Jamal Nusairat 11/24/2009 02:56PM

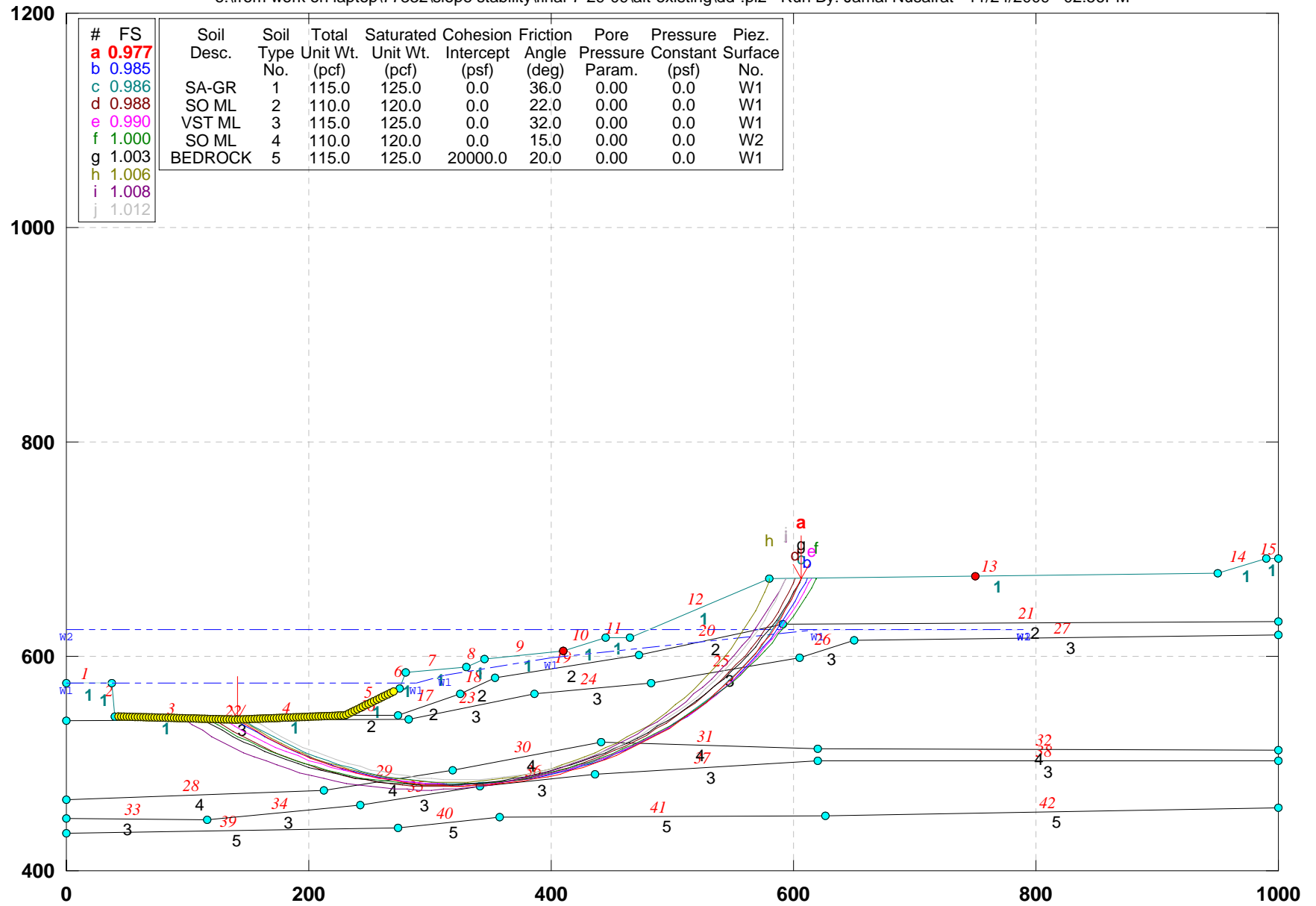

GSTABL7 v.2 FSmin=0.977

Safety Factors Are Calculated By The Simplified Janbu Method



# CUY-90-14.92 (Sec. E-E): EXISTING GEOMETRY

e:\from work on laptop\77332\slope stability\final-7-29-09\alt-existing\ee-ex.pl2 Run By: Jamal Nusairat 11/24/2009 02:58PM

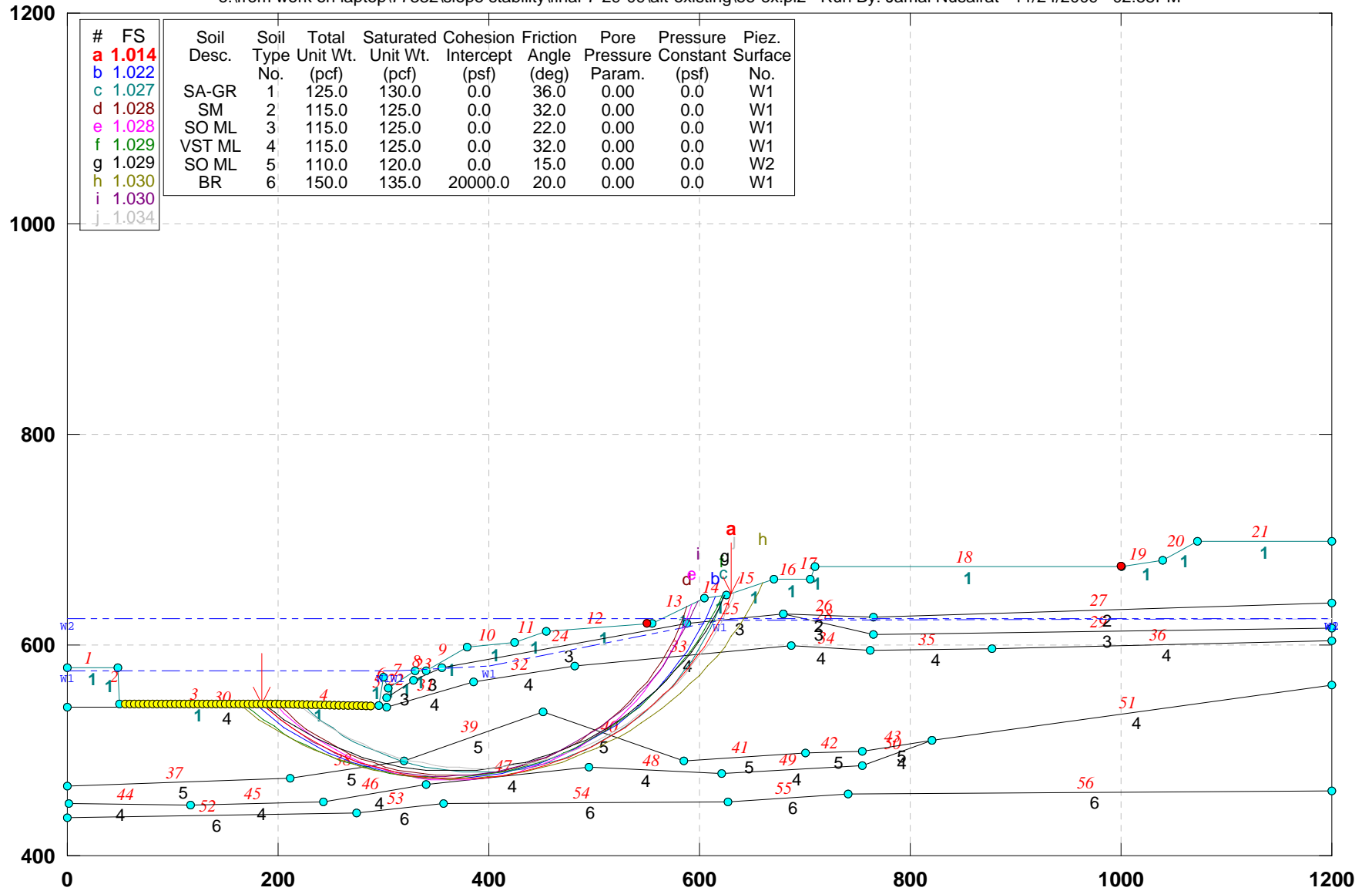

GSTABL7 v.2 FSmin=1.014

Safety Factors Are Calculated By The Simplified Janbu Method



## CUY-90-14.92 (Sec. F-F): EXISTING GEOMETRY

e:\from work on laptop\77332\slope stability\final-7-29-09\alt-existing\ff-ex.pl2 Run By: Jamal Nusairat 11/24/2009 03:23PM

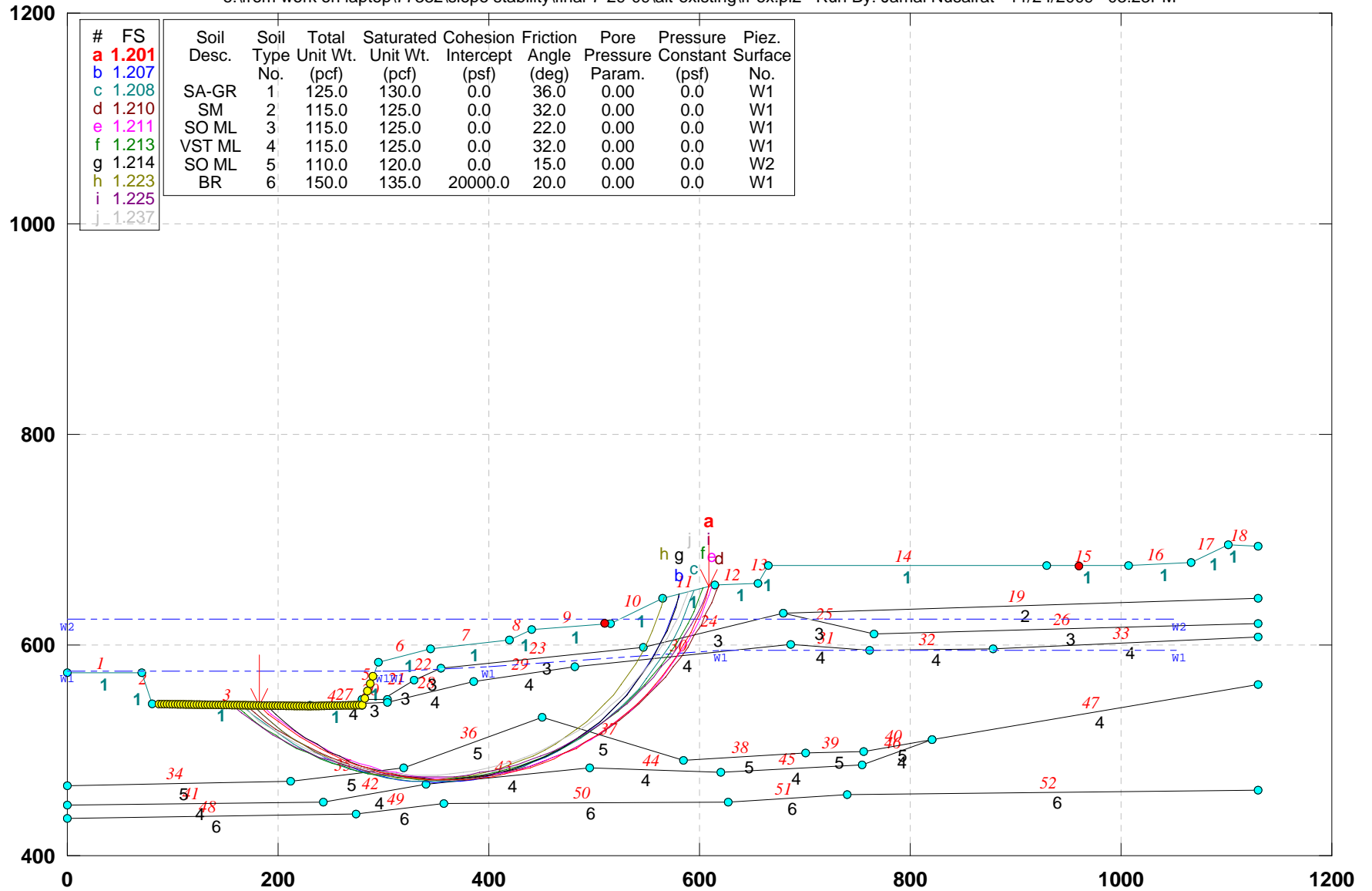

GSTABL7 v.2 FSmin=1.201

Safety Factors Are Calculated By The Simplified Janbu Method



### CUY-90-14.92 (Sec. G-G): Existing Geometry

e:\from work on laptop\77332\slope stability\final-7-29-09\alt-existing\gg-ex.pl2 Run By: Jamal Nusairat 11/24/2009 03:28PM

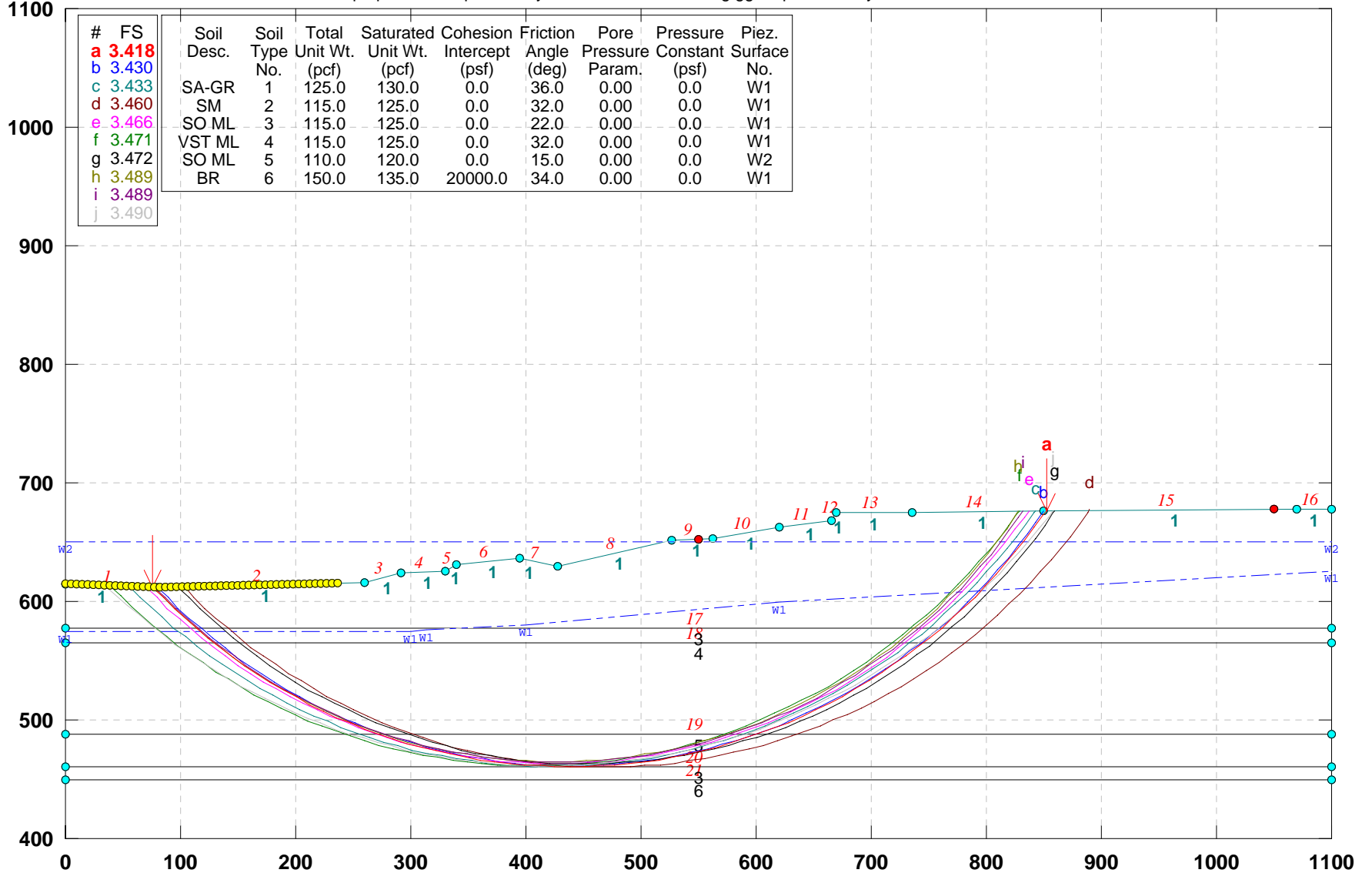

GSTABL7 v.2 FSmin=3.418

Safety Factors Are Calculated By The Simplified Janbu Method



# CUY-90-14.92 (Sec. W-W): EXISTING GEOMETRY

e:\from work on laptop\77332\slope stability\final-7-29-09\alt-existing\ww-ex.pl2 Run By: Jamal Nusairat 11/24/2009 03:31PM

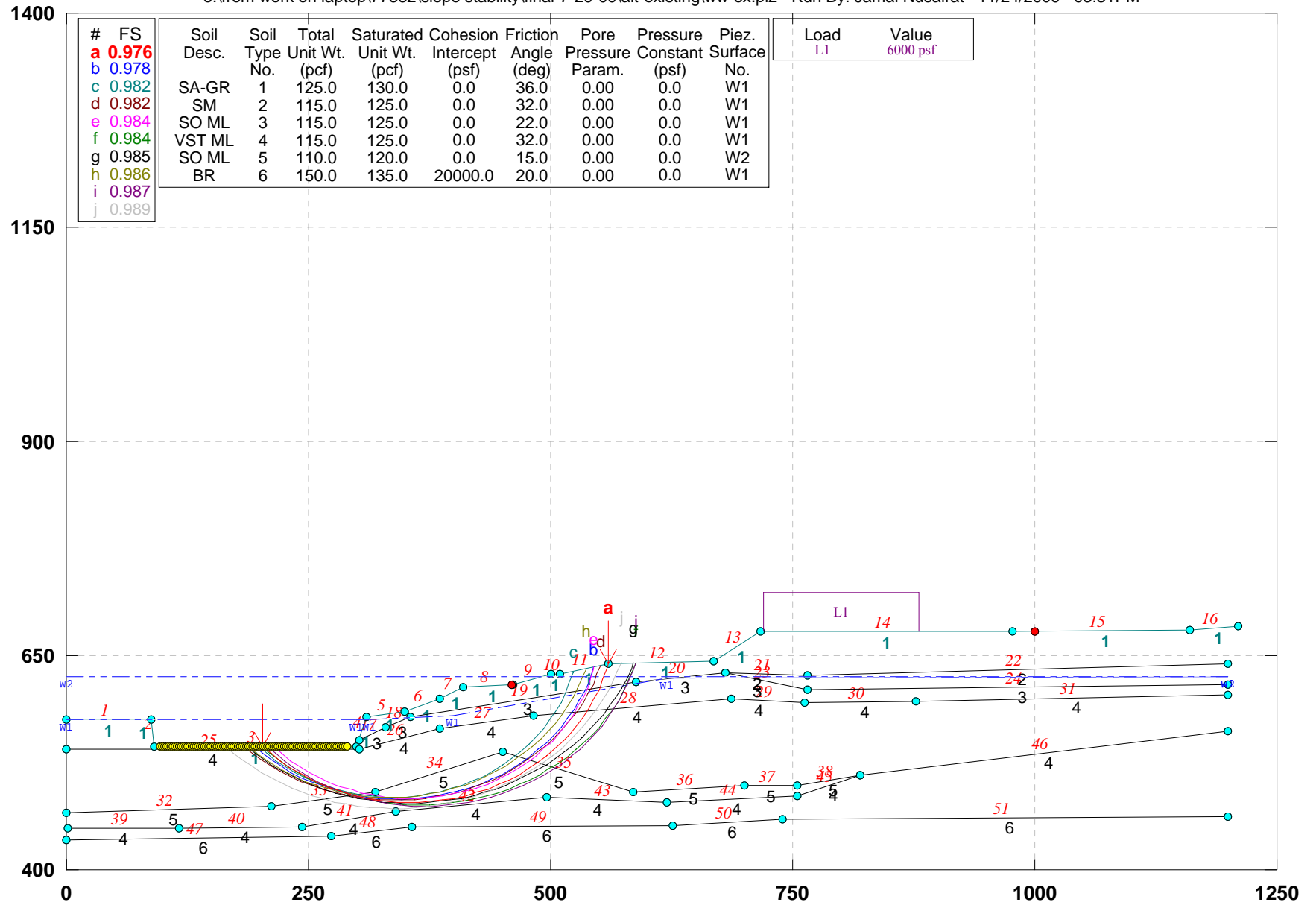

GSTABL7 v.2 FSmin=0.976

Safety Factors Are Calculated By The Simplified Janbu Method



# CUY-90-14.92 (Sec. Y-Y): EXISTING GEOMETRY

e:\from work on laptop\77332\slope stability\final-7-29-09\alt-existing\yy-ex.pl2 Run By: Jamal Nusairat 11/24/2009 03:32PM

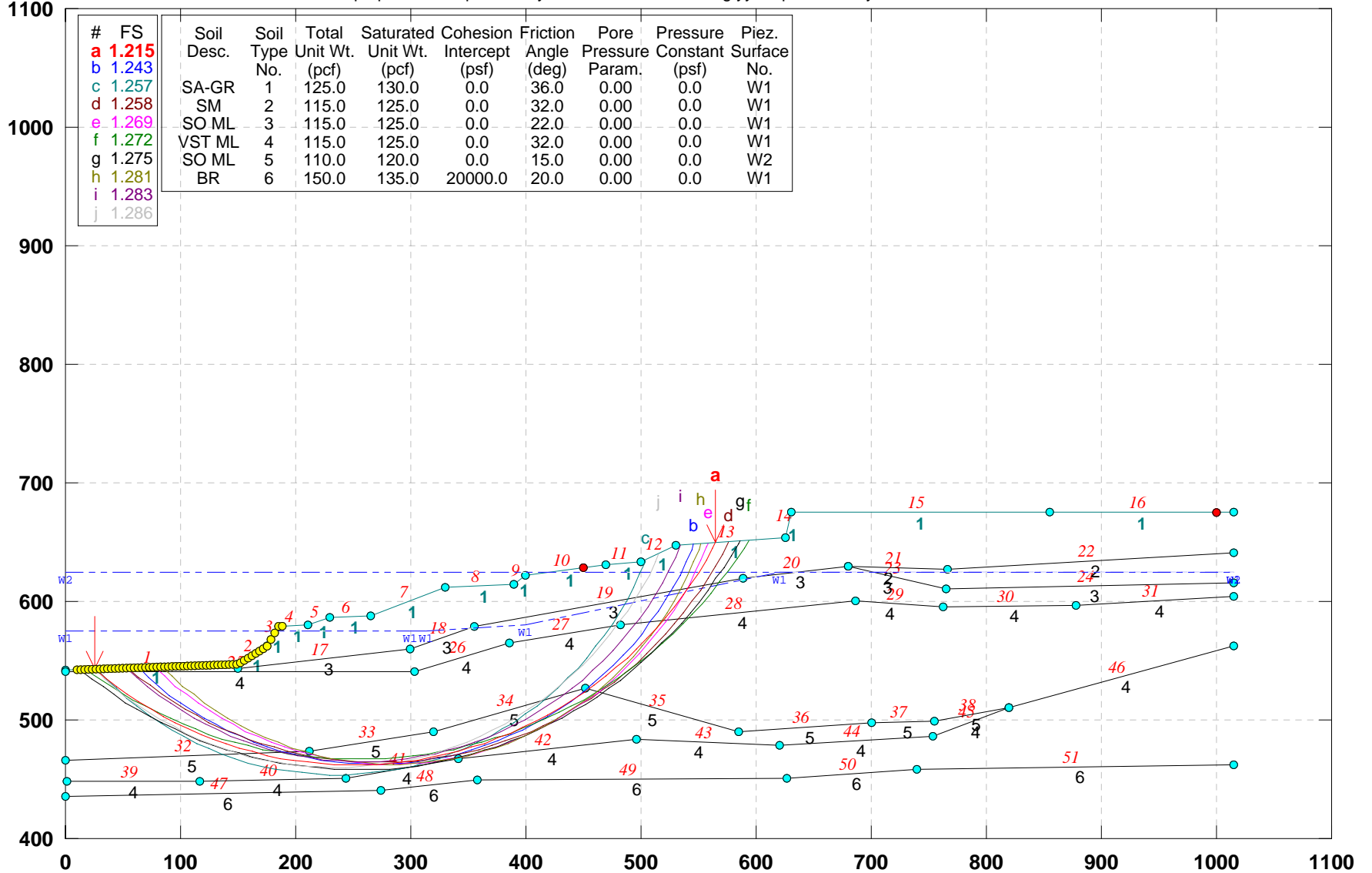

| # | FS    | Soil Desc. | Soil Type No. | Total Unit Wt. (pcf) | Saturated Unit Wt. (pcf) | Cohesion Intercept (psf) | Friction Angle (deg) | Pore Pressure Param. | Pressure Constant (psf) | Piez. Surface No. |
|---|-------|------------|---------------|----------------------|--------------------------|--------------------------|----------------------|----------------------|-------------------------|-------------------|
| a | 1.215 |            |               |                      |                          |                          |                      |                      |                         |                   |
| b | 1.243 |            |               |                      |                          |                          |                      |                      |                         |                   |
| c | 1.257 | SA-GR      | 1             | 125.0                | 130.0                    | 0.0                      | 36.0                 | 0.00                 | 0.0                     | W1                |
| d | 1.258 | SM         | 2             | 115.0                | 125.0                    | 0.0                      | 32.0                 | 0.00                 | 0.0                     | W1                |
| e | 1.269 | SO ML      | 3             | 115.0                | 125.0                    | 0.0                      | 22.0                 | 0.00                 | 0.0                     | W1                |
| f | 1.272 | VST ML     | 4             | 115.0                | 125.0                    | 0.0                      | 32.0                 | 0.00                 | 0.0                     | W1                |
| g | 1.275 | SO ML      | 5             | 110.0                | 120.0                    | 0.0                      | 15.0                 | 0.00                 | 0.0                     | W2                |
| h | 1.281 | BR         | 6             | 150.0                | 135.0                    | 20000.0                  | 20.0                 | 0.00                 | 0.0                     | W1                |
| i | 1.283 |            |               |                      |                          |                          |                      |                      |                         |                   |
| j | 1.286 |            |               |                      |                          |                          |                      |                      |                         |                   |

GSTABL7 v.2 FSmin=1.215

Safety Factors Are Calculated By The Simplified Janbu Method



# CUY-90-14.92 (Sec. Z-Z): EXISTING GEOMETRY

e:\from work on laptop\77332\slope stability\final-7-29-09\alt-existing\zz-ex.pl2 Run By: Jamal Nusairat 11/24/2009 03:34PM

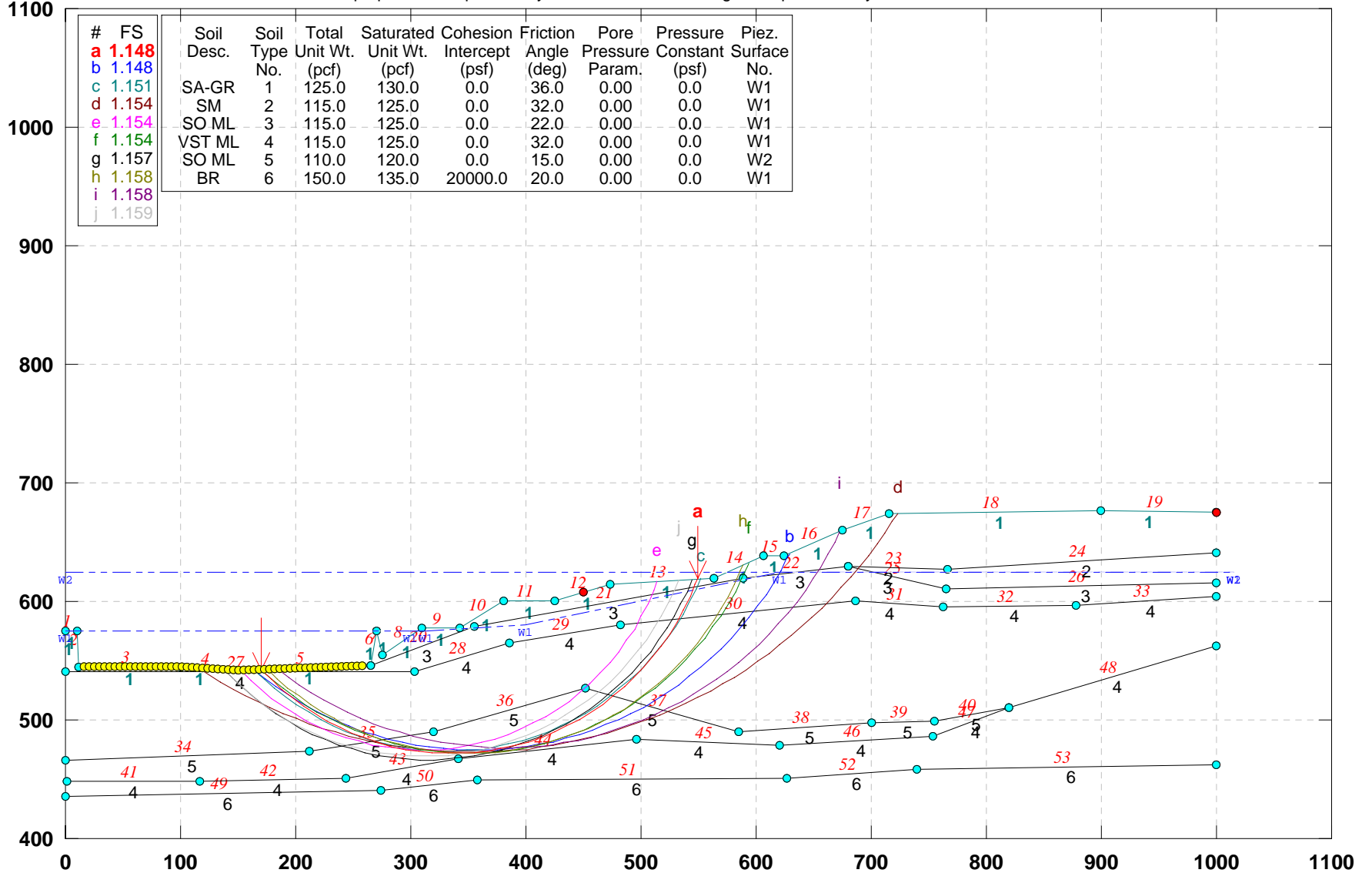

GSTABL7 v.2 FSmin=1.148

Safety Factors Are Calculated By The Simplified Janbu Method



**APPENDIX 7D**

**SLOPE STABILITY ANALYSES BASED ON  
ALTERNATIVE 1 GRADING**



# CUY-90-14.92 (Sec. A-A): PROPOSED GEOMETRY- (Alt 1)\_Block Search

e:\from work on laptop\77332\slope stability\final-7-29-09\alt-1\aa-p-a1b.pl2 Run By: Jamal Nusairat 11/25/2009 01:43AM

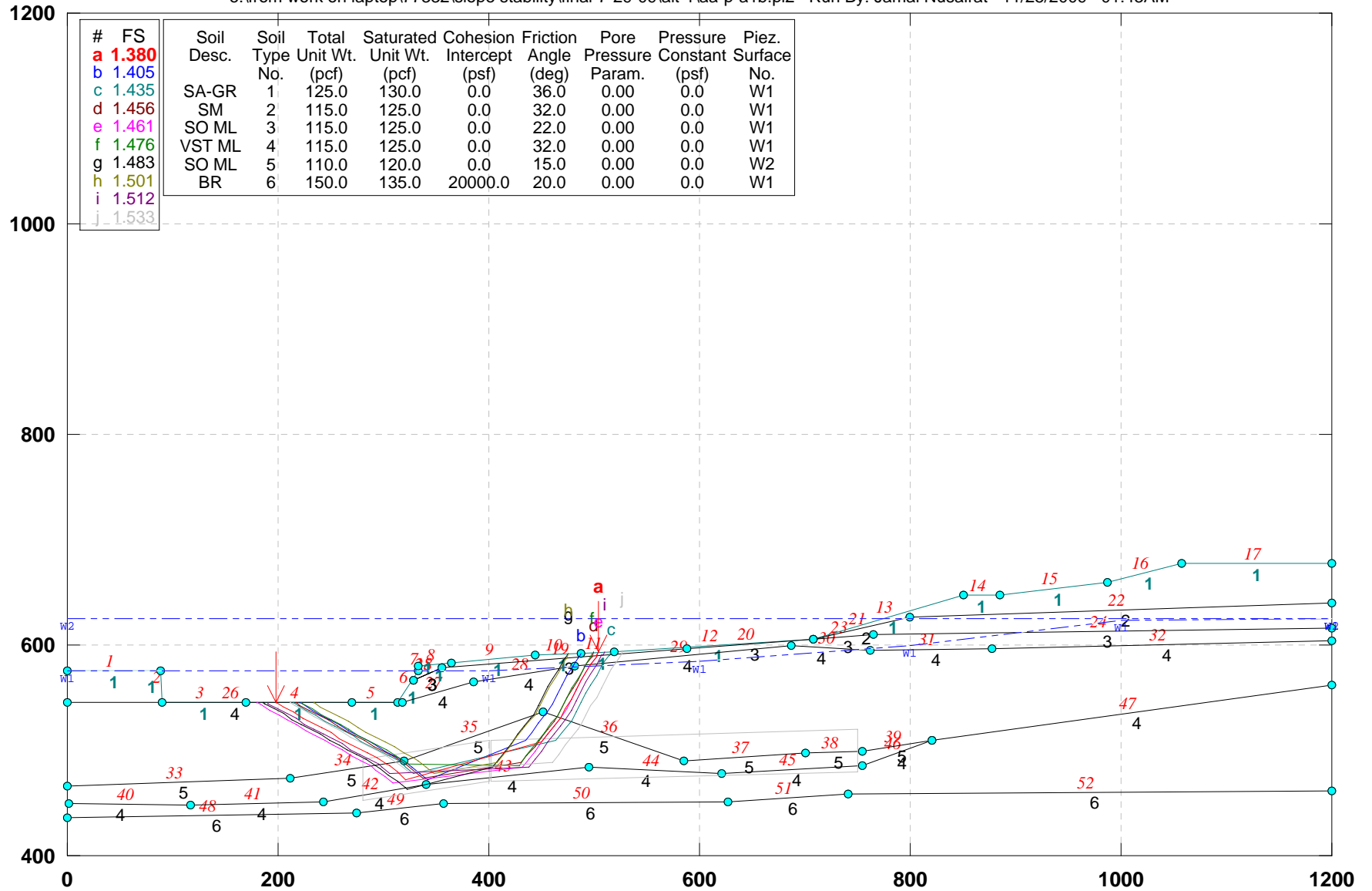

GSTABL7 v.2 FSmin=1.380

Safety Factors Are Calculated By The Simplified Janbu Method



# CUY-90-14.92 (Sec. B-B): PROPOSED GEOMETRY- (Alt 1)\_Block Search

e:\from work on laptop\77332\slope stability\final-7-29-09\alt-1\bb-p-a1b.pl2 Run By: Jamal Nusairat 11/24/2009 05:03PM

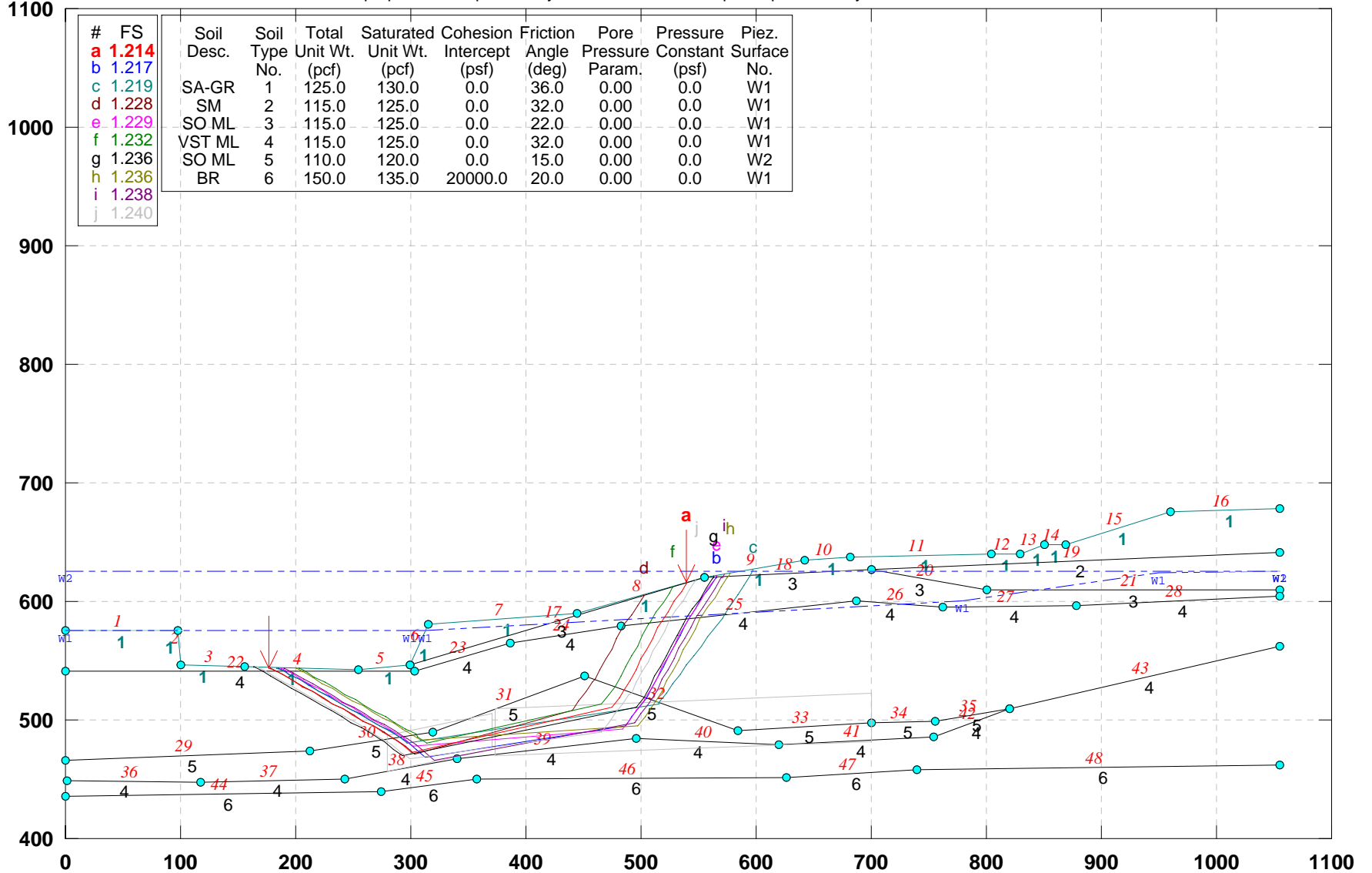

GSTABL7 v.2 FSmin=1.214

Safety Factors Are Calculated By The Simplified Janbu Method



# CUY-90-14.92 (Sec. E-E): PROPOSED GEOMETRY- ALT1\_Block Search

e:\from work on laptop\77332\slope stability\final-7-29-09\alt-1\ee-p-a1b.pl2 Run By: Jamal Nusairat 11/24/2009 04:35PM

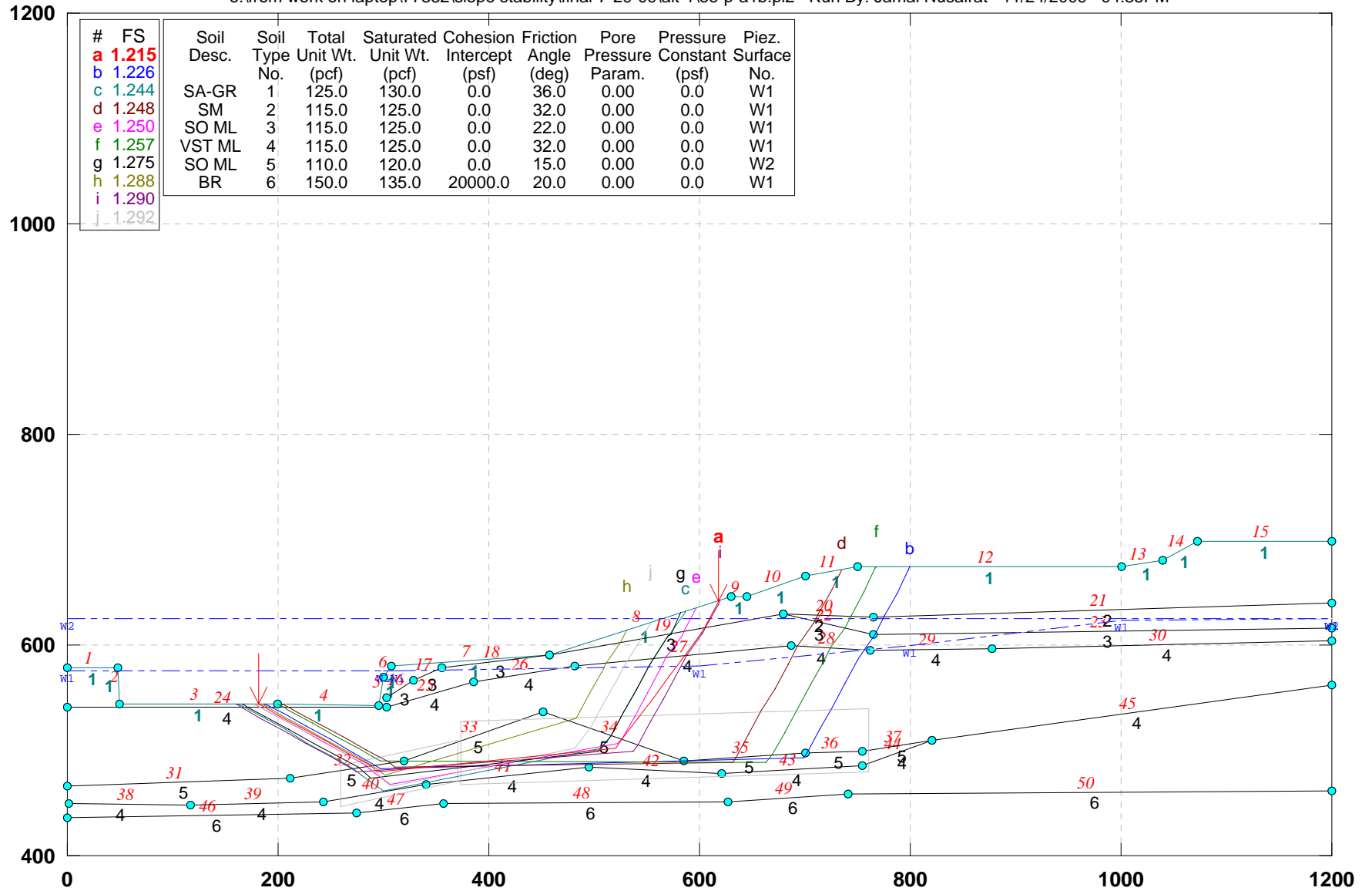

GSTABL7 v.2 FSmin=1.215

Safety Factors Are Calculated By The Simplified Janbu Method



# CUY-90-14.92 (Sec. F-F): PROPOSED GEOMETRY- ALT1\_Block Search

e:\from work on laptop\77332\slope stability\final-7-29-09\alt-1\ff-p-a1b.pl2 Run By: Jamal Nusairat 11/24/2009 04:34PM

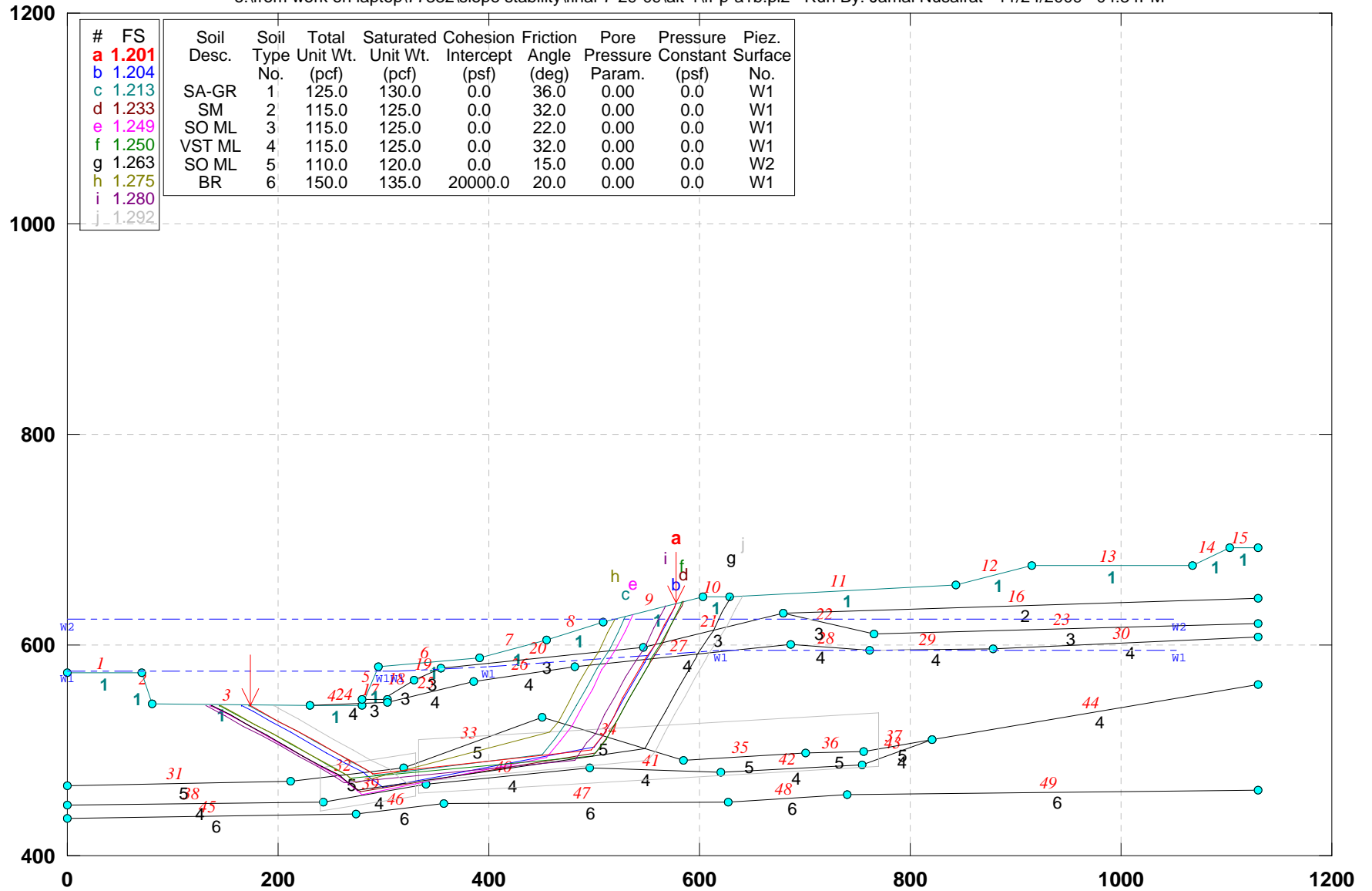

GSTABL7 v.2 FSmin=1.201

Safety Factors Are Calculated By The Simplified Janbu Method



# CUY-90-14.92 (Sec. G-G): PROPOSED EXCAVATION (ALT 1): Block Search

e:\from work on laptop\77332\slope stability\final-7-29-09\alt-1\gg-prb.pl2 Run By: Jamal Nusairat 11/24/2009 06:15PM

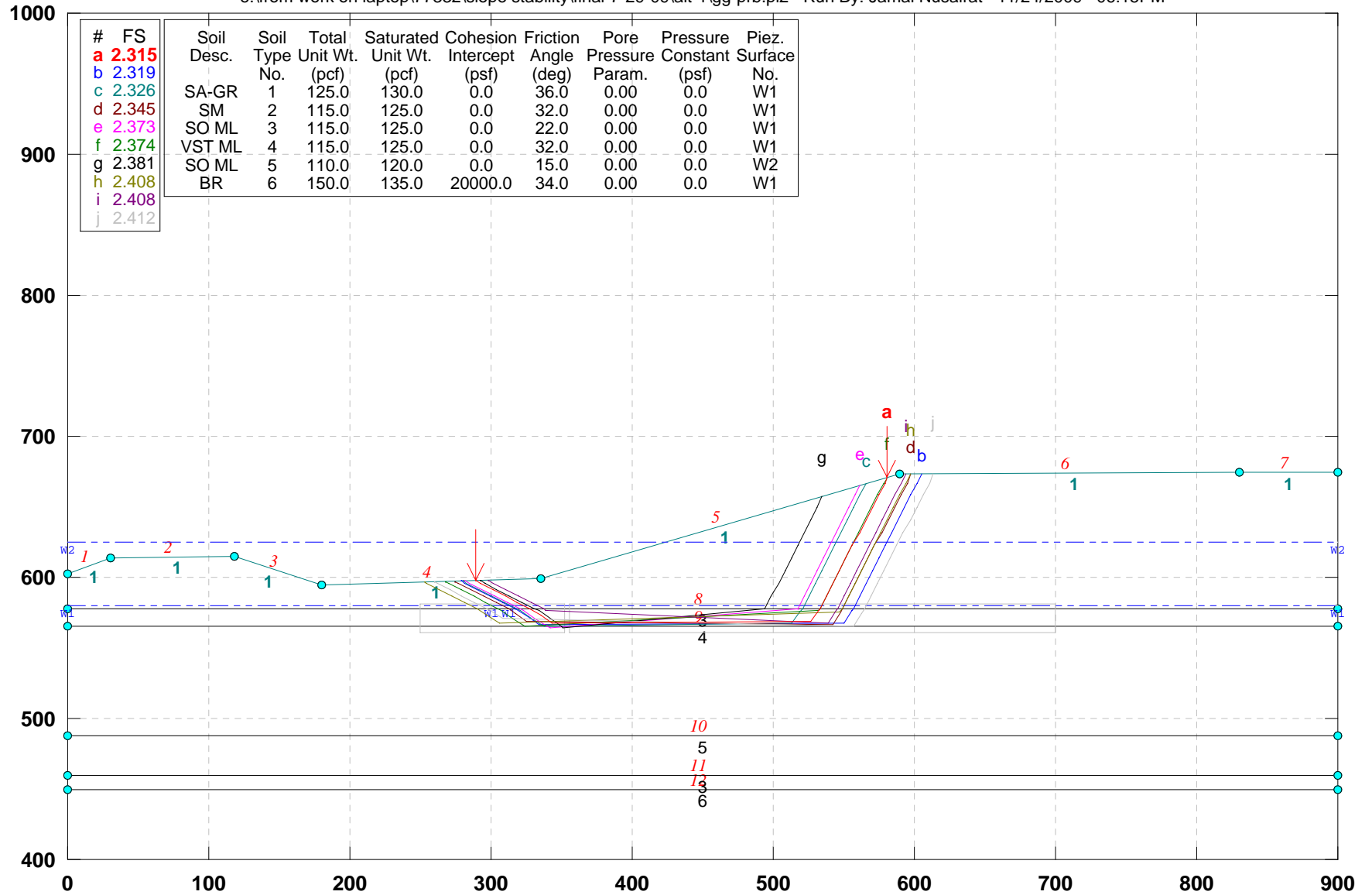

GSTABL7 v.2 FSmin=2.315

Safety Factors Are Calculated By The Simplified Janbu Method



# CUY-90-14.92 (Sec. U-U): PROPOSED EXCAVATION (Alt-1)\_Block Search

e:\from work on laptop\77332\slope stability\final-7-29-09\alt-1\uu-pr1b.pl2 Run By: Jamal Nusairat 11/25/2009 01:47AM

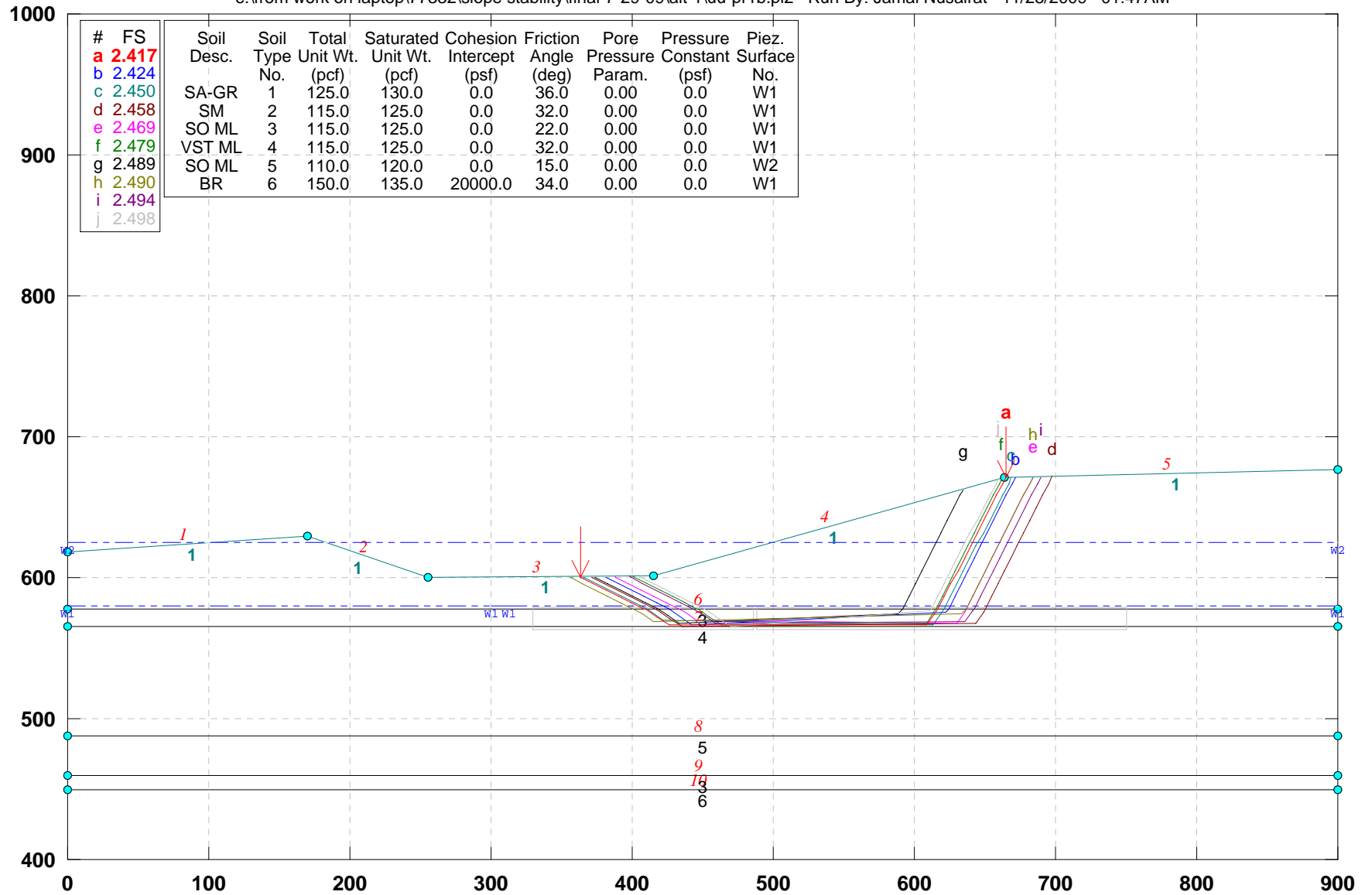

| # | FS    | Soil Desc. | Soil Type No. | Total Unit Wt. (pcf) | Saturated Unit Wt. (pcf) | Cohesion Intercept (psf) | Friction Angle (deg) | Pore Pressure Param. | Pressure Constant (psf) | Piez. Surface No. |
|---|-------|------------|---------------|----------------------|--------------------------|--------------------------|----------------------|----------------------|-------------------------|-------------------|
| a | 2.417 |            |               |                      |                          |                          |                      |                      |                         |                   |
| b | 2.424 |            |               |                      |                          |                          |                      |                      |                         |                   |
| c | 2.450 | SA-GR      | 1             | 125.0                | 130.0                    | 0.0                      | 36.0                 | 0.00                 | 0.0                     | W1                |
| d | 2.458 | SM         | 2             | 115.0                | 125.0                    | 0.0                      | 32.0                 | 0.00                 | 0.0                     | W1                |
| e | 2.469 | SO ML      | 3             | 115.0                | 125.0                    | 0.0                      | 22.0                 | 0.00                 | 0.0                     | W1                |
| f | 2.479 | VST ML     | 4             | 115.0                | 125.0                    | 0.0                      | 32.0                 | 0.00                 | 0.0                     | W1                |
| g | 2.489 | SO ML      | 5             | 110.0                | 120.0                    | 0.0                      | 15.0                 | 0.00                 | 0.0                     | W2                |
| h | 2.490 | BR         | 6             | 150.0                | 135.0                    | 20000.0                  | 34.0                 | 0.00                 | 0.0                     | W1                |
| i | 2.494 |            |               |                      |                          |                          |                      |                      |                         |                   |
| j | 2.498 |            |               |                      |                          |                          |                      |                      |                         |                   |

GSTABL7 v.2 FSmin=2.417

Safety Factors Are Calculated By The Simplified Janbu Method



# CUY-90-14.92 (Sec. W-W): PROPOSED GEOMETRY (ALT-1)\_Block Search

e:\from work on laptop\77332\slope stability\final-7-29-09\alt-1\ww-p-a1b.pl2 Run By: Jamal Nusairat 11/24/2009 04:36PM

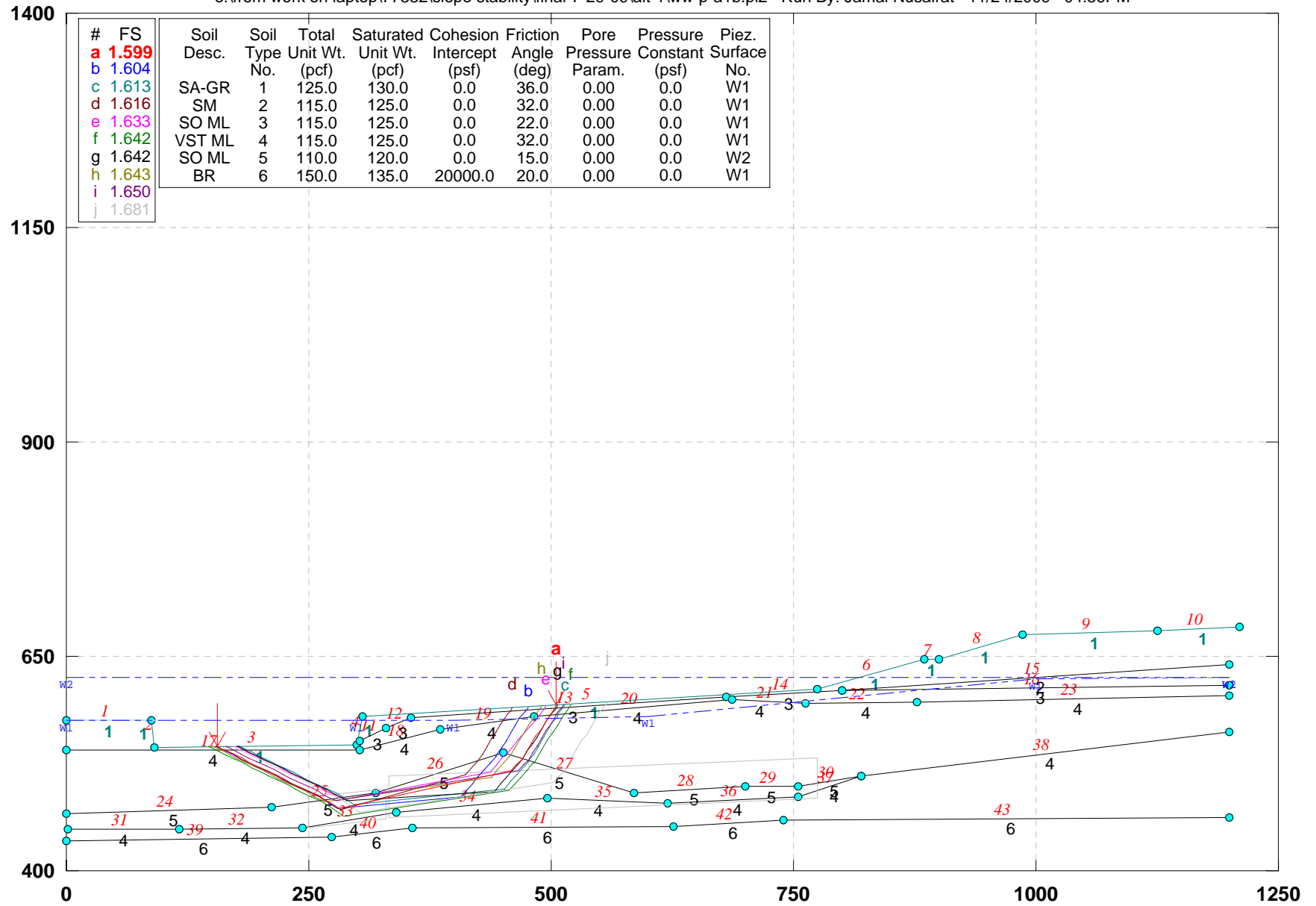

GSTABL7 v.2 FSmin=1.599

Safety Factors Are Calculated By The Simplified Janbu Method



# CUY-90-14.92 (Sec. Y-Y): PROPOSED GEOMETRY (ALT-1)\_Block Search

e:\from work on laptop\77332\slope stability\final-7-29-09\alt-1\yy-p-a1b.pl2 Run By: Jamal Nusairat 11/24/2009 04:37PM

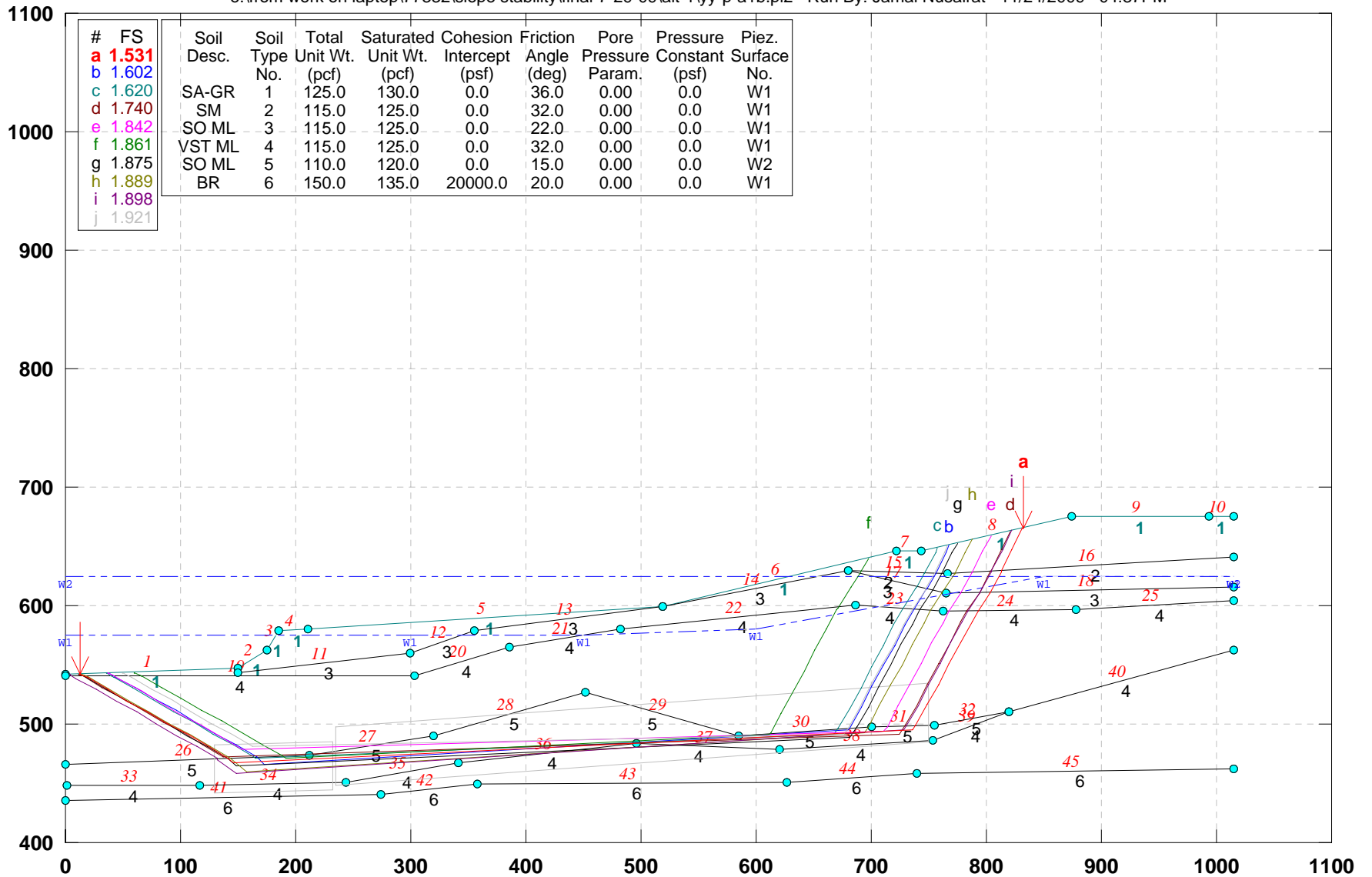

GSTABL7 v.2 FSmin=1.531

Safety Factors Are Calculated By The Simplified Janbu Method





# CUY-90-14.92 (Sec. Z-Z): PROPOSED GEOMETRY (ALT-1)-Block Search

e:\from work on laptop\77332\slope stability\final-7-29-09\alt-1\zz-p-a1b.pl2 Run By: Jamal Nusairat 11/24/2009 04:39PM

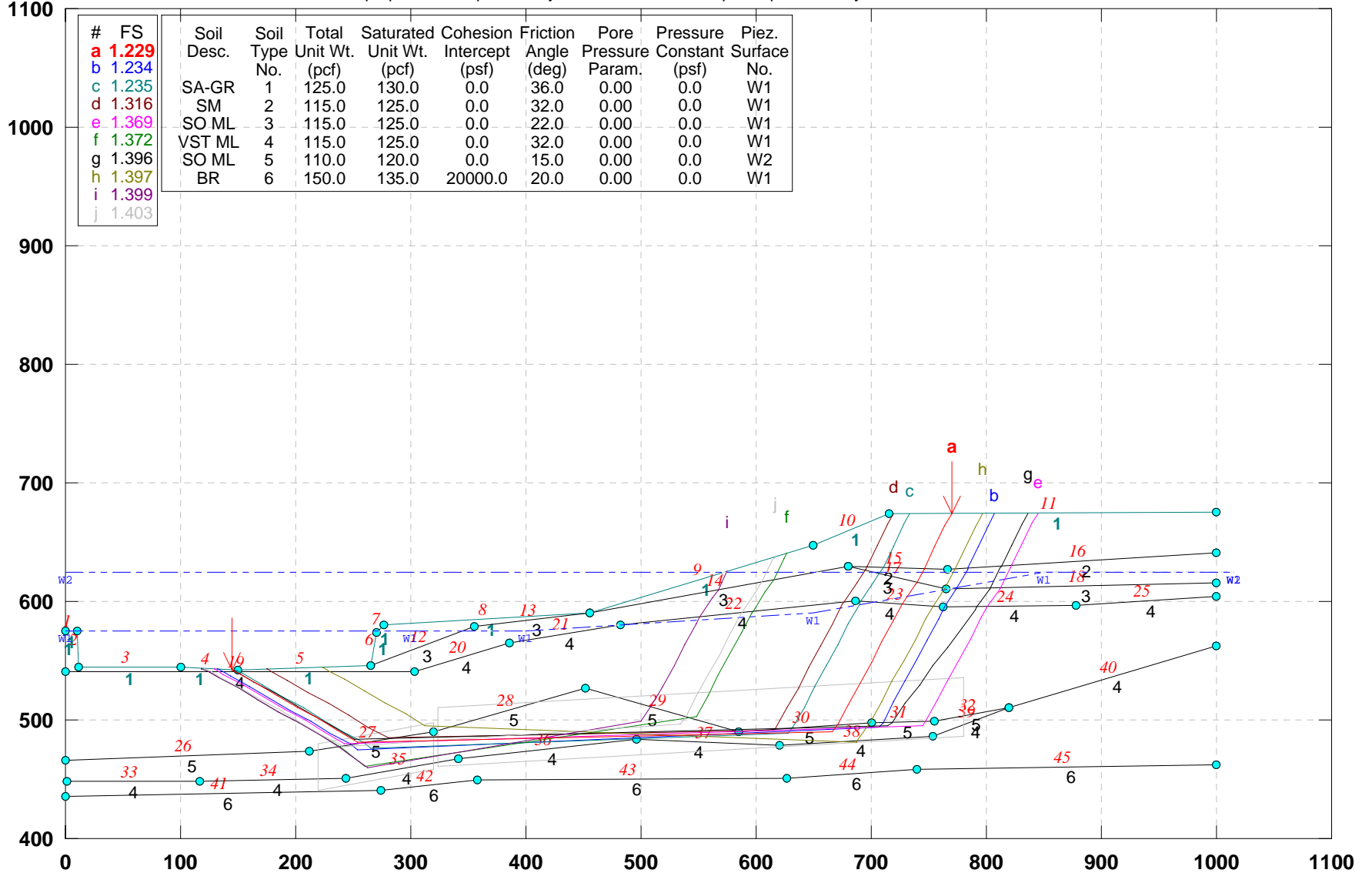

GSTABL7 v.2 FSmin=1.229

Safety Factors Are Calculated By The Simplified Janbu Method



# CUY-90-14.92 (Sec. A-A): PROPOSED GEOMETRY- (Alt 1)

e:\from work on laptop\77332\slope stability\final-7-29-09\alt-1\aa-pr-a1.pl2 Run By: Jamal Nusairat 11/24/2009 04:42PM

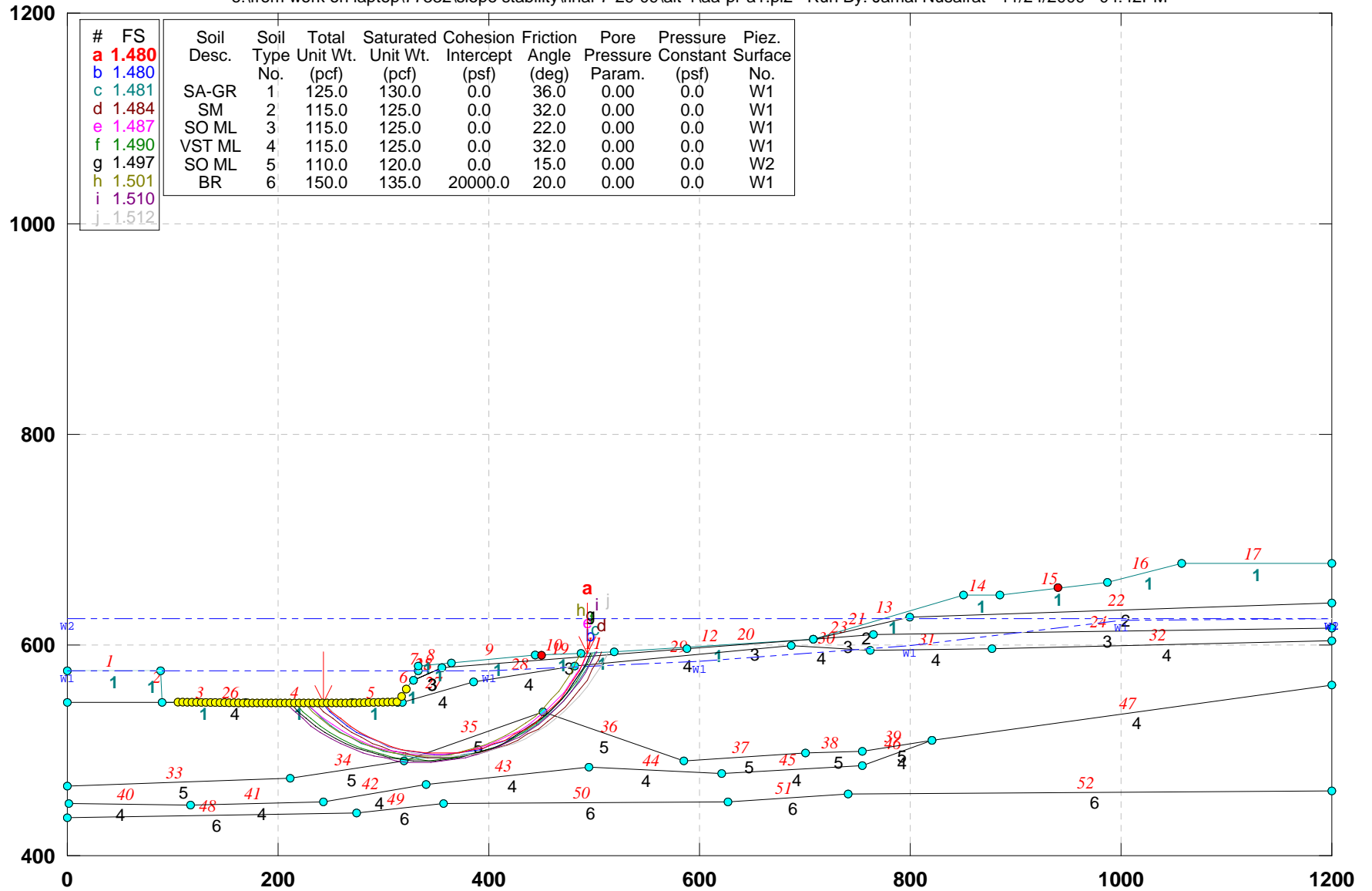

GSTABL7 v.2 FSmin=1.480

Safety Factors Are Calculated By The Simplified Janbu Method



# CUY-90-14.92 (Sec. B-B): PROPOSED GEOMETRY- (Alt 1)

e:\from work on laptop\77332\slope stability\final-7-29-09\alt-1\bb-pr-a1.pl2 Run By: Jamal Nusairat 11/24/2009 05:59PM

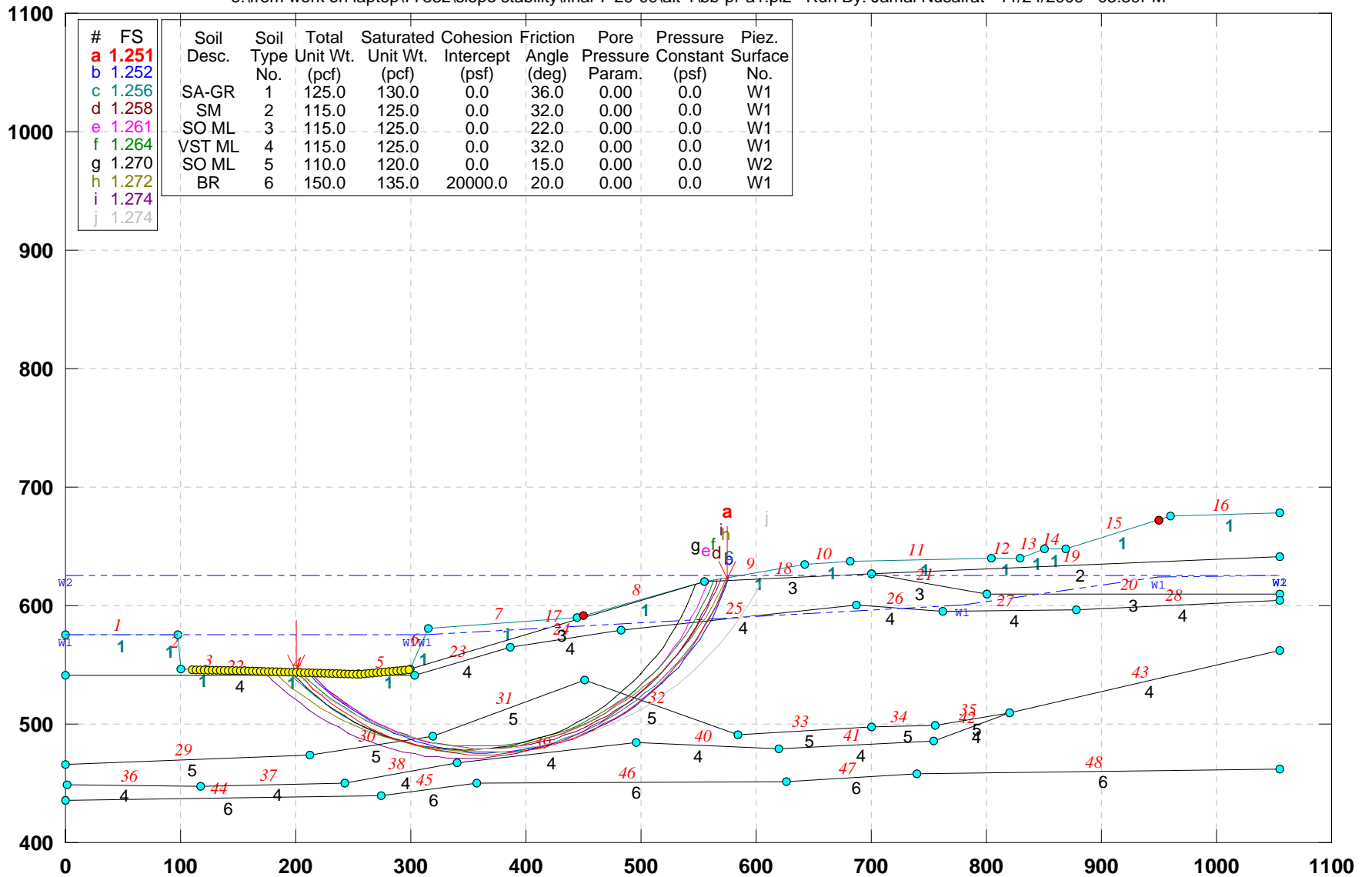

GSTABL7 v.2 FSmin=1.251

Safety Factors Are Calculated By The Simplified Janbu Method



# CUY-90-14.92: PROPOSED @ CENTERLINE OF BRIDGE - (Alt 1)

C:\WORK\77332\SLOPES-1\ALT-1\FINAL\CL-PR1.PL2 Run By: Jamal Nusairat 6/29/2009 6:24AM

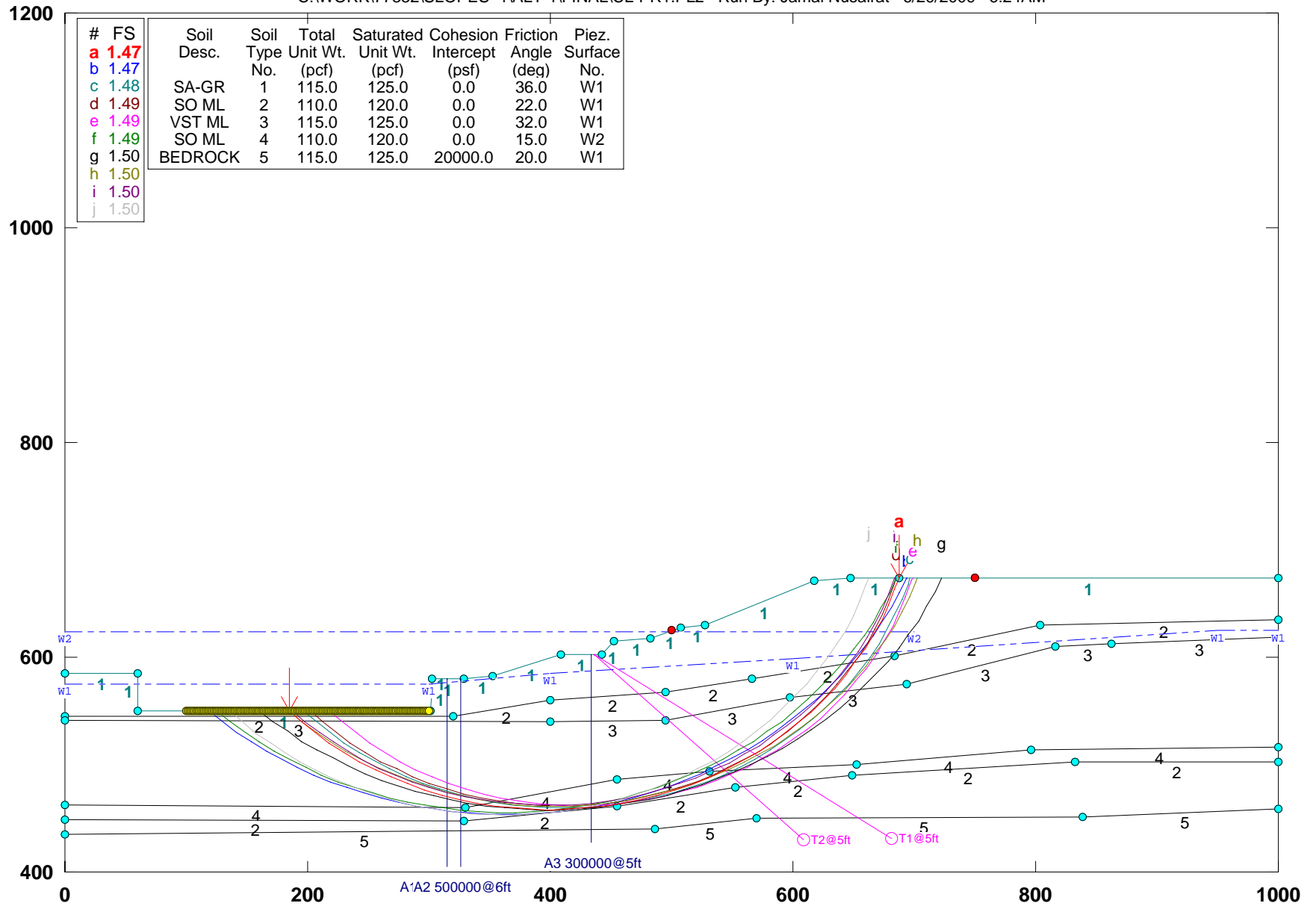

GSTABL7 v.2 FSmin=1.47

Safety Factors Are Calculated By The Simplified Janbu Method



# CUY-90-14.92 (Sec. E-E): PROPOSED GEOMETRY- ALT1

e:\from work on laptop\77332\slope stability\final-7-29-09\alt-1\ee-pr-a1.pl2 Run By: Jamal Nusairat 11/24/2009 06:07PM

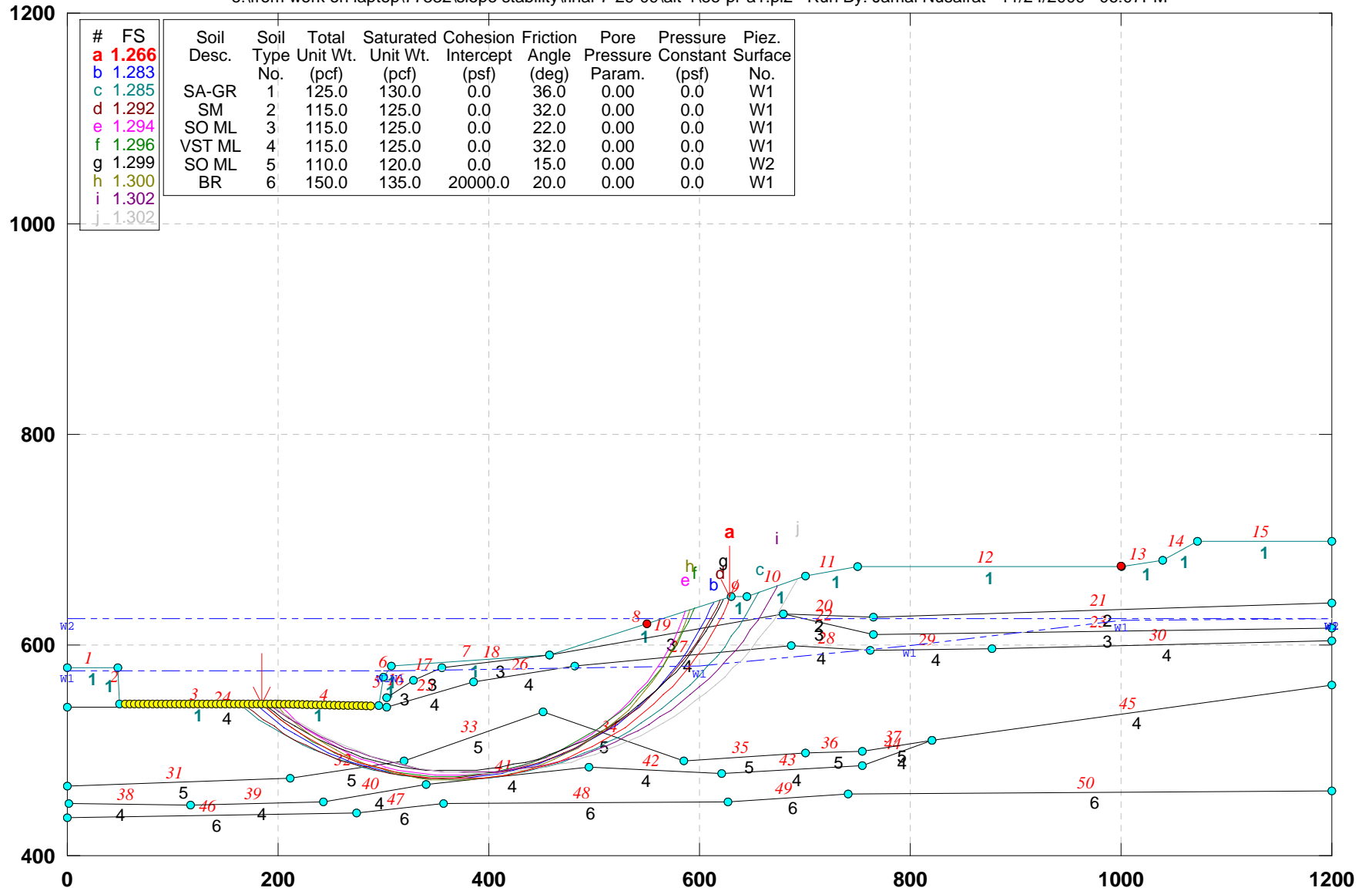

GSTABL7 v.2 FSmin=1.266

Safety Factors Are Calculated By The Simplified Janbu Method



# CUY-90-14.92 (Sec. F-F): PROPOSED GEOMETRY- ALT1

e:\from work on laptop\77332\slope stability\final-7-29-09\alt-1\ff-pr-a1.pl2 Run By: Jamal Nusairat 11/24/2009 06:12PM

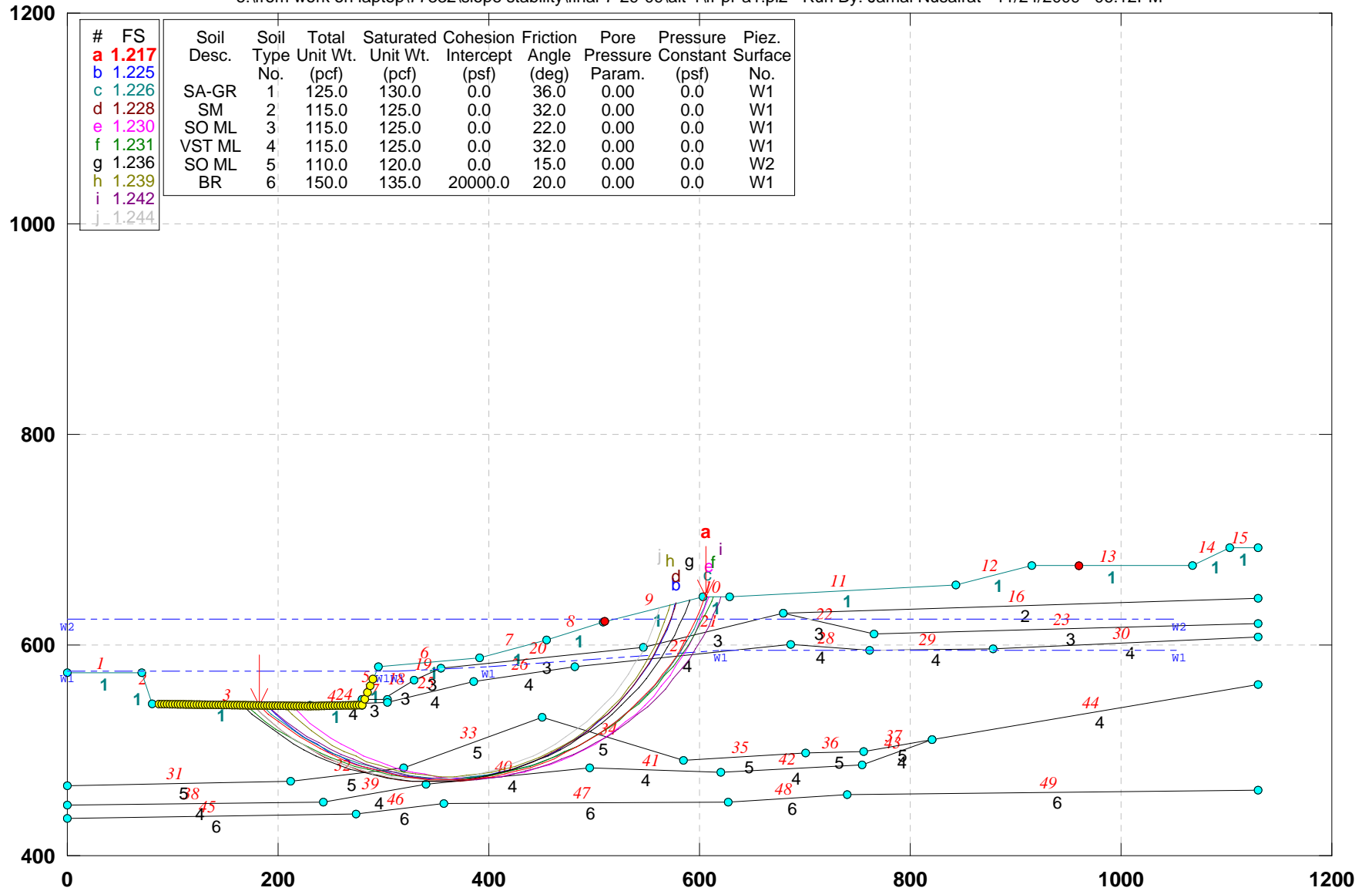

GSTABL7 v.2 FSmin=1.217

Safety Factors Are Calculated By The Simplified Janbu Method



# CUY-90-14.92 (Sec. G-G): PROPOSED EXCAVATED GEOMETRY- STABILITY - (Alt 1)

e:\from work on laptop\77332\slope stability\final-7-29-09\alt-1\gg-pr.pl2 Run By: Jamal Nusairat 11/24/2009 06:13PM

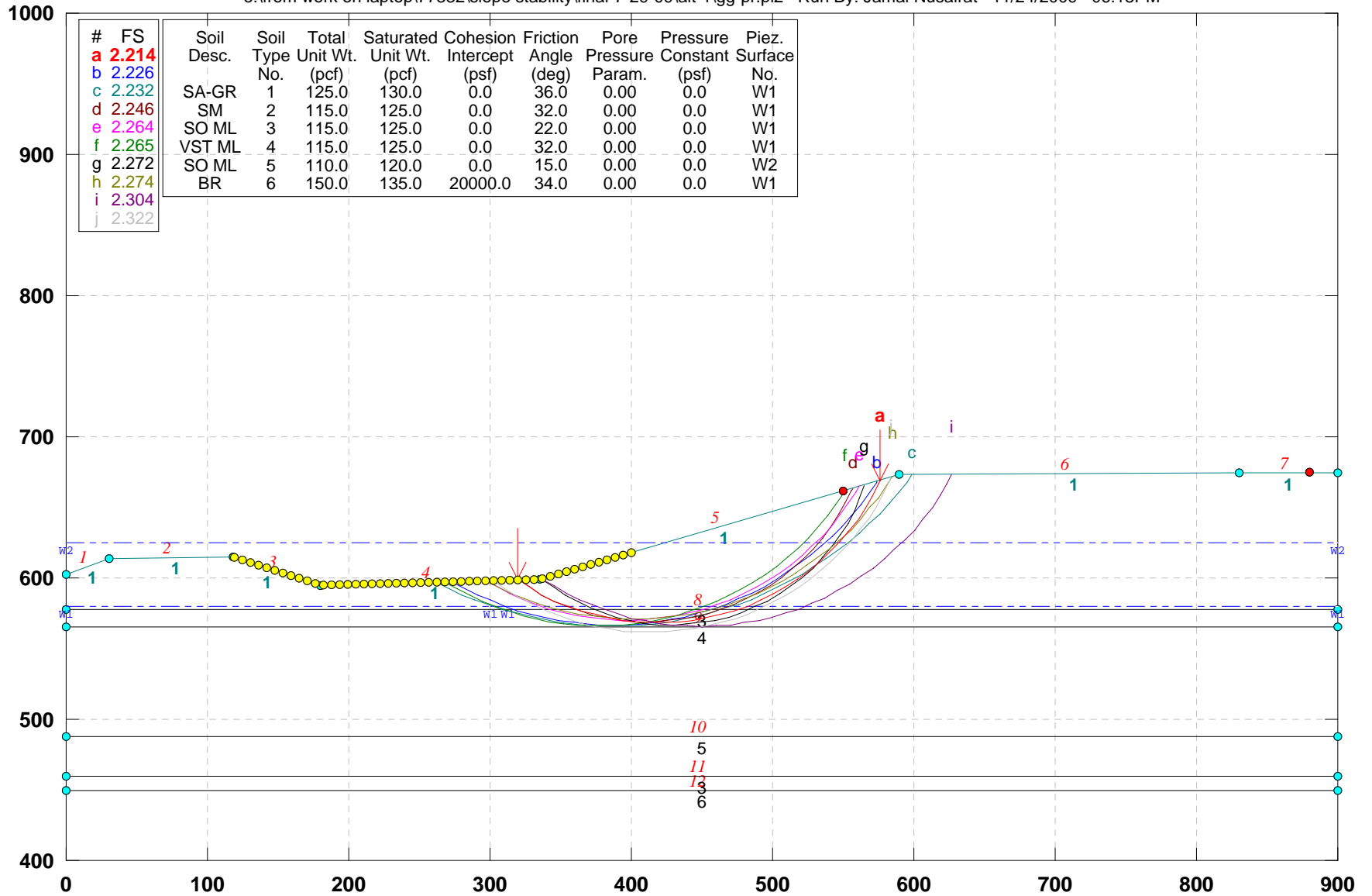

| # | FS    | Soil Desc. | Soil Type | Total Unit Wt. (pcf) | Saturated Unit Wt. (pcf) | Cohesion Intercept (psf) | Friction Angle (deg) | Pore Pressure Param. | Pressure Constant (psf) | Piez. Surface No. |
|---|-------|------------|-----------|----------------------|--------------------------|--------------------------|----------------------|----------------------|-------------------------|-------------------|
| a | 2.214 |            |           |                      |                          |                          |                      |                      |                         |                   |
| b | 2.226 |            |           |                      |                          |                          |                      |                      |                         |                   |
| c | 2.232 | SA-GR      | 1         | 125.0                | 130.0                    | 0.0                      | 36.0                 | 0.00                 | 0.0                     | W1                |
| d | 2.246 | SM         | 2         | 115.0                | 125.0                    | 0.0                      | 32.0                 | 0.00                 | 0.0                     | W1                |
| e | 2.264 | SO ML      | 3         | 115.0                | 125.0                    | 0.0                      | 22.0                 | 0.00                 | 0.0                     | W1                |
| f | 2.265 | VST ML     | 4         | 115.0                | 125.0                    | 0.0                      | 32.0                 | 0.00                 | 0.0                     | W1                |
| g | 2.272 | SO ML      | 5         | 110.0                | 120.0                    | 0.0                      | 15.0                 | 0.00                 | 0.0                     | W2                |
| h | 2.274 | BR         | 6         | 150.0                | 135.0                    | 20000.0                  | 34.0                 | 0.00                 | 0.0                     | W1                |
| i | 2.304 |            |           |                      |                          |                          |                      |                      |                         |                   |
| j | 2.322 |            |           |                      |                          |                          |                      |                      |                         |                   |

GSTABL7 v.2 FSmin=2.214

Safety Factors Are Calculated By The Simplified Janbu Method



# CUY-90-14.92 (Sec. U-U): PROPOSED EXCAVATED GEOMETRY- STABILITY (Alt-1)

e:\from work on laptop\77332\slope stability\final-7-29-09\alt-1\uu-pr.pl2 Run By: Jamal Nusairat 11/24/2009 06:16PM

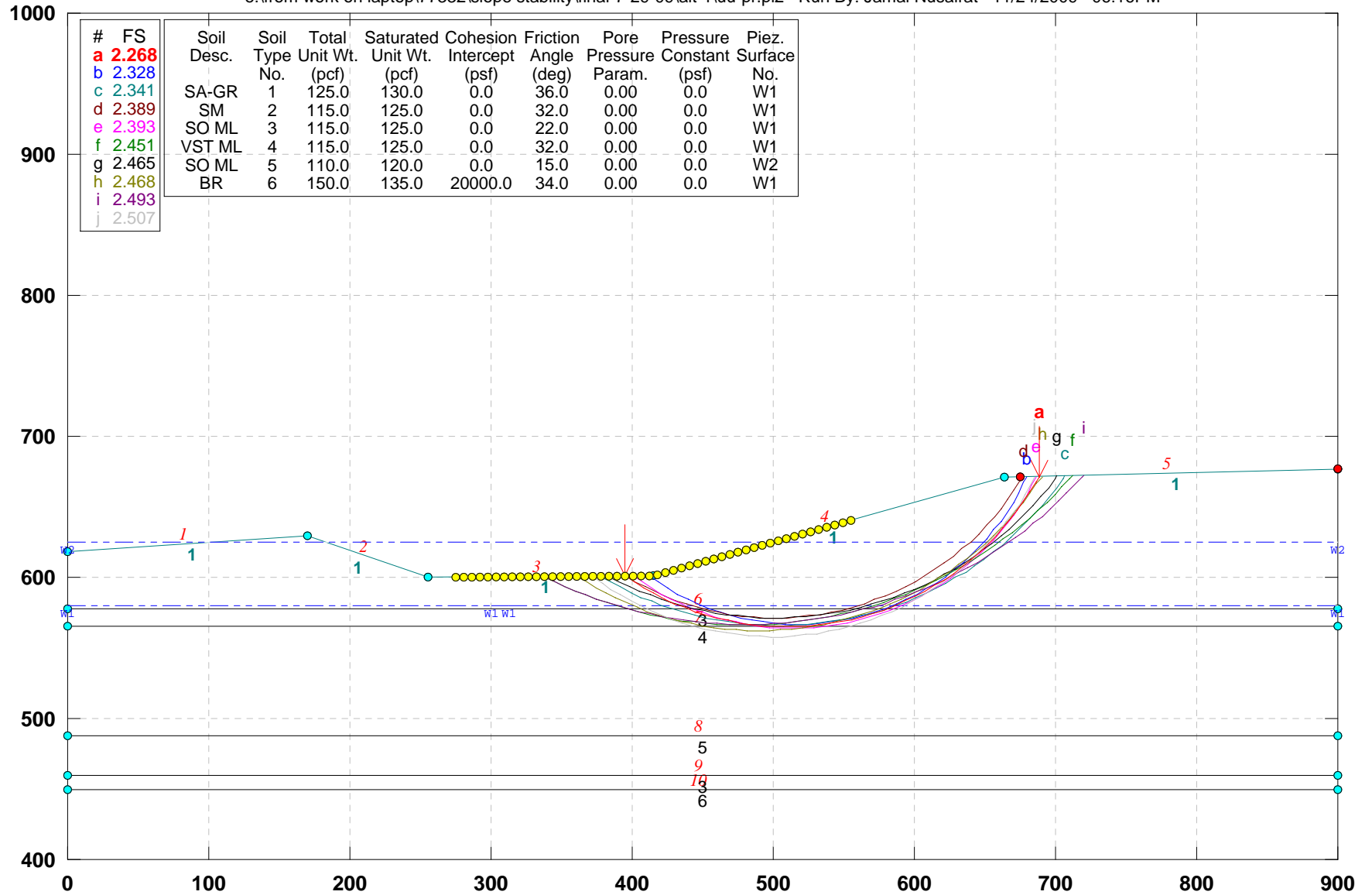

GSTABL7 v.2 FSmin=2.268

Safety Factors Are Calculated By The Simplified Janbu Method





# CUY-90-14.92 (Sec. W-W): PROPOSED GEOMETRY (ALT-1)

e:\from work on laptop\77332\slope stability\final-7-29-09\alt-1\ww-pr-a1.pl2 Run By: Jamal Nusairat 11/24/2009 06:18PM

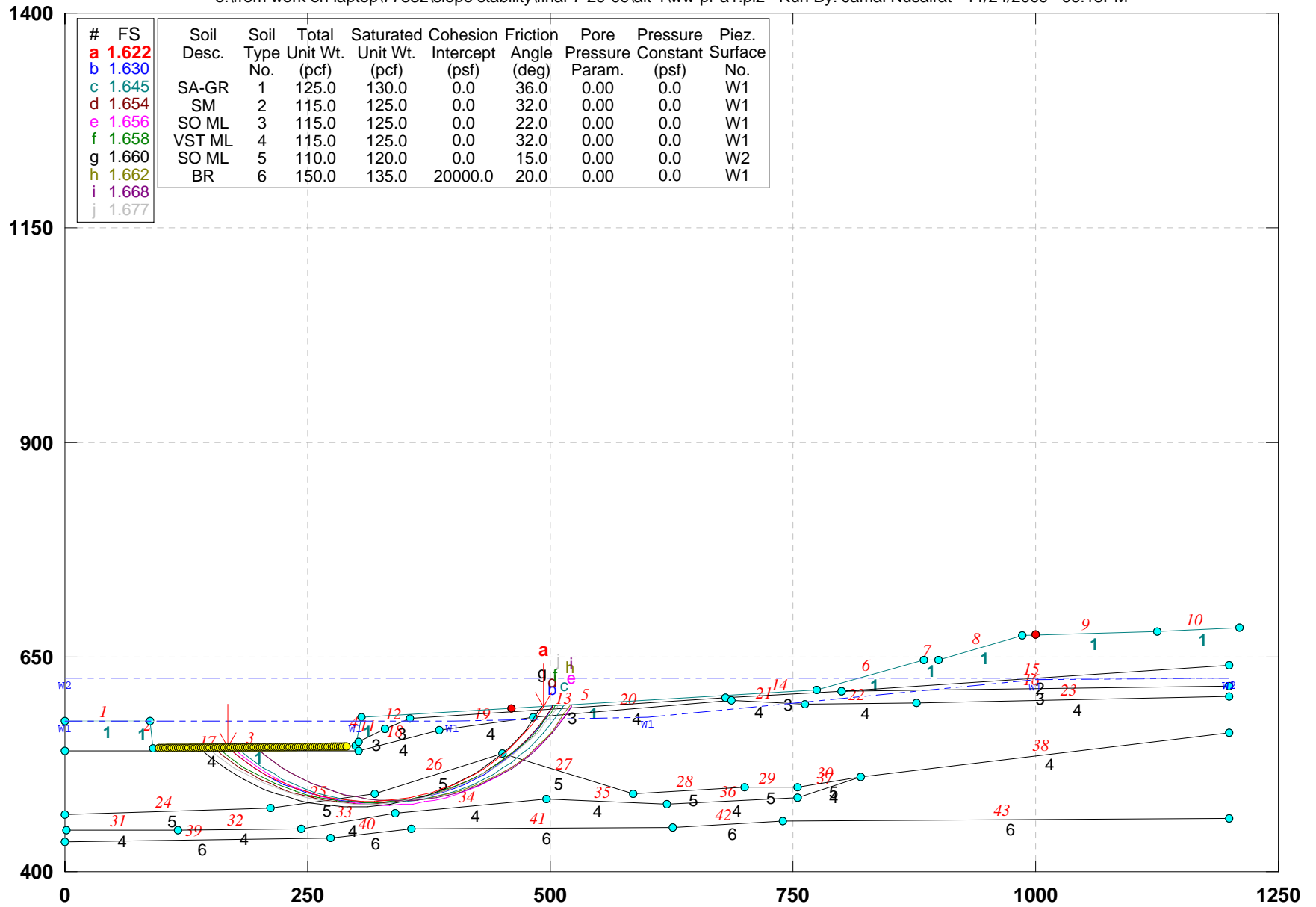

GSTABL7 v.2 FSmin=1.622

Safety Factors Are Calculated By The Simplified Janbu Method



# CUY-90-14.92 (Sec. Y-Y): PROPOSED GEOMETRY (ALT-1)

e:\from work on laptop\77332\slope stability\final-7-29-09\alt-1\yy-pr-a1.pl2 Run By: Jamal Nusairat 11/24/2009 06:21PM

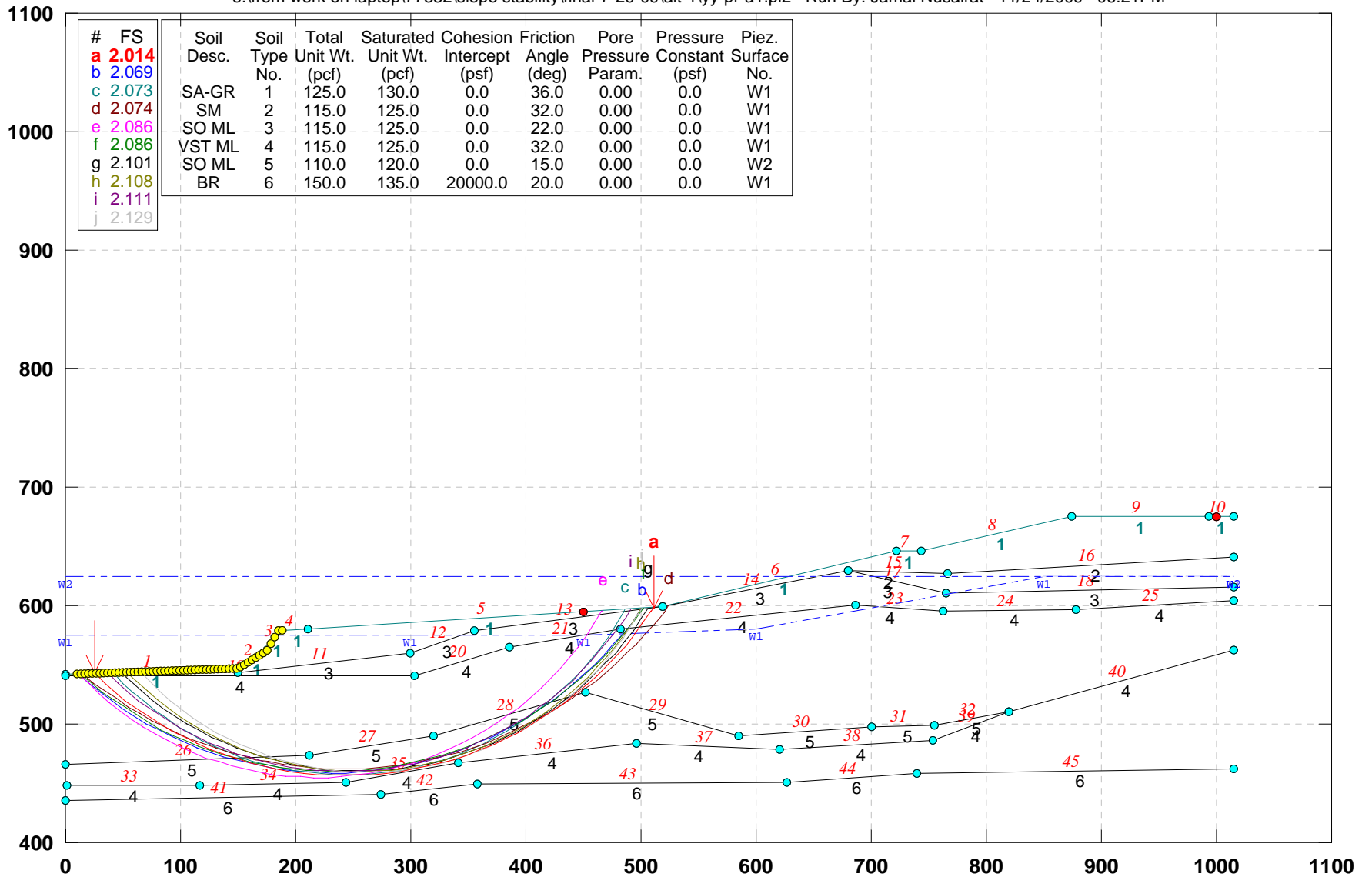

GSTABL7 v.2 FSmin=2.014

Safety Factors Are Calculated By The Simplified Janbu Method



# CUY-90-14.92 (Sec. Z-Z): PROPOSED GEOMETRY (ALT-1)

e:\from work on laptop\77332\slope stability\final-7-29-09\alt-1\zz-pr-a-1.pl2 Run By: Jamal Nusairat 11/24/2009 06:23PM

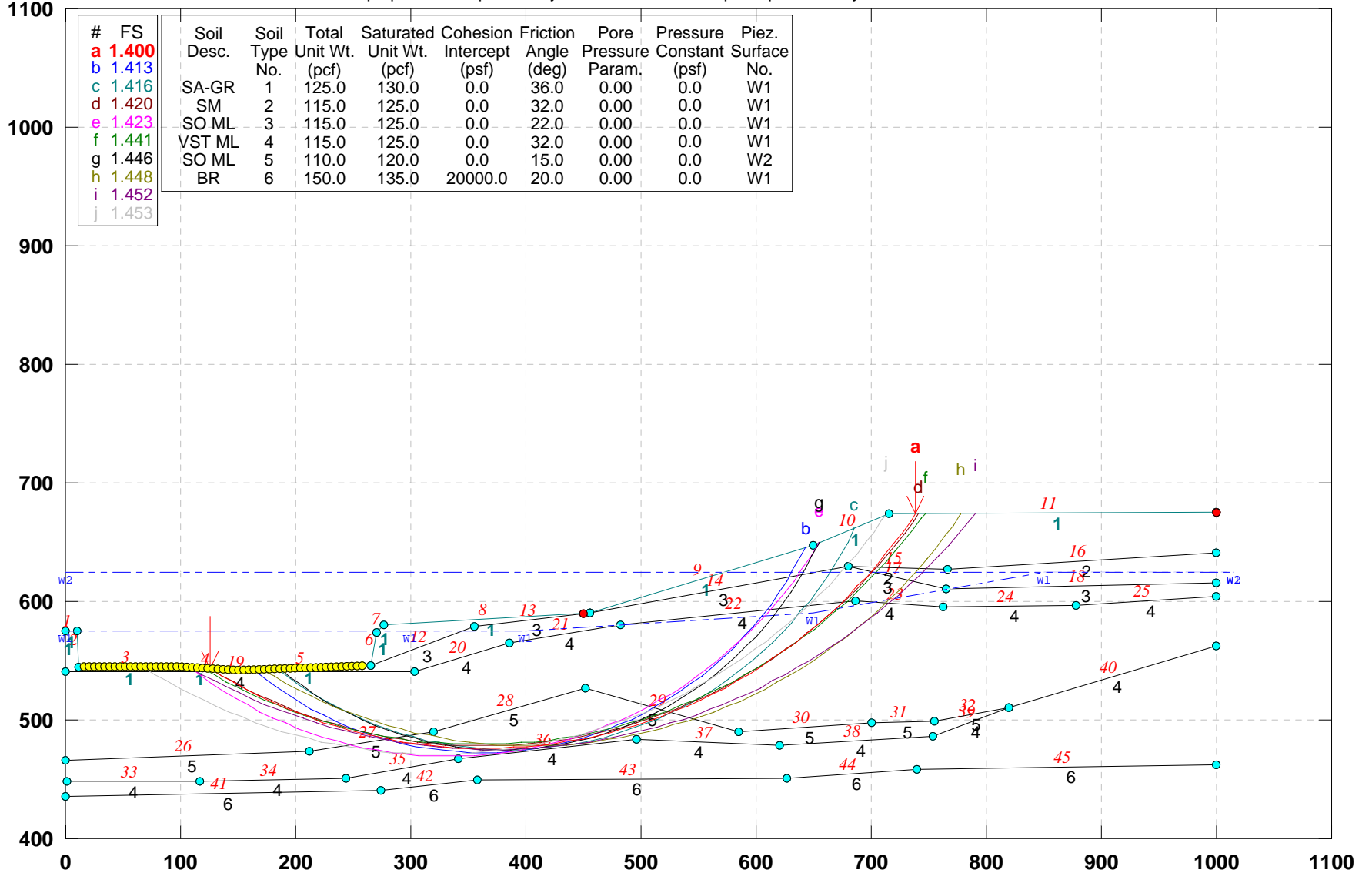

GSTABL7 v.2 FSmin=1.400

Safety Factors Are Calculated By The Simplified Janbu Method



**APPENDIX 7E**

**SLOPE STABILITY ANALYSES BASED ON  
ALTERNATIVE 2 GRADING**

# CUY-90-14.92 (Sec. A-A): PROPOSED GEOMETRY- (Alt-2)\_Block Search

e:\work on laptop\77332\slope stability\final-7-29-09\alt-2\aa-r-a2b.pl2 Run By: Jamal Nusairat 11/24/2009 06:25PM

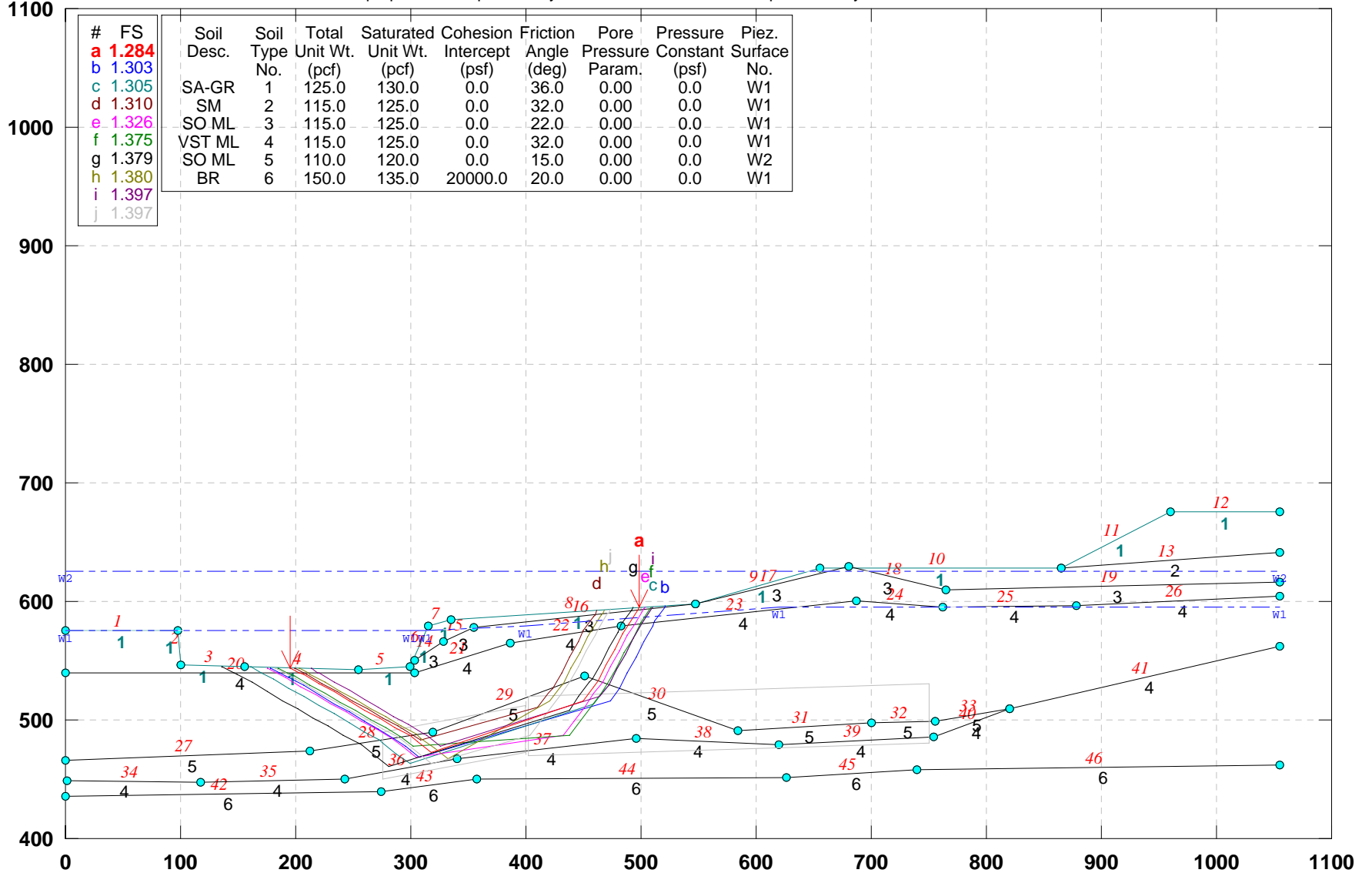

GSTABL7 v.2 FSmin=1.284

Safety Factors Are Calculated By The Simplified Janbu Method



# CUY-90-14.92 (Sec. B-B): PROPOSED GEOMETRY-(Alt-2)\_ Block Search

e:\from work on laptop\77332\slope stability\final-7-29-09\alt-2\bb-pr-a2b.pl2 Run By: Jamal Nusairat 11/24/2009 06:26PM

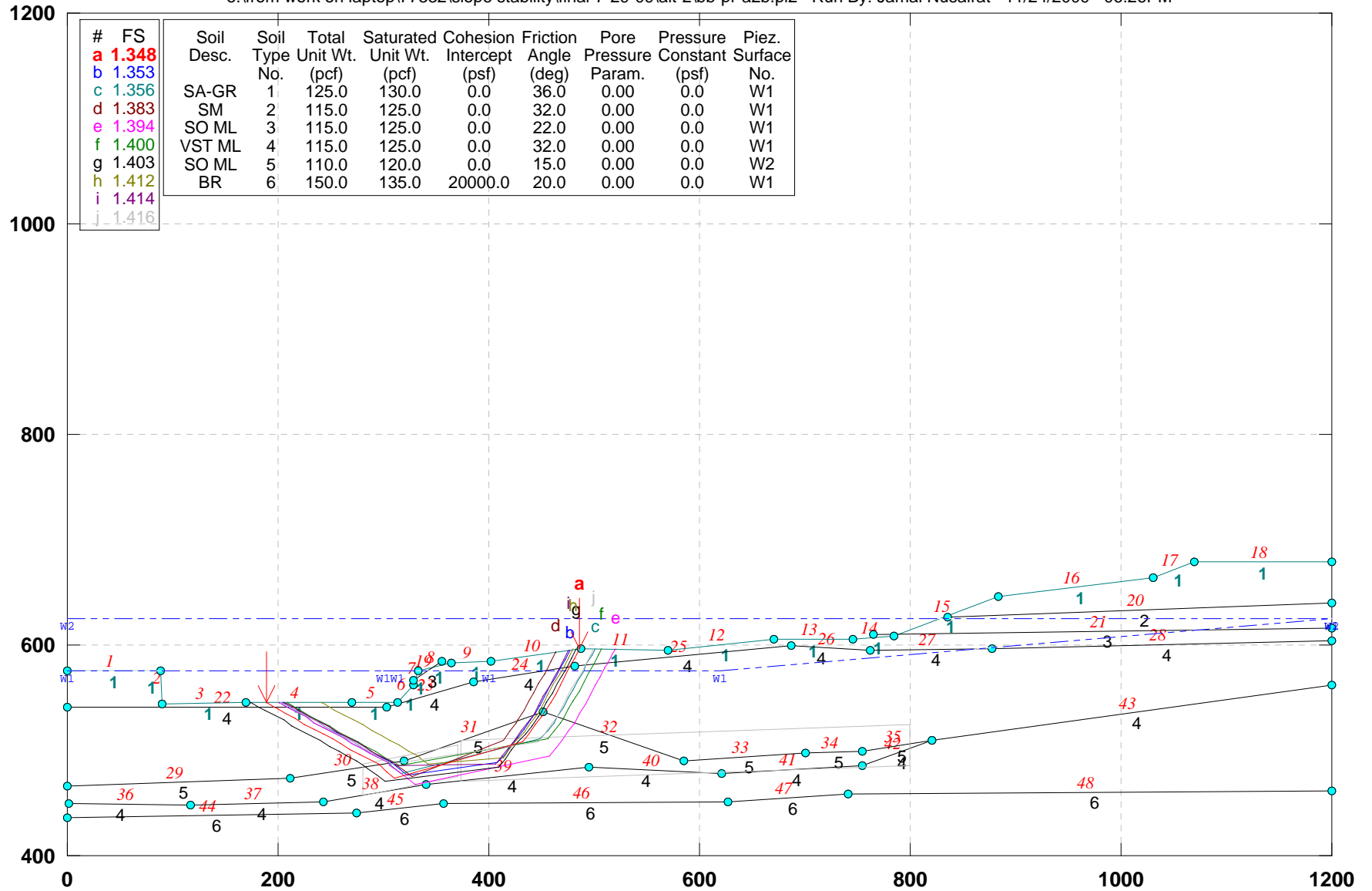

GSTABL7 v.2 FSmin=1.348

Safety Factors Are Calculated By The Simplified Janbu Method



# CUY-90-14.92 (Sec. E-E): PROPOSED GEOMETRY- (Alt-2)\_ Block search

e:\from work on laptop\77332\slope stability\final-7-29-09\alt-2\ee-p-a2b.pl2 Run By: Jamal Nusairat 11/24/2009 06:28PM

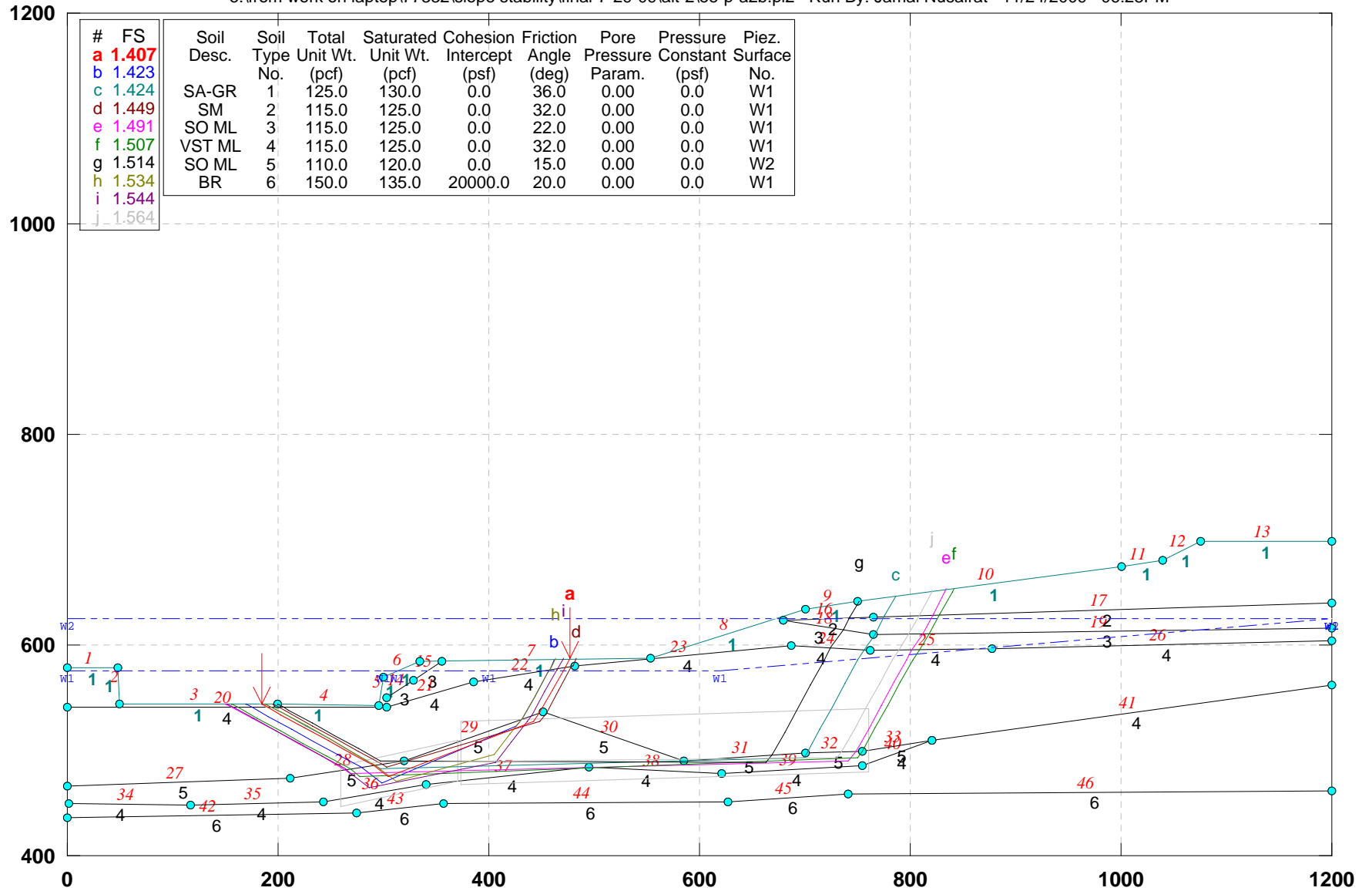

| # | FS    | Soil Desc. | Soil Type No. | Total Unit Wt. (pcf) | Saturated Unit Wt. (pcf) | Cohesion Intercept (psf) | Friction Angle (deg) | Pore Pressure Param. (psf) | Pressure Constant (psf) | Piez. Surface No. |
|---|-------|------------|---------------|----------------------|--------------------------|--------------------------|----------------------|----------------------------|-------------------------|-------------------|
| a | 1.407 |            |               |                      |                          |                          |                      |                            |                         |                   |
| b | 1.423 |            |               |                      |                          |                          |                      |                            |                         |                   |
| c | 1.424 | SA-GR      | 1             | 125.0                | 130.0                    | 0.0                      | 36.0                 | 0.00                       | 0.0                     | W1                |
| d | 1.449 | SM         | 2             | 115.0                | 125.0                    | 0.0                      | 32.0                 | 0.00                       | 0.0                     | W1                |
| e | 1.491 | SO ML      | 3             | 115.0                | 125.0                    | 0.0                      | 22.0                 | 0.00                       | 0.0                     | W1                |
| f | 1.507 | VST ML     | 4             | 115.0                | 125.0                    | 0.0                      | 32.0                 | 0.00                       | 0.0                     | W1                |
| g | 1.514 | SO ML      | 5             | 110.0                | 120.0                    | 0.0                      | 15.0                 | 0.00                       | 0.0                     | W2                |
| h | 1.534 | BR         | 6             | 150.0                | 135.0                    | 20000.0                  | 20.0                 | 0.00                       | 0.0                     | W1                |
| i | 1.544 |            |               |                      |                          |                          |                      |                            |                         |                   |
| j | 1.564 |            |               |                      |                          |                          |                      |                            |                         |                   |

GSTABL7 v.2 FSmin=1.407

Safety Factors Are Calculated By The Simplified Janbu Method



# CUY-90-14.92 (Sec. F-F): PROPOSED GEOMETRY-(Alt-2)\_BLOCK SEARCH

e:\from work on laptop\77332\slope stability\final-7-29-09\alt-2\ff-p-a2b.pl2 Run By: Jamal Nusairat 11/24/2009 06:30PM

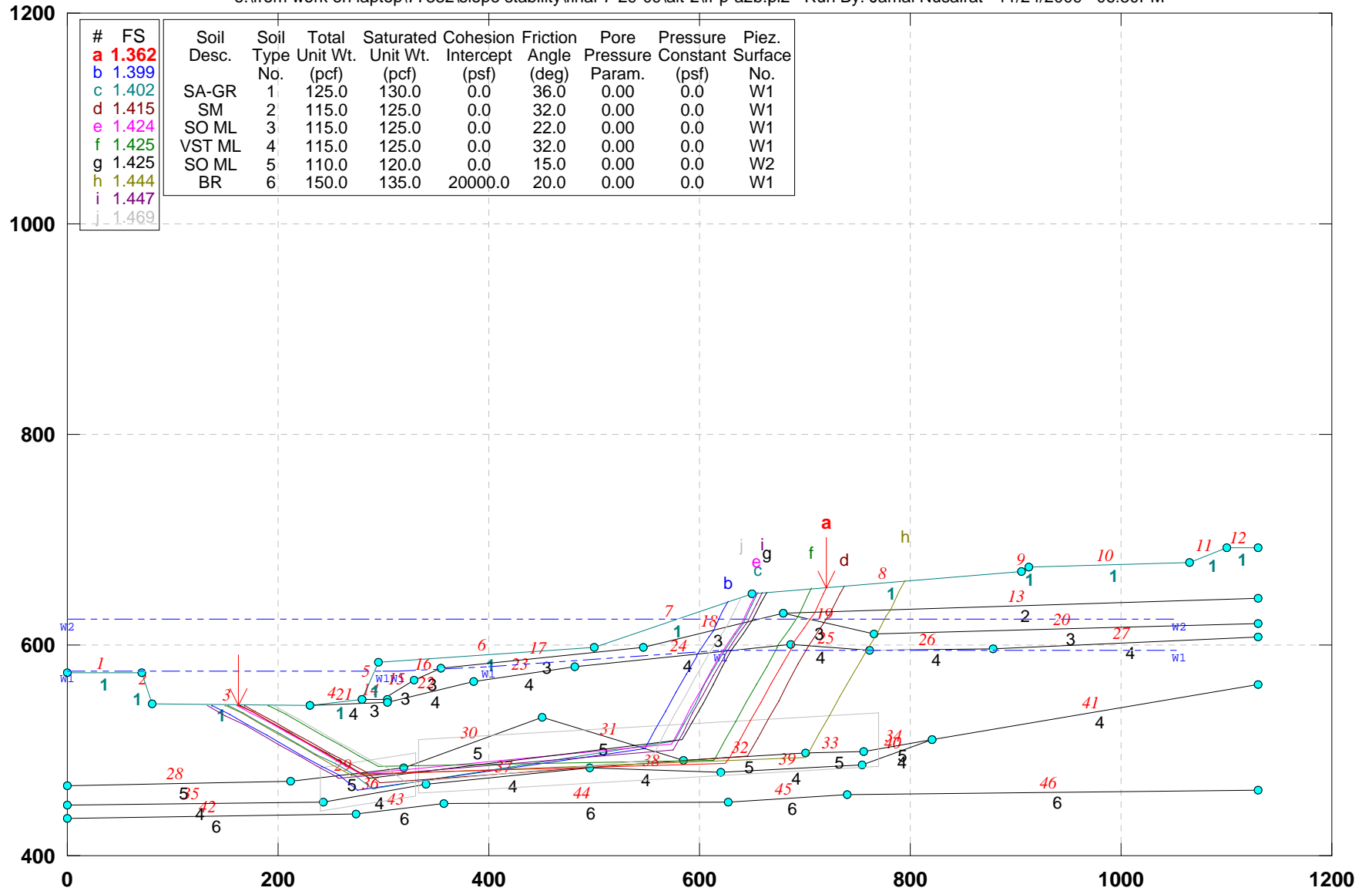

GSTABL7 v.2 FSmin=1.362

Safety Factors Are Calculated By The Simplified Janbu Method





# CUY-90-14.92 (Sec. G-G): PROPOSED EXCAVATION- (Alt-2)\_Block Search

e:\from work on laptop\77332\slope stability\final-7-29-09\alt-2\gg-prb.pl2 Run By: Jamal Nusairat 11/24/2009 06:31PM

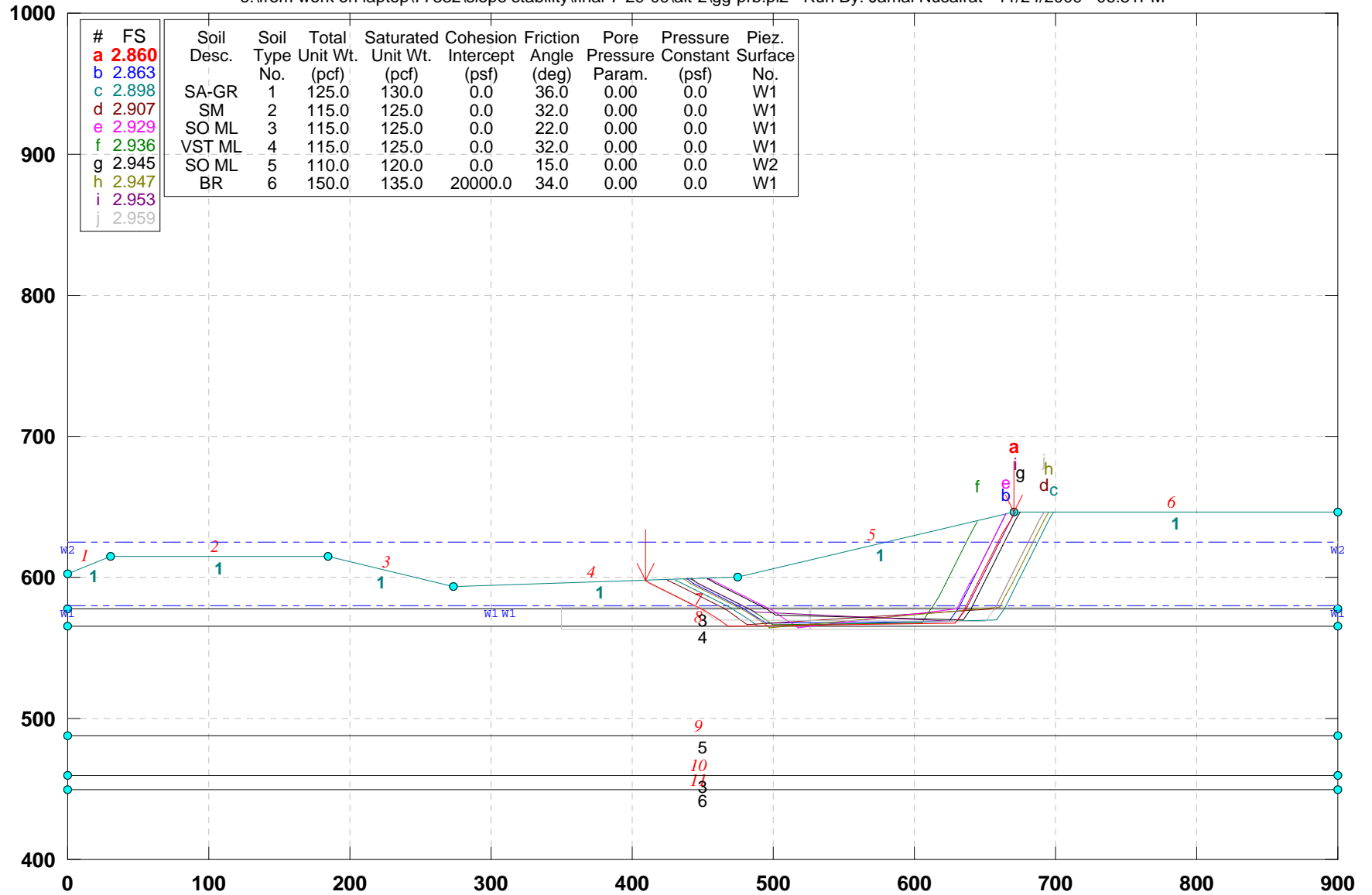

| # | FS    | Soil Desc. | Soil Type No. | Total Unit Wt. (pcf) | Saturated Unit Wt. (pcf) | Cohesion Intercept (psf) | Friction Angle (deg) | Pore Pressure Param. | Pressure Constant (psf) | Piez. Surface No. |
|---|-------|------------|---------------|----------------------|--------------------------|--------------------------|----------------------|----------------------|-------------------------|-------------------|
| a | 2.860 |            |               |                      |                          |                          |                      |                      |                         |                   |
| b | 2.863 |            |               |                      |                          |                          |                      |                      |                         |                   |
| c | 2.898 | SA-GR      | 1             | 125.0                | 130.0                    | 0.0                      | 36.0                 | 0.00                 | 0.0                     | W1                |
| d | 2.907 | SM         | 2             | 115.0                | 125.0                    | 0.0                      | 32.0                 | 0.00                 | 0.0                     | W1                |
| e | 2.929 | SO ML      | 3             | 115.0                | 125.0                    | 0.0                      | 22.0                 | 0.00                 | 0.0                     | W1                |
| f | 2.936 | VST ML     | 4             | 115.0                | 125.0                    | 0.0                      | 32.0                 | 0.00                 | 0.0                     | W1                |
| g | 2.945 | SO ML      | 5             | 110.0                | 120.0                    | 0.0                      | 15.0                 | 0.00                 | 0.0                     | W2                |
| h | 2.947 | BR         | 6             | 150.0                | 135.0                    | 20000.0                  | 34.0                 | 0.00                 | 0.0                     | W1                |
| i | 2.953 |            |               |                      |                          |                          |                      |                      |                         |                   |
| j | 2.959 |            |               |                      |                          |                          |                      |                      |                         |                   |

GSTABL7 v.2 FSmin=2.860

Safety Factors Are Calculated By The Simplified Janbu Method



# CUY-90-14.40 (Sec. U-U): PROPOSED EXCAVATION (Alt-2)\_Block Search

e:\from work on laptop\77332\slope stability\final-7-29-09\alt-2\uu-pr2b.pl2 Run By: Jamal Nusairat 11/24/2009 06:32PM

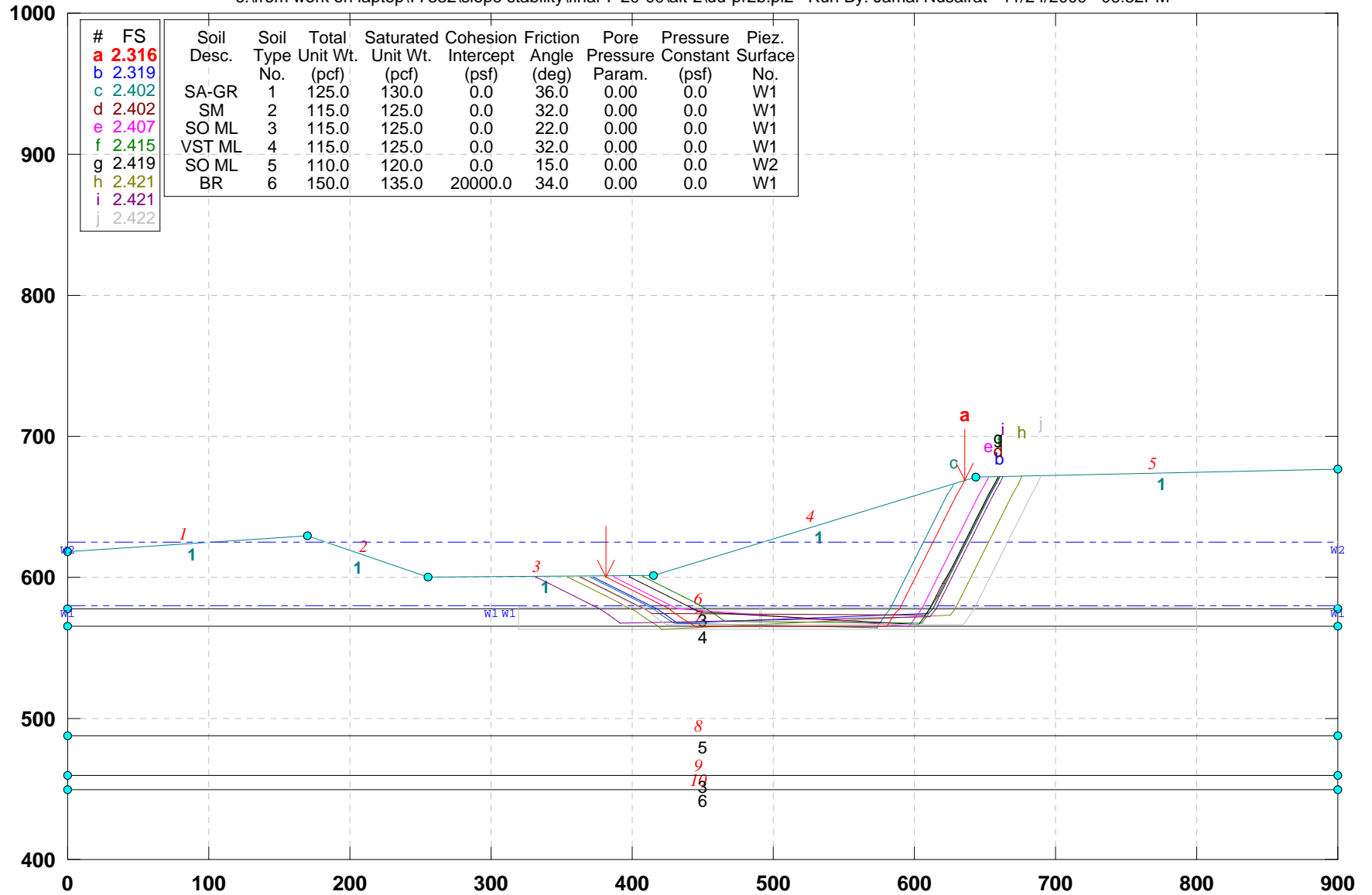

GSTABL7 v.2 FSmin=2.316

Safety Factors Are Calculated By The Simplified Janbu Method



# CUY-90-14.92 (Sec. W-W): PROPOSED GEOMETRY-(Alt-2)\_BLOCK SEARCH

e:\from work on laptop\77332\slope stability\final-7-29-09\alt-2\ww-p-a2b.pl2 Run By: Jamal Nusairat 11/24/2009 06:33PM

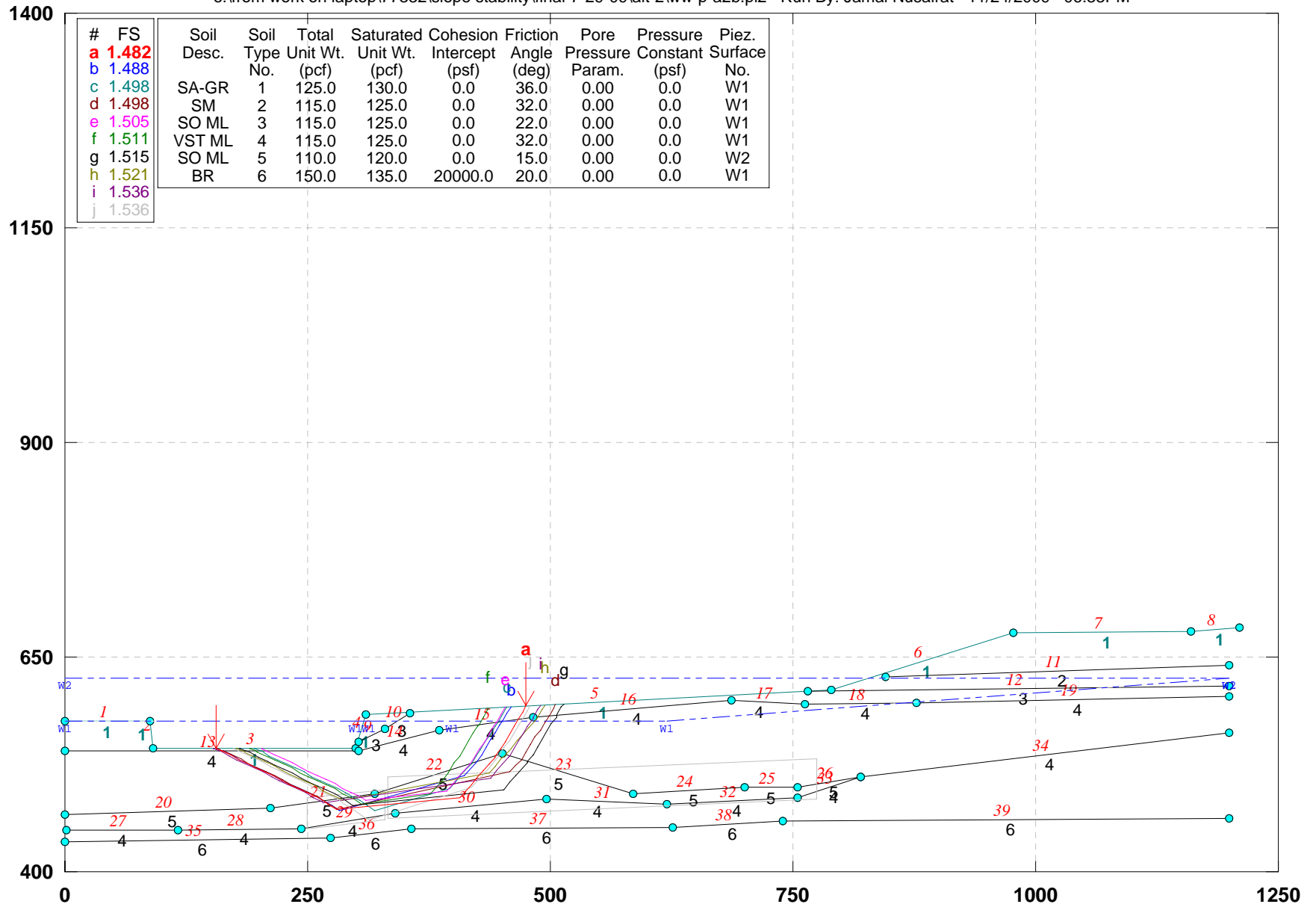

GSTABL7 v.2 FSmin=1.482

Safety Factors Are Calculated By The Simplified Janbu Method



# CUY-90-14.92 (Sec. Y-Y): PROPOSED GEOMETRY-(Alt-2)\_BLOCK SEARCH

e:\from work on laptop\77332\slope stability\final-7-29-09\alt-2\yy-p-a2b.pl2 Run By: Jamal Nusairat 11/24/2009 06:35PM

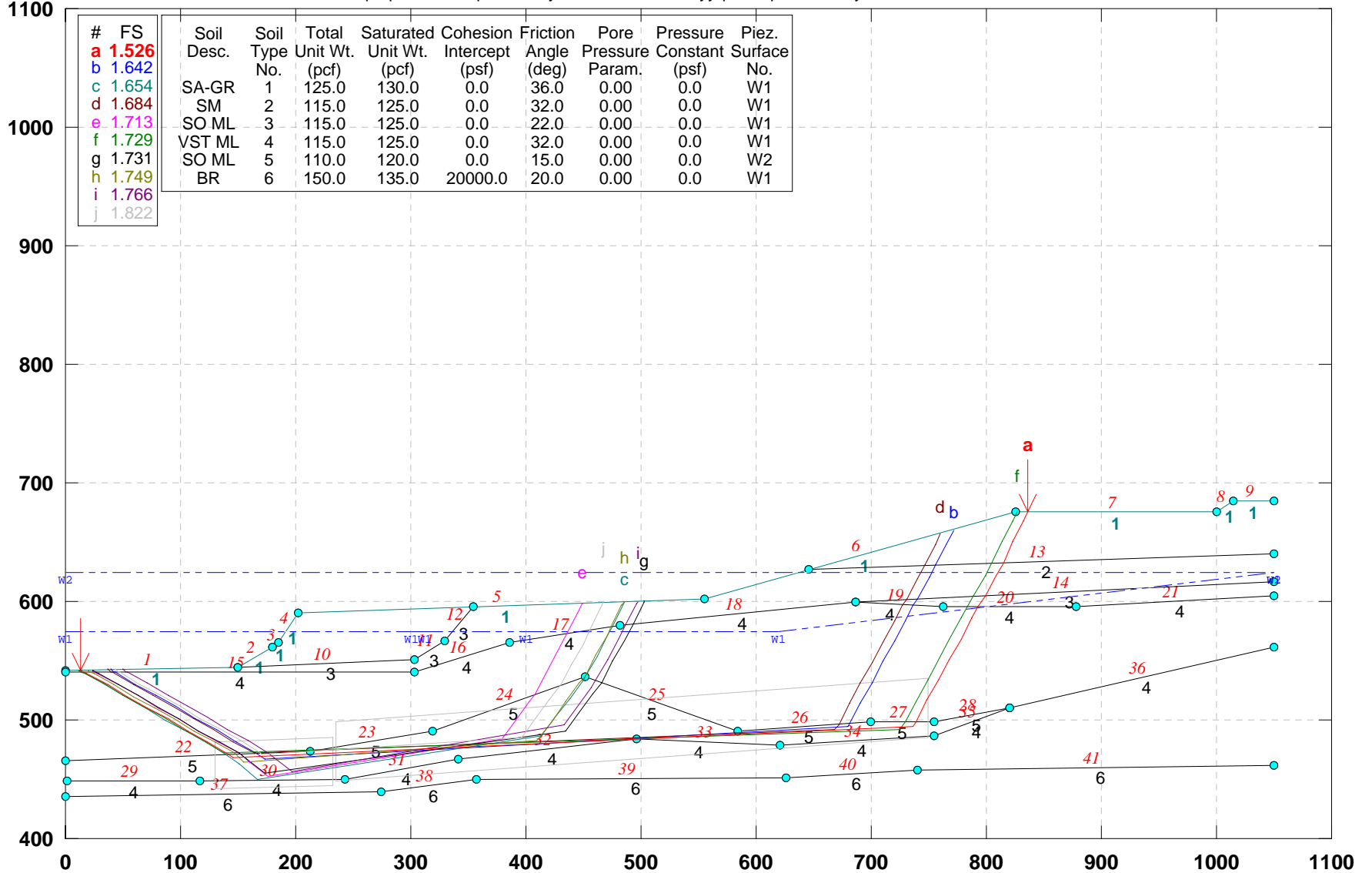

GSTABL7 v.2 FSmin=1.526

Safety Factors Are Calculated By The Simplified Janbu Method



# CUY-90-14.92 (Sec. Z-Z): PROPOSED GEOMETRY-(Alt-2)\_BLOCK SEARCH

e:\from work on laptop\77332\slope stability\final-7-29-09\alt-2\zz-p-a2b.pl2 Run By: Jamal Nusairat 11/24/2009 06:36PM

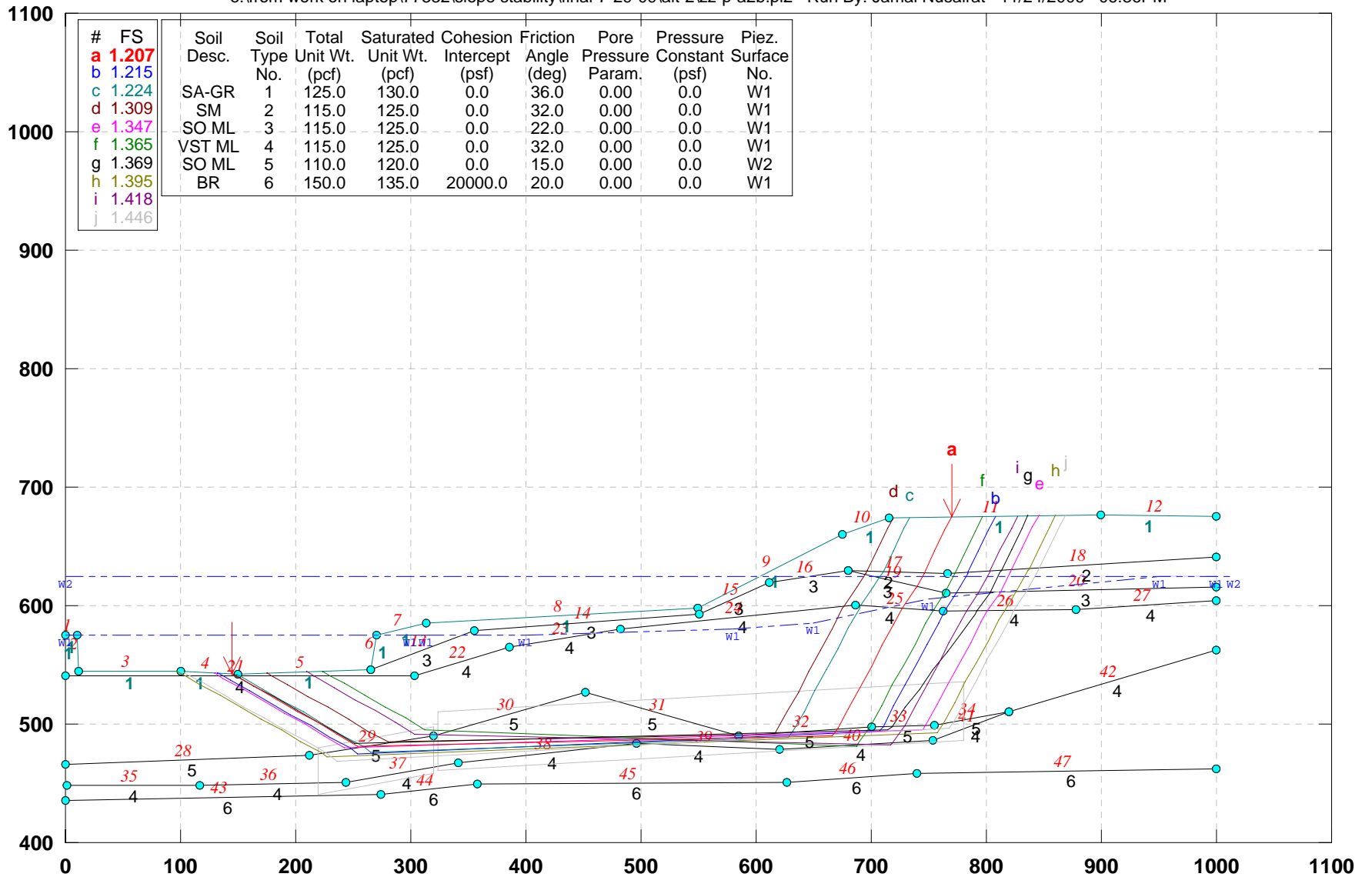

GSTABL7 v.2 FSmin=1.207

Safety Factors Are Calculated By The Simplified Janbu Method



# CUY-90-14.92 (Sec. A-A): PROPOSED GEOMETRY- (Alt-2)

e:\from work on laptop\77332\slope stability\final-7-29-09\alt-2\aa-pr-a2.pl2 Run By: Jamal Nusairat 11/24/2009 06:51PM

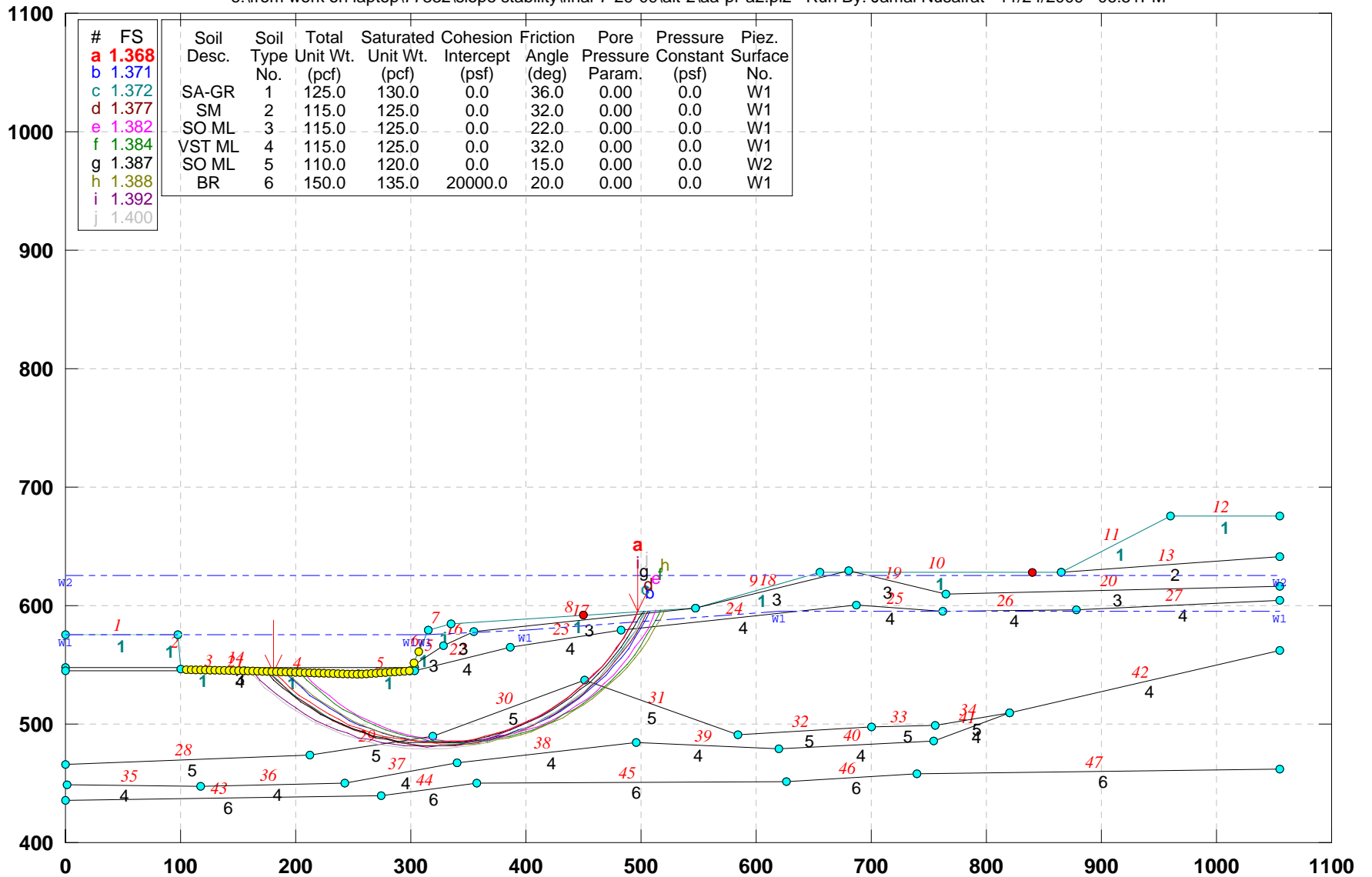

GSTABL7 v.2 FSmin=1.368

Safety Factors Are Calculated By The Simplified Janbu Method



## CUY-90-14.92 (Sec. B-B): PROPOSED GEOMETRY-(Alt-2)

e:\from work on laptop\77332\slope stability\final-7-29-09\alt-2\bb-pr-a2.pl2 Run By: Jamal Nusairat 11/24/2009 06:52PM

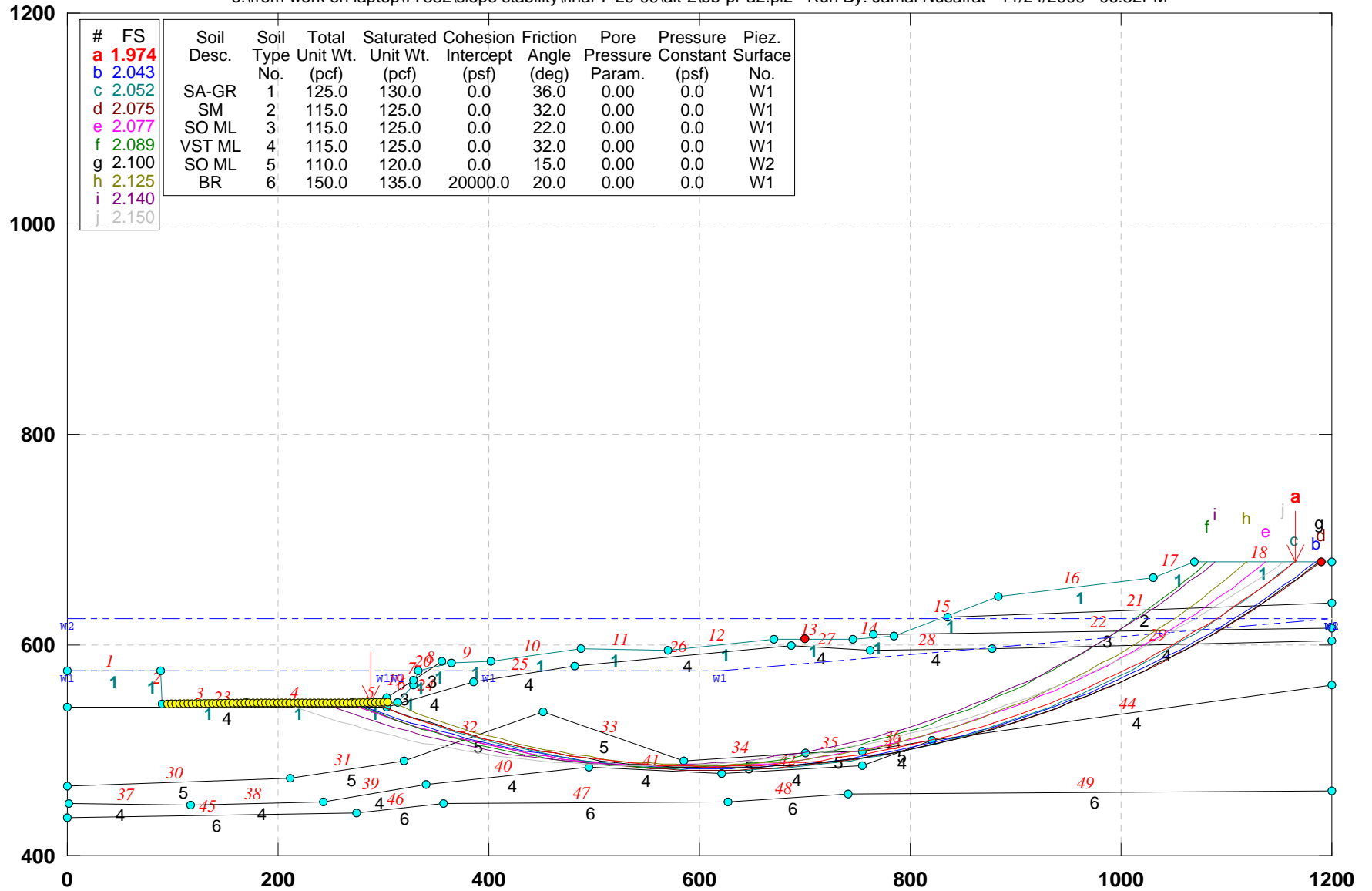

GSTABL7 v.2 FSmin=1.974

Safety Factors Are Calculated By The Simplified Janbu Method



# CUY-90-14.92 (Sec. E-E): PROPOSED GEOMETRY-(Alt-2)

e:\from work on laptop\77332\slope stability\final-7-29-09\alt-2\ee-pr-a2.pl2 Run By: Jamal Nusairat 11/24/2009 06:55PM

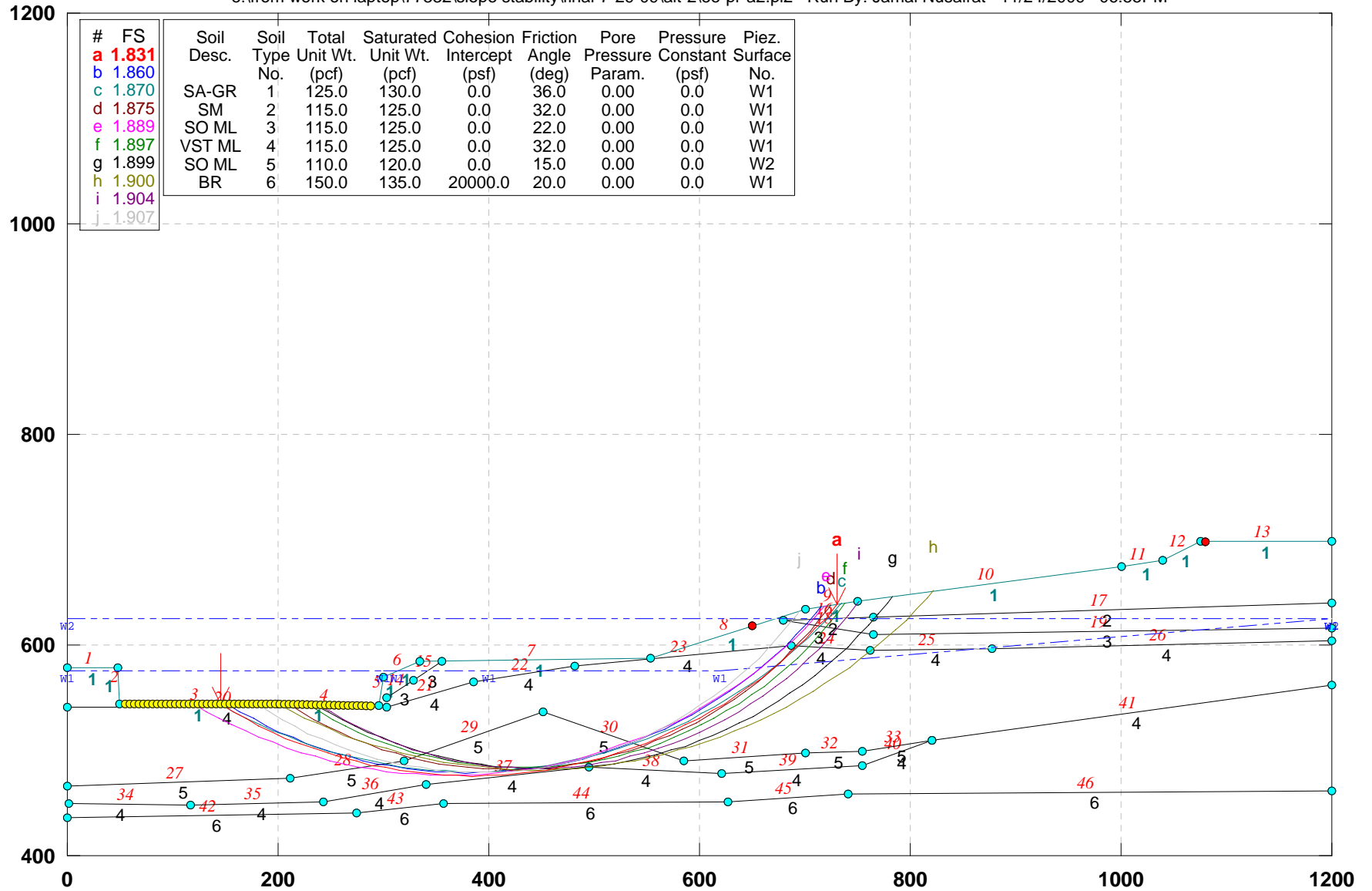

GSTABL7 v.2 FSmin=1.831

Safety Factors Are Calculated By The Simplified Janbu Method





### CUY-90-14.92 (Sec. F-F): PROPOSED GEOMETRY-(Alt-2)

e:\from work on laptop\77332\slope stability\final-7-29-09\alt-2\ff-pr-a2.pl2 Run By: Jamal Nusairat 11/24/2009 07:34PM

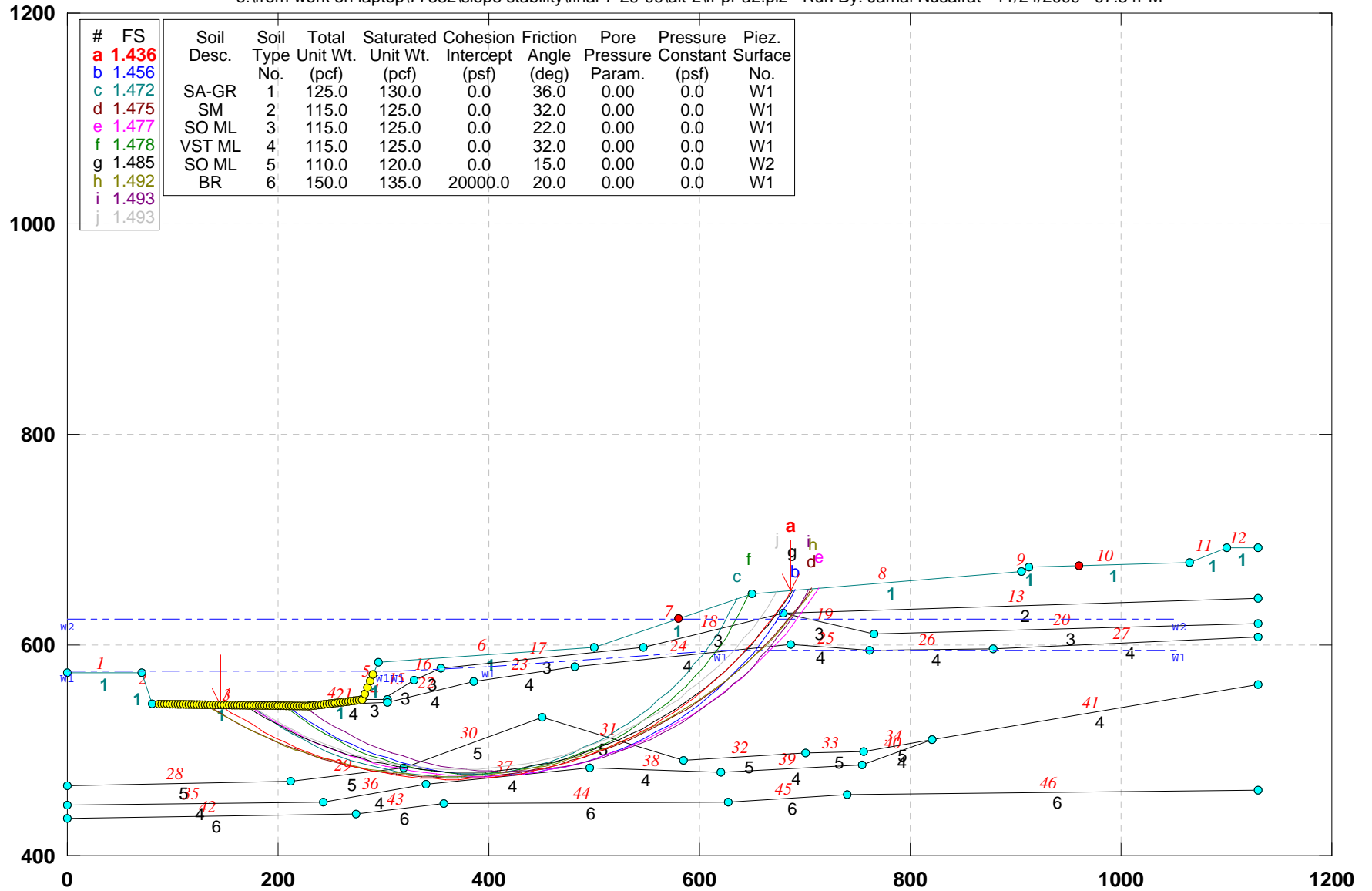

GSTABL7 v.2 FSmin=1.436

Safety Factors Are Calculated By The Simplified Janbu Method



# CUY-90-14.92 (Sec. G-G): PROPOSED EXCAVATED GEOMETRY- STABILITY-(Alt-2)

e:\from work on laptop\77332\slope stability\final-7-29-09\alt-2\gg-pr.pl2 Run By: Jamal Nusairat 11/24/2009 07:35PM

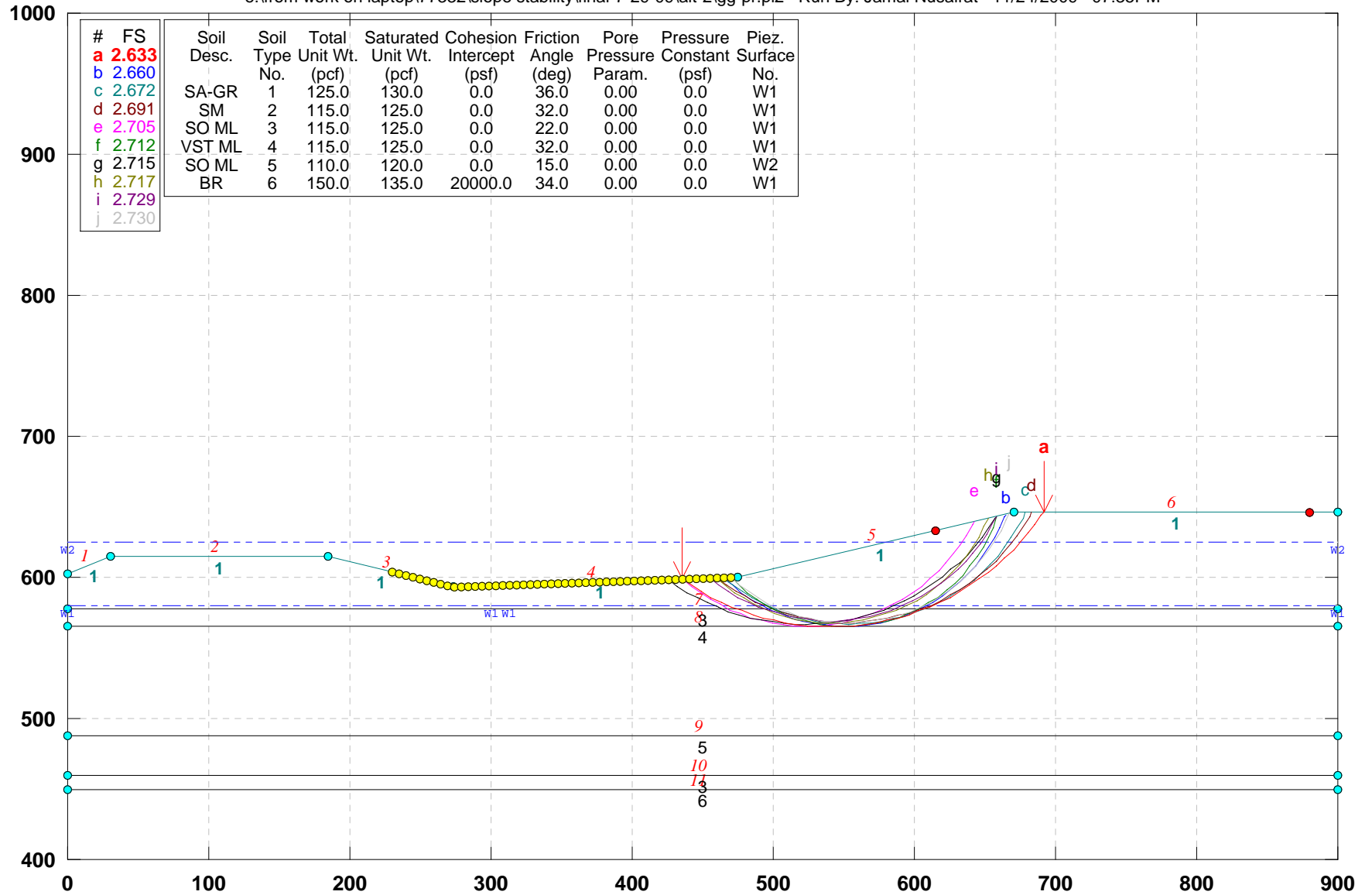

GSTABL7 v.2 FSmin=2.633

Safety Factors Are Calculated By The Simplified Janbu Method



# CUY-90-14.92 (Sec. I-I): PROPOSED EXCAVATION-(Alt-2)

e:\from work on laptop\77332\slope stability\final-7-29-09\alt-2\ii-pr.pl2 Run By: Jamal Nusairat 11/24/2009 07:36PM

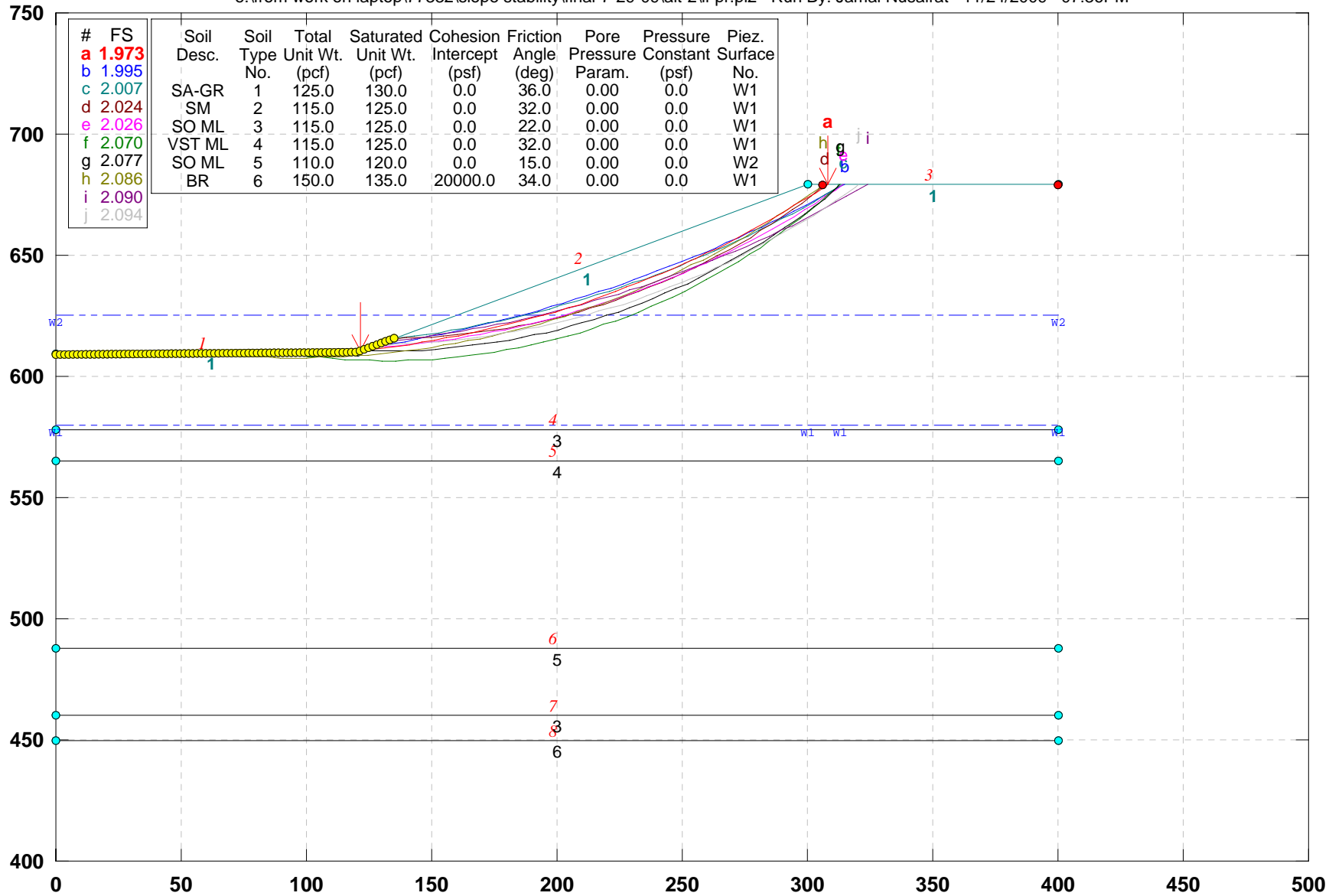

GSTABL7 v.2 FSmin=1.973

Safety Factors Are Calculated by GLE (Morgenstern-Price) Method (0-3)



# CUY-90-14.92 (Sec. J-J): PROPOSED EXCAVATED GEOMETRY- STABILITY IF SIDE SLOPE-(Alt-2)

e:\from work on laptop\77332\slope stability\final-7-29-09\alt-2\jj-pr.pl2 Run By: Jamal Nusairat 11/24/2009 07:37PM

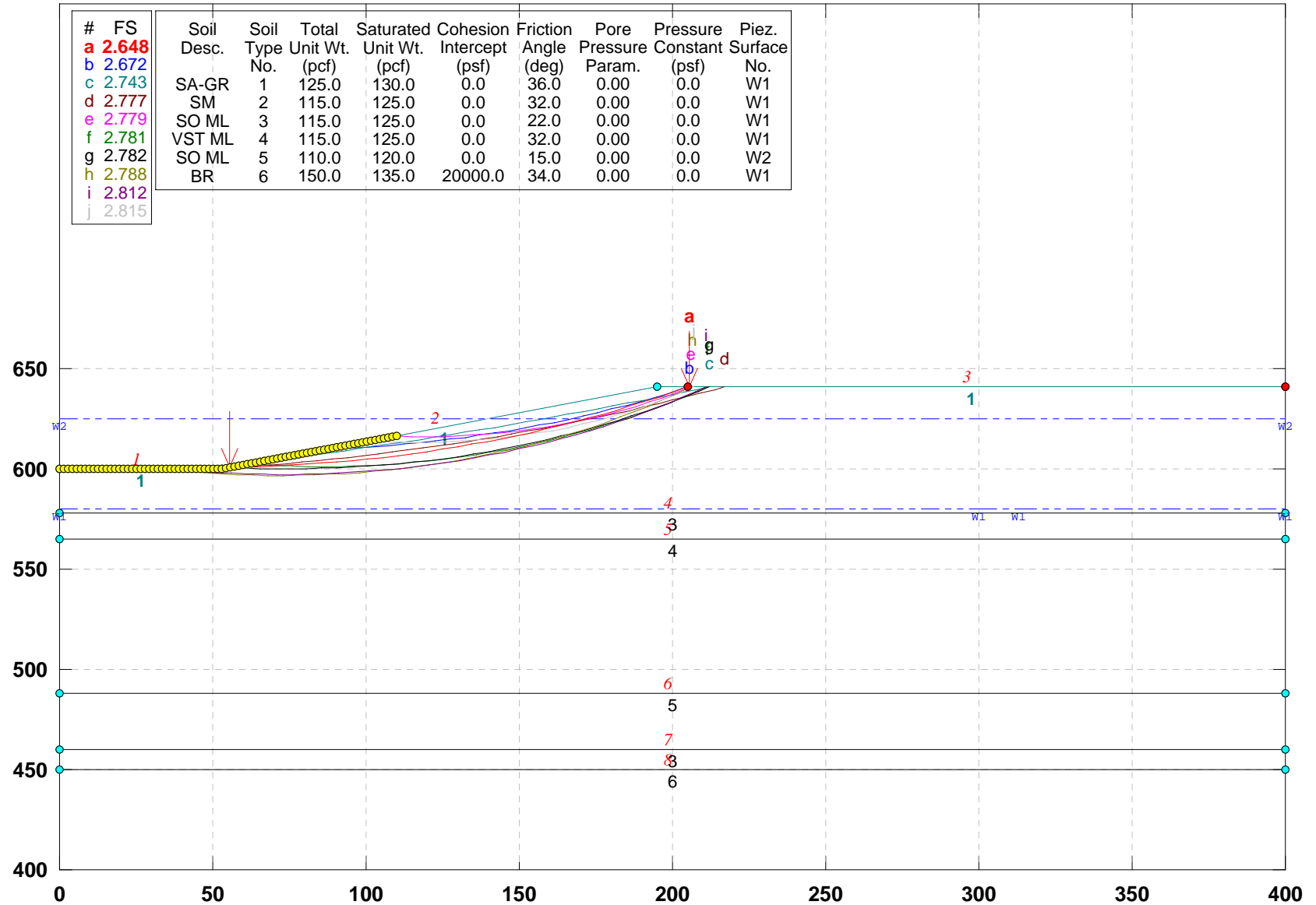

GSTABL7 v.2 FSmin=2.648

Safety Factors Are Calculated by GLE (Morgenstern-Price) Method (0-3)



# CUY-90-14.92 (Sec. U-U): PROPOSED EXCAVATED GEOMETRY- STABILITY-(Alt-2)

e:\from work on laptop\77332\slope stability\final-7-29-09\alt-2\uu-pr.pl2 Run By: Jamal Nusairat 11/24/2009 07:39PM

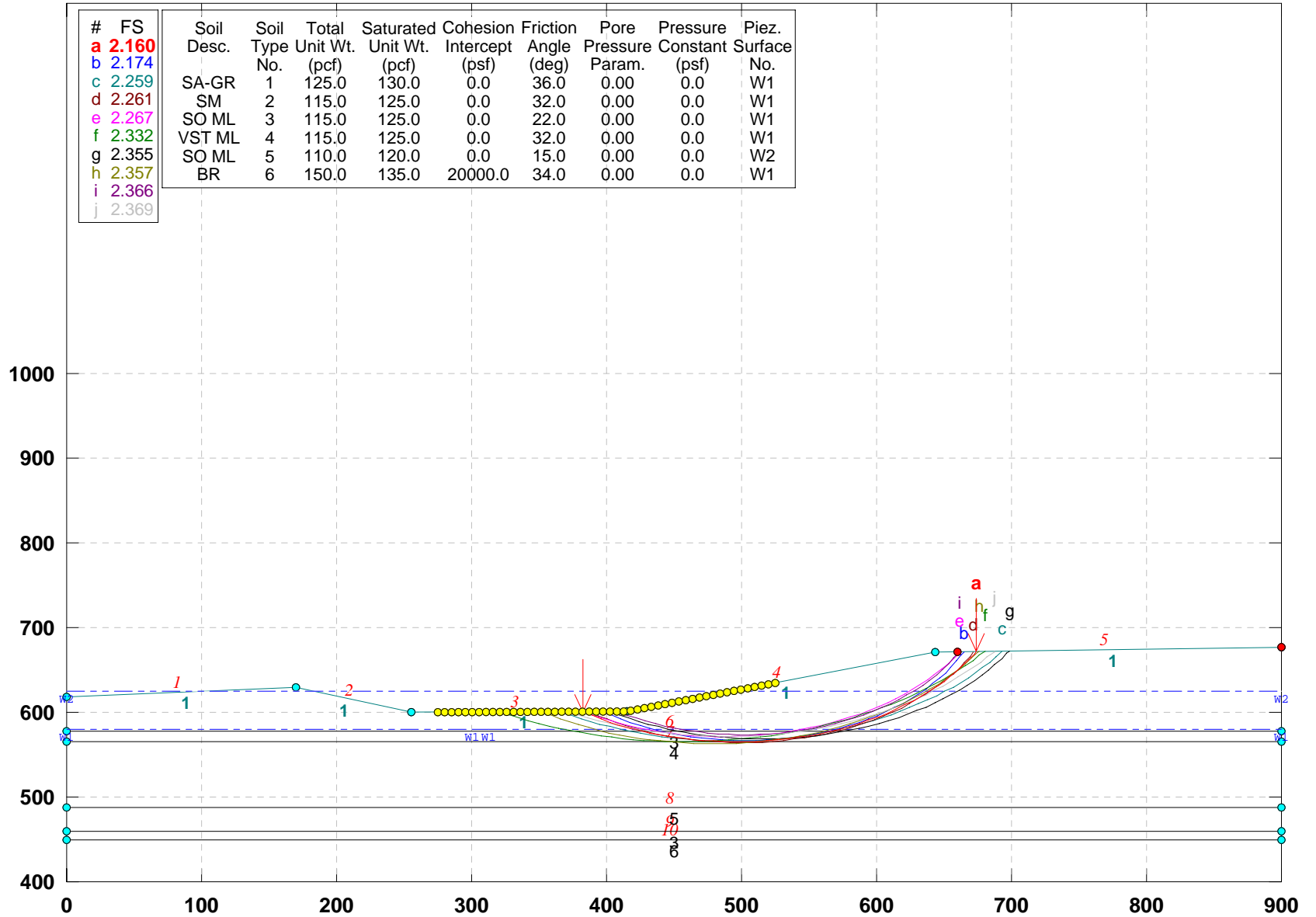

GSTABL7 v.2 FSmin=2.160

Safety Factors Are Calculated By The Simplified Janbu Method



## CUY-90-14.92 (Sec. W-W): PROPOSED GEOMETRY-(Alt-2)

e:\from work on laptop\77332\slope stability\final-7-29-09\alt-2\ww-pr-a2.pl2 Run By: Jamal Nusairat 11/24/2009 07:41PM

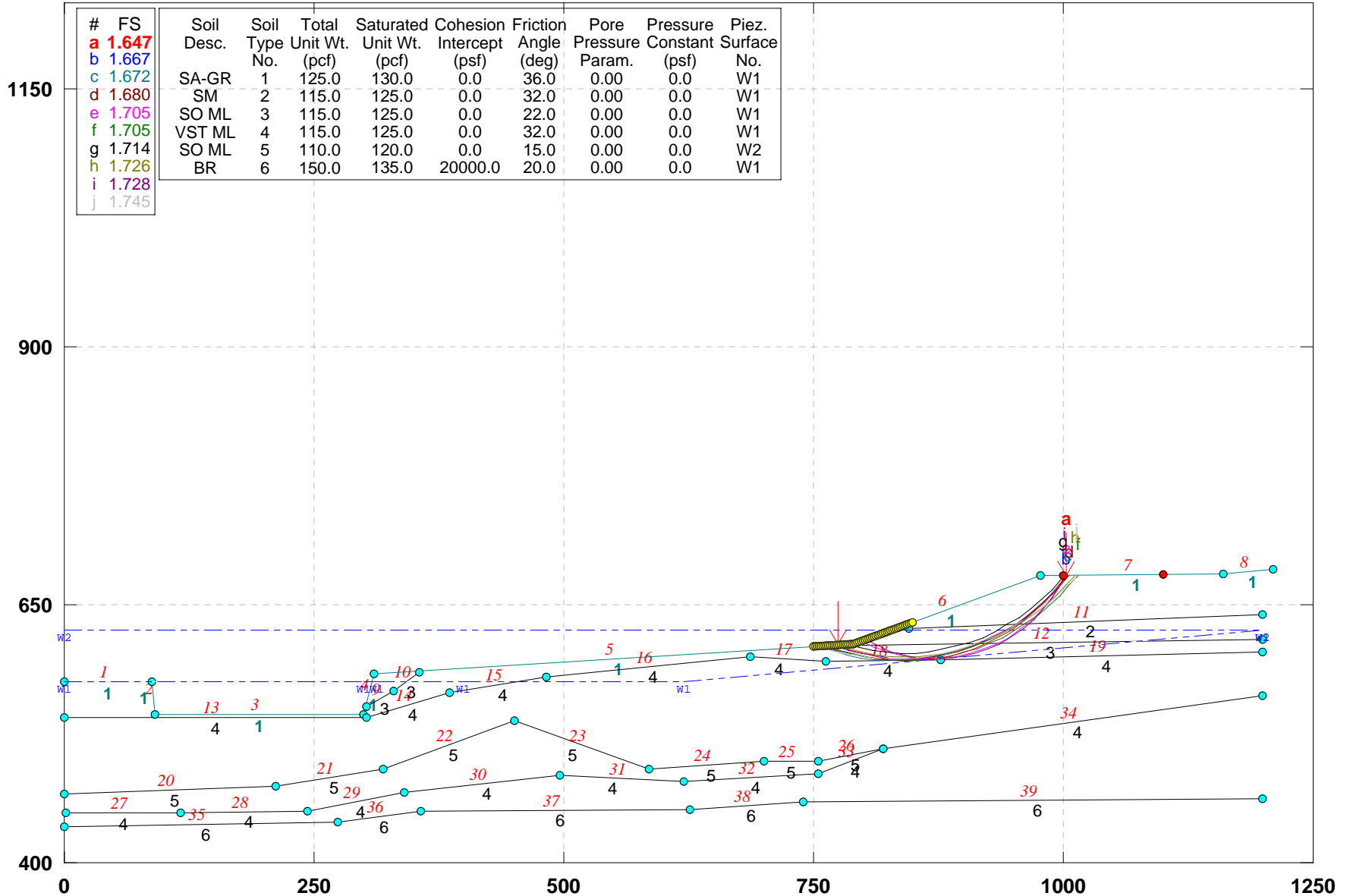

GSTABL7 v.2 FSmin=1.647

Safety Factors Are Calculated By The Simplified Janbu Method



# CUY-90-14.92 (Sec. Y-Y): PROPOSED GEOMETRY-(Alt-2)

e:\from work on laptop\77332\slope stability\final-7-29-09\alt-2\yy-pr-a2.pl2 Run By: Jamal Nusairat 11/24/2009 07:44PM

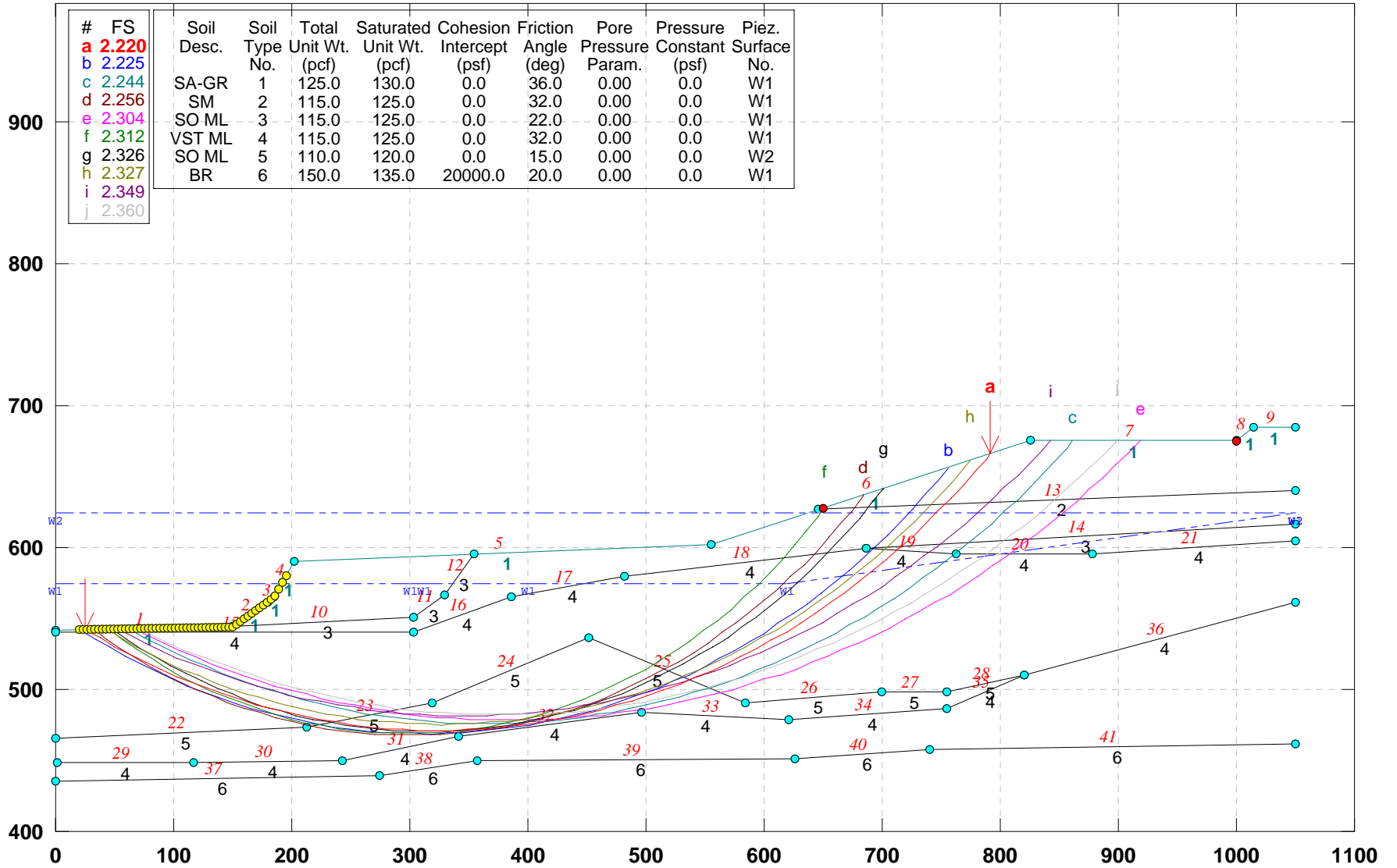

GSTABL7 v.2 FSmin=2.220

Safety Factors Are Calculated By The Simplified Janbu Method



### CUY-90-14.92 (Sec. Z-Z): PROPOSED GEOMETRY-(Alt-2)

e:\from work on laptop\77332\slope stability\final-7-29-09\alt-2\zz-pr-a2.pl2 Run By: Jamal Nusairat 11/24/2009 07:45PM

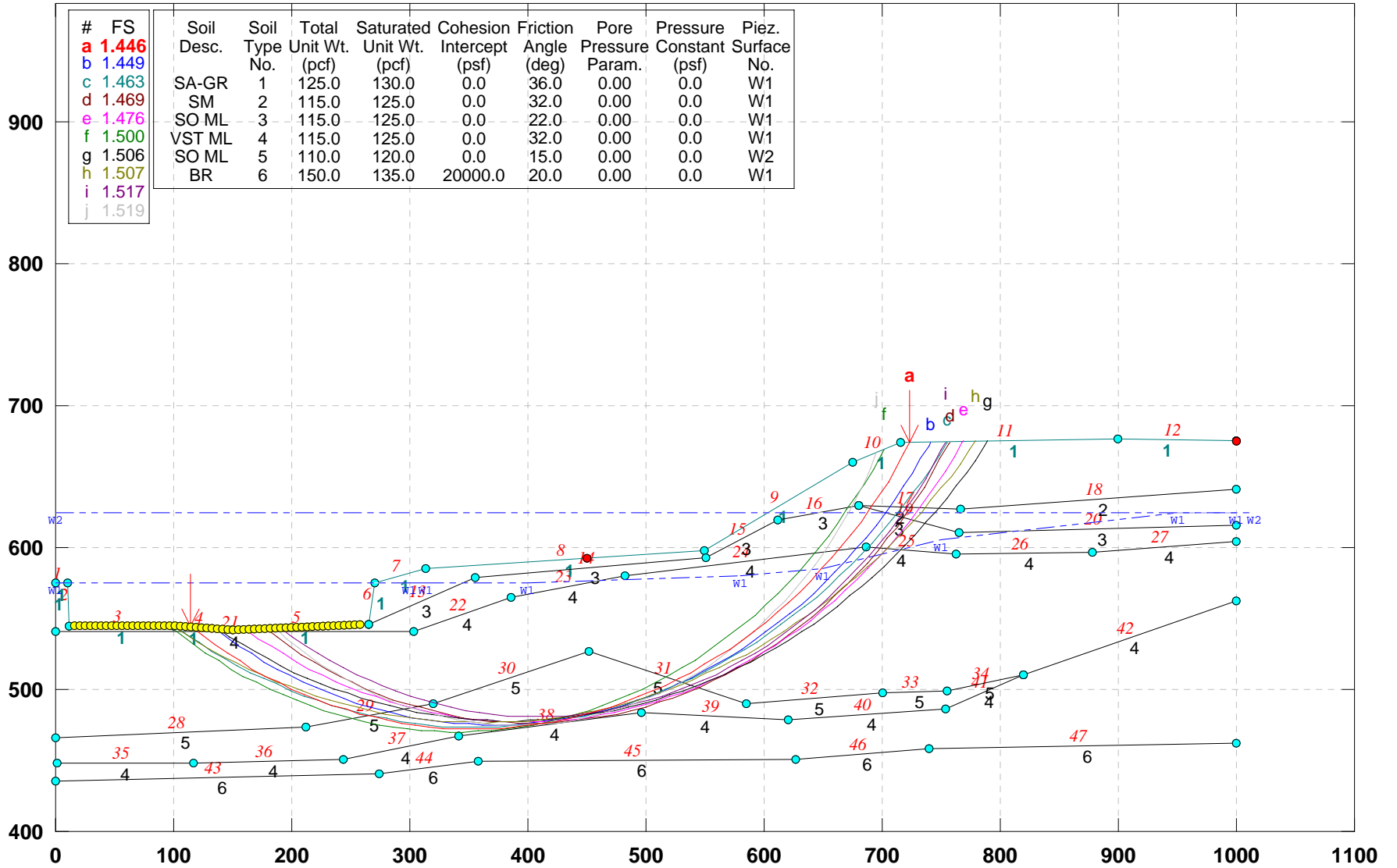

GSTABL7 v.2 FSmin=1.446

Safety Factors Are Calculated By The Simplified Janbu Method





**APPENDIX 7F**

**SLOPE STABILITY ANALYSES BASED ON  
ALTERNATIVE 3 GRADING**

# CUY-90-14.92 (Sec. A-A): PROPOSED GEOMETRY (Alt-3)\_Block Search

e:\from work on laptop\77332\slope stability\final-7-29-09\alt-3\aa-p-a3b.pl2 Run By: Jamal Nusairat 11/24/2009 07:48PM

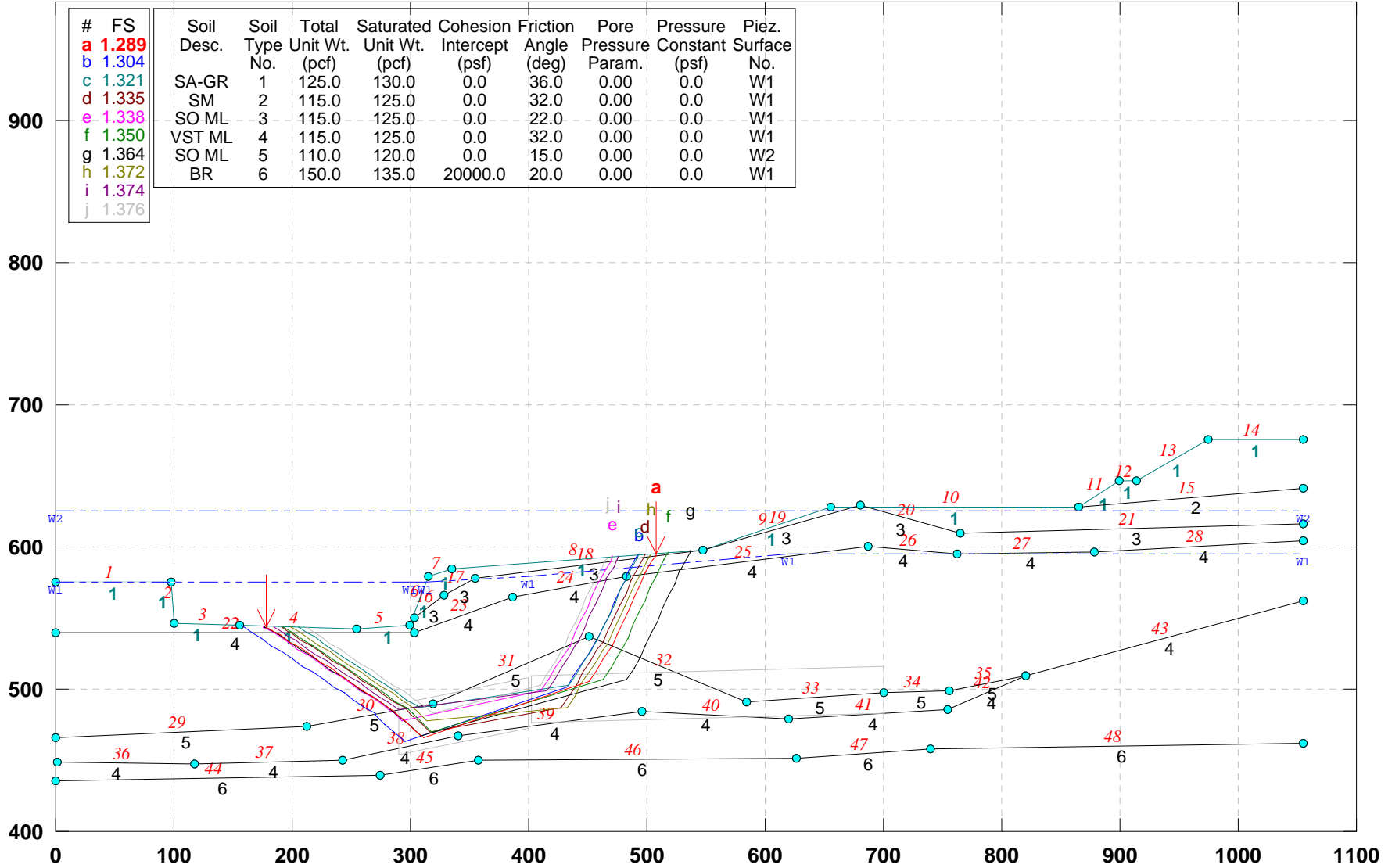

| # | FS    | Soil Desc. | Soil Type No. | Soil Unit Wt. (pcf) | Total Unit Wt. (pcf) | Saturated Unit Wt. (pcf) | Cohesion Intercept (psf) | Friction Angle (deg) | Pore Pressure Param. | Pressure Constant (psf) | Piez. Surface No. |
|---|-------|------------|---------------|---------------------|----------------------|--------------------------|--------------------------|----------------------|----------------------|-------------------------|-------------------|
| a | 1.289 |            |               |                     |                      |                          |                          |                      |                      |                         |                   |
| b | 1.304 |            |               |                     |                      |                          |                          |                      |                      |                         |                   |
| c | 1.321 | SA-GR      | 1             | 125.0               | 125.0                | 130.0                    | 0.0                      | 36.0                 | 0.00                 | 0.0                     | W1                |
| d | 1.335 | SM         | 2             | 115.0               | 125.0                | 125.0                    | 0.0                      | 32.0                 | 0.00                 | 0.0                     | W1                |
| e | 1.338 | SO ML      | 3             | 115.0               | 125.0                | 125.0                    | 0.0                      | 22.0                 | 0.00                 | 0.0                     | W1                |
| f | 1.350 | VST ML     | 4             | 115.0               | 125.0                | 125.0                    | 0.0                      | 32.0                 | 0.00                 | 0.0                     | W1                |
| g | 1.364 | SO ML      | 5             | 110.0               | 120.0                | 120.0                    | 0.0                      | 15.0                 | 0.00                 | 0.0                     | W2                |
| h | 1.372 | BR         | 6             | 150.0               | 150.0                | 135.0                    | 20000.0                  | 20.0                 | 0.00                 | 0.0                     | W1                |
| i | 1.374 |            |               |                     |                      |                          |                          |                      |                      |                         |                   |
| j | 1.376 |            |               |                     |                      |                          |                          |                      |                      |                         |                   |

GSTABL7 v.2 FSmin=1.289

Safety Factors Are Calculated By The Simplified Janbu Method



# CUY-90-14.92 (Sec. B-B): PROPOSED GEOMETRY (Alt-3)\_Block Search

e:\from work on laptop\77332\slope stability\final-7-29-09\alt-3\bb-p-a3b.pl2 Run By: Jamal Nusairat 11/24/2009 07:49PM

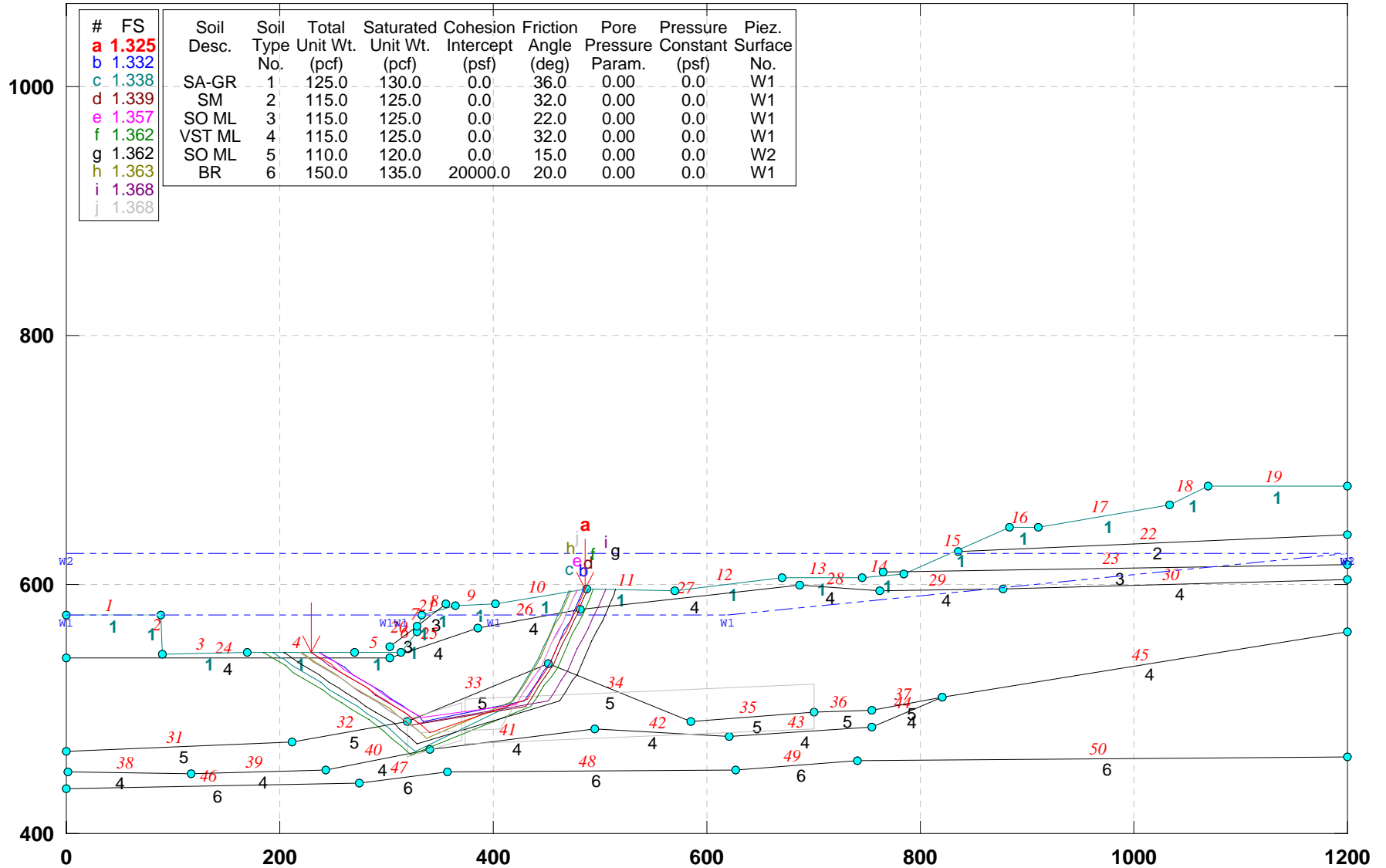

GSTABL7 v.2 FSmin=1.325

Safety Factors Are Calculated By The Simplified Janbu Method



# CUY-90-14.92 (Sec. E-E): PROPOSED GEOMETRY (Alt-3)

e:\from work on laptop\77332\slope stability\final-7-29-09\alt-3\ee-p-a3b.pl2 Run By: Jamal Nusairat 11/24/2009 07:50PM

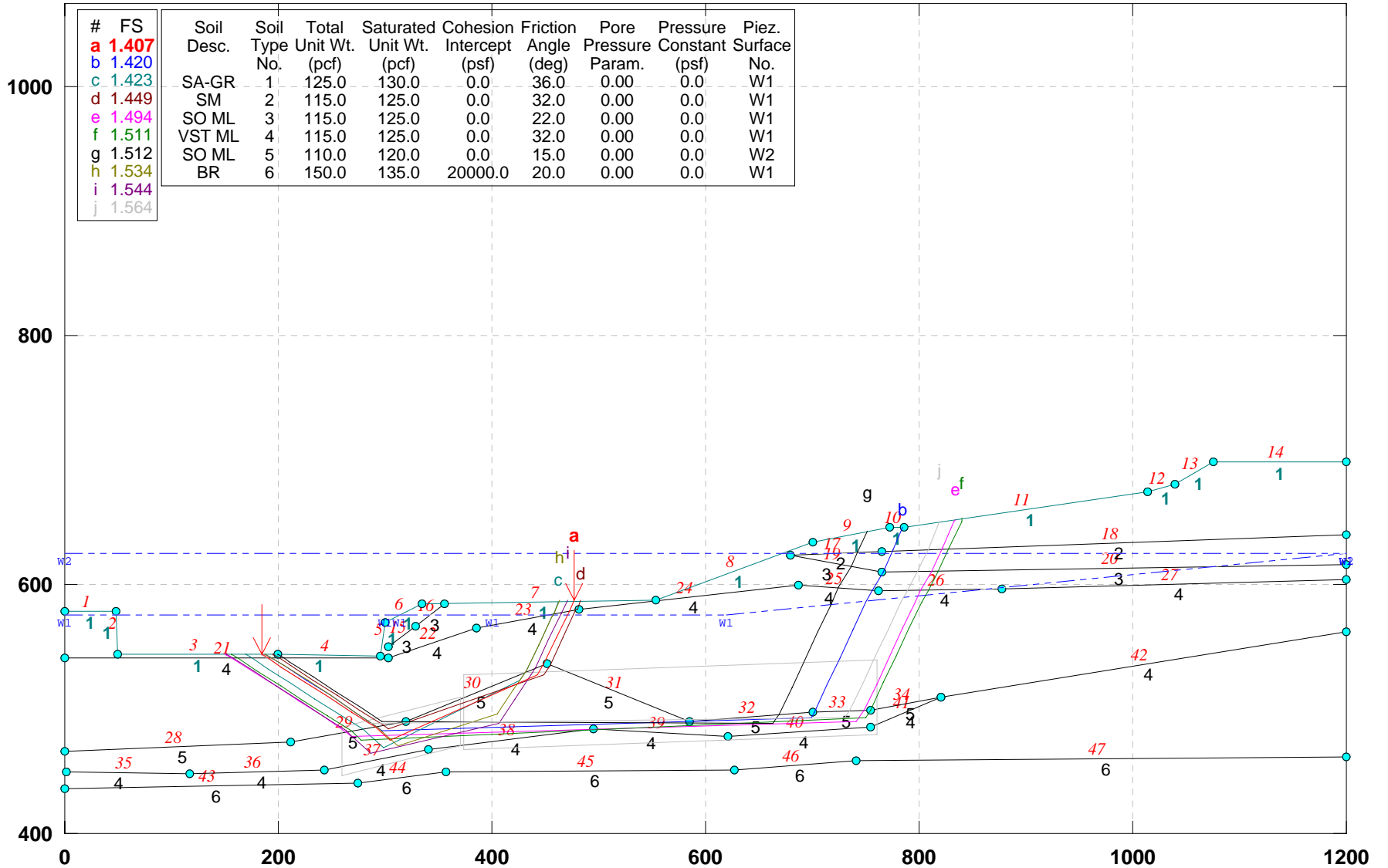

GSTABL7 v.2 FSmin=1.407

Safety Factors Are Calculated By The Simplified Janbu Method



# CUY-90-14.92 (Sec. F-F): PROPOSED GEOMETRY (Alt-3)\_Block Search

e:\from work on laptop\77332\slope stability\final-7-29-09\alt-3\ff-p-a3b.pl2 Run By: Jamal Nusairat 11/24/2009 08:24PM

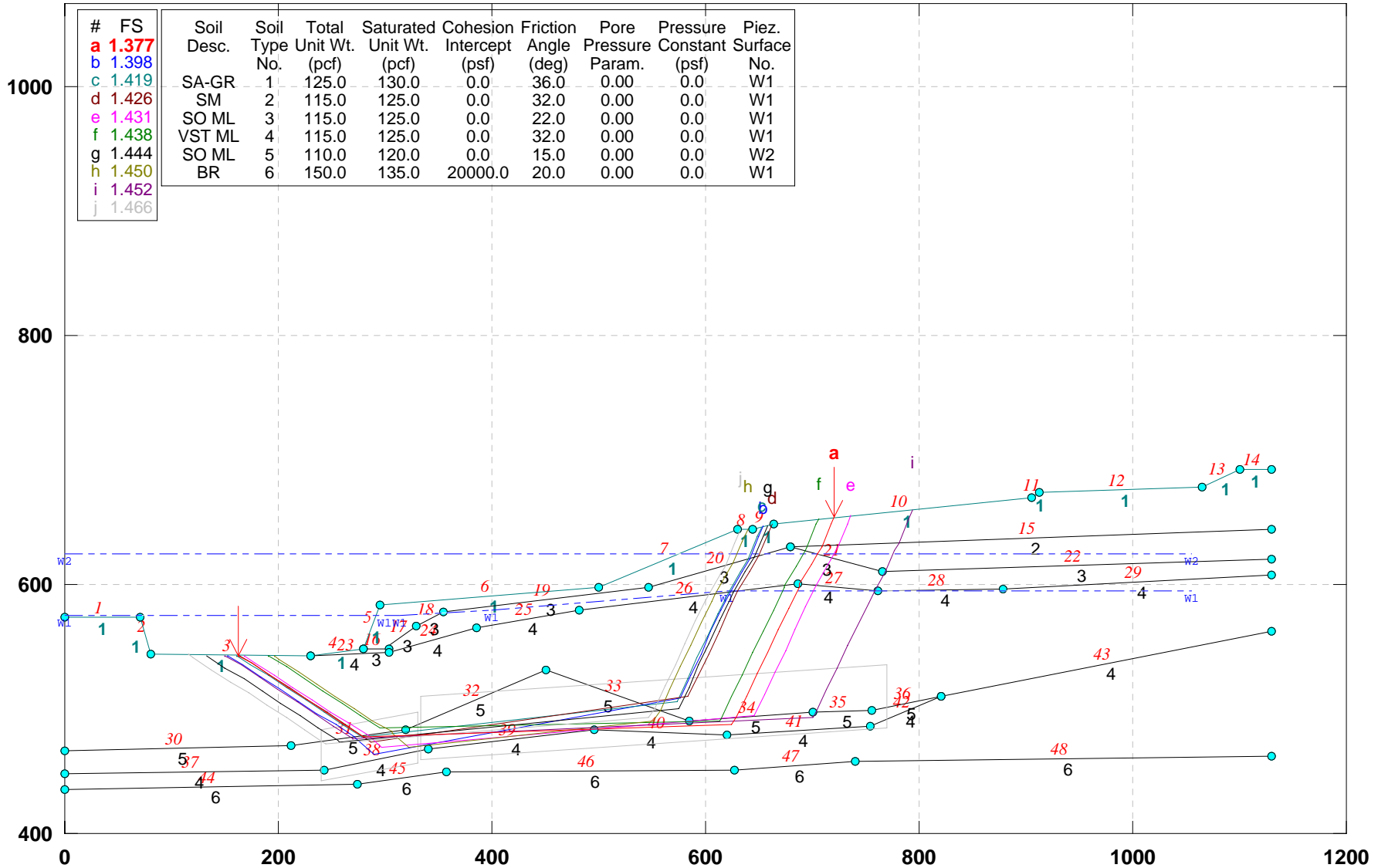

GSTABL7 v.2 FSmin=1.377

Safety Factors Are Calculated By The Simplified Janbu Method



# CUY-90-14.92 (Sec. G-G): PROPOSED EXCAVATION (ALT-3)\_Block Search

e:\from work on laptop\77332\slope stability\final-7-29-09\alt-3\gg-p3b.pl2 Run By: Jamal Nusairat 11/25/2009 02:08AM

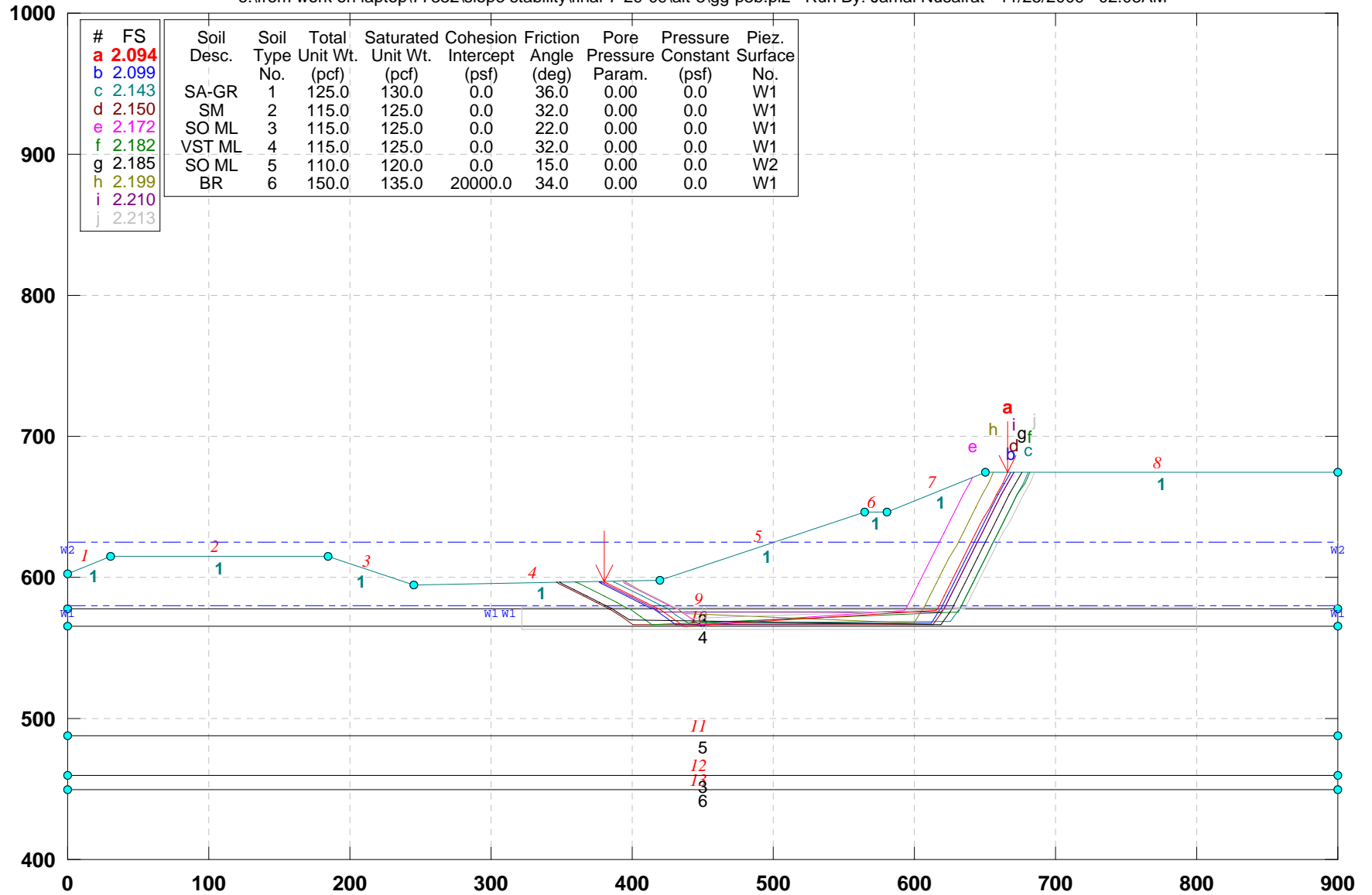

GSTABL7 v.2 FSmin=2.094

Safety Factors Are Calculated By The Simplified Janbu Method



# CUY-90-14.40 (Sec. U-U): PROPOSED EXCAVATION (Alt-3)\_Block Search

e:\from work on laptop\77332\slope stability\final-7-29-09\alt-3\uu-pr3b.pl2 Run By: Jamal Nusairat 11/25/2009 02:13AM

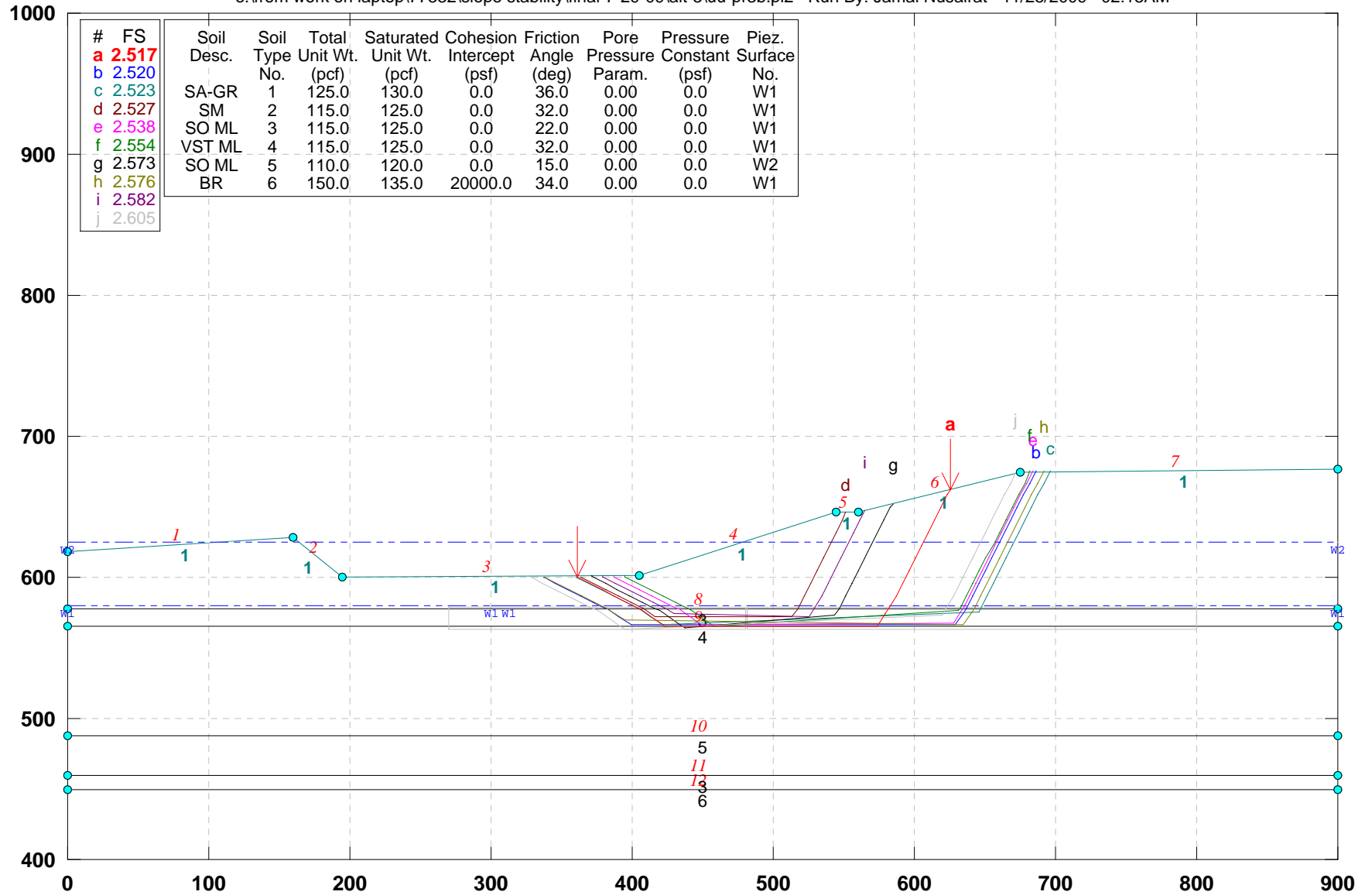

| # | FS    | Soil Desc. | Soil Type No. | Total Unit Wt. (pcf) | Saturated Unit Wt. (pcf) | Cohesion Intercept (psf) | Friction Angle (deg) | Pore Pressure Param. | Pressure Constant (psf) | Piez. Surface No. |
|---|-------|------------|---------------|----------------------|--------------------------|--------------------------|----------------------|----------------------|-------------------------|-------------------|
| a | 2.517 |            |               |                      |                          |                          |                      |                      |                         |                   |
| b | 2.520 |            |               |                      |                          |                          |                      |                      |                         |                   |
| c | 2.523 | SA-GR      | 1             | 125.0                | 130.0                    | 0.0                      | 36.0                 | 0.00                 | 0.0                     | W1                |
| d | 2.527 | SM         | 2             | 115.0                | 125.0                    | 0.0                      | 32.0                 | 0.00                 | 0.0                     | W1                |
| e | 2.538 | SO ML      | 3             | 115.0                | 125.0                    | 0.0                      | 22.0                 | 0.00                 | 0.0                     | W1                |
| f | 2.554 | VST ML     | 4             | 115.0                | 125.0                    | 0.0                      | 32.0                 | 0.00                 | 0.0                     | W1                |
| g | 2.573 | SO ML      | 5             | 110.0                | 120.0                    | 0.0                      | 15.0                 | 0.00                 | 0.0                     | W2                |
| h | 2.576 | BR         | 6             | 150.0                | 135.0                    | 20000.0                  | 34.0                 | 0.00                 | 0.0                     | W1                |
| i | 2.582 |            |               |                      |                          |                          |                      |                      |                         |                   |
| j | 2.605 |            |               |                      |                          |                          |                      |                      |                         |                   |

GSTABL7 v.2 FSmin=2.517

Safety Factors Are Calculated By The Simplified Janbu Method



# CUY-90-14.92 (Sec. W-W): PROPOSED GEOMETRY (Alt-3)\_Block Search

e:\from work on laptop\77332\slope stability\final-7-29-09\alt-3\ww-p-a3b.pl2 Run By: Jamal Nusairat 11/24/2009 08:29PM

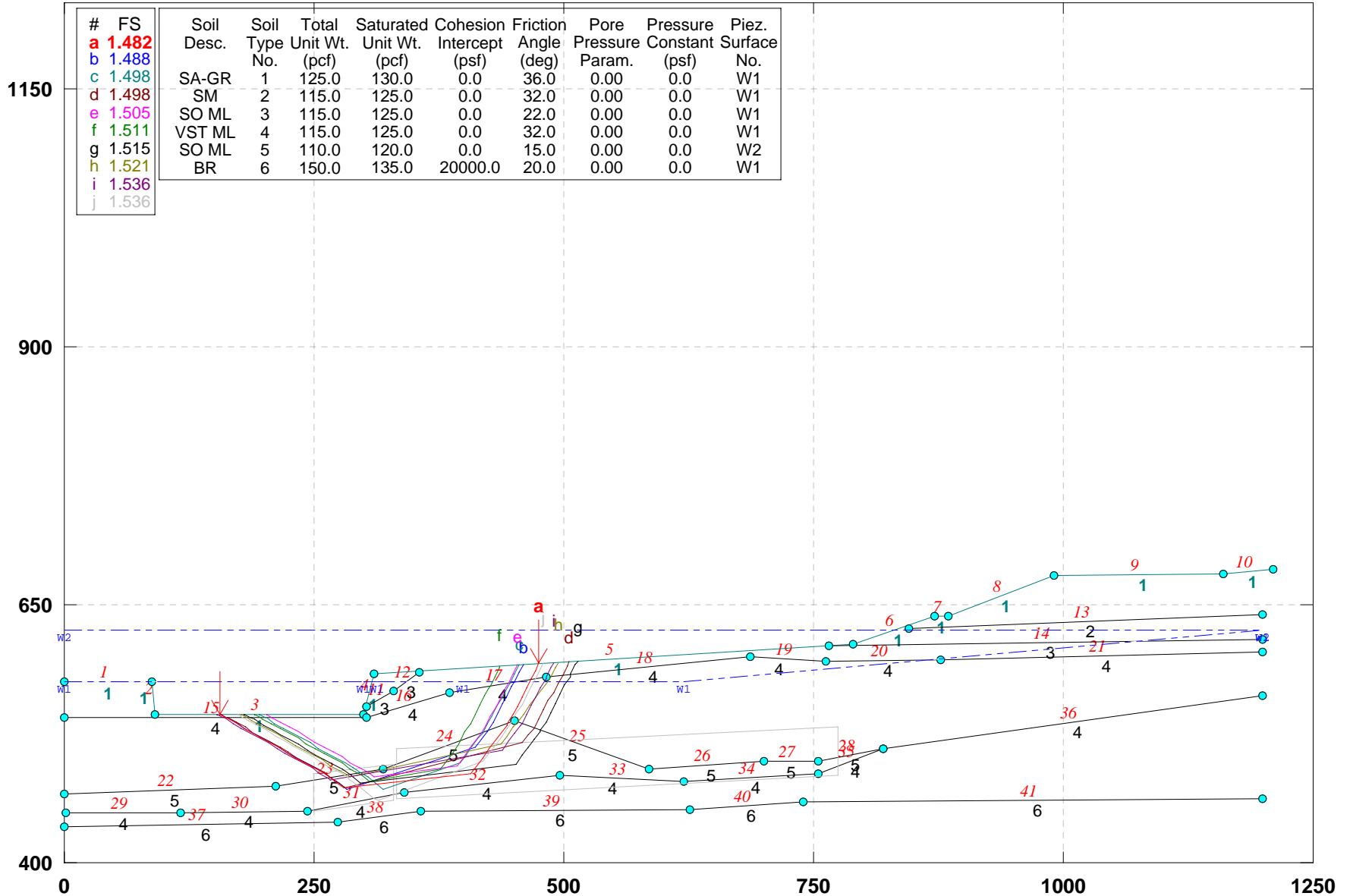

GSTABL7 v.2 FSmin=1.482

Safety Factors Are Calculated By The Simplified Janbu Method





# CUY-90-14.92 (Sec. Z-Z): PROPOSED GEOMETRY (Alt-3)\_Block Search

e:\from work on laptop\77332\slope stability\final-7-29-09\alt-3\zz-p-a3b.pl2 Run By: Jamal Nusairat 11/24/2009 08:33PM

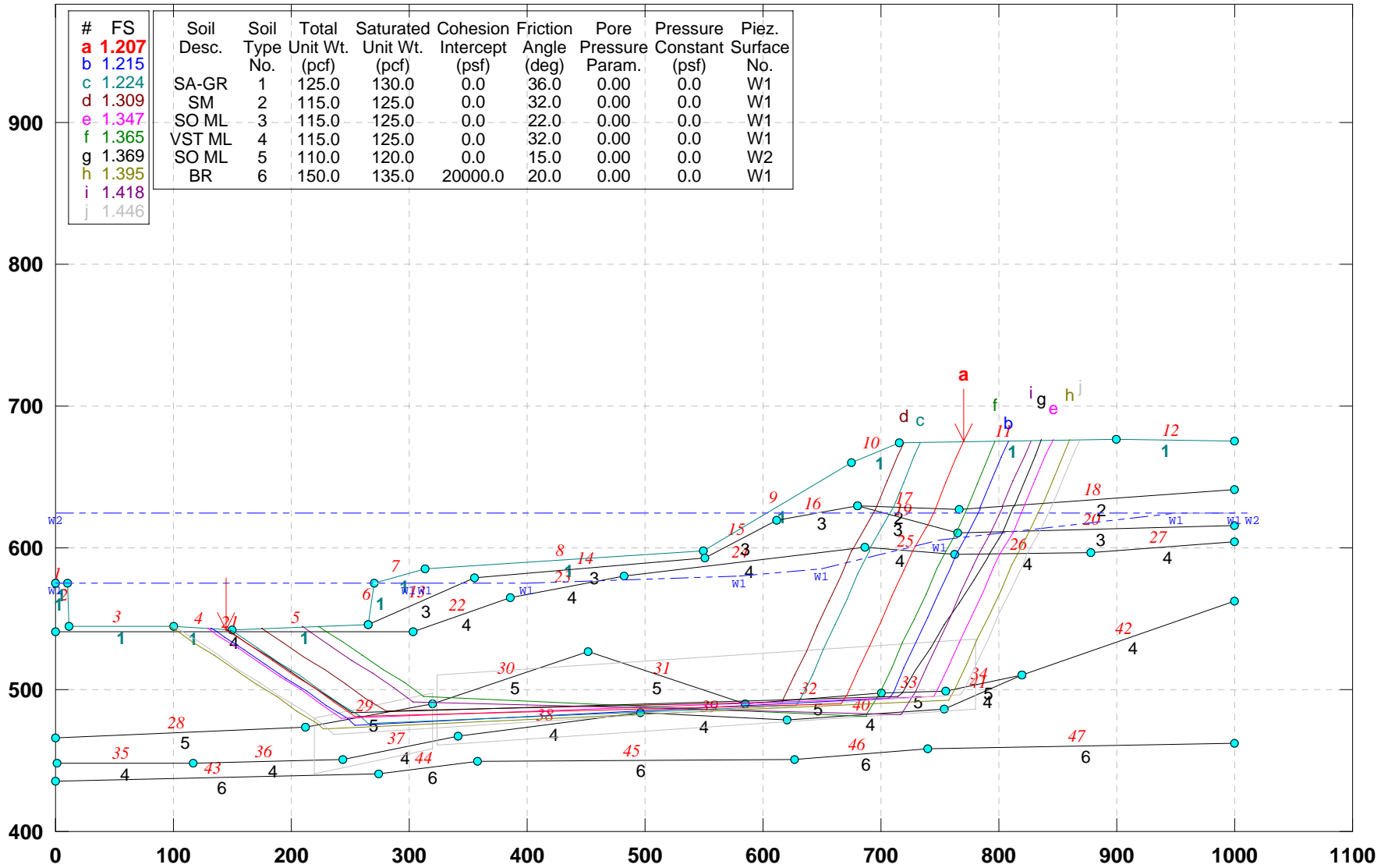

GSTABL7 v.2 FSmin=1.207

Safety Factors Are Calculated By The Simplified Janbu Method



# CUY-90-14.92 (Sec. Y-Y): PROPOSED GEOMETRY (ALT-3)\_Block Search

e:\from work on laptop\77332\slope stability\final-7-29-09\alt-3\yy-p3b.pl2 Run By: Jamal Nusairat 11/24/2009 08:32PM

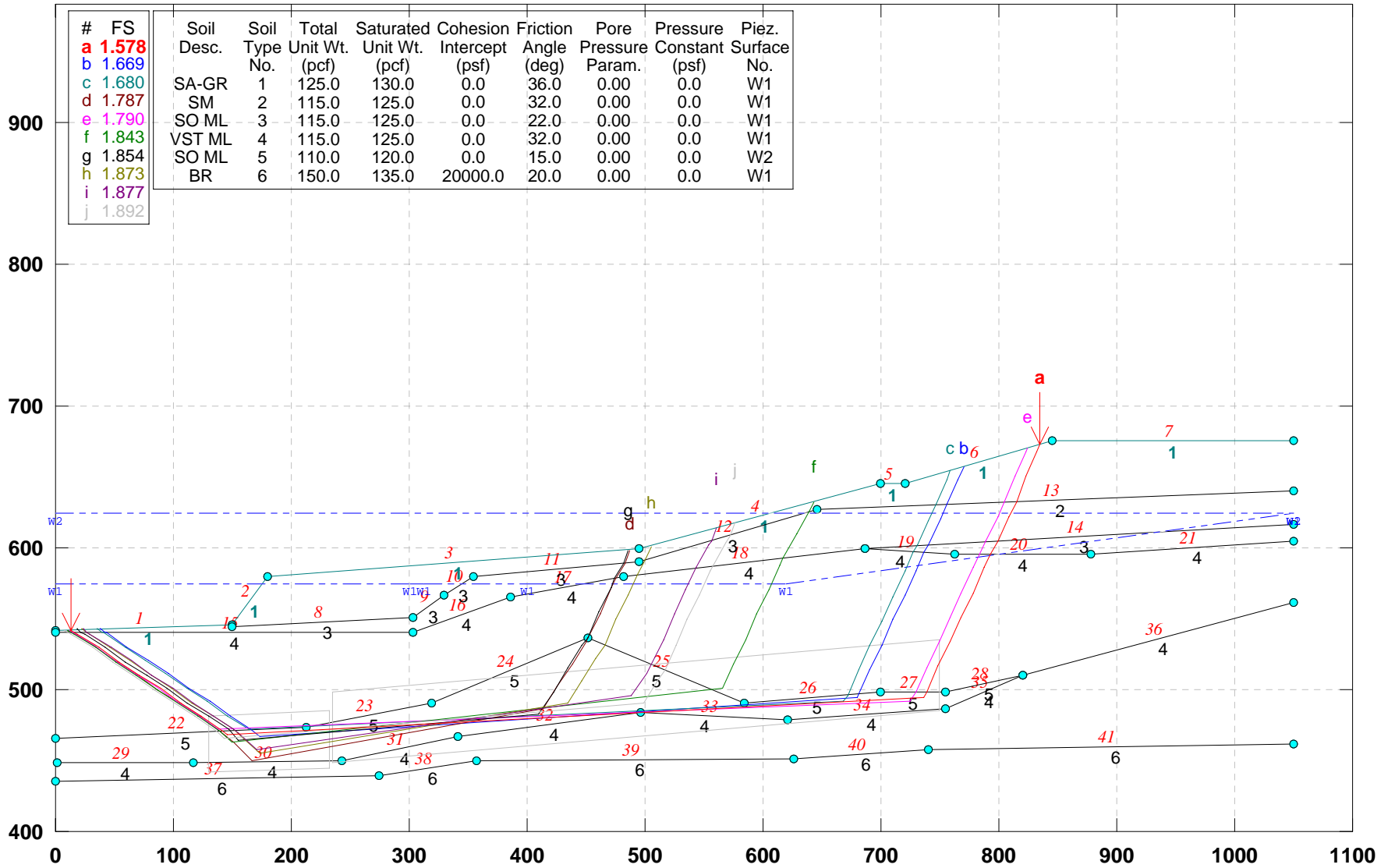

| # | FS    | Soil Desc. | Soil Type No. | Soil Unit Wt. (pcf) | Total Unit Wt. (pcf) | Saturated Unit Wt. (pcf) | Cohesion Intercept (psf) | Friction Angle (deg) | Pore Pressure Param. (psf) | Pressure Constant (psf) | Piez. Surface No. |
|---|-------|------------|---------------|---------------------|----------------------|--------------------------|--------------------------|----------------------|----------------------------|-------------------------|-------------------|
| a | 1.578 |            |               |                     |                      |                          |                          |                      |                            |                         |                   |
| b | 1.669 |            |               |                     |                      |                          |                          |                      |                            |                         |                   |
| c | 1.680 | SA-GR      | 1             | 125.0               | 130.0                | 0.0                      | 36.0                     | 0.00                 | 0.0                        | 0.0                     | W1                |
| d | 1.787 | SM         | 2             | 115.0               | 125.0                | 0.0                      | 32.0                     | 0.00                 | 0.0                        | 0.0                     | W1                |
| e | 1.790 | SO ML      | 3             | 115.0               | 125.0                | 0.0                      | 22.0                     | 0.00                 | 0.0                        | 0.0                     | W1                |
| f | 1.843 | VST ML     | 4             | 115.0               | 125.0                | 0.0                      | 32.0                     | 0.00                 | 0.0                        | 0.0                     | W1                |
| g | 1.854 | SO ML      | 5             | 110.0               | 120.0                | 0.0                      | 15.0                     | 0.00                 | 0.0                        | 0.0                     | W2                |
| h | 1.873 | BR         | 6             | 150.0               | 135.0                | 20000.0                  | 20.0                     | 0.00                 | 0.0                        | 0.0                     | W1                |
| i | 1.877 |            |               |                     |                      |                          |                          |                      |                            |                         |                   |
| j | 1.892 |            |               |                     |                      |                          |                          |                      |                            |                         |                   |

GSTABL7 v.2 FSmin=1.578

Safety Factors Are Calculated By The Simplified Janbu Method



### CUY-90-14.92 (Sec. A-A): PROPOSED GEOMETRY (Alt-3)

E:\REPORTS\CUY-90\2009WO-1\2009-S-1\ALT-3\_~1\AA-PR.PL2 Run By: Username 6/13/2009 12:42AM

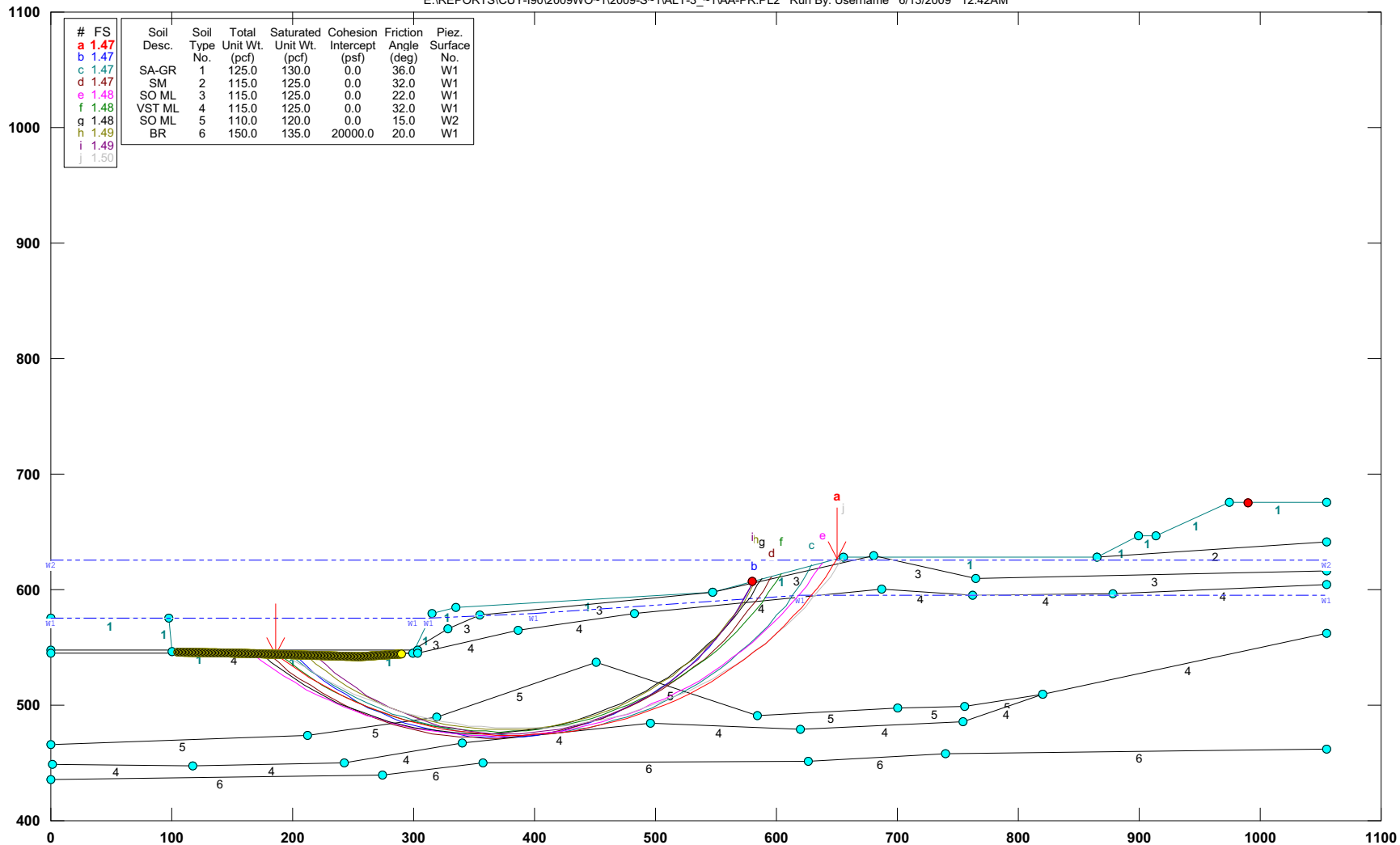

GSTABL7 v.2 FSmin=1.47  
Safety Factors Are Calculated By The Simplified Janbu Method



# CUY-90-14.92 (Sec. B-B): PROPOSED GEOMETRY (Alt-3)

e:\from work on laptop\77332\slope stability\final-7-29-09\alt-3\bb-pr-a3.pl2 Run By: Jamal Nusairat 11/24/2009 08:41PM

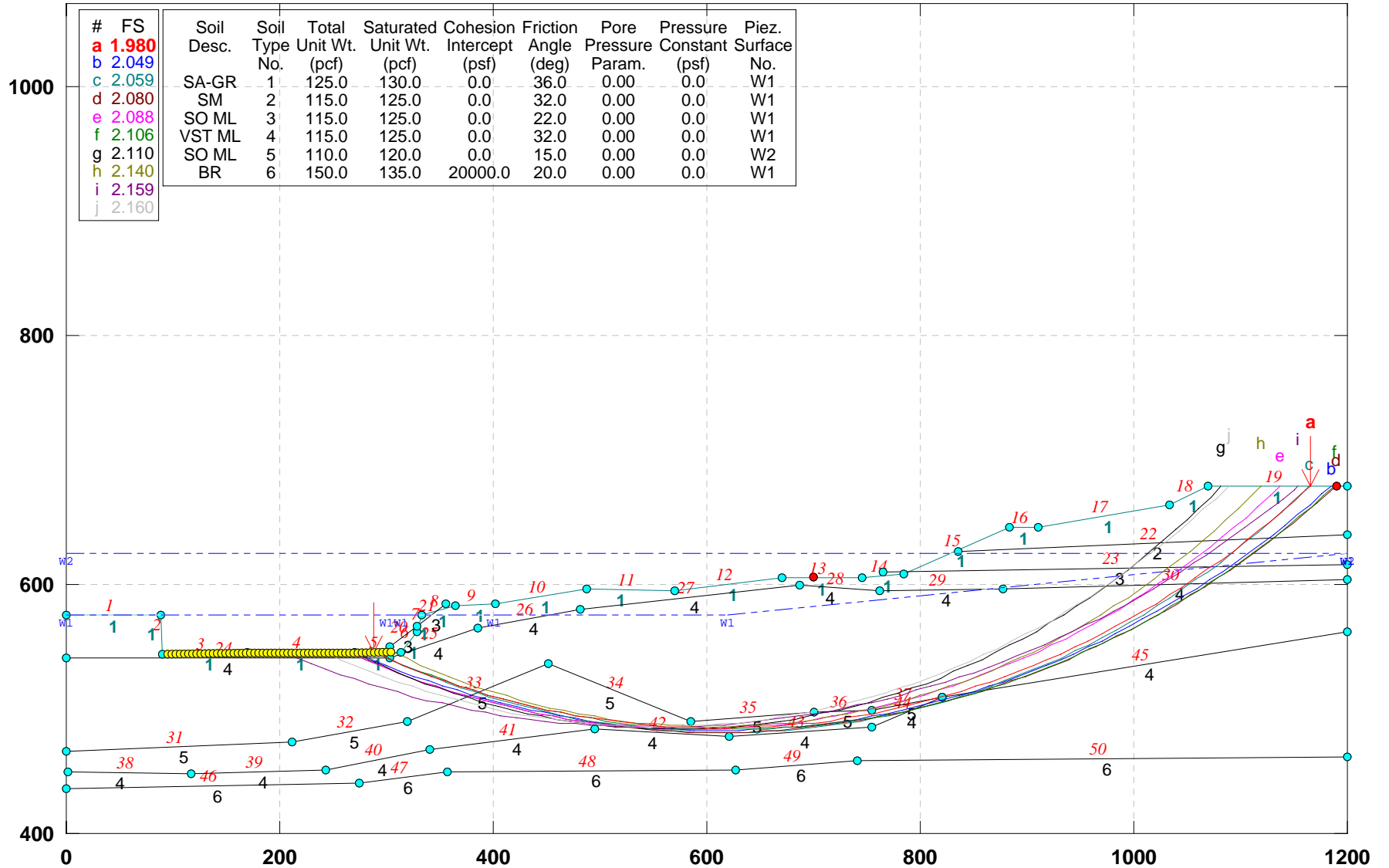

GSTABL7 v.2 FSmin=1.980

Safety Factors Are Calculated By The Simplified Janbu Method



# CUY-90-14.92 (Sec. E-E): PROPOSED GEOMETRY (Alt-3)

e:\from work on laptop\77332\slope stability\final-7-29-09\alt-3\ee-pr-a3.pl2 Run By: Jamal Nusairat 11/24/2009 08:42PM

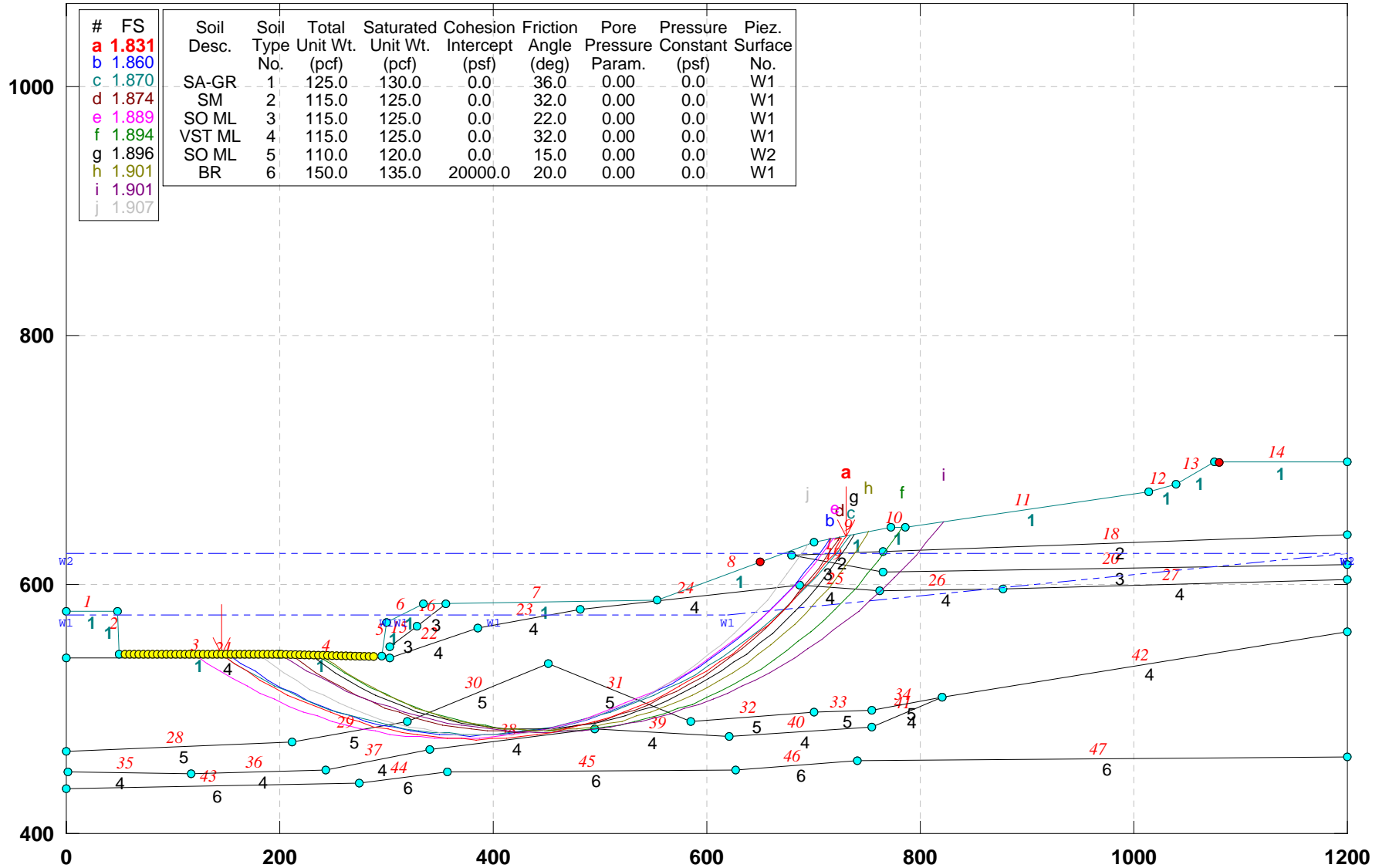

GSTABL7 v.2 FSmin=1.831

Safety Factors Are Calculated By The Simplified Janbu Method



# CUY-90-14.92 (Sec. F-F): PROPOSED GEOMETRY (Alt-3)

e:\from work on laptop\77332\slope stability\final-7-29-09\alt-3\ff-pr-a3.pl2 Run By: Jamal Nusairat 11/24/2009 08:44PM

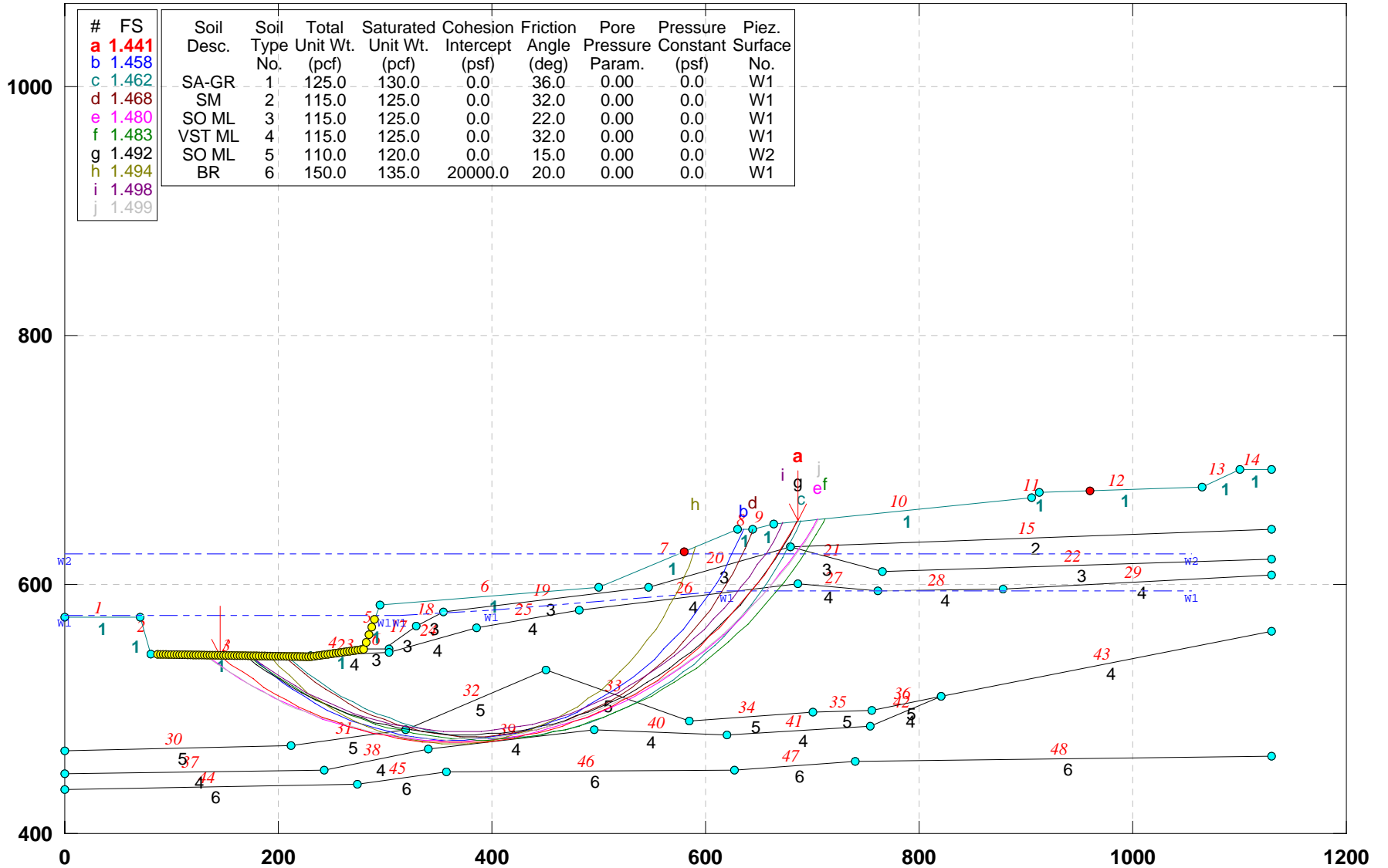

GSTABL7 v.2 FSmin=1.441

Safety Factors Are Calculated By The Simplified Janbu Method



# CUY-90-14.92 (Sec. G-G): PROPOSED EXCAVATED GEOMETRY- STABILITY (ALT-3)

e:\from work on laptop\77332\slope stability\final-7-29-09\alt-3\gg-pr3.pl2 Run By: Jamal Nusairat 11/24/2009 08:46PM

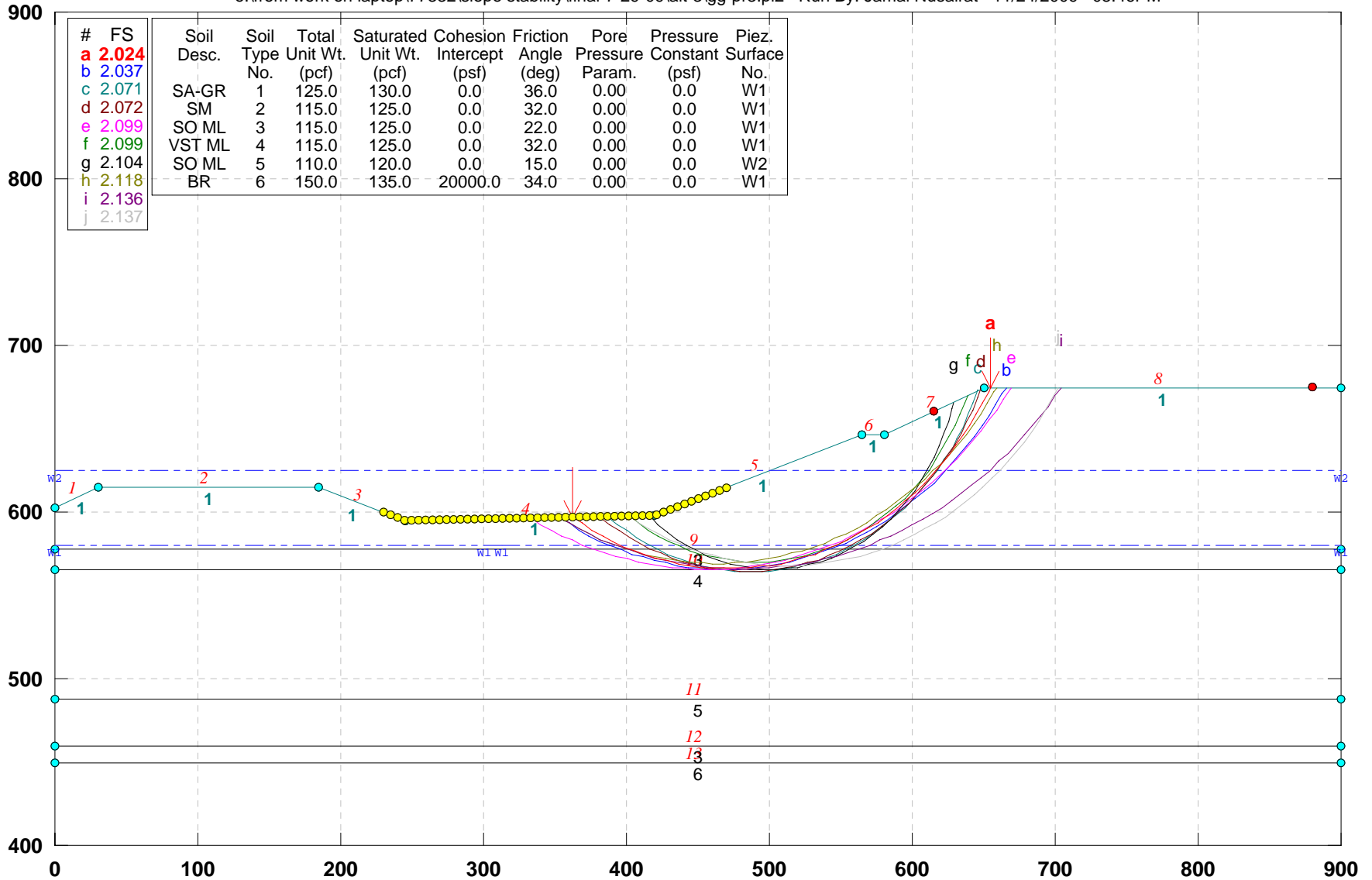

GSTABL7 v.2 FSmin=2.024

Safety Factors Are Calculated By The Simplified Janbu Method



# CUY-90-14.40 (Sec. I-I): PROPOSED EXCAVATION (Alt-3)

e:\from work on laptop\77332\slope stability\final-7-29-09\alt-3\ii-pr3.pl2 Run By: Jamal Nusairat 11/25/2009 02:24AM

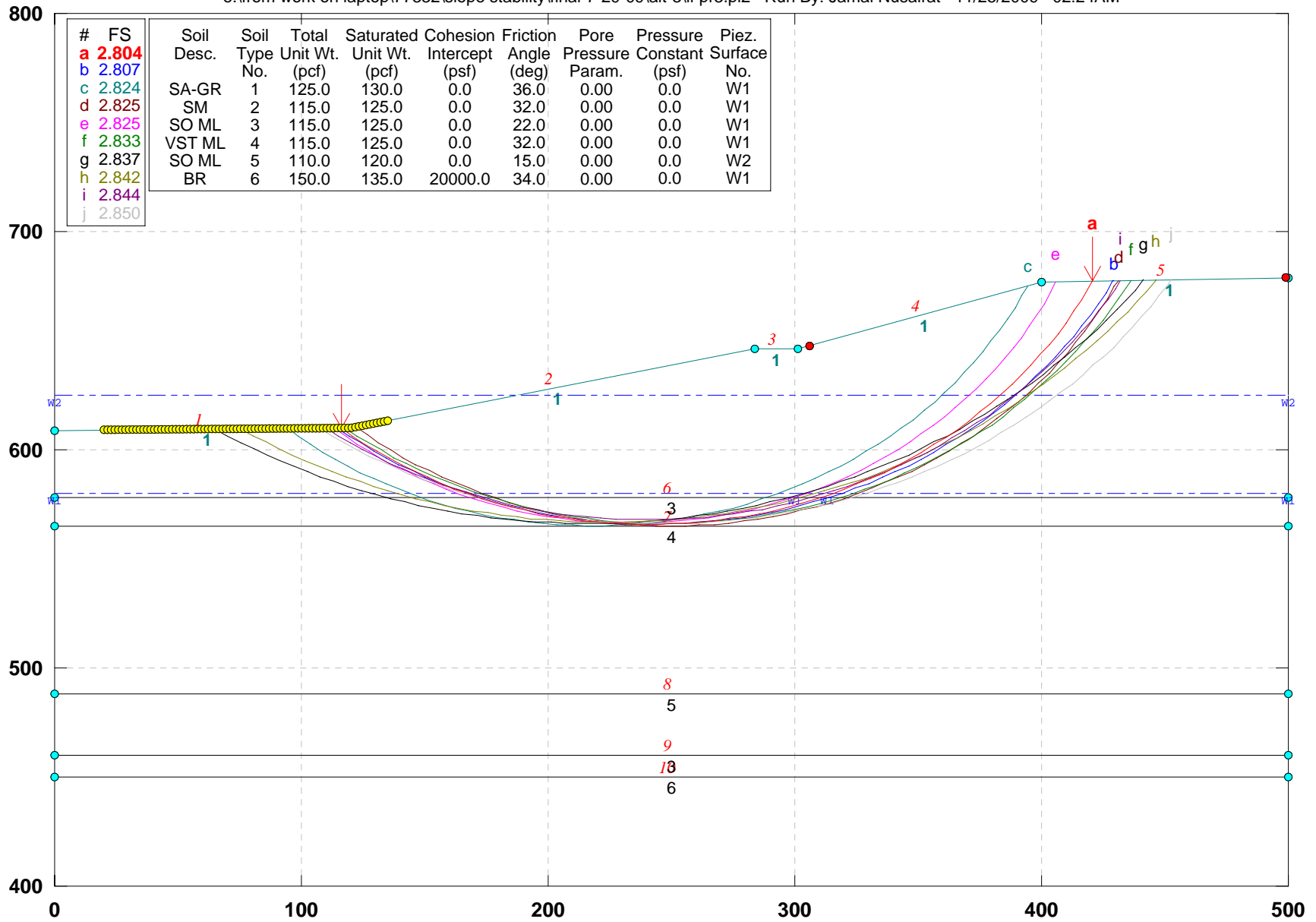

GSTABL7 v.2 FSmin=2.804

Safety Factors Are Calculated By The Simplified Janbu Method





## CUY-90-14.92 (Sec. U-U): PROPOSED EXCAVATION (Alt-3)

e:\from work on laptop\77332\slope stability\final-7-29-09\alt-3\uu-pr3.pl2 Run By: Jamal Nusairat 11/24/2009 08:48PM

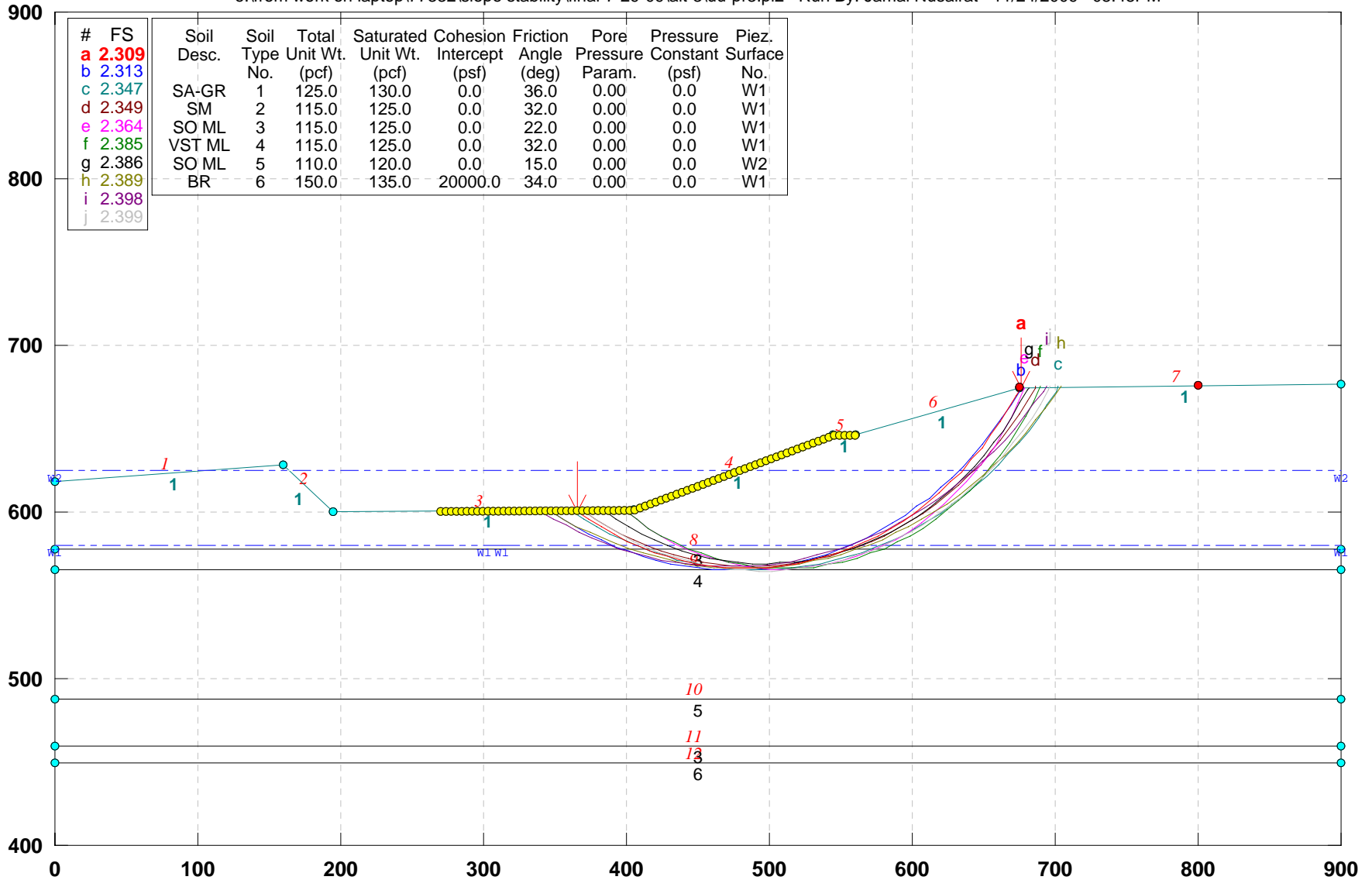

GSTABL7 v.2 FSmin=2.309

Safety Factors Are Calculated By The Simplified Janbu Method



# CUY-90-14.92 (Sec. W-W): PROPOSED GEOMETRY (Alt-3)

e:\from work on laptop\77332\slope stability\final-7-29-09\alt-3\ww-pr-a3.pl2 Run By: Jamal Nusairat 11/24/2009 08:50PM

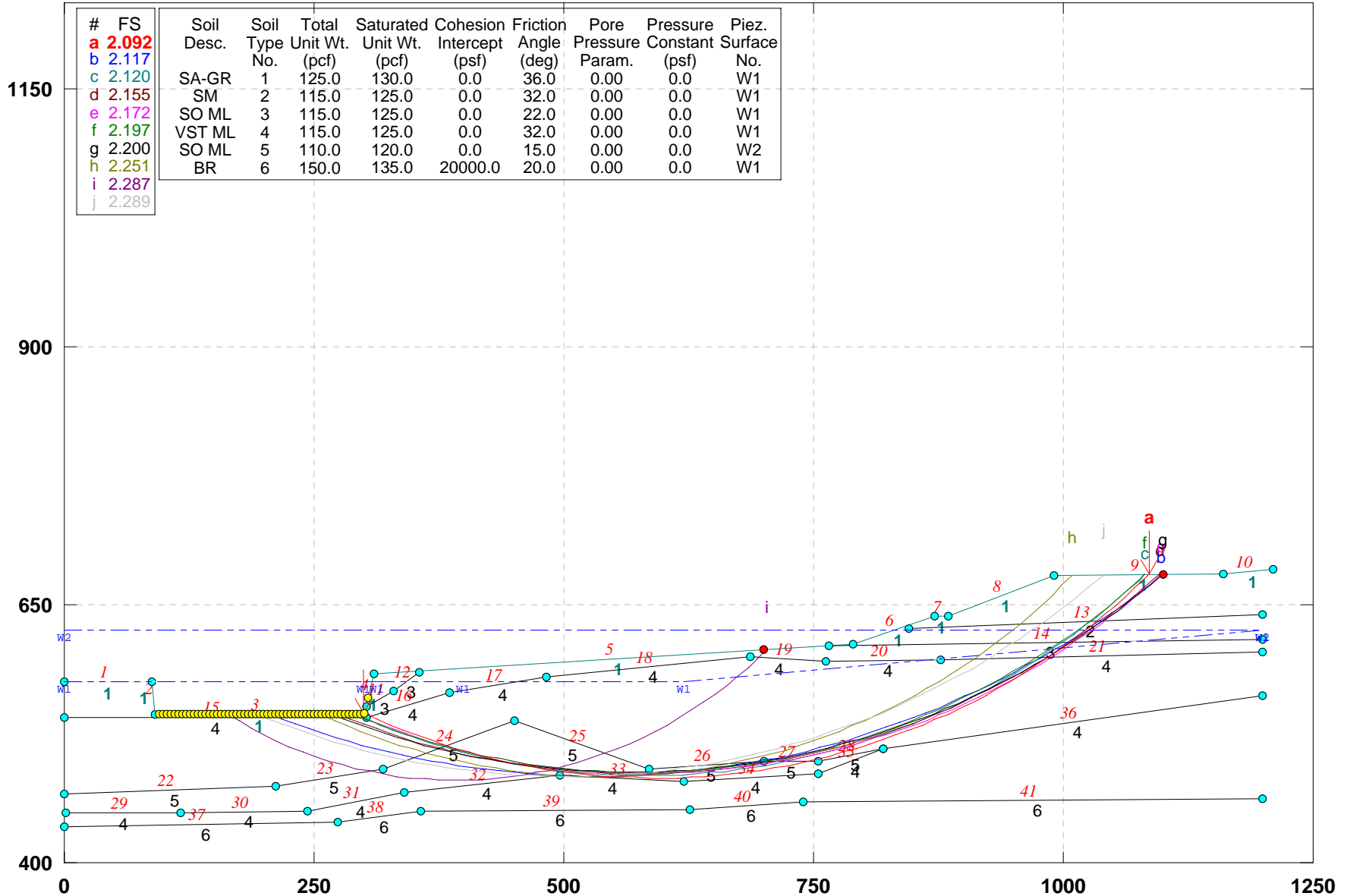

GSTABL7 v.2 FSmin=2.092

Safety Factors Are Calculated By The Simplified Janbu Method



# CUY-90-14.92 (Sec. Y-Y): PROPOSED GEOMETRY (ALT-3)

e:\from work on laptop\77332\slope stability\final-7-29-09\alt-3\yy-pr3.pl2 Run By: Jamal Nusairat 11/24/2009 08:57PM

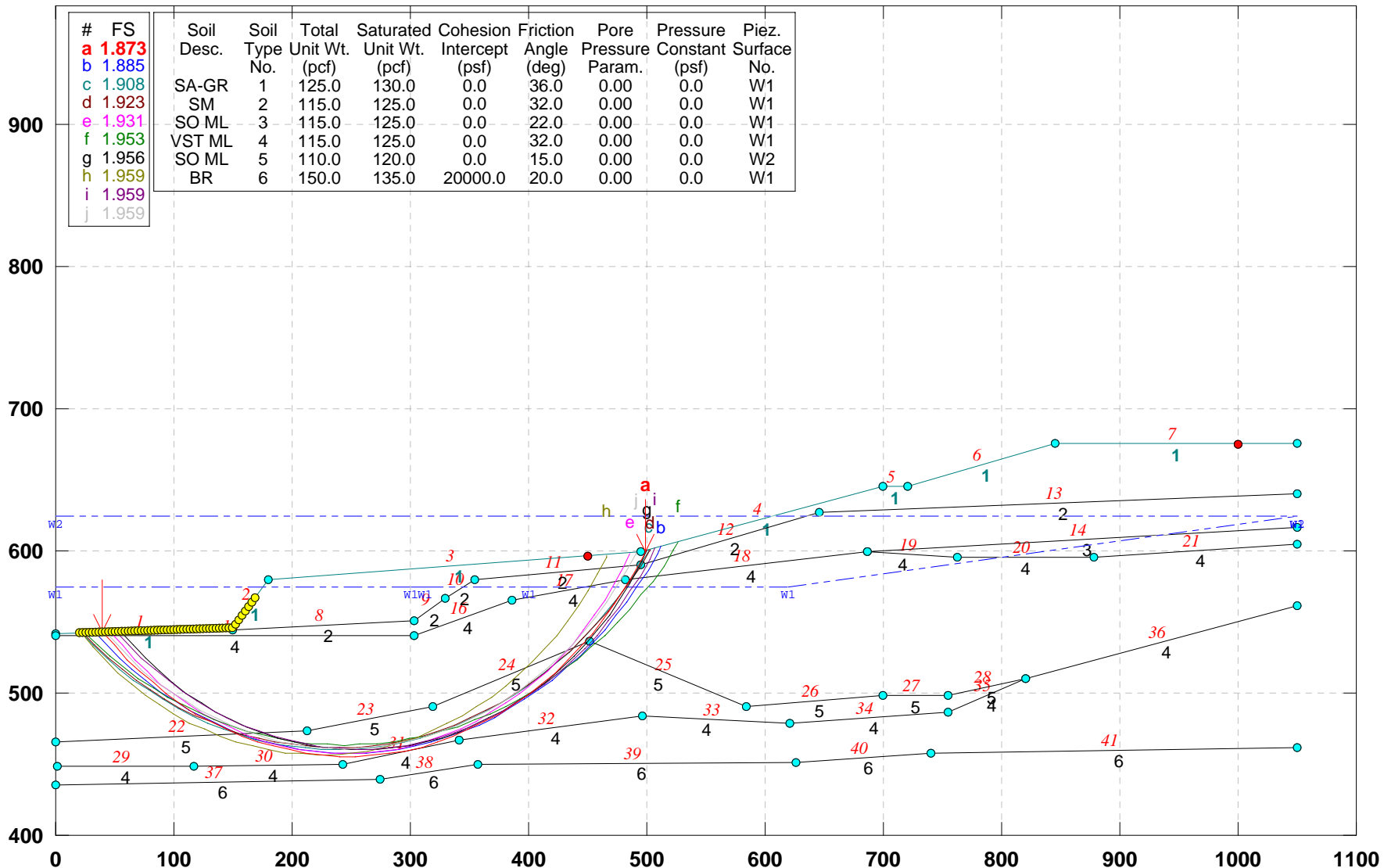

GSTABL7 v.2 FSmin=1.873

Safety Factors Are Calculated By The Simplified Janbu Method



# CUY-90-14.92 (Sec. Z-Z): PROPOSED GEOMETRY (Alt-3)

e:\from work on laptop\77332\slope stability\final-7-29-09\alt-3\zz-pr-a3.pl2 Run By: Jamal Nusairat 11/24/2009 08:55PM

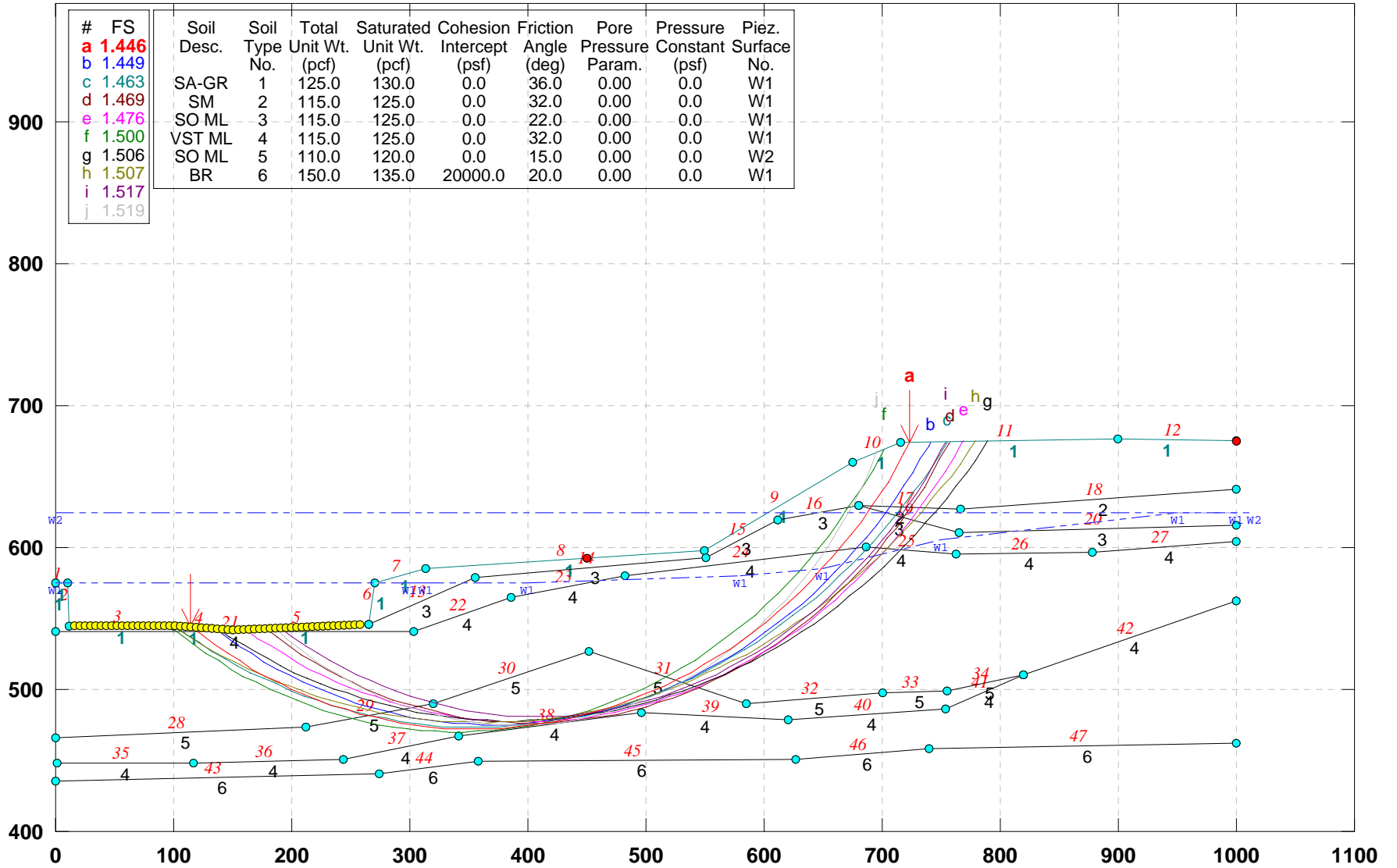

GSTABL7 v.2 FSmin=1.446

Safety Factors Are Calculated By The Simplified Janbu Method



**APPENDIX 7G**

**SLOPE STABILITY ANALYSES BASED ON  
ALTERNATIVE 4 GRADING**

# CUY-90-14.92 (Sec. A-A): PROPOSED GEOMETRY (Alt-4)\_Chech Block Search

e:\from work on laptop\77332\slope stability\final-7-29-09\alt-4\aa-p-a4c.plt Run By: Jamal Nusairat 11/24/2009 09:06PM

| Soil Desc. | Soil No. | Total Unit Wt. (pcf) | Saturated Unit Wt. (pcf) | Cohesion Intercept (psf) | Friction Angle (deg) | Pore Pressure Param. (psf) | Pressure Constant (psf) | Piez. Surface No. |
|------------|----------|----------------------|--------------------------|--------------------------|----------------------|----------------------------|-------------------------|-------------------|
| SA-GR      | 1        | 125.0                | 130.0                    | 0.0                      | 36.0                 | 0.00                       | 0.0                     | W1                |
| SM         | 2        | 115.0                | 125.0                    | 0.0                      | 32.0                 | 0.00                       | 0.0                     | W1                |
| SO ML      | 3        | 115.0                | 125.0                    | 0.0                      | 22.0                 | 0.00                       | 0.0                     | W1                |
| VST ML     | 4        | 115.0                | 125.0                    | 0.0                      | 32.0                 | 0.00                       | 0.0                     | W1                |
| SO ML      | 5        | 110.0                | 120.0                    | 0.0                      | 15.0                 | 0.00                       | 0.0                     | W2                |
| BR         | 6        | 150.0                | 135.0                    | 20000.0                  | 20.0                 | 0.00                       | 0.0                     | W1                |

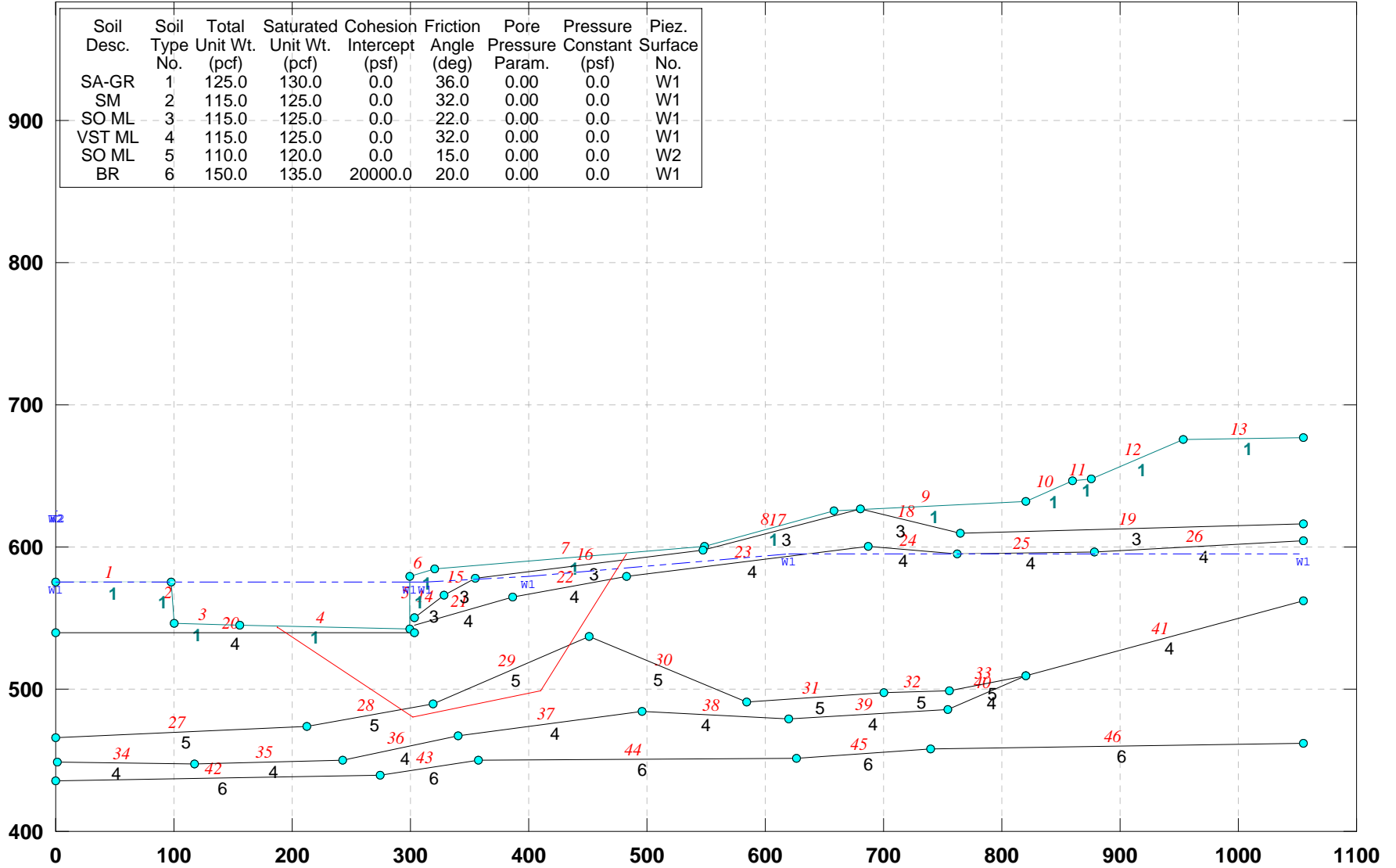

GSTABL7 v.2 FSmin=1.300

Factor Of Safety Is Calculated By The Simplified Janbu Method



# CUY-90-14.92 (Sec. A-A): PROPOSED GEOMETRY (Alt-4)\_Block Search

e:\from work on laptop\77332\slope stability\final-7-29-09\alt-4\aa-p-a4b.pl2 Run By: Jamal Nusairat 11/24/2009 09:09PM

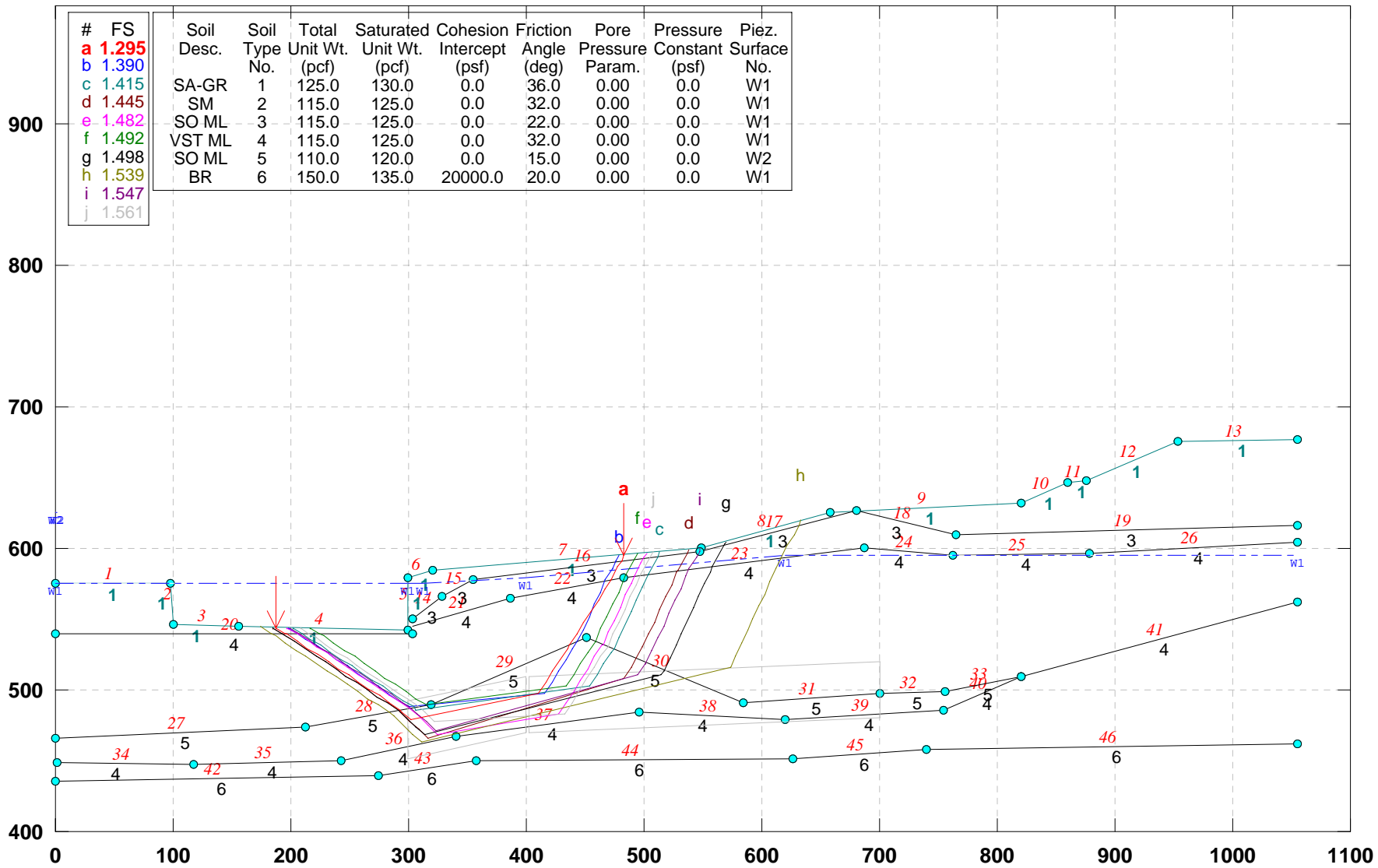

GSTABL7 v.2 FSmin=1.295

Safety Factors Are Calculated By The Simplified Janbu Method



# CUY-90-14.92 (Sec. A-A): PROPOSED GEOMETRY (Alt-4)\_Check Block Search\_ No W2

e:\from work on laptop\77332\slope stability\final-7-29-09\alt-4\aa-p-a4c.plt Run By: Jamal Nusairat 11/25/2009 02:29AM

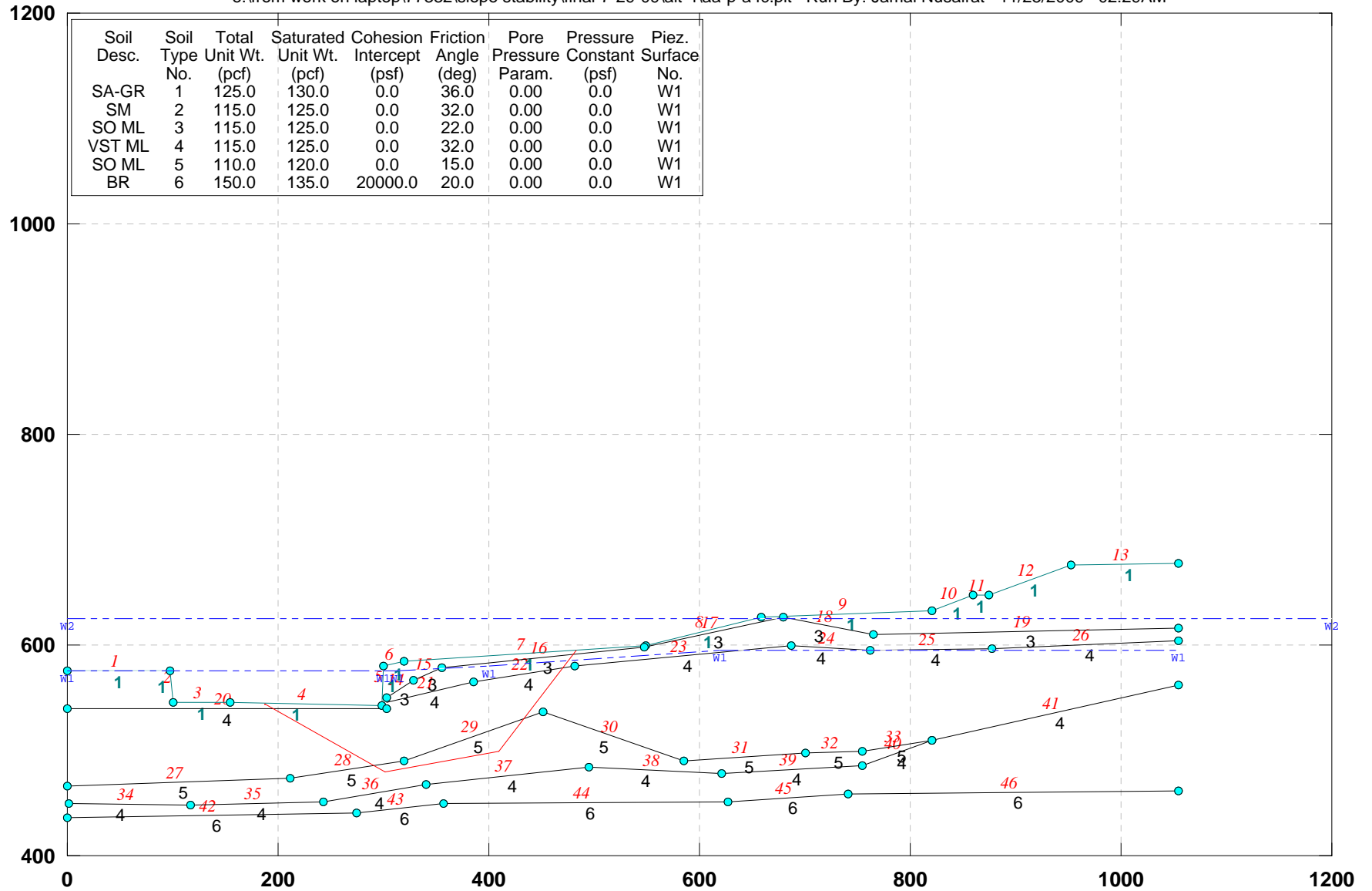

GSTABL7 v.2 FSmin=1.671

Factor Of Safety Is Calculated By The Simplified Janbu Method





# CUY-90-14.92 (Sec. B-B): PROPOSED GEOMETRY (Alt-4)\_block search

e:\from work on laptop\77332\slope stability\final-7-29-09\alt-4\bb-p-a4b.pl2 Run By: Jamal Nusairat 11/24/2009 09:11PM

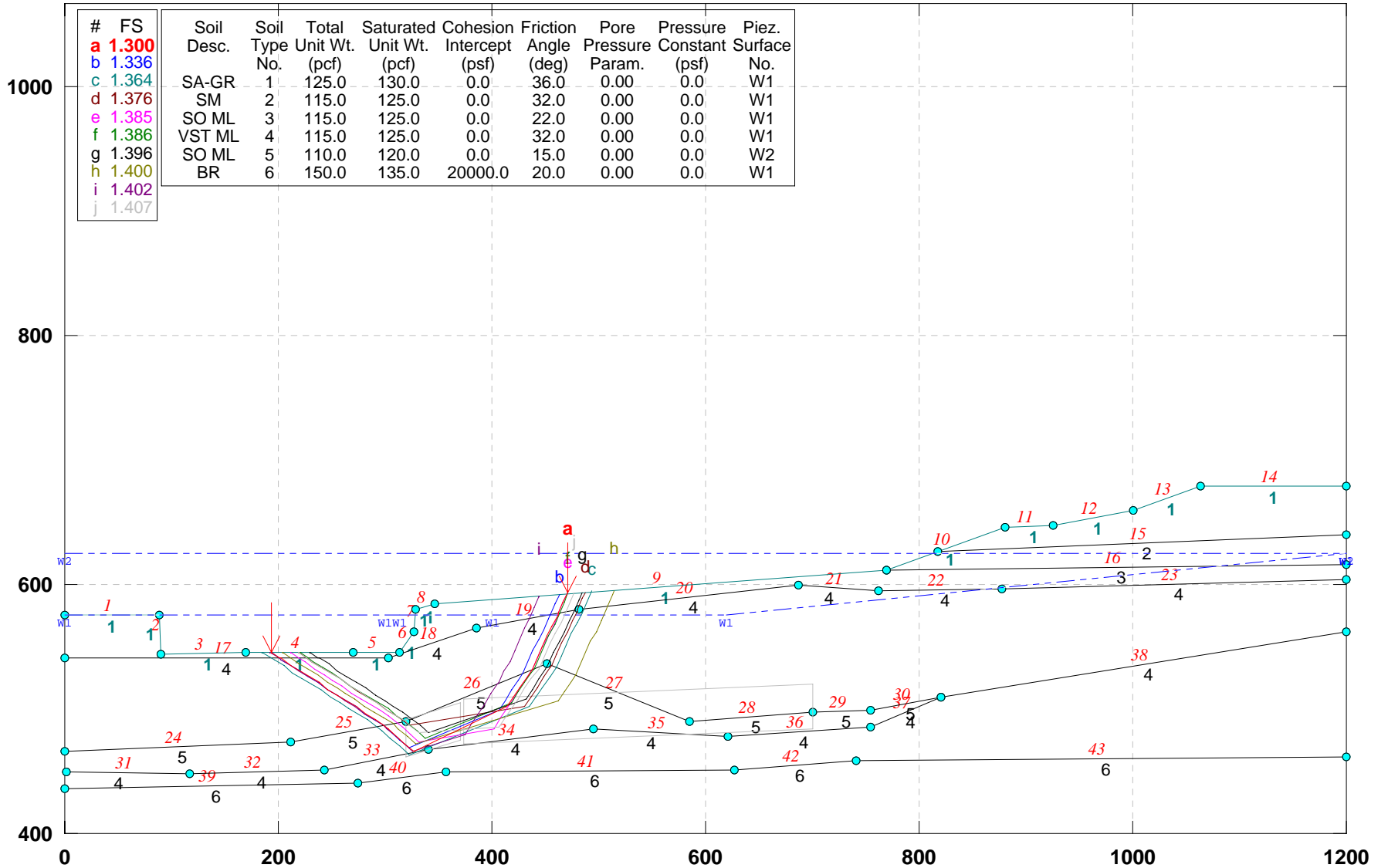

GSTABL7 v.2 FSmin=1.300

Safety Factors Are Calculated By The Simplified Janbu Method



# CUY-90-14.40 (Sec. B-B): PROPOSED GEOMETRY (Alt-4)\_Check block search\_ No W2

e:\from work on laptop\77332\slope stability\final-7-29-09\alt-4\bb-p-a4c.plt Run By: Jamal Nusairat 11/24/2009 10:37PM

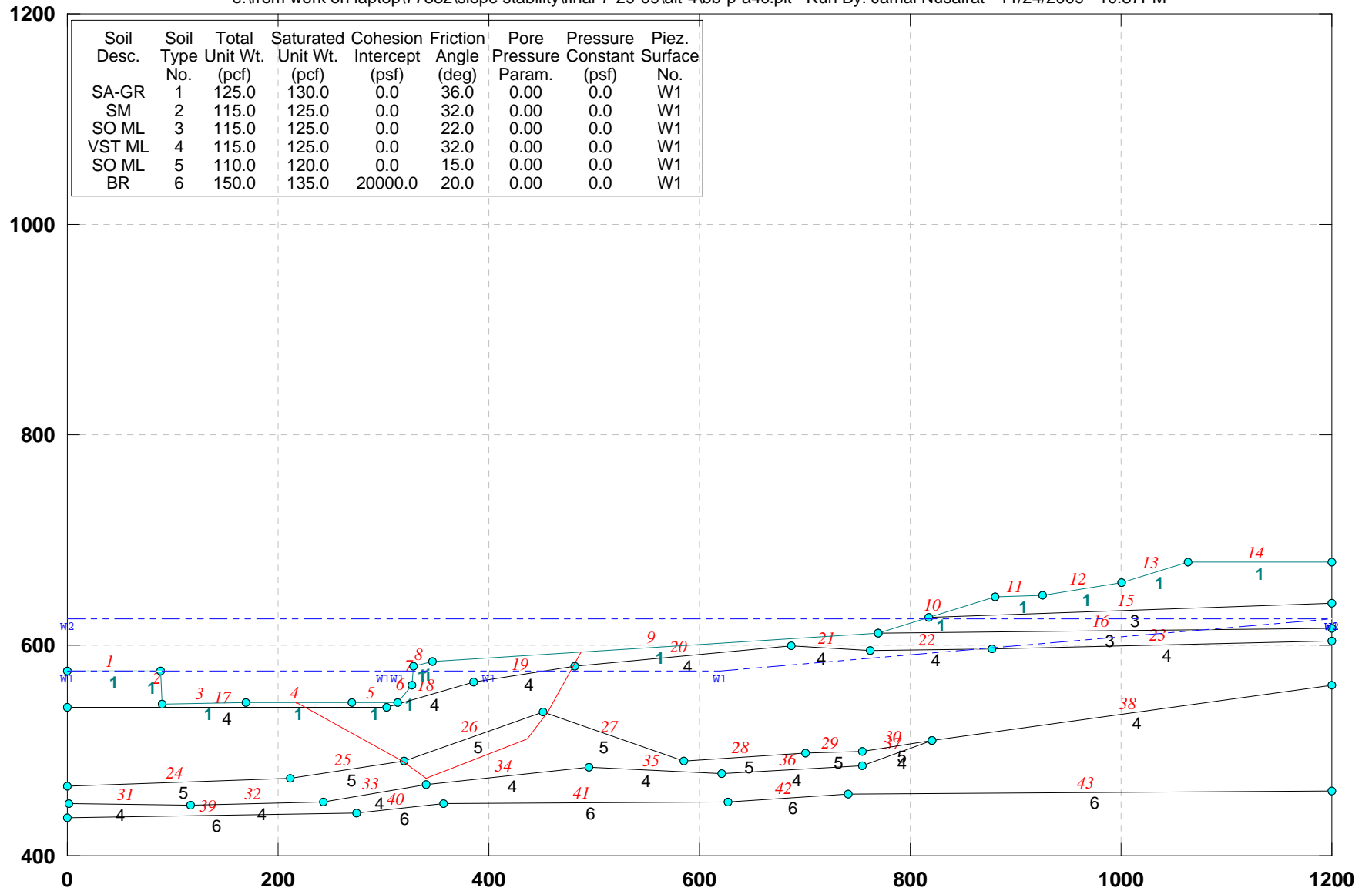

| Soil Desc. | Soil No. | Total Unit Wt. (pcf) | Saturated Unit Wt. (pcf) | Cohesion Intercept (psf) | Friction Angle (deg) | Pore Pressure Param. | Pressure Constant (psf) | Piez. Surface No. |
|------------|----------|----------------------|--------------------------|--------------------------|----------------------|----------------------|-------------------------|-------------------|
| SA-GR      | 1        | 125.0                | 130.0                    | 0.0                      | 36.0                 | 0.00                 | 0.0                     | W1                |
| SM         | 2        | 115.0                | 125.0                    | 0.0                      | 32.0                 | 0.00                 | 0.0                     | W1                |
| SO ML      | 3        | 115.0                | 125.0                    | 0.0                      | 22.0                 | 0.00                 | 0.0                     | W1                |
| VST ML     | 4        | 115.0                | 125.0                    | 0.0                      | 32.0                 | 0.00                 | 0.0                     | W1                |
| SO ML      | 5        | 110.0                | 120.0                    | 0.0                      | 15.0                 | 0.00                 | 0.0                     | W1                |
| BR         | 6        | 150.0                | 135.0                    | 20000.0                  | 20.0                 | 0.00                 | 0.0                     | W1                |

GSTABL7 v.2 FSmin=1.847

Factor Of Safety Is Calculated By The Simplified Janbu Method



# CUY-90-14.92 (Sec. D-D): PROPOSED GEOMETRY (ALT-4)- Block Search

e:\from work on laptop\77332\slope stability\final-7-29-09\alt-4\dd-p-a4b.pl2 Run By: Jamal Nusairat 11/24/2009 09:14PM

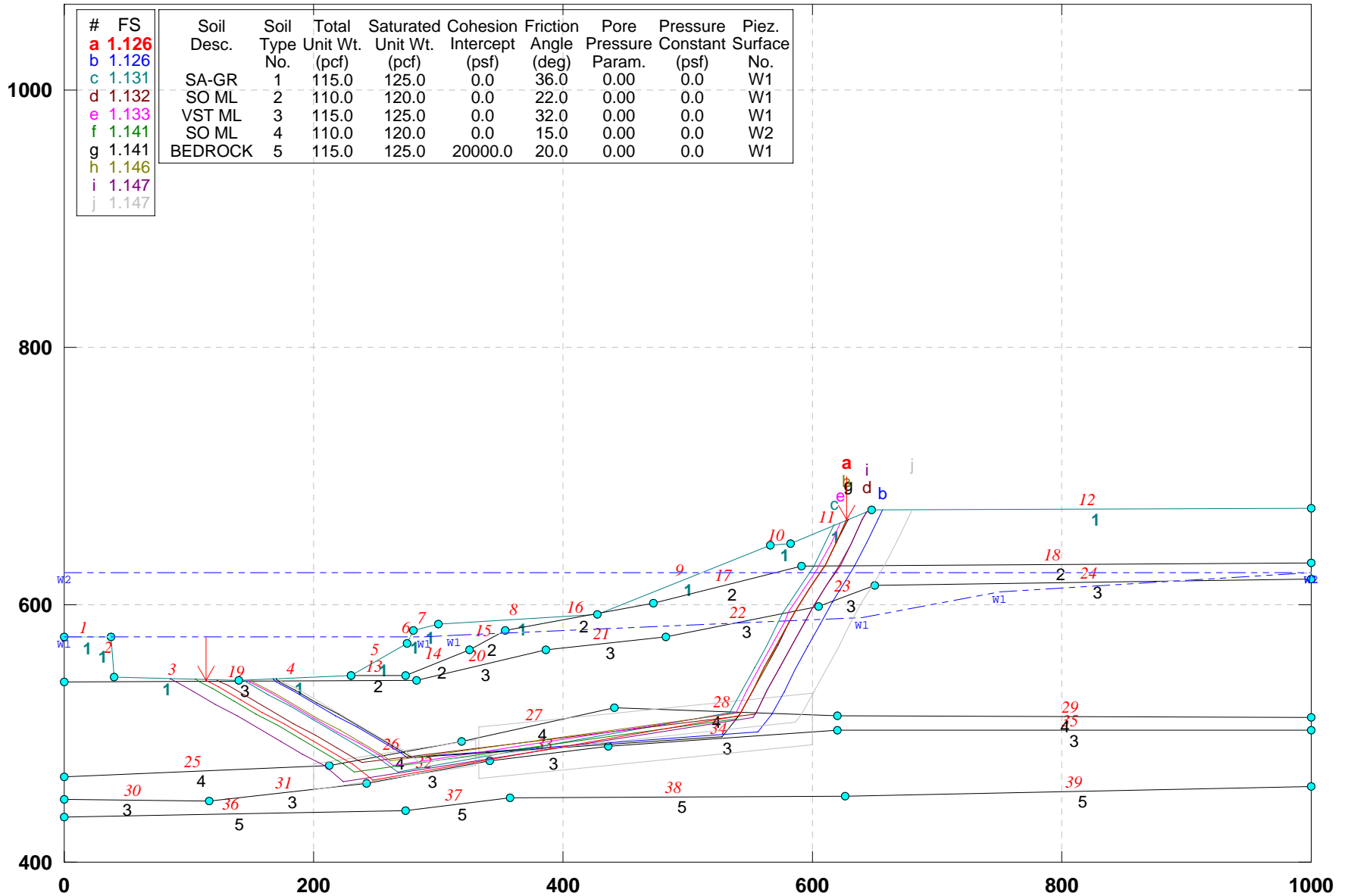

GSTABL7 v.2 FSmin=1.126

Safety Factors Are Calculated By The Simplified Janbu Method



# CUY-90-14.92 (Sec. D-D): PROPOSED GEOMETRY (ALT-4)- check block search

e:\from work on laptop\77332\slope stability\final-7-29-09\alt-4\dd-p-a4c.plt Run By: Jamal Nusairat 11/24/2009 09:32PM

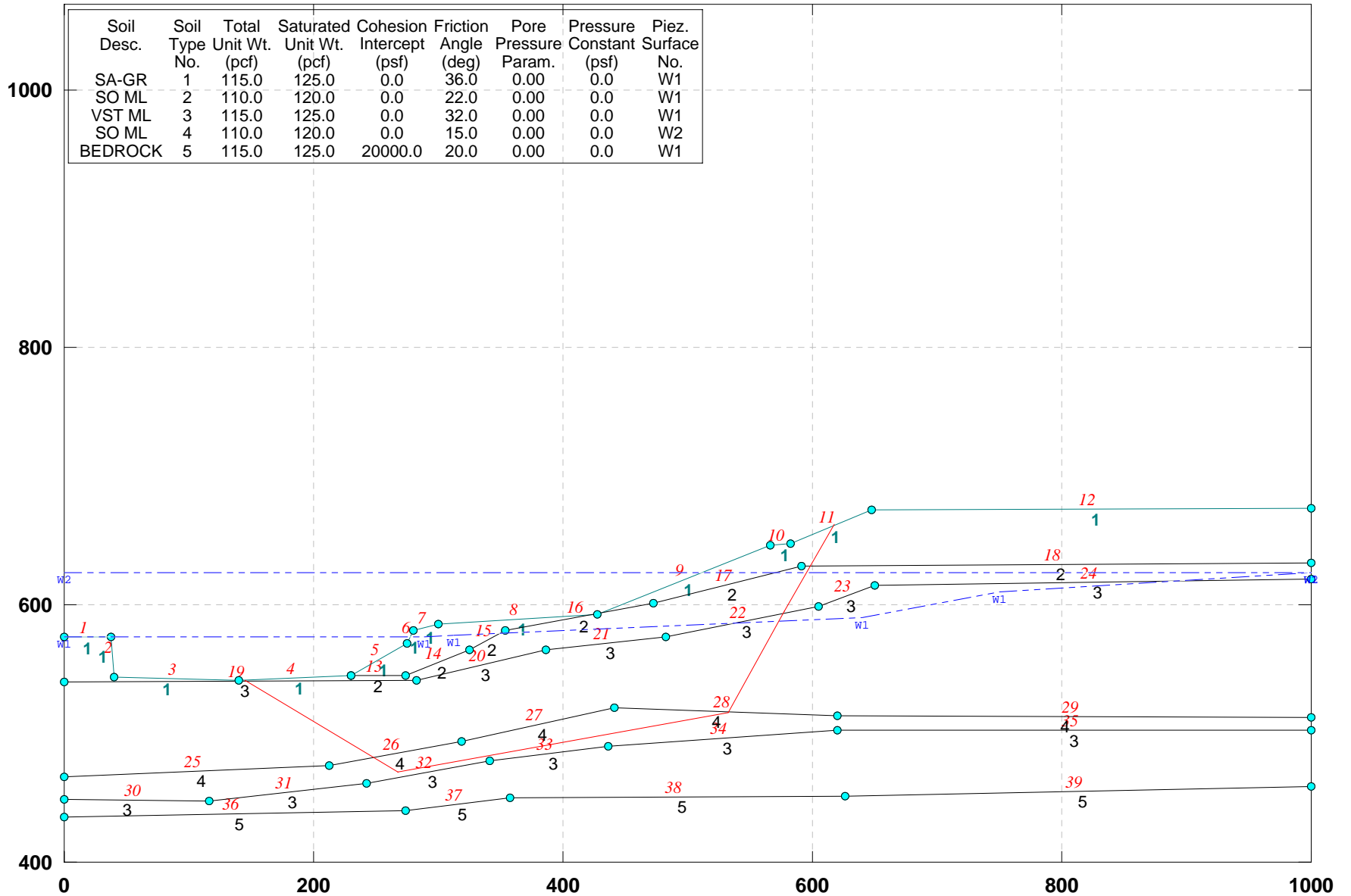

GSTABL7 v.2 FSmin=1.132

Factor Of Safety Is Calculated By The Simplified Janbu Method



# CUY-90-14.92 (Sec. D-D): PROPOSED GEOMETRY (ALT-4)- check block search\_ No W2

e:\from work on laptop\77332\slope stability\final-7-29-09\alt-4\dd-p-a4c.plt Run By: Jamal Nusairat 11/24/2009 10:38PM

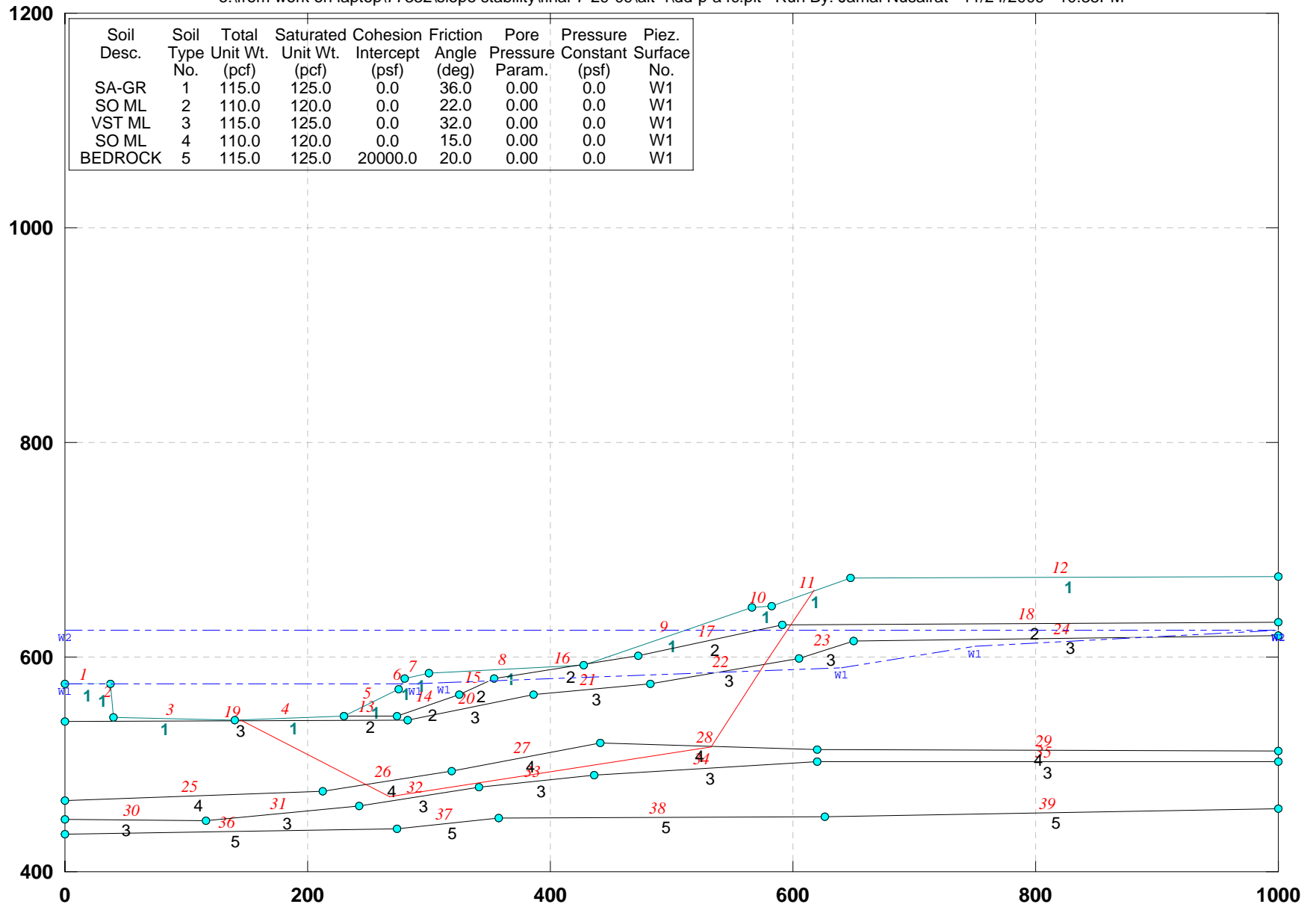

GSTABL7 v.2 FSmin=1.384

Factor Of Safety Is Calculated By The Simplified Janbu Method



# CUY-90-14.92 (Sec. E-E): PROPOSED GEOMETRY (Alt-4): Block Search

e:\from work on laptop\77332\slope stability\final-7-29-09\alt-4\ee-p-a4b.pl2 Run By: Jamal Nusairat 11/24/2009 09:35PM

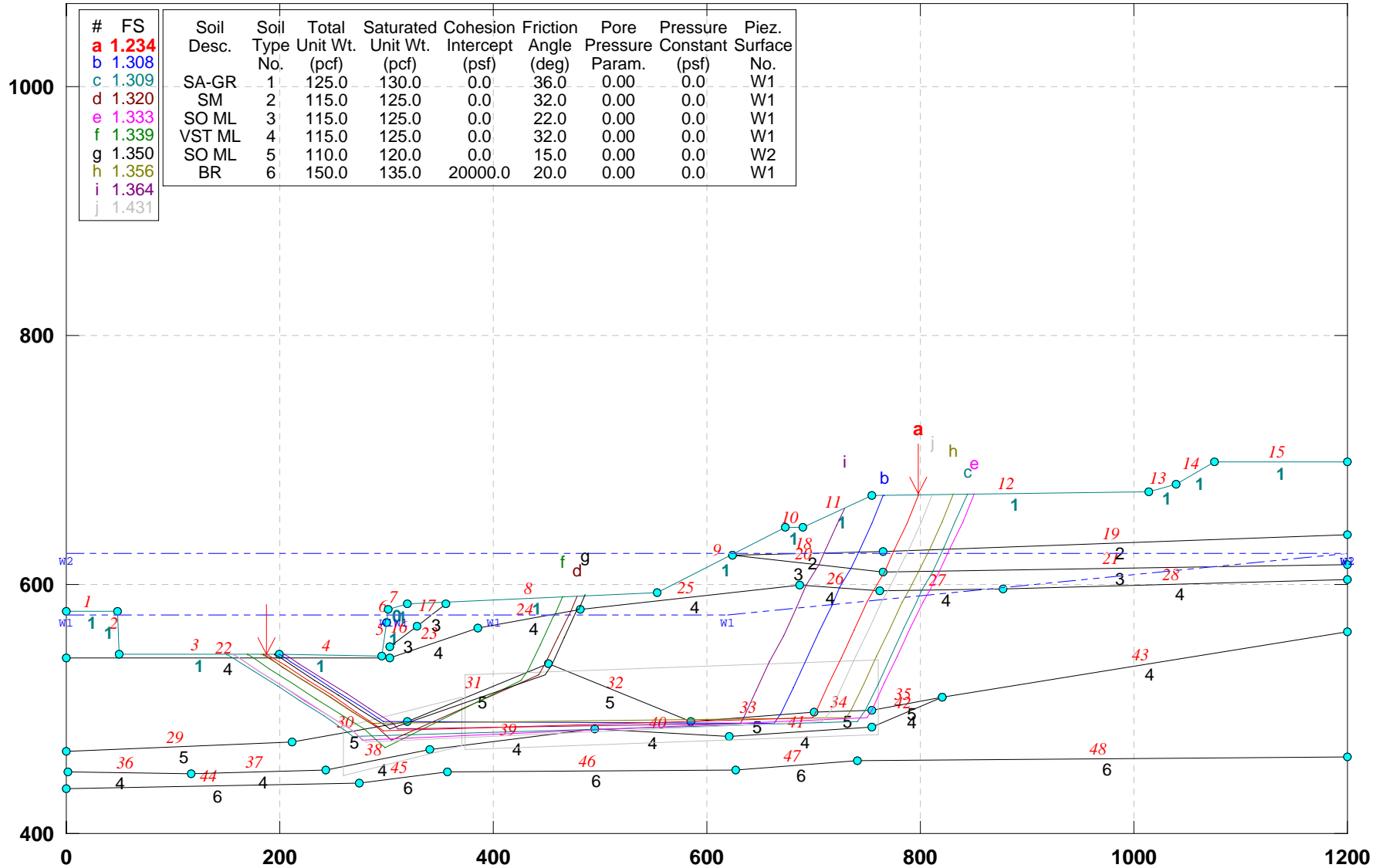

GSTABL7 v.2 FSmin=1.234

Safety Factors Are Calculated By The Simplified Janbu Method



# CUY-90-14.92 (Sec. E-E): PROPOSED GEOMETRY (Alt-4): Block Search

e:\from work on laptop\77332\slope stability\final-7-29-09\alt-4\ee-p-a4bw.pl2 Run By: Jamal Nusairat 11/25/2009 02:37AM

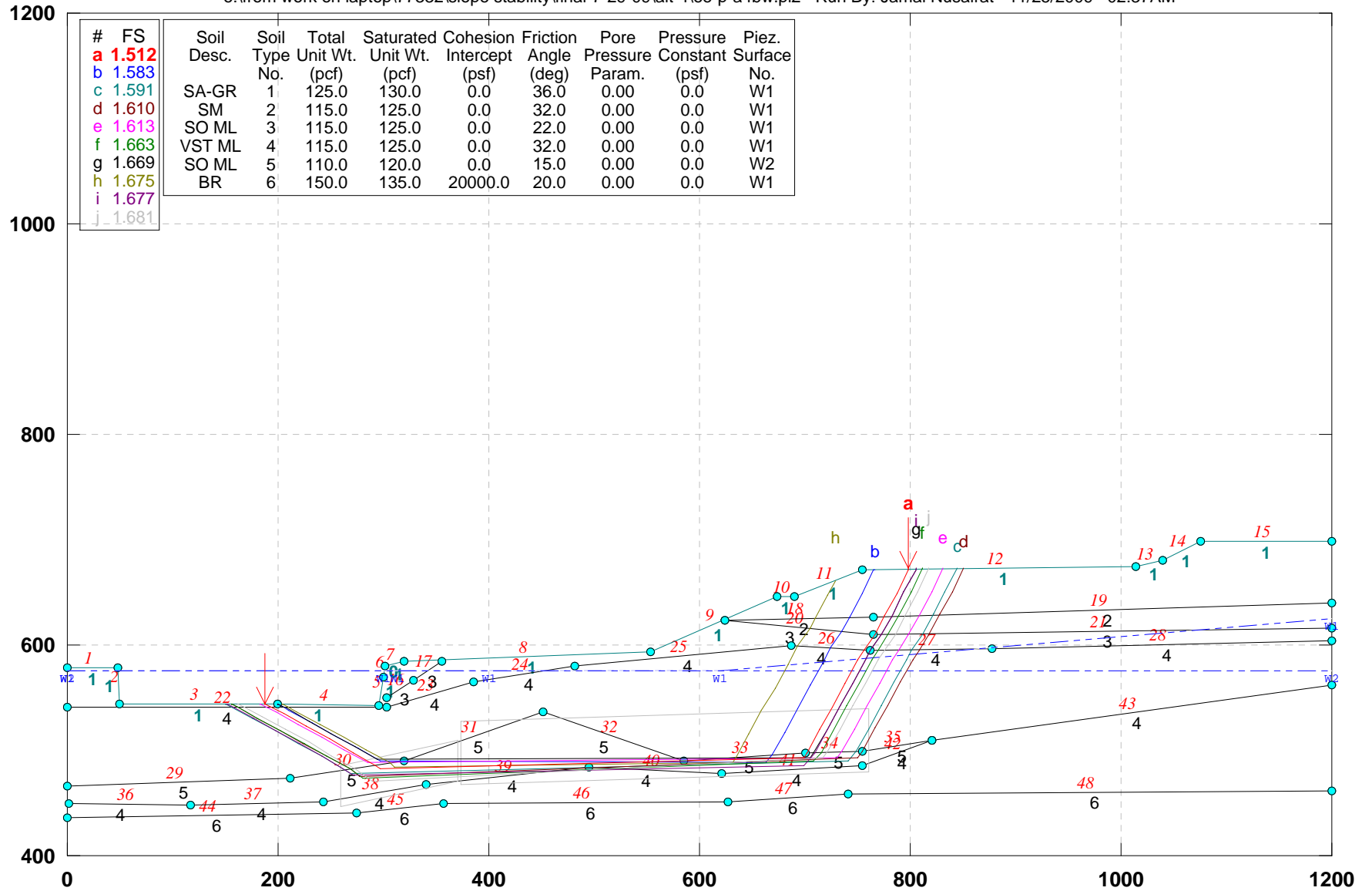

GSTABL7 v.2 FSmin=1.512

Safety Factors Are Calculated By The Simplified Janbu Method



# CUY-90-14.92 (Sec. F-F): PROPOSED GEOMETRY (Alt-4)\_block search

e:\from work on laptop\77332\slope stability\final-7-29-09\alt-4\fp-a4b.pl2 Run By: Jamal Nusairat 11/24/2009 09:38PM

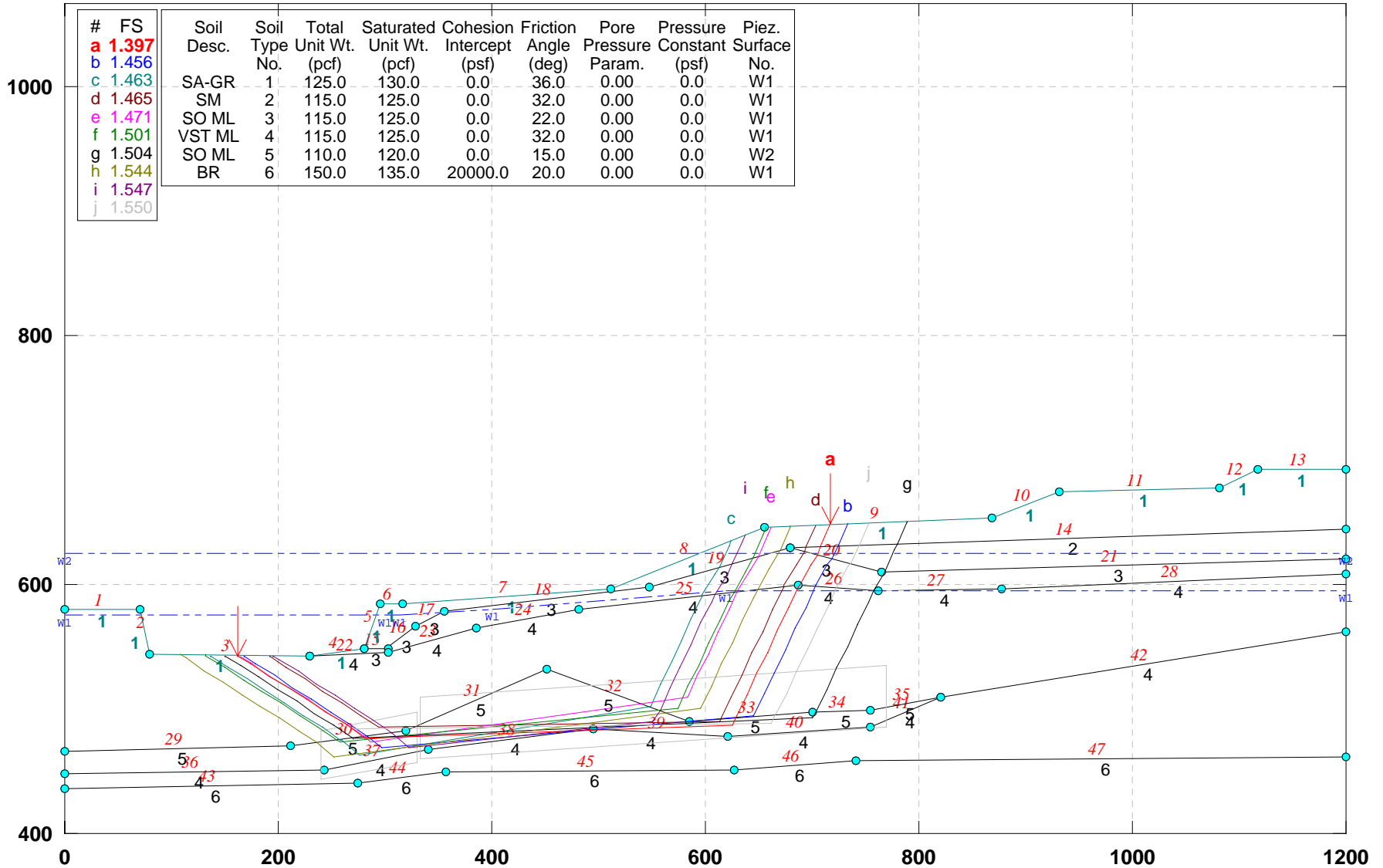

GSTABL7 v.2 FSmin=1.397

Safety Factors Are Calculated By The Simplified Janbu Method





# CUY-90-14.92 (Sec. W-W): PROPOSED GEOMETRY (ALT-4)

e:\from work on laptop\77332\slope stability\final-7-29-09\alt-4\ww-pr4b.pl2 Run By: Jamal Nusairat 11/24/2009 09:40PM

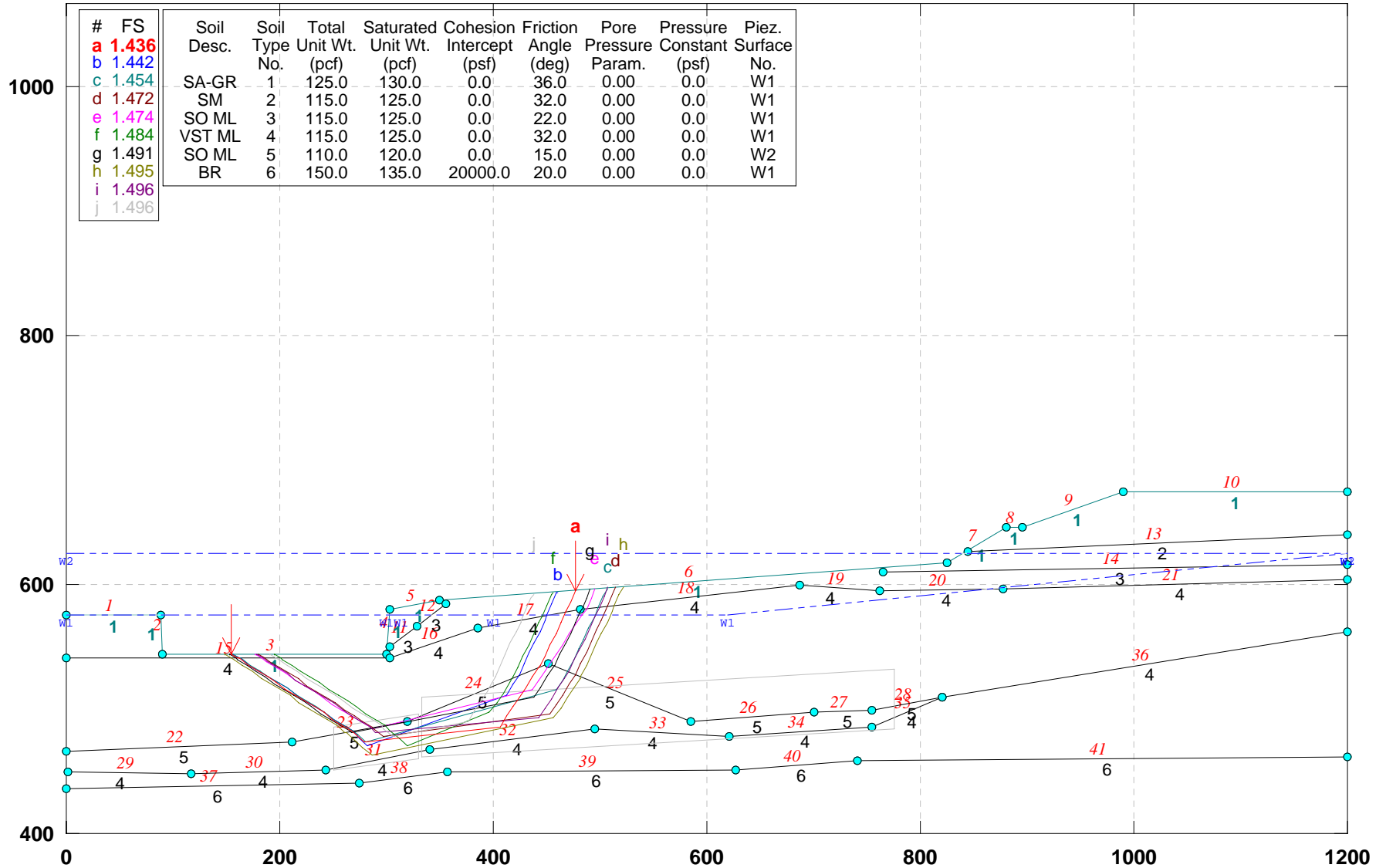

GSTABL7 v.2 FSmin=1.436

Safety Factors Are Calculated By The Simplified Janbu Method



# CUY-90-14.92 (Sec. Y-Y): PROPOSED GEOMETRY (ALT-4)\_block search

e:\from work on laptop\77332\slope stability\final-7-29-09\alt-4\yy-pr4-b.pl2 Run By: Jamal Nusairat 11/24/2009 09:43PM

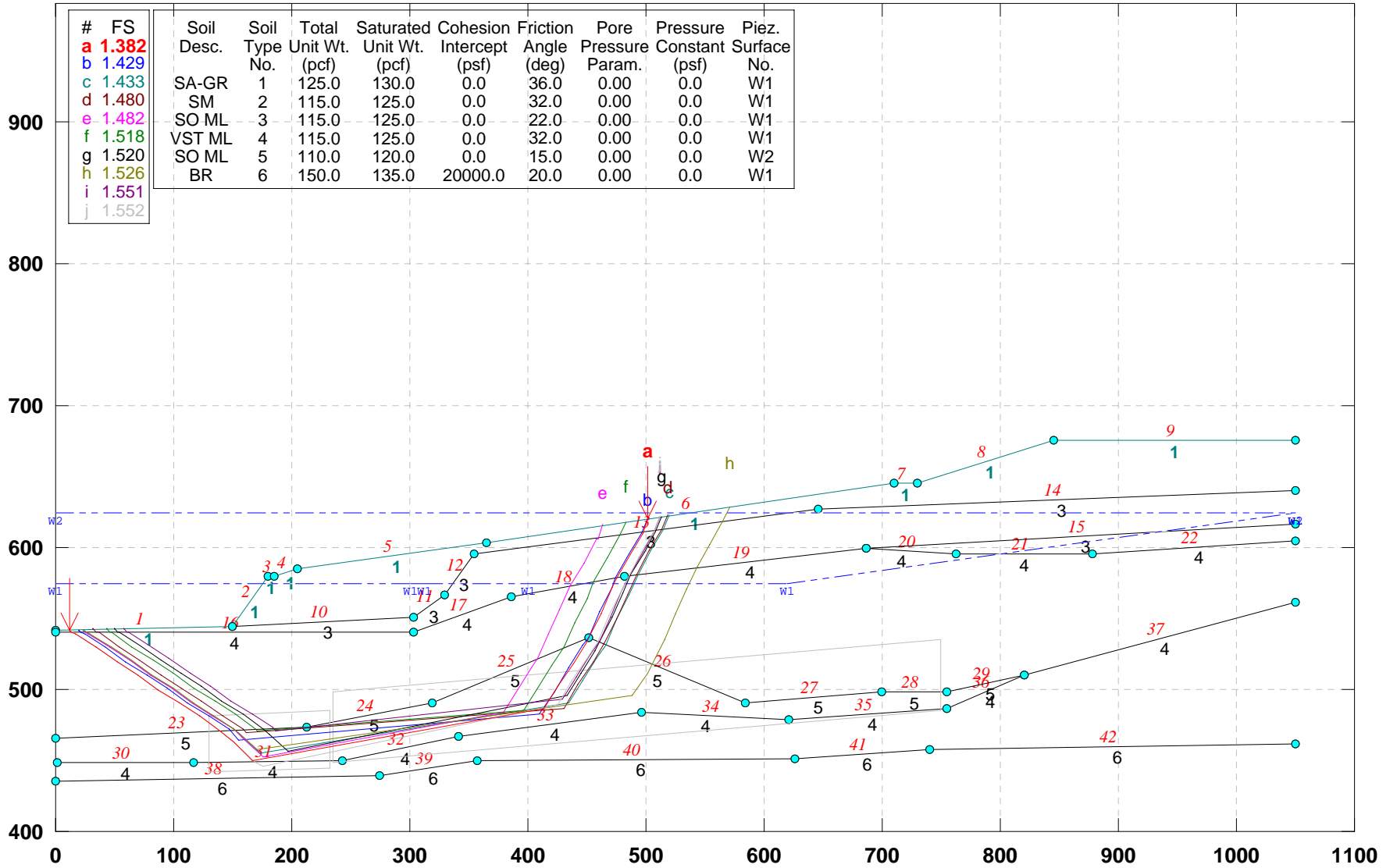

GSTABL7 v.2 FSmin=1.382

Safety Factors Are Calculated By The Simplified Janbu Method



# CUY-90-14.92 (Sec. Z-Z): PROPOSED GEOMETRY (Alt-4)\_Block search

e:\from work on laptop\77332\slope stability\final-7-29-09\alt-4\zz-pr4b.pl2 Run By: Jamal Nusairat 11/24/2009 09:44PM

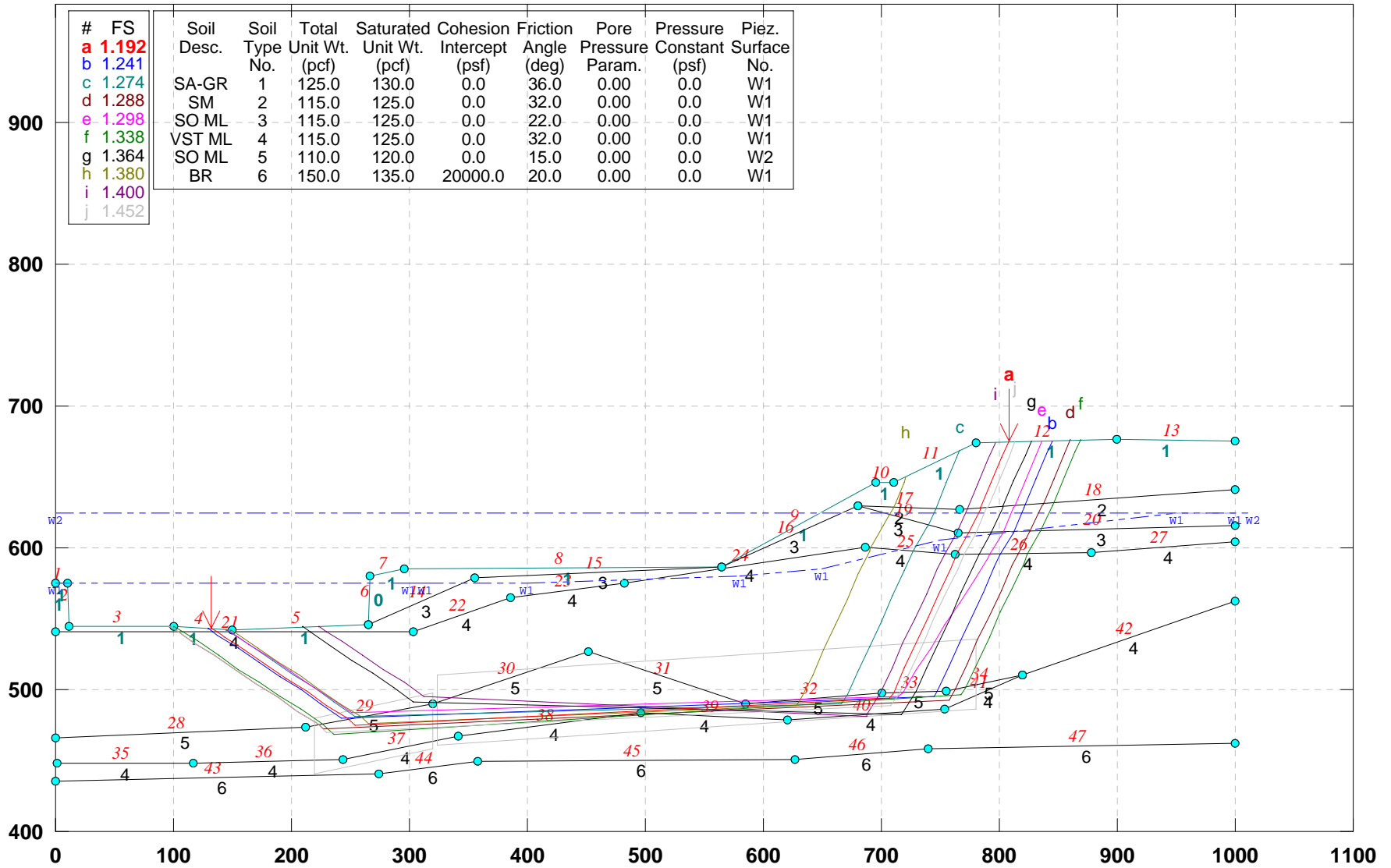

| # | FS    | Soil Desc. | Soil Type No. | Soil Unit Wt. (pcf) | Total Unit Wt. (pcf) | Saturated Unit Wt. (pcf) | Cohesion Intercept (psf) | Friction Angle (deg) | Pore Pressure Param. (psf) | Pressure Constant (psf) | Piez. Surface No. |
|---|-------|------------|---------------|---------------------|----------------------|--------------------------|--------------------------|----------------------|----------------------------|-------------------------|-------------------|
| a | 1.192 |            |               |                     |                      |                          |                          |                      |                            |                         |                   |
| b | 1.241 |            |               |                     |                      |                          |                          |                      |                            |                         |                   |
| c | 1.274 | SA-GR      | 1             | 125.0               | 130.0                | 0.0                      | 36.0                     | 0.00                 | 0.0                        | 0.0                     | W1                |
| d | 1.288 | SM         | 2             | 115.0               | 125.0                | 0.0                      | 32.0                     | 0.00                 | 0.0                        | 0.0                     | W1                |
| e | 1.298 | SO ML      | 3             | 115.0               | 125.0                | 0.0                      | 22.0                     | 0.00                 | 0.0                        | 0.0                     | W1                |
| f | 1.338 | VST ML     | 4             | 115.0               | 125.0                | 0.0                      | 32.0                     | 0.00                 | 0.0                        | 0.0                     | W1                |
| g | 1.364 | SO ML      | 5             | 110.0               | 120.0                | 0.0                      | 15.0                     | 0.00                 | 0.0                        | 0.0                     | W2                |
| h | 1.380 | BR         | 6             | 150.0               | 135.0                | 20000.0                  | 20.0                     | 0.00                 | 0.0                        | 0.0                     | W1                |
| i | 1.400 |            |               |                     |                      |                          |                          |                      |                            |                         |                   |
| j | 1.452 |            |               |                     |                      |                          |                          |                      |                            |                         |                   |

GSTABL7 v.2 FSmin=1.192

Safety Factors Are Calculated By The Simplified Janbu Method



### CUY-90-14.40 (Sec. A-A): PROPOSED GEOMETRY (Alt-4)

e:\from work on laptop\77332\slope stability\final-7-29-09\alt-4\aa-pr-w4.pl2 Run By: Jamal Nusairat 11/24/2009 09:47PM

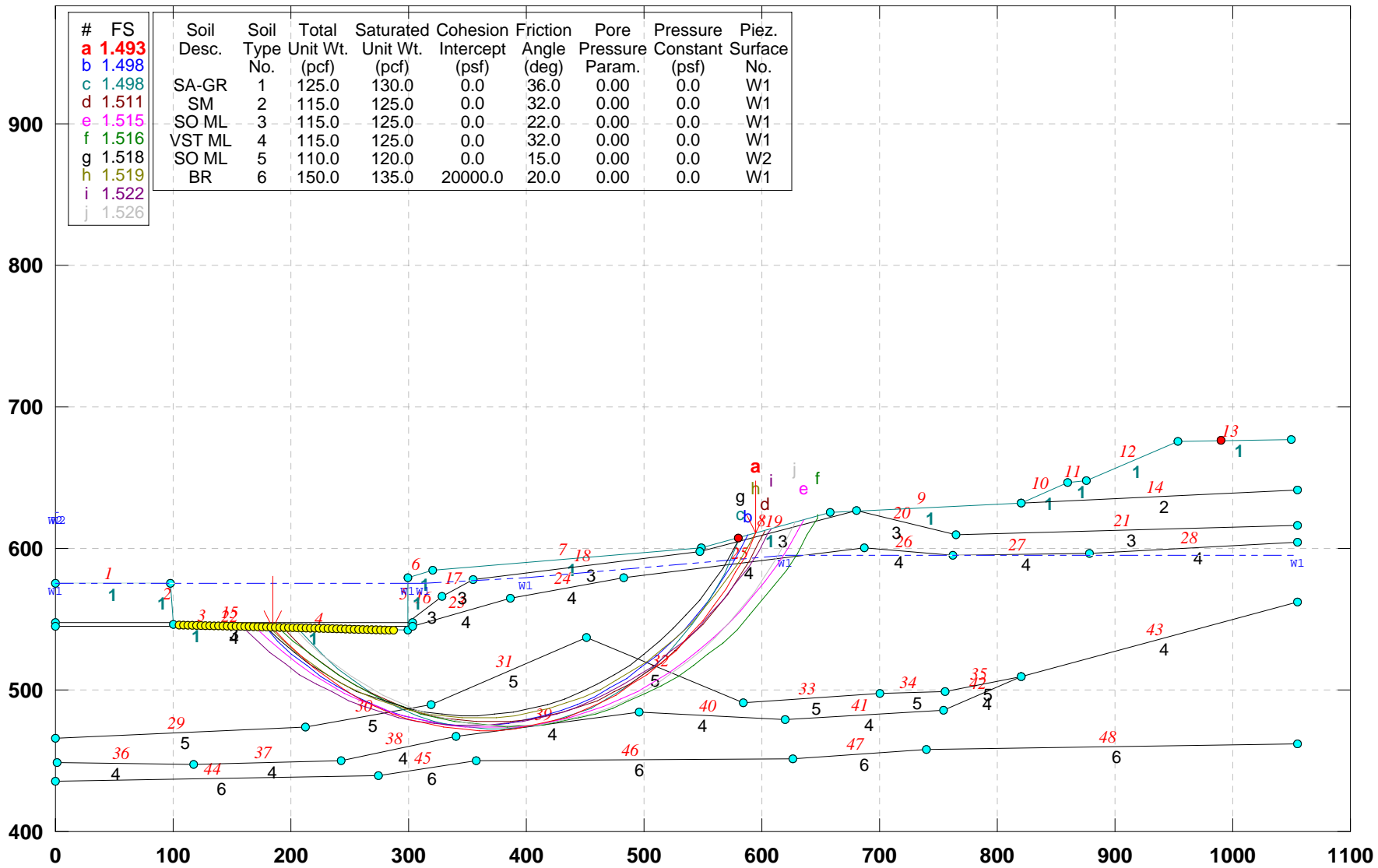

GSTABL7 v.2 FSmin=1.493

Safety Factors Are Calculated By The Simplified Janbu Method



# CUY-90-14.92 (Sec. B-B): PROPOSED GEOMETRY (Alt-4)

e:\from work on laptop\77332\slope stability\final-7-29-09\alt-4\bb-pr-w4.pl2 Run By: Jamal Nusairat 11/24/2009 09:50PM

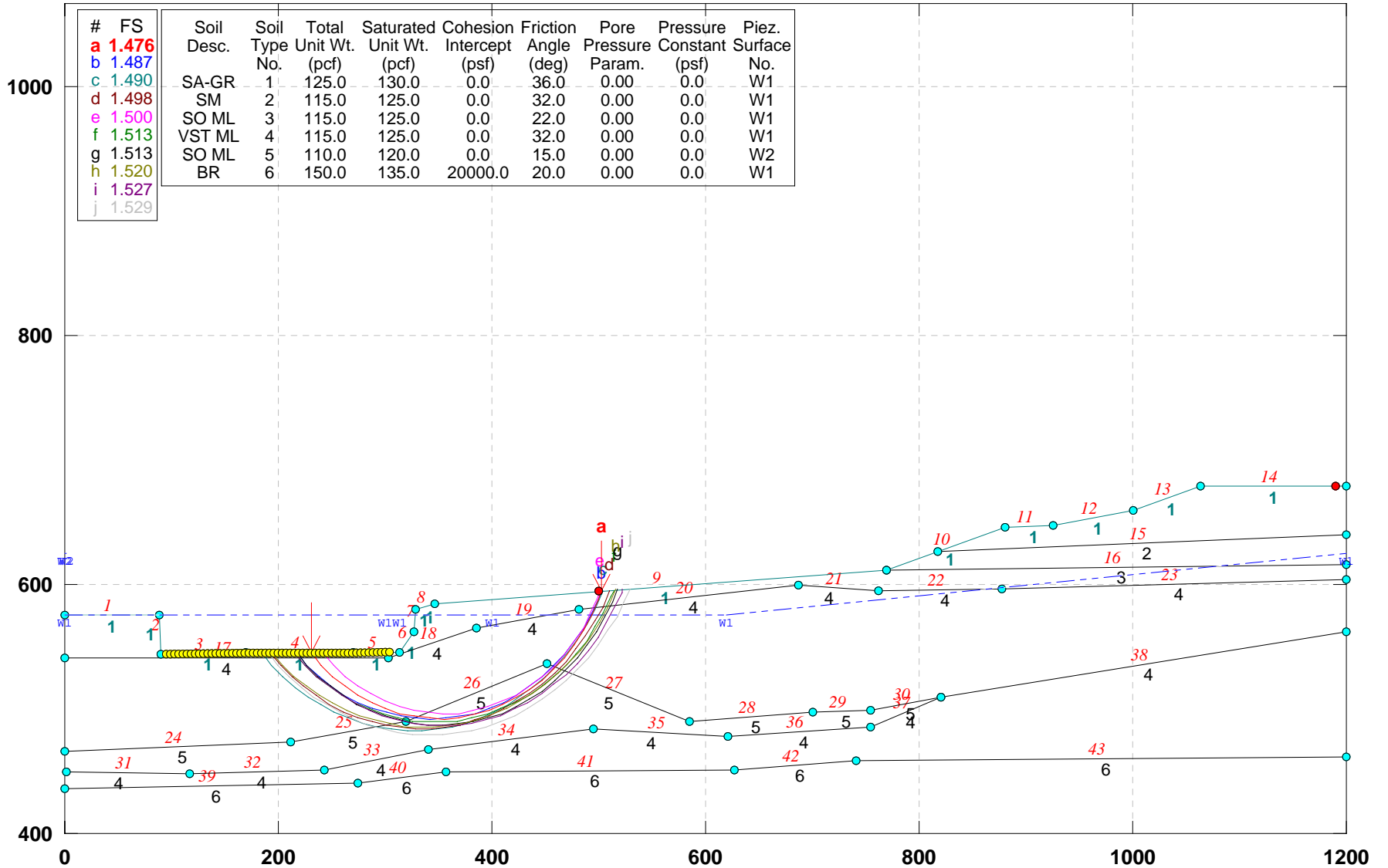

GSTABL7 v.2 FSmin=1.476

Safety Factors Are Calculated By The Simplified Janbu Method



# CUY-90-14.92 (Sec. E-E): PROPOSED GEOMETRY (Alt-4)

e:\from work on laptop\77332\slope stability\final-7-29-09\alt-4\ee-pr-a4.pl2 Run By: Jamal Nusairat 11/24/2009 10:01PM

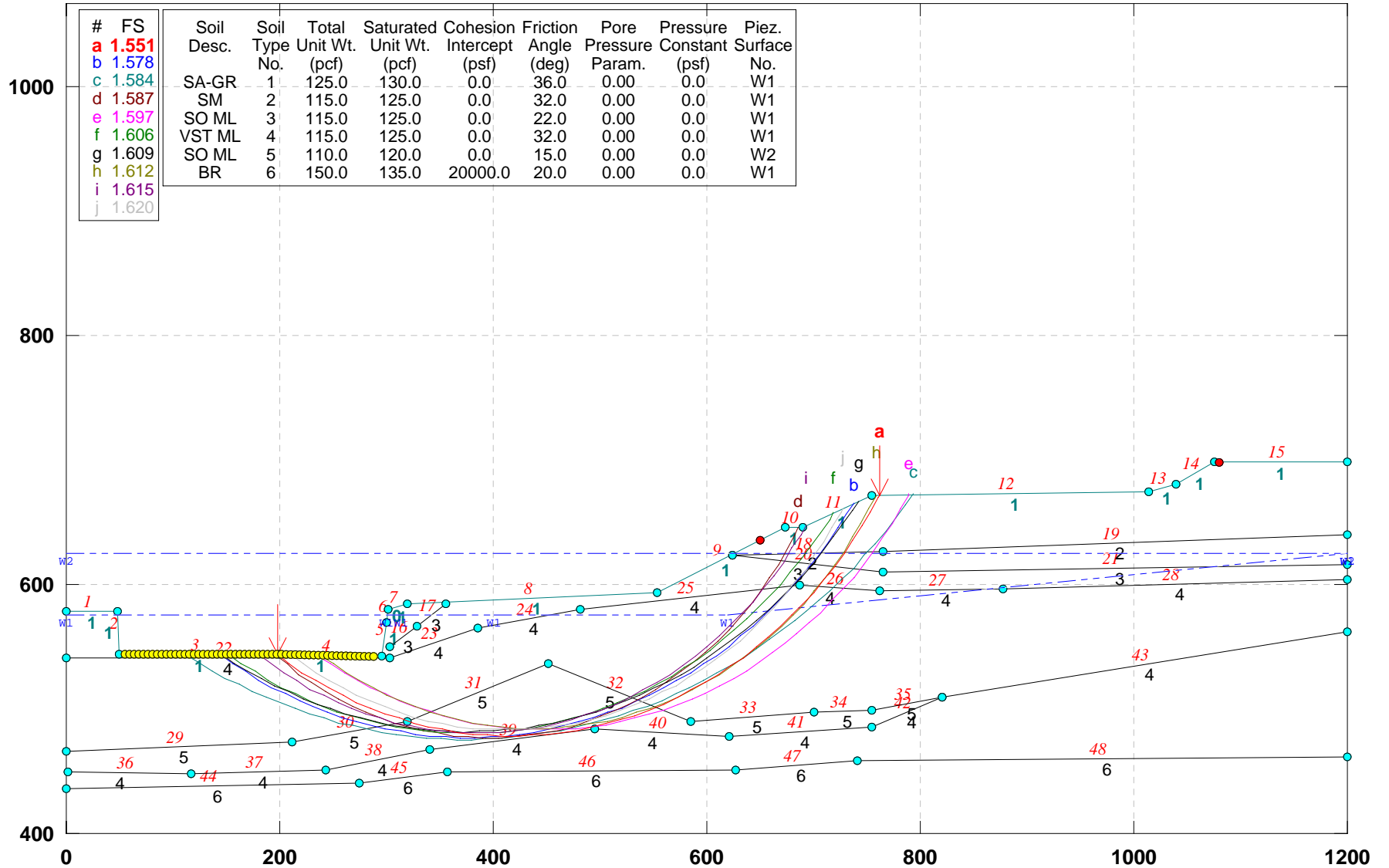

GSTABL7 v.2 FSmin=1.551

Safety Factors Are Calculated By The Simplified Janbu Method



# CUY-90-14.92 (Sec. FF): PROPOSED GEOMETRY (Alt-4)

e:\from work on laptop\77332\slope stability\final-7-29-09\alt-4\ff-pr-a4.pl2 Run By: Jamal Nusairat 11/24/2009 10:03PM

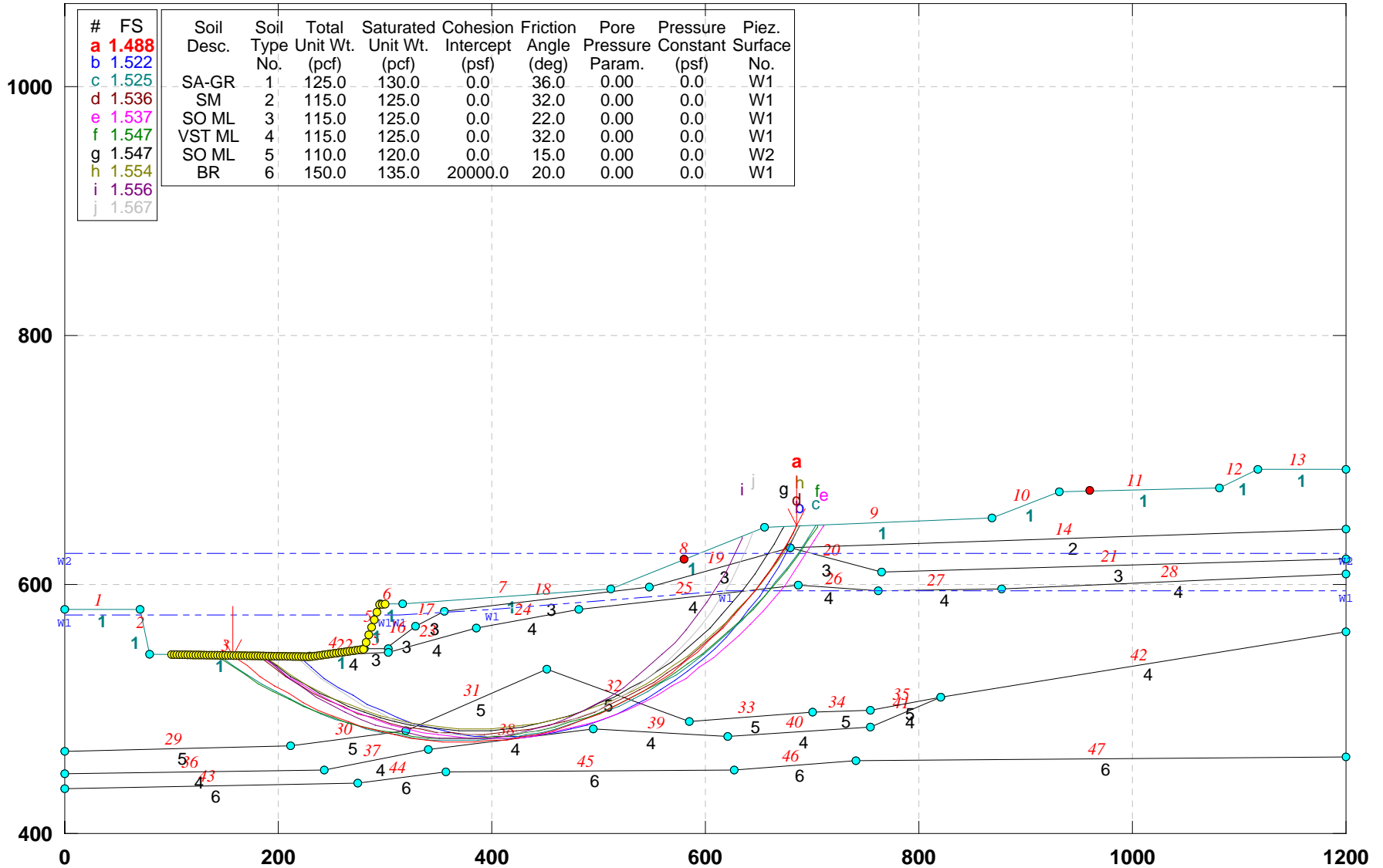

GSTABL7 v.2 FSmin=1.488

Safety Factors Are Calculated By The Simplified Janbu Method



# CUY-90-14.92 (Sec. G-G): PROPOSED EXCAVATED GEOMETRY- STABILITY (ALT-4)

e:\from work on laptop\77332\slope stability\final-7-29-09\alt-4\gg-pr4.pl2 Run By: Jamal Nusairat 11/24/2009 10:05PM

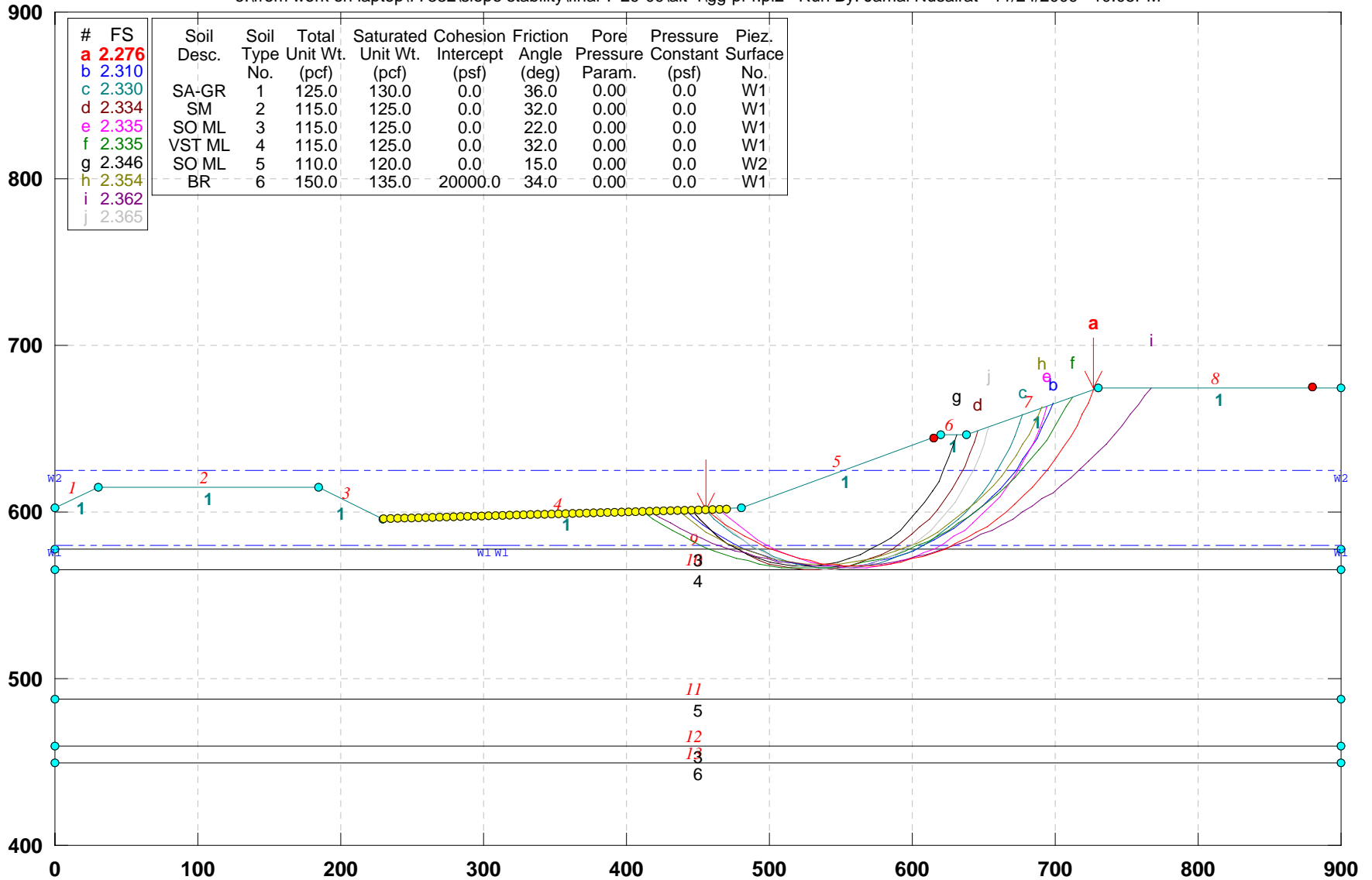

GSTABL7 v.2 FSmin=2.276

Safety Factors Are Calculated By The Simplified Janbu Method





# CUY-90-14.40 (Sec. K-K): PROPOSED EXCAVATED GEOMETRY (Animal Clinic Parking)

e:\from work on laptop\77332\slope stability\final-7-29-09\alt-4\kk-pr.pl2 Run By: Jamal Nusairat 11/24/2009 10:08PM

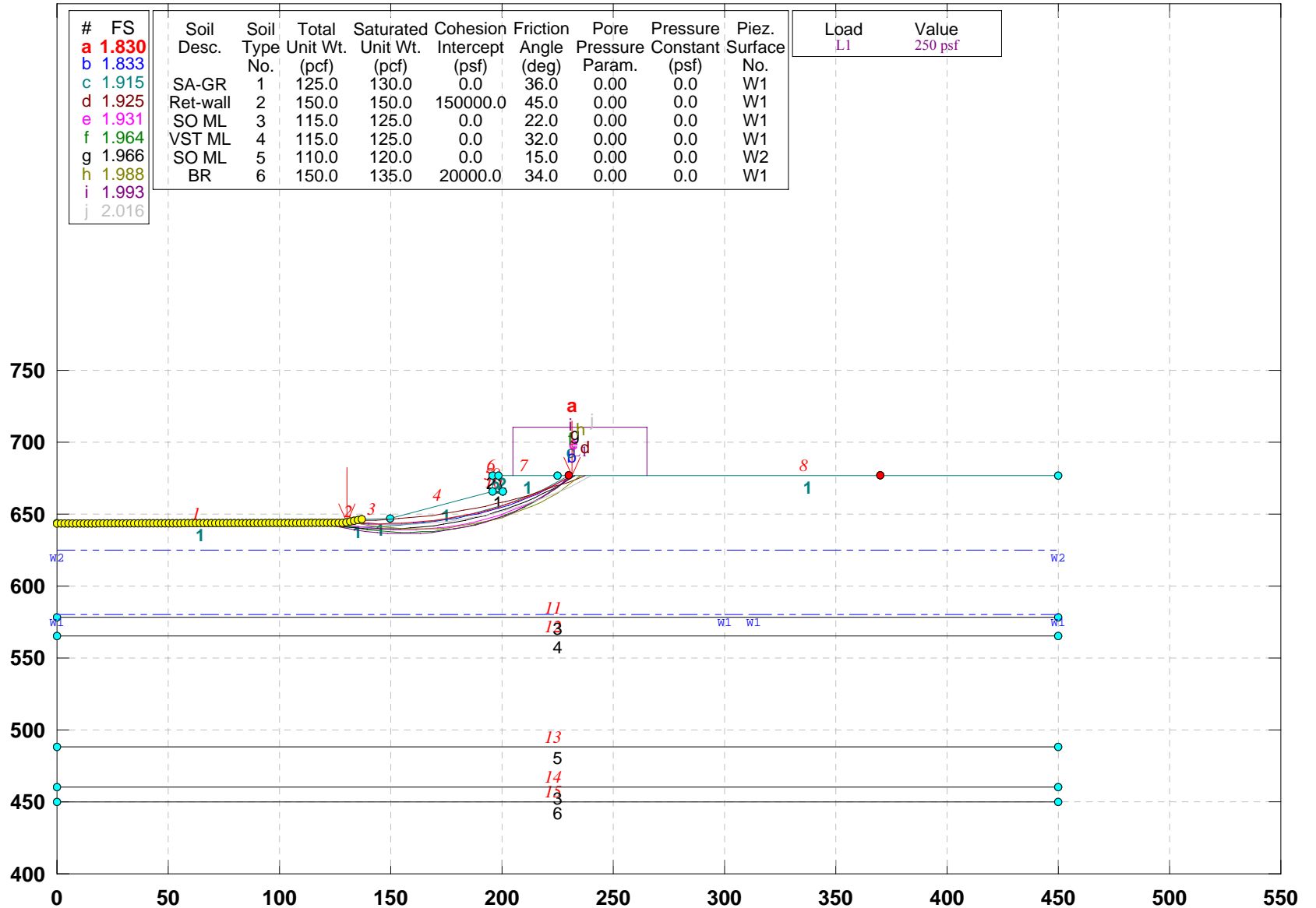

GSTABL7 v.2 FSmin=1.830

Safety Factors Are Calculated By The Simplified Janbu Method



# CUY-90-14.92 (Sec. U-U): PROPOSED EXCAVATED GEOMETRY- STABILITY (Alt-4)

e:\from work on laptop\77332\slope stability\final-7-29-09\alt-4\uu-pr4.pl2 Run By: Jamal Nusairat 11/24/2009 10:09PM

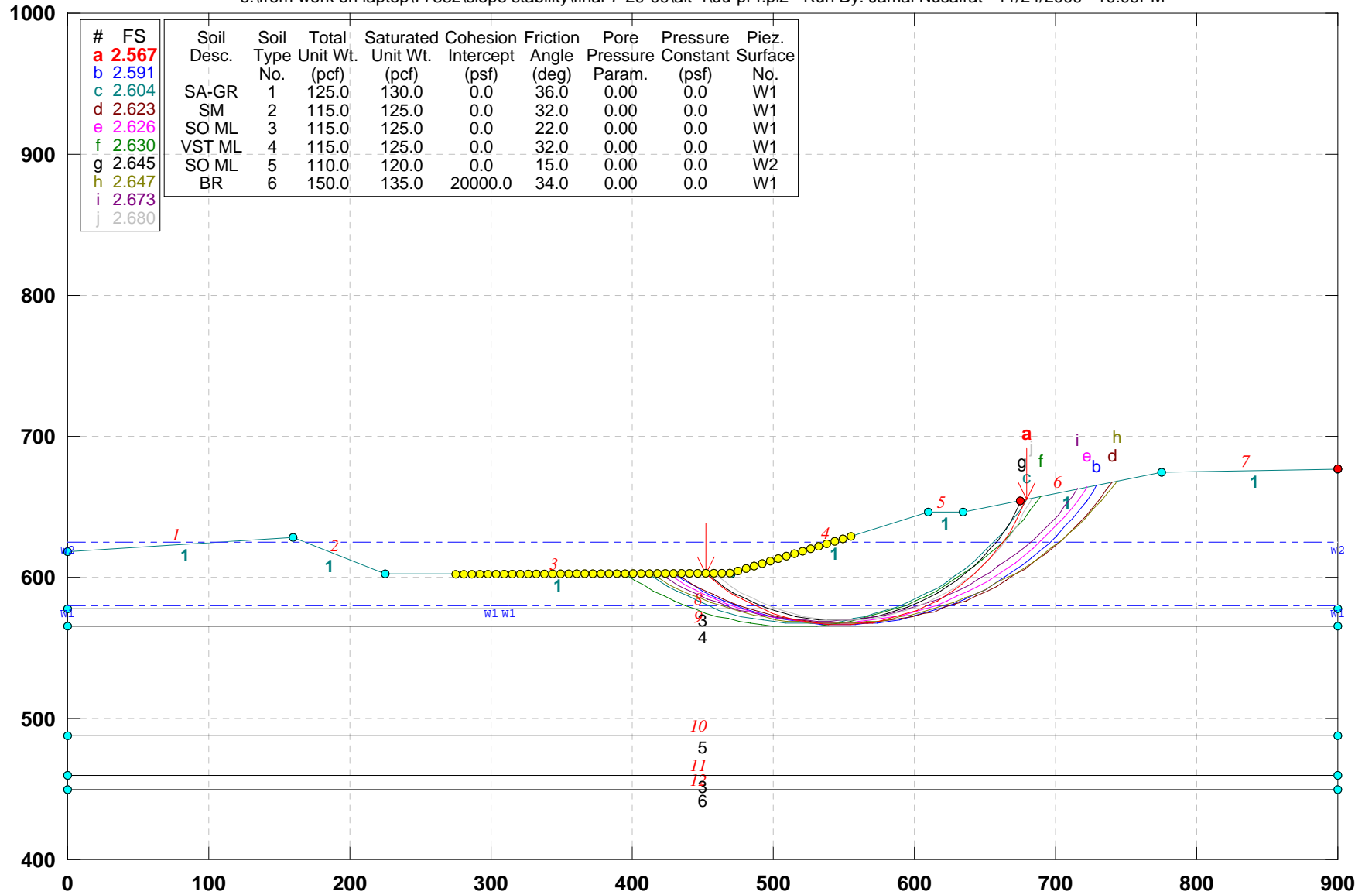

GSTABL7 v.2 FSmin=2.567

Safety Factors Are Calculated By The Simplified Janbu Method



# CUY-90-14.92 (Sec. W-W): PROPOSED GEOMETRY (ALT-4)

e:\from work on laptop\77332\slope stability\final-7-29-09\alt-4\ww-pr4.pl2 Run By: Jamal Nusairat 11/24/2009 10:14PM

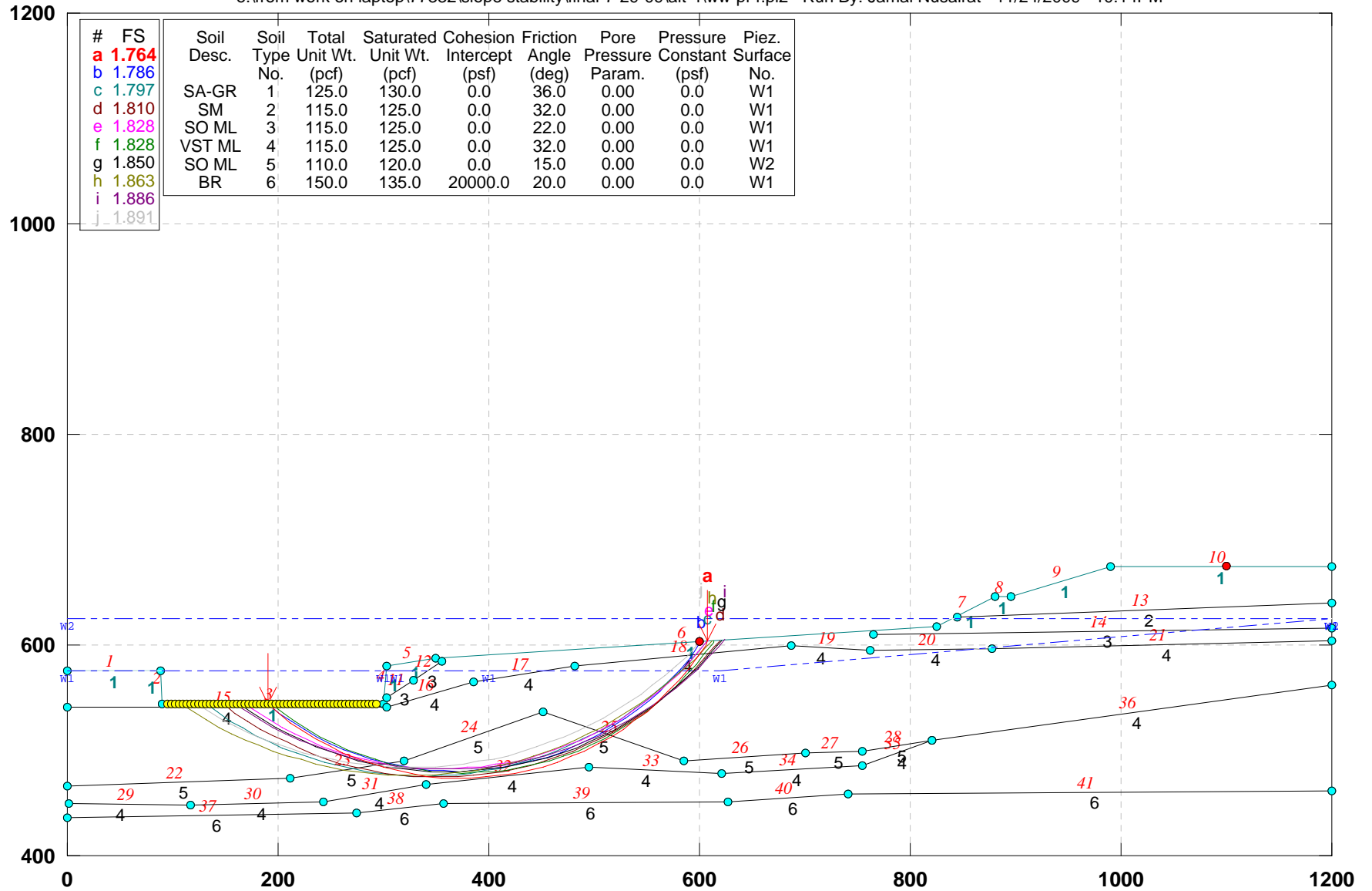

GSTABL7 v.2 FSmin=1.764

Safety Factors Are Calculated By The Simplified Janbu Method



# CUY-90-14.92 (Sec. W-W): PROPOSED GEOMETRY (ALT-4) SHALLOW BY ABBEY

e:\from work on laptop\77332\slope stability\final-7-29-09\alt-4\ww-pr4-s.pl2 Run By: Jamal Nusairat 11/24/2009 10:16PM

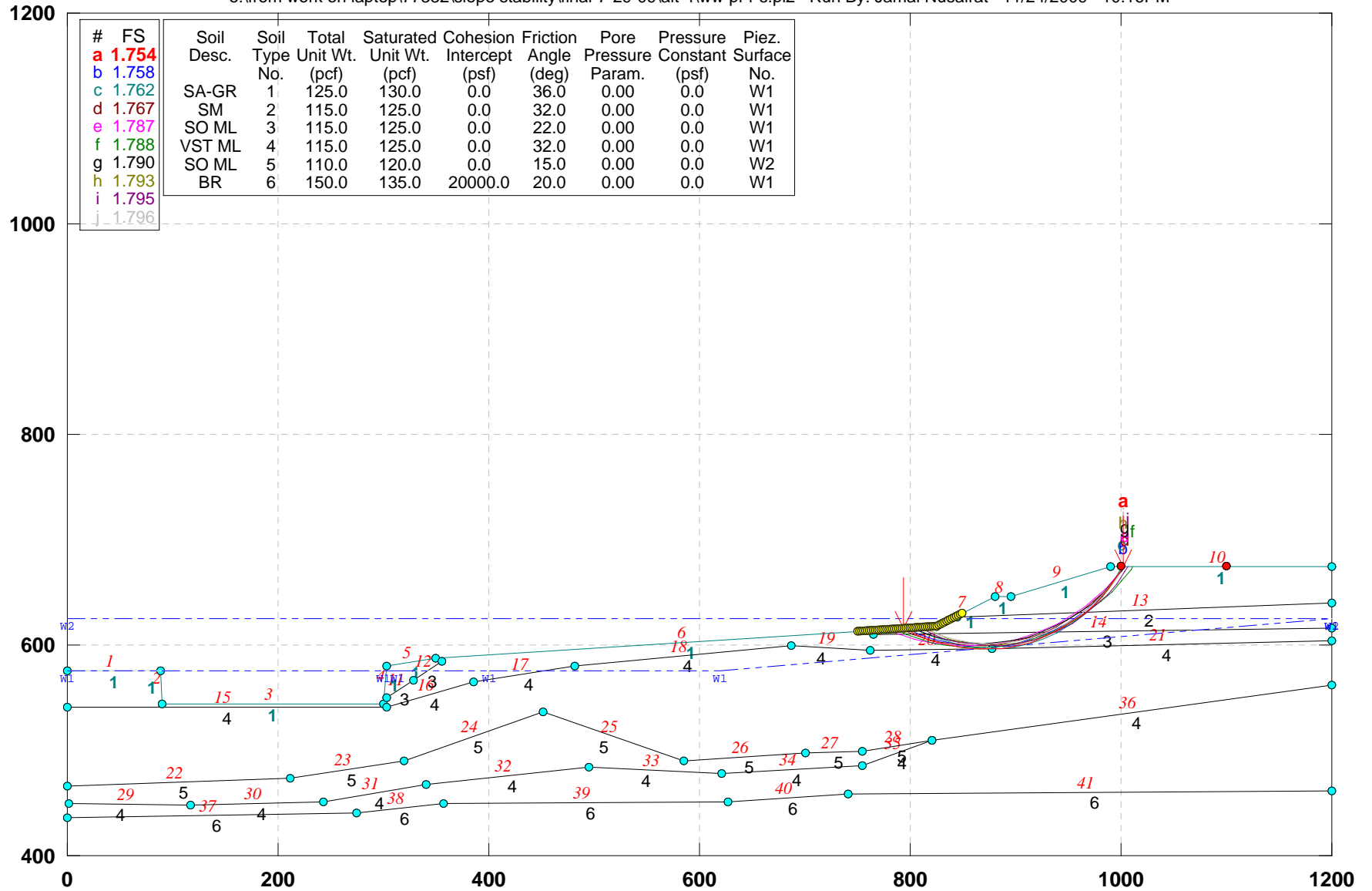

GSTABL7 v.2 FSmin=1.754

Safety Factors Are Calculated By The Simplified Janbu Method



# CUY-90-14.40 (Sec. Y-Y): PROPOSED GEOMETRY (ALT-4)

e:\from work on laptop\77332\slope stability\final-7-29-09\alt-4\yy-pr4.pl2 Run By: Jamal Nusairat 11/24/2009 10:17PM

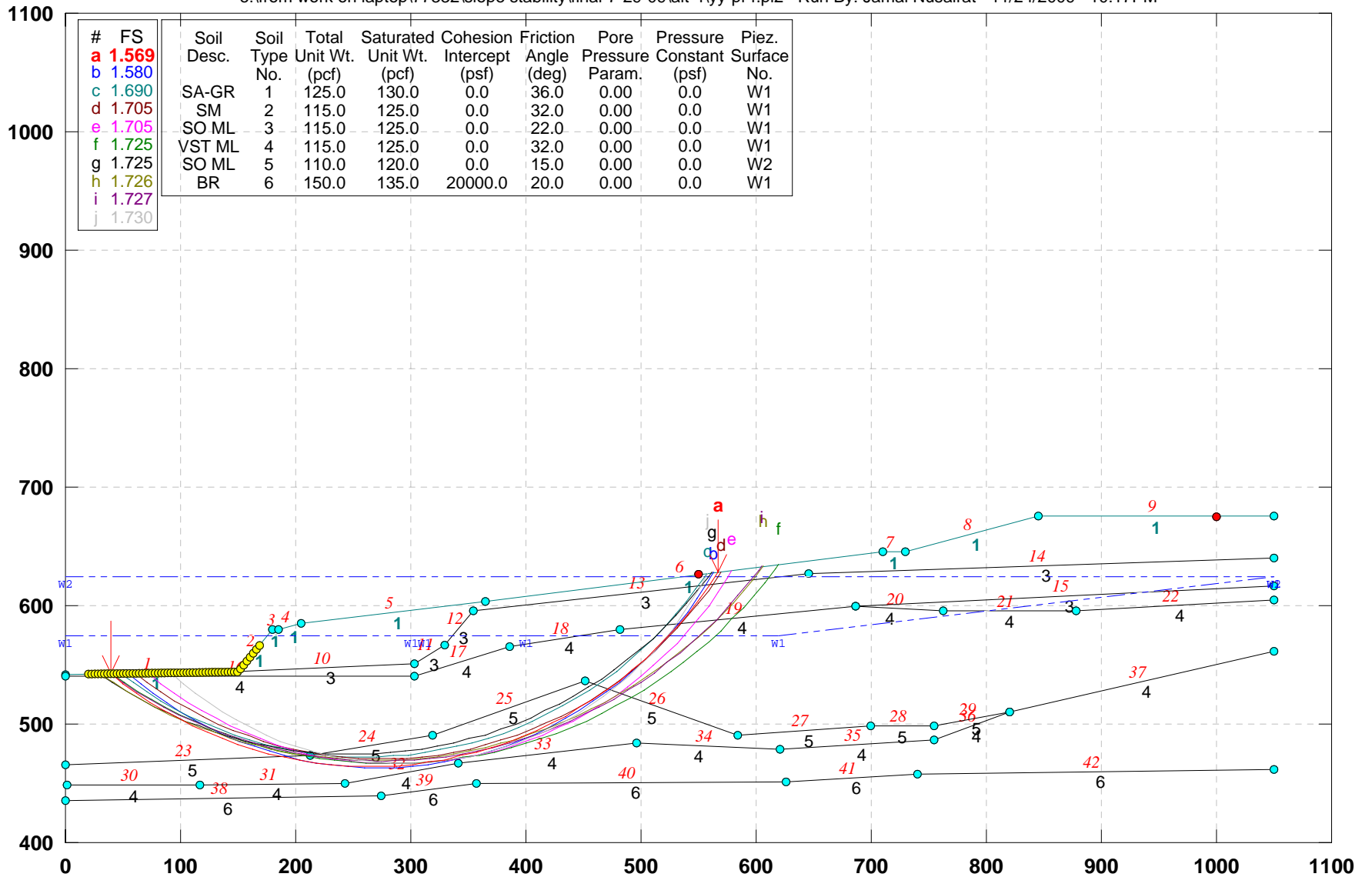

GSTABL7 v.2 FSmin=1.569

Safety Factors Are Calculated By The Simplified Janbu Method



# CUY-90-14.92 (Sec. Z-Z): PROPOSED GEOMETRY (Alt-4)

e:\from work on laptop\77332\slope stability\final-7-29-09\alt-4\zz-pr4.pl2 Run By: Jamal Nusairat 11/24/2009 10:20PM

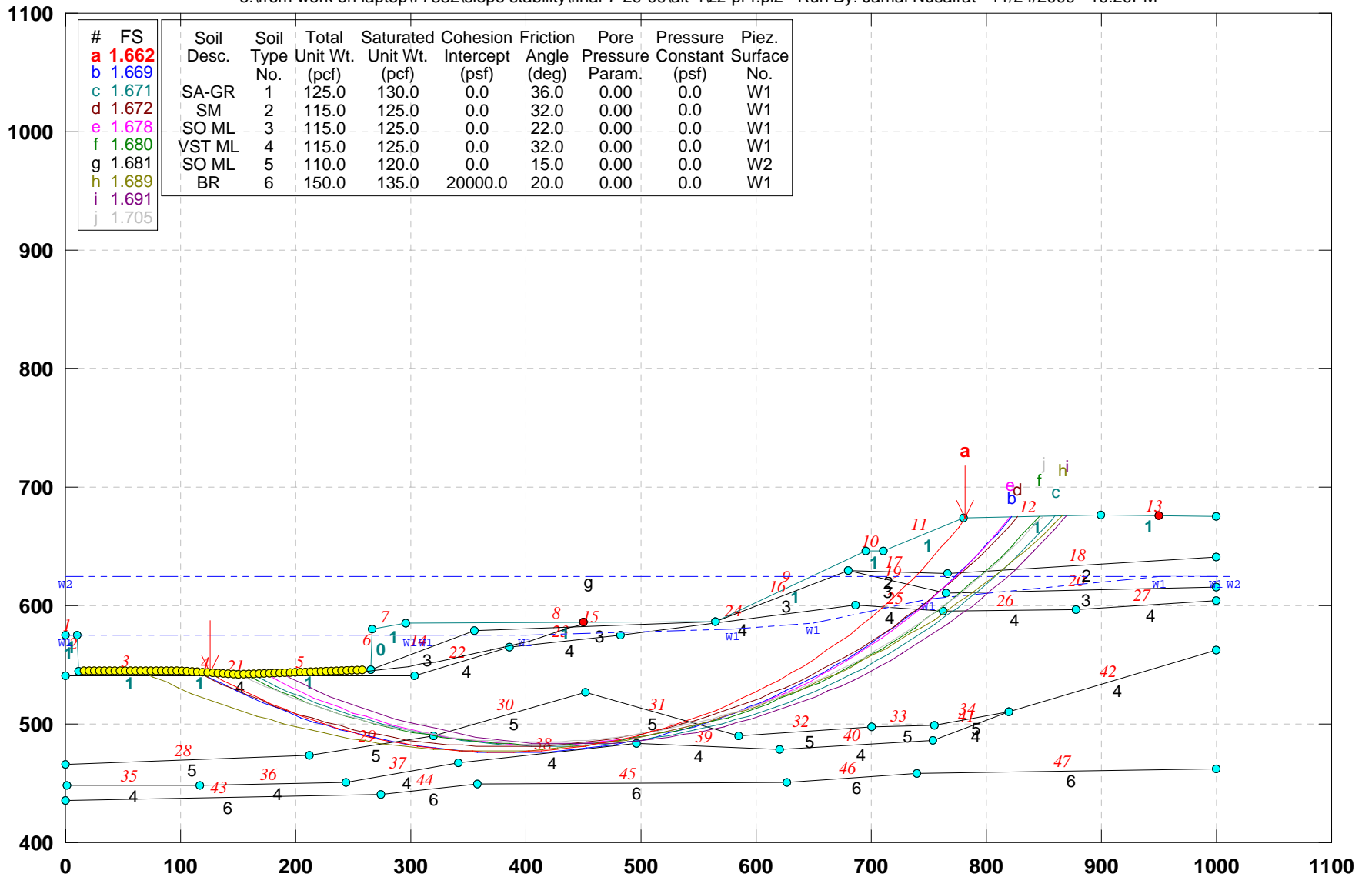

GSTABL7 v.2 FSmin=1.662

Safety Factors Are Calculated By The Simplified Janbu Method



**APPENDIX 7H**

**SLOPE STABILITY ANALYSES BASED ON  
ALTERNATIVE 5 GRADING**

# CUY-90-14.92 (Sec. A-A): PROPOSED GEOMETRY (Alt-5)\_Block Search

e:\from work on laptop\77332\slope stability\final-7-29-09\alt-5\aa-p-a5b.pl2 Run By: Jamal Nusairat 11/24/2009 10:46PM

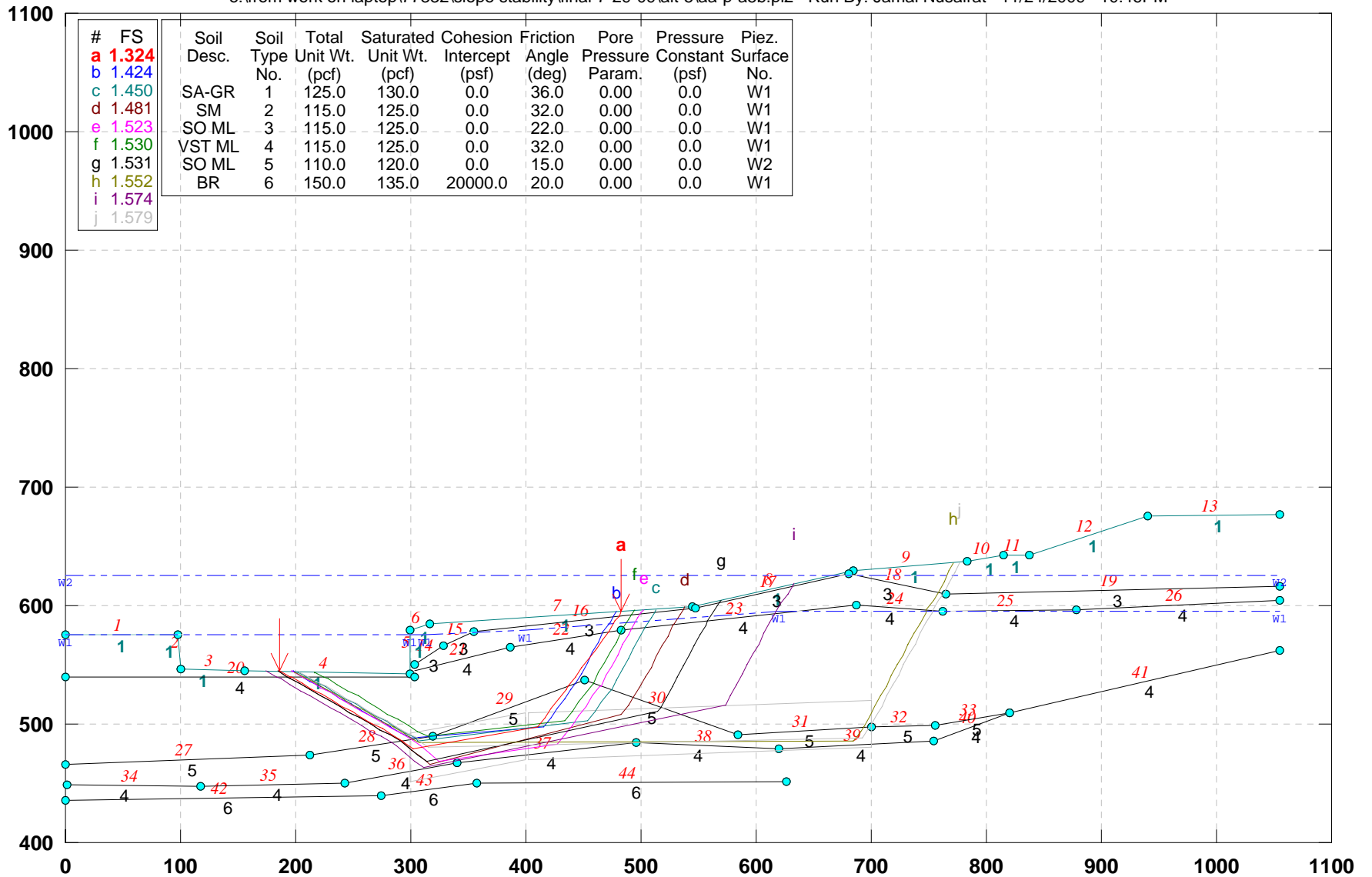

GSTABL7 v.2 FSmin=1.324

Safety Factors Are Calculated By The Simplified Janbu Method





# CUY-90-14.92 (Sec. A-A): PROPOSED GEOMETRY (Alt-5)\_Block Search: No Elev. Water

e:\from work on laptop\77332\slope stability\final-7-29-09\alt-5\aa-p-w5b.pl2 Run By: Jamal Nusairat 11/24/2009 10:48PM

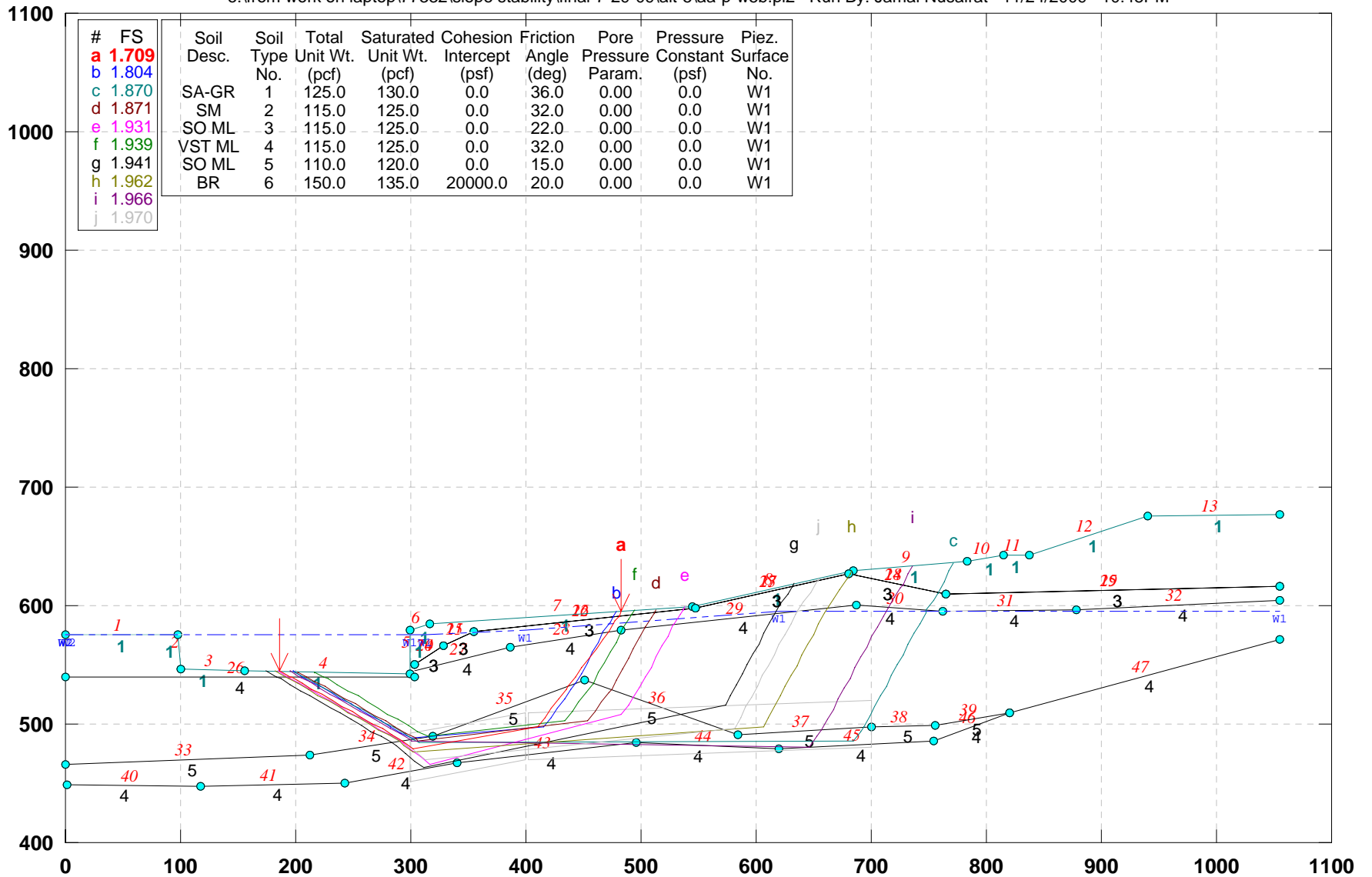

| # | FS    | Soil Desc. | Soil Type No. | Total Unit Wt. (pcf) | Saturated Unit Wt. (pcf) | Cohesion Intercept (psf) | Friction Angle (deg) | Pore Pressure Param. | Pressure Constant (psf) | Piez. Surface No. |
|---|-------|------------|---------------|----------------------|--------------------------|--------------------------|----------------------|----------------------|-------------------------|-------------------|
| a | 1.709 | SA-GR      | 1             | 125.0                | 130.0                    | 0.0                      | 36.0                 | 0.00                 | 0.0                     | W1                |
| b | 1.804 | SM         | 2             | 115.0                | 125.0                    | 0.0                      | 32.0                 | 0.00                 | 0.0                     | W1                |
| c | 1.870 | SO ML      | 3             | 115.0                | 125.0                    | 0.0                      | 22.0                 | 0.00                 | 0.0                     | W1                |
| d | 1.871 | VST ML     | 4             | 115.0                | 125.0                    | 0.0                      | 32.0                 | 0.00                 | 0.0                     | W1                |
| e | 1.931 | SO ML      | 5             | 110.0                | 120.0                    | 0.0                      | 15.0                 | 0.00                 | 0.0                     | W1                |
| f | 1.939 | BR         | 6             | 150.0                | 135.0                    | 20000.0                  | 20.0                 | 0.00                 | 0.0                     | W1                |
| g | 1.941 |            |               |                      |                          |                          |                      |                      |                         |                   |
| h | 1.962 |            |               |                      |                          |                          |                      |                      |                         |                   |
| i | 1.966 |            |               |                      |                          |                          |                      |                      |                         |                   |
| j | 1.970 |            |               |                      |                          |                          |                      |                      |                         |                   |

GSTABL7 v.2 FSmin=1.709

Safety Factors Are Calculated By The Simplified Janbu Method



# CUY-90-14.92 (Sec. B-B): PROPOSED GEOMETRY (Alt-5)\_block search

e:\from work on laptop\77332\slope stability\final-7-29-09\alt-5\bb-p-a5b.pl2 Run By: Jamal Nusairat 11/24/2009 10:54PM

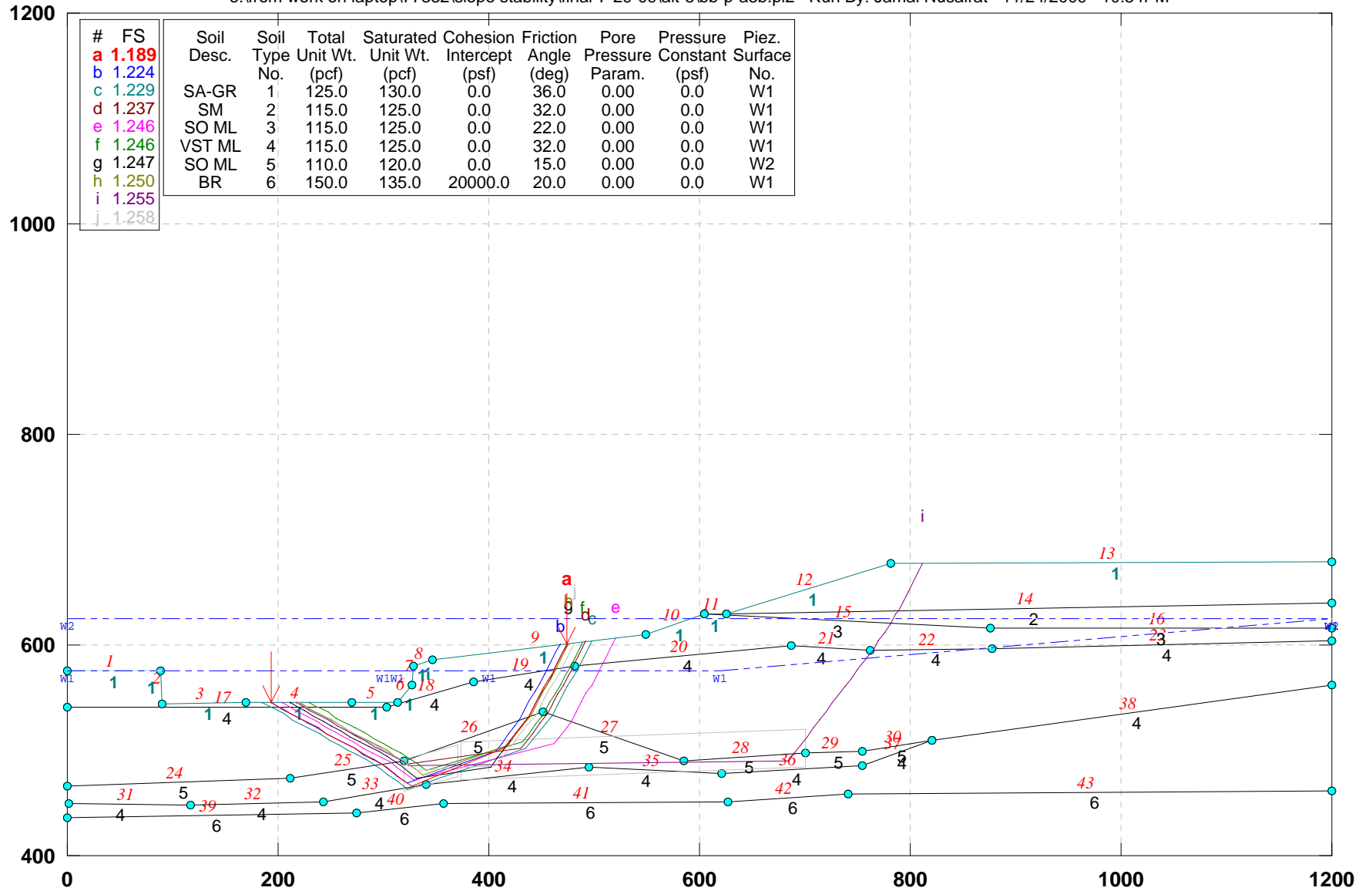

GSTABL7 v.2 FSmin=1.189

Safety Factors Are Calculated By The Simplified Janbu Method



# CUY-90-14.92 (Sec. B-B): PROPOSED GEOMETRY (Alt-5)\_block search

e:\from work on laptop\77332\slope stability\final-7-29-09\alt-5\bb-p-w5b.pl2 Run By: Jamal Nusairat 11/24/2009 10:56PM

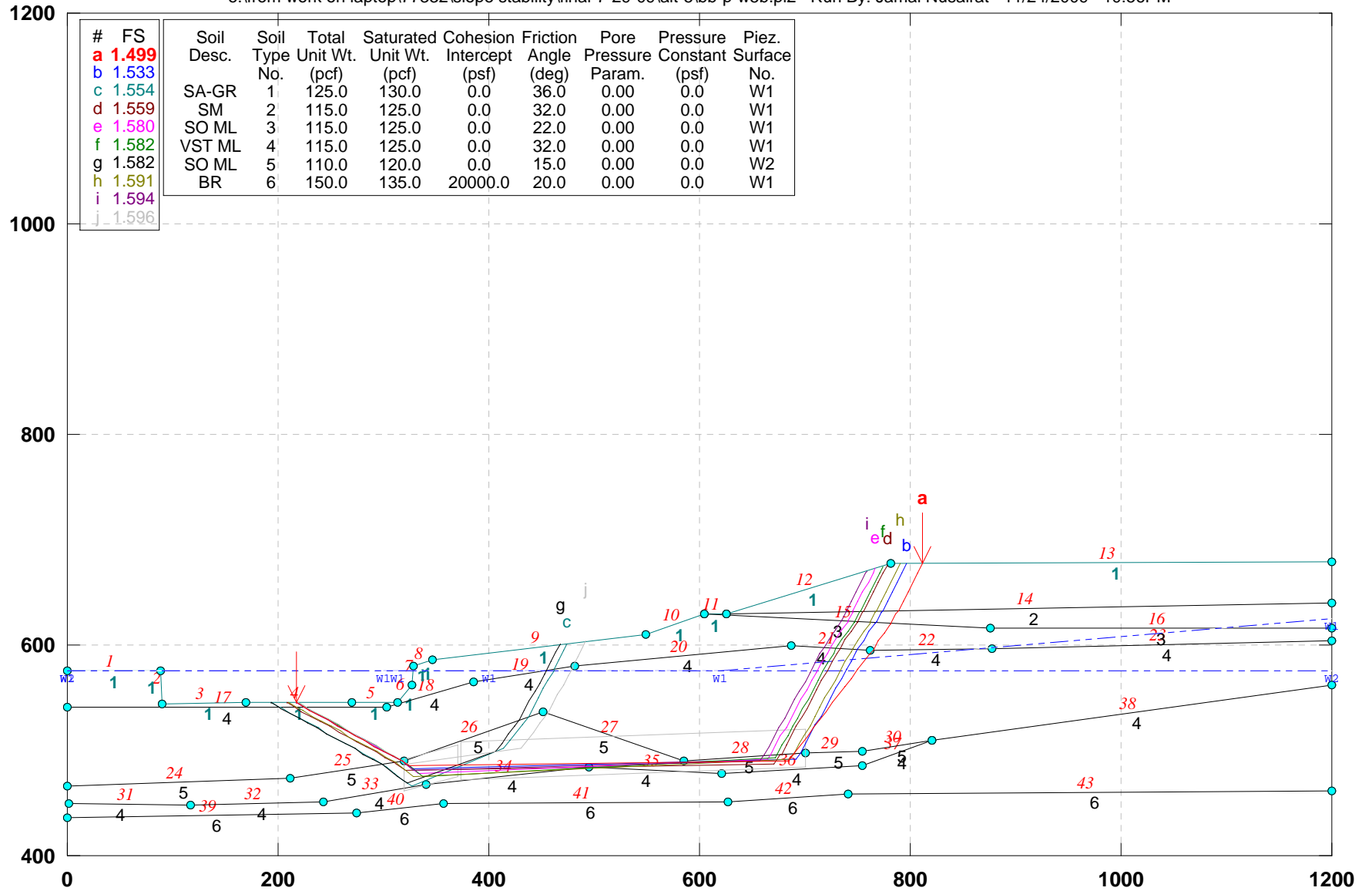

GSTABL7 v.2 FSmin=1.499

Safety Factors Are Calculated By The Simplified Janbu Method



# CUY-90-14.92 (Sec. D-D): PROPOSED GEOMETRY (ALT-5)- Block Search

e:\from work on laptop\77332\slope stability\final-7-29-09\alt-5\dd-p-a5b.pl2 Run By: Jamal Nusairat 11/24/2009 11:01PM

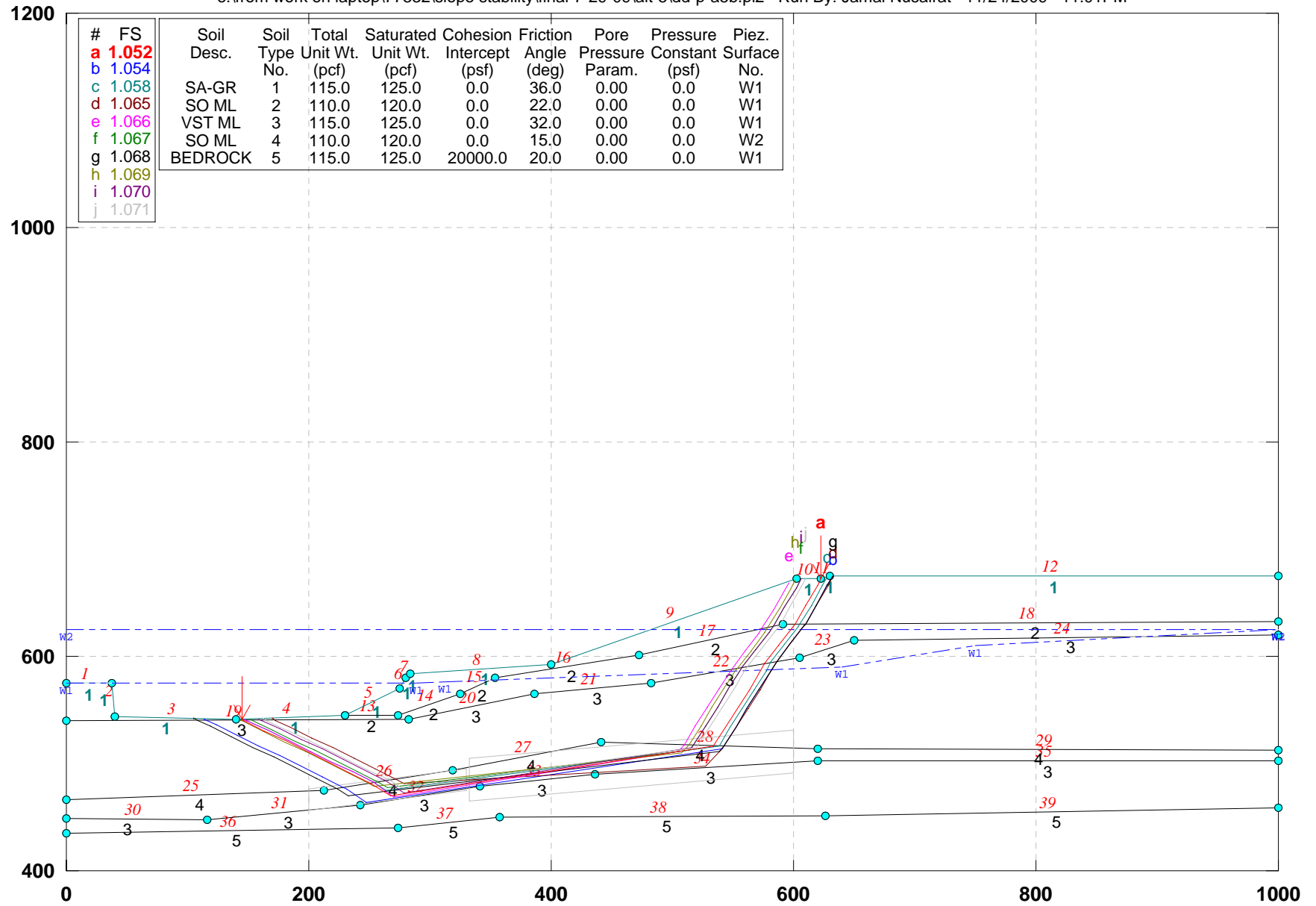

GSTABL7 v.2 FSmin=1.052

Safety Factors Are Calculated By The Simplified Janbu Method



# CUY-90-14.92 (Sec. D-D): PROPOSED GEOMETRY (ALT-5)- Block: No elevated water

e:\from work on laptop\77332\slope stability\final-7-29-09\alt-5\dd-p-w5b.pl2 Run By: Jamal Nusairat 11/24/2009 11:03PM

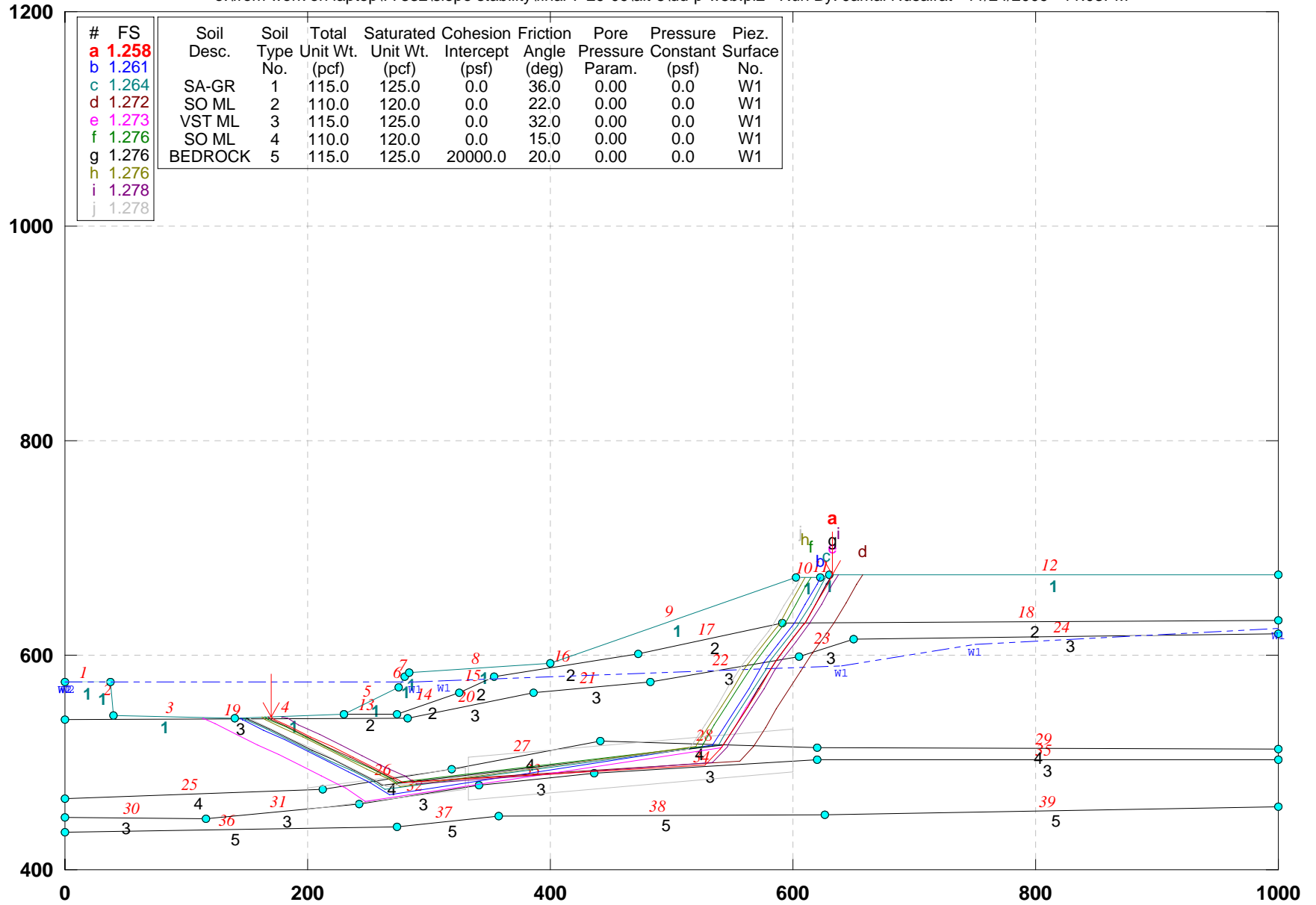

GSTABL7 v.2 FSmin=1.258

Safety Factors Are Calculated By The Simplified Janbu Method



# CUY-90-14.92 (Sec. E-E): PROPOSED GEOMETRY (Alt-5): Block Search

e:\from work on laptop\77332\slope stability\final-7-29-09\alt-5\ee-p-a5b.pl2 Run By: Jamal Nusairat 11/24/2009 11:05PM

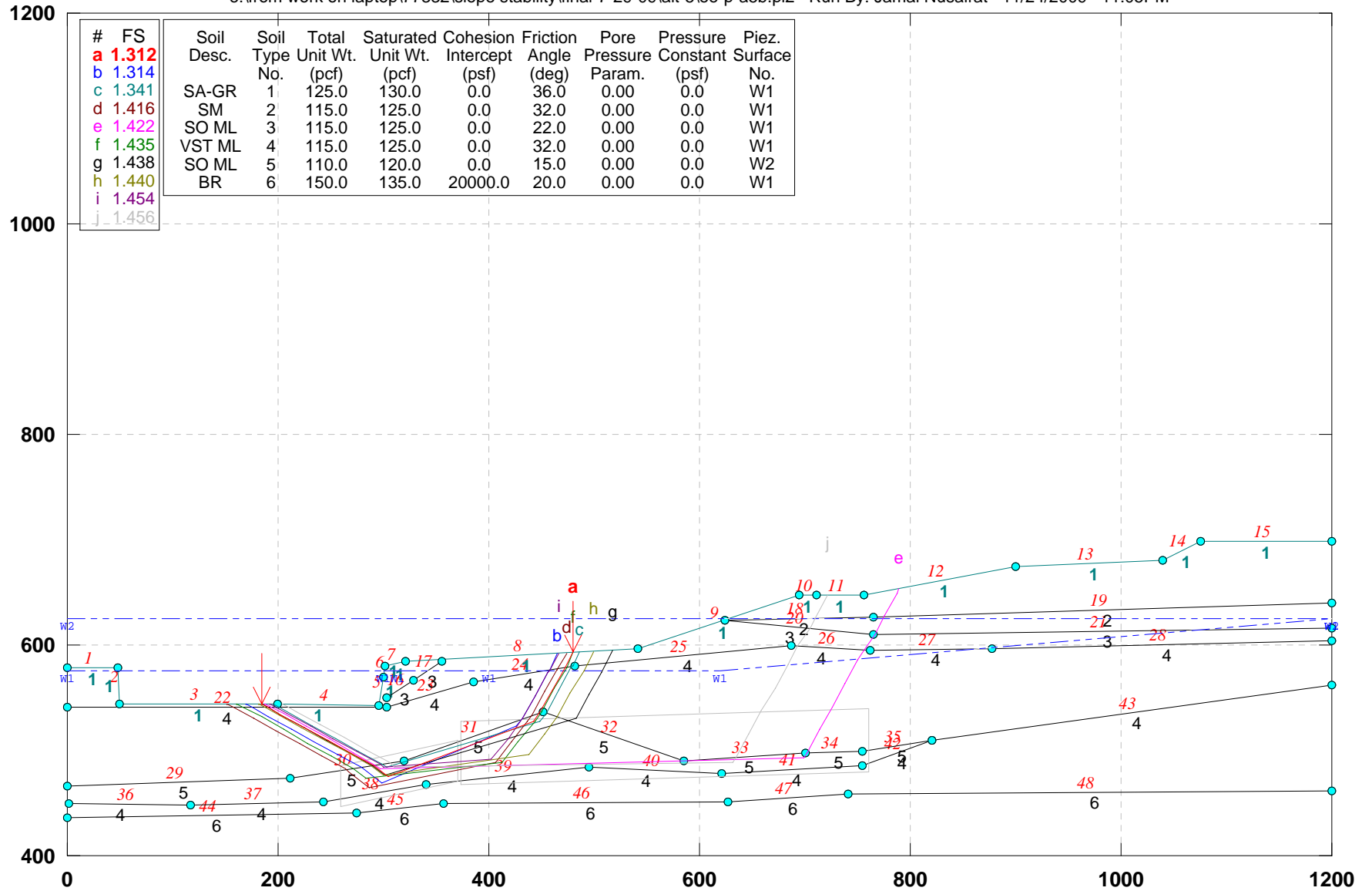

GSTABL7 v.2 FSmin=1.312

Safety Factors Are Calculated By The Simplified Janbu Method



# CUY-90-14.92 (Sec. E-E): PROPOSED GEOMETRY (Alt-5): Block Search\_No elev water

e:\from work on laptop\77332\slope stability\final-7-29-09\alt-5\ee-p-w5b.pl2 Run By: Jamal Nusairat 11/24/2009 11:08PM

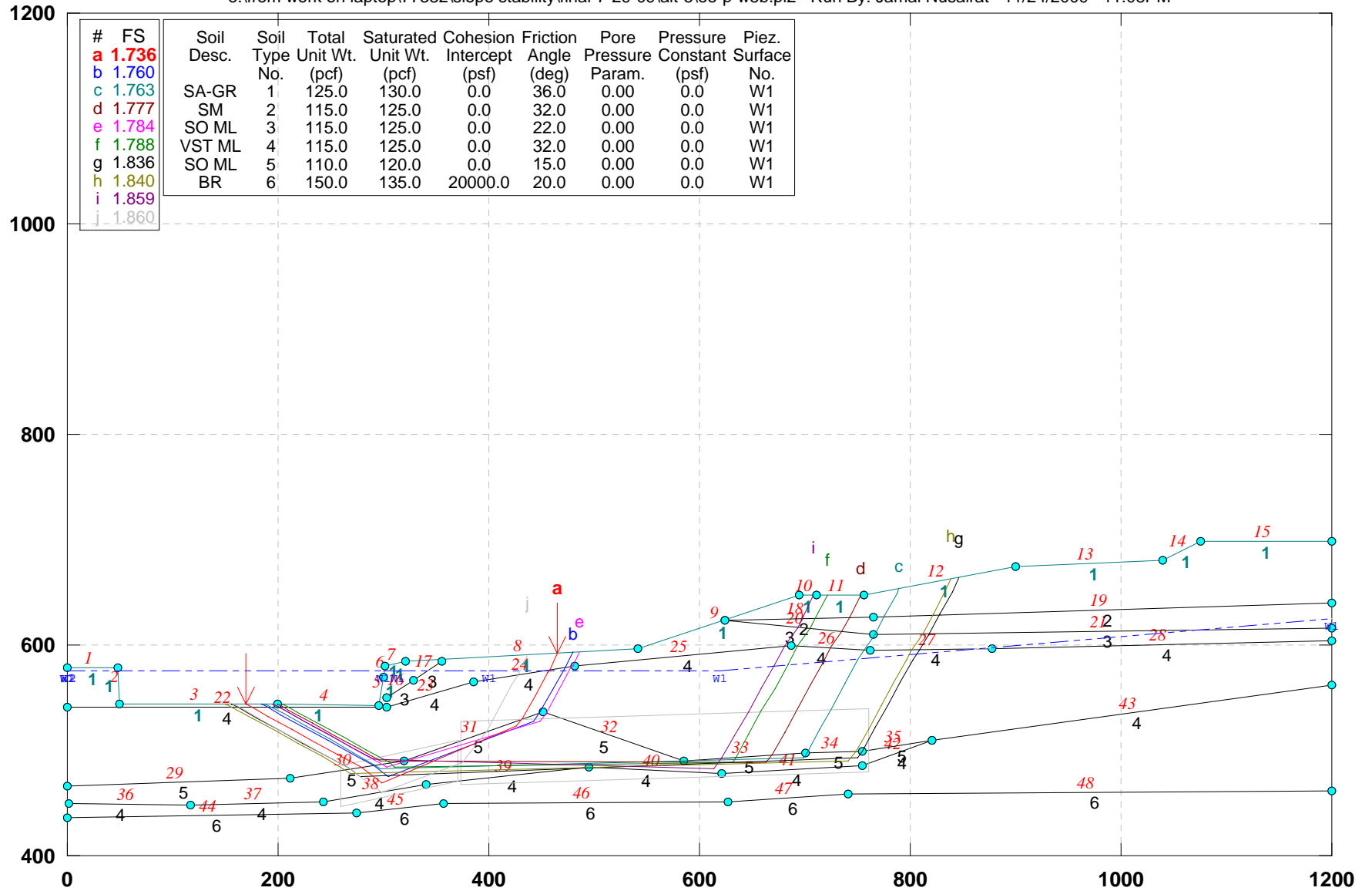

GSTABL7 v.2 FSmin=1.736

Safety Factors Are Calculated By The Simplified Janbu Method



# CUY-90-14.92 (Sec. FF): PROPOSED GEOMETRY (Alt-5)\_block search

E:\REPORTS\CUY-90\2009WO-1\2009-S-1\ALT-5--1\FF-P-A5B.PL2 Run By: Username 8/19/2009 2:03AM

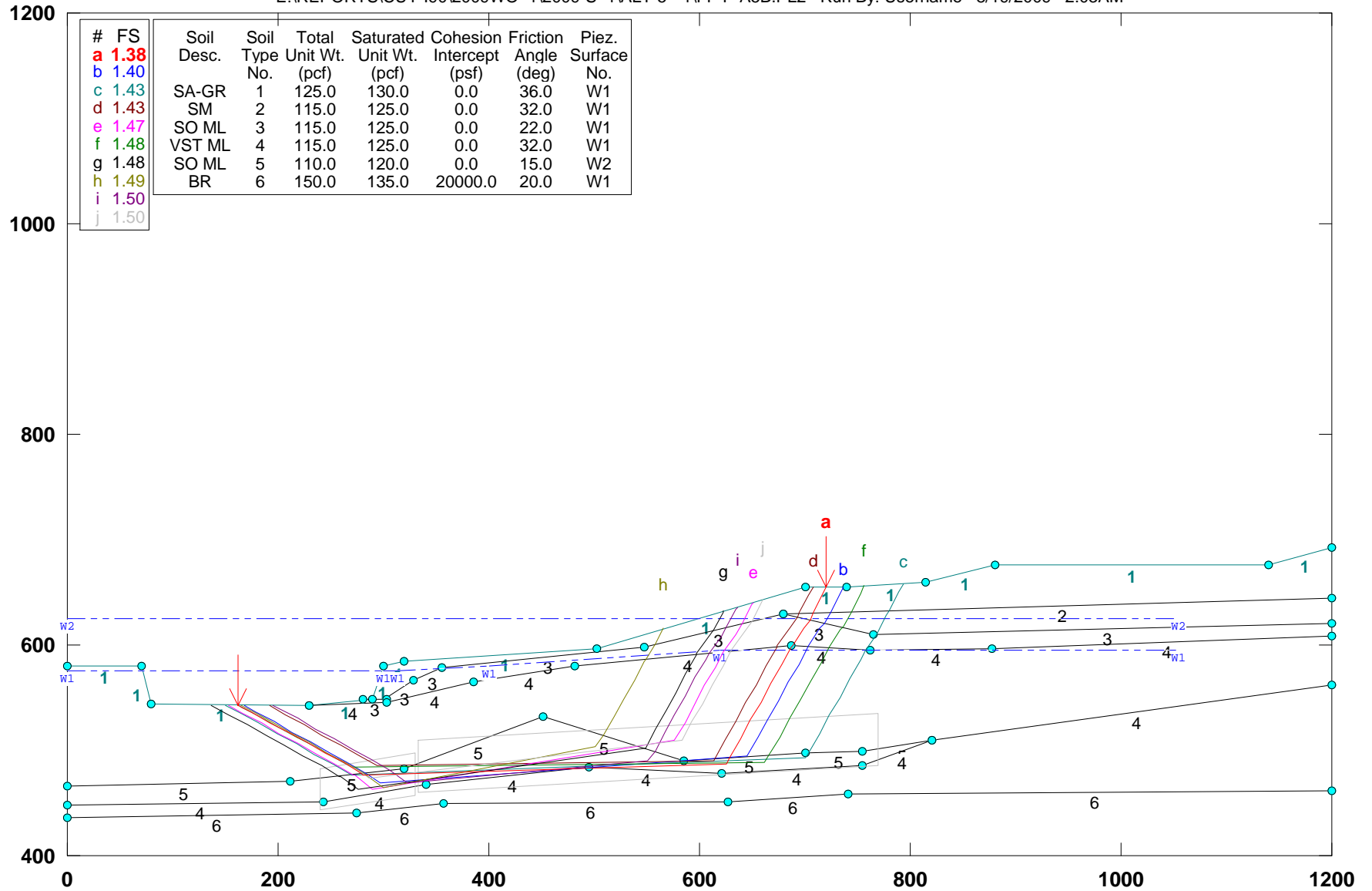

| # | FS   | Soil Desc. | Soil Type No. | Total Unit Wt. (pcf) | Saturated Unit Wt. (pcf) | Cohesion Intercept (psf) | Friction Angle (deg) | Piez. Surface No. |
|---|------|------------|---------------|----------------------|--------------------------|--------------------------|----------------------|-------------------|
| a | 1.38 | SA-GR      | 1             | 125.0                | 130.0                    | 0.0                      | 36.0                 | W1                |
| b | 1.40 | SM         | 2             | 115.0                | 125.0                    | 0.0                      | 32.0                 | W1                |
| c | 1.43 | SO ML      | 3             | 115.0                | 125.0                    | 0.0                      | 22.0                 | W1                |
| d | 1.43 | VST ML     | 4             | 115.0                | 125.0                    | 0.0                      | 32.0                 | W1                |
| e | 1.47 | SO ML      | 5             | 110.0                | 120.0                    | 0.0                      | 15.0                 | W2                |
| f | 1.48 | BR         | 6             | 150.0                | 135.0                    | 20000.0                  | 20.0                 | W1                |
| g | 1.48 |            |               |                      |                          |                          |                      |                   |
| h | 1.49 |            |               |                      |                          |                          |                      |                   |
| i | 1.50 |            |               |                      |                          |                          |                      |                   |
| j | 1.50 |            |               |                      |                          |                          |                      |                   |

GSTABL7 v.2 FSmin=1.38

Safety Factors Are Calculated By The Simplified Janbu Method





# CUY-90-14.92 (Sec. FF): PROPOSED GEOMETRY (Alt-5)\_block search: No elev water

E:\REPORTS\CUY-90\2009WO-1\2009-S-1\ALT-5-1\FF-P-W5B.PL2 Run By: Username 8/19/2009 2:05AM

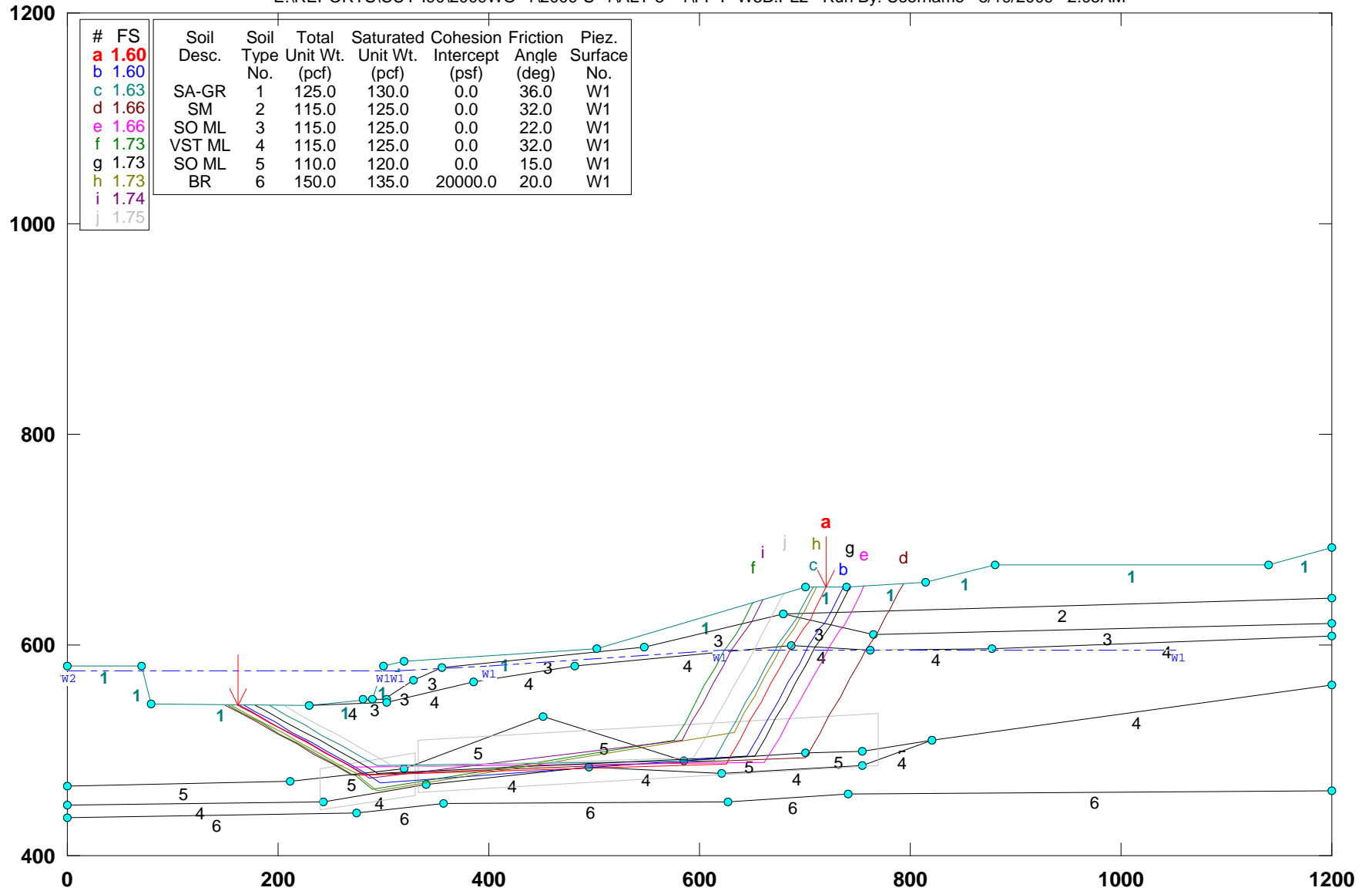

GSTABL7 v.2 FSmin=1.60

Safety Factors Are Calculated By The Simplified Janbu Method



# CUY-90-14.92 (Sec. G-G): PROPOSED EXCAVATION (ALT-5)\_Block Search: No elev water

E:\REPORTS\CUY-190\2009WO~1\2009-S-1\ALT-5--1\GG-PW5B.PL2 Run By: Username 8/19/2009 11:26PM

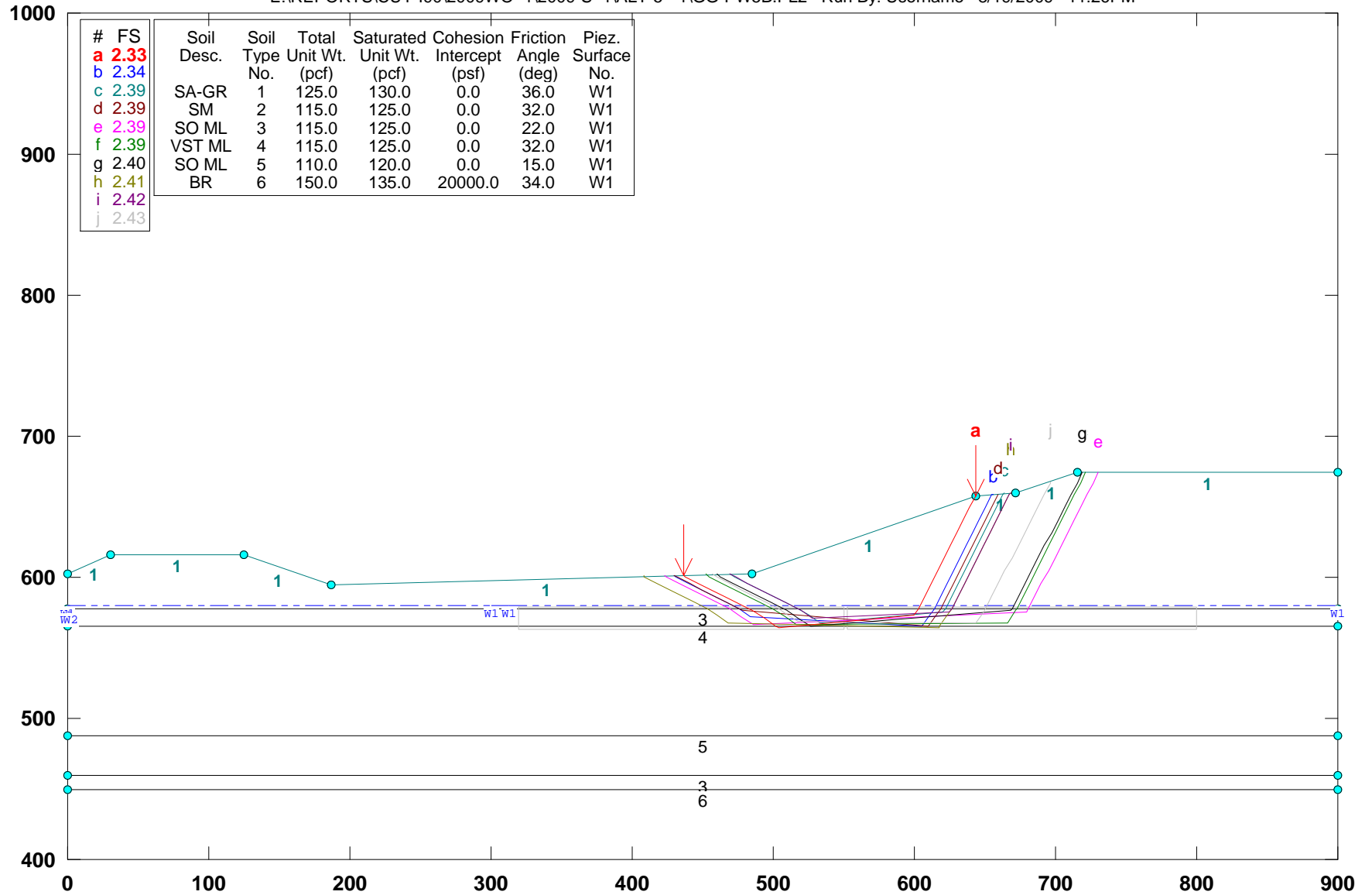

GSTABL7 v.2 FSmin=2.33

Safety Factors Are Calculated By The Simplified Janbu Method



# CUY-90-14.92 (Sec. G-G): PROPOSED EXCAVATION (ALT-5)\_Block Search

E:\REPORTS\CUY-190\2009WO-1\2009-S-1\ALT-5--1\GG-PR5B.PL2 Run By: Username 8/19/2009 11:24PM

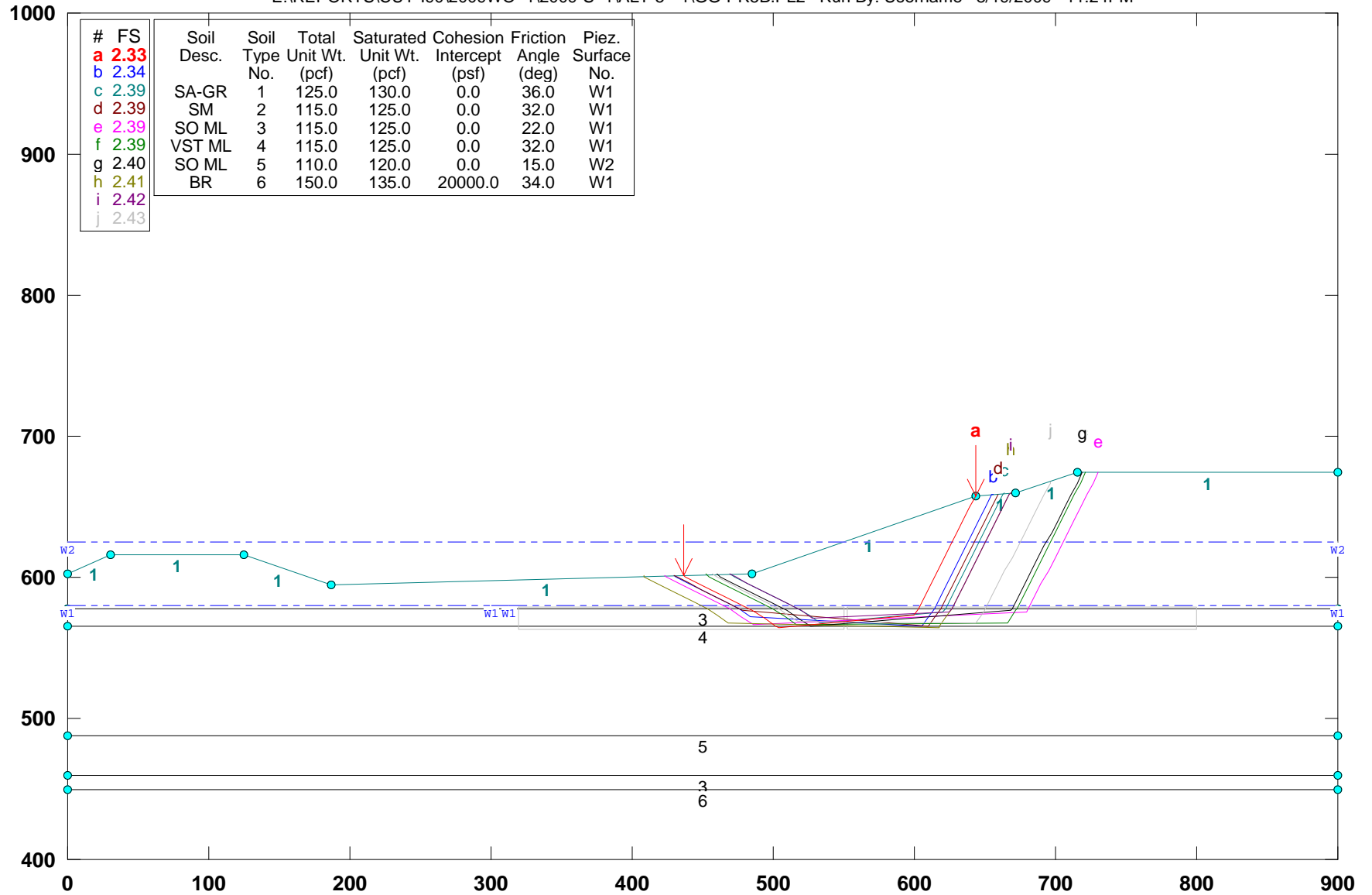

GSTABL7 v.2 FSmin=2.33

Safety Factors Are Calculated By The Simplified Janbu Method



# CUY-90-14.92 (Sec. U-U): PROPOSED EXCAV.GEOMETRY- (Alt-45): Block Search

E:\REPORTS\CUY-190\2009WO~1\2009-S~1\ALT-5--1\UU-P5B.PL2 Run By: Username 8/19/2009 11:50PM

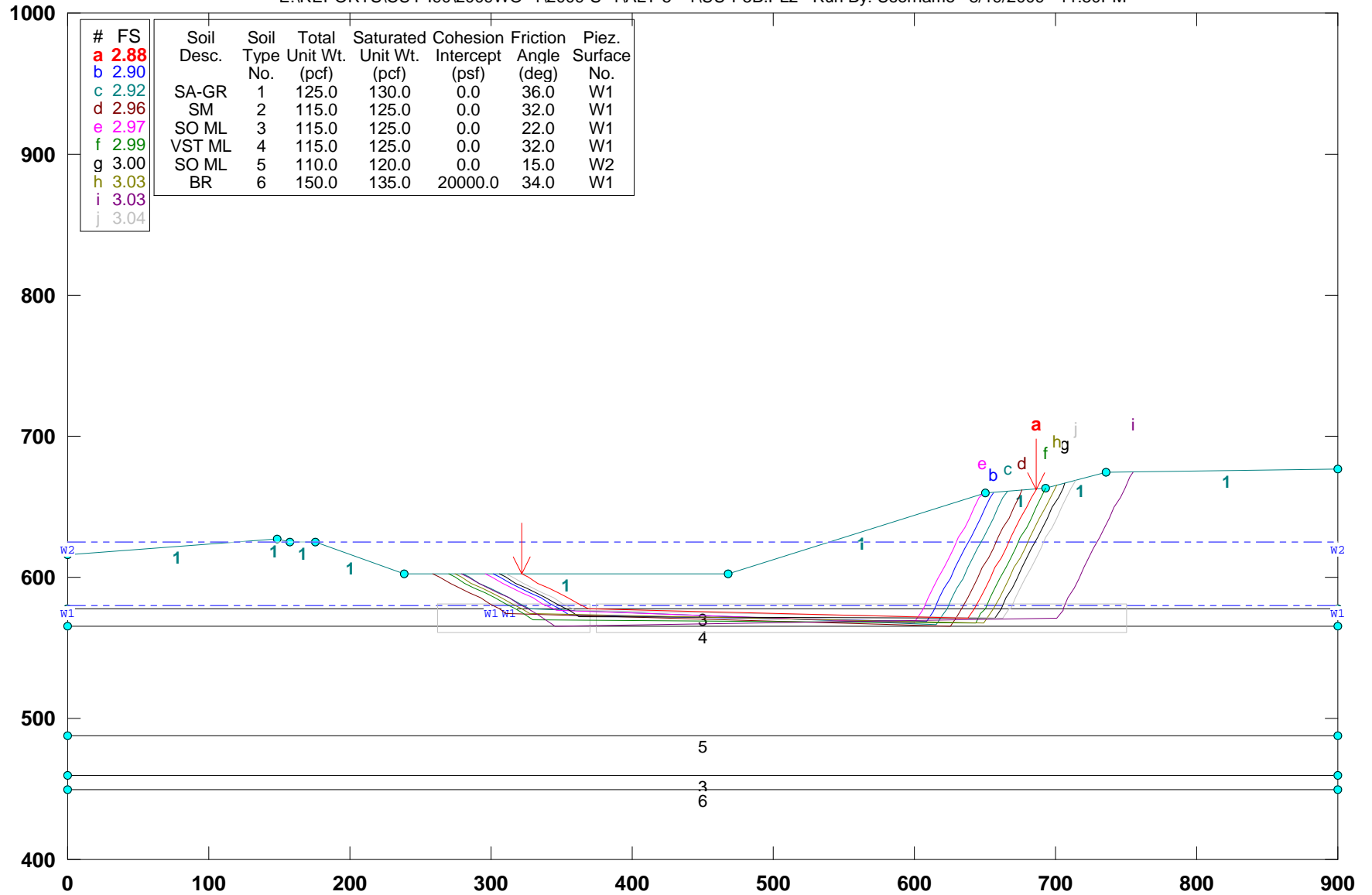

GSTABL7 v.2 FSmin=2.88

Safety Factors Are Calculated By The Simplified Janbu Method



# CUY-90-14.92 (Sec. W-W): PROPOSED GEOMETRY (ALT-5)\_Block search

C:\WORK\77332\SLOPES~1\ALT-5\WW-PR5B.PL2 Run By: Jamal Nusairat 8/19/2009 12:15AM

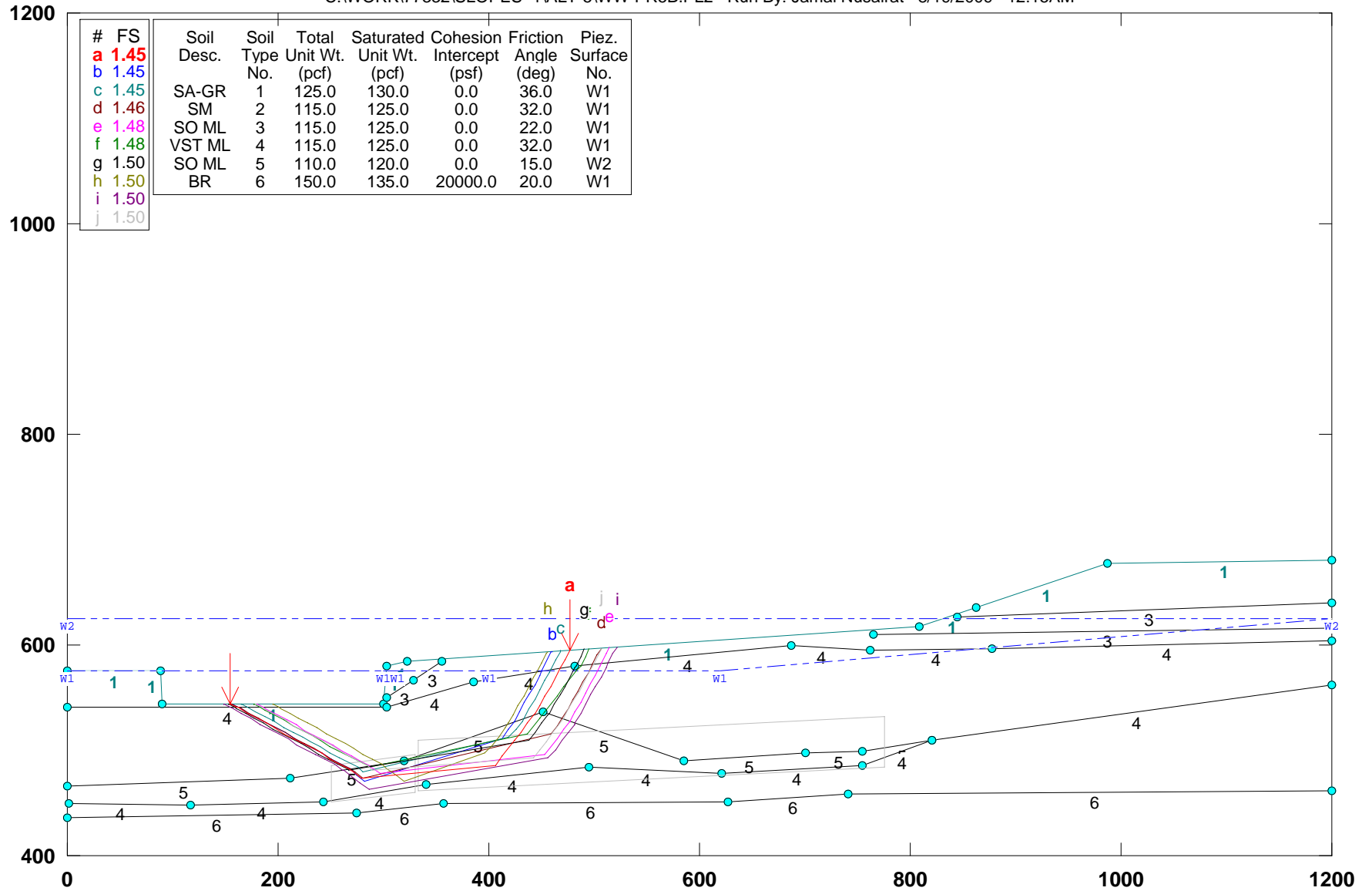

GSTABL7 v.2 FSmin=1.45

Safety Factors Are Calculated By The Simplified Janbu Method



# CUY-90-14.92 (Sec. W-W): PROPOSED GEOMETRY (ALT-5)\_Block search: No elev water

C:\WORK\77332\SLOPES~1\ALT-5\WW-PW5B.PL2 Run By: Jamal Nusairat 8/19/2009 12:18AM

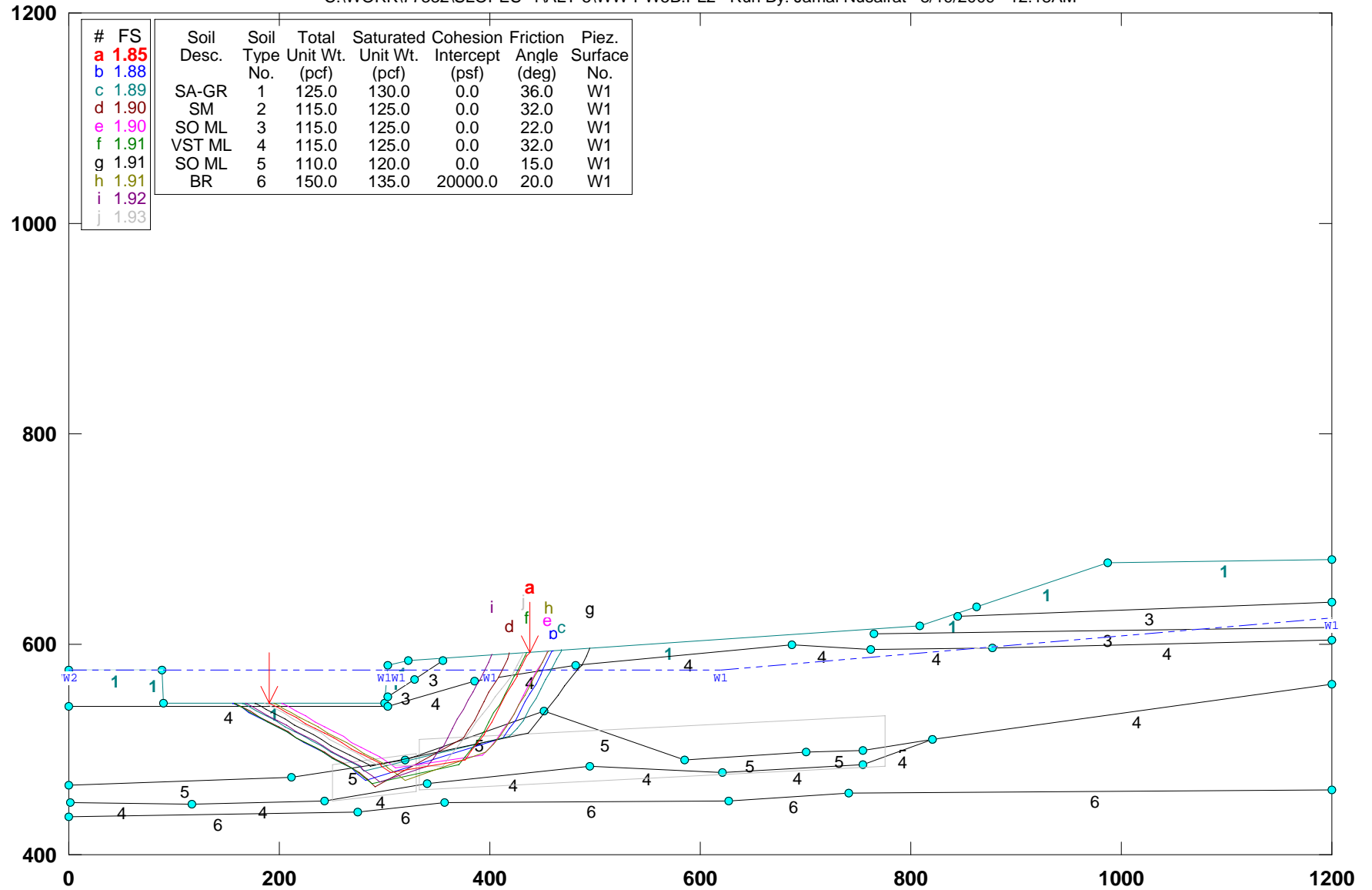

| # | FS   | Soil Desc. | Soil Type No. | Total Unit Wt. (pcf) | Saturated Unit Wt. (pcf) | Cohesion Intercept (psf) | Friction Angle (deg) | Piez. Surface No. |
|---|------|------------|---------------|----------------------|--------------------------|--------------------------|----------------------|-------------------|
| a | 1.85 |            |               |                      |                          |                          |                      |                   |
| b | 1.88 |            |               |                      |                          |                          |                      |                   |
| c | 1.89 | SA-GR      | 1             | 125.0                | 130.0                    | 0.0                      | 36.0                 | W1                |
| d | 1.90 | SM         | 2             | 115.0                | 125.0                    | 0.0                      | 32.0                 | W1                |
| e | 1.90 | SO ML      | 3             | 115.0                | 125.0                    | 0.0                      | 22.0                 | W1                |
| f | 1.91 | VST ML     | 4             | 115.0                | 125.0                    | 0.0                      | 32.0                 | W1                |
| g | 1.91 | SO ML      | 5             | 110.0                | 120.0                    | 0.0                      | 15.0                 | W1                |
| h | 1.91 | BR         | 6             | 150.0                | 135.0                    | 20000.0                  | 20.0                 | W1                |
| i | 1.92 |            |               |                      |                          |                          |                      |                   |
| j | 1.93 |            |               |                      |                          |                          |                      |                   |

GSTABL7 v.2 FSmin=1.85

Safety Factors Are Calculated By The Simplified Janbu Method



# CUY-90-14.92 (Sec. W-W): PROPOSED GEOMETRY (ALT-5)\_Block search

e:\from work on laptop\77332\slope stability\final-7-29-09\alt-5\ww-pr5b.pl2 Run By: Jamal Nusairat 11/24/2009 11:15PM

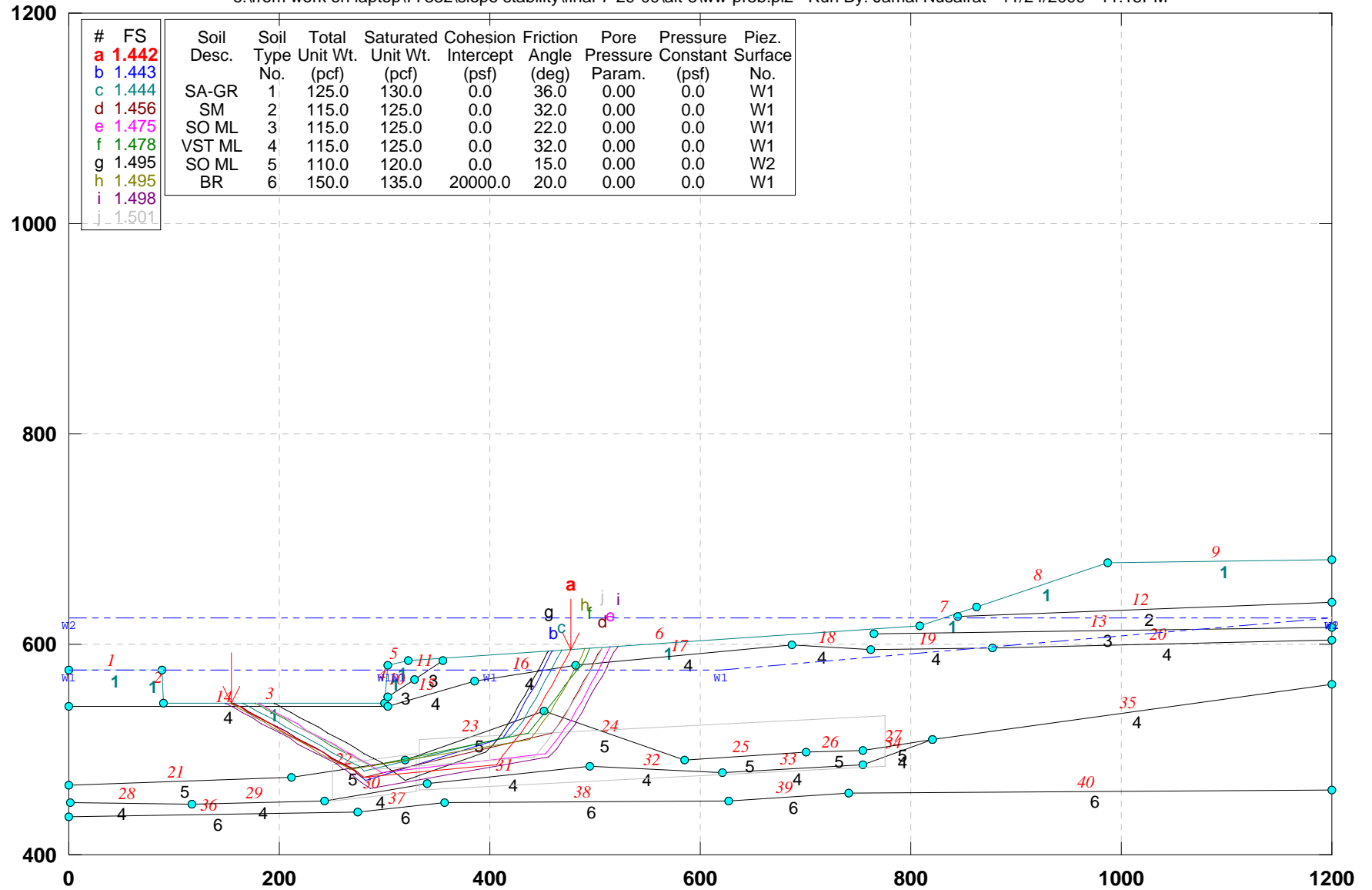

GSTABL7 v.2 FSmin=1.442

Safety Factors Are Calculated By The Simplified Janbu Method



# CUY-90-14.92 (Sec. W-W): PROPOSED GEOMETRY (ALT-5)\_Block search: No elev water

e:\from work on laptop\77332\slope stability\final-7-29-09\alt-5\ww-pw5b.pl2 Run By: Jamal Nusairat 11/24/2009 11:18PM

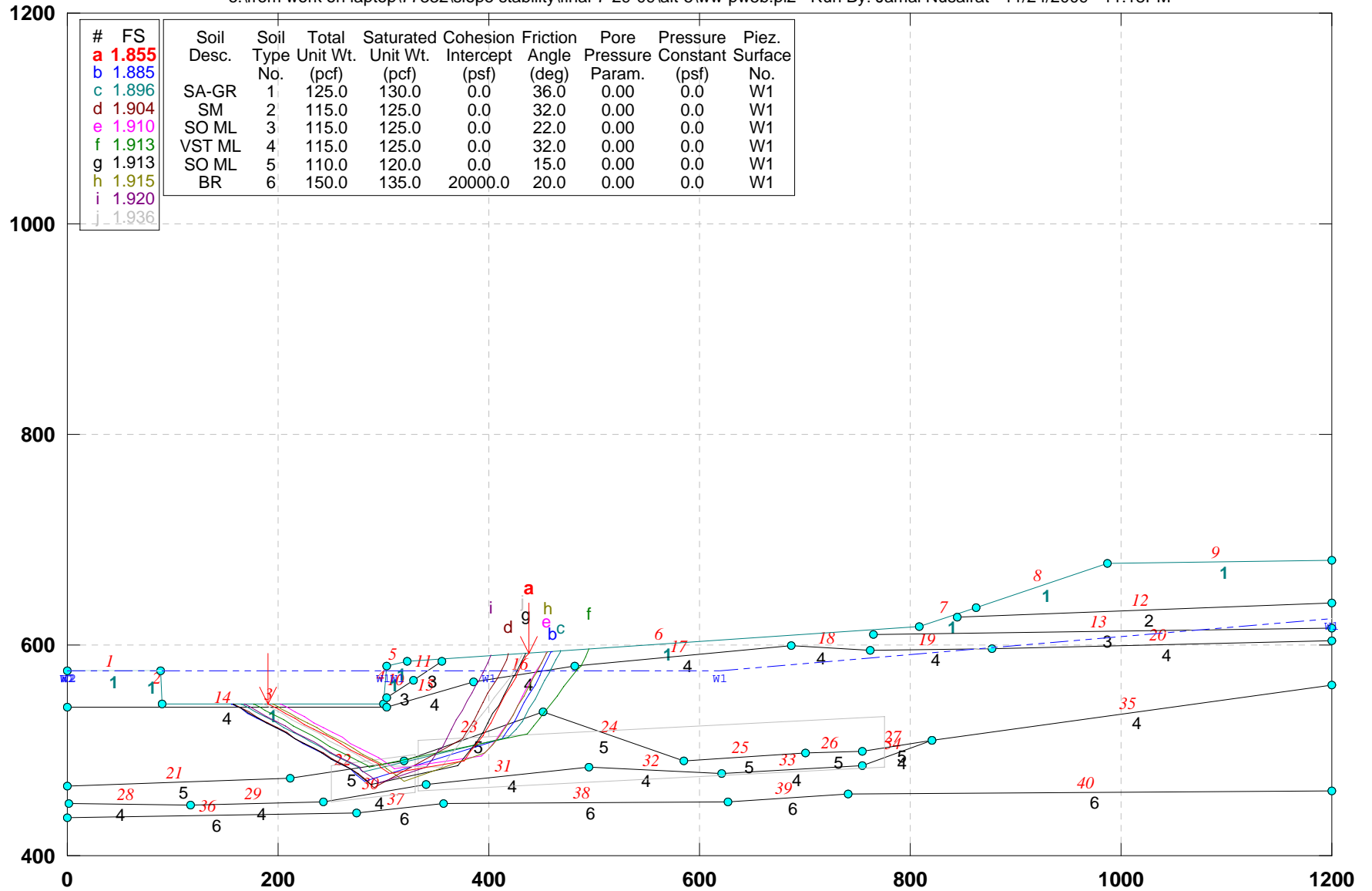

GSTABL7 v.2 FSmin=1.855

Safety Factors Are Calculated By The Simplified Janbu Method





# CUY-90-14.40 (Sec. Y-Y): PROPOSED GEOMETRY (ALT-5)\_block search

e:\from work on laptop\77332\slope stability\final-7-29-09\alt-5\yy-pr5-b.pl2 Run By: Jamal Nusairat 11/24/2009 11:25PM

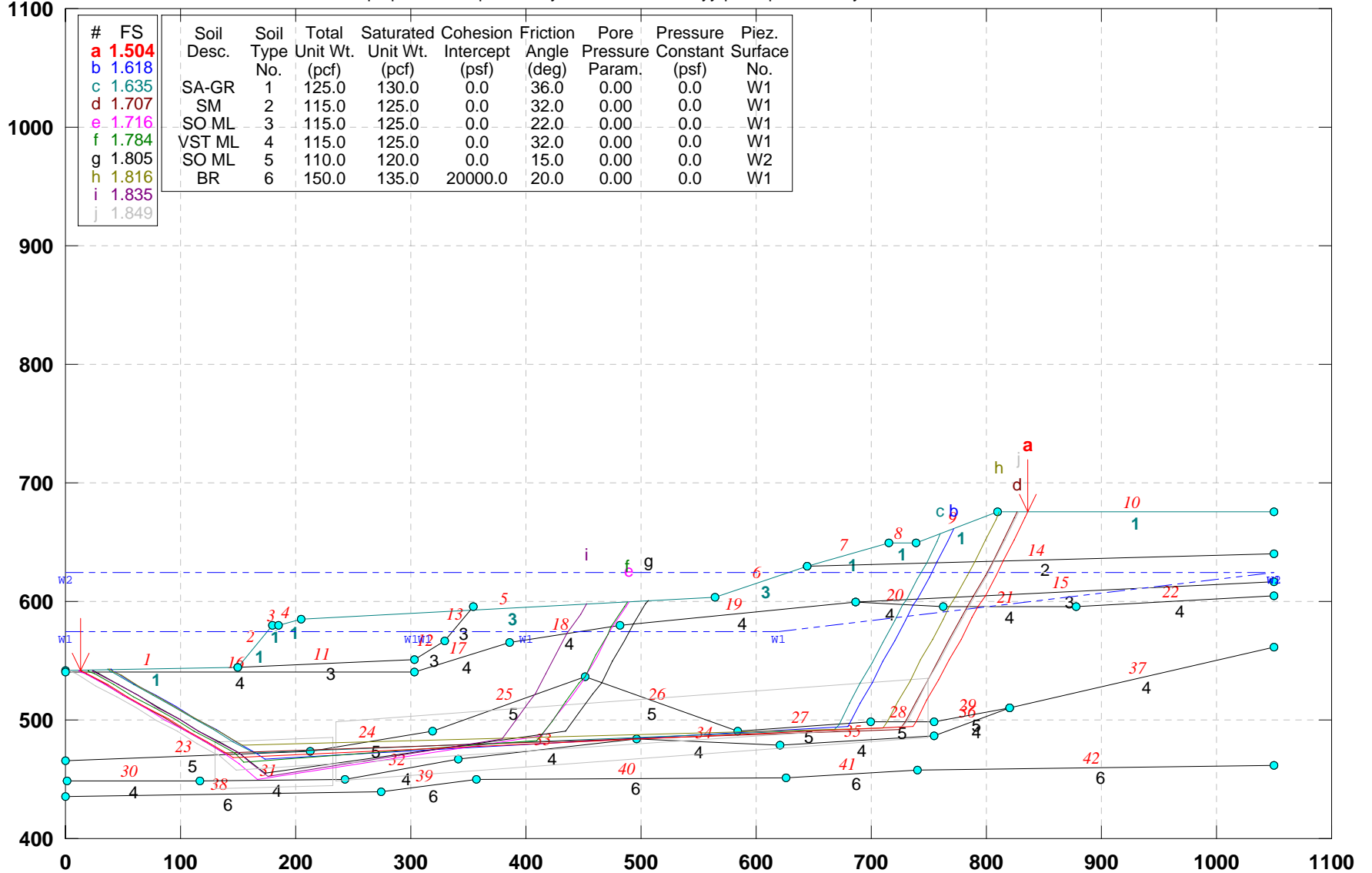

GSTABL7 v.2 FSmin=1.504

Safety Factors Are Calculated By The Simplified Janbu Method



# CUY-90-14.40 (Sec. Y-Y): PROPOSED GEOMETRY (ALT-5)\_block search\_ No Elev. Water

e:\from work on laptop\77332\slope stability\final-7-29-09\alt-5\bb-p-w5b.pl2 Run By: Jamal Nusairat 11/24/2009 11:28PM

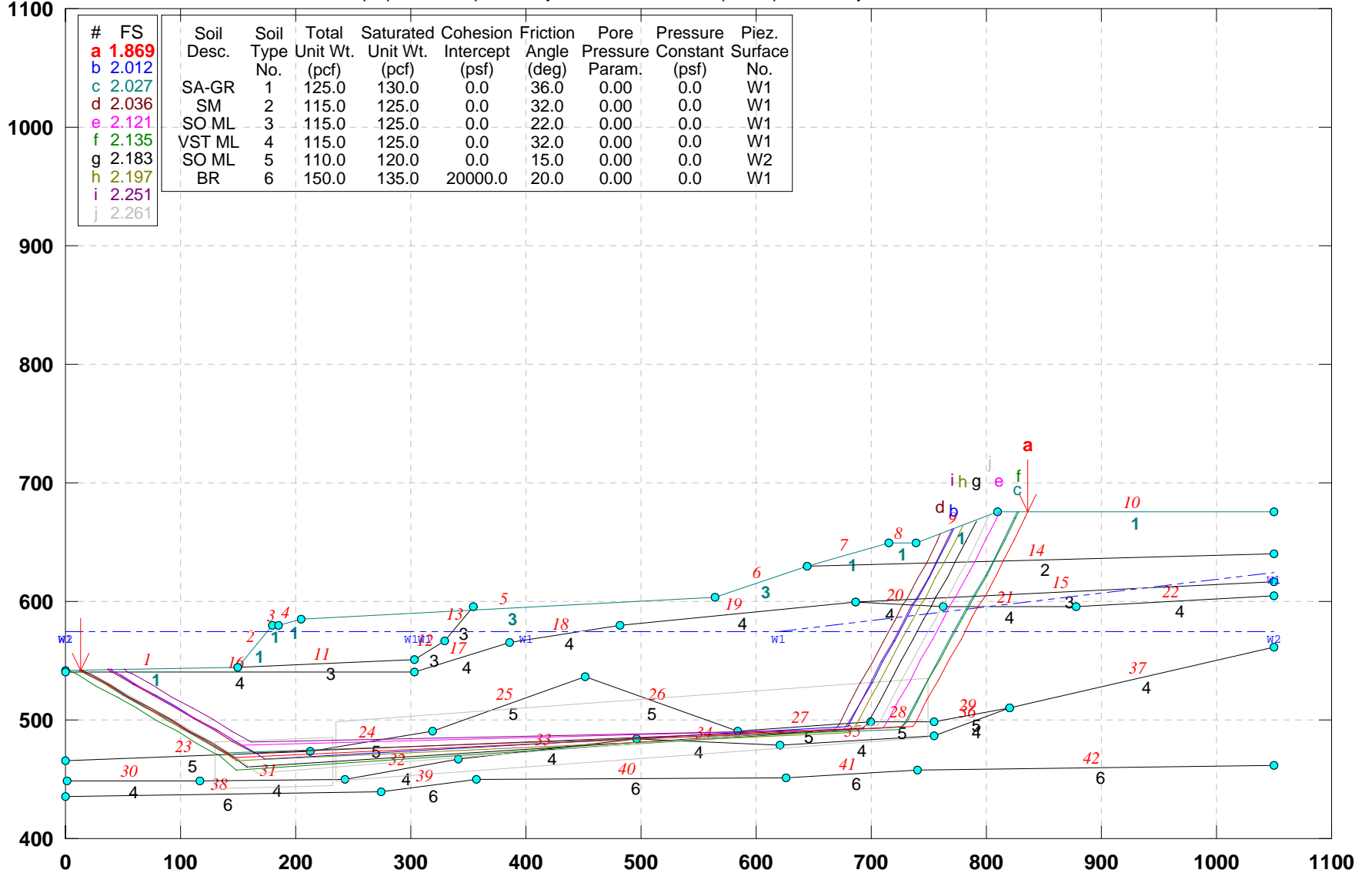

GSTABL7 v.2 FSmin=1.869

Safety Factors Are Calculated By The Simplified Janbu Method



# CUY-90-14.92 (Sec. Z-Z): PROPOSED GEOMETRY (Alt-5)\_Block search

e:\work on laptop\77332\slope stability\final-7-29-09\alt-5\zz-pr5b.pl2 Run By: Jamal Nusairat 11/24/2009 11:37PM

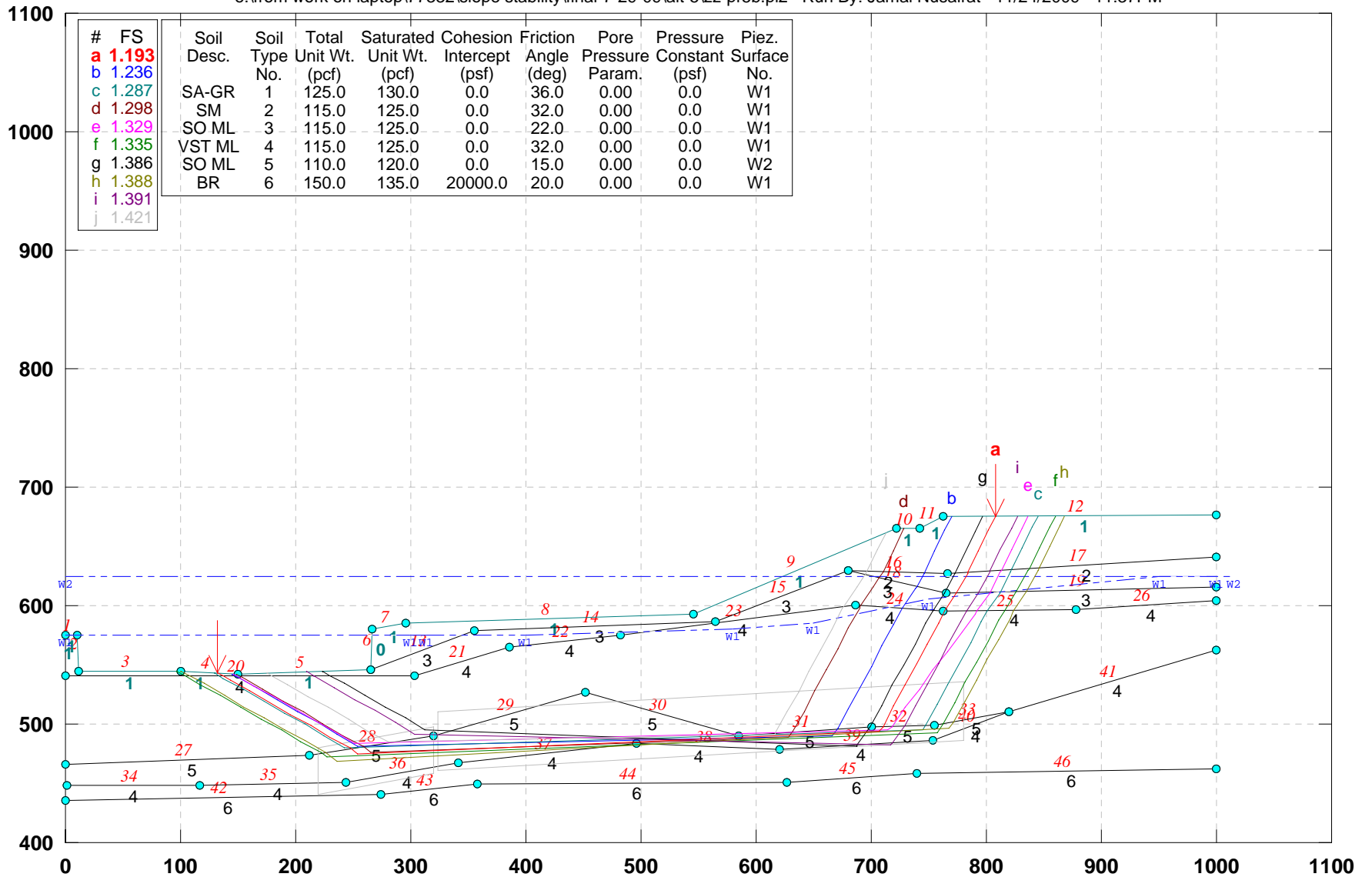

GSTABL7 v.2 FSmin=1.193

Safety Factors Are Calculated By The Simplified Janbu Method



# CUY-90-14.92 (Sec. Z-Z): PROPOSED GEOMETRY (Alt-5)\_Block search: No elev water

e:\from work on laptop\77332\slope stability\final-7-29-09\alt-5\zz-pw5b.pl2 Run By: Jamal Nusairat 11/24/2009 11:32PM

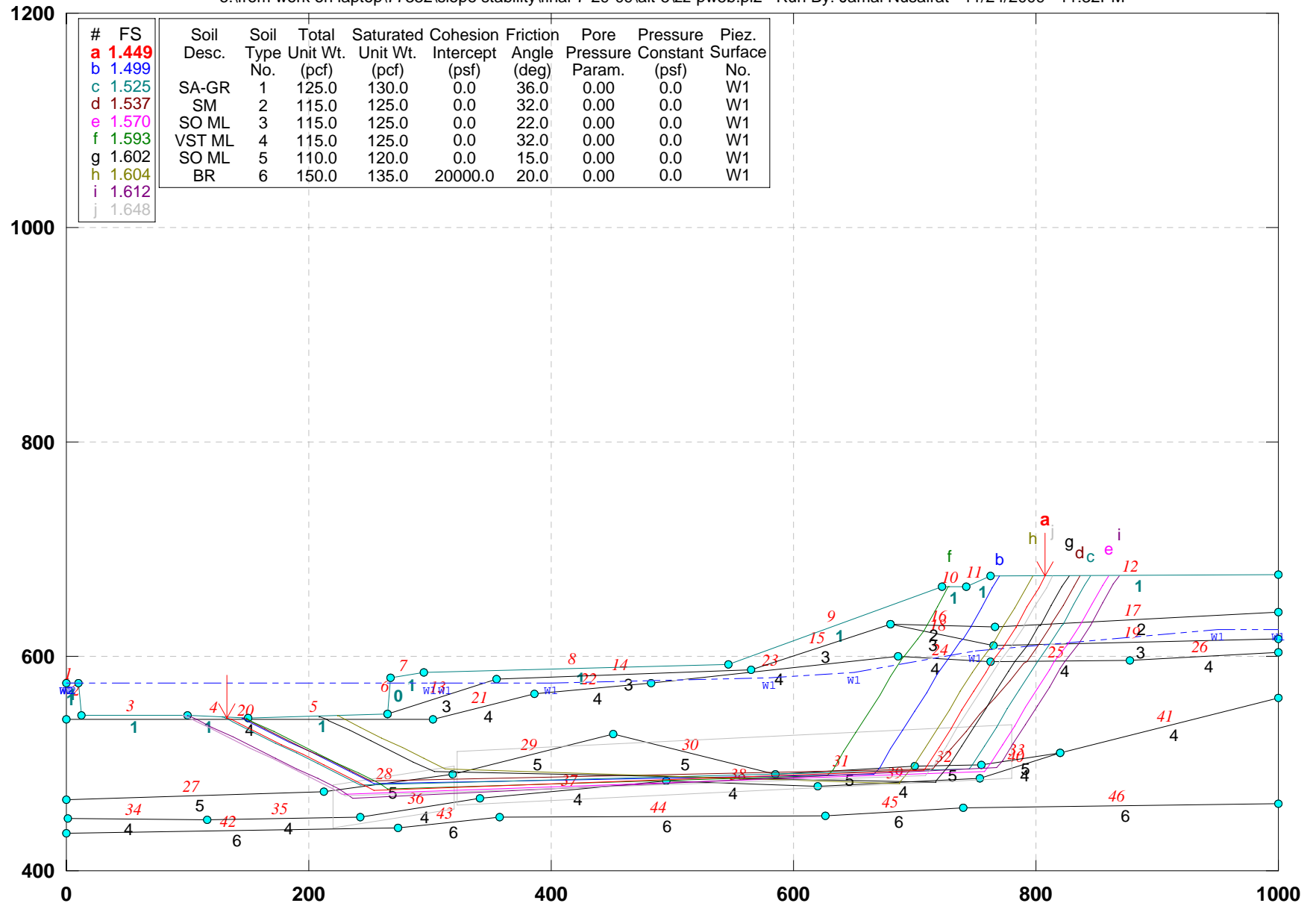

GSTABL7 v.2 FSmin=1.449

Safety Factors Are Calculated By The Simplified Janbu Method



# CUY-90-14.92 (Sec. A-A): PROPOSED GEOMETRY (Alt-5): No elevated water

e:\from work on laptop\77332\slope stability\final-7-29-09\alt-5\aa-pr-w5.pl2 Run By: Jamal Nusairat 11/24/2009 11:50PM

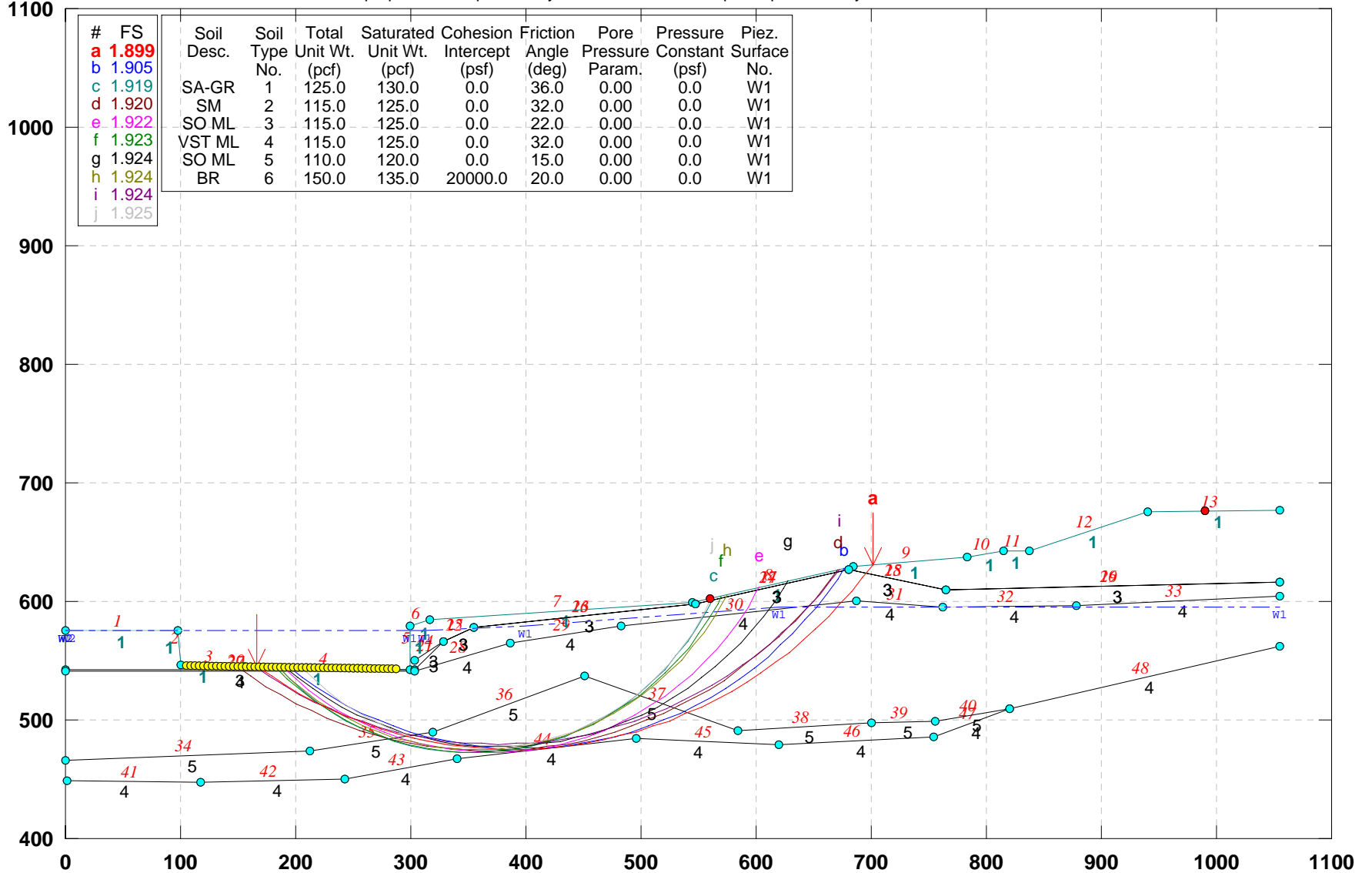

GSTABL7 v.2 FSmin=1.899

Safety Factors Are Calculated By The Simplified Janbu Method



# CUY-90-14.92 (Sec. B-B): PROPOSED GEOMETRY (Alt-5)

e:\from work on laptop\77332\slope stability\final-7-29-09\alt-5\bb-pr-a5.pl2 Run By: Jamal Nusairat 11/25/2009 12:07AM

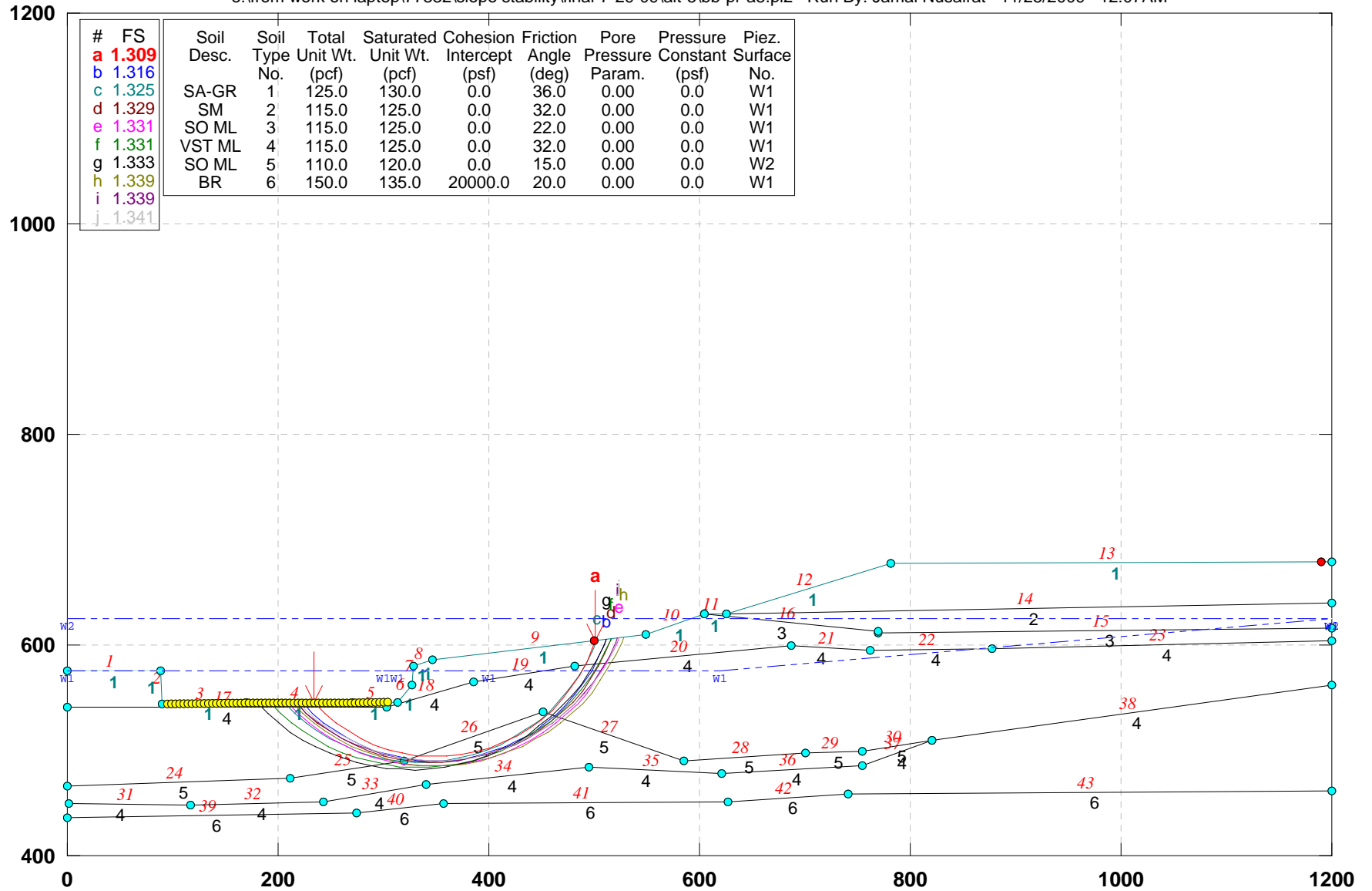

GSTABL7 v.2 FSmin=1.309

Safety Factors Are Calculated By The Simplified Janbu Method



# CUY-90-14.92 (Sec. B-B): PROPOSED GEOMETRY (Alt-5)\_ No Elev. Water

e:\from work on laptop\77332\slope stability\final-7-29-09\alt-5\bb-pr-w5.pl2 Run By: Jamal Nusairat 11/25/2009 12:11AM

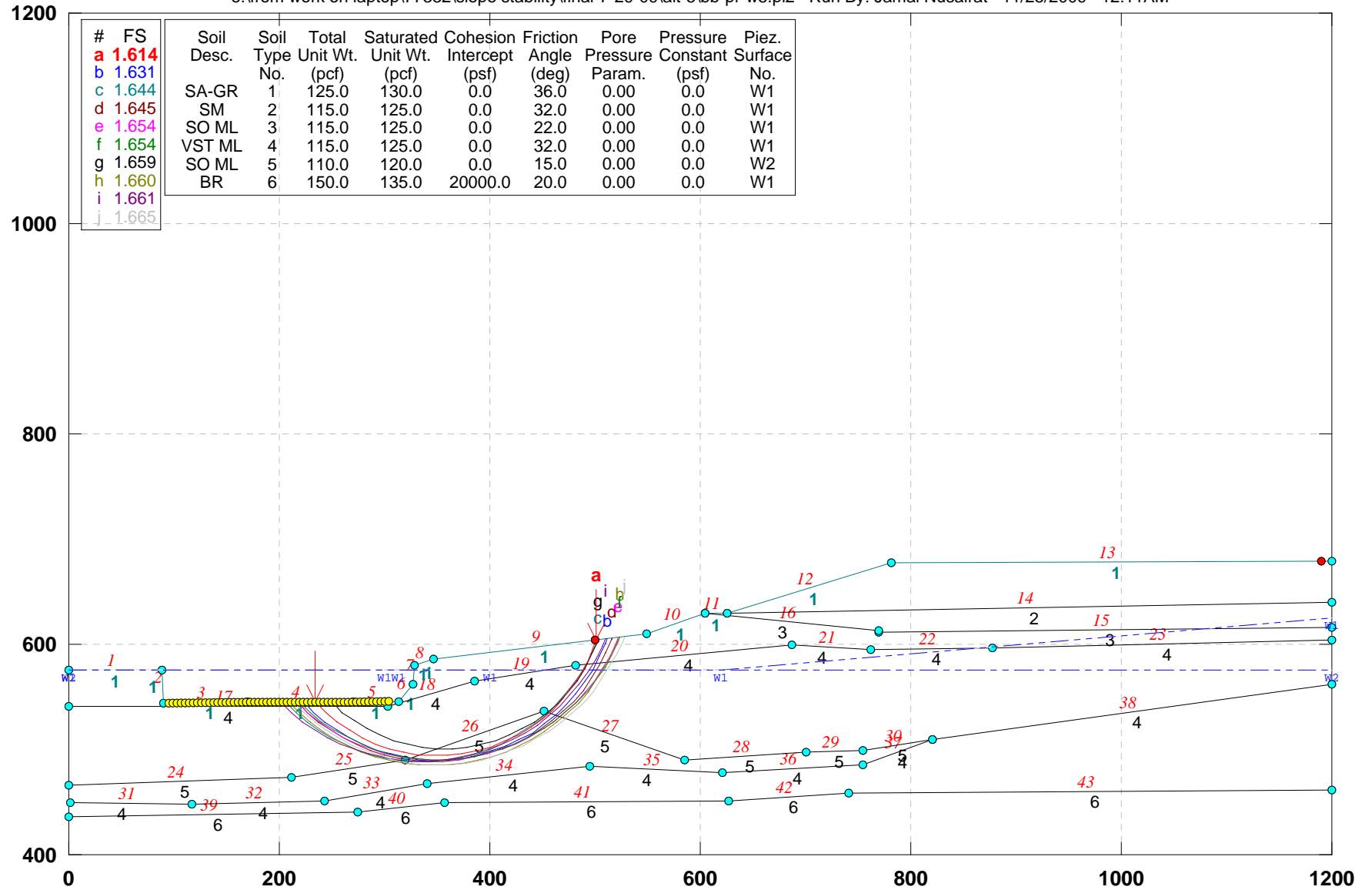

GSTABL7 v.2 FSmin=1.614

Safety Factors Are Calculated By The Simplified Janbu Method



# CUY-90-14.92 (Sec. A-A): PROPOSED GEOMETRY (Alt-5)

e:\from work on laptop\77332\slope stability\final-7-29-09\alt-5\aa-pr-a5.pl2 Run By: Jamal Nusairat 11/24/2009 11:44PM

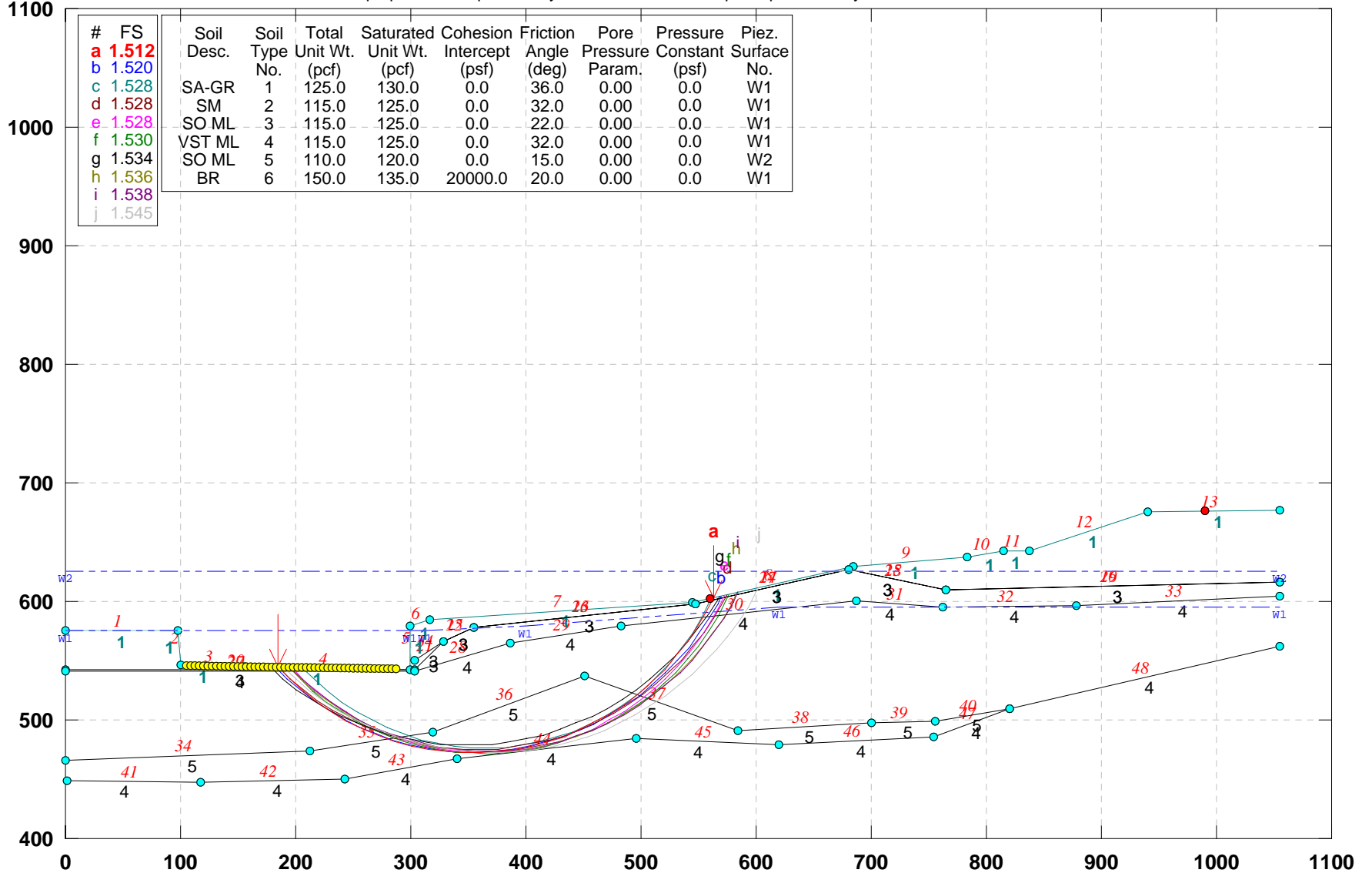

GSTABL7 v.2 FSmin=1.512

Safety Factors Are Calculated By The Simplified Janbu Method





# CUY-90-14.92 (Sec. D-D): PROPOSED GEOMETRY (ALT-5)- deep slip analysis

e:\from work on laptop\77332\slope stability\final-7-29-09\alt-5\dd-pra51.pl2 Run By: Jamal Nusairat 11/25/2009 12:15AM

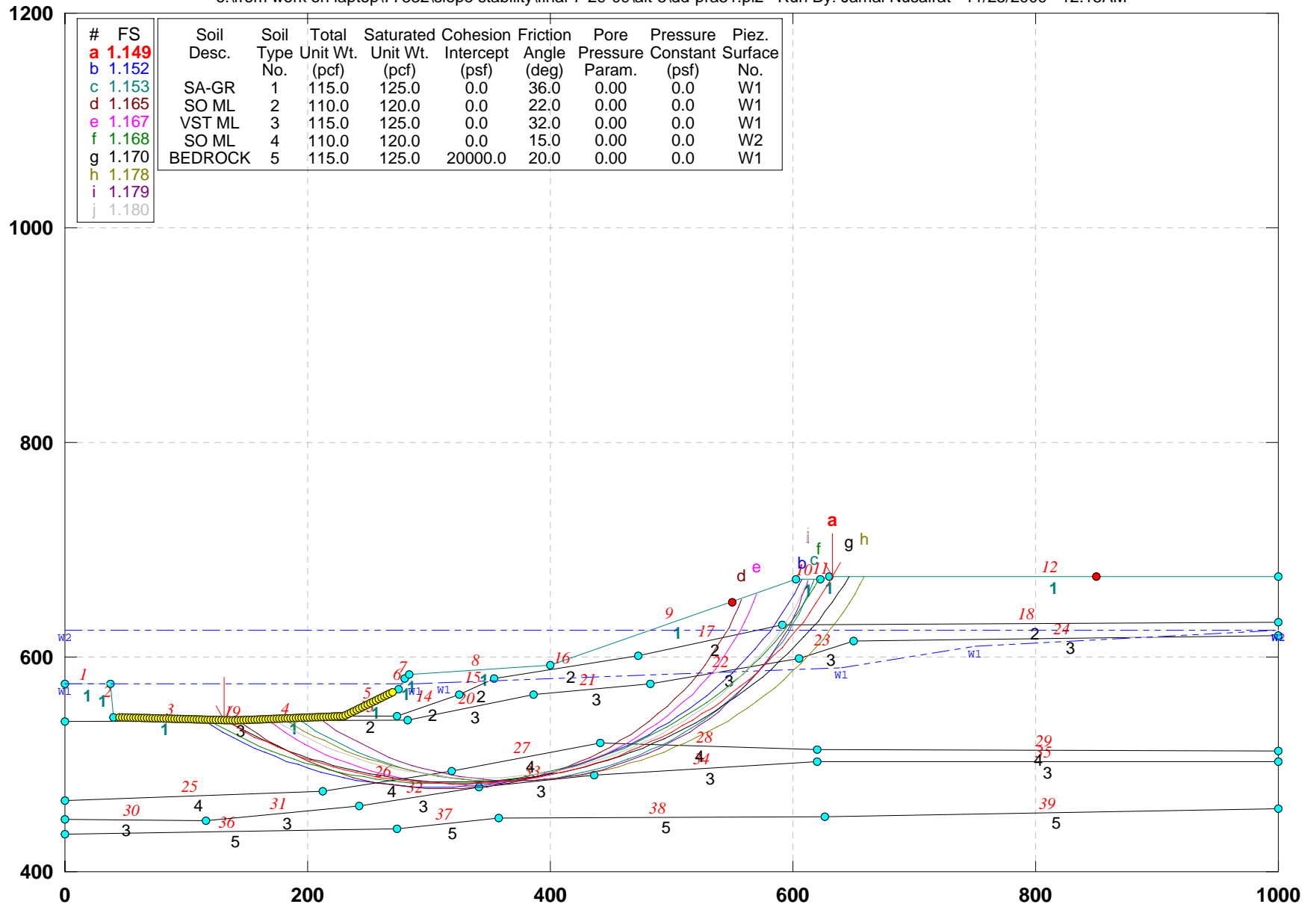

GSTABL7 v.2 FSmin=1.149

Safety Factors Are Calculated By The Simplified Janbu Method



# CUY-90-14.92 (Sec. D-D): PROPOSED GEOMETRY (ALT-5)- deep slip\_no elev water

e:\from work on laptop\77332\slope stability\final-7-29-09\alt-5\dd-prw51.pl2 Run By: Jamal Nusairat 11/25/2009 12:13AM

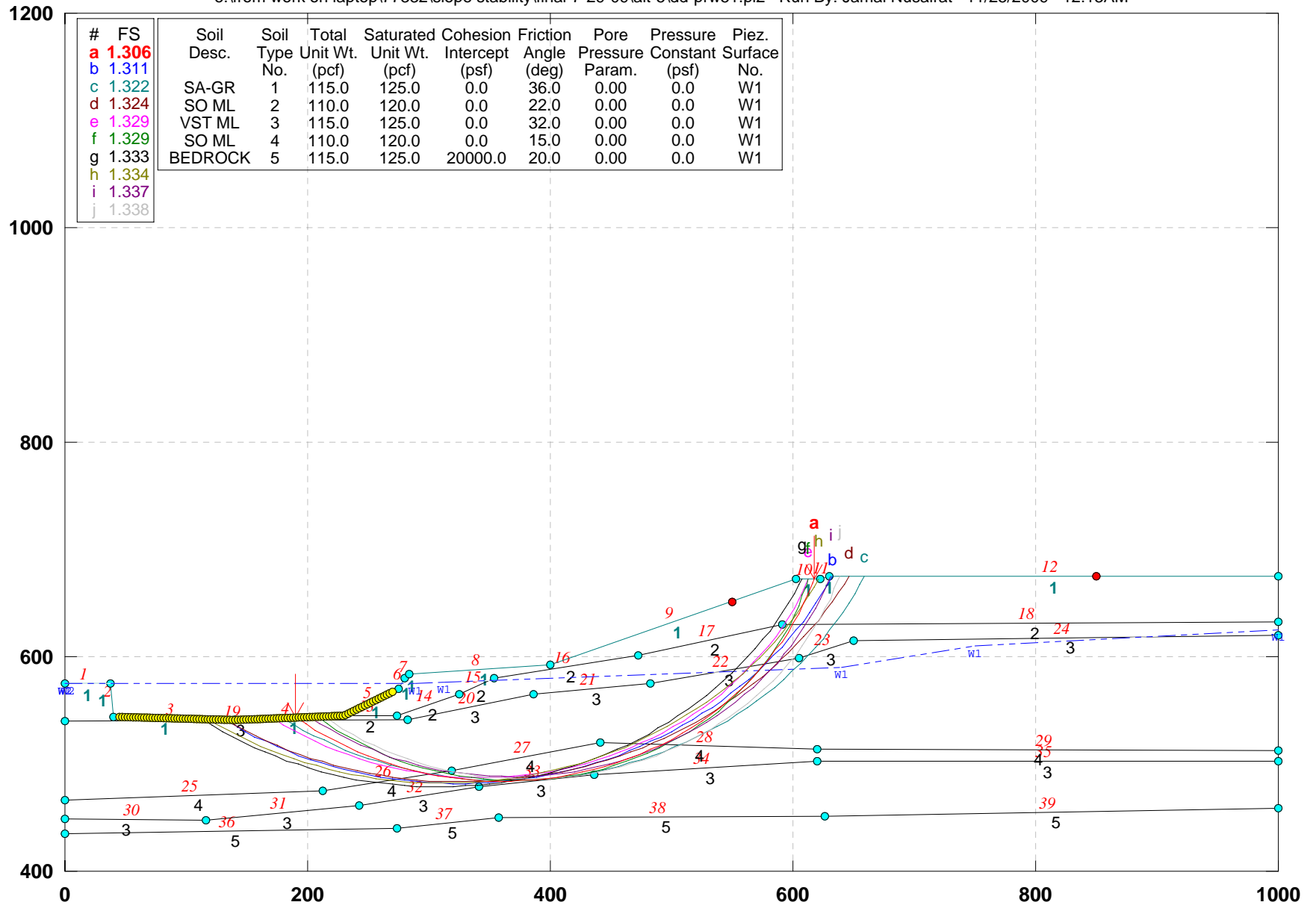

GSTABL7 v.2 FSmin=1.306

Safety Factors Are Calculated By The Simplified Janbu Method



# CUY-90-14.92 (Sec. D-D): PROPOSED GEOMETRY (ALT-5)- shallow slip analysis

e:\from work on laptop\77332\slope stability\final-7-29-09\alt-5\dd-pr-a5.pl2 Run By: Jamal Nusairat 11/25/2009 12:16AM

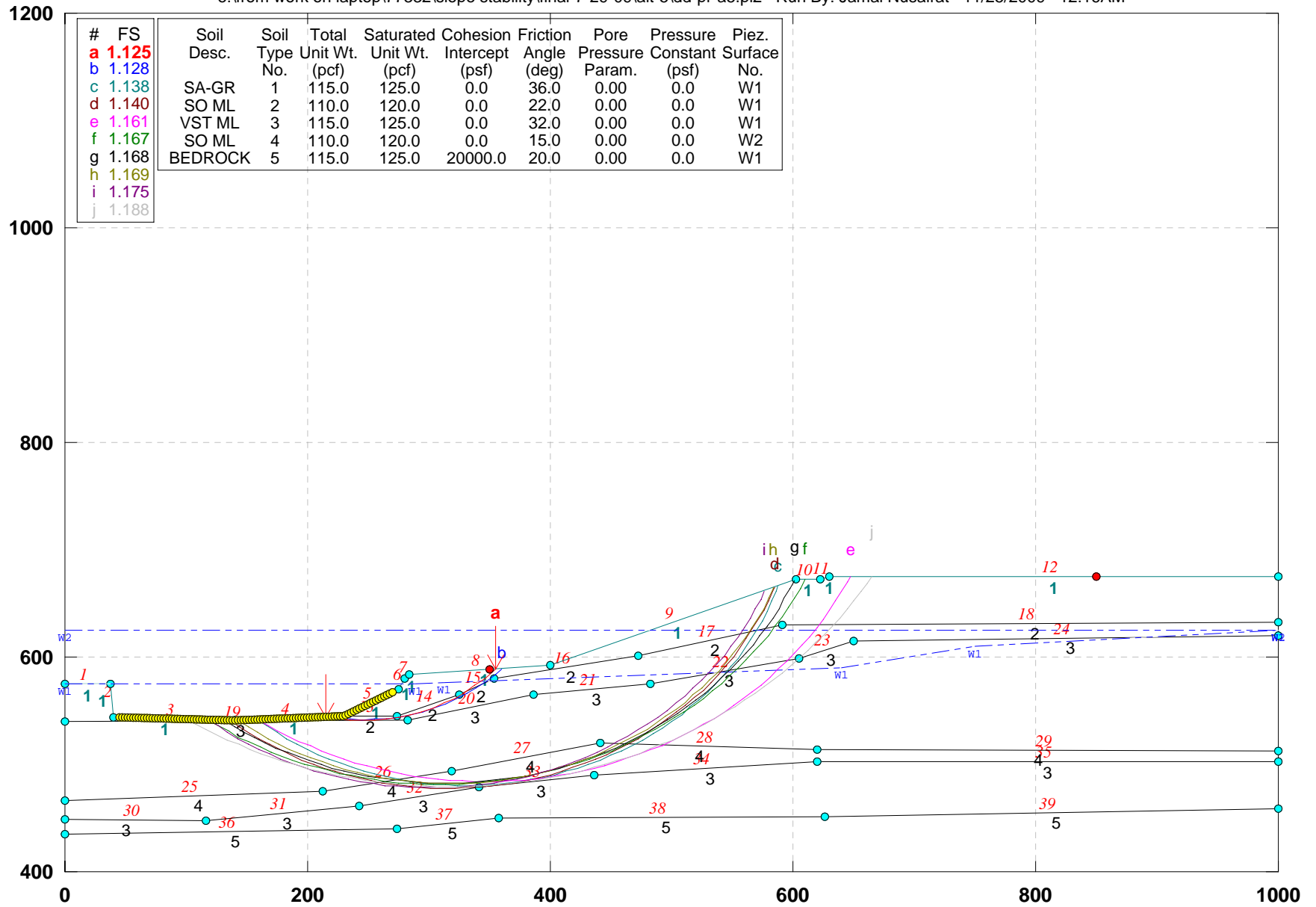

GSTABL7 v.2 FSmin=1.125

Safety Factors Are Calculated By The Simplified Janbu Method



# CUY-90-14.92 (Sec. E-E): PROPOSED GEOMETRY (Alt-5)

e:\from work on laptop\77332\slope stability\final-7-29-09\alt-5\ee-pr-a5.pl2 Run By: Jamal Nusairat 11/25/2009 12:18AM

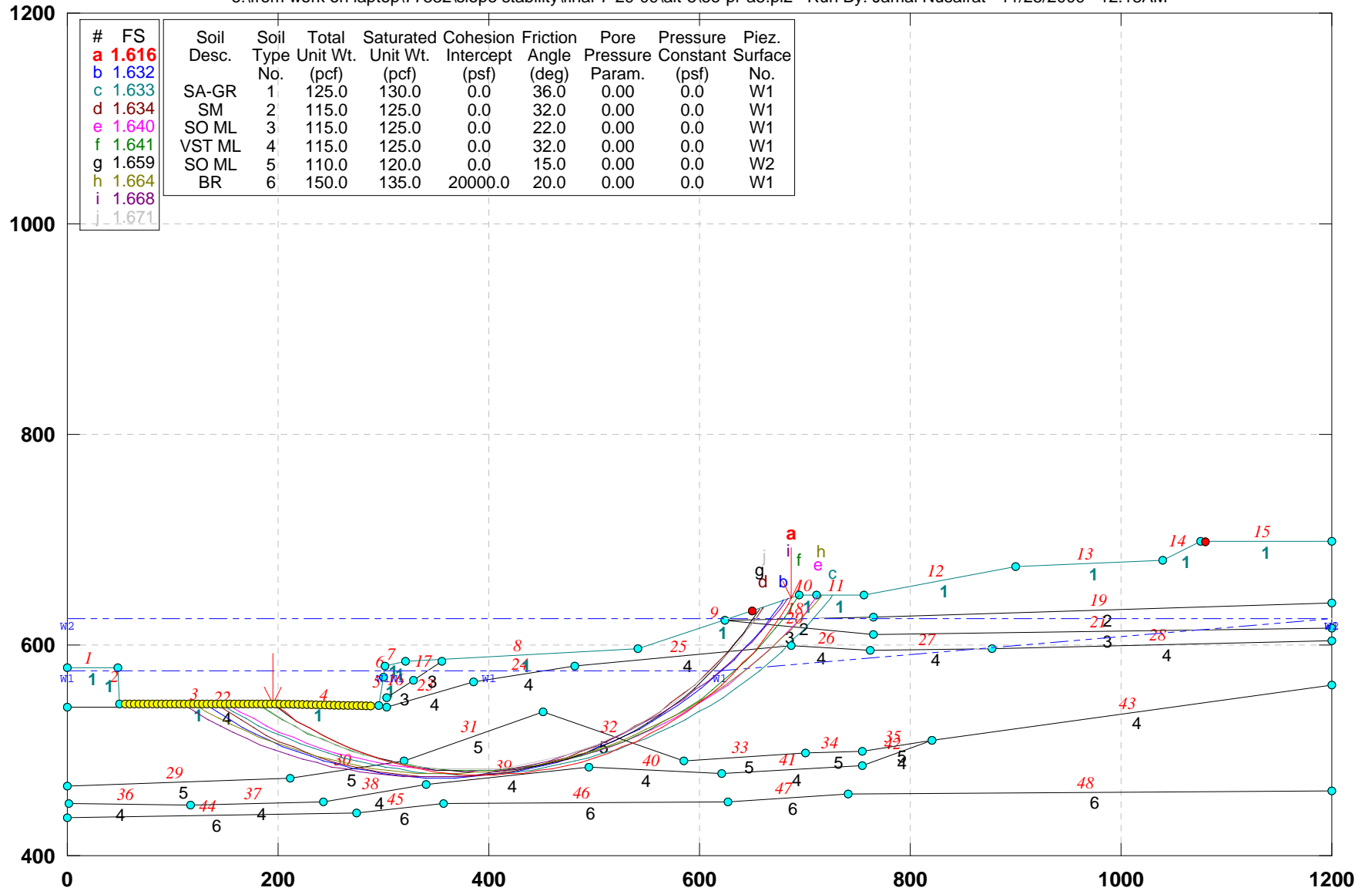

GSTABL7 v.2 FSmin=1.616

Safety Factors Are Calculated By The Simplified Janbu Method



# CUY-90-14.92 (Sec. E-E): PROPOSED GEOMETRY (Alt-5): No elevated water

e:\from work on laptop\77332\slope stability\final-7-29-09\alt-5\ee-pr-w5.pl2 Run By: Jamal Nusairat 11/25/2009 12:17AM

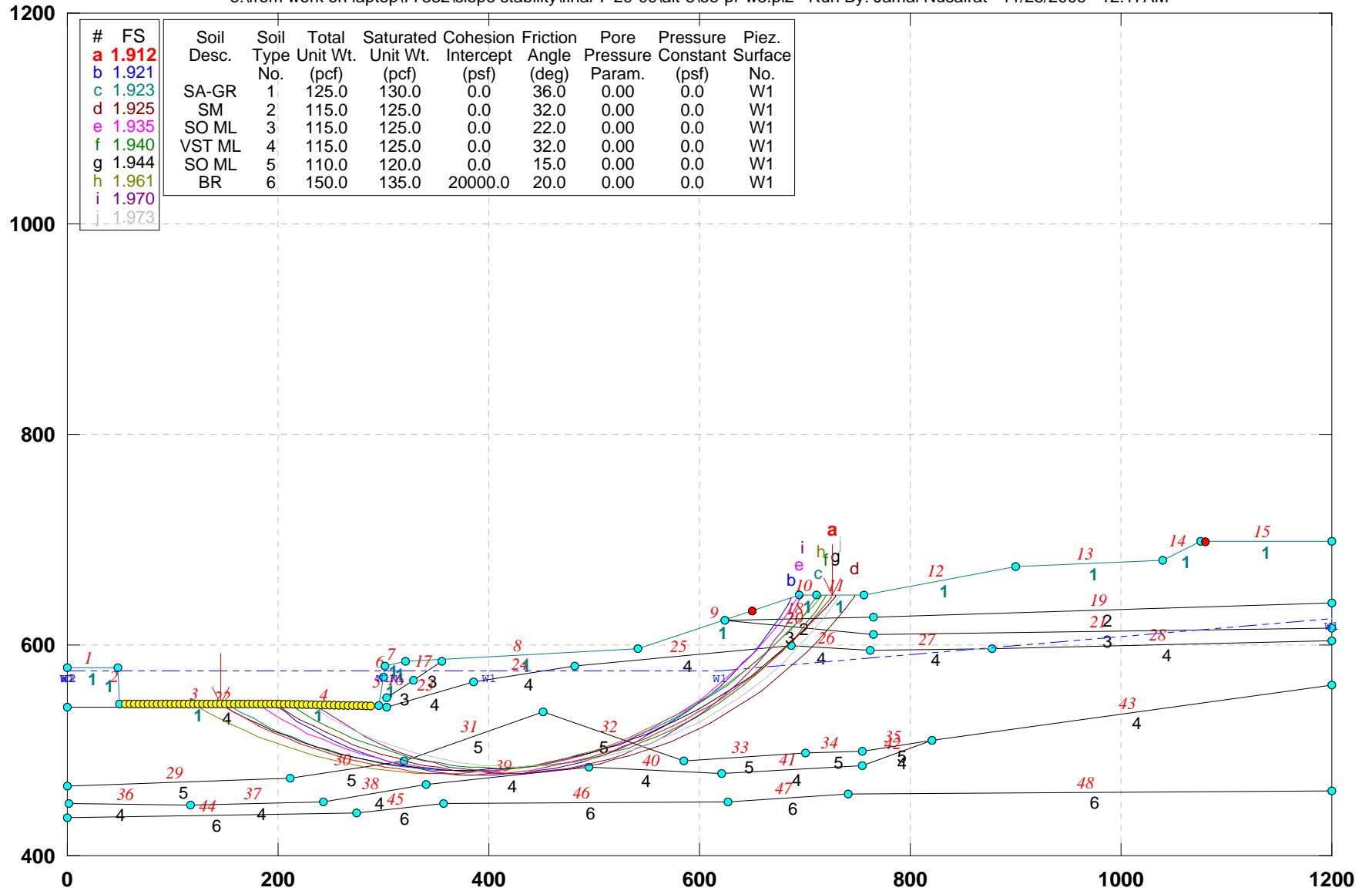

GSTABL7 v.2 FSmin=1.912

Safety Factors Are Calculated By The Simplified Janbu Method



# CUY-90-14.92 (Sec. FF): PROPOSED GEOMETRY (Alt-5)

E:\REPORTS\CUY-190\2009WO-1\2009-S-1\ALT-5-1\FF-PR-A5.PL2 Run By: Username 8/19/2009 1:59AM

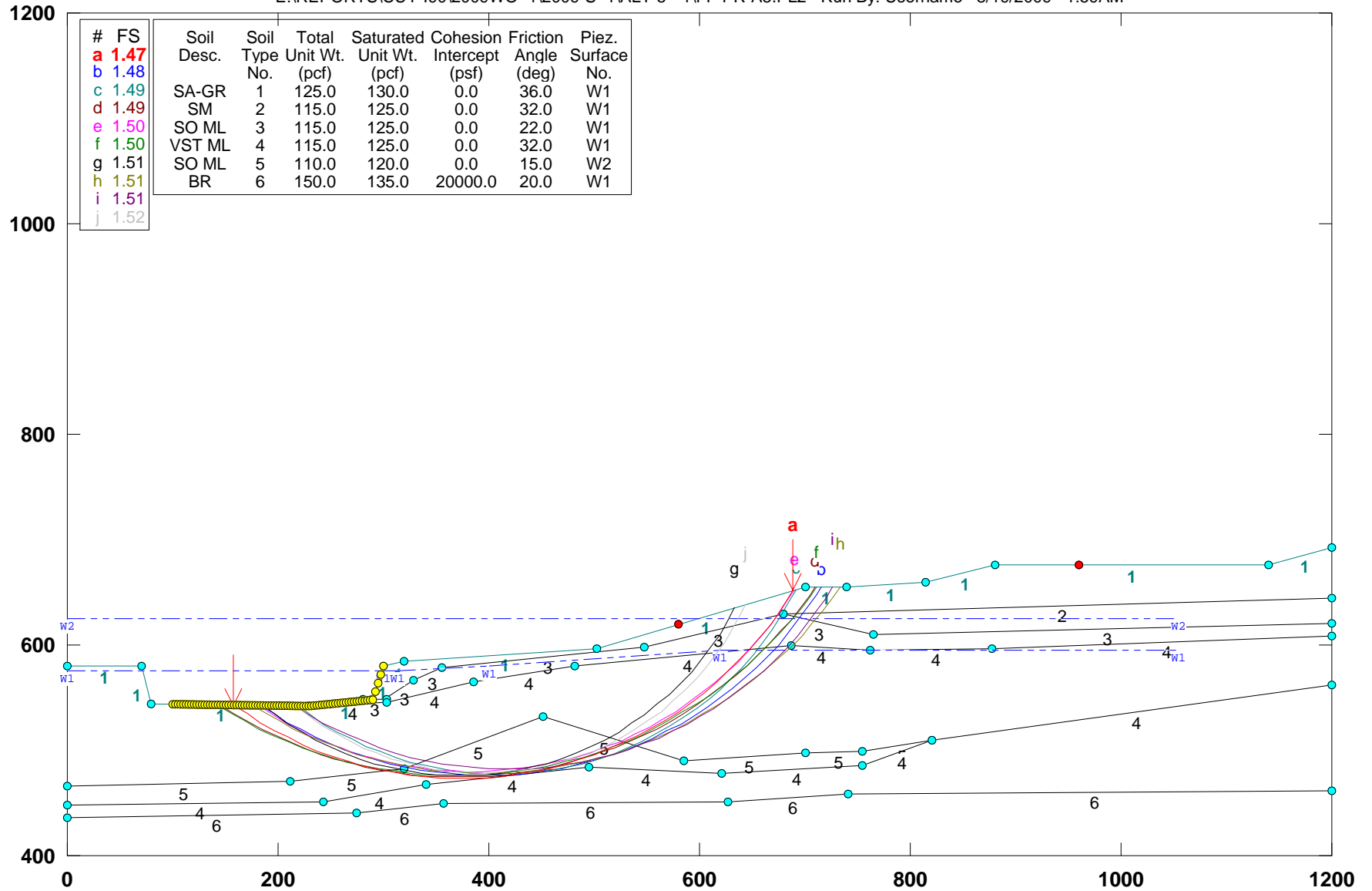

GSTABL7 v.2 FSmin=1.47

Safety Factors Are Calculated By The Simplified Janbu Method



# CUY-90-14.92 (Sec. FF): PROPOSED GEOMETRY (Alt-5): No elevated water

E:\REPORTS\CUY-90\2009WO-1\2009-S-1\ALT-5--1\FF-PR-W5.PL2 Run By: Username 8/19/2009 2:00AM

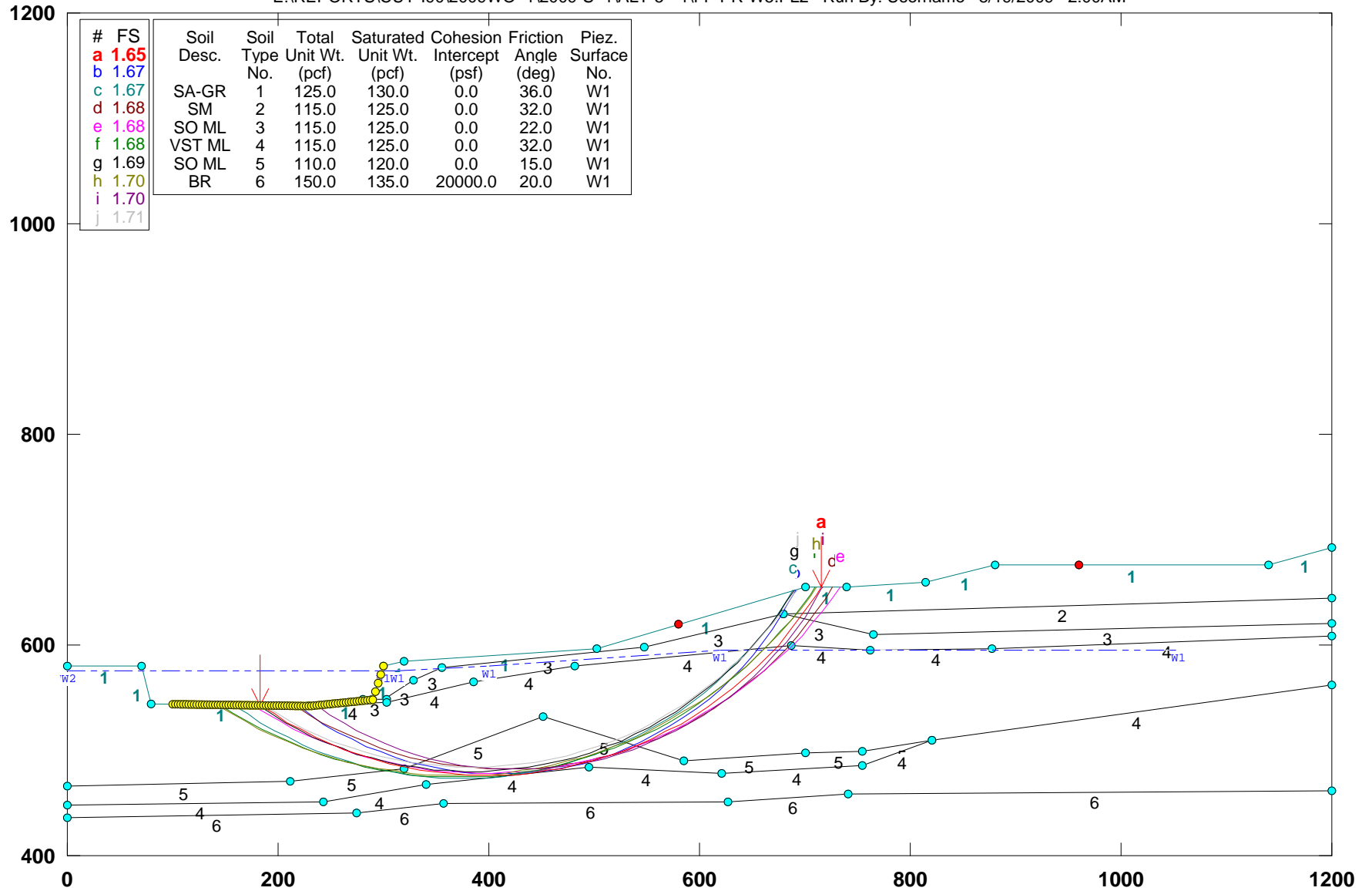

| # | FS   | Soil Desc. | Soil Type No. | Total Unit Wt. (pcf) | Saturated Unit Wt. (pcf) | Cohesion Intercept (psf) | Friction Angle (deg) | Piez. Surface No. |
|---|------|------------|---------------|----------------------|--------------------------|--------------------------|----------------------|-------------------|
| a | 1.65 |            |               |                      |                          |                          |                      |                   |
| b | 1.67 |            |               |                      |                          |                          |                      |                   |
| c | 1.67 | SA-GR      | 1             | 125.0                | 130.0                    | 0.0                      | 36.0                 | W1                |
| d | 1.68 | SM         | 2             | 115.0                | 125.0                    | 0.0                      | 32.0                 | W1                |
| e | 1.68 | SO ML      | 3             | 115.0                | 125.0                    | 0.0                      | 22.0                 | W1                |
| f | 1.68 | VST ML     | 4             | 115.0                | 125.0                    | 0.0                      | 32.0                 | W1                |
| g | 1.69 | SO ML      | 5             | 110.0                | 120.0                    | 0.0                      | 15.0                 | W1                |
| h | 1.70 | BR         | 6             | 150.0                | 135.0                    | 20000.0                  | 20.0                 | W1                |
| i | 1.70 |            |               |                      |                          |                          |                      |                   |
| j | 1.71 |            |               |                      |                          |                          |                      |                   |

GSTABL7 v.2 FSmin=1.65

Safety Factors Are Calculated By The Simplified Janbu Method



# CUY-90-14.92 (Sec. G-G): PROPOSED EXCAVATED GEOMETRY- STABILITY (ALT-5)

E:\REPORTS\CUY-190\2009WO-1\2009-S-1\ALT-5--1\GG-PR5.PL2 Run By: Username 8/19/2009 11:16PM

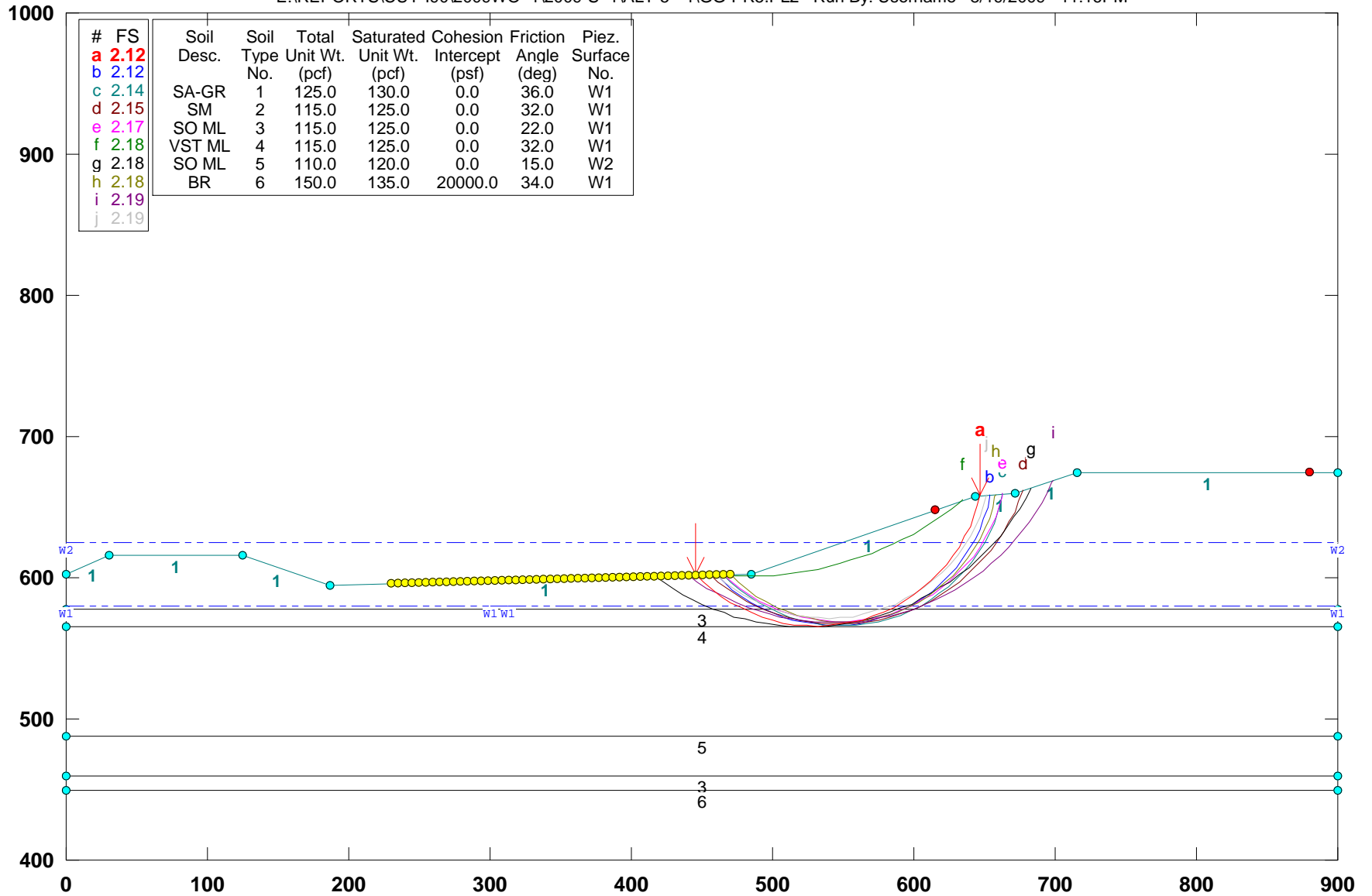

GSTABL7 v.2 FSmin=2.12

Safety Factors Are Calculated By The Simplified Janbu Method





# CUY-90-14.92 (Sec. G-G): PROPOSED EXCAV.GEOMETRY- (ALT-5): No elev. water

E:\REPORTS\CUY-190\2009WO-1\2009-S-1\ALT-5-1\GG-PW5.PL2 Run By: Username 8/19/2009 11:27PM

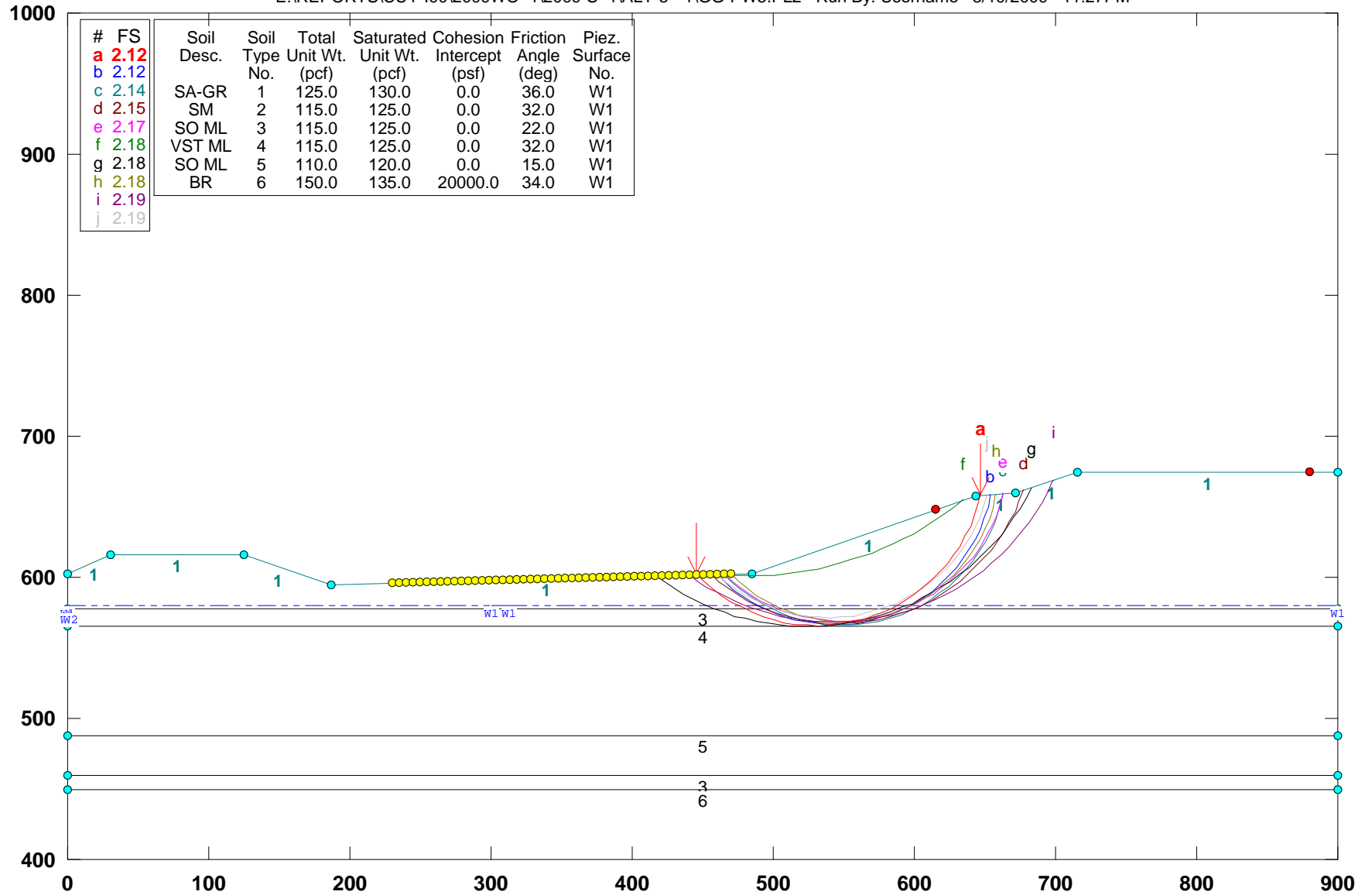

GSTABL7 v.2 FSmin=2.12

Safety Factors Are Calculated By The Simplified Janbu Method



# CUY-90-14.92 (Sec. I-I): PROPOSED EXCAVATION (Alt-5)

E:\REPORTS\CUY-I90\2009WO-1\2009-S-1\ALT-5--1\II-PR5.PL2 Run By: Username 8/20/2009 12:04AM

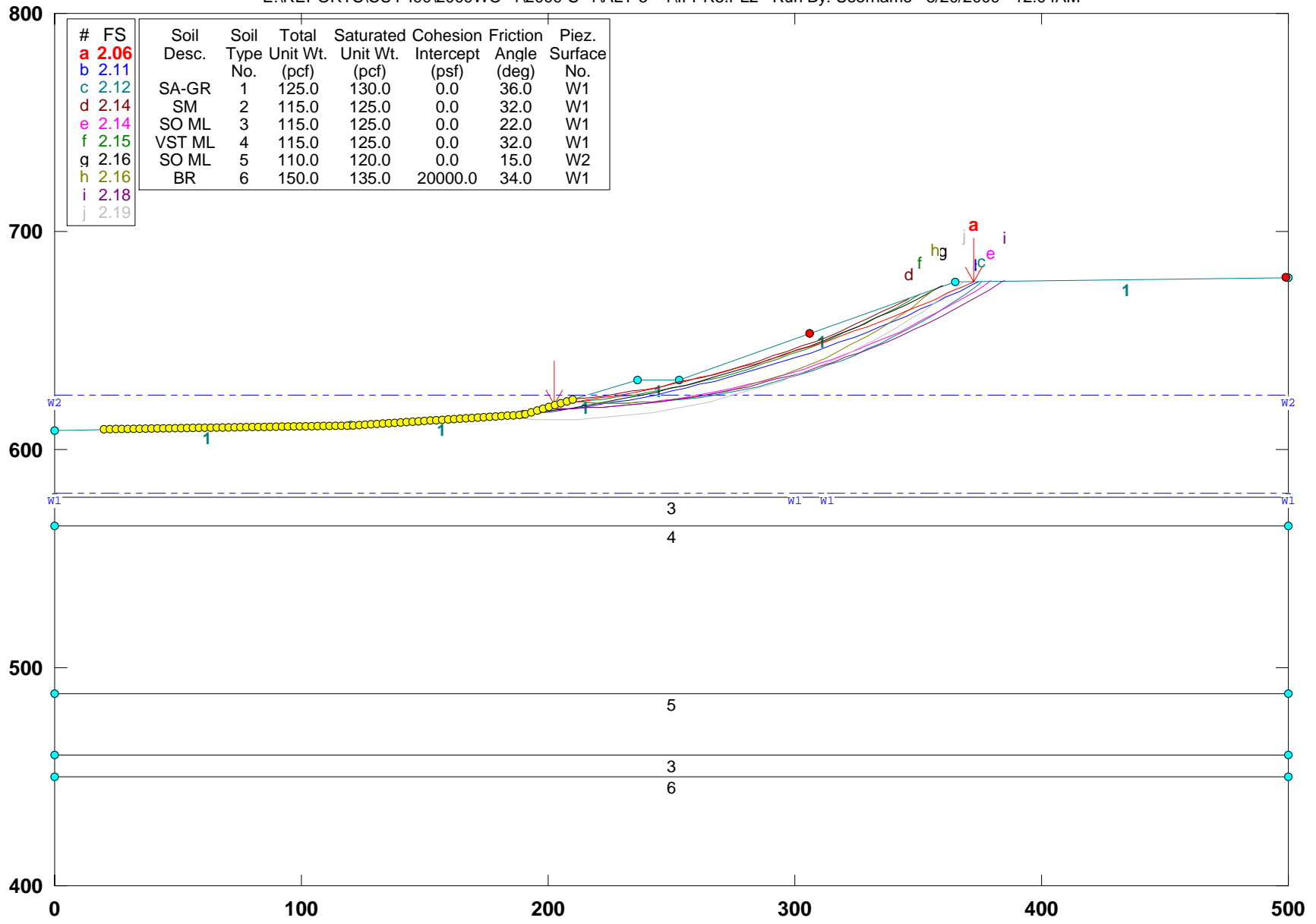

| # | FS   | Soil Desc. | Soil Type No. | Total Unit Wt. (pcf) | Saturated Unit Wt. (pcf) | Cohesion Intercept (psf) | Friction Angle (deg) | Piez. Surface No. |
|---|------|------------|---------------|----------------------|--------------------------|--------------------------|----------------------|-------------------|
| a | 2.06 | SA-GR      | 1             | 125.0                | 130.0                    | 0.0                      | 36.0                 | W1                |
| b | 2.11 | SM         | 2             | 115.0                | 125.0                    | 0.0                      | 32.0                 | W1                |
| c | 2.12 | SO ML      | 3             | 115.0                | 125.0                    | 0.0                      | 22.0                 | W1                |
| d | 2.14 | SO ML      | 3             | 115.0                | 125.0                    | 0.0                      | 22.0                 | W1                |
| e | 2.14 | SO ML      | 3             | 115.0                | 125.0                    | 0.0                      | 22.0                 | W1                |
| f | 2.15 | VST ML     | 4             | 115.0                | 125.0                    | 0.0                      | 32.0                 | W1                |
| g | 2.16 | SO ML      | 5             | 110.0                | 120.0                    | 0.0                      | 15.0                 | W2                |
| h | 2.16 | BR         | 6             | 150.0                | 135.0                    | 20000.0                  | 34.0                 | W1                |
| i | 2.18 |            |               |                      |                          |                          |                      |                   |
| j | 2.19 |            |               |                      |                          |                          |                      |                   |

GSTABL7 v.2 FSmin=2.06

Safety Factors Are Calculated By The Simplified Janbu Method



# CUY-90-14.92 (Sec. J-J): PROPOSED EXCAVATED GEOMETRY- Alt 5

E:\REPORTS\CUY-190\2009WO-1\2009-S-1\ALT-5--1\JJ-PR5.PL2 Run By: Username 8/20/2009 12:16AM

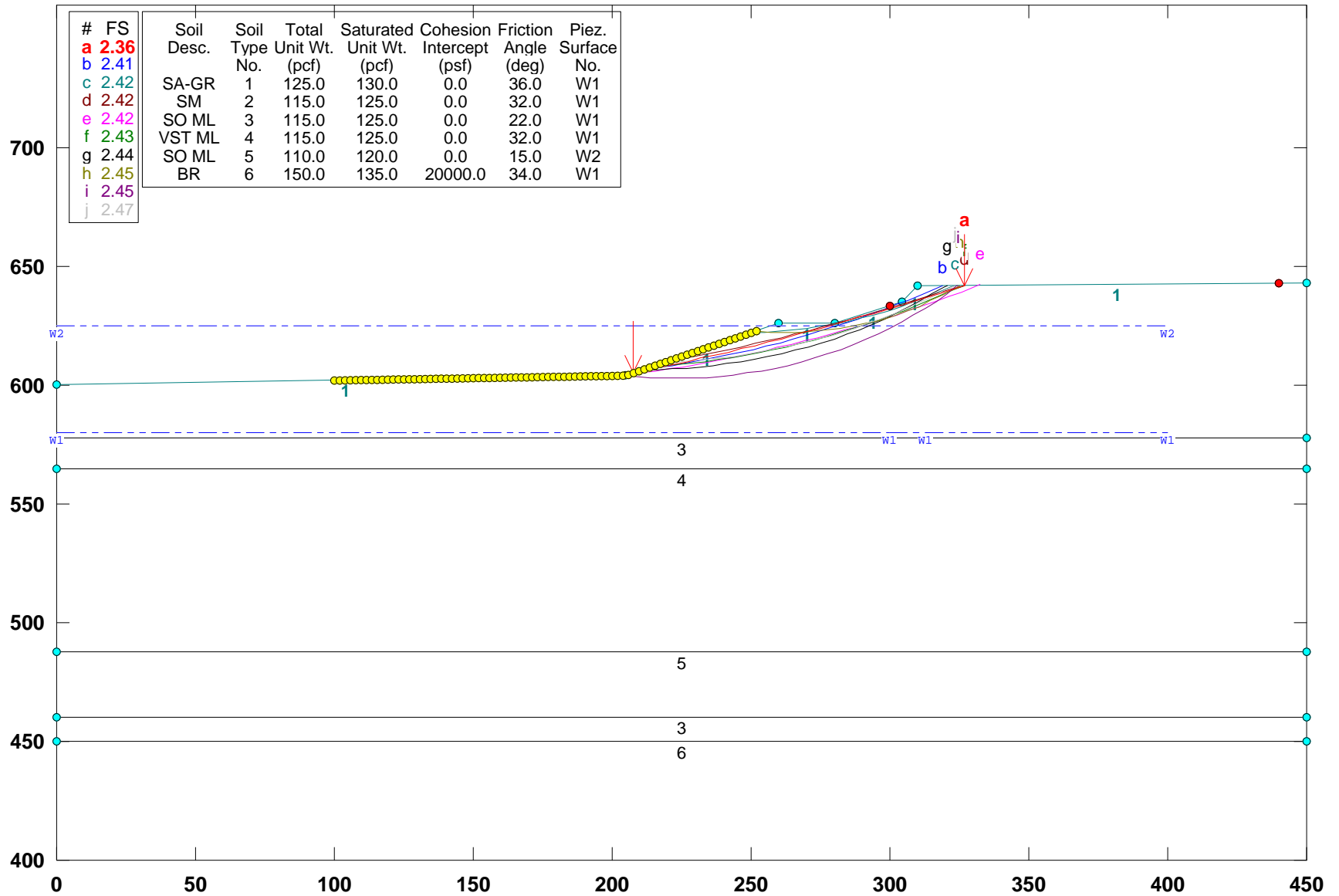

GSTABL7 v.2 FSmin=2.36

Safety Factors Are Calculated By The Simplified Janbu Method



# CUY-90-14.92 (Sec. U-U): PROPOSED EXCAVATED GEOMETRY- STABILITY (Alt-5)

E:\REPORTS\CUY-190\2009WO-1\2009-S-1\ALT-5--1\UU-PR5.PL2 Run By: Username 8/19/2009 11:42PM

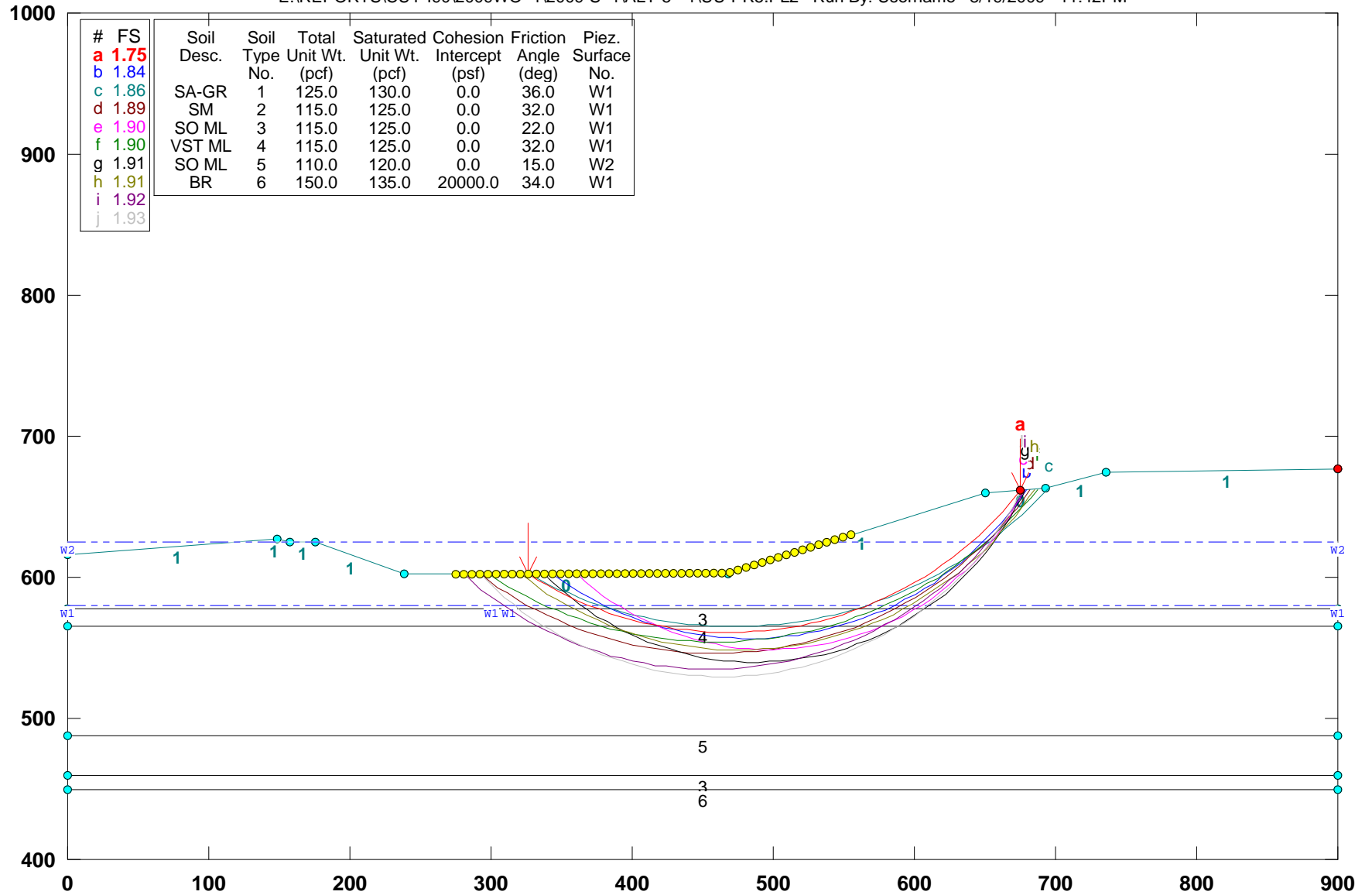

GSTABL7 v.2 FSmin=1.75

Safety Factors Are Calculated By The Simplified Janbu Method



# CUY-90-14.92 (Sec. W-W): PROPOSED GEOMETRY (ALT-5)

e:\from work on laptop\77332\slope stability\final-7-29-09\alt-5\ww-pr5.pl2 Run By: Jamal Nusairat 11/25/2009 12:21AM

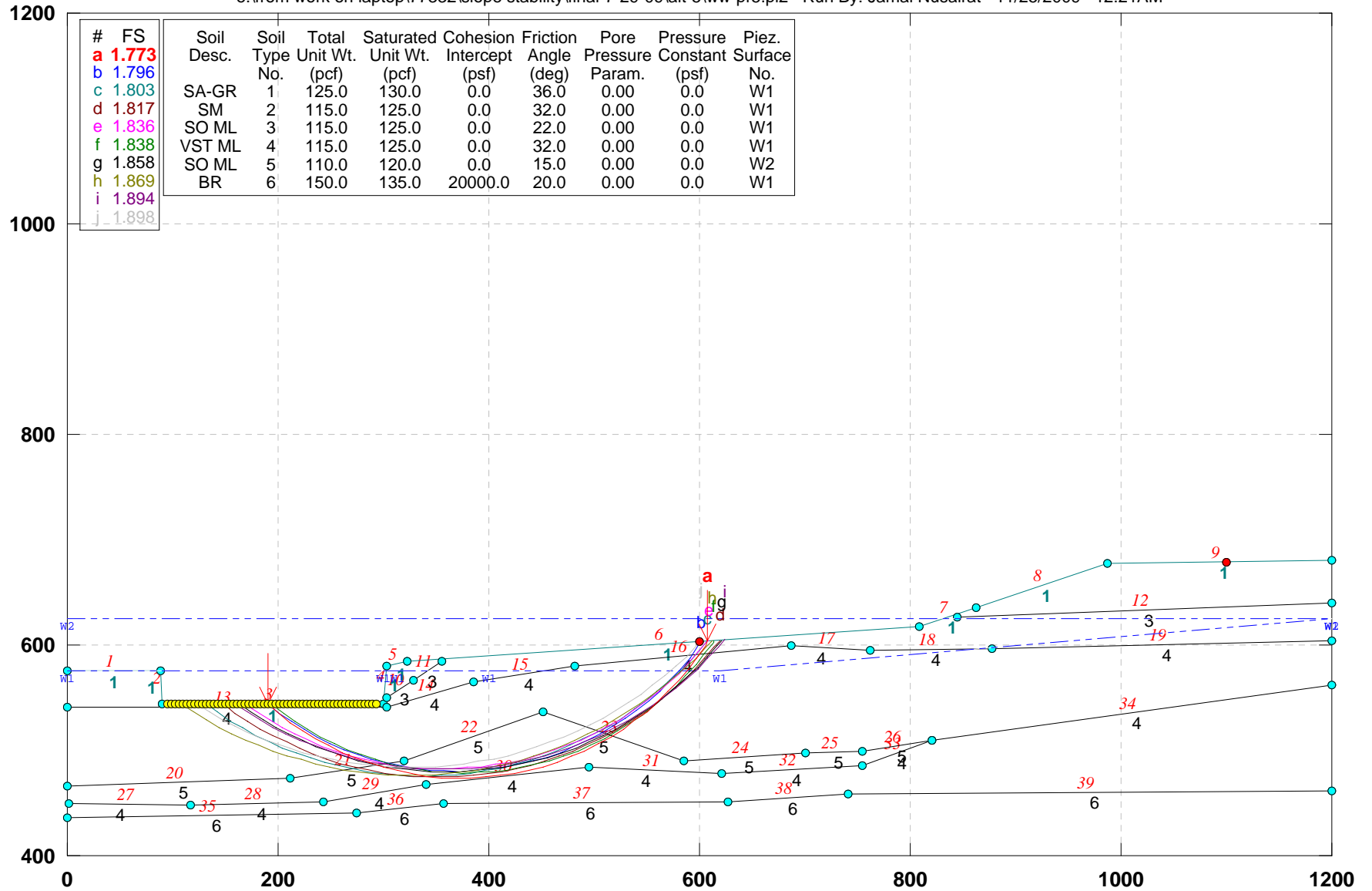

| # | FS    | Soil Desc. | Soil Type No. | Total Unit Wt. (pcf) | Saturated Unit Wt. (pcf) | Cohesion Intercept (psf) | Friction Angle (deg) | Pore Pressure Param. (psf) | Pressure Constant (psf) | Piez. Surface No. |
|---|-------|------------|---------------|----------------------|--------------------------|--------------------------|----------------------|----------------------------|-------------------------|-------------------|
| a | 1.773 |            |               |                      |                          |                          |                      |                            |                         |                   |
| b | 1.796 |            |               |                      |                          |                          |                      |                            |                         |                   |
| c | 1.803 | SA-GR      | 1             | 125.0                | 130.0                    | 0.0                      | 36.0                 | 0.00                       | 0.0                     | W1                |
| d | 1.817 | SM         | 2             | 115.0                | 125.0                    | 0.0                      | 32.0                 | 0.00                       | 0.0                     | W1                |
| e | 1.836 | SO ML      | 3             | 115.0                | 125.0                    | 0.0                      | 22.0                 | 0.00                       | 0.0                     | W1                |
| f | 1.838 | VST ML     | 4             | 115.0                | 125.0                    | 0.0                      | 32.0                 | 0.00                       | 0.0                     | W1                |
| g | 1.858 | SO ML      | 5             | 110.0                | 120.0                    | 0.0                      | 15.0                 | 0.00                       | 0.0                     | W2                |
| h | 1.869 | BR         | 6             | 150.0                | 135.0                    | 20000.0                  | 20.0                 | 0.00                       | 0.0                     | W1                |
| i | 1.894 |            |               |                      |                          |                          |                      |                            |                         |                   |
| j | 1.898 |            |               |                      |                          |                          |                      |                            |                         |                   |

GSTABL7 v.2 FSmin=1.773

Safety Factors Are Calculated By The Simplified Janbu Method



# CUY-90-14.92 (Sec. W-W): PROPOSED GEOMETRY (ALT-5): No elevated water

e:\from work on laptop\77332\slope stability\final-7-29-09\alt-5\ww-prw5.pl2 Run By: Jamal Nusairat 11/25/2009 12:22AM

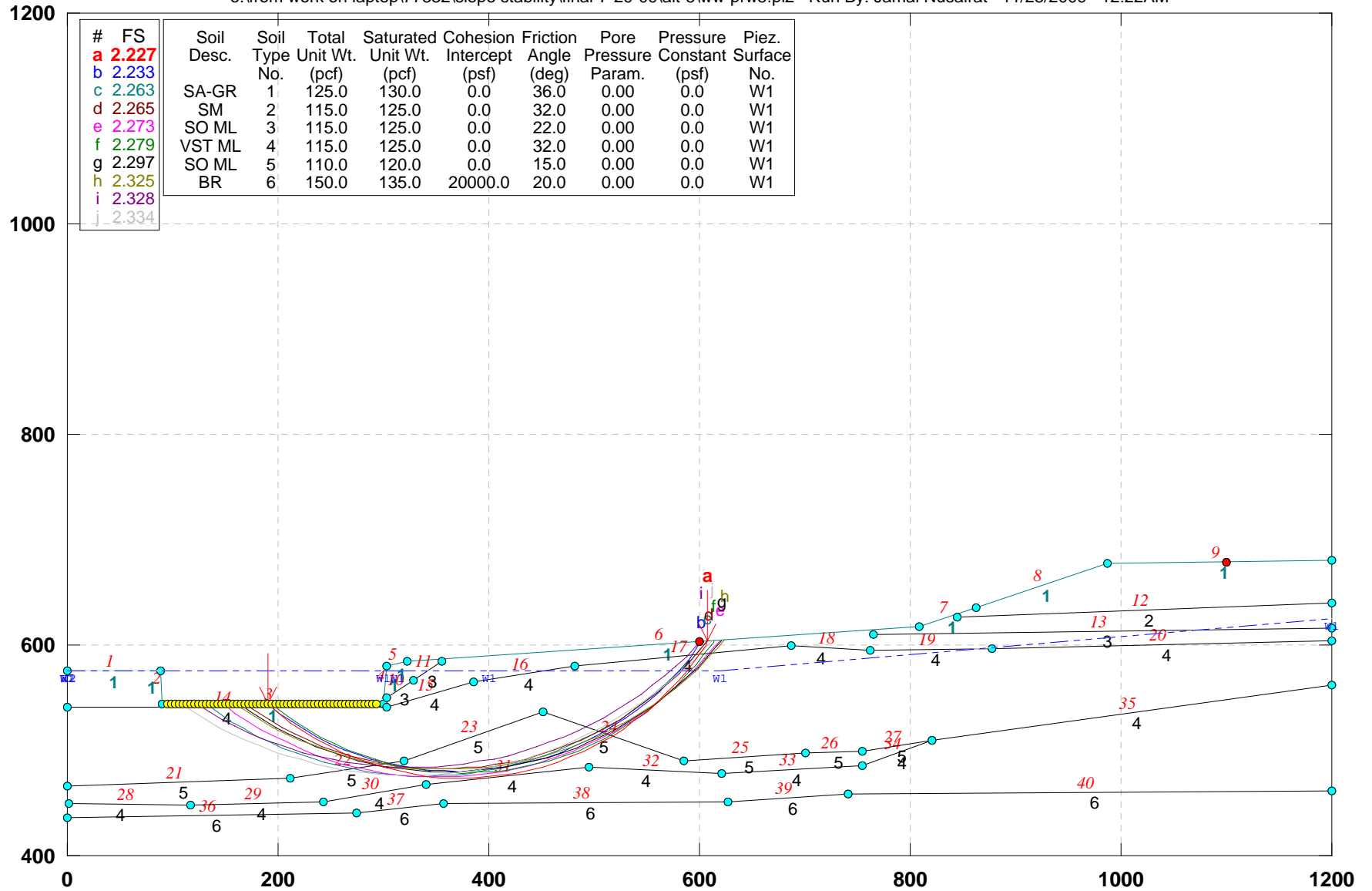

GSTABL7 v.2 FSmin=2.227

Safety Factors Are Calculated By The Simplified Janbu Method



# CUY-90-14.92 (Sec. Y-Y): PROPOSED GEOMETRY (ALT-5)

e:\from work on laptop\77332\slope stability\final-7-29-09\alt-5\yy-pr5.pl2 Run By: Jamal Nusairat 11/25/2009 12:31AM

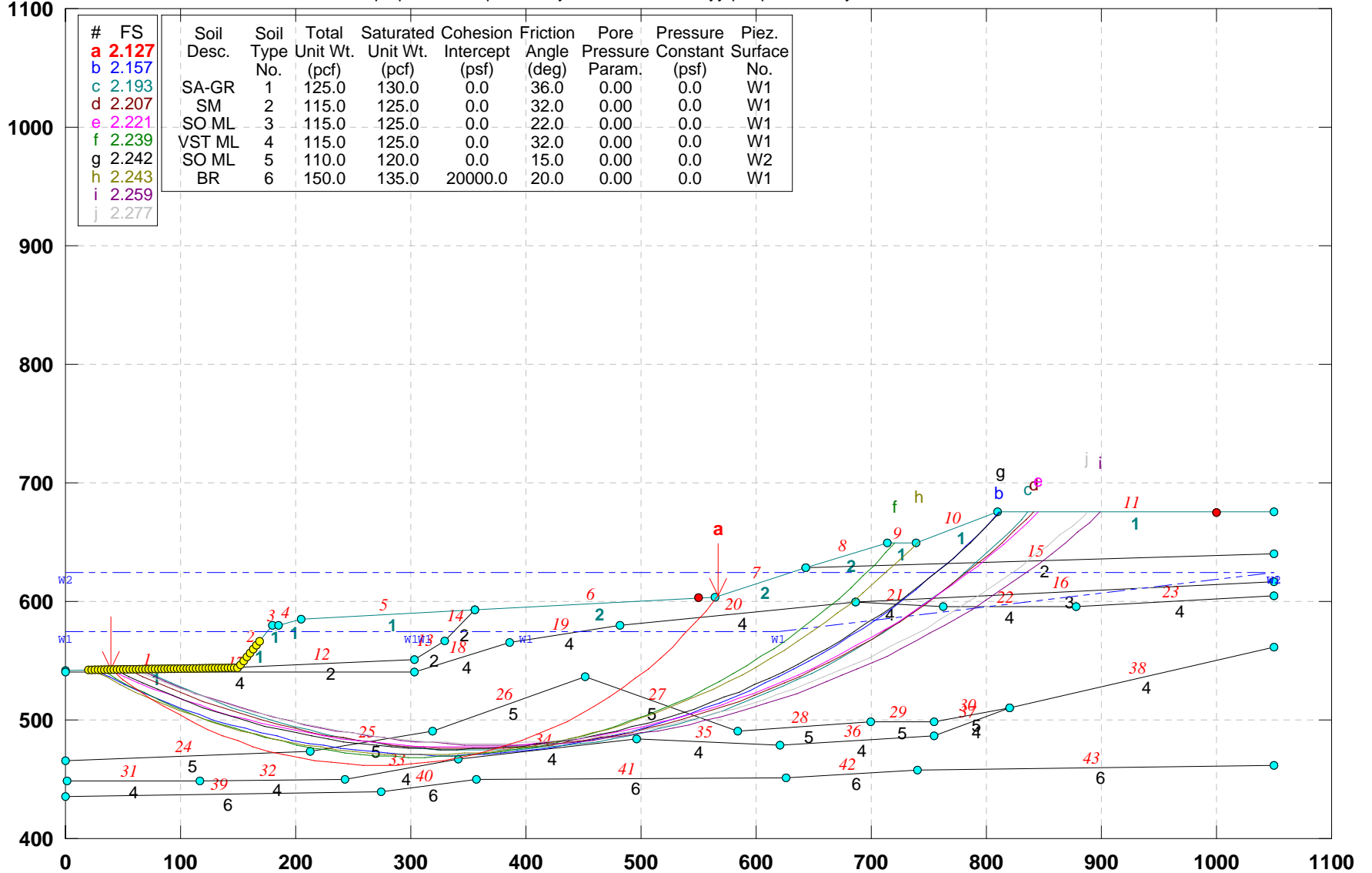

GSTABL7 v.2 FSmin=2.127

Safety Factors Are Calculated By The Simplified Janbu Method



# CUY-90-14.92 (Sec. Y-Y): PROPOSED GEOMETRY (ALT-5)\_No Elev. Water

e:\from work on laptop\77332\slope stability\final-7-29-09\alt-5\yy-pw5.pl2 Run By: Jamal Nusairat 11/25/2009 12:33AM

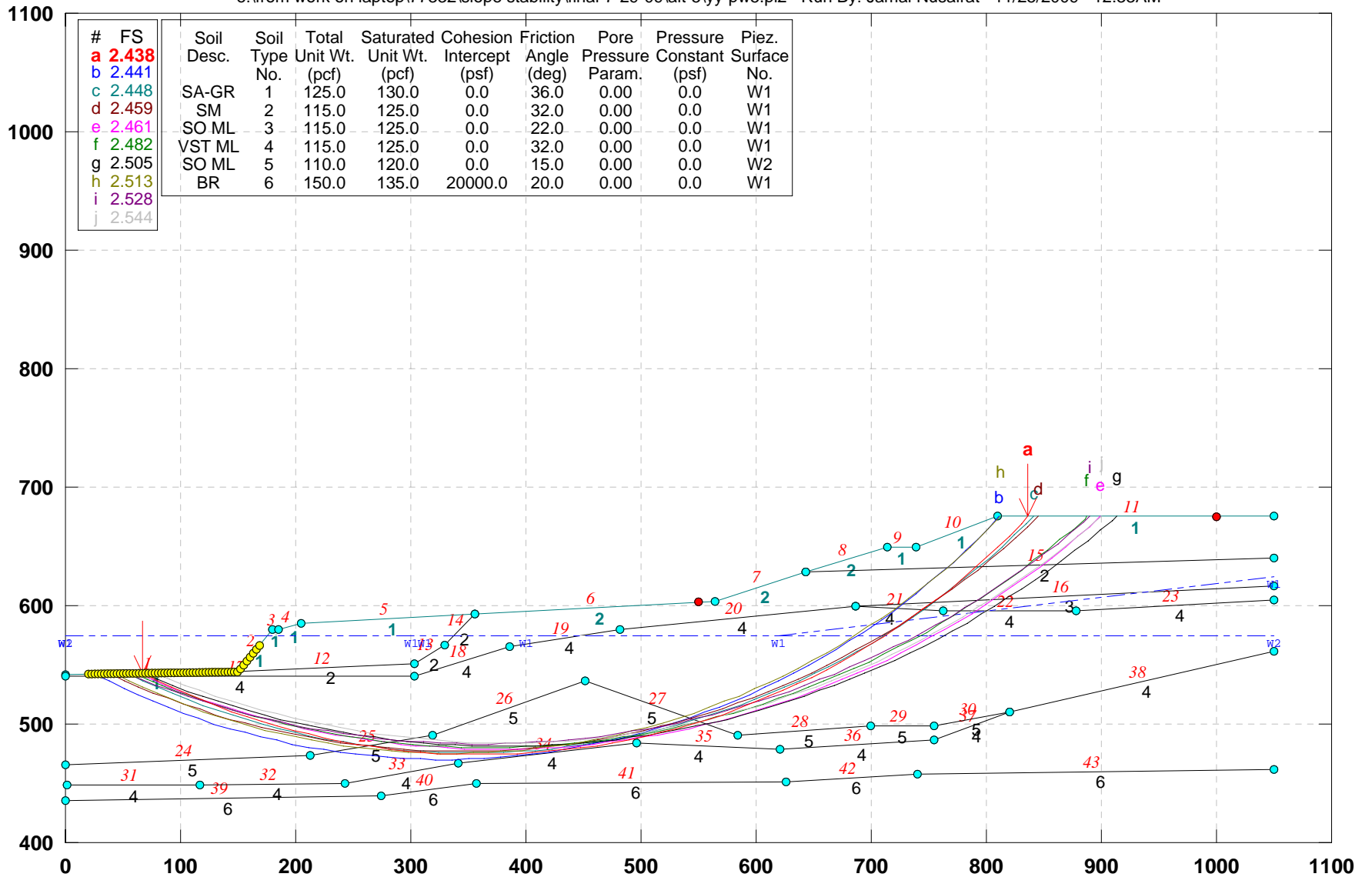

GSTABL7 v.2 FSmin=2.438

Safety Factors Are Calculated By The Simplified Janbu Method





# CUY-90-14.92 (Sec. Z-Z): PROPOSED GEOMETRY (Alt-5)

e:\from work on laptop\77332\slope stability\final-7-29-09\alt-5\zz-pr5.pl2 Run By: Jamal Nusairat 11/25/2009 12:34AM

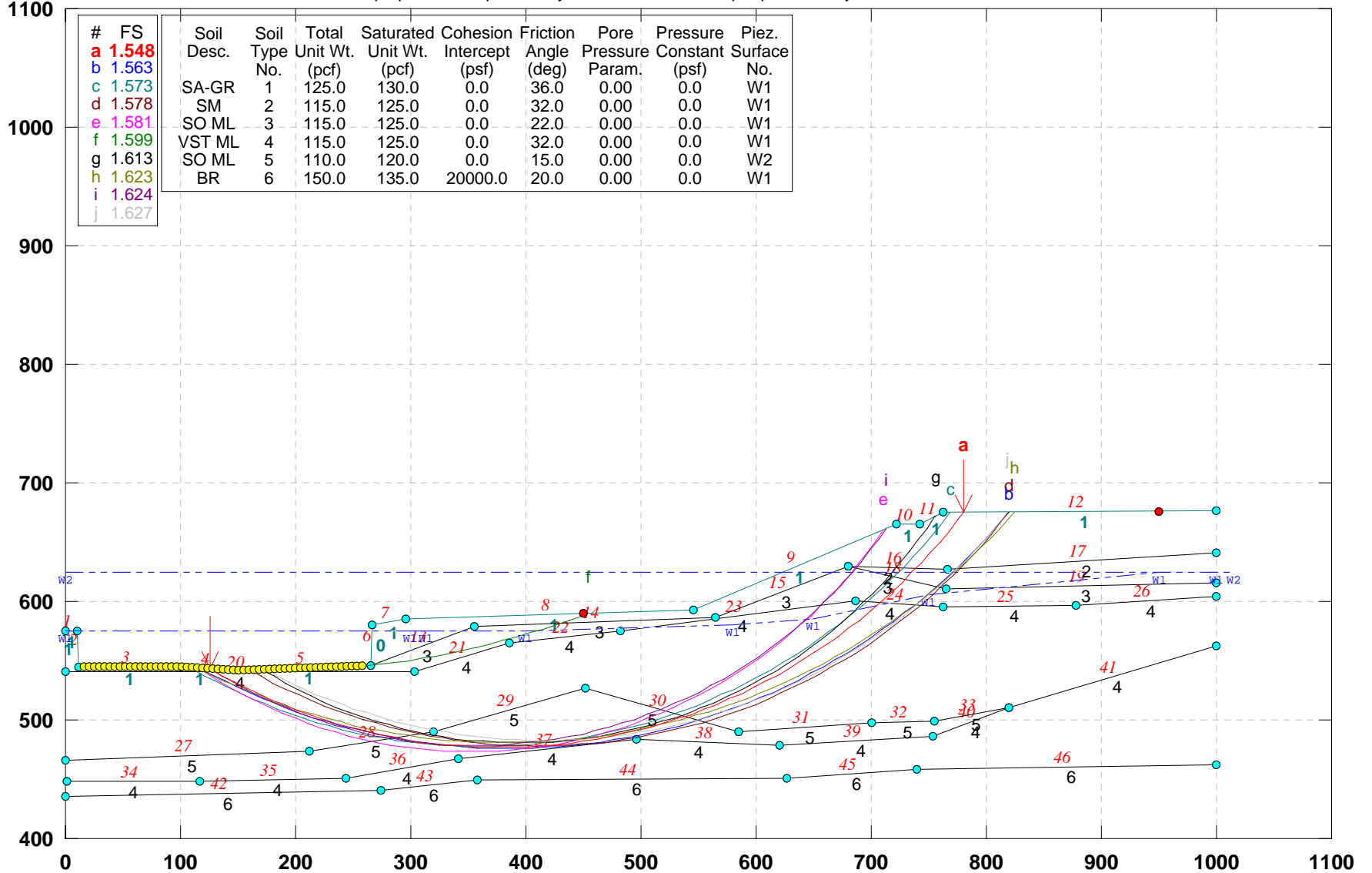

| # | FS    | Soil Desc. | Soil Type No. | Total Unit Wt. (pcf) | Saturated Unit Wt. (pcf) | Cohesion Intercept (psf) | Friction Angle (deg) | Pore Pressure Param. | Pressure Constant (psf) | Piez. Surface No. |
|---|-------|------------|---------------|----------------------|--------------------------|--------------------------|----------------------|----------------------|-------------------------|-------------------|
| a | 1.548 |            |               |                      |                          |                          |                      |                      |                         |                   |
| b | 1.563 |            |               |                      |                          |                          |                      |                      |                         |                   |
| c | 1.573 | SA-GR      | 1             | 125.0                | 130.0                    | 0.0                      | 36.0                 | 0.00                 | 0.0                     | W1                |
| d | 1.578 | SM         | 2             | 115.0                | 125.0                    | 0.0                      | 32.0                 | 0.00                 | 0.0                     | W1                |
| e | 1.581 | SO ML      | 3             | 115.0                | 125.0                    | 0.0                      | 22.0                 | 0.00                 | 0.0                     | W1                |
| f | 1.599 | VST ML     | 4             | 115.0                | 125.0                    | 0.0                      | 32.0                 | 0.00                 | 0.0                     | W1                |
| g | 1.613 | SO ML      | 5             | 110.0                | 120.0                    | 0.0                      | 15.0                 | 0.00                 | 0.0                     | W2                |
| h | 1.623 | BR         | 6             | 150.0                | 135.0                    | 20000.0                  | 20.0                 | 0.00                 | 0.0                     | W1                |
| i | 1.624 |            |               |                      |                          |                          |                      |                      |                         |                   |
| j | 1.627 |            |               |                      |                          |                          |                      |                      |                         |                   |

GSTABL7 v.2 FSmin=1.548

Safety Factors Are Calculated By The Simplified Janbu Method



# CUY-90-14.92 (Sec. Z-Z): PROPOSED GEOMETRY (Alt-5): No elevated water

e:\from work on laptop\77332\slope stability\final-7-29-09\alt-5\zz-pw5.pl2 Run By: Jamal Nusairat 11/25/2009 12:36AM

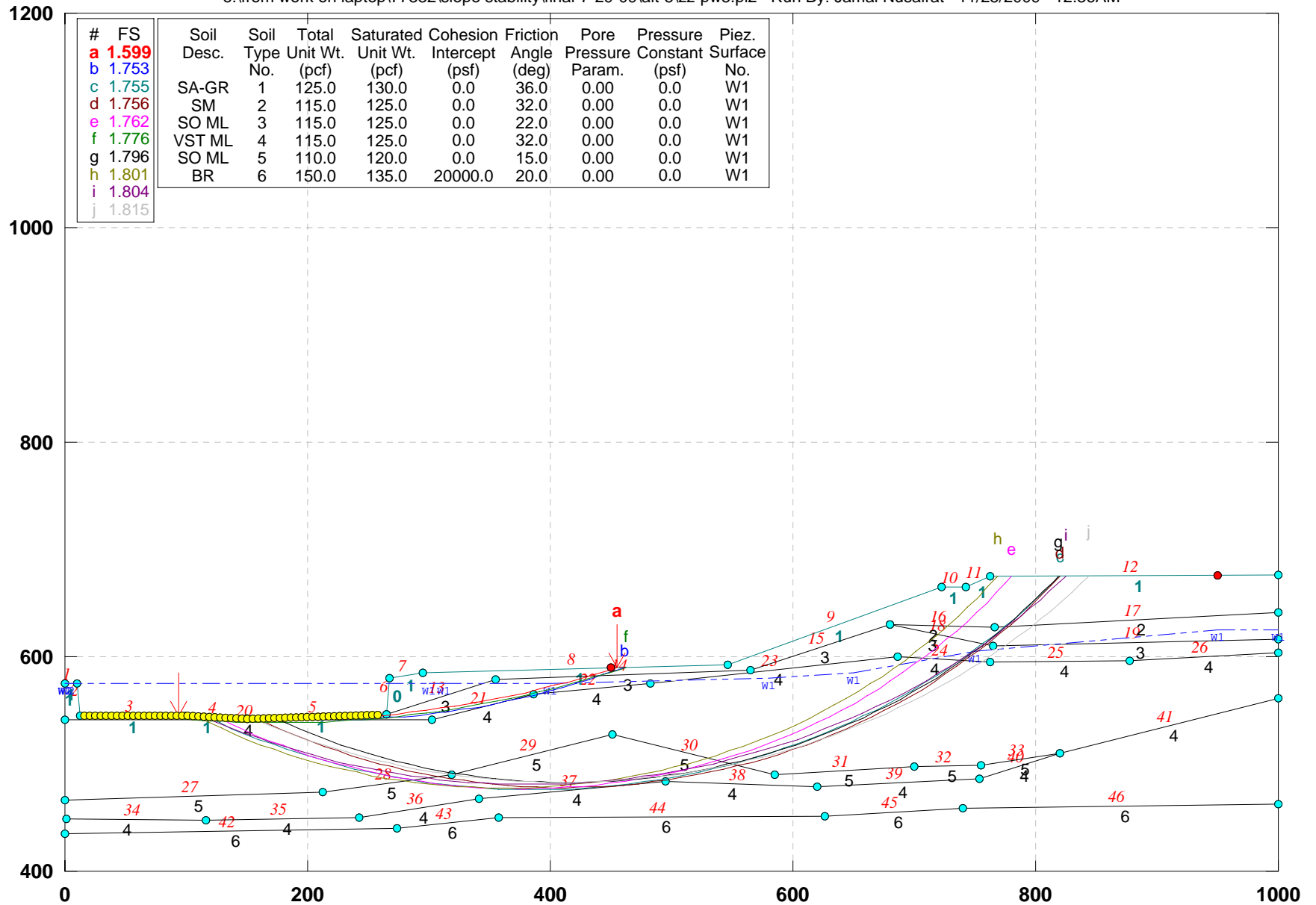

GSTABL7 v.2 FSmin=1.599

Safety Factors Are Calculated By The Simplified Janbu Method



## **APPENDIX 7I**

### **SLOPE STABILITY ANALYSES OF THE INFLUENCE OF SUBSTRUCTURE UNIT WEST OF ABBEY**

## CUY-90-14.92 (Sec. A-A): Alt 5 Substructure load\_Block (global)

p:\177332\admin\contracts\innerbelt construction contract group 1\2009-report\submittal to odot-8-31-09\chapter 7\appendix 7i\_footing beyond abbeylabutment load 50 feet\l-a-p-g5a5.pl2 Run By: Jamal Nusairat 11/25/2009 12

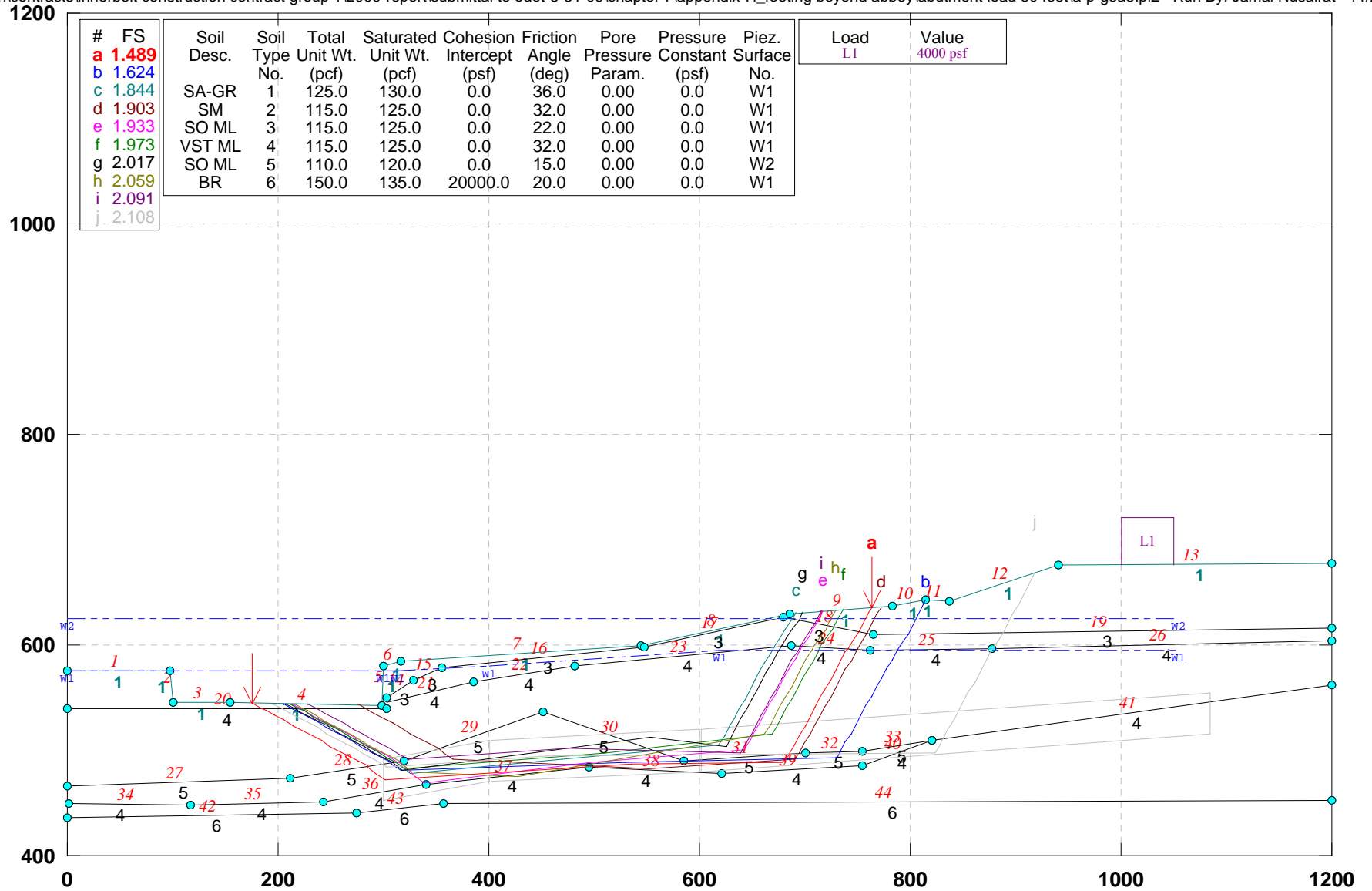

GSTABL7 v.2 FSmin=1.489

Safety Factors Are Calculated By The Simplified Janbu Method



## CUY-90-14.92 (Sec. F-F): PROPOSED GEOMETRY (Alt-5) block with Substructure

p:\77332\admin\contracts\innerbelt construction contract group 1\2009-report\submittal to odot-8-31-09\chapter 7\appendix 7i\_footing beyond abbey\abutment load 50 feet\ff-p-5b5.pl2 Run By: Jamal Nusairat 11/25/2009 12:00

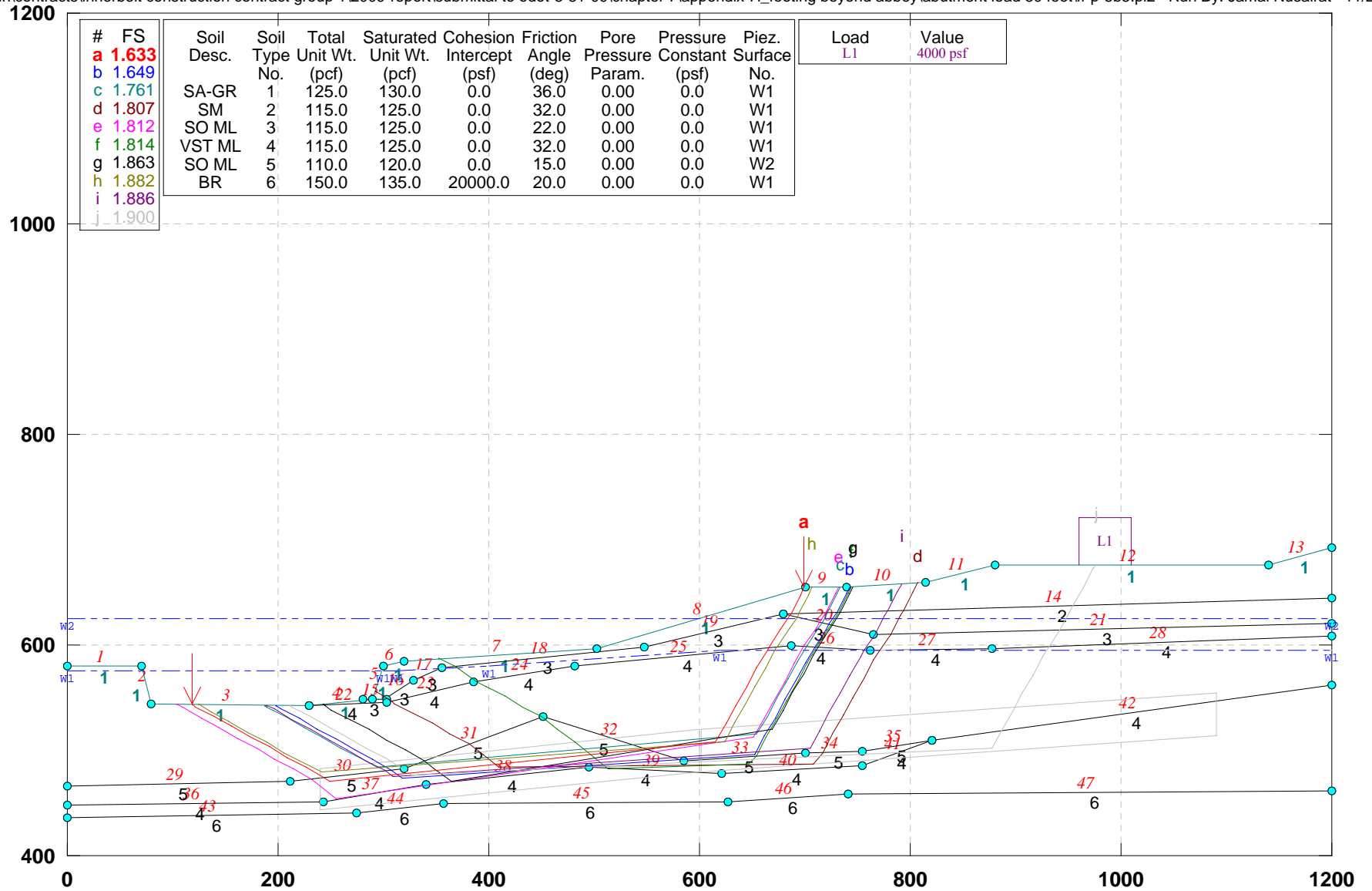

GSTABL7 v.2 FSmin=1.633

Safety Factors Are Calculated By The Simplified Janbu Method



## CUY-90-14.92 (Sec. W): Alt-5 with Abut. load\_Block search (50 ft wide load)

p:\177332\admin\contracts\innerbelt construction contract group 1\2009-report\submittal to odot-8-31-09\chapter 7\appendix 7i\_footing beyond abbey\abutment load 50 feet\w-5ab-b5.pl2 Run By: Jamal Nusairat 11/25/2009 12:5

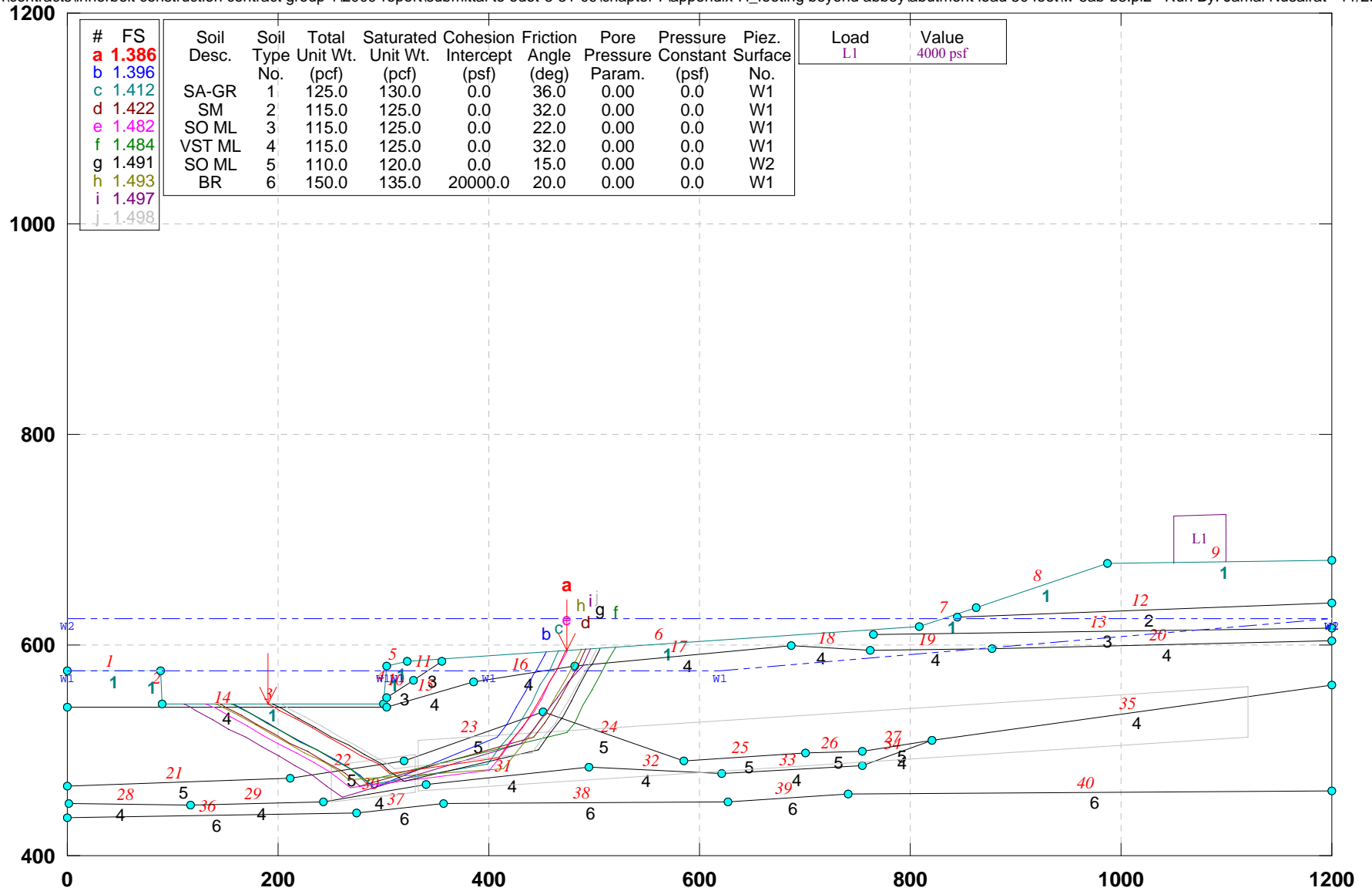

GSTABL7 v.2 FSmin=1.386

Safety Factors Are Calculated By The Simplified Janbu Method



## CUY-90-14.92 (Sec. W-W): Alt-5 with Substructure load\_local stability

p:\77332\admin\contracts\innerbelt construction contract group 1\2009-report\submittal to odot-8-31-09\chapter 7\appendix 7i\_footing beyond abbey\abutment load 50 feet\w-5ab-l5.pl2 Run By: Jamal Nusairat 11/25/2009 12:00

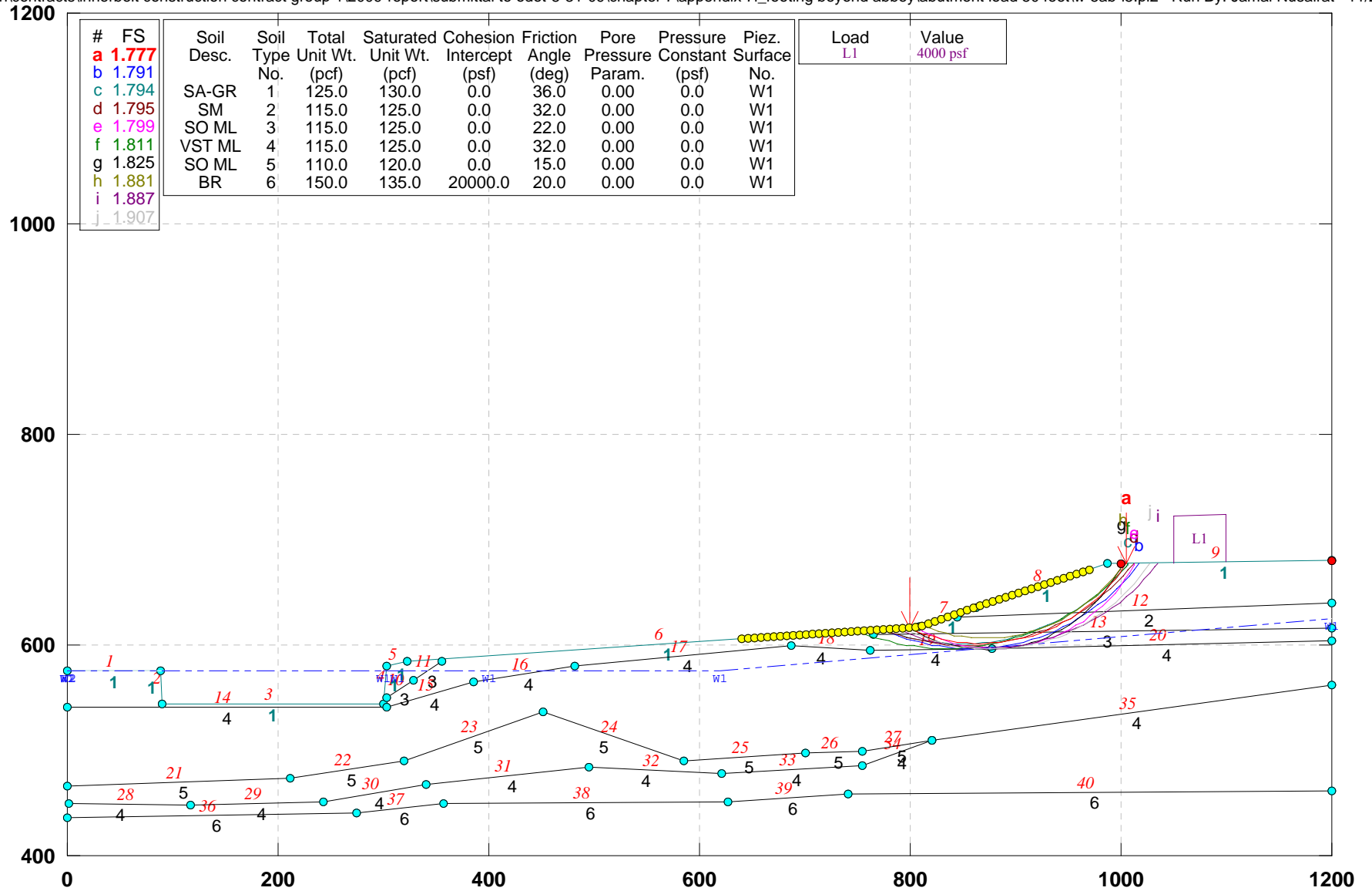

GSTABL7 v.2 FSmin=1.777

Safety Factors Are Calculated By The Simplified Janbu Method



**APPENDIX 7J**

**GEOCOMP CORPORATION STABILITY EVALUATION**



# **Appendix 7J**

## **REVIEW OF SLOPE STABILITY FOR THE CENTRAL VIADUCT PROJECT**

**CUY-90-14.91**

**Cuyahoga County, Ohio**

**By**

**GEOCOMP Consulting, Inc.  
Boxborough, Massachusetts**

**For**

**E.L. Robinson  
Columbus, Ohio**

**November 20, 2009**

## 1. INTRODUCTION

Geocomp Consulting, Inc. was retained by E.L. Robinson to provide independent review of slope stability evaluations for the West Bank Slope of the proposed new Westbound I-90 bridge across the Cuyahoga River. The results of the E.L. Robinson analyses are provided in Table 7.1 and Appendices 7B through 7I. Geocomp worked with E.L. Robinson to establish grading plans, soil parameters and ground water conditions for the E.L. Robinson stability analyses. To perform the independent review, Geocomp reviewed the geometry information used by E.L. Robinson. Geocomp then used the same geometry, soil parameters and water pressures to analyze stability with different computer programs.

E.L. Robinson prepared 15 sections designated A, B, CL, D, E, F, G, H, I, J, K, U, Y, W and Z and shown on the plan sheet in Appendix 7A of this report. Based on E.L. Robinson's results, Geocomp chose five sections (A, D, G, J and W) to use for independent stability checks. These sections are representative of the geometries with the lowest factors of safety for the different slopes in the project.

E. L. Robinson used GSTABL7 which uses the Simplified Janbu Method of slices to calculate limit equilibrium. In this method a failure surface comprised of a circular arc or sliding blocks is assumed. The soil above the failure surface is divided into vertical blocks and force equilibrium is calculated for each block and for the overall mass by assuming that the side forces between the blocks is always horizontal. Each slice is in force equilibrium but not necessarily in moment equilibrium. Many trial surfaces are generated to find the one with the lowest factor of safety (FOS). The method of limiting equilibrium assumes the mass is rigid and failure is rigid body motion.

Geocomp used UTEXAS4 which uses Spencer's Method of slices to calculate limit equilibrium. The method works similarly to the Simplified Janbu Method except that inclined side forces are included at locations that create force and moment equilibrium for each slice. Spencer's method is theoretically more rigorous and accurate. It generally gives a higher FOS than Janbu's method, which makes results from Janbu's method conservative and potentially more expensive. Spencer's method is increasingly used as the preferred method for important stability projects.

Geocomp also used the finite element program, PLAXIS, to separately determine factor of safety for some cases. The finite element method satisfies force and moment equilibrium at all locations and does not pre-define the shape or location of the failure surface. It also computes stresses and strains throughout the slope that are consistent with the stress-strain relationship for each soil. This method will find the most critical failure mode and failure surface location for any condition. It is theoretically superior to methods of limit equilibrium. It typically gives FOS a little lower than Spencer's method because it can more completely define the exact location and shape of the failure surface whereas programs using Spencer's method are constrained by the methods used to generate the failure surfaces.

## 2. Summary of Design Parameters

### 2.1 Stratigraphy

The subsurface soil conditions are summarized Chapter 4 of this report. All sections have the same soil layers with the same properties but each layer has a different thickness and geometry in each section. The analysis performed by Geocomp used the same geometry and parameters as used by E.L. Robinson but analyzed only sections A, D, G, J and W.

The soil strength parameters are shown in Table 1. For sections below the existing bridge the layer 2 (Sandy silt/sand and silt) was not present.

**Table 1: Stratification and Soil Strength Parameters for Stability Analysis**

| Layer No. | Description   | Unit Weight (pcf) | Total Stress Parameters |        | Effective Stress Parameters |         |
|-----------|---|-------------------|-------------------------|--------|-----------------------------|---------|
|           |   |                   | c (psf)                 | $\phi$ | c' (psf)                    | $\phi'$ |
| 1         | Medium dense gravel with sand (SA GR)                                       | 125               | 0.0                     | 36     | 0.0                         | 36      |
| 2         | Sandy silt/sand and silt (SM)   | 125               | 0.0                     | 32     | 0.0                         | 32      |
| 3         | Soft silty clay (SO ML)   | 125               | 800                     | 0      | 0.0                         | 22      |
| 4         | Very stiff silty clay (VST ML)  | 125               | 3500                    | 0      | 0.0                         | 32      |
| 5         | Soft silty clay, with pockets of loose silt and numerous silt seams (SO ML) | 120               | 800                     | 0      | 0.0                         | 15      |
| 6         | Bedrock-shale (BR)  | 135               | 20,000                  | 0      | 20,000                      | 20      |

### 2.1 Groundwater conditions

E.L. Robinson and Geocomp determined the ground water conditions for the analyses using information historical borings and piezometer data. Two distinct piezometric regimes were used and designated as w1 and w2.

Water table, w1, represents the static water table as measured in the borings and piezometers for much of the site. These groundwater pressures are defined as follows

- At the river the groundwater head is at the river elevation +575 feet.
- The groundwater head increases up the bank to an elevation of +595 feet at a distance of approximately 300 feet from the river, then constant at this level further back.

Water table, w2, is an elevated water table in Layer 5 to evaluate the effect of elevated pore water pressures in this layer. This elevated pore water pressures have caused artesian conditions seen in past boring programs where water and gas gushed out of the hole to heights up to 30 feet when a boring entered this layer. The water level w2 is applied only to soil strata 5 and is defined as a constant groundwater head of +625 feet throughout the layer.

Figure 1 shows a plot of the groundwater heads for the assumed existing conditions with w2 applied in the strata 5 zone, and w1 applied to all other soils.

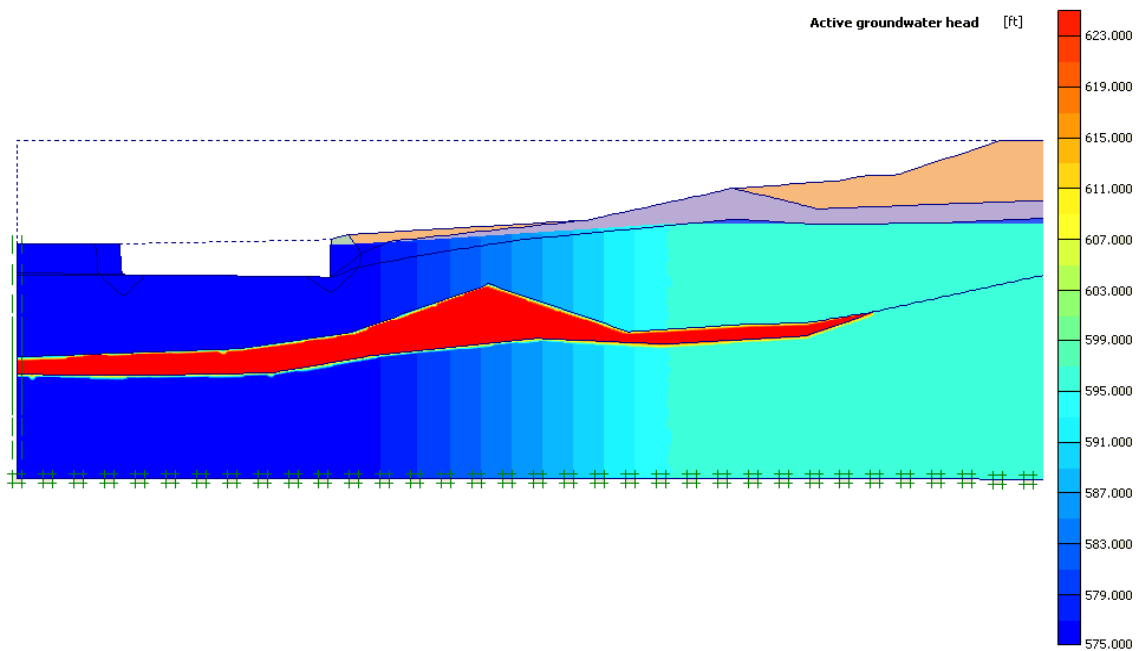

Figure 1: Ground Water Heads for Elevated Pore Pressure Conditions

Figure 2 shows the ground water heads for the conditions with the ground water heads lowered using a combination of horizontal and vertical drains.

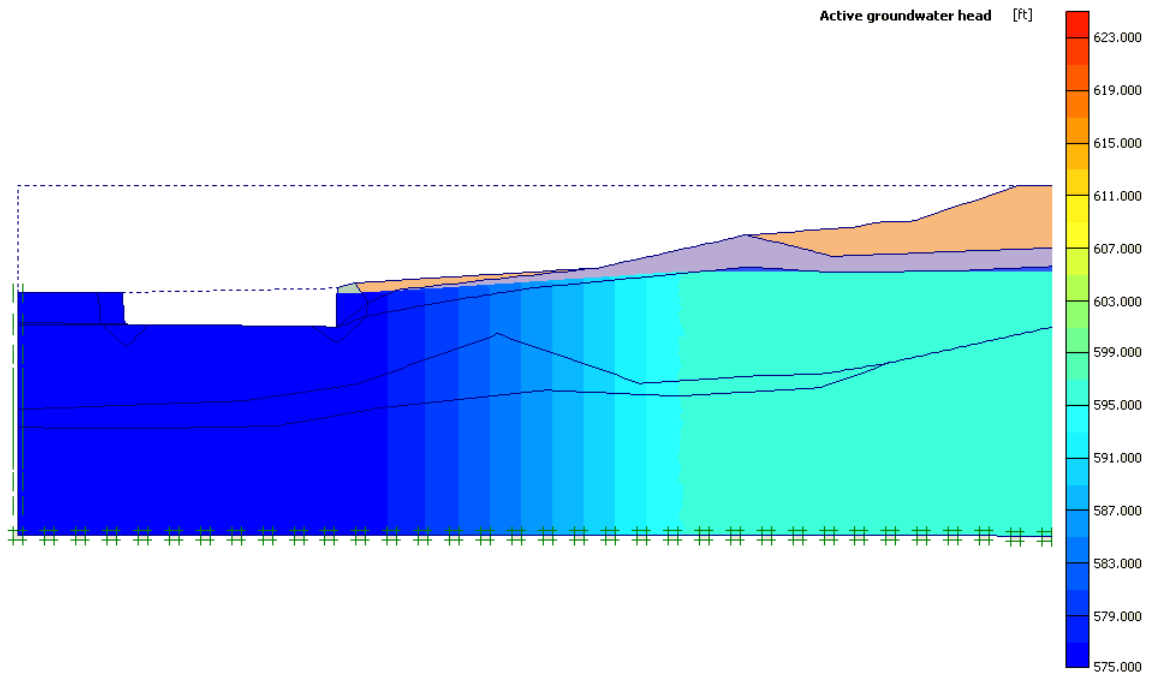

Figure 2: Ground Water Heads for Reduced Pore Pressure Conditions

### **3. Summary of Stability Analysis performed by E.L. Robinson**

Table 2 provides a summary of the results obtained by E.L. Robinson. Based on these results, Geocomp selected five sections for independent verification. These five sections were chosen for the following reasons:

- A-A representative of the most critical section for deep sliding of the existing geometry
- D-D existing section beneath existing bridge and parallel to the bridge that will not change with regarding
- G-G representative section for sliding of newly graded slope adjacent to existing bridge
- J-J representative section for sliding of newly graded slope adjacent to existing railroad bridge
- W-W representative of the most critical section for deep sliding of the final graded slope

The shaded boxes in Table 2 indicate the specific E.L. Robinson analyses that were independently checked by Geocomp.

Table 2: Stability Analyses by E.L. Robinson using Simplified Janbu Method

| Section | Case*  | Excavation side slopes |                |        | Berm (Y/N) | Water |      | Factor of Safety |       | Best Alternative             |
|---------|--------|------------------------|----------------|--------|------------|-------|------|------------------|-------|------------------------------|
|         |        | Top                    | Middle         | Bottom |            | w1    | w2   | Circular         | Block |                              |
| A-A     | Exist  | Flat                   | 2:1            | 6:1    |            | Y     | Y    | 0.99             | 0.91  | Alt. 4 & Alt. 5              |
|         |        |                        |                |        |            | Y     | N    | 1.13             | 1.09  |                              |
|         | A1     | 3:1                    | 13:1/<br>3.5:1 | 15:1   | N          | Y     | Y    | 1.48             | 1.38  |                              |
|         | A2     | 3:1                    | 7:1            | 15:1   | N          | Y     | Y    | 1.37             | 1.28  |                              |
|         | A3     | 3:1                    | 8:1            | 15:1   | Y          | Y     | Y    | 1.47             | 1.29  |                              |
|         |        |                        |                |        |            | Y     | N    | 1.49             | 1.30  |                              |
|         | A5     |                        |                |        | Y          | Y     | Y    | 1.50             | 1.32  |                              |
| Y       |        |                        |                |        |            | N     | 1.90 | 1.71             |       |                              |
| B-B     | Exist  | Flat                   | 1:1            | 6.5:1  |            | Y     | Y    | 1.02             | 0.98  | Alt. 2<br>Alt. 4<br>& Alt. 5 |
|         |        |                        |                |        |            | Y     | N    | 1.22             | 1.23  |                              |
|         | A1     | 6:1                    | 2.5:1          | 18:1   | N          | Y     | Y    | 1.25             | 1.21  |                              |
|         | A2     | 6:1                    | 2.5:1          | 20:1   | N          | Y     | Y    | 1.97             | 1.35  |                              |
|         | A3     | 6:1                    | 3.4:1          | 15:1   | Y          | Y     | Y    | 1.98             | 1.33  |                              |
|         |        |                        |                |        |            | Y     | N    | 1.48             | 1.30  |                              |
|         | A5     |                        |                |        | Y          | Y     | Y    | 1.31             | 1.19  |                              |
| Y       |        |                        |                |        |            | N     | 1.61 | 1.52             |       |                              |
| CL-CL   | Exist  | Flat                   | 2.25:1         | 5.5:1  |            | Y     | Y    | 1.51             | 1.84  | Alt. 4<br>& Alt. 5           |
|         | A1     | 2:1                    | 3:1            | 15:1   | N          | Y     | Y    | 1.47             | NA    |                              |
|         | A2     | 2:1                    | 3:1            | 15:1   | N          | Y     | Y    | NA               | NA    |                              |
|         | A3     | 2:1                    | 4:1            | 15:1   | Y          | Y     | Y    | NA               | NA    |                              |
|         |        |                        |                |        |            | Y     | N    | 1.59             | 1.55  |                              |
| A4      | 2.5:1  | 2.5:1                  | 15:1           | Y      | Y          | Y     | 1.59 | 1.55             |       |                              |
| D-D     | Exist  | Flat                   | 2:1            | 6:1    | -          | Y     | Y    | .98              | .94   | Alt. 4<br>& Alt. 5           |
|         | A1     | -                      | -              | -      | -          | Y     | Y    | NA               | NA    |                              |
|         | A2     | -                      | -              | -      | -          | Y     | Y    | NA               | NA    |                              |
|         | A3     | -                      | -              | -      | Y          | Y     | Y    | -                | -     |                              |
|         | A4     | 2.5:1                  | 2.5:1          | 15:1   | Y          | Y     | Y    | 1.13/<br>1.25    | 1.01  |                              |
|         |        |                        |                |        |            | Y     | N    | 1.43             | 1.38  |                              |
|         | A5     |                        |                |        | Y          | Y     | Y    | 1.15             | 1.05  |                              |
| Y       |        |                        |                |        |            | N     | 1.31 | 1.26             |       |                              |
| E-E     | Exist. | 5:1                    | 2:1            | 8:1    | -          | Y     | Y    | 1.01             | 0.99  | Alt. 5                       |
|         | A1     | 5:1                    | 2.5:1          | 15:1   | N          | Y     | Y    | 1.27             | 1.22  |                              |
|         | A2     | 5:1                    | 2.4:1          | 15:1   | N          | Y     | Y    | 1.83             | 1.41  |                              |
|         | A3     | 4:1                    | 3:1            | -      | Y          | Y     | Y    | 1.83             | 1.41  |                              |
|         |        |                        |                |        |            | Y     | N    | 1.55             | 1.23  |                              |
|         | A5     |                        |                |        | Y          | Y     | Y    | 1.62             | 1.31  |                              |
|         |        |                        |                |        |            | Y     | N    | 1.75             | 1.51  |                              |
|         |        |                        |                |        | Y          | N     | 1.91 | 1.74             |       |                              |

**Table 2: continued**

| Section | Case*  | Excavation slopes |                |               | Berm (Y/N) | Water |      | Factor of Safety |       | Best Alternative |
|---------|--------|-------------------|----------------|---------------|------------|-------|------|------------------|-------|------------------|
|         |        | Top               | Middle         | Bottom        |            | w1    | w2   | Circular         | Block |                  |
| F-F     | Exist. | flat              | 4:1            | 7:1           | -          | Y     | Y    | 1.20             | 1.19  | Alt. 4 & Alt. 5  |
|         | A1     | 12:1              | 3:1            | 15:1          | N          | Y     | Y    | 1.22             | 1.20  |                  |
|         | A2     | 12:1              | 3:1            | 13:1          | N          | Y     | Y    | 1.44             | 1.36  |                  |
|         | A3     | 4:1/<br>20:1      | 3.5:1          | 10:1          | Y          | Y     | Y    | 1.44             | 1.38  |                  |
|         | A4     | 2.5:1             | 15:1/<br>2.5:1 | 15:1          | Y          | Y     | Y    | 1.49             | 1.40  |                  |
|         |        |                   |                |               |            | Y     | N    | 1.69             | 1.62  |                  |
|         | A5     |                   |                |               | Y          | Y     | Y    | 1.47             | 1.38  |                  |
| Y       |        |                   |                |               |            | N     | 1.65 | 1.60             |       |                  |
| G-G     | Exist. | 10:1              | 6:1            | 12:1          | -          | Y     | Y    | 3.42             | OK    | All Alternatives |
|         | A1     | 2.5:1             | 25:1           | -5:1          | N          | Y     | Y    | 2.21             | 2.32  |                  |
|         | A2     | 2.5:1             | 20:1           | -4:1          | N          | Y     | Y    | 2.63             | 2.86  |                  |
|         | A3     | 2.5:1             | 3:1            | 35:1/<br>-3:1 | Y          | Y     | Y    | 2.02             | 2.09  |                  |
|         | A4     | 2.5:1             | 2.5:1          | 15:1          | Y          | Y     | Y    | 2.27             | 2.41  |                  |
|         |        |                   |                |               |            | Y     | N    | 2.27             | 2.41  |                  |
|         | A5     |                   |                |               | Y          | Y     | Y    | 2.12             | 2.33  |                  |
| Y       |        |                   |                |               |            | N     | 2.12 | 2.33             |       |                  |
| I-I     | Exist. | Flat              | Flat           | Flat          | -          | Y     | Y    | OK               | OK    | All Alternatives |
|         | A1     | 3:1               | 2.5:1          | 15:1          | N          | Y     | Y    | Ok               | NA    |                  |
|         | A2     | 3:1               | 2.5:1          | 15:1          | N          | Y     | Y    | 1.97             | NA    |                  |
|         | A3     | 3.5:1             | 3.5:1          | 15:1          | Y          | Y     | Y    | 2.80             | NA    |                  |
|         | A4     | 2.5:1             | 2.5:1          | 15:1          | Y          | Y     | Y    | 2.25             | NA    |                  |
|         | A5     |                   |                |               | Y          | Y     | Y    | 2.06             | NA    |                  |
| J-J     | Exist. | Flat              | Flat           | Flat          |            | Y     | Y    | OK               | OK    | All Alternatives |
|         | A1     | 3.5:1             | 15:1           | -             | N          | Y     | Y    | OK               | OK    |                  |
|         | A2     | 3:1               | 15:1           | -             | N          | Y     | Y    | 2.65             | OK    |                  |
|         | A3     | 2.5:1             | 15:1           | -             | Y          | Y     | Y    | OK               | OK    |                  |
|         | A4     | 2.5:1             | 15:1           | -             | Y          | Y     | Y    | OK               | OK    |                  |
|         | A5     |                   |                |               | Y          | Y     | Y    | 2.36             | NA    |                  |
| K-K     | Exist. |                   |                |               |            | Y     | Y    | OK               | OK    | All Alternatives |
|         | A1     |                   |                |               |            | Y     | Y    | OK               | OK    |                  |
|         | A2     |                   |                |               |            | Y     | Y    | OK               | OK    |                  |
|         | A3     |                   |                |               |            | Y     | Y    | OK               | OK    |                  |
|         | A4     |                   |                |               |            | Y     | Y    | 1.83             | NA    |                  |
| U-U     | Exist. | 12:1              | 12:1           | 12:1          |            | Y     | Y    | > 2.0            | OK    | All Alternatives |
|         | A1     | 3:1               | 30:1           | -3:1          | N          | Y     | Y    | 2.27             | 2.42  |                  |
|         | A2     | 3:1               | 30:1           | -3:1          | N          | Y     | Y    | 2.15             | 2.32  |                  |
|         | A3     | 3:1               | 3:1            | FLAT/<br>-3:1 | Y          | Y     | Y    | 2.31             | 2.52  |                  |
|         | A4     | 5:1               | 3:1            | FLAT/<br>-3:1 | Y          | Y     | Y    | 2.57             | 2.69  |                  |
|         | A5     |                   |                |               | Y          | Y     | Y    | 1.75             | NA    |                  |



Table 2: Continued

| Section | Case*  | Excavation slopes |        |        | Berm<br>(Y/N) | Water |      | Factor of Safety |       | Best Alternative  |
|---------|--------|-------------------|--------|--------|---------------|-------|------|------------------|-------|-------------------|
|         |        | Top               | Middle | Bottom |               | w1    | w2   | Circular         | Block |                   |
| W-W     | Exist. | Flat              | 1.3:1  | 7:1    |               | Y     | Y    | 0.98             | 0.97  | Alt. 5            |
|         | A1     | 3:1               | 15:1   | -      | N             | Y     | Y    | 1.62             | 1.60  |                   |
|         | A2     | 3:1               | 25:1   | 25:1   | N             | Y     | Y    | 1.65             | 1.48  |                   |
|         | A3     | 2.5:1             | 2.5:1  | 15:1   | Y             | Y     | Y    | 2.09             | 1.48  |                   |
|         |        |                   |        |        |               | Y     | N    | 1.76             | 1.44  |                   |
|         | A4     | 2.5:1             | 2.5:1  | 15:1   | Y             | Y     | Y    | 1.77             | 1.45  |                   |
|         |        |                   |        |        |               | Y     | N    | 2.37             | 1.86  |                   |
| Y-Y     | Exist. | Flat              | 2.5:1  | 7:1    |               | Y     | Y    | 1.22             | 1.23  | Alt. 5            |
|         | A1     | 4:1               | 2.5:1  | 17:1   | N             | Y     | Y    | 2.01             | 1.53  |                   |
|         | A2     | 4:1               | 2.5:1  | 15:1   | N             | Y     | Y    | 2.22             | 1.53  |                   |
|         | A3     | 4:1               | 4:1    | 15:1   | Y             | Y     | Y    | 1.87             | 1.58  |                   |
|         | A4     | 3:1               | 4:1    | 15:1   | Y             | Y     | Y    | 1.57             | 1.38  |                   |
|         |        |                   |        |        |               | Y     | N    | 1.90             | 1.79  |                   |
|         | A5     |                   |        |        |               |       |      | 2.13             | 1.49  |                   |
| 2.44    |        |                   |        |        |               |       |      | 1.83             |       |                   |
| Z-Z     | Exist. | Flat              | Flat   | 5:1    |               | Y     | Y    | 1.15             | 1.12  | Alt. 4 &<br>Alt 5 |
|         | A1     | 2:1               | 20:1   | 4:1    | N             | Y     | Y    | 1.40             | 1.23  |                   |
|         | A2     | 2:1               | 15:1   | 4:1    | N             | Y     | Y    | 1.45             | 1.21  |                   |
|         | A3     | 2:1               | 3.5:1  | 18:1   | Y             | Y     | Y    | 1.45             | 1.21  |                   |
|         | A4     | 2.75:1            | 2.75:1 | 20:1   | Y             | Y     | Y    | 1.66             | 1.19  |                   |
|         |        |                   |        |        |               | Y     | N    | 1.68             | 1.46  |                   |
|         | A5     |                   |        |        | A5            | Y     | Y    | 1.55             | 1.18  |                   |
| Y       |        |                   |        |        |               | N     | 1.60 | 1.43             |       |                   |

## 4. Stability Analysis performed by Geocomp

Geocomp performed independent stability analyses for 5 representative sections and 2 alternates from the 14 sections and 5 alternatives analyzed by E.L Robinson.

The following sections were analyzed because they represent the most important geometries for overall stability of the existing and proposed slopes.

1. Section A-A is located roughly parallel with the existing west bound bridge and is one critical section for the existing slope.
2. Section D-D is the existing slope beneath the existing bridge.
3. Section G-G is on a 70 degree skew to the proposed bridge. It examines stability of the steepest part of the excavated slope away from the bridge pier.
4. Section J-J is perpendicular to the excavated slope adjacent to the railroad tracks.
5. Section W-W is on a 15 degree skew to the proposed bridge, through the centerline of the proposed excavated slope.

Figure 3 presents a plan showing the locations of the 5 sections analyzed by Geocomp.

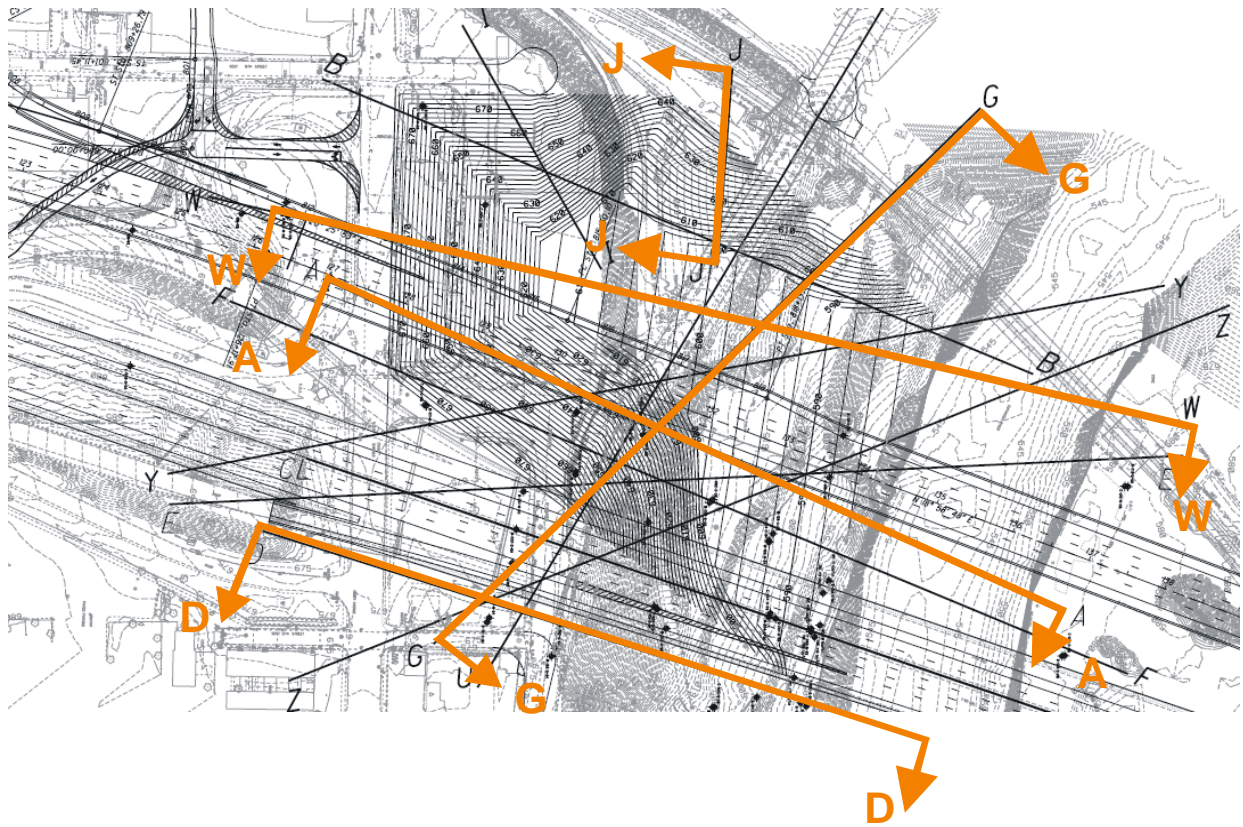

Figure 3: Stability Sections Analyzed by Geocomp

E.L. Robinson developed several alternative grading plans. Geocomp selected two of the alternatives on which to perform the independent stability analyses. Originally, Alternative 2 was selected as the most likely alternative. Later Alternative 5 developed as the preferred alternative. The two alternatives are shown in Figures 4 and 5.

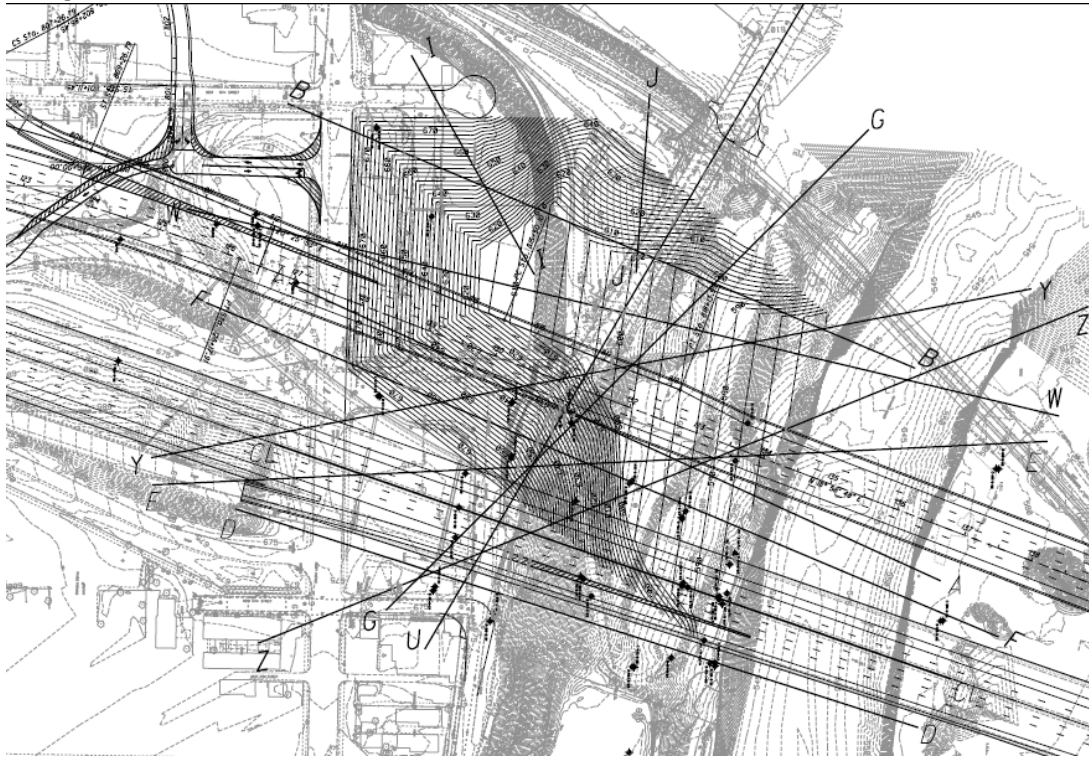

Figure 4: Proposed Slope Grading - Alternative 2



Figure 5: Proposed Slope Grading - Alternative 5

## 4.A Stability Analysis Using Limiting Equilibrium with UTEXAS4

Limiting Equilibrium analyses were performed using the computer code UTEXAS4. UTEXAS4 is developed and maintained by Dr. Stephen G. Wright of Shinoak Software, who is well-recognized as one of the leading experts in slope stability (Duncan and Wright, 2005).<sup>1</sup> The program is considered one of the best commercial software programs available to evaluate the two-dimensional stability of slopes using the limiting equilibrium method. The program is widely used by the US Army Corps of Engineers and other agencies.

The method of analysis used in UTEXAS4 is Spencer's procedure. In Spencer's procedure all side forces are assumed to have the same inclination and all requirements for static equilibrium are satisfied. Figure 6 shows a typical result for a UTEXAS4 slope stability analysis. The figure shows a contour plot of factor of safety for the slip circle centers, with details for the most critical circle. These details include:

- The geometry and soil parameters
- Minimum factor of safety obtained and the failure surface for that minimum.
- Pore pressure acting on this failure surface.
- Total or normal stress on this failure surface.
- Location of line of thrust for the side forces.

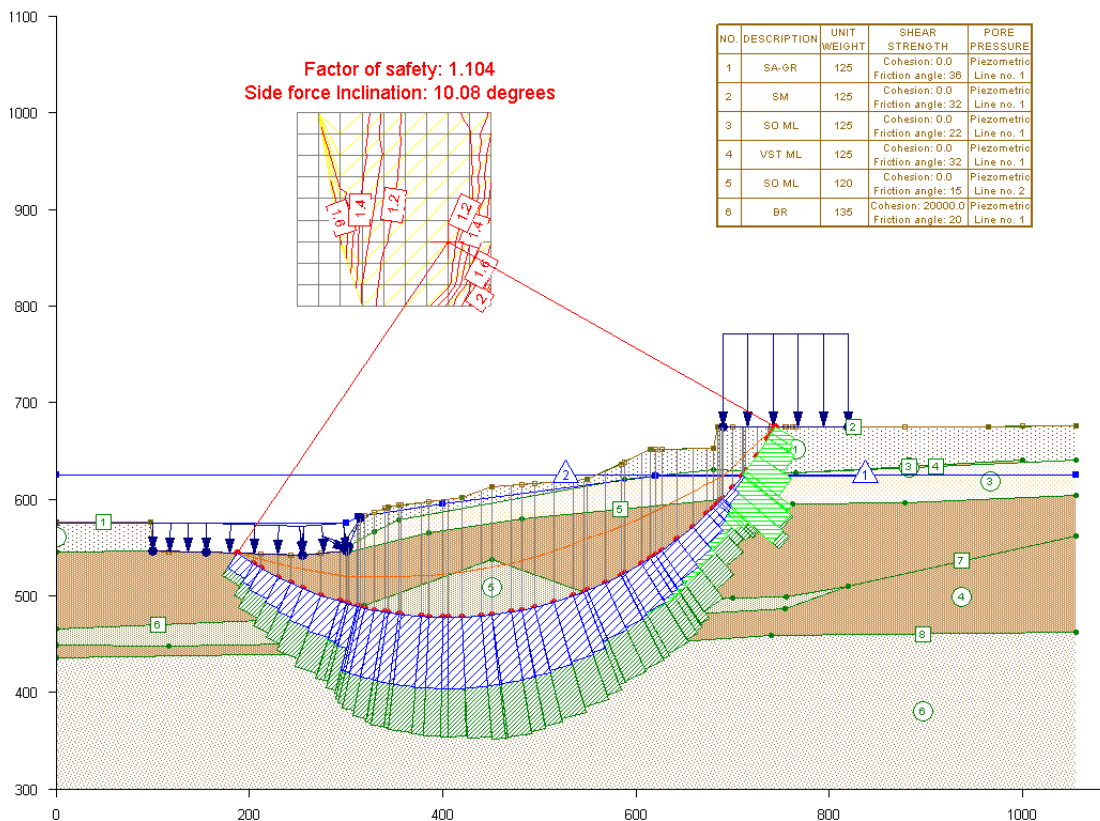

Figure 6: Typical UTEXAS4 Results

<sup>1</sup> Duncan, J.M. and Wright, S.G. "Soil Strength and Slope Stability," John Wiley & Sons, 2005.

## 4.B Slope Stability Analysis With Finite Element Method

FEM modeling of the critical sections was performed using Plaxis Version 8.6. Plaxis is a finite element software package that is specifically designed to do deformation and stability analysis in geotechnical engineering. Plaxis has features that enable it to perform stability analysis taking into consideration all aspects of the cross section geometry including structural elements, and user defined loading. The FEM analysis also takes into consideration stress redistributions from soil-structure interaction that are important for determining realistic earth pressure forces against retaining structures. The following items are considered in the stability analysis performed using FEM.

- Redistribution of stresses against the structures.
- Yielding and redistribution of stresses to form a failure surface.
- Limited resistance available from structures (limiting loads on anchors and bending stresses in wall to the design levels).
- Identification of the critical failure mode including sliding, overturning, base heave, anchor pullout, over stress in wall, internal and external stability.

Factor of safety for global stability is defined as the ratio of the available shear strength to the minimum shear strength needed for equilibrium. Plaxis can compute this factor of safety using a so-called 'phi-c reduction' procedure. In this procedure, the shear strength of all earthen materials is systematically decreased until large shear strains begin to develop. The inverse of the amount of strength reduction to reach this stage equals the factor of safety.

Geocomp's experience shows that this procedure gives results similar to limit equilibrium analyses using Spencer's method if the failure surfaces are similar. This method of stability analysis automatically determines the most critical failure surface without any preconditions on its location or shape. The failure surface is the surface or surfaces along which incremental strains become large during the final stages of the strength reduction. Figure 7 shows a typical incremental strain plot for the final strength reduction stage in a finite element computation. The zones of color grading from light blue to yellow to red indicate increasing levels of shear strain. These color bands show the shear zones that develop as the strength is decreased to a limiting value as the slope fails. This example shows two distinct shear zones developing into an overall global stability failure. These failure surfaces are neither circular nor sliding blocks but are more complex. Plaxis finds the failure surface that gives the least resistance without limits on location or shape. This means that in general the results from Plaxis should be slightly less or equal to those from Spencer's method provided that the failure surfaces are approximately the same.

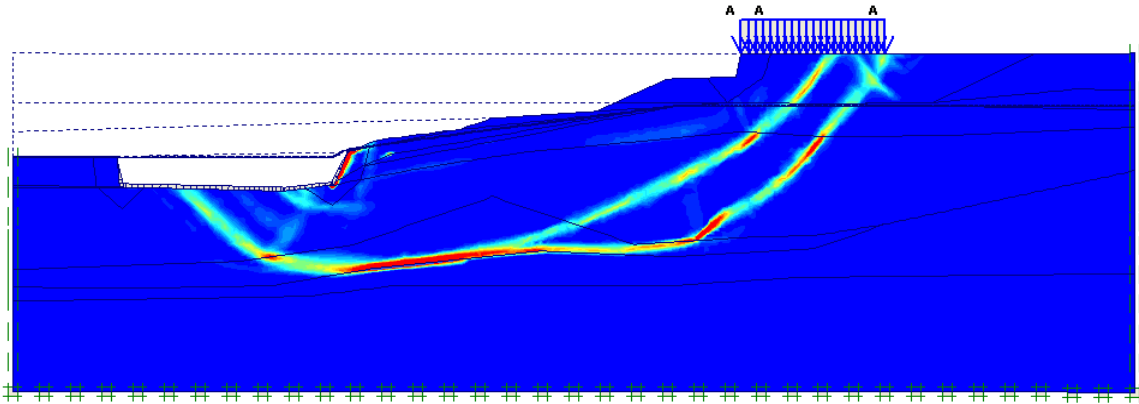

Figure 7: Finite Element Slope Stability – Incremental Strain Plot

## 5. Results

The following sections present summaries of the analyses performed by Geocomp and compare the results with those obtained by E.L. Robinson.

### 5. A Section A-A

We analyzed Section A-A for the following conditions:

- Existing geometry – with elevated pore water pressures
- Alternative 2 geometry – with elevated pore water pressures
- Alternative 5 geometry – with elevated pore water pressures
- Alternative 2 geometry – with reduced pore water pressures

The results are discussed in the following sections. The outputs of the calculations are summarized in Appendix A for Section A-A.

#### 5. A.1 Section A-A - Existing Conditions

The factor of safety for the Section A-A existing conditions are summarized in Table 3.

**Table 3: Stability Analyses for Section A-A Existing Conditions**

| Failure Surface | Factor Of Safety |               |
|-----------------|------------------|---------------|
|                 | Geocomp          | E.L. Robinson |
| Circular        | 1.10             | 0.99          |
| Block           | 1.08             | 0.92          |
| Plaxis          | 1.06             | ----          |

The Geocomp factors of safety obtained with Spencer's method are approximately 15% higher than those computed by E.L. Robinson with the Simplified Janbu method. This is the expected result. As described previously, Spencer's method should generally give a higher FOS than Simplified Janbu because it is more accurate. The difference between circular and block analysis is not very significant because the both failure surfaces are similar. The Plaxis result is similar but less than the Spencer result which is expected as discussed above.

These results demonstrate that for the existing conditions the FOS is close to 1. This should be expected because portions of the slope have previously failed and been repaired.

#### 5. A.2 Section A-A - Alternative 2 With Elevated Pore Water Pressures

The factors of safety for Section A-A Alternative 2 with elevated pore water pressures are summarized in Table 4.

**Table 4: Stability Analyses for Section A-A Alternative 2**

| Failure Surface | Factor Of Safety |               |
|-----------------|------------------|---------------|
|                 | Geocomp          | E.L. Robinson |
| Circular        | 1.46             | 1.37          |
| Block           | 1.31             | 1.29          |
| Plaxis          | 1.28             | ----          |

The circular method of analysis results are higher than for the block results because the critical surface is a block failure surface that differs considerably from a circle. The Spencer's side force inclination is only 4.1 degrees so the difference in results from Simplified Janbu and Spencer's Method should be small and they are. The results closely match the values reported by E.L. Robinson, which they should because of the low value of side force inclination. These results show unacceptably low values of factor and safety indicating the need for a pore pressure relief system. Independent analyses of this alternative with reduced pore water pressure were not done by Geocomp.

### 5. A.3 Section A-A - Alternative 5 With Elevated Pore Water Pressures

The factors of safety for Section A-A alternative 5 are summarized in the Table 5.

**Table 5: Stability Analyses for Section A-A Alternative 5**

| Failure Surface | Factor Of Safety |               |
|-----------------|------------------|---------------|
|                 | Geocomp          | E.L. Robinson |
| Circular        | 1.64             | 1.51          |
| Block           | 1.43             | 1.33          |
| Plaxis          | 1.55             | ----          |

Again, the factors of safety from Spencer's method are approximately 10% higher than computed by Simplified Janbu's method. The critical failure surface predicted by the sliding block analysis is different than the critical surface determined by the finite element analysis. This may be due to differences in the input data sets that could not be isolated, but the small discrepancy is of no consequence to the design.

### 5. A.4 Section A-A - Alternative 5 with Reduced Pore Water Pressures

The factors of safety for Section A-A Alternative 5 with reduced pore water pressures are summarized in Table 6.

**Table 6: Stability Analyses for Section A-A Alternative 5 with Reduced Pore Water Pressures**

| Failure Surface | Factor Of Safety |               |
|-----------------|------------------|---------------|
|                 | Geocomp          | E.L. Robinson |
| Circular        | 2.08             | ---           |
| Block           | 1.84             | 1.71          |
| Plaxis          | 1.83             | ----          |



The factor of safety from Spencer’s Method is higher than that from Simplified Janbu Method, the expected result. The critical failure surface is a long sliding block; therefore the circular failure surface gives a higher factor of safety. The Plaxis result is similar to the Sliding Block by Spencer’s Method.

## 5. B Section D-D

Section D-D was analyzed by Geocomp for the following conditions

- Alternative 5 geometry – with elevated pore water pressures
- Alternative 5 geometry – with reduced pore water pressures

The results are discussed in the following sections. The outputs of the calculations are summarized in Appendix B for Section D-D.

### 5. B.1 Section D-D - Alternative 5 with Elevated Pore Water Pressures

The factors of safety for the Section D-D with elevated pore water pressures are summarized Table 7.

**Table 7: Stability Analyses for Section D-D Alternative 5 with Elevated Pore Water Pressures**

| Failure Surface | Factor Of Safety |               |
|-----------------|------------------|---------------|
|                 | Geocomp          | E.L. Robinson |
| Circular        | 1.30             | 1.15          |
| Block           | 1.27             | 1.13          |
| Plaxis          | 1.17             | ----          |

The factors of safety from Spencer’s Method are approximately 13% higher than those from Simplified Janbu Method which is the expected result. The Plaxis factor of safety is less than that computed by sliding block method because the critical surface is a combination of circular and block shapes. The results show unacceptably low values of factor of safety.

### 5. B.3 Section D-D - Alternative 5 with no elevated water pressures

The factors of safety for the Section D-D existing conditions are summarized in Table 8.

**Table 8: Stability Analyses for Section D-D Alternative 5 with Reduced Pore Water Pressure**

| Failure Surface | Factor Of Safety |               | Comments                |
|-----------------|------------------|---------------|-------------------------|
|                 | Geocomp          | E.L. Robinson |                         |
| Circular        | 1.49             | 1.31          | Shallow failure surface |
|                 | 1.35             | ---           |                         |
| Block           | 1.54             | 1.35          |                         |
| Plaxis          | 1.30             | ----          |                         |

The factors of safety from Spencer’s Method are approximately 14% higher than those from Simplified Janbu Method. The Plaxis factor of safety is less than that computed by sliding block because the critical

surface is a shallow failure surface on the slope. The factor of safety with a circular failure surface and Spencer’s Method that approximates the Plaxis failure surface is 1.35.

## 5. C Section G-G

Section G-G was analyzed by Geocomp for the following conditions

- Existing Conditions
- Alternative 2 Geometry with elevated pore water pressures
- Alternative 5 geometry with elevated pore water pressures
- Alternative 5 geometry with reduced pore water pressures

The results are discussed in the following sections. The outputs of the calculations are summarized in Appendix C for Section G-G.

### 5. C.1 Section G-G Existing Conditions

The factors of safety for the Section G-G existing conditions are summarized in Table 9.

**Table 9: Stability Analyses for Section G-G Existing Conditions with Elevated Pore Water Pressures**

| Failure Surface | Factor Of Safety |               |
|-----------------|------------------|---------------|
|                 | Geocomp          | E.L. Robinson |
| Circular        | 3.76             | 3.41          |
| Block           | ---              | ---           |
| Plaxis          | 3.55             | ----          |

The factor of safety by Spencer’s Method is approximately 10% higher than that by Simplified Janbu Method. The Plaxis factor of safety somewhat less than the circular; it includes a combination of a circular and a block sliding surface.

### 5. C.2 Section G-G - Alternative 2 with Elevated Pore Water Pressures

The factor of safety for Section G-G alternative 2 are summarized in Table 10.

**Table 10: Stability Analyses for Section D-D Alternative 2 with Elevated Pore Water Pressures**

| Failure Surface | Factor Of Safety |               |
|-----------------|------------------|---------------|
|                 | Geocomp          | E.L. Robinson |
| Circular        | 1.86             | 2.63          |
| Block           | 1.86             | 2.86          |
| Plaxis          | 1.75             | ----          |

The results for Spencer’s Method are lower than those from Janbu’s Method because E.L. Robinson used different pore water pressures in this section than in others while Geocomp kept the pore water pressures that same as for other sections. Results from Spencer’s Method and Plaxis are similar as expected.

### 5. C.3 Section G-G - Alternative 5 with Elevated Pore Water Pressures

The factor of safety for the Section G-G Alternative 5 with the elevated water conditions are summarized in the following table.

**Table 11: Stability Analyses for Section G-G Alternative 5 with Elevated Pore Water Pressures**

| Failure Surface | Factor Of Safety |               |
|-----------------|------------------|---------------|
|                 | Geocomp          | E.L. Robinson |
| Circular        | 2.10             | 2.12          |
| Block           | 2.41             | 2.33          |
| Plaxis          | 2.24             | ---           |

The critical failure surface is a shallow failure surface on the slope above the water table. The factors of safety will be the same for the reduced pore water pressure condition.

### 5. D Section J-J

Section J-J was analyzed by Geocomp for two conditions:

- Alternative 2 geometry with elevated pore water pressures
- Alternative 5 geometry with elevated pore water pressures

The outputs of the calculations are summarized in Appendix D for Section J-J.

The factors of safety for Alternative 2 with elevated pore water pressures are summarized in Table 11.

**Table 11: Stability Analyses for Section J- J Alternative 2 with Elevated Pore Water Pressures**

| Failure Surface | Factor Of Safety |               |
|-----------------|------------------|---------------|
|                 | Geocomp          | E.L. Robinson |
| Circular        | 2.69             | 2.65          |
| Block           | ---              | ---           |
| Plaxis          | 2.72             | ----          |

The failure surface is a shallow circular surface through the slope face. The results from all three methods are similar and show this section to not be a critical one for the design.

Alternative 5 was also analyzed with elevated pore pressures.

| Failure Surface | Factor Of Safety |               |
|-----------------|------------------|---------------|
|                 | Geocomp          | E.L. Robinson |
| Circular        | 1.86             | 2.36          |
| Block           | ---              | ---           |
| Plaxis          | 2.32             | ----          |

We found a very shallow failure surface through the graded slope that gave a lower factor of safety than the one obtained by E.L. Robinson. However the factor of safety remains well above the minimum required value. The factor of safety from Plaxis is higher than from Spencer’s Method which is not the usual case but the failure mechanism is different. We suspect this occurs because the finite element was not sufficiently fine to pick up the shallow slip surface identified by the limit equilibrium method. This has no impact on the adequacy of the slope design.

## 5. E Section W-W

Section W-W was analyzed by Geocomp for the following conditions:

- Existing geometry with elevated pore water pressures
- Alternative 2 geometry with elevated pore water pressures
- Alternative 5 geometry with elevated pore water pressures
- Alternative 2 geometry with depressurized pore water pressures

The results are discussed in the following sections. The outputs of the calculations are summarized in Appendix E for Section W-W.

### 5. E.1 Section W-W - Existing Conditions

The factors of safety for Section W-W and existing conditions and elevated pore water pressures are summarized in Table 11.

**Table 11: Stability Analyses for Section D-D Existing Conditions with Elevated Pore Water Pressures**

| Failure Surface | Factor Of Safety |               |
|-----------------|------------------|---------------|
|                 | Geocomp          | E.L. Robinson |
| Circular        | 1.17             | 0.98          |
| Block           | 1.12             | 0.97          |
| Plaxis          | 1.09             | ----          |

The factors of safety by Spencer’s Method are approximately 20% greater than those from Simplified Janbu’s Method. The Plaxis result is slight lower than the block analysis with Spencer’s Method. These results follow the expected relationship. They also show that Section W-W is close to failure for existing conditions.

### 5. E.2 Section W-W - Alternative 2 with Elevated Pore Water Pressures

The factors of safety for Section W-W Alternative 2 are summarized in Table 12.

**Table 12: Stability Analyses for Section D-D Alternative 2 with Elevated Pore Water Pressures**

| Failure Surface | Factor Of Safety |               |
|-----------------|------------------|---------------|
|                 | Geocomp          | E.L. Robinson |
| Circular        | 1.83             | 2.02          |
| Block           | 1.58             | 1.50          |
| Plaxis          | 1.55             | ----          |

The E.L. Robinson computed value of 2.02 with Simplified Janbu Method and circular failure surfaces is for a deep circular failure surface that encompasses the whole slope but does not capture the most critical failure surface. A more critical failure surface exists that includes the lower portion of the slope and the river bank. The block surfaces analyzed the lower slope and agree well with the Plaxis results.

### 5. E.3 Section W-W - Alternative 5 with Elevated Pore Water Pressures

The factors of safety for Section W-W Alternative 5 with elevated pore water pressures are summarized in Table 13.

**Table 13: Stability Analyses for Section W-W Alternative 5 with Elevated Pore Water Pressures**

| Failure Surface | Factor Of Safety |               | Comments                  |
|-----------------|------------------|---------------|---------------------------|
|                 | Geocomp          | E.L. Robinson |                           |
| Circular        | 1.65             | 1.77          |                           |
| Block           | 1.76             | 1.45          |                           |
| Plaxis          | 1.62             | ----          | Lower bank stability      |
|                 | 1.39             | ---           | Upper cut slope stability |

The factor of safety by Spencer’s Method for a circular failure surface is lower than computed by E.L. Robinson using Simplified Janbu. This is not the expected result. The Janbu analysis did not include a failure surface which is closer to the river bank and has a slightly lower factor of safety. The E.L. Robinson results contain an incorrect strata boundary at the surface as shown in Figure 8. The upper surface layer should be SO ML rather than SA GR. Overall the factor of safety of this section is greater than 1.5 except for a shallow surface near the top of the graded slope where it is 1.39.

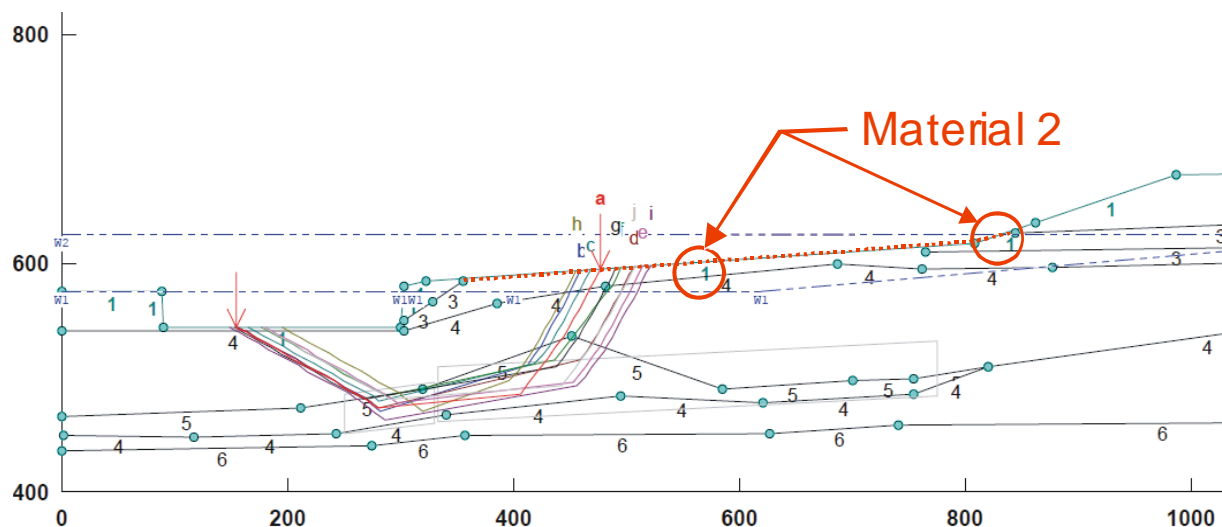

Figure 8: E.L. Robinson Section W-W Alternative 5

#### 5. E.4 Section W-W - Alternative 5 with Reduced Pore Water Pressures

The factors of safety for Section W-W Alternative 5 with reduced pore water pressures are summarized in Table 14.

**Table 14: Stability Analyses for Section W-W Alternative 5 with Reduced Pore Water Pressure**

| Failure Surface | Factor Of Safety |               | Comment                   |
|-----------------|------------------|---------------|---------------------------|
|                 | Geocomp          | E.L. Robinson |                           |
| Circular        | 2.18             | 2.37          | Lower bank stability      |
| Block           | 2.39             | 1.85          | Lower bank stability      |
| Plaxis          | 2.10             | ----          | Lower bank stability      |
|                 | 1.39             | ---           | Upper cut slope stability |

As with the elevated water pressure case the E.L. Robinson analysis does not include the critical failure surface which is closer to the river bank. The E.L. Robinson analysis also has an incorrect stratum at the surface. The Geocomp results show that the slope has adequate stability except at the upper part of the cut slope where the FOS is less than 1.5 This is a localized condition with no consequence to the overall performance of the slope

#### 5. F Summary of Stability Calculations

Table 15 collects all of the results from this section into one place for evaluation. In general the results follow the expected relationships that Geocomp's independent checks using Spencer's Method in UTEXAS4 give higher factors of safety than EL Robinson's results using Simplified Janbu's Method. This is the expected result. Factors of safety from Plaxis are generally the same or slightly below results obtained with Spencer's Method which is as expected.

Geocomp did check runs on two cases using the Simplified Janbu method and obtained essentially the same result as EL Robinson. This indicates that the two separate programs give similar results so there is no question about the adequacy of the software as applied for this work.

All slopes with reduced pore water pressures have adequate factors of safety except for the following:

- Section D-D has a factor of 1.3 with reduced pore water pressure. This is a section beneath the existing bridge in the direction towards the river. Failure of this section would not impact the new bridge. This slope will eventually be addressed with construction of a second new bridge.
- The upper part of the graded slope has a factor of safety of 1.39 for a shallow surface. This results from the steepened slope used in these stability analyses. Most likely this geometry will be adjusted somewhat if the final grading plans to produce a factor of safety greater than 1.5

**Table 15: Summary of Independent Verification of Slope Stability**

| Section | Existing Geometry |          |        | Proposed Geometry for Alternatives |          |        |             |          |        | Notes                             |             |
|---------|-------------------|----------|--------|------------------------------------|----------|--------|-------------|----------|--------|-----------------------------------|-------------|
|         | GSTABL7           | UTEXAS4  | PLAXIS | Alternate 2                        |          |        | Alternate 5 |          |        |                                   |             |
|         |                   |          |        | GSTABL7                            | UTEXAS4  | Plaxis | GSTABL7     | UTEXAS4  | Plaxis |                                   |             |
| A-A     | 0.99 (C)          | 1.10 (C) | 1.06   | 1.37 (C)                           | 1.46 (C) | 1.28   | 1.51 (C)    | 1.64 (C) | 1.55   | With elevated pore water pressure |             |
|         | 0.96 (C)*         | 1.08 (B) |        | 1.29 (B)                           | 1.31 (B) |        | 1.33 (B)    | 1.43 (B) |        | With reduced pore water pressure  |             |
|         | 0.92 (B)          |          |        |                                    |          |        | 1.71 (B)    | 2.08 (C) |        | 1.83                              | 1.84 (B)    |
| D-D     | ---               | ---      | ---    | ---                                | ---      | ---    | 1.15 (C)    | 1.30 (C) | 1.17   | With elevated pore water pressure |             |
|         |                   |          |        |                                    |          |        | 1.13 (B)    | 1.27 (B) |        | With reduced pore water pressure  |             |
|         |                   |          |        |                                    |          |        | 1.31 (C)    | 1.49 (C) |        | 1.30                              | 1.35 (B)    |
| G-G     | 3.41              | 3.76 (C) | 3.55   | 2.63 (C)                           | 1.86 (C) | 1.75   | 2.12 (C)    | 2.10 (C) | 2.24   | With elevated pore water pressure |             |
|         |                   | 3.55 (B) |        | 2.86 (B)                           | 1.86 (B) |        | 2.33 (B)    | 2.41 (B) |        |                                   |             |
| J-J     | ---               | ---      | ---    | 2.65 (C)                           | 2.69 (C) | 2.72   | 2.36 (C)    | 1.86 (C) | 2.32   | With elevated pore water pressure |             |
| W-W     | 0.98 (C)          | 1.17 (C) | 1.09   | 2.02 (C)                           | 1.83 (C) | 1.55   | 1.77 (C)    | 1.65 (C) | 1.62   | With elevated pore water pressure |             |
|         | 0.97 (C)*         | 1.12 (B) |        | 1.50 (B)                           | 1.58 (B) |        | 1.45 (B)    | 1.76 (B) |        | 1.39                              | Upper slope |
|         | 0.97 (B)          |          |        |                                    |          |        | 2.37 (C)    | 2.18 (C) |        | 2.10                              | 1.85 (B)    |

(C) failure surface consists of circular arc

(B) failure surface consists of three sliding blocks

\*Independent check analysis using UTEXAS4 with Simplified Janbu's Method

## 6. Probability of Failure

When involved with a potentially unstable slope, the engineer wants to know whether the slope will fail. In particular, the engineer desires a numerical measure of how the forces holding the mass in place compare with the destabilizing forces. That numerical measure, Factor of Safety, indicates the margin of safety which the engineer uses with his knowledge and experience to evaluate the possibility of the slope failing. The higher the Factor of Safety, the less likely the slope will fail. Much of the focus of the work described in this report was to get parameters and perform analyses to determine the Factor of Safety of the slope for various conditions and assumptions.

While meaningful to the engineer, Factor of Safety is not so useful to owners, contractors, regulators, and other interested parties. Many don't understand that the computed Factor of Safety can be higher than 1, but the slope still fail. A more understandable and universal yardstick of safety is probability of failure. Most people better understand what it means for a slope to have a probability of failure of 1% than the meaning of a Factor of Safety of 1.2.

In the mid 1970's, T. W. Lambe and W. Allen Marr began to apply risk analysis methodologies to dams and slopes to obtain estimates of probability of failure associated with factor of safety. An example of this work was described by Lambe, et. al. (1981).<sup>2</sup> This formalized approach required too much effort and took too much time for all but special projects. Lambe and Marr began to sketch out some approximate relationships between factor of safety and probability of failure of earthen slopes. These were based mostly on very little data and a lot of engineering judgment. It was clear from the beginning that this relationship had to somehow involve the level of engineering and care that went into the design, construction and operation of the facility.

Silva, Lambe and Marr (2008) recently published a convenient way to convert from factor of safety to probability of failure for a slope. Figure 9 reproduces the key figure from this paper and Table 16 provides the description of four categories of facilities used to determine which curve to use in Figure 9. The four categories correspond to the following types of facilities:

- Category I – facilities designed, built and operated with state-of-the-art or best possible practices. Generally these facilities are those that serve critical functions or have high failure consequences.
- Category II – facilities designed, built and operated using above average engineering practices. Many important facilities designed with “conservative practices” fall in this category.
- Category III – facilities without site-specific design and substandard construction or operation. Temporary facilities with low failure consequences often fall in this category.
- Category IV – facilities with little to no engineering.

---

<sup>2</sup> Lambe, T.W., Marr, W.A. and Silva, F. (1981) "Safety of a Constructed Facility: Geotechnical Aspects," Proc. ASCE:JGED, Vol. 107, No. GT3, pp. 339-352.



The family of curves as well as the table with the four levels of engineering reflect the generally accepted concept that – “A larger factor of safety does not necessarily imply a smaller risk, because its effect can be negated by the presence of larger uncertainties in the design environment” (Kulhawy and Phoon, 1996). The curves in Figure 9 also reflect the mathematical certainty that for the same factor of safety, the probability of failure decreases with increasing information content and data quality that result from a more detailed investigation, testing, evaluation, observation and remedial action.

Considering the importance of this structure, its design and construction should follow the attributes of a Level I facility in Table 16. For the minimum factor of safety of 1.55 determined with Plaxis for Section A-A after grading with Alternative 5, the annual probability of Failure from Figure 9 is about  $3 \times 10^{-7}$ . The probability of failure of the regarded slope over its design life of 75 years is about  $2 \times 10^{-5}$ . With the addition of horizontal drains and vertical relief vents, the minimum factor of safety of the regarded slope increases to 1.83 and the lifetime probability of failure decreases to about  $2 \times 10^{-6}$ . These values for factor of safety and probability of failure are predicated on the facility having the attributes described in Table 16 for a Level I facility over its design life and the pore pressure relief systems functioning as effective pressure relief systems throughout the life of the bridge.

As an indication of the value of the geotechnical work performed in this current investigation one can take a look at the existing conditions of the slope. The existing slope has a factor of safety of something in the vicinity of 1.1, in fact part of the slope near the river previously failed. The amount of information available for the slope was very limited to information from the adjacent slope beneath the existing bridge. Consider this a Category III structure in its existing condition. From Figure 9 the annual probability of failure of the slope is something like 10%. Improving the amount and quality of subsurface information on the slope, performing detailed geotechnical studies, peer reviewing those studies with independent analyses, regarding the slope and adding a permanent pore pressure control system has decreased this value by six orders of magnitude to a probability of failure that is practically zero.

Three cautionary points must be noted.

1. All elements identified in Table 16 for a Level I classification must be maintained throughout the design life of the regarded slope. Leaving out one, such as monitoring and maintenance during operation, will drop the Level below I and increase the probability of failure.
2. The probabilities obtained from Figure 9 are approximate and meant to aid in decision making only. For a specific structure the probability of failure will eventually become known. It will be 0 or 1. Unfortunately, we have to make decisions long before we know the outcome; hence the use of Figure 9.

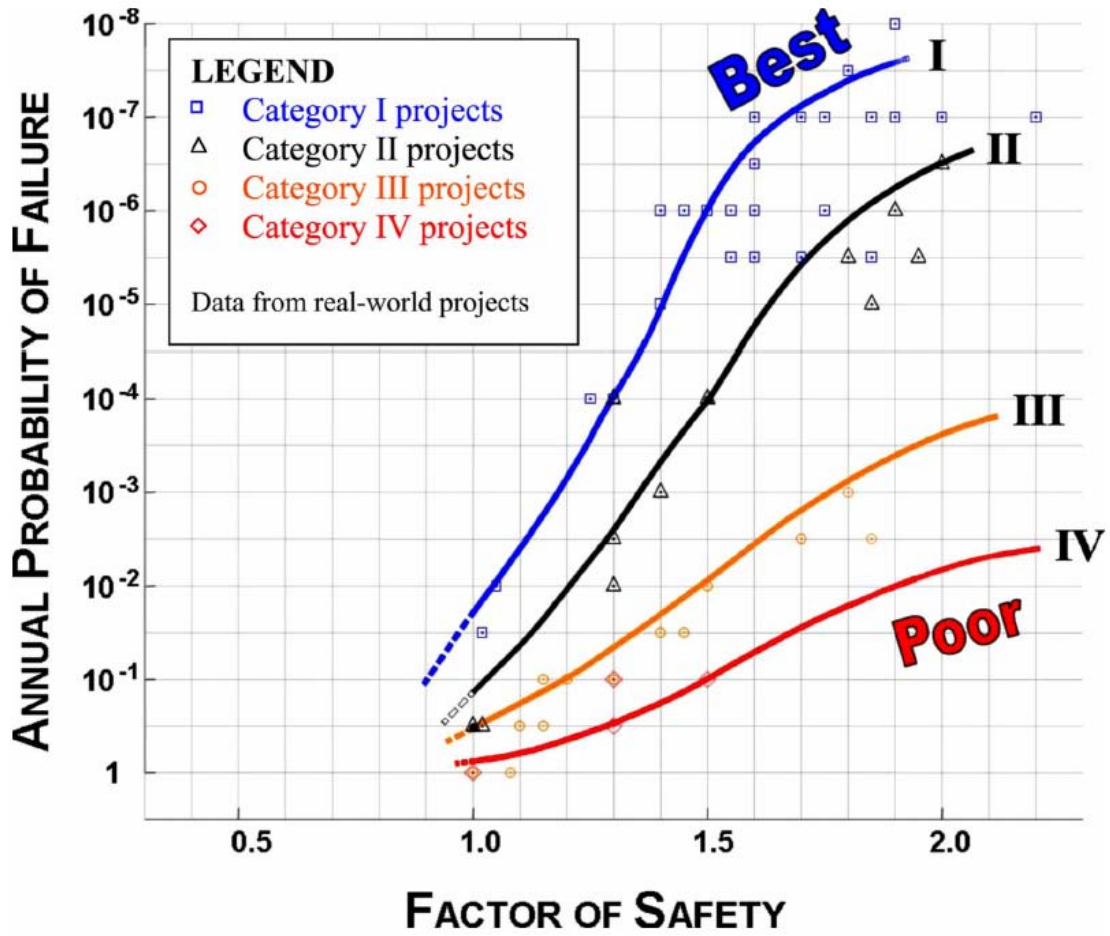

Figure 9: Probability of Failure of a Slope versus Factor of Safety

**Table 16: Categories of Structures for Silva, Lambe and Marr Method**

**Table 1.** Earth Structure Categories and Characteristics

| <i>Level of engineering</i>   | <i>Design</i>   |   |   | <i>Construction</i>  | <i>Operation and monitoring</i>   |
|---|---|---|---|--|---|
|   | <i>Investigation</i>  | <i>Testing</i>  | <i>Analyses and documentation</i>   |  |   |
| <b>I (Best)</b><br><br>Facilities with high failure consequences                              | <ul style="list-style-type: none"> <li>Evaluate design and performance of nearby structures</li> </ul>  | <ul style="list-style-type: none"> <li>Run lab tests on undisturbed specimens at field conditions</li> </ul>  | <ul style="list-style-type: none"> <li>Determine FS using effective stress parameters based on measured data (geometry, strength, pore pressure) for site</li> </ul>  | <ul style="list-style-type: none"> <li>Full time supervision by qualified engineer</li> </ul>  | <ul style="list-style-type: none"> <li>Complete performance program including comparison between predicted and measured performance (e.g., pore pressure, strength, deformations)</li> <li>No malfunctions (slides, cracks, artesian heads)</li> <li>Continuous maintenance by trained crews</li> </ul> |
|   | <ul style="list-style-type: none"> <li>Analyze historic aerial photographs</li> <li>Locate all nonuniformities (soft, wet, loose, high, or low permeability zones)</li> <li>Determine site geologic history</li> <li>Determine subsoil profile using continuous sampling</li> <li>Obtain undisturbed samples for lab testing of foundation soils</li> <li>Determine field pore pressures</li> </ul> | <ul style="list-style-type: none"> <li>Run strength test along field effective and total stress paths</li> <li>Run index field tests (e.g., field vane, cone penetrometer) to detect all soft, wet, loose, high, or low permeability zones</li> <li>Calibrate equipment and sensors prior to testing program</li> </ul> | <ul style="list-style-type: none"> <li>Consider field stress path in stability determination</li> <li>Prepare flow net for instrumented sections</li> <li>Predict pore pressure and other relevant performance parameters (e.g., stress, deformation, flow rates) for instrumented section</li> <li>Have design report clearly document parameters and analyses used for design</li> <li>No errors or omissions</li> <li>Peer review</li> </ul> | <ul style="list-style-type: none"> <li>Construction control tests by qualified engineers and technicians</li> <li>No errors or omissions</li> <li>Construction report clearly documents construction activities</li> </ul> |   |
|   | (0.20)  | (0.20)  | (0.20)  | (0.20)   | (0.20)  |
| <b>II (Above average)</b><br><br>Ordinary facilities  | <ul style="list-style-type: none"> <li>Evaluate design and performance of nearby structures</li> <li>Exploration program tailored to project conditions by qualified engineer</li> </ul>  | <ul style="list-style-type: none"> <li>Run standard lab tests on undisturbed specimens</li> <li>Measure pore pressure in strength tests</li> <li>Evaluate differences between laboratory test conditions and field conditions</li> </ul>  | <ul style="list-style-type: none"> <li>Determine FS using effective stress parameters and pore pressures</li> <li>Adjust for significant differences between field stress paths and stress path implied in analysis that could affect design</li> </ul>   | <ul style="list-style-type: none"> <li>Part-time supervision by qualified engineer</li> <li>No errors or omissions</li> </ul>  | <ul style="list-style-type: none"> <li>Periodic inspection by qualified engineer</li> <li>No uncorrected malfunctions</li> <li>Selected field measurements</li> <li>Routine maintenance</li> </ul>  |
|   | (0.40)  | (0.40)  | (0.40)  | (0.40)   | (0.40)  |
| <b>III (Average)</b><br><br>Unimportant or temporary facilities with low failure consequences | <ul style="list-style-type: none"> <li>Evaluate performance of nearby structures</li> <li>Estimate subsoil profile from existing data and borings</li> </ul>  | <ul style="list-style-type: none"> <li>Index tests on samples from site</li> </ul>  | <ul style="list-style-type: none"> <li>Rational analyses using parameters inferred from index tests</li> </ul>  | <ul style="list-style-type: none"> <li>Informal construction supervision</li> </ul>  | <ul style="list-style-type: none"> <li>Annual inspection by qualified engineer</li> <li>No field measurements</li> <li>Maintenance limited to emergency repairs</li> </ul>  |
|   | (0.60)  | (0.60)  | (0.60)  | (0.60)   | (0.60)  |
| <b>IV (Poor)</b><br><br>Little or no engineering  | <ul style="list-style-type: none"> <li>No field investigation</li> </ul>  | <ul style="list-style-type: none"> <li>No laboratory tests on samples obtained at the site</li> </ul>   | <ul style="list-style-type: none"> <li>Approximate analyses using assumed parameters</li> </ul>   | <ul style="list-style-type: none"> <li>No construction supervision by qualified engineer</li> <li>No construction control tests.</li> </ul>  | <ul style="list-style-type: none"> <li>Occasional inspection by non-qualified person</li> <li>No field measurements</li> </ul>  |
|   | (0.80)  | (0.80)  | (0.80)  | (0.80)   | (0.80)  |

## 7. Deformation Analyses

Deformations are computed from the Finite Element Analysis (Plaxis) for the unloading during excavation for the slopes. We used the same Plaxis model as used for the slope stability analysis. The deformation is directly related to the stiffness of the soils on and beneath the slope. The stiffness was computed from relations between stiffness and CPT QC and SPT N given by Bowles in Table 5.5 of Foundation Analysis and Design. The values are increased by a factor of 3 to account for increased stiffness in unloading.

The stiffness values used in the analysis are summarized in Table 17. Strength values used in the deformation analysis are the same as those used for the stability analyses.

**Table 17: Soil Stiffness Parameters for Deformation Analysis**

| Layer No.   | Description   | E <sub>50</sub> Loading Modulus * (ksf) |
|---|---|---|
| 1   | Medium dense gravel with sand (SA GR)                                       | 5,000*                                  |
| 2   | Sandy silt/sand and silt (SM)   | 2000*                                   |
| 3   | Soft silty clay (SO ML)   | 2000*                                   |
| 4   | Very stiff silty clay (VST ML)  | 4000*                                   |
| 5   | Soft silty clay, with pockets of loose silt and numerous silt seams (SO ML) | 2000*                                   |
| 6   | Bedrock-shale (BR)  | 10,000**                                |
| <p>* Soil modeled using a hyperbolic stress-strain model; modulus is a loading modulus at 50% ultimate strength. The unloading modulus is 3 times stiffer than the E<sub>50</sub> loading modulus.</p> <p>** Rock is modeled using a linear stress-strain mode.</p> |   |   |

Predicted deformations for Section A-A along the existing bridge, Section G-G perpendicular to the existing bridge and Section J-J perpendicular to the railroad were computed for Alternatives 2 and 5. The results are provided in Figures 10-15.

The maximum predicted long term vertical deformations resulting from excavating the slopes are 2-4 inches and occur where the maximum overburden is removed. Almost all of this movement is vertical heave resulting from unloading the underlying soils. The maximum horizontal deformation is about 1 inch outward and occurs at the face of the excavated slope.

Based on these results we estimate that the soil near the existing bridge foundations could heave by as much as ½ inch and move laterally by as much as ¼ inch. These movements are at the top of ground and decrease with depth.

Predicted maximum movements in the vicinity of the railroad are approximately ¼ inch at the ground surface. These are not sufficient to cause distress to the foundations of the existing railroad bridge.

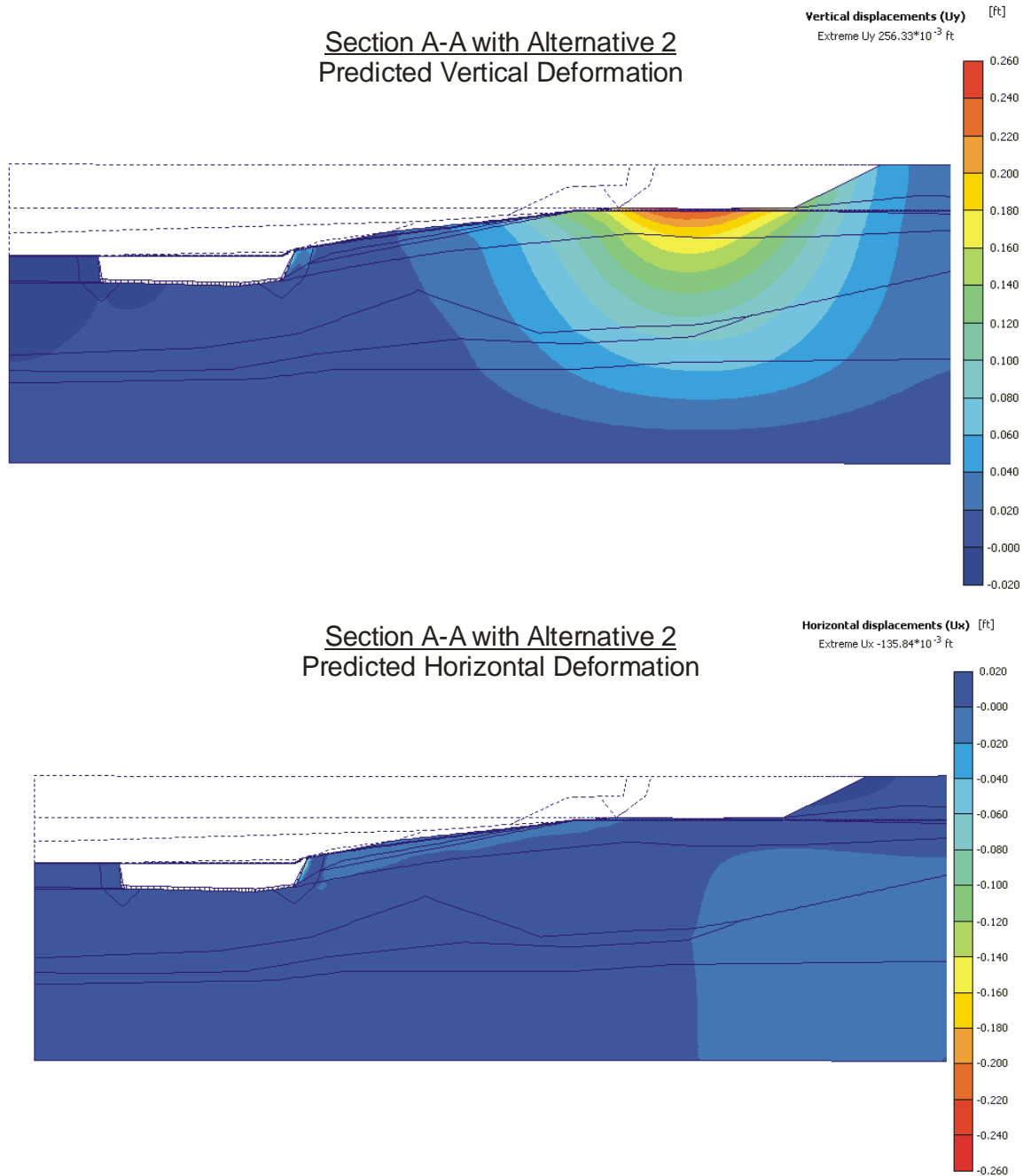

CUY-90-14.40

Figure 10: Predicted Deformations for Section A-A Alternative 2

### Section A-A with Alternative 5 Predicted Vertical Deformation

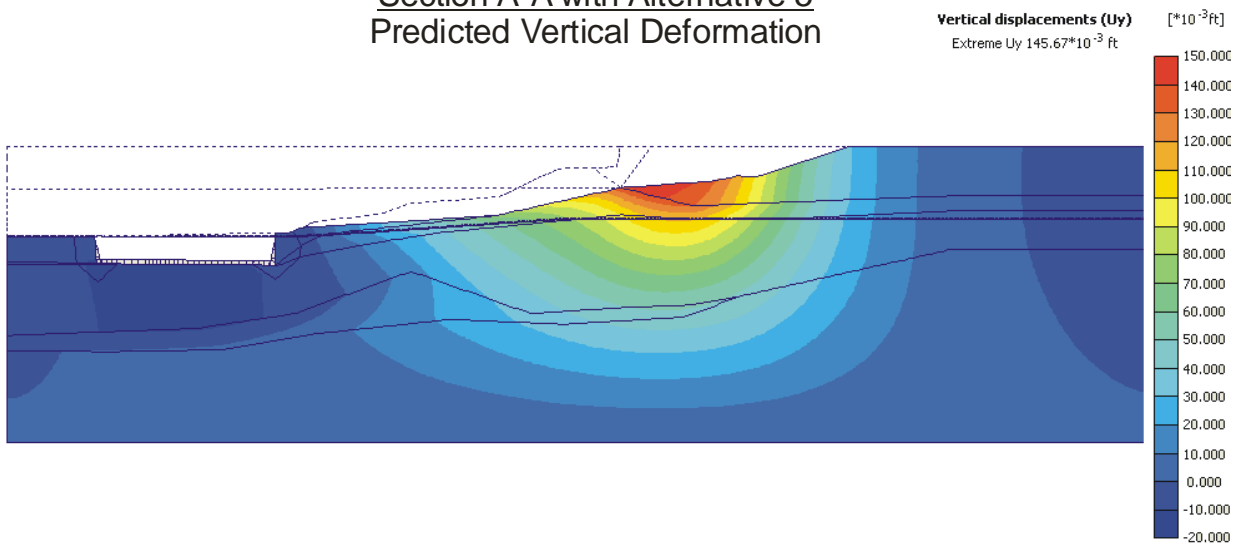

### Section A-A with Alternative 5 Predicted Horizontal Deformation

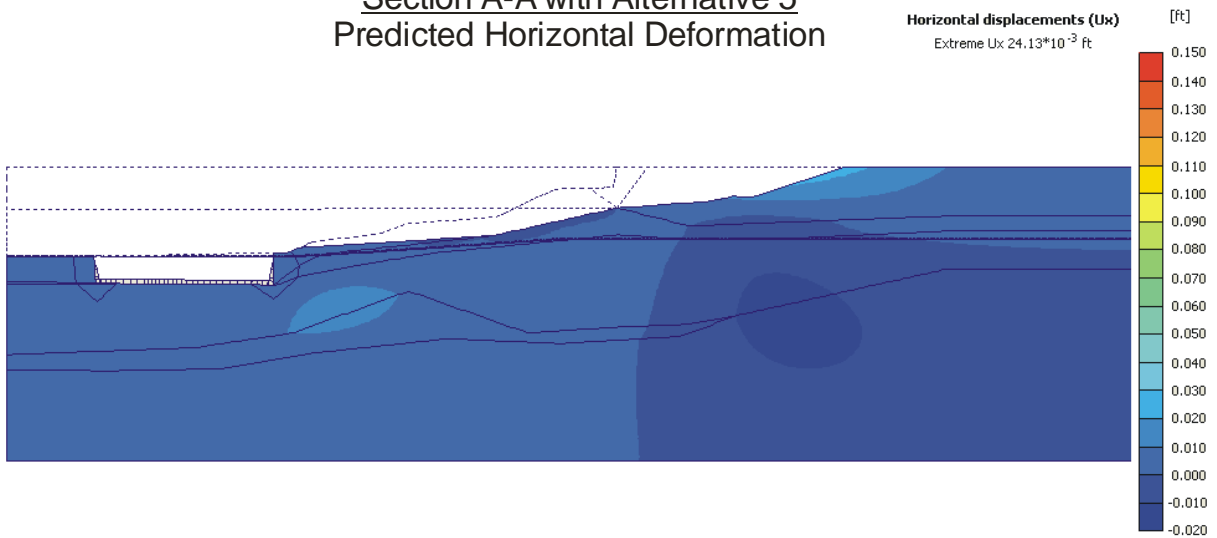
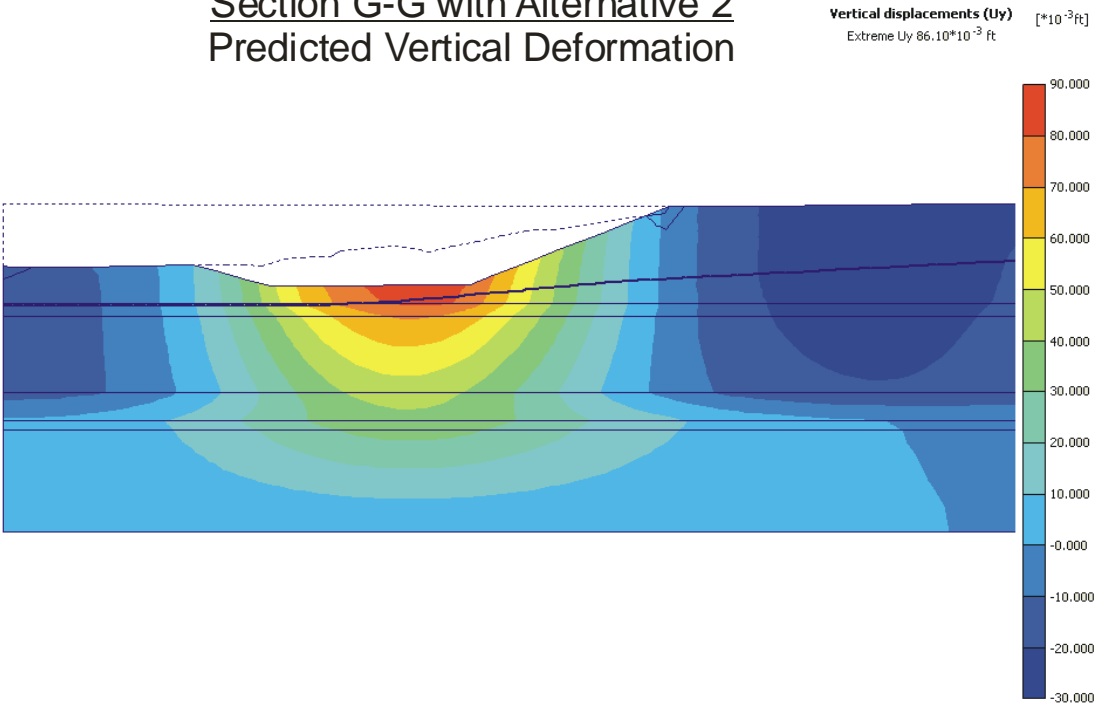

Figure 11: Predicted Deformations for Section A-A Alternative 5

### Section G-G with Alternative 2 Predicted Vertical Deformation



### Section G-G with Alternative 2 Predicted Horizontal Deformation

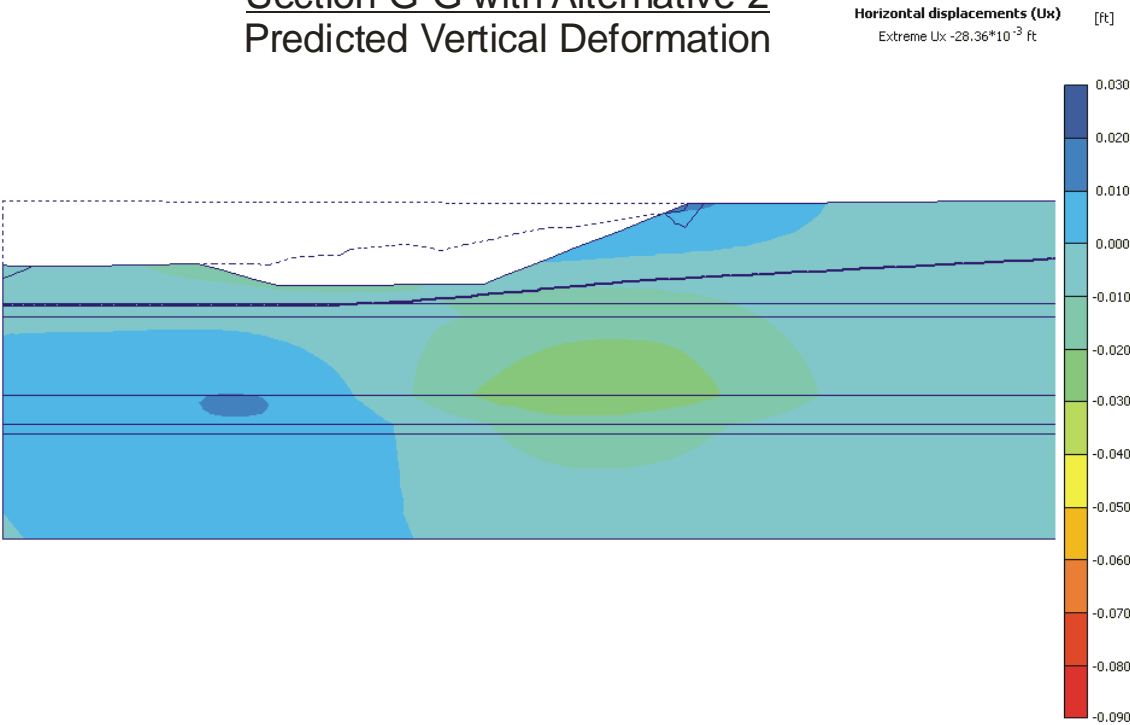
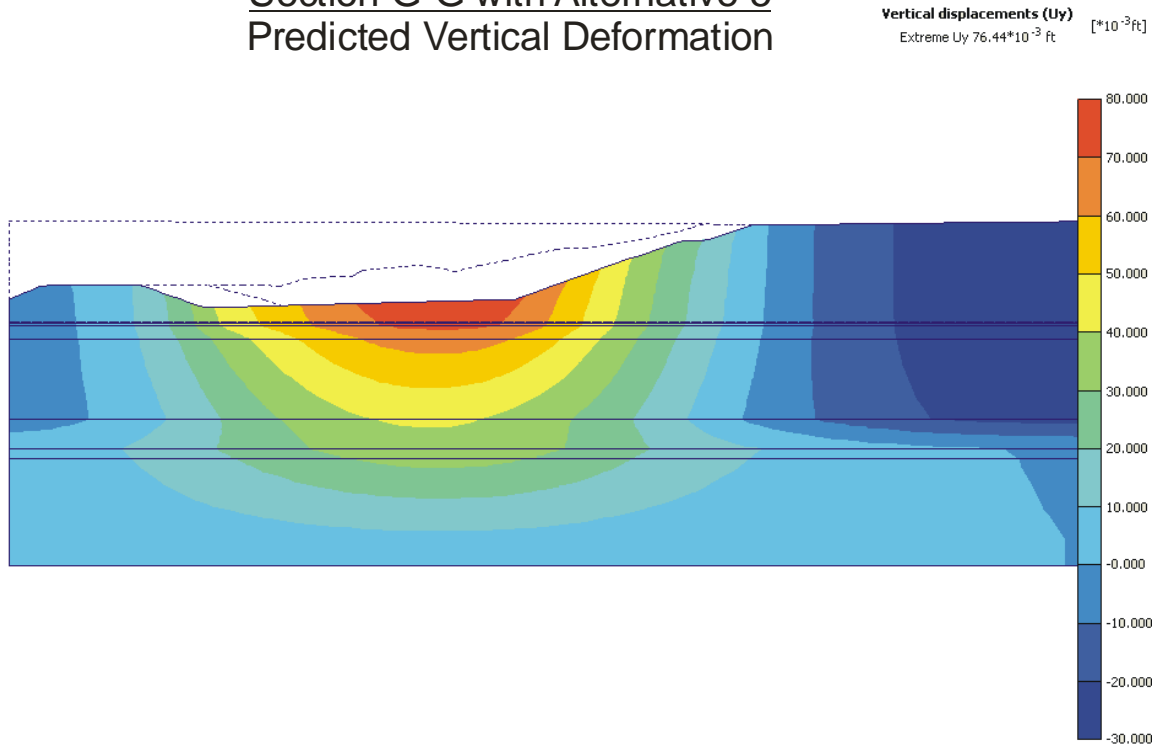

Figure 12: Predicted Deformations for Section G-G Alternative 2

### Section G-G with Alternative 5 Predicted Vertical Deformation



### Section G-G with Alternative 5 Predicted Horizontal Deformation

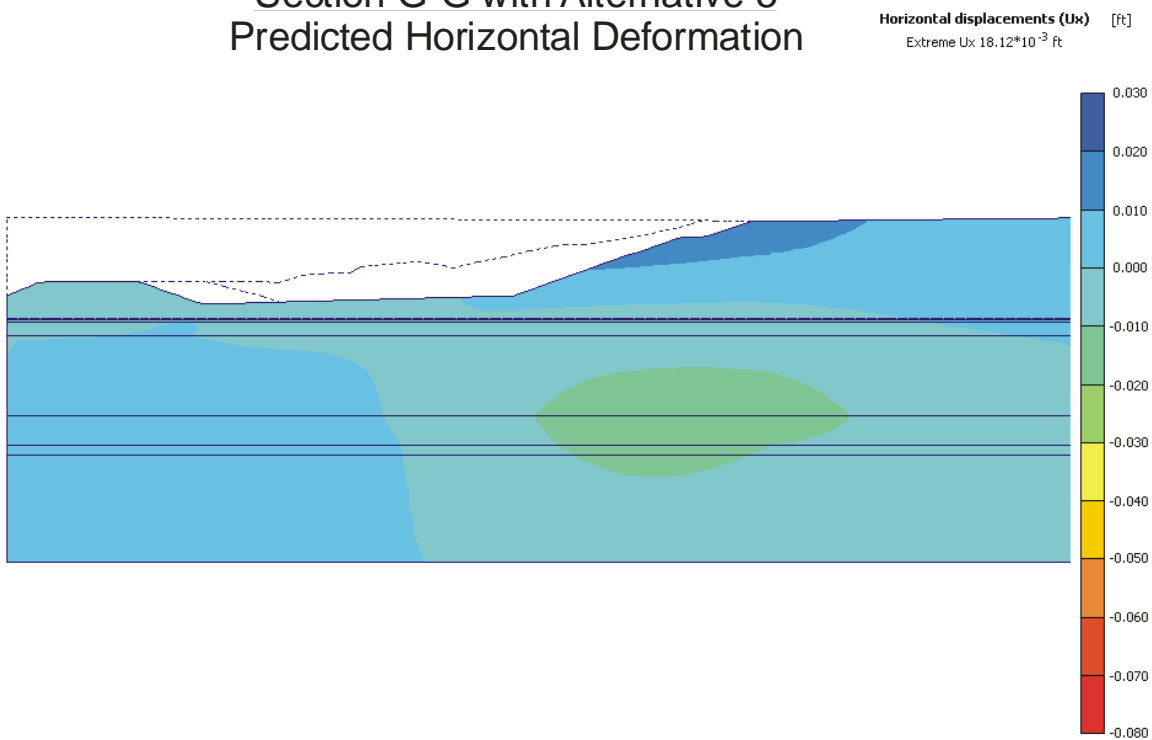
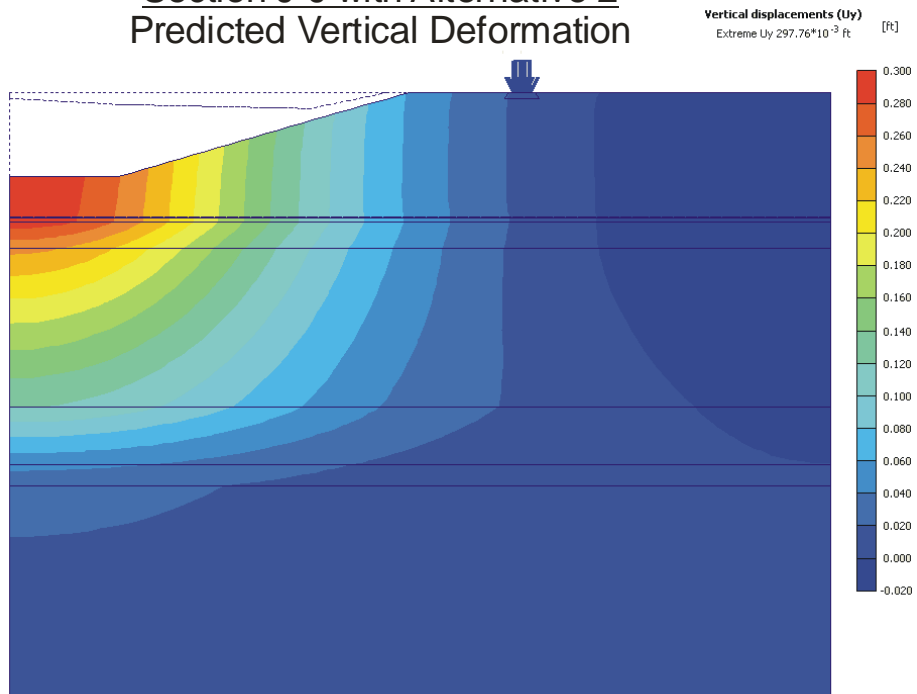

Figure 13: Predicted Deformations for Section G-G Alternative 5



### Section J-J with Alternative 2 Predicted Vertical Deformation



### Section J-J with Alternative 2 Predicted Horizontal Deformation

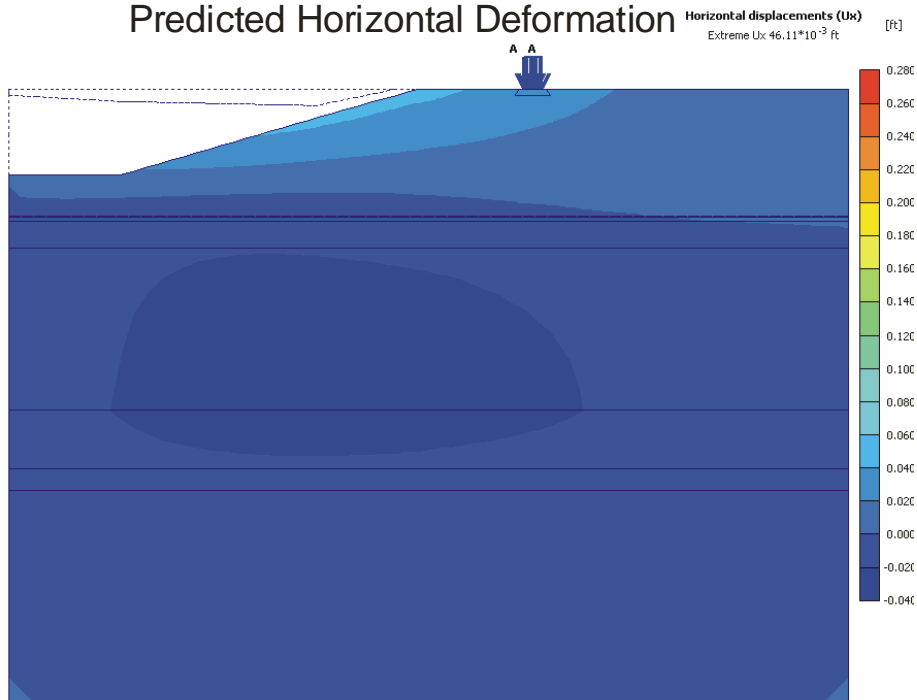
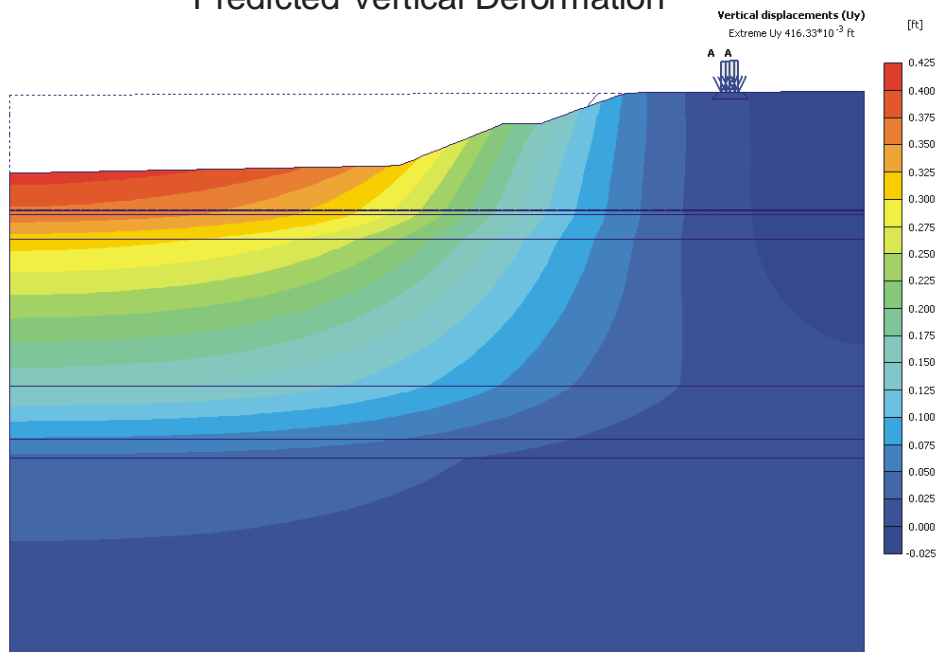
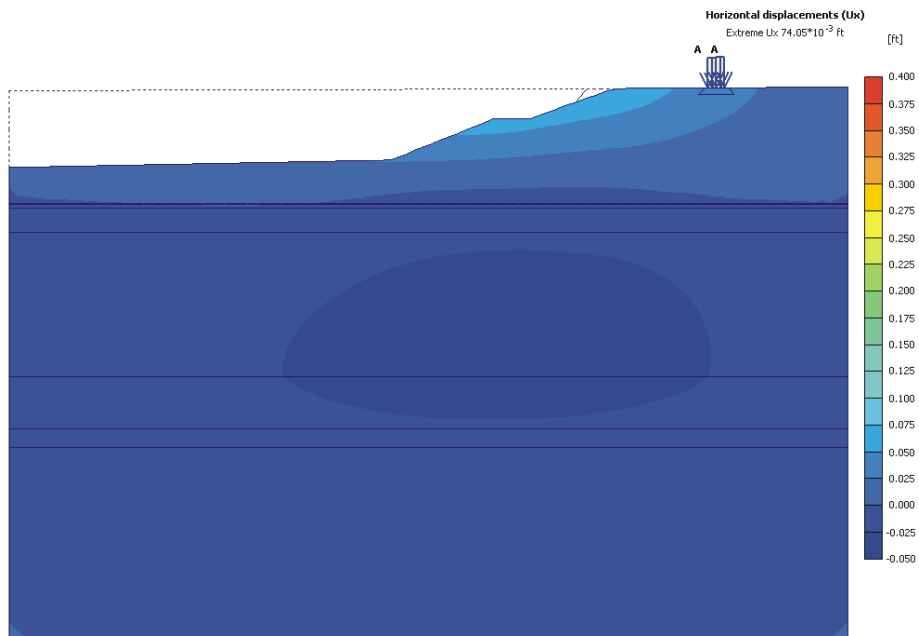

Figure 14: Predicted Deformations for Section J-J Alternative 2

### Section J-J with Alternative 5 Predicted Vertical Deformation



### Section J-J with Alternative 5 Predicted Horizontal Deformation



CUY-90-14.40

Figure 15: Predicted Deformations for Section J-J Alternative 5

## 8. Summary and Conclusions

Geocomp has completed two sets of completely independent stability analyses for selected cross sections using various grading plans for the new bridge. Sections A-A, D-D, G-G, J-J and W-W were analyzed using Spencer's Method in UTEXAS4 and the finite element program Plaxis. E.L. Robinson used the Simplified Janbu Method of stability analysis when in general gives lower and more conservative values of factor of safety than what is believed to be the theoretically correct values. Consequently, the results from UTEXAS4 and Plaxis were expected to be somewhat higher than those obtained by E.L. Robinson.

This process produced the following outcomes:

- Some inconsistencies were identified in the E.L. Robinson input files for their GSTABL7 runs. These were communicated to them and make the appropriate adjustments.
- Check runs using the Simplified Janbu Method in UTEXAS4 give similar results to those obtained by E.L. Robinson with GSTABL7. Since these programs are entirely independent, this indicates that both software packages should generally be correct for this application.
- Factors of safety obtained by Geocomp with Spencer's method were generally 10-20 percent higher than obtain by E.L. Robinson where the programs found similar failure surfaces. This is the expected result.
- In several cases, Spencer's method gave lower factors of safety than obtained by E.L. Robinson. This occurred because Geocomp used a more detailed search algorithm that identified more critical failure surfaces with lower factors of safety. These failure surfaces were confirmed with the independent Plaxis analyses.
- Factors of safety from Plaxis are comparable to or slightly lower than those from Spencer's Method except where Plaxis found a failure surface that was more critical than the trial surfaces generated by UTEXAS4 which limits surface shapes to circular arcs and sliding blocks. The factors of safety from Plaxis are considered the most accurate method of analysis.

All sections except D-D have a factor of safety greater than 1.5 with the exception of very shallow surfaces near the top of the slope that have a minimum factor of safety of 1.4. Section D-D is an existing section parallel to the existing bridge that will not be regarded during this work. It has an existing factor of safety of 1.17 that will be improved somewhat by the pore pressure reduction measures. Should it possibly move or even fail, that should not have an impact on the foundations for the new bridge.

Deformations resulting from regarding of the slope were computed for Sections A-A and J-J. The maximum predicted long term vertical deformations resulting from excavating the slopes are 2-4 inches and occur where the maximum overburden is removed. Almost all of this movement is vertical heave

resulting from unloading the underlying soils. The maximum horizontal deformation is about 1 inch outward and occurs at the face of the excavated slope.

Based on these results we estimate that the soil near the existing bridge foundations could heave by as much as ½ inch and move laterally by as much as ¼ inch. These movements are at the top of ground and decrease with depth.

Predicted maximum movements in the vicinity of the railroad are approximately ¼ inch at the ground surface. These are not sufficient to cause distress to the foundations of the existing railroad bridge.

All of these movements will cease within a few months of completion of the grading. There is no possibility of soil creep affecting the performance of this slope. Soil creep is a significant issue only in very soft plastic soils at factors of safety below 1.5. The soils in these slopes are overconsolidated sands, silts and clays with factors of safety above 1.5. Soil creep is not a design issue for the foundations of the new bridge.

## **Appendix “7J - A”**

### **Section A-A Results**

Section A-A was analyzed by Geocomp for the following conditions:

- Existing geometry – with elevated pore water pressures
- Alternative 2 geometry – with elevated pore water pressures
- Alternative 5 geometry – with elevated pore water pressures
- Alternative 2 geometry – with reduced pore water pressures

Stability results are provided using UTEXAS4 using Spencer’s Method and by using the Finite Element Phi-C reduction method in Plaxis.

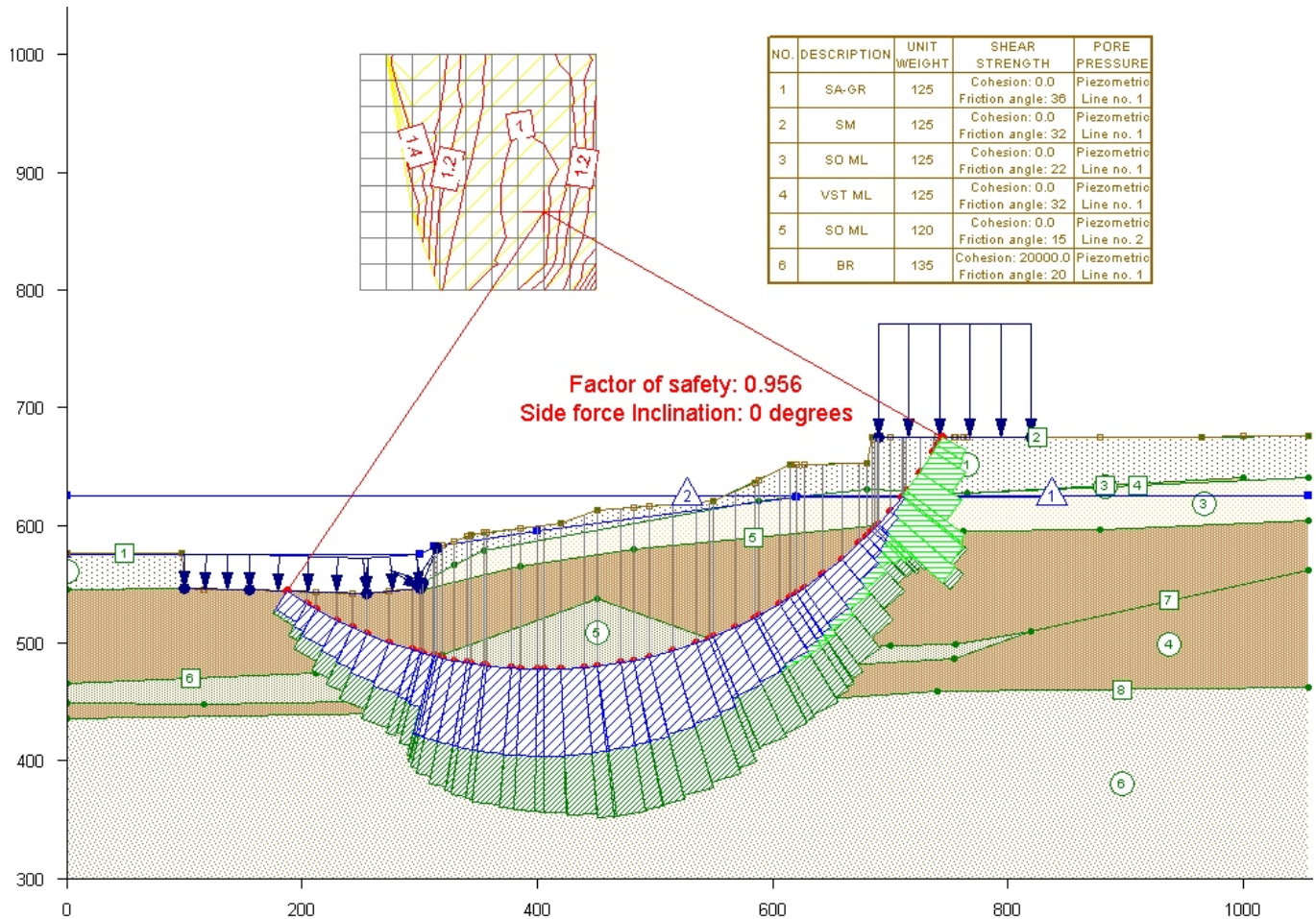
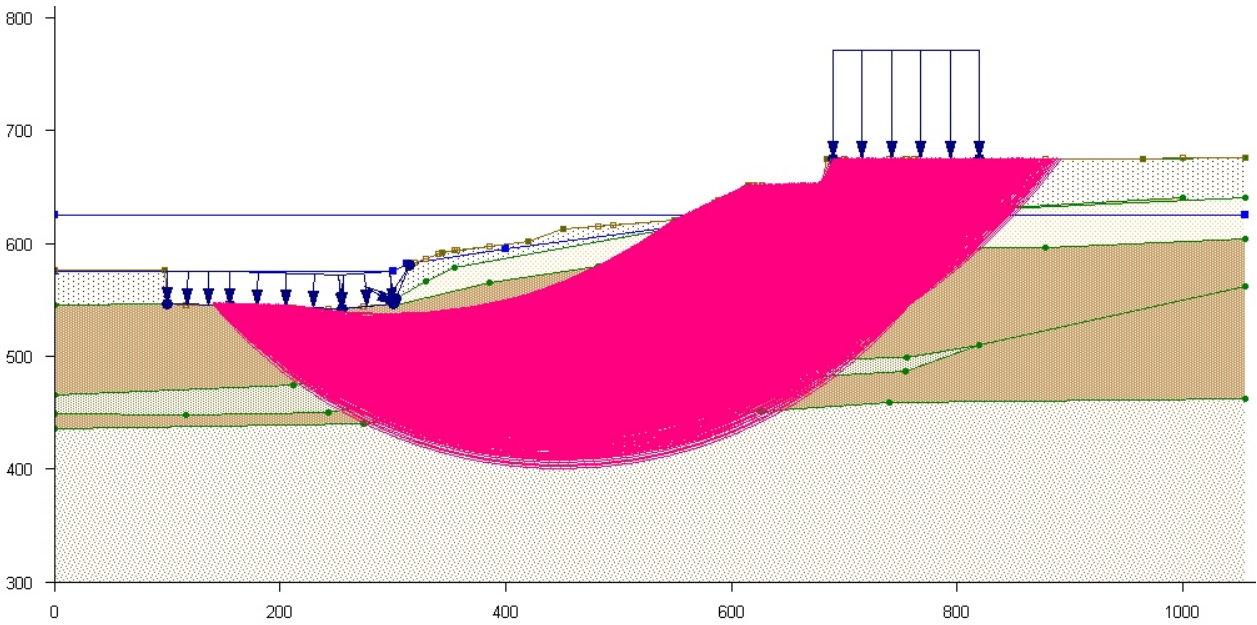

**NOTES :**

1. Data computed using UTEXAS4 Version 4.1.0.3
2. Method of computation set to Simplified Janbu procedure (side force inclination set to zero degrees).



CUY-90-14.40

**Section A-A with Existing Geometry  
Circular Surfaces  
Simplified Janbu Method**

November 2009

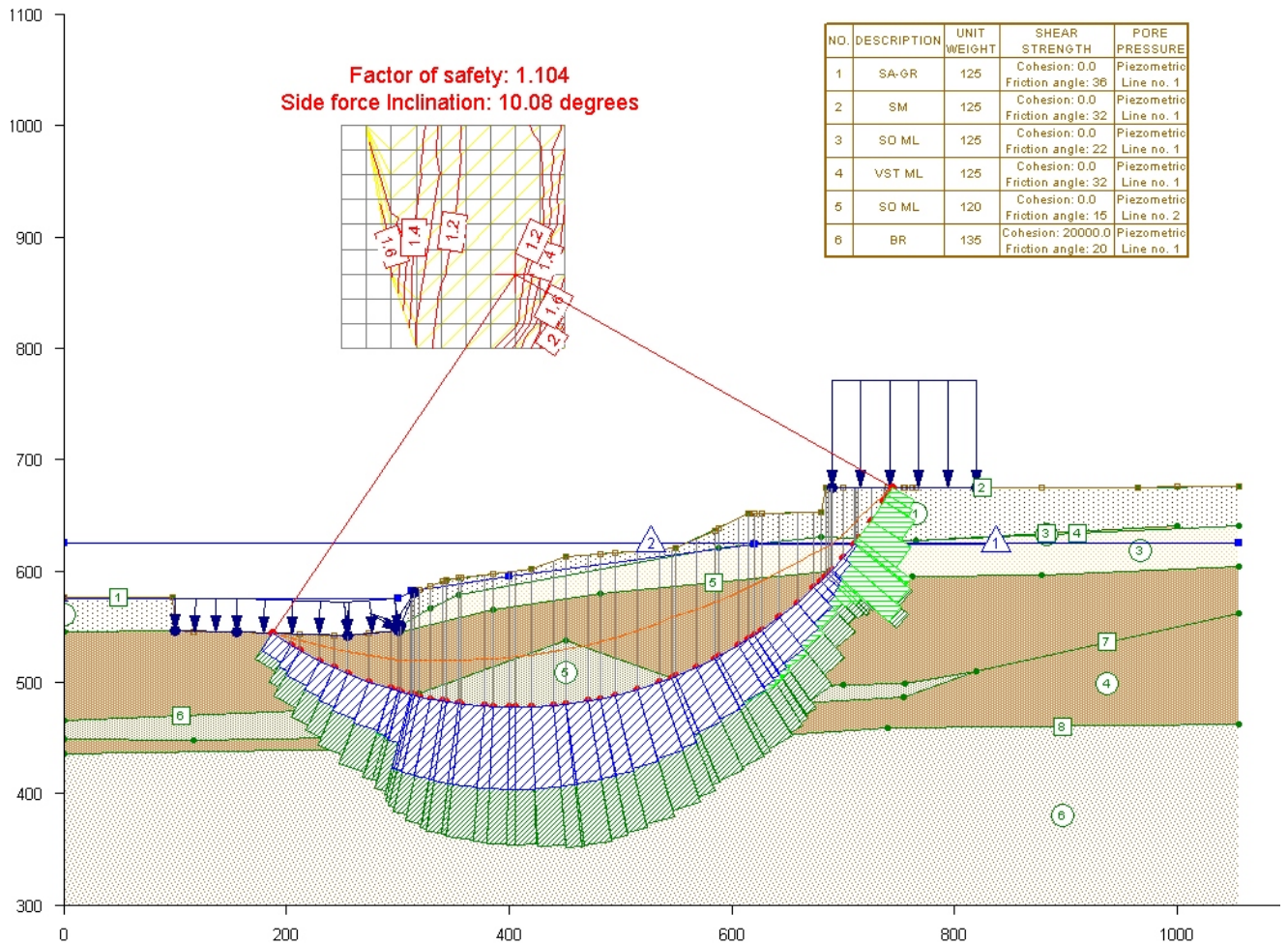
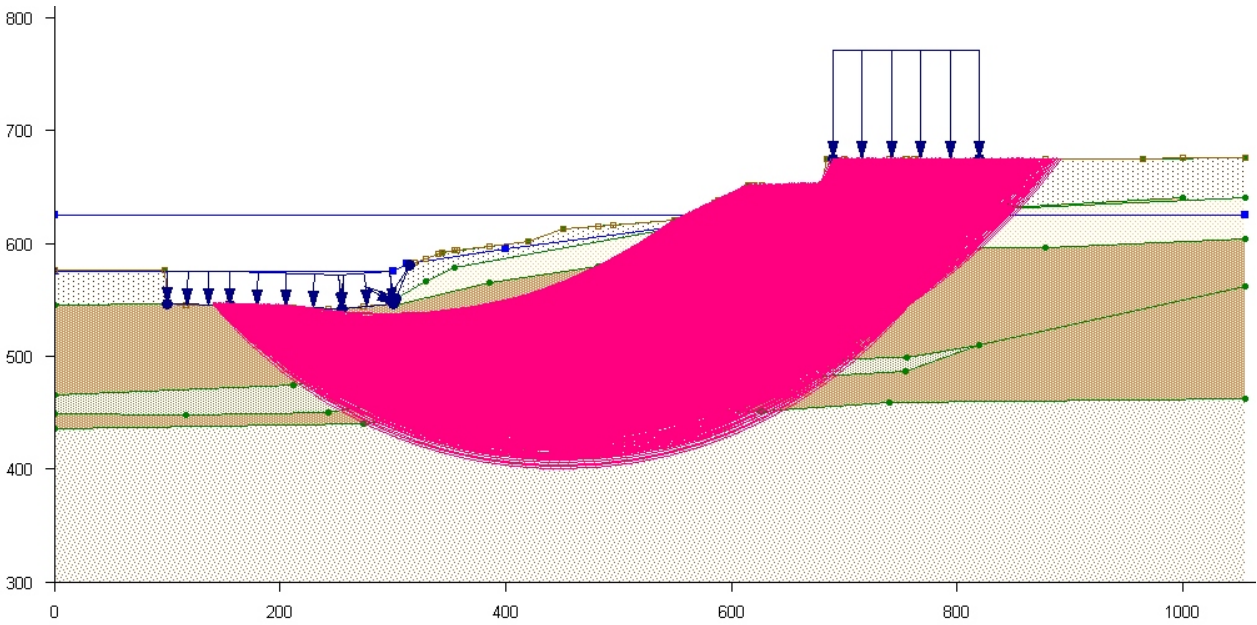

**NOTES :**

1. Data computed using UTEXAS4 Version 4.1.0.3
2. Method of computation set to Spencer's Method.



CUY-90-14.40  
**Section A-A with Existing Geometry**  
**Circular Surfaces**  
**Spencer's Method**

November 2009

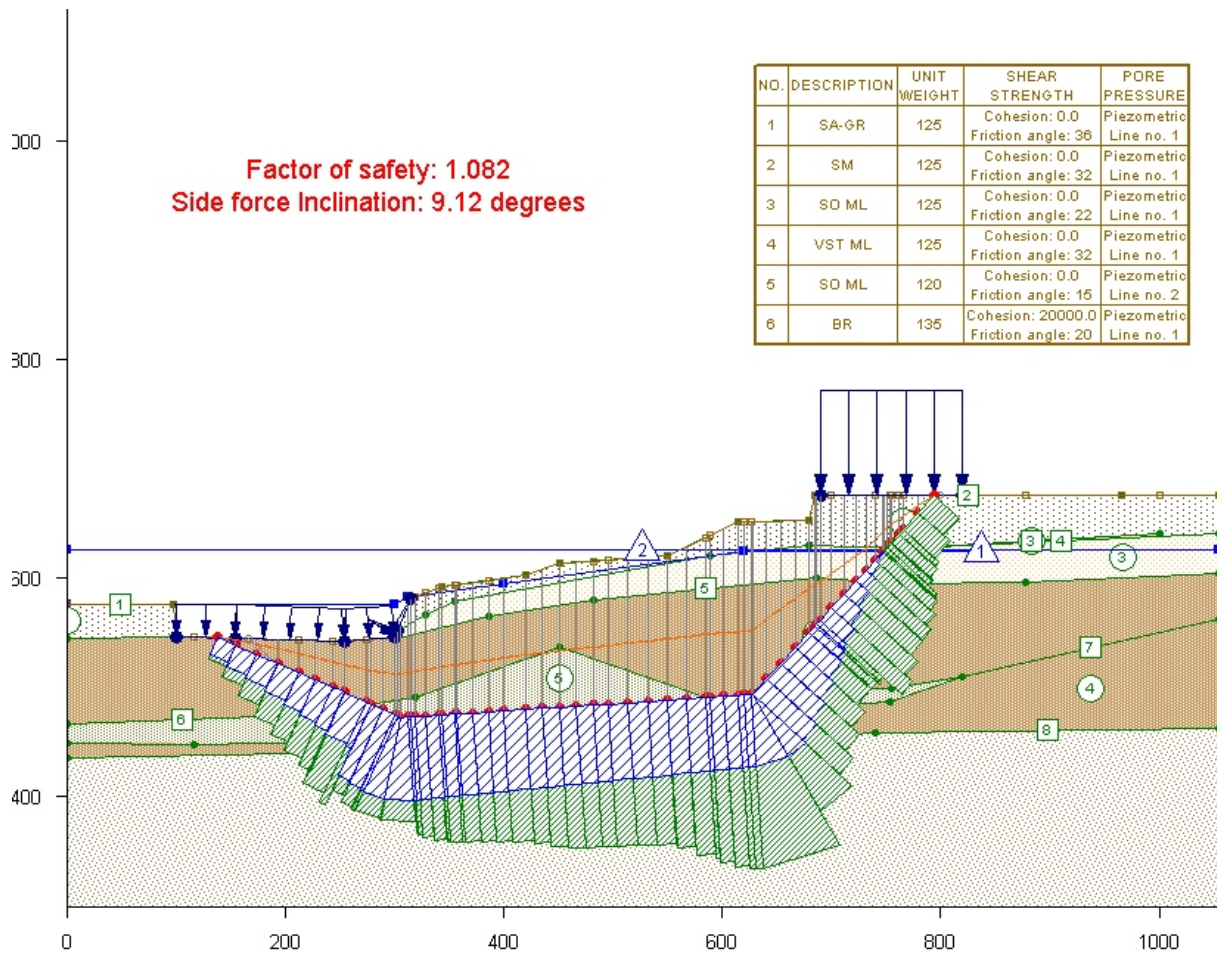
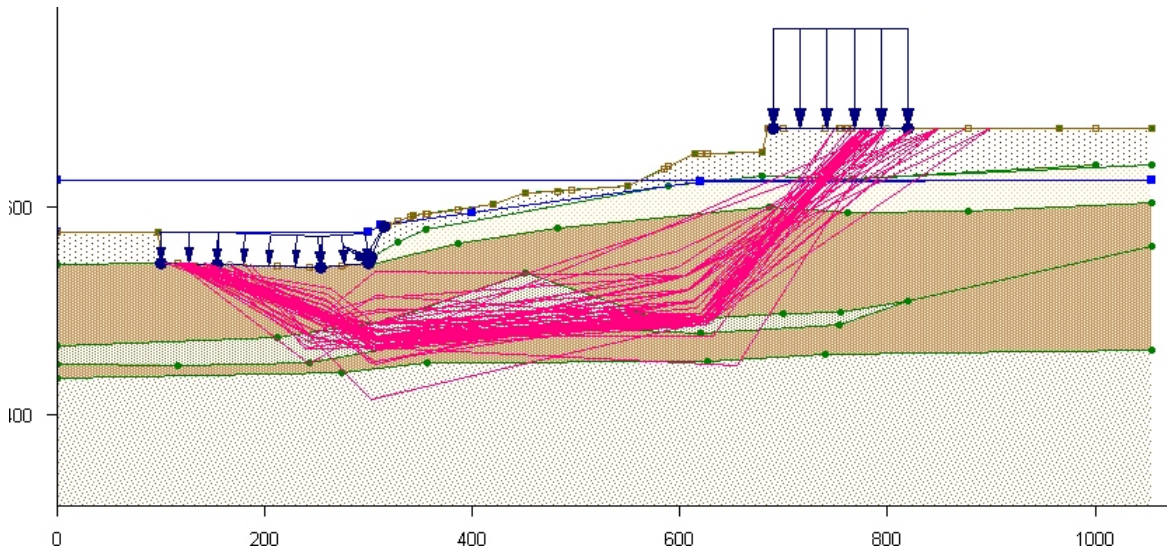

**NOTES :**

1. Data computed using UTEXAS4 Version 4.1.0.3
2. Method of computation set to Spencer's Method.



CUY-90-14.40  
**Section A-A with  
 Existing Geometry  
 Non-Circular Surfaces  
 Spencer's Method**

November 2009



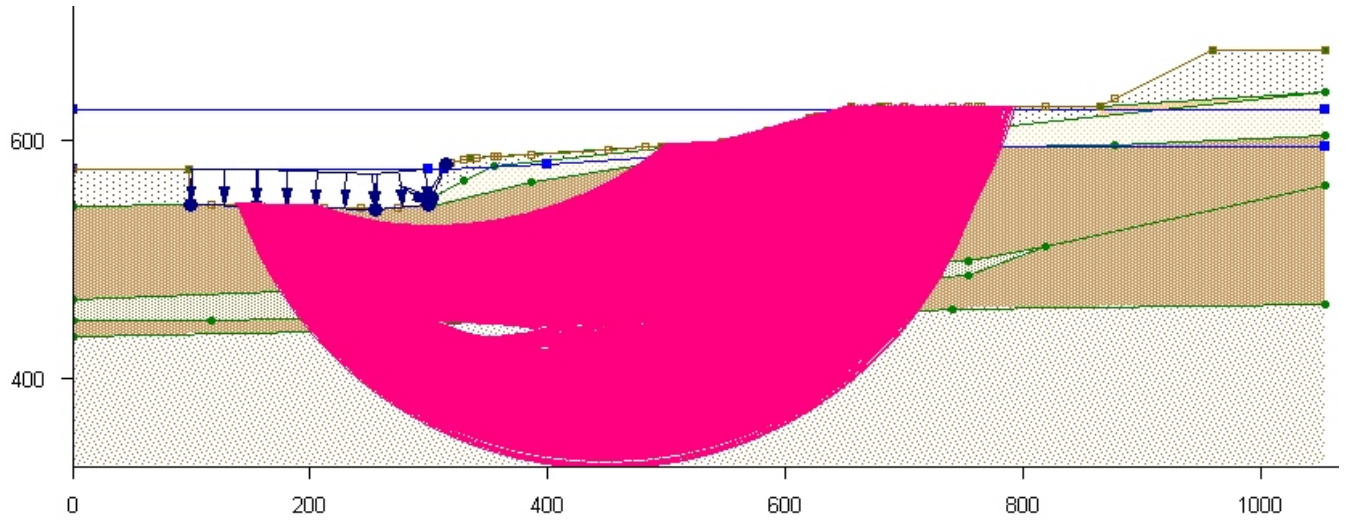

**Factor of safety: 1.464**  
**Side force Inclination: 3.91 degrees**

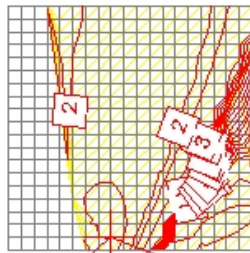

| NO. | DESCRIPTION | UNIT WEIGHT | SHEAR STRENGTH                          | PORE PRESSURE          |
|-----|-------------|-------------|---|------------------------|
| 1   | SA-GR       | 125         | Cohesion: 0.0<br>Friction angle: 36     | Piezometric Line no. 1 |
| 2   | SM          | 125         | Cohesion: 0.0<br>Friction angle: 32     | Piezometric Line no. 1 |
| 3   | SO ML       | 125         | Cohesion: 0.0<br>Friction angle: 22     | Piezometric Line no. 1 |
| 4   | VST ML      | 125         | Cohesion: 0.0<br>Friction angle: 32     | Piezometric Line no. 1 |
| 5   | SO ML       | 120         | Cohesion: 0.0<br>Friction angle: 15     | Piezometric Line no. 2 |
| 6   | BR          | 135         | Cohesion: 20000.0<br>Friction angle: 20 | Piezometric Line no. 1 |

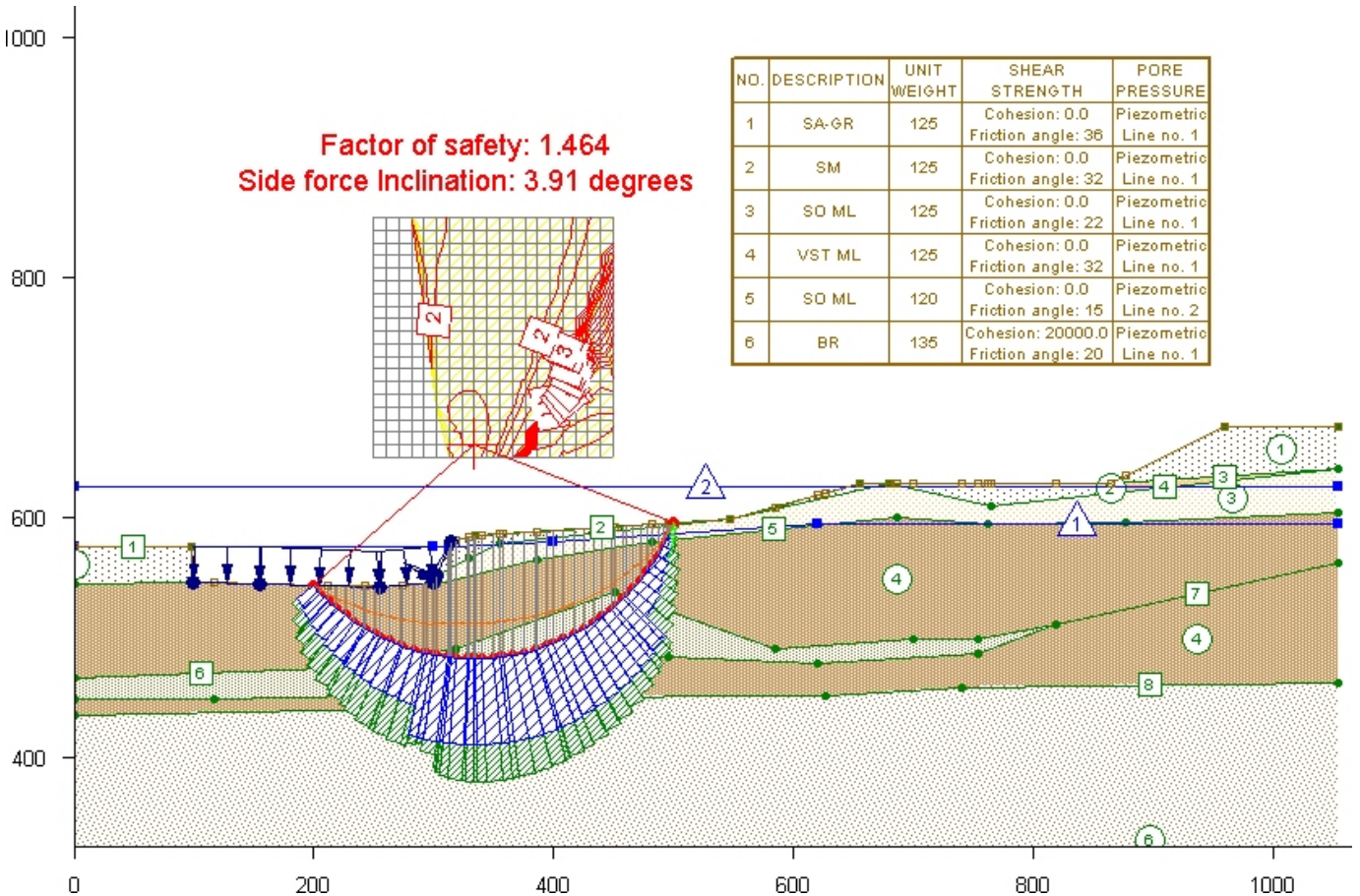

**NOTES :**

1. Data computed using UTEXAS4 Version 4.1.0.3
2. Method of computation set to Spencer's Method.



CUY-90-14.40

**Section A-A with  
 Alternative 2  
 Circular Surfaces  
 Spencer's Method**

November 2009

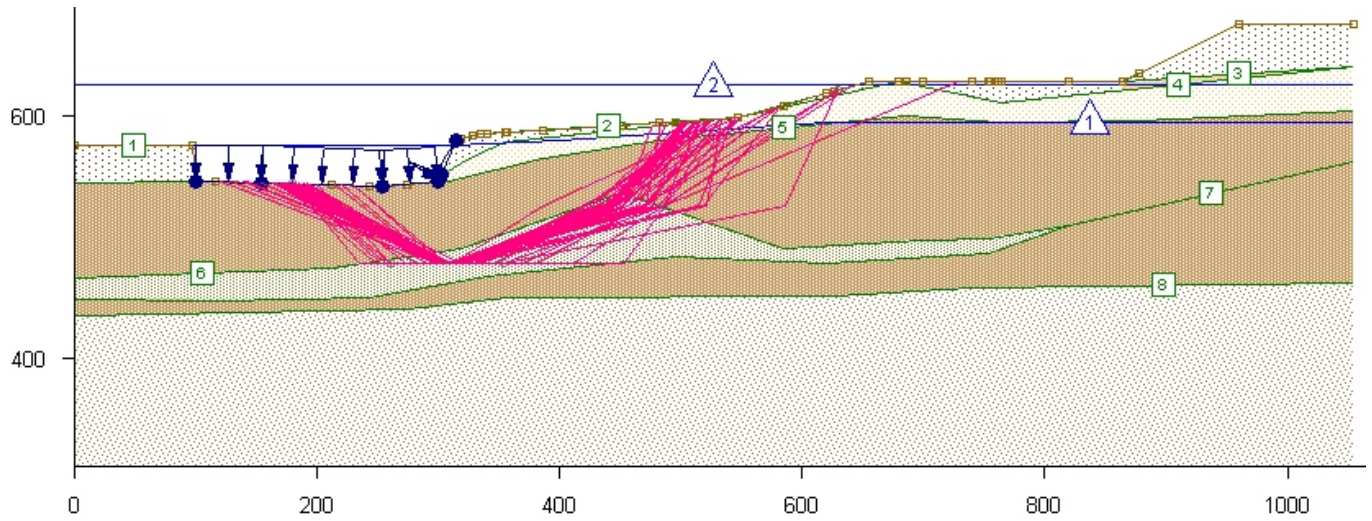

Factor of safety: 1.310  
Side force Inclination: 4.1 degrees

| NO. | DESCRIPTION | UNIT WEIGHT | SHEAR STRENGTH                          | PORE PRESSURE          |
|-----|-------------|-------------|---|------------------------|
| 1   | SA-GR       | 125         | Cohesion: 0.0<br>Friction angle: 36     | Piezometric Line no. 1 |
| 2   | SM          | 125         | Cohesion: 0.0<br>Friction angle: 32     | Piezometric Line no. 1 |
| 3   | SO ML       | 125         | Cohesion: 0.0<br>Friction angle: 22     | Piezometric Line no. 1 |
| 4   | VST ML      | 125         | Cohesion: 0.0<br>Friction angle: 32     | Piezometric Line no. 1 |
| 5   | SO ML       | 120         | Cohesion: 0.0<br>Friction angle: 15     | Piezometric Line no. 2 |
| 6   | BR          | 135         | Cohesion: 20000.0<br>Friction angle: 20 | Piezometric Line no. 1 |

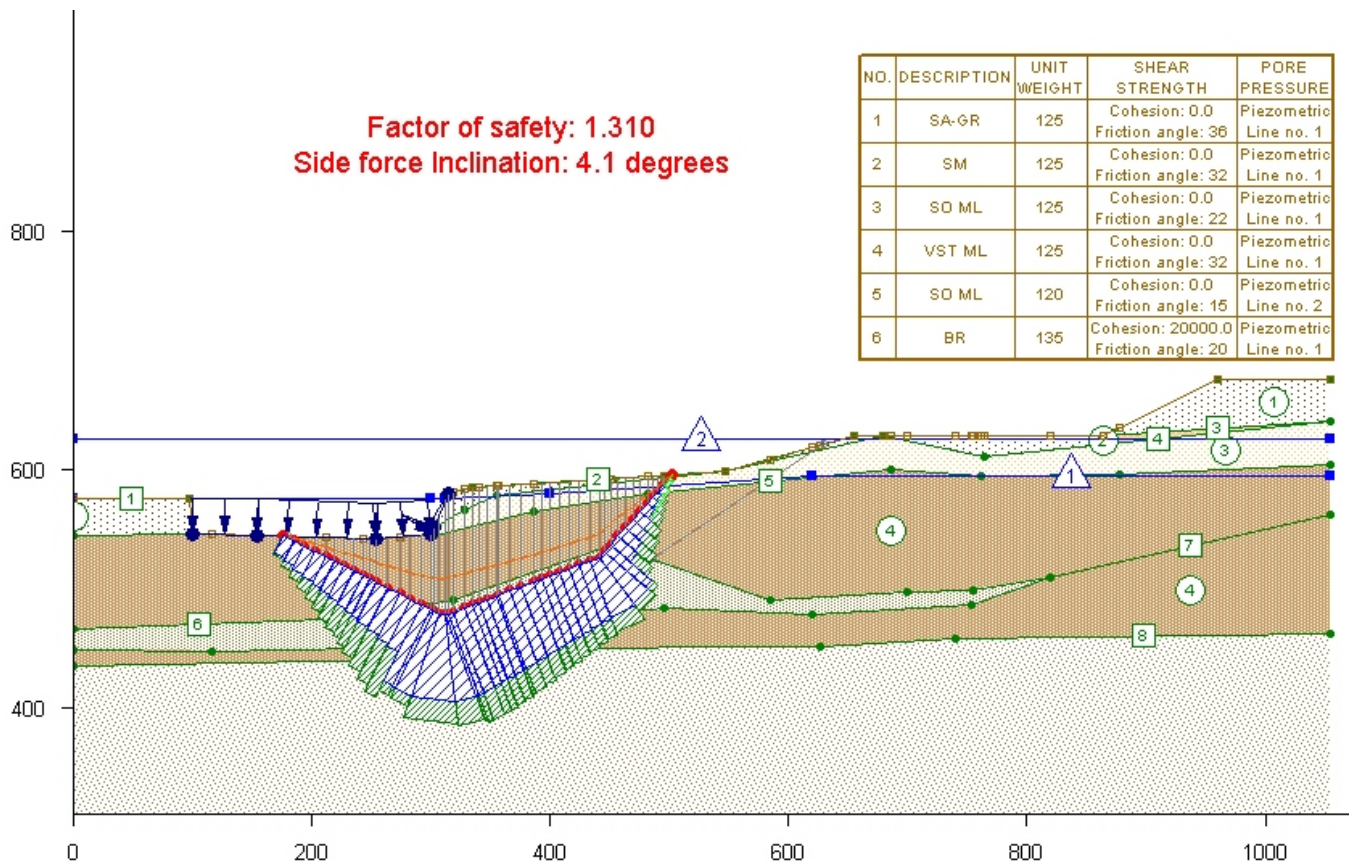

**NOTES :**

1. Data computed using UTEXAS4 Version 4.1.0.3
2. Method of computation set to Spencer's Method.



CUY-90-14.40  
Section A-A with  
Alternative 2  
Non Circular Surfaces  
Spencer's Method

November 2009

**Existing Geometry**  
**Factor of Safety=1.06**

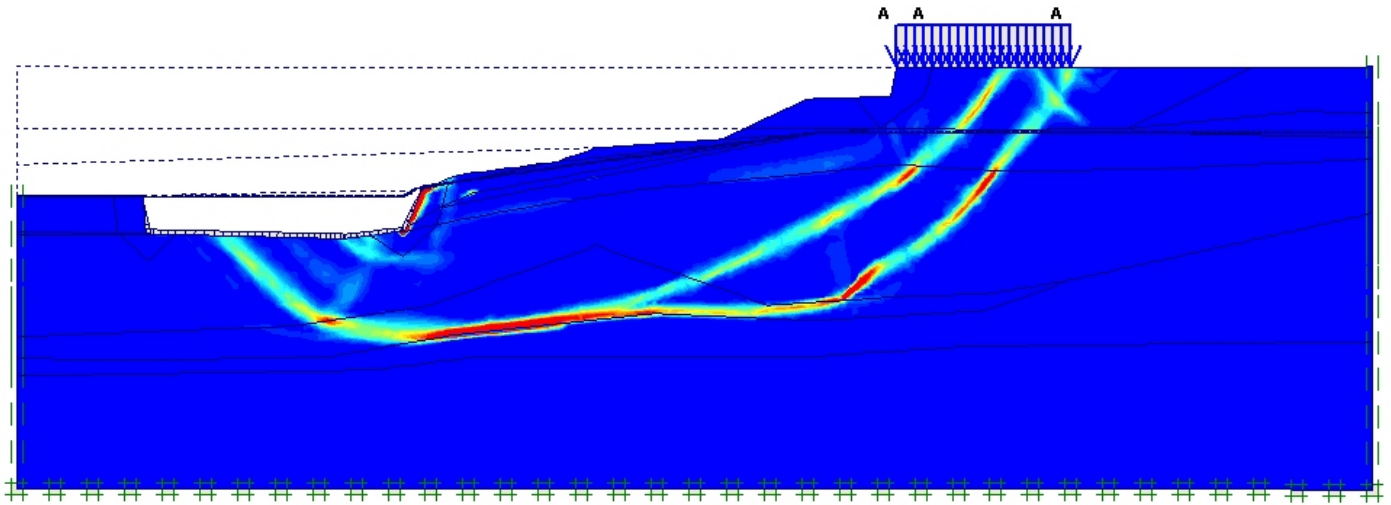

**Alternative 2**  
**Factor of Safety=1.28**

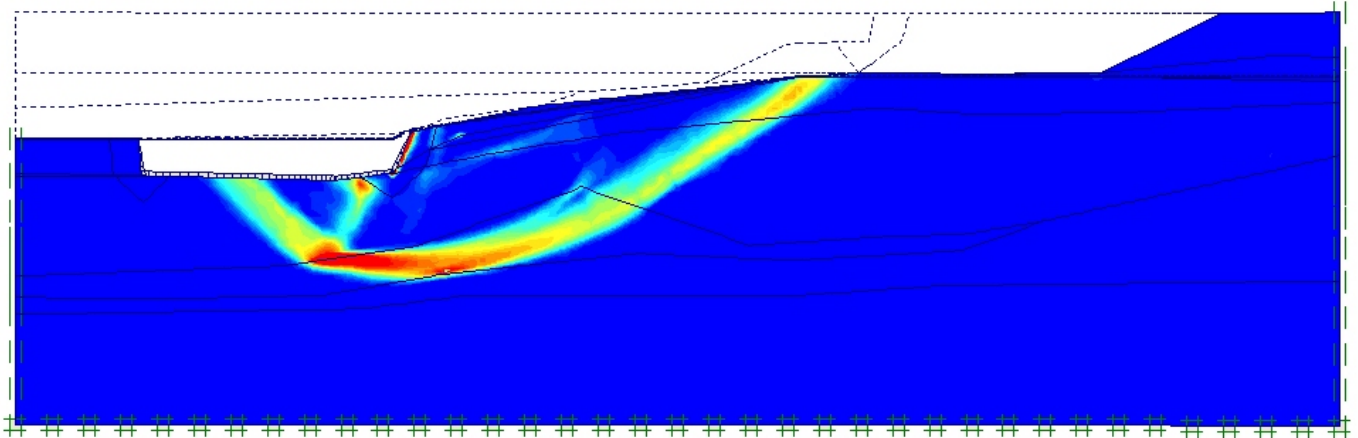

**NOTES :**

1. Data computed using Plaxis version 8.6
2. Method of computation Finite Element Analysis  
C-Phi Reduction



CUY-90-14.40

**Section A-A with  
Alternative 2  
FEA C-Phi Reduction  
Incremental Strain Plots**

**November 2009**

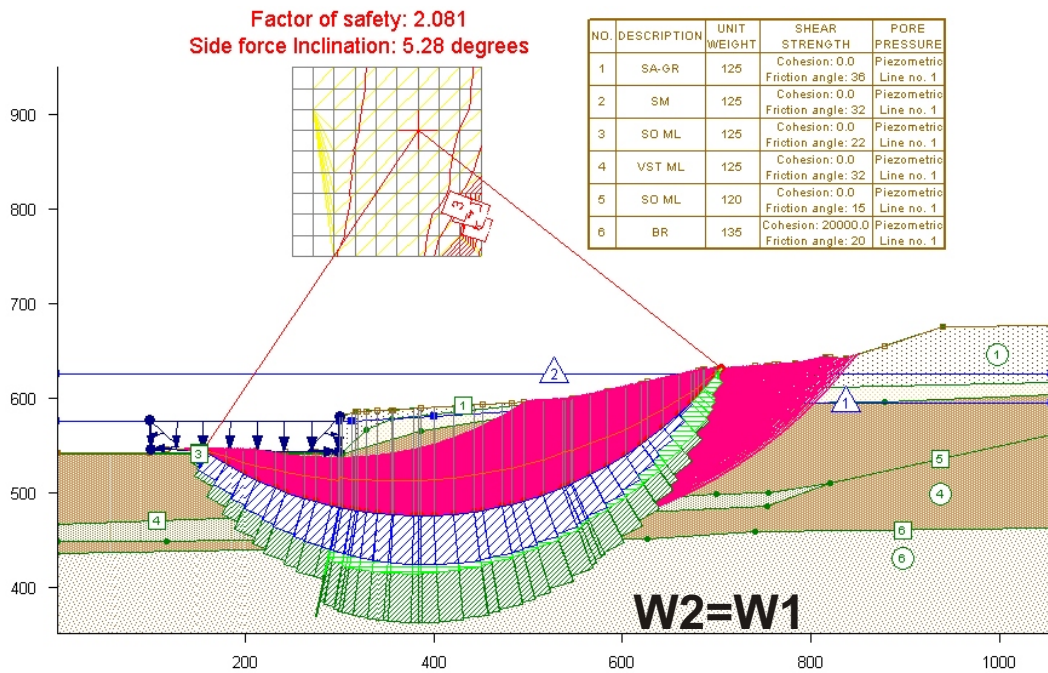
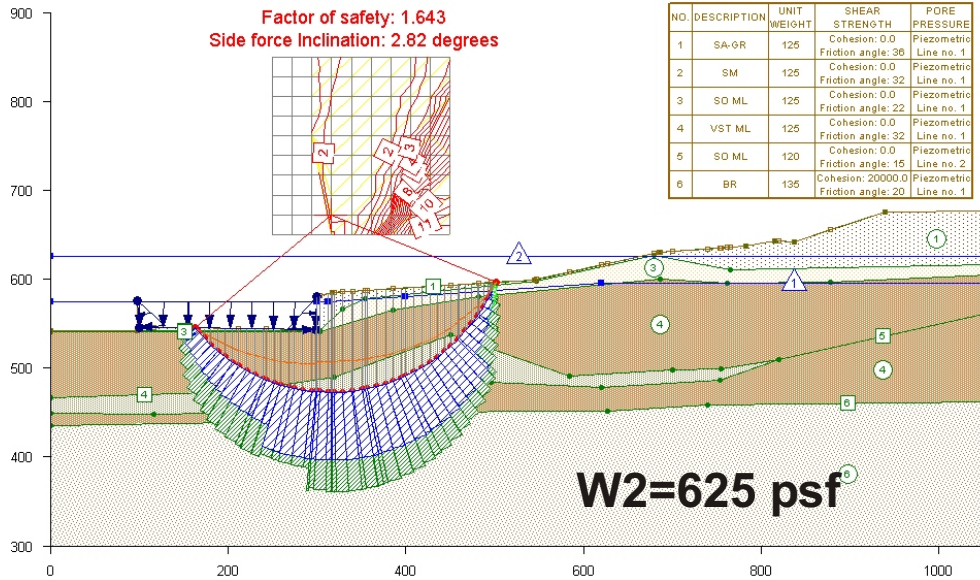
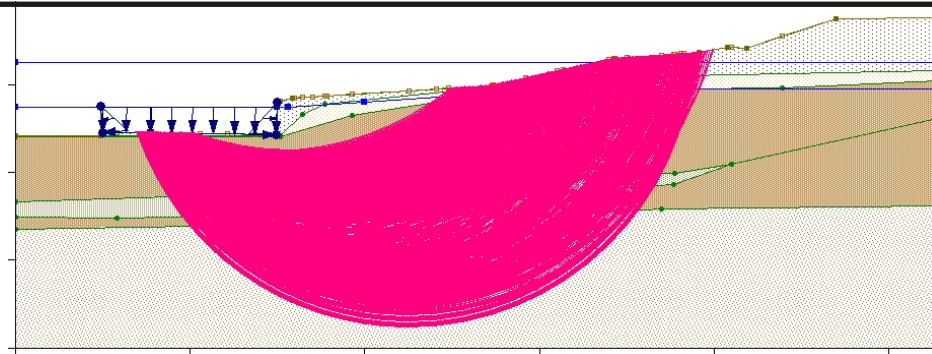

**NOTES :**

1. Data computed using UTEXAS4 Version 4.1.0.3
2. Method of computation set to Spencer's Method.



CUY-90-14.40

**Section A-A  
Alternative 5  
Spensor's Method  
Circular Surfaces**

Sept 2009

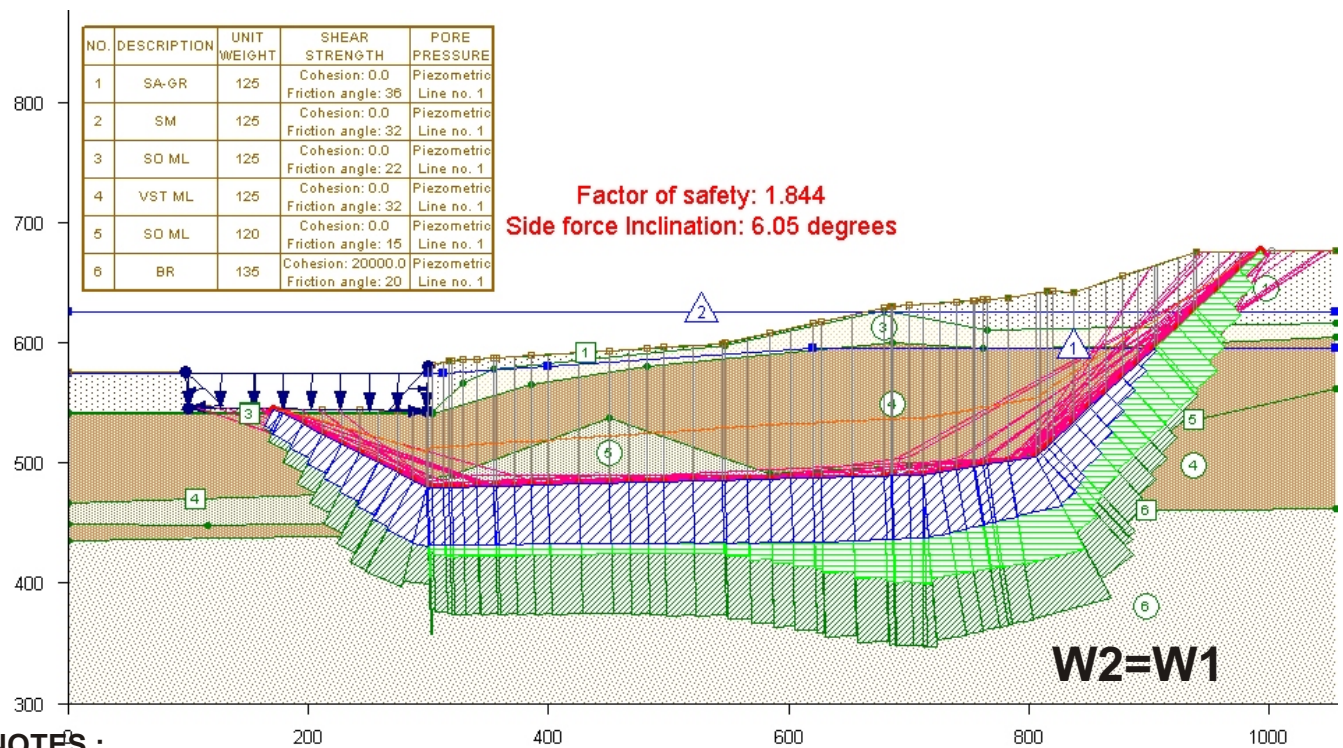
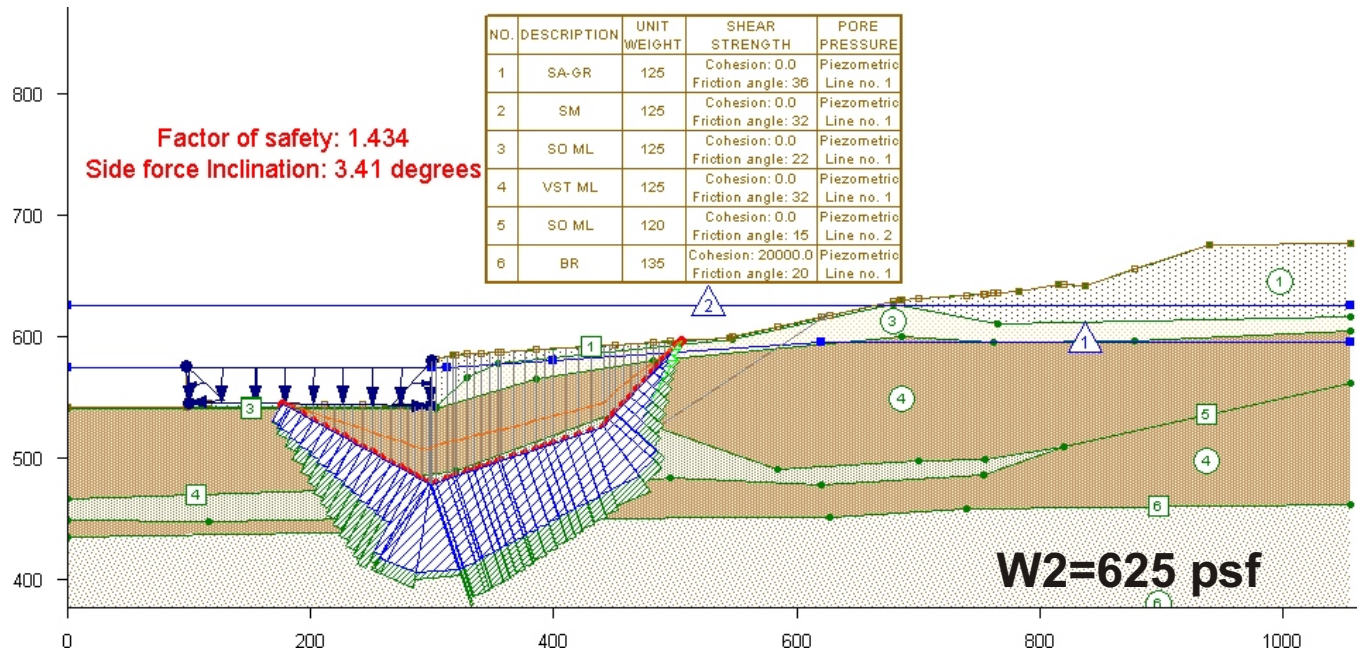

**NOTES :**

1. Data computed using UTEXAS4 Version 4.1.0.3
2. Method of computation set to Spencer's Method.



CUY-90-14.40

**Section A-A**  
**Alternative 5**  
**Spensor's Method**  
**Non Circular Surface**

Sept 2009

**W2=625 psf  
Factor of Safety=1.55**

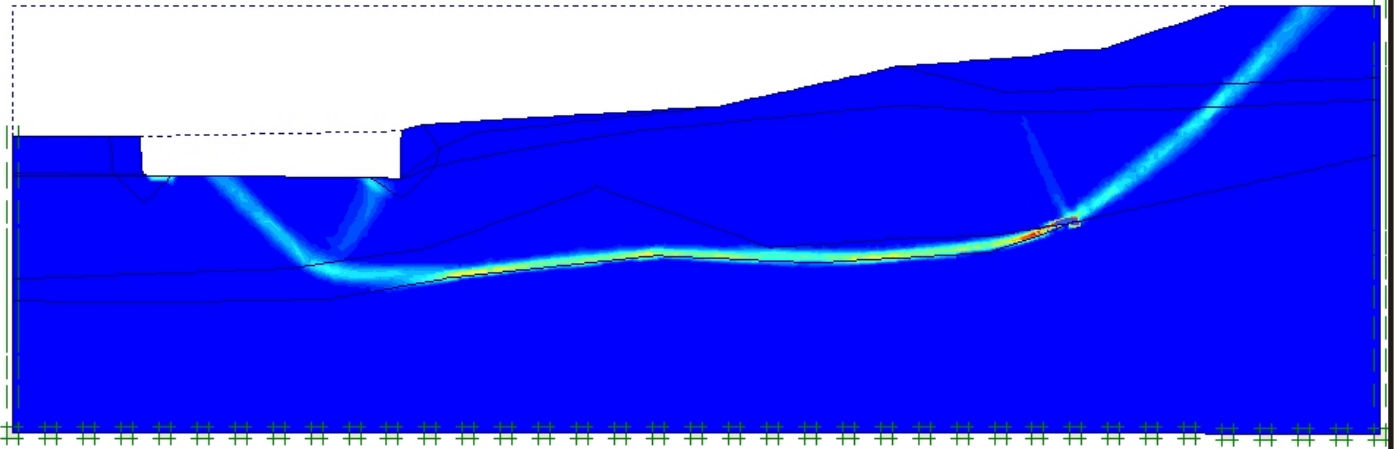

**W2=W1  
Factor of Safety=1.83**

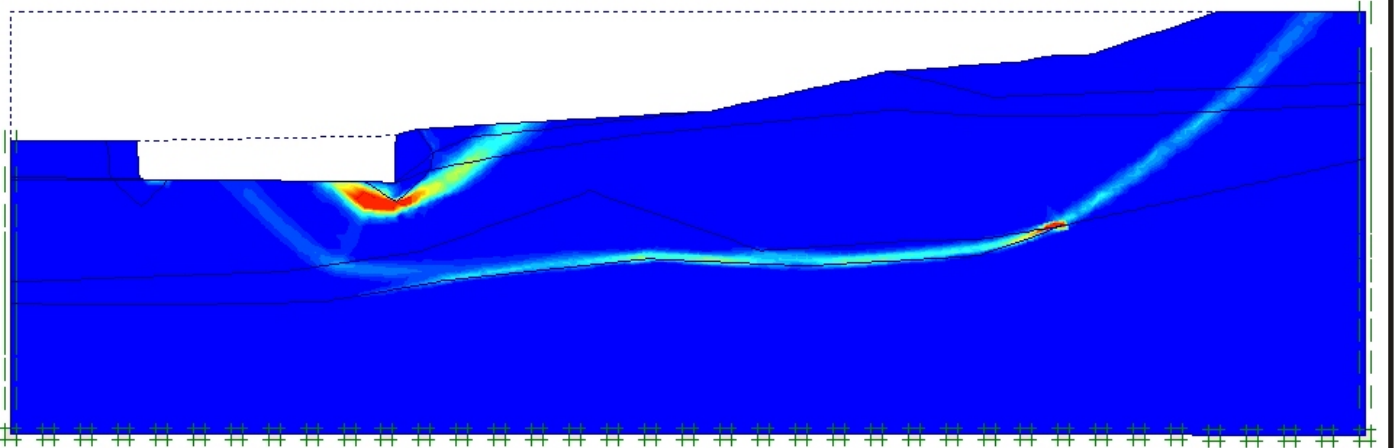

**NOTES :**

1. Data computed using Plaxis version 8.6
2. Method of computation Finite Element Analysis  
C-Phi Reduction



CUY-90-14.40

**Section A-A Alt. 5  
FEA C-Phi Reduction  
Incremental Strain Plots**

**Sept 2009**

## **Appendix “7J - B”**

### **Section D-D Results**

Section D-D was analyzed by Geocomp for the following conditions:

- Alternative 5 geometry – with elevated pore water pressures
- Alternative 5 geometry – with reduce pore water pressures

Stability results are provided using UTEXAS4 using Spencer’s Method and by using the Finite Element Phi-C reduction method in Plaxis.

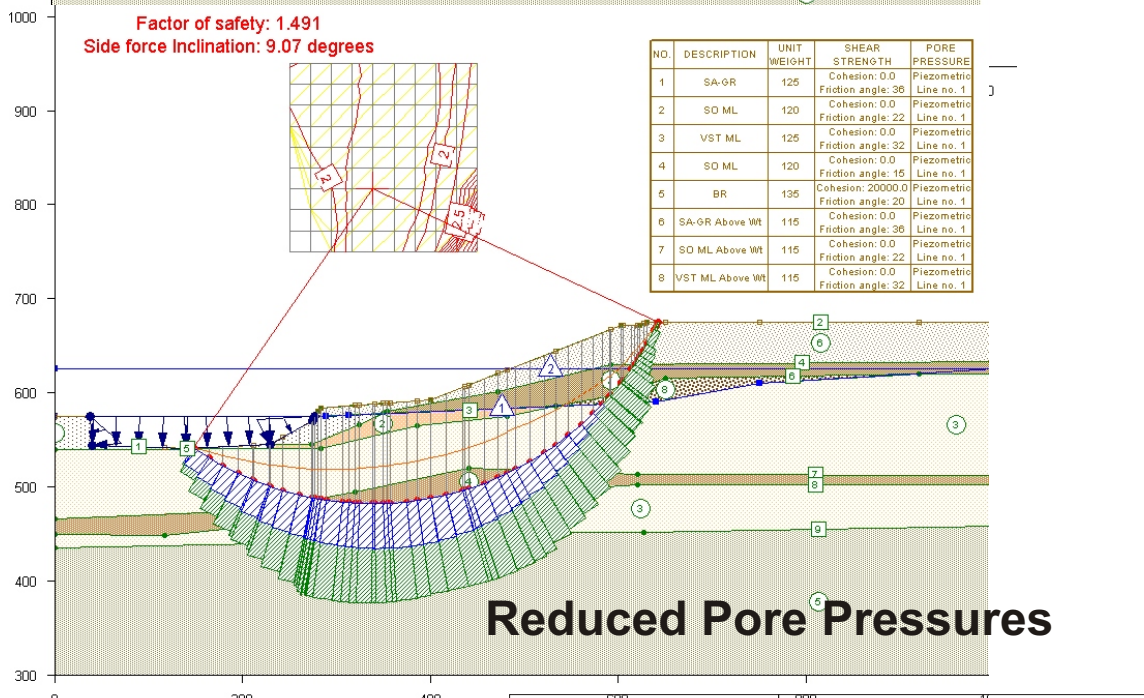
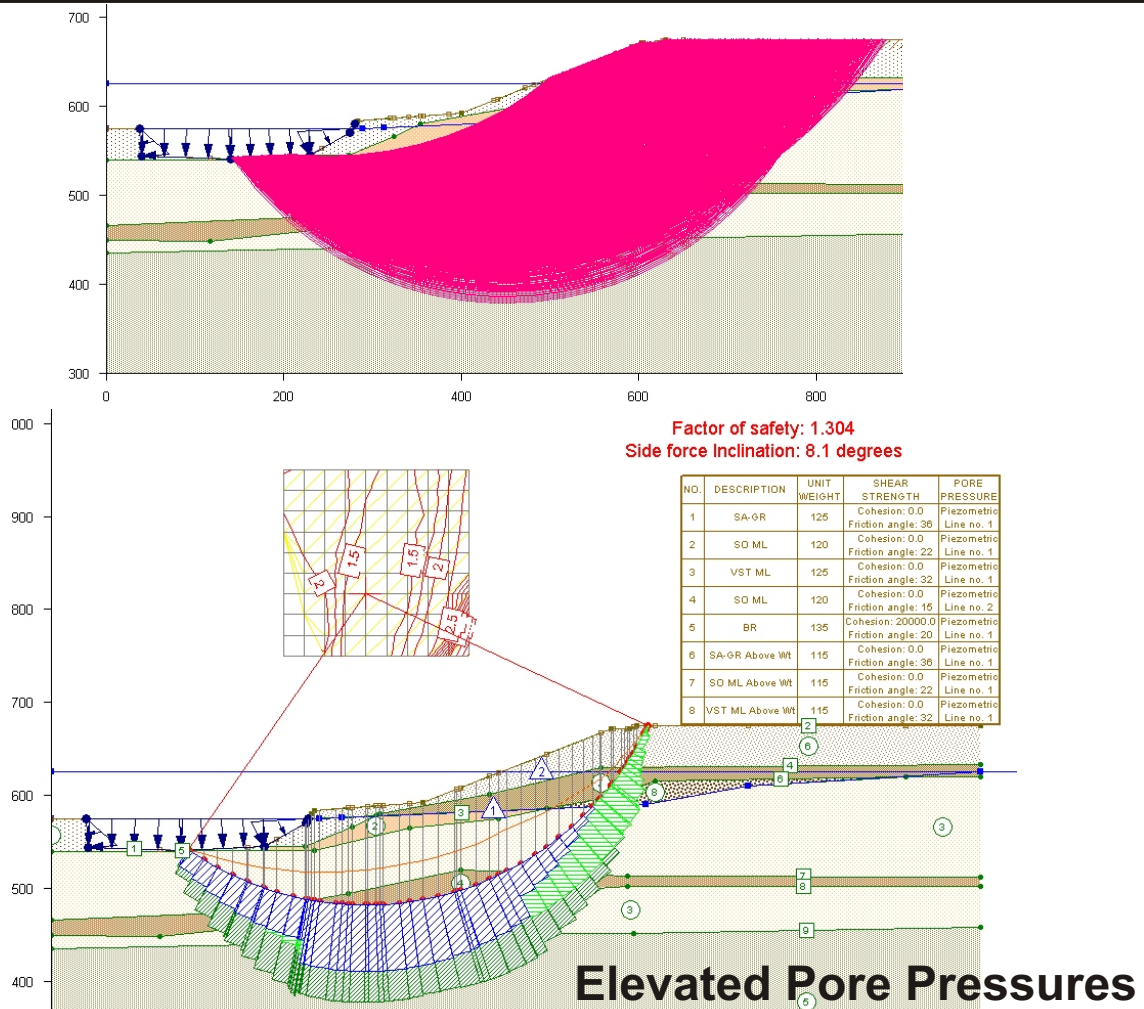

**NOTES :**

1. Data computed using UTEXAS4 Version 4.1.0.3
2. Method of computation set to Spencer's Method.



CUY-90-14.40

**Section D-D with  
Alternative 5  
Circular Surfaces  
Spencer's Method**

November 2009



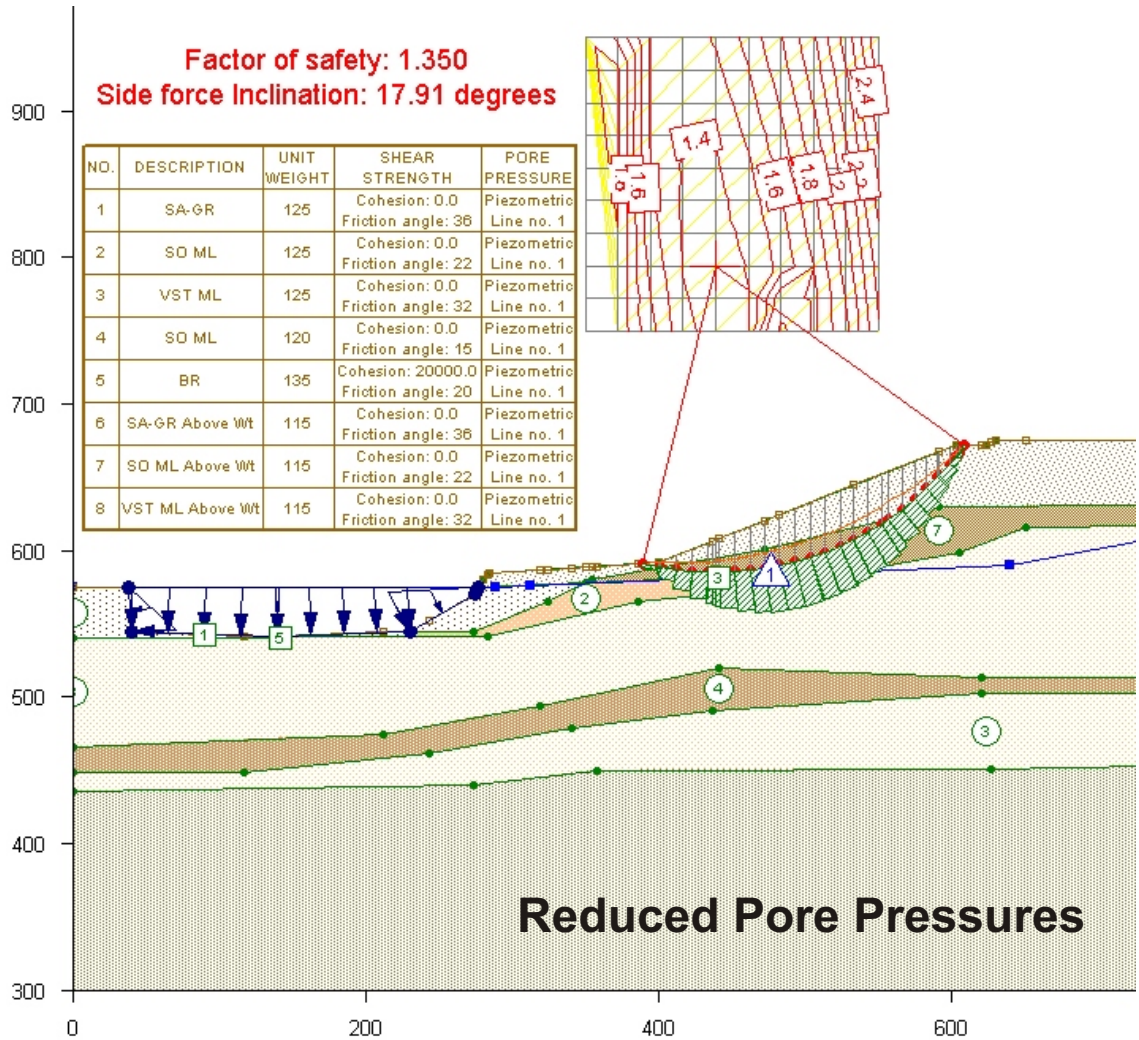
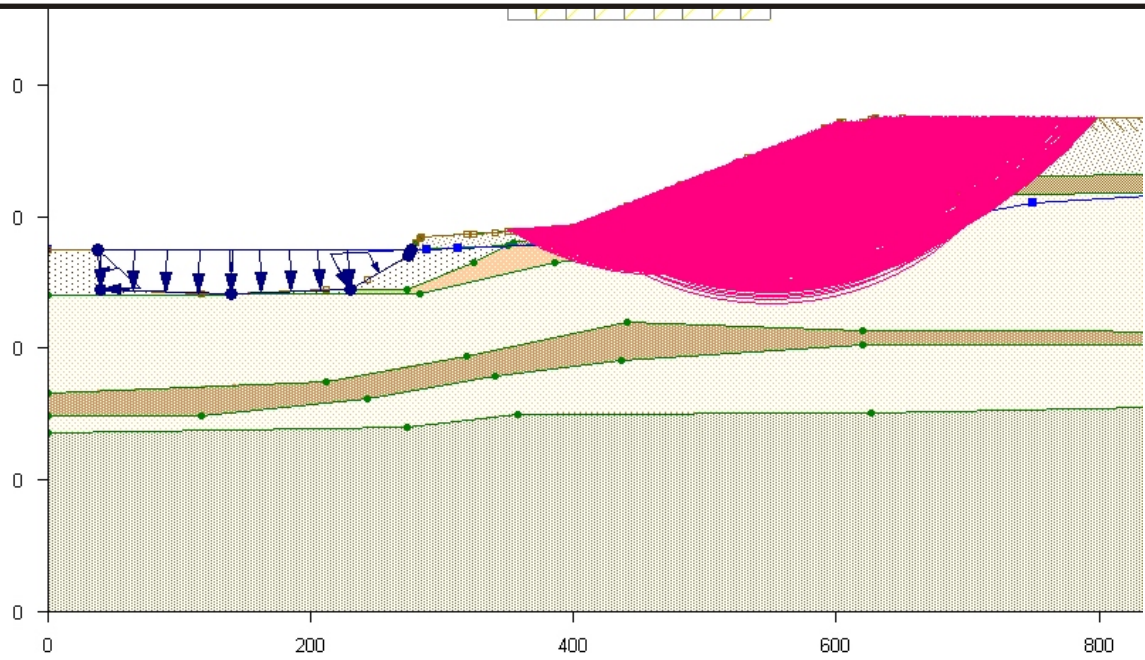

**NOTES :**

1. Data computed using UTEXAS4 Version 4.1.0.3
2. Method of computation set to Spencer's Method.



CUY-90-14.40

**Section D-D with  
Alternative 5  
Shallow Surfaces  
Spencer's Method**

November 2009

**Factor of safety: 1.267**  
**Side force Inclination: 6.21 degrees**

| NO. | DESCRIPTION     | UNIT WEIGHT | SHEAR STRENGTH                          | PORE PRESSURE             |
|-----|-----------------|-------------|---|---------------------------|
| 1   | SA-GR           | 125         | Cohesion: 0.0<br>Friction angle: 36     | Piezometric<br>Line no. 1 |
| 2   | SO ML           | 120         | Cohesion: 0.0<br>Friction angle: 22     | Piezometric<br>Line no. 1 |
| 3   | VST ML          | 125         | Cohesion: 0.0<br>Friction angle: 32     | Piezometric<br>Line no. 1 |
| 4   | SO ML           | 120         | Cohesion: 0.0<br>Friction angle: 15     | Piezometric<br>Line no. 2 |
| 5   | BR              | 135         | Cohesion: 20000.0<br>Friction angle: 20 | Piezometric<br>Line no. 1 |
| 6   | SA-GR Above Wt  | 115         | Cohesion: 0.0<br>Friction angle: 36     | Piezometric<br>Line no. 1 |
| 7   | SO ML Above Wt  | 115         | Cohesion: 0.0<br>Friction angle: 22     | Piezometric<br>Line no. 1 |
| 8   | VST ML Above Wt | 115         | Cohesion: 0.0<br>Friction angle: 32     | Piezometric<br>Line no. 1 |

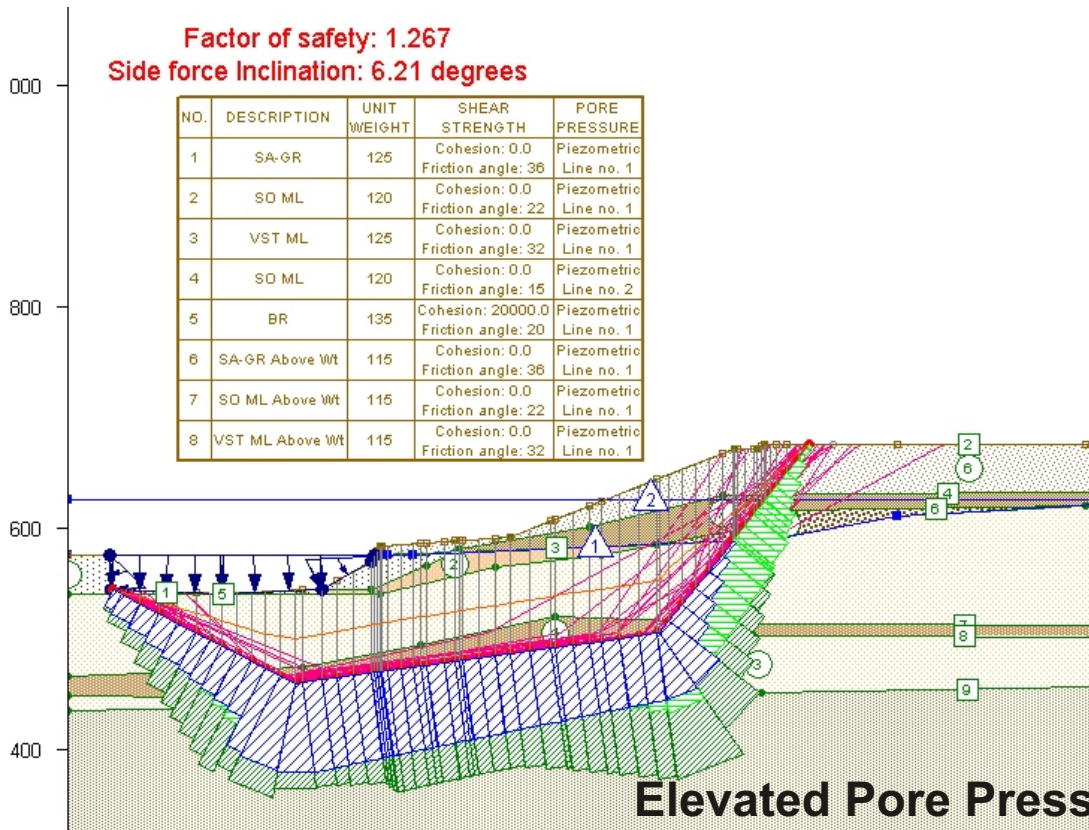

**Elevated Pore Pressures**

**Factor of safety: 1.538**  
**Side force Inclination: 7.24 degrees**

| NO. | DESCRIPTION     | UNIT WEIGHT | SHEAR STRENGTH                          | PORE PRESSURE             |
|-----|-----------------|-------------|---|---------------------------|
| 1   | SA-GR           | 125         | Cohesion: 0.0<br>Friction angle: 36     | Piezometric<br>Line no. 1 |
| 2   | SO ML           | 120         | Cohesion: 0.0<br>Friction angle: 22     | Piezometric<br>Line no. 1 |
| 3   | VST ML          | 125         | Cohesion: 0.0<br>Friction angle: 32     | Piezometric<br>Line no. 1 |
| 4   | SO ML           | 120         | Cohesion: 0.0<br>Friction angle: 15     | Piezometric<br>Line no. 1 |
| 5   | BR              | 135         | Cohesion: 20000.0<br>Friction angle: 20 | Piezometric<br>Line no. 1 |
| 6   | SA-GR Above Wt  | 115         | Cohesion: 0.0<br>Friction angle: 36     | Piezometric<br>Line no. 1 |
| 7   | SO ML Above Wt  | 115         | Cohesion: 0.0<br>Friction angle: 22     | Piezometric<br>Line no. 1 |
| 8   | VST ML Above Wt | 115         | Cohesion: 0.0<br>Friction angle: 32     | Piezometric<br>Line no. 1 |

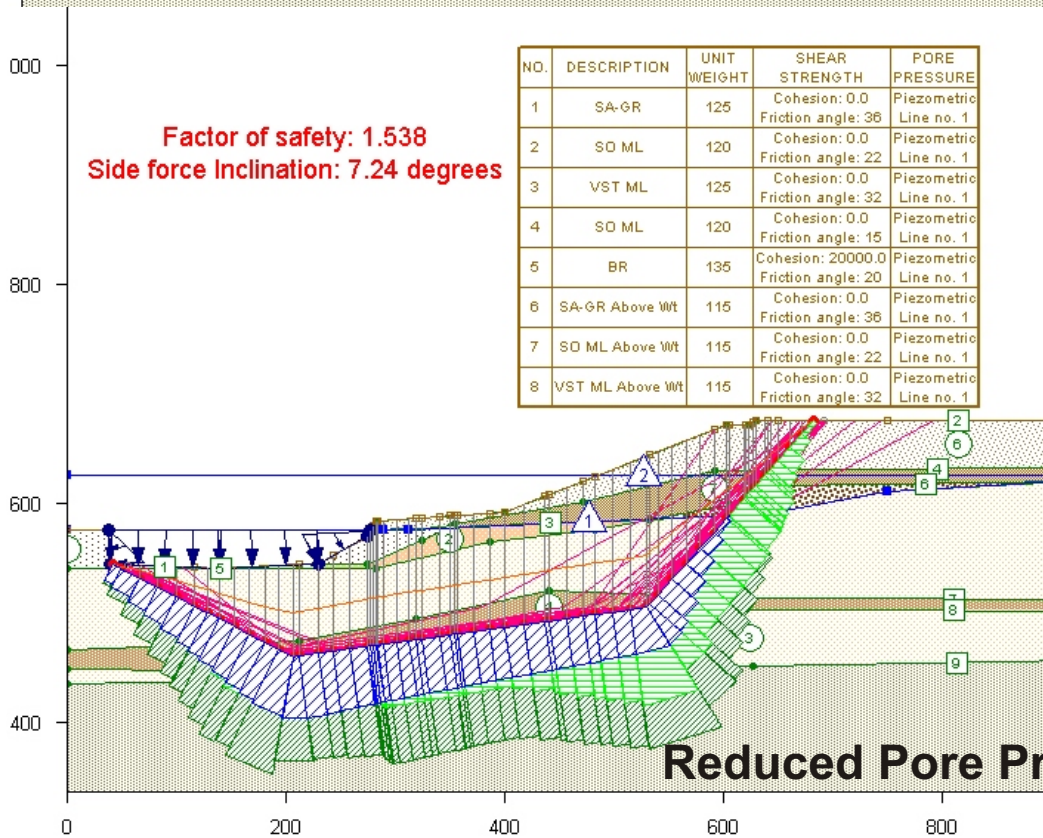

**Reduced Pore Pressures**

**NOTES :**

1. Data computed using UTEXAS4 Version 4.1.0.3
2. Method of computation set to Spencer's Method.



CUY-90-14.40

**Section D-D with  
 Alternative 5  
 Non-Circular Surface  
 Spencer's Method**

November 2009

## Elevated Pore pressures Factor of Safety=1.17

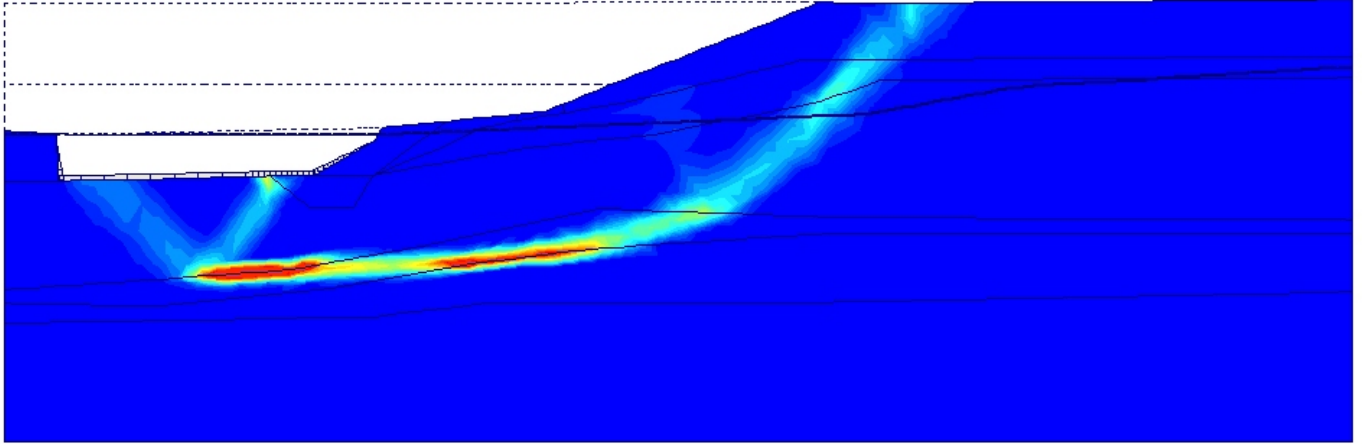

## Reduced Pore Pressures Factor of Safety=1.30

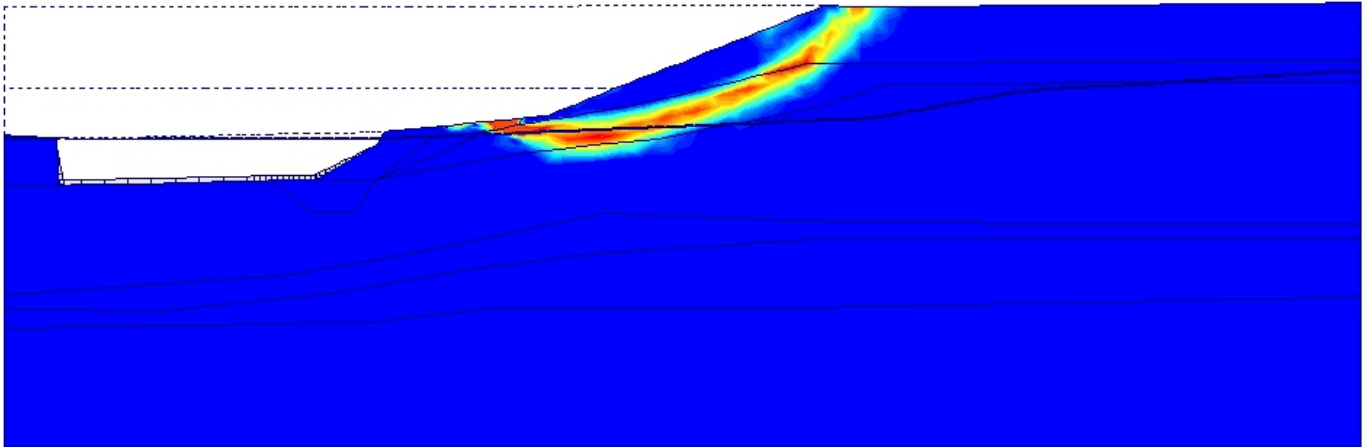

### NOTES :

1. Data computed using Plaxis version 8.6
2. Method of computation Finite Element Analysis  
C-Phi Reduction



CUY-90-14.40

Section D-D with  
Alternative 5  
FEA C-Phi Reduction  
Incremental Strain Plots

November 2009

## **Appendix “7J - C”**

### **Section G-G Results**

Section G-G was analyzed by Geocomp for the following conditions

- Existing Conditions
- Alternative 2 Geometry with elevated pore water pressures
- Alternative 5 geometry with elevated pore water pressures

Stability results are provided using UTEXAS4 using Spencer’s Method and by using the Finite Element Phi-C reduction method in Plaxis.

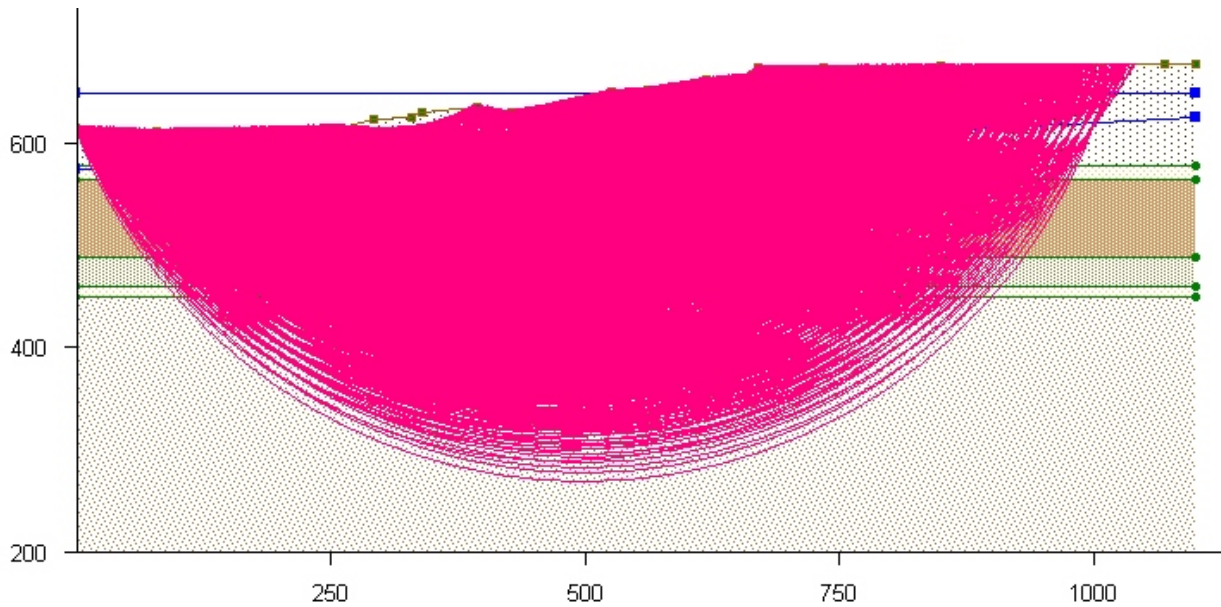

**Factor of safety: 3.410**  
**Side force Inclination: 0 degrees**

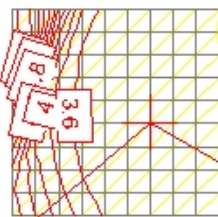

| NO. | DESCRIPTION | UNIT WEIGHT | SHEAR STRENGTH                          | PORE PRESSURE             |
|-----|-------------|-------------|---|---------------------------|
| 1   | SA-GR       | 125         | Cohesion: 0.0<br>Friction angle: 36     | Piezometric<br>Line no. 1 |
| 2   | SM          | 125         | Cohesion: 0.0<br>Friction angle: 32     | Piezometric<br>Line no. 1 |
| 3   | SO ML       | 125         | Cohesion: 0.0<br>Friction angle: 22     | Piezometric<br>Line no. 1 |
| 4   | VST ML      | 125         | Cohesion: 0.0<br>Friction angle: 32     | Piezometric<br>Line no. 1 |
| 5   | SO ML       | 120         | Cohesion: 0.0<br>Friction angle: 15     | Piezometric<br>Line no. 2 |
| 6   | BR          | 135         | Cohesion: 20000.0<br>Friction angle: 20 | Piezometric<br>Line no. 1 |

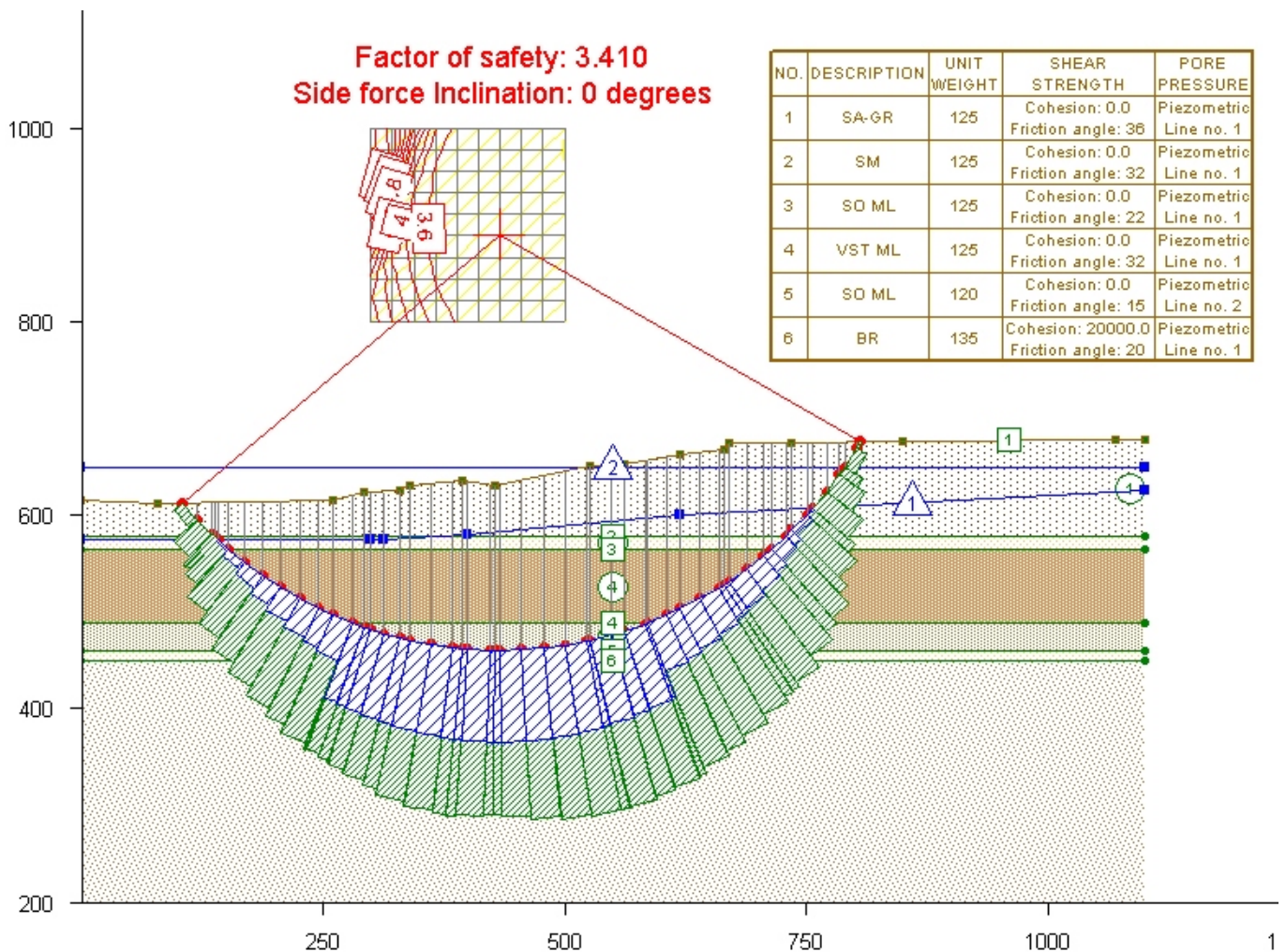

**NOTES :**

1. Data computed using UTEXAS4 Version 4.1.0.3
2. Method of computation set to Simplified Janbu procedure (side force inclination set to zero degrees).



CUY-90-14.40

**Section G with  
Existing Geometry  
Circular Surfaces  
Simplified Janbu Method**

November 2009

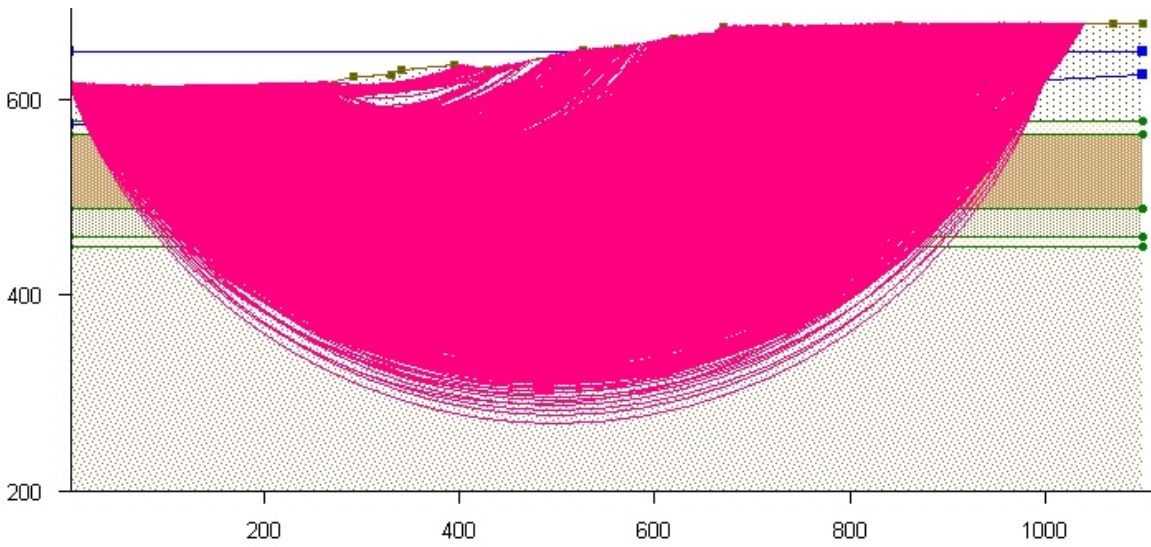

**Factor of safety: 3.762**  
**Side force Inclination: 2.77 degrees**

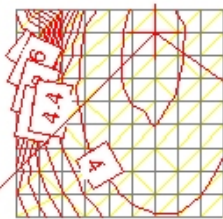

| NO. | DESCRIPTION | UNIT WEIGHT | SHEAR STRENGTH                          | PORE PRESSURE          |
|-----|-------------|-------------|---|------------------------|
| 1   | SA-GR       | 125         | Cohesion: 0.0<br>Friction angle: 36     | Piezometric Line no. 1 |
| 2   | SM          | 125         | Cohesion: 0.0<br>Friction angle: 32     | Piezometric Line no. 1 |
| 3   | SO ML       | 125         | Cohesion: 0.0<br>Friction angle: 22     | Piezometric Line no. 1 |
| 4   | VST ML      | 125         | Cohesion: 0.0<br>Friction angle: 32     | Piezometric Line no. 1 |
| 5   | SO ML       | 120         | Cohesion: 0.0<br>Friction angle: 15     | Piezometric Line no. 2 |
| 6   | BR          | 135         | Cohesion: 20000.0<br>Friction angle: 20 | Piezometric Line no. 1 |

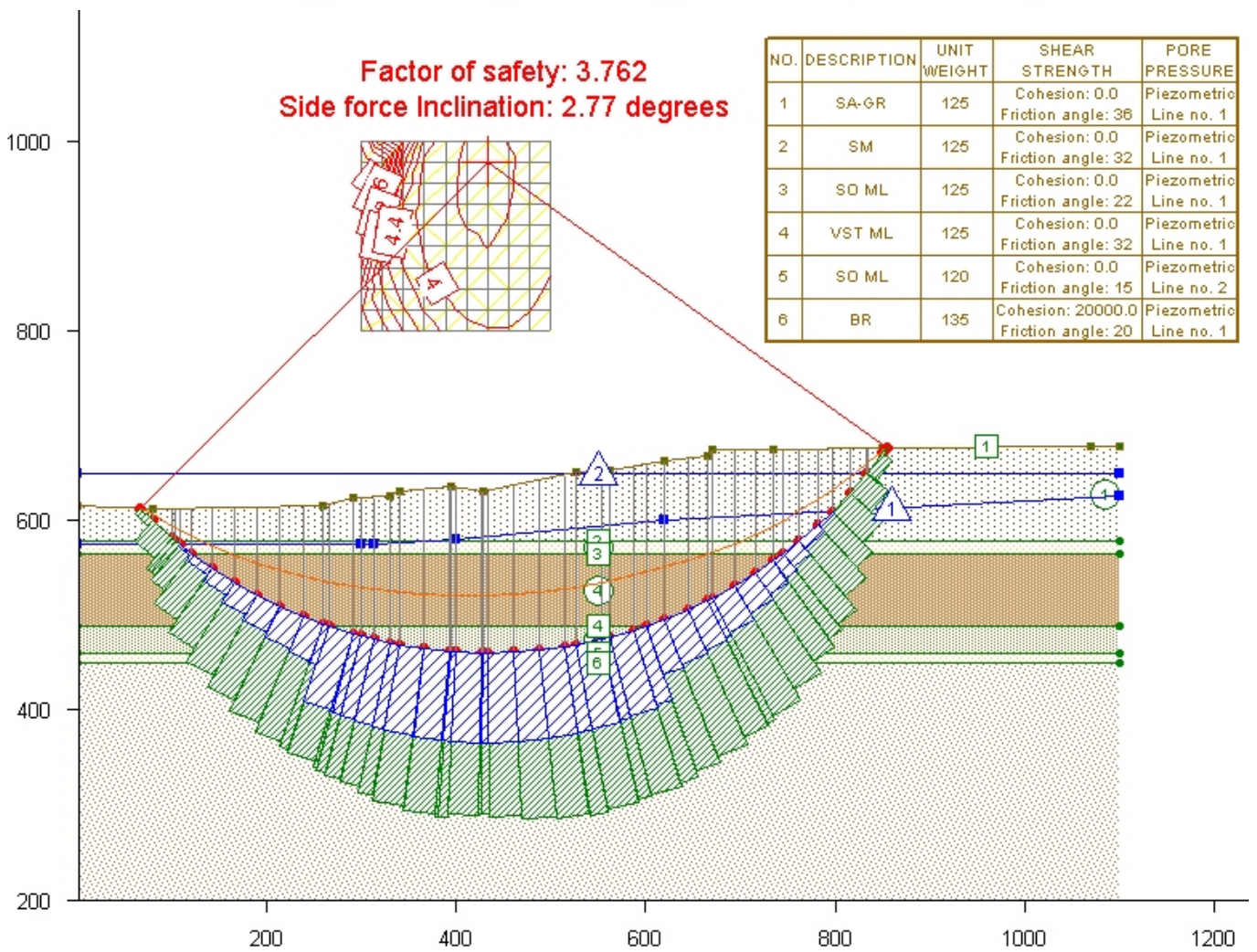

**NOTES :**

1. Data computed using UTEXAS4 Version 4.1.0.3
2. Method of computation set to Spencer's Method.



CUY-90-14.40

**Section G with  
Existing Geometry  
Circular Surfaces  
Spencer's Method**

November 2009

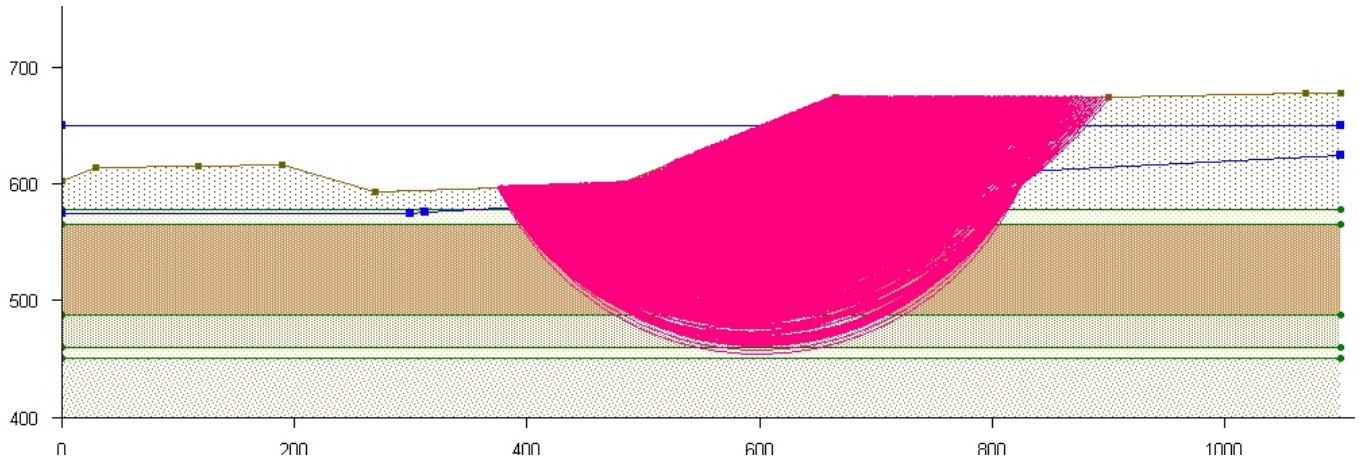

Factor of safety: 1.855  
Side force Inclination: 12.29 degrees

| NO. | DESCRIPTION | UNIT WEIGHT | SHEAR STRENGTH                          | PORE PRESSURE          |
|-----|-------------|-------------|---|------------------------|
| 1   | SA-GR       | 125         | Cohesion: 0.0<br>Friction angle: 36     | Piezometric Line no. 1 |
| 2   | SM          | 125         | Cohesion: 0.0<br>Friction angle: 32     | Piezometric Line no. 1 |
| 3   | SO ML       | 125         | Cohesion: 0.0<br>Friction angle: 22     | Piezometric Line no. 1 |
| 4   | VST ML      | 125         | Cohesion: 0.0<br>Friction angle: 32     | Piezometric Line no. 1 |
| 5   | SO ML       | 120         | Cohesion: 0.0<br>Friction angle: 15     | Piezometric Line no. 2 |
| 6   | BR          | 135         | Cohesion: 20000.0<br>Friction angle: 20 | Piezometric Line no. 1 |

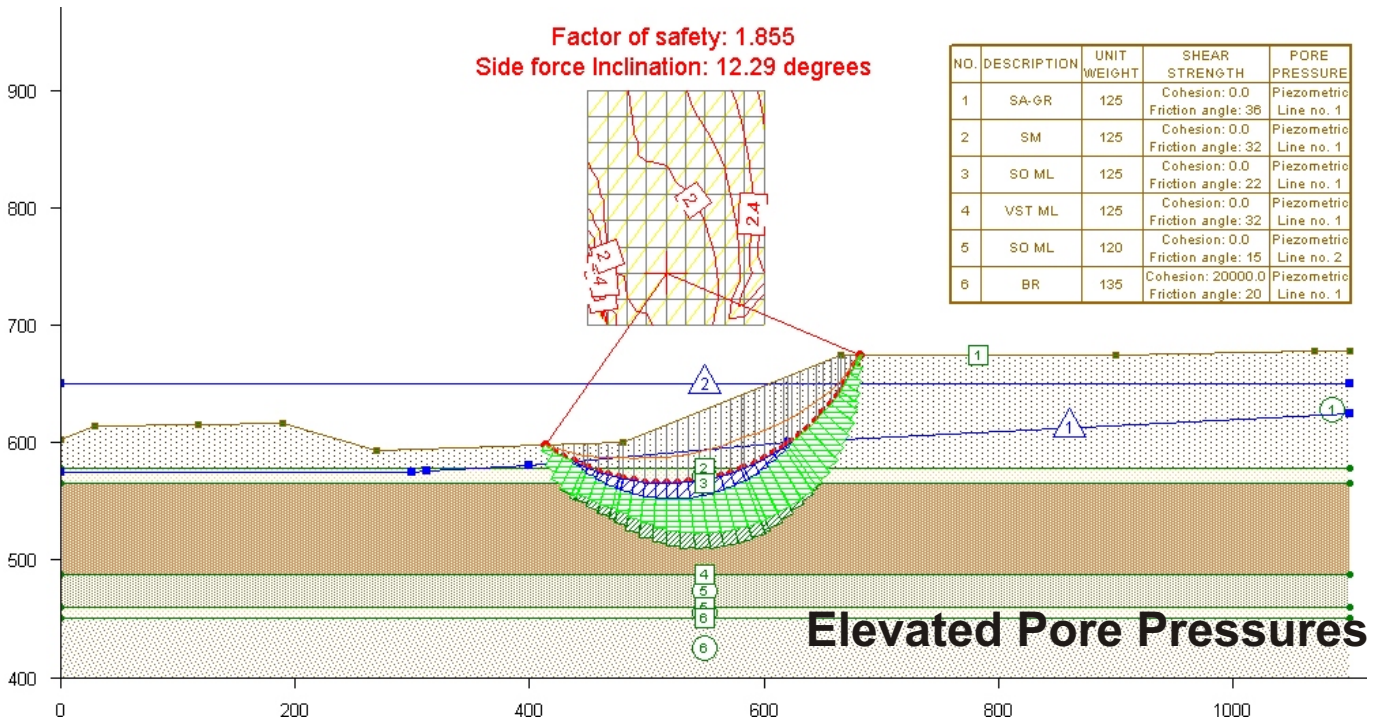

**NOTES :**

1. Data computed using UTEXAS4 Version 4.1.0.3
2. Method of computation set to Spencer's Method.



CUY-90-14.40  
Section G with  
Alternative 2  
Circular Surfaces  
Spencer's Method

November 2009

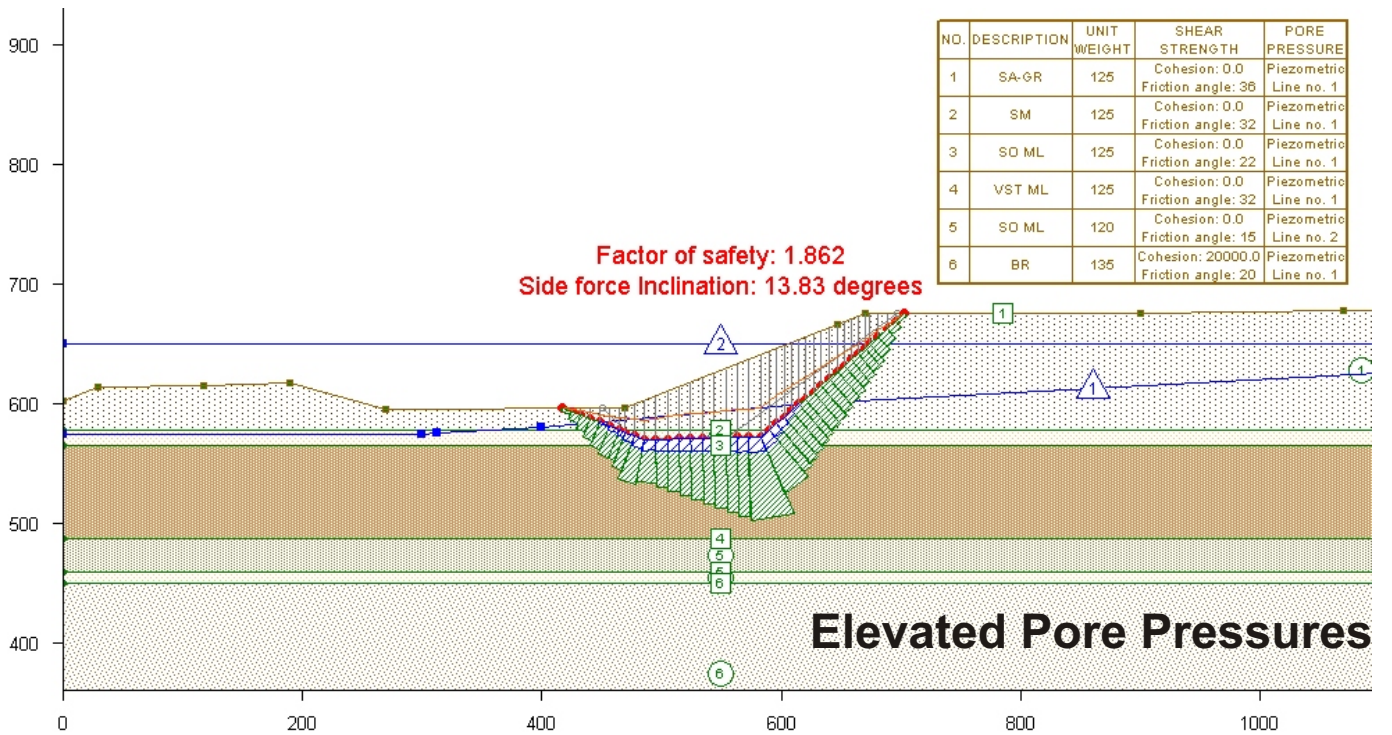
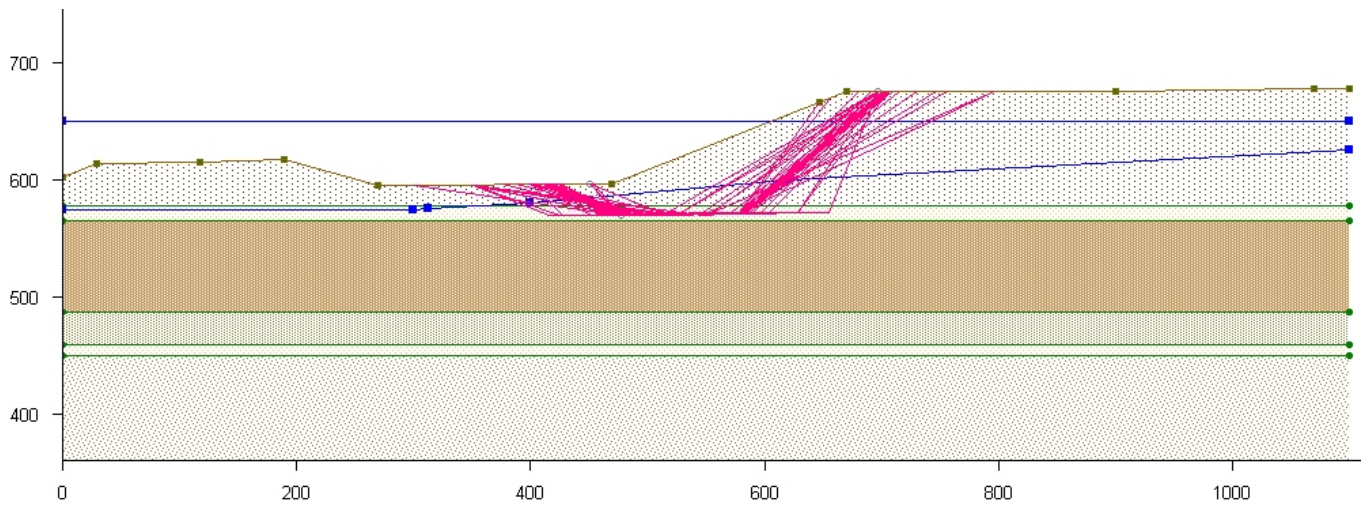

**NOTES :**

1. Data computed using UTEXAS4 Version 4.1.0.3
2. Method of computation set to Spencer's Method.



CUY-90-14.40

**Section G  
Alternative 2  
Non-Circular Surface  
Spencer's Method**

November 2009



## Existing Geometry Factor of Safety=3.55

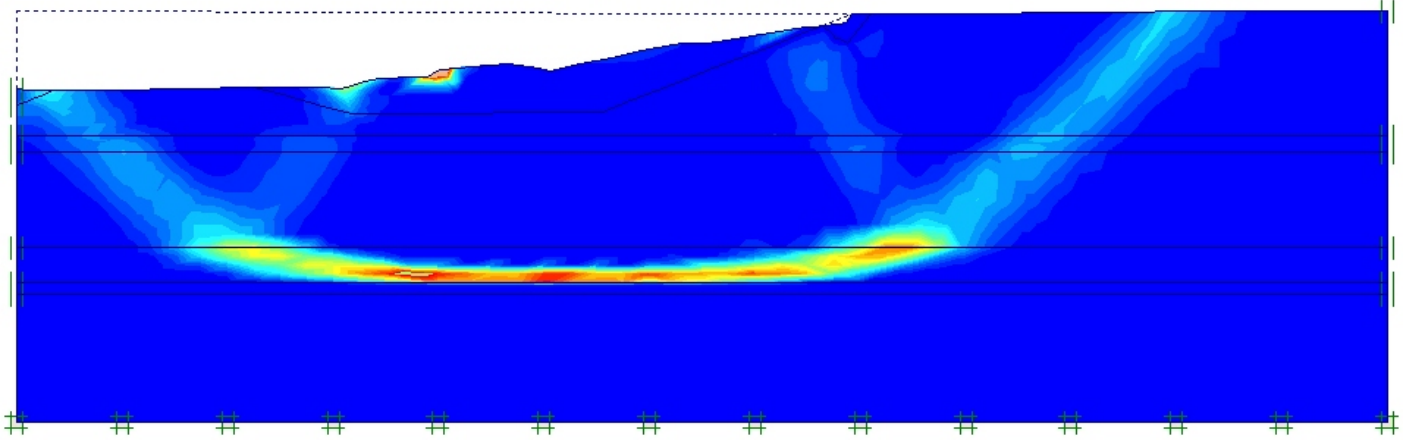

## Alternative 2 (Elevated Pore Pressures) Factor of Safety=1.75

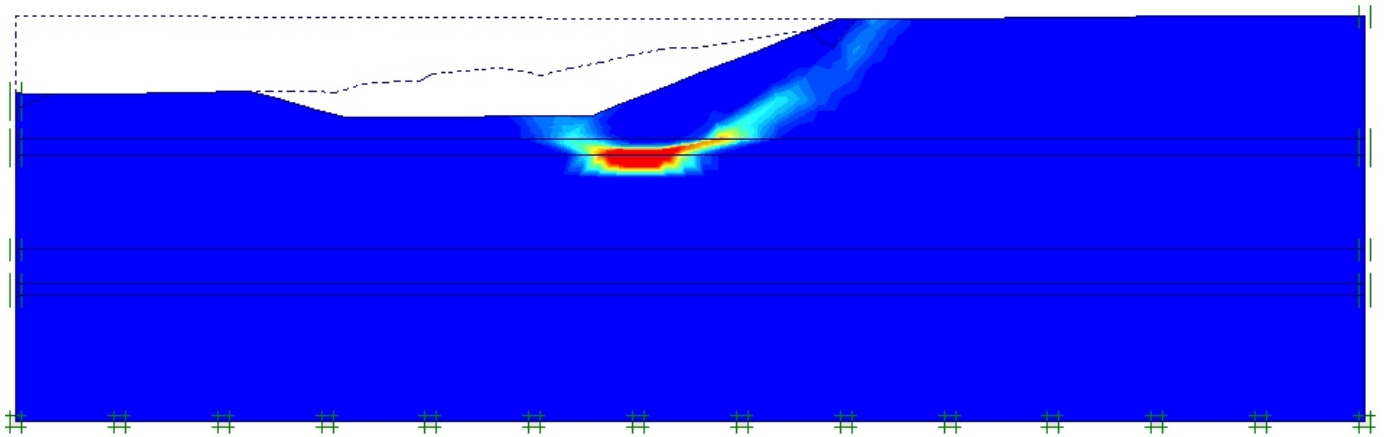

### NOTES :

1. Data computed using Plaxis version 8.6
2. Method of computation Finite Element Analysis  
C-Phi Reduction



CUY-90-14.40

Section G-G  
FEA C-Phi Reduction  
Incremental Strain Plot

November 2009

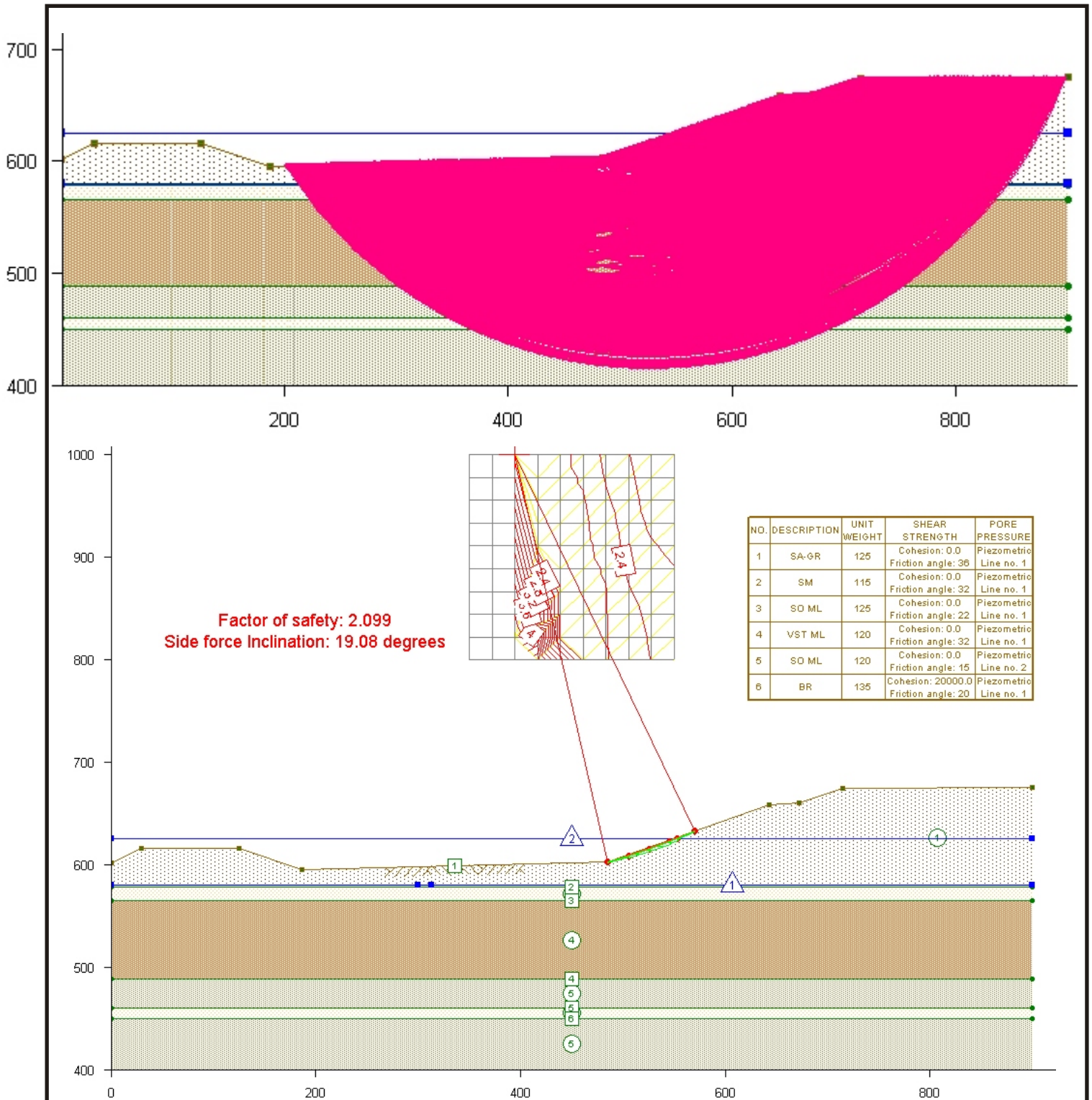

Section GG-Alt 5 Results.des

**NOTES :**

1. Data computed using UTEXAS4 Version 4.1.0.3
2. Method of computation set to Spencer's Method.



CUY-90-14.40

**Section G-G with  
Alternative 5  
Circular Surfaces  
Spencer's Method**

November 2009

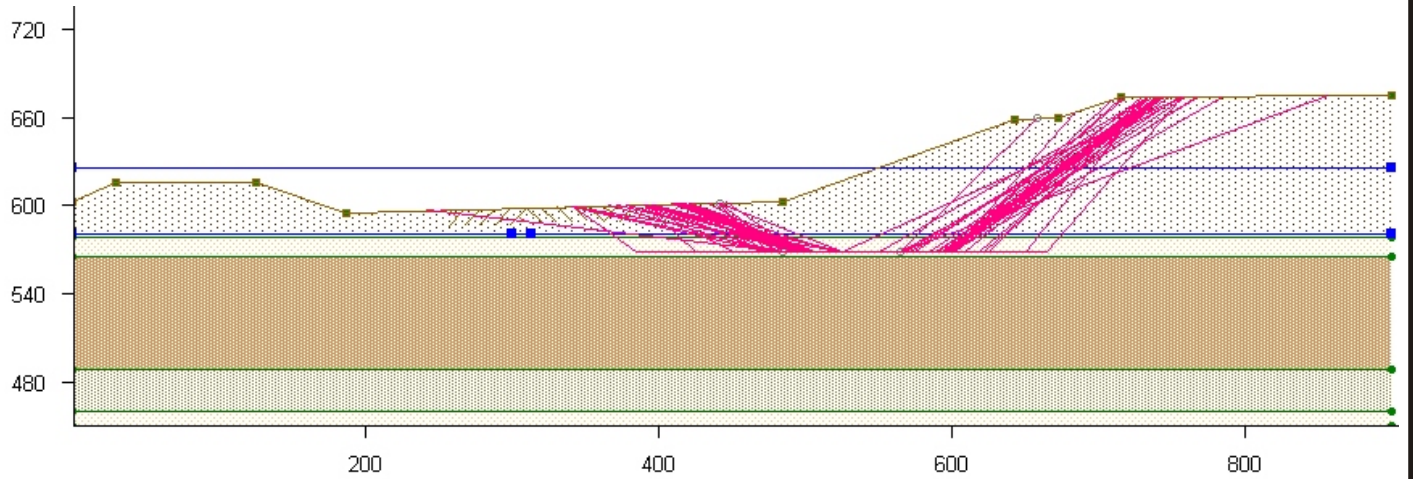

**Factor of safety: 2.414**  
**Side force Inclination: 11.19 degrees**

| NO. | DESCRIPTION | UNIT WEIGHT | SHEAR STRENGTH                          | PORE PRESSURE          |
|-----|-------------|-------------|---|------------------------|
| 1   | SA-GR       | 125         | Cohesion: 0.0<br>Friction angle: 38     | Piezometric Line no. 1 |
| 2   | SM          | 115         | Cohesion: 0.0<br>Friction angle: 32     | Piezometric Line no. 1 |
| 3   | SO ML       | 125         | Cohesion: 0.0<br>Friction angle: 22     | Piezometric Line no. 1 |
| 4   | VST ML      | 120         | Cohesion: 0.0<br>Friction angle: 32     | Piezometric Line no. 1 |
| 5   | SO ML       | 120         | Cohesion: 0.0<br>Friction angle: 15     | Piezometric Line no. 2 |
| 6   | BR          | 135         | Cohesion: 20000.0<br>Friction angle: 20 | Piezometric Line no. 1 |

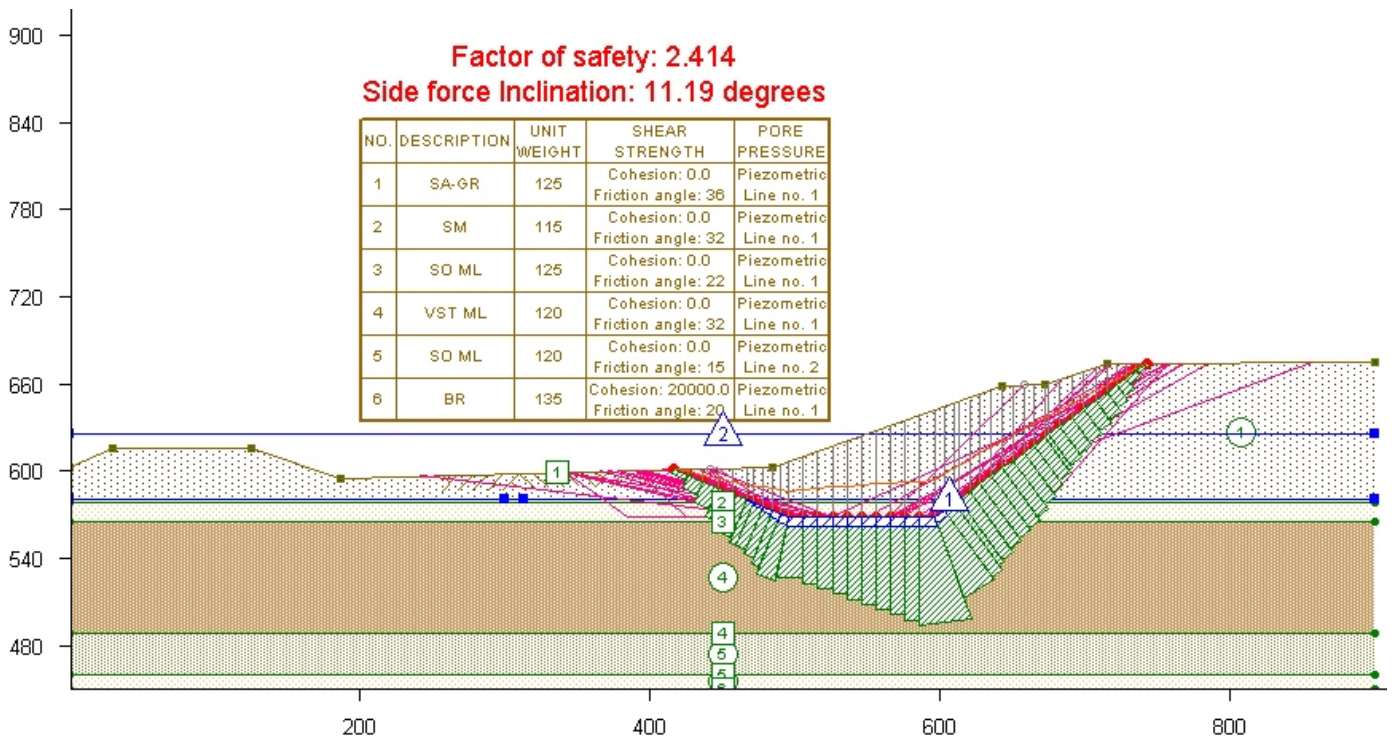

**NOTES :**

1. Data computed using UTEXAS4 Version 4.1.0.3
2. Method of computation set to Spencer's Method.



CUY-90-14.40

**Section G-G with  
 Alternative 5  
 Non-Circular Surface  
 Spencer's Method**

November 2009

**W2=625 psf  
Factor of Safety=2.24**

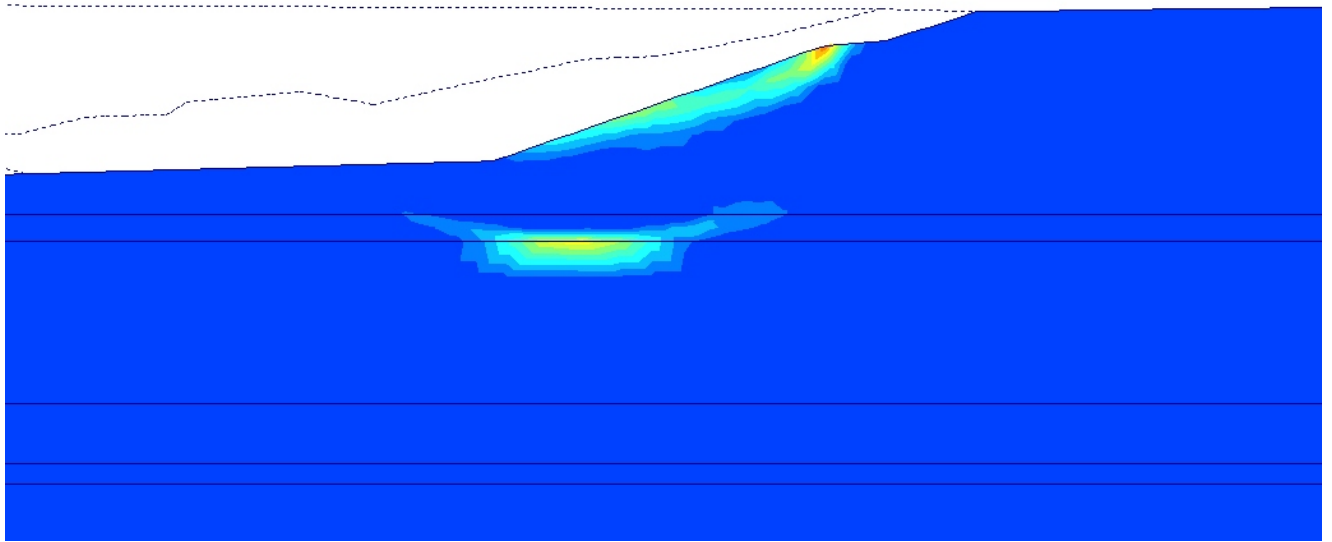

**W2=W1  
Factor of Safety=2.24**

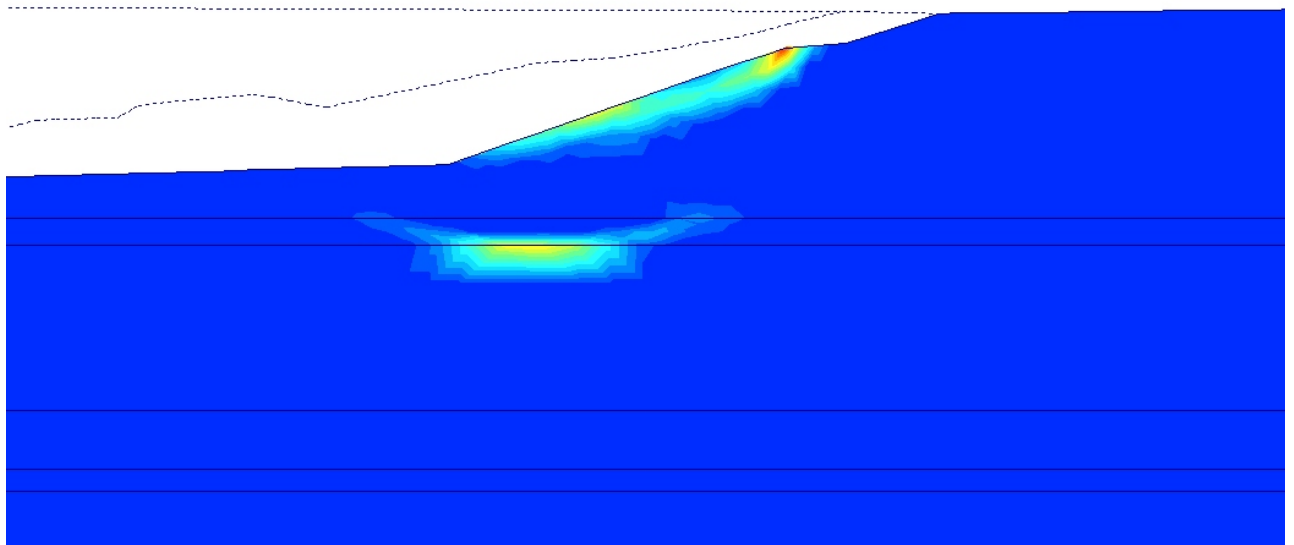

**NOTES :**

1. Data computed using Plaxis version 8.6
2. Method of computation Finite Element Analysis  
C-Phi Reduction



CUY-90-14.40

**Section G-G with  
Alternative 5  
FEA C-Phi Reduction  
Incremental Strain Plots**

**November 2009**

## **Appendix “7J - D”**

### **Section J-J Results**

Section J-J was analyzed by Geocomp for the following condition:

- Alternative 2 geometry with elevated pore water pressures

Stability results are provided using UTEXAS4 using Spencer’s Method and by using the Finite Element Phi-C reduction method in Plaxis.

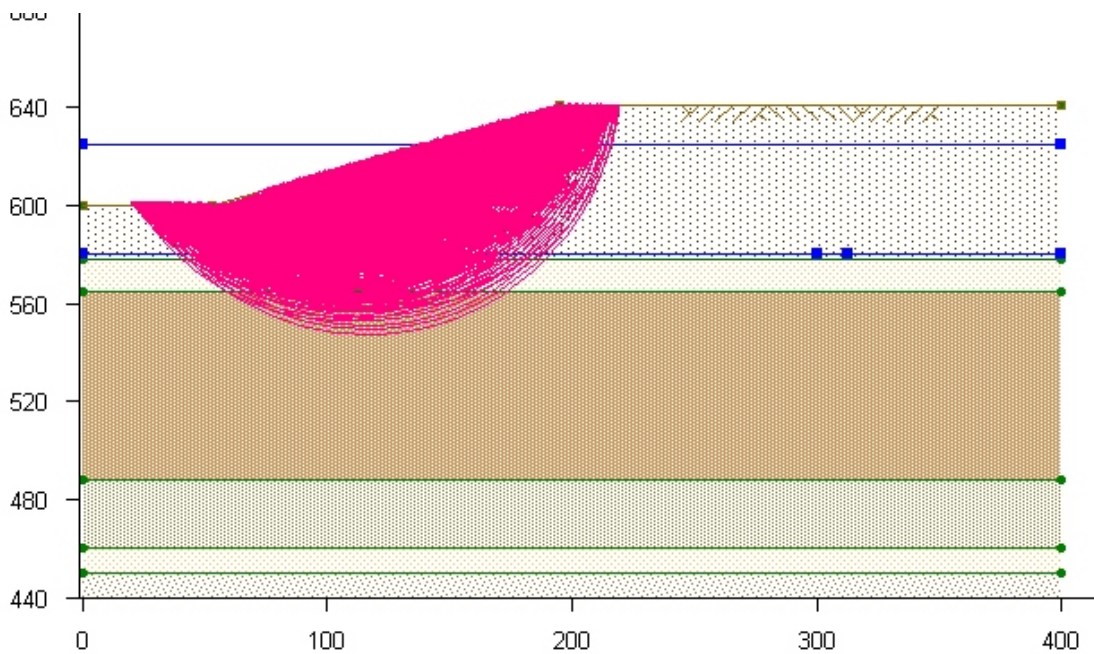

**Factor of safety: 2.685**  
**Side force Inclination: 15.29 degrees**

|   |        | WEIGHT | STRENGTH                                | PORE PRESSURE              |
|---|--------|--------|---|----------------------------|
| 1 | SA-GR  | 125    | Cohesion: 0.0<br>Friction angle: 36     | Piezometric<br>Line no. 1. |
| 2 | SM     | 125    | Cohesion: 0.0<br>Friction angle: 32     | Piezometric<br>Line no. 1. |
| 3 | SO ML  | 125    | Cohesion: 0.0<br>Friction angle: 22     | Piezometric<br>Line no. 1. |
| 4 | VST ML | 125    | Cohesion: 0.0<br>Friction angle: 32     | Piezometric<br>Line no. 1. |
| 5 | SO ML  | 120    | Cohesion: 0.0<br>Friction angle: 15     | Piezometric<br>Line no. 2. |
| 6 | BR     | 135    | Cohesion: 20000.0<br>Friction angle: 20 | Piezometric<br>Line no. 1. |

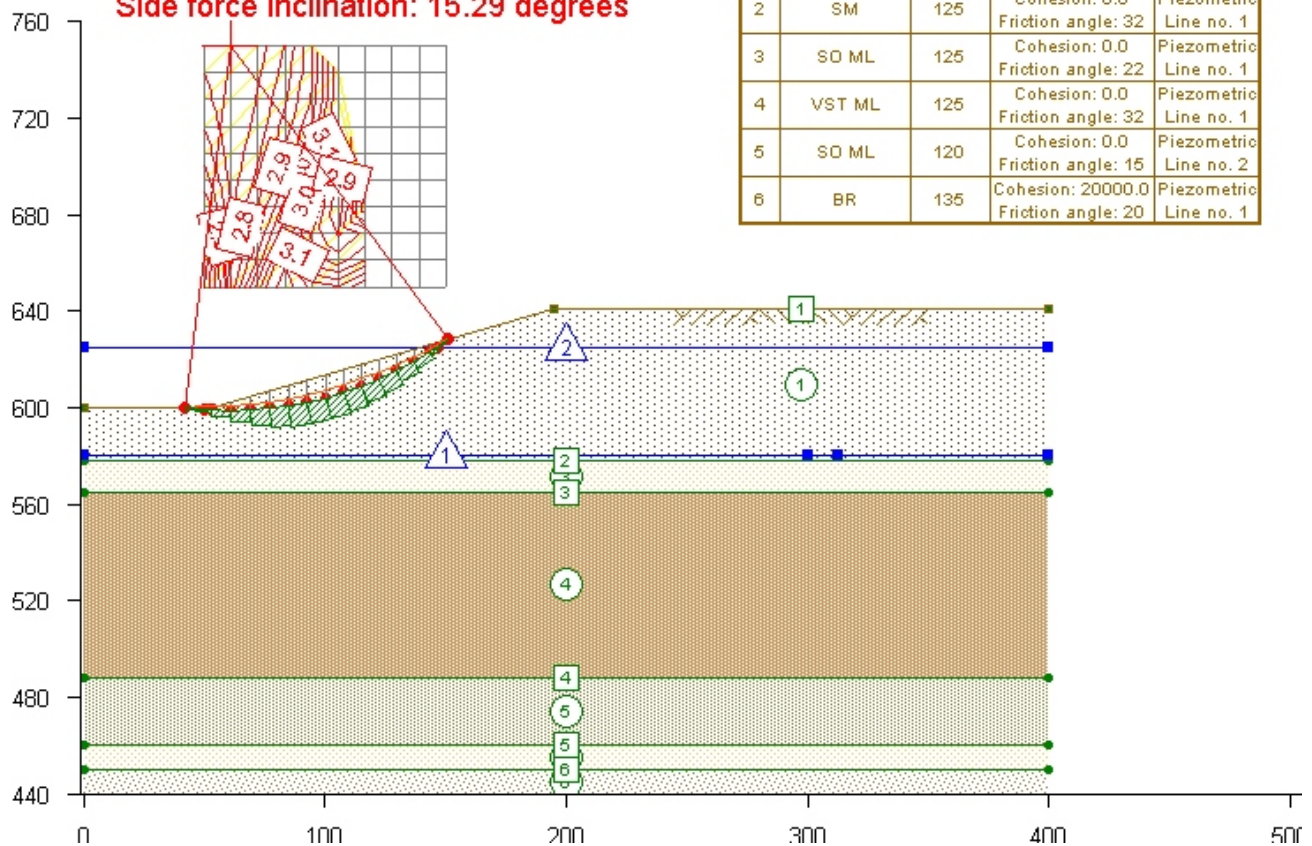

**NOTES :**

1. Data computed using UTEXAS4 Version 4.1.0.3
2. Method of computation set to Spencer's Method.



CUY-90-14.40

**Section J-J with  
 Alternative 2  
 Circular Surfaces  
 Spencer's Method**

November 2009

**Alternative 2**  
**Factor of Safety=2.72**

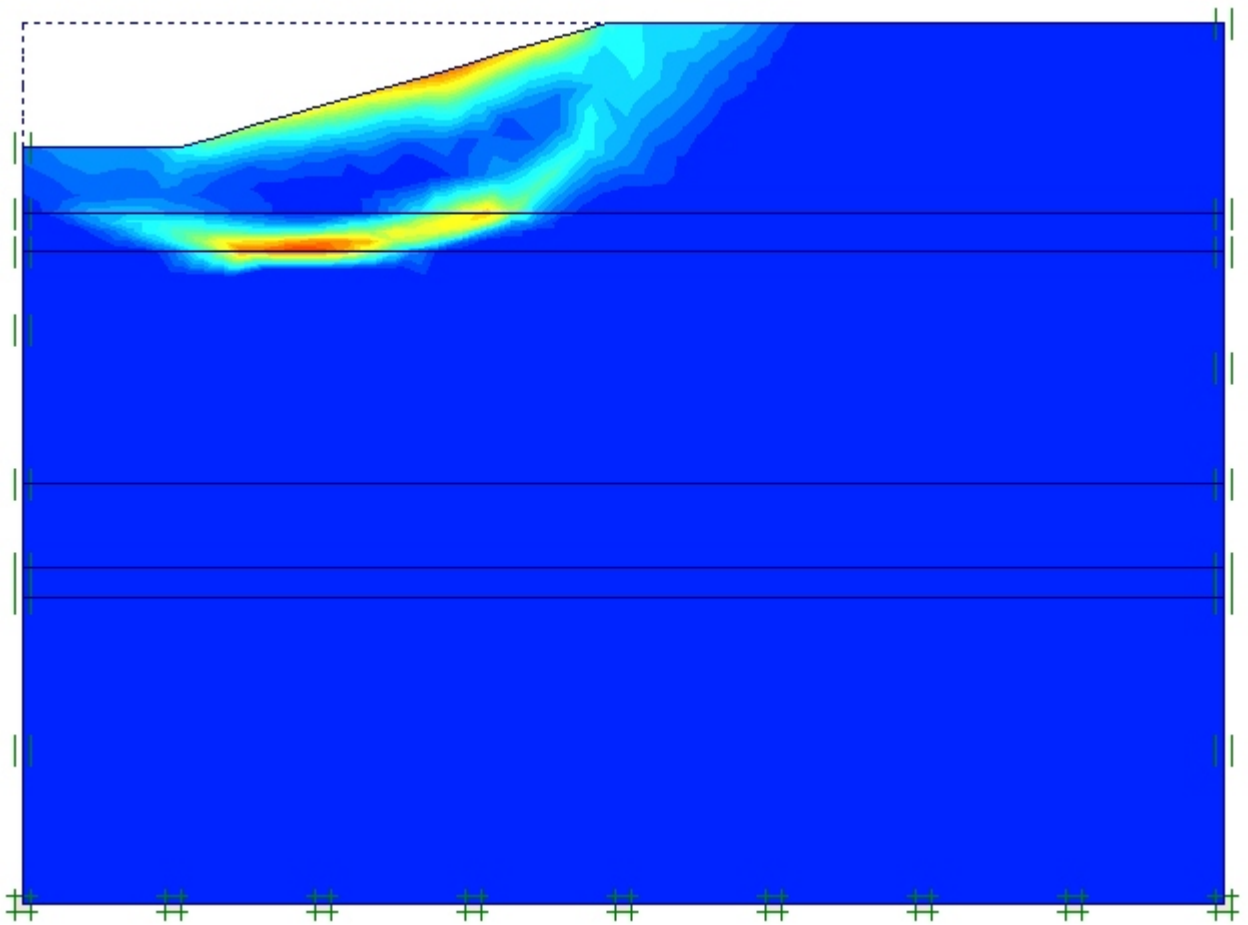

**NOTES :**

1. Data computed using Plaxis version 8.6
2. Method of computation Finite Element Analysis  
C-Phi Reduction



CUY-90-14.40

**Section J-J with  
Alternative 2  
FEA C-Phi Reduction  
Incremental Strain Plot**

**November 2009**

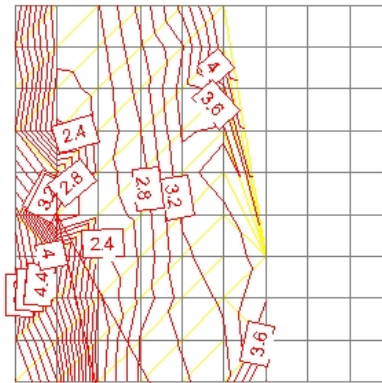
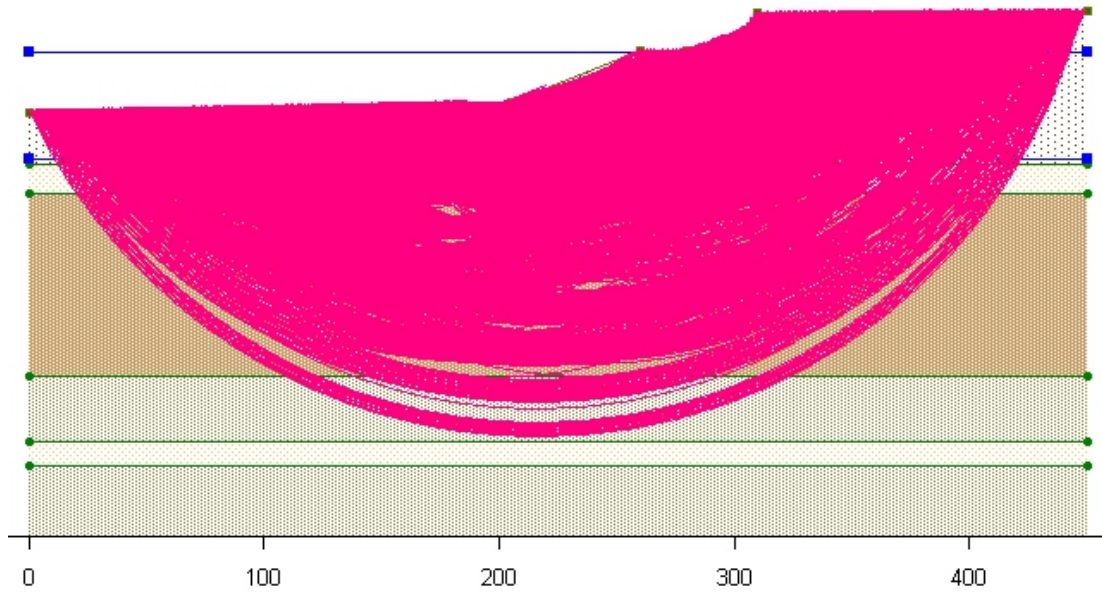

| NO. | DESCRIPTION | UNIT WEIGHT | SHEAR STRENGTH                          | PORE PRESSURE          |
|-----|-------------|-------------|---|------------------------|
| 1   | SA-GR       | 125         | Cohesion: 0.0<br>Friction angle: 38     | Piezometric Line no. 1 |
| 2   | SM          | 115         | Cohesion: 0.0<br>Friction angle: 32     | Piezometric Line no. 1 |
| 3   | SO ML       | 125         | Cohesion: 0.0<br>Friction angle: 22     | Piezometric Line no. 1 |
| 4   | VST ML      | 120         | Cohesion: 0.0<br>Friction angle: 32     | Piezometric Line no. 1 |
| 5   | SO ML       | 120         | Cohesion: 0.0<br>Friction angle: 15     | Piezometric Line no. 2 |
| 6   | BR          | 135         | Cohesion: 20000.0<br>Friction angle: 20 | Piezometric Line no. 1 |

Factor of safety: 1.861  
Side force Inclination: 21.16 degrees

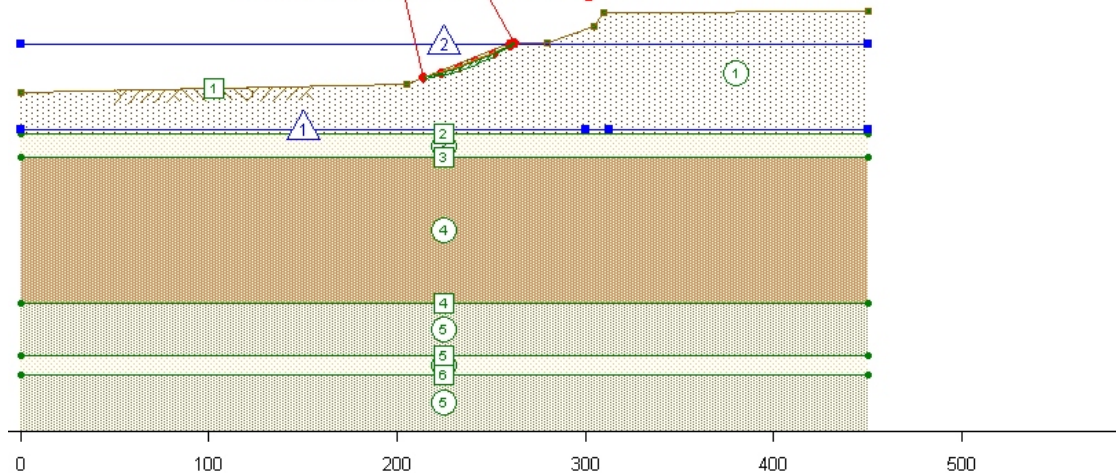

**NOTES :**

1. Data computed using UTEXAS4 Version 4.1.0.3
2. Method of computation set to Spencer's Method.



CUY-90-14.40  
**Section JJ with  
Alternative 5  
Circular Surfaces  
Spencer's Method**

November 2009



# Elevated Pore Pressures Factor of Safety=2.32

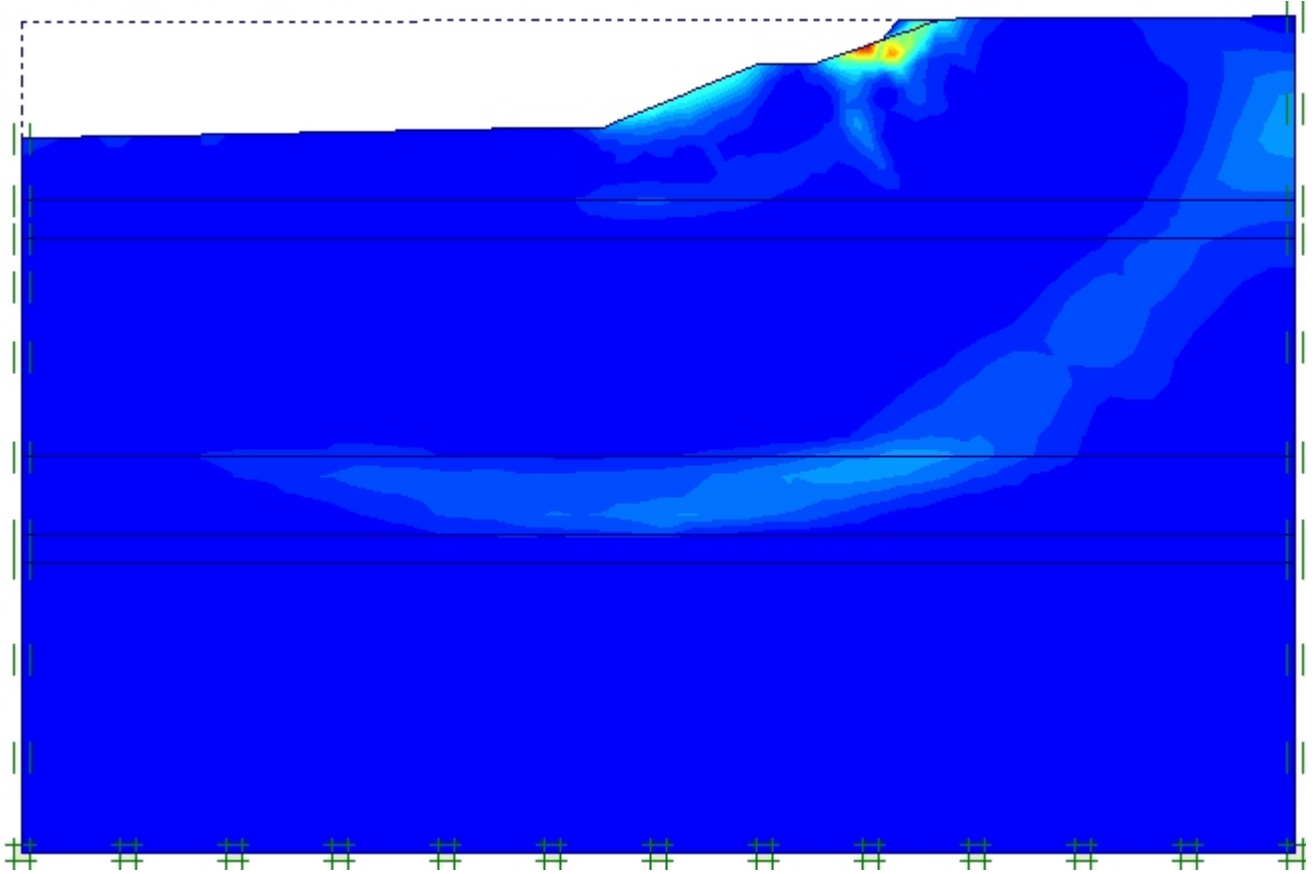

## **NOTES :**

1. Data computed using Plaxis version 8.6
2. Method of computation Finite Element Analysis  
C-Phi Reduction



CUY-90-14.40

**Section J-J with  
Alternative 5  
FEA C-Phi Reduction  
Incremental Strain Plots**

**November 2009**

## **Appendix “7J - E”**

### **Section W-W Results**

Section W-W was analyzed by Geocomp for the following conditions:

- Existing geometry with elevated pore water pressures
- Alternative 2 geometry with elevated pore water pressures
- Alternative 5 geometry – with elevated pore water pressures
- Alternative 5 geometry – with reduced pore water pressures

Stability results are provided using UTEXAS4 using Spencer’s Method and by using the Finite Element Phi-C reduction method in Plaxis.

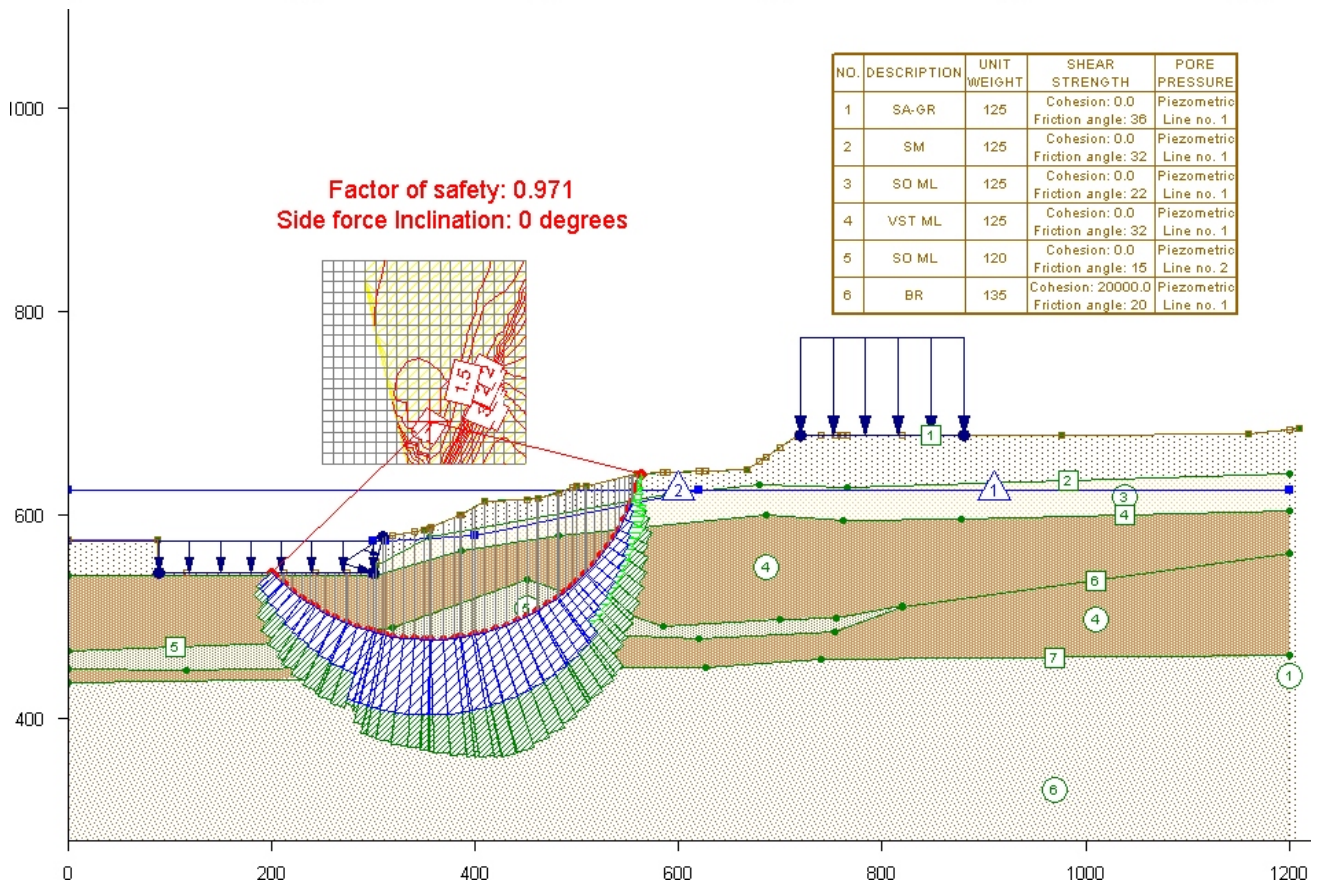
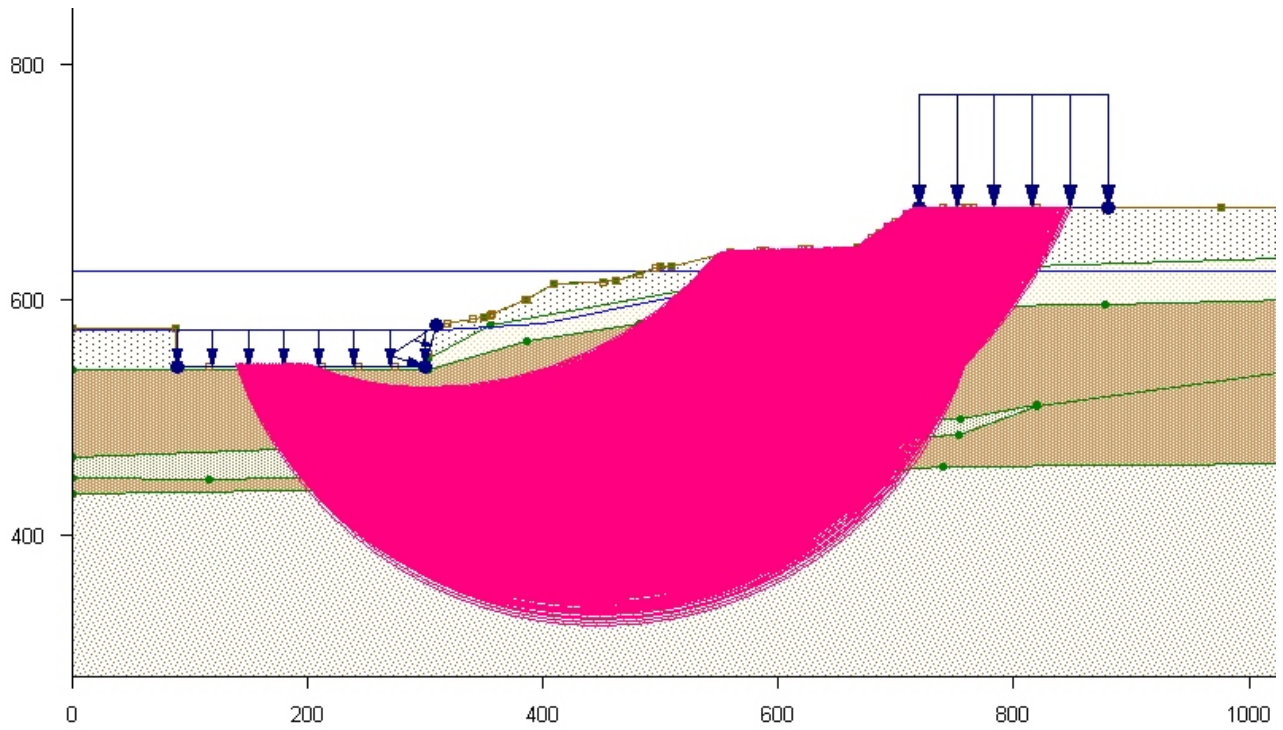

| NO. | DESCRIPTION | UNIT WEIGHT | SHEAR STRENGTH                          | PORE PRESSURE          |
|-----|-------------|-------------|---|------------------------|
| 1   | SA-GR       | 125         | Cohesion: 0.0<br>Friction angle: 36     | Piezometric Line no. 1 |
| 2   | SM          | 125         | Cohesion: 0.0<br>Friction angle: 32     | Piezometric Line no. 1 |
| 3   | SO ML       | 125         | Cohesion: 0.0<br>Friction angle: 22     | Piezometric Line no. 1 |
| 4   | VST ML      | 125         | Cohesion: 0.0<br>Friction angle: 32     | Piezometric Line no. 1 |
| 5   | SO ML       | 120         | Cohesion: 0.0<br>Friction angle: 15     | Piezometric Line no. 2 |
| 6   | BR          | 135         | Cohesion: 20000.0<br>Friction angle: 20 | Piezometric Line no. 1 |

**Factor of safety: 0.971**  
**Side force Inclination: 0 degrees**

**NOTES :**

1. Data computed using UTEXAS4 Version 4.1.0.3
2. Method of computation set to Simplified Janbu procedure (side force inclination set to zero degrees).



CUY-90-14.40

**Section W-W with Existing Geometry  
Circular Surfaces  
Simplified Janbu Method**

November 2009

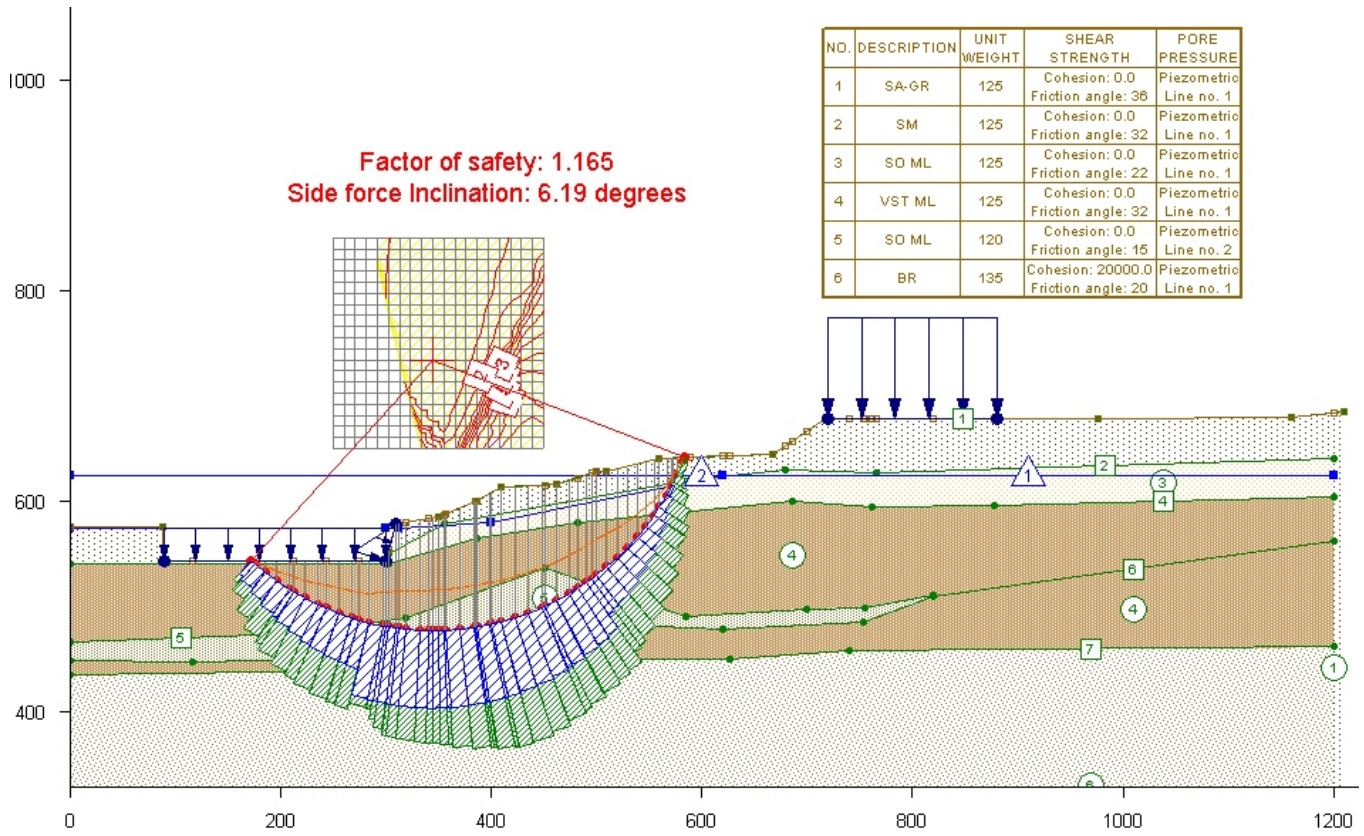
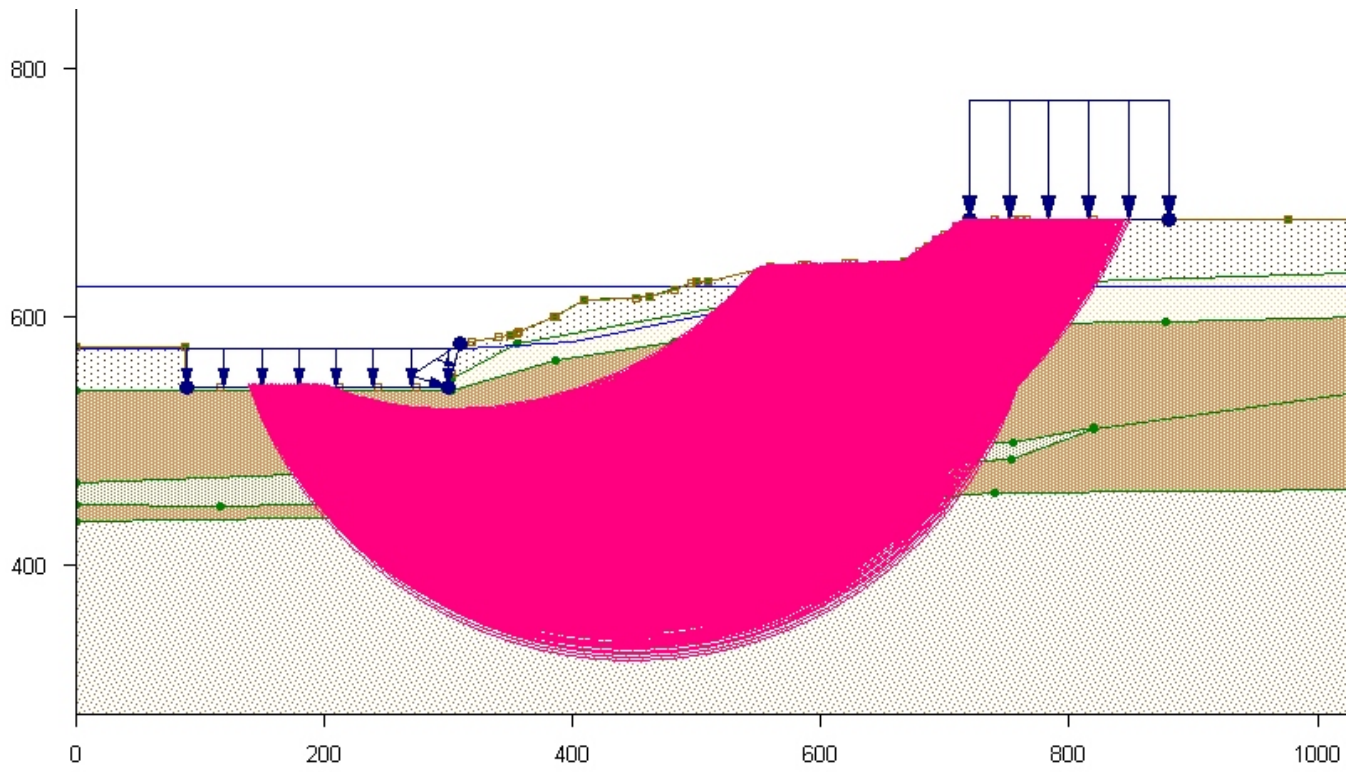

Section WW-Alt 2 Results.des

**NOTES :**

1. Data computed using UTEXAS4 Version 4.1.0.3
2. Method of computation set to Spencer's Method.



CUY-90-14.40  
**Section W-W with Existing Geometry**  
**Circular Surfaces**  
**Spencer's Method**  
 November 2009

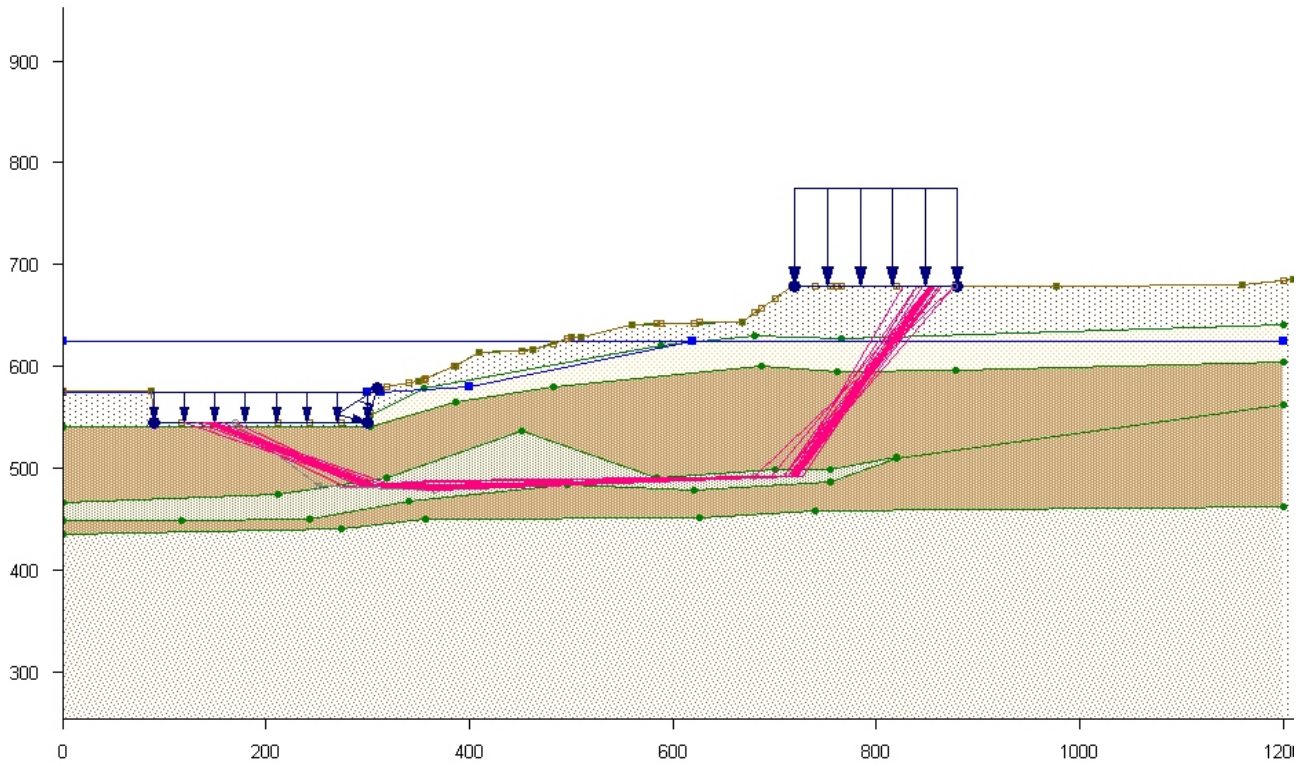

| NO. | DESCRIPTION | UNIT WEIGHT | SHEAR STRENGTH                          | PORE PRESSURE             |
|-----|-------------|-------------|---|---------------------------|
| 1   | SA-GR       | 125         | Cohesion: 0.0<br>Friction angle: 36     | Piezometric<br>Line no. 1 |
| 2   | SM          | 125         | Cohesion: 0.0<br>Friction angle: 32     | Piezometric<br>Line no. 1 |
| 3   | SO ML       | 125         | Cohesion: 0.0<br>Friction angle: 22     | Piezometric<br>Line no. 1 |
| 4   | VST ML      | 125         | Cohesion: 0.0<br>Friction angle: 32     | Piezometric<br>Line no. 1 |
| 5   | SO ML       | 120         | Cohesion: 0.0<br>Friction angle: 15     | Piezometric<br>Line no. 2 |
| 6   | BR          | 135         | Cohesion: 20000.0<br>Friction angle: 20 | Piezometric<br>Line no. 1 |

Factor of safety: 1.124  
Side force Inclination: 8.87 degrees

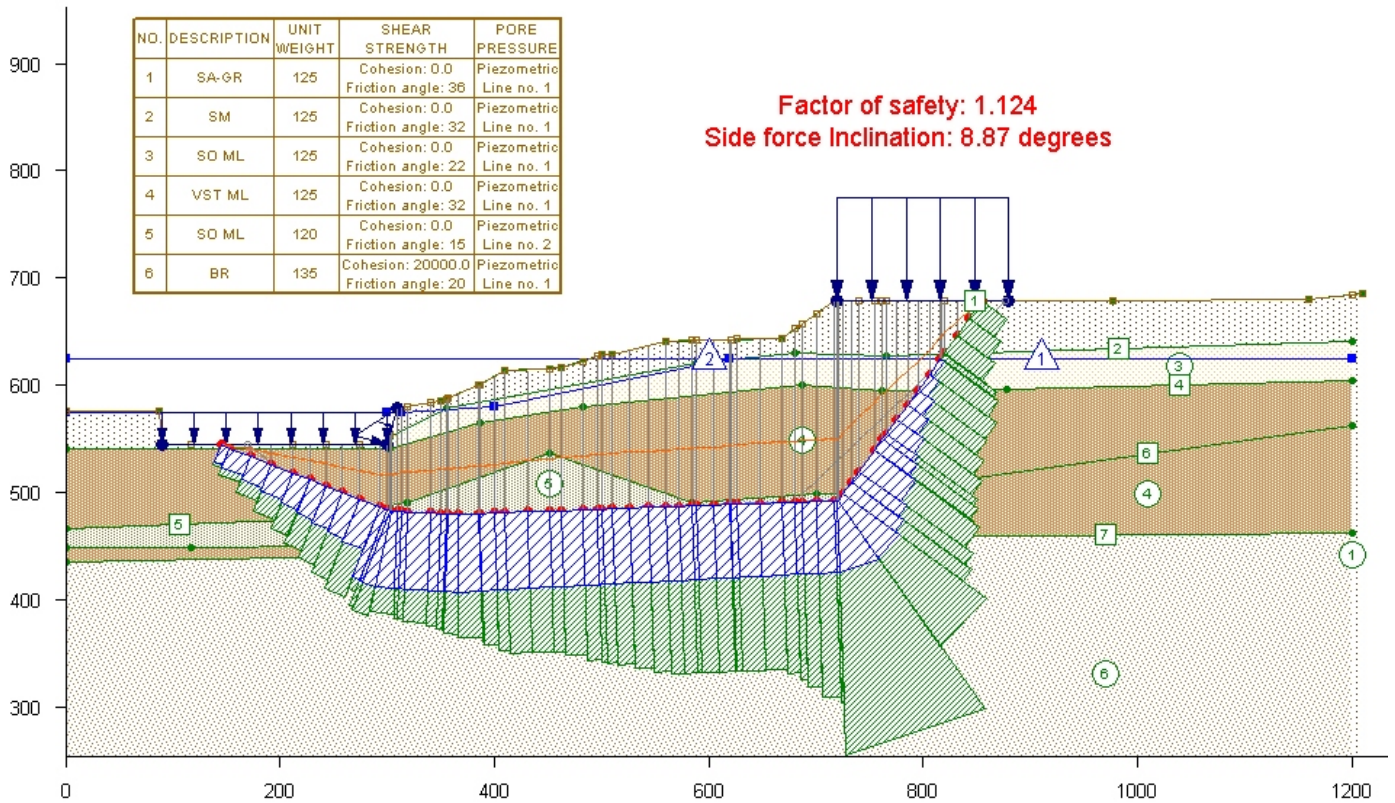

**NOTES :**

1. Data computed using UTEXAS4 Version 4.1.0.3
2. Method of computation set to Spencer's Method.



CUY-90-14.40

**Section W-W with  
Existing Geometry  
Non-Circular Surfaces  
Spencer's Method**

November 2009

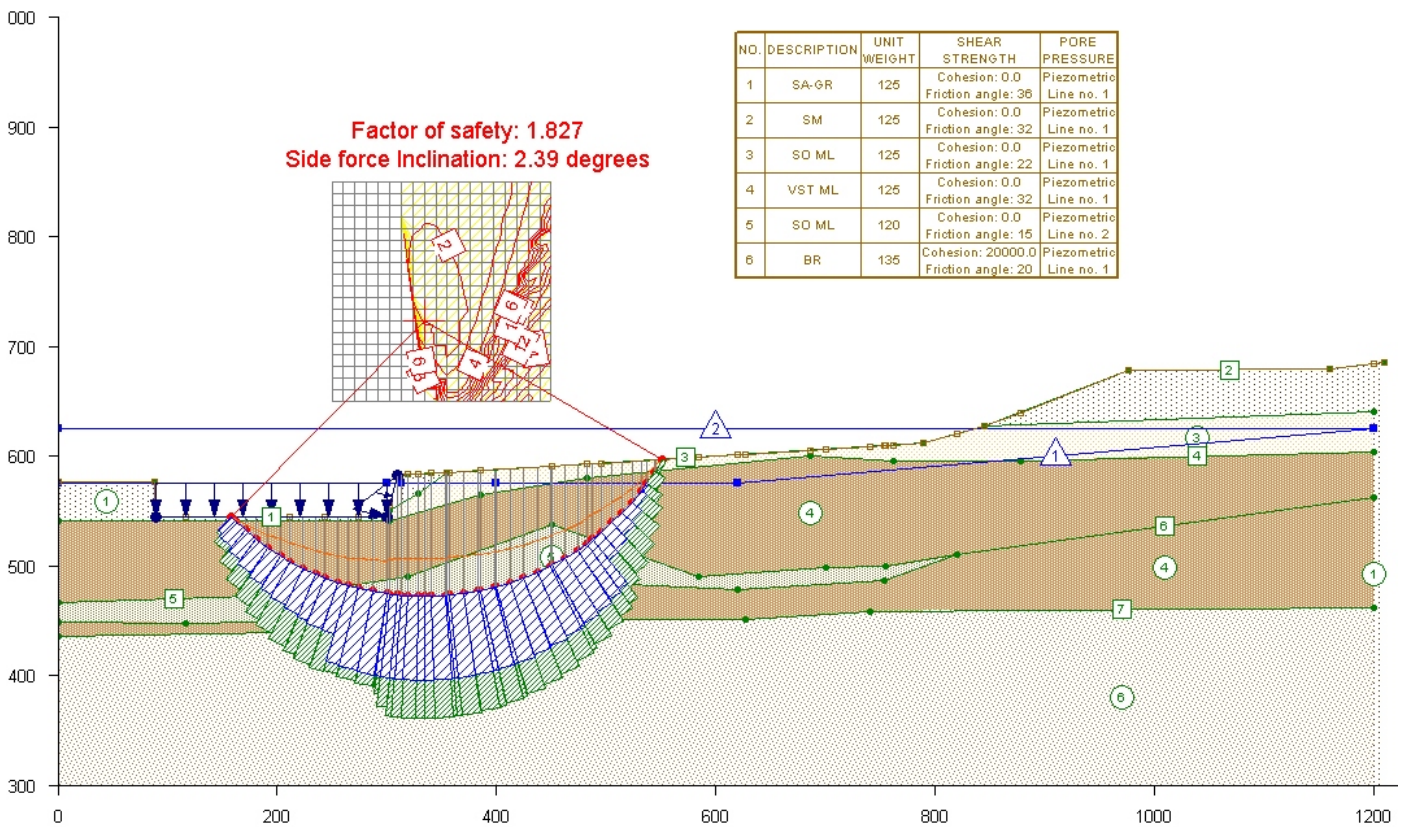
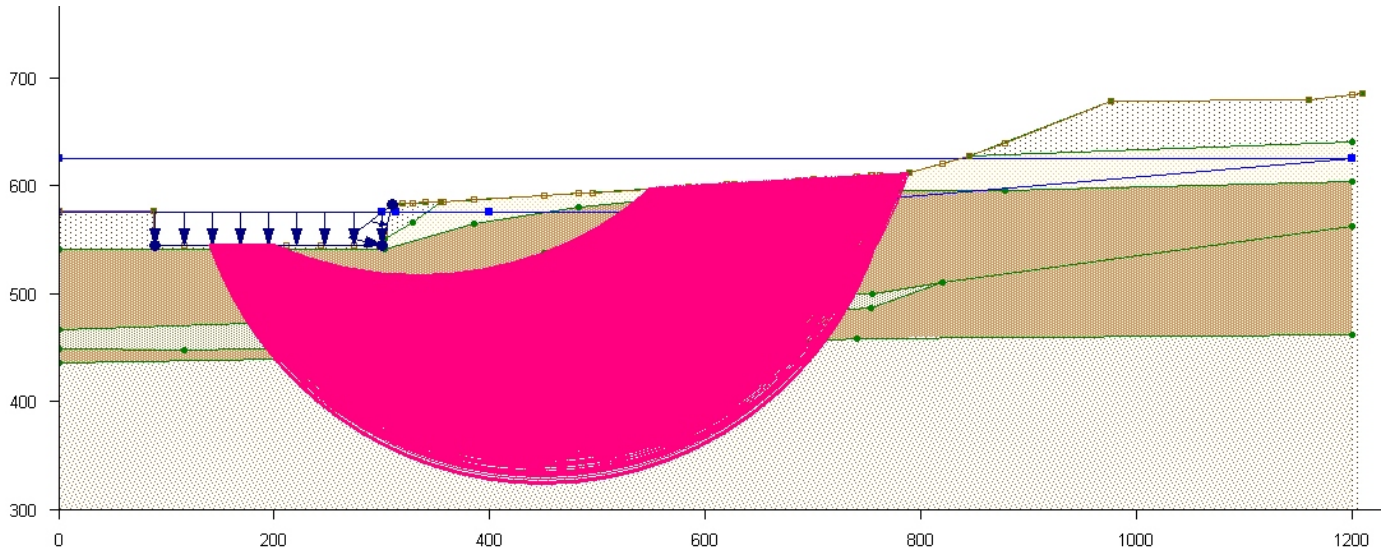

**NOTES :**

1. Data computed using UTEXAS4 Version 4.1.0.3
2. Method of computation set to Spencer's Method.



CUY-90-14.40

**Section W-W with  
Alternative 2  
Circular Surfaces  
Spencer's Method**

**November 2009**

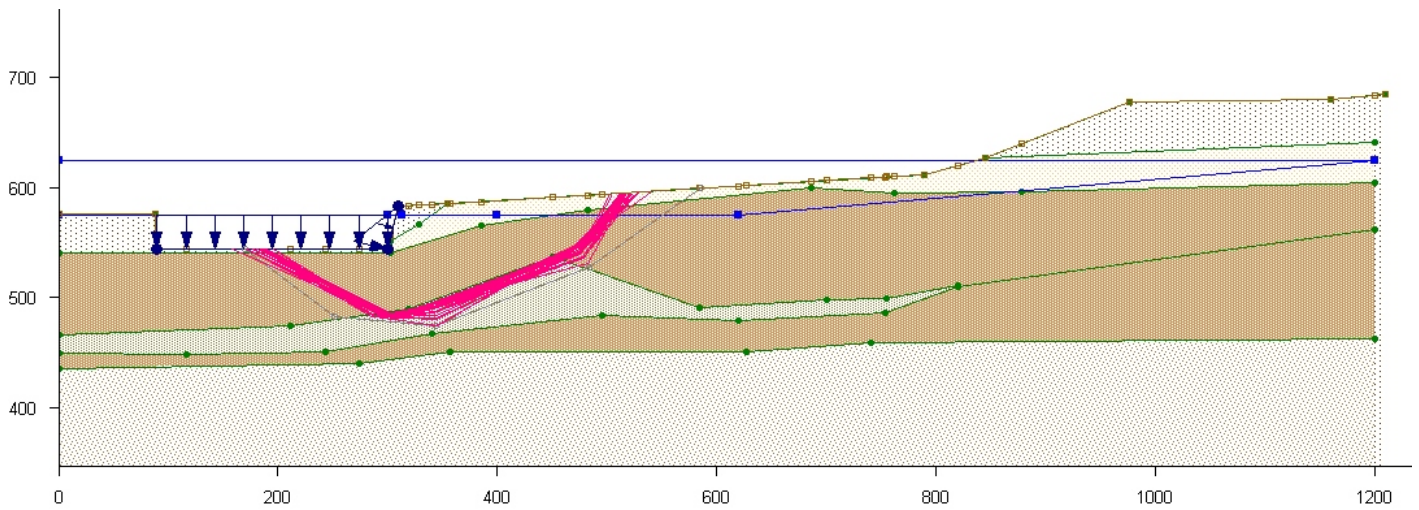

| NO. | DESCRIPTION | UNIT WEIGHT | SHEAR STRENGTH                          | PORE PRESSURE          |
|-----|-------------|-------------|---|------------------------|
| 1   | SA-GR       | 125         | Cohesion: 0.0<br>Friction angle: 36     | Piezometric Line no. 1 |
| 2   | SM          | 125         | Cohesion: 0.0<br>Friction angle: 32     | Piezometric Line no. 1 |
| 3   | SO ML       | 125         | Cohesion: 0.0<br>Friction angle: 22     | Piezometric Line no. 1 |
| 4   | VST ML      | 125         | Cohesion: 0.0<br>Friction angle: 32     | Piezometric Line no. 1 |
| 5   | SO ML       | 120         | Cohesion: 0.0<br>Friction angle: 15     | Piezometric Line no. 2 |
| 6   | BR          | 135         | Cohesion: 20000.0<br>Friction angle: 20 | Piezometric Line no. 1 |

Factor of safety: 1.581  
Side force Inclination: 2.91 degrees

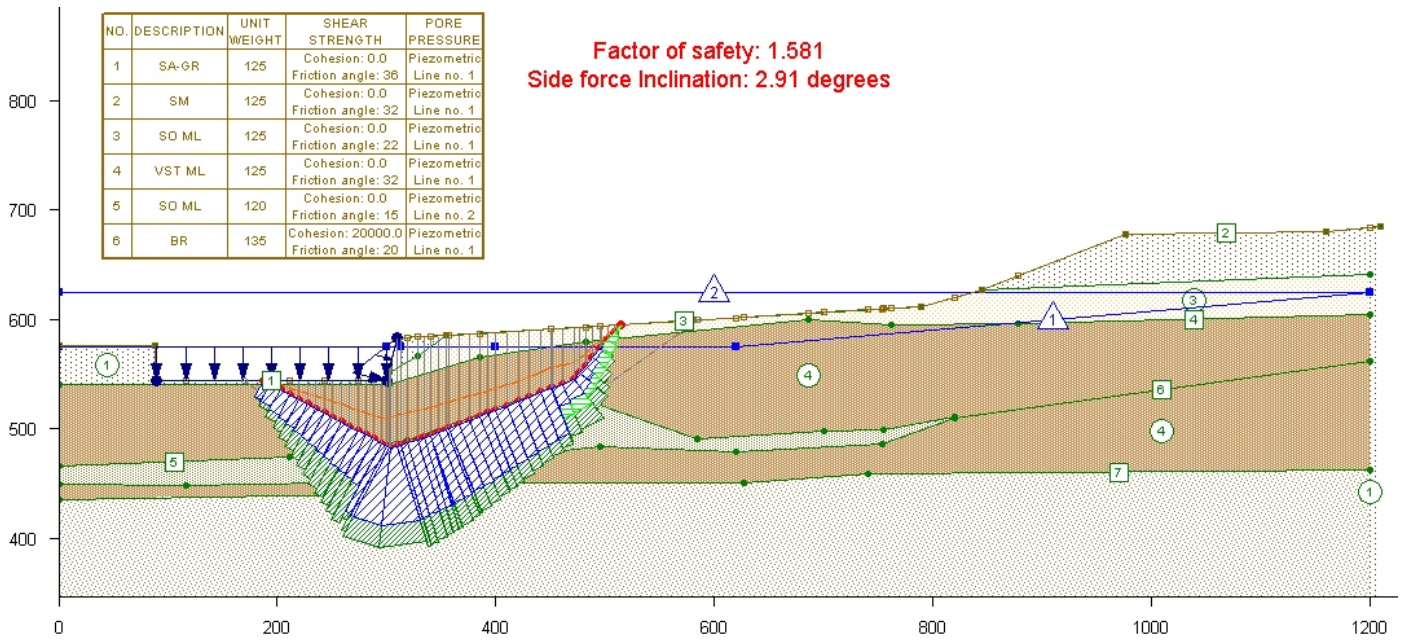

**NOTES :**

1. Data computed using UTEXAS4 Version 4.1.0.3
2. Method of computation set to Spencer's Method.



CUY-90-14.40

**Section W-W with  
Alternative 2  
Non-Circular Surface  
Spencer's Method**

November 2009

## Existing Geometry Factor of Safety=1.09

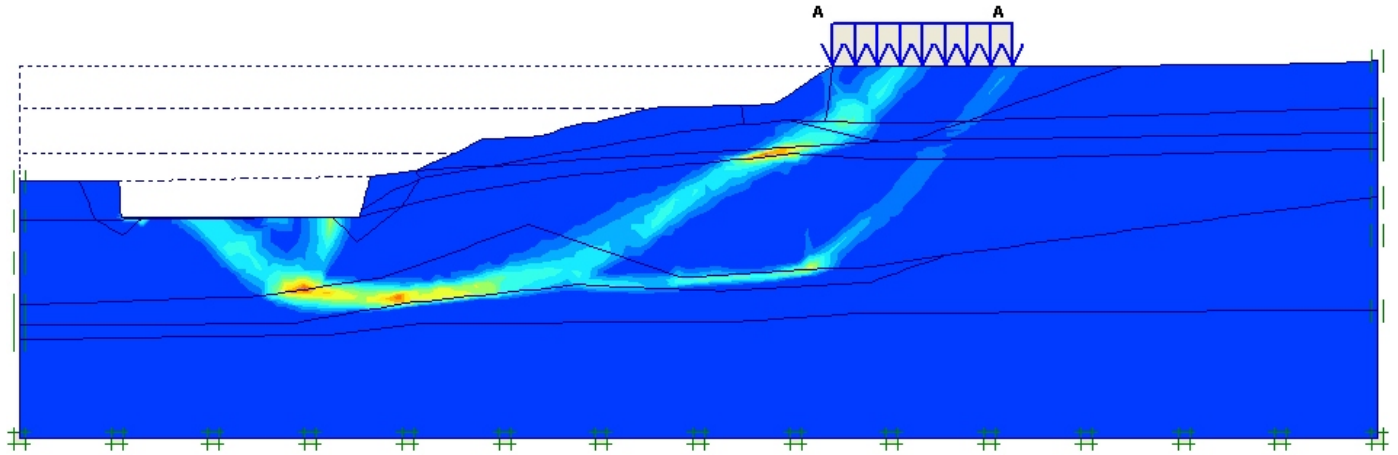

## Alternative 2 Factor of Safety=1.55

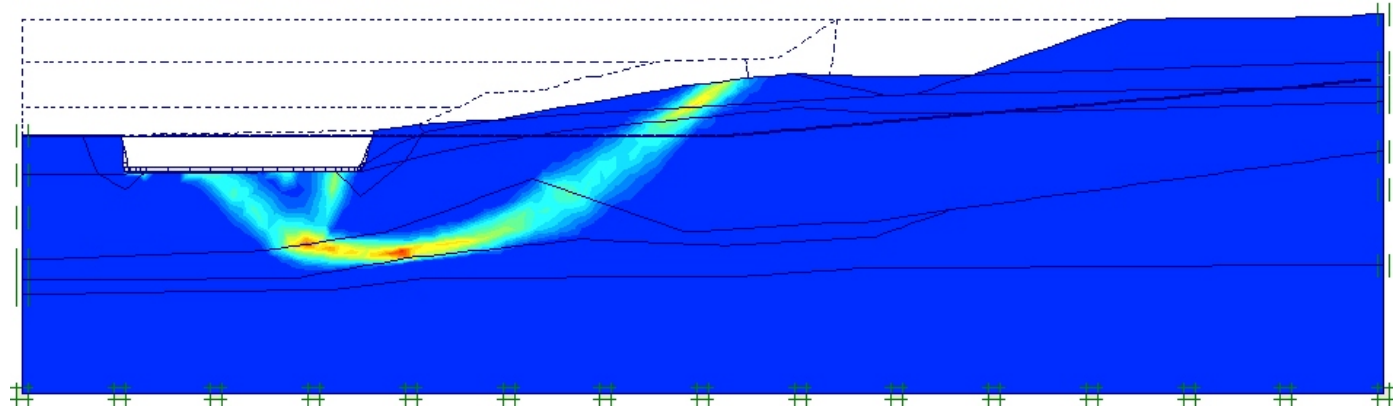

### NOTES :

1. Data computed using Plaxis version 8.6
2. Method of computation Finite Element Analysis  
C-Phi Reduction



CUY-90-14.40

Section W-W with  
Alternative 2  
FEA C-Phi Reduction  
Incremental Strain Plots

November 2009



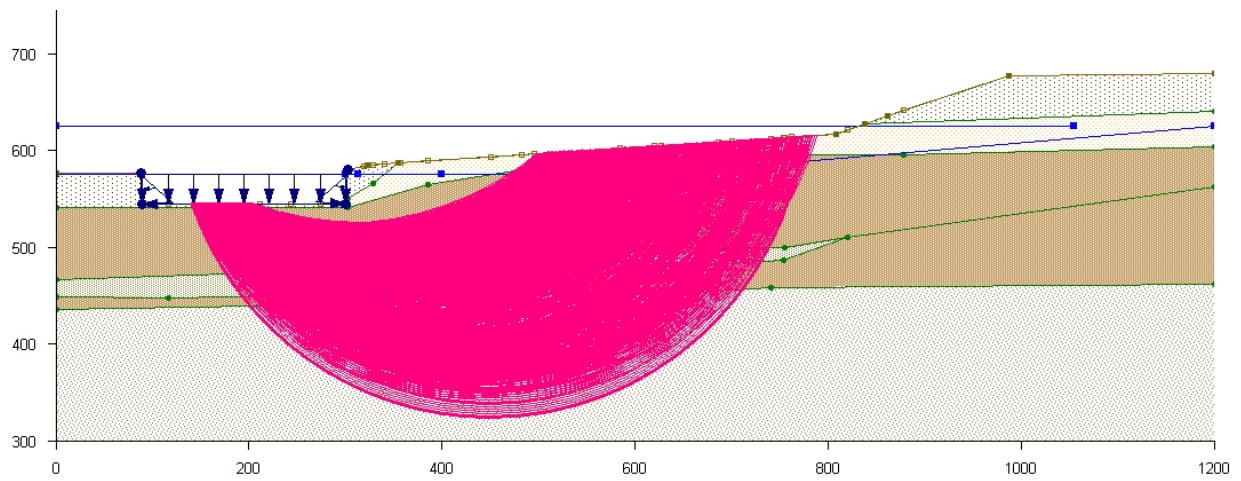

Factor of safety: 1.653  
Side force Inclination: 2.75 degrees

| NO. | DESCRIPTION | UNIT WEIGHT | SHEAR STRENGTH                          | PORE PRESSURE             |
|-----|-------------|-------------|---|---------------------------|
| 1   | SA-GR       | 125         | Cohesion: 0.0<br>Friction angle: 36     | Piezometric<br>Line no. 1 |
| 2   | SM          | 125         | Cohesion: 0.0<br>Friction angle: 32     | Piezometric<br>Line no. 1 |
| 3   | SO ML       | 125         | Cohesion: 0.0<br>Friction angle: 22     | Piezometric<br>Line no. 1 |
| 4   | VST ML      | 125         | Cohesion: 0.0<br>Friction angle: 32     | Piezometric<br>Line no. 1 |
| 5   | SO ML       | 120         | Cohesion: 0.0<br>Friction angle: 15     | Piezometric<br>Line no. 2 |
| 6   | BR          | 135         | Cohesion: 20000.0<br>Friction angle: 20 | Piezometric<br>Line no. 1 |

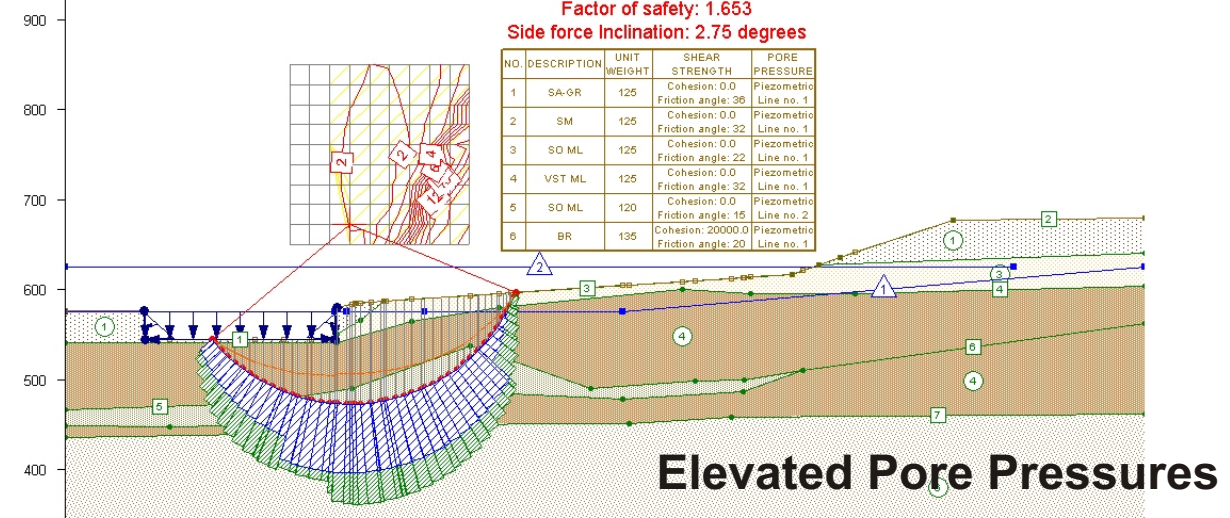

**Elevated Pore Pressures**

Factor of safety: 2.176  
Side force Inclination: 4.05 degrees

| NO. | DESCRIPTION | UNIT WEIGHT | SHEAR STRENGTH                          | PORE PRESSURE             |
|-----|-------------|-------------|---|---------------------------|
| 1   | SA-GR       | 125         | Cohesion: 0.0<br>Friction angle: 36     | Piezometric<br>Line no. 1 |
| 2   | SM          | 125         | Cohesion: 0.0<br>Friction angle: 32     | Piezometric<br>Line no. 1 |
| 3   | SO ML       | 125         | Cohesion: 0.0<br>Friction angle: 22     | Piezometric<br>Line no. 1 |
| 4   | VST ML      | 125         | Cohesion: 0.0<br>Friction angle: 32     | Piezometric<br>Line no. 1 |
| 5   | SO ML       | 120         | Cohesion: 0.0<br>Friction angle: 15     | Piezometric<br>Line no. 1 |
| 6   | BR          | 135         | Cohesion: 20000.0<br>Friction angle: 20 | Piezometric<br>Line no. 1 |

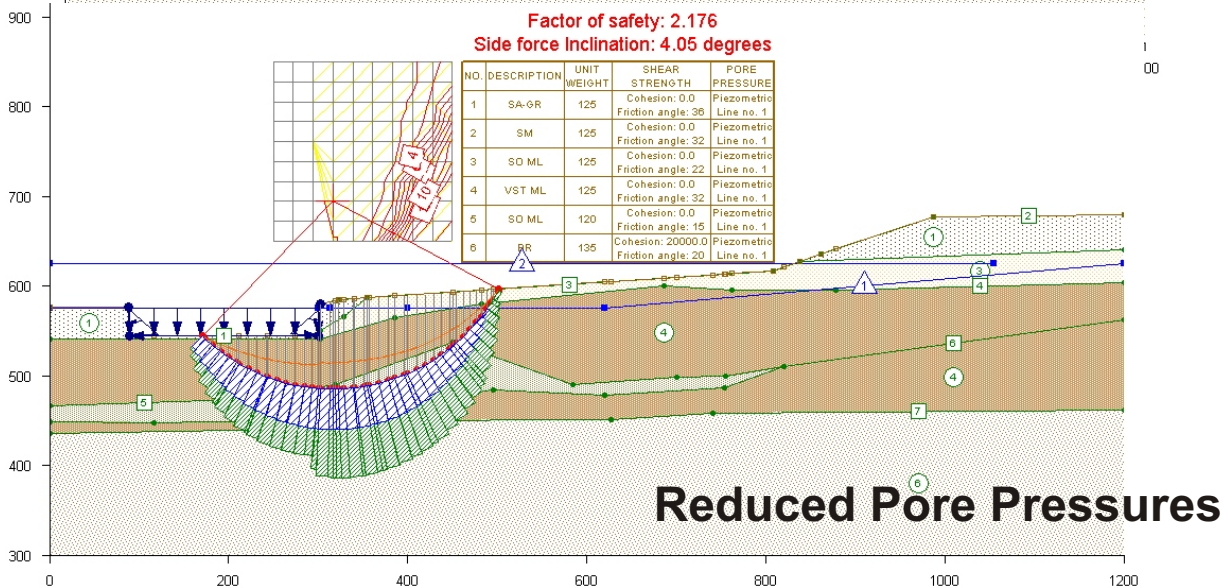

**Reduced Pore Pressures**

**NOTES :**

1. Data computed using UTEXAS4 Version 4.1.0.3
2. Method of computation set to Spencer's Method.



CUY-90-14.40

**Section W-W with  
Alternative 5  
Circular Surfaces  
Spencer's Method**

November 2009

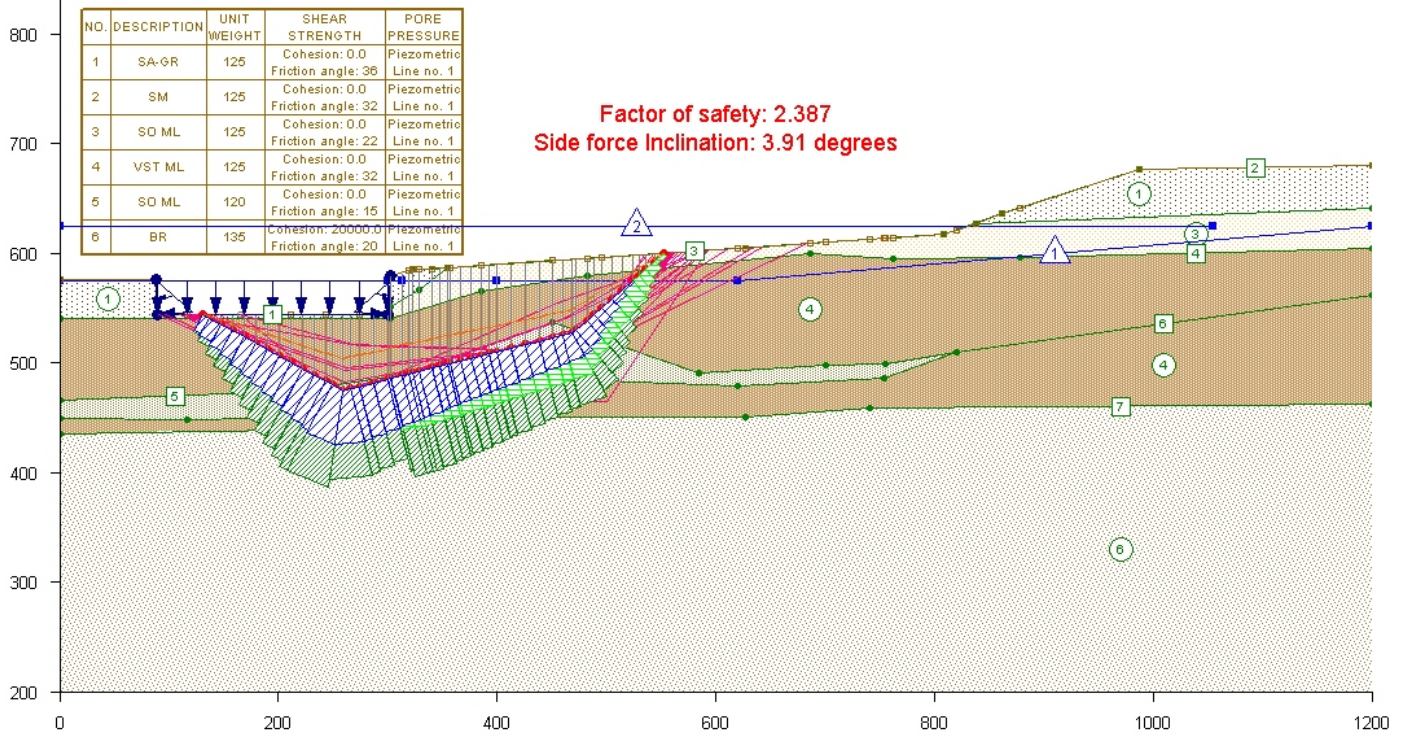
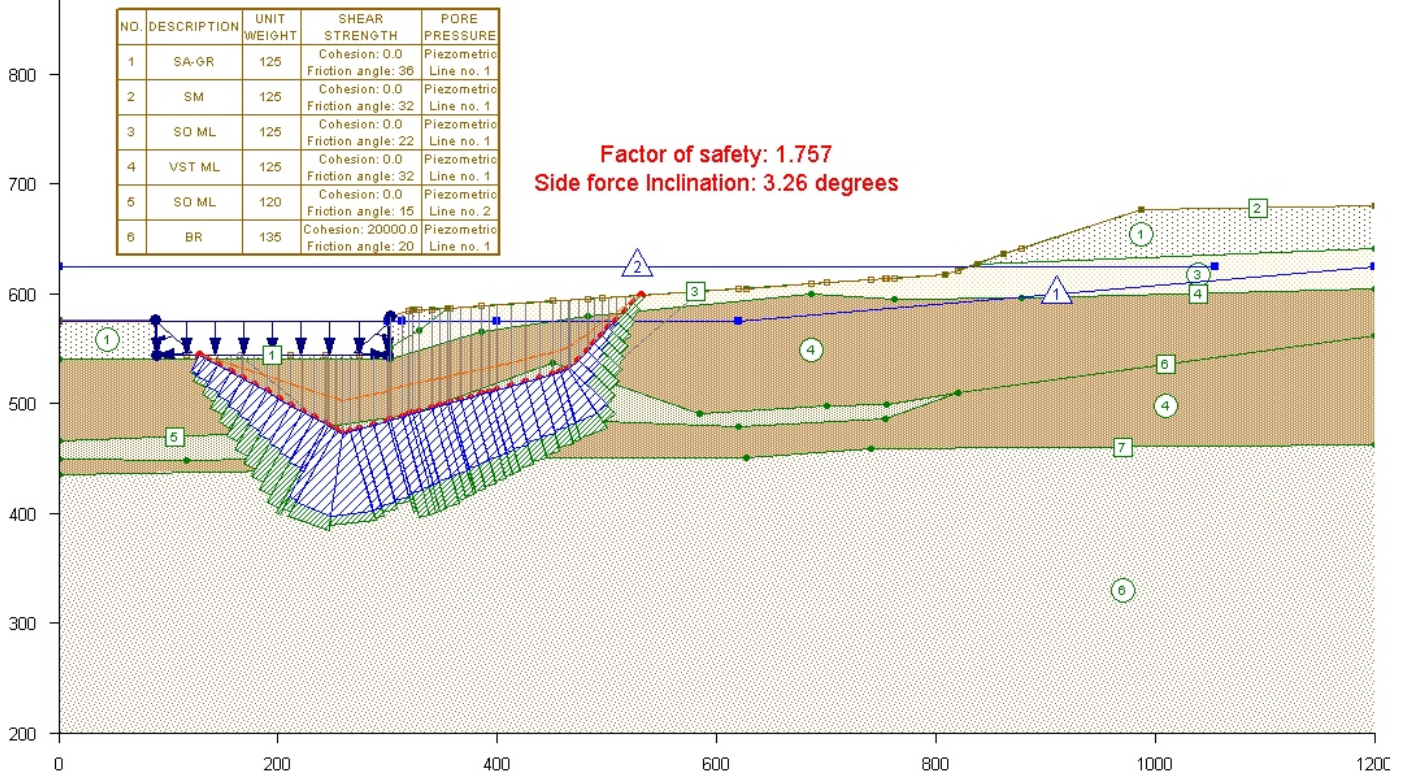

**NOTES :**

1. Data computed using UTEXAS4 Version 4.1.0.3
2. Method of computation set to Spencer's Method.



CUY-90-14.40

**Section W-W with  
Alternative 5  
Non-Circular Surface  
Spencer's Method**

**November 2009**

## Elevated Pore Pressures Factor of Safety=1.62

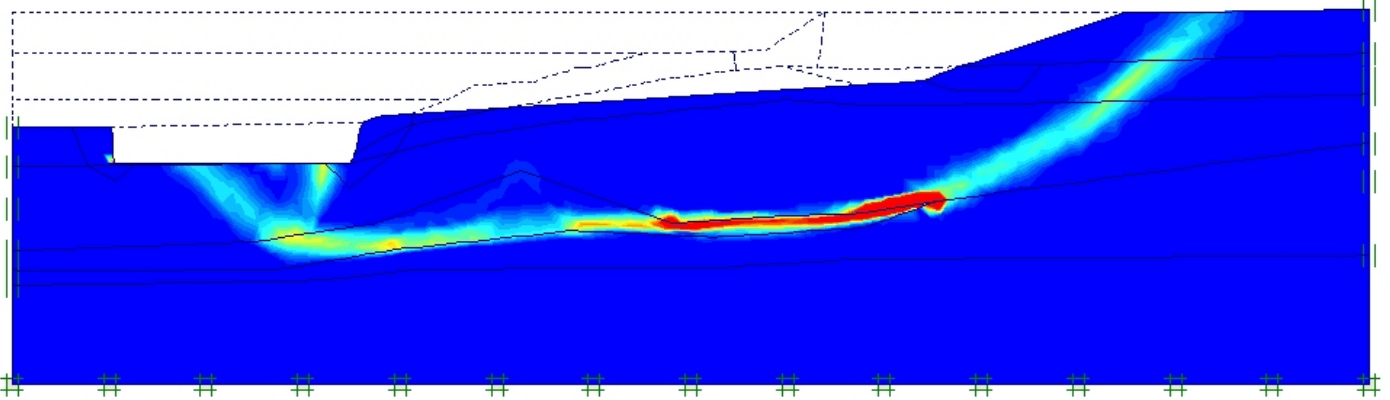

## Reduced Pore Pressures Factor of Safety=2.10

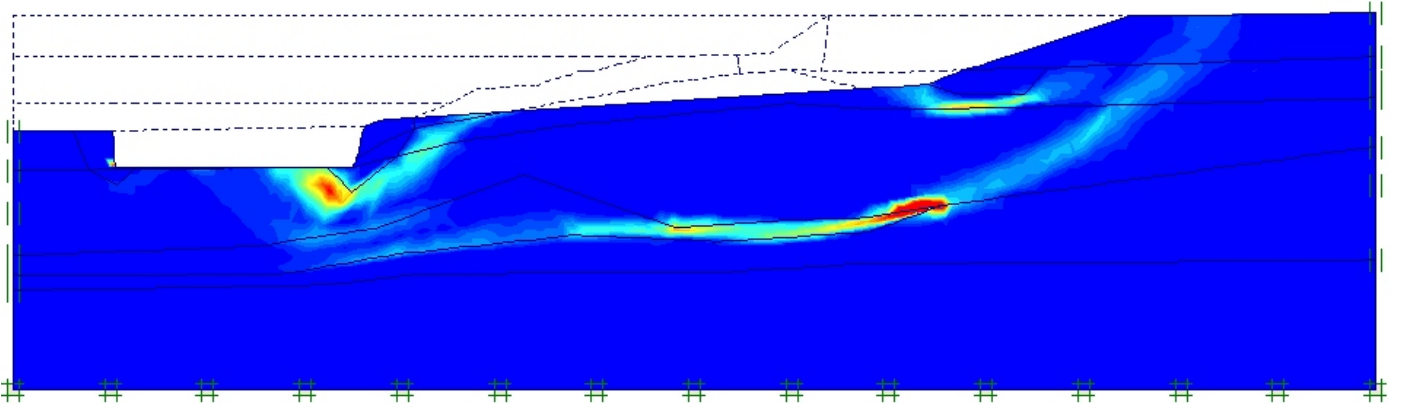

### NOTES :

1. Data computed using Plaxis version 8.6
2. Method of computation Finite Element Analysis  
C-Phi Reduction



CUY-90-14.40

Section W-W with  
Alternative 5  
FEA C-Phi Reduction  
Incremental Strain Plots

November 2009

## CHAPTER 8

### HORIZONTAL GRAVITY DRAINS AND VERTICAL PRESSURE RELIEF DUCTS

#### A. Horizontal Gravity Drains

##### 8.1 Introduction

The addition of horizontal gravity drains installed in the proposed regraded west bank slope is a very cost effective means to improve the overall stability of the slope by using a system that can be referred to as a secondary or complementary means to add integrity to the design. Horizontal drains have been used for over fifty years on marginally stable slopes to successfully lower the water table and ultimately increase the factor of safety against slope movements and overall failure.

A literature search reveals many references (thousands due to their over 50-year history in the United States) where horizontal drains have been successfully used. One experienced practitioner's opinion regarding the viability of utilizing horizontal drains used to collect water and to allow the water to escape from a slope is documented via our extensive literature search. Mr. Mike Oliver with The Government of British Columbia, Ministry of Transportation, Geotechnical Branch was interviewed regarding his experience with horizontal drains. His comments indicate that horizontal drains are often used as a secondary means to control hydrostatic pressure and maintenance is periodically necessary but not difficult or expensive. The British Columbia Ministry of Transportation has been using horizontal drains to stabilize slopes for more than 25 years. They have established installation and maintenance specifications used by the Ministry Districts on all projects involving horizontal drains. The Ministry's guidance includes methods of cleaning the drains. See attached information provided by the BC - Ministry of Transportation. Attached in Appendix 8A is a list of case histories documenting the use of horizontal drains.

The use of horizontal drains as a slope stabilization technique has been repeatedly reported in the literature. The Transportation Research Board series of special reports on landslides and slope stability (Special Reports 29, 176 and 247) discuss the prominence of subsurface drainage as a cost effective slope stabilization treatment over a period of fifty years. Other notable references include International Landslide Conferences including the 1<sup>st</sup> North American Landslide Conference in June 2007 as well as several Federal Highway Administration (FHWA) references including a current pool-funded research study on horizontal drains. Other FHWA references include “Advanced Technology for Soil Slope Stability” Volumes I and II, 1994 and FHWA-NHI—01-026 “Soil Slope and Embankment Design”, January 2002. The internationally recognized text by Dr. Harry Cedergren “Seepage, Drainage, and Flow Nets” addresses the importance and effective application of subsurface slope drainage. The numerous case studies and the design, construction, and maintenance guidance on horizontal drains are truly international with standard guidance identified in the Americas, Europe, and Asia.

One of the projects where horizontal drains were used was in the mitigation of the Templin Highway Landslide located in Los Angeles County, California. As shown in the letter of transmittal attached at the end of this chapter, an emergency dewatering contract was initiated during the project because of increased rate of movement in the slope. Both vertical and horizontal drains were installed. The vertical drains were installed first and appeared to be inefficient. Then the horizontal drains were installed and their performance exceeded expectations.

One horizontal drain contractor in the United States, Jensen Drilling, has been in this specialty business for over forty years and indicated horizontal drain installations currently exceed 700,000 linear feet per year.

The design of subsurface drains is a combination of art and science and periodic maintenance may be needed. In general subsurface drainage systems are employed as part of an overall design or remediation treatment. Seldom are they used as a sole solution to slope stability problems. Several studies have proposed general technical and

theoretical models for horizontal drains but success has generally been related to project specific designs and an in-depth knowledge of the subsurface hydraulic conditions at the project site.

## **8.2 Maintenance**

Horizontal drains are commonly cleaned by engaging a local drain cleaning company such as the Rotor Rooter Company. The frequency of needed maintenance should be based on local experience and intervals of up to ten (10) years for cleanout may be appropriate.

## **8.3 Cost**

Prices are influenced by drain installation access, drain length, subsurface drilling conditions, and total drain quantity. Necessary earthwork for drilling equipment access and a drainage collection system is an additional cost.

## **8.4 Design**

General design parameters for horizontal drains are as follows (references include CALTRANS and CDOT). This guidance may be used for the West Bank slope but project designers would develop a project-specific drain working drawing layout and collection system and the appropriate specifications:

- Length of drains can be 300 feet plus.
- Install at an upward angle of at least 5 degrees and less than 20 degrees.
- Typical drilling diameter is 4 inches and drain pipe is 2 inches.
- Typical horizontal spacing is 10 feet or drains can be installed in a fan array from several locations along the slope, both horizontally and vertically.
- Horizontal drains are made from 40 mm Schedule 80 polyvinyl chloride (PVC) pipes with flush connections.
- Horizontal drain pipes are slotted around the pipe perimeter. Solid-wall pipe is used for 10 to 20 feet at the exit end of the drain. The drain pipes are placed in holes drilled into aquifers or perched water zones.

- Normally horizontal drains are placed in cut slopes or under fills and their purpose is to reduce the possibility of slides or slope instability by reducing hydrostatic conditions and removing subsurface water.
- The contractor will follow the drain locations and sequence of placement based on plans, exploration work, and slope observations and monitoring results. The horizontal drain locations will be designated and identified on the plans.
- Collectors and outlets should be positioned for public safety and ease of maintenance operations.
- The designer will determine the length of non-perforated pipe to be placed at the drain exit points. A minimum specified length should be used when the aquifer extends to the ground surface. In most cases, a non-perforated length of 10 feet has been found to be adequate. In most cases, the outlet pipes should to be connected to the collector system.
- The specifications should indicate that the annular space between the drilled hole and the pipe be tightly plugged with earth following drain installation.
- The contractor and inspector should develop a boring log of material types encountered during drilling and a record of production rates.
- Each drain should be identified by a brass plate bearing an assigned number or other label.
- In many cases, horizontal drains are hidden from view, so complete as-built records should be developed.
- Horizontal drains are most effective as a permanent remediation measure when complemented with a project-specific surface drainage system in cases where the general objective is to minimize surface runoff and infiltration within the slope. Ditches or irrigation channels on slopes should be lined where practical. Tension cracks should be backfilled and slope scarps and depressions that could pond water should be contoured to drain. Slope benches should be sloped forward and have a positive grade away from the slope. Interceptor drains 10-15 feet deep and installed near the slope crest have also been used in conjunction with horizontal drain solutions.

The horizontal gravity drain system for this project will consist of five arrays with each array having seven horizontal gravity drains that are 50 to 145 feet long (for a total of 4290 linear feet). The horizontal gravity drains will be installed at a slope of 5 degrees upward from horizontal. The five arrays will be spaced uniformly along the toe of the 2.5:1 cut slopes.

**B. Vertical Pressure Relief Ducts**

It is recommended that vertical pressure relief ducts be located at the toe of the west bank cut near the river in the area where there is resistance to slope movement. Vertical pressure relief ducts/gas vents will allow the gas pressure, assumed to be located near the top of bedrock, to dissipate. There have been several isolated instances when drilling operations in this slope encountered a pocket of pressurized gas/water indicating hydrostatic pressure considerably above that found at the ground surface. Vertical pressure drains have been effective for slopes that are subject to the presence of either permanent or intermittent high water conditions (undesirable piezometric head) as an effective means of slope stabilization. The vertical ducts should be attached to a designed collection system located just below the ground surface and detailed to provide an appropriate number of surface exit locations.

The design details for the vertical gas vent solution will consist of 30 vents arranged in a rectangular grid pattern (5x6=30 vents). The vents will be spaced 50 feet apart and will be 120 feet in depth (30x120=3600 linear feet).





**An Innovator In Drilling Implementation  
And Technology**



Custom Horizontal Drilling Machine, Designed and Built by Jensen Drilling Company

**J**ensen Drilling was founded in 1966 by John J. Jensen. Previously employed by the Bureau of Public Roads, (Vancouver District), Mr. Jensen was involved with some of the first installations of horizontal drains in the U.S.

Recognizing the effectiveness of drains, along with the potential increase of usage as a method of slide stabilization, Jensen Drilling built its first horizontal drain drill in 1967.

From that time forward, Jensen Drilling has established itself as the largest installer of horizontal drains in the U.S. We now have fourteen horizontal drain drill rigs, which we continue to employ new and innovative technology to, resulting in the most effective and productive machines made for this type of drilling.

Along with the ability to build drill rigs, our extensive experience drilling in various geological formations across the U.S. as well as different parts of the world has resulted in the development of techniques and tools that can be employed to overcome problems in virtually any formation.

**World Wide Experience**



Horizontal Drilling in Chile

Since our first project of 14,000 feet in 1967, we now install annual amounts up to 700,000 feet.

While horizontal drains are our expertise, we also drill and install de-watering wells, tie backs, rock bolts, soil nails, as well as pressure grouting, core drilling, and various other types of drilling.

JDC's edge over our competitors has been our ability to design and manufacture drilling equipment and components to meet specific needs. Our specially designed products are used in our drilling operations as well as sold nationally.

**Contact Information**

**Home Office**

1775 Henderson Avenue  
Eugene, Oregon 97403

Ph (541)726-7435  
Fax (541)726-6140

Email [Sales & Information](mailto:Sales & Information)

**Tennessee Office**

230 Cusick Road  
Alcoa, Tennessee 37701

Ph (865)984-4627  
Fax (865)970-3151

Email [Sales & Information](mailto:Sales & Information)

**Figure 8.1: Horizontal drains Installation Company Information**



**Figure 8.2: Pictures of horizontal drain installation equipment**

**CHAPTER 8**

**APPENDICES**

**APPENDIX 8A**

**HORIZONTAL GRAVITY DRAINS AND VERTICAL RELIEF WELLS  
CASE HISTORIES**

**FHWA Pool Funded Study: BC Hydro, CA, MD, MS, MT, NH, OH, PA, TX, WA, WYDOT**

Subsurface drainage is generally understood to be an important concept; nevertheless, the underlying principles, design, construction and maintenance considerations are not fully realized nor is the state-of-the-practice adequately documented. As a result, subsurface drains are often installed in a makeshift manner with varying degrees of success. Although subsurface drainage and horizontal drains have been used for many years, the amount of applied research directed at improving subsurface drainage techniques for slope stabilization applications is limited.

Research is needed to identify, collect and develop best practices and guidelines to raise the standards for subsurface drainage design, installation and maintenance. This research is especially important because subsurface drainage is typically the most cost-effective stabilization measure, often being an order of magnitude less than other commonly employed slope stabilization measures. In addition, the research should explore new applications of existing materials and technologies that can be advantageously applied to subsurface drainage systems for slope stabilization. Examples could include trenchless technologies as well as other innovative excavation equipment and techniques that could be adapted to provide more effective, efficient installation and function of subsurface drainage systems within marginally stable slopes. Properly designed, installed and maintained subsurface drainage systems can, in many instances, be the most cost effective solution to stabilize slopes by lowering and controlling groundwater flow. Unfortunately, concerns with the effectiveness and long-term performance of drainage methods have limited the application of such techniques as a primary means to mitigate slope instability. This uncertainty has limited their use even when subsurface information and stability analyses clearly indicate that stabilization could be achieved with proper modification and control of groundwater conditions. The research and development proposed herein will potentially advance more extensive use of subsurface drainage systems for slope stabilization, significantly reduce expenditures for slope stabilization, improve performance, and provide for more rapid installation

## Use of Horizontal Drains for Slope Stabilisation in Hong Kong

**R P MARTIN** BSc PhD CEng CGeol MHKIE MIMM  
Geotechnical Engineering Office, Civil Engineering Department, Hong Kong

**K L SIU** BSc MEng CEng MHKIE MICE FASCE  
Geotechnical Engineering Office, Civil Engineering Department, Hong Kong

In a review completed recently by the Geotechnical Engineering Office, information was gathered on horizontal drains installed at 87 sites in Hong Kong, of which eight cases were selected for detailed assessment. Although a number of design theories exist, in practice the design of horizontal drains in soil slopes is based on modified precedent, using general experience and knowledge of site conditions to select an initial drainage layout and the observational method to finalize the layout during construction. This is in keeping with the variable near-surface hydrogeological conditions encountered in typical Hong Kong slopes. Analysis of piezometric and drain discharge data shows that the drains at the eight selected sites have caused significant lowering of main groundwater levels; also that clogging of drains does not appear to be a major concern for the longer-term. Various investigation, design and construction aspects are discussed, including the use of different drain types and materials, grouting of drain inverts, contractual arrangements and installation costs. Recommendations are given for good practice in monitoring and maintenance. There are good prospects for greater use of such drains for slope stabilization in Hong Kong.

**LAND FORM ALTERATION POLICY  
GUIDANCE**

**ATTACHMENT 3: Overview of  
Engineering Techniques to  
Reduce Grading**

**Subsurface Drainage Systems**

Stability of a slope generally increases with decreased seepage, pore-water pressure, and slope weight, all of which may be achieved with installation of subdrains (Gedney and Weber, 1978). The main functions of subdrains are to remove subsurface water directly from an unstable slope, to redirect adjacent groundwater sources away from the subject property and to reduce hydrostatic pressures beneath and adjacent to engineered structures (Scullin, 1983). Control of subsurface drainage is generally attained by installing a network of horizontal and/or vertical subdrains which channel and remove groundwater from potentially unstable slopes (Figure 3). Many slopes cannot be effectively dewatered and therefore, this technique cannot be applied everywhere.

**FIGURE 3: HORIZONTAL AND VERTICAL DRAINS INSTALLED FOR SURFSURFACE DRAINAGE CONTROL (modified after Gedney and Weber, 1978)**

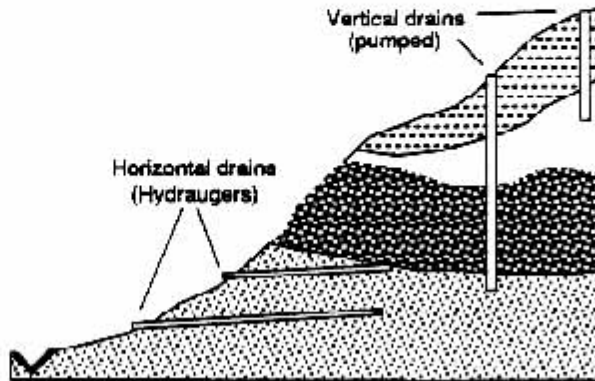

**A. Horizontal and vertical drains to lower groundwater in natural slope**

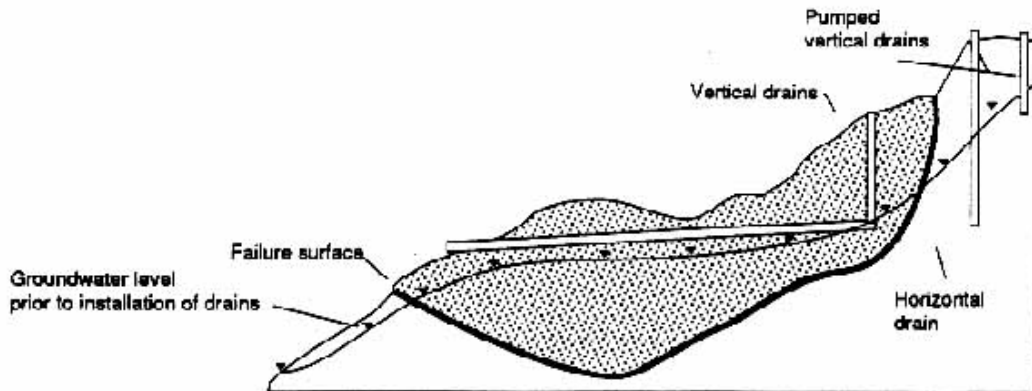

**B. Stabilization of landslide by dewatering; generally used in conjunction with other methods of stabilization**

An important consideration in design of all drainage systems is short and long term maintenance. Over time drainage systems can clog; pipes can corrode or rupture, and other problems can arise which would prevent the system from functioning properly. Such problems can counter or diminish the beneficial effects of the drainage system, possibly leading to slope damage or failure, structural damage or the need for extensive remedial grading.



# **2007 AEG Student Professional Paper: Graduate Division: Horizontal Landslide Drain Design: State of the Art and Suggested Improvements**

**Diana I. Cook<sup>1</sup>, Paul M. Santi<sup>1</sup> and Jerry D. Higgins<sup>1</sup>**

<sup>1</sup> Department of Geology and Geological Engineering, Colorado School of Mines, Golden, CO 80401

The removal of groundwater from the subsurface is one of the most common remediation practices in slope stabilization. The use of horizontal drains has often proved to be an efficient and economical dewatering option for slope stability. Despite their frequent use, a comprehensive review of the state of the art that includes modern research and contributions from related fields has not been performed for nearly 30 years. The objective of this paper is to provide a summary of the current state of practice, including application of recent research. In addition, this paper provides some suggestions for possible improvements to areas of current practice that have been identified as lacking complete answers. Recent research that may be applied to the design of horizontal drains includes (1) Zhou and Maerz's (2002) method for optimizing drilling directions to intersect as many discontinuities as possible in a rock mass, (2) Crenshaw and Santi's (2004) method for calculating an average drain spacing for designs implementing nonuniform drain spacing, and (3) Crenshaw and Santi's (2004) method for calculating an average two-dimensional groundwater profile representative of a corrugated three-dimensional groundwater table, which is low at drain locations and high between drains. Examples of issues that are not adequately addressed by current practice include (1) calculation of drain spacing values required to lower the groundwater level in a slope by a specific amount, (2) prediction of groundwater changes at various distances away from a drain, and (3) proper approaches to modeling complex landslide and groundwater geometries in two dimensions

## **CHAPTER 9**

### **DESIGN AND CONSTRUCTION OF SUBSTRUCTURES**

#### **IN THE WEST BANK SLOPE**

##### **9.1 Introduction**

This chapter provides the background and logic that form the basis of the provided guidance for the design and construction of substructures in the west end slope. Other chapters in this report address topics such as the geotechnical behavior and work history of the slope, soil strength parameters, measurements and data interpretation obtained from geotechnical instrumentation, ground water conditions, subsurface gas pressure, slope stability conditions before and after the designed excavation is constructed, future grading plans, and the load influence caused by the weight of the cold storage building on the stability of the slope. Information extracted from studying these topics and engineering judgment was utilized to establish criteria and limitations for the design and construction of proposed pier foundations that may be located within the west bank slope between the Cuyahoga River and the north side of Abbey Avenue.

It is imperative that new bridge pier foundations be located and founded in a stable slope environment. When existing manmade or natural slopes are identified to be unstable (slowly moving downslope), it is prudent engineering practice to stabilize the slope before constructing new foundations within the slope's influence. A stable slope requires that temporary and permanent grades provide a state of equilibrium within the slope mass. Substructure foundations placed in the designed west bank slope will be subjected to gravity forces generated by elevation differences of the soil surface on opposite (upslope and downslope) sides of the proposed substructure foundation. Lateral loads and moments associated with unstable slope conditions (downslope movements) will not exist because the proposed west bank slope is designed to be in a state of equilibrium with a target reserve level of safety provided by a factor of safety of at least 1.5.

## **9.2 Pier Construction in the Slope Between the Cuyahoga River and Abbey Avenue**

This section addresses engineering topics related to the design and construction of pier foundations in the slope between the Cuyahoga River and Abbey Avenue.

### **9.21 Existing and Proposed Profile of the West End Slope**

By reducing the soil weight/driving force from portions of the existing west bank slope, the final slope configuration will be sufficiently stable such that new piers can be located within the slope area. A number of slope improvement methods are included in the overall design to provide a relatively low degree of risk for the future performance of the proposed structure. These improvement methods include (a) removal of earth material from the slope, (b) reduction of perched ground water levels by use of horizontal drains, (c) reduction of gas pore pressure by use of vertical pressure relief ducts, and (d) total removal of the cold storage building.

Profile A-A on plan sheet 23 of 34 shows the existing and proposed profiles near the centerline of the proposed bridge. A relatively large excavation is required to arrive at the proposed final graded surface. This excavation is required to improve the factor of safety for the existing and proposed slopes from 1.1 to 1.7, respectively. These improvements to the safety factor are the result of reducing the dead load driving force by excavating over 200 thousand cubic yards of soil and by removing the cold storage building.

### **9.22 Horizontal Drains**

The addition of horizontal drains installed in the regraded west bank slope is a very cost effective means to improve the overall stability of the slope. Horizontal drains increase safety and provide redundancy to the slope by reducing the possibility of the formation of perched water pockets that increase pore water pressure, reduce strength and lower the factor of safety.

### **9.23 Vertical Pressure Relief Ducts**

Soil shear strength is reduced by increases in water and gas pore pressures. There is significant evidence that high groundwater level/artisan pressures (water level higher than the ground surface) exist at some locations within the slope. Since the locations of potential changes of pore pressure are somewhat uncertain, provision for some cost effective means of limiting ground

water pressure in the slope should be a part of the final design. Vertical pressure relief ducts are proposed to be located south of the Cuyahoga River in a location where resistance to slope movement can be generated. The design for the vertical ducts includes a collection system leading to ventilation at a single exit point. The elimination of elevated pore pressures results in improved factors of safety from 1.5 to 1.7 to further reduce the risk of down slope movements.

#### **9.24 Future Grading for the Companion Structure**

In the future, the Eastbound Central Viaduct will be constructed in the west end slope. A grading plan has been developed for the construction of the Westbound Central Viaduct and a conceptual grading plan has been prepared for the future Eastbound Central Viaduct. The conceptual grading plan for the Eastbound Central Viaduct shows that 30 feet of additional excavation will be made under the Westbound Central Viaduct in order to complete the grading for the Eastbound Central Viaduct. The design of the Westbound Central Viaduct must provide a foundation design that will be compatible with the excavation made for the future Eastbound Central Viaduct. The Profile P-P (2) on plan sheet 30 of 34 shows how the grading plan for the Eastbound Central Viaduct will create a new top of slope surface beneath the Westbound Central Viaduct. Therefore, all footings for the Westbound Central Viaduct must be designed at an elevation that will provide the required three feet of cover over the Westbound Central Viaduct footing when the Eastbound Central Viaduct slope grading is completed.

#### **9.25 Pier Foundations**

The performance history of marginal stability at the west bank slope, best engineering practices, and other relevant discussion topics in this report suggest that all pier foundations constructed in the west bank slope between the Cuyahoga River and the north side of Abbey Avenue must be supported by foundations that extend to bedrock. The requirement for all pier foundations to be supported on bedrock reflects our best effort to avoid the application of dead and live load from the bridge to the overburden material in the slope and further reduce the potential for movement of the pier.

Use an end bearing H-pile foundation supported on bedrock has been eliminated as an acceptable bridge foundation type in the west end slope of the Westbound Central viaduct bridge because of a desire to discourage the construction of a large footing excavation in the slope. The

large excavation would be necessary to provide access to the bottom of footing elevation for the Westbound Central Viaduct (see section P-P (2) on sheet 30 of 34). If a pier is located in the new graded slope, we estimate that a 30-foot deep excavation will be required to place the top of footing three feet below the ground surface of the future Eastbound Central Viaduct grading design. This excavation would most likely require a 30-foot deep cofferdam in the slope. Due to the above concerns, a driven pile foundation is not permitted for piers located in the west end slope of the Westbound Central Viaduct. A drilled shaft foundation will minimize the construction concerns, is technically feasible based on site conditions and is a cost effective solution for the bridge foundations.

### **9.26 Contractual Requirements**

The contract plans must contain appropriate information directing the contractor to use drilled shaft foundations in the west end slope north of Abby Avenue and south of the Cuyahoga River.

### **9.3 Sequence of Construction**

The construction of the grading for the west end slope and the new piers located south of the Cuyahoga River and north of Abbey Avenue should be performed based on the following plan notes:

Perform the excavation and specified related work located between Stations 128+00 and 134+50 for the full width of the project limits according to the requirements stated in the sequence of construction list provided below.

1. Install the demonstration drilled shaft and evaluate the structural integrity of the shaft using the Gamma-Gamma and Crosshole Sonic Logging test methods. Load test the shaft, if the shaft is to be load tested, prior to excavating the west end slope surface below the top elevation of the demonstration drilled shaft.
2. Remove the Cold Storage Building to the existing ground surface line.
3. Perform all Stage 1 excavation work down to the elevation of the bench located near Elevation 640. Construct the Gateway Animal Clinic parking lot retaining wall, as the excavation proceeds. Remove underground portions of the Cold Storage Building and retaining walls as the excavation proceeds.

4. Perform all Stage 2 and 3 excavation work: Stage 2 excavation shall begin not less than 20 days after completion of Stage 1. Stage 3 excavation shall proceed to finished grade except for the area of Stage 4 excavation. (See sheet 27 of 34).
5. Perform the Stage 4 excavation not less than 20 days after completion of Stage 3.
6. Commence CUY-90 Westbound Innerbelt Bridge Foundation work after completion of Stage 4 excavation.
7. Begin installing the Horizontal Drains within 20 days after the date when access to the location where Horizontal Drains are to be installed has become accessible.
8. Begin installing the Vertical Pressure Relief Ducts within 20 days after the date when complete access to the location where Vertical Pressure Relief Ducts are to be installed has become available.

#### **9.4 Instrumentation of New Piers Within The Slope**

An on-site monitoring system will be installed to collect measurements related to critical design and performance parameters for the slope and the bridge piers. These measurements will be obtained during construction and for a portion of the service life of the bridge. The monitoring system will primarily consist of electronic transducers as detailed in the plans and specifications and the supporting wiring, conduits, main cabinet, and data acquisition equipment. The sensors will be installed during various stages of construction at the following locations:

- at locations specified in the instrumentation plan attached to the west bank slope grading plans, see sheets 31, 32, 33, and 34 of 34.
- in the pier footings
- in the pier columns
- at the bearings for the piers.

The contractor will be responsible for protecting existing and new instrumentation from damage during all the work. The contractor will pay for the time and materials required to replace any instrumentation damaged for the duration of his contract. The contractor will be provided with all readings from the instrumentation within xx days after they are obtained.

### **9.5 Bearings for Proposed Piers within the Slope**

Since the slope has been stabilized to a reasonable factor of safety and the piers are to be supported on drilled shafts founded on bedrock, all types of bearing or degrees of fixity are considered appropriate for the subject piers.

### **9.6 Pier Load Transferred to the Slope**

All pier foundations constructed in the west bank slope should be designed in a manner that minimizes the transfer of bridge loads to the overburden slope materials above bedrock. The best method to avoid the transfer of bridge foundation loads to the slope is to support the piers on foundations that extend to bedrock. We acknowledge that the elastic deformation of the drilled shaft foundation will result in side friction/adhesion, which will transfer loads to the subsurface material. For example, the magnitude of the load transferred from a six foot diameter drilled shaft pier foundation to the slope subsurface material has been calculated to be approximately 1800 Kips. The magnitude of side friction load applied from the drilled shafts founded on bedrock to the subsurface material is considered insignificant in their impacts on global stability when compared to the global stability forces that are present within the slope.

### **9.7 Foundation Load South of Abbey Avenue**

The stability of the slope was evaluated with an assumption that a 40-foot by 100-foot spread footing bridge foundation would be placed immediately to the south of Abbey Avenue. The footing produces a uniformly distributed load of two tons per square foot beneath the footing. The stability of the slope is not significantly affected by the proposed footing load.

## CHAPTER 10

### CONCLUSIONS

The Central Viaduct west bank slope has been evaluated by a team of two independent and specialized consultant firms: E.L. Robinson Engineering (ELR) and Geocomp Corporation. The firms worked independently, in the context that the work was performed in two different offices with different computer programs and subtle differences to the methods of analysis. Geocomp Corporation reviewed and checked the analyses performed by ELR and examined several key and important parameters that influence the outcome of the slope evaluation. The independent work program included periodic exchange of analysis results to identify discrepancies and resolve analysis problems.

This work approach was established to provide quality control and assurance to the analysis process through independent review and team member interaction. The Team is very confident in the results of their work because the overall analyses results and conclusions developed by the firms are reasonably similar. Technical specialists at ODOT also reviewed the analysis, results and conclusions and the final report reflects their comments and suggestions.

Below is a list of conclusions resulting from the work effort and process described above.

1. The failure mechanism for the slope is one in which the shear stress caused by gravity exceeds the shear strength of the soil.
2. The removal of soil from the slope and/or lowering the ground water table reduces the shear stress and increases the factor of safety.
3. . The soils in the slope generally have an effective friction angle of  $32^\circ$  where the failure plane is inclined by more than about  $25^\circ$ . Some of the soils in the slope currently have an effective friction angle of  $15^\circ$  where the sliding plane is close to horizontal.
4. Laboratory shear tests show that the drained strength is less than the undrained strength of the soils relevant to the slope movement. Consequently the shear strength appropriate



for analysis of the existing conditions and future design is use of effective stress strength parameters and steady state pore pressures.

5. Sufficient displacement has occurred along the most critical failure planes such that the soils have reached their residual strength. Further reduction in the effective stress strength parameters by mechanisms, such as creep, are not possible.
6. Shear strength parameters of the soil are complex but they have been reasonably established with values that relate well to the history of the stability, are consistent between the two laboratories and correlate to recognized aspects of soil behavior for overconsolidated materials.
7. Shear strength is directly reduced by increasing pore pressures. There is significant evidence of a high groundwater level within the slope and the local presence of artesian pressures (water level higher than the ground surface) at some locations within the slope. The team's investigation suggests that potential changes of pore pressure are unpredictable, and therefore means of limiting pore pressures in the slope are recommended and incorporated in the grading plans.
8. As recommended by the Baker team, fourteen slope sections were analyzed for stability. Some sections considered are longitudinal and represent typical slope configurations which would be critical geometries parallel to the bridge direction. The number of sections that were investigated assured that the entire graded slope area was evaluated.
9. At various times subsurface investigation drillers encountered zones where water and gas exited 10 to 15 feet above the slope surface for hours. Artesian pressures of this maximum have a significant negative influence on the stability of the slope and are extremely difficult to consistently map throughout the affected area. These excess pressures can be released and controlled by the use of vertical gas relief ducts. Vertical gas relief ducts can be installed easily and quickly and are a very economical stabilization treatment. Some drilling through the dense soils will be required to install drains to relief ducts but overall the installation procedure can be accomplished by use of conventional drilling methods.

10. The primary objective of this project was to design a graded slope that provides a satisfactory factor of safety, i.e. one that causes no distress or significant loads to the bridge foundations from slope movement. The performance objective is to design a slope that when excavated and graded provides a factor of safety of at least 1.5 for all conceivable conditions. Slopes having a factor of safety of 1.5, as determined using appropriate strength and pore pressure values, will experience negligible movement.
11. The grading plan design was engineered to also maintain the integrity of the existing bridge and adapt to the requirements of a future replacement bridge.. Our evaluation results show that these performance requirements can be achieved by removing soil from the slope to Abbey Ave. The evaluation focused on simple geometries for excavation and confirmed that a factor of safety above 1.5 can be achieved.. The entire slope, excluding any space required for areas could be made a green space that could include localized irregularities in the ground surface and specialized contouring to provide an appealing landscape.
12. The geotechnical information and laboratory testing results assembled over the years provide sufficient information to define the strength properties of soils for design. Information on the groundwater flow regime and the associated pore water pressures however, is limited and information on artesian pore pressure conditions is very limited. These limitations may be overcome by adopting stabilization options to control excessive pore pressure conditions as recommended in this report.
13. A sheet pile revetment wall exists at the toe of the slope. This wall is required by the US Army Corps of Engineers to maintain a navigable water way. The sheet piling are 65 feet long, and have horizontal steel rods spaced at 8 ft intervals which extend from the top of the sheeting to an existing deadman anchor located 40 ft behind the sheeting. These anchors failed over time, likely due to corrosion, with the consequence that soil and water pressures acting on the back of the sheeting caused the sheeting to displace outward by several feet. The current owner has excavated soil from behind the sheeting with the hope that the sheeting can be pulled back into place, new anchors installed and the slope backfilled. This sequence of natural and manmade occurrences has reduced the overall

factor of safety of the existing slope by approximately 0.1 (Figure 7.15). The project requirements include replacement of the revetment wall based on current commonly recognized standards..

14. The proposed roadway alignment intersects the cold storage building. The effects of the weight of the cold storage building on the existing slope was evaluated. A slope stability model programmed to compute the factor of safety of a failure surface that intersects the bottom of the building was analyzed and then reevaluated without the presents of the building (See figures 7B.16A and 7B.16B). Removing the cold storage building increases the factor of safety by approximately 0.15.
15. The team conducted a complete and detailed examination of all available strength data which included results from tests by BBC&M, results from tests by Geocomp and other published data on strength of highly plastic clays. One of the undisturbed tube samples obtained during this investigation actually captured a shear plane. This sample was positioned into a direct shear test cell such that the field shear plane would align with the shear plane of the test device. This special testing opportunity indicated a measured peak strength equivalent to soils with zero cohesion and a drained friction angle of  $13.6^\circ$ . Several test series indicated residual strength values of  $15^\circ$  for the more plastic clays within the slope. In addition, thin seams of plastic clay may exist at various locations within the slope. The critical failure surface for stability will develop through these weaker existing shear planes and horizontal seams.. Therefore, we concluded that horizontal to near-horizontal portions of all shear surfaces should use an effective stress strength value of zero cohesion and  $15^\circ$ . Test data for the less plastic layers of soil in the slope indicate a residual strength similar to their peak strength. Laboratory tests indicate a friction angle range of  $22$  to  $33^\circ$ ; however, these tests focused on the more clayey samples without considering the inclination of the shear plane. We recommended a friction angle of  $32^\circ$  with zero cohesion be used for design on all shear surfaces inclined at more than  $25^\circ$  from horizontal. This value of strength provides factors of safety for past and present conditions that correlate reasonably well with the past performance of similar slopes. The strength parameters are defined with reasonable certainty based on the extent of testing, interpretation of the test results and the historical behavior of the slope.

16. Gas and gas pressures have been noted in seven locations as detailed in previous subsurface investigation reports performed by BBC&M Engineering, Inc. The stability of the slope and the computed factor of safety are directly influenced by internal pore pressure. Also, the exact source of groundwater in the slope has not been identified which means water pressures cannot accurately predicted for existing and future groundwater conditions. Our approach to address this condition was to minimize risk and design appropriate and standard measures to control pore pressure so that assumed design values would not be exceeded. Vertical gas relief ducts and horizontal drains are proposed to control the uncertainty related to the pore water and gas pressures present at this site. Horizontal drains and vertical gas relief ducts are discussed in Chapter 8.
17. Members of the team used three different computer programs to analyze current and future stability conditions. EL Robinson used GSTABL7 with STEDWIN which is based on the Simplified Janbu method of analysis. Geocomp used UTEXAS4 which is based on Spencer's analysis method. The fact that the final results were similar provides strong verification that no significant errors or misapplications were made in the various analyses. Geocomp also used an entirely different analytical approach based on the finite element method to check that the results from limit equilibrium studies. Results from the PLAXIS computer program analysis for factor of safety were similar to those from the limiting equilibrium methods for the limited number of conditions.
18. The factor of safety of the slope in its existing condition is near 1.15. A revised water table from the vibrating wire piezometers installed in 2006 was used in the analysis and showed minor change in the safety factor when compared to the water table used in previous analysis prior to July, 2006.
19. The factor of safety of the existing slope is unsatisfactory (too low) for the slope to serve as a foundation for any new structure. The team examined various means to improve the factor of safety and the most effective and recommended solution is to remove the existing warehouse building, flatten the slope by removing selected portions of soil and installation of pore pressure control measures.

20. Results of the slope stability analysis for an excavated and graded slope indicated a minimum safety factor of 1.6 (Chapter 7). This value is above the minimum 1.5 which is recommended for this facility. This higher factor of safety of 1.6 also minimizes the risk associated of substantial movements resulting from the slope being unloaded due to the grading process. This degree of safety allows the e location of bridge substructure units placed in the slope without use of isolation treatments.
21. The critical section for the slope beneath the existing bridge is down slope in the direction of the bridge. The proposed grading will not affect the down slope factor of safety for the existing bridge. The proposed grading for the new bridge will create side slopes where the potential sliding planes will be orthogonal to the existing critical sliding planes. The grading design considered the stability of these slopes and adopted the performance criteria of a minimum factor of safety of 1.5 for these slopes as well.
22. The present rate of movements of the slope at the location of the new bridge for the deep slip plane is 0.01 inch per year. The shallow slip plane, which is located close to the sheet pile wall, is 0.08 inches per year due to the failure of the wall.
23. A performance monitoring system has been incorporated as part in the grading plan design to identify any undesirable developments in the slope, both during construction and in the short term service life, and develop appropriate remedial actions.
24. The previously installed stabilization structure at the existing I-90 bridge is performing well. The forces and movements in the drilled shafts are within the elastic range of the drilled shafts. An estimated additional service life of approximately 30 years is expected before the drilled shafts reach their structural capacity assuming a constant rate of lateral movement in the shafts of 0.12 inches/year. Recent reports of field measurements indicate that the rate of movement is reducing with time.
25. The current movement to date of the existing slope beneath the existing bridge has been evaluated. The instrumentation readings (see inclinometer B-204 plots in chapter 5 of the final report), indicate that the current rate of movement can be interpreted to be 0.01

inches per year at the shallow slip plane (15 to 19 feet below ground), and 0.03 inch/year at the deep slip plane (approximately 120' below ground).

26. The movement of the existing slope along Section A-A can only be related to inclinometers B-110 and B-107 and it can be concluded (see inclinometer plots in chapter 5 of the final report), that the current rate of movement is 0.08 inches per year at the shallow slip plane (23 to 31 feet below ground), and 0.01 inch/year at the deep slip plane (approximately 119' below ground).
27. Based on the inclinometer data collected since 1994, the extent of the movement excluding the construction related movement is to the south of the area where inclinometer B-108 is located. The data collected from inclinometer B-110 at the deep slip plane (~120 feet) showed less than 0.03 inches in 5 years, which is a very low rate of movement. The inclinometers plots presented in chapter 5 show details of the rates of movement at each plane. A summary of the horizontal movement at various depths in the inclinometers is presented in Table 5.1 of the report. The expected future movement at the location of the proposed bridge as seen from the existing B-110, B-108, and B107 inclinometers will be negligible, as the only movement in these inclinometers took place during construction of the stabilization structure for Pier 1 of the existing I-90 bridge. The future rate can be interpreted to be 0.01 inches per year and is assumed to be constant with the current rate.
28. The review of the long term monitoring data from the inclinometers installed in the area around the existing bridge and close to the alignment of the proposed structure, suggests that there is very little evidence of any creep movement in this area. The movement measured in some inclinometers is due solely to the construction activities for the stabilization structure for Pier 1 of the existing bridge. The movement recorded in B-108 at shallow depths was due to the failure of the sheet pile wall along the river bank.
29. Utilities located in the existing slope should be relocated.
30. There may be some environmental issues that must be addressed from the excavation of the material located beneath the cold storage building.

31. The stability conditions related to the shallow slip plane will be significantly improved due to the relatively large excavation associated with the grading plan.
32. The potential for creep related movements have been mitigated by the relatively large excavation and the performance requirement of a minimum safety factor of 1.5.