



CUY-90-14.90

PID 77332/85531

APPENDIX GE-05

**Baker Slope Stability Study Report
(Reference Document)**

State of Ohio
Department of Transportation
Jolene M. Molitoris, Director

**Innerbelt Bridge
Construction Contract Group 1 (CCG1)**



Slope Stability Evaluation Report of the West Bank

CUY-90-14.92
PID 77332



Baker

December 6, 2006 – Revised
September 15, 2006



Baker

Michael Baker Jr., Inc.
The Halle Building
1228 Euclid Avenue, Suite 1050
Cleveland, Ohio 44115

216-664-6493
FAX 216-664-6532

December 6, 2006

Joseph Seif, P.E., Phd., Project Manager
Ohio Department of Transportation, District 12
5500 Transportation Boulevard
Garfield Heights, Ohio 44125

RE: PID 77332, CUY-90-14.52
Disposition of Comments for Slope Stability Evaluation Report

Dear Joseph:

Enclosed please find three copies of the disposition of the comments and revised components of the Slope Stability Evaluation Report. The disposition addresses ODOT and FHWA comments presented to the Baker team via letter dated October 13, 2006 and November 2, 2006. No changes were made to the individual sections of the Slope Stability Evaluation Report, which were performed by multiple Baker Team consultants; however, the Executive Summary has been rewritten to address ODOT and FHWA comments. Please replace the existing executive summary, cover, and spine in the Slope Stability Evaluation Report with this updated version.

If there are any questions or if you would like additional clarification, please do not hesitate to contact me at (216) 776-6614.

Sincerely,

MICHAEL BAKER JR., INC.



Robert B. Parker
Project Manager

Enclosures:

Slope Stability Report Disposition of Comments
Slope Stability Report Executive Summary, Cover and Spine

cc: Eugene C. Gieger, PE, ODOT Central Office
Timothy Keller, PE, ODOT Central Office (Two Copies of the report)
Scott Phinney, P.E., ODOT Central Office (letter and disposition of comments only)
Rick Engel, P.E., E.L. Robinson
Steve Pasternack, Ph.D., P.E., BBC&M

ChallengeUs.

Executive Summary

The Central Viaduct west bank slope was evaluated by three firms: BBC&M, E.L. Robinson Engineering and Geocomp. The firms worked independently, in the context that the work was performed in three different offices with different methods of analysis. The three independent approaches were supplemented with collaboration on the important parameters that were anticipated to influence slope stability evaluation. The collaboration included periodic exchange of analysis results and two project team coordination meetings, including Baker, Richland, BBC&M, E.L. Robinson, and Geocomp. The results of the independent studies were discussed, including discrepancies between various studies, conclusions, and recommendations.

Each of the three firms utilized an internal quality control protocol to ensure a quality slope stability analysis. The above inter-firm exchange was established to provide quality assurance to the analysis process through independent review and external peer review. The team is confident in the results of the slope stability analysis because the overall results and conclusions drawn by the three independent teams are reasonably similar.

Below is a list of preliminary discussion topics that contain the present position of the Baker Team:

1. The analyses show that the present slope north of the existing bridge has a factor of safety against slope failure ranging from 1.06 to 1.09.
2. Though the current factor of safety is above 1.0, slope creep has been documented by inclinometers and can be expected to continue, if the slope is not excavated and graded to reduce the steepness of the slope.
3. Preliminary analyses indicate that removing the building on the top of the slope increases the factor of safety to about 1.25 and removing soil from the slope can produce a factor of safety near 1.5.
4. For practical purposes, slopes with a factor of safety greater than 1.5 tend to have minimal movement; however, since there is very limited field measurement at the proposed bridge site, potential creep movements are still considered a concern.
5. Sufficient displacement has occurred along the most critical failure planes that the soils have reached their residual strength (lower bound). Further reduction in the effective stress strength parameters by mechanisms such as creep are not likely.
6. Shear strength parameters of the material in this slope are complex but they have been reasonably established with values that make sense, are consistent across two laboratories and follow recognized aspects of soil behavior for overconsolidated materials.

7. Shear strength is reduced by increasing pore pressures. There is evidence that high piezometric pressures exist, due to trapped natural gas pockets in the slope and even artisan pressures (water level higher than the ground surface) exist at some locations within the slope. Since the potential changes of pore pressure are unpredictable, monitoring the pore pressures in the slope are recommended for final design.
8. Aside from the potential for trapped natural gas pockets, there is no reason to expect a sudden increase in pore pressure of the magnitude mentioned in the report. Consequently, should a monitoring system indicate that pore pressures in the slope are increasing beyond those used for the design, sufficient time should be available to mobilize and complete remedial work before the bridge pier would be affected. Monitoring of pore pressures will continue and installation of horizontal drains will be performed if the pore pressure head approaches 650'. Even at a pore pressure head of 650' the factor of safety would be 1.5 which is the recommended factor of safety for this slope. The current piezometric and phreatic pressures will be better defined through additional monitoring. The anticipated pore pressures will be modeled for the proposed slope remediation. In the unlikely event that future slope movement occurs after remediation, the movement should be slow enough to allow time for remediation isolation measures to be implemented.
9. By removing soil from parts of the existing west bank slope, preliminary analyses indicate that the slope can be stabilized sufficiently to allow for construction of a new pier on the slope. Improvement of the slope factor of safety to acceptable levels will minimize risks to the proposed structure foundation but may not rule out the potential for creep movements; therefore, long term monitoring of slope movements is recommended to provide ODOT with advanced knowledge of potentially adverse situations and allow time for implementation of any required remediation measures.
10. The stability of the existing structure should be evaluated in concert with the final design for the new structure. We recommend that the entire slope from the north end to the south end of the DOT right-of-way be evaluated.
11. Removal of material from the slope will likely require many of the existing utilities to be relocated.
12. Lightweight fill such as styrofoam may be used to elevate the surface of the unloaded slope if required for purposes such as maintaining University Ave., at its present level or on relocated alignment and profile.

13. The potential for a shallow slope failure may exist at the southern end of W. 15th Street, just north of Fairfield Ave. Depending on the future use of this property, a more detailed analysis of the area may be required.

Based on these discussions points, the following course of action is suggested:

1. Unload portions of the slope to increase overall slope stability. Preliminary analyses show a 7 H:1V cut beginning along the north edge of Abbey Avenue would significantly increase the factor of safety and correspondingly reduce the anticipated creep. Unloading the existing slope is recommended regardless of the proposed location of the pier. The final grading scheme to unload the slope should be determined after the selection of the preferred structure type, and in concert with the determination of University Avenue disposition, and potential locations of the towpath trail. This solution is considered feasible on the basis of current information available and analyses performed; other viable solutions will be investigated, if appropriate, based on future geotechnical information, analyses, and design considerations.
2. The proposed pier should be constructed in the slope, near the location of the existing pier, but not closer than 100 feet to the existing river revetment wall. This buffer of approximately 100 feet is recommended to provide an area for construction of the revetment wall which has tiebacks as a component of the wall's support system. This will allow the revetment wall to be designed independently of the bridge pier. The revetment wall is located at the toe of the slope adjacent to the Cuyahoga River.
3. The use of horizontal drains (to lower groundwater and reduce pore pressure) and vertical drains (to relieve gas pressures) has been explored in this report. While drains have some technical merit as a secondary remediation method, the long term effectiveness of both types is questionable. Therefore, the use of either horizontal or vertical drains is not recommended. If during the monitoring of the slope it is determined these drains are needed, they can be installed in a subsequent contract.

A long-term performance monitoring system is recommended as part of the design to identify any undesirable movements in the slope so that appropriate remedial actions can be developed, if required, before the structure is negatively impacted. This monitoring plan will be included in the bridge design phase of the project.

4. Once the final grading scheme is determined, as discussed above, a slope stability analysis should be performed on five specific cross sections. The exact location of the cross sections to be analyzed will be determined collaboratively between the design team and ODOT.



5. Based on the proposed reconfiguration of the Abbey/W. 14th Street interchange, the area at the south end of W. 15th Street, north of Fairfield, should be further investigated for stability.

Disposition of the CUY-90-14.92 Draft Slope Stability Analysis Review Comments

Review comments were received from ODOT District 2 on July 10, 2006.

1. Comment: The stated goal of this work is to estimate the extent of current or future creep related movement of the hillside and provide recommendations on pier location. The extent of current or future movements is not well documented or summarized.

Response: The current movement to date of the existing slope under the existing bridge has been evaluated and we conclude from the instrumentation readings (see inclinometer B-110 plots in chapter 5 of the final report), that the current rate of movement can be interpreted to be 0.08 inches per year at the shallow slip plane (25 to 30 feet below ground) due to the failure of the sheet pile retaining wall, and 0.01 inch/year at the deep slip plane (approximately 120' below ground). The current movement to date of the existing slope along Section A-A can only be related to inclinometers B-110 and B-107x. We have evaluated this information and as can be concluded from the instrumentation readings of the inclinometer plots in Chapter 5, very little movement is present at this section.

Based on the inclinometer data collected since 1994, the extent of the movement excluding the construction related movement is to the south of the area where inclinometer B-108 is located. The data collected from inclinometer B-110 at the deep slip plane (~120 feet) showed less than 0.03 inches in 5 years. This is not a concern.

The pier can be located anywhere in the slope, taking into consideration the recommended grading and improvement measures to the slope, except within 100 ft of the river revetment.

The inclinometer plots presented in chapter 5 of E.L. Robinson report show details of the rates of movement at each plane. A summary of the horizontal movement at various depths in the inclinometers is presented in Table 5.1 of the report. The expected future movement at Section A-A, as seen from the existing B-110, B-108, and B107 inclinometers, will be negligible, as the only movement in these inclinometers took place during construction of the stabilization structure for Pier 1 of the existing I-90 bridge. The future rate extrapolated from the current rate of movement is about 0.01 inches per year, provided no changes are made to the existing slope and the existing stabilization measures remain effective. As can be seen in the review of the long term monitoring data from the inclinometers installed around the existing bridge and close to the alignment of the proposed structure, there is very little evidence of any creep movement. The movement measured in some of the inclinometers is due to the construction activities for the stabilization structure for Pier 1 of the existing bridge. The movement recorded in B-108 at shallow depths was due the failure of the sheet pile wall along the river bank.

2. Comment: A substructure design criteria must be a part of the recommendations in the report. We understand that at the present time the structure type and size has not been established and therefore the location of the pier can vary substantially within the slope. A load-displacement design criteria, with or without isolation of the pier foundation depending on the location of the substructure within the slope, would suffice.

Response: Based on the analysis presented in the final report, we believe that the substructure units located between Abbey Avenue and the Cuyahoga River can be designed for traditional at-rest earth pressures. Special design requirements are not anticipated.

3. Comment: Baker's Executive Summary, page 2, Item #9, discusses an evaluation of the stability of the existing structure in concert with the design of the new structure. It should be clarified that the new bridge, proposed future EB bridge, and existing bridge must all be evaluated. The future construction of an EB bridge which may need to include excavation of the slope might encroach upon the existing bridge and/or affect its stability. At what stage will this analysis be performed?

Response: As part of the report prepared by ELR, the stability of the existing bridge was briefly studied. Two cross sections, one along the centerline of the existing bridge and one south of the existing bridge were analyzed. The critical section for the slope beneath the existing bridge is downslope in the direction of the bridge. The proposed grading will not affect the downslope factor of safety for the existing bridge. The proposed grading for the new bridge will create side slopes where the potential sliding planes will be orthogonal to the existing critical sliding planes. Final design must include consideration of the stability of these slopes and the design adapted to give a minimum factor of safety of at least 1.5 for these slopes as well. Horizontal and vertical drains should be placed in the slope under the existing structure. The influence of the change of slope geometry on the stability of the existing bridge will be further addressed in the Structure Type Study phase when a specific bridge span arrangement is proposed.

4. Comment: Based on comments from several readers of the draft report, an explanation is needed as to why the stabilization effort is the same regardless of pier location, and that there is no preferred pier location. A statement that loading from the new bridge will need to bear below the failure surfaces and that therefore no loading from the bridge would contribute to driving the landslide would be helpful.

Response: The proposed grading will improve the stability of the slope and provide a safety factor greater than 1.5. The location of the substructure units between Abbey Avenue and the river will be checked to make sure that the design of the new substructure units will not reduce the safety factor of the slope. We anticipate that

the proposed structure will be supported by relatively deep foundations so that the stability of the slope will not be a concern. The foundations will most likely penetrate below the weakest slip plane and into rock.

5. Comment: The BBC&M report, page 19, states that proposed bridge foundations should be founded south of Abbey Avenue and therefore contradicts the recommendations summarized by Baker. Should the BBC&M statement be revisited in light of the proposed remediation measures for the proposed alignment?

Response: While reference to founding the proposed foundations south of Abbey remains in BBC&M's report, this statement quotes a previous Bridge Alignment Report dated September 26, 2005. Based on the information presented throughout this report, the piers can be founded anywhere in the west bank, except within 100 feet of the river bank.

6. Comment: The BBC&M report, page 39, states that the average creep rate in inclinometer B-110 is 0.15 inches per year. Data from the Monitoring Services Annual Report shows that inclinometer had 0.45 inches of movement for the shallow slide plane over the 10-year history, or an average of 0.045 inches per year. Since 2004, the rate of movement is about 0.03 inches per year for the shallow slide plane. For the deep failure plane, the average rate over ten years is 0.012 inches per year and since 2004 it has been 0.005 inches per year.

The trend of decreasing rates of movement are typical for the inclinometers at the site as rates of movement are decreasing as the effects of the slope disturbance that occurred during construction of the stabilization structure wane and the stabilization structure takes increasingly more load. Reporting values derived by linear regression appear to not be appropriate, as the reader should be made aware of the nonlinear trend of decreasing rates of movement, as is done in Chapter 5 of the E.L. Robinson report on the stabilization system for the existing bridge.

Response: The rate of movement (0.15 in/yr) provided in the BBC&M report, page 39, was taken from Table 1a of the 2005-2006 annual monitoring report. The value of 0.15 in/yr was determined by summing the displacement from 7 to 25 feet, 25 to 31 feet and 43 to 47 feet (see displacement time history plot for B-110 of the 2005-2006 annual monitoring report). This was done to quantify the total displacement as is shown in the B-110 displacement figure below.

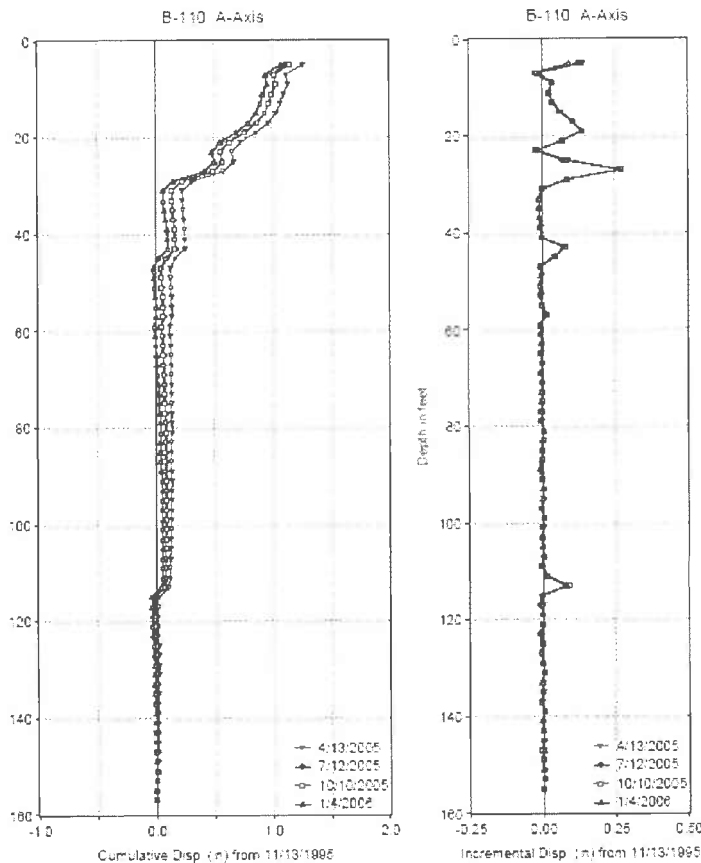

Stating the rate of movement of 0.15 in/yr may be misleading as it includes displacement along at least two slip planes and indicates cantilever deflection. However, it was done in an attempt to quantify the total relative shallow movement observed in inclinometer B-110. Presenting the relative displacement between the ground surface and a depth of 47 feet is more relevant than simply presenting the displacement along one slip plane as all of this shallow movement would be transferred to a pier if it were placed in the vicinity of inclinometer B-110.

However, the reviewer presents a very good point and is exactly correct about many of the inclinometers indicating a trend of decreasing creep rates. After the stabilization structure construction activities, most of the inclinometers indicate a significant increase in the creep rate. At this point in time, a new primary creep phase was initiated in the soil mass. As discussed in the third paragraph of BBC&M's report, section 4.4, and illustrated in Figure 13a, upon change of stress conditions sufficient to initiate creep, the primary creep phase begins. During this phase, the initially high creep rate decreases continuously. The secondary creep phase initiated when a nearly constant creep rate has developed. BBC&M agrees that using linear average value of creep may be inappropriate for some of the inclinometers as it appears that many of the inclinometers are transitioning from a

primary creep phase to a secondary phase, or already in secondary creep. Tables 1a and 1b of the most recent annual monitoring report describe over what period the linear creep rate is assumed. In general, the time period over which a linear trend is being used is realistic. Due to error in inclinometer readings, transitions from linear to non-linear trend, or changing the time frame associated with a linear trend is likely not justified in most of the inclinometers. A description of this methodology is provided in the annual report and has been reprinted below for clarification:

“The rates of movement were computed using linear regression for the depth ranges shown on the Time-Displacement plots in the Appendix. Linear regression provided a best-fit match through the data points on each of the time-displacement curves. The time period for the linear regression was chosen based on a visual observation of each curve at the time when the rate was believed to have last changed significantly. For each analyzed slide plane the 95% confidence interval of regression falls within the range of the expected precision of the inclinometer measurements (about 0.2 inches per 100 ft). Therefore it is the opinion of BBC&M that rates of movements have remained relatively constant (with only slight changes subsequently discussed) over the selected time ranges, the shortest of which is 4 ½ years for B-204. A plot of the linear regression and the 95% confidence interval is provided for B-303 in the Appendix.”

The Bullet point conclusion on page 39 has been clarified.

7. Comment: The BBC&M report, page 38, bullet #2, states that an unrehabilitated slope will have constant or accelerating creep movements. The available information on the site geology, subsurface information, and instrumentation do not support this statement. The evidence supports a conclusion that continuing movements can be expected. This report is to be specifically about the proposed north alignment, which can be rehabilitated, and factors like slope loading, slope geometry, pore pressures can be reasonably controlled, and shear strengths can't be further reduced below residual strengths. Thus this statement is irrelevant for a rehabilitated slope.

It is not clear whether the slope at the existing bridge is considered rehabilitated or not. Therefore the reader could conclude that the existing bridge has a short or unpredictable remaining life. It is inconsistent with other aspects of the report and therefore must be resolved.

Response: The statement on Page 38, bullet #2, has been changed from constant to nearly constant, as this is the typical behavior that occurs during the secondary creep rate. The existing bridge may have a finite, unpredictable remaining life, as was discussed in Richland Engineering report for the West Side Pier System of the

Central Viaduct Bridge report, dated May 10, 2005. The evaluation of remediation necessary to improve the stability and decrease the rate of creep in the existing bridge was not part of this scope. We have recommended further investigations during final design to ensure the proposed unloading for the proposed bridge does not adversely affect the existing bridge.

8. **Comment:** The increase in slope movement during and immediately after the construction of the stabilization structure should not be attributed to creep phenomenon (BBC&M, page 22) since the stress state changed during this time period. Thus the suggestion that the increasing rate of slope movements can be attributed to a transition from secondary to tertiary creep is not valid. Human activity, rather than soil behavior, was a direct cause of the movements.

The cited article by Brooker and Peck (1993), if applicable to this site's geology, does not describe the failure mechanism as creep. Moreover, the article observes that first-time movements where the sliding mass overcomes the peak strengths can be catastrophic, but "once a first-time slide has occurred and the strength on the surface of sliding has been reduced to residual, the mass has come to rest in a stable state. Very small increases in driving forces or reductions in resistance ... are likely to cause reactivation of movement. Yet the shearing resistance is at residual value and movements occur slowly". The threat of a creep rupture failure is unlikely. Stating it is a possibility, as with the previous comment, could lead the reader to conclude unpredictability with regard to both a new and the existing structure. It is inconsistent with other aspects of the report (Executive Summary, Item #5 and ELR page 157, Item #7) and therefore must be resolved.

Response: The design team agrees that the rate of creep increased due to human activities. The appropriate sections of BBC&M's report have been revised.

9. **Comment:** There is a discussion of horizontal displacements in relation to factor of safety in the E.L. Robinson report, pages 144-5. The Executive Summary by Baker, page 1, Item #4, states "for practical purposes, slopes with a factor of safety greater than 1.5 do not move". These are contradicted by the BBC&M report, page 38, bullet #3, which states that "it is impossible to predict with any certainty" slope movements.

Response: There will be movement in any slope under any change in stress. What was meant by the statement in the executive summary by Baker, page 1, item #4, is that the movement is negligible and of no significant consequence. We think that of the mechanism causing movement is understood and that the future deformation of the slope can be predicted with reasonable certainty to be very minimal.

10. **Comment:** Removal of the cold storage building has been extensively analyzed with respect to slope stability. The BBC&M report, page 38, bullet #4, states that

the building “has an unknown influence on the stability of the slope”. The impact of removal of the building seems to conflict in the Executive Summary, Item #3 and ELR, page 112, first paragraph of Section 7.2. Perhaps it would be better stated that the proposed slope excavation, which happens to include removal of the building, is needed to provide adequate stability to the slope.

Response: We agree that removing the building will improve the safety factor of the slope as the building lies within the driving force portion of the slope. Figures 7.16C thru 7.16E in the report show the effect of the building on the stability of the slope. The factor of safety of the slope with a slip plane forced to initiate close to the middle of the building increased by 0.2 after removing the building.

11. Comment: Dr. Marr’s presentation included probabilities of failure for various scenarios including the existing slope, removing the building, excavation, pore pressure relief, and monitoring. This information, although a qualitative illustration, would be useful to the reader and should be included in the report.

Response: Additional information has been added to E.L. Robinson’s report in chapter 7, to provide this information.

12. Comment: Clarification of the statement in the ELR report, page 111, Item #2 that the proposed locations either side of the existing bridge have a lower factor of safety than the existing bridge is needed. The higher factor of safety at the existing bridge, if due to the stabilization structure, should be stated as such.

Response: The higher factor of safety is due to the Pier 1 stabilization system. The drilled shafts, driven piles, and tiebacks were included in the slope stability model. That resulted in a higher factor of safety for the slope under the existing bridge compared to the sections to the north and south of it.

the Challenge.

Finding the right
firm to handle
your projects
from inception to
completion.

the Choice.

E.L.ROBINSON

the Challenge. the Choice.

Engineering
Architecture
Landscape
Architecture
Construction
Administration
Surveying
Planning

STATE OF OHIO

DEPARTMENT OF TRANSPORTATION



Central Viaduct Project

Cuyahoga County, Ohio

CUY-90-14.92

PID 77332

SLOPE STABILITY EVALUATION REPORT

Prepared for

Baker

Cleveland, Ohio

Prepared by

E.L.ROBINSON

the Challenge. the Choice.

6000 Memorial Dr., Dublin, OH 43017

September, 2006



9/11/2006

Mr. Robert Parker, PE
Michael Baker Jr., Inc.
The Halle Building
1228 Euclid Avenue, Suite 1050
Cleveland, OH 44115

Reference: CUY-90-14.92
Stability Evaluation of the Slope to the west of the Cuyahoga River

Attn. Mr. Parker;

Please find enclosed a copy of our *final report* addressing the stability of the CUY-90-14.92 west bank slope. As a member of the Design Team for this project, EL Robinson Engineering (ELR) is tasked with the assignment to review the history of the existing project, work with BBC&M Engineering, Inc. as they evaluate the slope and perform an independent evaluation of the alternatives available to improve the overall stability of the slope located under the proposed bridge. BBC&M Engineering, Inc. report is included within this document and can be found in Appendix B.

If you have any questions regarding the status of this report please contact Rick Engel at 614-923-7473.

Respectfully,

A handwritten signature in blue ink that reads "Jamal Nusairat".

Jamal Nusairat, PE, Ph.D.
Project Manager

A handwritten signature in blue ink that reads "Rick Engel".

Rick Engel, PE
Vice President



CUY-90-14.92
SLOPE STABILITY EVALUATION REPORT

TABLE OF CONTENTS

Chapter	Title	Page
1	INTRODUCTION	1-1
2	OBJECTIVES AND SCOPE OF WORK	2-1
3	REQUIREMENTS AND CONSTRAINTS	
	3.1 Introductions	3-1
	3.2 Slope Concerns Related to Selection of the Pier Location	3-1
	3.3 Operational and Maintenance Requirements	3-4
4	SUMMARY OF GEOLOGIC CONDITIONS	4-1
	4.1 Geology of the Site	4-1
	4.2 Subsurface Investigations	4-2
	4.3 Cone Penetration Testing	4-2
	4.4 Summary of Laboratory Results	4-3
	4.5 Recommended Strength Values for Slope Design	4-5
	4.6 Slope Stability Analysis Performed in this Report	4-5
5	REVIEW OF EXISTING BRIDGE STABILIZATION SYSTEM INSTRUMENTATION AND MONITORING FINDINGS	5-1
	5.1 Introduction	5-1
	5.2 Stabilization System Instrumentation Plan	5-1
	5.3 QA/QC Review of Instrumentation Results	5-1
	5.3.1 Slope Movement Measurements	5-1
	5.3.2 Drilled Shafts	5-2
	5.3.2 Tie Beams	5-3
	5.3.4 Rock Anchors	5-4
	5.3.5 Piles	5-4
	5.3.6 Inclinometers installed in the drilled shafts	5-5
	5.3.7 Status of Monitoring as of July 2006	5-5
6	SLOPE STABILITY MODEL DEVELOPMENT	6-1
	6.1 Geometry, Boundary Loads, and Stratigraphy	6-1
	6.2 Soil Parameters and Groundwater	6-2
	6.3 Studied Sections	6-3
7	EVALUATION OF EXISTING SLOPE AND SLOPE IMPROVEMENT	7-1
	7.1 Stability of Existing Slope	7-1
	7.2 Considerations for Improving Slope Stability	7-4
7.B	INDEPENDENT EVALUATION BY GEOCOMP CORPORATION	7-73
	7B.1 Introductions	7-73
	7B.2 Summary of Lab Data	7-73
	7B.3 Summary of Analyses	7-78
	7B.4 Probability of Slope Failure	7-90

Chapter	Title	Page
8	HORIZONTAL DRAINS AND VERTICAL PRESSURE RELIEF DUCTS	8-1
A.	Horizontal Drains	8-1
8.1	Introduction	8-1
8.2	Maintenance	8-2
8.3	Cost	8-2
8.4	Design	8-2
B.	Vertical Pressure Relief Ducts	8-4
9	ISOLATION SYSTEMS	9-1
9.1	Introduction	9-1
10	COST COMPARISONS	10-1
10.1	Introduction	10-1
11	DISCUSSION AND CONCLUSIONS	11-1
11.1	Introduction	11-1

APPENDICES

Appendix A: Geotechnical Test Report-Geo Testing Express

**Appendix B: Slope Stability Investigation for West Bank of
Cuyahoga River (BBC&M Report, Dated
May 2006)**

LIST OF TABLES

Table	Title	Page
4.1	Summary of Lab Test Results	4-6 to 4-10
5.1	Horizontal Movements Measured using Inclinometers	5-6
5.2	Strain Measurements during the Lateral Load Test on Shafts # 1 and # 3	5-7
6.1	Stratification and Soil Strength Parameters for Section A-A	6-3
6.2	Stratification and Soil Strength Parameters for Section D-D and Bridge Centerline (Section CL).	6-3
7.1	Summary of Stability Analyses Results	7-6
7.2a	Alternatives Considered for Improving Slope Stability of CUY-90-15.24 Bridge by All Consultants	7-7
7.2b	Alternatives Considered for Improving Slope Stability of CUY-90-15.24 Bridge by All Consultants	7-8
7.2c	Alternatives Considered for Improving Slope Stability of CUY-90-15.24 Bridge by All Consultants	7-9
7.3a	Summary of Stability Analyses Performed for CUY-90-15.24 Bridge for Existing Conditions (Section A-A)	7-10
7.3b	Summary of Stability Analyses Performed for CUY-90-15.24 Bridge for Modified Conditions (Section A-A)	7-11
7B.1	Summary of Soil Properties from Lab Tests	7-76 to 7-77
7B.2	Summary of Results for Factor of Safety	7-80
7B.3	Earth Structure Categories and Characteristics	7-95
9.1	Summary of Cost Estimate of the Isolation System and Pier Foundation for various drilled shaft sizes	9-9
10.1	Cost Comparison	10-1

LIST OF FIGURES

Figure	Title	Page
3.1	Pictures showing the failed sheet pile wall	3-3
5.1	Plan view of the stabilization structure and instrumentation layout	5-8
5.2	Plan view showing the location of the inclinometers in the project area	5-9
5.3	Ground movements at each slip plane during phase 1	5-10
5.4	Ground movements at each slip plane during phase 2	5-11
5.5	Ground movements at each slip plane during phase 3	5-12
5.6	Ground movements at each slip plane during phase 4	5-13
5.7	Ground movement along section A-A during phase 1	5-14
5.8	Ground movement along section A-A during phase 2	5-15
5.9	Ground movement along section A-A during phase 3	5-16
5.10	Ground movement along section A-A during phase 4	5-17
5.11	Ground movement along section D-D during phase 1	5-18
5.12	Ground movement along section D-D during phase 2	5-19
5.13	Ground movement along section D-D during phase 3	5-20
5.14	Ground movement along section D-D during phase 4	5-21
5.15	Deflection vs. Depth from Shaft # 1 during the lateral load test	5-22
5.16	Interaction Diagram for Drilled shafts in the stabilization structure	5-23
5.17	Rate of increase in Drilled shaft # 9 moment	5-24
5.18	Rate of increase in Drilled shaft # 9 Axial Force	5-25
5.19	Photo showing the construction of the tie beams and the buildup of fill on top	5-26
5.20	Anchor # 1: Force vs. time plot	5-27
5.21	Anchor # 8: Force vs. time plot	5-28
5.22	Anchor # 9: Force vs. time plot	5-29
5.23	Anchor # 17: Force vs. time plot	5-30
6.1	Plan view of the project showing the studied sections	6-4
6.2	Comparison CPT vs. Corrected SPT for: A) B-05-01/C-05-01, b) B-05-02/C-05-02	6-5
6.3	Comparison CPT vs. Corrected SPT for: A) B-05-03/C-05-03, b) B-05-08/C-05-08	6-6
6.4	Comparison CPT vs. Corrected SPT for: A) B-05-011/C-05-11, b) B-05-12/C-05-12	6-7
7.1	Geometry and Material Properties at Section A-A	7-12
7.2	Geometry and Material Properties at Section A-A After Removal of Existing Building	7-13
7.3	Geometry and Material Properties at Section A-A After Flattening of Upper Slope	7-14
7.4	Geometry and Material Properties at Centerline of Existing Bridge Section	7-15
7.5	Geometry and Material Properties at Section D-D	7-16
7.6	Stability of Existing Slope at Section A-A	7-17

Figure	Title	Page
7.6A	Stability of Existing Slope at Section A-A (Revised W.T.)	7-18
7.7	Stability of Existing Slope at Section A-A Using Undrained Analyses	7-19
7.7A	Stability of Existing Slope at Section A-A Using Undrained Analyses (Revised W.T.)	7-20
7.8	Stability of Existing Slope at Section A-A With Elevated Pore Pressure (w2 = 650)	7-21
7.8A	Stability of Existing Slope at Section A-A With Elevated Pore Pressure (w2 = 650)	7-22
7.9	Stability of Existing Slope at BRIDGE CL Section With Elevated Pore Pressure	7-23
7.9A	Stability of Existing Slope at BRIDGE CL Section With Elevated Pore Pressure (w2 = 625 Revised W.T.)	7-24
7.10	Stability of Existing Slope at BRIDGE CL Section With Elevated Pore Pressure (w2 = 650)	7-25
7.10A	Stability of Existing Slope at BRIDGE CL Section With Elevated Pore Pressure (w2 = 650 and Revised W.T. from new Piezometers)	7-26
7.11	Stability of Existing Slope at Section D-D With Elevated Pore Pressure (w2 = 625)	7-27
7.11A	Stability of Existing Slope at Section D-D With Elevated Pore Pressure (w2 = 625)	7-28
7.12	Stability of Existing Slope at Section A-A Using Block Search	7-29
7.12A	Stability of Existing Slope at Section A-A Using Block Search (Revised W.T.)	7-30
7.13	Stability of Existing Slope at Section A-A Using Block Search and Residual Strength for Bottom Layer	7-31
7.13A	Stability of Existing Slope at Section A-A Using Block Search and Residual Strength for Bottom Layer (Revised W.T.)	7-32
7.14	Stability of Existing Slope at Section A-A with Bottom Layer at Residual Strength, and Elevated Pore Water Pressure (w2 = 650)	7-33
7.14A	Stability of Existing Slope at Section A-A with Bottom Layer at Residual Strength, and Elevated Pore Water Pressure (w2 = 650) (Revised W.T.)	7-34
7.15	Effects of Recent Construction involving Removing Sheet Piles and Flattening Slope on the Stability of Existing Section A-A	7-35
7.15A	Effects of Recent Construction involving Removing Sheet Piles and Flattening Slope on the Stability of Existing Section A-A (Revised W.T.)	7-36
7.16	Effect of Removal of Existing Building on Stability of Section A-A	7-37
7.16A	Effect of Removal of Existing Building on Stability of Section A-A (Revised W.T.)	7-38
7.16B	Existing Conditions Stability of Section A-A, Slip Surface is Forced Under the Building (Revised W.T.)	7-39
7.16C	Effect of Removal of Upper Part of Existing Building on Stability of Section A-A, Slip Surface is Forced Under the Building Location (Revised W.T.)	7-40

Figure	Title	Page
7.16D	Effect of Removal of Lower Part of Existing Building Stability of Section A-A, Slip Surface is Forced Under the Building Location (Revised W.T.)	7-41
7.16E	Effect of Removal of Lower Part of Existing Building Stability of Section A-A, Slip Surface is Forced Under the Building Location (Revised W.T.) ($W_2=0^\circ$)	7-42
7.17	Effect of Horizontal Drains on Stability of Section A-A	7-43
7.17A	Effect of Horizontal Drains on Stability of Section A-A (Revised W.T.)	7-44
7.18	Effect of Horizontal Drains on Stability of Bridge CL Section	7-45
7.18A	Effect of Horizontal Drains on Stability of Bridge CL Section (Revised W.T.)	7-46
7.19	Effect of Horizontal Drains on Stability of Section D-D	7-47
7.19A	Effect of Horizontal Drains on Stability of Section D-D (Revised W.T.)	7-48
7.20	Effect of Horizontal Drains and Slope Flattening On Stability of Section A-A	7-49
7.20A	Effect of Horizontal Drains and Slope Flattening on Stability of Section A-A	7-50
7.21	Effect of Horizontal Drains on Stability of Section A-A Using Block Search and Residual Strength For Bottom Layer	7-51
7.21A	Effect of Horizontal Drains on Stability of Section A-A Using Block Search and Residual Strength For Bottom Layer (Revised W.T.)	7-52
7.22	Effect of Horizontal and Vertical Drains on Stability of Section A-A	7-53
7.22A	Effect of Horizontal and Vertical Drains on Stability of Section A-A (Revised W.T.)	7-54
7.23	Effect of Horizontal and Vertical Drains on Stability of Bridge CL Section	7-55
7.23A	Effect of Horizontal and Vertical Drains on Stability of Bridge CL Section (Revised W.T.)	7-56
7.24	Effect of Horizontal and Vertical Drains on Stability of Section D-D	7-57
7.24A	Effect of Horizontal and Vertical Drains on Stability of Section D-D (Revised W.T.)	7-58
7.25	Effect of Horizontal and Vertical Drains & Slope Flattening on Stability of Section A-A	7-59
7.25A	Effect of Horizontal and Vertical Drains & Slope Flattening on Stability of Section A-A (Revised W.T.)	7-60
7.26	Slope Grading for Improving Stability of Section A-A (9:1 then 5:1)	7-61
7.26A	Slope Grading for Improving Stability of Section A-A (10:1 then 5:1) (Revised W.T.)	7-62
7.27	Recommended Grading for Improving Stability of Section A-A (15:1 then 2.5:1)	7-63
7.27A	Recommended Grading for Improving Stability of Section A-A (15:1 then 2.5:1)	7-64

Figure	Title	Page
7.28	Recommended Grading for Improving Stability of Section A-A (15:1 then 2.5:1 and W2 at 600')	7-65
7.28A	Recommended Grading for Improving Stability of Section A-A (15:1 then 2.5:1) (Revised W.T. and W2 at 600')	7-66
7.29	Stability of 2.5:1 Slope at Abbey Avenue Along Section A-A (Revised W.T.)	7-67
7.30A	Slope Grading Plan	7-68
7.30B	Slope Grading Cross Sections	7-69
7.30C	Slope Grading Cross Sections	7-70
7.30D	Slope Grading Cross Sections	7-71
7.30E	Slope Grading Cross Sections	7-72
7B.1	Geometry for Section A-A	7-80
7B.2	Results of Stability Analysis of Existing Slope with PLAXIS	7-83
7B.3	Horizontal Movements in Existing Slope from Increasing Pore Pressure in Soil #5 by 20 ft	7-83
7B.4	Vertical Movement in Existing Slope from Increasing Pore Pressure in Soil #5 by 20 ft	7-84
7B.5	PLAXIS Geometry for Unloaded Slope	7-85
7B.6	Stability Analysis with PLAXIS for Unloaded Slope	7-86
7B.7	Horizontal Displacements for Unloaded Slope from an Increase in Pore Pressure of 20 ft in Soil #5	7-87
7B.8	Vertical Displacements of Unloaded Slope from an Increase in Pore Pressure in Soil #5 of 20 ft	7-88
7B.9	Effect of Increasing Pore Pressure on Stability of Unloaded Slope	7-89
7B.10	Factor of Safety /Probability of Failure Curves (Lambe 1985)	7-94
7B.11	Current version of Factor of Safety/Probability of Failure Curves (Lambe, Marr, Silva – in review)	7-94
8.1	Horizontal drains Installation Company Information	8-5
8.2	Pictures of horizontal drain installation equipment	8-6
9.1	Plan view of a possible pier foundation configuration	9-2
9.2	Elevation view of Figure 9.1	9-2
9.3	Isometric view of Figure 9.1	9-3
9.4	Sacrificial shafts isolation system	9-4
9.5	Structural fenders isolation system	9-4
9.6	Example of a drilled shaft tied back for resistance of lateral soil forces	9-5
9.7	Pier foundation with casing isolation system	9-6
9.8	Example of an isolated drilled shaft	9-7
9.9	Pier foundation with casing isolation	9-8

CHAPTER 1

INTRODUCTION

Bridge Number CUY-90-1524, the Central Viaduct, also known as the Inner Belt Bridge, is a very important component of the Interstate Highway System in Cleveland, Ohio. The Central Viaduct Bridge carries the IR-90 traffic over the Cuyahoga River Valley. The existing bridge piers are supported on pile foundations. The 5080 foot long Central Viaduct Bridge was constructed and opened to traffic in 1959. Due to excessive movements within the west bank slope during its operation, a slope stabilization system was proposed, designed and constructed during the period from 1997 to 1999. The stabilization system is composed of drilled shafts, driven piles, tie beams, and rock anchors. Richland Engineering Limited (REL) has prepared numerous detailed reports documenting the historical performance of the structure. Ohio Department of Transportation (ODOT) is planning on designing and constructing a companion structure immediately to the north of the existing bridge. This report addresses the concerns for building the proposed structure in the vicinity of the west bank slope. Additional project background information is offered in the BBC&M Engineering Inc. (BBC&M) report provided in Appendix B.

REL has inspected the bridge annually since 1988, and prior to 1988 the bridge was inspected in 1970 and 1974.

One of the first items of work to be completed under the present design contract has been identified by ODOT and is referred to as the "Subsurface Investigation." This work is to specifically determine the appropriate location for the proposed west abutment and also to perform slope stability analyses along sections recommended by ODOT. This work item has been assigned to BBC&M. The slope stability study consisted of Cone Penetration Testing (CPT), drilling boreholes for Standard Penetration Testing (SPT), obtaining samples for laboratory testing, installing and monitoring inclinometers and piezometers, and performing stability analyses. EL Robinson Engineering (ELR) is to offer an independent alternative evaluation of the slope's stability and subsequently prepare the Step 7 Foundation

Recommendation and Step 8 Final Foundation Report for the Central Viaduct Bridge. Dr. W. Allen Marr of Geocomp Corporation is assisting ELR in performing an overall assessment of the integrity of the west end slope area. He also performed an independent slope stability analysis. Dr. Marr's international experience helps to ensure that risks related to the geotechnical issues are appropriately mitigated.

CHAPTER 2

OBJECTIVES AND SCOPE OF WORK

The objectives, scope, and work items are as follows:

1. Review all previous and recent reports generated from investigations performed on the Cuyahoga River west bank bridge foundation and/or slope, including subsurface investigations and instrumentation monitoring.
2. Provide Quality Control (QC) for recent subsurface investigations and slope stability evaluations which were performed by BBC&M and Quality Assurance (QA) on selected slope stabilization and design alternatives.
3. Explain the extent and cause of past slope movements, determine the locations of soil layers that are weak or have been weakened due to slope movements, and establish the shear strength parameters for the soil profile.
4. Evaluate all slope stability related issues with regards to their influence on the state of stability of the west bank slope along the alignment of the proposed bridge. Analyze the stability of the existing slope and evaluate the effects of all stability related parameters on the slope's performance to better understand what specifically is driving the slope movements, and which design efforts will contribute to the success of the slope remediation plan and bridge foundation designs.
5. Identify the feasible locations for all bridge substructure units that can be safely located within the west bank. Provide design criteria for typical loads applied to the potential bridge substructure units placed within the limits of the west bank slope.
6. Recommend a grading plan for improving the stability of the west bank slope.
7. Quantify the potential risks associated with constructing in and near the west bank slope. Determine whether it is necessary to isolate any of the proposed substructure units for the new bridge from future ground movements.

8. Study the overall stability of the existing slopes located below the existing structure on the west bank slope. Explain the relationship between the grading of the slopes for the new structure and the related influence of this work on the overall stability of the slope below the existing structure.
9. Evaluate all geotechnical aspects of this project as they relate to establishing design criteria for the various bridge alternatives.
10. Estimate the related relative earthwork and foundation costs for each proposed alternative design.
11. Provide a discussion on the probability of slope failures as it relates to the west bank after excavating to the designed final grading plan.
12. Provide cost estimates for all of the alternatives.
13. Provide any special loading requirements for building substructure units within the slope.

CHAPTER 3

REQUIREMENTS AND CONSTRAINTS

3.1 Introduction

As we began to study this project and progressed through the evaluation of the overall stability and the performance of the slope, a number of concerns were identified by various members of the Project Team. This section contains some of the design requirements, goals and constraints that need to be addressed to have a complete understanding of the geotechnical and structural issues that are related to this proposed project. The main goal is to provide a minimum factor of safety of 1.5 for all related cut slopes.

3.2 Slope Concerns Related to Selection of the Pier Location

Field measurements at existing Bridge Number CUY-90-14.52 have documented undesirable movements of the west end slope. A new companion bridge is to be constructed to the north of the existing structure. The slope at the location of the new bridge must be evaluated to ensure that when the new bridge is constructed, unacceptable movements will not occur. The Design Team is challenged with establishing what are the specific stability concerns at this site for the measured soil properties of the existing subsurface materials and how can stability be reasonably ensured by using engineering solutions.

A long history of slope movements beneath the existing bridge suggests that the existing slope for the new location has a low margin of safety against a stability failure. There are three primary geotechnical issues:

- I. Existing information shows that some of the geologic layers exhibit a peak drained shear strength followed by a substantial reduction in strength with continued displacement. This behavior complicates design for long term stability.
- II. Visual inspections and measurements of groundwater levels show elevated water pressures within the slope which decrease the stability of the slope. The sources of water are unknown.

III. There have been a number of occurrences of water and gas shooting tens of feet into the air and lasting hours. This indicates excessive pore pressures at depth in the slope that reduce stability. The source and locations of high gas pressures are unknown. Approximately seven isolated locations have been identified

The major mass of the existing slope at the new bridge location has been stable during recent geologic time with no surface indications of significant prior displacements. Significant shear movements within clay layers probably occurred in the geologic past that left these plastic clay layers in a state of residual strength. The calculated factor of safety for a typical section through the existing slope with existing pore pressures is about 1.15 (w1-A). This is a sufficient factor of safety to keep the slope intact without significant displacements. However, an increase of pore pressure within the slope of a few feet or loss of soil mass at the toe of the slope, such as might occur in a flood would lower the factor of safety and trigger down slope movements. Either of these occurrences have a significant probability of occurrence during the life of the new bridge. A lower factor of safety would initiate down slope movement of the slope mass and cause large lateral forces to build up on the bridge foundation.

A sheet pile revetment wall exists at the toe of the slope. It is required by the US Army Corps of Engineers to help maintain a navigable water way. The sheets are 65 feet long. Horizontal steel rods spaced at 8 ft intervals extend from the top of the sheeting to anchor located approximately 40 ft behind the sheeting. These tiebacks failed over time with the consequence that soil and water pressures acting on the back of the sheeting caused the sheeting to displace outward by several feet as shown in the pictures in Figure 3.1. The current owner has excavated soil from behind the sheeting with the hope that the sheeting can be pulled back into place, new tiebacks placed and the slope backfilled. This operation has reduced the overall factor of safety of the existing slope approximately 0.13. This revetment wall should be replaced with a strong, reliable revetment. A new pier should be located to avoid the sheet pile wall tie-backs.



Figure 3.1: Pictures showing the failed sheet pile wall.

3.3 Operational and Maintenance Requirements

Factor of safety is directly related to internal pore pressure. The exact source of groundwater in the slope has not been identified which means that we cannot accurately predict the future groundwater conditions. In such a circumstance the best approach is to build in measures to control pore pressure so that it cannot exceed values used in the design and potentially, if controlled, provide a much higher factor of safety for the stability of the slope.

The critical section for the slope beneath the existing bridge is down slope in approximately the direction of the centerline of bridge. The proposed grading will have a very minimal negative affect on the down slope factor of safety for the existing bridge. The proposed grading for the new bridge will create side slopes where the potential sliding planes will be orthogonal to the existing critical sliding planes. Final design must include consideration of the stability of these slopes and the design adapted to give a minimum factor of safety of at least 1.5 for these slopes as well. The expectation is that these side slopes will need to be 2.5:1.

CHAPTER 4

SUMMARY OF GEOLOGIC CONDITIONS

4.1 Geology of the Site

Interstate-90 crosses the Cuyahoga River Valley at approximately one mile from the shore of Lake Erie. The surficial deposits along the shore line of Lake Erie are mostly lake plain deposits of glacial origin and extend from 2 to 10 miles from the lake southward into the city. The lake plain deposits are predominately sand and gravel deposits that are interbedded with till above the shale bedrock. According to Hansen (1999); Szabo et al. (2003); and BBC&M (2006), this shale contains organic matters and natural gas, which is believed to become trapped in pockets within the overlying sediments. According to BBC&M (2006), after the completion of a CPT test, water/gas vertical fountain formed for a height of approximately 10 feet above the ground surface, also a 3 foot high vertical fountain formed for about two hours near the CPT hole located adjacent to a 30 foot pre-drilled boring (BBC&M, 2006).

The lake plain is delineated at the location of the major river valleys, such as the Rocky River, the Cuyahoga River and Euclid Creek. The Cuyahoga River Valley is deeply cut into the bedrock that underlies the plain and is 2.5 to 4.0 miles wide across the top and has a relief of over 400 feet. Bedrock elevations range from 600 feet at the west side of the valley to 0 feet at the east side of the valley, which indicates that the preglacial bedrock valley is located east of the present surficial river valley. The existing valley is a relatively minor depression in the ground surface compared to a much more impressive depressed valley in the bedrock surface. Much of the bedrock valley is filled with deposits of clay till and glacial lacustrine clay or silty clay. These deposits extend upward to about Elev. 560. They are overlain by sand and silty sand.

Changing lake levels over long periods of time led to the alternating erosion events and deposition of delta materials at the mouth of the river. The deposited materials were mostly silty and sometimes organic. It can be expected that the soil deposits at the bridge are horizontally stratified, variable in thickness and overlying deep shale bedrock which continues to dip to the east well beyond the immediate location of the bridge structure. The stability

analysis of the bridge must take into account weak and possibly thin layers of material which may exist and govern the overall stability of the structure.

4.2 Subsurface Investigations

Four borings were obtained by ODOT in the area of the West End Pier and Pier No. 1 during the original soils investigation in 1954. These borings were used to obtain standard penetration testing data and the classification distinction between surficial granular materials and underlying clays. In 1990, nine borings (B-1 thru B-9) were obtained by ODOT while installing inclinometers. In 1992, an additional boring was obtained (B-10) by ODOT. In 1994, ten borings were drilled by BBC&M in the slope in the vicinity of Pier 1 and the West End Pier (BBC&M, 1994 and 2006). Slope inclinometers were installed in all ten (10) borings. A monitoring program has been ongoing for these instruments from the time of installation.

In 2006, BBC&M was assigned to perform a preliminary subsurface investigation for evaluating the stability of the existing slope and to provide recommendations on the placement of substructures for the proposed bridge. The subsurface investigation program included drilling eleven (11) borings (Borings B-05-01 through B-05-04, B-05-07, B-05-08, and B-05-11 through B-05-15), installing inclinometers in all of these borings, and performing Cone Penetration Testing (CPT), laboratory testing, and slope stability evaluations and recommendations. The boring logs, laboratory testing results, and CPT measurements are available in the BBC&M (2006) report enclosed as Appendix B.

4.3 Cone Penetration Testing

The subsurface investigation performed by BBC&M in 2006 included 15 Cone Penetration Tests (CPT) on the locations marked as C-05-01 through C-05-15. The CPT tests were performed by the Ohio University to depths ranging from 116.5 to 193.2 feet, and are enclosed as Appendix C in the BBC&M Report for Cuy-90-15.24 dated May 2006. The CPT also included Pore Pressure Dissipation Tests for eleven (11) locations (C-05-01, C-05-02, C-05-04 through C-05-11, and C-05-14) at the bottom of each. The tests were terminated prior to reaching the equilibrium static pore pressure values; accordingly, they can only be used for

estimating rough trends. Based on the time dissipation curves, the time required for reaching a static pore pressure is anticipated between two (2) to eight (8) hours for majority of the CPT locations. The dissipation tests revealed high initial excess pore pressures at the cone tip, a relatively slow dissipation rate. At the end of the tests, the estimated excess pore pressures ranged from 50 to 200 psi. This is equivalent to 115.0 to 460.0 feet of free water column.

4.4 Summary of Laboratory Test Results

During the recent work in 2006, BBC&M obtained undisturbed Shelby tube samples for laboratory testing to determine strength of the soils comprising the slope. BBC&M arranged for the following mechanical properties tests to be performed on some of these samples:

Direct shear with residual strength	4
Direct simple shear strength	4
Torsional residual shear strength	4
Consolidated undrained triaxial strength	3

Results of these tests are provided in Appendix E of the BBC&M Report.

As part of their QC/QA responsibilities, E.L. Robinson obtained specific samples from BBC&M and sent them to Dr. Marr’s geotechnical lab, GeoTesting Express, Inc., (GTX) for verification testing. Results of the GTX tests are provided in Appendix A of this report. GTX completed the following tests:

Residual Shear test points	10
Direct Simple Shear tests	3
CIU Triaxial tests	2
Incremental Consolidation tests	2
Constant Rate of Strain Consolidation test	1
Gradations	5
Atterberg Limits	5
Specific Gravity	2
Moisture Content	2
USCS Soil Classification	2

Table 4.1 summaries the important information from these tests. The test data support the following conclusions:

1. Results of the consolidation tests and the behavior of the undrained triaxial tests indicate that materials in the slope are considerably overconsolidated. One consolidation test indicates an effective pre-consolidation stress greater than 20 tsf. This indicates that strains and displacements preceding an unloading failure will be relatively small.
2. Results of the consolidated undrained triaxial tests indicate that negative excess pore pressures develop during undrained shear. These negative pore pressures increase the short-term strength until enough time passes for water to flow into the pores and return pore pressures to steady state values. Therefore, the critical strength for design in this slope is the drained strength. This conclusion is supported by the fact that peak strengths measured in the undrained triaxial tests are higher than the peak strengths computed with effective stress strength parameters for the same effective consolidation stress.
3. Shear strength parameters measured on shear planes inclined at well above horizontal indicate $c_p' = 0$ and $\phi_p' = 32^\circ - 33^\circ$ except for one sample taken directly out of the lower shear zone at the site. This sample indicated a secant friction angle of 26° .
4. Shear strength parameters measured on horizontal planes are less than those measured on inclined planes and they vary with position in the slope. Secant friction angles determined from the effective stress path plots indicate friction angles varying from 33° to 17° . The tests that gave lower values appear to coincide with samples taken from zones where inclinometer measurements showed the largest shear from slope movement.
5. The residual strength measured in repeated direct shear testing gave residual friction angles of 30° to 13.6° . The lowest value was measured on a specimen taken directly from the lower shear zone where GTX personnel observed indications of pre-existing shear planes in the specimen prior to lab testing. Residual friction angle is a direct function of plasticity of the soil. Soils with higher plasticity give lower residual friction angles. We suspect that the soils in the west slope have thin seams of more plastic materials that give rise to the lower residual friction values of 13° to 17° . These seams are sufficiently thin and sandwiched between layers of silty material, that their presence is not readily apparent. Event classification tests don't clearly show the presence of a

more plastic seam in a sample. However, this is explained by the fact that classification tests are performed on remolded samples where the more plastic seam material is thoroughly blended with the surrounding silty soil.

6. Test results obtained by BBC&M and those obtained by GTX generally agree when looked at in a total context.

4.5 Recommended Strength Values for Slope Design

The test results indicate that all designs for slope stability and foundation loading in the slope soils should use drained strength parameters with realistic “worst-case” pore pressures. The following strength parameters apply:

- a. For horizontal and near-horizontal slip surfaces use $c'=0$ and $\phi' = 15^\circ$
- b. For failure surfaces inclined more than 25° , use $c'=0$ and $\phi' = 32^\circ$

4.6 Slope Stability Analyses Performed in this Report

E.L. Robinson performed an independent slope stability analysis as part of the QA work. The analyses are presented in detail in Chapter 7-A.

Dr. Marr of Geocomp Corporation performed an independent slope stability analysis as part of the QC work. Dr. Marr’s analysis is presented in detail in Chapter 7-B.

BBC&M performed stability analyses for the existing slopes within the west bank of the Cuyahoga River. BBC&M analysis is included in their report attached at the end of this report in Appendix B.

Sample				Classification							
Boring ID	Sample ID	Depth, ft	Description	Natural Moisture Content, %	Specific Gravity	ASTM D2487 Group Symbol	Gravel, %	Sand, %	Fines, %	Liquid Limit, %	Plasticity Index, %
Tests by GeoTexting Express, Inc.											
C-05-03	COY-90-15.24	116.5-118.5	Moist, dark gray clay	27	2.75	CL	0	2.1	97.9	35	17
C-05-03	COY-90-15.24/S-30	118.5-120.5	Moist, dark gray clay	26	2.73	CL	0	0.3	99.7	33	15
C-05-04	S-27	72-74	Moist, very dark gray/ish brown clay	21		CL	3.2	8.9	87.9	29	13
B-05-08	S-27	116-118	Moist, dark olive gray clay	22		CL	0	2.2	97.8	27	11
B-105A	S-20	90-92	Moist, dark gray clay	23		CL	0	1	99	32	16
Tests reported by BBC&M											
B-05-01	S-13	55-57	medium to very stiff gray silt							28	8
B-05-02	S-14	44-46	lean clay with occasional coarse sand							19	NP
B-05-02	S-32	122-124	lean clay mixture with silt							24	7
B-05-03	S-8	32-33.5									
B-05-07	S-22	104-106									
B-108	S-8	35-37	stiff gray silty clay, trace f to m sand.								
B-105A	S-23	103-105								34	16

Table 4.1: Laboratory Test Results

Sample			Constant Rate of Strain Consolidation Test							
Boring ID	Sample ID	Depth, ft	Initial Moisture Content, %	Bulk Density, lb/ft ³	Vertical Strain at In Situ	CR at steepest part of curve	RR at Current Vertical Effective Stress	RR at for 1 log cycle of unloading	Preconsolidation Stress, tsf	Coefficient of Consolidation at Overburden Stress, in ² /sec
Tests by GeoTexting Express, Inc.										
C-05-03	COY-90-15.24	116.5-118.5	28	123.3	6		0.1	0.04	>20	3.00E-04
C-05-03	COY-90-15.24/S-30	118.5-120.5	16	130.0			0.08			7.00E-04
			31.5	120.5	6		0.08	0.03		2.00E-03
C-05-04	S-27	72-74								
B-05-08	S-27	116-118								
B-105A	S-20	90-92								
Tests reported by BBC&M										
B-05-01	S-13	55-57								
B-05-02	S-14	44-46								
B-05-02	S-32	122-124								
B-05-03	S-8	32-33.5								
B-05-07	S-22	104-106								
B-108	S-8	35-37								
B-105A	S-23	103-105								

Table 4.1 (Cont'd)

Sample	Direct Simple Shear										
	Initial Moisture Content, %	Bulk Density, kN/m ³	Effective Vertical Stress After Consolidation, psf	Moisture Content At Shear, %	Shear Stress at Failure Condition, kPa	Shear Stress/Effective Consolidation Stress	Vertical Strain at half of Peak Deviator Stress	G ₅₀ , psf	G ₅₀ /Effective Confining Stress	G ₁ , MPa	Friction Angle
Tests by GeoTexting Express, Inc.	C-05-03	124.2	9500	28	2167	0.228	0.025	86680	9.12421	173360	17.9
	C-05-03	125.1	9500	29	2436	0.256	0.04	60900	6.41053	121800	19.7
	C-05-03	COY-90-15.24/S-30	118.5-120.5								
C-05-04	S-27	130.5	5506	21	2028	0.368	0.02	101400	18.4163	202800	25.4
B-05-08	S-27										
B-105A	S-20										
Tests reported by BBC&M											
B-05-01	S-13	5600	1520	0.271	0.014	108571	19.3878	217143	30.3		
B-05-02	S-14	10600	3200	0.302	0.022	145455	13.7221	290909	23.0		
B-05-02	S-32	3800	1170	0.308	0.03	39000	10.2632	78000	23.3		
B-05-03	S-8	10600	2080	0.196	0.012	173333	16.3522	346667	17.1		
B-05-07	S-22										
B-108	S-8										
B-105A	S-23										

Table 4.1 (Cont 'd)

Sample	Triaxial Test						
	Initial Moisture Content, %	Bulk Density, kN/m ³	Effective Vertical Stress After Consolidation, psf	Moisture Content At Shear, %	Peak Shear Stress at Failure Condition, psf	Effective Stress Cohesion, KPa	Effective Stress Friction, degrees
Boring ID Sample ID Depth, ft Tests by GeoTexting Express, Inc. C-05-03 COY-90-15.24 116.5-118.5 C-05-03 COY-90-15.24/S-30 118.5-120.5	26.7	120.5	9493	25.2	3934	assume 0	26.3
	22.2	128.4	8267	19.5	6882	assume 0	33.4
Tests reported by BBC&M B-05-01 S-13 55-57 B-05-02 S-14 44-46 B-05-02 S-32 122-124 B-05-03 S-8 32-33.5 B-05-07 S-22 104-106 B-108 S-8 35-37 B-105A S-23 103-105	21.3	134.6	3000	18.3	3400	0	32
	22.4	131.9	6800	20.1	4600		
	21.5	130.2	9900	19.0	5500		

Table 4.1 (Cont'd)

Sample	Direct shear										
	Initial Moisture Content, %	Bulk Density, kN/m ³	Effective Vertical Stress After Consolidation, psf	Moisture Content After Shear, %	Peak Shear Stress at Failure Condition, psf	Peak Secant Friction Angle, degrees	Post Peak Shear Stress at Failure Condition, psf	Post Peak Secant Friction Angle, degrees	Peak Shear Stress at Failure Condition, psf	Peak Secant Friction Angle, degrees	Post Peak Shear Stress at Failure Condition, psf
Tests by GeoTexting Express, Inc.											
C-05-03	20	123.6	4748	31	2433	27.1	2400	26.8	2433	26.8	2400
C-05-03	28	126.7	9500	25	4818	26.9	3658	22.1	4818	22.1	3658
C-05-03	21	113.7	14249	22	5111	19.7	3444	13.6	5111	13.6	3444
C-05-03	26	122.7	9500	25	3849	22.1	2559	15.1	3849	15.1	2559
C-05-04	24	122.9	14249	22	6367	24.1	5611	21.5	6367	21.5	5611
B-05-08	22	130.5	2752	23	1580	29.9	1374	26.5	1580	26.5	1374
B-05-08	21	129.5	3519	23	1891	28.3	1681	25.5	1891	25.5	1681
B-105A	22	130.5	8258	20	4519	28.7	4393	28.0	4519	28.0	4393
B-105A	21	130.7	4130	19	2677	33.0	2385	30.0	2677	30.0	2385
Tests reported by BBC&M											
B-05-01	26	127.3	2250	28	4146	28	4000	15	4146	15	4000
B-05-02	26	126.0	4500	22	4146	22	4000	15	4146	15	4000
B-05-02	28	121.6	9000	18	4146	18	4000	15	4146	15	4000
B-05-03	27.9	120.4	7900	24	4146	24	4000	15	4146	15	4000
B-05-07	26	127.3	2250	28	4146	28	4000	15	4146	15	4000
B-108	26	126.0	4500	22	4146	22	4000	15	4146	15	4000
B-108	28	121.6	9000	18	4146	18	4000	15	4146	15	4000
B-105A	27.9	120.4	7900	24	4146	24	4000	15	4146	15	4000

Table 4.1 (Cont 'd)

CHAPTER 5

REVIEW OF EXISTING BRIDGE STABILIZATION SYSTEM INSTRUMENTATION AND MONITORING FINDINGS

5.1 Introduction

The existing data collected from the instruments installed at the job site were requested by ODOT District 12 and transferred to ELR to be used to understand the mechanism and limits of movement in the slope.

5.2 Stabilization System Instrumentation Plan

The stabilization system consisted of two rows of drilled shafts with a reinforced concrete cap, tension tieback beams, driven piles with a reinforced concrete cap, and relatively long rock anchors. The drilled shaft reinforced concrete cap was tied to the pile cap with steel W 8x35 members. Figure 5.1 shows a plan view of the stabilization system.

5.3 QA/QC Review of Instrumentation Monitoring Results

As part of the QA/QC work, ELR reviewed the data collected from the instrumentation installed in the slope since 1994 and in the stabilization structure since 1999.

5.3.1 Slope Movement Measurements

The collected data was reviewed and updated to reflect the latest quarterly readings obtained in July of 2006. Data from the earth inclinometers installed and monitored by BBC&M was independently analyzed by E.L. Robinson to provide an alternative opinion. The data was processed using the GTILT Plus software. Figures showing movement versus depth and rates of movement were developed. A plan view showing the location of the inclinometers at the project site is provided in Figure 5.2. The figures which show the magnitude movement versus depth and also the rates of movement are attached at the end of Chapter 5.

The rate of movement at each slip plane depth was thoroughly investigated. The data was

divided into four phases:

1. Phase 1: before construction started in 1997.
2. Phase 2: from 1997 until 6/1999.
3. Phase 3: From 6/1999 until 12/2001.
4. Phase 4: long term monitoring from 1/2002-to the present.

The movements at each slip plane during each of the four phases are presented in Figures 5.3 to 5.6.

Soil profiles developed from old and new boring information was used to show the movement along the center line of the proposed structure (Section A-A) and to the south of the existing structure (Section D-D). The movement along Section A-A is shown in Figures 5.7 through 5.10, respectively for the four phases mentioned earlier. Figures 5.11 through 5.14 present the movements along section D-D. Table 5.1 summarizes the total movement and the rate of movement during each of the four phases.

The movement plots and plan views show that at the area of the new structure there is minor movement in the deep slip plane, the rate of movement is estimated to be 0.01 inches per year.

5.3.2 Drilled Shafts Stress Condition Assessment

During construction of the drilled shafts for the stabilization structure, a lateral load test was conducted between shafts #1 and #3. The maximum applied lateral load was 800 kips. The deflection associated with a lateral load of 800 kips was 5 inches as shown in Figure 5.15. The maximum bending strain along the depth of shaft #1 associated with the 800 kips lateral load was 1614 micro strains as shown in Table 5.2. From long term monitoring data obtained from instrumentation installed in drilled shaft #9, measurements indicated a maximum bending strain located at a depth of 95 feet to have a magnitude equal to 151 micro strains. This value is 10% of the 1614 value measured during the lateral load test.

For shaft #17, which experienced a maximum movement of 1.7 inches, the strain equivalent to this value from the lateral load test is equal to 231 micro strains. Figure 5.16 shows the interaction diagram for the stabilization drilled shafts. The concrete strength used was 6000 psi, which was taken from the drilled shaft inspection record attached at the end of this chapter.

Based on the findings from the lateral load test, the drilled shafts have the ability to move up to 5 inches elastically (which was the maximum movement reported in the lateral load test). The rate of movement in drilled shaft #17 was the highest (i.e. 0.12 inch/yr). Assuming a constant rate of 0.12 inch/yr, it will take 15 years to reach a total movement of 3.5 inches (1.7 + 1.8). Assuming a constant rate of 0.12 inch/yr, it will take 28 years to reach a total movement of 5 inches (1.7 + 3.3). This indicates that the safe life of the stabilization shafts is approximately 30 years before getting beyond the condition as tested in 1998. From the long term monitoring data, the rate of increase in the moment and axial force in shaft #9 at a depth of 95 feet appears to have decreased as shown in Figures 5.17 and 5.18. The recently collected data from the July 2006 readings show minimal increase in the strain in the shaft.

5.3.3 Tie Beams

Tie beam measurements are experiencing a steady state condition with no indication of any trend to vary with time except for slight stress changes which are most likely a result of changes in temperature. Note that there is a relatively high frictional resistance from the soil around and on top of the beams. The tie beams were insulated in a 24" diameter corrugated PVC, which was filled with concrete after tensioning of the anchors. Due to the corrugated pipe and the concrete filling, the tie beams are acting as a composite 24" diameter corrugated section. The steel beam inside the section is not indicating any increase in stress in response to the movement of the caps. The force transmitted through the PVC composite sections has to overcome the friction of the surrounding soil. It appears that the drilled shaft cap and the pile cap are moving similar distances laterally, which allows the tie beams to remain in a constant state of stress. Pictures in Figure 5.19 show the construction of the tie beams and the

placement of substantial embankment on top of the tie beams.

5.3.4 Rock Anchors

Rock anchor data was reviewed and plots were updated to reflect the collected data that was available prior to and including the April 2006 quarterly data. A trend indicating a loss of load was noticed in all anchors. The rate of loss in load was the highest in anchor #17, which is in line with drilled shaft #17, which showed the most movement. Anchor #17 showed a loss in the range of 8.5 kips per year, while anchor #1 showed a loss of 5.5 kips per year.

The variation in load loss is in agreement with the movement trend in the drilled shafts which can be explained by the rotation of the reinforced concrete pile cap.

The plots of anchor load vs. time since lock-off in 1999 until April 2006 are shown in Figures 5.20 thru 5.23 for anchors 1, 8, 9, and 17, respectively.

5.3.5 Piles

The driven piles experienced an increase in the axial force after the completion of construction ranging from 40 to 150 kips. The bending moment increase was in the range of 30 ft-k to 150 ft-k in the down slope direction (river side of the pile) and 1 to 55 ft-k in the direction 90° from down slope. The axial force and bending moment are below the allowable values for the HP14 x 89 pile section. The mechanism of force and moment build up can be explained as follows: the tensioning of the rock anchors caused an axial force in the piles due to the 45 degree downward angle of the anchors. The cap rotated several degrees by the time the 17 anchors were tensioned. The corrugated tubes around the tie beams were concreted after completion of tensioning the anchors. After the placement of concrete in the PVC pipe that was placed around the tie beams, the 25 feet of embankment was constructed on top of the tie beams and the anchor cap. This resulted in additional dead load on the pile cap from the weight of the soil carried by the cap and the tie beams. The pile cap was somewhat restrained from rotating backwards due to the force in the anchors and the framed in 34 tie

beams embedded in the opposite side. The pile cap deflected elastically downward because of the weight of the soil on the tie beams.

5.3.6 Inclinator Installed in the Drilled Shafts

The movements in the inclinometers installed in shafts #1, 3, 8, 9, 10, and 17 have been monitored since 1999. The data indicates a trend for an increase in the lateral movement at shaft #17 equal to almost twice the movement observed in shaft #1.

The consolidation of the embankment caused an increase in dead load supported by the top of the tie beams.

5.3.7 Status of Monitoring as of July 2006

The latest measurement readings collected from instrumentation in the stabilization structure for the existing bridge and in various locations in the slope indicated no change in magnitude from the April 2006 readings. The quarterly report titled "July 2006 Quarterly Report Field Monitoring Services," dated August 2006, was prepared by BBC&M Engineering Inc.

Our conclusion is that the slope retention structure has a 30 year remaining safe life before reaching the stress condition that existed when tested in 1998.

Table 5.1: Horizontal Movements Measured using Inclinerometers

Inclinometer No.	Elevation (Feet)	Date of the Measurements			
		9/23/1997	6/30/1999	12/30/2001	1/1/2006
		Inclinometer Movement Horizontal (Inch)			
B101	505	0.000	0.000	0.000	0.000
	492	0.000	0.000	0.000	0.060
B102	607	0.000	0.000	0.000	0.000
B105	490	0.000	0.210	0.170	0.100
	475	0.130	0.730	0.340	0.520
B107	614	0.000	0.000	0.000	0.000
	515	0.000	0.000	0.000	0.000
	478	0.000	0.000	0.000	0.000
B108	592	-	-	-	0.000
	542	-	-	-	0.100
	540	-	-	-	0.100
B110	567	0.000	0.000	0.191	0.230
	552	0.000	0.000	0.000	0.000
	479	0.000	0.000	0.000	0.000
B203	599	-	0.341	0.000	0.055
	579	-	0.050	0.000	0.000
	561	-	0.272	0.076	0.114
B204	582	-	-	-	0.000
	498	-	-	-	0.000
	482	-	-	-	0.200
B303	573	-	0.250	0.110	0.220
	566	-	0.411	0.083	0.102
	525	-	1.002	0.331	0.370

Table 5.2: Strain Measurements during the Lateral Load Test on Shafts #1 and #3

SHAFT # 1 - SOUTH (TENSION SIDE), REDUCED STRAIN DATA															
Depth (ft)	SB-12269	SB-12229	SB-12270	SB-12271	SB-12268	SB-12274	SB-12272	SB-12226	SB-12238	SB-12257	SB-12258	SB-12228	SB-12255	SB-12273	SB-12273
Load (K)	4.5	11	17.5	24	30.5	37	42.33	49.83	59.83	69.83	79.83	89.83	110	130	130
0	0.00	0.00	0.00	0.00	0.00	0.00	0.00	0.00	0.00	0.00	0.00	0.00	0.00	0.00	0.00
50	1.43	7.71	8.33	5.60	3.44	1.04	0.29	0.04	-0.21	0.00	-0.30	0.14	0.22	0.11	0.11
100	1.46	8.63	9.14	6.30	3.89	1.22	0.40	0.18	-0.28	0.04	-0.41	0.22	0.18	0.11	0.11
200	8.55	38.36	51.55	41.17	28.71	10.41	3.90	2.43	-0.18	-0.29	0.37	0.76	0.63	0.25	0.25
300	13.90	64.90	95.05	82.21	64.78	24.63	10.00	8.16	0.32	-0.92	0.04	1.09	0.89	0.36	0.36
400	19.18	91.43	131.84	145.49	97.77	38.39	16.26	14.17	2.43	-1.40	-0.11	1.66	1.22	0.50	0.50
500	25.91	120.27	473.54	379.36	145.12	57.66	25.52	23.56	5.59	-1.44	-0.33	2.50	1.81	0.75	0.75
600	35.22	308.53	574.73	718.38	231.32	68.64	30.52	29.72	8.20	-1.21	0.59	3.37	2.36	0.93	0.93
680	42.81	457.92	631.01	1528.79	1352.42	80.42	38.17	38.03	13.01	-1.40	0.74	4.16	2.73	1.18	1.18
720	46.94	569.07	736.89	1586.51	1406.40	89.75	43.25	42.88	14.63	-1.29	0.52	4.70	3.17	1.32	1.32
800	51.19	622.56	862.69	1614.50	1461.09	95.15	47.77	48.68	16.99	-1.62	0.19	4.99	3.43	1.42	1.42
0	12.58	136.86	18.01	321.88	610.18	67.89	36.08	45.02	19.21	-3.97	-4.82	0.22	0.52	0.11	0.11

SHAFT # 1 - NORTH (COMPRESSION SIDE), REDUCED STRAIN DATA															
Depth (ft)	SB-12266	SB-12250	SB-12227	SB-12236	SB-12256	SB-12224	SB-12252	SB-12237	SB-12251	SB-12239	SB-12259	SB-12253	SB-12225	SB-12267	SB-12267
Load (K)	4.5	11	17.5	24	30.5	37	42.33	49.83	59.83	69.83	79.83	89.83	110	130	130
0	0.00	0.00	0.00	0.00	0.00	0.00	0.00	0.00	0.00	0.00	0.00	0.00	0.00	0.00	0.00
50	-2.50	-7.22	-9.34	-7.22	-5.10	-0.89	-0.14	-0.07	0.55	0.11	0.15	0.44	-0.07	0.22	0.22
100	-3.12	-8.03	-10.39	-8.25	-5.85	-1.03	-0.18	0.11	0.96	0.33	0.34	0.44	-0.07	-0.11	-0.11
200	-12.94	-42.82	-58.23	-52.17	-38.82	-8.29	-5.15	-2.55	2.43	2.47	1.13	0.77	0.61	0.18	0.18
300	-18.89	-70.84	-104.46	-103.34	-84.93	-21.07	-14.76	-12.05	2.35	4.50	2.56	0.95	0.65	0.07	0.07
400	-24.30	-95.61	-160.14	-208.95	-125.83	-31.75	-23.62	-21.12	2.02	7.20	4.18	1.42	0.72	0.37	0.37
500	-30.18	-125.58	-317.20	-327.35	-176.28	-46.48	-35.27	-35.25	-0.18	10.67	6.21	2.15	1.15	0.22	0.22
600	-47.60	-249.00	-460.12	-456.76	-334.18	-55.66	-41.10	-41.28	-0.11	13.36	8.95	62.32	1.83	-0.11	-0.11
680	-57.71	-303.92	-554.04	-618.26	-477.71	-68.51	-49.03	-51.69	-1.99	16.32	11.43	3.98	2.41	0.48	0.48
720	-64.40	-378.80	-646.90	-712.68	-582.21	-82.96	-55.75	-58.67	-3.09	18.24	12.64	4.78	2.84	0.85	0.85
800	-70.65	-404.24	-716.73	-774.65	-674.32	-101.14	-62.65	-65.55	-4.34	19.97	14.63	5.95	2.30	0.96	0.96
0	-10.33	-70.49	-216.91	-304.33	-355.04	-70.89	-55.96	-75.33	-24.58	7.57	8.16	0.69	0.25	0.22	0.22

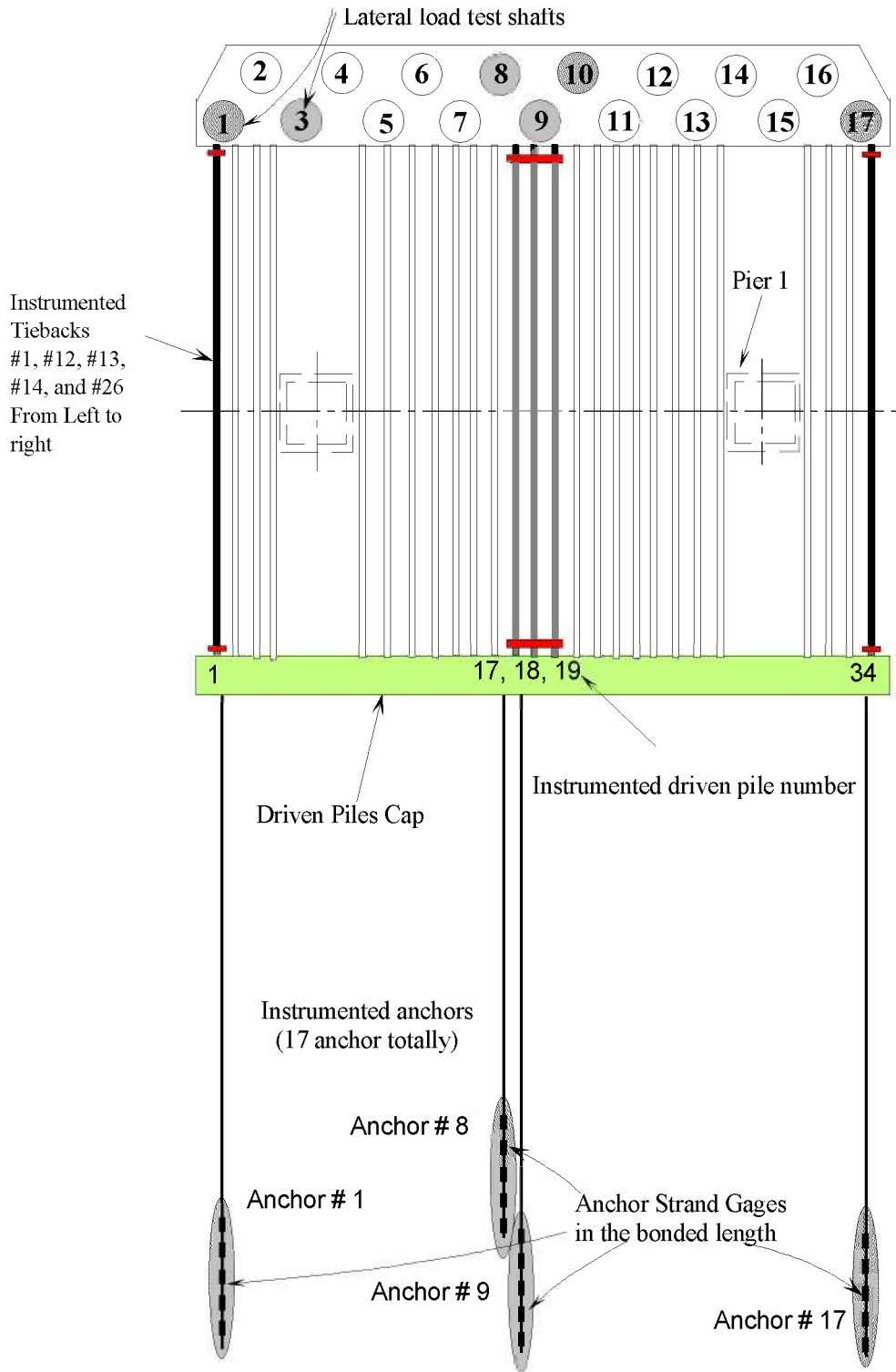

Figure 5.1 Plan view of the stabilization structure and instrumentation layout

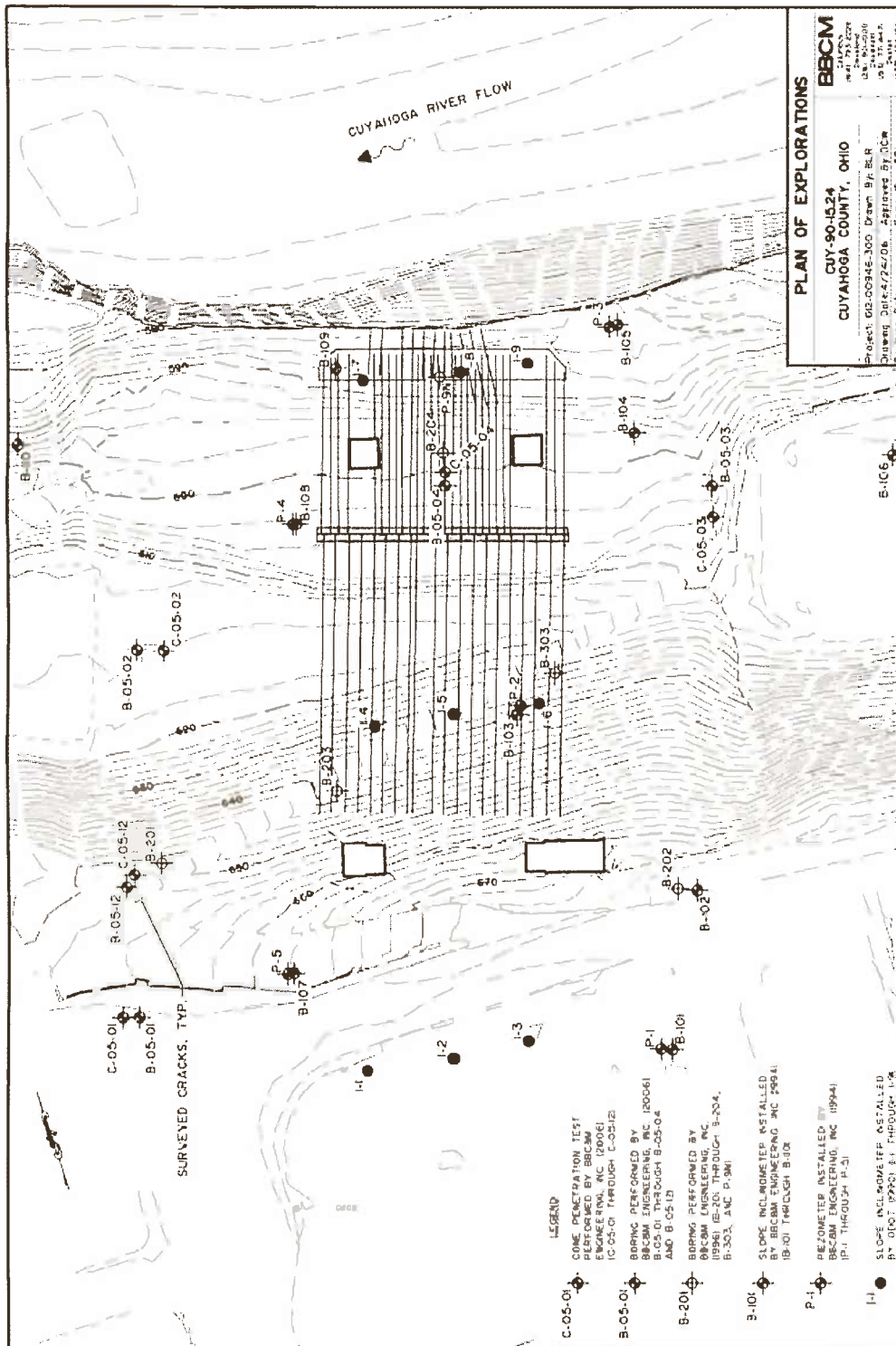

Figure 5.2 Plan view showing the location of the inclinometers in the project area

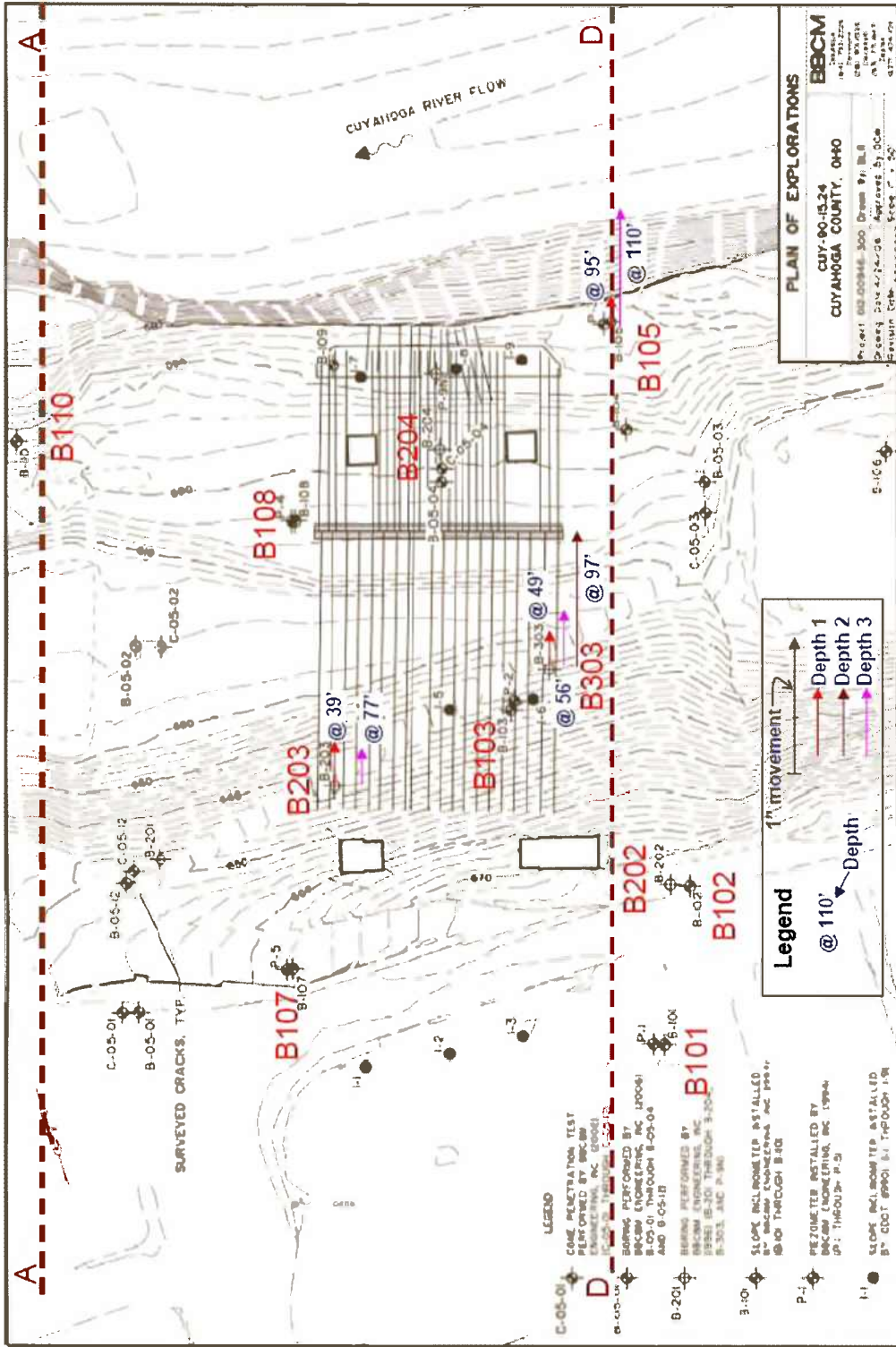

Figure 5.4 Ground movements at each slip plane during phase 2

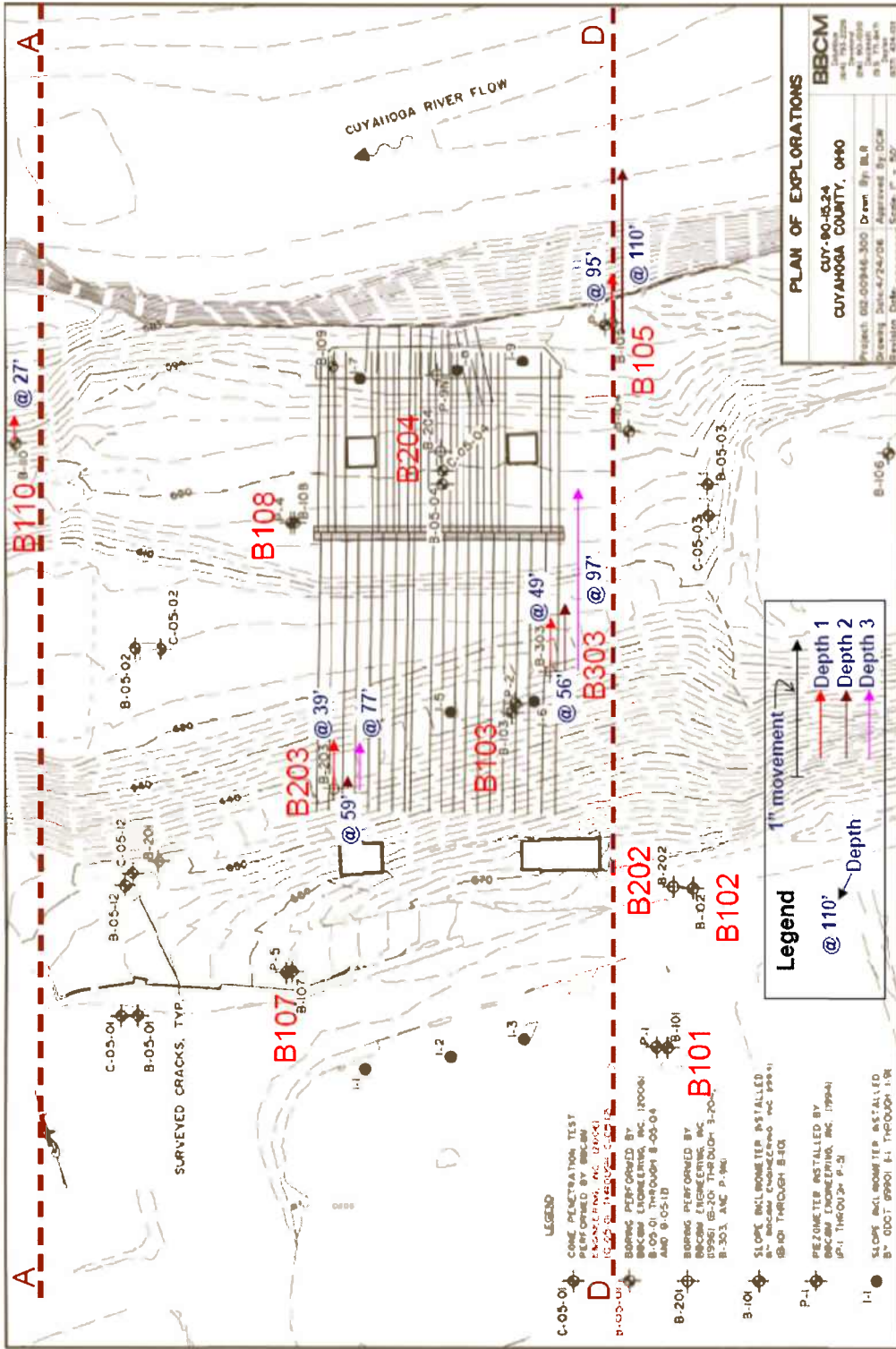
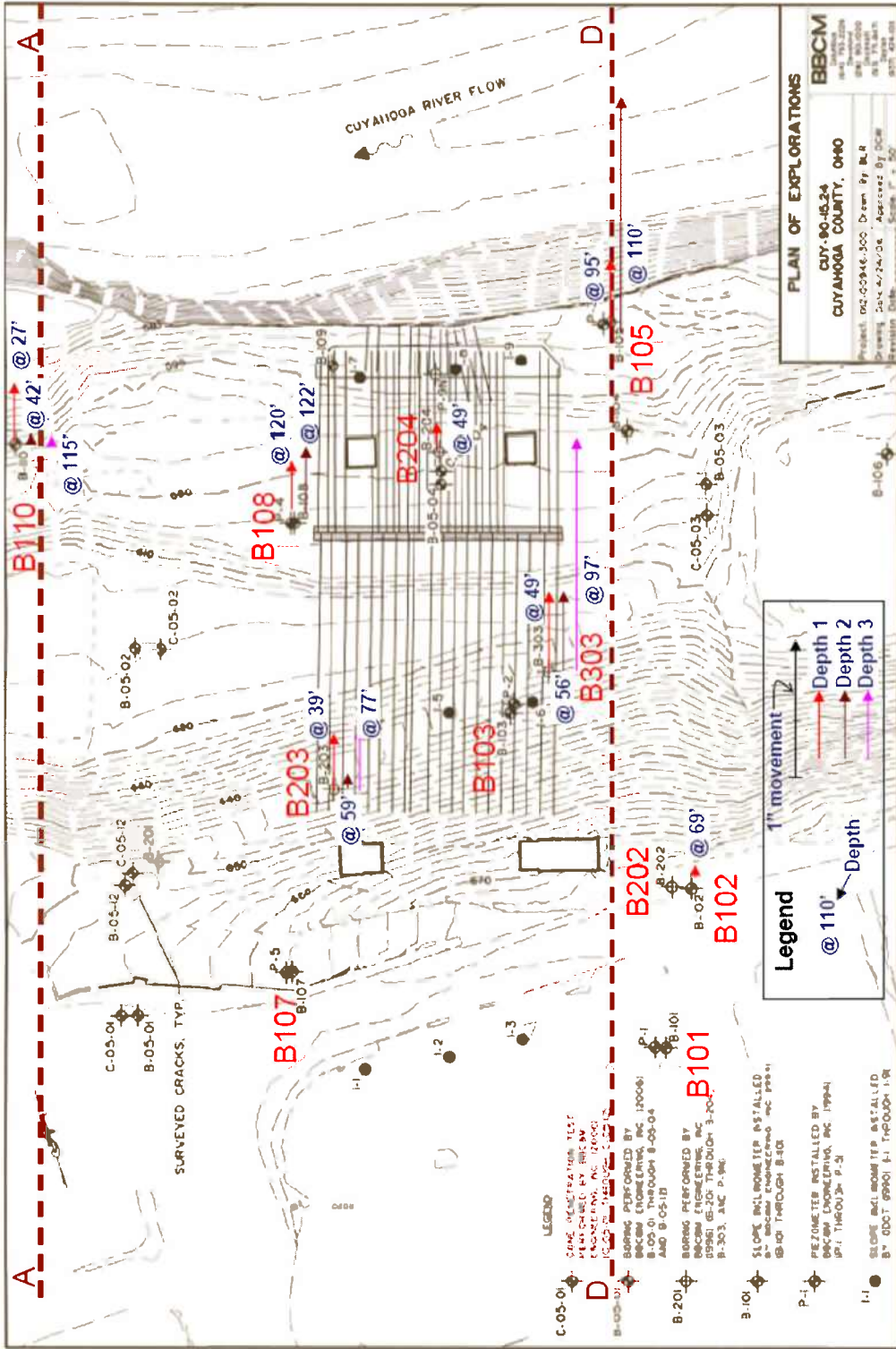

Figure 5.5 Ground movements at each slip plane during phase 3



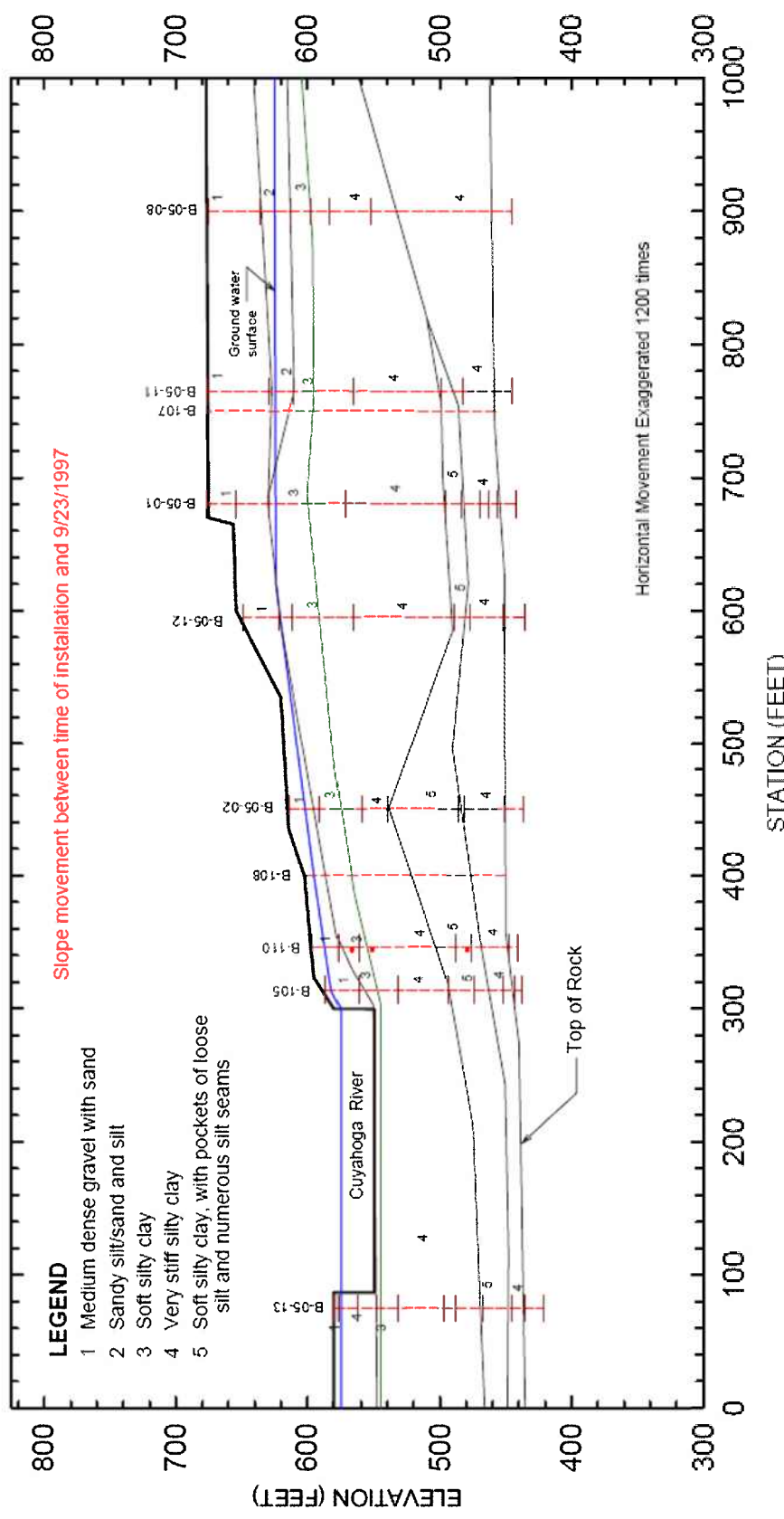

Figure 5.7 Ground movement along section A-A during phase I

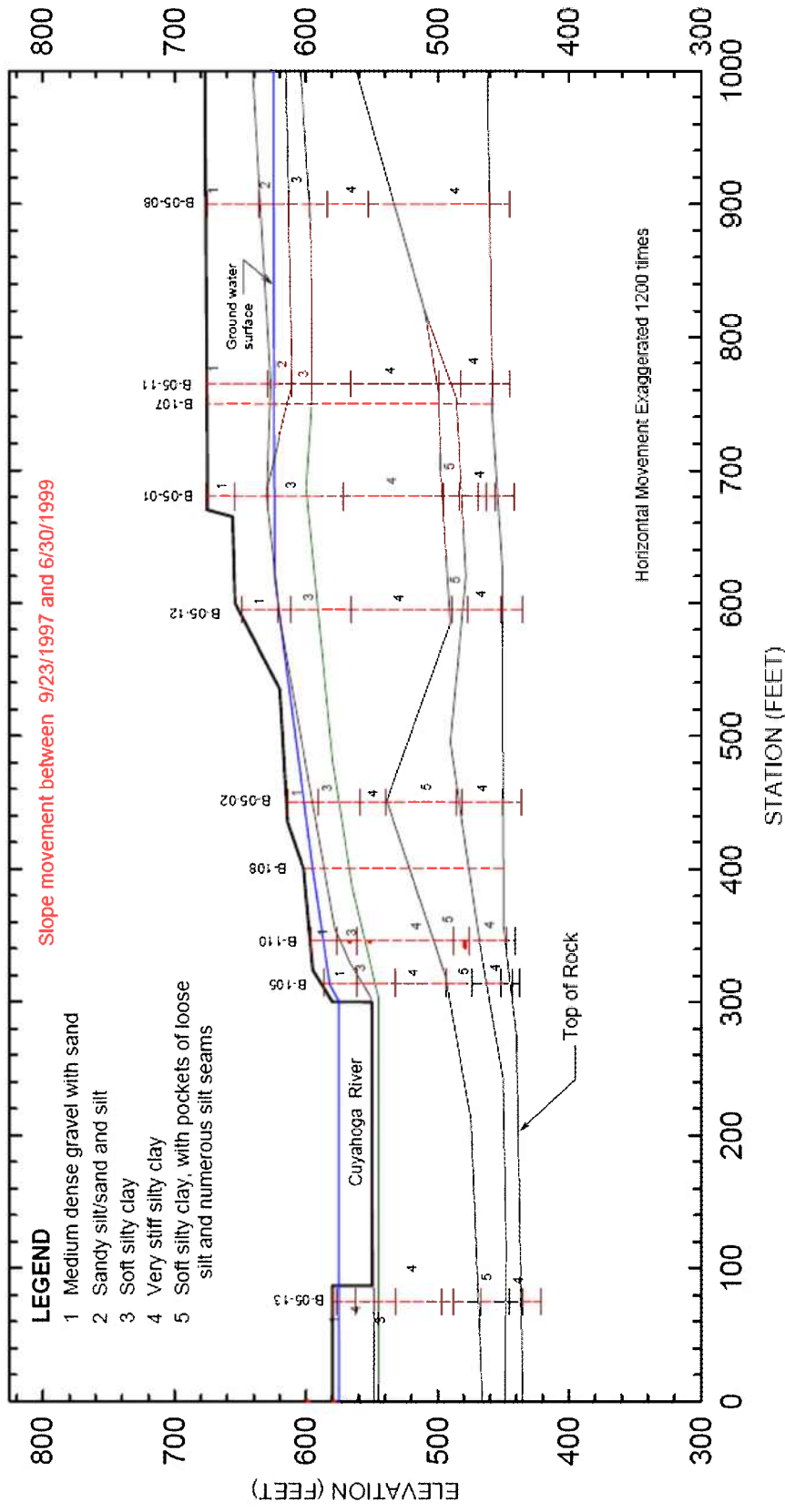

Figure 5.8 Ground movement along section A-A during phase 2

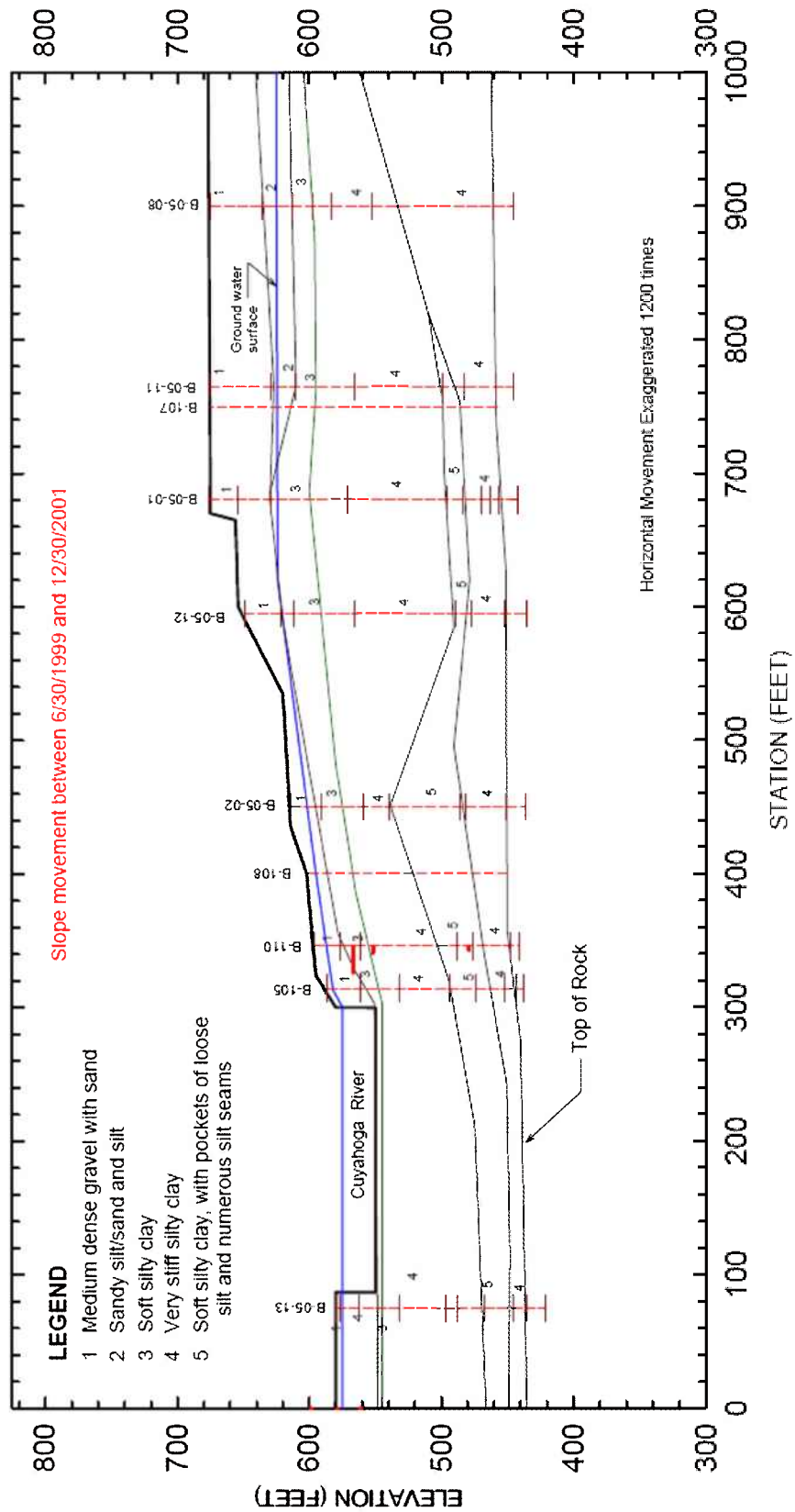

Figure 5.9 Ground movement along section A-A during phase 3

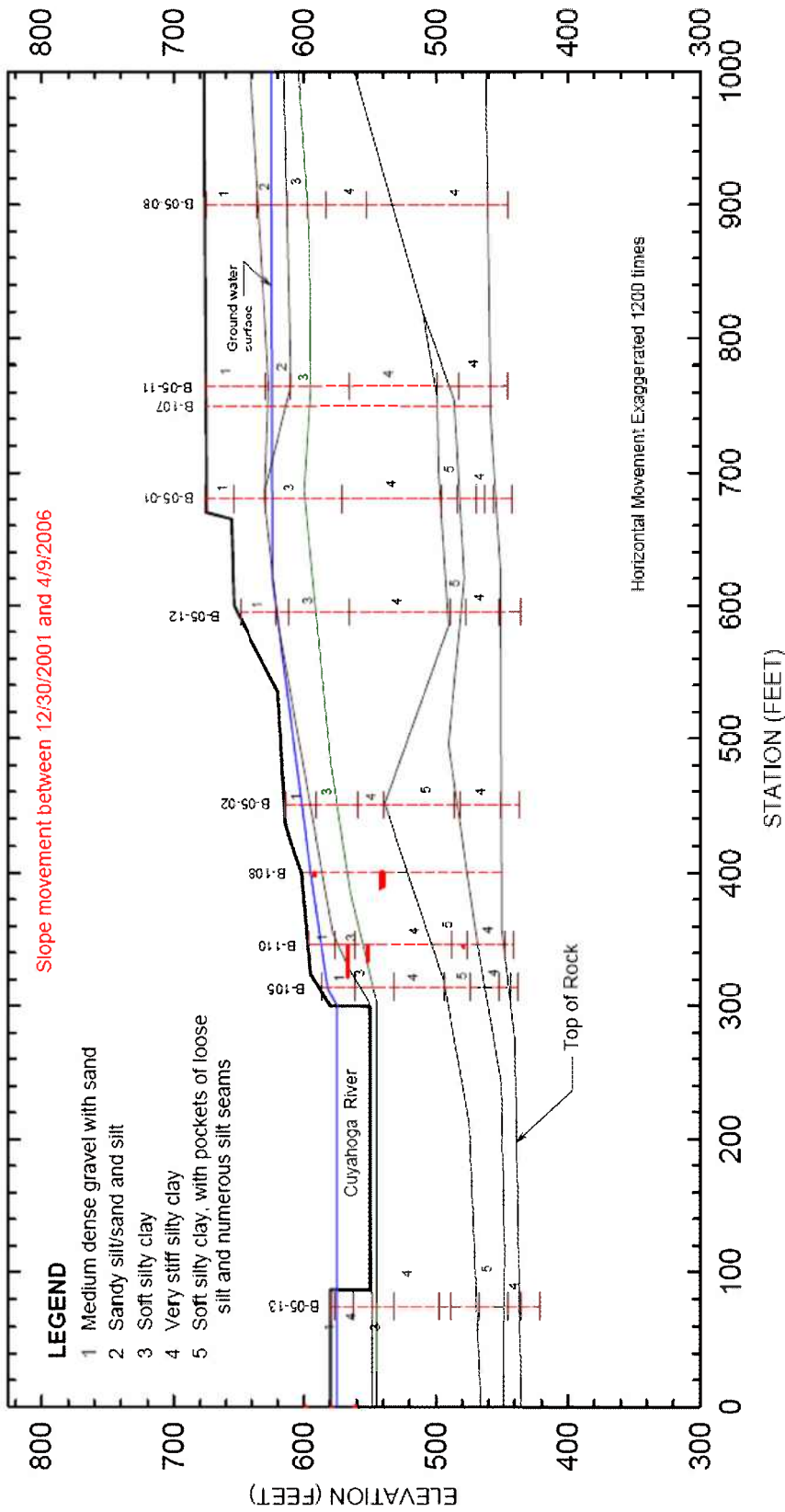

Figure 5.10 Ground movement along section A-A during phase 4

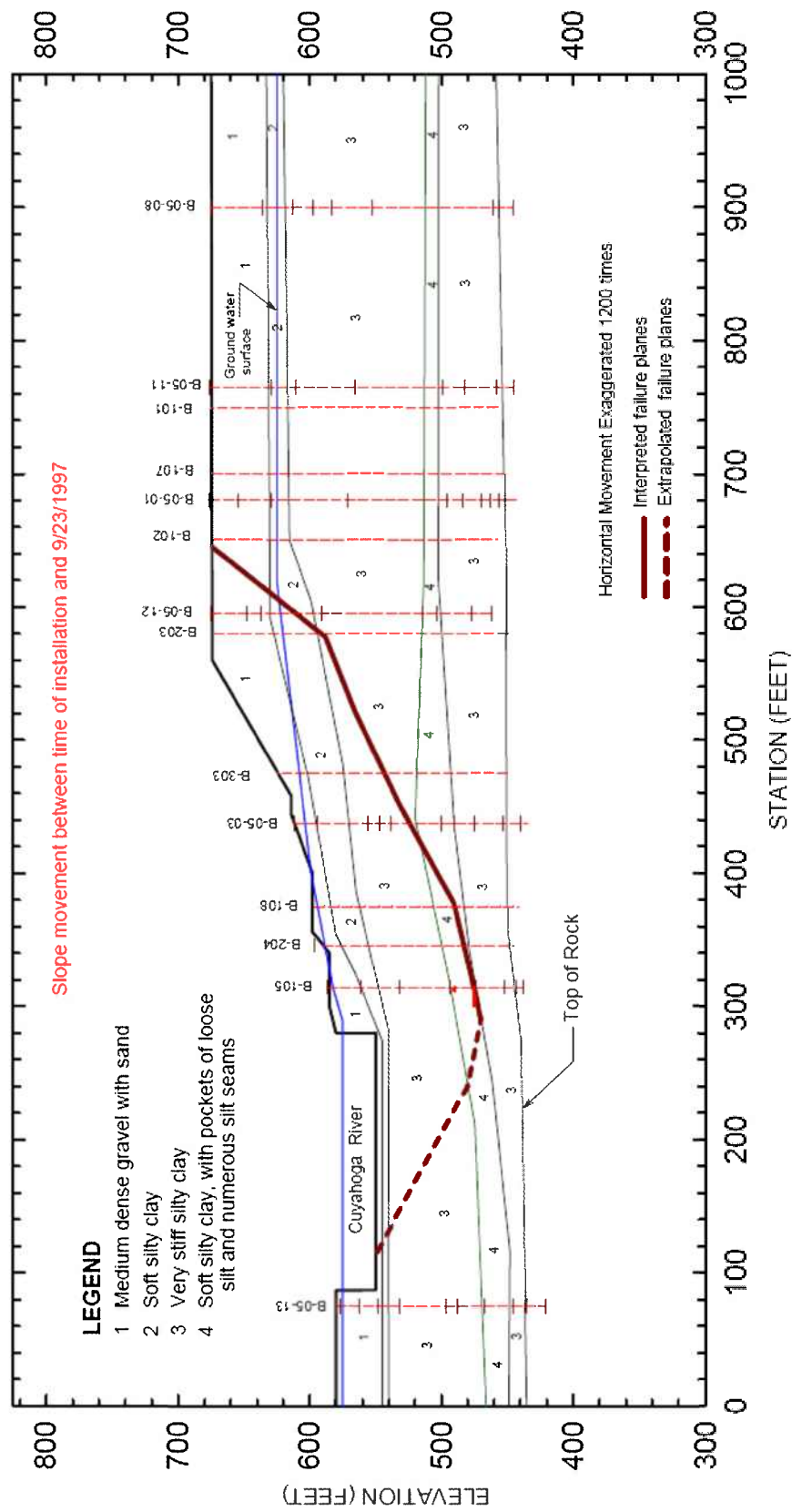

Figure 5.11 Ground movements along section D-D during phase I

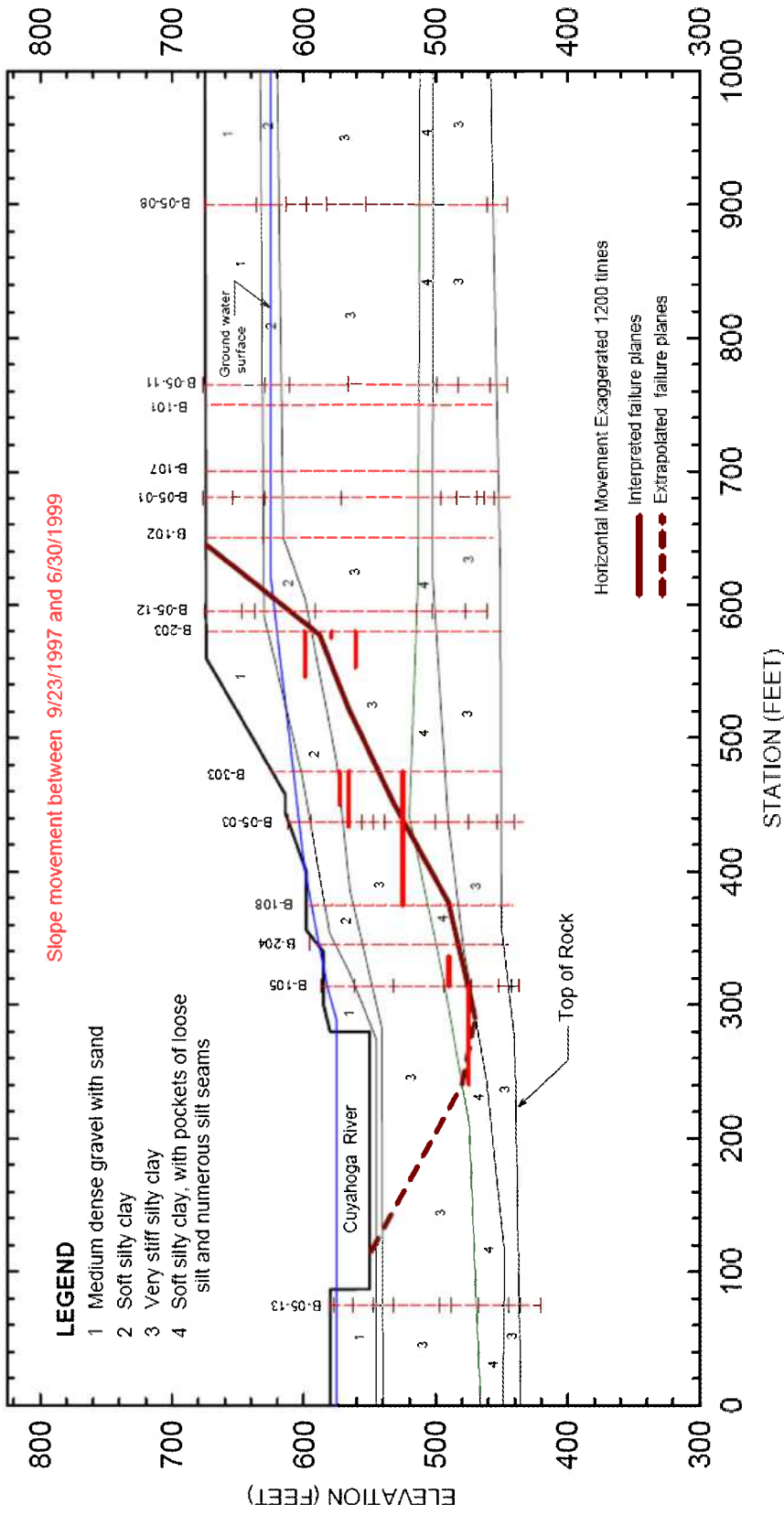

Figure 5.12 Ground movements along section D-D during phase 2

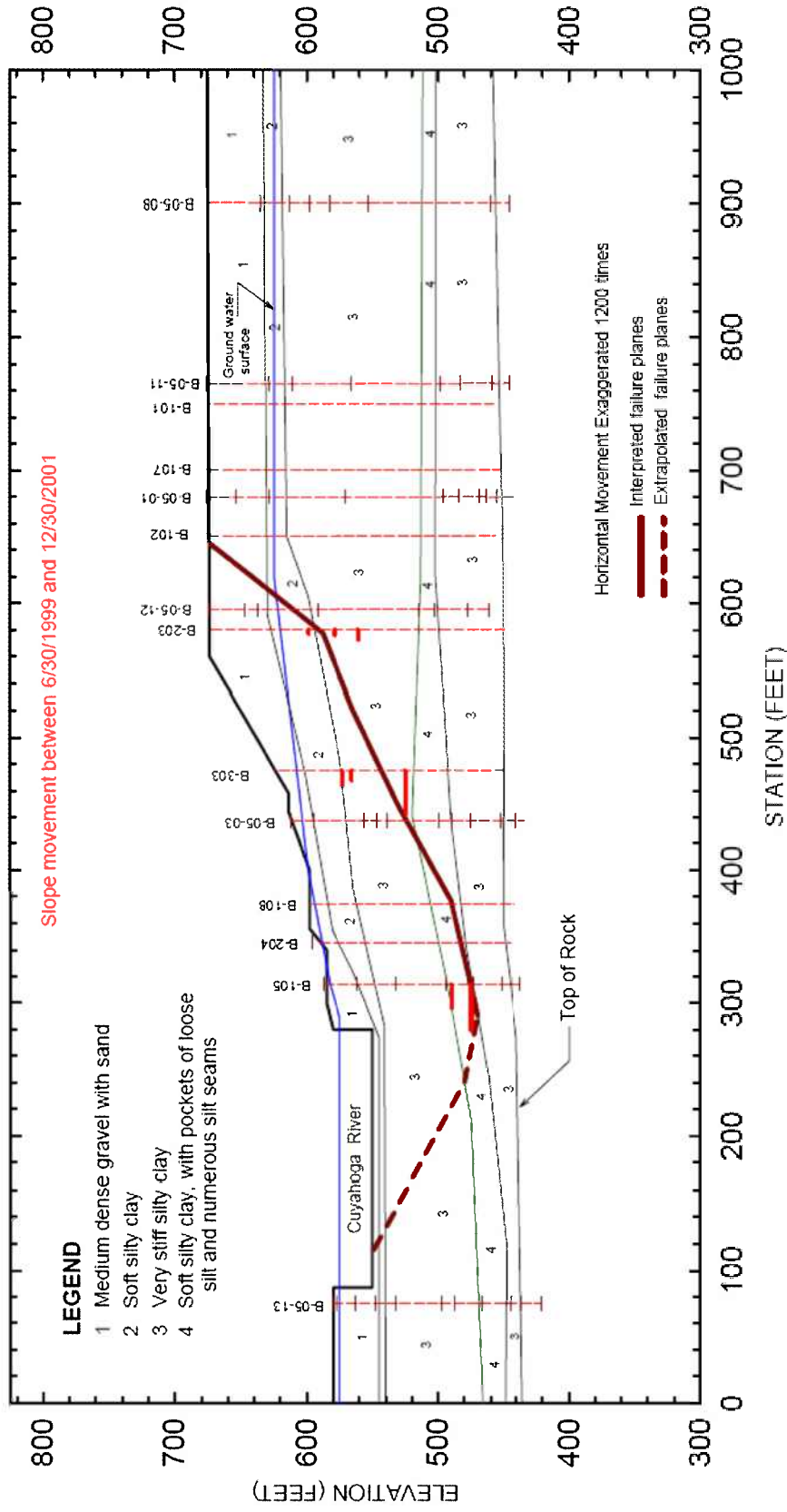

Figure 5.13 Ground movements along section D-D during phase 3

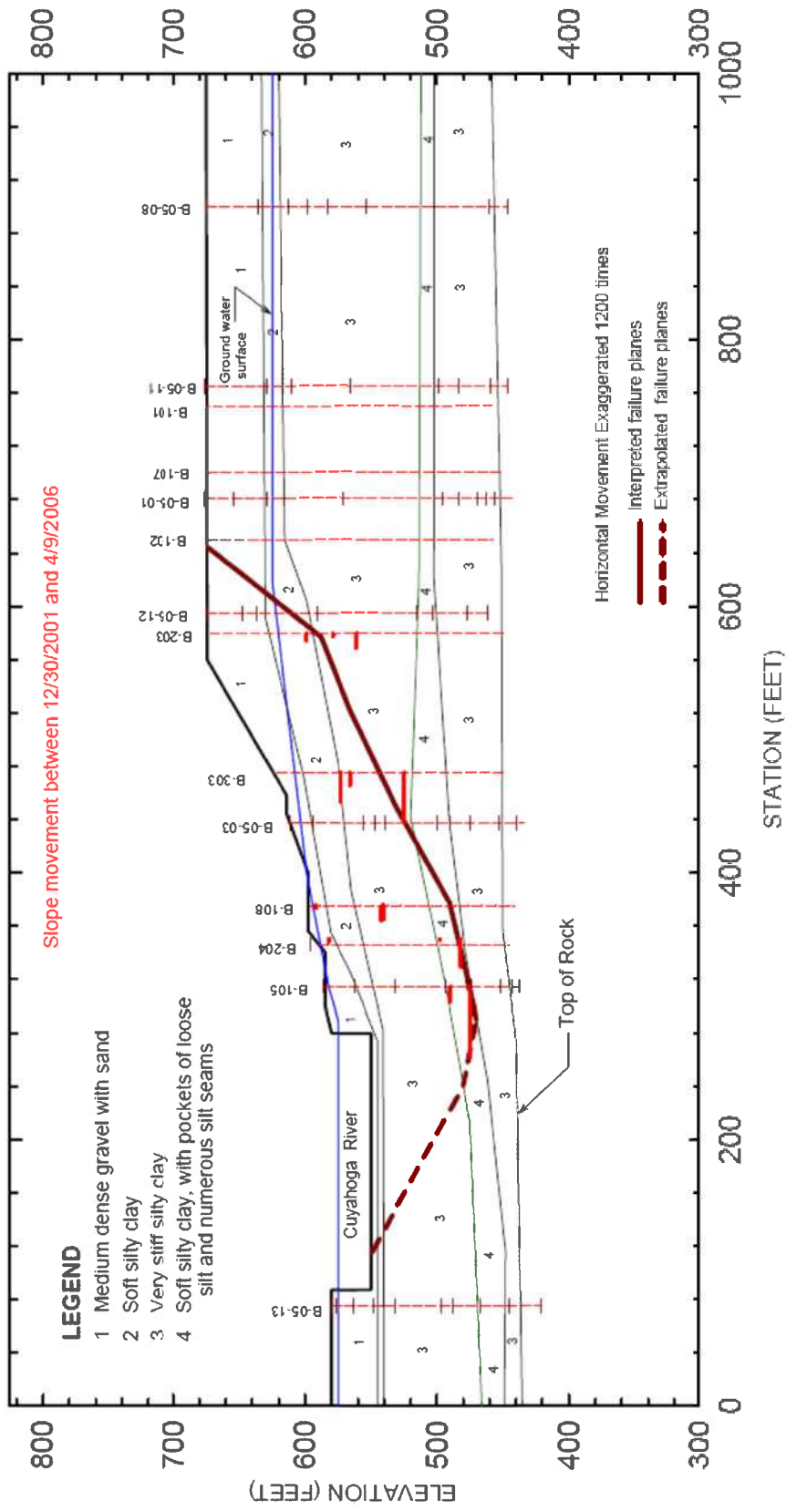

Figure 5.14 Ground movements along section D-D during phase 4

CUY-90-15.24 Lateral load test Shaft - 1 Direction vs. depth

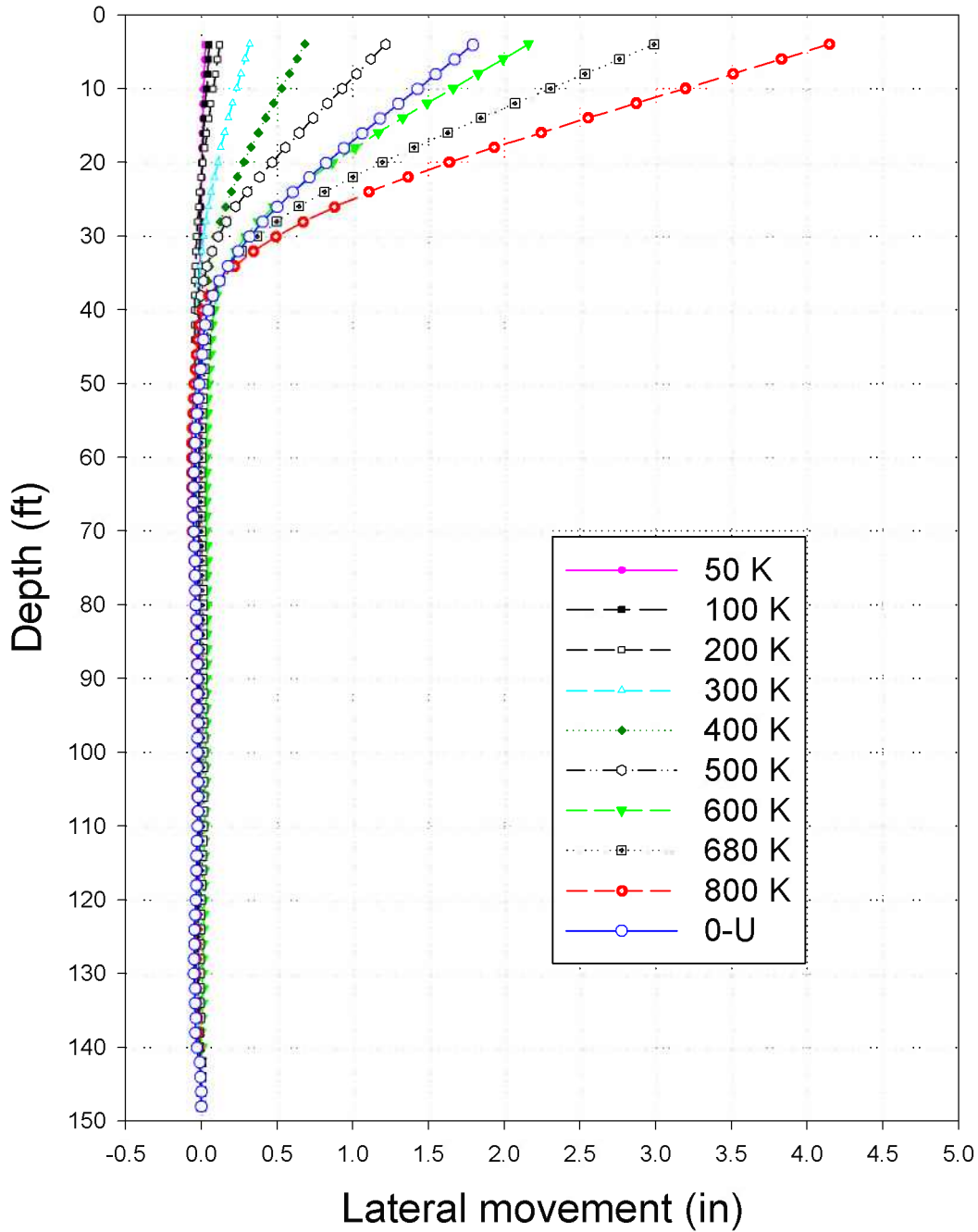

Figure 5.15 Deflection vs. Depth from Shaft #1 during the lateral load test.

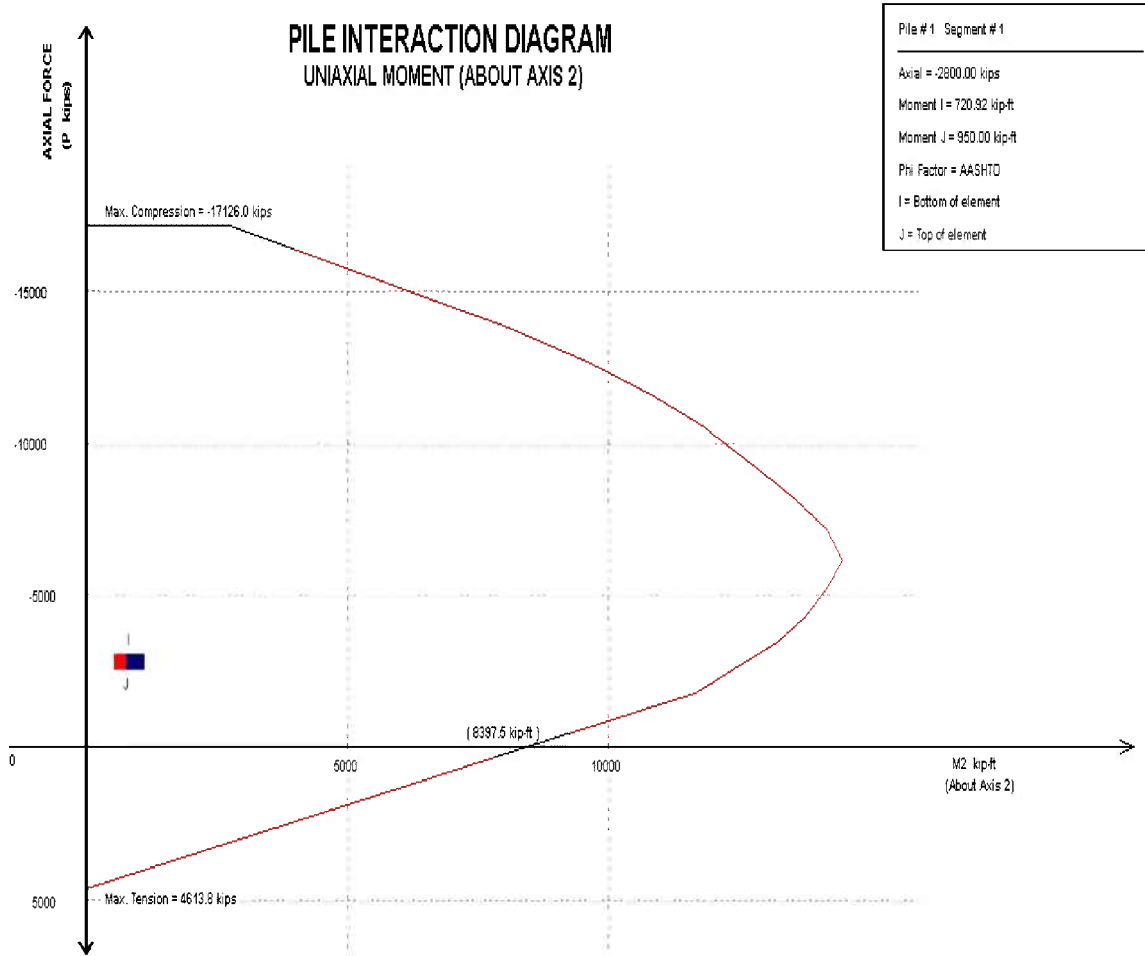
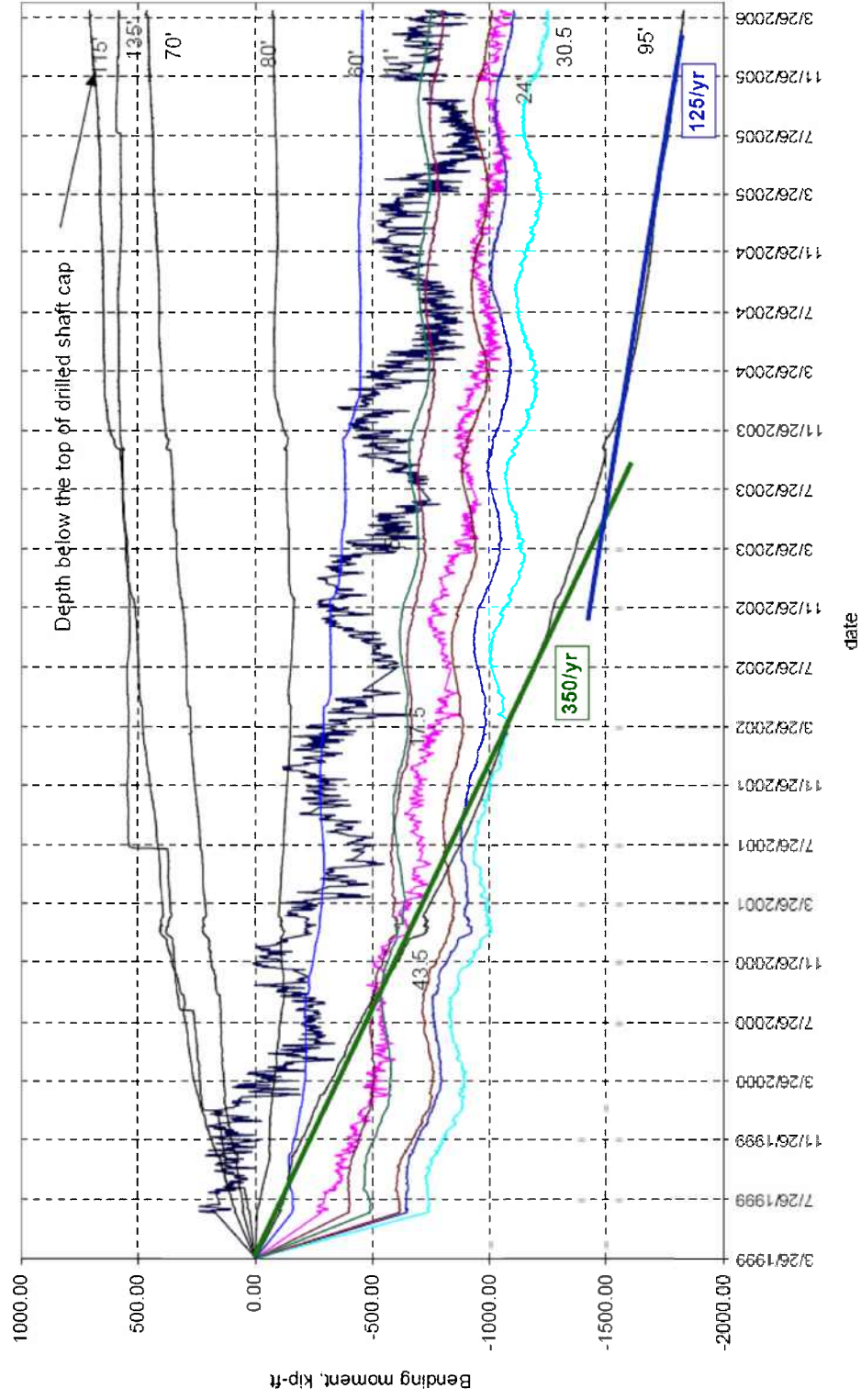
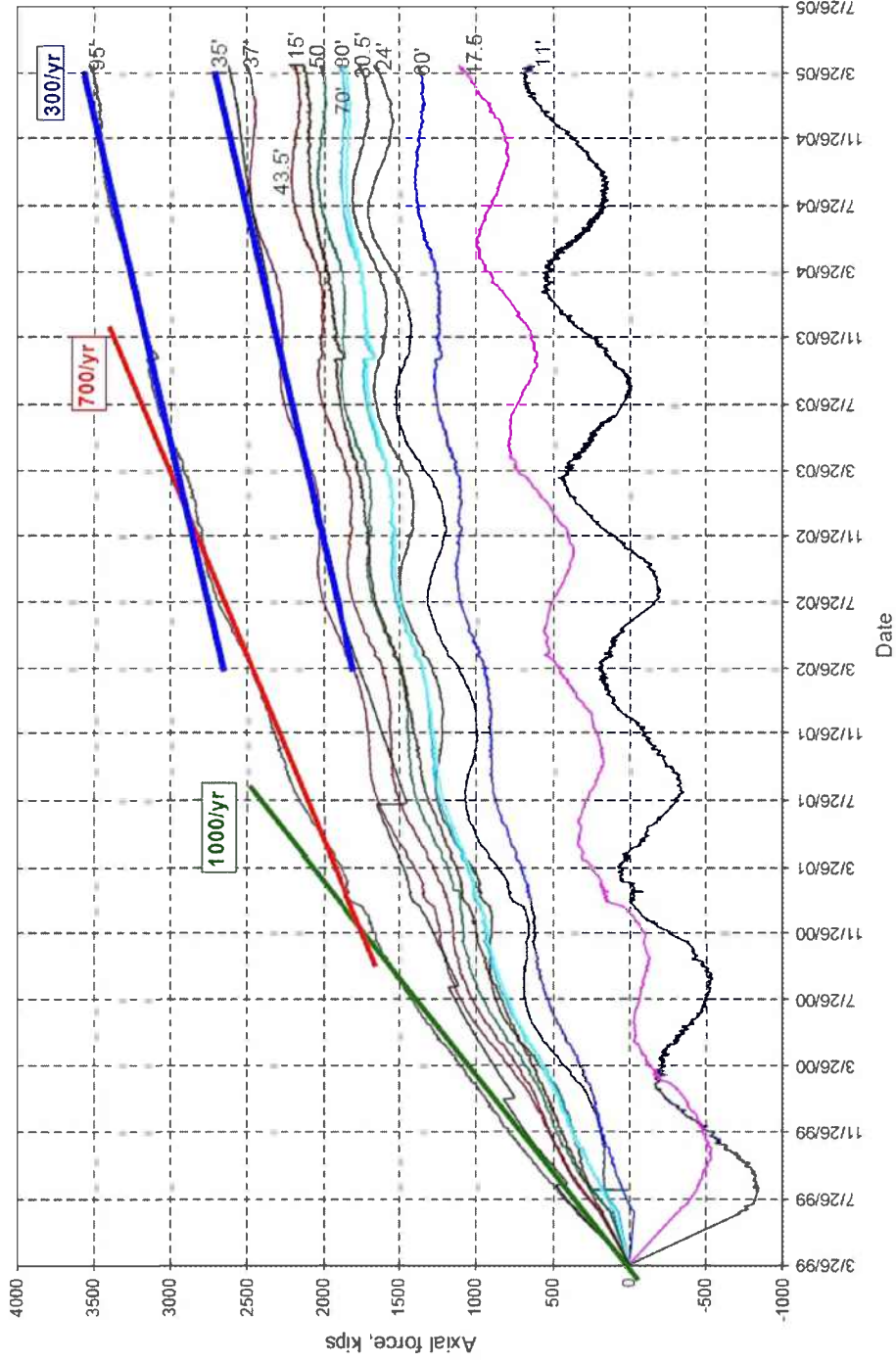

Figure 5.16 Interaction Diagram for Drilled shafts in the stabilization structure.



Shaft #9, Bending moment vs. date in different elevations below the top of cap

Figure 5.17 Rate of increase in Drilled shaft # 9 moment



Shaft #9, Axial force vs. date in different elevations below the top of cap

Figure 5.18 Rate of increase in Drilled shaft # 9 Axial Force



Figure 5.19 Photo showing the construction of the tie beams and the buildup of fill on top

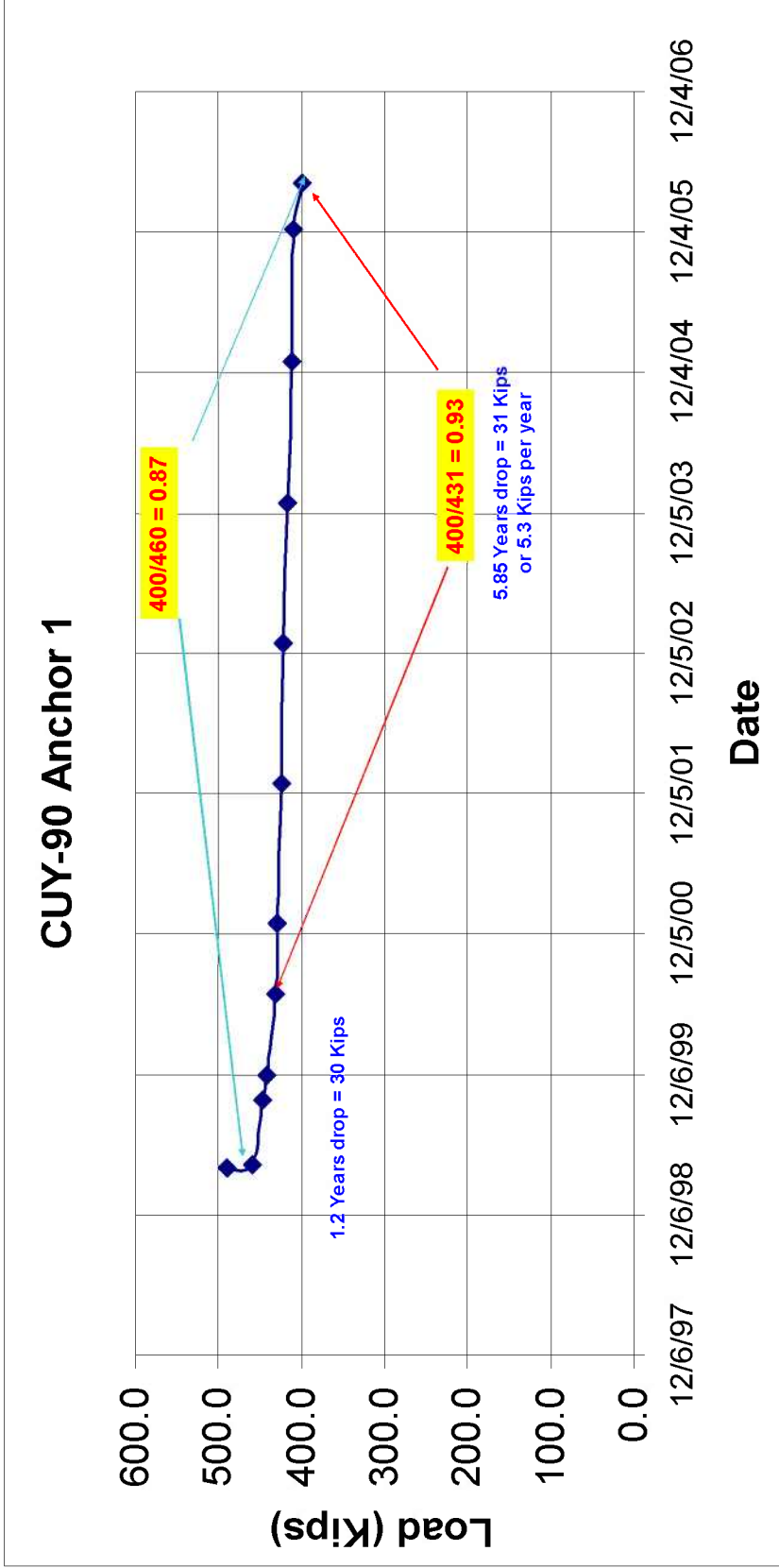

Figure 5.20 Anchor # 1: Force vs. time plot

CUY-90 Anchor 8

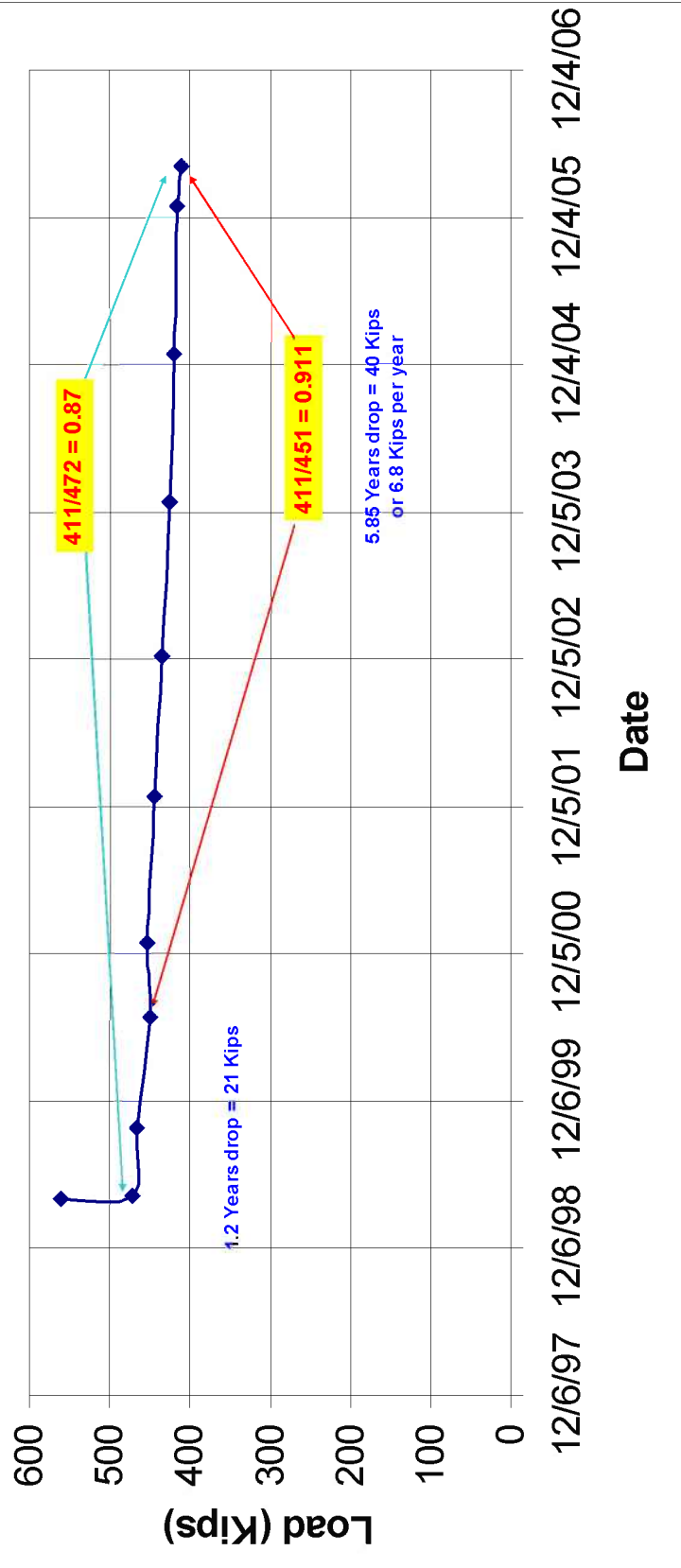

Figure 5.21 Anchor # 8: Force vs. time plot

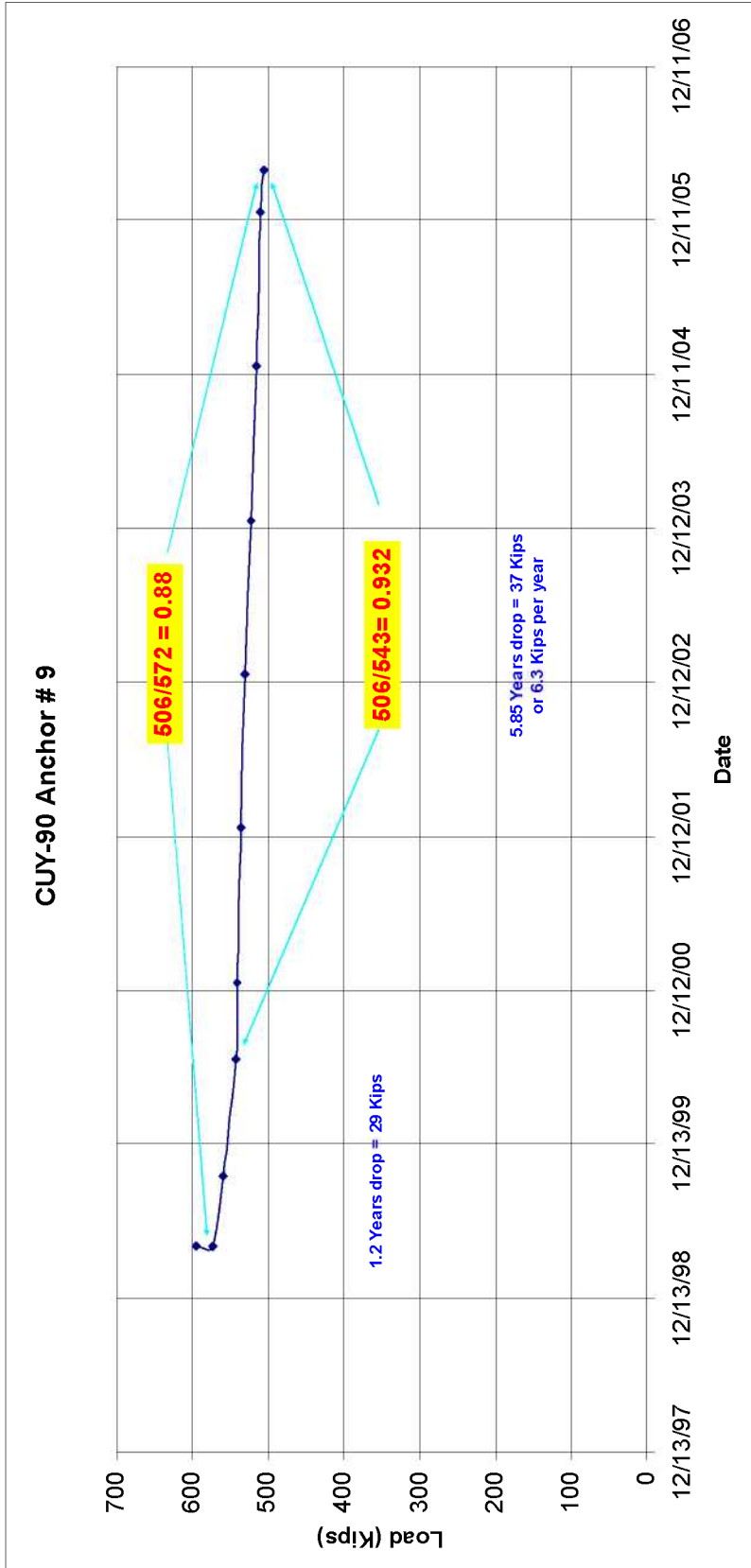

Figure 5.22 Anchor # 9: Force vs. time plot

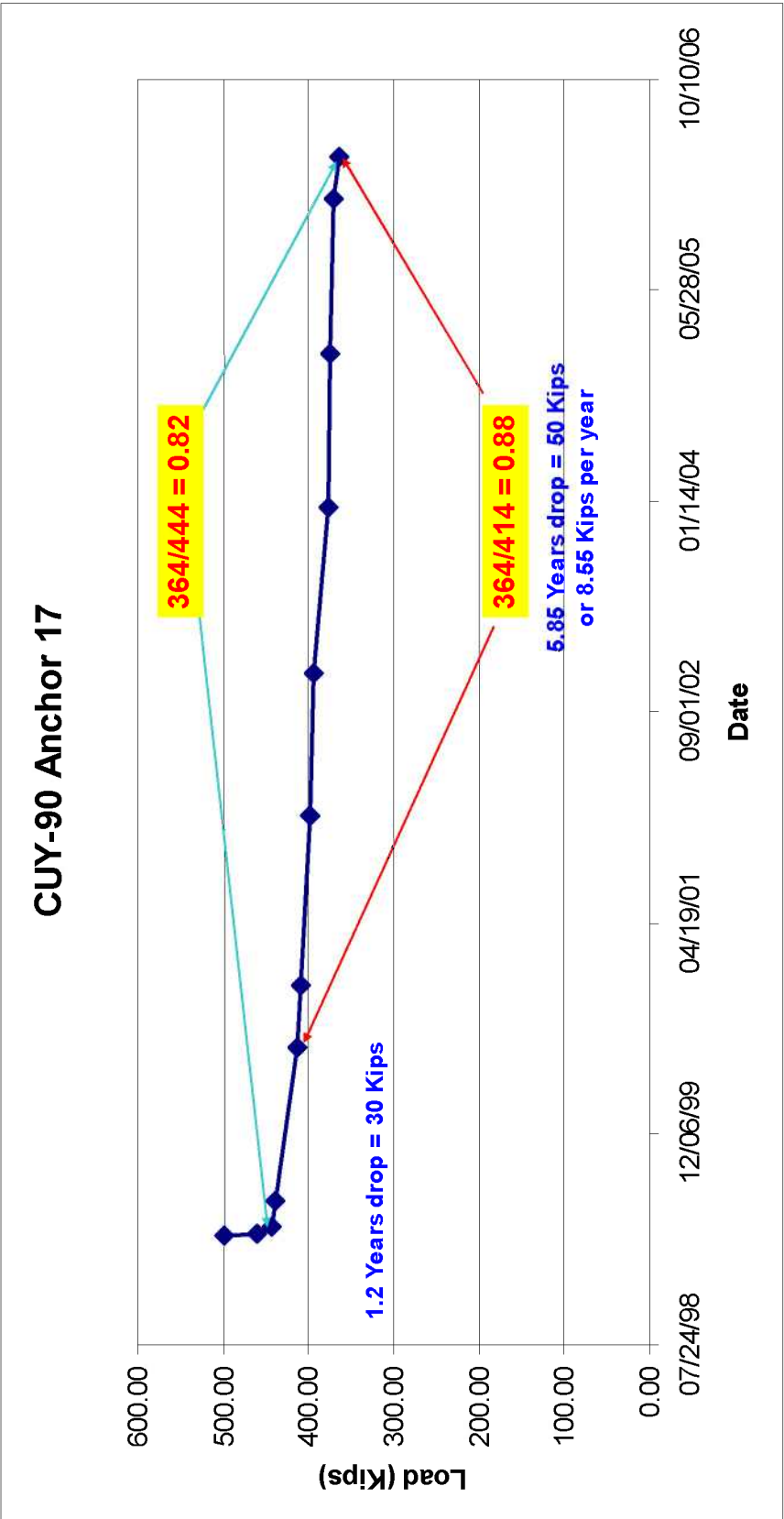
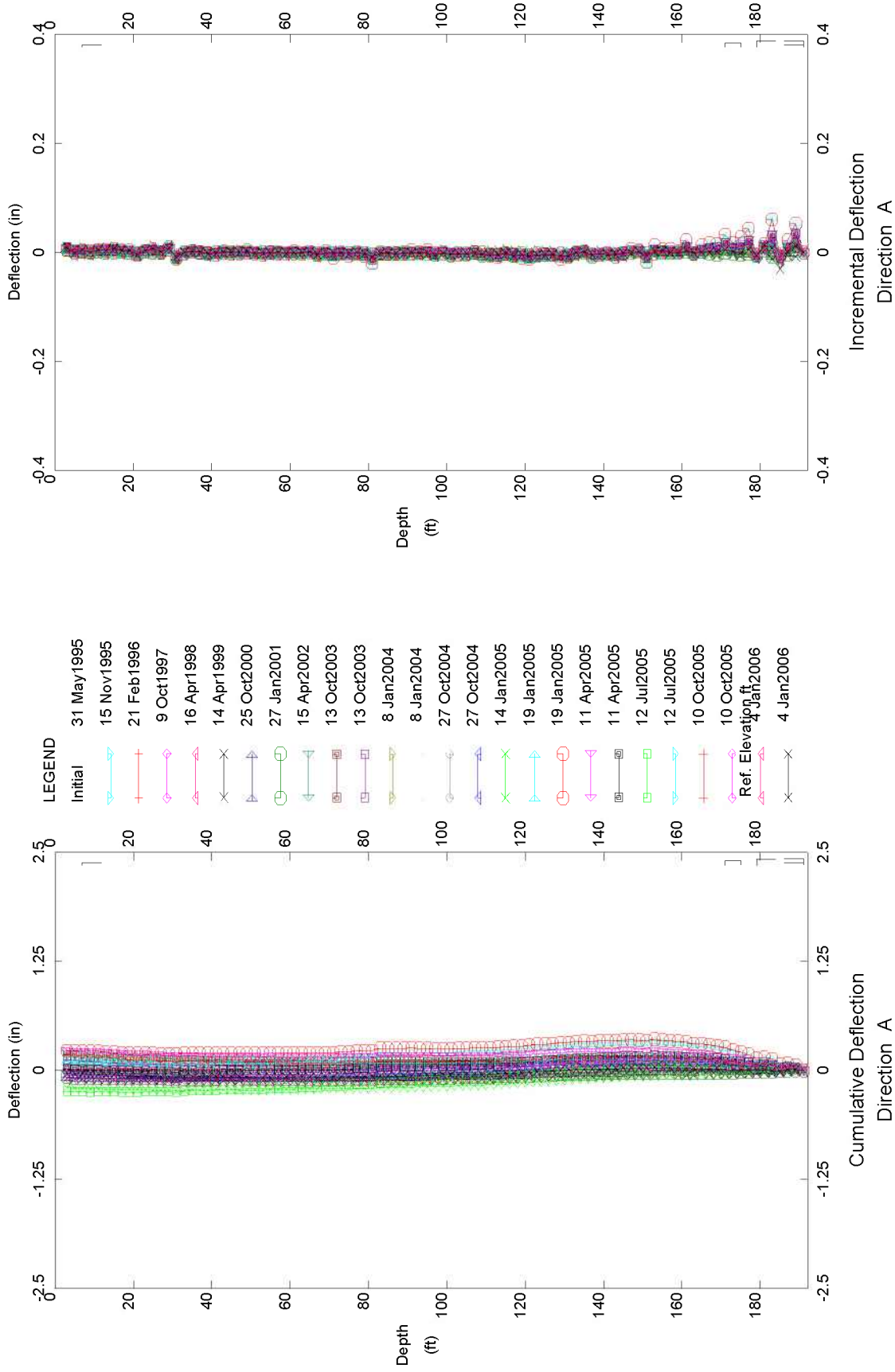

Figure 5.23 Anchor # 17: Force vs. time plot

E.L. Robinson - Dublin, OH



CUY-90, Inclinator B-101

E.L. Robinson - Dublin, OH

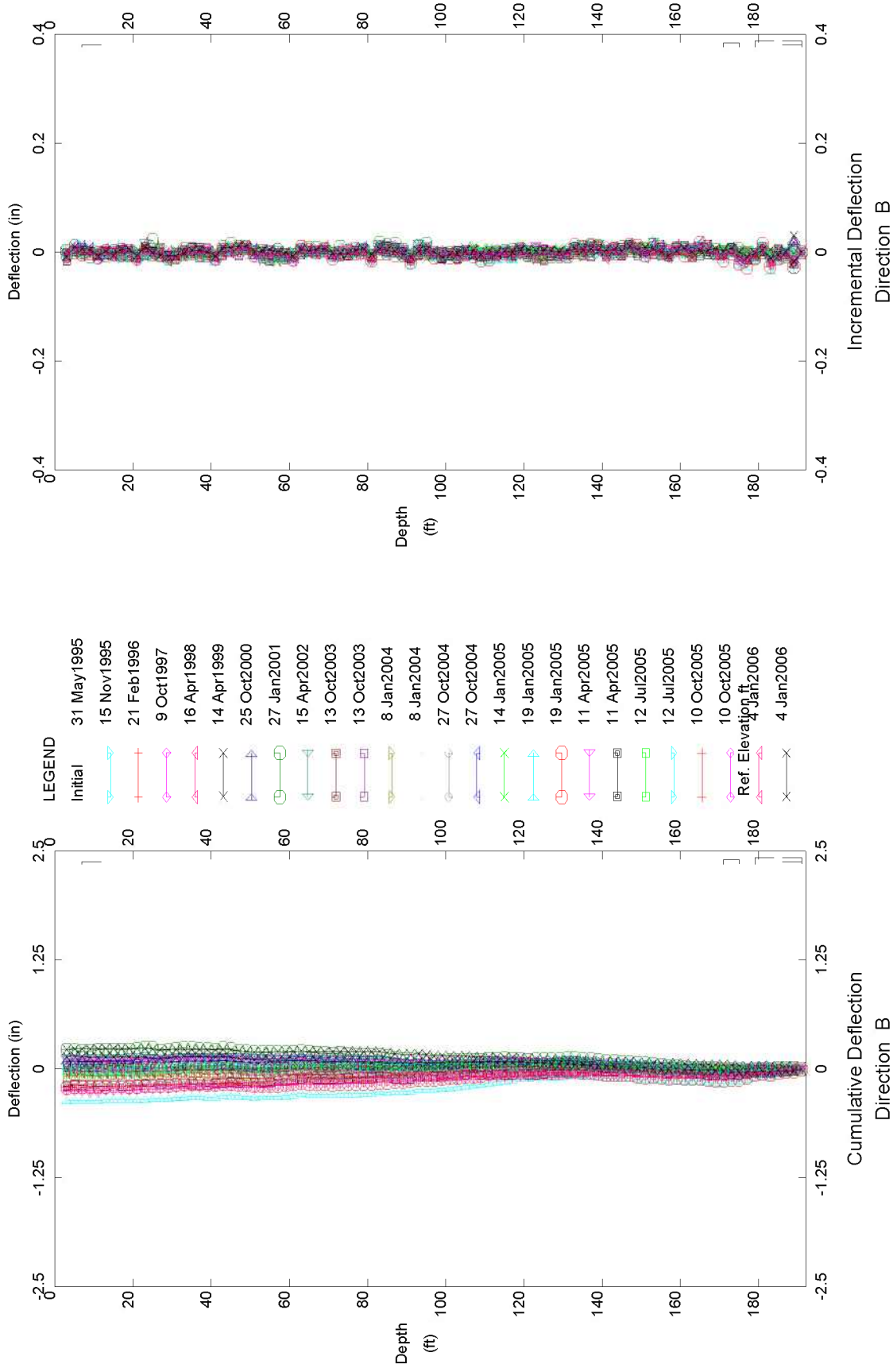

CUY-90, Inclinometer B-101

E.L. Robinson - Dublin, OH

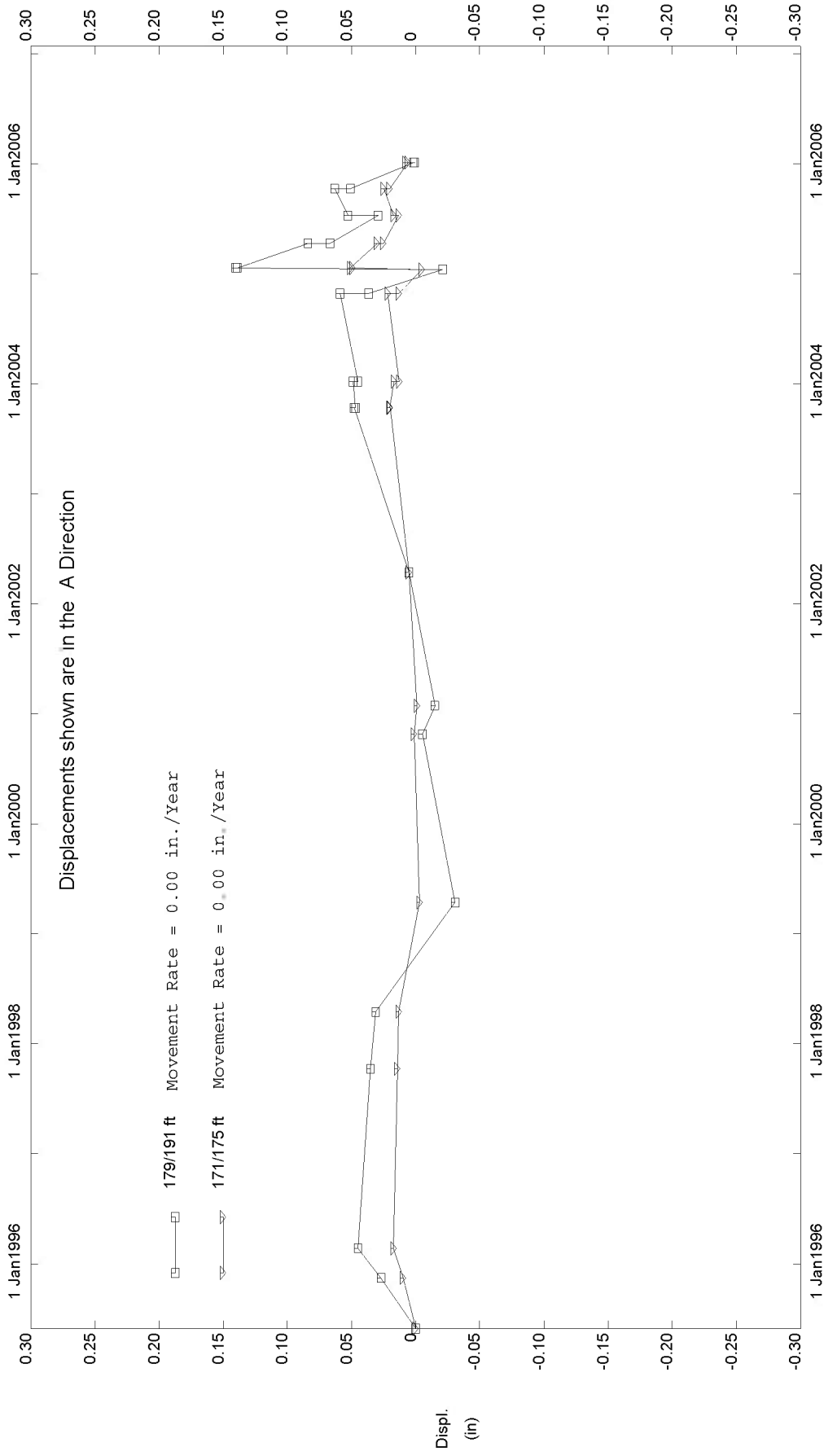

CUY-90, Inclinometer B-101

E.L. Robinson - Dublin, OH

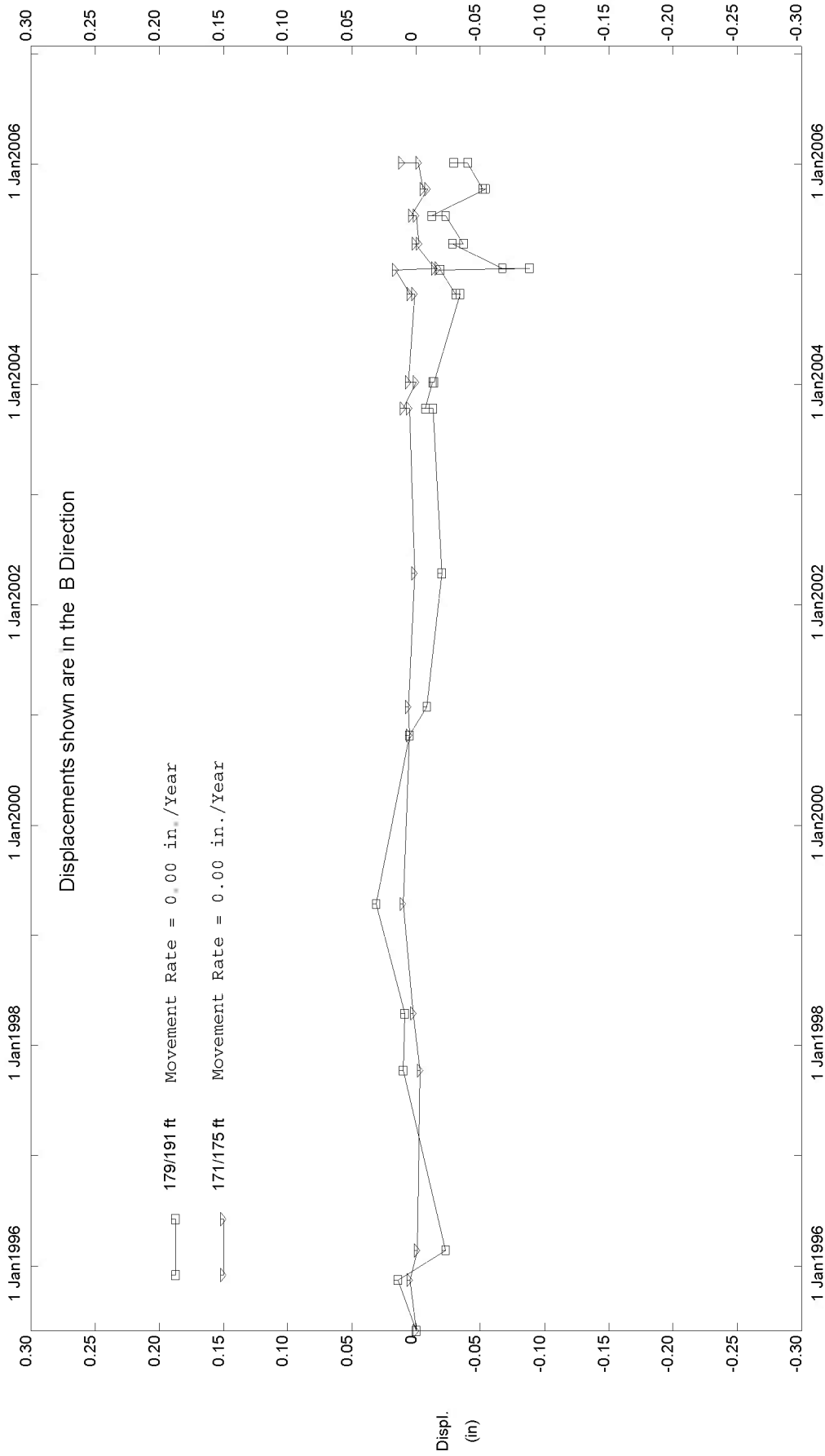

CUY-90, Inclinometer B-101

E.L. Robinson - Dublin, OH

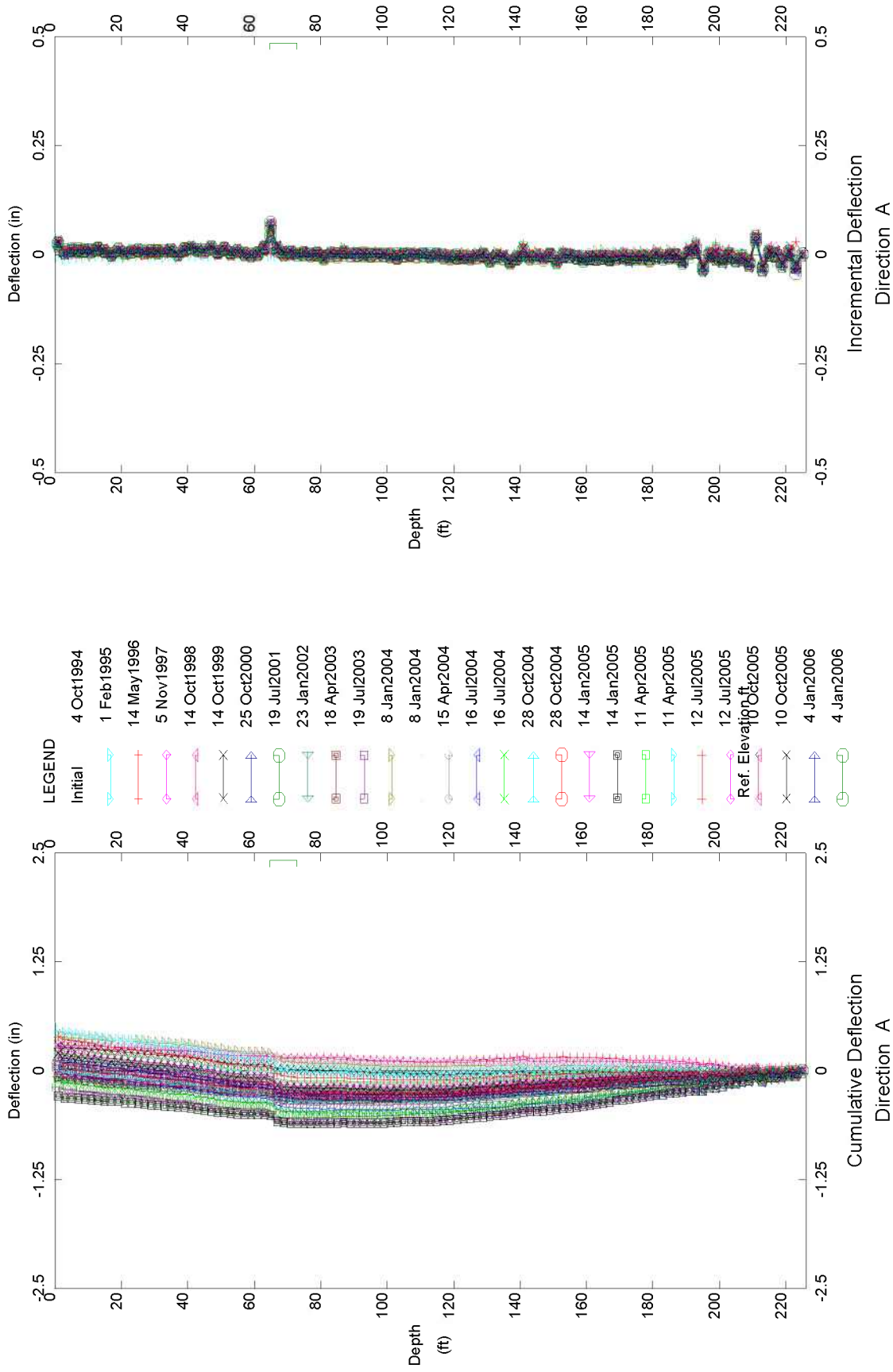

CUY-90, Inclinometer B-102

E.L. Robinson - Dublin, OH

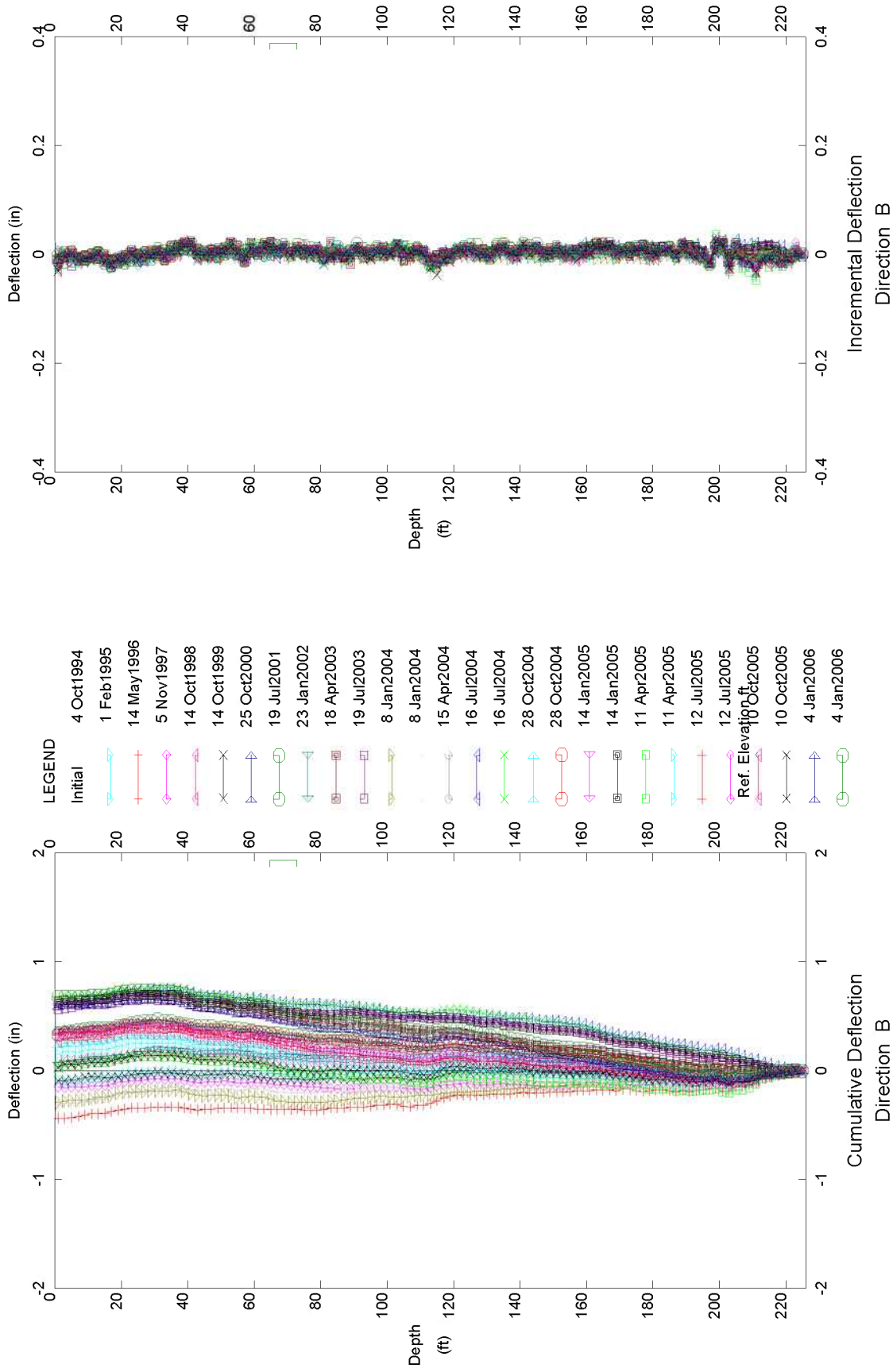

CUY-90, Inclinator B-102

E.L. Robinson - Dublin, OH

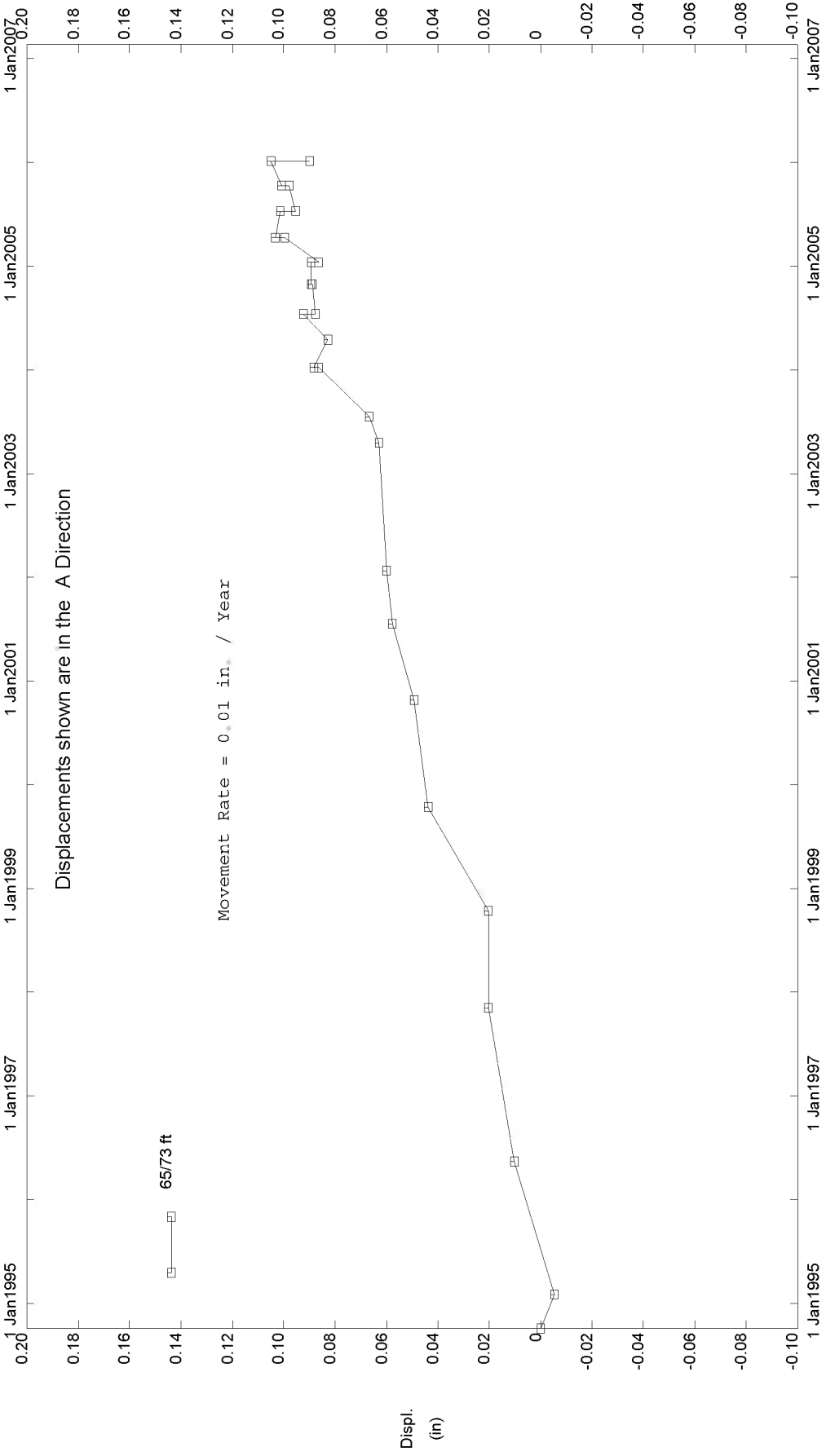

CUY-90, Inclinator B-102

E.L. Robinson - Dublin, OH

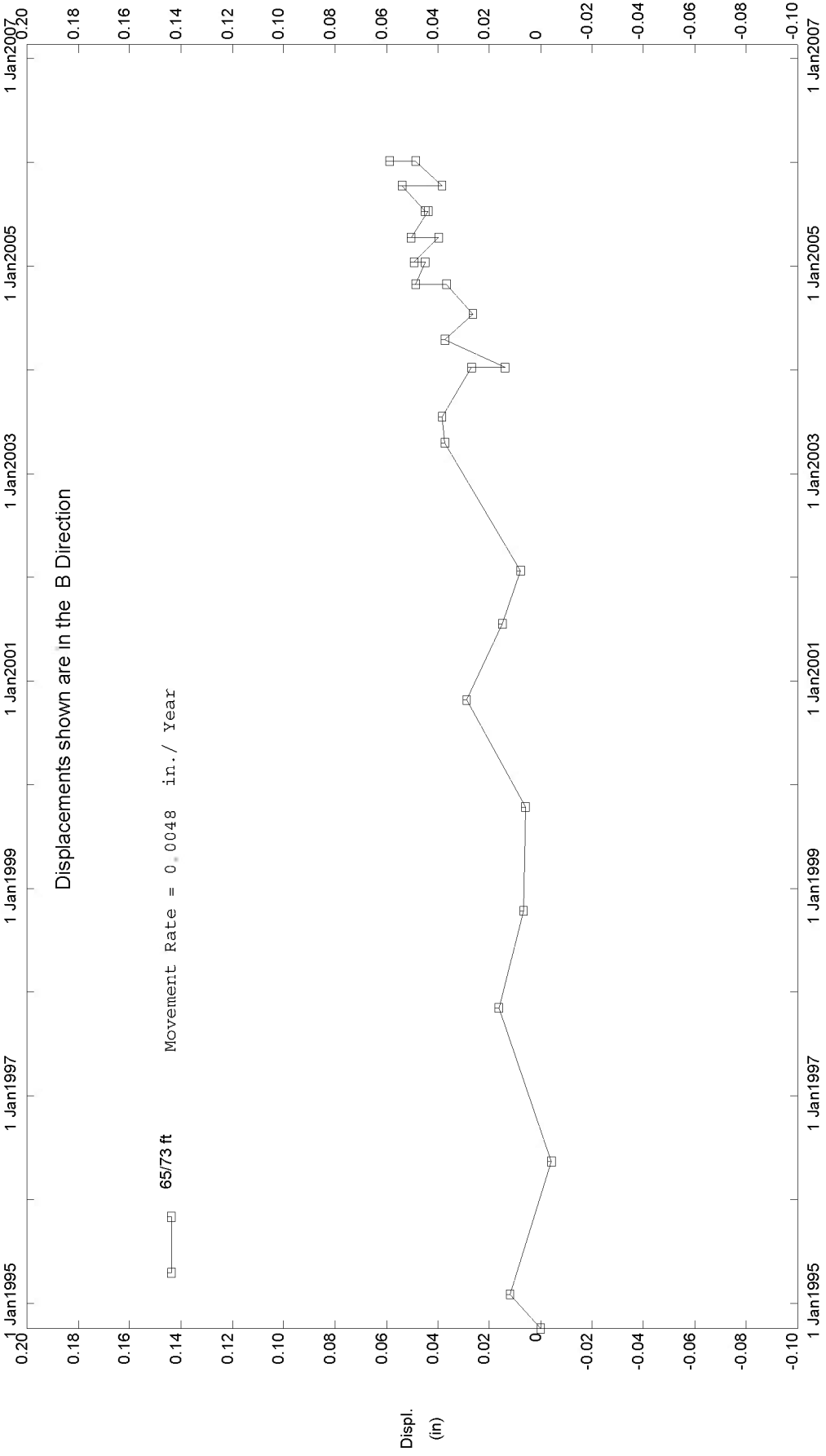

CUY-90, Inclinator B-102

E.L. Robinson - Dublin, OH

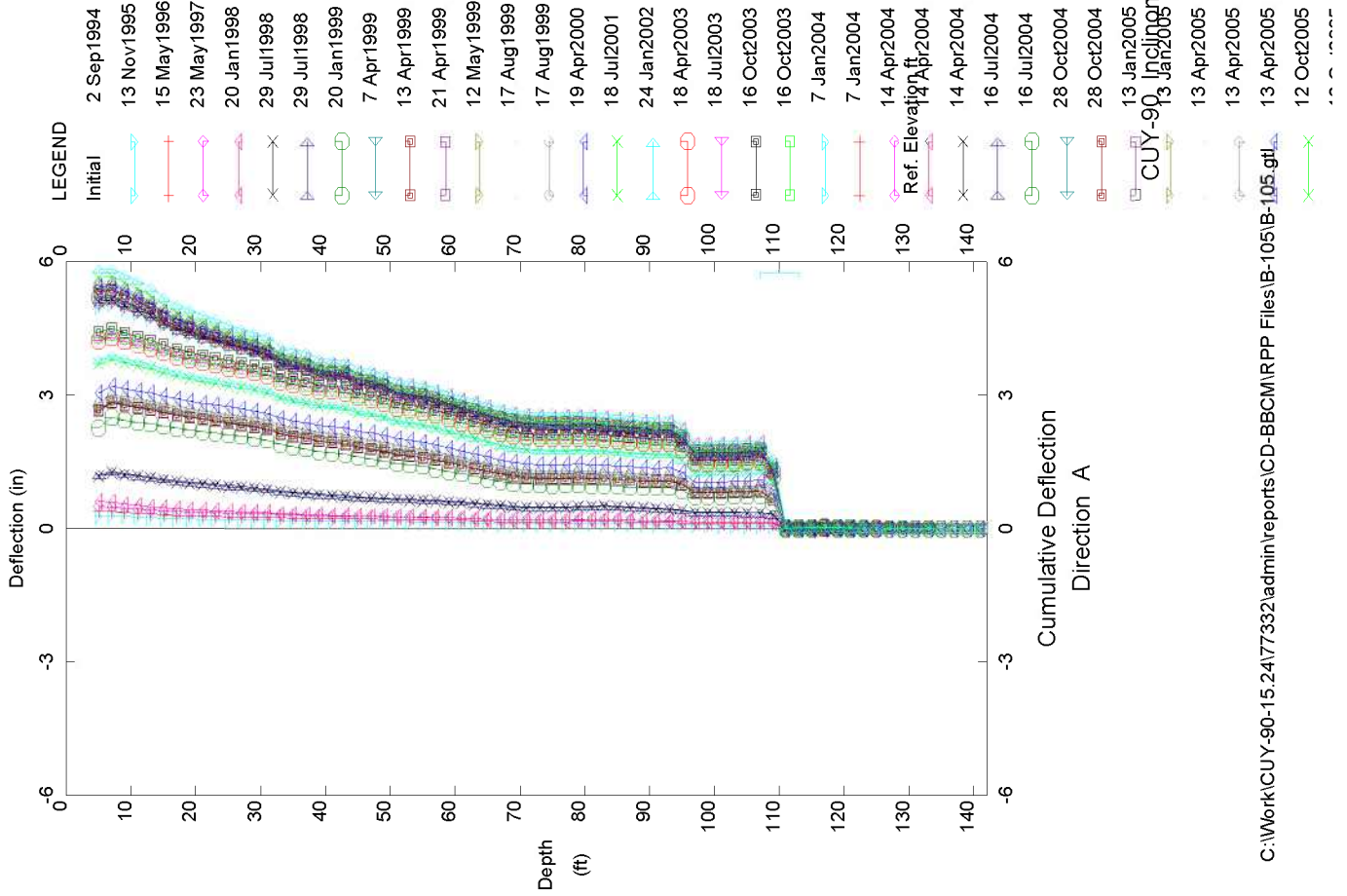
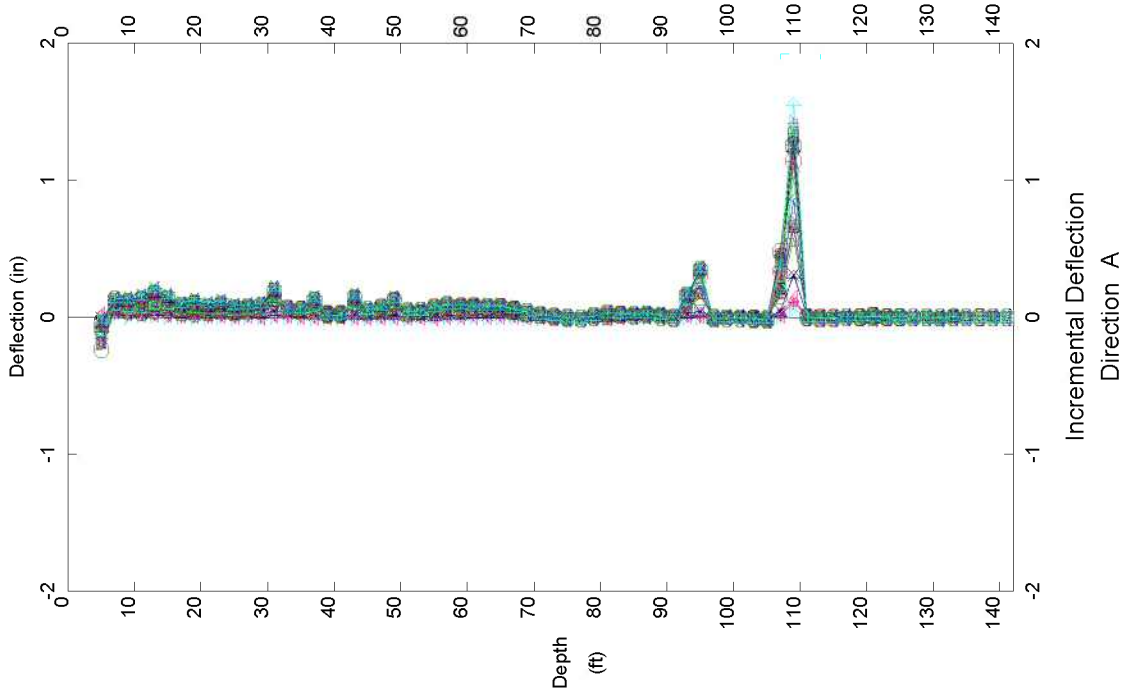

LEGEND

Initial	2 Sep 1994
13 Nov 1995	13 Nov 1995
15 May 1996	15 May 1996
23 May 1997	23 May 1997
20 Jan 1998	20 Jan 1998
29 Jul 1998	29 Jul 1998
29 Jul 1998	29 Jul 1998
20 Jan 1999	20 Jan 1999
7 Apr 1999	7 Apr 1999
13 Apr 1999	13 Apr 1999
21 Apr 1999	21 Apr 1999
12 May 1999	12 May 1999
17 Aug 1999	17 Aug 1999
17 Aug 1999	17 Aug 1999
19 Apr 2000	19 Apr 2000
18 Jul 2001	18 Jul 2001
24 Jan 2002	24 Jan 2002
18 Apr 2003	18 Apr 2003
18 Jul 2003	18 Jul 2003
16 Oct 2003	16 Oct 2003
16 Oct 2003	16 Oct 2003
7 Jan 2004	7 Jan 2004
7 Jan 2004	7 Jan 2004
14 Apr 2004	14 Apr 2004
Ref. Elevation ft	Ref. Elevation ft
14 Apr 2004	14 Apr 2004
16 Jul 2004	16 Jul 2004
16 Jul 2004	16 Jul 2004
28 Oct 2004	28 Oct 2004
28 Oct 2004	28 Oct 2004
CUY-90 Inclinometer B-105	CUY-90 Inclinometer B-105
13 Jan 2005	13 Jan 2005
13 Jan 2005	13 Jan 2005
13 Apr 2005	13 Apr 2005
13 Apr 2005	13 Apr 2005
13 Apr 2005	13 Apr 2005
12 Oct 2005	12 Oct 2005
12 Oct 2005	12 Oct 2005

E.L. Robinson - Dublin, OH

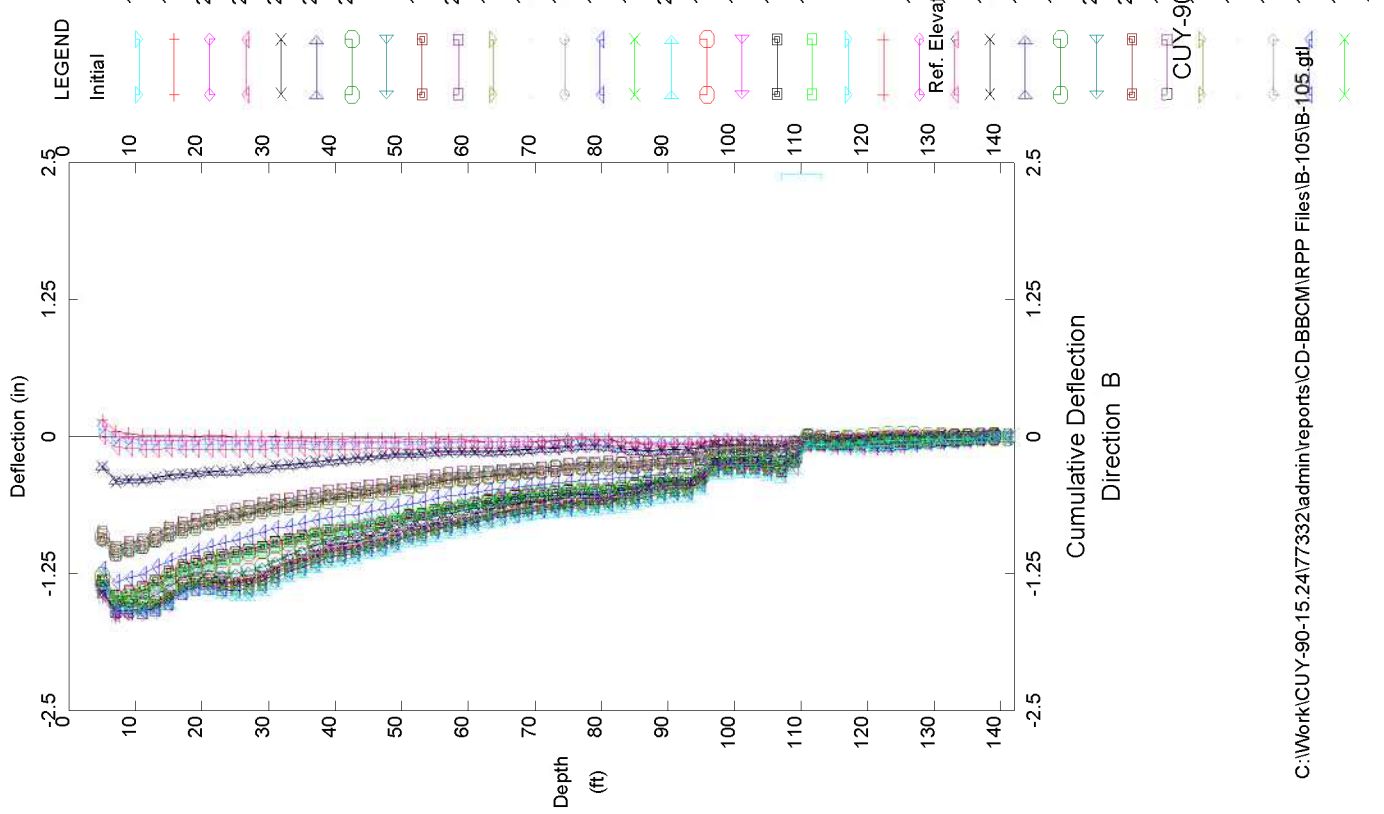
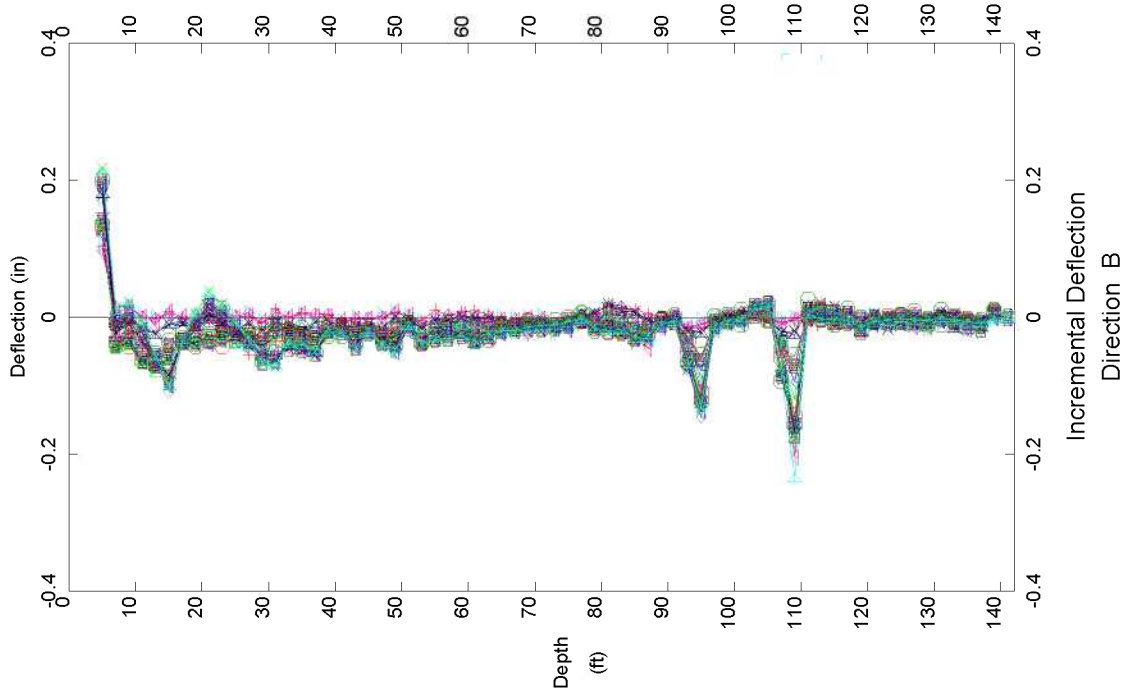

LEGEND

- Initial
- 2 Sep 1994
- 13 Nov 1995
- 15 May 1996
- 23 May 1997
- 20 Jan 1998
- 29 Jul 1998
- 29 Jul 1998
- 20 Jan 1999
- 7 Apr 1999
- 13 Apr 1999
- 21 Apr 1999
- 12 May 1999
- 17 Aug 1999
- 17 Aug 1999
- 19 Apr 2000
- 18 Jul 2001
- 24 Jan 2002
- 18 Apr 2003
- 18 Jul 2003
- 16 Oct 2003
- 16 Oct 2003
- 7 Jan 2004
- 7 Jan 2004
- 14 Apr 2004
- Ref. Elevation ft
- Apr 2004
- 14 Apr 2004
- 16 Jul 2004
- 16 Jul 2004
- 28 Oct 2004
- 28 Oct 2004
- CUY-90 Inclinometer B-105
- 13 Jan 2005
- 13 Jan 2005
- 13 Apr 2005
- 13 Apr 2005
- 13 Apr 2005
- 12 Oct 2005
- 12 Oct 2005

E.L. Robinson - Dublin, OH

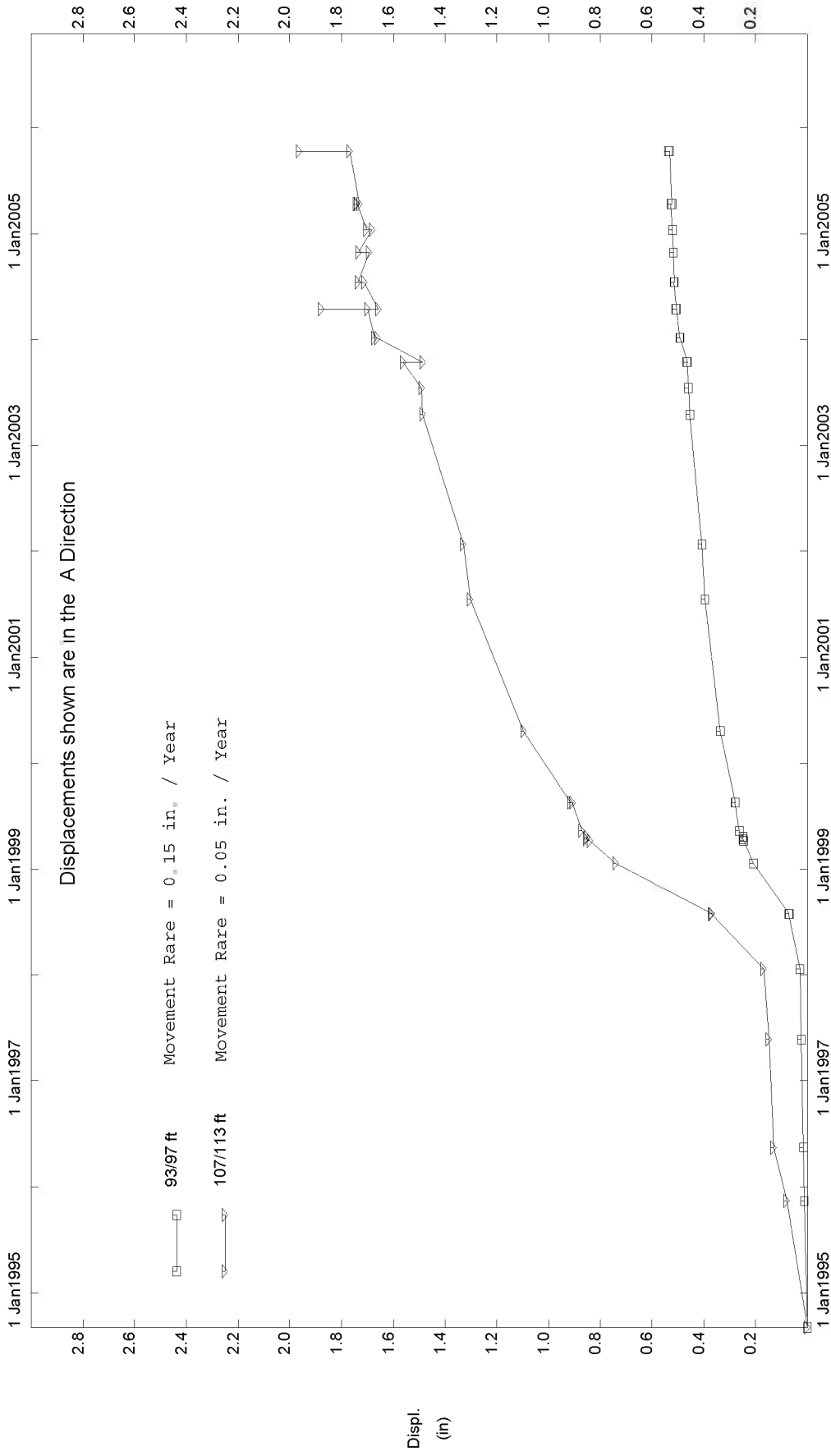

CUY-90, Inclinator B-105

E.L. Robinson - Dublin, OH

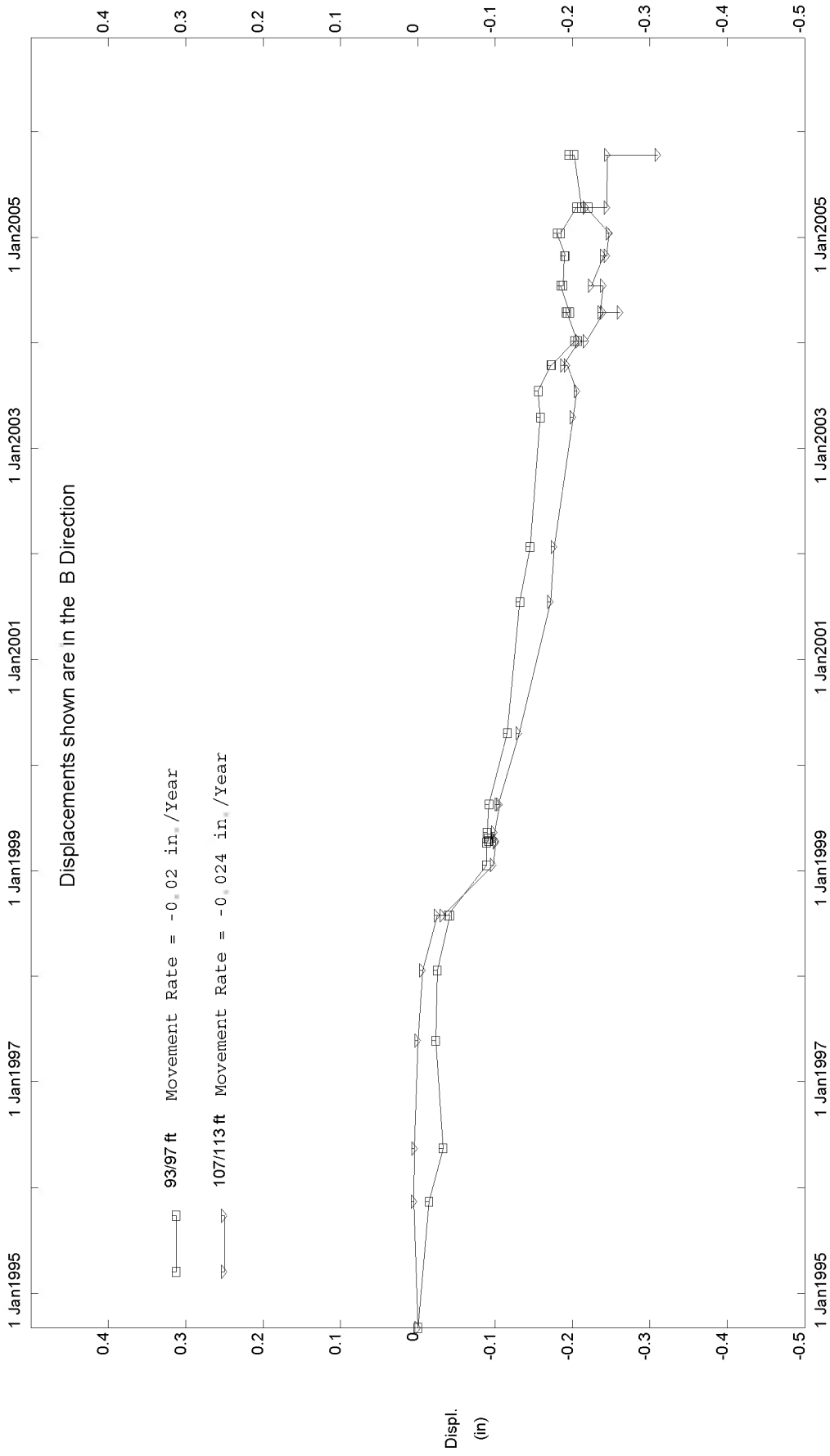

CUY-90, Inclinometer B-105

E.L. Robinson - Dublin, OH

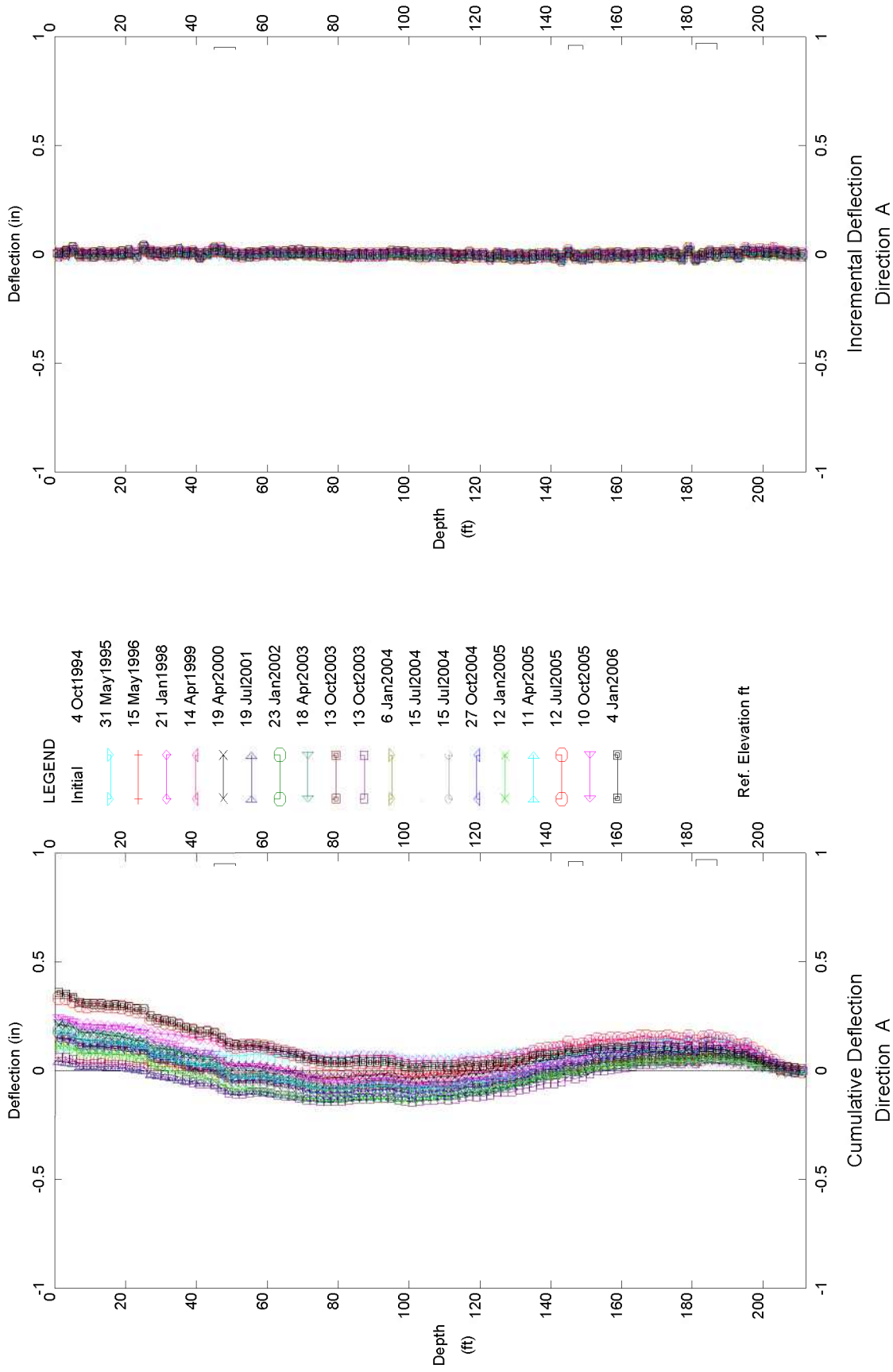

CUY-90, Inclinometer B-107

E.L. Robinson - Dublin, OH

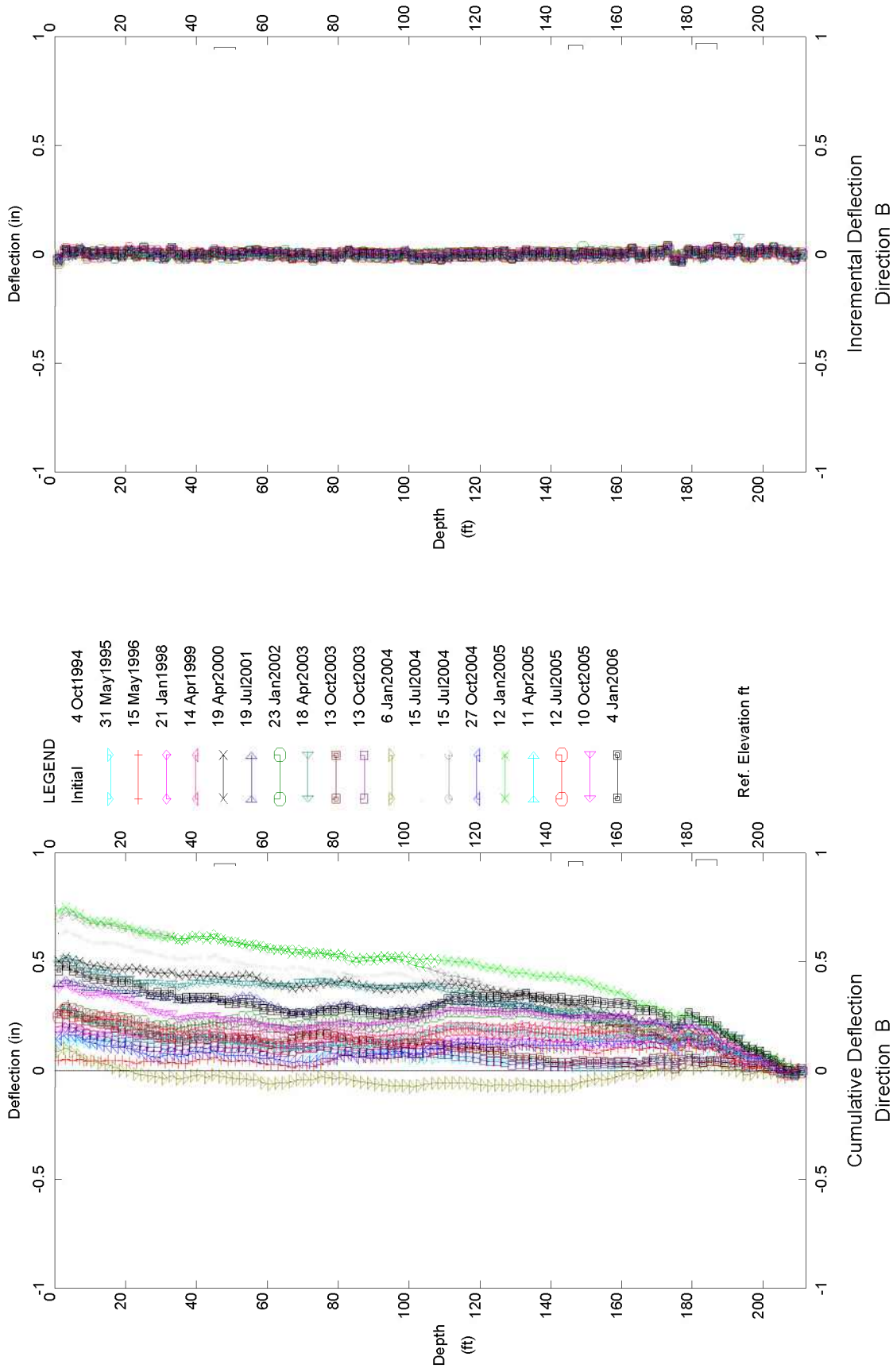

CUY-90, Inclinometer B-107

E.L. Robinson - Dublin, OH

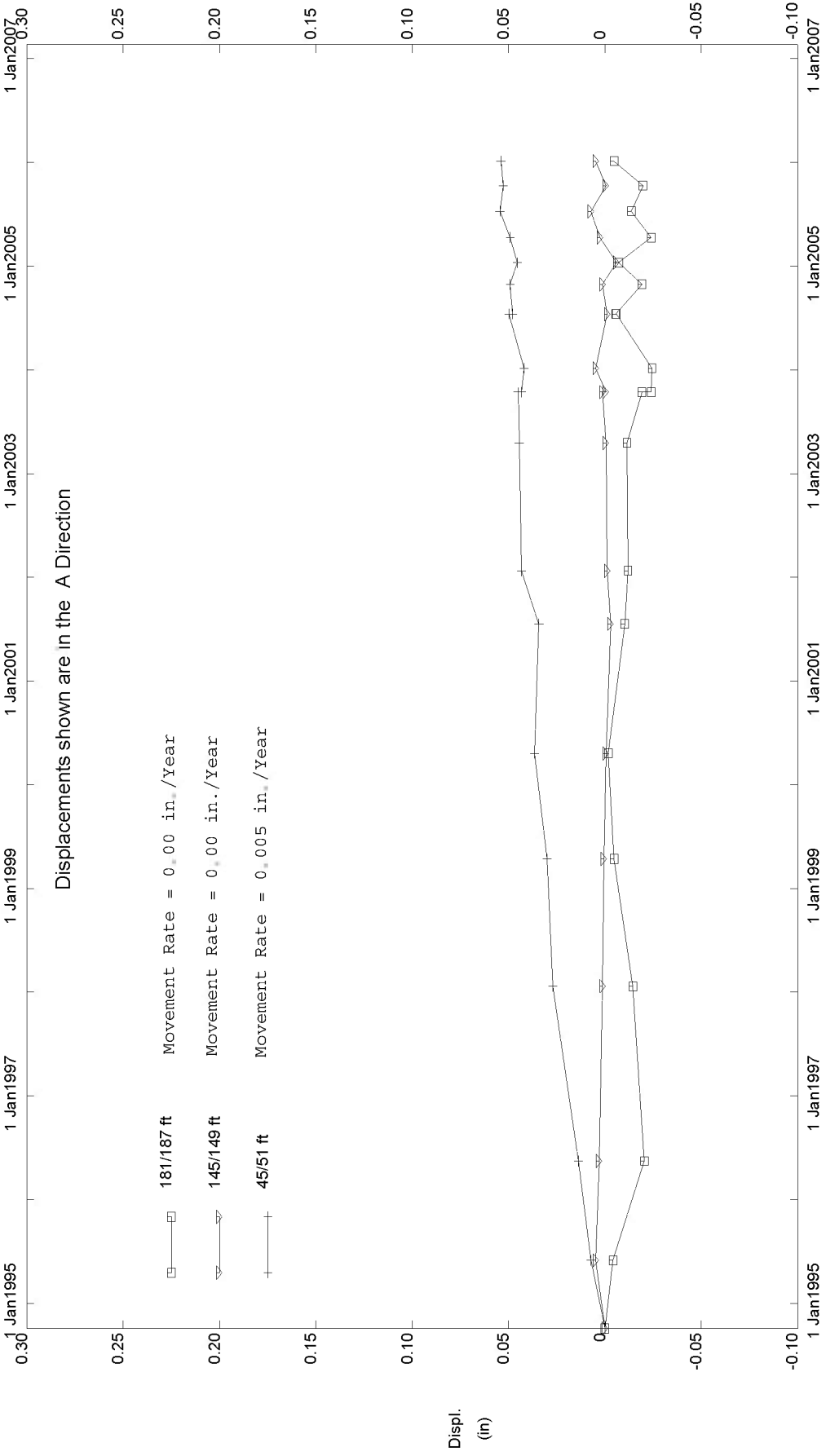

CUY-90, Inclinometer B-107

E.L. Robinson - Dublin, OH

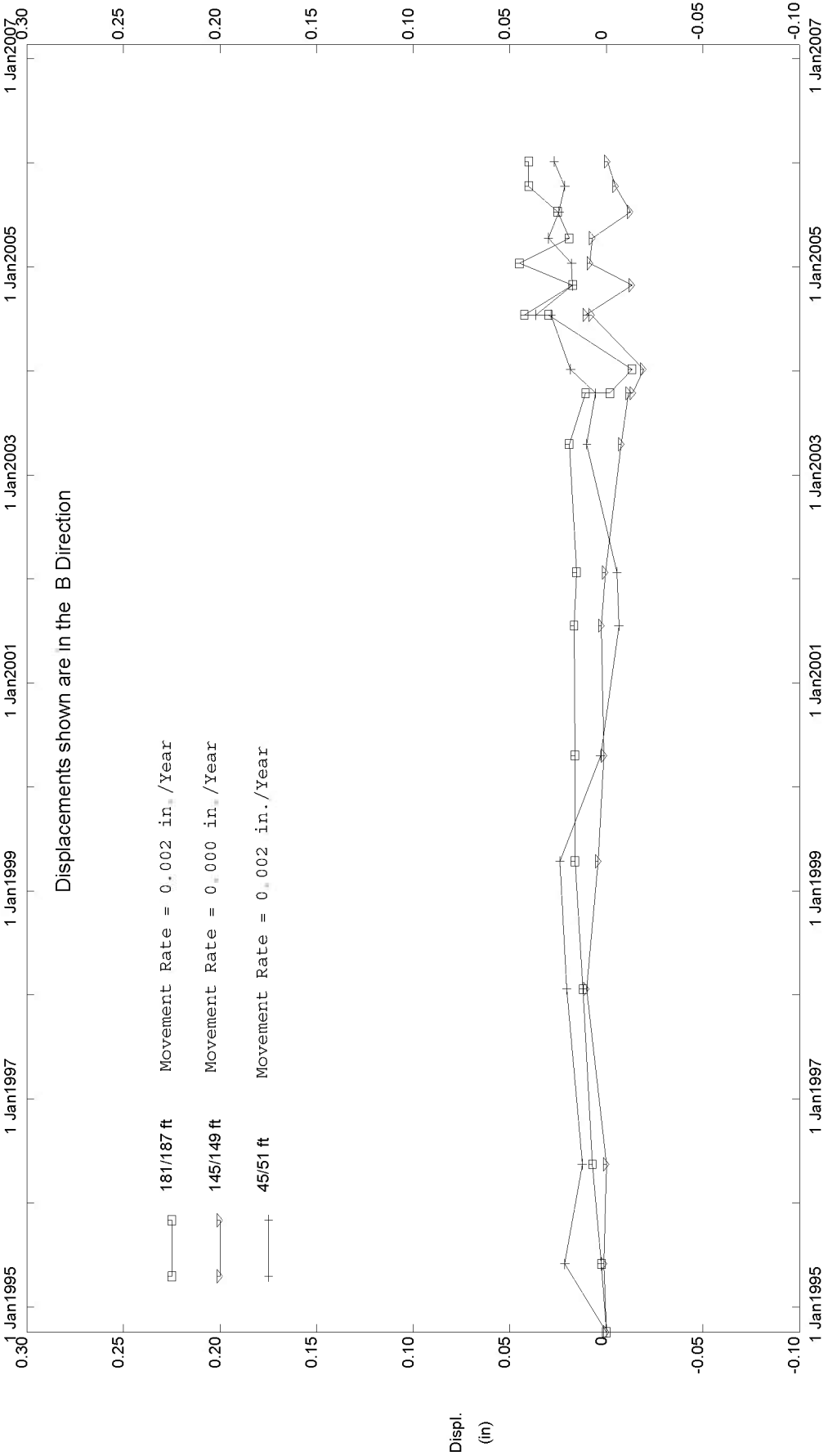

CUY-90, Inclinometer B-107

E.L. Robinson - Dublin, OH

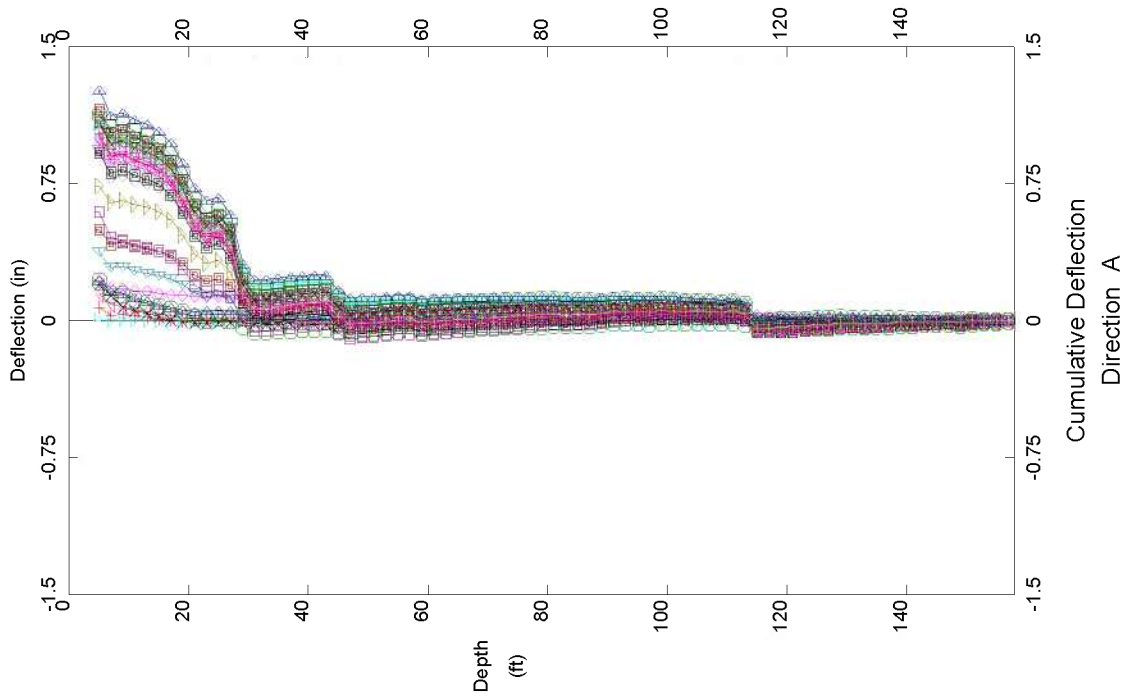
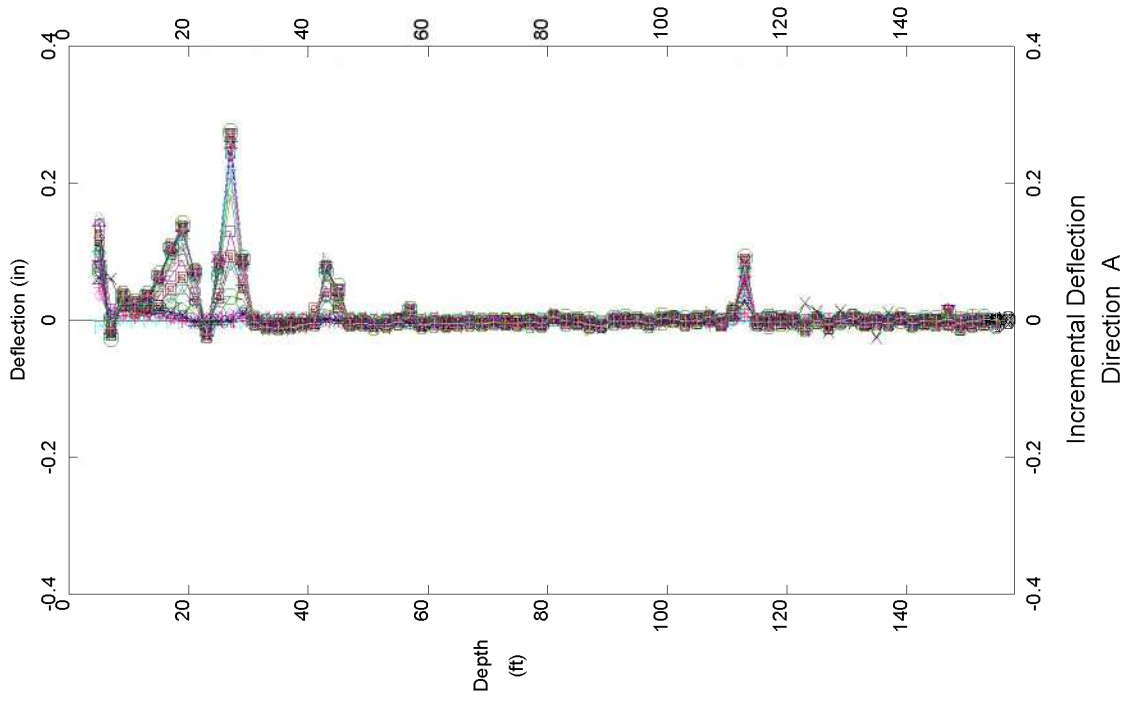

LEGEND

Initial	13 Nov1995
20 Feb1996	20 Feb1996
8 Oct1997	8 Oct1997
20 Jan1998	20 Jan1998
13 Apr1999	13 Apr1999
15 Jul1999	15 Jul1999
13 Oct1999	13 Oct1999
19 Apr2000	19 Apr2000
24 Oct2000	24 Oct2000
30 Jan2001	30 Jan2001
24 Jan2002	24 Jan2002
21 Apr2003	21 Apr2003
22 Jul2003	22 Jul2003
15 Oct2003	15 Oct2003
15 Apr2004	15 Apr2004
16 Jul2004	16 Jul2004
16 Jul2004	16 Jul2004
28 Oct2004	28 Oct2004
28 Oct2004	28 Oct2004
12 Jan2005	12 Jan2005
12 Jan2005	12 Jan2005
13 Apr2005	13 Apr2005
13 Apr2005	13 Apr2005
13 Apr2005	13 Apr2005
13 Apr2005	13 Apr2005
Ref. Elevation	13 Apr2005
12 Jul2005	12 Jul2005
10 Oct2005	10 Oct2005
10 Oct2005	10 Oct2005
4 Jan2006	4 Jan2006
4 Jan2006	4 Jan2006

CUY-90, Inclinator B-110

E.L. Robinson - Dublin, OH

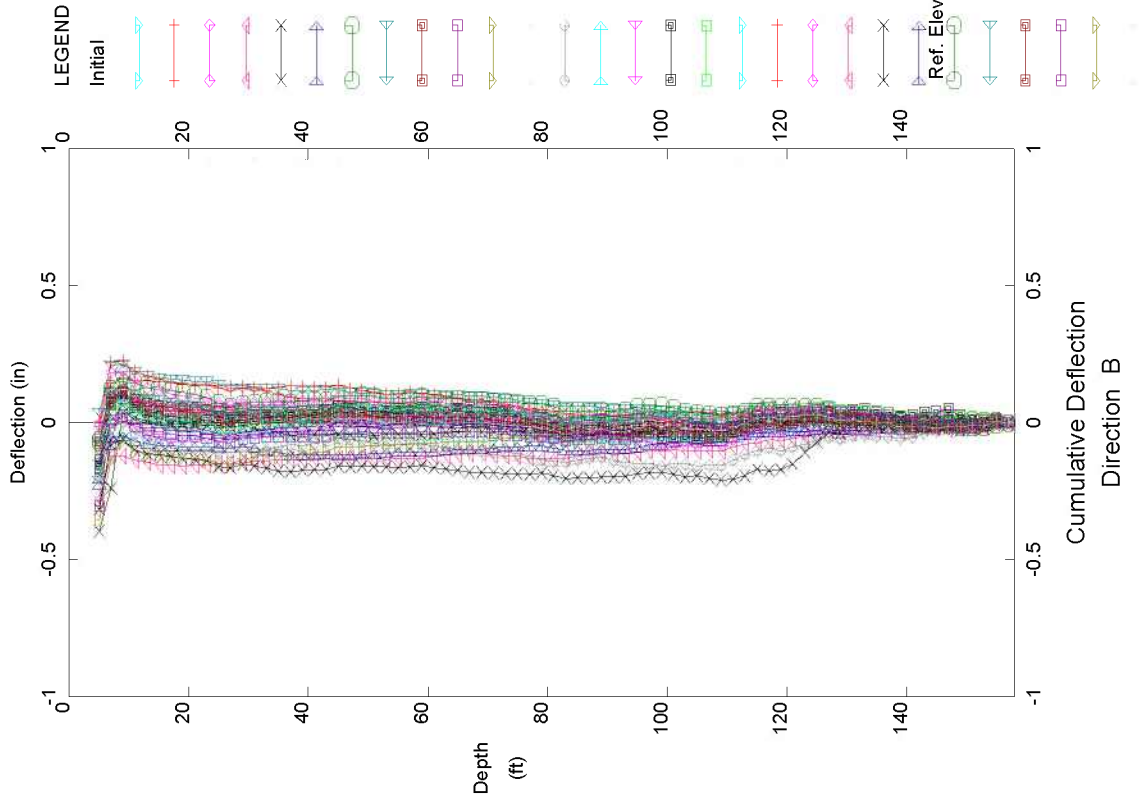
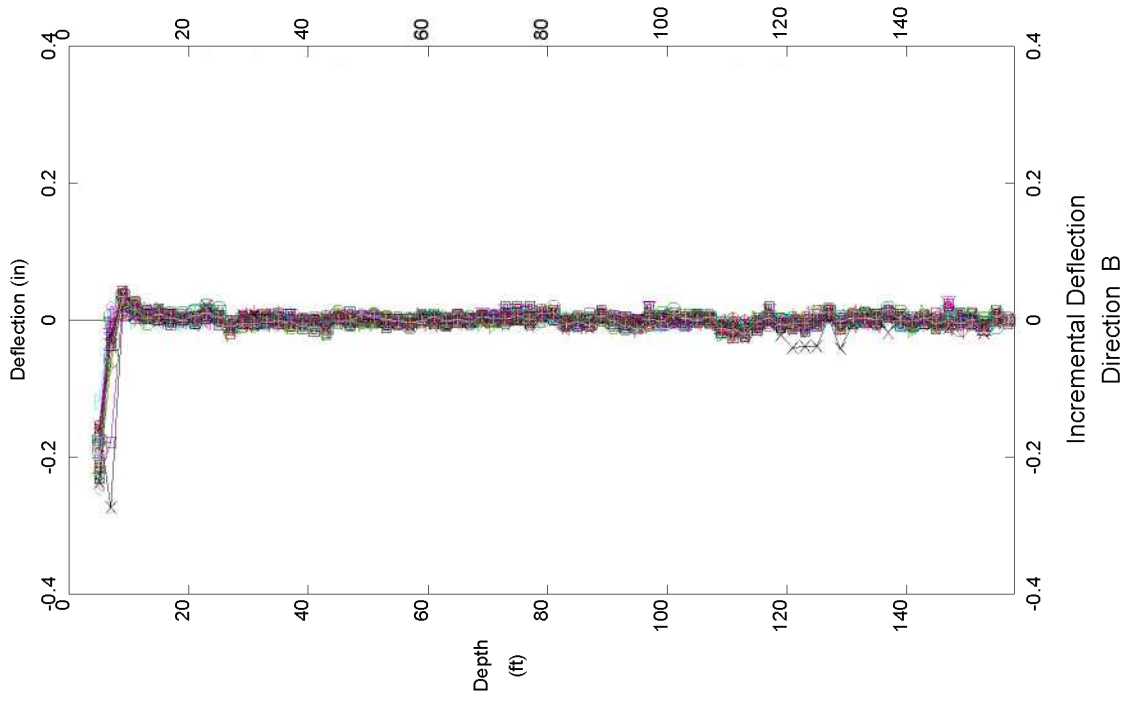

LEGEND

- Initial
- 13 Nov1995
- 20 Feb1996
- 8 Oct1997
- 20 Jan1998
- 13 Apr1999
- 15 Jul1999
- 13 Oct1999
- 19 Apr2000
- 24 Oct2000
- 30 Jan2001
- 24 Jan2002
- 21 Apr2003
- 22 Jul2003
- 15 Oct2003
- 15 Apr2004
- 16 Jul2004
- 16 Jul2004
- 28 Oct2004
- 28 Oct2004
- 12 Jan2005
- 12 Jan2005
- 13 Apr2005
- 13 Apr2005
- 13 Apr2005
- 13 Apr2005
- Ref. Elevation
- 12 Jul2005
- 10 Oct2005
- 10 Oct2005
- 4 Jan2006
- 4 Jan2006

CUY-90, Inclinator B-110

E.L. Robinson - Dublin, OH

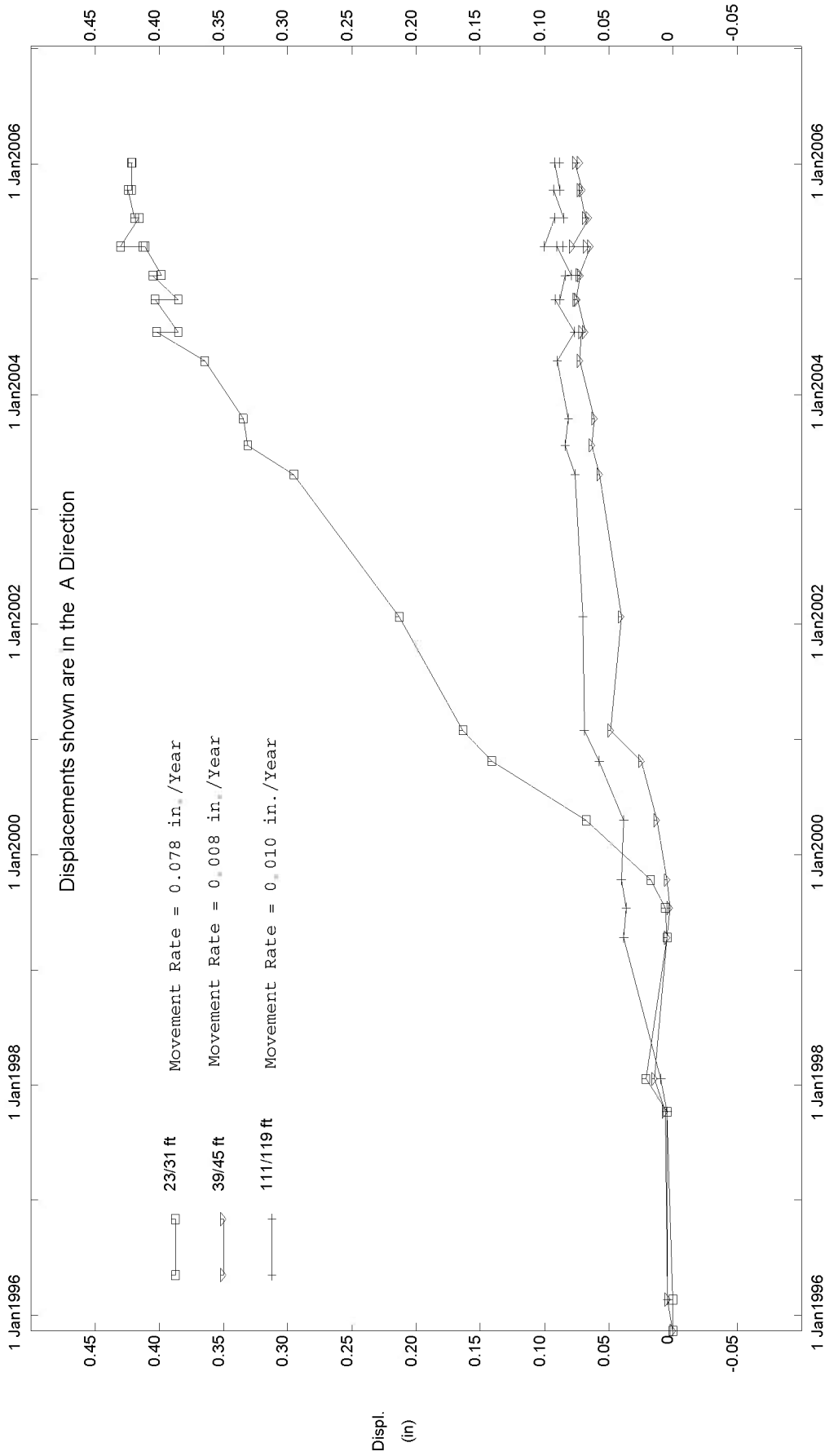

CUY-90, Inclinator B-110

E.L. Robinson - Dublin, OH

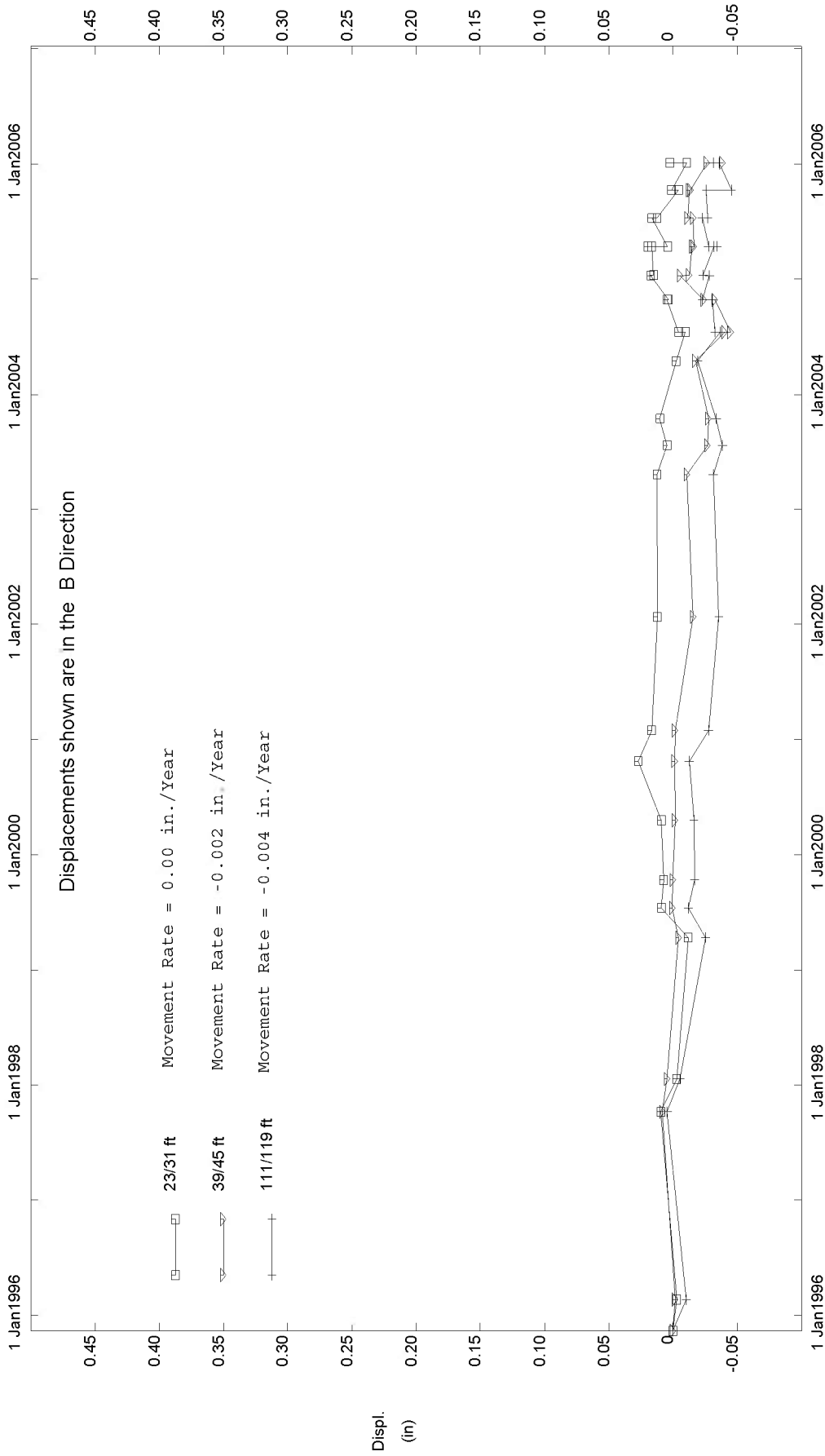

CUY-90, Inclinator B-110

E.L. Robinson - Dublin, OH

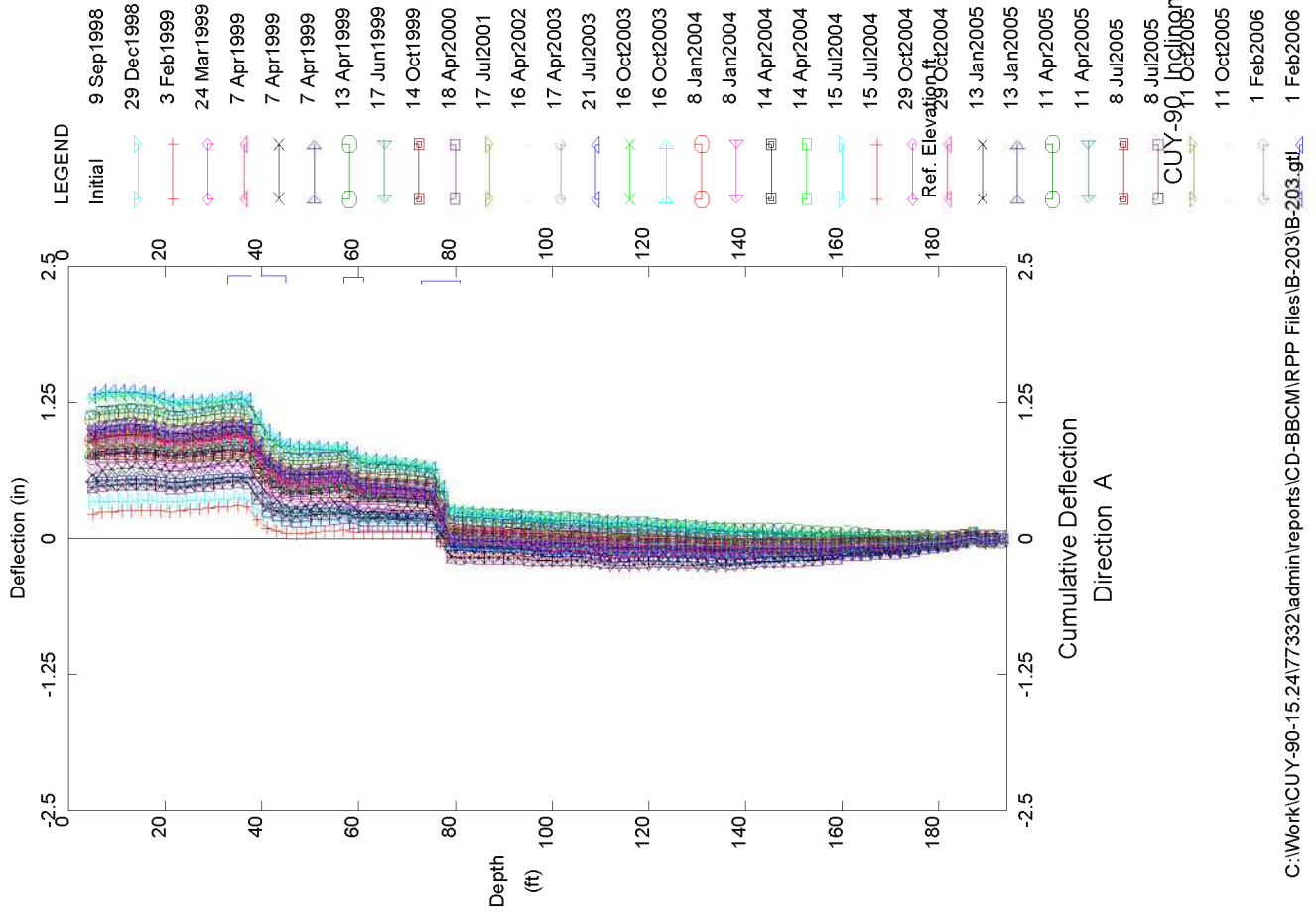
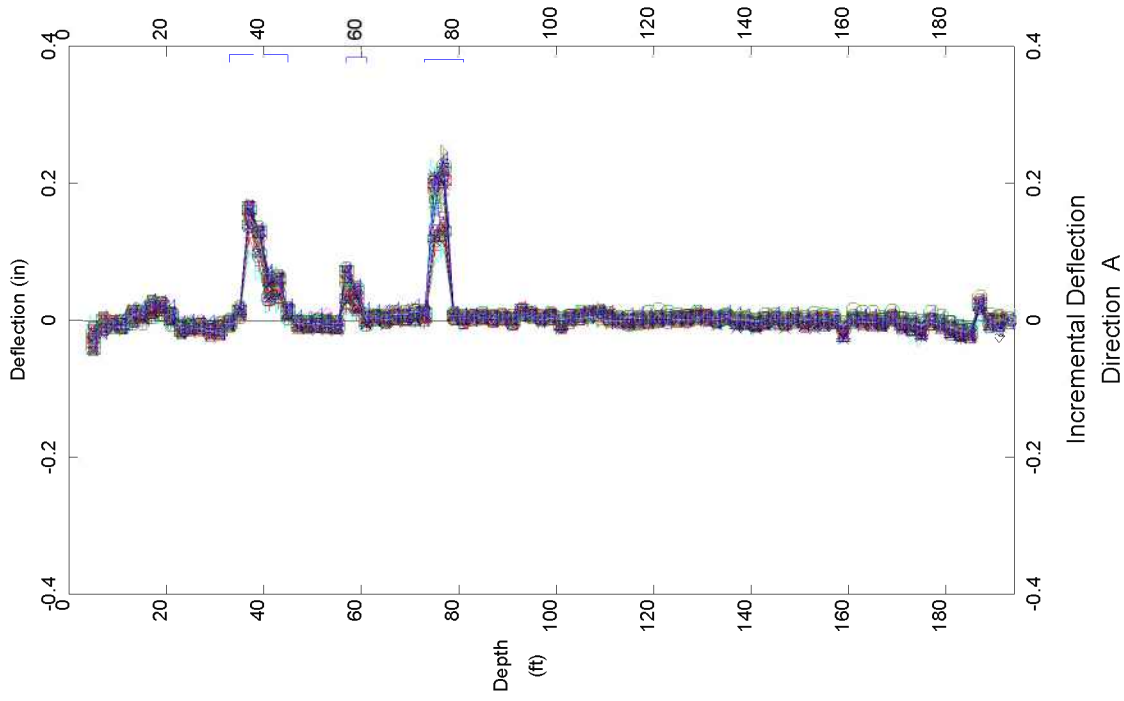

LEGEND

- Initial
- 9 Sep 1998
- 29 Dec 1998
- 3 Feb 1999
- 24 Mar 1999
- 7 Apr 1999
- 7 Apr 1999
- 7 Apr 1999
- 13 Apr 1999
- 17 Jun 1999
- 14 Oct 1999
- 18 Apr 2000
- 17 Jul 2001
- 16 Apr 2002
- 17 Apr 2003
- 21 Jul 2003
- 16 Oct 2003
- 16 Oct 2003
- 8 Jan 2004
- 8 Jan 2004
- 14 Apr 2004
- 14 Apr 2004
- 15 Jul 2004
- 15 Jul 2004
- 29 Oct 2004
- Ref. Elevation
- 29 Oct 2004
- 13 Jan 2005
- 13 Jan 2005
- 11 Apr 2005
- 11 Apr 2005
- 8 Jul 2005
- 8 Jul 2005
- CUY-90-15-2417332admin\reports\CD-BBCM\IRPP Files\B-203\B-203.gtl
- 11 Oct 2005
- 11 Oct 2005
- 1 Feb 2006
- 1 Feb 2006

E.L. Robinson - Dublin, OH

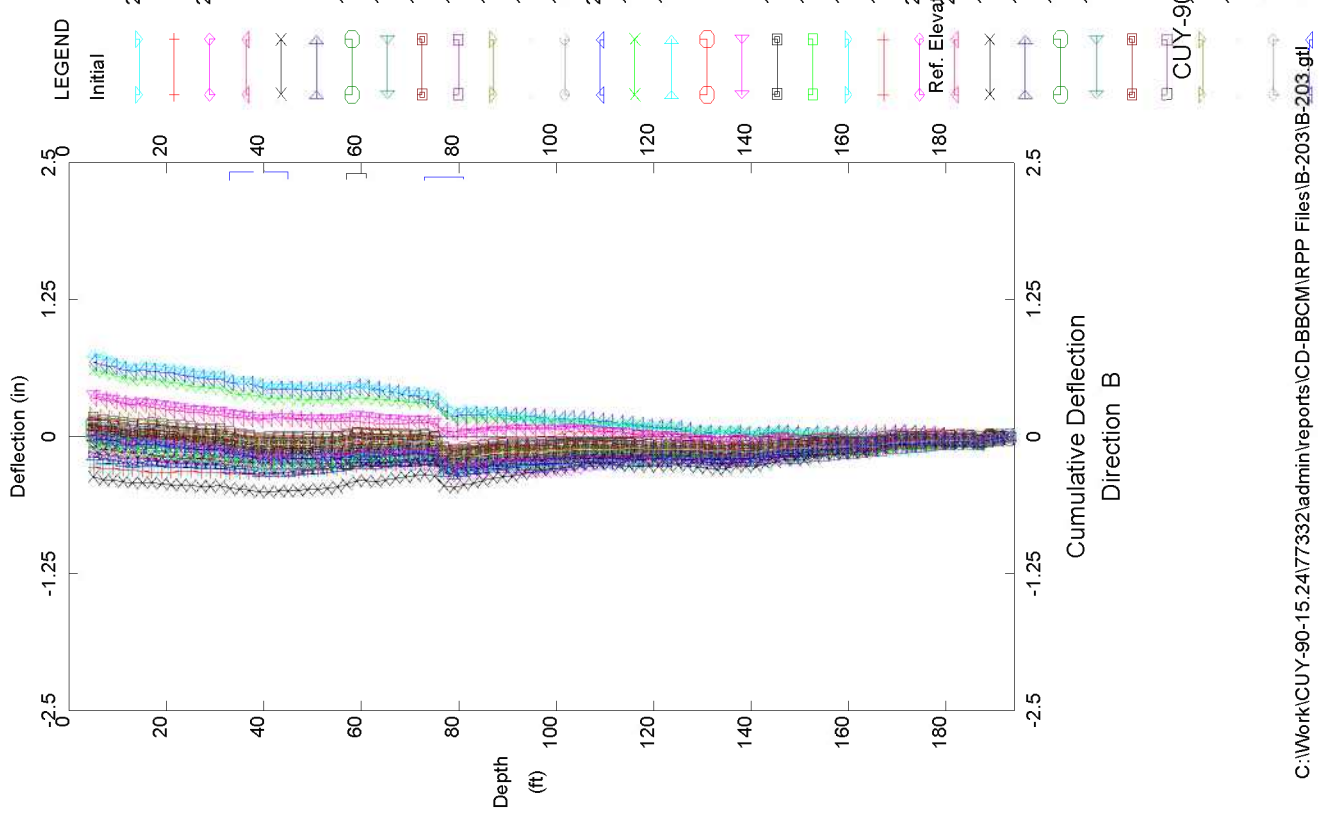
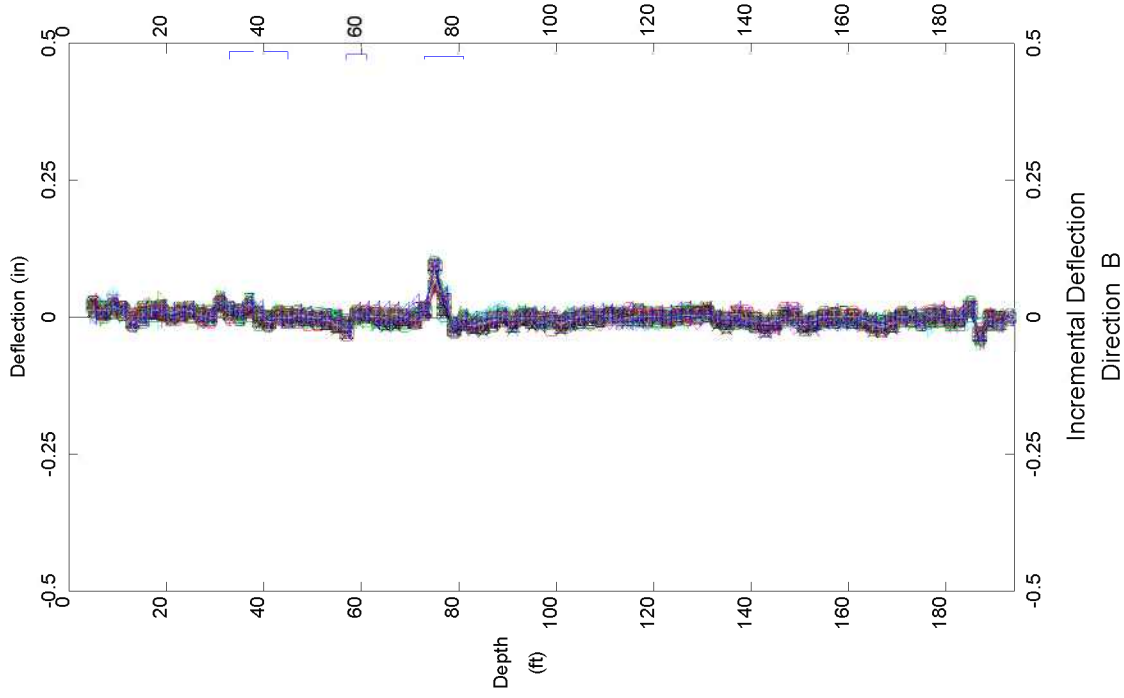

LEGEND

Initial	9 Sep 1998
29 Dec 1998	3 Feb 1999
24 Mar 1999	7 Apr 1999
7 Apr 1999	7 Apr 1999
7 Apr 1999	13 Apr 1999
17 Jun 1999	14 Oct 1999
18 Apr 2000	17 Jul 2001
16 Apr 2002	17 Apr 2003
21 Jul 2003	16 Oct 2003
16 Oct 2003	8 Jan 2004
8 Jan 2004	8 Jan 2004
14 Apr 2004	14 Apr 2004
14 Apr 2004	15 Jul 2004
15 Jul 2004	29 Oct 2004
29 Oct 2004	Ref. Elevation
Ref. Elevation	13 Jan 2005
13 Jan 2005	13 Jan 2005
11 Apr 2005	11 Apr 2005
11 Apr 2005	8 Jul 2005
8 Jul 2005	8 Jul 2005
8 Jul 2005	CUY-90-15 Cellingmeter B-203
CUY-90-15 Cellingmeter B-203	11 Oct 2005
11 Oct 2005	1 Feb 2006
1 Feb 2006	1 Feb 2006
1 Feb 2006	CUY-90-15 Cellingmeter B-203.gtl

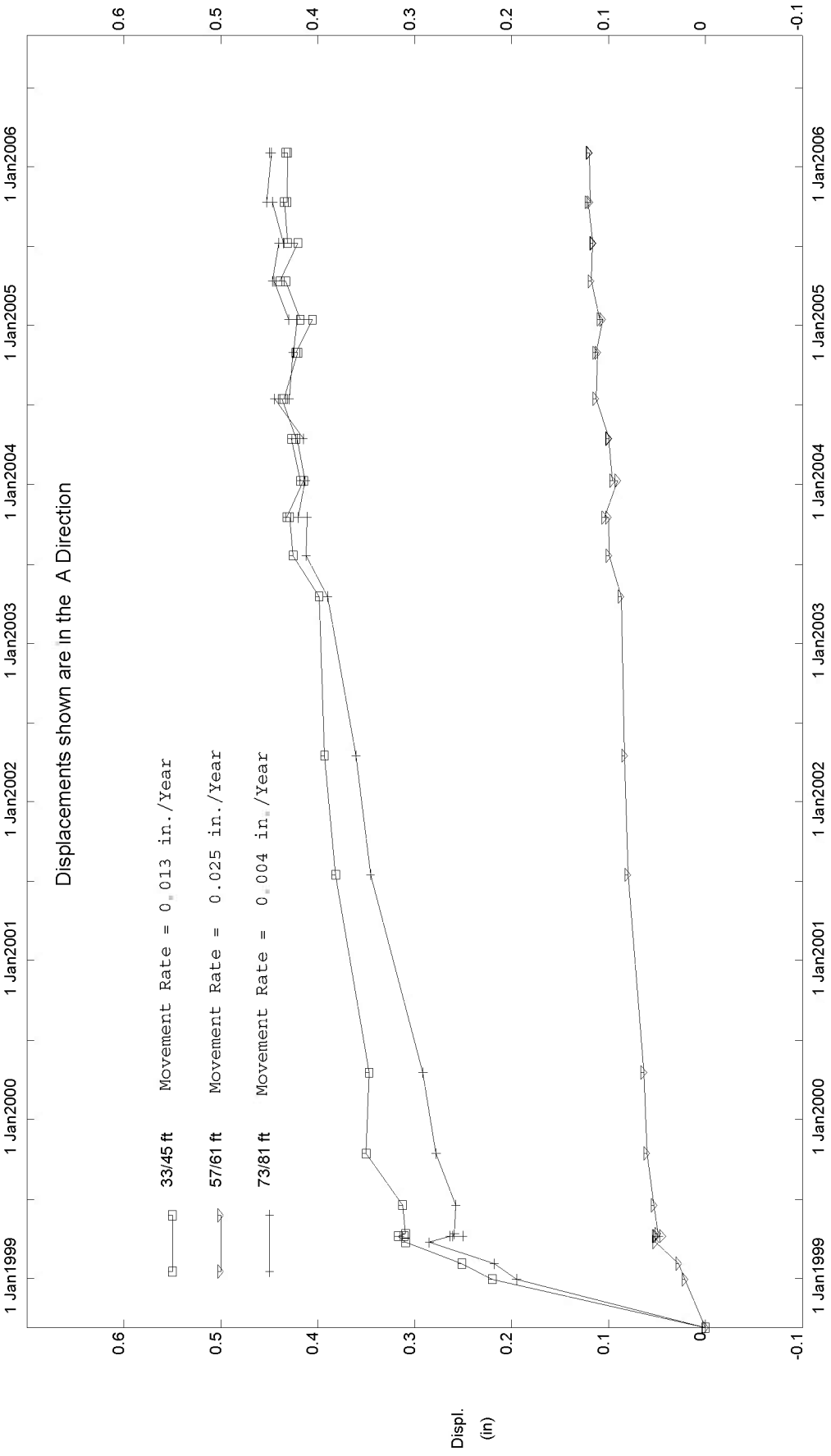

CUY-90, Inclinator B-203

E.L. Robinson - Dublin, OH

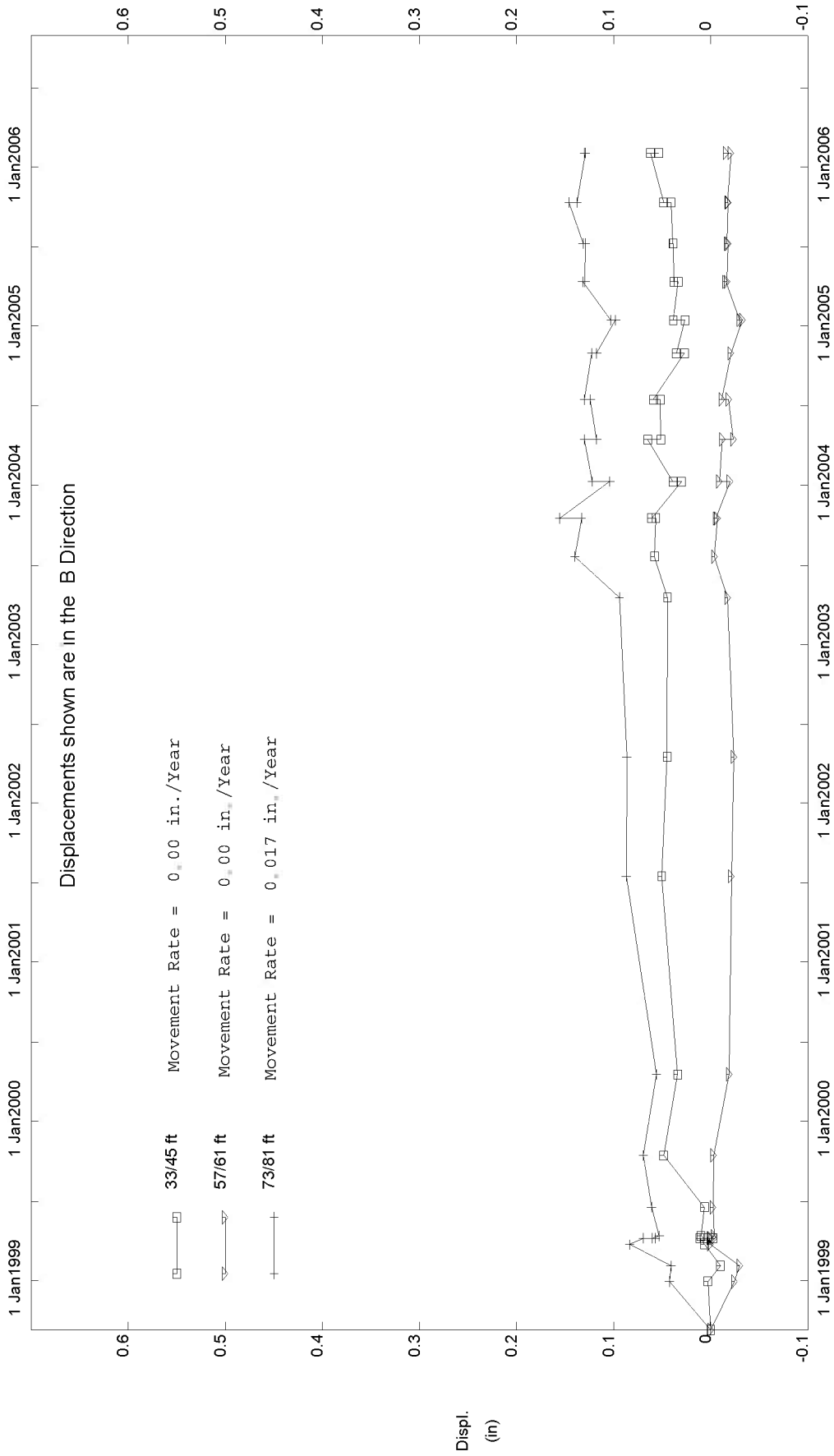

CUY-90, Inclinator B-203

E.L. Robinson - Dublin, OH

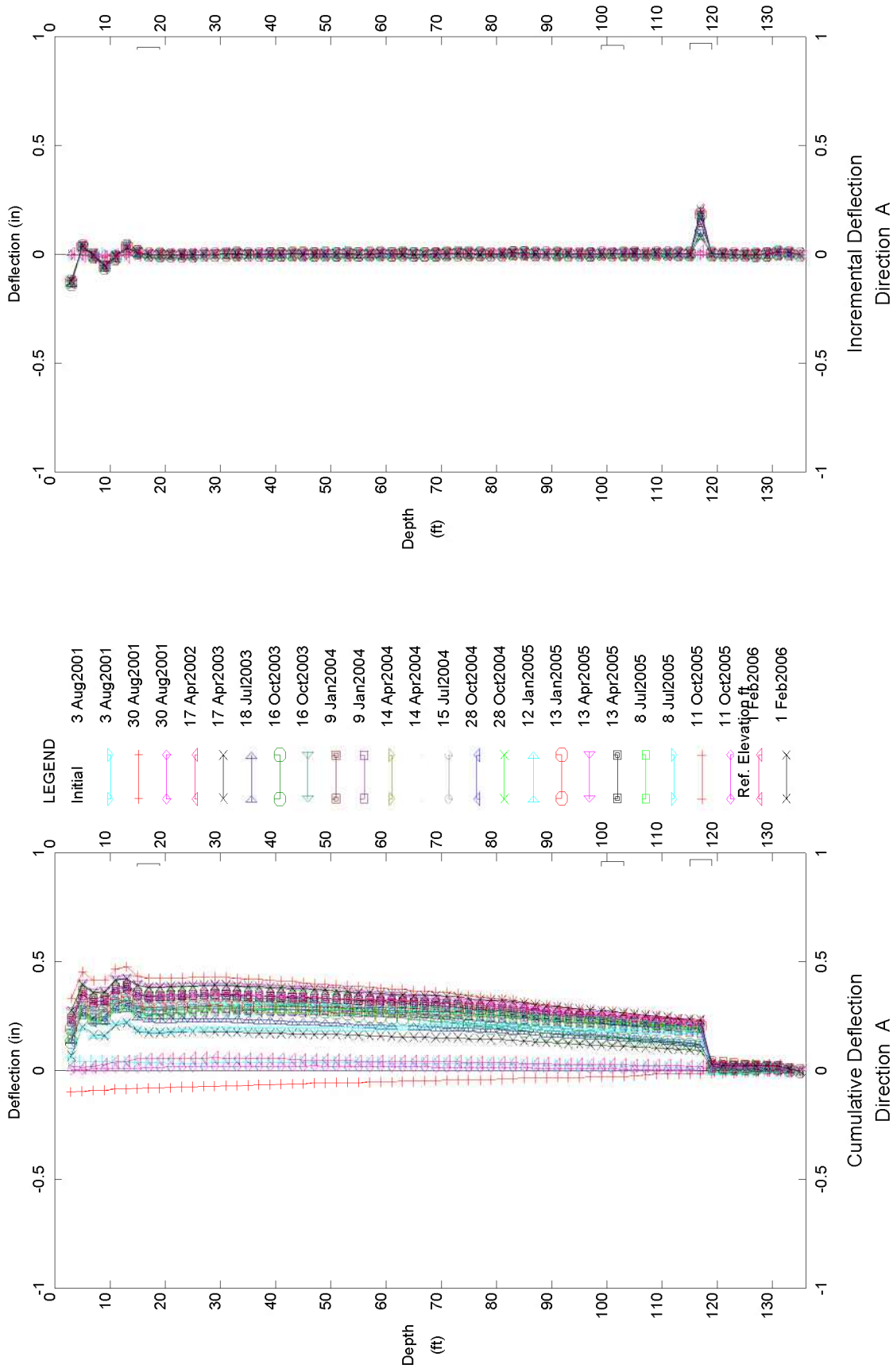

CUY-90, Inclinator B-204

E.L. Robinson - Dublin, OH

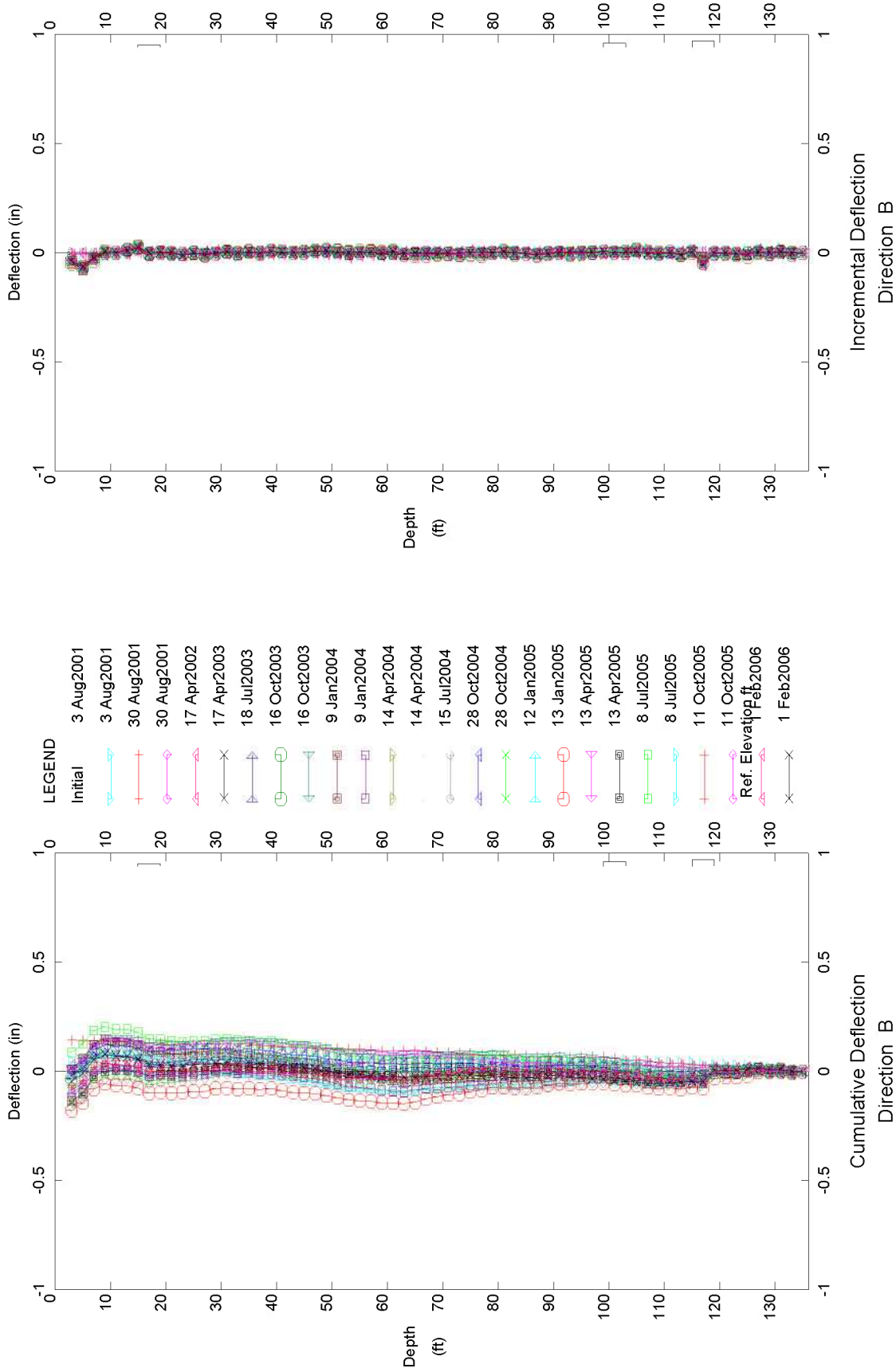

CUY-90, Inclinator B-204

E.L. Robinson - Dublin, OH

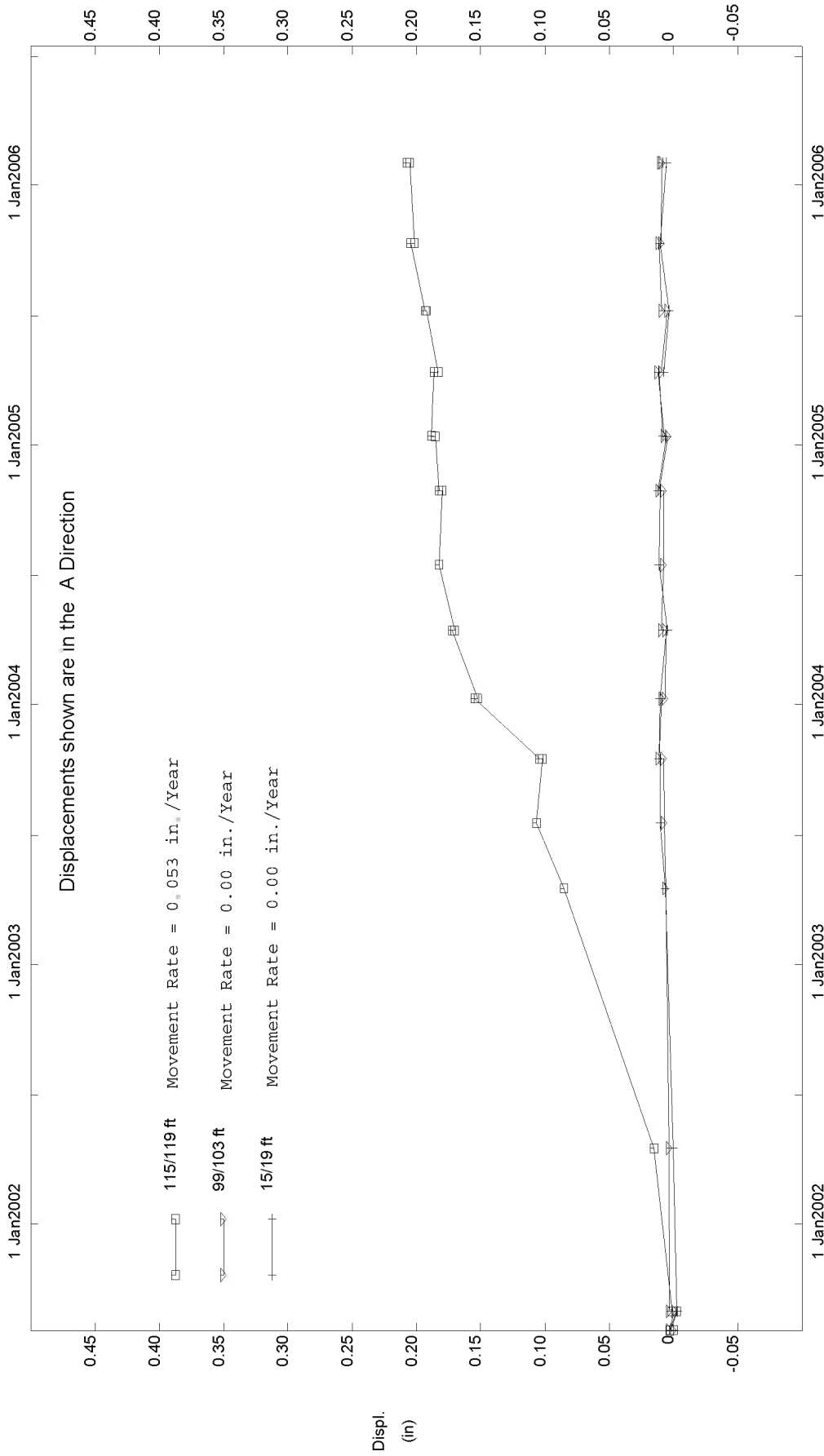

CUY-90, Inclinator B-204

E.L. Robinson - Dublin, OH

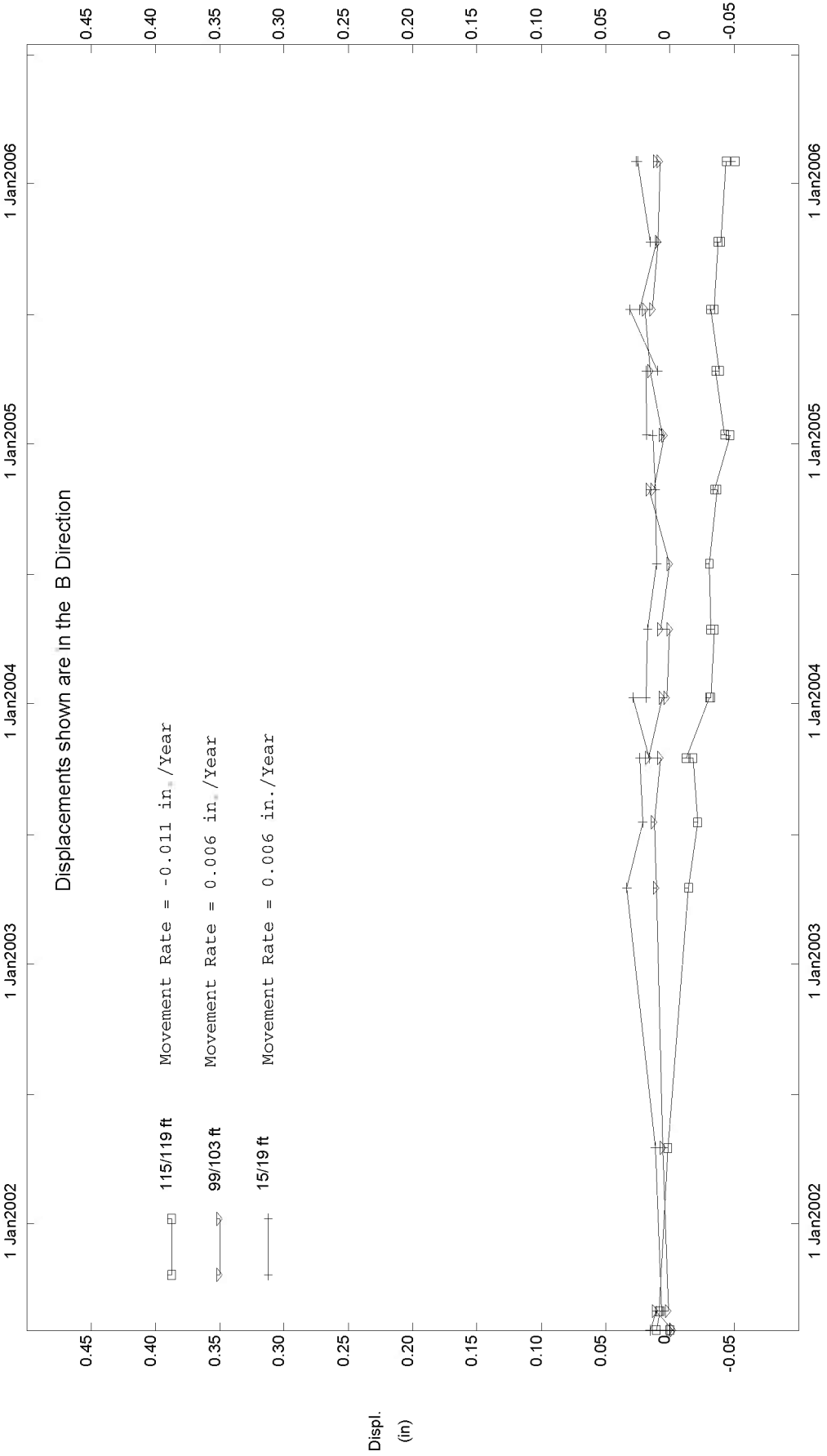

CUY-90, Inclinometer B-204

E.L. Robinson - Dublin, OH

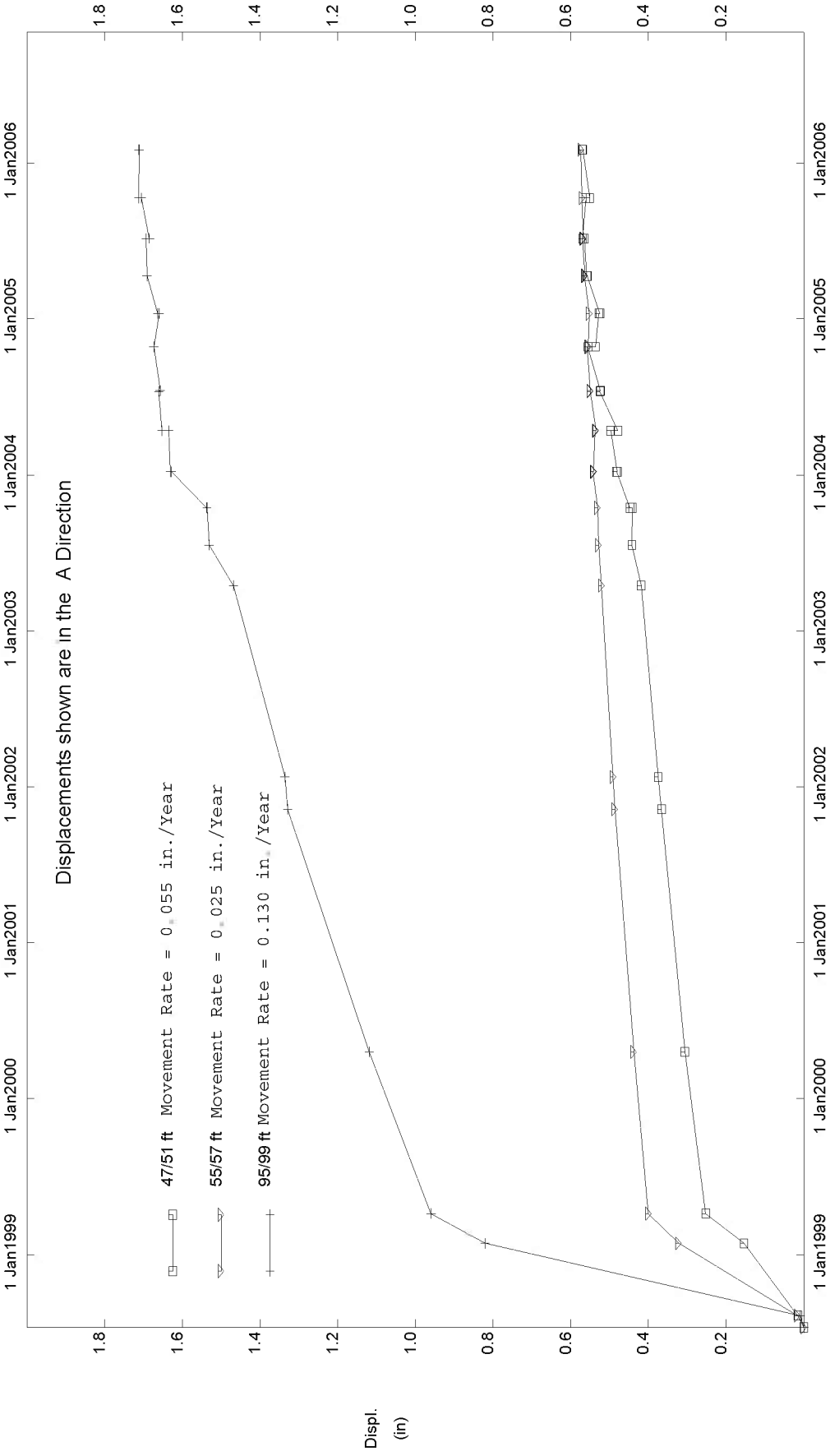

CUY-90, Inclinator B-303

E.L. Robinson - Dublin, OH

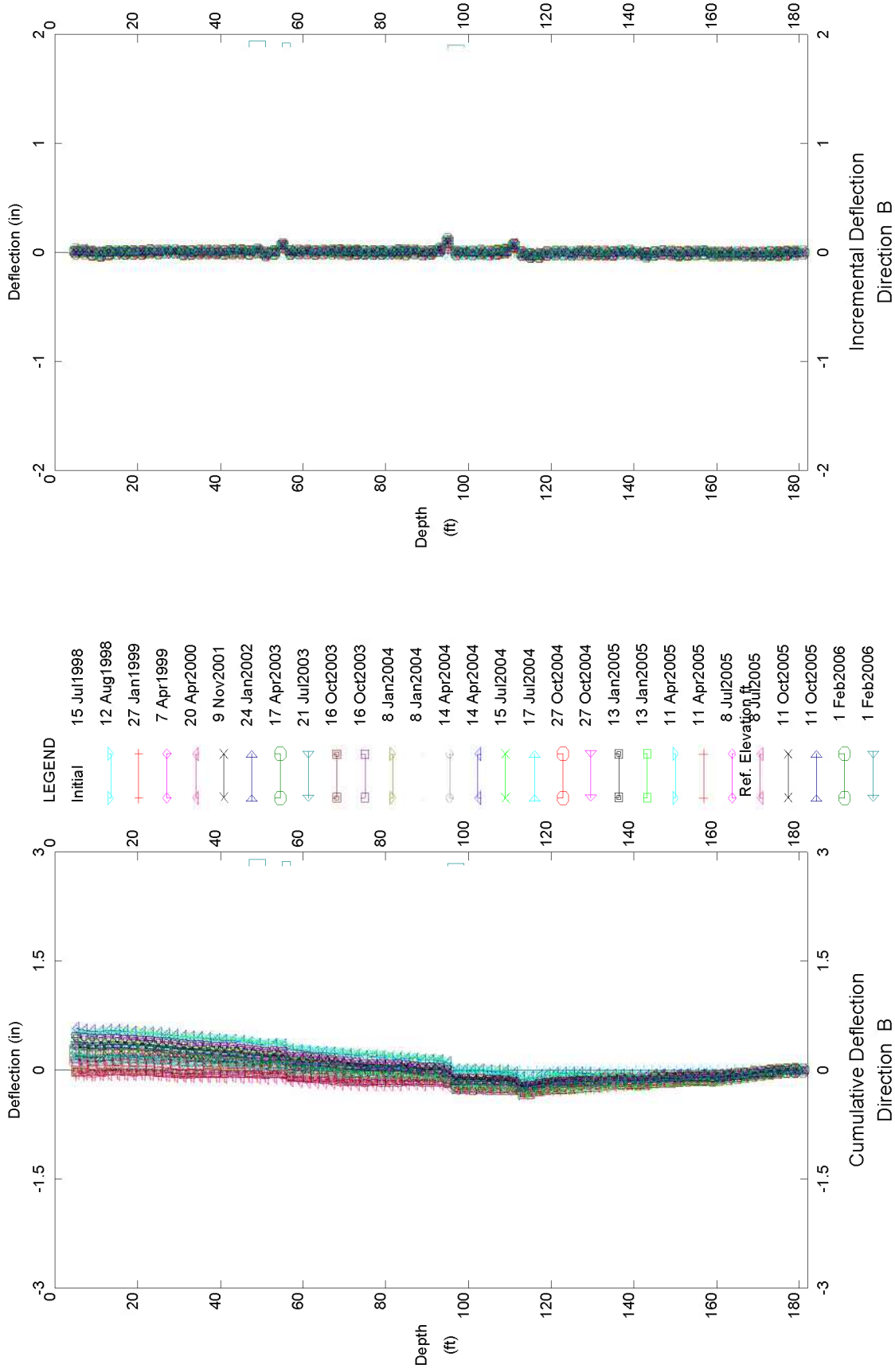

CUY-90, Inclinator B-303

E.L. Robinson - Dublin, OH

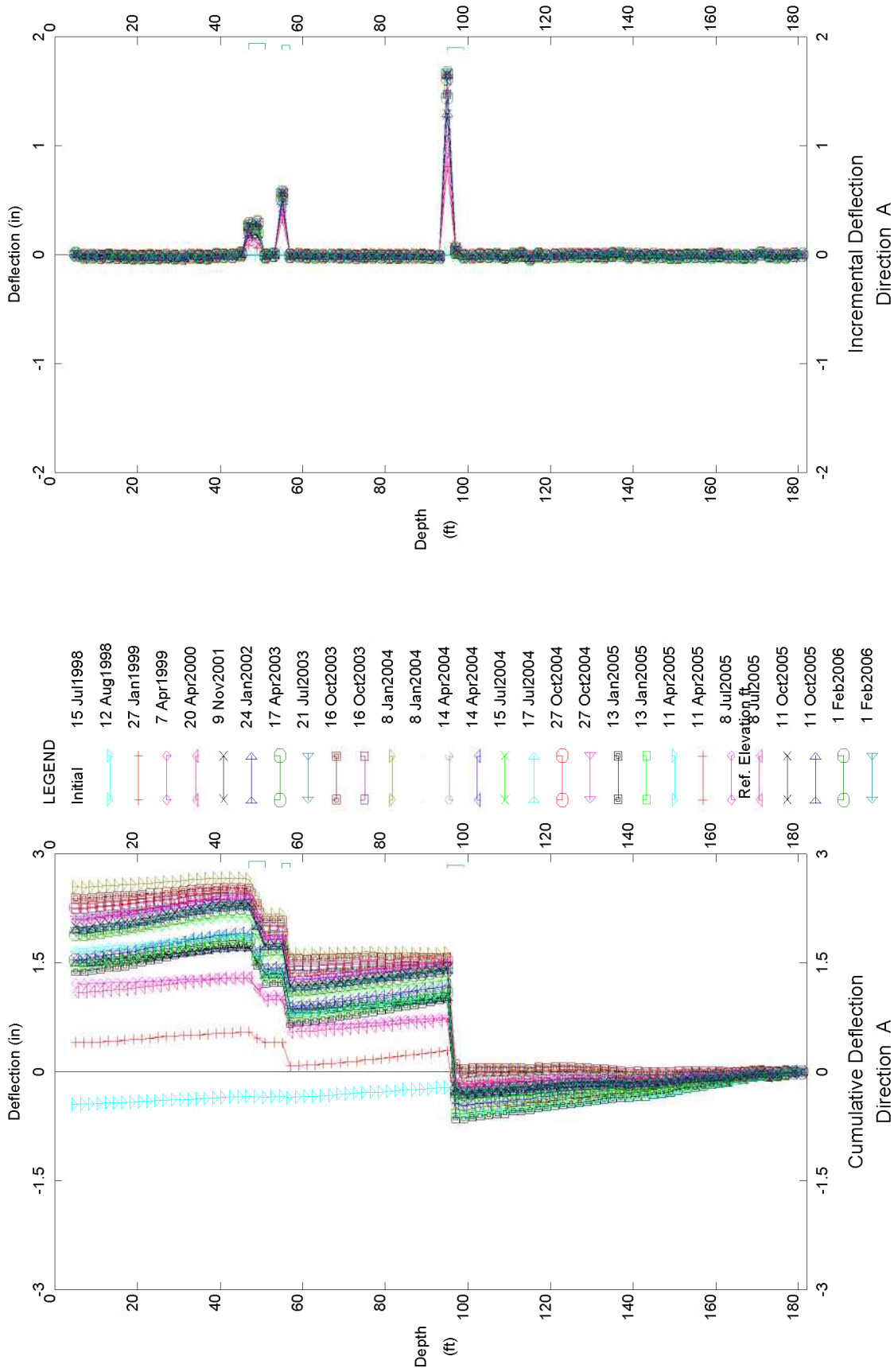

CUY-90, Inclinometer B-303

E.L. Robinson - Dublin, OH

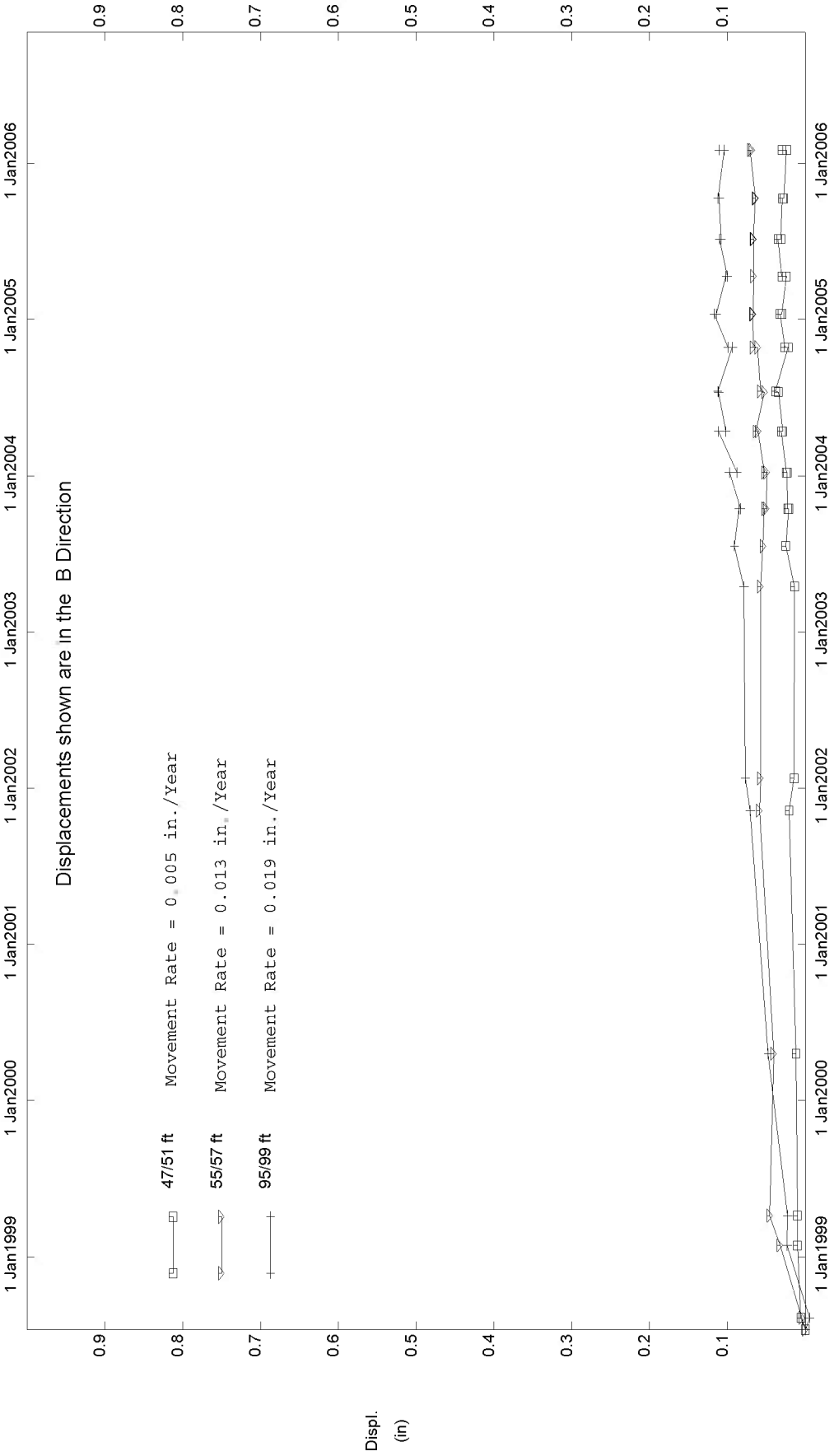

CUY-90, Inclinator B-303

Appendix B: Sequence of installation and detailed inspection of the drilled shafts.

INSPECTION RECORD FOR DRILLED SHAFTS

Project Number 457-97	Drilling Contractor Agra Foundations		Type and Model of Drilling Machinery CMV TH18-50 Crawler Hydraulic Piling Rig	Bid Price Above Bedrock (\$/ft) 713			
Bridge Number CUY-90-15.24	Project Engineer Kirk M. Gegick, PE		Max. Continuous Torque (ft-lbs) 132,752 @ 7.4 RPM	Bid Price in Bedrock Socket (\$/ft) 1620			
Structure File Number 1809393	CROWD (max. Cont. Downward Force (lbs)) 44,805 (Which is Equal To The Extraction Force)		Type of Shurry Used KB Technologies' "Shurry Pro"				
				Type of Bedrock Soft to Medium Hard Shale			
DRILLED SHAFT NUMBER			1	3	5	7	
DATE & TIME OF DRILLING	STARTED	DATE	9/9/98	11/9/98	10/30/98	10/19/98	
		TIME	9:00 AM	9:30 AM	1:30 PM	3:00 PM	
	FINISHED	DATE	10/13/98	11/12/98	11/4/98	10/22/98	
		TIME	5:00 PM	9:00 AM	11:00 AM	1:30 PM	
APPROXIMATE ELEVATION OF TOP OF OVERBURDEN			586.00	586.00	586.00	586.00	
LENGTH OF DRILLED SHAFTS ABOVE THE BEDROCK SOCKET	THROUGH AIR (FT)		N/A	N/A	N/A	N/A	
	THROUGH OVERBURDEN (FT)		140.00	141.50	143.00	142.50	
	PAY LENGTH (FT)		140.00	141.50	143.00	142.50	
OBSTRUCTIONS ENCOUNTERED	NUMBER		1	2	2	2	
	SIZE (IN)		See Below	See Below	See Below	See Below	
	TIME OF REMOVAL (HR)		See Below	See Below	See Below	See Below	
LENGTH OF DRILLED SHAFTS IN BEDROCK SOCKET	ELEV., TOP OF BEDROCK SOCKET		446.00	444.50	443.00	443.50	
	ELEV., BOTTOM OF BEDROCK		439.00	438.50	437.00	437.50	
	LENGTH OF BEDROCK SOCKET		7	6	6	6	
STEEL CASING	CASING THICKNESS (IN)		5/8	5/8	5/8	5/8	
	CASING LEFT IN PLACE (FT)		0	0	0	0	
REINFORCING STEEL	VERTICAL	BAR SIZE-NUMBER	#11	#11	#11	#11	
		NUMBER OF REBAR	24	24	24	24	
	SPIRAL	BAR SIZE-NUMBER	#4	#4	#4	#4	
		PITCH (IN)	4.5	4.5	4.5	4.5	
CONCRETE	SLUMP (IN)		7-9	7-9	7-9	7-9	
	CYLINDER STRENGTH (PSI)		4390/5190	6700/6580	6290/6360	5906/5900	
	AIR TEMPERATURE		64/46	48/34	52/46	65/45	
	DATE PLACED		10/15/98	11/13/98	11/6/98	10/27/98	
	QUANTITY (CY)		205	189	202	187	
TOLERANCES	LATERAL DEVIATION	N-S (FT)	0.50-N	0.02-N	0.42-N	0.24-N	
		E-W (FT)	0.50-W	0.30-E	0.24-W	0.60-W	
PLAN SHAFT DIAMETER ABOVE/BELOW BEDROCK SOCKET (IN)			72/66	72/66	72/66	72/66	
ACTUAL DIAMETER ABOVE/BELOW BEDROCK SOCKET (IN)			72/72	72/72	72/72	72/72	
PROJECT ENGINEER'S COMMENTS: See Obstruction Table Below.							
Drilled Shaft #	Date	Time	Type			Depth	
1	9/9 - 10/8	3 pm - 5:30pm	H-Pile			48'	
3	11/9	9:30am - 3 pm	Timber			12'	
3	11/9 - 11/11	4 pm - 4:30 pm	H-Pile			54'	
5	10/30 - 11/2	4 pm - 9 am	Timber			16'	
5	11/2	9 am - 4 pm	H-Pile			54'	
7	10/19 - 10/20	4 pm - 11 am	Timber			17'	
7	10/20 - 10/21	11 am - 11:30 am	H-Pile x2			42'	

INSPECTION RECORD FOR DRILLED SHAFTS

Project Number 457-97	Drilling Contractor Agra Foundations	Type and Model of Drilling Machinery CMV TH18-50 Crawler Hydraulic Piling Rig	Bid Price Above Bedrock (\$/ft) 713			
Bridge Number CUY-90-15.24		Max. Continuous Torque (ft-lbs) 132,752 @ 7.4 RPM	Bid Price in Bedrock Socket (\$/ft) 1620			
Structure File Number 1809393	Project Engineer Kirk M. Gegick, PE	CROWD (max. Cont. Downward Force (lbs)) 44,805 (Which is Equal To The Extraction Force)	Type of Slurry Used KB Technologies' "Slurry Pro"			
			Type of Bedrock Soft to Medium Hard Shale			
DRILLED SHAFT NUMBER		9	11	13	15	
DATE & TIME OF DRILLING	STARTED	DATE	10/30/98	9/23/98	11/4/98	10/22/98
		TIME	3:30 PM	8:30 AM	11:00 AM	1:30 PM
	FINISHED	DATE	11/19/98	9/30/98	11/6/98	10/30/98
		TIME	5:30 PM	3:30 PM	11:30 AM	1:30 PM
APPROXIMATE ELEVATION OF TOP OF OVERBURDEN		586.00	586.00	586.00	586.00	
LENGTH OF DRILLED SHAFTS ABOVE THE BEDROCK SOCKET	THROUGH AIR (FT)	N/A	N/A	N/A	N/A	
	THROUGH OVERBURDEN (FT)	143.00	140.50	144.00	144.50	
	PAY LENGTH (FT)	143.00	140.50	144.00	144.50	
OBSTRUCTIONS ENCOUNTERED	NUMBER	1	3	0	4	
	SIZE (IN)	See Below	See Below	N/A	See Below	
	TIME OF REMOVAL (HR)	See Below	See Below	N/A	See Below	
LENGTH OF DRILLED SHAFTS IN BEDROCK SOCKET	ELEV., TOP OF BEDROCK SOCKET	443.00	442.50	442.00	441.50	
	ELEV., BOTTOM OF BEDROCK	437.00	436.50	436.00	435.50	
	LENGTH OF BEDROCK SOCKET	6	9	6	6	
STEEL CASING	CASING THICKNESS (IN)	5/8	5/8	5/8	5/8	
	CASING LEFT IN PLACE (FT)	0	0	0	0	
REINFORCING STEEL	VERTICAL	BAR SIZE-NUMBER	#11	#11	#11	#11
		NUMBER OF REBAR	24	24	24	24
	SPIRAL	BAR SIZE-NUMBER	#4	#4	#4	#4
		PITCH (IN)	4.5	4.5	4.5	4.5
CONCRETE	SLUMP (IN)	7-9	7-9	7-9	7-9	
	CYLINDER STRENGTH (PSI)	6790/6960	6530/6620	4970/4780	7880/7730	
	AIR TEMPERATURE	50/36	72/45	51/45	47/36	
	DATE PLACED	11/23/98	10/2/98	11/10/98	11/3/98	
	QUANTITY (CY)	214	196	198	200	
TOLERANCES	LATERAL DEVIATION	N-S (FT)	0.29-N	0.83-N	0.03-N	0.52-N
		E-W (FT)	0.65-W	0.17-W	0.07-E	0.25-W
PLAN SHAFT DIAMETER ABOVE/BELOW BEDROCK SOCKET (IN)		72/66	72/66	72/66	72/66	
ACTUAL DIAMETER ABOVE/BELOW BEDROCK SOCKET (IN)		72/72	72/72	72/72	72/72	
PROJECT ENGINEER'S COMMENTS: See Obstruction Table Below						
Drilled Shaft #	Date	Time	Type			Depth
9	11/2 - 11/19	4 pm - 5:30pm	H-Pile			48'
11	9/23	8:30am - 1:30pm	Timber			18'
11	9/23 - 9/24	5 pm - 2 pm	H-Pile (Stub) #1			50'
11	9/24 - 9/25	5 pm - 10 am	H-Pile (Stub) #2			55'
15	10/22	2 pm - 4 pm	Timber			18'
15	10/22 - 10/27	4 pm - 5pm	H-Pile #1			52'
15	10/27 - 10/28	5 pm - 2 pm	H-Pile #2			60'
15	10/28 - 10/29	2 pm - 5 pm	H-Pile #3			69'

INSPECTION RECORD FOR DRILLED SHAFTS

Project Number 457-97	Drilling Contractor Agra Foundations		Type and Model of Drilling Machinery CMV TH18-50 Crawler Hydraulic Piling Rig	Bid Price Above Bedrock (\$/ft) 713
Bridge Number CUY-90-15.24			Max. Continuous Torque (ft-lbs) 132,752 @ 7.4 RPM	Bid Price in Bedrock Socket (\$/ft) 1620
Structure File Number 1809393	Project Engineer Kirk M. Gegick, PE		CROWD (max. Cont. Downward Force (lbs)) 44,805 (Which is Equal To The Extraction Force)	Type of Slurry Used KB Technologies' "Slurry Pro"
			Type of Bedrock Soft to Medium Hard Shale	
DRILLED SHAFT NUMBER			17	
DATE & TIME OF DRILLING	STARTED	DATE	11/20/98	
		TIME	7:00 am	
	FINISHED	DATE	11/23/98	
		TIME	5:30 pm	
APPROXIMATE ELEVATION OF TOP OF OVERBURDEN			586.00	
LENGTH OF DRILLED SHAFTS ABOVE THE BEDROCK SOCKET	THROUGH AIR (FT)		N/A	
	THROUGH OVERBURDEN (FT)		145.00	
	PAY LENGTH (FT)		145.00	
OBSTRUCTIONS ENCOUNTERED	NUMBER		2	
	SIZE (IN)		See Below	
	TIME OF REMOVAL (HR)		See Below	
LENGTH OF DRILLED SHAFTS IN BEDROCK SOCKET	ELEV., TOP OF BEDROCK SOCKET		441.00	
	ELEV., BOTTOM OF BEDROCK		435.00	
	LENGTH OF BEDROCK SOCKET		6	
STEEL CASING	CASING THICKNESS (IN)		5/8	
	CASING LEFT IN PLACE (FT)		0	
REINFORCING STEEL	VERTICAL	BAR SIZE-NUMBER	#11	
		NUMBER OF REBAR	24	
	SPIRAL	BAR SIZE-NUMBER	#4	
		PITCH (IN)	4.5	
CONCRETE	SLUMP (IN)		7-9	
	CYLINDER STRENGTH (PSI)		5760/5790	
	AIR TEMPERATURE		54/40	
	DATE PLACED		11/25/98	
	QUANTITY (CY)		186	
TOLERANCES	LATERAL DEVIATION	N-S (FT)	0.7-N	
		E-W (FT)	0.42-E	
PLAN SHAFT DIAMETER ABOVE/BELOW BEDROCK SOCKET (IN)			72/66	
ACTUAL DIAMETER ABOVE/BELOW BEDROCK SOCKET (IN)			72/72	
PROJECT ENGINEER'S COMMENTS: See Obstruction Table Below				
Drilled Shaft #	Date	Time	Type	Depth
17	11/20	8 am - 1 pm	Timber	6'
17	11/20 - 11/21	1:30 pm - 9:30 am	H-Pile	48'

INSPECTION RECORD FOR DRILLED SHAFTS

Project Number 457-97	Drilling Contractor Agra Foundations	Type and Model of Drilling Machinery CMV TH18-50 Crawler Hydraulic Piling Rig	Bid Price Above Bedrock (\$/ft) 713			
Bridge Number CUY-90-15.24		Max. Continuous Torque (ft-lbs) 132,752 @ 7.4 RPM	Bid Price in Bedrock Socket (\$/ft) 1620			
Structure File Number 1809393	Project Engineer Kirk M. Gepick, PE	CROWD (max. Cont. Downward Force (lbs)) 44,805 (Which is Equal To The Extraction Force)	Type of Slurry Used KB Technologies' "Slurry Pro"			
			Type of Bedrock Soft to Medium Hard Shale			
DRILLED SHAFT NUMBER		2	4	6	8	
DATE & TIME OF DRILLING	STARTED	DATE	8/20/98	8/3/98	9/17/98	8/24/98
		TIME	10:00 AM	11:30 AM	1:30 PM	12:00 PM
	FINISHED	DATE	8/27/98	8/13/98	9/22/98	9/8/98
		TIME	10:30 AM	9:00 AM	6:30 PM	5:30 PM
APPROXIMATE ELEVATION OF TOP OF OVERBURDEN		586.00	586.00	586.00	586.00	
LENGTH OF DRILLED SHAFTS ABOVE THE BEDROCK SOCKET	THROUGH AIR (FT)	N/A	N/A	N/A	N/A	
	THROUGH OVERBURDEN (FT)	133.80	141.75	142.25	142.75	
	PAY LENGTH (FT)	133.80	141.75	142.25	142.75	
OBSTRUCTIONS ENCOUNTERED	NUMBER	2	0	1	2	
	SIZE (IN)	See Below	N/A	See Below	See Below	
	TIME OF REMOVAL (HR)	See Below	N/A	See Below	See Below	
LENGTH OF DRILLED SHAFTS IN BEDROCK SOCKET	ELEV., TOP OF BEDROCK SOCKET	452.20	444.25	443.75	443.25	
	ELEV., BOTTOM OF BEDROCK	443.00	438.25	437.75	437.25	
	LENGTH OF BEDROCK SOCKET	9.2	6	6	6	
STEEL CASING	CASING THICKNESS (IN)	5/8	5/8	5/8	5/8	
	CASING LEFT IN PLACE (FT)	0	0	0	0	
REINFORCING STEEL	VERTICAL	BAR SIZE-NUMBER	#11	#11	#11	#11
		NUMBER OF REBAR	24	24	24	24
	SPIRAL	BAR SIZE-NUMBER	#4	#4	#4	#4
		PITCH (IN)	4.5	4.5	4.5	4.5
CONCRETE	SLUMP (IN)	7-9	7-9	7-9	7-9	
	CYLINDER STRENGTH (PSI)	5060/5110	5740/5950	5090/5300	4210/4070	
	AIR TEMPERATURE	84/66	80/67	69/45	65/50	
	DATE PLACED	8/28/98	8/19/98	9/24/98	9/10/98	
	QUANTITY (CY)	180	202	185	180	
TOLERANCES	LATERAL DEVIATION	N-S (FT)	0.28-N	0.05-N	1.16-N	1.24-N
		E-W (FT)	0.01-E	0.28-E	0.31-W	0.21-E
PLAN SHAFT DIAMETER ABOVE/BELOW BEDROCK SOCKET (IN)		72/66	72/66	72/66	72/66	
ACTUAL DIAMETER ABOVE/BELOW BEDROCK SOCKET (IN)		72/72	72/72	72/72	72/72	
PROJECT ENGINEER'S COMMENTS: See Obstruction Table Below.						
Drilled Shaft #	Date	Time	Type			Depth
2	8/21 - 8/24	1 pm - 9am	H-Pile (Stub)			75'
2	8/24 - 8/25	11am - 1pm	Methane			117'
6	9/18 - 9/21	1.30pm - 3:30pm	H-Pile (Stub)			74'
8	8/24	1pm - 3pm	Timber			15'
8	8/24 - 9/3	4pm - 3pm	H-Pile (Stub)			65'

INSPECTION RECORD FOR DRILLED SHAFTS

Project Number 457-97	Drilling Contractor Agra Foundations	Type and Model of Drilling Machinery CMV TH18-50 Crawler Hydraulic Piling Rig	Bid Price Above Bedrock (\$/ft) 713			
Bridge Number CUY-90-15.24		Max. Continuous Torque (ft-lbs) 132,752 @ 7.4 RPM	Bid Price in Bedrock Socket (\$/ft) 1620			
Structure File Number 1809393	Project Engineer Kirk M. Gegick, PE	CROWD (max. Cont. Downward Force (lbs) 44,805 (Which is Equal To The Extraction Force)	Type of Slurry Used KB Technologies' "Slurry Pro"			
			Type of Bedrock Soft to Medium Hard Shale			
DRILLED SHAFT NUMBER			10	12	14	16
DATE & TIME OF DRILLING	STARTED	DATE	8/13/98	8/27/98	10/9/98	11/12/98
		TIME	10:00 am	2:00 pm	3:00 pm	2:00 pm
	FINISHED	DATE	8/20/98	9/2/98	10/19/98	11/18/98
		TIME	9:00 am	5:30 pm	3:00 pm	5:30 pm
APPROXIMATE ELEVATION OF TOP OF OVERBURDEN			586.00	586.00	586.00	586.00
LENGTH OF DRILLED SHAFTS ABOVE THE BEDROCK SOCKET	THROUGH AIR (FT)		N/A	N/A	N/A	N/A
	THROUGH OVERBURDEN (FT)		143.25	143.75	144.25	144.75
	PAY LENGTH (FT)		143.25	143.75	144.25	144.75
OBSTRUCTIONS ENCOUNTERED	NUMBER		0	0	2	2
	SIZE (IN)		N/A	N/A	See below	See below
	TIME OF REMOVAL (HR)		N/A	N/A	See below	See below
LENGTH OF DRILLED SHAFTS IN BEDROCK SOCKET	ELEV., TOP OF BEDROCK SOCKET		442.75	442.25	441.75	441.25
	ELEV., BOTTOM OF BEDROCK		436.75	436.25	435.75	435.25
	LENGTH OF BEDROCK SOCKET		6	6	6	6
STEEL CASING	CASING THICKNESS (IN)		5/8	5/8	5/8	5/8
	CASING LEFT IN PLACE (FT)		0	0	0	0
REINFORCING STEEL	VERTICAL	BAR SIZE-NUMBER	#11	#11	#11	#11
		NUMBER OF REBAR	24	24	24	24
	SPIRAL	BAR SIZE-NUMBER	#4	#4	#4	#4
		PITCH (IN)	4.5	4.5	4.5	4.5
CONCRETE	SLUMP (IN)		7-9	7-9	7-9	7-9
	CYLINDER STRENGTH (PSI)		6260/6590	5560/5780	6250/6190	4740/4730
	AIR TEMPERATURE		82/62	76/53	48/36	58/42
	DATE PLACED		8/21/98	9/4/98	10/21/98	11/18/98
	QUANTITY (CY)		195	186	180	190
TOLERANCES	LATERAL DEVIATION	N-S (FT)	0.07-S	0.99-S	0.60-N	0.47-N
		E-W (FT)	0.01-W	0.25-W	0.02-E	0.26-W
PLAN SHAFT DIAMETER ABOVE/BELOW BEDROCK SOCKET (IN)			72/66	72/66	72/66	72/66
ACTUAL DIAMETER ABOVE/BELOW BEDROCK SOCKET (IN)			72/72	72/72	72/72	72/72
PROJECT ENGINEER'S COMMENTS: See Obstruction Table Below.						
Drilled Shaft #	Date	Time	Type			Depth
14	10/9 - 10/12	4 pm - 9 am	Timber			19'
14	10/12 - 10/16	5 pm - 12 pm	H-Pile			34'
16	11/13	8 am - 4 pm	H-Pile #1			35'
16	11/13 - 11/14	4 pm - 3 pm	H-Pile #2			45'

ODOT PROJECT 457-97

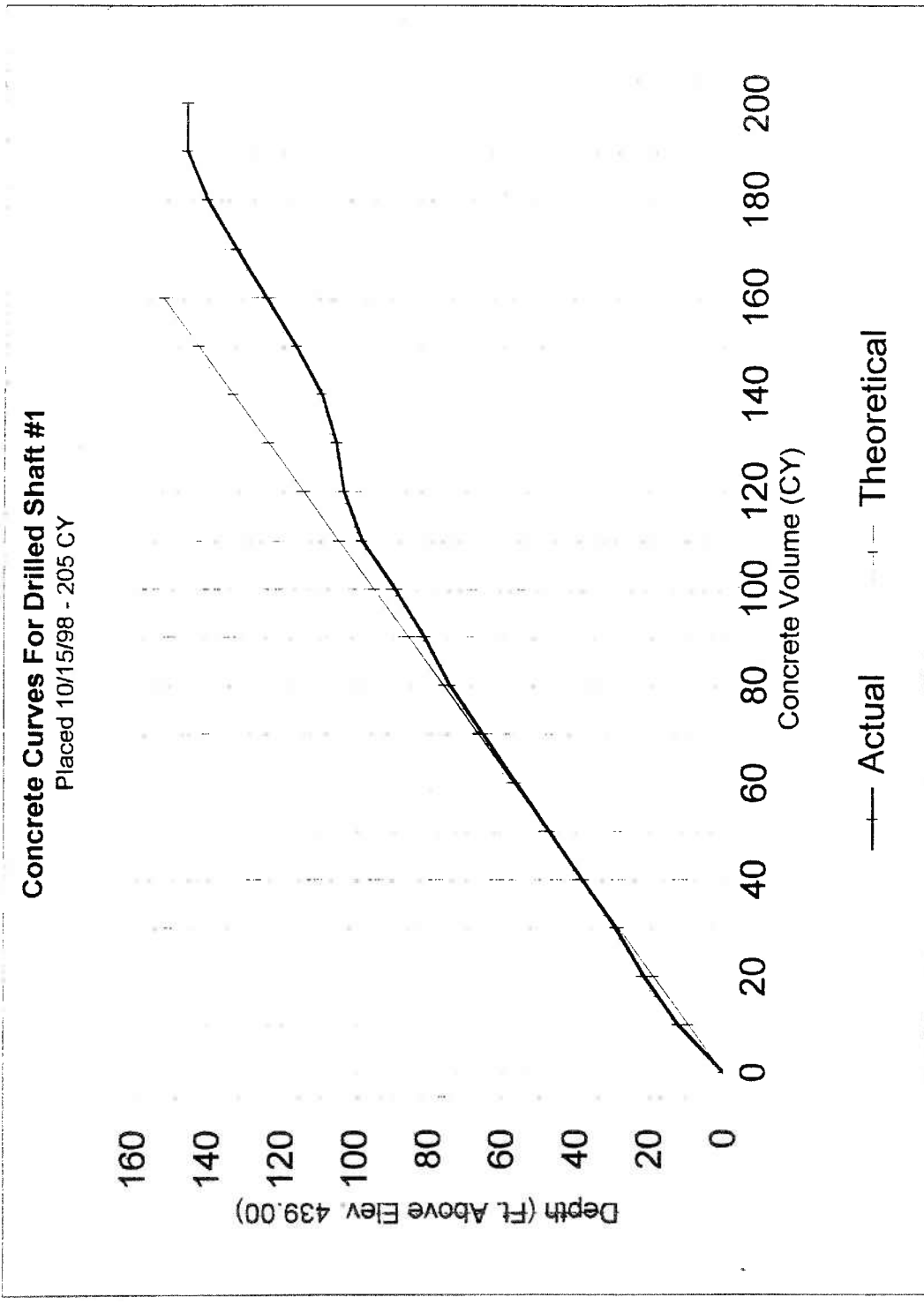

ODOT PROJECT 457-97

Concrete Curves For Drilled Shaft #2

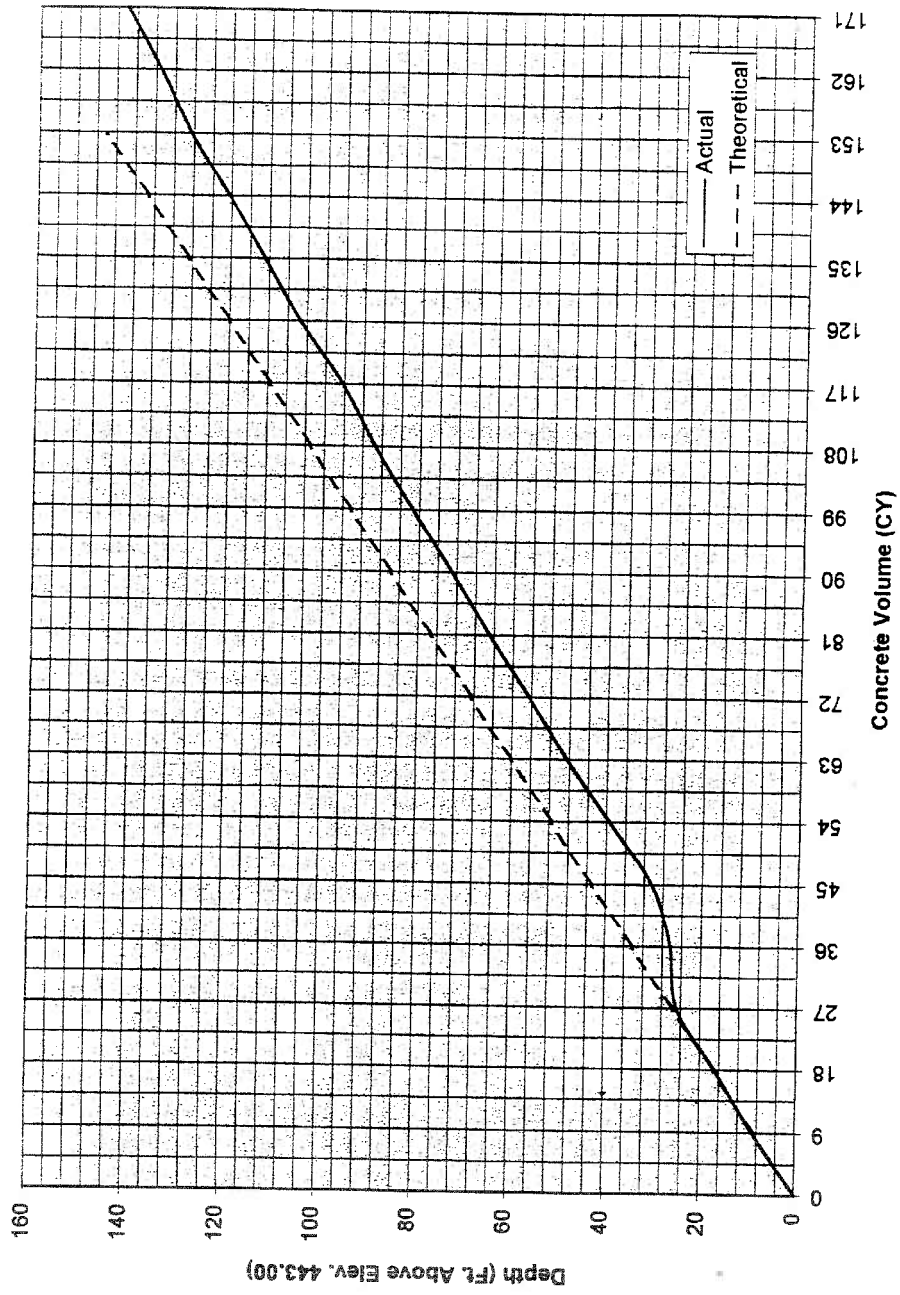

ODOT PROJECT 457-97

Concrete Curves For Drilled Shaft #3

Placed 11/13/98 - 189 CY

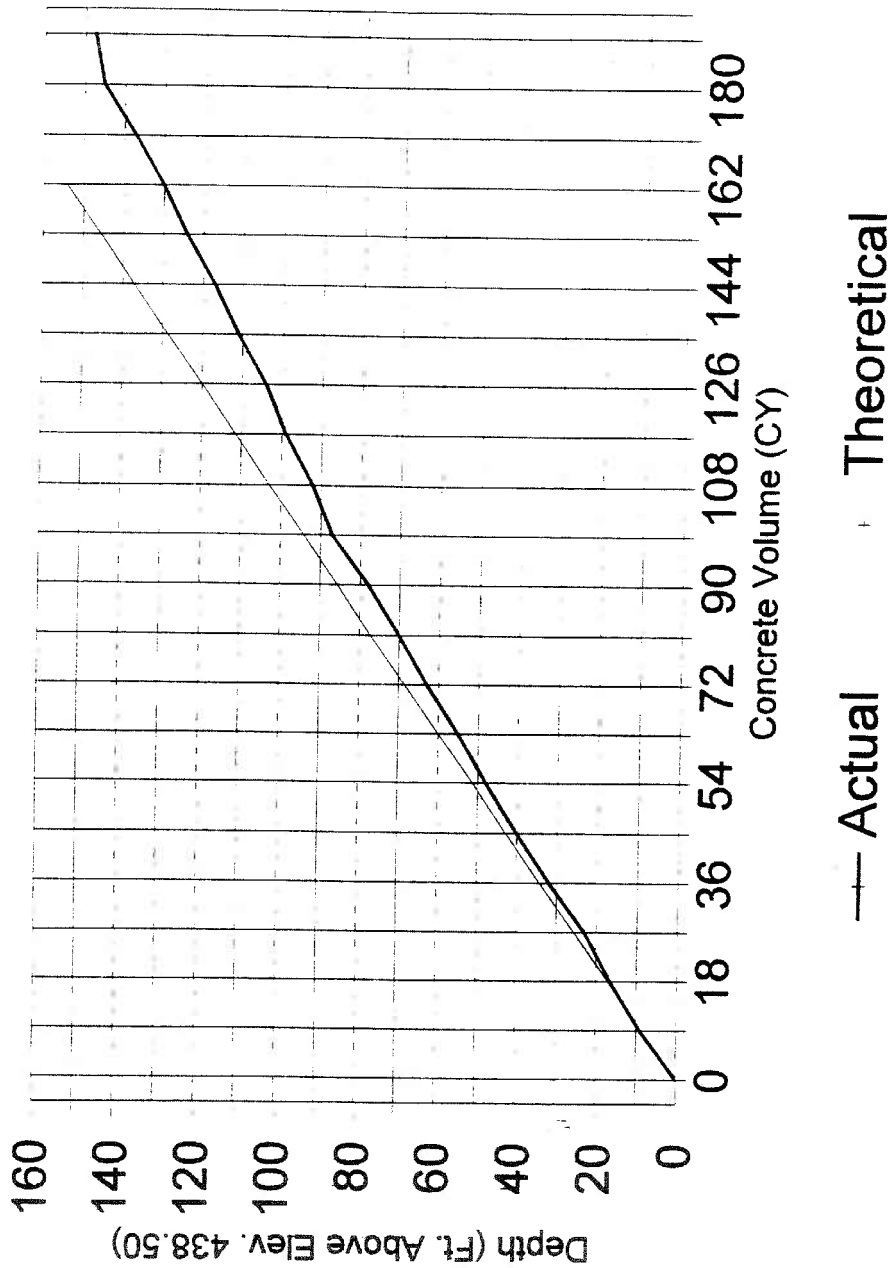

ODOT PROJECT 457-97

Concrete Curves For Drilled Shaft #4

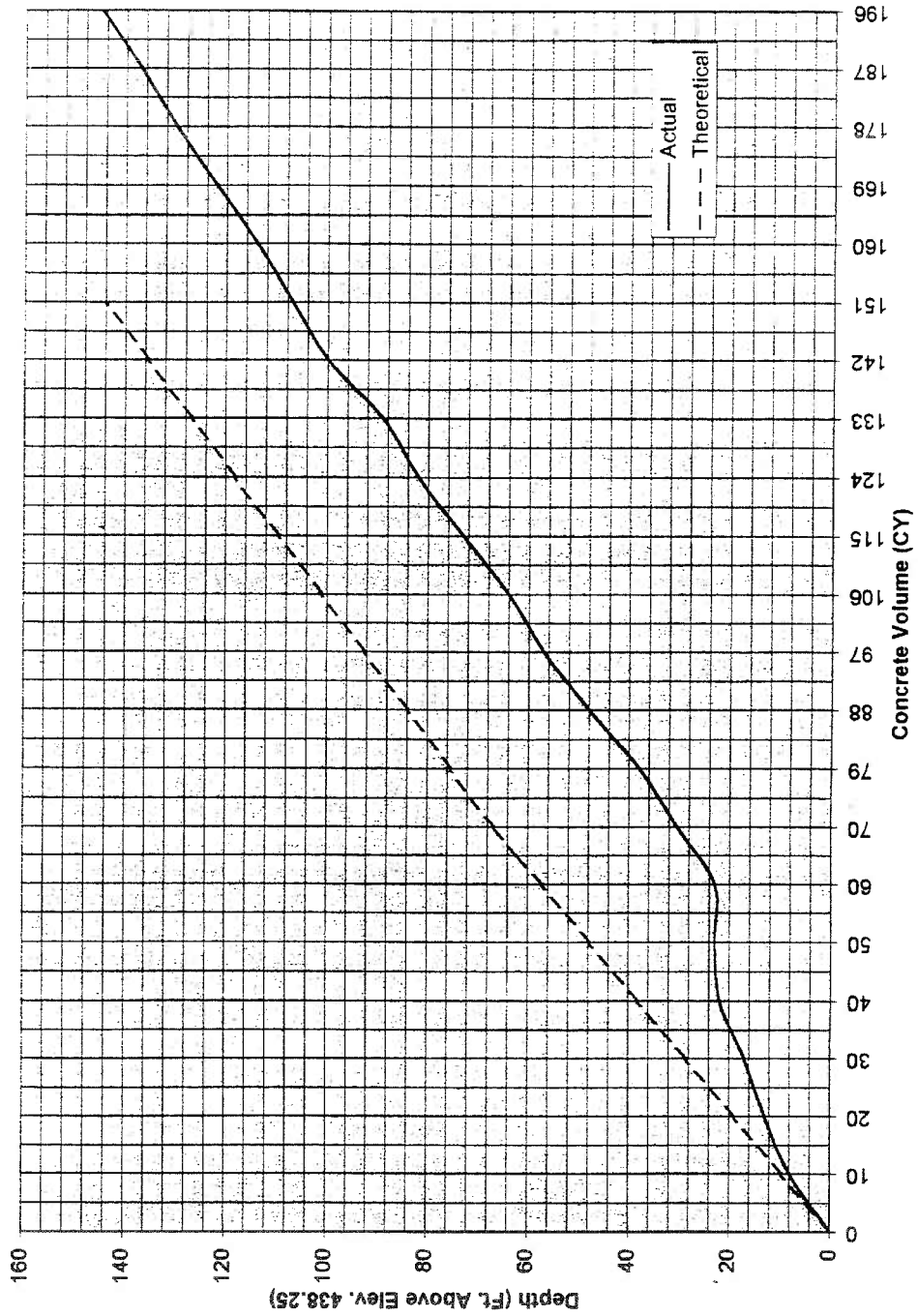

ODOT PROJECT 457-97

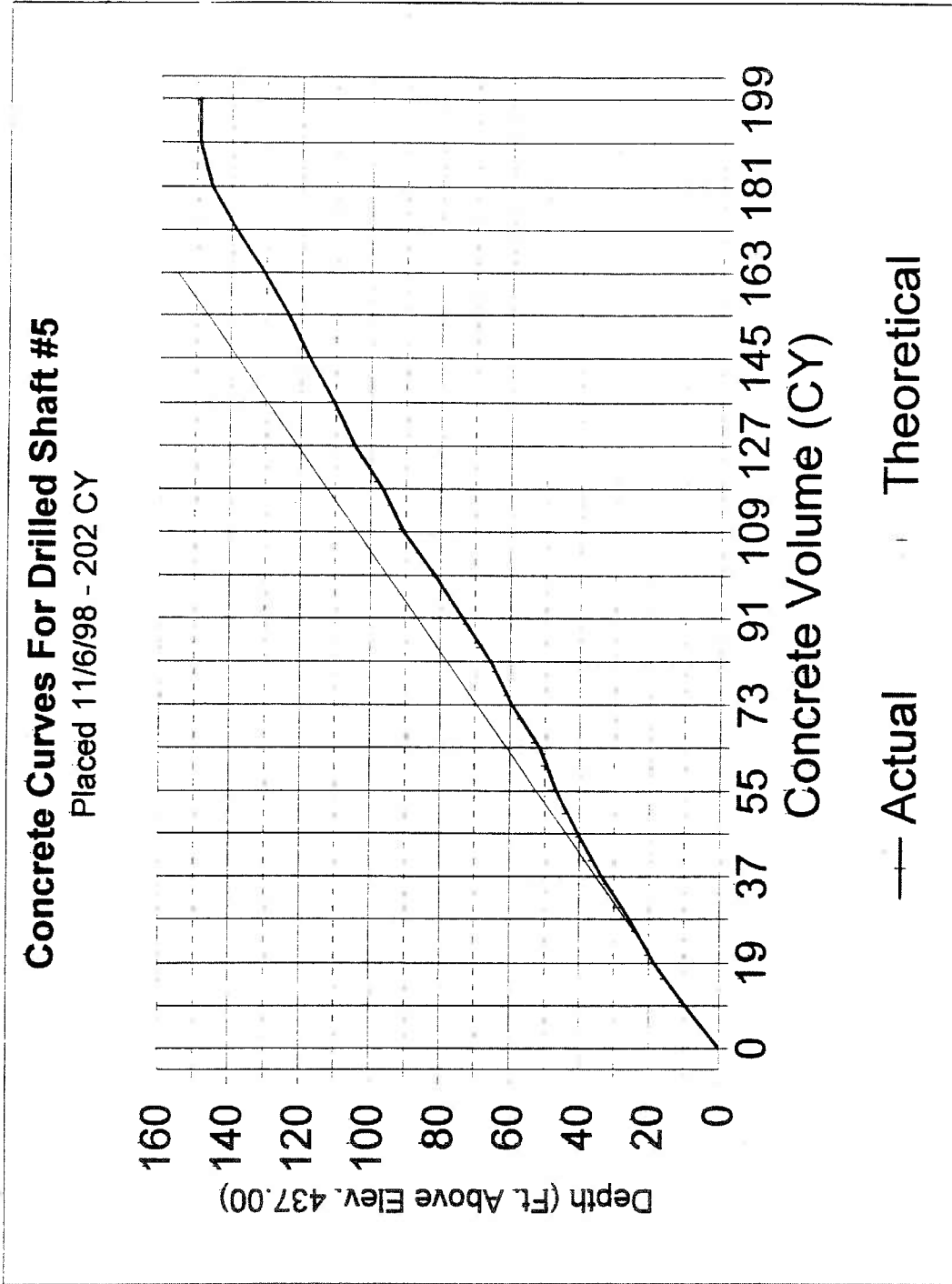

ODOT PROJECT 457-97

Concrete Curves For Drilled Shaft #6

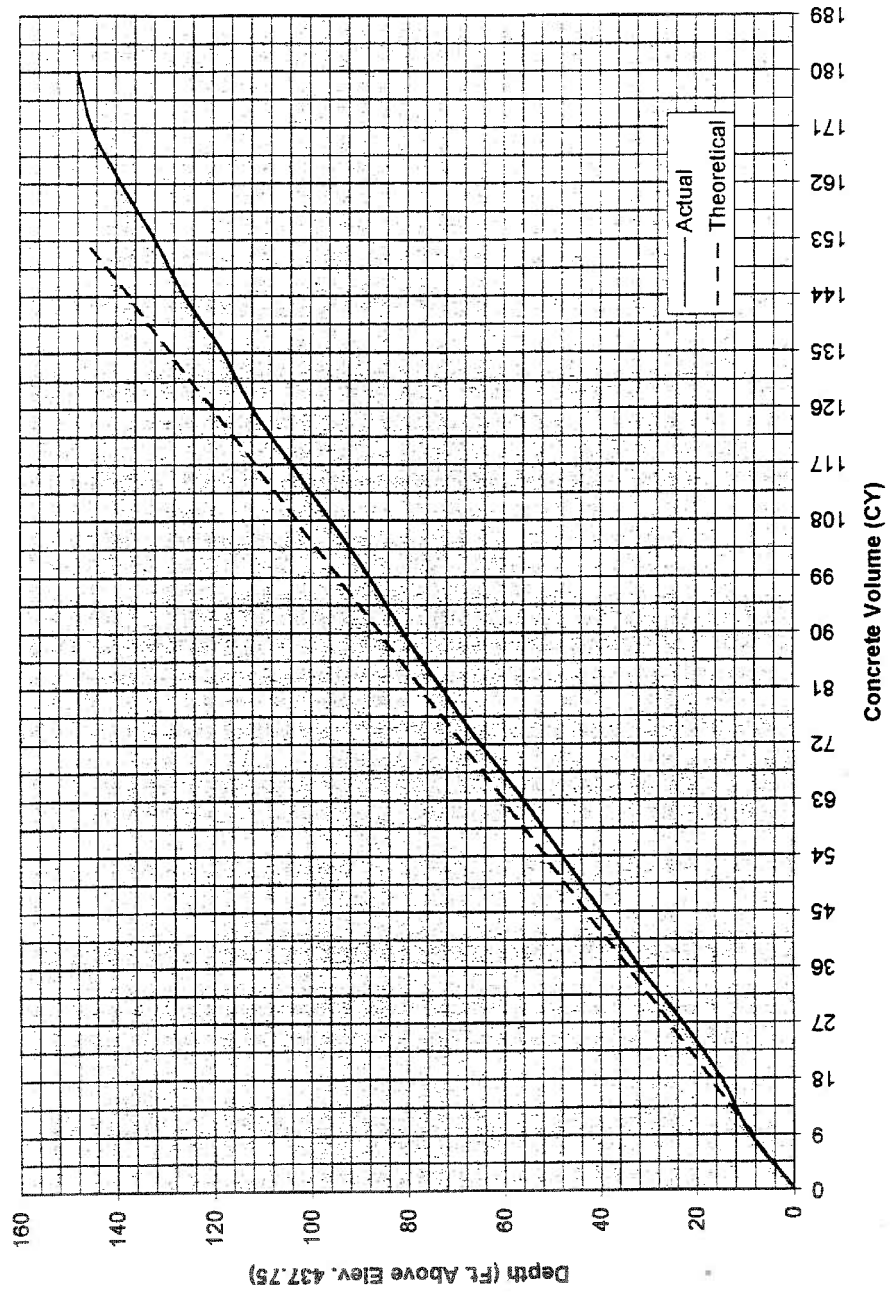

ODOT PROJECT 457-97

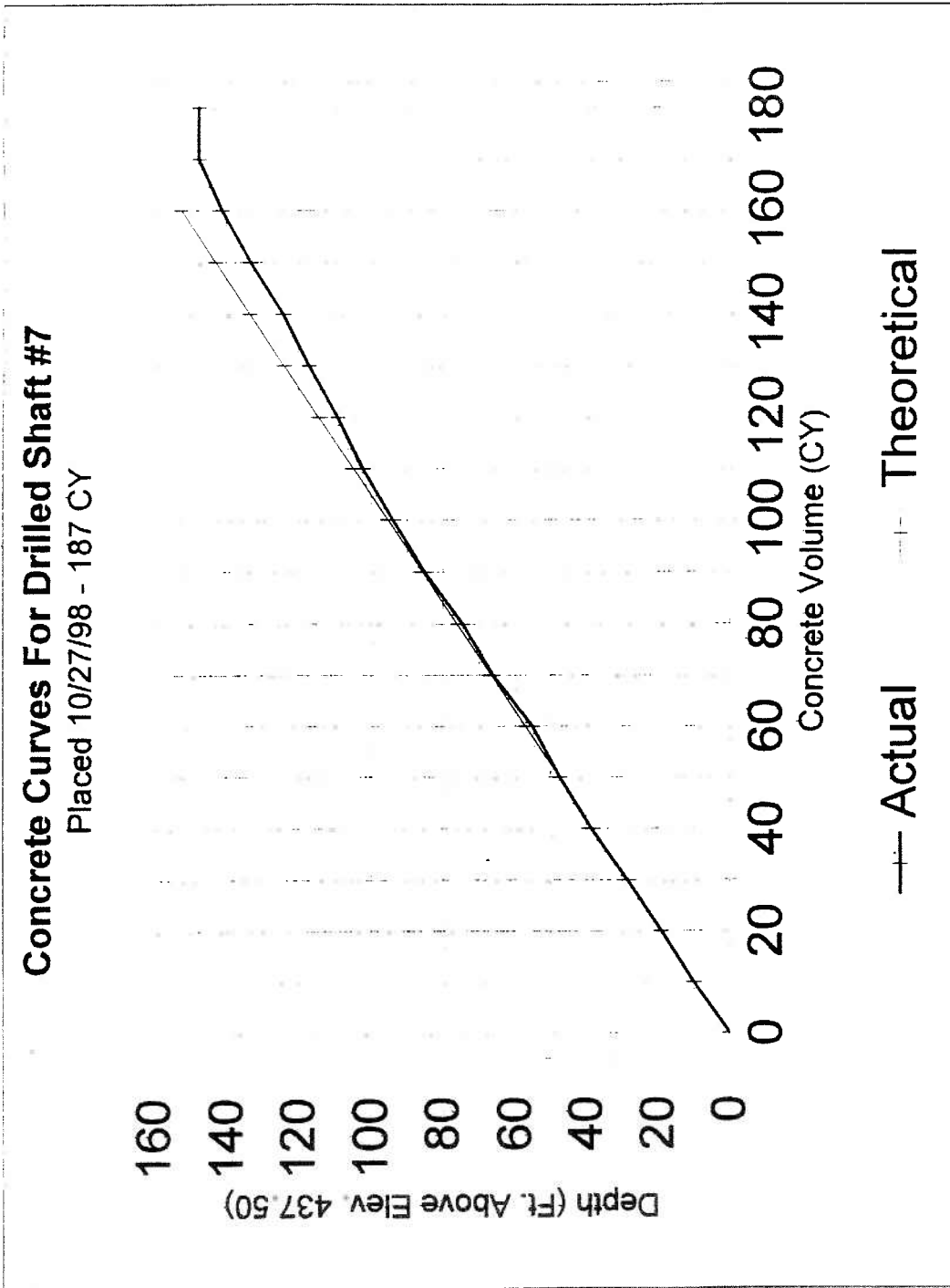

ODOT PROJECT 457-97

Concrete Curves For Drilled Shaft #8

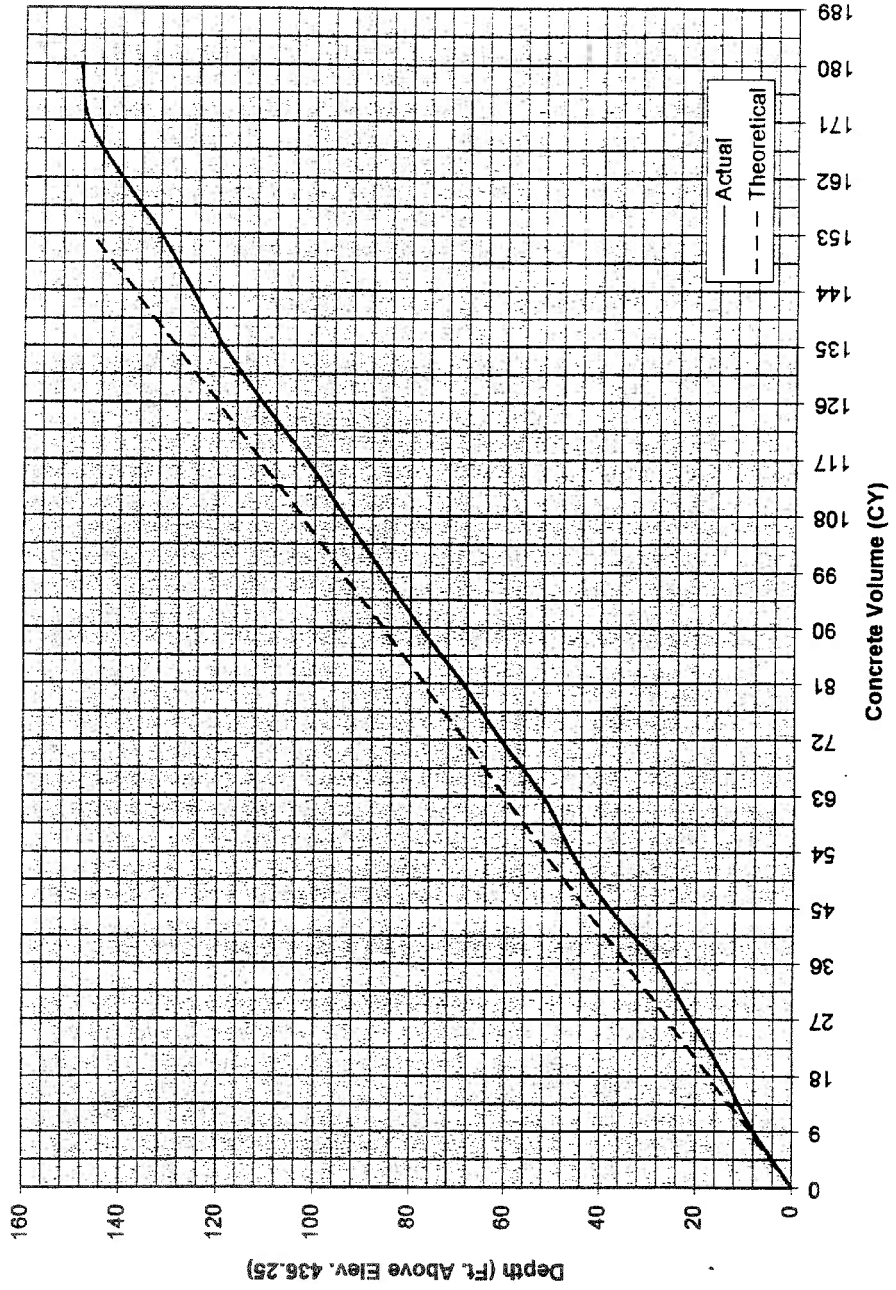

ODOT PROJECT 457-97

Concrete Curves For Drilled Shaft #9

Placed 11/23/98 - 214 CY

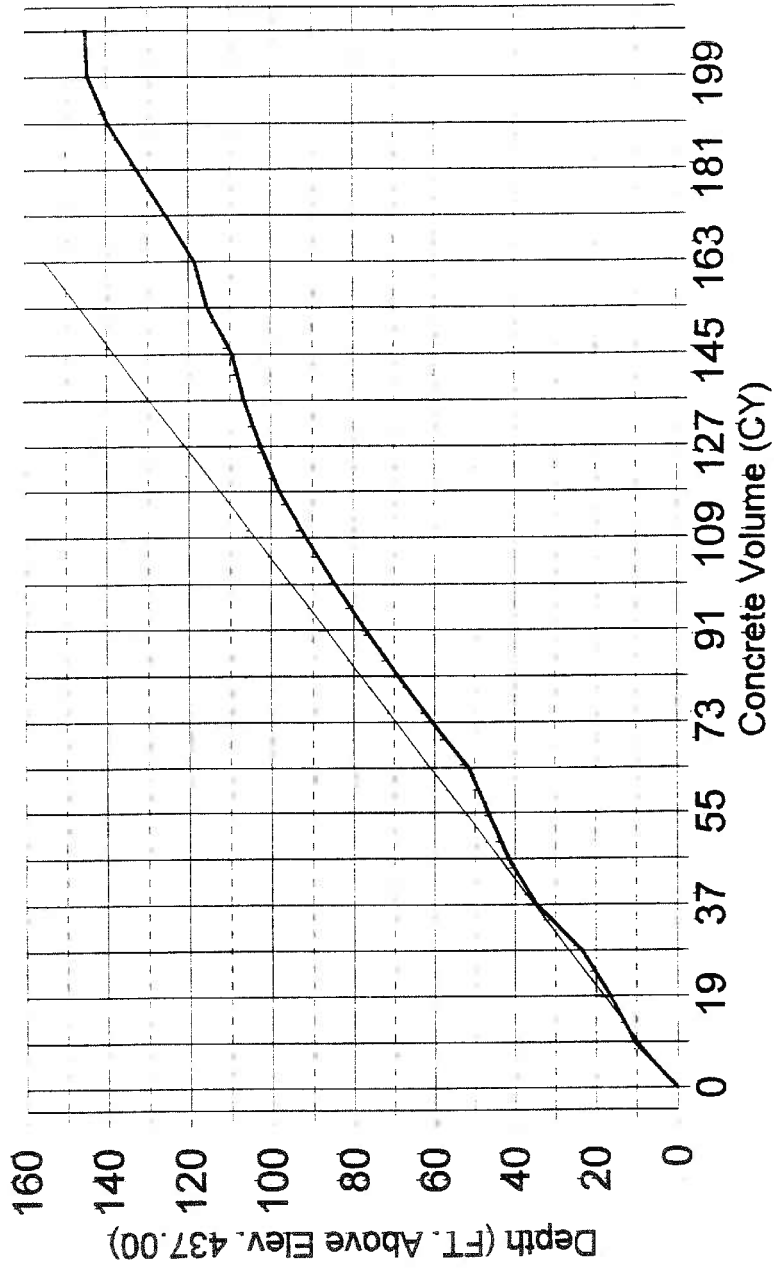

— Actual - - - Theoretical

ODOT PROJECT 457-97

Concrete Curves For Drilled Shaft #10

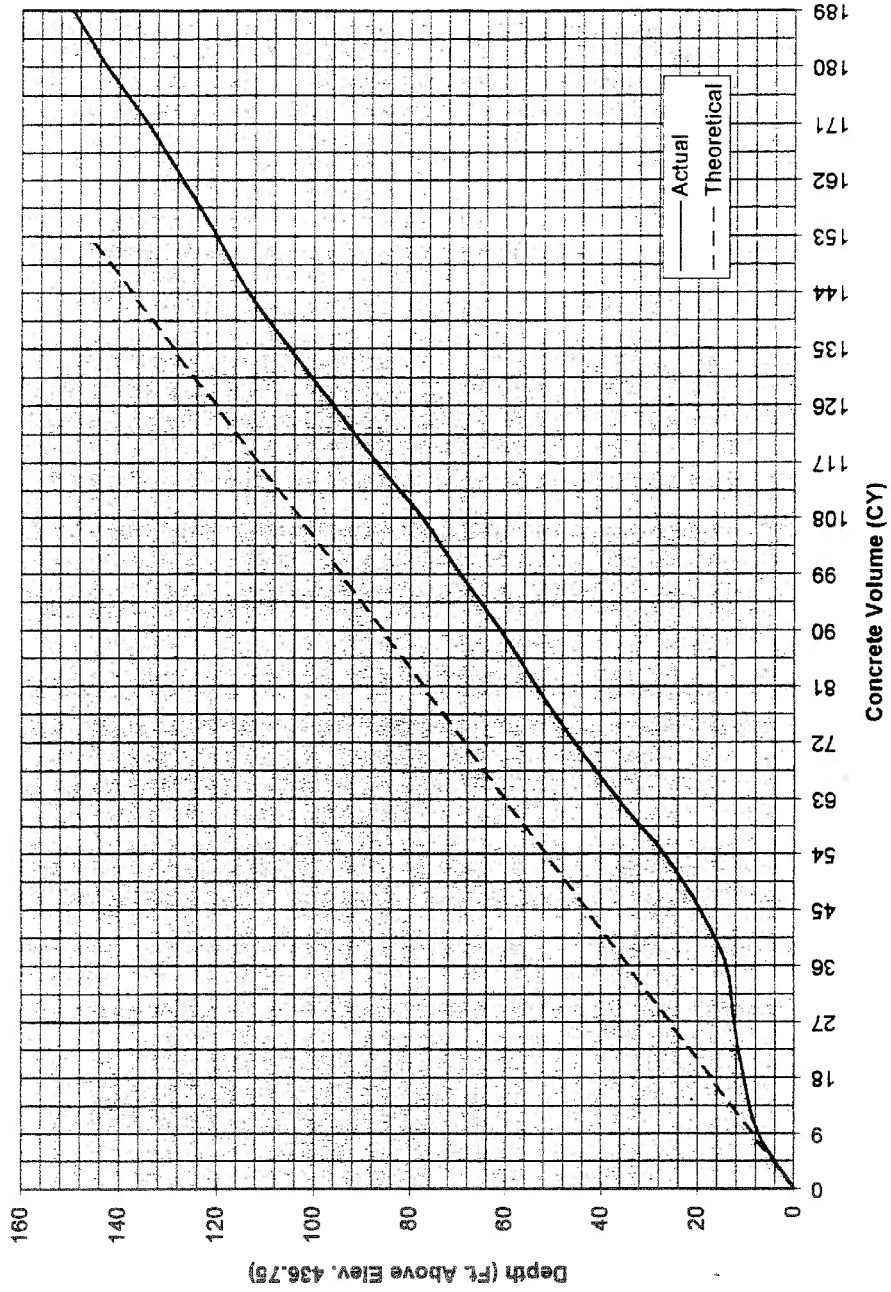

ODOT PROJECT 457-97

Concrete Curves For Drilled Shaft #11

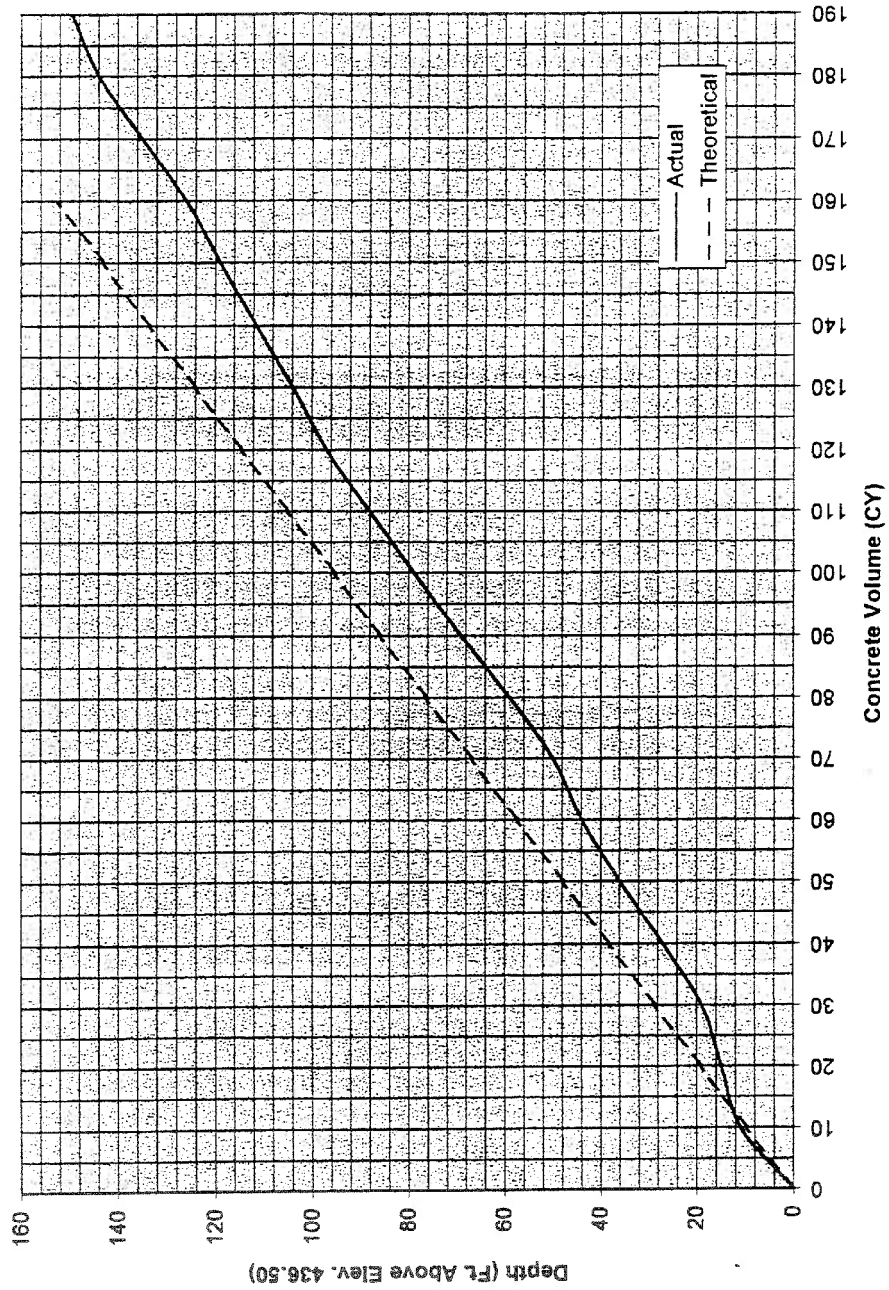

ODOT PROJECT 457-97

Concrete Curves For Drilled Shaft #12

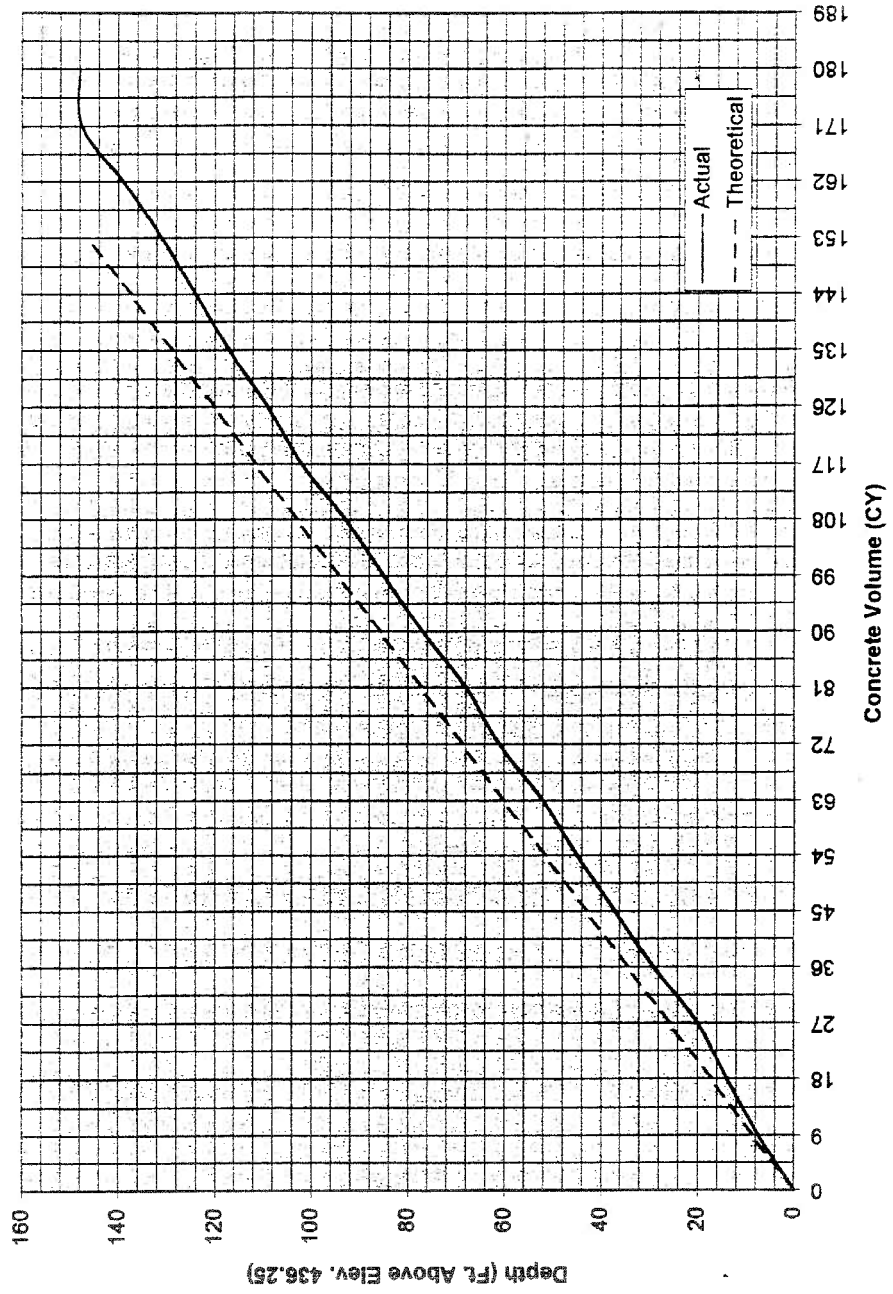

ODOT PROJECT 457-97

Concrete Curves For Drilled Shaft #13

Placed 11/10/98 - 198 CY

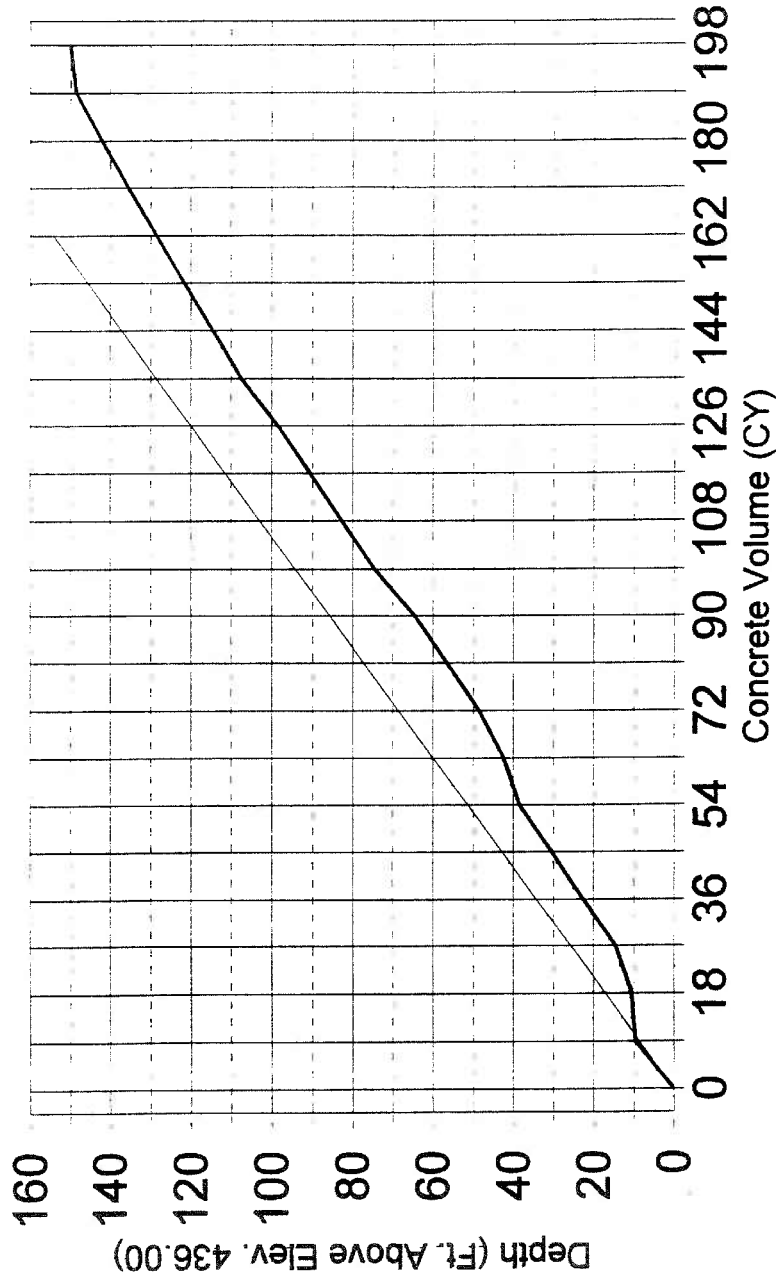

— Actual - - - Theoretical

ODOT PROJECT 457-97

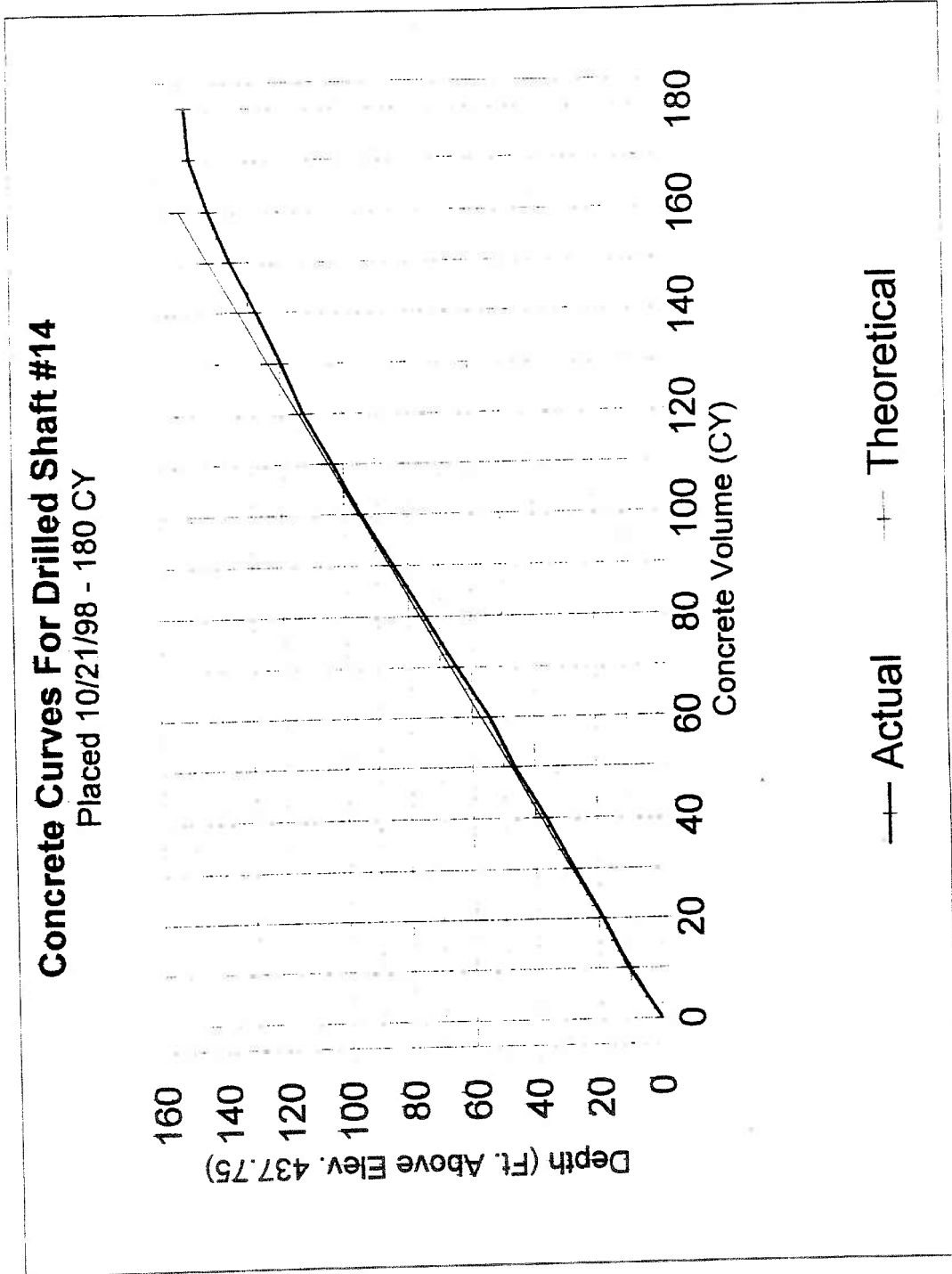

ODOT PROJECT 457-97

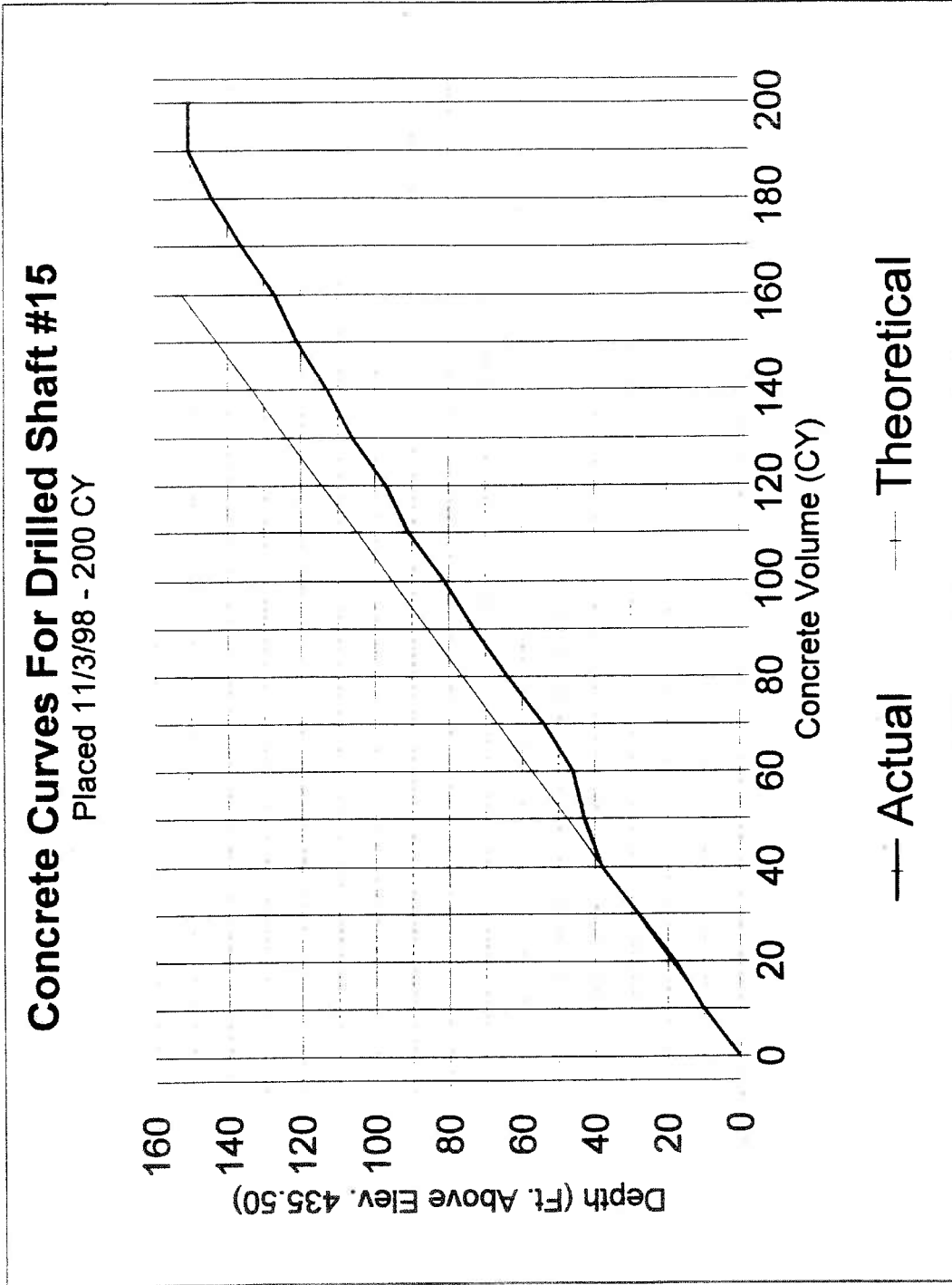

ODOT PROJECT 457-97

Concrete Curves For Drilled Shaft #16

Placed 11/18/98 - 190 CY

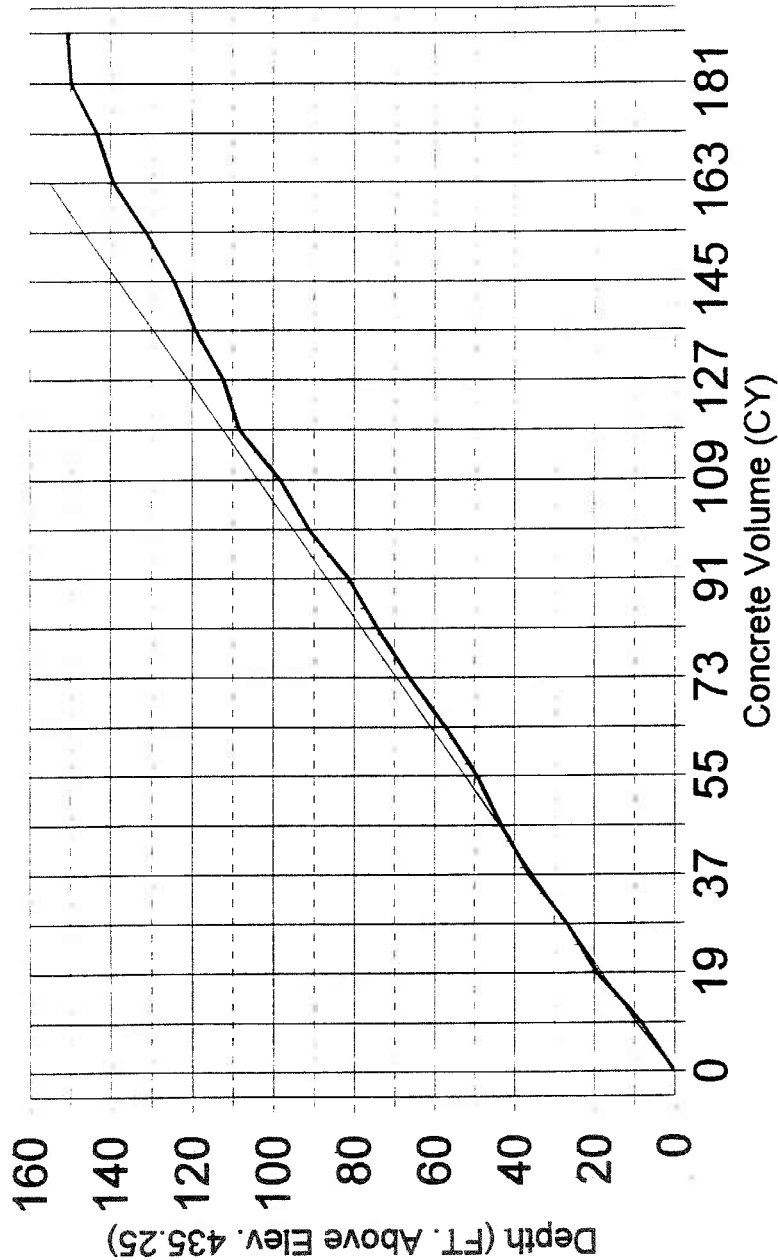

— Actual - - - Theoretical

ODOT PROJECT 457-97

Concrete Curves For Drilled Shaft #17

Placed 11/25/98 - 186 CY

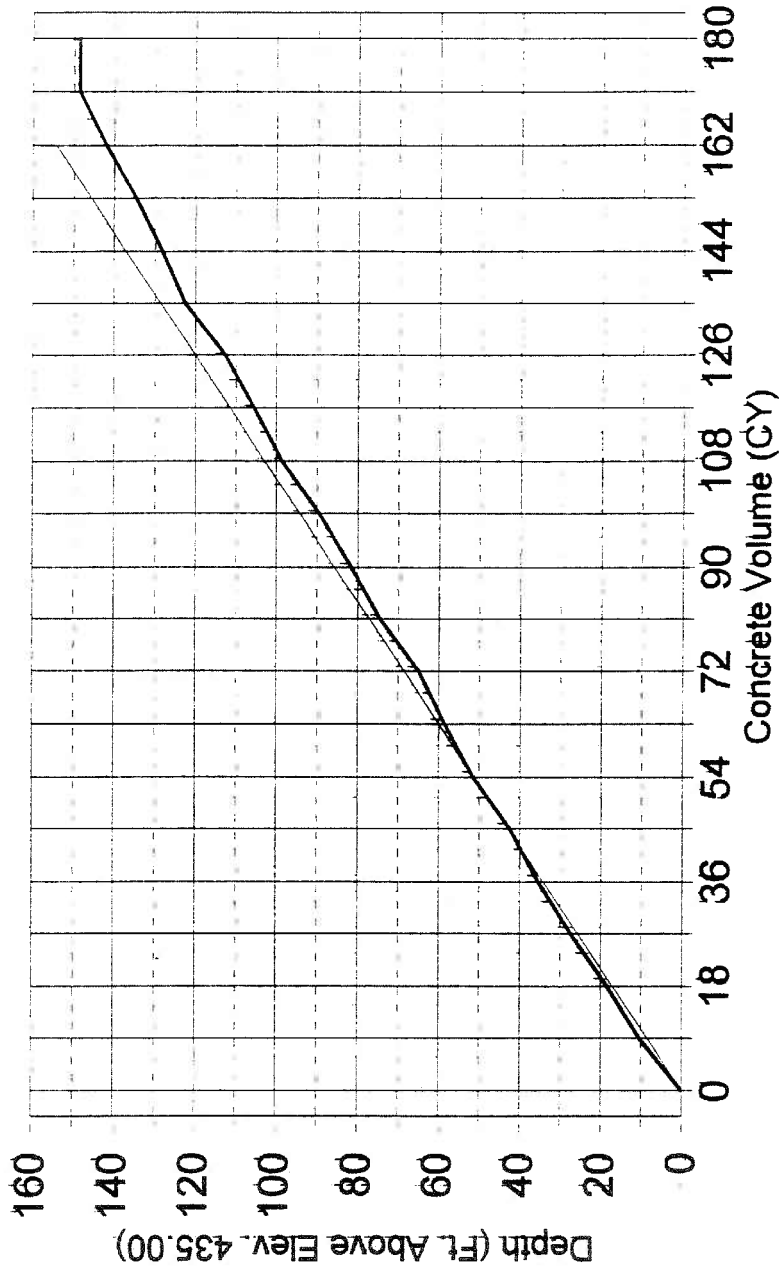

— Actual - - - Theoretical

CHAPTER 6

SLOPE STABILITY MODEL DEVELOPMENT

6.1 Geometry, Boundary Loads, and Stratigraphy

One of the first steps in evaluating the stability of a slope is to prepare the subsurface profile. The subsurface profile for the project was very meticulously prepared using all of the available exploratory information. The surface geometry of each cross-section was derived using the topographic information obtained from the survey provided by Michael Baker, Jr. and the original plans for the existing bridge slope remediation work. The studied cross sections are presented on the plan view of the project shown in Figure 6.1. The subsurface stratigraphy was developed using the 1994 and 2006 borings, the 2006 Cone Penetration Tests, and the ground movement measurements from the earth inclinometers that were installed in 1994. A step-by-step procedure for developing the subsurface profile at the three modeled sections is as follows:

- 1) The log of each boring was refined by considering the Standard Penetration Test (SPT) blow counts (N_f) at each sampling depth. Blow counts (N_f) were then corrected for overburden and rod length effects, and the resulting corrected blow counts (N') were recorded against depth intervals of a similar soil type and N' values.
- 2) The estimated profiles and corresponding N' values were then compared with the CPT tip resistances (Figures 6.2 through 6.4). As shown in these figures, the corrected blow count (N') trend matched reasonably well with the trend for the tip resistances, these trends indicated the presence of some relatively weak layers. The CPT tip resistances were only used to verify the reliability of using the SPT- N' to determine the relative strength and/or stiffness of soil layers using the SPT.

- 3) The information from inclinometer measurements was studied and the locations of the excessive incremental movements were used to locate depths at which the soil strength would have been decreased to the residual state.

Figures 6.5 and 6.6 show the subsurface profiles produced based on the SPT and CPT results and adjustments were made using inclinometer measured values for sections A-A, and D-D. The profiles were used in the slope stability analyses of existing sections and the proposed remediation alternatives presented in Chapter 7. The centerline section is assumed to have similar stratigraphy and material properties to Section D-D.

6.2 Soil Parameters and Ground Water

6.2.1 Soil Strength Parameters

The shear strength parameters for the subsurface profile layers were estimated using the laboratory test results performed by BBC&M and Cooper Testing Laboratory. The estimation of the shear strength parameters was augmented by values obtained from the interpreting of the CPT and SPT results, as well as from the inclinometers measurements, the shear strength parameters for the soil layers are listed in Tables 6.1 and 6.2. The estimated strength parameters of bedrock are also provided.

6.2.2 Ground Water Elevation:

For all stability analyses performed prior to August 2006, the location of the static groundwater table was estimated from the information in the existing soil borings and from the available peizometers data. This water table location was designated as w1. Recently, in the course of this project, several vibrating wire peizometers were installed to provide a better estimation of the water table elevation. The piezometers were installed by BBC&M between March and June 2006. They were connected to a single channel datalogger and monitoring started in May 2006.

6.3 Studied Sections

To understand the slope behavior, three soil profiles (models) were developed to represent the variation of the geometry and soil properties existing on the site. The three models are designated as Section A-A (located to the north of the existing bridge and along the new alignment); Section CL (located along the centerline of the existing bridge); and Section D-D (located to the south of the existing bridge). The locations of the three cross sections are shown in Figure 6.1.

Table 6.1: Stratification and Soil Strength Parameters for Section A-A.

Layer No.	Description	C_u	ϕ	C'	ϕ'
1	Medium dense gravel with sand	0.0	36.0	0.0	36.0
2	Sandy silt/sand and silt	0.0	32.0	0.0	32.0
3*	Soft silty clay	800.0	0.0	0.0	22.0
4	Very stiff silty clay	3500.0	0.0	0.0	32.0
5*	Soft silty clay, with pockets of loose silt and numerous silt seams	800.0	0.0	0.0	15.0
6	Bedrock-shale	20000.0	20.0	20000	20.0

* Layers where low SPT blow count, low CPT tip resistance or/and excessive movements have been recorded in inclinometers.

Table 6.2: Stratification and Soil Strength Parameters for Section D-D and Bridge Centerline (Section CL).

Layer No.	Description	C_u	ϕ	C'	ϕ'
1	Medium dense gravel with sand	0.0	36.0	0.0	36.0
2*	Soft silty clay	800.0	0.0	0.0	22.0
3	Very stiff silty clay	3500.0	0.0	0.0	32.0
4*	Soft silty clay, with pockets of loose silt and numerous silt seams	800.0	0.0	0.0	15.0
5	Bedrock-shale	20000.0	20.0	20000	20.0

* Layers where low SPT blow count, low CPT tip resistance or/and excessive movements have been recorded in inclinometers.

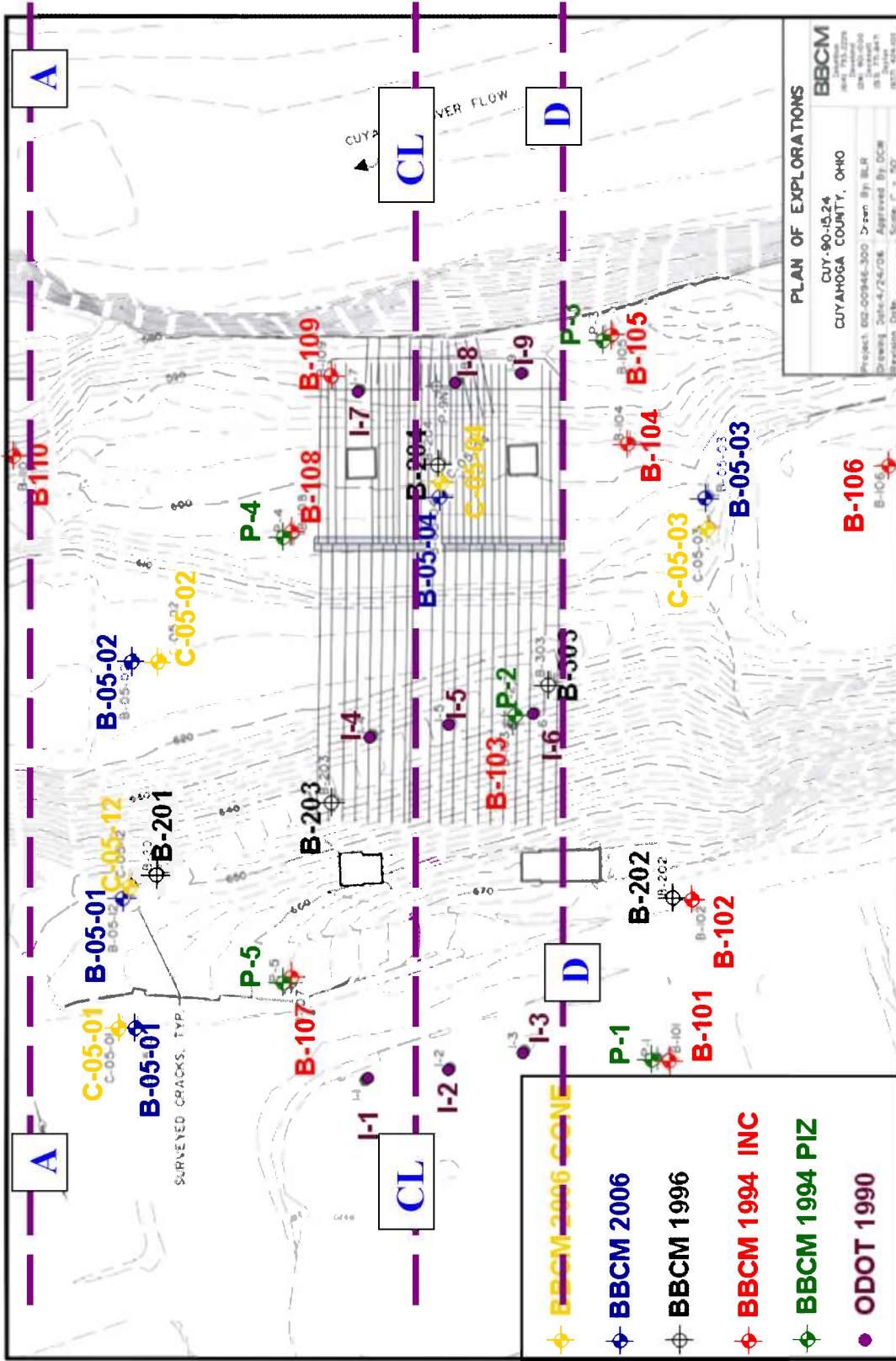

Figure 6.1: Plan view of the project showing the studied sections.

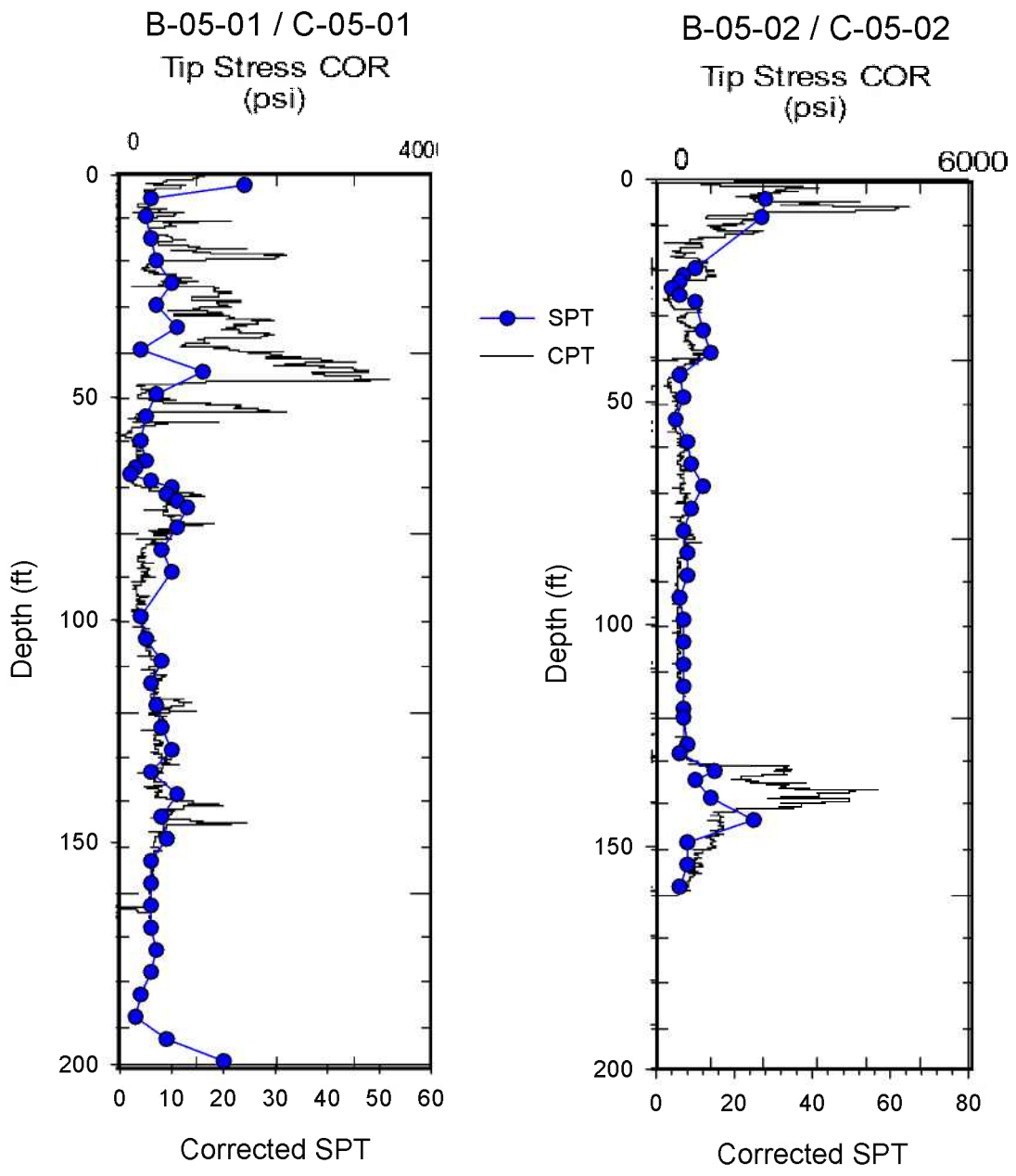

Figure 6.2: Comparison CPT vs. Corrected SPT for:
 a) B-05-01/C-05-01, b) B-05-02/C-05-02

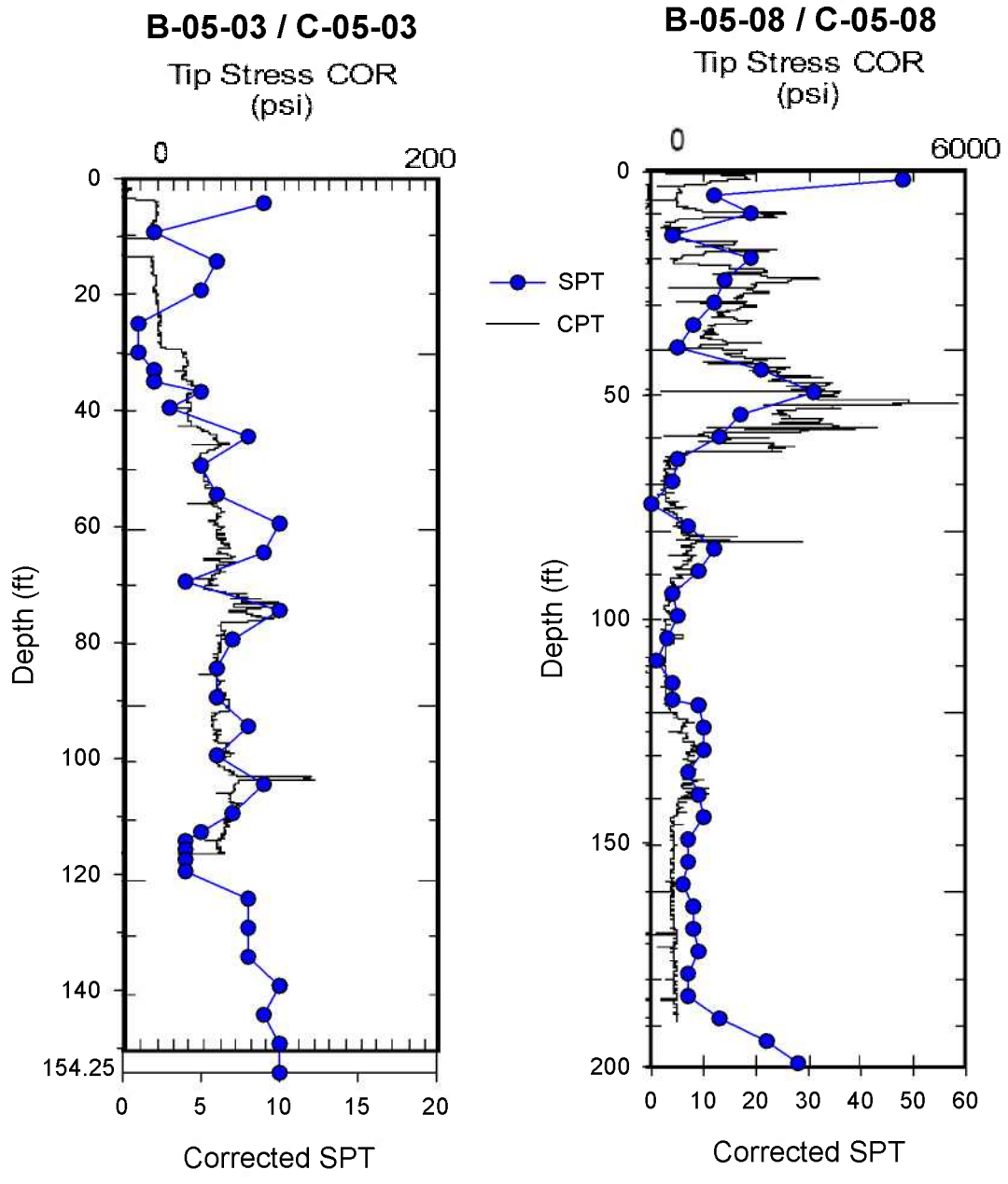

Figure 6.3: Comparison CPT vs. Corrected SPT for:
 a) B-05-03/C-05-03, b) B-05-08/C-05-08

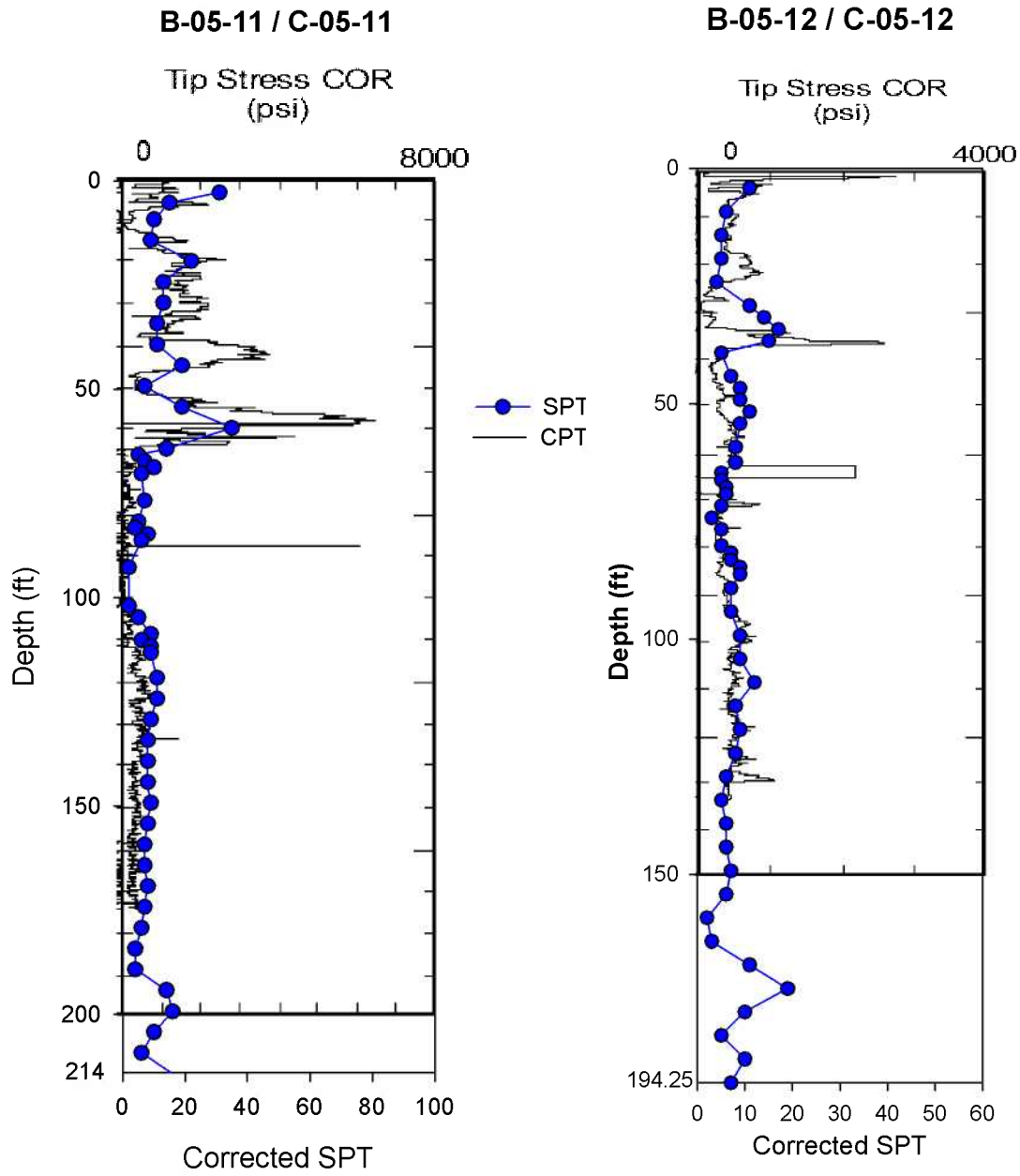
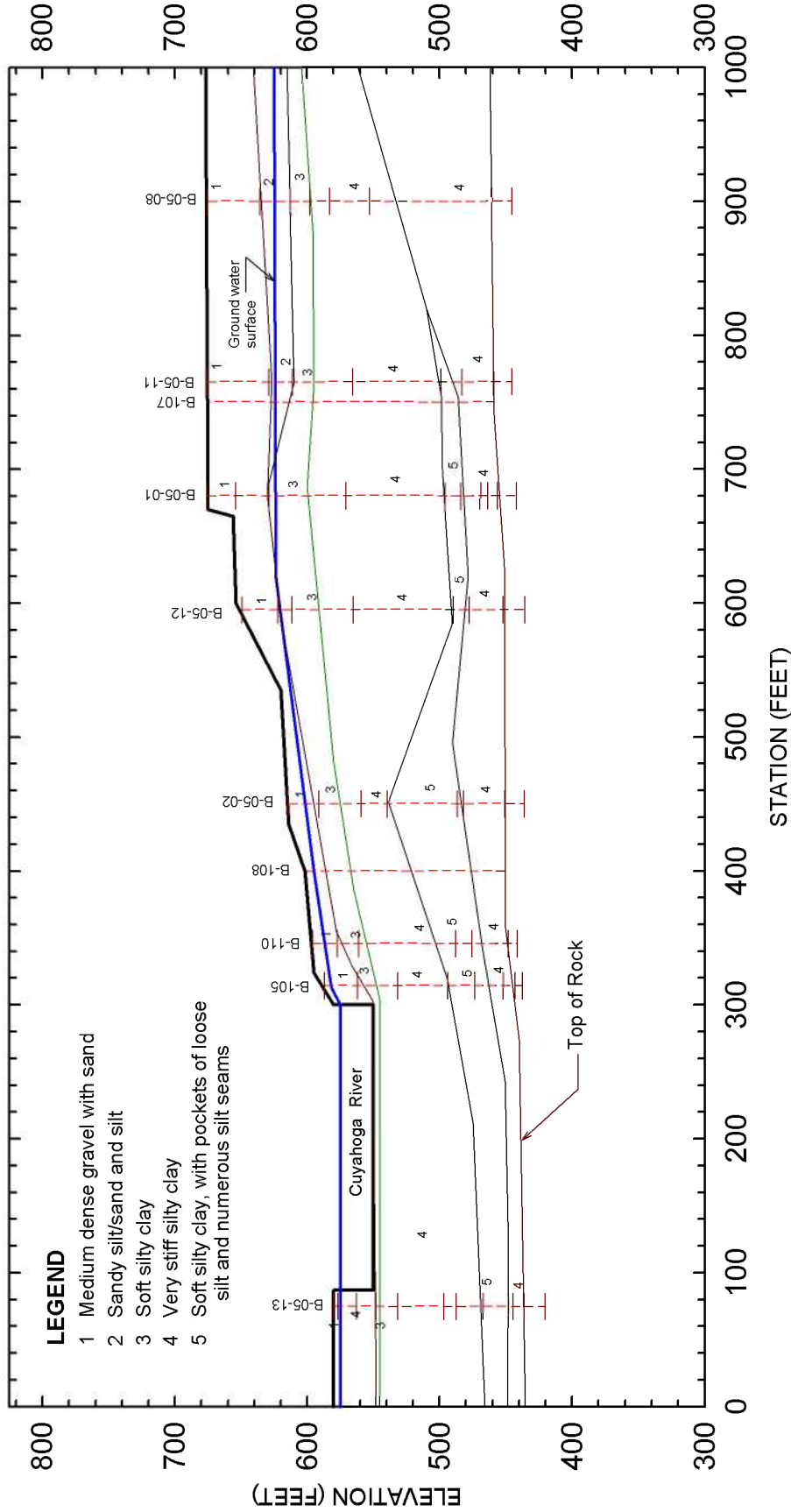
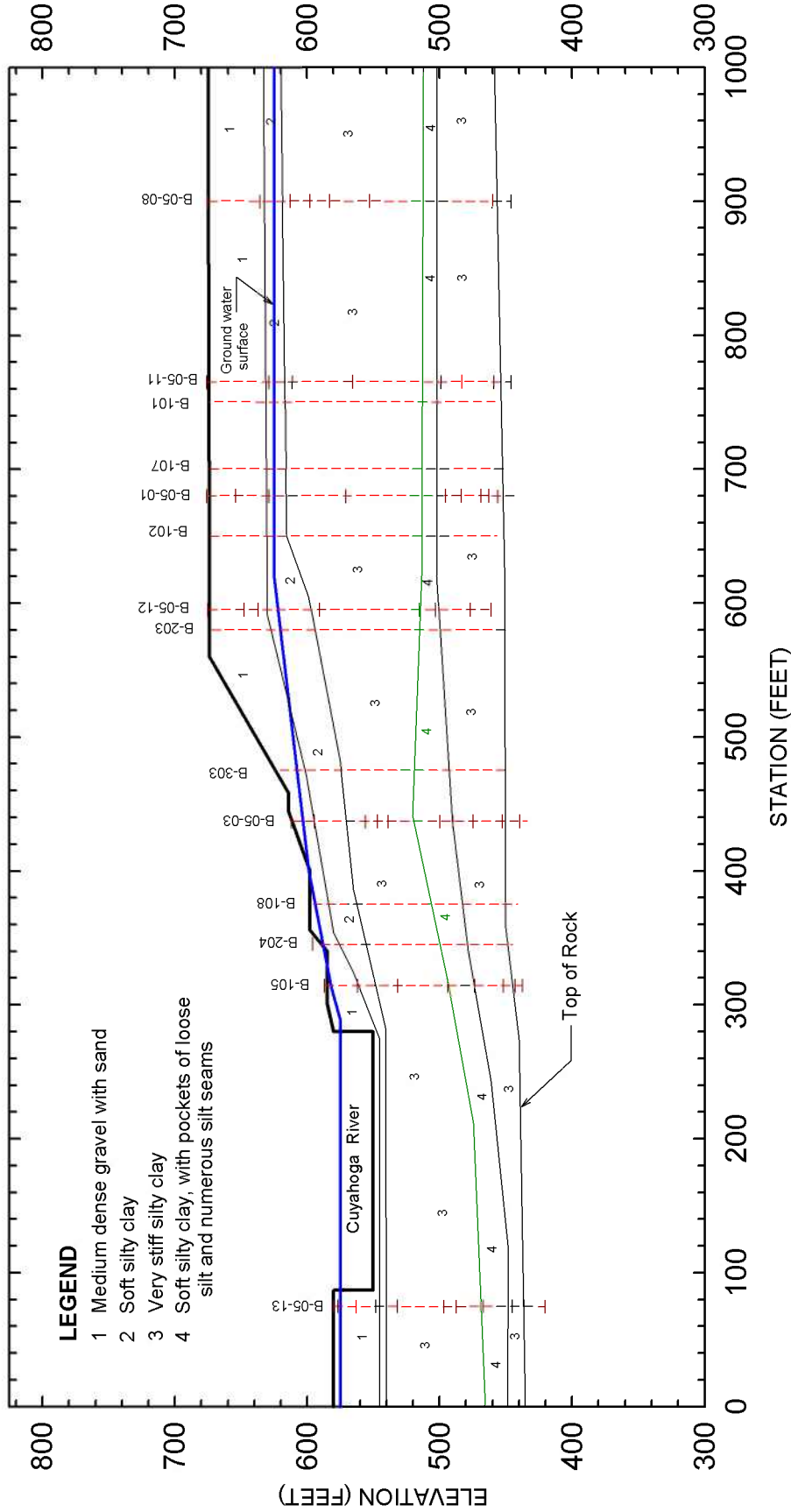

Figure 6.4: Comparison CPT vs. Corrected SPT for:
a) B-05-11/C-05-11, b) B-05-12/C-05-12



CLIENT		Ohio Department of Transportation			TITLE		SOIL PROFILE AT CROSS-SECTION A-A	
PROJ		Slope Stability Investigation for Wet Bank of Cuyahoga River			PROJ NO		CUY-90-15.24	
REVISION NO	FIRST	DES BY	JHN	5/21/06	FIGURE		6.5	
SCALE	NTS	DR BY	MAA	5/21/06				
FILE		CHK BY	JHN	5/21/06				





CLIENT		Ohio Department of Transportation		TITLE		SOIL PROFILE AT CROSS-SECTION D-D	
PROJ		Slope Stability Investigation for Wet Bank of Cuyahoga River		PROJ NO	CUY-90-15.24		
REVISION NO	FIRST	DES BY	JHN	5/21/06	FIGURE	6.6	
SCALE	NTS	DR BY	MAA	5/21/06			
FILE		CHK BY	JHN	5/21/06			



CHAPTER 7

EVALUATION OF EXISTING SLOPE AND SLOPE IMPROVEMENT

Slope stability analyses were performed on three sections located within the west bank of the Cuyahoga River: (1) along the centerline of the existing I-90 bridge (Section CL), (2) to the north of the existing I-90 bridge along the proposed bridge alignment (sections A-A), and (3) to the south and along the alignment of the existing I-90 bridge (Section D-D). Stability analyses were performed using the computer program GSTABL7 with STEDWIN. The analyses aimed at evaluating the effects of geometric (topography and steep slopes), gravimetric (water table and elevated pore water pressures), and environmental (existing building and construction activity) variables on the stability/instability of the existing slopes. The design recommendations for improving the stability of the slope will essentially be based on the effects caused by these variables. The slope stability models and evaluation results are described separately in the next sections.

Figures 7.1 through 7.5 show the soil subsurface profile models produced, based on the actual 31 soil borings drilled at the site, which also includes data from numerous SPT values and from 15 CPT and, lastly, refinements to the geometry to match inclinometer measured ground movement values for Sections A-A, CL, and D-D. Figures 7.1 through 7.3 show the three different geometries/grading plans for section A-A, which will be used in the upcoming analyses. These geometries/grading plans consist of the existing slope with the cold storage building, the existing slope with the removal of the building, and the removal of the building with an excavated regarded slope. In the analysis of the Centerline cross section (Section CL), the surface inclined loads were introduced in order to represent the contributions of the anchors and drilled shafts. The loads shown are smaller than the actual loads to ensure a conservative model is evaluated.

7.1 Stability of Existing Slope

The slope stability analysis for the existing conditions at the location of the three sections evaluated was performed utilizing the developed subsurface profile models presented in

Chapter 6 of this report. The location of section A-A was recommended by ODOT and the surface elevations were provided by Baker. Section A-A is shown in Figure 6.5. This section was selected by ODOT to study the stability of the slope to the west of the Cuyahoga River and to be used to help decide on an appropriate location for the bridge abutment near Abbey.

It is important to understand the agents that can reduce the stability of the slopes so that the appropriate remedial measures can be specified by the designer.

The analyses were conducted using several geotechnical related variables to cover all possible mechanisms that may induce some additional load or reduce the shear strength of the slope material.

Figure 7.1 presents the geometry and material properties used in the analyses at section A-A. The analyses included two distinct water table profiles. Water table (w1) represents the static water table as measured from the peizometers. Water table (w2) is an elevated hypothetical water table to simulate the effect of the potential gas pockets. Water table w2 is used only to create elevated water pressure in the weak soil layer (number 5) as described in Table 6.1.

The geometry and material properties used in the analysis of Section CL along the centerline of the existing bridge are shown in Figure 7.4. Figure 7.5 presents the geometry and material properties for Section D-D, which is parallel to the existing bridge and located approximately 30 feet to the south of the existing structure.

Preliminary slope stability analyses were performed using the groundwater table provided in the previous subsurface investigation and long term monitoring reports. As stated in Chapter 6 of this report, the newly installed peizometers data was collected in July 2006. The water table was revised to reflect the water elevation based on the new July 2006 peizometers readings. The slope stability analysis was updated to reflect the effects of the July 2006 measured water table. The figures that show the effect of the old and the new water table elevations are both documented in this chapter. The July 2006 water table plots are distinguished with the letter A at the end of the figure name.

The results of the stability analyses of the existing slopes at three cross-sections (Section A-A, centerline-section CL, and Section D-D) are graphically represented in Figures 7.6 through 7.15, and are also listed in Table 7.1. The results of the stability analyses for the various slope cross sections follow:

1. The effective stress analysis is shown to be more critical than the total stress analysis. The resulting safety factor based on effective stress analysis of section A-A (Figures 7.6 and 7.6A, with FS=1.08 (w2) and 1.05 (w2), respectively) is less than the safety factor based on the total analysis (Figures 7.7 and 7.7A with FS=1.16 (w2) and 1.15 (w2), respectively). Accordingly, effective stress analyses were used for all sections and for examining the effects of different factors on the stability of the existing slopes.
2. The existing slope at both sides of the centerline of the existing bridge (Sections A-A and D-D) has a relatively low factor of safety, whereas the existing bridge centerline slope has a factor of safety (F.S.) that is greater than 1.5 (w2). This is attributed to the existence of the stabilization structure, which includes drilled shafts, piles and tiebacks.
3. The hypothetical pore water pressure, represented by water table w2 is shown to be the most influential factor leading to the stability/instability of the slopes. Increasing the elevation of the w2 water table to elevations 625 or 650 significantly reduced the safety factors of sections A-A, CL and D-D (Figures 7.8 to 7.11A). The effects of this elevated pore water are further investigated in the next subsection.
4. Block search with non-circular slip surface models were also used for studying the stability of section A-A (Figures 7.12 through 7.14A). In Figures 7.12 and 7.12A the strength parameters of the bottom layer, which is located immediately above bedrock, are based on the laboratory results and the field SPT blow counts, whereas in Figure 7.13, this layer was assumed to have strength equal to the soil residual strength. In Figures 7.14 and 7.14A this layer was also assumed to have residual strength with elevated water table (w2) conditions. The block search for

all conditions is shown to result in higher safety factors than those obtained from the circular or semicircular surfaces.

5. The recent construction activities (removal of sheet piles and excavating a portion of the toe of the slope and placing the excavated material on the existing slope are shown to slightly reduce the safety factor of the slope (Figures 7.15 and 7.15A)).

7.2 Considerations for Improving Slope Stability

The construction of the proposed bridge will require the removal of the existing huge abandoned cold storage building and possibly some of the soil which is immediately under the building. Accordingly, the stability of section A-A after removing the building and the uppermost slope was determined and the results of the evaluation are shown in Figure 7-16. For the purpose of studying the effect of the removal of the building, a series of analyses were performed by forcing the slip plane to terminate under the building, then removing the building and reanalyzing the slope forcing the slip plane to stay within the limits of the building foot print. When removing the building the safety factor improved from 1.03 (w2) to 1.25 (w2) as demonstrated in Figures 7.16B thru 7.16D. All of the subsequent analyses for section A-A will assume that this building structure has been removed.

Numerous slope grading models were analyzed to evaluate the stability of the slopes. The added stability caused by lowering the elevations of water tables w1 and w2 was quantified. Lowering the water tables can be accomplished by using horizontal and vertical drains as follows:

1. Horizontal drains installed above the existing river pool elevation (El. 580.0 feet) can help in reducing the w1 water table elevation to approximately 580.0 feet within the west bank slope. The results of stability analyses based on these assumptions are shown in Figures 7.17, 7.17A, 7.18, 7.18A, 7.19 and 7.19A for sections A-A, centerline (Section CL), and Section D-D, respectively.
2. By installing horizontal drains and excavating the slope at section A-A, stability is significantly improved (Figure 7.20). Slope excavations and lowering the water table are shown to increase the safety factor from 1.37 (w1) to 1.51 (w1).

3. Using the Block Search and non-circular slip surfaces, the stability of section A-A, with the bottom layer at residual strength, is also shown to significantly increase as indicated by a safety factor of 1.69 (w1,w2@600') (Figure 7.21).
4. The advantages of horizontal drains are: (1) facilitate a fast dissipation of pore pressures, thus reducing the elevations of w1 to approximate elevation 580 feet within the slope area, (2) improve the strength and compressibility of the weak cohesive soil layers by increasing the preconsolidation stress, at least by an amount equivalent to the excess pore pressures (estimated between 7.0 and 15.0 ksf, depending on the location within the slope and the existing pore pressures).

The results of the stability analyses, shown in Figures 7.22 thru 7.24A, indicate that the vertical and horizontal drains provide significant improvements in the safety factors for the slopes.

Additional improvement to the stability of the slope at section A-A was also obtained by excavating the slope as shown in Figures 7.25 and 7.25A. The resulting safety factor was further increased to 1.66. Slope excavation (grading) without the aid of vertical or horizontal drains is shown to improve the stability of the slope and result in a safety factor of 1.47, as shown in Figures 7.26 and 7.26A. The recommended grading starting with 2.5:1 at Abbey and transitioning to 15:1 and extending to the river resulted in a safety factor of 1.67 (w1 and w2@625') as shown in Figures 7.27 and 7.27A. Assuming the hypothetical water surface w2 is lowered from elevation 625 feet to elevation 600 feet, the factor of safety will increase from 1.67 to 1.93 as shown in Figures 7.28 and 7.28A. The stability of the 2.5:1 slope by Abbey was analyzed and the minimum factor of safety is 1.53, as shown in Figure 7.29. A summary of the results of the stability analyses is provided in Table 7.1.

The detailed summary of the slope stability analysis performed by the three independent consultants is summarized in Tables 7.2 and 7.3. The proposed plan of the grading and associated cross sections are presented in Figures 7.30A thru 7.30D.

Table 7.1 Summary of Stability Analyses Results

Case Description	Factor of Safety					
	A-A		CL		D-D	
	Old* w1	New** w1	Old w1	New w1	Old w1	New w1
Existing slope condition with hypothetical water table(w2) @ 625.0'	1.08 (7.6) ⁺	1.05 (7.6A)	1.55 (7.9)	1.52 (7.9A)	0.97 (7.11)	0.93 (7.11A)
Existing slope condition with hypothetical water table(w2) @ 625.0' (Undrained Analysis)	1.17 (7.7)	1.15 (7.7A)	---		---	
Existing slope condition with hypothetical water table(w2) @ 625.0' (using Block Search)	1.11 (7.12)	1.08 (7.12A)	---		---	
Existing slope condition with hypothetical water table(w2) @ 625.0' (using Block Search) - Residual Strength for Bottom Soil Layer 5	1.06 (7.13)	1.0 (7.13A)	---		---	
Existing slope condition with hypothetical water table (w2) @ 650.0'	0.98 (7.8)	0.96 (7.8A)	1.49 (7.10)	1.46 (7.10A)	---	
Existing slope condition with hypothetical water table(w2) @ 650.0' (using Block Search) - Residual Strength for Bottom Soil Layer 5	1.26 (7.14)	1.23 (7.14A)	---		---	
Recent Construction (Removal of Sheet Pile wall and excavation) Effects with hypothetical water table (w2) @ 625.0'	0.95 (7.15)	0.9 (7.15A)	---		---	
Removal of Building and Upper slope with hypothetical water table (w2) @ 650.0'	0.98 (7.16)	0.96 (7.16A)	---		---	
Using Horizontal Drains at elev. 580, with hypothetical water table (w2) @ 600.0'	1.37 (7.17)	1.35 (7.17A)	1.99 (7.18)	1.99 (7.18A)	1.37 (7.19)	1.37 (7.19A)
Slope Flattening (12:1) Using Horizontal Drains at elev. 580', with hypothetical water table (w2) @ 600.0'	1.51 (7.20)	1.51 (7.20A)	---		---	
Using Horizontal Drains at elev. 580', with hypothetical water table (w2) @ 600.0'. Block Search- Bottom Soil Layer 5 in Residual Strength	1.69 (7.21)	1.59 (7.21A)	---		---	
Using Horizontal Drains at elev. 580', and vertical drains, Bottom Soil Layer in Residual Strength	1.48 (7.22)	1.48 (7.22A)	2.07 (7.23)	2.04 (7.23A)	1.41 (7.24)	1.41 (7.24A)
Slope Flattening (12:1) and using both Horizontal Drains at elev. 580', and vertical drains	1.66 (7.25)	1.66 (7.25A)	---		---	
Design Slope Excavation (10:1 then 5:1), with hypothetical water table (w2) @ 625.0'	1.44 (7.26)	1.44 (7.26A)	---		---	
Recommended Design Slope Excavation (15:1 then 2.5:1) with hypothetical water table (w2) @ 625.0'	1.67 (7.27)	1.67 (7.27A)	---		---	
Recommended Design Slope Excavation (15:1 then 2.5:1) with hypothetical water table (w2) @ 600.0'	1.93 (7.28)	1.93 (7.28A)	---		---	
Stability of Slope at Abbey Avenue (2.5:1)	1.53 (7.29)	1.53 (7.29A)	---		---	

* Old w1 is the water table measured in the old peizometers as of April, 2006.

** New w1 is the water table measured in the new peizometers as of July, 2006.

+ Figure number

Table 7.2a: Alternatives Considered for Improving Slope Stability of CUY-90-15.24 Bridge by All Consultants.

Case No.	Model ⁽¹⁾	Alternative No.	Description	
			Brief	Detailed ⁽²⁾
BBC&M: SLIDE Slope Stability Software				
1	BBCM-0	None	Existing	Existing slope
2	BBCM-1	1 (20/50)	Vertical Excavation	20-foot vertical excavation located approximately 50 feet south of University Avenue
3	BBCM-2	2 (30/50)	Vertical Excavation	30-foot vertical excavation located approximately 50 feet south of University Avenue
4	BBCM-3	3 (20/100)	Vertical Excavation	20-foot vertical excavation located approximately 100 feet south of University Avenue
5	BBCM-4	4 (30/100)	Vertical Excavation	30-foot vertical excavation located approximately 100 feet south of University Avenue
6	BBCM-5	5 (10/150 and 20/50)	Terraced & Vertical Excavation	Terraced excavation with a 10-foot vertical excavation located approximately 150 feet south of University Avenue and a 20-foot vertical excavation located approximately 50 feet south of University Avenue
7	BBCM-6	6 (20/150 and 10/50)	Terraced & Vertical Excavation	Terraced excavation with a 20-foot vertical excavation located approximately 150 feet south of University Avenue and a 10-foot vertical excavation located approximately 50 feet south of University Avenue
8	BBCM-7	7 (20/Abbey)	Vertical Excavation	20-foot vertical excavation located on the north side of Abbey Avenue
9	BBCM-8	8 (30/Abbey)	Vertical Excavation	30-foot vertical excavation located on the north side of Abbey Avenue
10	BBCM-9	9 (7:1/Abbey)	Slope Excavation	7(H):1(V) slope beginning north of Abbey Avenue extending down to El. 620 feet
11	BBCM-10	10 (3:1/Abbey)	Slope Excavation	3(H):1(V) slope beginning north of Abbey Avenue extending down to El. 620 feet

⁽¹⁾ All models were analyzed assuming drained conditions and block failure.

⁽²⁾ Soil layer immediately above bedrock assumed in residual strength and elevated pore pressure (Elev. w2 = 625) for all cases.

Table 7.2b: Alternatives Considered for Improving Slope Stability of CUY-90-15.24 Bridge by All Consultants.

Case No.	Model ⁽¹⁾	Alternative No.	Description	
			Brief	Detailed ^(1,2)
Geocomp Corporation: UTEXAS4 and PLAXIS for Slope Stability; PLAXIS for estimating Displacements				
	ELR-00	None	Existing	Existing slope with elevated pore pressure (w2=575)
12	ELR-01	None	Existing	Existing slope with no elevated pore pressure (only w1 is present)
	ELR-02	None	Existing	Case with 30 to 35 ft of aggregate pile
13	ELR-02	None	Existing	Case 12 with 30 to 35 ft of aggregate pile
14	ELR-03	None	Existing	Existing slope with elevated pore pressure (w2 = 625)
16	ELR-05	None	Existing	Existing slope with elevated pore pressure (w2 = 690)
19	ELR-1	11	Remove Building	Removal of existing Building with elevated pore pressure (w2 = 625)
20	ELR-2	12	Slope Excavation & Horizontal Drains	Slope Excavation with horizontal drains (w2 = 595)
24	ELR-3	13	Slope Excavation & Horizontal and Vertical Drains	Slope Excavation with horizontal and vertical drains (w2 = 575)

⁽¹⁾ Model developed by E.L. Robinson. All models were analyzed assuming drained conditions.

⁽²⁾ All models include a weak layer in residual strength (**second** layer above bedrock). This layer is determined based on inclinometer movement, SPT, and CPT.

Table 7.2c: Alternatives Considered for Improving Slope Stability of CUY-90-15.24 Bridge by All Consultants.

Case No.	Model ⁽¹⁾	Alternative No.	Description	
			Brief	Detailed ⁽²⁾
E.L. Robinson (ELR): GSTABL7 with STEWIN Slope Stability Software				
12	ELR-01	None	Existing	Existing slope with no elevated pore pressure (only w1 is present)
13	ELR-02	None	Existing	Case 12 with 30 to 35 ft of aggregate pile
14	ELR-03	None	Existing	Existing slope with elevated pore pressure (w2 = 625)
15	ELR-04	None	Existing	Existing slope with elevated pore pressure (w2 = 650)
16	ELR-05	None	Existing	Existing slope with elevated pore pressure (w2 = 690)
17	ELR-05	None	Existing	Existing slope with elevated pore pressure (Elev. w2 = 625). Soil layer immediately above bedrock assumed in residual strength
18	ELR-06	None	Existing	Existing slope applying recent construction at river side (removal of sheet pile) with elevated pore pressure (Elev. w2 = 650)
19	ELR-1	11	Building Removed	Removal of Building (w2 = 625)
20	ELR-2	12	Horizontal Drain	Horizontal drains (w1 & w2; both reduced by dw-1, w2 =595)
21	ELR-3	13	Horizontal Drain & Residual Strength	Horizontal drains (w1 & w2; both reduced by dw-1, w2 =595) Soil Layer immediately above bedrock in Residual Strength
22	ELR-4	14	Slope Excavation & Horizontal Drains	Slope excavation with Horizontal Drains (w1 & w2; both reduced by dw-1, w2 =595)
23	ELR-5	15	Horizontal & Vertical Drains	Horizontal and vertical drains (w1 = w2)
24	ELR-6	16	Slope Excavation & Horizontal & Vertical Drains	Slope excavation with horizontal and vertical drains (w1 =w2= static constant)
25	ELR-7	10 (3:1/Abbey)	BBCM Slope Excavation	(3:1) slope beginning north of Abbey Avenue extending down to El. 620 feet
26	ELR-7	17	Recommended Excavation	(5:1) slope beginning north of Abbey Avenue; and (9:1) slope starting just north of west pier
26	ELR-7	18	Recommended Excavation & Drains	Design Slope Excavation with vertical and horizontal drains; no excess pore pressures. (w2 = w1)

(1) All models were analyzed assuming drained conditions unless otherwise specified.

(2) All models include a weak layer in residual strength (second layer above bedrock), determined based on inclinometer movement, SPT, and CPT.

Table 7.3a Summary of Stability Analyses Performed for CUY-90-15.24 Bridge for Existing Conditions (Section A-A)

Case No	Model	Alternative No.	Slip Surface				W1	W2	Existing	Building	Excavation	Horizontal Drain	Vertical Drains	Drained	Undrained	Factor of Safety			Comments
			circle	Block	Grid	Non-circular										BBCM SLIDE	GSTABL7	UTEXAS4	
1	BBCM-0	None		X			625	X	X				X	1.065				Bottom Soil layer in Residual Strength ($\phi = 14^\circ$)	
1-a	BBCM-0	None	X				625	X	X				X	1.041				Shallow Bottom Soil layer in Residual Strength ($\phi = 14^\circ$)	
12	ELR-01	None	X					X	X				X			1.47	1.453	Slip surface forced to lay within University Ave.	
13	ELR-01	None	X		X			X	X				X			1.382		Search with floating grid	
14	ELR-01	None				X		X	X				X			1.268	1.18	Non-circular slip surface	
15	ELR-01	None			X			X					X			1.458			
16	ELR-02	None	X					X	X				X			1.35	1.377	Addition of surcharge for 30 to 35 ft of aggregate pile	
17	ELR-02	None	X					X	X				X				1.316		Addition of surcharge for 30 to 35 ft of aggregate pile
18	ELR-03	None	X				625	X	X				X			1.08	1.265	Slip surface forced to lay within University Ave.	
19	ELR-03	None			X		625	X	X				X				1.102		
20	ELR-03	None			X		625	X	X				X					<1.0	
21	ELR-03	None	X				625	X	X				X						
22	ELR-03	None	X				625	X	X				X						
23	ELR-03	None	X				625	X	X				X				1.222		
24	ELR-04	None	X				650	X	X				X						
25	ELR-04	None	X				690	X	X				X				0.916		
26	ELR-04	None			X		690	X	X				X				0.913		
27	ELR-04	None			X		690	X	X				X				0.862	<1.0	
28	ELR-05	None	X				650	X	X				X						Soil layer immediately above bedrock assumed in residual strength
28	ELR-05	None	X				625	X	X				X						Soil layer immediately above bedrock assumed in residual strength
29	ELR-06	None	X				650	X	X				X						Recent construction (removal of sheet piles and surface excavation)

Table 7.3b Summary of Stability Analyses Performed for CUY-90-15.24 Bridge for Modified Conditions (Section A-A)

Case No.	Model	Alternative No.	Slip Surface				W2	W1	Excavation	Horizontal Drain	Vertical Drains	Drained	Undrained	Factor of Safety			Comments
			circle	Block	Grid	Non-circular								BBCM SLIDE	ELR GSTABL7	UTEXAS4	
2	BBCM-1	1 (20/50)	X				X	X			X			1.143		20-foot vertical excavation located approximately 50 feet south of University Avenue	
3	BBCM-2	2 (30/50)	X				X	X			X			1.162		30-foot vertical excavation located approximately 50 feet south of University Avenue	
4	BBCM-3	3 (20/100)	X				X	X			X			1.195		20-foot vertical excavation located approximately 100 feet south of University Avenue	
5	BBCM-4	4 (30/100)	X				X	X			X			1.251		30-foot vertical excavation located approximately 100 feet south of University Avenue	
6	BBCM-5	5 (10/150 & 20/50)	X				X	X			X			1.199		Terraaced excavation; 1) 10 ft vertical @ 150 ft S of Univ. Ave., and 2) 20 ft vertical @ 50 ft S of Univ. Ave.	
7	BBCM-6	6 (20/150 & 10/50)	X				X	X			X			1.231		Terraaced excavation: 1) 20-foot vertical @ 150 ft S of Univ. Ave., and 2) 10-foot vertical @ 50 ft S of Univ. Ave.	
8	BBCM-7	7 (20/Abbey)	X				X	X			X			1.256		20-foot vertical excavation located on the north side of Abbey Avenue	
9	BBCM-8	8 (30/Abbey)	X				X	X			X			1.255		30-foot vertical excavation located on the north side of Abbey Avenue	
10	BBCM-9	9 (7/1/Abbey)	X				X	X			X			1.259		7(H):1(V) slope beginning north of Abbey Avenue extending down to El. 620 feet	
11	BBCM-10	10 (3/1/Abbey)	X				X	X			X			1.33		3(H):1(V) slope beginning north of Abbey Avenue extending down to El. 620 feet	
8-a	BBCM-7	7 (20/Abbey)	X				X	X			X			1.345		Shallow slip surface	
10-a	BBCM-9	9 (7/1/Abbey)	X				X	X			X			1.794		Shallow slip surface	
11-a	BBCM-10	10 (3/1/Abbey)	X				X	X			X			1.688		Shallow slip surface	
30	ELR-1	11	X				X	X			X			0.98		Slip surface forced to lay under the building	
31	ELR-1	11	X				X	X			X			0.895			
32	ELR-2	12	X				575	600			X			1.37			
33	ELR-2	13	X				575	595			X				1.49		
34	ELR-3	14	X				575	600			X			1.69		Soil layer immediately above bedrock assumed in residual strength	
35	ELR-4	15	X				575	600			X			1.93		(2.5:1) slope beginning north of Abbey Ave. & (15:1) slope to river with horizontal drains (W2=600)	
35	ELR-4	15	X				575	625			X			1.67		(2.5:1) slope beginning north of Abbey Ave. & (15:1) slope to river with horizontal drains (W2=625)	
36	ELR-5	16	X				575	600			X			2.06		(2.5:1) slope beginning north of Abbey Ave. & (15:1) slope to river with horizontal drains Block	
37	ELR-6	17	X				575	575			X			1.48			
38	ELR-7	18	X				575	575			X				1.54		
39	ELR-7	19	X				575	575			X			1.66		Slope Flattening	
39-a	ELR-7	19	X				575	575			X			1.66		Slope Flattening	
40	ELR-7	20	X				X	625			X			1.53		(3:1) slope beginning north of Abbey Ave. & (12:1) slope to river	
41	ELR-7	21	X				X	625			X			1.44		(5:1) slope beginning north of Abbey Ave. & (9:1) slope to river; w2 = 625	
42	ELR-7	22	X				X	X			X			1.61		(5:1) slope beginning north of Abbey Ave. & (9:1) slope to river; w2 = reduced accordingly	
43	ELR-7	23	X				575	575			X					(5:1) slope beginning north of Abbey Ave. & (9:1) slope to river & horizontal and vertical drains w2 = w1 = 575 within drainage area	
44	ELR-7	20	X				X	625			X			1.53		Shallow (2.5:1) slope beginning north of Abbey Ave. & (15:1) slope to river	

CUY-90-14.40 (SECTION A-A)

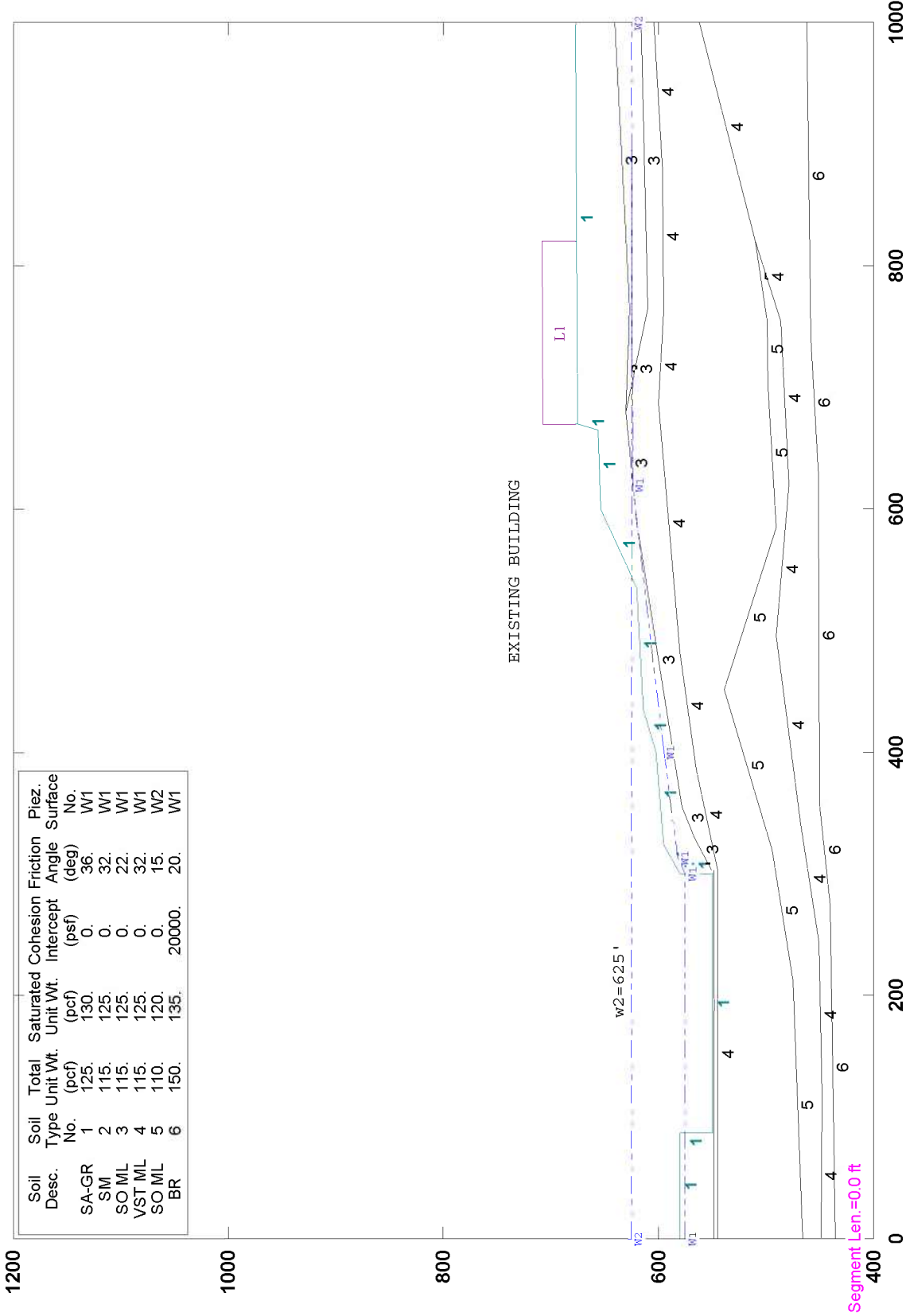

Soil Desc.	Soil Type No.	Total Unit Wt. (pcf)	Saturated Unit Wt. (pcf)	Cohesion (psf)	Friction Angle (deg)	Piez. Surface No.
SA-GR	1	125.	130.	0.	36.	W1
SM	2	115.	125.	0.	32.	W1
SO ML	3	115.	125.	0.	22.	W1
VST ML	4	115.	125.	0.	32.	W1
SO ML	5	110.	120.	0.	15.	W2
BR	6	150.	135.	20000.	20.	W1



CUY-90-14.40 (SECTION A-A)

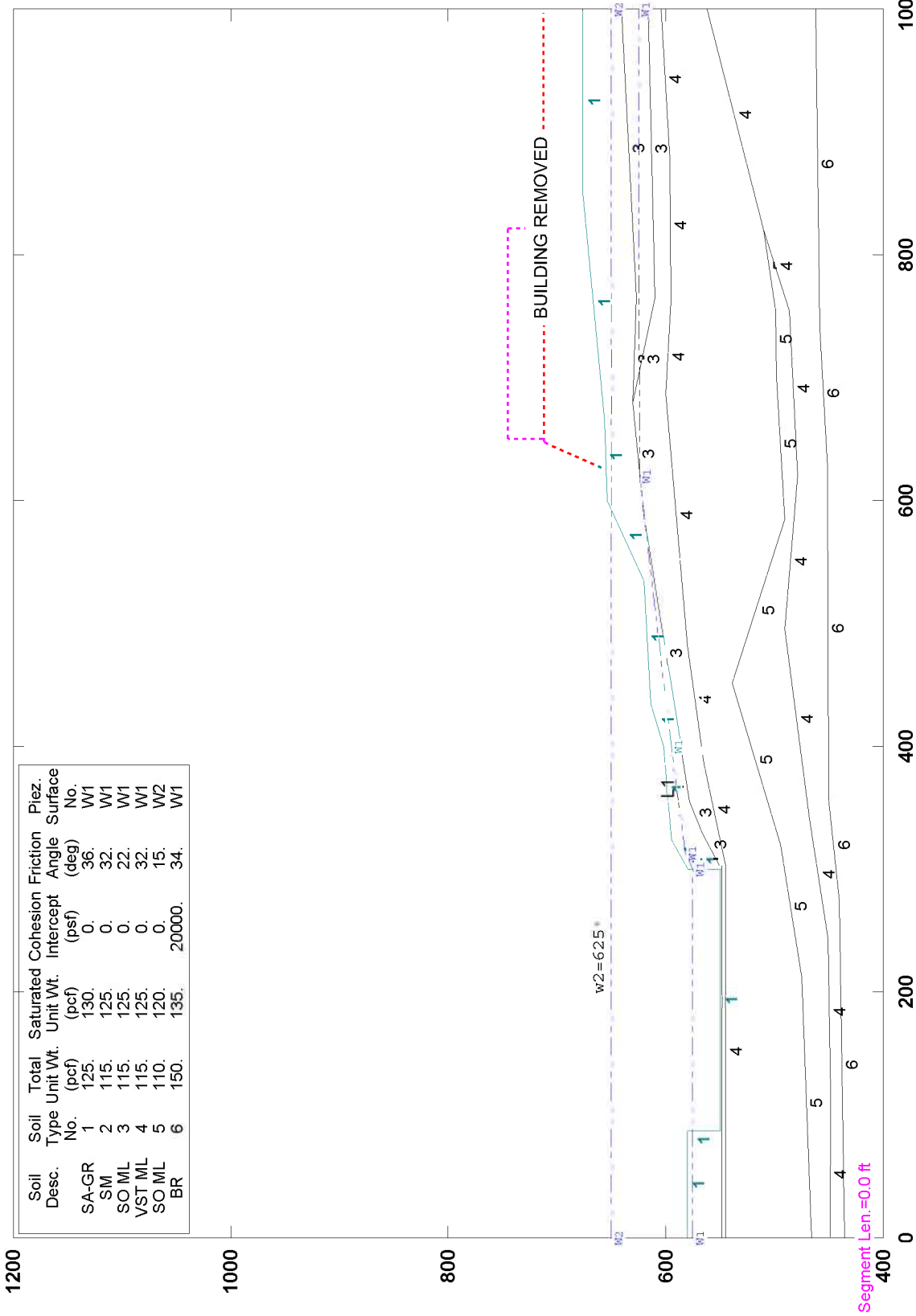

Soil Desc.	Soil Type No.	Total Unit Wt. (pcf)	Saturated Unit Wt. (pcf)	Cohesion (psf)	Friction Angle (deg)	Piez. Surface No.
SA-GR	1	125.	130.	0.	36.	W1
SM	2	115.	125.	0.	32.	W1
SO ML	3	115.	125.	0.	22.	W1
VST ML	4	115.	125.	0.	32.	W1
SO ML	5	110.	120.	0.	15.	W2
BR	6	150.	135.	20000.	34.	W1

Segment Len.=0.0 ft



CUY-90-14.40 (SECTION A-A)

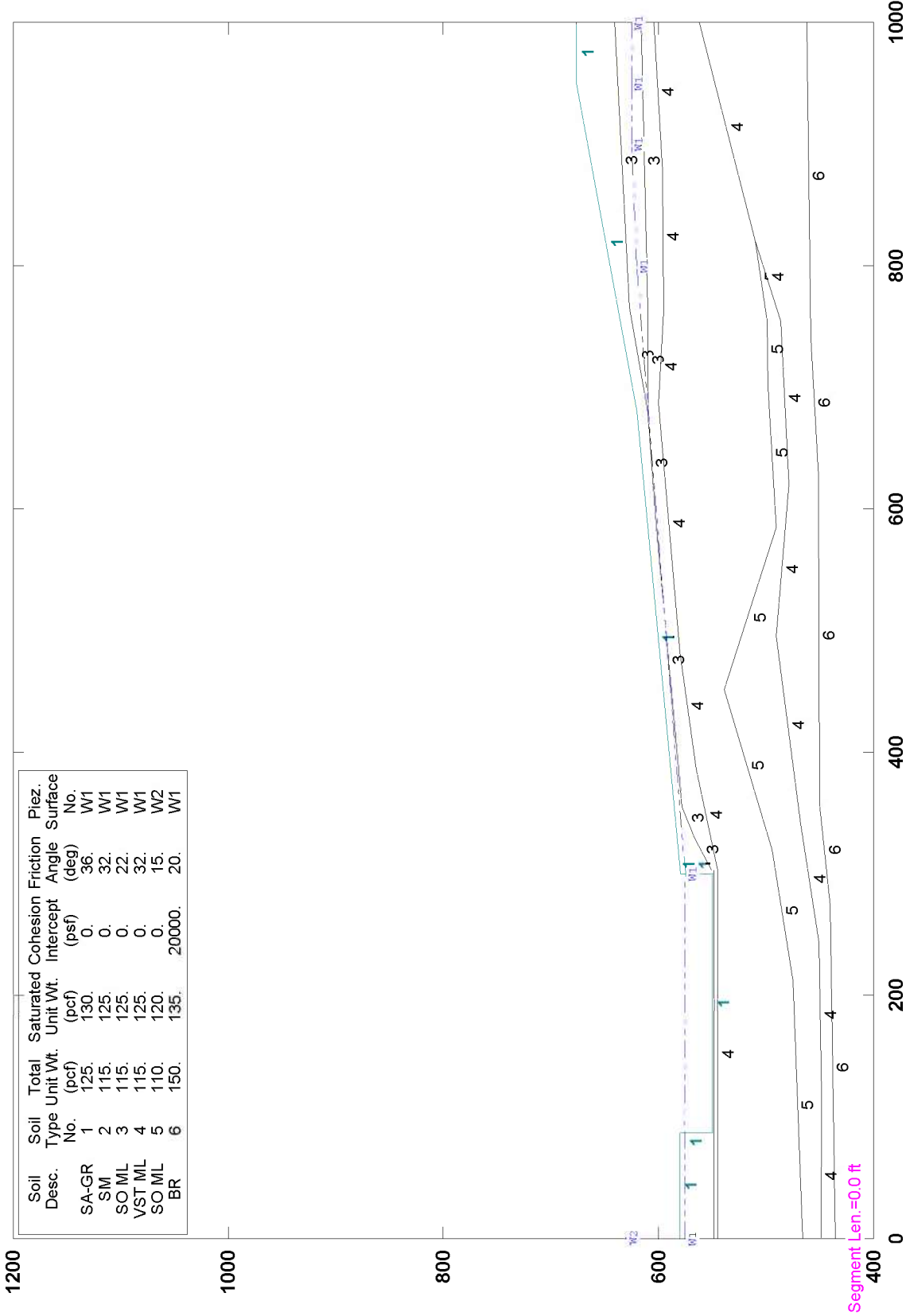

Soil Desc.	Soil Type No.	Total Unit Wt. (pcf)	Saturated Unit Wt. (pcf)	Cohesion (psf)	Friction Angle (deg)	Piez. Surface No.
SA-GR	1	125.	130.	0.	36.	W1
SM	2	115.	125.	0.	32.	W1
SO ML	3	115.	125.	0.	22.	W1
VST ML	4	115.	125.	0.	32.	W1
SO ML	5	110.	120.	0.	15.	W2
BR	6	150.	135.	20000.	20.	W1

Segment Len.=0.0 ft



CUY-90-14.40 (BRIDGE CL)

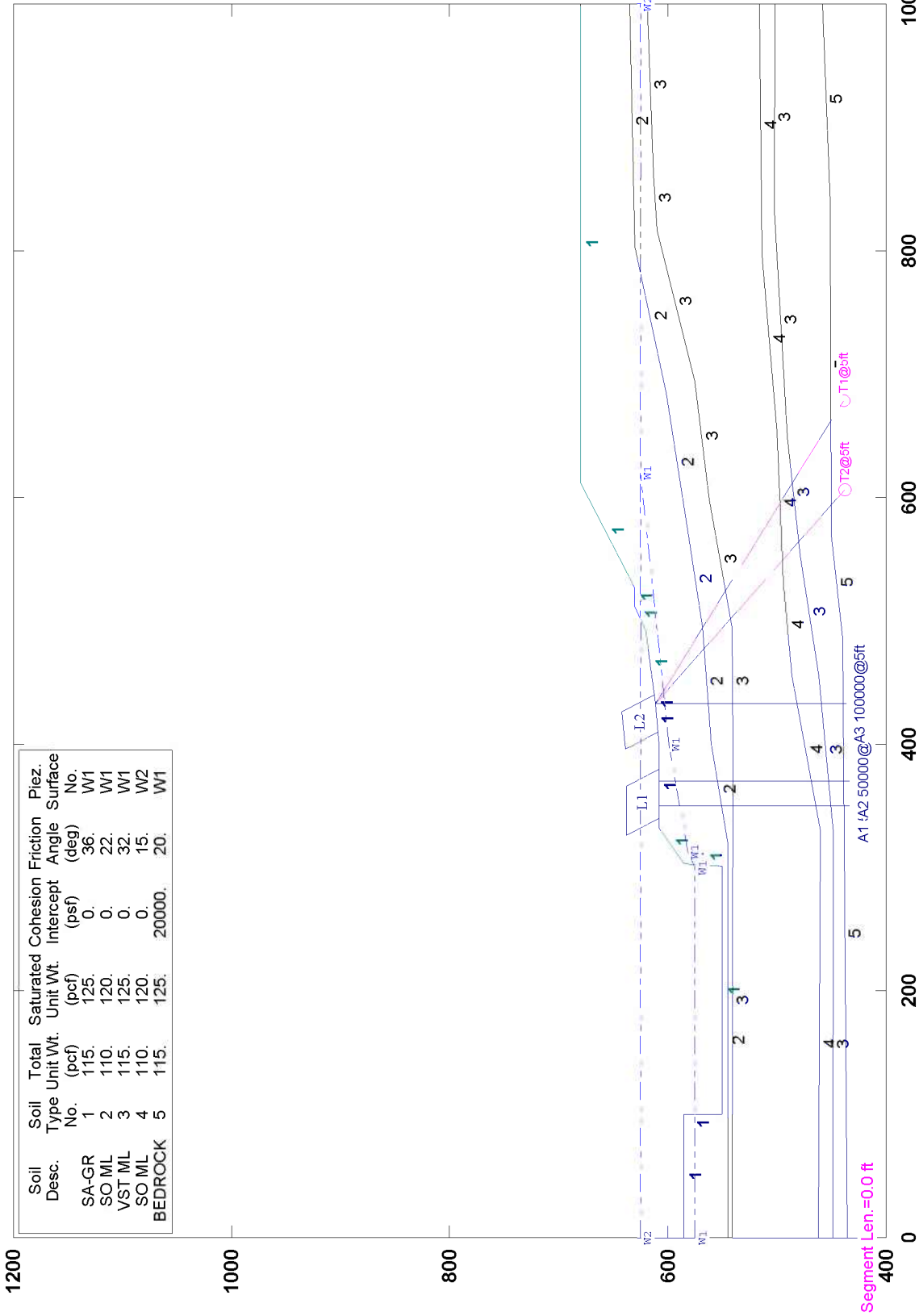

CUY-90-14.40 (SECTION D-D)

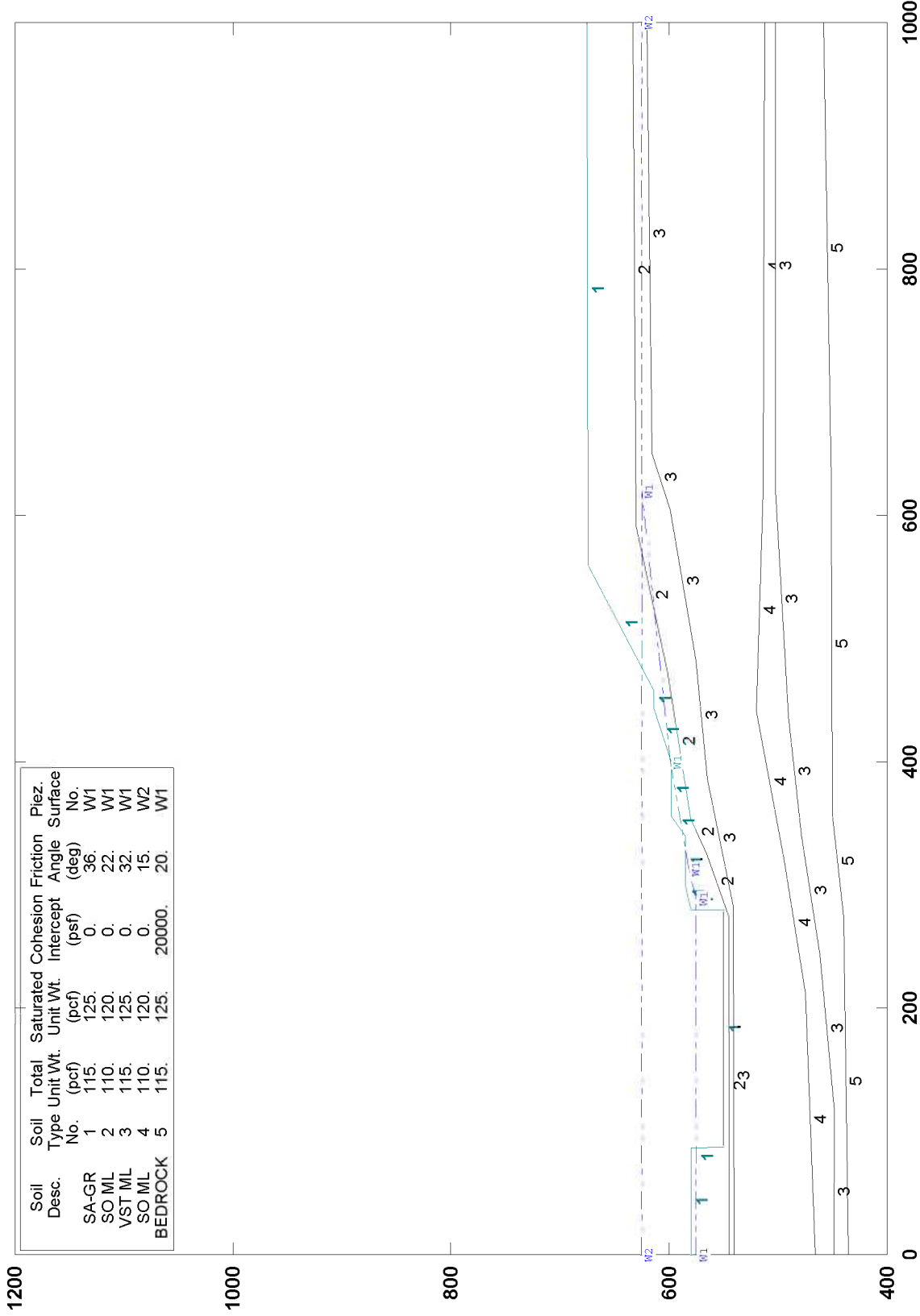

Soil Desc.	Soil Type No.	Total Unit Wt. (pcf)	Saturated Unit Wt. (pcf)	Cohesion (psf)	Friction Angle (deg)	Piez. Surface No.
SA-GR	1	115.	125.	0.	36.	W1
SO ML	2	110.	120.	0.	22.	W1
VST ML	3	115.	125.	0.	32.	W1
SO ML	4	110.	120.	0.	15.	W2
BEDROCK	5	115.	125.	20000.	20.	W1



CUY-90-14.40 (SECTION A-A)

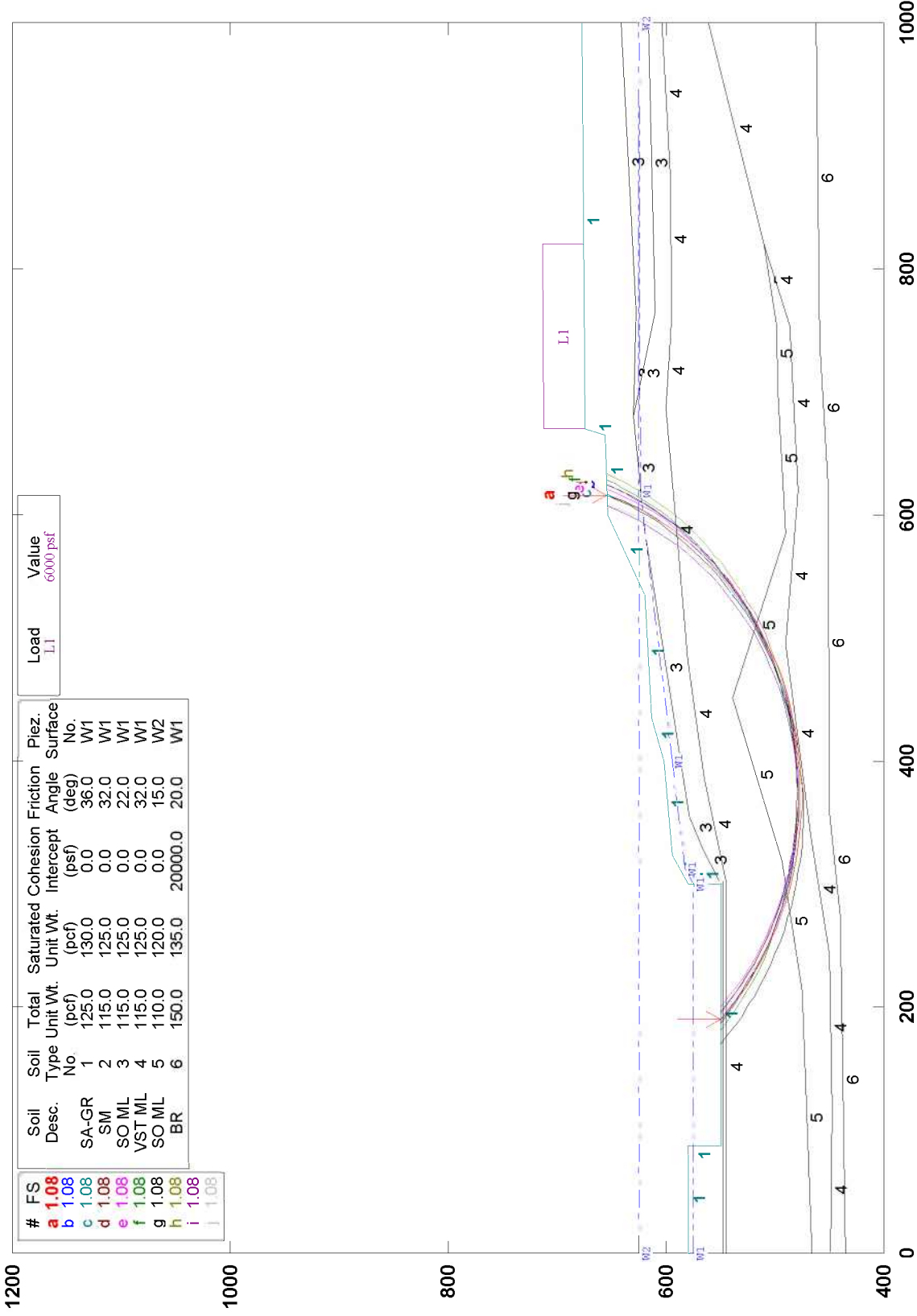

#	FS	Soil Desc.	Soil Type No.	Total Unit Wt. (pcf)	Saturated Unit Wt. (pcf)	Cohesion (psf)	Friction Angle (deg)	Piez. Surface No.
a	1.08	SA-GR	1	125.0	130.0	0.0	36.0	W1
b	1.08	SM	2	115.0	125.0	0.0	32.0	W1
c	1.08	SO ML	3	115.0	125.0	0.0	22.0	W1
d	1.08	VST ML	4	115.0	125.0	0.0	32.0	W1
e	1.08	SO ML	5	110.0	120.0	0.0	15.0	W2
f	1.08	BR	6	150.0	135.0	20000.0	20.0	W1

Load	Value
L1	6000 psf



CUY-90-14.40 (SECTION A-A)

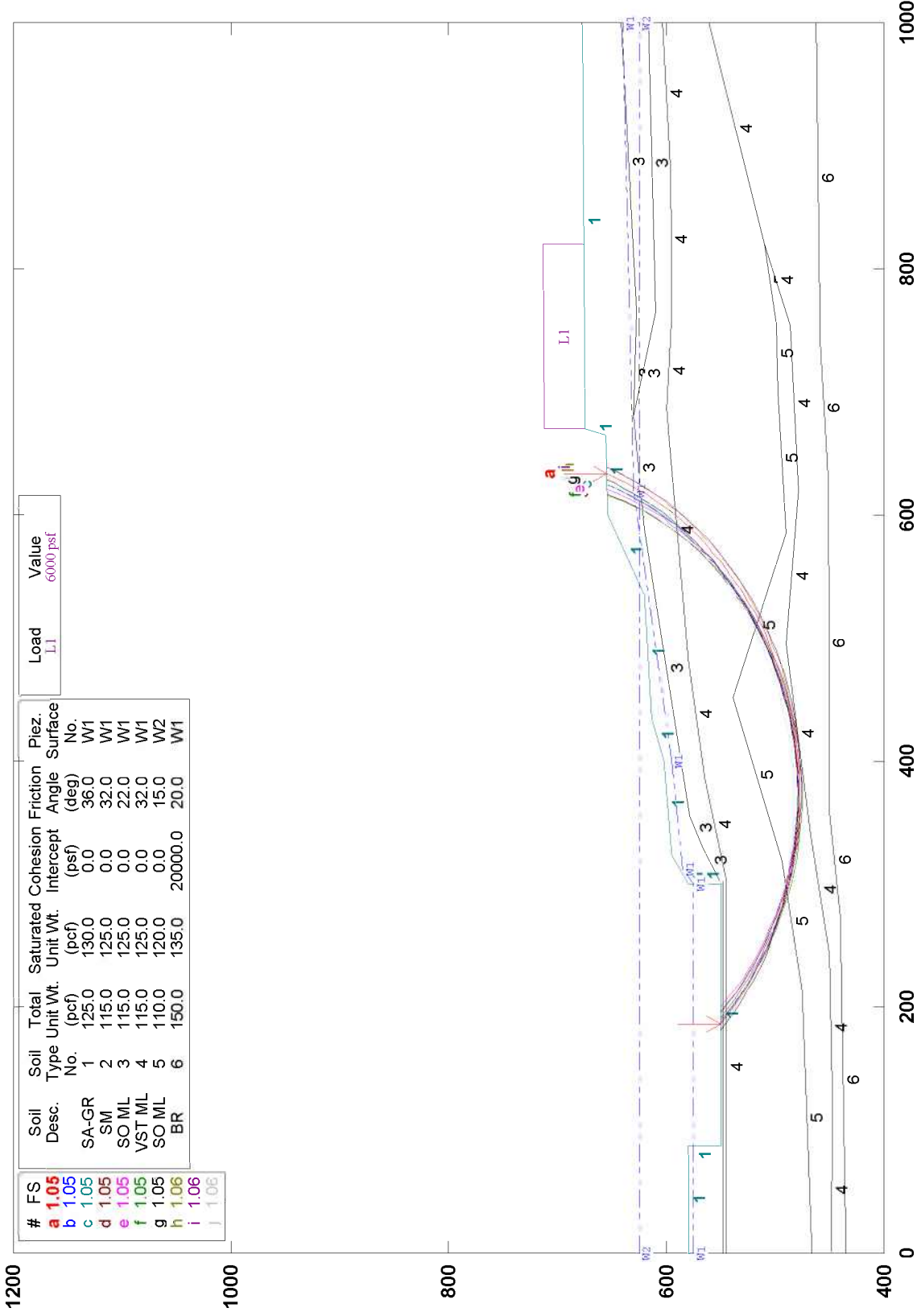

#	FS
a	1.05
b	1.05
c	1.05
d	1.05
e	1.05
f	1.05
g	1.05
h	1.06
i	1.06
j	1.06

Soil Desc.	Soil Type No.	Total Unit Wt. (pcf)	Saturated Unit Wt. (pcf)	Cohesion Intercept (psf)	Friction Angle (deg)	Piez. Surface No.
SA-GR	1	125.0	130.0	0.0	36.0	W1
SM	2	115.0	125.0	0.0	32.0	W1
SO ML	3	115.0	125.0	0.0	22.0	W1
VST ML	4	115.0	125.0	0.0	32.0	W1
SO ML	5	110.0	120.0	0.0	15.0	W2
BR	6	150.0	135.0	20000.0	20.0	W1

Load	Value
L1	6000 psf

GSTABL7 v.2 FSmin=1.05



CUY-90-14.40 (SECTION A-A)

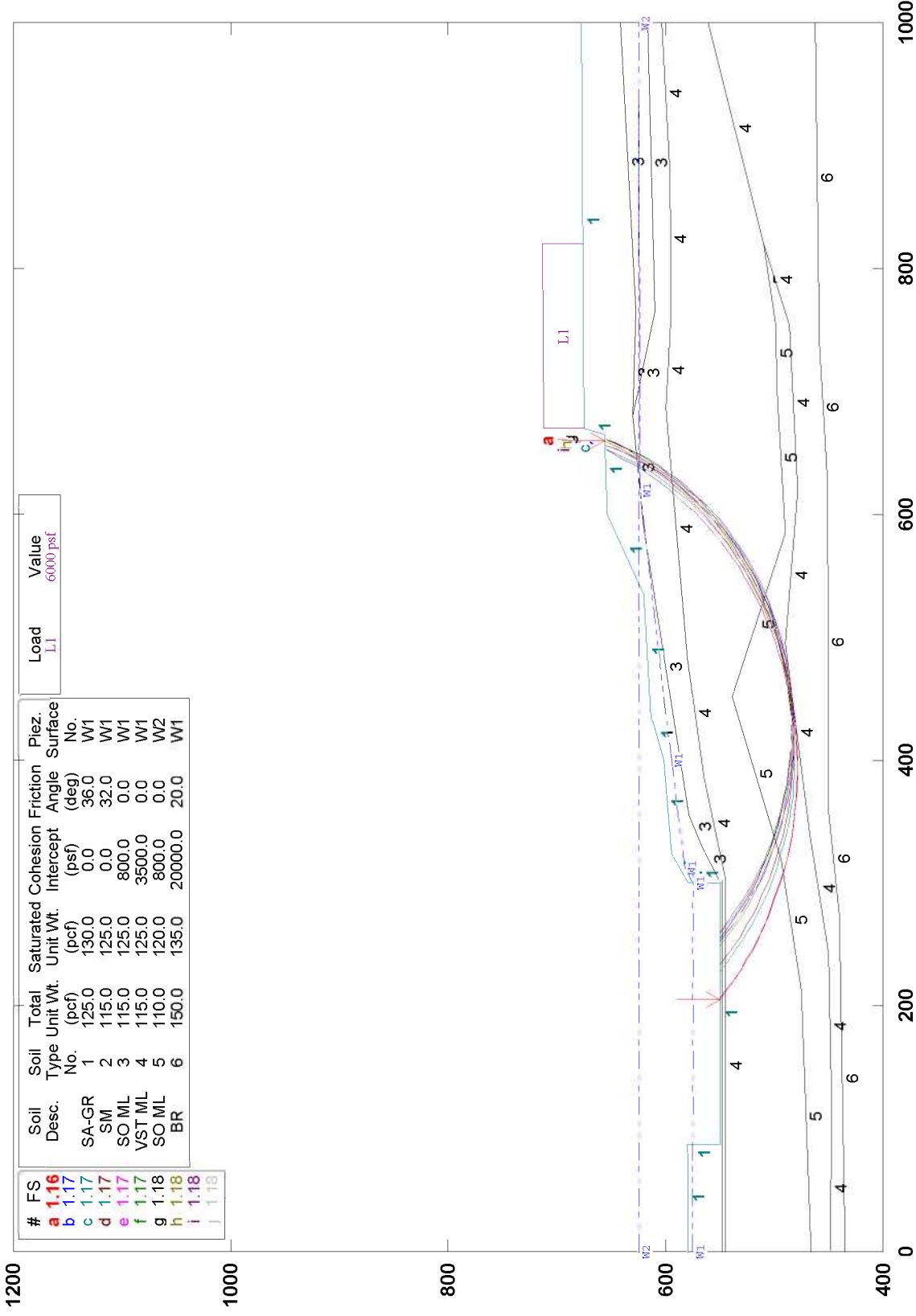

GSTABL7 v.2 FSmin=1.16

#	FS	Soil Desc.	Soil Type No.	Total Unit Wt. (pcf)	Saturated Unit Wt. (pcf)	Cohesion Intercept (psf)	Friction Angle (deg)	Piez. Surface No.	Value
a	1.16	SA-GR	1	125.0	130.0	0.0	36.0	W1	6000 psf
b	1.17	SM	2	115.0	125.0	0.0	32.0	W1	
c	1.17	SO ML	3	115.0	125.0	800.0	0.0	W1	
d	1.17	VST ML	4	115.0	125.0	3500.0	0.0	W1	
e	1.17	SO ML	5	110.0	120.0	800.0	0.0	W2	
f	1.18	BR	6	150.0	135.0	20000.0	20.0	W1	



CUY-90-14.40 (SECTION A-A)

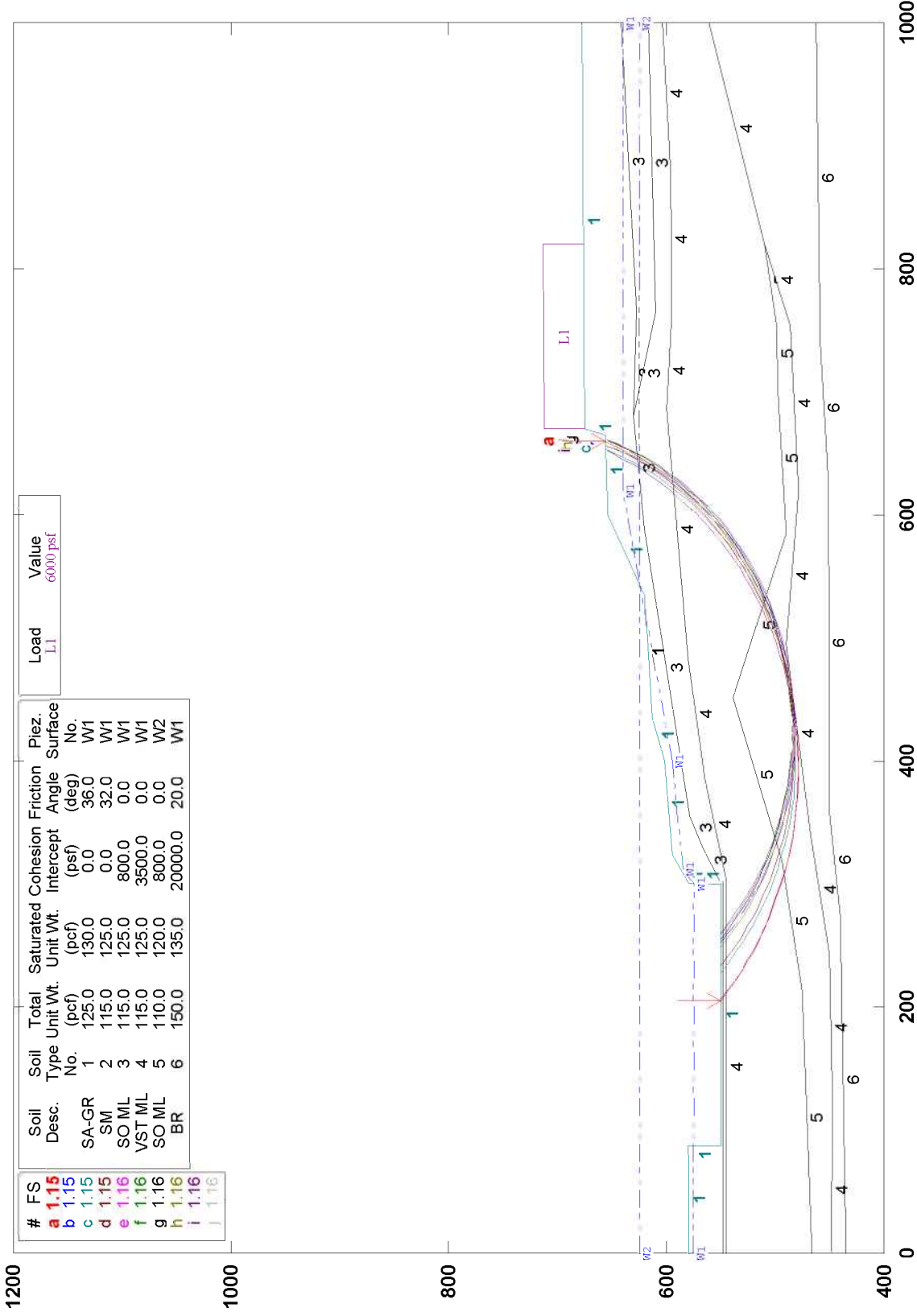

#	FS	Soil Desc.	Soil Type No.	Total Unit Wt. (pcf)	Saturated Unit Wt. (pcf)	Cohesion (psf)	Friction Angle (deg)	Piez. Surface No.
a	1.15	SA-GR	1	125.0	130.0	0.0	36.0	W1
b	1.15	SM	2	115.0	125.0	0.0	32.0	W1
c	1.15	SO ML	3	115.0	125.0	800.0	0.0	W1
d	1.16	VST ML	4	115.0	125.0	3500.0	0.0	W1
e	1.16	SO ML	5	110.0	120.0	800.0	0.0	W2
f	1.16	BR	6	150.0	135.0	20000.0	20.0	W1

Load	Value
L1	6000 psf

GSTABL7 v.2 FSmin=1.15



CUY-90-14.40 (SECTION A-A)

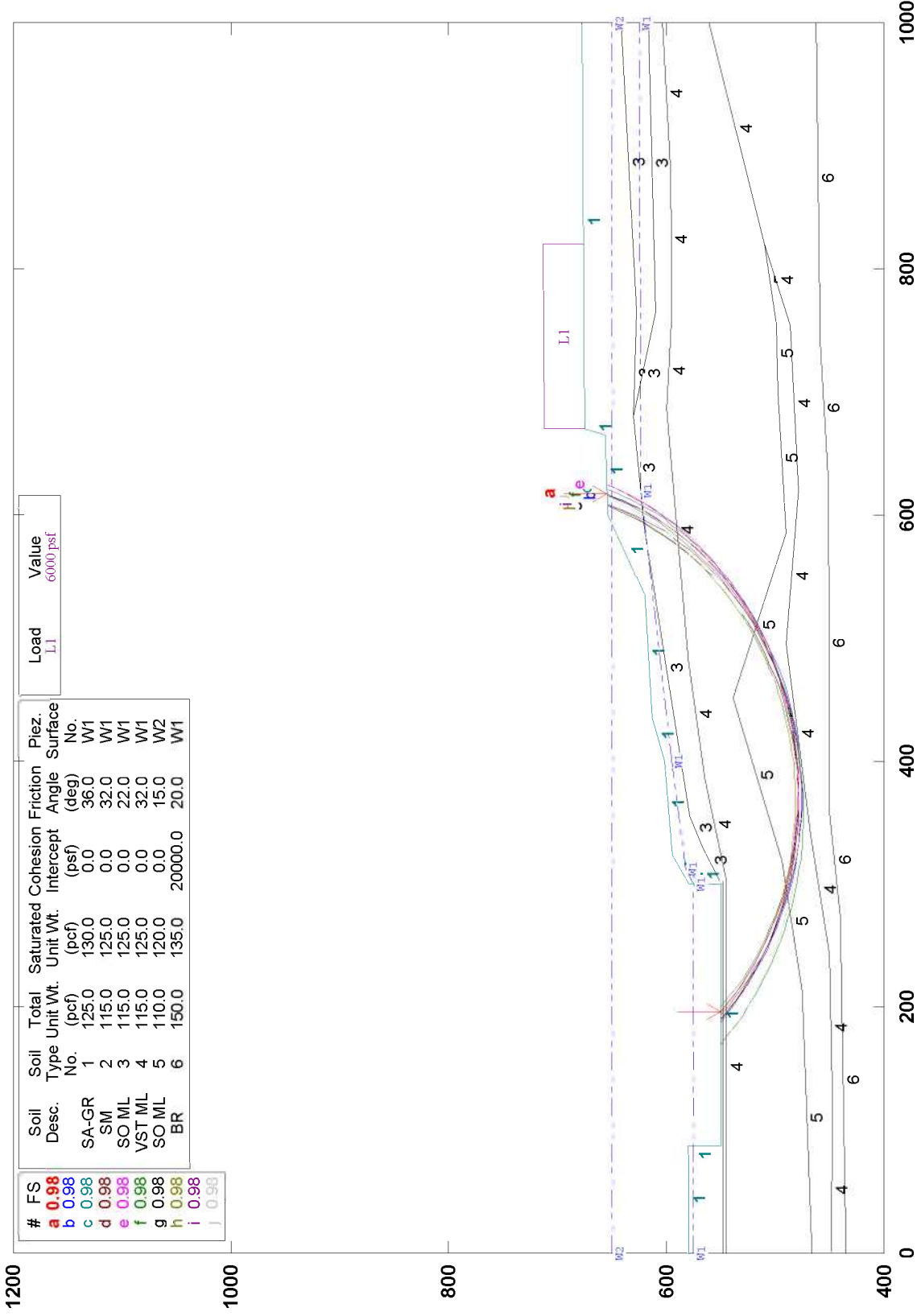

#	FS	Soil Desc.	Soil Type No.	Total Unit Wt. (pcf)	Saturated Unit Wt. (pcf)	Cohesion Intercept (psf)	Friction Angle (deg)	Piez. Surface No.
a	0.98	SA-GR	1	125.0	130.0	0.0	36.0	W1
b	0.98	SM	2	115.0	125.0	0.0	32.0	W1
c	0.98	SO ML	3	115.0	125.0	0.0	22.0	W1
d	0.98	VST ML	4	115.0	125.0	0.0	32.0	W1
e	0.98	SO ML	5	110.0	120.0	0.0	15.0	W2
f	0.98	BR	6	150.0	135.0	20000.0	20.0	W1

Load	Value
L1	6000 psf

GSTABL7 v.2 FSmin=0.98



CUY-90-14.40 (SECTION A-A)

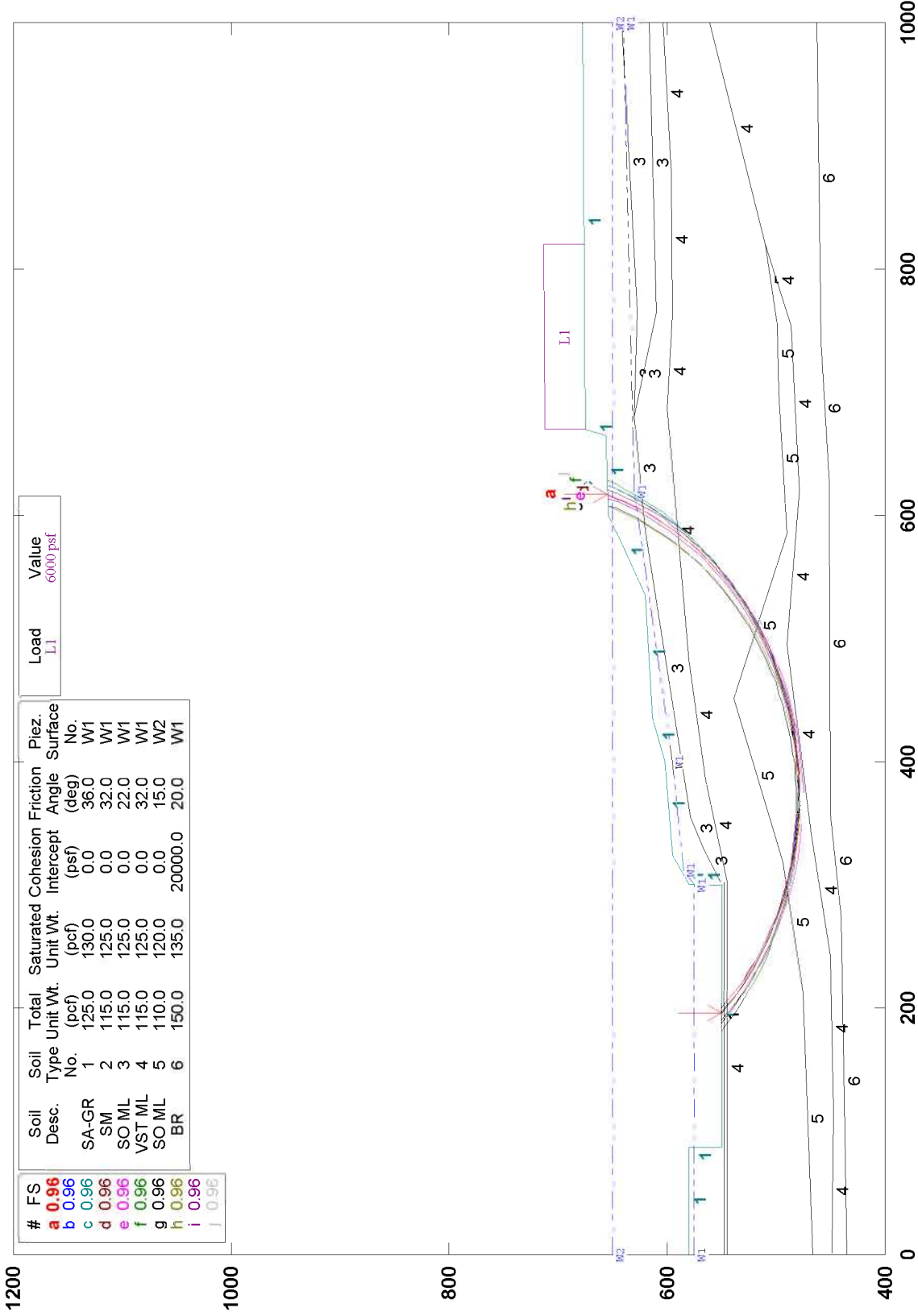

#	FS	Soil Desc.	Soil Type No.	Total Unit Wt. (pcf)	Saturated Unit Wt. (pcf)	Cohesion Intercept (psf)	Friction Angle (deg)	Piez. Surface No.
a	0.96	SA-GR	1	125.0	130.0	0.0	36.0	W1
b	0.96	SM	2	115.0	125.0	0.0	32.0	W1
c	0.96	SO ML	3	115.0	125.0	0.0	22.0	W1
d	0.96	VST ML	4	115.0	125.0	0.0	32.0	W1
e	0.96	SO ML	5	110.0	120.0	0.0	15.0	W2
f	0.96	BR	6	150.0	135.0	20000.0	20.0	W1

Load	Value
L1	6000 psf

GSTABL7 v.2 FSmin=0.96



CUY-90-14.40 (BRIDGE CL)

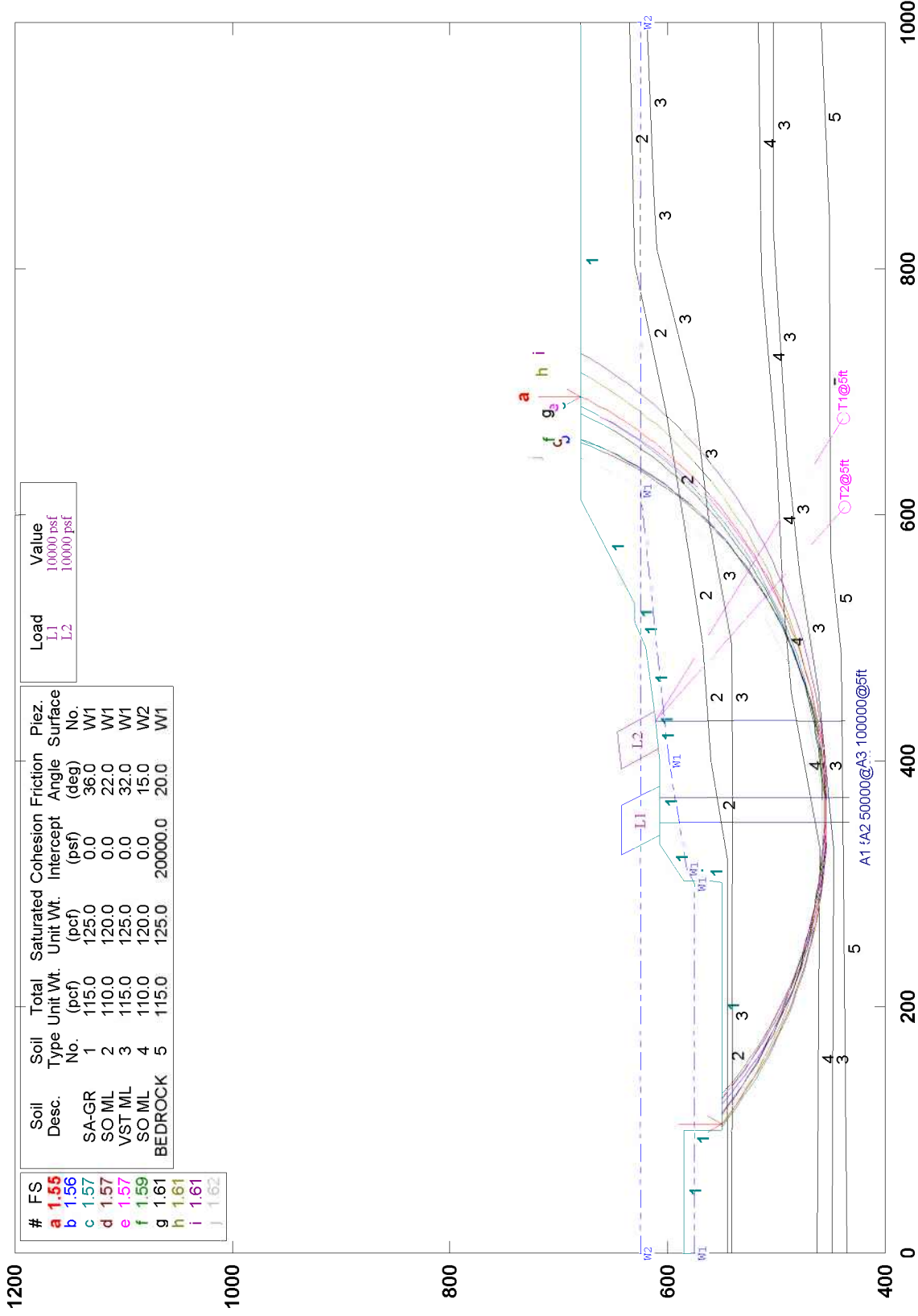

GSTABL7 v.2 FSmin=1.55



CUY-90-14.40 (BRIDGE CL)

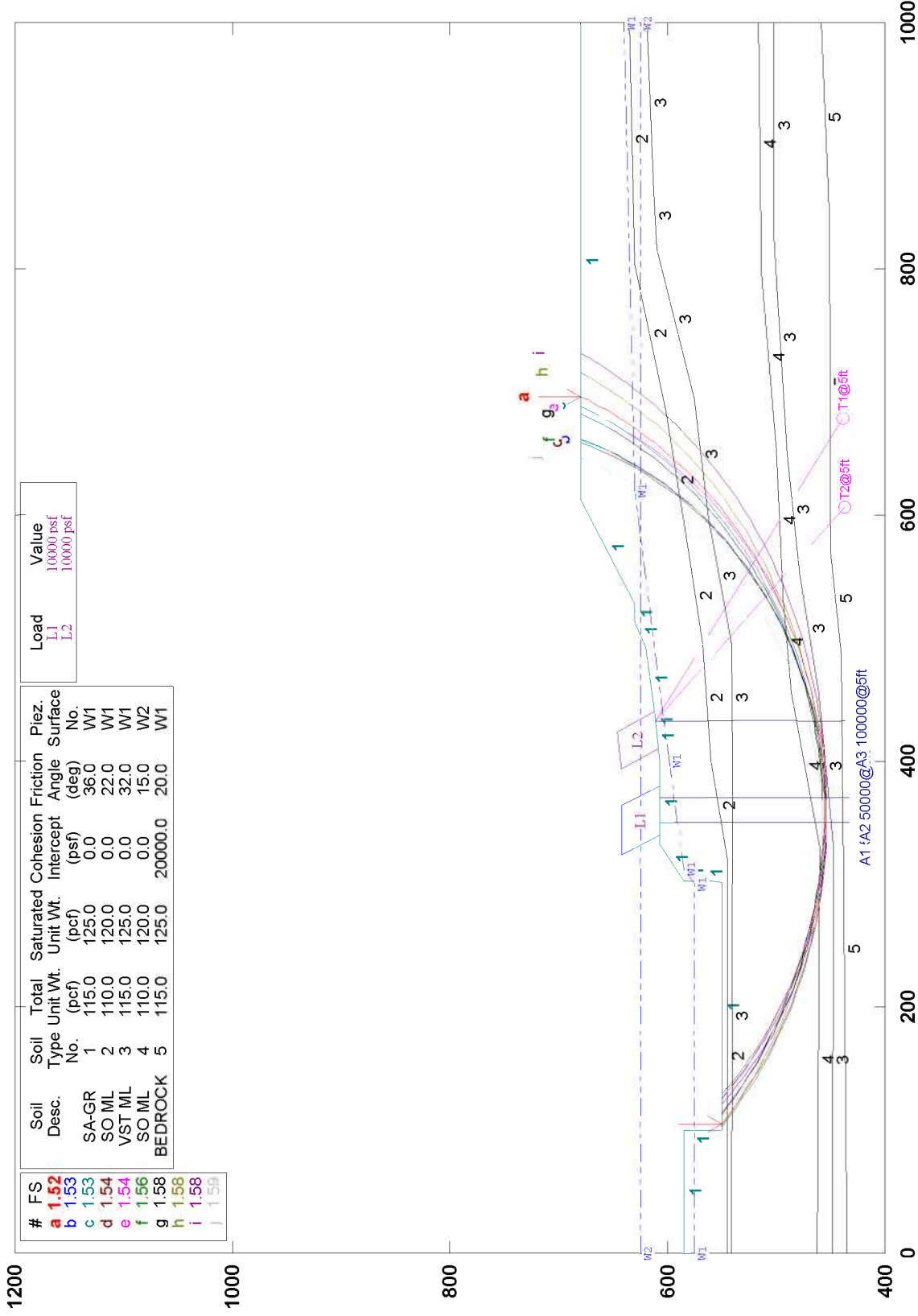

GSTABL7 v.2 FSmin=1.52



CUY-90-14.40 (BRIDGE CL)

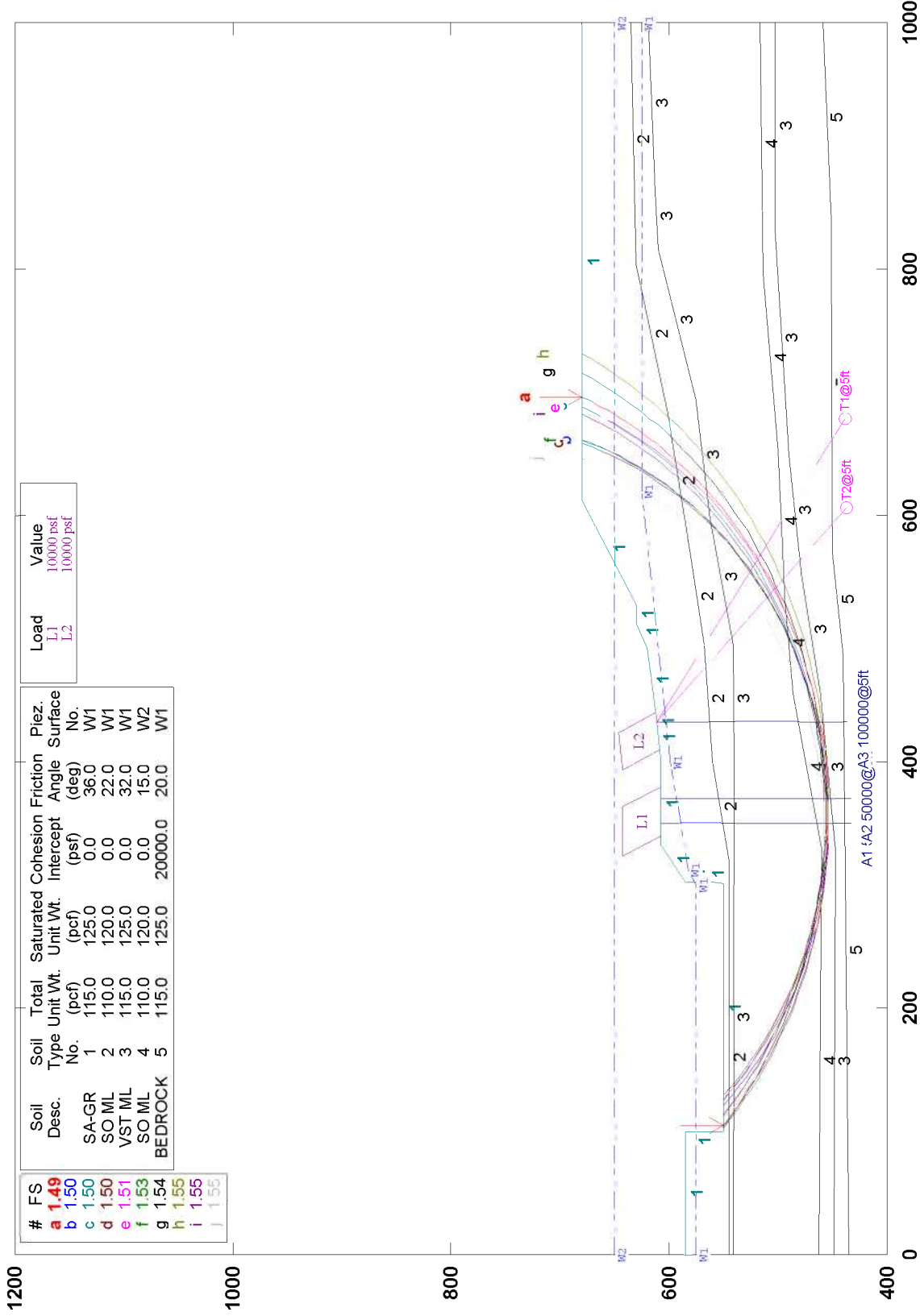

#	FS	Soil Desc.	Soil Type No.	Total Unit Wt. (pcf)	Saturated Unit Wt. (pcf)	Cohesion (psf)	Friction Angle (deg)	Piez. Surface No.
a	1.49	SA-GR	1	115.0	125.0	0.0	36.0	W1
b	1.50	SO ML	2	110.0	120.0	0.0	22.0	W1
c	1.50	VST ML	3	115.0	125.0	0.0	32.0	W1
d	1.51	SO ML	4	110.0	120.0	0.0	15.0	W2
e	1.53	BEDROCK	5	115.0	125.0	20000.0	20.0	W1
f	1.54							
g	1.55							
h	1.55							
i	1.55							
j	1.55							

Load	Value
L1	10000 psf
L2	10000 psf



CUY-90-14.40 (BRIDGE CL)

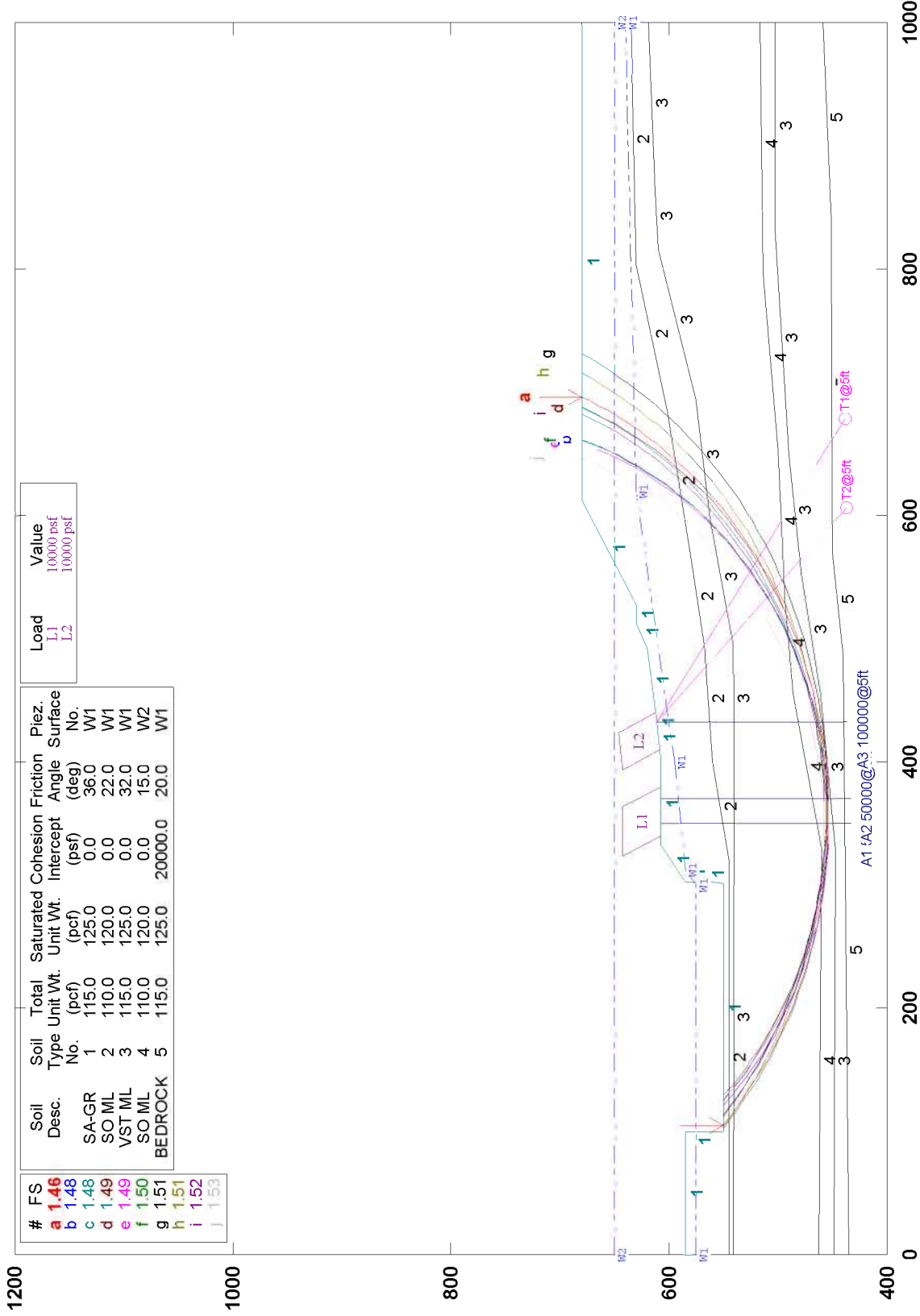

#	FS	Soil Desc.	Soil Type No.	Total Unit Wt. (pcf)	Saturated Unit Wt. (pcf)	Cohesion Intercept (psf)	Friction Angle (deg)	Piez. Surface No.
a	1.46	SA-GR	1	115.0	125.0	0.0	36.0	W1
b	1.48	SO ML	2	110.0	120.0	0.0	22.0	W1
c	1.48	VST ML	3	115.0	125.0	0.0	32.0	W1
d	1.49	SO ML	4	110.0	120.0	0.0	15.0	W2
e	1.49	SO ML	4	110.0	120.0	0.0	15.0	W2
f	1.50	BEDROCK	5	115.0	125.0	20000.0	20.0	W1
g	1.51							
h	1.51							
i	1.52							
j	1.53							

Load	Value
L1	10000 psf
L2	10000 psf

GSTABL7 v.2 FSmin=1.46



CUY-90-14.40: (SECTION D-D)

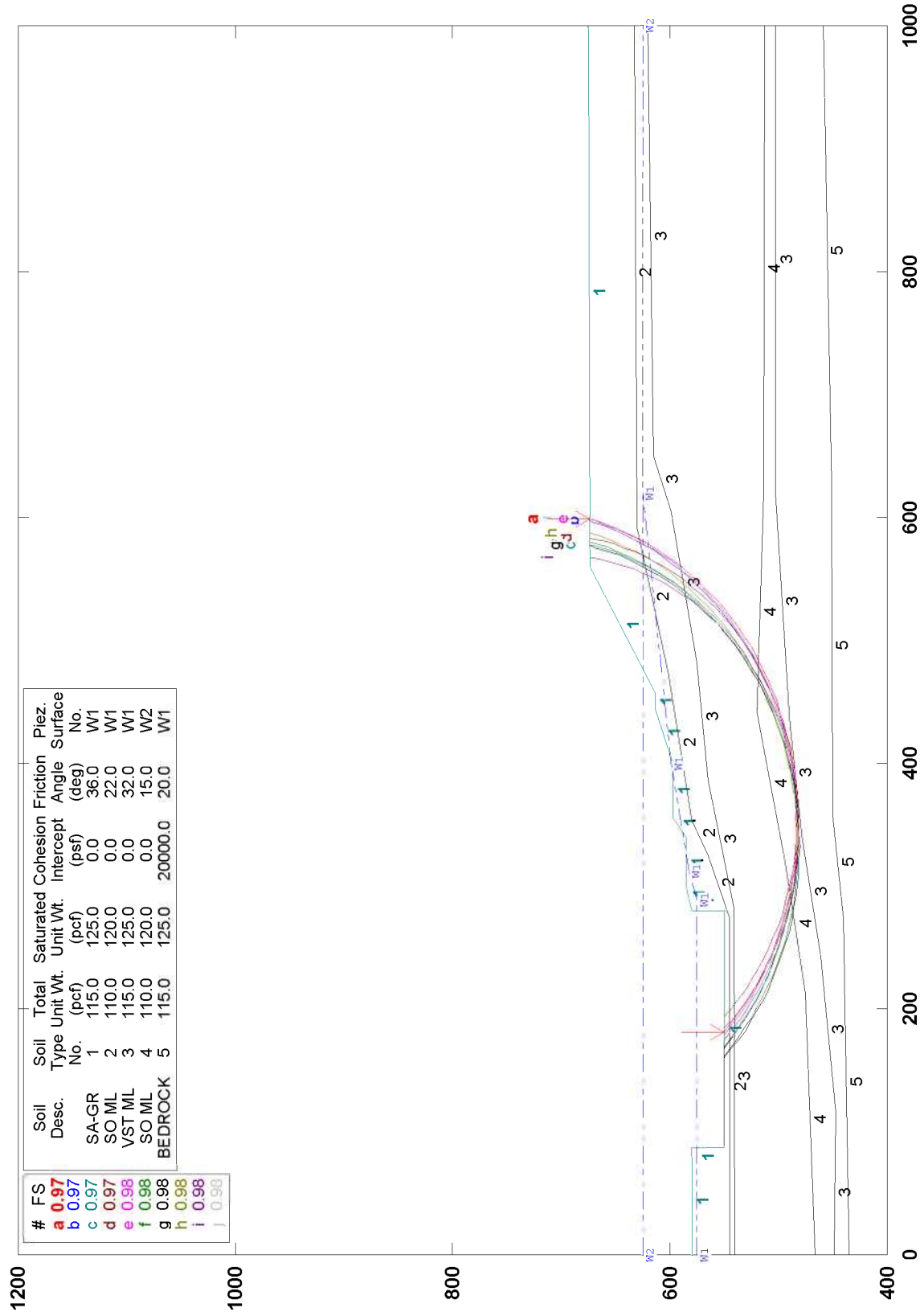

GSTABL7 v.2 FSmin=0.97



CUY-90-14.40: (SECTION D-D)

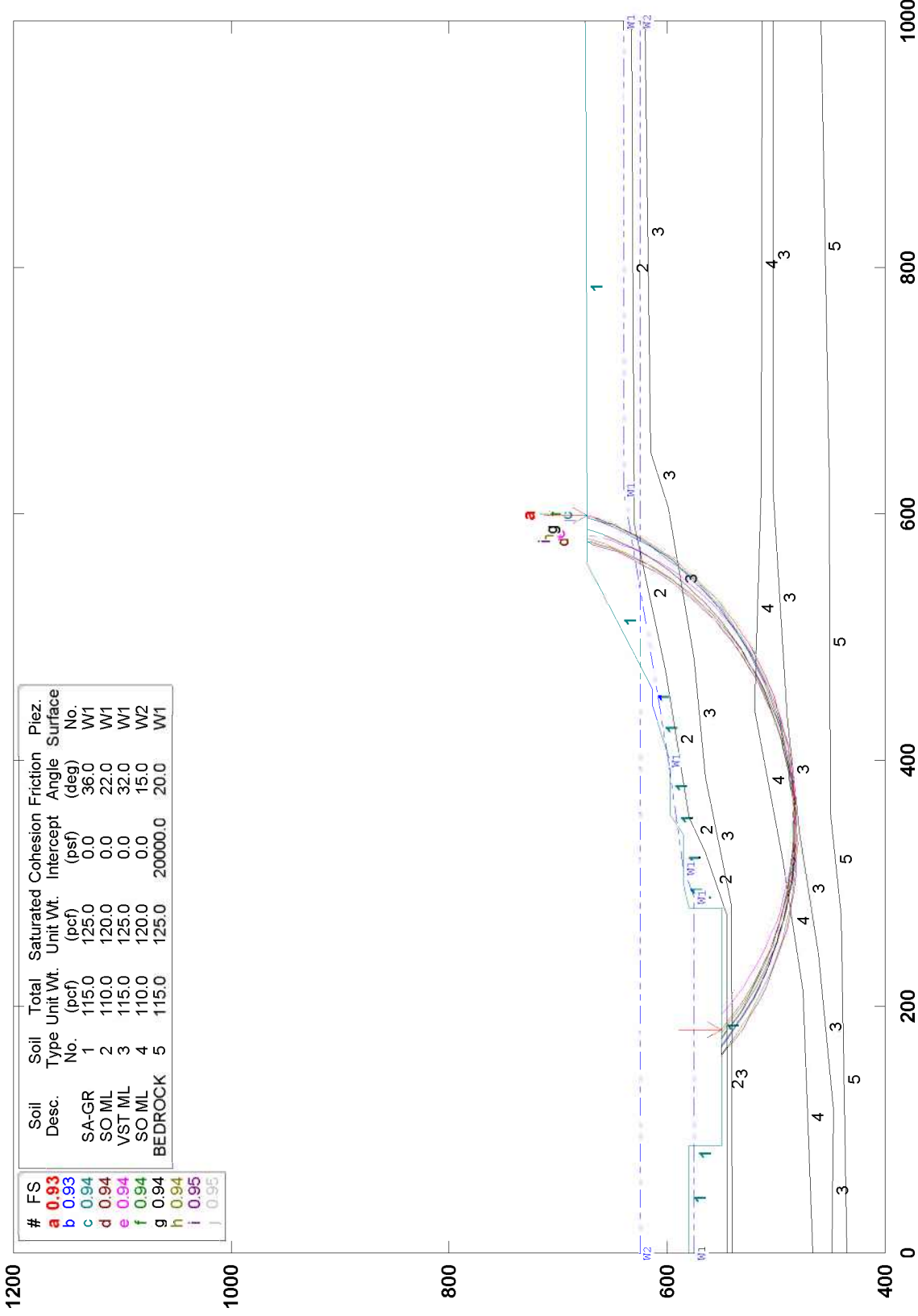

#	FS	Soil Desc.	Soil Type No.	Total Unit Wt. (pcf)	Saturated Unit Wt. (pcf)	Cohesion (psf)	Friction Angle (deg)	Piez. Surface No.
a	0.93	SA-GR	1	115.0	125.0	0.0	36.0	W1
b	0.93	SO ML	2	110.0	120.0	0.0	22.0	W1
c	0.94	VST ML	3	115.0	125.0	0.0	32.0	W1
d	0.94	SO ML	4	110.0	120.0	0.0	15.0	W2
e	0.94	BEDROCK	5	115.0	125.0	20000.0	20.0	W1

GSTABL7 v.2 FSmin=0.93



CUY-90-14.40 (SECTION A-A)

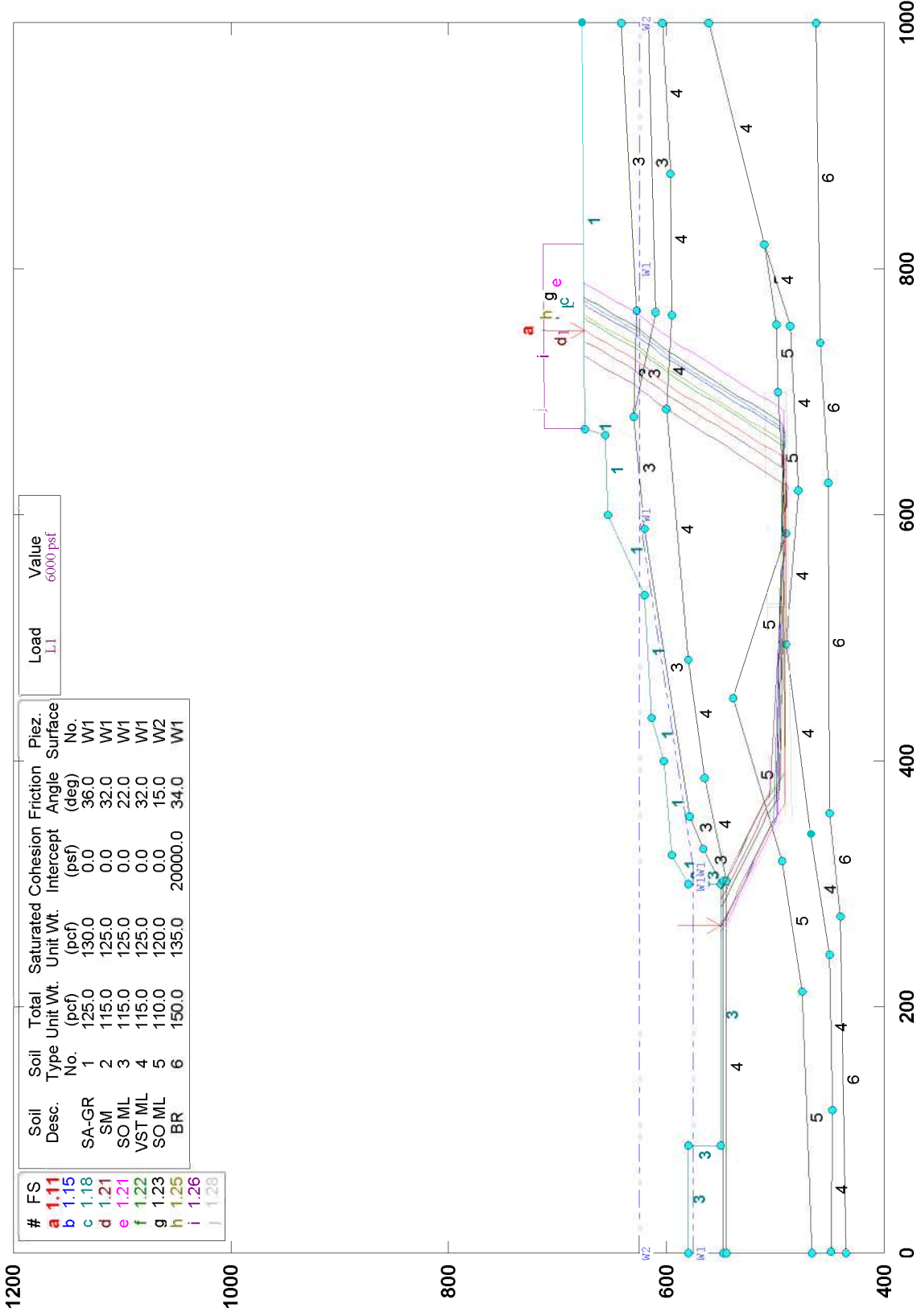

GSTABL7 v.2 FSmin=1.11



CUY-90-14.40 (SECTION A-A)

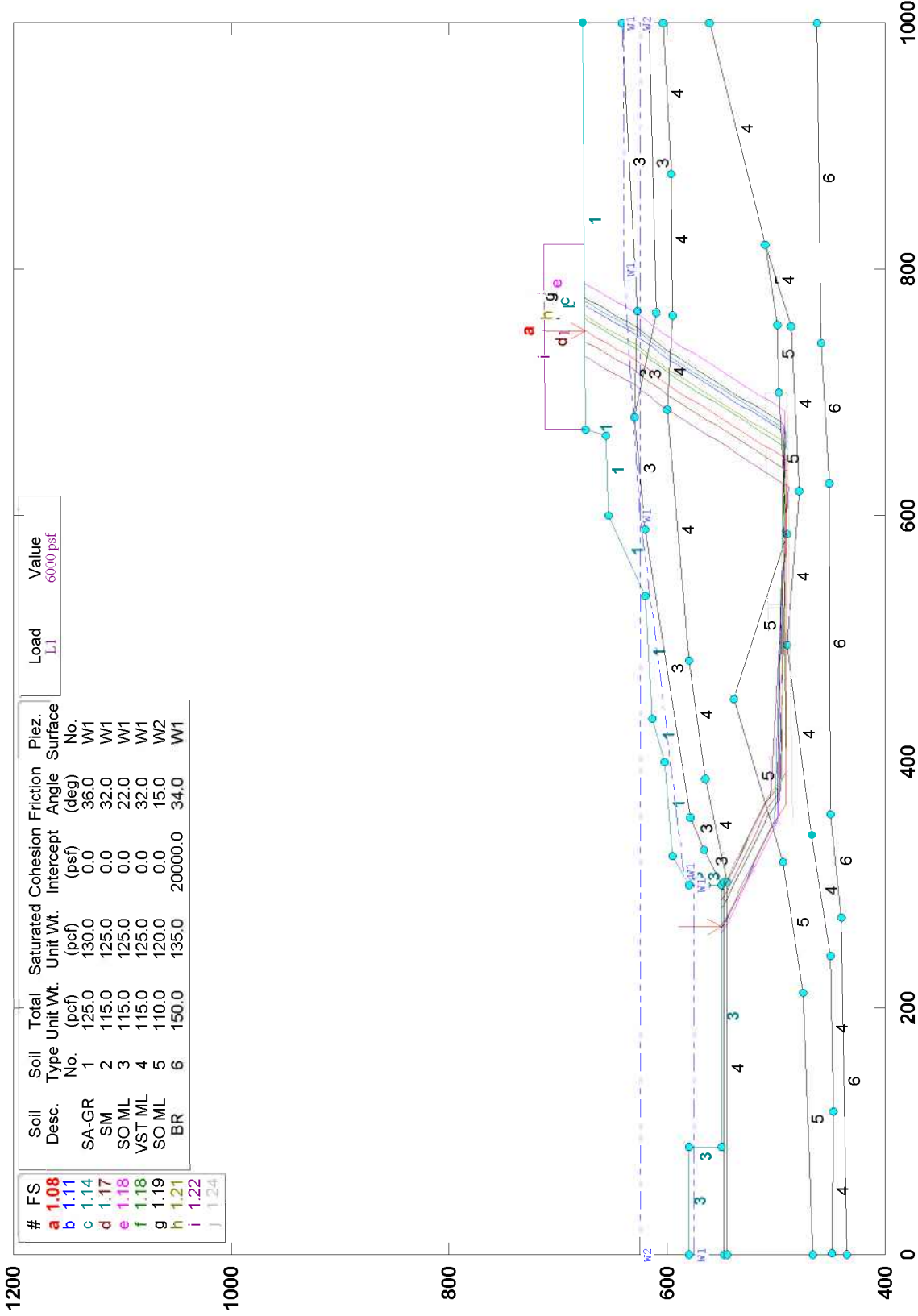

#	FS	Soil Desc.	Soil Type No.	Total Unit Wt. (pcf)	Saturated Unit Wt. (pcf)	Cohesion Intercept (psf)	Friction Angle (deg)	Piez. Surface No.
a	1.08	SA-GR	1	125.0	130.0	0.0	36.0	W1
b	1.11	SM	2	115.0	125.0	0.0	32.0	W1
c	1.14	SO ML	3	115.0	125.0	0.0	22.0	W1
d	1.17	VST ML	4	115.0	125.0	0.0	32.0	W1
e	1.18	SO ML	5	110.0	120.0	0.0	15.0	W2
f	1.18	BR	6	150.0	135.0	20000.0	34.0	W1
g	1.19							
h	1.21							
i	1.22							
j	1.24							

GSTABL7 v.2 FSmin=1.08



CUY-90-14.40 (SECTION A-A)

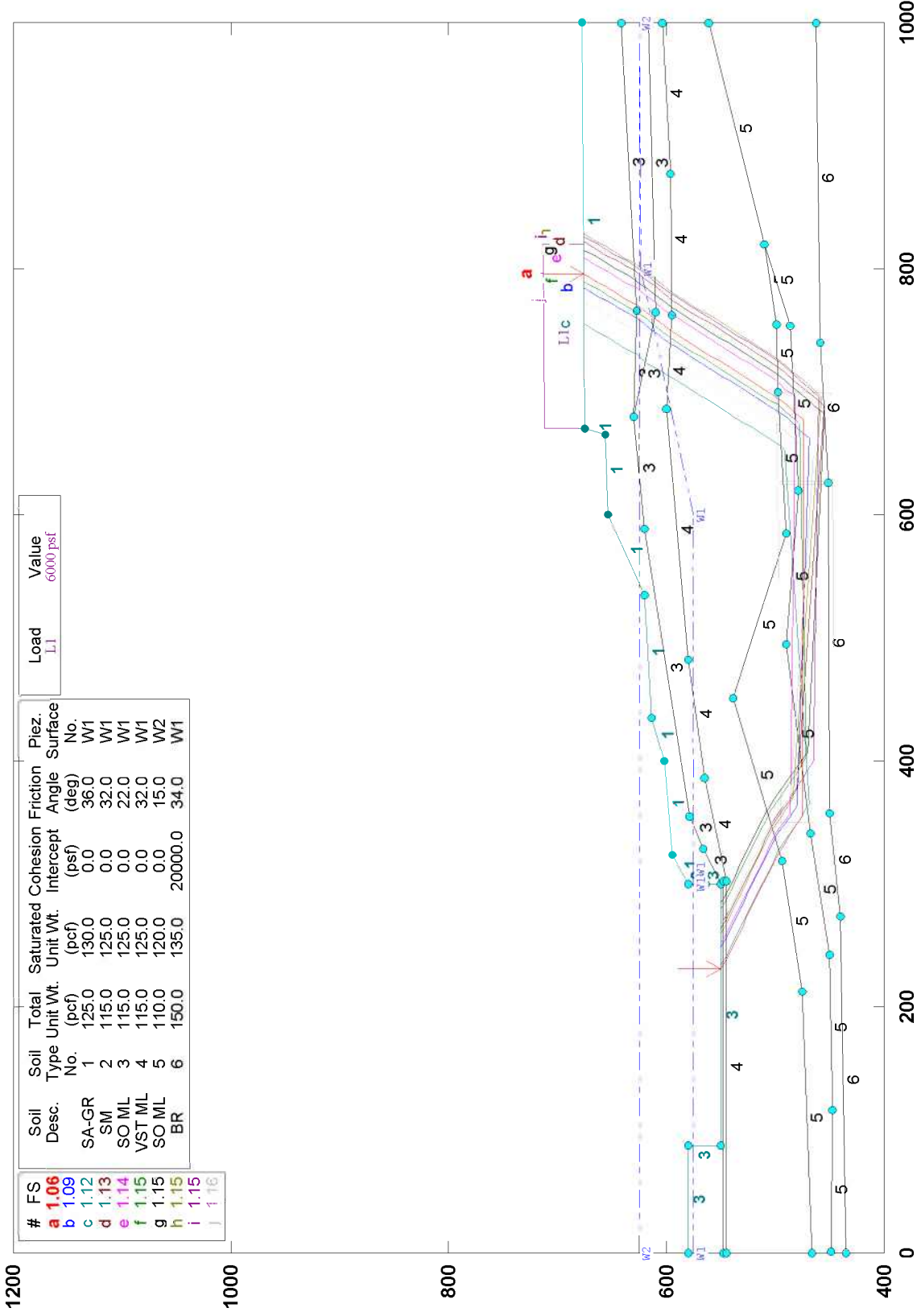

GSTABL7 v.2 FSmin=1.0

#	FS	Soil Desc.	Soil Type No.	Total Unit Wt. (pcf)	Saturated Unit Wt. (pcf)	Cohesion Intercept (psf)	Friction Angle (deg)	Piez. Surface No.
a	1.06	SA-GR	1	125.0	130.0	0.0	36.0	W1
b	1.09	SM	2	115.0	125.0	0.0	32.0	W1
c	1.12	SO ML	3	115.0	125.0	0.0	22.0	W1
d	1.13	VST ML	4	115.0	125.0	0.0	32.0	W1
e	1.14	SO ML	5	110.0	120.0	0.0	15.0	W2
f	1.15	BR	6	150.0	135.0	20000.0	34.0	W1
g	1.15							
h	1.15							
i	1.15							
j	1.16							



CUY-90-14.40 (SECTION A-A)

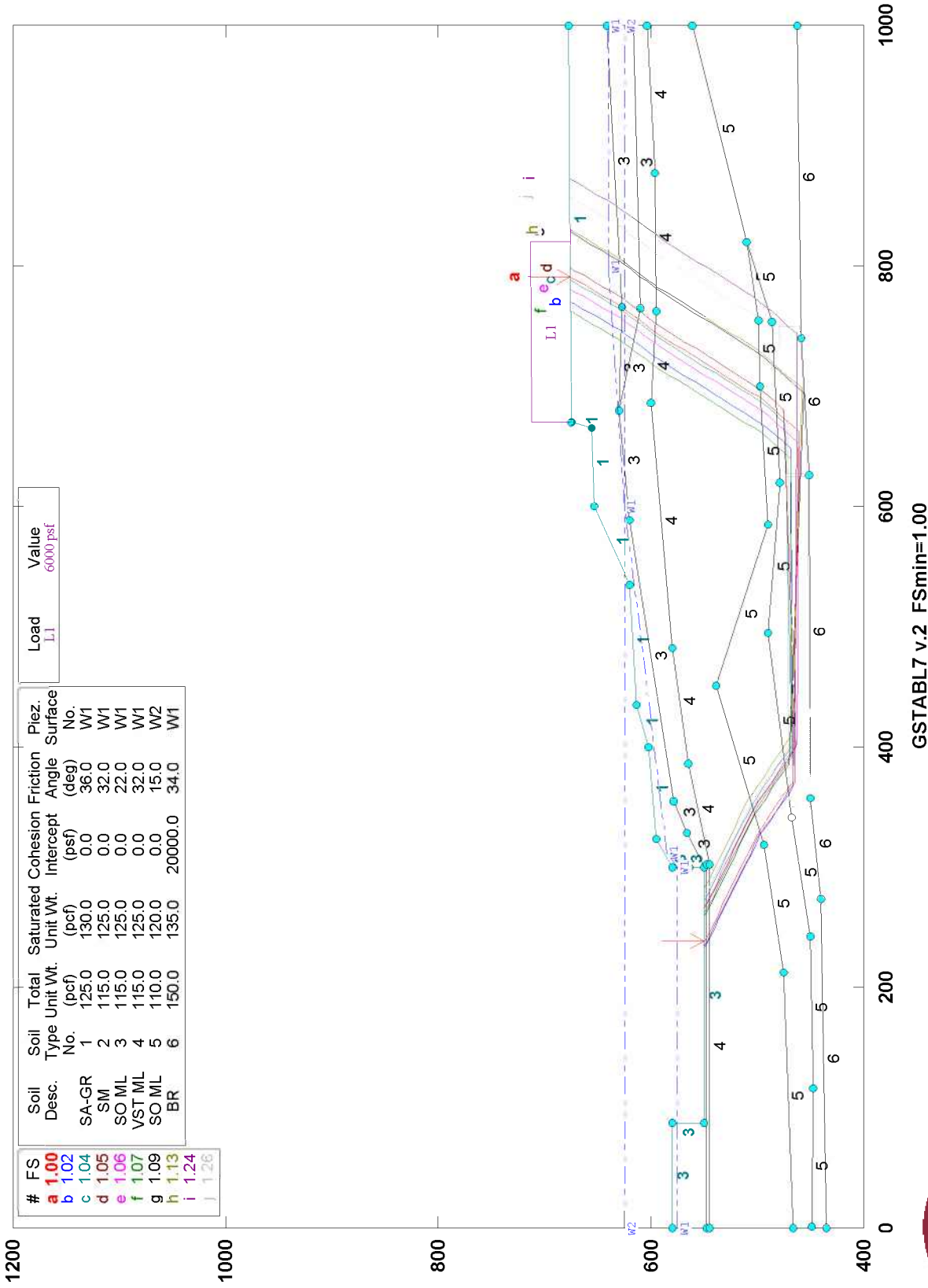

GSTABL7 v.2 FSmin=1.00

#	FS	Soil Desc.	Soil Type No.	Total Unit Wt. (pcf)	Saturated Unit Wt. (pcf)	Cohesion Intercept (psf)	Friction Angle (deg)	Piez. Surface No.
a	1.00	SA-GR	1	125.0	130.0	0.0	36.0	W1
b	1.02	SM	2	115.0	125.0	0.0	32.0	W1
c	1.04	SO ML	3	115.0	125.0	0.0	22.0	W1
d	1.05	VST ML	4	115.0	125.0	0.0	32.0	W1
e	1.06	SO ML	5	110.0	120.0	0.0	15.0	W2
f	1.07	BR	6	150.0	135.0	20000.0	34.0	W1
g	1.09							
h	1.13							
i	1.24							
j	1.26							

Load	Value
L1	6000 psf



CUY-90-14.40 (SECTION A-A)

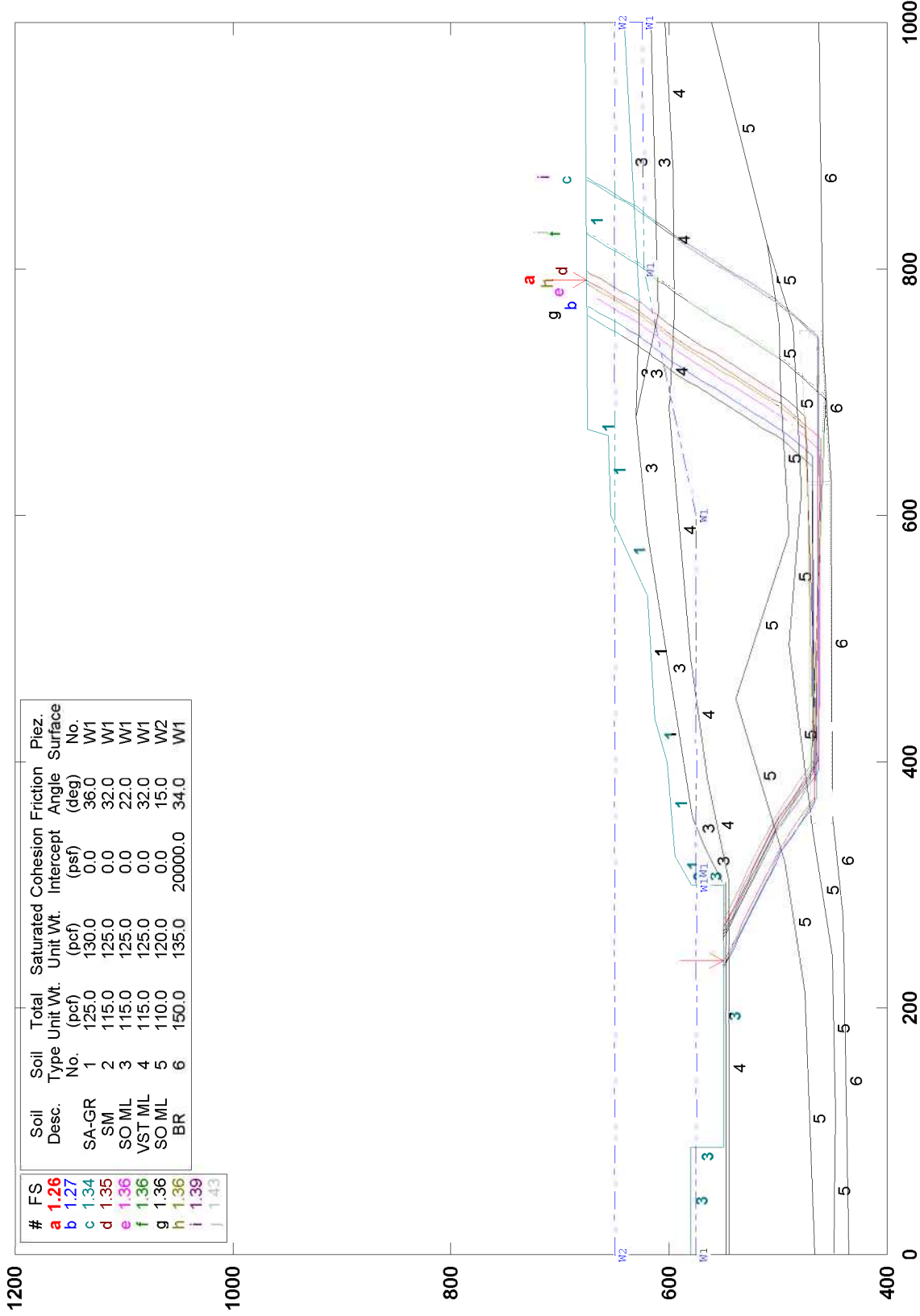

GSTABL7 v.2 FSmin=1.26

#	FS	Soil Desc.	Soil Type No.	Total Unit Wt. (pcf)	Saturated Unit Wt. (pcf)	Cohesion (psf)	Friction Angle (deg)	Piez. Surface No.
a	1.26	SA-GR	1	125.0	130.0	0.0	36.0	W1
b	1.27	SM	2	115.0	125.0	0.0	32.0	W1
c	1.34	SO ML	3	115.0	125.0	0.0	22.0	W1
d	1.35	VST ML	4	115.0	125.0	0.0	32.0	W1
e	1.36	SO ML	5	110.0	120.0	0.0	15.0	W2
f	1.36	BR	6	150.0	135.0	20000.0	34.0	W1
g	1.36							
h	1.36							
i	1.39							
j	1.43							



CUY-90-14.40 (SECTION A-A)

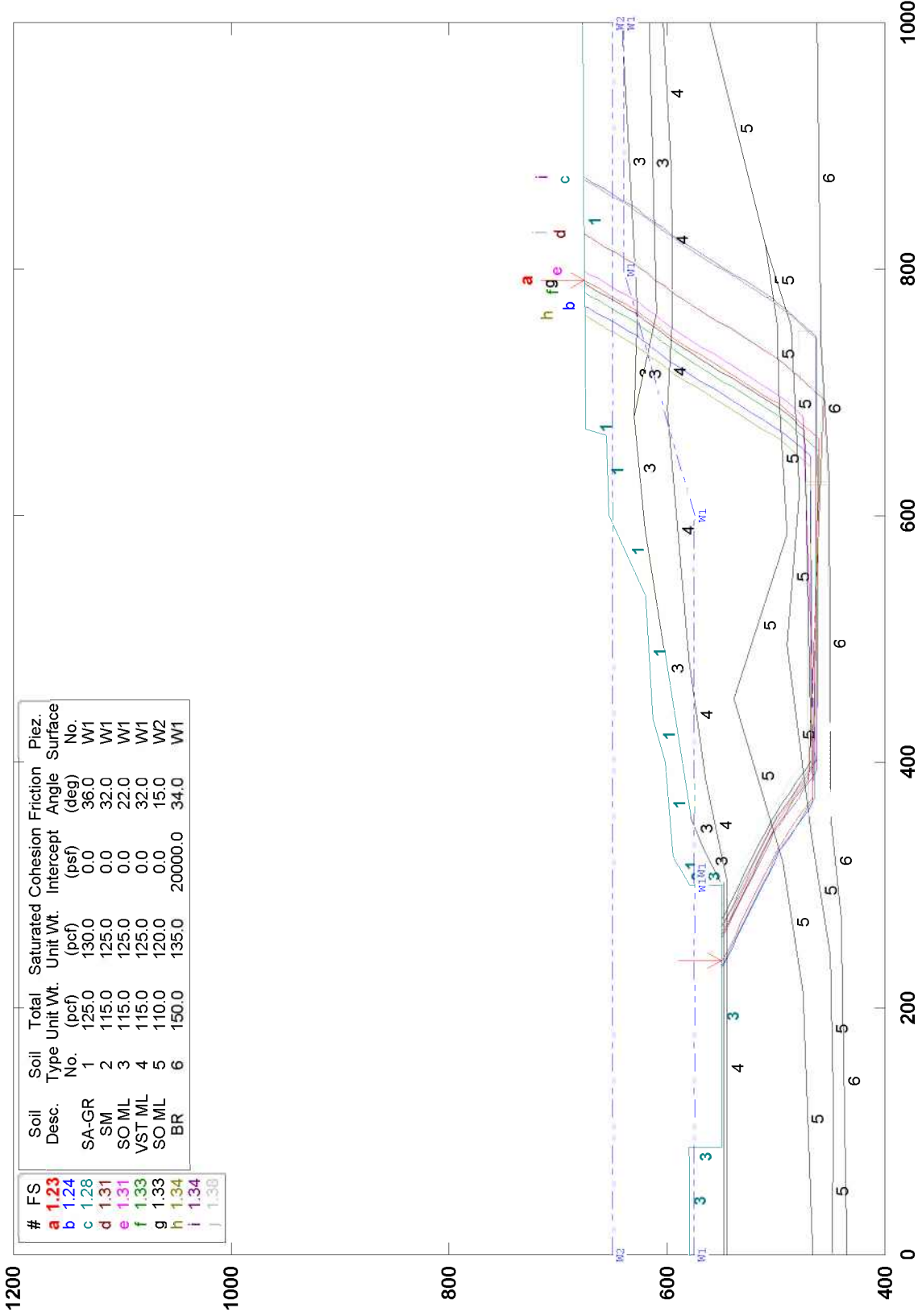

GSTABL7 v.2 FSmin=1.23

#	FS	Soil Desc.	Soil Type No.	Total Unit Wt. (pcf)	Saturated Unit Wt. (pcf)	Cohesion Intercept (psf)	Friction Angle (deg)	Piez. Surface No.
a	1.23	SA-GR	1	125.0	130.0	0.0	36.0	W1
b	1.24	SM	2	115.0	125.0	0.0	32.0	W1
c	1.28	SO ML	3	115.0	125.0	0.0	22.0	W1
d	1.31	VST ML	4	115.0	125.0	0.0	32.0	W1
e	1.33	SO ML	5	110.0	120.0	0.0	15.0	W2
f	1.33	BR	6	150.0	135.0	20000.0	34.0	W1
g	1.33							
h	1.34							
i	1.34							
j	1.38							



CUY-90-14.40 (SECTION A-A)

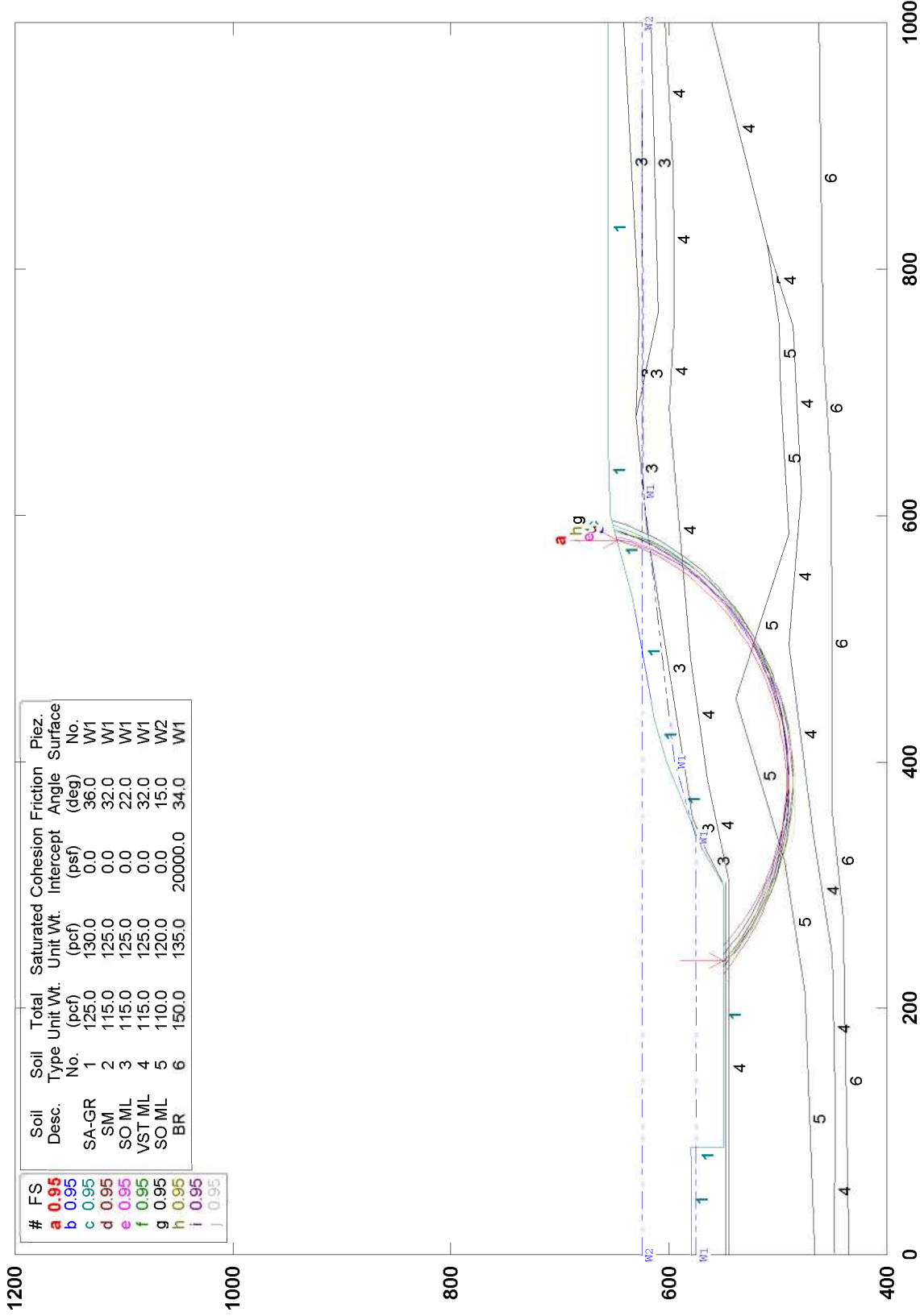

GSTABL7 v.2 FSmin=0.95

#	FS	Soil Desc.	Soil Type No.	Total Unit Wt. (pcf)	Saturated Unit Wt. (pcf)	Cohesion (psf)	Friction Angle (deg)	Piez. Surface No.
a	0.95	SA-GR	1	125.0	130.0	0.0	36.0	W1
b	0.95	SM	2	115.0	125.0	0.0	32.0	W1
c	0.95	SO ML	3	115.0	125.0	0.0	22.0	W1
d	0.95	VST ML	4	115.0	125.0	0.0	32.0	W1
e	0.95	SO ML	5	110.0	120.0	0.0	15.0	W2
f	0.95	BR	6	150.0	135.0	20000.0	34.0	W1



CUY-90-14.40 (SECTION A-A)

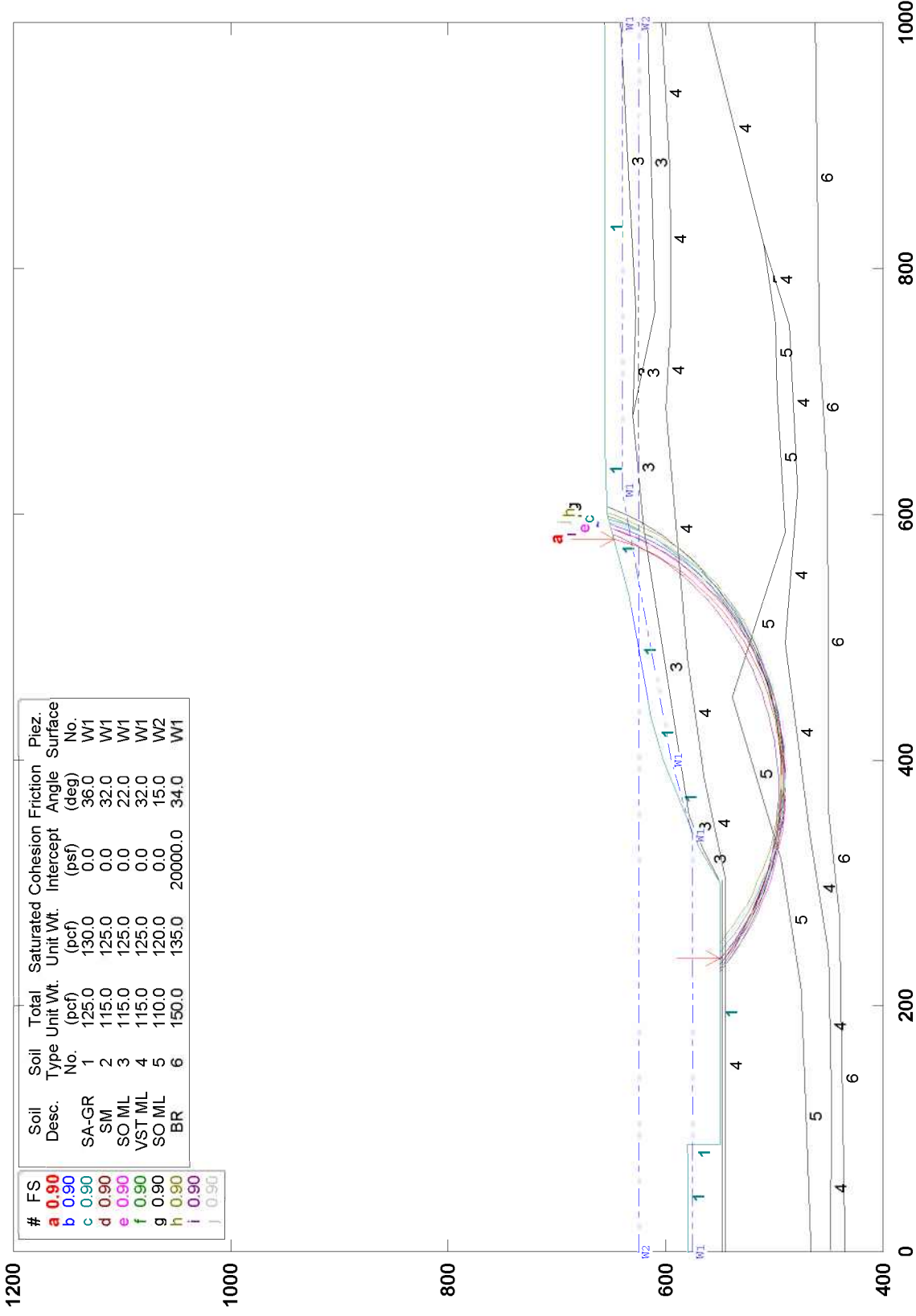

#	FS	Soil Desc.	Soil Type No.	Total Unit Wt. (pcf)	Saturated Unit Wt. (pcf)	Cohesion (psf)	Friction Angle (deg)	Piez. Surface No.
a	0.90	SA-GR	1	125.0	130.0	0.0	36.0	W1
b	0.90	SM	2	115.0	125.0	0.0	32.0	W1
c	0.90	SO ML	3	115.0	125.0	0.0	22.0	W1
d	0.90	VST ML	4	115.0	125.0	0.0	32.0	W1
e	0.90	SO ML	5	110.0	120.0	0.0	15.0	W2
f	0.90	BR	6	150.0	135.0	20000.0	34.0	W1

GSTABL7 v.2 FSmin=0.90



CUY-90-14.40 (SECTION A-A)

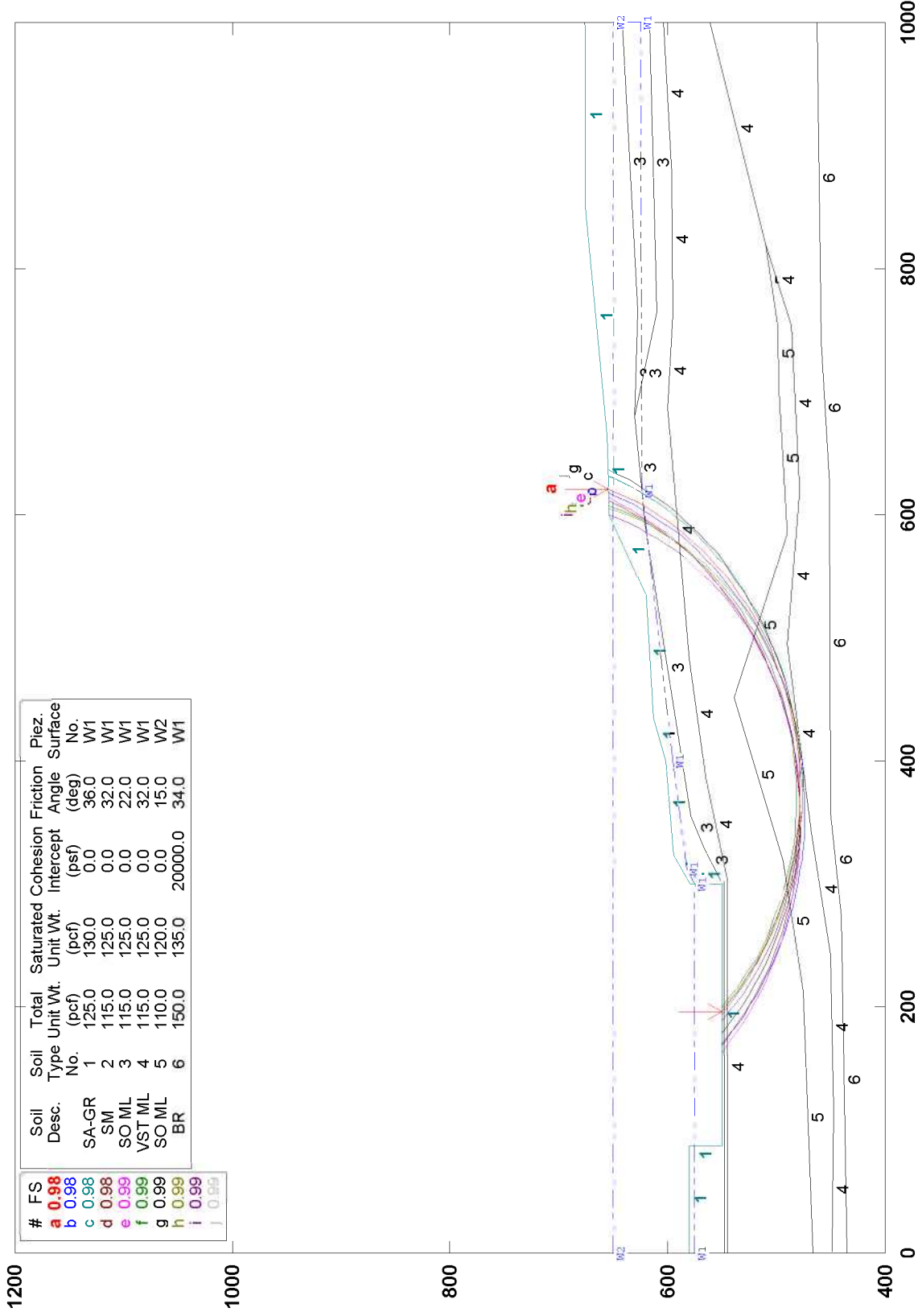

GSTABL7 v.2 FSmin=0.98

#	FS	Soil Desc.	Soil Type No.	Total Unit Wt. (pcf)	Saturated Unit Wt. (pcf)	Cohesion (psf)	Friction Angle (deg)	Piez. Surface No.
a	0.98	SA-GR	1	125.0	130.0	0.0	36.0	W1
b	0.98	SM	2	115.0	125.0	0.0	32.0	W1
c	0.98	SO ML	3	115.0	125.0	0.0	22.0	W1
d	0.99	VST ML	4	115.0	125.0	0.0	32.0	W1
e	0.99	SO ML	5	110.0	120.0	0.0	15.0	W2
f	0.99	BR	6	150.0	135.0	20000.0	34.0	W1
g	0.99							
h	0.99							
i	0.99							
j	0.99							



CUY-90-14.40 (SECTION A-A)

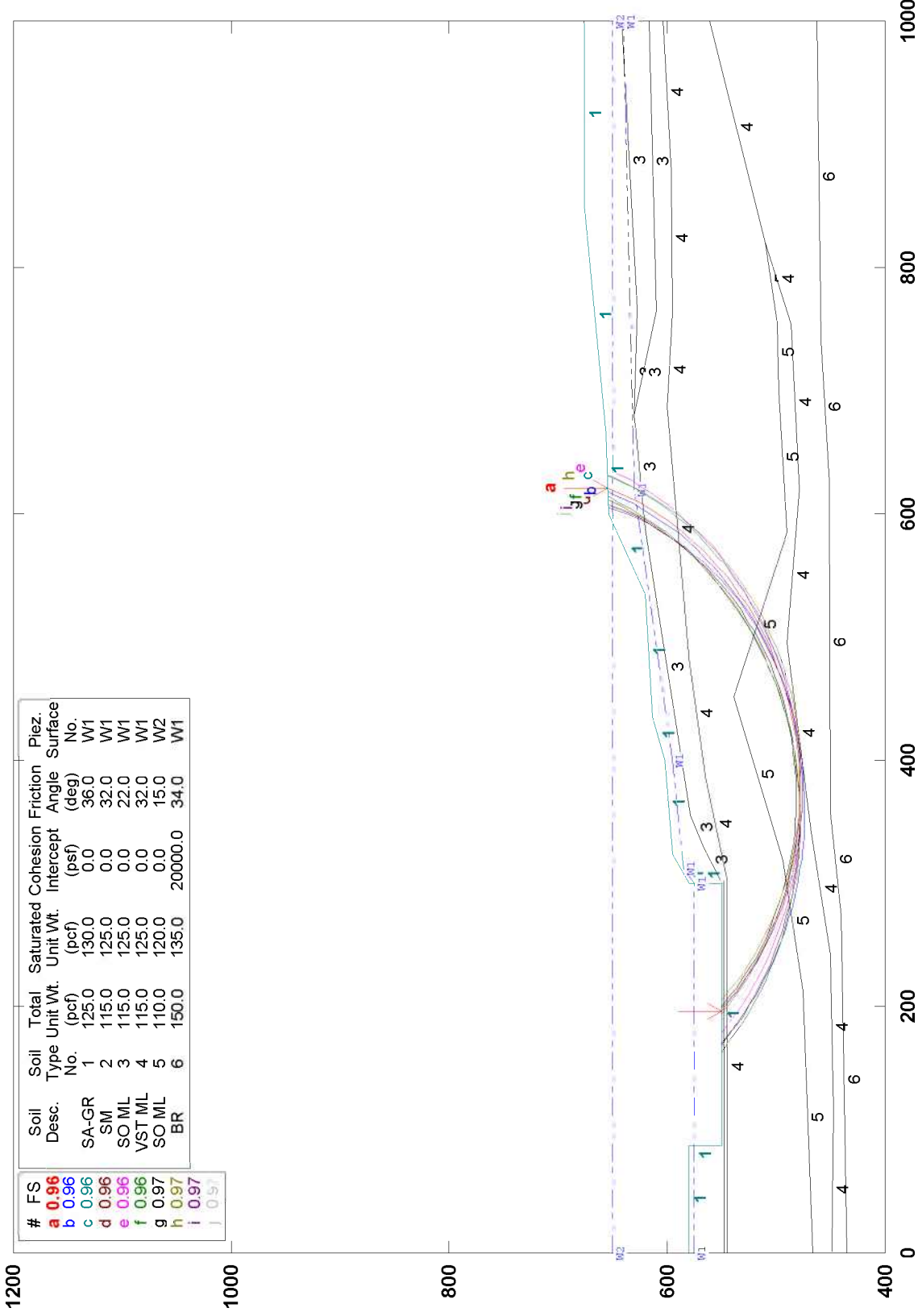

GSTABL7 v.2 FSmin=0.96

#	FS	Soil Desc.	Soil Type No.	Total Unit Wt. (pcf)	Saturated Unit Wt. (pcf)	Cohesion (psf)	Friction Angle (deg)	Piez. Surface No.
a	0.96	SA-GR	1	125.0	130.0	0.0	36.0	W1
b	0.96	SM	2	115.0	125.0	0.0	32.0	W1
c	0.96	SO ML	3	115.0	125.0	0.0	22.0	W1
d	0.96	VST ML	4	115.0	125.0	0.0	32.0	W1
e	0.96	SO ML	5	110.0	120.0	0.0	15.0	W2
f	0.97	BR	6	150.0	135.0	20000.0	34.0	W1
g	0.97							
h	0.97							
i	0.97							
j	0.97							



CUY-90-14.40 (SECTION A-A)

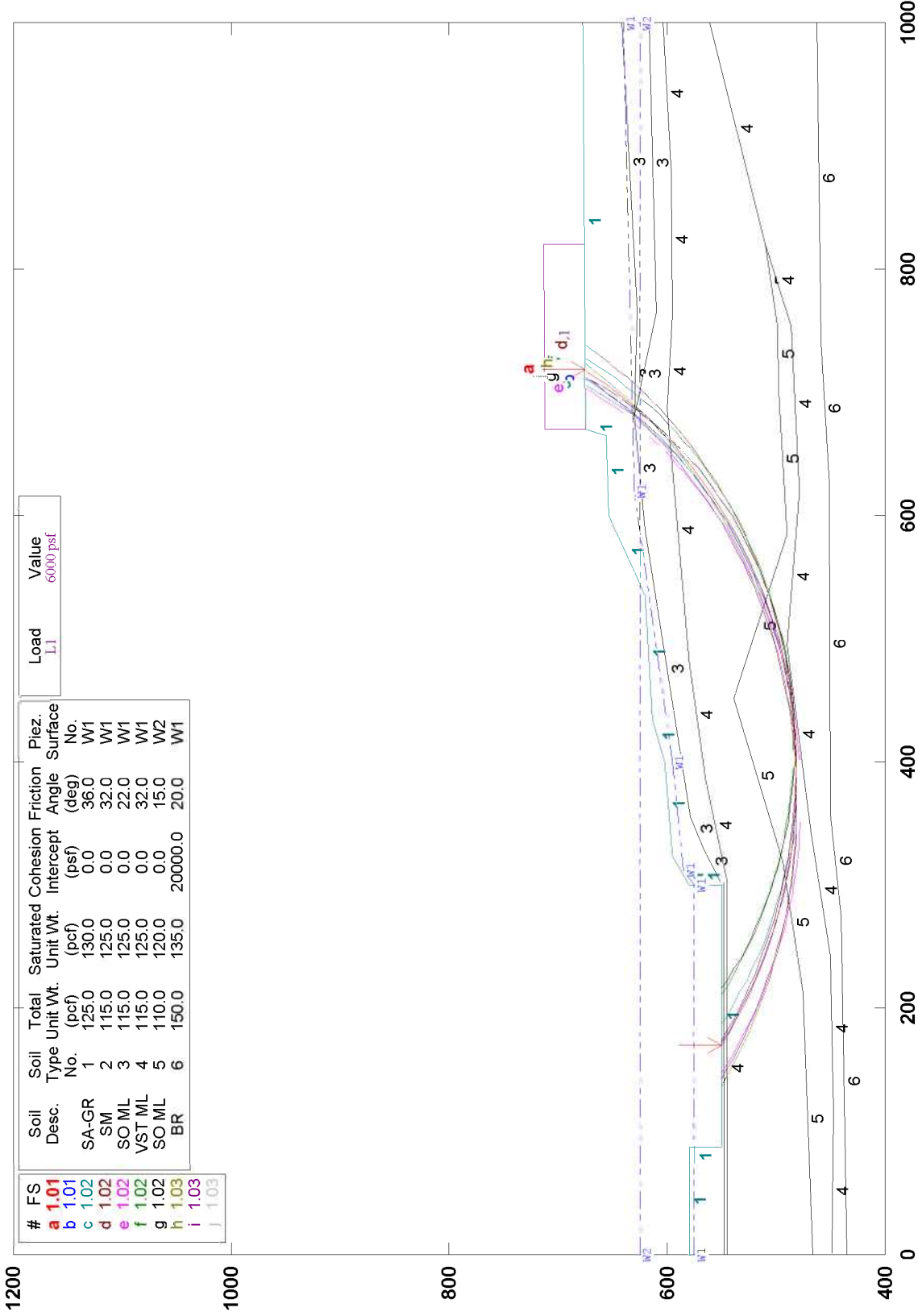

#	FS	Soil Desc.	Soil Type No.	Total Unit Wt. (pcf)	Saturated Unit Wt. (pcf)	Cohesion Intercept (psf)	Friction Angle (deg)	Piez. Surface No.
a	1.01	SA-GR	1	125.0	130.0	0.0	36.0	W1
b	1.01	SM	2	115.0	125.0	0.0	32.0	W1
c	1.02	SO ML	3	115.0	125.0	0.0	22.0	W1
d	1.02	VST ML	4	115.0	125.0	0.0	32.0	W1
e	1.02	SO ML	5	110.0	120.0	0.0	15.0	W2
f	1.02	BR	6	150.0	135.0	20000.0	20.0	W1
g	1.02							
h	1.03							
i	1.03							
j	1.03							

Load	Value
L1	6000 psf

GSTABL7 v.2 FSmin=1.01



CUY-90-14.40 (SECTION A-A)

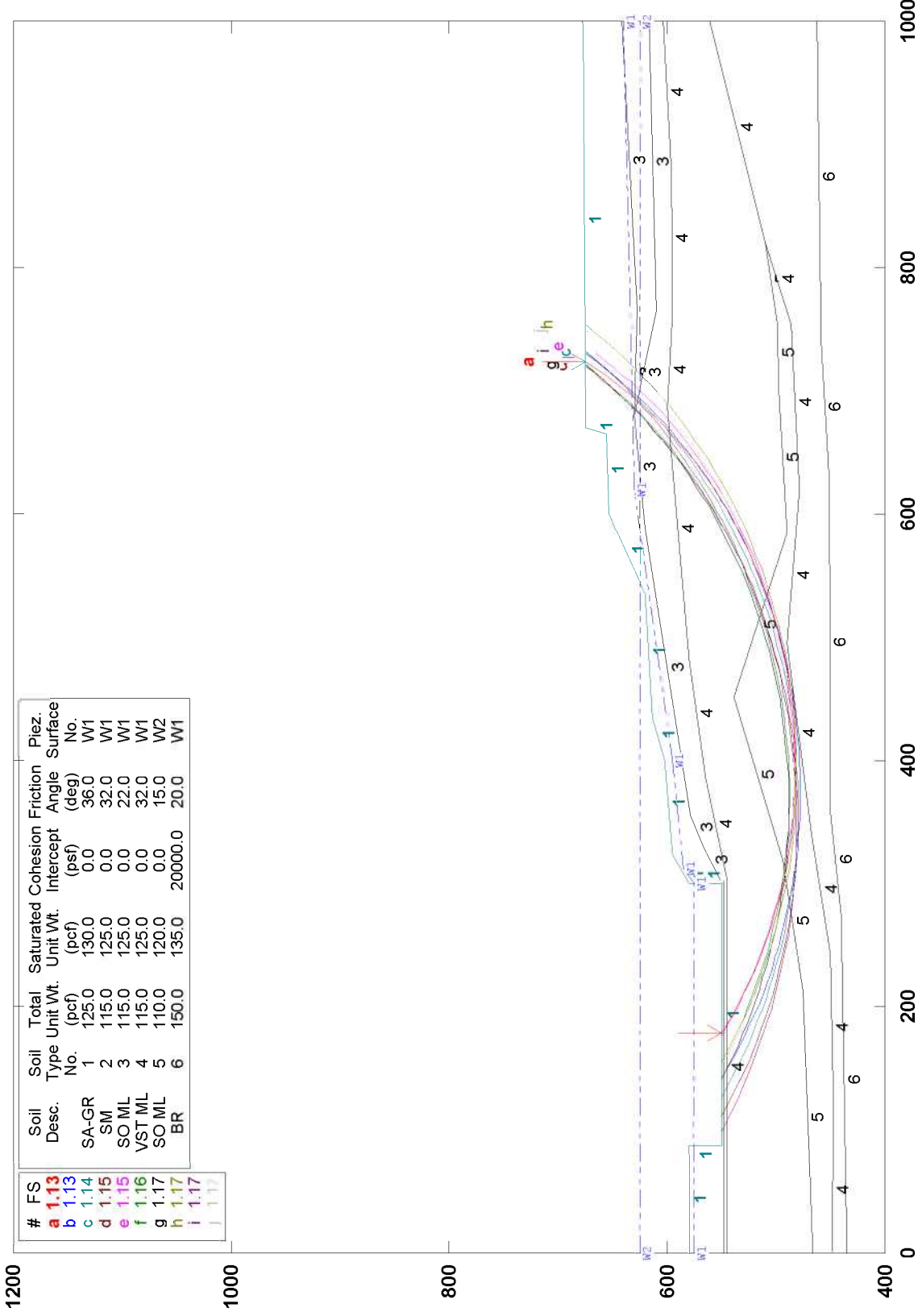

#	FS	Soil Desc.	Soil Type No.	Total Unit Wt. (pcf)	Saturated Unit Wt. (pcf)	Cohesion (psf)	Friction Angle (deg)	Piez. Surface No.
a	1.13	SA-GR	1	125.0	130.0	0.0	36.0	W1
b	1.14	SM	2	115.0	125.0	0.0	32.0	W1
c	1.15	SO ML	3	115.0	125.0	0.0	22.0	W1
d	1.16	VST ML	4	115.0	125.0	0.0	32.0	W1
e	1.17	SO ML	5	110.0	120.0	0.0	15.0	W2
f	1.17	BR	6	150.0	135.0	20000.0	20.0	W1



CUY-90-14.40 (SECTION A-A)

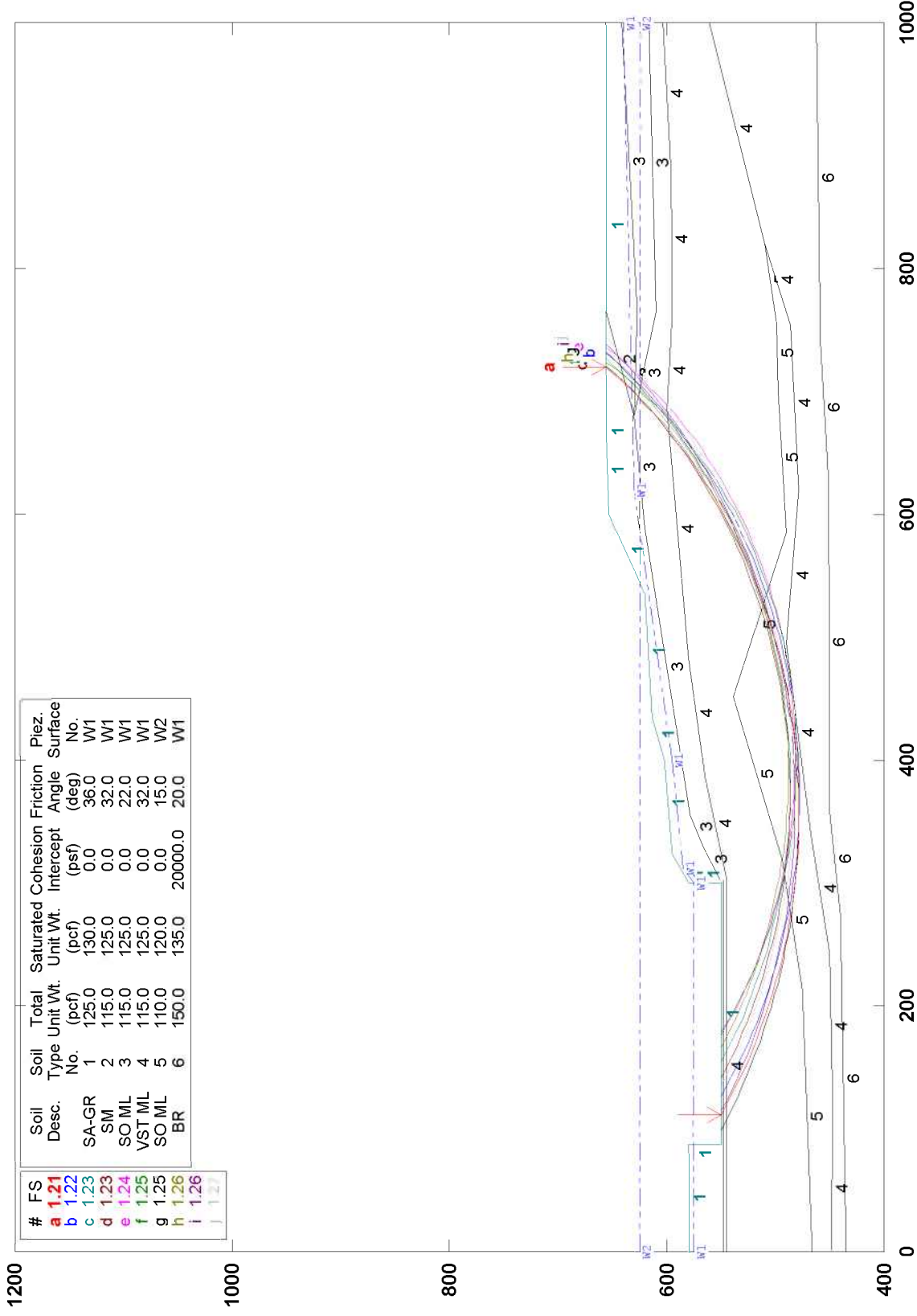

GSTABL7 v.2 FSmin=1.21

#	FS	Soil Desc.	Soil Type No.	Total Unit Wt. (pcf)	Saturated Unit Wt. (pcf)	Cohesion (psf)	Friction Angle (deg)	Piez. Surface No.
a	1.21	SA-GR	1	125.0	130.0	0.0	36.0	W1
b	1.22	SM	2	115.0	125.0	0.0	32.0	W1
c	1.23	SO ML	3	115.0	125.0	0.0	22.0	W1
d	1.24	VST ML	4	115.0	125.0	0.0	32.0	W1
e	1.25	SO ML	5	110.0	120.0	0.0	15.0	W2
f	1.26	BR	6	150.0	135.0	20000.0	20.0	W1



CUY-90-14.40 (SECTION A-A)

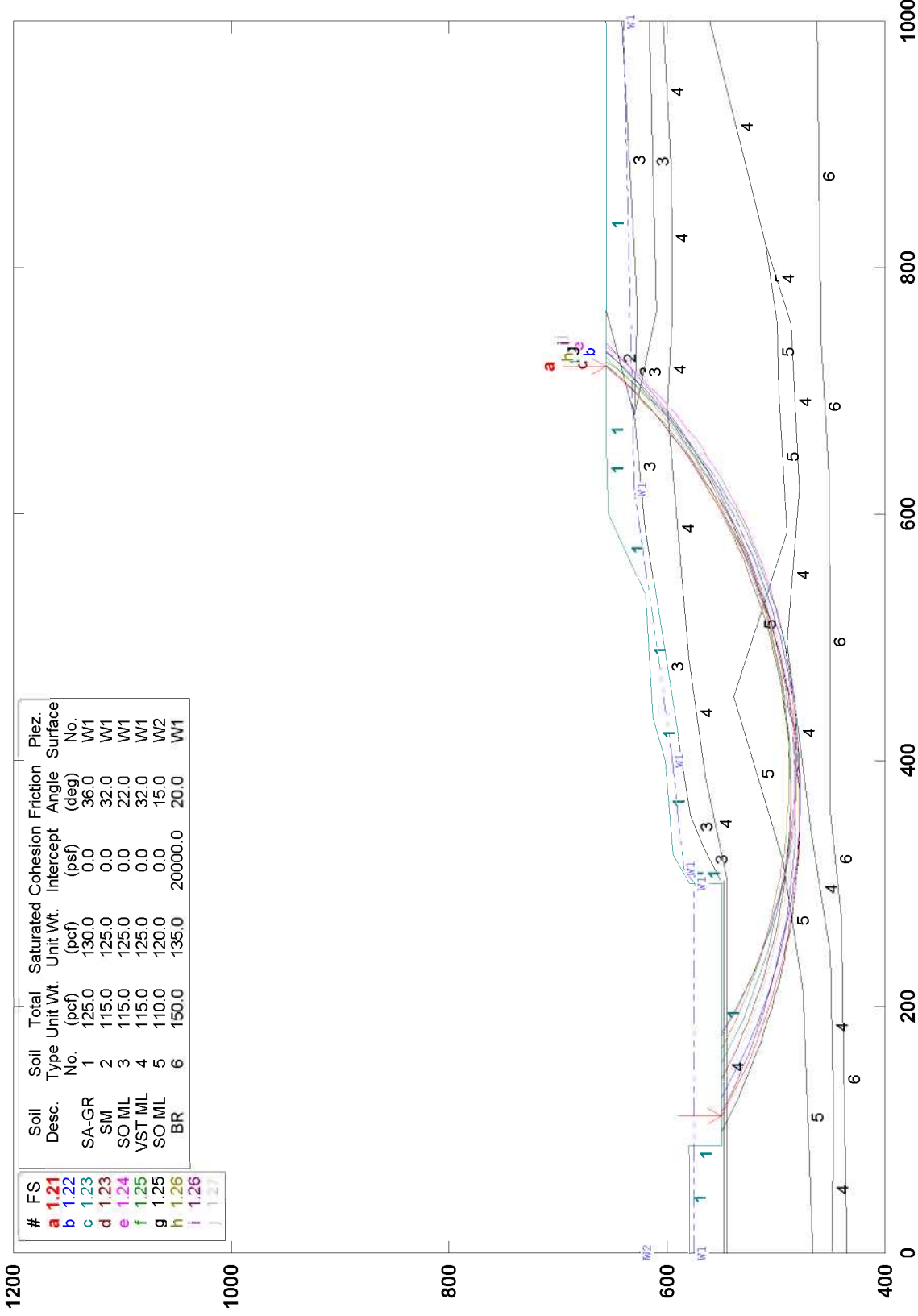

#	FS	Soil Desc.	Soil Type No.	Total Unit Wt. (pcf)	Saturated Unit Wt. (pcf)	Cohesion (psf)	Friction Angle (deg)	Piez. Surface No.
a	1.21	SA-GR	1	125.0	130.0	0.0	36.0	W1
b	1.22	SM	2	115.0	125.0	0.0	32.0	W1
c	1.23	SO ML	3	115.0	125.0	0.0	22.0	W1
d	1.24	VST ML	4	115.0	125.0	0.0	32.0	W1
e	1.25	SO ML	5	110.0	120.0	0.0	15.0	W2
f	1.26	BR	6	150.0	135.0	20000.0	20.0	W1

GSTABL7 v.2 FSmin=1.21



CUY-90-14.40 (SECTION A-A)

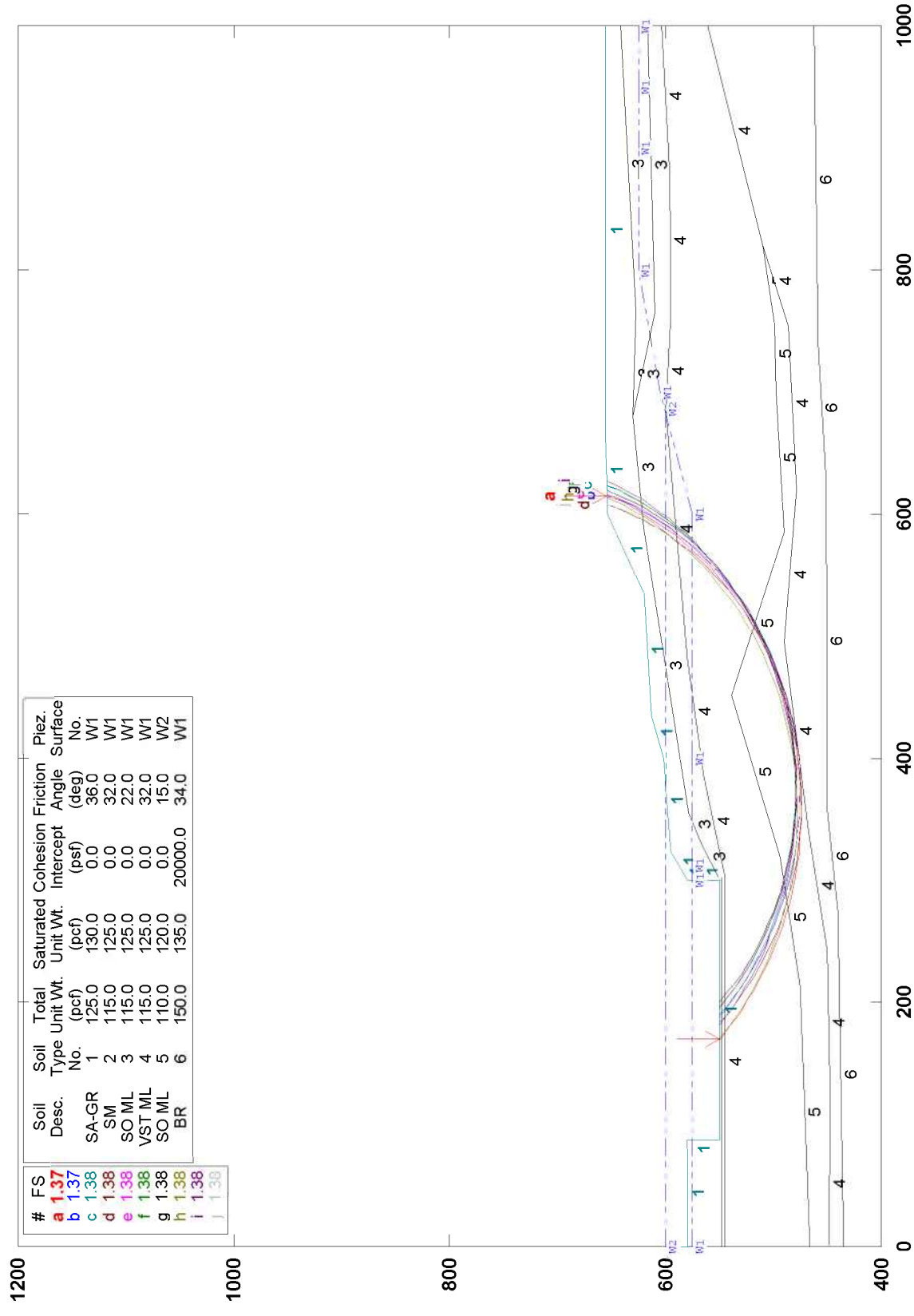

#	FS	Soil Desc.	Soil Type No.	Total Unit Wt. (pcf)	Saturated Unit Wt. (pcf)	Cohesion (psf)	Friction Angle (deg)	Piez. Surface No.
a	1.37	SA-GR	1	125.0	130.0	0.0	36.0	W1
b	1.38	SM	2	115.0	125.0	0.0	32.0	W1
c	1.38	SO ML	3	115.0	125.0	0.0	22.0	W1
d	1.38	VST ML	4	115.0	125.0	0.0	32.0	W1
e	1.38	SO ML	5	110.0	120.0	0.0	15.0	W2
f	1.38	BR	6	150.0	135.0	20000.0	34.0	W1



CUY-90-14.40 (SECTION A-A)

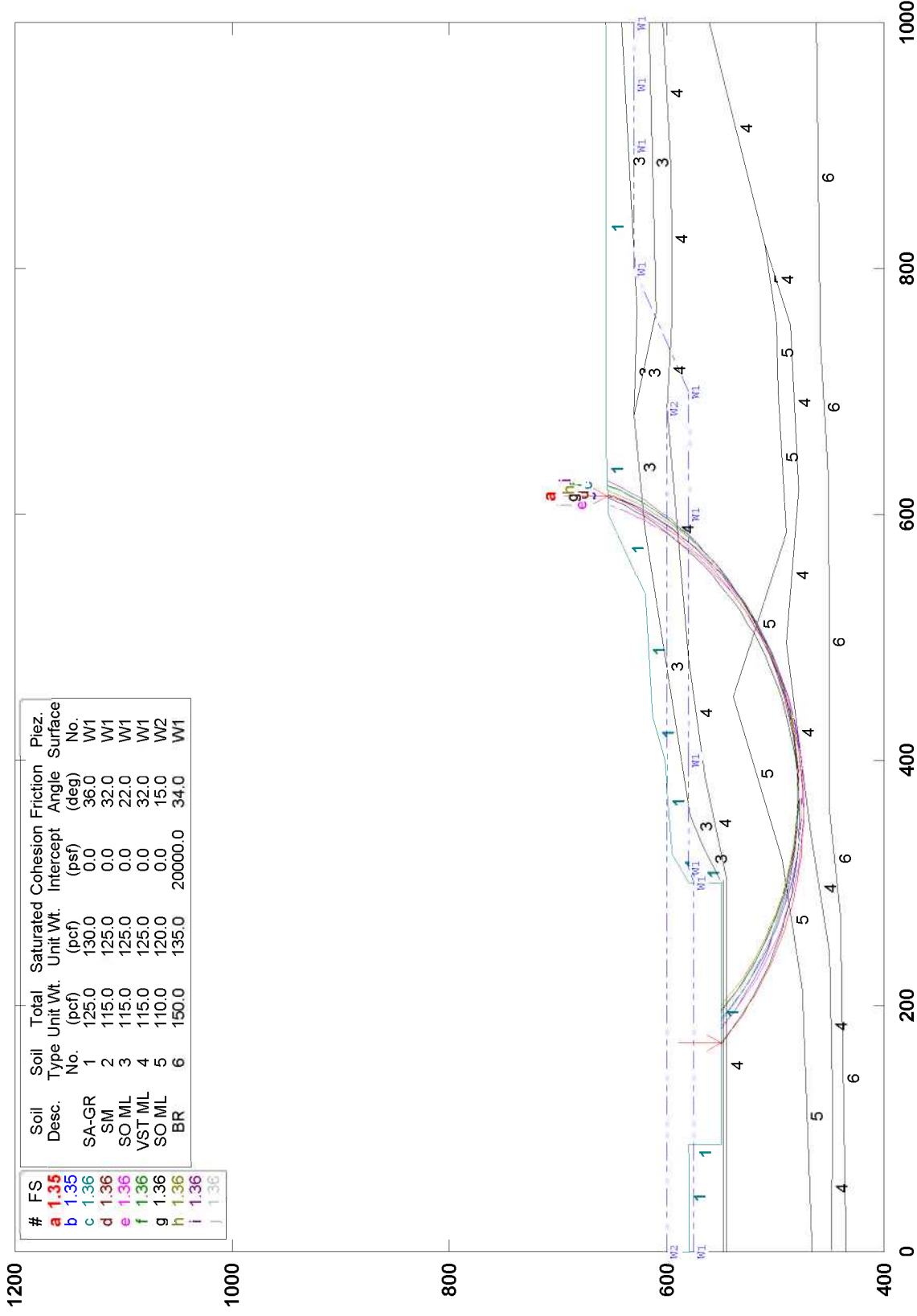

GSTABL7 v.2 FSmin=1.35

#	FS	Soil Desc.	Soil Type No.	Total Unit Wt. (pcf)	Saturated Unit Wt. (pcf)	Cohesion (psf)	Friction Angle (deg)	Piez. Surface No.
a	1.35	SA-GR	1	125.0	130.0	0.0	36.0	W1
b	1.36	SM	2	115.0	125.0	0.0	32.0	W1
c	1.36	SO ML	3	115.0	125.0	0.0	22.0	W1
d	1.36	VST ML	4	115.0	125.0	0.0	32.0	W1
e	1.36	SO ML	5	110.0	120.0	0.0	15.0	W2
f	1.36	BR	6	150.0	135.0	20000.0	34.0	W1



CUY-90-14.40 (BRIDGE CL)

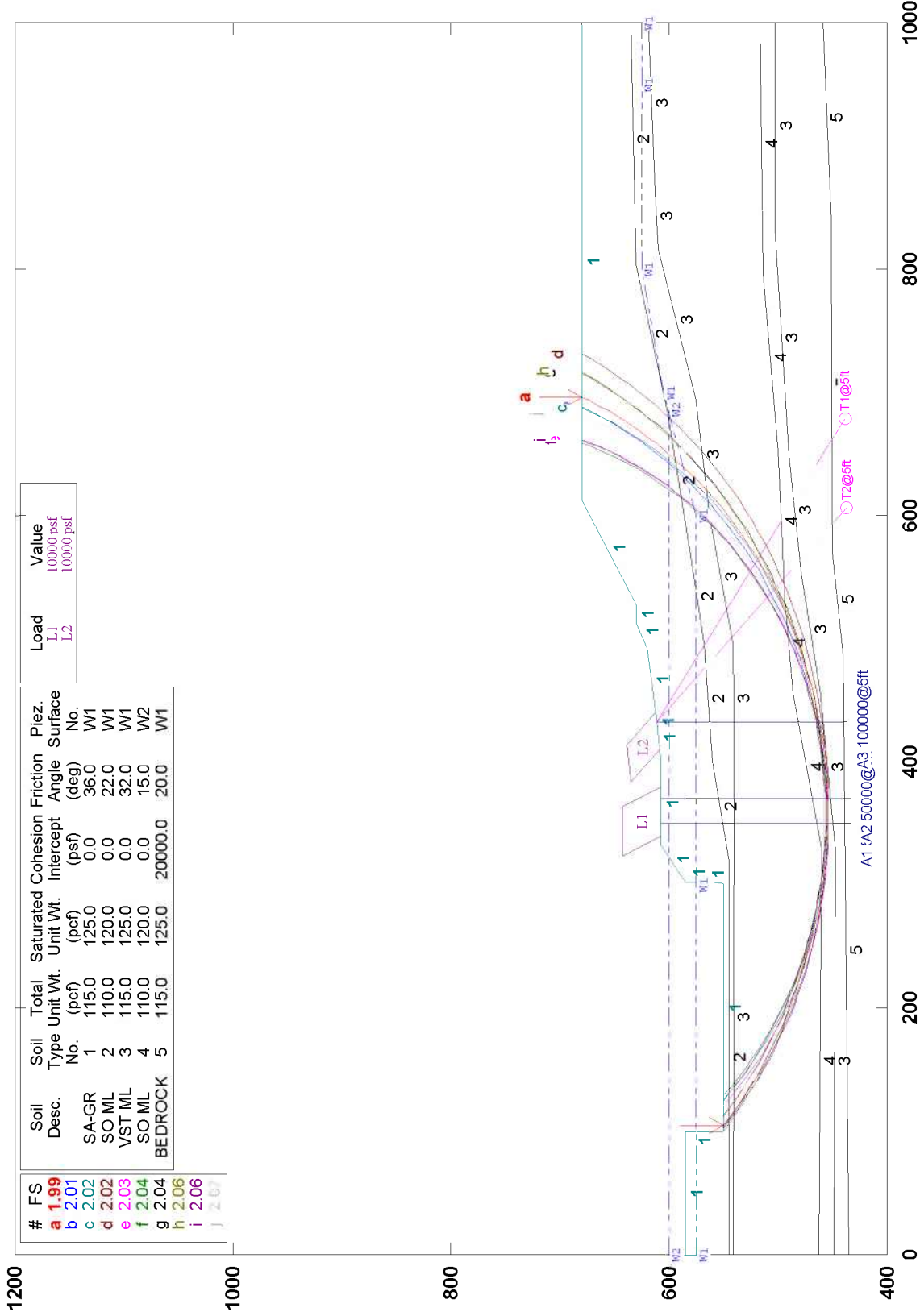

GSTABL7 v.2 FSmin=1.99

Load	Value
L1	10000 psf
L2	10000 psf

Soil Desc.	Soil Type No.	Total Unit Wt. (pcf)	Saturated Unit Wt. (pcf)	Cohesion (psf)	Friction Angle (deg)	Piez. Surface No.
SA-GR	1	115.0	125.0	0.0	36.0	W1
SO ML	2	110.0	120.0	0.0	22.0	W1
VST ML	3	115.0	125.0	0.0	32.0	W1
SO ML	4	110.0	120.0	0.0	15.0	W2
BEDROCK	5	115.0	125.0	20000.0	20.0	W1

#	FS
a	1.99
b	2.01
c	2.02
d	2.02
e	2.03
f	2.04
g	2.04
h	2.06
i	2.06
j	2.07



CUY-90-14.40 (BRIDGE CL)

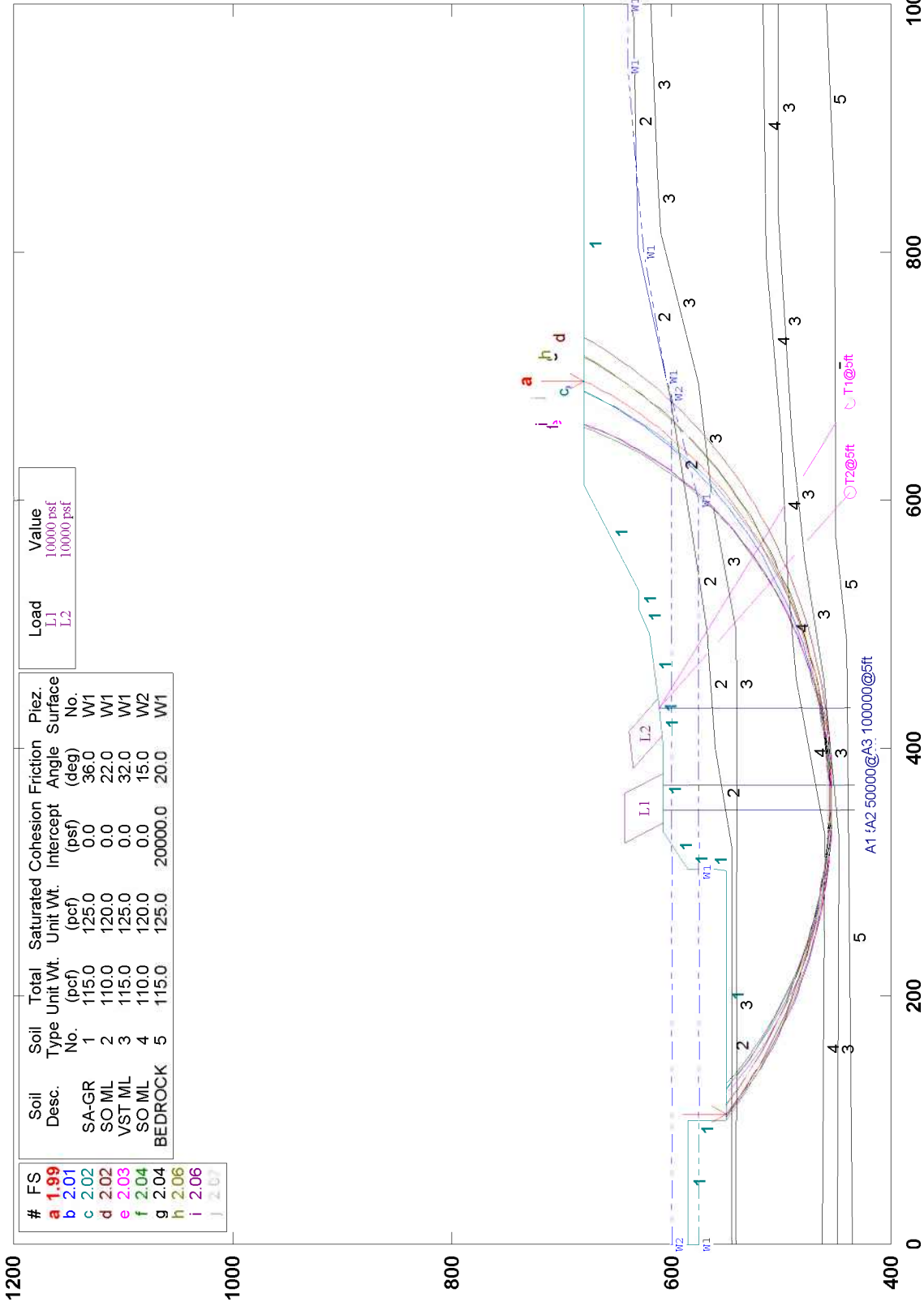

CUY-90-14.40: (SECTION D-D)

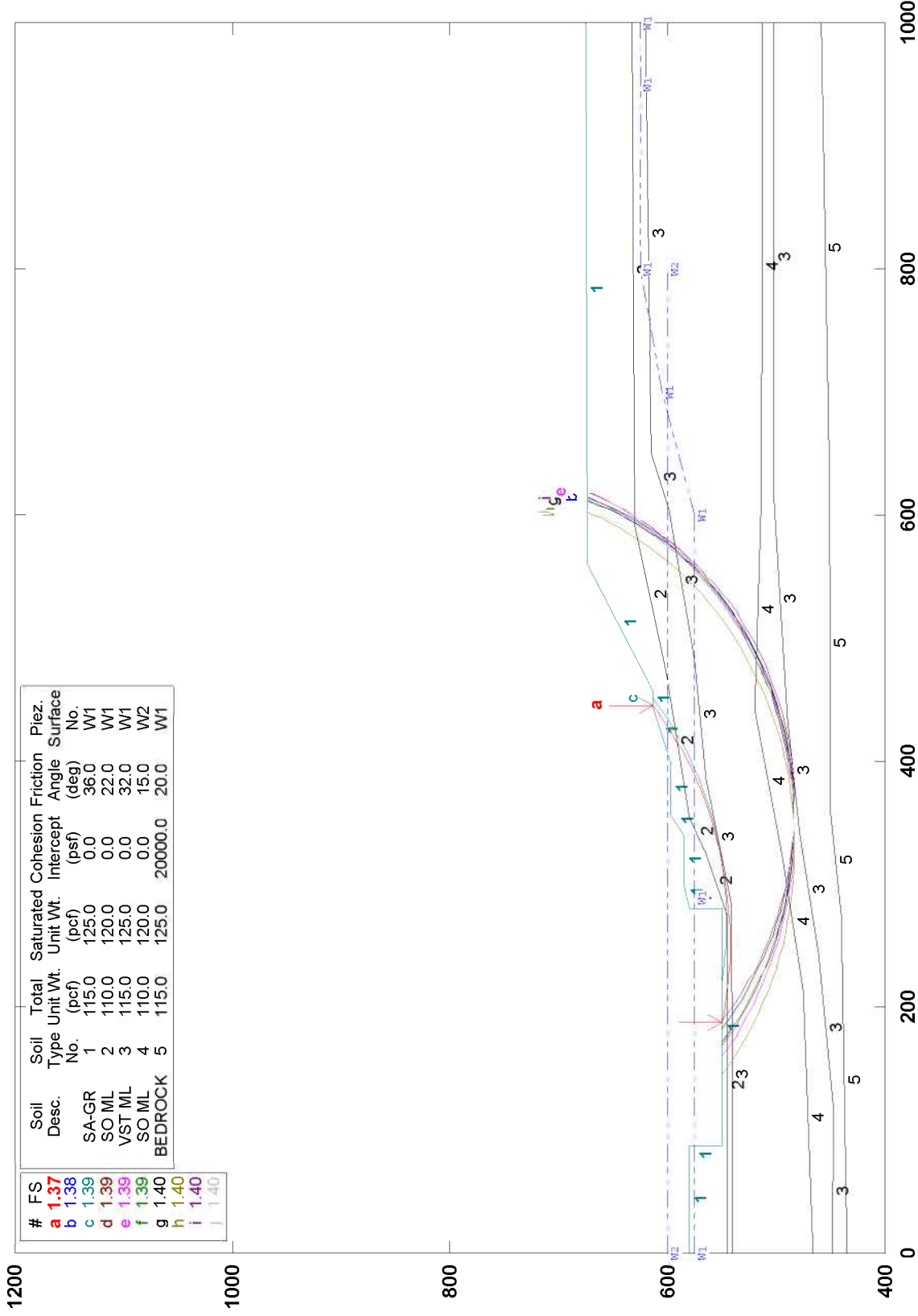

GSTABL7 v.2 FSmin=1.37

#	FS	Soil Desc.	Soil Type No.	Total Unit Wt. (pcf)	Saturated Unit Wt. (pcf)	Cohesion Intercept (psf)	Friction Angle (deg)	Piez. Surface No.
a	1.37	SA-GR	1	115.0	125.0	0.0	36.0	W1
b	1.38	SO ML	2	110.0	120.0	0.0	22.0	W1
c	1.39	VST ML	3	115.0	125.0	0.0	32.0	W1
d	1.39	SO ML	4	110.0	120.0	0.0	15.0	W2
e	1.39	BEDROCK	5	115.0	125.0	20000.0	20.0	W1
g	1.40							
h	1.40							
i	1.40							
j	1.40							



CUY-90-14.40: (SECTION D-D)

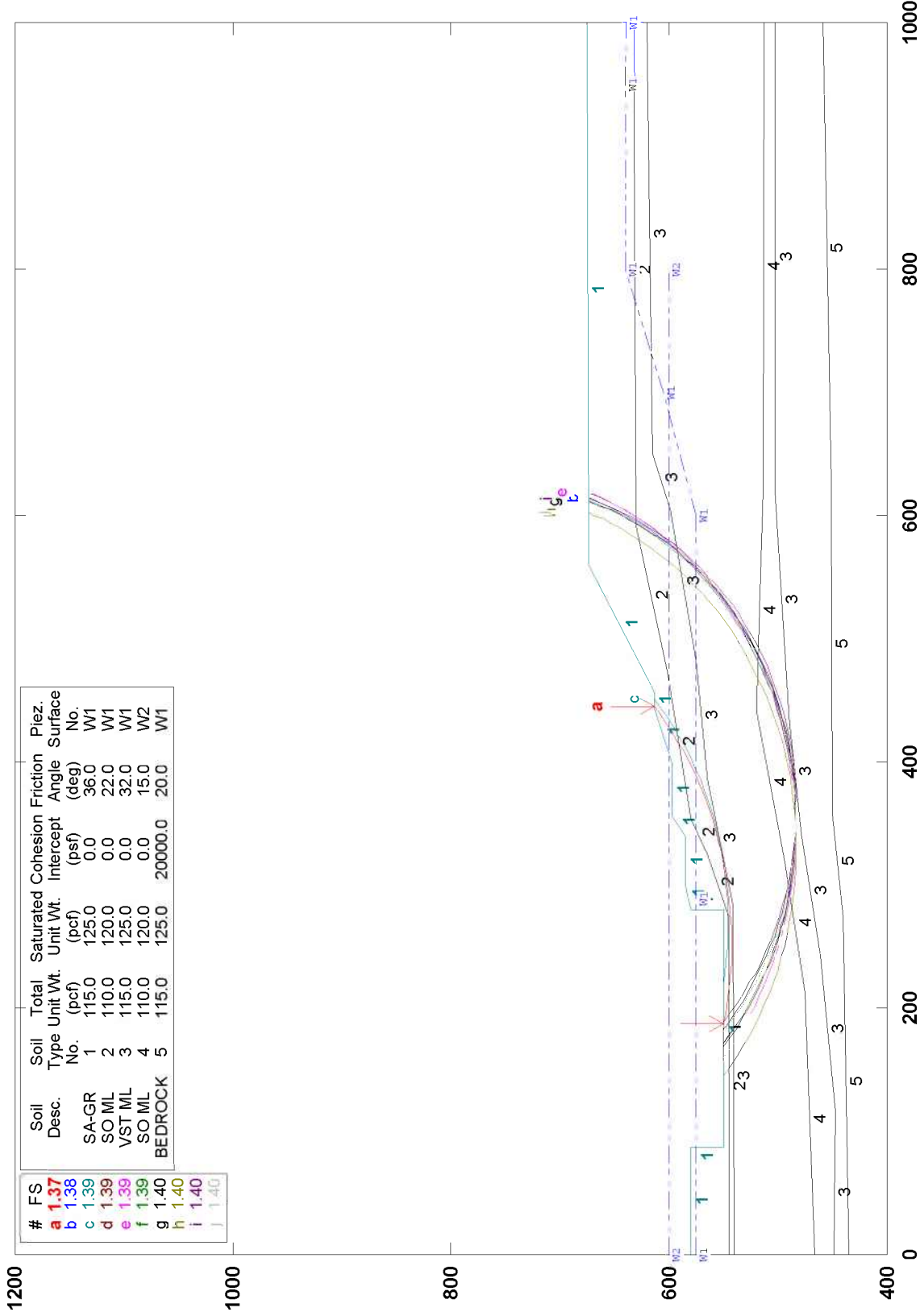

GSTABL7 v.2 FSmin=1.37

#	FS	Soil Desc.	Soil Type No.	Total Unit Wt. (pcf)	Saturated Unit Wt. (pcf)	Cohesion (psf)	Friction Angle (deg)	Piez. Surface No.
a	1.37	SA-GR	1	115.0	125.0	0.0	36.0	W1
b	1.38	SO ML	2	110.0	120.0	0.0	22.0	W1
c	1.39	VST ML	3	115.0	125.0	0.0	32.0	W1
d	1.39	SO ML	4	110.0	120.0	0.0	15.0	W2
e	1.39	SO ML	4	110.0	120.0	0.0	15.0	W2
f	1.39	SO ML	4	110.0	120.0	0.0	15.0	W2
g	1.40	BEDROCK	5	115.0	125.0	20000.0	20.0	W1
h	1.40							
i	1.40							
j	1.40							



CUY-90-14.40 (SECTION A-A)

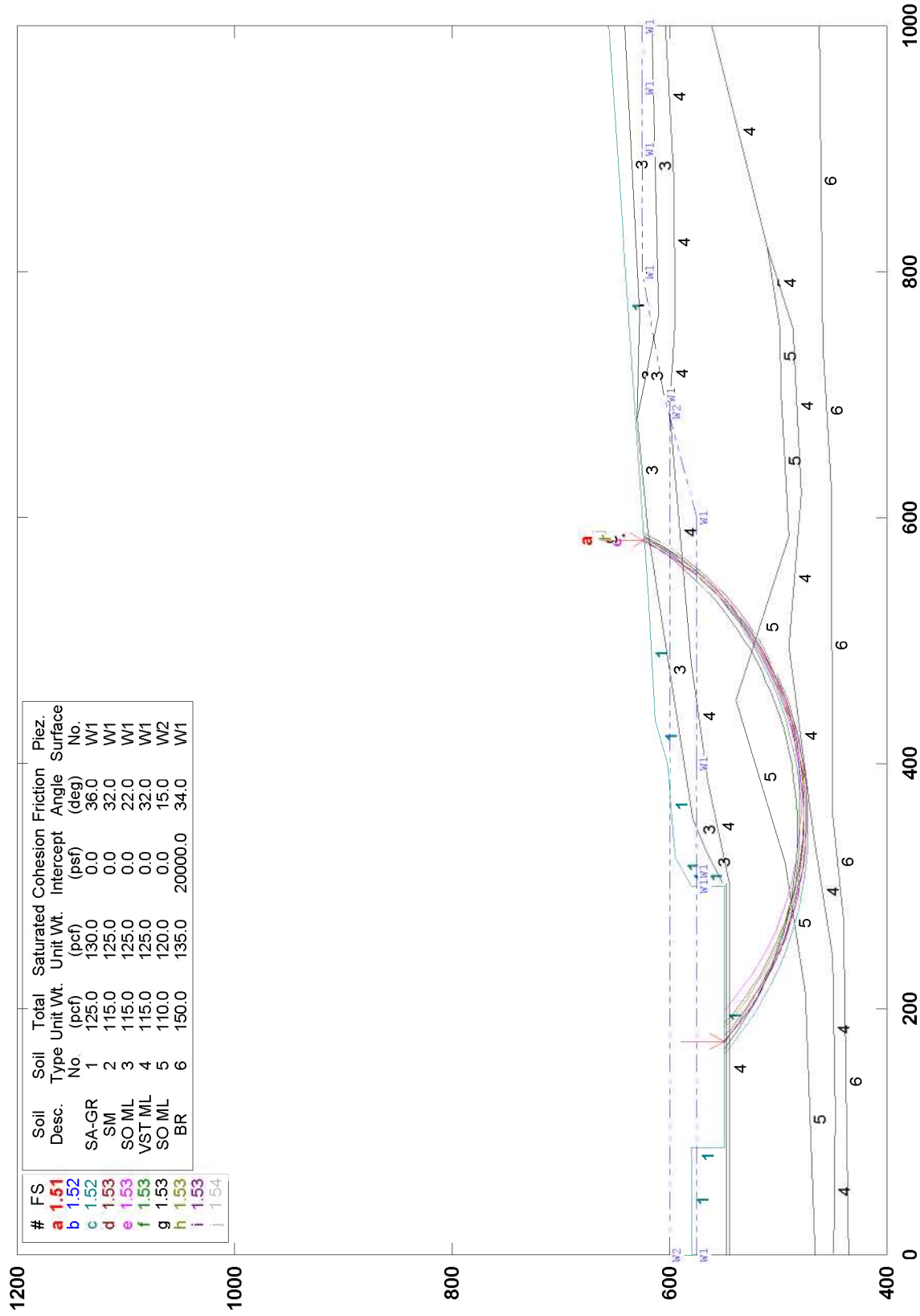

#	FS	Soil Desc.	Soil Type No.	Total Unit Wt. (pcf)	Saturated Unit Wt. (pcf)	Cohesion (psf)	Friction Angle (deg)	Piez. Surface No.
a	1.51	SA-GR	1	125.0	130.0	0.0	36.0	W1
b	1.52	SM	2	115.0	125.0	0.0	32.0	W1
c	1.53	SO ML	3	115.0	125.0	0.0	22.0	W1
d	1.53	VST ML	4	115.0	125.0	0.0	32.0	W1
e	1.53	SO ML	5	110.0	120.0	0.0	15.0	W2
f	1.53	BR	6	150.0	135.0	20000.0	34.0	W1

GSTABL7 v.2 FSmin=1.51



CUY-90-14.40 (SECTION A-A)

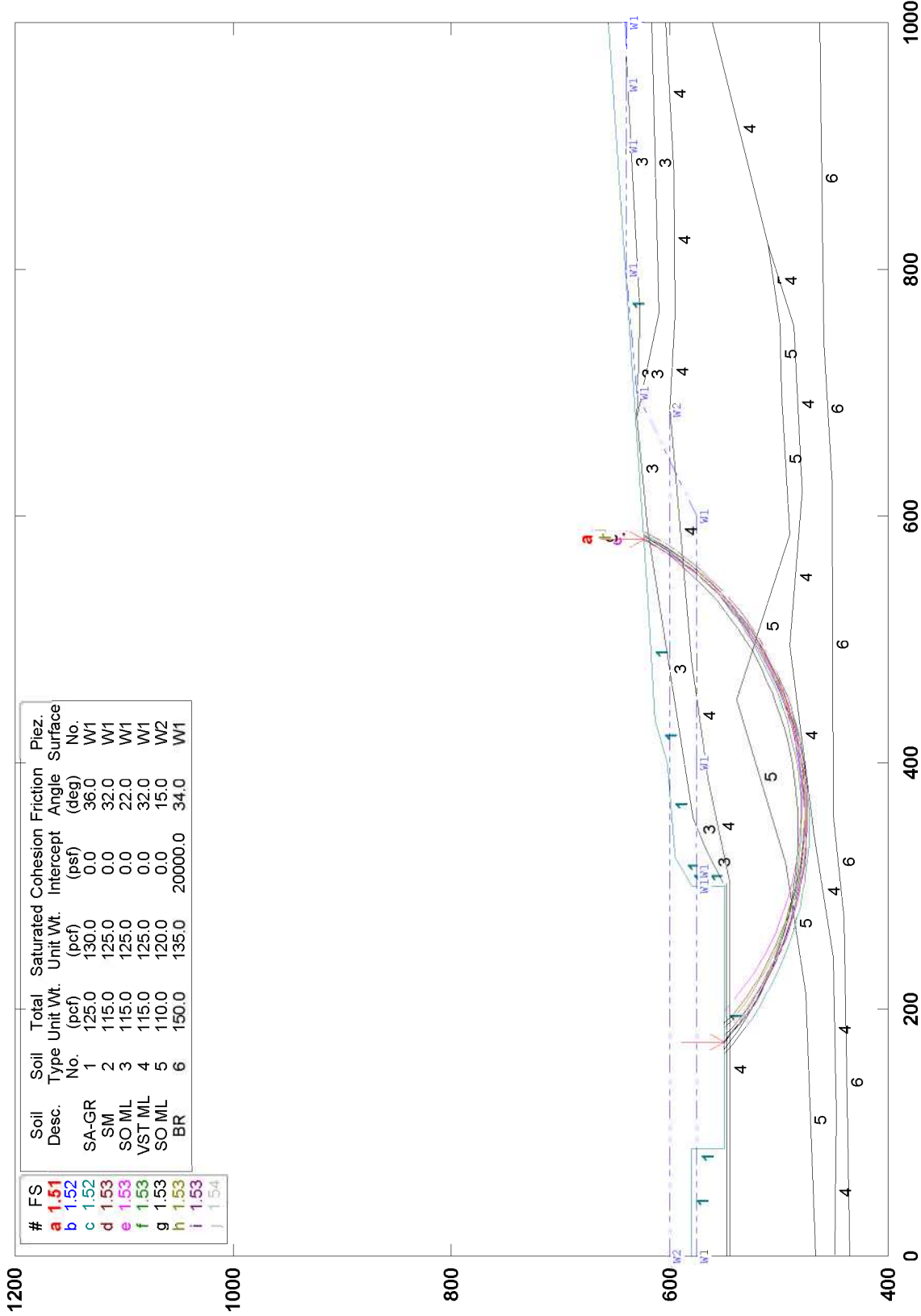

GSTABL7 v.2 FSmin=1.51

#	FS	Soil Desc.	Soil Type No.	Total Unit Wt. (pcf)	Saturated Unit Wt. (pcf)	Cohesion (psf)	Friction Angle (deg)	Piez. Surface No.
a	1.51	SA-GR	1	125.0	130.0	0.0	36.0	W1
b	1.52	SM	2	115.0	125.0	0.0	32.0	W1
c	1.52	SO ML	3	115.0	125.0	0.0	22.0	W1
d	1.53	VST ML	4	115.0	125.0	0.0	32.0	W1
e	1.53	SO ML	5	110.0	120.0	0.0	15.0	W2
f	1.53	BR	6	150.0	135.0	20000.0	34.0	W1



CUY-90-14.40 (SECTION A-A)

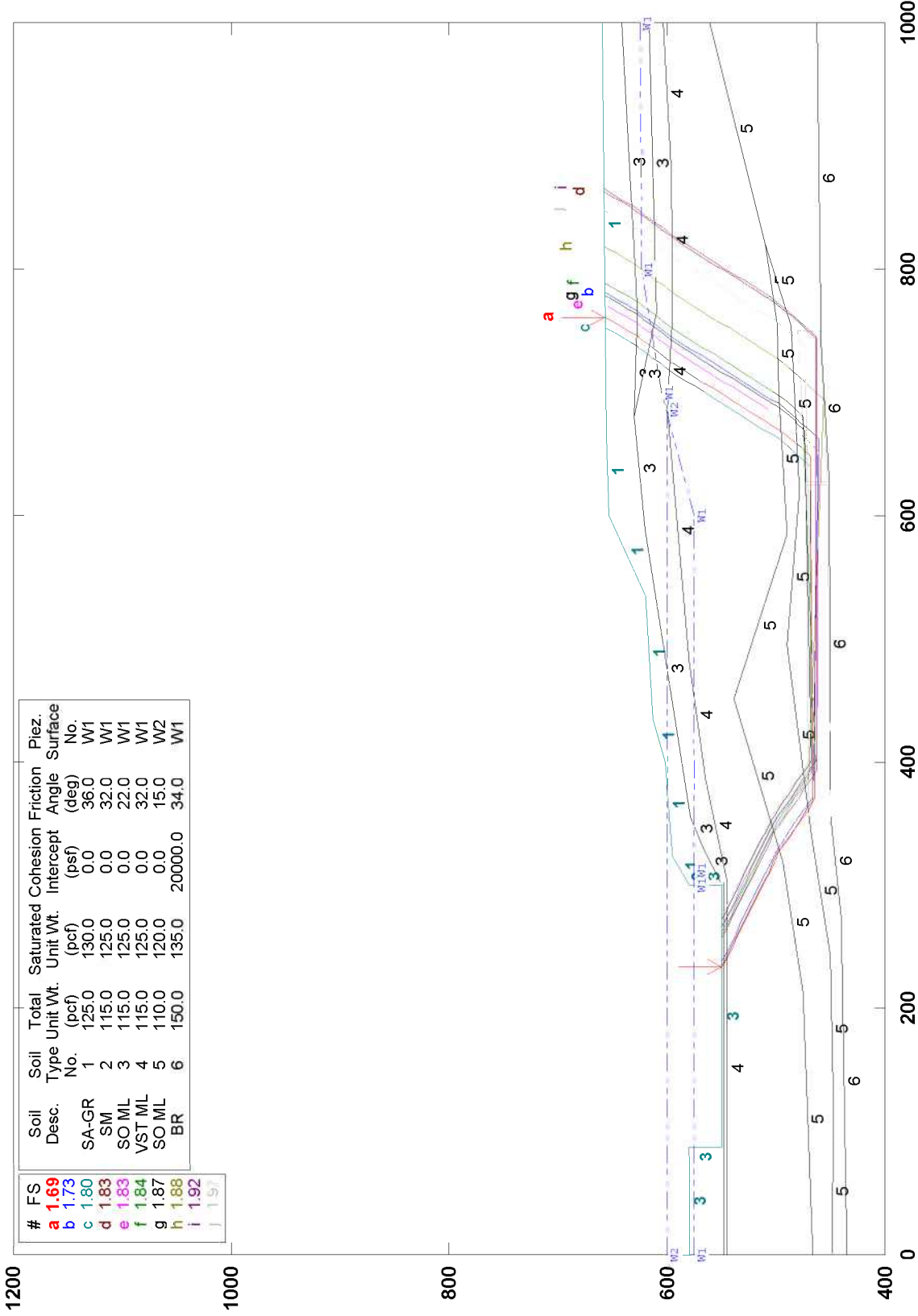

#	FS	Soil Desc.	Soil Type No.	Total Unit Wt. (pcf)	Saturated Unit Wt. (pcf)	Cohesion (psf)	Friction Angle (deg)	Piez. Surface No.
a	1.69	SA-GR	1	125.0	130.0	0.0	36.0	W1
b	1.73	SM	2	115.0	125.0	0.0	32.0	W1
c	1.80	SO ML	3	115.0	125.0	0.0	22.0	W1
d	1.83	VST ML	4	115.0	125.0	0.0	32.0	W1
e	1.84	SO ML	5	110.0	120.0	0.0	15.0	W2
f	1.87	BR	6	150.0	135.0	20000.0	34.0	W1
g	1.88							
h	1.92							
i	1.92							
j	1.92							

GSTABL7 v.2 FSmin=1.69



CUY-90-14.40 (SECTION A-A)

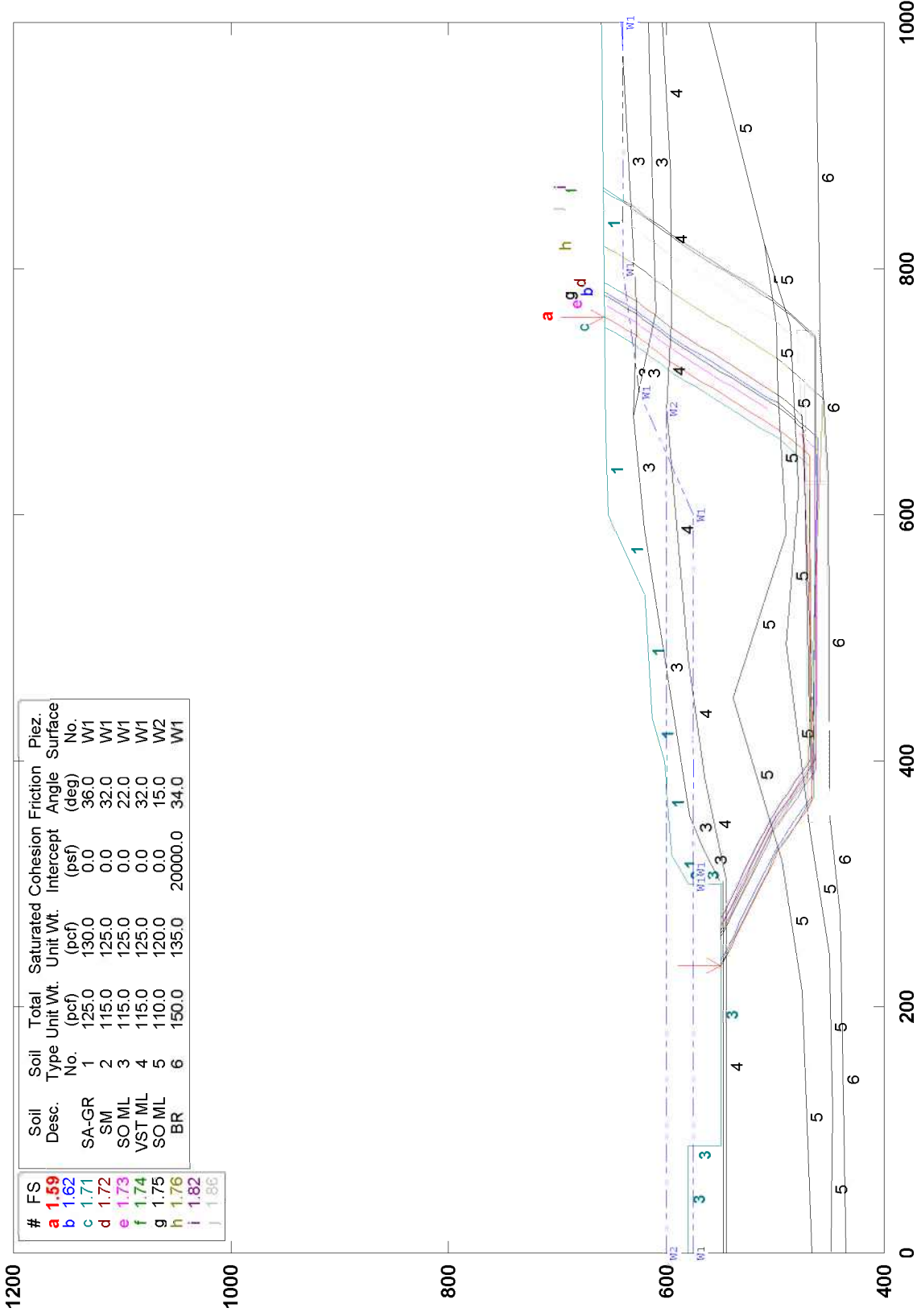

GSTABL7 v.2 FSmin=1.59

#	FS	Soil Desc.	Soil Type No.	Total Unit Wt. (pcf)	Saturated Unit Wt. (pcf)	Cohesion Intercept (psf)	Friction Angle (deg)	Piez. Surface No.
a	1.59	SA-GR	1	125.0	130.0	0.0	36.0	W1
b	1.71	SM	2	115.0	125.0	0.0	32.0	W1
c	1.72	SO ML	3	115.0	125.0	0.0	22.0	W1
d	1.73	VST ML	4	115.0	125.0	0.0	32.0	W1
e	1.74	SO ML	5	110.0	120.0	0.0	15.0	W2
f	1.75	BR	6	150.0	135.0	20000.0	34.0	W1
g	1.76							
h	1.82							
i	1.86							
j	1.86							



CUY-90-14.40 (SECTION A-A)

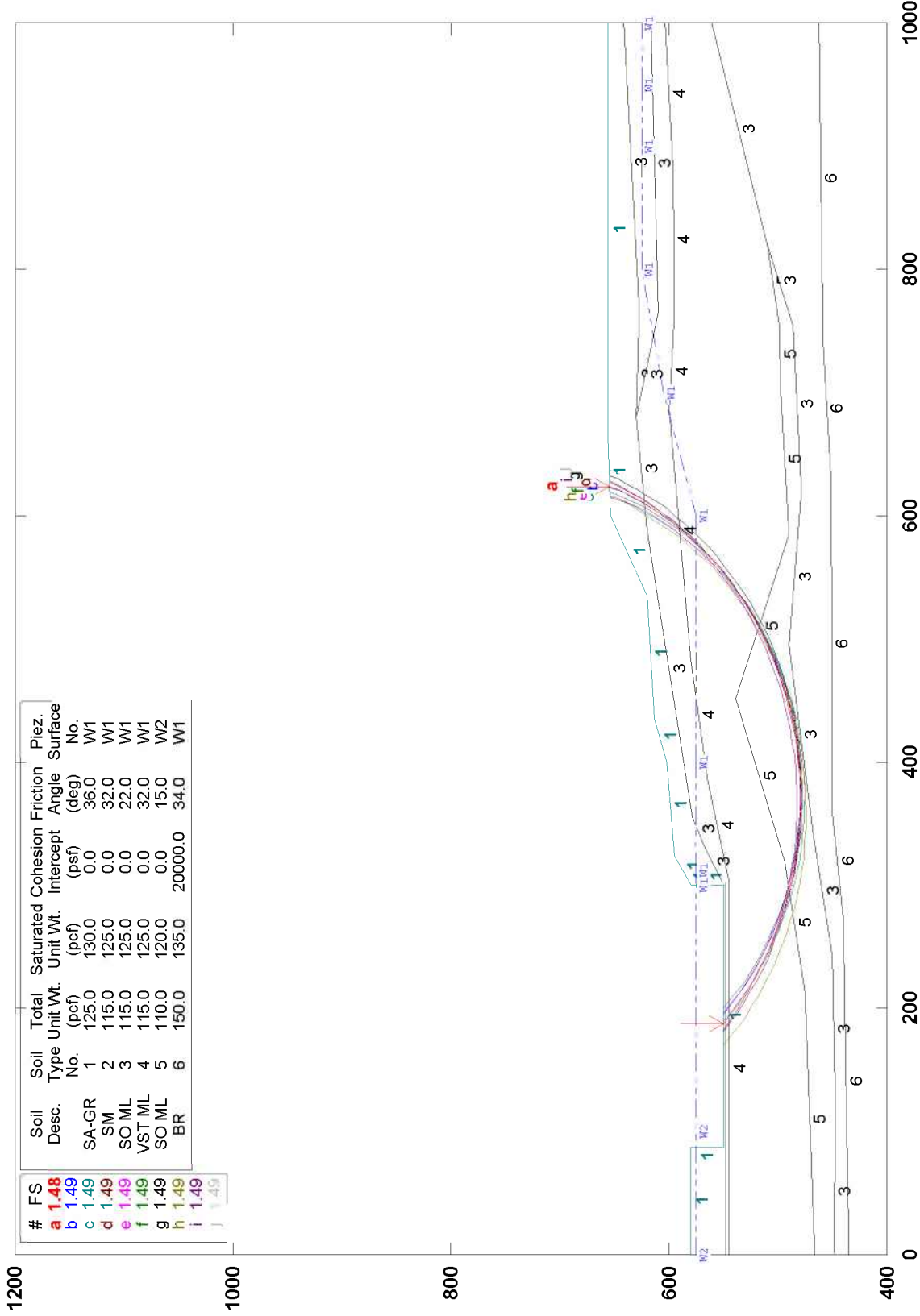

GSTABL7 v.2 FSmin=1.48

#	FS	Soil Desc.	Soil Type No.	Total Unit Wt. (pcf)	Saturated Unit Wt. (pcf)	Cohesion (psf)	Friction Angle (deg)	Piez. Surface No.
a	1.48	SA-GR	1	125.0	130.0	0.0	36.0	W1
b	1.49	SM	2	115.0	125.0	0.0	32.0	W1
c	1.49	SO ML	3	115.0	125.0	0.0	22.0	W1
d	1.49	VST ML	4	115.0	125.0	0.0	32.0	W1
e	1.49	SO ML	5	110.0	120.0	0.0	15.0	W2
f	1.49	BR	6	150.0	135.0	20000.0	34.0	W1



CUY-90-14.40 (SECTION A-A)

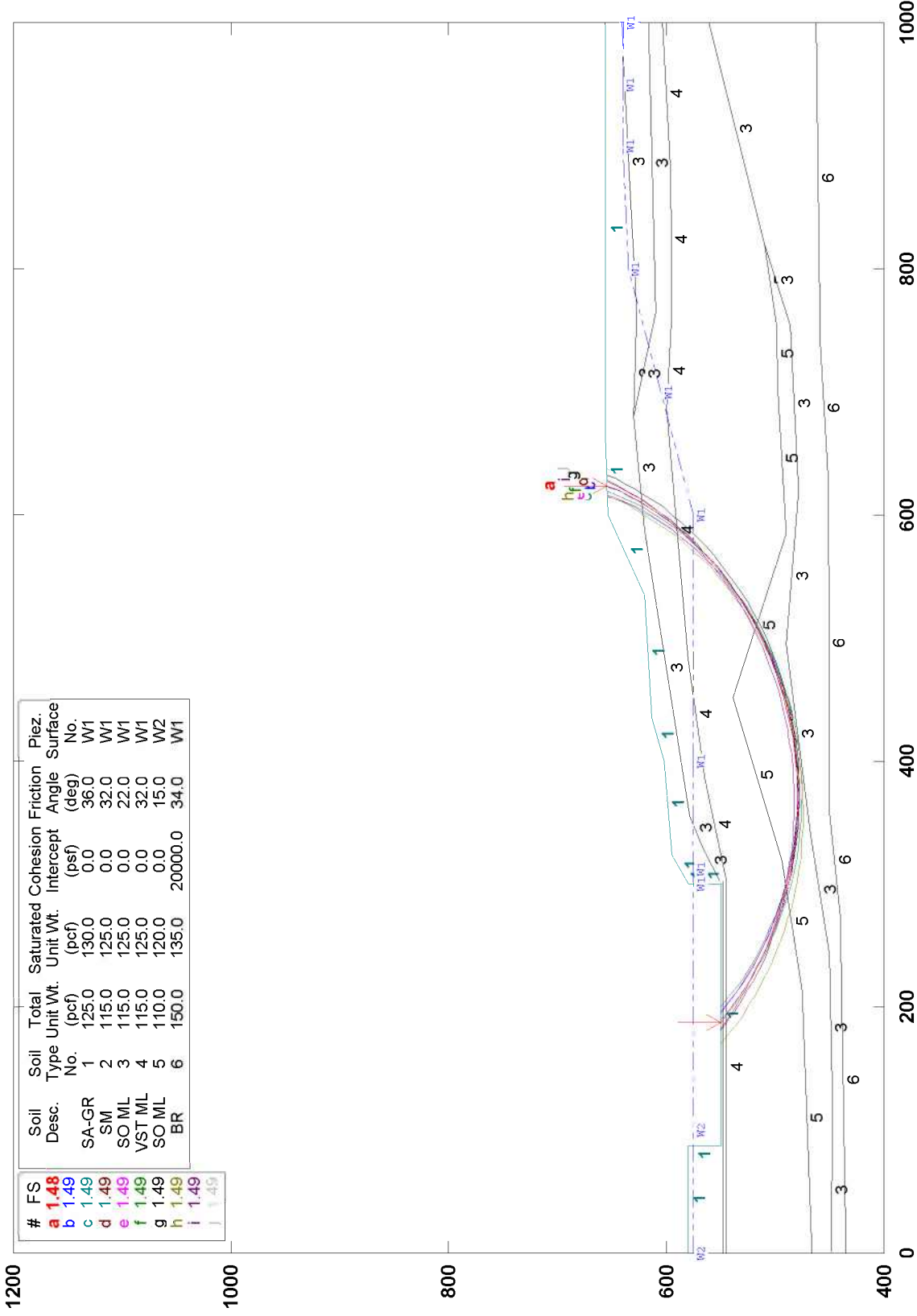

GSTABL7 v.2 FSmin=1.48



CUY-90-14.40: (BRIDGE CL)

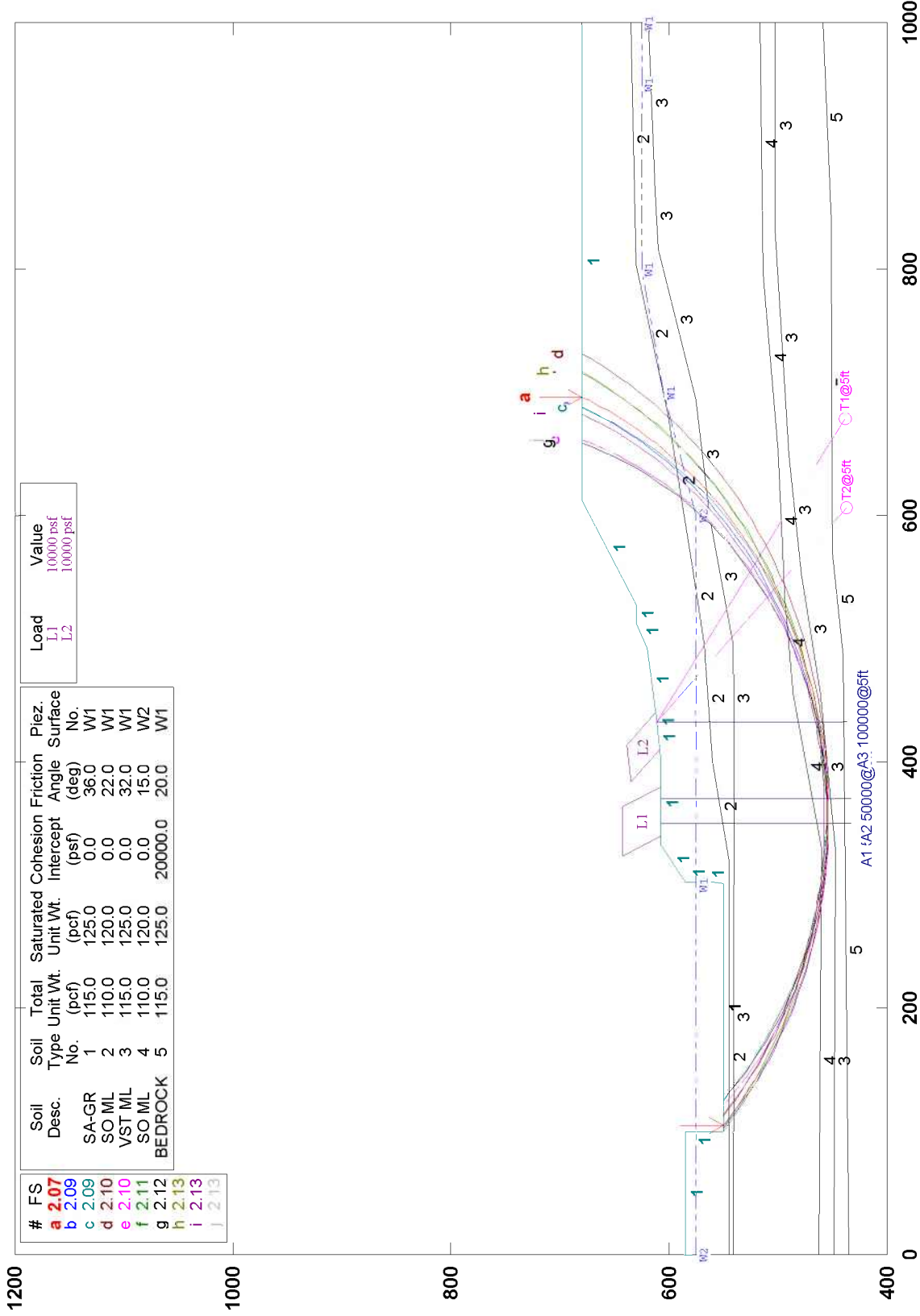

GSTABL7 v.2 FSmin=2.07

#	FS
a	2.07
b	2.09
c	2.09
d	2.10
e	2.10
f	2.11
g	2.12
h	2.13
i	2.13
j	2.13

Soil Desc.	Soil Type No.	Total Unit Wt. (pcf)	Saturated Unit Wt. (pcf)	Cohesion (psf)	Friction Angle (deg)	Piez. Surface No.
SA-GR	1	115.0	125.0	0.0	36.0	W1
SO ML	2	110.0	120.0	0.0	22.0	W1
VST ML	3	115.0	125.0	0.0	32.0	W1
SO ML	4	110.0	120.0	0.0	15.0	W2
BEDROCK	5	115.0	125.0	20000.0	20.0	W1

Load	Value
L1	10000 psf
L2	10000 psf



CUY-90-14.40: (BRIDGE CL)

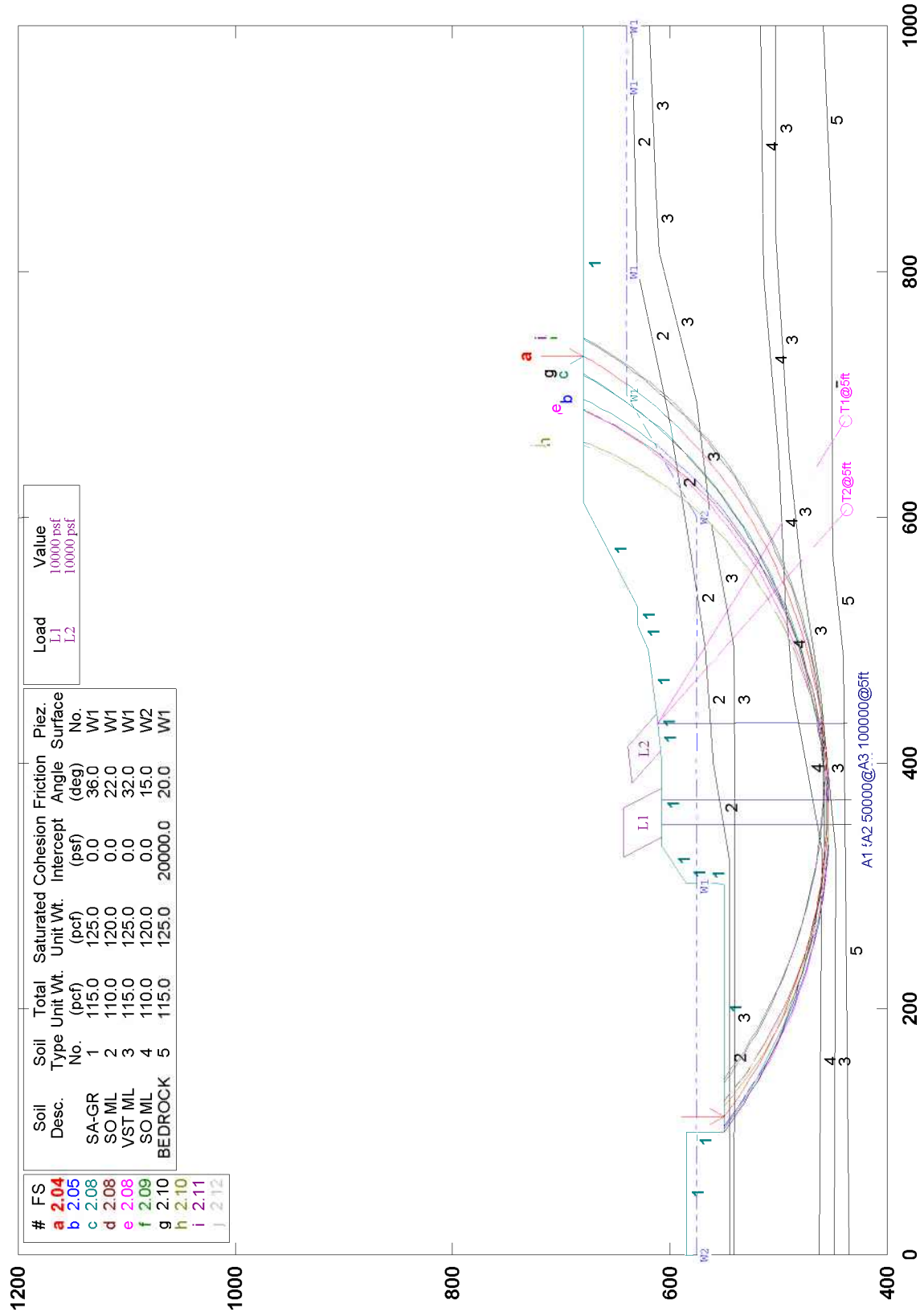

#	FS	Soil Desc.	Soil Type No.	Total Unit Wt. (pcf)	Saturated Unit Wt. (pcf)	Cohesion (psf)	Friction Angle (deg)	Piez. Surface No.
a	2.04	SA-GR	1	115.0	125.0	0.0	36.0	W1
b	2.05	SO ML	2	110.0	120.0	0.0	22.0	W1
c	2.08	VST ML	3	115.0	125.0	0.0	32.0	W1
d	2.08	SO ML	4	110.0	120.0	0.0	15.0	W2
e	2.08	SO ML	5	115.0	125.0	20000.0	20.0	W1
f	2.09	BEDROCK						
g	2.10							
h	2.10							
i	2.11							
j	2.12							

Load	Value
L1	10000 psf
L2	10000 psf

GSTABL7 v.2 FSmin=2.04



CUY-90-14.40: (SECTION D-D)

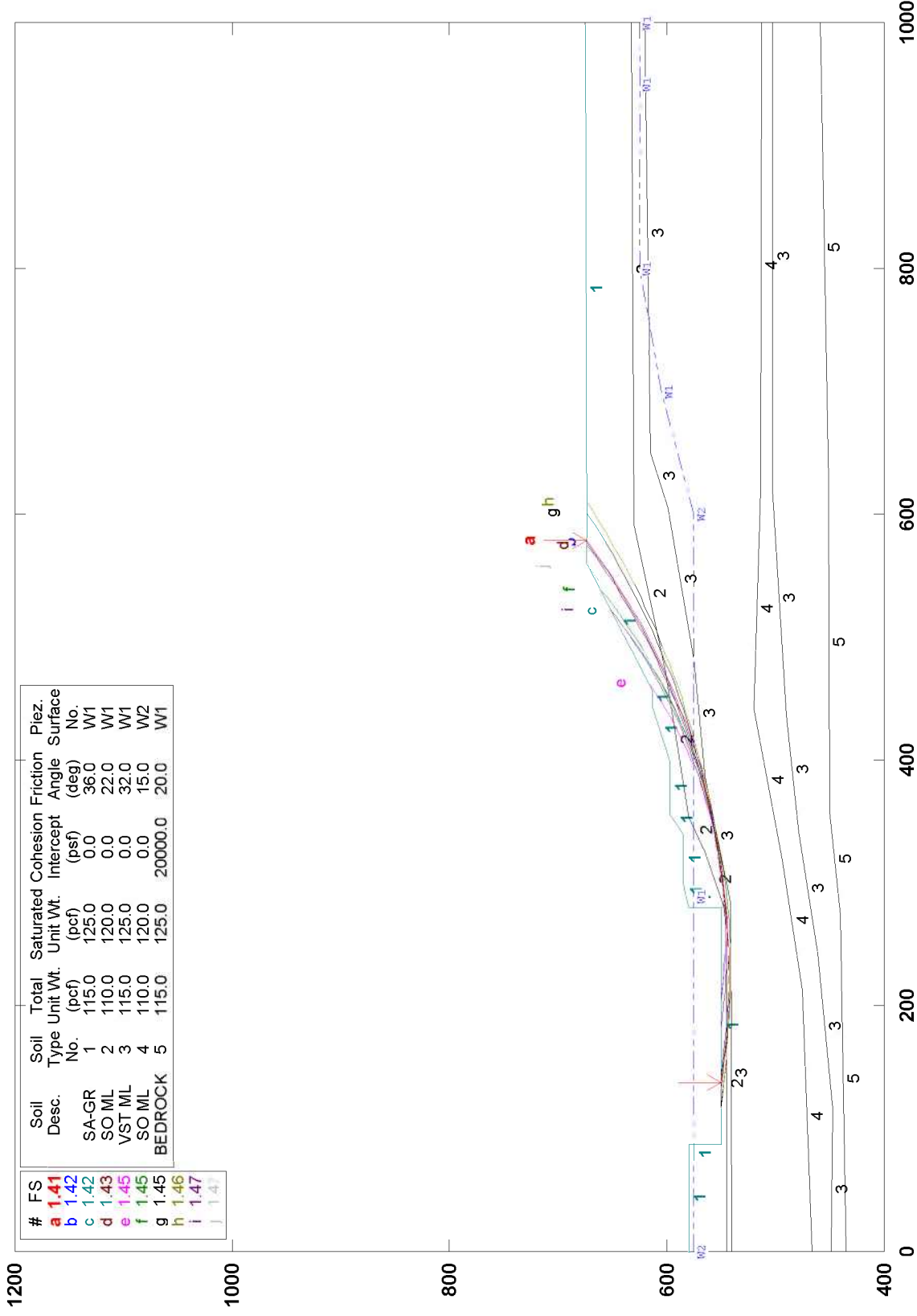

GSTABL7 v.2 FSmin=1.41

#	FS	Soil Desc.	Soil Type No.	Total Unit Wt. (pcf)	Saturated Unit Wt. (pcf)	Cohesion (psf)	Friction Angle (deg)	Piez. Surface No.
a	1.41	SA-GR	1	115.0	125.0	0.0	36.0	W1
b	1.42	SO ML	2	110.0	120.0	0.0	22.0	W1
c	1.43	VST ML	3	115.0	125.0	0.0	32.0	W1
d	1.45	SO ML	4	110.0	120.0	0.0	15.0	W2
e	1.45	BEDROCK	5	115.0	125.0	20000.0	20.0	W1

g	1.45
h	1.46
i	1.47
j	1.47



CUY-90-14.40: (SECTION D-D)

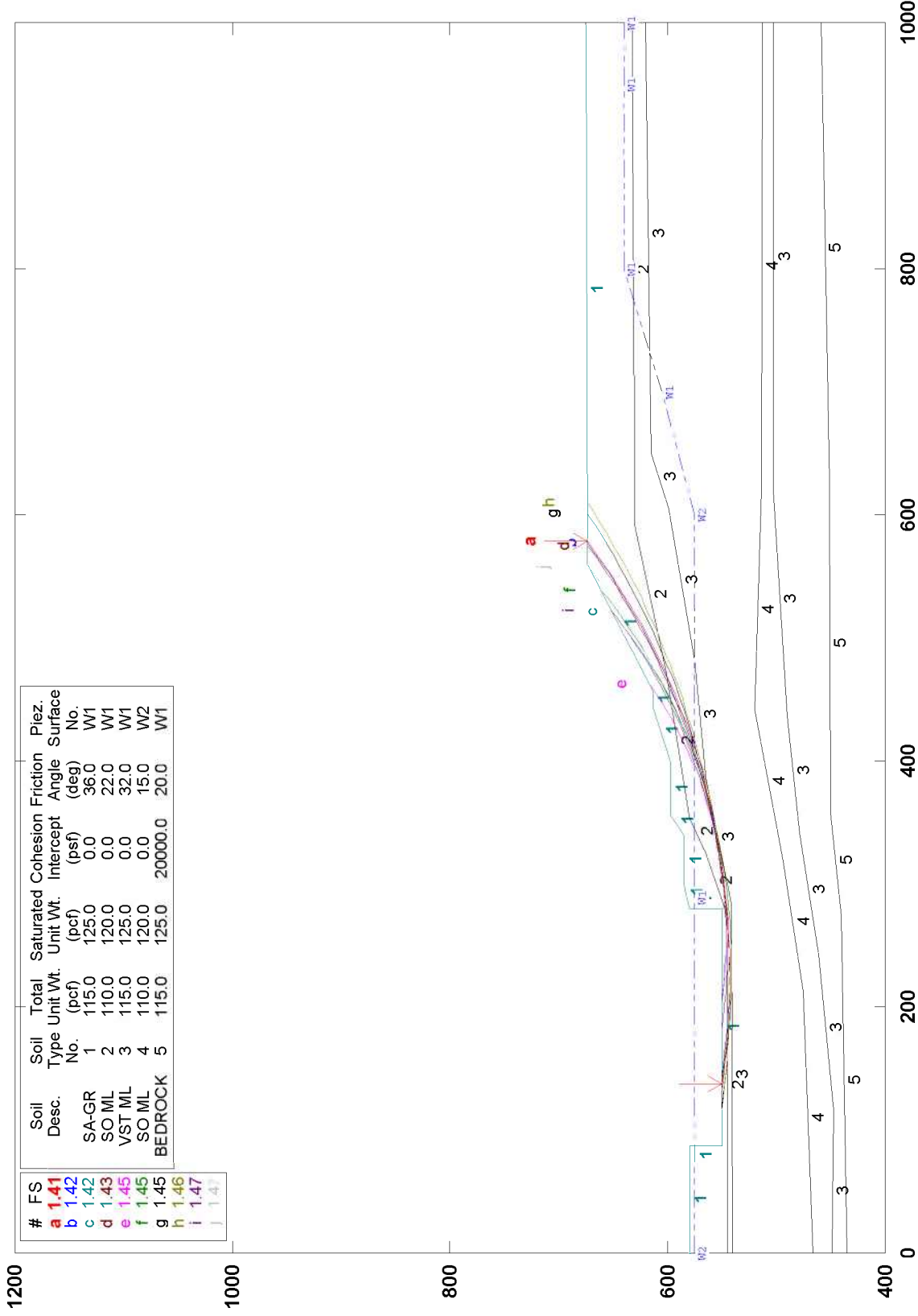

GSTABL7 v.2 FSmin=1.41

#	FS	Soil Desc.	Soil Type No.	Total Unit Wt. (pcf)	Saturated Unit Wt. (pcf)	Cohesion (psf)	Friction Angle (deg)	Piez. Surface No.
a	1.41	SA-GR	1	115.0	125.0	0.0	36.0	W1
b	1.42	SO ML	2	110.0	120.0	0.0	22.0	W1
c	1.43	VST ML	3	115.0	125.0	0.0	32.0	W1
d	1.45	SO ML	4	110.0	120.0	0.0	15.0	W2
e	1.45	BEDROCK	5	115.0	125.0	20000.0	20.0	W1

f	1.46
g	1.47
h	1.47
i	1.47
j	1.47



CUY-90-14.40 (SECTION A-A)

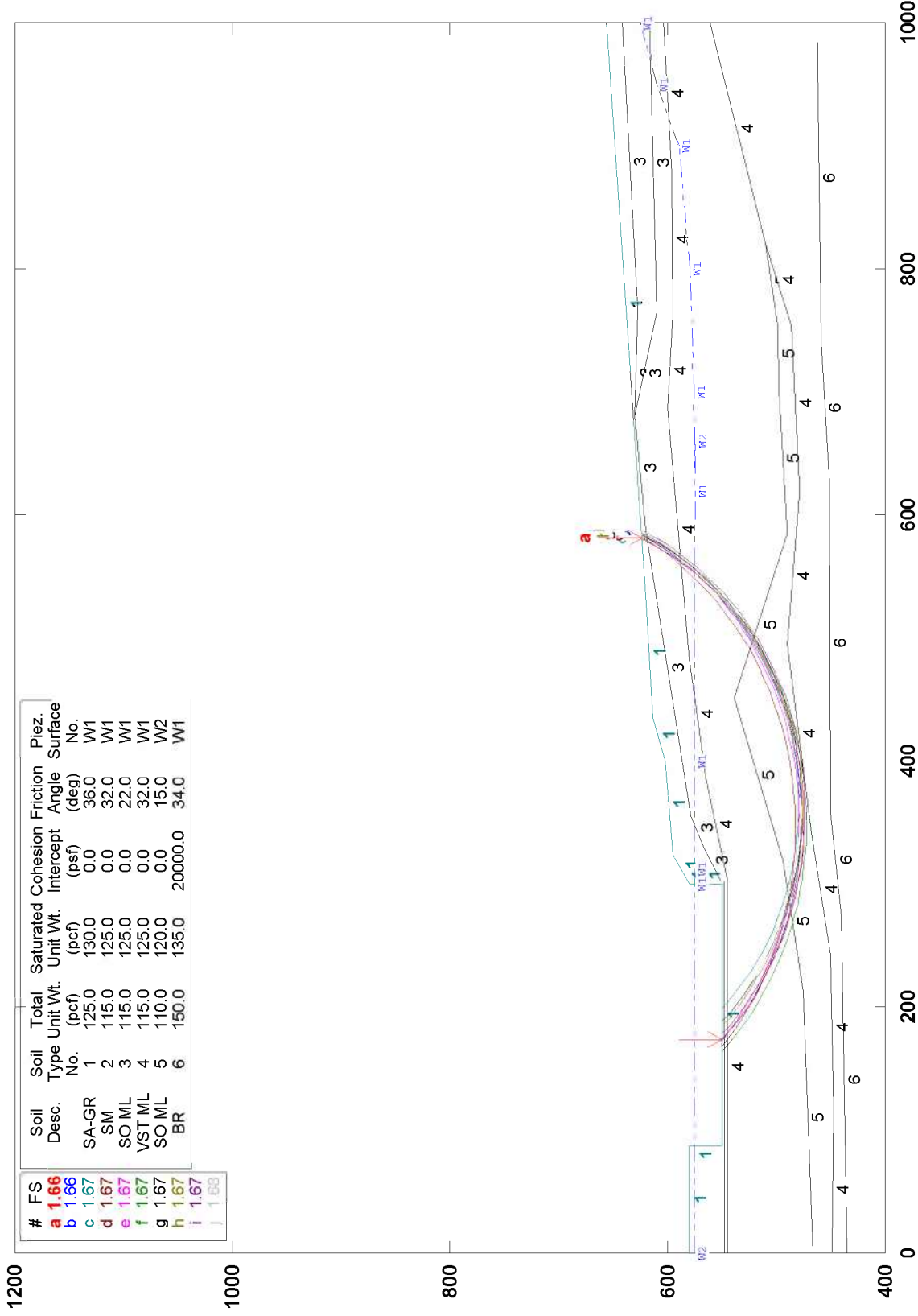

GSTABL7 v.2 FSmin=1.66

#	FS	Soil Desc.	Soil Type No.	Total Unit Wt. (pcf)	Saturated Unit Wt. (pcf)	Cohesion (psf)	Friction Angle (deg)	Piez. Surface No.
a	1.66	SA-GR	1	125.0	130.0	0.0	36.0	W1
b	1.66	SM	2	115.0	125.0	0.0	32.0	W1
c	1.67	SO ML	3	115.0	125.0	0.0	22.0	W1
d	1.67	VST ML	4	115.0	125.0	0.0	32.0	W1
e	1.67	SO ML	5	110.0	120.0	0.0	15.0	W2
f	1.67	BR	6	150.0	135.0	20000.0	34.0	W1



CUY-90-14.40 (SECTION A-A)

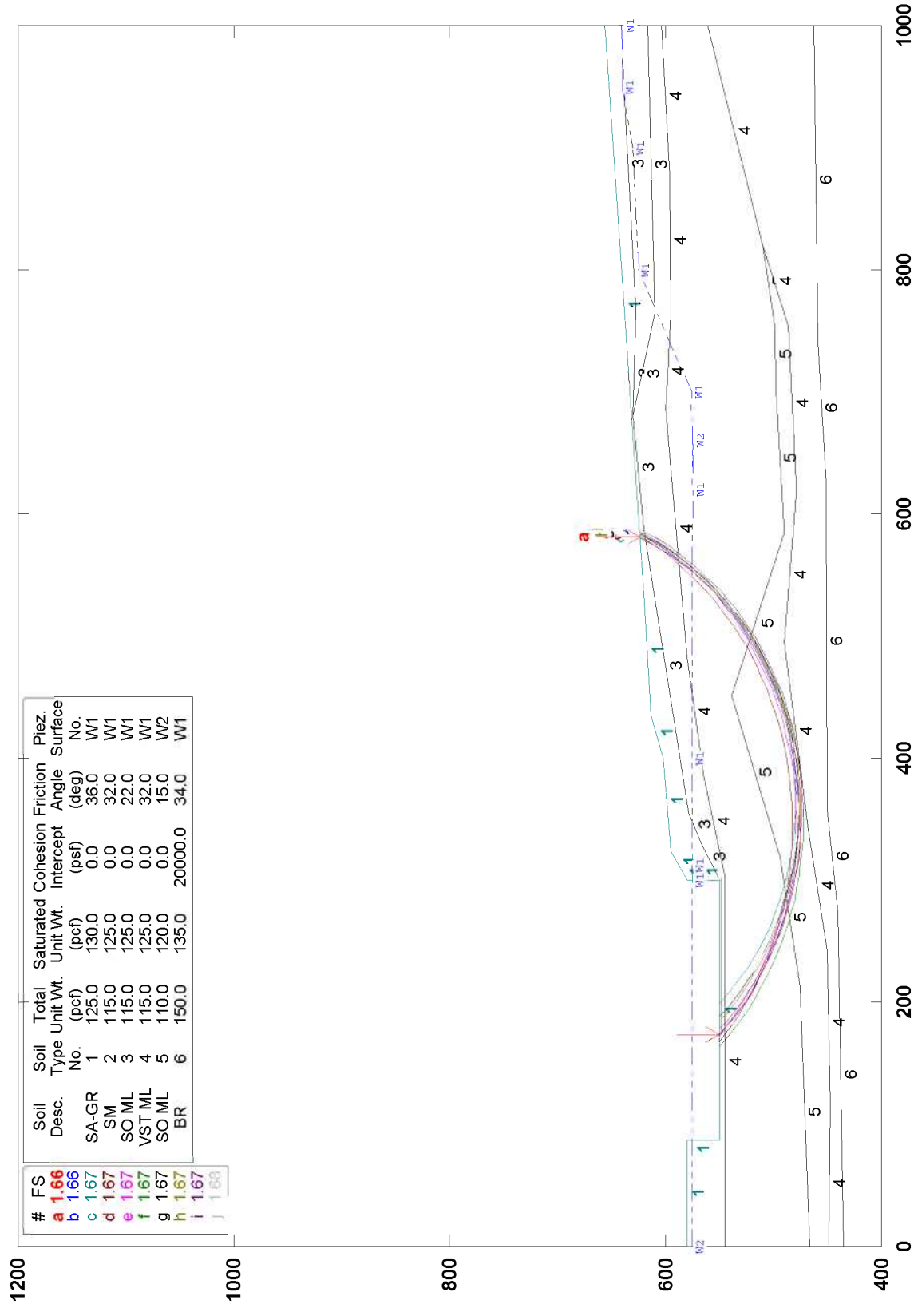

GSTABL7 v.2 FSmin=1.66

#	FS	Soil Desc.	Soil Type No.	Total Unit Wt. (pcf)	Saturated Unit Wt. (pcf)	Cohesion (psf)	Friction Angle (deg)	Piez. Surface No.
a	1.66	SA-GR	1	125.0	130.0	0.0	36.0	W1
b	1.67	SM	2	115.0	125.0	0.0	32.0	W1
c	1.67	SO ML	3	115.0	125.0	0.0	22.0	W1
d	1.67	VST ML	4	115.0	125.0	0.0	32.0	W1
e	1.67	SO ML	5	110.0	120.0	0.0	15.0	W2
f	1.67	BR	6	150.0	135.0	20000.0	34.0	W1



CUY-90-14.90 (SECTION A-A)

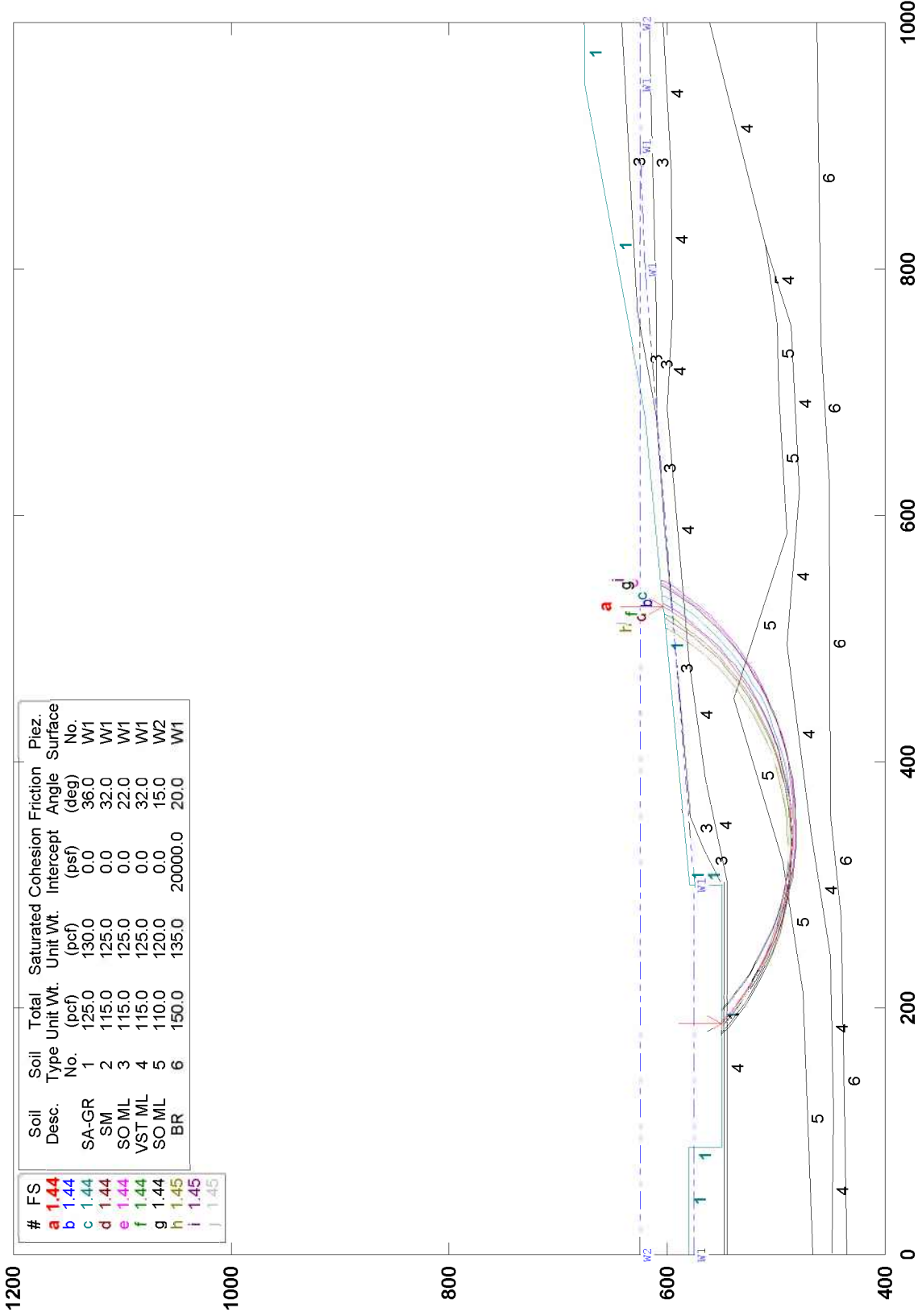

GSTABL7 v.2 FSmin=1.44

#	FS	Soil Desc.	Soil Type No.	Total Unit Wt. (pcf)	Saturated Unit Wt. (pcf)	Cohesion (psf)	Friction Angle (deg)	Piez. Surface No.
a	1.44	SA-GR	1	125.0	130.0	0.0	36.0	W1
b	1.44	SM	2	115.0	125.0	0.0	32.0	W1
c	1.44	SO ML	3	115.0	125.0	0.0	22.0	W1
d	1.44	VST ML	4	115.0	125.0	0.0	32.0	W1
e	1.44	SO ML	5	110.0	120.0	0.0	15.0	W2
f	1.44	BR	6	150.0	135.0	20000.0	20.0	W1
g	1.45							
h	1.45							
i	1.45							
j	1.45							



CUY-90-14.40 (SECTION A-A)

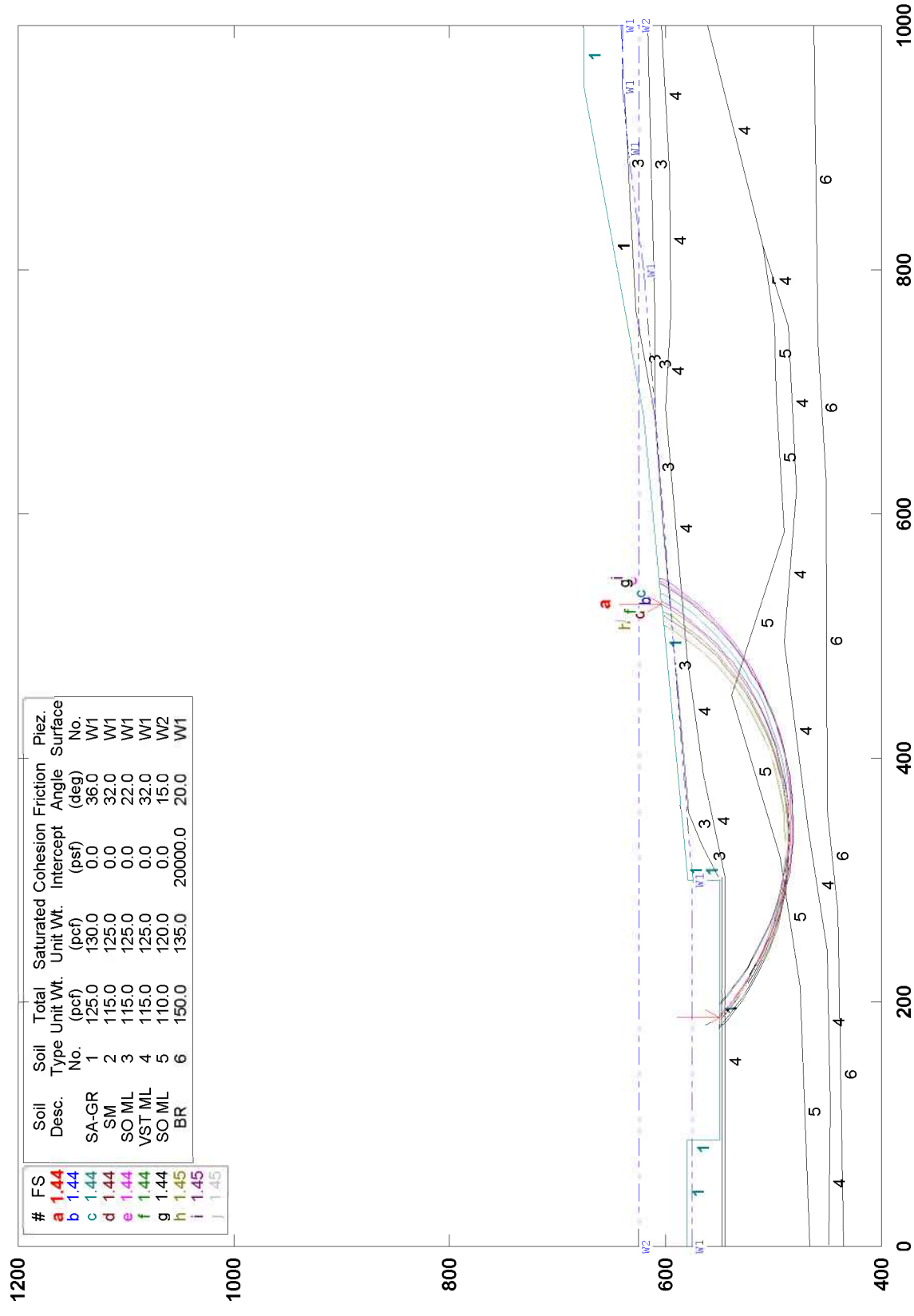

GSTABL7 v.2 FSmin=1.44

#	FS	Soil Desc.	Soil Type No.	Total Unit Wt. (pcf)	Saturated Unit Wt. (pcf)	Cohesion (psf)	Friction Angle (deg)	Piez. Surface No.
a	1.44	SA-GR	1	125.0	130.0	0.0	36.0	W1
b	1.44	SM	2	115.0	125.0	0.0	32.0	W1
c	1.44	SO ML	3	115.0	125.0	0.0	22.0	W1
d	1.44	VST ML	4	115.0	125.0	0.0	32.0	W1
e	1.44	SO ML	5	110.0	120.0	0.0	15.0	W2
f	1.44	BR	6	150.0	135.0	20000.0	20.0	W1
g	1.44							
h	1.45							
i	1.45							
j	1.45							



CUY-90-14.40 (SECTION A-A)

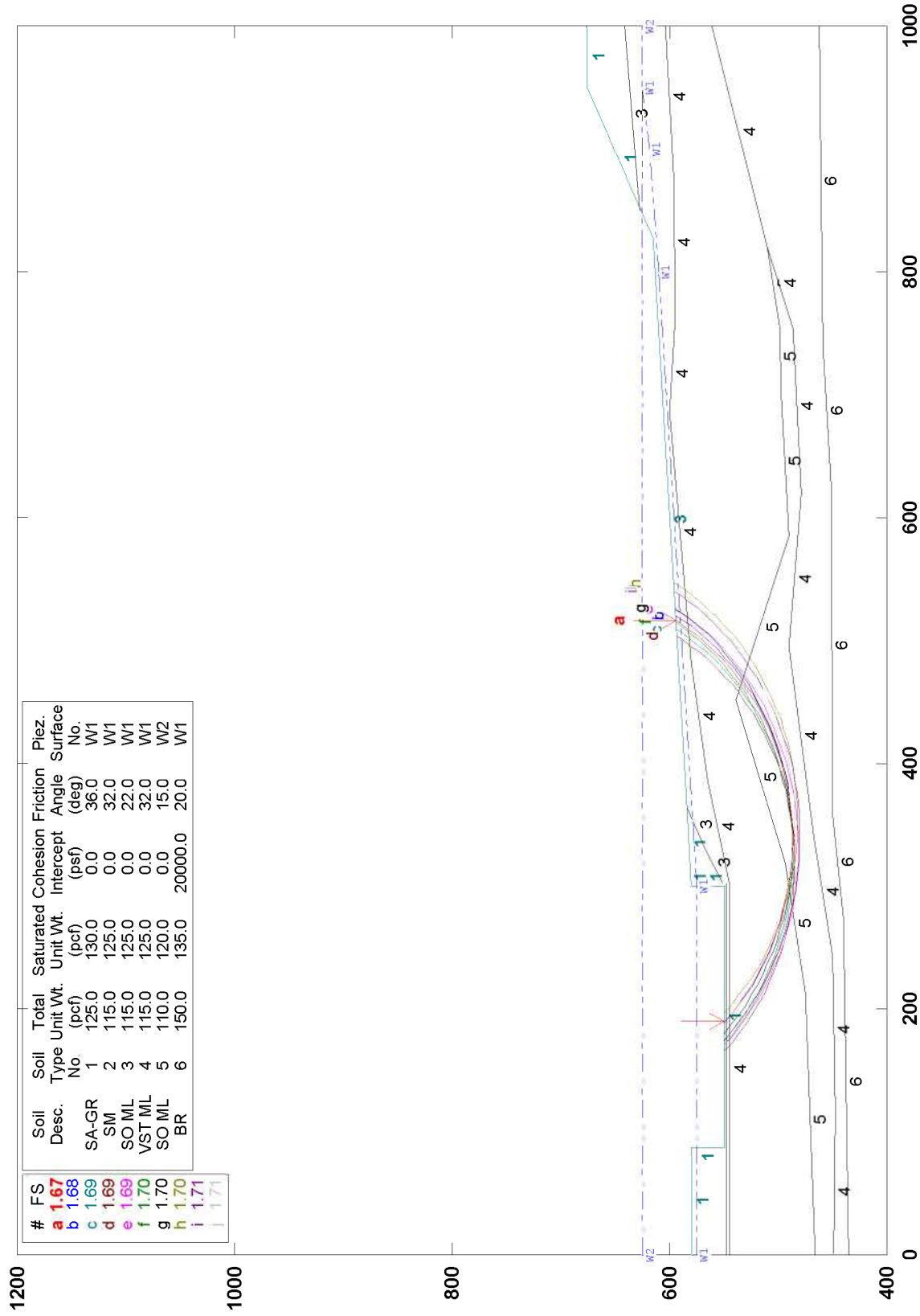

GSTABL7 v.2 FSmin=1.67



CUY-90-14.40 (SECTION A-A)

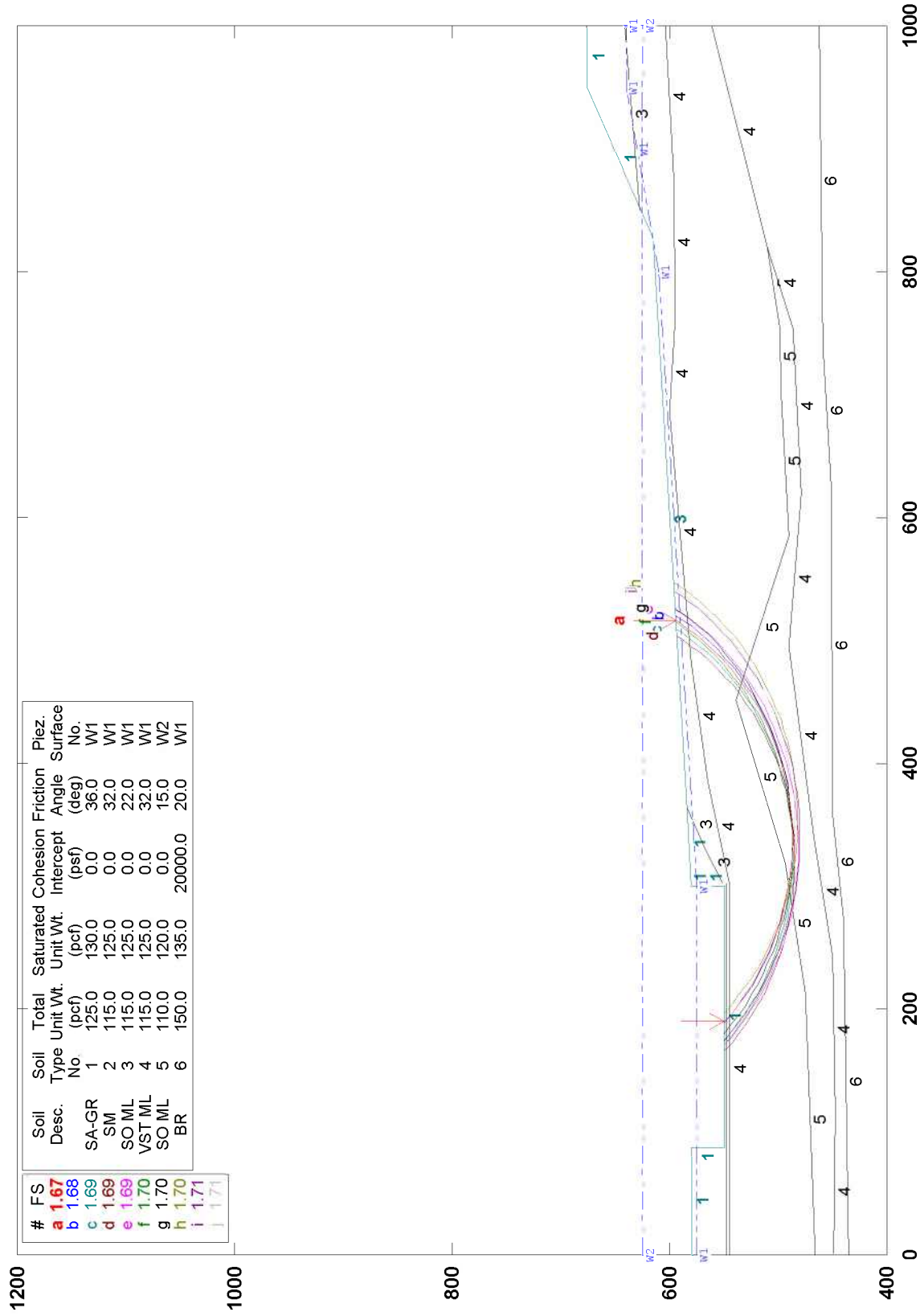

#	FS	Soil Desc.	Soil Type No.	Total Unit Wt. (pcf)	Saturated Unit Wt. (pcf)	Cohesion (psf)	Friction Angle (deg)	Piez. Surface No.
a	1.67	SA-GR	1	125.0	130.0	0.0	36.0	W1
b	1.69	SM	2	115.0	125.0	0.0	32.0	W1
c	1.69	SO ML	3	115.0	125.0	0.0	22.0	W1
d	1.69	VST ML	4	115.0	125.0	0.0	32.0	W1
e	1.70	SO ML	5	110.0	120.0	0.0	15.0	W2
f	1.70	BR	6	150.0	135.0	20000.0	20.0	W1
g	1.70							
h	1.71							
i	1.71							

GSTABL7 v.2 FSmin=1.67



CUY-90-14.40 (SECTION A-A)

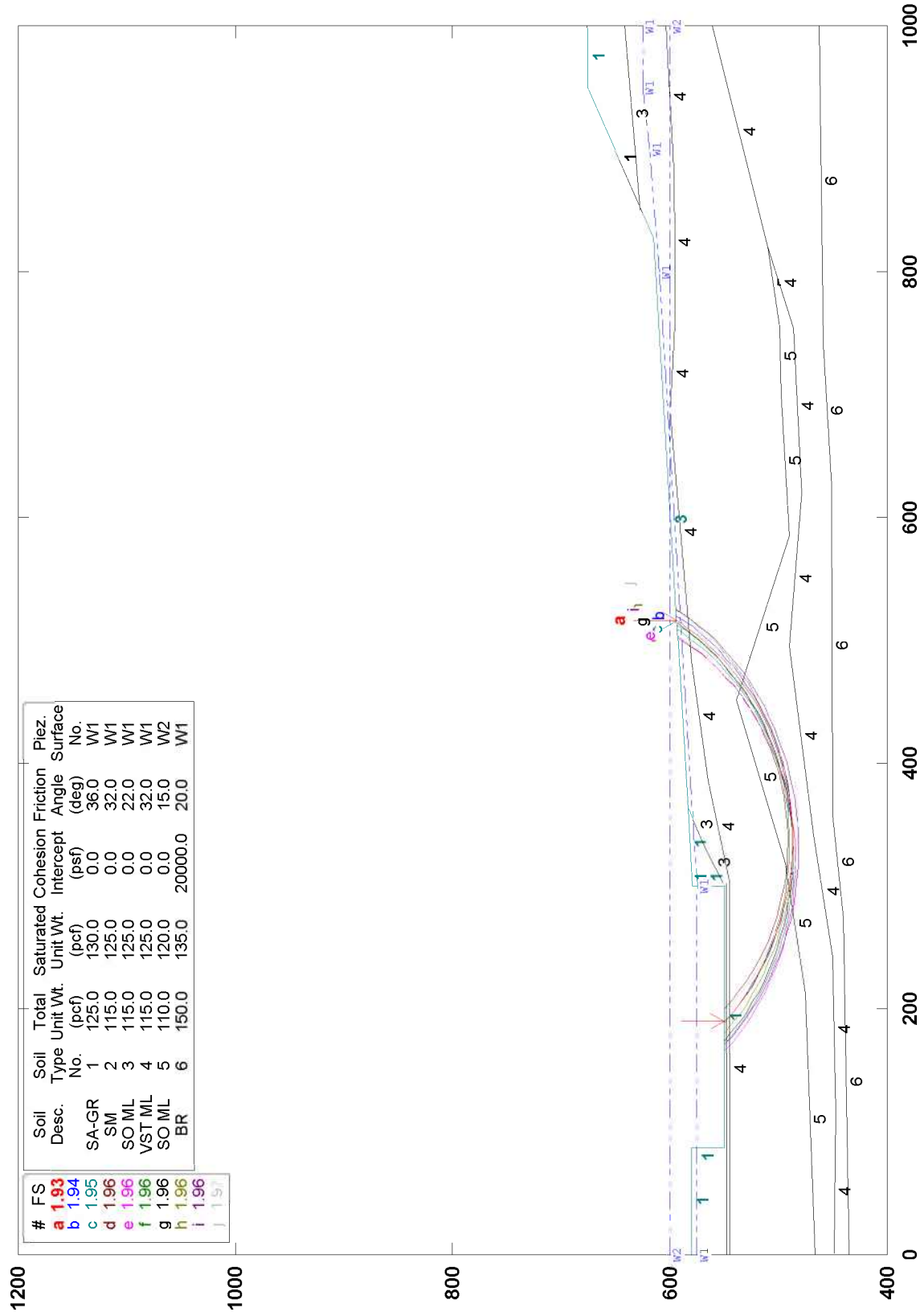

GSTABL7 v.2 FSmin=1.93

#	FS	Soil Desc.	Soil Type No.	Total Unit Wt. (pcf)	Saturated Unit Wt. (pcf)	Cohesion (psf)	Friction Angle (deg)	Piez. Surface No.
a	1.93	SA-GR	1	125.0	130.0	0.0	36.0	W1
b	1.94	SM	2	115.0	125.0	0.0	32.0	W1
c	1.95	SO ML	3	115.0	125.0	0.0	22.0	W1
d	1.96	VST ML	4	115.0	125.0	0.0	32.0	W1
e	1.96	SO ML	5	110.0	120.0	0.0	15.0	W2
f	1.96	BR	6	150.0	135.0	20000.0	20.0	W1



CUY-90-14.40 (SECTION A-A)

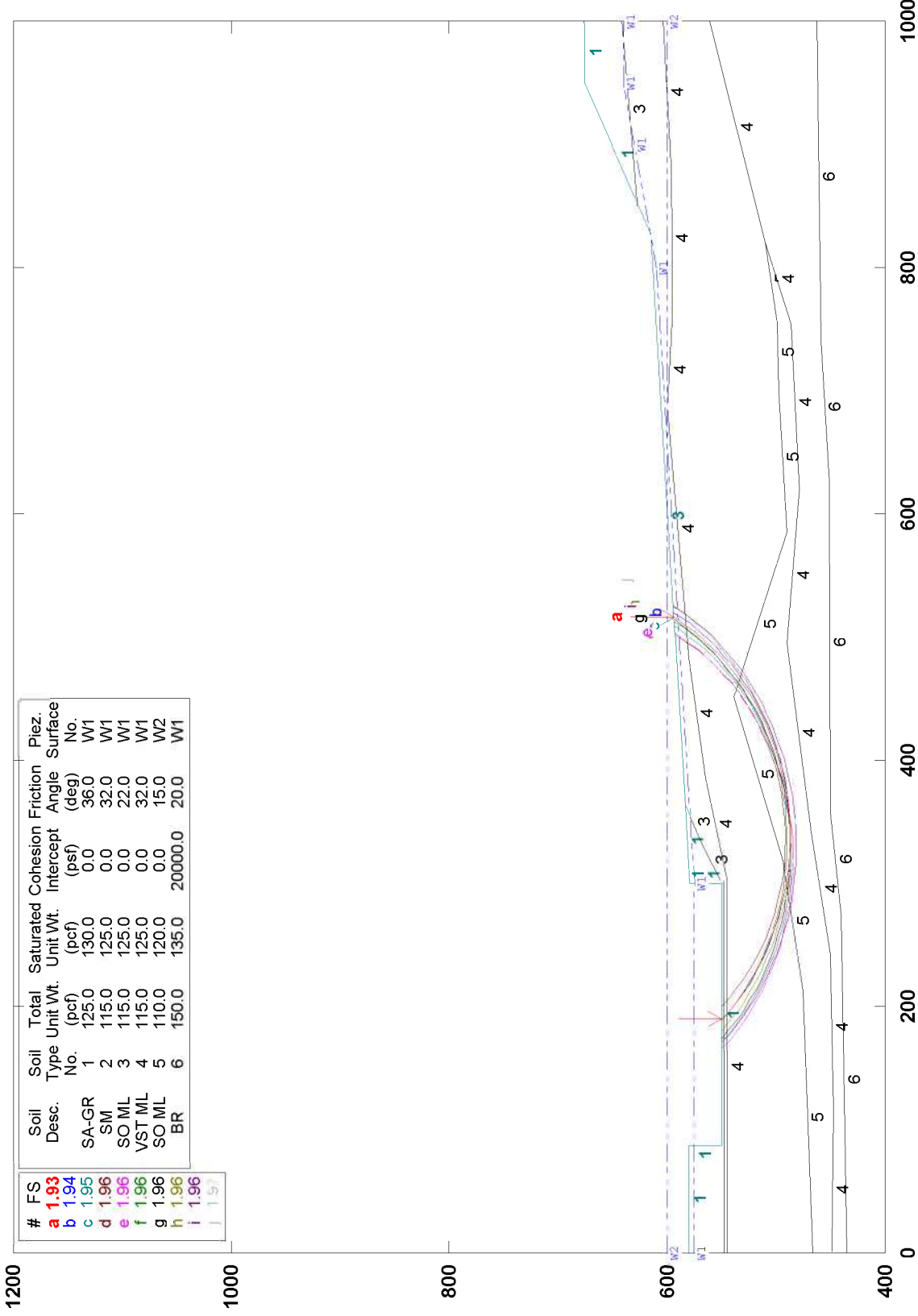

#	FS	Soil Desc.	Soil Type No.	Total Unit Wt. (pcf)	Saturated Unit Wt. (pcf)	Cohesion (psf)	Friction Angle (deg)	Piez. Surface No.
a	1.93	SA-GR	1	125.0	130.0	0.0	36.0	W1
b	1.94	SM	2	115.0	125.0	0.0	32.0	W1
c	1.95	SO ML	3	115.0	125.0	0.0	22.0	W1
d	1.96	VST ML	4	115.0	125.0	0.0	32.0	W1
e	1.96	SO ML	5	110.0	120.0	0.0	15.0	W2
f	1.96	BR	6	150.0	135.0	20000.0	20.0	W1



CUY-90-14.40 (SECTION A-A)

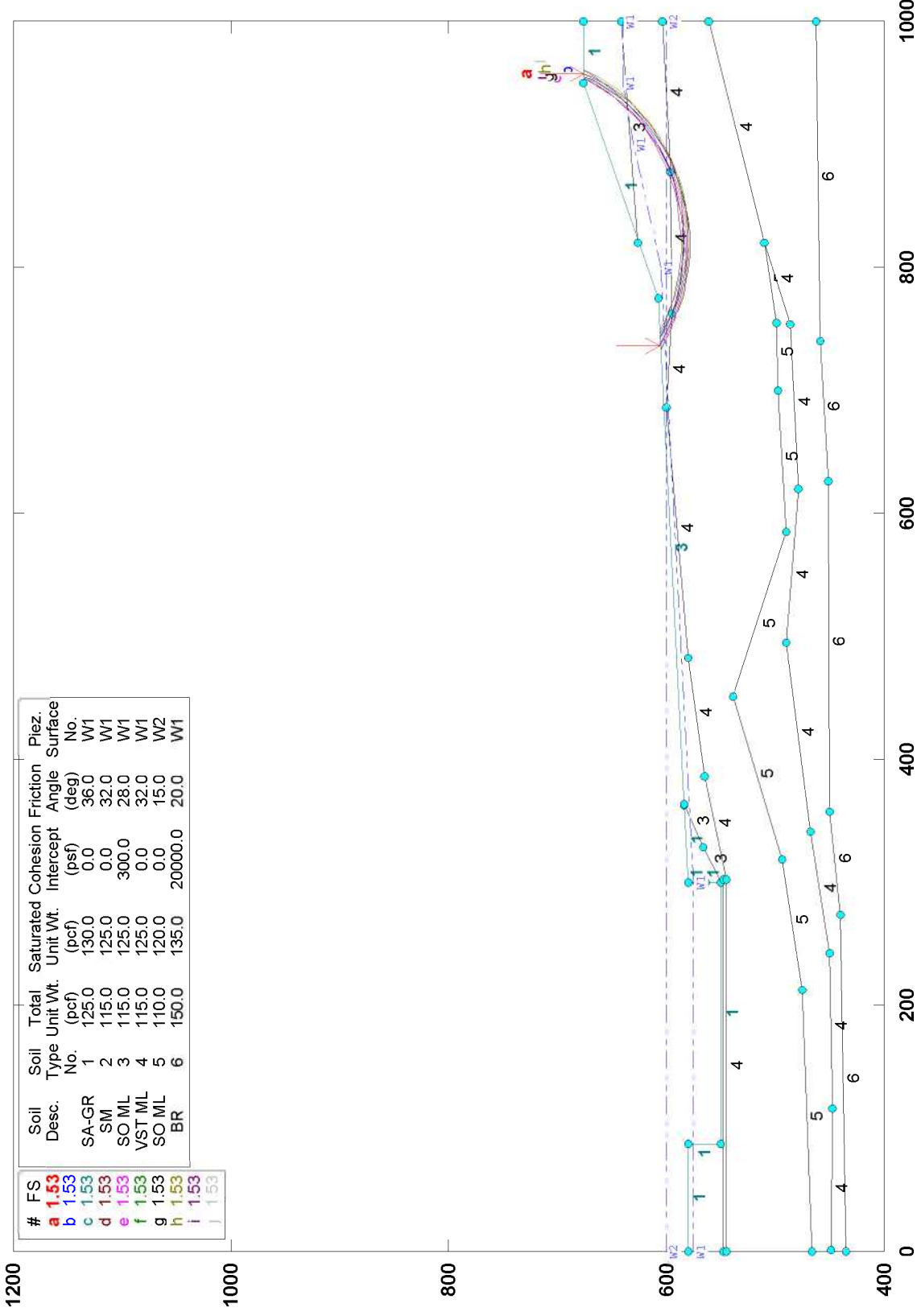

GSTABL7 v.2 FSmin=1.53

#	FS	Soil Desc.	Soil Type No.	Total Unit Wt. (pcf)	Saturated Unit Wt. (pcf)	Cohesion (psf)	Friction Angle (deg)	Piez. Surface No.
a	1.53	SA-GR	1	125.0	130.0	0.0	36.0	W1
b	1.53	SM	2	115.0	125.0	0.0	32.0	W1
c	1.53	SO ML	3	115.0	125.0	300.0	28.0	W1
d	1.53	VST ML	4	115.0	125.0	0.0	32.0	W1
e	1.53	SO ML	5	110.0	120.0	0.0	15.0	W2
f	1.53	BR	6	150.0	135.0	20000.0	20.0	W1



DESIGNED	JM
CHECKED	DB
REVISION	DB
DATE	09-08-2008

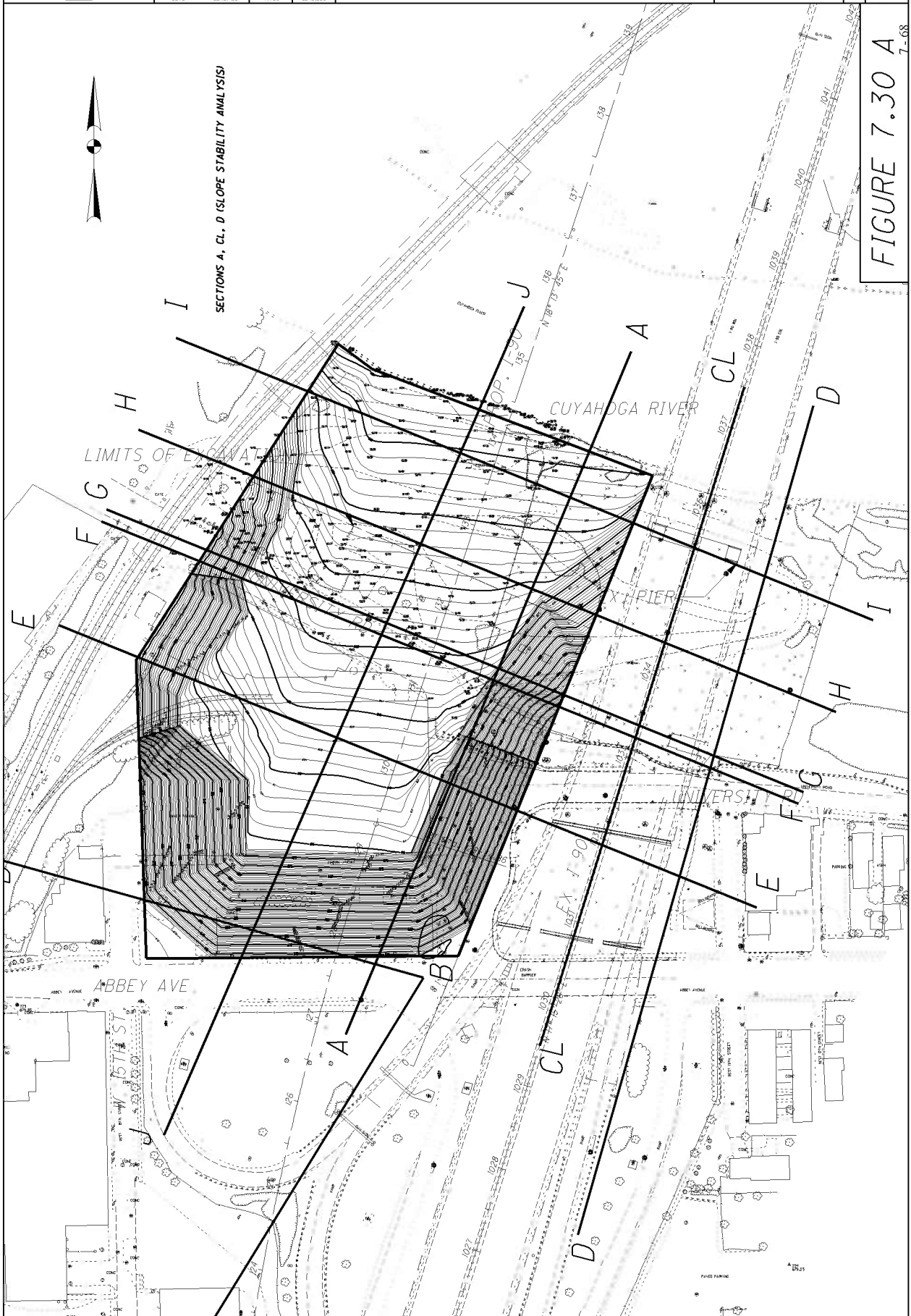

FIGURE 7.30 A
 7-68

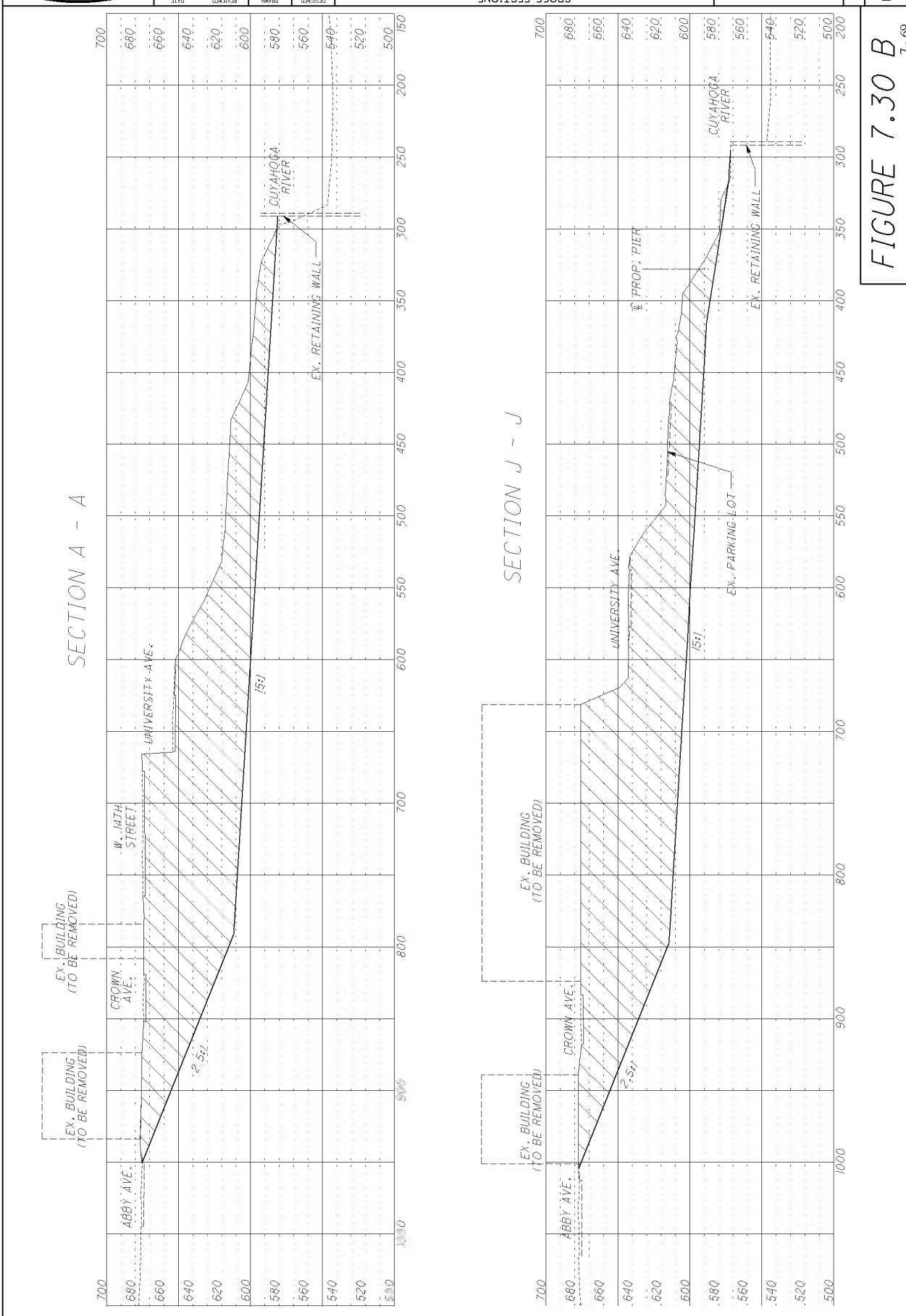
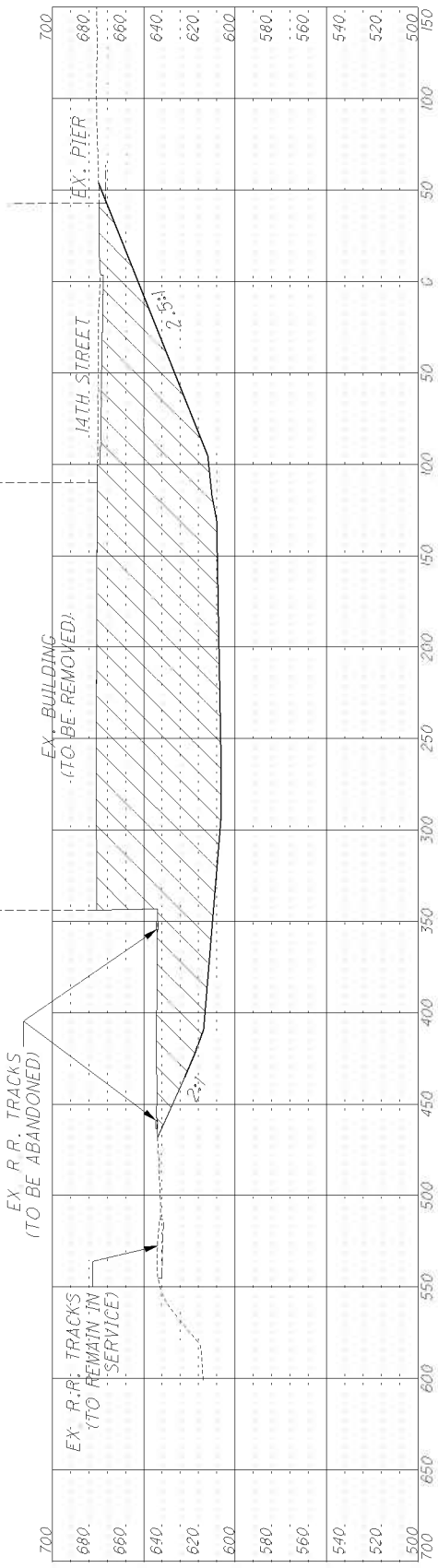

FIGURE 7.30 B

FIGURE 7.30 C
 7-70

SECTION E-E



SECTION F-F

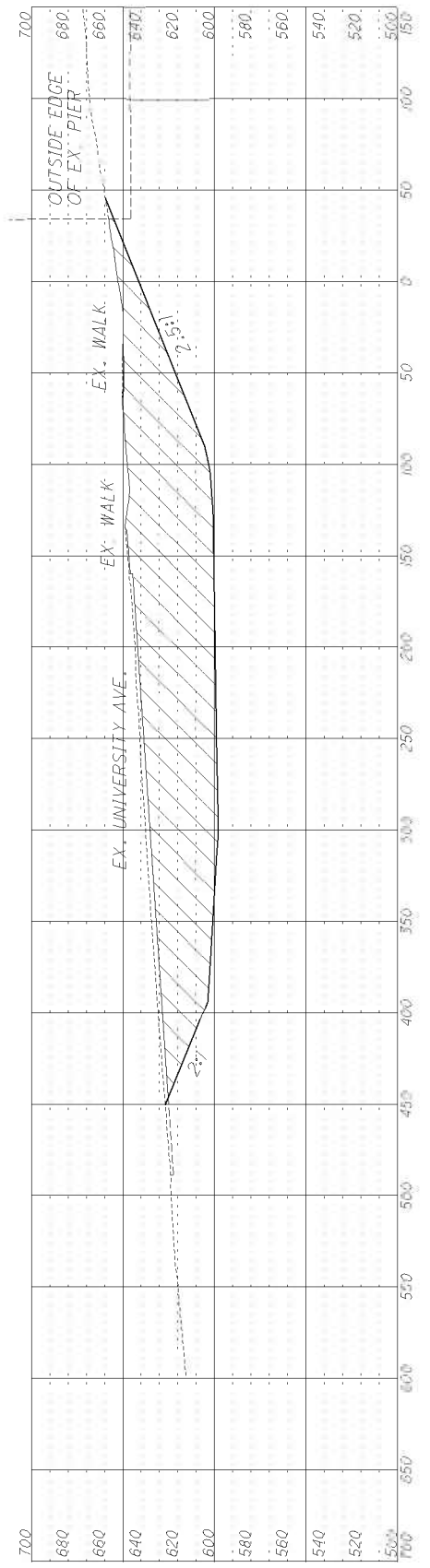



FIGURE 7.30 D
7-71

CUY-90-14.92
PID No. 77382

CROSS SECTIONS
CUYAHOGA RIVER WEST BANK

DESIGNED	JN
DRAWN	DWB
REVIEWED	
FILE	09-08-2006
STRUCTURE FILE NUMBER	

15000 KENNEDY DRIVE
DIVISION, OHIO 43072
EL ROBINSON
THE CHALLENGE IN CHOICE

SECTION G-G

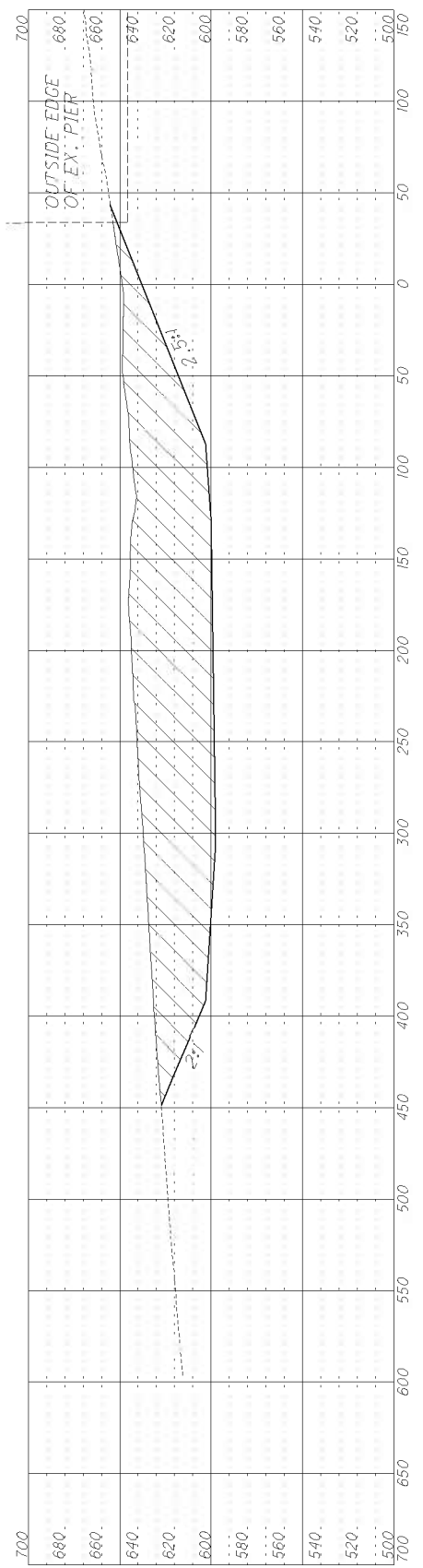

SECTION H-H

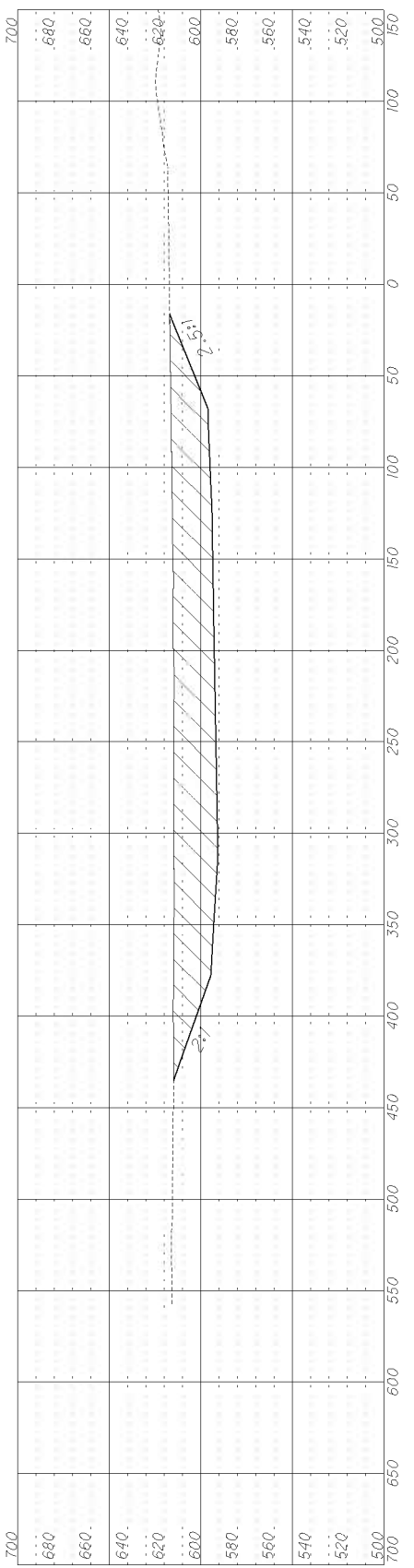
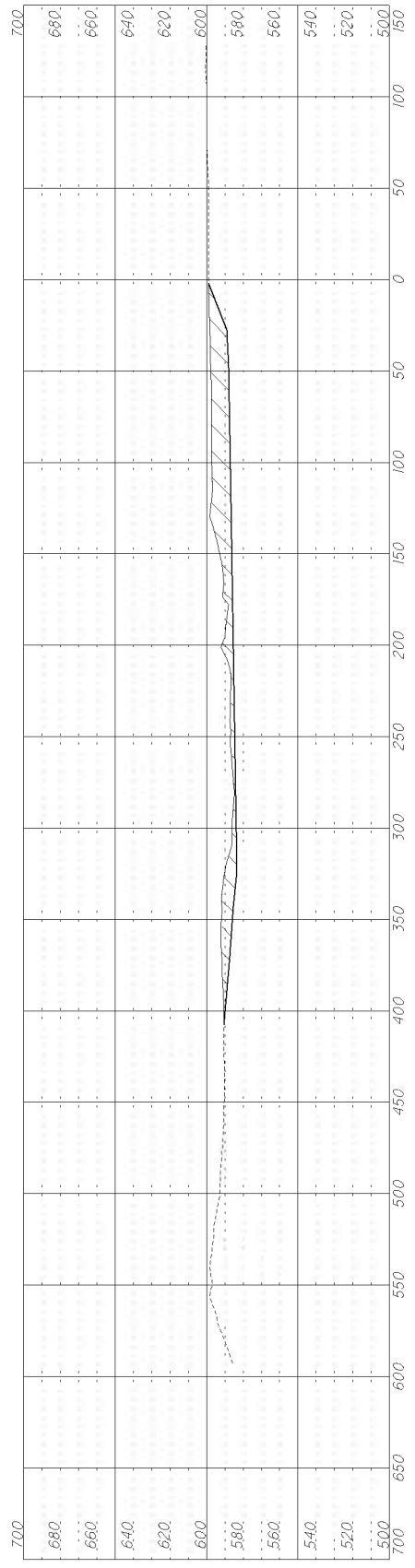

FIGURE 7.30 E
7.7



SECTION I-I

DESIGNED JN		DRAWN DMB		CHECKED JAB		JOB		CROSS SECTIONS		PID No. 77332		CUYAHOGA RIVER WEST BANK	
DATE		REVISED		FILE		STRUCTURE FILE NUMBER		E.L. ROBINSON THE CHALLENGE IN CHOICE		9/11/2006		4:01:29 PM	
09-08-2006		09-08-2006		09-08-2006		09-08-2006		E.L. ROBINSON THE CHALLENGE IN CHOICE		9/11/2006		4:01:29 PM	

5000 KENNEDY DRIVE
DIVISION, OHIO 43071

SECTION 7B

INDEPENDENT EVALUATION BY GEOCOMP CORPORATION

7B.1 Introduction

E.L. Robinson retained Dr. W. Allen Marr of Geocomp Corporation to provide an independent assessment of the stability of the slope at section A-A'. Dr. Marr visited the site, reviewed the site investigation program with BBC&M, and attended three meetings with various members of the project team. He requested and was provided undisturbed samples from the soils critical to stability of the slope. With help from Geocomp staff he ran independent stability analyses to determine the factor of safety of the existing and modified slope. He assisted the Project Team to identify means to manage the critical items that affect stability of the slopes and to characterize slope stability in terms of probability of failure.

7B.2 Summary of Lab Data

During the recent work, BBC&M obtained undisturbed Shelby tube samples for laboratory testing to determine strength of the soils comprising the slope. BBC&M arranged for the following mechanical properties tests to be performed on some of these samples:

Direct shear with residual strength	4
Direct simple shear strength	4
Torsional residual shear strength	4
Consolidated undrained triaxial strength	3

Results of these tests are provided in Appendix E of the BBC&M Report.

As part of their QC/QA responsibilities, E.L. Robinson obtained specific samples from BBC&M and sent them to Dr. Marr's geotechnical lab (GeoTesting Express, Inc.) for verification testing. Results of the GTX tests are provided in Appendix A to this report. GTX completed the following tests:

Residual Shear test points	10
Direct Simple Shear tests	3
CIU Triaxial tests	2
Incremental Consolidation tests	2
Constant Rate of Strain Consolidation test	1
Gradations	5
Atterberg Limits	5
Specific Gravity	2
Moisture Content	2
USCS Soil Classification	2

Table 7B.1 summarizes the important information from these tests. The test data support the following conclusions:

1. Results of the consolidation tests and the behavior of the undrained triaxial tests indicate that materials in the slope are considerably overconsolidated. One consolidation test indicates an effective pre-consolidation stress greater than 20 tsf. This indicates that strains and displacements preceding an unloading failure will be relatively small.
2. Results of the consolidated undrained triaxial tests indicate that negative excess pore pressures develop during undrained shear. These negative pore pressures increase the short-term strength until enough time passes for water to flow into the pores and return pore pressures to steady state values. Therefore, the critical strength for design in this slope is the drained strength. This conclusion is supported by the fact that peak strengths measured in the undrained triaxial tests are higher than the peak strengths computed with effective stress strength parameters for the same effective consolidation stress.
3. Shear strength parameters measured on shear planes inclined at well above horizontal indicate $c_p' = 0$ and $\phi_p' = 32-33^\circ$ except for one sample taken directly out of the lower shear zone at the site. This sample indicated a secant friction angle of 26° .

4. Shear strength parameters measured on horizontal planes are less than those measured on inclined planes and they vary with position in the slope. Secant friction angles determined from the effective stress path plots indicate friction angles varying from 33 to 17°. The tests that gave lower values appear to coincide with samples taken from zones where inclinometer measurements showed the largest shear from slope movement.
5. The residual strength measured in repeated direct shear testing gave residual friction angles of 30 to 13.6°. The lowest value was measured on a specimen taken directly from the lower shear zone where GTX personnel observed indications of pre-existing shear planes in the specimen prior to lab testing. Residual friction angle is a direct function of plasticity of the soil. Soils with higher plasticity give lower residual friction angles. We suspect that the soils in the west slope have thin seams of more plastic materials that give rise to the lower residual friction values of 13 to 17°. These seams are sufficiently thin and sandwiched between layers of silty material, and that their presence is not readily apparent. Event classification tests don't clearly show the presence of a more plastic seam in a sample. However, this is explained by the fact that classification tests are performed on remolded samples where the more plastic seam material is thoroughly blended with the surrounding silty soil.
6. Test results obtained by BBC&M and those obtained by GTX generally agree when looked at in total context.
7. The test results indicate that all designs for slope stability and foundation loading in the slope soils should use drained strength parameters with realistic "worst-case" pore pressures. The following strength parameters apply:
 - a. For horizontal and near-horizontal slip surfaces use $c' = 0$ and $\phi' = 15^\circ$
 - b. For failure surfaces inclined more than 25° use $c' = 0$ and $\phi' = 32^\circ$

Table 7B.1: Summary of Soil Properties from Lab Tests

Sample	Classification				Constant Rate of Strain Consolidation Test						Direct Sample Shear																													
	Description	Natural Moisture Content, %	Specific Gravity	ASTM D2487 Group Symbol	Gravel, %	Sand, %	Fines, %	Liquid Limit, %	Plasticity Index, %	Initial Moisture Content, %	Bulk Density, lb/ft ³	Vertical Strain at In Situ Vertical Effective Stress, %	CR at steepest part of curve	RR at Current Vertical Effective Stress	RR at first log cycle of unloading	Preconsolidation Stress, tsf	Coefficient of Consolidation at Overburden Stress, in ² /sec	Initial Moisture Content, %	Bulk Density, kN/m ³	Effective Vertical Stress After Consolidation, psf	Moisture Content At Shear, %	Shear Stress at Failure Condition, kPa	Shear Stress/Effective Consolidation Stress	Vertical Strain at half of Peak Deviator Stress	q _{av} , psf	σ _v /Effective Confining Stress	φ, MPa	Friction Angle												
Tests by GeoTexting Express, Inc.																																								
C-05-03	COV-80-15-246-30	118.5-120.5								26	2.73	CL	0	0.3	99.7	33	15	3.15	130.0	16	123.3	6	0	0.04	>20	3.00E-04	28	124.2	8500	28	2.67	0.208	0.255	86500	0.19261	173000	17.9			
C-05-03	COV-80-15-246-30	118.5-120.5								26	2.73	CL	0	0.3	99.7	33	15	3.15	130.0	16	123.3	6	0	0.04	>20	3.00E-04	28	125.1	8500	28	2.68	0.256	0.104	86900	8.41863	121800	19.7			
C-05-04	S-27	72-74								21	CL	3.2	8.9	87.9	28	13				22	130.5	5506	21	2028	0.368	0.02	101400	18.4183	202800	35.4										
B-05-08	S-27	116-118								22	CL	0	2.2	97.8	27	11																								
B-105A	S-20	90-92								23	CL	0	1	89	32	16																								
Tests reported by BBC&M																																								
B-05-01	S-13	55-57																																						
B-05-02	S-14	44-46																																						
B-05-02	S-32	122-124																																						
B-05-03	S-8	32-33.5																																						
B-05-07	S-22	104-106																																						
B-108	S-8	36-37																																						
B-105A	S-23	103-105																																						

Table 7B.1: Summary of Soil Properties from Lab Tests (Continued)

Sample	Triaxial Test			Direct Shear			
	Initial Moisture Content, %	Bulk Density, kN/m ³	Effective Vertical Stress After Consolidation, psf	Moisture Content At Shear, %	Peak Shear Stress at Failure Condition, psf	Effective Stress Cohesion, kPa	Effective Stress Friction, degrees
Tests by GeoTesting Express, Inc. C-05-03 C-05-03 COV-90-15,24(S-30 116.5-118.5	26.7	120.5	9493	25.2	3894	assume 0	26.3
	20	123.6	4748	31	2433		27.1
	28	128.7	9500	35	4718		26.8
C-05-04 S-27 72-74	24	122.9	14249	22	6387		21.5
	22	130.5	2752	23	1580		26.5
	21	129.5	6289	23	4574		26.5
B-05-08 S-27 116-118	22.2	128.4	8267	19.5	6882	assume 0	33.4
	21	130.7	4130	19	2677		33.0
B-105A S-20 90-92							
Tests reported by BEC&M B-05-01 S-13 55-57 B-05-02 S-14 44-46 B-05-02 S-32 122-124 B-05-03 S-8 32-33.5 B-05-07 S-22 104-106 B-108 S-8 35-37 B-105A S-23 103-105	21.3	124.6	3000	18.3	3400	0	32
	27.7	131.6	6830	19.0	5500		
	21.5	130.2	9900	19.0	5500		
	26	127.8	2950				28
	26	126.0	4500				22
	28	121.6	9000				18
	27.9	129.4	7000	24	4146		28
							26
							4000
							27

Dr. Marr examined all available strength data, which included results from tests by BBC&M, results from tests by Geocomp and other published data on strength of plastic clays. One of the undisturbed tube samples obtained during this investigation actually captured a shear plane. This sample was positioned into a direct shear test cell so that the field shear plane would align with the shear plane of the test device. Geocomp measured a peak strength equivalent to soils with zero cohesion and a drained friction angle of 13.6° . Several test series indicated residual strength values of 15° for the more plastic clays. Thin seams of plastic clay may exist at various locations within the slope. The critical failure surface for stability will develop through these weaker horizontal seams to the maximum extent possible. Therefore, we concluded that horizontal to near-horizontal portions of all shear surfaces should use an effective stress strength value of zero cohesion and 15° . Data for the less plastic layers of soil in the slope indicate a residual strength similar to the peak strength. Lab tests indicate friction angles of 22 to 33° ; however, these tests focused on the more clayey samples. We recommended a friction angle of 32° with zero cohesion be used for design on all shear surfaces inclined at more than 25° from horizontal. These values of strength give factors of safety for past and present conditions that correlate reasonably well with the past performance of the slopes. We think the strength parameters are defined with reasonable certainty.

7B.3 Summary of Analyses

Members of the Baker Team used three different computer programs for method of slices to analyze stability. BBC&M used SLIDE with the Spencer method of analysis. E.L. Robinson used GSTABL7 with the Simplified Janbu method of analysis. Geocomp used UTEXAS4 with Spencer's method. Each of these programs is widely used in the profession. A particular organization will tend to use the program with which they are the most familiar and comfortable. Each program has its own nuances and peculiarities. Our Team decided to allow each team member to carry out its work choosing its own analysis tools. This approach helped us identify discrepancies and inconsistencies in the input data among the team members that were isolated and removed. The fact that the final results were similar provides strong verification that no significant errors were made in the various analyses.

Geocomp also used an entirely different analytical approach to check that the results from limit equilibrium are appropriate for this case. The analyses were run with the finite element method using PLAXIS. In this program both limit equilibrium and stress-strain relationships are maintained. Its strength reduction option allows one to systematically reduce strength parameters until large incremental shear strains occur. The analysis determines that actual shape of the shear surface with maximum incremental strain without having to preset that surface as is done in limit equilibrium methods. This provides an independent verification that the limiting equilibrium methods identified the most critical surfaces for sliding. PLAXIS also gives deformations resulting from changes in the condition of the slope. We used it to estimate how much and where movement might occur so we could determine potential locations for the bridge foundation.

The geometry and soil properties used to analyze section A-A along the new bridge alignment were the same for GSTABL7, UTEXAS4 and PLAXIS. Figure 7B.1 shows the geometry in the PLAXIS analysis.

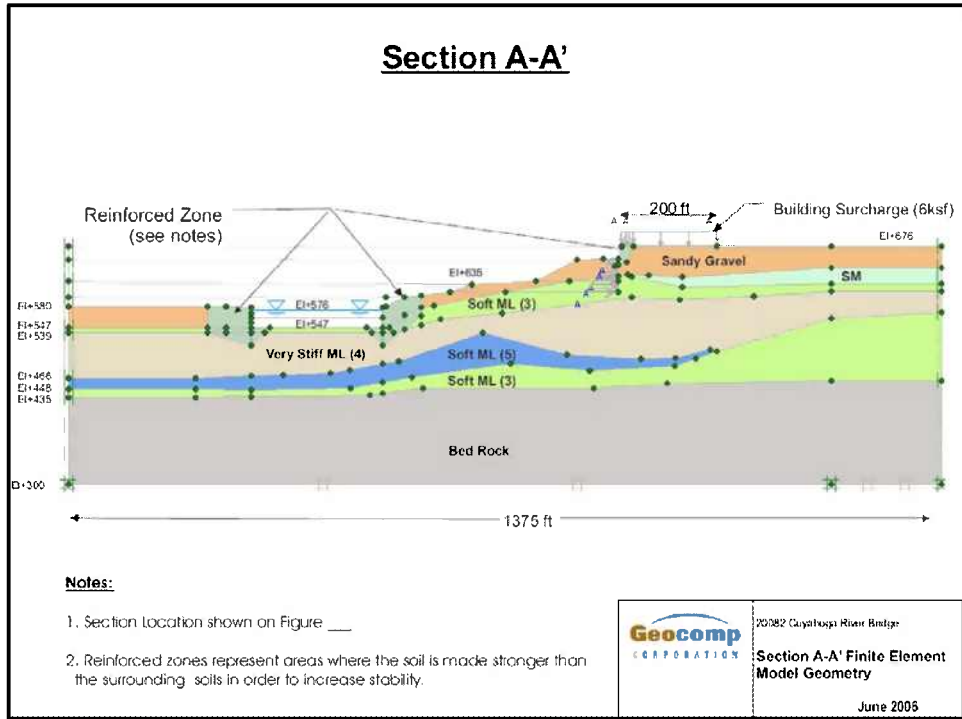

2 Geometyrdes

Figure

Figure 7B.1: Geometry for Section A-A

Table 7B.2 summarizes results for factor of safety determined by Geocomp and those determined by E.L. Robinson:

Table 7B.2: Summary of Results for Factor of Safety

Cross Section	ID	Description	With building in place				Remove Building	
			Circular failure		Non-Circular		Non-Circular	PLAXIS
			F.S. (GSTABL7) by E.L. Robinson	F.S. (UTEXAS4) following E.L. Robinson's Crit Surface	F.S. (UTEXAS4) search with Floating Grid	F.S. (UTEXAS4) search with non-Circular failure	PLAXIS Analysis by Geocomp Corp. (K _g =1.5)	F.S. (UTEXAS4) search with non-Circular failure
A-A	1a	a-5-25ef 3 - Section as it exists now with existing water conditions - W1 follows W2(EL575)	1.521	1.453	1.382	1.269	1.180	1.458
	1b	a-5-25ef 3 Section as it exists now with all pore pressure at W1.	N/A	N/A	N/A	1.191	1.120	1.339
	1c	a-5-25ef 4 Section as it exists now and surcharge representing the aggregate pile of 30 to 35 feet in height - water levels same as 1a	1.366	1.377	1.247	1.316	N/A	N/A
	1d	a-5-25ef 4 Section as it exists now and surcharge representing the aggregate pile of 30 to 35 feet in height - water levels is the same as 1b	N/A	N/A	N/A	1.239	N/A	N/A
	2	a-5-25ef 2 Section as it exists now and the water table is as modeled by BBC&M W1. Only soil#6 follow W2 at (EL625)	1.294	1.265	1.256	1.102	< 1	1.222
	3	a-5-25ef 2 Section as it exists now and the water table is as modeled by BBC&M W1. Only soil#6 follow W2 at(EL690)	0.969	0.916	0.913	0.862	< 1	0.895
	4	Slope unloaded with Soil#6 having W2(EL675)						1.54
	5	Slope unloaded with Soil#6 having W2(EL695)						1.49

* GSTABL7 was used by E.L. Robinson. UTEXAS4 was used by Geocomp Corp.

The results in Table 7B.2 show the following:

1. UTEXAS4 results for circular failure surfaces are a little lower than comparable analyses with GSTABL7. This is due to the larger number of trial surfaces used in the UTEXAS4 analyses, which increase the likelihood of finding a more critical failure surface with a lower factor of safety.
2. UTEXAS4 analyses show that non-circular failure surfaces are more critical than circular ones. This is the expected result due to Soil #5 having a weak strength in the horizontal direction.
3. PLAXIS gives a lower factor of safety by as much as 0.1. This is due to its ability to analyze all possible failure modes in the same analysis, which results in failure in ways that are not included in limit equilibrium analysis.

Figure 7B.2 shows the results of a PLAXIS strength reduction analysis on the as-is slope. The contours show incremental shear strains that develop in the strength reduction analysis. Blue is low strain and red is high strain. The zones of high strain indicate the shape of the failure mode that PLAXIS determines. These early results were very useful to the Team's work for four reasons:

1. The PLAXIS analysis confirmed that the factor of safety for the slope is low.
2. The PLAXIS analysis showed that a non-circular failure surface was the most critical.
3. The PLAXIS results showed that the existing building is clearly involved in the most critical failure mode.
4. The PLAXIS analysis suggested that removing the building and the soil beneath the building might be very effective to improve the stability of the slope.

These outcomes lead E.L. Robinson to direct more of its analysis attention to non-circular failure surfaces.

To consider ways to improve the stability of the slope one needs to determine the mechanisms that may drive the factor of safety lower. For this project they are the following:

1. Unloading by removal of support from the toe area.
2. Loading by adding load to the upper half of the sliding geometry.
3. Loss of strength from displacement on the slip surface.
4. Loss of strength from increased pore pressure.
5. Added driving force from increased pore pressure.

Number 1 will have to be addressed in final design by replacing the existing sheet pile revetment with something that can hold the slope in place for the slope geometry and the anticipated river flood stages. Number 2 can be addressed by not adding load to the upper half of the slope. Number 3 is already being addressed by using residual strength parameters for all stability analyses. Residual strength is the lowest the effective stress strength can go. Numbers 4 and 5 are controlled by controlling the pore pressures in the slope.

Figure 7B.3 shows the horizontal displacements computed with PLAXIS for a 20 ft increase of pore pressure in Soil #5 (the blue horizontal clay layer with residual strength of 15°). Figure 7B.4 shows the vertical displacements for the same analysis. The calculated horizontal movements are about 2 inches at the edge of University Avenue and decrease to about 1 inch beyond a distance of 200 ft from University Avenue. Likewise, the vertical deformations are about 1 inch at the edge of University Avenue and decrease to less than $\frac{1}{2}$ inch beyond a distance of 100 ft from University Avenue. These results indicate that a bridge foundation could be located anywhere beyond a distance of 200 ft back from the river side of University Avenue and not be affected by the current condition of the slope, assuming that condition does not further degrade.

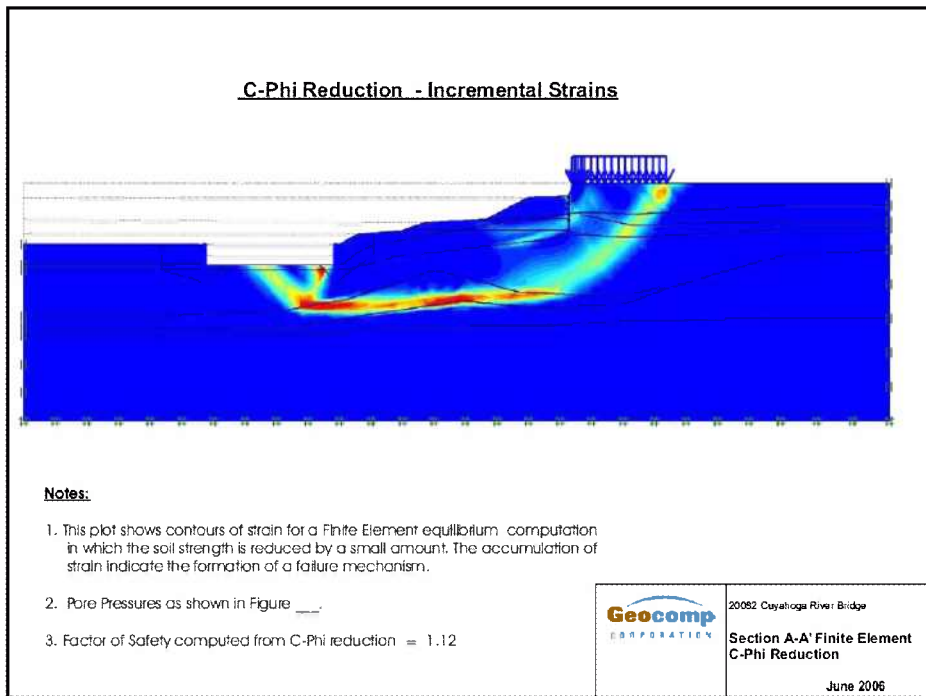

20082-FoS Case 1.dwg

Figure

Figure 7B.2: Results of Stability Analysis of Existing Slope with PLAXIS

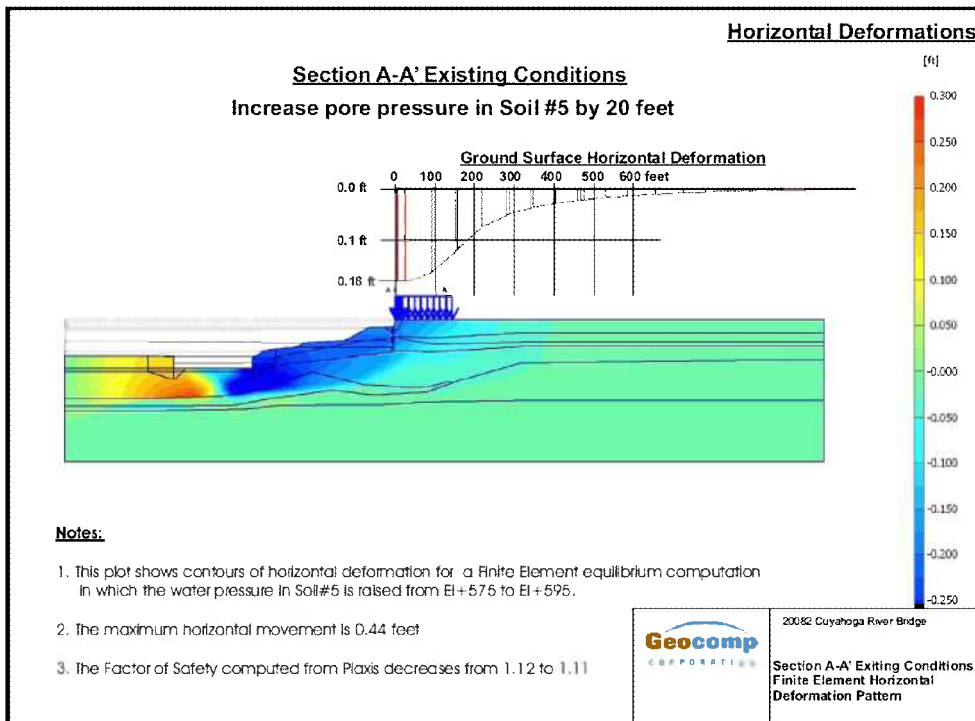

20082-HD Case 1.dwg

Figure

Figure 7B.3: Horizontal Movements in Existing Slope from Increasing Pore Pressure in Soil #5 by 20 ft

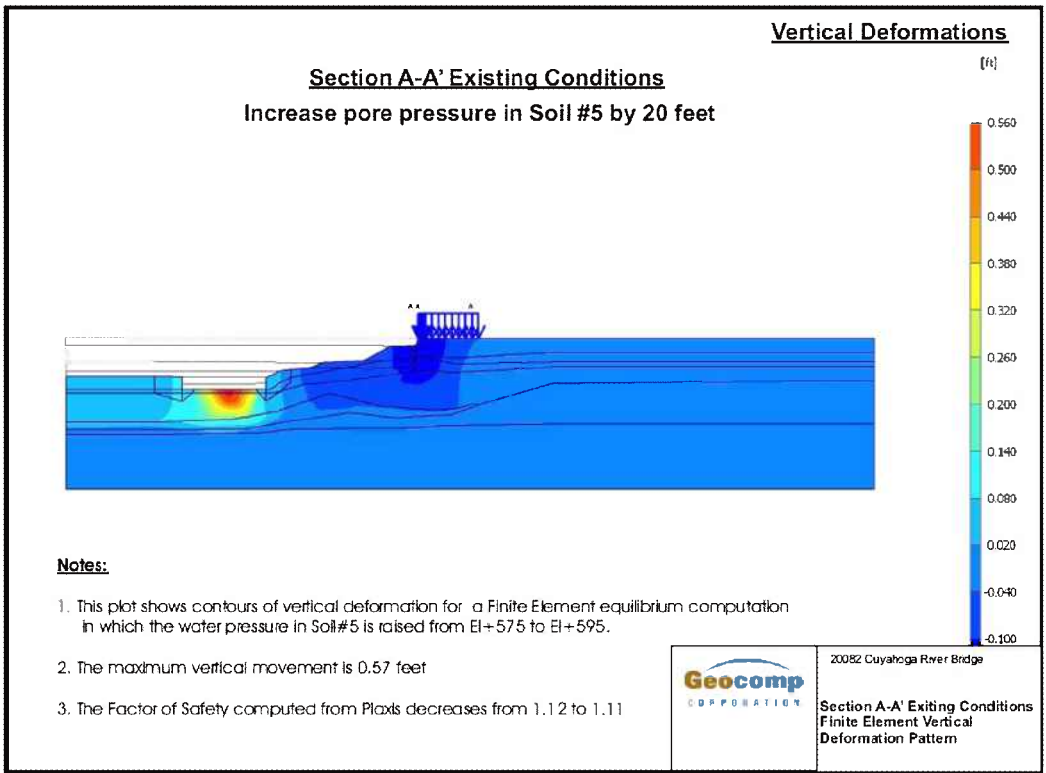
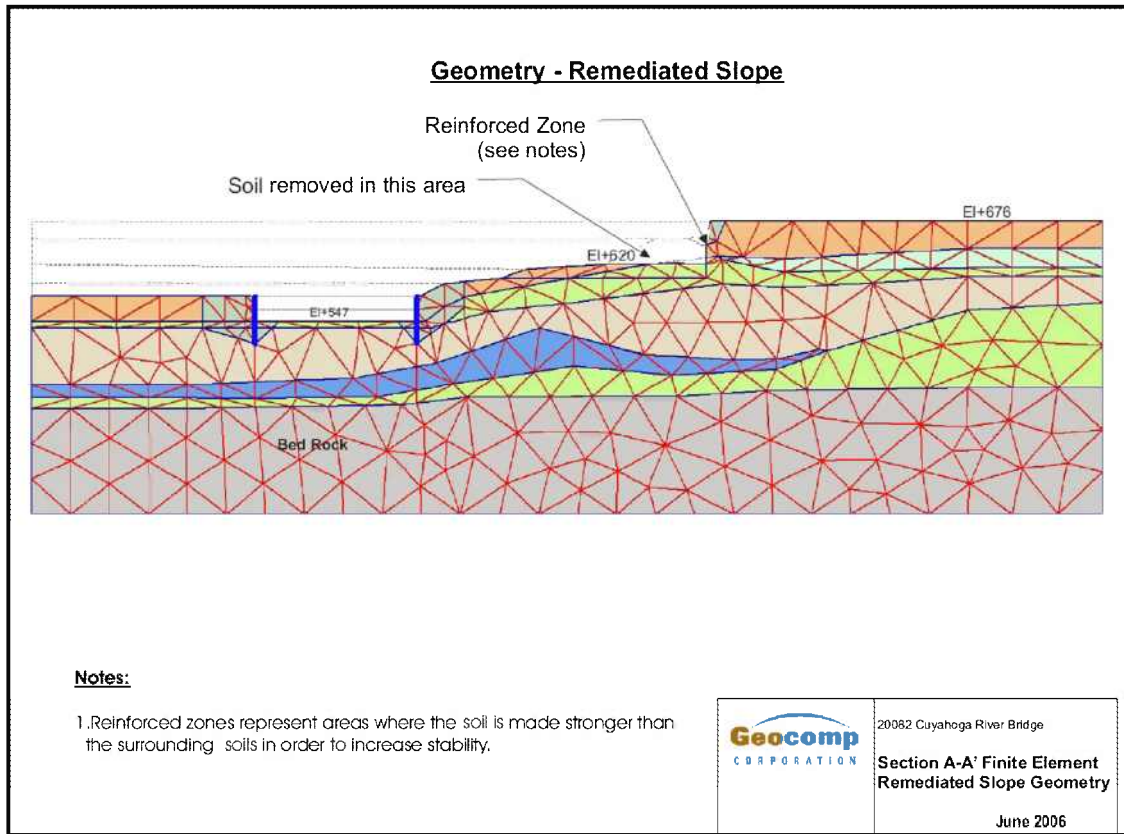

Figure 7B.4: Vertical Movement in Existing Slope from Increasing Pore Pressure in Soil #5 by 20 ft.

We also used PLAXIS to evaluate the benefits of unloading the slope. Figure 7B.5 shows the analyzed geometry. It includes removal of the warehouse building and unloading of the slope to El +620 back to University Ave. The analysis assumes some type of retaining wall would be used to support University Ave.



20082 Geometry.Repaired.dwg

Figure

Figure 7B.5: PLAXIS Geometry for Unloaded Slope

Figure 7B.6 shows the PLAXIS strength reduction analysis for the slope upgraded by unloading. Removing the building and soil up to University Ave. increases the factor of safety determined with PLAXIS from 1.12 to 1.54. The critical failure surface also moves more towards the river. This should result in smaller horizontal movements behind the slope from the FOS decreasing.

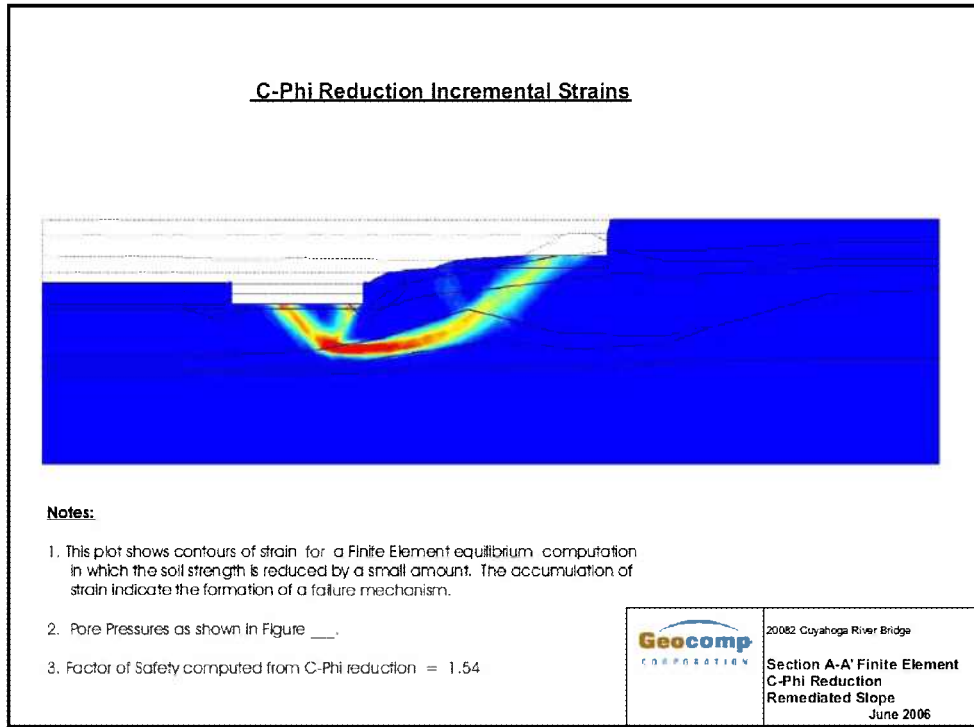
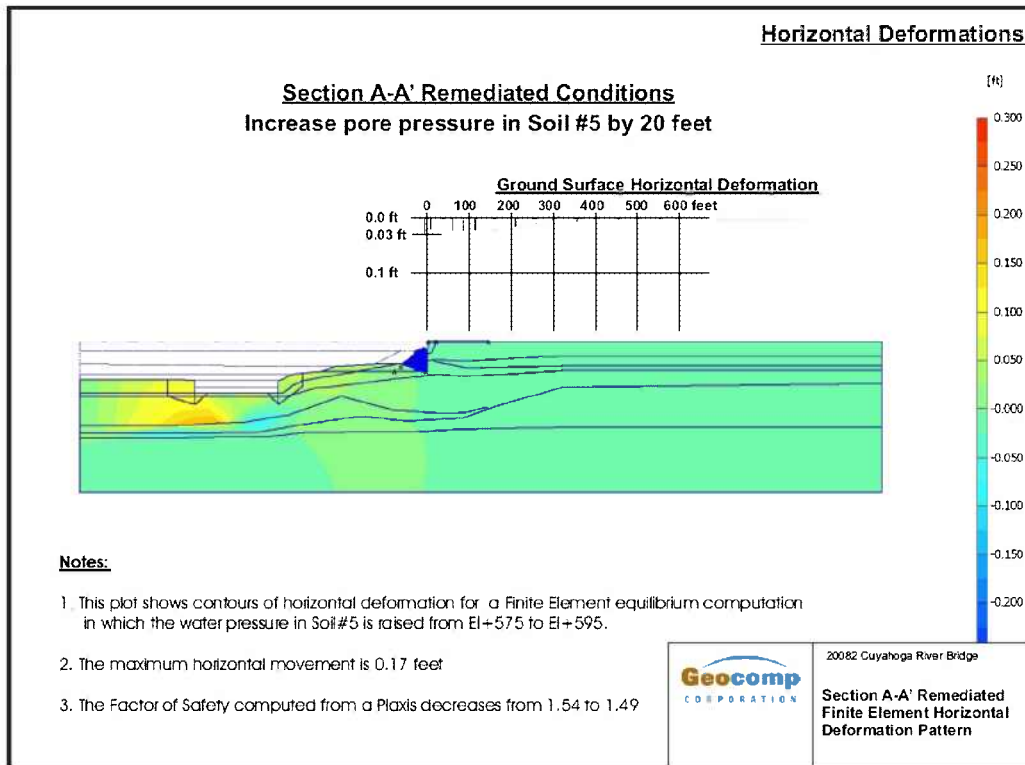

Figure 7B.6: Stability Analysis with PLAXIS for Unloaded Slope

Figure 7B.7 shows the horizontal displacements that result from the unloaded slope if the pore pressure in Soil #5 is increased by 20 ft. Figure 7B.8 shows the vertical displacements for the same condition. The Factor of Safety is reduced from 1.54 to 1.49. Horizontal movement at the edge of University Avenue is less than ½ inch. Vertical displacement at the edge of University Avenue is about 1 inch at the edge of University Avenue but quickly decreases away from the slope to small values.

These results show that by unloading the slope a factor of safety greater than 1.5 can be obtained. With careful consideration to the final slope geometry, a bridge foundation could be located any where on the slope and back of the slope, except within about 100 ft of the existing river revetment.



20082 HD Case 2.dwg

Figure 7B.7: Horizontal Displacements of Unloaded Slope from an Increase in Pore Pressure of 20 ft in Soil #5

The above results were for an arbitrary increase in pore pressure of 20 ft in Soil #5. Figure 7B.9 shows the effect on Factor of Safety of increasing pore pressure in the slope as determined by PLAXIS. Once the piezometric elevation in Soil #5 increases above about 600 ft, the effect of rising pore pressure on factor of safety becomes more pronounced. Using the results from the above deformation analysis, we can conclude that horizontal movements behind the slope will be less than 1 inch for the unloaded slope as long as pore pressures in the slope are prevented from rising above elev. 600 ft. This should be easily accomplished with horizontal drains.

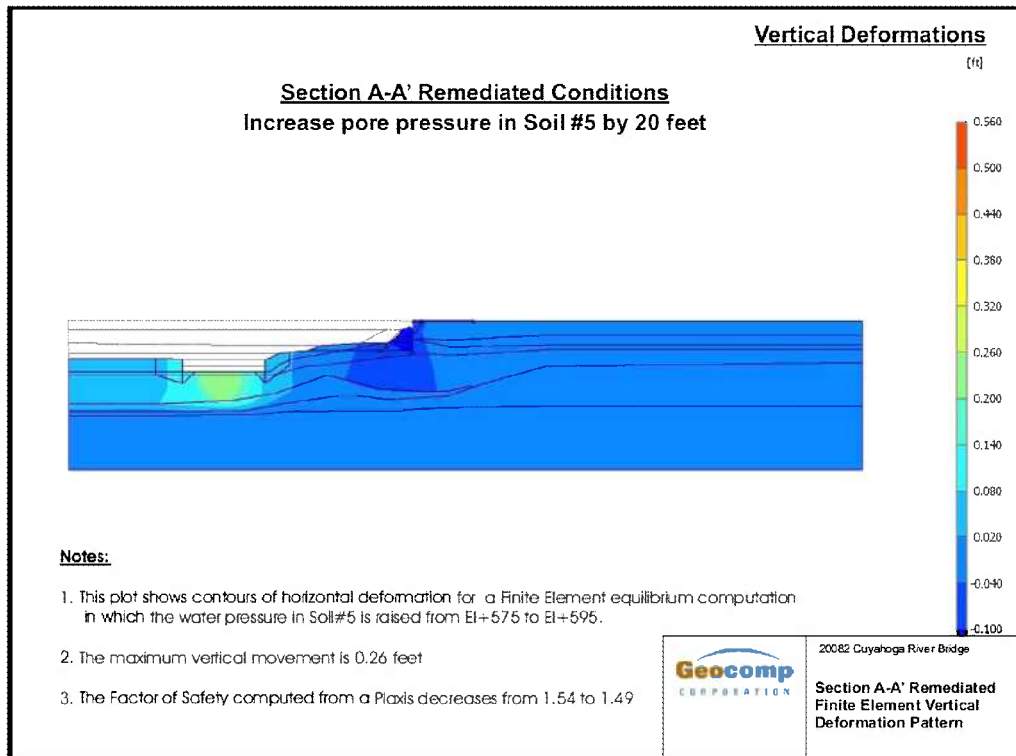

20082 HD Case 2.dwg

Figure 7B.8: Vertical Displacements of Unloaded Slope from an Increase in Pore Pressure in Soil #5 of 20 ft.

The results of Geocomp's independent review of the stability of the slope lead to the following conclusions:

1. Strength parameters for the design of the slope should use drained strength residual values. For horizontal failure surfaces in the clay layers residual strength is 0 cohesion and a friction angle of 15°. For failure surfaces inclined by more than 25°, the recommended strength values are a cohesion of 0 and a friction angle of 32°.
2. Stability results obtained by BBC&M, E.L. Robinson and Geocomp are comparable when the same condition is analyzed. This means that no major errors exist in the mechanics of doing the analyses.
3. The analyses indicate a factor of safety along section A-A' of the existing slope of about 1.15±. Anything that appreciably decreases this value will result in visible movements of the slope.

4. The analyses show that removing the warehouse building and soil to unload the slope are very effective in improving the factor of safety to greater than 1.5.
5. PLAXIS analyses show that displacements resulting from increases in pore pressure in Soil #5 are acceptably small as long as no pore pressure exceeds elevation 600 ft. Measures must be included in the final design to control pore pressures from water and gas so that they do not exceed elevation 600 ft.

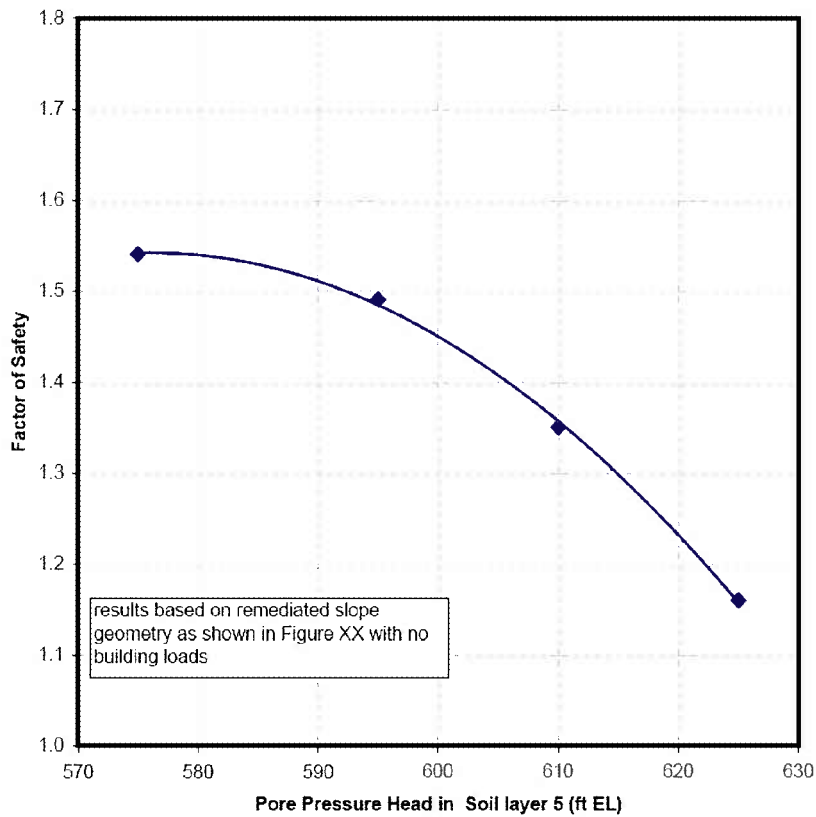

	20082 Cuyahoga River Bridge
	Effects of water level on Factor of Safety Remediated Conditions

Figure

Figure 7B.9 Effect of Increasing Pore Pressure on Stability of Unloaded Slope

7B.4 Probability of Slope Failure

When involved with a potentially unstable slope, the engineer wants to know whether the slope will fail. In particular, the engineer desires a numerical measure of how the forces holding the mass in place compare with the destabilizing forces. That numerical measure, Factor of Safety, indicates the margin of safety which the engineer uses with his knowledge and experience to evaluate the possibility of the slope failing. The higher the Factor of Safety, the less likely the slope will fail. Much of the focus of the work described in this report was to get parameters and perform analyses to determine the Factor of Safety of the slope for various conditions and assumptions.

While meaningful to the engineer, Factor of Safety is not so useful to owners, contractors, regulators, and other interested parties. Many don't understand that the computed Factor of Safety can be higher than 1, but the slope still fail. A more understandable and universal yardstick of safety is probability of failure. Most people better understand what it means for a slope to have a probability of failure of 1% than the meaning of a Factor of Safety of 1.2 .

In the mid 1970's, T. W. Lambe and W. Allen Marr began to apply risk analysis methodologies to dams and slopes to obtain estimates of probability of failure associated with factor of safety. An example of this work was described by Lambe, et. al. (1981).¹ This formalized approach required too much effort and took too much time for all but special projects. Lambe and Marr began to sketch out some approximate relationships between factor of safety and probability of failure of earthen slopes. These were based mostly on very little data and a lot of engineering judgment. It was clear from the beginning that this relationship had to somehow involve the level of engineering and care that went into the design, construction and operation of the facility.

¹ Lambe, T.W., Marr, W.A. and Silva, F. (1981) "Safety of a Constructed Facility: Geotechnical Aspects," Proc. ASCE:JGED, Vol. 107, No. GT3, pp. 339-352.

These ideas were first published in Lambe's Terzaghi Oration.² Figure 7B.10 shows the first published relationship. Level I indicated a project with a high level of engineering, construction observation and monitoring. Level IV indicated little to no or poor engineering in all phases. Level III indicated average engineering practice and Level II indicated above average engineering practice. Lambe, Marr and Silva further developed the ideas over the years and currently have a paper in review for publication that reflects the current version. Figure 7B.11 shows the latest version. Table 7B.3 provides a more detailed explanation of the factors that distinguish among the four levels of engineering for a project. The four categories correspond to the following types of facilities:

- Category I – facilities designed, built and operated with state-of-the-art or best possible practices. Generally these facilities are those that serve critical functions or have high failure consequences.
- Category II – facilities designed, built and operated using above average engineering practices. Many important facilities designed with “conservative practices” fall in this category.
- Category III – facilities without site-specific design and substandard construction or operation. Temporary facilities with low failure consequences often fall in this category.
- Category IV – facilities with little to no engineering.

The family of curves as well as the table with the four levels of engineering reflect the generally accepted concept that – “A larger factor of safety does not necessarily imply a smaller risk, because its effect can be negated by the presence of larger uncertainties in the design environment” (Kulhawy and Phoon, 1996). The curves in Figure 7B.11 also reflect the mathematical certainty that for the same factor of safety, the probability of failure decreases with increasing information content and data quality that result from a more detailed investigation, testing, evaluation, observation and remedial action. We based Figure 7B.11 on data from over 75 projects spanning over four decades. The

² Lambe, T.W. (1985). The First Terzaghi Oration: Amuay landslides. Proceedings of the 11th International Conference on Soil Mechanics and Foundation Engineering, San Francisco, Golden Jubilee Volume, pp 137-158.

projects included zoned and homogeneous earth dams, tailings dams, natural and cut slopes, and earth retaining structures.

As an example of how to use Figure 7B.11, consider a deep failure in the section A-A' slope for the new bridge. We concluded from stability analyses that in its present condition it has a Factor of Safety in the vicinity of 1.15. The slope did not previously receive much engineering attention nor was it monitored very closely, except as peripheral to the monitoring of the slope for the existing bridge; therefore, its classification is between I and II. From Figure 7B.11 we can see that the probability of a failure of this slope over time is in the vicinity of 10 to 25% (1 in 10 to 1 in 4). The slope in its present condition is not where one would position a large bridge pier.

Additional analyses in this report show that by flattening the slope and controlling pore pressures in the soil within the slope, the factor of safety can be improved to above 1.5. Considering the importance of this structure, its design and construction should follow the attributes of a Level II facility in Table 7B.3. The lifetime probability of failure becomes less than 0.1% (1 in 1,000). This value decreases to less than 0.01% (1 in 10,000) if the factor of safety is increased above 1.75. At this level, geotechnical risks from slope failure are well below other risks to the bridge and a further reduction in factor of safety and probability of failure would not be justifiable.

Three cautionary points must be noted.

1. All elements identified in Table 7B.3 for a Level II classification must be met. Leaving out one, such as monitoring and maintenance during operation, will drop the Level below II and increase the probability of failure. It is possible to have different levels in each of the columns by adding up the partial values in the lower right hand square of one box in each column. For example, if Level II engineering is used in all aspects of design and construction of the new bridge but there is little to no inspection of the slope and no monitoring, the Level becomes

$4 \times 0.4 = 0.8$, or 2.4. The probability of failure for a factor of safety of 1.5 would drop to about 0.4% (1 in 250).

2. The probabilities in Table 7B.3 are lifetime probabilities. There is evidence in the literature that suggests about a third of this risk occurs during construction, a third during the design life and a third after the structure exceeds its original design life. The message is that even though a slope is stable at the end of construction, risk remains that the slope may fail during its operational life. This point is why inspections and monitoring are important elements of an overall risk management strategy.
3. The probabilities obtained from Table 7B.3 are approximate and meant to aid in decision making only. For a specific structure the probability of failure will eventually become known. It will be 0 or 1. Unfortunately, we have to make decisions long before we know the outcome. Figure 7B.11 is one useful way to help people of different backgrounds evaluate the benefits of various design alternatives and make approximate comparisons of risk from geotechnical causes to other risks.

In summary, the slope in its present condition has a probability of failure over time in the vicinity of 10 to 25% (1 in 10 to 1 in 4). By unloading the slope and controlling pore pressures within the slope, this value can be lowered to the vicinity of 0.01% (1 in 10,000). At this level, geotechnical risks from slope failure are well below other risks to the project and a further reduction in factor of safety and probability of failure would probably not be justifiable.

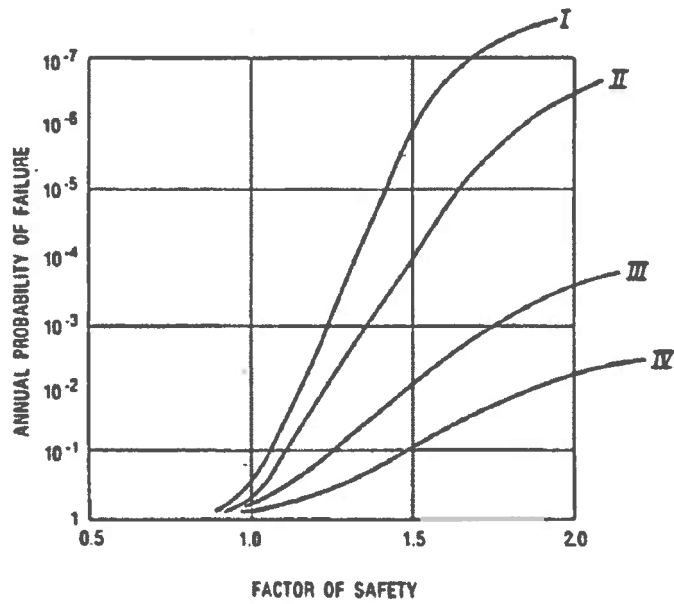

Figure 7B.10: Factor of Safety/Probability of Failure Curves (Lambe 1985)



Figure 7B.11: Current version of Factor of Safety/Probability of Failure Curves (Lambe, Marr, Silva - in review)

Table 7B.3: Earth Structure Categories and Characteristics

LEVEL OF ENGINEERING	DESIGN			CONSTRUCTION AND INSPECTION AND OBSERVATION	OPERATION AND RISK MONITORING
	Investigation	Testing	Analyses and Documentation		
<p>I (Best Possible) Critical facilities and those high consequences from failure.</p>	<ul style="list-style-type: none"> Evaluate design and performance of nearby structures Analyze historic aerial photographs Locate all non-uniformities (soft, wet, loose, high or low permeability zones) Determine site geologic history Determine subsurface profile using continuous sampling Obtain undisturbed samples for lab testing of foundation soils Determine field pore pressures 	<ul style="list-style-type: none"> Run lab tests on undisturbed specimens at field conditions Run strength test along field effective and total stress paths Run index field tests (e.g., field vane, cone penetrometer) to detect all soft, wet, loose, high or low permeability zones Calibrate equipment and sensors prior to testing program 	<ul style="list-style-type: none"> Determine FS using effective stress parameters based on measured data (geometry, strength, pore pressure) for site Consider field stress path in stability determination Prepare flow net for instrumented sections Predict pore pressures and other relevant performance parameters (e.g., stress, deformation, flow rates) for instrumented section Have design report clearly document parameters and analyses used for design No errors or omissions Peer review 	<ul style="list-style-type: none"> Full time observation by qualified engineer Construction control tests by qualified engineers and technicians No errors or omissions Construction report clearly documents construction activities 	<ul style="list-style-type: none"> Complete performance monitoring including comparison between predicted and measured performance (e.g., pore pressure, strength, deformations) <ul style="list-style-type: none"> All monitoring results in green zone. No malfunctions (slides, cracks, artesian heads) Immediate remedial actions by trained crews
<p>II (Above Average) Important facilities and those with significant consequences.</p>	<ul style="list-style-type: none"> Evaluate design and performance of nearby structures Exploration program tailored to project conditions by qualified engineer 	<ul style="list-style-type: none"> Run lab tests on undisturbed specimens Measure pore pressure in strength tests Evaluate differences between laboratory test conditions and field conditions. 	<ul style="list-style-type: none"> Determine FS using effective stress parameters and pore pressures Adjust for significant differences between field stress paths and stress path implied in analysis that could affect design 	<ul style="list-style-type: none"> Part-time observation by qualified engineer 	<ul style="list-style-type: none"> Periodic inspection by qualified engineer No uncorrected malfunctions Limited field measurements obtained manually Remedial action by pre-arrangement
<p>III (Average) Ordinary facilities and those with low failure consequences.</p>	<ul style="list-style-type: none"> Evaluate performance of nearby structures Estimate subsurface profile from existing data and borings 	<ul style="list-style-type: none"> Index tests on samples from site Field tests using SPT and similar technologies 	<ul style="list-style-type: none"> Rational analyses using parameters inferred from index tests 	<ul style="list-style-type: none"> Visual observation occasionally 	<ul style="list-style-type: none"> Annual inspection by trained person Annual to no field measurements Remedial work limited to emergency repairs
<p>IV (Below Average) Limited or no engineering.</p>	<ul style="list-style-type: none"> No field investigation or site visit only. 	<ul style="list-style-type: none"> No laboratory tests on samples from the site 	<ul style="list-style-type: none"> Approximate analyses using assumed parameters 	<ul style="list-style-type: none"> No construction observation by qualified engineer No construction control tests. 	<ul style="list-style-type: none"> Occasional inspection by non-engineer or no inspection. No measurements.

CHAPTER 8

HORIZONTAL DRAINS AND VERTICAL PRESSURE RELIEF DUCTS

A. Horizontal Drains

8.1 Introduction

The addition of horizontal drains installed in the proposed regraded west bank slope would be a very cost effective means to improve the overall stability of the slope by using a system that can be referred to as a secondary or complimentary means to add integrity to the design. Please note that to-date there are not any field measurements that support the conservative position that an extensive undesirable hydrostatic condition is present at this site. There have been approximately seven isolated instances where, during drilling, the bore hole hit a pocket of confined gas/water pressure that indicated a hydrostatic pressure that is well above the ground surface. For slopes that are subject to the presents of a high water table (undesirable piezometric head), an effective means of slope stabilization is to lower the water level within the slope. Horizontal drains have often been used on marginally stable slopes to successfully lower the water table and ultimately increase the factor of safety against slope failure. Vertical pressure relief ducts/drains can be used to allow the gas pressure to dissipate.

A literature search reveals a number of sources where one can discuss with an experienced practitioner the viability of utilizing horizontal drains used to collect water and to allow the water to escape from a slope. One example is The Government of British Columbia - Ministry of Transportation – Geotechnical Branch – Mr. Mike Oliver was interviewed regarding his experience with horizontal drains. His comments are that horizontal drains are often used as a secondary means to control hydrostatic pressure, the cost is \$10 per foot, and maintenance is necessary but not difficult. The British Columbia Ministry of Transportation has been using horizontal drains to stabilize slopes for more than 25 years. They have established installation and maintenance specifications to be used by the Ministries districts on all jobs with horizontal drains. These specifications

include the methods of cleaning the drains. See attached information provided by the BC - Ministry of Transportation.

The use of horizontal drains as a slope stabilization technique has been repeatedly reported in the literature. One of the projects at which horizontal drains were used was in the mitigation of the Templin Highway Landslide located in Los Angeles County, California. As shown in the letter of transmittal, attached at the end of this chapter, during the course of the referenced project and as a consequence of the increased rate of movement in the landslide, an emergency dewatering contract was initiated. Vertical and horizontal drains were installed. While vertical drains appeared to be inefficient horizontal dewatering exceeded expectations. In addition, Krohn, J.P. (1992) reported successful use of horizontal drains in landslide mitigation.

8.2 Maintenance

Horizontal drains are commonly cleaned out by entering into an annual contract with the local Rotor Rooter Company. Experience may support a longer interval of up to five (5) years for clean out.

8.3 Cost

Horizontal drains cost between \$10 and \$15 per linear foot. Vertical drains cost between \$60 and \$75 per linear foot.

8.4 Design

General design parameters for horizontal drains are as follows (some of the information came from CALTRANS and CDOT):

- Length of drain can be 300 feet plus
- Install at an upward angle of at least 5 degrees
- Typical diameter is 4 inches
- Typical spacing is 10 feet

- Horizontal drains are made from 40-mm schedule 80 polyvinyl chloride (PVC) pipes.
- Horizontal drains can be slotted, perforated or plain. They are placed in holes drilled into aquifers.
- Normally they are placed in cut slopes or under fills and their purpose is to reduce the possibility of slides or slipouts.
- Determine the drain locations and sequence of placement based on plans, exploration work, and observations during excavation. Determine the system by which horizontal drains will be designated and marked, and provide the contractor with this information.
- Plan the placement of collectors and outlets so they are positioned for public safety and ease of maintenance operations.
- Determine the length of non-perforated pipe to be placed at the drain mouths. Use the minimum specified length when the aquifer extends to the surface. Require outlet pipes to be connected to the collector system.
- Require the space between the drilled hole and the pipe to be tightly plugged with earth as specified.
- Keep a boring log of material types encountered during drilling and also keep a log of production rates.
- Each drain must be identified by a brass plate bearing an assigned number or other label.
- For the most part, horizontal drains are hidden from view, so ensure complete as-built records are created.
- CDOT Recommends that a surface drainage be designed to prevent water infiltration into the slope. Ditches or irrigation channels on slopes should be lined when practical. Tension cracks should be filled in and slope scarps and depressions that could pond water should be contoured so they drain. The last 10 ft of pipe should be left unperforated to assure that water flows out.
- Filter material or filter fabric should be used if clogging is expected. This can greatly extend the life of the drain but is extremely difficult to install.

- They are commonly installed in fan-shaped arrays of several pipes emanating from a common point.

B. Vertical Pressure Relief Ducts

Vertical pressure relief ducts are recommended to be located in the area where there is resistance to slope movement. Consider attaching the vertical ducts to a designed collection system located just below the ground surface and equipped to provide an appropriate number of surface exit locations. The cost of providing the vertical pressure relief ducts ranges from \$60 to \$75 per foot; total estimated cost is \$2,000,000.

Directional drilling can also be considered on this site.



Jensen Drilling was founded in 1966 by John J. Jensen. Previously employed by the Bureau of Public Roads, (Vancouver District), Mr. Jensen was involved with some of the first installations of horizontal drains in the U.S.

Recognizing the effectiveness of drains, along with the potential increase of usage as a method of slide stabilization, Jensen Drilling built its first horizontal drain drill in 1967.

From that time forward, Jensen Drilling has established itself as the largest installer of horizontal drains in the U.S. We now have fourteen horizontal drain drill rigs, which we continue to employ new and innovative technology to, resulting in the most effective and productive machines made for this type of drilling.

An Innovator In Drilling Implementation And Technology



Custom Horizontal Drilling Machine, Designed and Built by Jensen Drilling Company

Along with the ability to build drill rigs, our extensive experience drilling in various geological formations across the U.S. as well as different parts of the world has resulted in the development of techniques and tools that can be employed to overcome problems in virtually any formation.

World Wide Experience



Horizontal Drilling in Chile

Since our first project of 14,000 feet in 1967, we now install annual amounts up to 700,000 feet.

While horizontal drains are our expertise, we also drill and install de-watering wells, tie backs, rock bolts, soil nails, as well as pressure grouting, core drilling, and various other types of drilling.

JDC's edge over our competitors has been our ability to design and manufacture drilling equipment and components to meet specific needs. Our specially designed products are used in our drilling operations as well as sold nationally.

Contact Information

Home Office

1775 Henderson Avenue
Eugene, Oregon 97403

Ph (541)726-7435
Fax (541)726-6140

Email Sales & Information

Tennessee Office

230 Cusick Road
Alcoa, Tennessee 37701

Ph (865)984-4627
Fax (865)970-3151

Email Sales & Information

Figure 8.1: Horizontal drains Installation Company Information



Figure 8.2: Pictures of horizontal drain installation equipment

CHAPTER 9

FOUNDATION ISOLATION SYSTEMS

9.1 Introduction

If it is desired to include the addition of a foundation isolation system with the substructure designs for this project, this section suggests some preliminary design ideas for consideration. In this chapter, the term “Foundation Isolation System” is defined as any means added to the foundation design for the purpose of eliminating the development of differential lateral earth forces from being applied to the proposed substructure foundations. For discussion purposes, four different isolation systems and their respective costs will be discussed in this chapter.

The foundation layout in Figures 9.1 through 9.3 show a foundation with a drilled shaft pattern arranged in positions that would intercept minimal lateral soil forces generated from any additional transverse slope movement. This basic pier foundation used to support approximately a 400 foot span is estimated to cost \$4.4 Million (a span was assumed so that loads could be estimated to be used to approximate a foundation design). Figure 9.4 shows two assemblages of four hollow shafts two feet in diameter with relatively thin casings. These shafts are designed to collapse under any lateral pressure that exceeds the soil at-rest pressure. Structural tied-back fenders (drilled shafts) are provided as yet another alternative in Figure 9.5 with example of the tieback isolation system construction shown in Figure 9.6. Figure 9.7 demonstrates a means to completely isolate the 9 foot diameter steel cased drilled shafts from the soil lateral forces by placing them inside an 11 foot diameter steel casing with example of the casing isolation system construction shown in Figure 9.8. Figure 9.9 is the same as Figure 9.7, except that it assumes that two more shafts are needed to support the design loads. Note that the options shown in Figures 9.4 and 9.5 could be added at a later date if the monitoring instrumentation indicates small movements are present. Table 9.1 summarizes how the costs were estimated for the isolation system and pier foundation.

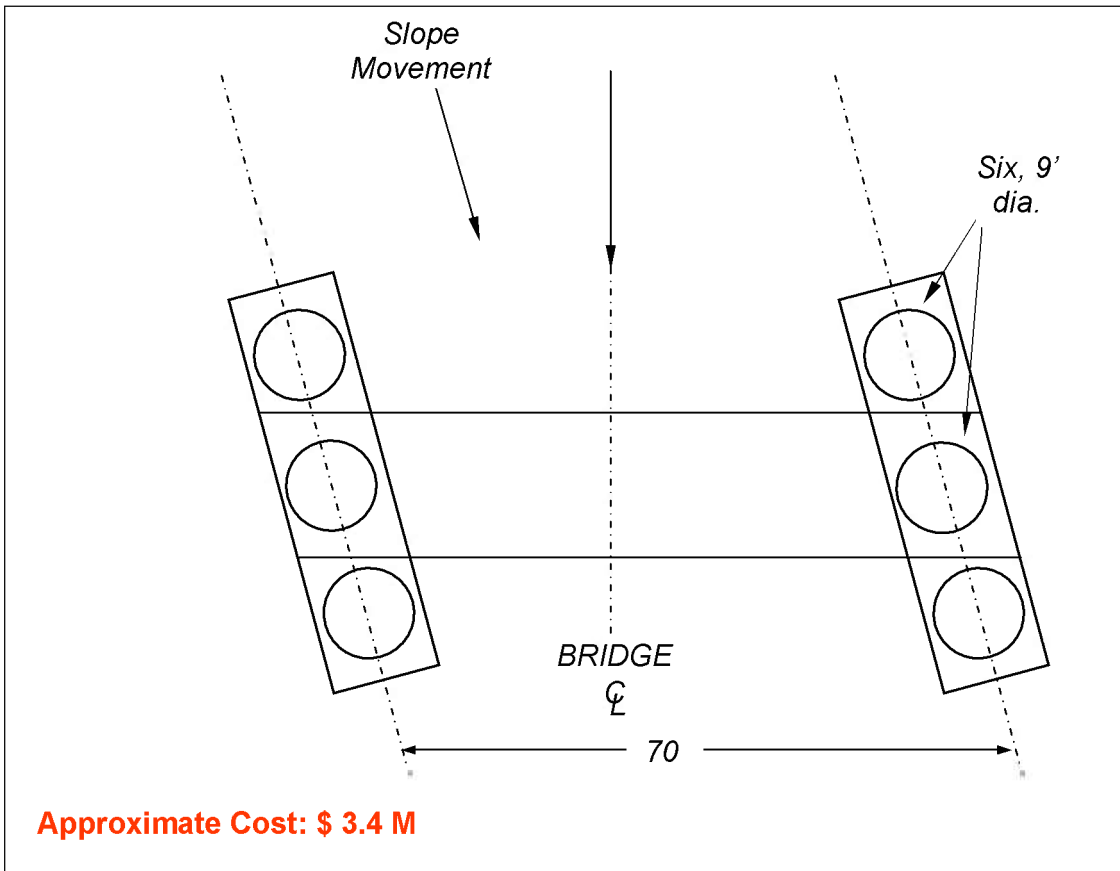

Figure 9.1: Plan view of a possible pier foundation configuration

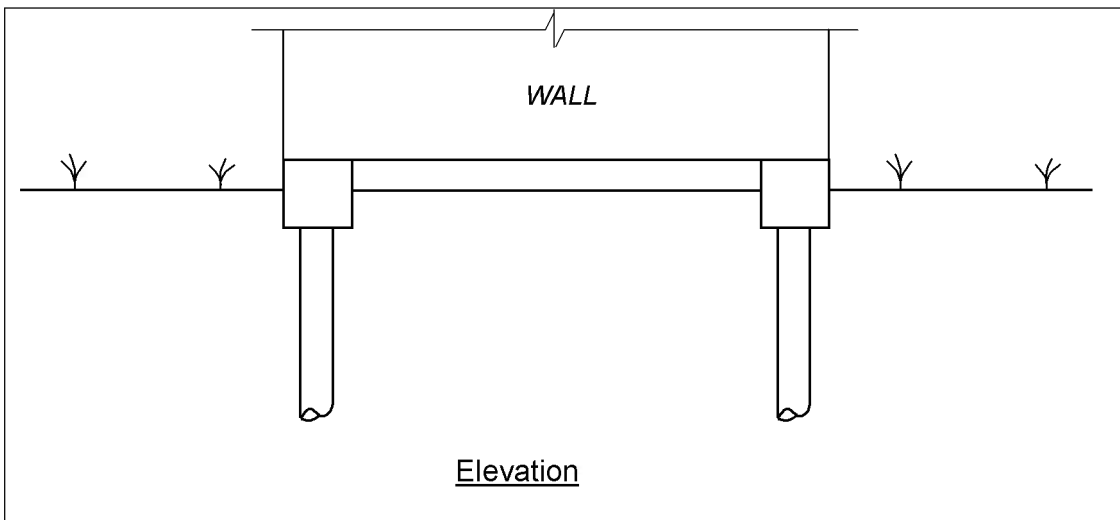

Figure 9.2: Elevation view of Figure 1

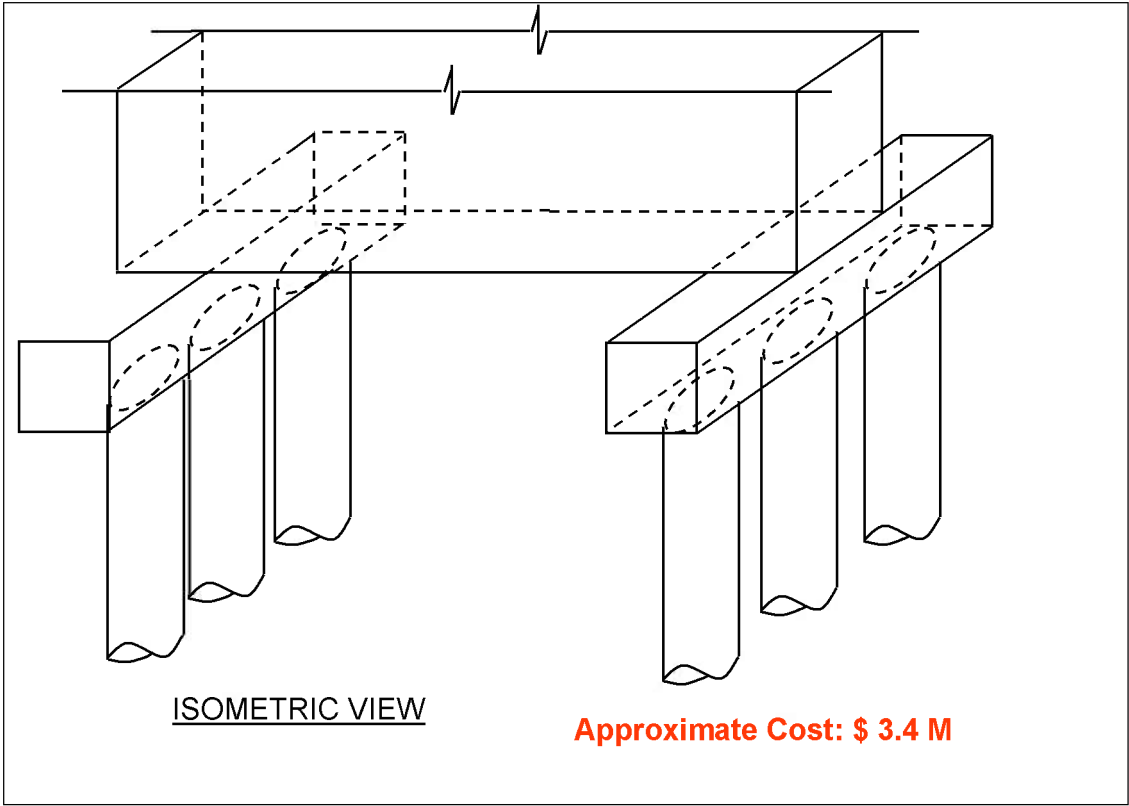

Figure 9.3: Isometric view of Figure 1

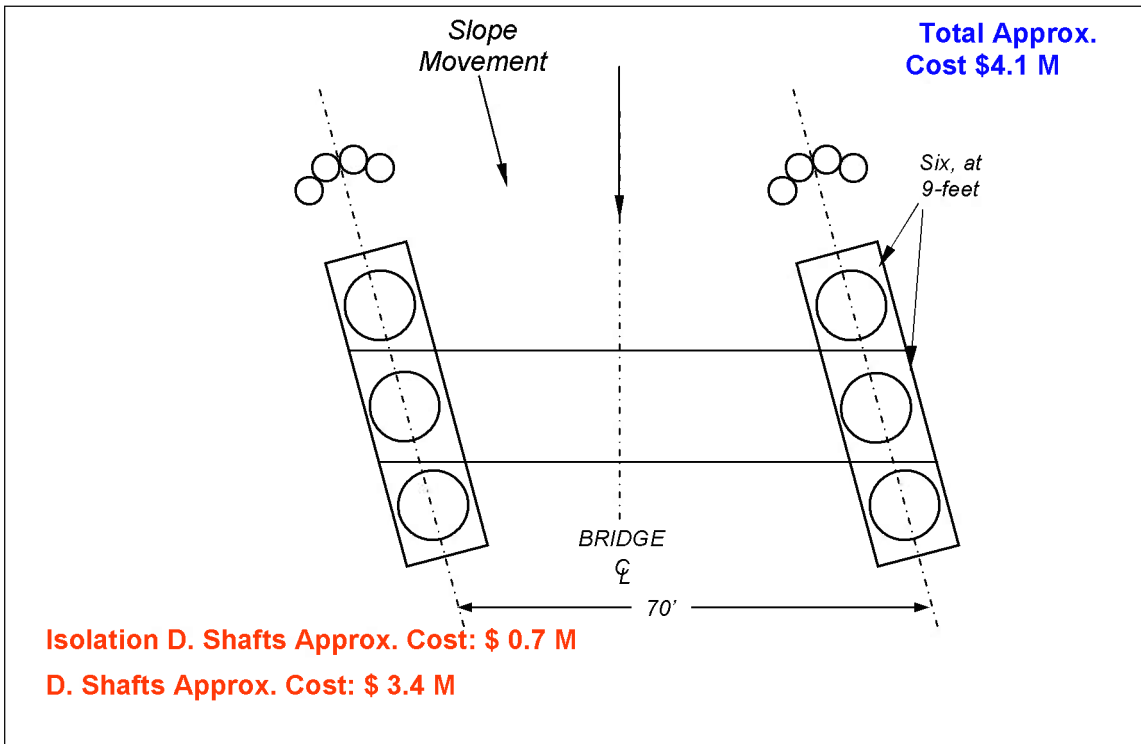

Figure 9.4: sacrificial shafts isolation system

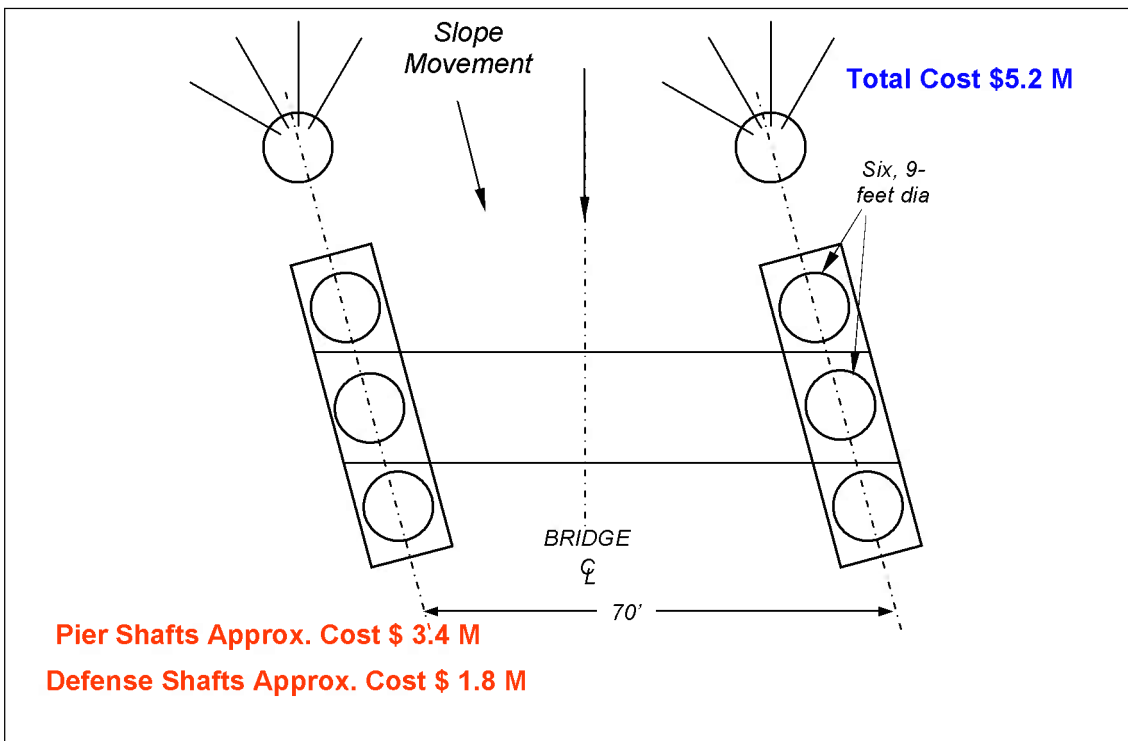

Figure 9.5: Structural fenders isolation system



Figure 9.6: Example of a drilled shaft tied back for resistance of lateral soil forces

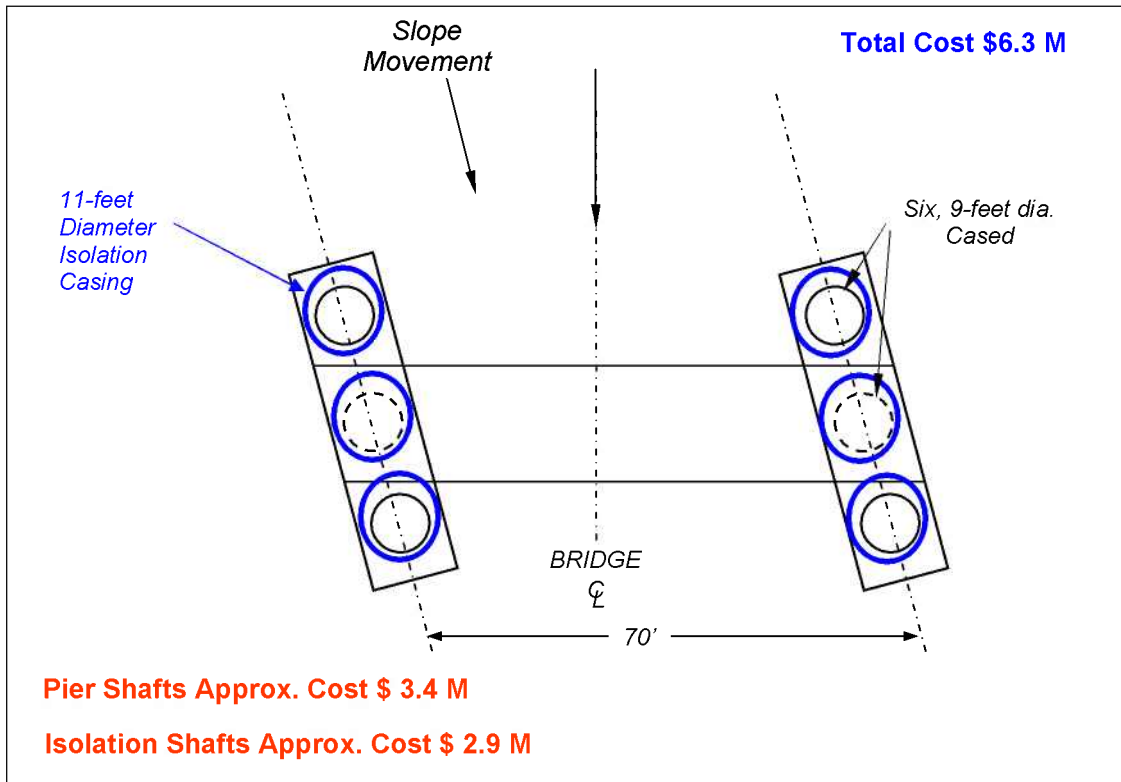

Figure 9.7. Pier foundation with casing isolation system

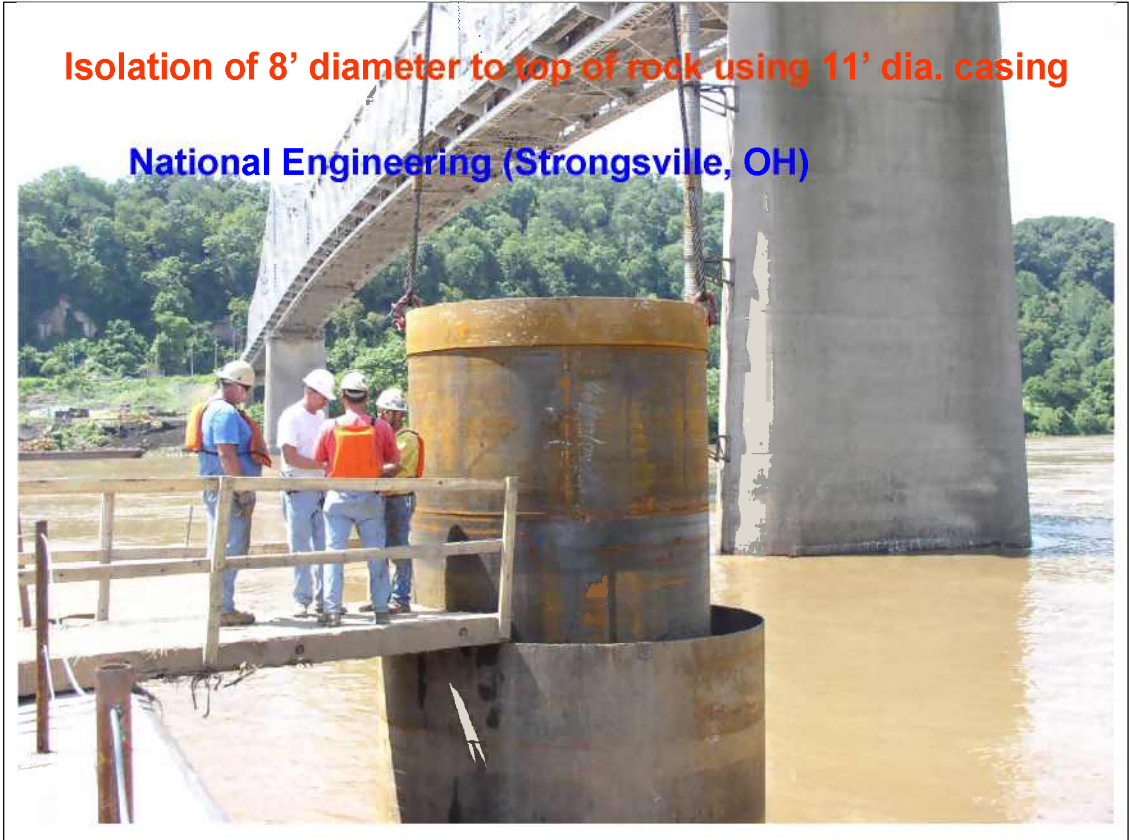

Figure 9.8: Example of an isolated drilled shaft

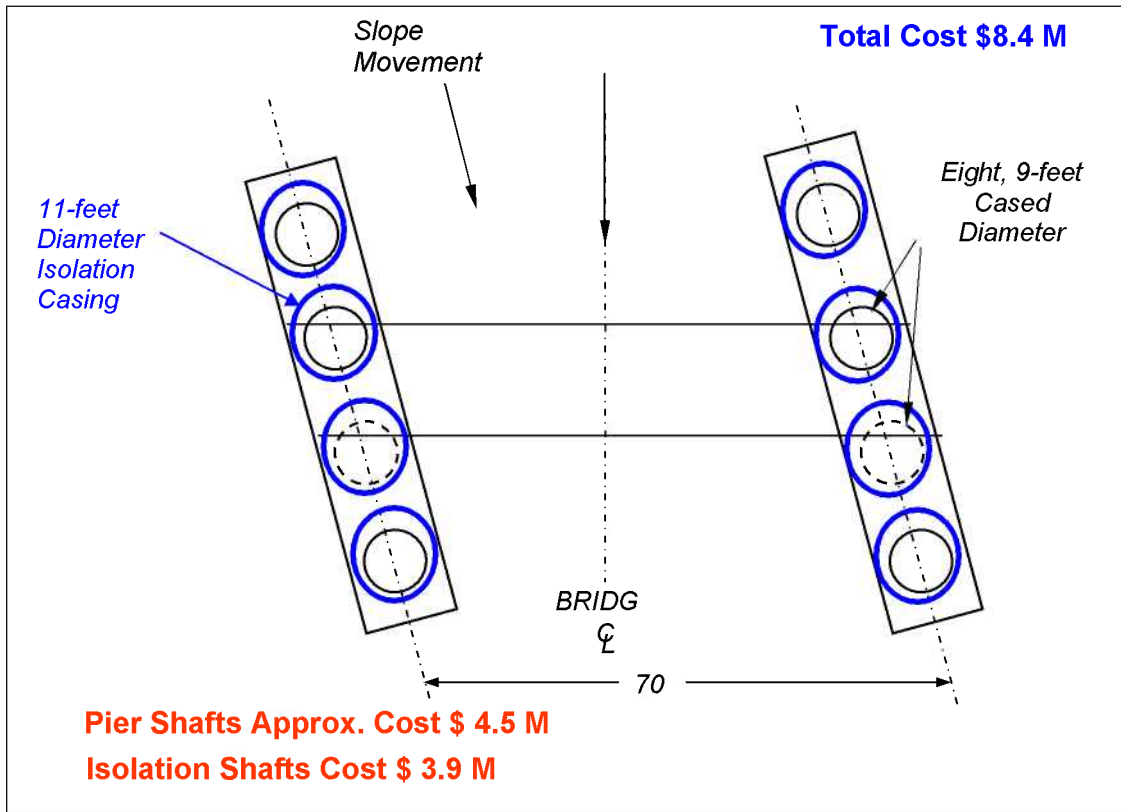

Figure 9.9: Pier foundation with casing isolation

Table 9.1 Summary of Cost Estimate of the Isolation System and Pier Foundation for various drilled shaft sizes.

DRILLED SHAFT COST COMPARISON															
Diameter (ft)	Area (sf)	Depth (ft)		Volume (C.Y.)		Cost			Casing		Drilled Shaft Cost (each)		Capacity Tons	Total Load tons	No. of DS Needed
		Soil	Rock	Soil	Rock	Soil	Rock	Rock	Cost	Without Casing	With Casing				
4	12.57	140	20	65.18	9.31	\$52,144	\$9,310	\$1,000	\$26,374	\$61,454	\$87,828	566	15000	27	
5	19.63	140	20	101.79	14.54	\$81,432	\$14,540	\$32,916	\$95,972	\$128,888	883	15000	17		
6	28.27	140	20	146.59	20.94	\$117,272	\$20,940	\$39,459	\$138,212	\$177,671	1272	15000	12		
7	38.48	140	20	199.53	28.5	\$159,624	\$28,500	\$46,001	\$188,124	\$234,125	1732	15000	9		
8	50.27	140	20	260.66	37.24	\$208,528	\$37,240	\$52,543	\$245,768	\$298,311	2262	15000	7		
9	63.62	140	20	329.88	47.13	\$263,904	\$47,130	\$59,086	\$311,034	\$370,120	2863	15000	6		
10	78.54	140	20	407.24	58.18	\$325,792	\$58,180	\$65,628	\$383,972	\$449,600	3534	15000	5		
11	95.03	140	20	492.75	70.39	\$394,200	\$70,390	\$72,170	\$464,590	\$536,760	4276	15000	4		
12	113.1	140	20	586.44	83.78	\$469,152	\$83,780	\$78,713	\$552,932	\$631,645	5090	15000	3		

DRILLED SHAFT COST COMPARISON

Diameter (ft)	Cost			Drilled Shaft Cost (each)			Capacity Tons	No. of DS Needed
	Soil \$800/ft	Rock \$1000/ft	Casing Cost	Without Casing	With Casing			
4	52144	9310	26374	61454	87828	566	27	
5	81432	14540	32916	95972	128888	883	17	
6	117272	20940	39459	138212	177671	1272	12	
7	159624	28500	46001	188124	234125	1732	9	
8	208528	37240	52543	245768	298311	2262	7	
9	263904	47130	59086	311034	370120	2863	6	
10	325792	58180	65628	383972	449600	3534	5	
11	394200	70390	72170	464590	536760	4276	4	
12	469152	83780	78713	552932	631645	5090	3	

CHAPTER 10

COST COMPARISONS

10.1 Introduction

This chapter contains a summary of the geotechnical design related costs that have been considered in this report. Table 10.1 shown below compares the costs related to spanning the slope to the costs related to building shorter spans with piers placed on the west end slope.

Table 10.1: Cost Comparison

Work Item	Spanning the slope	Building in the slope
Span the Slope	27,500,000*	0
Horizontal Drains	0	500,000
Vertical Pressure relief ducts	0	2,000,000
Pier isolation cost	0	1,000,000 to 3,500,000
Excavation to flatten the slope	0	2,000,000
Placing University Ave. on a bridge	0	400'x40'x\$120= 1,900,000
Total cost	27,500,000	11,900,000

* This cost item represents the differential extra cost to build a span over the slope vs. building shorter spans that place piers on the west end slope. The cost of the additional piers for the shorter spans has been accounted for in this differential cost. The relative difference/savings is approximately \$15,600,000.

CHAPTER 11

DISCUSSION AND CONCLUSIONS

11.1 Introduction

The Central Viaduct west bank slope has been evaluated by a team of three somewhat independent Firms: BBC&M Engineering Inc., E.L. Robinson Engineering and Geocomp Corporation. The Firms worked independently, in the context that the work was performed in three different offices with different computer programs and subtle modifications to the methods of analysis. But there was continuous collaboration on the important parameters that influence the outcome of the evaluation of the slope and periodic exchange of analysis results to allow for discrepancies to be identified and analysis problems removed.

This approach was established to provide quality control and quality assurance to the analysis process through independent review and external peer review. At this time the Team feels very confident in the results of the slope stability analyses work because the overall analyses results and conclusions drawn by the three Firms are reasonably similar. Below is a list of the Baker Team conclusions arrived at from the results of this work.

1. The failure mechanism for the slope is one in which the shear stress caused by gravity exceeds the shear strength of the soil.
2. Removing soil from the slope and/or lowering the ground water table reduces the shear stress and increases the factor of safety.
3. Shear strength is controlled by the strength parameters of the soils and the pore pressures within the soil voids. Some of the soils in the slope currently have an effective friction angle of 15° where the sliding plane is close to horizontal. The soils in the slope generally have an effective friction angle of 32° where the failure plane is inclined by more than about 25° .
4. Laboratory tests show that the drained strength is less than the undrained strength of these soils. Consequently the strength appropriate for design is one with effective stress strength parameters and steady state pore pressures.

5. Sufficient displacement has occurred along the most critical failure planes such that the soils have reached their residual strength. Further reduction in the effective stress strength parameters by mechanisms such as creep are not possible.
6. Shear strength parameters of the material in this slope are complex but they have been reasonably established with values that make sense, are consistent across two laboratories and follow recognized aspects of soil behavior for overconsolidated materials.
7. Shear strength is reduced by increasing pore pressures. There is significant evidence that a high groundwater level exists in the slope and even artesian pressures (water level higher than the ground surface) exist at some locations within the slope. Since the potential changes of pore pressure are unpredictable, some means of limiting pore pressure in the slope must be a part of the final design.
8. As recommended by ODOT, Section A-A has been analyzed for stability. Other longitudinal sections were considered, defined and plotted for evaluation. We determined that Section A-A is a typical representation of the critical stability geometry for the main slope in the bridge direction.
9. At various times drillers encountered zones where water and gas shot 10 to 15 feet into the air for hours. Such artesian pressures degrade the stability of the slope. These excess pressures can be released by using vertical drains. Vertical wick drains are very economical and quick to install; however some of the in situ soils are too dense to drive wick drains. Drilling through the dense soils will likely be required to install drains to release excess gas pressures.
10. The primary objective is to design a graded slope that provides a satisfactory factor of safety, i.e. one that causes no distress to the bridge foundation from slope movements, for the conditions that exist at this site. The target is to design for a slope that when excavated and graded provides a factor of safety of at least 1.5. for all conceivable conditions. Slopes with a factor of safety of 1.5, as determined using appropriate strength and pore pressure values, will experience negligible movement which will be of no significant consequence. This design must also maintain the integrity of the existing bridge and adapt to the requirements of a replacement bridge in the future. Results of our evaluation show that these conditions can be achieved by removing soil from the slope back to Abbey Ave. The evaluation focused on simple geometries for excavation and

showed that a factor of safety above 1.5 can be achieved (Figure 7.27). The entire area less any space required for other areas could be made a green space that could include localized irregularities in the ground surface and specialized contouring to provide an appealing landscape.

11. We believe that the supplemental information obtained by BBC&M and the additional lab testing performed by Geocomp provides sufficient information to define the strength properties of soils in the slope for design. Information on the groundwater flow regime and the associated pore water pressures is limited. Information on artesian pore pressure conditions is very limited. However options exist to control excessive pore pressure conditions. There is little to no information on pore pressures at the locations of the south and west slopes of the proposed excavation. We will recommend additional geotechnical studies of these conditions be performed as part of the final design effort.
12. A sheet pile revetment wall exists at the toe of the slope. It is required by the US Army Corps of Engineers to help maintain a navigable water way. The sheets are 65 feet long. Horizontal steel rods spaced at 8 ft intervals extend from the top of the sheeting to an existing anchor located 40 ft behind the sheeting. These tiebacks failed over time with the consequence that soil and water pressures acting on the back of the sheeting caused the sheeting to displace outward by several feet. The current owner has excavated soil from behind the sheeting with the hope that the sheeting can be pulled back into place, new tiebacks placed and the slope backfilled. This operation has reduced the overall factor of safety of the existing slope by approximately 0.1 (Figure 7.15). This revetment wall will have to be replaced with a strong, reliable revetment.
13. The proposed roadway alignment and Section A-A intersect the cold storage building. In order to evaluate the affects of the weight of the cold storage building on the existing slope, a slope stability model programmed to compute the factor of safety of a failure surface that intersects the bottom of the building was analyzed and then reevaluated without the presents of the building (See figures 7.16B thru 7.16E). Removing the cold storage building increases the factor of safety by approximately 0.2.
14. Dr. Marr examined all available strength data which included results from tests by BBC&M, results from tests by Geocomp and other published data on strength of plastic clays. One of the undisturbed tube samples obtained during this investigation actually

captured a shear plane. This sample was positioned into a direct shear test cell so that the field shear plane would align with the shear plane of the test device. Geocomp measured a peak strength equivalent to soils with zero cohesion and a drained friction angle of 13.6° . Several test series indicated residual strength values of 15° for the more plastic clays. Thin seams of plastic clay may exist at various locations within the slope. The critical failure surface for stability will develop through these weaker horizontal seams to the maximum extent possible. Therefore, we concluded that horizontal to near-horizontal portions of all shear surfaces should use an effective stress strength value of zero cohesion and 15° . Data for the less plastic layers of soil in the slope indicate a residual strength similar to the peak strength. Lab tests indicate friction angles of 22 to 33° ; however, these tests focused on the more clayey samples. We recommended a friction angle of 32° with zero cohesion be used for design on all shear surfaces inclined at more than 25° from horizontal. These values of strength give factors of safety for past and present conditions that correlate reasonably well with the past performance of the slopes. We think the strength parameters are defined with reasonable certainty.

15. The gas was noticed in seven locations as detailed in Appendix H of the final report prepared by BBC&M dated May, 2006. Factor of safety is directly related to internal pore pressure. The exact source of groundwater in the slope has not been identified which means that we cannot accurately predict the future groundwater conditions. In such a circumstance the best approach is to build in measures to control pore pressure so that it cannot exceed values used in the design. Vertical and horizontal drains could be used to control the uncertainty related to the pore water and gas pressures present at this site. Horizontal drains have been discussed in Chapter 8.
16. Members of the team used three different computer programs for method of slices to analyze stability. BBC&M used SLIDE with the Spencer method of analysis. EL Robinson used GSTABL7 with the Simplified Janbu method of analysis. Geocomp used UTEXAS4 with Spencer's method. The fact that the final results were similar provides strong verification that no significant errors were made in the various analyses. Geocomp also used an entirely different analytical approach based on the finite element method to check that the results from limit equilibrium are appropriate for this case. Results from

PLAXIS for factor of safety were similar to those from the limiting equilibrium methods for the limited number of conditions that were checked.

17. The factor of safety of the slope in its existing condition is near 1.15. The revised water table from the recently installed vibrating wire piezometers was used in the analysis and showed minor change in the safety factor from the water table used in previous analysis before July, 2006. Table 7.1 summarizes the analysis results from both water tables.
18. The factor of safety of the existing slope is too low for the slope to serve as a foundation for any new structure. We examined various means to improve the factor of safety. The most effective appear to be to remove the existing warehouse building, flatten the slope by removing soil and controlling pore pressures internal to the slope.
19. The slope stability analysis for an excavated and graded slope indicated a minimum safety factor of 1.67 (Figure 7.27). This is above the minimum value of 1.5 that we recommend for this facility. Due to the higher factor of safety, we expect no substantial movements of the unloaded slope. We also believe that the bridge substructure may be placed in the slope without using any isolation for the substructure units.
20. The critical section for the slope beneath the existing bridge is down slope in the direction of the bridge. The proposed grading will not affect the down slope factor of safety for the existing bridge. The proposed grading for the new bridge will create side slopes where the potential sliding planes will be orthogonal to the existing critical sliding planes. Final design must include consideration of the stability of these slopes and the design adapted to give a minimum factor of safety of at least 1.5 for these slopes as well.
21. The present rate of movements of the slope at the location of the new bridge for the deep slip plane is 0.01 inch per year. The shallow slip plane which is located close to the sheet pile wall is 0.08 inches per year due to the failure of the wall.
22. The PLAXIS analyses indicate that horizontal soil movements behind the slope can be kept below 1 inch if the factor of safety of the slope is prevented from decreasing by more than 10%. Pore pressure must increase by 20 to 30 ft of head on the critical failure surface to cause a 10% reduction in factor of safety. There is no reason to expect a sudden increase in pore pressure of this magnitude. Consequently should a monitoring system indicate that pore pressures in the slope are increasing beyond those used for the

design, sufficient time would be available to mobilize and complete remedial work before the bridge pier became affected. Based on the results available at this time we concluded that a pier or abutment can be placed safely anywhere on top of the slope. By removing material to flatten the slope, the pier can be placed anywhere on the slope except within 100 ft of the existing sheet pile bulkhead.

23. In order to provide a relatively low degree of risk for the future performance of the proposed structure, various related slope improvement means could be included in the overall design and/or added at a later time if monitoring shows the need. These approaches include (a) reduction of ground water levels with the use of horizontal drains, (b) reduction of artesian pore pressures with the use of vertical drains and (c) provide some form of pier foundation isolation system.
24. A backup approach which could be implemented in the rare event that the slope unexpectedly begins to move at some future time is a system to isolate the pier from future slope movements leading to unbalanced lateral forces. This system would limit the lateral loads transferred to the rigid pier from movement of the surrounding soil.
25. The stability of the existing structure must be evaluated in concert with the final design for the new structure. We recommend that the entire slope from the north end to the south end of the DOT right-of-way be evaluated in detail as part of the final design.
26. A performance monitoring system will be required as part of the long-term design to identify any undesirable developments in the slope and develop appropriate remedial actions.
27. The stabilization structure at the existing I-90 bridge is performing well. The forces and movements in the drilled shafts are within the elastic range of the shafts. An estimated additional life of approximately 30 years is expected before the drilled shafts reach their capacity assuming a constant rate of lateral movement in the shafts of 0.12 inches/year. Recent reports of field measurements, indicate that the rate of movement is becoming slower as time passes..
28. Once the location of the bridge foundation is finalized, an additional evaluation of slope stability should be made to determine the optimum approach to unload the slope and meet other requirements of the project for infrastructure, final grading, and landscaping.

29. If any type of drain pressure relief system is used, a plan must be developed for maintaining the system.
30. The current movement to date of the existing slope under the existing bridge has been evaluated and we conclude from the instrumentation readings (see inclinometer B-204 plots in chapter 5 of the final report), that the current rate of movement can be interpreted to be 0.01 inches per year at the shallow slip plane (15 to 19 feet below ground), and 0.03 inch/year at the deep slip plane (approximately 120' below ground).
31. The current movement to date of the existing slope along Section A-A can only be related to inclinometers B-110 and B-107 has been evaluated and it can be concluded from the instrumentation readings (see inclinometer plots in chapter 5 of the final report), that the current rate of movement is 0.08 inches per year at the shallow slip plane (23 to 31 feet below ground), and 0.01 inch/year at the deep slip plane (approximately 119' below ground).
32. Based on the inclinometer data collected since 1994, the extent of the movement excluding the construction related movement is to the south of the area where inclinometer B-108 is located. The data collected from inclinometer B-110 at the deep slip plane (~120 feet) showed less than 0.03 inches in 5 years. This is not a concern. The inclinometers plots presented in chapter 5 of E.L. Robinson report shows details of the rates of movement at each plane. A summary of the horizontal movement at various depths in the inclinometers is presented in Table 5.1 of the report. The expected future movement at Section A-A, as seen from the existing B-110, B-108, and B107 inclinometers, will be negligible, as the only movement in these inclinometers took place during construction of the stabilization structure for Pier 1 of the existing I-90 bridge. The future rate consist of the current rate of movement can be interpreted to be 0.01 inches per year.
33. As can be seen in the review of the long term monitoring data from the inclinometers installed around the existing bridge and close to the alignment of the proposed structure, there is very little evidence of any creep movement in the area of the proposed alignment. The movement measured in some of the inclinometers is due to the construction activities for the stabilization structure for Pier 1 of the existing bridge. The movement recorded in B-108 at shallow depths was due the failure of the sheet pile wall along the river bank.

34. Utilities located in the existing slope should be relocated.
35. Please be aware that there may be some environmental concerns from the excavation of the material located below the cold storage building.
36. The shallow slip plane stability will be significantly improved due to the relatively large excavation.
37. Lightweight fill such as styrofoam or elastizell can be used to elevate the surface of the unloaded slope if required for other purposes, such as maintaining University Avenue at its present level or providing a passage way parallel to University Avenue but under the bridges. Alternatively, University Avenue can be placed on a bridge, relocated, built on light weight fill, or eliminated.
38. The 298,000 cubic yards of required excavation can be used on other locations on this project as this is a borrow project.
39. A discussion on probability of failure of the slope can be found in Section 7B.4.
The difference in the cost to span the west end slope vs. building in the slope is presented as \$15,600,000 in Chapter 10.
40. Since we are recommending a relatively large excavation to remediate the slope and have increased the factor of safety to over 1.5, the susceptibility to creep has been mitigated.
41. Sections CL and D-D, as shown in Figure 7-30, were evaluated in a preliminary manner to gain a general understanding of their overall stability. In general, it appears that the stability of the CL section is satisfactory and that Section D-D is slightly less stable than Section CL and A-A. In order to better understand the performance of these two sections, a more detailed study is necessary.

APPENDICES

APPENDIX A

Geotechnical Test Report

GeoTesting Express



a subsidiary of Geocomp Corporation

1145 Massachusetts Avenue
Boxborough, MA 01719
978 635 0424 Tel
978 635 0266 Fax

Geotechnical Test Report

June 14, 2006

GTX-6678 I-90 Central Viaduct Project

Cleveland, OH

Prepared for:



EXECUTIVE SUMMARY

This report documents the results of laboratory tests performed by GeoTesting Express, Inc. on undisturbed samples of soils obtained from the I-90 Central Viaduct project in Cleveland, OH. Testing was performed under the direction of W. Allen Marr. Samples were 2.87 inch diameter Shelby tube samples shipped to GeoTesting Express's laboratory in Boxborough, MA. A total of 5 samples were provided.

The samples were received in two separate shipments. The first shipment contained two samples from Boring B-05-03. The second shipment contained three samples from separate borings; B-05-08, B-105A and C-05-04. The samples were shipped to the laboratory inside specially designed and insulated soil sample tube shipping containers to minimize disturbance to the soil.

GeoTesting Express, Inc., has completed the following tests on these samples:

- 10 Residual Shear test points
- 3 Direct Simple Shear tests
- 2 CIU Triaxial tests
- 2 Incremental Consolidation tests
- 1 Constant Rate of Strain Consolidation test
- 5 Gradations
- 5 Atterberg Limits
- 2 Specific Gravity
- 2 Moisture Content
- 2 USCS Soil Classification

Table of Contents

Executive Summary.....1
Table of Contents.....2
List of Tables.....2
Introduction.....3
Sample Preparation.....3
Test Methods.....4
Test Results.....5
Tables.....6
Appendix A: Classification Results.....7
Appendix B: Consolidation Results.....21
Appendix C: Direct Simple Shear Results.....53
Appendix D: Residual Shear Results.....64
Appendix E: CIU Triaxial Test Results.....91
Appendix F: Photographs.....96

List of Tables

Table 1 Sample Information

Introduction

E.L. Robinson of Columbus, Ohio retained Geocomp Corporation to perform advanced consolidation and strength testing on undisturbed samples of soils obtained from the vicinity of the I-90 Central Viaduct in Cleveland, OH. The tests were performed by Geocomp's subsidiary laboratory, GeoTesting Express Inc. (GTX) in their Boxborough, MA facility under the direction and supervision of W. Allen Marr.

Tests were performed on specimens trimmed from 2.87-inch Shelby tube samples provided by BBC&M of Cleveland, Ohio. The samples were shipped to the laboratory inside specially designed and insulated shipping containers to minimize disturbance to the soil. Upon arrival the samples were unpacked and inspected for any damage. The tubes arrived in excellent condition. At GTX the samples were kept at 70°F in a 100% humid environment at all times except when removed to trim out test specimens.

Table 1 summarizes the samples and their depths. Figure 1 shows the locations of the borings from which these samples were obtained.

Specimen Preparation

The tube samples were kept stored in humid conditions at all times except when being used to obtain test specimens. Trimming occurred under a hood with a humidifier operating inside. After a specimen was obtained the sample was returned to the humid storage container.

Specimens were trimmed to fit into the test ring, of the appropriate test being performed. The Constant Rate of Strain, Incremental Consolidation and Residual Shear devices all use a stainless steel ring with an internal diameter of 2.5 inches and a height of 1- inch. The Direct Simple Shear device uses a wire-reinforced latex membrane with an internal diameter of 2.62-inches and a height of 1-inch to hold a one-inch high sample.

The CIU Triaxial tests were performed on 2.87-inch diameter specimens approximately 6-inches tall. All trimming was performed by experienced personnel.

Test Methods

Test methods and procedures followed the applicable ASTM and US COE test methods, utilizing the most current edition. These included the following:

US COE EM 1110	Residual Shear
ASTM D 6528-00	Standard Test Method for Consolidated Undrained Direct Simple Shear Testing of Cohesive Soil
ASTM D 4767-04	Standard Test Method for Consolidated Undrained Triaxial Compression Test for Cohesive Soil
ASTM D 2435-04	Standard Test Method for One-Dimensional Consolidation Properties of Soil Using Incremental Loading
ASTM D 4186-89 (Re-approved 1998)	Standard Test Method for One-Dimension Consolidation Properties of Soils Using Controlled-Strain Loading
ASTM D 422-63 (Re-approved 2002)	Standard Test Method for Particle-Size Analysis of Soils
ASTM D 4318-05	Standard Test Methods for Liquid Limit, Plastic Limit, and Plasticity Index of Soils
ASTM D 854-05	Standard Test Methods for Specific Gravity of Soil Solids By Water Pycnometer
ASTM D 2216-05	Standard Test Methods for Laboratory Determination of Water (Moisture) Content of Soil and Rock by Mass
ASTM D 2487-00	Standard Test Methods for Classification of Soils for Engineering Purposes (Unified Soil Classification System)

Test Results

Results for the tests reduced to engineering units are provided in appendices attached to this report. Appendix A contains the results of classification tests made on the samples. These include soil classification, moisture content, specific gravity, gradation and Atterberg Limit tests.

Appendix B contains the test results for the consolidation tests performed, both the incremental consolidation and the constant rate of strain consolidation.

Results of the Direct Simple Shear tests are in Appendix C. Peak strengths were corrected for membrane stiffness with the calibration curves measured on the membrane used for the test. The calibration curve is also included in Appendix C.

Residual Shear Summaries for three-3 point series and one-1 point test, as well as the individual point test curves are in Appendix D.

CIU Triaxial test results are located in Appendix E.

Prepared and submitted by:

Joseph Tomei
Laboratory Manager
GeoTesting Express, Inc.

Table 1:

SAMPLE INFORMATION		
BORING ID	SAMPLE ID	DEPTH (ft)
C-05-03	COY-90-15.24	116.5-118.5
C-05-03	COY-90-15.24	118.5-120.3
B-05-08	S-27	116-118
B-105A	S-20	90-92
C-05-04	S-27	72-74

Appendix A

Classification Tests

Client: Geocomp Consulting	Project No: GTX-6678
Project: I-90 Central Viaduct	
Location: Cleveland, OH	
Boring ID: ---	Sample Type: ---
Sample ID:---	Test Date: 06/12/06
Depth : ---	Sample Id: ---
	Tested By: pcs
	Checked By: jdt

Moisture Content of Soil - ASTM D 2216

Boring ID	Sample ID	Depth	Description	Moisture Content,%
C-05-03	S-29	116.5-118.5	Moist, dark gray clay	27
C-05-03	S-30	118.5-120.5	Moist, dark gray clay	26

Notes: Temperature of Drying : 110° Celsius

Client: Geocomp Consulting	Project: I-90 Central Viaduct	Location: Cleveland, OH	Project No: GTX-6678
Boring ID: ---	Sample Type: ---	Tested By: pcs	
Sample ID:---	Test Date: 05/31/06	Checked By: jdt	
Depth : ---	Test Id: 89806		

USCS Classification - ASTM D 2487

Boring ID	Sample ID	Depth	Group Name	Group Symbol	Gravel, %	Sand, %	Fines, %
C-05-03	S-29	116.5-118.5	lean clay	CL	0.0	2.1	97.9
C-05-03	S-30	118.5-120.5	lean clay	CL	0.0	0.3	99.7

Remarks: Grain Size analysis performed by ASTM D422, results enclosed
 Atterbeg Limits performed by ASTM 4318, results enclosed

Client: Geocomp Consulting	Project: I-90 Central Viaduct	Location: Cleveland, OH	Project No: GTX-6678
Boring ID: C-05-03	Sample Type: tube	Tested By: pcs	Sample ID: S-29
Depth: 116.5-118.5	Test Date: 05/11/06	Checked By: jdt	Test ID: 89803
Test Comment: ---			
Sample Description: Moist, dark gray clay			
Sample Comment: ---			

Particle Size Analysis - ASTM D 422

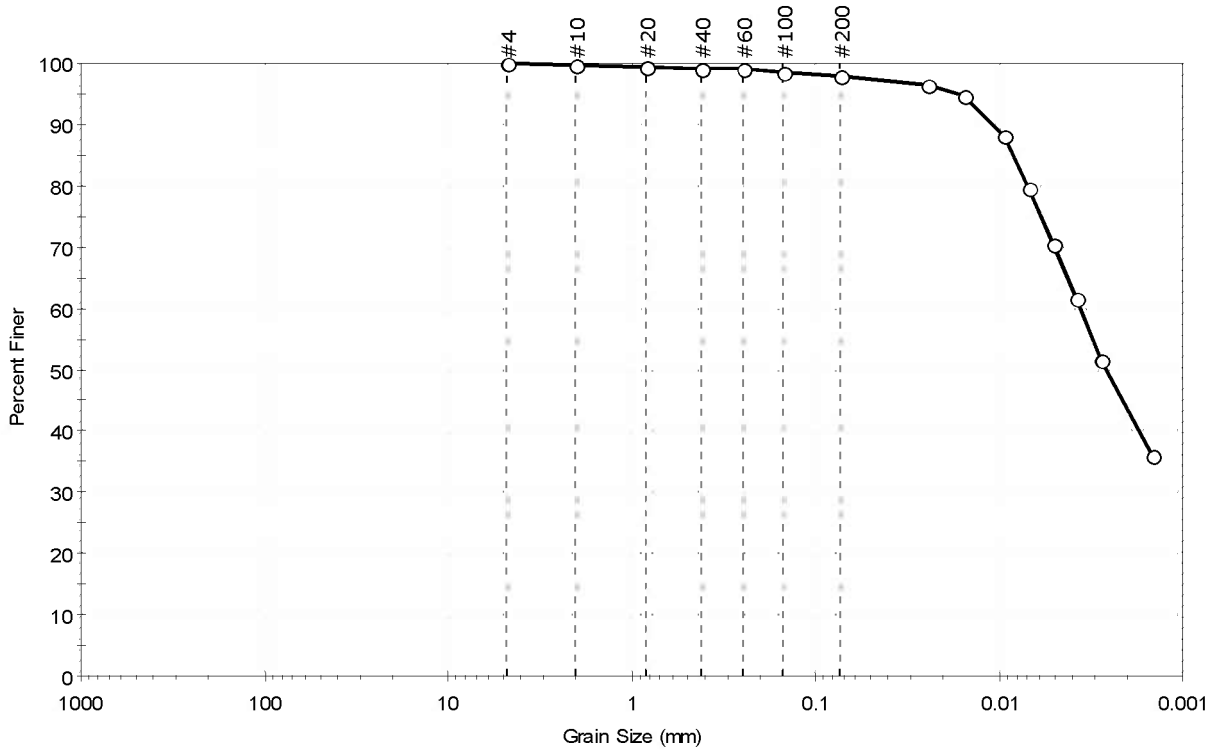

% Cobble	% Gravel	% Sand	% Silt & Clay Size
—	0.0	2.1	97.9

Sieve Name	Sieve Size, mm	Percent Finer	Spec. Percent	Complies
#4	4.75	100		
#10	2.00	100		
#20	0.84	99		
#40	0.42	99		
#60	0.25	99		
#100	0.15	99		
#200	0.074	98		
---	Particle Size (mm)	Percent Finer	Spec. Percent	Complies
---	0.0244	97		
---	0.0156	95		
---	0.0094	88		
---	0.0069	80		
---	0.0051	71		
---	0.0038	62		
---	0.0028	52		
---	0.0015	36		

Coefficients	
D ₈₅ = 0.0084 mm	D ₃₀ = N/A
D ₆₀ = 0.0036 mm	D ₁₅ = N/A
D ₅₀ = 0.0026 mm	D ₁₀ = N/A
C _u = N/A	C _c = N/A

Classification	
ASTM	lean clay (CL)
AASHTO	Clayey Soils (A-6 (18))

Sample/Test Description
Sand/Gravel Particle Shape : ---
Sand/Gravel Hardness : ---

Client: Geocomp Consulting	Project: I-90 Central Viaduct	Location: Cleveland, OH	Project No: GTX-6678
Boring ID: C-05-03	Sample Type: tube	Tested By: pcs	
Sample ID: S-29	Test Date: 05/11/06	Checked By: jdt	
Depth: 116.5-118.5	Test Id: 89801		
Test Comment: ---			
Sample Description: Moist, dark gray clay			
Sample Comment: ---			

Atterberg Limits - ASTM D 4318

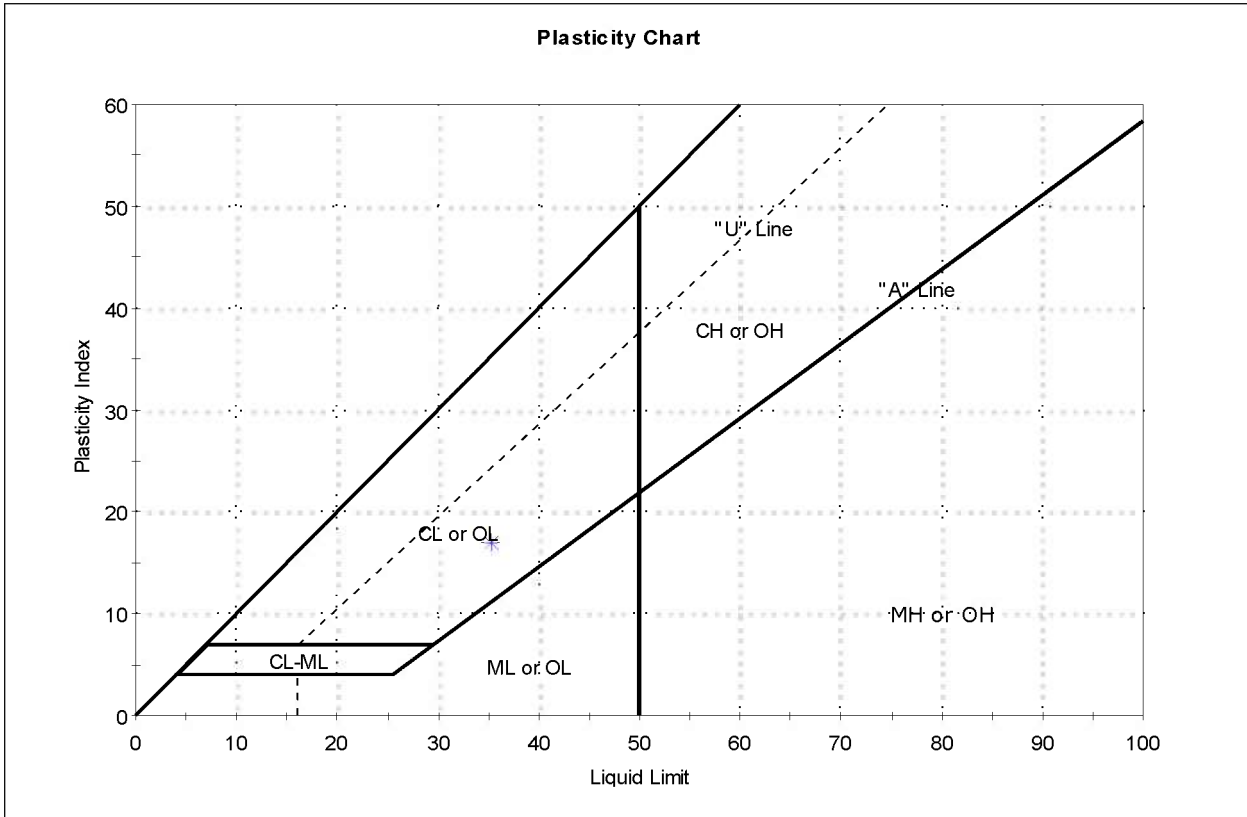

Symbol	Sample ID	Boring	Depth	Natural Moisture Content, %	Liquid Limit	Plastic Limit	Plasticity Index	Liquidity Index	Soil Classification
*	S-29	C-05-03	116.5-118.5	27	35	18	17	0	lean clay (CL)

Sample Prepared using the WET method
 1% Retained on #40 Sieve
 Dry Strength: HIGH
 Dilatancy: NONE
 Toughness: LOW

Client: Geocomp Consulting	Project: I-90 Central Viaduct	Location: Cleveland, OH	Project No: GTX-6678
Boring ID: C-05-03	Sample Type: tube	Tested By: pcs	Sample ID: S-30
Depth: 118.5-120.5	Test Date: 05/11/06	Checked By: jdt	Test ID: 89804
Test Comment: ---			
Sample Description: Moist, dark gray clay			
Sample Comment: ---			

Particle Size Analysis - ASTM D 422

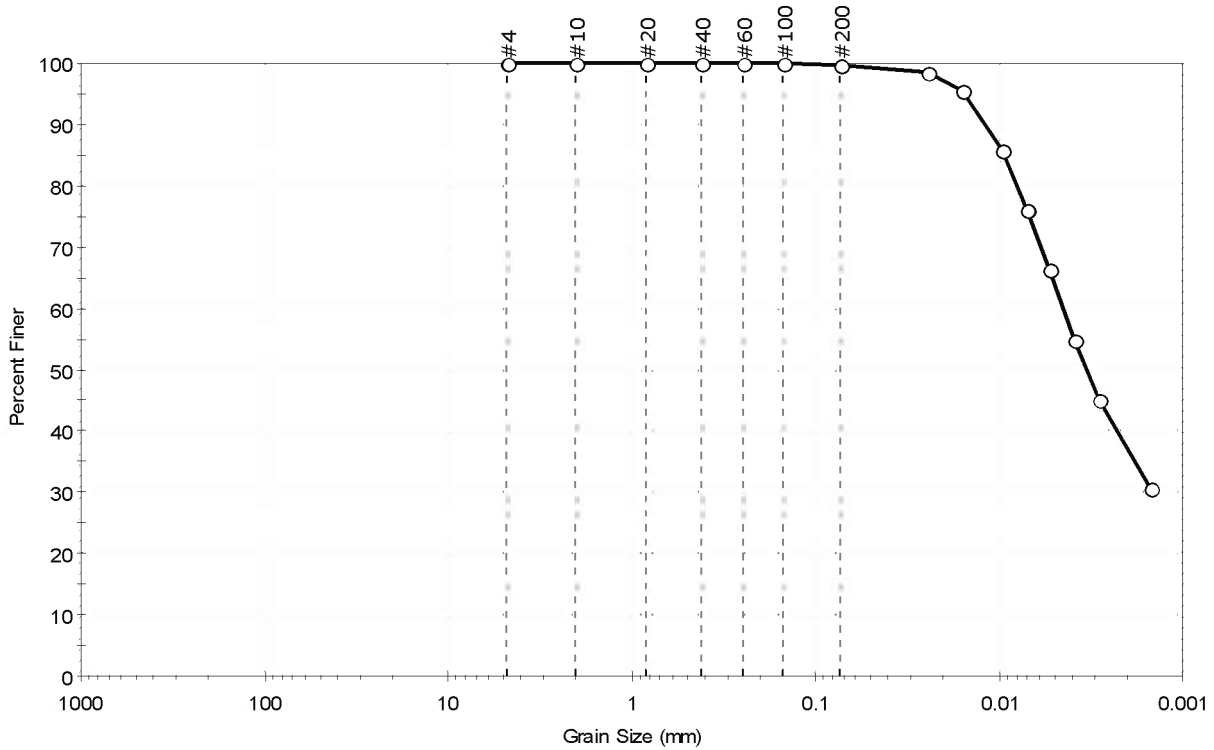

% Cobble	% Gravel	% Sand	% Silt & Clay Size
—	0.0	0.3	99.7

Sieve Name	Sieve Size, mm	Percent Finer	Spec. Percent	Complies
#4	4.75	100		
#10	2.00	100		
#20	0.84	100		
#40	0.42	100		
#60	0.25	100		
#100	0.15	100		
#200	0.074	100		
---	Particle Size (mm)	Percent Finer	Spec. Percent	Complies
---	0.0246	98		
---	0.0158	96		
---	0.0096	86		
---	0.0071	76		
---	0.0053	66		
---	0.0039	55		
---	0.0029	45		
---	0.0015	31		

<u>Coefficients</u>	
D ₈₅ = 0.0094 mm	D ₃₀ = N/A
D ₆₀ = 0.0045 mm	D ₁₅ = N/A
D ₅₀ = 0.0033 mm	D ₁₀ = N/A
C _u = N/A	C _c = N/A

<u>Classification</u>	
ASTM	lean clay (CL)
AASHTO	Clayey Soils (A-6 (16))

<u>Sample/Test Description</u>	
Sand/Gravel Particle Shape	: ---
Sand/Gravel Hardness	: ---

Client: Geocomp Consulting	Project: I-90 Central Viaduct	Location: Cleveland, OH	Project No: GTX-6678
Boring ID: C-05-03	Sample Type: tube	Tested By: pcs	
Sample ID: S-30	Test Date: 05/12/06	Checked By: jdt	
Depth: 118.5-120.5	Test Id: 89802		
Test Comment: ---			
Sample Description: Moist, dark gray clay			
Sample Comment: ---			

Atterberg Limits - ASTM D 4318

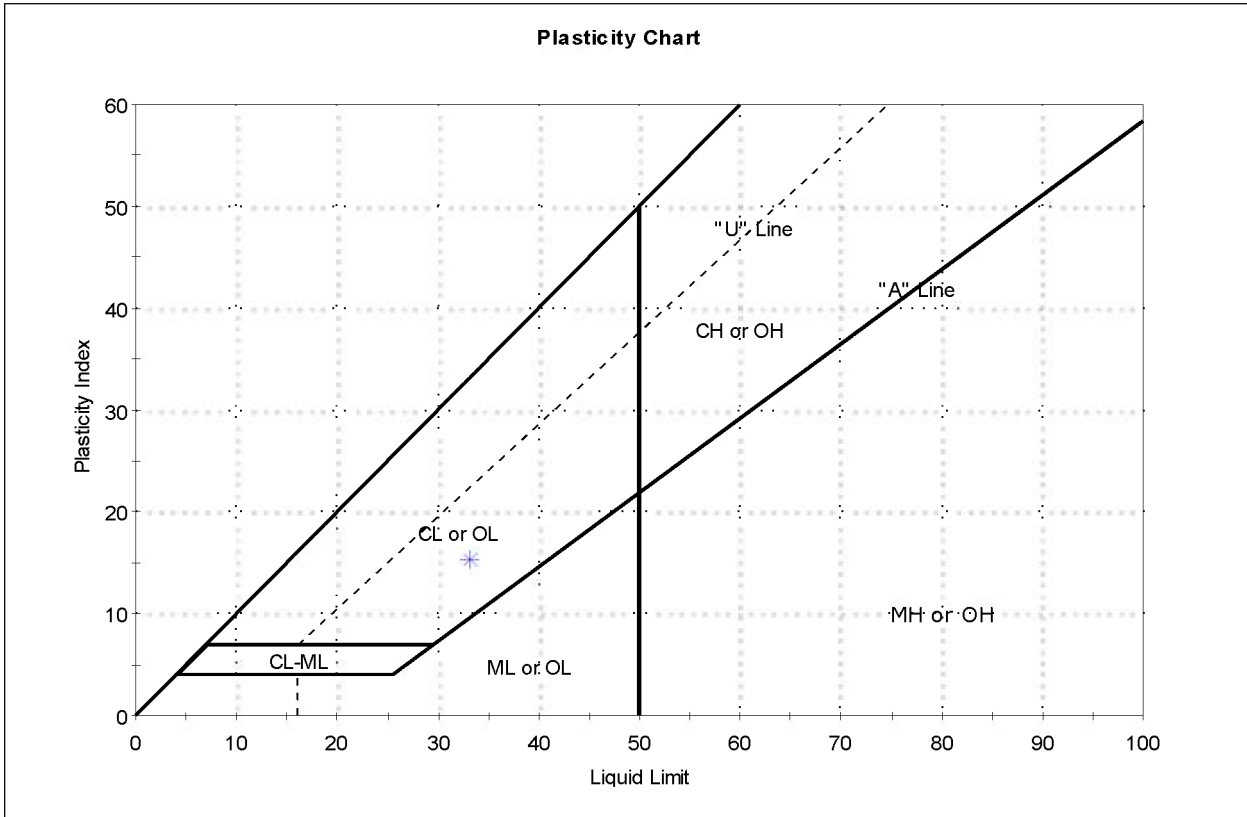

Symbol	Sample ID	Boring	Depth	Natural Moisture Content, %	Liquid Limit	Plastic Limit	Plasticity Index	Liquidity Index	Soil Classification
*	S-30	C-05-03	118.5-120.5	26	33	18	15	1	lean clay (CL)

Sample Prepared using the WET method
 0% Retained on #40 Sieve
 Dry Strength: HIGH
 Dilatancy: NONE
 Toughness: LOW

Client: Geocomp Consulting	Project: I-90 Central Viaduct	Location: Cleveland, OH	Project No: GTX-6678
Boring ID: ---	Sample Type: ---	Tested By: pcs	
Sample ID:---	Test Date: 05/11/06	Checked By: jdt	
Depth : ---	Test Id: 89812		

Specific Gravity of Soils by ASTM D 854

Boring ID	Sample ID	Depth	Visual Description	Specific Gravity
C-05-03	S-29	116.5-118.5	Moist, dark gray clay	2.75
C-05-03	S-30	118.5-120.5	Moist, dark gray clay	2.73

Notes: Specific Gravity performed by using method A (oven dried specimens) of ASTM D 854
 Moisture Content determined by ASTM D 2216.

Client: Geocomp Consulting	Project: I-90 Central Viaduct	Location: Cleveland, OH	Project No: GTX-6678
Boring ID: C-05-04	Sample Type: tube	Tested By: pcs	Sample ID: S-27
Depth: 72-74 ft	Test Date: 05/31/06	Checked By: jdt	Test Id: 90387
Test Comment: ---			
Sample Description: Moist, very dark grayish brown clay			
Sample Comment: ---			

Particle Size Analysis - ASTM D 422

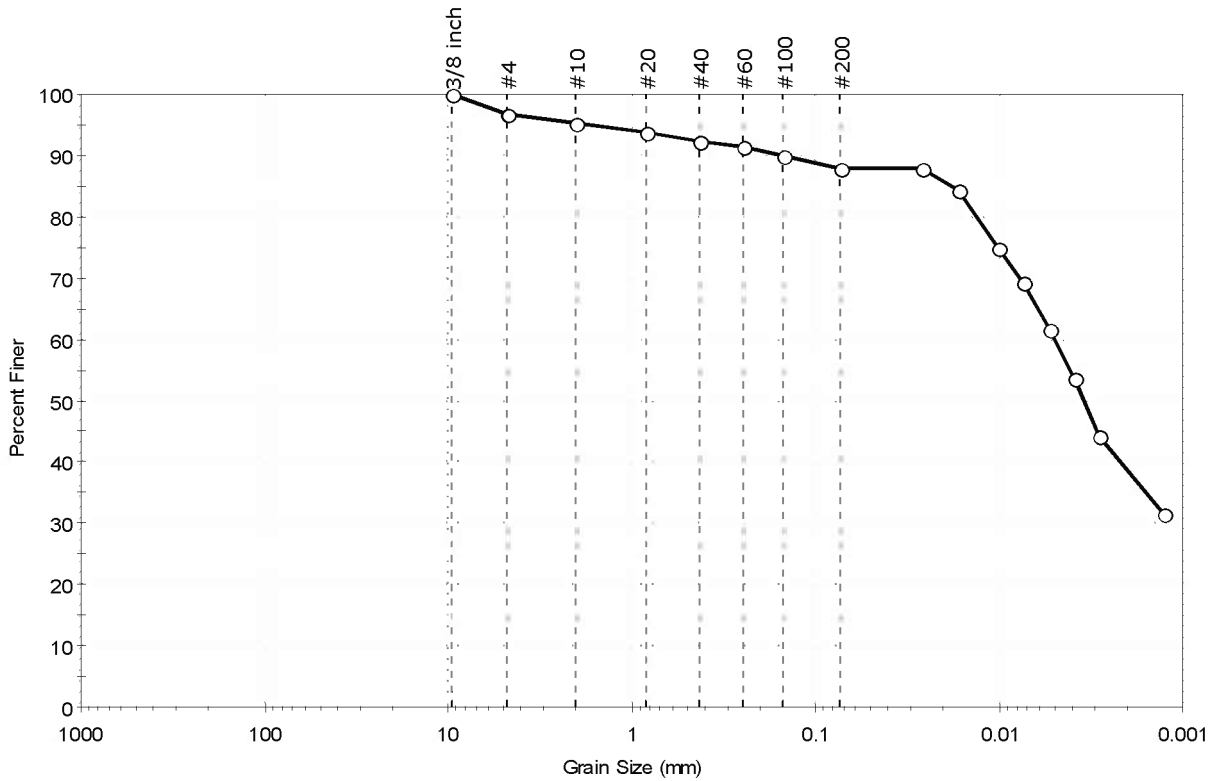

% Cobble	% Gravel	% Sand	% Silt & Clay Size
—	3.2	8.9	87.9

Sieve Name	Sieve Size, mm	Percent Finer	Spec. Percent	Complies
3/8 inch	9.50	100		
#4	4.75	97		
#10	2.00	95		
#20	0.84	94		
#40	0.42	92		
#60	0.25	91		
#100	0.15	90		
#200	0.074	88		
---	Particle Size (mm)	Percent Finer	Spec. Percent	Complies
---	0.0265	88		
---	0.0168	84		
---	0.0101	75		
---	0.0074	69		
---	0.0054	62		
---	0.0039	54		
---	0.0029	44		
---	0.0013	32		

Coefficients	
D ₈₅ = 0.0184 mm	D ₃₀ = N/A
D ₆₀ = 0.0050 mm	D ₁₅ = N/A
D ₅₀ = 0.0035 mm	D ₁₀ = N/A
C _u = N/A	C _c = N/A

Classification	
ASTM	lean clay (CL)
AASHTO	Clayey Soils (A-6 (10))

Sample/Test Description	
Sand/Gravel Particle Shape	: ANGULAR
Sand/Gravel Hardness	: HARD

Client: Geocomp Consulting	Project: I-90 Central Viaduct	Location: Cleveland, OH	Project No: GTX-6678
Boring ID: C-05-04	Sample Type: tube	Tested By: pcs	
Sample ID: S-27	Test Date: 05/24/06	Checked By: jdt	
Depth: 72-74 ft	Test Id: 90390		
Test Comment: ---			
Sample Description: Moist, very dark grayish brown clay			
Sample Comment: ---			

Atterberg Limits - ASTM D 4318

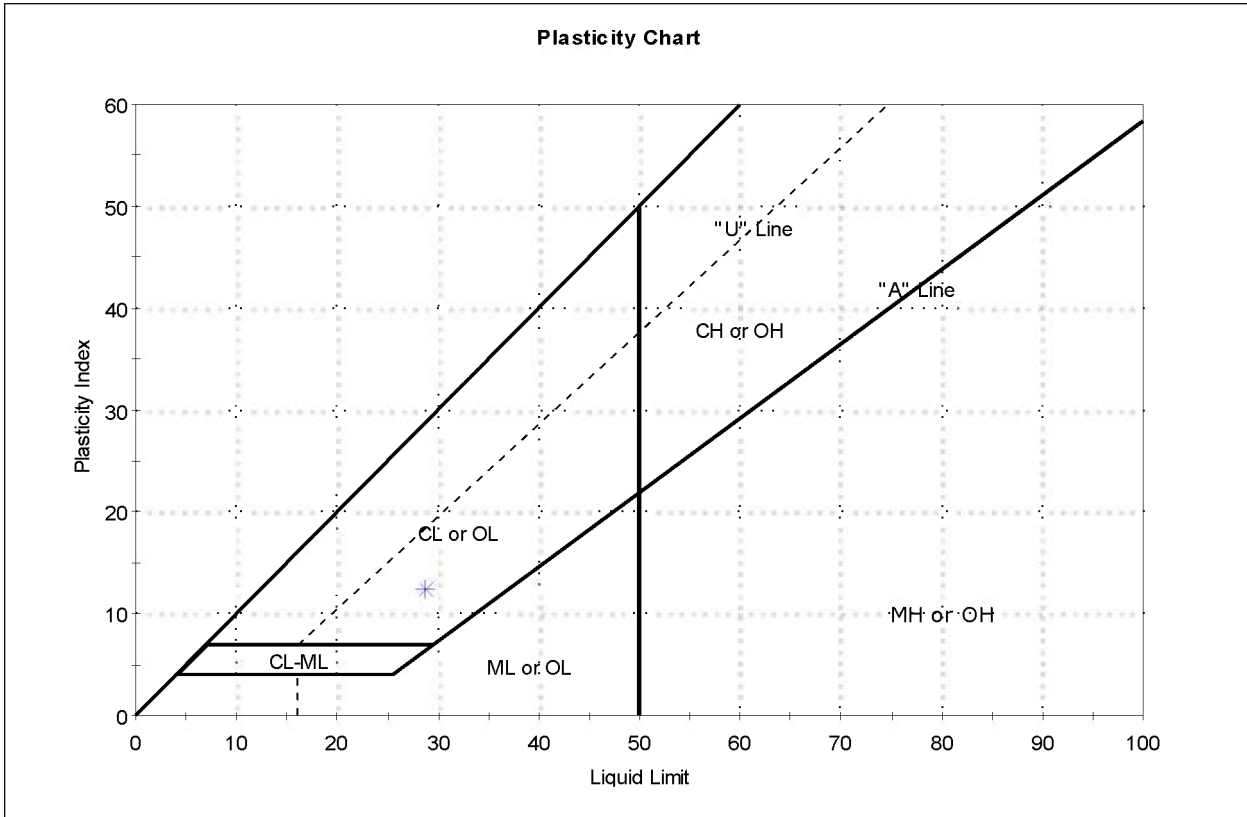

Symbol	Sample ID	Boring	Depth	Natural Moisture Content, %	Liquid Limit	Plastic Limit	Plasticity Index	Liquidity Index	Soil Classification
*	S-27	C-05-04	72-74 ft	21	29	16	13	0	lean clay (CL)

Sample Prepared using the WET method
 8% Retained on #40 Sieve
 Dry Strength: HIGH
 Dilatancy: NONE
 Toughness: LOW

Client: Geocomp Consulting	Project: I-90 Central Viaduct	Location: Cleveland, OH	Project No: GTX-6678
Boring ID: B-05-08	Sample Type: tube	Tested By: pcs	Sample ID: S-27
Depth: 116-118 ft	Test Date: 06/01/06	Checked By: jdt	Test ID: 90389
Test Comment: ---			
Sample Description: Moist, dark olive gray clay			
Sample Comment: ---			

Particle Size Analysis - ASTM D 422

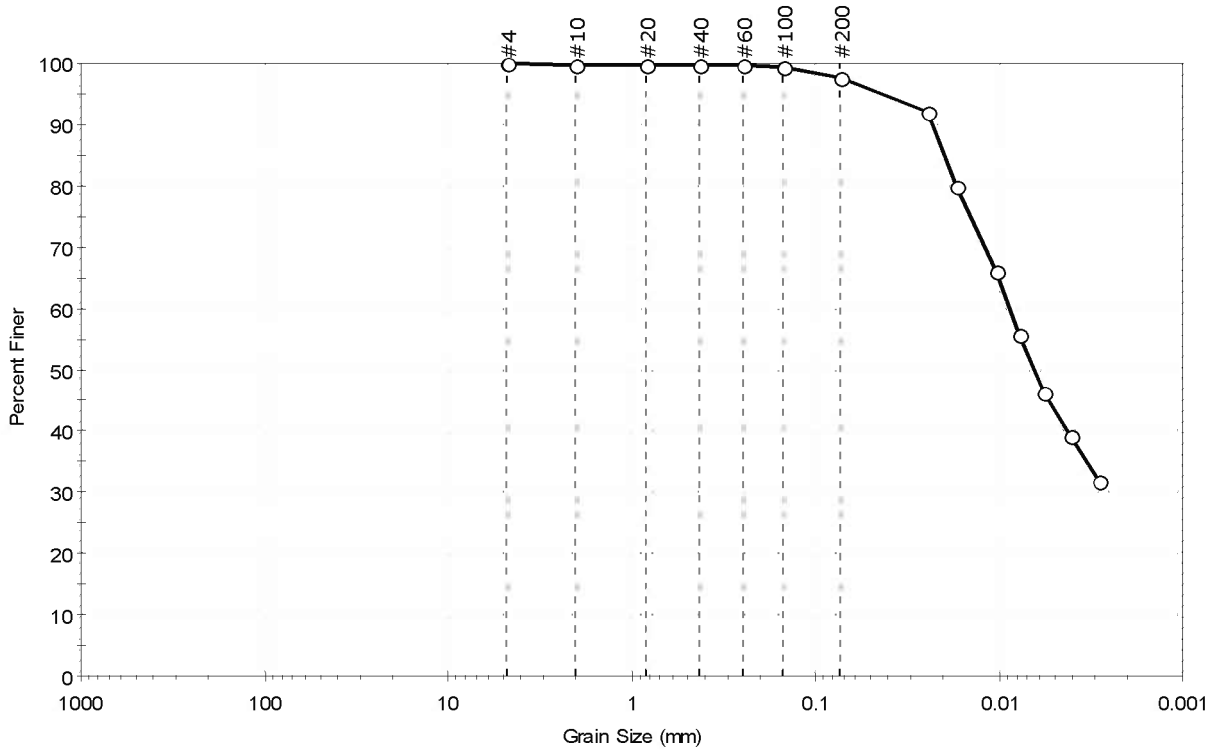

% Cobble	% Gravel	% Sand	% Silt & Clay Size
—	0.0	2.2	97.8

Sieve Name	Sieve Size, mm	Percent Finer	Spec. Percent	Complies
#4	4.75	100		
#10	2.00	100		
#20	0.84	100		
#40	0.42	100		
#60	0.25	100		
#100	0.15	99		
#200	0.074	98		
---	Particle Size (mm)	Percent Finer	Spec. Percent	Complies
---	0.0245	92		
---	0.0169	80		
---	0.0104	66		
---	0.0077	56		
---	0.0057	46		
---	0.0041	39		
---	0.0029	32		

Coefficients	
D ₈₅ = 0.0197 mm	D ₃₀ = N/A
D ₆₀ = 0.0088 mm	D ₁₅ = N/A
D ₅₀ = 0.0064 mm	D ₁₀ = N/A
C _u = N/A	C _c = N/A

Classification	
ASTM	lean clay (CL)
AASHTO	Clayey Soils (A-6 (9))

Sample/Test Description	
Sand/Gravel Particle Shape	: ANGULAR
Sand/Gravel Hardness	: HARD

Client: Geocomp Consulting	Project: I-90 Central Viaduct	Location: Cleveland, OH	Project No: GTX-6678
Boring ID: B-05-08	Sample Type: tube	Tested By: pcs	
Sample ID: S-27	Test Date: 05/31/06	Checked By: jdt	
Depth: 116-118 ft	Test Id: 90392		
Test Comment: ---			
Sample Description: Moist, dark olive gray clay			
Sample Comment: ---			

Atterberg Limits - ASTM D 4318

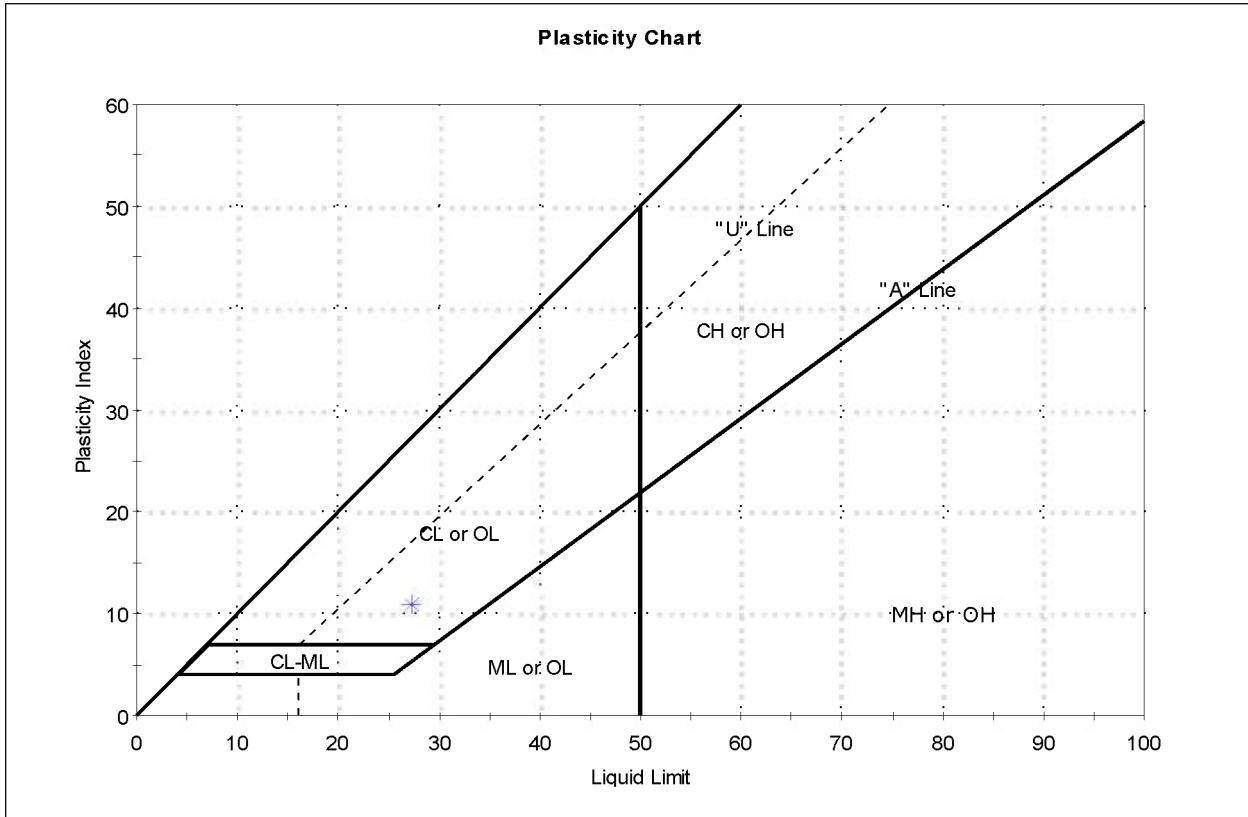

Symbol	Sample ID	Boring	Depth	Natural Moisture Content, %	Liquid Limit	Plastic Limit	Plasticity Index	Liquidity Index	Soil Classification
*	S-27	B-05-08	116-118 ft	22	27	16	11	1	lean clay (CL)

Sample Prepared using the WET method
 0% Retained on #40 Sieve
 Dry Strength: VERY HIGH
 Dilatancy: SLOW
 Toughness: LOW

Client: Geocomp Consulting	Project: I-90 Central Viaduct	Location: Cleveland, OH	Project No: GTX-6678
Boring ID: B-105A	Sample Type: tube	Tested By: pcs	
Sample ID: S-20	Test Date: 05/30/06	Checked By: jdt	
Depth: 90-92 ft	Test Id: 90388		
Test Comment: ---			
Sample Description: Moist, dark gray clay			
Sample Comment: ---			

Particle Size Analysis - ASTM D 422

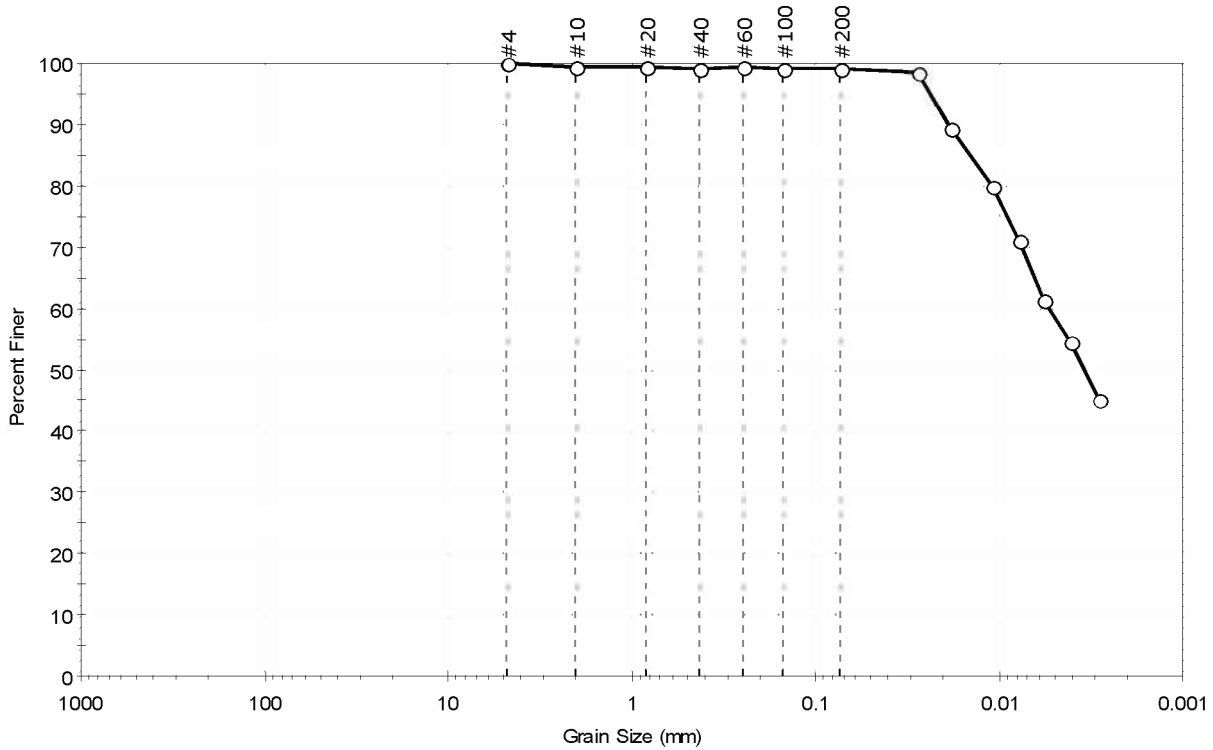

% Cobble	% Gravel	% Sand	% Silt & Clay Size
—	0.0	1.0	99.0

Sieve Name	Sieve Size, mm	Percent Finer	Spec. Percent	Complies
#4	4.75	100		
#10	2.00	100		
#20	0.84	99		
#40	0.42	99		
#60	0.25	99		
#100	0.15	99		
#200	0.074	99		
---	Particle Size (mm)	Percent Finer	Spec. Percent	Complies
---	0.0274	99		
---	0.0183	89		
---	0.0108	80		
---	0.0078	71		
---	0.0057	61		
---	0.0041	55		
---	0.0029	45		

Coefficients	
D ₈₅ = 0.0143 mm	D ₃₀ = N/A
D ₆₀ = 0.0053 mm	D ₁₅ = N/A
D ₅₀ = 0.0034 mm	D ₁₀ = N/A
C _u = N/A	C _c = N/A

Classification	
ASTM	lean clay (CL)
AASHTO	Clayey Soils (A-6 (16))

Sample/Test Description	
Sand/Gravel Particle Shape	: ANGULAR
Sand/Gravel Hardness	: HARD

Client: Geocomp Consulting	Project: I-90 Central Viaduct	Location: Cleveland, OH	Project No: GTX-6678
Boring ID: B-105A	Sample Type: tube	Tested By: pcs	
Sample ID: S-20	Test Date: 06/01/06	Checked By: jdt	
Depth: 90-92 ft	Test Id: 90391		
Test Comment: ---			
Sample Description: Moist, dark gray clay			
Sample Comment: ---			

Atterberg Limits - ASTM D 4318

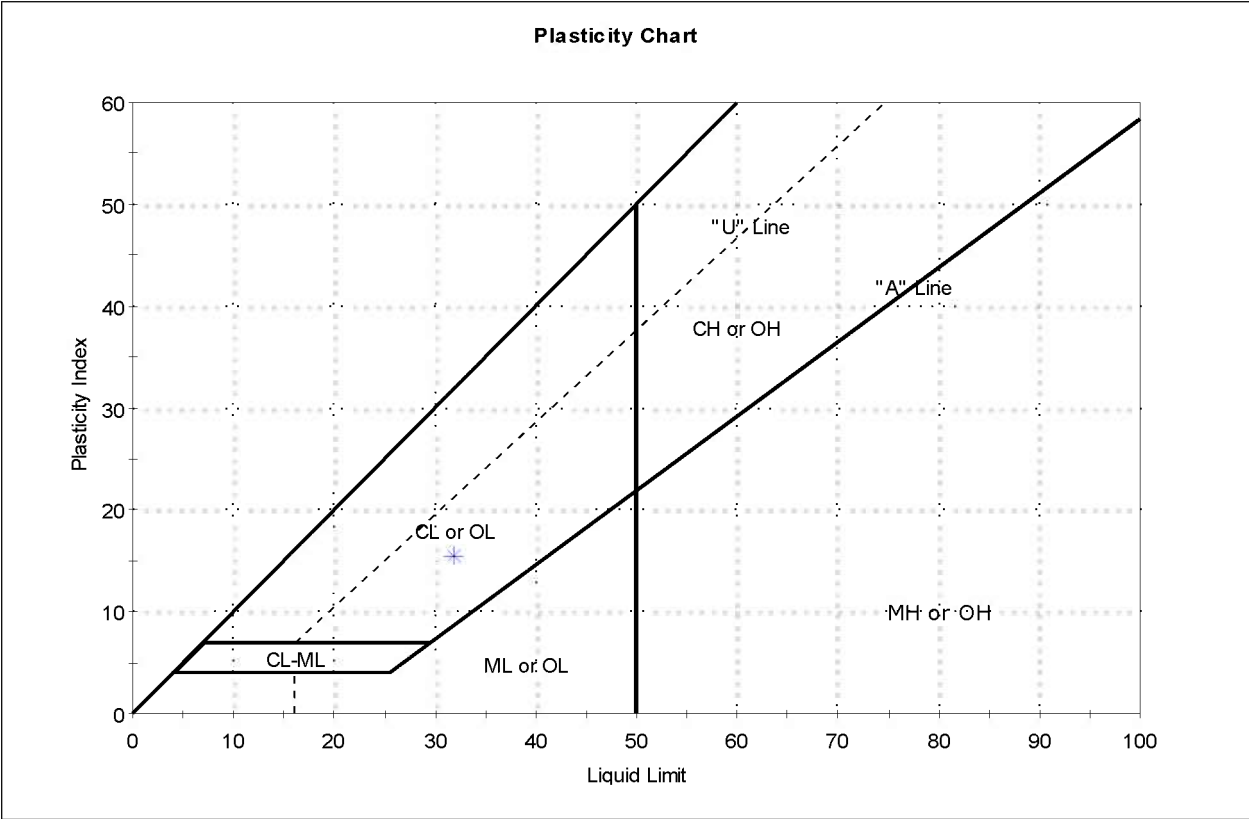

Symbol	Sample ID	Boring	Depth	Natural Moisture Content, %	Liquid Limit	Plastic Limit	Plasticity Index	Liquidity Index	Soil Classification
*	S-20	B-105A	90-92 ft	23	32	16	16	0	lean clay (CL)

Sample Prepared using the WET method
 1% Retained on #40 Sieve
 Dry Strength: HIGH
 Dilatancy: SLOW
 Toughness: LOW

Appendix B

Consolidation Tests

CONSOLIDATION TEST DATA

SUMMARY REPORT

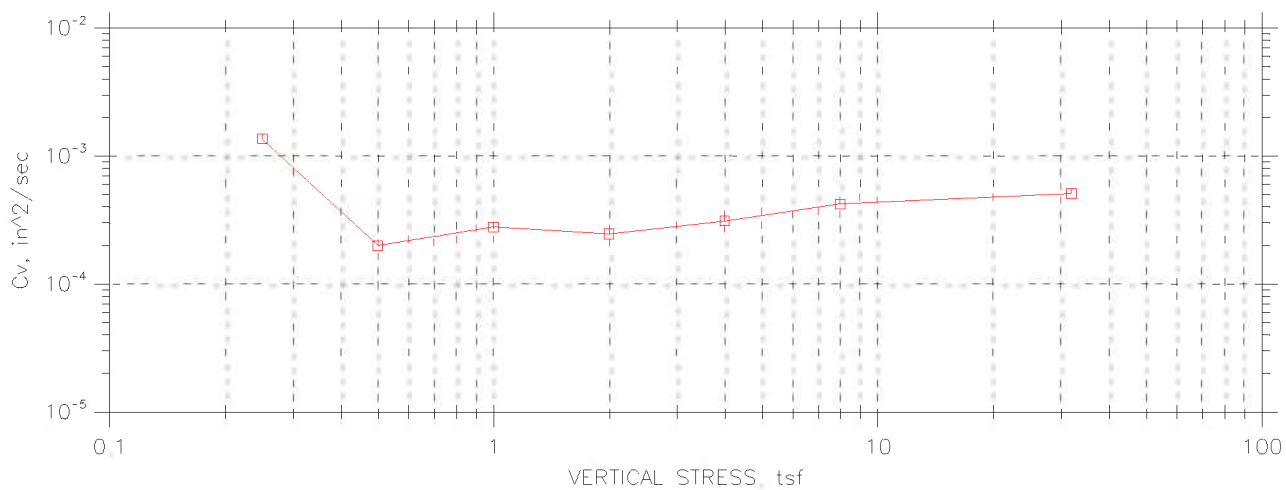
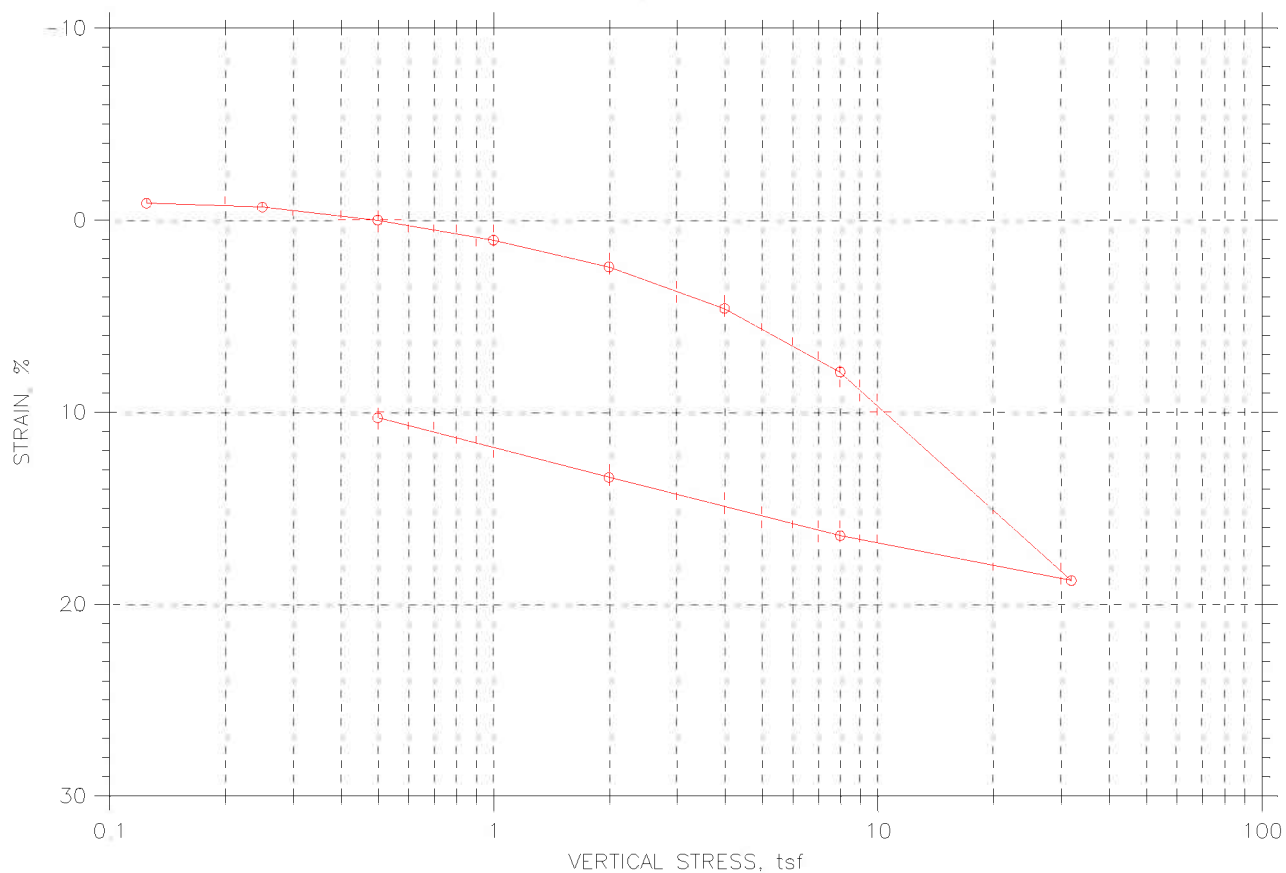

	Project: I90 Central Viaduct	Location: Cleveland, OH	Project No.: GTX-6678
	Boring No.: C-05-03	Tested By: jdt	Checked By: njh
	Sample No.: S-29	Test Date: 05/05/06	Depth: 116.5-118.5
	Test No.: C-1	Sample Type: Tube	Elevation: ---
	Description: Moist, dark gray clay		
	Remarks: ---		

CONSOLIDATION TEST DATA

SUMMARY REPORT

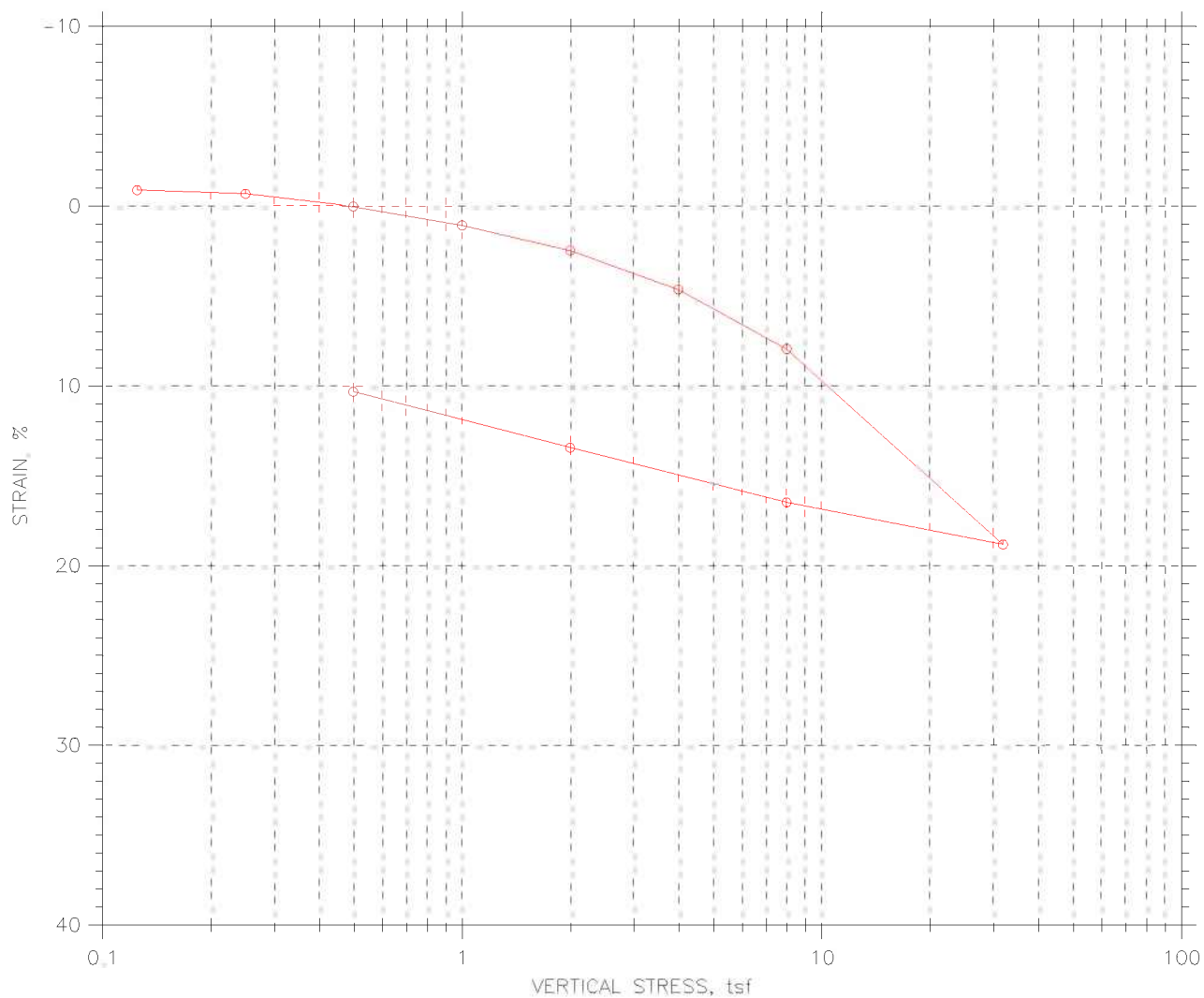

				Before Test	After Test	
Overburden Pressure: ---				Water Content, %	28.73	22.08
Preconsolidation Pressure: ---				Dry Unit Weight, pcf	95.81	106.8
Compression Index: 2.54639e-313				Saturation, %	99.78	99.99
Diameter: 2.5 in		Height: 1 in		Void Ratio	0.79	0.61
LL: 35	PL: 18	PI: 17	GS: 2.75			

	Project: I90 Central Viaduct	Location: Cleveland, OH	Project No.: GTX-6678
	Boring No.: C-05-03	Tested By: jdt	Checked By: njh
	Sample No.: S-29	Test Date: 05/05/06	Depth: 116.5-118.5
	Test No.: C-1	Sample Type: Tube	Elevation: ---
	Description: Moist, dark gray clay		
	Remarks: ---		

CONSOLIDATION TEST DATA

TIME CURVES

Constant Load Step: 1 of 11

Stress: 0.125 tsf

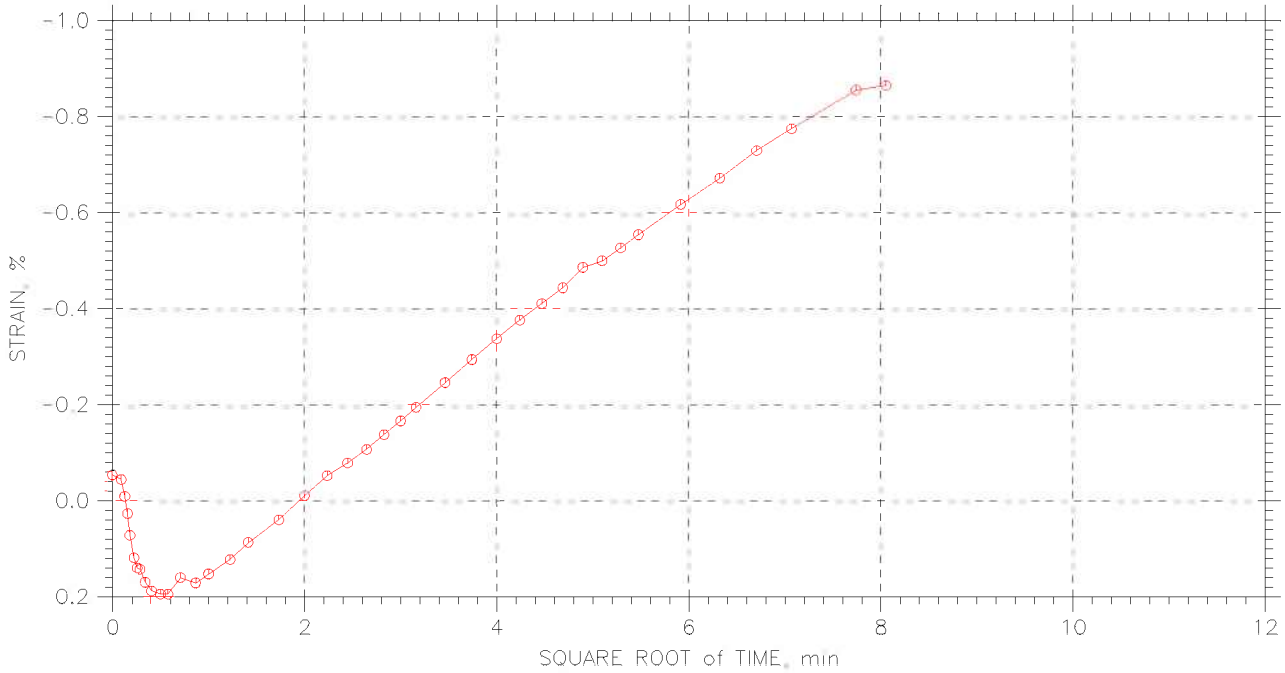
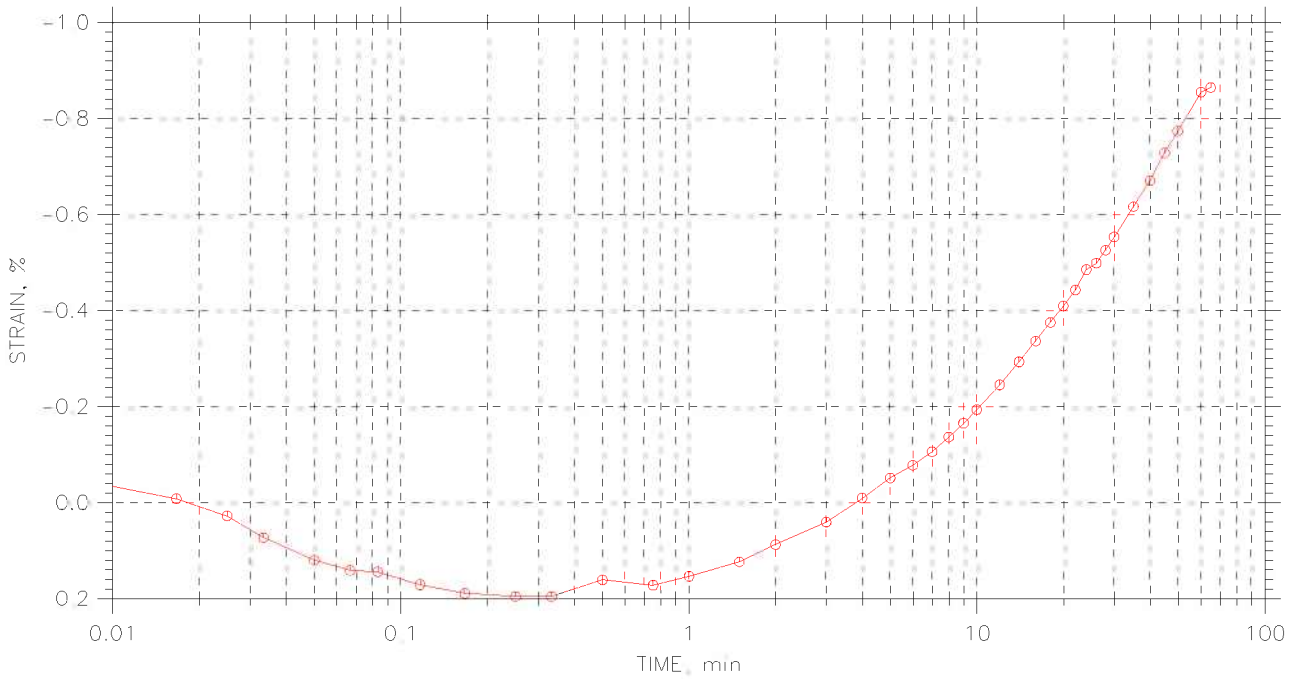

	Project: I90 Central Viaduct	Location: Cleveland, OH	Project No.: GTX-6678
	Boring No.: C-05-03	Tested By: jdt	Checked By: njh
	Sample No.: S-29	Test Date: 05/05/06	Depth: 116.5-118.5
	Test No.: C-1	Sample Type: Tube	Elevation: ---
	Description: Moist, dark gray clay		
	Remarks: ---		

CONSOLIDATION TEST DATA

TIME CURVES

Constant Load Step: 2 of 11

Stress: 0.25 tsf

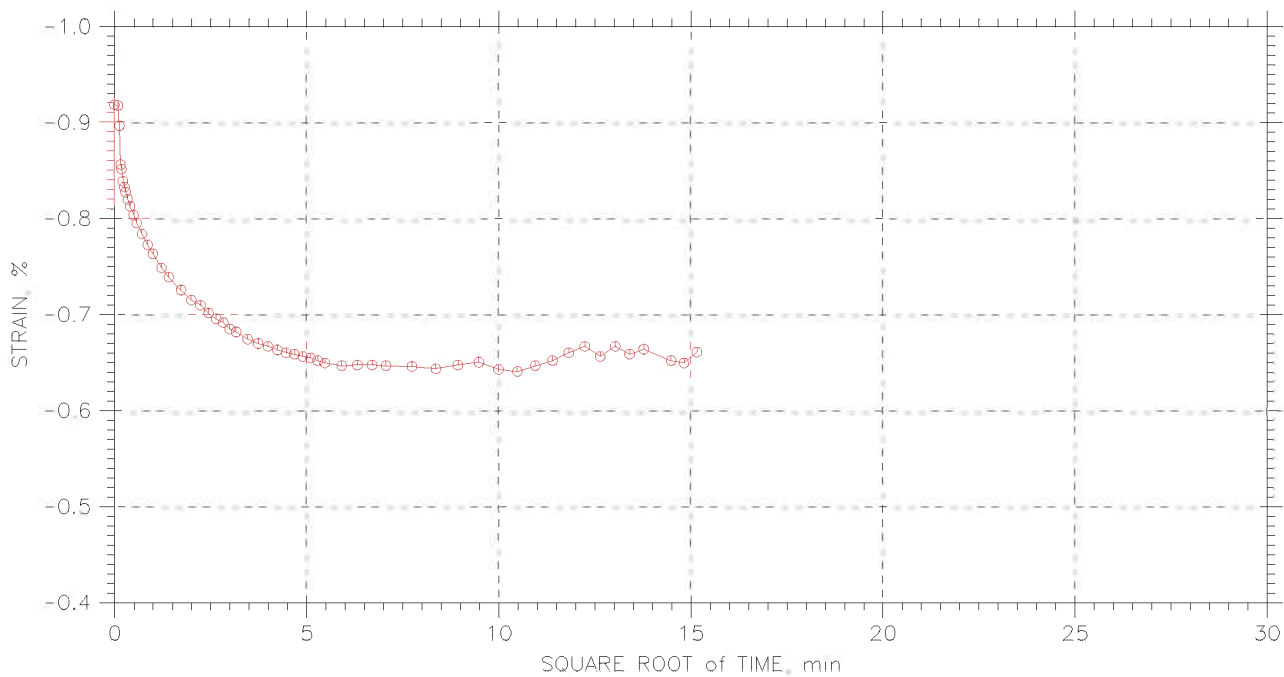
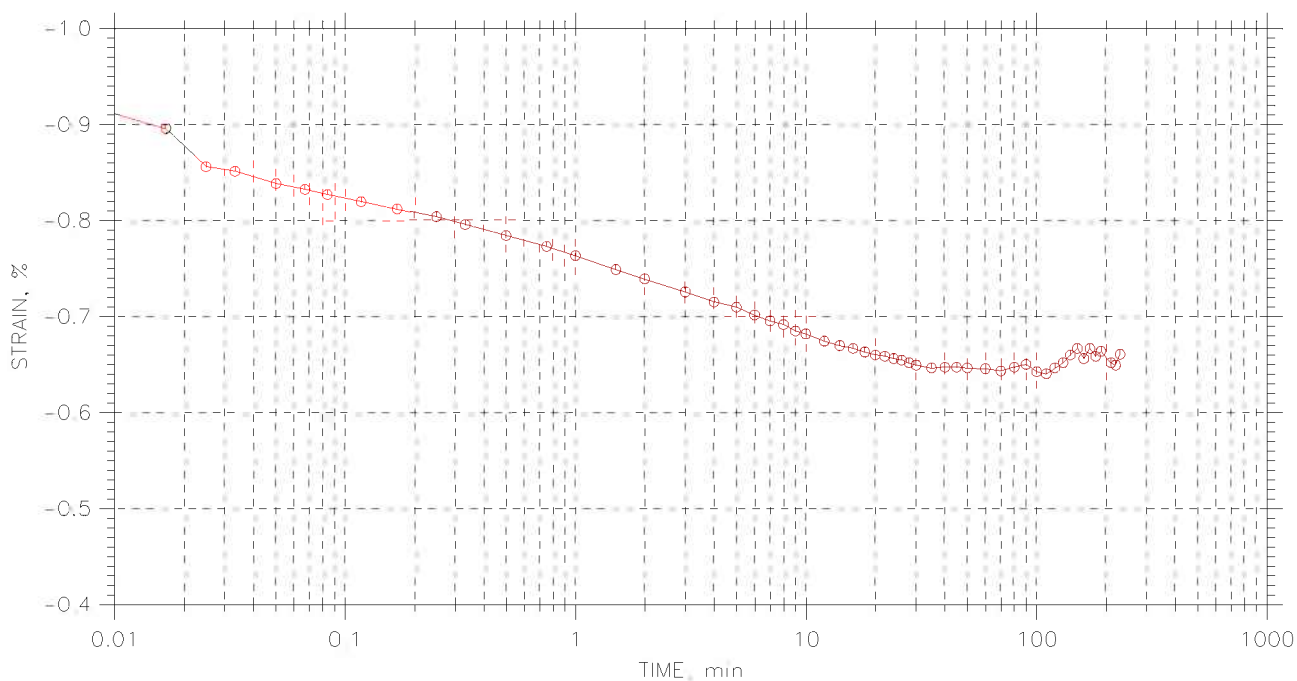

	Project: I90 Central Viaduct	Location: Cleveland, OH	Project No.: GTX-6678
	Boring No.: C-05-03	Tested By: jdt	Checked By: njh
	Sample No.: S-29	Test Date: 05/05/06	Depth: 116.5-118.5
	Test No.: C-1	Sample Type: Tube	Elevation: ---
	Description: Moist, dark gray clay		
	Remarks: ---		

CONSOLIDATION TEST DATA

TIME CURVES

Constant Load Step: 3 of 11

Stress: 0.5 tsf

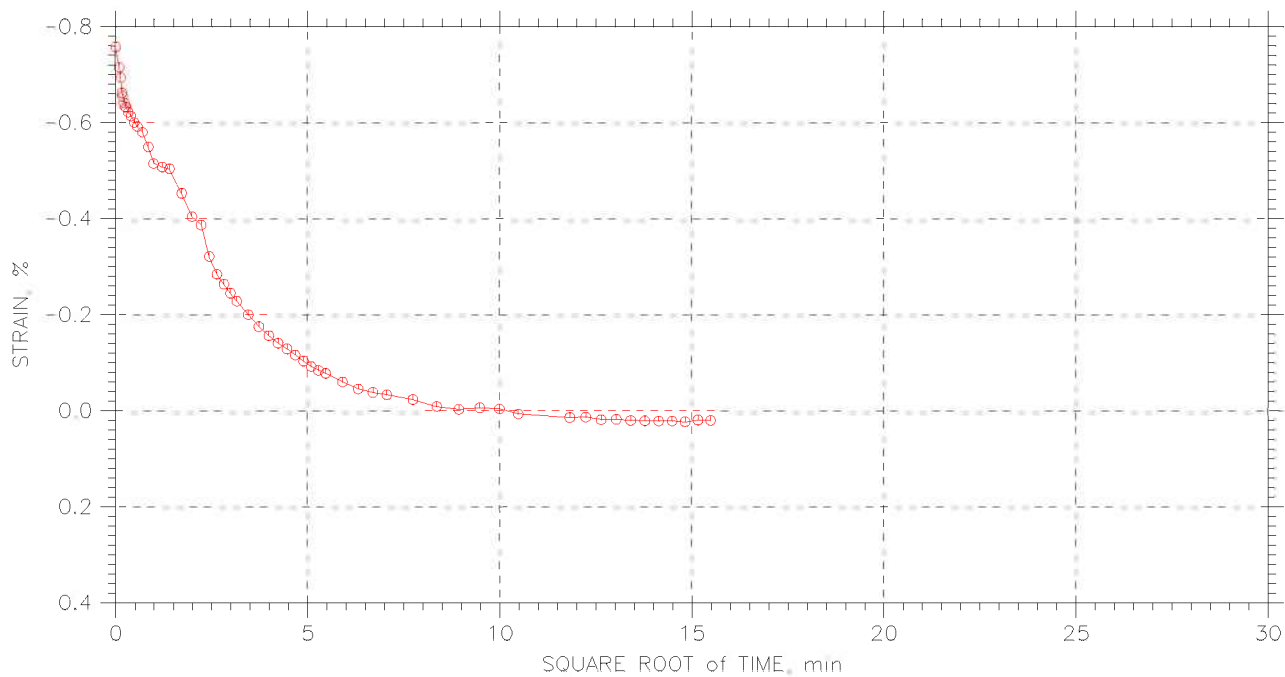
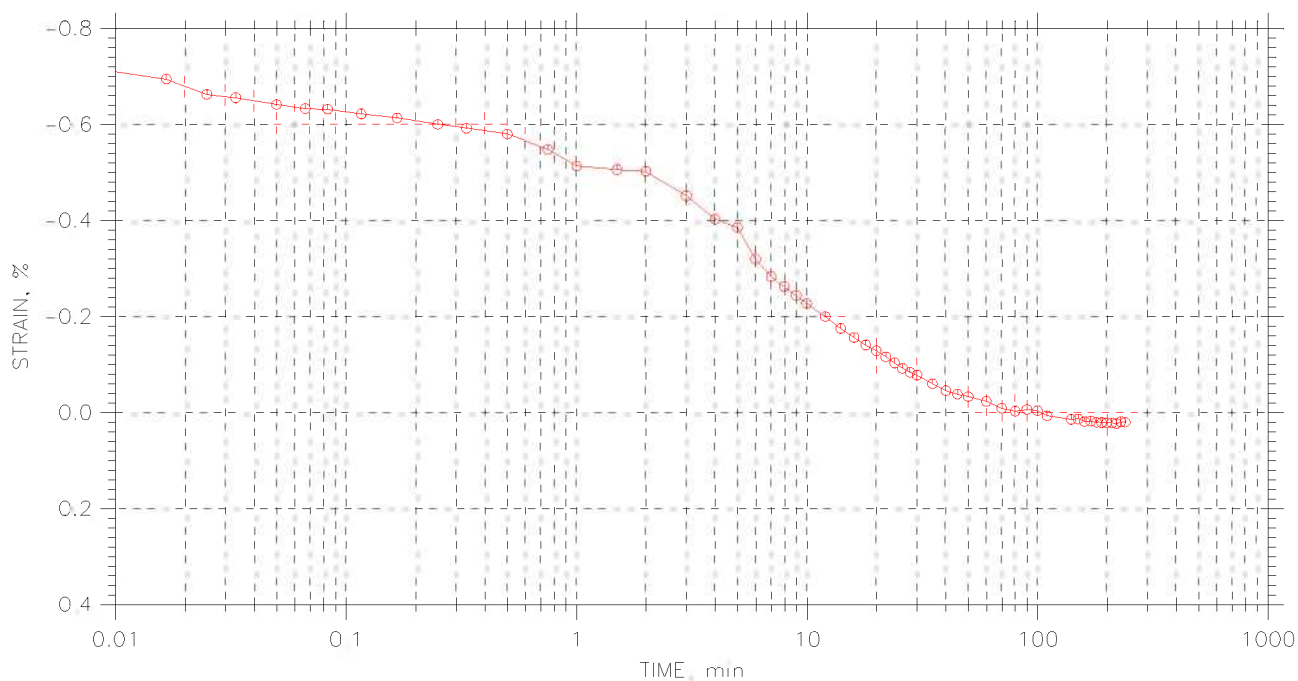

	Project: I90 Central Viaduct	Location: Cleveland, OH	Project No.: GTX-6678
	Boring No.: C-05-03	Tested By: jdt	Checked By: njh
	Sample No.: S-29	Test Date: 05/05/06	Depth: 116.5-118.5
	Test No.: C-1	Sample Type: Tube	Elevation: ---
	Description: Moist, dark gray clay		
	Remarks: ---		

CONSOLIDATION TEST DATA

TIME CURVES

Constant Load Step: 4 of 11

Stress: 1. tsf

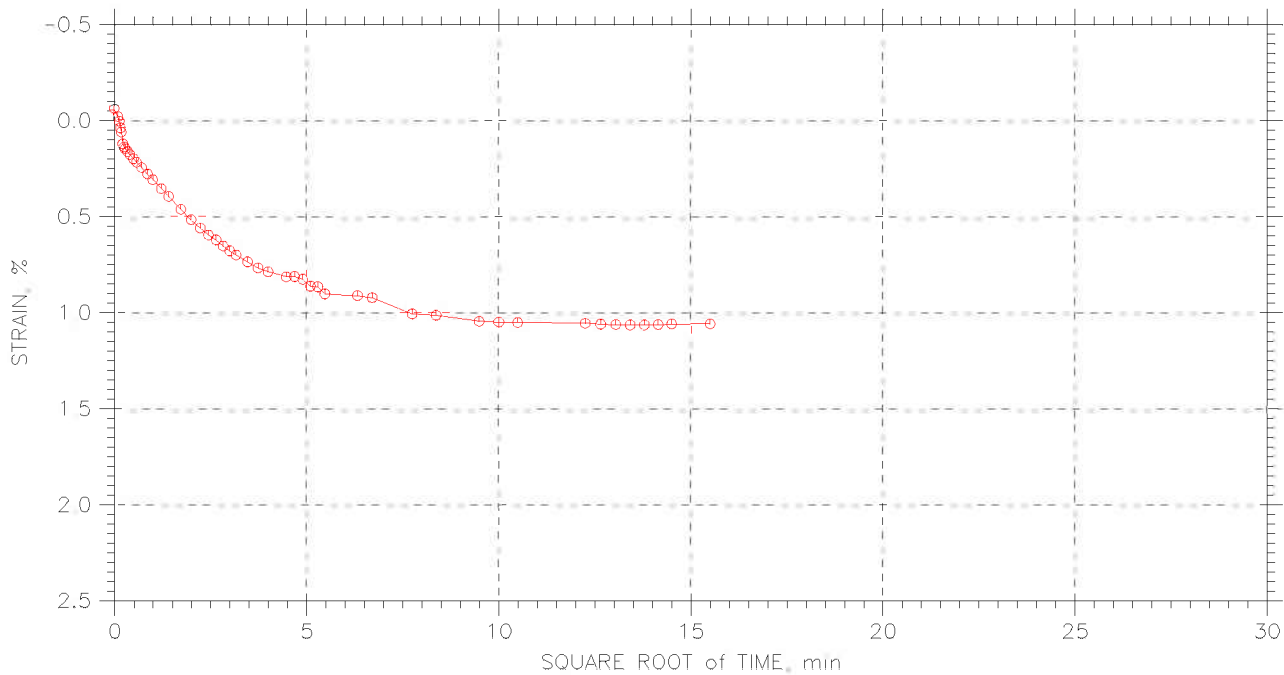
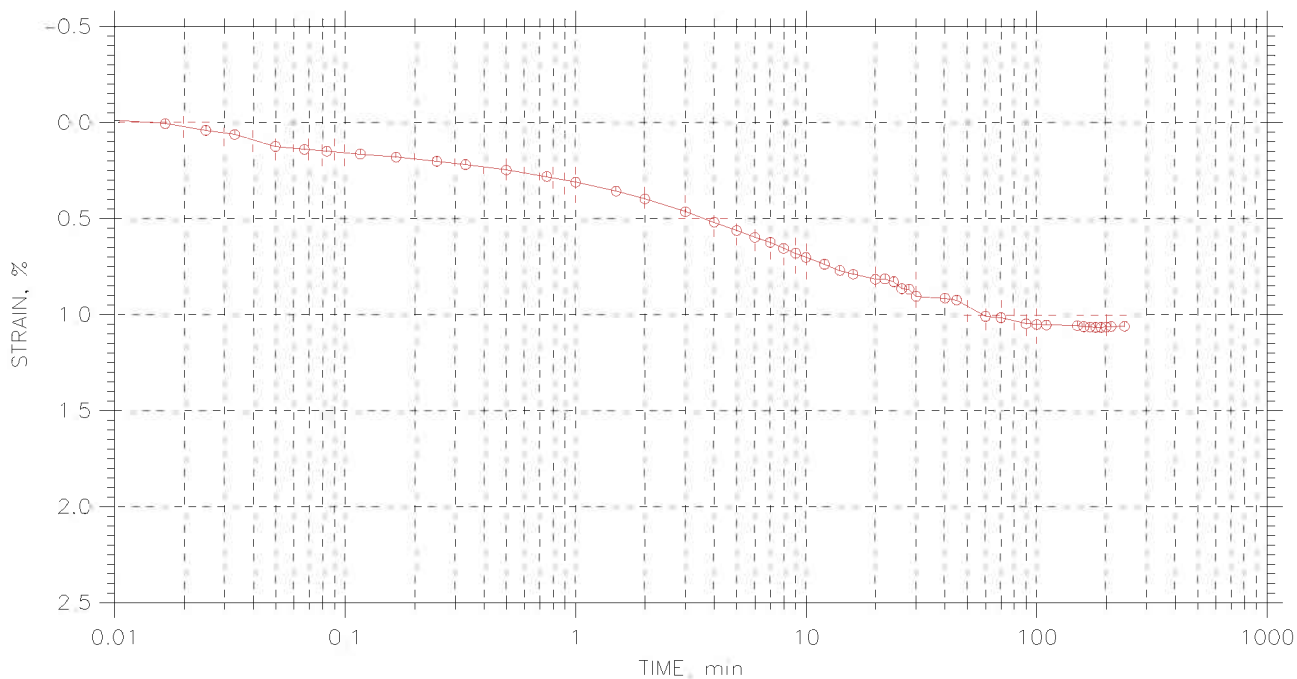

	Project: I90 Central Viaduct	Location: Cleveland, OH	Project No.: GTX-6678
	Boring No.: C-05-03	Tested By: jdt	Checked By: njh
	Sample No.: S-29	Test Date: 05/05/06	Depth: 116.5-118.5
	Test No.: C-1	Sample Type: Tube	Elevation: ---
	Description: Moist, dark gray clay		
	Remarks: ---		

CONSOLIDATION TEST DATA

TIME CURVES

Constant Load Step: 5 of 11

Stress: 2. tsf

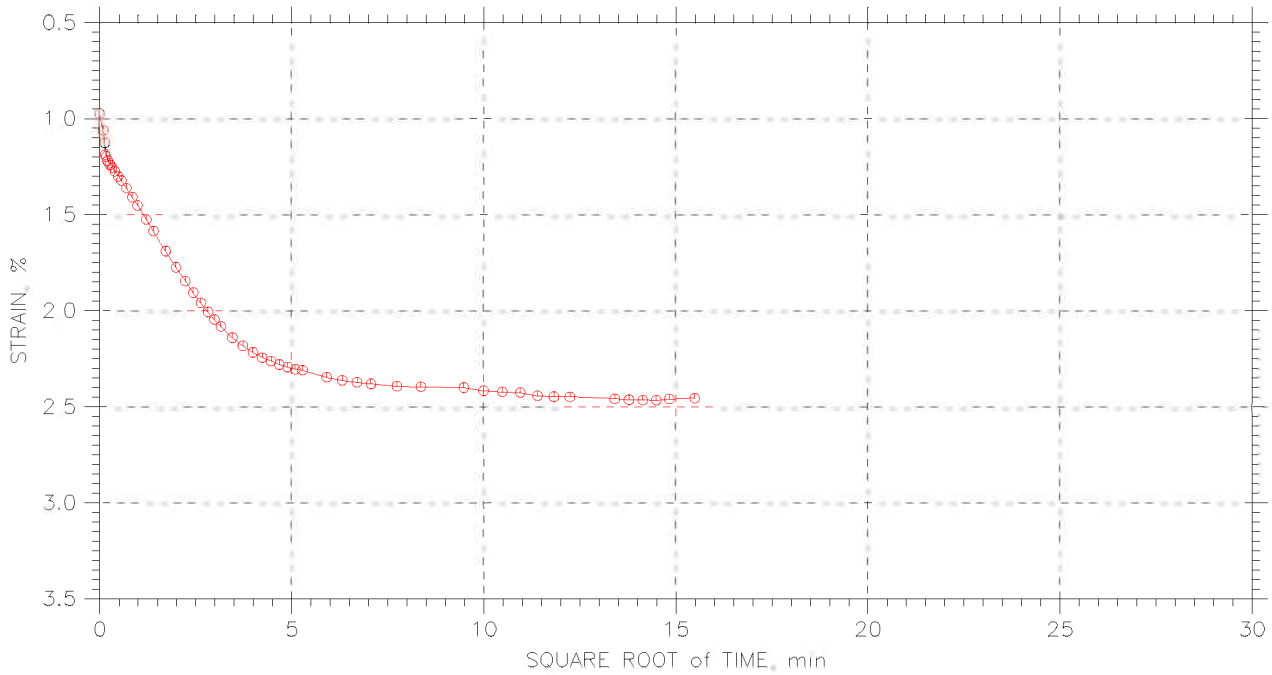
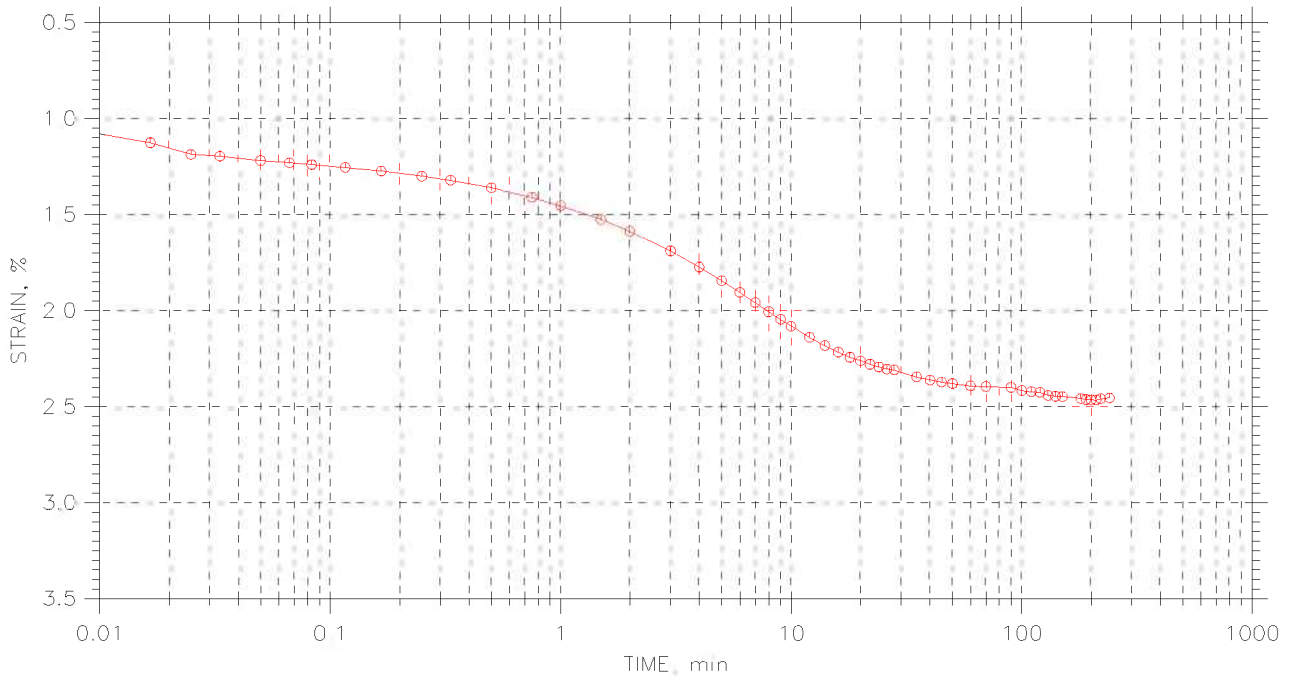

	Project: I90 Central Viaduct	Location: Cleveland, OH	Project No.: GTX-6678
	Boring No.: C-05-03	Tested By: jdt	Checked By: njh
	Sample No.: S-29	Test Date: 05/05/06	Depth: 116.5-118.5
	Test No.: C-1	Sample Type: Tube	Elevation: ---
	Description: Moist, dark gray clay		
	Remarks: ---		

CONSOLIDATION TEST DATA

TIME CURVES

Constant Load Step: 6 of 11

Stress: 4. tsf

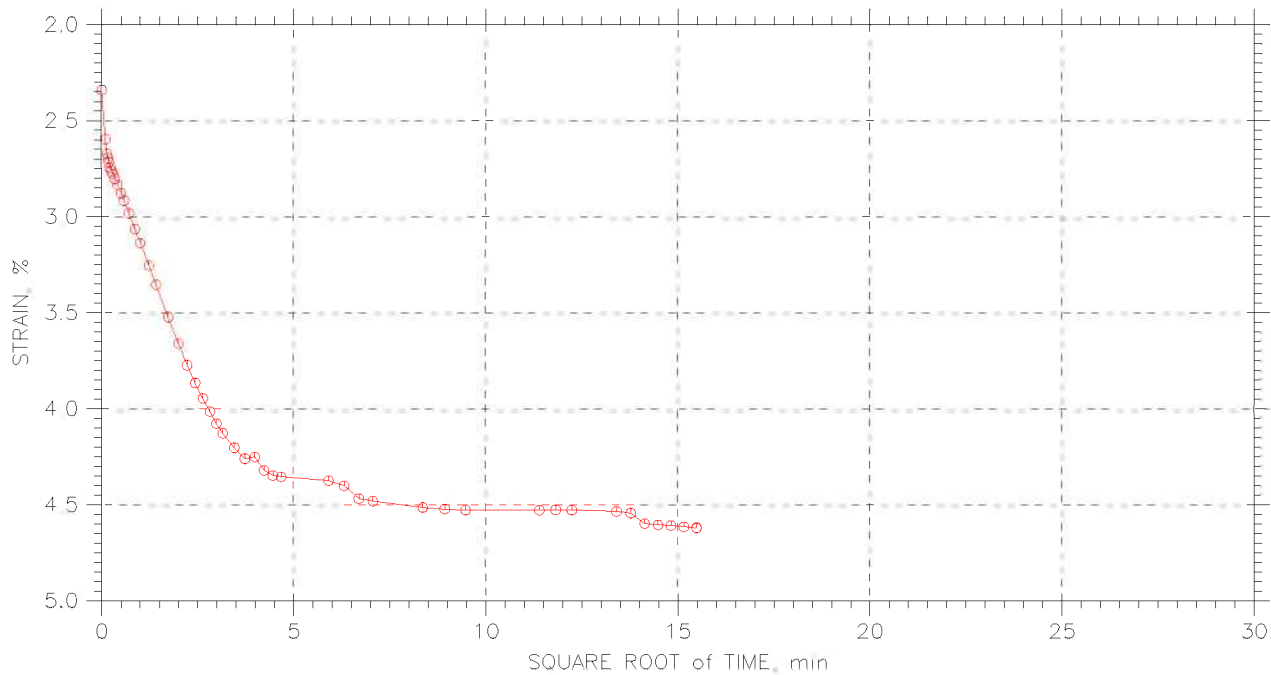
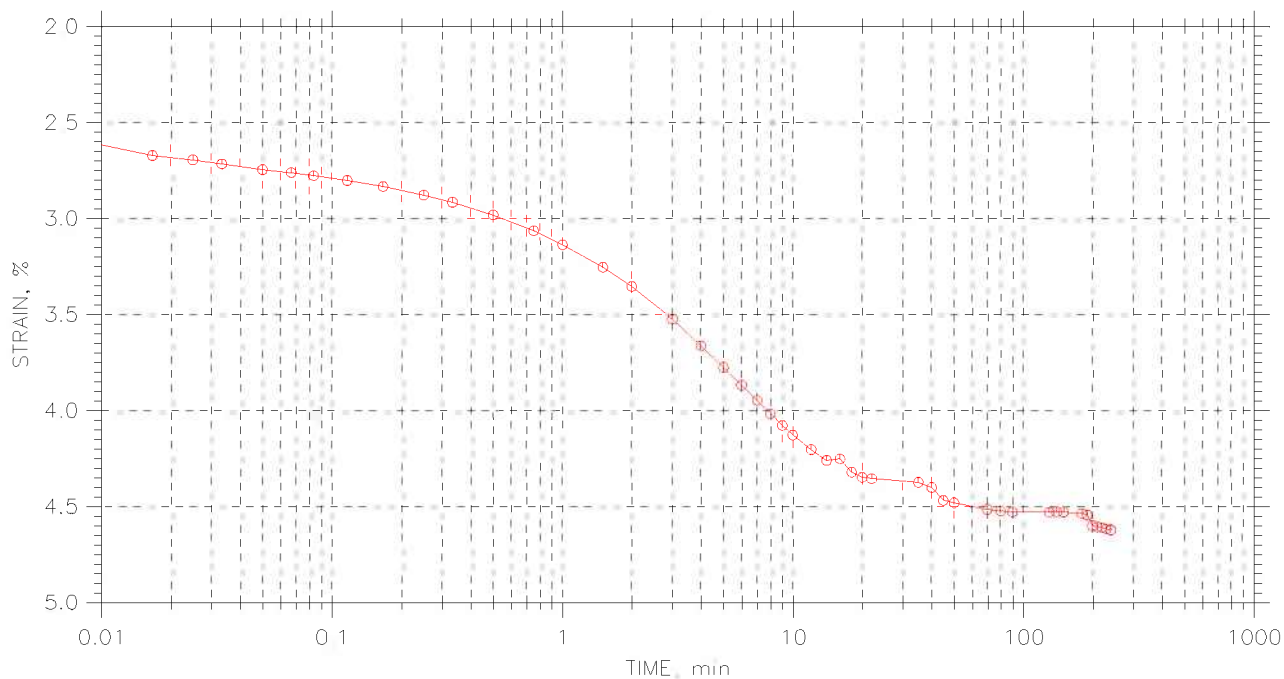

	Project: I90 Central Viaduct	Location: Cleveland, OH	Project No.: GTX-6678
	Boring No.: C-05-03	Tested By: jdt	Checked By: njh
	Sample No.: S-29	Test Date: 05/05/06	Depth: 116.5-118.5
	Test No.: C-1	Sample Type: Tube	Elevation: ---
	Description: Moist, dark gray clay		
	Remarks: ---		

CONSOLIDATION TEST DATA

TIME CURVES

Constant Load Step: 7 of 11

Stress: 8. tsf

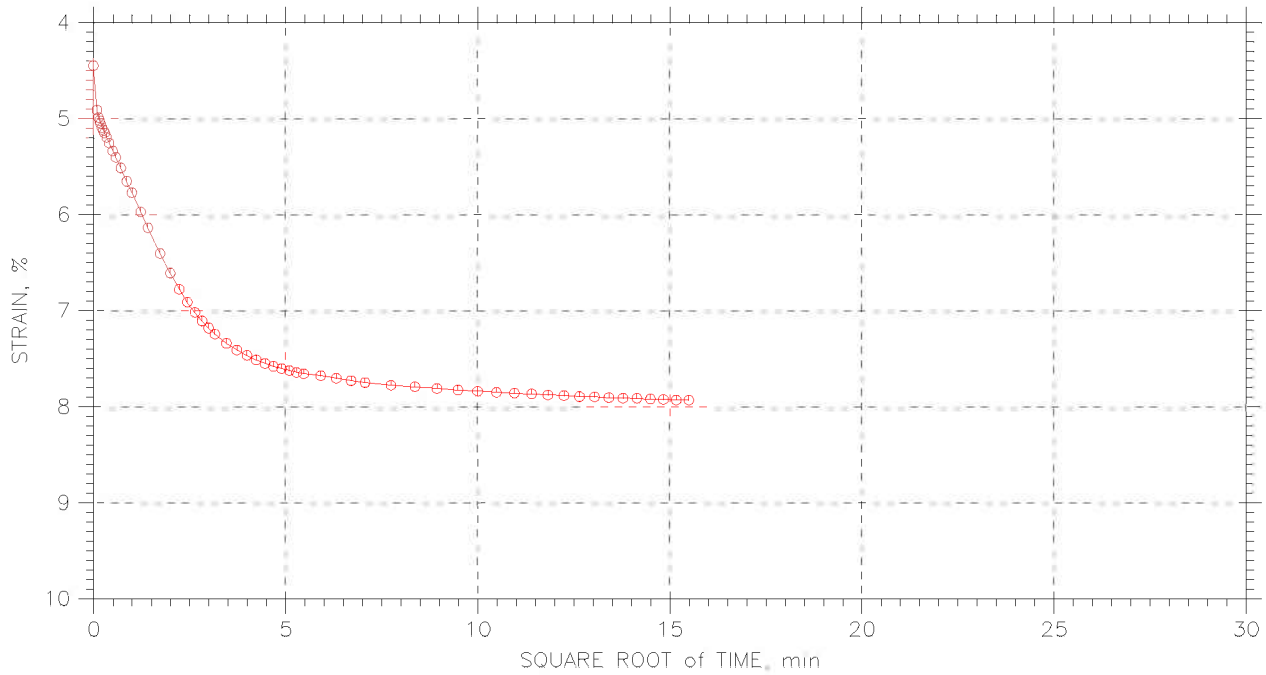
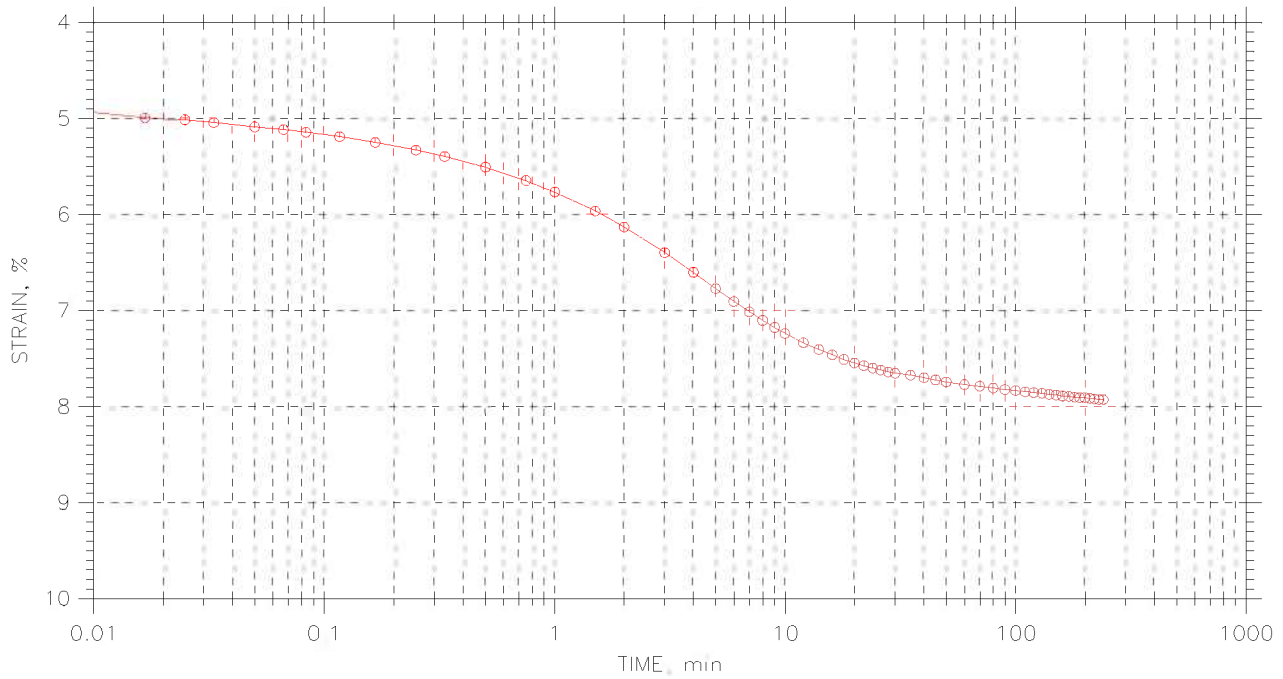

	Project: I90 Central Viaduct	Location: Cleveland, OH	Project No.: GTX-6678
	Boring No.: C-05-03	Tested By: jdt	Checked By: njh
	Sample No.: S-29	Test Date: 05/05/06	Depth: 116.5-118.5
	Test No.: C-1	Sample Type: Tube	Elevation: ---
	Description: Moist, dark gray clay		
	Remarks: ---		

CONSOLIDATION TEST DATA

TIME CURVES

Constant Load Step: 8 of 11

Stress: 32 tsf

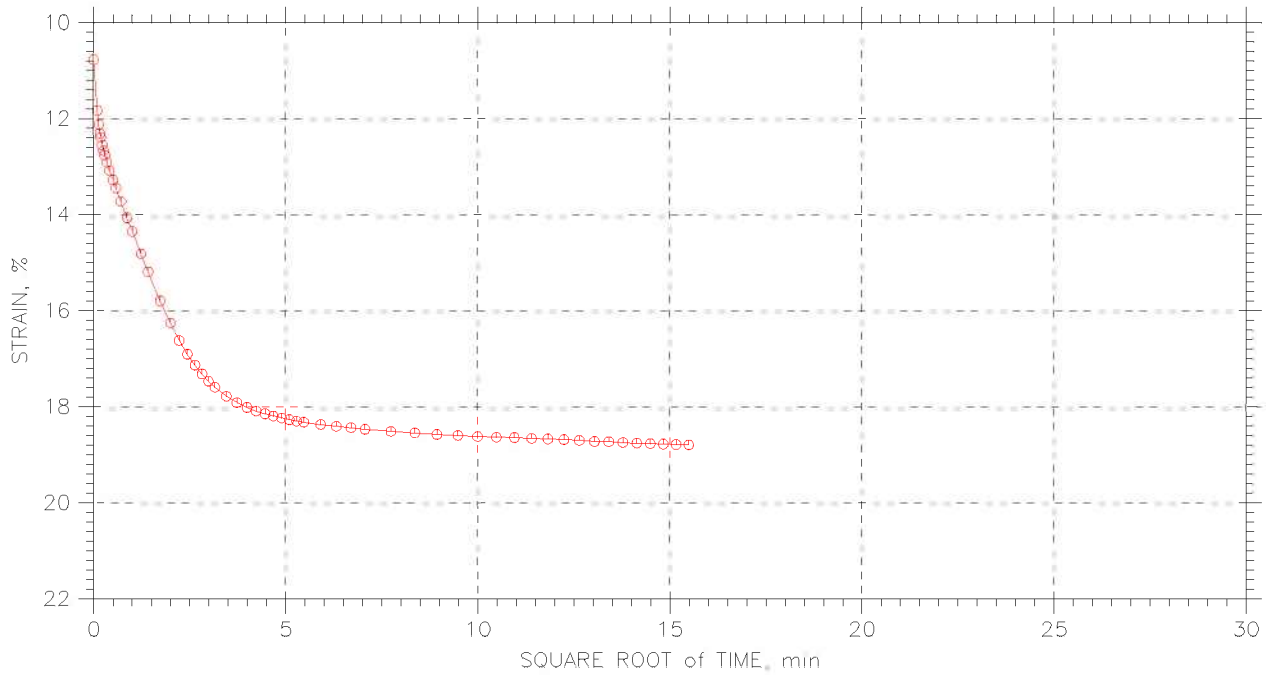
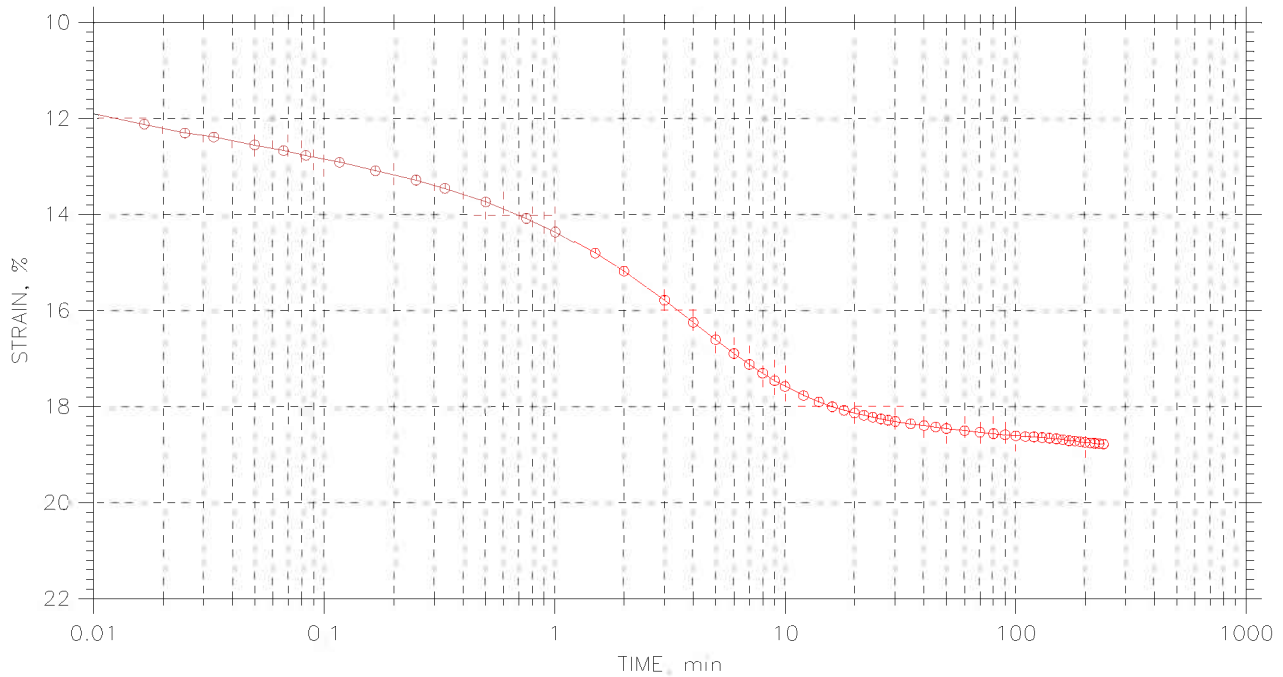

	Project: I90 Central Viaduct	Location: Cleveland, OH	Project No.: GTX-6678
	Boring No.: C-05-03	Tested By: jdt	Checked By: njh
	Sample No.: S-29	Test Date: 05/05/06	Depth: 116.5-118.5
	Test No.: C-1	Sample Type: Tube	Elevation: ---
	Description: Moist, dark gray clay		
	Remarks: ---		

CONSOLIDATION TEST DATA

TIME CURVES

Constant Load Step: 9 of 11

Stress: 8. tsf

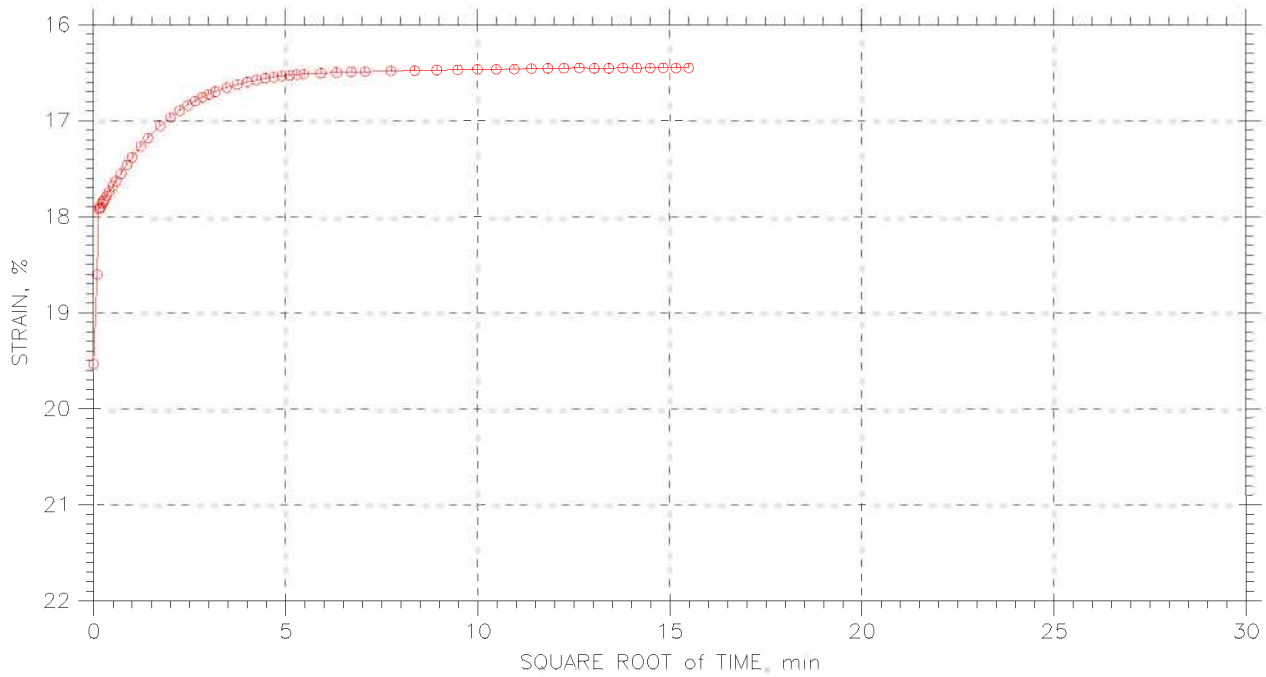
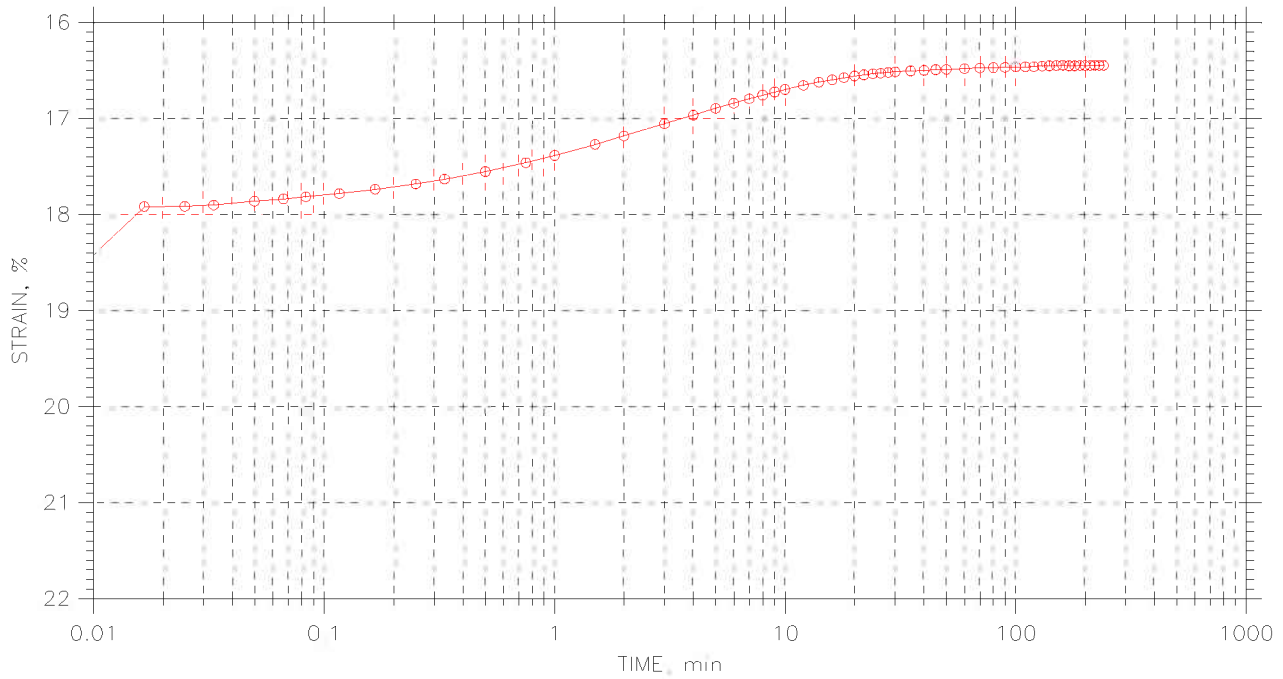

	Project: I90 Central Viaduct	Location: Cleveland, OH	Project No.: GTX-6678
	Boring No.: C-05-03	Tested By: jdt	Checked By: njh
	Sample No.: S-29	Test Date: 05/05/06	Depth: 116.5-118.5
	Test No.: C-1	Sample Type: Tube	Elevation: ---
	Description: Moist, dark gray clay		
	Remarks: ---		

CONSOLIDATION TEST DATA

TIME CURVES

Constant Load Step: 10 of 11

Stress: 2. tsf

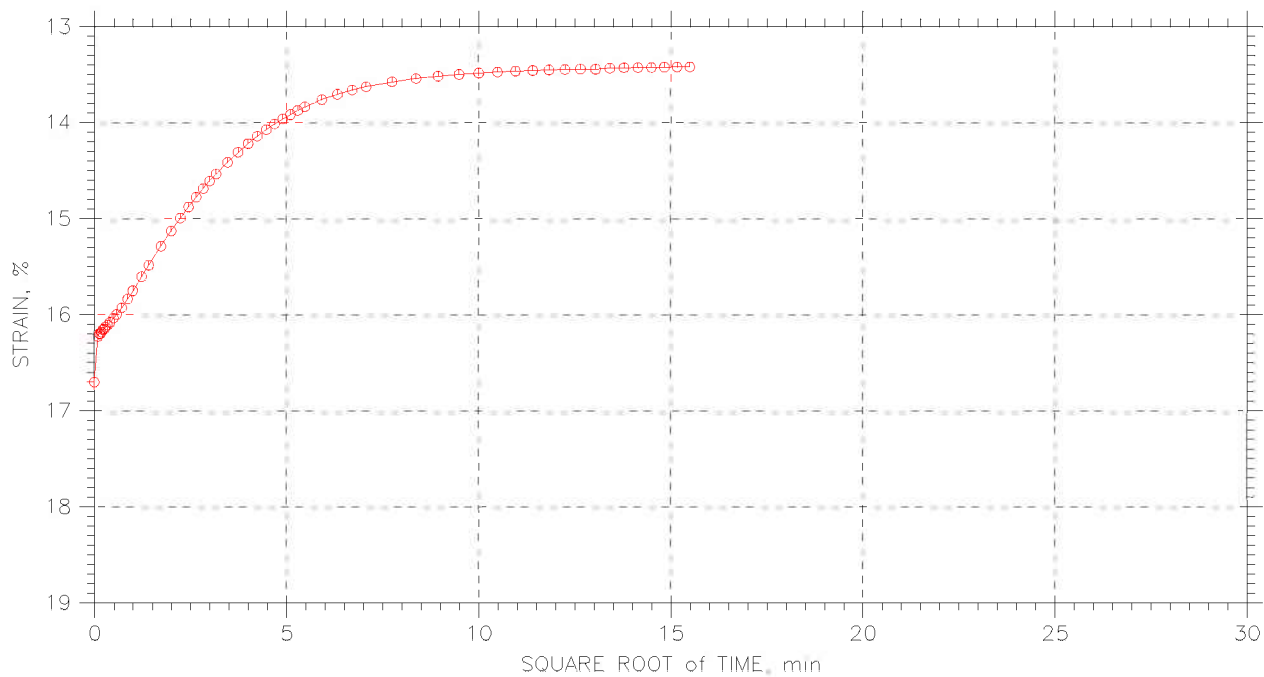
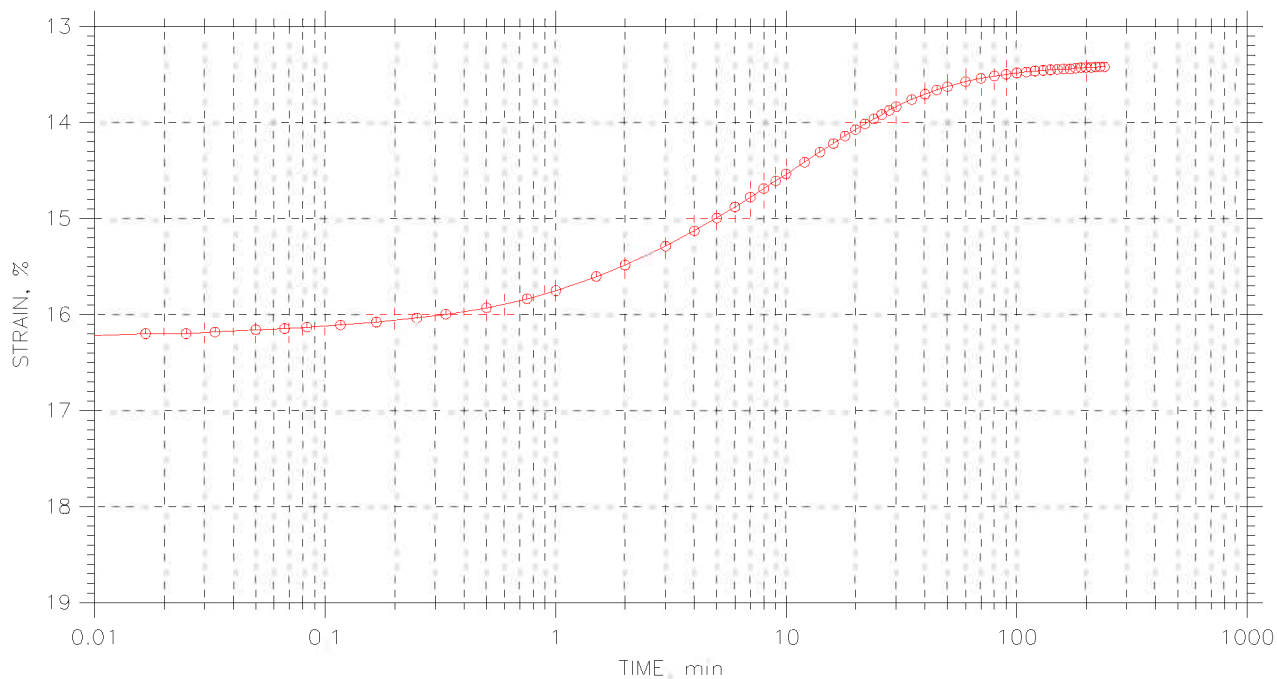

	Project: I90 Central Viaduct	Location: Cleveland, OH	Project No.: GTX-6678
	Boring No.: C-05-03	Tested By: jdt	Checked By: njh
	Sample No.: S-29	Test Date: 05/05/06	Depth: 116.5-118.5
	Test No.: C-1	Sample Type: Tube	Elevation: ---
	Description: Moist, dark gray clay		
	Remarks: ---		

CONSOLIDATION TEST DATA

TIME CURVES

Constant Load Step: 11 of 11

Stress: 0.5 tsf

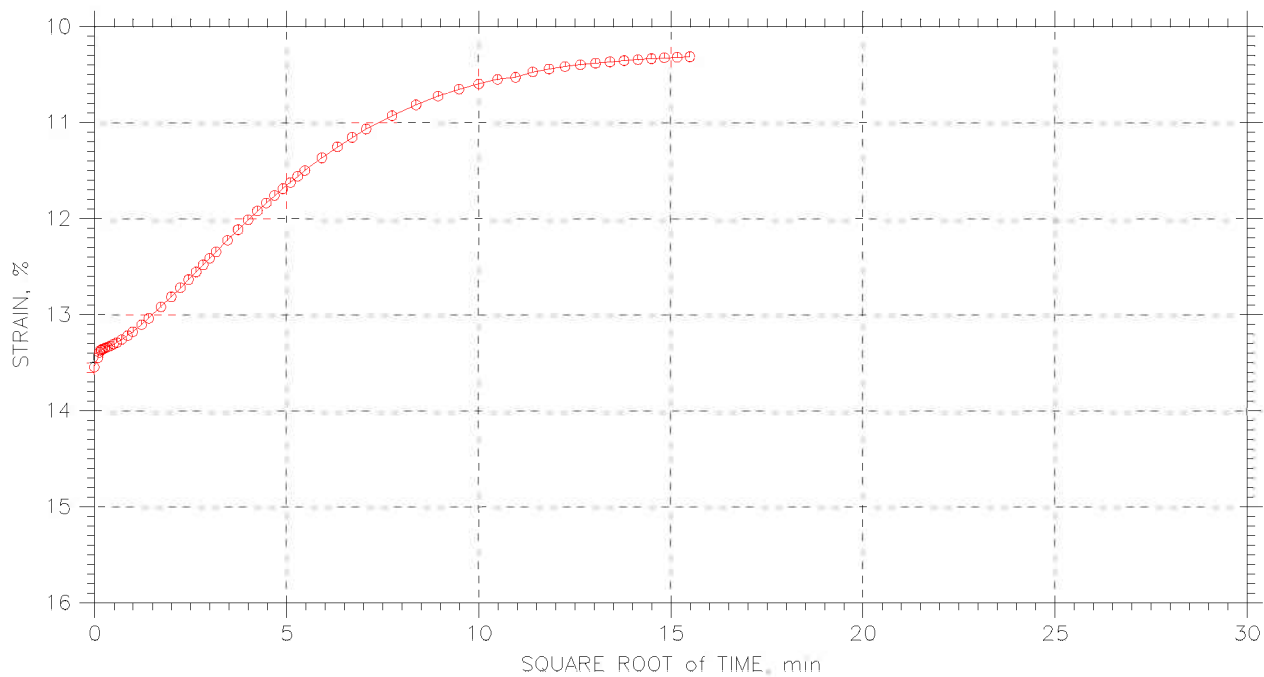
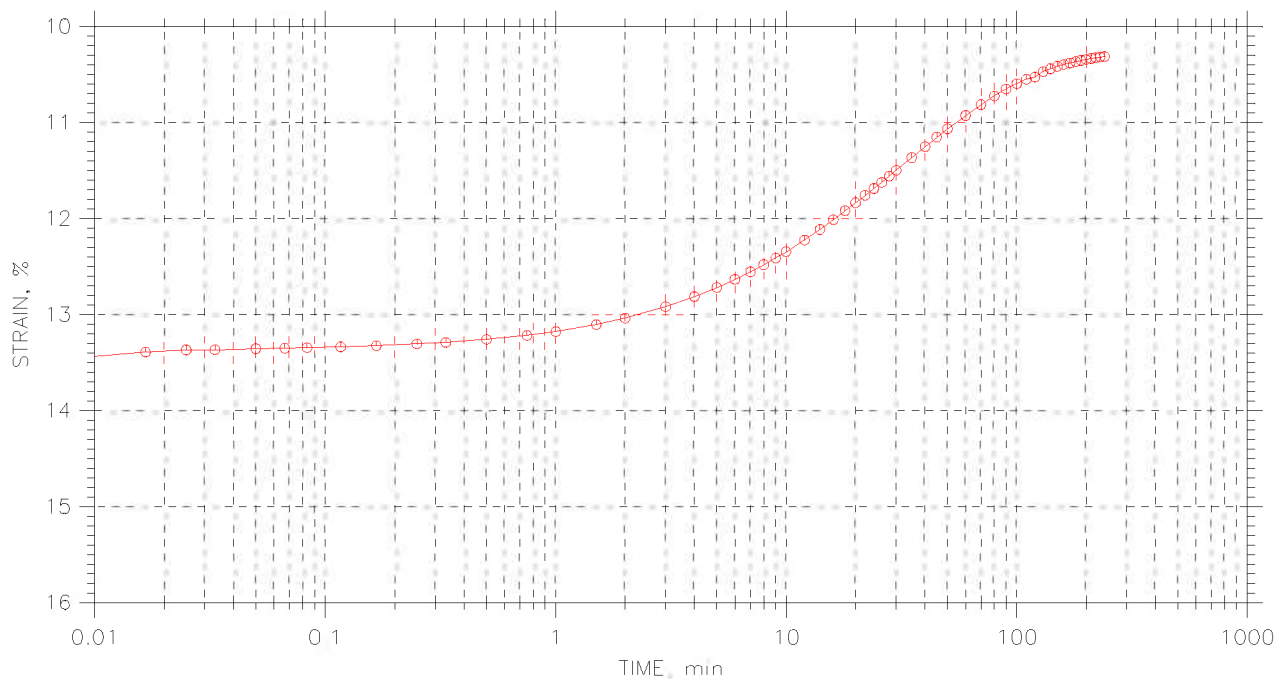

	Project: I90 Central Viaduct	Location: Cleveland, OH	Project No.: GTX-6678
	Boring No.: C-05-03	Tested By: jdt	Checked By: njh
	Sample No.: S-29	Test Date: 05/05/06	Depth: 116.5-118.5
	Test No.: C-1	Sample Type: Tube	Elevation: ---
	Description: Moist, dark gray clay		
	Remarks: ---		

CONSOLIDATION TEST DATA

Project: I90 Central Viaduct
 Boring No.: C-05-03
 Sample No.: S-29
 Test No.: C-1

Location: Cleveland, OH
 Tested By: jdt
 Test Date: 05/05/06
 Sample Type: Tube

Project No.: GTX-6678
 Checked By: njh
 Depth: 116.5-118.5
 Elevation: ---

Soil Description: Moist, dark gray clay
 Remarks: ---

Measured Specific Gravity: 2.75
 Initial Void Ratio: 0.79
 Final Void Ratio: 0.61

Liquid Limit: 35
 Plastic Limit: 18
 Plasticity Index: 17

Initial Height: 1.00 in
 Specimen Diameter: 2.50 in

Container ID	Before Consolidation		After Consolidation	
	Trimmings	Specimen+Ring	Specimen+Ring	Trimmings
dodge9		RING		30912
Wt. Container + Wet Soil, gm	93.18	370	361.78	157.13
Wt. Container + Dry Soil, gm	77.74	334.53	334.53	130.18
Wt. Container, gm	8.27	211.08	211.08	8.1
Wt. Dry Soil, gm	69.47	123.45	123.45	122.08
Water Content, %	22.23	28.73	22.08	22.08
Void Ratio	---	0.79	0.61	---
Degree of Saturation, %	---	99.78	99.99	---
Dry Unit Weight, pcf	---	95.806	106.82	---

CONSOLIDATION TEST DATA

SUMMARY REPORT

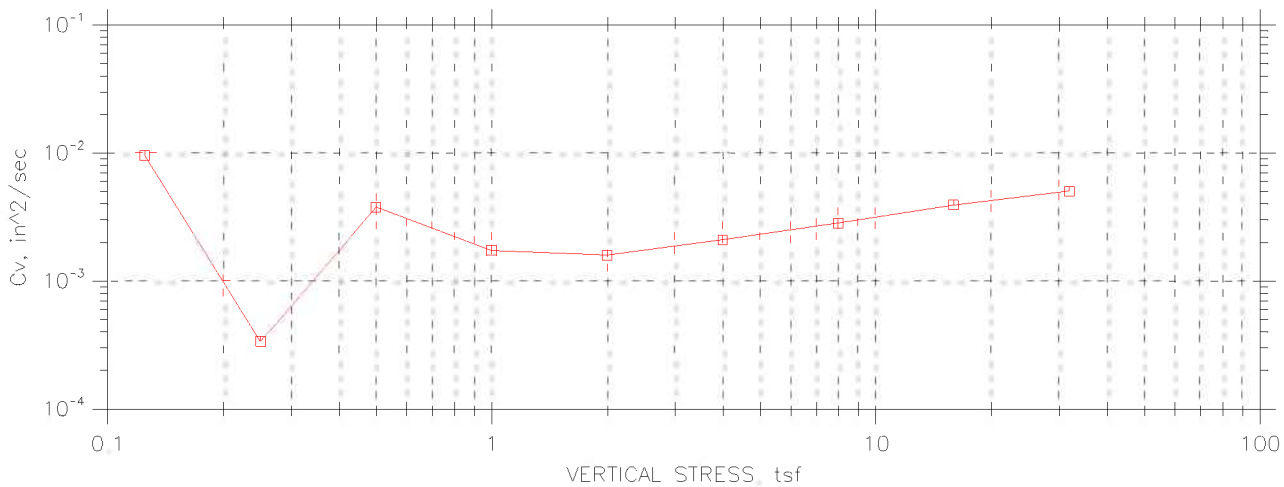
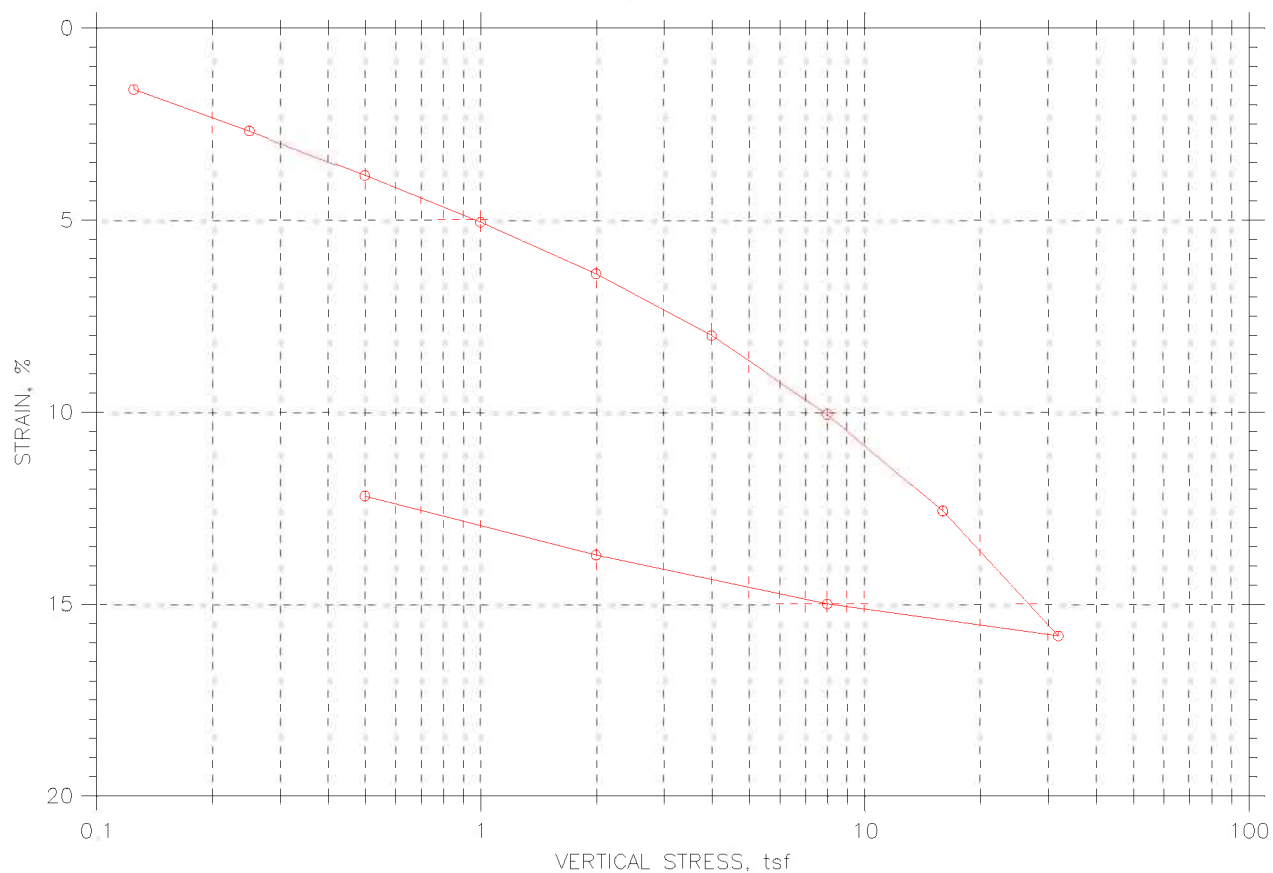

	Project: I90 Central Viaduct	Location: Cleveland, OH	Project No.: GTX-6678
	Boring No.: C-05-03	Tested By: fy	Checked By: jdt
	Sample No.: S-30	Test Date: 05/05/06	Depth: 118.5-120.5
	Test No.: C-2	Sample Type: Tube	Elevation: ---
	Description: Moist, dark gray clay		
	Remarks: ---		

CONSOLIDATION TEST DATA

SUMMARY REPORT

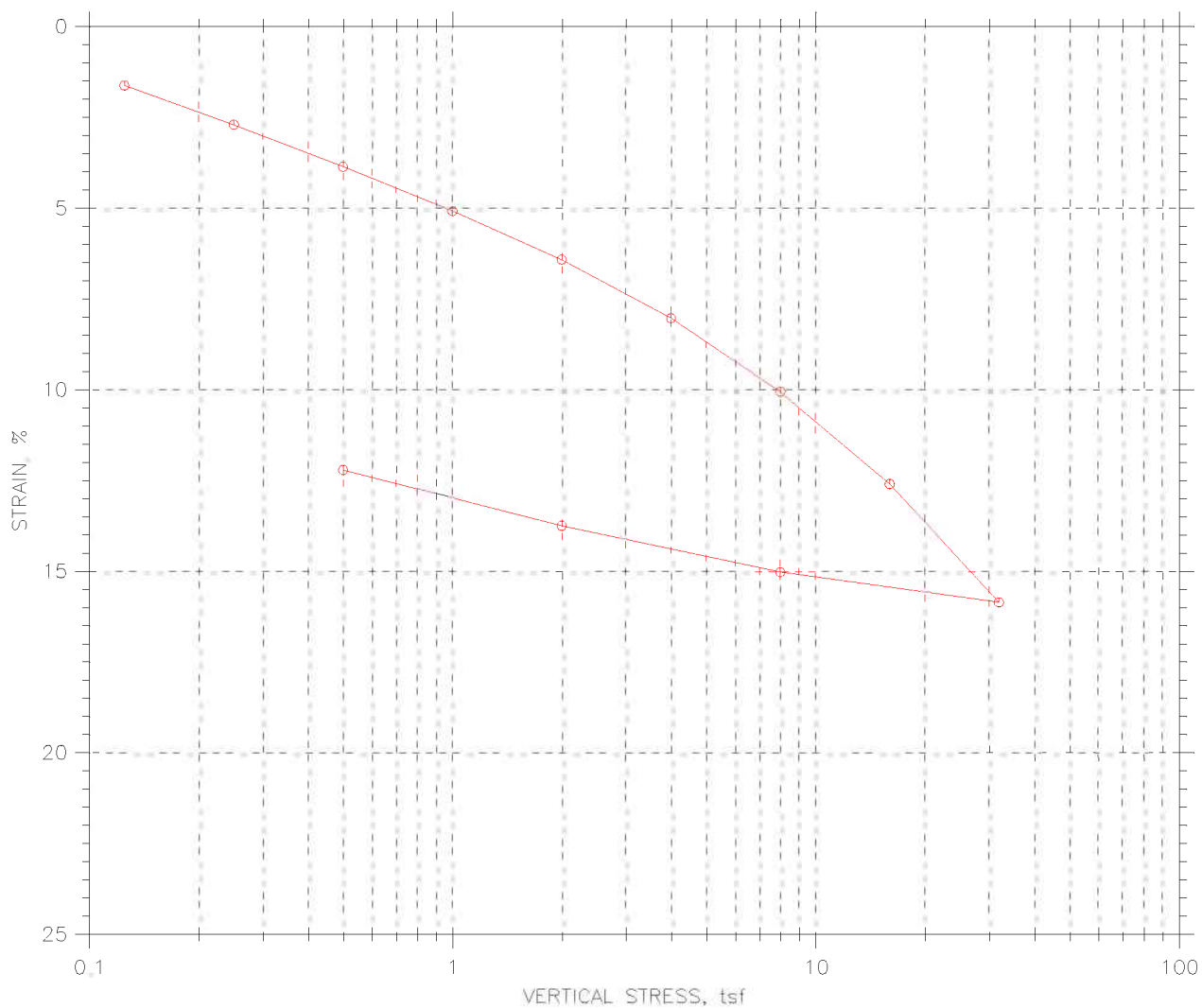

				Before Test	After Test
Overburden Pressure: 0 tsf		Water Content, %		31.49	22.77
Preconsolidation Pressure: 0 tsf		Dry Unit Weight, pcf		91.64	104.4
Compression Index: 2.75859e-313		Saturation, %		100.00	98.23
Diameter: 2.5 in		Height: 1 in		0.86	0.63
LL: 33	PL: 18	PI: 15	GS: 2.73		

	Project: I90 Central Viaduct	Location: Cleveland, OH	Project No.: GTX-6678
	Boring No.: C-05-03	Tested By: fy	Checked By: jdt
	Sample No.: S-30	Test Date: 05/05/06	Depth: 118.5-120.5
	Test No.: C-2	Sample Type: Tube	Elevation: ---
	Description: Moist, dark gray clay		
	Remarks: ---		

CONSOLIDATION TEST DATA

TIME CURVES

Constant Load Step: 1 of 12

Stress: 0.125 tsf

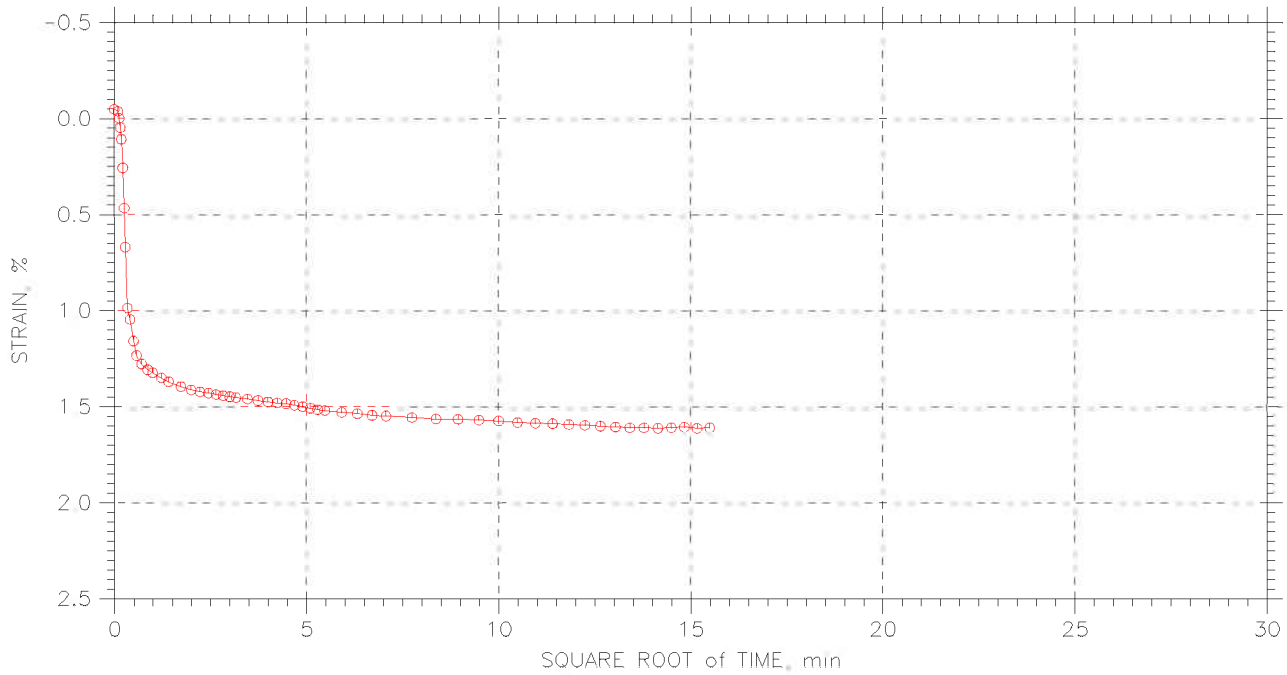
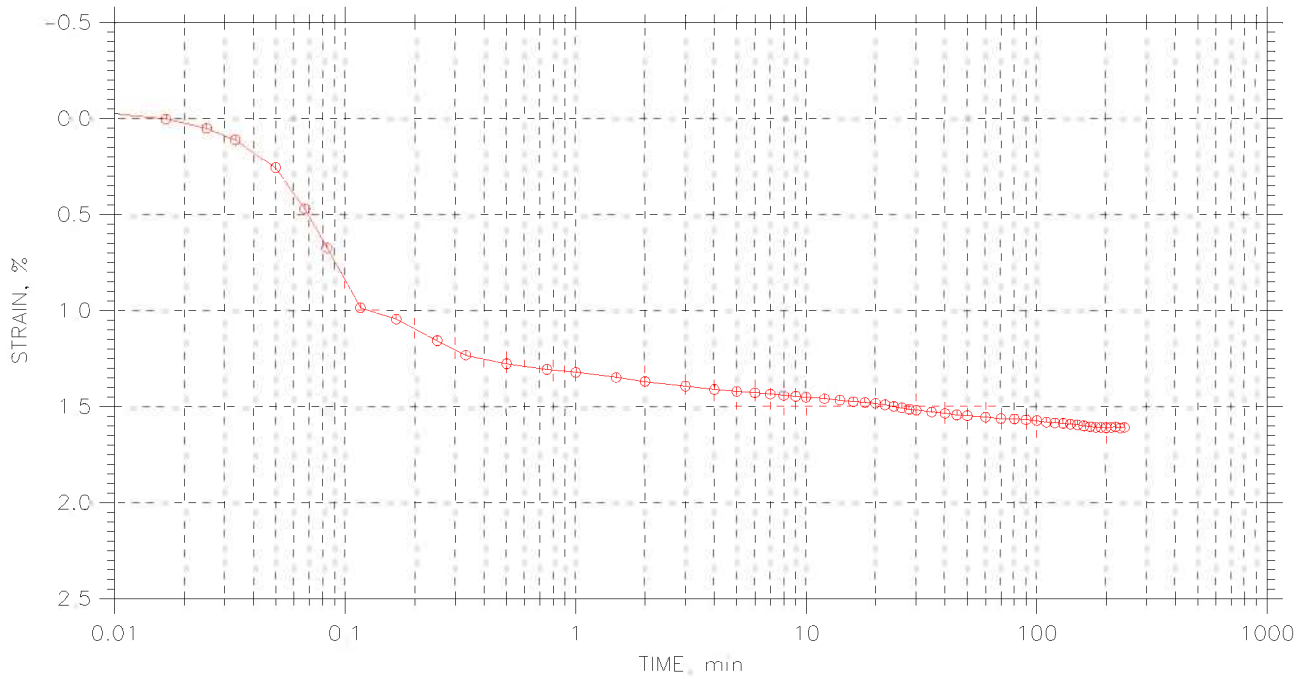

	Project: I90 Central Viaduct	Location: Cleveland, OH	Project No.: GTX-6678
	Boring No.: C-05-03	Tested By: fy	Checked By: jdt
	Sample No.: S-30	Test Date: 05/05/06	Depth: 118.5-120.5
	Test No.: C-2	Sample Type: Tube	Elevation: ---
	Description: Moist, dark gray clay		
	Remarks: ---		

CONSOLIDATION TEST DATA

TIME CURVES

Constant Load Step: 2 of 12

Stress: 0.25 tsf

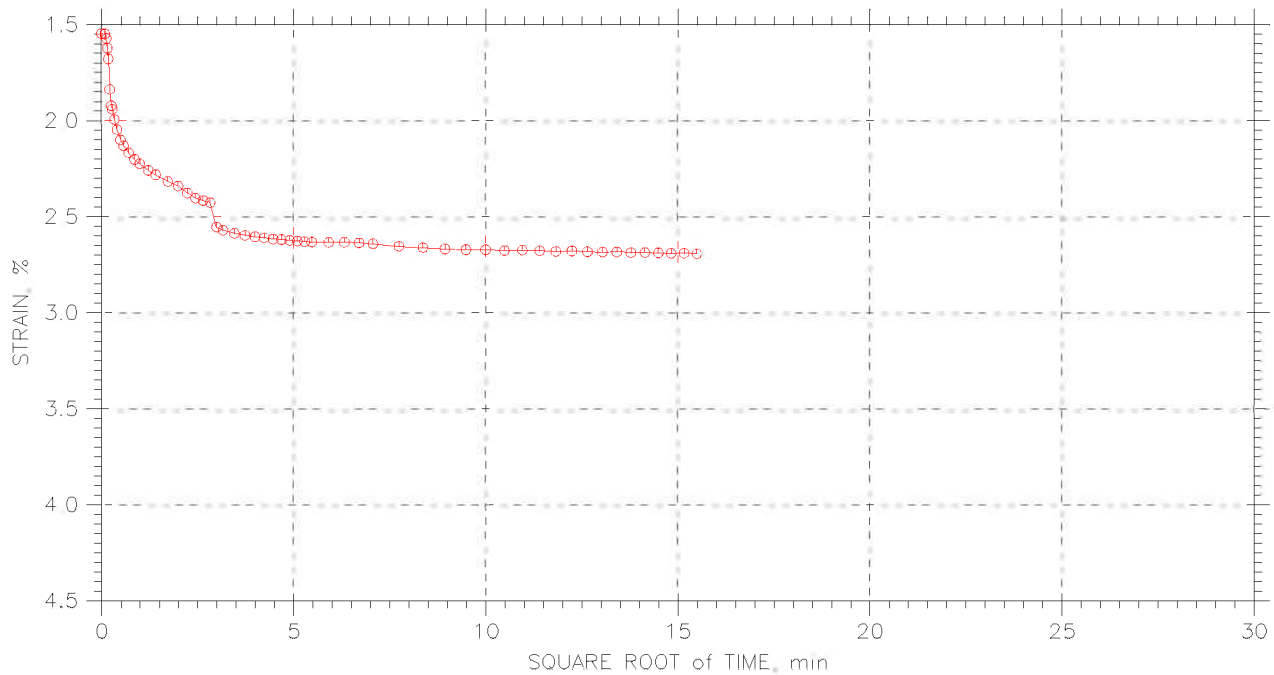
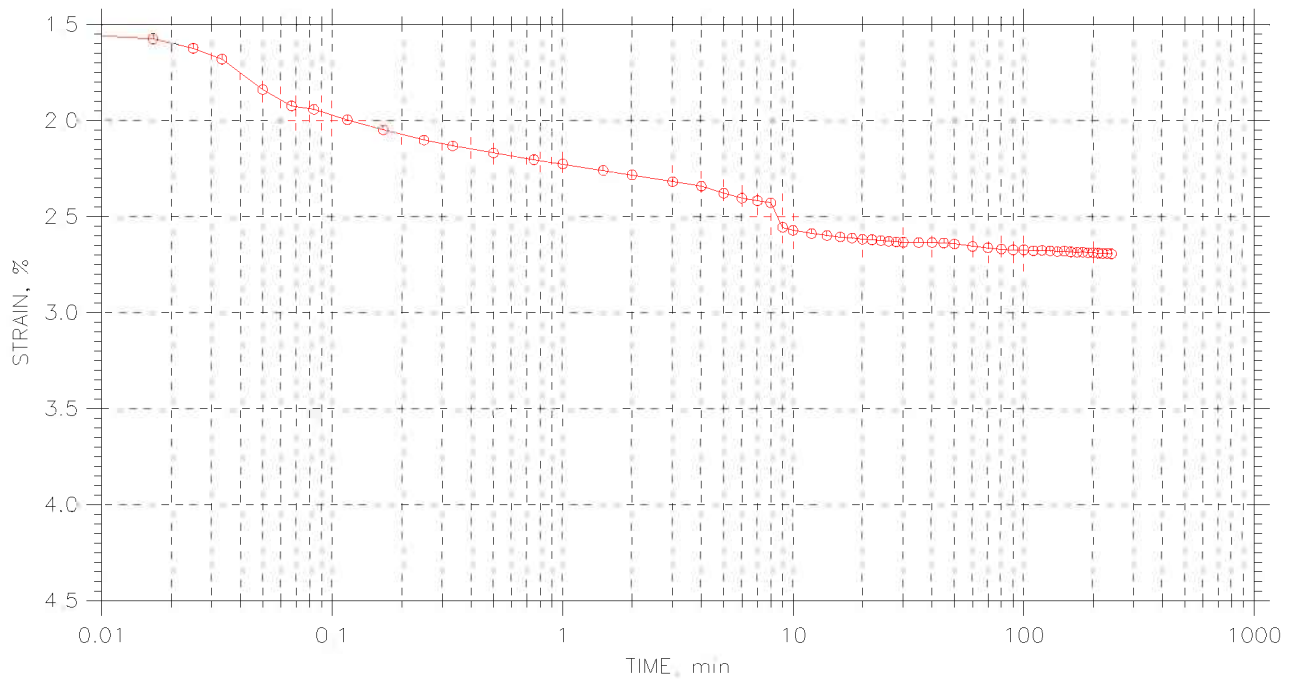

	Project: I90 Central Viaduct	Location: Cleveland, OH	Project No.: GTX-6678
	Boring No.: C-05-03	Tested By: fy	Checked By: jdt
	Sample No.: S-30	Test Date: 05/05/06	Depth: 118.5-120.5
	Test No.: C-2	Sample Type: Tube	Elevation: ---
	Description: Moist, dark gray clay		
	Remarks: ---		

CONSOLIDATION TEST DATA

TIME CURVES

Constant Load Step: 3 of 12

Stress: 0.5 tsf

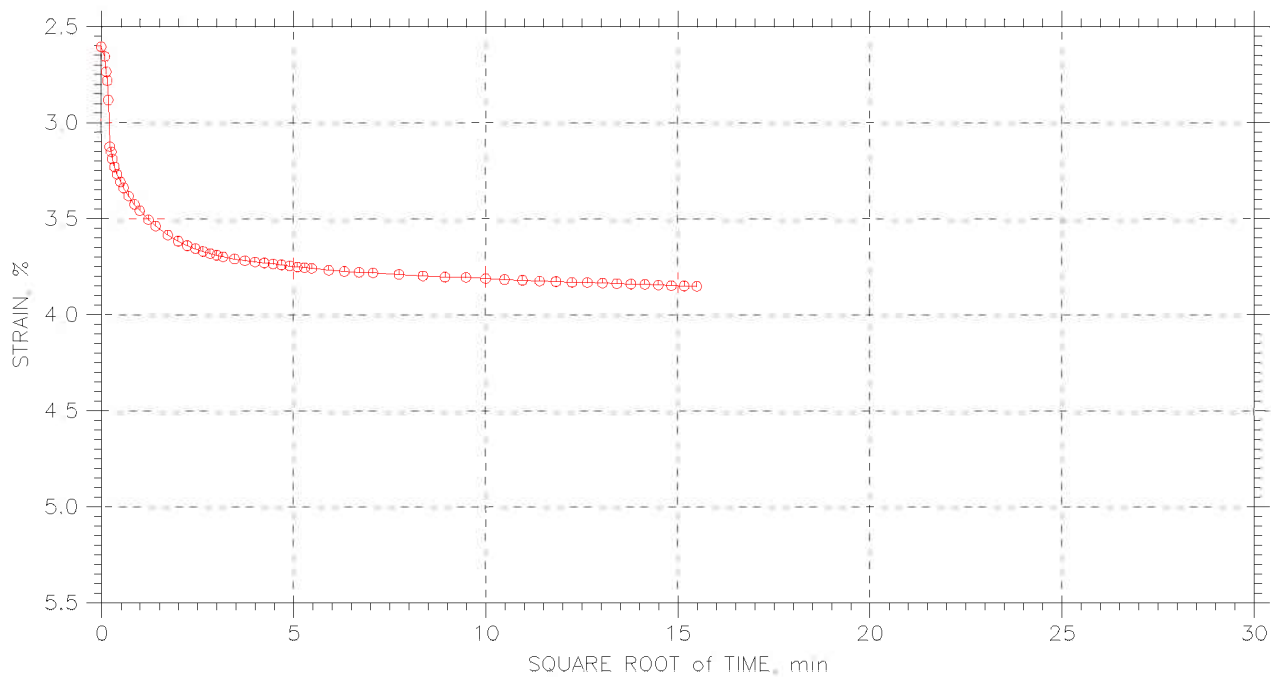
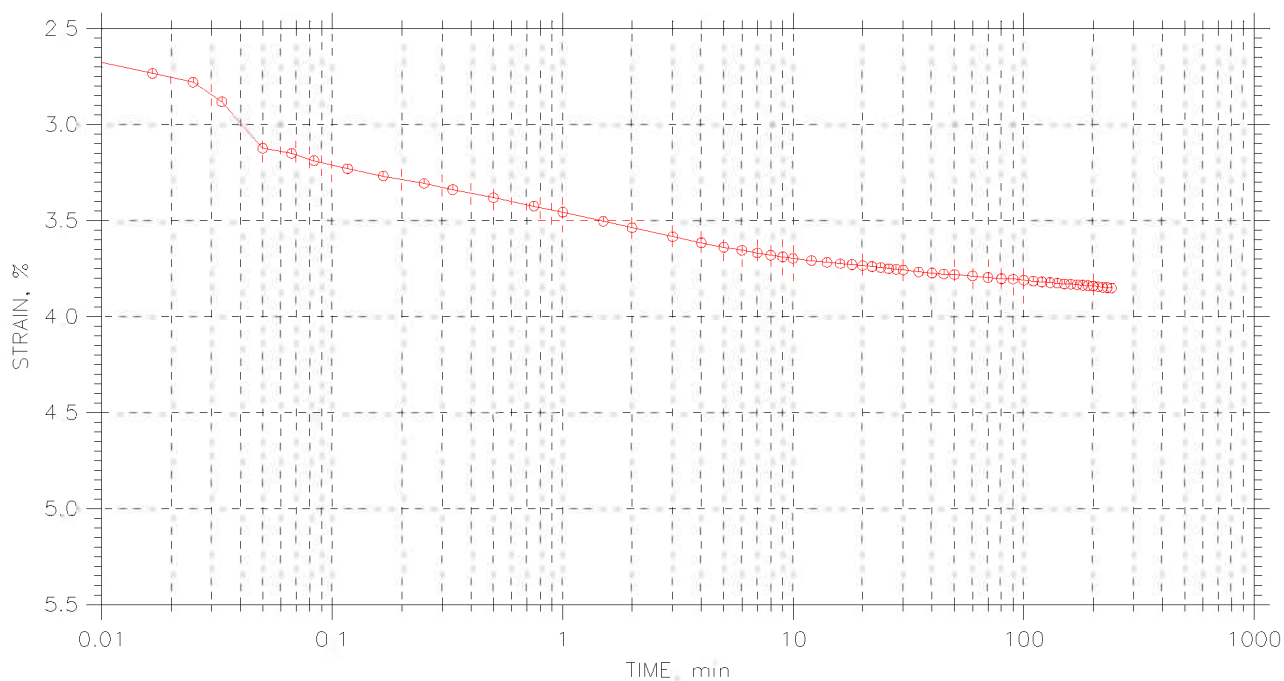

	Project: I90 Central Viaduct	Location: Cleveland, OH	Project No.: GTX-6678
	Boring No.: C-05-03	Tested By: fy	Checked By: jdt
	Sample No.: S-30	Test Date: 05/05/06	Depth: 118.5-120.5
	Test No.: C-2	Sample Type: Tube	Elevation: ---
	Description: Moist, dark gray clay		
	Remarks: ---		

CONSOLIDATION TEST DATA

TIME CURVES

Constant Load Step: 4 of 12

Stress: 1. tsf

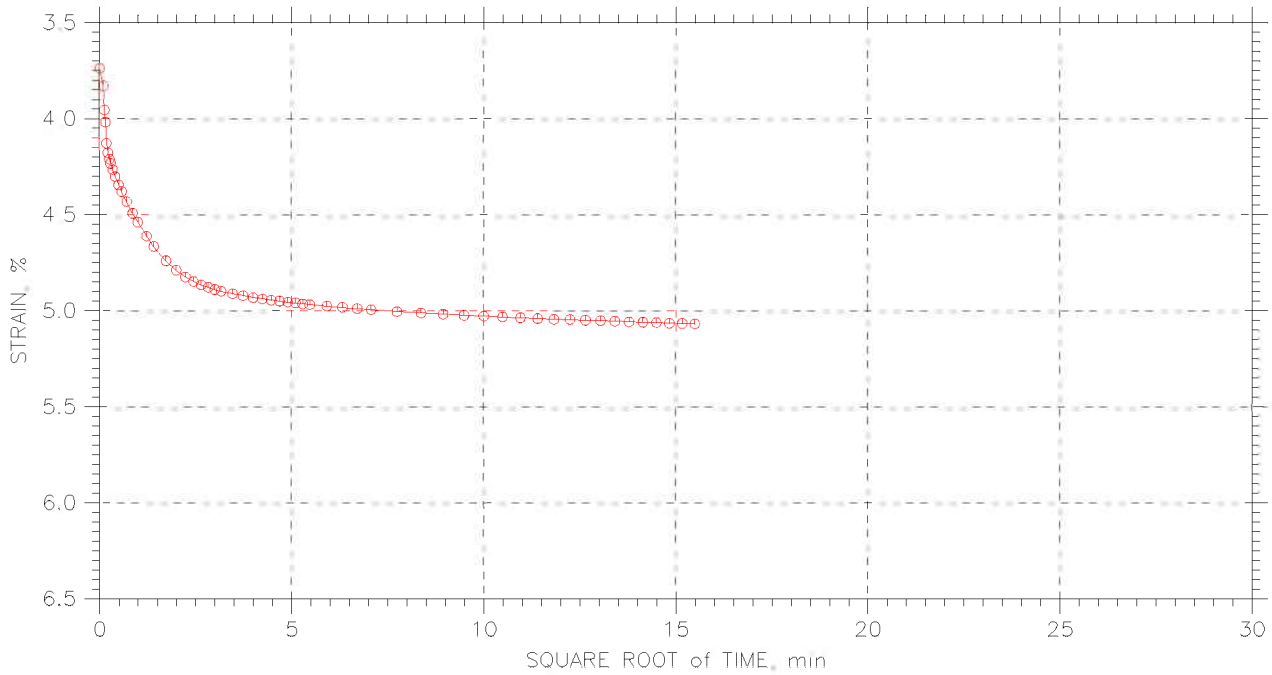
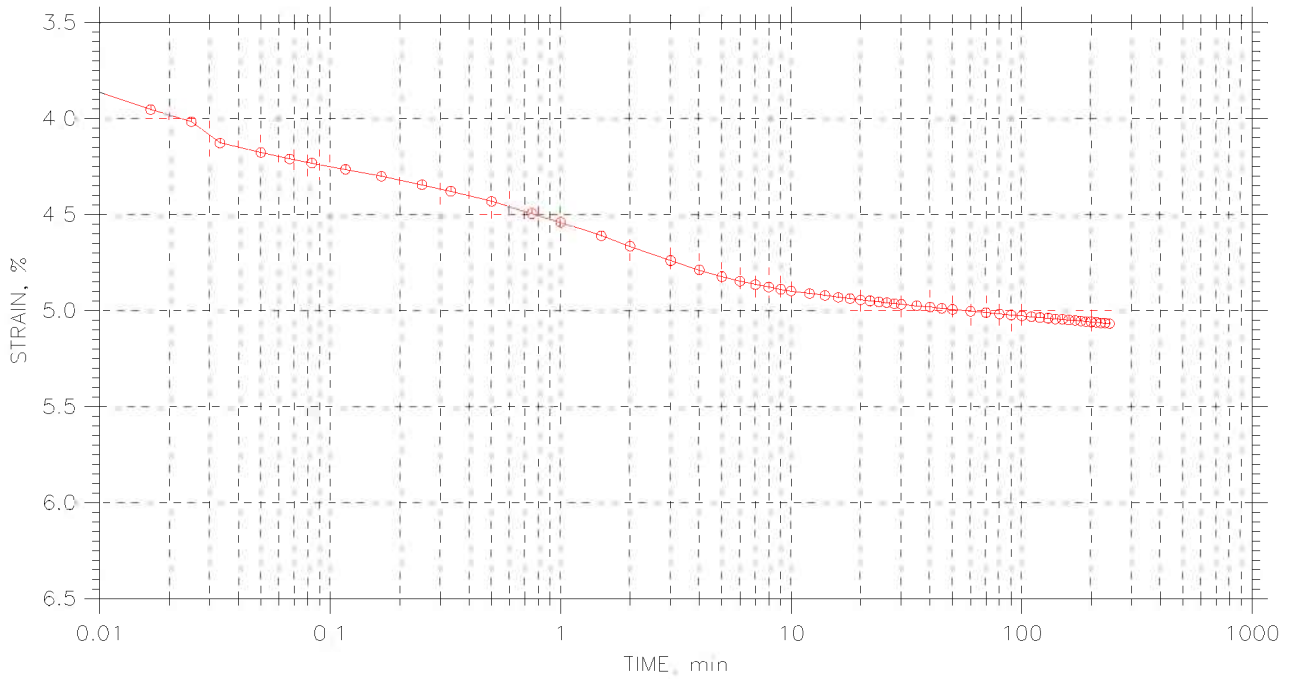

	Project: I90 Central Viaduct	Location: Cleveland, OH	Project No.: GTX-6678
	Boring No.: C-05-03	Tested By: fy	Checked By: jdt
	Sample No.: S-30	Test Date: 05/05/06	Depth: 118.5-120.5
	Test No.: C-2	Sample Type: Tube	Elevation: ---
	Description: Moist, dark gray clay		
	Remarks: ---		

CONSOLIDATION TEST DATA

TIME CURVES

Constant Load Step: 5 of 12

Stress: 2. tsf

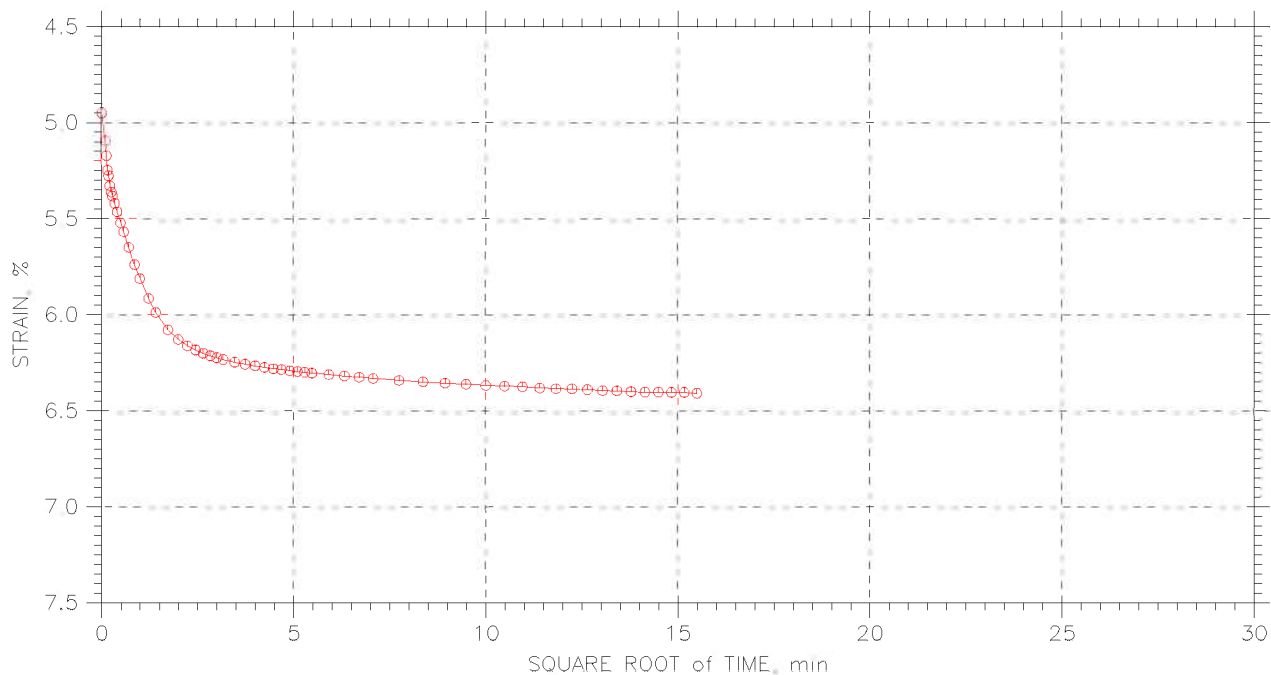
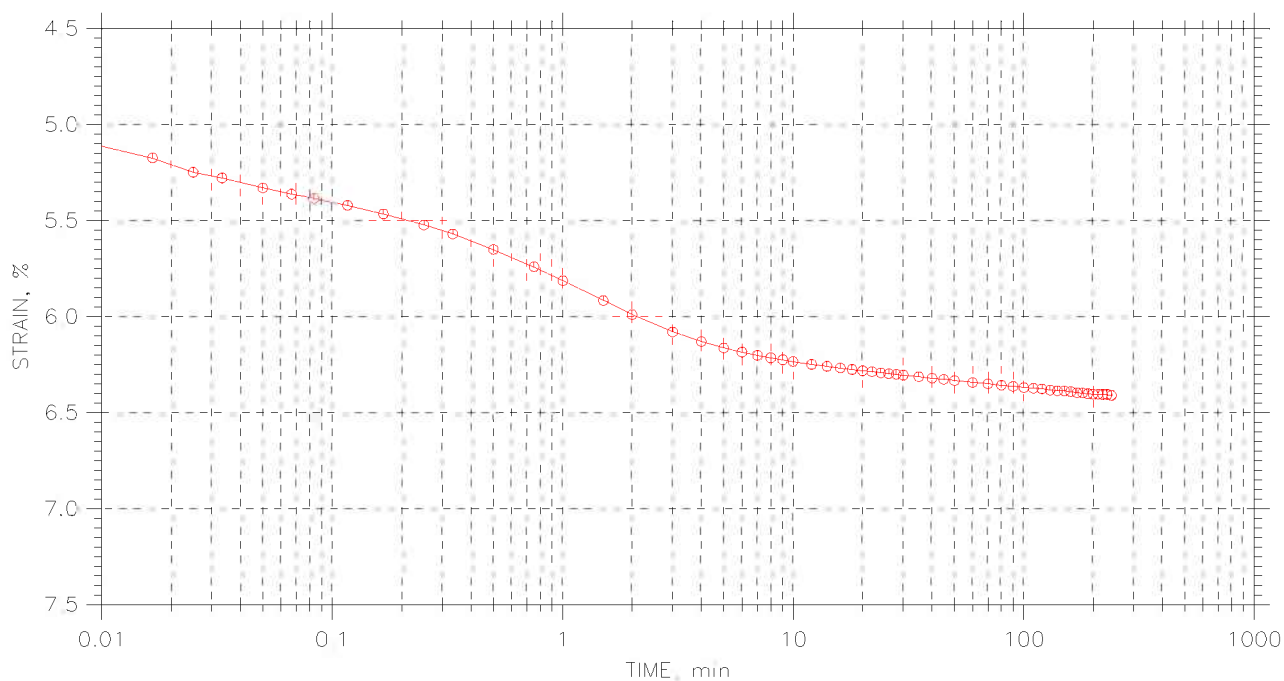

	Project: I90 Central Viaduct	Location: Cleveland, OH	Project No.: GTX-6678
	Boring No.: C-05-03	Tested By: fy	Checked By: jdt
	Sample No.: S-30	Test Date: 05/05/06	Depth: 118.5-120.5
	Test No.: C-2	Sample Type: Tube	Elevation: ---
	Description: Moist, dark gray clay		
	Remarks: ---		

CONSOLIDATION TEST DATA

TIME CURVES

Constant Load Step: 6 of 12

Stress: 4. tsf

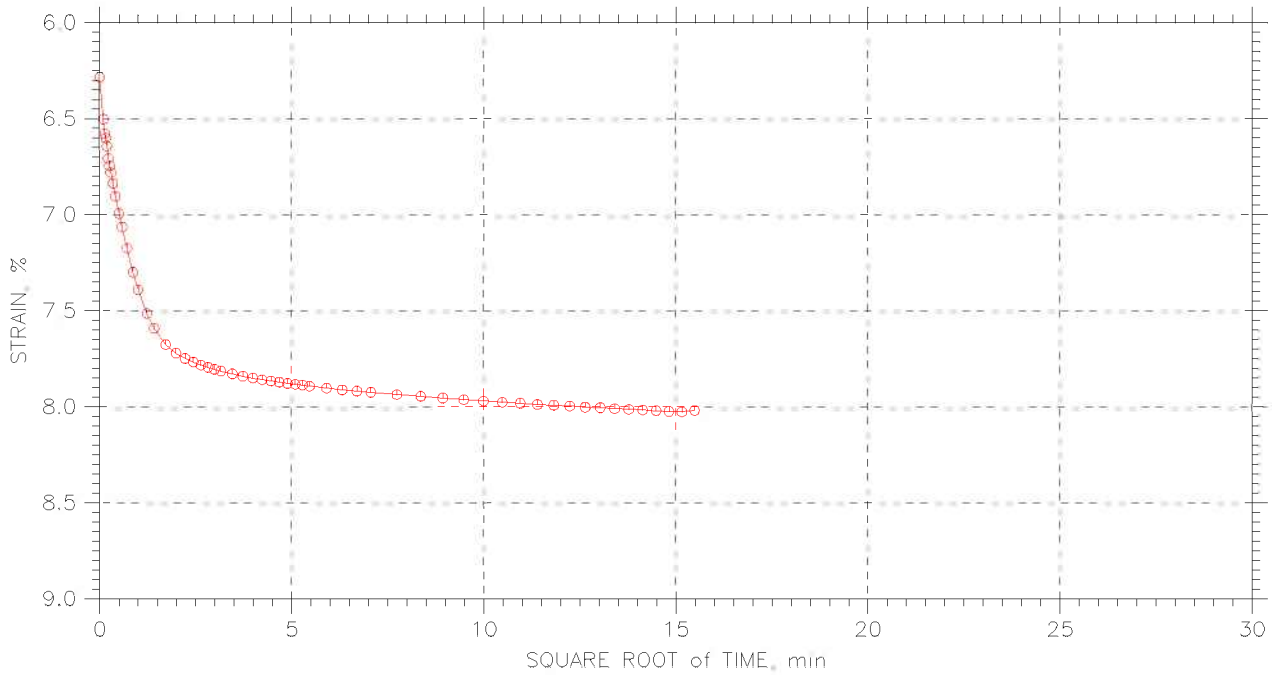
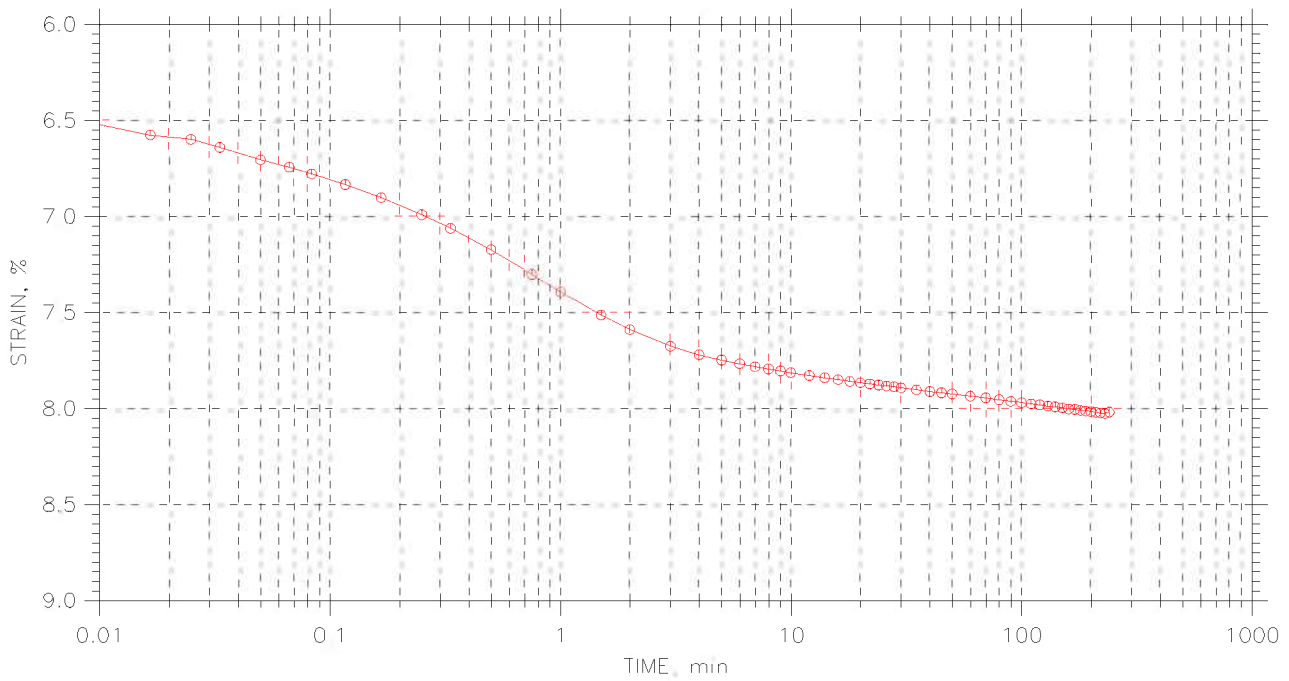

	Project: I90 Central Viaduct	Location: Cleveland, OH	Project No.: GTX-6678
	Boring No.: C-05-03	Tested By: fy	Checked By: jdt
	Sample No.: S-30	Test Date: 05/05/06	Depth: 118.5-120.5
	Test No.: C-2	Sample Type: Tube	Elevation: ---
	Description: Moist, dark gray clay		
	Remarks: ---		

CONSOLIDATION TEST DATA

TIME CURVES

Constant Load Step: 7 of 12

Stress: 8. tsf

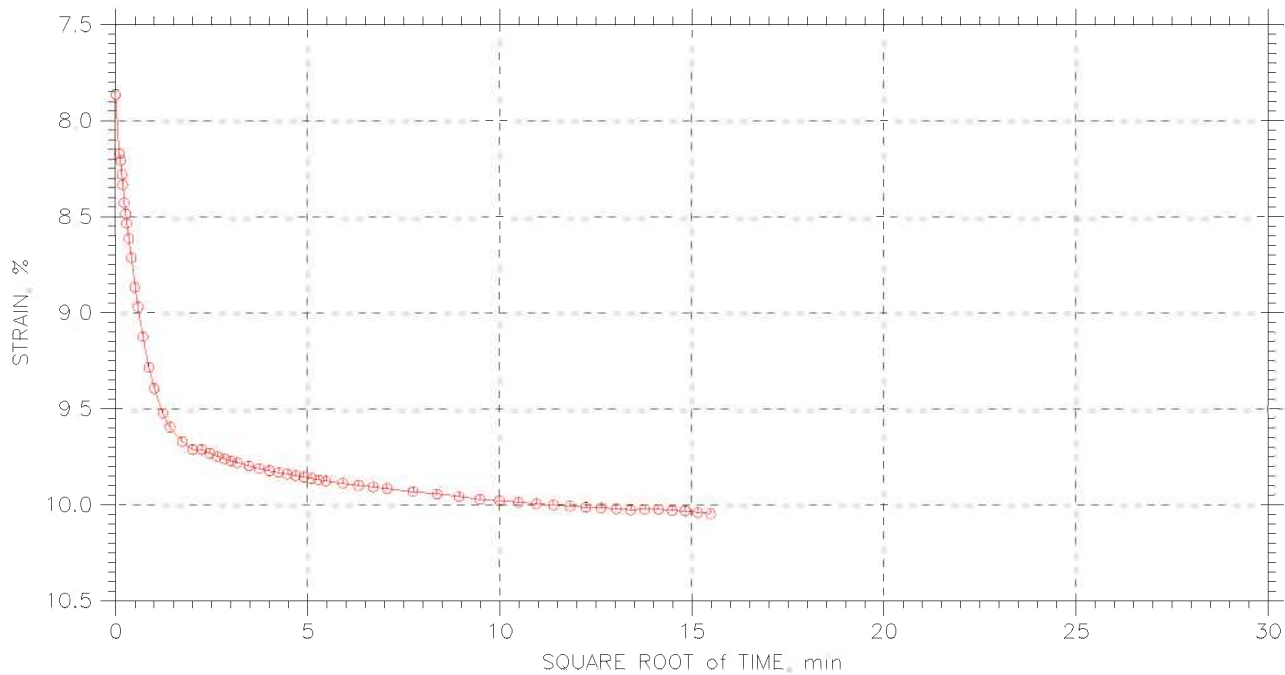
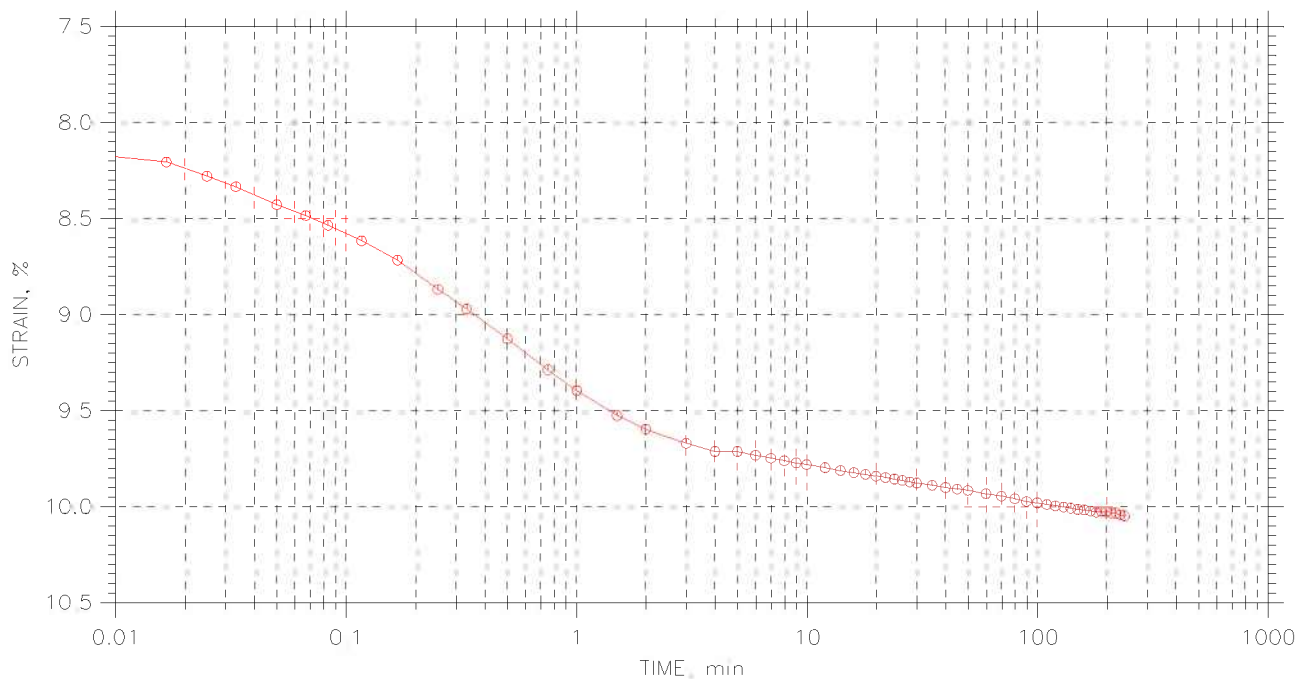

	Project: I90 Central Viaduct	Location: Cleveland, OH	Project No.: GTX-6678
	Boring No.: C-05-03	Tested By: fy	Checked By: jdt
	Sample No.: S-30	Test Date: 05/05/06	Depth: 118.5-120.5
	Test No.: C-2	Sample Type: Tube	Elevation: ---
	Description: Moist, dark gray clay		
	Remarks: ---		

CONSOLIDATION TEST DATA

TIME CURVES

Constant Load Step: 8 of 12

Stress: 16. tsf

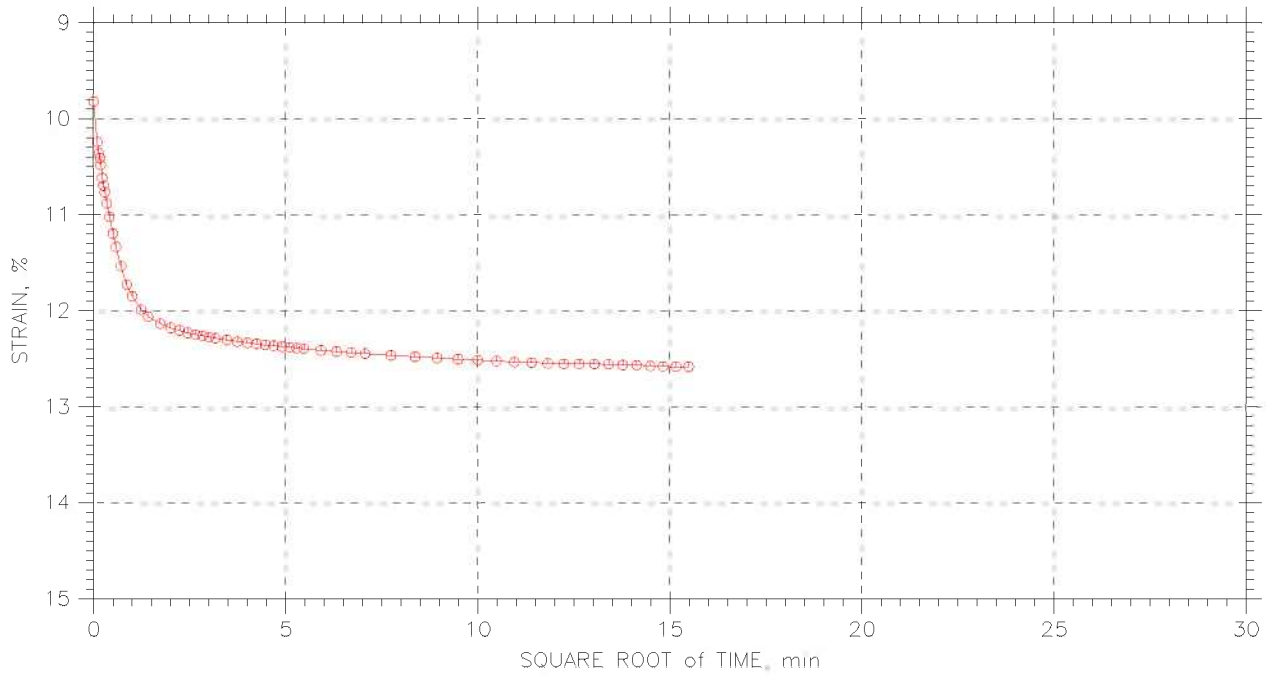
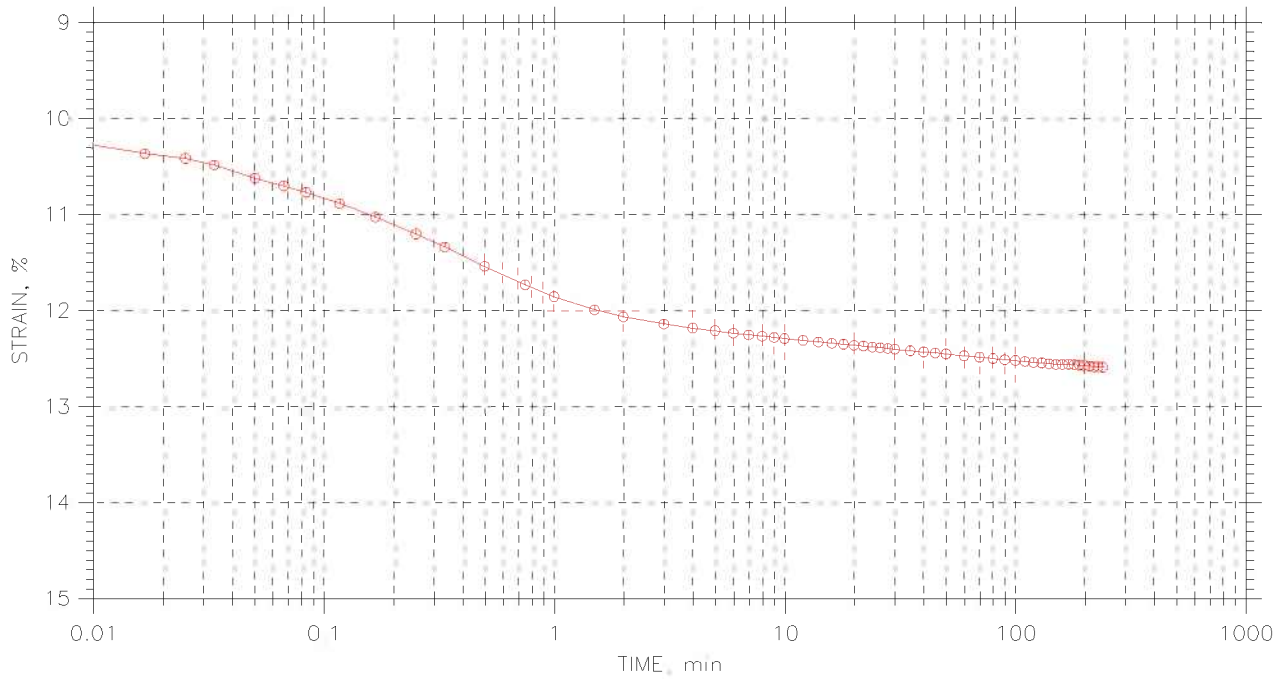

	Project: I90 Central Viaduct	Location: Cleveland, OH	Project No.: GTX-6678
	Boring No.: C-05-03	Tested By: fy	Checked By: jdt
	Sample No.: S-30	Test Date: 05/05/06	Depth: 118.5-120.5
	Test No.: C-2	Sample Type: Tube	Elevation: ---
	Description: Moist, dark gray clay		
	Remarks: ---		

CONSOLIDATION TEST DATA

TIME CURVES

Constant Load Step: 9 of 12

Stress: 32 tsf

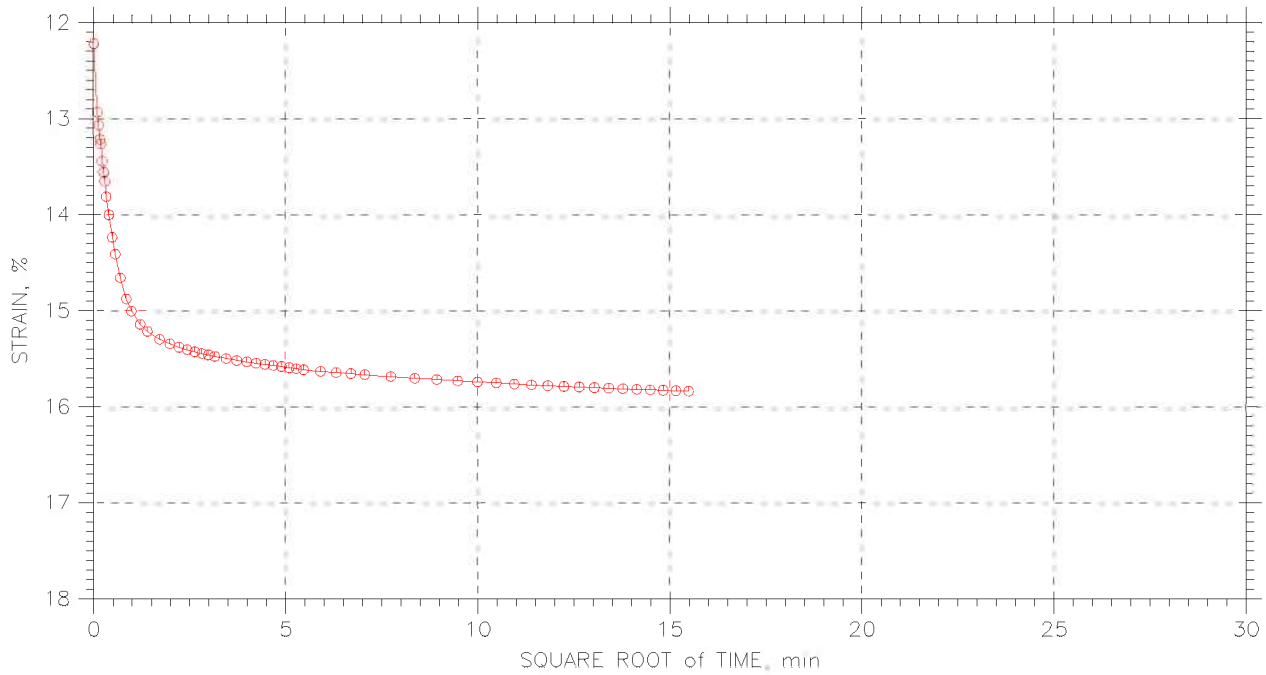
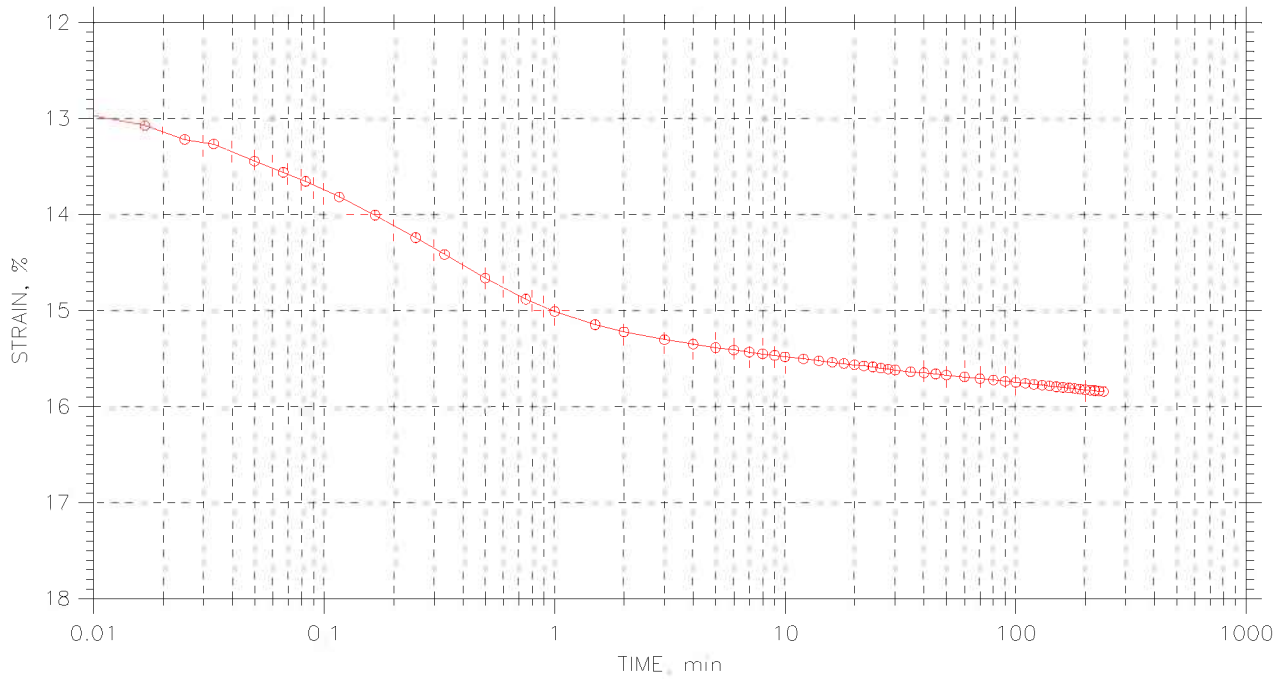

	Project: I90 Central Viaduct	Location: Cleveland, OH	Project No.: GTX-6678
	Boring No.: C-05-03	Tested By: fy	Checked By: jdt
	Sample No.: S-30	Test Date: 05/05/06	Depth: 118.5-120.5
	Test No.: C-2	Sample Type: Tube	Elevation: ---
	Description: Moist, dark gray clay		
	Remarks: ---		

CONSOLIDATION TEST DATA

TIME CURVES

Constant Load Step: 10 of 12

Stress: 8. tsf

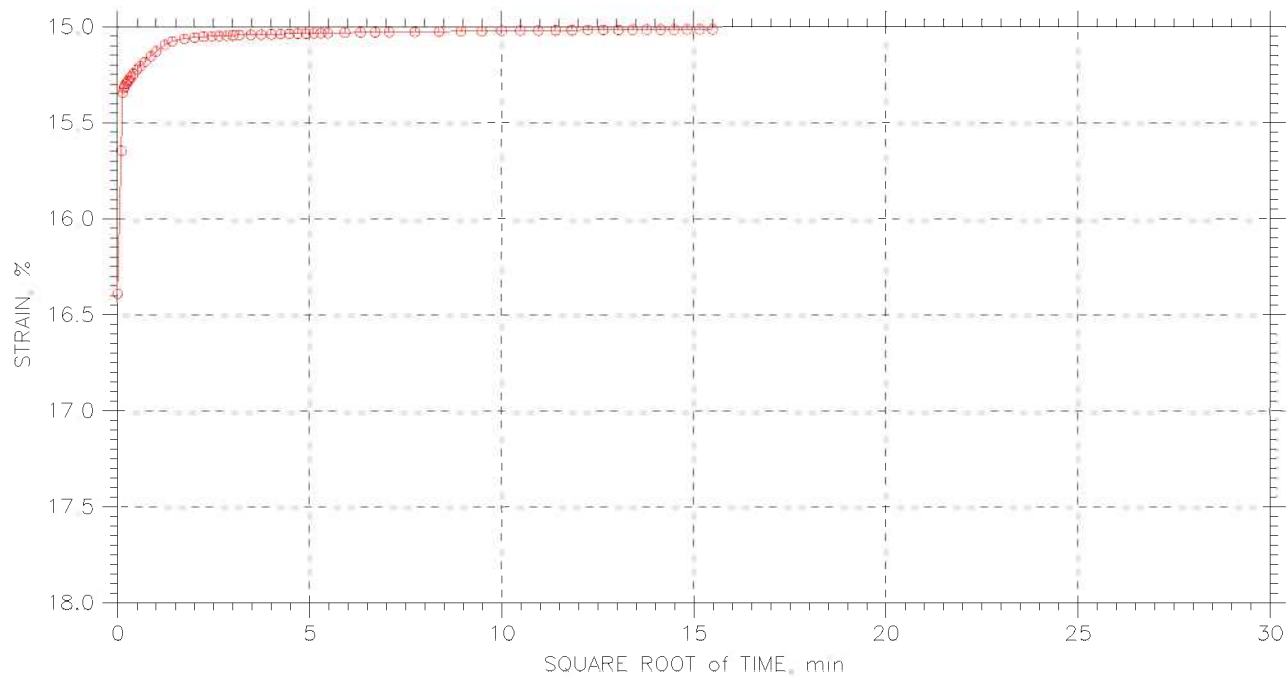
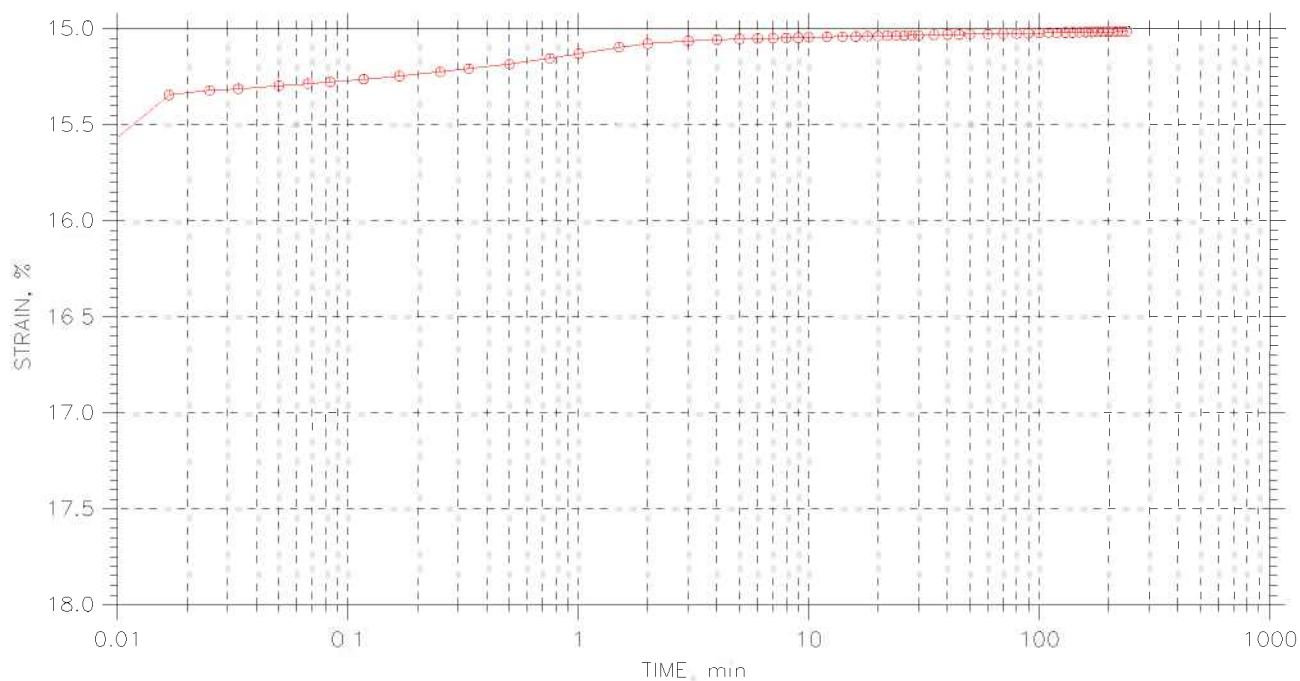

	Project: I90 Central Viaduct	Location: Cleveland, OH	Project No.: GTX-6678
	Boring No.: C-05-03	Tested By: fy	Checked By: jdt
	Sample No.: S-30	Test Date: 05/05/06	Depth: 118.5-120.5
	Test No.: C-2	Sample Type: Tube	Elevation: ---
	Description: Moist, dark gray clay		
	Remarks: ---		

CONSOLIDATION TEST DATA

TIME CURVES

Constant Load Step: 11 of 12

Stress: 2. tsf

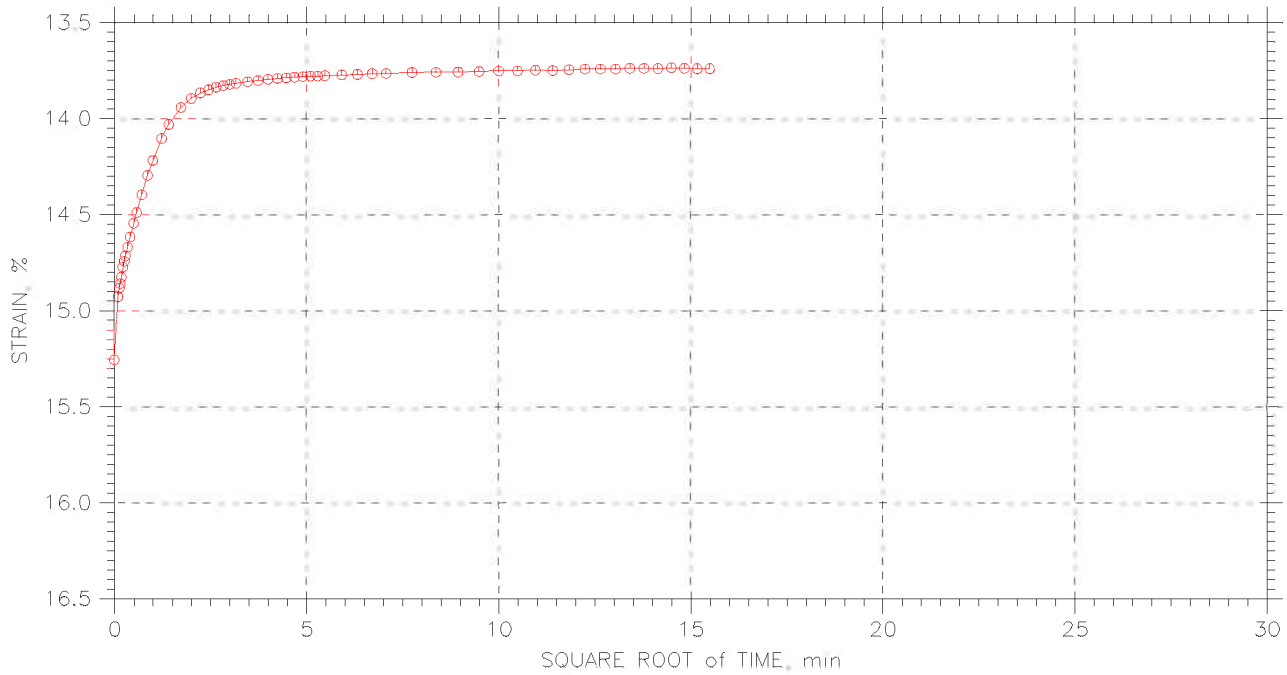
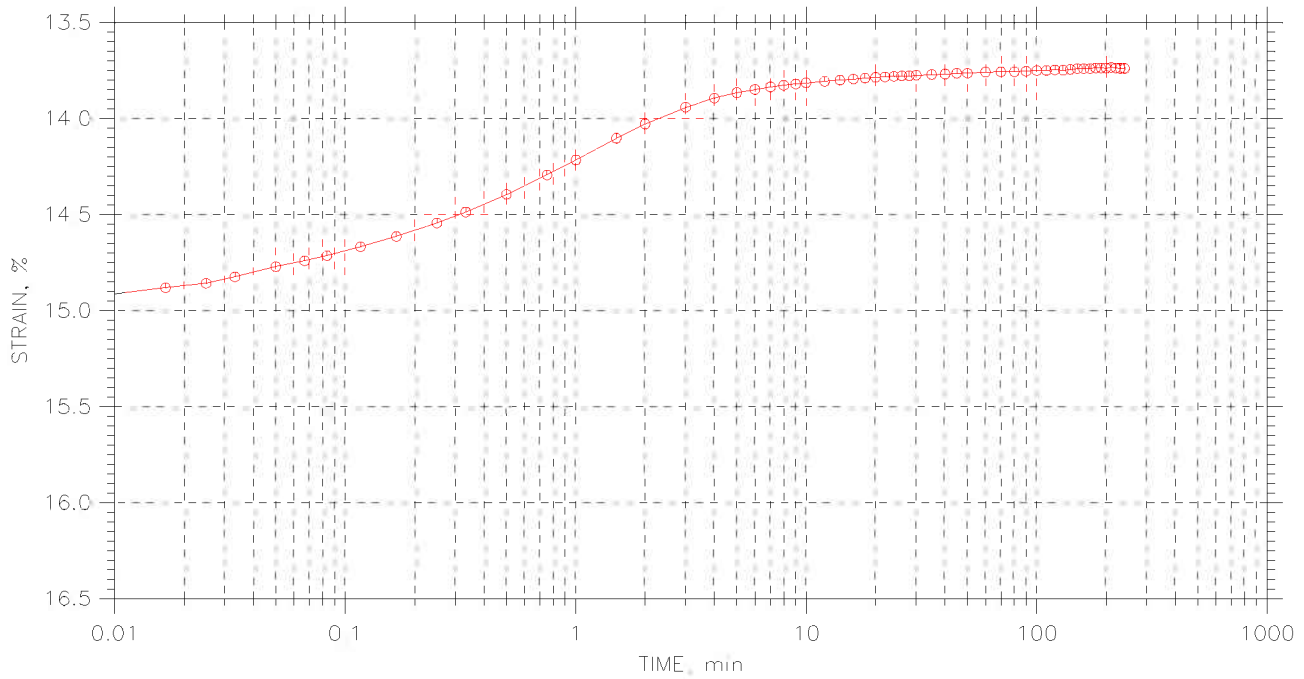

	Project: I90 Central Viaduct	Location: Cleveland, OH	Project No.: GTX-6678
	Boring No.: C-05-03	Tested By: fy	Checked By: jdt
	Sample No.: S-30	Test Date: 05/05/06	Depth: 118.5-120.5
	Test No.: C-2	Sample Type: Tube	Elevation: ---
	Description: Moist, dark gray clay		
	Remarks: ---		

CONSOLIDATION TEST DATA

TIME CURVES

Constant Load Step: 12 of 12

Stress: 0.5 tsf

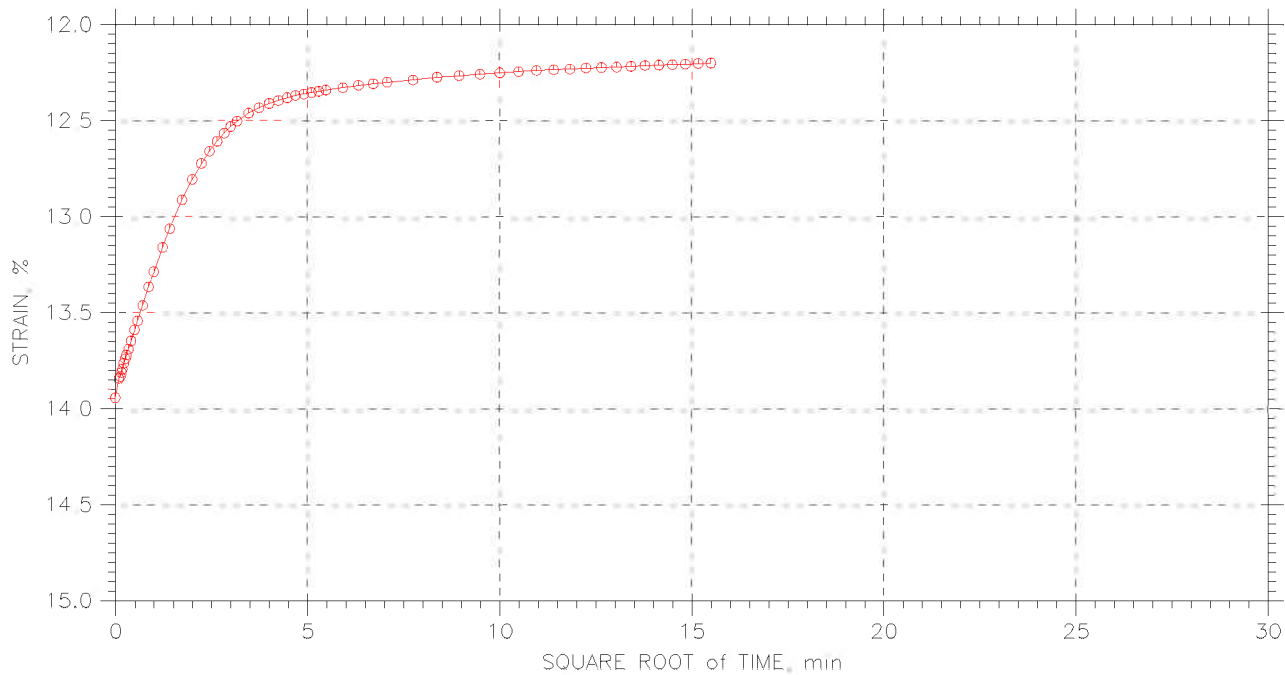
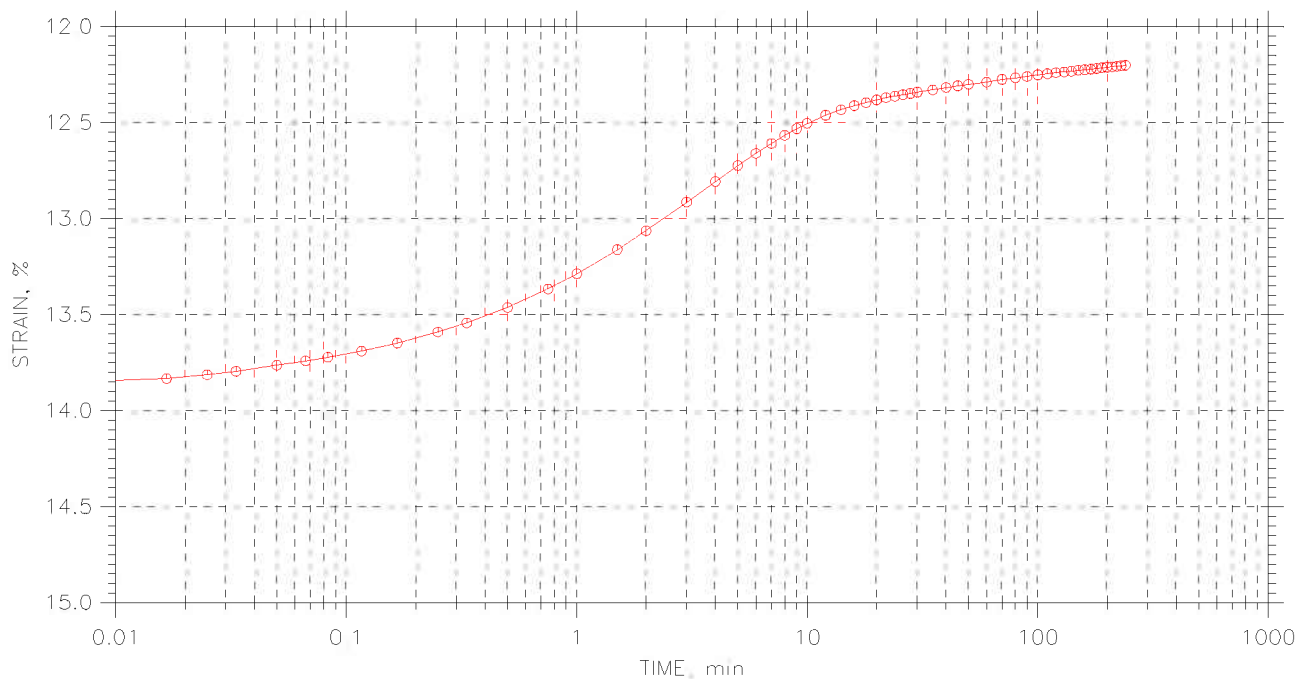

	Project: I90 Central Viaduct	Location: Cleveland, OH	Project No.: GTX-6678
	Boring No.: C-05-03	Tested By: fy	Checked By: jdt
	Sample No.: S-30	Test Date: 05/05/06	Depth: 118.5-120.5
	Test No.: C-2	Sample Type: Tube	Elevation: ---
	Description: Moist, dark gray clay		
	Remarks: ---		

CONSOLIDATION TEST DATA

Project: I90 Central Viaduct
 Boring No.: C-05-03
 Sample No.: S-30
 Test No.: C-2

Location: Cleveland, OH
 Tested By: fy
 Test Date: 05/05/06
 Sample Type: Tube

Project No.: GTX-6678
 Checked By: jdt
 Depth: 118.5-120.5
 Elevation: ---

Soil Description: Moist, dark gray clay
 Remarks: ---

Measured Specific Gravity: 2.73
 Initial Void Ratio: 0.86
 Final Void Ratio: 0.63

Liquid Limit: 33
 Plastic Limit: 18
 Plasticity Index: 15

Initial Height: 1.00 in
 Specimen Diameter: 2.50 in

Container ID	Before Consolidation		After Consolidation	
	Trimmings	Specimen+Ring	Specimen+Ring	Trimmings
	xtw	RING		dodge 5
Wt. Container + Wet Soil, gm	147.11	371.8	361.5	157.16
Wt. Container + Dry Soil, gm	117.33	334.62	334.62	129.53
Wt. Container, gm	8.26	216.53	216.53	8.17
Wt. Dry Soil, gm	109.07	118.09	118.09	121.36
Water Content, %	27.30	31.49	22.77	22.77
Void Ratio	---	0.86	0.63	---
Degree of Saturation, %	---	100.00	98.23	---
Dry Unit Weight, pcf	---	91.644	104.38	---

Constant Rate of Consolidation
 Constant Strain Rate by ASTM D4186
 Summary Report

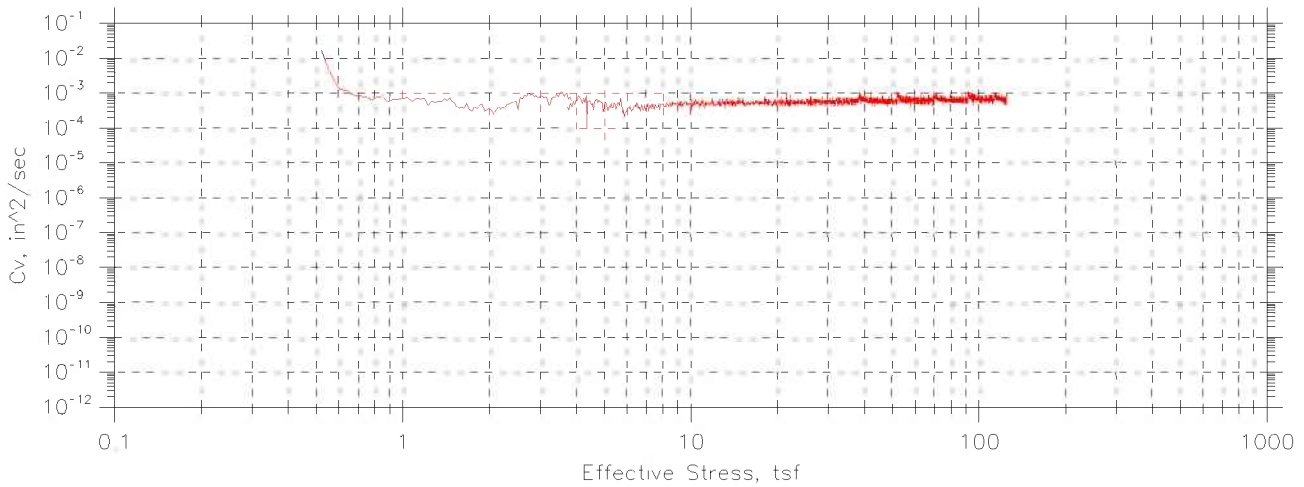
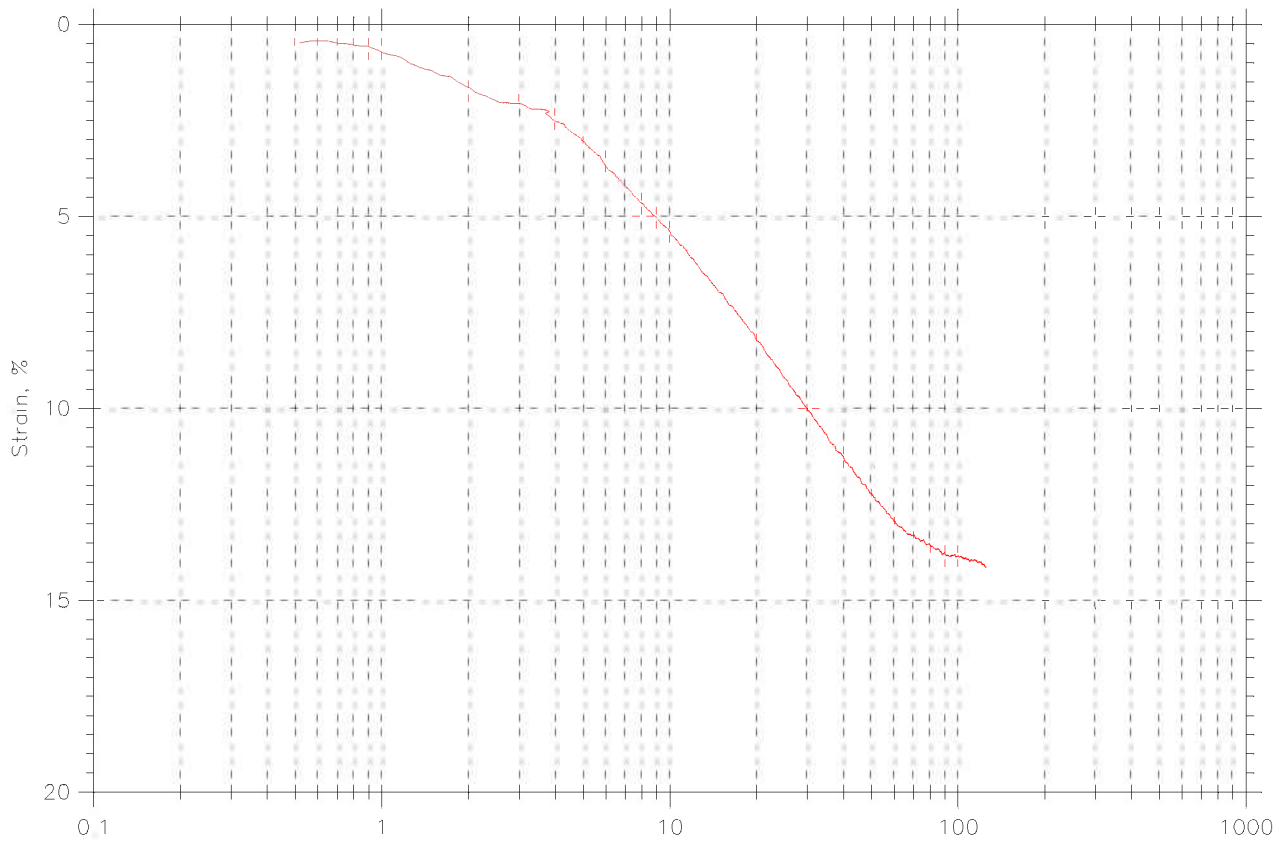

Project: I-90 Central Viaduct	Location: Cleveland, OH	Project No.: GTX-6678
Boring No.: C-05-03	Tested By: njh	Checked By: jdt
Sample No.: S-29	Test Date: 05/15/06	Depth: 116.5-118.5
Test No.: crc-1	Sample Type: tube	Elevation: ---
Description: Moist, dark gray clay		
Remarks:		

CRC TEST DATA

Project: I-90 Central Viaduct
 Boring No.: C-05-03
 Sample No.: S-29
 Test No.: crc-1

Location: Cleveland, OH
 Tested By: njh
 Test Date: 05/15/06
 Sample Type: tube

Project No.: GTX-6678
 Checked By: jdt
 Depth: 116.5-118.5
 Elevation: ---

Soil Description: Moist, dark gray clay
 Remarks:

Measured Specific Gravity: 2.75
 Initial Void Ratio: 0.53
 Final Void Ratio: 0.34

Liquid Limit: 35
 Plastic Limit: 18
 Plasticity Index: 17

Initial Height: 1.00 in
 Specimen Diameter: 2.50 in

	Before Consolidation		After Consolidation	
	Trimmings	Specimen+Ring	Specimen+Ring	Trimmings
Container ID	sweet	RING		1355
Wt. Container + Wet Soil, gm	135.17	383.55	378.55	168.61
Wt. Container + Dry Soil, gm	111.25	360.47	360.47	150.77
Wt. Container, gm	7.98	216.07	216.07	8.32
Wt. Dry Soil, gm	103.27	144.4	144.4	142.45
Water Content, %	23.16	15.99	12.52	12.52
Void Ratio	---	0.53	0.34	---
Degree of Saturation, %	---	82.64	100.00	---
Dry Unit Weight, pcf	---	112.06	127.7	---

Appendix C

Direct Simple Shear Tests

**Consolidated Undrained Direct Simple Shear Test of Cohesive Soil
by ASTM D 6528**

Client: Geocomp Consulting GTX#: 6678
 Project Name: I-90 Central Viaduct Test Date: 05/07/06
 Project Location: Cleveland, OH

Boring ID: C-05-03
 Sample ID: S-29
 Depth, ft: 116.5-118.5 ft

Visual Description: Moist, dark gray clay

Test Equipment: Top and bottom box (circular) = 2.62 in diameter. Load cells and LVDT's connected to data acquisition system for shear force, normal load, horizontal and vertical displacement; surface area = 5.39 in², soil height = 1 inch

Test Condition: inundated

Sample Type and Preparation: Extruded from tube, cut, trimmed and placed into apparatus at as-received density and moisture content.

Parameter	Point 1	Point 2	Point 3	Point 4	Point 5
Test No.	DSS-1				
Initial Moisture Content, %	29				
Initial Dry Density, pcf	96.3				
Nominal Rate of Shear Strain, %/min	0.0008				
Vertical Consolidation Stress, psf	9500				
Final Moisture Content, %	28				
Measured Peak Shear Stress, psf	2240				
Shear Strain at Peak Shear Stress, %	15.6				
Membrane Correction, psf	73				
S / σ'_{vc}	0.23				

Comments: Tested By: njh Checked By: jdt

Notes: These results apply only to the sample tested for the specific test conditions. The test procedures employed follow accepted industry practice and the indicated test method. GeoTesting Express has no specific knowledge as to conditioning, origin, sampling procedure or intended use of the material.

DIRECT SIMPLE SHEAR TEST

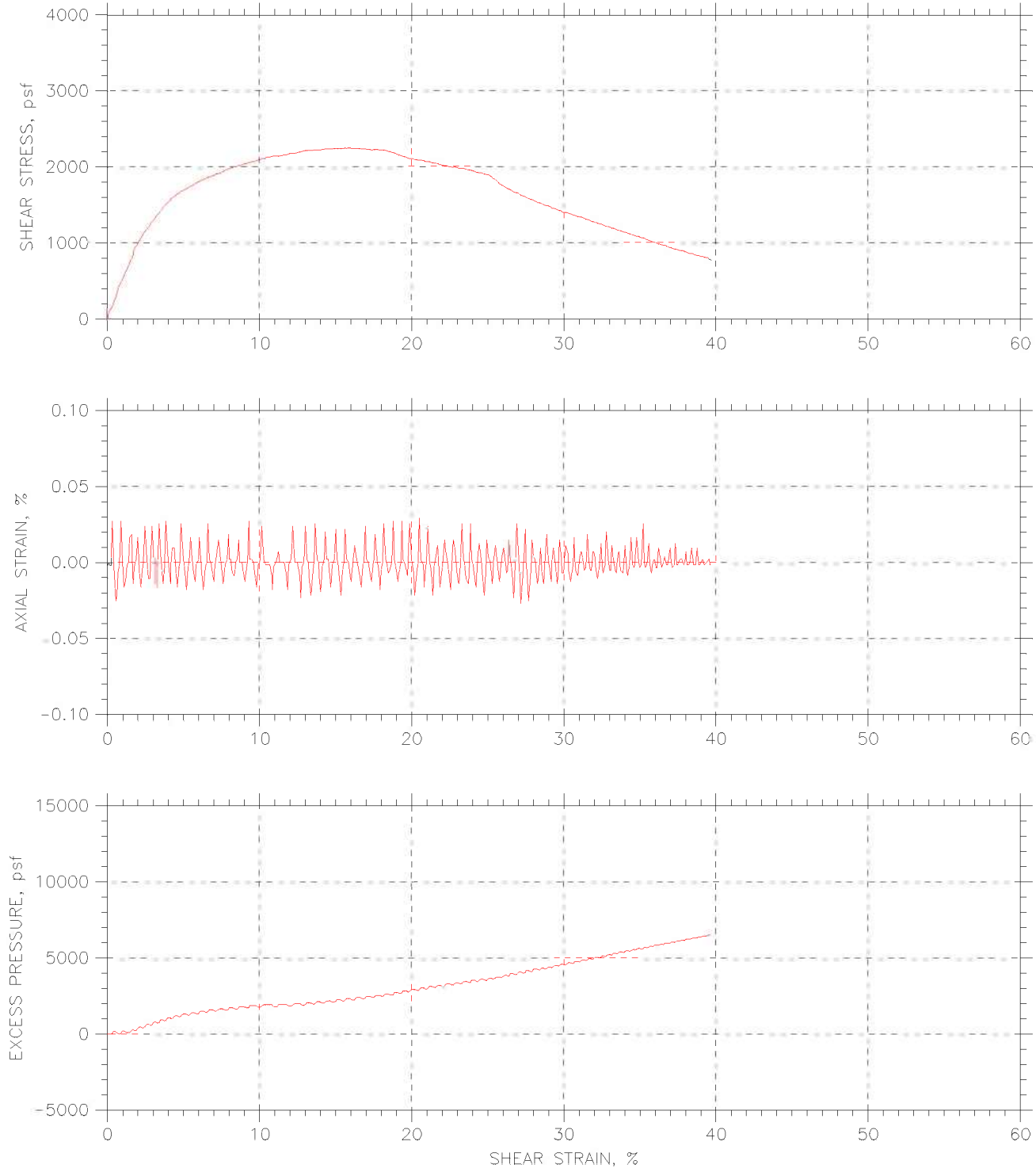

Project: I-90 Central Viaduct	Location: Cleveland, OH	Project No.: GTX-6678
Boring No.: C-05-03	Tested By: njh	Checked By: jdt
Sample No.: S-29	Test Date: 05/05/06	Depth: 115.5-118.5
Test No.: DSS-1	Sample Type: tube	Elevation: ---
Description: Moist, dark gray clay		
Remarks: 500 lb vertical load cell - 500 lb low profile horizontal load cell		1.5 membrane
File: \\Geocomp\db1\projects\GTX6678\6678-DSS-1.dat		

DIRECT SIMPLE SHEAR TEST

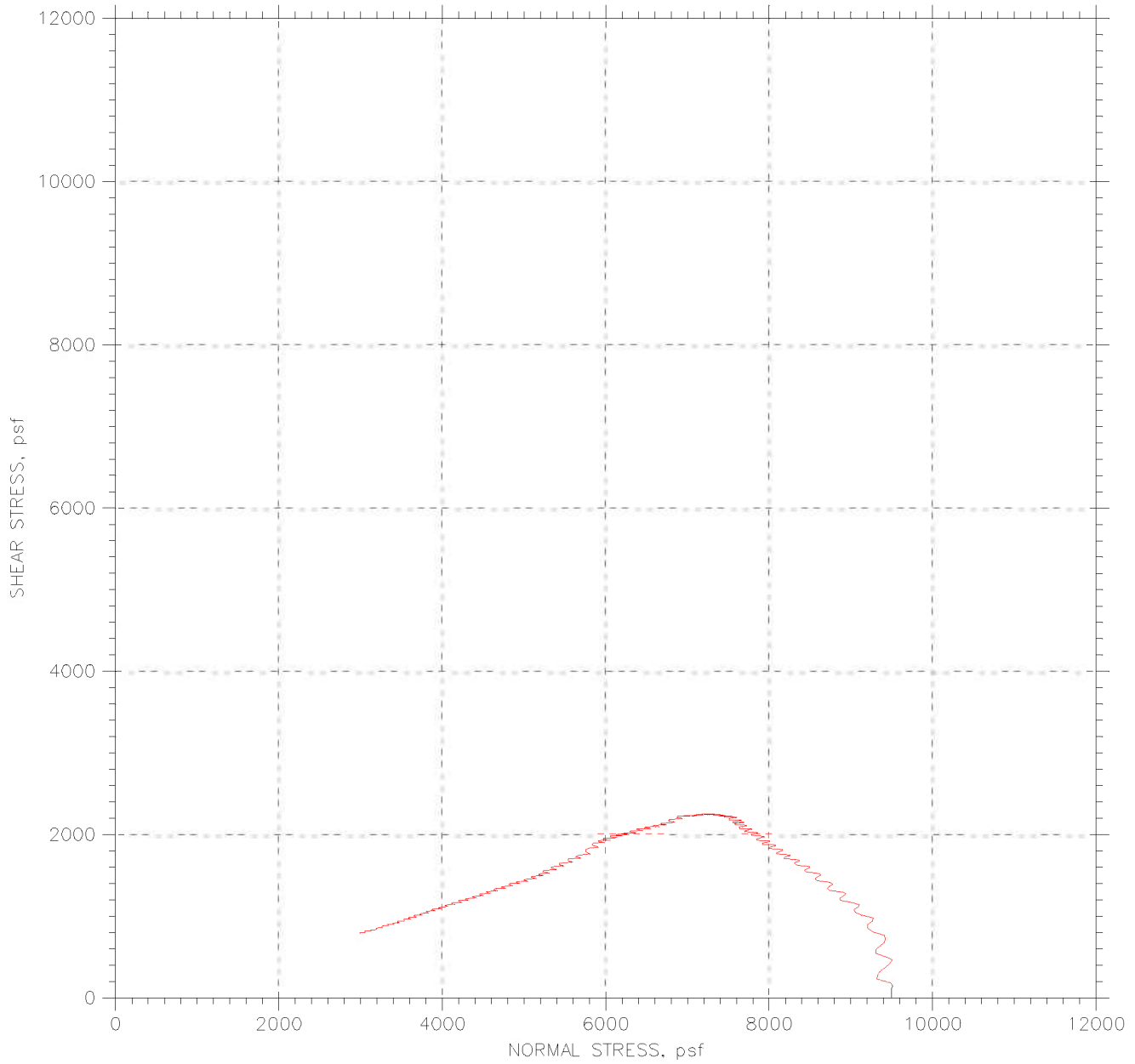

Project: I-90 Central Viaduct	Location: Cleveland, OH	Project No.: GTX-6678
Boring No.: C-05-03	Tested By: njh	Checked By: jdt
Sample No.: S-29	Test Date: 05/05/06	Depth: 115.5-118.5
Test No.: DSS-1	Sample Type: tube	Elevation: ---
Description: Moist, dark gray clay		
Remarks: 500 lb vertical load cell - 500 lb low profile horizontal load cell		1.5 membrane
File: \\Geocompdb1\projects\GTX6678\6678-DSS-1.dat		

**Consolidated Undrained Direct Simple Shear Test of Cohesive Soil
by ASTM D 6528**

Client: Geocomp Consulting GTX#: 6678
 Project Name: I-90 Central Viaduct Test Date: 05/08/06
 Project Location: Cleveland, OH

Boring ID: C-05-03
 Sample ID: S-30
 Depth, ft: 118.5-120.3 ft

Visual Description: Moist, dark gray clay

Test Equipment: Top and bottom box (circular) = 2.62 in diameter. Load cells and LVDT's connected to data acquisition system for shear force, normal load, horizontal and vertical displacement; surface area = 5.39 in², soil height = 1 inch

Test Condition: inundated

Sample Type and Preparation: Extruded from tube, cut, trimmed and placed into apparatus at as-received density and moisture content.

Parameter	Point 1	Point 2	Point 3	Point 4	Point 5
Test No.	DSS-2				
Initial Moisture Content, %	26				
Initial Dry Density, pcf	99.3				
Nominal Rate of Shear Strain, %/min	0.0008				
Vertical Consolidation Stress, psf	9500				
Final Moisture Content, %	29				
Measured Peak Shear Stress, psf	2514				
Shear Strain at Peak Shear Stress, %	20.0				
Membrane Correction, psf	78				
S / σ'_{vc}	0.26				

Comments: Tested By: njh Checked By: jdt

Notes: These results apply only to the sample tested for the specific test conditions. The test procedures employed follow accepted industry practice and the indicated test method. GeoTesting Express has no specific knowledge as to conditioning, origin, sampling procedure or intended use of the material.

DIRECT SIMPLE SHEAR TEST

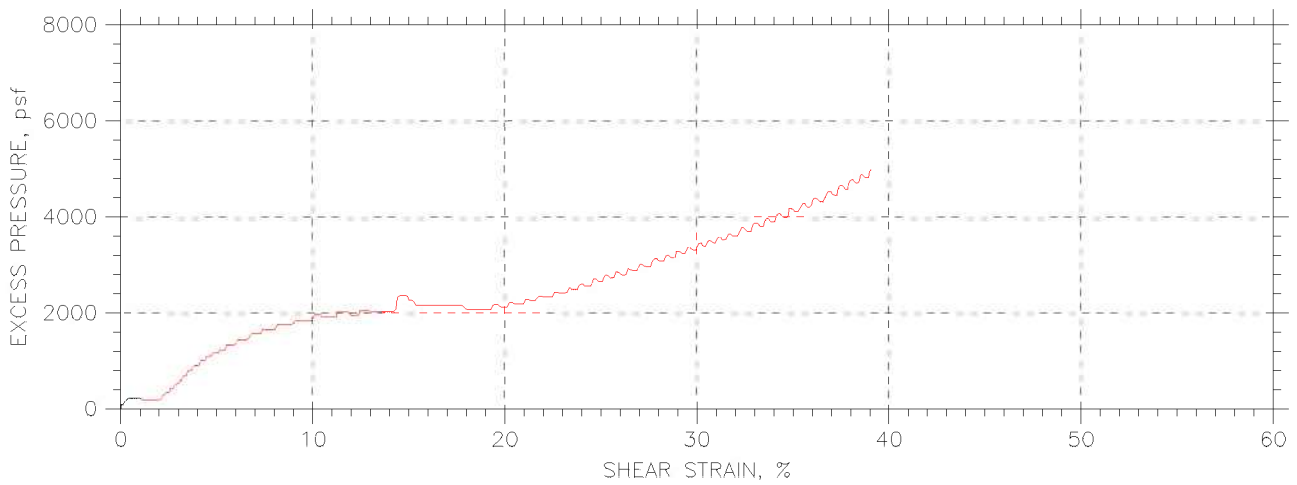
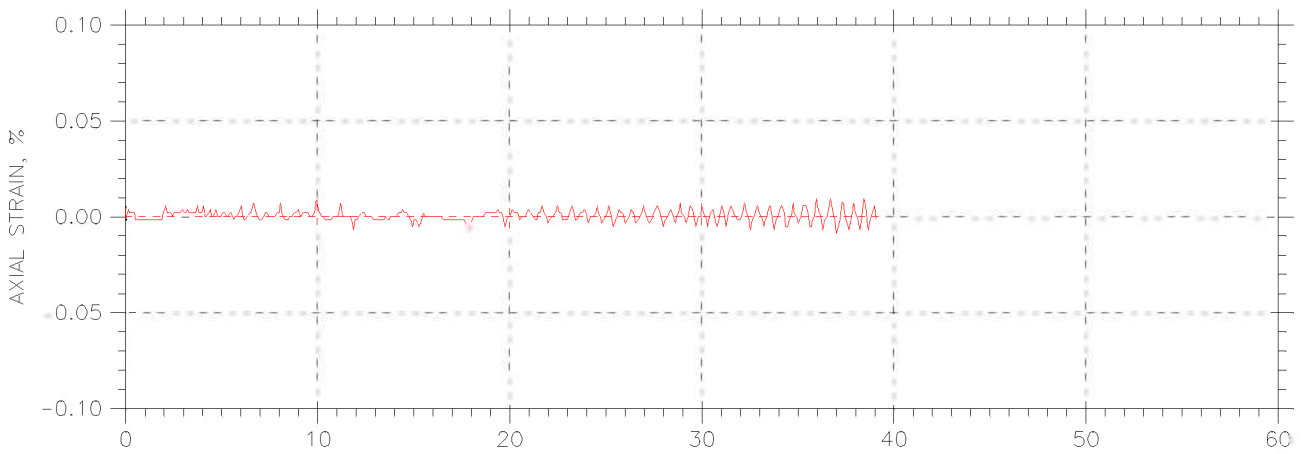
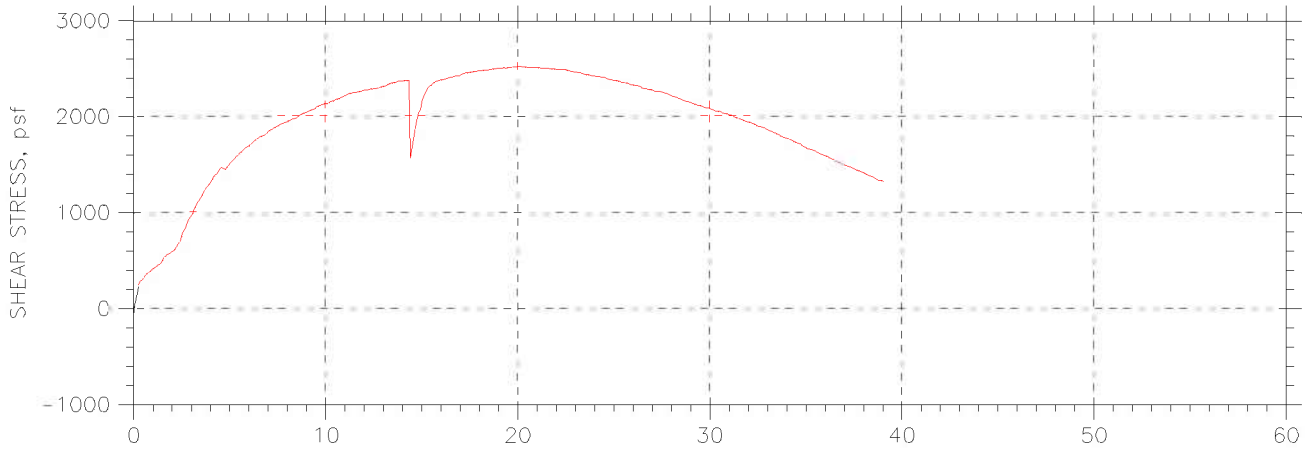

Project: I-90 Central Viaduct	Location: Cleveland, OH	Project No.: GTX-6678
Boring No.: C-05-03	Tested By: njh	Checked By: jdt
Sample No.: S-30	Test Date: 05/06/06	Depth: 118.5-120.3
Test No.: DSS-2	Sample Type: tube	Elevation: ---
Description: Moist, dark gray clay		
Remarks: 500 lb vertical load cell - 500 lb low profile horizontal load cell		1.5 membrane
File: \\Geocomp\db1\projects\GTX6678\6678-DSS-2.dat		

DIRECT SIMPLE SHEAR TEST

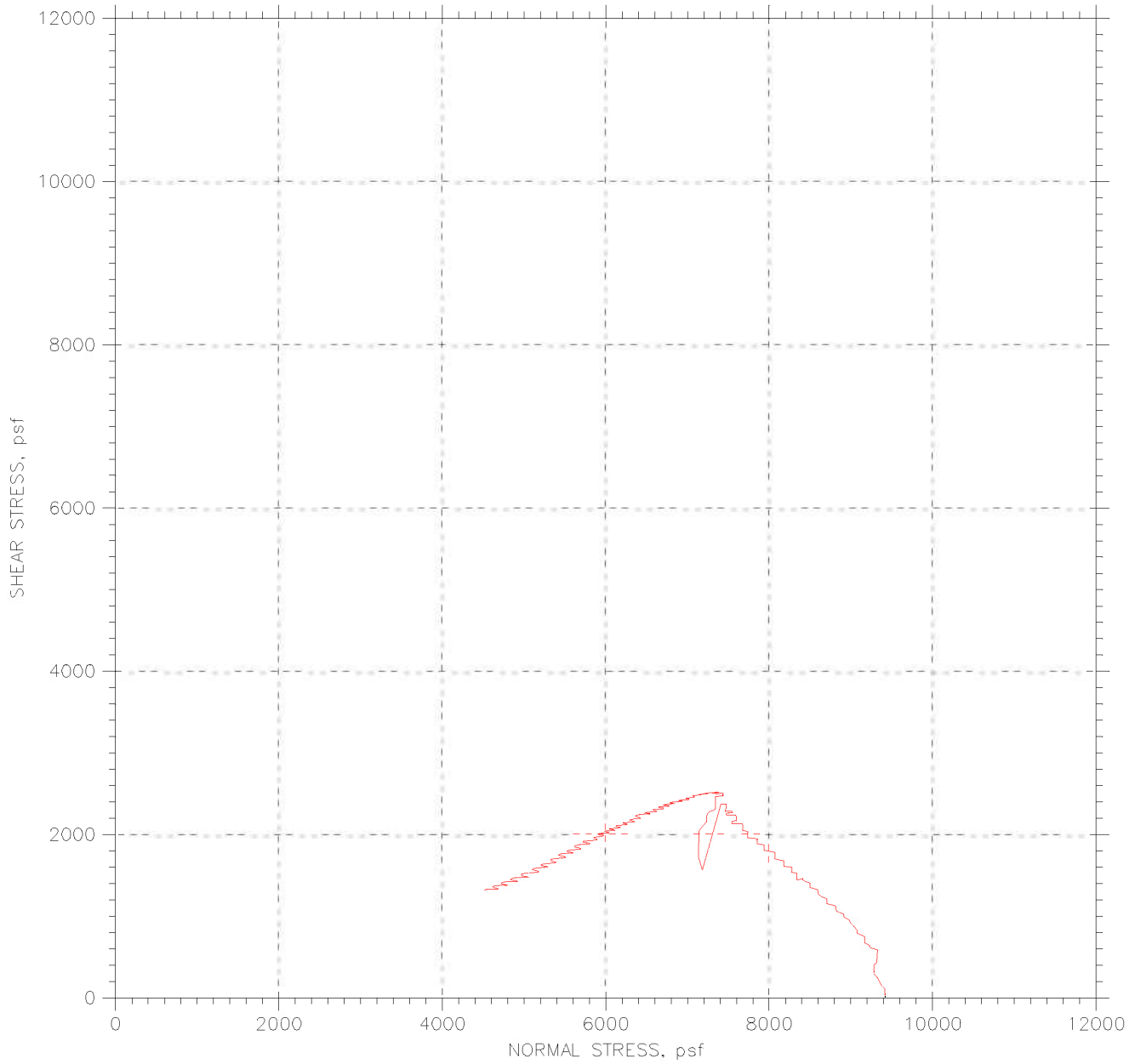

Project: I-90 Central Viaduct	Location: Cleveland, OH	Project No.: GTX-6678
Boring No.: C-05-03	Tested By: njh	Checked By: jdt
Sample No.: S-30	Test Date: 05/06/06	Depth: 118.5-120.3
Test No.: DSS-2	Sample Type: tube	Elevation: ---
Description: Moist, dark gray clay		
Remarks: 500 lb vertical load cell - 500 lb low profile horizontal load cell		1.5 membrane
File: \\Geocomp\db1\projects\GTX6678\6678-DSS-2.dat		

Consolidated Undrained Direct Simple Shear Test of Cohesive Soil by ASTM D 6528

Client: Geocomp Consulting GTX#: 6678
 Project Name: I-90 Central Viaduct Test Date: 05/30/06
 Project Location: Cleveland, OH

Boring ID: C-05-04
 Sample ID: S-27
 Depth, ft: 72-74 ft

Visual Description: Moist, very dark grayish brown clay

Test Equipment: Top and bottom box (circular) = 2.62 in diameter. Load cells and LVDT's connected to data acquisition system for shear force, normal load, horizontal and vertical displacement; surface area = 5.39 in², soil height = 1 inch

Test Condition: inundated

Sample Type and Preparation: Extruded from tube, cut, trimmed and placed into apparatus at as-received density and moisture content.

Parameter	Point 1	Point 2	Point 3	Point 4	Point 5
Test No.	DSS-3				
Initial Moisture Content, %	22				
Initial Dry Density, pcf	107				
Nominal Rate of Shear Strain, %/min	0.0008				
Vertical Consolidation Stress, psf	5506				
Final Moisture Content, %	21				
Measured Peak Shear Stress, psf	2092				
Shear Strain at Peak Shear Stress, %	10.7				
Membrane Correction, psf	64				
S / σ'_{vc}	0.37				

Comments: Tested By: njh Checked By: jdt

Notes: These results apply only to the sample tested for the specific test conditions. The test procedures employed follow accepted industry practice and the indicated test method. GeoTesting Express has no specific knowledge as to conditioning, origin, sampling procedure or intended use of the material.

DIRECT SIMPLE SHEAR TEST

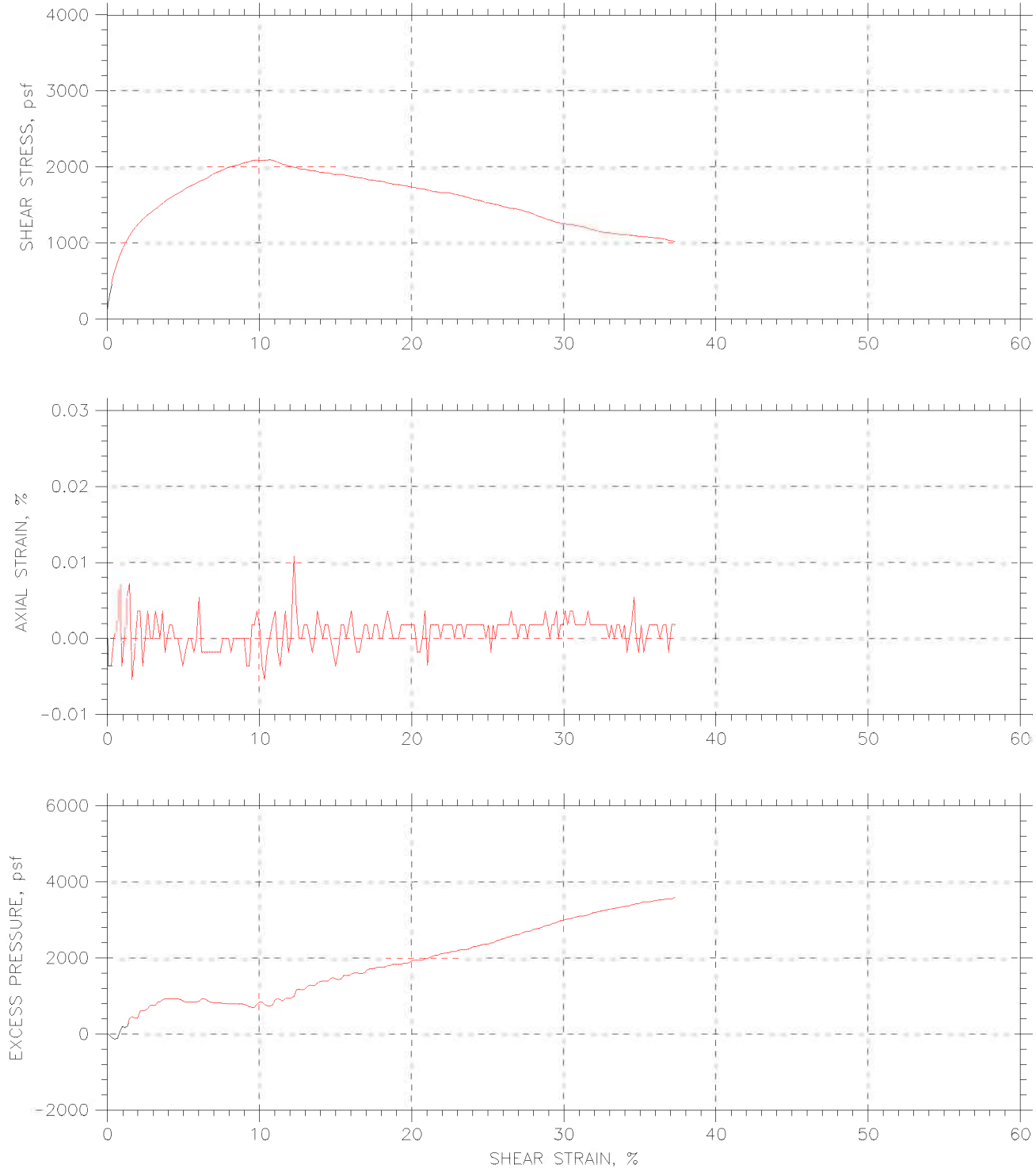

Project: I-90 Central Viaduct	Location: Cleveland, OH	Project No.: GTX-6678
Boring No.: C-05-04	Tested By: njh	Checked By: jdt
Sample No.: S-27	Test Date: 05/30/06	Depth: 72-74 ft
Test No.: DSS-3	Sample Type: ---	Elevation: ---
Description: Moist, very dark grayish brown clay		
Remarks: 1.5 membrane		
File: \\Geocompdb1\projects\GTX6678\6678-DSS3.dat		

DIRECT SIMPLE SHEAR TEST

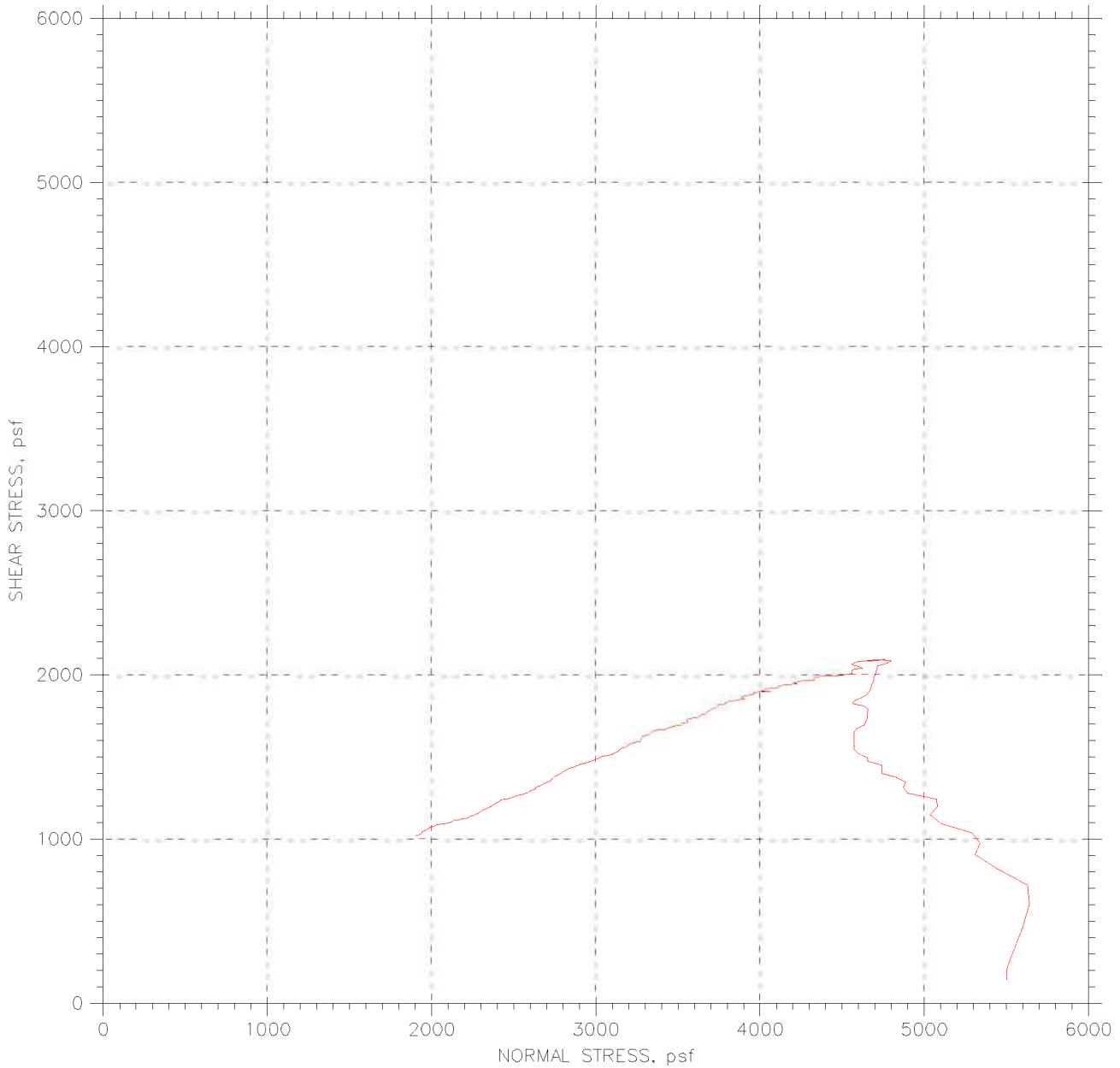

Project: I-90 Central Viaduct	Location: Cleveland, OH	Project No.: GTX-6678
Boring No.: C-05-04	Tested By: njh	Checked By: jdt
Sample No.: S-27	Test Date: 05/30/06	Depth: 72-74 ft
Test No.: DSS-3	Sample Type: ---	Elevation: ---
Description: Moist, very dark grayish brown clay		
Remarks: 1.5 membrane		
File: \\Geocompdb1\projects\GTX6678\6678-DSS3.dat		

DIRECT SIMPLE SHEAR TEST

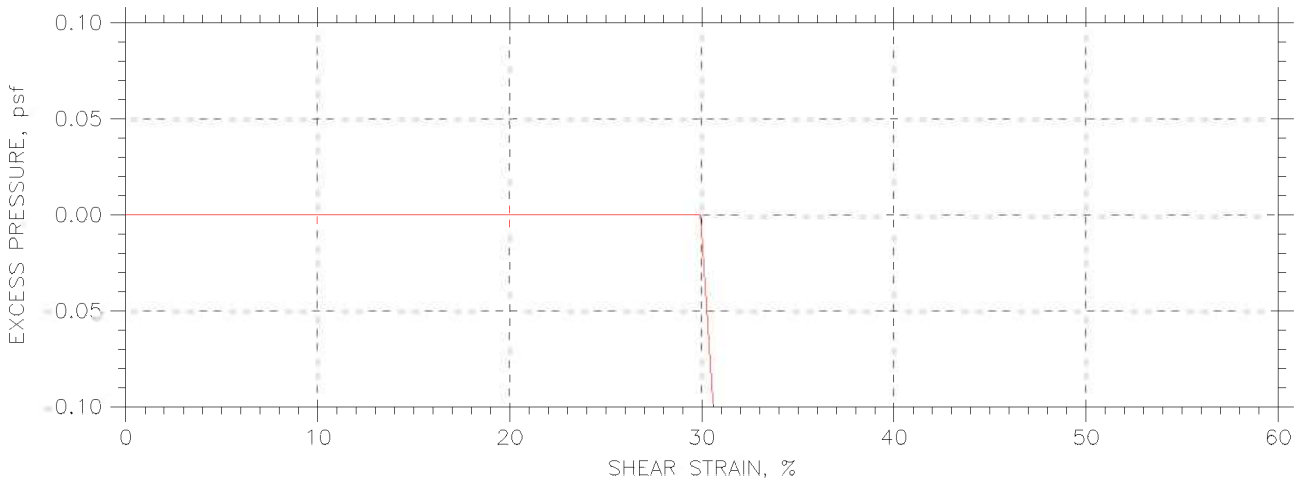
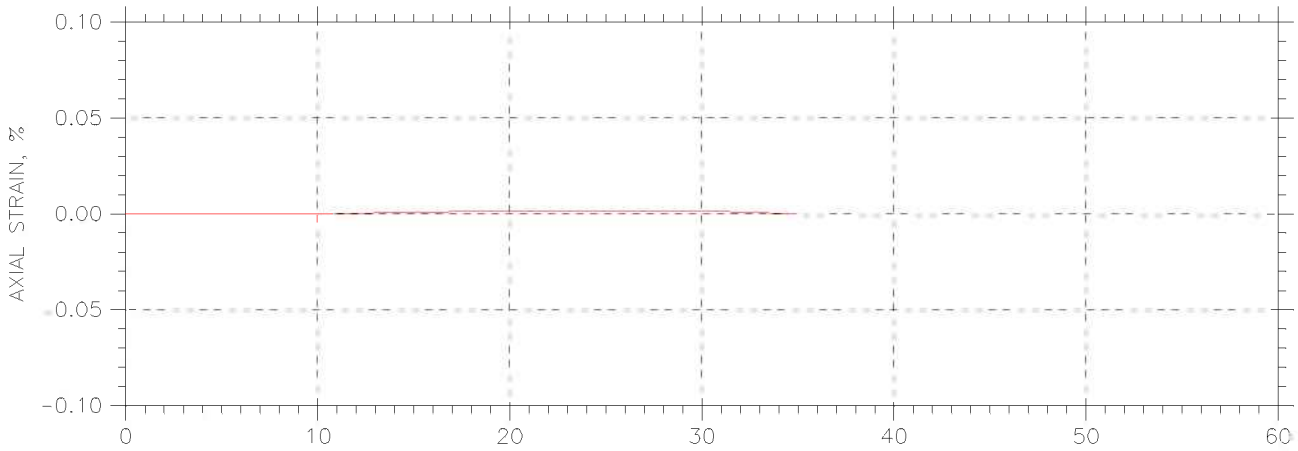
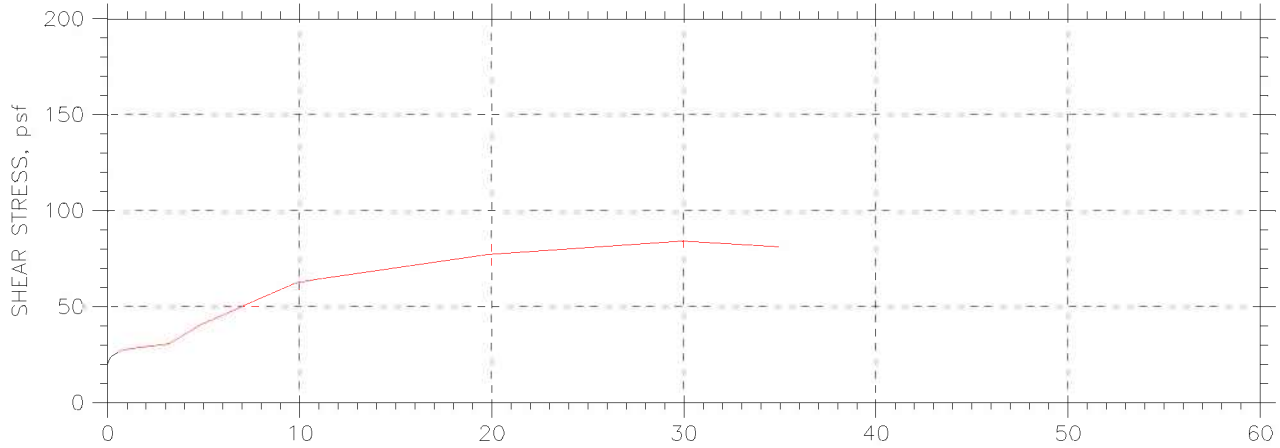

Project: MEMBRANE CORRECTION	Location:	Project No.:
Boring No.:	Tested By: md	Checked By:
Sample No.: 1.5	Test Date: 04/04/06	Depth:
Test No.:	Sample Type:	Elevation:
Description: Membrane Correction Curve		
Remarks:		
File: \\Geocomp\db1\projects\Calibration\Membrane Correction Files\Mem cal-take4(1.5).dat		

Appendix D

Residual Shear Tests



Client:	Geocomp Consulting		
Project Name:	I-90 Central Viaduct		
Project Location:	Cleveland, OH		
GTX #:	6678	Tested By:	njh/md
Test Date:	05/06-05/19/06	Checked By:	jdt
Boring ID:	C-05-03		
Sample ID:	S-29		
Depth, ft.	116.5-118.5 ft		
Description:	Moist, dark gray clay		
Preparation:	Extruded from tube, cut and trimmed and tested at the as-received moisture and density.		

Direct Shear and Residual Shear by ASTM D 3080

Parameter	Point 1	Point 2	Point 3
Test No.	RS5	RS4	RS6
Initial Moisture Content, %	26	26	24
Initial Dry Density, pcf	98.2	97.4	99.1
Nominal Rate of Shear Strain, inches/min	0.003	0.003	0.001
Vertical Consolidation Stress, psf	4748	9500	14249
Peak Shear Stress, psf	2519	3849	6367
Post-Peak Shear Stress, psf	1851	2559	5611
Final Moisture Content, %	31	25	22

Notes: Residual values taken near the end of the final shear step.	Peak Friction Angle:	22.0	degrees
	Peak Cohesion:	398	psf
	Post Peak Friction Angle:	19.7	degrees
	Post Peak Cohesion:	0	psf

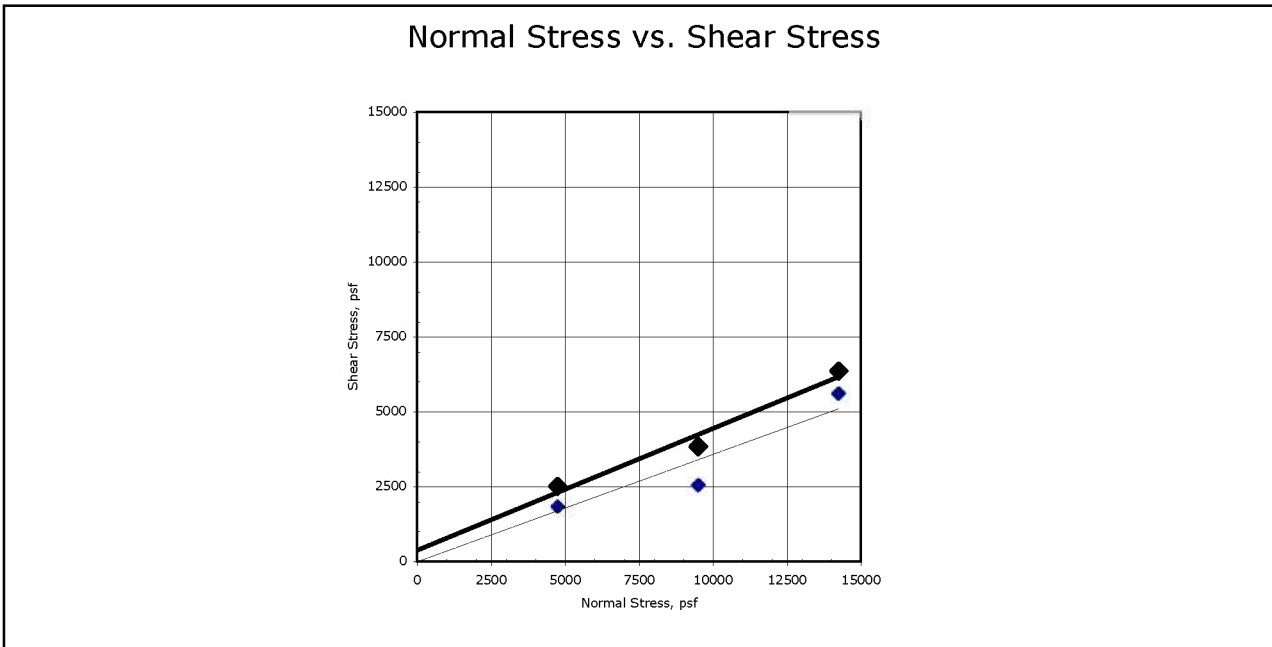

Comments: See attached plots for additional information

RESIDUAL SHEAR TEST

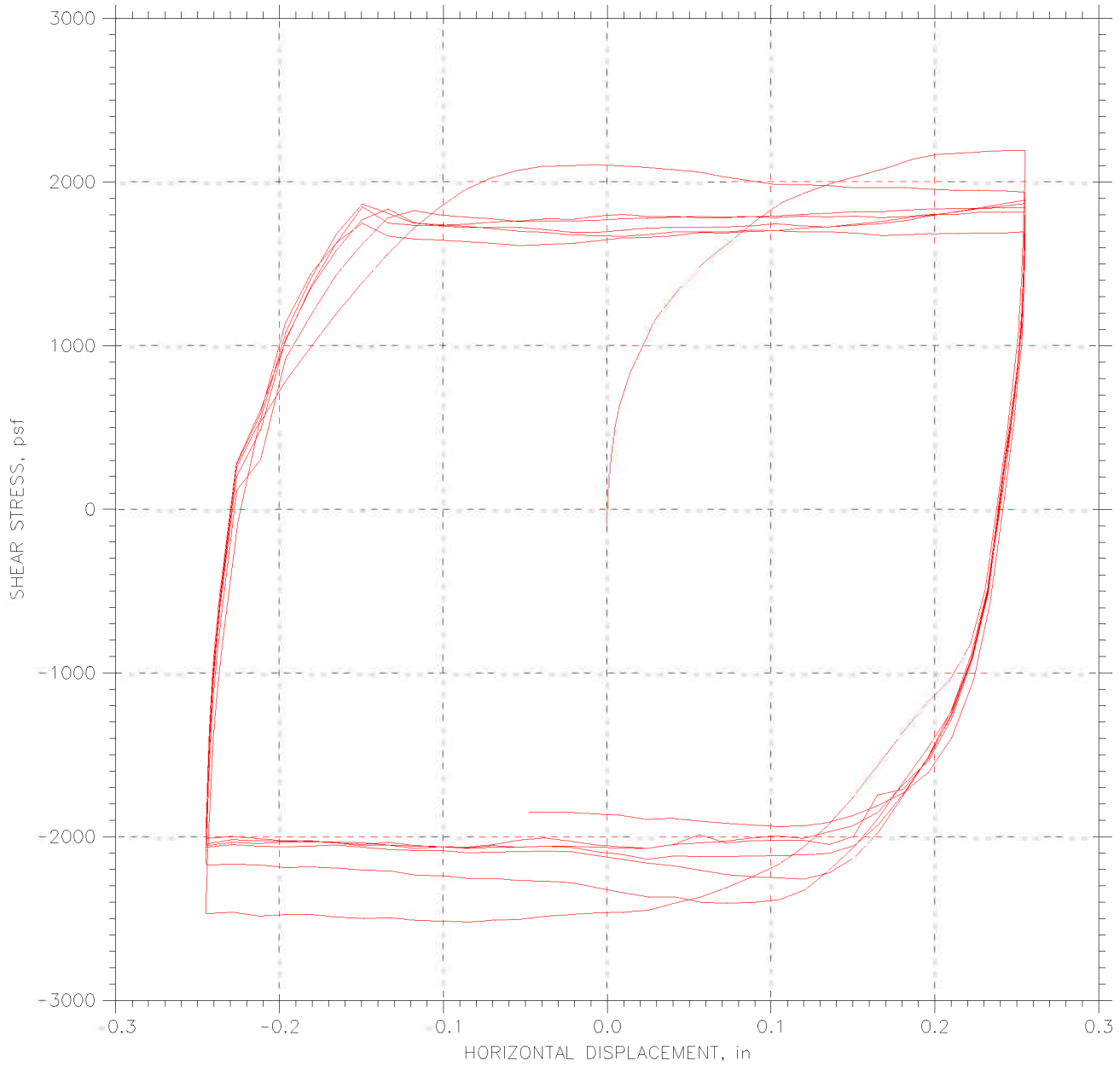

Project: I-90 Central Viaduct	Location: Cleveland, OH	Project No.: GTX-6678
Boring No.: C-05-03	Tested By: njh	Checked By: jdt
Sample No.: S-29	Test Date: 05/11/06	Depth: 116.5-118.5
Test No.: RS-5	Sample Type: tube	Elevation: ---
Description: Moist, dark gray clay		
Remarks: Shear Loop rates (in/min): All loops @ .003.		
File: \\Geocomp\db1\projects\GTX6678\6678-rs5.dat		

RESIDUAL SHEAR TEST

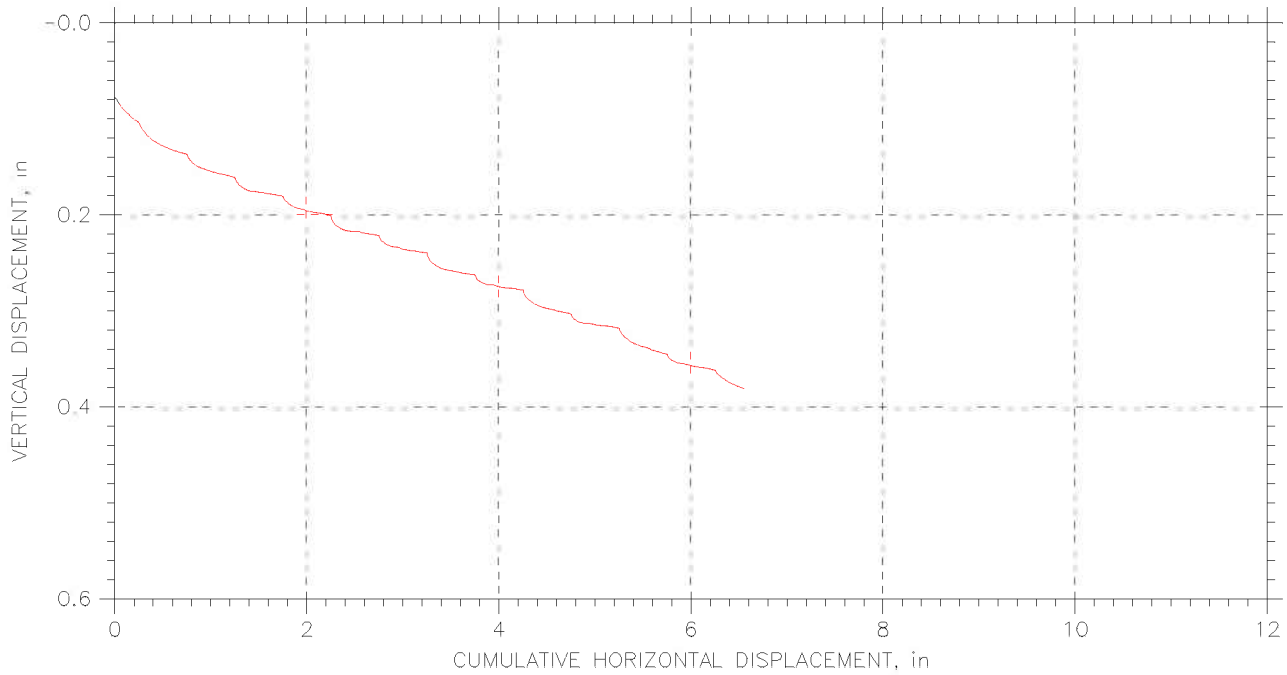
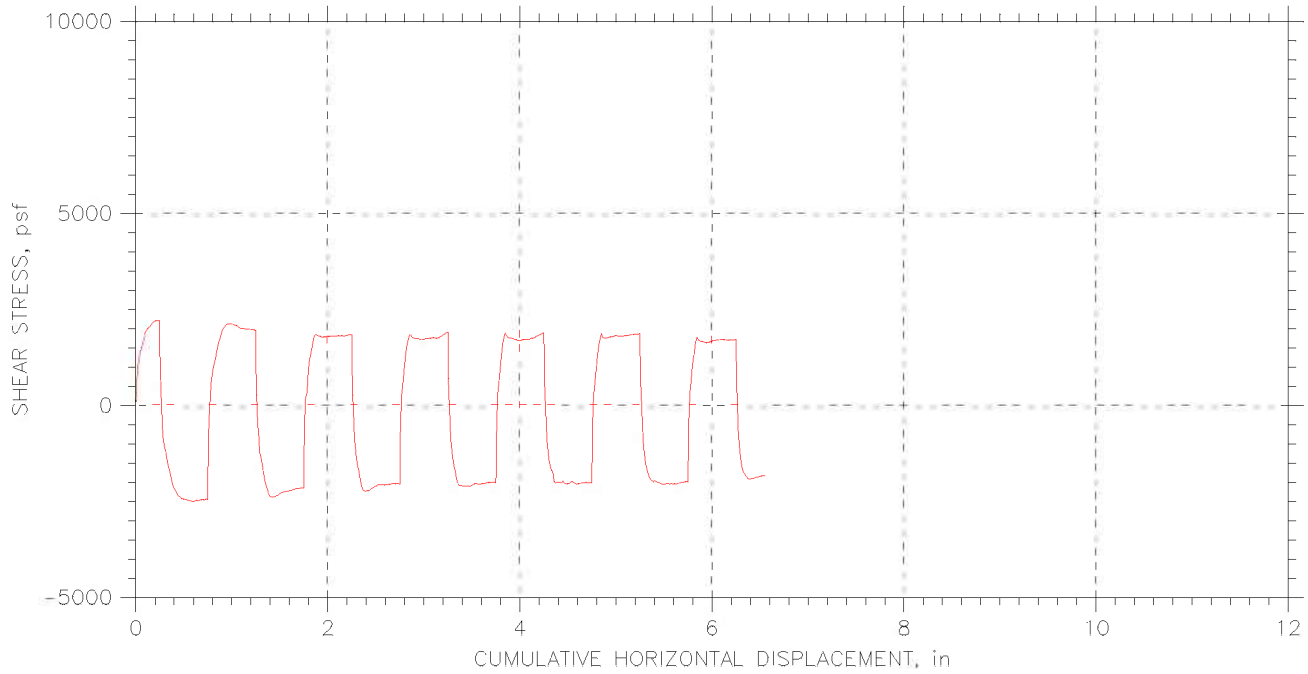

Project: I-90 Central Viaduct	Location: Cleveland, OH	Project No.: GTX-6678
Boring No.: C-05-03	Tested By: njh	Checked By: jdt
Sample No.: S-29	Test Date: 05/11/06	Depth: 116.5-118.5
Test No.: RS-5	Sample Type: tube	Elevation: ---
Description: Moist, dark gray clay		
Remarks: Shear Loop rates (in/min): All loops @ .003.		
File: \\Geocompdb1\projects\GTX6678\6678-rs5.dat		

RESIDUAL SHEAR TEST

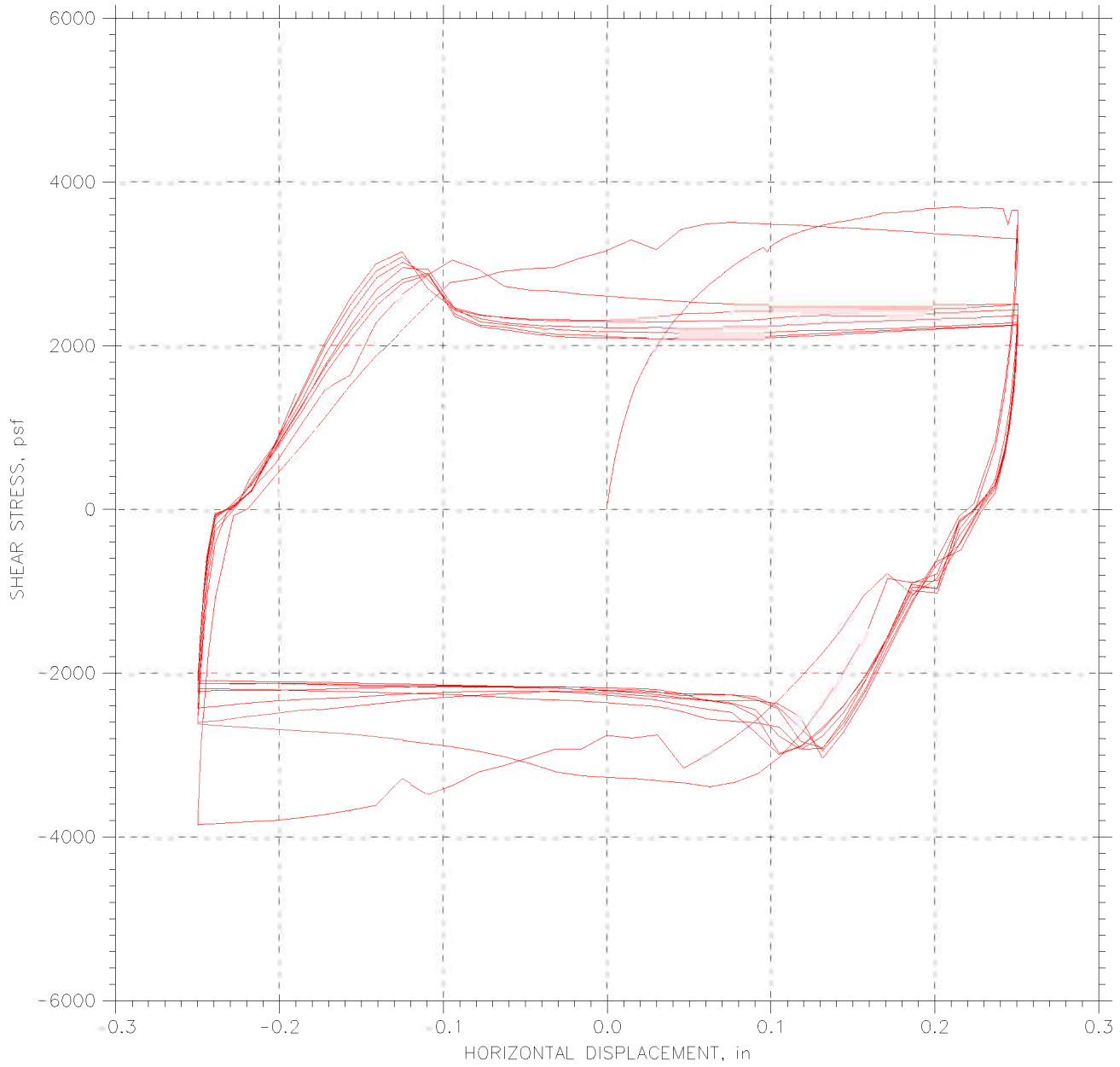

Project: I-90 Central Viaduct	Location: Cleveland, OH	Project No.: GTX-6678
Boring No.: C-05-03	Tested By: njh	Checked By: jdt
Sample No.: S-29	Test Date: 05/05/06	Depth: 116.5-118.5
Test No.: RS-4	Sample Type: tube	Elevation: ---
Description: Moist, dark gray clay		
Remarks: Shear Loop rates (in/min): First .25 @.0005, then 1 @ .00005, then 9 @.003.		
File: \\Geocomp\db1\projects\GTX6678\6678-rs4.dat		

RESIDUAL SHEAR TEST

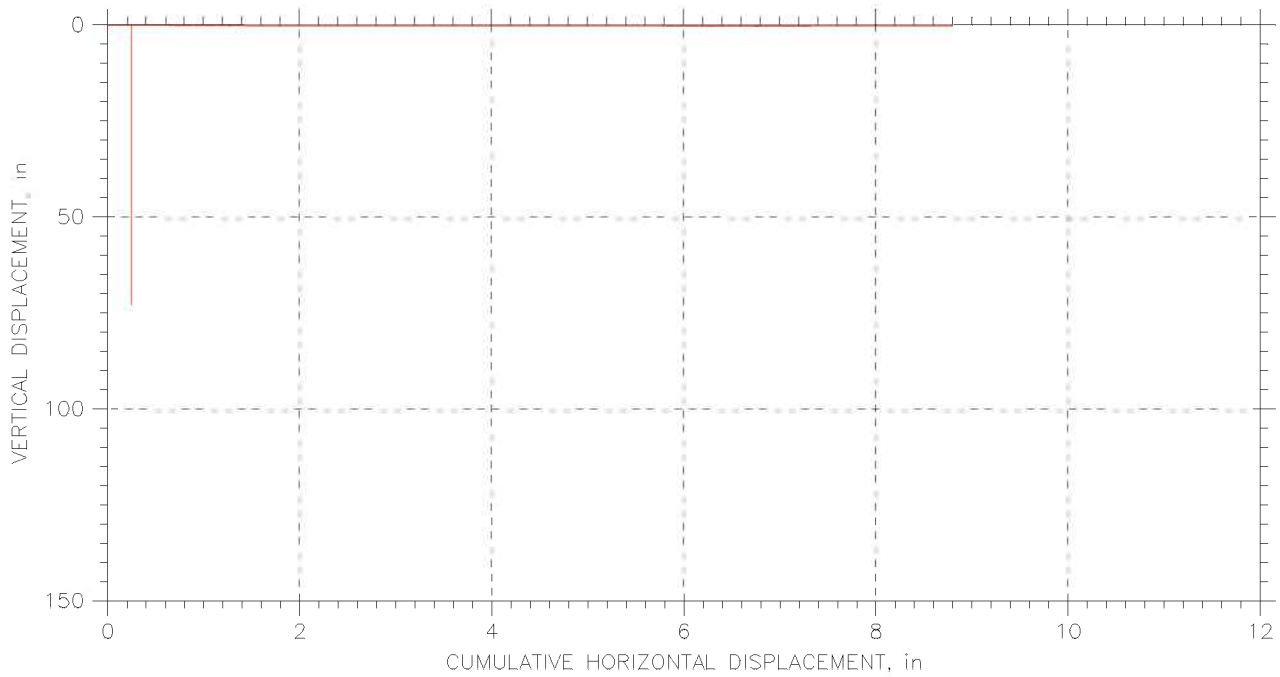
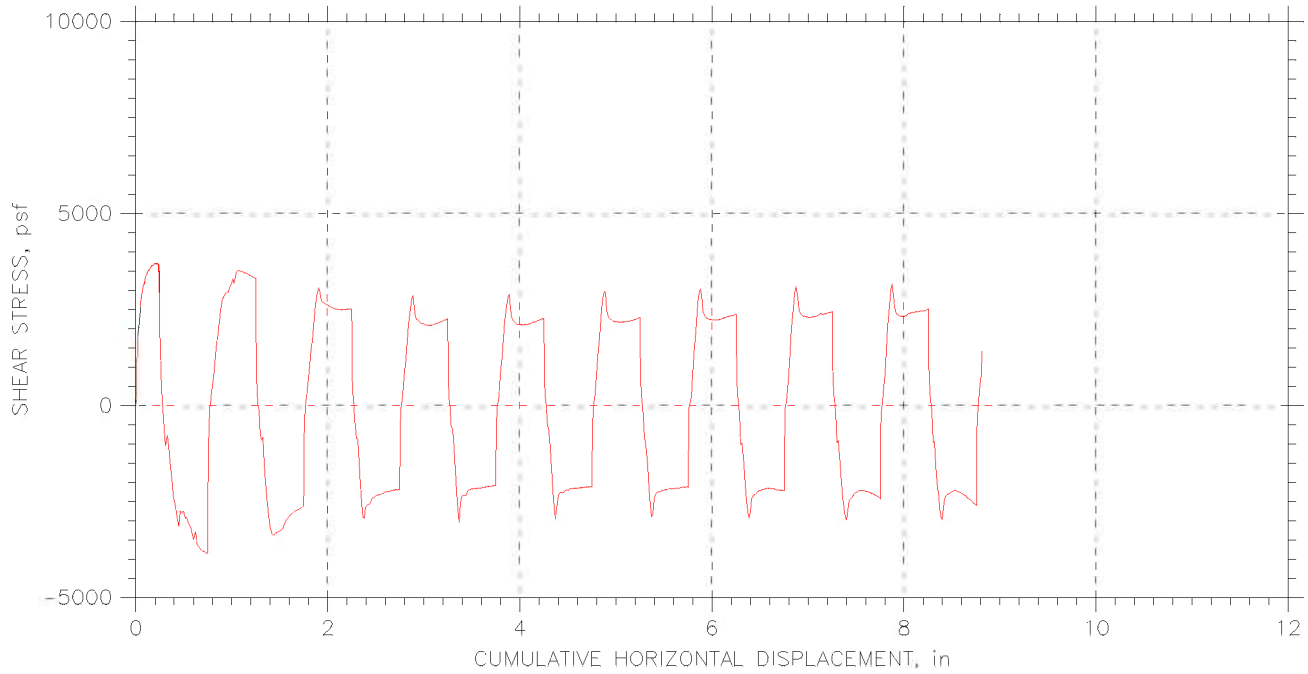

Project: I-90 Central Viaduct	Location: Cleveland, OH	Project No.: GTX-6678
Boring No.: C-05-03	Tested By: njh	Checked By: jdt
Sample No.: S-29	Test Date: 05/05/06	Depth: 116.5-118.5
Test No.: RS-4	Sample Type: tube	Elevation: ---
Description: Moist, dark gray clay		
Remarks: Shear Loop rates (in/min): First .25 @.0005, then 1 @ .00005, then 9 @.003.		
File: \\Geocompb1\projects\GTX6678\6678-rs4.dat		

RESIDUAL SHEAR TEST

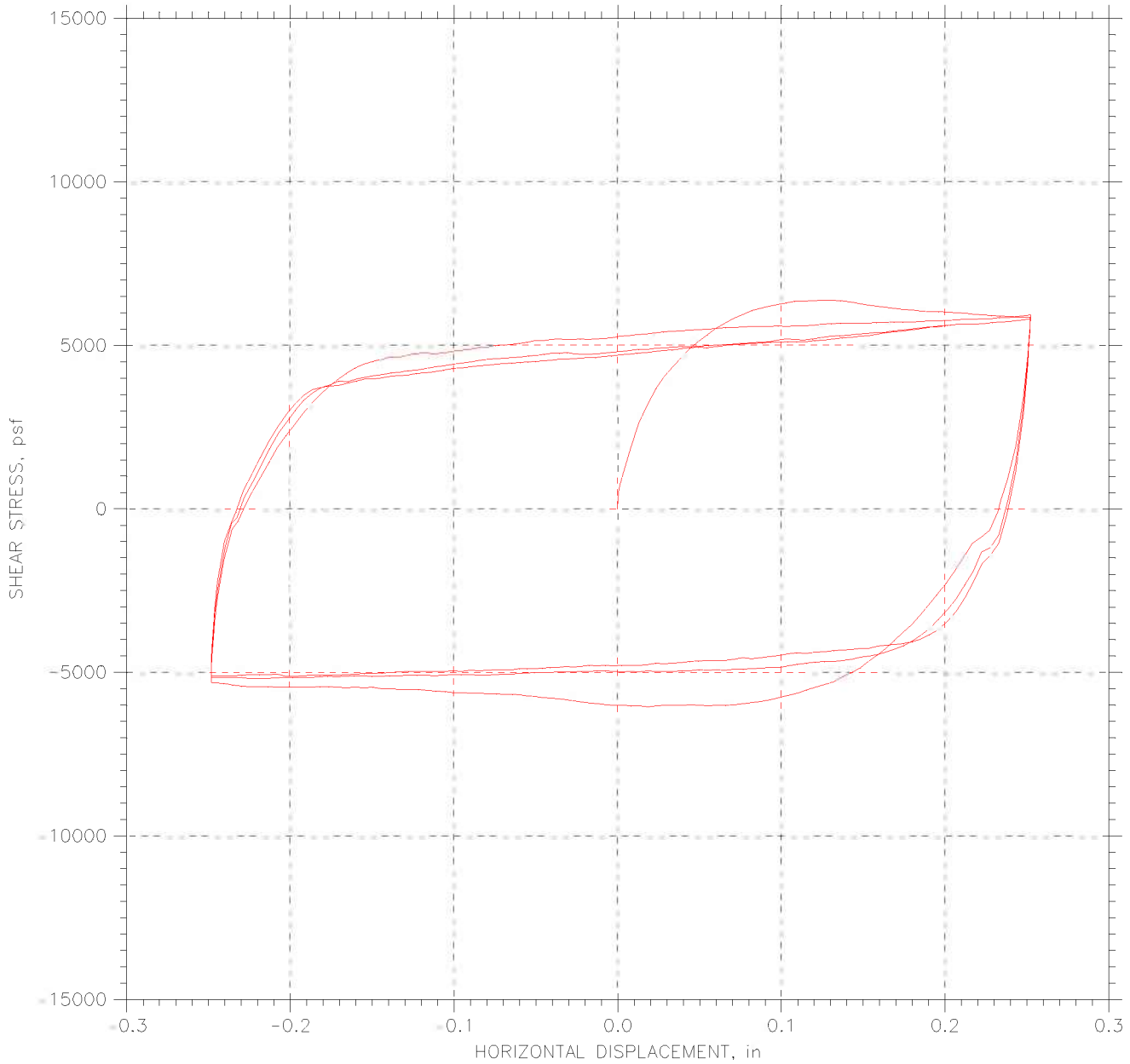

Project: I-90 Central Viaduct	Location: Cleveland, OH	Project No.: GTX-6678
Boring No.: C-05-03	Tested By: md	Checked By: jdt
Sample No.: S-29	Test Date: 05/15/06	Depth: 116.5-118.5
Test No.: RS-6	Sample Type: tube	Elevation: ---
Description: Moist, dark gray clay		
Remarks: Shear Loop rates (in/min): All loops @ .001.		
File: \\Geocomp\db1\projects\GTX6678\6678-rs6.dat		

RESIDUAL SHEAR TEST

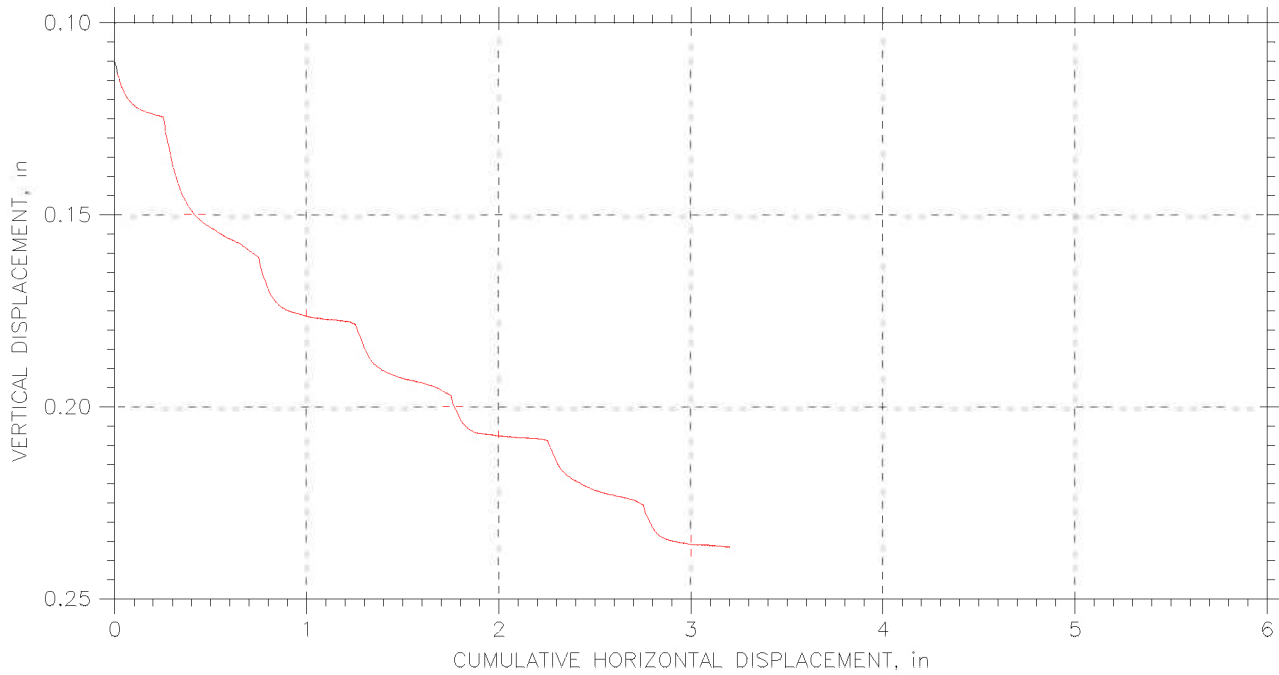
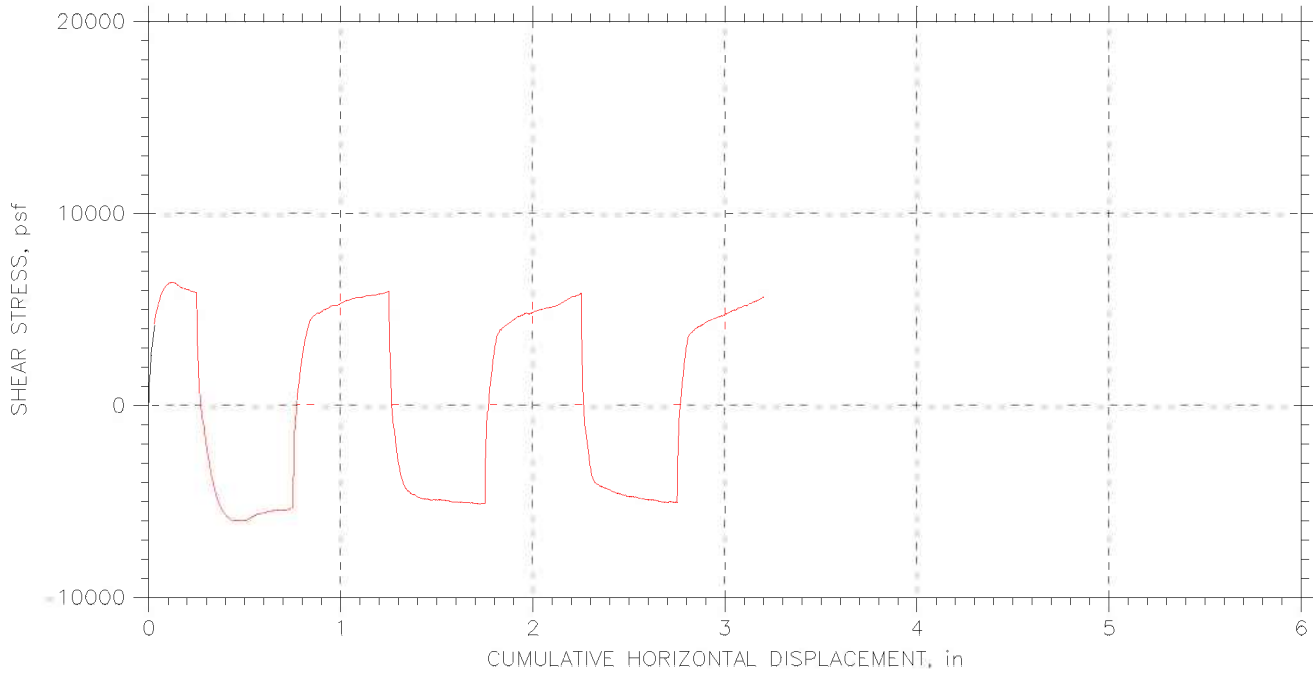

Project: I-90 Central Viaduct	Location: Cleveland, OH	Project No.: GTX-6678
Boring No.: C-05-03	Tested By: md	Checked By: jdt
Sample No.: S-29	Test Date: 05/15/06	Depth: 116.5-118.5
Test No.: RS-6	Sample Type: tube	Elevation: ---
Description: Moist, dark gray clay		
Remarks: Shear Loop rates (in/min): All loops @ .001.		
File: \\Geocompb1\projects\GTX6678\6678-rs6.dat		



Client:	Geocomp Consulting		
Project Name:	I-90 Central Viaduct		
Project Location:	Cleveland, OH		
GTX #:	6678	Tested By:	njh/md
Test Date:	05/06-05/19/06	Checked By:	jdt
Boring ID:	C-05-03		
Sample ID:	S-30		
Depth, ft.	118.5-120.3 ft		
Description:	Moist, dark gray clay		
Preparation:	Extruded from tube, cut and trimmed and tested at the as-received moisture and density.		

Direct Shear and Residual Shear by ASTM D 3080

Parameter	Point 1	Point 2	Point 3
Test No.	RS1	RS2	RS3
Initial Moisture Content, %	20	28	21
Initial Dry Density, pcf	103	99.0	94.7
Nominal Rate of Shear Strain, inches/min	0.003	0.003	0.001
Vertical Consolidation Stress, psf	4749	9500	14249
Peak Shear Stress, psf	2433	4818	5111
Post-Peak Shear Stress, psf	2400	3858	3444
Final Moisture Content, %	23	24	22

Notes: Residual values taken near the end of the final shear step.	Peak Friction Angle:	15.7	degrees
	Peak Cohesion:	1444	psf
	Post Peak Friction Angle:	6.3	degrees
	Post Peak Cohesion:	2190	psf

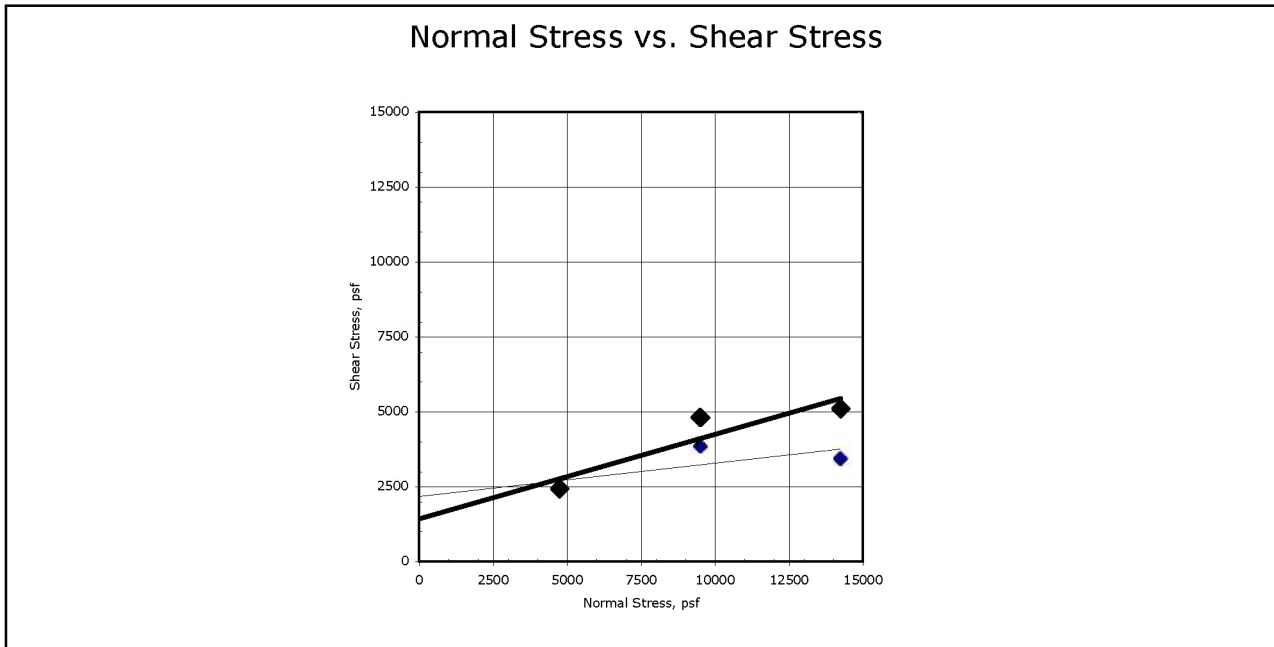

Comments: See attached plots for additional information

RESIDUAL SHEAR TEST

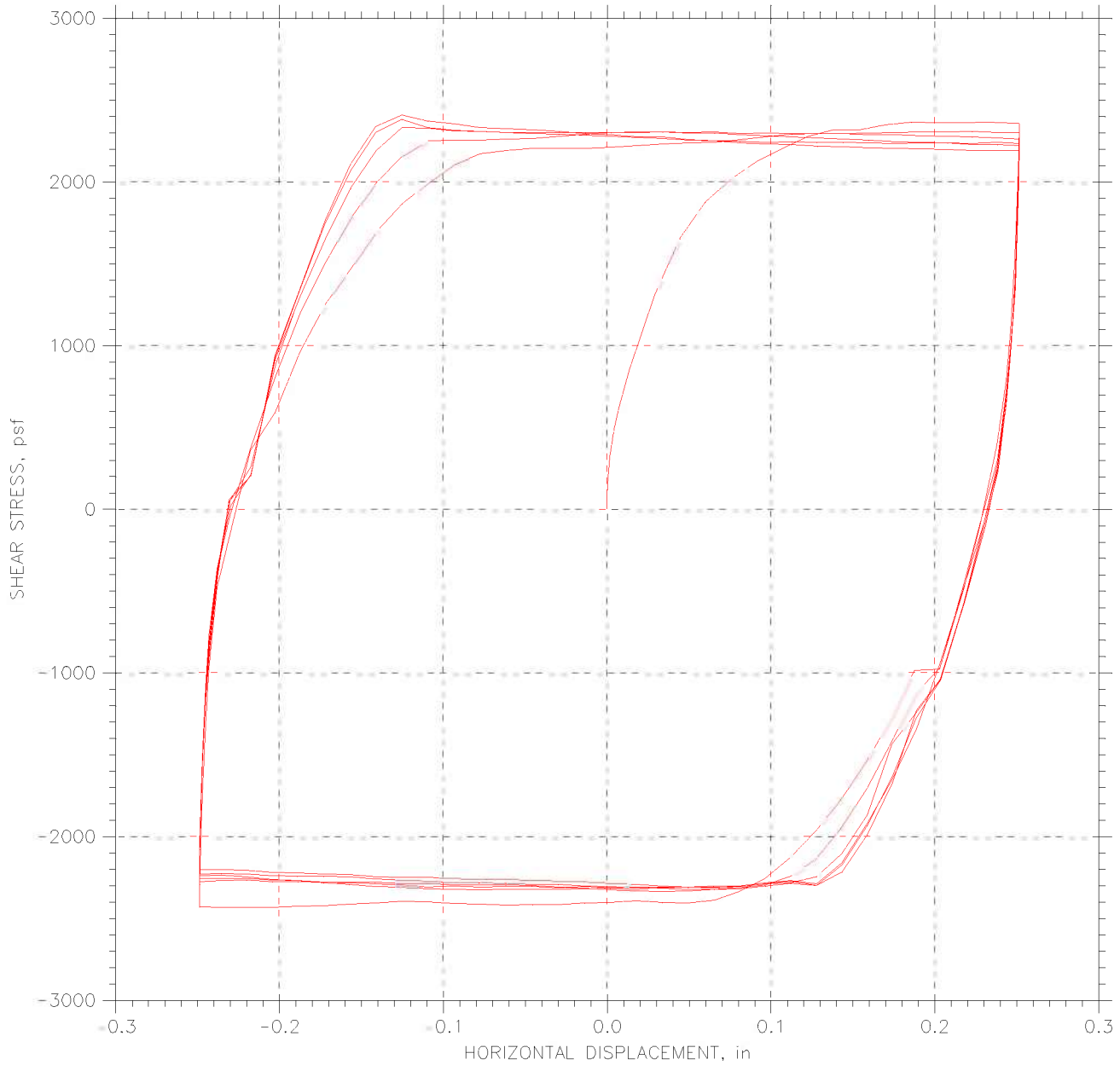

Project: I-90 Central Viaduct	Location: Cleveland, OH	Project No.: GTX-6678
Boring No.: C-05-03	Tested By: njh	Checked By: jdt
Sample No.: S-30	Test Date: 05/09/06	Depth: 118.5-120.3
Test No.: RS-1	Sample Type: tube	Elevation: ---
Description: Moist, dark gray clay		
Remarks: Shear Loop rates (in/min): All loops @ .003		
File: \\Geocomp\db1\projects\GTX6678\6678-rs1.dat		

RESIDUAL SHEAR TEST

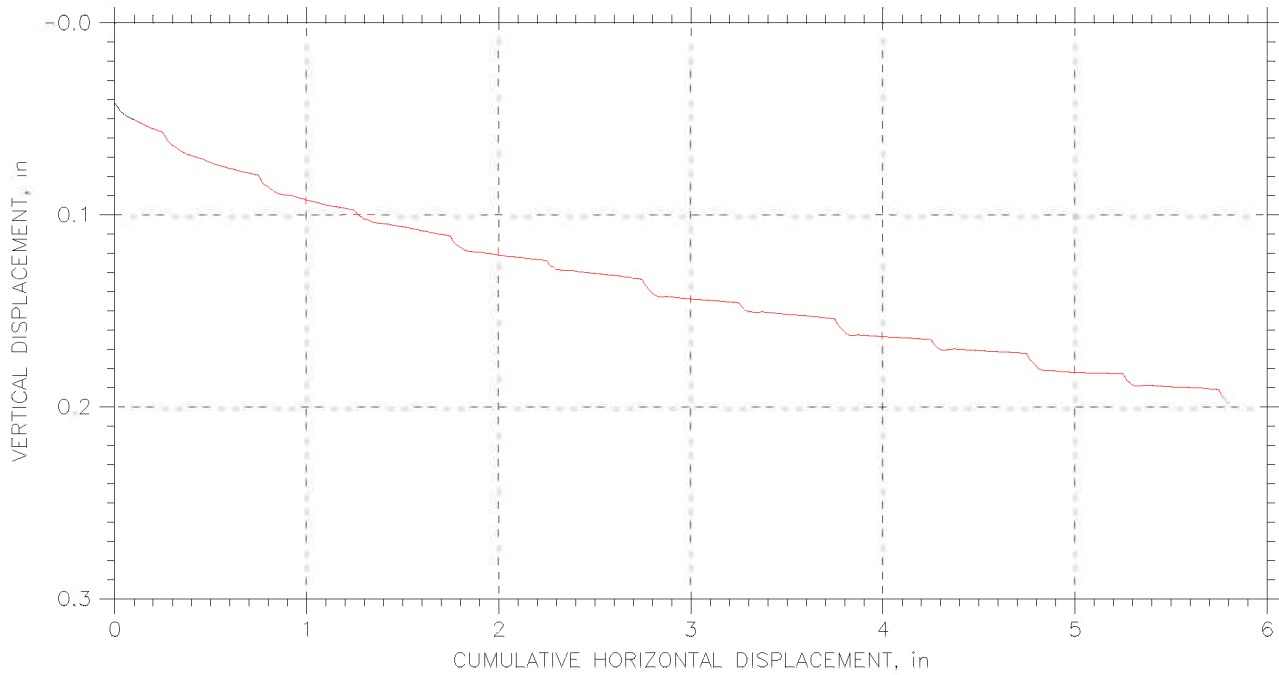
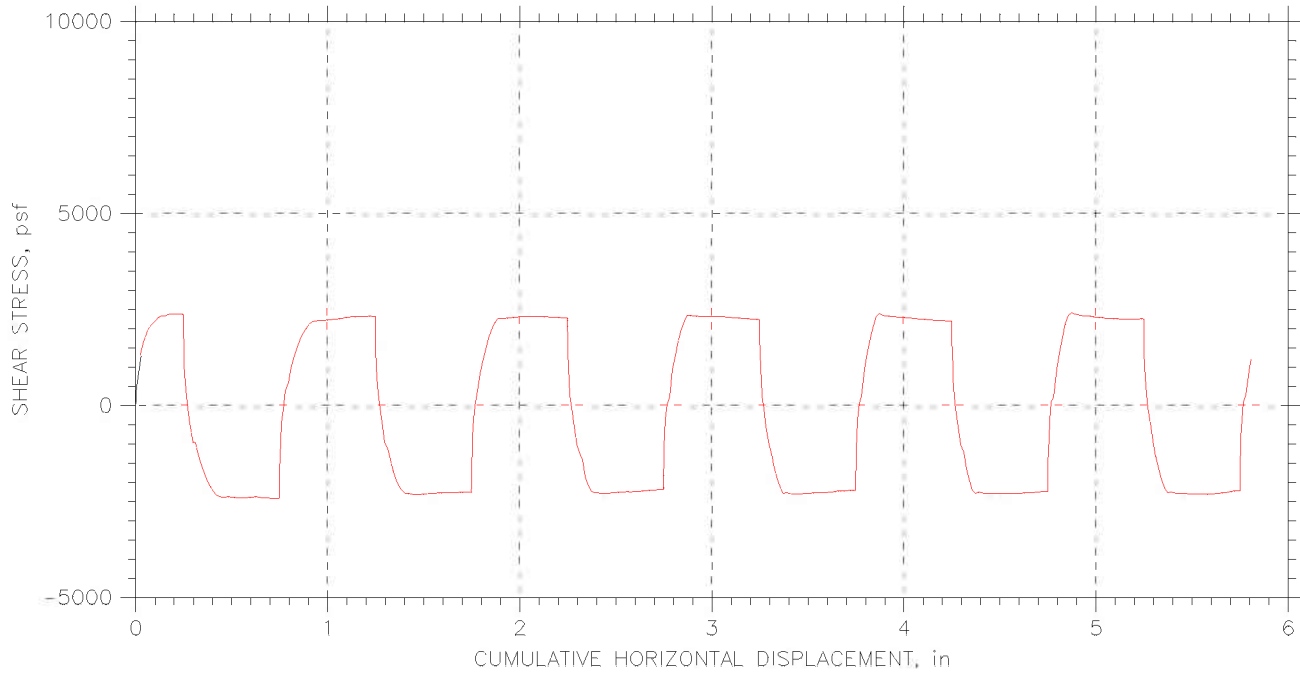

Project: I-90 Central Viaduct	Location: Cleveland, OH	Project No.: GTX-6678
Boring No.: C-05-03	Tested By: njh	Checked By: jdt
Sample No.: S-30	Test Date: 05/09/06	Depth: 118.5-120.3
Test No.: RS-1	Sample Type: tube	Elevation: ---
Description: Moist, dark gray clay		
Remarks: Shear Loop rates (in/min): All loops @ .003		
File: \\Geocomp\db1\projects\GTX6678\6678-rs1.dat		

RESIDUAL SHEAR TEST

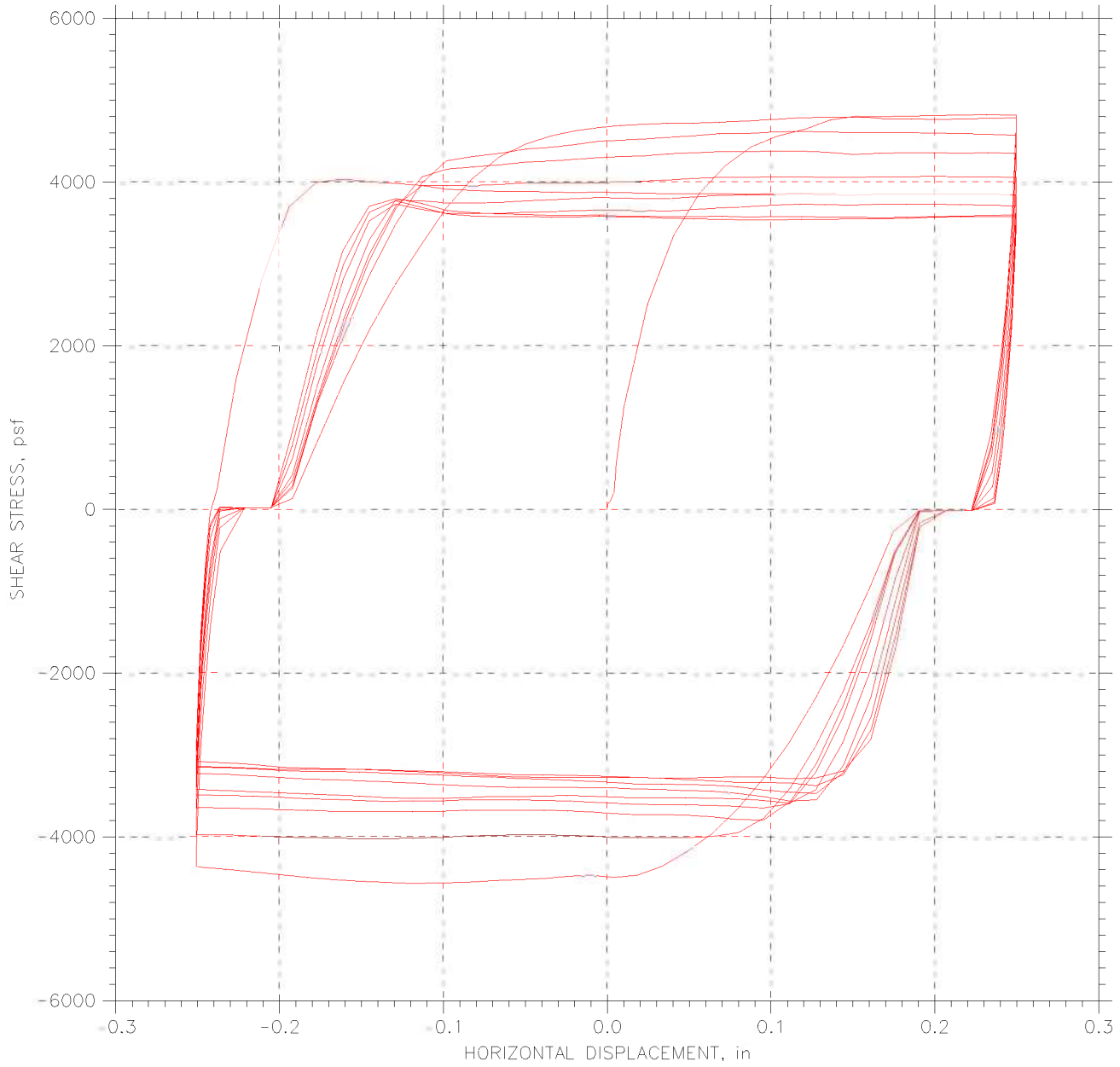

Project: I-90 Central Viaduct	Location: Cleveland, OH	Project No.: GTX-6678
Boring No.: C-05-03	Tested By: njh	Checked By: jdt
Sample No.: S-30	Test Date: 05/06/06	Depth: 118.5-120.3
Test No.: RS-2	Sample Type: tube	Elevation: ---
Description: Moist, dark gray clay		
Remarks: Shear Loop rates (in/min): All loops run @ .003		
File: \\Geocompdb1\projects\GTX6678\6678-rs2.dat		

RESIDUAL SHEAR TEST

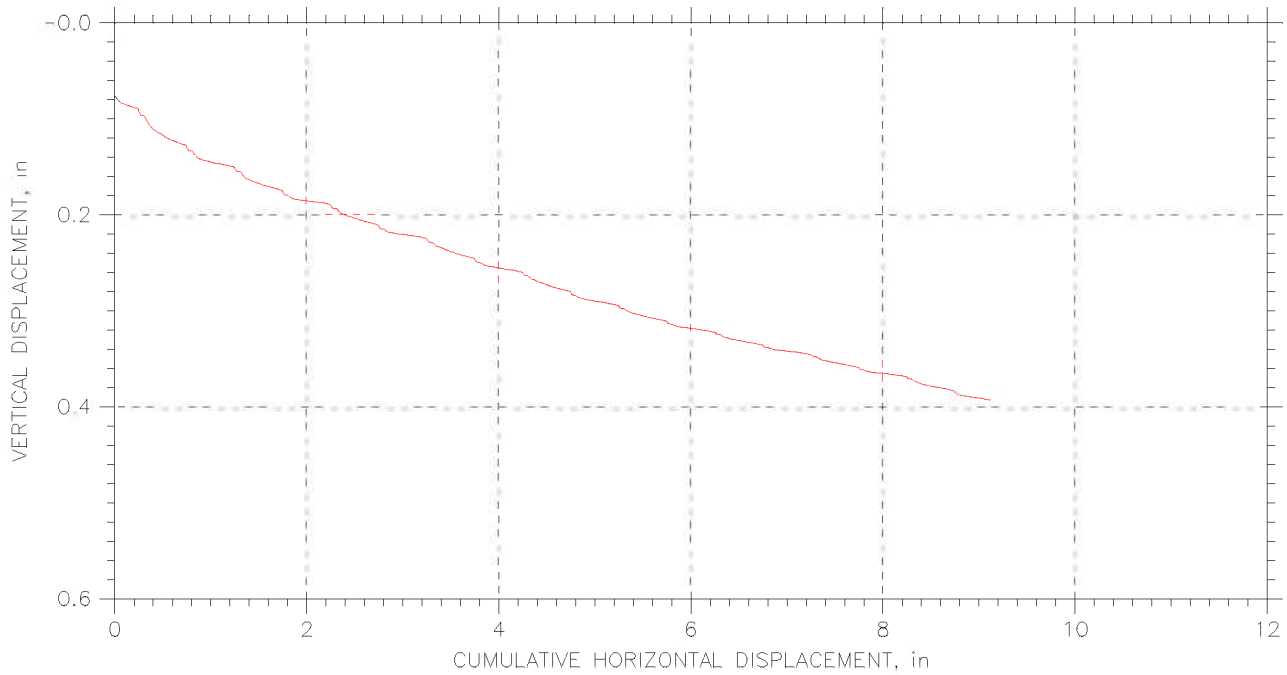
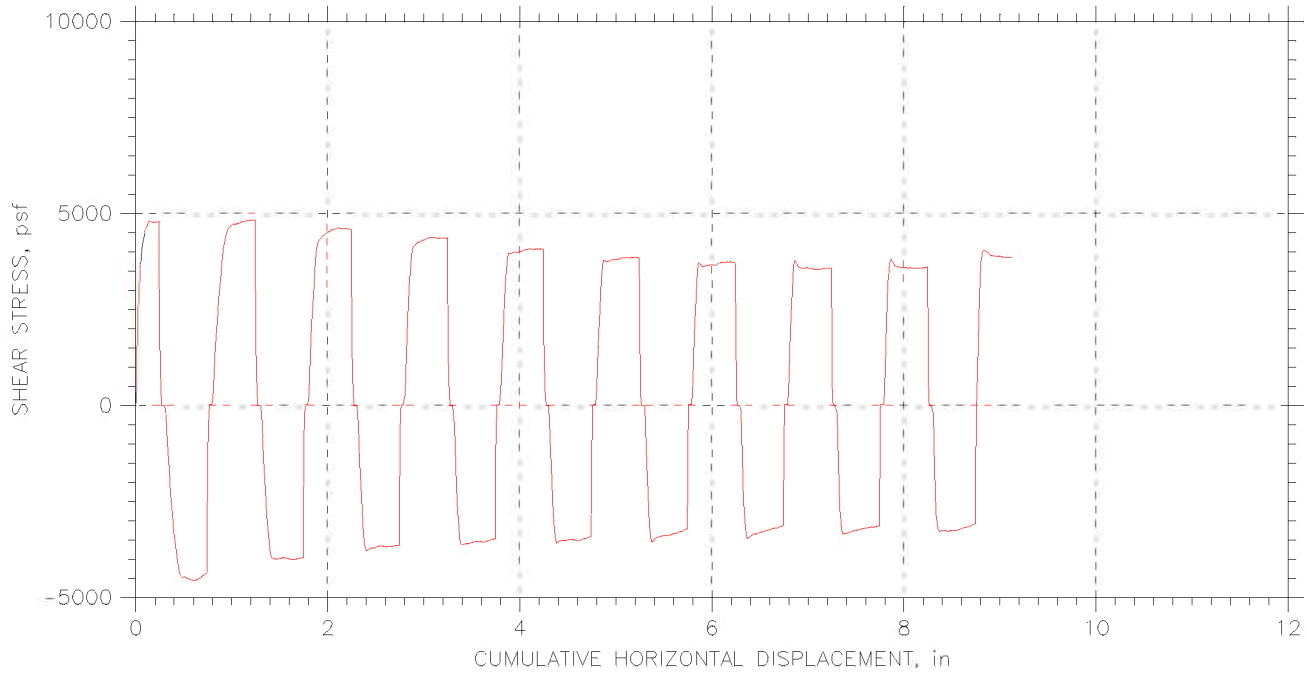

Project: I-90 Central Viaduct	Location: Cleveland, OH	Project No.: GTX-6678
Boring No.: C-05-03	Tested By: njh	Checked By: jdt
Sample No.: S-30	Test Date: 05/06/06	Depth: 118.5-120.3
Test No.: RS-2	Sample Type: tube	Elevation: ---
Description: Moist, dark gray clay		
Remarks: Shear Loop rates (in/min): All loops run @ .003		
File: \\Geocompdb1\projects\GTX6678\6678-rs2.dat		

RESIDUAL SHEAR TEST

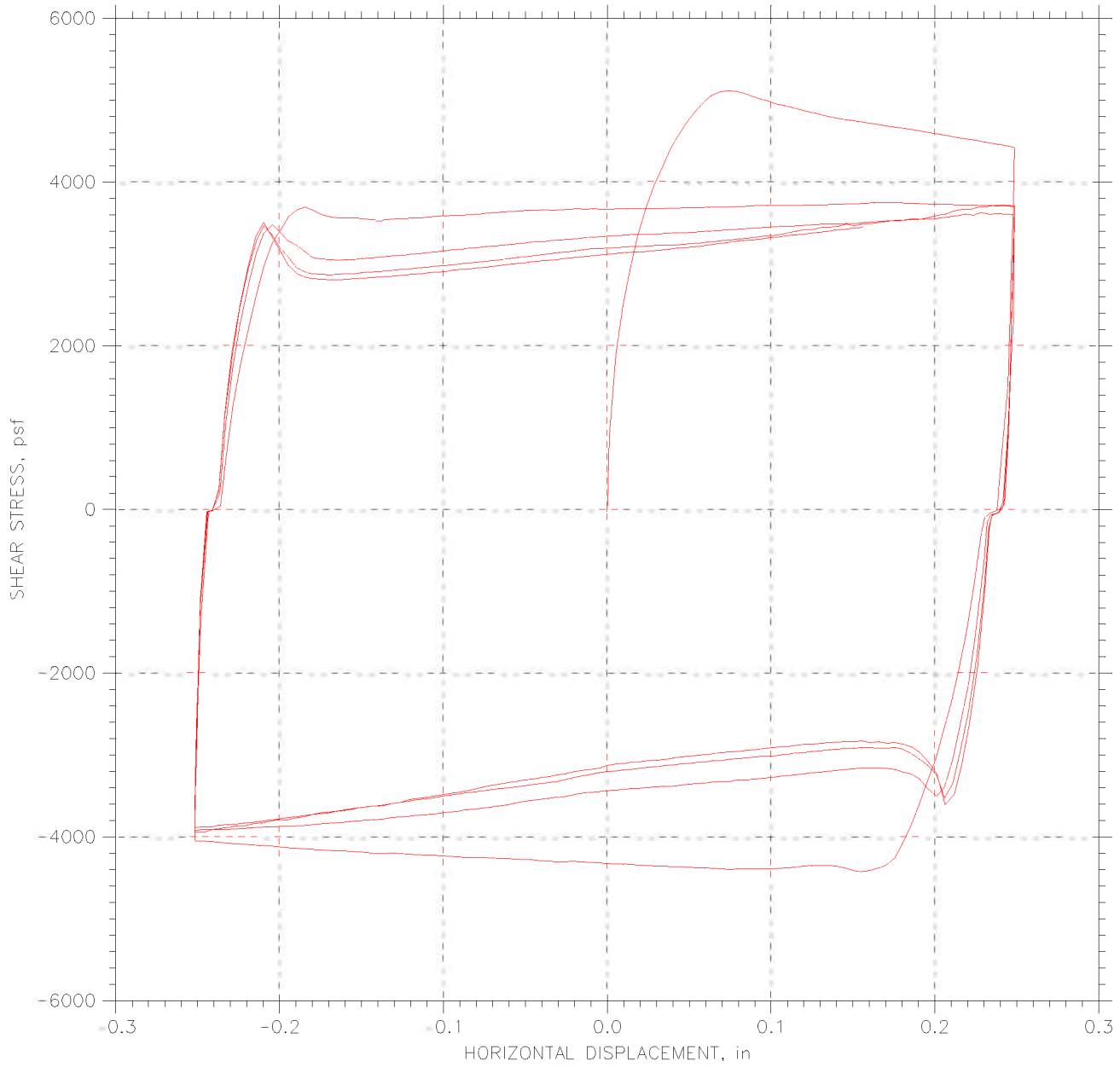

Project: I-90 Central Viaduct	Location: Cleveland OH	Project No.: Gtx-6678
Boring No.: C-05-03	Tested By: md	Checked By: jdt
Sample No.: S-30	Test Date: 05/15/06	Depth: 118.5-120.3
Test No.: RS3	Sample Type: tube	Elevation: ---
Description: Moist, dark gray clay		
Remarks: Shear Loop rates (in/min): All loops @ .001		
File: \\Geocomp\db1\projects\GTX6678\6678-rs3.dat		

RESIDUAL SHEAR TEST

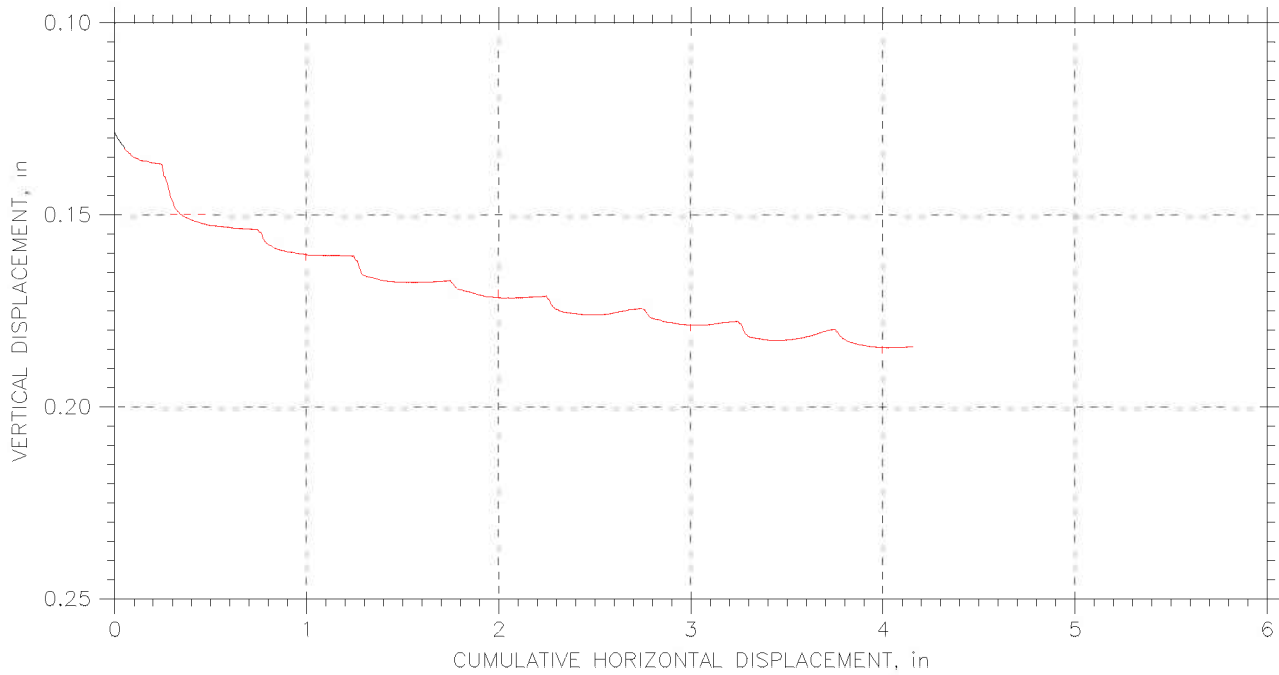
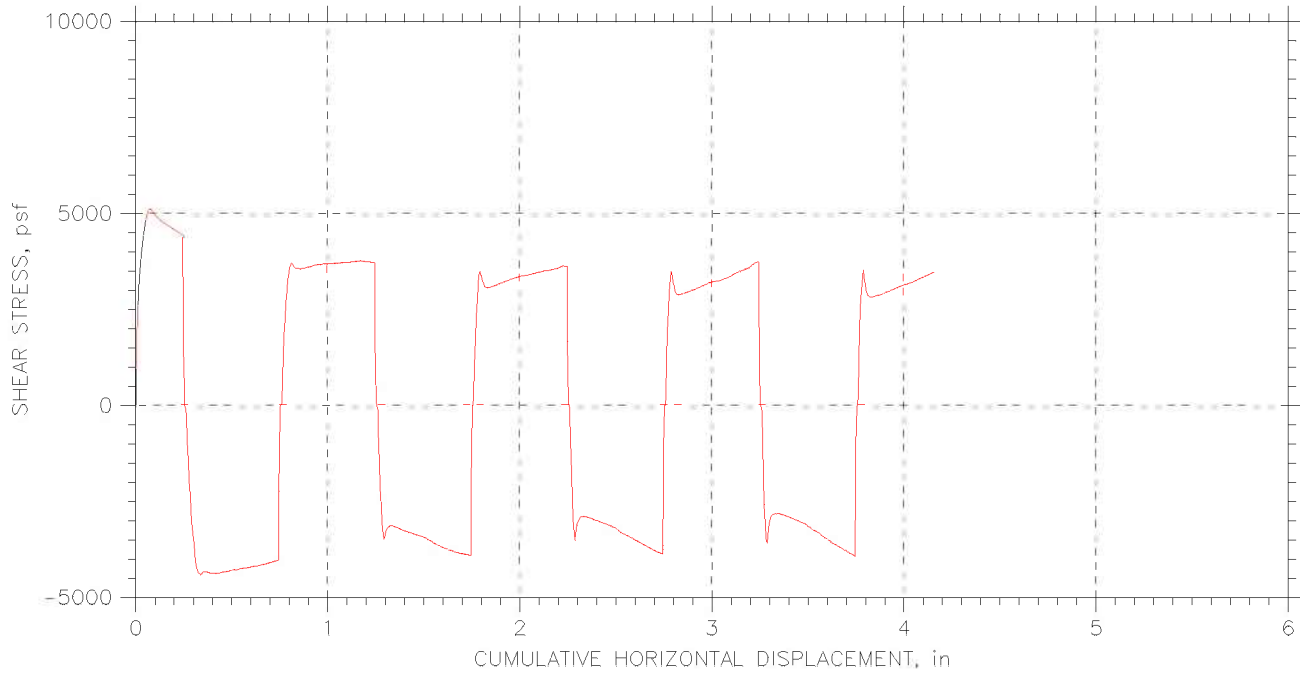

Project: I-90 Central Viaduct	Location: Cleveland OH	Project No.: Gtx-6678
Boring No.: C-05-03	Tested By: md	Checked By: jdt
Sample No.: S-30	Test Date: 05/15/06	Depth: 118.5-120.3
Test No.: RS3	Sample Type: tube	Elevation: ---
Description: Moist, dark gray clay		
Remarks: Shear Loop rates (in/min): All loops @ .001		
File: \\Geocompdb1\projects\GTX6678\6678-rs3.dat		



Client:	Geocomp Consulting		
Project Name:	I-90 Central Viaduct		
Project Location:	Cleveland, OH		
GTX #:	6678	Tested By:	njh/md
Test Date:	05/06-05/19/06	Checked By:	jdt
Boring ID:	C-05-04		
Sample ID:	S-27		
Depth, ft.	72-74 ft.		
Description:	Moist, very dark grayish brown clay		
Preparation:	Extruded from tube, cut and trimmed and tested at the as-received moisture and density.		

Direct Shear and Residual Shear by ASTM D 3080

Parameter	Point 1	Point 2	Point 3
Test No.	RS7	RS8	RS9
Initial Moisture Content, %	22	21	22
Initial Dry Density, pcf	107	107	107
Nominal Rate of Shear Strain, inches/min	0.0004	0.0004	0.0004
Vertical Consolidation Stress, psf	2752	3519	8258
Peak Shear Stress, psf	1580	1891	4519
Post-Peak Shear Stress, psf	1374	1681	4393
Final Moisture Content, %	23	23	20

Notes: Residual values taken near the end of the final shear step.	Peak Friction Angle:	28.4	degrees
	Peak Cohesion:	43	psf
	Post Peak Friction Angle:	27.5	degrees
	Post Peak Cohesion:	0	psf

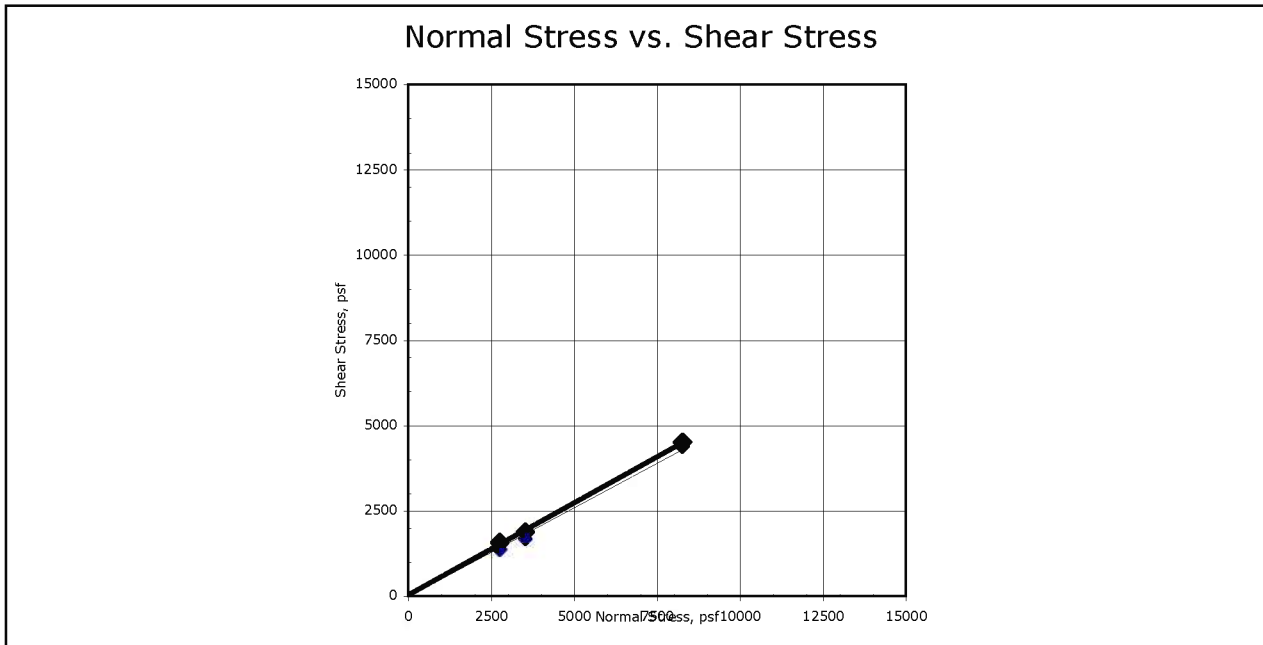

Comments: See attached plots for additional information

RESIDUAL SHEAR TEST

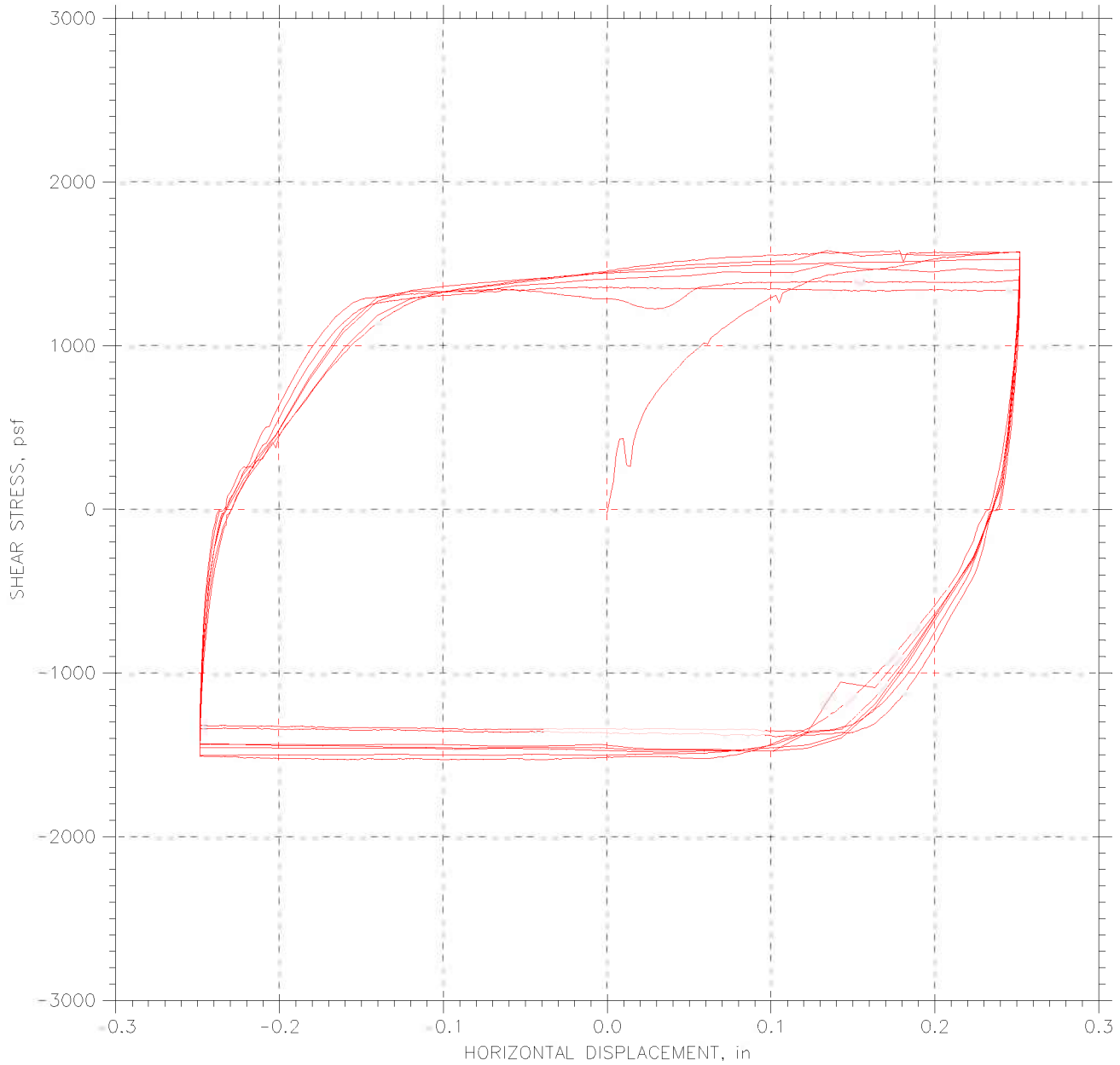

Project: I-90 Central Viaduct	Location: Cleveland, OH	Project No.: GTX-6678
Boring No.: C-05-04	Tested By: md	Checked By: jdt
Sample No.: S-27	Test Date: 05/19/06	Depth: 72-74 ft.
Test No.: RS-7	Sample Type: tube	Elevation: ---
Description: Moist, very dark grayish brown clay		
Remarks: Shear Loop rates (in/min): First 1.25 @ .0004, then 4 @ .004, then 2 @ .0004.		
File: \\Geocomp\db1\projects\GTX6678\6678-rs7.dat		

RESIDUAL SHEAR TEST

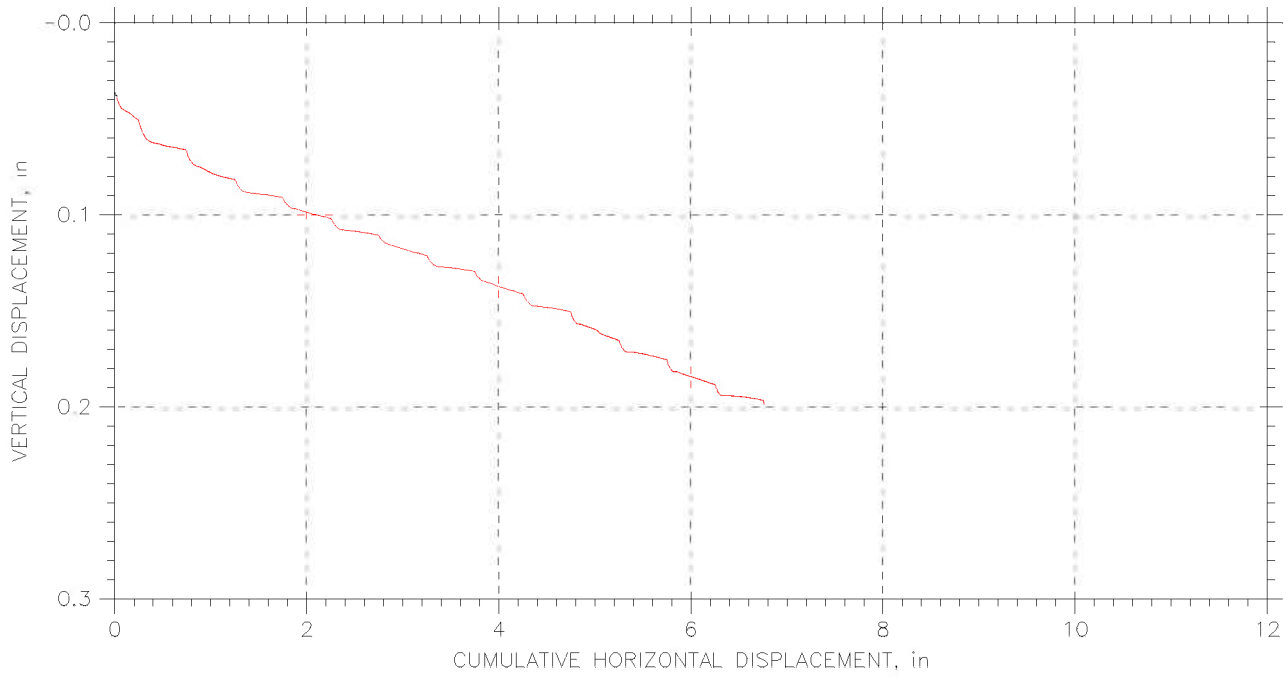
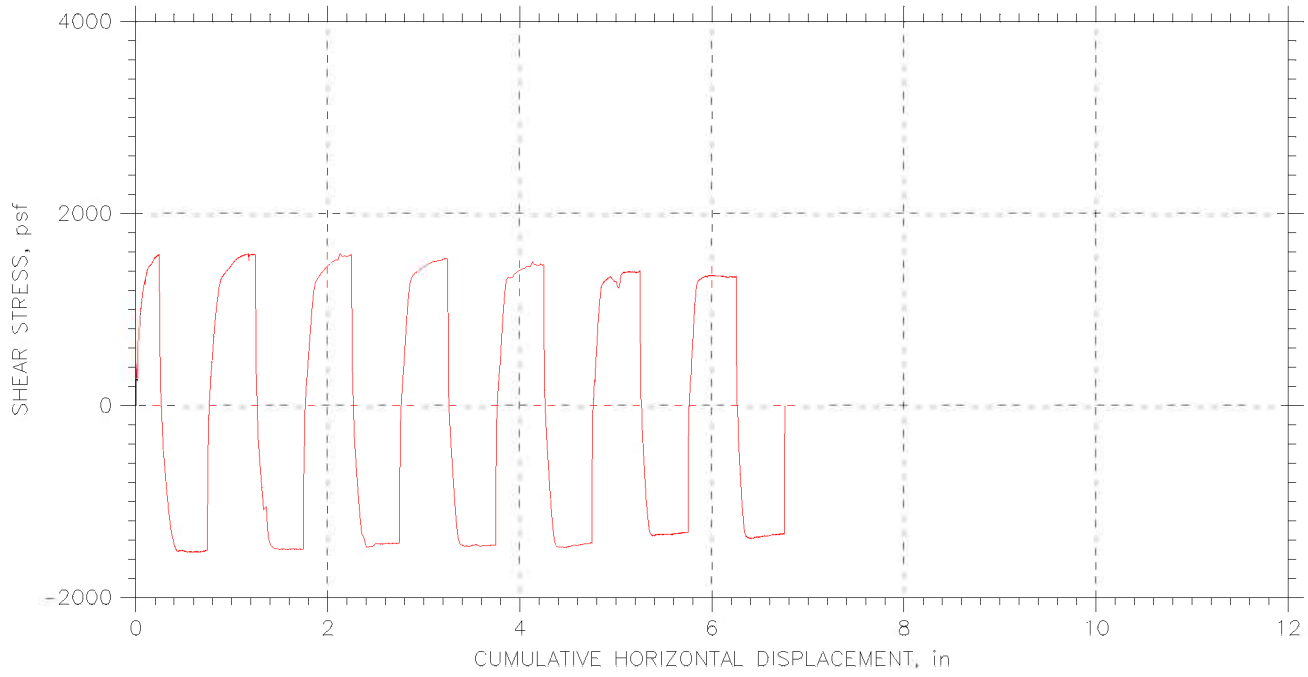

Project: I-90 Central Viaduct	Location: Cleveland, OH	Project No.: GTX-6678
Boring No.: C-05-04	Tested By: md	Checked By: jdt
Sample No.: S-27	Test Date: 05/19/06	Depth: 72-74 ft.
Test No.: RS-7	Sample Type: tube	Elevation: ---
Description: Moist, very dark grayish brown clay		
Remarks: Shear Loop rates (in/min): First 1.25 @ .0004, then 4 @ .004, then 2 @ .0004.		
File: \\Geocompb1\projects\GTX6678\6678-rs7.dat		

RESIDUAL SHEAR TEST

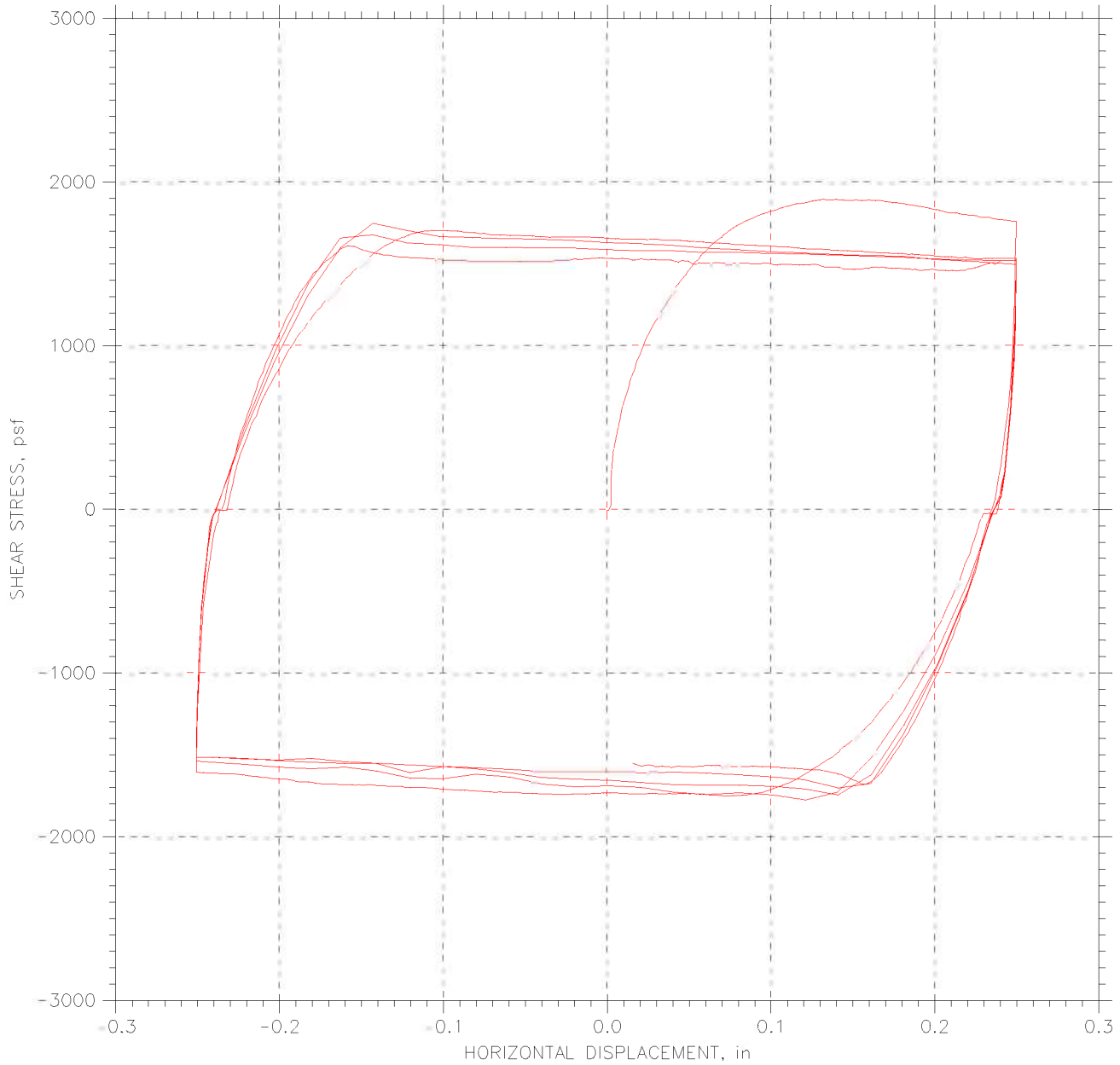

Project: I-90 Central Viaduct	Location: Cleveland OH	Project No.: Gtx-6678
Boring No.: C-05-04	Tested By: md	Checked By: jdt
Sample No.: S-27	Test Date: 05/19/06	Depth: 72-74 ft
Test No.: RS-8	Sample Type: tube	Elevation: ---
Description: Moist, very dark grayish brown clay		
Remarks: Shear Loop rates (in/min): First 1.25 @ .0004, then 2.5 @ .004, then 1 @ .0004.		
File: \\Geocomp\db1\projects\GTX6678\6678-RS8njh2-final test.dat		

RESIDUAL SHEAR TEST

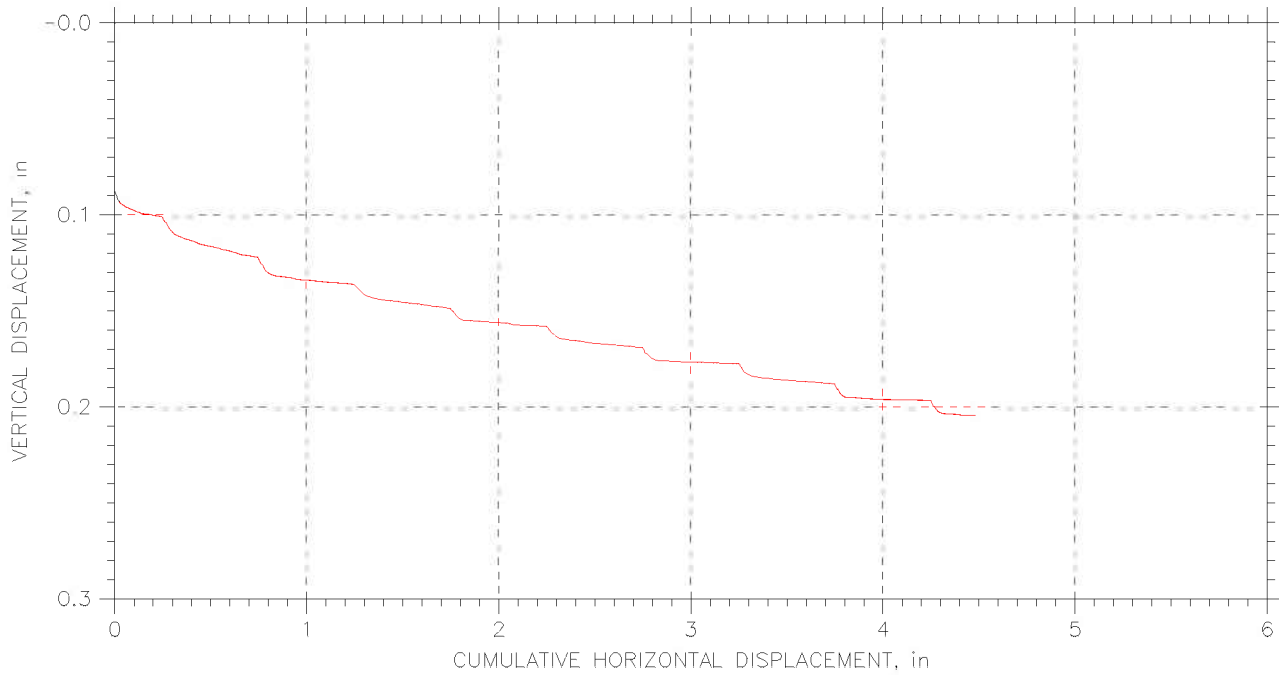
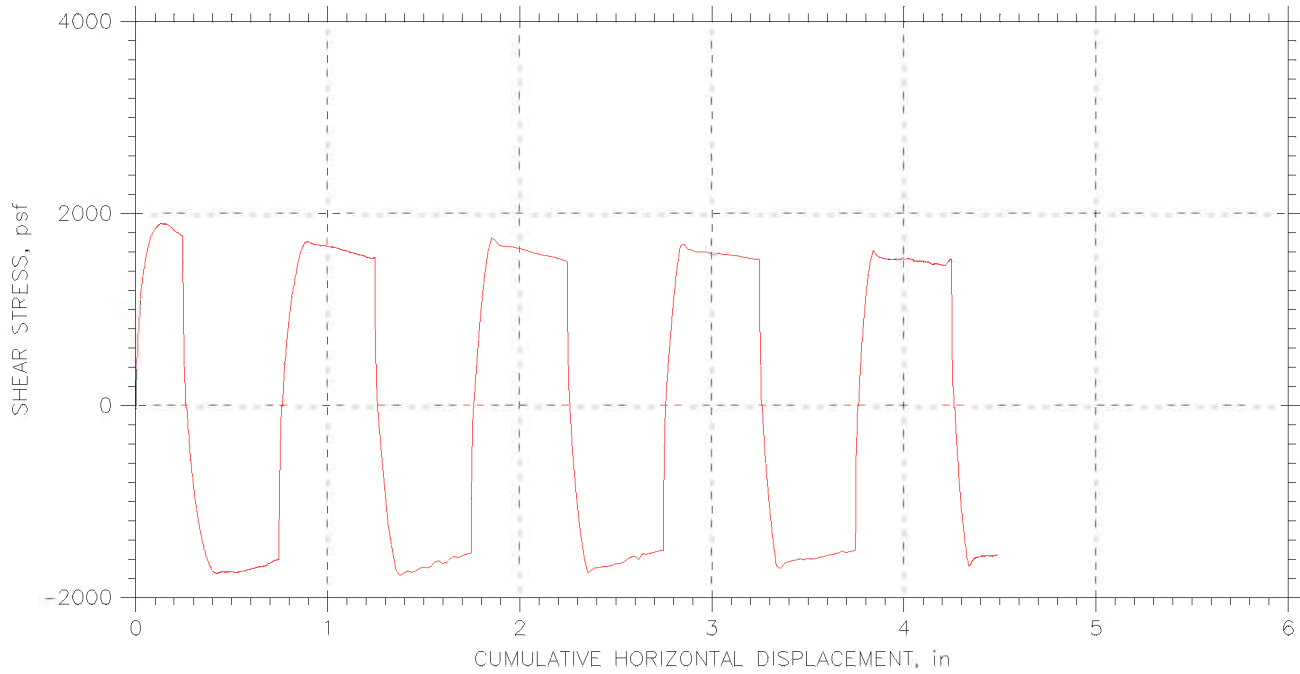

Project: I-90 Central Viaduct	Location: Cleveland OH	Project No.: Gtx-6678
Boring No.: C-05-04	Tested By: md	Checked By: jdt
Sample No.: S-27	Test Date: 05/19/06	Depth: 72-74 ft
Test No.: RS-8	Sample Type: tube	Elevation: ---
Description: Moist, very dark grayish brown clay		
Remarks: Shear Loop rates (in/min): First 1.25 @ .0004, then 2.5 @ .004, then 1 @ .0004.		
File: \\Geocomp\db1\projects\GTX6678\6678-RS8njh2-final test.dat		

RESIDUAL SHEAR TEST

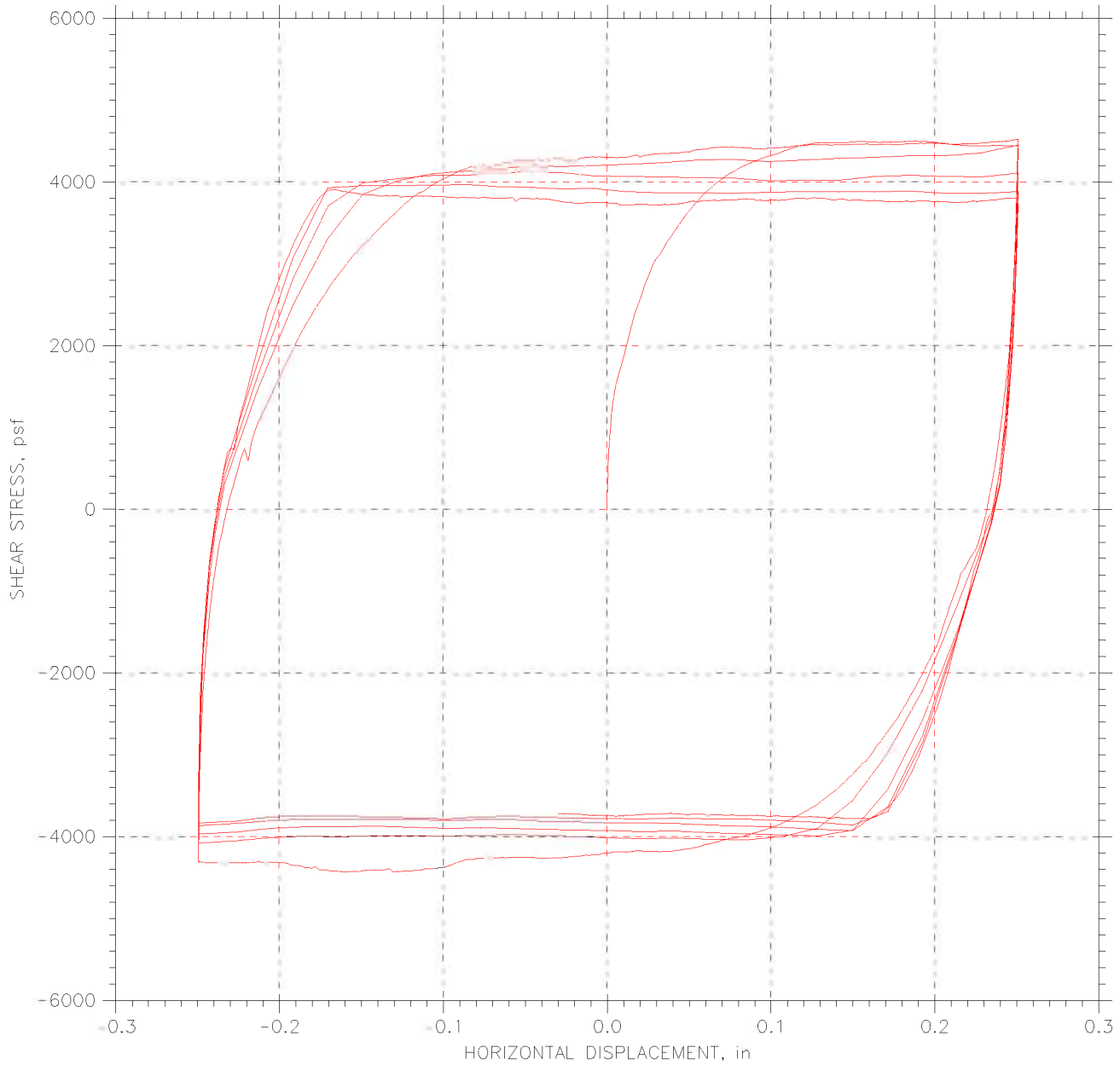

Project: I-90 Central Viaduct	Location: Cleveland, OH	Project No.: GTX-6678
Boring No.: C-05-04	Tested By: md	Checked By: jdt
Sample No.: S-27	Test Date: 05/19/06	Depth: 72-74 ft
Test No.: RS-9	Sample Type: tube	Elevation: ---
Description: Moist, very dark grayish brown clay		
Remarks: Shear Loop rates (in/min): First 1.25 @ .0004, then 3.5 @ .004, then 1 @ .0004.		
File: \\Geocomp\db1\projects\GTX6678\6678-rs9njh1.dat		

RESIDUAL SHEAR TEST

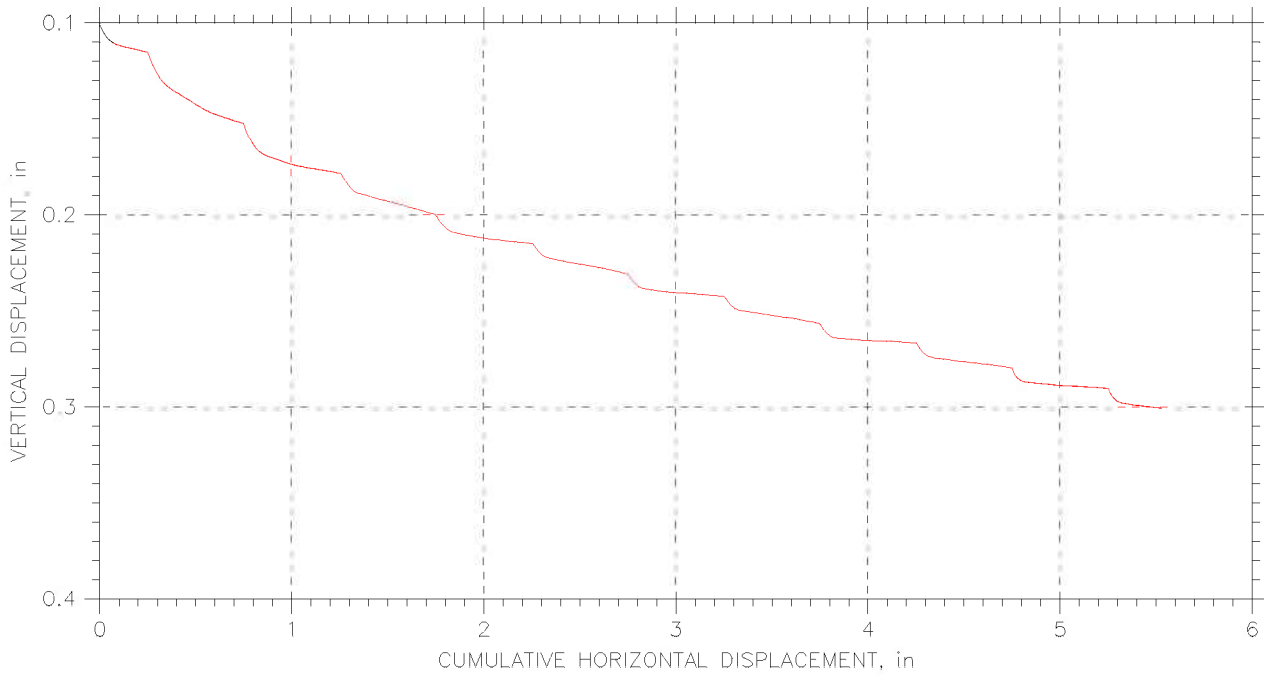
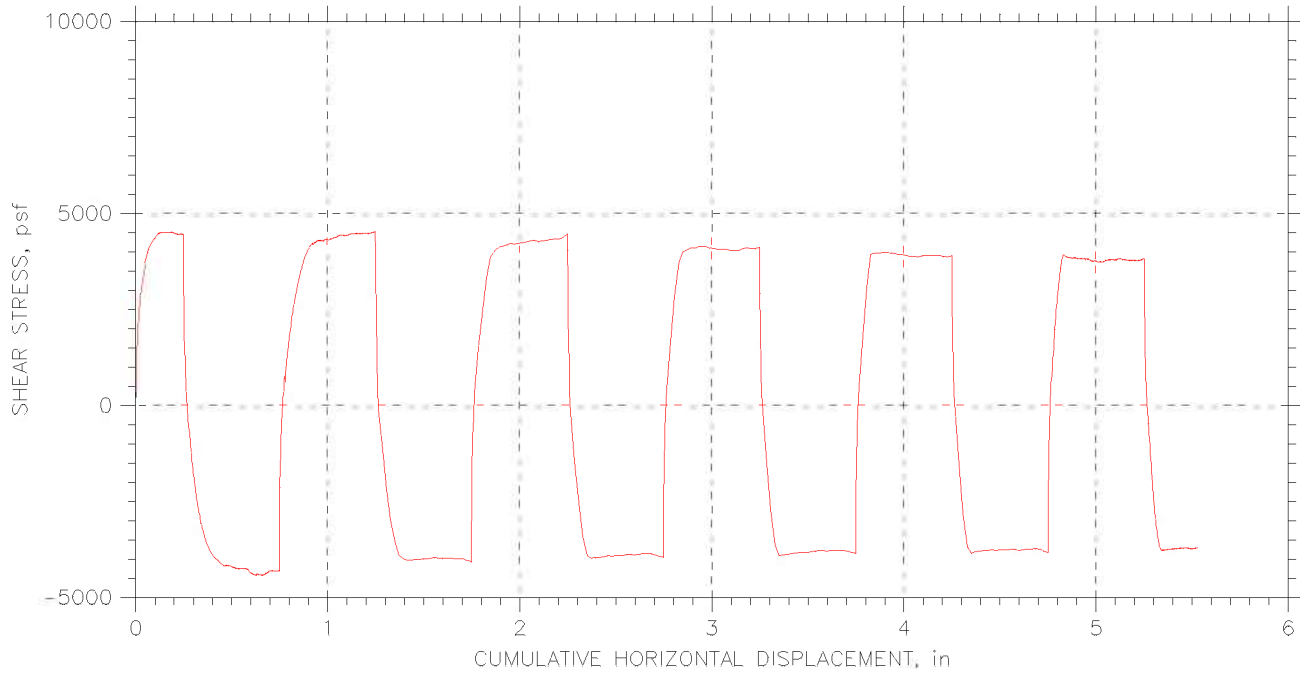

Project: I-90 Central Viaduct	Location: Cleveland, OH	Project No.: GTX-6678
Boring No.: C-05-04	Tested By: md	Checked By: jdt
Sample No.: S-27	Test Date: 05/19/06	Depth: 72-74 ft
Test No.: RS-9	Sample Type: tube	Elevation: ---
Description: Moist, very dark grayish brown clay		
Remarks: Shear Loop rates (in/min): First 1.25 @ .0004, then 3.5 @ .004, then 1 @ .0004.		
File: \\Geocomp\db1\projects\GTX6678\6678-rs9njh1.dat		

RESIDUAL SHEAR TEST

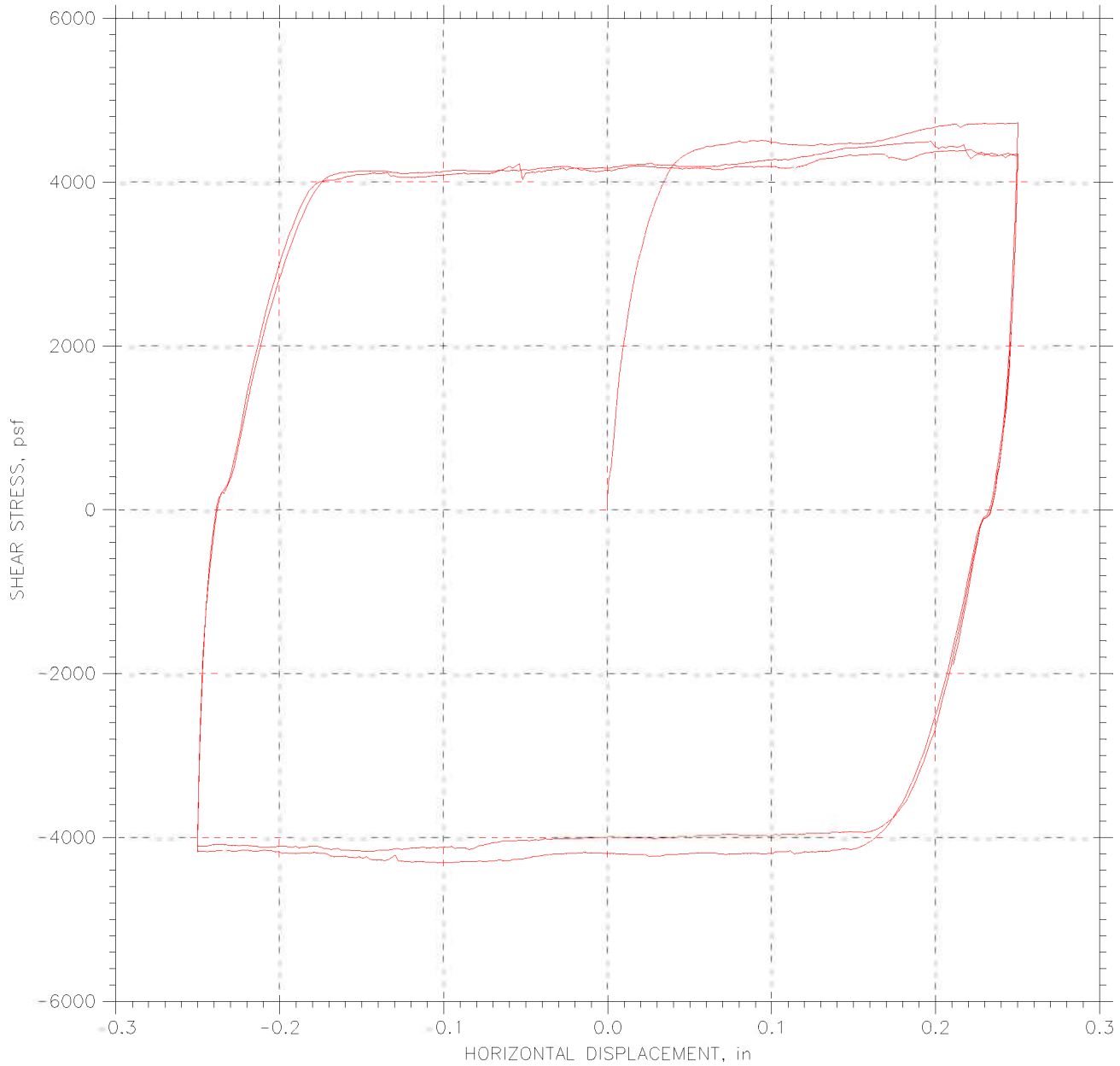

Project: I-90 Central Viaduct	Location: Cleveland, OH	Project No.: GTX-6678
Boring No.: C-05-04	Tested By: md	Checked By: jdt
Sample No.: S-27	Test Date: 05/19/06	Depth: 72-74 ft
Test No.: RS-9	Sample Type: tube	Elevation: ---
Description: Moist, very dark grayish brown clay		
Remarks: Shear Loop rates (in/min): All loops @ .0004. Continuation of test after normal load was lost and reapplied.		
File: \\Geocomp\db1\projects\GTX6678\6678-rs9a.dat		

RESIDUAL SHEAR TEST

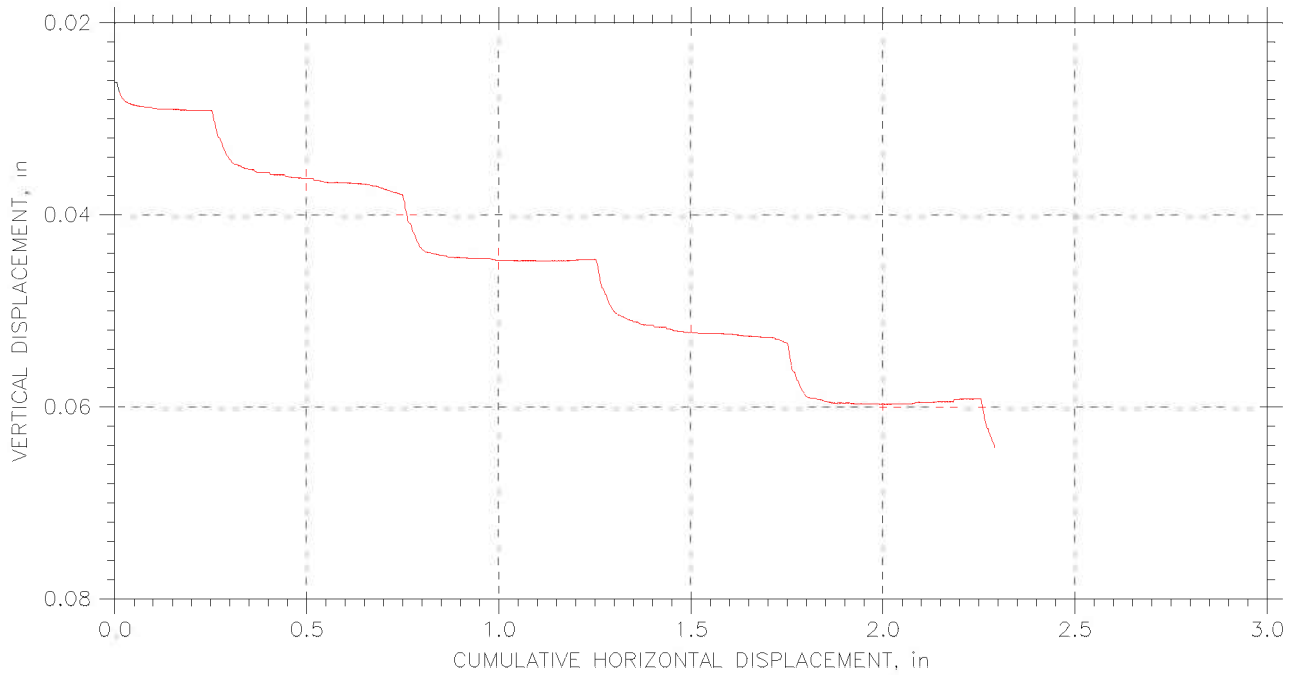
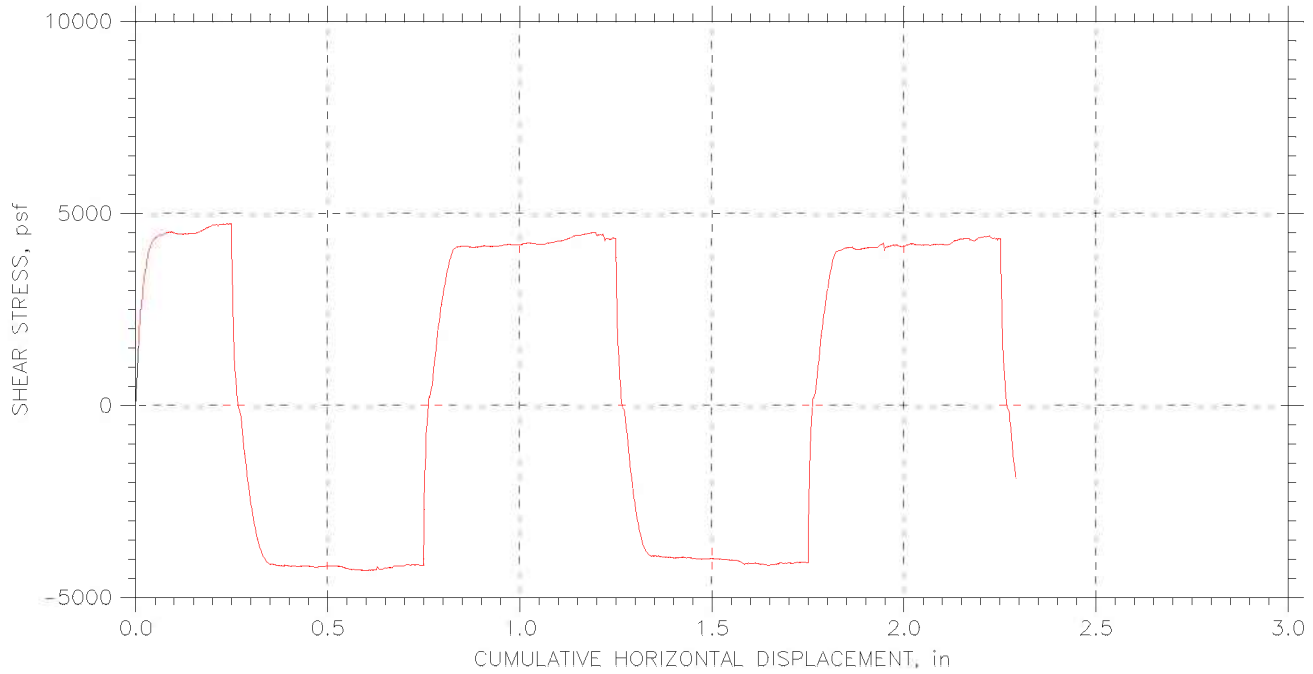

Project: I-90 Central Viaduct	Location: Cleveland, OH	Project No.: GTX-6678
Boring No.: C-05-04	Tested By: md	Checked By: jdt
Sample No.: S-27	Test Date: 05/19/06	Depth: 72-74 ft
Test No.: RS-9	Sample Type: tube	Elevation: ---
Description: Moist, very dark grayish brown clay		
Remarks: Shear Loop rates (in/min): All loops @ .0004. Continuation of test after normal load was lost and reapplied.		
File: \\Geocomp\db1\projects\GTX6678\6678-rs9a.dat		

Client:	Geocomp Consulting		
Project Name:	I-90 Central Viaduct		
Project Location:	Cleveland, OH		
GTX #:	6678	Tested By:	njh/md
Test Date:	05/30/06	Checked By:	jdt
Boring ID:	B-05-08		
Sample ID:	S-27		
Depth, ft.	116-118 ft		
Description:	Moist, olive gray clay		
Preparation:	Extruded from tube, cut and trimmed and tested at the as-received moisture and density.		

Direct Shear and Residual Shear by ASTM D 3080

Parameter	Point 1	Point 2	Point 3
Test No.	RS10		
Initial Moisture Content, %	21		
Initial Dry Density, pcf	108		
Nominal Rate of Shear Strain, inches/min	0.0002		
Vertical Consolidation Stress, psf	4130		
Peak Shear Stress, psf	2677		
Post-Peak Shear Stress, psf	2385		
Final Moisture Content, %	19		

Notes: Residual values taken near the end of the final shear step.	Peak Friction Angle:	33.0	degrees
	Peak Cohesion:	0	psf
	Post Peak Friction Angle:	30.0	degrees
	Post Peak Cohesion:	0	psf

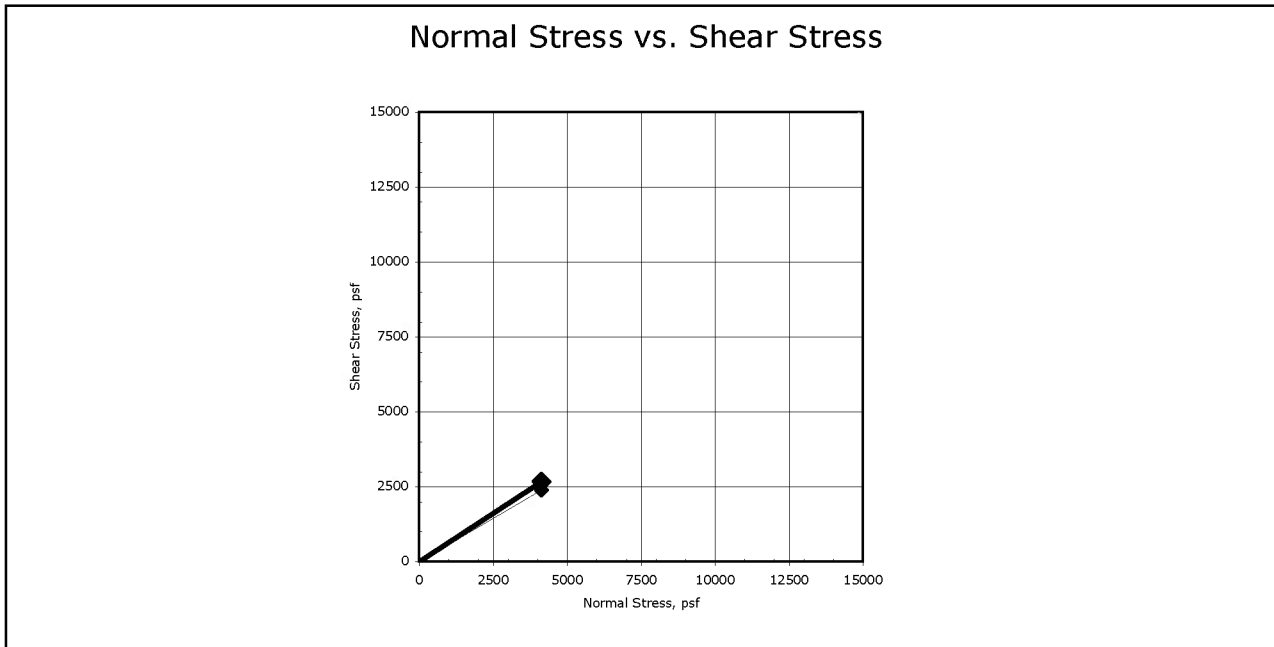

Comments: See attached plots for additional information

RESIDUAL SHEAR TEST

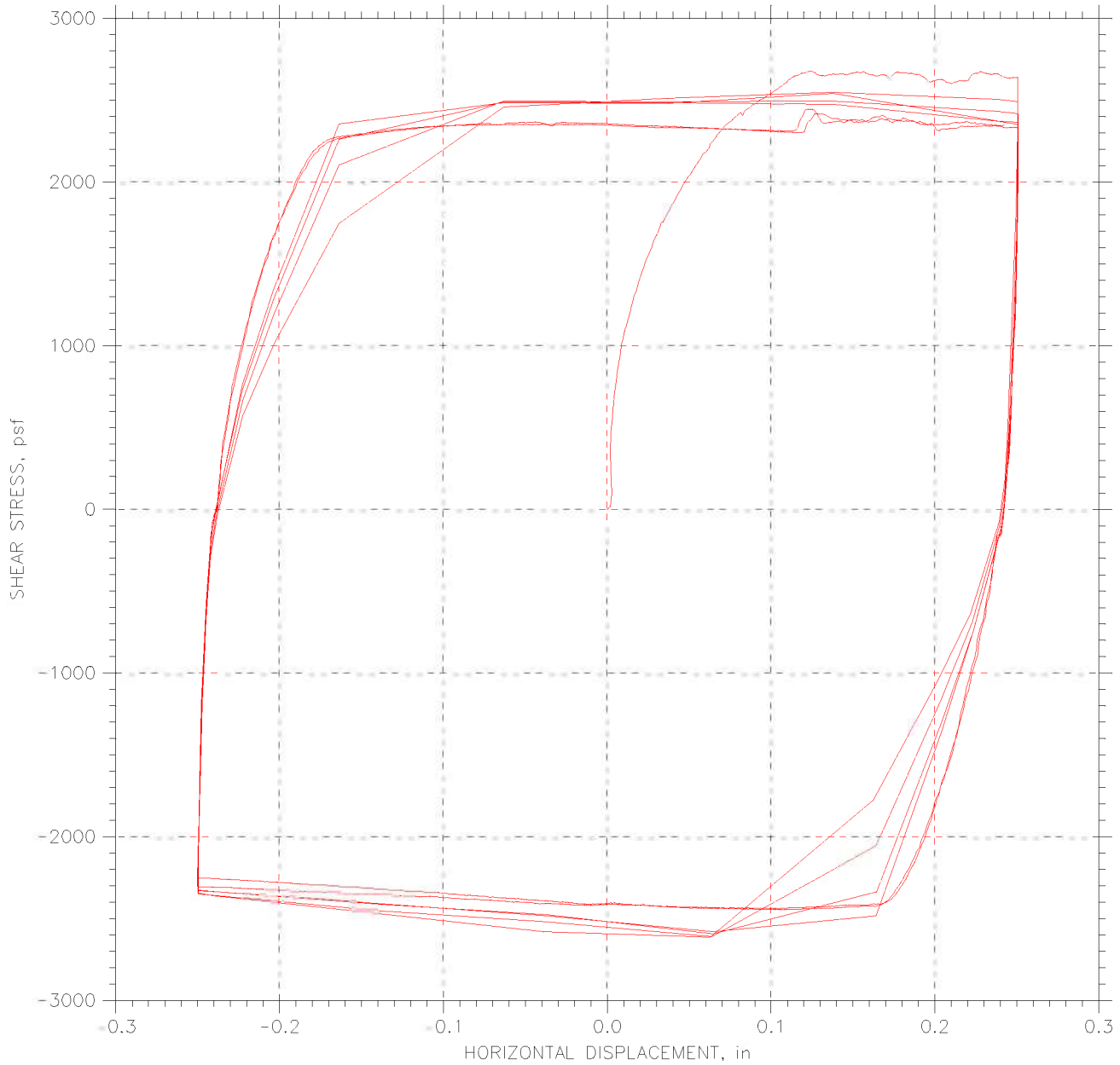

Project: I-90 Central Viaduct	Location: Cleveland, OH	Project No.: Gtx-6678
Boring No.: S-27	Tested By: md	Checked By: jdt
Sample No.: B-05-08	Test Date: 05/30/06	Depth: 116-118 ft
Test No.: RS-10	Sample Type: tube	Elevation: ---
Description: Moist, olive gray clay		
Remarks: Shear Loop rates (in/min): First .25 @ .0002, then 4 @ .02, then 2 @ .0002.		
File: \\Geocompdb1\projects\GTX6678\6678-RS10.dat		

RESIDUAL SHEAR TEST

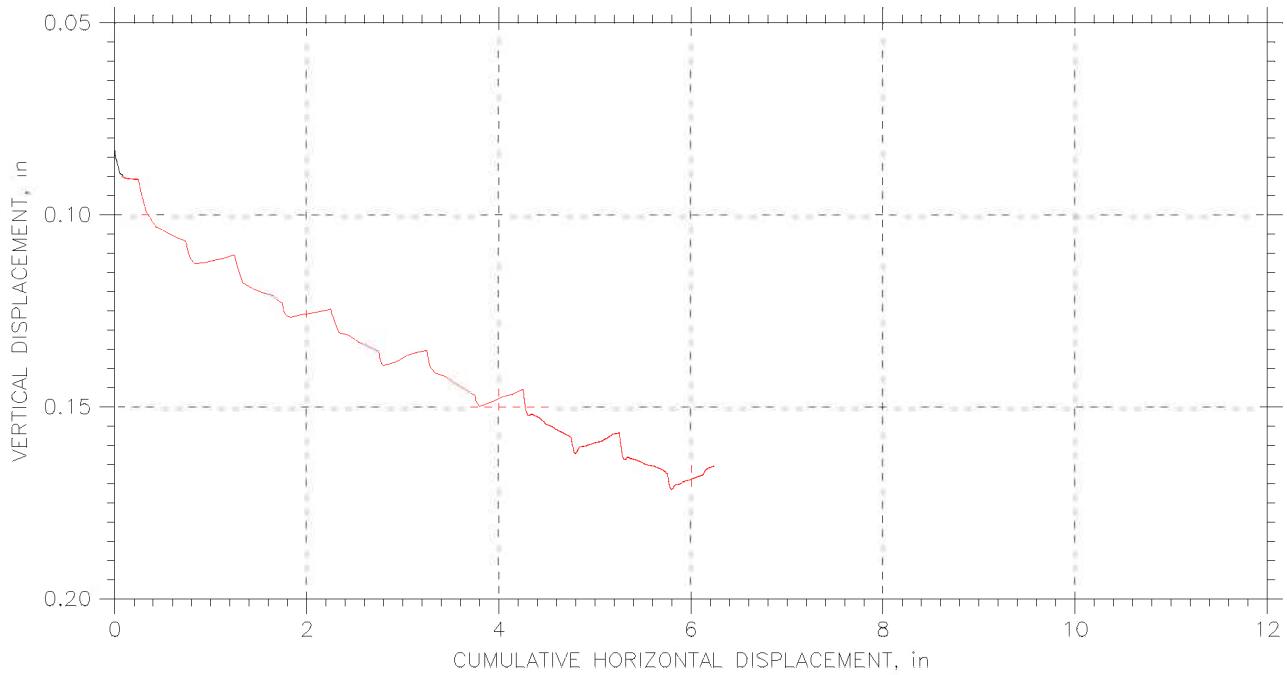
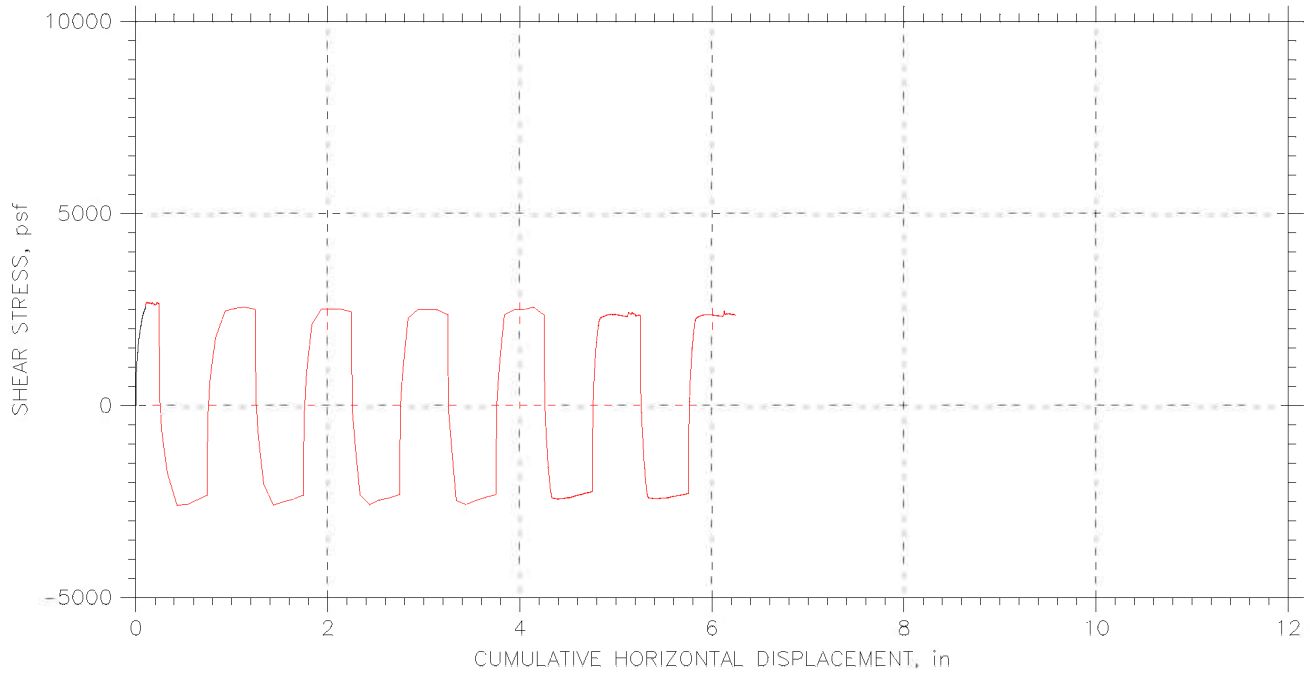

Project: I-90 Central Viaduct	Location: Cleveland, OH	Project No.: Gtx-6678
Boring No.: S-27	Tested By: md	Checked By: jdt
Sample No.: B-05-08	Test Date: 05/30/06	Depth: 116-118 ft
Test No.: RS-10	Sample Type: tube	Elevation: ---
Description: Moist, olive gray clay		
Remarks: Shear Loop rates (in/min): First .25 @ .0002, then 4 @ .02, then 2 @ .0002.		
File: \\Geocompdb1\projects\GTX6678\6678-RS10.dat		

Appendix E

CIU Triaxial Tests

CONSOLIDATED UNDRAINED TRIAXIAL TEST by ASTM D4767

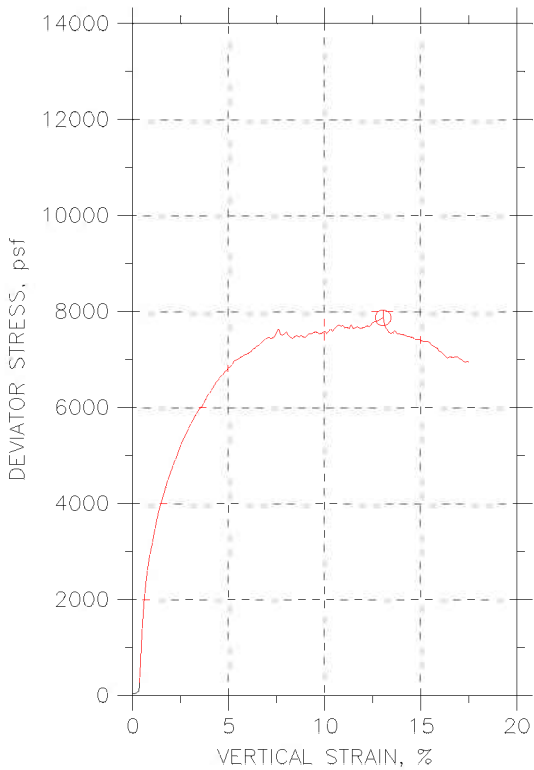
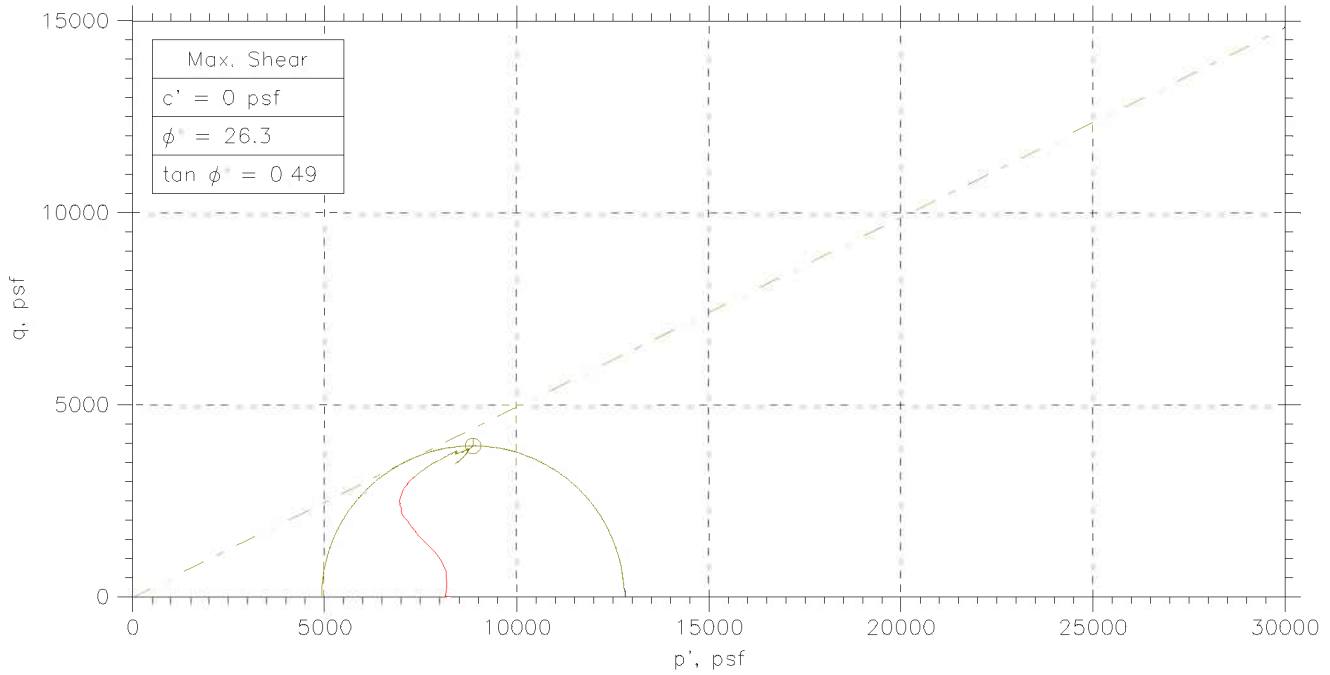

Symbol	⊙		
Sample No.	S-30		
Test No.	CU1		
Depth	118.5-120.3		
Initial	Diameter, in	2.87	
	Height, in	5.96	
	Water Content, %	26.7	
	Dry Density, pcf	95.1	
	Saturation, %	91.9	
Before Shear	Void Ratio	0.792	
	Water Content, %	25.2	
	Dry Density, pcf	100.9	
	Saturation*, %	100.0	
	Void Ratio	0.688	
	Back Press., psf	14410	
	Ver. Eff. Cons. Stress, psf	9493	
	Shear Strength, psf	3934	
	Strain at Failure, %	13	
	Strain Rate, %/min	0.05	
	B-Value	0.95	
	Measured Specific Gravity	2.73	
	Liquid Limit	33	
	Plastic Limit	18	

	Project: I-90 Central Viaduct				
	Location: Cleveland, OH				
	Project No.: GTX-6678				
	Boring No.: C-05-03				
	Sample Type: tube				
	Description: Moist, dark gray clay				
Remarks: ---					

CONSOLIDATED UNDRAINED TRIAXIAL TEST by ASTM D4767

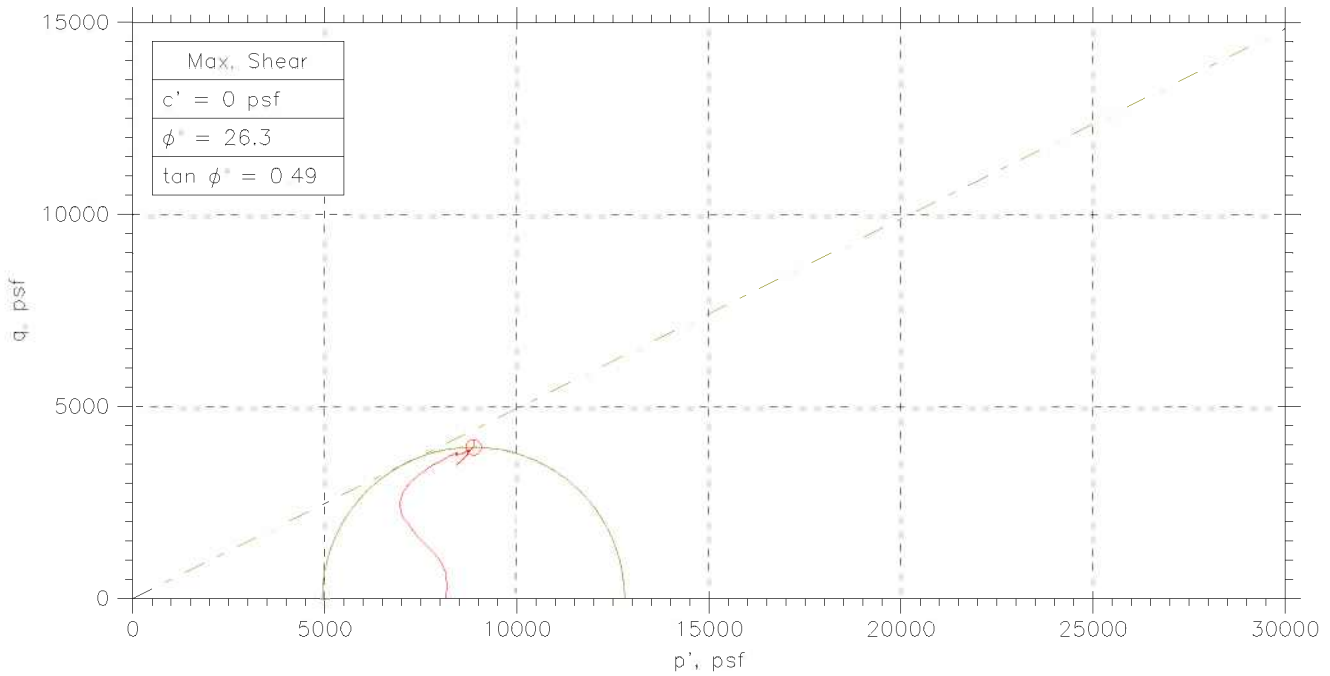
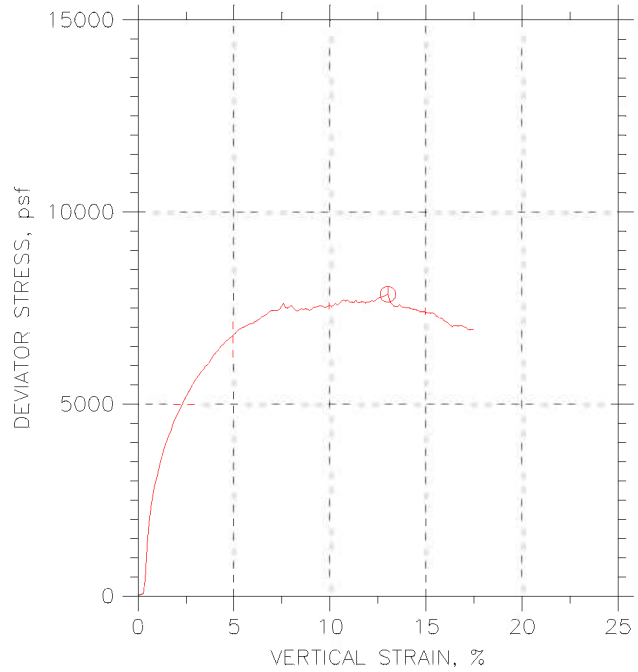
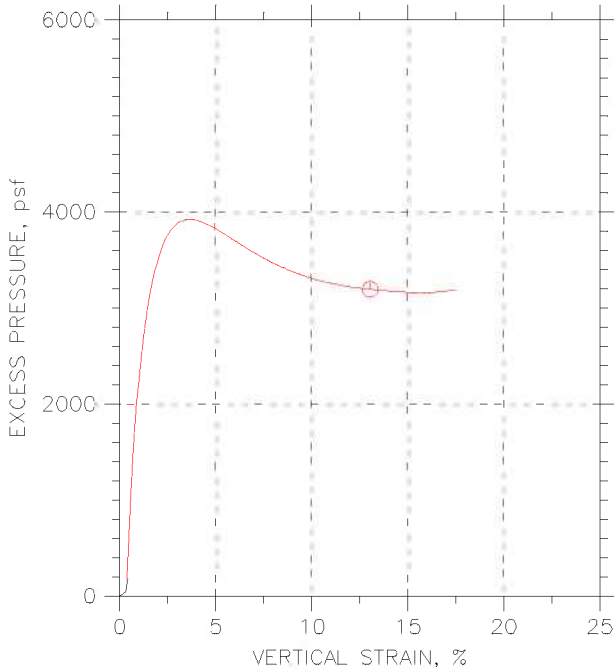

Sample No.	Test No.	Depth	Tested By	Test Date	Checked By	Check Date	Test File
⊙ S-30	CU1	118.5-120.3 njh		05/31/06	jdt		6678-cu1c.dat

	Project: I-90 Central Viaduct	Location: Cleveland, OH	Project No.: GTX-6678
	Boring No.: C-05-03	Sample Type: tube	
	Description: Moist, dark gray clay		
	Remarks: ---		

CONSOLIDATED UNDRAINED TRIAXIAL TEST by ASTM D4767

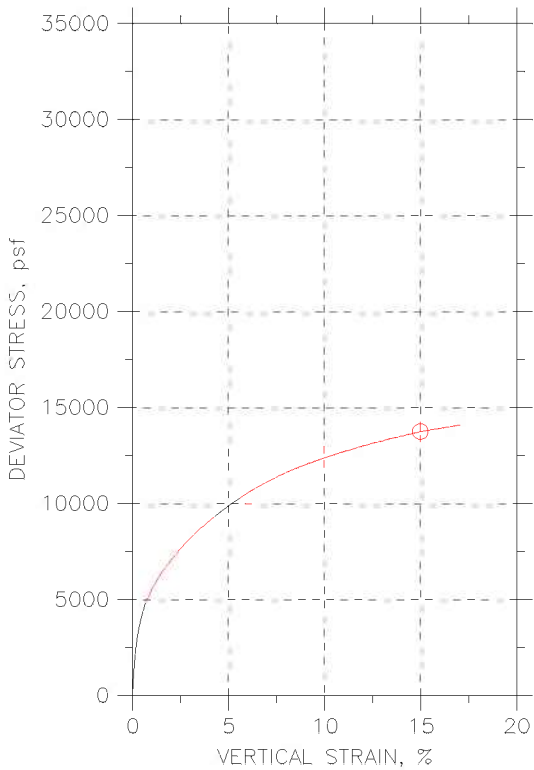
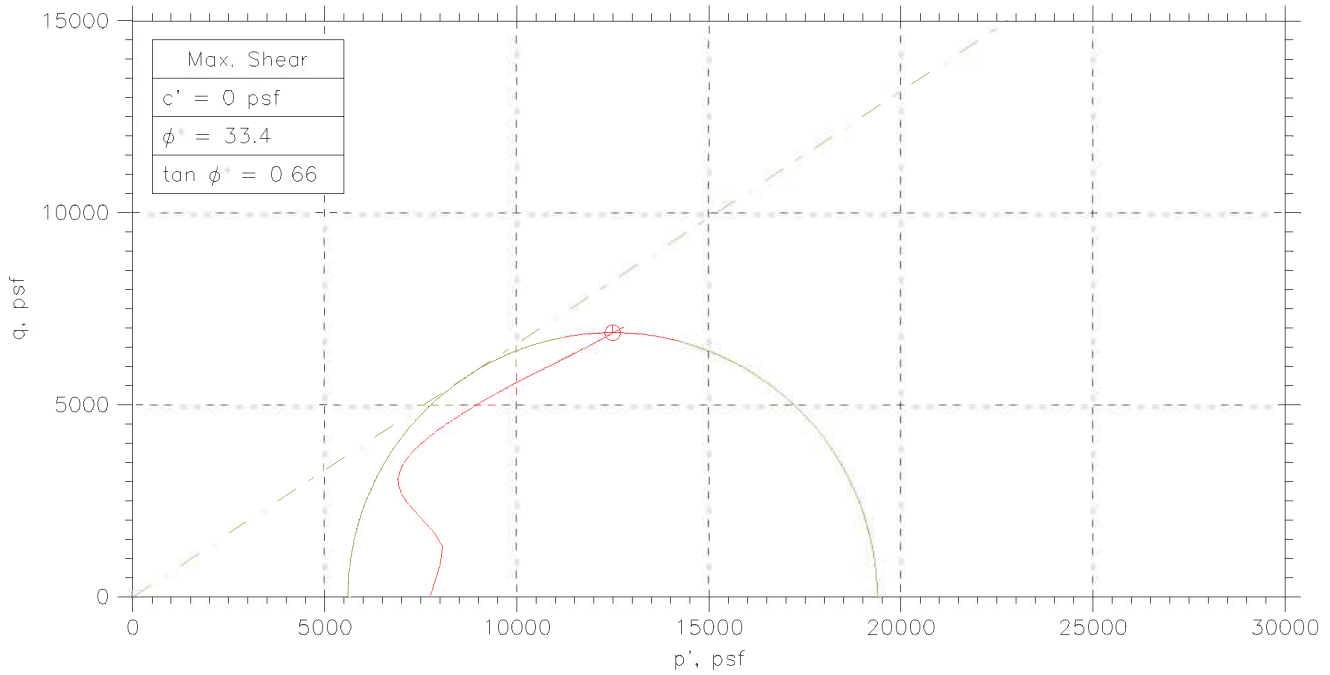

Symbol	⊙		
Sample No.	S-27		
Test No.	CU2		
Depth	116-118 ft		
Initial	Diameter, in	2.87	
	Height, in	6.1	
	Water Content, %	22.2	
	Dry Density, pcf	105.1	
	Saturation, %	97.1	
Before Shear	Water Content, %	19.5	
	Dry Density, pcf	111.4	
	Saturation*, %	100.0	
	Void Ratio	0.536	
Back Press., psf	11370		
Ver. Eff. Cons. Stress, psf	8267		
Shear Strength, psf	6882		
Strain at Failure, %	15		
Strain Rate, %/min	0.05		
B-Value	0.92		
Estimated Specific Gravity	2.74		
Liquid Limit	27		
Plastic Limit	16		

	Project: I-90 Central Viaduct				
	Location: Cleveland, OH				
	Project No.: GTX-6678				
	Boring No.: B-05-08				
	Sample Type: tube				
	Description: Moist, dark olive gray clay				
Remarks: ---					

Appendices

Phase calculations based on start and end of test.

* Saturation is set to 100% for phase calculations

CONSOLIDATED UNDRAINED TRIAXIAL TEST by ASTM D4767

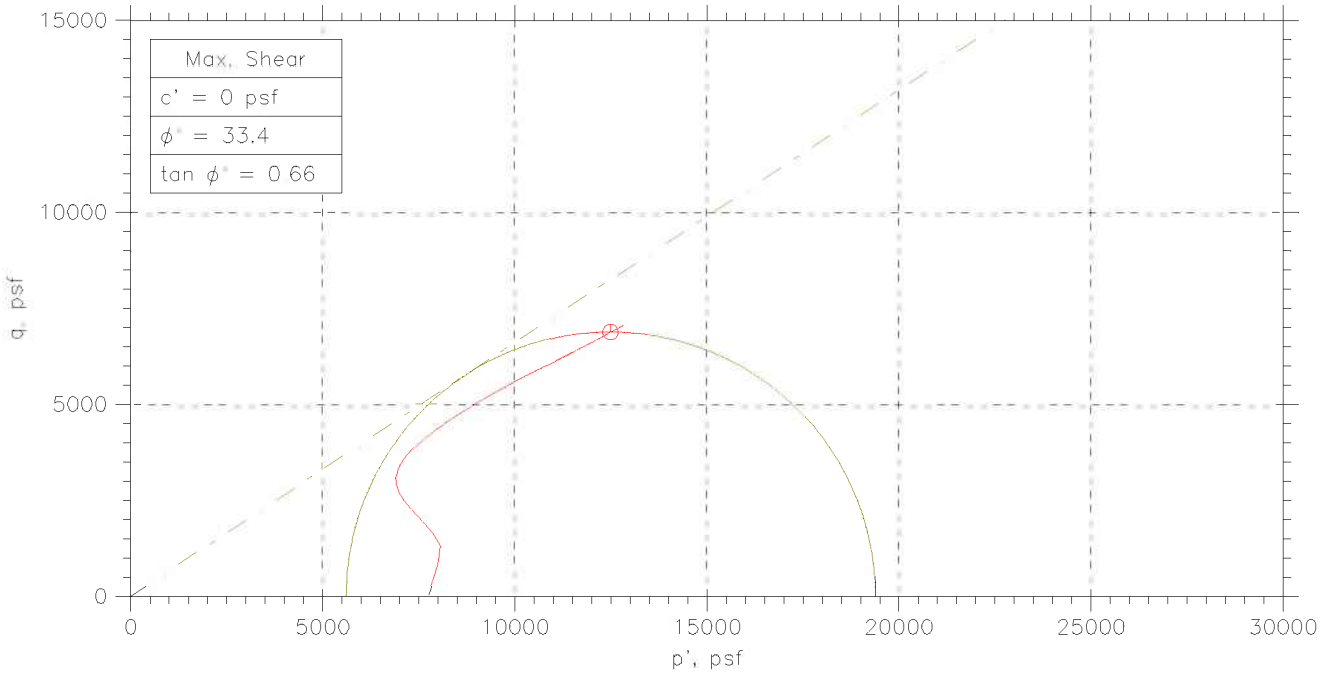
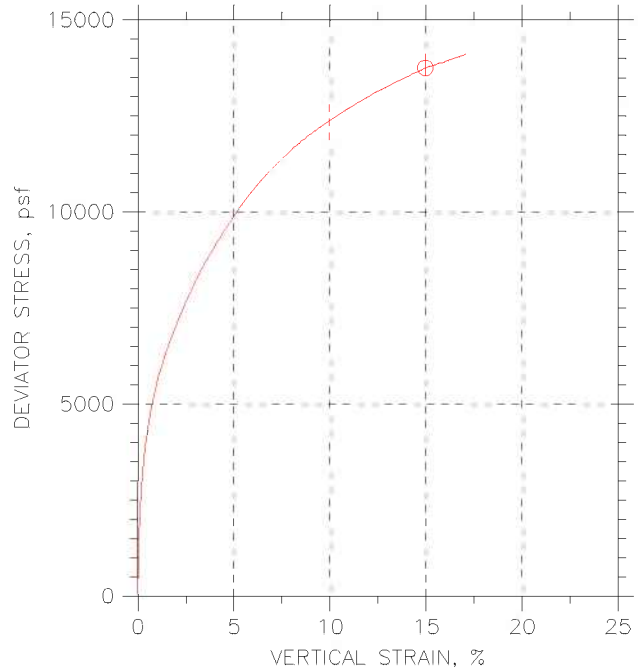
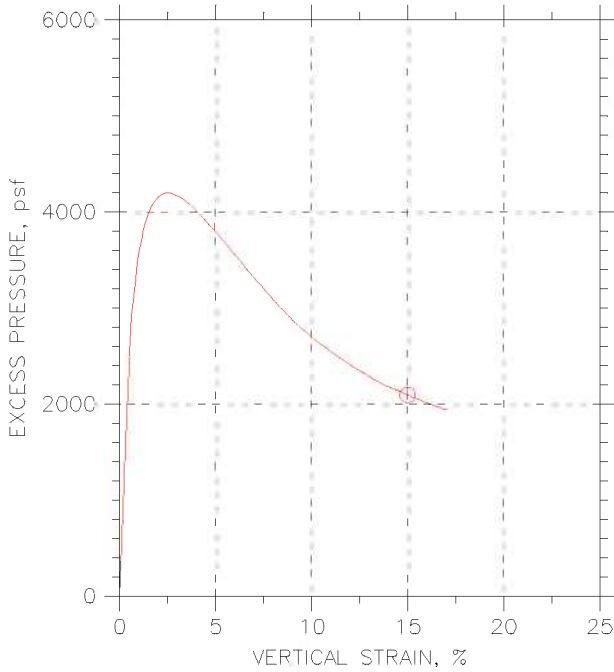

Sample No.	Test No.	Depth	Tested By	Test Date	Checked By	Check Date	Test File
⊙ S-27	CU2	116-118 ft	njh	06/01/06	jdt		6678-cu2b.dat

	Project: I-90 Central Viaduct		Location: Cleveland, OH		Project No.: GTX-6678	
	Boring No.: B-05-08		Sample Type: tube			
	Description: Moist, dark olive gray clay					
	Remarks: ---					

Appendix F

Photos

Client:	Geocomp Consulting
Project Name:	I-90 Central Viaduct
Project Location:	Cleveland, OH
GTX #:	6678
Test Date:	05/06/06
Tested By:	njh
Checked By:	jdt
Boring ID:	C-05-03
Sample ID:	S-30
Depth, ft:	118.5-120.3



Extruded sample showing in-situ shear plane. Side view.
Direct Simple Shear test, DSS-2 was trimmed from this piece.

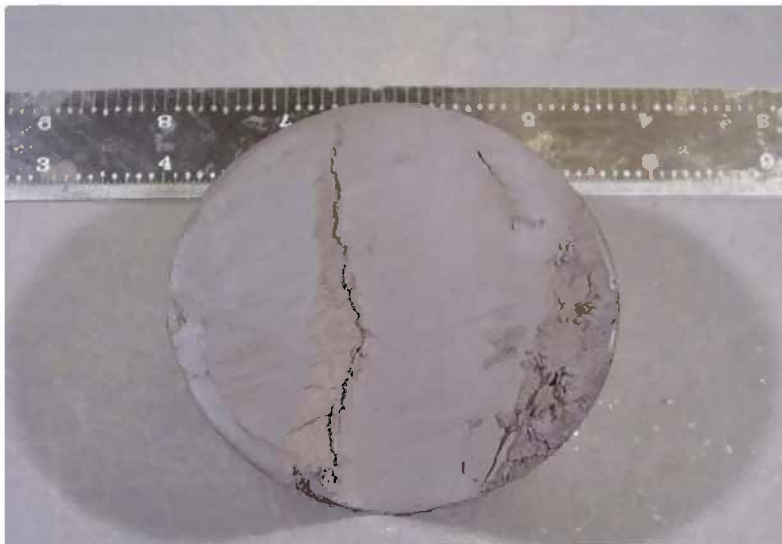

Same extruded sample showing in-situ shear plane. Top view.

Client:	Geocomp Consulting
Project Name:	I-90 Central Viaduct
Project Location:	Cleveland, OH
GTX #:	6678
Test Date:	05/06/06
Tested By:	njh
Checked By:	jdt
Boring ID:	C-05-03
Sample ID:	S-30
Depth, ft:	118.5-120.3



Post test picture, after pulling apart and putting back together. Shows development of an angular shear plane. Direct Simple Shear (DSS-2) test sample.



Same sample, pulled apart view of the internal structure along horizontal planes. The material appeared rough. There were no visible polished surfaces.

Client:	Geocomp Consulting
Project Name:	I-90 Central Viaduct
Project Location:	Cleveland, OH
GTX #:	6678
Test Date:	05/06/06
Tested By:	njh
Checked By:	jdt
Boring ID:	C-05-03
Sample ID:	S-30
Depth, ft:	118.5-120.3



Post test showing failure lean to the left. Slight shear plane developing angling back. Direct Simple Shear (DSS-2) test specimen.



Same sample, broken to show the cross section through the middle of specimen. Shows horizontal layers, some with an almost blocky structure at a very small scale.

Client:	Geocomp Consulting
Project Name:	I-90 Central Viaduct
Project Location:	Cleveland, OH
GTX #:	6678
Test Date:	05/06/06
Tested By:	njh
Checked By:	jdt
Boring ID:	C-05-03
Sample ID:	S-30
Depth, ft:	118.5-120.3



Sample in trimming ring showing an in-situ shear plane in the material as received. Residual Shear test (RS-2), angled view.

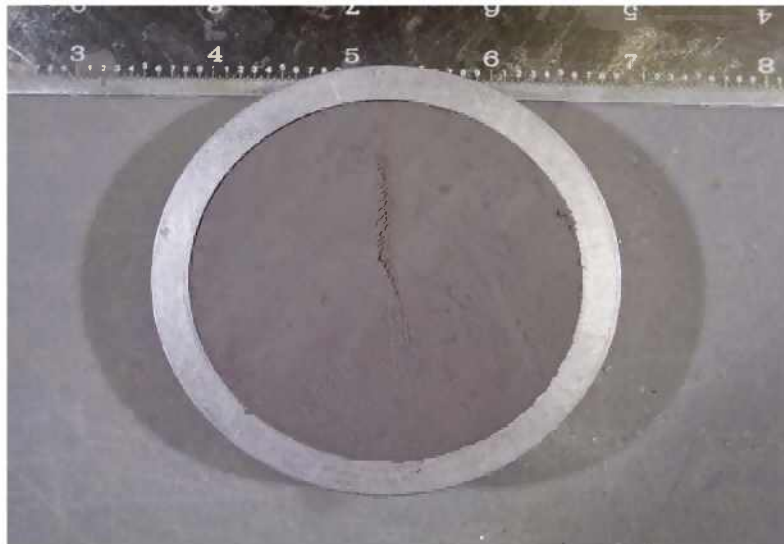

Same sample, in trimming ring showing an in-situ shear plane in the material as received. Residual Shear test (RS-2), top view.

**SLOPE STABILITY INVESTIGATION FOR WEST
BANK OF CUYAHOGA RIVER**

CUY-90-15.24

Submitted to

Michael Baker Jr., Inc.

BBC&M Engineering, Inc.

Cleveland, Ohio

May 2006

First Revision – September 14, 2006

BBCM Project Number 012-00946.300



July 12, 2006
012 00946.300

Mr. Robert B. Parker, P.E.
Ohio Manager/Assistant Vice President
Michael Baker Jr., Inc.
The Halle Building
1228 Euclid Avenue, Suite 1050
Cleveland, Ohio 44115

Re: Slope Stability Investigation – West Bank of Cuyahoga River
CUY-90-15.24 Central Viaduct Innerbelt Bridge
Cleveland, Cuyahoga County, Ohio

Dear Mr. Parker:

BBC&M Engineering, Inc. is pleased to submit the Subsurface and Slope Stability Investigation Report for the west bank of the Cuyahoga River, located in the vicinity of the existing I-90 Central Viaduct Innerbelt Bridge in Cleveland, Ohio. The scope of work for this report is referenced in our proposal dated February 1, 2006.

We appreciate being given the opportunity to be of service to you on this project and look forward to further collaboration in the future. Please do not hesitate to call our office should you require further information.

Respectfully submitted,
BBC&M Engineering, Inc.
Cleveland, Ohio



Donald C. Wotring, Ph.D.
Project Engineer

Peter S. Lee, Ph.D., P.E.
Senior Project Engineer

Stephen C. Pasternack, Ph.D., P.E.
President

Submitted: One (1) bound and one (1) unbound copy

TABLE OF CONTENTS

		<u>Page</u>
1.0	EXECUTIVE SUMMARY	1
2.0	PROJECT INFORMATION	5
2.1	INTRODUCTION	5
2.2	SCOPE OF WORK	6
2.3	PURPOSE OF STUDY	6
2.4	DESCRIPTION OF SITE	7
2.5	AVAILABLE INFORMATION	7
2.6	GEOLOGY	7
2.7	CONE PENETRATION TESTING INVESTIGATION.....	10
2.8	SOIL BORING FIELD INVESTIGATION	10
2.9	LABORATORY INVESTIGATION	12
3.0	REVIEW OF PREVIOUS WORK	13
3.1	THE CLEVELAND UNION TERMINALS CO. (1923).....	13
3.2	K. BRADLEY, M.S. THESIS – CLEVELAND STATE UNIVERSITY (2002)	14
3.3	BBC&M ENGINEERING, INC. (2005A)	15
3.4	BBC&M ENGINEERING, INC. (2005B).....	16
3.5	BBC&M ENGINEERING, INC. (2006).....	20
4.0	DISCUSSION OF SLOPE STABILITY PARAMETERS	21
4.1	GROUND SURFACE TOPOGRAPHY	21
4.2	SOIL STRATIGRAPHY	21
4.3	GROUNDWATER	22
4.4	TYPE OF SLOPE FAILURE	22
4.5	SOIL STRENGTH APPROPRIATE FOR FAILURE AND DRAINAGE CONDITIONS.....	23
4.6	GEOMETRY OF FAILURE SURFACE.....	24
4.7	SUMMARY OF CRITICAL INFORMATION STILL OUTSTANDING	24
5.0	STABILITY ANALYSES OF EXISTING CONDITIONS	25
5.1	SUBSURFACE DATA SUMMARY	25
5.2	REPRESENTATIVE CROSS SECTION	28
5.3	STABILITY OF REPRESENTATIVE CROSS-SECTION	28
5.3.1	CROSS-SECTION A-A	29
5.3.2	CROSS-SECTION B-B.....	30
5.3.3	CROSS-SECTION C-C.....	ERROR! BOOKMARK NOT DEFINED.
6.0	GENERALIZED STABILIZATION TECHNIQUES	31
7.0	REHABILITATION ALTERNATIVES	35
7.1	DEEP SLIP SURFACE	37
7.2	SHALLOW SLIP SURFACE.....	37
8.0	PROBABILISTIC AND SENSITIVITY ANALYSIS	37
9.0	CONCLUSIONS	40
10.0	ODOT GEOTECHNICAL CHECKLISTS	44
10.1	RECONNAISSANCE AND PLANNING CHECKLIST	44
10.2	GENERAL EARTHWORK DESIGN CHECKLIST – CENTERLINE CUTS	45
10.3	GENERAL EARTHWORK DESIGN CHECKLIST – EMBANKMENTS.....	45
10.4	GENERAL EARTHWORK DESIGN CHECKLIST – SUBGRADES	46
10.5	STRUCTURAL DESIGN CHECKLIST – FOUNDATIONS/STRUCTURES – NON-BRIDGE APPLICATIONS	46
10.6	STRUCTURAL DESIGN CHECKLIST – RETAINING WALLS	46

Subsurface and Slope Stability Investigation – West Bank (012 00946.300)
 CUY-90-15.24, Cleveland, Ohio

10.7	GEOLOGIC HAZARD DESIGN CHECKLIST – LANDSLIDE CORRECTIONS	47
10.8	GEOLOGIC HAZARD DESIGN CHECKLIST – ROCKFALL CORRECTIONS	49
10.9	GEOLOGIC HAZARD DESIGN CHECKLIST – WETLAND OR PEAT CORRECTIONS	49
10.10	GEOLOGIC HAZARD DESIGN CHECKLIST – UNDERGROUND MINE CORRECTIONS	49
10.11	GEOLOGIC HAZARD DESIGN CHECKLIST – SURFACE MINE CORRECTIONS	49
10.12	GEOLOGIC HAZARD DESIGN CHECKLIST – KARST CORRECTIONS	49

TABLE OF APPENDICES

APPENDIX A – GENERAL PROJECT INFORMATION

Plate 1: Project vicinity map

Plate 2: Plan of borings summarizing all subsurface investigation performed since 1990 in the vicinity of the I-90 west bank foundation structures. The locations of the 2006 investigation are approximate only.

Plate 3: Plan of borings summarizing all subsurface investigation performed since 1990 in the vicinity of the I-90 west bank foundation structures. The locations of the 2006 investigation are approximate only. Cross sections A-A, B-B, and C-C illustrate the approximate locations of the three slope stability analyses performed; although, this preliminary report only discusses the results of the slope stability evaluation within cross section A-A

Plate 4: Explanation of Terms and Symbols Used on Boring Logs (Soil).

Plate 5: Explanation of Terms and Symbols Used on Boring Logs (Rock)

APPENDIX B – FIGURES

Figure 1: West bank slope in the vicinity of the existing I-90 West Abutment and Pier 1 foundation and stabilization structure (BBCM, 2005a). Dashed lines indicate the surveyed location of surface cracking.

Figure 2: Existing I-90 pier system and stabilization structure (BBCM, 2005a).

Figure 3: Glacial and surficial geology of the Upper Cuyahoga River Valley (after Ford, 1987).

Figure 4: Lake Erie basin lake phases correlated with probable lake outlet and glacial ice boundary (after Calkin and Feenstra, 1985).

Figure 5: Evolution of a river valley by: a) river meandering and b) river valley cross-sections (after Longwell et al., 1947).

Figure 6: Cross section through the Cuyahoga River Valley near the Eagle Avenue bridge (after Bradley, 2002).

Figure 7: Conceptual diagram of the ground deformation associated with an adjacent creeping soil mass (BBCM, 2005b).

Figure 8: 1201 University Avenue (Sokolowski's University Inn). Photo is taken from inside looking at the north-west corner of the building. This photo illustrates settlement that occurred approximately 5 years ago. The maximum vertical displacement is at least 9-inches (BBCM, 2005b).

Figure 9: Crack mapping for the warehouse (cold storage) west of I-90 on University Avenue. The location and extent of the cracking is approximate only (BBCM, 2005b).

Figure 10: Warehouse (cold storage) west of I-90 on University Avenue. Photo is looking at the east wall of the warehouse (BBCM, 2005b).

Figure 11: Expected creep influenced zone as estimated from the geologic history, river geometry, numerical analyses and exterior masonry condition survey (BBCM, 2005b).

Figure 12: Modes of shear modeled in laboratory testing in relation to field failure conditions (after Terzaghi et al., 1996; Ladd and DeGroot, 2003).

Figure 13: Examples of typical laboratory derived creep behavior (Mitchell, 1993).

Figure 14: Possible micro-fabric of a hypothetical shear zone.

Figure 15: Qualitative diagram of excavation alternatives 1 and 2.

- Figure 16: Qualitative diagram of excavation alternatives 3 and 4.
Figure 17: Qualitative diagram of excavation alternatives 5 and 6.
Figure 18: Qualitative diagram of excavation alternatives 7 and 8.
Figure 19: Qualitative diagram of excavation alternatives 9 and 10.

APPENDIX C – LOGS OF CONE PENETRATION TESTS

- Plate 1: Cone Penetration Testing Results for C-05-01.
Plate 2: Pore Pressure Dissipation for C-05-01 taken at an approximate depth of 167 feet.
Plate 3: Cone Penetration Testing Results for C-05-02.
Plate 4: Pore Pressure Dissipation for C-05-02 taken at an approximate depth of 160 feet.
Plate 5: Cone Penetration Testing Results for C-05-03, run number 2.
Plate 6: Cone Penetration Testing Results for C-05-04, run number 3.
Plate 7: Pore Pressure Dissipation for C-05-04, run number 3, taken at an approximate depth of 120 feet.
Plate 8: Cone Penetration Testing Results for C-05-05.
Plate 9: Pore Pressure Dissipation for C-05-05 taken at an approximate depth of 164 feet.
Plate 10: Cone Penetration Testing Results for C-05-06.
Plate 11: Pore Pressure Dissipation for C-05-06 taken at an approximate depth of 192 feet.
Plate 12: Cone Penetration Testing Results for C-05-07.
Plate 13: Pore Pressure Dissipation for C-05-07 taken at an approximate depth of 193 feet.
Plate 14: Cone Penetration Testing Results for C-05-08.
Plate 15: Pore Pressure Dissipation for C-05-08 taken at an approximate depth of 190 feet.
Plate 16: Cone Penetration Testing Results for C-05-09.
Plate 17: Pore Pressure Dissipation for C-05-09 taken at an approximate depth of 190 feet.
Plate 18: Cone Penetration Testing Results for C-05-10.
Plate 19: Pore Pressure Dissipation for C-05-10 taken at an approximate depth of 188 feet.
Plate 20: Cone Penetration Testing Results for C-05-11.
Plate 21: Pore Pressure Dissipation for C-05-11 taken at an approximate depth of 175 feet.
Plate 22: Cone Penetration Testing Results for C-05-12.
Plate 23: Cone Penetration Testing Results for C-05-13.
Plate 24: Pore Pressure Dissipation for C-05-13 taken at an approximate depth of 120 feet.
Plate 25: Cone Penetration Testing Results for C-05-14.
Plate 26: Cone Penetration Testing Results for C-05-15.

APPENDIX D – LOGS OF BORINGS

- Boring Logs (B-05-01 through B-05-04, B-05-07, B-05-08, and B-05-11 through B-05-16)
Boring Logs (B-105A and B-108A)

APPENDIX E – LABORATORY TEST RESULTS

- Laboratory Specialty Test Results Summary (3 sheets)
Log of Shelby Tubes (5 sheets)
ODOT Summary of Laboratory Test Results (1 sheet)
Consolidated Undrained Triaxial Compression Test (1994) Results (1 sheet)
Consolidated Drained Direct Shear Test Result (1994) (1 sheet)
Anisotropically Consolidated Undrained Triaxial Compression Test Results (3 sheets)
Isotropically Consolidated Undrained Triaxial Compression Test Results (2 sheets)

Direct Shear Test Results (5 sheets)
Torsional Ring Shear Index Test Results (3 sheets)
Torsional Ring Shear Test Results (6 sheets)
Residual Shear Strength Empirical Correlation and Test Summary (1 sheet)
Undrained Direct Simple Shear Index Test Results (1 sheet)
Undrained Direct Simple Shear Test Results (12 sheets)
Unconfined Compression Rock Test Results (14 sheets)
Unconfined Compression Rock Test w/ Poisson Ratio Results (6 sheets)

APPENDIX F – LIMIT EQUILIBRIUM SLOPE STABILITY ANALYSES

- Plate 1: Existing conditions modeled along cross section A-A (file: AA P_625.sli).
- Plate 2: Results of the slope stability analysis within cross section A-A for the existing conditions (file: AA P_625.sli). The minimum Factor of Safety equals 1.065. The estimated Factor of Safety along Abbey Ave. approximately ranges between 1.36 and 1.56.
- Plate 3: Results of the slope stability analysis within cross section A-A for the existing conditions assuming the residual friction angle within the deep slip plane is equal to 13 degrees (file: AA P_625_13.sli). The minimum Factor of Safety equals 1.042.
- Plate 4: Results of the slope stability analysis for the existing conditions assuming the residual friction angle within the deep slip plane is equal to 15 degrees (file: AA P_625_15.sli). The minimum Factor of Safety equals 1.094.
- Plate 5: Results of the slope stability analysis for the existing conditions for a potential shallow slip plane (file: AA P_625SH.sli). The minimum Factor of Safety equals 1.041.
- Plate 6: Existing conditions assuming a deep slip plane at residual shear strength conditions modeled along cross section B-B (file: BB.sli).
- Plate 7: Results of the slope stability analyses for existing conditions along cross section B-B assuming a deep slip surface at residual shear strength conditions (file: BB.sli). The minimum Factor of Safety equals 2.52. The results presented were obtained by using the Simplified Janbu method instead of the Spencer method since the resulting Factor of Safety exceeds the allowable maximum Factor of Safety produced by the Spencer method.
- Plate 8: Results of the slope stability analysis for existing conditions along cross section B-B for a potential shallow slip plane (file: BBSH.sli). The minimum Factor of Safety equals 2.671.
- Plate 9: Existing conditions modeled along cross section C-C (file: CCsearch.sli).
- Plate 10: Results of the slope stability analyses for existing conditions along cross section C-C assuming a deep block slip surface (file: CCsearch.sli). The minimum Factor of Safety equals 3.275. The results presented were obtained by using the Simplified Janbu method instead of the Spencer method since the resulting Factor of Safety exceeds the allowable maximum Factor of Safety produced by the Spencer method.
- Plate 11: Results of the slope stability analyses for existing conditions along cross section C-C assuming a deep circular slip surface (file: CCsearchC.sli). The minimum Factor of Safety equals 2.677. The results presented were obtained by using the Simplified Bishop method.

- Plate 12: Results of the slope stability analyses for existing conditions along cross section C-C assuming a shallow circular slip surface (file: CCsearchC2.sli). The minimum Factor of Safety equals 1.237. The results presented were obtained by using the Simplified Bishop method.
- Plate 13: Results of the slope stability analysis within cross section A-A for (alternative 1), which includes a 20-foot vertical excavation located 50 feet behind University Ave. (file: AA P_625 E20.sli). The minimum Factor of Safety equals 1.143 (Δ FS = 0.078 increase from baseline conditions shown in Plate 2). The estimated Factor of Safety along Abbey Ave. approximately ranges between 1.29 and 1.44.
- Plate 14: Results of the slope stability analysis within cross section A-A for (alternative 2), which includes a 30-foot vertical excavation located 50 feet behind University Ave. (file: AA P_625 E30.sli). The minimum Factor of Safety equals 1.162 (Δ FS = 0.097 increase from baseline conditions shown in Plate 2). The estimated Factor of Safety along Abbey Ave. approximately ranges between 1.29 and 1.45.
- Plate 15: Results of the slope stability analysis within cross section A-A for (alternative 3), which includes a 20-foot vertical excavation located 100 feet behind University Ave. (file: AA P_625 E20_100.sli). The minimum Factor of Safety equals 1.195 (Δ FS = 0.13 increase from baseline conditions shown in Plate 2). The estimated Factor of Safety along Abbey Ave. approximately ranges between 1.26 and 1.42.
- Plate 16: Results of the slope stability analysis within cross section A-A for (alternative 4), which includes a 30-foot vertical excavation located 100 feet behind University Ave. (file: AA P_625 E30_100.sli). The minimum Factor of Safety equals 1.227 (Δ FS = 0.16 increase from baseline conditions shown in Plate 2). The estimated Factor of Safety along Abbey Ave. approximately ranges between 1.30 and 1.41.
- Plate 17: Results of the slope stability analysis within cross section A-A for (alternative 5), which includes a terraced 10-foot vertical excavation located 150 feet behind University Ave. and a 20-foot vertical excavation located 50 feet behind University Ave. (file: AA P_625 E10_20.sli). The minimum Factor of Safety equals 1.199 (Δ FS = 0.13 increase from baseline conditions shown in Plate 2). The estimated Factor of Safety along Abbey Ave. approximately ranges between 1.32 and 1.41.
- Plate 18: Results of the slope stability analysis within cross section A-A for (alternative 6), which includes a terraced 20-foot vertical excavation located 150 feet behind University Ave. and a 10-foot vertical excavation located 50 feet behind University Ave. (file: AA P_625 E20_10.sli). The minimum Factor of Safety equals 1.231 (Δ FS = 0.17 increase from baseline conditions shown in Plate 2). The estimated Factor of Safety along Abbey Ave. approximately ranges between 1.33 and 1.39.
- Plate 19: Results of the slope stability analysis within cross section A-A for (alternative 7), which includes a 20-foot vertical excavation north of Abbey Ave. (file: AA P_625 E Abbey20.sli). The minimum Factor of Safety equals 1.256 (Δ FS = 0.19 increase from baseline conditions shown in Plate 2). The estimated Factor of Safety along Abbey Ave. approximately ranges between 1.56 and 1.90.
- Plate 20: Results of the slope stability analysis within cross section A-A for (alternative 8), which includes a 30-foot vertical excavation north of Abbey Ave. (file: AA P_625 E Abbey30.sli). The minimum Factor of Safety equals 1.256 (Δ FS = 0.19 increase from baseline conditions shown in Plate 2). The estimated Factor of Safety along Abbey Ave. approximately ranges between 1.62 and 1.64.

- Plate 21: Results of the slope stability analysis within cross section A-A for (alternative 9), which includes a 7(H):1(V) sloped excavation beginning north of Abbey Ave. (file: AA P_625 E Abbey7on1.sli). The minimum Factor of Safety equals 1.256 (Δ FS = 0.19 increase from baseline conditions shown in Plate 2). The estimated Factor of Safety along Abbey Ave. approximately ranges between 1.40 and 1.47.
- Plate 22: Results of the slope stability analysis within cross section A-A for (alternative 10), which includes a 3(H):1(V) sloped excavation beginning north of Abbey Ave. (file: AA P_625 E Abbey3on1.sli). The minimum Factor of Safety equals 1.33 (Δ FS = 0.265 increase from baseline conditions shown in Plate 2). The estimated Factor of Safety along Abbey Ave. approximately ranges between 1.46 and 1.61.
- Plate 23: Results of the slope stability analysis within cross section A-A for (alternative 7), which includes a 20-foot vertical excavation north of Abbey Ave. (file: AA P_625 E Abbey20SH.sli) for a potential shallow slip plane. The minimum Factor of Safety equals 1.345 (Δ FS = 0.30 increase from baseline conditions shown in Plate 15). The estimated Factor of Safety along Abbey Ave. approximately ranges between 1.73 and 1.85.
- Plate 24: Results of the slope stability analysis within cross section A-A for (alternative 9), which includes a 7(H):1(V) sloped excavation beginning north of Abbey Ave. (file: AA P_625 E Abbey7on1SH.sli) for a potential shall slip plane. The minimum Factor of Safety equals 1.794 (Δ FS = 0.75 increase from baseline conditions shown in Plate 15). The estimated Factor of Safety along Abbey Ave. approximately ranges between 1.81 and 1.85.
- Plate 25: Results of the slope stability analysis within cross section A-A for (alternative 10), which includes a 3(H):1(V) sloped excavation beginning north of Abbey Ave. (file: AA P_625 E Abbey3on1SH.sli) for a potential shallow slip plane. The minimum Factor of Safety equals 1.688 (Δ FS = 0.64 increase from baseline conditions shown in Plate 15). The estimated Factor of Safety along Abbey Ave. approximately ranges between 1.69 and 1.70.
- Plate 26: Sensitivity analysis (cross section A-A) of the effective strength property ϕ' . The Factor of Safety is sensitive to only the effective strength of the clay and clay (residual) soil units.
- Plate 27: Sensitivity analysis (cross section A-A) of soil unit weight. The Factor of Safety is sensitive to only the unit weight of the clay.

APPENDIX G – EXISTING LOGS OF BORINGS

BBCM Boring Logs B-101 through B-110

ODOT Boring Logs B-1 through B-9

APPENDIX H – MONITORING INSTRUMENTATION SUMMARY

Table 1: Average Movement Rate in Existing Inclinometers on Shallow Slip Plane (after REL, 2006).

Table 2: Average Movement Rate in Existing Inclinometers on Deep Slip Plane (after REL, 2006).

Table 3: Piezometer Readings for Last Four Quarters (after REL, 2006).

Table 4: Summary of Existing Field Instrumentation.

Table 5: Timeline of major construction events at the I-90 project site.

Table 6: Summary of Known Information During Artesian Conditions Encountered During Soil Subsurface Investigations.

Table 7: New Inclinometer and Piezometer Installation Summary.

Figure 1: Cone penetration testing pictures (performed by Ohio University).

Figure 2: Typical Slope Inclinometer.

Figure 3: Typical Vibrating Wire Piezometer Setup.

Figure 4: Vibrating Wire piezometer pictures.

Figure 5: Examples of artesian gas pressures that were encountered during field operations.

Figure 6: Pressuremeter testing pictures (performed by E.L. Robinson).

1.0 EXECUTIVE SUMMARY

As part of the planning study for the CUY-90-15.24 Central Viaduct Bridge project, BBC&M Engineering, Inc. (BBCM) has reviewed the stability of the hillside west of the existing I-90 bridge, along the general alignment of the proposed bridge over the Cuyahoga River in Cleveland, Ohio. BBCM, as a subconsultant of Michael Baker Jr. Inc. (Baker), was contracted to perform a subsurface investigation developed by ODOT, install long-term field monitoring equipment, and perform a slope stability evaluation along three cross sections chosen by ODOT. BBCM was also asked to evaluate the benefits of an excavation remediation along the alignment of the proposed I-90 bridge. The purpose of the stability analyses presented herein is not necessarily to characterize and quantify the unstable slope as it exists currently. Rather, the goal of this investigation is to estimate the location where the pier of the proposed I-90 bridge can be founded on the west bank such that its location would be outside of the influence of creep related slope movement. To achieve this goal, the slope stability analyses presented in this report are modeled to reflect possible future instability as influenced by the geologic history of the region. For a discussion of the slope stability and detailed characterization of the existing slope, refer to the BBCM (2005a) report, dated May 10, 2005, submitted to Richland Engineering, Limited (REL).

Background

By the late 1980's, downslope soil creep movement of the west bank slope caused sufficient movement in the superstructure of the existing I-90 bridge to precipitate the need for remediation. With a limited amount of data and a short time frame available for monitoring the slope prior to design, geotechnical recommendations were presented by BBCM and the stabilization structure was designed by REL to protect Pier 1 from continued slope movement. Construction of the Pier 1 Stabilization Structure was completed in 1999. The Ohio Department of Transportation (ODOT) implemented a continuous subsurface monitoring program to assess the performance of the stabilization structure over time.

ODOT has approved the design of an additional bridge to be constructed just north of the existing I-90 bridge. The present slope instability will likely continue to negatively impact the existing I-90 bridge, and may potentially impact the proposed I-90 bridge. In addition, the existing slope instability could also negatively impact two of the remaining five feasible alternatives for the proposed Cuyahoga River Valley Intermodal Connector roadway, which would pass adjacent to the Cuyahoga River beneath the existing and proposed I-90 bridges.

Existing Slope Stability of the West Bank of the Cuyahoga River (Cross Section A-A)

Of the three cross sections BBCM was asked to evaluate for slope instability, only the slope within cross section A-A is known to be unstable. Cross section A-A is parallel to and beneath the proposed I-90 bridge alignment. The other two cross sections (B-B and C-C) were evaluated to assess the possibility that unstable conditions could exist elsewhere in the vicinity of the proposed I-90 alignment. Existing inclinometer information from Borings B-108 and B-110, which are located near the alignment of the proposed I-90 bridge and are in the vicinity of cross section A-A, indicate that active downslope creep movement is occurring on at least one slip plane located approximately 120 feet below the existing ground surface at those two

inclinometers. Natural pressurized gas pockets, which are present at the site, present the most challenging geotechnical obstacle to accurately assessing and modeling the existing slope conditions. Slope stability analyses indicate that the estimated Factor of Safety against overall slope failure of the existing west bank along the alignment of the proposed structure is between 1.0 and 1.1 for both the deep and shallow slip planes. These values of Factor of Safety are consistent with the behavior of the slope movement recorded in the existing inclinometer casings.

The fact that the slope is creeping complicates slope stability modeling. Literature suggests that a significant increase in the Factor of Safety against slope failure should also be accompanied by a decrease in the creep rate of the soil mass. Unfortunately, there is no definitive way to accurately predict at what Factor of Safety creep movement will cease. Traditionally, ODOT has required that slopes supporting structures have a minimum Factor of Safety of 1.5. However, for this proposed bridge and slope improvement, the governing behavior of the slope remediation and foundation design is likely future creep movement, and not necessarily an increase to a prescribed Factor of Safety.

Slope Rehabilitation of the West Bank of the Cuyahoga River (Cross Section A-A)

Due to the nature of natural gas pocket development and unknown locations, a rehabilitation method designed to relieve these pressures may not achieve the desired results. While a system designed to relieve these gas pressures could be employed, BBCM does not recommend relying solely on a deep well pressure relief system; rather, it should be a redundant feature of the whole rehabilitation design. It should be understood by all parties that the positive benefits of a deep well pressure relief system may not be fully realized and would require maintenance for the life of the system. However, at the request of ODOT, BBCM only evaluated the influence of excavation rehabilitation alternatives. According to FHWA-SA-94-005, the most promising known method of rehabilitation for correcting a landslide is unloading. The following excavation alternatives, some of which would be supported by a conventional retaining wall system, were evaluated:

Alternative 1 (20/50):

20-foot vertical excavation located approximately 50 feet south of University Avenue;

Alternative 2 (30/50):

30-foot vertical excavation located approximately 50 feet south of University Avenue;

Alternative 3 (20/100):

20-foot vertical excavation located approximately 100 feet south of University Avenue;

Alternative 4 (30/100):

30-foot vertical excavation located approximately 100 feet south of University Avenue;

Alternative 5 (10/150 and 20/50):

Terraced excavation with a 10-foot vertical excavation located approximately 150 feet south of University Avenue and a 20-foot vertical excavation located approximately 50 feet south of University Avenue;

Alternative 6 (20/150 and 10/50):

Terraced excavation with a 20-foot vertical excavation located approximately 150 feet south of University Avenue and a 10-foot vertical excavation located approximately 50 feet south of University Avenue;

Alternative 7 (20/Abbey):

20-foot vertical excavation located on the north side of Abbey Avenue;

Alternative 8 (30/Abbey):

30-foot vertical excavation located on the north side of Abbey Avenue;

Alternative 9 (7:1/Abbey):

7(H):1(V) slope beginning north of Abbey Avenue extending down to El. 620 feet; and,

Alternative 10 (3:1/Abbey):

3(H):1(V) slope beginning north of Abbey Avenue extending down to El. 620 feet.

Conclusions for Cross Section A-A

If rehabilitation is not performed at the project site in the vicinity of cross section A-A, the current creep rate can be expected to either remain constant or accelerate in the future. Literature suggests that if the Factor of Safety can be increased significantly, the creep rate along the failure planes can be expected to decrease. In general, each of the excavation rehabilitation alternatives improve the overall slope stability. Alternative 10 demonstrates the greatest overall benefit and alternatives 7, 8, and 9 all show similar benefits as well. BBCM recommends that ODOT consider unloading the slope for the following reasons:

- Minimum deterministic and mean Factor of Safety would be increased
- Excavation rehabilitation will have a positive benefit in the range of the 95% Factor of Safety confidence interval, thus increasing the confidence in the Factors of Safety as they relate to the sensitivity of the soil strength properties;
- Increase in Factor of Safety will likely decrease the future creep rate;
- Improvement to the global stability will improve the performance of any new river wall structures; and,
- Reduced slope creep could extend the life of the existing I-90 bridge and would help stabilize the hillside, which would be required in the event that either Cuyahoga River Valley Intermodal Connector roadway alternatives 3 or 4 are constructed.

BBCM recommends that an excavation rehabilitation alternative (alternative 10 provides the greatest improvement to Factor of Safety) be performed prior to the construction of any west bank pier, regardless of the location of the pier. If the pier is placed in the slope (north of

University Avenue), then the pier should be designed such that it is isolated from anticipated future creep movement. Piers founded on top of slope (south of University Avenue) should be further evaluated to determine if isolation, design for lesser creep movement, or design for lateral load should be incorporated into the final design, based upon the degree of improvement to stability from the excavation alternative.

The most recent monitoring annual report submitted by Richland Engineering (2006) indicates that the average creep rate measured in inclinometer B-110 (north of University Avenue near proposed alignment) is approximately 0.15 in/year. The average creep rate measure in inclinometers B-102 and B-107, located southwest of the West End Pier of the existing I-90 bridge near the proposed alignment, is approximately 0.02 in/year. These creep rates are expected to either remain constant or decrease if one of the excavation rehabilitation alternatives are performed.

Any excavation rehabilitation alternative should be extended perpendicular to the proposed bridge alignment footprint sufficiently to allow for plane strain conditions to prevail such that the results of the 2-D limit equilibrium analyses are valid. Alternatives 9 and 10, which consist of a sloping excavation, would require the greatest amount of area. A long-term monitoring program should be continued, regardless of what rehabilitation option is chosen or where the bridge foundation is placed.

Factors other than the optimal increase in Factor of Safety may determine which unloading alternative may be the most feasible. This evaluation did not consider any other factors such as engineering, political, right-of-way acquisition, or community desires in determining the optimal alternatives. Unloading the slope, in a manner as modeled in this report, will likely not stop slope movement, but simply reduce the rate of movement. It is possible that unloading could reduce future creep rates to movements that may be inconsequential. The problem is that there is no way to know the future creep rate until long after the new bridge structure is complete and in service.

Conclusions for Cross Sections B-B and C-C

Slope stability analyses indicate that the existing cross sections B-B and C-C are likely stable for a deep global slope failure, assumed drained strength conditions. However, when a shallow, local surficial slope failure is modeled in the hillside between Fairfield Avenue and the southern dead-end of West 15th Street (cross section C-C), the results indicate that a smaller local slope failure is possible. BBCM recommends that if ODOT plans to place a bridge abutment or pier between Fairfield Avenue and the top of the hillside near West 15th Street, an additional subsurface investigation be performed in the vicinity to support a detailed slope stability evaluation. This work could be performed as part of the subsurface investigation and foundation recommendations will be performed for the bridge structure over Fairfield Avenue.

2.0 PROJECT INFORMATION

2.1 Introduction

The I-90 Central Viaduct Bridge crossing over the Cuyahoga River was completed in 1959 and consists of multiple truss spans. The total length of the existing bridge is 5,080 feet. The trusses are supported on a series of piers, which are supported on either Cast-in-Place piles or H-piles. Two sets of piers (Pier 1 and West End Pier) are founded on the west bank of the Cuyahoga River. Pier 1 is adjacent to the river and the West End Pier is located near the top of the west bank. The West Bank beneath the I-90 Bridge is on the outer bank of a tight river bend, which causes the Cuyahoga River to undercut the west bank at this location, as shown in the project vicinity map of Plate 1 in Appendix A.

Downslope soil creep movement of the west bank slope caused lateral displacement in the bridge superstructure supported on Pier 1 and the West End Pier. By the late 1980's, sufficient superstructure movement had occurred to precipitate the need for remediation. Additional subsurface information was collected by BBCM in the early 1990's in support of a design for the stabilization of Pier 1. With a limited amount of data and a short time frame available for monitoring the slope prior to design, geotechnical recommendations were presented by BBCM and the stabilization structure was designed by Richland Engineering Limited to protect Pier 1 from continued slope movement.

The Pier 1 stabilization structure, consisting of a drilled shaft wall located between the Cuyahoga River and Pier 1, is tied-back with steel H-piles to an anchor block located upslope of Pier 1. The drilled shafts are socketed into bedrock approximately 140 feet below ground surface. The anchor block is supported on a series of H-piles driven to refusal in bedrock. A series of rock anchors extend downward from the anchor block, approximately 45° from the horizontal, into bedrock upslope of the stabilization structure. Construction of the Pier 1 stabilization structure was completed in 1999.

ODOT implemented a continuous subsurface monitoring program to assess the performance of the stabilization structure over time. This program consisted of BBCM installing additional slope inclinometer casings, Case Western Reserve University installing tiltmeters and strain gages, and the University of Akron installing load cells, strain gages and slope inclinometer casings. Quarterly readings of these devices have been performed, creating a current, extensive data set from which to assess the behavior of the stabilization structure. A collaborative report was developed in April 2005 by Richland Engineering Limited, with the support of BBCM, Case Western Reserve University, and the University of Akron. This collaborative report presents an evaluation of the behavior of the bridge structure, the stabilization structure, and the continued creep movement of the west bank slope.

ODOT proposed preliminary plans to build an additional bridge just north of the existing I-90 bridge. This report presents the results of a preliminary slope stability investigation performed to estimate the limits of the unstable slope and provide recommendations on the proposed bridge foundation location such that it is not adversely affected by current or future creep movement.

2.2 Scope of Work

The proposed scope of work, as detailed in the revised proposal dated February 1, 2006, was to perform a subsurface investigation, designed by ODOT, to support a slope stability evaluation of the west bank of the Cuyahoga River within the Central Viaduct corridor. The goal of this work is to estimate the extent of current or future creep related movement of the hillside and provide recommendations on the location to found the west pier of the proposed I-90 bridge. Plates 2 and 3, located in Appendix A, depict the approximate boring layout and the approximate location of three ODOT chosen cross sections (A-A, B-B, and C-C). Slope stability analyses were performed for each of these three cross sections. At the request of ODOT, the only rehabilitation method that was analyzed is excavation unloading. The slope stability analyses and geotechnical recommendations presented herein are not based on the results of monitoring data from the newly installed inclinometer and piezometer instrumentation. The project schedule prohibits waiting the required time for an adequate amount of movement to be registered in an inclinometer. Based on the current creep rate at the site, it is anticipated that it could take up to two years of monitoring before the measured inclinometer movement is out of the error threshold of a typical inclinometer reading. The stability analyses performed as part of this report are based on: existing inclinometer data; existing pore pressure data; CPT profiles; and, both existing and new laboratory strength data.

2.3 Purpose of Study

The purpose of this subsurface investigation and corresponding report is to estimate the extent of current and future creep movement in order for the design team to make an educated decision on where to found the west pier to minimize the potential of the foundation systems being adversely affected by creep of the existing slope. As a result, the slope stability analyses presented in this report are modeled to reflect possible future instability as influenced by the geologic history of the region. For a discussion of the slope stability and detailed characterization of the existing slope, refer to the BBCM (2005a) report, dated May 10, 2005, submitted to Richland Engineering, Limited (REL).

It is important that all parties clearly understand the following facts:

1. The west bank is creeping towards the river with the deepest failure surface extending below the river.
2. There is no absolute way of establishing if an area is stable from future lateral creep movement without the benefit of a long term field instrumentation program.
3. There is no guarantee that an area determined to be free of creep related movement might not experience creep in the future due to the scarp progression away from the crest of the slope, which is a natural geologic process that results due to the hillside trying to reach a state of equilibrium.

It could be possible that future long-term monitoring might reveal creep movement beyond the limits presented in this report that are currently undetected. It is also possible that monitoring could reveal no future soil creep.

2.4 Description of Site

Figure 1 (Appendix A), which was taken from the BBCM (2005a) report, illustrates the location of the existing I-90 west abutment and pier 1 foundation systems in relation to the west bank of the Cuyahoga River. The difference in ground surface elevation between the west abutment (termed the West End Pier) and Pier 1 is approximately 70 feet. This figure also illustrates the approximate location and extent of ground surface cracking present when the figure was prepared. The ground surface cracking the west end pier, adjacent to University Ave, is likely associated with the principal scarp or secondary scarp cracks. The cracking downslope of the west end pier and the area slightly upstream are likely associated with diagonal shear or tensions cracks. The cracking downslope of Pier 1, both upstream and downstream of the Pier 1 foundations could be associated with bulging cracks near the toe of the unstable slope; however, they are more likely associated with local failures of the bulkhead wall.

Figure 2 presents an elevation profile of the west bank slope and the existing I-90 Central Viaduct bridge and stabilization structure. The stabilization structure consists of 17 72-inch diameter drilled shafts socketed approximately five feet into bedrock. The drilled shafts are connected with a reinforced concrete cap approximately five feet thick. The drilled shaft cap is tied back with a series of H-piles to an anchor block upslope. The anchor block is supported on a series of H-piles driven to refusal on bedrock. A series of rock anchors extend downward from the anchor block, approximately 45° from the horizontal, into bedrock upslope of the stabilization structure. Construction of the stabilization structure was completed in 1999.

2.5 Available Information

BBCM is in receipt of existing ODOT boring logs B-1 through B-9, performed between May 16, 1990, and June 1, 1990. Inclinometers were installed in these nine borings. In addition, BBCM performed a subsurface investigation between August 8, 1994, and September 28, 1994, and developed boring logs B-101 through B-110 and P-1 through P-5. These boring logs are presented in Appendix G. Inclinometers were installed in borings B-101 through B-110 and two or three pneumatic piezometers installed in borings P-1 through P-5. Tables 1 and 2 of Appendix H summarize the average rates of movement noted in the existing inclinometers. Table 3 of Appendix H summarizes the existing piezometer readings for the most recent four quarters (July 14, 2005 through April 20, 2006). Tables 1 through 3 were obtained from the June 2006 Monitoring Services Annual Report, compiled by Richland Engineering (REL, 2006). The REL (2006) report should be referenced for more detailed field monitoring information. Table 4 of Appendix H summarizes the status of the existing field instrumentation that has been installed since 1990 in the vicinity of the existing I-90 bridge and west bank. Table 5 of Appendix H summarizes the timeline of the major events that have occurred since 1990 at the project site.

2.6 Geology

Within the Cleveland metropolitan area, the present Cuyahoga River Valley runs parallel to the western bench of a buried ancient river valley. The axis of the buried ancient river valley is at an elevation near sea level (Peck, 1954, Gardner, 1972, and Ford 1987). The uppermost stratum of bedrock in the Lower Cuyahoga River Valley is composed of Devonian Ohio Shale, which contains a large amount of organic matter and natural gas (Hansen, 1999 and Szabo et al., 2003).

This gas is known to percolate upwards through the shale becoming trapped in pockets throughout the lower portion of the overlying sediments. Two such gas pockets were encountered in recent subsurface explorations by: 1) BBCM for the Stonebridge Condominiums (near the Detroit-Superior Bridge) and 2) Ohio Department of Transportation for I-90 Central Viaduct Bridge. Evidence suggests that gas pressures in these pockets can be high enough to shoot drilling mud 30 feet into the air. An elevated pore pressure condition has also been observed in the sediments underlying the RTA Bridge approximately, one mile downriver of the I-90 Bridge.

Figure 3 illustrates the glacial and surficial geology of the Upper Cuyahoga River Valley (Ford, 1987). The majority of the soils within the buried ancient river valley are of glacial or lacustrine origin. These soils were deposited during the Illinoian glacial period (302,000 – 132,000 years before present, yBP) and the Wisconsinan glacial period (65,000 – 10,000 yBP). Near the end of the Wisconsinan glacial period, a series of large proglacial lakes covered the greater Cleveland area. Figure 4 presents the Lake Erie Wisconsinan glacial lake phases, which are correlated with drainage outlet (Calkin and Feenstra, 1985). Due to ice lobe advancing and retreating, various drain outlets closed and opened, increasing or decreasing the size of the proglacial lake (each lake elevation stage is distinguished with a different name). One such outlet was through the Mohawk Valley to the Hudson River in New York and another was through the Niagara Gorge in New York. Literature suggests the earliest stages of the proglacial lake (Lake Maumee stages, elevation range of 760–800 feet) deposited cohesive soils (lacustrine clays) in the Cuyahoga River Valley.

Prior to the final reopening of the Niagara Gorge, the proglacial lake (termed Lake Whittlesey, 13,000 yBP) was at its highest elevation, approximately 740 feet. During the Lake Whittlesey stage, the precursor to the Cuyahoga River built a large delta of sands and silts over the greater Cleveland area to an elevation approaching that of the lake (i.e., approximate Elevation 740 feet, or about 90 feet above the high ground in the downtown Cleveland area).

The lake elevation gradually lowered with further retreat of the glacier, eroding much of the deltaic sediments deposited over the greater Cleveland area. The removal of deltaic sediments caused an overconsolidation of the underlying lacustrine clays and glacial tills. During this period of time geologists have identified at least two events, corresponding to the opening of large drain outlets, which resulted in significant rapid lowering of lake elevation (see Figure 4 from Calkin and Feenstra, 1985). The first of these events drained the lake through a channel in the Mohawk Valley to approximate elevation 510 feet. The second event drained the lake upon final reopening of the Niagara Gorge to approximate elevation 430 feet (termed Early Lake Erie). These rapid lake elevation lowering events caused the Cuyahoga River to incise rapidly through the remaining deltaic sand and silt into the underlying lacustrine clays and glacial tills.

Deep river incising most likely triggered large slope instabilities throughout the Cuyahoga River Valley. One such landslide is considered large enough to temporarily block the entire river valley near the present Southerly Waste Water Treatment Plant (Miller, 1983). Even where landslides did not occur, large shear stresses were imposed in the cohesive sediments along the deeply cut valley slopes. These shear stresses could have created multiple planes of weakness, with features such as slickensides, which have been encountered by ODOT and others during

subsurface explorations in the Lower Cuyahoga River Valley. One such exploration was performed in the 1970's for the I-77/I-480 interchange in Independence, Ohio, where at least two layers of slickensides were discovered in the cohesive soils. Evidence of previous sliding activity exists also in fluvial sediments where multiple large clay blocks have been discovered below the present river elevation (Szabo et al., 1985).

ODOT has documented evidence of active slide plane movements at two different depths beneath the I-90 Bridge and in the vicinity of the I-77/I-480 Interchange. The Cuyahoga Metropolitan Housing Authority (CMHA) has documented active slope movements in the west bank of the Cuyahoga River between the Detroit Superior Bridge and the Columbus Avenue Lift Bridge.

The Niagara area compressed due to glacial overburden, lowering the ground surface approximately 150 feet below present elevation. After the final retreat of the glacier, subsequent rebound of the Niagara area gradually increased the elevation of Early Lake Erie to present Lake Erie elevation. During lake elevation rise after these two incising events, the Cuyahoga River Valley aggraded with fluvial deposits (Bradley, 2002, Szabo et al., 2003), burying the scoured river valley and presheared planes. In the vicinity of the Eagle Avenue Bridge, approximately 0.5 river miles downstream of the I-90 Bridge, Szabo et al. (2003) identified the bottom of the scoured river valley at elevation 445 feet, 130 feet below present river elevation.

Historically the Cuyahoga River was a meandering river. Recently (last 100+ years), river bulkheads have been placed causing the river to maintain its present course. Figure 5 illustrates the typical evolution of a river valley by a meandering river (Longwell et al., 1947). Initially, a V-shaped river valley is formed as the river incises into the soil (shown by cross section 1-1 in Figure 5b). The river gradually curves and swings laterally wearing the valley along the outer and downstream sides of the curves, creating steep banks adjacent to the river. The steepest banks, deepest water, and strongest currents lie on the outer side of the curves. The steep banks eventually experience slope failure creating flatter slopes, as shown by going from cross section 1-1 to 3-3 in Figure 5b. The meandering river swings wider, eventually forming a broad valley floor, as shown by cross section 5-5 in Figure 5b.

Based upon this geological review, it is the opinion of BBCM that multiple planes of weakness (ancient landslides or presheared zones with features such as slickensides) exist throughout the Lower Cuyahoga River Valley. These planes have a significant influence on the stability and creep movement of slopes and any constructed facilities located therein. It is considered likely that the two active slide planes within the West Bank Slope are remnants of ancient slide planes or presheared zones that were at or near a state of failure prior to human activities in the vicinity. It is also likely that elevated pore pressures exist in these sediments due to the entrapment of gases migrating out of the shale. Gas pockets are located at or near these planes of weakness at various positions throughout the valley. The elevated pore pressures in the location of Pier 1 are most likely induced by gas pockets and these pressures are expected to increase over time. In addition, due to the natural geologic process of valley formation (due to a meandering river), the area of greatest creep movement is expected to occur on the outer bank or a tight river bend. The geometry of the zone of creep movement is expected to extend upslope of the river curving around the steep bank with a shape mimicking that of the river curvature.

2.7 Cone Penetration Testing Investigation

As part of the subsurface investigation for the west pier of the CUY-90 project, a total of fifteen (15) cone penetration tests (CPT), designated C-05-01 through C-05-15, were performed by Ohio University (OU) during the period of March 20, 2006, through April 27, 2006. The CPT results are illustrated in Appendix C.

CPT results were used in conjunction with existing inclinometer data to develop the soil sampling program and vibrating wire piezometers installation elevations. These two proposed tasks were reviewed by Peter Narsavage from ODOT Office of Structural Engineering (OSE) prior to commencing field work.

CPT locations C-05-12, C-05-04, and C-05-03 were performed first. The depths of penetration for these three CPT locations ranged between 116.5 and 134.2 feet, where probe refusal was met. As these penetration depths were shallower than expected based on conversation between ODOT and OU, various techniques were attempted to assist OU with the means of deeper penetration. A CPT was performed at location C-05-03 through 30 feet of pre-augered 2.25-inch hollow stem augers. However, OU was unable to penetrate their probe deeper than what was performed without the use of augers. Ultimately, OU used an expansion rod placed directly behind the probe to create an annulus slightly larger than the feed rods for the purpose of reducing the frictional resistance acting along the feed rods. The remaining borings performed on the south side of the river (C-05-01, C-05-02, and C-05-05 through C-05-11) were performed using the expansion feed rod and the depths of penetration for these CPT locations ranged between 160.2 and 193.2.

Due to a sheared probe and cable, OU was only able to perform the three CPTs (C-05-13 through C-05-15) on the north side of river with 130-foot replacement cable. As a result, the depths of penetration for these three CPT locations ranged between 105.2 and 130.7 feet. In addition, many cobbles/boulders were encountered on the north side of the river. It became necessary to pre-auger the upper 20 to 30 feet of material to allow OU the means of penetrating the CPT probe below the cobbles/boulders.

Time dissipation tests were performed at the bottom of the CPT holes for locations C-05-01, C-05-02, C-05-4 through C-05-11, and C-05-14. The purpose of the dissipation tests was to allow pore pressures that develop during the CPT process to dissipate and reveal the static pore pressure head at the particular test depth. However, many of the dissipation test results are inconclusive due to accelerated drilling schedule and the excessive length of time that would be required for pore pressures to equilibrate. Figure 1 of Appendix H illustrates three pictures taken during CPT operations.

2.8 Soil Boring Field Investigation

As a part of the subsurface investigation for the west pier of the CUY-90 project, a total of 11 borings, designated B-05-01 through B-05-04, B-05-07, B-05-08, and B-05-11 through B-05-15 were performed. Inclinometers (3.34-in casing) were installed in borings B-05-01 through B-05-04, B-05-07, B-05-08, and B-05-11 through B-05-13. Three additional borings were performed to replace existing inactive inclinometers: B-105A to replace B-105, B-108A to replace B-108,

and B-05-16 to replace B-110. At the request of ODOT, B-05-16 was placed in ODOT property as close as possible to the excavation that is currently present west of ODOT property that was performed in order to allow the room necessary to pull the failed sheetpile bulkhead back vertical (construction activities performed by others). The borings were performed during the period of March 24, 2006 through June 14, 2006, and were advanced to depths ranging from 156.0 feet to 233.7 feet below the existing ground surface. Figure 2 of Appendix H illustrates a cross section of a typical inclinometer installed as part of this subsurface investigation.

Two vibrating wire (VW) piezometers were installed in an offset hole at each of the following boring locations: B-05-01 through B-05-04, B-05-07, B-05-08, and B-05-11 through B-05-13. Figure 3 of Appendix H illustrates a cross section of a typical VW-piezometer setup performed as part of this subsurface investigation. Each offset boring was augered five feet deeper than the planned depth of the deepest VW-piezometer. The VW-piezometers were installed on 1 ¼-inch PVC pipe. Each VW-piezometer cable runs up through the PVC pipe and is attached to a MiniLogger, which stores the pore pressure data. A flush mount protective cover was installed at each offset boring location to house the two MiniLoggers. Figure 4 of Appendix H illustrates pictures of installed VW-piezometer MiniLoggers.

Table 6 in Appendix H summarizes BBCM's information base about gas pockets encountered during subsurface investigation operations in the Lower Cuyahoga River Valley, including the gas pockets that were encountered during this field investigation. Figure 5 of Appendix H illustrates two examples of water/gas erupting above the ground surface during field operations. Table 7 in Appendix H summarizes the inclinometer and vibrating wire piezometer instrumentation information for the borings associated with this subsurface investigation.

During the subsurface investigation for borings B-05-13 through B-05-14, E.L. Robinson performed pressuremeter testing at the following depths:

B-05-13	31 to 33 feet, 41 to 43 feet, and 52 to 54 feet
B-05-14	40 to 42 feet, 62 to 64 feet, and 71 to 73 feet

Figure 6 of Appendix H illustrates pressuremeter testing being conducted at boring B-05-13.

ODOT provided BBCM with the approximate boring locations. BBCM adjusted the locations of each boring in order to clear utilities or other obstructions. REL provided BBCM with boring stationing, offset, and ground surface elevation. The stationing and offset for each boring are relative to the proposed I-90 centerline. The boring locations are shown on the plans of borings (Plates 2 and 3) in Appendix A.

The borings were drilled with either a truck or an all terrain (ATV) mounted drilling rig using 3¼-inch I.D. hollow-stem augers. Disturbed, but representative, soil samples were obtained by lowering to the sampling depth a 2-inch O.D. split-barrel sampler and driving it into the soil by blows from a 140-pound hammer freely falling 30 inches (ASTM D1586 - Standard Penetration Test). Upon encountering coreable bedrock at each boring location, 10 feet of bedrock was cored using an NX diamond bit rock core barrel, with water used as a circulating/cooling fluid. Retrieved rock core samples were stored in compartmental core boxes. Soil samples were

examined in the field, and representative portions were preserved in airtight glass jars and transported to the BBCM soils laboratory for further examination and testing.

In addition to the split-barrel samples, relatively undisturbed (Shelby tube) samples were retrieved in each boring location. The depth of Shelby tube sampling was determined in part from CPT and inclinometer data. BBCM obtained approval from Peter Narsavage on Shelby tube sampling locations prior to commencing field work. Shelby tube samples were obtained by hydraulically pushing, at a constant rate of penetration, a 3-inch O.D. thin wall Shelby tube a total of 24 inches. Shelby tubes were cleaned free of soil cuttings then preserved by sealing each end with wax then were transported to the BBCM soils laboratory for examination and testing. At the request of ODOT, additional Shelby Tubes were retrieved than was originally proposed to perform the BBCM laboratory testing program. At Baker's and E.L. Robinson's request, five of these extra Shelby tubes were given to Dr. Allen Marr in order to provide additional laboratory testing for QA/QC purposes. At the time of this report submission, any additional laboratory testing information has not been made available to BBCM. There are currently 24 additional Shelby Tubes that are being stored at BBCM's laboratory for future use if ODOT desires to perform additional testing. At the request of Baker and E.L. Robinson, BBCM also retrieved and is storing four additional Shelby tubes for E.L. Robinson's future use.

In the field, experienced personnel from BBCM supervised the drilling procedures and performed the following specific duties: preserved all recovered soil samples in airtight glass jars; prepared a log of each boring; made seepage and groundwater observations; obtained hand-penetrometer measurements in soil samples exhibiting cohesion; and, provided liaison between the field work and the Project Engineer so that the program of explorations could be modified, if necessary, because of unanticipated conditions. All samples were transported to the soil laboratory of BBCM Engineering for further identification and testing. Upon completion of the soil borings, the water level was measured and all borings were backfilled or sealed in accordance with ODOT requirements after inclinometer installation.

2.9 Laboratory Investigation

In the laboratory, all samples were visually identified and, on selected representative specimens, natural moisture content, liquid and plastic limit determinations, and grain-size analyses were performed. The results of all laboratory tests are recorded numerically on individual boring logs.

In addition to the above described index tests, one anisotropically consolidated undrained triaxial compression (CK₀UTXC) test, one isotropically consolidated undrained triaxial compression (CIUTXC) test, four direct simple shear (DSS), five direct shear (DS) tests, and five torsional ring shear (TRS) tests were performed for this project. Soil Engineering Testing, Inc. (Bloomington, MN) was subcontracted to perform the DSS tests and Cooper Testing Laboratory (Palo Alto, CA) was subcontracted to perform the TRS tests.

The DSS test was designed to simulate conditions along a thin shear zone separating two rigid masses that slide with respect to each other, a condition similar to a planar surface along a nearly horizontal portion of a slip surface in a landslide. The details of this test can be found in ASTM D 6528.

The TRS test was designed to test a soil sample at very large strains, something that all other test apparatuses are typically incapable of doing. The TRS test is designed to permit uninterrupted shear displacement and is suitable for measuring the drained residual shear strength of clay and shale. The details of this test can be found in ASTM D 6467.

At the request of ODOT, three unconfined compression (UC) tests, with a measurement of Poisson's ratio, were performed on a rock core sample taken from each of the borings located north of the river (B-05-13 through B-05-15). BBCM subcontracted Ackenheil Engineering, Inc. to perform these three UC tests with a Poisson ratio determination. In addition to these three special UC tests, 14 additional UC tests were performed on rock core samples.

Many laboratory tests results are recorded on the individual boring logs. Based on the results of the laboratory testing program, soil descriptions contained on the field logs were modified, if necessary. Laboratory-corrected boring logs are provided in Appendix D and include: a description of the soil stratigraphy encountered; depths from which samples were obtained; sampling efforts (blow counts) required to obtain the specimens; seepage and groundwater observations; and, hand-penetrometer values measured in soil samples exhibiting cohesion. Penetrometer strength values are roughly equivalent to the unconfined compressive strength of the cohesive fraction of the soil sample.

Soils described in this report have been classified in general accordance with the Unified Soil Classification System (USCS). However, the USCS system is augmented, with the use of special adjectives, to designate approximate percentages of minor soil components. An explanation of the symbols and terms used on the boring logs, and definitions of the special adjectives used to denote the minor soil/rock components, are presented in Plates 4 and 5 of Appendix A. Highway Research Board Symbols, as modified by ODOT, have been included on the logs, along with Group Indices determined from the laboratory testing program. The individual boring logs are presented as Plates 1 through 65 of Appendix D. Appendix E summarizes the specialty testing results performed as part of this subsurface investigation.

3.0 REVIEW OF PREVIOUS WORK

As part of this investigation, BBCM reviewed past geotechnical and geological investigations that were performed in the general vicinity of the project limits. The following sections summarize the purpose of each of the investigations and the significant aspects of the work performed with respect to the west bank slope stability evaluation for the CUY-90-15.24 Central Viaduct Innerbelt Bridge project.

3.1 The Cleveland Union Terminals Co. (1923)

The Cleveland Union Terminals Co. performed a subsurface investigation in 1923 in support of the design of the railroad grade that runs in a semi-circular fashion approximately parallel to Columbus Road, West Huron Road, State Route 14 (Ontario Street), and State Route 43 (Broadway Avenue). The subsurface investigation was performed along this general alignment starting near Freeman Avenue and ending near East 34th Street. The boring depths ranged approximately between 20 and 127 feet below the Cuyahoga River elevation.

The following item summarizes the significant contribution of this investigation as it relates to the current planning study.

- Boring profiles indicate the presence of a thin layer of material within the till generally described as “very wet, soft, sloppy, soapy mixture of blue clay and sand. Note: the hole filled with water.”

The very wet, soft soil encountered in the borings, located approximately between Elevation 488 and Elevation 496, **may** be indicative of a failure plane or shear zone along which creep movement may have developed or may develop in the future.

3.2 K. Bradley, M.S. Thesis – Cleveland State University (2002)

This thesis investigated and evaluated the geologic significance of soil samples obtained in the Tower City area and is also summarized in Szabo et al. (2003). The investigation in this thesis included subsurface information within the Cuyahoga River Valley near the Eagle Avenue bridge, which is located approximately ½-mile downstream from the current project location. Figure 6 illustrates the geologic cross section developed by Bradley (2002) near the Eagle Avenue bridge. Note the dramatic difference in elevation between the current Cuyahoga River and the buried ancient river bed.

The following points summarize the significant contribution of this investigation to the current investigation.

- K. Bradley encountered an ancient river valley, filled with fluvial deposits, the bottom of which was at approximate Elevation 450, or approximately 125 feet below the current Cuyahoga River elevation, and,
- K. Bradley discovered lacustrine clay within the Illinoian aged till approximately between Elevation 475 and Elevation 482 (shown in Figure 6).

The fact that an ancient river valley was found, which is discussed in Calkin and Feenstra (1985) and is summarized in the BBCM (2005a,b) reports, is very significant. This thesis provides evidence that the bed of the Cuyahoga River was at least 125 feet below existing Cuyahoga River elevation. Steep bluffs adjacent to the ancient Cuyahoga River would have been created during this rapid river downcutting event that created this buried valley. As a result, evidence of ancient shear planes, due to soil mass creep and landsliding of the exposed steep bluffs, can be expected down to at least 140 feet below the existing Cuyahoga River elevation.

BBCM discussed this study (Szabo, 2005) with Dr. Szabo, a professor in the geology department at the University of Akron. In particular, BBCM questioned Dr. Szabo as to the significance of the lacustrine clay layer, found in the Illinoian aged till layer, encountered in the subsurface investigation as part of the Bradley (2002) thesis. Dr. Szabo stated he believed the lacustrine clay was deposited during an interglacial phase within the Illinoian glacial period. The elevation of this lacustrine clay layer (Elevation 475-482) approximately corresponds with the elevation (Elevation 488-496) of the “very wet, sloppy” material encountered in the Union Terminals Co. investigation. He believes that the “very wet, sloppy” material, encountered in the Union

Terminals Co. investigation, and the lacustrine clay, found in the Bradley (2002) thesis, could be the same clay layer. He suspects that this layer may be hydraulically connected with the buried ancient river valley.

The Bradley (2002) thesis investigation does not yield specific subsurface information for the current project location; however, it provides a geologic framework for understanding the subsurface conditions at the west bank slope.

3.3 BBC&M Engineering, Inc. (2005a)

BBC&M Engineering, Inc. performed a geotechnical evaluation of the west bank slope and pier stabilization structure beneath the existing I-90 bridge. Nine inclinometers, (I-1 through I-9) were installed by ODOT in 1990. To BBCM's knowledge, these nine inclinometers have been abandoned. Five piezometers (P-1 through P-5) were installed by BBCM in 1994. Ten inclinometers (B-101 through B-110) were installed by BBCM in 1994. Six inclinometers (B-201 through B-204, B-303, and P-9N) were installed by BBCM in 1996. In addition, the University of Akron installed inclinometers and strain gages in/on the stabilization structure and Case Western Reserve University installed strain gages and tiltmeters on the I-90 bridge in an effort to monitor and assess the behavior of the stabilization structure and I-90 bridge.

The following items summarize the conclusions of the west bank slope investigation, from the Geotechnical Evaluation (BBCM, 2005a), which was submitted as part of the collaborative report developed in April, 2005 by Richland Engineering Limited.

Conclusions from Geology

1. Multiple thin weakened zones, that at or near residual strength conditions, much less than the strength of the surrounding overconsolidated soil, exist in the sediments along which creep movements are occurring;
2. Thin weak zones likely predated the construction of the I-90 bridge;
3. Geometry of the weakened zones should be better defined in the design of any future remedial repairs;
4. Soil mass creep rates can be so slow that a short term monitoring program may not recognize all slide planes;
5. High piezometric pressures are expected within the sediments near the bedrock interface as natural gas percolates up from the underlying shale becoming trapped in pockets within the cohesive sediments; and,
6. High piezometric pressures can accelerate the creep rate and lower the Factor of Safety of global slope stability.

Conclusions from Slope Kinematics

1. Slope movement is complex and occurs on two slide planes. One plane is approximately 40 feet below ground surface and the other is approximately 105 feet below existing ground surface, in the vicinity of Pier 1;
2. Orientation of movement varies between the shallow and deep slide planes and at different locations in the slope. The orientation of movement ranges from a maximum of 42° downriver of the bridge axis to 30° upriver;

3. Construction of the Pier 1 stabilization structure caused a significant increase in the creep rates of both the shallow and deep slide planes (by almost an order of magnitude in both instances);
4. The Pier 1 stabilization structure halted movement on the shallow slide plane in the immediate vicinity of the stabilization structure; and
5. The Pier 1 stabilization structure caused the movements on the deep slide plane to decrease, in the vicinity of the stabilization structure, below the rates of movement of the adjacent slope.

Conclusions from Slope Stability

1. Modeled pore pressure significantly affects the global slope stability. Pore pressures are expected to vary over time with climatic changes and buildup of natural gas pockets from the underlying shale deposit;
2. The Pier 1 stabilization structure increased the Factor of Safety for the deep slide plane by approximately 10%; and,
3. The slope may be near a tertiary creep condition where a very small decrease in the Factor of Safety from the current level could cause a significant increase in the creep rate of the soil mass.

Pressurized natural gas pockets, which have been found (ODOT, 1990 and BBCM 1999) during drilling operations to blow drilling mud up to 30 feet above the ground surface, will significantly reduce the available shear strength along a slide plane that passes near or through these pockets. It is likely that pockets of elevated pore pressure exist in the lower portion of the sediments at the project location. Since the elevated pore pressures occur as pockets, identifying and monitoring these pockets may be difficult, if not impossible. Drilling operations may also release the pressure of any pocket that is encountered prior to the installation of piezometers.

It is important to note that the sub-horizontal portion of the lower failure surface at the I-90 location corresponds to approximately the same elevation as the “very wet, sloppy” material encountered in the Union Terminals Co. investigation (1923) and the lacustrine clay encountered in the Bradley (2002) thesis.

3.4 BBC&M Engineering, Inc. (2005b)

BBC&M Engineering, Inc. performed a planning level study of the west bank slope and pier stabilization structure beneath the existing I-90 bridge. The purpose of this report was to estimate limits where the west pier of a proposed I-90 bridge, west (or north) of current bridge alignment, could be placed to minimize the potential of the foundation system being adversely affected by creep of the existing slope. Additional soil borings were not performed as part of this report. This report included an exterior masonry condition survey of the vicinity and slope stability evaluation for three cross sections. The slope stability evaluation was performed using limit equilibrium analyses and it was necessary to estimate the soil stratigraphy based on available information for two of the cross sections (B-B and C-C).

Masonry/brick buildings are good indicators of strain-induced damage. Boscardin and Cording (1989) developed damage category chart, which is based on horizontal strain and angular distortion. Six qualitative measures of distress ranging from negligible to very severe are used in this methodology and are based on a description of damage and approximate crack width, and frequency of cracking.

Figure 7 presents a conceptual diagram of ground displacements that occurs adjacent to but outside of, a creeping soil mass. The lateral deflection and ground surface subsidence cause damage in buildings founded on shallow foundations. The deformations that cause damage to buildings on shallow foundations is expected to cause a lateral load on deep foundations. While it may not be reasonable to assume that all cracking identified in an exterior crack condition survey be solely related to creep induced damage, there should be a trend that exists where more damage is noted closer to the creeping hillside. Any trend that exists could then be used to help estimate the extent of negative influence of the creeping hillside.

Two buildings in particular were noted to have damage likely related to the creeping hillside. Figure 8 depicts the inside northwestern corner of 1201 University Avenue (Sokolowski's University Inn). According to the owner of this establishment, the corner floor slab illustrated in this picture rapidly settled approximately 9-12 inches approximately 5-6 years ago. He stated that this settlement occurred when there were construction activities occurring downslope of University Avenue. The settlement of the floor slab at the wall next to the "wet floor" sign in the middle of the picture was approximately 9 inches. The crack that developed as a result of this settlement is visible in the foreground of this picture.

Figure 9 illustrates an approximate crack map for the cold storage warehouse located west of the existing I-90 bridge and Figure 10 depicts a view of the eastern wall of this warehouse. According to locals, the warehouse has 4-foot thick reinforced concrete walls. Measurements indicate that the outside columns are 3½ feet thick. Due to the size, shape and rigidity of this building, it is likely acting as a deep beam. The crack distribution and shapes illustrated in Figure 9 help to support this theory. Long flexural cracking originating from the top of the building and diagonal shear cracking is visible on each of the four walls.

Figure 11 presents a summary of the crack damage survey performed in the vicinity of the existing I-90 bridge. This figure illustrates the different estimated damage categories for each building in the area survey with the use of cross hatching. All building located north of Abbey Avenue had an estimated damage category range between slight and severe, while only one building (2053-2071 West 13th Street) south of Abbey Avenue was assigned a damage category (very slight) and the remaining had negligible or no visible exterior damage. This is significant because many of the buildings south of Abbey Avenue were built in the same era (late 1800's) as the buildings north of Abbey Avenue. BBCM understands that not all of the damage noted in the buildings is a result of the creeping hillside; however, a trend exists that shows that, in general, buildings south of Abbey Avenue are significantly less distressed than buildings north of Abbey Avenue.

Slope stability analyses using limit equilibrium methods were performed on three ODOT chosen cross sections A-A, B-B, and C-C. However, since all of the existing soil boring data is in the vicinity of cross section A-A, it was necessary to estimate the stratigraphy for cross sections B-B and C-C. Results of the slope stability analyses indicate that the hillside is also unstable within cross section B-B. The slope stability analyses were performed assuming that the deep slope failure was occurring at elevations defined by the existing inclinometer information. The limit equilibrium slope stability analysis derived predicted maximum distance of the scarp behind the crest of the hill adjacent to University Avenue is also shown in Figure 11. The maximum predicted location of the scarp behind the crest of the hill is approximately 75 feet in cross section A-A and 45 feet in cross section B-B.

Two semi-circular shaded areas are shown in the vicinity of the I-90 bridge. The innermost semi-circle is shaded gray and represents the estimated extent of known ground surface cracking and inclinometer movement. The estimated semi-circular shape results due to the shape of the river bend in this location. As discussed previously, the area outside of a tight river bend is prone to landsliding due to the natural progression of the river and hillside sliding to reach a state of equilibrium. The outer semi-circle, shaded using gray and white vertical stripes, is an estimate of the area of negative influence due to the river curvature, crack damage survey, and limit equilibrium slope stability analysis results. The following items summarize the conclusions obtained from this report.

Conclusions from Geology

1. Multiple thin weakened zones, that at or near residual strength conditions, much less than the strength of the surrounding overconsolidated soil, exist in the sediments along which creep movements are occurring;
2. Thin weak zones likely predated the construction of the I-90 bridge;
3. Geometry of the weakened zones should be better defined in the design of any future remedial repairs;
4. Soil mass creep rates can be so slow that a short term monitoring program may not recognize all slide planes;
5. High fluid pressures are expected within the sediments near the bedrock interface as natural gas percolates up from the underlying shale becoming trapped in pockets within the cohesive sediments;
6. High fluid pressures can accelerate the creep rate and lower the Factor of Safety of global slope stability; and,
7. Slope instability is expected to occur on the outer bank of a river meander due to the natural progression of long-term bank failure creating a flatter, more stable, valley wall. The shape of this expected zone of creep movement will likely have the approximate shape of the river meander.

Conclusions from Exterior Masonry Condition Survey

1. A trend exists where as one gets closer to the west bank slope the estimated building damage category changes from negligible to moderate or severe; and,
2. Buildings with slight to severe damage categories are north of Abbey Avenue and west of West 15th Street, while buildings south of Abbey Avenue and east of West 15th Street have negligible to very slight damage categories.

Conclusions from Limit Equilibrium Slope Stability Analyses

1. The resultant Factors of Safety against slope instability for cross sections A-A and B-B are within the range of expected soil mass creep movement;
2. The maximum predicted distance behind the crest of the bluff to the location of the scarp is approximately 75 feet in cross section A-A and 45 feet in cross section B-B;
3. The maximum predicted distance in front of the bulkhead to the location of the toe is approximately 200 feet in cross section A-A and 115 feet in cross section B-B;
4. The resultant Factor of Safety against slope instability for cross section C-C is significantly larger than 1.2 and a slope instability is not likely to occur for the trial surfaces investigated;
5. The estimated distance behind the crest of the slope, within cross section A-A, assuming that a long-term 3H:1V slope angle is safe, is approximately 310 feet.

Conclusions from Geotechnical Behavior

1. A creeping soil mass is expected to cause lateral ground deformation and an accompanying ground surface subsidence;
2. There is a zone where the maximum damage occurs to buildings on shallow foundations due to lateral deformation and ground surface subsidence;
3. Lateral deformation and ground subsidence that cause damage to buildings on shallow foundations are expected to cause a lateral load on deep foundations of the bridge;
4. The magnitude of lateral load that would act on a deep foundation due to an adjacent creeping soil mass is very difficult to determine accurately and the load is expected to accumulate with time. The ultimate value of lateral load expected is defined by the passive pressure of the soil; and,
5. The stress distribution of lateral earth loading is very difficult to determine accurately. Since the soil mass is likely creeping along a thin plane, a stress concentration is expected to occur where the slip plane and deep foundation intersect.

General Conclusions from the Planning Level Study

We have performed the preliminary evaluation of Section A-A with the direction of determining the location where the west slope pier could be founded which should have no significant influence from the known creeping slope. For planning purposes only, using the conclusions developed from the following information:

- a) geologic history of the Cuyahoga River Valley,
- b) geometry of the Cuyahoga River,
- c) exterior masonry conditions survey, and
- d) limit equilibrium stability analyses.

BBCM believes that the proposed bridge foundations should be founded **south of Abbey Avenue and east of West 15th Street in order to span the area of expected lateral displacement** due to the creeping West Bank.

As discussed, unloading the slope presents many advantages, improvement to the Factor of Safety and anticipated decrease in rate of creep, to name a few. However, any substructure constructed on the existing slope, even if it is remediated, will undergo future lateral creep

movement. Due to cost considerations and bridge type selection, it may be advantageous to consider placing the pier within the limits of the moving slope. However, if ODOT chooses to place the pier north of Abbey Avenue, they should do so **knowing that creep will continue**. Long term slope movement monitoring **is a necessary component** and the **only way to verify** if the areas selected for the foundations of the Cuyahoga River crossing are subject to the influence of the current slope creep movement. Failure to conduct verification testing should be performed only with the **understanding by ODOT that there is a risk of future lateral movement** of these proposed foundation structures due to creep. This **movement may not become evident until after the completion of the bridge construction and use of the bridge for several years**.

3.5 BBC&M Engineering, Inc. (2006)

As part of the planning study for the Cuyahoga River Valley Intermodal Connector (CRVIC), BBC&M Engineering, Inc. reviewed the stability of the existing hillside located along Riverbed Street between the Detroit-Superior Bridge and Columbus Road in Cleveland, Ohio. This hillside is known to be unstable and a large number of past investigations have studied portions of it and suggested various stabilization alternatives. BBCM previously performed a preliminary geotechnical analysis of this slope (report dated September 2003) which suggested that the present instabilities are apparently caused by: 1) a series of smaller landslides occurring on the west bank of the Cuyahoga River with scarps running through Riverbed Street; and, 2) a much larger landslide involving a significant portion of the west side of the river valley with a large exposed scarp on the upper terrace of the slope running parallel to the river, ranging from about 150 ft to 230 ft east of West 25th Street and extending continuously from Detroit Avenue to Franklin Boulevard. Field reconnaissance supports this hypothesis. BBCM was asked to develop conceptual stabilization options and associated preliminary opinions of probable costs using the subsurface information presently available from past studies of the site to refine the recommendations contained in BBCM's previous project report.

As part of this work, BBCM reviewed these past investigations, performed by others, and created limit equilibrium slope stability models at three sections through the slope using the subsurface data and laboratory test results contained in the past reports. No new field or laboratory work was performed as part of this work.

The presence of the large slide masses at the I-90 site and the CRVIC project site is significant because the geologic history is the same for both locations. The sub-horizontal portion of the upper failure surface at the I-90 location corresponds to approximately the elevation of known movement along a sub-horizontal slide plane at the CRVIC project site. Additionally, the sub-horizontal portion of the lower failure surface at the I-90 location corresponds to approximately the same elevation as the "very wet, sloppy" material encountered in the Union Terminals Co. investigation and the lacustrine clay encountered in the Bradley (2002) thesis.

Geologic history and evidence as well as observed geotechnical behavior at not only the I-90 project site, but also at the CRVIC project site, Eagle Avenue vicinity (Bradley, 2002), and the Cleveland Union Terminal Co. (1923) investigation indicate that the pre-existing pre-sheared slide surfaces are present not only directly beneath the existing I-90 bridge but are present

throughout the lower Cuyahoga River valley near downtown Cleveland. Geologic evidence and observed geotechnical behavior throughout the region suggests it is reasonable to assume that the pre-sheared planes, along which soil creep is occurring directly beneath the I-90 bridge, extend northwest and are present in the hillside beneath the alignment of the proposed new I-90 Central Viaduct bridge.

4.0 DISCUSSION OF SLOPE STABILITY PARAMETERS

As part of any slope stability evaluation, six key parameters are critical to adequately modeling the existing conditions and developing rehabilitation alternatives: 1) ground surface topography (including river bottom profile); 2) subsurface stratigraphy; 3) soil strength appropriate for failure type and drainage conditions along failure plane; 4) typical and worst case groundwater conditions including the presence of any elevated pore pressures (in excess of hydrostatic); 5) type of slope failure; and, 6) geometry of failure surface or surfaces.

The following sections summarize and discuss the information available to BBCM from all sources with respect to these key parameters, as well as concerns with the data or the lack thereof.

4.1 Ground Surface Topography

Baker provided BBCM with topographic information for each of the three cross sections. However, it should be noted that this topographic information was obtained prior to the excavation that was performed by others (in support of a bulkhead repair) adjacent to the Cuyahoga River west of the existing I-90 bridge. As a result, the available ground surface topography does not accurately reflect the actual ground surface within cross section A-A at the time this report was submitted.

Bathymetric information was not provided to BBCM, therefore, BBCM developed the river bottom topography using interpolation from known data.

4.2 Soil Stratigraphy

Existing boring logs (ODOT borings B-1 through B-9, BBCM borings B-101 through B-110, and BBCM borings P-1 through P-5) as well as new subsurface information obtained from the CPTs (C-05-01 through C-05-15) and soil borings B-05-01 through B-05-04, B-05-07, B-05-08, and B-05-11 through B-05-15 were used to develop the soil stratigraphy for the slope stability cross sections. In particular, the soil stratigraphy for cross section A-A was based predominately on soil borings B-05-01, B-05-02, B-05-08, B-05-11, B-05-12, B-108, and B-110 and CPT results from C-05-01, C-05-02, C-05-08, C-05-11, C-05-12.

Soil stratigraphy for cross section B-B will be based predominately on soil borings B-05-07 and B-05-08 and CPT results from C-05-07, C-05-08, C-05-09, C-05-10, and C-05-11. Soil stratigraphy for cross section C-C will be based predominately on soil borings B-05-07 and B-05-08 and CPT results from C-05-05, C-05-06, C-05-08, and C-05-09.

4.3 Groundwater

Existing groundwater information obtained by quarterly readings of the six piezometers (located in B-101, B-105, B-107, and B-303) as well as newly acquired CPT pore pressure results, were used to develop the ground water surface (phreatic surface) profile.

The locally high pore pressure that develops within the lowermost soil stratum due to trapped pressurized natural gas pockets is difficult to estimate. Table 4 in Appendix H summarizes BBCM's information base about gas pockets encountered during subsurface investigation operations in the Lower Cuyahoga River Valley, including the gas pockets that were encountered during this field investigation. This information was used as a basis in developing an assumed reasonable piezometric profile over the life of the structure for the soil near the bedrock. The stability analyses are sensitive to the value of the estimated excess pore pressure used in analyses. In other words, a spike in excess pore pressure along the failure surface, can lead to a decrease in stability and an unpredictable increase in the future rate of slope creep.

4.4 Type of Slope Failure

Geologic history, observed geotechnical behavior, and literature (e.g. see Brooker and Peck, 1993; Terzaghi et al., 1996; Wu, 1996; and Cornforth, 2005) suggest the slope is experiencing **drained creep failure**. Figure 12 presents a cross section of a typical block failure (see Brooker and Peck, 1993), which is the mode of failure for the creeping soil masses of the west bank. There are three major sections of this type of landslide: 1) *active wedge* defined by the portion of the failure surface that rises up to the ground surface, crossing the predominant horizontal bedding that is present in most overconsolidated cohesive material, to form the scarp; *translational wedge* defined by the portion of the failure surface that is nearly horizontal; and, *passive wedge* defined by the portion of the failure surface that rises up to the ground surface to form the toe.

A detailed discussion of creep is provided in Terzaghi (1950), Mitchell (1993) and Terzaghi et al. (1996). Creep is long-term time-dependent deformation under sustained loading. Time-dependent deformation can result from both volumetric (volumetric creep) and shear (deviatoric creep) stresses. Deviatoric creep is occurring within the west bank slope in the vicinity of the I-90 bridge. Unfortunately, most laboratory tested creep behavior is derived from the application of normal stresses instead of an applied shear stress similar to the field stress state. However, laboratory data is still useful in describing general soil creep behavior.

Figure 13 qualitatively illustrates typical creep behavior derived from triaxial compression testing. Figure 13a illustrates the three phases of creep deformation. Upon application of a stress, transient creep is initiated. This initial phase is termed primary creep and is characterized by a constantly decreasing strain rate. The next phase, termed secondary creep, is characterized by a nearly constant strain rate. If the shear stresses are high enough, the final phase of creep, termed tertiary creep, will occur as the creep rate accelerates until creep rupture. (Mitchell, 1993) The closer the in-situ soil stress state is to the shear strength of the material, the lower is the Factor of Safety against shear failure. "The rate of creep increases with increasing values of shear stress (Peck et al., 1974)." This important point is further illustrated in Figure 13b, which qualitatively depicts the creep rate as a function of time to failure and Factor of Safety.

Both the creep rate and creep strain are a function of stress state. The closer the soil is to a state of shear failure; a faster creep rate can be anticipated. Therefore, if the stress state in the west bank creeping soil mass can be altered to increase the factor of safety against slope failure (e.g. removing the head of the slide) the creep rate would likely decrease.

Inclinometer instrumentation data obtained during the construction of the pier 1 stabilization structure provides further proof to the type of slope failure. During excavation for the Pier 1 stabilization structure, the Factor of Safety against slope failure decreased temporarily. This decrease in Factor of Safety and corresponding increase in creep rate measured in the inclinometers is indicative of either a transition from secondary to tertiary creep (see Figure 13a), an increase in the creep rate similar to changing from point 'a' to point 'b' in Figure 13b, or both.

4.5 Soil Strength Appropriate for Failure and Drainage Conditions

As described previously, evidence suggests that the west bank of the Cuyahoga River, within the project limits, is experiencing drained creep failure. As a result of the three major portions of the failure plane (see Figure 12) and geologic history, three predominant modes of shear occur in a typical block failure. The strength along the active failure wedge is defined by a compression mode of shear, the strength along the translational wedge is defined by a simple shear mode of shear, and the strength along the passive wedge is defined by the extension mode of shear.

The two most critical and prominent portions of the failure surface are defined by the active and translational wedges. The geologic conditions and history suggest, under these failure conditions, the portion of the slip surface, which is oftentimes very thin and is oriented nearly horizontally (translational wedge), is aligned parallel to the horizontal bedding planes prevalent in an overconsolidated clay material. Drained residual shear strength conditions (Skempton, 1970, 1977, and 1985; Duncan, 1996; and Mesri and Shahien, 2003) with a simple shear mode of shearing (see Figure 12) control along the failure surface of the translational wedge. The portion of the slip surface along the active wedge intersects the horizontal bedding planes and may not have experienced as much displacement along the slip surface; therefore, fully softened strength conditions are likely more appropriate (Mesri, 2000; Mesri and Shahien, 2003) with a compression mode of shear (see Figure 12).

Mesri and Shahien (2003) explain the development of residual shear strength conditions for stiff clays (such as the overconsolidated clays in the Lower Cuyahoga River Valley) prior to a first-time slope failure. Processes active during deposition, consolidation, erosion, and pre-shearing can facilitate lithological and structural discontinuities that can reduce the strength to or near residual strength conditions after only a small shear displacement. They describe this process in three phases:

1. Consolidation under the weight of overburden, while increasing the shear strength and stiffness of the material, also tends to reorient the plate-shaped clay particles into horizontal orientation producing fissile weak planes;

2. The removal of overburden and lateral confinement causes overconsolidation as erosion and/or glacial retreat occurs. As a result, discontinuities such as joints and fissures develop. Shear strains become localized, which can reduce the shear strength along the fissile planes developed in phase 1 to or near residual shear strength conditions; and,
3. An unstable slope is formed by natural processes, such as fluvial downcutting, causing swelling, softening, and localized shear strains to begin, continue, or accelerate.

Using this methodology and back analyses from 99 case histories, Mesri and Shahien (2003) recommend modeling first-time landslides with this geologic history with the drained residual shear strength for the nearly horizontal portion of the slip surface and the drained fully softened shear strength for the portion of the slip surface defined by the active wedge. Imrie (1991) and later reiterated by Brooker and Peck (1993) state the following:

“... beneath and behind valley floors where bedding planes shears could exist, they should be assumed to be present, with strengths at residual values, unless their absence can be conclusively demonstrated. This is rarely possible. Geomorphic history and geologic evidence support the likelihood that the shears do exist. The likelihood of inducing a first-time slide must be assumed if bedding plane shears are known or suspected to exist near the slope toe, even if the topography is devoid of scarps, and other signs of sliding. Prudence requires assuming that bedding plane shears are present and that the corresponding residual strength prevails along the entire distance.”

4.6 Geometry of Failure Surface

The modeled deep failure surface for cross section A-A was developed from existing inclinometer information and ground surface cracking. In particular, the inclinometer movement from inclinometers installed in Borings B-108, B-110, and B-203 were used to develop the geometry of the failure surface for cross section A-A.

Brooker and Peck (1993) state the following:

“The highly stressed beds may be found not only beneath the toe of the slope, but also extending for some distance under the floor of the valley. Moreover, their presence is a function not only of the present slope geometry of the riverbank, but also of earlier slope geometries as the valley developed.”

4.7 Summary of Critical Information Still Outstanding

Considering the available information, the issues which are least well defined relate to the unstable slope geometry and its extent for all cross sections, pore fluid pressure information resulting from trapped natural gas pockets, and the ground surface topography for cross section A-A. The quantity and locations of the natural gas pockets are very uncertain. Very little is known about their presence and magnitude of trapped gas pressure other than what is observed when they are encountered during drilling operations. The aerial extent of the creep movement outside of the existing inclinometer information is unclear. The newly installed inclinometers will likely require a minimum of 1 to 2 years of monitoring before reliable trends can be inferred.

5.0 STABILITY ANALYSES OF EXISTING CONDITIONS

5.1 Subsurface Data Summary

Table 1 summarizes the idealized soil strength properties (mean strength properties) that were used in the slope stability analyses. Geologic history and observed geotechnical behavior indicate the slope is failing in a drained creep mode of failure; therefore, drained strength parameters were used for analysis. These values were estimated based on results of in-situ tests, laboratory tests, empirical correlations, and local experience.

The slope stability analyses software used for the stability evaluation is SLIDE 5.0. SLIDE has probabilistic and sensitivity analysis capabilities, which are performed to determine the effect of the uncertainty or variability of input parameters on the results of the slope stability analysis. Table 1 also includes three additional columns of strength values (standard deviation, relative minimum, and relative maximum) that are used as part of a probability and sensitivity evaluation presented in Section 8.0. The maximum and minimum values were set equal to 3 standard deviations above or below the mean value. The range defined by the maximum and minimum values was chosen to represent a typical range for the particular material type and is not intended to be a complete representation of potential values.

Appendix E presents the results of the laboratory test data that have been completed by the submission of this report.

The drained soil strength parameters for the fill, sand (upper and lower), and till were estimated primarily based on comparing the results of standard penetration testing and empirical correlations provided in FHWA (2002), GEC No. 5, and Peck et al. (1974). In general, the fill that was encountered was predominately composed of sand and/or gravel.

The portion of the modeled slip plane that passes through the upper silt layer is associated with the active failure wedge and experiences a compression mode of shear (see Figure 12). Consequently, the strength of the silt layer is based on the effective strength parameters obtained from the anisotropically consolidated undrained triaxial compression (CK₀UTXC) test, the results of which are presented in Appendix E. However, the results of the CK₀UTXC test were also compared with expected values based on a comparison of standard penetration results and empirical correlations (FHWA, 2002; Peck et al., 1974).

Table 1: Soil properties used for stability analyses.

Material	Soil Property	Primary Reference Source	Mean Value	Standard Deviation	Relative Minimum Value	Relative Maximum Value
Fill	ϕ'	1, 2	30°	3°	21°	39°
Fill	γ	3	120 pcf	5 pcf	105 pcf	135 pcf
Sand – upper	ϕ'	1, 2	30°	2°	24°	36°
Sand – upper	γ	3	120 pcf	5 pcf	105 pcf	135 pcf
Silt – upper	ϕ'	1, 2	32°	2°	26°	38°
Silt – upper	γ	3	120 pcf	5 pcf	105 pcf	135 pcf
Clay (FS)	ϕ'_{FS}	4	27°	2°	21°	33°
Clay (R)	ϕ'_R	4	14°	2°	8°	20°
Clay (FS, R)	γ	3	125 pcf	5 pcf	110 pcf	140 pcf
Sand – lower	ϕ'	1, 2	36°	Not used	Not used	Not used
Sand – lower	γ	3	128 pcf	Not used	Not used	Not used
Silt – lower	ϕ'	1, 2	32°	Not used	Not used	Not used
Silt - lower	γ	3	120 pcf	Not used	Not used	Not used
Till	ϕ'	1	38°	Not used	Not used	Not used
Till	γ	3	140 pcf	Not used	Not used	Not used
ϕ' – effective friction angle		γ – soil unit weight				
Primary Reference Source:		1 – FHWA (2002) Geotechnical Engineering Circular No. 5, Table 34. 2 – Peck et al. (1974), Figure 19-5. 3 – Bowles (1996), Table 3-4. 4 – Stark and Eid (1994), Terzaghi et al. (1996), and Mesri and Shahien (2003).				

Determining the appropriate shear strength for the clay is more complicated. Two separate portions of the modeled slip plane are present within the silty clay layer. The portion of the slip plane within the silty clay along the translational wedge would be under a simple shear mode of shear (see Figure 12). Figure 14 illustrates a possible micro-fabric within a hypothetical shear zone. Shearing is expected to occur along one, or possibly multiple, thin zone(s) of horizontally oriented, dispersed (i.e. flocculated aggregates of clay particles broken down into individual particles) clay particles. Soil samples obtained during this investigation indicate that the sand and silt particles are oftentimes present as pockets and lenses. The micro-fabric illustrated in Figure 14 presents many difficulties associated with accurately testing the residual shear strength of the deposit. Three such difficulties include:

1. Available shear strength in the field will be a function of the shearing resistance mobilized along the face-to-face contact of the horizontally oriented individual clay particles, not related to the shearing resistance of the silt or sand particles;
2. Testing the strength of only the clay along such a thin shear zone is difficult;
3. Tests such as Atterberg Limits (liquid and plastic limits) index tests and the torsional ring shear test are performed after the soil sample has been reconstituted. Therefore the micro-fabric is broken down, which creates a more homogeneous mix of clay, silt, and sand.

The results of Atterberg Limits tests are often used to represent the mineralogy of a soil deposit. Stark and Eid (1994), among many others (see for example Skempton, 1970), developed a correlation between the liquid limit, clay fraction, and secant residual friction of a soil deposit as a function of the average normal effective stress acting on the failure plane. As part of this investigation, TRS tests were performed on samples of both ‘bulging’ silt seams and silty clay samples. As described above, the remolded samples of silty clay demonstrate a siltier composition than what is present along the thin shear zones present within the field (Figure 14). As a result, the measured liquid limit and clay fraction are lower and the measured residual shear strength is higher than what is actually present along the thin shear zones within the field. A summary of the TRS test data and direct shear test data, which is superimposed on the Stark and Eid (1994) chart is provided in Appendix E. As expected, the siltier samples demonstrate much higher measured residual shear strength than the less silty clay samples due to lower plasticity (i.e. a different mineralogy). However, all of the test data correlate very well with the Stark and Eid (1994) chart. Therefore, the value of the residual friction angle (14°) presented in Table 1 and used for the slope stability analyses is based on:

- Results of the 1994 test data;
- Results of the TRS and direct shear test data as a function of the test specimen’s liquid limit (i.e. mineralogy);
- Stark and Eid (1994) chart used to estimate the residual shear strength along a thin shear zone composed of clay particles (see Figure 14) as a function of the anticipated liquid limit and clay fraction values determined from all soil boring performed at this site since 1990. For values of clay fraction greater than 50%, the liquid limit and clay fraction corrections recommended by Stark et al. (2005) were used to ‘modify’ the ASTM derived index values into equivalent ball-milled derived index values, which were used to develop the Stark and Eid (1994) chart; and,
- BBCM experience with TRS data for the same lacustrine silty clay layer within a slope approximately one mile downstream of the I-90 bridge.

The portion of the slip plane along the active wedge would be under a compression mode of shear (see Figure 12). The available strength would be defined by the fully softened shear strength because: a) the slip plane cuts across the predominate horizontal clay particle layering; b) the overconsolidated clay is made up of micro-fissures, thus reducing its strength from peak to fully softened conditions; and, c) the slip plane along the active wedge has likely experienced less strain than necessary to reduce its available strength to residual shear strength conditions. The value of the fully softened friction angle (27°) presented in Table 1 is based on:

- Stark et al. (2005) – Correlation between the liquid limit, clay fraction, and secant fully softened friction angle of the deposit as a function of the average effective normal stress acting on the failure plane; and,
- Terzaghi et al. (1996) – Correlation between the residual friction angle and fully softened friction angle.

5.2 Representative Cross Section

Baker provided BBCM with the ground surface topographic information needed to create cross sections A-A through C-C. The approximate locations of each of these three cross sections are shown on Plate 3 in Appendix A. It is well documented (field monitoring since 1994) that the slope within and adjacent to cross section A-A is unstable and creeping downslope. Prior slope stability evaluations (BBCM 2005a and BBCM 2005b) were performed to characterize the unstable slope in the vicinity of cross section A-A. The purpose of performing slope stability analyses within cross section A-A of this report is not to amend or re-characterize the stability analyses performed in the past. However, the testing results associated with the subsurface investigation summarized in this report substantiate that the strength parameters used in previous reports were reasonable. Rather, at the request of ODOT and Baker, the purpose of performing slope stability analyses within cross section A-A is to determine locations where piers could be placed, along with defining the potential limits for future slope movement (creep) and the determination of conceptual remedial approaches which could be considered in the final design of the substructure units.

At the request of ODOT, slope stability analyses were also performed within cross sections B-B and C-C to evaluate the potential of unstable slopes, not necessarily because there is visible evidence of instability in the vicinity of cross sections B-B and C-C.

The idealized soil stratigraphy, in descending order, for all three cross sections generally consists of: non-engineered fill, fluvial sand, fluvial and/or lacustrine silt, lacustrine clay, silt (likely of fluvial origin, sand (likely of fluvial origin), till, and shale bedrock. The idealized stratigraphy for each cross-section was based on both existing and new soil boring and cone penetration test information.

5.3 Stability of Representative Cross-Section

For slopes of arbitrary shape, limit equilibrium methods that satisfy all conditions of equilibrium are more accurate than less rigorous methods (Collins et al., 2002). As such, the slope stability analyses presented herein were performed using the Spencer's limit equilibrium method, unless stated otherwise, which satisfies complete force and moment equilibrium. However, all limit equilibrium analyses are inherently limited due to several weaknesses, which include:

- Failure is assumed at an overall factor of safety equal to one;
- Factor of safety is assumed constant along the entire slip surface, thus ignoring progressive deformation and differing soil conditions along the failure surface;
- Soil stress-strain constitutive behavior, which is highly nonlinear, is not modeled;
- Limitations incurred by modeling a three-dimensional field situation using a two-dimensional model; and,
- Limitations incurred by attempting to represent the exact field geologic conditions.

For these primary reasons, limit equilibrium analyses should be used primarily to compare the effectiveness of various rehabilitation alternatives rather than to attempt to identify the exact Factor of Safety. Stated another way, the changes in Factor of Safety are generally more

meaningful than the absolute magnitude of a Factor of Safety. It should be noted that slopes failing in creep complicate the situation. Again, for the above listed primary weaknesses in modeling, it is difficult to identify at what Factor of Safety creep will cease. There are many examples in literature that illustrate this point (e.g. see Brooker and Peck, 1993). As stated in Section 4.4, as the Factor of Safety is increased from an initial baseline value, the creep rate can be expected to reduce. However, the only reliable method to verify the effect of changes in Factor of Safety on the creep rate behavior of the west bank slope is to perform long-term field monitoring.

5.3.1 Cross-Section A-A

Prior to using the slope stability models to examine possible rehabilitation alternatives, BBCM calibrated the model based on the: existing geometry; known displacement information from inclinometers; soil strength properties; and, pore pressure conditions. The calibration of slope stability models involves the adjustment of parameters to match the current condition (i.e. both inclinometers installed in B-108 and B-110 indicate active creep movement, therefore, a Factor of Safety close to 1.0 is expected).

The initial slope stability model conditions are presented in Plate 1 of Appendix F. The approximate locations of University Avenue, Crown Avenue, and Abbey Avenue are illustrated on Plate 1 (see Plate 3 of Appendix A for approximate location of cross section A-A). Also shown on Plate 1 are arrows that indicate the distances of 50 feet, 100 feet and 150 feet behind the retaining wall at University Avenue. These three distances are used to describe the various excavation rehabilitation alternatives investigated as part of the slope stability evaluation presented in this report. The location of the horizontal portion of the deep slip plane was estimated from data obtained predominately from existing inclinometers installed in Borings B-108, B-110, and B-203. To model the nearly horizontal portion of the slip surface, a relatively thin sublayer at residual strength conditions was modeled within the lacustrine clay.

As stated previously, slopes failing in creep complicate the selection of a baseline calibration point because the limit equilibrium Factor of Safety may be significantly higher than 1.0, yet still exhibit creep behavior. Using the strength parameters summarized in Table 1 and the ground water table profile, based on existing piezometric data, the initial Factor of Safety for cross section A-A along the deep slip plane is 1.065, as shown in Plate 2 of Appendix F. A sensitivity analysis was performed to assess the affect the residual friction angle has on the resultant Factor of Safety. Plates 3 and 4 of Appendix F and Table 2 illustrate the calculated Factor of Safety values approximately range between 1.04 and 1.09 for residual friction angles between 13 and 15 degrees.

The stability analyses performed by BBCM (2005a) indicate that in the slope beneath the existing I-90 bridge, there are both deep and shallow slip surfaces. Since cross section A-A is adjacent to the existing bridge, it is reasonable and prudent to expect that the shallow slip plane is also present in the slope within cross section A-A. The stability within cross section A-A for a shallow slip plane, which is at residual strength conditions, is presented in Plate 5 of Appendix F. Slope stability analyses suggest that the minimum Factor of Safety for a failure occurring along the shallow slip plane is approximately 1.04.

Table 2: Calculated Factor of Safety as a function of residual friction angle for angles ranging from 13 to 15 degrees.

Residual Friction Angle	Factor of Safety
13	1.042
14	1.065
15	1.094

5.3.2 Cross-Section B-B

Plate 6 of Appendix F illustrates the existing conditions for cross section B-B (see Plate 3 of Appendix A for approximate location of cross section B-B) assuming the deep slip surface extends from the vicinity of cross section A-A to cross section B-B, a modeling assumption based on geologic history recommended by Brooker and Peck (1993). Also shown on Plate 6 are the approximate locations of West 15th Street and the railroad tracks.

Plate 7 illustrates that within cross section B-B for a potential failure along a deep slip plane at residual strength conditions, the minimum Factor of Safety is equal to approximately 2.52. The results illustrated in Plate 7 were determined using the Simplified Janbu limit equilibrium method because the calculated Factors of Safety determined using the Spencer method exceeded the Spencer’s method maximum allowable Factor of Safety threshold.

Plate 8 presents the slope stability results within cross section B-B assuming a potential failure along a shallow slip plane at residual strength conditions. The assumed shallow slip plane elevation corresponds to the known elevation of the shallow slip plane in the vicinity of cross section A-A. Again, this modeling assumption was based on geologic history and recommendations provided by Brooker and Peck (1993). The minimum Factor of Safety presented on Plate 8 is equal to approximately 2.67.

The results presented in Plates 7 and 8 of Appendix F indicate that under the assumptions presented herein, the slope modeled within cross section B-B is likely stable.

5.3.3 Cross-Section C-C

Plate 9 of Appendix F illustrates the existing conditions for cross section C-C (see Plate 3 of Appendix A for approximate location of cross section C-C). Also illustrated on Plate 9 are the approximate locations of Fairfield Avenue and the I-90 WB Abbey Avenue off ramp. Since the small slope within cross section C-C does not appear to be definitively connected with the Cuyahoga River Valley, BBCM did not model pre-existing slip planes within cross section C-C.

Plate 10 presents the results of the stability analysis for a potential block failure geometry. The minimum Factor of Safety is equal to 3.275 as was determined using the Simplified Janbu limit equilibrium method because the calculated Factors of Safety determined using the Spencer method exceeded the Spencer's method maximum allowable Factor of Safety threshold.

Plate 11 illustrates the results for a potential circular failure geometry. The minimum calculated Factor of Safety is equal to 2.677 and was determined using the Simplified Bishop limit equilibrium method. The Simplified Bishop method is the preferred method of performing slope stability analyses for a circular failure surface because it yields similar results as the more rigorous methods that satisfy complete equilibrium, such as the Spencer method. Plate 11 illustrates that the circular failure surface with the minimum Factor of Safety is shallow and occurs entirely above the lacustrine clay layer. As a result, a much smaller local slope failure was modeled and presented in Plate 12 for the hillside between Fairfield Avenue and the southern deadend of West 15th Street. The minimum calculated Factor of Safety for a potential local slide between West 15th Street and Fairfield Avenue is 1.237 (Plate 12).

The results presented in Plates 10 and 11 of Appendix F indicate that under the assumptions presented herein, the slope modeled within cross section C-C is likely stable for a deep global slope failure. However, when a much smaller local slope failure is modeled in the hillside between Fairfield Avenue and the southern deadend of West 15th Street, the calculated Factor of Safety indicates that a much smaller local slope failure is possible. BBCM understands that there is a proposed bridge to carry I-90 WB traffic over Fairfield Avenue. Additionally, a loop ramp may be added in the areas where a shallow failure plane currently exists. As such, BBCM recommends that if ODOT plans to place a bridge abutment or pier between Fairfield Avenue and the top of the hillside near West 15th Street, an additional subsurface investigation be performed in the vicinity to support a detailed slope stability evaluation.

6.0 GENERALIZED STABILIZATION TECHNIQUES

A large number of specific methods have historically been used to mitigate failing slopes. However, the majority of such methods fall into a relatively small number of generalized categories. The FHWA manual "Advanced Technology for Soil Slope Stability" (SA-94-005) presents a table, reproduced as Table 1 on the following pages, which summarizes the range of general methods of slope rehabilitation. In addition to complete avoidance of an unstable slope, there are four different general categories of slope rehabilitation, which are:

- Drainage (primarily subsurface drainage but also redirection/control of surface water);
- Earthwork (geometrical changes to the existing ground surface configuration);

- Retaining structures (includes various wall and tieback options); and,
- Soil modification (various methods intended to increase the strength of the soil at the failure surface).

At the request of ODOT, BBCM only investigated one rehabilitation method in addition to complete avoidance of an unstable slope. BBCM investigated the influence of earth removal at the head of the creeping soil mass (in the vicinity of University Avenue). Table 3 indicates that earthwork, in particular the removal of the head or driving force of the slide, has the greatest frequency of success. By removing the head of the slide, a portion of the driving force is eliminated. In recognition of this, BBCM is of the opinion that strong consideration should be given to unloading, either by itself or in combination with another method, if it is determined that a rehabilitation alternative be performed at this site.

Table 3: Summary of Methods for Correcting and Preventing Landslides (from FHWA-SA-94-005).

Treatment Method - Effect on Stability	Treatment	General Use		Frequency of Success ^a			Position of Treatment Related to the Actual or Potential Sliding Mass	Possibilities and Limitations
		Prevent	Correct	Collapse	Slide	Flow		
Avoidance - No effect	Relocation	X	X	2	2	2	Outside slide limits	Best method if economical
	Construction of viaduct	X	X	3	3	3	Outside slide limits	Applicable to short stresses of sloping hillsides
Movement of earth – Reduction in shear stresses	Removal from the head	X	X	N	1	N	Upper part and head	Large masses of cohesive material
	Slope flattening	X	X	1	1	1	In the cut or embankment slopes	More effective in earth fills on frictional soils
	Terracing in slopes	X	X	1	1	1	In the cut or embankment slopes	
	Removal of all unstable material	X	X	2	2	2	Throughout the slide	In relatively small superficial masses of moving material
	Surface							
Drainage – Reduction in shear stresses and increase in shear strength of soil	Ditches	X	X	1	1	1	Above the crown	Essential in all types
	Slope treatment	X	X	3	3	3	On surface of sliding mass	Rock covering or permeable apron to control flow
	Subgrade trimming	X	X	1	1	1	On surface of sliding mass	Beneficial in all types
	Sealing of cracks	X	X	2	2	2	Throughout, crest to toe	Beneficial in all types
	Sealing of joint and fissure planes	X	X	3	3	3	Throughout, crest to toe	Applicable in Rock formations
	Subdrainage	X	X	N	2	2	Locate to intercept and divert underground water	Large masses of soil with underground flow
	Horizontal drains	X	X	N	1	3		Relatively superficial masses of soil with underground flow
	Stabilizing trenches	X	X	N	3	3		Deep-seated and large masses of soil with significant permeability
	Drainage galleries	X	X	N	3	3		Deep-seated sliding masses, underground water in strata or lenses
	Vertical drainage wells	X	X	N	3	3		Chiefly used as a ditch or drainage well opening
Continuous siphon	X	X	N	2	3			

Table 3 (cont.) Summary of Methods for Correcting and Preventing Landslides (from FHWA-SA-94-005).

Retaining Structures – Sliding resistance increases	Support at the base	X	X	N	1	1	Base and toe	Sound rock or firm soil at reasonable depth
	Rock fill	X	X	N	1	1	Base and toe	As counterweight in the toe gives additional strength
	Earth fill	X	X	N	1	1	Base and toe	Relatively small moving masses
	Common or crib retaining walls	X	X	3	3	3	Base	
Piles	Fixed in the slip surface		X	N	3	N	Base	The strength of the failure surface is increased by the amount of stress required to make the piles fail
	Not fixed to the slip surface		X	N	3	N	Base	
	Anchorage in rock	X	X	3	3	N	Uphill from the highway or structure (cuts)	Stratified rock
	Short anchorages in slopes	X	X	3	3	N	Uphill from the highway or structure	Eroding slope protected by screen anchored to a solid underlying formation
Other Methods – Chiefly an increase in shear strength	Harden the sliding mass							
	Cementing or chemical treatment		X	3	3	3	Base and toe	Cohesionless soils
	At the base		X	N	3	N	Throughout sliding mass	Cohesionless soils
	Throughout mass	X		N	3	3	Throughout sliding mass	Top prevent temporary movement in large masses
	Freezing	X		N	3	3	Throughout sliding mass	Hardens the soil by reducing the water content
	Electro-osmosis							Relatively superficial
Explosives		X	N	3	3	In the lower portion of slide	cohesive mass overlying a mass of rock. Fragmented sliding surface. Explosives may also enable water to drain from the sliding mass	

Note: a: 1: Frequent, 2: Occasional, 3: Rare, N: Not Applicable

7.0 REHABILITATION ALTERNATIVES

The stabilization alternatives assessed as part this planning study were not intended be an inclusive representation of all possible specific stabilization alternatives. At the request of ODOT, BBCM only evaluated the influence of excavation rehabilitation alternatives. Traditionally, ODOT has required that the minimum Factor of Safety against slope failure is 1.5 for slopes supporting a structure. However, for this proposed bridge and slope improvement, the governing behavior of the slope remediation and foundation design is future creep movement, and not necessarily an increase to a prescribed Factor of Safety. The following excavation alternatives were evaluated for the slope in the vicinity of cross section A-A:

Alternative 1 (20/50):

20-foot vertical excavation located approximately 50 feet south of University Avenue as shown in Figure 15a and Plate 13 of Appendix F;

Alternative 2 (30/50):

30-foot vertical excavation located approximately 50 feet south of University Avenue as shown in Figure 15b and Plate 14 of Appendix F;

Alternative 3 (20/100):

20-foot vertical excavation located approximately 100 feet south of University Avenue as shown in Figure 16a and Plate 15 of Appendix F;

Alternative 4 (30/100):

30-foot vertical excavation located approximately 100 feet south of University Avenue as shown in Figure 16b and Plate 16 of Appendix F;

Alternative 5 (10/150 and 20/50):

Terraced excavation with a 10-foot vertical excavation located approximately 150 feet south of University Avenue and a 20-foot vertical excavation located approximately 50 feet south of University Avenue as shown in Figure 17a and Plate 17 of Appendix F;

Alternative 6 (20/150 and 10/50):

Terraced excavation with a 20-foot vertical excavation located approximately 150 feet south of University Avenue and a 10-foot vertical excavation located approximately 50 feet south of University Avenue, as shown in Figure 17b and Plate 18 of Appendix F;

Alternative 7 (20/Abbey):

20-foot vertical excavation located on the north side of Abbey Avenue as shown in Figure 18a and Plate 19 of Appendix F;

Alternative 8 (30/Abbey):

30-foot vertical excavation located on the north side of Abbey Avenue as shown in Figure 18b and Plate 20 of Appendix F;

Alternative 9 (7:1/Abbey):

7(H):1(V) slope beginning north of Abbey Avenue extending down to El. 620 feet, as shown in Figure 19a and Plate 21 of Appendix F; and,

Alternative 10 (3:1/Abbey):

3(H):1(V) slope beginning north of Abbey Avenue extending down to El. 620 feet, as shown in Figure 19b and Plate 22 of Appendix F.

In recognition of the planning nature of these analyses, focusing strictly on the magnitude of the factor of safety is not advised, as this value is a function of the inevitable weaknesses inherent in modeling a 3-D field slope failure with a 2-D limit equilibrium analysis and is subject to change. Rather, the change in Factor of Safety is a more useful parameter for comparison purposes. While it is not possible to state with certainty that creep movement will cease for values in Factor of Safety above a threshold value, it is important to note that a significant increase in the Factor of Safety against slope failure would likely reduce the creep rate. Table 4 summarizes the computed Factor of Safety for each of the excavation alternatives. Table 4 also provides an approximate range in calculated Factors of Safety for trial failure surfaces that extend southward such that the scarp is located within the footprint of Abbey Avenue.

Table 4: Summary of the calculated Factor of Safety for each excavation alternative.

Rehabilitation Method	Cross Section A-A			Abbey Ave. FS	Appendix F Plate No.
	FS	Δ FS	Δ FS/FS _{existing}		
Deep Slip Surface					
Existing Conditions	1.065	---	0	1.36-1.56	2
Alternative 1 (20/50)	1.143	0.078	7.3%	1.29-1.44	13
Alternative 2 (30/50)	1.162	0.097	9.1%	1.29-1.45	14
Alternative 3 (20/100)	1.195	0.130	12.2%	1.26-1.42	15
Alternative 4 (30/100)	1.251	0.186	17.5%	1.30-1.41	16
Alternative 5 (10/150 and 20/50)	1.199	0.134	12.6%	1.32-1.41	17
Alternative 6 (20/150 and 10/50)	1.231	0.166	15.6%	1.33-1.39	18
Alternative 7 (20/Abbey)	1.256	0.191	17.9%	1.56-1.90	19
Alternative 8 (30/Abbey)	1.255	0.190	17.8%	1.62-1.64	20
Alternative 9 (7on1/Abbey)	<i>1.259</i>	<i>0.194</i>	<i>18.2%</i>	1.40-1.47	21
Alternative 10 (3on1/Abbey)	1.330	0.265	24.9%	1.46-1.61	22
Shallow Slip Surface					
Existing Conditions	1.041	---	---	1.57-1.81	5
Alternative 7 (20/Abbey)	1.345	0.304	29.2%	1.73-1.85	23
Alternative 9 (7on1/Abbey)	1.794	0.753	72.3%	1.81-1.85	24
Alternative 10 (3on1/Abbey)	<i>1.688</i>	<i>0.647</i>	<i>62.2%</i>	1.69-1.70	25

Bold – indicates the best alternative in the particular category

Italic – indicates the second best alternative in the particular category

7.1 Deep Slip Surface

Slope stability analyses were performed along the proposed alignment of the I-90 bridge to model the deep slip surface that is present as indicated by existing slope inclinometer data. Table 4 indicates that the excavation alternatives (Plates 13 through 22) increase the minimum Factor of Safety. Slope stability analyses indicate that the Factor of Safety against slope failure for existing conditions is approximately 1.07 (Plate 2) and the calculated range in Factor of Safety for trial failure surfaces extending back to Abbey Avenue is 1.36 to 1.56. Excavation alternative 10 (3on1/Abbey), shown in Plate 22, demonstrates the greatest change in Factor of Safety having nearly a 25% increase from initial conditions. Alternatives 4, 7, 8, and 9 (Plate 16, and Plates 19 through 21) all demonstrate a similar change in Factor of Safety, which for these four alternatives ranges from 17.5% to 18.2% increase from initial conditions. For alternative 10, trial slip surfaces extending southward to Abbey Avenue yield a calculated range in Factor of Safety between 1.46 and 1.61. Similarly, stability analyses yield a range in Factors of Safety between 1.3 and 1.9 for trial slip surfaces extending southward to Abbey Avenue for rehabilitation alternatives 4, 7, 8, and 9.

7.2 Shallow Slip Surface

A shallow slip surface was modeled for the existing conditions based on inclinometer data and geologic history. Table 4 indicates that for existing conditions assuming a shallow slip surface the estimated Factor of Safety is approximately 1.04 (Plate 5). For trial slip surfaces extending southward to Abbey Avenue, the estimated range in Factor of Safety is between 1.57 and 1.81. Excavation rehabilitation alternatives 7, 9, and 10 (Plates 23 through 25), which exhibited the greatest increase in Factor of Safety for the deep slip surface, were modeled for the shallow slip surface scenario. These three excavation alternatives exhibited a Factor of Safety increase between 29% and 72% from existing conditions.

8.0 PROBABILISTIC AND SENSITIVITY ANALYSIS

As stated previously, SLIDE 5.0 has probabilistic and sensitivity analysis capabilities, which are performed to determine the effect of the uncertainty or variability of input parameters on the results of the slope stability analysis. To better understand the most sensitive parameters, probability and sensitivity analyses were performed on the slope stability model of cross section A-A. The probability and sensitivity analyses were performed using the soil parameters summarized in Table 1. A deterministic Factor of Safety (presented in Table 4) is calculated independent of the probability analysis and results when all the mean soil strength values are used. The probability and sensitivity analyses were performed on only the global minimum slip surfaces calculated from the deterministic analyses presented in Section 7.0. The probability and sensitivity analyses were performed, assuming a normal distribution, using the following steps:

1. Use only the critical deterministic slip surface for each rehabilitation option (i.e. the critical slip surfaces summarized in Table 4 and Appendix F);
2. Use a Monte Carlo sampling routine to generate a random set of input properties based on the constraints given in Table 1;
3. Using the slip surface from step No. 1 and the soil parameter set from step No. 2, run the stability analysis to obtain a Factor of Safety; and,

4. Repeat steps No. 2 and No. 3 to obtain a total of 2000 separate randomly generated data sets and resulting Factors of Safety for a given slip surface.

Table 5 summarizes the results of the probability analyses for the minimum slip surfaces of each excavation alternative evaluated within cross section A-A. The deterministic Factors of Safety presented in Table 5 are equal to the values of Factors of Safety presented in Table 4. In contrast to the deterministic Factor of Safety, the mean Factor of Safety is simply the mean Factor of Safety that results from the four step procedure summarized above.

Table 5: Probability analysis results for cross-section A-A using Spencer’s LEM.

Rehabilitation Alternative	Deterministic FS (see Table 4)	Probability Analysis Results					
		Mean FS	Δ Mean FS	Standard Deviation	95% Confidence Interval	Min. FS	Max. FS
Existing Conditions	1.065	1.092	---	0.089	1.088-1.096	0.820	1.386
Alternative 1 (20/50)	1.143	1.168	0.076	<i>0.102</i>	1.163-1.172	0.833	1.519
Alternative 2 (30/50)	1.162	1.185	0.093	0.105	1.180-1.190	0.838	1.557
Alternative 3 (20/100)	1.195	1.220	0.128	0.110	1.215-1.225	0.864	1.607
Alternative 4 (30/100)	1.251	1.227	0.135	0.115	1.222-1.232	0.880	1.658
Alternative 5 (10/150 and 20/50)	1.199	1.222	0.130	0.112	1.217-1.227	0.854	1.608
Alternative 6 (20/150 and 10/50)	1.231	1.253	0.161	0.113	1.248-1.258	0.922	1.653
Alternative 7 (20/Abbey)	1.256	1.266	0.174	0.113	1.261-1.271	0.915	1.653
Alternative 8 (30/Abbey)	1.255	1.270	0.178	0.110	1.265-1.275	<i>0.933</i>	1.646
Alternative 9 (7on1/Abbey)	<i>1.259</i>	<i>1.285</i>	<i>0.193</i>	0.114	<i>1.280-1.290</i>	0.921	<i>1.675</i>
Alternative 10 (3on1/Abbey)	1.330	1.341	0.249	0.118	1.336-1.346	0.996	1.745
Shallow Slip Surface							
Existing Conditions	1.041	1.042	---	0.105	0.831-1.251	0.666	1.467
Alternative 7 (20/Abbey)	1.345	1.343	0.301	<i>0.142</i>	1.061-1.629	0.833	1.910
Alternative 9 (7on1/Abbey)	1.794	1.801	0.759	0.164	1.466-2.122	<i>1.217</i>	2.452
Alternative 10 (3on1/Abbey)	<i>1.688</i>	<i>1.692</i>	<i>0.650</i>	0.152	<i>1.384-1.992</i>	1.162	<i>2.307</i>

Bold – indicates the best alternative in the particular category

Italic – indicates the second best alternative in the particular category

Table 5 also presents the standard deviation, 95% confidence interval, and minimum and maximum Factors of Safety determined from the probability analyses. Probability analyses based on the material properties provided in Table 1 and the number of samples (2000) indicates that we can be 95% confident that the actual modeled mean Factor of Safety will be within the range in Factors of Safety denoted by the 95% confidence interval presented in Table 4. The minimum and maximum Factors of Safety that result from the probability analysis.

It is important to understand the significance and implication of performing a probability analysis. Rather than comparing the results of the probability analysis to the deterministic analysis to obtain a gauge of accuracy, one should keep in mind what each analysis is specifically determining.

Deterministic Analysis – A deterministic analysis is the typical analysis performed in a slope stability model. It is performed by first providing the stability model with a best estimate of the soil strength parameters. The model is then run using these strength parameters and results in a specific slip surface geometry that provides the minimum Factor of Safety. Most stability analyses are stopped here and the resulting deterministic Factor of Safety is reported.

Probabilistic Analysis – A probability analysis goes one step further than the deterministic analysis in that an attempt is made to provide a level of confidence to the stability analysis results performed on the resulting deterministic critical slip surface geometry. Rather than simply relying on the calculated deterministic Factor of Safety, the probabilistic analysis is performed by randomly varying the soil strength parameters. In this fashion, one can assign a level of confidence in the knowledge of the soil strength parameters.

Of the probability parameters listed in Table 5, the most important parameters for comparison purposes are the mean Factor of Safety, change in mean Factor of Safety, and the 95% confidence interval. Since for each alternative the probability analysis was performed on the slip surface that results from the deterministic evaluation (results presented in Table 4), the mean Factor of Safety is expected to be close in magnitude to the deterministic Factor of Safety. As indicated previously in other words, based on the sampling scheme, we can be approximately 95% confident that the actual calculated mean Factor of Safety should be within the range of Factors of Safety indicated by the 95% confidence interval. The mean Factor of Safety, change in mean Factor of Safety, and 95% confidence interval presented in Table 5 likely provide much better values for use in comparison between different excavation alternatives than the deterministic and change in deterministic Factors of Safety presented in Table 4.

The probability results of the existing conditions for the deep slip surface are very important. Using the global slip surface that results from the deterministic analysis, the resulting mean Factor of Safety for the 2000 randomly generated data sets based on the constraints of Table 1, is 1.092. A confidence of 95% can be assigned such that the actual modeled mean Factor of Safety lies somewhere between 1.088 and 1.096. This small range in Factors of Safety implies that the modeled results aren't strongly influenced by the exact choice of strength properties.

The probability analyses presented in Table 5 indicate similar trends to what was noted for the deterministic analyses results presented in Table 4. Excavation alternative 10 provides the greatest increase in mean Factor of Safety ($\Delta FS = 0.249$) for the deep slip plane, which is defined by a 95% confidence Factor of Safety interval between 1.336 and 1.346. Excavation alternatives 7, 8, and 9 provide similar probability analyses results to each other with a change in mean Factor of Safety ranging between 0.174 and 0.193. For the shallow slip plane, excavation alternative 9 provides the greatest increase in the mean Factor of Safety ($\Delta FS = 0.759$), which is defined by a 95% confidence Factor of Safety interval between 1.446 and 2.122.

Plates 19 and 20 of Appendix F present the sensitivity of the calculated deterministic Factor of Safety to the effective strength parameter ϕ' and the soil unit weight. Plate 19 indicates that the clay and clay (residual) strength values have the most influence on the resultant Factor of Safety, while Plate 20 indicates that the clay unit weight has the most influence on the Factor of Safety. Therefore, since the Factor of Safety is sensitive to these values, future laboratory testing, if performed, should focus on better defining these parameters. However, a significant laboratory testing program would likely be necessary to sufficiently change the values listed in Table 1 such that the confidence interval presented in Table 5 would change significantly.

However, stability analyses results aren't only a function of soil strength properties. The results are also strongly influenced by modeled pore pressures. BBCM believes that the confidence in the soil strength properties is much greater than the confidence in the pore pressure values, especially the pore pressures resulting from the natural gas pockets. Unfortunately, because the pockets of natural gas are sporadic and the pressures vary with time and location, it would be difficult to accurately access the magnitude of the pressures within these pockets. It would likely require a long-term monitoring program consisting of very close laterally spaced vibrating wire piezometers located within the bedrock and overlying sediment.

9.0 CONCLUSIONS

As is the case in any slope stability analysis, there are inherent limitations in the ability to accurately model a 3-D, rate-dependent slope failure using 2-D limit equilibrium methods. The key factors to adequately modeling a slope failure are: ground surface topography, soil stratigraphy, material strength along the failure plane, pore pressures, and the slope failure geometry. The greatest limitations in the currently available behavioral information relate to existing ground surface topography due to the recent excavation activities adjacent to the existing I-90 bridge, pore pressures and failure surface geometry. Pore pressures due to the ground water table change with time, and significant evidence suggests it is likely that there are pressurized pockets of natural gas in the lower portion of the sediments that increase the pore pressure significantly above hydrostatic conditions. Because these elevated pore pressures are believed to exist in the form of pockets, it makes both modeling these pressures difficult as well as the potential for reducing these pressures using deep pressure relief wells. Existing inclinometer data provides useful geometry information with depth; however, the aerial extent of the sliding mass is uncertain.

The following items summarize the conclusions developed as part of this planning level study:

- The existing cross section A-A is likely near a Factor of Safety somewhere between 1.0 and 1.1. Existing inclinometers B-108 and B-110 indicate that active creep is occurring within cross section A-A along at least one and possibly two separate slip planes;
- Slope stability analyses indicate that the existing cross sections B-B and C-C are likely stable for a deep global slope failure, assumed drained strength conditions. However, when a much smaller local slope failure is modeled in the hillside between Fairfield Avenue and the southern deadend of West 15th Street (cross section C-C), the calculated Factor of Safety indicates that a much smaller local slope failure is possible. BBCM recommends that if ODOT plans to place a bridge abutment or pier between Fairfield Avenue and the top of the hillside near West 15th Street; or if a loop ramp is added in the area of noted shallow failure, then an additional subsurface investigation should be performed in the vicinity to support a detailed slope stability evaluation; however, this proposed scope of work is typically performed for a normal bridge foundation subsurface investigation.
- If rehabilitation is performed at the project site in the vicinity of cross section A-A, the current creep rate can be expected to either remain constant or decelerate in the future. Excavation rehabilitation would help to reduce the negative influence that an increase in excess pore pressure due to trapped natural gas pockets would have on the stability of the slope. An excavation rehabilitation may increase the usable life of the existing pier 1 stabilization structure and would reduce the possibility of tertiary creep initiating in the slope;
- Literature suggests that if the Factor of Safety against global slope failure can be increased significantly, thus reducing the applied shear stress along the failure plane(s), the creep rate along the failure planes can be expected to decrease. However, it is impossible to predict with any certainty what Factor of Safety is required for creep to cease or how much of an influence changes in Factors of Safety will have on the creep rate without the use of a long term monitoring program. BBCM recommends a long term monitoring program must be installed as part of this project.
- The cold storage warehouse at the top of the hillside, while not within cross section A-A, has an unknown influence on the stability of the slope. However, the portion of the hillside east of the existing I-90 bridge is also unstable and is not influenced by the cold storage warehouse;
- At the request of ODOT, BBCM only evaluated excavation rehabilitation alternatives. According to FHWA-SA-94-005, the most promising known method of rehabilitation for correcting a landslide is unloading;
- Cross section A-A excavation alternative 10 (3:1 slope beginning north of Abbey Avenue and extending down to Elevation 620) provides the greatest increase in both the deterministic and mean Factors of Safety. The increase in the mean Factor of Safety is

0.25, in relation to the initial mean Factor of Safety of 1.09, or an increase in approximately 23% for the deep slip surface. For the shallow slip surface, the increase in the mean Factor of Safety is 0.65, in relation to the initial mean Factor of Safety of 1.042, or an increase from initial conditions of approximately 62%. The 95% Factor of Safety confidence interval for the deep slip surface is 1.336-1.346, while the 95% confidence interval for the shallow slip surface is 1.384-1.992;

- BBCM recommends that unloading the slope in the vicinity of cross section A-A be incorporated into the bridge design for the following reasons:
 - The minimum deterministic and mean Factor of Safety would be increased
 - Probability analyses indicate that an excavation rehabilitation will have a positive benefit in the magnitude of the 95% confidence interval, thus increasing the confidence in the resultant Factors of Safety as they relate to the sensitivity of the soil strength properties
 - Due to the increase in Factor of Safety, corresponding to a decrease in the applied shear stress on the failure plane(s), the creep rate of the slope will likely decrease
 - Improvement to the global stability will improve the performance of any new river wall structures
 - Reduced slope creep could potentially extend the life of the existing I-90 bridge and would help stabilize the hillside, which is required in the event that either Cuyahoga River Valley Intermodal Connector roadway alternatives 3 or 4 are constructed;
- Natural pressurized gas pockets present the most challenging geotechnical obstacle to accurately assessing and modeling the existing slope conditions. Due to the nature of their development and unknown locations, a rehabilitation method designed to relieve these pressures may not achieve the desired results. While a system designed to relieve these gas pressures could be employed, BBCM does not recommend relying solely on a deep well pressure relief system; rather, it should be a redundant feature of the whole rehabilitation design. It should be understood by all parties that the positive benefits of a deep well pressure relief system may not be fully realized and would require maintenance for the life of the system;
- Factors other than the optimal increase in Factor of Safety may determine which unloading alternative may be the most feasible. This evaluation did not consider any other factors such as engineering, political, right-of-way acquisition, or community desires in determining the optimal alternatives. Unloading the slope will likely not stop slope movement, but simply reduce the rate of movement;
- BBCM recommends that the final remediation of the slope in the vicinity of cross section A-A involve the following steps:

- Regardless of where the pier is founded, unload the slope (alternative 10 provides the greatest improvement to Factor of Safety)
 - If the pier is founded in the slope (north of University Avenue):
 - Isolate the pier from future movements
 - If the pier is founded on top of slope (south of University Avenue):
 - Further evaluate to determine if isolation, bridge design for lesser creep movements, or design for lateral load should be incorporated into the final design.
- The most recent monitoring annual report submitted by Richland Engineering (2006) indicates that the average creep rate measured over the life of inclinometer B-110 (north of University Avenue near proposed alignment) is approximately 0.15 in/year. Since the completion of remedial construction, the rate of creep is 0.01 in/year. The average creep rate measure in inclinometers B-102 and B-107, located southwest of the West End Pier of the existing I-90 bridge near the proposed alignment, is approximately 0.02 in/year. These creep rates are expected to either remain constant or decrease if one of the excavation rehabilitation alternatives are performed.
 - Any excavation rehabilitation alternative should be extended perpendicular to the proposed bridge alignment footprint sufficiently to allow for plane strain conditions to prevail such that the results of the 2-D limit equilibrium analyses are valid. Alternatives 9 and 10, which consist of sloping excavations would require the greatest amount of area;
 - A long-term monitoring program should be continued, regardless of where the bridge foundations are placed and which excavation rehabilitation alternative is chosen. The monitoring program should be continued until it becomes clear that slope movement is not adversely affecting the proposed bridge structure (minimum of five years following the completion of the bridge construction). In addition, the monitoring program for the existing I-90 bridge should be continued for the remaining life of the structure.

10.0 ODOT GEOTECHNICAL CHECKLISTS

10.1 Reconnaissance and Planning Checklist

Y	1	Has the “Planning and Reconnaissance” section of the ODOT <u>Specifications for Subsurface Investigations</u> been followed?		Sections 2.1 through 2.6, Appendices A, B, C, D, and E		
Y	2	Have the following ODOT sources of geotechnical information been reviewed?				
Y	a	Past construction plans, including soil profile sheet				
N	b	Past project construction diaries				
Y	c	Interviews with people knowledgeable of the project site				
Y	d	Boring logs on file with the OGE Operations Section		Appendix G		
N	e	Past District and County Garage maintenance records				
Y	f	Field reconnaissance				
Y	3	Has ODNR geotechnical information been reviewed and incorporated into the project design information?		Section 2.6		
		Indicate which references were reviewed:				
		X	“Bedrock Geologic Map(s)”		“Bedrock Structure Map(s)”	
		X	“Bedrock Topography Map(s)”	X	“Geologic Map of Ohio”	
			“Known and Probable Karst in Ohio”	X	“Quaternary Geology of Ohio”	
			“Soil Survey(s)”		National Wetland Inventory Map	
			Ohio Wetland Inventory Map	X	Report of Investigations	
		X	Aerial photographs		Measured geologic section(s)	
		X	Boring Logs		X	Information Circulars
		X	Water well logs	X	Bulletins	X
		X	Other	List Other Items: Journal articles and theses related to geologic history		
	4	Has information regarding the possible existence of geologic hazards in, or adjacent to, the project area been requested and obtained from individuals in the project area?		Section 3.0		
		Indicate which individuals were consulted:				
		ODOT construction and maintenance employees		Township Trustees and employees		

	X	ODOT employees (active or retired) who were involved with the original construction?		Local planning and zoning officials
	X	Current, former, adjacent landowner(s)		City or Village officials
		County Engineer / County employees	X	Local geotechnical experts
	X	Other	List Other Items:	Local universities and engineering consultants
N	5	Has information pertaining to the existence of underground mines within, or adjacent to, the project area (requested from District AUMIRA Coordinator, DMRM, and DGS) been reviewed?		Not applicable
N	6	Has the information from DMRM and DGS been reviewed regarding the existence of active, reclaimed, or abandoned surface mines within, or adjacent to, the project areas?		Not applicable
N	7	Has the "Known and Probable Karst in Ohio" map been reviewed during investigations?		Not applicable
N	8	Has the DGS been consulted regarding the documented existence of Karstic conditions within, or adjacent to, the project area?		Not applicable
N	9	Has the potential for rockfall from proposed cuts or existing rock slopes been evaluated?		Not applicable
N	10	Has the USGS Open File Map Series #78-1057 entitled "landslides and Related Features" (Available from DGS) been reviewed during investigations?		
Y	11	Has any of the geotechnical information gathered in Question 3, indicated the potential presence of lake bed sediments, organic soil, or peat deposits?		Lake bed deposits, Sections 2.6 and 2.8 and Appendices C and D
	12	Identify the geologic features that should be further investigated on this project:		
	X	Landslide	Wetland or Peat	Fractures / Faults in exposed rock faces
		Rockfall	Karst	Underground Mine Surface Mine
Notes:				

10.2 General Earthwork Design Checklist – Centerline Cuts

Not applicable to this report.

10.3 General Earthwork Design Checklist – Embankments

Not applicable to this report.

10.4 General Earthwork Design Checklist – Subgrades

Not applicable to this report.

10.5 Structural Design Checklist – Foundations/Structures – Non-bridge Applications

Not applicable to this report.

10.6 Structural Design Checklist – Retaining Walls

Not applicable to this report.

10.7 Geologic Hazard Design Checklist – Landslide Corrections

Investigation			
Y	1.	Has a site reconnaissance been conducted to define the limits of the landslide?	Sections 2.4, 3.3, 3.4, 4.6, and 5.2, and Appendices B and H
		If yes, specify the visible signs that were observed:	
	X	Cracks in pavement	Pinched stream channel
	X	Sloughed slopes	X Scarp
		Bulging toe	Hydrophytic vegetation
		Water seepage, flow from embankment, or ice	X Bent, cracked, or crushed pipe, culvert, or structure
	X	Rotated guardrail	Slanted or fallen trees or utility poles
	X	Deflection of linear structures	
		Other:	Exterior building damage survey
Y	2.	Have a site plan and cross sections been provided to compare ground surface conditions before and after failure?	Section 5.2 and Appendices B and F
Y	3.	Has the history of the landslide area been researched, including movement history, maintenance work, pavement drainage, and past corrective measures?	Sections 2.6 and 3.0 and Appendix H
Y	4.	Has a site specific geotechnical investigation been performed to investigate the landslide area?	Sections 2.7, 2.8, 2.9, 4.5 and Appendices D and H
Y	5.	Has a groundwater monitoring program been performed to identify the phreatic surface through the landslide area?	Sections 2.7 and 4.3 and Appendix H
Y	6.	Has a landslide failure plane been determined from field observations or instrumentation?	Sections 2.6, 3.0, 4.6, and 5.2 and Appendices B and H
Y	7.	Has the landslide mode of failure been determined?	Section 4.4, 4.5, 4.6, 5.3 and Appendices B and H
		Specify those that apply:	
		Rotational failure	Surface sloughing
	X	Block failure	Slump
	X	Translational failure	X Predisposed
		Sheet failure	
	X	Other:	Creeping soil mass under drained strength conditions
Y	8.	Have the subsurface conditions been identified that are the expected source of the failure mode?	Sections 2.6, 2.7, 2.8, 2.9, 3.0, 4.5, 5.1, and 5.2 and Appendices B, D, E, and F
		Check those that apply:	
	X	General shear strength failure of foundation soils	Loading
		Along rock surface(s)	Erosion
	X	Through thin, weak soil layer(s)	Permeable material
	X	Surface/groundwater	Structure
		Anthropogenic disturbance	Weathering
		Impeded drainage	

Subsurface and Slope Stability Investigation – West Bank (012 00946.300)
 CUY-90-15.24, Cleveland, Ohio

		Other:	
Y	9.	If water (static or transient) significantly influences the stability of the landslide, has the source of water been identified, quantified, and water quality accessed?	Sections 2.6, 3.0, and 4.3 and Appendices F and H
Y	10.	Has a stability analysis been performed?	Sections 5.3, 7.0, and 8.0 and Appendix F
Y	11.	Have calculations been performed to determine the F.S. for stability?	
		Check method used:	
	X	STABL, XSTABLE, or equivalent software	Sections 5.3, 7.0, and 8.0 and Appendix F
		Hand calculations	
N	12.	Have the following F.S. been met or exceeded, as determined by the calculations, for the given stability conditions:	Short term and flood condition are not applicable
		1.3 for short term condition	1.1 for rapid drawdown, flood condition
		1.3 for long term condition	1.5 for embankment supporting structures
Y	13.	When differing soil or loading conditions occur throughout the embankment area, have sufficient analyses been completed to evaluate the stability at locations representative of the most critical considerations?	Sections 5.0, 7.0, and 8.0 and Appendix F See Note 1
Y	14.	Does the stability model adequately depict the soil, rock, and ground conditions at the site?	Sections 2.6, 2.7, 2.8, 2.9, 4.0, and 5.0 and Appendices B, C, D, E, F, G, and H
Design			
If not applicable, skip to question 18.			
Y	15.	Has a landslide correction method been determined?	Sections 6.0, 7.0, and 8.0 and Appendix F
		If yes, check the methods that were evaluated and circle the chosen correction	See Note 2
	X	Benching and regrading	Soil anchoring
		Counter berm and regrading	Relocate existing alignments
	X	Flatten slope	Lightweight fills
		Geotextile reinforcing	Soil removal/treatment
		Install surface/subsurface drainage system	Chemical treatment
		Shear key	Dynamic compaction
		Soil nails or tiebacks	Bioengineering
		Walls, sheeting, or drilled shafts	
	X	Other:	Unloading excavation rehabilitation alternatives
Y	16.	Based on accepted design practices, and where applicable, adhering to published guidelines and design recommendations from FHWA, were calculations performed to evaluate the effectiveness of the chosen solutions? (The minimum required F.S. is 1.25)	Sections 6.0, 7.0, and 8.0 and Appendix F See Note 2
	17.	Has a cost comparison been performed to evaluate a recommended solution compared to others?	Not part of BBCM's scope. To be performed by others.

Subsurface and Slope Stability Investigation – West Bank (012 00946.300)
 CUY-90-15.24, Cleveland, Ohio

Plans and Contract Documents			
If not applicable, skip to Rockfall Corrections checklist.			
N	18.	Have all necessary notes, specifications, and plan details been developed?	Not part of BBCM's scope. To be performed by others.
N	19.	Has the vertical and lateral extent of defined landslide conditions been included on the cross sections and plan and profile sheets?	Not part of BBCM's scope.
Y	20.	Has the information obtained from the investigation and analysis been incorporated into the project design?	Baker is performing design based in part on BBCM's geotechnical recommendations
Y	21.	Have the need, location, plan notes, and monitoring schedule of instrumentation been determined?	Section 9.0 (only need)
N	22.	Have the effects of the stability solution of the construction schedule and maintenance of traffic been accounted for in the plans?	Not part of BBCM's scope. To be performed by others.
N	23.	Have the effects of the original failure and proposed correction on any structures (e.g., bridges, buildings, culverts, utilities) or adjacent properties been evaluated and solutions to any issues incorporated into final design?	Not part of BBCM's scope. To be performed by others.
Notes:			
1) ODOT provided BBCM with the three desired cross sections and Baker provided BBCM with the ground surface topography for each of these three cross sections. 2) At the request of ODOT, only unloading excavation rehabilitation alternatives were evaluated.			

10.8 Geologic Hazard Design Checklist – Rockfall Corrections

Not applicable to this report.

10.9 Geologic Hazard Design Checklist – Wetland or Peat Corrections

Not applicable to this report.

10.10 Geologic Hazard Design Checklist – Underground Mine Corrections

Not applicable to this report.

10.11 Geologic Hazard Design Checklist – Surface Mine Corrections

Not applicable to this report.

10.12 Geologic Hazard Design Checklist – Karst Corrections

Not applicable to this report.

REFERENCES

- BBC&M Engineering, Inc. (1999). "Subsurface investigation for the Stonebridge Apartments." Subsurface Investigation Report, Project No. 0181.1CL, Cleveland, OH.
- BBC&M Engineering, Inc. (2005a). "Geotechnical evaluation of the west side pier system for the Central Viaduct bridge." Subsurface Investigation Report, Project No. 012 00829.300, Cleveland, OH.
- BBC&M Engineering, Inc. (2005b). "Geotechnical Planning Study for Proposed I-90 Bridge Alignment." Planning Study Report, Project No. 012 00829.301, Cleveland, OH.
- BBC&M Engineering, Inc. (2006). "Planning Level Study: Slope Stability Alternatives Analysis Existing Slope between Detroit-Superior Bridge and Columbus Road Cuyahoga River Valley Intermodal Connector." Project No. 012 00720.302, Cleveland, OH.
- Boscardin, M.D. and Cording, E.J. (1989). "Building Response to Excavation-Induced Settlement," *J. Geotech. Geoenviron. Eng.*, 115(1), 1-21.
- Bowles, J.E. (1996). Foundation analysis and design. 5th Ed., McGraw Hill, New York, pp. 1175.
- Bradley, K. (2002). "Environmental and climatic significance of sediment cores from the Tower City area, Cleveland, OH." MS thesis, Department of Environmental Science, Cleveland State University, Cleveland, OH.
- Brooker, E.W., Peck, R.B., "Rational design treatment of slides in overconsolidated clays and clay shales," *Can. Geotechnical J.*, 30, 526-544.
- Calkin, P.E. and Feenstra, B.H. (1985). "Evolution of the Erie-basin Great Lakes," *Quaternary Evolution of the Great Lakes*, Karrow, P.F., and Calkin, P.E., ed., Geological Association of Canada Special Paper No. 30, 149-170.
- Cleveland Union Terminals Co. (1923). "Location and Record of Borings – Test Holes T-1 through T-8, T-9 through T-15, T-47 through T-58 through T-63 through T-67, Cleveland, OH.
- Collin, J.G, Hung, C.-J. J., Lee, T.S., and Lee, W.-S. (2002). "Soil slope and embankment design reference manual." Federal Highway Administration, Report No. FHWA NHI-01-026, Washington, D.C., pp. 338.
- Cornforth, D.H. (2005). *Landslides in Practice, Investigation, Analysis, and Remedial/Preventive Options in Soils*, John Wiley & Sons, New Jersey.
- Federal Highway Administration (FHWA). (2002). Geotechnical Engineering Circular No. 5, Evaluation of soil and rock properties, Report No. FHWA-IF-02-034, U.S. Department of Transportation, Washington D.C., pp. 385.

Subsurface and Slope Stability Investigation – West Bank (012 00946.300)
CUY-90-15.24, Cleveland, Ohio

- Ford, J.P. (1987). "Glacial and Surficial Geology of Cuyahoga County, Ohio," Ohio Department of Natural Resources, Division of Geological Survey, Report of Investigations No. 134, pp. 29.
- Gardner, G.D. (1972). "A regional study of landsliding in the lower Cuyahoga River valley, OH." MS thesis, Kent State University.
- Hansen, M.C. (1999). "The geology of Ohio – the Devonian." *Ohio Geology*, Ohio Department of Natural Resources, Division of Geological Survey, No.1, ODNR website, accessed February, 2005.
- Imrie, A.S. (1991). "Stress-induced response from both natural and construction-related processes in the deepening of the Peace River Valley, B.C.," *Can. Geotechnical J.*, 28, 719-728.
- Ladd, C.C., DeGroot, D.J. (2003). "Recommended Practice for Soft Ground Site Characterization: Arthur Casagrande Lecture." *12th Pan American Conf. Soil Mech. and Geot. Eng.*, Cambridge, MA, June 22-25.
- Longwell, C.R., Knopf, A., and Flint, R.F. (1947). Textbook of Geology, Part I – Physical Geology, John Wiley & Sons, Inc., New York, pp. 543
- Mesri, G. and Shahien, M. (2003). "Residual shear strength mobilized in first-time slope failures," *J. Geotech. Geoenviron. Eng.*, (129)12, 12-31.
- Miller, B.B. (1983). "Late quaternary fluvial history of the lower Cuyahoga River in northeastern Ohio." *J. Great Lakes Research*, 9(1), 97-105.
- Mitchell, J.K. (1993). *Fundamentals of Soil Behavior*, 2nd Ed., John Wiley & Sons, Inc., New York, pp. 437.
- Mitchell, J.K. (1996). "Soil slope stability analysis," Landslides Investigation and Mitigation, TRB Special Report No. 247, Turner, A.K. and Schuster, R.L. eds., National Academy Press, Washington D.C., pp. 337-371.
- Ohio Department of Transportation (ODOT). (1990). "Subsurface Investigation for CUY-90-15.24." Division of Highways and Testing Laboratory, Cleveland, OH.
- Peck, R.B. (1954). "Foundation conditions in the Cuyahoga River valley." *Proceedings of the American Society of Civil Engineers*, 80(Separate No. 513), 1-20.
- Peck, R.B., Hanson, W.E., and Thornburn, T.H. (1974). Foundation Engineering, 2nd Ed., John Wiley & Sons, Inc., New York, pp. 514.
- Richland Engineering Limited (2006). Monitoring Services Annual Report, CUY-90-1524 Central Viaduct PID No. 20752.

- Skempton, A.W. (1970). "First-time slides in overconsolidated clays," *Geotechnique*, 20(4), 320-324.
- Skempton, A.W. (1977). "Slope stability of cuttings in London clay," *9th Int. Conf. Soil Mech. and Found. Eng.*, Tokyo, pp. 261-270.
- Skempton, A.W. (1985). "Residual strength of clays in landslides, folded strata, and the laboratory," *Geotechnique*, 35(1), 3-18.
- Stark, T.D. and Eid, H.T. (1994). "Drained residual strength of cohesive soils," *J. Geotech. Geoenviron. Eng.*, (123)4, 335-343.
- Stark, T.D., Choi, H., and McCone, S. (2005). "Drained shear strength parameters for analysis of landslides," *J. Geotech. Geoenviron. Eng.*, (131)5, 575-588.
- Szabo, J.P., Bradley, K., Tevesz, M.J.S. (2003). "Foundations from the past: clues to understanding late Quaternary stratigraphy beneath Cleveland, OH." *J. Great Lake Research*, 29(4), 566-580.
- Szabo, J. (2005). Professor, Department of Geology, University of Akron, Personal communication.
- Terzaghi, K. (1950). "Mechanism of landslides." *Application of Geology to Engineering Practice, Berkeley Vol.*, Geological Society of America, pp. 83-123. reprinted in From Theory to Practice in Soil Mechanics, 1960, John Wiley & Sons, New York, pp. 202-245.
- Terzaghi, K., Peck, R.B., and Mesri, G. (1996). Soil Mechanics in Engineering Practice. 3rd Ed., John Wiley & Sons, Inc., New York.
- Wu, T.H. (1996). "Soil strength properties and their measurement," Landslides Investigation and Mitigation, TRB Special Report No. 247, Turner, A.K. and Schuster, R.L. eds., National Academy Press, Washington D.C., pp. 319-336.

APPENDIX A
GENERAL PROJECT INFORMATION

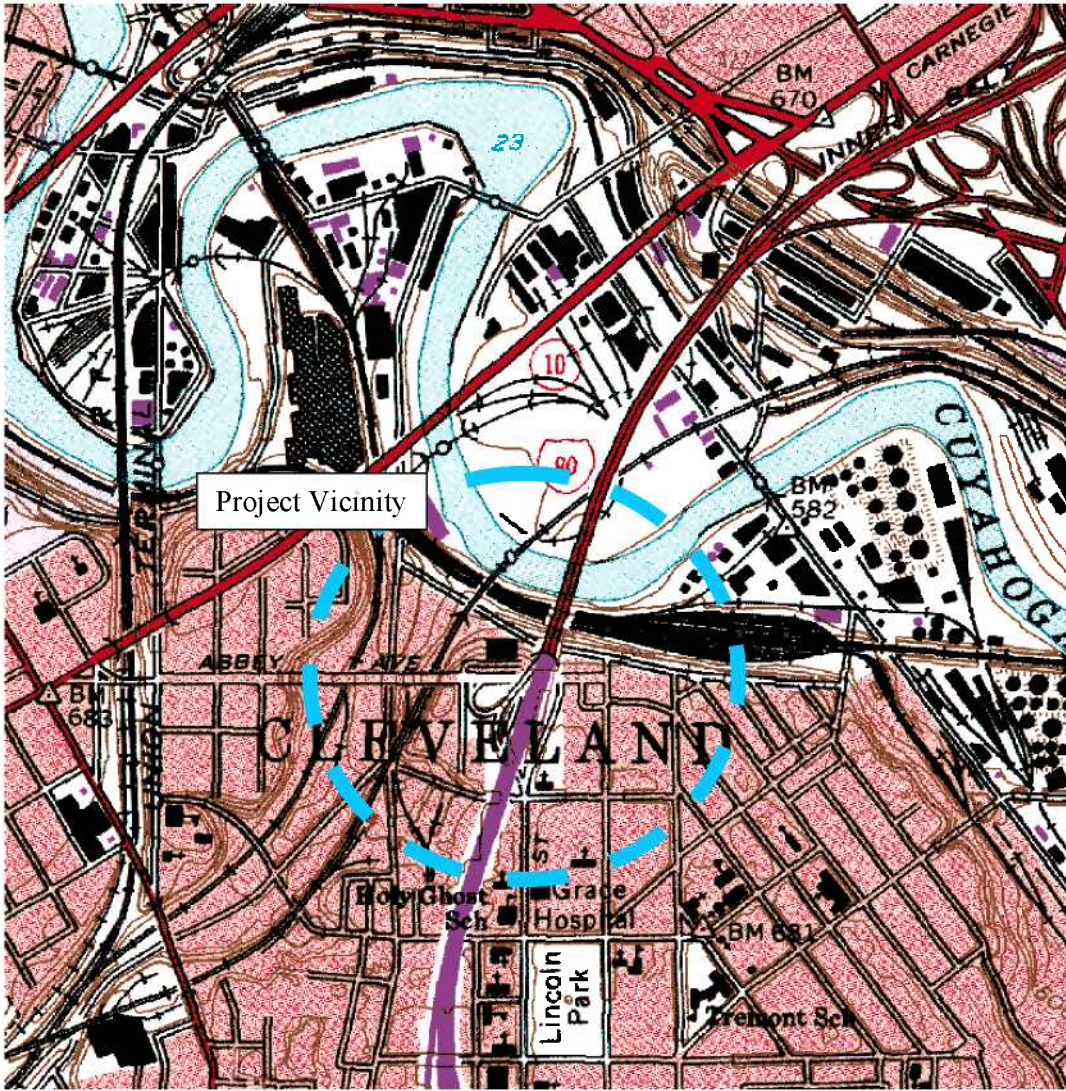

Plate 1: Topography of west bank slope and vicinity.

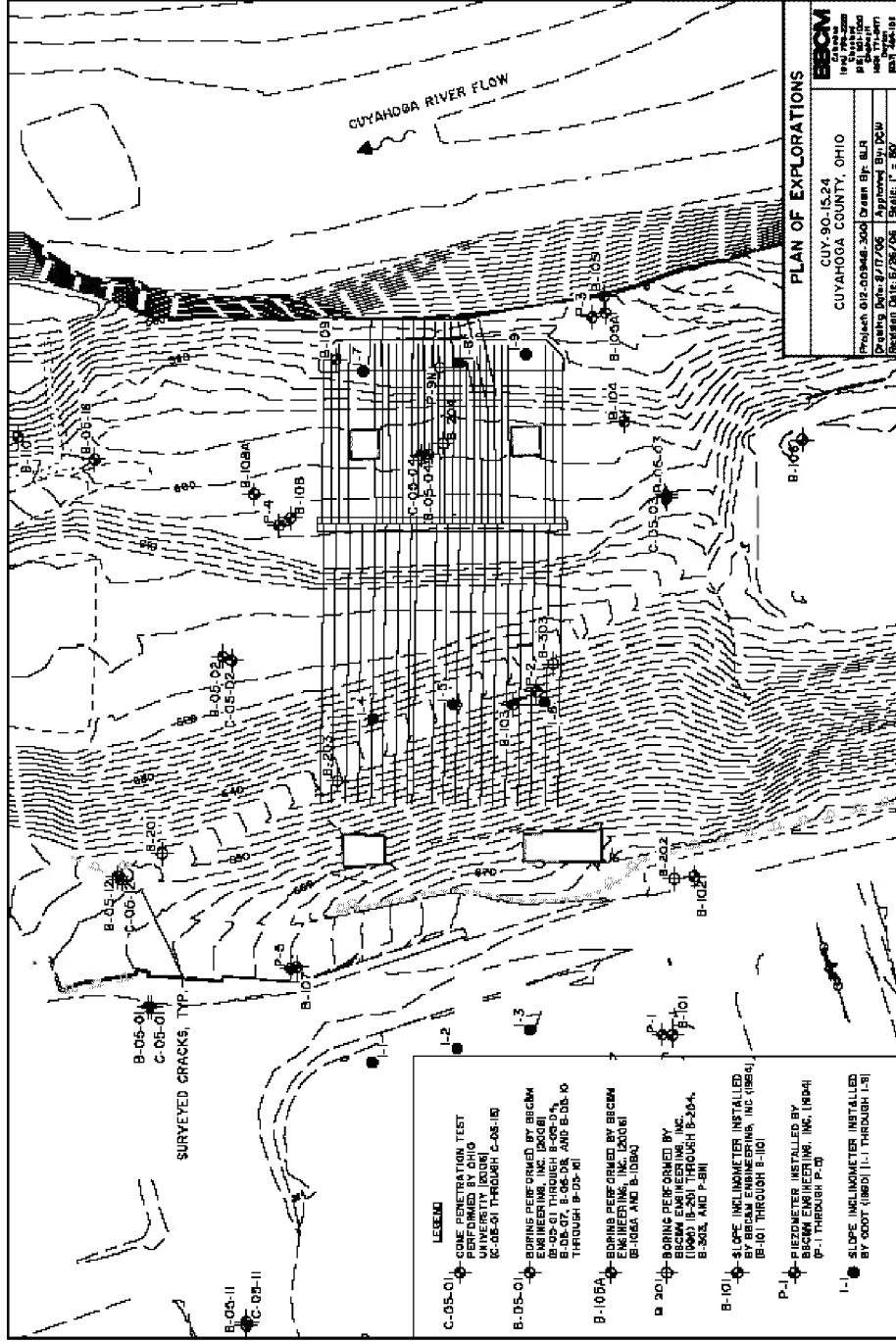

PLATE 2

Plate 2: Plan of borings summarizing all subsurface investigation performed since 1990 in the vicinity of the I-90 west bank foundation structures. The locations of the 2006 investigation are approximate only.

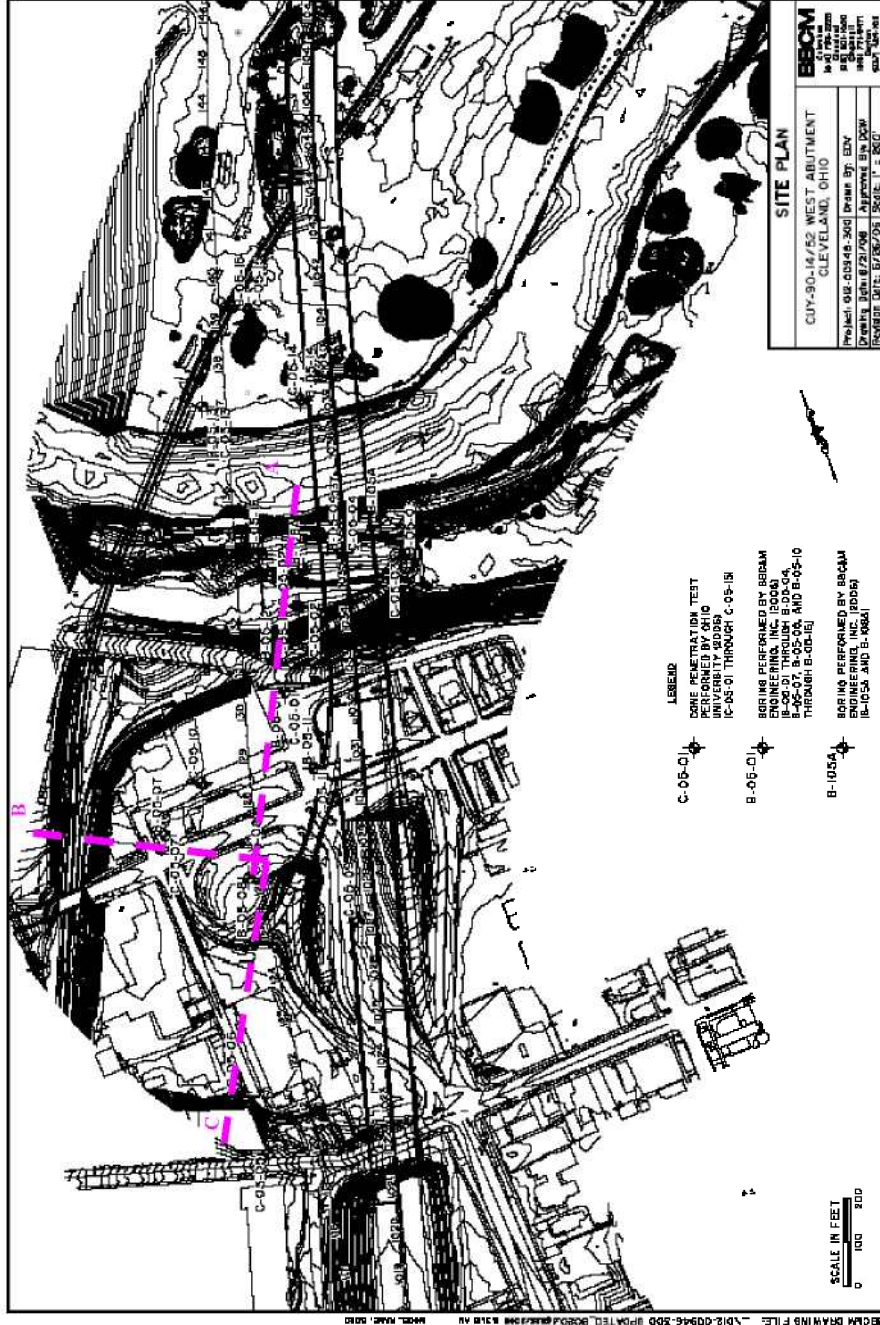





Plate 3: Plan of borings summarizing all subsurface investigation performed since 1990 in the vicinity of the I-90 west bank foundation structures. The locations of the 2006 investigation are approximate only. Cross sections A-A, B-B, and C-C illustrate the approximate locations of the three slope stability analyses performed; although, this preliminary report only discusses the results of the slope stability evaluation within cross section A-A.

**EXPLANATION OF SYMBOLS AND TERMS USED ON BORING LOGS
FOR SAMPLING AND DESCRIPTION OF SOIL**

SAMPLING DATA

-  - Blocked-in "SAMPLES" column indicates sample was attempted and recovered within this depth interval.
-  - Sample was attempted within this interval but not recovered.
- 2/5/9 - The number of blows required for each 6-inch increment of penetration of a "Standard" 2-inch O.D. split-barrel sampler, driven a distance of 18 inches by a 140-pound hammer freely falling 30 inches. Addition of one of the following symbols indicates the use of a split-barrel other than the 2" O.D. sampler:
 -  - 2½" O.D. split-barrel sampler
 -  - 3" O.D. split-barrel sampler
- P - Shelby tube sampler, 3" O.D., hydraulically pushed.
- R - Refusal of sampler in very-hard or dense soil, or on a resistant surface.
- 50-2" - Number of blows (50) to drive a split-barrel sampler a certain number of inches (2), other than the normal 6-inch increment.
- S/D - Split-barrel sampler (S) advanced by weight of drill rods (D),
- S/HI - Split-barrel sampler (S) advanced by combined weight of rods and drive hammer (HI).

SOIL DESCRIPTIONS

All soils have been classified basically in accordance with the Unified Soil Classification System, but this system has been augmented by the use of special adjectives to designate the approximate percentages of minor components as follows:

<u>Adjective</u>	<u>Percent by Weight</u>
trace	1 to 10
little	11 to 20
some	21 to 35
"and"	36 to 50

The following terms are used to describe density and consistency of soils:

<u>Term (Granular Soils)</u>	<u>Blows per foot</u>
Very-loose	Less than 5
Loose	5 to 10
Medium-dense	11 to 30
Dense	31 to 50
Very-dense	Over 50
<u>Term (Cohesive Soils)</u>	<u>Qu (tsf)</u>
Very-soft	Less than 0.25
Soft	0.25 to 0.5
Medium-stiff	0.5 to 1.0
Stiff	1.0 to 2.0
Very-stiff	2.0 to 4.0
Hard	Over 4.0

Plate 4: Explanation of terms and symbols used on boring logs for sampling and description of soil.

EXPLANATION OF SYMBOLS AND TERMS USED ON BORING LOGS FOR SAMPLING AND DESCRIPTION OF ROCK

SAMPLING DATA

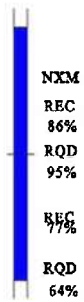

When bedrock is encountered and rock core samples are attempted, the "SAMPLING EFFORT" column is used to record the type of core barrel used (NXM), the percentage of core recovered (REC) for each run of the sampler, and the Rock Quality Designation (RQD) value. Rock-core barrels can be of either single- or double-tube construction, and a special series of double-tube barrels, designated by the suffix M, is commonly used to obtain maximum core recovery in very-soft or fractured rock. Three basic groups of barrels are used most often in subsurface investigations for engineering purposes, and these groups and the diameters of the cores obtained are as follows:

- AX, AW, AXM, AWM - 1-1/8 inches
- BX, BW, BXM, BWM - 1-5/8 inches
- NX, NW, NXM, NWM - 2-1/8 inches

Rock Quality Designation (RQD) is expressed as a percentage and is obtained by summing the total length of all core pieces which are at least 4 inches long and then dividing this sum by the total length of core run. It has been found that there is a reasonably good relationship between the RQD value and the general quality of rock for engineering purposes. This relationship is shown as follows:

<u>RQD - %</u>	<u>General Quality</u>
0 - 25	Very-poor
25 - 50	Poor
50 - 75	Fair
75 - 90	Good
90 - 100	Excellent

ROCK HARDNESS

THE FOLLOWING TERMS ARE USED TO DESCRIBE ROCK HARDNESS:

<u>Term</u>	<u>Meaning</u>	<u>Mohs' Hardness</u>
Very-soft	Rock such as shale can be easily picked apart by the fingers. Sandstone is poorly cemented and very friable. The rock resembles hard clay or dense sand, but has rock structure.	Less than 1
Soft	Rock such as shale, siltstone or limestone can be scratched or powdered by fingernail pressure. Sandstone is mostly poorly cemented, and individual sand grains can be separated from the main rock mass by a fingernail.	1 to 1½
Medium-hard	Rock cannot be scratched by a fingernail, but can be powdered by a knife. Sandstone is mostly well cemented, but individual grains can be removed by scratching with a knife.	2½ to 5½
Hard	Rock is well cemented and cannot be powdered by a knife. Rock can be powdered by a steel file.	5½ to 6½
Very-hard	Rock cannot be scratched by a steel file and the core sample rings when struck with a hammer.	Greater than 6½

Plate 5: Explanation of terms and symbols used on boring logs for sampling and description of rock.

APPENDIX B
FIGURES

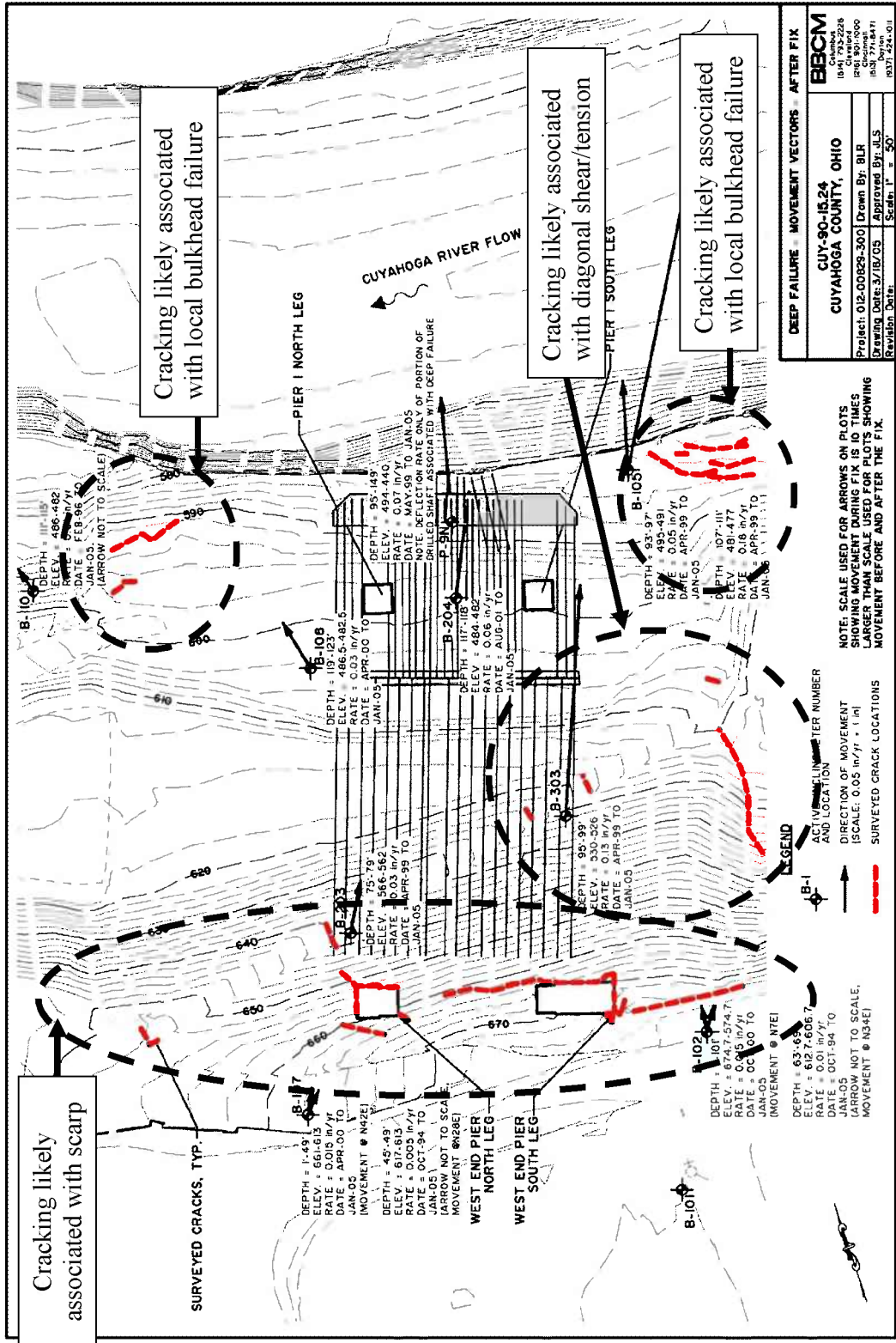

Figure 1: West bank slope in the vicinity of the existing I-90 West Abutment and Pier I foundation and stabilization structure (BBCM, 2005a). Dashed lines indicate the surveyed location of surface cracking.

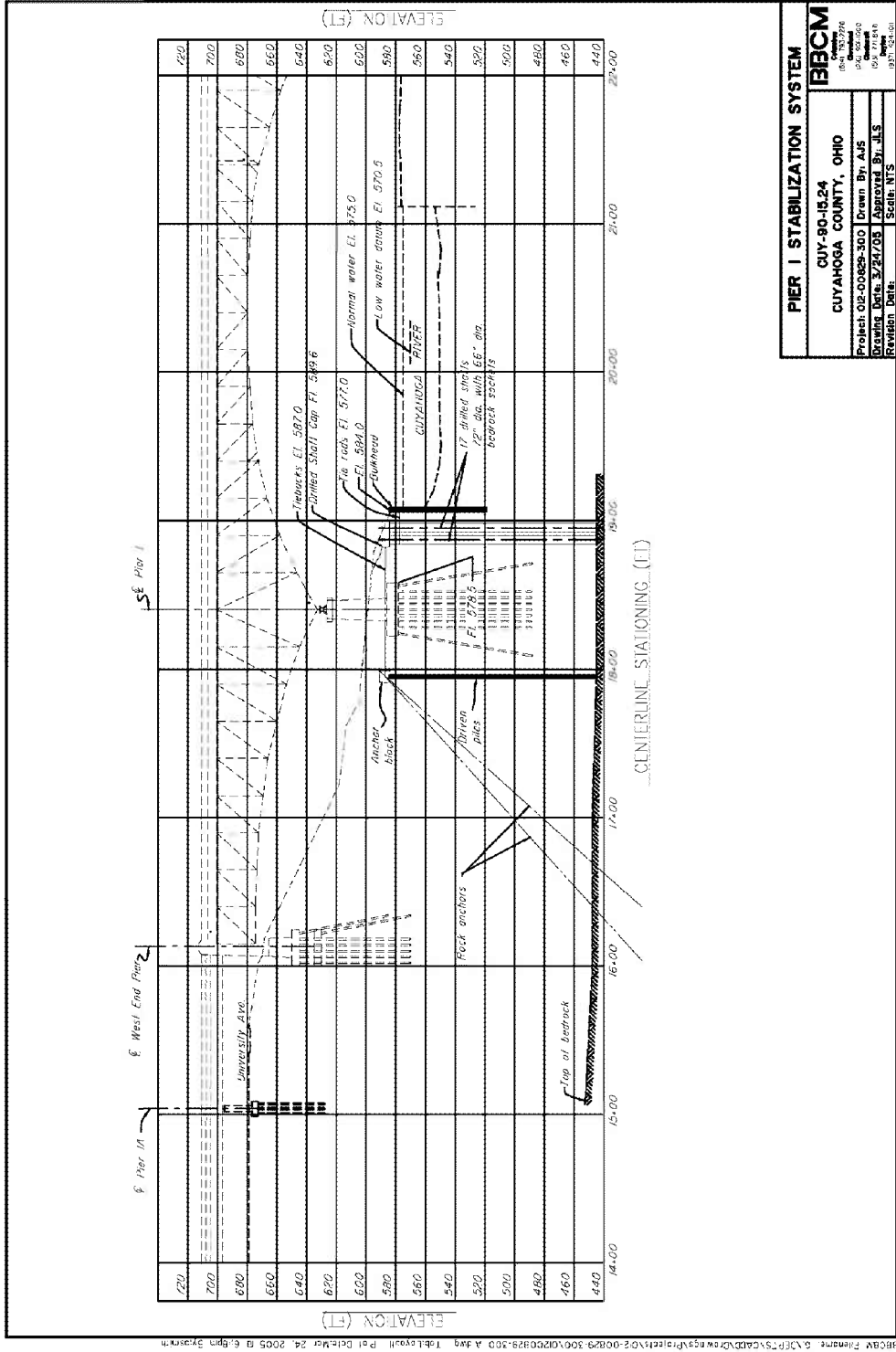

Figure 2: Existing I-90 pier system and stabilization structure (BBCM, 2005a).

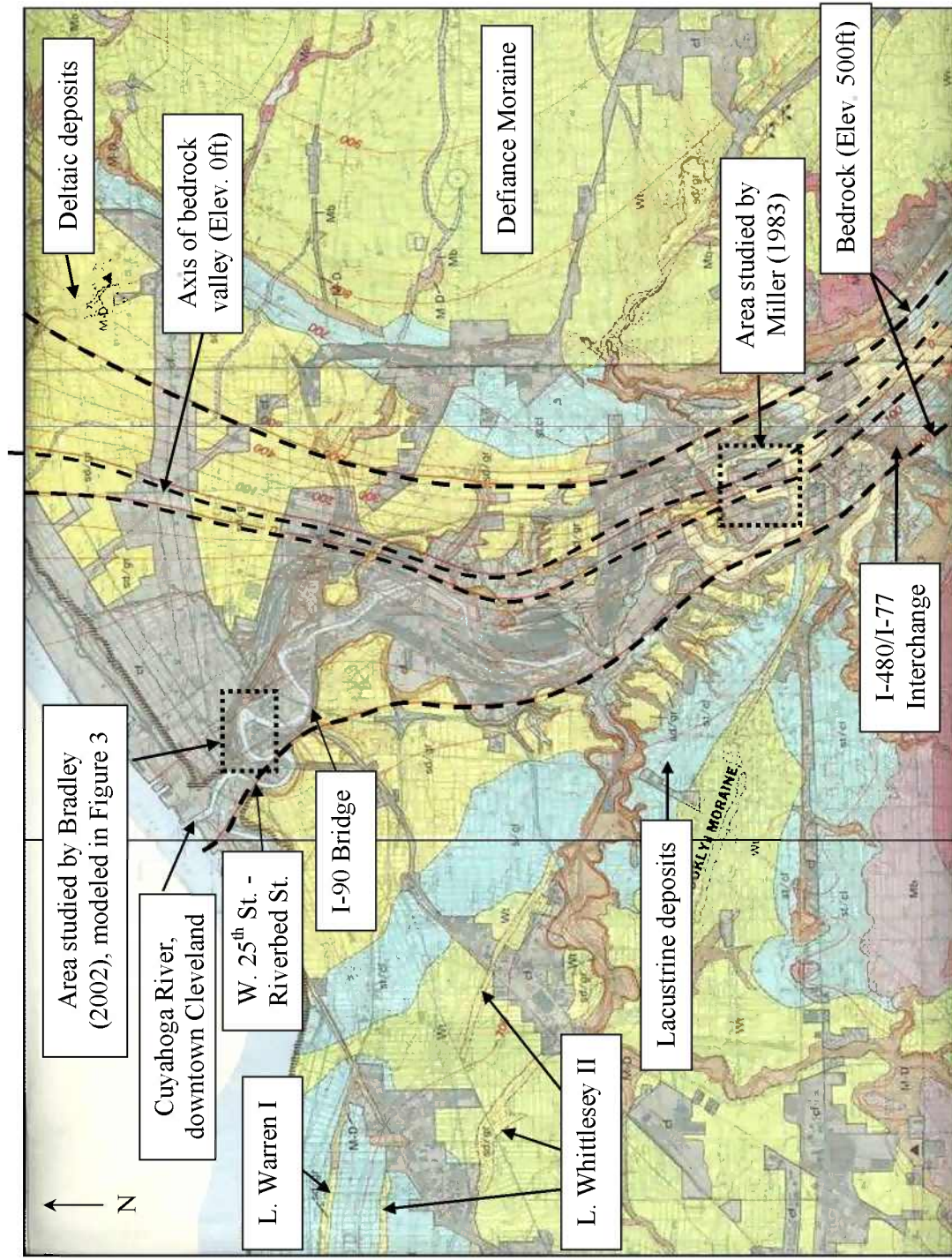

Figure 3: Glacial and surficial geology of the Upper Cuyahoga River Valley (after Ford, 1987).

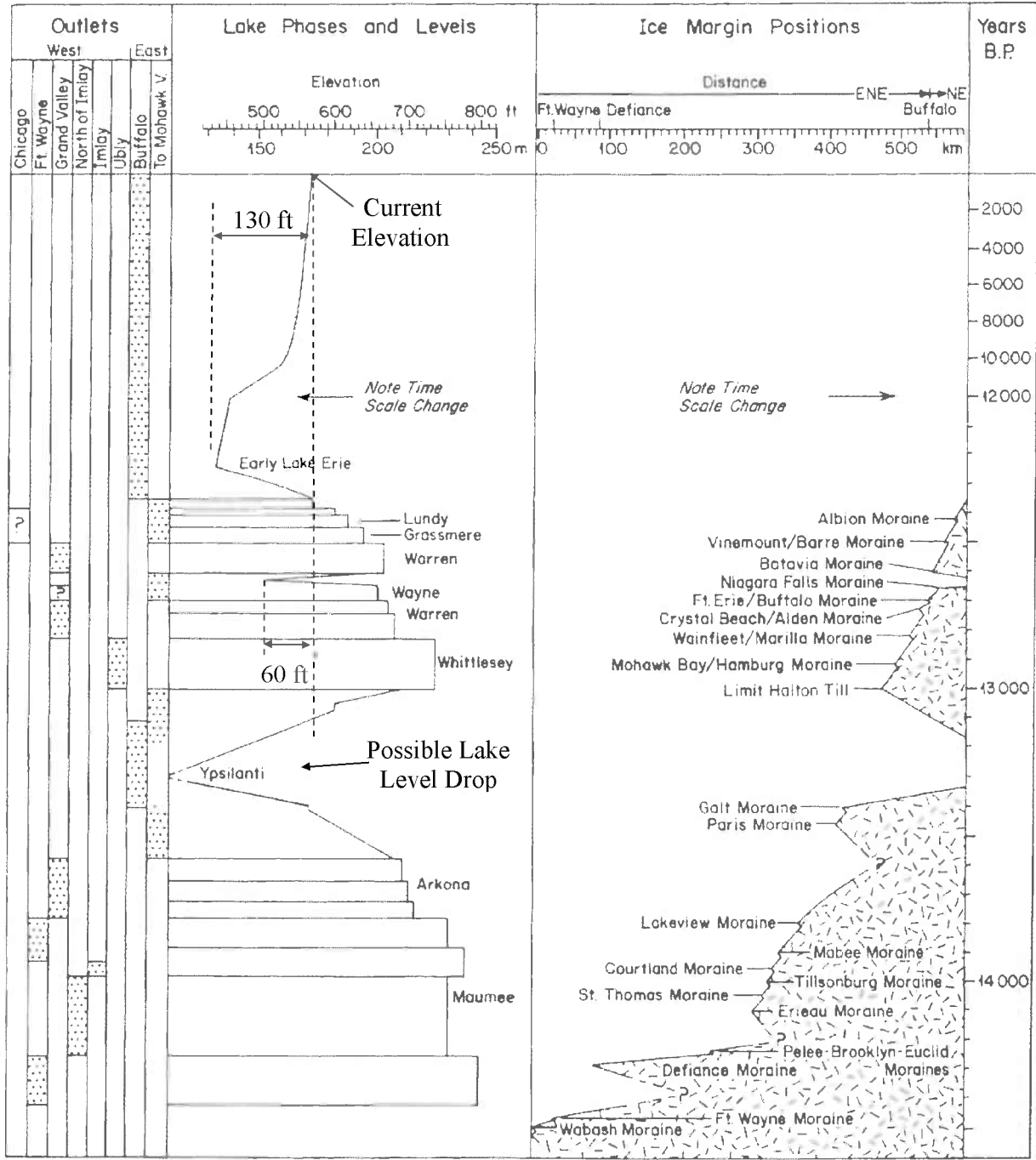
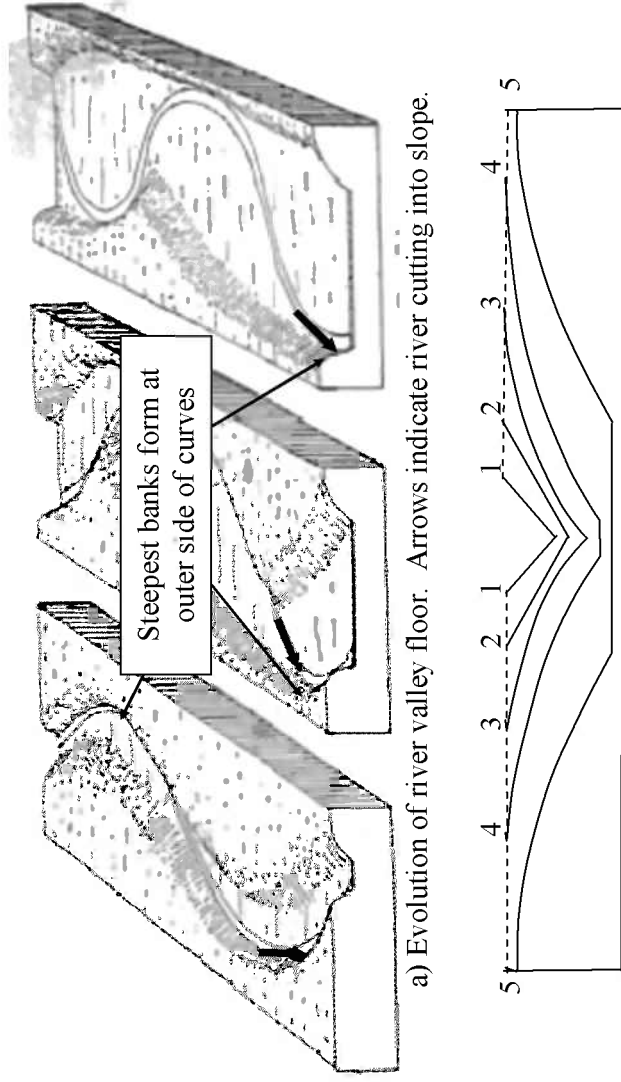

Figure 4: Lake Erie basin lake phases correlated with probable lake outlet and glacial ice boundary (after Calkin and Feenstra, 1985).



b) Cross sections of river valley. Valley banks flatten out as river meanders and slope failures occur (i.e. Valley banks go from cross section 1-1 to 5-5).

Figure 5: Evolution of a river valley by: a) river meandering and b) river valley cross-sections (after Longwell et al., 1947).

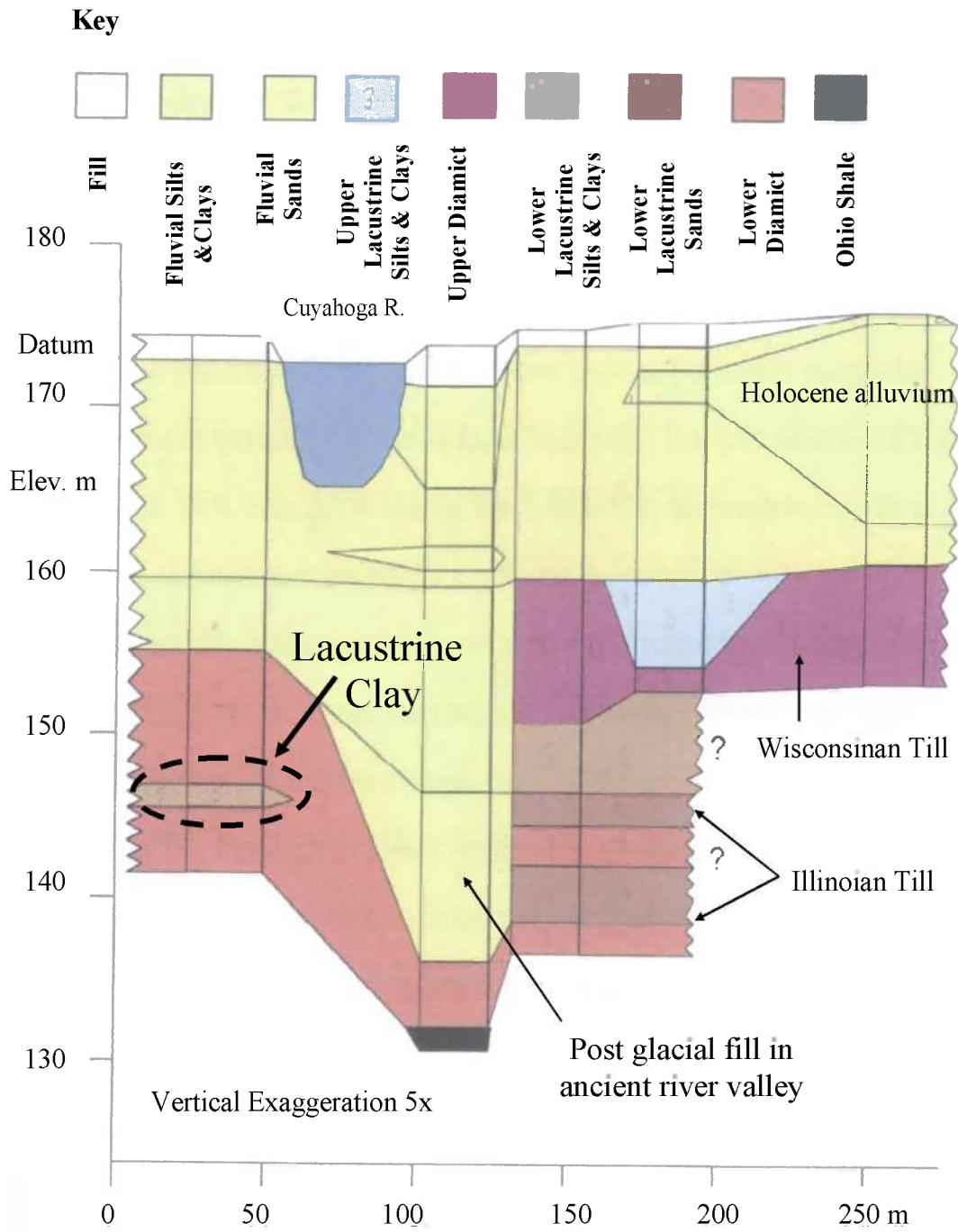

Figure 6: Cross section through the Cuyahoga River Valley near the Eagle Avenue bridge (after Bradley, 2002).

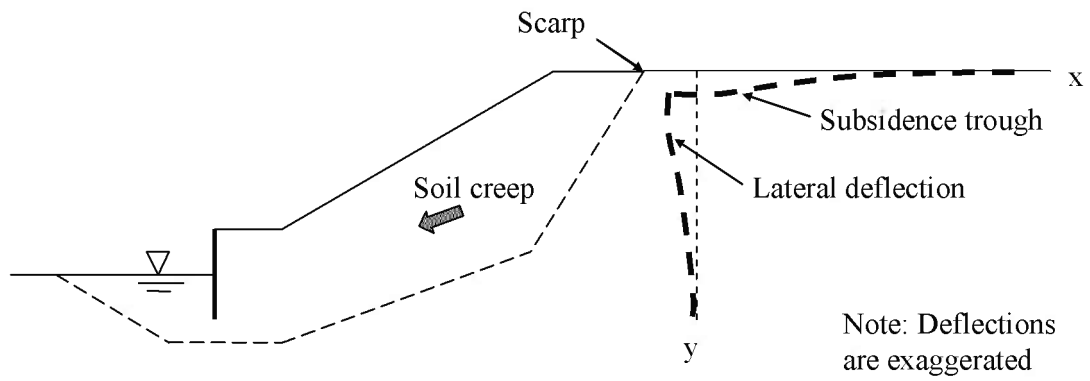

Figure 7: Conceptual diagram of the ground deformation associated with an adjacent creeping soil mass (BBCM, 2005b).



Figure 8: 1201 University Avenue (Sokolowski's University Inn). Photo is taken from inside looking at the north-west corner of the building. This photo illustrates settlement that occurred approximately 5 years ago. The maximum vertical displacement is at least 9-inches (BBCM, 2005b).

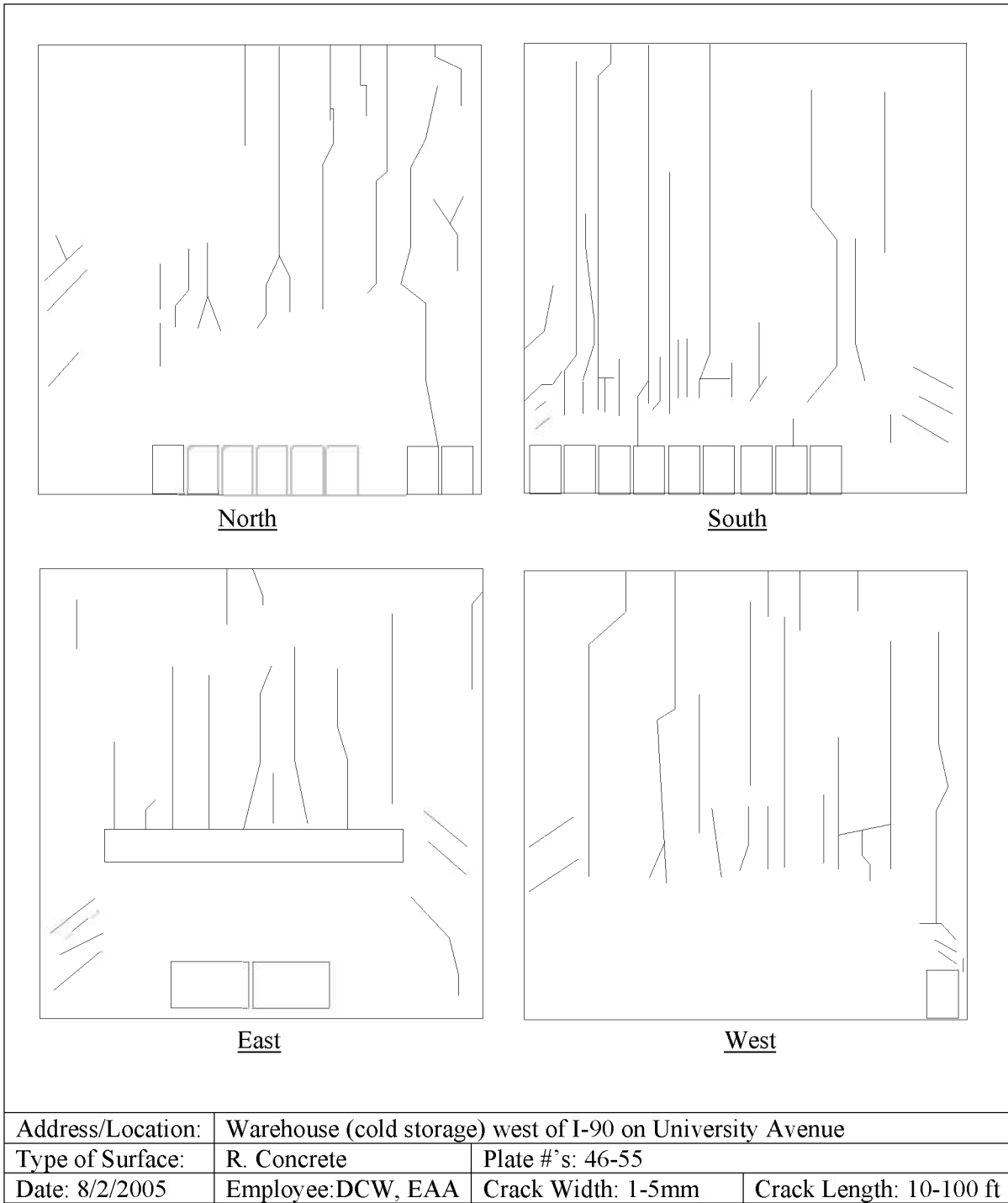

Figure 9: Crack mapping for the warehouse (cold storage) west of I-90 on University Avenue. The location and extent of the cracking is approximate only (BBCM, 2005b).



Figure 10: Warehouse (cold storage) west of I-90 on University Avenue. Photo is looking at the east wall of the warehouse (BBCM, 2005b).

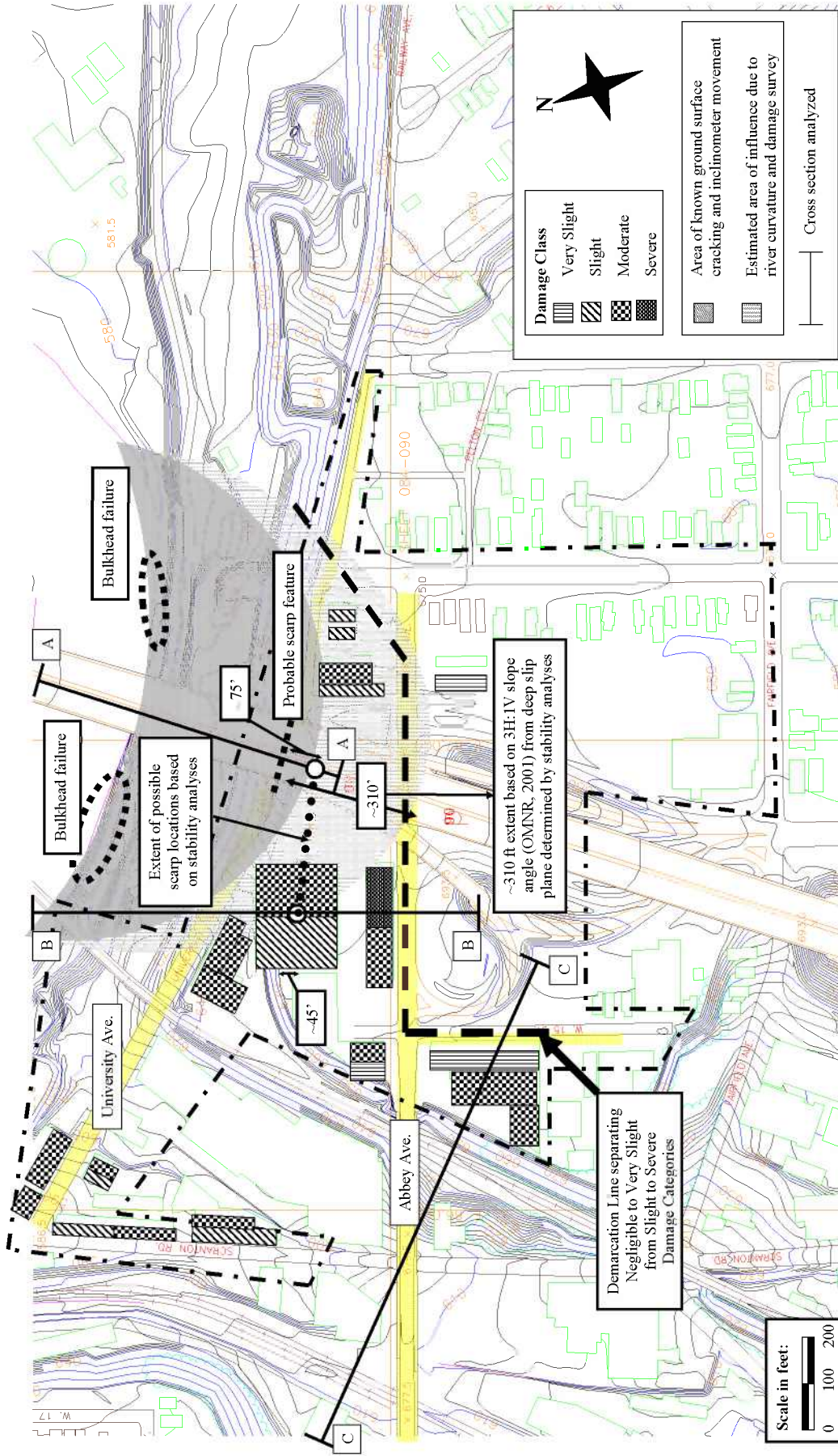

Figure 11: Expected creep influenced zone as estimated from the geologic history, river geometry, numerical analyses and exterior masonry condition survey (BBCM, 2005b).

Typical block failure illustrating three separate modes of shear

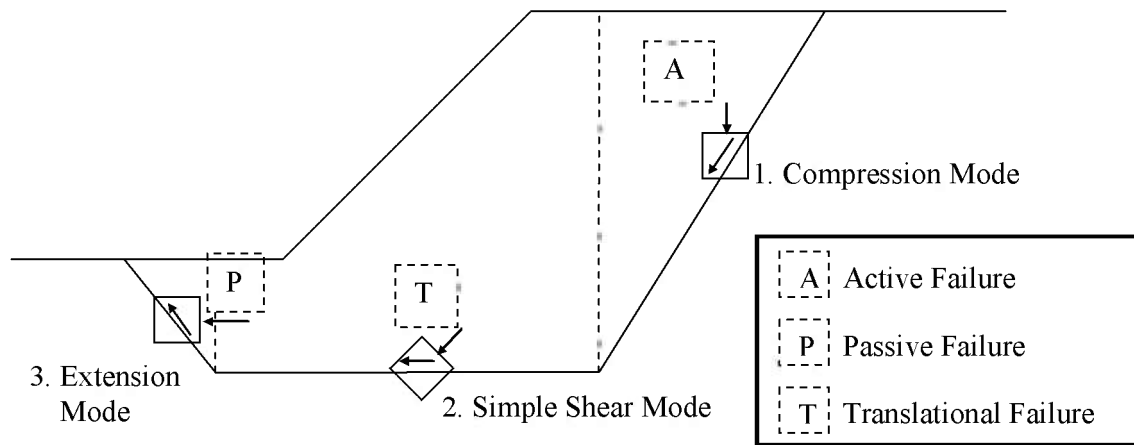
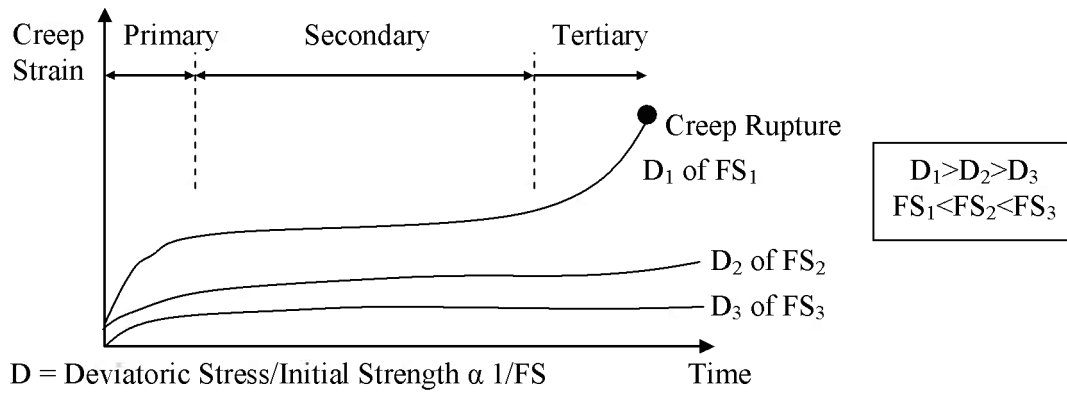
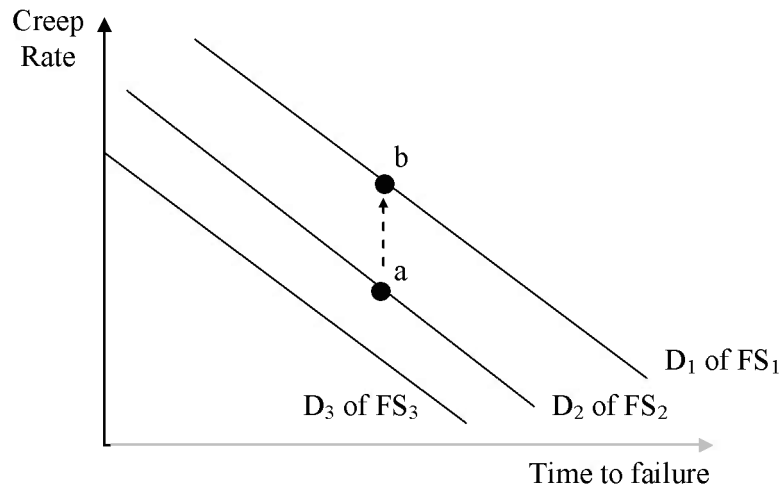

Figure 12: Modes of shear modeled in laboratory testing in relation to field failure conditions (after Terzaghi et al., 1996; Ladd and DeGroot, 2003).



a) Typical creep strain behavior as a function of time and initial stress state.



b) Typical creep rate behavior as a function of time and initial stress state.

Figure 13: Examples of typical laboratory derived creep behavior (Mitchell, 1993).

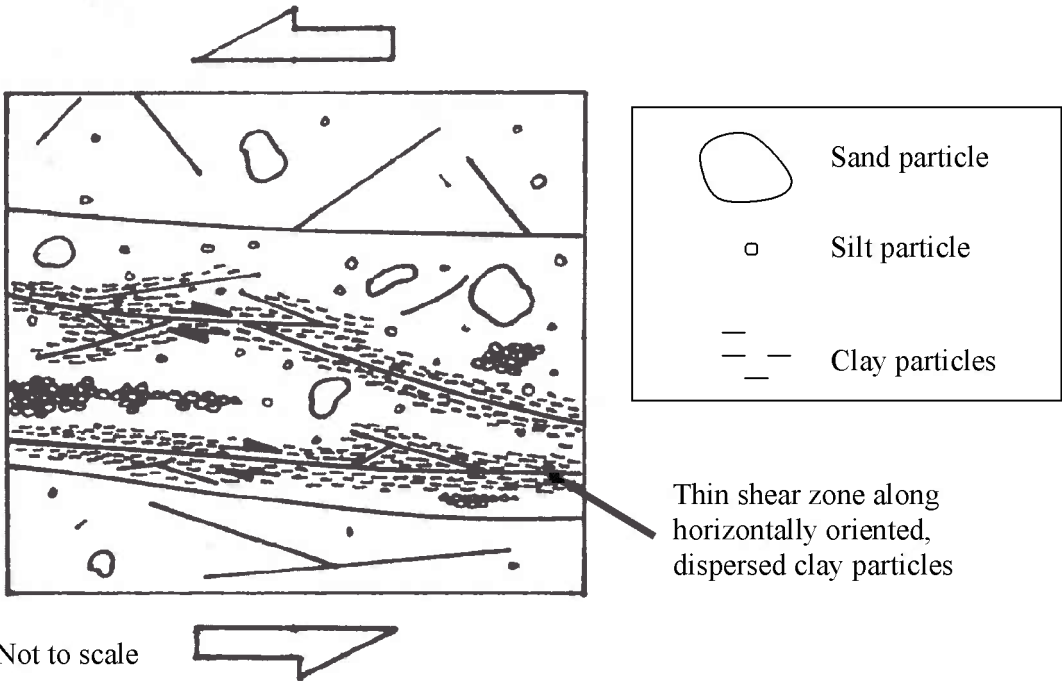
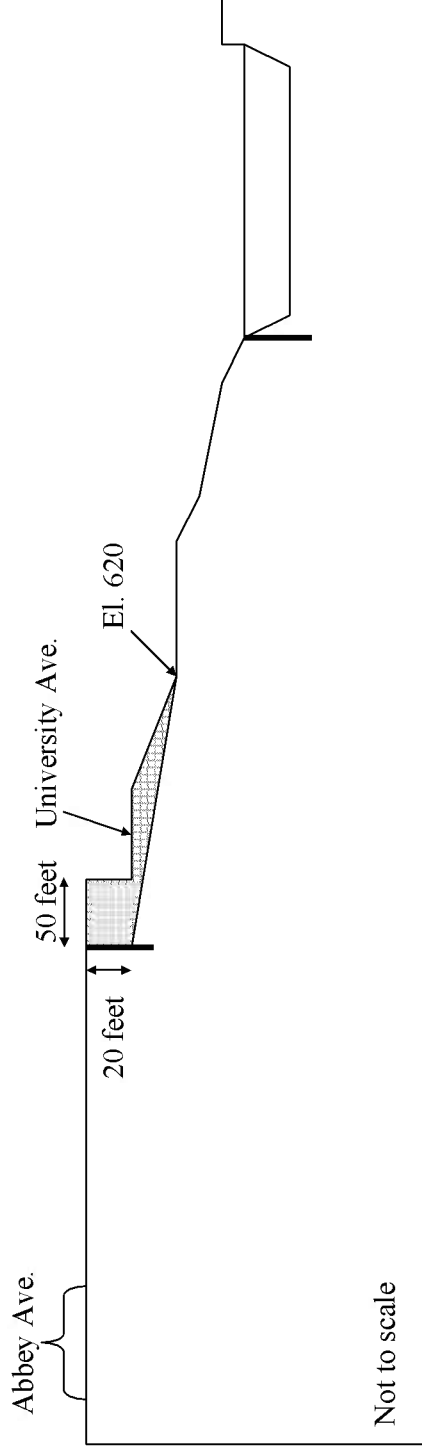
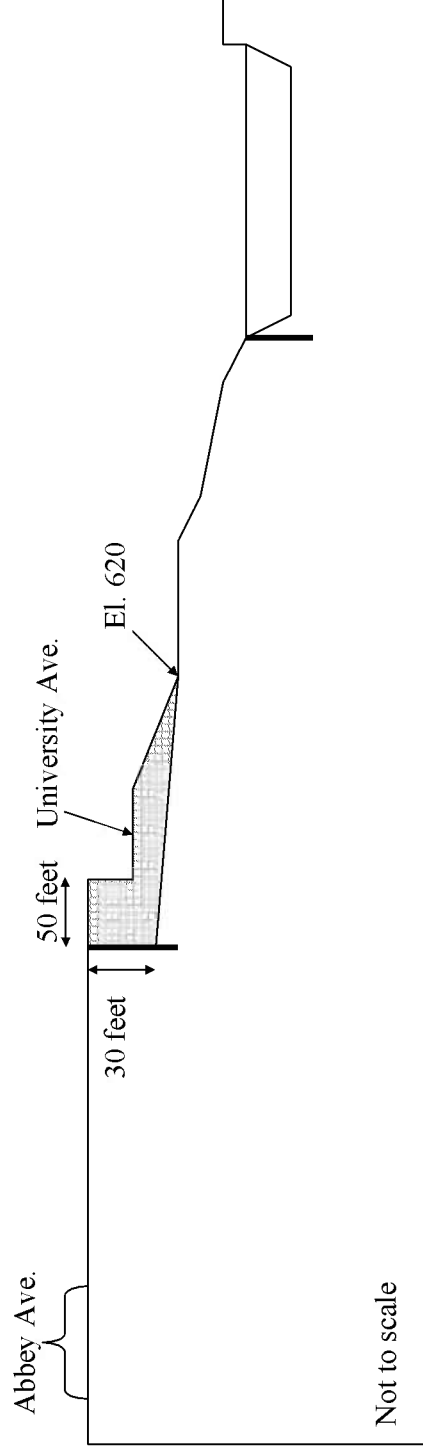

Figure 14: Possible micro-fabric of a hypothetical shear zone.



a) Alternative 1. 20-foot vertical excavation located 50 feet behind University Avenue.



b) Alternative 2. 30-foot vertical excavation located 50 feet behind University Avenue.

Figure 15: Qualitative diagram of excavation alternatives 1 and 2.

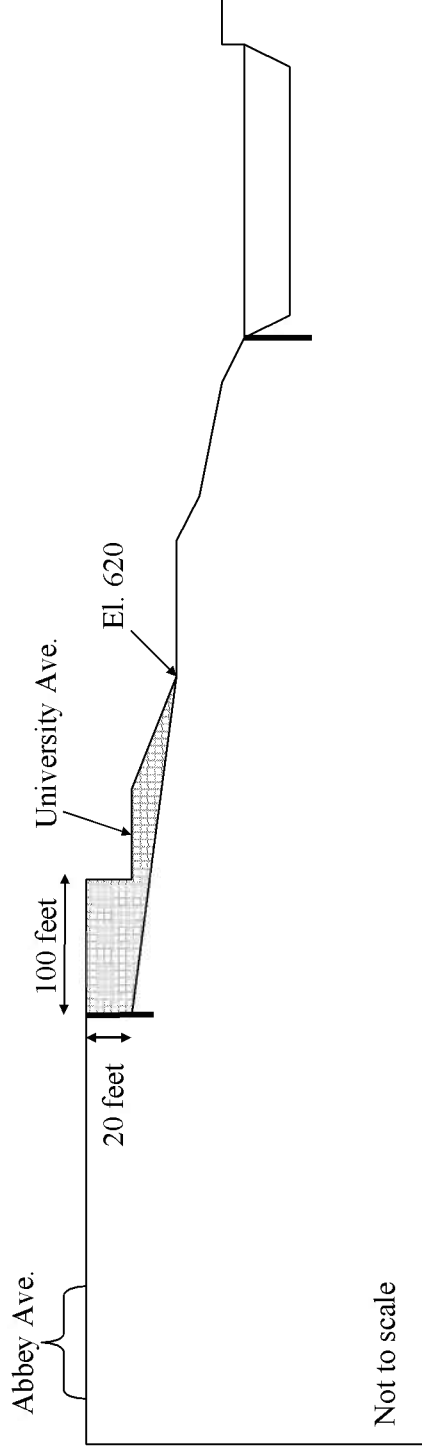

a) Alternative 3: 20-foot vertical excavation located 100 feet behind University Avenue.

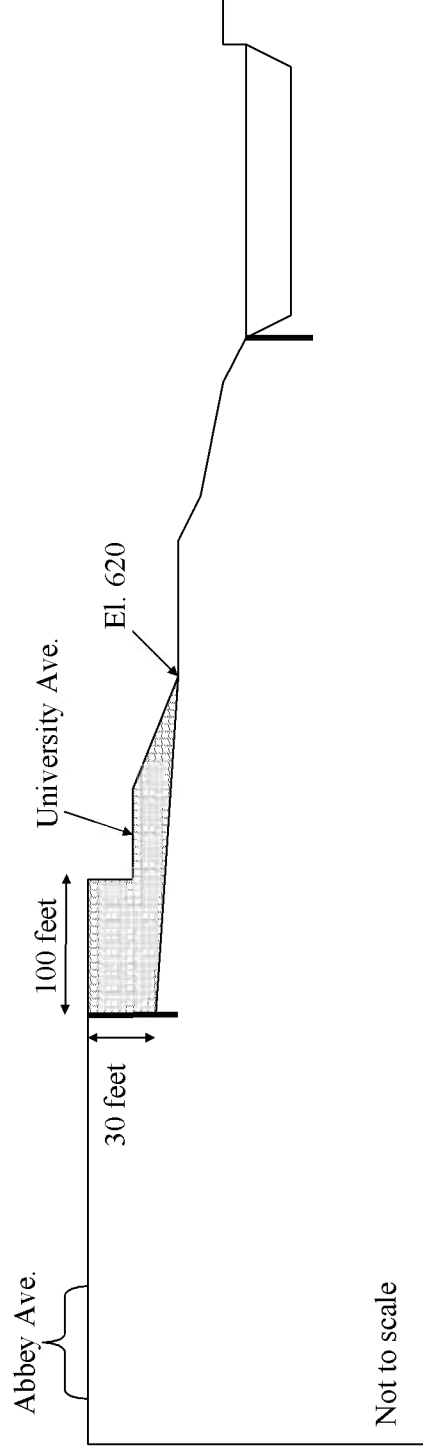

b) Alternative 4: 30-foot vertical excavation located 100 feet behind University Avenue.

Figure 16: Qualitative diagram of excavation alternatives 3 and 4.

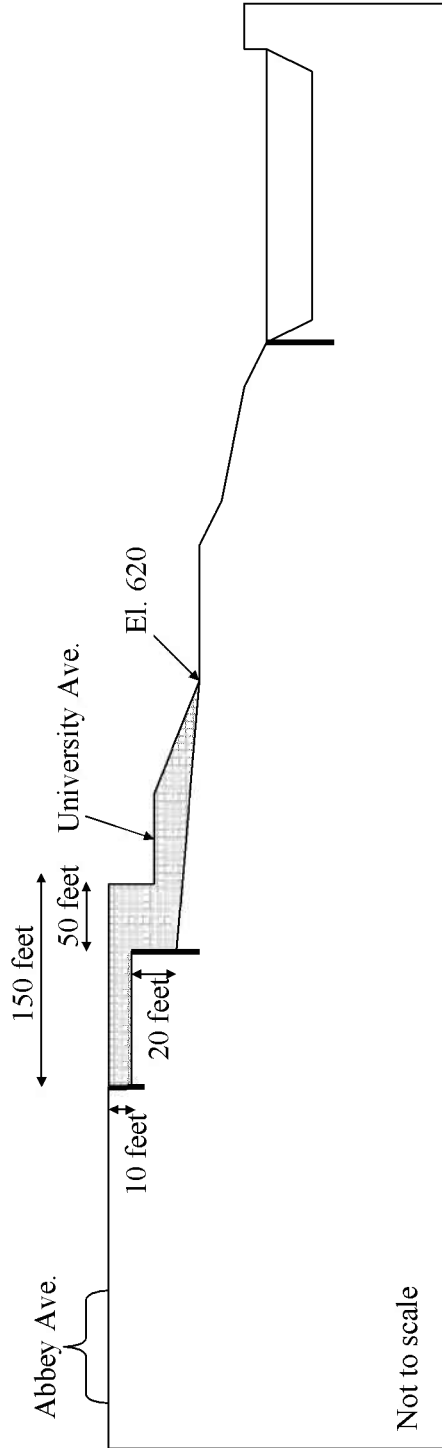

a) Alternative 5: 10-foot vertical excavation located 150 feet behind University Avenue and a 20-foot vertical excavation located 50 feet behind University Avenue.

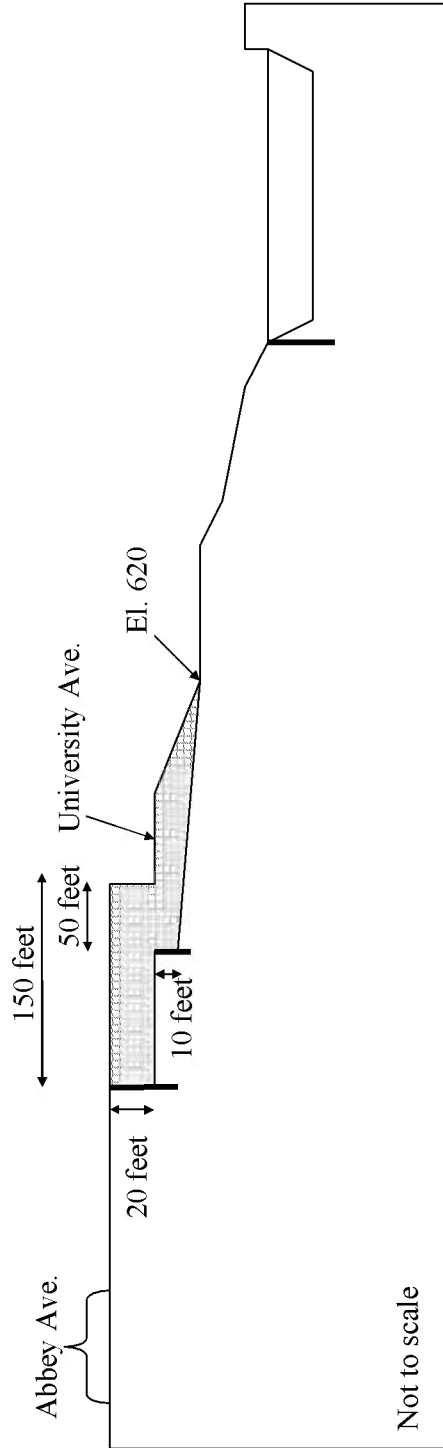

b) Alternative 6: 20-foot vertical excavation located 150 feet behind University Avenue and a 10-foot vertical excavation located 50 feet behind University Avenue.

Figure 17: Qualitative diagram of excavation alternatives 5 and 6.

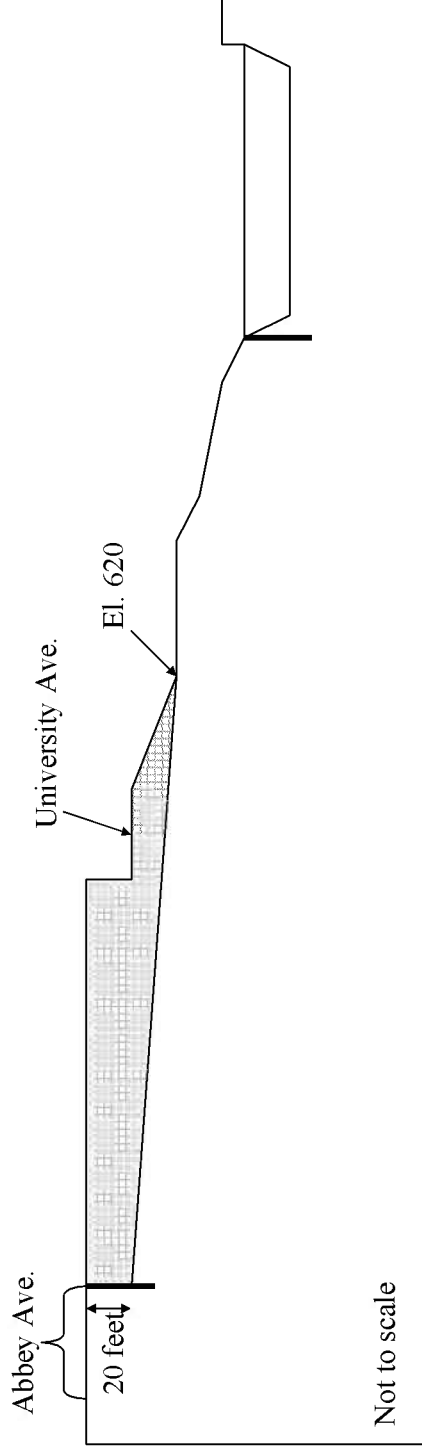

a) Alternative 7: 20-foot vertical excavation north of Abbey Avenue.

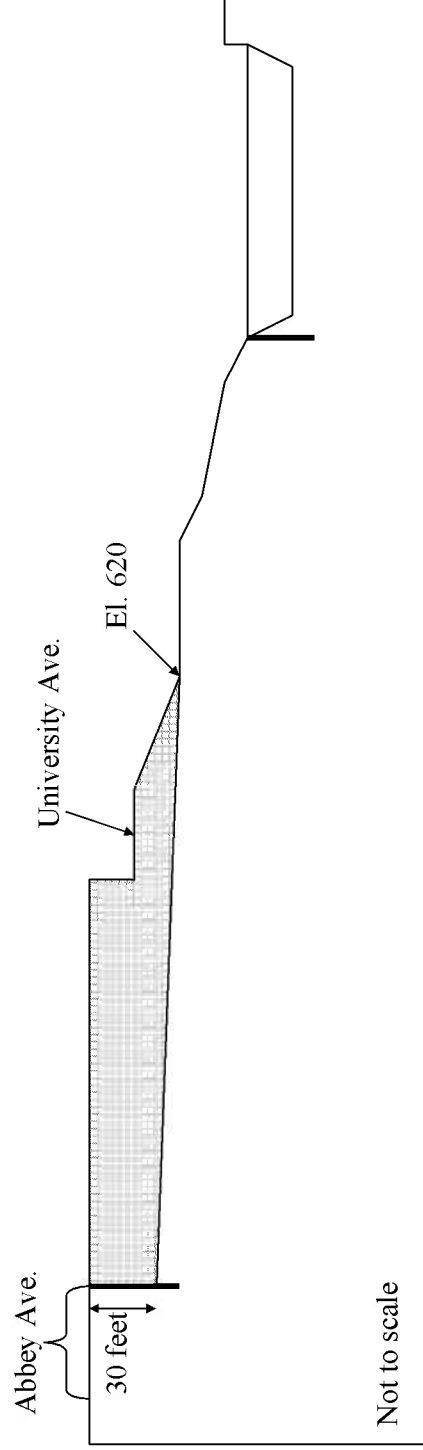

b) Alternative 8: 30-foot vertical excavation north of Abbey Avenue.

Figure 18: Qualitative diagram of excavation alternatives 7 and 8.

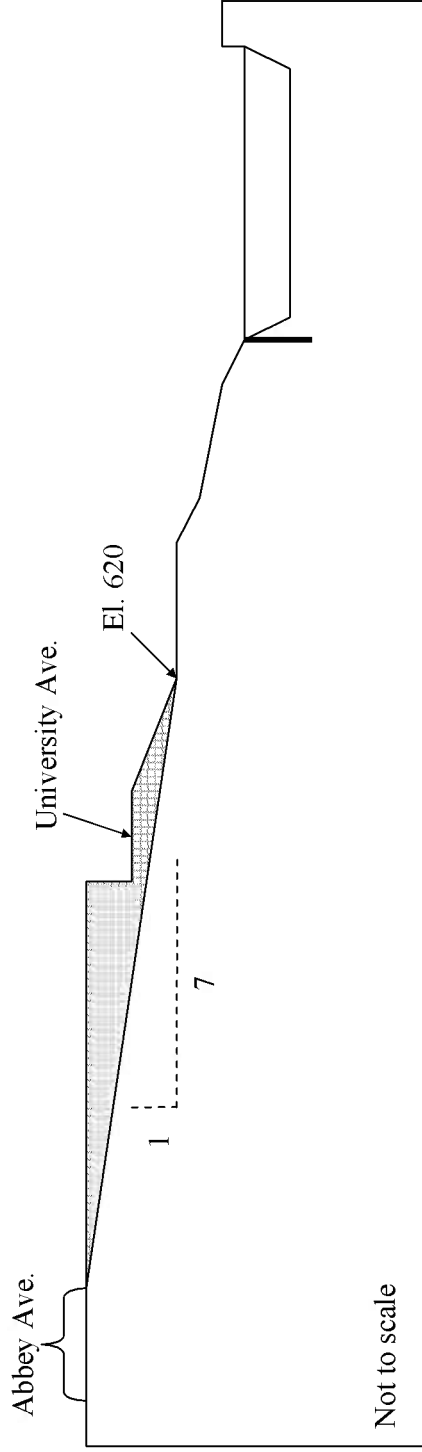

a) Alternative 9: 7(H):1(V) slope beginning north of Abbey Avenue.

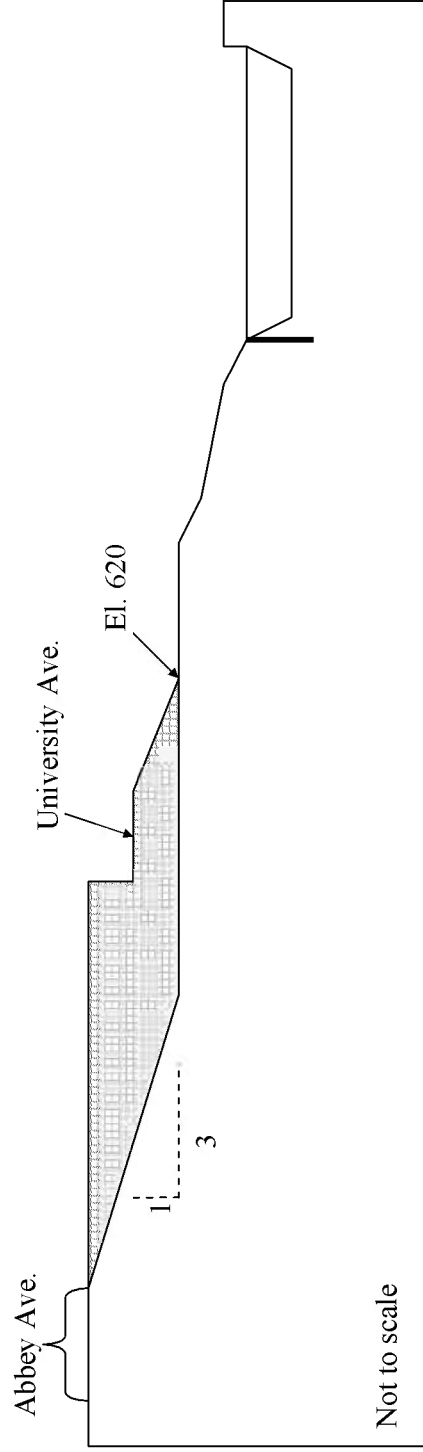

b) Alternative 10: 3(H):1(V) slope beginning at Abbey Avenue extending to El. 620 feet.

Figure 19: Qualitative diagram of excavation alternatives 9 and 10.

APPENDIX C
LOGS OF CONE PENETRATION TESTING

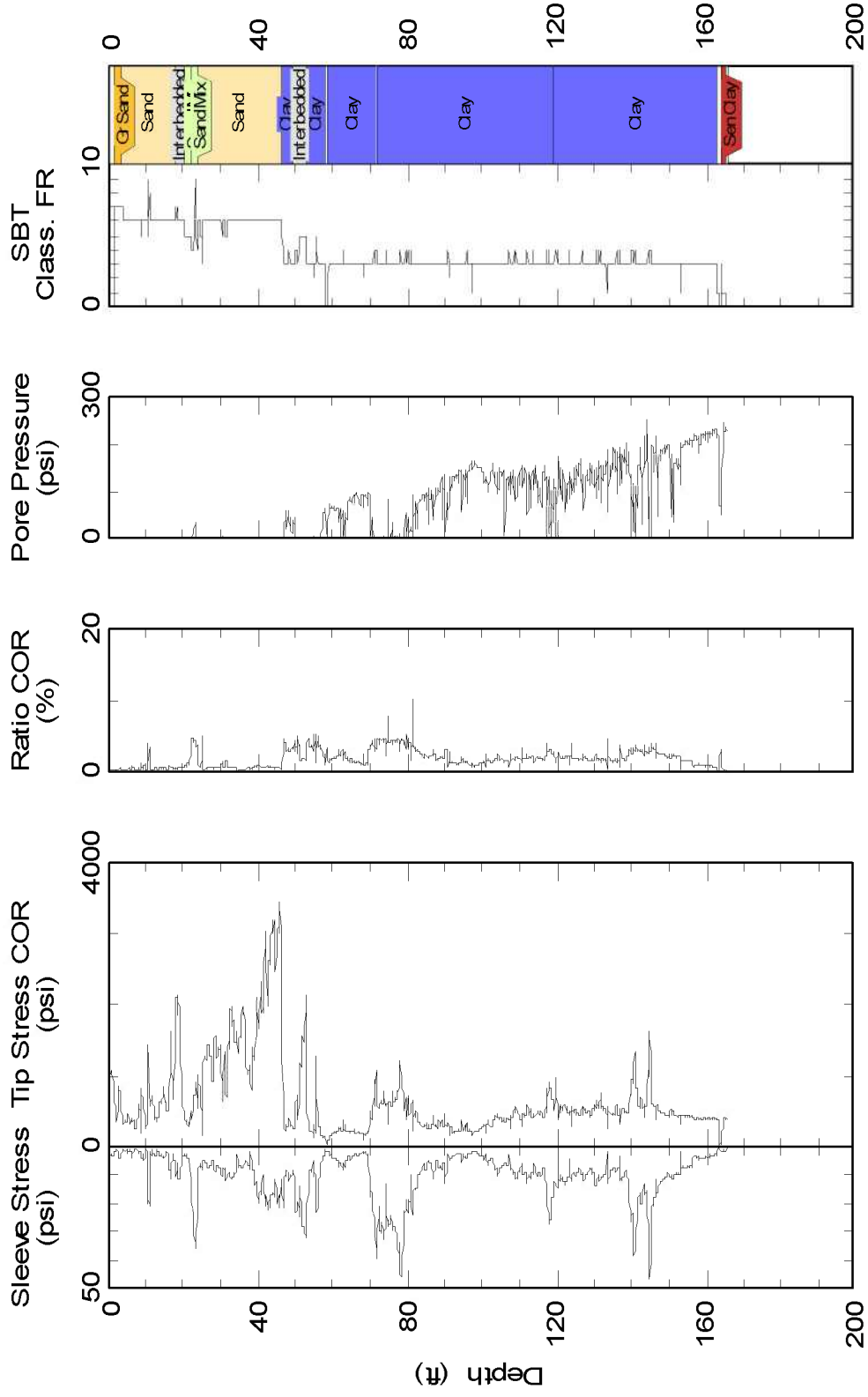

Plate 1: Cone Penetration Testing Results for C-05-01

C-05-01

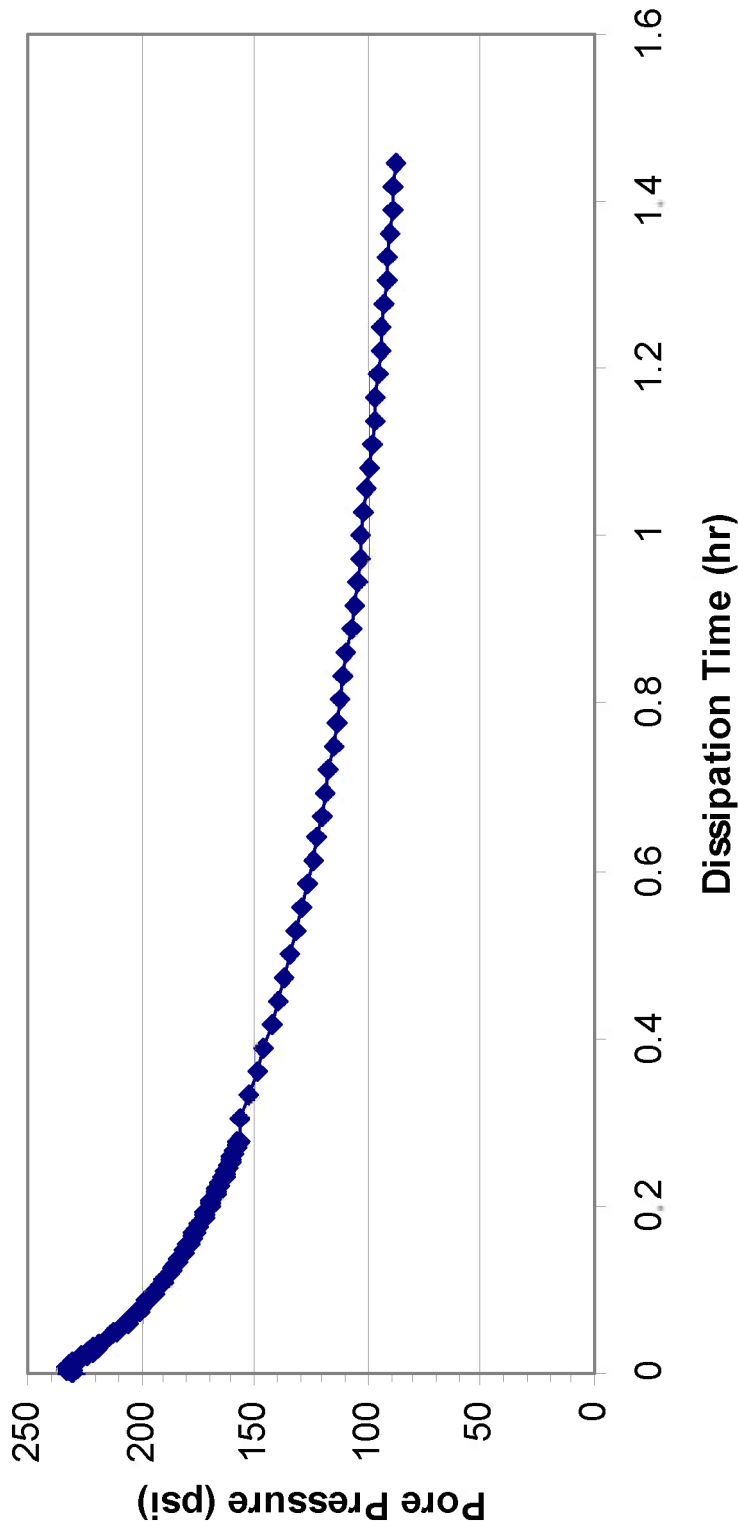

Plate 2: Pore Pressure Dissipation for C-05-01 taken at an approximate depth of 167 feet.

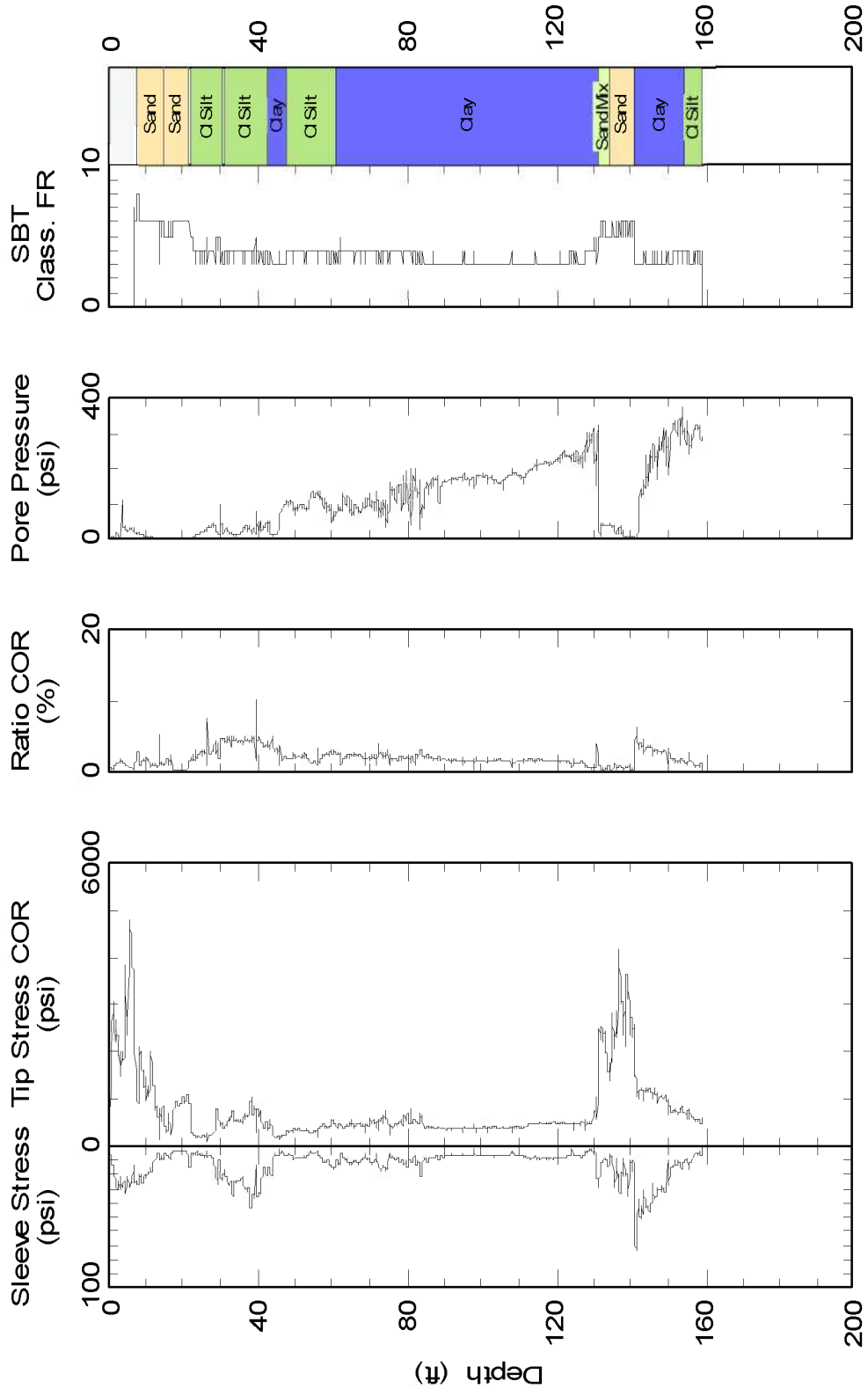

Plate 3: Cone Penetration Testing Results for C-05-02.

C-05-02

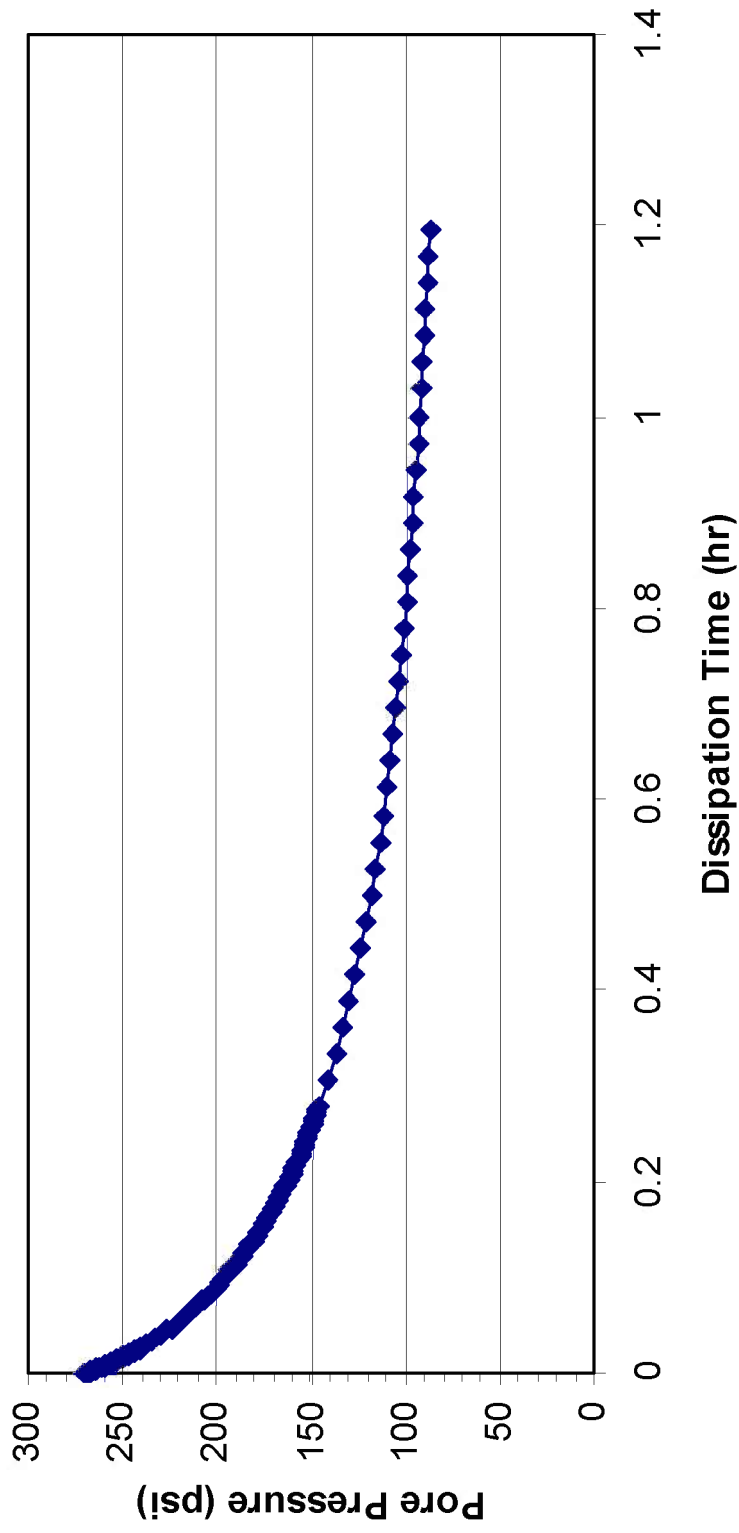

Plate 4: Pore Pressure Dissipation for C-05-02 taken at an approximate depth of 160 feet.

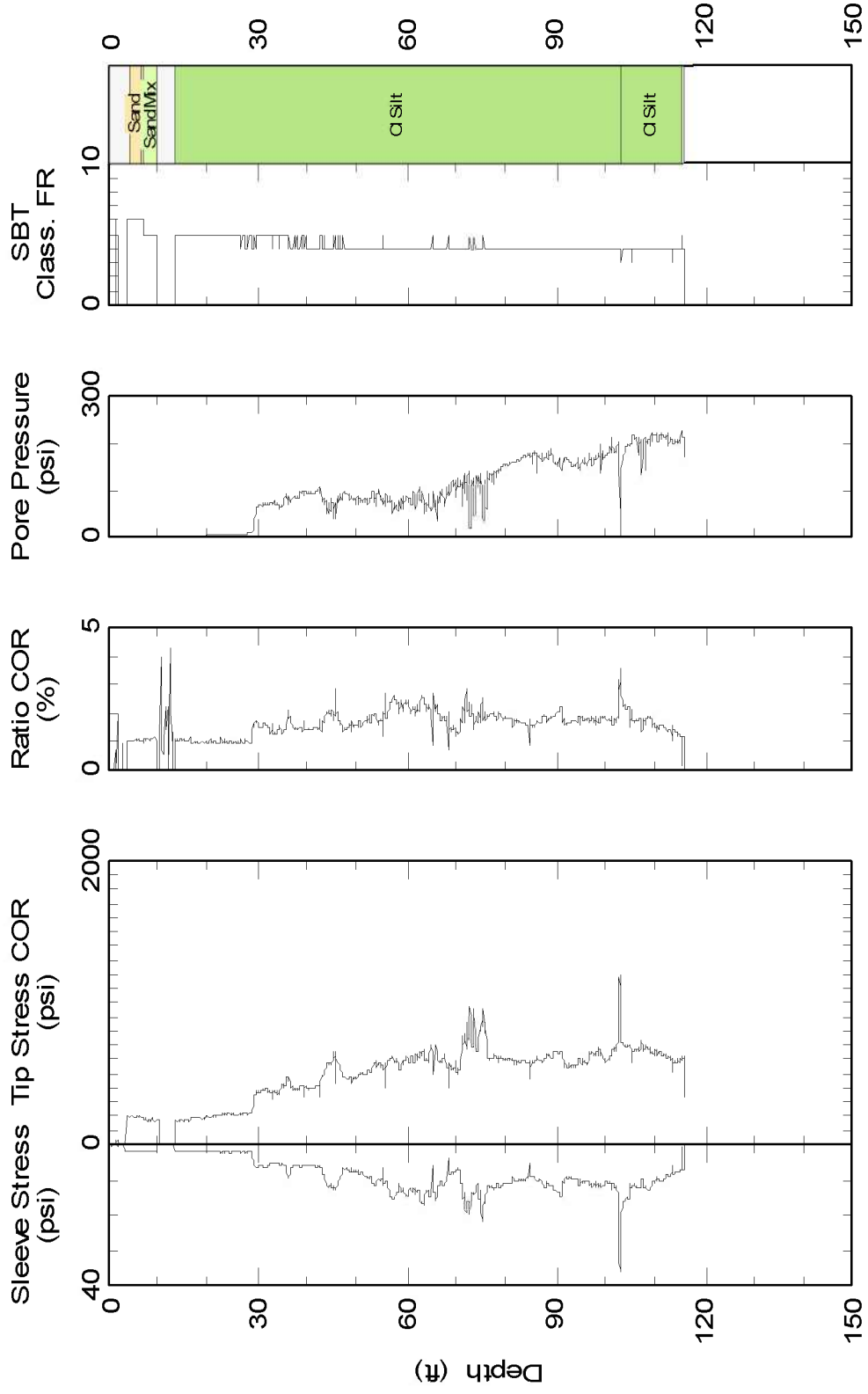

Plate 5: Cone Penetration Testing Results for C-05-03, run number 2.

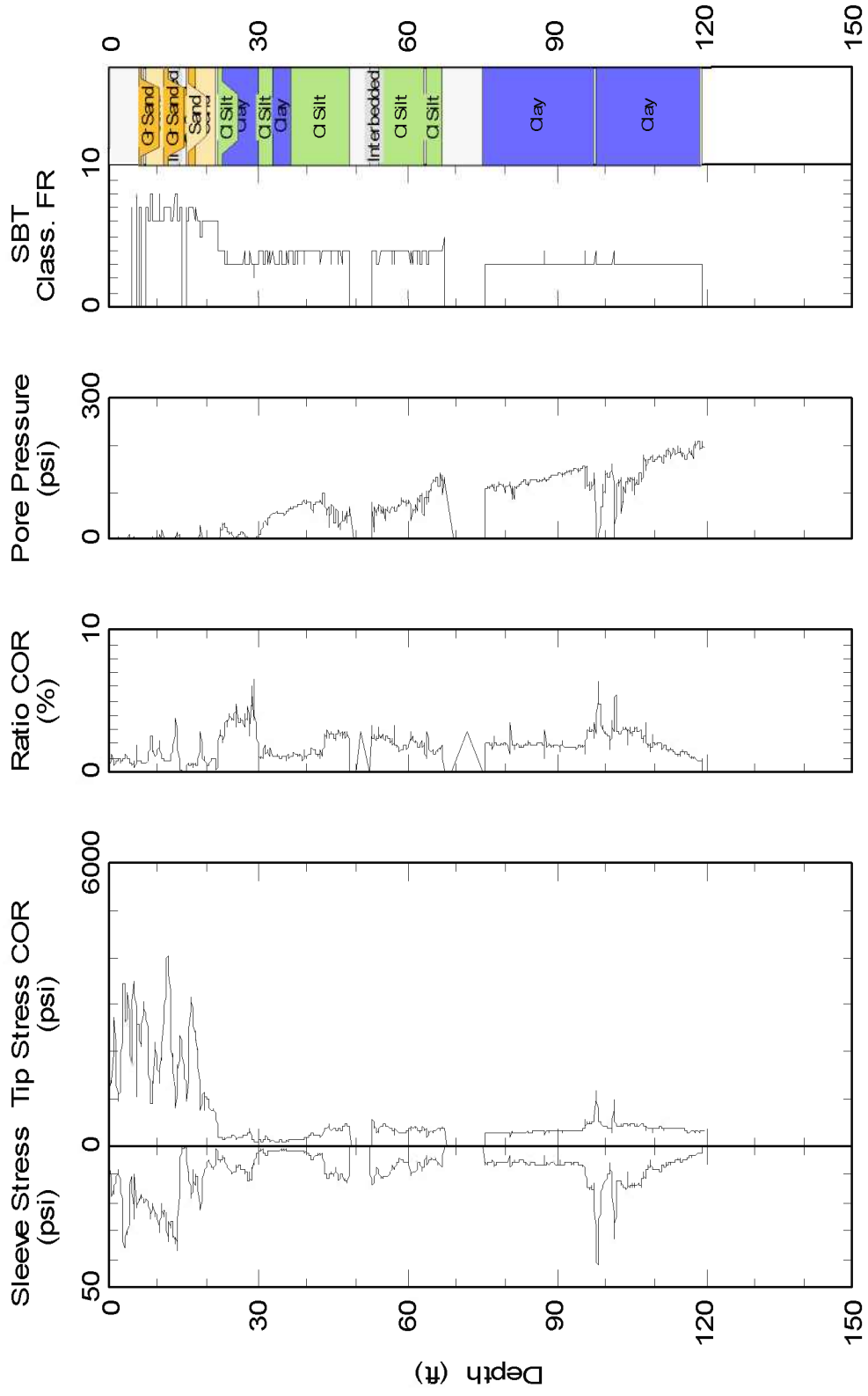

Plate 6: Cone Penetration Testing Results for C-05-04, run number 3.

C-05-04

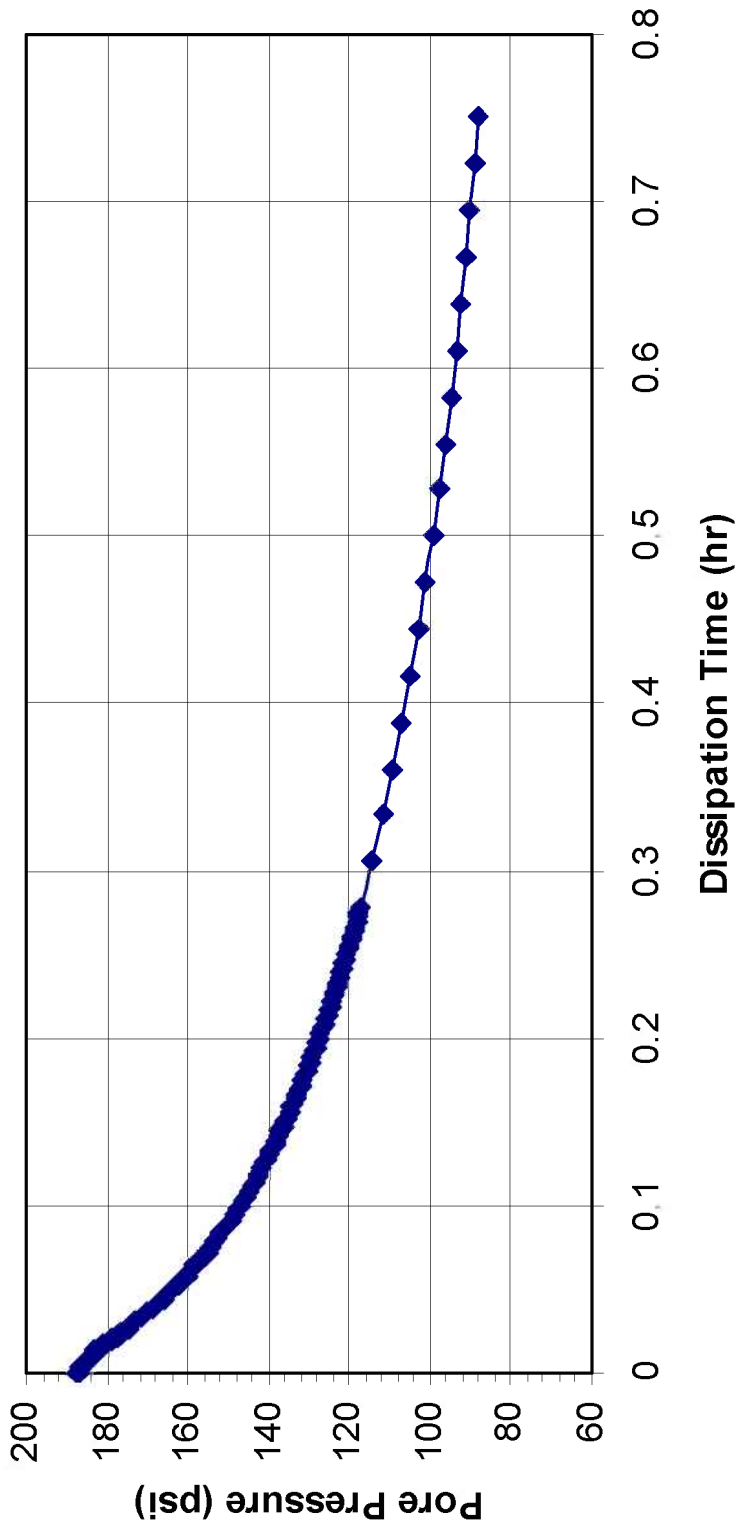

Plate 7: Pore Pressure Dissipation for C-05-04, run number 3, taken at an approximate depth of 120 feet.

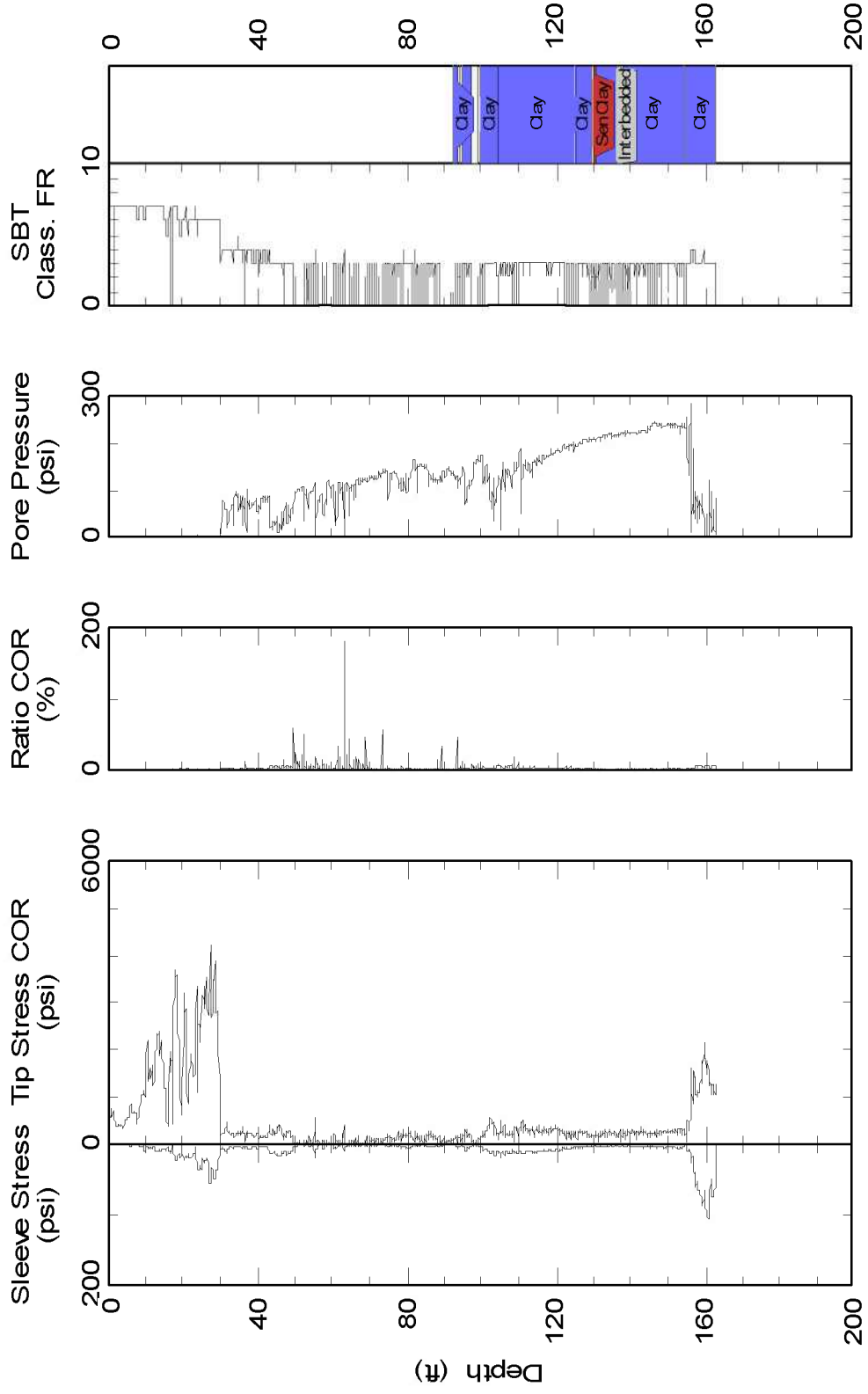

Plate 8: Cone Penetration Testing Results for C-05-05.

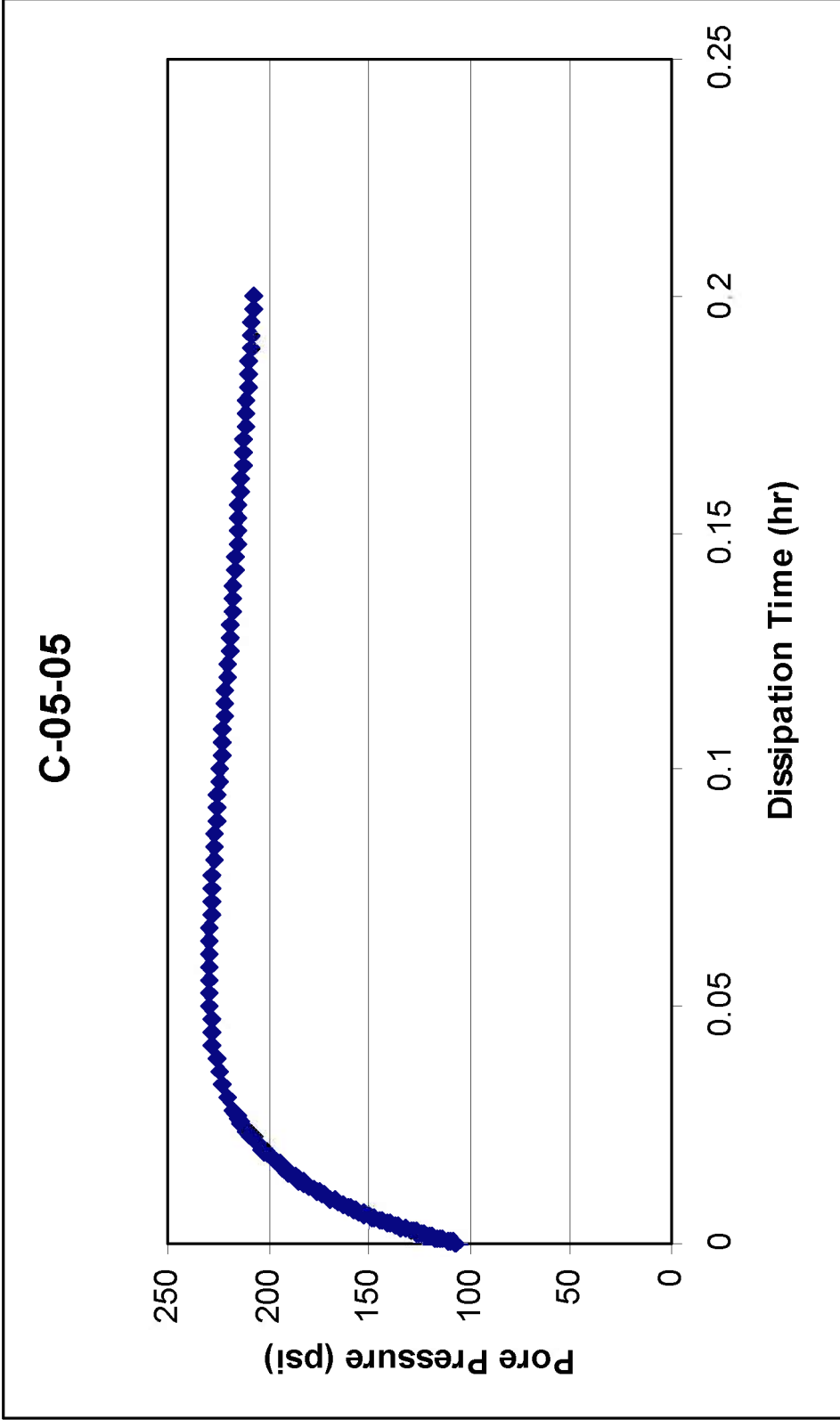

Plate 9: Pore Pressure Dissipation for C-05-05 taken at an approximate depth of 164 feet.

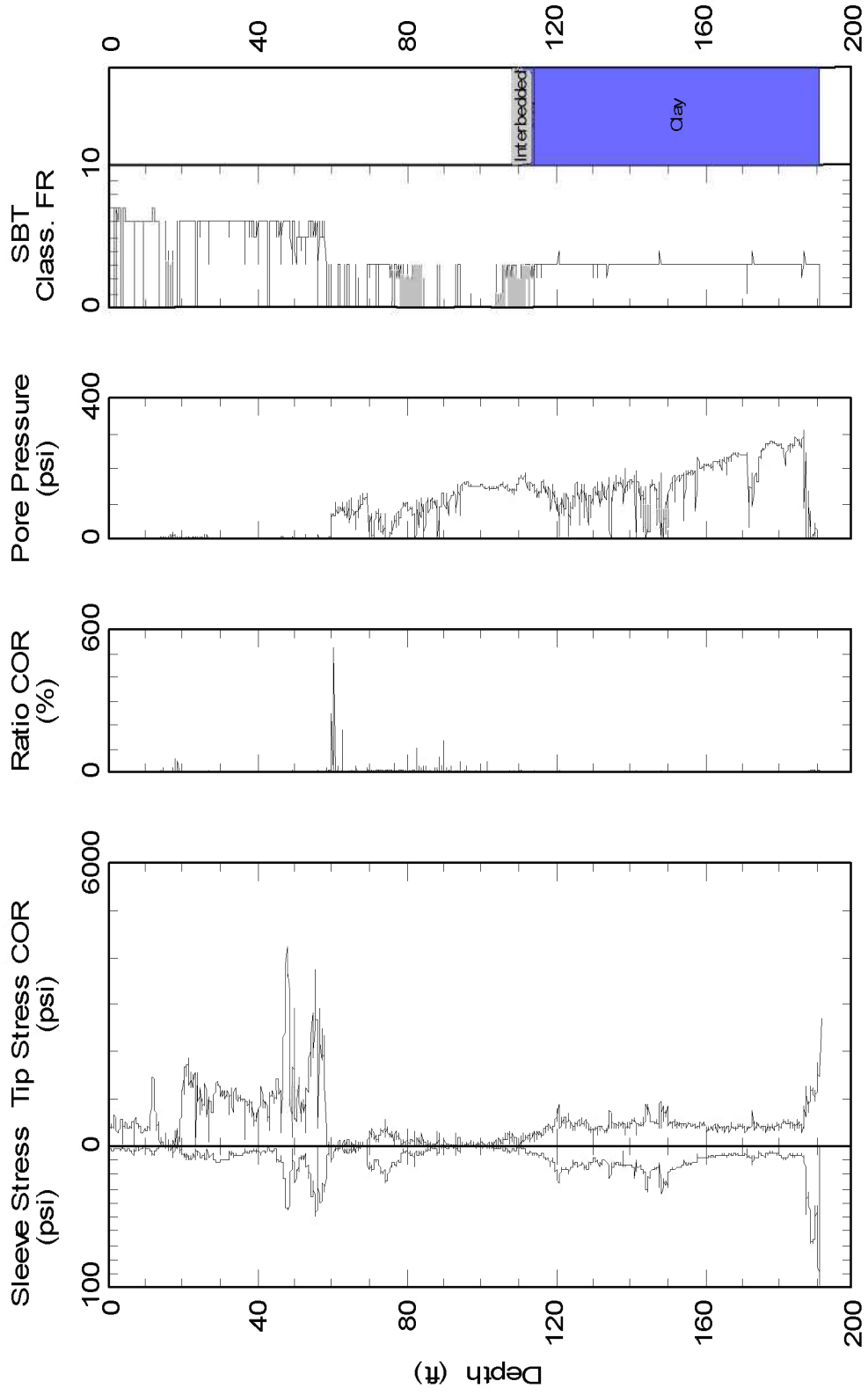

Plate 10: Cone Penetration Testing Results for C-05-06.

C-05-06

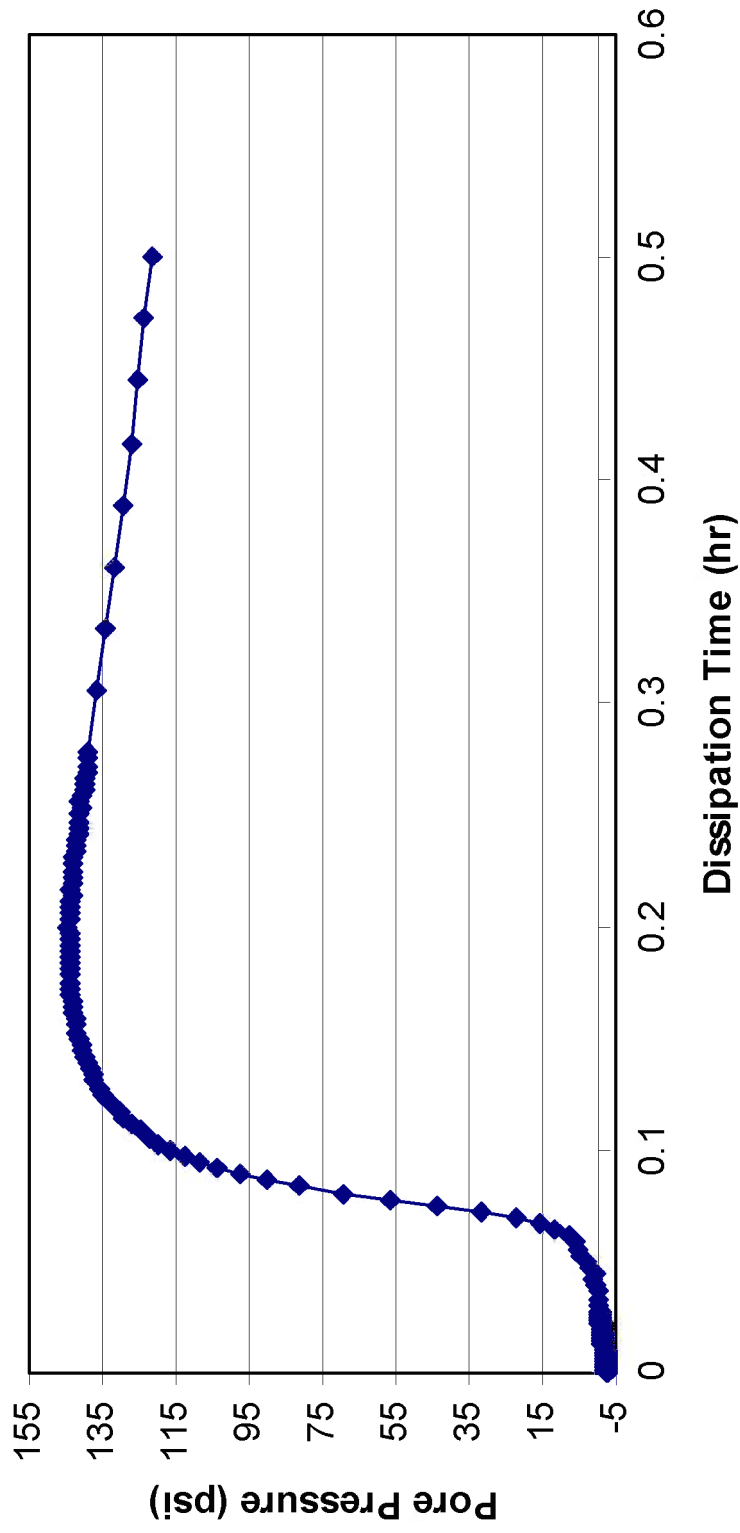

Plate 11: Pore Pressure Dissipation for C-05-06 taken at an approximate depth of 192 feet.

Test ID: C0507A

Project: CUY901524

Date: 05/Apr/2006

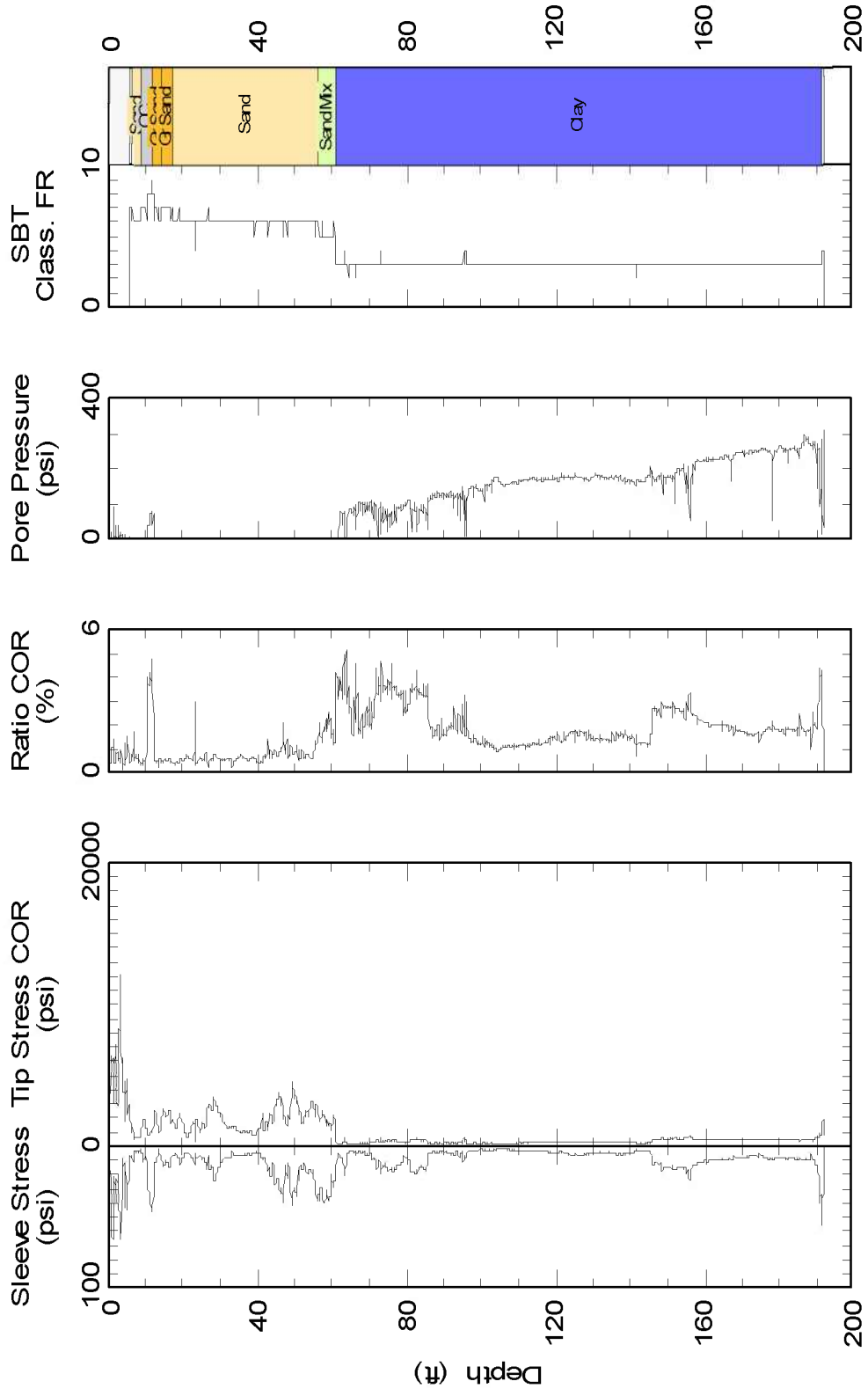

Plate 12: Cone Penetration Testing Results for C-05-07.

C-05-07

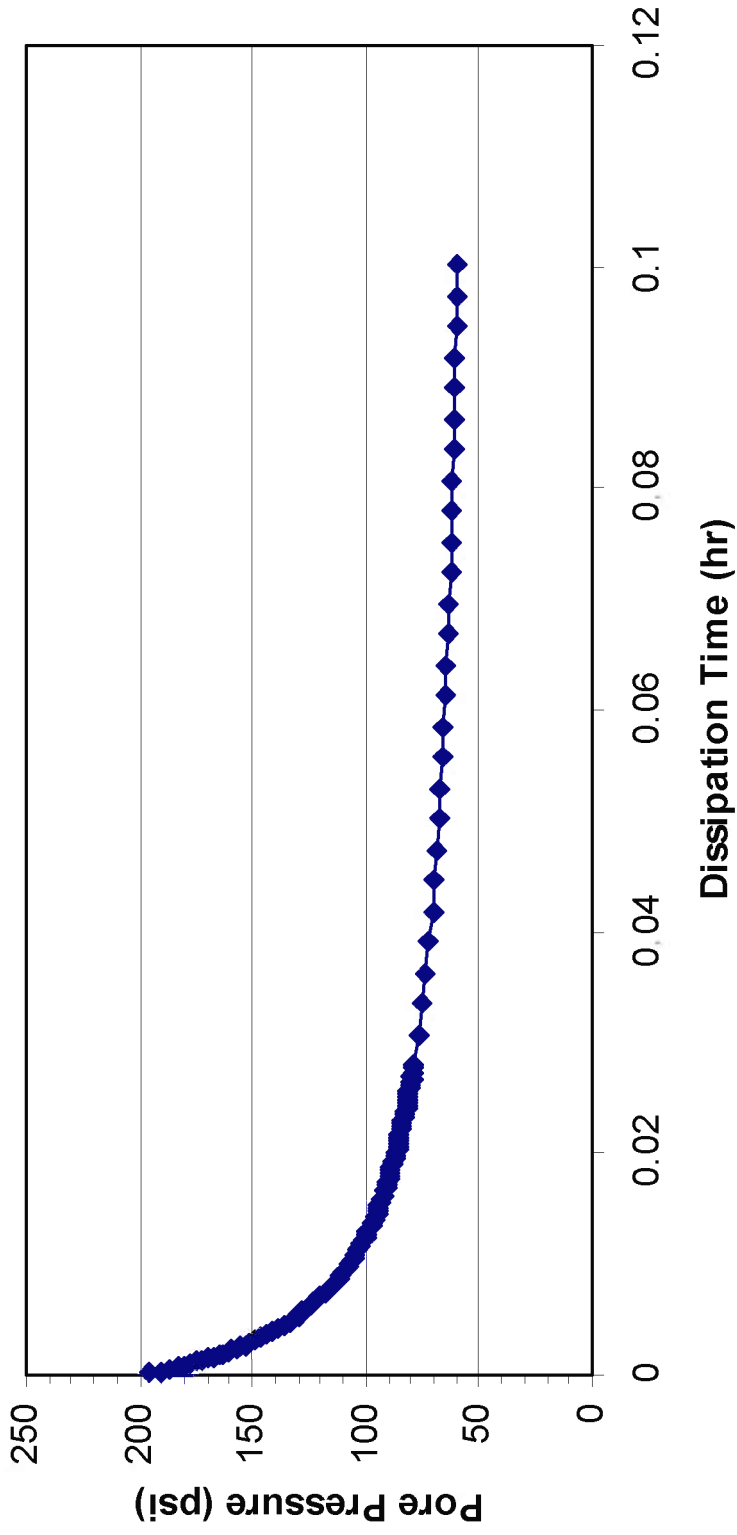

Plate 13: Pore Pressure Dissipation for C-05-07 taken at an approximate depth of 193 feet.

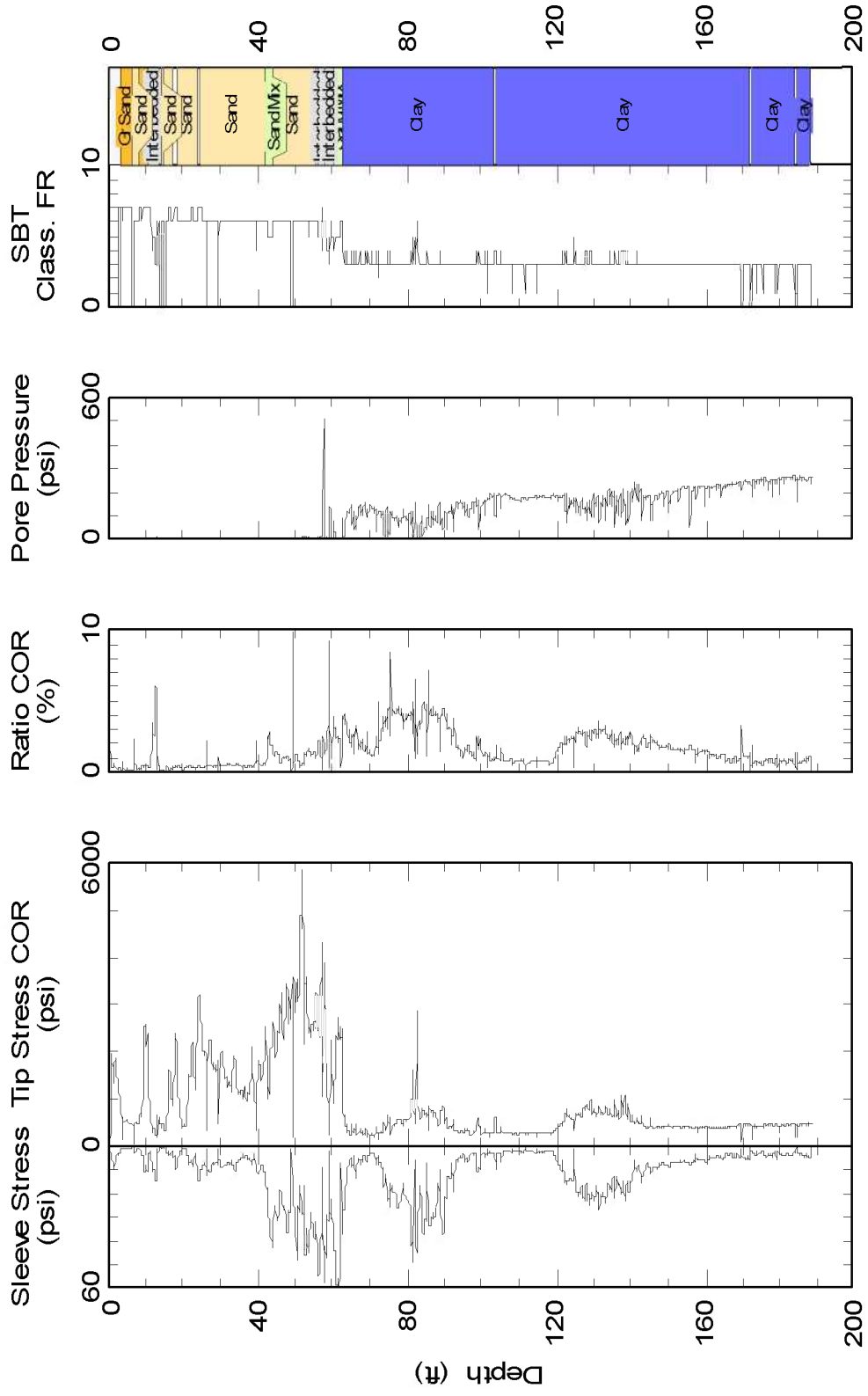

Plate 14: Cone Penetration Testing Results for C-05-08.

C-05-08

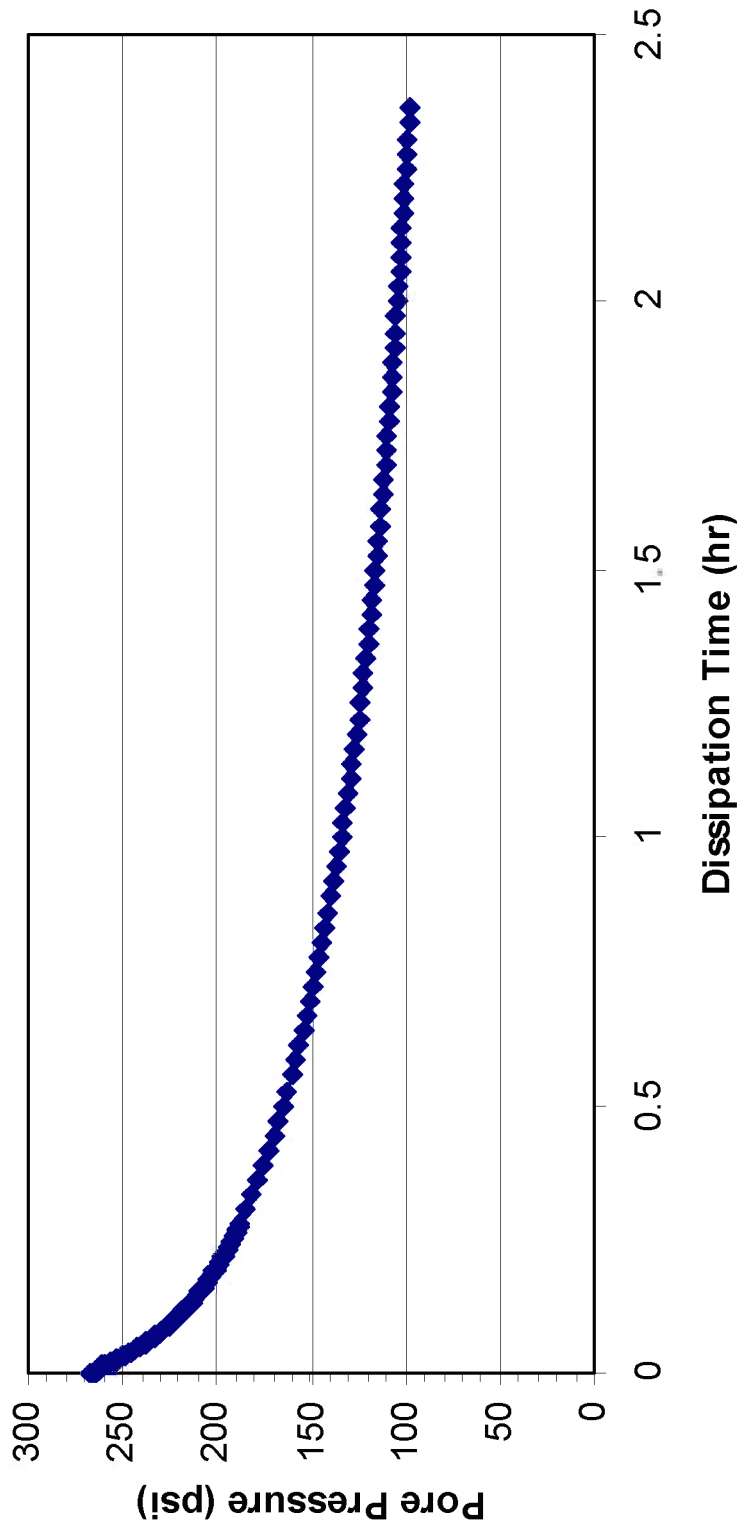

Plate 15: Pore Pressure Dissipation for C-05-08 taken at an approximate depth of 190 feet.

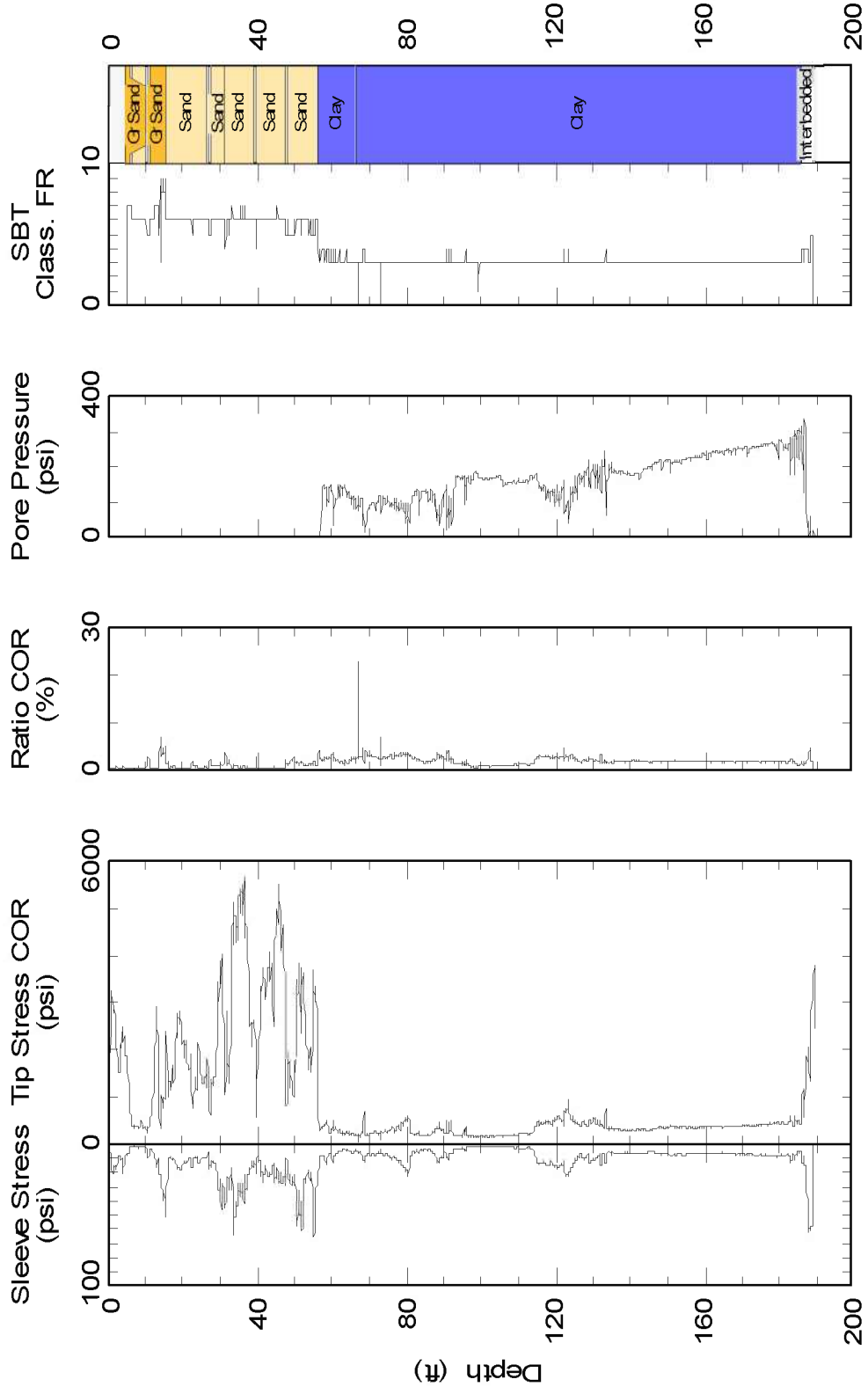

Plate 16: Cone Penetration Testing Results for C-05-09.

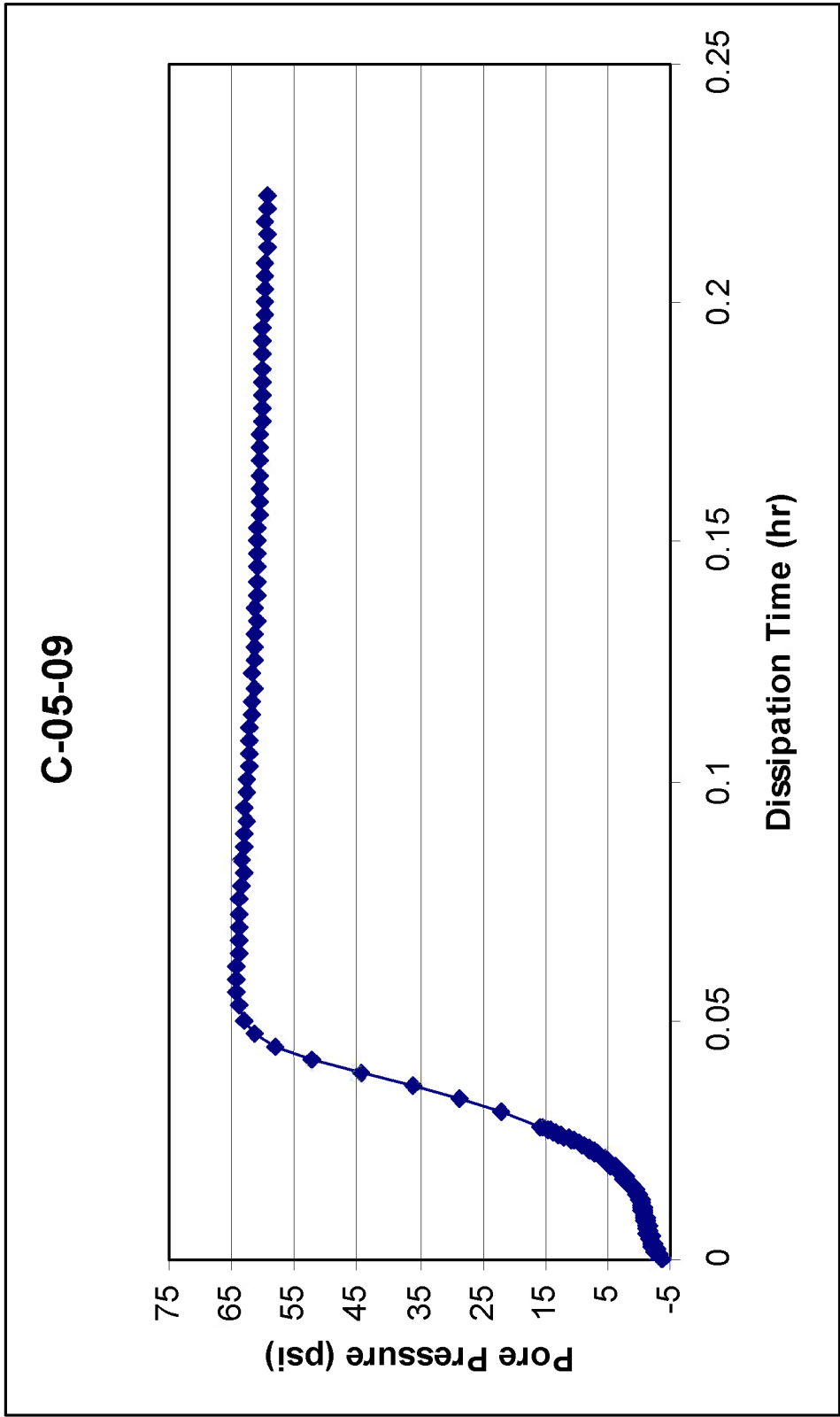

Plate 17: Pore Pressure Dissipation for C-05-09 taken at an approximate depth of 190 feet.

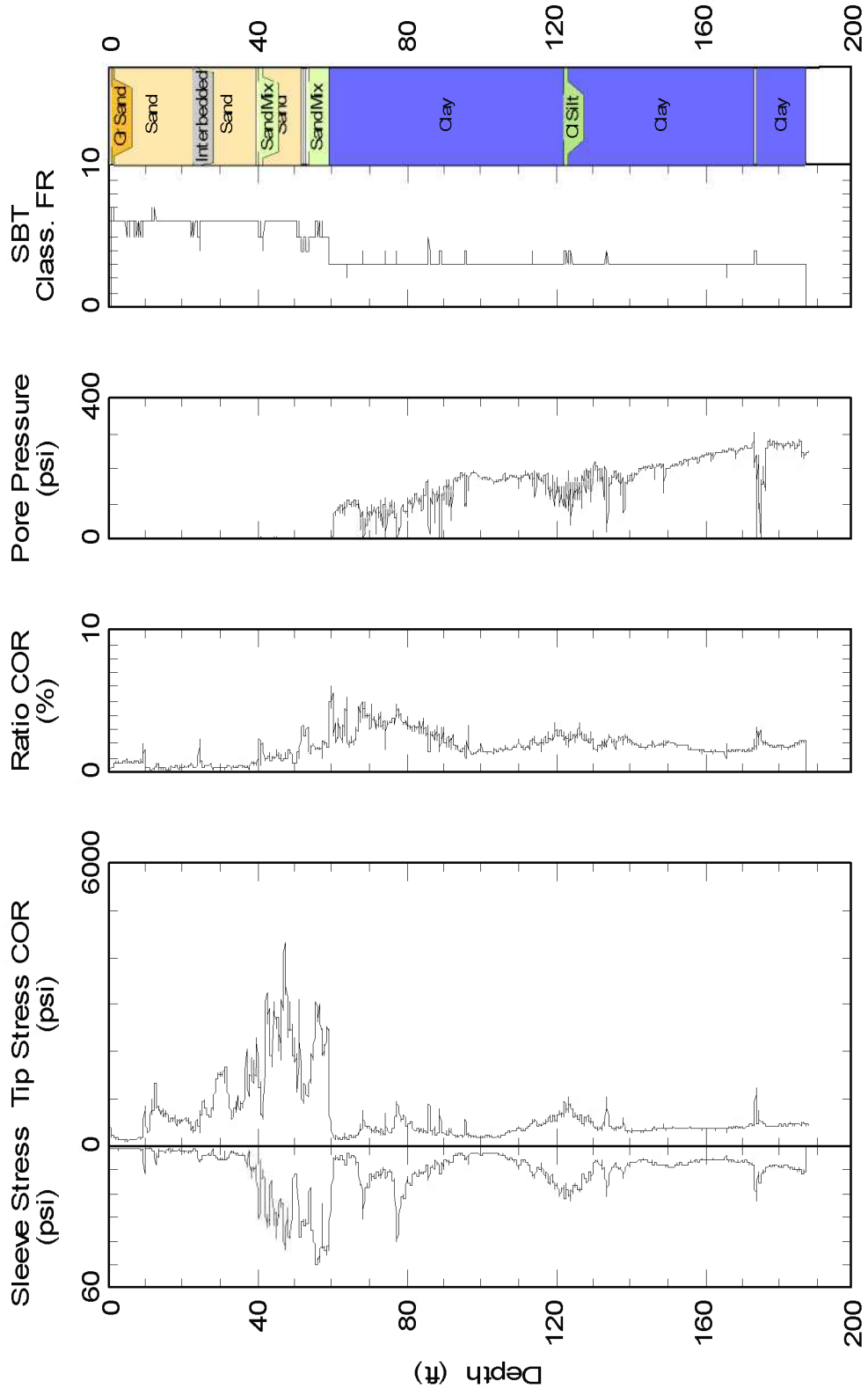

Plate 18: Cone Penetration Testing Results for C-05-10.

C-05-10

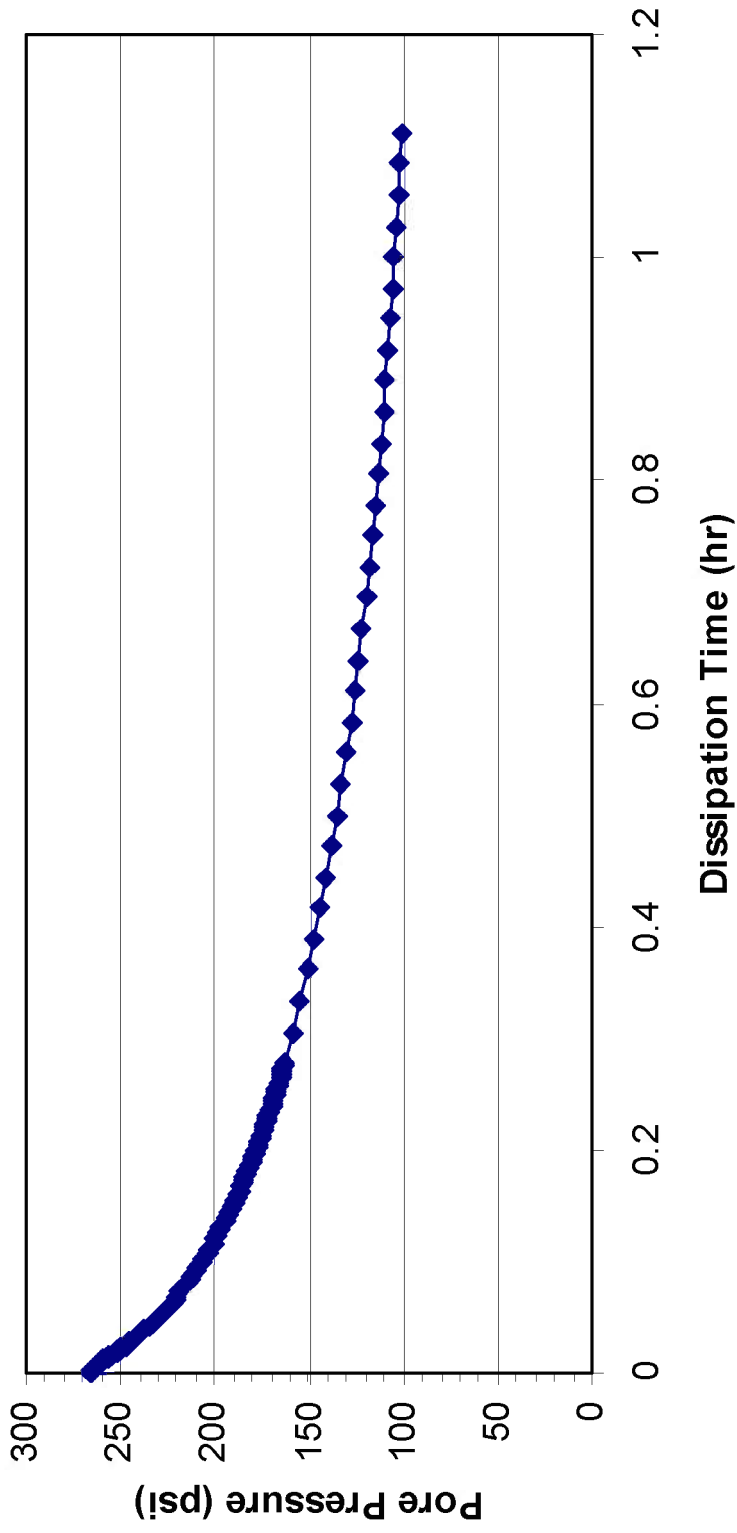

Plate 19. Pore Pressure Dissipation for C-05-10 taken at an approximate depth of 188 feet.

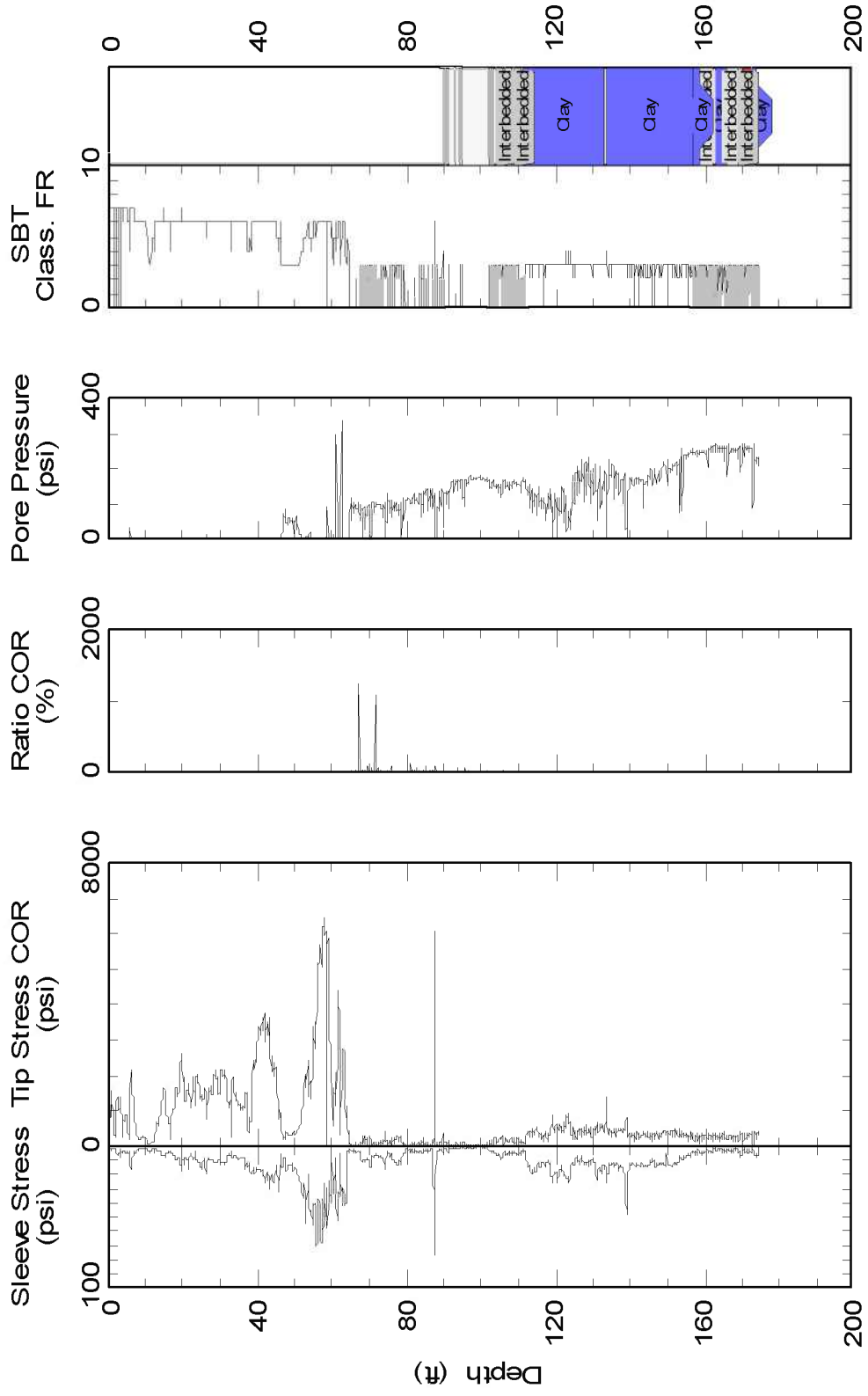

Plate 20: Cone Penetration Testing Results for C-05-11.

C-05-11

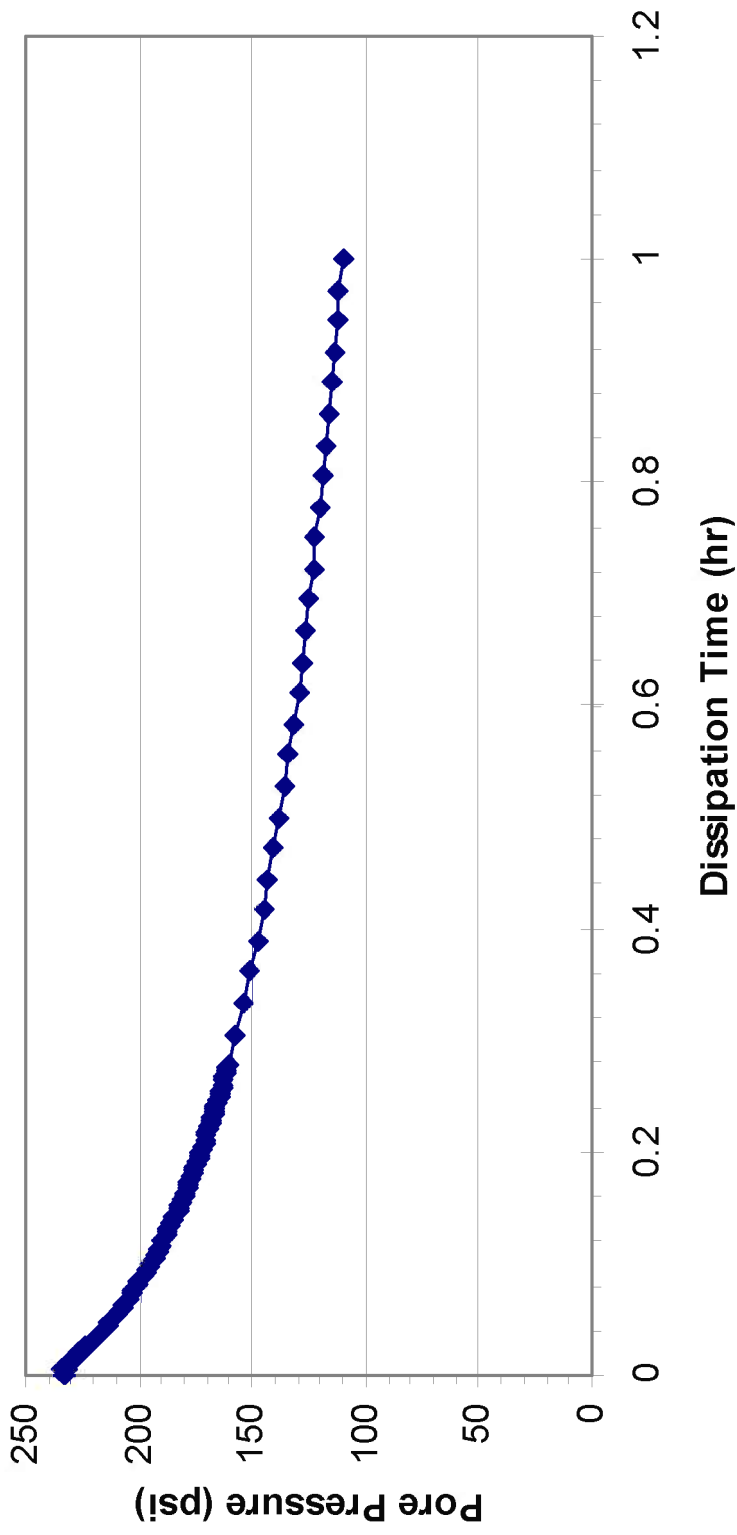

Plate 21: Pore Pressure Dissipation for C-05-11 taken at an approximate depth of 175 feet.

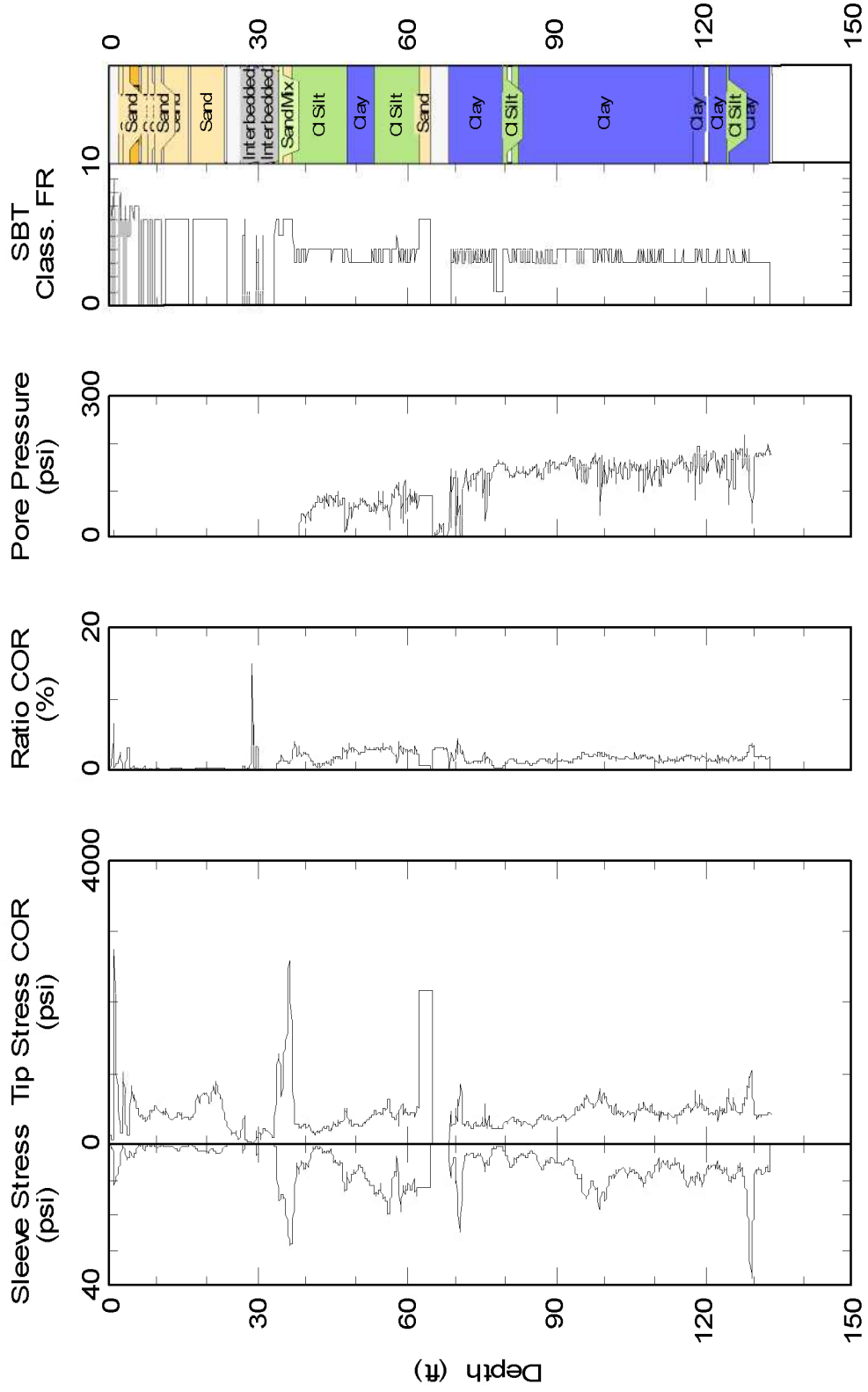

Plate 22: Cone Penetration Testing Results for C-05-12.

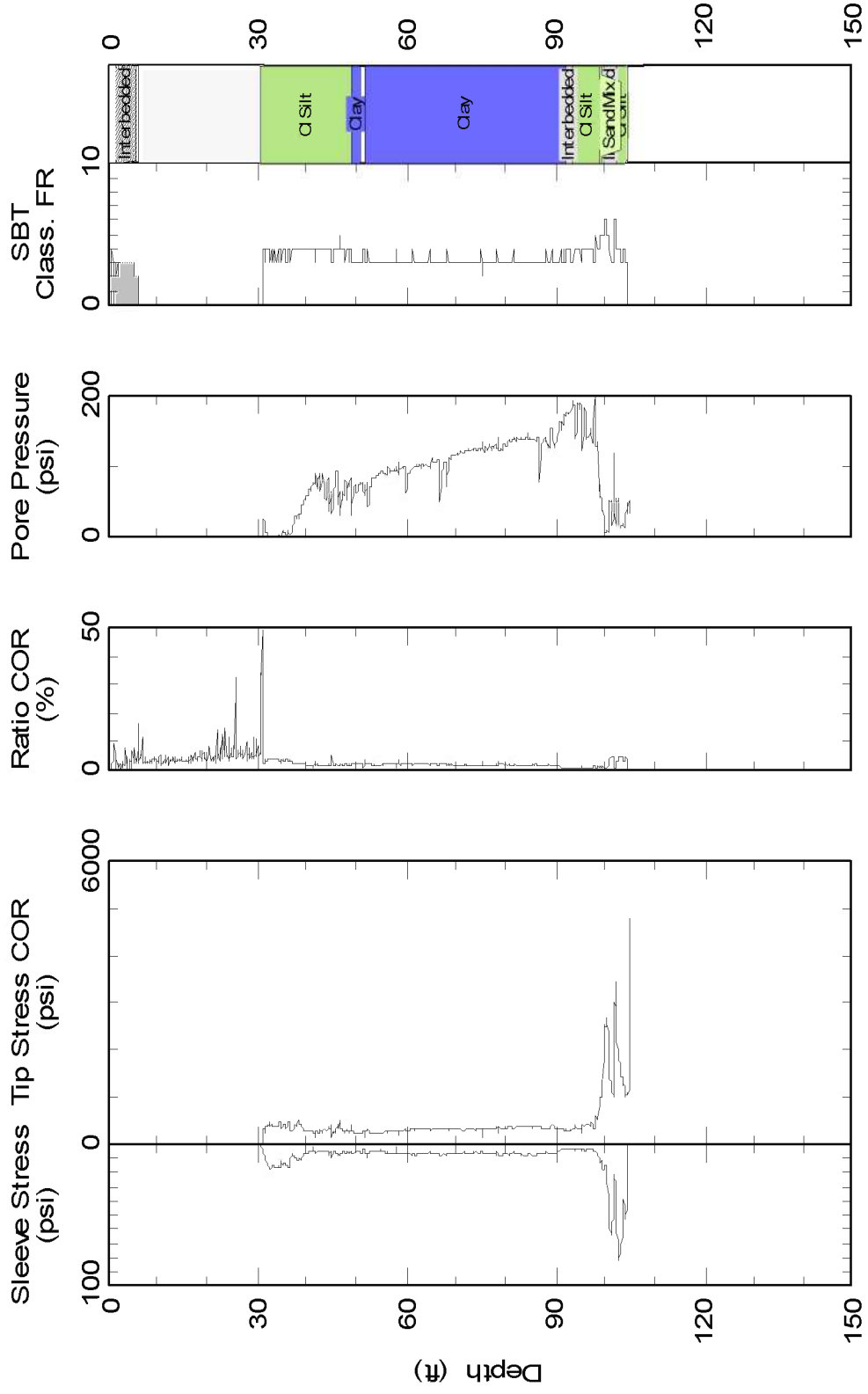

Plate 23: Cone Penetration Testing Results for C-05-13.

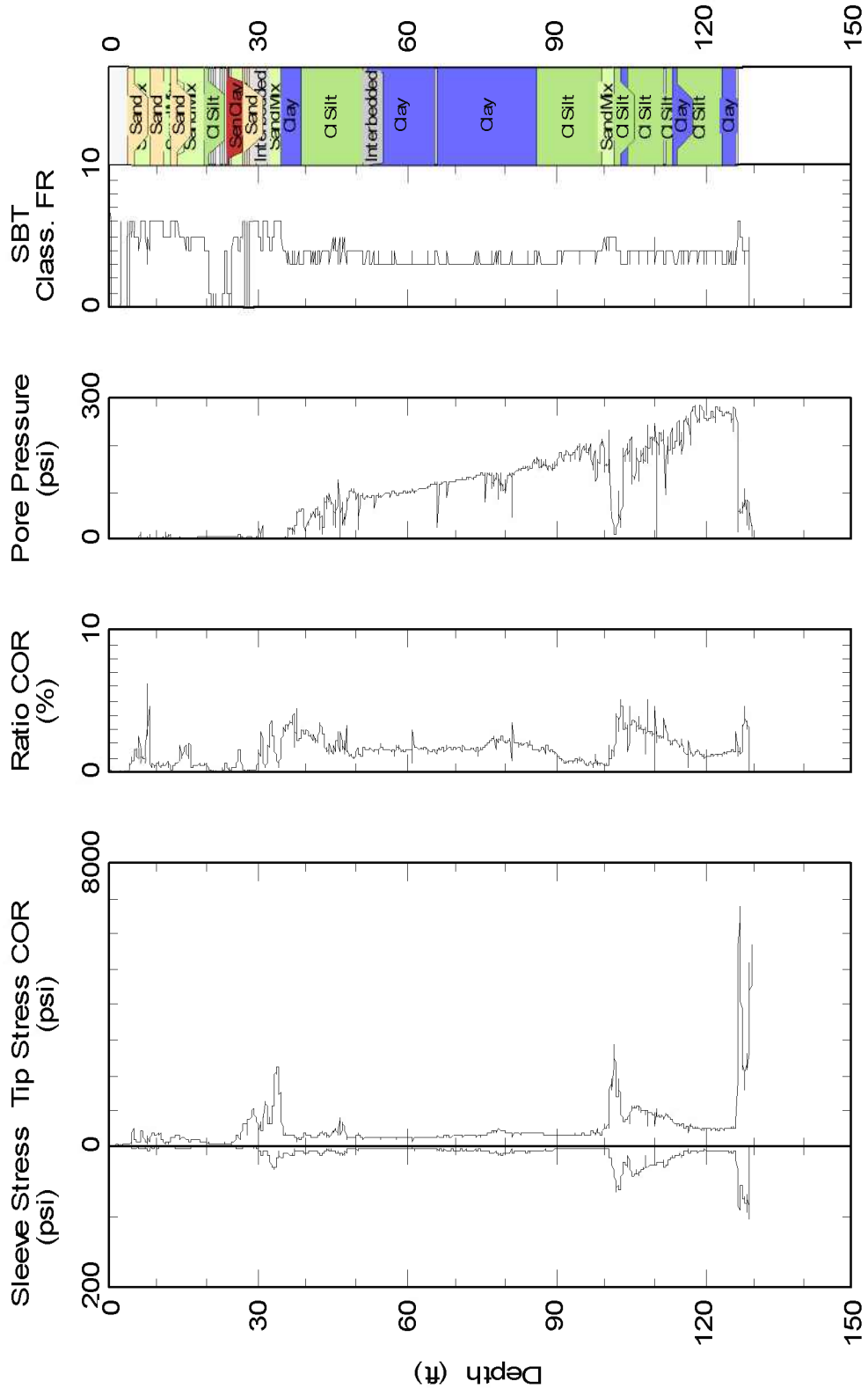

Plate 24: Cone Penetration Testing Results for C-05-14.

C-05-14

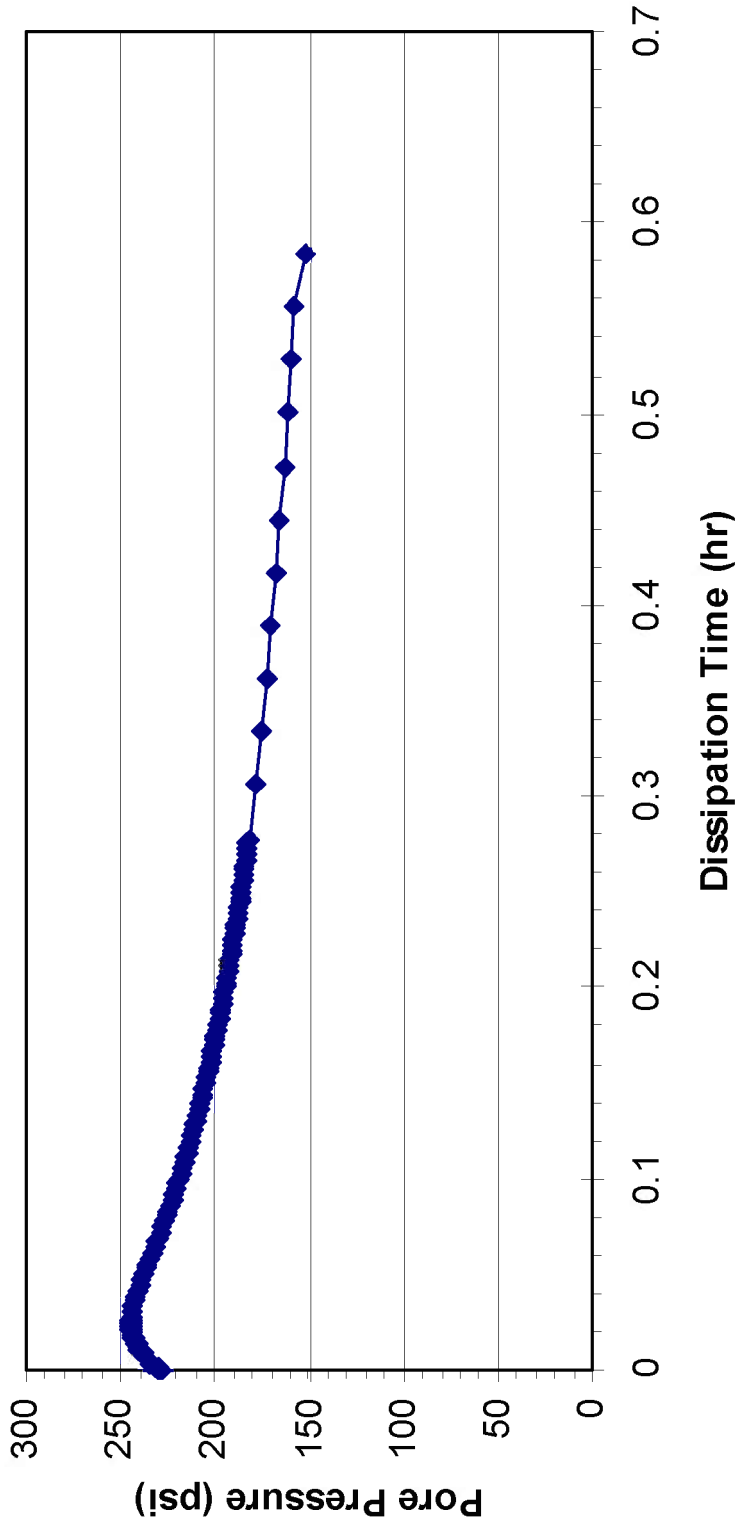

Plate 25: Pore Pressure Dissipation for C-05-13 taken at an approximate depth of 112 feet.

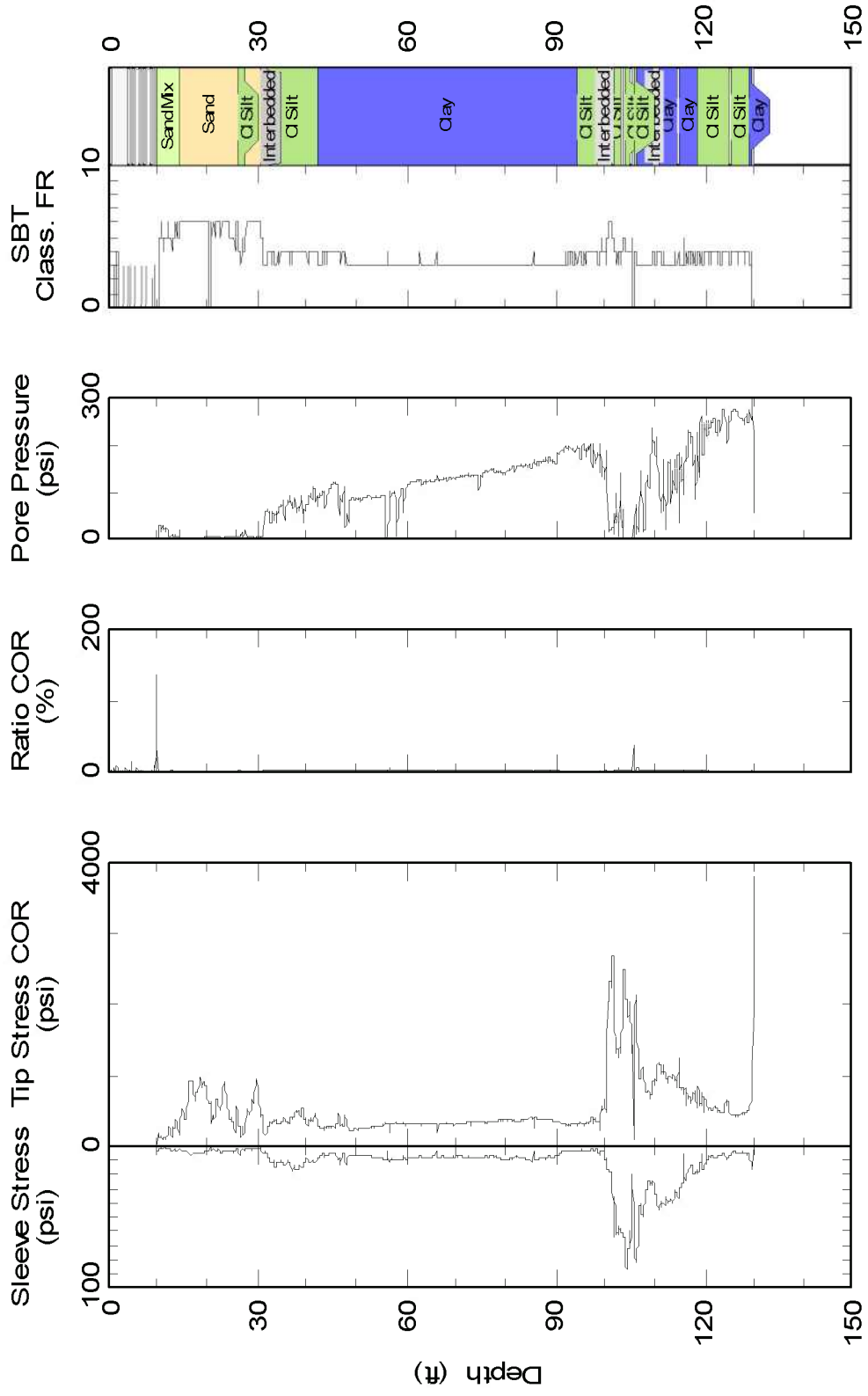

Plate 26: Cone Penetration Testing Results for C-05-15.

APPENDIX D
LOGS OF BORINGS



LOG OF BORING NO. B-05-01
CUY-90-15.24 West Abutment
CUYAHOGA COUNTY, OHIO

BBCM JOB: 012409046 300

TYPE: 3-1/4" I.D. Hollow-stem Auger LOCATION: Proposed I-90 Central Viaduct COMPLETION DEPTH: 233.7'
2" O.D. Split-barrel Sampler 3" O.D. Shelby Tube Sampler STA. 130+41.92 ELEVATION: 675.4
NX Rock Core Barrel 91.59' Rt. of Centerline DATE: 4/3/06 - 4/10/06

Elev (feet)	Depth (feet)	Samp. No	Std. Pen. / RQD	Hand Pen. (tsf)	Rec./Loss (feet)	CLASSIFICATION: DESCRIPTION	Samp. No	Physical Characteristics					ODOT Class			
								% AGG.	% C.S.	% F.S.	% SILT	% CLAY		LL	PI	WC
675.4	0	1	3/5/4			ASPHALT - 4 INCHES CONCRETE - 9 INCHES COARSE AND FINE SAND (FILL): Very-loose to loose brown fine to coarse sand, some fine to coarse gravel, trace silt, trace clay, contains few clayey silt pockets.	1								Est. A-3a	
674.3	5	2	3/2/2				2									Est. A-3a
	10	3	2/2/2				3									Est. A-3a
	15	4	2/3/3				4	21	37	29	7	6			9	Est. A-3a
	20	5	2/3/5				5									Est. A-3a
653.4	22	6	4/6/7	3.0-4.5+	22.0	SILT: Very-stiff to hard brown silt, some clay, trace fine to coarse sand.	6	0	1	3	72	24	27	7	20	A-4b(8)
648.4	25	7	4/4/6		27.0	FINE SAND: Loose to medium-dense gray fine sand, trace coarse sand, trace silt, trace clay.	7									Est. A-3
	30	8	5/8/9		37.0		8	0	8	83	4	5	NP	NP	7	A-3(0)
638.4	35	9	3/3/4			SILT: Loose to medium-dense brown and gray silt, some fine sand, trace to little clay, contains few fine sand lenses.	9									Est. A-4b
	40	10	11/13/15		47.0		10									Est. A-4b
628.4	45	11	3/5/9	1.25-4.25		SILT: Medium-stiff to stiff gray silt, some to "and" clay, trace fine sand, contains few very-stiff to hard zones.	11									Est. A-4b
	50															

WATER LEVEL: 38.5 21.0 25.5
 WATER NOTE: After HSA Removed - Prior to Washbore Inside Casing - Prior to Washbore
 DATE: 4/3/06 4/3/06 4/4/06

-CONTINUED-



LOG OF BORING NO. B-05-01
CUY-90-15.24 West Abutment
CUYAHOGA COUNTY, OHIO

BBC&M JOB: 012-00946-300

TYPE: **3-1/4" I.D. Hollow-stem Auger** **3-7/8" Tricone Roller Bit** LOCATION: **Proposed I-90 Central Viaduct** COMPLETION DEPTH: 233.7'
2" O.D. Split-barrel Sampler **3" O.D. Shelby Tube Sampler** **Sta. 130+41.92** ELEVATION: 675.4
NX Rock Core Barrel **91.59' Rt. of Centerline** DATE: 4/3/06 - 4/10/06

Elev. (feet)	Depth (feet)	Samp.	Std. Pen. / RQD	Hand Pen. (tsf)	Rec./Loss (feet)	CLASSIFICATION: DESCRIPTION	Samp. No.	Physical Characteristics					ODOJ Class		
								% AGG. C.S.	% F.S.	% SILT CLAY	LL	PI		WC	
605.9	50					<p>SILT: Medium-stiff to stiff gray silt, some to "and" clay, trace fine sand, contains few very-stiff to hard zones.</p> <p>SILT AND CLAY: Very-stiff to hard gray clay, "and" silt, contains many interbedded silt seams.</p> <p>SILT AND CLAY: Stiff to very-stiff gray clay, some silt, trace fine to coarse sand, trace fine gravel, contains few to many fine sand and silt seams, and few medium-stiff zones.</p>	12							Est. A-4b	
	55		6/4/6	0.75-2.0			13	0	2	67	31	28	8	22	A-4b(8)
	60		P	1.5-2.5			14								Est. A-4b
	65		P	1.25-1.5			15								Est. A-4b
			2/4/5	0.75-2.0			16								Est. A-4b
			3/6/5	1.0-2.5			17								Est. A-4b
			2/3/4	1.0-1.75			18								Est. A-4b
			2/2/4	0.75-1.25			19								A-4b(8)
			3/6/7	1.5-2.5	69.5		20								Est. A-4b
			6/9/13	2.75-4.5+			21								Est. A-6a
			4/7/13	4.0-4.5+			22								Est. A-6a
			7/10/14	4.0-4.5+			23								Est. A-6a
			6/12/18	4.5+			24								Est. A-6a
			8/11/14	2.25-4.5+			25								A-6a(8)
			4/8/11	2.0-3.0			26								Est. A-6a
584.4	90		9/10/14	2.0-3.25	91.0		27								Est. A-6a
	95		P	1.25-1.5			28								Est. A-6a
			P	1.25			29								Est. A-6a
	100		3/4/6	0.5-1.25			29	1	0	28	70	38	14	28	A-6a(10)

WATER LEVEL: 38.5 21.0 25.5
 WATER NOTE: Encountered After HSA Removed - Prior to Washbore Inside Casing - Prior to Washbore
 DATE: 4/3/06 4/3/06 4/4/06

-CONTINUED-



LOG OF BORING NO. B-05-01
CUY-90-15.24 West Abutment
CUYAHOGA COUNTY, OHIO

BBC&M JOB: 012-00946-100

TYPE: **3-1/4" I.D. Hollow-stem Auger** LOCATION: **Proposed I-90 Central Viaduct** COMPLETION DEPTH: **233.7'**
2" O.D. Split-barrel Sampler **3" O.D. Shelby Tube Sampler** STA. **130+41.92** ELEVATION: **675.4**
NX Rock Core Barrel DATE: **4/3/06 - 4/10/06**

Elev. (feet)	Depth (feet)	Samp. No.	Std. Pen. / RQD	Hand Pen. (tsf)	Rec./Loss (feet)	CLASSIFICATION-DESCRIPTION	Samp. No.	Physical Characteristics					ODOT Class							
								% AGG. C.S.	% F.S.	% SILT	% CLAY	LL		PI	WC					
558.4	-100																			
	-105		4/6/8	1.75-2.5		SILT AND CLAY: Stiff to very-stiff gray clay, some silt, trace fine to coarse sand, trace fine gravel, contains few to many fine sand and silt seams, and few medium-stiff zones.	30													Est. A-6a
	-110		6/9/13	2.0-2.75			31													Est. A-6a
	-115		6/8/9	2.25-3.0			32													Est. A-6a
	-120		5/8/12	1.25-2.5		SILT: Stiff to very-stiff gray silt, "and" clay, trace fine to coarse sand, trace fine gravel.	33	0	0	1	53	46	29	9	23					A-4b(8)
	-125		8/11/12	1.75-3.75			34													Est. A-4b
	-130		11/13/17	2.25-3.75			35													Est. A-4b
	-135		5/8/10	1.75-3.0			36	1	1	2	54	42	28	9	23					A-4b(8)
538.4	-140		8/13/21	3.0-3.5		SILT AND CLAY: Stiff to very-stiff gray clay, some silt, trace fine to coarse sand, trace fine gravel, contains few silt seams, pockets and lenses, and few medium-stiff zones.	37													Est. A-6a
	-145		7/11/16	2.5-3.75			38													Est. A-6a
	-150		8/12/16	2.0-3.5			39	1	2	4	33	60	34	13	21					A-6a(9)

WATER LEVEL: **38.5** After HSA Removed - Prior to Washbore **4/3/06** Inside Casing - Prior to Washbore **4/4/06**
 WATER NOTE: **Encountered**
 DATE: **4/3/06**

-CONTINUED-

TYPE: 3-1/4" I.D. Hollow-stem Auger LOCATION: Proposed I-90 Central Viaduct COMPLETION DEPTH: 233.7'
2" O.D. Split-barrel Sampler 3" O.D. Shelby Tube Sampler Sta. 130+41.92 ELEVATION: 675.4
NX Rock Core Barrel 91.59' Rt. of Centerline DATE: 4/3/06 - 4/10/06

Elev (feet)	Depth (feet)	Samp	Std Pen. / RQD	Hand Pen (tsf)	Rec./Loss (feet)	CLASSIFICATION: DESCRIPTION	Samp. No.	Physical Characteristics					ODOT Class			
								% AGG.	% C.S.	% F.S.	% SILT	% CLAY		LL	PI	WC
-150						SILT AND CLAY: Stiff to very-stiff gray clay, some silt, trace fine to coarse sand, trace fine gravel, contains few silt seams, pockets and lenses, and few medium-stiff zones.	40								Est. A-6a	
-155			6/9/12	1.75-2.75			41									Est. A-6a
-160			6/8/11	1.75-2.5			42	1	2	3	33	61	32	13	22	A-6a(9)
-165			7/9/12	0.75-2.5			43									Est. A-6a
-170			8/9/13	1.75-2.5			44									Est. A-6a
-175			7/11/15	2.0-3.75			45	0	0	1	31	68	37	15	24	A-6a(10)
-180			5/9/12	1.75-2.75			46									Est. A-6a
-185			4/7/8	0.5-1.75			47									Est. A-6a
-190			5/6/7	0.5-1.75			48	22	31	14	20	13				Est. A-3a
483.4			15/16/17				49									Est. A-4a
478.4			15/28/45	2.0-4.25												

WATER LEVEL: 21.0 25.5
 WATER NOTE: After HSA Removed - Prior to Washbore Inside Casing - Prior to Washbore
 DATE: 4/3/06 4/3/06

-CONTINUED-



LOG OF BORING NO. B-05-01
CUY-90-15.24 West Abutment
CUYAHOGA COUNTY, OHIO

BBC&M JOB 012-00946.000

Page 5 of 5

TYPE: **3-1/4" I.D. Hollow-stem Auger** 3-7/8" Tricone Roller Bit LOCATION: **Proposed I-90 Central Viaduct** COMPLETION DEPTH: **233.7**
2" O.D. Split-barrel Sampler 3" O.D. Shelby Tube Sampler Sta. **130+41.92** ELEVATION: **675.4**
NX Rock Core Barrel 91.59' Rt. of Centerline DATE: **4/3/06 - 4/10/06**

Elev. (feet)	Depth (feet)	Samp. No.	Sid. Pen. / RQD	Hand Pen. (tsf)	Rec./Loss (feet)	CLASSIFICATION: DESCRIPTION	Samp. No.	Physical Characteristics					ODOT Class			
								% AGG. C.S.	% F.S.	% SILT CLAY	LL	PI		WC		
468.4	200-205		11/17/20	2.75-4.5+		SANDY SILT: Very-stiff to hard gray clay, "and" silt, trace fine to coarse sand, contains few silt pockets and shale fragments.	50	0	1	2	34	63	32	10	26	A-4a(8)
458.9	210-215		5/7/9	0.75-2.25		SILT AND CLAY: Stiff to very-stiff gray clay, some silt, trace fine to coarse sand, trace fine gravel, contains many silt lenses, and few medium-stiff zones.	51	1	1	2	21	75	35	11	25	A-6a(8)
455.4	220		7/10/25	1.5-2.5		SANDY SILT: Hard gray silt, some clay, little fine to coarse sand, little fine to coarse gravel, contains shale fragments.	52									Est. A-6a
451.7	225-230		23/38/50-5"R	4.5+		SHALE: Very-soft gray shale, fragmented.	53	19	12	8	33	28	25	7	10	A-4a(5)
441.7	235-240		50-1.5"R	5.0/0.0		SHALE: Soft to medium-hard dark gray and gray shale, nearly horizontally bedded, few horizontal fractures from 223.7' to 228.7', many horizontal and few vertical fractures from 229.3' to 230.7', contains diagonal fractures from 224.7' to 225.2' with a fracture angle of ranging between 20 and 25 degrees, and at 227.0' with a fracture angle of ranging between 15 and 20 degrees, contains few silty clay seams at 226.7' and 230.2', arenaceous.	54									Visual
	245-250		67%	4.7/0.3		SHALE: Very-soft gray shale, fragmented.	55									Visual
						SHALE: Very-soft gray shale, fragmented.	56									Visual

Qu=1477 psi at 229.0'
 NOTES:
 - Encountered water at 38.5'.
 - Water added to borehole at 40.0' to facilitate drilling.
 - Switched to washbore at 57.0'.
 - Base of inclinometer installed at an approximate depth of 231'.
 - Two vibrating wire piezometers installed in an offset hole between 5/23/06 and 5/26/06. Transducers were installed at approximate depths of 65' and 95'. The piezometer offset hole was backfilled with grout.

WATER LEVEL: 38.5 Encountered 4/3/06
 WATER NOTE: After HSA Removed - Prior to Washbore Inside Casing - Prior to Washbore
 DATE: 4/3/06 4/4/06



LOG OF BORING NO. B-05-02
CUY-90-15.24 West Abutment
CUYAHOGA COUNTY, OHIO

BBC&M JOB: 012-00946-300

TYPE: **3-1/4" I.D. Hollow-stem Auger** **3-1/8" Tricone Roller Bit** LOCATION: **Proposed I-90 Central Viaduct** COMPLETION DEPTH: **178.5'**
2" O.D. Split-barrel Sampler **3" O.D. Shelby Tube Sampler** Sta. **132+38.69** ELEVATION: **617.9**
NX Rock Core Barrel **132.15' Rt. of Centerline** DATE: **4/10/06 - 4/13/06**

Elev. (feet)	Depth (feet)	Samp. No.	Std. Pen. / RQD	Hand Pen. (tsf)	Rec./Loss (feet)	CLASSIFICATION: DESCRIPTION	Physical Characteristics						ODOOT Class		
							AGG. C.S.	F.S.	% SILT	% CLAY	LL	PI		WC	
617.7	0	1	15/23/38			TOPSOIL/ROOTMAT - 2 INCHES COARSE AND FINE SAND (FILL): Very-dense becoming medium-dense gray becoming brown fine to coarse sand, little silt, little clay, trace fine gravel, contains few slag and wood fragments.								Est. A-3a	
	5	2	12/15/13												A-3a(0)
	10	3	7/10/9												Est. A-3a
	15	4	3/5/6												Est. A-3a
598.9	20	5	3/4/4			SANDY SILT: Loose gray and brown fine sand, "and" silt, little clay. contains few interbedded silty clay seams.									Est. A-4a
594.9	23	6	3/4/3												A-4a(0)
	25	7	2/2/3	1.0-2.0		SILT: Stiff to very-stiff gray mottled with red silt, "and" clay, trace fine sand.									Est. A-4b
590.4	27.5	8	2/3/5	1.5-2.5											A-4b(8)
	30	9	2/3/5	1.0-2.25											Est. A-4b
	32.5	10	2/5/8	3.0-4.0		SILT AND CLAY: Very-stiff to hard gray silt, "and" clay, contains many silt pockets and lenses.									A-6a(9)
585.4	35	11	5/7/10	4.5+		SILT: Hard gray silt, "and" clay, trace fine to coarse sand.									A-4b(8)
580.4	40	12	4/11/10	2.0-4.0		SILT: Very-stiff to hard gray mottled with red silt, "and" clay, trace fine sand, boulder encountered at 37.5'.									Est. A-4b
576.4	45	13	4/4/6	0.5-2.0		CLAY: Medium-stiff to stiff gray clay, some silt, trace fine sand, contains many interbedded silt seams, and few very-stiff zones.									A-7-6(12)
569.9	50	14	P	0.5-0.75											Est. A-7-6
		15	P	1.5-2.25											Est. A-7-6
		16	3/6/7	1.5-4.0											Est. A-4b

WATER LEVEL: "Dry"
WATER NOTE: Inside IISA - Prior to Washbore
DATE: 4/10/06

-CONTINUED-



LOG OF BORING NO. B-05-02
CUY-90-15.24 West Abutment
CUYAHOGA COUNTY, OHIO

TYPE: **3-1/4" I.D. Hollow-stem Auger** LOCATION: **Proposed I-90 Central Viaduct** COMPLETION DEPTH: 178.5'
2" O.D. Split-barrel Sampler **3" O.D. Shelby Tube Sampler** ELEVATION: 617.9
NX Rock Core Barrel **132.15' Rt. of Centerline** DATE: 4/10/06 - 4/13/06

Elev. (feet)	Depth (feet)	Samp.	Std. Pen. / RQD	Hand Pen. (isf)	Rec./Loss (feet)	CLASSIFICATION: DESCRIPTION	Samp. No.	Physical Characteristics					ODOT Class							
								% AGG.	% C.S.	% F.S.	% SILT CLAY	LL		PI	WC					
545.4	-50																			
	-55		3/5/5	1.25-2.25		SILT: Stiff to very-stiff becoming very-stiff to hard gray silt, "and" clay, trace fine sand, contains many interbedded silty clay seams, lenses and pockets.	17	0	0	2	51	47	30	10	24	A-4b(8)				
	-60		4/7/8	1.25-3.0			18									Est. A-4b				
	-65		6/9/10	2.5-4.25			19	0	0	3	56	41	28	9	22	A-4b(8)				
	-70		6/11/14	3.0-4.5+			20									Est. A-4b				
	-75		6/9/10	2.5-4.0		SANDY SILT: Stiff to very-stiff gray clay, "and" silt, trace fine sand, contains few to many interbedded silt seams, contains few medium-stiff zones.	21									Est. A-4a				
	-80		4/7/9	0.5-2.5			22	0	0	2	47	51	29	10	24	A-4a(8)				
	-85		5/8/11	1.5-3.75			23									Est. A-4a				
530.9	-90		4/8/11	1.0-2.0		SILT AND CLAY: Medium-stiff to stiff gray clay, "and" silt, trace fine to coarse sand, trace fine gravel, contains few silt pockets.	24									Est. A-6a				
	-95		5/7/9	1.25-2.0			25	1	2	3	35	59	34	12	22	A-6a(9)				
	-100		5/8/9	0.75-2.0			26									Est. A-6a				

WATER LEVEL: "Dry"
WATER NOTE: Inside HSA - Prior to Washbore
DATE: 4/10/06

-CONTINUED-



TYPE **3-1/4" I.D. Hollow-stem Auger** **3-1/8" Tricone Roller Bit** LOCATION: **Proposed I-90 Central Viaduct**
2" O.D. Split-barrel Sampler **3" O.D. Shelby Tube Sampler** **Sta. 132+38.69**
NX Rock Core Barrel **132.15' Rt. of Centerline** DATE: **4/10/06 - 4/13/06**

Elev (feet)	Depth (feet)	Samp.	Std. Pen. / RQD	Hand Pen. (tsf)	Rec./Loss (feet)	CLASSIFICATION: DESCRIPTION	Samp. No.	Physical Characteristics					ODOT Class						
								% AGG.	% C.S.	% F.S.	% SILT	% CLAY		LL	PI	WC			
510.4	-105		5/9/10	1.0-2.0		SILT AND CLAY: Medium-stiff to stiff gray clay, "and" silt, trace fine to coarse sand, trace fine gravel, contains few silt pockets.	27												
	-110		5/8/10	1.5-2.25		SILT AND CLAY: Stiff to very-stiff gray clay, "and" silt, trace fine to coarse sand, trace fine gravel.	28												
	-115		5/8/11	1.0-2.5			29	1	2	3	34	60	33	13	22				A-6a(9)
	-120		7/8/12	2.0-2.5			30												Est. A-6a
	-125		6/9/10	1.0-2.5			31												Est. A-6a
	-130		P	1.5-2.0			32						30	11					Est. A-6a
	-135		P	2.0-2.5			33												Est. A-6a
	-140		6/9/14	1.75-3.25			34												Est. A-6a
	-145		7/9/8			SILT: Medium-dense gray silt, trace fine sand, contains few fine sand seams and lenses.	35						NP	NP					Est. A-4b
	-150		14/14/14			COARSE AND FINE SAND: Medium-dense gray coarse sand, little fine gravel, trace fine sand, trace silt, trace clay, boulder encountered at 137.5'	36	12	64	5	9	10			16				Est. A-3a
	-155		30/18/22	2.75-4.5+		SILTY CLAY: Very-stiff to hard gray silty clay, trace fine to coarse sand, trace fine gravel, contains few silt pockets.	37A 37B												Est. A-3a Est. A-6b
	-160		18/34/40	4.5+			38	2	3	5	32	58	34	16	17				A-6b(10)
	-165		9/11/14	2.5-3.25			39												Est. A-6a

WATER LEVEL: "Dry"
 WATER NOTE: Inside USA - Prior to Washbore
 DATE: **4/10/06**



LOG OF BORING NO. B-05-02
CUY-90-15.24 West Abutment
CUYAHOGA COUNTY, OHIO

BBC&M JOB: 012-00946.000

Page 4 of 4

TYPE: **3-1/4" I.D. Hollow-stem Auger** LOCATION: **Proposed I-90 Central Viaduct** COMPLETION DEPTH: 178.5'
2" O.D. Split-barrel Sampler LOCATION: **Sta. 132+38.69** ELEVATION: 617.9
3" O.D. Shelby Tube Sampler LOCATION: **132.15' Rl. of Centerline** DATE: 4/10/06 - 4/13/06
NX Rock Core Barrel

Elev (feet)	Depth (feet)	Samp	Sid Pen. / RQD	Hand Pen. (tsf)	Rec. Loss (feet)	CLASSIFICATION: DESCRIPTION	Samp. No.	Physical Characteristics					ODOT Class			
								% AGG.	% C.S.	% F.S.	% SILT	% CLAY		LL	PI	WC
453.9	-150					SILT AND CLAY: Stiff to very-stiff gray clay, "and" silt, trace fine to coarse sand, trace fine gravel, contains few silt pockets, seams and lenses.										
	-155		8/12/13	2.0-3.5												
	-160		7/9/11	1.25-2.5												
449.4	-165		10/50-4"R	1.25-2.0		SHALE: Very-soft gray shale, fragmented.	42A									
	-170				4.7/0.3	SHALE: Very-soft to soft gray shale, nearly horizontally bedded, many horizontal and few vertical fractures, contains many interbedded silty clay and few arenaceous siltstone layers.	42B									
	-175				4.5/0.5		43									
439.4	-180															
	-185															
	-190															
	-195															
	-200															

NOTES:

- Encountered seepage at 20.0'
- Encountered a boulder at 37.5' and 137.5'
- Switched to washbore at 41.5'
- Base of inclinometer installed at an approximate depth of 176'
- Two vibrating wire piezometers installed in an offset hole between 5/18/06 and 5/22/06. Transducers were installed at approximate depths of 46' and 122'. The piezometer offset hole was backfilled with grout.
- Constant 2' to 3' eruption of water/gas above the ground surface at the CPT location for approximately 2 hours have occasional 10' to 15' spurts. In addition, a constant spurting of water/gas occurred from a nearby 30' open boring cased with 2.25" hollow stem auger.

WATER LEVEL: ∇ "Dry"
 WATER NOTE: ∇ Inside HSA - Prior to Washbore
 DATE: 4/10/06



LOG OF BORING NO. B-05-03
CUY-90-15.24 West Abutment
CUYAHOGA COUNTY, OHIO

BBC&M JOB 012-00946.000

TYPE: 3-1/4" I.D. Hollow-stem Auger LOCATION: Proposed I-90 Central Viaduct COMPLETION DEPTH: 172.0'
2" O.D. Split-barrel Sampler 3" O.D. Shelby Tube Sampler Sta. 133+30.45 ELEVATION: 605.1
NX Rock Core Barrel 380.00' Rt. of Centerline DATE: 4/3/06 - 4/7/06

Elev. (feet)	Depth (feet)	Samp. No.	Sid. Pen. / RQD	Hand Pen. (tsf)	Rec./Loss (feet)	CLASSIFICATION: DESCRIPTION	Physical Characteristics					ODOT Class			
							% AGG.	% C.S.	% F.S.	% SILT	% CLAY		LL	PI	WC
604.8	0	1	7/7/6			TOPSOIL - 4 INCHES GRAVEL WITH SAND (FILL): Loose to medium-dense dark brown and black fine to coarse sand, some to "and" fine to coarse gravel, little silt, trace to little clay, contains few coal and concrete fragments.								Est. A-1-b	
597.1	5	2	2/2/3		8.0	COARSE AND FINE SAND: Very-loose to loose brown fine sand, little coarse sand, some silt, little clay.									Est. A-1-b
591.2	10	3	1/1/1		13.9	SILT: Loose gray silt, "and" fine sand, little clay, contains few silty clay lenses.									Est. A-3
587.6	15	4A 4B	2/2/4		17.5	SILT AND CLAY: Medium-stiff to stiff gray silt, "and" clay, trace fine to coarse sand, trace fine gravel, contains few interbedded silt seams.									Est. A-3 Est. A-4b
582.6	20	5	2/2/4	1.0-1.75	22.5	SILT: Very-soft to soft gray silt, "and" clay, trace fine sand, contains few silt pockets and seams, and few medium-stiff to stiff zones.									A-6a(8)
574.1	25	6	1-18" 2	0.0-1.75	31.0	SILT AND CLAY: Medium-stiff to stiff gray clay, trace fine sand, trace fine gravel, contains few silt seams.									A-4b(8)
569.1	30	7	SD SD	0.0-0.5	36.0	SILT AND CLAY: Very-soft to soft gray silty clay, trace fine to coarse sand, contains few silt seams.									Est. A-4b
567.1	35	8	P	0.0-0.5	38.0	SILT AND CLAY: Medium-stiff to stiff gray clay, some silt, trace fine sand, contains few silt seams.									Est. A-6b
562.6	40	9	P	0.0-0.5	42.5	SILT AND CLAY: Soft to medium-stiff gray silty clay, trace fine to coarse sand, contains few silt seams.									Est. A-6b
	45	10	4/4/5	0.75-1.75		SILT AND CLAY: Stiff to very-stiff gray clay, "and" silt, trace fine sand, contains few silt seams and lenses.									A-6a(10)
	50	11	3/3/3	0.5-0.75											A-6b(10)
		12	4/6/9	2.25-3.75											Est. A-6a
		13	4/4/6	1.25-2.25											Est. A-6a

WATER LEVEL: 13.0
 WATER NOTE: Encountered
 DATE: 4/4/06

-CONTINUED-



LOG OF BORING NO. B-05-03
CUY-90-15.24 West Abutment
CUYAHOGA COUNTY, OHIO

UBC&M JOB: 012-00946.300

Page 2 of 4

TYPE: **3-1/4" I.D. Hollow-stem Auger** **3-7/8" Tricone Roller Bit** LOCATION: **Proposed I-90 Central Viaduct** COMPLETION DEPTH: **172.0'**
2" O.D. Split-barrel Sampler **3" O.D. Shelby Tube Sampler** Sta. **133+30.45** ELEVATION: **605.1**
NX Rock Core Barrel **380.00' Rt. of Centerline** DATE: **4/3/06 - 4/7/06**

Elev (feet)	Depth (feet)	Samp.	Std. Pen. / RQD	Hand Pen. (tsf)	Rec./Loss (feet)	CLASSIFICATION: DESCRIPTION	Samp. No.	Physical Characteristics					ODOT Class			
								% AGG.	% C.S.	% F.S.	% SILT	% CLAY		LL	PI	WC
549.1	55		4/6/6	1.5-2.25		SILT AND CLAY: Stiff to very-stiff gray clay, "and" silt, trace fine sand, contains few silt seams and lenses.	14	0	0	1	48	51	32	12	23	A-6a(9)
	60		5/8/10	2.0-4.5+		SANDY SILT: Stiff to hard gray clay, "and" silt, trace fine sand, contains few silt seams and pockets.	15									Est. A-4a
	65		5/9/11	2.0-3.5			16									Est. A-4a
	70		4/4/6	1.5-2.75			17	0	0	1	42	57	30	9	25	A-4a(8)
532.6	75		5/9/14	2.5-4.5+		SANDY SILT: Very-stiff to hard gray mottled with red silt, "and" clay, little fine to coarse sand, trace fine gravel, contains few silt seams and lenses.	18	3	7	12	41	37	23	7	15	A-4a(8)
527.6	80		5/7/9	2.0-2.5		SILT AND CLAY: Stiff to very-stiff gray clay, little silt, trace fine to coarse sand, contains few silt seams.	19									Est. A-6a
	85		4/6/10	1.25-2.25			20									Est. A-6a
	90		4/6/9	1.25-2.75			21	0	1	1	20	78	39	15	27	A-6a(10)
	95		7/9/11	2.0-3.25			22									Est. A-6a
	100		6/7/9	1.75-3.0			23									Est. A-6a

WATER LEVEL: **13.0** WATER NOTE: **Encountered**
DATE: **4/4/06**

-CONTINUED-



LOG OF BORING NO. B-05-03
CUY-90-15.24 West Abutment
CUYAHOGA COUNTY, OHIO

BBC&M JOB: 012-00946-300

TYPE: **3-1/4" I.D. Hollow-stem Auger** 3-7/8" Tritone Roller Bit LOCATION: **Proposed I-90 Central Viaduct** COMPLETION DEPTH: 172.0'
2" O.D. Split-barrel Sampler 3" O.D. Shelby Tube Sampler Sta. **133+30.45** ELEVATION: 605.1
NX Rock Core Barrel 380.00' Rt. of Centerline DATE: 4/3/06 - 4/7/06

Elev. (feet)	Depth (feet)	Samp. No.	Std. Pen. / RQD	Hand Pen. (tsf)	Rec./Loss (feet)	CLASSIFICATION: DESCRIPTION	Samp. No.	Physical Characteristics					ODOOT Class						
								% AGG.	% C.S.	% F.S.	% SILT	% CLAY		LL	PI	WC			
502.6	100																		
	105		8/11/13	2.0-2.25		SILT AND CLAY: Stiff to very-stiff gray clay, some silt, trace fine to coarse sand, trace fine gravel.	24												Est. A-6a
	110		6/9/11	2.0-3.75			25	2	1	2	34	61	36	13	24			A-6a(9)	
			5/6/8	1.5-2.5			26											Est. A-6a	
490.1	115		5/5/7	1.25-2.25			27											Est. A-6a	
			5/5/6	0.75-1.5		SILT AND CLAY: Medium-stiff to stiff gray clay, little silt, trace fine to coarse sand, contains few very-soft zones.	28	0	1	2	17	80	39	15	29			A-6a(10)	
			P	1.5-2.0			29											Est. A-6a	
			P	1.25-1.5			30											Est. A-6a	
481.3	120			0.0-1.25			31A											Est. A-6a	
480.9	125		5/9/14			SILT: Medium-dense gray silt, trace fine sand, contains many silty clay seams. COARSE AND FINE SAND: Medium-dense gray fine to coarse sand, little silt, little clay, trace fine gravel.	31B						NP	NP				Est. A-4b	
							31C											Est. A-3a	
472.6	130		9/11/12				32	6	35	34	11	14		16				Est. A-3a	
			8/11/14	2.5-4.0		SANDY SILT: Very-stiff to hard gray clay, some silt, contains few interbedded silt seams.	33	0	0	0	35	65	31	9	23			A-4a(8)	
467.6	135																		
			14/16/15			COARSE AND FINE SAND: Medium-dense to dense gray fine to coarse sand, little silt, little clay, trace fine gravel.	34												Est. A-3a
	140																		
	145		11/15/15				35	4	36	37	12	11		19				Est. A-3a	
457.6	150		14/16/17			GRAVEL WITH SAND: Dense gray fine to coarse sand, some fine gravel, trace silt, trace clay.	36	26	41	14	10	9		14					Est. A-1-b

WATER LEVEL: 13.0 Encountered
WATER NOTE: 4/4/06
DATE: _____

-CONTINUED-



LOG OF BORING NO. B-05-03
CUY-90-15.24 West Abutment
CUYAHOGA COUNTY, OHIO

BBC&M JOB: 012-00946.100

TYPE: **3-1/4" I.D. Hollow-stem Auger** **3-7/8" Tritone Roller Bit** LOCATION: **Proposed I-90 Central Viaduct** COMPLETION DEPTH: **172.0'**
2" O.D. Split-barrel Sampler **3" O.D. Shelby Tube Sampler** Sta. **133+30.45** ELEVATION: **605.1**
NX Rock Core Barrel **380.00' Rt. of Centerline** DATE: **4/3/06 - 4/7/06**

Elev. (feet)	Depth (feet)	Std. Pen. / RQD	Hand Pen. (tsf)	Rec./Loss (feet)	CLASSIFICATION: DESCRIPTION	Samp. No.	Physical Characteristics					ODOJ Class					
							% AGG.	% C.S.	% F.S.	% SILT	% CLAY		LL	PI	WC		
448.1	-155	12/14/19			GRAVEL WITH SAND: Dense gray fine to coarse sand, some fine gravel, trace silt, trace clay. SILT AND CLAY: Hard gray silt, "and" clay, some fine to coarse sand, some fine gravel, contains many siltstone and shale fragments. SHALE: Very-soft gray shale, similar to hard silty clay. SHALE: Very-soft to soft gray and dark gray shale, nearly horizontally bedded, many horizontal and few vertical fractures, contains many interbedded silty clay seams from 162.7' to 163.0' and from 168.1' to 168.3'. - Qu=1311 psi at 165.5'. NOTES: - Encountered seepage at 8.0'. - Encountered water at 13.0'. - Switched to washbore at 37.0'. - Base of inclinometer installed to an approximate depth of 170'. - Two vibrating wire piezometers installed in an offset hole between 5/12/06 and 5/16/06. Transducers were installed at approximate depths of 32' and 112'. The piezometer offset hole was backfilled with grout.	37								Est. A-1-b			
446.2	-160	28/50-3"R	4.5+				38A										Est. A-6a Visual
443.1	-165	27%		4.8/0.2			39										Visual
433.1	-170	35%		4.4/0.6			40										Visual
	-175																
	-180																
	-185																
	-190																
	-195																
	-200																

WATER LEVEL: **13.0**
 WATER NOTE: **Encountered**
 DATE: **4/4/06**



LOG OF BORING NO. B-05-04
CUY-90-15.24 West Abutment
CUYAHOGA COUNTY, OHIO

BBC&M JOB: 012-00946.300

TYPE: **3-1/4" I.D. Hollow-stem Auger** **3-7/8" Tritone Roller Bit** LOCATION: **Proposed I-90 Central Viaduct** COMPLETION DEPTH: **174.0'**
2" O.D. Split-barrel Sampler **3" O.D. Shelby Tube Sampler** Sta. **133+51.67** ELEVATION: **600.8**
NX Rock Core Barrel **242.09' Rt. of Centerline** DATE: **3/24/06 - 3/30/06**

Elev. (feet)	Depth (feet)	Samp. No.	Std. Pen. / RQD	Hand Pen. (tsf)	Rec./Loss (feet)	CLASSIFICATION: DESCRIPTION	Physical Characteristics					ODOT Class			
							% AGG.	% C.S.	% F.S.	% SILT	% CLAY		LL	PI	WC
587.3	0	1	4/5/4			COARSE AND FINE SAND (FILL): Loose to medium-dense brown fine to coarse sand, little fine gravel, some silt, little clay, contains few slag fragments.								Est. A-3a	
	5	2	4/6/5												Est. A-3a
	10	3	6/9/8												Est. A-3a
		4	6/9/11												A-3a(0)
		5	6/8/10												Est. A-3a
584.3	15	6	3/3/4				COARSE AND FINE SAND (FILL): Loose gray fine to coarse sand, some to "and" fine to coarse gravel.								Est. A-3a
582.8		7A	5/5/4				COARSE AND FINE SAND (POSSIBLE FILL): Loose brown fine to coarse sand, trace silt.								Est. A-3a
		7B	2/3/2												
577.8	20	8	3/3/3				SILT: Loose brown silt, little clay, some fine sand, trace coarse sand, trace fine gravel.	1	8	34	45	12			Est. A-4b
		9													Est. A-4b
		10	2/2/3	1.0-2.0		SILTY CLAY: Stiff gray silty clay, trace fine to coarse sand, trace fine gravel, contains few silt lenses and pockets.								Est. A-6b	
572.8	25	11	3/4/5	1.0-1.75										A-6b(11)	
		12	2/3/3	0.25-1.0		SILT AND CLAY: Soft to medium stiff gray clay, some silt, trace fine to coarse sand, contains many silt lenses and pockets.								Est. A-6a	
	30	13	1/2/3	0.25-1.0										Est. A-6a	
		14	1/2/2	0.5-1.0										A-6a(10)	
565.3	35	15	2/3/4	0.5-1.25		SANDY SILT: Stiff to very-stiff gray clay, "and" silt, trace fine sand, contains few silt lenses and seams, and few medium-stiff zones.								A-4a(8)	
	40	16	2/3/4	1.5-2.5											Est. A-4a
		17	5/5/6	1.5-2.75											Est. A-4a
	45	18	3/3/5	1.5-3.0										Est. A-4a	
		19	3/4/6	1.5-3.0											A-4a(8)
	50	20	P											Est. A-4a	

WATER LEVEL: 18.5 "Dry"
WATER NOTE: Encountered Inside HSA - Prior to Washbore
DATE: **3/27/06** **3/24/06**

-CONTINUED-



LOG OF BORING NO. B-05-04
CUY-90-15.24 West Abutment
CUYAHOGA COUNTY, OHIO

BBC&M JOB: 012-00946-300

TYPE: 3-1/4" I.D. Hollow-stem Auger LOCATION: Proposed I-90 Central Viaduct COMPLETION DEPTH: 174.0'
2" O.D. Split-barrel Sampler 3" O.D. Shelby Tube Sampler STA. 133+51.67 ELEVATION: 600.8
NX Rock Core Barrel 242.09' Rt. of Centerline DATE: 3/24/06 - 3/30/06

Elev (feet)	Depth (feet)	Samp.	Std. Pen. / RQD	Hand Pen. (tsf)	Rec./Loss (feet)	CLASSIFICATION: DESCRIPTION	Samp. No.	Physical Characteristics						ODOT Class		
								% AGG.	% C.S.	% F.S.	% SILT	% CLAY	LL		PI	WC
547.8	50	P		2.0			21									Est. A-4a
	55	3/4/5		1.75-3.5		SILT: Stiff to very-stiff gray silt, "and" clay, trace fine sand.	22									Est. A-4b
	60	4/4/4		1.25-3.0			23	0	0	2	61	37	28	8	25	A-4b(8)
	65	4/5/6		1.25-2.5			24									Est. A-4b
533.8	70	P		1.75-2.0		SILT AND CLAY: Stiff to very-stiff gray clay, some silt, trace fine to coarse sand, trace fine gravel.	25	2	4	6	33	55	31	12	20	A-6a(9)
	75	P		1.5-1.75			26									Est. A-6a
	80	P		1.75-2.0			27									Est. A-6a
	85	P		1.5-2.0			28									Est. A-6a
523.8	90	4/6/8		1.25-2.0		SILTY CLAY: Stiff to very-stiff gray silty clay, trace fine to coarse sand, trace fine gravel, contains few silt lenses.	29									Est. A-6b
	95	4/6/7		1.5-1.75			30	2	1	3	31	63	35	16	22	A-6b(10)
	100	5/6/8		1.25-2.25			31									Est. A-6b
		6/9/12		1.5-3.5			32									Est. A-6b
503.3		5/8/10		1.5-2.5			33									Est. A-6a

WATER LEVEL: 18.5 "Dry" ✓
WATER NOTE: Encountered Inside HSA - Prior to Washbore ✓
DATE: 3/27/06 3/24/06

-CONTINUED-



LOG OF BORING NO. B-05-04
CUY-90-15.24 West Abutment
CUYAHOGA COUNTY, OHIO

BBC&M JOB: 012-00946-300

TYPE: **3-1/4" I.D. Hollow-stem Auger** **3-7/8" Tricone Roller Bit** LOCATION: **Proposed I-90 Central Viaduct** COMPLETION DEPTH: **174.0'**
2" O.D. Split-barrel Sampler **3" O.D. Shelby Tube Sampler** Sta. **133+51.67** ELEVATION: **600.8**
NX Rock Core Barrel **242.09' Rt. of Centerline** DATE: **3/24/06 - 3/30/06**

Elev (feet)	Depth (feet)	Samp.	Std. Pen. / RQD	Hand Pen. (tsf)	Rec./Loss (feet)	CLASSIFICATION DESCRIPTION	Samp. No.	Physical Characteristics					ODOJ Class			
								% AGG.	% C.S.	% F.S.	% SILT	% CLAY		LL	PI	WC
483.8	-105		5/7/9	1.25-2.25		SILT AND CLAY: Very-stiff becoming medium-stiff gray clay, little silt, trace fine to coarse sand, contains few silt pockets.	34	0	1	1	19	79	38	15	31	Est. A-6a
481.8	-110		3/4/5	0.5-1.25			35	0	1	1	19	79	38	15	31	A-6a(10)
473.3	-115		4/5/6	0.5-1.25			36	0	1	1	19	79	38	15	31	Est. A-6a
468.3	-120		P 11/11/13 11/11/14			SILT: Loose to medium-dense (est.) gray silt, little clay, some fine sand, trace to little fine gravel, contains many silty clay seams. GRAVEL WITH SAND: Medium-dense to dense gray fine to coarse sand, "and" fine to coarse gravel, trace silt, trace clay, contains silt seam from 120.3' to 120.5'.	37 38 39	0	1	1	19	79	38	15	31	Est. A-4b Est. A-1-b Est. A-1-b
	-125		16/16/21				40	0	1	1	19	79	38	15	31	A-1-b(0)
	-130		10/20/30	3.75-4.5+		SILT AND CLAY: Very-stiff to hard gray clay, some silt, trace fine to coarse sand, trace fine gravel, contains many silt and fine sand lenses.	41	3	3	5	24	65	33	12	19	A-6a(9)
	-135		14/13/18			GRAVEL WITH SAND: Dense gray fine to coarse sand, little fine to coarse gravel, trace silt, trace clay.	42	0	1	1	19	79	38	15	31	Est. A-1-b
	-140		14/17/20				43	0	1	1	19	79	38	15	31	Est. A-1-b
	-145		12/14/18				44	15	45	22	8	10	NP	NP	16	A-1-b(0)
	-150		22/18/18				45	15	45	22	8	10	NP	NP	16	Est. A-1-b

WATER LEVEL: **18.5** "Dry"
 WATER NOTE: **Encountered** Inside HSA - Prior to Washbore
 DATE: **3/27/06** 3/24/06

-CONTINUED-



LOG OF BORING NO. B-05-04
CUY-90-15.24 West Abutment
CUYAHOGA COUNTY, OHIO

BBC&M JOB: 012-00946.300

Page 4 of 4

TYPE: **3-1/4" I.D. Hollow-stem Auger** 3-7/8" Tricone Roller Bit LOCATION: **Proposed I-90 Central Viaduct** COMPLETION DEPTH: 174.0'
2" O.D. Split-barrel Sampler 3" O.D. Shelby Tube Sampler Sta. **133+51.67** ELEVATION: 600.8
NX Rock Core Barrel 242.09' Rt. of Centerline DATE: 3/24/06 - 3/30/06

Elev (feet)	Depth (feet)	Samp.	Std. Pen. / RQD	Hand Pen. (tsf)	Rec./Loss (feet)	CLASSIFICATION: DESCRIPTION	Physical Characteristics					Samp. No.	ODOF Class			
							% AGG.	% C.S.	% F.S.	% SILT/CLAY	LL			PI	WC	
448.8	-150															
446.9	-155		24/34/50			SILT: Very-dense gray silt, "and" fine to coarse sand, little fine gravel, trace clay. GRAVEL WITH SAND: Very-dense gray fine to coarse sand, "and" fine to coarse gravel, little silty clay. SHALE: Very-soft gray shale, fragmented.									Est. A-4b Est. A-1-b	
443.3	-160		50-4"R													Visual
436.8	-165		50-4"R 100%		1.1/0.0	SHALE: Soft dark gray shale, nearly horizontally bedded, few horizontal fractures.										Visual
435.7	-170		64%		3.8/0.1	SHALE: Soft to medium-hard dark gray shale, interbedded with siltstone, many horizontal and few vertical and diagonal fractures, contains few silty clay seams, fossiliferous.										Visual
426.8	-175		50%		5.0/0.0											Visual
	-180															
	-185															
	-190															
	-195															
	-200															

NOTES:
- Encountered seepage at 12.0' and 16.5'.
- Encountered water at 18.5'.
- Switched to washbore at 41.0'.
- Base of inclinometer installed at an approximate depth of 172'.
- Two vibrating wire piezometers installed in an offset hole between 5/16/06 and 5/17/06. Transducers were installed at approximate depths of 59' and 119'. The piezometer offset hole was backfilled with grout.

WATER LEVEL: 18.5 "Dry" Y
WATER NOTE: Encountered Inside HSA - Prior to Washbore Y
DATE: 3/27/06 3/24/06



LOG OF BORING NO. B-05-07
CUY-90-15.24 West Abutment
CUYAHOGA COUNTY, OHIO

BBC&M JOB: 012-00946 300

TYPE: **3-1/4" I.D. Hollow-stem Auger** **3-7/8" Tritone Roller Bit** LOCATION: **Proposed I-90 Central Viaduct** COMPLETION DEPTH: **229.0'**
2/2.5" O.D. Split-barrel Sampler **3" O.D. Shelby Tube Sampler** Sta. **127+43.46** ELEVATION: **678.9**
NQ Rock Core Barrel 206.83' Lt. of Centerline DATE: **4/18/06 - 4/24/06**

Elev (feet)	Depth (feet)	Samp	Std. Pen. / RQD	Hand Pen. (tsf)	Rec./Loss (feet)	CLASSIFICATION: DESCRIPTION	Physical Characteristics						Samp No.	ODOT Class				
							% AGG.	% C.S.	% F.S.	% SILT	% CLAY	LL			PI	WC		
678.4	0																	
675.4	5	1	4/4/4			0.5-3.5 GRANULAR BASE - 6 INCHES COARSE AND FINE SAND (FILL): Loose brown fine to coarse sand, little silt, little clay, contains few clayey silt seams.												Est. A-3a
	10	2	3/3/2			GRAVEL WITH SAND (FILL): Very-loose becoming medium-dense brown fine to coarse sand, some fine to coarse gravel, trace silt, trace clay, contains few slag and brick fragments.												Est. A-1-b
	15	3	5/3/3															Est. A-1-b
	20	4	2/2/2															Est. A-1-b
656.9	25	5	6/8/9															Est. A-1-b
	30	6	5/7/8			FINE SAND: Medium-dense brown fine sand, little coarse sand, trace fine gravel, trace silt, trace clay.												Est. A-3
	35	7	7/10/12															A-3(0)
641.9	40	8	8/9/11															Est. A-3
	45	9	4/4/5			COARSE AND FINE SAND: Loose becoming very-dense brown and gray fine sand, trace silt, trace clay.												A-3a(0)
	50	10	8/10/8															Est. A-3a
		11	16/31/25															Est. A-3a

WATER LEVEL: 38.5
WATER NOTE: Encountered
DATE: 4/18/06

-CONTINUED-



LOG OF BORING NO. B-05-07
CUY-90-15.24 West Abutment
CUYAHOGA COUNTY, OHIO

BBC&M JOB: 012-00946-3100

TYPE: 3-1/4" I.D. Hollow-stem Auger 3-7/8" Tricone Roller Bit LOCATION: Proposed I-90 Central Viaduct
 2/2.5" O.D. Split-barrel Sampler 3" O.D. Shelby Tube Sampler
 NQ Rock Core Barrel

COMPLETION DEPTH: 229.0'
 ELEVATION: 678.9
 DATE: 4/18/06 - 4/24/06

Elev. (feet)	Depth (feet)	Samp. No.	Std. Pen. / RQD	Hand Pen. (tsf)	Rec./Loss (feet)	CLASSIFICATION: DESCRIPTION	Physical Characteristics							ODOI Class			
							% AGG.	% C.S.	% F.S.	% SILT	% CLAY	LL	PI		WC		
626.9	50																
621.9	55	12	8/14/24			SANDY SILT: Dense brown and gray fine sand, "and" silt, trace coarse sand, trace clay, contains few silty clay seams.	0	1	54	38	7	NP	NP	23			A-4a(0)
616.9	60	13	8/12/17			SILT: Medium-dense gray silt, little clay, trace fine to coarse sand, trace fine gravel, contains few silty clay lenses.	1	1	1	83	14	NP	NP	20			A-4b(0)
	65	14	5/8/8	1.5-2.5		SILT: Stiff to very-stiff gray mottled with red silt, "and" clay, trace fine to coarse sand, contains few silty clay seams.											Est. A-4b
606.9	70	15	4/8/9	1.5-2.5			0	1	3	55	41	28	9	17			A-4b(8)
	75	16	6/10/14	2.25-3.0		SILT: Very-stiff becoming medium-stiff to stiff gray silt, "and" clay, trace fine to coarse sand, contains many silty clay seams.											Est. A-4b
	80	17	7/12/15	2.0-4.0			0	1	1	50	48	30	10	27			A-4b(8)
	85	18	4/6/8	0.75-1.5													Est. A-4b
586.9	90	19	3/5/6	0.5-1.0													Est. A-4b
	95	20	4/6/7	0.5-1.25		SANDY SILT: Medium-stiff to stiff gray clay, some silt, trace fine to coarse sand, trace fine to coarse gravel, contains few shale fragments.	7	1	5	35	52	30	10	24			A-4a(8)
581.9	97.0	21	5/4/7	0.25-0.75		SILTY CLAY: Soft to medium-stiff gray silty clay, trace fine sand.											Est. A-6b
	100																

WATER LEVEL: 38.5
 WATER NOTE: Encountered
 DATE: 4/18/06

-CONTINUED-



LOG OF BORING NO. B-05-07
CUY-90-15.24 West Abutment
CUYAHOGA COUNTY, OHIO

BBC&M JOB: 012-88946.100

TYPE: 3-1/4" I.D. Hollow-stem Auger 3-7/8" Tritone Roller Bit LOCATION: Proposed I-90 Central Viaduct
 2/2.5" O.D. Split-barrel Sampler 3" O.D. Shelby Tube Sampler
 NQ Rock Core Barrel

COMPLETION DEPTH: 229.0'
 ELEVATION: 678.9
 DATE: 4/18/06 - 4/24/06

Elev (feet)	Depth (feet)	Samp	Std. Pen. / RQD	Hand Pen. (tsf)	Rec./Loss (feet)	CLASSIFICATION: DESCRIPTION	Samp. No.	Physical Characteristics						ODOT Class	
								% AGG.	% C.S.	% F.S.	% SILT	% CLAY	LL		PI
571.9	-105		P	0.25-0.5		SILTY CLAY: Soft to medium-stiff gray silty clay, trace fine sand.	22					40	17		Est. A-6b
	-110		3/5/7	0.25-0.75	107.0	SILT AND CLAY: Soft to medium-stiff gray clay, "and" silt, trace fine to coarse sand, contains few stiff zones.	23	0	1	2	37	60	15	26	A-6a(10)
561.9	-115		4/5/7	0.25-1.25	117.0	SANDY SILT: Soft to medium-stiff gray clay, "and" silt, trace fine to coarse sand, trace fine gravel, contains few silt seams, and few stiff zones.	24								Est. A-6a
	-120		4/6/9	0.25-0.75			25								Est. A-4a
551.9	-125		5/6/9	0.25-1.25			26	1	1	1	42	55	10	24	A-4a(8)
	-130		6/8/10	2.0-2.75	127.0	SANDY SILT: Very-stiff to hard gray clay, "and" silt, trace fine to coarse sand, contains many silt seams, lenses and pockets.	27								Est. A-4a
	-135		6/12/15	2.5-4.5+			28								Est. A-4a
537.9	-140		9/12/15	2.75-3.75	141.0	SILT AND CLAY: Stiff to very-stiff gray clay, some silt, trace fine to coarse sand, trace fine gravel, contains few hard zones.	29	0	1	1	46	52	9	22	A-4a(8)
	-145		P	4.5+			30								Est. A-6a
			P	2.5-3.25			31								Est. A-6a
	-150		8/15/20	2.75-4.25			32	2	3	5	32	58	12	20	A-6a(9)

WATER LEVEL: 38.5' Encountered 4/18/06
 WATER NOTE: _____
 DATE: _____

-CONTINUED-



LOG OF BORING NO. B-05-07
CUY-90-15.24 West Abutment
CUYAHOGA COUNTY, OHIO

BBC&M JOB: 012-08946.300

TYPE: **3-1/4" I.D. Hollow-stem Auger** **3-7/8" Tricone Roller Bit** LOCATION: **Proposed I-90 Central Viaduct** COMPLETION DEPTH: **229.0'**
2/2.5" O.D. Split-barrel Sampler **3" O.D. Shelby Tube Sampler** Sta. **127+43.46** ELEVATION: **678.9**
NQ Rock Core Barrel **206.83' Lt. of Centerline** DATE: **4/18/06 - 4/24/06**

Elev. (feet)	Depth (feet)	Samp.	Std. Pen. / RQD	Hand Pen. (tsf)	Rec./Loss (feet)	CLASSIFICATION: DESCRIPTION	Samp No.	Physical Characteristics					ODOT Class								
								% AGG.	% C.S.	% F.S.	% SILT	% CLAY		LL	PJ	WC					
491.9	-150																				
490.1	-155	2S	7/13/18 50-5"R	2.0-3.25		SILT AND CLAY: Stiff to very-stiff gray clay, some silt, trace fine to coarse sand, trace fine gravel, contains few hard zones.	33													Est. A-6a	
486.9	-160		7/10/17	2.25-3.25			34														Est. A-6a
	-165		7/11/15	2.25-2.75			35														Est. A-6a
	-170		6/9/13	1.75-2.25			36	5	3	4	33	55	33	13	21						A-6a(9)
	-175		6/9/14	2.0-2.25			37														Est. A-6a
	-180	2S	6/9/12 38	1.75-2.75			38	0	0	1	32	67	33	12	23						A-6a(9)
	-185		6/9/13	2.0-2.75			39														Est. A-6a
	-190		19/46/63				40A 40B														Est. A-4b Est. A-3a
	-195		50-4"R	4.5+			41														Est. A-6a
	-200		16/36/47	4.5+			42	3	6	8	24	59	30	11	16						A-6a(8)

WATER LEVEL: **38.5** WATER NOTE: **Encountered**
DATE: **4/18/06**



LOG OF BORING NO. B-05-08
CUY-90-15.24 West Abutment
CUYAHOGA COUNTY, OHIO

BBC&M JOB: 013-00946.300

TYPE: **3-1/4" I.D. Hollow-stem Auger** **3-7/8" Tricone Roller Bit** LOCATION: **Proposed I-90 Central Viaduct** COMPLETION DEPTH: **229.0'**
2/2.5" O.D. Split-barrel Sampler **3" O.D. Shelby Tube Sampler** Sta. **126+26.08** ELEVATION: **679.9**
NO Rock Core Barrel **28.31' Lt. of Centerline** DATE: **4/27/06 - 5/3/06**

Elev. (feet)	Depth (feet)	Samp. No.	Std. Pen. / RQD	Hand Pen. (tsf)	Rec./Loss (feet)	CLASSIFICATION: DESCRIPTION	Samp. No.	Physical Characteristics						ODOT Class			
								% AGG. C.S.	% F.S.	% SILT:CLAY	LL	PI	WC				
632.9	45																
627.9	50		19/26/30			SANDY SILT: Very-dense gray fine sand, "and" silt, little clay.	11	0	0	49	37	14	NP	NP	20	A-4a(0)	
	55		13/14/18			SILT: Medium-dense to dense gray silt, trace clay, trace fine sand.	12									Est. A-4b	
617.9	60		10/12/14				13	0	0	2	93	5	26	6	20	A-4b(8)	
	65		6/4/7	0.75-1.5		SILT AND CLAY: Soft to medium-stiff gray silt, "and" clay, trace fine to coarse sand, contains many interbedded gray and black silt lenses and seams, and many stiff zones.	14	0	1	2	53	44	32	12	33	A-6a(9)	
606.9	70		3/4/5	0.25-1.25			15									Est. A-6a	
	75		P	0.25-0.5			16									Est. A-6a	
602.9	75		5/8/11			SILT: Medium-dense gray silt, trace fine sand, contains many interbedded silty clay seams.	17									Est. A-4b	
	80		5/11/16	1.75-2.75			18									Est. A-4b	
	85		8/12/16	1.75-4.5+		SILT: Stiff to very-stiff gray silt, "and" clay, contains many interbedded silt lenses, and few hard zones.	19	0	0	0	50	50	29	10	20	A-4b(8)	
	90		6/9/14	2.0-3.5			20									Est. A-4b	

WATER LEVEL: **38.0** **Encountered**
WATER NOTE: **4/27/06**
DATE: **4/27/06**

-CONTINUED-



LOG OF BORING NO. B-05-08
CUY-90-15.24 West Abutment
CUYAHOGA COUNTY, OHIO

TYPE: 3-1/4" I.D. Hollow-stem Auger 3-7/8" Tricone Roller Bit
2/2.5" O.D. Split-barrel Sampler 3" O.D. Shelby Tube Sampler
NQ Rock Core Barrel

LOCATION: Proposed I-90 Central Viaduct
Sta. 126+26.08
28.31' Lt. of Centerline

COMPLETION DEPTH: 229.0'
ELEVATION: 679.9
DATE: 4/27/06 - 5/3/06

Elev. (feet)	Depth (feet)	Samp.	Std. Pen. / RQD	Hand Pen. (tsf)	Rec./Loss (feet)	CLASSIFICATION: DESCRIPTION	Samp. No.	Physical Characteristics						ODOT Class		
								% AGG. C.S.	% F.S.	% SILT	% CLAY	LL	PI		WC	
537.9	-135					SILT: Stiff to very-stiff gray silt, "and" clay, trace fine sand, contains many interbedded silty clay seams and pockets.	32									Est. A-4b
	-140		7/11/16	1.5-2.75												
	-145		7/13/19	2.25-3.75		SANDY SILT: Stiff to very-stiff gray silt, "and" clay, little fine to coarse sand, trace fine gravel, contains many silty clay lenses.	33	4	8	11	39	38	25	7	16	A-4a(8)
	-150		6/9/13	1.5-1.75			34									Est. A-4a
527.9	-155		6/11/13	1.25-2.0		SILT AND CLAY: Medium-stiff to stiff gray clay, some silt, trace fine to coarse sand, trace fine gravel.	35	2	2	3	33	60	32	11	23	A-6a(8)
	-160		5/9/12	1.25-2.0			36									Est. A-6a
	-165		6/10/16	1.0-1.5			37									Est. A-6a
	-170		7/11/16	0.5-1.25			38	2	2	3	32	61	33	12	23	A-6a(9)
	-175		6/8/12	0.5-1.75			39									Est. A-6a
	-180		6/11/13	1.0-1.75			40	8	1	1	22	68	35	15	23	A-6a(10)

WATER LEVEL: 38.0
 WATER NOTE: Encountered
 DATE: 4/27/06

-CONTINUED-

TYPE: 3-1/4" I.D. Hollow-stem Auger 3-7/8" Tricone Roller Bit
 2/2.5" O.D. Split-barrel Sampler 3" O.D. Shelby Tube Sampler
 NQ Rock Core Barrel

LOCATION: Proposed I-90 Central Viaduct
 Sta. 126+26.08
 28.31' Lt. of Centerline

COMPLETION DEPTH: 229.0'
 ELEVATION: 479.9
 DATE: 4/27/06 - 5/3/06

Elev. (feet)	Depth (feet)	Samp.	Std. Pen. / RQD	Hand Pen. (tsf)	Rec./Loss (feet)	CLASSIFICATION: DESCRIPTION	Samp. No.	Physical Characteristics					ODOT Class			
								% AGG.	% C.S.	% F.S.	% SILT-CLAY	LL		PI	WC	
492.9	-185		8/12/15	1.25-2.0		SILT AND CLAY: Medium-stiff to stiff gray clay, some silt, trace fine to coarse sand, trace fine gravel.	41								Est. A-6a	
487.9	-190		11/17/29	1.5-3.25		SILT: Stiff to very-stiff gray silt, "and" clay, trace fine to coarse sand, trace fine gravel.	42	7	1	1	49	42	25	6	22	A-4a(8)
477.9	-195		22/36/ 50-5"R	4.5+		SILT AND CLAY: Hard gray clay, "and" silt, little to some fine to coarse sand, trace fine gravel, contains few cobbles.	43									Est. A-6a
	-200		21/42/ 50-5"R	4.5+			44									Est. A-6a
	-205		15/26/32	2.5-3.75		SANDY SILT: Stiff to very-stiff gray clay, some silt, trace fine to coarse sand, contains few to many silt lenses, pockets and shale fragments, and few hard zones.	45	0	1	2	21	76	33	10	24	A-4a(8)
465.7	-210		9/14/15	1.5-3.25			46									Est. A-4a
	-215		26/37/ 50-5"R	1.75-4.5+		SHALE: Very-soft gray shale.	47A 47B									Est. A-4a Visual
460.9	-220		50-2"R			SHALE: Soft dark gray and gray shale, nearly horizontally bedded, many horizontal, few vertical and diagonal fractures, contains a significant diagonal fracture of 70 degrees from 222.1' to 222.3' and few interbedded silty clay seams.	48									Visual
	-225		45%		5.0/0.0		49									Visual

WATER LEVEL: 38.0
 WATER NOTE: Encountered
 DATE: 4/27/06



LOG OF BORING NO. B-05-11
CUY-90-15.24 West Abutment
CUYAHOGA COUNTY, OHIO

BBC&M JOB: 012-00946.300

TYPE: 3-1/4" I.D. Hollow-stem Auger 3-7/8" Tri-cone Roller Bit 3-7/8" Central Viaduct
 2" O.D. Split-barrel Sampler 3" O.D. Shelby Tube Sampler Sta. 128+63.03
 NQ Rock Core Barrel 147.49' Rt. of Centerline DATE: 4/11/06 - 4/17/06

COMPLETION DEPTH: 230.0'
 ELEVATION: 675.1
 DATE: 4/11/06 - 4/17/06

Elev. (feet)	Depth (feet)	Std. Pen. / RQD	Hand Pen. (tsf)	Rec./Loss (feet)	CLASSIFICATION: DESCRIPTION	Physical Characteristics							ODOT Class				
						% AGG.	% C.S.	% F.S.	% SILT	% CLAY	LL	PI		WC			
674.6	0				ASPHALT - 6 INCHES												
673.9					CONCRETE - 9 INCHES												
	5	4/6/7			GRAVEL WITH SAND (FILL): Loose to medium-dense brown fine to coarse sand, little fine to coarse gravel, trace silt, trace clay.												
	10	6/5/4															
	15	3/4/4															5
	17.0	3/5/4			COARSE AND FINE SAND: Medium-dense brown fine sand, little silt, trace clay, trace coarse sand, contains few iron oxide stains.												
658.1	20	7/11/14															
	25	6/8/9															
	30	9/9/9															
	35	6/7/8															
638.1	37.0				SANDY SILT: Medium-dense to dense brown and gray fine sand, "and" silt, little clay.												
	40	9/9/9															
	45	9/15/18															
628.1	47.0																
	50	3/5/8															

WATER LEVEL:
 WATER NOTE:
 DATE:

TYPE: 3-1/4" I.D. Hollow-stem Auger 3-7/8" Tricone Roller Bit LOCATION: Proposed I-90 Central Viaduct
 2" O.D. Split-barrel Sampler 3" O.D. Shelby Tube Sampler
 NO Rock Core Barrel

COMPLETION DEPTH: 230.0'
 ELEVATION: 675.1
 DATE: 4/11/06 - 4/17/06

Elev. (feet)	Depth (feet)	Samp.	Std. Pen. / ROD	Hand Pen. (tsf)	Rec./Loss (feet)	CLASSIFICATION: DESCRIPTION	Physical Characteristics						ODOT Class			
							AGG.	C.S.	F.S.	% SILT	% CLAY	LL		PI	WC	
615.6	50-55	12	10/16/20			SILT: Medium-dense becoming very-dense gray silt, little to some clay, little fine sand, trace coarse sand, contains few silty clay seams.	0	1	11	70	18	NP	NP		15	Est. A-4b
610.1	60-65	13A 13B	24/29/40			COARSE AND FINE SAND: Very-dense becoming medium-dense gray fine to coarse sand, trace to little silt, trace to little clay, contains few silty clay seams.										A-4b(9) Est. A-3a
601.6	70-75	14 15 16 17 18	14/18/12 3/5/6 4/6/9 5/10/11 5/6/7	0.75-1.5 0.5-2.0 2.0-3.75 1.5-2.5		SANDY SILT: Medium-stiff to stiff becoming stiff to very-stiff brown and gray clay, "and" silt, trace fine to coarse sand, contains many interbedded silt seams.										Est. A-3a Est. A-4a Est. A-4a Est. A-4a A-4a(8)
		19	5/8/9	1.5-3.0		SILT: Medium-stiff to stiff brown and gray silt, "and" clay, contains many silty clay seams and pockets, and few very-stiff zones.										Est. A-4b
585.6	80-85	20 21 22 23	3/6/6 3/5/6 6/8/11 4/6/9	1.0-2.75 0.5-1.25 0.5-2.0 0.75-1.25												Est. A-4b A-4b(8) Est. A-4b Est. A-4b
	90-95	24 25	2/3/3 P	0.75 0.75		SILT AND CLAY: Medium-stiff gray silt, "and" clay, contains many silty clay seams and pockets.										Est. A-6a Est. A-6a
	100	26	P	0.75												Est. A-6a

WATER LEVEL: WATER NC DA



LOG OF BORING NO. B-05-11
CUY-90-15.24 West Abutment
CUYAHOGA COUNTY, OHIO

BRC&M JOB: 012-00946300

Page 3 of 5

TYPE: 3-1/4" I.D. Hollow-stem Auger 3-7/8" Tricone Roller Bit LOCATION: Proposed I-90 Central Viaduct
 2" O.D. Split-barrel Sampler 3" O.D. Shelby Tube Sampler Sta. 128+63.03
 NQ Rock Core Barrel 147.49' Rt. of Centerline DATE: 4/11/06 - 4/17/06

COMPLETION DEPTH: 230.0'
 ELEVATION: 675.1
 DATE: 4/11/06 - 4/17/06

Elev. (feet)	Depth (feet)	Samp.	Std. Pen. / RQD	Hand Pen. (tsf)	Rec./Loss (feet)	CLASSIFICATION: DESCRIPTION	Physical Characteristics						ODOT Class									
							AGG. C.S.	F.S.	% SILT	% CLAY	LL	PI		WC								
573.1	-100																					
	-105		5/7/8	1.5-2.25		102.0 SILT: Very stiff to hard gray silt, "and" clay, trace fine sand, contains many fine sand and silt pockets, and few stiff zones.															Est. A-4b	
	-110		8/10/15	3.0-4.25		132.0 SILT AND CLAY: Stiff to very-stiff gray clay, some silt, trace fine to coarse sand, trace fine gravel, contains few interbedded silt seams and pockets, and few medium-stiff zones.															A-4b(8)	
	-115		5/6/11	3.0-4.25																		Est. A-4b
	-120		6/12/14	3.5-4.5																		Est. A-4b
	-125		7/11/14	1.75-3.75																		Est. A-4b
	-130		8/13/18	3.25-4.5+																		A-4b(8)
	-135		8/13/18	4.0-4.5+																		Est. A-4b
	-140		6/11/15	2.5-4.0																		Est. A-4b
	-145		7/11/15	2.0-3.25																		Est. A-6a
	-150		6/10/15	1.75-3.25																		Est. A-6a
	-155		5/10/17	2.0-2.75																		A-6a(8)
	-160		8/11/17	2.0-3.5																		Est. A-6a

WATER LEVEL:
 WATER NOTE:
 DATE:

LOG OF BORING NO. B-05-11
CUY-90-15.24 West Abutment
CUYAHOGA COUNTY, OHIO

TYPE: 3-1/4" I.D. Hollow-stem Auger 3-7/8" Tricone Roller Bit LOCATION: Proposed I-90 Central Viaduct
 2" O.D. Split-barrel Sampler 3" O.D. Shelby Tube Sampler Str. 128+63.03
 NQ Rock Core Barrel 147.49' Rt. of Centerline DATE: 4/11/06 - 4/17/06

COMPLETION DEPTH: 230.0'
 ELEVATION: 675.1

Elev. (feet)	Depth (feet)	Samp. No.	Std. Pen. / RQD	Hand Pen. (tsf)	Rec. Loss (feet)	CLASSIFICATION: DESCRIPTION	Physical Characteristics						ODOT Class		
							% AGG.	% C.S.	% F.S.	SILT	CLAY	LL		PI	WC
155	155	39	7/12/13	0.5-1.5		SILT AND CLAY: Stiff to very-stiff gray clay, some silt, trace fine to coarse sand, trace fine gravel, contains few interbedded silt seams and pockets, and few medium-stiff zones. SANDY SILT: Medium-stiff to stiff gray clay, some to "and" silt, trace fine to coarse sand, trace fine gravel, contains few interbedded silt seams and pockets, and many very-stiff to hard zones.	2	2	3	32	61	33	12	24	A-6a(9)
160	160	40	7/10/13	1.5-1.75			4	0	1	32	63	35	14	22	Est. A-6a
165	165	41	7/10/14	1.5-2.25			4	0	1	32	63	35	14	22	Est. A-6a
170	170	42	7/11/16	1.75-3.0			4	0	1	32	63	35	14	22	Est. A-6a
175	175	43	6/10/14	1.75-2.75			4	0	1	32	63	35	14	22	A-6a(10)
180	180	44	6/9/12	1.5-2.5			4	0	1	32	63	35	14	22	Est. A-4a
185	185	45	6/7/7	0.5-2.25			4	0	1	32	63	35	14	22	Est. A-4a
190	190	46	6/6/9	0.5-1.25			4	0	1	32	63	35	14	22	A-4a(8)
195	195	47	10/19/32	3.0-4.5+			4	0	1	32	63	35	14	22	Est. A-4a
200	200	48	12/22/36	4.5+			4	0	1	32	63	35	14	22	Est. A-4a

WATER LEVEL: WATER IN Dk.



LOG OF BORING NO. B-05-11
CUY-90-15.24 West Abutment
CUYAHOGA COUNTY, OHIO

BBC&M JOB: 01240946300

TYPE: 3-1/4" I.D. Hollow-stem Auger 3-7/8" Tricone Roller Bit LOCATION: Proposed I-90 Central Viaduct COMPLETION DEPTH: 230.0'
 2" O.D. Split-barrel Sampler 3" O.D. Shelby Tube Sampler Sta. 128+63.03 ELEVATION: 675.1
 NQ Rock Core Barrel 147.49' Rt. of Centerline DATE: 4/11/06 - 4/17/06

Elev. (feet)	Depth (feet)	Stamp.	Std. Pen. / RQD	Hand Pen. (tsf)	Ret./Loss (feet)	CLASSIFICATION/DESCRIPTION	Samp. No.	Physical Characteristics						ODOT Class		
								% AGG.	% C.S.	% F.S.	% SILT/CLAY	LL	PI		WC	
463.1	205		11/16/21	1.75-4.0		SANDY SILT: Medium-stiff to stiff gray clay, some to "and" silt, trace fine to coarse sand, trace fine gravel, contains few interbedded silt seams and pockets, and many very-stiff to hard zones.	49	1	1	0	34	64	31	8	23	A-4a(8)
458.1	210		7/10/14	1.0-1.75		SANDY SILT: Hard gray silt, little clay, some fine to coarse sand, some fine to coarse gravel, contains many shale fragments, similar to very-soft shale.	50	23	12	10	35	20	24	6	12	A-4a(4)
455.1	215		18/28/33	4.5+		SHALE: Very-soft gray shale, fragmented.	51									Visual
445.1	220		50-3"R			SHALE: Soft gray shale, nearly horizontally bedded, many horizontal and few vertical fractures, contains few interbedded silty clay seams, possible slickenside at 229.0', arenaceous.	52									Visual
445.1	225		18%		5.0/0.0	- Qu=209 psi at 225.0'.	53									Visual
445.1	230		37%		4.8/0.2		54									Visual

NOTES:

- Encountered seepage at 33.5'.
- Water added to borehole at 35.0' to facilitate drilling.
- Switched to washbore at 55.0'.
- Base of inclinometer installed at an approximate depth of 229'.
- Two vibrating wire piezometers installed in an offset hole between 6/7/06 and 6/9/06. Transducers were installed at approximate depths of 95' and 130'. The piezometer offset hole was backfilled with grout.
- Possible gas pocket encountered at 218.0'. Water bubbled to surface of drilling fluid.

WATER LEVEL: WATER NOTE: DATE:



LOG OF BORING NO. B-05-12
CUY-90-15.24 West Abutment
CUYAHOGA COUNTY, OHIO

BBC&M JOB: D12-00946.BPD

TYPE: 3-1/4" I.D. Hollow-stem Auger 3-7/8" Teflon Roller Bit LOCATION: Proposed I-90 Central Viaduct COMPLETION DEPTH: 213.5'
2" O.D. Split-barrel Sampler 3" O.D. Shelby Tube Sampler Sta. 131+14.70 ELEVATION: 652.7
NX Rock Core Barrel 74.16' Rt. of Centerline DATE: 4/17/06 - 4/21/06

Elev. (feet)	Depth (feet)	Samp.	Std. Pen. / RQD	Hand Pen. (tsf)	Rec./Loss (feet)	CLASSIFICATION: DESCRIPTION	Physical Characteristics						ODOT Class				
							AGG. %	C.S. %	F.S. %	SILT %	CLAY %	LL		PI	WC		
651.8	0					CONCRETE - 10 1/2 INCHES GRANULAR BASE - 1 1/2 INCHES											
651.7	5		5/6/5			dark brown and brown fine to coarse sand, little fine to coarse gravel, trace silt, trace clay, contains few slag fragments.											Est. A-1-b
640.7	10		3/2/3														Est. A-1-b
	15		2/2/3			COARSE AND FINE SAND: Loose brown and gray fine sand, trace coarse sand, little silt, trace clay, contains many iron oxide stains.											A-3a(0)
	20		2/3/3														Est. A-3a
625.2	25		2/3/2														Est. A-3a
	30		6/8/8			SILT: Medium-dense gray silt, little clay, trace fine to coarse sand.											Est. A-4b
	35		8/9/11														Est. A-4b
	40		10/13/13														A-4b(0)
614.7	45		10/12/11														Est. A-4b
	50		2/4/5	3.0-4.25		SILT AND CLAY: Stiff to very-stiff gray silt, "and" clay, trace fine to coarse sand, contains few hard zones.											Est. A-6a
			P	1.5-1.75													Est. A-6a
			P	3.0-4.0													Est. A-6a
			4/5/7	1.5-2.0													Est. A-6a
			6/7/10	3.0-4.0													A-6a(9)
			5/7/9	3.0-4.5													Est. A-6a

WATER LEVEL: "Dry" Inside Casing - Prior to Washb 4/17/06

WATER N° DA Encountered 4/17/06



LOG OF BORING NO. B-05-12
CUY-90-15.24 West Abutment
CUYAHOGA COUNTY, OHIO

BBCM JOB: 012-005463300

TYPE: 3-1/4" I.D. Hollow-stem Auger 3-7/8" Tricone Roller Bit LOCATION: Proposed I-90 Central Viaduct
 2" O.D. Split-barrel Sampler 3" O.D. Shelby Tube Sampler Sta. 131+14.70
 NX Rock Core Barrel 74.16' Rt. of Centerline DATE: 4/17/06

COMPLETION DEPTH: 213.5'
 ELEVATION: 552.7
 DATE: 4/17/06 - 4/21/06

Elev. (feet)	Depth (feet)	Sampl. No.	Std. Pen. / RQD	Hand Pen. (tsf)	Rec./Loss (feet)	CLASSIFICATION: DESCRIPTION	Physical Characteristics							ODOI Class		
							AGG.	C.S.	F.S.	% SILT	% CLAY	LL	PI		WC	
588.7	50-55	16	5/9/11	3.0-4.5		SILT AND CLAY: Stiff to very-stiff gray silt, "and" clay, trace fine to coarse sand, contains few hard zones.										Est. A-6a
		17	6/8/10	2.0-3.0												A-6a(9)
	60	18	5/6/11	2.0-3.0												Est. A-6a
	65	19	6/6/10	1.75-3.0	64.0											Est. A-6a
		20	4/5/7	1.0-2.0		SILT: Stiff to very-stiff gray mottled with red silt, "and" clay, trace fine to coarse sand, trace fine gravel, contains many interbedded silty clay seams.										A-4b(8)
		21	3/4/7	1.75-2.5												Est. A-4b
		22	4/6/7	1.25-2.0												Est. A-4b
		23	3/6/7	1.0-1.25												Est. A-4b
582.2	70	24	3/5/7	0.75-1.25	70.5	SANDY SILT: Medium-stiff to stiff gray clay, "and" silt, trace fine to coarse sand, contains few silt seams and lenses.										A-4a(8)
	75	25	3/4/3	0.5-0.75												Est. A-4a
		26	4/5/7	1.0-1.5												Est. A-4a
		27	P	1.5-2.0												Est. A-4a
573.2	80	28	4/5/8	1.25-1.75	79.5											Est. A-4b
		29	4/7/9	2.0-2.25		SILT: Stiff to very-stiff gray silt, "and" clay, trace fine sand, contains many interbedded silty clay seams, few cobbles.										A-4b(8)
		30	5/7/11	2.25-3.0												Est. A-4b
	85	31	5/8/13	2.5-3.0												Est. A-4b
		32	5/10/12	3.0-3.75												Est. A-4b
	90	33	5/7/10	2.0-3.5												Est. A-4b
	95	34	5/8/11	1.5-2.0												A-4b(8)
100		35	6/10/13	1.5-2.25												Est. A-4b

WATER LEVEL: "Dry" Inside Casing - Prior to Washbore 4/17/06
 WATER NOTE: Encountered 4/17/06
 DATE: 4/17/06



**LOG OF BORING NO. B-05-12
 CUY-90-15.24 West Abutment
 CUYAHOGA COUNTY, OHIO**

BBC&M JOB: 012-00946.300

Page 3 of 5

TYPE: 3-1/4" I.D. Hollow-stem Auger LOCATION: Proposed I-90 Central Viaduct COMPLETION DEPTH: 213.5'
2" O.D. Split-barrel Sampler 3" O.D. Shelby Tube Sampler Sta. 131+14.70 ELEVATION: 652.7
NX Rock Core Barrel 74.16' Rt. of Centerline DATE: 4/17/06 - 4/21/06

Elev. (feet)	Depth (feet)	Samp. No.	Std. Pen. / RQD	Hand Pen. (fsf)	Rec./Loss (feet)	CLASSIFICATION: DESCRIPTION	Physical Characteristics						ODOT Class			
							AGG. %	C.S. %	F.S. %	% SILT	LL	PI		WC		
540.2	100	36	6/10/14	2.75-3.0		SILT: Stiff to very-stiff gray silt, "and" clay, trace fine sand, contains many interbedded silty clay seams, few cobbles.									Est. A-4b	
	105															
	110		7/12/14	2.25-3.0												Est. A-4b
	115		8/14/18	3.0-4.0		SANDY SILT: Very-stiff to hard gray silt, "and" clay, little fine to coarse sand, trace fine gravel.										A-4a(8)
	120		7/10/14	2.5-3.25												Est. A-4a
	125		7/11/14	2.5-2.75												Est. A-4a
525.2	130	41	7/10/13	2.0-2.5		SILT AND CLAY: Stiff to very-stiff gray clay, "and" silt, trace fine to coarse sand, trace fine gravel.										Est. A-6a
	135		6/8/11	1.75-2.0												Est. A-6a
	140		5/7/10	1.5-1.75												A-6a(9)
	145		5/9/11	1.5-1.75												Est. A-6a
505.7	150	45	5/8/11	1.75-2.25		SILTY CLAY: Stiff to very-stiff gray silty clay, trace fine sand.										Est. A-6b

WATER LEVEL: "Dry" "Encountered" "Inside Casing - Prior to Washbo" "Dry" "Encountered" "Inside Casing - Prior to Washbo"
 WATER NC DA 4/17/06 4/17/06

LOG OF BORING NO. B-05-12
CUY-90-1524 West Abutment
CUYAHOGA COUNTY, OHIO



Elev. (feet)	Depth Stamp (feet)	Std. Pen. / RQD	Hand Pen. (tsf)	Rec./Loss (feet)	CLASSIFICATION: DESCRIPTION	Physical Characteristics							ODOT Class	
						% AGG.	% C.S.	% F.S.	SILT CLAY	LL	PI	WC		
490.2	150	7/11/13	2.0-2.75		SILTY CLAY: Stiff to very-stiff gray silty clay, trace fine sand.	0	0	1	33	66	36	16	24	A-6b(10)
485.2	155	5/8/11	1.75-2.25											Est. A-6b
483.2	160	SD-9"/4/5	0.5-0.75		SILT AND CLAY: Soft to medium-stiff gray clay, some silt, trace fine sand.	0	0	1	25	74	35	13	29	A-6a(9)
480.2	165	5/5/5	1.0-1.5		SILT: Medium-stiff to stiff gray silt, "and" clay.	0	0	0	61	39	25	6	28	A-4b(8) Est. A-6a
478.3	170	13/18/20	0.75		SILT AND CLAY: Medium-stiff gray clay, some silt, trace fine sand, contains few silt lenses.	5	11	40	29	15			17	Est. A-4a Est. A-4a
465.2	175	18/21/42	4.5+		SANDY SILT: Dense gray fine sand, some silt, little clay, little coarse sand, trace fine gravel.	3	5	8	29	55	28	10	16	A-4a(8)
	180	11/16/19	4.5+		SANDY SILT: Very-stiff to hard gray clay, some silt, little fine to coarse sand, trace fine gravel, contains few silt seams, few cobbles.									Est. A-4a
	185	7/9/11	2.5-4.5		SILT AND CLAY: Stiff to very-stiff gray clay, "and" silt, contains few to many silt seams and lenses.	0	0	0	46	54	31	11	25	A-6a(8)
	190	8/11/15	2.5-3.25											Est. A-6a
455.0	195	26/50-\$"R			SHALE: Very-soft gray shale, fragmented.									Visual

TYPE: 3-1/4" I.D. Hollow-stem Auger 3-7/8" Tricone Roller Bit LOCATION: Proposed I-90 Central Viaduct COMPLETION DEPTH: 213.5'
 2" O.D. Split-barrel Sampler 3" O.D. Shelby Tube Sampler Sta. 131+14.70 ELEVATION: 652.7
 NX Rock Core Barrel 74.16' Rt. of Centerline DATE: 4/17/06 - 4/21/06

WATER LEVEL: "Dry" Inside Casing - Prior to Washbore 23.0
 WATER NOTE: Encountered 4/17/06
 DATE: 4/17/06

TYPE: 3-1/4" I.D. Hollow-stem Auger 3-7/8" Tricone Roller Bit LOCATION: Proposed I-90 Central Viaduct COMPLETION DEPTH: 213.5'
 2" O.D. Split-barrel Sampler 3" O.D. Shelby Tube Sampler Sta. 131+14.70 ELEVATION: 652.7'
 NX Rock Core Barrel 74.16' Rt. of Centerline DATE: 4/17/06 - 4/21/06

Elev. (feet)	Depth (feet)	Samp.	Std. Pen. / RQD	Hand Pen. (sf)	Rec./Loss (feet)	CLASSIFICATION: DESCRIPTION	Physical Characteristics					ODOT Class											
							AGG. C.S.	F.S.	SILT CLAY	LL	PI		WC										
450.7	200																						
444.2	203		10%		4.9/0.1	202.0 SHALE: Very-soft gray shale, fragmented. SHALE: Very-soft to soft gray and dark gray shale, nearly horizontally bedded, many horizontal and few vertical fractures, contains many interbedded silty clay seams from 203.8' to 205.2' and from 205.6' to 206.8'. - Q _v = 1021 psi at 208.0'. 208.5															Visual		
439.2	210		23%		4.6/0.4	213.5 SHALE: Soft dark gray and gray shale, nearly horizontally bedded, few to many horizontal and diagonal fractures, arenaceous, contains a possible slickenside at 209.9'. 215																Visual	
	215					NOTES: - Encountered seepage at 8.0'. - Encountered water at 23.0'. - Switched to washbore at 45.5'. - Encountered cobbles at 111.5' and 176.5'. - Base of inclinometer installed at an approximate depth of 212'. - Two vibrating wire piezometers installed in an offset hole between 5/22/06 and 5/24/06. Transducers were installed at approximate depths of 75' and 120'. The piezometer offset hole was backfilled with grout.																	
	220																						
	225																						
	230																						
	235																						
	240																						
	245																						
	250																						

WATER LEVEL: "Dry"
 WATER NC: Inside Casing - Prior to Washbr 4/17/06
 DA: ...

LOG OF BORING NO. B-05-13
CUY-90-15.24 West Abutment
CUYAHOGA COUNTY, OHIO



TYPE: 3-1/4" I.D. Hollow-stem Auger LOCATION: Proposed I-90 Central Viaduct COMPLETION DEPTH: 189.0'
2/2.5" O.D. Split-barrel Sampler 3" O.D. Shelby Tube Sampler Sta. 137+07.46 ELEVATION: 588.0
NQ Rock Core Barrel 53.17' Rt. of Centerline DATE: 5/4/06 - 5/10/06

Elev. (feet)	Depth (feet)	Samp.	Std. Pen. / ROD	Hand Pen. (tsf)	Rec./Loss (feet)	CLASSIFICATION: DESCRIPTION	Physical Characteristics							ODOT Class	
							AGG. C.S.	F.S.	% SILT	% CLAY	LL	PI	WC		
579.0	0	1	12/5/5			GRANULAR BASE - 12 INCHES COARSE AND FINE SAND (FILL): Very-loose to loose black and brown fine to coarse sand, little fine gravel, little silt, little clay, contains few asphalt fragments, slightly organic.									Est. A-3a
575.0	5	2A	2/2/1	0.0		SILT AND CLAY: Very-soft black and gray silt, "and" clay, contains a hydrocarbon odor.									Est. A-3a
572.5	10	2B	1/1-12"			SANDY SILT: Very-loose gray and brown silt, some clay, some fine sand, trace coarse sand, trace fine gravel.									Est. A-6a
568.0	15	3	1/1/3			SANDY SILT: Very-loose brown and gray fine sand, "and" silt, little clay.									A-4a(7)
563.0	20	4	2/7/5			GRAVEL WITH SAND: Loose to medium-dense brown and gray fine to coarse sand, trace fine gravel, trace silt, trace clay.									A-4a(0)
	25	5	3/4/7												Est. A-1-b
	30	6	8/5/4												A-1-b(0)
	35	7	4/5/7			SILT: Medium-stiff to stiff gray silt, "and" clay, trace fine sand, contains many silty clay lenses and pockets, and few very-stiff zones.									Est. A-1-b
548.0	40	8	3/4/5	0.75-2.25											Est. A-4b
	45	9	P	1.25-1.5											A-4b(8)
		10	3/4/6	0.5-1.25											Est. A-4b
		11													Est. A-4b

WATER LEVEL: ✓ 13.5 ✓
 WATER NOTE: ✓ Encountered ✓



LOG OF BORING NO. B-05-13
CUY-90-15.24 West Abutment
CUYAHOGA COUNTY, OHIO

BBCOM JOB: 012-00946300

TYPE: 3-1/4" I.D. Hollow-stem Auger 3-7/8" Tricone Roller Bit
 2 1/2" O.D. Split-barrel Sampler 3" O.D. Shelby Tube Sampler
 NQ Rock Core Barrel

LOCATION: Proposed I-90 Central Viaduct
 Sta. 137+07.46
 53.17 Rt. of Centerline

COMPLETION DEPTH: 189.0'
 ELEVATION: 580.0
 DATE: 5/4/06 - 5/10/06

Elev. (feet)	Depth (feet)	Samp.	Sid. Pen. / RQD	Hand Pen. (tsf)	Rec./Loss (feet)	CLASSIFICATION: DESCRIPTION	Physical Characteristics						ODOT Class						
							% AGG.	C.S.	F.S.	% SILT	% CLAY	LL		PI	WC				
488.0	90																		
	95		1/16/18			SANDY SILT: Dense to very-dense gray silt, some clay, some fine to coarse sand, trace fine gravel, contains a fine to coarse sand seam from 98.5' to 98.8'.													Est. A-4a
	100		15/27/23																A-4a(6)
	105		15/27/44																Est. A-4a
473.0	110		15/24/34	4.5+		SILT AND CLAY: Hard gray clay, some silt, trace fine to coarse sand, trace fine gravel.													A-6a(10)
468.0	115		7/12/13	1.25-2.5		SILT AND CLAY: Medium-stiff to stiff gray clay, some silt, contains many silt seams and lenses, and few soft and very-stiff zones.													Est. A-6a
	120		5/8/10	0.5-1.5															A-6a(10)
	125		7/8/10	0.5-1.5															Est. A-6a
451.0	130	30A	17/26/26	0.25-0.5		COARSE AND FINE SAND: Very-dense gray fine to coarse sand, little fine to coarse gravel, trace silt, trace clay.													Est. A-6a
448.0	135	30B	23/34/35			SANDY SILT: Very-dense gray fine sand, "and" silt, little clay, trace fine to coarse sand, trace fine gravel.													Est. A-3a
		31																	A-4a(0)

WATER LEVEL: 13.5
 WATER NOTE: Encountered
 DATE: 5/4/06

TYPE: 3-1/4" I.D. Hollow-stem Auger 3-7/8" Tricone Roller Bit LOCATION: Proposed I-90 Central Viaduct
 2/2.5" O.D. Split-barrel Sampler 3" O.D. Shelby Tube Sampler Sta. 137+07.46
 NQ Rock Core Barrel 53.17' Rt. of Centerline DATE: 5/4/06 - 5/10/06

COMPLETION DEPTH: 189.0'
 ELEVATION: 580.0
 DATE: 5/4/06 - 5/10/06

Elev. (feet)	Depth (feet)	Samp. No.	Std. Pen. / RQD	Hand Pen. (tsf)	Rec./Loss (feet)	CLASSIFICATION: DESCRIPTION	Physical Characteristics						ODOT Class						
							% AGG.	% C.S.	% F.S.	% SILT	% CLAY	LL		PI	WC				
443.0	135																		
	140		20/41/48			GRAVEL WITH SAND AND SILT: Very-dense gray fine to coarse gravel, some fine to coarse sand, some clay, little silt, contains many siltstone fragments and a silty clay seam from 138.8' to 139.8'.													
436.2	145		45/50-4"R			SHALE: Very-soft gray shale.													
431.0	150		50-2"R			SHALE: Soft to medium-hard dark gray and gray shale, nearly horizontally bedded, few horizontal fractures, contains nodules, and many silty clay pockets, seams and nodules, highly fractured from 149.4' to 149.8'.													
	155		78%		5.0/0.0	- Qu=1553 psi at 152.5'.													
421.0	160				4.9/0.1														
	165		42%		4.5/0.5	SHALE: Medium-hard dark gray and gray shale interbedded with siltstone, nearly horizontally bedded, many horizontal and few diagonal fractures, nodules, contains many silty lenses and pockets.													
	170		48%		2.8/2.2	- Qu=2955 psi at 160.5'. - μ =0.39 at 160.5'.													
406.0	175		20%		2.1/2.9														
	180		88%		5.0/0.0														

WATER LEVEL: 13.5' Encountered
 WATER NC
 DA

LOG OF BORING NO. B-05-13
CUY-90-15.24 West Abutment
CUYAHOGA COUNTY, OHIO

TYPE: 3-1/4" I.D. Hollow-stem Auger 3-7/8" Tricone Roller Bit LOCATION: Proposed I-90 Central Viaduct
2/2.5" O.D. Split-barrel Sampler 3" O.D. Shelby Tube Sampler Sta. 137+07.46
NQ Rock Core Barrel 53.17' Rt. of Centerline DATE: 5/4/06 - 5/10/06

COMPLETION DEPTH: 189.0'
 ELEVATION: 580.0

Elev. (feet)	Depth Samp. (feet)	Std. Pen. RQD	Hand Pen. (tsf)	Rec./Loss (feet)	CLASSIFICATION: DESCRIPTION	Samp. No.	Physical Characteristics					ODOT Class			
							% AGG.	% C.S.	% F.S.	% SILT	% CLAY		LL	PI	WC
391.0	180					41								Visual	
185		63%		5.0/0.0	SHALE: Medium-hard dark gray and gray shale, nearly horizontally bedded, few horizontal and few diagonal fractures at 177.8', 180.2' and 181.0', contains many silty clay seams and nodules.										
190		87%		4.7/0.3	- Qu=348 psi at 178.5'	42								Visual	
195					<p>NOTES:</p> <ul style="list-style-type: none"> - Encountered seepage at 5.0'. - Encountered water at 13.5'. - Pressure Tests were performed by EL Robinson on 5/5/06 between the depths of 31.0' to 33.0', 41.0' to 43.0', and 52.5' to 54.5'. - Switched to washbore at 40.0'. - Encountered a gas pocket during rock coring. Water bubbled to surface of drilling fluid. - Base of inclinometer installed at an approximate depth of 141'. - Two vibrating wire piezometers installed in an offset hole between 6/8/06 and 6/12/06. Transducers were installed at approximate depths of 60' and 135'. The piezometer offset hole was backfilled with grout. 										
200															
205															
210															
215															
220															
225															

WATER LEVEL: 13.5 Y
 WATER NOTE: Encountered Y
 DATE: 5/4/06 Y

TYPE: 3-1/4" I.D. Hollow-stem Auger 3-7/8" Tritone Roller Bit LOCATION: Proposed I-90 Central Viaduct
22.5" O.D. Split-barrel Sampler 3" O.D. Shelby Tube Sampler Sta. 137+07.98
NQ Rock Core Barrel 172.70' Rt. of Centerline 5/11/06 - 5/18/06

COMPLETION DEPTH: 199.0'
 ELEVATION: 579.7
 DATE: 5/11/06 - 5/18/06

Elev. (feet)	Depth (feet)	Samp. No.	Std. Pen. / RQD	Hand Pen. (tsf)	Rec./Loss (feet)	CLASSIFICATION: DESCRIPTION	Physical Characteristics							ODOI Class		
							% AGG	% C.S.	% F.S.	% SILT	% CLAY	LL	PI		WC	
579.7	0	1	7/21/13			0.5 GRAVEL WITH SAND (FILL): Dense gray fine to coarse sand, "and" fine to coarse gravel, trace silt, trace clay, contains many limestone fragments.										Est. A-1-b
572.2	5	2	28/21/28			7.5 SANDY SILT (POSSIBLE FILL): Medium-stiff to stiff greenish brown silt, some clay, some fine to coarse sand, contains few fine to coarse sand seams, slightly organic.										A-1-b(0)
567.7	10	3	5/3/2	0.5-1.5		12.0 FINE SAND: Very-loose to loose gray fine sand, trace coarse sand, trace silt, trace clay.										Est. A-4a
557.7	15	4	2/3/3													A-3a(0)
	20	5	1/1/3													Est. A-3a
	25	6	5/4/4													A-3a(0)
	30	7	3/2/2													A-3a(0)
545.8	35	8A	10/11/7	1.0-1.75		33.9 SILT: Medium-dense gray silt, little clay, little fine sand.										Est. A-3a
		8B				34.5 SILTY CLAY: Medium-stiff to stiff gray silty clay, trace fine sand, contains few soft zones.										A-4b(0)
		8C														Est. A-6b
	40	9	4/5/8	1.0-2.0												Est. A-6b
	45	10	4/4/5	0.25-1.0												A-6b(10)

WATER LEVEL: Y 10.0 Y
 WATER IN: Y Encountered Y
 DATE: 5/11/06



LOG OF BORING NO. B-05-14
CUY-90-15.24 West Abutment
CUYAHOGA COUNTY, OHIO

BBC&M JOB: 012-00946.000

Page 2 of 5

TYPE: 3-1/4" I.D. Hollow-stem Auger LOCATION: Proposed I-90 Central Viaduct
27.5" O.D. Split-barrel Sampler 3" O.D. Shelby Tube Sampler
NQ Rock Core Barrel

COMPLETION DEPTH: 199.0'
 ELEVATION: 579.7
 DATE: 5/11/06 - 5/18/06

Elev. (feet)	Depth (feet)	Samp.	Std. Pen. / RQD	Hand Pen. (tsf)	Rec./Loss (feet)	CLASSIFICATION: DESCRIPTION	Physical Characteristics							ODOT Class							
							% AGG.	C.S.	F.S.	% SILT	% CLAY	LL	PI		WC						
527.7	45																				
	50		4/7/8	0.5-1.0		SILTY CLAY: Medium-stiff to stiff gray silty clay, trace fine sand, contains few soft zones.															Est. A-6b
	55		6/9/9 21	0.25-0.75	52.0	SILT AND CLAY: Medium-stiff to stiff gray clay, some silt, trace fine to coarse sand, trace fine gravel, contains many silt seams and shale fragments, and few soft zones.															A-6a(9)
	60		3/6/9	0.5-1.75																	Est. A-6a
	65		P 4/8/10	0.5-1.5																	Est. A-6a
	70		4/7/9	0.75-1.5																	A-6a(9)
	75		5/8/12	1.0-1.5																	Est. A-6a
	80		6/9/14	1.25-2.0																	Est. A-6a
497.7	85		7/9/12	1.0-2.0	82.0	SILT AND CLAY: Medium-stiff to stiff gray clay, "and" silt, trace fine to coarse sand, trace fine gravel, contains many silt seams.															A-6a(10)
	90		5/6/6	0.5-0.75																	Est. A-6a

WATER LEVEL: 10.0
 WATER NOTE: Encountered
 DATE: 5/11/06



LOG OF BORING NO. B-05-14
CUY-90-15.24 West Abutment
CUYAHOGA COUNTY, OHIO

BBC&M JOB: 012-00946.300

Page 3 of 5

TYPE: 3-1/4" I.D. Hollow-stem Auger 3-7/8" Tricone Roller Bit
 2/2.5" O.D. Split-barrel Sampler 3" O.D. Shelby Tube Sampler
 NO Rock Core Barrel

LOCATION: Proposed I-90 Central Viaduct
 Sta. 137+07.98
 172.70' Rt. of Centerline

COMPLETION DEPTH: 199.0'
 ELEVATION: 579.7
 DATE: 5/11/06 - 5/18/06

Elev. (feet)	Depth (feet)	Samp. No.	Std. Pen. / RQD	Hand Pen. (tsf)	Rec./Loss (feet)	CLASSIFICATION: DESCRIPTION	Physical Characteristics						ODOT Class		
							% AGG.	% C.S.	% F.S.	% SILT	% CLAY	LL		PI	WC
482.7	95	21	3/5/5	0.5-0.75		SILT AND CLAY: Medium-stiff to stiff gray clay, "and" silt, trace fine to coarse sand, trace fine gravel, contains many silt seams.	1	1	1	41	56	31	11	27	A-6a(8)
	100	22	P	4.5+	97.0	SILT AND CLAY: Very-stiff to hard gray clay, some silt, little fine to coarse sand, trace fine gravel, contains many shale fragments, few cobbles and fine sand lenses.									Est. A-6a
	105	23	19/48/ 50-5"R	4.5+											Est. A-6a
467.7	110	24	21/27/38 50-4"R	3.0-3.5	112.0		3	5	8	29	55	33	14	18	A-6a(10)
	115	25	13/13/13	0.75-1.75		SILT AND CLAY: Medium-stiff to stiff gray clay, some silt, trace fine to coarse sand, trace fine gravel, contains few fine to coarse sand and silt seams.									Est. A-6a
	120	26	7/10/12	0.75-1.5											Est. A-6a
455.1	125	27A 27B	6/13/26	0.75-1.25 0.75	124.6		4	3	4	30	59	32	11	25	A-6a(8) Est. A-4a
	130	28	30/50-5"R	3.5-4.5+		SANDY SILT: Medium-stiff becoming hard silt, some clay, "and" fine to coarse sand, little fine to coarse gravel, contains few cobbles.									Est. A-4a
447.7	135	29	33/48/38	3.5-4.25	132.0		2	3	5	47	43	27	9	16	A-4a(8)

WATER LEVELS: 10.0 Encountered 5/11/06

WATER NC DA.

TYPE: 3-1/4" I.D. Hollow-stem Auger 3-7/8" Tricone Roller Bit LOCATION: Proposed I-90 Central Viaduct
 2/2.5" O.D. Split-barrel Sampler 3" O.D. Shelby Tube Sampler Sgs. 137+07.98
 NQ Rock Core Barrel 172.70' Rt. of Centerline

COMPLETION DEPTH: 199.0'
 ELEVATION: 579.7
 DATE: 5/11/06 - 5/18/06

Elev. (feet)	Depth (feet)	Samp. No.	Std. Pen. / RQD	Hand Pen. (tsf)	Rec./Loss (feet)	CLASSIFICATION: DESCRIPTION	Physical Characteristics						ODOT Class				
							% AGG.	% C.S.	% F.S.	% SILT	% CLAY	LL		PI	WC		
435.9	-135	30	26/30/ 50-3"R	2.75-4.5+		SANDY SILT: Very-stiff to hard gray silt, "and" clay, trace fine to coarse sand, trace fine gravel, contains many silt lenses, and few stiff zones.										Est. A-4a	
432.7	-140	31A 31B	38/28/42	1.5-4.5+ 0.5-1.5		SILT AND CLAY: Medium-stiff to stiff gray clay, some silt, little fine to coarse sand, little fine gravel, contains many shale fragments.	143.8										Est. A-4a A-6a(8)
422.7	-145	32	50/50-3"R			SANDY SILT: Very-dense gray fine to coarse sand, trace fine gravel, little silt, little clay.	147.0										Est. A-4a
420.7	-150	33	37/50-5"R			SHALE: Very-soft gray shale.	157.0										Est. A-4a
	-155	34	50-3"R			SHALE: Soft dark gray and gray shale, nearly horizontally bedded, few horizontal, diagonal, and vertical fractures, contains many interbedded siltstone layers, nodules.	159.0										Visual
	-160	35	77%		5.0/0.0												Visual
413.1	-165	36	53%		2.6/0.0												Visual
407.0	-170		54%		6.1/0.0												Visual
	-175		64%		1.3/0.0												Visual
	-180	37	79%		10.0/0.0												Visual

WATER LEVEL: 10.0
 WATER NOTE: Encountered
 DATE: 5/11/06



LOG OF BORING NO. B-05-15
CUY-90-15.24 West Abutment
CUYAHOGA COUNTY, OHIO

BBC&M JOB: 012-00946.300

TYPE: 3-1/4" I.D. Hollow-stem Auger 3-7/8" Tricone Roller Bit
 2/2.5" O.D. Split-barrel Sampler 3" O.D. Shelby Tube Sampler
 NQ Rock Core Barrel

LOCATION: Proposed I-90 Central Viaduct
 Sta. 139+23.33
 65.91' Rt. of Centerline

COMPLETION DEPTH: 214.0'
 ELEVATION: 581.1
 DATE: 5/18/06 - 5/24/06

Elev. (feet)	Depth (feet)	Samp.	Std. Pen. / ROD	Hand Pen. (tsf)	Rec./Loss (feet)	CLASSIFICATION: DESCRIPTION	Physical Characteristics							ODOT Class		
							AGG.	C.S.	F.S.	SILT	CLAY	LL	PI		WC	
579.8	0	1A				1.3 GRANULAR BASE - 16 INCHES										Visual Est. A-3a
576.4	3	1B	20/14/7			COARSE AND FINE SAND (FILL): Loose to medium-dense black intermixed with brown fine to coarse sand, little fine to coarse gravel.										Est. A-3a
573.6	5	2A	3/3/5	2.0-4.5+		SANDY SILT: Very-loose brown and gray silt, some clay, some fine sand, contains many silty clay pockets and seams.										Est. A-6a
569.1	10	2B	1/1/1			SILT AND CLAY (FILL): Very-stiff to hard brown intermixed with black clay, "and" silt, some fine to coarse sand, little fine to coarse gravel.										A-4a(0)
564.1	15	3	2/2/2			COARSE AND FINE SAND: Very-loose gray fine sand, some silt, little clay, trace coarse sand.	0	0	35	41	24	NP	NP	25		A-3a(0)
557.1	20	4	2/3/3			COARSE AND FINE SAND: Loose gray fine to coarse sand, trace fine gravel, trace silt, trace clay.	0	1	66	22	11	NP	NP	30		A-3a(0)
549.1	25	5	2/3/3			COARSE AND FINE SAND: Loose gray fine to coarse sand, little to some fine gravel, trace silt, trace clay.	1	22	61	9	7	NP	NP	23		Est. A-3a
	30	6A	5/5/5			COARSE AND FINE SAND: Loose gray fine to coarse sand, little to some fine gravel, trace silt, trace clay.										Est. A-6a
	35	6B	P	2.25-3.75		SILT AND CLAY: Stiff to very-stiff becoming soft to medium-stiff gray clay, "and" silt, trace fine sand, contains few silt seams.										Est. A-6a
	40	7	5/8/12	1.25-2.75												Est. A-6a
	45	8	4/6/9	1.75-2.5												A-6a(9)
533.1	50	9	2/3/5	0.5-1.0												Est. A-6a
		10	P	0.25-0.5												Est. A-6a
		11	4/7/11	0.75-3.0												A-4a(8)
		12														Est. A-6a
		13														Est. A-6a

WATER LEVEL: 8.0 0.5 4.0
 WATER NOTE: After HSA Removed - Prior to Washbore Augers Pulled - Prior to Washbore
 DATE: 5/18/06 5/18/06

TYPE: 3-1/4" I.D. Hollow-stem Auger 3-7/8" Tricone Roller Bit
22.5" O.D. Split-barrel Sampler 3" O.D. Shelby Tube Sampler
NQ Rock Core Barrel

LOCATION: Proposed I-90 Central Viaduct
Sta. 139+23.33
65.91' Rt. of Centerline

COMPLETION DEPTH: 214.0'
 ELEVATION: 531.1
 DATE: 5/18/06 - 5/24/06

Elev. (feet)	Depth (feet)	Samp.	Std. Pen. / RQD	Hand Pen. (tsf)	Rec./Loss (feet)	CLASSIFICATION: DESCRIPTION	Physical Characteristics						Samp. No.	ODOT Class						
							AGG.	C.S.	F.S.	SILT	CLAY	LL			PI	WC				
514.1	50																			
	55		4/8/11	1.0-1.75		SANDY SILT: Medium-stiff to stiff gray clay, some silt, little fine to coarse sand, trace fine gravel, contains few very-stiff zones.														Est. A-4a
	60		5/9/12	1.25-2.0																Est. A-4a
	65		5/9/13	0.75-1.75																Est. A-4a
	70		P																	Est. A-6a
	75		P																	Est. A-6a
	80		5/8/10	1.25-1.5		SILT AND CLAY: Stiff gray clay, some silt, trace fine to coarse sand, trace fine gravel.														A-6a(10)
498.6	82.5		5/9/12	1.0-1.5																Est. A-6a
	85		P																	Est. A-6a
	88		7/10/16	1.5-1.75																Est. A-6a
	90		7/10/13	1.75-2.25		SILTY CLAY: Stiff to very-stiff gray silty clay, trace fine to coarse sand, trace fine gravel.														A-6b(10)
494.1	92		6/9/12	1.25-2.0																Est. A-6a
	95		3/4/6	0.5-1.25		SILT AND CLAY: Medium-stiff to stiff gray clay, some silt, trace fine to coarse sand, trace fine gravel, contains few soft zones.														A-6a(10)
	100		P																	Est. A-6a
	105		5/6/10	0.25-1.25																Est. A-6a

WATER LEVEL: Encountered 8.0 After HSA Removed - Prior to Was' 5/18/06
 Augers Pulled - Prior to Washbore 5/19/06



LOG OF BORING NO. B-05-15
CUY-90-15.24 West Abutment
CUYAHOGA COUNTY, OHIO

BBC&M JOB: 012-00946.300

TYPE: 3-1/4" I.D. Hollow-stem Auger 3-7/8" Tricone Roller Bit LOCATION: Proposed I-90 Central Viaduct
 2 1/2" O.D. Split-barrel Sampler 3" O.D. Shelby Tube Sampler
 NQ Rock Core Barrel

COMPLETION DEPTH: 214.0'
 ELEVATION: 581.1
 DATE: 5/18/06 - 5/24/06

Elev. (feet)	Depth (feet)	Samp. No.	Std. Pen. RQD	Hand Pen. (tsf)	Rec./Loss (feet)	CLASSIFICATION: DESCRIPTION	Physical Characteristics							ODOI Class				
							% AGG.	% C.S.	% F.S.	% SILT	% CLAY	LL	PI		WC			
479.1	100																	
474.1	105		13/31/44	4.5+		SANDY SILT: Hard gray clay, some silt, some fine to coarse sand.	9	12	15	31	33	22	7	11			A-4a(6)	
	110		15/29/44	4.0-4.5+		SILT AND CLAY: Very-stiff to hard gray clay, some silt, trace fine to coarse sand, trace fine gravel, contains few silt lenses.											Est. A-6a	
	115		13/28/39	3.75-4.5+			2	3	3	29	63	36	14	19			A-6a(10)	
459.1	120		9/16/21	2.5-4.0		SILTY CLAY: Stiff gray silty clay, contains few silt lenses.											Est. A-6a	
454.1	125		9/11/11	1.25-1.5			31	0	0	27	73	39	16	29			A-6b(10)	
	130		31/25/33			SANDY SILT: Very-dense gray fine to coarse sand, some silt, little clay, little fine gravel.											Est. A-4a	
449.1	135		22/44/50-5"R	4.5+		SILTY CLAY: Hard gray silty clay, trace fine to coarse sand, contains few shale fragments.											Est. A-6b	
	140		17/39/33	4.5+			34	0	1	2	26	71	39	16	22		A-6b(10)	
439.1	145		14/27/35	4.0-4.25		SILT AND CLAY: Hard gray clay, "and" silt, trace fine to coarse sand, trace fine gravel, contains few silt lenses.											Est. A-6a	
	150		17/31/39	4.5+			36										Est. A-6a	

WATER LEVEL: 8.0
 WATER NOTE: Encountered
 DATE: 5/18/06

After HSA Removed - Prior to Washbore
 Augers Pulled - Prior to Washbore
 DATE: 5/18/06



LOG OF BORING NO. B-05-15
CUY-90-15.24 West Abutment
CUYAHOGA COUNTY, OHIO

BBCOM JOB: 012-00946.000

TYPE: 3-1/4" I.D. Hollow-stem Auger 3-7/8" Tricone Roller Bit LOCATION: Proposed I-90 Central Viaduct
22.5" O.D. Split-barrel Sampler 3" O.D. Shelby Tube Sampler Sls. 139+23.33
NQ Rock Core Barrel 63.91' Rt. of Centerline
 COMPLETION DEPTH: 214.0'
 ELEVATION: 581.1
 DATE: 5/18/06 - 5/24/06

Elev. (feet)	Depth (feet)	Samp	Std. Pen. / ROD	Hand Pen. (tsf)	Rec. Loss (feet)	CLASSIFICATION: DESCRIPTION	Physical Characteristics					ODOT Class			
							Agg.	C.S.	F.S.	% SILT	% CLAY		LL	PI	WC
419.1	-155	37	19/33/45	4.5+		SILT AND CLAY: Hard gray clay, "and" silt, trace fine to coarse sand, trace fine gravel, contains few silt lenses.	1	1	1	41	56	34	12	20	A-6a(9)
414.1	-160	38	23/33/39	4.5+	162.0	SANDY SILT: Hard gray silt, "and" clay, trace fine to coarse sand, trace fine gravel, contains few shale fragments.	4	5	5	45	41	27	9	15	A-4a(8)
407.1	-165	39	18/33/43	4.5+	167.0	SHALE: Very soft gray shale, contains few silty clay seams.									Visual
397.1	-170	40	50-5"R		174.0	SHALE: Soft dark gray to gray shale, nearly horizontally bedded, many horizontal and few vertical fractures, contains few interbedded siltstone and silty clay layers, vertical fracture from 183.4' to 184.0'.									Visual
392.1	-175	41	50-1"R		184.0	SHALE: Very soft to soft dark gray and gray shale, nearly horizontally bedded, many horizontal fractures, contains many interbedded silty clay and few siltstone layers.									Visual
	-180	42	35%		189.0										Visual
	-185	43	47%												Visual
	-190	44	0%												Visual
	-195	45	68%												Visual
	-200	46	68%												Visual

WATER LEVEL: Encountered 8.0 After HSA Removed - Prior to Wash 0.5 Augers Pulled - Prior to Wash 4.0
 WATER NC 5/18/06 5/19/06

LOG OF BORING NO. B-05-15
CUY-90-15.24 West Abutment
CUYAHOGA COUNTY, OHIO

TYPE: 3-1/4" I.D. Hollow-stem Auger 3-7/8" Tricone Roller Bit
 2/2.5" O.D. Split-barrel Sampler 3" O.D. Shelby Tube Sampler
 NQ Rock Core Barrel

LOCATION: Proposed I-90 Central Viaduct
 Sta. 139+23.33
 65.91' Rt. of Centerline

COMPLETION DEPTH: 214.0'
 ELEVATION: 581.1
 DATE: 5/18/06 - 5/24/06

Elev. (feet)	Depth (feet)	Samp. No.	Std. Pen. / RQD	Hand Pen. (tsf)	Rec./Loss (feet)	CLASSIFICATION: DESCRIPTION	Physical Characteristics					ODOT Class	
							AGG.	C.S.	F.S.	SILT	CLAY		LL
367.1	200	47	52%		5.0/0.0	SHALE: Soft gray and dark gray shale, nearly horizontally bedded, few to many horizontal and few diagonal fractures, major diagonal fractures located at 196.1', 197.2', 199.3', and 199.7'. - Qu=2057 psi at 202.5'. - Qu=2916 psi at 208.5'. - Qu=2322 psi at 213.5'. - $\mu=0.40$ at 213.5'. NOTES - Encountered water at 8'. - Water added at 15.0' to prevent heave. - Switched to washbore at 35.0'. - Constant 8' to 10' eruption of water/gas above casing for 10 minutes during first core run. Water/gas also erupted during core barrel removal. Water escaped from top of core barrel, which was lifted up approximately 15 feet above ground surface. Water/gas/debris also escaped horizontally from the top of the core barrel connection and sprayed approximately 40' horizontally from drill rig.							Visual
	205	48	52%		4.2/0.8								Visual
	210	49	73%		5.0/0.0								Visual

WATER LEVEL: 8.0 Encountered 4.0
 WATER NOTE: After HSA Removed - Prior to Washbore Augers Pulled - Prior to Washbore
 DATE: 5/18/06 5/19/06



LOG OF BORING NO. B-05-16
CUY-90-15.24 West Abutment
CUYAHOGA COUNTY, OHIO

BBC&M JOB: 012-00946310

TYPE: 3-1/4" I.D. Hollow-stem Auger 3-7/8" Tricone Roller Bit LOCATION: Proposed 1-90 Central Viaduct
 2" O.D. Split-barrel Sampler 3" O.D. Shelby Tube Sampler Sta. 133+62.01
 NX Rock Core Barrel 61.67' Rt. of Centerline DATE: 6/8/06 - 6/14/06

Elev. (feet)	Depth (feet)	Std. Pen. / RQD	Hand Pen. (isf)	Rec. Loss (feet)	CLASSIFICATION: DESCRIPTION	Physical Characteristics						ODOT Class											
						Agg.	C.S.	F.S.	% SILT	% CLAY	LL		PI	WC									
598.7	0																						
595.0	5	5/6/12			0.2' TOPSOIL/ROOTMAT - 2 1/2 INCHES GRAVEL WITH SAND (FILL): Medium-dense dark brown and black fine to coarse sand, little fine to coarse gravel, trace silt, contains few slag fragments.																		Est. A-1-b
		3/2/3			GRAVEL WITH SAND (FILL): Very-loose to loose brown and black fine to coarse sand, "and" fine to coarse gravel, trace silt, trace clay, contains many slag and coal fragments.																		Est. A-1-b
586.0	10	3/2/1																					Est. A-1-b
		1/1/1			COARSE AND FINE SAND: Very-loose brown fine to coarse sand, trace fine gravel, trace silt, trace clay.																		A-3a(0)
580.0	15	1/2/1																					
578.5	20				COARSE AND FINE SAND: Very-loose black and brown fine to coarse sand, trace fine gravel, little silt, trace clay, contains few coal fragments, slightly organic.																		Est. A-3a
576.0		P	0.5-1.25																				Est. A-4b
575.5		2/2/1			SILT: Very-loose brown silt, "and" fine sand, trace coarse sand.																		A-4b(8)
		P	1.5-2.0		SILT: Medium-stiff to stiff gray silt, "and" clay, trace fine to coarse sand, trace fine gravel, contains many silty clay lenses and seams.																		A-6b(10)
		1/2/3	0.5-1.5		SILTY CLAY: Medium-stiff gray silty clay, trace fine to coarse sand, trace fine gravel, contains few silt lenses.																		A-6b(10)
566.5	30																						
		3/4/3	1.0-1.75		SILT AND CLAY: Stiff to very-stiff gray silt, "and" clay, trace fine gravel, contains many silt pockets and lenses, and few hard zones.																		Est. A-6a
		3/4/6	1.75-3.5																				Est. A-6a
		5/8/11	2.75-4.25																				A-6a(8)

WATER LEVEL: Encountered 21.0 DA. 6/8/06



LOG OF BORING NO. B-05-16
CUY-90-15.24 West Abutment
CUYAHOGA COUNTY, OHIO

BBCM JOB: 012-00946.300

TYPE: 3-1/4" I.D. Hollow-stem Auger 3-7/8" Tricone Roller Bit LOCATION: Proposed I-90 Central Viaduct
 2" O.D. Split-barrel Sampler 3" O.D. Shelby Tube Sampler Sta. 133+62.01
 NX Rock Core Barrel 51.67' Rt. of Centerline

COMPLETION DEPTH: 164.0'
 ELEVATION: 598.5
 DATE: 6/8/06 - 6/14/06

Elev. (feet)	Depth (feet)	Std. Samp.	Std. Pen. / RQD	Hand Pen. (tsf)	Rec./Loss (feet)	CLASSIFICATION: DESCRIPTION	Samp. No.	Physical Characteristics						ODOT Class			
								AGG. C.S.	F.S.	SILT	CLAY	LL	PI		WC		
551.0	45																
	50		6/8/11	4.25		47.5 SILT: Stiff to very-stiff gray silt, "and" clay, trace fine sand, contains many silty clay seams, and few hard zones.	12										Est. A-4b
	55		4/6/9	1.75-2.25			13										Est. A-4b
	60		4/7/7	1.75-2.25			14	0	0	1	53	46	27	10	26		A-4b(8)
536.0	65		4/7/7	1.25-2.5		62.5 SILT AND CLAY: Stiff to very-stiff gray clay, some silt, trace fine to coarse sand, trace fine gravel, contains few medium-stiff zones, and a fine to coarse sand seam from 69.5' to 69.6'.	15										Est. A-6a
	70		4/6/7	0.75-1.5			16	1	2	6	27	64	32	13	26		A-6a(9)
	75		5/7/10	1.25-1.75			17										Est. A-6a
	80		5/6/8	1.25-1.75			18										Est. A-6a
	85		4/7/10	1.0-1.75			19	1	2	3	28	66	31	12	24		A-6a(9)
	90		5/5/9	1.25-1.75			20										Est. A-6a

WATER LEVEL: 21.0
 WATER NOTE: Encountered
 DATE: 6/8/06



LOG OF BORING NO. B-05-16
CUY-90-15.24 West Abutment
CUYAHOGA COUNTY, OHIO

BBC&M JOB: 012-20946300

Page 3 of 4

TYPE: 3-1/4" I.D. Hollow-stem Auger 3-7/8" Tricone Roller Bit LOCATION: Proposed I-90 Central Viaduct
 2" O.D. Split-barrel Sampler 3" O.D. Shelby Tube Sampler Sta. 133+62.01
 NX Rock Core Barrel 61.67' R.C. of Centerline

COMPLETION DEPTH: 164.0'
 ELEVATION: 598.5
 DATE: 6/8/06 - 6/14/06

Elev. (feet)	Depth (feet)	Samp.	Std. Pen. / RQD	Hand Pen. (tsf)	Rec./Loss (feet)	CLASSIFICATION: DESCRIPTION	Physical Characteristics							ODOT Class	
							% AGG.	% C.S.	% F.S.	% SILT	% CLAY	LL	PI		WC
488.0	-110	21	7/10/13	1.5-2.5		SILT AND CLAY: Stiff to very-stiff gray clay, some silt, trace fine to coarse sand, trace fine gravel, contains few medium-stiff zones, and a fine to coarse sand seam from 69.5' to 69.6'. 110.5	0	0	1	33	66	33	13	24	Est. A-6a
485.5	-115	22	5/9/11	1.75-2.25		SILT: Stiff gray silt, "and" clay, trace fine sand, contains 113.0 many silty clay seams. SILT: Loose (estimated) gray silt, trace clay, trace fine to coarse sand, trace fine gravel. 117.0	0	0	1	52	47	27	7	30	A-4b(8)
481.5	-120	23	5/7/10	1.5-2.5		SILT AND CLAY: Hard gray clay, some silt, trace fine to coarse sand. 127.5	1	1	5	84	9	NP	NP	25	A-4b(0)
471.0	-135	24	5/7/8	1.5-2.25		SILT AND CLAY: Stiff to very-stiff gray clay, some silt, trace fine sand. 127.5	0	0	1	25	74	37	14	30	A-6a(10)
	-95	25	7/10/13	1.5-2.5			0	0	1	25	74	37	14	30	A-6a(10)
	-100	26	5/9/11	1.75-2.25			0	0	1	25	74	37	14	30	A-6a(10)
	-105	27	5/7/10	1.5-2.5			0	0	1	25	74	37	14	30	A-6a(10)
	-110	28	5/7/8	1.5-2.25			0	0	1	25	74	37	14	30	A-6a(10)
	-115	29	P	1.5-1.75			0	0	1	25	74	37	14	30	A-6a(10)
	-120	30	P	1.5-1.75			0	0	1	25	74	37	14	30	A-6a(10)
	-125		12/24/44	4.5+			0	0	1	25	74	37	14	30	A-6a(10)
	-130		12/24/31	4.5+			0	0	1	25	74	37	14	30	A-6a(10)
	-135		5/9/11	1.0-2.25			0	0	1	25	74	37	14	30	A-6a(10)
	-140		5/7/8	1.0-1.75			0	0	1	25	74	37	14	30	A-6a(10)

WATER LEV' 21.0
 WATER NO. Encountered
 DATE: 6/8/06



LOG OF BORING NO. B-105A
CUY-90-15.24 West Abutment
CUYAHOGA COUNTY, OHIO

BBCM JOB: 02L-00946.000

TYPE: 3-1/4" I.D. Hollow-stem Auger 3-7/8" Tritone Roller Bit LOCATION: Proposed I-90 Central Viaduct
2/2.5" O.D. Split-barrel Sampler 3" O.D. Shelby Tube Sampler Sta. 134+26.02
NX Rock Core Barrel DATE: 5/5/06

COMPLETION DEPTH: 156.0'
 ELEVATION: 585.7
 DATE: 5/5/06 - 5/10/06

Elev. (feet)	Depth (feet)	Std. Pen. / RQD	Hand Pen. (tsf)	Rec./Loss (feet)	CLASSIFICATION: DESCRIPTION	Sampl. No.	Physical Characteristics						ODOT Class							
							AGG.	C.S.	F.S.	% SILT	% CLAY	LL		PI	WC					
585.3	0					1														
576.6	5	4/7/8			0.2' TOPSOIL/ROOTMAT - 2 INCHES GRAVEL WITH SAND (FILL): Medium-dense becoming very-loose dark brown, black and brown fine gravel, "and" fine to coarse sand, trace silt, trace clay, contains many slag and asphalt fragments.	2	46	28	15	7	4	NP	NP	18						A-1-b(0)
	10	1/1/2			9.1 GRAVEL WITH SAND AND SILT (FILL): Very-loose to loose dark brown, black and brown fine to coarse sand, some fine gravel, little silt, trace clay, contains few to many asphalt and slag fragments.	3A 3B														Est. A-1-b Est. A-2-4
566.0	15	1/1/1				4														Est. A-2-4
563.2	20	4/4/3			19.7 COARSE AND FINE SAND: Loose brown, black and gray fine to coarse sand, little silt, trace clay.	5A 5B	30	19	22	20	9	NP	NP	32						A-2-4(0) Est. A-3a
	25	2/4/4	0.75-2.5		22.5 SILT AND CLAY: Medium-stiff to stiff gray clay, "and" silt, trace fine to coarse sand, trace fine gravel, contains few silt pockets and fine to coarse sand seams, and few very-stiff zones.	6	1	3	4	39	53	33	13	23						A-6a(9)
	30	2/3/3	0.75-2.0			7														Est. A-6a
553.2	35	4/6/7	1.25-3.0		32.5 SILT: Stiff to very-stiff gray silt, "and" clay, trace fine sand, contains many silt lenses, few pockets and seams.	8	0	0	1	51	48	29	9	22						A-4b(8)
	40	4/7/8	1.25-3.5			9														Est. A-4b
	45	4/5/6	1.5-2.5			10														Est. A-4b
	50	4/5/7	1.5-3.5			11	0	0	1	52	47	29	10	24						A-4b(8)

WATER LEVEL: Y 13.5 Encountered Y 12.6
 WATER NO. Y After HSA Removed - Prior to Wash Y
 DATE: 5/5/06



**LOG OF BORING NO. B-105A
 CUY-90-15.24 West Abutment
 CUYAHOCA COUNTY, OHIO**

BBCM JOB: 012-00946.100

Page 3 of 4

TYPE: 3-1/4" I.D. Hollow-stem Auger 3-7/8" Tricone Roller Bit
 2/2.5" O.D. Split-barrel Sampler 3" O.D. Shelby Tube Sampler
 NX Rock Core Barrel

LOCATION: Proposed I-90 Central Viaduct
 Sta. 134+26.02
 338.66' Rt. of Centerline

COMPLETION DEPTH: 156.0'
 ELEVATION: 585.7
 DATE: 5/5/06 - 5/18/06

Elev. (feet)	Depth (feet)	Samp. No.	Std. Pen. / RQD	Hand Pen. (tsf)	Rec./Loss (feet)	CLASSIFICATION DESCRIPTION	Physical Characteristics						ODOT Class		
							Agg.	C.S.	F.S.	% SILT	% CLAY	LL		PI	WC
480.7	105	23	P	0.75-1.25		SILTY CLAY: Medium-stiff to stiff gray silty clay, trace fine to coarse sand, contains few soft zones.	0	1	1	37	61	34	16	28	A-6b(10)
478.7		24	P	0.5-1.25	105.0	CLAY: Medium-stiff to stiff gray clay, "and" silt, trace fine sand.	0	0	1	49	50	45	21	34	A-7-6(13)
474.7		25	P	1.0-1.75	107.0	SILT AND CLAY: Stiff gray clay, some silt, trace fine to coarse sand, trace fine gravel.	1	1	1	22	75	29	11	28	A-6a(8)
		26		4.0-4.5+	111.0	SILT AND CLAY: Very-stiff to hard gray clay, some silt, little fine to coarse sand, trace fine gravel.	4	7	8	27	54	30	12	16	A-6a(9)
463.7		27		2.0-4.5+	122.0										Est. A-6a
		28		1.0-3.25		SILT AND CLAY: Stiff to very-stiff gray clay, some silt, trace fine to coarse sand, trace fine gravel, contains many silt lenses and pockets.									Est. A-6a
		29		1.25-2.75			1	1	1	29	68	36	13	28	A-6a(9)
449.2		30		1.25-2.0	136.5	SANDY SILT: Dense gray fine to coarse sand, some silt, little clay, some fine to coarse gravel.									Est. A-6a
444.7		31			141.0	SHALE: Very-soft to soft dark gray and gray shale, nearly horizontally bedded, many horizontal and few vertical and diagonal fractures, contains many silty clay layers from 148' to 152', diagonal joints at 146.6' and 153.0'. - Qu=828 psi at 155.0'.									Est. A-4a
		32													Visual
		33			5.0/0.0										Visual

WATER LEVEL: 13.5 Encountered 12.6 After HSA Removed - Prior to Wa
 WATER NC DA: 5/5/06 5/5/06



LOG OF BORING NO. B-108A
CUY-90-15.24 West Abutment
CUYAHOGA COUNTY, OHIO

BBC&M JOB: 012-00946.300

TYPE: 3-1/4" I.D. Hollow-stem Auger 3-7/8" Tricone Roller Bit LOCATION: Proposed I-90 Central Viaduct
 27.5" O.D. Split-barrel Sampler 3" O.D. Shelby Tube Sampler Sta. 133+21.32
 NX Rock Core Barrel 151.63' Rt. of Centerline

COMPLETION DEPTH: 168.7'
 ELEVATION: 603.0
 DATE: 4/28/06 - 5/3/06

Elev. (feet)	Depth (feet)	Samp.	Std. Pen. / RQD	Hand Pen. (tsf)	Rec./Loss (feet)	CLASSIFICATION: DESCRIPTION	Physical Characteristics						ODOT Class		
							AGG	C.S.	F.S.	% SILT	% CLAY	LL		PI	WC
602.7	0	1	4 5/3			TOPSOIL - 3 INCHES									Est. A-3a
600.0	3	2	2 5/6			COARSE AND FINE SAND (FILL): Loose dark brown fine to coarse sand, trace silt, trace clay, trace fine to coarse gravel, contains few concrete fragments.									Est. A-4a
590.5	10	3	3 5/5			SANDY SILT (FILL): Loose to medium-dense dark brown and brown fine to coarse sand, some silt, little clay, little fine to coarse gravel, contains many slag and coal fragments.	14	18	23	27	18	22	4	14	A-4a(2)
585.5	15	4	3 4/3			COARSE AND FINE SAND (POSSIBLE FILL): Loose dark brown fine to coarse sand, little fine gravel, little silt, trace clay, contains many coal fragments.	19	26	26	19	10	NP	NP	16	A-3a(0)
582.0	20	5	4 4/4			GRAVEL WITH SAND: Loose light gray fine to coarse sand, some fine to coarse gravel, trace silt.	1	1	1	24	73	42	19	28	A-7-6(12)
	25		3 4/6	1.5-2.25		CLAY: Stiff to very-stiff gray clay, little to some silt, trace fine to coarse sand, trace fine gravel.									Est. A-1-b
	30		2 3/4	1.5-2.5											Est. A-7-6
	35		2 2/3	1.0-1.25											A-7-6(12)
565.5	40	9	3 5/6	2.0-4.5+		SANDY SILT: Stiff to very-stiff gray silt, "and" clay, contains many silt pockets and lenses, and few hard zones.	0	1	1	20	78	42	19	31	Est. A-4b
	45		4 5/7	2.0-3.5											Est. A-4b
	50	11	4 5/7	1.75-3.0			0	0	0	53	47	29	10	23	A-4b(8)

WATER LEVEL: "Dry" "Dry"
 WATER NO. Inside HSA - Prior to Washbore Inside HSA - Prior to Washbor
 DA. 4/28/06 5/1/06



LOG OF BORING NO. B-108A
CUY-90-15.24 West Abutment
CUYAHOGA COUNTY, OHIO

BBCM JOB: 012-00946.300

TYPE: 3-1/4" I.D. Hollow-stem Auger 3-7/8" Tricone Roller Bit
 2/2.5" O.D. Split-barrel Sampler 3" O.D. Shelby Tube Sampler
 NX Rock Core Barrel

LOCATION: Proposed I-90 Central Viaduct
 Sta. 133+21.32
 151.63' Rt. of Centerline

COMPLETION DEPTH: 168.7'
 ELEVATION: 603.0
 DATE: 4/28/06 - 5/3/06

Elev. (feet)	Depth (feet)	Samp. No.	Std. Pen. / RQD	Hand Pen. (sf)	Rec. Loss (feet)	CLASSIFICATION: DESCRIPTION	Physical Characteristics						ODOT Class			
							AGG.	C.S.	F.S.	% SILT	% CLAY	LL		PI	WC	
530.5		12	4/5/8	1.5-3.5		SANDY SILT: Stiff to very-stiff gray silt, "and" clay, contains many silt pockets and lenses, and few hard zones. SILT AND CLAY: Stiff to very-stiff gray clay, some silt, trace to little fine to coarse sand, trace fine gravel.								Est. A-4b		
	55															
	60		5/7/8	2.0-4.0												Est. A-4b
	65		P	1.25-1.5												Est. A-4b
	70		4/4/5	1.5-2.0												Est. A-4b
	75		5/8/10	2.0-3.0												Est. A-6a
	80		8/11/13 24	1.5-3.0												A-6a(9)
	85		5/7/10	2.25-2.5												Est. A-6a
	90		4/6/10	1.75-2.5												Est. A-6a
	95		5/8/9	1.25-2.5												A-6a(9)
	100		4/7/10	1.25-2.5												Est. A-6a

WATER LEVEL: "Dry" "Dry"
 WATER NOTE: Inside HSA - Prior to Washbore Inside HSA - Prior to Washbore
 DATE: 4/28/06 5/1/06



LOG OF BORING NO. B-108A
CUY-90-15.24 West Abutment
CUYAHOGA COUNTY, OHIO

BBCOM JOB: 012-00946.000

TYPE: 3-1/4" I.D. Hollow-stem Auger 3-7/8" Tricone Roller Bit LOCATION: Proposed I-90 Central Viaduct
 2/2.5" O.D. Split-barrel Sampler 3" O.D. Shelby Tube Sampler Sta. 133+21.32
 NX Rock Core Barrel 151.63' Rt. of Centerline DATE: 4/28/06 - 5/3/06

COMPLETION DEPTH: 168.7'
 ELEVATION: 603.0
 DATE: 4/28/06 - 5/3/06

Elev. (feet)	Depth (feet)	Samp. No.	Std. Pen. / RQD	Hand Pen. (tsf)	Rec. Loss (feet)	CLASSIFICATION: DESCRIPTION	Physical Characteristics							ODOT Class		
							AGG.	C.S.	F.S.	SILT	CLAY	LL	PI		WC	
488.0	105	22	57/11	1.25-2.5		SILT AND CLAY: Stiff to very-stiff gray clay, some silt, trace to little fine to coarse sand, trace fine gravel.										Est. A-6a
486.0	110	23	4/6/8	1.25-2.25												Est. A-6a
484.0	115	24	P	1.25-1.5	115.0											A-6a(9)
478.9	120	25	P	0.75-1.75	117.0	SANDY SILT: Medium-stiff to stiff gray clay, "and" silt, contains many silt seams and lenses.										A-4a(8)
		26A	P		119.0	SILT: Loose (est.) gray silt, some clay, contains many silt seams and lenses.										A-4b(8)
		26B			124.1	GRAVEL WITH SAND: Dense gray fine to coarse sand, "and" fine to coarse gravel, trace silt, trace clay.										A-4b(0)
470.5	125	27A	20/18/23	4.5+	124.1	SILT AND CLAY: Hard gray clay, some silt, little fine to coarse sand, trace fine gravel.										A-1-b(0)
		27B														Est. A-6a
	130	28	14/30/43	4.5+												A-6a(10)
	133	29	6/8/10	1.5-3.5	132.5	SILT AND CLAY: Stiff to very-stiff gray clay, "and" silt, trace fine sand, contains many silt seams and lenses.										Est. A-6a
	140	30	7/12/15	1.5-3.0												Est. A-6a
	145	31	6/10/12	1.25-3.0												A-6a(9)
	150	32	7/10/15	1.25-3.0												Est. A-6a

WATER LEV? "Dry" "Dry"
 WATER NO Inside HSA - Prior to Washbore Inside HSA - Prior to Washbor
 DATE: 4/28/06 5/1/06



LOG OF BORING NO. B-108A
CUY-90-15.24 West Abutment
CUYAHOGA COUNTY, OHIO

BBCM YDR: 012-00946,300

TYPE: 3-1/4" I.D. Hollow-stem Auger 3-7/8" Tricone Roller Bit
 2/2.5" O.D. Split-barrel Sampler 3" O.D. Shelby Tube Sampler
 NX Rock Core Barrel

LOCATION: Proposed I-90 Central Viaduct
 Sta. 133+21.32
 151.63' Rt. of Centerline

COMPLETION DEPTH: 168.7'
 ELEVATION: 603.0
 DATE: 4/28/06 - 5/3/06

Elev. (feet)	Depth (feet)	Sampl.	Std. Pen. / RQD	Hand Pen. (tsf)	Rec./Loss (feet)	CLASSIFICATION: DESCRIPTION	Sampl. No.	Physical Characteristics					ODOT Class			
								AGG. C.S.	% P.S.	% SILT	% CLAY	LL		PI	WC	
450.0	150					SILT AND CLAY: Stiff to very-stiff gray clay, "and" silt, trace fine sand, contains many silt seams and lenses. SHALE: Very-soft gray shale, similar to hard silty clay.	33								Visual	
446.7	155		21/21/30			SHALE: Very-soft gray shale, fragmented.	34								Visual	
444.3	160		50-2"R 15%		4.6/0.4	SHALE: Very-soft to soft dark gray and gray shale, nearly horizontally bedded, many horizontal fractures, few vertical and diagonal fractures, contains diagonal joints at 165.2' and 168.2'; highly fractured from 159.4' to 159.9' and from 164.6' to 165.1', and few interbedded silty clay seams.	35								Visual	
434.3	165		10%		4.7/0.3		36								Visual	
	170															
	175															
	180															
	185															
	190															
	195															
	200															

NOTES:

- Encountered seepage at 18.5'.
- Switched to washbore at 41.5'.
- Base of inclinometer installed at an approximate depth of 168'.
- Encountered gas pocket. Water pressure rocked drill rods and water bubbled up to surface of drilling fluid.

WATER LEVEL: "Dry"
 WATER NOTE: Inside HSA - Prior to Washbore
 DATE: 4/28/06

"Dry"
 Inside HSA - Prior to Washbore
 DATE: 5/1/06

APPENDIX E
LABORATORY TEST RESULTS

LABORATORY TEST RESULTS SUMMARY

Anisotropically Consolidated Triaxial Compression Tests							
Boring No.	Depth (ft)	Sample No.	σ'_{vc} (ksf)	σ'_{hc} (ksf)	K_0	Effective Stress	
						s_u (ksf)	$c' \text{ (ksf)}$ $\phi'_{secant} (\circ)$
B-05-01	55'-57'	S-13 I	3.04	2.46	0.81	3.4	0 32
		S-13 II	6.83	3.72	0.54	4.6	0 32
		S-13 III	9.94	4.99	0.50	5.5	0 32
Isotropically Consolidated Triaxial Compression Tests							
Boring No.	Depth (ft)	Sample No.	σ'_{vc} (ksf)	σ'_{hc} (ksf)	K_0	Effective Stress	
						s_u (ksf)	$c' \text{ (ksf)}$ $\phi'_{secant} (\circ)$
B-05-13	70'-71.6'	S-18 I	2.82	2.82	1.0	1.8	0 26
		S-18 II	5.63	5.63	1.0	3.5	0 26
		S-18 III	11.26	11.26	1.0	5.6	0 26

Direct Simple Shear Tests					
Boring No.	Depth (ft)	Sample No.	σ'_{vc} (ksf)	s_u (ksf)	s_u/σ'_{vc}
B-05-02	44'-46'	14	5.6	1.5	0.27
B-05-02	122'-124'	32	10.6	3.2	0.30
B-05-03	32'-33.5'	8	3.9	1.16	0.3
B-05-07	104'-106'	22	10.6	2.0	0.19

LABORATORY TEST RESULTS SUMMARY (cont.)

Torsional Ring Shear Tests				
Boring No.	Depth (ft)	Sample No.	σ'_{vc} (ksf)	$\phi'_{R(secant)}$ (°)
B-05-02	128.5'-130'	S-35	5.0	33
			11.1	32
			16.2	32
B-05-03	30'-30.5'	S-7	1.0	31
			3.5	30
			6.0	29
B-05-03	123.8'-124.5'	S-31B	5.0	33
			9.6	33
			15.1	33
B-05-04	58.8'-59.2'	S-23	3.0	32
			5.6	32
			8.0	32
B-05-04	113.5'-114.5'	S-36	9.0	24
			2	22
B-05-11	92'-93.5'	S-24	4	19
			15.7	17

Direct Shear Tests				
Boring No.	Depth (ft)	Sample No.	σ'_{vc} (ksf)	$\phi'_{R(secant)}$ (°)
B-105A	103'-105'	S-23 I	7.9	24
B-108A	117'-117.5'	S-26 I	8.6	25
B-05-16	24' - 26'	S-7 I	2.4	32
B-05-16	111' - 113'	S-25 I	7.0	36
B-05-16	113' - 115'	S-26 III	7.0	41

LABORATORY TEST RESULTS SUMMARY (cont.)

Boring No.	Unconfined Compression Tests			
	Depth (ft)	Sample No.	q _u (psi)	v (tangent over linear range)
B-05-01	228.8 - 229.3	56	1476.67	---
B-05-03	165.2 - 165.9	39	1311.26	---
B-05-04	169.9 - 170.4	50	1115.95	---
B-05-07	224.0 - 224.5	48	1112.63	---
B-05-11	225.0 - 225.5	55	209.37	---
B-05-12	207.6 - 208.1	56	1020.94	---
B-05-13	152.5 - 153.0	35	1553.10	---
B-05-13	178.5 - 179.0	40	347.96	---
B-05-13	160.1 - 160.6	37	2955.0	0.39
B-05-14	168.4 - 169.0	36	1313.31	---
B-05-14	180.0 - 180.4	37	1198.22	---
B-05-14	190.5 - 191.0	39	3228.0	0.13
B-05-15	202.4 - 203.0	47	2056.59	---
B-05-15	208.4 - 209.0	48	2916.94	---
B-05-15	213.1 - 213.6	49	2322.0	0.40
B-05-16	163.5 - 163.8	36	2295.18	---
B-105A	154.4 - 155.2	34	827.76	---

JOB NUMBER : 012-00946-300

PROJECT : CUY-90-15.24 West Abutment

LABORATORY LOG OF SHELBY TUBES

Boring : B-05-01	Sample : 13	Boring : B-05-13	Sample : 18	Boring : Sample :	Sample :
Depth : 55.0' to 57.0'	Recovery : 20.50"	Depth : 70.0' to 71.6'	Recovery : 18.00"	Depth :	Recovery :
<p>disturbed - discarded</p> <p>Gray silt inter-bedded with silty clay, trace fine sand.</p> <p>-@ 55.0' to 55.2' many lenses of fine to coarse sand.</p> <p>A-4b (8)</p> <p>30.50" tube</p>	<p>disturbed - discarded</p> <p>Stiff to very-stiff gray silty clay, trace fine to coarse sand, trace fine gravel, few lenses of silt.</p> <p>-@ 70.0' to 70.3' Soft</p> <p>A-6a (9)</p> <p>H=2.25</p> <p>H=1.3</p> <p>AL/MA on Sections I,II,III</p> <p>30.00" tube</p>				

LEGEND

- Wax
- Consolidation, Vertical
- Permeability, Vertical / Horizontal
- Unconfined Compression Test
- Triaxial Compression Test
- Hand Penetrometer (tsf)
- Direct Shear
- Loss on Ignition
- Atterberg Limits
- Mechanical Analysis
- Specific Gravity
- Porosity
- Unit Dry Weight
- Moisture Content
- Relative Density
- Sieve

JL NUMBER : 012-00946.300
PROJECT : CUY-90-15.24 West Abutment

LABORATORY LOG OF SHELBY TUBES

Boring : B-05-04	Sample : S-25	Sample : S-37	Sample :
Depth : 68.0' to 70.0' Recovery : 20.50"	Depth : 118.0' to 119.0' Recovery : 12.00"	Depth : 118.0' to 119.0' Recovery : 12.00"	Depth : Recovery :
<p> I 12- II III 24- IV </p>	<p> I II 24- </p>		

LEGEND

- Wax
- Consolidation, Vertical
- Permeability, Vertical / Horizontal
- Unconfined Compression Test
- Triaxial Compression Test

LEGEND

- H - Hand Penetrometer (tsf)
- Ds - Direct Shear
- LOI - Loss on Ignition
- AL - Atterberg Limits
- MA - Mechanical Analysis
- SG - Specific Gravity
- POR - Porosity
- UDW - Unit Dry Weight
- MC - Moisture Content
- DR - Relative Density
- S - Sieve

JOB NUMBER : 012-00946.300

PROJECT : CUY-90-15.24 West Abutment



LABORATORY LOG OF SHELBY TUBES

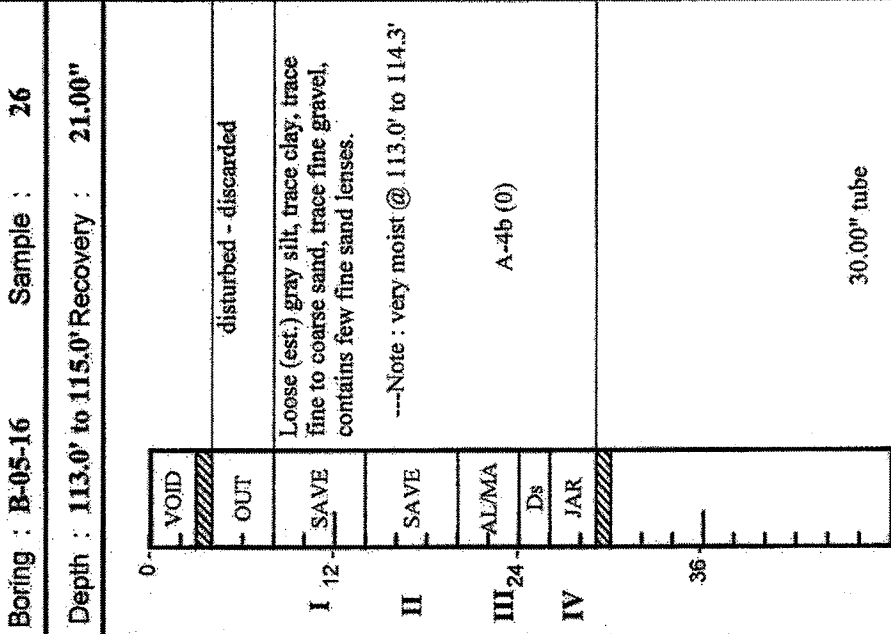
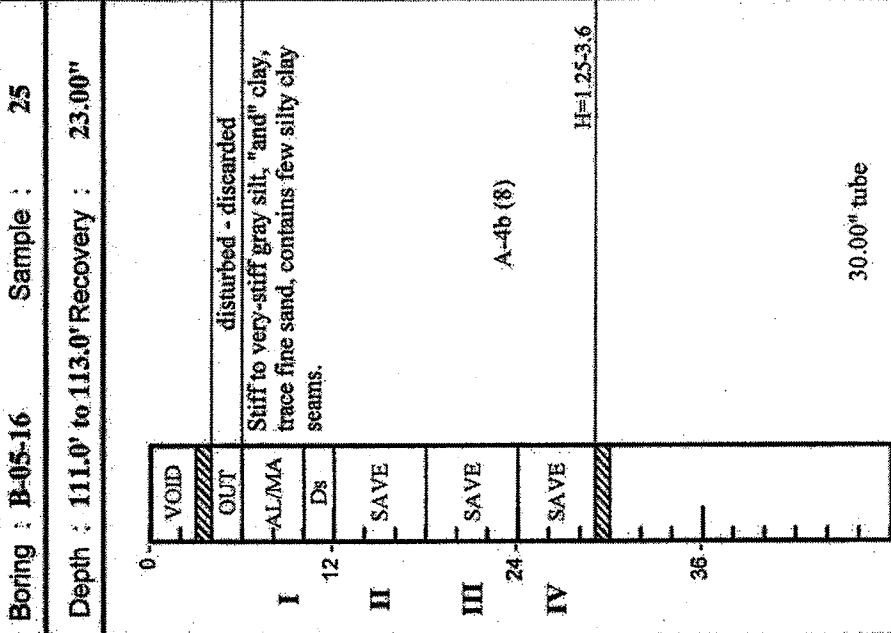
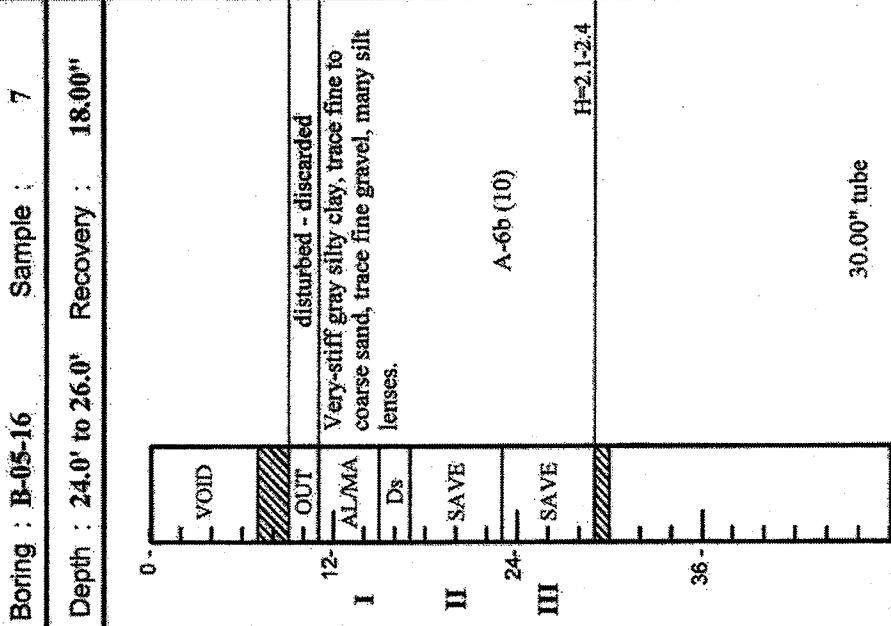

LEGEND

- Wax
- Consolidation, Vertical
- Permeability, Vertical / Horizontal
- Unconfined Compression Test
- Triaxial Compression Test
- Hand Penetrometer (tsf)
- Ds - Direct Shear
- LOI - Loss on Ignition
- AL - Atterberg Limits
- MA - Mechanical Analysis
- SG - Specific Gravity
- POR - Porosity
- UDW - Unit Dry Weight
- MC - Moisture Content
- DR - Relative Density
- S - Sieve

JOB NUMBER : 012-00946-300

PROJECT : CUY-90-15.24 West Abutment

LABORATORY LOG OF SHELBY TUBES

Boring : B-105A	Sample : 23	Boring : B-105A	Sample : 24	Boring : B-105A	Sample : 25
Depth : 103.0' to 105.0'	Recovery : 24.00"	Depth : 105.0' to 107.0'	Recovery : 25.50"	Depth : 107.0' to 109.0'	Recovery : 25.00"

LEGEND

- Wax
- Consolidation, Vertical
- Unconfined Compression Test
- Permeability, Vertical / Horizontal
- Triaxial Compression Test
- Hand Penetrometer (tsf)
- Direct Shear
- Loss on Ignition
- Atterberg Limits
- Mechanical Analysis
- Specific Gravity
- Porosity
- Unit Dry Weight
- Moisture Content
- Relative Density
- Sieve

JOB NUMBER : 012-00946.300
 PROJECT : CUY-90-15.24 West Abutment

LABORATORY LOG OF SHELBY TUBES

Boring : B-108A	Sample : S-24	Boring : B-108A	Sample : S-25	Boring : B-108A	Sample : S-26
Depth : 113.0' to 115.0' Recovery : 24.00"	Depth : 113.0' to 115.0' Recovery : 24.00"	Depth : 115.0' to 117.0' Recovery : 24.00"	Depth : 115.0' to 117.0' Recovery : 24.00"	Depth : 117.0' to 119.0' Recovery : 24.00"	Depth : 117.0' to 119.0' Recovery : 24.00"

LEGEND

- Wax
- Consolidation, Vertical
- Permeability, Vertical / Horizontal
- Unconfined Compression Test
- Triaxial Compression Test
- H** - Hand Penetrometer (tsf)
- Ds** - Direct Shear
- LOI** - Loss on Ignition
- AL** - Atterberg Limits
- MA** - Mechanical Analysis
- SG** - Specific Gravity
- POR** - Porosity
- UDW** - Unit Dry Weight
- MC** - Moisture Content
- DR** - Relative Density
- S** - Sieve

SUMMARY OF TRIAXIAL COMPRESSION TESTS

SATURATED, CONSOLIDATED, UNDRAINED
(RESIDUAL PLOTTED)

SHEAR STRESS VS NORMAL STRESS

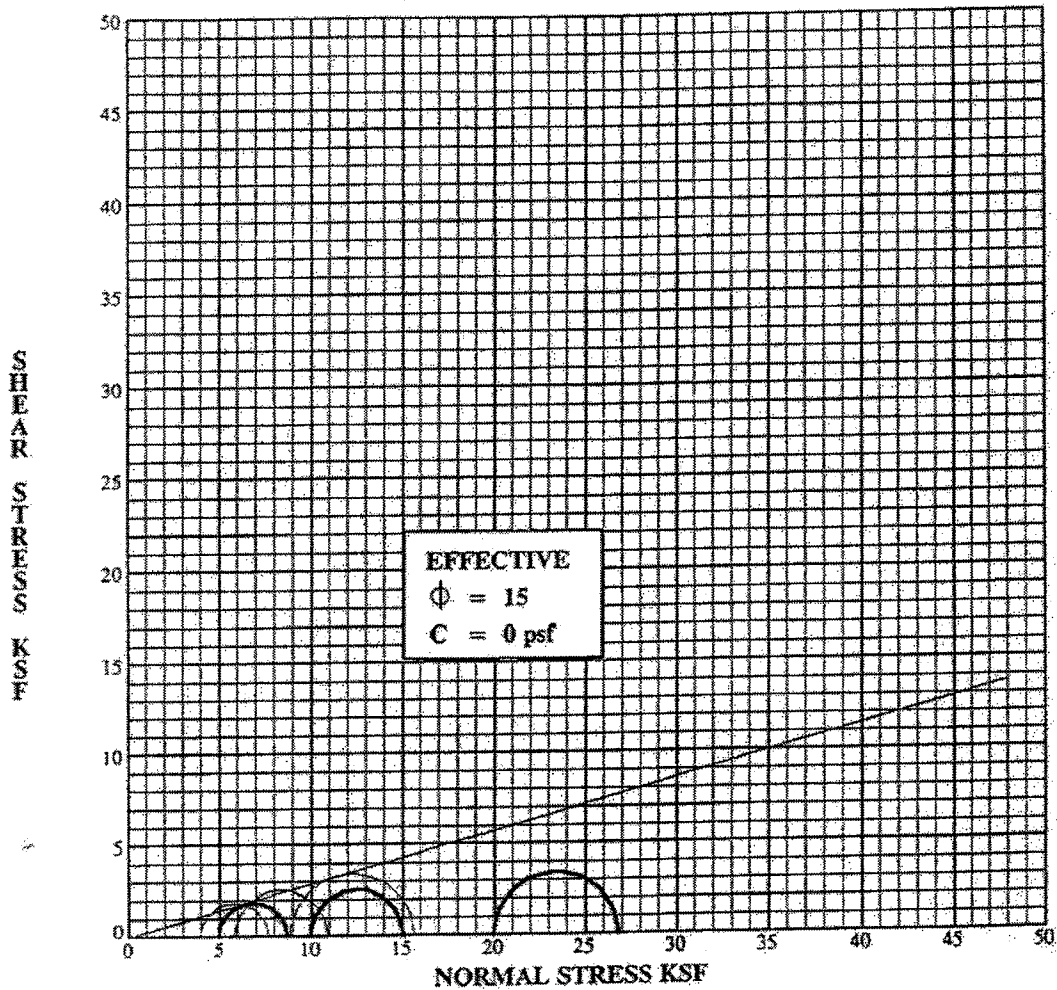

TOTAL STRESS

EFFECTIVE STRESS

Specimen Identification	Classification	DD	MC%
B-109 S-24 I 124.5'-126.2'	Very-stiff gray silty clay, trace fine to coarse sand, trace fine gravel, contains few lenses of silt. A-6b (10)	103	23
B-109 S-24 II 124.5'-126.2'	Very-stiff gray silty clay, trace fine to coarse sand, trace fine gravel, contains few lenses of silt. A-6b (10)	98	27
B-109 S-24 III 124.5'-126.2'	Very-stiff gray silty clay, trace fine to coarse sand, trace fine gravel, contains few lenses of silt. A-6b (10)	107	20



PROJECT CUY-90-15.24
 LOCATION CLEVELAND, OHIO
 JOB NO. 4500 DATE 12/10/94

SUMMARY OF DIRECT SHEAR TESTS

SATURATED, CONSOLIDATED, DRAINED

SHEAR STRESS VS NORMAL LOAD

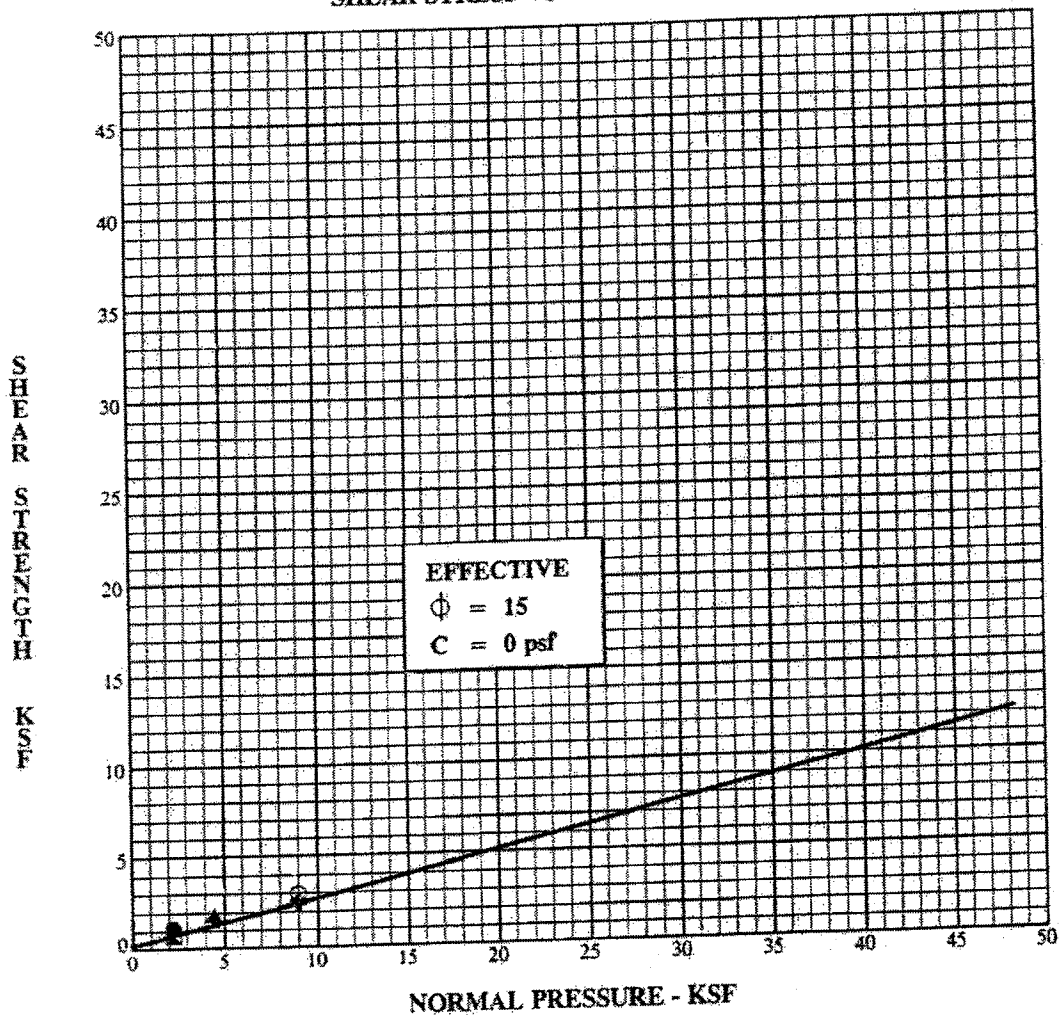

Specimen Identification	Normal Load	Type Plot	Classification	DD	MC%
● B-108 S-8 IV 35.0'-37.0'	2.25 KSF	Peak	Stiff gray silty clay, trace fine	101	26
■	2.25 KSF	RESIDUAL	to medium sand. A-6a (10)		
▲	4.50 KSF	Peak		100	26
★	4.50 KSF	RESIDUAL			
○	9.00 KSF	Peak		95	28
⊗	9.00 KSF	RESIDUAL			



PROJECT CUY-90-15.24
 LOCATION Cleveland, Ohio
 JOB NO. 4500 DATE 10/29/94

Figure:

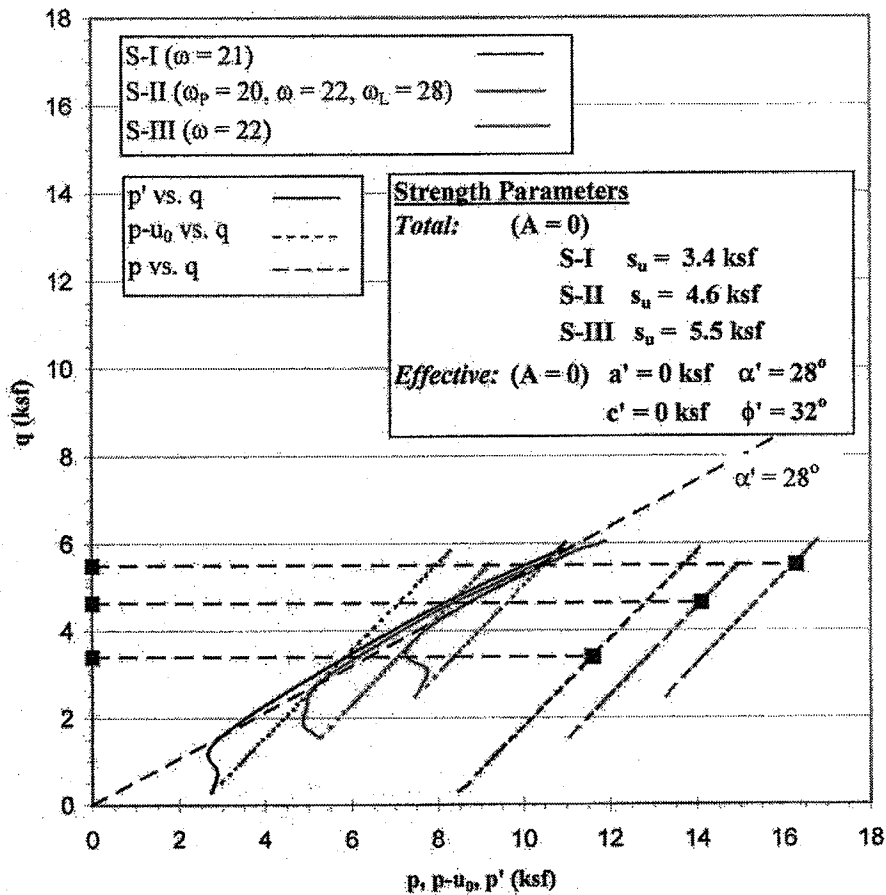

Type of Test: CK₀UTXC with pore pressure measurements
Description: SILT - Medium-stiff to very-stiff gray silt, some to "and" clay, trace fine sand.
Assumed Specific Gravity: 2.75

Sample No.		I	II	III
Initial	Water Content	21.3	22.4	21.5
	Dry Density, pcf	111.0	107.8	107.2
	Saturation	107.2	103.9	98.3
	Void Ratio	0.546	0.592	0.602
	Diameter, in	2.87	2.86	2.88
	Height, in	5.60	5.61	5.59
At Test	Water Content	18.3	20.1	19.0
	Dry Density, pcf	115.7	113.3	112.6
	Saturation	103.8	107.3	99.5
	Void Ratio	0.484	0.516	0.525
	Diameter, in	2.82	2.82	2.85
	Height, in	5.55	5.48	5.41

BBC&M ENGINEERING, INC. - Triaxial Compression Test Report

Boring: B-05-01 **Project:** CUY-90.15.24 West Abutment
Sample: S13, Sec I to III **Project No:** 012 00946.300
Depth: 55' to 57' **Client:** Micheal Baker Jr. Inc.

Figure:

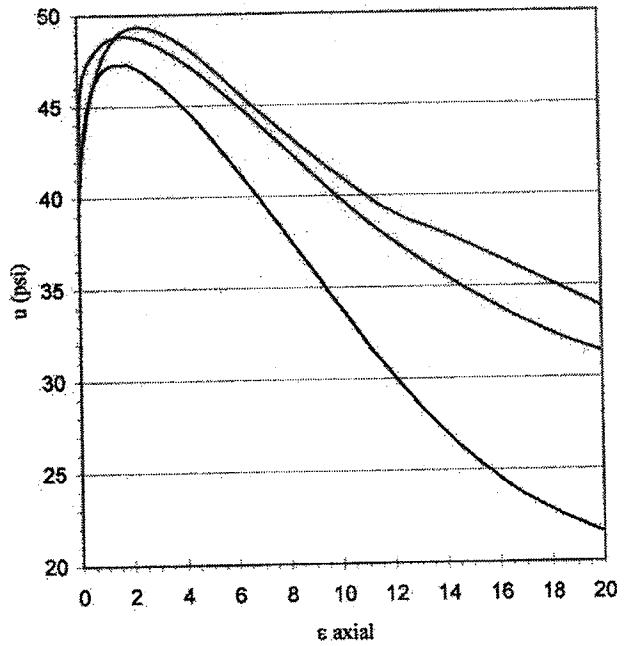
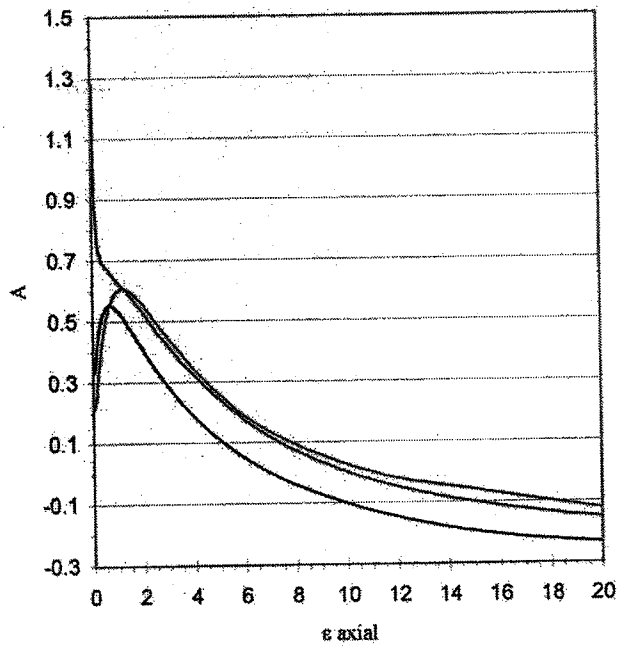
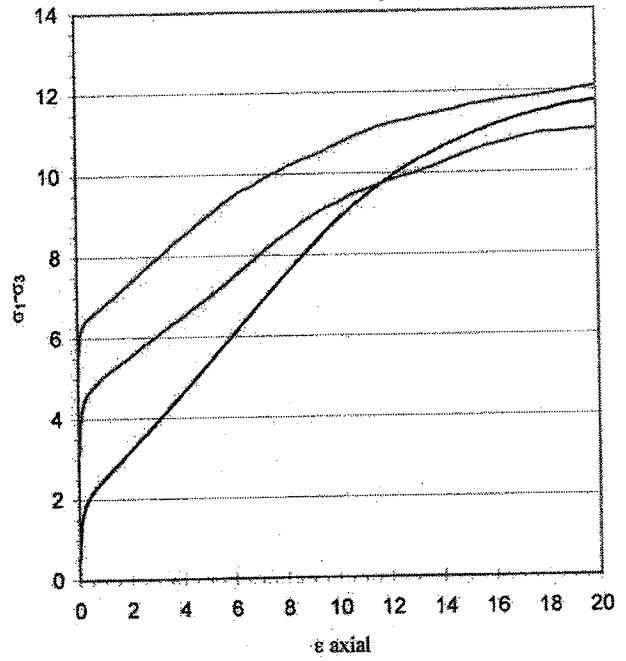
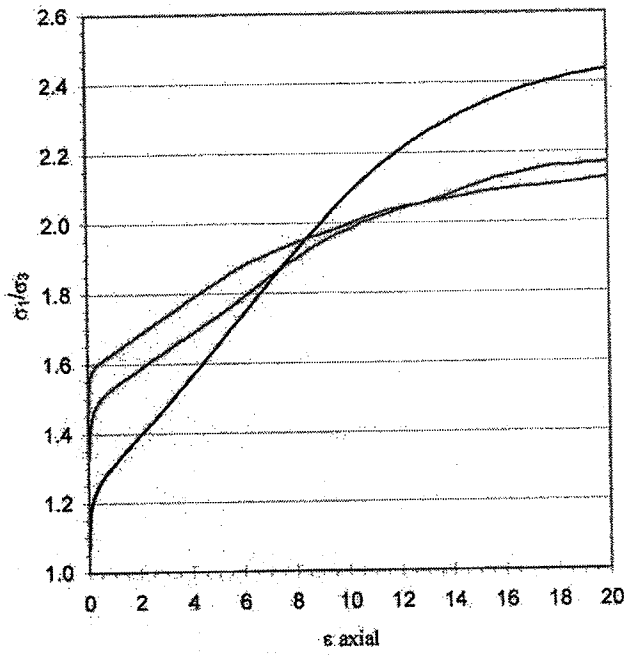

BBC&M ENGINEERING, INC. - Triaxial Compression Test Report

Boring: B-05-01
Sample: S13, Sec I to III

Depth: 55' to 57'

Project: CUY-90.15.24 West Abutment
Project No: 012 00946.300
Client: Micheal Baker Jr. Inc.

Figure:

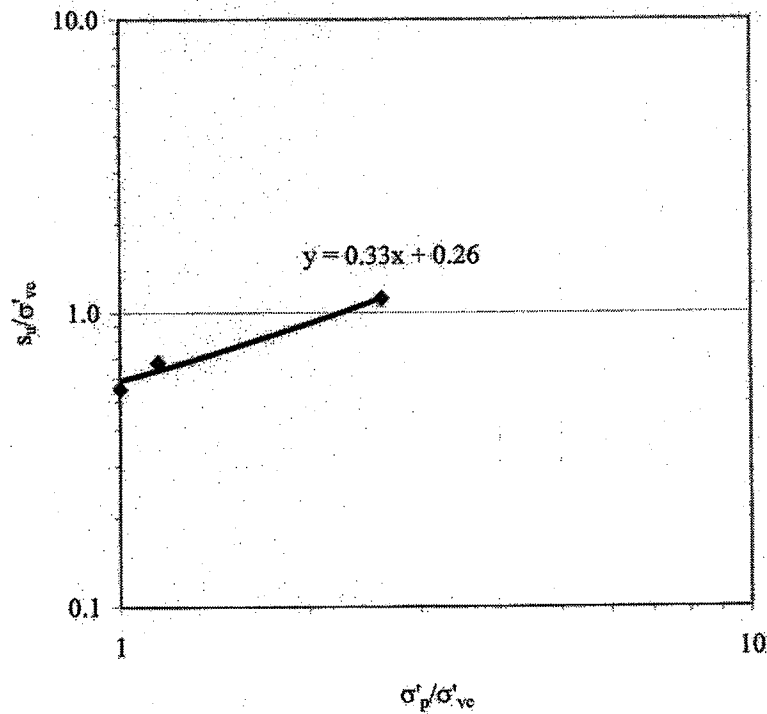
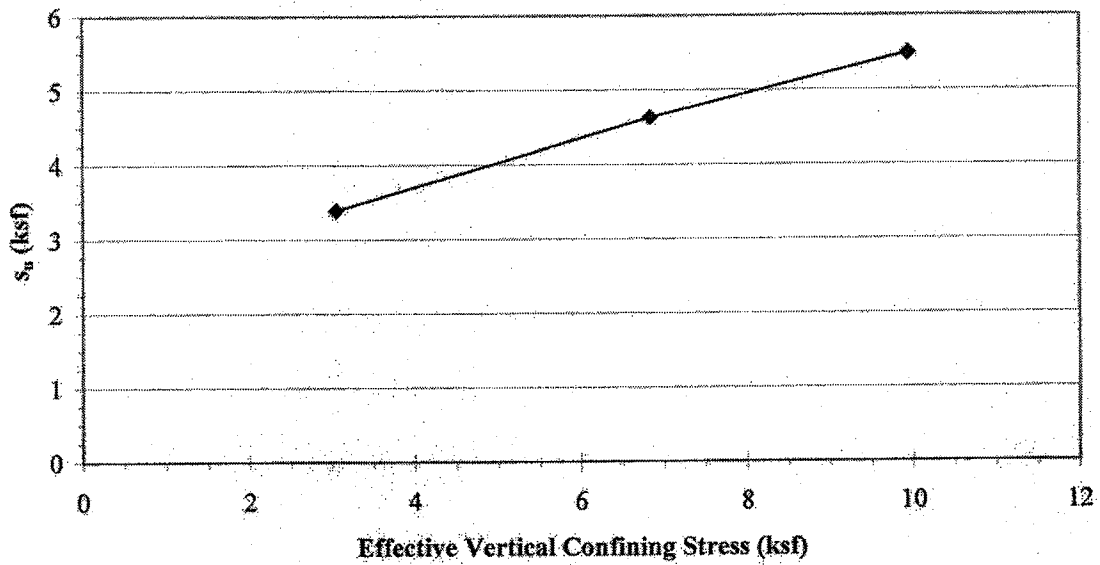

BBC&M ENGINEERING, INC. - Triaxial Compression Test Report

Boring: B-05-01
Sample: S13, Sec I to III

Depth: 55' to 57'

Project: CUY-90.15.24 West Abutment
Project No: 012 00946.300
Client: Micheal Baker Jr. Inc.

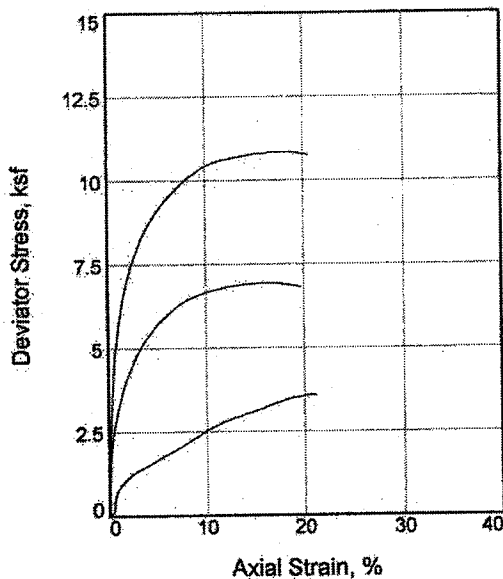
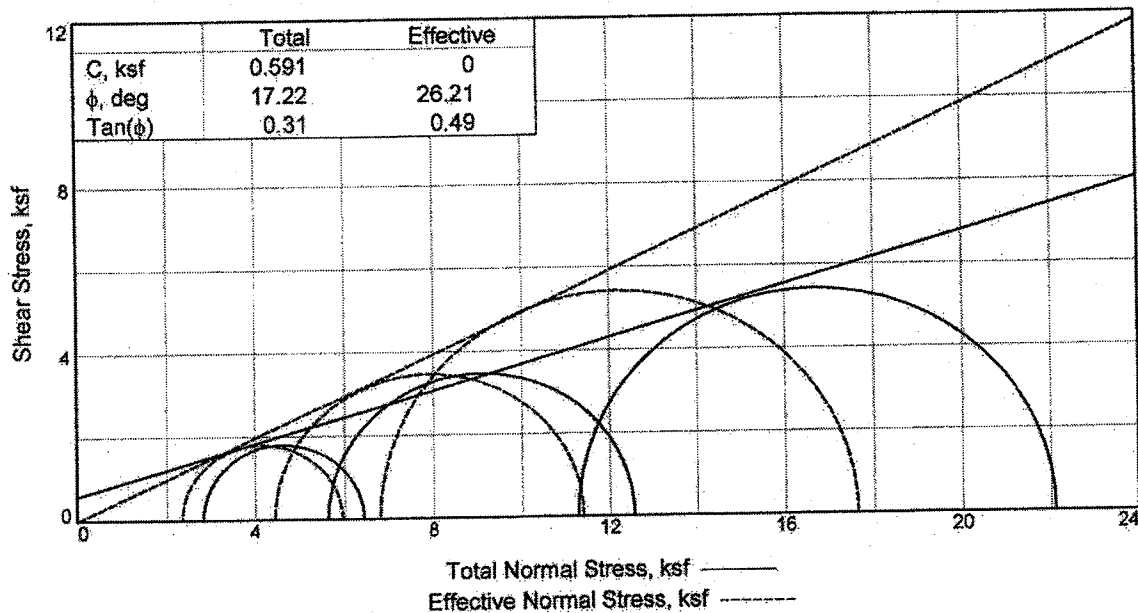

Sample No.	1	2	3
Initial			
Water Content,	23.5	21.8	21.2
Dry Density, pcf	98.2	105.5	107.1
Saturation,	86.3	95.7	96.8
Void Ratio	0.7488	0.6278	0.6029
Diameter, in.	2.878	2.868	2.866
Height, in.	5.590	5.600	5.590
At Test			
Water Content,	21.4	19.9	18.7
Dry Density, pcf	108.0	111.0	115.9
Saturation,	99.9	99.8	106.7
Void Ratio	0.5894	0.5472	0.4808
Diameter, in.	2.823	2.827	2.792
Height, in.	5.279	5.477	5.442
1			
Strain rate, in./min.	0.002	0.002	0.002
Eff. Cell Pressure, ksf	2.82	5.63	11.26
Fail. Stress, ksf	3.60	6.94	10.85
Excess Pore Pr., ksf	0.47	1.18	4.48
Strain, %	20.7	15.9	17.8
Ult. Stress, ksf	3.33		
Excess Pore Pr., ksf	0.77		
Strain, %	17.0		
$\bar{\sigma}_1$ Failure, ksf	5.95	11.39	17.63
$\bar{\sigma}_3$ Failure, ksf	2.35	4.45	6.79

Type of Test:

CU with Pore Pressures

Sample Type: Shelby Tube

Description: Stiff to very-stiff gray silty clay, little fine to coarse sand, trace fine gravel. A-6a

LL= 30 PL= 17 PI= 13

Assumed Specific Gravity= 2.75

Remarks: top 3" of Section I disturbed

Report Date 05/16-19/06

Client:

Project: CUY-90-15.24 West Abutment

Cleveland, Ohio

Location: B-05-13

Sample Number: 18 Section I,II,III

Proj. No.: 012-00946-300

Date: 05/19/06

TRIAXIAL SHEAR TEST REPORT

BBC&M Engineering, Inc.

Tested By: JJ

Checked By: JJ

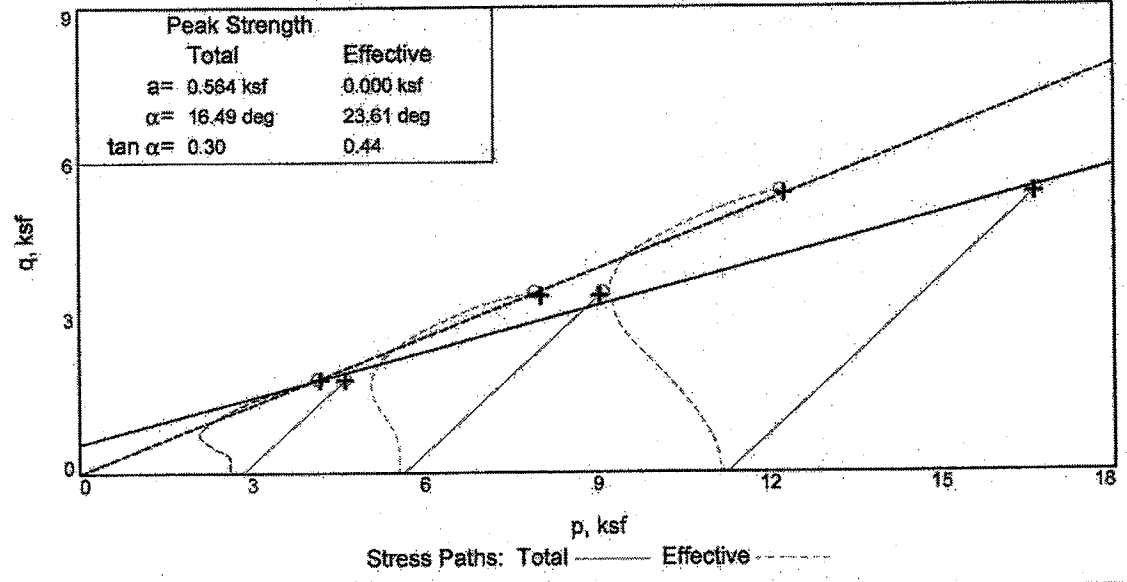
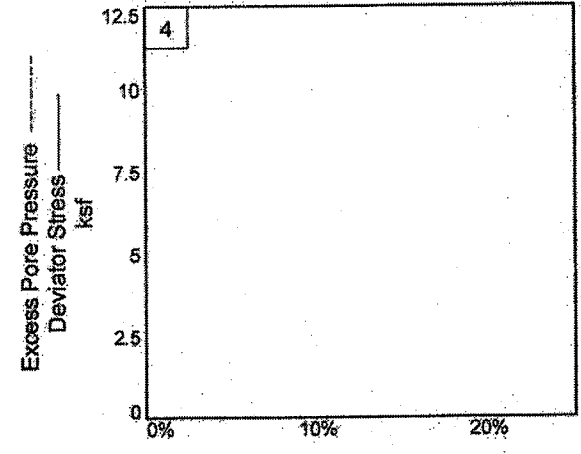
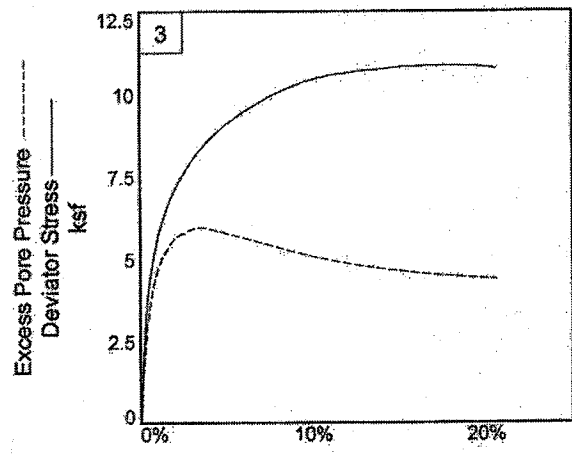
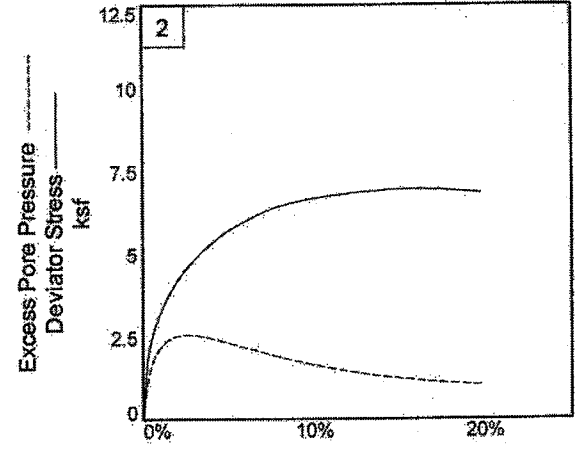
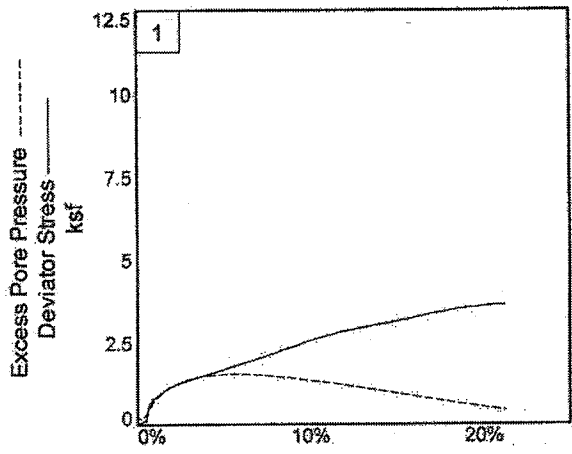

Client:
 Project: CUY-90-15.24 West Abutment
 Location: B-05-13 Depth: 70.0' to 71.6' Sample Number: 18 Section I,II,III
 Project No.: 012-00946-300 Report Date: _____ **BBC&M Engineering, Inc.**

Tested By: JJ Checked By: JJ

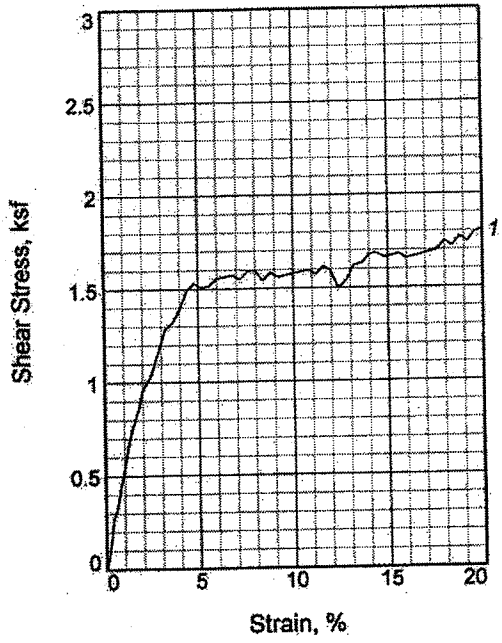
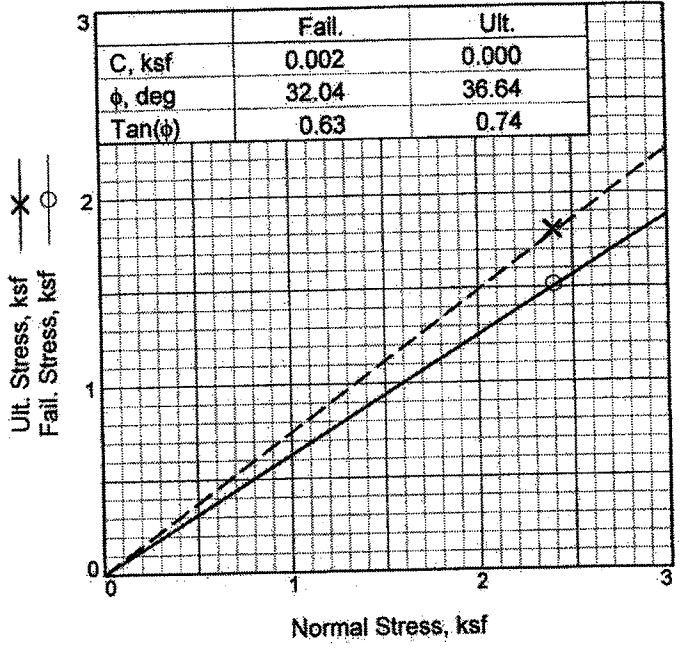
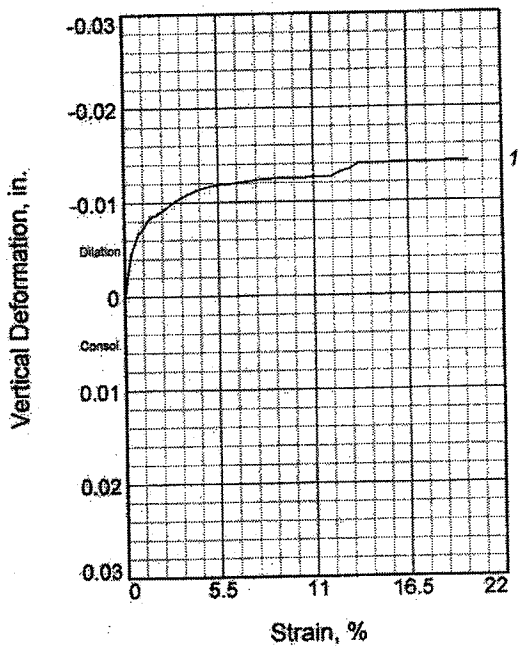

Sample No.		1
Initial	Water Content, %	23.6
	Dry Density, pcf	104.1
	Saturation, %	99.9
	Void Ratio	0.6494
	Diameter, in.	2.500
At Test	Height, in.	1.000
	Water Content, %	20.9
	Dry Density, pcf	109.1
	Saturation, %	100.4
	Void Ratio	0.5737
	Diameter, in.	2.500
	Height, in.	0.954
	Normal Stress, ksf	2.400
	Fail. Stress, ksf	1.516
	Strain, %	5.6
	Ult. Stress, ksf	1.806
	Strain, %	20.0
	Strain rate, in./min.	0.002

Sample Type: Shelby Tube
Description: Very-stiff gray silty clay, trace fine to coarse sand, trace fine gravel, many lenses of silt.
LL= 36 PL= 20 PI= 16
Assumed Specific Gravity= 2.75
Remarks: Residual Shear
 A-6b(10)

Client:
Project: CUY-90-15.24 West Abutment
 Cleveland, Ohio
Location: B-05-16
Sample Number: 7 **Depth:** 24.0' to 26.0'
 Proj. No.: 012-00946-300 **Date:** 06/16-19/06

Figure 06/20/06

DIRECT SHEAR TEST REPORT
BBC&M Engineering, Inc.

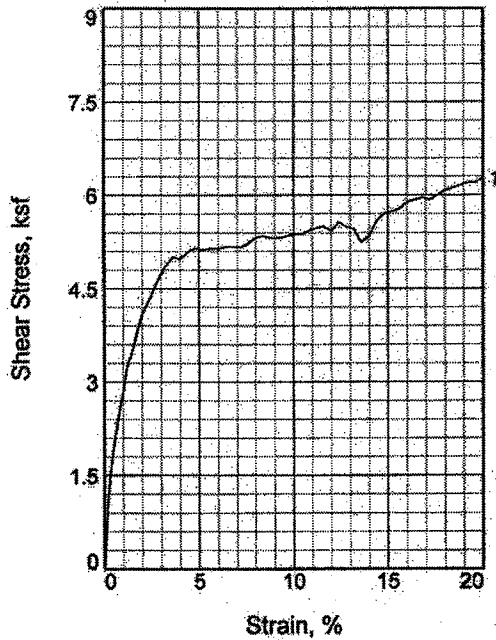
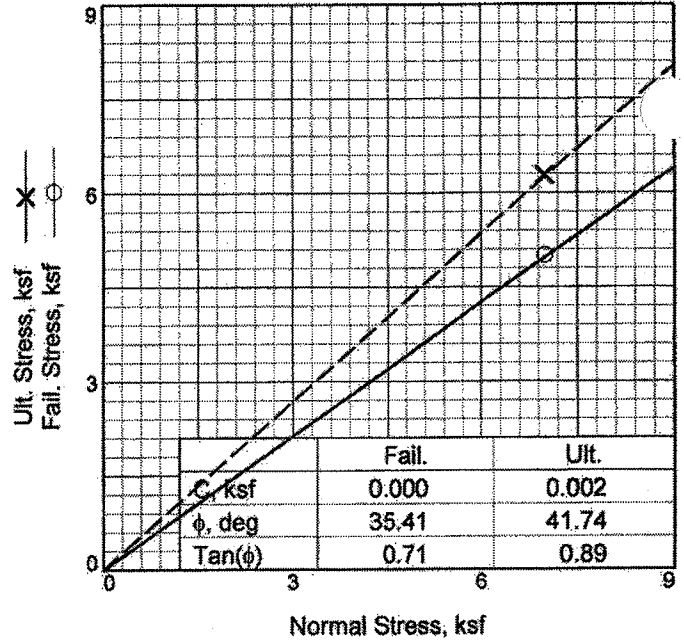
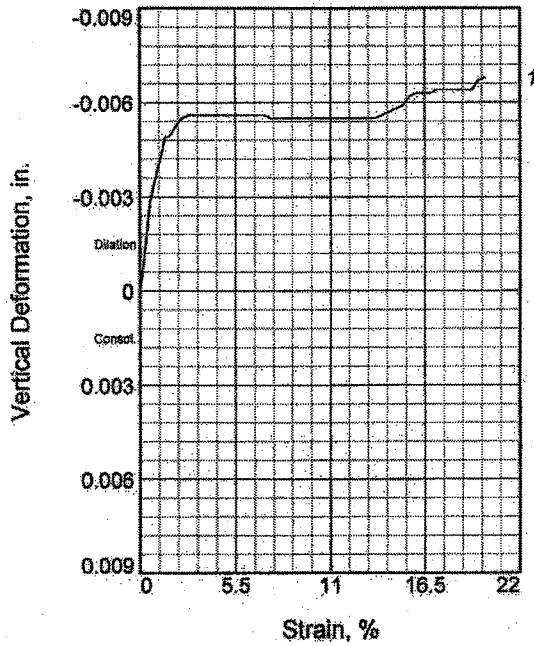

Sample No.	1	
Initial	Water Content, %	30.5
	Dry Density, pcf	98.6
	Saturation, %	113.1
	Void Ratio	0.7412
	Diameter, in.	2.500
At Test	Height, in.	1.000
	Water Content, %	22.8
	Dry Density, pcf	103.2
	Saturation, %	94.6
	Void Ratio	0.6640
	Diameter, in.	2.500
	Height, in.	0.956
	Normal Stress, ksf	7.000
	Fail. Stress, ksf	5.011
	Strain, %	3.6
	Ult. Stress, ksf	6.283
	Strain, %	20.0
	Strain rate, in./min.	0.002

Sample Type: Shelby Tube
Description: Stiff to very-stiff gray silty clay interbedded with silt, trace fine sand.
LL= 27 PL= 20 PI= 7
Assumed Specific Gravity= 2.75
Remarks: Residual Shear
 A-4b(8)

Client:
Project: CUY-90-15.24 West Abutment
 Cleveland, Ohio
Location: B-05-16
Sample Number: 25 Section I **Depth:** 111.0' to 113.0'
 Proj. No.: 012-00946-300 **Date:** 06/19-20/06

Figure 06/23/06

DIRECT SHEAR TEST REPORT
BBC&M Engineering, Inc.

Tested By: SW

Checked By: JJ

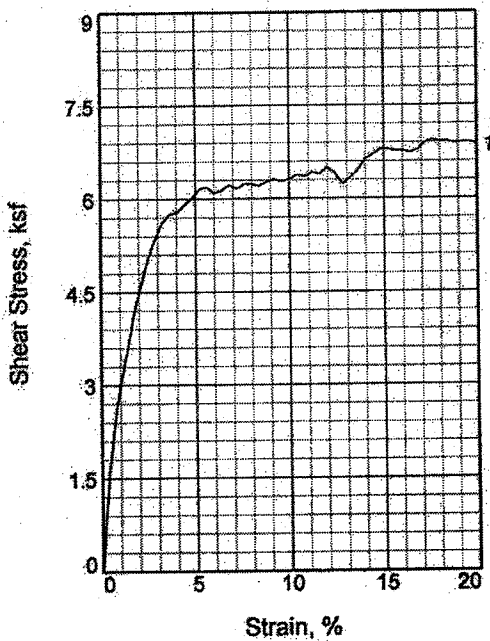
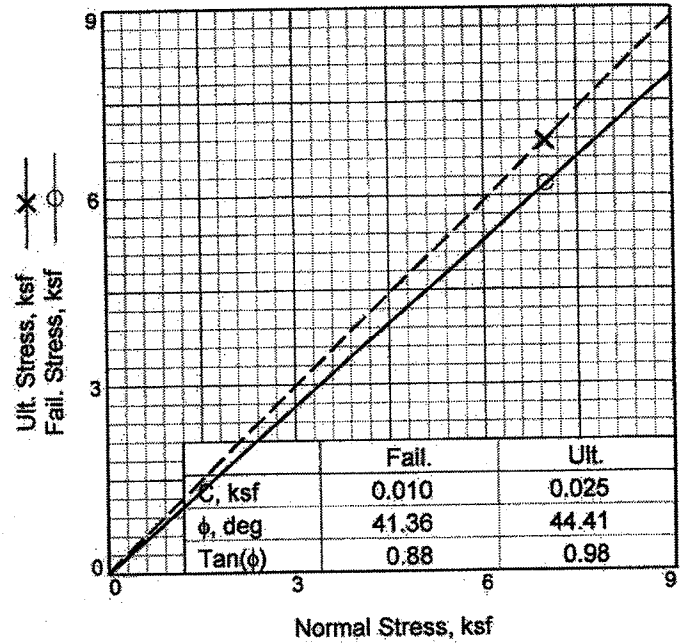
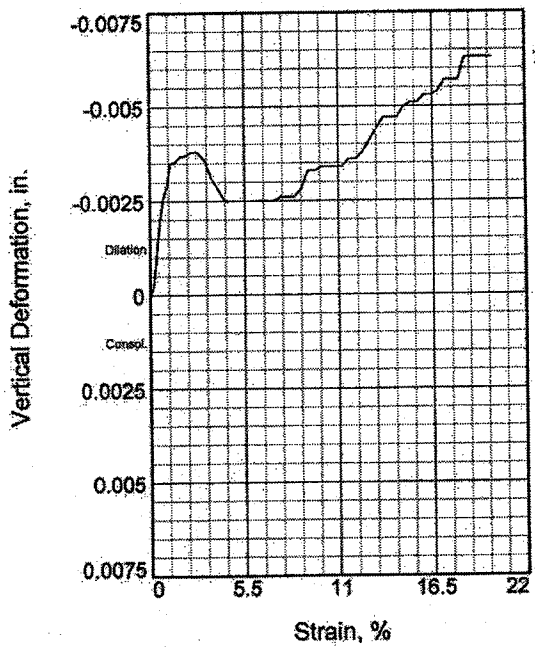

Sample No.		1
Initial	Water Content, %	25.2
	Dry Density, pcf	100.7
	Saturation, %	98.4
	Void Ratio	0.7043
	Diameter, in.	2.500
At Test	Height, in.	1.000
	Water Content, %	22.1
	Dry Density, pcf	104.9
	Saturation, %	95.2
	Void Ratio	0.6370
	Diameter, in.	2.500
	Height, in.	0.961
	Normal Stress, ksf	7.000
	Fail. Stress, ksf	6.191
	Strain, %	5.6
	Ult. Stress, ksf	6.872
	Strain, %	20.0
	Strain rate, in./min.	0.002

Sample Type: Shelby Tube
Description: Gray silt, trace clay, trace fine to coarse sand, trace fine gravel, few lenses of fine
LL= NP **PI= NP**
Assumed Specific Gravity= 2.75.
Remarks: Residual Shear
 A-4b(0)

Client:
Project: CUY-90-15.24 West Abutment
 Cleveland, Ohio
Location: B-05-16
Sample Number: 26 Sec. III **Depth:** 113.0' to 115.0'
Date: 06-20-21/06
 Proj. No.: 012-00946-300

Figure 06/22/06

DIRECT SHEAR TEST REPORT
BBC&M Engineering, Inc.

Tested By: SW

Checked By: JJ

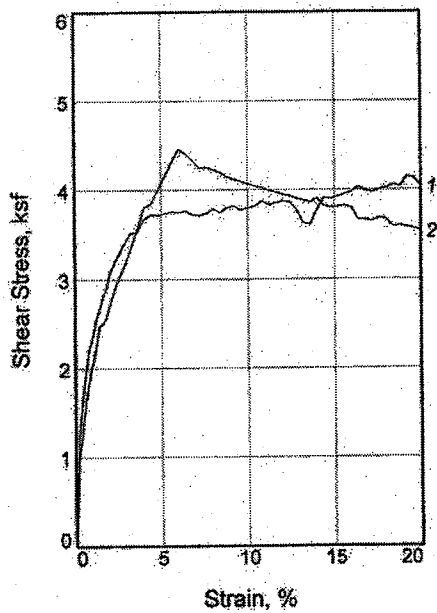
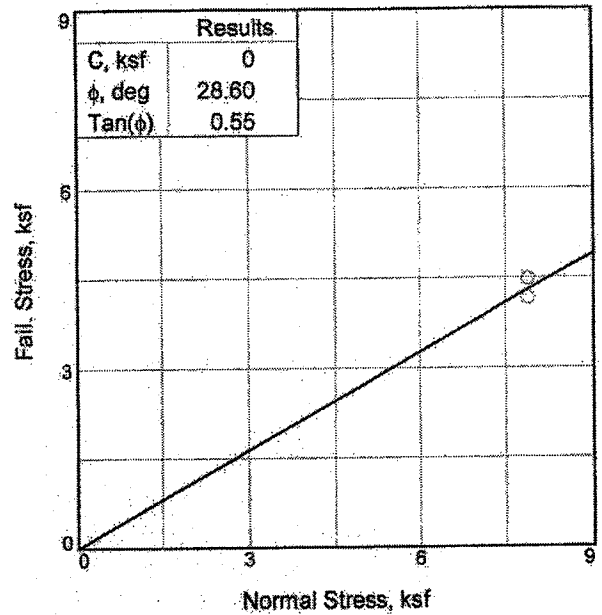
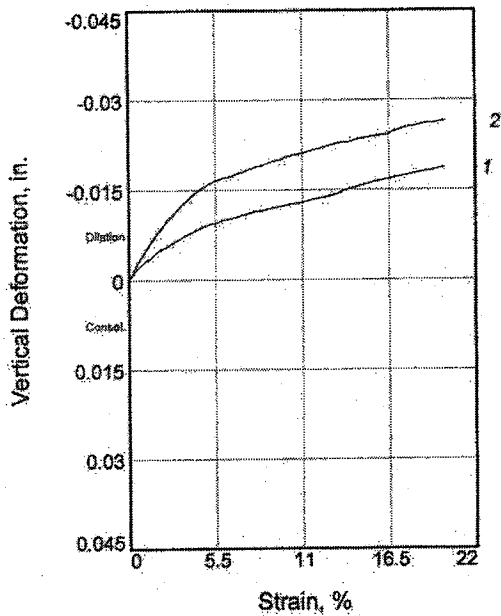

Sample No.	1	2	
Initial	Water Content, %	27.9	27.9
	Dry Density, pcf	94.1	94.1
	Saturation, %	93.1	93.1
	Void Ratio	0.8238	0.8238
	Diameter, in.	2.500	2.500
	Height, in.	1.000	1.000
At Test	Water Content, %	24.0	24.0
	Dry Density, pcf	103.5	103.5
	Saturation, %	99.9	99.9
	Void Ratio	0.6593	0.6593
	Diameter, in.	2.500	2.500
	Height, in.	0.910	0.910
Normal Stress, ksf	7.900	7.900	
Fail. Stress, ksf	4.146	4.467	
Strain, %	19.2	6.0	
Ult. Stress, ksf			
Strain, %			
Strain rate, in./min.	0.012	0.002	

Sample Type: Shelby Tube
Description: Medium-stiff gray silty clay, trace fine sand.
LL= 34 PL= 18 PI= 16
Assumed Specific Gravity= 2.75
Remarks: 1= initial Shear
 2= Residual Shear

Client:
Project: CUY-90-15.24 West Abutment
 Cleveland, Ohio
Location: B-105A
Sample Number: 23 I **Depth:** 103.0' to 105.0'
 Proj. No.: 012-00946-300 **Date:** 02/24/06

Report Date 05/25/06

DIRECT SHEAR TEST REPORT

BBC&M Engineering, Inc.

Tested By: MA

Checked By: JJ

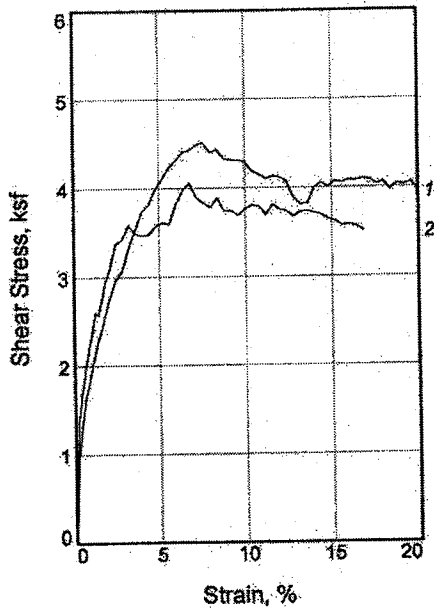
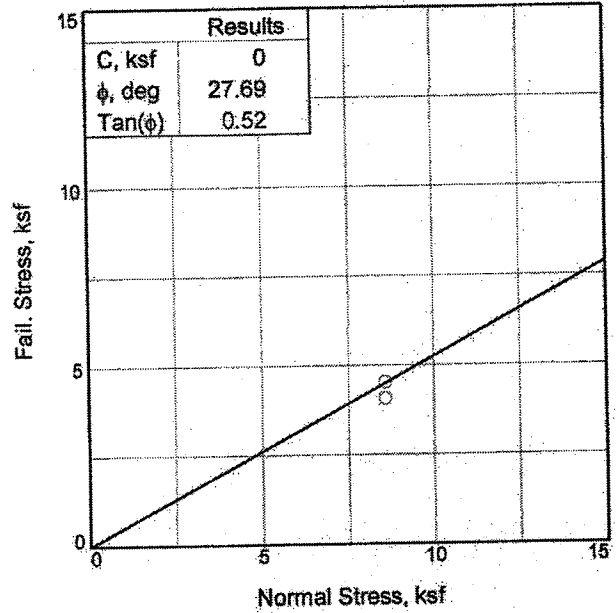
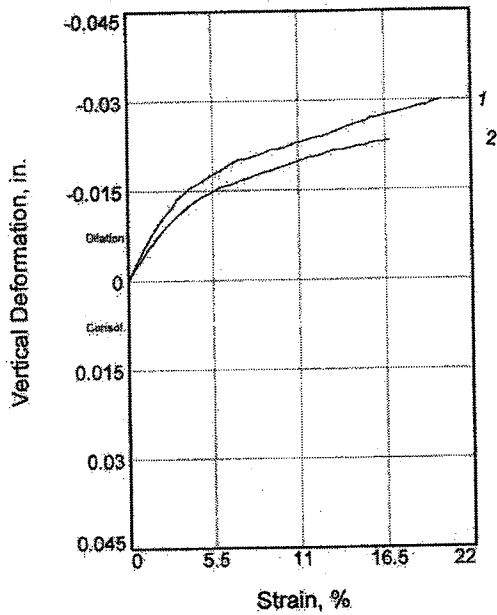

	1	2	
Sample No.	1	2	
Initial	Water Content, %	28.1	28.1
	Dry Density, pcf	91.9	91.9
	Saturation, %	91.0	91.0
	Void Ratio	0.8333	0.8333
	Diameter, in.	2.500	2.500
	Height, in.	1.000	1.000
At Test	Water Content, %	20.9	20.9
	Dry Density, pcf	107.6	107.6
	Saturation, %	99.8	99.8
	Void Ratio	0.5662	0.5662
	Diameter, in.	2.500	2.500
	Height, in.	0.854	0.854
Normal Stress, ksf	8.600	8.600	
Fail. Stress, ksf	4.514	4.059	
Strain, %	7.6	6.8	
Ult. Stress, ksf			
Strain, %			
Strain rate, in./min.	0.001	0.001	

Sample Type: Shelby Tube
Description: Soft to medium gray silty clay, trace fine sand, many lenses of silt.
LL= 35 PL= 20 PI= 15
Assumed Specific Gravity= 2.7
Remarks:

Report Date 05/16/06

Client:

Project: CUY-90-15.24 West Abutment

Cleveland, Ohio

Location: B-108A

Sample Number: 26 Section I

Depth: 117.0' to 117.5'

Proj. No.: 012-00946-300

Date: 05/14-16/06

DIRECT SHEAR TEST REPORT

BBC&M Engineering, Inc.

Tested By: BR

Checked By: JJ

LIQUID AND PLASTIC LIMITS TEST REPORT

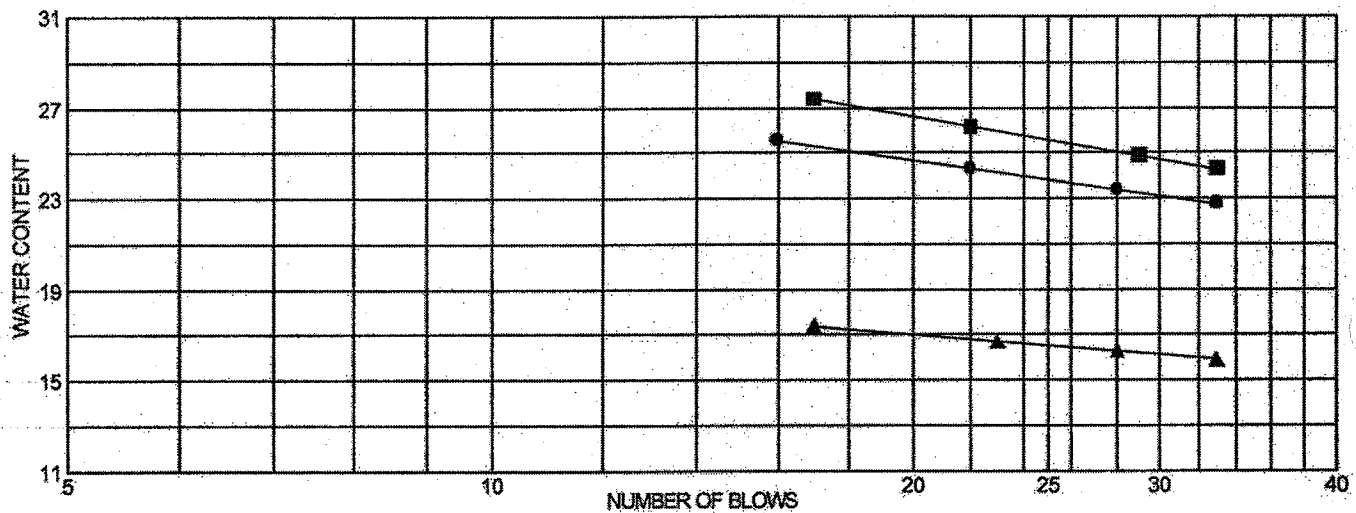
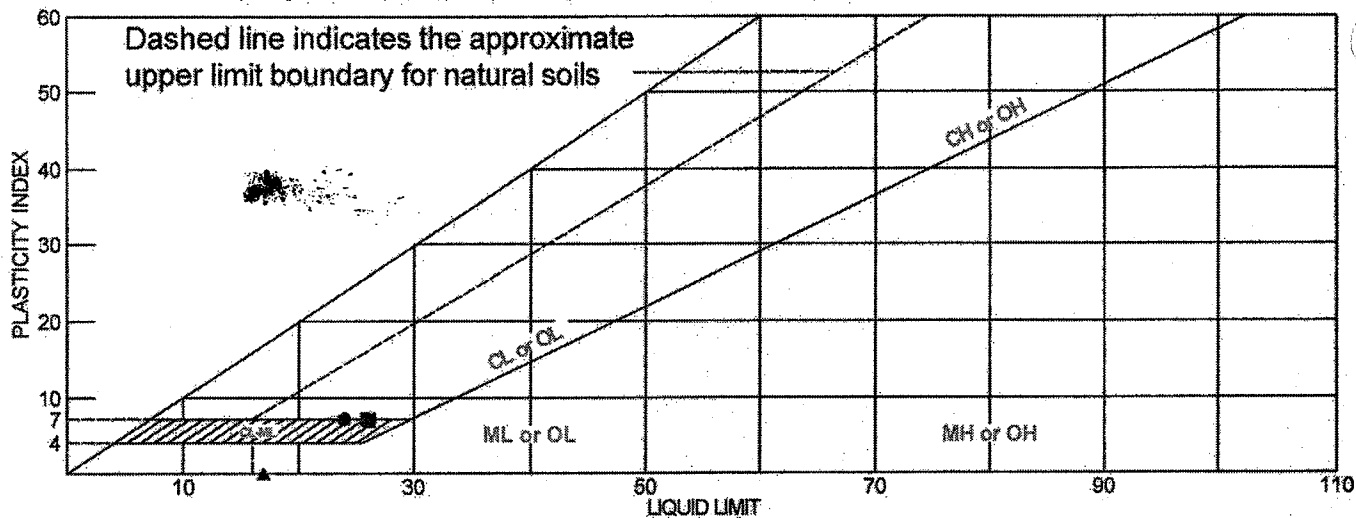

	MATERIAL DESCRIPTION	LL	PL	PI	%<#40	%<#200	USCS
●	Bluish Gray SILTY CLAY	24	17	7			
■	Greenish Gray SILTY CLAY w/ Sand	26	19	7			
▲	Gray SILT w/ Sand near Sandy SILT	17	18	NP			

Project No. 607-001 **Client:** BBCM Engineering
Project: CUY-90 WEST ABUTMENT - 012-00946-300

● Source: S-7 **Sample No.:** C-05-03 **Elev./Depth:** 30-30.5'
■ Source: S-23 **Sample No.:** C-05-04 **Elev./Depth:** 58.8-59.2'
▲ Source: S-31b **Sample No.:** C-05-03 **Elev./Depth:** 123.8-124.5'

Remarks:

●
■
▲

LIQUID AND PLASTIC LIMITS TEST REPORT

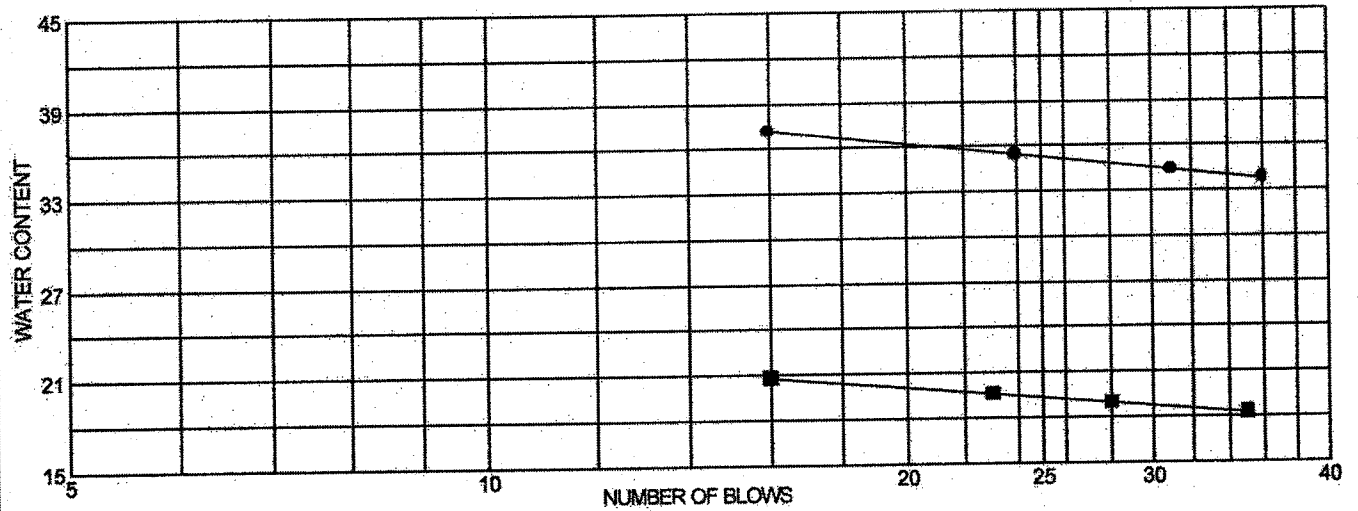
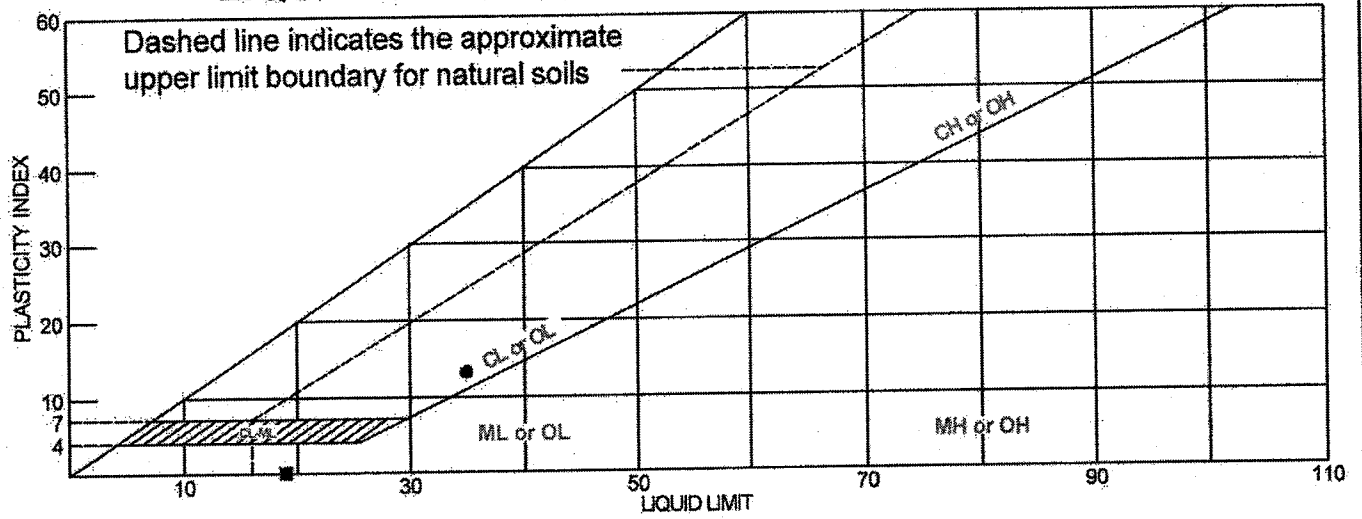

MATERIAL DESCRIPTION	LL	PL	PI	%<#40	%<#200	USCS
● Gray Lean CLAY	35	22	13			
■ Gray SILT	19	21	NP			

Project No. 607-002 **Client:** BBC&M Engineering
Project: 190 West Abutment - 012-00946.300

 ● **Source:** S-24 **Sample No.:** B-05-11 **Elev./Depth:** 92.0-93.5'
 ■ **Source:** S-35 **Sample No.:** B-05-02 **Elev./Depth:** 128.5-130'

Remarks:

●

■

Figure

LIQUID AND PLASTIC LIMITS TEST REPORT

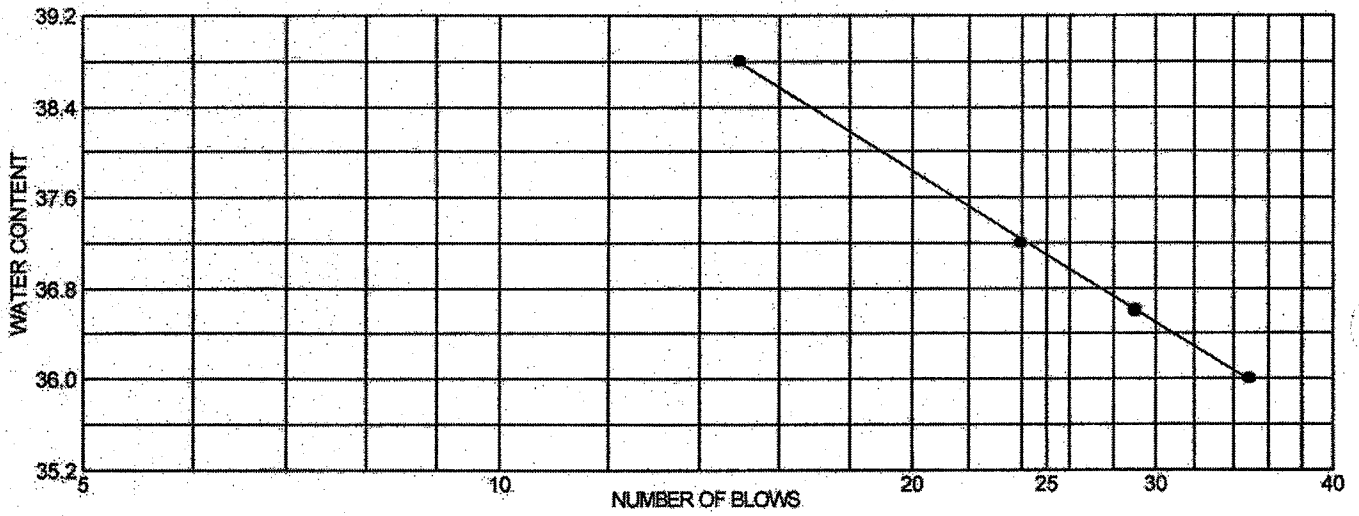
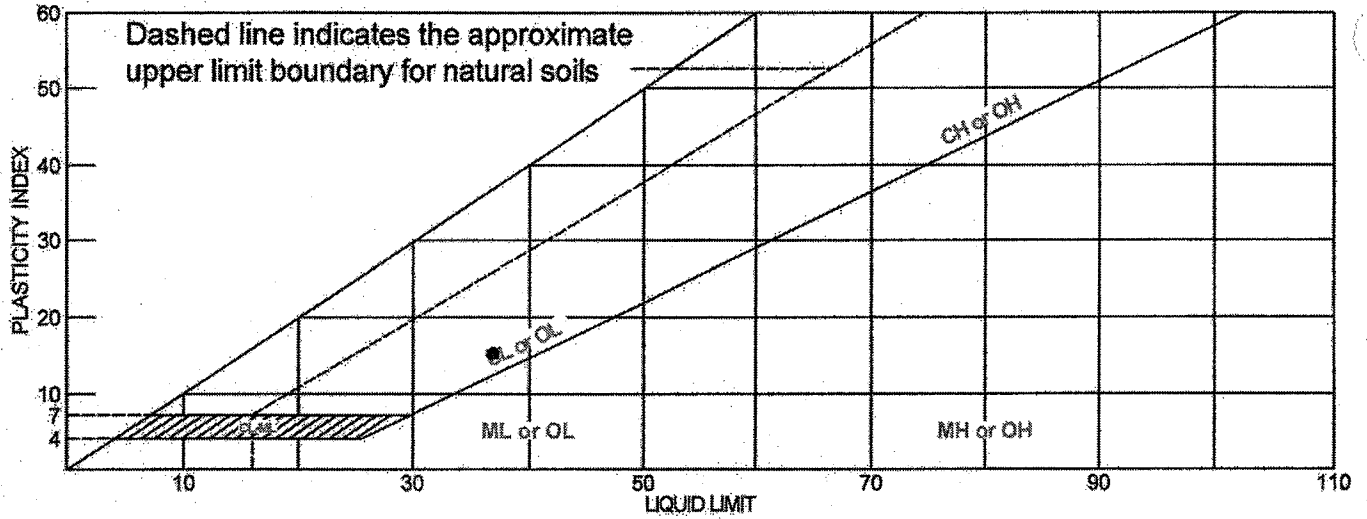

MATERIAL DESCRIPTION	LL	PL	PI	%<#40	%<#200	USCS
● Gray Lean CLAY, trace Sand	37	22	15			

Project No. 607-003 **Client:** BBCM
Project: CUY-90 West Abutment - 012 00946.300
Source: C-05-04 **Sample No.:** S-36 **Elev./Depth:** 113.5-114.5'

Remarks:

●



**Drained, Residual Torsional Ring Shear
Test ASTM D 6467**

Job No.:	607-002	Boring:	B-05-02	Date:	5/5/2006	Undisturbed:	
Client:	BBCM	Sample:	S-35	By:	PJ	Peak:	
Project:	I90 West Abutment	Depth:	128.5-130'	Checked:	DC	Residual:	
Soil Type:	Gray SILT			Clay, %:		Fully Softened:	X
Remarks:	Dropped high load to 16.2ksf to avoid exceeding equip. capacity.			LL:	19	Peak:	
Normal Stress, psf	5000	11100	16200	PL:	21	Residual:	X
Secant Phi, deg.	33	32	32				

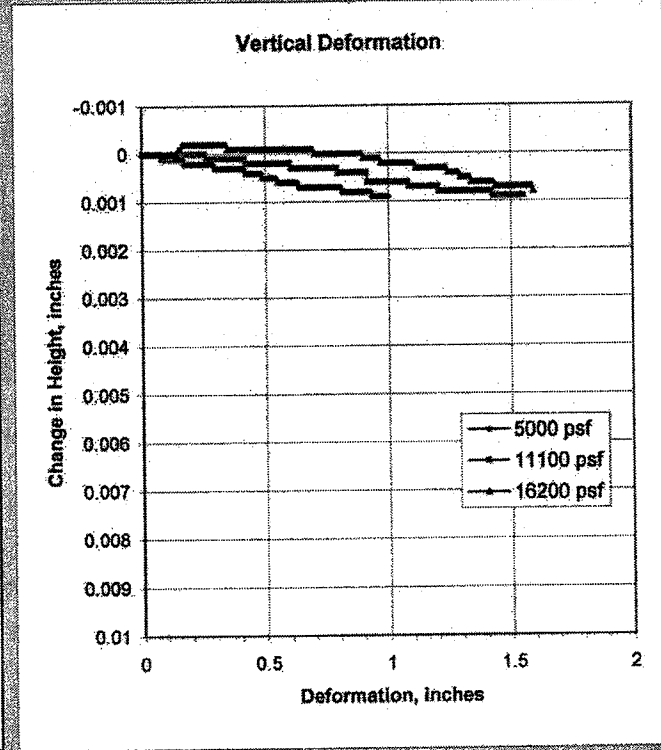
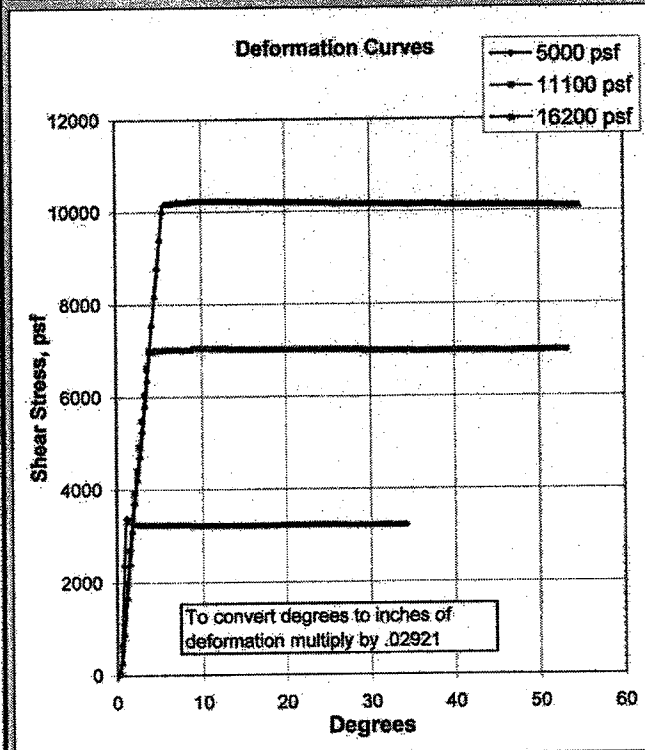
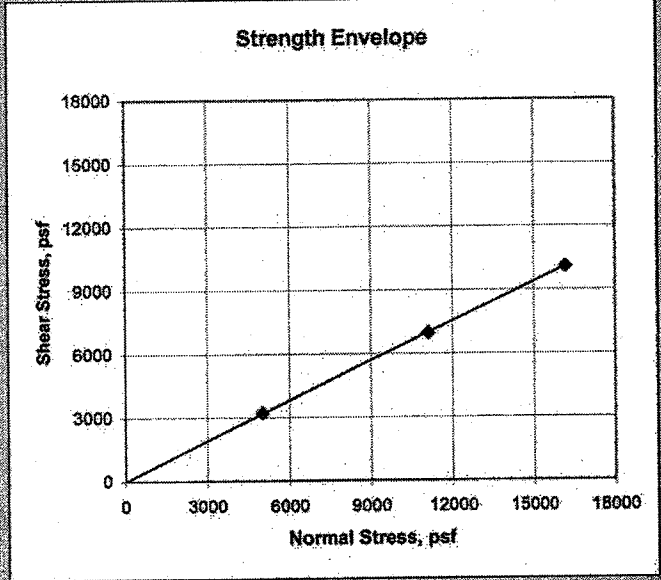
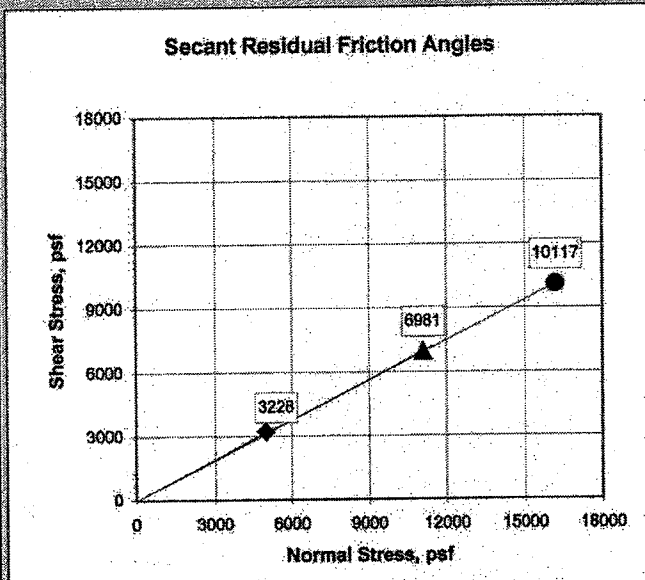



Drained, Residual Torsional Ring Shear Test ASTM D 6467

Job No.:	607-001A	Boring:	C-05-03	Date:	5/1/2006	Undisturbed:	
Client:	BBCM	Sample:	S-7	By:	PJ	Peak:	
Project:	012 00946.300	Depth:	30-30.5'	Checked:	DC	Residual:	
Soil Type:	Bluish Gray CLAY (silty)			Clay, %:		Fully Softened:	X
Remarks:	A small friction correction applied to each point.			LL:	24	Peak:	
Normal Stress, psf	1000	3500	6000	PL:	17	Residual:	X
Secant Phi, deg.	31	30	29				

Secant Residual Friction Angles

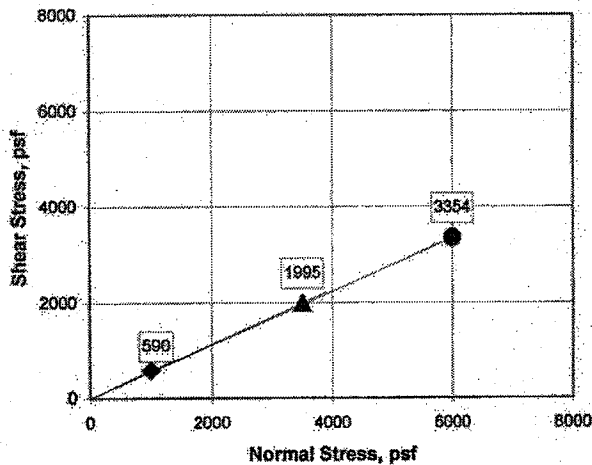

Strength Envelope

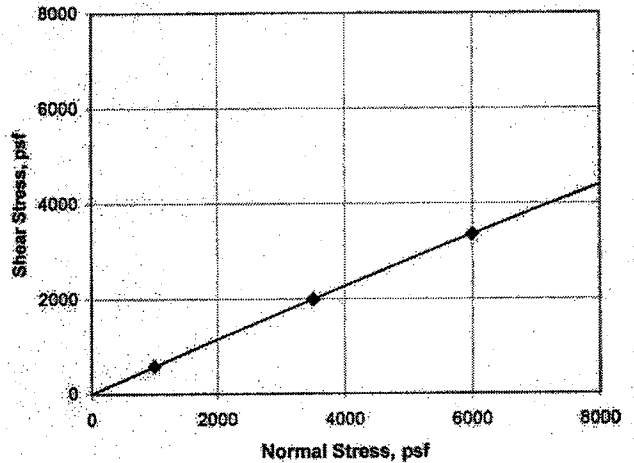

Deformation Curves

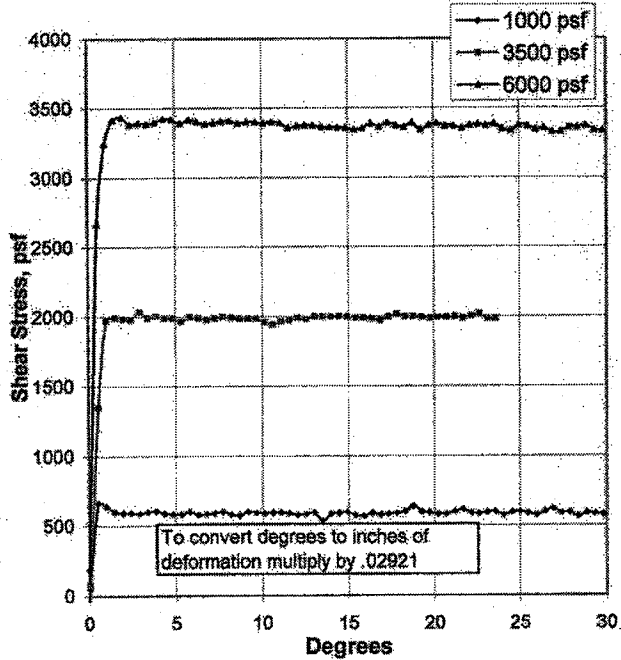

Vertical Deformation

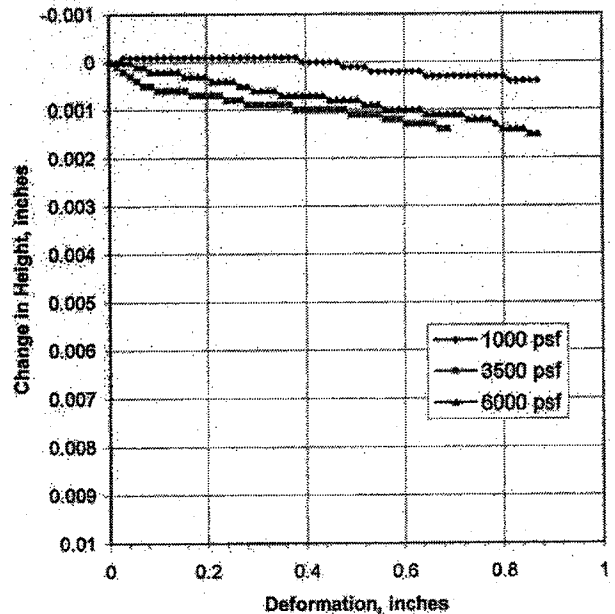



Drained, Residual Torsional Ring Shear Test ASTM D 6467

Job No.:	607-001B	Boring:	C-05-03	Date:	5/1/2006	Undisturbed:	
Client:	BBCM	Sample:	S-31B	By:	PJ	Peak:	
Project:	012 00946.300	Depth:	123.8-124.5	Checked:	DC	Residual:	X
Soil Type:	Gray Silt w/ Sand / Sandy SILT			Clay, %:		Fully Softened:	X
Remarks:	A small friction correction was applied to each point						
Normal Stress, psf	5000	9600	15100	LL:	17	Peak:	
Secant Phi, deg.	33	33	33	PL:	18	Residual:	X

Secant Residual Friction Angles

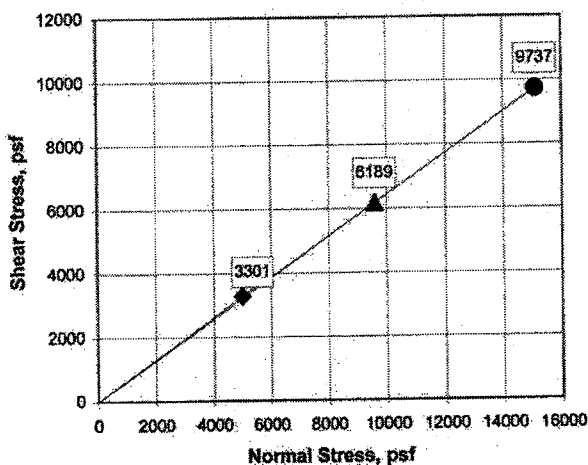

Strength Envelope

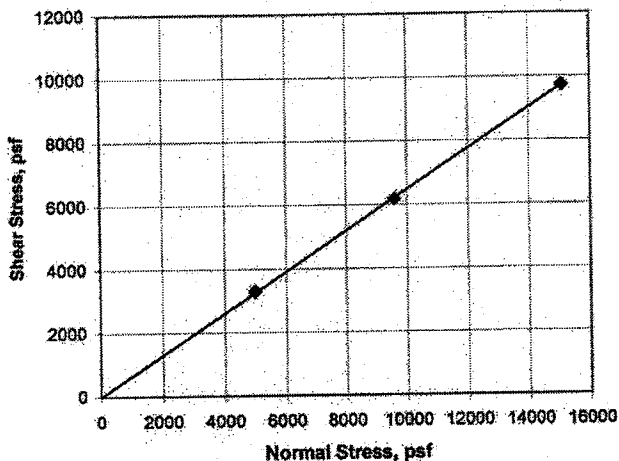

Deformation Curves

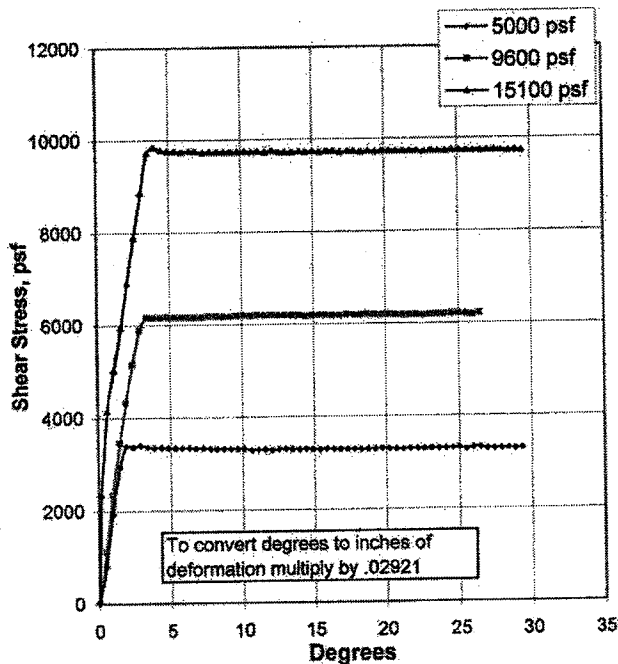

Vertical Deformation

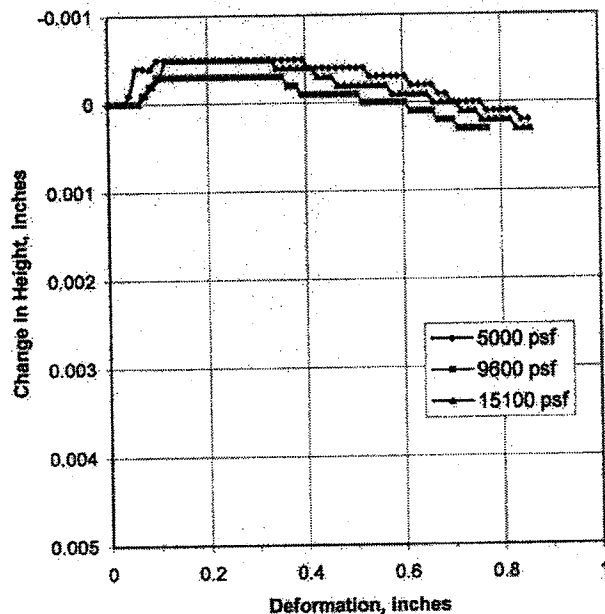



Drained, Residual Torsional Ring Shear Test ASTM D 6467

Job No.:	607-001C	Boring:	C-05-04	Date:	5/1/2006	Undisturbed:	
Client:	BBCM	Sample:	S-23	By:	PJ	Peak:	
Project:	012 00946.300	Depth:	58.8-59.2'	Checked:	DC	Residual:	
Soil Type:	Greenish Gray SILTY CLAY w/ Sand			Clay, %:		Fully Softened:	X
Remarks:	A small friction correction was applied to the 8 KSF POIN			LL:	26	Peak:	
Normal Stress, psf	3000	5600	8000	PL:	19	Residual:	X
Secant Phi, deg.	32	32	32				

Secant Residual Friction Angles

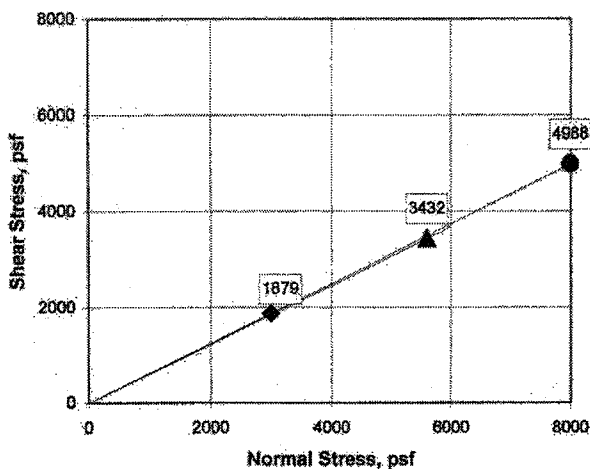

Strength Envelope

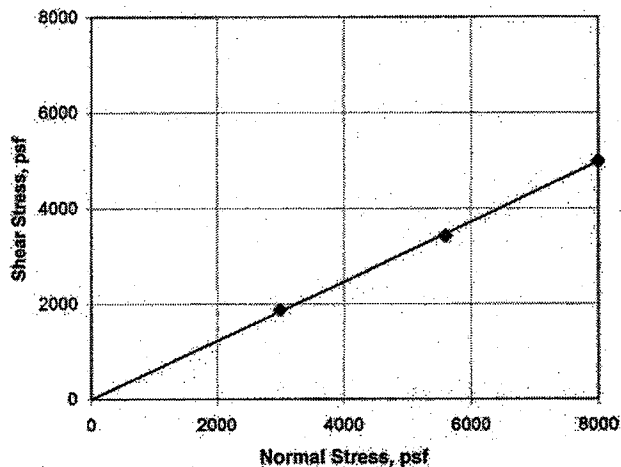

Deformation Curves

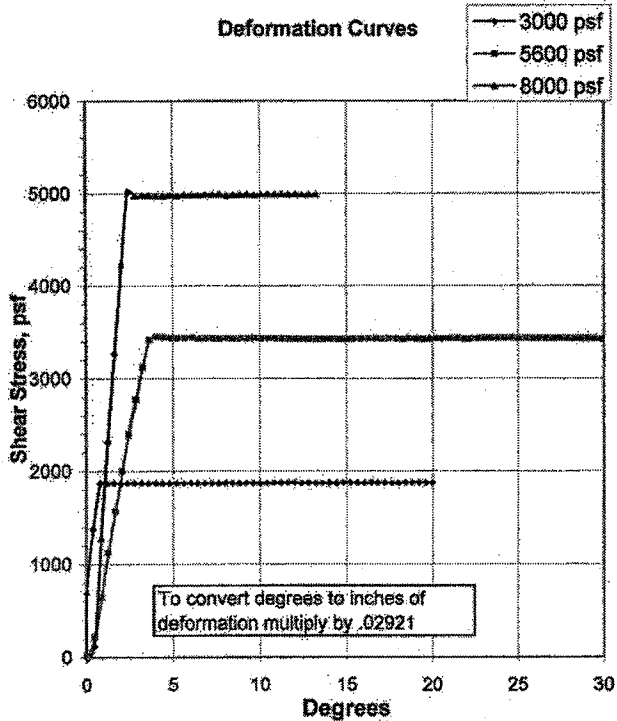

Vertical Deformation

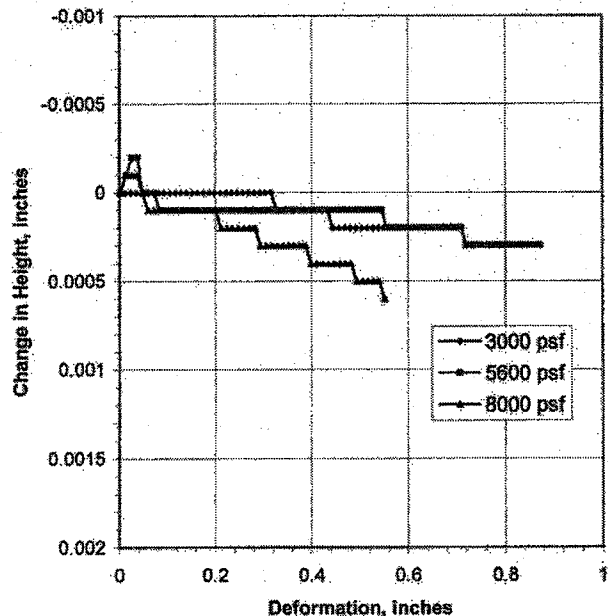



**Drained, Residual Torsional Ring Shear
Test ASTM D 6467**

Job No.:	607-003	Boring:	C-05-04	Date:	5/19/2006	Undisturbed:	
Client:	BBCM	Sample:	S-36	By:	PJ	Peak:	
Project:	I-90 West Abutment	Depth:	113.5-114.5	Checked:	DC	Residual:	
Soil Type:	Gray Lean CLAY, trace Sand			Clay, %:		Fully Softened:	X
Remarks:	A small friction correction was applied to this point.			LL:	37	Peak:	
Normal Stress, psf	9000	PL:	22	Residual:			X
Secant Phi, deg.	24						

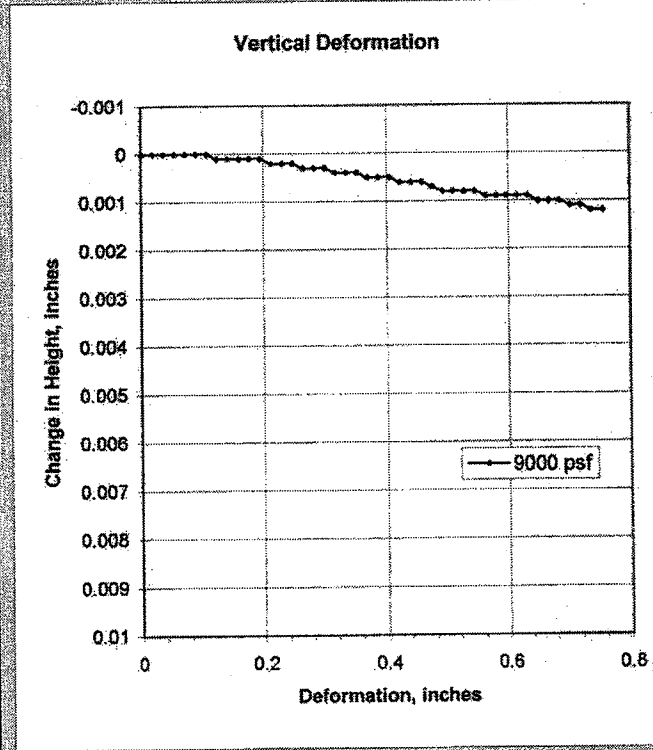
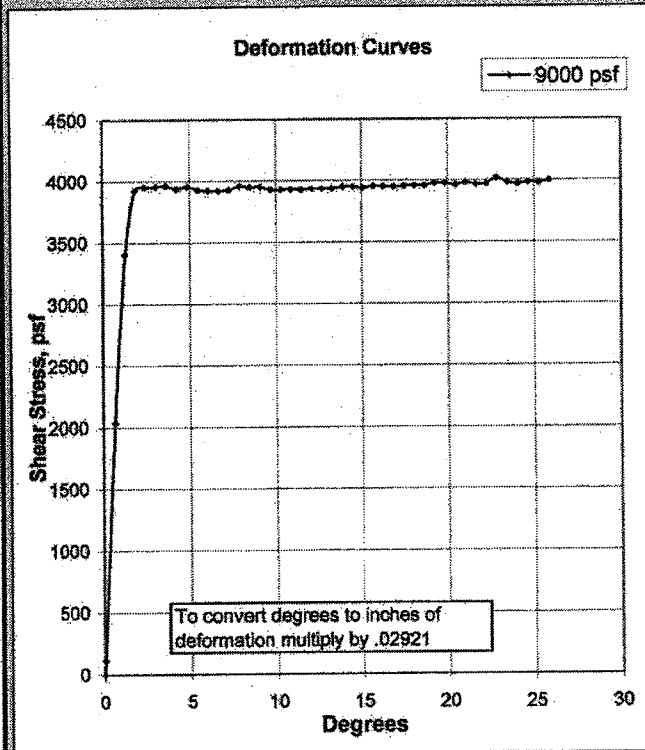
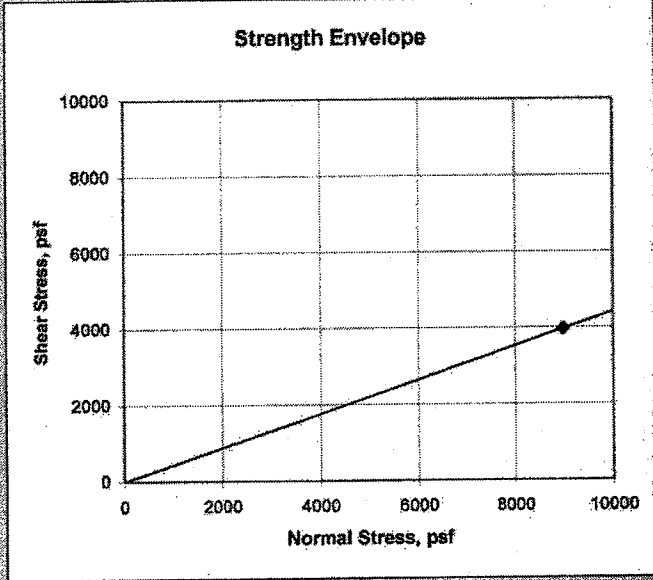
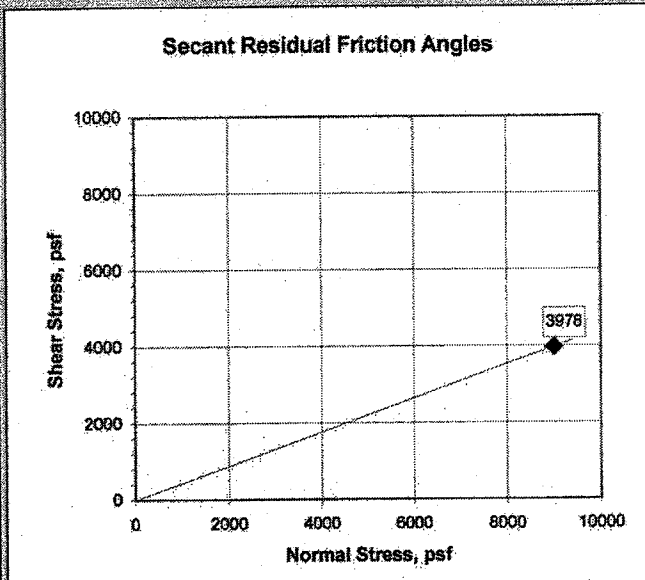



Drained, Residual Torsional Ring Shear Test ASTM D 6467

Job No.:	607-002B	Boring:	B-05-11	Date:	5/5/2006	Undisturbed:		
Client:	BBCM	Sample:	S-24	By:	PJ	Peak:		
Project:	I-90 West Abutment	Depth:	92-93.5'	Checked:	DC	Residual:		
Soil Type:	Gray Lean CLAY			Clay, %:		Fully Softened:	X	
Remarks:	A small friction correction was applied to each point. This material exhibited a tendency to break down during shearing. Lower strengths may be possible with further deformation.						LL:	35
						Peak:		
Normal Stress, psf	4000	8000	15700	PL:	22	Residual:	X	
Secant Phi, deg.	22	19	17					

Secant Residual Friction Angles

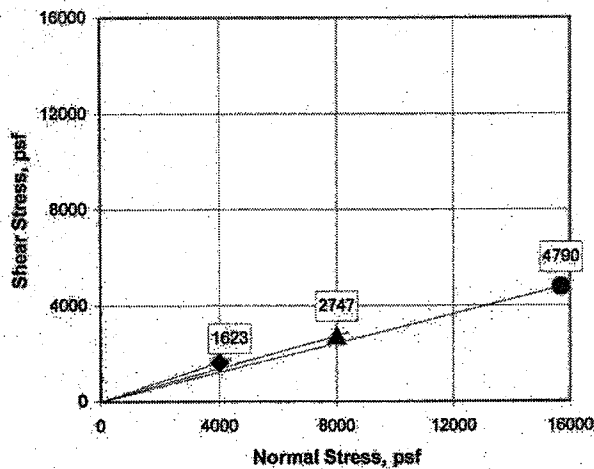

Strength Envelope

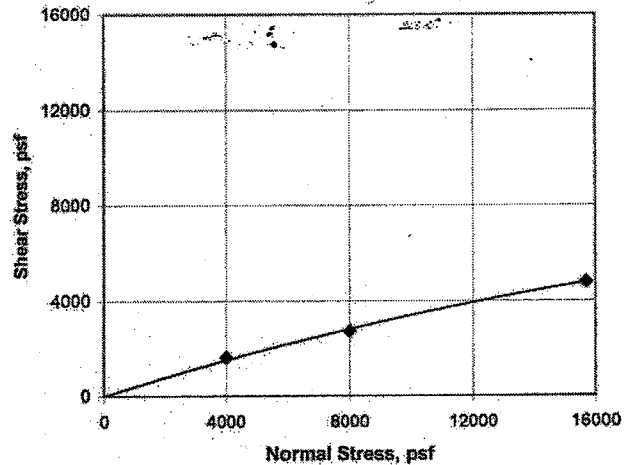

Deformation Curves

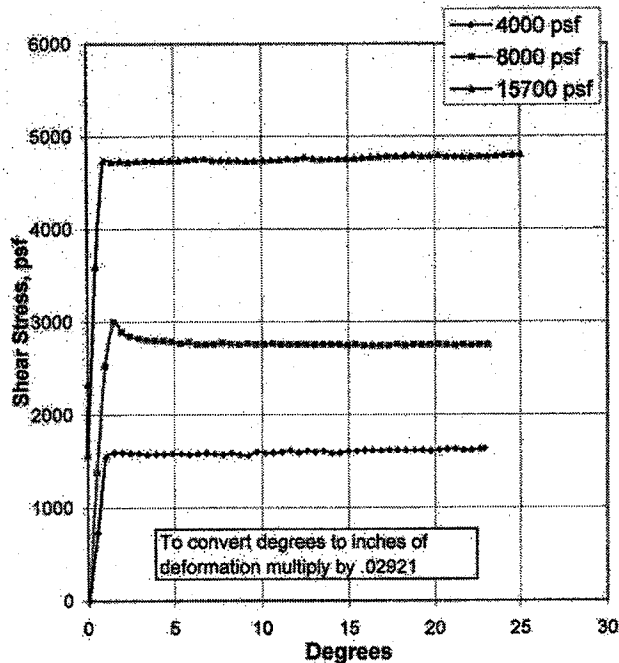

Vertical Deformation

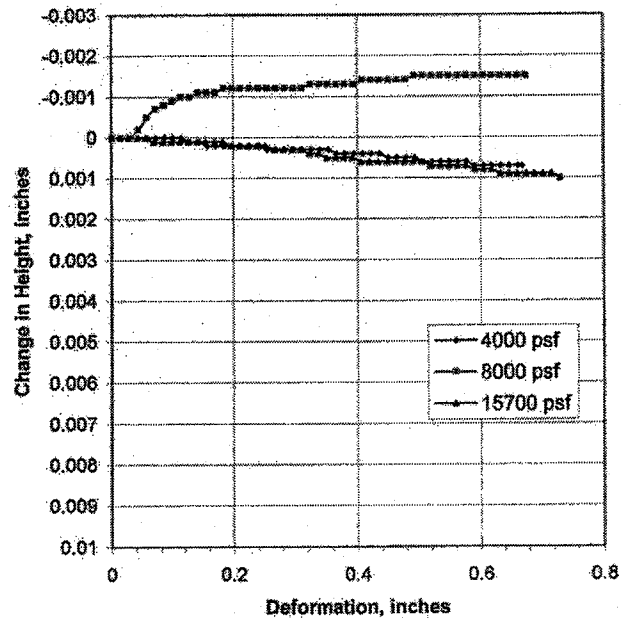

Residual Shear Strength Test Summary

Boring	Sample	σ'_{vc} (ksf)	σ'_{vc} (kPa)	CF	LL	TRS	Stark Chart Values	
						ϕ'_R	LL	ϕ'_R
B-05-03	31B	15.1	723	<20	17	33	N/A	33
B-05-02	35	16.2	776	<21	19	32	N/A	32
B-05-03	7	6	287	16	24	29	N/A	29
B-05-04	23	8	383	23	26	32	N/A	32
B-05-11	24	15.7	752	~50	35	17	47	16
B-05-04	36	9	431	<50	37	24	N/A	24

For CF > 50%, perform Stark Chart conversion to account for ball milling used for chart

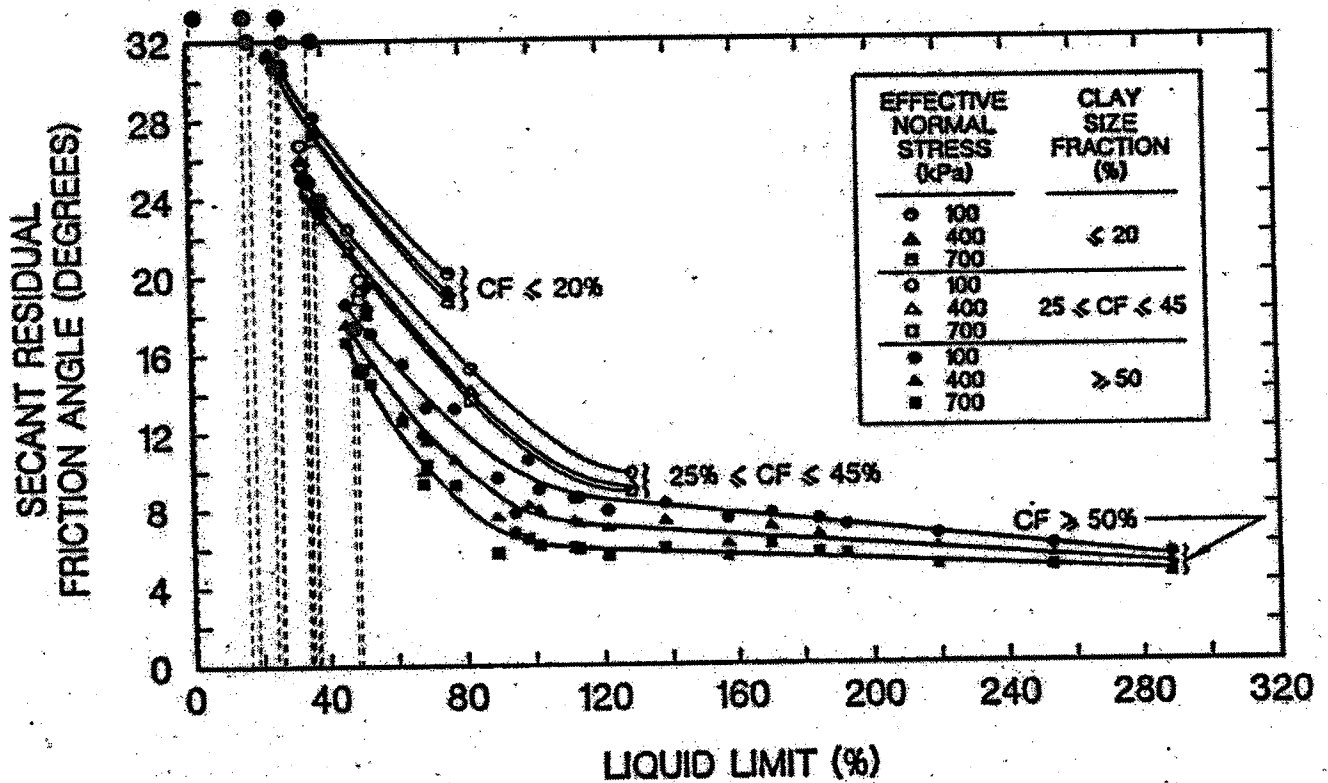

Direct Shear Test Results Summary

Boring	Sample	σ'_{vc} (ksf)	σ'_{vc} (kPa)	CF	LL	DS	Stark Chart Values	
						ϕ'_R	LL	ϕ'_R
B-101	32	20	958	<50	37	24	N/A	23
B-108	8	9	431	>50	36	15	48	16
B-108A	26	8.6	412	~20	35	25	N/A	24
B-105A	23	7.9	378	<50	34	24	N/A	24
B-05-16	7	2.4	115	<25	36	32	N/A	29
B-05-16	25	7	335	<25	27	36	N/A	>32
B-05-16	26	7	335	~5	0	41	N/A	>32

Sample Info For DSS Specimens

Project: **CUY-90 West Abutment** Job: **5653**
 Client: **BBC&M Engineering, Inc.** Date: **5/9/2006**

Test #	Boring	Sample #	Depth (ft)	WC %	Initial Density (PCF)	Before Shear Density (PCF)	Normal Load (TSF)	Additional Testing			
								Gs	LL	PL	PI
1	B-05-07	S-22	104-106	34.4	88.5	99.0	5.3 tsf	-----	40.1	22.5	17.6
2	B-05-02	S-14	44-46	28.8	94.3	99.9	2.8 tsf	-----	37.7	21.4	16.3
3	B-05-03	S-8	32-33.5	25.9	100.8	107.0	1.95 tsf	-----	34.8	18.8	16.0
4	B-05-02	S-32	122-124	21.2	103.2	110.1	5.3 tsf	-----	30.3	18.8	11.5

DIRECT SIMPLE SHEAR TEST

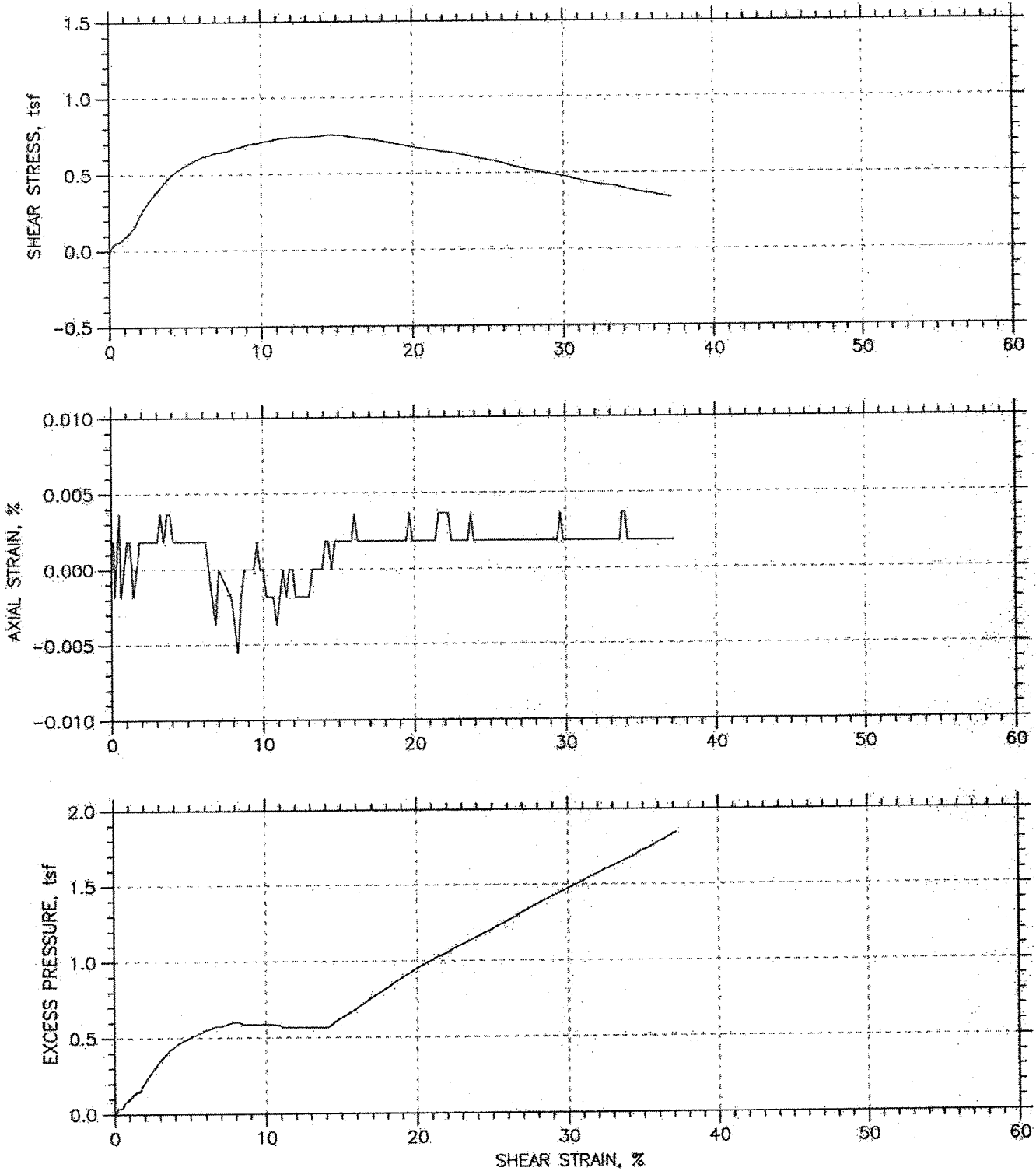

Project: CUY-90 West Abutment	Location: 14" from Bottom	Project No.: 5653
Boring No.: B-05-02	Tested By: SO	Checked By: JW
Sample No.: S-14	Test Date: 11-6-05	Depth: 44-46
Test No.: 2	Sample Type: Undisturbed	Elevation:
Description: Lean Clay w/an occasional piece of coarse sand (CL)		
Remarks: ASTM D 6528		
File: \\dell\GeoComp\Software\DSS\5653-s14-mod2.dat		

DIRECT SIMPLE SHEAR TEST

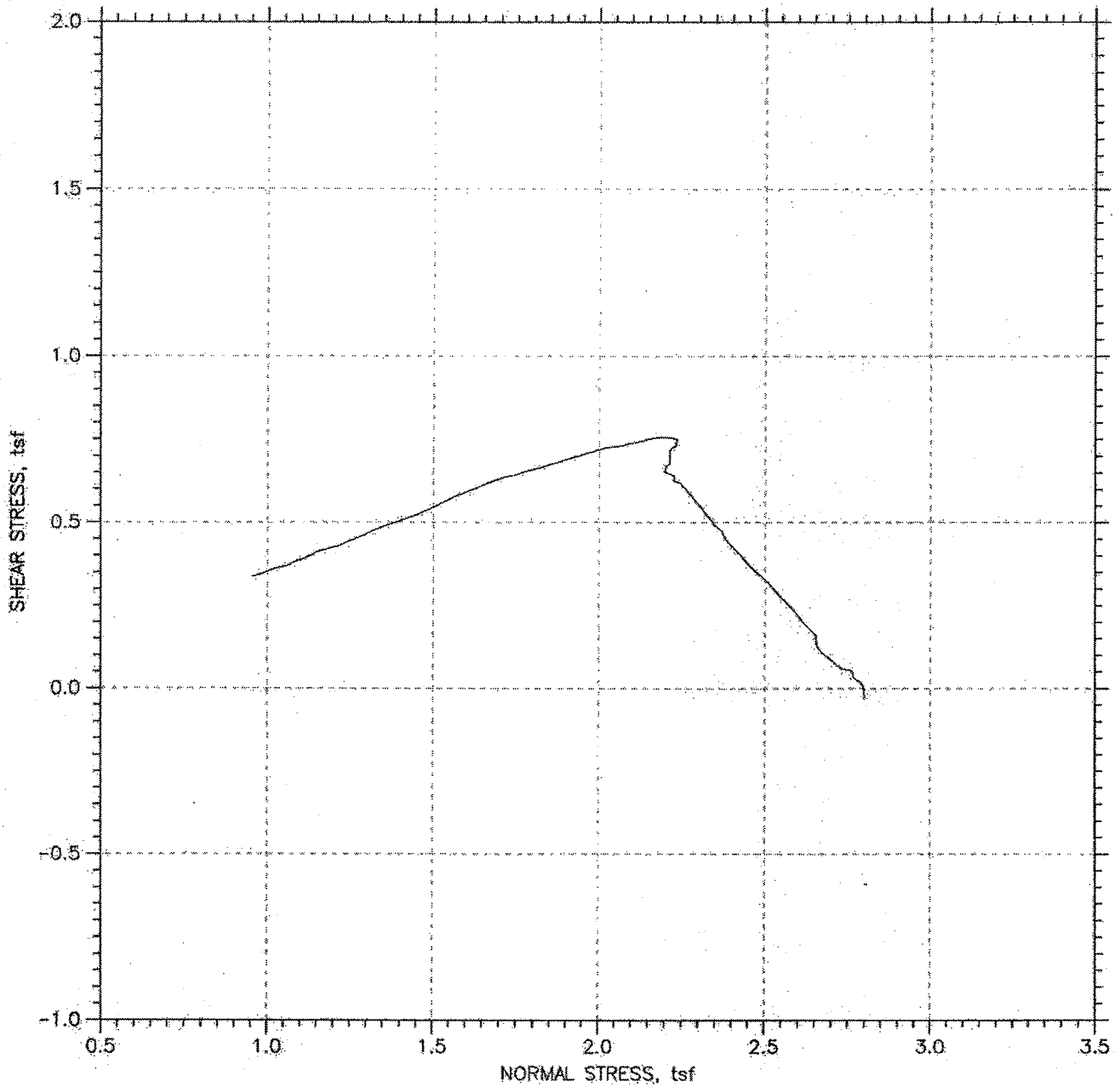

Project: CUY-90 West Abutment	Location: 14" from Bottom	Project No.: 5653
Boring No.: B-05-02	Tested By: SO	Checked By: JW
Sample No.: S-14	Test Date: 11-6-05	Depth: 44-46
Test No.: 2	Sample Type: Undisturbed	Elevation:
Description: Lean Clay w/an occasional piece of coarse sand (CL)		
Remarks: ASTM D 6528		
File: \\del\GeoComp\Software\DSS\5653-s14-mod2.dat		

DIRECT SIMPLE SHEAR TEST

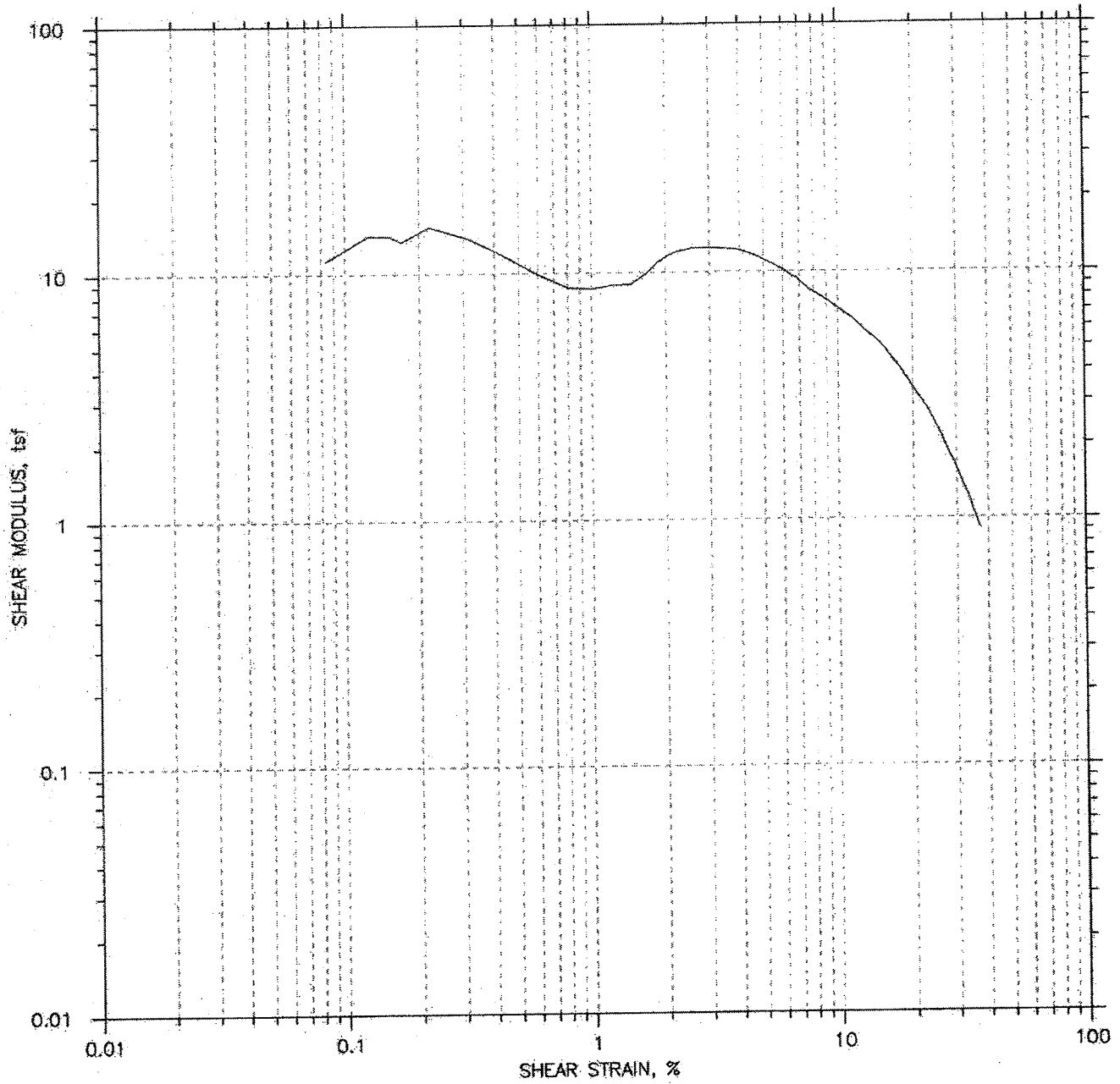

Project: CUY-90 West Abutment	Location: 14" from Bottom	Project No.: 5653
Boring No.: B-05-02	Tested By: SO	Checked By: JW
Sample No.: S-14	Test Date: 11-6-05	Depth: 44-46
Test No.: 2	Sample Type: Undisturbed	Elevation:
Description: Lean Clay w/an occasional piece of coarse sand (CL)		
Remarks: ASTM D 6528		
File: \\dell\GeoComp\Software\DSS\5653-s14-mod2.dat		

DIRECT SIMPLE SHEAR TEST

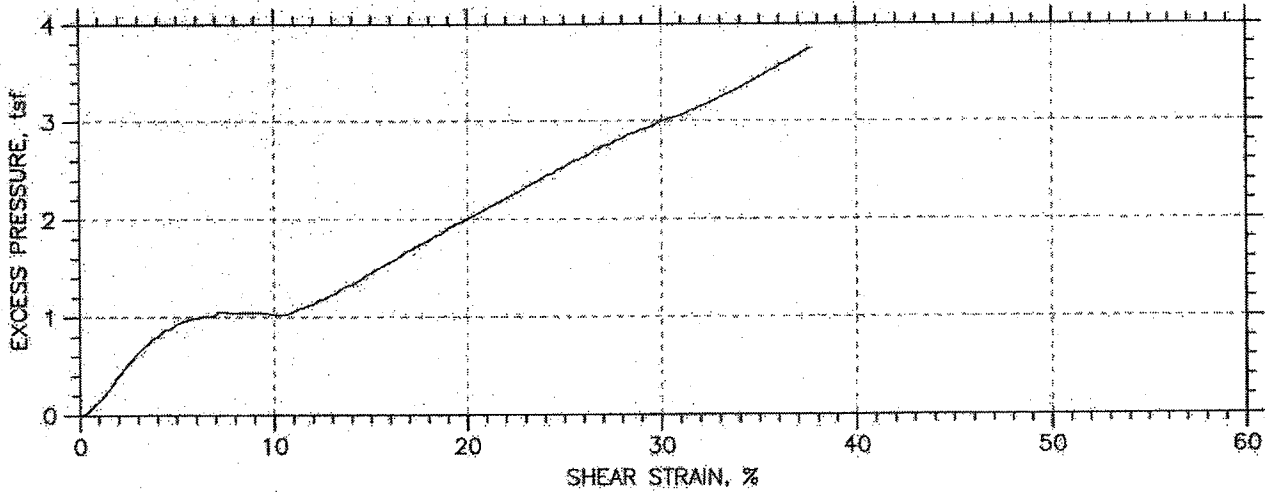
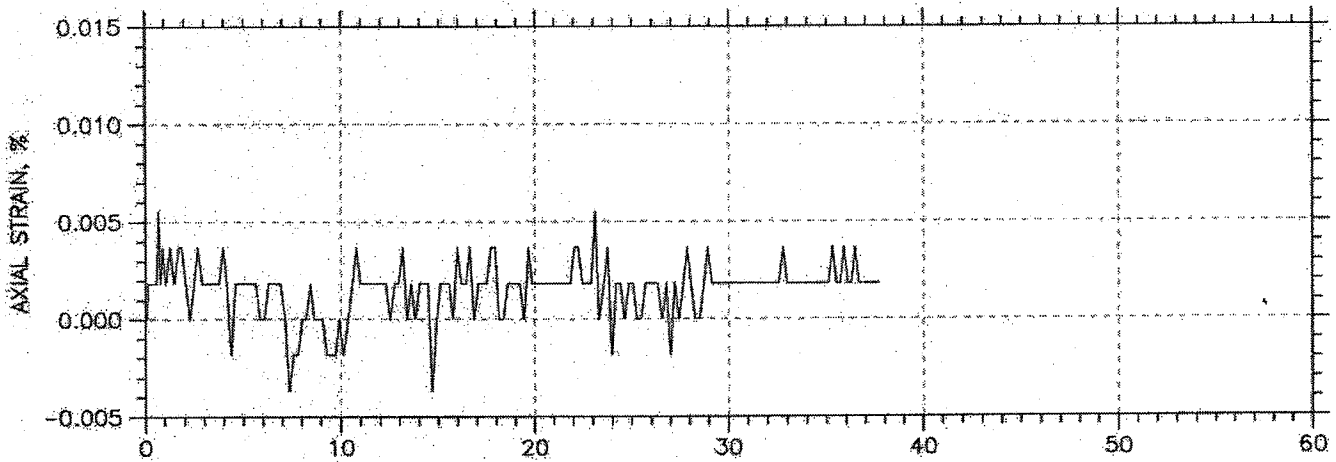
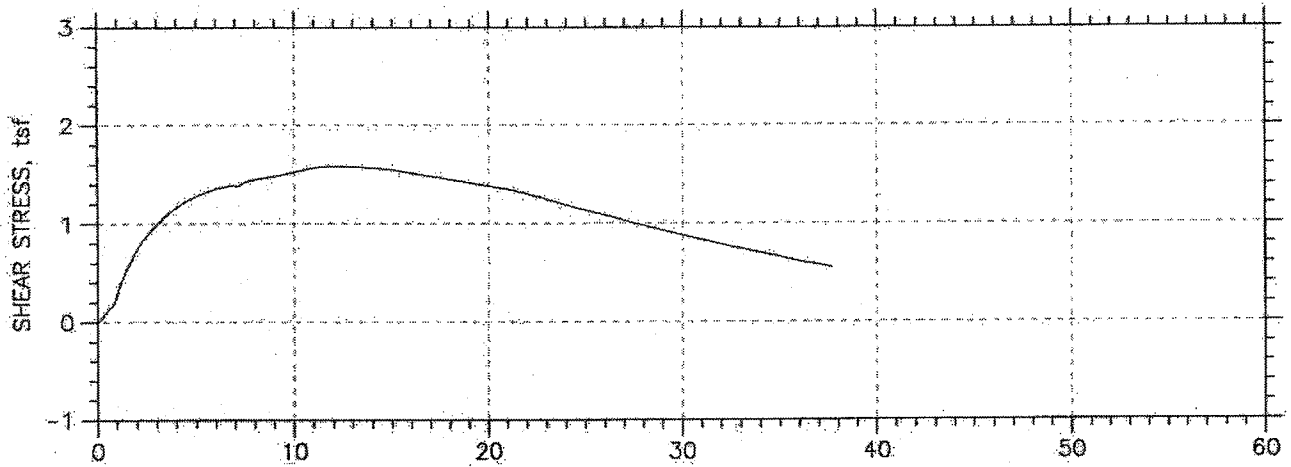

Project: CUY-90 West Abutment	Location: 8" from bottom	Project No.: 5653
Boring No.: B-05-02	Tested By: SO	Checked By: JW
Sample No.: S-32	Test Date: 5-5-06	Depth: 122-124
Test No.: 4	Sample Type: Undisturbed	Elevation:
Description: Lean Clay mixture with silt (CL) & (ML)		
Remarks: ASTM D 6528		
File: \\dell\GeoComp\Software\DSS\5653-s32.dot		

DIRECT SIMPLE SHEAR TEST

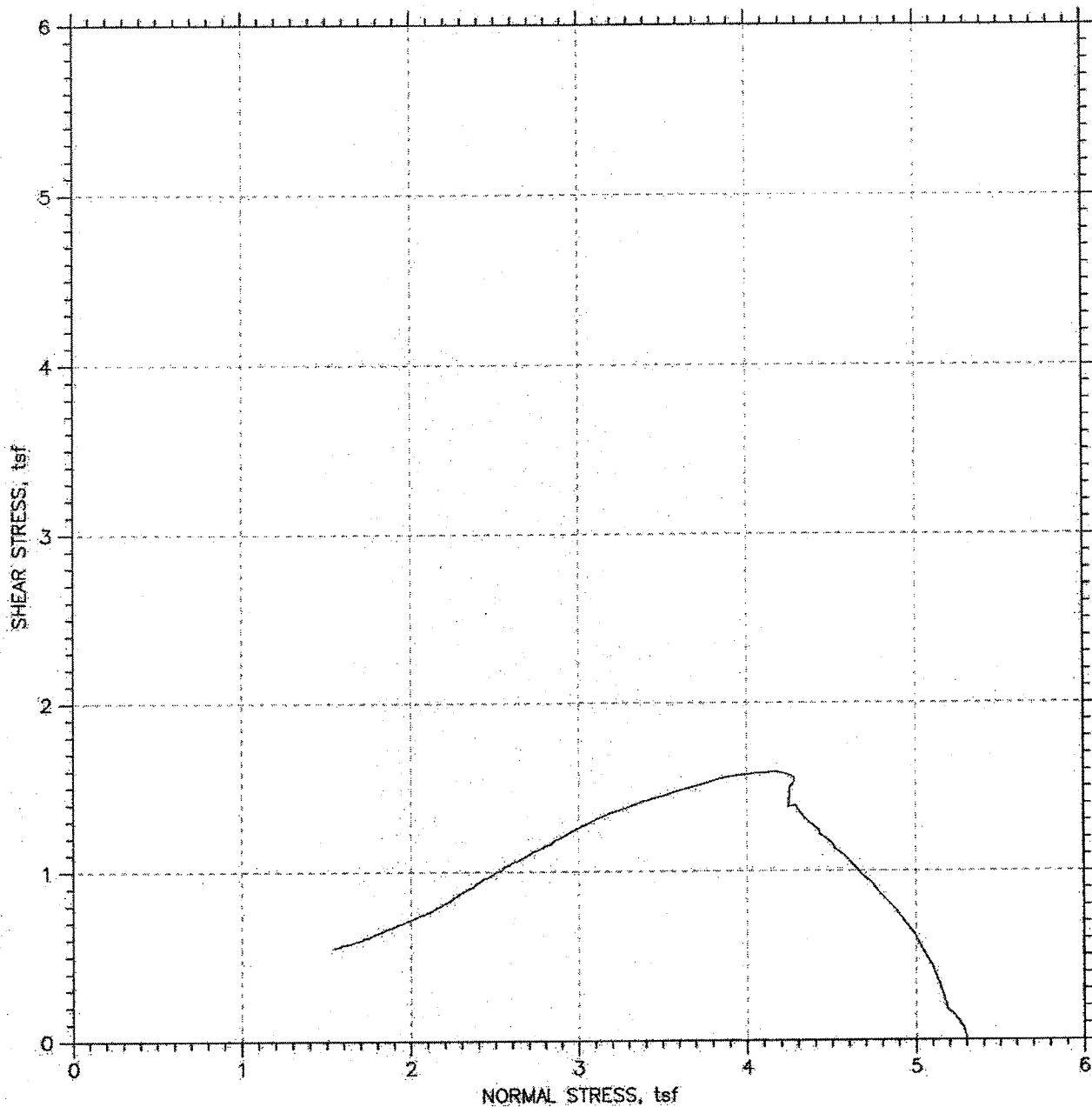

Project: CUY-90 West Abutment	Location: 8" from bottom	Project No.: 5653
Boring No.: B-05-02	Tested By: SO	Checked By: JW
Sample No.: S-32	Test Date: 5-5-06	Depth: 122-124
Test No.: 4	Sample Type: Undisturbed	Elevation:
Description: Lean Clay mixture with silt (CL) & (ML)		
Remarks: ASTM D 6528		
File: \\dell\GeoComp\Software\DSS\5653-s32.dat		

DIRECT SIMPLE SHEAR TEST

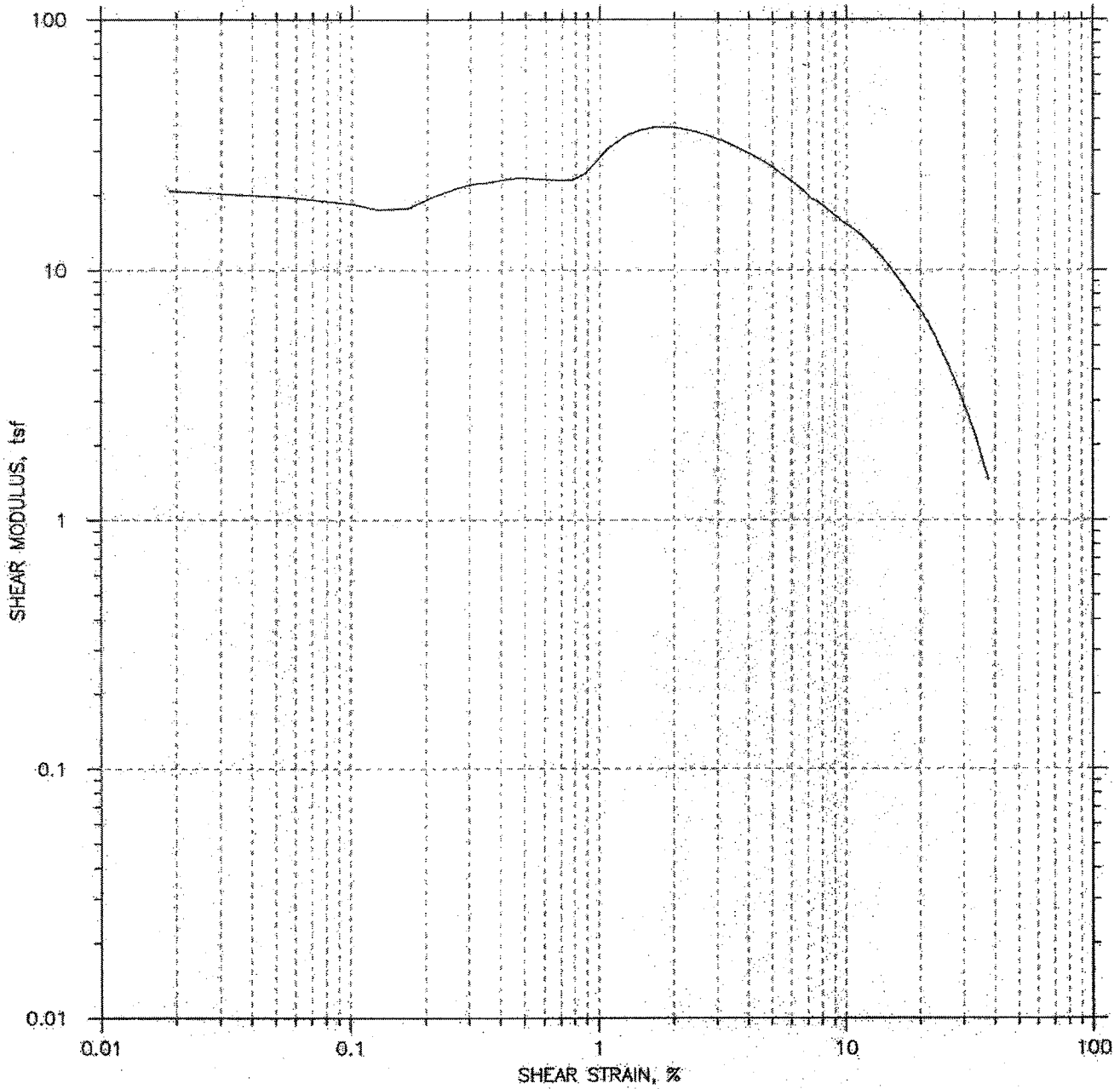

Project: CUY-90 West Abutment	Location: 8" from bottom	Project No.: 5653
Boring No.: B-05-02	Tested By: SO	Checked By: JW
Sample No.: S-32	Test Date: 5-5-06	Depth: 122-124
Test No.: 4	Sample Type: Undisturbed	Elevation:
Description: Lean Clay mixture with silt (CL) & (ML)		
Remarks: ASTM D 6528		
File: \\dell\GeoComp\Software\DSS\5653-s32.dat		

DIRECT SIMPLE SHEAR TEST

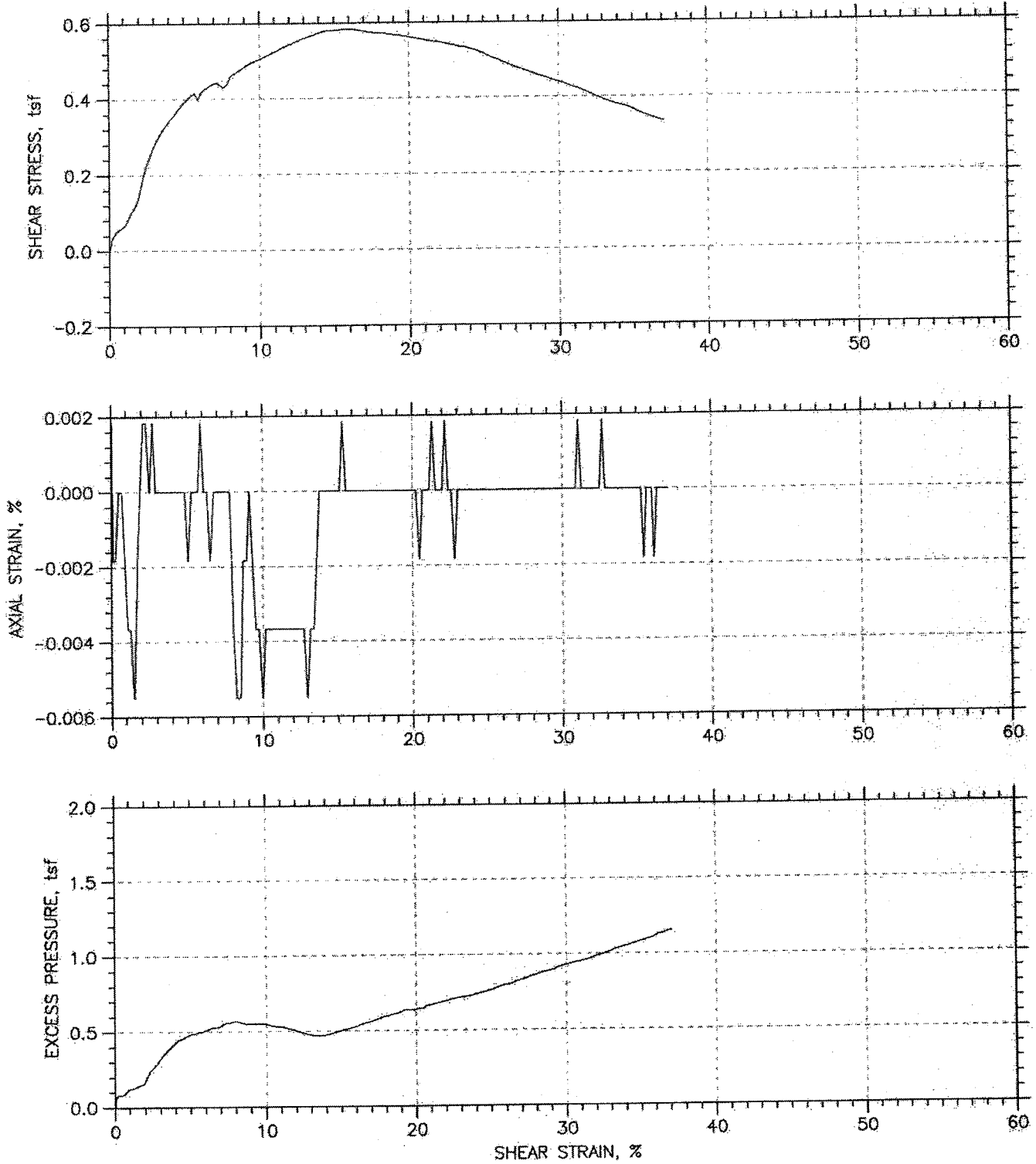

Project: CUY-90 West Abutment	Location:	Project No.: 5653
Boring No.: B-05-03	Tested By: SO	Checked By: JW
Sample No.: S-8	Test Date: 5-4-06	Depth: 32-33.5
Test No.: 3	Sample Type: Undisturbed	Elevation:
Description: Lean Clay w/an occasional piece of sand (CL)		
Remarks: ASTM D 6528		
File: \\dell\GeoComp\Software\DSS\5653-s8.dat		

DIRECT SIMPLE SHEAR TEST

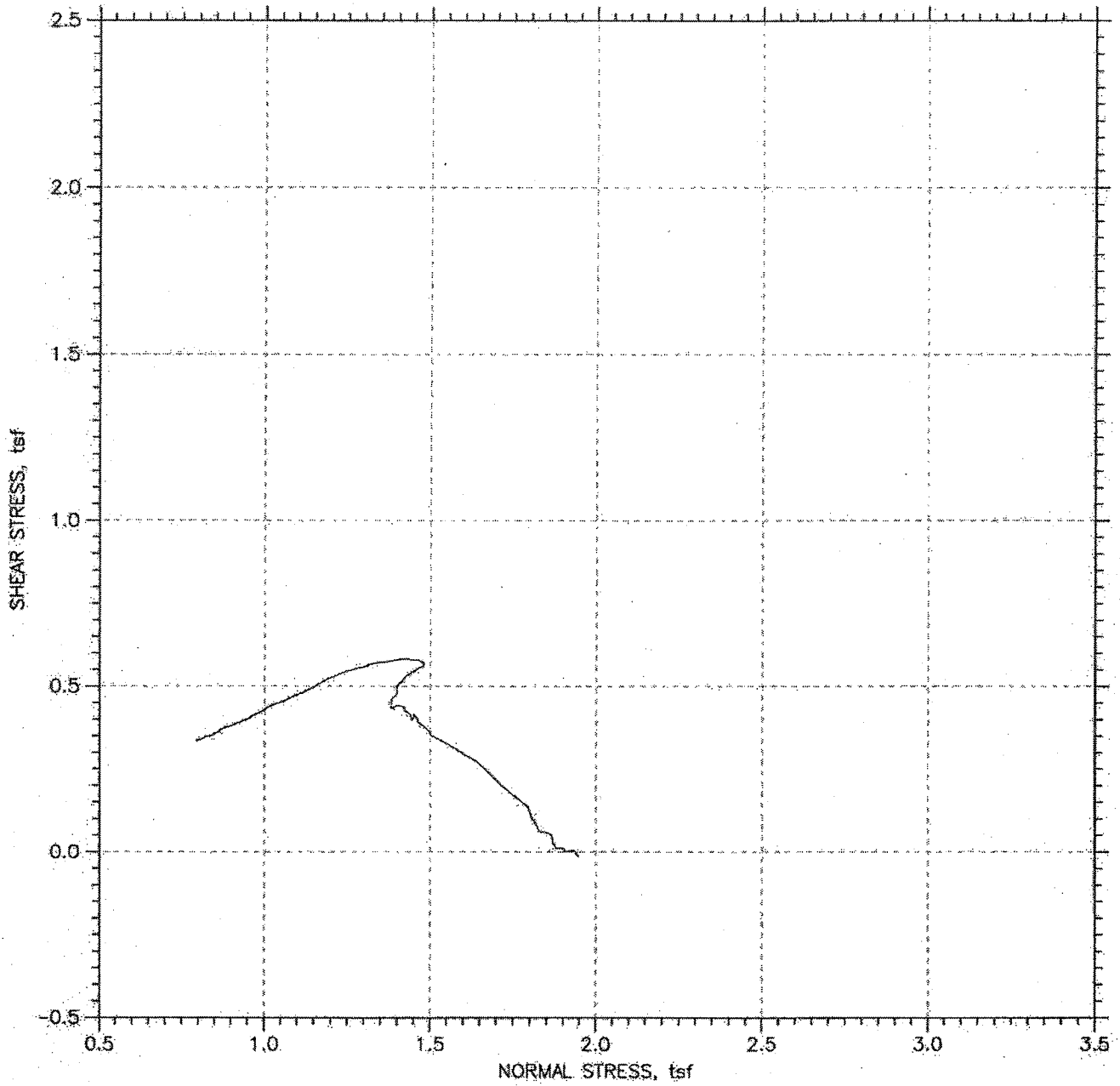

Project: CUY-90 West Abutment	Location:	Project No.: 5653
Boring No.: B-05-03	Tested By: SO	Checked By: JW
Sample No.: S-8	Test Date: 5-4-06	Depth: 32-33.5
Test No.: 3	Sample Type: Undisturbed	Elevation:
Description: Lean Clay w/an occasional piece of sand (CL)		
Remarks: ASTM D 6528		
File: \\dell\GeoComp\Software\DSS\5653-s8.dat		

DIRECT SIMPLE SHEAR TEST

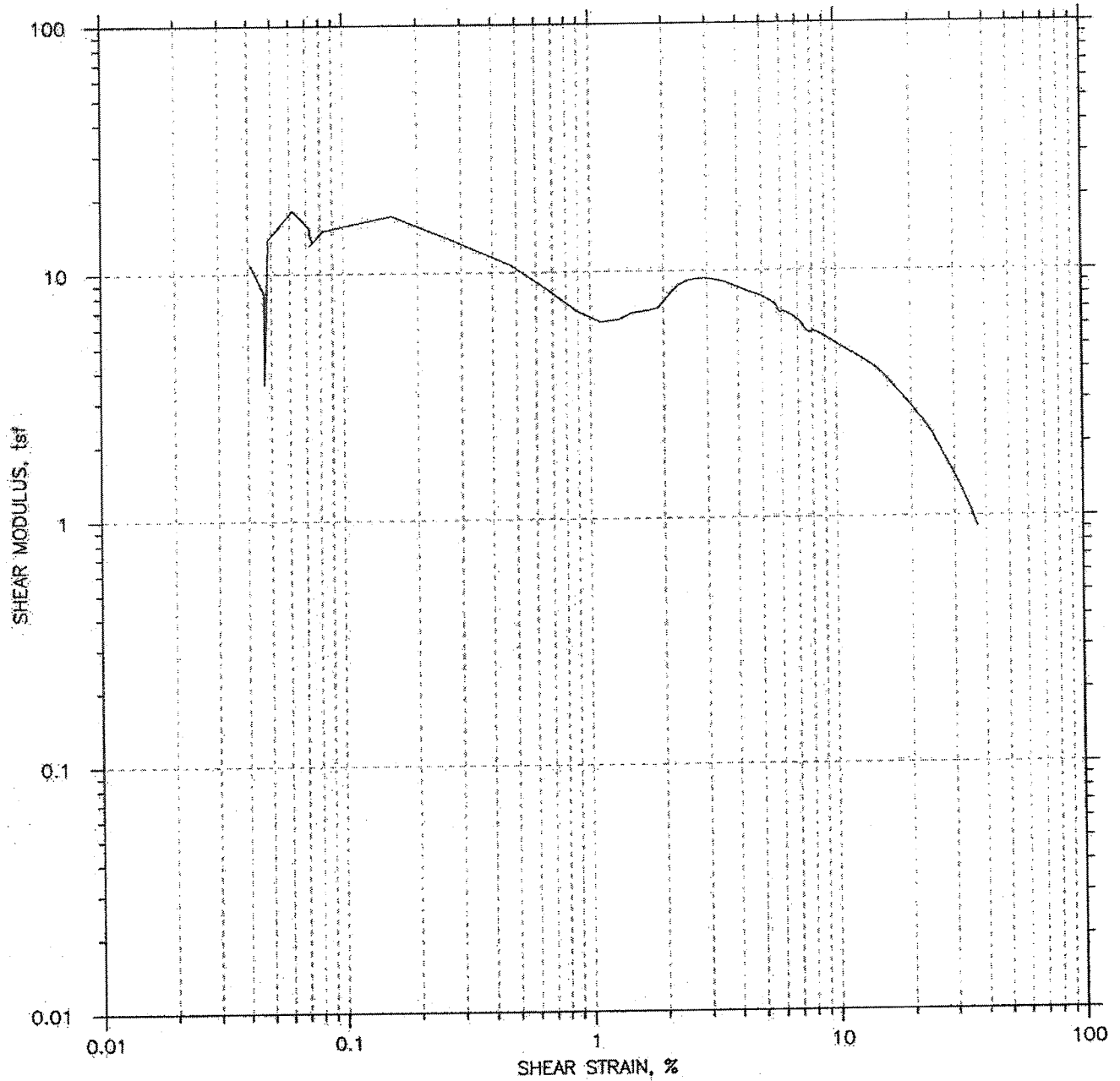

Project: CUY-90 West Abutment.	Location:	Project No.: 5653
Boring No.: B-05-03	Tested By: SO	Checked By: JW
Sample No.: S-8	Test Date: 5-4-06	Depth: 32-33.5
Test No.: 3	Sample Type: Undisturbed	Elevation:
Description: Lean Clay w/an occasional piece of sand (CL)		
Remarks: ASTM D 6528		
File: \\del\GeoComp\Software\DSS\5653-s8.dat		

DIRECT SIMPLE SHEAR TEST

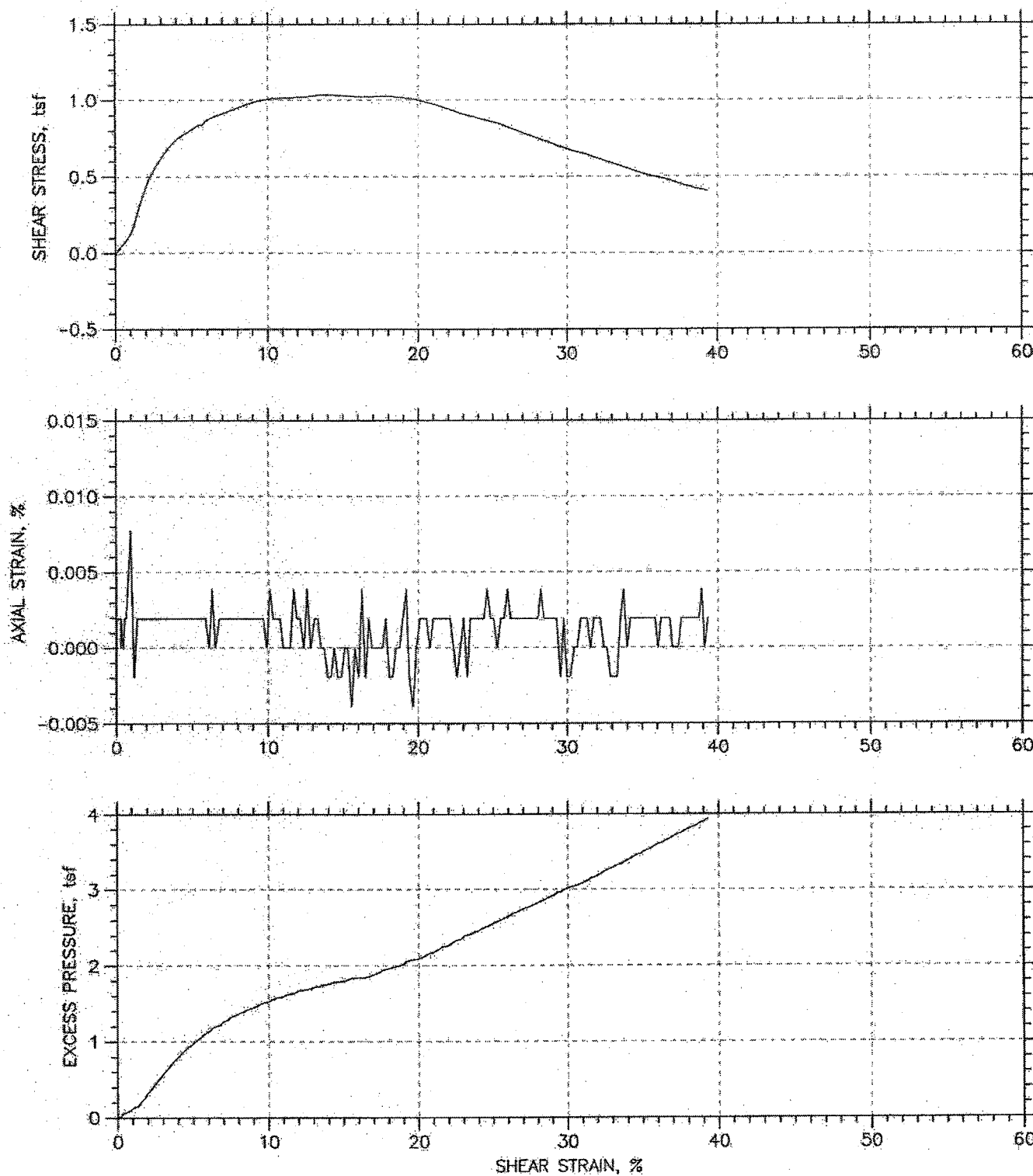

Project: CUY-90 West Abutment	Location: 14" from Bottom	Project No.: 5653
Boring No.: B-05-07	Tested By: SO	Checked By: JW
Sample No.: S-22	Test Date: 5-2-06	Depth: 104-106
Test No.: 1	Sample Type: Undisturbed	Elevation:
Description: Lean Clay w/pockets of silt (CL)		
Remarks: ASTM D 6528		
File: \\dell\GeoComp\Software\DSS\5653-s22.dat		

DIRECT SIMPLE SHEAR TEST

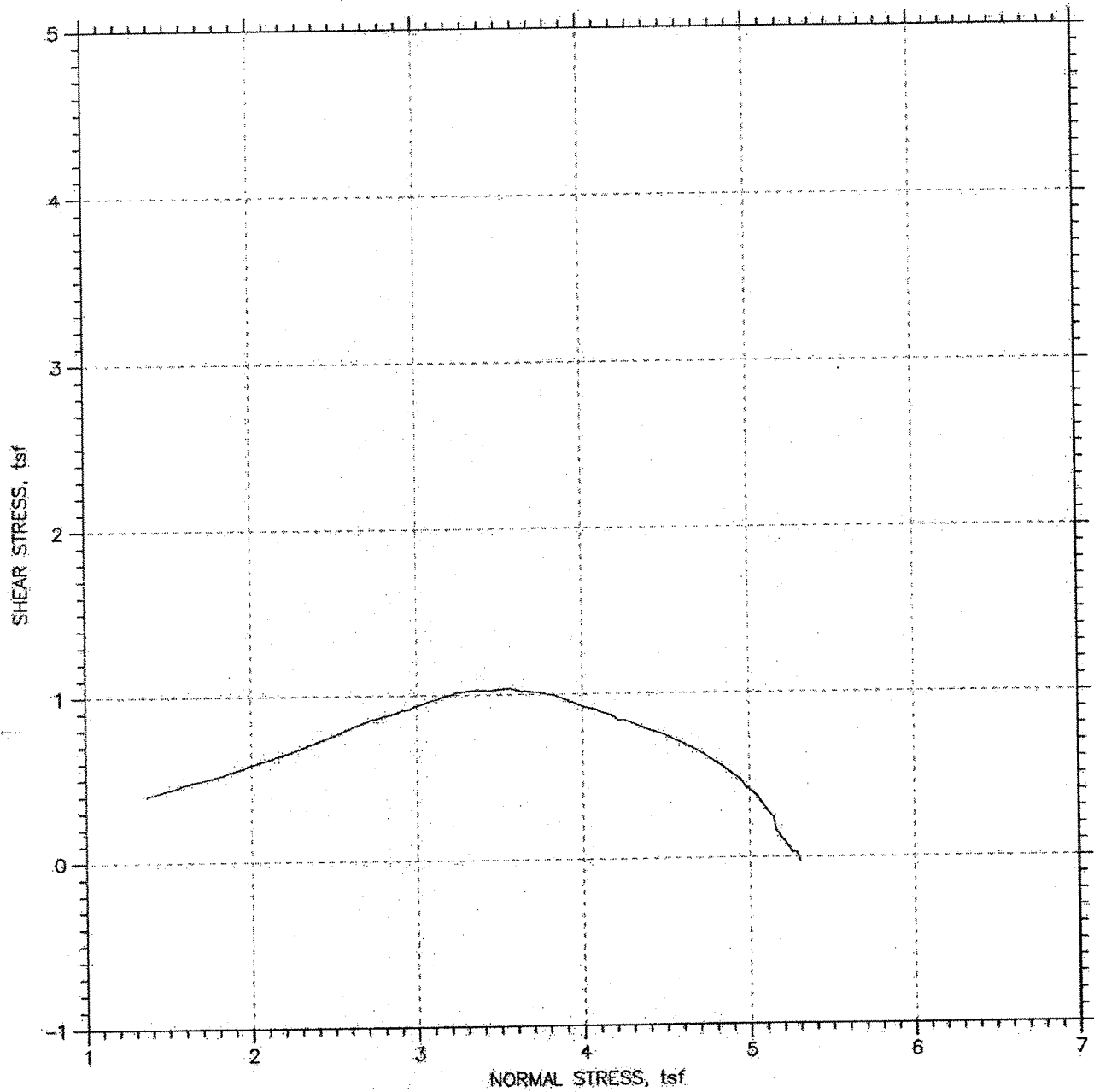

Project: CUY-90 West Abutment	Location: 14" from Bottom	Project No.: 5653
Boring No.: B-05-07	Tested By: S0	Checked By: JW
Sample No.: S-22	Test Date: 5-2-06	Depth: 104-106
Test No.: 1	Sample Type: Undisturbed	Elevation:
Description: León Clay w/pockets of silt (CL)		
Remarks: ASTM D 6528		
File: \\dell\GeoComp\Software\DSS\5653-s22.dat		

DIRECT SIMPLE SHEAR TEST

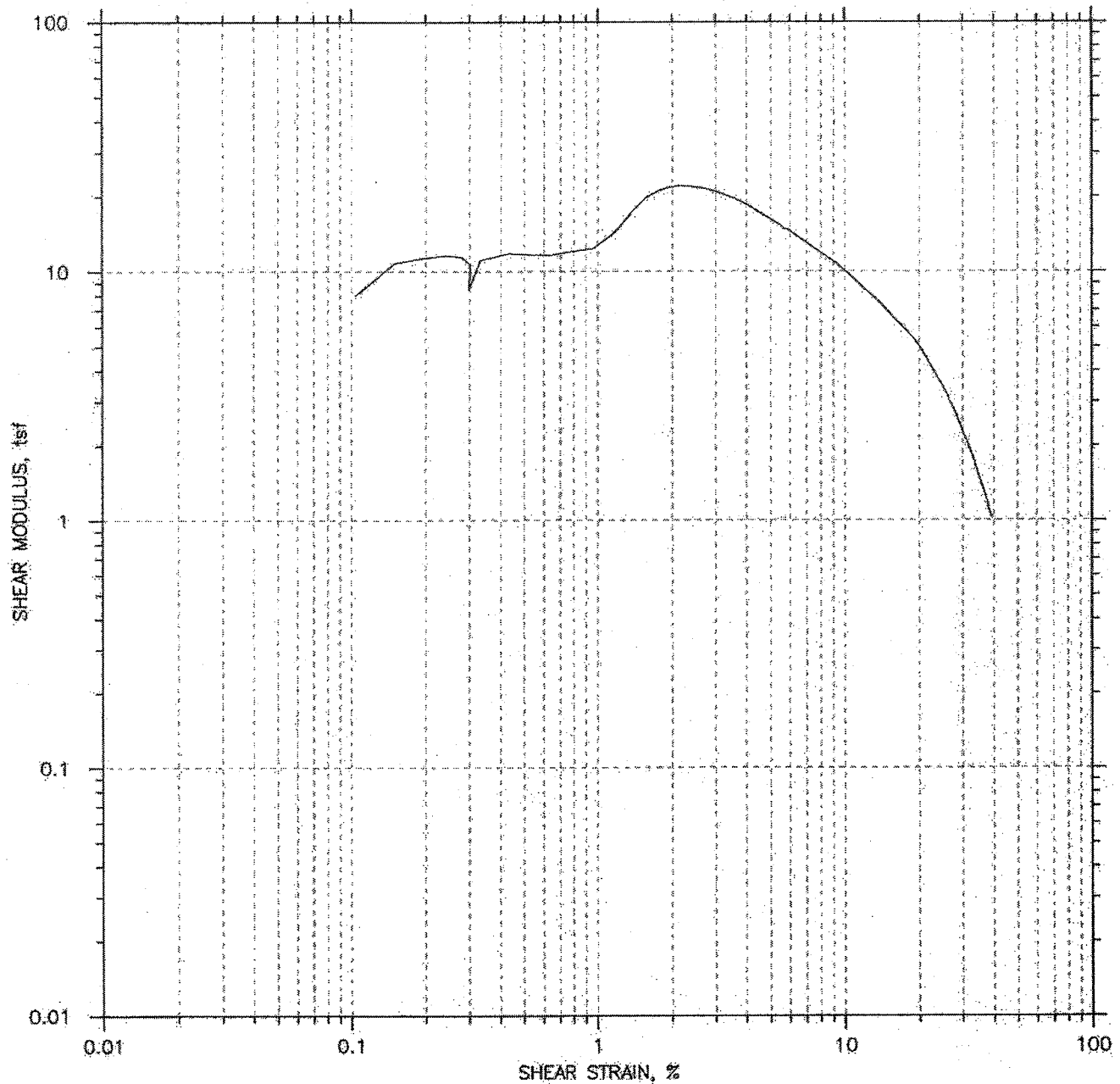

Project: CUY-90 West Abutment	Location: 14" from Bottom	Project No.: 5653
Boring No.: B-05-07	Tested By: SO	Checked By: JW
Sample No.: S-22	Test Date: 5-2-06	Depth: 104-106
Test No.: 1	Sample Type: Undisturbed	Elevation:
Description: Lean Clay w/pockets of silt (CL)		
Remarks: ASTM D 6528		
File: \\del\GeoComp\Software\DSS\5653-s22.dat		

UNCONFINED COMPRESSION TEST

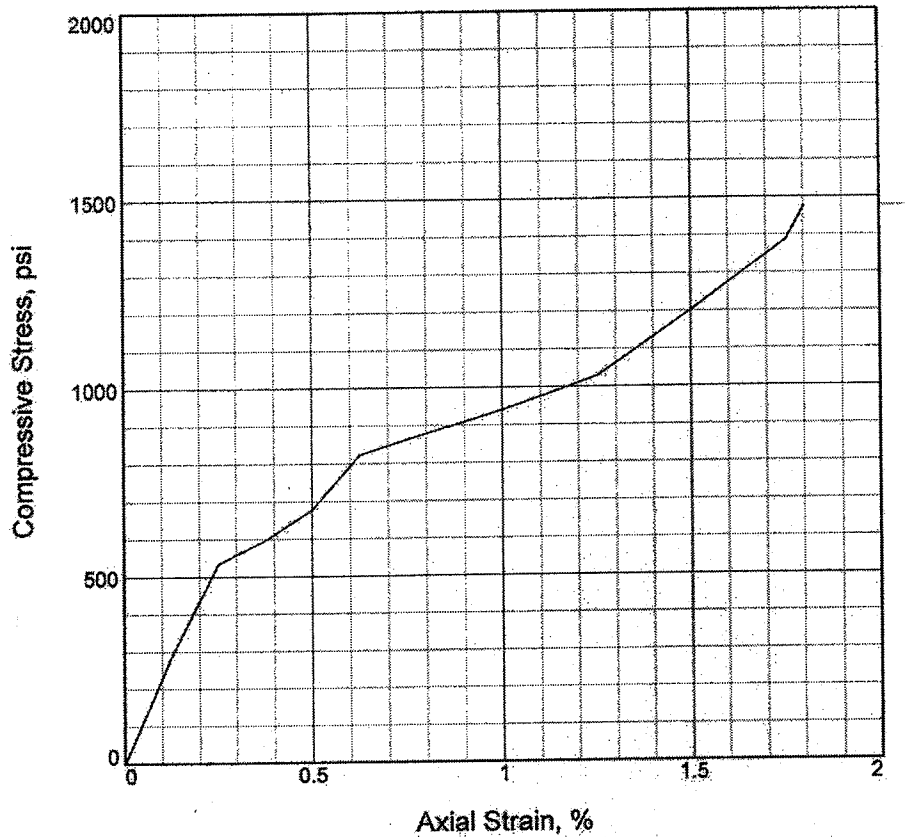

Sample No.	1			
Unconfined strength, psi	1476.67			
Undrained shear strength, psi	738.34			
Failure strain, %	1.8			
Strain rate, in./min.	1.00			
Water content, %	17.0			
Wet density, pcf	160.7			
Dry density, pcf	137.3			
Saturation, %	220.5			
Void ratio	0.2046			
Specimen diameter, in.	2.04			
Specimen height, in.	3.99			
Height/diameter ratio	1.96			

Description: Soft dark gray shale, nearly horizontally bedded, many horizontal fractures, contains many interbedded siltstone

LL = PL = PI = Assumed GS= 2.65 Type: Rock core

Project No.: 012 00946300

Date: 4/19/06

Remarks:

Client: Michael Baker Inc.

Project: Cuy-90-15.24 West Abutment

Location: B-05-01

Sample Number: S-56 **Depth:** 228.8 - 229.3

UNCONFINED COMPRESSION TEST

BBC&M Engineering, Inc.

Figure _____

Tested By: RAK

Checked By: RAK

UNCONFINED COMPRESSION TEST

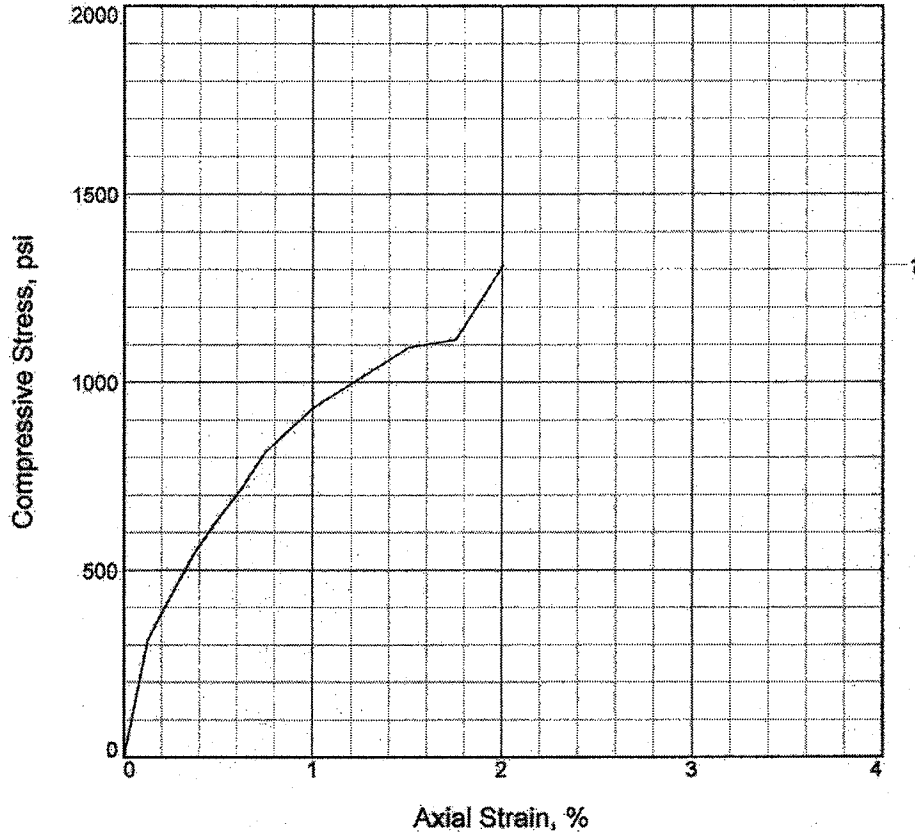

Sample No.	1			
Unconfined strength, psi	1311.26			
Undrained shear strength, psi	655.63			
Failure strain, %	2.0			
Strain rate, in./min.	1.00			
Water content, %	4.3			
Wet density, pcf	171.6			
Dry density, pcf	164.5			
Saturation, %	271.3			
Void ratio	0.0435			
Specimen diameter, in.	1.95			
Specimen height, in.	3.99			
Height/diameter ratio	2.05			

Description: Soft dark gray and gray shale, nearly horizontally bedded, many horizontal and few diagonal and vertical

LL = **PL =** **PI =** **Assumed GS= 2.75** **Type: Rock Core**

Project No.: 012 00946.300

Date: 6/14/06

Remarks:

Client: Michael Baker Inc.

Project: Cuy-90-15.24 West Abutment

Location: B-05-03

Sample Number: S-39 **Depth:** 165.2' - 165.9'

UNCONFINED COMPRESSION TEST

BBC&M Engineering, Inc.

Figure _____

Tested By: RAK

Checked By: RAK

UNCONFINED COMPRESSION TEST

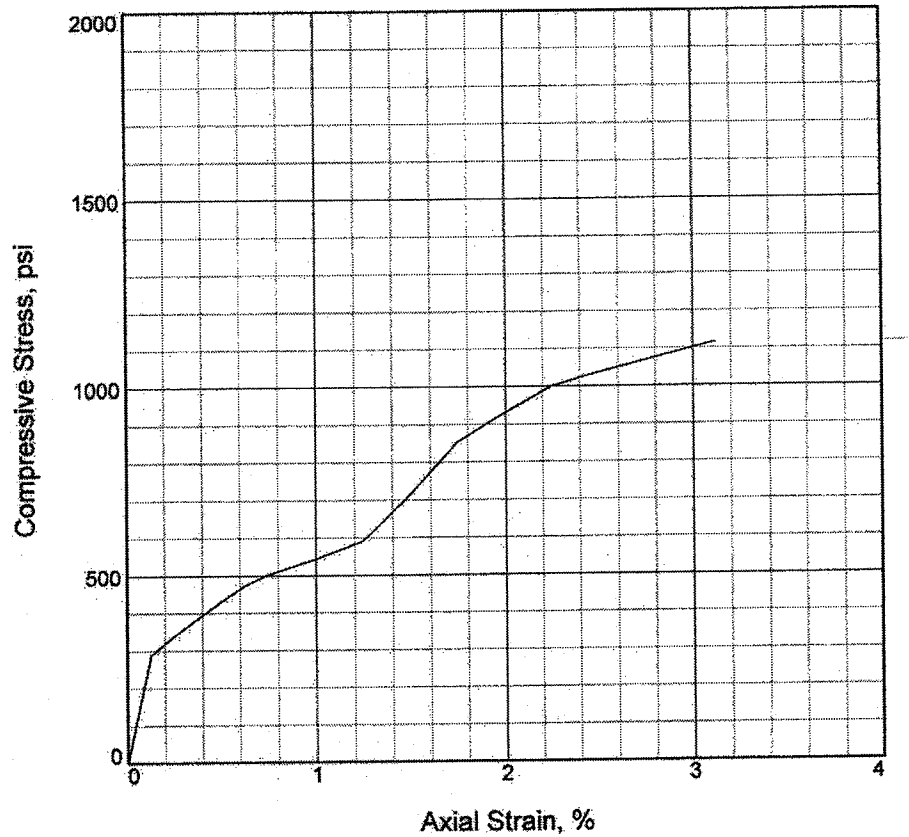

Sample No.	1		
Unconfined strength, psi	1115.95		
Undrained shear strength, psi	557.97		
Failure strain, %	3.1		
Strain rate, in./min.	1.00		
Water content, %	3.1		
Wet density, pcf	167.1		
Dry density, pcf	162.0		
Saturation, %	391.3		
Void ratio	0.0210		
Specimen diameter, in.	2.04		
Specimen height, in.	4.01		
Height/diameter ratio	1.97		

Description: Soft dark gray and gray shale interbedded with siltstone, NEarly horizontally bedded, few horizontal fractures.

LL = PL = PI = Assumed GS= 2.65 Type: Rock Core

Project No.: 012 00946.300

Date: 4/5/06

Remarks:

Client: Michael Baker Inc.

Project: Cuy-90-15.24 West Abutment

Location: B-05-04

Sample Number: S-50 **Depth:** 169.9 - 170.4

UNCONFINED COMPRESSION TEST

BBC&M Engineering, Inc.

Figure _____

Tested By: RAK

Checked By: RAK

UNCONFINED COMPRESSION TEST

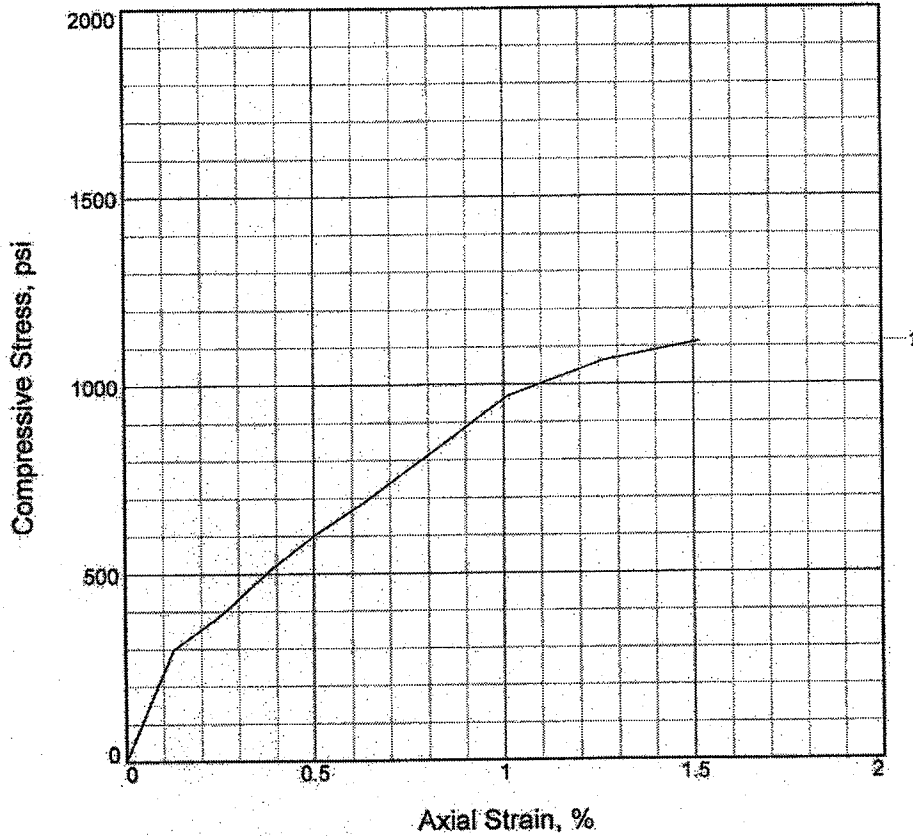

Sample No.	1		
Unconfined strength, psi	1112.63		
Undrained shear strength, psi	556.32		
Failure strain, %	1.5		
Strain rate, in./min.	1.00		
Water content, %	3.7		
Wet density, pcf	167.6		
Dry density, pcf	161.6		
Saturation, %	164.0		
Void ratio	0.0622		
Specimen diameter, in.	1.97		
Specimen height, in.	3.96		
Height/diameter ratio	2.01		

Description: Soft dark gray and gray shale, nearly horizontally bedded, many horizontal and few diagonal and vertical

LL =	PL =	PI =	Assumed GS= 2.75	Type: Rock Core
------	------	------	------------------	-----------------

Project No.: 012 00946300

Date: 6/14/06

Remarks:

Client: Michael Baker Inc.

Project: Cuy-90-15.24 West Abutment

Location: B-05-07

Sample Number: S-48

Depth: 224.0' - 224.5'

UNCONFINED COMPRESSION TEST

BBC&M Engineering, Inc.

Figure _____

Tested By: RAK

Checked By: RAK

UNCONFINED COMPRESSION TEST

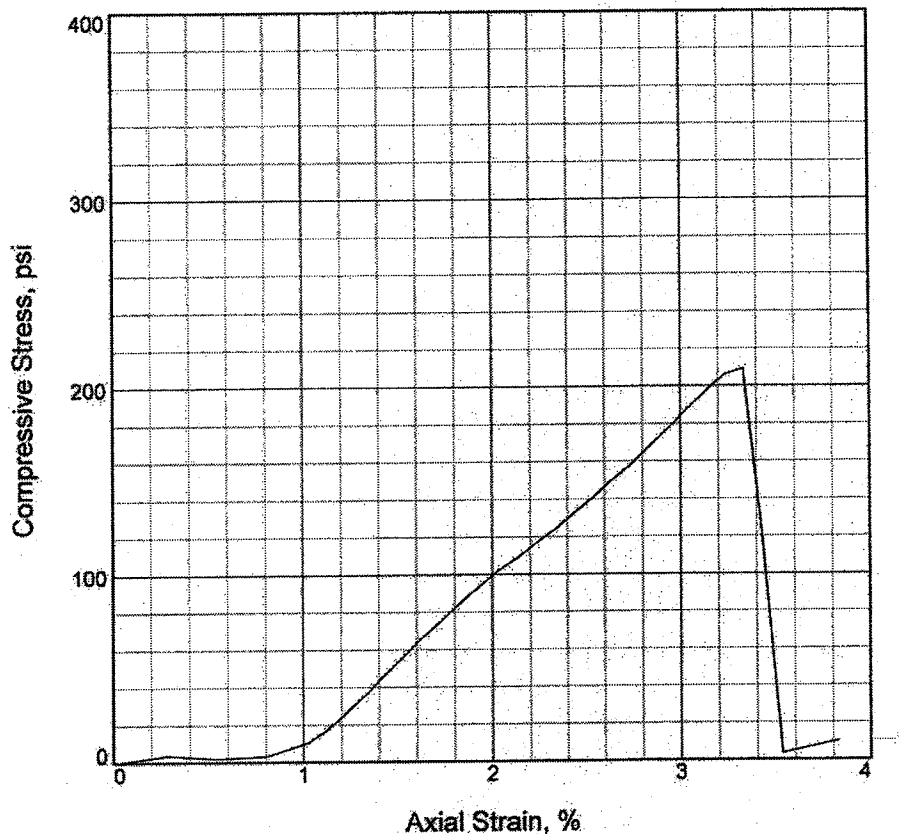

Sample No.	1			
Unconfined strength, psi	209.37			
Undrained shear strength, psi	104.69			
Failure strain, %	3.3			
Strain rate, in./min.	3.98			
Water content, %	0.0			
Wet density, pcf	160.3			
Dry density, pcf	160.3			
Saturation, %	0.0			
Void ratio	0.0515			
Specimen diameter, in.	2.05			
Specimen height, in.	3.95			
Height/diameter ratio	1.93			

Description: Soft dark gray and gray shale, nearly horizontally bedded, many horizontal and few diagonal and vertical

LL =	PL =	PI =	Assumed GS= 2.7	Type: Rock core
------	------	------	-----------------	-----------------

Project No.: 012 00946.300
 Date: 5/1/06
 Remarks:
 Figure _____

Client: Michael Baker Inc.
Project: Cuy-90-15.24 West Abutment
Location: B-05-11
Sample Number: S-55 **Depth:** 225.0' -225.5'
 UNCONFINED COMPRESSION TEST
BBC&M Engineering, Inc.

Tested By: RAK Checked By: RAK

UNCONFINED COMPRESSION TEST

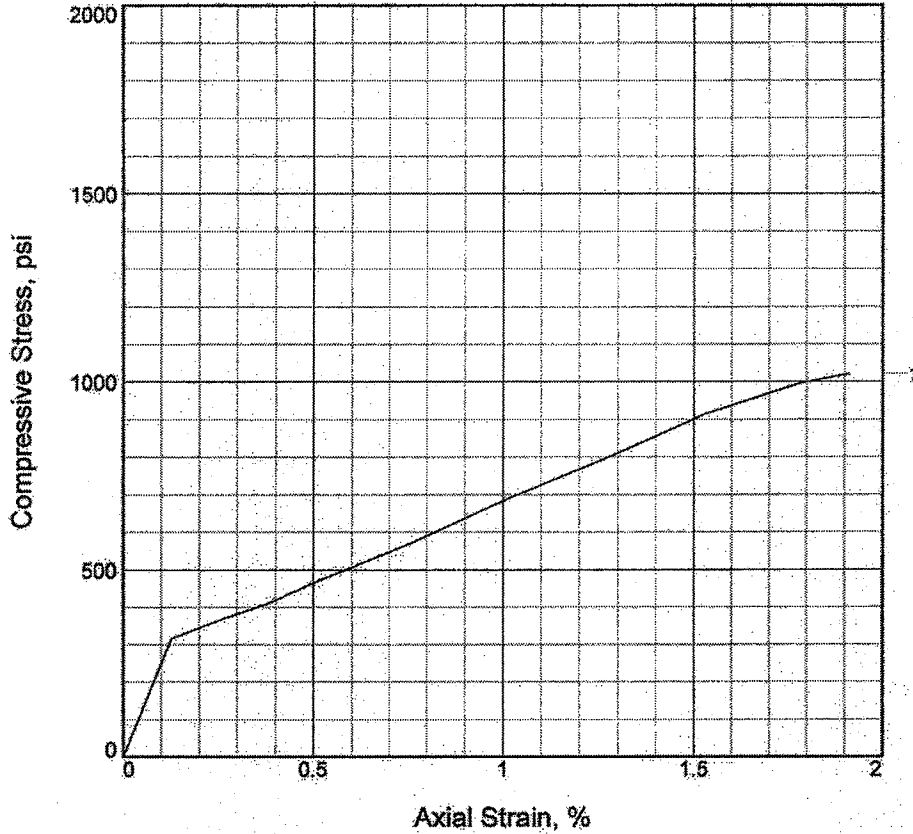

Sample No.	1			
Unconfined strength, psi	1020.94			
Undrained shear strength, psi	510.47			
Failure strain, %	1.9			
Strain rate, in./min.	1.00			
Water content, %	4.0			
Wet density, pcf	167.4			
Dry density, pcf	161.0			
Saturation, %	165.6			
Void ratio	0.0663			
Specimen diameter, in.	1.96			
Specimen height, in.	3.92			
Height/diameter ratio	2.00			

Description: Soft dark gray and gray shale, nearly horizontally bedded, many horizontal and few diagonal and vertical

LL = PL = PI = Assumed GS= 2.75 Type: Rock Core

Project No.: 012 00946.300

Date: 6/14/06

Remarks:

Client: Michael Baker Inc.

Project: Cuy-90-15.24 West Abutment

Location: B-05-12

Sample Number: S-56 **Depth:** 207.6' - 208.1'

UNCONFINED COMPRESSION TEST

BBC&M Engineering, Inc.

Figure _____

Tested By: RAK

Checked By: RAK

UNCONFINED COMPRESSION TEST

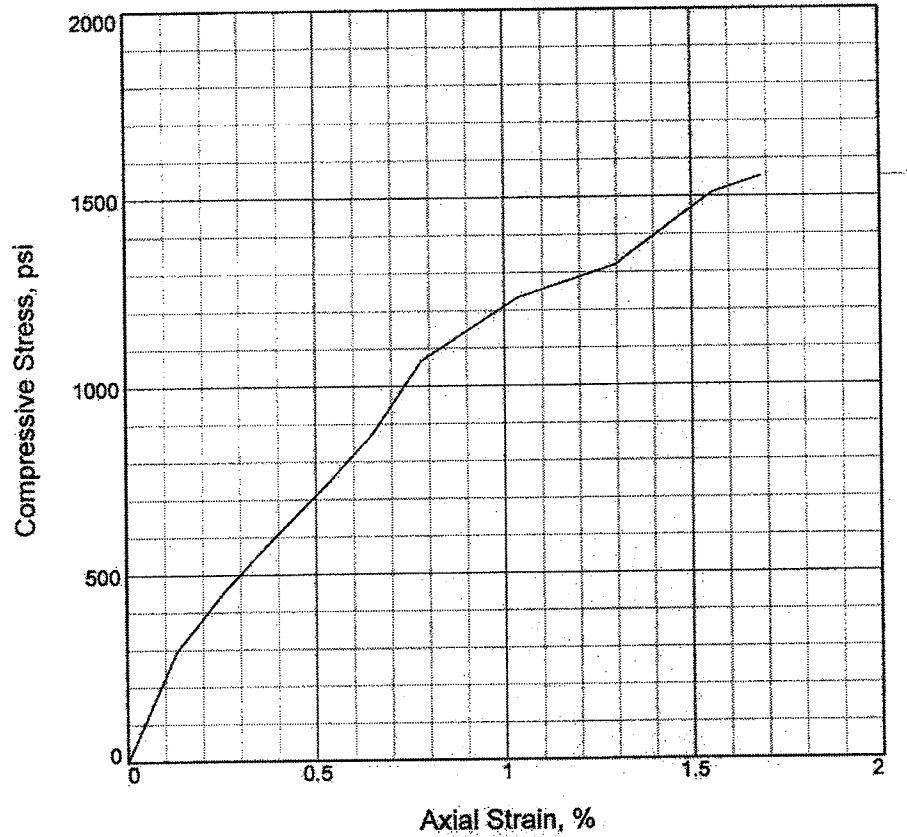

Sample No.	1			
Unconfined strength, psi	1553.10			
Undrained shear strength, psi	776.55			
Failure strain, %	1.7			
Strain rate, in./min.	1.00			
Water content, %	0.0			
Wet density, pcf	162.6			
Dry density, pcf	162.6			
Saturation, %	0.0			
Void ratio	0.0175			
Specimen diameter, in.	1.97			
Specimen height, in.	3.86			
Height/diameter ratio	1.96			

Description: Soft dark gray and gray shale, nearly horizontally bedded, many horizontal and few diagonal and vertical

LL =	PL =	PI =	Assumed GS= 2.65	Type: Rock Core
------	------	------	------------------	-----------------

Project No.: 012 00946.300

Date: 5/20/06

Remarks:

Client: Michael Baker Inc.

Project: Cuy-90-15.24 West Abutment

Location: B-05-13

Sample Number: S-37 **Depth:** 152.5' - 153.0'

UNCONFINED COMPRESSION TEST

BBC&M Engineering, Inc.

Figure _____

Tested By: RAK

Checked By: RAK

UNCONFINED COMPRESSION TEST

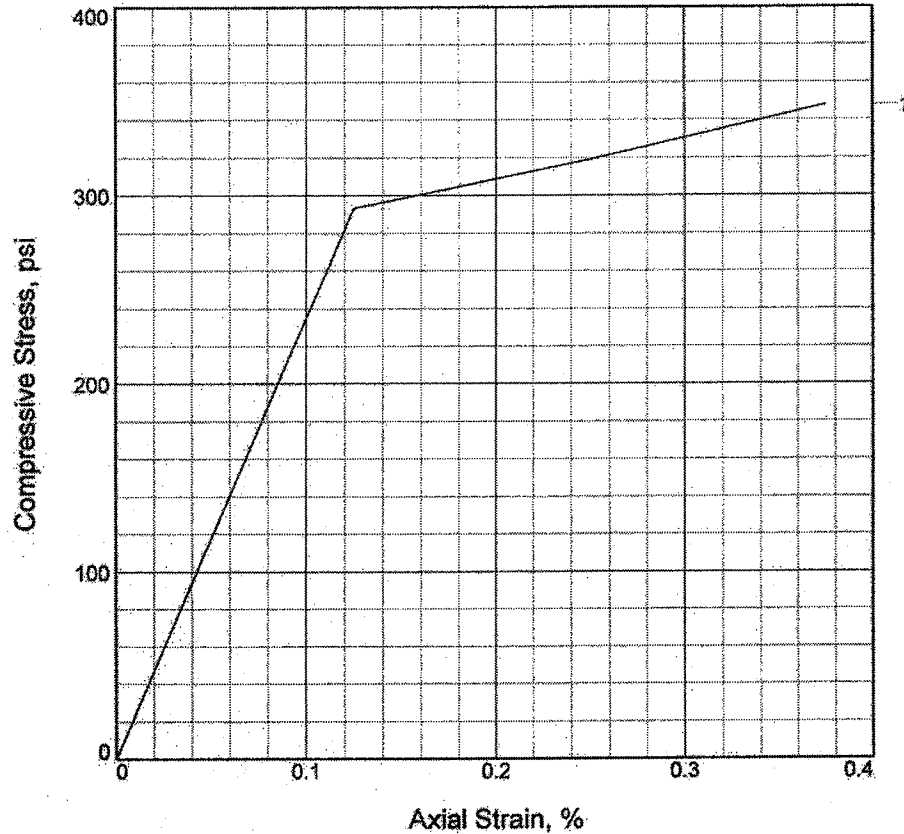

Sample No.	1			
Unconfined strength, psi	347.96			
Undrained shear strength, psi	173.98			
Failure strain, %	0.4			
Strain rate, in./min.	1.00			
Water content, %	0.0			
Wet density, pcf	162.6			
Dry density, pcf	162.6			
Saturation, %	0.0			
Void ratio	0.0172			
Specimen diameter, in.	1.98			
Specimen height, in.	4.01			
Height/diameter ratio	2.03			

Description: Soft dark gray and gray shale, nearly horizontally bedded, many horizontal and few diagonal and vertical

LL =	PL =	PI =	Assumed GS= 2.65	Type: Rock Core
------	------	------	------------------	-----------------

Project No.: 012 00946.300

Date: 5/20/06

Remarks:

Client: Michael Baker Inc.

Project: Cuy-90-15.24 West Abutment

Location: B-05-13

Sample Number: S-40 **Depth:** 178.5' - 179.0'

UNCONFINED COMPRESSION TEST

BBC&M Engineering, Inc.

Figure _____

Tested By: RAK

Checked By: RAK

UNCONFINED COMPRESSION TEST

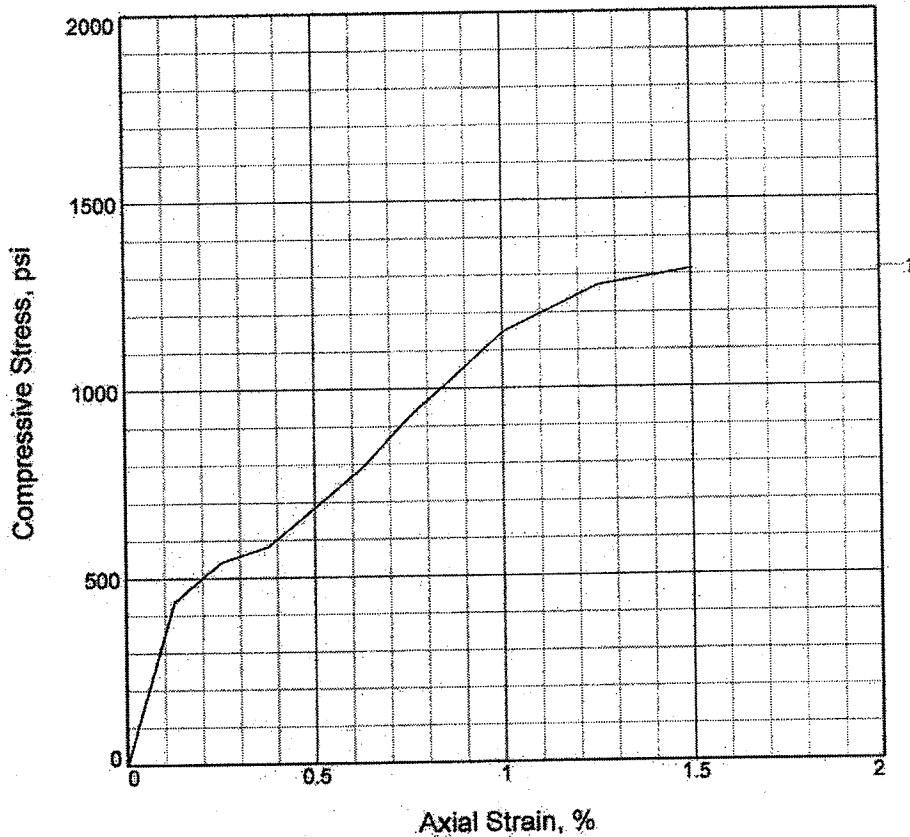

Sample No.	1			
Unconfined strength, psi	1313.31			
Undrained shear strength, psi	656.65			
Failure strain, %	1.5			
Strain rate, in./min.	1.00			
Water content, %	0.4			
Wet density, pcf	161.5			
Dry density, pcf	160.9			
Saturation, %	36.2			
Void ratio	0.0282			
Specimen diameter, in.	1.98			
Specimen height, in.	3.99			
Height/diameter ratio	2.01			

Description: Soft dark gray and gray shale, nearly horizontally bedded, many horizontal and few diagonal and vertical

LL =	PL =	PI =	Assumed GS = 2.65	Type: Rock Core
------	------	------	--------------------------	-----------------

Project No.: 012 00946.300

Date: 5/20/06

Remarks:

Client: Michael Baker Inc.

Project: Cuy-90-15.24 West Abutment

Location: B-05-14

Sample Number: S-36 **Depth:** 168.4' - 169.0'

UNCONFINED COMPRESSION TEST

BBC&M Engineering, Inc.

Figure _____

Tested By: RAK

Checked By: RAK

UNCONFINED COMPRESSION TEST

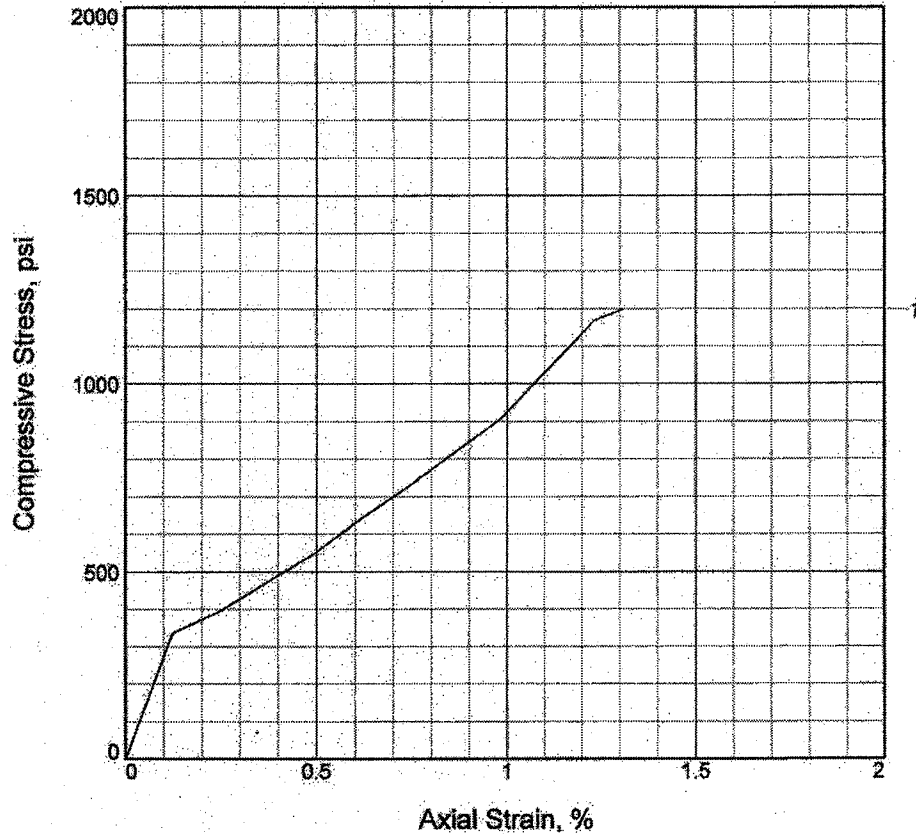

Sample No.	1		
Unconfined strength, psi	1198.22		
Undrained shear strength, psi	599.11		
Failure strain, %	1.3		
Strain rate, in./min.	1.00		
Water content, %	0.0		
Wet density, pcf	168.8		
Dry density, pcf	168.8		
Saturation, %	0.0		
Void ratio	-0.0199		
Specimen diameter, in.	1.97		
Specimen height, in.	4.06		
Height/diameter ratio	2.06		

Description: Soft dark gray and gray shale, nearly horizontally bedded, many horizontal and few diagonal and vertical

LL = **PL =** **PI =** **Assumed GS= 2.65** **Type: Rock Core**

Project No.: 012 00946.300

Date: 5/20/06

Remarks:

Client: Michael Baker Inc.

Project: Cuy-90-15.24 West Abutment

Location: B-05-14

Sample Number: S-37 **Depth:** 180.0' - 180.4'

UNCONFINED COMPRESSION TEST

BBC&M Engineering, Inc.

Figure _____

Tested By: RAK

Checked By: RAK

UNCONFINED COMPRESSION TEST

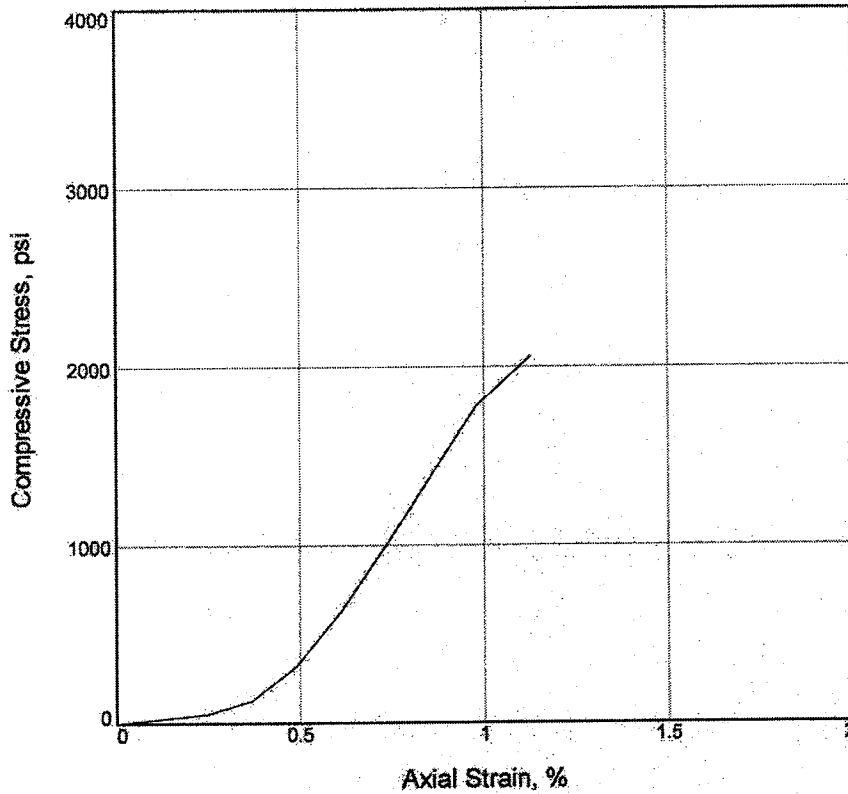

Sample No.	1		
Unconfined strength, psi	2056.59		
Undrained shear strength, psi	1028.29		
Failure strain, %	1.1		
Strain rate, in./min.	0.04		
Water content, %	3.0		
Wet density, pcf	158.9		
Dry density, pcf	154.3		
Saturation, %	87.3		
Void ratio	0.0922		
Specimen diameter, in.	1.98		
Specimen height, in.	4.08		
Height/diameter ratio	2.06		

Description: Medium-hard dark gray shale.

LL =	PL =	PI =	Assumed GS= 2.7	Type: Rock Core
------	------	------	-----------------	-----------------

Project No.: 012-00946-309

Date: 6/3/06

Remarks:

Client:

Project: CUY-90 WEST A

Cleveland, Ohio

Location: B-05-15

Sample Number: S-47

Depth: 202.4' to 203.0'

UNCONFINED COMPRESSION TEST

BBC&M Engineering, Inc.

Figure 1

Tested By: CBP

Checked By: PJW

UNCONFINED COMPRESSION TEST

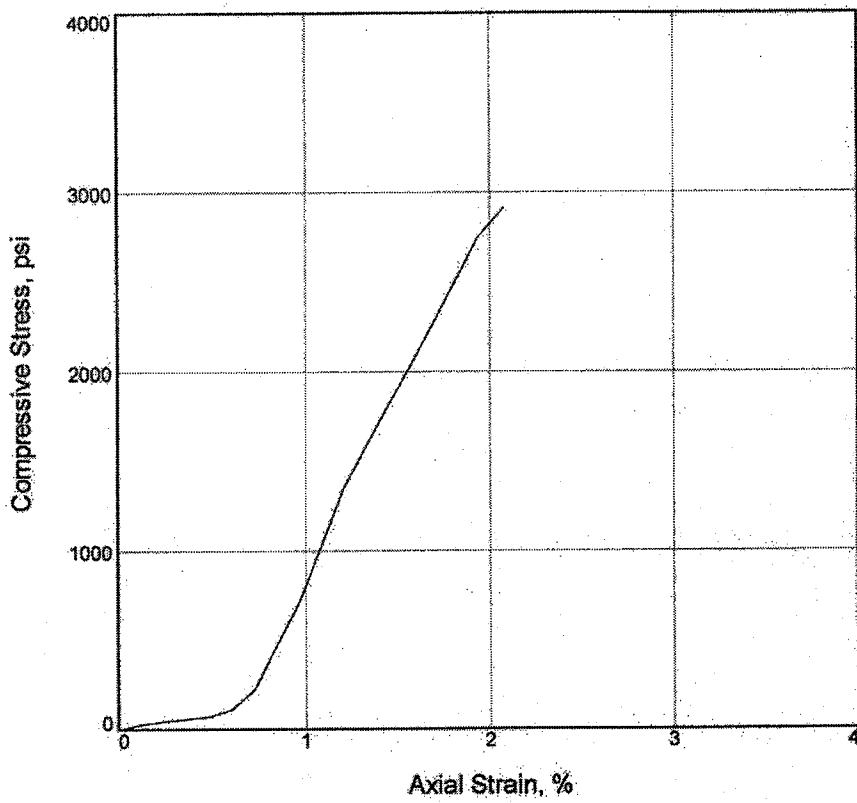

Sample No.	1		
Unconfined strength, psi	2915.94		
Undrained shear strength, psi	1457.97		
Failure strain, %	2.1		
Strain rate, in./min.	0.04		
Water content, %	3.0		
Wet density, pcf	163.4		
Dry density, pcf	158.6		
Saturation, %	96.4		
Void ratio	0.0862		
Specimen diameter, in.	1.98		
Specimen height, in.	4.14		
Height/diameter ratio	2.09		

Description: Medium-hard dark gray shale.

LL =	PL =	PI =	Assumed GS= 2.76	Type: Rock Core
------	------	------	------------------	-----------------

Project No.: 012-00946-300
 Date: 6/3/06
 Remarks:

Figure 1

Client:
 Project: CUY-90 WEST A.
 Cleveland, Ohio
 Location: B-05-15
 Sample Number: S-48 Depth: 208.4' to 209.0'

UNCONFINED COMPRESSION TEST

BBC&M Engineering, Inc.

Tested By: CBP

Checked By: PJW

UNCONFINED COMPRESSION TEST

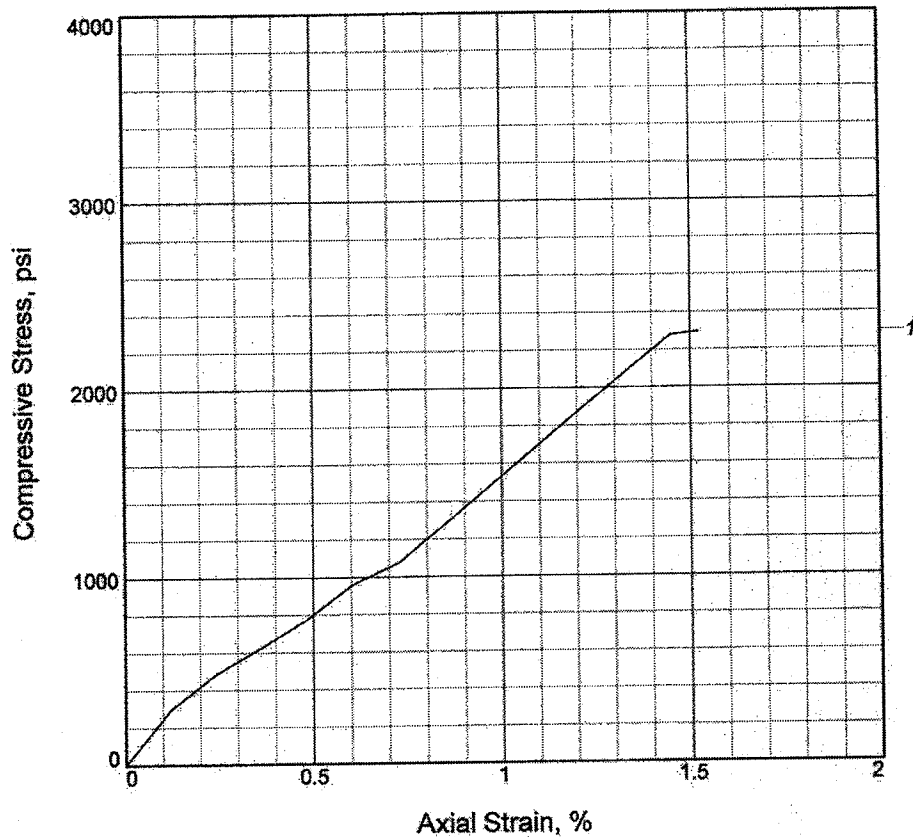

Sample No.	1			
Unconfined strength, psi	2295.18			
Undrained shear strength, psi	1147.59			
Failure strain, %	1.5			
Strain rate, in./min.	1.00			
Water content, %	3.1			
Wet density, pcf	163.1			
Dry density, pcf	158.3			
Saturation, %	100.0			
Void ratio	0.0848			
Specimen diameter, in.	1.96			
Specimen height, in.	4.14			
Height/diameter ratio	2.11			

Description: Soft dark gray and gray shale, nearly horizontally bedded, many horizontal and few diagonal and vertical

LL = **PL =** **PI =** **Assumed GS= 2.75** **Type: Rock Core**

Project No.: 012 00946.300

Date: 6/14/06

Remarks:

Client: Michael Baker Inc.

Project: Cuy-90-15.24 West Abutment

Location: B-05-16

Sample Number: S-36 **Depth:** 163.5' - 163.8'

UNCONFINED COMPRESSION TEST

BBC&M Engineering, Inc.

Figure _____

Tested By: RAK

Checked By: RAK

UNCONFINED COMPRESSION TEST

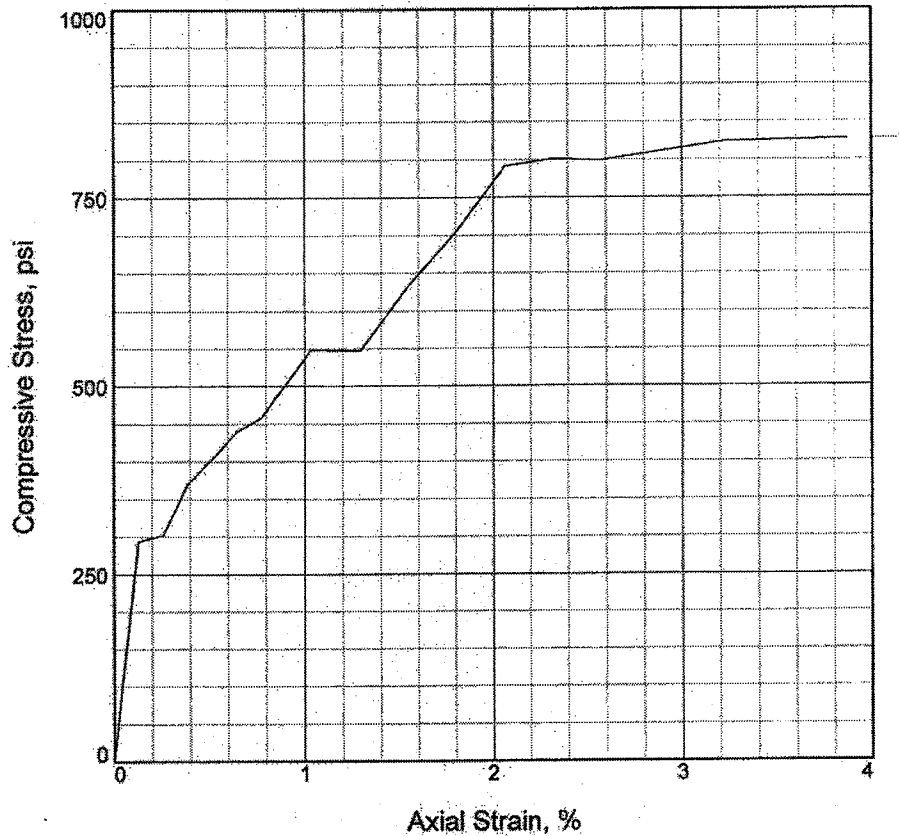

Sample No.	1		
Unconfined strength, psi	827.76		
Undrained shear strength, psi	413.88		
Failure strain, %	3.9		
Strain rate, in./min.	1.00		
Water content, %	0.0		
Wet density, pcf	161.8		
Dry density, pcf	161.8		
Saturation, %	0.0		
Void ratio	0.0223		
Specimen diameter, in.	2.03		
Specimen height, in.	3.88		
Height/diameter ratio	1.91		

Description: Soft dark gray and gray shale, nearly horizontally bedded, many horizontal and few diagonal and vertical

LL = **PL =** **PI =** **Assumed GS= 2.65** **Type: Rock Core**

Project No.: 012 00946.300

Date: 5/20/06

Remarks:

Client: Michael Baker Inc.

Project: Cuy-90-15.24 West Abutment

Location: B-105A

Sample Number: S-34 **Depth:** 154.4' - 155.2'

UNCONFINED COMPRESSION TEST

BBC&M Engineering, Inc.

Figure _____

Tested By: RAK

Checked By: RAK

Ackenheil Engineers, Inc.
ASTM D3148 ROCK MODULUS TEST RESULTS

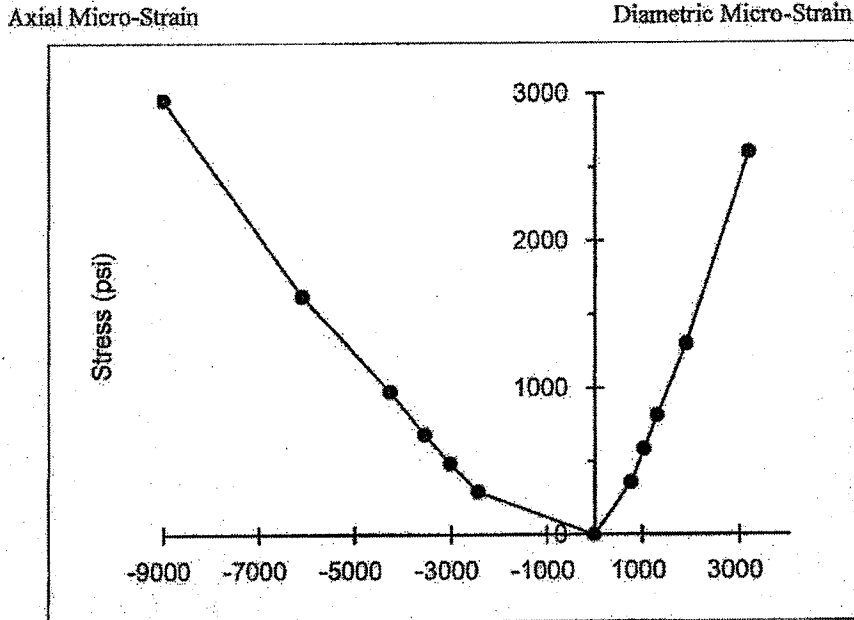

PROJECT INFO

CUY - 90, West Abutment

Project No. 04607

SAMPLE AND TEST METHOD DATA

VALUE UNITS

Specimen Boring No.	B-05-13
Specimen Boring Inclination	Vertical
Specimen Depth	160.1-160.6 ft.
Specimen Description	SHALE, Dark Gray, Argillaceous, Silty
Specimen Received Date	06/01/06 mo/dy/yr
Specimen Tested Date	06/03/06 mo/dy/yr
Specimen Moisture (As Received, Dried ...)	As Received
Specimen End Prep'n. Mthd. (Ground, Capped...)	Saw-cut, Capped
Diameter	1.98 in.
Height	4.63 in.
Aspect Ratio	2.34
Test Duration (at failure)	13.2 min.
Moist Unit Weight	160 pcf
Moisture Content as Tested	3.1 %

TEST RESULTS

Unconfined Compressive Strength	2,955 psi
Modulus of Deformation (tangent over linear range)	26,052 tsf
Poisson Ratio (tangent over linear range)	0.39

NOTES

1) Micro-Strain is the change of length divided by the length reported as millionths inch per inch.

Ackenheil Engineers, Inc.
ASTM D3148 ROCK MODULUS TEST RESULTS

SKETCH
OF
FAILURE

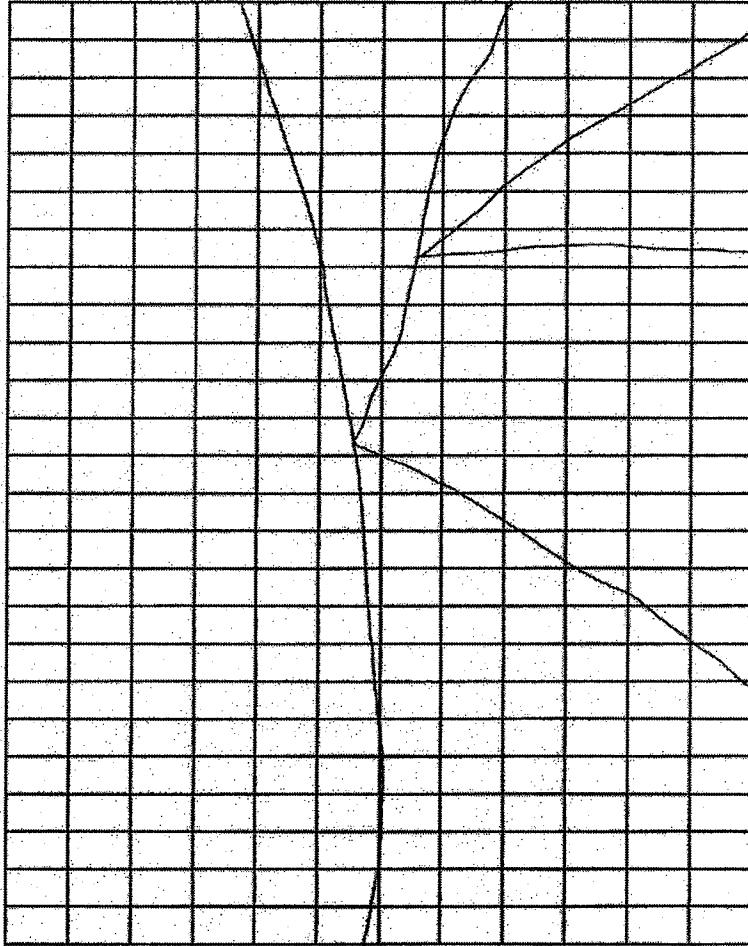

PROJECT INFO

CUY - 90, West Abutment

Project No. 04607

SAMPLE AND TEST METHOD DATA

Specimen Boring No.

Specimen Boring Inclination

Specimen Depth

Specimen Description

VALUE UNITS

B-05-13

Vertical

160.1-160.6 ft.

SHALE, Dark Gray, Argillaceous, Silty

Ackenheil Engineers, Inc.
ASTM D3148 ROCK MODULUS TEST RESULTS

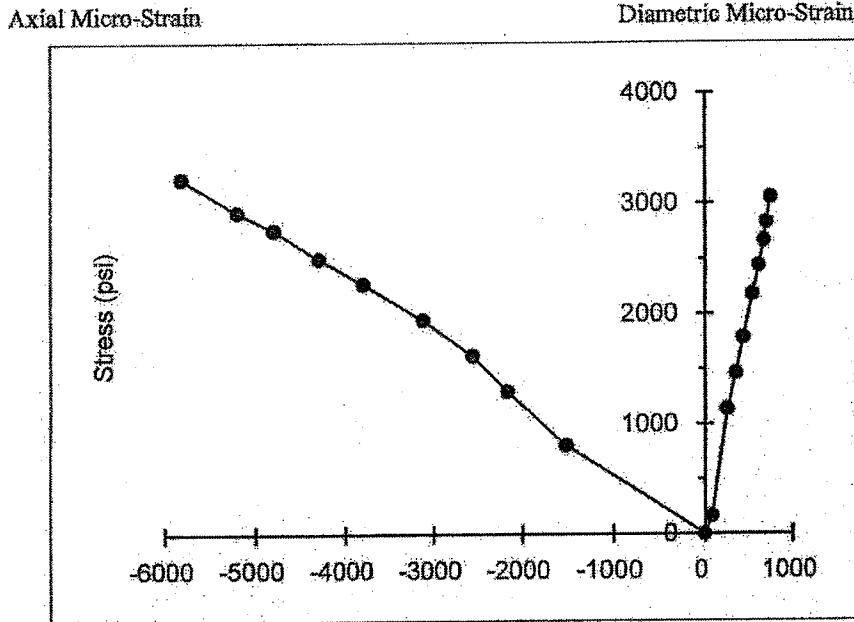

PROJECT INFO

CUY - 90, West Abutment

Project No. 04607

SAMPLE AND TEST METHOD DATA

Specimen Boring No.

B-05-14

Specimen Boring Inclination

Vertical

Specimen Depth

190.5-191.0 ft.

Specimen Description

SHALE, Dark Gray, Argillaceous, Silty

Specimen Received Date

06/01/06 mo/dy/yr

Specimen Tested Date

06/03/06 mo/dy/yr

Specimen Moisture (As Received, Dried ...)

As Received

Specimen End Prep'n. Mthd. (Ground, Capped...)

Saw-cut, Capped

Diameter

1.98 in.

Height

4.90 in.

Aspect Ratio

2.47

Test Duration (at failure)

15.0 min.

Moist Unit Weight

167 pcf

Moisture Content as Tested

3.1 %

TEST RESULTS

Unconfined Compressive Strength

3,228 psi

Modulus of Deformation (tangent over linear range)

35,430 tsf

Poisson Ratio (tangent over linear range)

0.13

NOTES

1) Micro-Strain is the change of length divided by the length reported as millionths inch per inch.

Ackenheil Engineers, Inc.
ASTM D3148 ROCK MODULUS TEST RESULTS

SKETCH
OF
FAILURE

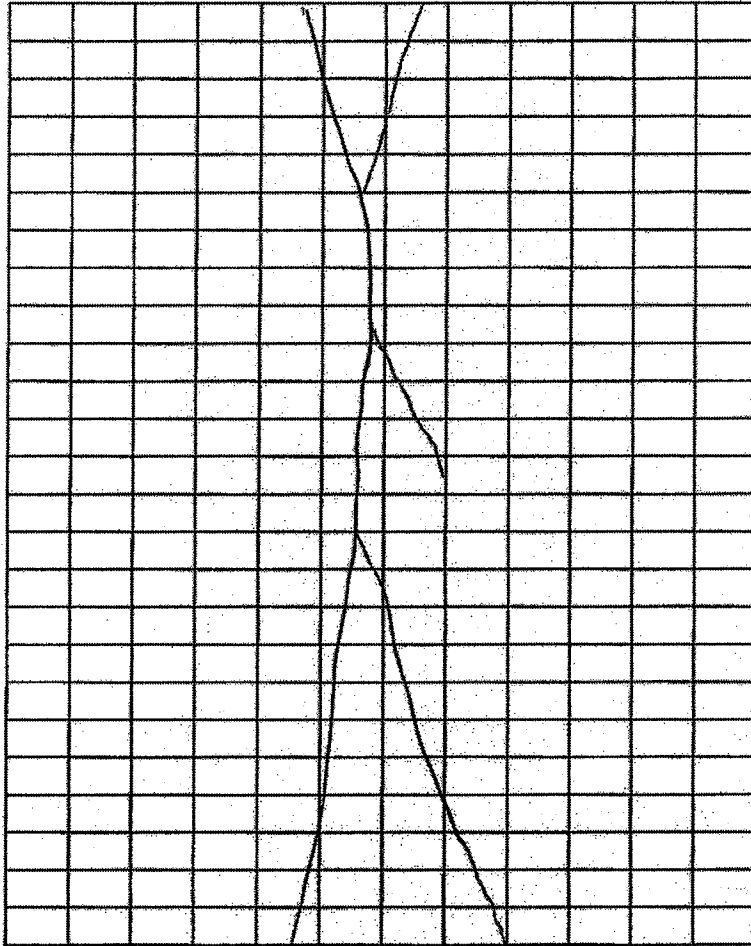

PROJECT INFO

CUY - 90, West Abutment

Project No. 04607

SAMPLE AND TEST METHOD DATA

Specimen Boring No.
Specimen Boring Inclination
Specimen Depth
Specimen Description

VALUE UNITS

B-05-14
Vertical
190.5-191.0 ft.
SHALE, Dark Gray, Argillaceous, Silty

Ackenheil Engineers, Inc.
ASTM D3148 ROCK MODULUS TEST RESULTS

Axial Micro-Strain

Diametric Micro-Strain

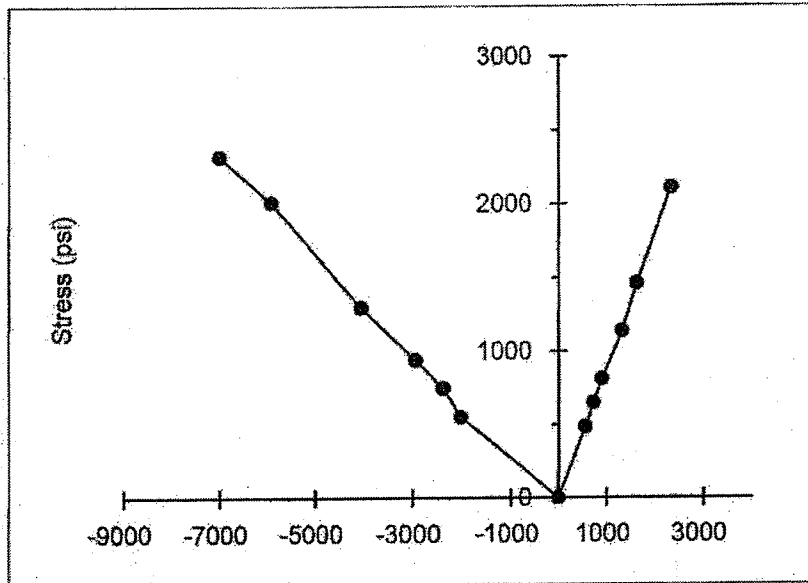

PROJECT INFO

CUY - 90, West Abutment

Project No. 04607

SAMPLE AND TEST METHOD DATA

VALUE UNITS

Specimen Boring No.	B-05-15
Specimen Boring Inclination	Vertical
Specimen Depth	213.1-213.6 ft.
Specimen Description	SHALE, Dark Gray, Argillaceous, Silty
Specimen Received Date	06/01/06 mo/dy/yr
Specimen Tested Date	06/03/06 mo/dy/yr
Specimen Moisture (As Received, Dried ...)	As Received
Specimen End Prep'n. Mthd. (Ground, Capped...)	Saw-cut, Capped
Diameter	1.98 in.
Height	4.09 in.
Aspect Ratio	2.07
Test Duration (at failure)	14.6 min.
Moist Unit Weight	163 pcf
Moisture Content as Tested	2.4 %

TEST RESULTS

Unconfined Compressive Strength	2,322 psi
Modulus of Deformation (tangent over linear range)	26,442 tsf
Poisson Ratio (tangent over linear range)	0.40

NOTES

1) Micro-Strain is the change of length divided by the length reported as millionths inch per inch.

Ackenheil Engineers, Inc.
ASTM D3148 ROCK MODULUS TEST RESULTS

SKETCH
OF
FAILURE

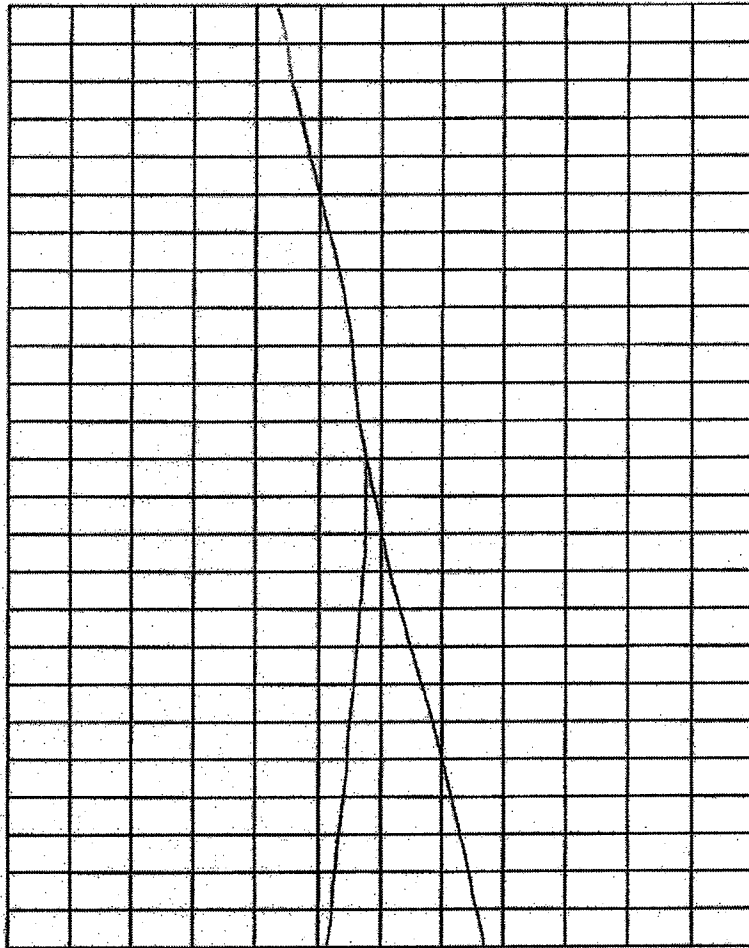

PROJECT INFO

CUY - 90, West Abutment

Project No. 04607

SAMPLE AND TEST METHOD DATA

Specimen Boring No.

Specimen Boring Inclination

Specimen Depth

Specimen Description

VALUE UNITS

B-05-15

Vertical

213.1-213.6 ft.

SHALE, Dark Gray, Argillaceous, Silty

APPENDIX F
LIMIT EQUILIBRIUM SLOPE STABILITY ANALYSES

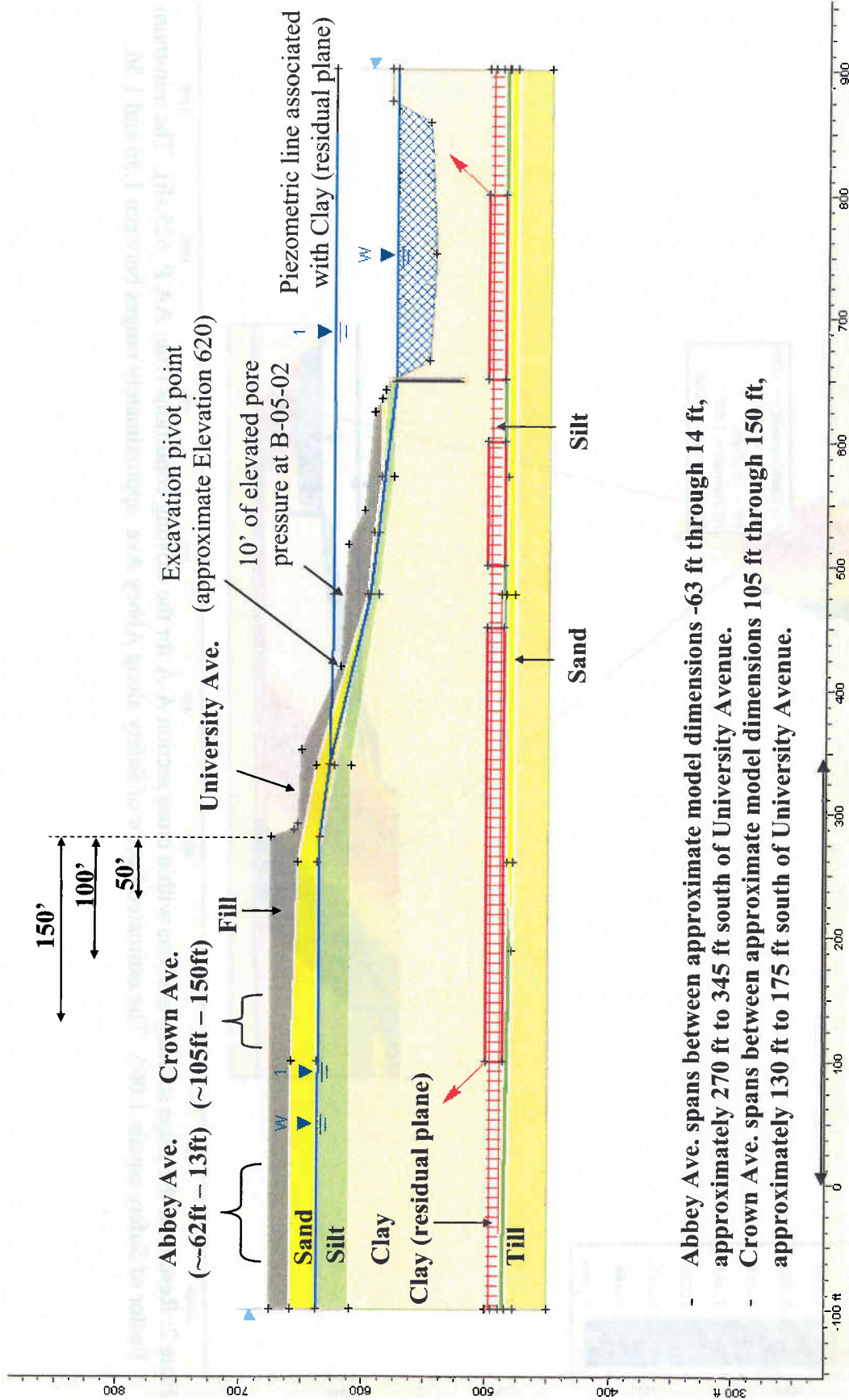

- Abbey Ave. spans between approximate model dimensions -63 ft through 14 ft, approximately 270 ft to 345 ft south of University Avenue.
- Crown Ave. spans between approximate model dimensions 105 ft through 150 ft, approximately 130 ft to 175 ft south of University Avenue.

Plate 1: Existing conditions modeled along cross section A-A (file: AA_P_625.sli).

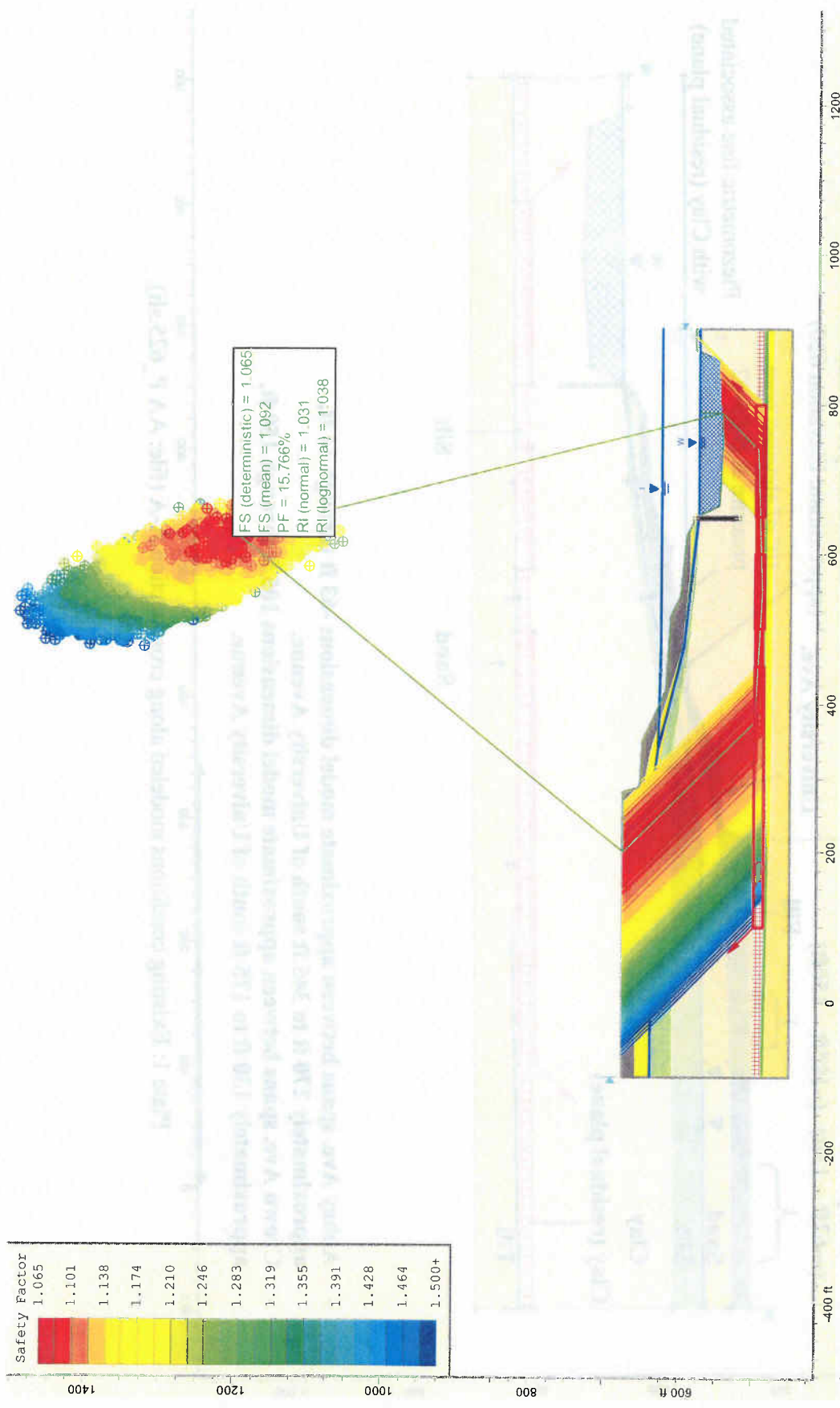

Plate 2: Results of the slope stability analysis within cross section A-A for the existing conditions (file: AA_P_625.sli). The minimum Factor of Safety equals 1.065. The estimated Factor of Safety along Abbey Ave. approximately ranges between 1.36 and 1.56.

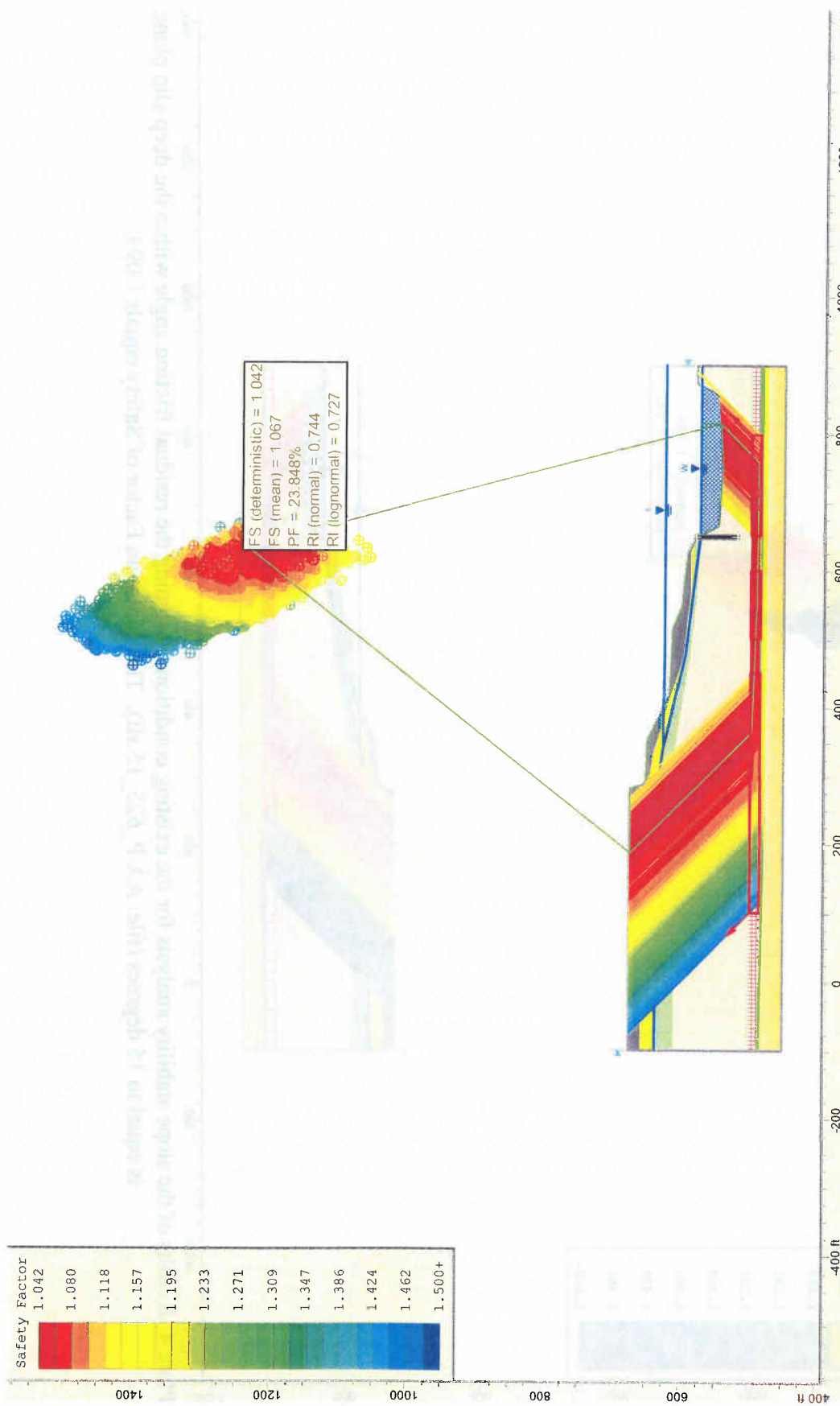

Plate 3: Results of the slope stability analysis within cross section A-A for the existing conditions assuming the residual friction angle within the deep slip plane is equal to 13 degrees (file: AA P_625_13.sli). The minimum Factor of Safety equals 1.042.

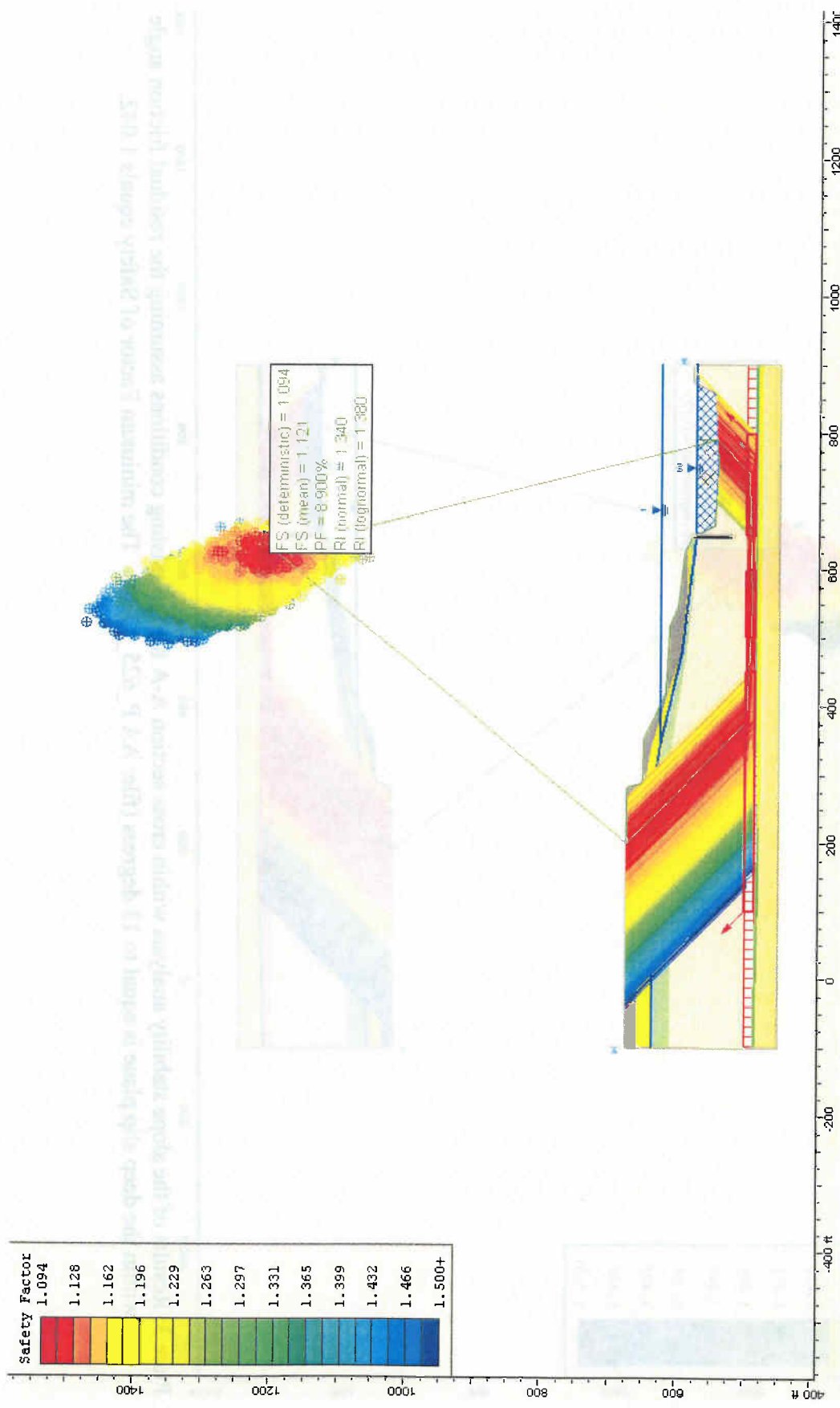

Plate 4: Results of the slope stability analysis for the existing conditions assuming the residual friction angle within the deep slip plane is equal to 15 degrees (file: AA P_625_15.sli). The minimum Factor of Safety equals 1.094.

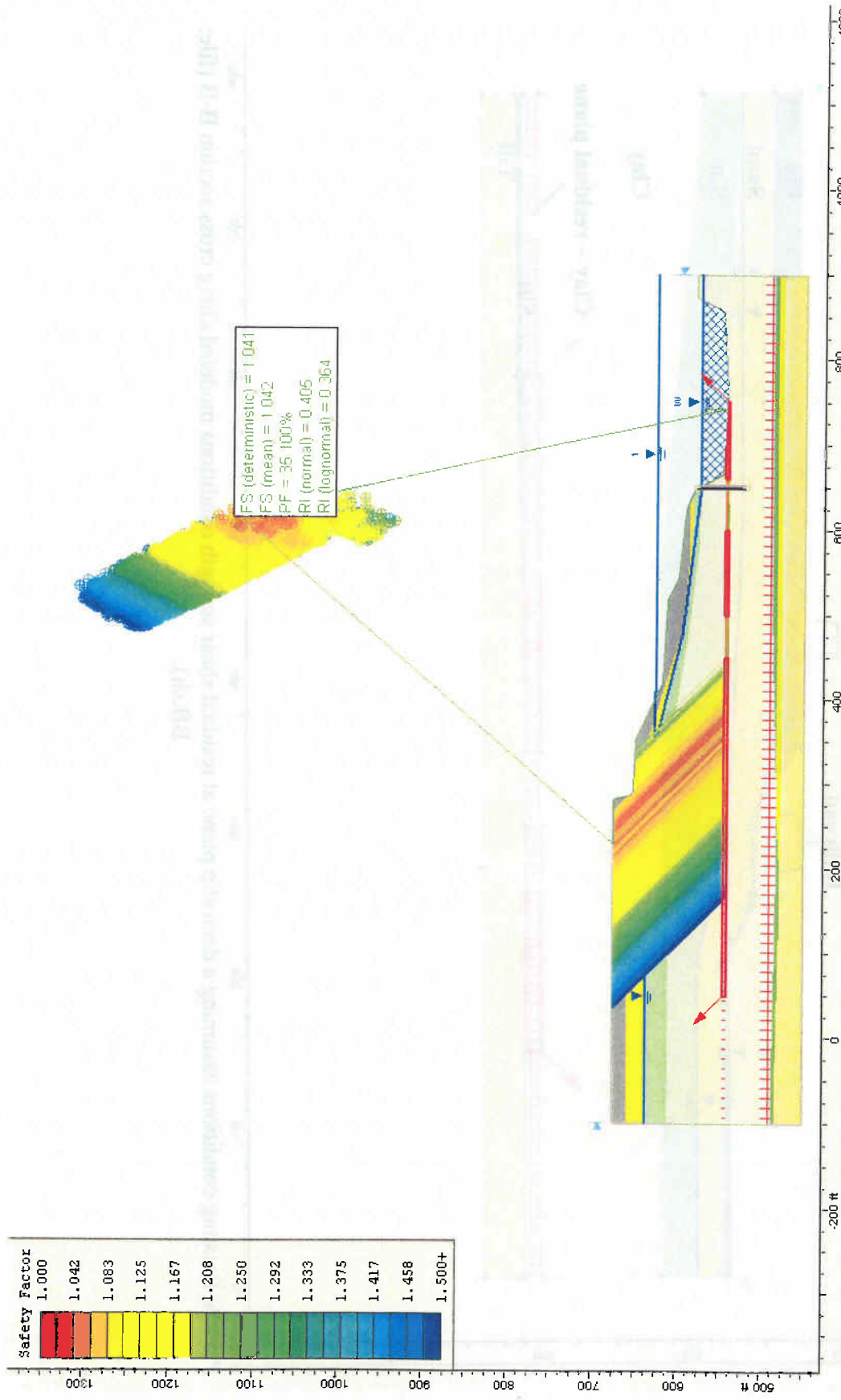

Plate 5: Results of the slope stability analysis for the existing conditions for a potential shallow slip plane (file: AA P_625SH.sli). The minimum Factor of Safety equals 1.041.

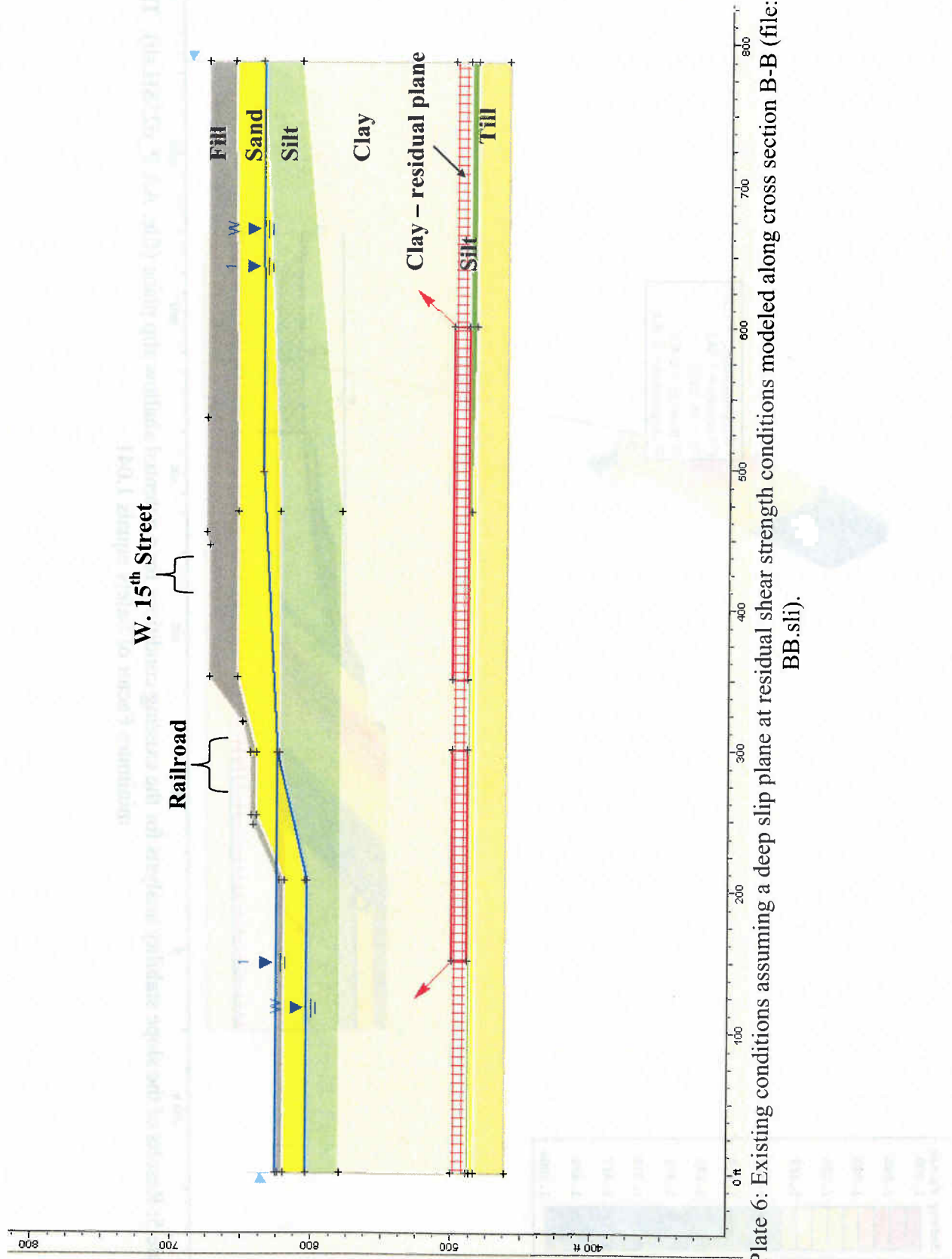

Plate 6: Existing conditions assuming a deep slip plane at residual shear strength conditions modeled along cross section B-B (file: BB.sli).

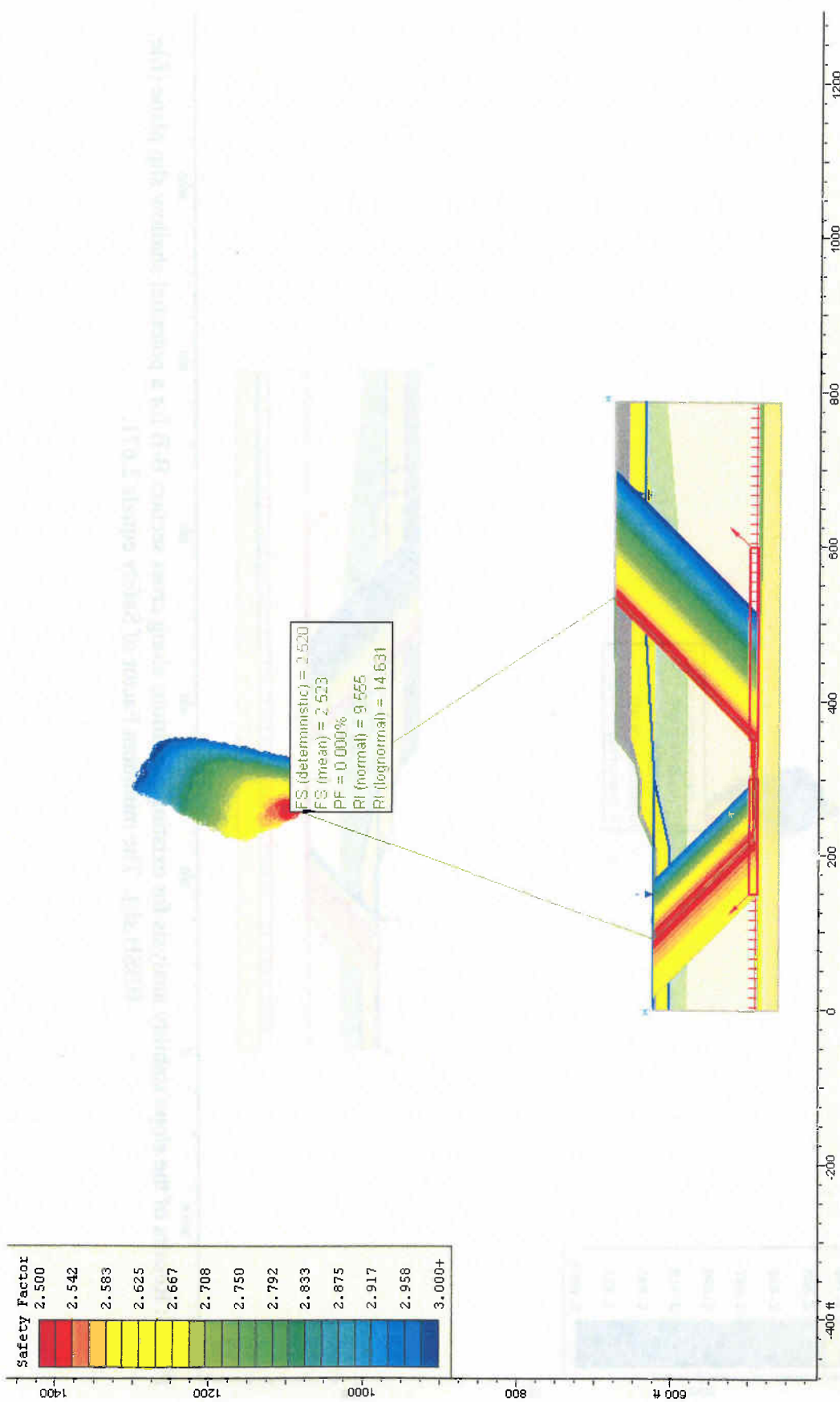

Plate 7: Results of the slope stability analyses for existing conditions along cross section B-B assuming a deep slip surface at residual shear strength conditions (file: BB.sli). The minimum Factor of Safety equals 2.52. The results presented were obtained by using the Simplified Janbu method instead of the Spencer method since the resulting Factor of Safety exceeds the allowable maximum Factor of Safety produced by the Spencer method.

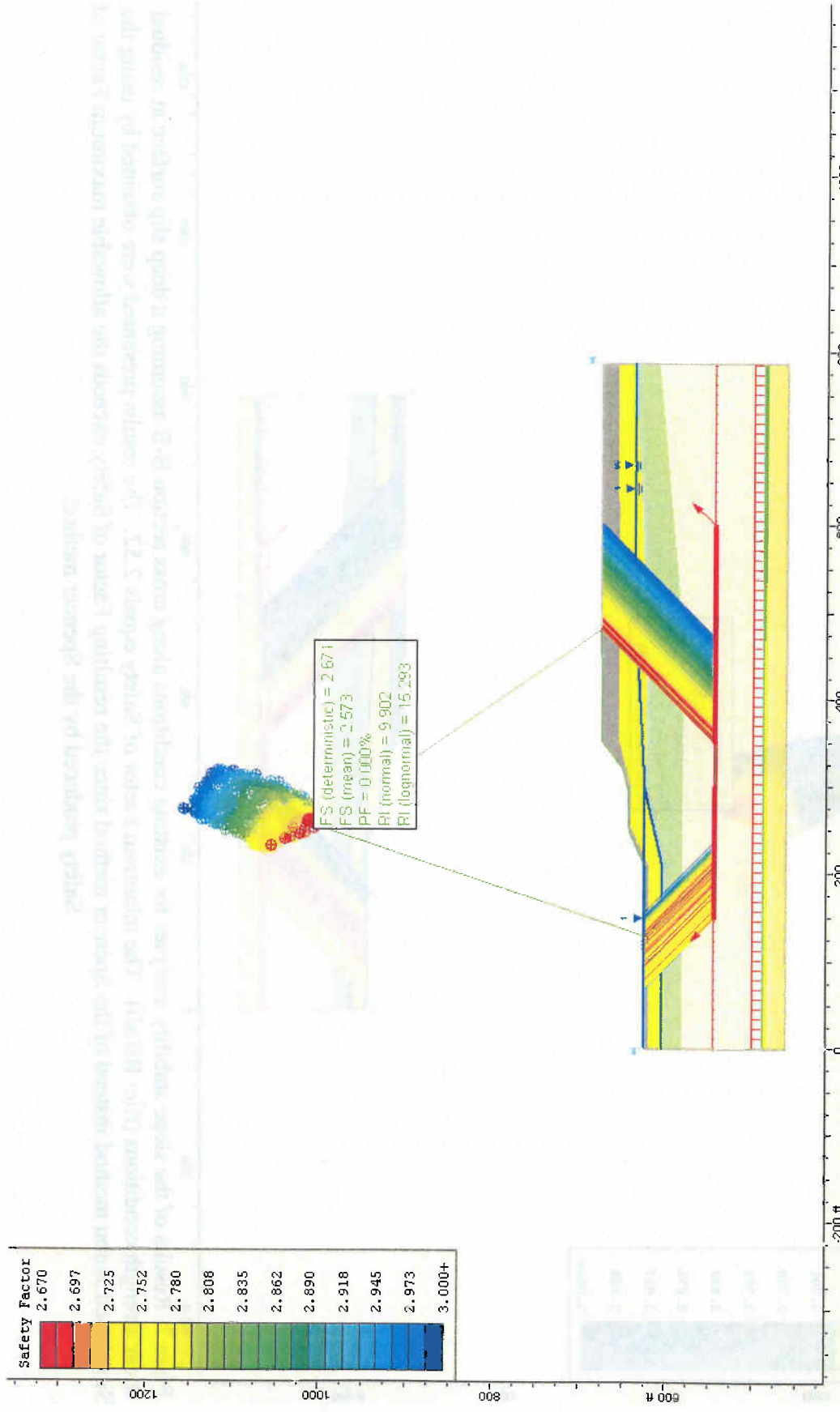

Plate 8: Results of the slope stability analysis for existing conditions along cross section B-B for a potential shallow slip plane (file: BBSH.sli). The minimum Factor of Safety equals 2.671.

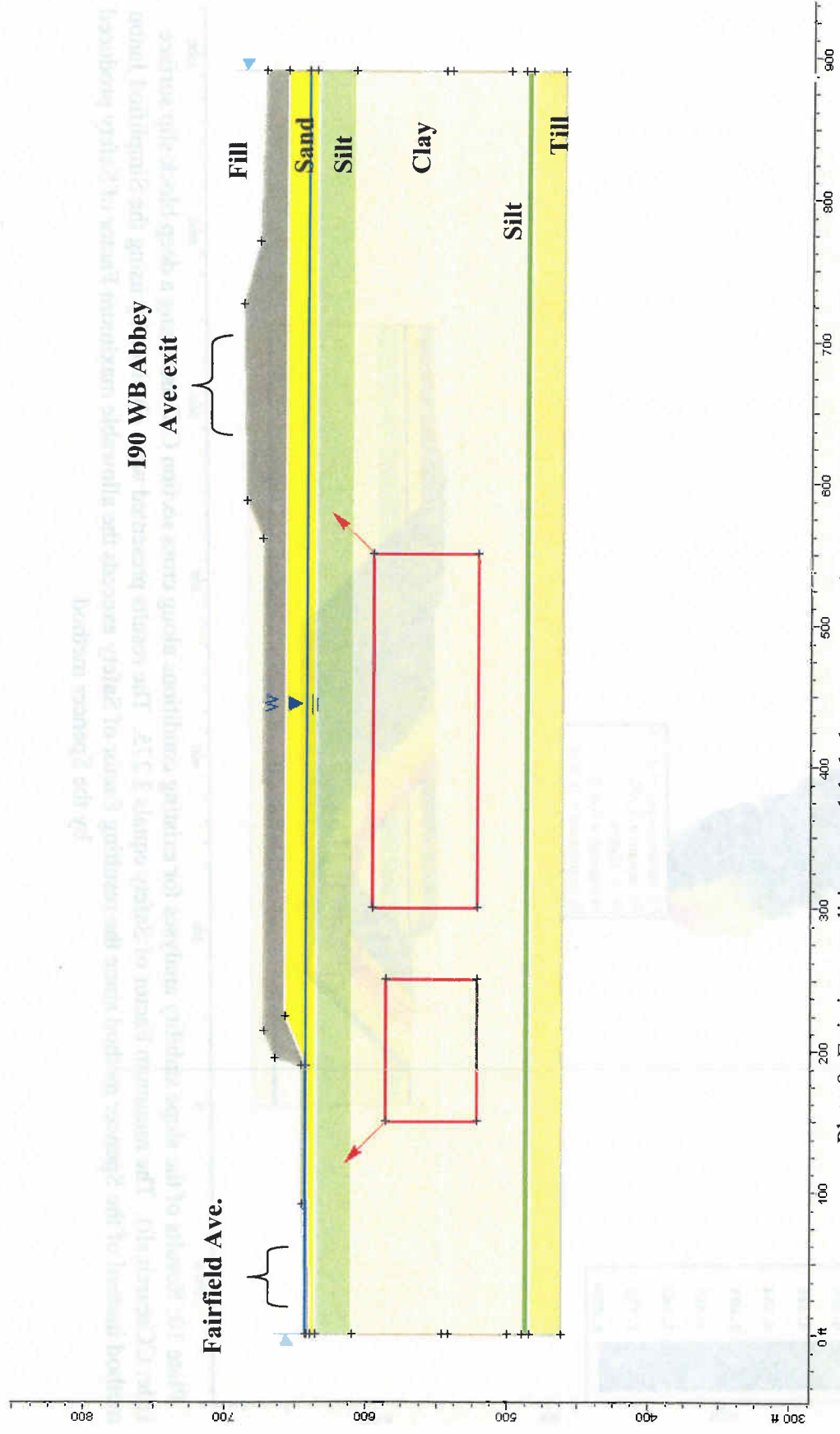

Plate 9: Existing conditions modeled along cross section C-C (file: CCsearch.sli).

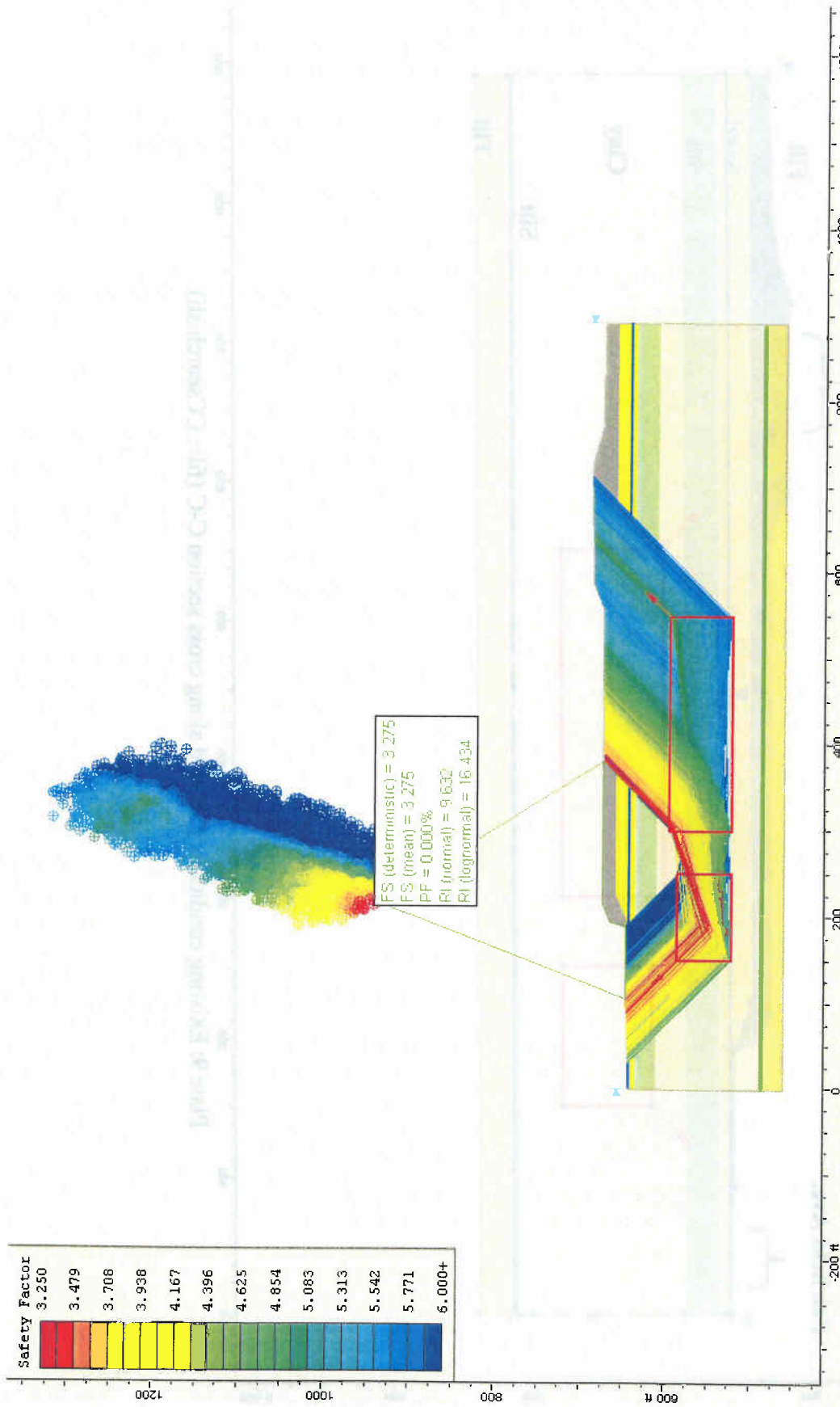

Plate 10: Results of the slope stability analyses for existing conditions along cross section C-C assuming a deep block slip surface (file: CCsearch.sli). The minimum Factor of Safety equals 3.275. The results presented were obtained by using the Simplified Janbu method instead of the Spencer method since the resulting Factor of Safety exceeds the allowable maximum Factor of Safety produced by the Spencer method.

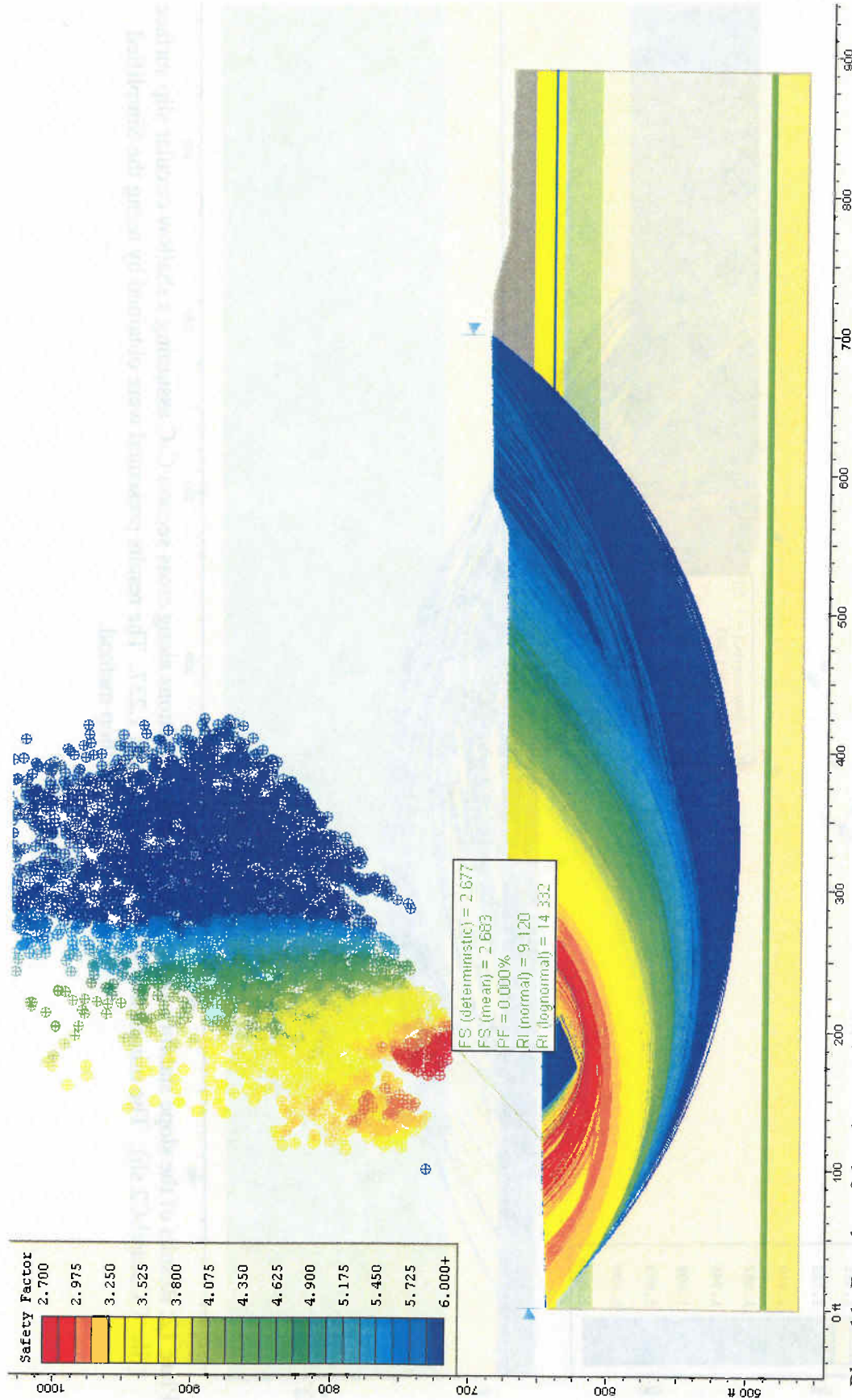

Plate 11: Results of the slope stability analyses for existing conditions along cross section C-C assuming a deep circular slip surface (file: CCsearchC.sli). The minimum Factor of Safety equals 2.677. The results presented were obtained by using the Simplified Bishop method.

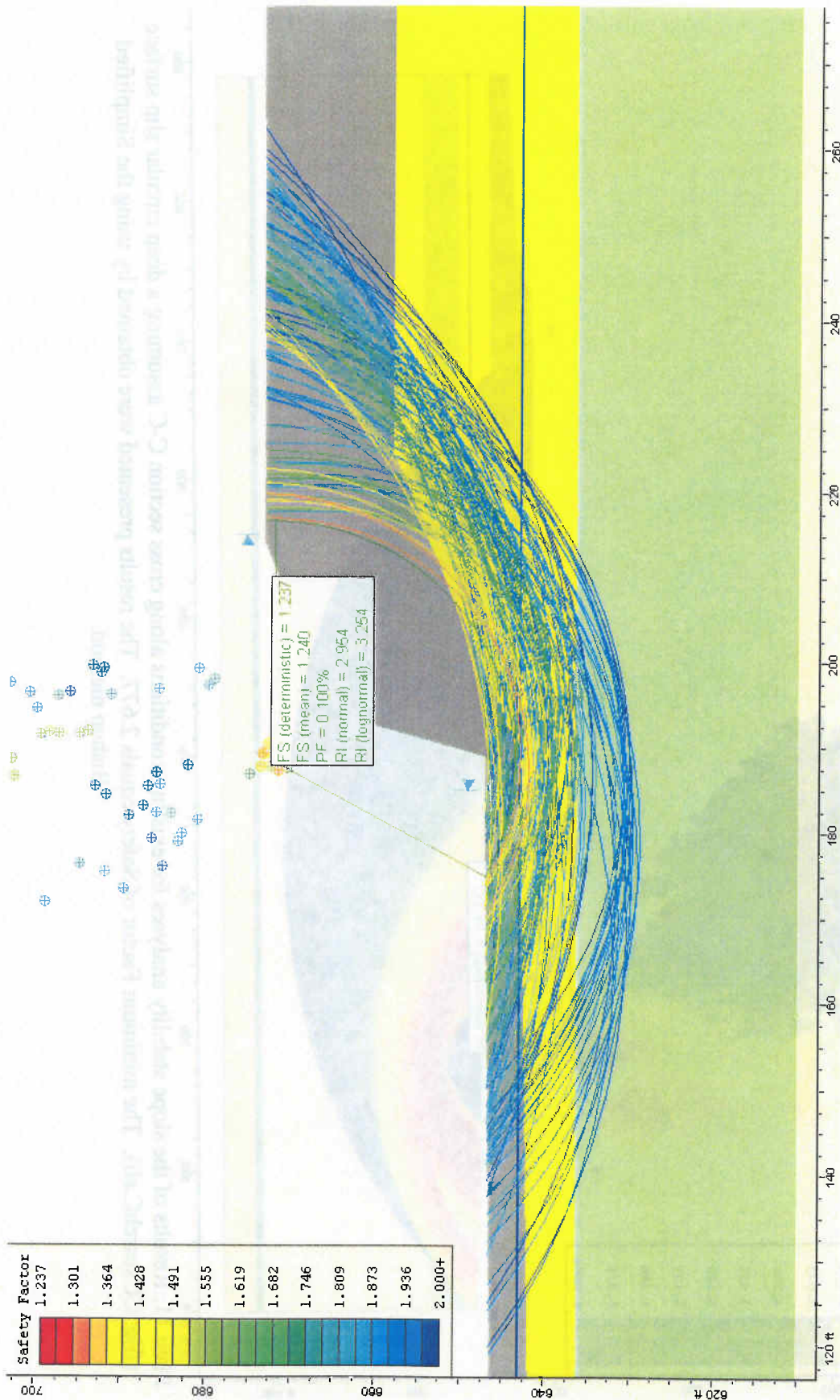

Plate 12: Results of the slope stability analyses for existing conditions along cross section C-C assuming a shallow circular slip surface (file: CCsearchC2.sli). The minimum Factor of Safety equals 1.237. The results presented were obtained by using the Simplified Bishop method.

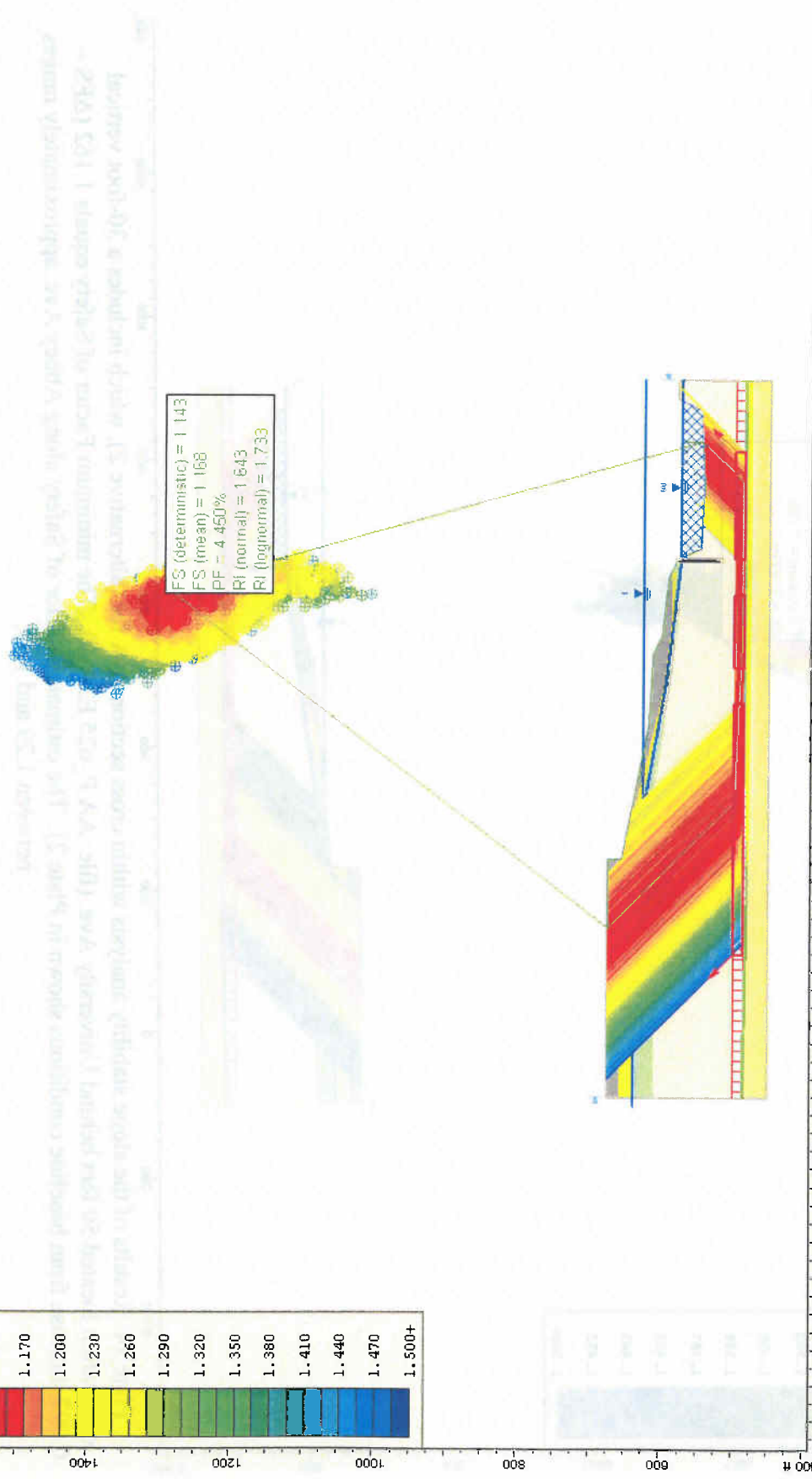
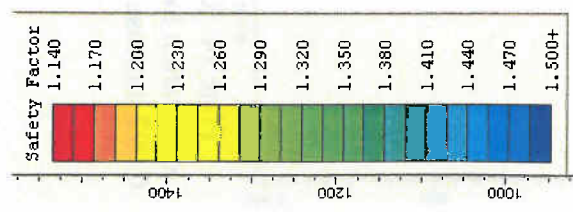

Plate 13: Results of the slope stability analysis within cross section A-A for (alternative 1), which includes a 20-foot vertical excavation located 50 feet behind University Ave. (file: AA_P_625 E20.sli). The minimum Factor of Safety equals 1.143 (Δ FS = 0.078 increase from baseline conditions shown in Plate 2). The estimated Factor of Safety along Abbey Ave. approximately ranges between 1.29 and 1.44.

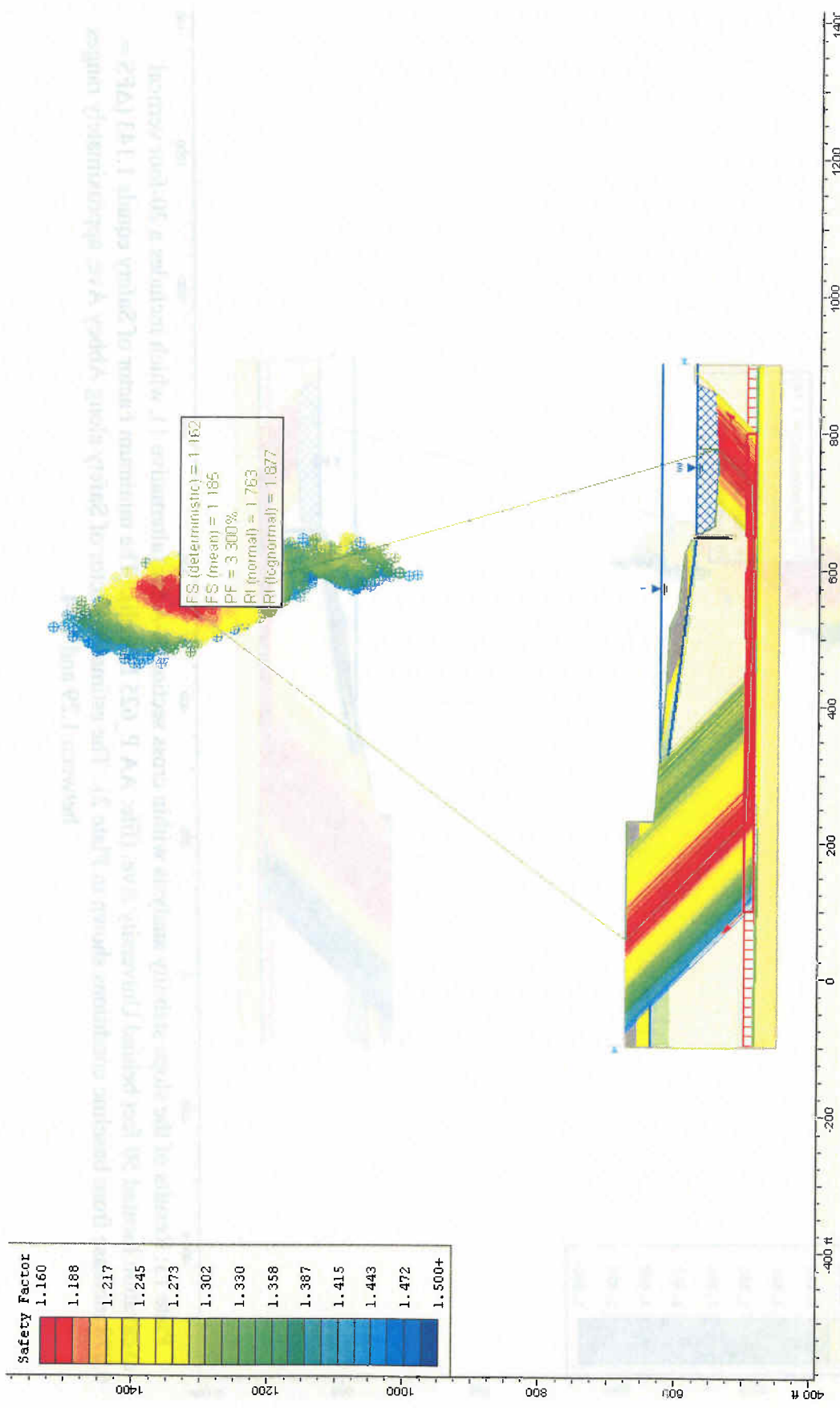

Plate 14: Results of the slope stability analysis within cross section A-A for (alternative 2), which includes a 30-foot vertical excavation located 50 feet behind University Ave. (file: AA_P_625_E30.sli). The minimum Factor of Safety equals 1.162 (Δ FS = 0.097 increase from baseline conditions shown in Plate 2). The estimated Factor of Safety along Abbey Ave. approximately ranges between 1.29 and 1.45.

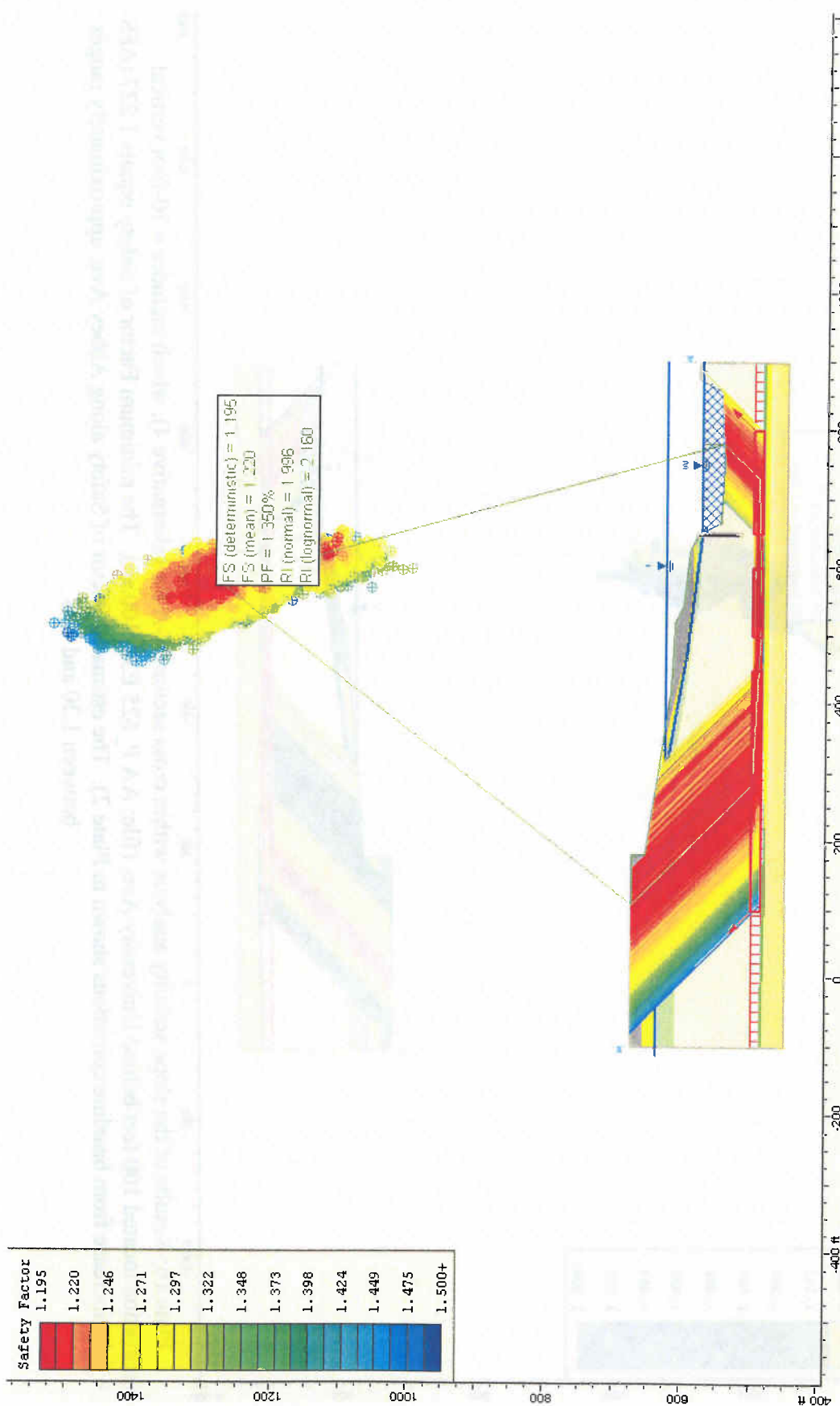

Plate 15: Results of the slope stability analysis within cross section A-A for (alternative 3), which includes a 20-foot vertical excavation located 100 feet behind University Ave. (file: AA_P_625 E20_100.sli). The minimum Factor of Safety equals 1.195 (Δ FS = 0.13 increase from baseline conditions shown in Plate 2). The estimated Factor of Safety along Abbey Ave. approximately ranges between 1.26 and 1.42.

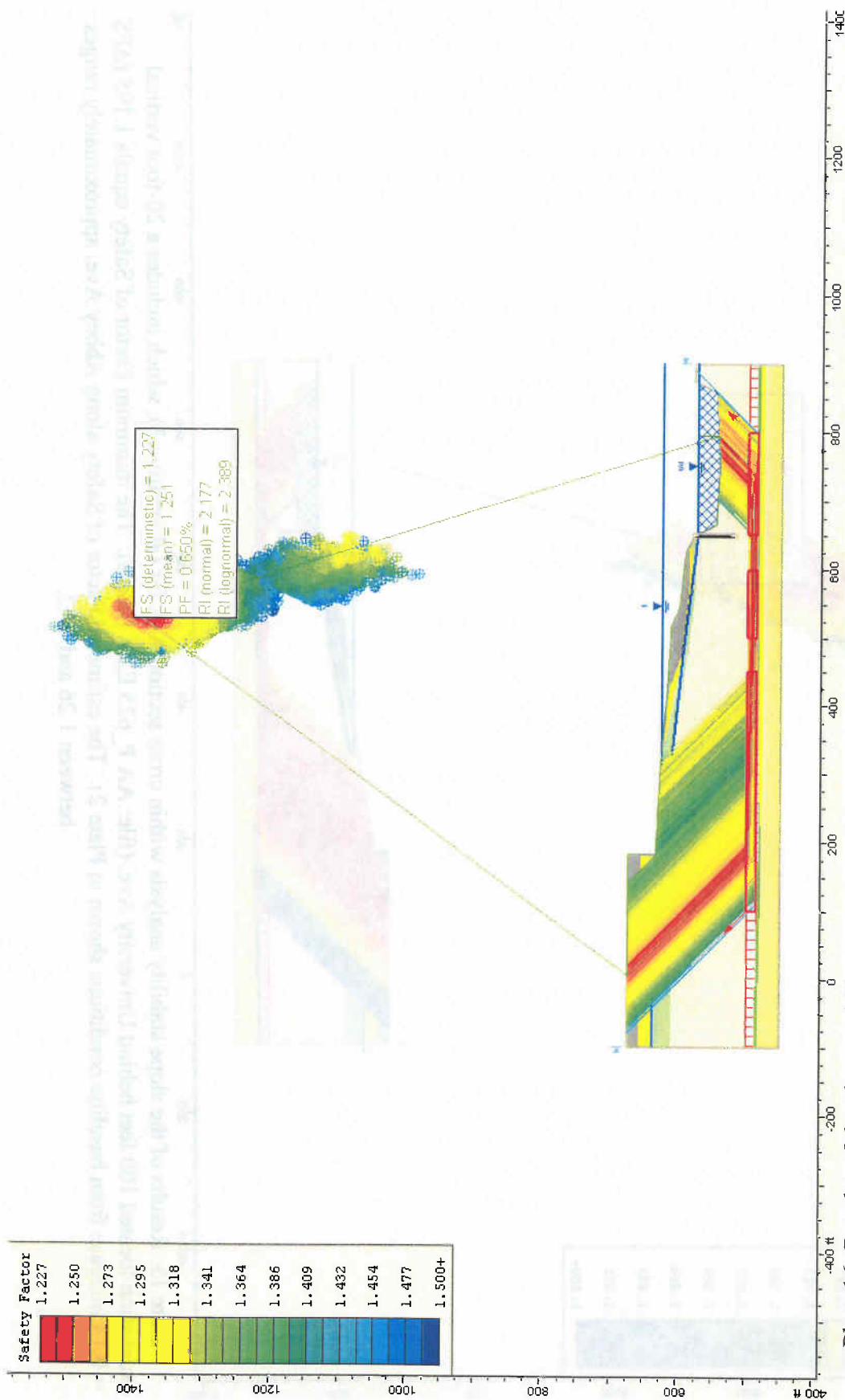

Plate 16: Results of the slope stability analysis within cross section A-A for (alternative 4), which includes a 30-foot vertical excavation located 100 feet behind University Ave. (file: AA_P_625 E30_100.sli). The minimum Factor of Safety equals 1.227 (Δ FS = 0.16 increase from baseline conditions shown in Plate 2). The estimated Factor of Safety along Abbey Ave. approximately ranges between 1.30 and 1.41.

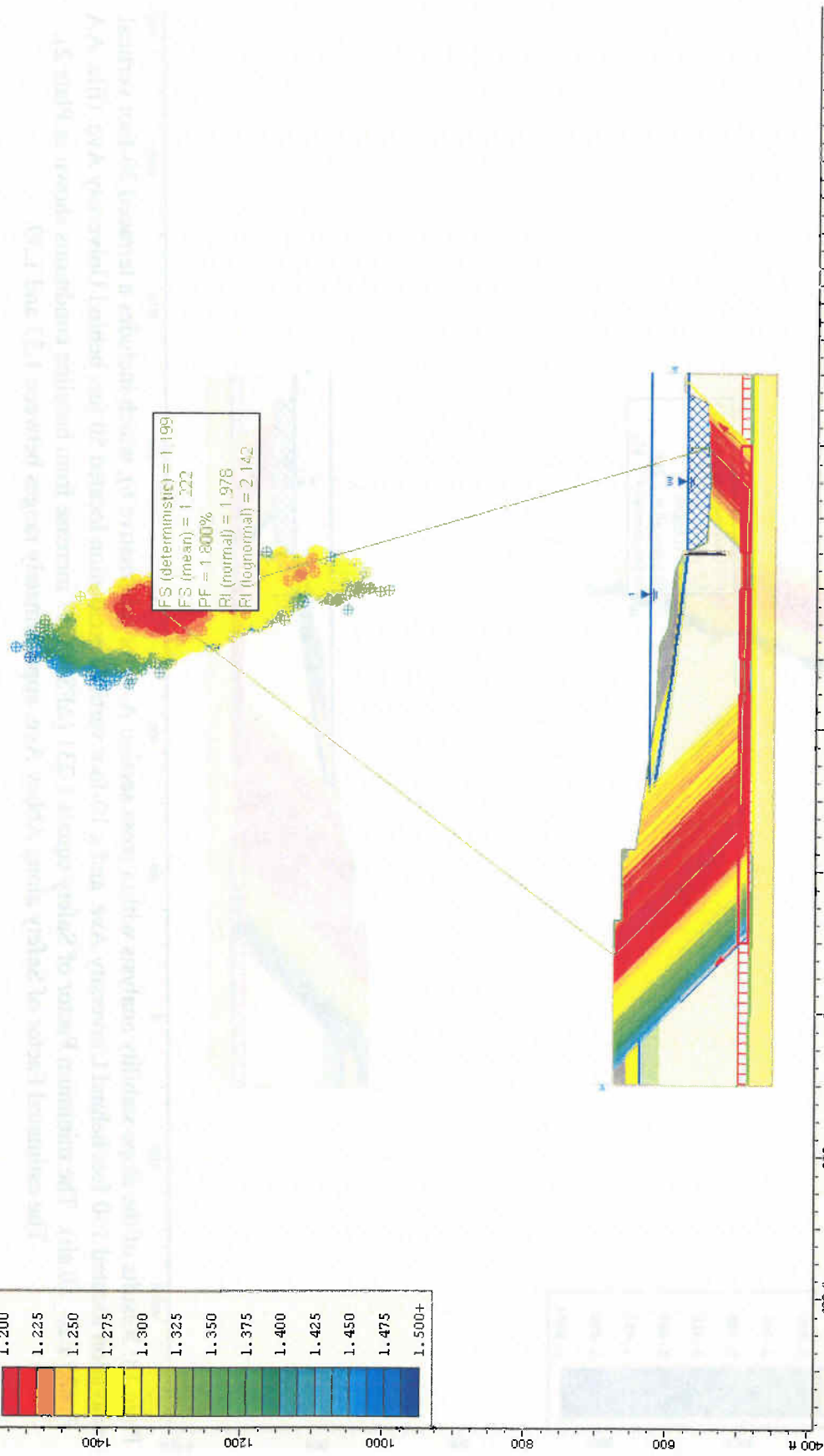
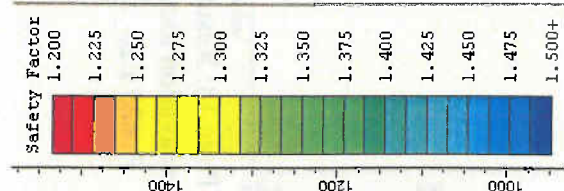

Plate 17: Results of the slope stability analysis within cross section A-A for (alternative 5), which includes a terraced 10-foot vertical excavation located 150 feet behind University Ave. and a 20-foot vertical excavation located 50 feet behind University Ave. (file: AA_P_625 E10_20.sli). The minimum Factor of Safety equals 1.199 ($\Delta FS = 0.13$ increase from baseline conditions shown in Plate 2). The estimated Factor of Safety along Abbey Ave. approximately ranges between 1.32 and 1.41.

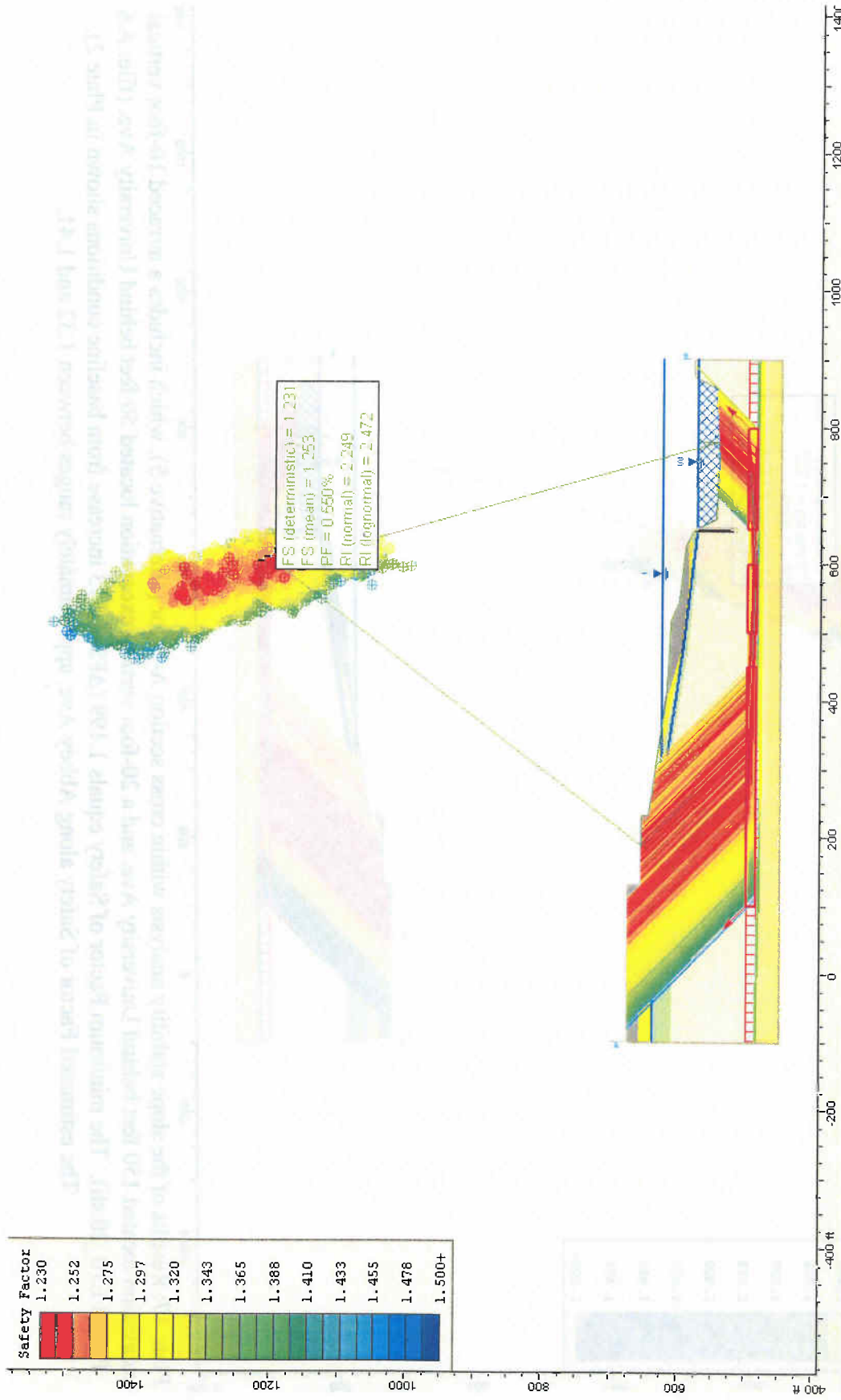

Plate 18: Results of the slope stability analysis within cross section A-A for (alternative 6), which includes a terraced 20-foot vertical excavation located 150 feet behind University Ave. and a 10-foot vertical excavation located 50 feet behind University Ave. (file: AA_P_625 E20_10.sli). The minimum Factor of Safety equals 1.231 ($\Delta FS = 0.17$ increase from baseline conditions shown in Plate 2). The estimated Factor of Safety along Abbey Ave. approximately ranges between 1.33 and 1.39.

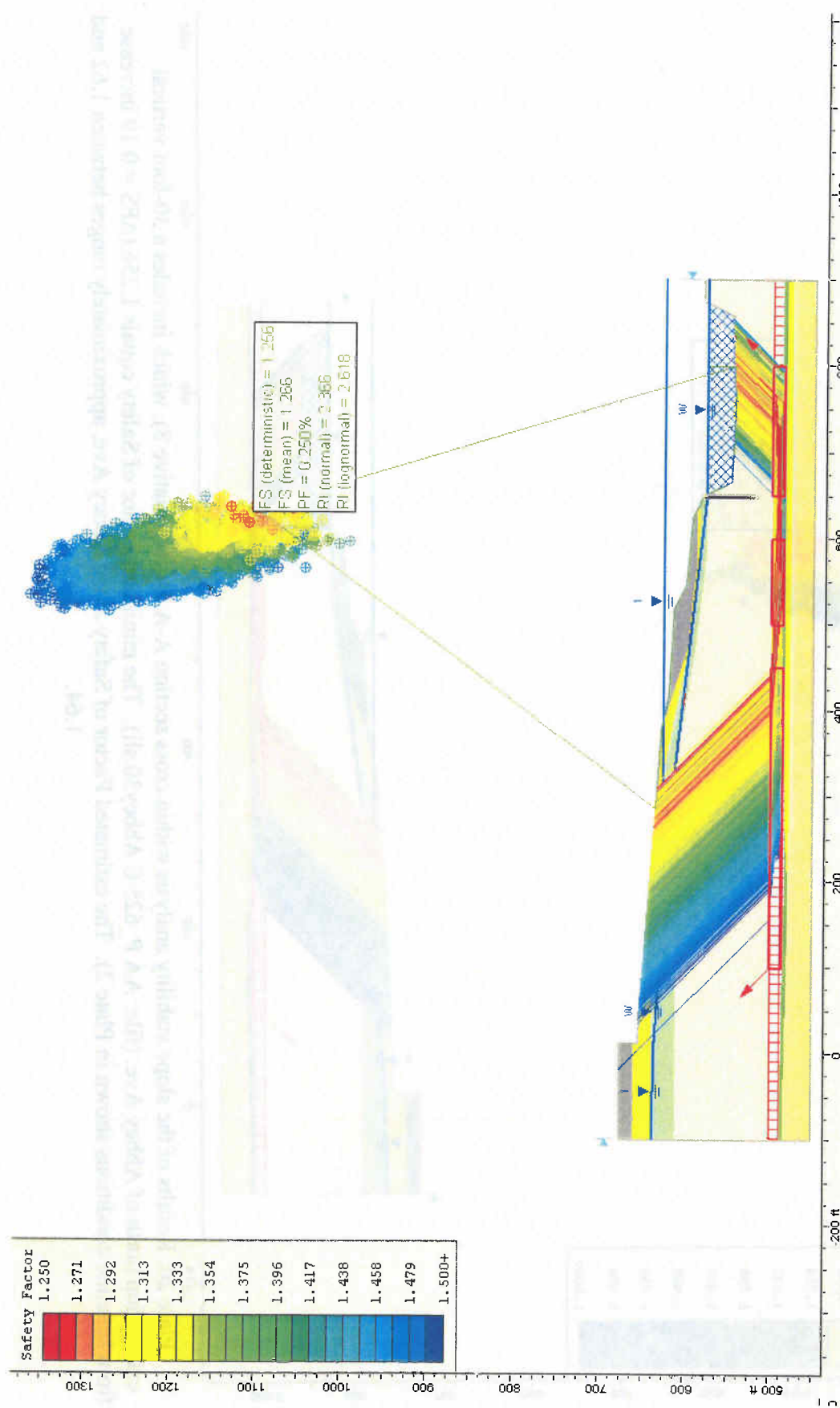

Plate 19: Results of the slope stability analysis within cross section A-A for (alternative 7), which includes a 20-foot vertical excavation north of Abbey Ave. (file: AA_P_625 E Abbey20.sli). The minimum Factor of Safety equals 1.256 ($\Delta FS = 0.19$ increase from baseline conditions shown in Plate 2). The estimated Factor of Safety along Abbey Ave. approximately ranges between 1.56 and 1.90.

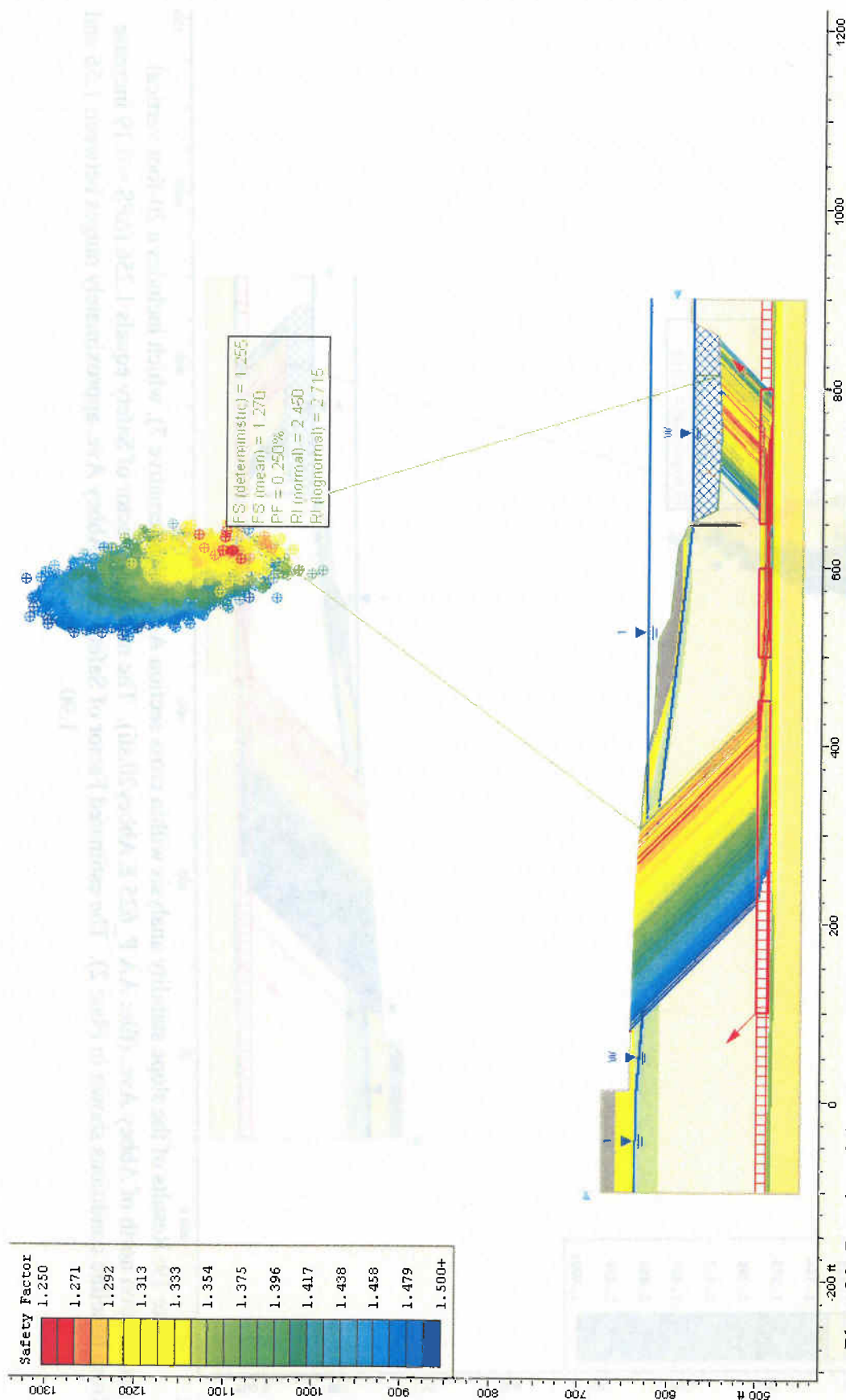

Plate 20: Results of the slope stability analysis within cross section A-A for (alternative 8), which includes a 30-foot vertical excavation north of Abbey Ave. (file: AA_P_625 E Abbey30.sli). The minimum Factor of Safety equals 1.256 (Δ FS = 0.19 increase from baseline conditions shown in Plate 2). The estimated Factor of Safety along Abbey Ave. approximately ranges between 1.62 and 1.64.

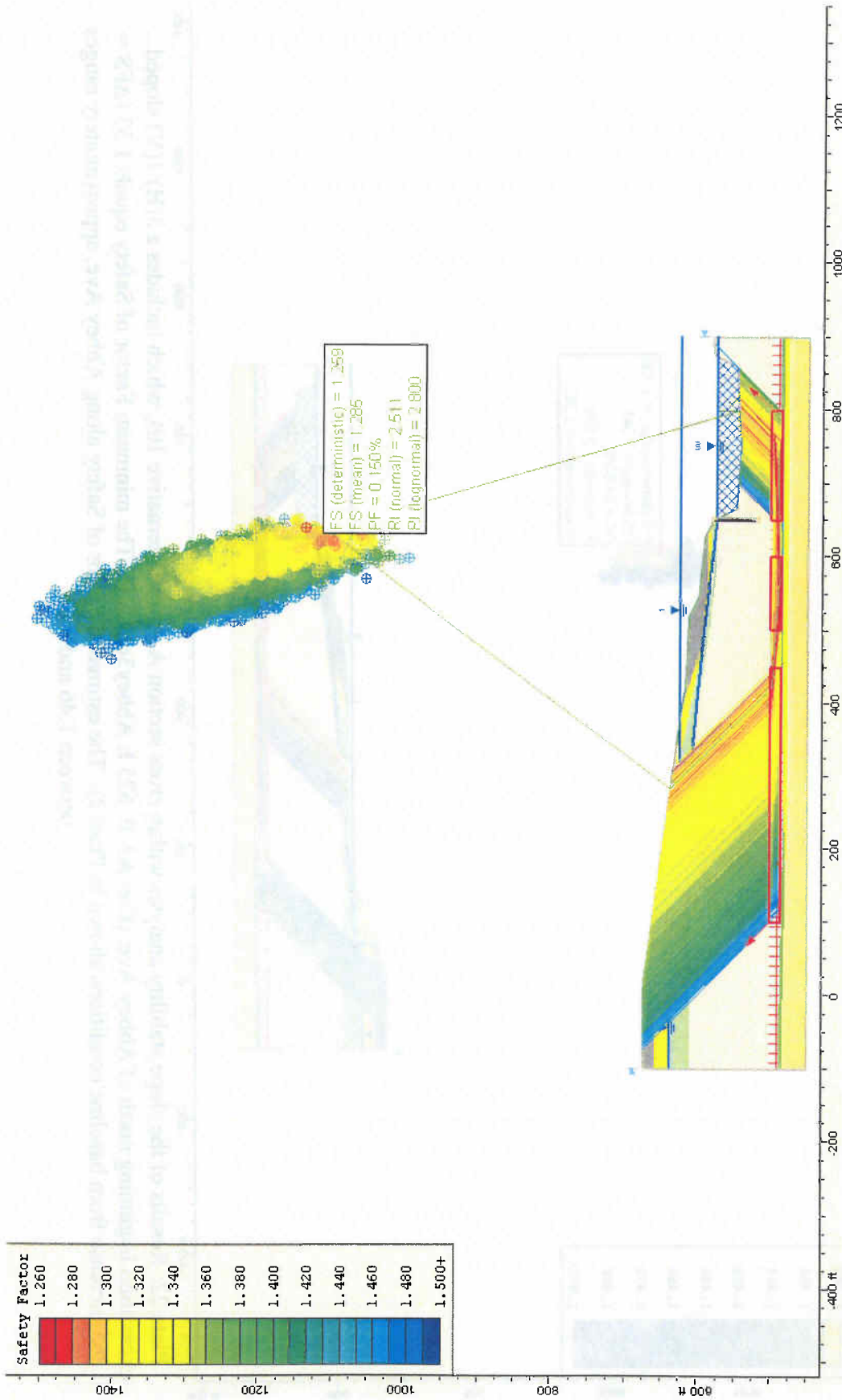

Plate 21: Results of the slope stability analysis within cross section A-A for (alternative 9), which includes a 7(H):1(V) sloped excavation beginning north of Abbey Ave. (file: AA_P_625 E Abbey7on1.sli). The minimum Factor of Safety equals 1.256 (Δ FS = 0.19 increase from baseline conditions shown in Plate 2). The estimated Factor of Safety along Abbey Ave. approximately ranges between 1.40 and 1.47.

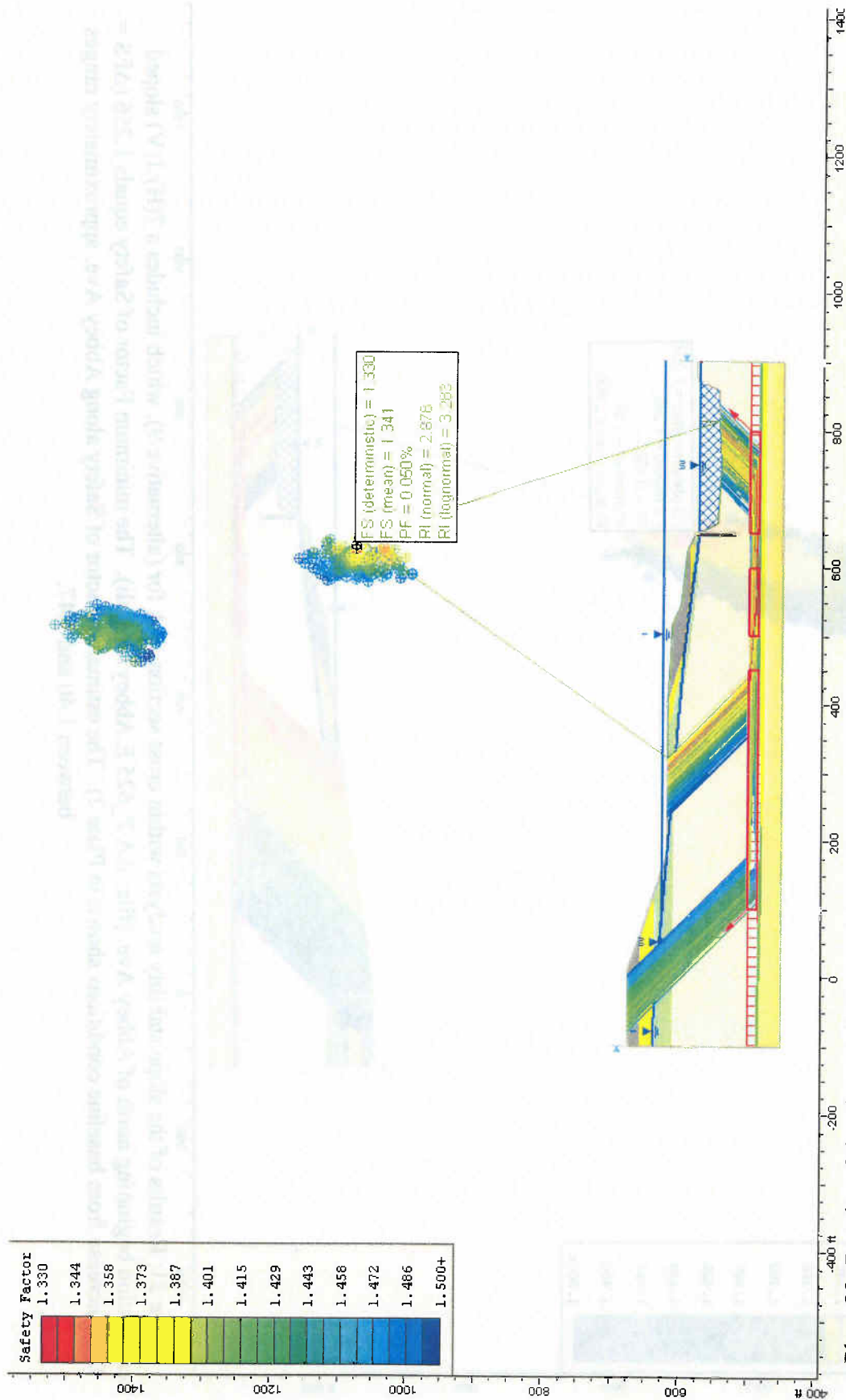

Plate 22: Results of the slope stability analysis within cross section A-A for (alternative 10), which includes a 3(H):1(V) sloped excavation beginning north of Abbey Ave. (file: AA_P_625 E_Abbey3on1.sli). The minimum Factor of Safety equals 1.33 (Δ FS = 0.265 increase from baseline conditions shown in Plate 2). The estimated Factor of Safety along Abbey Ave. approximately ranges between 1.46 and 1.61.

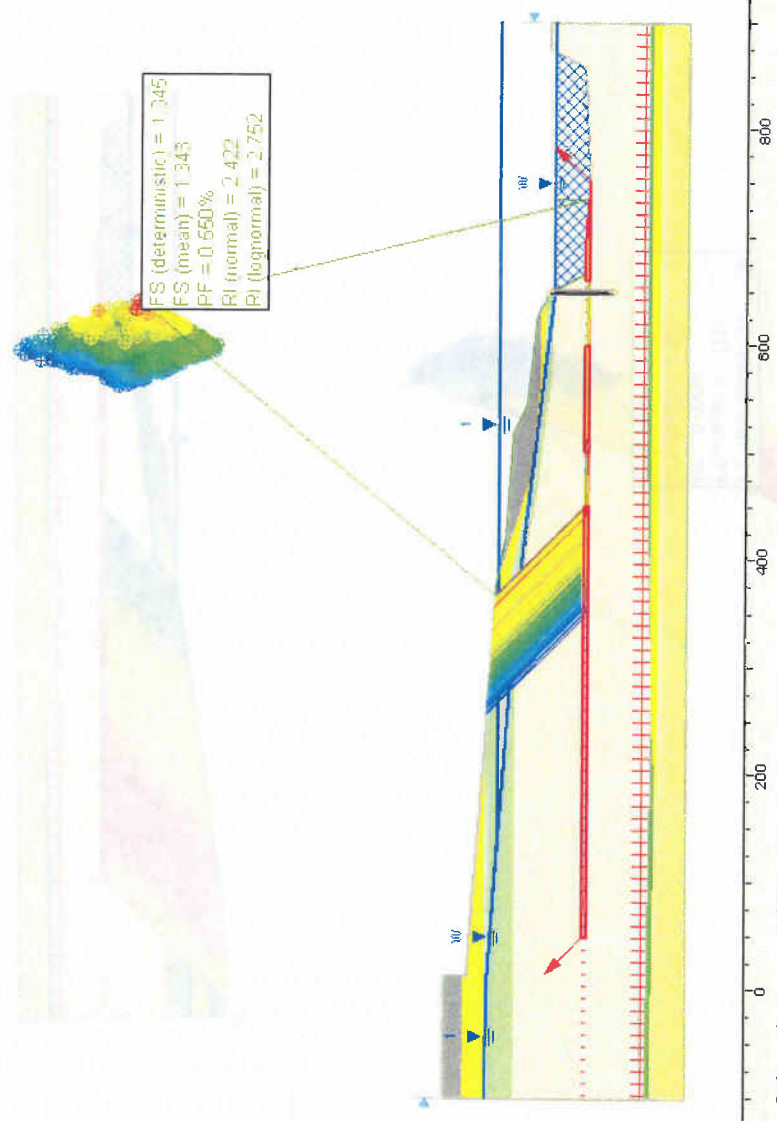
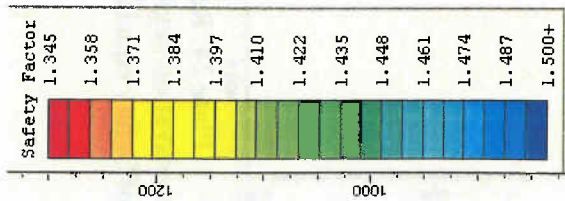

Plate 23: Results of the slope stability analysis within cross section A-A for (alternative 7), which includes a 20-foot vertical excavation north of Abbey Ave. (file: AA_P_625 E Abbey20SH.sli) for a potential shallow slip plane. The minimum Factor of Safety equals 1.345 (Δ FS = 0.30 increase from baseline conditions shown in Plate 15). The estimated Factor of Safety along Abbey Ave. approximately ranges between 1.73 and 1.85.

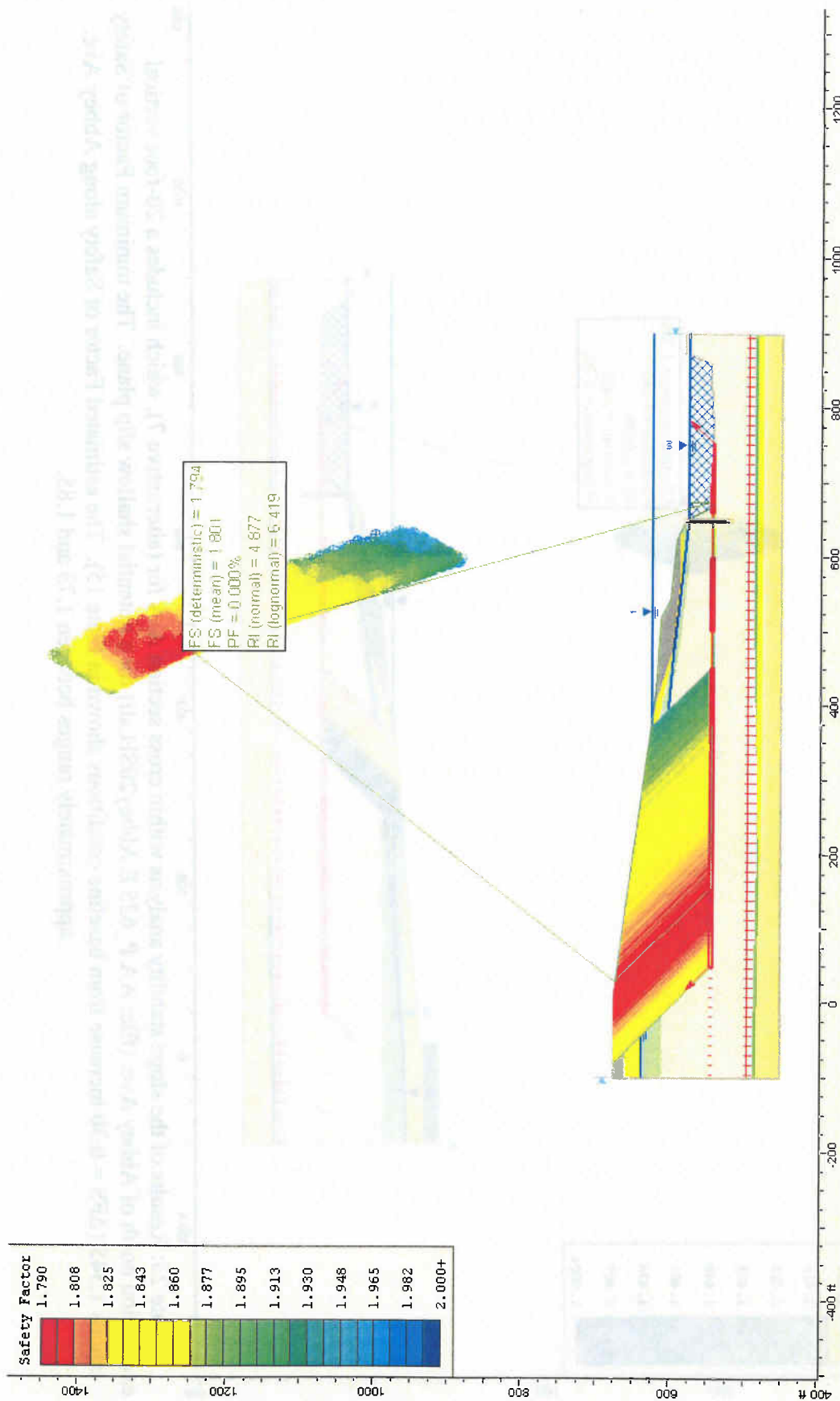

Plate 24: Results of the slope stability analysis within cross section A-A for (alternative 9), which includes a 7(H):1(V) sloped excavation beginning north of Abbey Ave. (file: AA_P_625 E Abbey7on1SH.sli) for a potential shall slip plane. The minimum Factor of Safety equals 1.794 (Δ FS = 0.75 increase from baseline conditions shown in Plate 15). The estimated Factor of Safety along Abbey Ave. approximately ranges between 1.81 and 1.85.

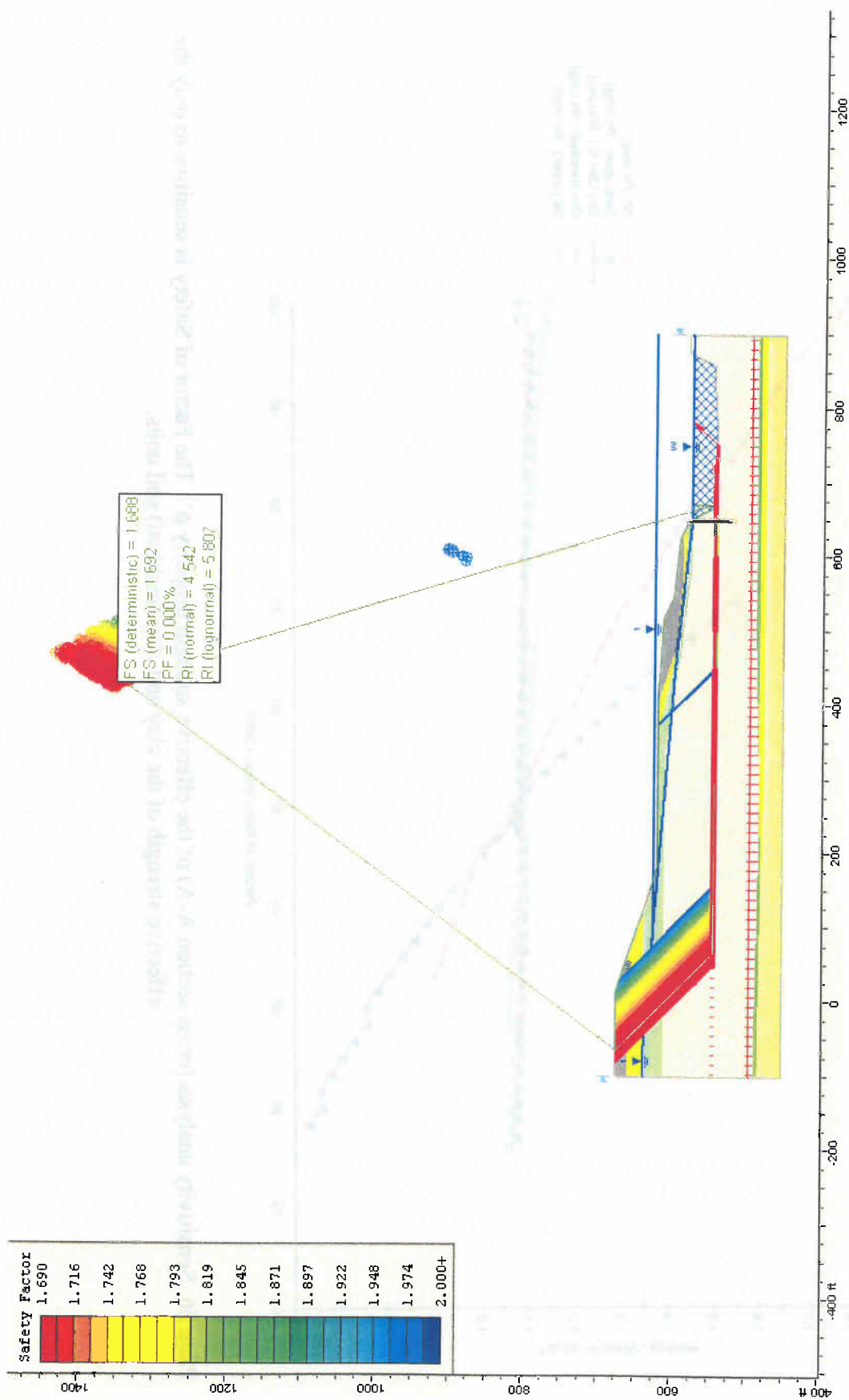

Plate 25: Results of the slope stability analysis within cross section A-A for (alternative 10), which includes a 3(H):1(V) sloped excavation beginning north of Abbey Ave. (file: AA_P_625 E Abbey3on1SH.sli) for a potential shallow slip plane. The minimum Factor of Safety equals 1.688 (Δ FS = 0.64 increase from baseline conditions shown in Plate 15). The estimated Factor of Safety along Abbey Ave. approximately ranges between 1.69 and 1.70.

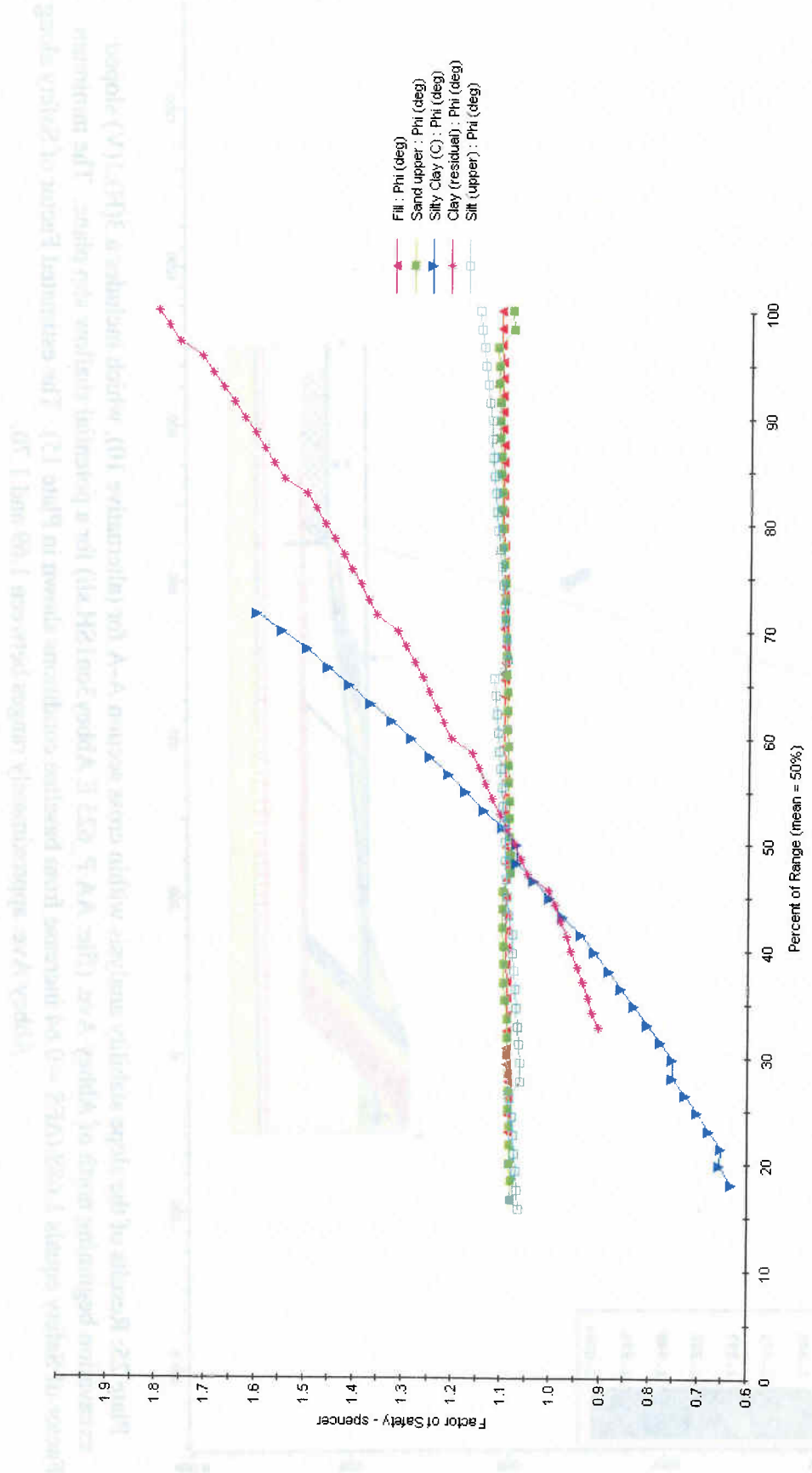

Plate 26: Sensitivity analysis (cross section A-A) of the effective strength property ϕ' . The Factor of Safety is sensitive to only the effective strength of the clay and clay (residual) soil units.

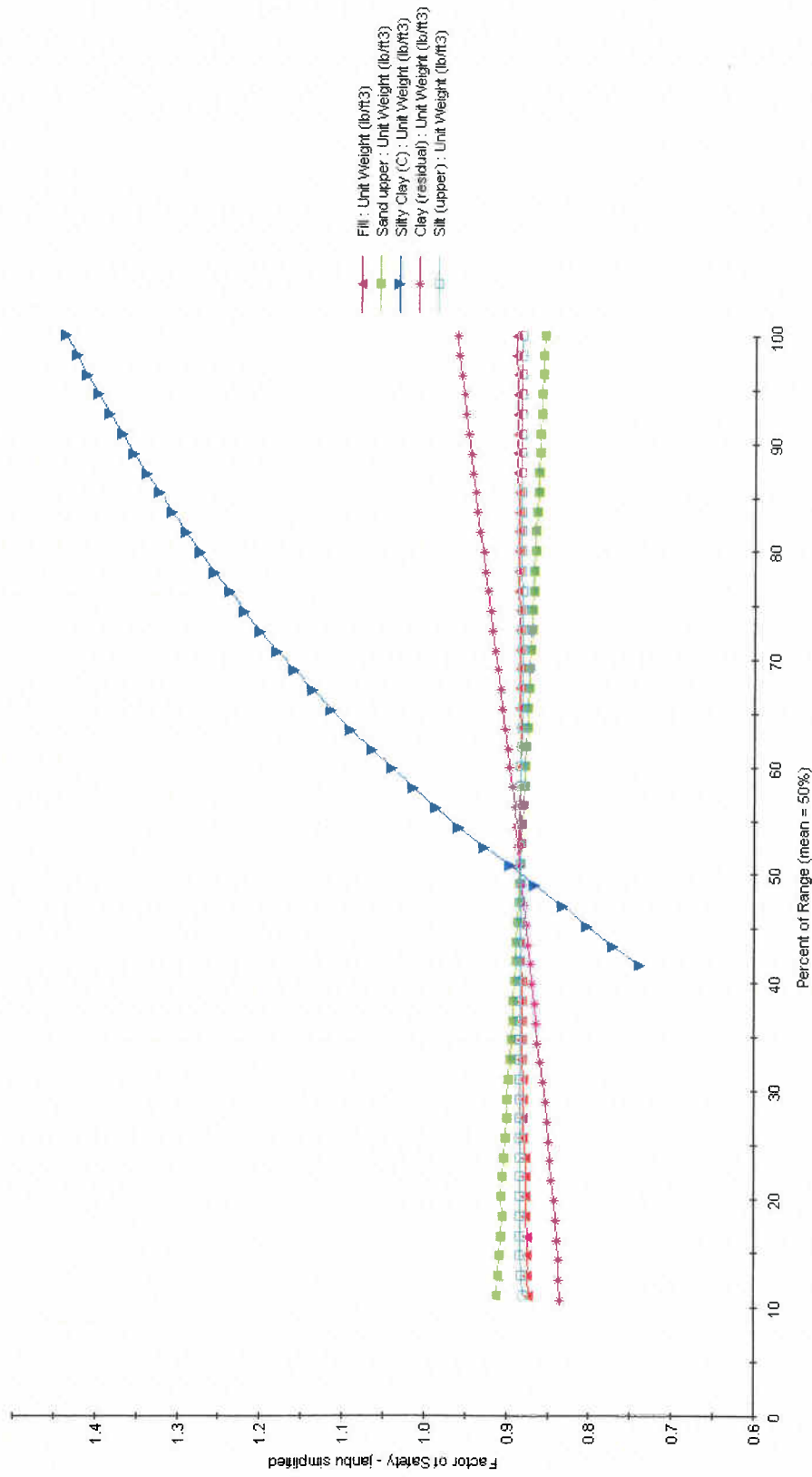

Plate 27: Sensitivity analysis (cross section A-A) of soil unit weight. The Factor of Safety is sensitive to only the unit weight of the clay.

APPENDIX G
EXISTING LOGS OF BORINGS



CUY-90-15.24
CLEVELAND, OHIO

TYPE: 2" O.D. Split-barrel Sampler LOCATION: Sta. 15+06.50
3" O.D. Shelby Tube 120.7' Rt. of
NXM Rock-core Barrel Centerline

COMPLETION DEPTH: 230.1' ELEVATION: 676.6 DATE: 8/23/94 8/25/94

DEP. FEET	SAMPLE NO.	SAMPLES SAMPLING EFFORT	HAND PENE-TROMETER	MOISTURE CONTENT	LIQUID LIMIT	PLASTIC LIMIT	AGG. C. S. F. S. SILT:CLAY				DESCRIPTION
							tsf	%	%	%	
0											FILL: Loose brown fine to coarse sand, trace to little fine to coarse gravel, interbedded with fine to medium sand, trace coarse sand, trace fine gravel.
5	1	3/3/3									Est. A-2-4
10	2A 2B	3/3/4									Loose brown and gray fine to medium sand, trace coarse sand, trace fine gravel. - From 10.4' to 12.0': Seam of clayey silt.
15	3	6/10/10				36	43	14	7		Est. A-1-b
20	4	5/7/8									Medium-dense brown fine to coarse sand, little fine to coarse gravel, trace silt, occasional seam of fine to coarse gravel, some to "and" fine to coarse sand.
25	5	8/11/12				10	54	26	10		A-1-b(0)
30	6A 6B	5/9/14									Medium-dense brown fine to medium sand, trace to little silt, trace coarse sand, trace fine gravel, contains seams (1 to 6 inches) of silt, fine sand, and silty clay. - Sample 5: Medium-dense fine to coarse sand, trace fine gravel, trace silt, A-1-b(0).
35	7A 7B	10/12/15									
40	8	3/6/11				0	2	84	14		A-3a(0)
45	9	6/7/15				0	0	21	71	8	Medium-dense gray silt, little fine sand, trace clay.
50											A-4b(8)

DESCRIPTION ON NEXT PAGE

50 WATER LEVEL:
 WATER NOTE:
 DATE:



CUY-90-15.24
CLEVELAND, OHIO

TYPE: 2" O.D. Split-barrel Sampler LOCATION: Sta. 15+06.50
3" O.D. Shelby Tube 120.7 Rt. of
NXM Rock-core Barrel Centerline

COMPLETION DEPTH: 230.1' ELEVATION: 676.6 DATE: 8/23/94 8/25/94

DEPTH FEET	SAMPLE NO.	SAMPLES	HAND SAMPLING EFFORT	HAND PENE-TROMETER	MOISTURE CONTENT	LIQUID LIMIT	PLASTIC LIMIT	TYPE				LOCATION		DESCRIPTION - CONTINUED
								tsf	%	%	%	AGG.	C.S.	
50	10	3	15/7	1.5-2.0	21	24	17	0	0	10	66	24	Medium-dense to dense gray silt interbedded with silty clay, trace fine to medium sand.	
55	11	P			19	25	18	0	0	3	80	17	A-4b(8) Dense gray silt, little to "and" fine sand, trace clay interbedded with dense gray fine sand, little to "and" silt, trace clay.	
60	12	15	22/32											
60	13	21	32/49		15			0	0	38	54	8		
65	14	29	46/48										A-4b(5) Stiff to hard gray silt clay, trace fine to medium sand, few lenses of silt, horizontal structure.	
70	15	3	6/9	1.5-2.2	22	32	16	0	0	1	57	42		
75	16	9	15/21	4.5+									- From 73.4' to 87.0': Hard in consistency.	
80	17	7	14/19	4.0-4.5+									- From 80.0' to 92.0': Contains seams of silt.	
85	18	7	12/15	4.5+										
90	19	5	8/12	2.0-4.0	22	33	17	0	0	0	56	44		
95	20	4	4/5	1.0-1.5									A-6b(10)	

DESCRIPTION ON NEXT PAGE

100 WATER LEVEL:
 WATER NOTE:
 DATE:



LOG OF BORING NO. B-101
 CUY-90-15.24
 CLEVELAND, OHIO

TYPE: 2" O.D. Split-barrel Sampler LOCATION: Sta. 15+06.50
3" O.D. Shelby Tube 120.7 Ft. of
NXM Rock-core Barrel Centerline
 COMPLETION DEPTH: 230.1' ELEVATION: 676.6 DATE: 8/23/94 8/25/94

DEPT FEET	SAMPLE NO.	SAMPLES SAMPLING EFFORT	HAND PENE- TROMETER	MOISTURE CONTENT	LIQUID LIMIT	PLASTIC LIMIT	AGG.	C.S.	F.S.	SILT	CLAY	DESCRIPTION - CONTINUED	
												tsf	%
150	35	8 1/2 / 18	2.0-2.5									DESCRIPTION ON PREVIOUS PAGE	
155	36	7 1/5 / 21	3.0-3.3	20	36	19	1	2	3	32	62	Very-stiff gray silty clay, trace fine to coarse sand, trace fine to coarse gravel, some horizontal structures.	
160	37	10 1/16 / 24	2.5-3.5										
165	38	9 1/17 / 26	3.4-3.7										
170	39	9 1/14 / 21	2.3-3.8	21	34	20	1	1	2	35	61	A-6a, A-6b(10,11)	
175	40	7 1/13 / 18	2.5-3.0									Stiff to very-stiff gray silty clay, trace fine to medium sand, horizontal structure, contains streaks of silt and clayey silt.	
180	41	6 1/10 / 16	2.2-3.0									- From 179.5' to 180.2': Diorite boulder.	
185	42	4 1/7 / 7	1.0-1.7	27	39	22	0	0	1	28	71	A-6b(11)	
190	43	9 1/15 / 26		20	20	14	2	2	16	61	19	Dense gray silt, little fine sand, trace medium to coarse sand interbedded with silty clay.	
195	44	29 / 90-1'R										A-4b(8)	
												Dense gray fine to coarse sand, little fine gravel, some silty clay.	
												- From 195.5' to 196.3': Granite boulder. Est. A-1-b	
												DESCRIPTION ON NEXT PAGE	

200 WATER LEVEL:
 WATER NOTE:
 DATE:



CUY-90-15.24
CLEVELAND, OHIO

TYPE: 2" O.D. Split-barrel Sampler
3" O.D. Shelby Tube
NXM Rock-core Barrel

LOCATION: Sta. 15+06.50
120.7' Rt. of
Centerline

COMPLETION DEPTH: 230.1' ELEVATION: 676.6 DATE: 8/23/94 8/25/94

DEP. FEET	SAMPLE NO.	SAMPLES SAMPLING EFFORT	HAND PENE-TROMETER	MOISTURE CONTENT	LIQUID LIMIT	PLASTIC LIMIT	DESCRIPTION - CONTINUED														
							tsf	%	%	%	AGG.	C. S.	F. S.	SILT	CLAY						
200	45	36/60	4.5+																		Very-stiff to hard gray silty clay, trace to little fine to coarse sand, trace fine to coarse gravel, few lenses of silt.
205	46	28/47/67	4.5+																		- From 210.0; to 211.5': Contains slickenside planes.
210	47	27/32/32	2.5-4.5																		- From 217.2' to 217.4': Cobble or cobble gravel.
215	48	9/13/18	2.5-3.5																		
220	49	11/14/18	2.2-2.8	19	29	17	1	5	9	33	52										A-6a(9)
225	50	77-1"R NXM REC	RQD																		Soft to medium-hard gray and dark-gray shale, nearly horizontally bedded, fissile, 1/4" to 13" core pieces.
230	51	98%	76%																		- Encountered water at 36.0'.
235																					- From 0.0' to 55.0': 3-1/4" I.D. Hollow-stem Auger with plug, replaced with 4" I.D. Flush-coupled casing from 0.0' to 60.0'.
240																					- From 55.0' to 225.0': 3-7/8" Tricone Bit.
245																					- From 58.3' to 230.1': Recirculated water used for drilling fluid.

WATER LEVEL: WATER NOTE: _____ DATE: _____



CUY-90-15.24
CLEVELAND, OHIO

TYPE: 2" O.D. Split-barrel Sampler LOCATION: Sta. 15+95.34
3" O.D. Shelby Tube 134.7' Rt. of
NXM Rock-core Barrel Centerline

COMPLETION DEPTH: 232.0' ELEVATION: 675.7 DATE: 9/9/94 9/14/94

DEPT. FEET	SAMPLE NO.	SAMPLES	SAMPLING EFFORT	HAND PENE-TROMETER	MOISTURE CONTENT	LIQUID LIMIT	PLASTIC LIMIT	COMPLETION DEPTH: 232.0' ELEVATION: 675.7 DATE: 9/9/94 9/14/94				DESCRIPTION
								tsf	%	%	%	
0												FILL: Loose gray coarse gravel. Est. A-1-a
5	1	3	14/6									FILL: Medium-dense to dense black fine to medium sand, trace coarse sand, trace fine to coarse gravel. Est. A-3a
10	2	2	13/2									Medium-dense brown fine to coarse sand, trace to little fine gravel, trace silt.
15	3	4	18/10									
20	4	9	13/15									
25	5	6	11/13									
30	6	7	10/14									- At 32.1': Contains seams of fine sand, some to "and" silt.
35	7	6	9/10									Est. A-3a
40	8	17	18/22									Dense brown fine sand, trace to little silt, trace medium to coarse sand, trace fine gravel.
45	9A 9B	20	25/30									Est. A-3a
DESCRIPTION ON NEXT PAGE												

50 WATER LEVEL:
 WATER NOTE:
 DATE:



LOG OF BORING NO. B-102
 CUY-90-15,24
 CLEVELAND, OHIO

TYPE: 2" O.D. Split-barrel Sampler LOCATION: Sta. 15+95.34
3" O.D. Shelby Tube 134.7' Rt. of
NXM Rock-core Barrel Centerline

COMPLETION DEPTH: 232.0' ELEVATION: 675.7 DATE: 9/9/94 9/14/94

DEPTH FEET	SAMPLE NO.	SAMPLES	SAMPLING EFFORT	HAND PENE-TROMETER	MOISTURE CONTENT	LIQUID LIMIT	PLASTIC LIMIT	COMPLETION DEPTH				DESCRIPTION - CONTINUED	
								tsf	%	%	%	AGG.	C.S.
50	10	4	10 1/11	2.8-3.5	18	23	18	0	0	10	65	25	Very-stiff gray clayey silt interbedded with silt, trace fine to medium sand. A-4b(8)
55	11	16	24 1/22										Medium-dense to dense gray silt, little to "and" fine sand.
60	12	12	12 1/14					0	0	5	79	16	A-4b(8) Interbedded medium-stiff gray silty clay and very-loose to loose silt, some fine sand, horizontal laminated structure.
65	13	2	3 1/2	0.5-0.7									Est. A-6a Stiff to hard gray silty clay, trace fine to medium sand, contains seams of silt, horizontal structure.
70	14	P		0.8-1.0									
75	15	5	9 1/12	1.5-4.5+									
80	16	P		4.5+									
85	17	5	7 1/13	1.5-2.5									
90	18	P		1.0									Est. A-6b Medium-stiff to stiff gray silty clay, trace fine to coarse sand, trace fine gravel, few seams of silt.
95	19	2	2 1/2	0.5-1.0									A-6a, A-6b(9,11)

100 WATER LEVEL:
 WATER NOTE:
 DATE:



LOG OF BORING NO. B-102
 CUY-90-15.24
 CLEVELAND, OHIO

TYPE: 2" O.D. Split-barrel Sampler LOCATION: Sta. 15+95.34
3" O.D. Shelby Tube 134.7' Rt. of
NXM Rock-core Barrel Centerline

COMPLETION DEPTH: 232.0' ELEVATION: 675.7 DATE: 9/9/94 9/14/94

DEPT. FEET	SAMPLE NO.	SAMPLES SAMPLING EFFORT	HAND PENE-TROMETER	MOISTURE CONTENT	LIQUID LIMIT	PLASTIC LIMIT	COMPLETION DEPTH				ELEVATION		DATE	DESCRIPTION - CONTINUED
							tsf	%	%	%	AGG.	C.S.		
100	20		0.8-1.2											Medium-stiff to stiff gray silty clay, trace fine to coarse sand, trace fine gravel, few seams of silt.
105	21	S/H-12" 4	0.5-0.8	33	41	22	1	1	1	10	87			- Sample 21: Medium-stiff gray silty clay, trace fine to coarse sand, A-7-6(12).
110	22	P S/H-8" 9	0.5											
115	23	P	1.0-1.5	30	38	20	1	1	1	31	66			
120	24	S/H-11" 13.5	0.6-0.8											
125	25	P	1.5-2.0	24	29	17	0	0	1	53	46			
130	26	S/H-12" 17	0.5-1.0	24	30	18	0	0	1	49	50			
135	27	S/H-18"	0.7-1.0											
140	28	8/H-7" 23	2.5-3.5											A-6a, A-6b(9,11) Stiff to very-stiff gray silty clay, trace fine to coarse sand, trace fine gravel, horizontal structure, contains thin seams of clayey silt and silt.
145	29	10/H-18" 26	3.2-3.5											

150 WATER LEVEL:
 WATER NOTE:
 DATE:

LOG OF BORING NO. B-102
 CUY-90-15.24
 CLEVELAND, OHIO



TYPE: 2" O.D. Split-barrel Sampler LOCATION: Sta. 15+95.34
3" O.D. Shelby Tube 134.7' Rt. of
NXM Rock-core Barrel Centerline

COMPLETION DEPTH: 232.0' ELEVATION: 675.7 DATE: 9/9/94 9/14/94

DEP FEET	SAMPLE NO.	SAMPLES SAMPLING EFFORT	HAND PENE- TROMETER	MOISTURE CONTENT	LIQUID LIMIT	PLASTIC LIMIT	AGG. C. S. F. S. SILT/CLAY				DESCRIPTION - CONTINUED	
							tsf	%	%	%		
150	30	8 / 17 / 24	3.0-3.5									Stiff to very-stiff gray silty clay, trace fine to coarse sand, trace fine gravel, horizontal structure, contains thin seams of clayey silt and silt.
155	31	10 / 16 / 20	2.0-3.0									
160	32	6 / 11 / 16	1.8-2.4									
165	33	8 / 13 / 18	2.0-2.5									
170	34	12 / 17 / 20	1.5-2.0	28	35	19	0	2	2	27	69	
175	35	7 / 13 / 18	2.5-3.0									
180	36	7 / 11 / 14	2.4-3.0									
185	37	P	1.0-1.5									
190	38	P	1.5									
195	39	P	2.5-3.0									

A-6b(10)

DESCRIPTION ON NEXT PAGE

200
 WATER LEVEL:
 WATER NOTE:
 DATE:

LOG OF BORING NO. B-102
 CUY-90-15.24
 CLEVELAND, OHIO



TYPE: 2" O.D. Split-barrel Sampler LOCATION: Sta. 15+95.34
3" O.D. Shelby Tube 134.7 Rt. of
NXM Rock-core Barrel Centerline

COMPLETION DEPTH: 232.0' ELEVATION: 675.7 DATE: 9/9/94 9/14/94

DEP. FEET	SAMPLE NO.	SAMPLES	SAMPLING EFFORT	HAND PENE-TROMETER	MOISTURE CONTENT	LIQUID LIMIT	PLASTIC LIMIT	DESCRIPTION - CONTINUED													
								tsf	%	%	%	AGG.	C. S.	F. S.	SILT	CLAY					
200	40	19	132/44	4.5+																	Very-stiff gray silty clay, trace fine to coarse sand, trace fine gravel, few lenses of silt.
205	41	11	21/25	4.3-4.5+																	- From 198.4' to 200.0': Few seams of fine to coarse gravel. - From 200.1' to 200.4': Cobble.
210	42	13	19/23	3.0-3.8																	
215	43	8	14/17	2.0-3.0																	
220	44	6	12/14	2.0-2.5																	
225			NXM REC	RQD																	
230	45		100%	50%																	Est. A-6b Dense gray fine to coarse gravel, "and" silty clay, some fine to coarse sand. Est. A-1-b Medium-hard gray shale, nearly horizontally bedded, slightly fissile. - From 230.7' to 231.2': Several vertical fractures. - From 231.8' to 232.0': Few diagonal fractures.
235																					
240																					
245																					

250 WATER LEVEL:
 WATER NOTE:
 DATE:



LOG OF BORING NO. B-103
 CUY-90-15.24
 CLEVELAND, OHIO

TYPE: 2" O.D. Split-barrel Sampler LOCATION: Sta. 16+93.83
 3" O.D. Shelby Tube 34.49' Rt. of
 NXM Rock-core Barrel Centerline
 COMPLETION DEPTH: 175.0' ELEVATION: 616.2 DATE: 8/15/94 8/17/94

DEPT. FEET	SAMPLE NO.	SAMPLES	SAMPLING EFFORT	HAND PENE-TROMETER	MOISTURE CONTENT	LIQUID LIMIT	PLASTIC LIMIT	DESCRIPTION											
								tsf	%	%	%	AGG.	C.S.	F.S.	SILT/CLAY				
0																			FILL: Loose light-gray fine gravel (crushed stone).
																			FILL: Medium-dense black fine to coarse gravel, some fine to coarse sand, little silt. Est. A-1-b
5	1	1/1/3																	FILL: Very-loose to loose brown and black fine to medium sand, trace silt, few fragments of decayed wood. Est. A-3
10	2A 2B	4/7/8																	Medium-dense gray silt, little fine sand, little clay, contains thin seams of fine and fine to medium sand. Est. A-3
15	3	5/10/13			17	24	18	0	0	12	66	22							
20	4 5A 5B	P/R 9/12/14		4.2-4.5+	20	37	20	0	0	1	57	42							Very-stiff to hard gray silty clay, trace fine to medium sand, contains seams of silt. A-4b(8)
25	6	P		4.5+	20	29	20	0	0	0	57	43							
30	7	4/7/12		3.5-4.5+															
35	8	5/9/15		2.5-3.3															
40	9	2/4/5		0.8-1.8															Medium-stiff to stiff gray silty clay, trace fine to coarse sand, trace fine gravel, horizontal structure. A-6b(11)
45	10	2/4/4		0.8-2.0	30	39	21	0	1	2	20	77							

50 WATER LEVEL: WATER NOTE: _____ DATE: _____



LOG OF BORING NO. B-103
 CUY-90-15.24
 CLEVELAND, OHIO

TYPE: 2" O.D. Split-barrel Sampler LOCATION: Sta. 16+93.83
3" O.D. Shelby Tube 34.49' Rt. of
NXM Rock-core Barrel Centerline
 COMPLETION DEPTH: 175.0' ELEVATION: 616.2 DATE: 8/15/94 8/17/94

DEP. FEET	SAMPLE NO.	SAMPLES	SAMPLING EFFORT	HAND PENE-TROMETER	MOISTURE CONTENT	LIQUID LIMIT	PLASTIC LIMIT	DESCRIPTION - CONTINUED										
								tsf	%	%	%	AGG.	C.S.	F.S.	SILT:CLAY			
50	11	2	1/4/5	0.9-1.3														Medium-stiff to stiff gray silty clay, trace fine to coarse sand, trace fine gravel, horizontal structure. A-6b(11)
55	12	3	1/6/10	1.6-2.5														Stiff to very-stiff gray silty clay, trace fine to coarse sand, trace fine gravel, contains seams of clayey silt and silt.
60	13	5	1/8/11	2.0-3.3	22	30	20	0	0	2	66	32						- Sample 13: Very-stiff brown-gray clayey silt, trace fine to medium sand, A-4b(8).
65	14	5	1/8/12	2.5-3.5	21	32	17	0	0	2	61	37						
70	15	5	1/9/12	3.3-4.0														
75	16	4	1/9/11	2.0-3.0														
80	17	7	1/11/15	2.5-3.0														
85	18	7	1/12/16	2.3-2.9														
90	19	5	1/11/14	2.0-2.5														
95	20	5	1/9/15	1.5-2.0	21	31	17	2	2	6	41	49						

A-6a(10)

100 WATER LEVEL:
 WATER NOTE:
 DATE:

LOG OF BORING NO. B-103
 CUY-90-15.24
 CLEVELAND, OHIO



TYPE: 2" O.D. Split-barrel Sampler
3" O.D. Shelby Tube
NXM Rock-core Barrel

LOCATION: Sta. 16+93.83
34.49' Rt. of
Centerline

COMPLETION DEPTH: 175.0' ELEVATION: 616.2 DATE: 8/15/94 8/17/94

DEPT FEET	SAMPLE NO.	SAMPLES SAMPLING EFFORT	HAND PENE- TROMETER	MOISTURE CONTENT	LIQUID LIMIT	PLASTIC LIMIT	COMPLETION DEPTH: 175.0' ELEVATION: 616.2 DATE: 8/15/94 8/17/94				DESCRIPTION - CONTINUED		
							tsf	%	%	%	AGG.	C.S.	F.S.
100	21	5/9/12	1.5-2.0										Stiff to very-stiff gray silty clay, trace fine to coarse sand, trace fine gravel, contains seams of clayey silt and silt.
105	22	5/9/13	1.5-2.3	20	34	19	6	2	3	38	51		
110	23	6/11/17	2.5										A-6a(10)
115	24	6/13/17	2.5-3.2										Stiff to very-stiff gray silty clay, trace fine to coarse sand, trace fine gravel, horizontal structure, few lenses of silt.
120	25	P	2.5										
	26	7/10/12	1.0-1.7	26	41	21	0	1	1	29	69		- Sample 26: Stiff to very-stiff gray silty clay, A-7-6(12).
125	27	P	1.8-2.0	29	40	20	0	0	1	23	76		
	28	4/6/8	1.0-1.5	26	36	21	1	1	1	19	78		A-6a, A-6b(10)
130	29A	P	1.0	21	NP	NP	0	0	1	82	17		Interbedded: Medium-stiff to stiff gray clayey silt, silty clay, medium-dense silt, and dense fine sand, some silt, 1/2" to 6"+ each soil type.
	29B												A-4b(8)
	29C												
135	30	7/20/28					35	41	12		12		Dense gray fine to coarse sand, little fine gravel, little clayey silt.
													A-1-b(0)
140	31	24/50/77	4.5+										Very-hard gray silty clay, little to some fine to coarse sand, trace fine to coarse gravel.
													- From 142.1' tp 142.5': Cobbles or boulders.
													- At 146.0': Slickensided plane.
145	32	18/41/64	4.5+										- From 150.0' to 151.5': Contains slickensided planes.
													Est. A-6a

150 WATER LEVEL:
 WATER NOTE:
 DATE:

LOG OF BORING NO. B-104
CUY-90-15.24
CLEVELAND, OHIO



TYPE: 2" O.D. Split-barrel Sampler LOCATION: Sta. 18+50.53
3" O.D. Shelby Tube 100.2' Rt. of
NXM Rock-core Barrel Centerline

COMPLETION DEPTH: 165.5' ELEVATION: 601.8 DATE: 9/13/94 9/15/94

DEPTH FEET	SAMPLE NO.	SAMPLES SAMPLING EFFORT	HAND PENE- TROMETER	MOISTURE CONTENT	LIQUID LIMIT	PLASTIC LIMIT	AGG. C. S. F. S. SILT:CLAY				DESCRIPTION	
							tsf	%	%	%		
0												FILL: (Estimated) Medium-dense to dense brown and gray fine to coarse gravel, little fine to coarse sand. Est. A-1-a
5	1	5 / 5 / 7										FILL: Medium-dense to dense black fine to coarse sand, some fine to coarse gravel, trace clayey silt, (cinders), and shale fragments. Est. A-1-b
10	2A 2B	2 / 3 / 4										Loose brown fine to medium sand, trace coarse sand, trace silt. Est. A-3a
15	3A 3B	3 / 2 / 2										Gray silt, little fine sand. Est. A-4b
20	4A 4B	P										Very-stiff to hard gray silty clay, trace fine sand, few lenses of silt. Est. A-6b
25	5	3 / 4 / 7	3.7-4.3									Stiff gray silty clay, trace fine to coarse sand, trace fine gravel, few seams and lenses of silt. A-7-6(12)
30	6	P	1.1-1.2									Very-stiff gray silty clay, trace fine sand, many seams and lenses of silt, horizontal structure. A-4b(8)
35	7	2 / 3 / 4	1.2-1.3	30	42	24	1	1	1	22	75	
40	8	P	2.3-2.7		24	30	20	0	0	0	50	50
45	9	4 / 4 / 5	2.2-2.6									

50 WATER LEVEL:
WATER NOTE:
DATE:



LOG OF BORING NO. B-104
 CUY-90-15.24
 CLEVELAND, OHIO

TYPE: 2" O.D. Split-barrel Sampler
3" O.D. Shelby Tube
NXM Rock-core Barrel

LOCATION: Sta. 18+50.53
100.2' Rt. of
Centerline

COMPLETION DEPTH: 165.5' ELEVATION: 601.8 DATE: 9/13/94 9/15/94

DEPTH FEET	SAMPLE NO.	SAMPLES SAMPLING EFFORT	HAND PENE- TROMETER	MOISTURE CONTENT	LIQUID LIMIT	PLASTIC LIMIT	AGG. C.S.F.S.				SILT:CLAY	DESCRIPTION - CONTINUED
							tsf	%	%	%		
50	10	P										Very-stiff to hard gray silty clay, trace fine sand, many seams and lenses of silt, horizontal structure.
55	11	4 / 4 / 7	2.4-2.7									
60	12	P										Stiff to hard gray silty clay, trace fine to coarse sand, trace fine gravel, many seams and lenses of silt, horizontal structure.
65	13	5 / 7 / 10	2.5-3.2									
70	14	4 / 5 / 9	2.4-2.7									A-4b(8)
75	15	3 / 4 / 3	1.4-1.8	24	29	19	0	0	1	60	39	
80	16	4 / 6 / 8	1.8-2.2									A-6a(10)
85	17	4 / 7 / 8	2.1-2.3									
90	18	4 / 7 / 9	2.4-2.7									
95	19	4 / 7 / 9	2.0-2.7									

100 WATER LEVEL:

WATER NOTE:

DATE:



LOG OF BORING NO. B-104
 CUY-90-15.24
 CLEVELAND, OHIO

TYPE: 2" O.D. Split-barrel Sampler LOCATION: Sta. 18+50.53
3" O.D. Shelby Tube 100.2' Rt. of
NXM Rock-core Barrel Centerline

COMPLETION DEPTH: 165.5' ELEVATION: 601.8 DATE: 9/13/94 9/15/94

DEPTH FEET	SAMPLE NO.	SAMPLES SAMPLING EFFORT	HAND PENE-TROMETER	MOISTURE CONTENT	LIQUID LIMIT	PLASTIC LIMIT	DESCRIPTION												
							tsf	%	%	%	AGG.	C.S.	F.S.	SILT	CLAY				
0																			FILL: (Estimated) Medium-dense to dense brown and gray fine to coarse gravel, little fine to coarse sand. Est. A-1-a
5	1	5 / 5 / 7																	FILL: Medium-dense to dense black fine to coarse sand, some fine to coarse gravel, trace clayey silt, (cinders), and shale fragments.
10	2A 2B	2 / 3 / 4																	Est. A-1-b
15	3A 3B	3 / 2 / 2																	Loose brown fine to medium sand, trace coarse sand, trace silt.
20	4A 4B	P																	Gray silt, little fine sand.
25	5	3 / 4 / 7	3.7-4.3																Very-stiff to hard gray silty clay, trace fine sand, few lenses of silt.
30	6	P	1.1-1.2																Est. A-6b
35	7	2 / 3 / 4	1.2-1.3	30	42	24	1	1	1	22	75								Stiff gray silty clay, trace fine to coarse sand, trace fine gravel, few seams and lenses of silt.
40	8	P	2.3-2.7		24	30	20	0	0	0	50	50							Very-stiff gray silty clay, trace fine sand, many seams and lenses of silt, horizontal structure.
45	9	4 / 4 / 5	2.2-2.6																A-7-6(12)
50																			A-4b(8)

50 WATER LEVEL:
 WATER NOTE:
 DATE:



LOG OF BORING NO. B-104
 CUY-90-15.24
 CLEVELAND, OHIO

TYPE: 2" O.D. Split-barrel Sampler
 3" O.D. Shelby Tube
 NXM Rock-core Barrel

LOCATION: Sta. 18+50.53
 100.2' Rt. of
 Centerline

COMPLETION DEPTH: 165.5' ELEVATION: 601.8 DATE: 9/13/94 9/15/94

DEPTH FEET	SAMPLE NO.	SAMPLES SAMPLING EFFORT	HAND PENE- TRMETER	MOISTURE CONTENT	LIQUID LIMIT	PLASTIC LIMIT	AGG. C. S. F. S.				SILT/CLAY			
							tsf	%	%	%				
50	10	P												
55	11	4 / 4 / 7	2.4-2.7											
60	12	P												
65	13	5 / 7 / 10	2.5-3.2											
70	14	4 / 5 / 9	2.4-2.7											
75	15	3 / 4 / 3	1.4-1.8	24	29	19	0	0	1	60	39			
80	16	4 / 6 / 8	1.8-2.2											
85	17	4 / 7 / 8	2.1-2.3											
90	18	4 / 7 / 9	2.4-2.7											
95	19	4 / 7 / 9	2.0-2.7											

DESCRIPTION - CONTINUED

Very-stiff to hard gray silty clay, trace fine sand, many seams and lenses of silt, horizontal structure.

A-4b(8)

Stiff to hard gray silty clay, trace fine to coarse sand, trace fine gravel, many seams and lenses of silt, horizontal structure.

A-6a(1)

100 WATER LEVEL: WATER NOTE: DATE:



LOG OF BORING NO. B-104
 CUY-90-15.24
 CLEVELAND, OHIO

TYPE: 2' O.D. Split-barrel Sampler LOCATION: Sta. 18+50.53
3' O.D. Shelby Tube 100.2' Rt. of
NXM Rock-core Barrel Centerline
 COMPLETION DEPTH: 165.5' ELEVATION: 601.8 DATE: 9/13/94 9/15/94

DEPT FEET	SAMPLE NO.	SAMPLES SAMPLING EFFORT	HAND PENE- TROMETER	MOISTURE CONTENT	LIQUID LIMIT	PLASTIC LIMIT	AGG. C. S. F. S.				SILT:CLAY		DESCRIPTION - CONTINUED
							tsf	%	%	%			
100	20	7 / 13 / 20	4.2-4.4										Stiff to hard gray silty clay, trace fine to coarse sand, trace fine gravel, many seams and lenses of silt, horizontal structure.
105	21	6 / 10 / 17	3.1-3.7	22	35	20	0	0	1	36	63		
110	22	6 / 7 / 10	2.3-2.5										A-6a(10)
115	23	5 / 7 / 9	1.5										Stiff gray silty clay, some fine to coarse sand, trace fine gravel.
120	24	P											Est. A-6a
125	25	19 / 23 / 24					40	32	15		13		Dense gray fine to coarse sand, little fine gravel, little silty clay.
130	26	11 / 21 / 24	4.5+										A-1-b(0)
135	27	8 / 15 / 16	3.2-4.5+										Very-stiff to hard gray silty clay, trace fine to coarse sand, seams and lenses of silt.
140	28	P	2.0-2.2		22	39	22	0	0	0	27	73	
145	29A 29B	6 / 11 / 21	2.5-3.2 4.5+										A-6b(11)
150													Hard gray silty clay interbedded with silt and clayey silt, some fine to coarse sand, little fine to coarse gravel.

WATER LEVEL: WATER NOTE: DATE:



LOG OF BORING NO. B-104
 CUY-90-15.24
 CLEVELAND, OHIO

TYPE: 2" O.D. Split-barrel Sampler LOCATION: Sta. 18+50.53
3" O.D. Shelby Tube 100.2' Rt. of
NXM Rock-core Barrel Centerline

COMPLETION DEPTH: 165.5' ELEVATION: 601.8 DATE: 9/13/94 9/15/94

DEPT. FEET	SAMPLE NO.	SAMPLES	HAND PENE-TROMETER	MOISTURE CONTENT	LIQUID LIMIT	PLASTIC LIMIT	DESCRIPTION - CONTINUED					
							tsf	%	%	%	AGG.	C.S.
150	30	P										Dense gray fine to coarse sand, some fine to coarse gravel, trace silt.
155	31	29/27/33					40	29	11	20		A-1-b(0)
160	32	NXM REC 89%	RQD 26%	0								Hard gray silty clay, some fine to coarse sand, little fine gravel (shale fragments). Est. A-6a Medium-hard gray shale, nearly horizontally bedded. - From 163.1' to 163.8': Contains zones of clay.
165												- Encountered water from 25.0' to 165.5'.
170												- From 0.0' to 29.0': 3-1/4" I.D. Hollow-stem Auger with plug, replaced with 4" I.D. Flush-coupled casing from 0.0' to 29.0'.
175												- From 29.0' to 159.5': 3-7/8" Tricone Bit.
180												- From 29.0' to 165.5': Recirculated water used for drilling fluid.
185												
190												
195												

200 WATER LEVEL:
 WATER NOTE:
 DATE:

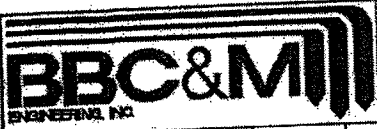

LOG OF BORING NO. B-105
CUY-90-15.24
CLEVELAND, OHIO

DEPT. FEET	SAMPLE NO.	SAMPLES	SAMPLING EFFORT	HAND PENE-TROMETER	MOISTURE CONTENT	LIQUID LIMIT	PLASTIC LIMIT	TYPE: <u>2" O.D. Split-barrel Sampler</u>				LOCATION: <u>Sta. 19+11.38</u>					
								TYPE: <u>3" O.D. Shelby Tube</u>				LOCATION: <u>90.9' Rt. of Centerline</u>					
								TYPE: <u>NXM Rock-core Barrel</u>				COMPLETION DEPTH: <u>149.5'</u>		ELEVATION: <u>585.4</u>		DATE: <u>8/17/94 8/18/94</u>	
												DESCRIPTION					
				tsf	%	%	%	AGG.	C.S.	F.S.	SILT	CLAY					
0													FILL: Loose to medium-dense (Estimated) brown fine to coarse gravel, some fine to coarse sand, little clayey silt, contains cinders and slag.				
5	1		3/2/3										FILL: Very-loose dark-gray and gray fine to coarse sand, little to some fine to coarse gravel, trace to some clayey silt, contains cinders, slag, and wood pieces.				
10	2		2/2/1														
15	3		2/3/1		60			27	15	30		28					
20	4A 4B		4/5/4										Loose brown and gray fine to medium sand, little silt, trace coarse sand. Est. A-2-4				
25	5A 5B		2/4/6	1.2-1.7	23	31	18	8	2	5	40	45	Stiff gray silty clay, trace fine to coarse sand, trace fine gravel, many seams and lenses of silt. Est. A-3a A-6a(9)				
30	6		1/3/3	0.4-0.7	25	38	18	0	1	2	25	72	Soft to medium-stiff gray silty clay, trace fine to medium sand. A-6b(12)				
35	7		P	1.0-1.6													
40	8		7/7/10	1.6-3.4	22	28	18	0	0	2	54	44					
45	9		4/6/8	2.1-4.0									A-4b(8)				
50	10		P	1.2-1.6		27	31	17	0	0	1	48	51	Stiff to very-stiff gray silty clay, trace fine to coarse sand, trace fine gravel, few lenses of silt.			
	11		3/4/5	1.0-2.4	25	36	18	0	0	0	63	37	A-6a, A-6b(10,11)				

50 WATER LEVEL: 11.0 11.0 11.0 11.0 11.0 11.0

WATER NOTE: _____

DATE: 08/17/94

-CONTINUED- 3 - 2 - 20



LOG OF BORING NO. B-105
 CUY-90-15.24
 CLEVELAND, OHIO

TYPE: 2" O.D. Split-barrel Sampler LOCATION: Sta. 19+11.38
3" O.D. Shelby Tube 90.9' Rt. of
NXM Rock-core Barrel Centerline

COMPLETION DEPTH: 149.5' ELEVATION: 585.4 DATE: 8/17/94 8/18/94

DEP. FEET	SAMPLE NO.	SAMPLES	SAMPLING EFFORT	HAND PENE-TROMETER	MOISTURE CONTENT	LIQUID LIMIT	PLASTIC LIMIT	DESCRIPTION - CONTINUED										
								tsf	%	%	%	AGG.	C.S.	F.S.	SILT	CLAY		
50	12		4 1/6 / 7	1.3-2.5														Stiff to very-stiff gray silty clay, trace fine to coarse sand, trace fine gravel, few lenses of silt.
55	13		P															
	14A		4 1/6 / 10	1.6-2.2														
	14B			1.3-1.8														
60	15		5 1/6 / 9	1.2-1.7	21	32	18	0	0	2	21	77						
65	16		P	1.8-1.9														
	17		5 1/8 / 12	1.4-1.7														
70	18		7 1/8 / 10	1.3-1.9														
75	19		4 1/7 / 11	1.6-2.0	22	32	18	1	2	4	43	50						
80	20		4 1/8 / 11	1.5-2.2														
85	21		P	1.3-1.5														
	22		4 1/7 / 9	1.2-2.0	27	40	22	0	1	1	24	74						
90	23		5 1/8 / 11	1.2-2.0														
	24		P	1.0-2.0	30	42	23	0	1	1	13	85						
	25		3 1/4 / 6	0.5-0.6														

- Below 77.5': Few seams of 1/8" silt.

A-6a, A-6b(10,11)

Medium-stiff to stiff gray silty clay, trace fine to coarse sand, few seams of silt, horizontal structure.

A-6a(10)

100 WATER LEVEL: 11.0

WATER NOTE: _____

DATE: 08/17/94



LOG OF BORING NO. B-105
 CUY-90-15.24
 CLEVELAND, OHIO

TYPE: 2" O.D. Split-barrel Sampler LOCATION: Sta. 19+11.38
3" O.D. Shelby Tube 90.9' Rt. of
NXM Rock-core Barrel Centerline
 COMPLETION DEPTH: 149.5' ELEVATION: 585.4 DATE: 8/17/94 8/18/94

DEPT FEET	SAMPLE NO.	SAMPLES SAMPLING EFFORT	HAND PENE- TROMETER	MOISTURE CONTENT	LIQUID LIMIT	PLASTIC LIMIT	DESCRIPTION - CONTINUED						
							tsf	%	%	%	AGG.	C. S.	F. S.
100	26	1/3/4	0.5-1.1										Medium-stiff to stiff gray silty clay, trace fine to coarse sand, few seams of silt, horizontal structure.
105	27	P	1.0-1.5										- From 107.5' to 109.0': Numerous seams of 1/8" silt. A-6a(10)
	28	4/7/7	0.6-1.3										
110	29A 29B	3/4/5	0.5-0.8	27	NP	NP	0	0	0	86	14		Loose gray silt, trace clay. A-4b(8)
115	30	10/16/24	3.0-4.1										Very-stiff to hard gray silty clay, trace fine to coarse sand, many seams of silt, few slickensides, horizontal structure.
120	31	8/12/14	2.2-3.5										- From 124.5' to 126': Little fine to coarse sand, little fine to coarse gravel.
125	32	5/8/12	2.0-2.8	24	36	21	4	4	6	31	55		
130	33	7/9/13	2.0-3.2										- From 134.5' to 135.4': Interbedded with fine to coarse sand. A-6a(10)
135	34A 34B 34C	8/18/26	2.5-3.0 2.0-3.0										Dense gray fine to coarse sand, trace silt, trace fine to coarse gravel. Est. A-3a
140	35A 35B	24/32/35											Gray shale "and" gray silty clay, little fine to coarse sand, possible top of rock. Est. A-2-6
145	36	NXM REC 94%	ROD 45%										Very-soft to soft gray shale.

150 WATER LEVEL: 11.0
 WATER NOTE: _____
 DATE: 08/17/94



LOG OF BORING NO. B-105
 CUY-90-15.24
 CLEVELAND, OHIO

TYPE: 2" O.D. Split-barrel Sampler LOCATION: Sta. 19+11.38
3" O.D. Shelby Tube 90.9' Rt. of
NXM Rock-core Barrel Centerline

COMPLETION DEPTH: 149.5' ELEVATION: 585.4 DATE: 8/17/94 8/18/94

DEP. FEET	SAMPLE NO.	SAMPLES	SAMPLING EFFORT	HAND PENE-TROMETER	MOISTURE CONTENT	LIQUID LIMIT	PLASTIC LIMIT	AGG. C. S. F. S. SILT:CLAY				DESCRIPTION - CONTINUED	
								tsf	%	%	%		
150													
155													
160													
165													
170													
175													
180													
185													
190													
195													

- Encountered slight seepage at 9.3' to 12.0'.
 - Encountered water at 12.0' to 24.9'.
 - Encountered seepage at 110.0' to 113.5'.
 - From 0.0' to 30.2': 3-1/4" I.D. Hollow-stem Auger with plug, replaced with 4" I.D. Flush-coupled casing from 0.0' to 30.2'.
 - From 30.2' to 144.5': 3-7/8" Tricone Bit.
 - From 30.2' to 149.5': Recirculated water used for drilling fluid.

200 WATER LEVEL: ✓ 11.0 ✓ ✓ ✓ ✓ ✓
 WATER NOTE: _____
 DATE: 08/17/94



LOG OF BORING NO. B-106
 CUY-90-15.24
 CLEVELAND, OHIO

TYPE: 2" O.D. Split-barrel Sampler LOCATION: Sta. 18+38.12
3" O.D. Shelby Tube 243.9' Rt. of
NXM Rock-core Barrel Centerline
 COMPLETION DEPTH: 174.2' ELEVATION: 612.3 DATE: 9/8/94 9/12/94

DEPT. FEET	SAMPLE NO.	SAMPLES SAMPLING EFFORT	HAND PENE-TROMETER	MOISTURE CONTENT	LIQUID LIMIT	PLASTIC LIMIT	DESCRIPTION					
							tsf	%	%	%	AGG.	C.S.
0												FILL: Very-loose to loose black fine to coarse sand, some fine to coarse gravel, trace silt, (cinders).
5	1	4 / 4 / 4										
10	2	2 / 2 / 2										
15	3	2 / 1 / 3										
20	4	3 / 4 / 8					0	0	74	26	0	Est. A-1-b Medium-dense brown fine sand, trace medium sand, some silt. A-3a(0)
25	5	3 / 4 / 5	2.2-4.3									Stiff to hard gray silty clay, trace fine to coarse sand, few seams and lenses of silt, horizontal structure.
30	6A 6B 6C	P	3.3-3.7 4.1 4.2									
35	7	P	2.6-3.2									
40	8	2 / 4 / 4	1.5-3.0									
45	9	P	1.2-1.5									A-6a(10)

50 WATER LEVEL: WATER NOTE: _____ DATE: _____



LOG OF BORING NO. B-106
 CUY-90-15.24
 CLEVELAND, OHIO

TYPE: 2" O.D. Split-barrel Sampler
 3" O.D. Shelby Tube
 NXM Rock-core Barrel

LOCATION: Sta. 18+38.12
 243.9' Rt. of
 Centerline

COMPLETION DEPTH: 174.2' ELEVATION: 612.3 DATE: 9/8/94 9/12/94

DEP. FEET	SAMPLE NO.	SAMPLES SAMPLING EFFORT	HAND PENE-TROMETER	MOISTURE CONTENT	LIQUID LIMIT	PLASTIC LIMIT	DESCRIPTION - CONTINUED											
							tsf	%	%	%	AGG.	C.S.	F.S.	SILT/CLAY				
50	10	4 / 4 / 6	1.9-2.1															Stiff to hard gray silty clay, trace fine to coarse sand, few seams and lenses of silt, horizontal structure.
55	11	4 / 4 / 5	1.7-1.9	23	33	19	0	0	2	52	46							A-6a(10)
60	12	3 / 5 / 8	2.2-2.8															Very-stiff to hard gray silty clay, trace fine to medium sand, trace fine gravel, few seams and lenses of silt.
65	13	4 / 6 / 6	2.0-2.1															
70	14	4 / 8 / 10	2.5-3.4															
75	15	5 / 8 / 12	3.6-4.5+															
80	16	5 / 11 / 13	2.7-3.4															
85	17	9 / 11 / 16	4.2-4.5+															
90	18	5 / 9 / 11	2.0-2.3	21	35	19	1	2	3	34	60							
95	19	5 / 8 / 10	2.1-2.3															

A-6b(10)

100 WATER LEVEL: WATER NOTE: _____ DATE: _____

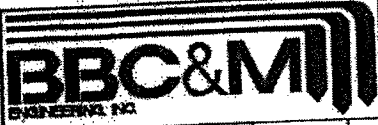

LOG OF BORING NO. B-106
 CUY-90-15.24
 CLEVELAND, OHIO

TYPE: 2" O.D. Split-barrel Sampler
3" O.D. Shelby Tube
NXM Rock-core Barrel

LOCATION: Sta. 18+38.12
243.9' Rt. of
Centerline

COMPLETION DEPTH: 174.2' ELEVATION: 612.3 DATE: 9/8/94 9/12/94

DEPT. FEET	SAMPLE NO.	SAMPLES SAMPLING EFFORT	HAND PENE- TROMETER	MOISTURE CONTENT	LIQUID LIMIT	PLASTIC LIMIT	DESCRIPTION - CONTINUED														
							tsf	%	%	%	AGG.	C. S.	F. S.	SILT	CLAY						
100		7 / 12 1/4																			Very-stiff to hard gray silty clay, trace fine to medium sand, trace fine gravel, few seams and lenses of silt.
105	20	8 / 12 1/2	3.4-3.8																		
110	21	6 / 13 1/8	3.1-3.4																		
115	22	8 / 11 1/5	3.8-4.1																		
120	23	5 / 17 1/8	2.0-2.3																		
125	24	4 / 16 1/8	2.1-2.2																		
130	25	8 / 14 1/20			11		8	41	20	26	5										Dense gray fine to medium sand, some silty clay, trace coarse sand, trace fine gravel.
135	26	P																			
140	27	13 / 22 1/26	4.5+																		Very-stiff to hard gray silty clay, trace fine to coarse sand, trace fine gravel, few lenses of silt.
145	28	P	2.3-2.6																		

A-6b(10)

A-3a(0)

Est. A-6b

150 WATER LEVEL:
 WATER NOTE:
 DATE:



LOG OF BORING NO. B-106
 CUY-90-15.24
 CLEVELAND, OHIO

TYPE: 2" O.D. Split-barrel Sampler	LOCATION: Sta. 18+38.12
3" O.D. Shelby Tube	243.9' Rt. of Centerline
NXM Rock-core Barrel	
COMPLETION DEPTH: 174.2'	ELEVATION: 612.3
DATE: 9/8/94 9/12/94	

DEPT. FEET	SAMPLE NO.	SAMPLES SAMPLING EFFORT	HAND PENE-TROMETER	MOISTURE CONTENT	LIQUID LIMIT	PLASTIC LIMIT	COMPLETION DEPTH				SILT:CLAY	DESCRIPTION - CONTINUED
							tsf	%	%	%		
150	29	7/19/11	2.7-3.2									Very-stiff to hard gray silty clay, trace fine to coarse sand, trace fine gravel, few lenses of silt. Est. A-6b
155	30	25/30/30										Dense gray fine to coarse sand, little to some silty clay, little fine gravel.
160	31	57/38/30		13			35	15	27	19	4	
165	32	28/22/24										
170	33	50-2"R NXM REC	RQD 67%									Soft gray shale, nearly horizontally bedded. A-1-b(0)
175	34	77%										
180	35	85%	0%									- Encountered seepage at 18.0'. - From 0.0' to 30.8': 3-1/4" I.D. Hollow-stem Auger with plug, replaced with 4" I.D. Flush-coupled casing from 0.0' to 30.8'. - From 30.8' to 169.2': 3-7/8" Tricone Bit. - From 30.8' to 147.2': Recirculated water used for drilling fluid.

200 WATER LEVEL: _____ _____ _____ _____ _____ _____

WATER NOTE: _____

DATE: _____



LOG OF BORING NO. B-107
 CUY-90-15.24
 CLEVELAND, OHIO

DEPT FEET	SAMPLE NO.	SAMPLES SAMPLING EFFORT	HAND PENE- TROMETER	MOISTURE CONTENT	LIQUID LIMIT	PLASTIC LIMIT	TYPE: 2" O.D. Split-barrel Sampler 3" O.D. Shelby Tube NXM Rock-core Barrel				LOCATION: Sta. 15+49.05 89.6' Lt. of Centerline		
							tsf	%	%	%	AGG.	C.S.	F.S.
0													DESCRIPTION ASPHALT - 13 INCHES
													FILL: Loose brown fine to coarse sand, some fine to coarse gravel. Est. A-1-b
5	1	3/4/4											Loose brown fine to medium sand, little coarse sand, trace silt. Est. A-3a
10	2A 2B	4/7/7											Loose brown silt, little fine sand. Est. A-4a
15	3	P											Medium-dense brown fine sand, trace medium to coarse sand, trace silt.
20	4	6/7/8											Loose brown fine sand, some silt, trace medium to coarse sand. Est. A-3a
25	5	2/3/3		25			0	0	70	30			
30	6	7/10/4											Very-stiff gray silty clay, little fine to coarse sand, many seams and lenses of silt. A-3a(0)
35	7	5/6/9		19			0	0	11	63	26		Dense gray fine sand, trace medium to coarse sand, little silt. Est. A-4b
40	8	16/28/40											Dense gray fine sand, trace medium to coarse sand, little silt. Est. A-3a
45	9	12/10/19					0	0	2	79	19		Medium-dense to dense gray silt interbedded with silty clay, trace fine to medium sand. Est. A-4b
50													

WATER LEVEL: _____
 WATER NOTE: _____
 DATE: _____



LOG OF BORING NO. B-107
 CUY-90-15.24
 CLEVELAND, OHIO

TYPE: 2" O.D. Split-barrel Sampler
3" O.D. Shelby Tube
NXM Rock-core Barrel

LOCATION: Sta. 15+49.05
89.6' Lt. of
Centerline

COMPLETION DEPTH: 215.0' ELEVATION: 662.7 DATE: 9/19/94 9/22/94

DEPT. FEET	SAMPLE NO.	SAMPLES SAMPLING EFFORT	HAND PENE-TROMETER	MOISTURE CONTENT	LIQUID LIMIT	PLASTIC LIMIT	AGG.				SILT/CLAY		DESCRIPTION - CONTINUED
							C.	S.	F.	S.	SILT	CLAY	
50	10	7/6/8	2.7-3.4										Stiff to very-stiff gray silty clay, trace fine to medium sand, few to many seams and lenses of silt, horizontal structure. - From 64.0' to 65.5': Very-stiff to hard.
55	11	3/5/5	1.7-2.2										
60	12	P	3.2-3.3										
65	13	4/11/15	3.4-4.5+										
70	14	P	2.2-2.6										
75	15	5/9/14	2.8-3.6										
80	16	P	1.7-2.1										
85	17	3/3/4	1.3-1.8	31	38	20	0	1	1	18	80		
90	18	5/7/8	2.2-2.8										
95	19	4/6/8	1.9-2.7										

A-6b(11)

100 WATER LEVEL:
 WATER NOTE:
 DATE:

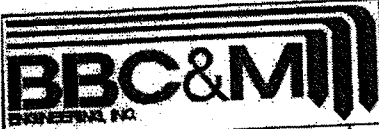

LOG OF BORING NO. B-107
 CUY-90-15.24
 CLEVELAND, OHIO

TYPE: 2" O.D. Split-barrel Sampler
3" O.D. Shelby Tube
NXM Rock-core Barrel

LOCATION: Sta. 15+49.05
89.6' Lt. of
Centerline

COMPLETION DEPTH: 215.0' ELEVATION: 662.7 DATE: 9/19/94 9/22/94

DEPTH FEET	SAMPLE NO.	SAMPLES SAMPLING EFFORT	HAND PENE- TROMETER	MOISTURE CONTENT	LIQUID LIMIT	PLASTIC LIMIT	DESCRIPTION - CONTINUED											
							tsf	%	%	%	AGG.	C.S.	F.S.	SILT	CLAY			
100	20	5 / 6 / 8	1.3-1.8															Stiff to very-stiff gray silty clay, trace fine to medium sand, few to many seams and lenses of silt, horizontal structure. A-6b(11)
105	21	6 / 10 / 15	3.3-4.5+															Very-stiff to hard gray silty clay, trace fine to medium sand, few to many seams and lenses of silt, horizontal structure.
110	22	8 / 12 / 16	2.7-4.5+															
115	23	7 / 12 / 19	2.9-3.7															Est. A-6b
120	24	P	1.7-2.0															
125	25	3 / 6 / 12	1.8-2.8	23	31	19	0	1	1	52	46							
130	26	P	3.2-3.3															
135		9 / 15 / 21																
140	27	P	2.0-2.3															
145	28	6 / 10 / 14	2.2-2.7															

150 WATER LEVEL: _____ _____ _____ _____ _____
 WATER NOTE: _____
 DATE: _____

LOG OF BORING NO. B-107
 CUY-90-15.24
 CLEVELAND, OHIO



TYPE: 2" O.D. Split-barrel Sampler
 3" O.D. Shelby Tube
 NXM Rock-core Barrel

LOCATION: Sta. 15+49.05
 89.6' Lt. of
 Centerline

COMPLETION DEPTH: 215.0' ELEVATION: 662.7 DATE: 9/19/94 9/22/94

DEPTH FEET	SAMPLE NO.	SAMPLES SAMPLING EFFORT	HAND PENE-TROMETER	MOISTURE CONTENT	LIQUID LIMIT	PLASTIC LIMIT	DESCRIPTION - CONTINUED										
							tsf	%	%	%	AGG.	C. S.	F. S.	SILT/CLAY			
150	29	6 / 10 / 15	1.8-2.1														Stiff to very-stiff gray silty clay, trace fine to coarse sand, few lenses of silt. A-6a(9)
155	30	S/H-18" / 23	2.1-2.4														Very-stiff to hard gray silty clay, trace fine to coarse sand, trace fine gravel.
160	31	7 / 13 / 18	3.2-3.3														
165	32	7 / 12 / 17	3.0-3.4														
170	33	7 / 11 / 15	2.7-4.2														Est. A-6a
175	34	5 / 8 / 10	1.7-2.8	26	32	18	0	0	1	38	61						Stiff to very-stiff gray silty clay, trace fine to coarse sand, few seams and lenses of silt. A-6a(10)
180	35	16 / 27 / 38															Dense gray fine to medium sand, little silt, trace coarse sand. Est. A-3a
185	36	16 / 43 / 50-4" R	4.5+														Hard gray silty clay, trace to little fine to coarse sand, trace fine gravel, few lenses of silt.
190	37	18 / 38 / 50-5" R	4.5+														
195	38	11 / 22 / 30	4.5+														Est. A-6

200 WATER LEVEL: WATER NOTE: _____ DATE: _____



TYPE: 2" O.D. Split-barrel Sampler LOCATION: Sta. 15+49.05
3" O.D. Shelby Tube 89.6' Lt. of
NXM Rock-core Barrel Centerline
 COMPLETION DEPTH: 215.0' ELEVATION: 662.7 DATE: 9/19/94 9/22/94

DEPTH	SAMPLE NO.	SAMPLES	HAND PENE-TROMETER EFFORT	MOISTURE CONTENT	LIQUID LIMIT	PLASTIC LIMIT	AGG.	C.S.	F.S.	SILT	CLAY	DESCRIPTION - CONTINUED
200	39	8	12/14	2.3-3.5								Hard gray silty clay, trace to little fine to coarse sand, trace fine gravel, few lenses of silt.
	40A	11	20	2.4-3.5								
205	40B	30		3.4-4.5+								
	41	25		4.2-4.5+								
210		50-2" R NXM RBC		RQD								Very-soft to soft gray shale, nearly horizontally bedded, contains few horizontal to diagonal fractures.
	42	100%		83%								
215												- Encountered water from 0.0' to 215.0'. - From 0.0' to 59.4': 3-1/4" I.D. Hollow-stem Auger with plug, replaced with 4" I.D. Flush-coupled casing from 0.0' to 59.4'. - From 59.4' to 210.0': 3-7/8" Tricone Bit. - From 0.0' to 215.0': Recirculated water used for drilling fluid.
220												
225												
230												
235												
240												
245												
250												

WATER LEVEL:
 WATER NOTE:
 DATE:



LOG OF BORING NO. B-108
 CUY-90-15.24
 CLEVELAND, OHIO

DEP FEET	SAMPLE NO.	SAMPLES SAMPLING EFFORT	HAND PENE- TRMETER	MOISTURE CONTENT	LIQUID LIMIT	PLASTIC LIMIT	TYPE: 2" O.D. Split-barrel Sampler				LOCATION: Sta. 18+00.15	
							AGG.	C.S.	F.S.	SILT	CLAY	87.8' Lt. of Centerline
0												
5												
10	1	P										FILL: Loose black cinders and slag, contains seams or lenses of: Silt; clayey silt; fine to coarse gravel; and brown fine to medium sand, trace brick or tile fragments. Est. A-3a
	2	3/4/4										POSSIBLE FILL: Loose brown fine to coarse sand, little fine to coarse gravel, trace to little silt.
15	3	4/4/3					32	40	17		11	A-1-b(0) Loose brown fine to medium sand, trace silt.
20	4	P										Est. A-3 Loose brown fine to medium sand, little silt, trace coarse sand.
	5A	4/4/5	1.8-2.0	22	26	19	0	0	2	74	24	Est. A-3a Stiff gray silty clay interbedded with clayey silt, "and" silt, few thin seams of fine sand.
25	6	5/7/10	2.0-4.5+									A-4b(8) Medium-stiff to stiff gray silty clay, little fine to coarse sand, few lenses of silt and fine sand.
30	7	P 2/3/5	1.0-1.8	28	39	22	1	3	4	18	74	- From 25.0' to 26.5': Hard.
35	8	P	1.3-1.5	26	36	21	0	0	1	33	66	
	9	3/3/5	1.0									
40	10	P	1.0									
	11	2/3/3	0.7-1.0	28	39	22	0	1	1	32	66	A-6a, A-6b(10,11) Stiff to very-stiff gray silty clay, trace to little fine to medium sand, contains many seams and lenses of silt.
45	12	P	2.5	26	38	20	0	1	2	35	62	
	13	3/6/7	1.5-2.0	22	30	18	0	0	1	55	44	- From 44.0' to 49.0': Irregular "disturbed" structure. A-6a(8,9)

50 WATER LEVEL: _____
 WATER NOTE: None to 48.5'
 DATE: 08/10/94



TYPE: 2" O.D. Split-barrel Sampler LOCATION: Sta. 18+00.15
3" O.D. Shelby Tube 87.8' Lt. of
NXM Rock-core Barrel Centerline

COMPLETION DEPTH: 170.2' ELEVATION: 610.4 DATE: 8/8/94 8/10/94

DEPT FEET	SAMPLE NO.	SAMPLES SAMPLING EFFORT	HAND PENE- TROMETER	MOISTURE CONTENT				AGG.	C.S.	F.S.	SILT:CLAY		DESCRIPTION - CONTINUED
				tsf	%	%	%						
50	14	3/6/7	1.5-1.8										Stiff to very-stiff gray silty clay, trace to little fine to medium sand, contains many seams and lenses of silt. A-6a(8,9) Stiff to very-stiff gray silty clay, trace to little fine to coarse sand, trace fine gravel, few lenses of silt. A-6a, A-6b(10,11)
55	15	3/6/6	1.3-1.8	23	30	17	0	0	1	56	43		
60	16	3/7/8	2.0-3.0*										
65	17	5/8/10	2.0-4.0*	22	29	18	1	1	2	62	34		
70	18	2/5/5	1.0-1.5										
75	19	5/8/11	1.5-1.7	22	33	18	1	2	6	31	60		
80	20	4/7/11	1.5-2.0										
85	21	6/11/16	2.0-2.3										
90	22	5/11/15	2.0-2.3	21	33	18	2	3	4	33	58		
95	23	6/11/14	2.0-2.3										

100 WATER LEVEL: None to 48.5'
 WATER NOTE: _____
 DATE: 08/10/94

-CONTINUED-



LOG OF BORING NO. B-108
 CUY-90-15.24
 CLEVELAND, OHIO

TYPE: 2" O.D. Split-barrel Sampler LOCATION: Sta. 18+00.15
3" O.D. Shelby Tube
NXM Rock-core Barrel 87.8' Lt. of Centerline

COMPLETION DEPTH: 170.2' ELEVATION: 610.4 DATE: 8/8/94 8/10/94

DEPT. FEET	SAMPLE NO.	SAMPLES SAMPLING EFFORT	HAND PENE-TROMETER	MOISTURE CONTENT	LIQUID LIMIT	PLASTIC LIMIT	COMPLETION DEPTH: 170.2' ELEVATION: 610.4 DATE: 8/8/94 8/10/94					SILT:CLAY	DESCRIPTION - CONTINUED
							tsf	%	%	%	AGG.		
100	24	5/9/12	1.6-1.9	22	33	20	4	3	3	30	60	Stiff to very-stiff gray silty clay, trace to little fine to coarse sand, trace fine gravel, few lenses of silt.	
105	25	5/9/13	1.9-2.3										
110	26	5/9/13	2.0-2.5	23	34	19	0	0	1	37	62		
115	27	5/7/11	1.7-2.3										
120	28A 28B	3/6/9	1.0-1.3 2.0-2.5	29	38	20	0	1	3	22	74	A-6a, A-6b(10,11) Interbedded: Medium-dense gray silt, stiff gray silty clay, and fine sand.	
125	29A 29B	4/6/5	1.0									Est. A-4b Very-stiff to hard gray silty clay, trace to little fine to coarse sand, trace fine gravel.	
130	30	15/20/27										- From 129.8' to 131.8': Seam of dense gray fine to coarse sand, "and" fine gravel, little silt.	
135	31	18/40/58	4.5+	16	32	18	5	3	6	29	57	- From 135.0' to 135.7': Contains many slickensided partings.	
140	32	16/31/58	3.5-4.5+									A-6a(10) Stiff to very-stiff gray silty clay, trace fine to coarse sand, trace fine to coarse gravel, many lenses of silt.	
145	33	7/10/13	2.0-2.6	25	32	20	0	0	0	95	5	A-6a(8,9)	

150 WATER LEVEL: None to 48.5'
 WATER NOTE: _____
 DATE: 08/10/94



LOG OF BORING NO. B-108
CUY-90-15.24
CLEVELAND, OHIO

DEPTH FEET	SAMPLE NO.	SAMPLES SAMPLING EFFORT	HAND PENE- TRONETER	MOISTURE CONTENT	LIQUID LIMIT	PLASTIC LIMIT	TYPE: <u>2" O.D. Split-barrel Sampler</u> LOCATION: <u>Sta. 18+00.15</u>					DESCRIPTION - CONTINUED
							COMPLETION DEPTH: <u>170.2'</u> ELEVATION: <u>610.4</u> DATE: <u>8/8/94 8/10/94</u>			3" O.D. Shelby Tube		
							AGG.	C.S.	F.S.	SILT	CLAY	
150	34	SH-12" 46	1.0-2.0	23	31	20	13	0	1	33	53	Stiff to very-stiff gray silty clay, trace fine to coarse sand, trace fine to coarse gravel, many lenses of silt.
155	35	7 10, 15	2.0-2.5									A-6a(8,9)
160	36	P/R	4.5+				43	11	4		42	Hard gray silty clay, little to some fine to coarse sand, trace to little fine to coarse gravel. Est. A-6a
	37	20, 28, 52	4.5+									Dense gray fine to coarse gravel, some fine to coarse sand, "and" clayey silt. A-4a(1)
165	38	100-2" R NXM REC	RQD									Soft to medium-hard black and gray shale. Very-soft to soft gray shale, nearly horizontally bedded, partly similar to hard soil.
	39	100%	64%									Soft to medium-hard black and gray shale, nearly horizontally bedded, fissile. - From 165.9' to 166.2': Iron carbonate seams. - From 169.5' to 170.2': Near-vertical fracture, filled with broken shale fragments and soft clay.
170												- From 0.0' to 45.0': 3-1/4" I.D. Hollow-stem Auger with plug, replaced with 4" I.D. Flush-coupled casing from 0.0' to 45.0'. - From 45.0' to 165.2': 3-7/8" Tricone Bit. - From 45.0' to 170.2': Recirculated water used for drilling fluid.
175												
180												
185												
190												
195												

200
 WATER LEVEL: ∇
 WATER NOTE: None to 48.5'
 DATE: 08/10/94



LOG OF BORING NO. B-109
 CUY-90-15.24
 CLEVELAND, OHIO

TYPE: 2" O.D. Split-barrel Sampler
3" O.D. Shelby Tube
NXM Rock-core Barrel

LOCATION: Sta. 18+86.96
65.6' Lt. of
Centerline

COMPLETION DEPTH: 163.2' ELEVATION: 593.3 DATE: 8/25/94

DEPT. FEET	SAMPLE NO.	SAMPLES	SAMPLING EFFORT	HAND PENE-TROMETER	MOISTURE CONTENT	LIQUID LIMIT	PLASTIC LIMIT	AGG.				SILT		CLAY	DESCRIPTION
								tsf	%	%	%	C.S.	F.S.		
0															FILL: Dense black fine to coarse sand, little fine to coarse gravel, trace silt, (cinders, slag, and foundry sand).
5	1	24/34	31												
10	2	5/6	4												
15	3	2/1	1												
20	4	3/2	2												
25	5	2/3	5	1.5-3.5	21	34	19	0	0	1	66	33		Stiff to very-stiff gray silty clay, trace fine to medium sand, horizontal structure. Est. A-1-b A-6a(10)	
30	6	2/3	5	0.3-0.5											Medium-stiff to stiff gray silty clay, trace fine to medium sand, trace fine gravel, few lenses of silt.
35	7	1/3	6	0.5-1.5	24	32	19	0	1	1	64	34		A-6a(9)	
	8	P			25	32	18	0	1	1	55	43		Stiff to very-stiff gray silty clay, trace fine to coarse sand, few seams and lenses of silt.	
45	9	P		3.0-3.5											

50 WATER LEVEL:
 WATER NOTE:
 DATE:



LOG OF BORING NO. B-109
 CUY-90-15.24
 CLEVELAND, OHIO

TYPE: 2" O.D. Split-barrel Sampler LOCATION: Sta. 18+86.96
3" O.D. Shelby Tube 65.6' Lt. of
NXM Rock-core Barrel Centerline

COMPLETION DEPTH: 163.2' ELEVATION: 593.3 DATE: 8/25/94

DEPT. FEET	SAMPLE NO.	SAMPLES SAMPLING EFFORT	HAND PENE-TROMETER	MOISTURE CONTENT			AGG.	C.S.	F.S.	SILT:CLAY		DESCRIPTION - CONTINUED
				%	%	%						
50	10	5/5/6	2.0-3.0	23	31	19	0	1	4	44	51	Stiff to very-stiff gray silty clay, trace fine to coarse sand, few seams and lenses of silt.
55	11	P										
60	12	P	3.0-4.5+									- At 60.0': Very-stiff to hard.
65		P										
70	13	P	1.5-2.0									
75	14	4/6/9	1.5-2.5									
80	15	4/7/8	1.0-2.0	23	35	19	1	2	4	36	57	
85	16	5/7/11	1.5-2.5									
90	17	6/8/11	1.5-2.0									
95	18	5/8/11										

A-6a, A-6b(9,10)

100 WATER LEVEL:
 WATER NOTE:
 DATE:

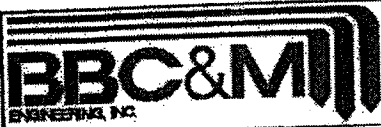

LOG OF BORING NO. B-109
 CUY-90-15.24
 CLEVELAND, OHIO

TYPE: 2" O.D. Split-barrel Sampler LOCATION: Sta. 18+86.96
3" O.D. Shelby Tube 65.6' Lt. of
NXM Rock-core Barrel Centerline

COMPLETION DEPTH: 163.2' ELEVATION: 593.3 DATE: 8/25/94

DEP. FEET	SAMPLE NO.	SAMPLES	SAMPLING EFFORT	HAND PENE-TROMETER	MOISTURE CONTENT	LIQUID LIMIT	PLASTIC LIMIT	AGG. C. S. F. S.				SILT:CLAY		DESCRIPTION - CONTINUED
								tsf	%	%	%			
100	19	P		2.0-3.0										Stiff to very-stiff gray silty clay, trace fine to coarse sand, few seams and lenses of silt.
105	20	P		2.0-2.5										- From 110.0' to 113.0': Very-stiff to hard.
110	21	P		2.5										A-6a, A-6b(9,10)
115	22A 22B	10/14, 19		2.5-4.5+				9	9	33	49			(Estimated) Medium-dense fine to medium sand intermixed with clayey silt, trace coarse sand, trace fine gravel. Est. A-4a
120	23	15/21, 27		4.5+										
125	24	P		4.5+			37	21	1	1	2	33	64	
130		P												Est. A-6b
135	25	19/19, 27			2			16	35	31	15	3		Dense gray fine to coarse sand, little clayey silt, trace coarse sand, trace fine gravel.
140	26	15/19, 20												A-1-b(0)
145	27	23/34, 38												Dense gray fine to coarse gravel, some fine to coarse sand, trace clayey silt.
150	28	52		4.5+										Est. A-1-a

DESCRIPTION ON NEXT PAGE

WATER LEVEL:
 WATER NOTE:
 DATE:

LOG OF BORING NO. B-109
 CUY-90-15.24
 CLEVELAND, OHIO



TYPE: 2" O.D. Split-barrel Sampler LOCATION: Sta. 18+86.96
3" O.D. Shelby Tube 65.6' Lt. of
NXM Rock-core Barrel Centerline

COMPLETION DEPTH: 163.2' ELEVATION: 593.3 DATE: 8/25/94

DEP. FEET	SAMPLE NO.	SAMPLES SAMPLING EFFORT	HAND PENE-TROMETER	MOISTURE CONTENT	LIQUID LIMIT	PLASTIC LIMIT	AGG. C. S. F. S.			SILT:CLAY	DESCRIPTION - CONTINUED
							tsf	%	%		
150											Very-soft to soft gray shale, nearly horizontally bedded, partly similar to hard soil.
155	29	36 50-1"R	4.5+								
160	30	100-2"R NXM REC	RQD								
165	31	84%	27%								Soft to medium-hard gray shale, nearly horizontally bedded, fissile. - From 161.5' to 162.1': Diagonal fractures, partly clay filled. - Encountered slight seepage at 19.7'. - From 0.0' to 35.0': 3-1/4" I.D. Hollow-stem Auger with plug, replaced with 4" I.D. Flush-coupled casing from 0.0' to 35.0'. - From 35.0' to 158.7': 3-7/8" Tricone Bit. - From 35.0' to 163.2': Recirculated water used for drilling fluid.
170											
175											
180											
185											
190											
195											

200
 WATER LEVEL: ✓ ✓ ✓ ✓ ✓ ✓
 WATER NOTE: _____
 DATE: _____



LOG OF BORING NO. B-110
 CUY-90-15.24
 CLEVELAND, OHIO

TYPE: 2" O.D. Split-barrel Sampler LOCATION: Sta. 18+43.85
3" O.D. Shelby Tube 243.9' Lt. of
NXM Rock-core Barrel Centerline

COMPLETION DEPTH: 155.0' ELEVATION: 596.7 DATE: 8/31/94 9/8/94

DEP. FEET	SAMPLE NO.	SAMPLES SAMPLING EFFORT	HAND PENE-TROMETER	MOISTURE CONTENT	LIQUID LIMIT	PLASTIC LIMIT	AGG. C. S. F. S. SILT/CLAY				DESCRIPTION	
							tsf	%	%	%		
0												FILL: Loose brown and black fine to coarse gravel, some to "and" fine to coarse sand, trace to little clayey silt, (cinders and slag).
5	1	3/3/3										Est. A-1-b
10	2	2/1/2										Very-loose brown and gray silt, "and" fine sand, trace medium to coarse sand.
15	3A 3B	1/3/2					0	1	43	56		Est. A-4a
20	4	1/3/5	0.8-2.0	22	31	19	0	0	1	57	42	Medium-stiff to stiff gray silty clay, trace fine to medium sand, few lenses of silt.
25	5	3/4/5	0.8-1.8									A-6a(9)
30	6	P	2.0									Stiff to very-stiff gray silty clay, trace fine to medium sand, many lenses of silt and fine sand.
35	7	3/6/8	1.3-2.0	24	31	18	0	0	2	52	46	A-6a(9)
40	8	P	2.0-3.0									Stiff to hard gray silty clay interbedded with silt, trace fine to medium sand, horizontal structure.
45	9	5/9/13	3.5-4.5									A-6a(8)

50 WATER LEVEL:
 WATER NOTE:
 DATE:



LOG OF BORING NO. B-110
 CUY-90-15.24
 CLEVELAND, OHIO

TYPE: 2" O.D. Split-barrel Sampler LOCATION: Sta. 18+43.85
3" O.D. Shelby Tube 243.9' Lt. of
NXM Rock-core Barrel Centerline
 COMPLETION DEPTH: 155.0' ELEVATION: 596.7 DATE: 8/31/94 9/8/94

DEPTH FEET	SAMPLE NO.	SAMPLES SAMPLING EFFORT	HAND PENE- TRMETER	MOISTURE CONTENT	LIQUID LIMIT	PLASTIC LIMIT	AGG. C.S.F.S.				SILT:CLAY		DESCRIPTION - CONTINUED
							tsf	%	%	%			
50	10	P	2.0-2.5										Stiff to hard gray silty clay interbedded with silt, trace fine to medium sand, horizontal structure.
55	11	4/5/7	1.0-1.5	25	29	18	0	0	1	55	44		
60	12	P	1.5-1.8										Stiff to very-stiff gray silty clay, trace fine to coarse sand, trace fine gravel.
65	13	5/8/13	2.0-2.4										
70	14	4/8/12	1.5-2.3	21	33	19	7	3	5	29	56		
75	15	4/7/12	1.8-2.4										
80	16	4/10/11	1.2-1.5	24	34	20	1	2	2	32	63		
85	17	4/8/12	1.5-2.0										
90	18	5/8/13	1.5-1.8	23	34	20	2	2	2	32	62		
95	19	5/9/13	1.8-2.0										

A-6a(8)

A-6a, A-6b(10)

100 WATER LEVEL:
 WATER NOTE:
 DATE:



CUY-90-15.24
CLEVELAND, OHIO

TYPE: 2" O.D. Split-barrel Sampler LOCATION: Sta. 18+43.85
3" O.D. Shelby Tube 243.9' Lt. of
NXM Rock-core Barrel Centerline

COMPLETION DEPTH: 155.0' ELEVATION: 596.7 DATE: 8/31/94 9/8/94

DEPT. FEET	SAMPLE NO.	SAMPLES SAMPLING EFFORT	HAND PENE-TROMETER	MOISTURE CONTENT	LIQUID LIMIT	PLASTIC LIMIT	COMPLETION DEPTH				ELEVATION		DATE	DESCRIPTION - CONTINUED
							tsf	%	%	%	AGG.	C.S.		
100	20	5/8 ₄₁	1.5-2.0	25	37	21	0	1	1	29	69		Stiff to very-stiff gray silty clay, trace fine to coarse sand, trace fine gravel.	
105	21	5/9 ₄₁	1.0-2.0											
110	22	P											A-6a, A-6b(10) Medium-dense gray silt, little to some fine sand. Est. A-4b	
115	23	11/14 ₄₉					13	28	39	20			Dense gray fine to coarse sand, trace silt, trace fine gravel. - From 119.6' to 119.9': Seam of fine to coarse gravel. A-3a(0)	
120	24A 24B	15/37 ₅₈	4.5+										Hard gray silty clay, trace to little fine to coarse sand, trace fine gravel, contains slickensided surfaces.	
125	25	14/36 ₅₂	4.5+	18	35	18	2	3	5	27	63		A-6b(11) Medium-stiff to stiff gray silty clay, trace fine to coarse sand, trace fine to coarse gravel.	
130	26	7/12 ₁₄	1.3-2.0											
135	27	P-R	0.8-1.0										- From 140.1' to 140.8': fine sandstone boulder. Est. A-6a	
140	28	80-4" R	2.0										Hard gray silty clay, some fine to coarse gravel (shale fragments).	
145	29	20/41 ₆₇	4.5+										Est. A-6a	

DESCRIPTION ON NEXT PAGE

150 WATER LEVEL:
 WATER NOTE:
 DATE:



LOG OF BORING NO. B-110
CUY-90-15.24
CLEVELAND, OHIO

TYPE: 2' O.D. Split-barrel Sampler LOCATION: Sta. 18+43.85
3' O.D. Shelby Tube
NXM Rock-core Barrel 243.9' Lt. of Centerline

COMPLETION DEPTH: 155.0' ELEVATION: 596.7 DATE: 8/31/94 9/8/94

DEPTH FEET	SAMPLE NO.	SAMPLES SAMPLING EFFORT	HAND PENE-TROMETER	MOISTURE CONTENT	LIQUID LIMIT	PLASTIC LIMIT	COMPLETION DEPTH: 155.0' ELEVATION: 596.7 DATE: 8/31/94 9/8/94				SILT:CLAY	DESCRIPTION - CONTINUED
							tsf	%	%	%		
100	20	5/8/11	1.5-2.0	25	37	21	0	1	1	29	69	Stiff to very-stiff gray silty clay, trace fine to coarse sand, trace fine gravel.
105	21	5/9/11	1.0-2.0									
110	22	P										A-6a, A-6b(10) Medium-dense gray silt, little to some fine sand. Est. A-4b
115	23	11/14/19					13	28	39	20		Dense gray fine to coarse sand, trace silt, trace fine gravel. - From 119.6' to 119.9': Seam of fine to coarse gravel. A-3a(0)
120	24A 24B	15/37/58	4.5+									Hard gray silty clay, trace to little fine to coarse sand, trace fine gravel, contains slickensided surfaces.
125	25	14/36/52	4.5+	18	35	18	2	3	5	27	63	A-6b(11) Medium-stiff to stiff gray silty clay, trace fine to coarse sand, trace fine to coarse gravel.
130	26	7/12/14	1.3-2.0									
135	27	P-R	0.8-1.0									- From 140.1' to 140.8': fine sandstone boulder. Est. A-6a
140	28	80-4" R	2.0									Hard gray silty clay, some fine to coarse gravel (shale fragments).
145	29	20/41/67	4.5+									Est. A-6a

DESCRIPTION ON NEXT PAGE

150 WATER LEVEL:
 WATER NOTE:
 DATE:



CUY-90-15.24

CLEVELAND, OHIO

TYPE: 2" O.D. Split-barrel Sampler
3" O.D. Shelby Tube
NXM Rock-core Barrel

LOCATION: Sta. 18+43.85
243.9' Lt. of
Centerline

COMPLETION DEPTH: 155.0' ELEVATION: 596.7 DATE: 8/31/94 9/8/94

DEP. FEET	SAMPLE NO.	SAMPLES	SAMPLING EFFORT	HAND PENE-TROMETER	MOISTURE CONTENT	LIQUID LIMIT	PLASTIC LIMIT	DESCRIPTION - CONTINUED												
								tsf	%	%	%	AGG.	C. S.	F. S.	SILT	CLAY				
150	30		NXM REC 100%	RQD 92%																Soft to medium-hard dark-gray to light-gray shale, nearly horizontally bedded, 2" to 9" core pieces, few cemented vertical fractures, contains few thin seams of hard siltstone.
155																				- Encountered water at 11.0'.
160																				- From 0.0' to 29.5': 3-1/4" I.D. Hollow-stem Auger with plug, replaced with 4" I.D. Flush-coupled casing from 0.0' to 34.0'.
165																				- From 29.5' to 150.0': 3-7/8" Tricone Bit.
170																				- From 29.5' to 120.0': Circulated water used for drilling fluid.
175																				- From 120.0' to 155.0': Bentonite drilling mud used.
180																				
185																				
190																				
195																				

200 WATER LEVEL:
 WATER NOTE:
 DATE:



LOG OF BORING NO. P-1
 CUY-90-15.24
 CLEVELAND, OHIO

TYPE: 2" O.D. Split-barrel Sampler LOCATION: Sta. 15+06.89
3" O.D. Shelby Tube
NXM Rock-core Barrel
114.5' Rt. of Centerline
 COMPLETION DEPTH: 158.5' ELEVATION: 676.6 DATE: 9/1/94 9/2/94

DEPTH FEET	SAMPLE NO.	SAMPLES SAMPLING EFFORT	HAND PENE-TROMETER	MOISTURE CONTENT	LIQUID LIMIT	PLASTIC LIMIT	COMPLETION DEPTH: 158.5' ELEVATION: 676.6 DATE: 9/1/94 9/2/94				DESCRIPTION	
							tsf	%	%	%		AGG.
0												FILL: Loose black and brown fine to coarse sand and cinders, little to some fine to coarse gravel. - At 4.5': Brick fragments. Est. A-1-b
5												Medium-dense brown fine to medium sand, trace coarse sand, trace to little fine to coarse gravel, contains occasional thin seam of silt or clayey silt. Est. A-1-b
10	1	6 / 8 / 10										
15	2	5 / 5 / 6										Medium-dense brown fine to coarse sand, little fine to coarse gravel, trace silt. Est. A-1-b
20	3	11 / 12 / 14										
25	4	4 / 9 / 12					1	9	59	31		Medium-dense to dense brown fine to medium sand, trace to little silt, trace coarse sand, trace fine gravel, contains seams (1 to 6 inches) of silt, fine sand, and silty clay. Est. A-1-b
30	5	6 / 9 / 7										
35	6A 6B	5 / 8 / 12										
40	7A 7B	3 / 6 / 8										
45	8	4 / 15 / 28					8	9	69	14		Dense gray silt, little fine sand, trace clay. A-3a (0)
50	9	15 / 14 / 19										Est. A-4b

DESCRIPTION ON NEXT PAGE

50 WATER LEVEL:
 WATER NOTE:
 DATE:

LOG OF BORING NO. P-1
 CUY-90-15.24
 CLEVELAND, OHIO



TYPE: 2" O.D. Split-barrel Sampler LOCATION: Sta. 15+06.89
3" O.D. Shelby Tube 114.5' Rt. of
NXM Rock-core Barrel Centerline
 COMPLETION DEPTH: 158.5' ELEVATION: 676.6 DATE: 9/1/94 9/2/94

DEPT FEET	SAMPLE NO.	SAMPLES SAMPLING EFFORT	HAND PENE- TRMETER	MOISTURE CONTENT	LIQUID LIMIT	PLASTIC LIMIT	TYPE				DESCRIPTION - CONTINUED		
							tsf	%	%	%	AGG.	C.S.	P.S.
50													Medium-dense gray silt interbedded with silty clay, trace fine to medium sand.
10		3 / 7 / 9	2.0-2.7										Est. A-4b
55													Dense gray silt, little to "and" fine sand, little clay, interbedded with fine sand, some to "and" silt.
11		20 / 28 / 33					0	0	10	78	12		
60													
12		26 / 37 / 50											A-4b(8)
65													Medium-stiff gray silty clay interbedded with silt, trace fine to medium sand.
13		4 / 5 / 5	0.5-0.7	26	30	19	0	0	1	62	37		A-6a(8)
70		P	1.5-2.5										Stiff to hard gray silty clay, trace fine sand, few thin seams of clayey silt and silt.
75													
15		6 / 13 / 19	4.5+										
80													
16		6 / 10 / 18	2.5-3.5	21	32	19	0	0	0	51	49		
85													
17		5 / 10 / 15	2.7-4.3										
90													
18		3 / 5 / 8	1.0-2.0										
95													
19		P	0.8-1.0										A-6a(9)

DESCRIPTION ON NEXT PAGE

100 WATER LEVEL: ✓ ✓ ✓ ✓ ✓ ✓
 WATER NOTE: _____
 DATE: _____

LOG OF BORING NO. P-1
 CUY-90-15.24
 CLEVELAND, OHIO



TYPE: 2" O.D. Split-barrel Sampler LOCATION: Sta. 15+06.89
3" O.D. Shelby Tube 114.5' Rt. of
NXM Rock-core Barrel Centerline

COMPLETION DEPTH: 158.5' ELEVATION: 676.6 DATE: 9/1/94 9/2/94

DEPT FEET	SAMPLE NO.	SAMPLES SAMPLING EFFORT	HAND PENE- TROMETER	MOISTURE CONTENT	LIQUID LIMIT	PLASTIC LIMIT	DESCRIPTION - CONTINUED					
							tsf	%	%	%	AGG.	C. S.
100	20	2 / 3/4	0.5-0.8	31	43	22	0	1	1	20	78	Medium-stiff to stiff gray silty clay, trace fine to coarse sand, trace fine gravel, few lenses of silt.
105	21	P	1.5									
110	22	3 / 5/8	1.2-1.8									
115	23	P	1.5-1.8									A-7-6(13)
120	24	4 / 1 1/4	1.5-3.0	21	31	19	0	0	1	52	47	
125	25	P	3.0-4.0									Stiff to very-stiff gray silty clay, trace fine to medium sand, contains thin seams of silt and clayey silt, mostly with horizontal structure.
130	26	5 / 1 1/4	2.2-2.5									
135	27	P	2.0-3.0									
140	28	6 / 1 1/2	1.5-2.5	24	34	21	0	0	0	43	57	A-6a(9)
145	29	5 / 1 3/4	2.5-3.0									

150 WATER LEVEL:
 WATER NOTE:
 DATE:

LOG OF BORING NO. P-1
 CUY-90-15.24
 CLEVELAND, OHIO



TYPE: 2" O.D. Split-barrel Sampler LOCATION: Sta. 15+06.89
3" O.D. Shelby Tube 114.5' Rt. of
NXM Rock-core Barrel Centerline

COMPLETION DEPTH: 158.5' ELEVATION: 676.6 DATE: 9/1/94 9/2/94

DEPTH FEET	SAMPLE NO.	SAMPLES SAMPLING EFFORT	HAND PENE- TROMETER	MOISTURE CONTENT	LIQUID LIMIT	PLASTIC LIMIT	COMPLETION DEPTH: 158.5' ELEVATION: 676.6 DATE: 9/1/94 9/2/94				DESCRIPTION - CONTINUED DESCRIPTION ON PREVIOUS PAGE	
							tsf	%	%	%		AGG.
150												
30		8 1/16, 22	2.0-3.8									Very-stiff gray silty clay, trace fine to coarse sand, trace fine to coarse gravel, horizontal structure.
155												
31		9 1/16, 24	2.5-3.0									Est. A-6b
160												- Encountered water at 36.0'.
165												- From 0.0' to 52.5': 3-1/4" I.D. Hollow-stem Auger with plug, replaced with 4" I.D. Flush-coupled casing from 0.0' to 54.0'.
170												- From 52.5' to 158.5': 3-7/8" Tricone Bit.
175												- From 52.5' to 158.5': Recirculated water used for drilling fluid.
180												
185												
190												
195												

200 WATER LEVEL: ✓ ✓ ✓ ✓ ✓ ✓

WATER NOTE: _____

DATE: _____



CUY-90-15.24
CLEVELAND, OHIO

TYPE: 2" O.D. Split-barrel Sampler
3" O.D. Shelby Tube
NXM Rock-core Barrel

LOCATION: Sta. 16+98.90
36.2' Rt. of
Centerline

COMPLETION DEPTH: 168.1' ELEVATION: 616.3 DATE: 8/18/94 8/19/94

DEPTH FEET	SAMPLE NO.	SAMPLES	SAMPLING EFFORT	HAND PENE-TROMETER	MOISTURE CONTENT	LIQUID LIMIT	PLASTIC LIMIT	DESCRIPTION												
								tsf	%	%	%	AGG.	C.S.	F.S.	SILT	CLAY				
0																				FILL: Medium-dense gray and brown fine to coarse gravel. Est. A-1-b/
1		5	17/11																	POSSIBLE FILL: Medium-dense brown fine to medium sand. Est. A-3
5		2A	6	16/7																Medium-dense gray silt, trace to little clay, trace to little fine sand. Est. A-4b
10		3	5	18/11																
15		4	8	11/12																
20		5	5	19/14	3.5-4.5+															Very-stiff to hard gray silty clay, trace fine to medium sand, contains seams of silt. Est. A-6b
25		6	6	11/16	4.5+	20														
30		7	8	14/20	4.5+															
35		8	6	11/16	2.7-4.5+															
40		9	P		1.2-1.7	31	35	21	2	1	1	23	73							Medium-stiff to stiff gray silty clay, trace to little fine to coarse sand, trace fine gravel, horizontal structure. A-6b(12)
45		10	3	14/5	0.5-1.8	32														
50		11	P		1.3-1.5															

WATER LEVEL: _____
 WATER NOTE: _____
 DATE: _____



CUY-90-15.24

CLEVELAND, OHIO

TYPE: 2" O.D. Split-barrel Sampler
 3" O.D. Shelby Tube
 NXM Rock-core Barrel

LOCATION: Sta. 16+98.90
 36.2' Rt. of
 Centerline

COMPLETION DEPTH: 168.1' ELEVATION: 616.3 DATE: 8/18/94 8/19/94

DEPTH FEET	SAMPLE NO.	SAMPLES SAMPLING EFFORT	HAND PENE-TROMETER	MOISTURE CONTENT	LIQUID LIMIT	PLASTIC LIMIT	DESCRIPTION - CONTINUED					
							tsf	%	%	%	AGG.	C.S.
50	12	3/4/6	1.0	30	40	21	0	1	1	32	66	Medium-stiff to stiff gray silty clay, trace to little fine to coarse sand, trace fine gravel, horizontal structure. A-6b(12)
	13	2/5/6	1.0									
55												Stiff to very-stiff gray silty clay, trace fine to coarse sand, trace fine gravel, contains seams of clayey silt and silt.
	14	5/8/12	1.7-3.0									
60												- Sample 15: Contains seam of silt, A-4b(8).
	15	5/10/13	1.5-3.0	23	28	18	0	0	2	64	34	
65												
	16	6/10/15	2.0-2.5									
70												
	17	7/19/13	2.7-4.0									
75												
	18	4/8/13	2.0-3.0									
80												
	19	6/10/17	1.8-2.5									
85												
	20	6/10/14	2.0-2.5									
90												
	21	5/10/15	2.0-2.2									
95												
	22	5/19/13	1.5-2.0	21	33	18	2	2	2	42	52	

A-6a, A-6b(10)

100 WATER LEVEL: WATER NOTE: _____ DATE: _____

TYPE: 2" O.D. Split-barrel Sampler LOCATION: Sta. 16+98.90
3" O.D. Shelby Tube
NXM Rock-core Barrel
36.2' Rt. of Centerline

COMPLETION DEPTH: 168.1' ELEVATION: 616.3 DATE: 8/18/94 8/19/94

FEET	SAMPLE NO.	SAMPLES SAMPLING EFFORT	HAND PENE-TROMETER	MOISTURE CONTENT	LIQUID LIMIT	PLASTIC LIMIT	AGG.				SILT		CLAY	DESCRIPTION - CONTINUED
							tsf	%	%	%	C.	S.		
100	23	4 / 9 / 13	1.5-1.7											Stiff to very-stiff gray silty clay, trace fine to coarse sand, trace fine gravel, contains seams of clayey silt and silt.
105	24	5 / 10 / 14	1.7-2.1											
110	25	6 / 10 / 16	1.8-2.4	22	34	18	6	1	1	41	51			
115	26	8 / 13 / 17	1.9-2.2											
120	27	P	1.0-1.5											
125	28	P												
130	29A 29B	5 / 8 / 9	1.0-2.0	26	26	19	0	0	0	75	25		A-6a, A-6b(10) Interbedded: Stiff gray silty clay, and medium-dense gray silt, 1/4" to 8"+ layers of each soil type. A-4b(8)	
135	30 31	P-R 10 / 24 / 23		12			35	39	12		14		Dense gray fine to coarse sand, little to some fine to coarse gravel, trace to little silt. A-1-b(0)	
140	32A 32B	18 / 22 / 22	4.5+										Hard gray silty clay, little to some fine to coarse sand, trace fine to coarse gravel, contains slickensided planes.	
145	33	35 / 60 20 / 40 / 62	4.5+	15	31	17	3	5	8	32	52		A-6a(10)	

150 WATER LEVEL:
 WATER NOTE:
 DATE:



CUY-90-15.24
CLEVELAND, OHIO

TYPE: 2" O.D. Split-barrel Sampler
3" O.D. Shelby Tube
NXM Rock-core Barrel

LOCATION: Sta. 16+98.90
36.2' Rt. of
Centerline

COMPLETION DEPTH: 168.1' ELEVATION: 616.3 DATE: 8/18/94 8/19/94

DEPT. FEET	SAMPLE NO.	SAMPLES SAMPLING EFFORT	HAND PENE-TROMETER	MOISTURE CONTENT			AGG.	C.S.	F.S.	SILT/CLAY		DESCRIPTION - CONTINUED
				%	%	%						
150	34	12 21 27	4.5+									Hard gray silty clay, little to some fine to coarse sand, trace fine to coarse gravel, contains slickensided planes. A-6a(10)
155	35	4 9 10	1.5-2.5	13	33	20	0	0	0	43	57	Stiff to very-stiff gray silty clay, trace fine to coarse sand, trace fine to coarse gravel, few seams of fine to medium sand. A-6a(10)
160	36	10 13 17	1.2-2.0	23	30	20	22	0	0	37	41	Stiff gray clayey silt, trace fine to coarse sand, trace fine to coarse gravel. A-4a(8)
165	37A 37B	44 50-1"R	1.5-2.0									Dense gray fine to coarse gravel, some silty clay, some fine to coarse sand. Est. A-2-4'
170												- Encountered water at 19.0'.
175												- From 0.0' to 27.5': 3-1/4" I.D. Hollow-stem Auger with plug, replaced with 4" I.D. Flush-coupled casing from 0.0' to 30.0'.
180												- From 27.5' to 140.0': 3-7/8" Tricone Bit.
185												- From 27.5' to 175': Recirculated water used for drilling fluid.
190												
195												

200 WATER LEVEL: _____ _____ _____ _____ _____ _____
 WATER NOTE: _____
 DATE: _____

LOG OF BORING NO. P-3
 CUY-90-15.24
 CLEVELAND, OHIO



TYPE: 2" O.D. Split-barrel Sampler LOCATION: Sta. 19+10.11
3" O.D. Shelby Tube 86.4' Rt. of
NXM Rock-core Barrel Centerline

COMPLETION DEPTH: 140.0' ELEVATION: 585.6 DATE: 8/22/94

DEPT FEET	SAMPLE NO.	SAMPLES SAMPLING EFFORT	HAND PENE- TROMETER	MOISTURE CONTENT	LIQUID LIMIT	PLASTIC LIMIT	AGG. C. S. F. S. SILT:CLAY				DESCRIPTION - CONTINUED	
							tsf	%	%	%		
100												Medium-stiff to stiff gray silty clay, trace fine to coarse sand, few seams of silt.
105	20	P	1.25									A-6b(12)
110	21A 21B	2 1/4 / 7	0.8	24	NP	NP	0	0	2	79	19	Medium-dense gray silt, trace clay.
115	22	P	3.5									A-4b(8)
120	23	10 13/13	2.5-3.5	28	42	21	0	0	1	16	83	Stiff to very-stiff gray silty clay, trace fine to coarse sand, few seams and lenses of silt. - Sample 23: Stiff to very-stiff silty clay, A-7-6(13). - From 0.0' to 27.5': 3-1/4" I.D. Hollow-stem Auger with plug; replaced with 4" I.D. Flush-coupled casing from 0.0' to 27.5'. - From 27.5' to 140.0': 3-7/8" Tricone Bit. - From 30.2' to 149.5': Recirculated water used for drilling fluid.
125	24	7 11/13	1.5-2.0									
130	25	6 7/9	2.0-2.2									
135	26	12 11/13		21	34	19	1	6	7	28	58	A-6a(10)
140	27A 27B	10 14/19	2.2									Medium-dense gray fine to coarse sand, trace silt, trace fine to coarse gravel. Est. A-3a Very-stiff gray silty clay, some fine to coarse sand, trace fine gravel. Est. A-6b'
145												- Encountered slight seepage at 13.0'. - Encountered water at 17.0'.

150 WATER LEVEL:
 WATER NOTE:
 DATE:

LOG OF BORING NO. P-4
 CUY-90-15.24
 CLEVELAND, OHIO



TYPE: 2" O.D. Split-barrel Sampler LOCATION: Sta. 18+00.08
3" O.D. Shelby Tube 89.7' Lt. of
NXM Rock-core Barrel Centerline
 COMPLETION DEPTH: 200.0' ELEVATION: 610.1 DATE: 8/11/94 8/12/94

DEPT. FEET	SAMPLE NO.	SAMPLES SAMPLING EFFORT	HAND PENE-TROMETER	MOISTURE CONTENT	LIQUID LIMIT	PLASTIC LIMIT	COMPLETION DEPTH				ELEVATION		DESCRIPTION - CONTINUED	
							tsf	%	%	%	AGG.	C.S.		F.S.
50	13	4/6/8	1.2-2.0											Stiff to very-stiff gray silty clay, trace to little fine to medium sand, contains many seams and lenses of silt.
	14	4/8/9	1.0-2.0	17	29	17	0	0	1	57	42			
55														
	15	4/6/10	1.2-1.9											
60														
	16	4/5/10	1.8-3.0											
65														
	17	4/6/9	1.9-2.5											- From 69.0' to 75.0': With horizontal structure.
70														
	18	2/2/4	0.8-1.2	26	31	18	0	0	0	50	50			- From 72.5' to 74.0': Medium-stiff to stiff. A-6a(9)
75														Stiff to very-stiff gray silty clay, trace to little fine to coarse sand, trace fine gravel, few lenses of silt.
	19	P	1.3-1.8											
80														
	20	5/8/14	1.5-2.2											
	21	8/9/13	1.7-2.0	22	33	17	0	2	4	32	62			
85														
	22	7/11/15	1.8-2.1											
90														
	23	6/11/17	2.2-2.8	22	33	19	1	2	3	30	64			
95														
	24	6/10/14	1.8-2.2	22	33	18	1	2	3	34	60			A-6a, A-6b(10)

100 WATER LEVEL:
 WATER NOTE:
 DATE:



TYPE: 2" O.D. Split-barrel Sampler LOCATION: Sta. 18+00.08
3" O.D. Shelby Tube
NXM Rock-core Barrel 89.7 Lt. of
Centerline

COMPLETION DEPTH: 200.0' ELEVATION: 610.1 DATE: 8/11/94 8/12/94

DEPTH FEET	SAMPLE NO.	SAMPLES SAMPLING EFFORT	HAND PENE-TROMETER	MOISTURE CONTENT	LIQUID LIMIT	PLASTIC LIMIT	COMPLETION DEPTH: 200.0' ELEVATION: 610.1 DATE: 8/11/94 8/12/94				AGG.	C.S.	F.S.	SILT-CLAY	DESCRIPTION - CONTINUED
							tsf	%	%	%					
100															Stiff to very-stiff gray silty clay, trace to little fine to coarse sand, trace fine gravel, few lenses of silt.
25		5 / 9 1/4	1.7-2.0												- From 0.0' to 27.5': 3-1/4" I.D. Hollow-stem Auger with plug, replaced with 4" I.D. Flush-coupled casing from 0.0' to 31.5'. - From 27.5' to 149.0': 3-7/8" Tricone Bit. - From 45.0' to 170.2': Recirculated water used for drilling fluid.
105		6 / 11 1/5	1.8-2.2	23	34	20	1	1	1	31	66				
110		7 / 10 1/4	1.8-2.5												
115		5 / 8 1/4	1.5-1.8	26	36	21	0	2	2	21	75				
120															
125	30A	5 / 17 1/7	1.0-1.5	27	25	18	0	0	1	83	16			Medium-dense gray silt, with seams of stiff gray silty clay A-4b(8)	
	31A	5 / 20 1/20	1.5				39	17	21		23			Dense gray fine to coarse sand, some fine to coarse gravel, some clayey silt. A-1-b(0)	
130	31B														
135	32	20 / 50 1/19	4.5+	15	31	18	0	4	7	31	58			Hard gray silty clay, trace to little fine to coarse sand, trace fine gravel. - Sample at 132.5' contains slicken-sided partings. - From 139.0' to 141.0': Gradually becomes less hard. A-6a(9)	
140	33	15 / 32 1/47	4.5+												
145	34	5 / 9 1/12	1.2-1.5	24	34	19	0	0	1	27	72			Stiff to very-stiff gray silty clay, trace fine to coarse sand, trace fine to coarse gravel, many lenses of silt. A-6a(10)	
150	35	5 / 9 1/12	1.9-2.5												

WATER LEVEL: WATER NOTE: DATE:

CUY-90-15.24

CLEVELAND, OHIO



BORING NO.

TYPE: 2" O.D. Split-barrel Sampler

LOCATION: Sta. 15+48.44

3" O.D. Shelby Tube

93.1' Lt. of

NXM Rock-core Barrel

Centerline

COMPLETION DEPTH: 173.0' ELEVATION: 662.3 DATE: 9/26/94 9/28/94

DEPTH FEET	SAMPLE NO.	SAMPLES SAMPLING EFFORT	HAND PENE- TROMETER	MOISTURE CONTENT	LIQUID LIMIT	PLASTIC LIMIT	COMPLETION DEPTH: 173.0' ELEVATION: 662.3 DATE: 9/26/94 9/28/94				DESCRIPTION	
							tsf	%	%	%		AGG.
0												ASPHALT - 10 INCHES
												Granite paver blocks.
												FILL: Loose brown fine to coarse sand, some fine to coarse gravel, trace silt. Est. A-1-b
												FILL: Stiff brown silty clay, little fine to coarse sand, trace fine gravel. Est. A-6b
1		2/2/3										Loose to medium-dense brown fine to medium sand, trace coarse sand, trace silt.
5												
10												
15		2/3/5										
20		5/6/8										
25		P										
30	5A 5B	3/4/7					0	0	10	90		Est. A-3a Medium-dense brown silt, little fine to coarse sand, trace clay. Est. A-4a
35												Dense brown fine sand, "and" silt, trace medium sand. Est. A-4a
40												Very-stiff to hard gray silty clay interbedded with silt, trace fine to medium sand. Est. A-6a
45	8A 8B	20/25/23	3.5-4.5+									Dense gray fine to medium sand, little silt. Est. A-3a
50												Dense gray silt interbedded with silty clay, trace fine to medium sand. Est. A-4a
												Stiff to very-stiff gray silty clay, trace to little fine to medium sand, few seams and lenses of silt. A-6a(9)

50 WATER LEVEL: WATER NOTE: _____ DATE: _____



LOG OF BORING NO. P-5
 CUY-90-15.24
 CLEVELAND, OHIO

TYPE: 2" O.D. Split-barrel Sampler LOCATION: Sta. 15+48.44
3" O.D. Shelby Tube 93.1' Lt. of
NXM Rock-core Barrel Centerline

COMPLETION DEPTH: 173.0' ELEVATION: 662.3 DATE: 9/26/94 9/28/94

DEP. FEET	SAMPLE NO.	SAMPLES	SAMPLING EFFORT	HAND PENE-TROMETER	MOISTURE CONTENT	LIQUID LIMIT	PLASTIC LIMIT	AGG. C.S. F.S. SILT/CLAY				DESCRIPTION - CONTINUED
								tsf	%	%	%	
100	20	7	13/18	1.6-4.3								Stiff to very-stiff gray silty clay, trace fine to medium sand, few to many seams and lenses of silt. A-6a(9)
105	21	6	10/14	2.4-3.3								Very-stiff to hard gray silty clay, trace fine to medium sand, few to many seams and lenses of silt, horizontal structure.
110	22	8	15/20	4.1-4.5+								
115	23	5	10/11	2.1-3.4								
120	24	2	5/7	1.5-2.7								- From 121.5' to 123.0': Stiff to very-stiff.
125	25	P		4.5+								Est. A-6a
130	26	8	18/26	4.3-4.5+								Very-stiff to hard gray silty clay, trace to little fine to coarse sand, trace fine gravel.
135	27	P		2.1-2.3								
140	28	5	10/12	2.2-2.3								
145	29	P		2.0-2.1								A-6a(9)

150 WATER LEVEL: ✓ ✓ ✓ ✓ ✓ ✓
 WATER NOTE: _____
 DATE: _____

LOG OF BORING NO. P-5
 CUY-90-15.24
 CLEVELAND, OHIO



TYPE: 2" O.D. Split-barrel Sampler LOCATION: Sta. 15+48.44
3" O.D. Shelby Tube 93.1' Lt. of
NXM Rock-core Barrel Centerline

COMPLETION DEPTH: 173.0' ELEVATION: 662.3 DATE: 9/26/94 9/28/94

DEPT. FEET	SAMPLE NO.	SAMPLES SAMPLING EFFORT	HAND PENE-TROMETER	MOISTURE CONTENT	LIQUID LIMIT	PLASTIC LIMIT	COMPLETION DEPTH: 173.0' ELEVATION: 662.3				DATE: 9/26/94 9/28/94		DESCRIPTION - CONTINUED
							tsf	%	%	%	AGG.	C. S.	
150	30	5 / 11 / 13	2.4-2.7	23	33	20	1	2	2	35	60	Very-stiff to hard gray silty clay, trace to little fine to coarse sand, trace fine gravel. - Encountered water at 27.5'. - From 0.0' to 54.0': 3-1/4" I.D. Hollow-stem Auger with plug, replaced with 4" I.D. Flush-coupled casing from 0.0' to 54.0'. - From 54.0' to 173.0': 3-7/8" Tricone Bit. - From 54.0' to 173.0': Recirculated water used for drilling fluid.	
155	31	7 / 13 / 18	2.7-3.0										
160	32	8 / 14 / 20	2.0-2.2										
165	33	10 / 12 / 17	2.3-2.7										
170	34	8 / 14 / 16	2.5-2.7										

A-6a(9)

200 WATER LEVEL: ✓ ✓ ✓ ✓ ✓ ✓
 WATER NOTE: _____
 DATE: _____

Division
Testing Laboratory

LOG OF BORING

Date Started 5/30/90 Sampler Type SS Dia. 1 3/8" Water Elev. 639.6'
 Date Completed 6/14/90 Casing Length Dia. _____
 Project Identification: CUYAHOGA
 CUY-90-15.24
 STABILITY ANALYSIS
 SUBSURFACE INVESTIGATION

Boring No. B-1 Station & Offset _____ Surface Elev. 675.6'

Elev.	Depth	Std. Pen. (N)	Reg. Rec. Loss ft.	Description	Field No.	Lab. Nos.	Physical Characteristics						SHTL Class		
							% Ag.	% C.S.	% F.S.	% Sil.	% Clay	L.I.		P.I.	W.C.
675.6	0			GRAVELLY SANDY TOPSOIL										VISUAL	
	2	AUGERED													
	4	AUGERED		BROWN GRAVELLY SAND										VISUAL	
668.1	6														
665.6	8	AUGERED		BROWN GRAVELLY SAND										VISUAL	
663.1	10														
	12														
	14	3/5/5		BROWN SILTY GRAVELLY SAND	1	63050	25	35	22	12	6	NP	NP	6	A-1-B
	16														
	18														
	20														
	22														
653.1	24	9/16/24		BROWN SILTY SAND	2	63051	8	42	30	14	6	NP	NP	4	A-1-B
	26														
	28														
	30														
	32														
643.1	34	9/15/12		BROWN SILTY SAND	3	63052	0	3	72	19	6	NP	NP	16	A-3A
	36														

Particle Sizes: Agg > 2.00 mm, Coarse Sand = 2.00 - 0.42 mm, Fine Sand = 0.42 - 0.074 mm, Silt = 0.074 - 0.005 mm, Clay < 0.005 mm

Boring No.	Elev.	Depth	Std. Pen. (N)	Station & Offset	Rec. ft.	Loss ft.	Description	Field No.	Lab. Nos. So.	Physical Characteristics					SHTL Class			
										% Agg.	% S.	% F.S.	% Silt	% Clay		LL	PL	W.C.
	545.6	126																
	544.1	128																
		130																
		132	12/20/23				GRAY CLAYEY SILT	13	63062	0	0	2	55	43	30	10	20	A-1B
		134																
		136																
		138																
		140																
		142																
		144																
		146																
		148																
		150																
		152																
		154																
		156																
		158																
		160																
		162																
		164																
		166																
		168																

← BOTTOM OF BORING

NOTE: SLOPE INDICATOR PIPE INSTALLED AT 131.0'

Surface Elev. 675.1' Project: CUY-90-15.24

Boring No. B-2 Station & Offset

Elev	Depth	Std. Pen. (N)	Rec. Loc. ft.	Los. ft.	Description	Field No.	Lab. Nos. So.	Physical Characteristics							SHTL Class	
								% Add. C.S.	% F.S.	% Silt	% Clay	L.L.	P.I.	W.C.		
550.1	126	4/6/12			GRAY CLAYEY SILT	13	63019	0	1	2	52	45	28	8	22	A-4B
540.1	128															
	130															
	132															
	134															
538.6	136	10/18/35			GRAY SILT AND CLAY	14	63020	0	0	1	51	48	34	15	22	A-6A
	138															
	140															
	142															
	144															
	146															
	148															
	150															
	152															
	154															
	156															
	158															
	160															
	162															
	164															
	166															

— BOTTOM OF BORING

NOTE: SLOPE INDICATOR PIPE INSTALLED AT 138.0'

Boring No. B-3 Station B Offset

Surface Elev. 675.1' Project: CUY-90-15.24

Elev.	Depth	Std. Pen. (N)	Rec. ft.	Los. ft.	Description	Field No.	Lab. Nos. So.	Physical Characteristics						SHTL Class			
								% Agg. C.S.	% F.S.	% Silt	% Clay	LL	PL		W.C.		
545.1	126																
	128																
	130																
	132	6/12/20			GRAY CLAYEY SILT	13	63005	0	0	1	59	40	27	7	22		A-4B
	134																
	136																
	138																
535.1	140																
533.6	142	13/18/25			GRAY CLAY	14	63006	9	3	6	33	49	40	21	20		A-6B
	144																
	146																
	148																
	150																
	152																
	154																
	156																
	158																
	160																
	162																
	164																
	166																

← BOTTOM OF BORING

NOTE: SLOPE INDICATOR PIPE INSTALLED AT 142.0'

14
34

Boring No. Station B Offset

Surface Elev. 616.5' Project: CUY-90-15.24

Elev.	Depth	Std. Pen. (N)	Rec. ft.	Loss ft.	Description	Field No.	Lab. Nos. So.	Physical Characteristics							SHTL Class	
								% Agg. C.S.	% F.S.	% Silt	% Clay	L.L.	P.I.	W.C.		
576.5	38				GRAY CLAYEY SILT	4	62953	0	0	1	55	44	31	10	19	A-4B
	40															
	42	5/9/16'														
	44															
	46															
	48															
566.5	50				GRAY CLAY	5	62954	0	1	2	35	62	30	80	22	A-7-6
	52	6/6/8														
	54															
	56															
	58															
556.5	60				GRAY SILTY CLAY	6	62955	0	0	2	56	42	36	17	23	A-6B
	62	7/14/17														
	64															
	66															
	68															
546.5	70				GRAY CLAYEY SILT	7	62956	0	0	1	56	43	29	10	21	A-4B
	72	4/7/10														
	74															
	76															
	78															

Boring No. B-5 Station 8 Offset

Surface Elev. 617.41 Project

CUY-90-15.24

Elev.	Depth	Std. Pen. (N)	Rec. ft.	Loss ft.	Description	Field No.	Lab. Nos. So.	Physical Characteristics							
								% Agg. S.S.	% F.S.	% Silt	% Clay	LL	PI	W.C.	
572.4	38				GRAY SILT AND CLAY	5	62969	0	1	2	38	59	36	15	30
	40														
	42														
	44														
	46	2/4/9													
	48														
	50														
	52														
562.4	54				GRAY SILTY CLAY	6	62970	0	1	.1	32	66	40	16	29
	56	7/11/10													
	58														
	60														
	62														
	64														
	66														
	68														
552.4	70				GRAY CLAYEY SILT	7	62971	0	0	2	53	45	30	10	22
	72														
	74														
	76	15/19/21													
	78														
	80														
	82														
	84														
542.4	86				GRAY CLAYEY SILT	8	62972	0	1	2	54	43	30	10	22
	88	12/22/20													

CUY-90-15.24

Project: 617.41

Surface Elev. 617.41

Spring No. B-5 Station & Offset

Elev	Depth	Std. Dep. (N)	Rec. Los. ft	Description	Field No.	Lab. Nos. Se.	Physical Characteristics					SF			
							% Agg.	% F.S.	% Silt	% Clay	LL		PL	WC	
492.4	126	8/15/22		GRAY SILTY CLAY	13	62977	0	0	1	29	70	41	16	28	A
490.9	128			BOTTOM OF BORING											
	130														
	132														
	134														
	136														
	138														
	140														
	142														
	144														
	146														
	148														
	150														
	152														
	154														
	156														
	158														
	160														
	162														
	164														
	166														

NOTE: SLOPE INDICATOR PIPE INSTALLED AT 125.0'

Project: CUY-90-15.24

Surface Elev. 617.5'

Boring No. B-6 Station & Offset

Elev.	Depth	Srd. Pen. (N)	Rec. Loss ft.	Description	Field No.	Lab. Nos. So.	Physical Characteristics							
							% Agg. C.S.	% F.S.	% Silt	% Clay	L.L.	P.I.	W.C.	
575.0	38			GRAY CLAYEY SILT	4	63066	0	2	4	42	52	34	10	18
	40													
	42													
	44	7/8/12												
	46													
	48													
	50													
	52													
	54	5/6/12												
	56													
565.0	58			GRAY CLAYEY SILT	5	63067	0	1	1	37	61	34	8	29
	60													
	62													
	64	10/17/21												
	66													
	68													
555.0	70			GRAY SILT AND CLAY	6	63068	0	0	1	54	45	34	14	21
	72													
	74	11/17/23												
	76													
	78													
	80													
545.0	82			GRAY CLAYEY SILT	7	63069	0	0	1	60	39	30	9	20
	84													

Project: CUY-90-15.24

Surface Elev. 617.5'

Boring No. B-6 Station & Offset

Elev.	Depth	Std. Pen. (N)	Rec. Loss ft.	Description	Field No.	Lab. Nos.	Physical Characteristics					SHTL Class		
							% Agg. C.S.	% F.S.	% Silt	% Clay	LL		PL	W.C.
535.0	82				8	63070	0	4	49	38	25	6	13	A-4A
	84	8/20/25		GRAY SILT										
	86													
	88													
	90													
525.0	92				9	63071	0	2	37	57	25	2	21	A-4A
	94	17/24/34		GRAY SILT										
	96													
	98													
	100													
515.0	102				10	63072	0	1	3	38	58	34	10	23
	104	8/15/19		GRAY CLAYEY SILT										
	106													
	108													
	110													
505.0	112				11	63073	0	2	3	38	57	35	12	18
	114	13/16/19		GRAY SILT AND CLAY										
	116													
	118													
	120													
495.0	122				12	63074	0	1	2	38	59	36	12	23
														A-6A

BOTTOM OF BORING

END OF BORING

LOG OF BORING
A LARGE AMOUNT AT
Water Elev. 588.5' AT
1 3/8" Dia.
SEE NOTE ON BOTTOM
OF LOG

Project Identification: CUYAHOGA
CUY-90-15-24

STABILITY ANALYSIS
SUBSURFACE INVESTIGATION

Date Started 5/23/90
Date Completed 5/23/90
Sampler Type SS
Casing Length Dia.

Surface Elev. 588.5'

Boring No. B-7 Station & Offset

Elev.	Depth	Std Pen.	Rec. Loss	Description	Field No.	Lab. Nos.	Physical Characteristics										
							% Ag.	% S.S.	% Sil.	% Clay	LL	PI	WC				
588.5	0																
576.0	12	3/3/4		BLACK SANDY SILT WITH CINDERS AND ASHES	14	63034	26	24	26	20	4	NP	NP	19			
566.0	22			BLACK SILTY GRAVELLY SAND WITH CINDERS AND ASHES													
	24			SLAG BOULDERS (19.5 - 20.5')													
	24	12/7/20		GRAY GRAVELLY SILT WITH SLAG AND COBBLES	15	63035	43	1	2	33	21	-	-	23			
556.0	34			GRAY SILTY CLAY W/BRICK FRAGMENTS AND WOOD (TIMBER PIE)	16	63036	50	2	2	44	52	36	15	23			

CUY-90-15.24

Surface Elev. 588.5' Project

Boring No. B-7 Station & Offset

Elev.	Depth	Std. Pen. (N)	Rec. Loss ft.	Description	Field No.	Lab. Nos. So.	Physical Characteristics							
							% Agg.	% C.S.	% F.S.	% Silt	% Clay	LL	PI	W.C.
506.0	82	22/15/19		GRAY SILT AND WOOD (TIMBER PILE)	21	63041	0	3	4	35	58	NP	NP	29
	84													
	86													
	88													
	90													
	92													
496.0	94	14/12/20		GRAY SILT AND WOOD (TIMBER PILE)	22	63042	-	-	-	-	-	-	-	42
	96													
	98													
	100													
	102													
	104	12/12/17												
486.0	106			GRAY SILT	23	63043	0	2	2	55	41	NP	NP	35
	108													
	110													
	112													
	114	20/31/63												
476.0	116						GRAY SILT	24	63044	0	4	8	33	55
	118													
	120													
	122													
466.0				HYDROSTATIC PRESSURE WAS ENCOUNTERED AT 102' BLEW WATER OVER DRILL. RIG APPROX. 30'	25	63045				0	54	19	26	-
				BOTTOM OF BORING										

50/45 45-70 21. GRAY SILTY SAND

Department of Transportation
Division of Highways
Testing Laboratory

LOG OF BORING

Date Started 5/22/90" Sampler: Type SS Dia. 1 3/8" Water Elev. 501.3' Project Identification: CUYAHOGA
 Date Completed 5/22/90 Casing: Length Dia. STABILITY ANALYSIS
 SUBSURFACE INVESTIGATION

Boring No. B-8 Station & Offset Surface Elev. 591.3'

Elev.	Depth	Sig. Pen.	Rec. Loss	Description	Field No.	Lab. Nos. So.	Physical Characteristics						SHTL Class				
							% Agg.	% S.S.	% Silt	% Clay	L.L.	P.I.		W.C.			
591.3	0																
581.3	2	1/2/2		DARK BROWN SILTY GRAVELLY SAND	1	63021	22	32	22	24	0	NP	NP	20			A-1-B
571.3	20	4/6/9		GRAY SILTY CLAY	2	63022	0	1	1	52	46	38	17	20			A-6B
561.3	30	2/2/4		GRAY SILT	3	63023	0	1	1	34	64	28	6	26			A-4A

Silt = 0.074 - 0.005 mm. Clay = <0.005 mm. Fine Sand = 0.42 - 0.074 mm.

Surface Elev. 591.3' Project: CUY-90-15.24

Boring No. B-8 Station & Offset

Elev.	Depth	Std. Pen. (N)	Rec. ft.	Loss ft.	Description	Field No.	Lab. Nos. So.	Physical Characteristics							
								% Agg.	% C.S.	% F.S.	% Silt	% Clay	LL	PI	W.C.
551.3	38				GRAY SILTY CLAY	4	63024	0	0	1	50	49	36	16	22
	40	6/9/12													
	42														
	44														
	46														
	48														
541.3	50				GRAY SILTY CLAY	5	63025	0	0	1	61	38	37	17	22
	52	8/12/16													
	54														
	56														
	58														
	60														
531.3	62				GRAY SANDY CLAY	6	63026	0	9	15	43	33	28	11	13
	64	14/25/32													
	66														
	68														
	70														
	72														
521.3	74				GRAY SILT AND CLAY	7	63027	0	2	3	37	58	36	15	21
	76	6/11/15													
	78														

Project: CUY-90-15.24

Surface Elev. 591.3'

Boring No. B-8 Station B Offset

Elev.	Depth	Std. Peg. (N)	Rec. Loc. ft.	Description	Field No.	Lab. Nos. So	Physical Characteristics						SH	CI	
							% Agg.	% C.S.	% F.S.	% Silt	% Clay	L.L.			PI
461.3	126				13	63033	13	4	6	29	48	NP	NP	16	A
459.8	128														
	130			GRAY GRAVELLY SILT											
	132		25/26/33												
	134														
	136														
	138														
	140														
	142														
	144														
	146														
	148														
	150														
	152														
	154														
	156														
	158														
	160														
	162														
	164														
	166														

— BOTTOM OF BORING

NOTE: SLOPE INDICATOR PIPE INSTALLED AT 130.0'

State of Ohio
Department of Transportation
Division of Highways
Testing Laboratory

LOG OF BORING

Project Identification: CUYAHOGA
CUY-90-15.24

Date Started: 5/17/90
Date Completed: 5/19/90
Sampler Type: SS
Casing Length: Dka.
Dia. 1 3/8" Water Elev. 481.2'

STABILITY ANALYSIS
SUBSURFACE INVESTIGATION

Boring No. B-9 Station & Offset Surface Elev. 586.2'

Elev.	Depth	Std. Pen.	Rqc. Loss ft.	Description	Field No.	Lab. Nos.	Physical Characteristics				SHTL Class							
							% Agg.	% S.F.S.	% Silty Clay	LL		P.I.	W.C.					
586.2	0																	
581.2	2				14	62978	19	35	27	17	2	NP	NP	21				A-1-B
	4																	
	6	8/14/7		DARK GRAY SILTY GRAVELLY SAND														
	8																	
	10																	
	12																	
	14																	
571.2	16	5/7/12		DARK GRAY SILTY SAND	15	62979	0	40	33	26	1	NP	NP	46				A-3A
	18																	
	20																	
	22																	
	24																	
561.2	26	4/7/12		GRAY SILTY CLAY	16	62980	0	1	3	27	69	41	16	31				A-7-6
	28																	
	30																	
	32																	
	34																	
551.2	36	7/11/13		GRAY CLAYEY SILT	17	62981	0	0	2	61	37	29	9	21				A-4B

Boring No. B-9 Station & Offset 586.2' Project: CUY-90-15.2A

Elev.	Depth	Std. Pen. (N)	Strat. Rec. ft.	Loss ft.	Description	Field No.	Lab. Nos. So.	Physical Characteristics							
								% Agg.	% C.S.	% F.S.	% Silt	% Clay	LL	PL	W.C.
461.2	126	22/32/45			GRAY SILTY CLAY	26	62990	0	2	7	32	59	38	16	17
456.2	128														
454.7	130														
	132	17/21/27			GRAY CLAYEY SILT	27	62991	0	1	1	29	69	35	10	23
	134														
	136														
	138														
	140														
	142														
	144														
	146														
	148														
	150														
	152														
	154														
	156														
	158														
	160														
	162														
	164														
	166														

BOTTOM OF BORING

NOTE: SLOPE INDICATOR PIPE INSTALLED AT 130.0'

APPENDIX H
MONITORING INSTRUMENTATION SUMMARY

Table 1: Average Movement Rate in Existing Inclinometers
on Shallow Slip Plane (after REL, 2006).

Shallow Slip Plane			
Inclinometer	Location	Time Range	Avg. Rate of Movement (in/yr)
B-203	Upslope from Pier 1	April '99 to April '06	0.03
B-303	Upslope from Pier 1	April '99 to April '06	0.08
<i>Average Rate of Movement – Upslope of Pier 1</i>			0.06
B-110	North of Pier 1 area	July '99 to Jan. '06	0.15

Table 2: Average Movement Rate in Existing Inclinometers
on Deep Slip Plane (after REL, 2006).

Shallow Slip Plane			
Inclinometer	Location	Time Range	Avg. Rate of Movement (in/yr)
B-102	South of West End Pier	Oct. '00 to April '06	0.02
B-107	South of West End Pier	April '00 to April '06	0.015
<i>Average Rate of Movement – South of West End Pier</i>			0.02
B-105	Immediate vicinity of Pier 1	April '00 to Oct. '05 ¹	0.20
B-108	Immediate vicinity of Pier 1	April '00 ¹ to April '06	0.03
B-204	Immediate vicinity of Pier 1	Aug. '01 ¹ to April '06	0.05
B-203	Upslope of Pier 1	April '99 to April '06	0.03
B-303	Upslope of Pier 1	April '99 to April '06	0.12
<i>Average Rate of Movement – Upslope/Immediate Vicinity of Pier 1</i>			0.09
B-110	North of Pier 1 area	Nov. '95 to Jan. '06	0.01

¹ Inclinometer reinitialized on the date shown, which does not necessarily indicate the date when a significant change in the movement rate occurred.

Table 3: Piezometer Readings for Last Four Quarters (after REL, 2006).

Piezometer Identifier		Ground Surface Elev. (ft)	Pressure Transducer Elev. (ft)	Water Elevation (ft)			
Boring Number	Color Code			July 14, 2005	October 12, 2005	February 1, 2006	April 20, 2006
P-1 (B-101)	Green	676.6	626.3	626.5	626.5	627.7	627.0
P-1 (B-101)	Pink	676.6	552.3	625.7	625.5	625.2	625.7
P-3 (B-105)	Pink	585.6	497.6	586.4	585.8	584.8	585.8
P-3 (B-105)	Blue	585.6	479.9	591.6	590.7	589.7	590.2
P-5 (B-107)	Orange	662.3	562.3	620.2	620.2	620.2	620.7
B-303	Green	627.0	586.2	602.8	602.4	601.9	602.1

Table 4: Summary of Existing Field Instrumentation.

Instrument	Actively Monitored (Y/N)	Reason for Inactivity
Inclinometers		
I-1 through I-9	N	Most of these were destroyed during construction of the Pier 1 stabilization structure. Only I-1 and I-2 are still readable.
B-101	Y	
B-102	Y	
B-103	N	Inclinometer became unreadable during construction of the Pier 1 stabilization structure. Inclinometer B-303 was installed to replace this inclinometer.
B-104	N	Inclinometer became unreadable during construction of the Pier 1 stabilization structure.
B-105	N	Inclinometer became unreadable due to excessive displacement (April 2006). Inclinometer B-105A was installed to replace this inclinometer.
B-106	N	Inclinometer was damaged and became unreadable in 1998.
B-107	Y	
B-108	N	Inclinometer became unreadable due to excessive displacement (April 2006). Inclinometer B-108A was installed to replace this inclinometer.
B-109	N	Inclinometer was removed during construction of the Pier 1 stabilization structure.
B-110	N	Inclinometer was removed during construction activities related to pulling back sheet pile bulkhead (March 2006). Inclinometer B-05-16 was installed to replace this inclinometer.
P-9N	Y	
B-203	Y	
B-204	Y	
B-303	Y	
Pneumatic Piezometers		
P-1 (50.5')	Y	
P-1 (124.1')	Y	
P-2 (30')	N	Abandoned because readings were no longer consistent.
P-2 (123.5')	N	Abandoned because readings were no longer consistent.
P-3 (38')	N	Abandoned because readings were no longer consistent.
P-3 (88')	Y	
P-3 (106')	Y	
P-4 (50')	N	Abandoned because readings were no longer consistent.
P-4 (125')	N	Abandoned because readings were no longer consistent.
P-5 (60')	N	Abandoned because readings were no longer consistent.
P-5 (100')	Y	
P-5 (170')	Y	

Table 5: Timeline of major construction events at the I-90 project site.

Goal	Event	Date
SSI/I	ODOT performed a subsurface investigation and installed inclinometers I-1 through I-9.	5/16/1990 - /1/1990
	BBCM performed a subsurface investigation and installed inclinometers B-101 through B-110 and also installed pneumatic piezometers in borings P-1 through P-5.	8/8/1994 – 9/28/1994
	BBCM installed inclinometers B-201 through B-204	1996
PISS	Excavation for anchor pile cap structure	9/23/1997
	Start of pile driving	10/3/1997
	Halted pile driving to install temporary drilled shafts and lagging	10/30/1997
	Resumed pile driving	12/11/1997
SSI/I	BBCM installed inclinometer B-303	1998
PISS	Pile driving completed	1/19/1998
	Poured concrete for anchor cap	2/11/1998
	Backfilled part of the cut trench on the anchor cap to flatten the slope in an effort to reduce slope movement	2/23/1998
	Drilled shaft construction commences	8/4/1998
	Drilled shaft construction is completed	12/10/1998
	Lateral load tests on drilled shafts 1 and 3	1/13/1998
	Rock anchor installation commences	12/12/1998
	Drilled shaft cap construction completed	12/19/1999
	Rock anchor installation is completed	2/18/1999
	Tie beam installation commences	3/15/1999
	Tie beam installation is completed	4/1/1999
	Rock anchor tensioning commences	4/6/1999
	Rock anchor tensioning is completed	4/14/1999
	Grouting of corrugated tie beam tubes commences	4/20/1999
	Backfilling the slope to the final grade commences	4/23/1999
Backfilling the slope to the final grade is completed	5/7/1999	
SSI/I	Ohio University, subconsultant to BBCM, performs cone penetration testing at locations C-05-01 through C-05-15	3/20/2006 – 4/27/2006
	BBCM performs a subsurface investigation at borings B-05-01 through B-05-04, B-05-07, B-05-08, B-05-11 through B-05-16, B-105A, and B-108A. Inclinometers are installed in borings B-05-01 through B-05-04, B-05-07, B-05-08, B-05-11 through B-05-13, B-05-16, B-105A, and B-108A. Two vibrating wire piezometers were also installed in an offset boring for each of the borings B-05-01 through B-05-04, B-05-07, B-05-08, B-05-11 through B-05-13.	3/24/2006 – 6/15/2006
---	Excavation is performed along the bulkhead west of ODOT property in an effort to pull back the sheetpile	3/2006 – 4/2006

Goals: SSI/I – Subsurface investigation or installation of field instrumentation
PISS – Construction activities for the Pier 1 stabilization structure

Table 6: Summary of Known Information During Artesian Conditions Encountered During Soil Subsurface Investigations.

Boring No./Location	Year	Estimated Depth (ft)	Notes
I-90 Project			
B-4 (I-4)	1990	140	Water erupted approximately 8' above the ground surface during inclinometer installation
Drilled Shaft No. 2	1998	117	Drilled shaft No. 2 construction was halted between 11 AM on 8/24/98 through 1 PM on 8/25/98 due to encountering a methane pocket.
B-5-02	2006	160	Constant 2'-3' eruption of water/gas above the ground surface at the CPT location for approximately 2 hours having occasional 10' to 15' spurts. In addition, a constant spurting of water/gas occurred from a nearby 30' open boring cased with a 2.25" hollow stem auger.
B-05-07	2006	219	Water erupted approximately 10' above ground surface for approximately one minute
B-05-11	2006	218	Water bubbled to surface of drilling fluid
B-05-13	2006	149	Water bubbled to surface of drilling fluid
B-05-14	2006	159	Gas vapors visible during rock coring
B-05-15	2006	174	Constant 8' to 10' eruption of water/gas above casing for 10 minutes during first core run. Water/gas also erupted during core barrel removal. Water escaped from top of core barrel, which was lifted up approximately 15 feet above ground surface. Water/gas/debris also escaped horizontally from the top of the core barrel connection and sprayed approximately 40' horizontally from drill rig.
B-108A	2006	120	Water pressure rocked drill rods and water bubbled up to surface of drilling fluid
Stone Bridge Apartment Project			
Riverbed St. and Center St.	2000	Above bedrock	Constant ~60' eruption of water/gas/gravel for approximately 5 hours followed by a constant eruption of between 30' and 40' having occasional 60' spurts until emergency grouting completed (approximately 12 hours after initial eruption)

Table 7: New Inclinometer and Piezometer Installation Summary.

Boring No.	Estimated Inclinometer Base Depth (ft)	VW Piezometers	
		Transducer Depths (ft)	Transducer Range (psi)
B-05-01	231	65	0-50
		95	0-50
B-05-02	176	46	0-50
		122	0-50
B-05-03	170	32	0-50
		112	0-50
B-05-04	172	59	0-50
		119	0-50
B-05-07	228	102	0-50
		220	0-100
B-05-08	228	65.5	0-50
		110.5	0-50
B-05-11	229	95	0-50
		130	0-100
B-05-12	212	75	0-50
		120	0-50
B-05-13	141	60	0-50
		135	0-100
B-05-14	---	---	---
B-05-15	---	---	---
B-05-16 (replaces B-110)	163	---	---
B-105A (replaces B-105)	155	---	---
B-108A (replaces B-108)	168	---	---



a) Cone Penetration Testing at C-05-03.

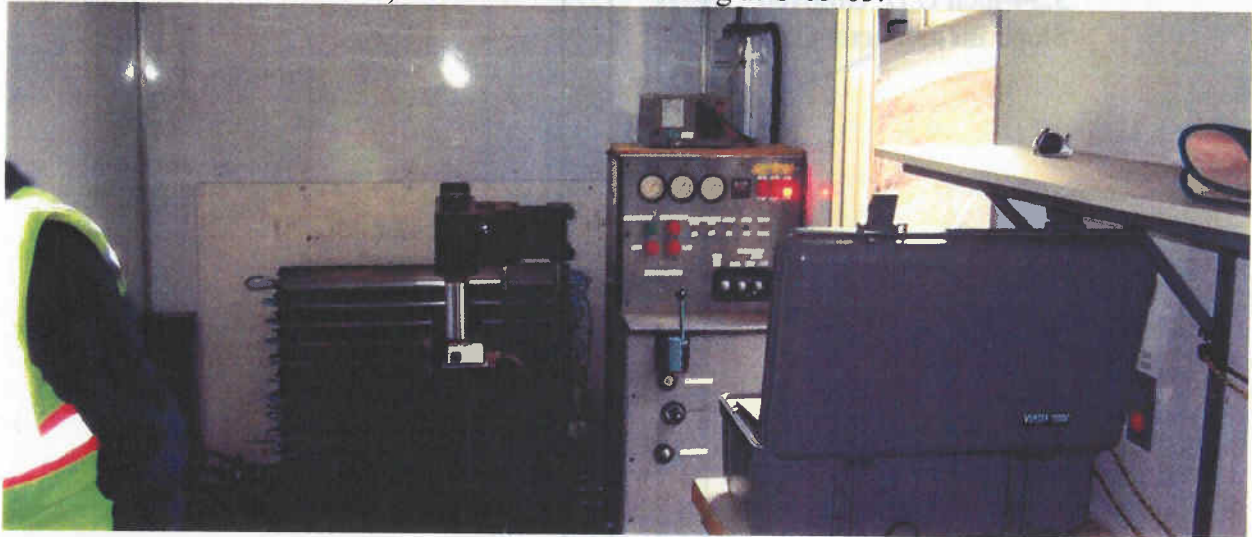

b) Inside of CPT rig.

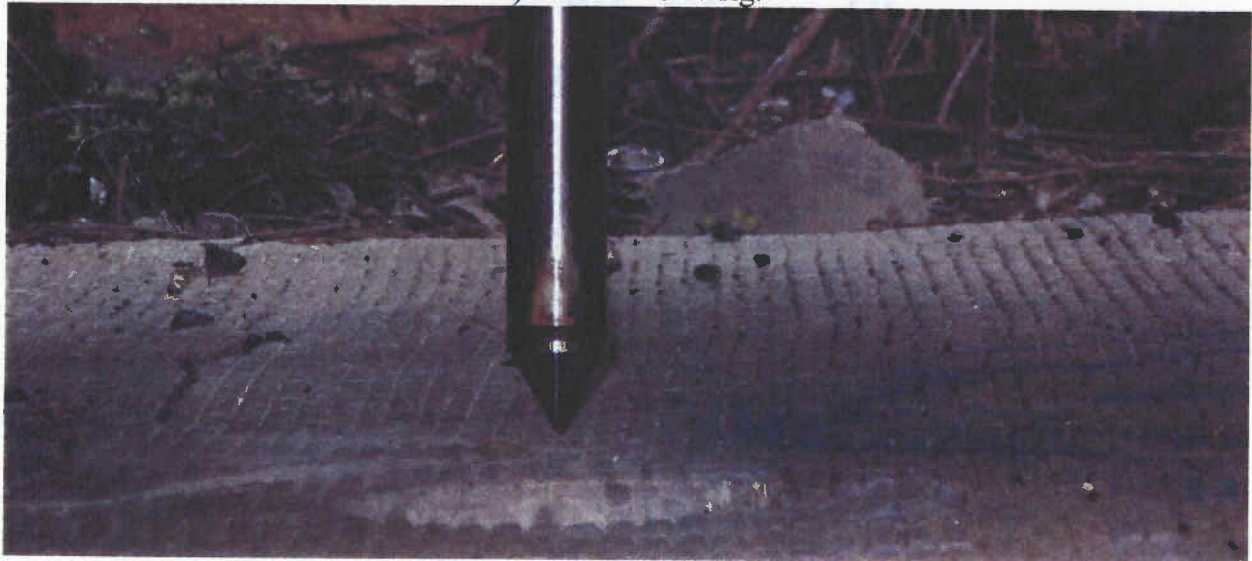

c) CPT probe entering cored pavement.

Figure 1: Cone penetration testing pictures (performed by Ohio University).

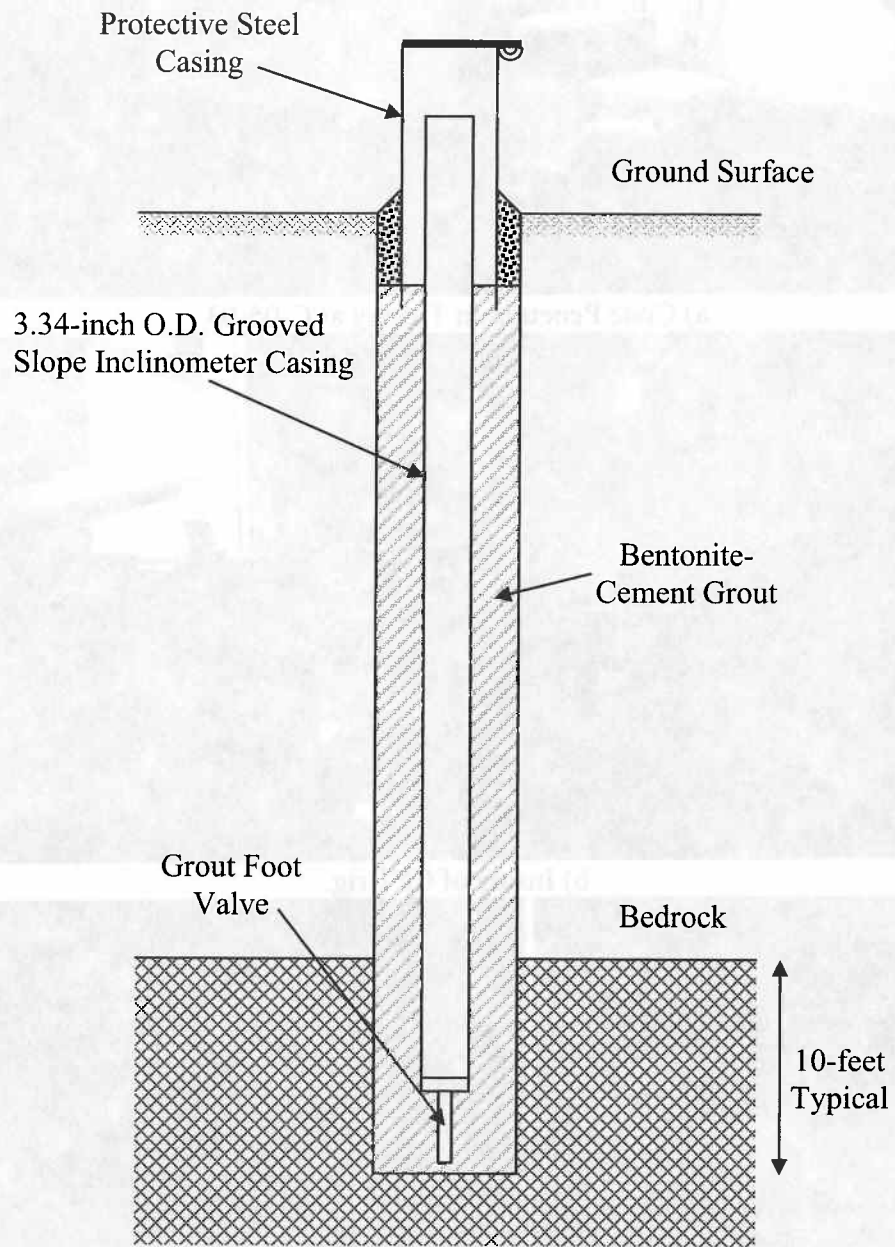

Figure 2: Typical Slope Inclinometer.

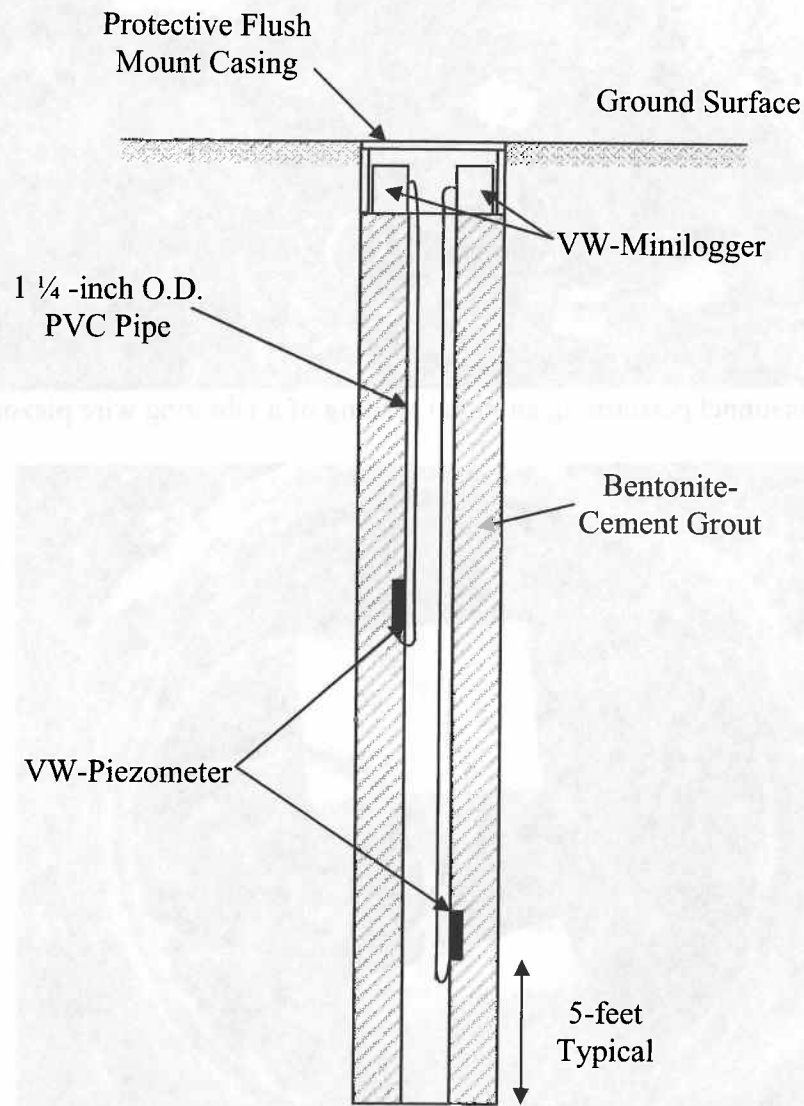
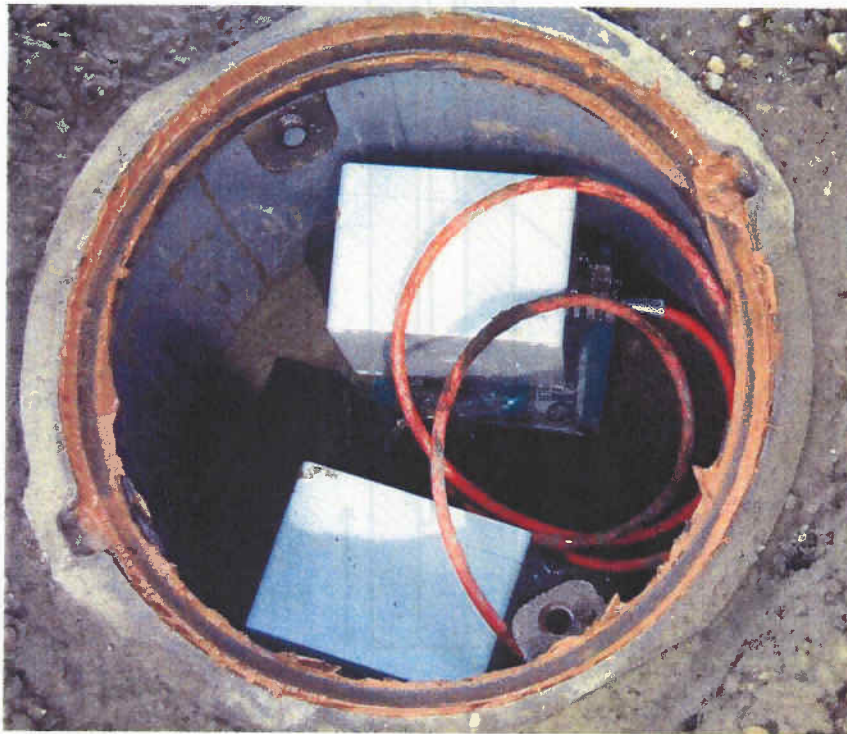

Figure 3: Typical Vibrating Wire Piezometer Setup.



a) BBCM personnel performing an initial reading of a vibrating wire piezometer.



b) Typical VW-piezometer setup including a flushmount protective cover and two miniloggers.

Figure 4: Vibrating Wire piezometer pictures.



a) Water/gas erupting beneath the CPT rig at C-05-02.



b) Water/gas erupting during drilling operations at B-05-15.

Figure 5: Examples of artesian gas pressures that were encountered during field operations.

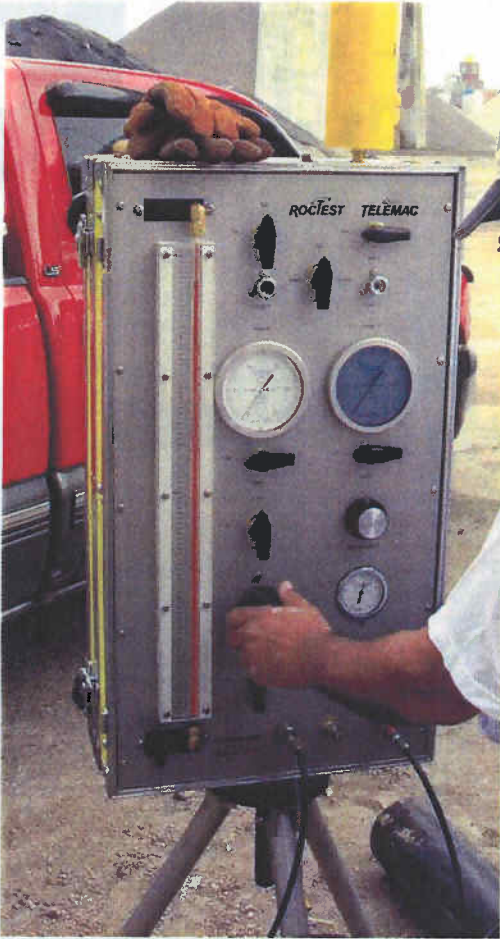

a) Pressuremeter readings device.



b) Pressuremeter probe.

Figure 6: Pressuremeter testing pictures (performed by E.L. Robinson).