

| | | | |
|------------------|-----|-----------------|---|
| Cut Area (SF): | 9 | Cut Vol. (CY): | 0 |
| Fill Area (SF): | 495 | Fill Vol. (CY): | 0 |
| Seed Width (FT): | | Seed Area (SY): | |

PGL 685.40
 STA. 303+50.14
 XGL 667.47

| Sheet Totals | | |
|--------------|-----|------|
| Seeding | Cut | Fill |
| . | . | . |

| | | |
|---------------|-------|--|
| DESIGN AGENCY | 82382 | |
| DESIGNER | -- | |
| REVIEWER | -- | |
| PROJECT ID | 82382 | |
| SHEET | TOTAL | |
| 616 | 2339 | |

CROSS SECTIONS
 RAMP A1

DESIGN AGENCY



DESIGNER

REVIEWER

PROJECT ID

SHEET

TOTAL

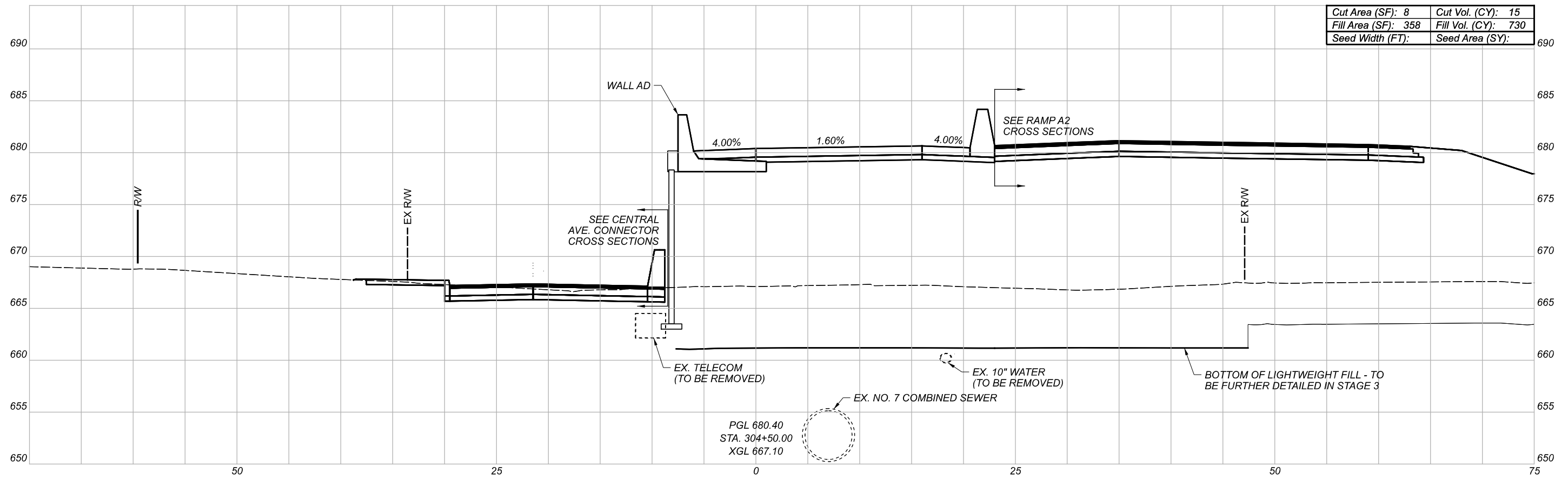

| | |
|---------------------|---------------------|
| Cut Area (SF): 8 | Cut Vol. (CY): 15 |
| Fill Area (SF): 358 | Fill Vol. (CY): 730 |
| Seed Width (FT): | Seed Area (SY): |

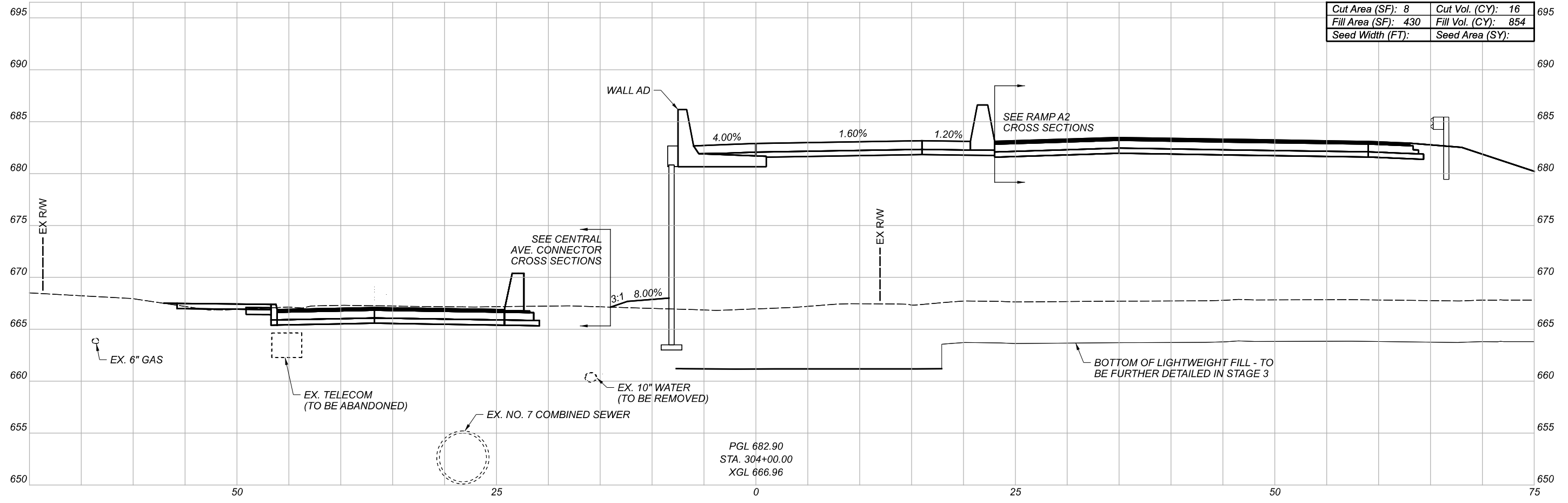

| | |
|---------------------|---------------------|
| Cut Area (SF): 8 | Cut Vol. (CY): 16 |
| Fill Area (SF): 430 | Fill Vol. (CY): 854 |
| Seed Width (FT): | Seed Area (SY): |

CROSS SECTIONS
RAMP A1

DESIGN AGENCY



DESIGNER

REVIEWER

PROJECT ID

82382

| Sheet Totals | | | SHEET | TOTAL |
|--------------|-----|------|-------|-------|
| Seeding | Cut | Fill | | |
| . | . | . | 617 | 2339 |

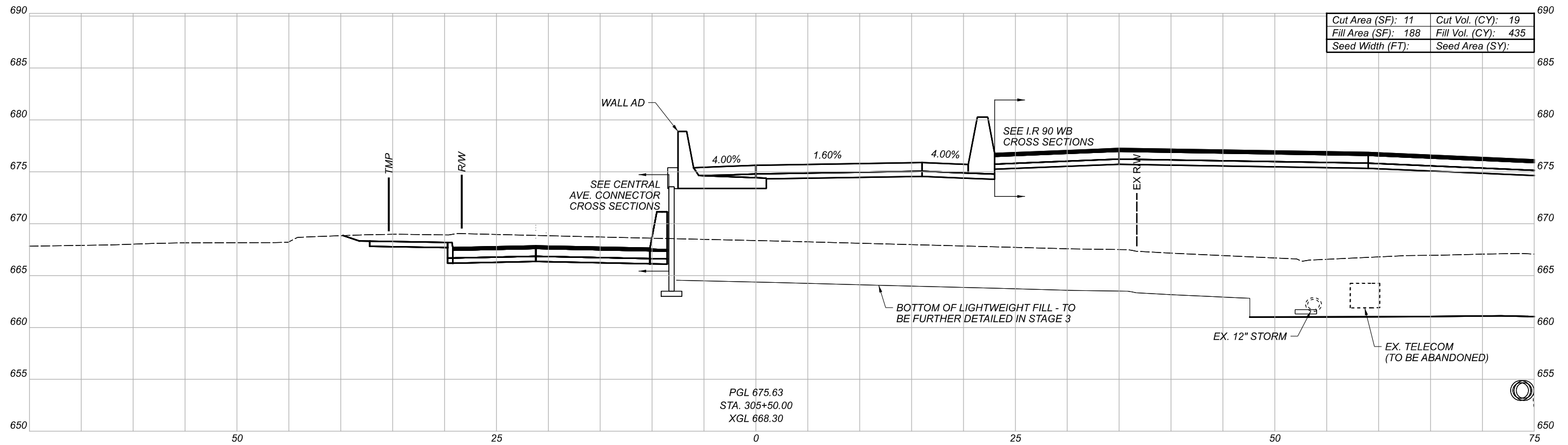

CROSS SECTIONS
RAMP A1

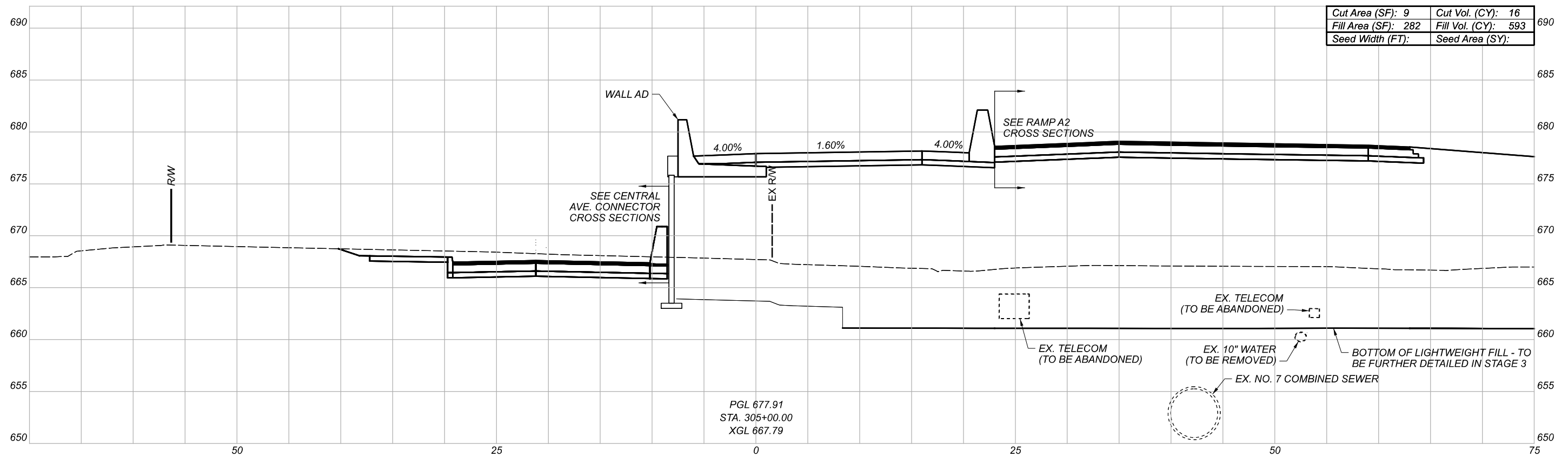

DESIGN AGENCY
HR
 DESIGNER
 REVIEWER
 PROJECT ID

| Sheet Totals | | | 82382 | |
|--------------|-----|------|-------|-------|
| Seeding | Cut | Fill | SHEET | TOTAL |
| . | . | . | 618 | 2339 |

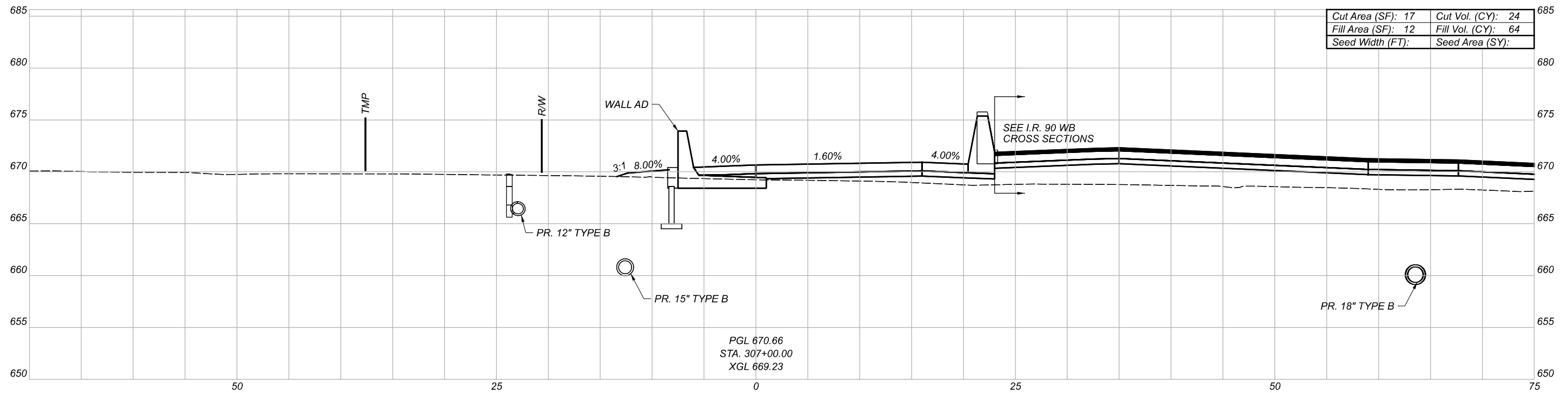
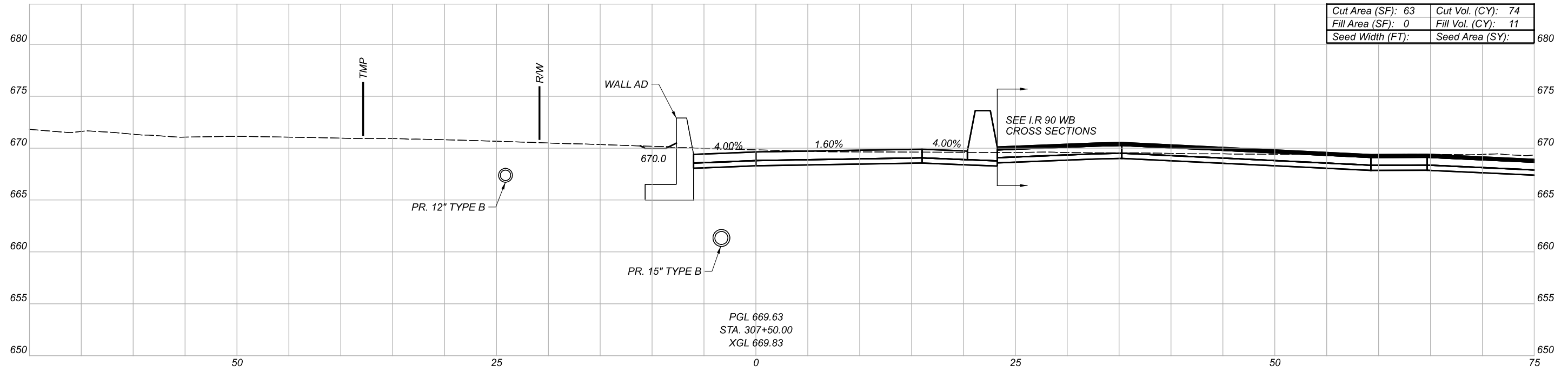

CROSS SECTIONS
RAMP A1

DESIGN AGENCY



DESIGNER

REVIEWER

PROJECT ID

82382

| Sheet Totals | | | SHEET | TOTAL |
|--------------|-----|------|-------|-------|
| Seeding | Cut | Fill | 620 | 2339 |

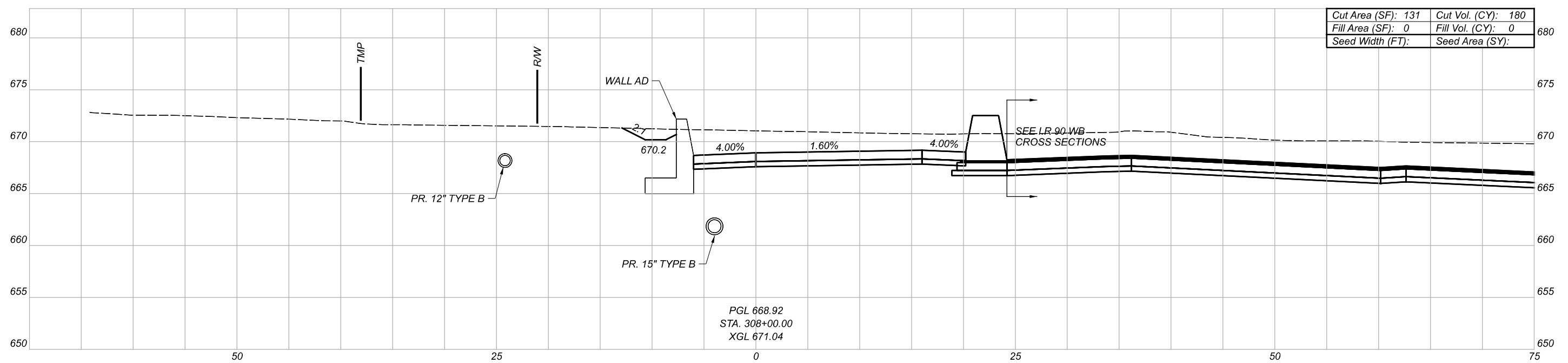
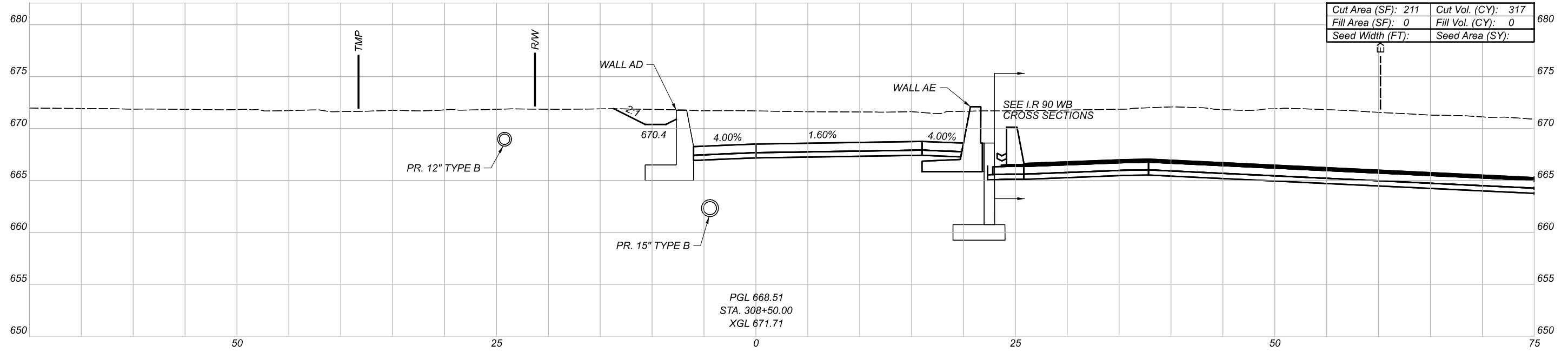

CROSS SECTIONS
RAMP A1

DESIGN AGENCY



DESIGNER

REVIEWER

PROJECT ID

82382

| Sheet Totals | | | SHEET | TOTAL |
|--------------|-----|------|-------|-------|
| Seeding | Cut | Fill | | |
| . | . | . | 621 | 2339 |

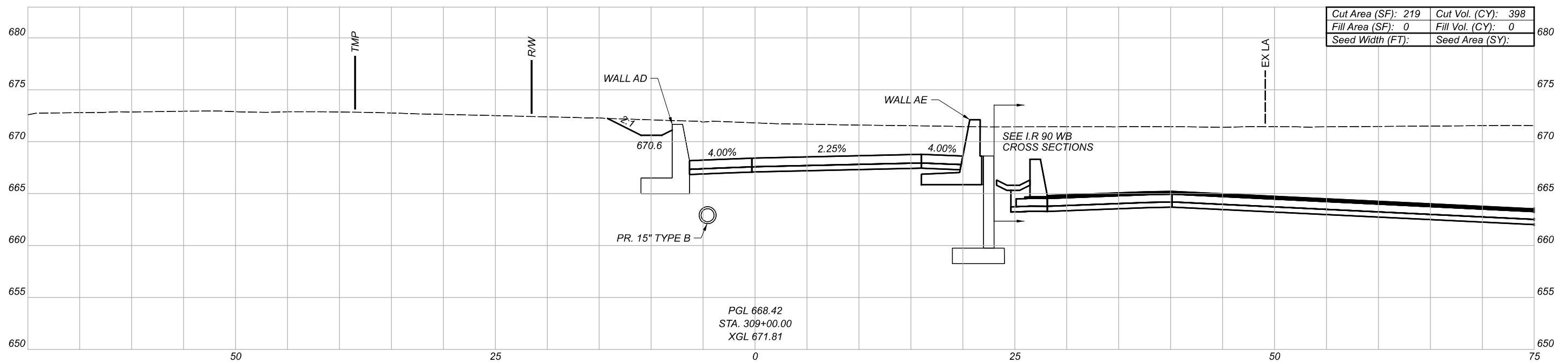
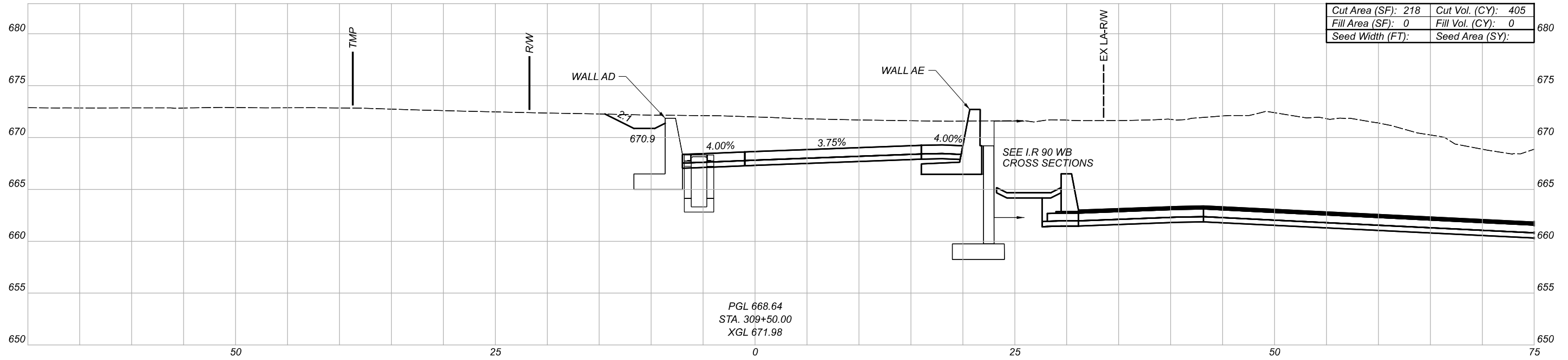

CROSS SECTIONS
 RAMP A1

DESIGN AGENCY



DESIGNER

REVIEWER

PROJECT ID

82382

| Sheet Totals | | | SHEET | TOTAL |
|--------------|-----|------|-------|-------|
| Seeding | Cut | Fill | | |
| . | . | . | 622 | 2339 |

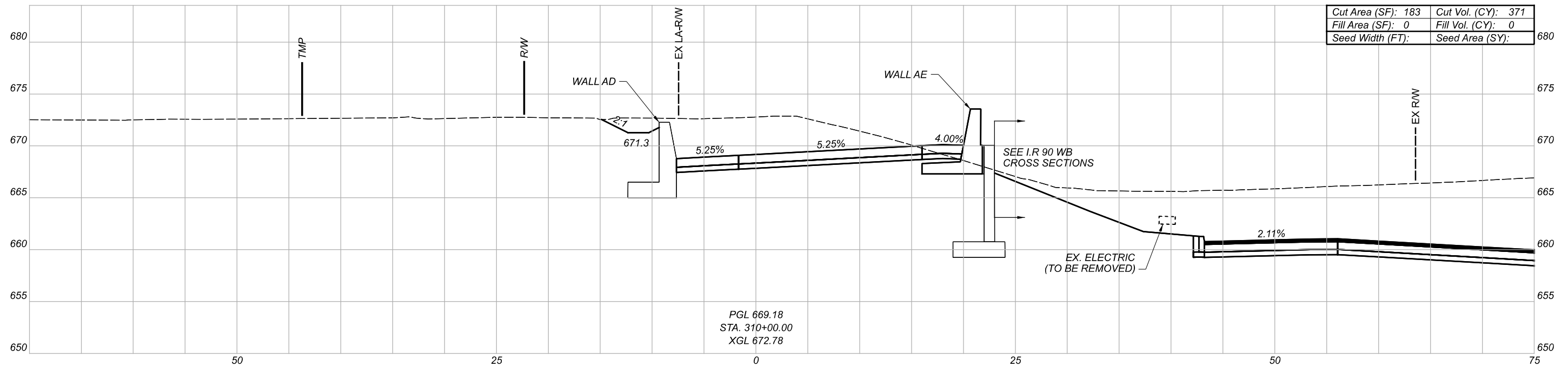
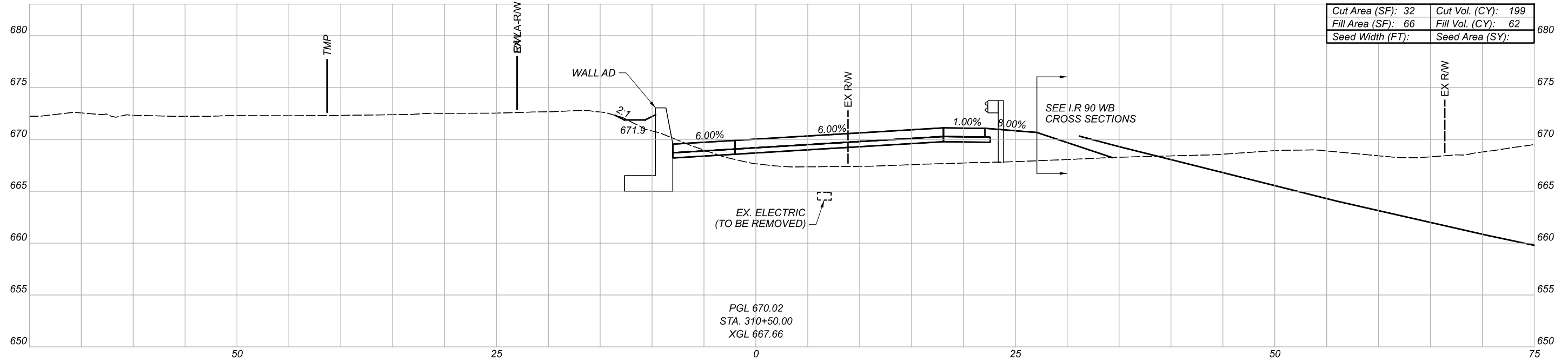

CROSS SECTIONS
RAMP A1

DESIGN AGENCY



DESIGNER

REVIEWER

PROJECT ID

82382

| Sheet Totals | | | SHEET | TOTAL |
|--------------|-----|------|-------|-------|
| Seeding | Cut | Fill | | |
| . | . | . | 623 | 2339 |

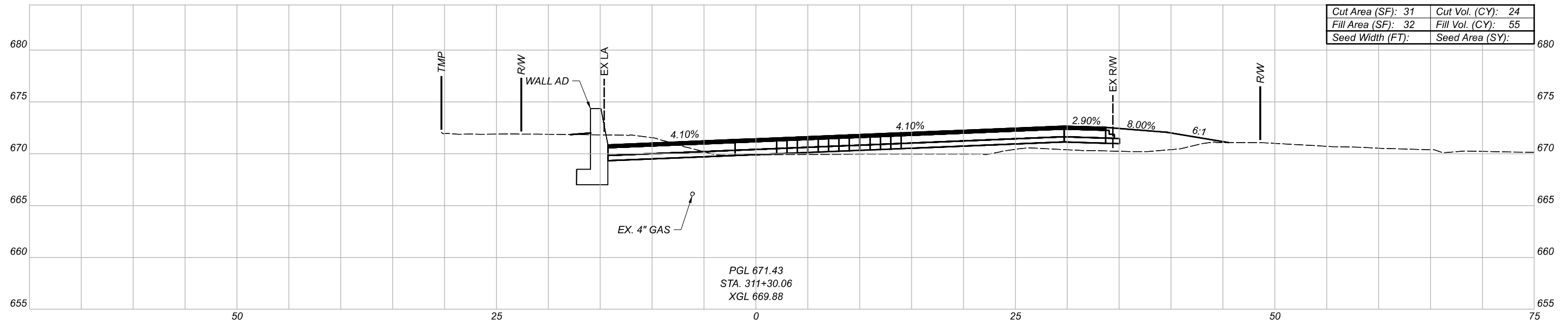

| | |
|--------------------|--------------------|
| Cut Area (SF): 31 | Cut Vol. (CY): 24 |
| Fill Area (SF): 32 | Fill Vol. (CY): 55 |
| Seed Width (FT): | Seed Area (SY): |

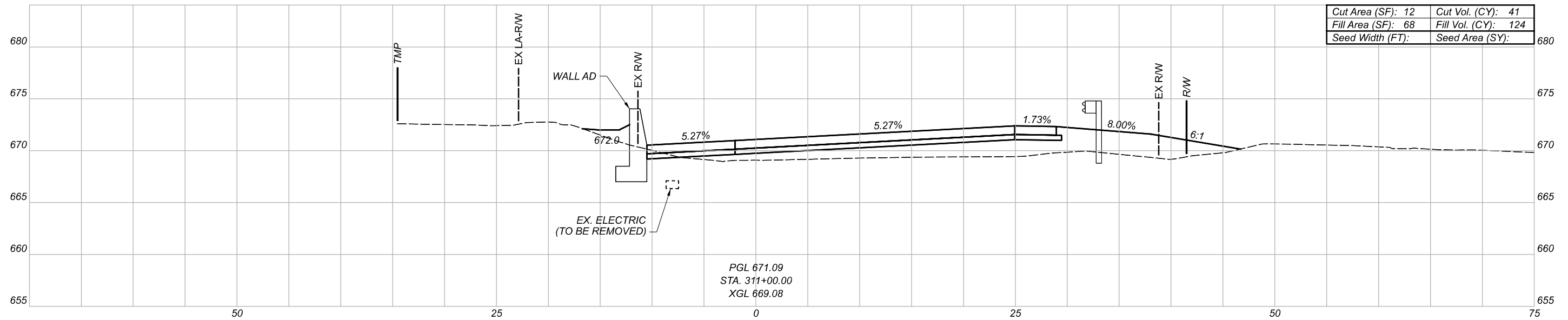

| | |
|--------------------|---------------------|
| Cut Area (SF): 12 | Cut Vol. (CY): 41 |
| Fill Area (SF): 68 | Fill Vol. (CY): 124 |
| Seed Width (FT): | Seed Area (SY): |

CROSS SECTIONS
RAMP A1

DESIGN AGENCY



DESIGNER

REVIEWER

PROJECT ID

82382

| Sheet Totals | | | SHEET | TOTAL |
|--------------|-----|------|-------|-------|
| Seeding | Cut | Fill | | |
| . | . | . | 624 | 2339 |

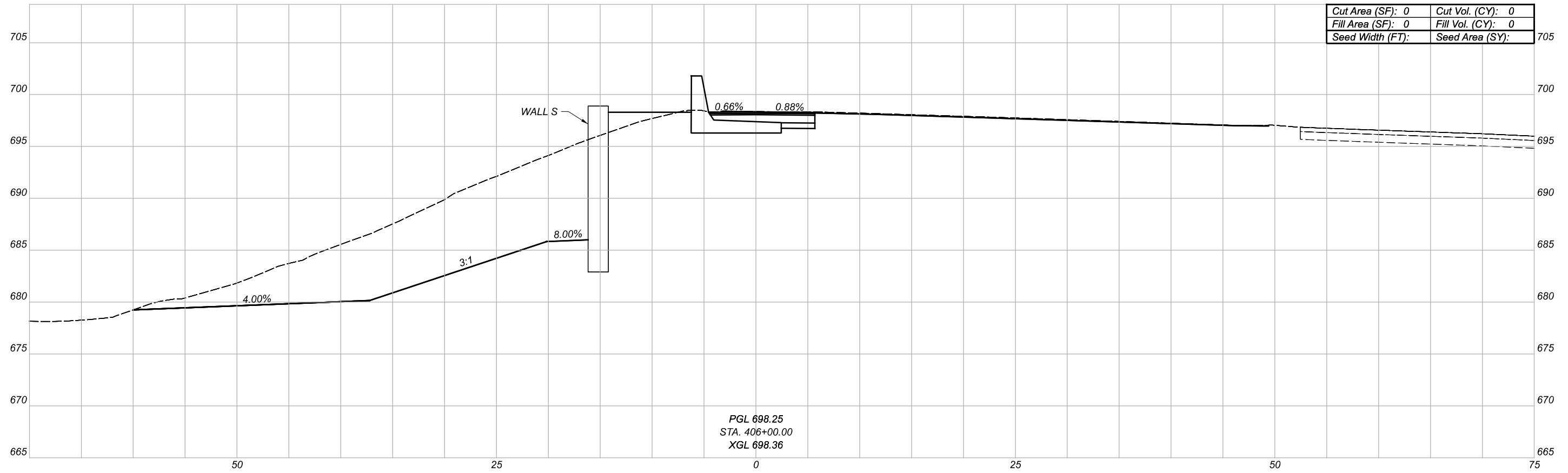

PGL 698.25
 STA. 406+00.00
 XGL 698.36

| | |
|-------------------|-------------------|
| Cut Area (SF): 0 | Cut Vol. (CY): 0 |
| Fill Area (SF): 0 | Fill Vol. (CY): 0 |
| Seed Width (FT): | Seed Area (SY): |

CROSS SECTIONS
 RAMP A2

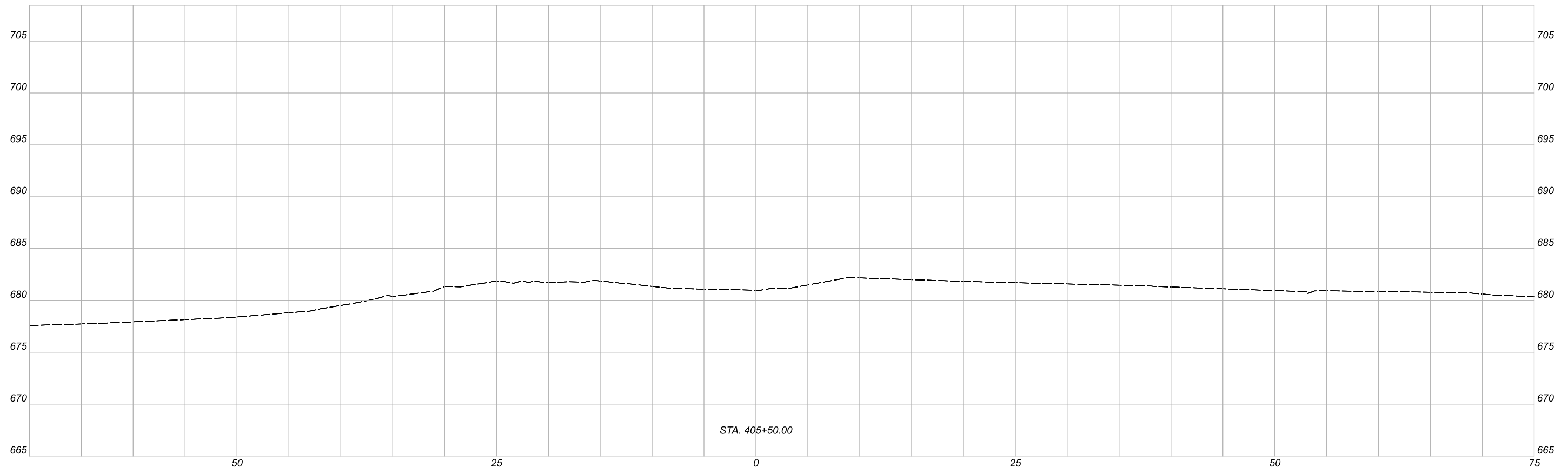

STA. 405+50.00

| Sheet Totals | | | 82382 | |
|--------------|-----|------|-------|-------|
| Seeding | Cut | Fill | SHEET | TOTAL |
| . | . | . | 625 | 2339 |

DESIGN AGENCY



DESIGNER

REVIEWER

PROJECT ID

82382

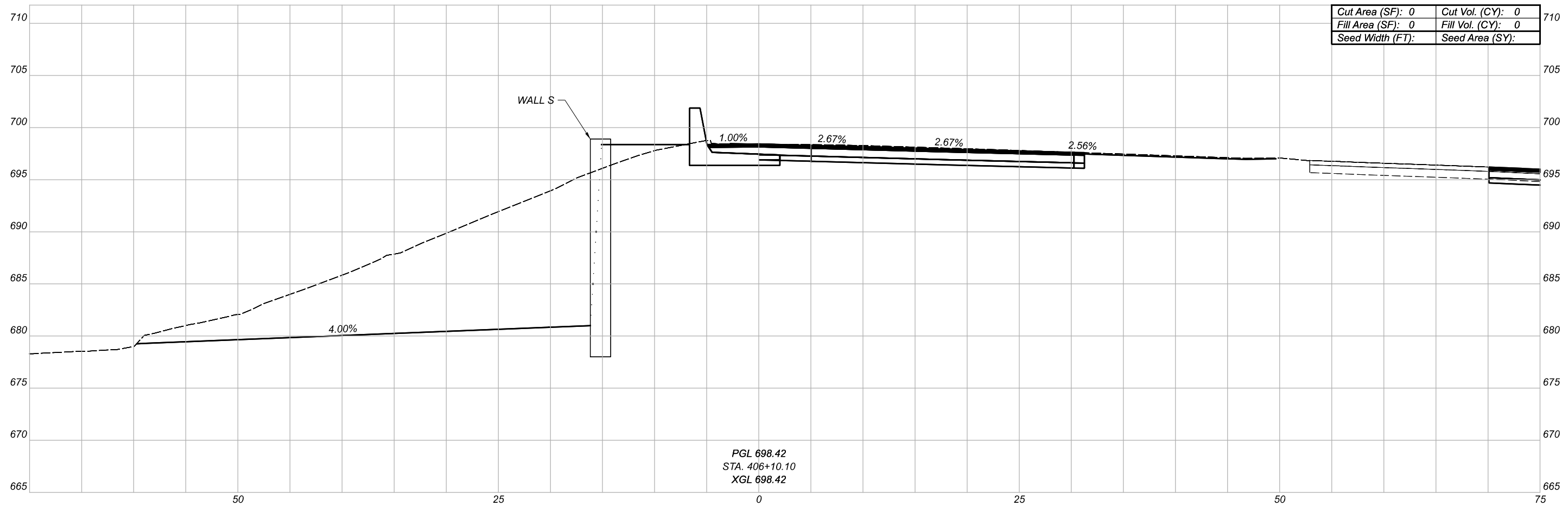

PGL 698.42
 STA. 406+10.10
 XGL 698.42

CROSS SECTIONS
 RAMP A2

DESIGN AGENCY



DESIGNER

REVIEWER

PROJECT ID

82382

| Sheet Totals | | | SHEET | TOTAL |
|--------------|-----|------|-------|-------|
| Seeding | Cut | Fill | | |
| . | . | . | 626 | 2339 |

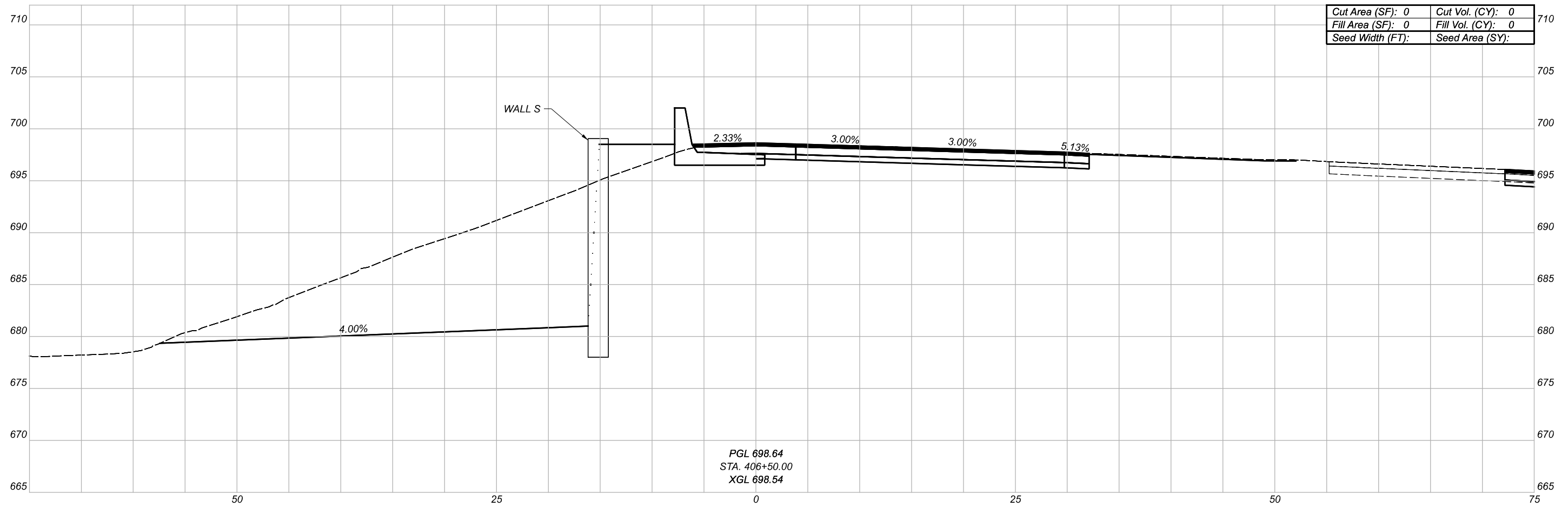

PGL 698.64
 STA. 406+50.00
 XGL 698.54

CROSS SECTIONS
 RAMP A2

DESIGN AGENCY



DESIGNER

REVIEWER

PROJECT ID

82382

| Sheet Totals | | | SHEET | TOTAL |
|--------------|-----|------|-------|-------|
| Seeding | Cut | Fill | | |
| . | . | . | 627 | 2339 |

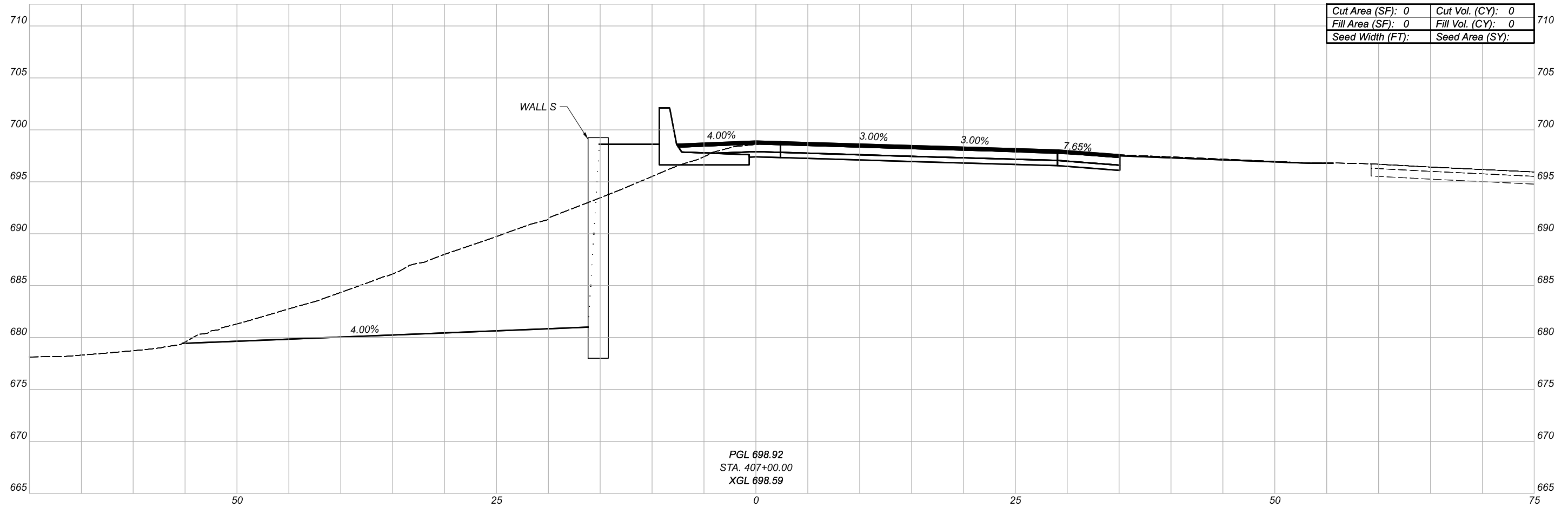

PGL 698.92
 STA. 407+00.00
 XGL 698.59

CROSS SECTIONS
 RAMP A2

DESIGN AGENCY



DESIGNER

REVIEWER

PROJECT ID

82382

| Sheet Totals | | | SHEET | TOTAL |
|--------------|-----|------|-------|-------|
| Seeding | Cut | Fill | | |
| . | . | . | 628 | 2339 |

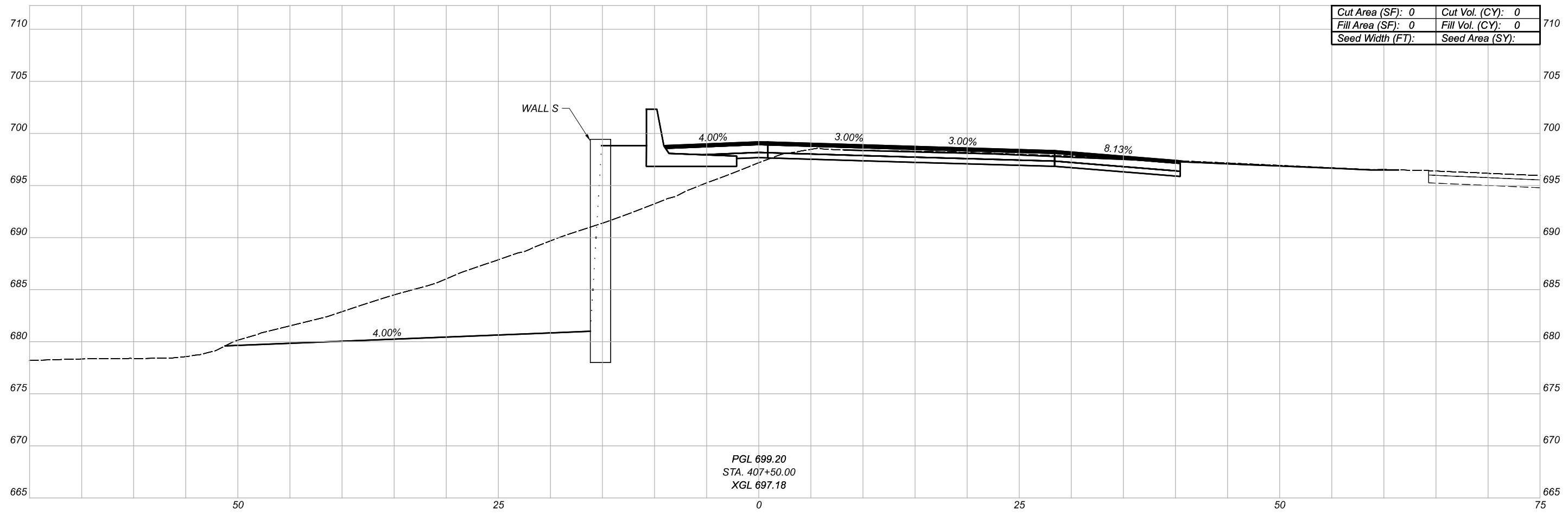

PGL 699.20
 STA. 407+50.00
 XGL 697.18

CROSS SECTIONS
 RAMP A2

| | |
|---|-------|
| DESIGN AGENCY | |
|  | |
| DESIGNER | -- |
| REVIEWER | -- |
| PROJECT ID | 82382 |

| Sheet Totals | | | SHEET | TOTAL |
|--------------|-----|------|-------|-------|
| Seeding | Cut | Fill | | |
| . | . | . | 629 | 2339 |

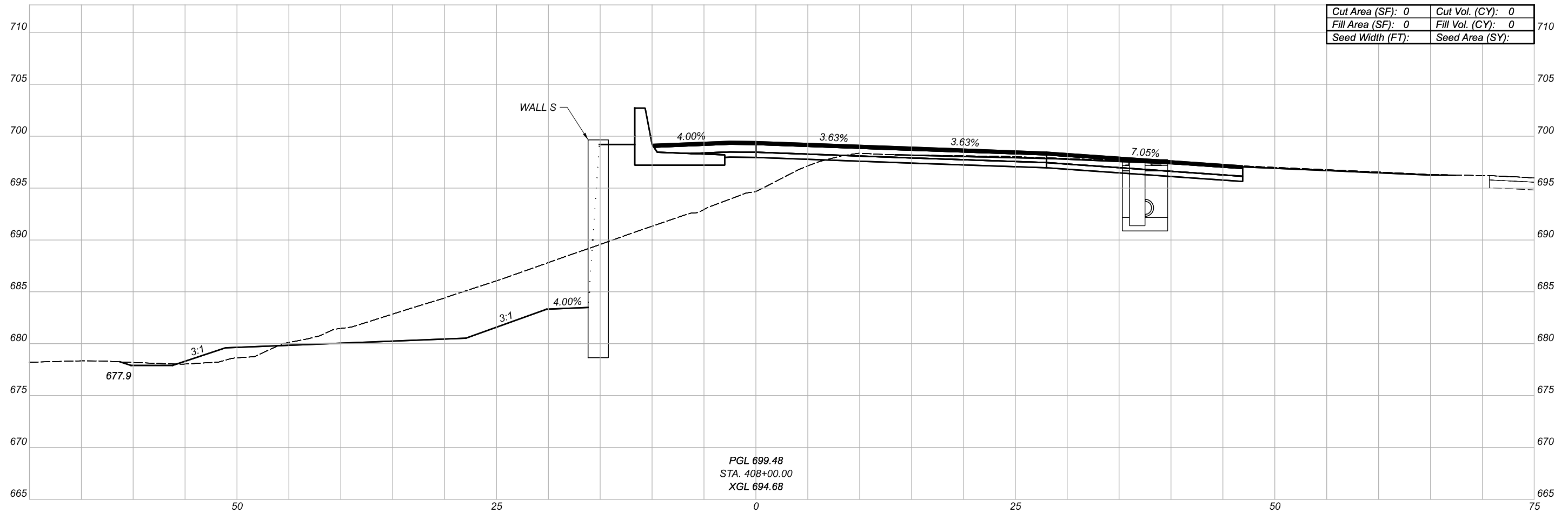

PGL 699.48
 STA. 408+00.00
 XGL 694.68

CROSS SECTIONS
 RAMP A2

DESIGN AGENCY



DESIGNER

REVIEWER

PROJECT ID

82382

| Sheet Totals | | | SHEET | TOTAL |
|--------------|-----|------|-------|-------|
| Seeding | Cut | Fill | 630 | 2339 |

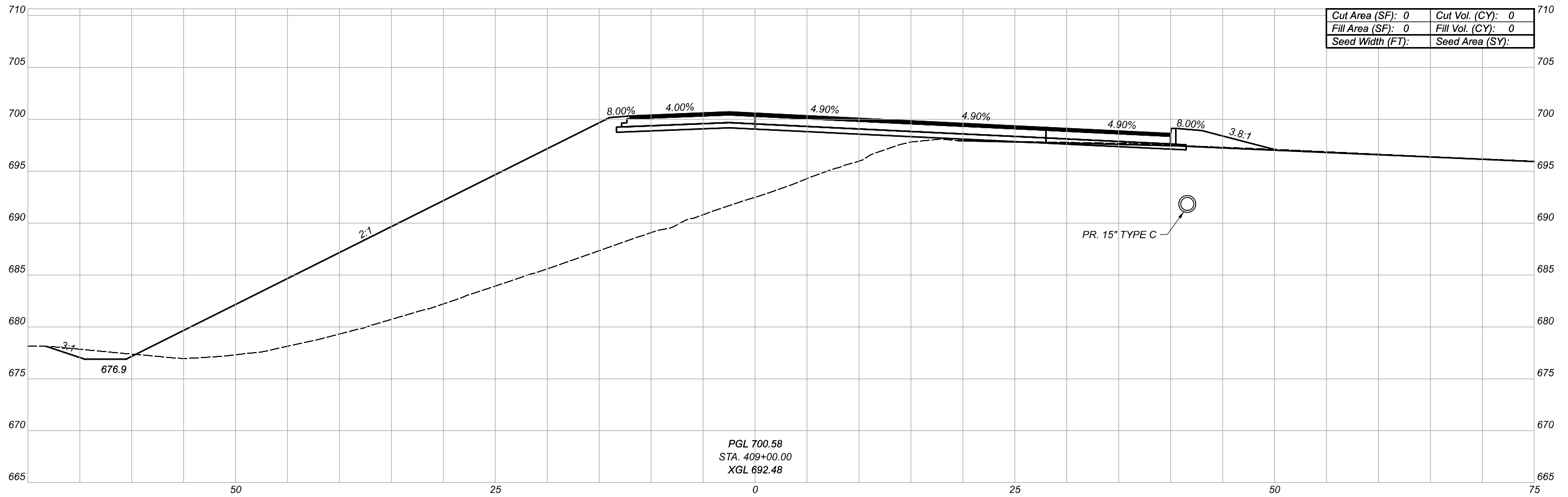

PGL 700.58
 STA. 409+00.00
 XGL 692.48

| | |
|-------------------|-------------------|
| Cut Area (SF): 0 | Cut Vol. (CY): 0 |
| Fill Area (SF): 0 | Fill Vol. (CY): 0 |
| Seed Width (FT): | Seed Area (SY): |

CROSS SECTIONS
 RAMP A2

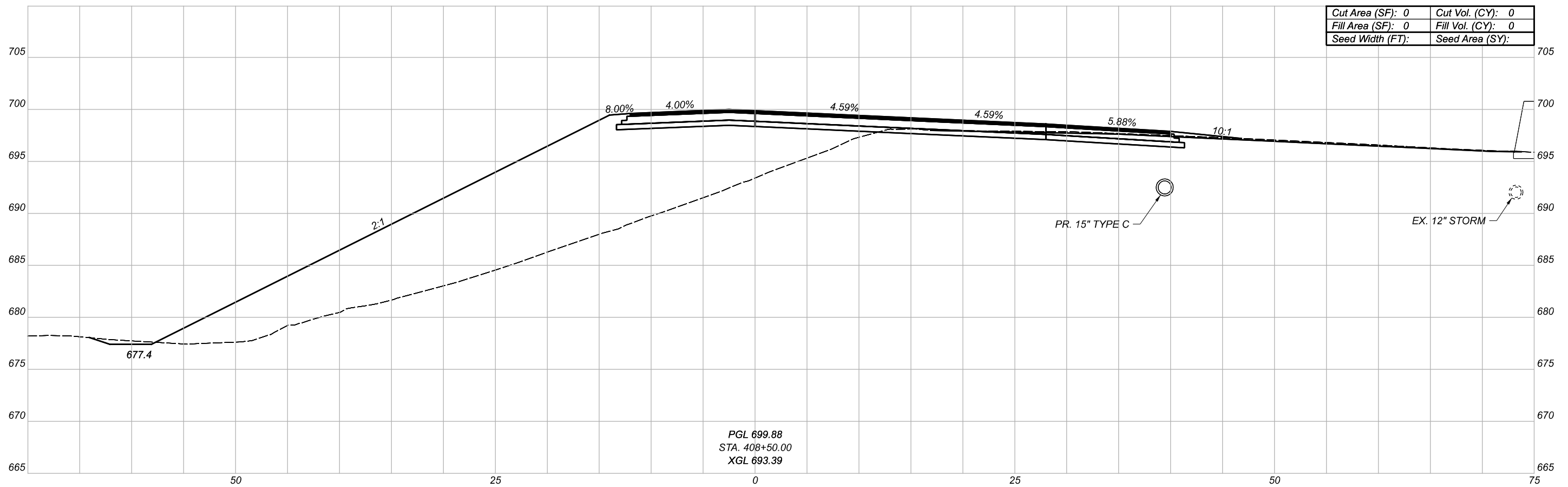

PGL 699.88
 STA. 408+50.00
 XGL 693.39

| | |
|-------------------|-------------------|
| Cut Area (SF): 0 | Cut Vol. (CY): 0 |
| Fill Area (SF): 0 | Fill Vol. (CY): 0 |
| Seed Width (FT): | Seed Area (SY): |

| Sheet Totals | | | PROJECT ID | |
|--------------|-----|------|------------|-------|
| Seeding | Cut | Fill | SHEET | TOTAL |
| . | . | . | 631 | 2339 |

DESIGN AGENCY



DESIGNER

REVIEWER

PROJECT ID

82382

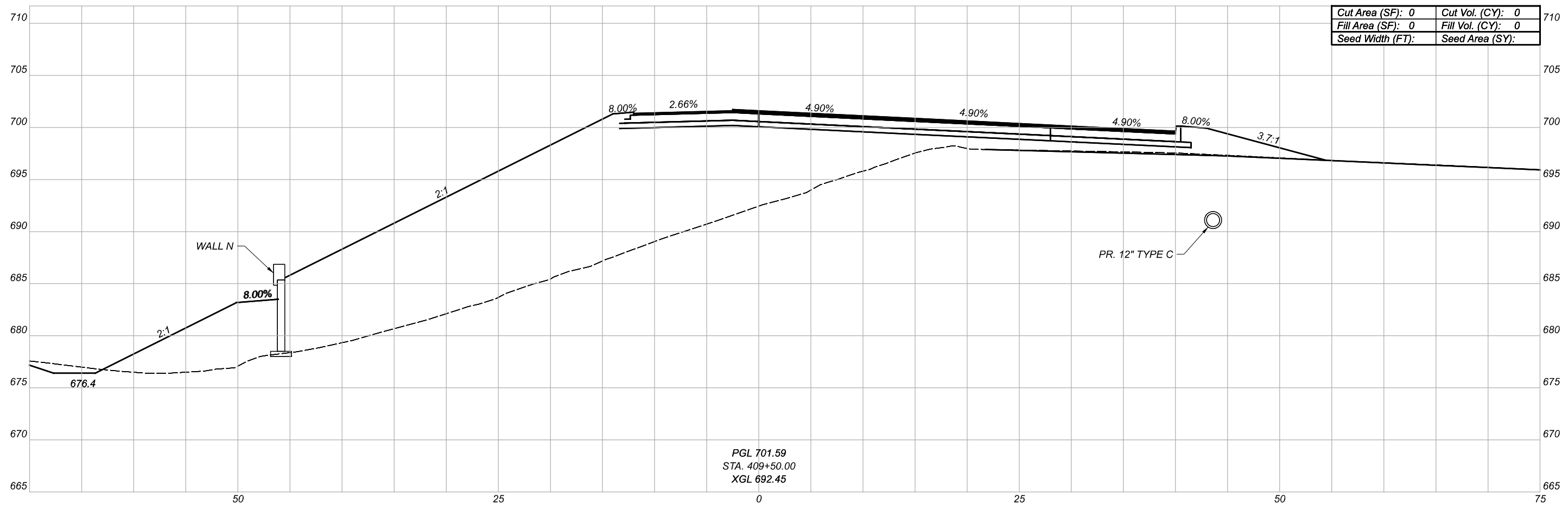

PGL 701.59
 STA. 409+50.00
 XGL 692.45

| | |
|-------------------|-------------------|
| Cut Area (SF): 0 | Cut Vol. (CY): 0 |
| Fill Area (SF): 0 | Fill Vol. (CY): 0 |
| Seed Width (FT): | Seed Area (SY): |

CROSS SECTIONS
 RAMP A2

DESIGN AGENCY



DESIGNER

REVIEWER

PROJECT ID

82382

| Sheet Totals | | | SHEET | TOTAL |
|--------------|-----|------|-------|-------|
| Seeding | Cut | Fill | | |
| . | . | . | 632 | 2339 |

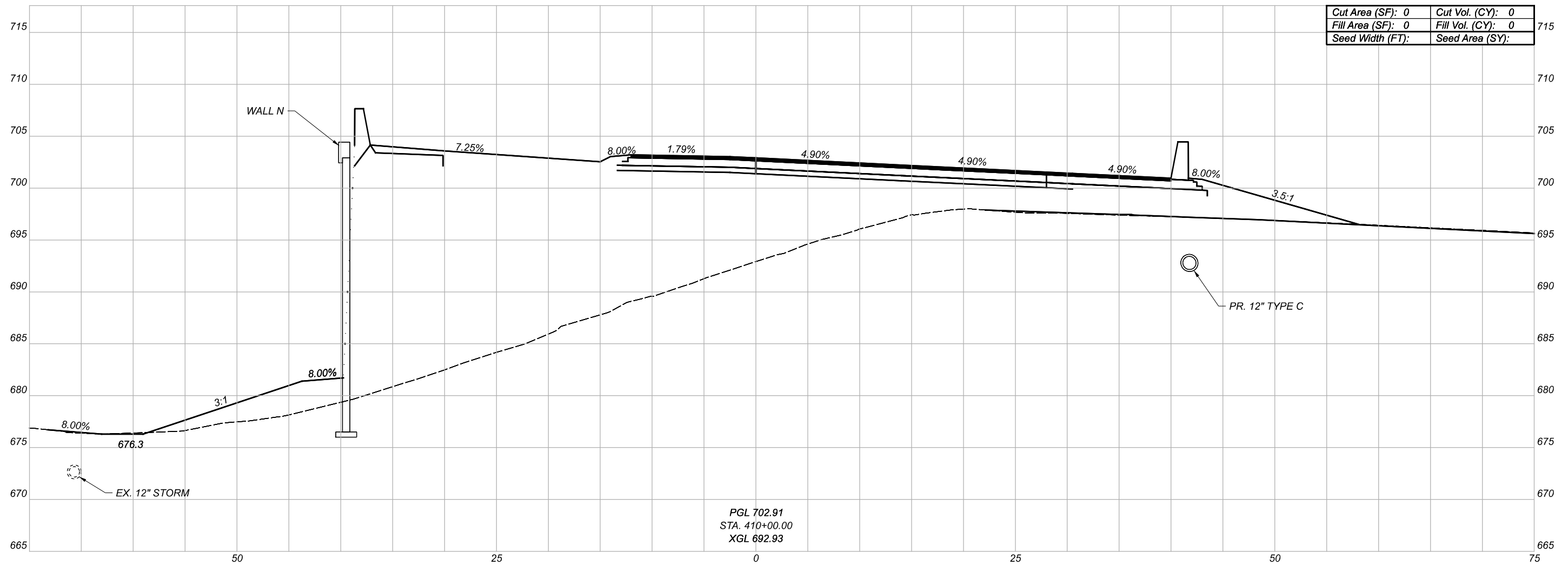

| | | | |
|------------------|---|-----------------|---|
| Cut Area (SF): | 0 | Cut Vol. (CY): | 0 |
| Fill Area (SF): | 0 | Fill Vol. (CY): | 0 |
| Seed Width (FT): | | Seed Area (SY): | |

PGL 702.91
 STA. 410+00.00
 XGL 692.93

CROSS SECTIONS
 RAMP A2

DESIGN AGENCY



DESIGNER

REVIEWER

PROJECT ID

82382

| Sheet Totals | | | SHEET | TOTAL |
|--------------|-----|------|-------|-------|
| Seeding | Cut | Fill | | |
| . | . | . | 633 | 2339 |

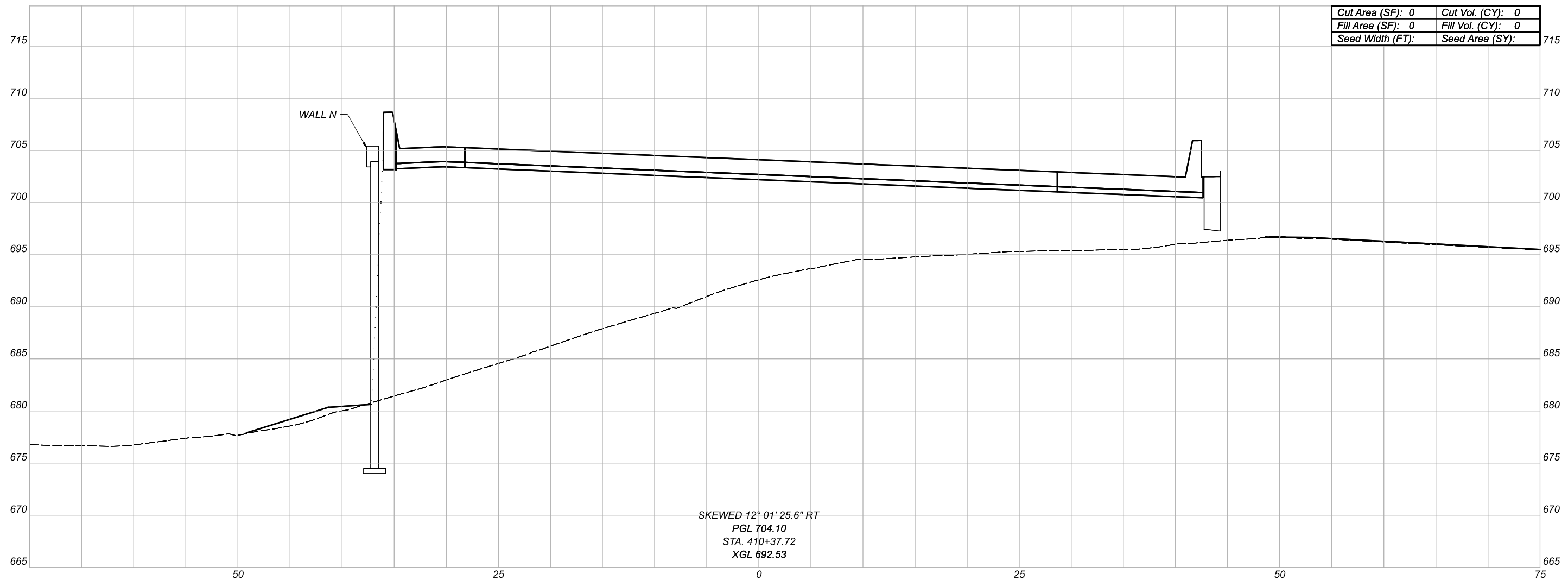

SKEWED 12° 01' 25.6" RT
 PGL 704.10
 STA. 410+37.72
 XGL 692.53

CROSS SECTIONS
 RAMP A2

| | |
|---|-------|
| DESIGN AGENCY | |
|  | |
| DESIGNER | -- |
| REVIEWER | -- |
| PROJECT ID | 82382 |
| SHEET | 634 |
| TOTAL | 2339 |

| Sheet Totals | | |
|--------------|-----|------|
| Seeding | Cut | Fill |
| . | . | . |

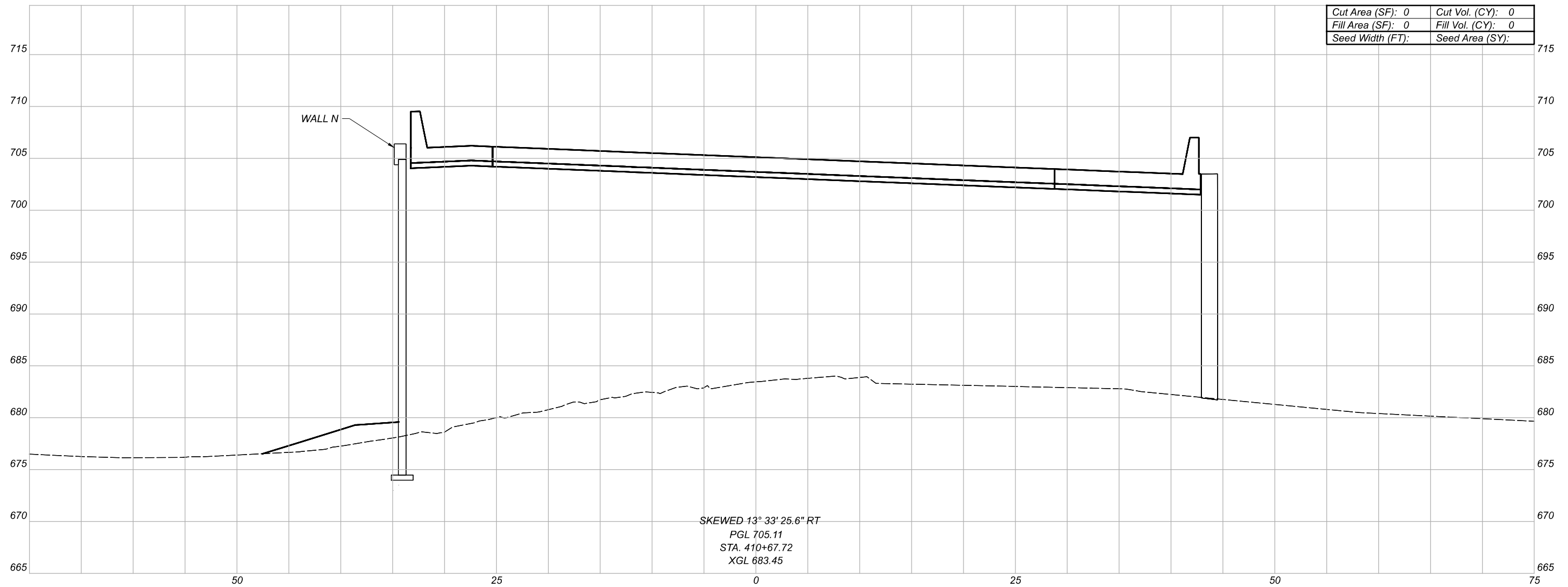

CROSS SECTIONS
RAMP A2

DESIGN AGENCY



DESIGNER

REVIEWER

PROJECT ID

82382

| Sheet Totals | | | SHEET | TOTAL |
|--------------|-----|------|-------|-------|
| Seeding | Cut | Fill | | |
| . | . | . | 635 | 2339 |

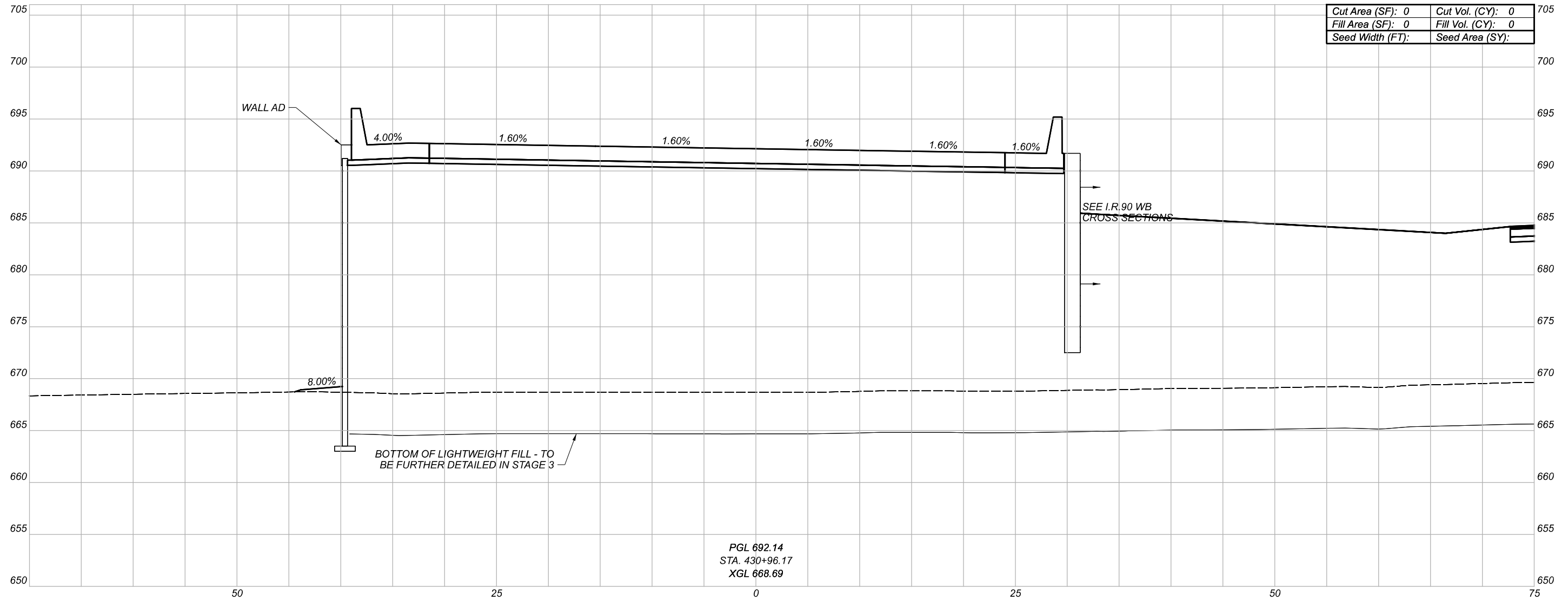

| | |
|-------------------|-------------------|
| Cut Area (SF): 0 | Cut Vol. (CY): 0 |
| Fill Area (SF): 0 | Fill Vol. (CY): 0 |
| Seed Width (FT): | Seed Area (SY): |

PGL 692.14
 STA. 430+96.17
 XGL 668.69

CROSS SECTIONS
 RAMP A2

DESIGN AGENCY



DESIGNER

REVIEWER

PROJECT ID

82382

| Sheet Totals | | | SHEET | TOTAL |
|--------------|-----|------|-------|-------|
| Seeding | Cut | Fill | | |
| . | . | . | 636 | 2339 |

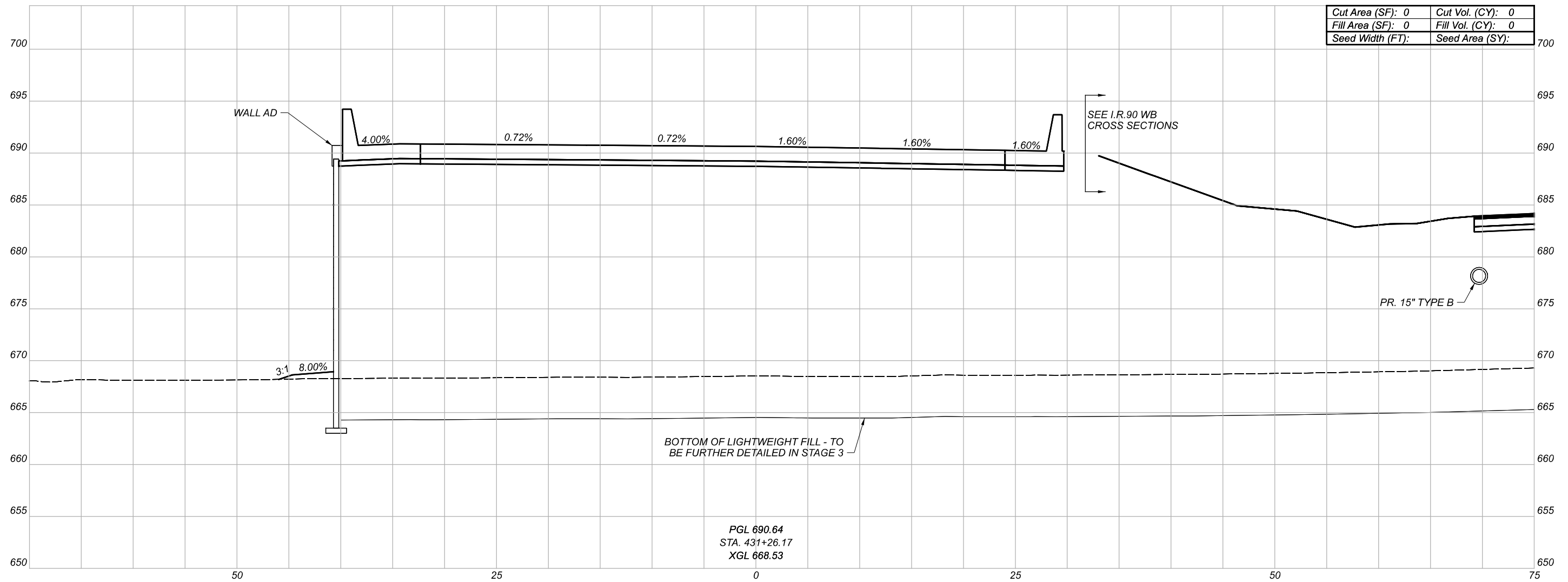

BOTTOM OF LIGHTWEIGHT FILL - TO BE FURTHER DETAILED IN STAGE 3

PGL 690.64
 STA. 431+26.17
 XGL 668.53

SEE I.R.90 WB CROSS SECTIONS

PR. 15" TYPE B

| | |
|-------------------|-------------------|
| Cut Area (SF): 0 | Cut Vol. (CY): 0 |
| Fill Area (SF): 0 | Fill Vol. (CY): 0 |
| Seed Width (FT): | Seed Area (SY): |

CROSS SECTIONS
 RAMP A2

DESIGN AGENCY



DESIGNER

REVIEWER

PROJECT ID

82382

| Sheet Totals | | | SHEET | TOTAL |
|--------------|-----|------|-------|-------|
| Seeding | Cut | Fill | | |
| . | . | . | 637 | 2339 |

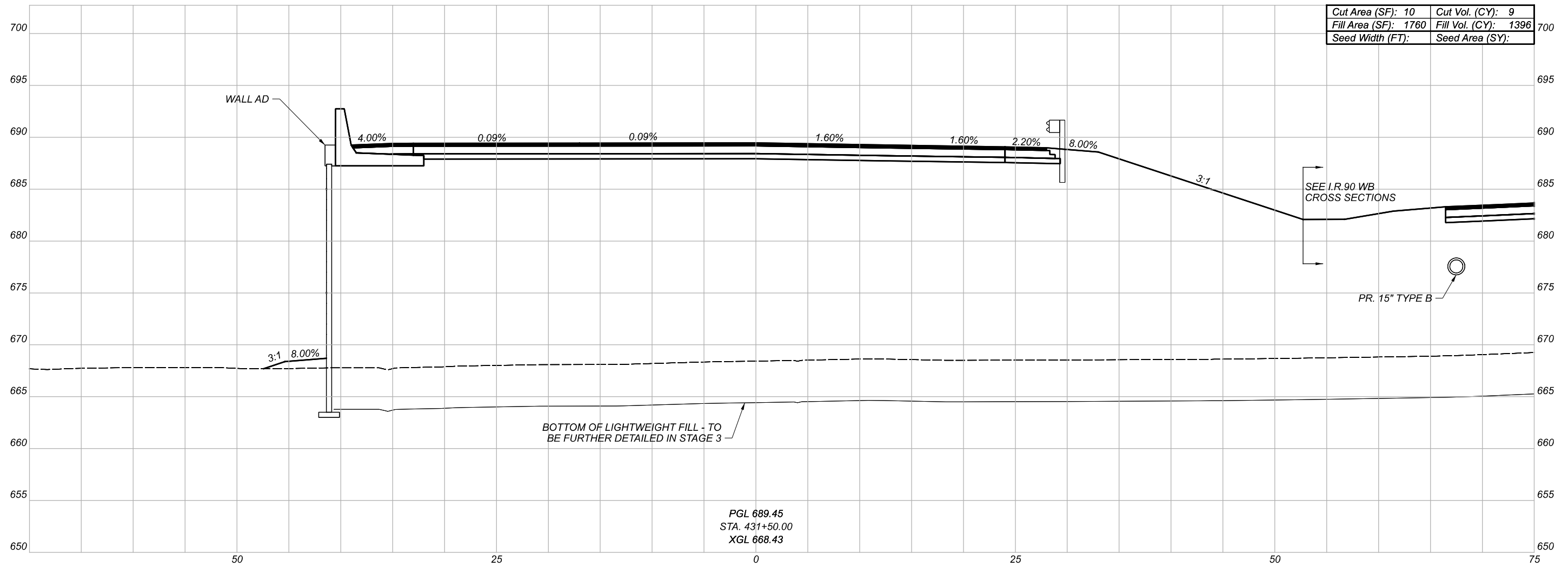

| | |
|----------------------|----------------------|
| Cut Area (SF): 10 | Cut Vol. (CY): 9 |
| Fill Area (SF): 1760 | Fill Vol. (CY): 1396 |
| Seed Width (FT): | Seed Area (SY): |

PGL 689.45
 STA. 431+50.00
 XGL 668.43

CROSS SECTIONS
 RAMP A2

DESIGN AGENCY



DESIGNER

REVIEWER

PROJECT ID

82382

| Sheet Totals | | | SHEET | TOTAL |
|--------------|-----|------|-------|-------|
| Seeding | Cut | Fill | | |
| . | . | . | 638 | 2339 |

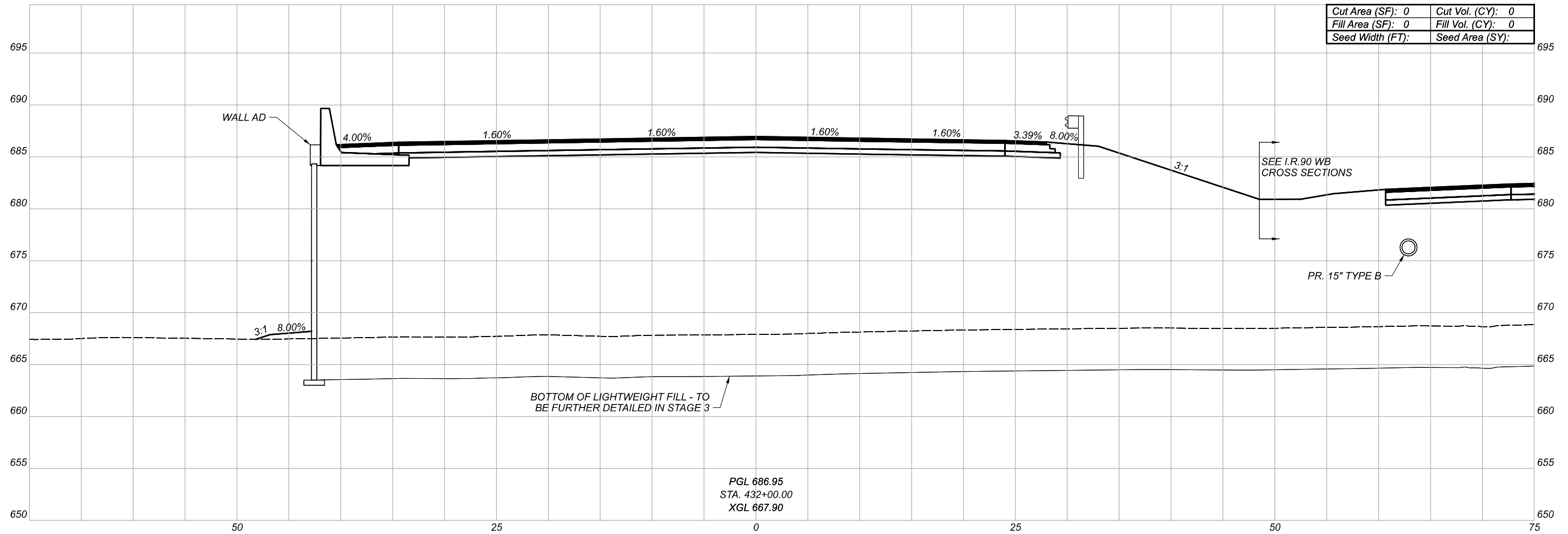

| | |
|-------------------|-------------------|
| Cut Area (SF): 0 | Cut Vol. (CY): 0 |
| Fill Area (SF): 0 | Fill Vol. (CY): 0 |
| Seed Width (FT): | Seed Area (SY): |

PGL 686.95
 STA. 432+00.00
 XGL 667.90

CROSS SECTIONS
 RAMP A2

DESIGN AGENCY



DESIGNER

REVIEWER

PROJECT ID

82382

| Sheet Totals | | | SHEET | TOTAL |
|--------------|-----|------|-------|-------|
| Seeding | Cut | Fill | | |
| . | . | . | 639 | 2339 |

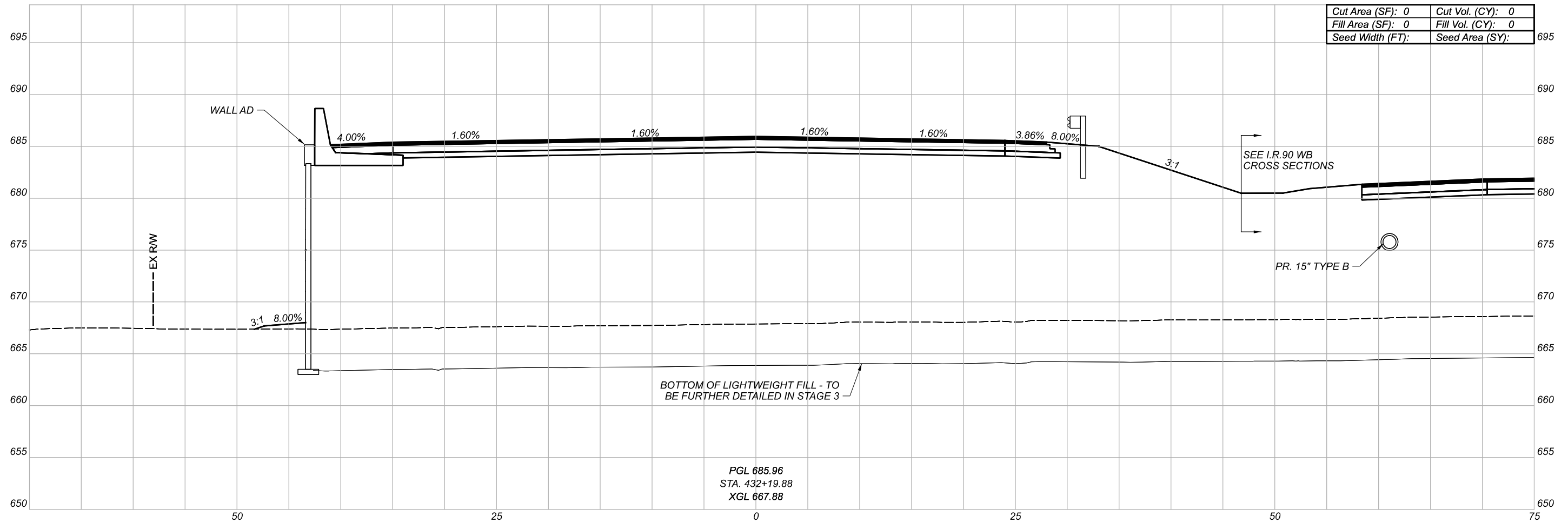

BOTTOM OF LIGHTWEIGHT FILL - TO BE FURTHER DETAILED IN STAGE 3

PGL 685.96
 STA. 432+19.88
 XGL 667.88

| | | | |
|------------------|---|-----------------|---|
| Cut Area (SF): | 0 | Cut Vol. (CY): | 0 |
| Fill Area (SF): | 0 | Fill Vol. (CY): | 0 |
| Seed Width (FT): | | Seed Area (SY): | |

SEE I.R. 90 WB CROSS SECTIONS

PR. 15" TYPE B

| Sheet Totals | | | PROJECT ID | |
|--------------|-----|------|------------|-------|
| Seeding | Cut | Fill | SHEET | TOTAL |
| . | . | . | 640 | 2339 |

DESIGN AGENCY



DESIGNER

REVIEWER

PROJECT ID

82382

SHEET TOTAL

640 2339

CROSS SECTIONS
 RAMP A2

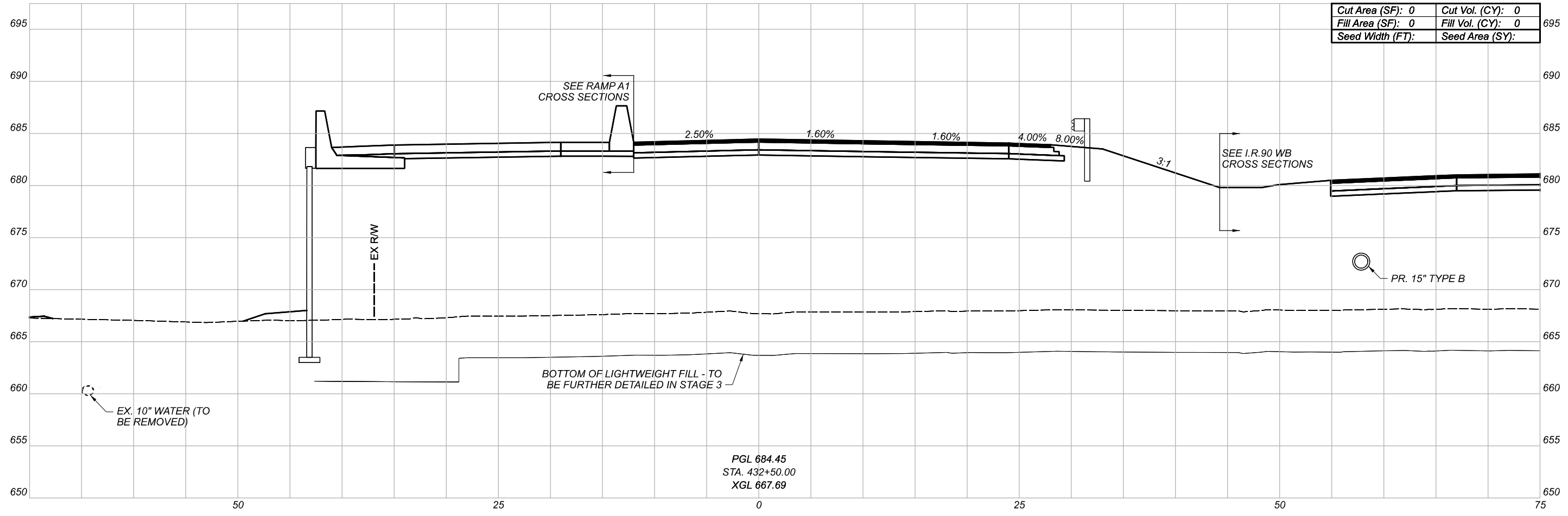

| | |
|-------------------|-------------------|
| Cut Area (SF): 0 | Cut Vol. (CY): 0 |
| Fill Area (SF): 0 | Fill Vol. (CY): 0 |
| Seed Width (FT): | Seed Area (SY): |

CROSS SECTIONS
RAMP A2

DESIGN AGENCY



DESIGNER

REVIEWER

PROJECT ID

82382

| Sheet Totals | | | SHEET | TOTAL |
|--------------|-----|------|-------|-------|
| Seeding | Cut | Fill | | |
| . | . | . | 641 | 2339 |

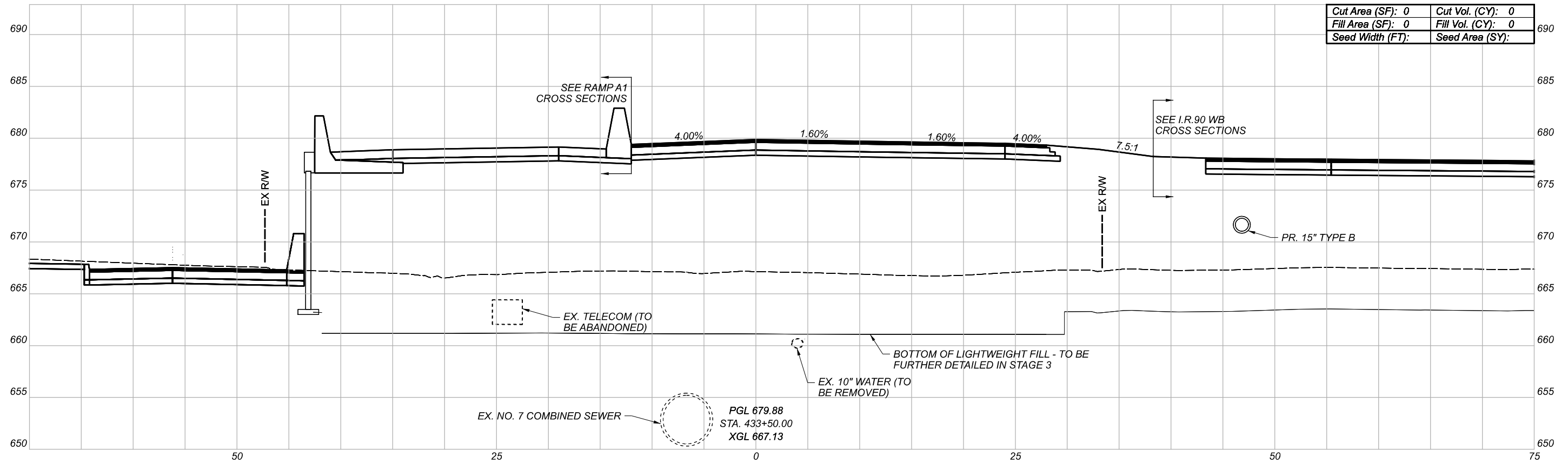

| | | | |
|------------------|---|-----------------|---|
| Cut Area (SF): | 0 | Cut Vol. (CY): | 0 |
| Fill Area (SF): | 0 | Fill Vol. (CY): | 0 |
| Seed Width (FT): | | Seed Area (SY): | |

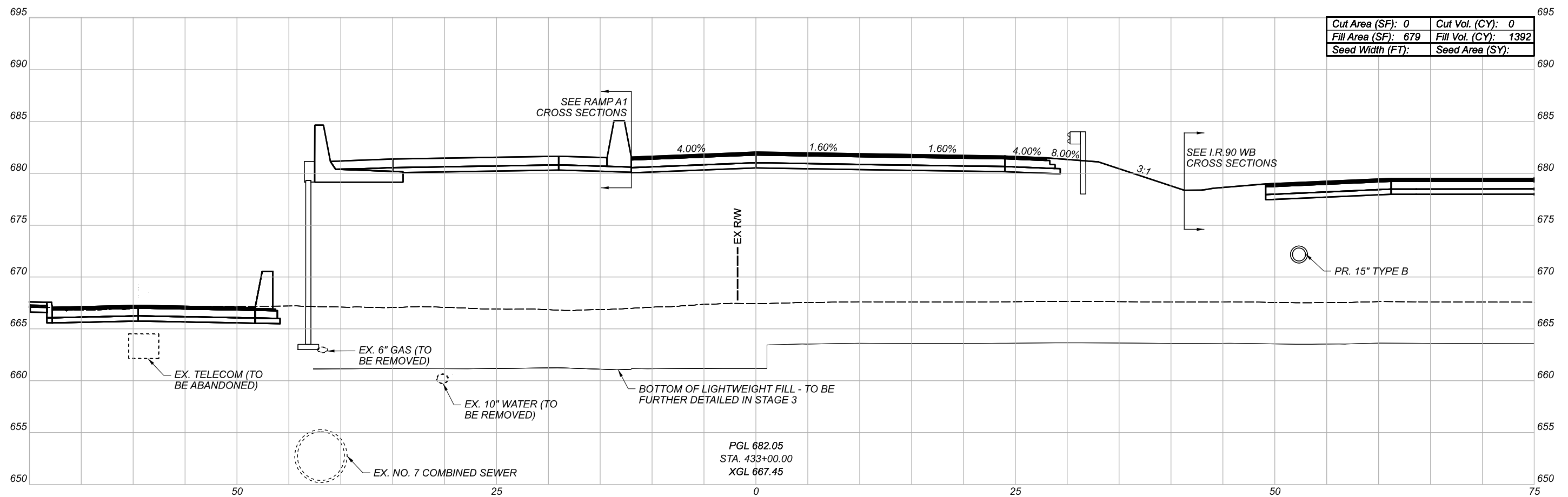

| | | | |
|------------------|-----|-----------------|------|
| Cut Area (SF): | 0 | Cut Vol. (CY): | 0 |
| Fill Area (SF): | 679 | Fill Vol. (CY): | 1392 |
| Seed Width (FT): | | Seed Area (SY): | |

CROSS SECTIONS
RAMP A2

DESIGN AGENCY



DESIGNER

REVIEWER

PROJECT ID

82382

| Sheet Totals | | | SHEET TOTAL | |
|--------------|-----|------|-------------|-------|
| Seeding | Cut | Fill | SHEET | TOTAL |
| . | . | . | 642 | 2339 |

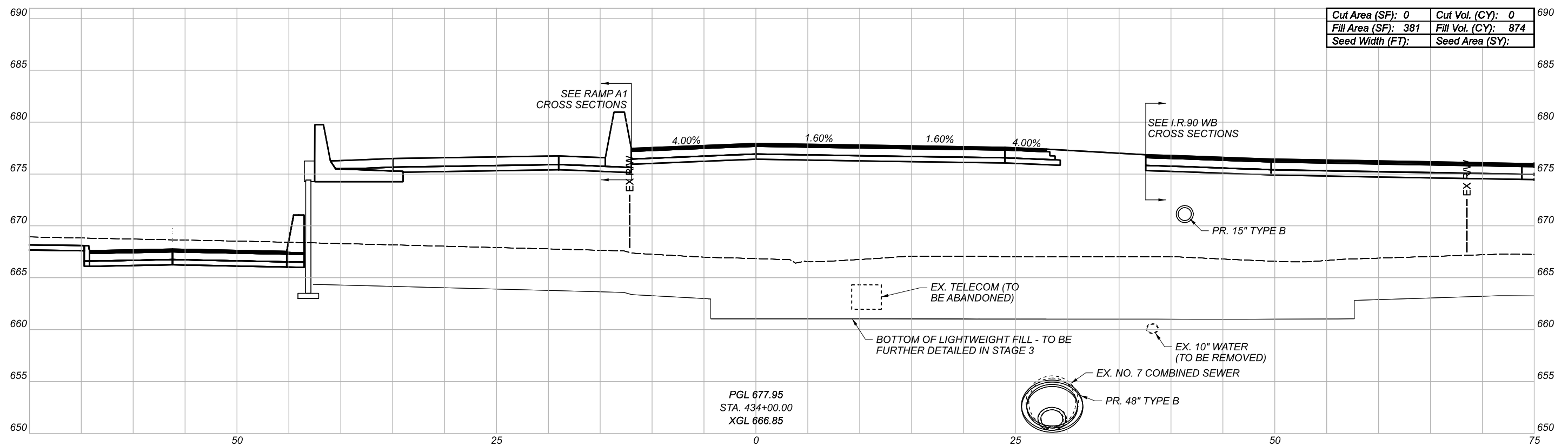
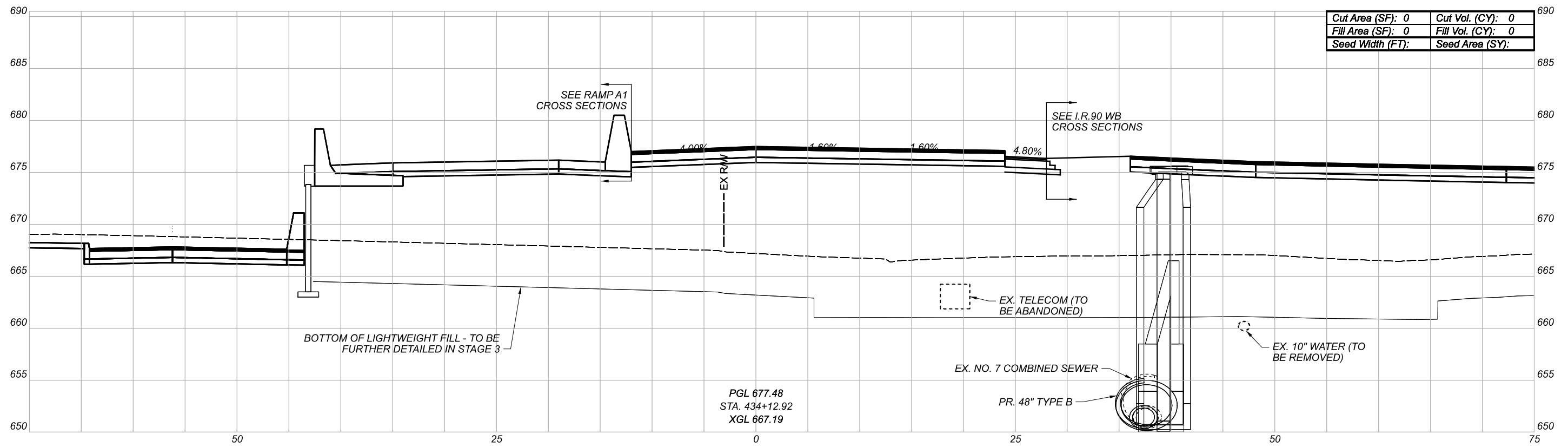

CROSS SECTIONS
RAMP A2

| Sheet Totals | | | SHEET TOTAL | |
|--------------|-----|------|-------------|------|
| Seeding | Cut | Fill | 643 | 2339 |
| . | . | . | | |

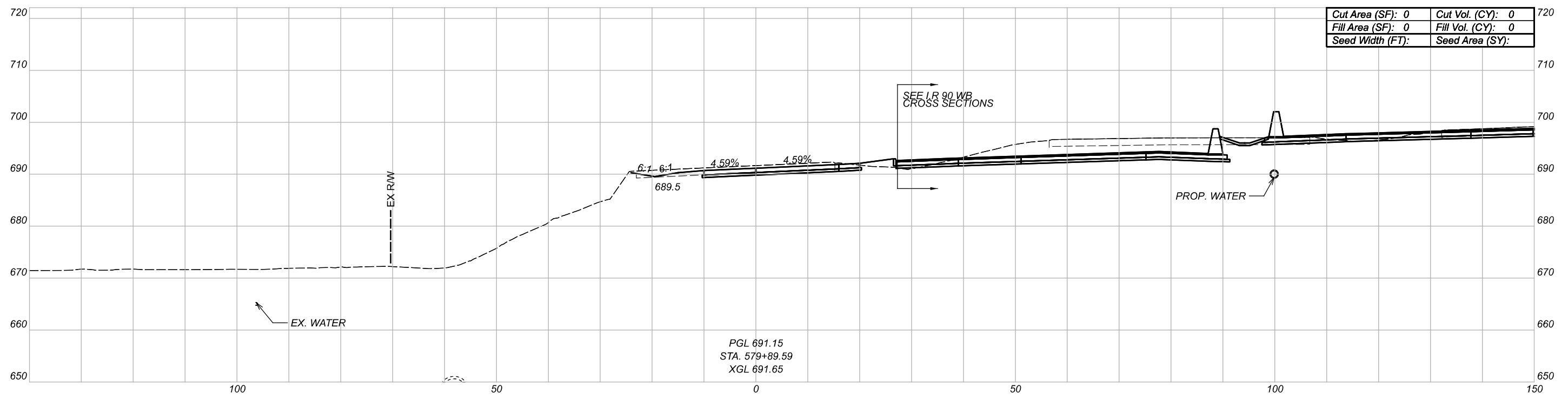
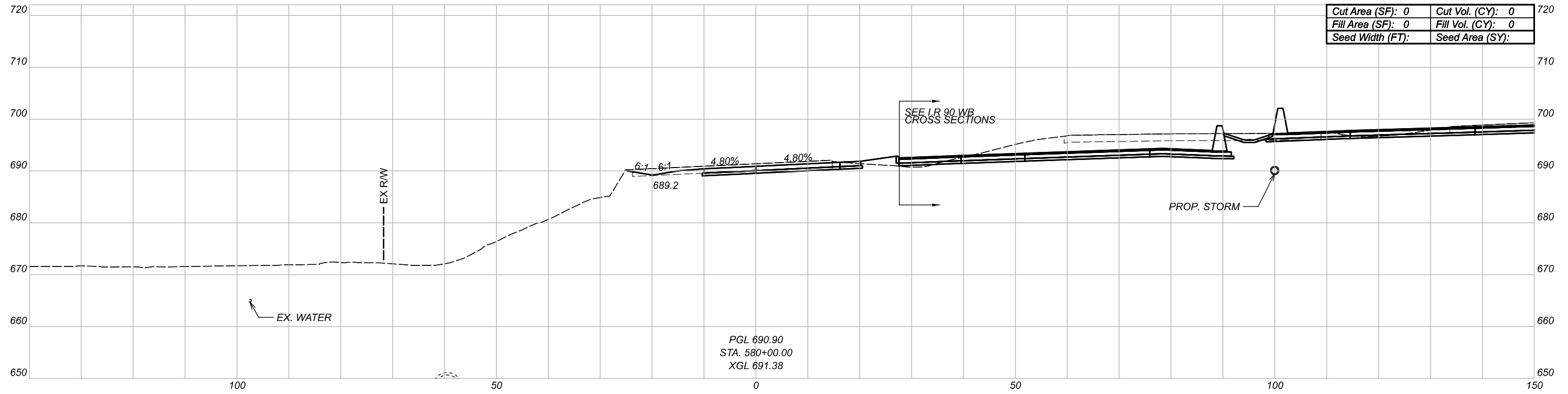

CROSS SECTIONS
RAMP A3

DESIGN AGENCY

BURGESS & NIPLE
100 WEST BIRE STREET
PARMERSVILLE, OHIO 44077

DESIGNER

REVIEWER

PROJECT ID

82382

| Sheet Totals | | | SHEET | TOTAL |
|--------------|-----|------|-------|-------|
| Seeding | Cut | Fill | | |
| . | . | . | 644 | 2339 |

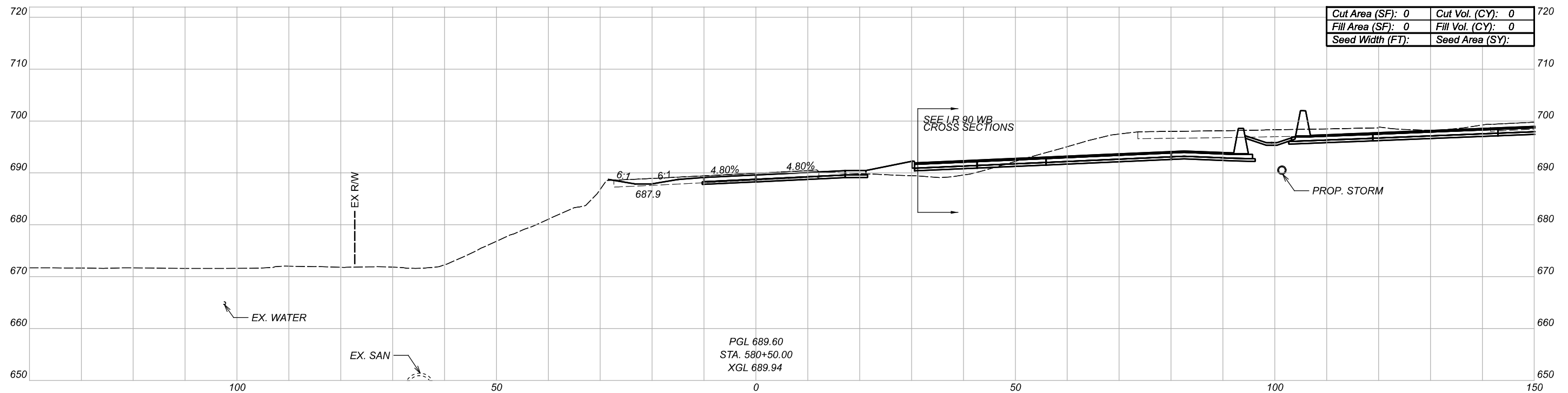
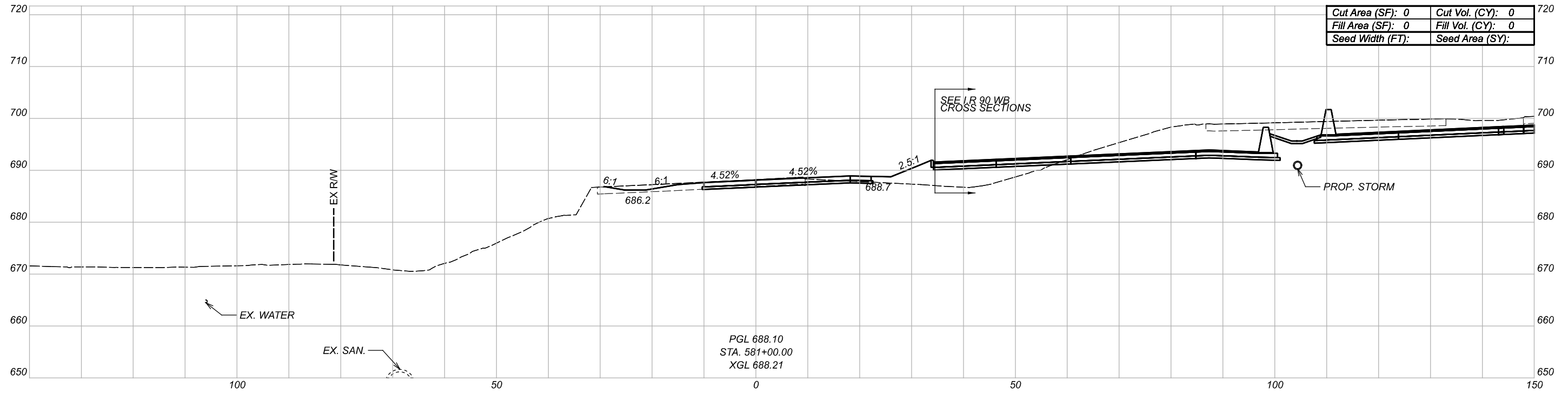

CROSS SECTIONS
RAMP A3

DESIGN AGENCY

BURGESS & NIPLE
100 WEST BIRE STREET
PARMERSVILLE, OHIO 44077

DESIGNER

REVIEWER

PROJECT ID

82382

| Sheet Totals | | | SHEET | TOTAL |
|--------------|-----|------|-------|-------|
| Seeding | Cut | Fill | | |
| . | . | . | 645 | 2339 |

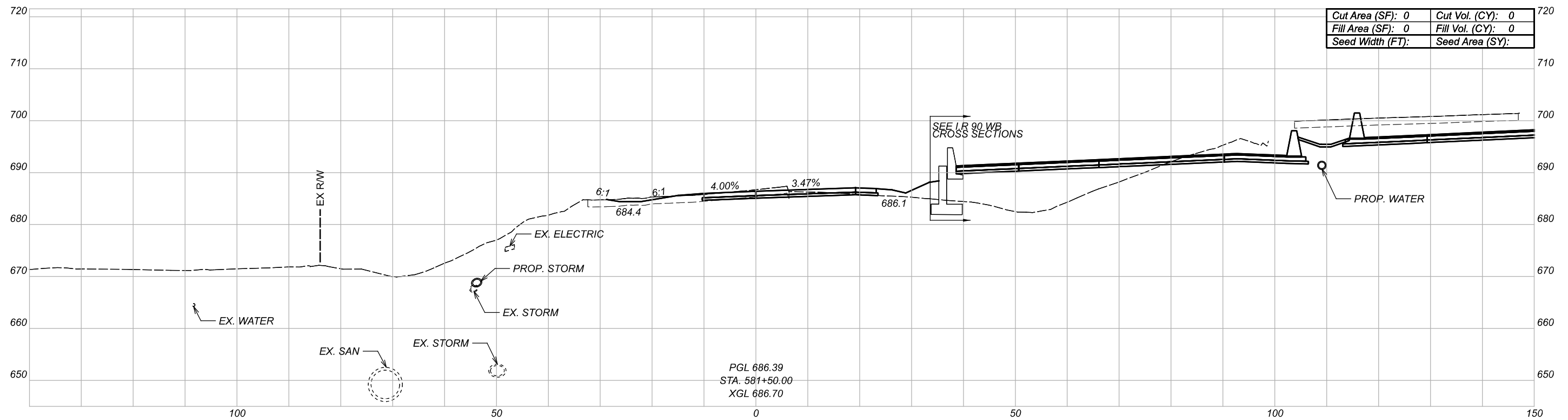
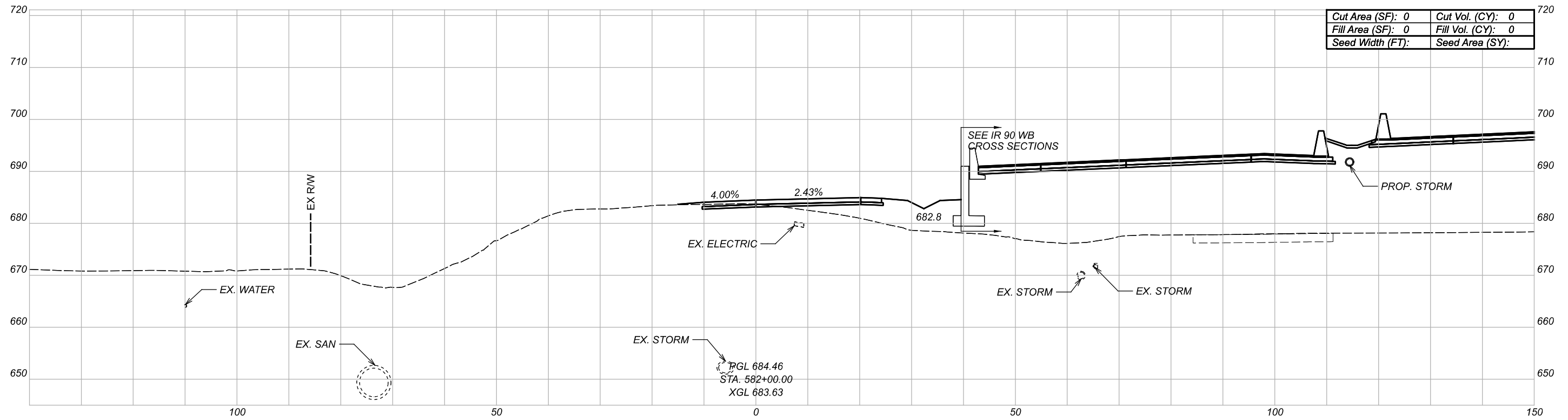

CROSS SECTIONS
RAMP A3

DESIGN AGENCY

BURGESS & NIPLE
100 WEST BIRE STREET
PARMESVILLE, OHIO 44077

DESIGNER

REVIEWER

PROJECT ID

82382

| Sheet Totals | | | SHEET | TOTAL |
|--------------|-----|------|-------|-------|
| Seeding | Cut | Fill | | |
| . | . | . | 646 | 2339 |

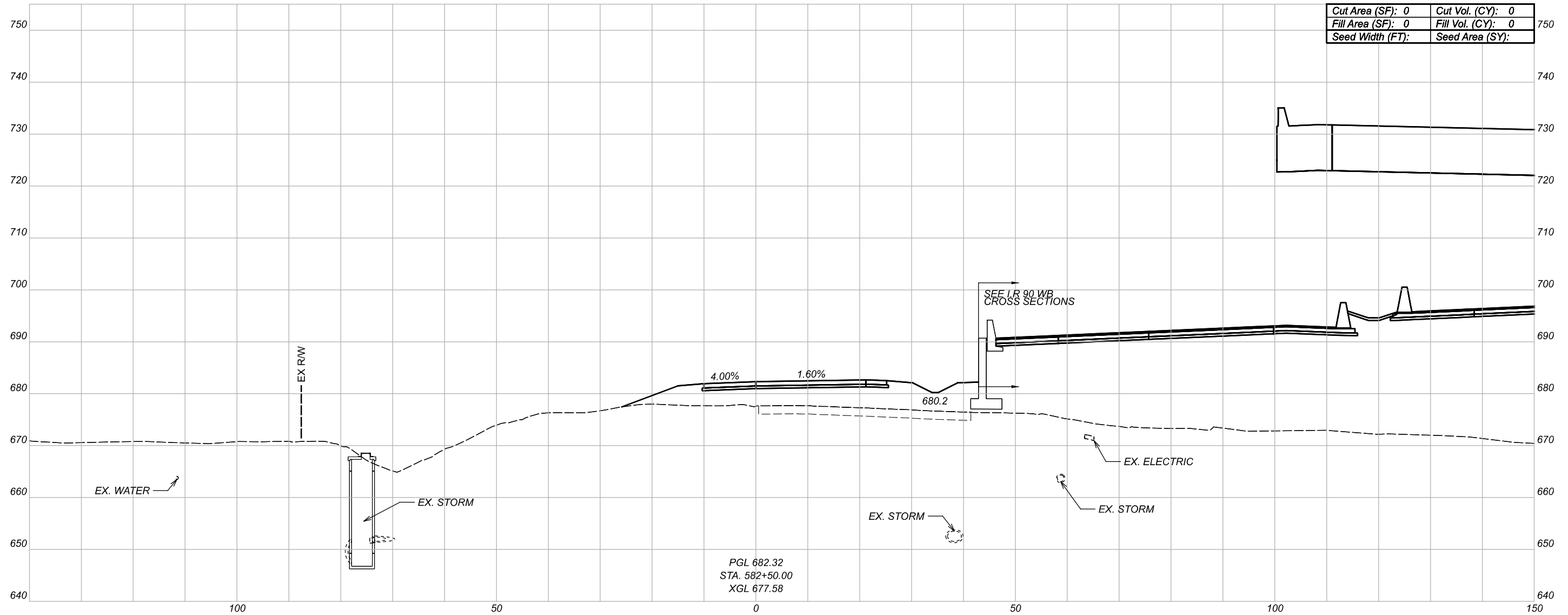

PGL 682.32
 STA. 582+50.00
 XGL 677.58

CROSS SECTIONS
 RAMP A3

DESIGN AGENCY

BURGESS & NIPLE
 100 WEST BIRE STREET
 PAINESVILLE, OHIO 44077

DESIGNER

REVIEWER

PROJECT ID

82382

| Sheet Totals | | | SHEET | TOTAL |
|--------------|-----|------|-------|-------|
| Seeding | Cut | Fill | | |
| . | . | . | 647 | 2339 |



| | |
|-------------------|-------------------|
| Cut Area (SF): 0 | Cut Vol. (CY): 0 |
| Fill Area (SF): 0 | Fill Vol. (CY): 0 |
| Seed Width (FT): | Seed Area (SY): |

PGL 679.97
 STA. 583+00.00
 XGL 675.99

CROSS SECTIONS
 RAMP A3

DESIGN AGENCY
BURGESS & NIPLE
 100 WEST BIRE STREET
 PAINESVILLE, OHIO 44077

DESIGNER
 REVIEWER
 PROJECT ID
 82382

| Sheet Totals | | | SHEET | TOTAL |
|--------------|-----|------|-------|-------|
| Seeding | Cut | Fill | | |
| . | . | . | 648 | 2339 |

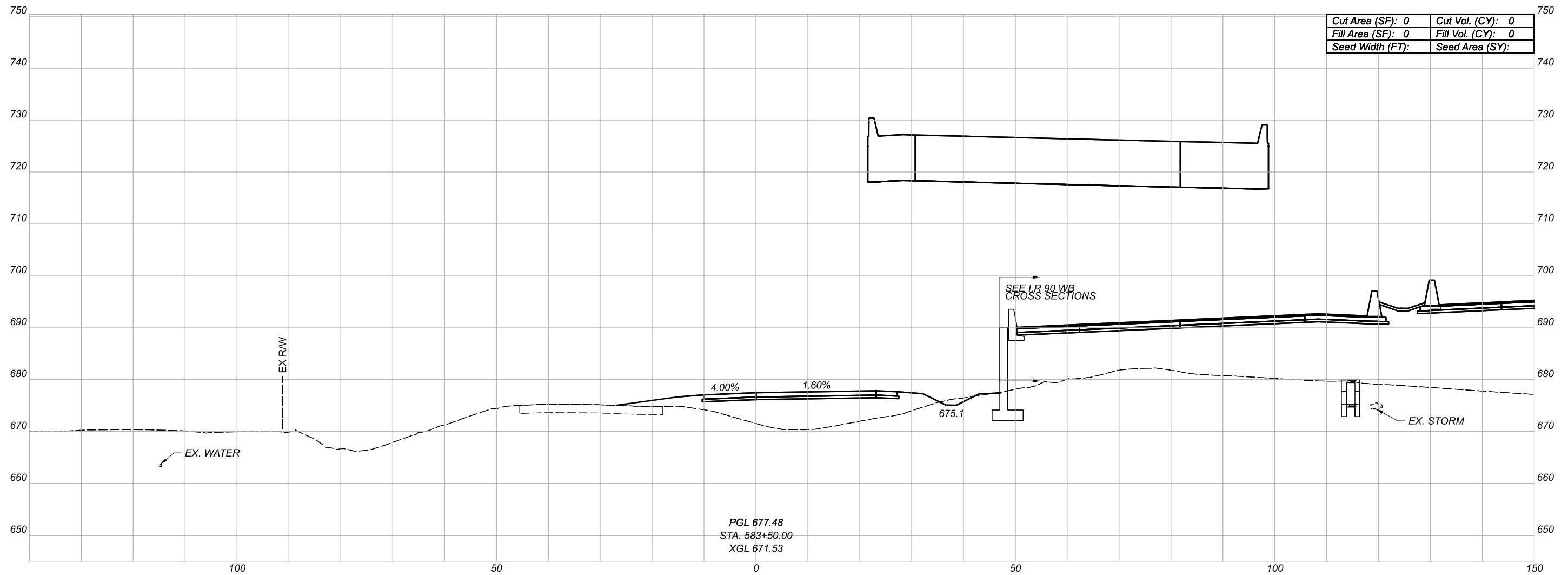

PGL 677.48
 STA. 583+50.00
 XGL 671.53

| | |
|-------------------|-------------------|
| Cut Area (SF): 0 | Cut Vol. (CY): 0 |
| Fill Area (SF): 0 | Fill Vol. (CY): 0 |
| Seed Width (FT): | Seed Area (SY): |

CROSS SECTIONS
 RAMP A3

DESIGN AGENCY

BURGESS & NIPLE
 100 WEST BIRE STREET
 PAINESVILLE, OHIO 44077

DESIGNER

REVIEWER

PROJECT ID

82382

| Sheet Totals | | | SHEET | TOTAL |
|--------------|-----|------|-------|-------|
| Seeding | Cut | Fill | | |
| . | . | . | 649 | 2339 |



| | | | |
|------------------|---|-----------------|---|
| Cut Area (SF): | 0 | Cut Vol. (CY): | 0 |
| Fill Area (SF): | 0 | Fill Vol. (CY): | 0 |
| Seed Width (FT): | | Seed Area (SY): | |

PGL 674.98
 STA. 584+00.00
 XGL 672.37

CROSS SECTIONS
 RAMP A3

DESIGN AGENCY
BURGESS & NIPLE
 100 WEST BIRE STREET
 PAINESVILLE, OHIO 44077

DESIGNER
 REVIEWER
 PROJECT ID
 82382

| Sheet Totals | | | SHEET | TOTAL |
|--------------|-----|------|-------|-------|
| Seeding | Cut | Fill | | |
| . | . | . | 650 | 2339 |

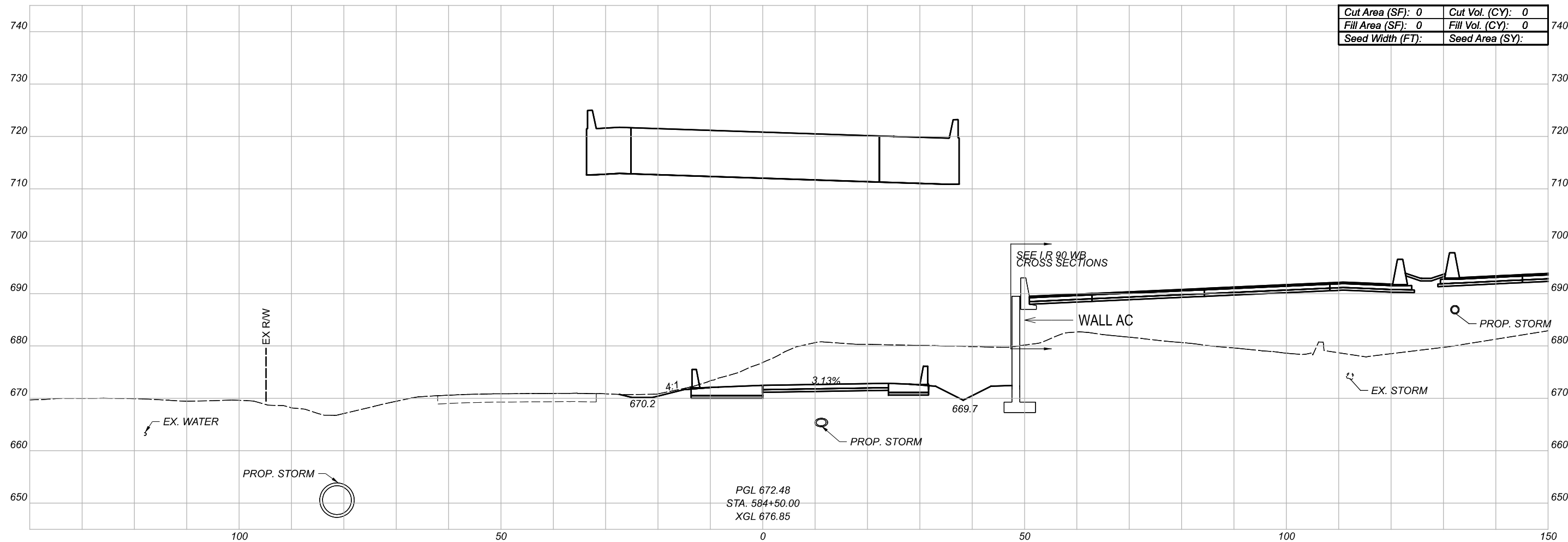

PGL 672.48
 STA. 584+50.00
 XGL 676.85

CROSS SECTIONS
 RAMP A3

DESIGN AGENCY
BURGESS & NIPLE
 100 WEST BIRE STREET
 PAINESVILLE, OHIO 44077

DESIGNER
 REVIEWER
 PROJECT ID
 82382

| Sheet Totals | | | SHEET | TOTAL |
|--------------|-----|------|-------|-------|
| Seeding | Cut | Fill | | |
| . | . | . | 651 | 2339 |

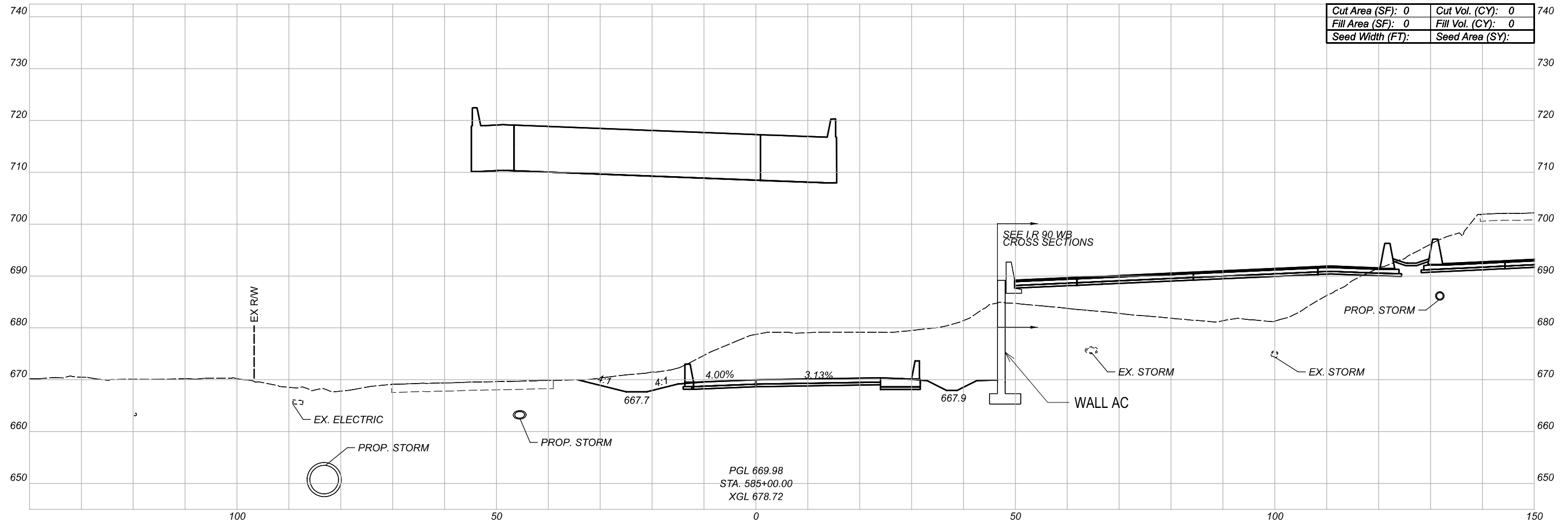

PGL 669.98
 STA. 585+00.00
 XGL 678.72

CROSS SECTIONS
 RAMP A3

DESIGN AGENCY

BURGESS & NIPLE
 100 WEST BIRE STREET
 PAINESVILLE, OHIO 44077

DESIGNER

REVIEWER

PROJECT ID

82382

| Sheet Totals | | | SHEET | TOTAL |
|--------------|-----|------|-------|-------|
| Seeding | Cut | Fill | | |
| . | . | . | 652 | 2339 |

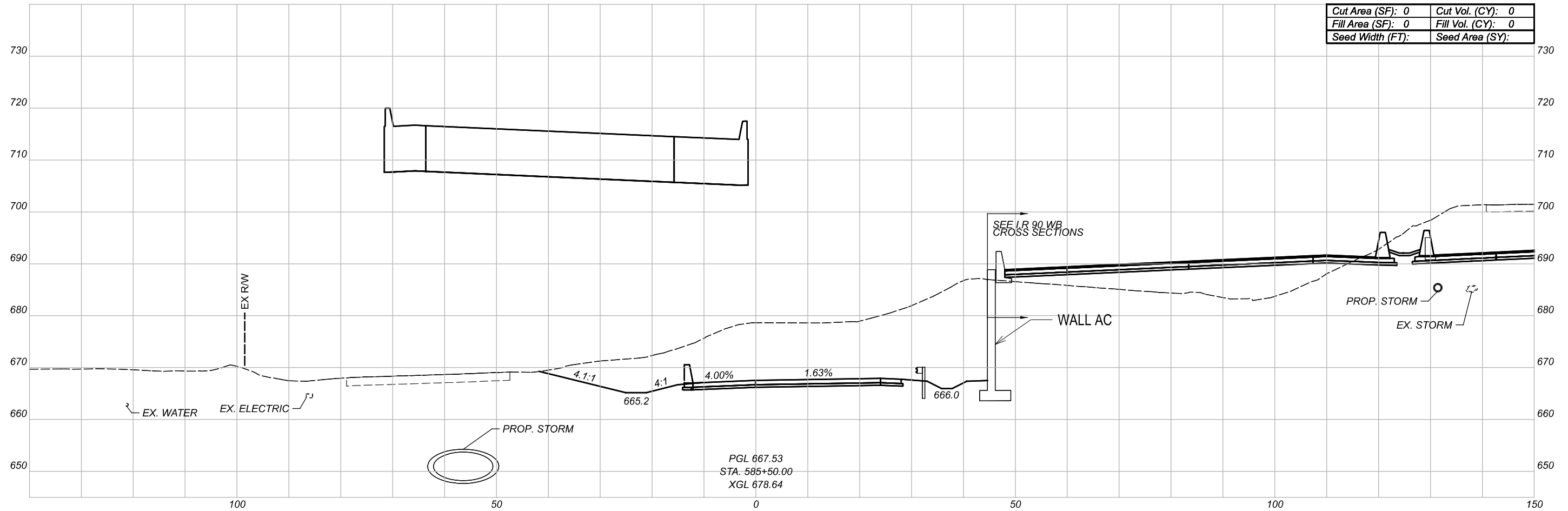

PGL 667.53
 STA. 585+50.00
 XGL 678.64

| | | | |
|------------------|---|-----------------|---|
| Cut Area (SF): | 0 | Cut Vol. (CY): | 0 |
| Fill Area (SF): | 0 | Fill Vol. (CY): | 0 |
| Seed Width (FT): | | Seed Area (SY): | |

CROSS SECTIONS
 RAMP A3

DESIGN AGENCY

BURGESS & NIPLE
 100 WEST BIRE STREET
 PAINESVILLE, OHIO 44077

DESIGNER

REVIEWER

PROJECT ID

82382

| Sheet Totals | | | SHEET | TOTAL |
|--------------|-----|------|-------|-------|
| Seeding | Cut | Fill | | |
| . | . | . | 653 | 2339 |

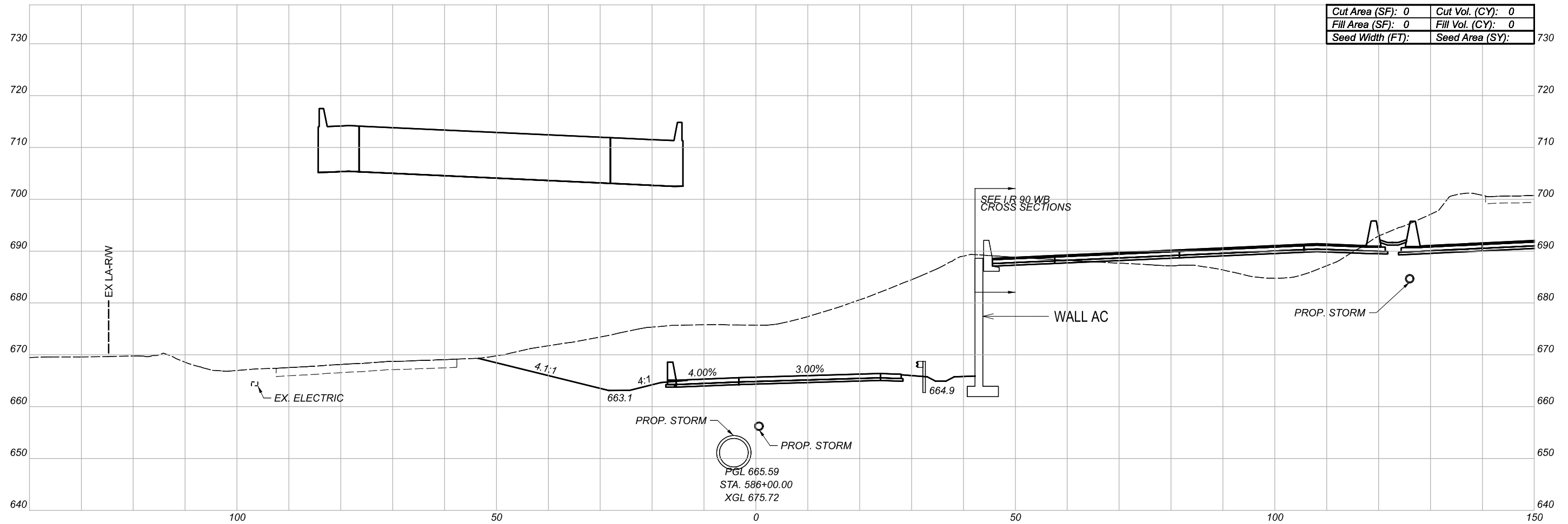

CROSS SECTIONS
RAMP A3

DESIGN AGENCY

BURGESS & NIPLE
 100 WEST BIRCH STREET
 PAINESVILLE, OHIO 44077

DESIGNER

REVIEWER

PROJECT ID

82382

| Sheet Totals | | | SHEET | TOTAL |
|--------------|-----|------|-------|-------|
| Seeding | Cut | Fill | | |
| . | . | . | 654 | 2339 |

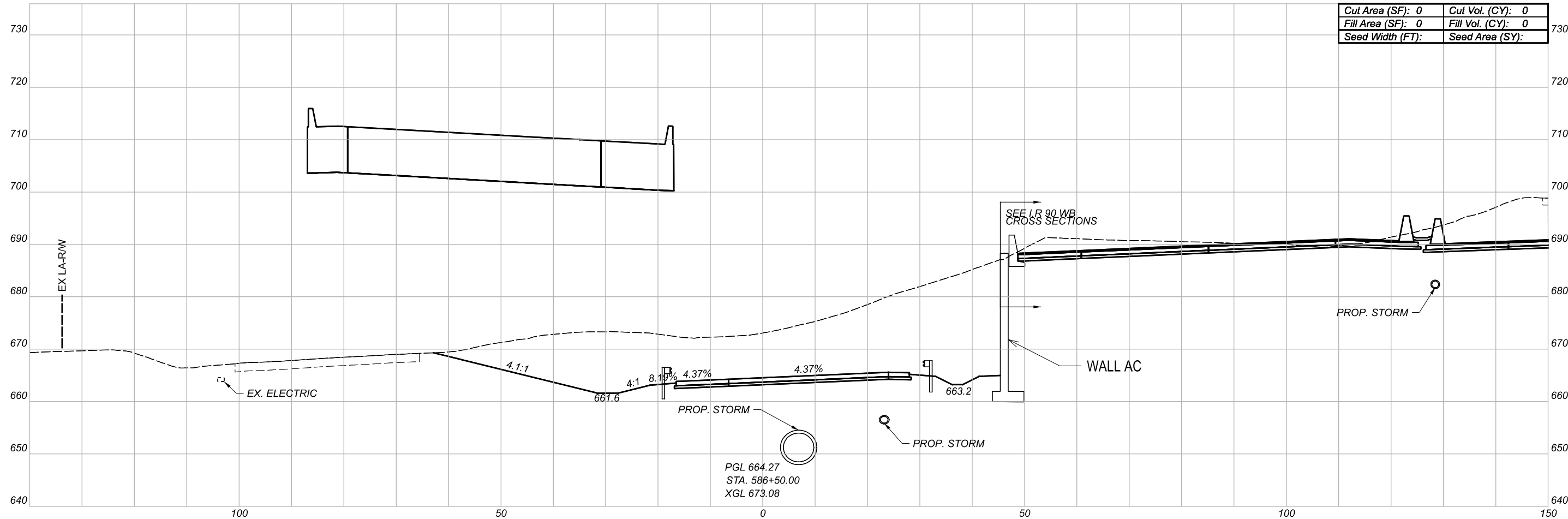

CROSS SECTIONS
RAMP A3

DESIGN AGENCY

BURGESS & NIPLE
 100 WEST BIRCH STREET
 PAINESVILLE, OHIO 44077

DESIGNER

REVIEWER

PROJECT ID

82382

| Sheet Totals | | | SHEET | TOTAL |
|--------------|-----|------|-------|-------|
| Seeding | Cut | Fill | | |
| . | . | . | 655 | 2339 |

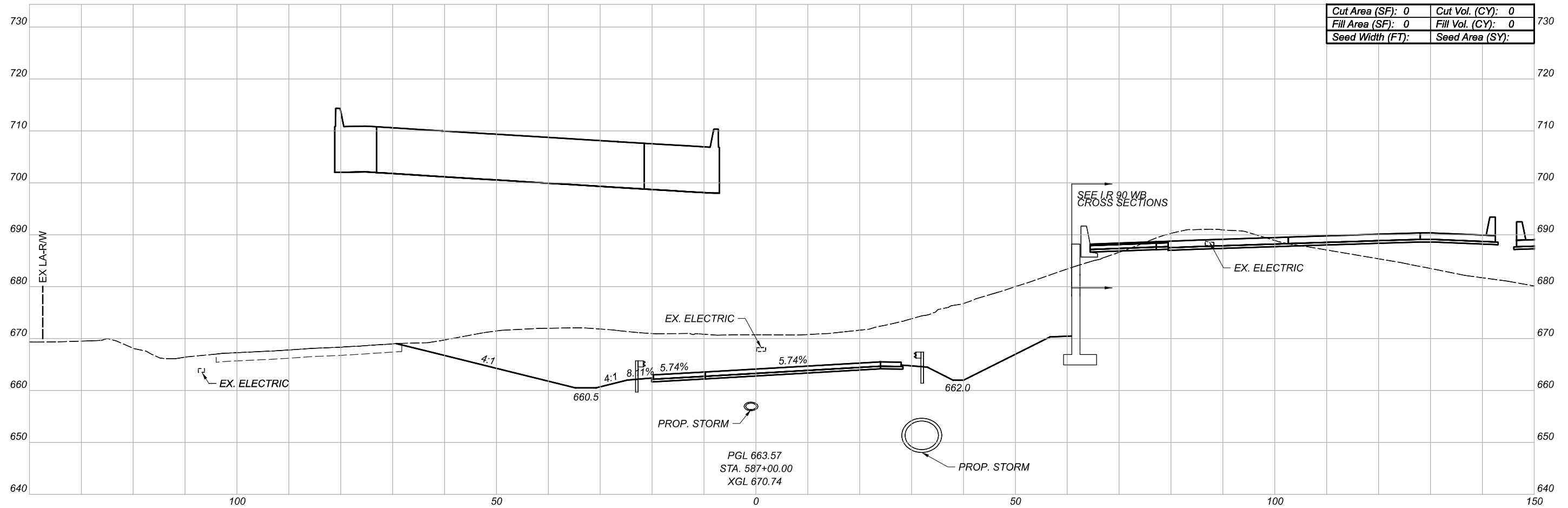

PGL 663.57
 STA. 587+00.00
 XGL 670.74

| | | | |
|------------------|---|-----------------|---|
| Cut Area (SF): | 0 | Cut Vol. (CY): | 0 |
| Fill Area (SF): | 0 | Fill Vol. (CY): | 0 |
| Seed Width (FT): | | Seed Area (SY): | |

CROSS SECTIONS
 RAMP A3

DESIGN AGENCY

BURGESS & NIPLE
 100 WEST BIRE STREET
 PAINESVILLE, OHIO 44077

DESIGNER

REVIEWER

PROJECT ID

82382

| Sheet Totals | | | SHEET | TOTAL |
|--------------|-----|------|-------|-------|
| Seeding | Cut | Fill | 656 | 2339 |

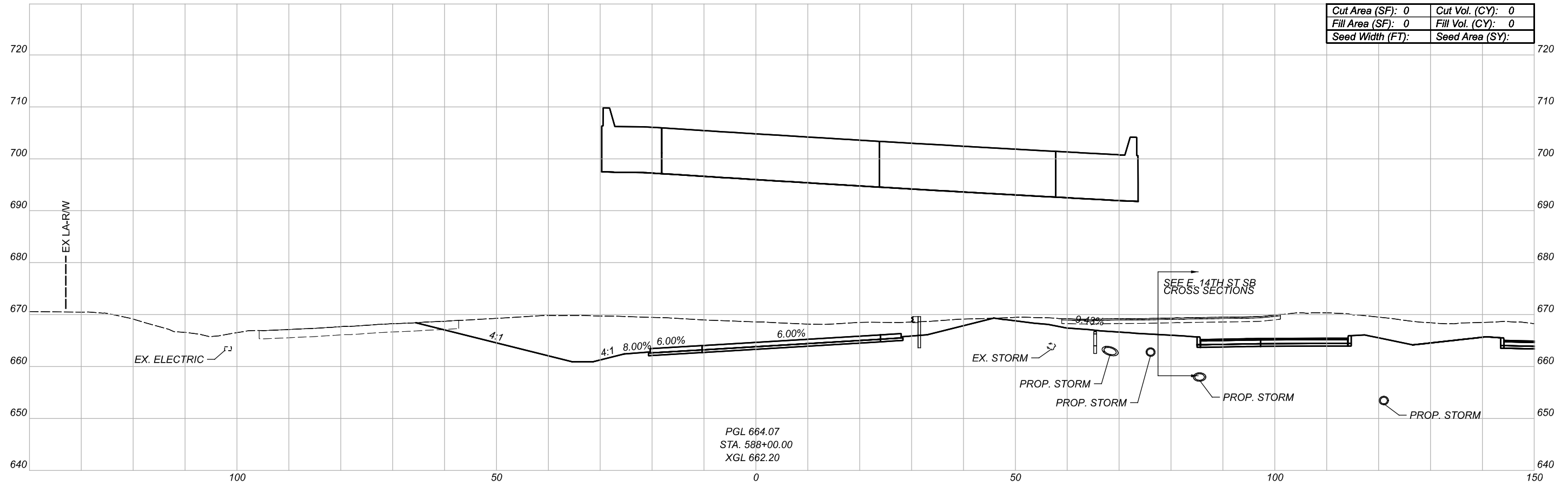

PGL 664.07
 STA. 588+00.00
 XGL 662.20

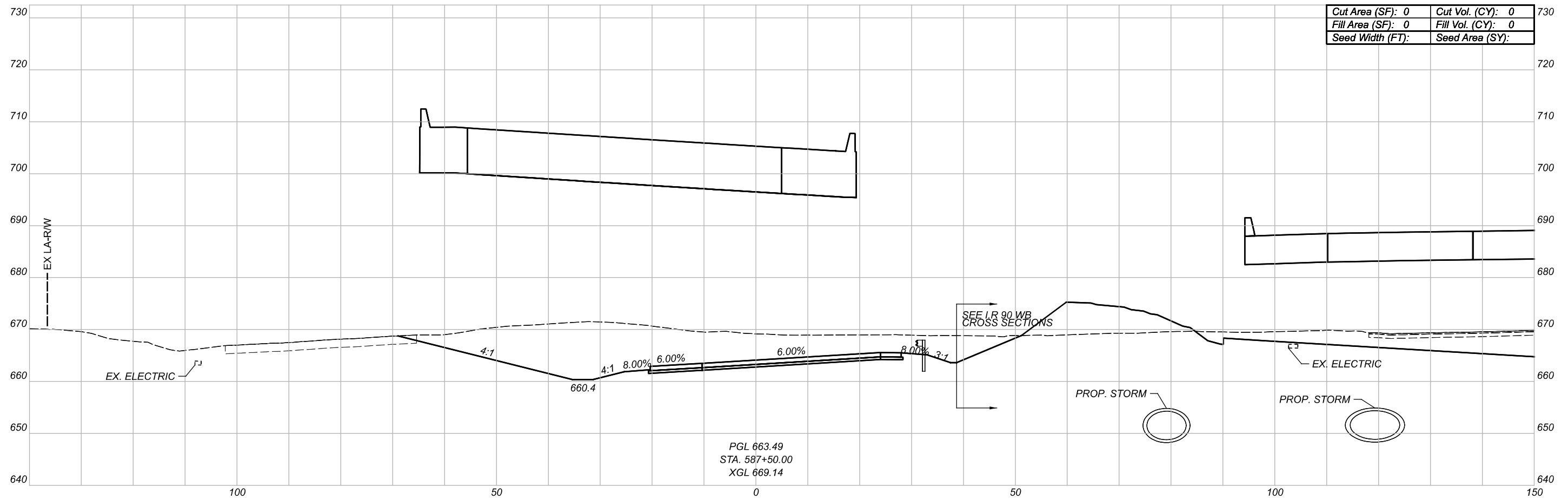

PGL 663.49
 STA. 587+50.00
 XGL 669.14

CROSS SECTIONS
 RAMP A3

DESIGN AGENCY

BURGESS & NIPLE
 100 WEST BIRCH STREET
 PAINESVILLE, OHIO 44077

DESIGNER

REVIEWER

PROJECT ID

82382

| Sheet Totals | | | SHEET | TOTAL |
|--------------|-----|------|-------|-------|
| Seeding | Cut | Fill | | |
| . | . | . | 657 | 2339 |

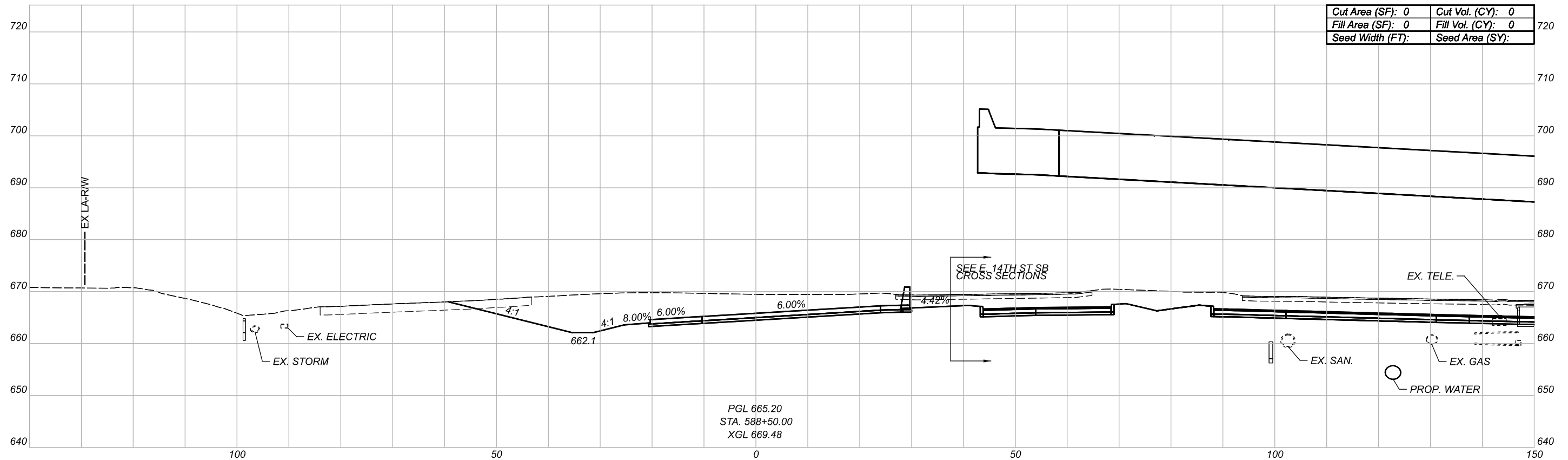
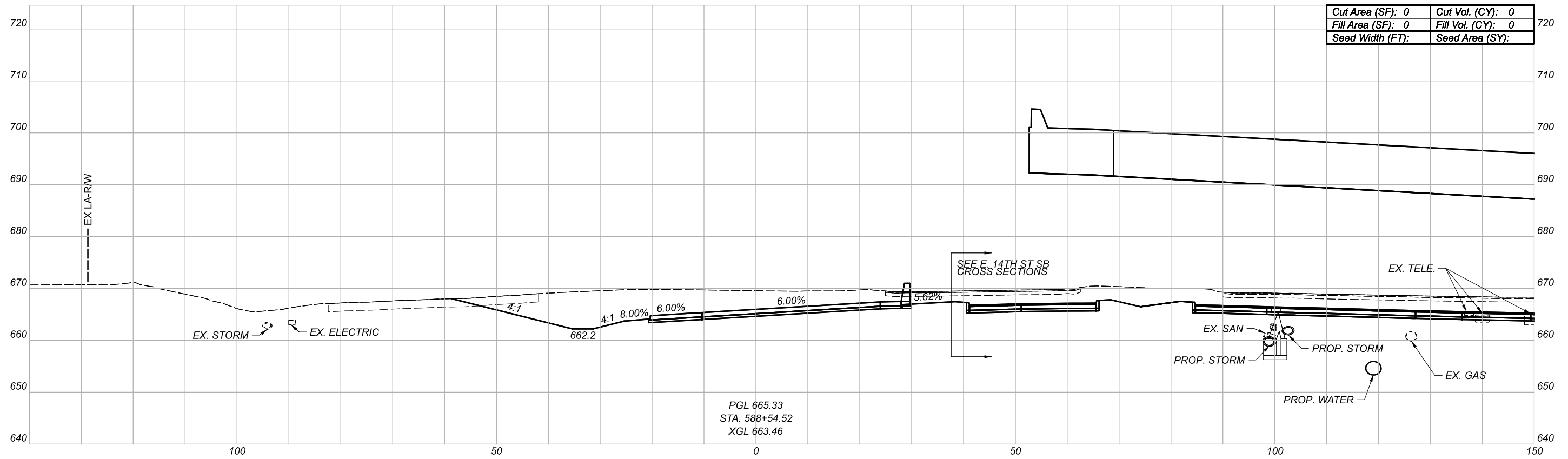

CROSS SECTIONS
RAMP A3

DESIGN AGENCY
BURGESS & NIPLE
100 WEST BIRCH STREET
PAINESVILLE, OHIO 44077

DESIGNER
REVIEWER
PROJECT ID

| Sheet Totals | | | 82382 | |
|--------------|-----|------|-------|-------|
| Seeding | Cut | Fill | SHEET | TOTAL |
| . | . | . | 658 | 2339 |

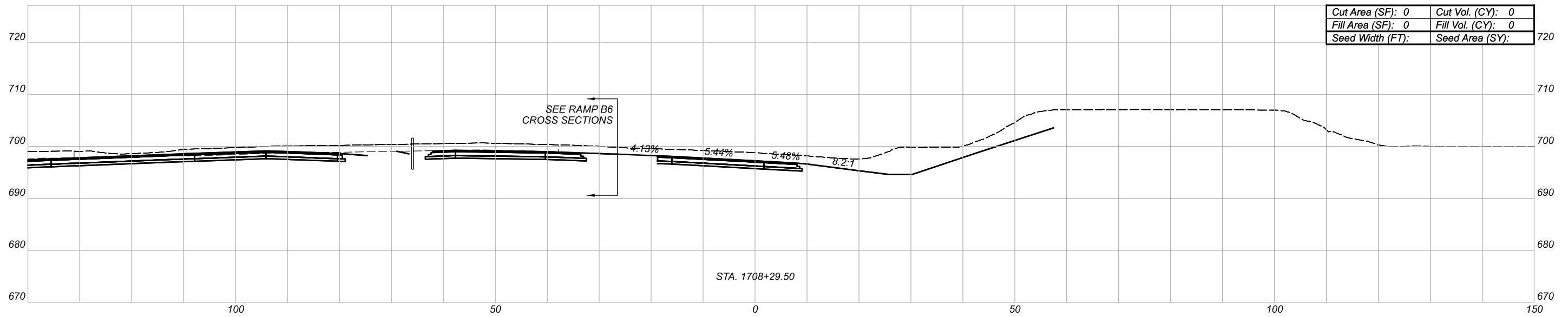
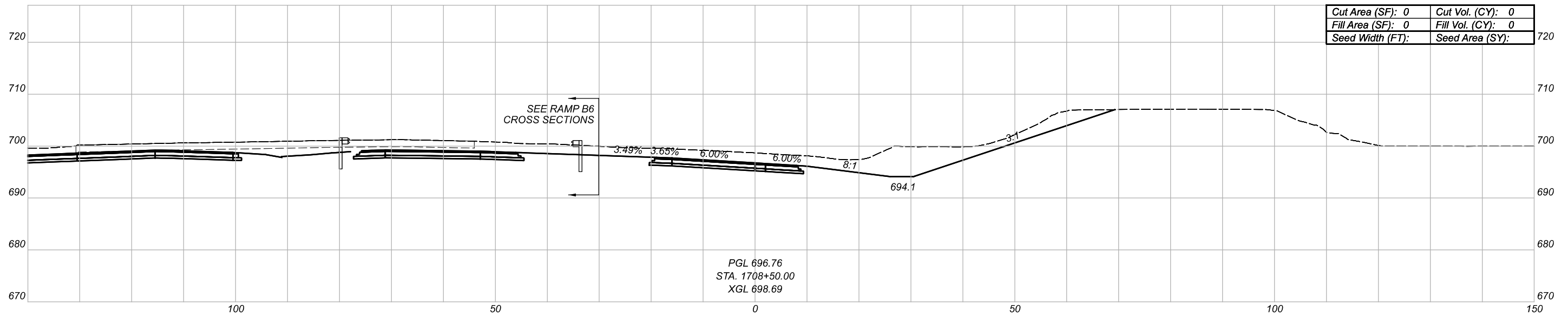
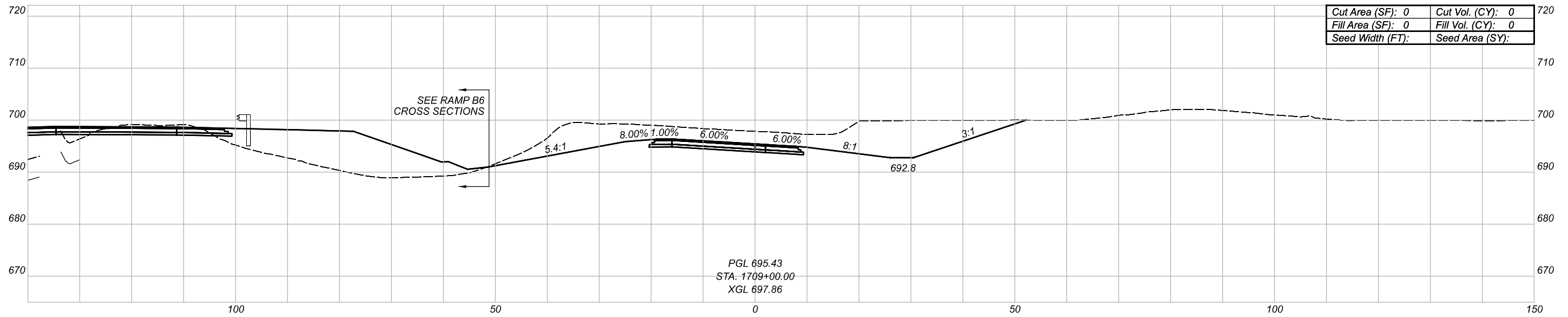

CROSS SECTIONS
RAMP IB5

DESIGN AGENCY



DESIGNER

REVIEWER

PROJECT ID

82382

| Sheet Totals | | | SHEET | TOTAL |
|--------------|-----|------|-------|-------|
| Seeding | Cut | Fill | | |
| . | . | . | 659 | 2339 |

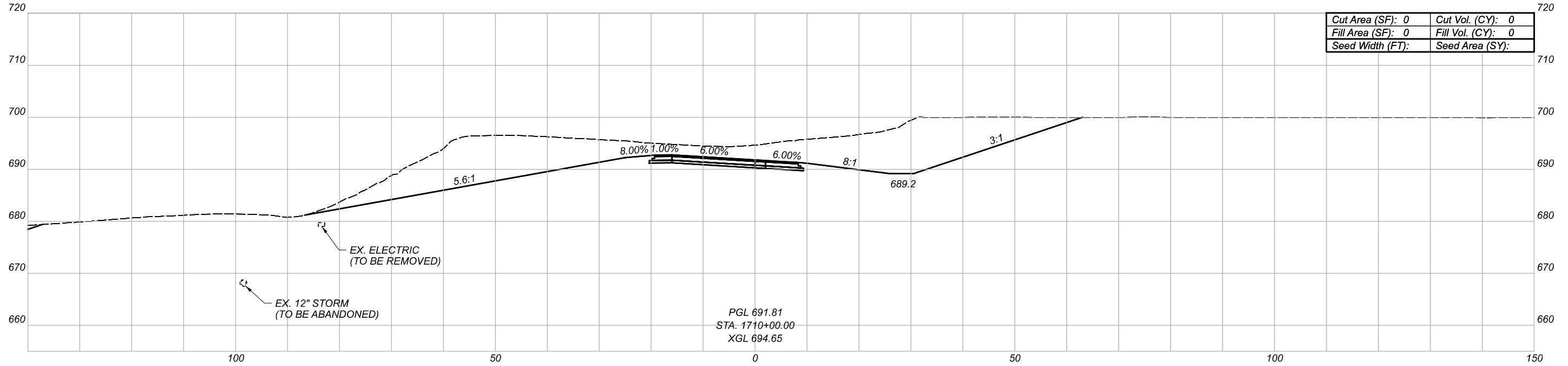

| | | | |
|------------------|---|-----------------|---|
| Cut Area (SF): | 0 | Cut Vol. (CY): | 0 |
| Fill Area (SF): | 0 | Fill Vol. (CY): | 0 |
| Seed Width (FT): | | Seed Area (SY): | |

PGL 691.81
 STA. 1710+00.00
 XGL 694.65

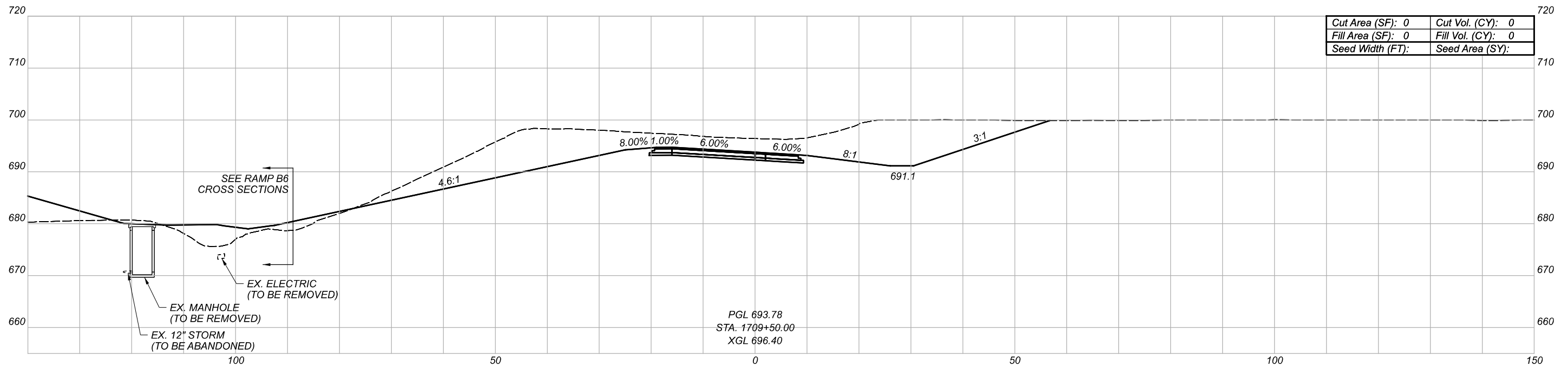

| | | | |
|------------------|---|-----------------|---|
| Cut Area (SF): | 0 | Cut Vol. (CY): | 0 |
| Fill Area (SF): | 0 | Fill Vol. (CY): | 0 |
| Seed Width (FT): | | Seed Area (SY): | |

PGL 693.78
 STA. 1709+50.00
 XGL 696.40

CROSS SECTIONS
 RAMP IB5

DESIGN AGENCY



DESIGNER

REVIEWER

PROJECT ID

82382

| Sheet Totals | | | SHEET | TOTAL |
|--------------|-----|------|-------|-------|
| Seeding | Cut | Fill | | |
| . | . | . | 660 | 2339 |

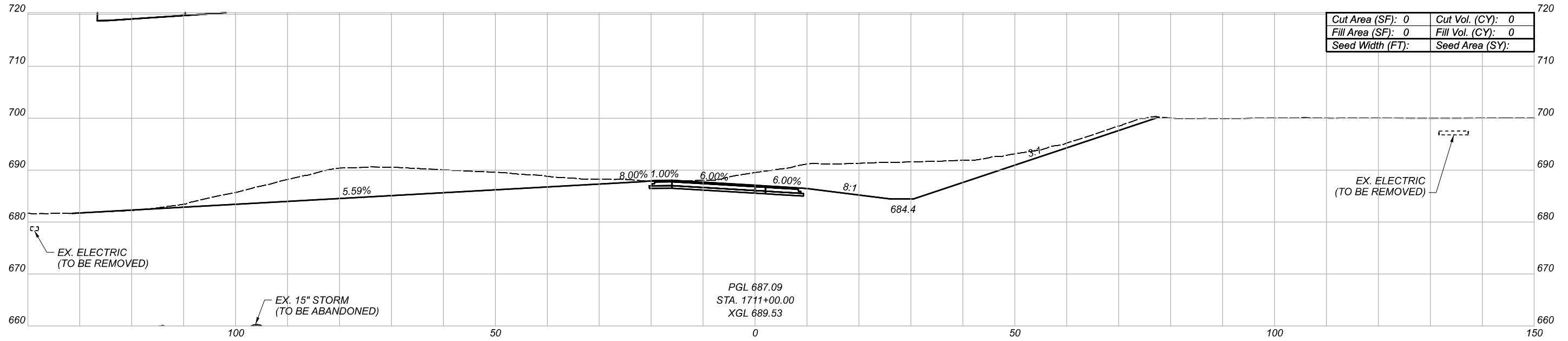

| | | | |
|------------------|---|-----------------|---|
| Cut Area (SF): | 0 | Cut Vol. (CY): | 0 |
| Fill Area (SF): | 0 | Fill Vol. (CY): | 0 |
| Seed Width (FT): | | Seed Area (SY): | |

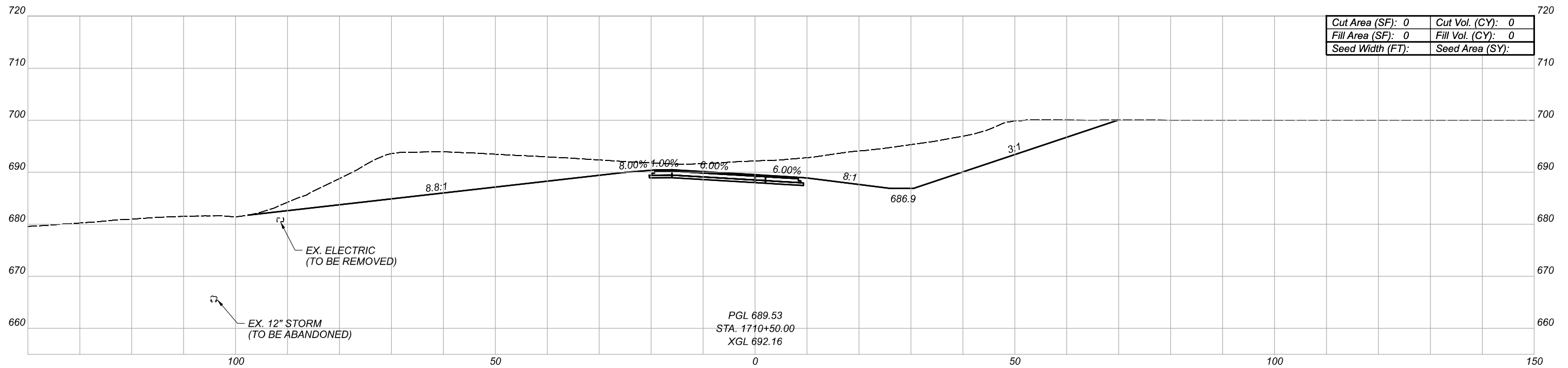

| | | | |
|------------------|---|-----------------|---|
| Cut Area (SF): | 0 | Cut Vol. (CY): | 0 |
| Fill Area (SF): | 0 | Fill Vol. (CY): | 0 |
| Seed Width (FT): | | Seed Area (SY): | |

CROSS SECTIONS
RAMP IB5

DESIGN AGENCY



DESIGNER

REVIEWER

PROJECT ID

82382

| Sheet Totals | | | SHEET | TOTAL |
|--------------|-----|------|-------|-------|
| Seeding | Cut | Fill | | |
| . | . | . | 661 | 2339 |

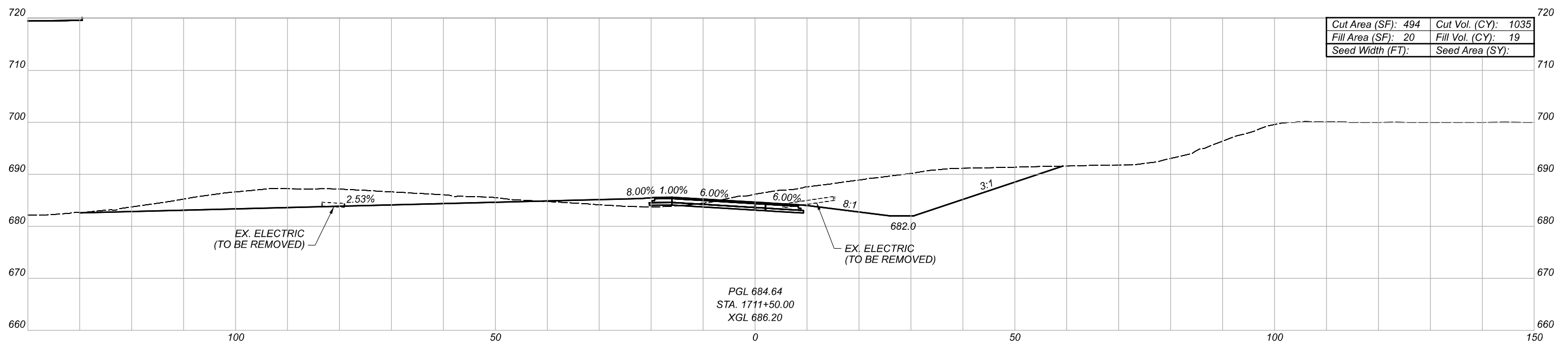
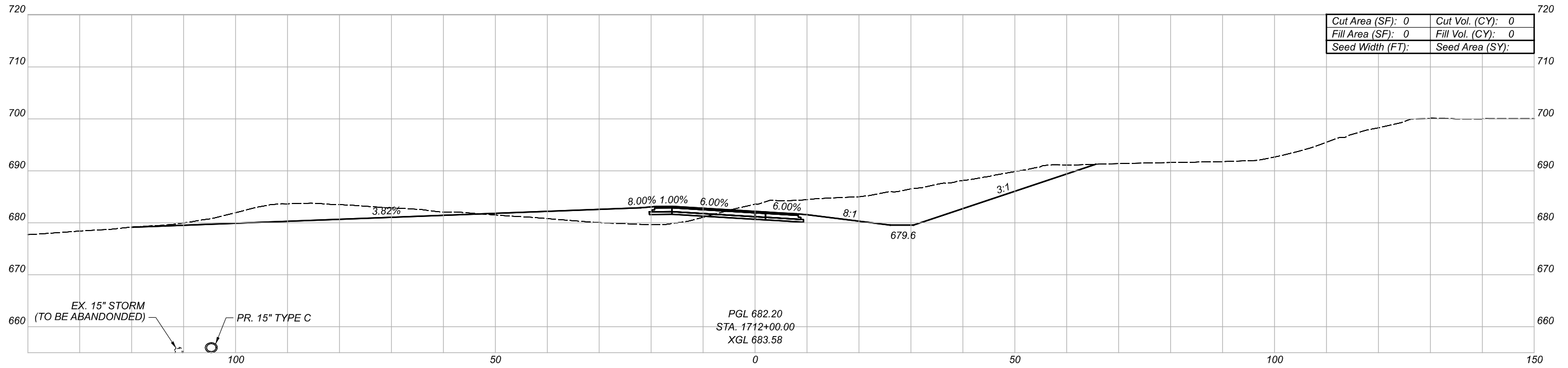

CROSS SECTIONS
RAMP IB5

DESIGN AGENCY



DESIGNER

REVIEWER

PROJECT ID

82382

| Sheet Totals | | | SHEET | TOTAL |
|--------------|-----|------|-------|-------|
| Seeding | Cut | Fill | | |
| . | . | . | 662 | 2339 |

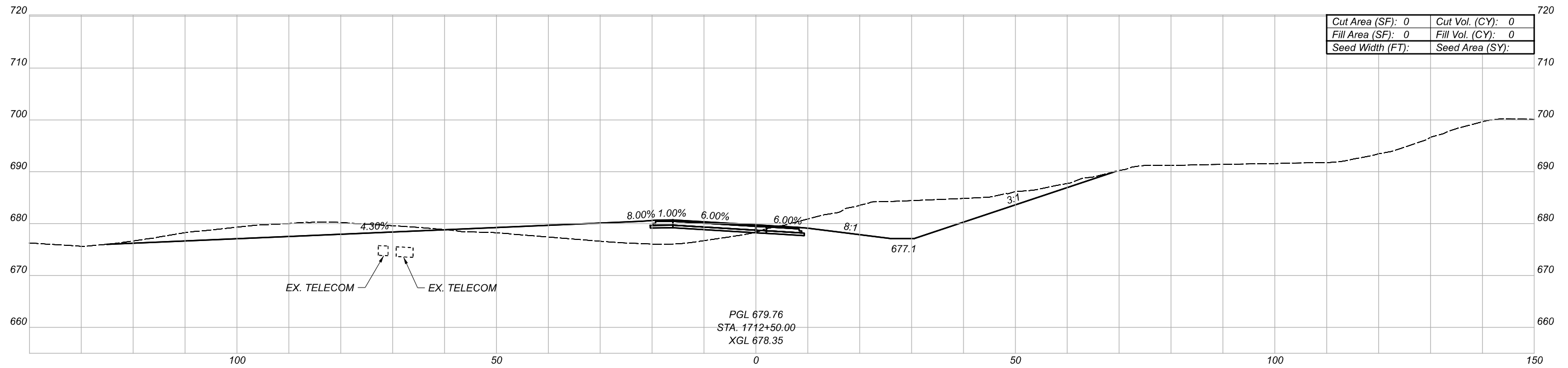
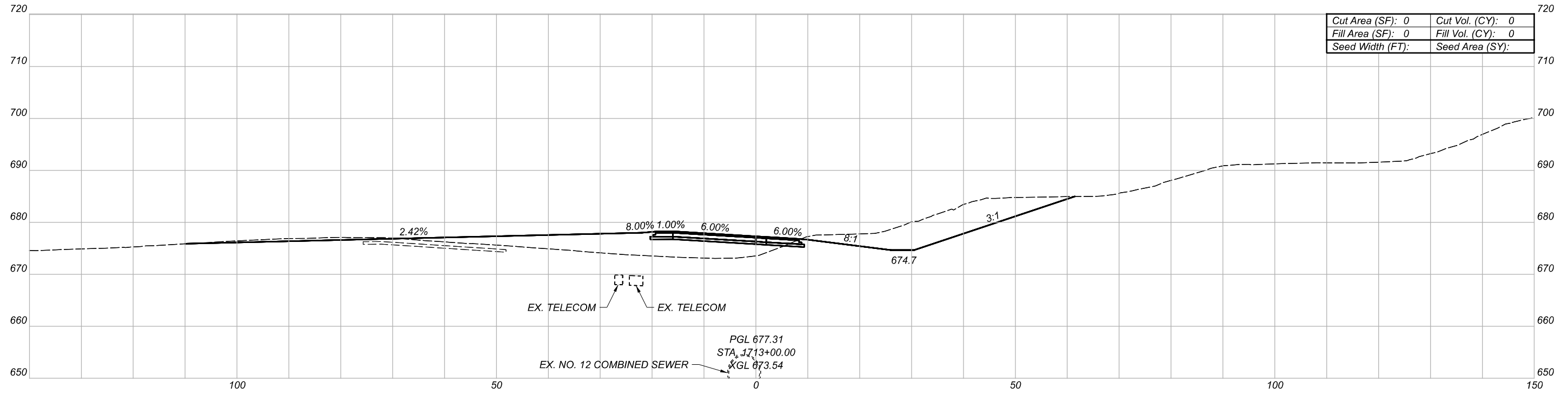

CROSS SECTIONS
RAMP IB5

DESIGN AGENCY



DESIGNER

REVIEWER

PROJECT ID

82382

| Sheet Totals | | | SHEET | TOTAL |
|--------------|-----|------|-------|-------|
| Seeding | Cut | Fill | | |
| . | . | . | 663 | 2339 |

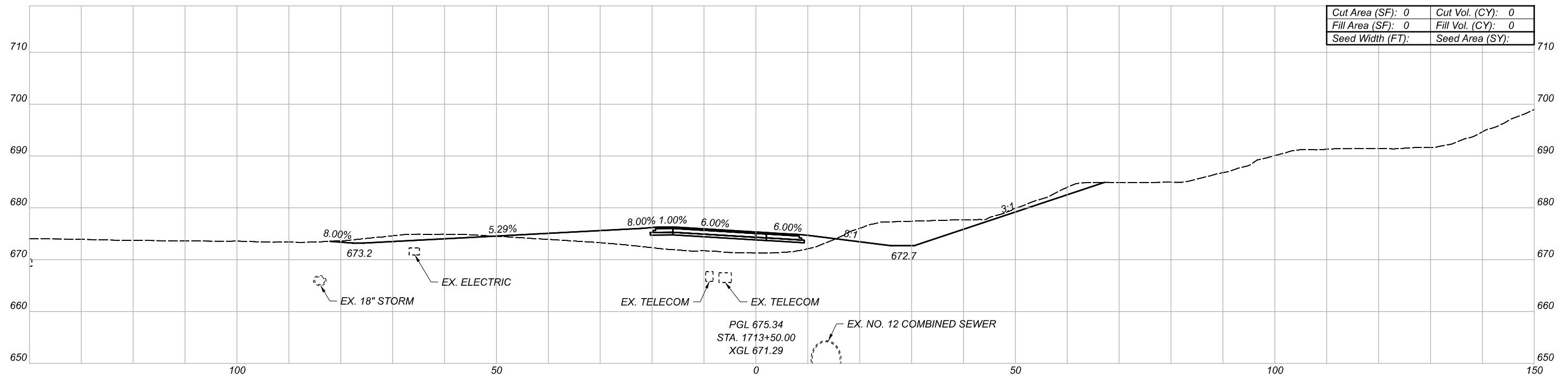
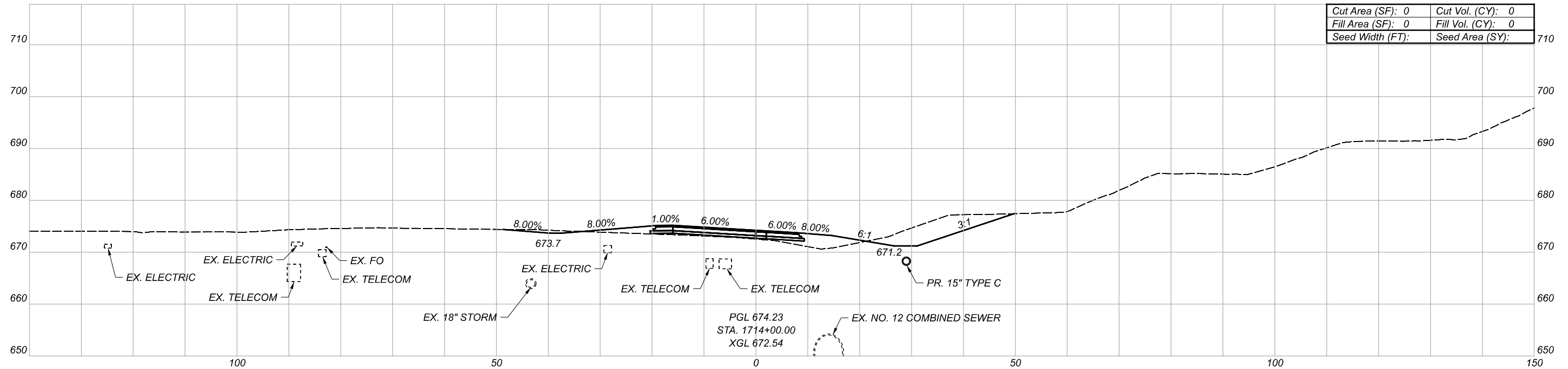

CROSS SECTIONS
RAMP IB5

DESIGN AGENCY



DESIGNER

REVIEWER

PROJECT ID

82382

| Sheet Totals | | | SHEET | TOTAL |
|--------------|-----|------|-------|-------|
| Seeding | Cut | Fill | | |
| . | . | . | 664 | 2339 |

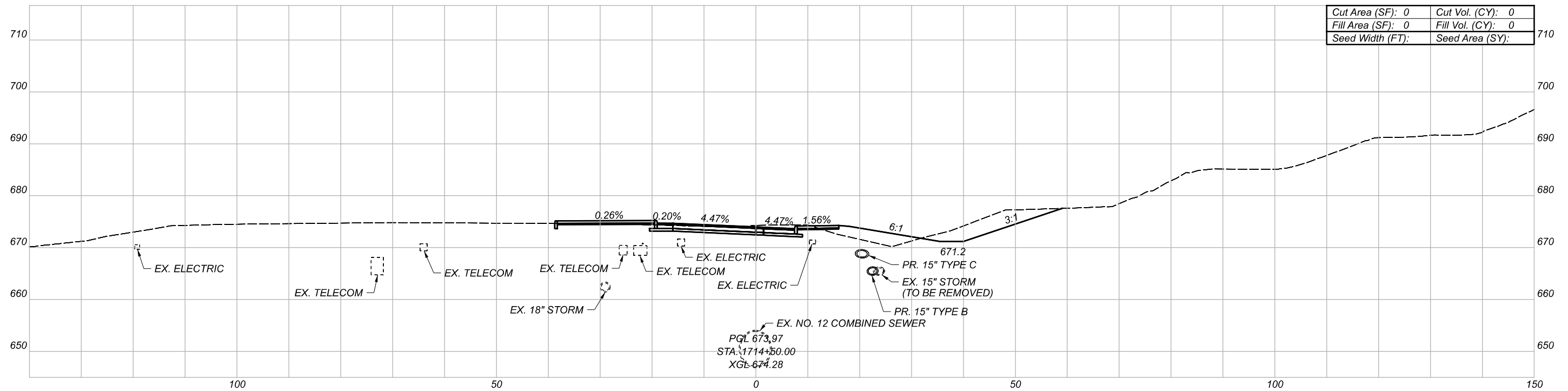
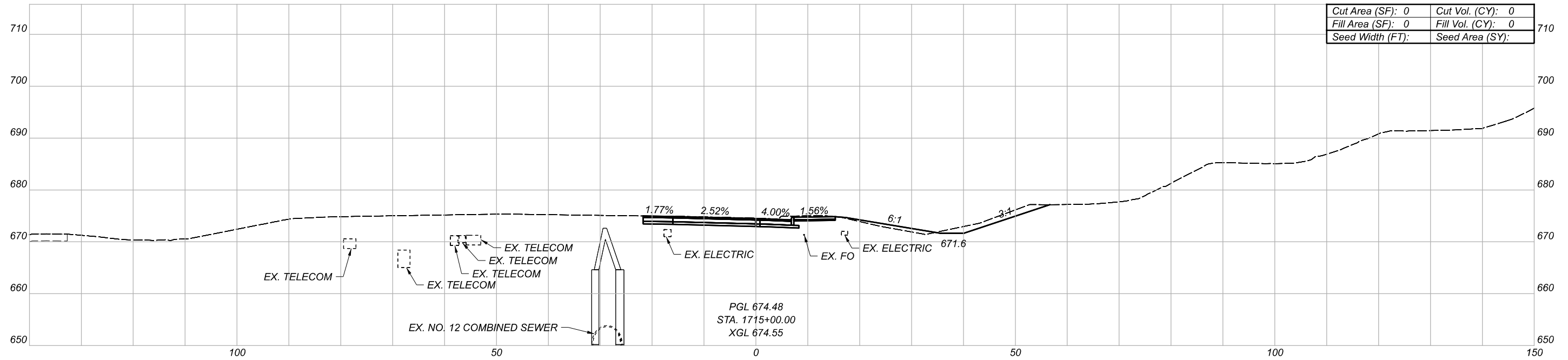

CROSS SECTIONS
RAMP IB5

DESIGN AGENCY



DESIGNER

REVIEWER

PROJECT ID

82382

| Sheet Totals | | | SHEET | TOTAL |
|--------------|-----|------|-------|-------|
| Seeding | Cut | Fill | | |
| . | . | . | 665 | 2339 |

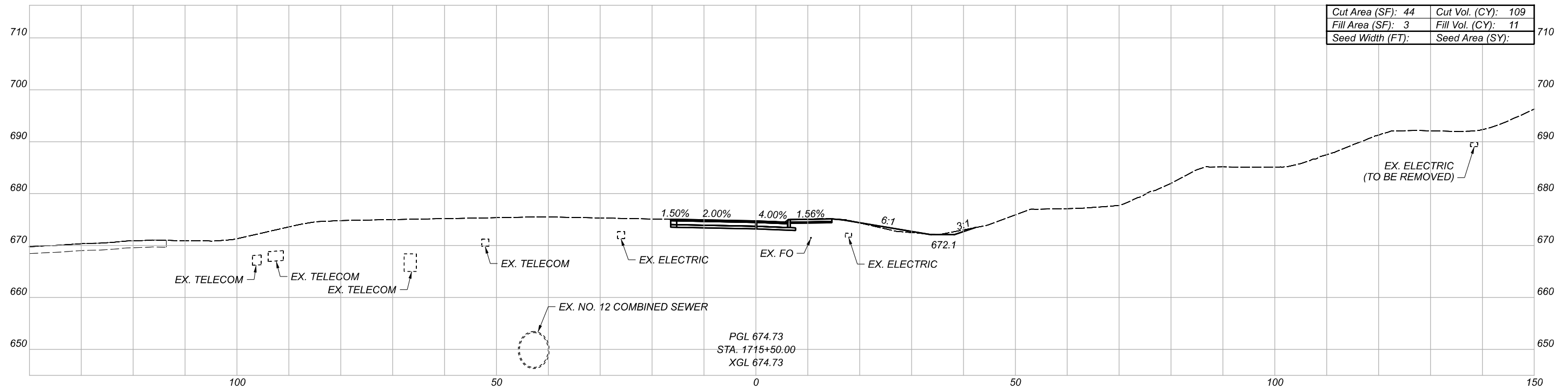
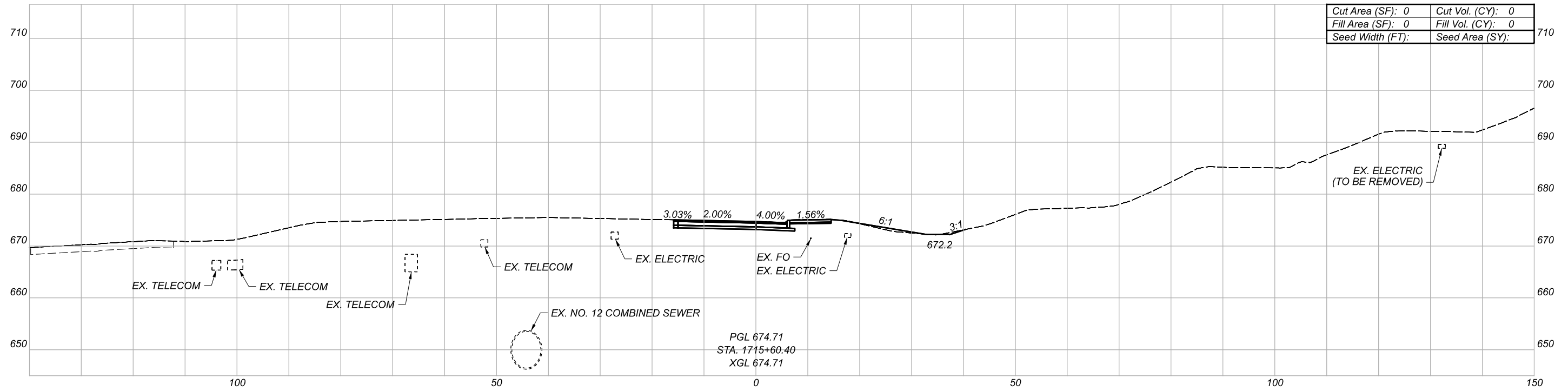

CROSS SECTIONS
RAMP IB5

DESIGN AGENCY



DESIGNER

REVIEWER

PROJECT ID

82382

| Sheet Totals | | | SHEET | TOTAL |
|--------------|-----|------|-------|-------|
| Seeding | Cut | Fill | | |
| . | . | . | 666 | 2339 |

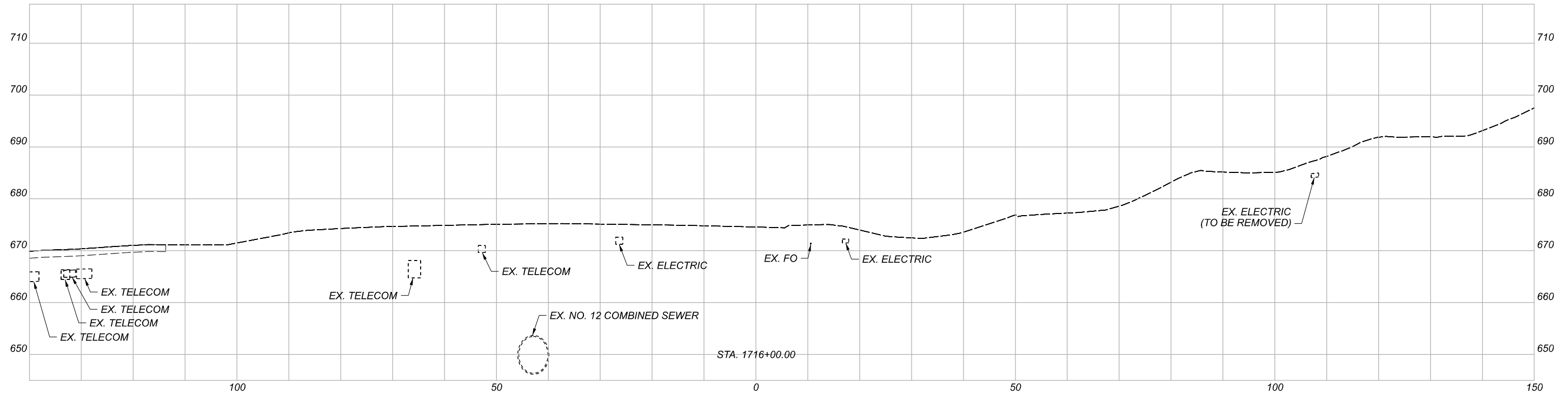

CROSS SECTIONS
RAMP IB5

DESIGN AGENCY



DESIGNER

REVIEWER

PROJECT ID

82382

| Sheet Totals | | | SHEET | TOTAL |
|--------------|-----|------|-------|-------|
| Seeding | Cut | Fill | | |
| . | . | . | 667 | 2339 |

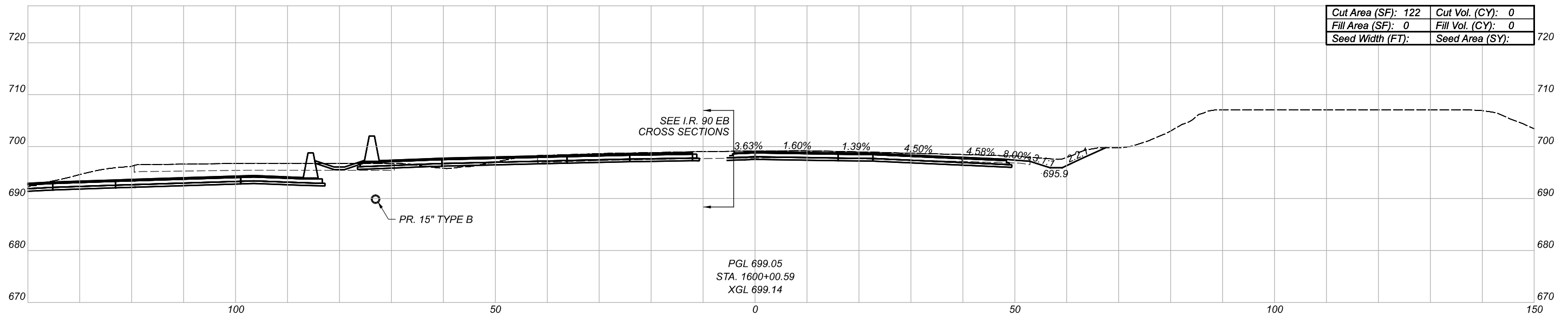
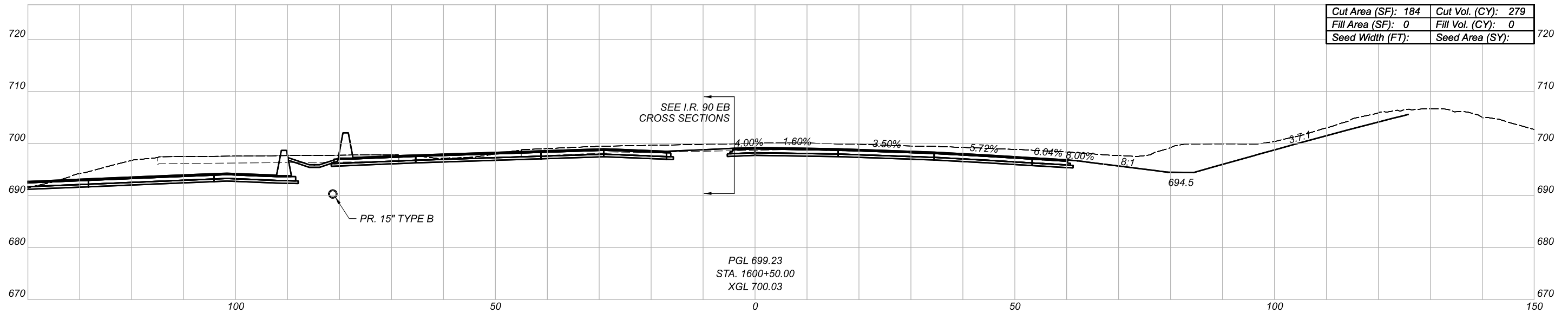
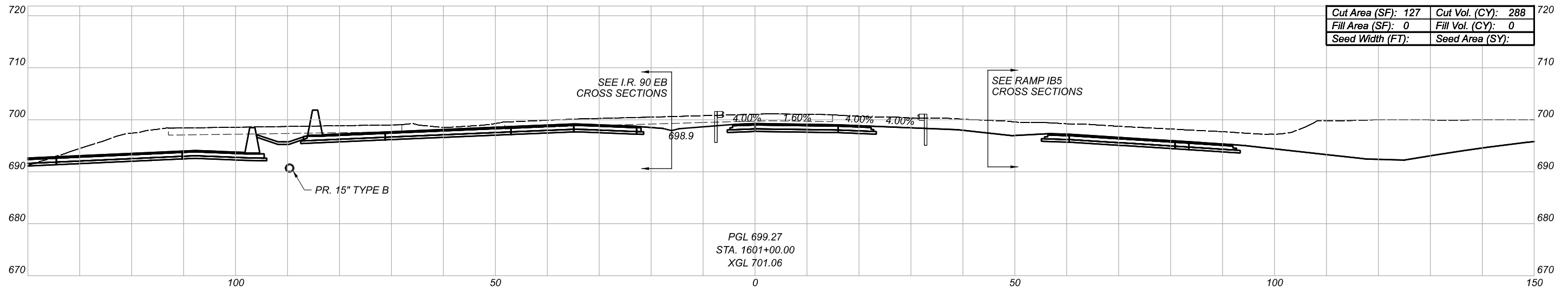

CROSS SECTIONS
RAMP B6

DESIGN AGENCY



DESIGNER

REVIEWER

PROJECT ID

82382

| Sheet Totals | | | SHEET | TOTAL |
|--------------|-----|------|-------|-------|
| Seeding | Cut | Fill | 668 | 2339 |

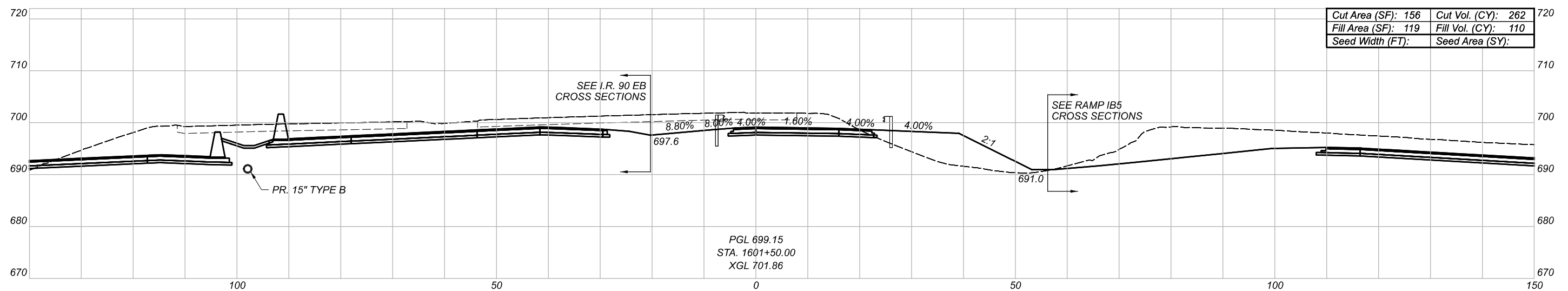
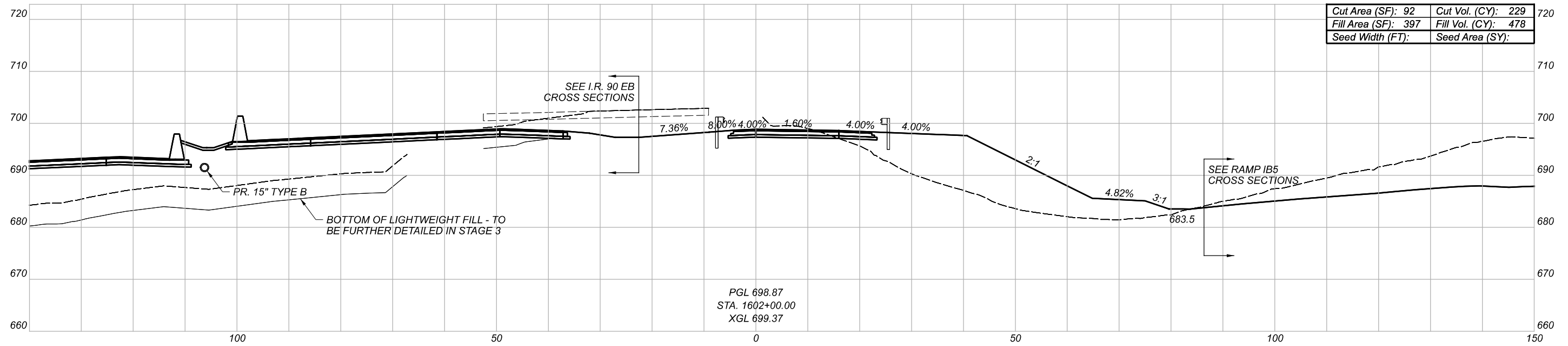

CROSS SECTIONS
RAMP B6

DESIGN AGENCY



DESIGNER

REVIEWER

PROJECT ID

82382

| Sheet Totals | | | SHEET | TOTAL |
|--------------|-----|------|-------|-------|
| Seeding | Cut | Fill | | |
| . | . | . | 669 | 2339 |

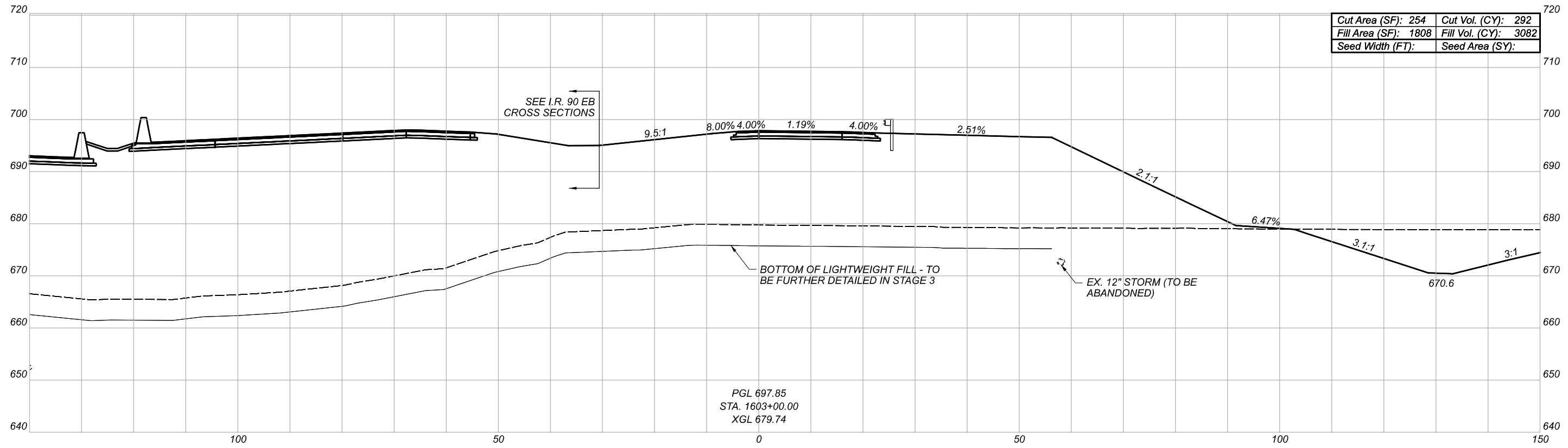

| | |
|----------------------|----------------------|
| Cut Area (SF): 254 | Cut Vol. (CY): 292 |
| Fill Area (SF): 1808 | Fill Vol. (CY): 3082 |
| Seed Width (FT): | Seed Area (SY): |

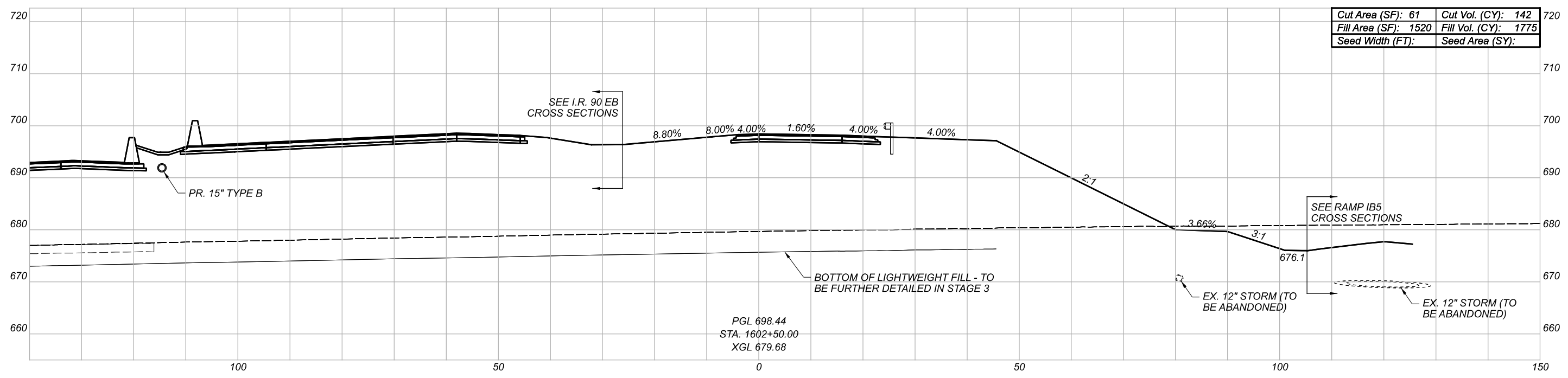

| | |
|----------------------|----------------------|
| Cut Area (SF): 61 | Cut Vol. (CY): 142 |
| Fill Area (SF): 1520 | Fill Vol. (CY): 1775 |
| Seed Width (FT): | Seed Area (SY): |

CROSS SECTIONS
RAMP B6

DESIGN AGENCY



DESIGNER

REVIEWER

PROJECT ID

82382

| Sheet Totals | | | SHEET | TOTAL |
|--------------|-----|------|-------|-------|
| Seeding | Cut | Fill | | |
| . | . | . | 670 | 2339 |

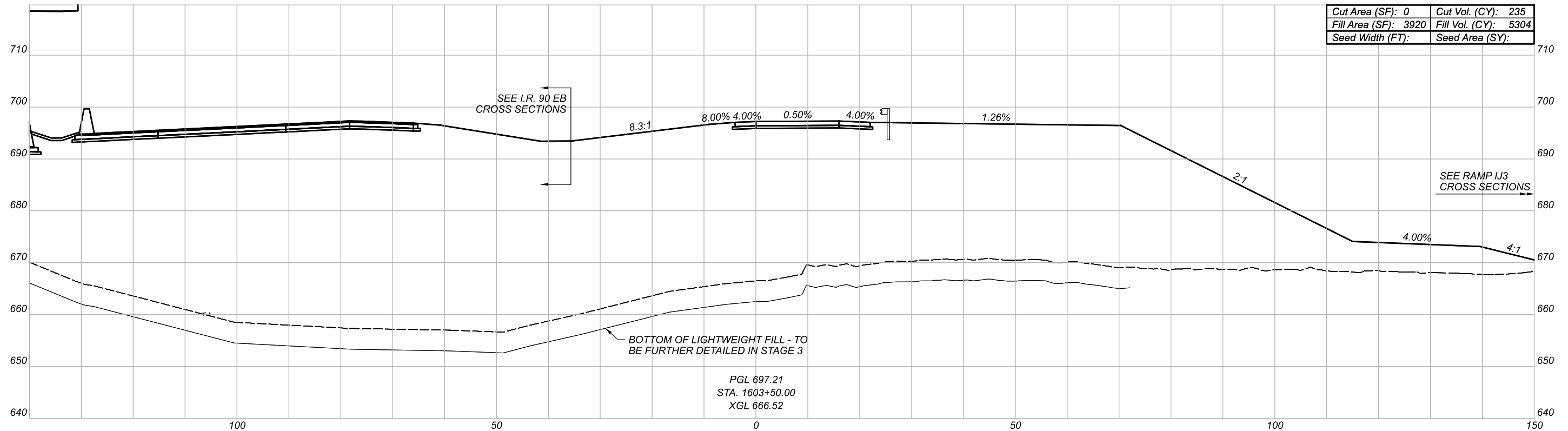
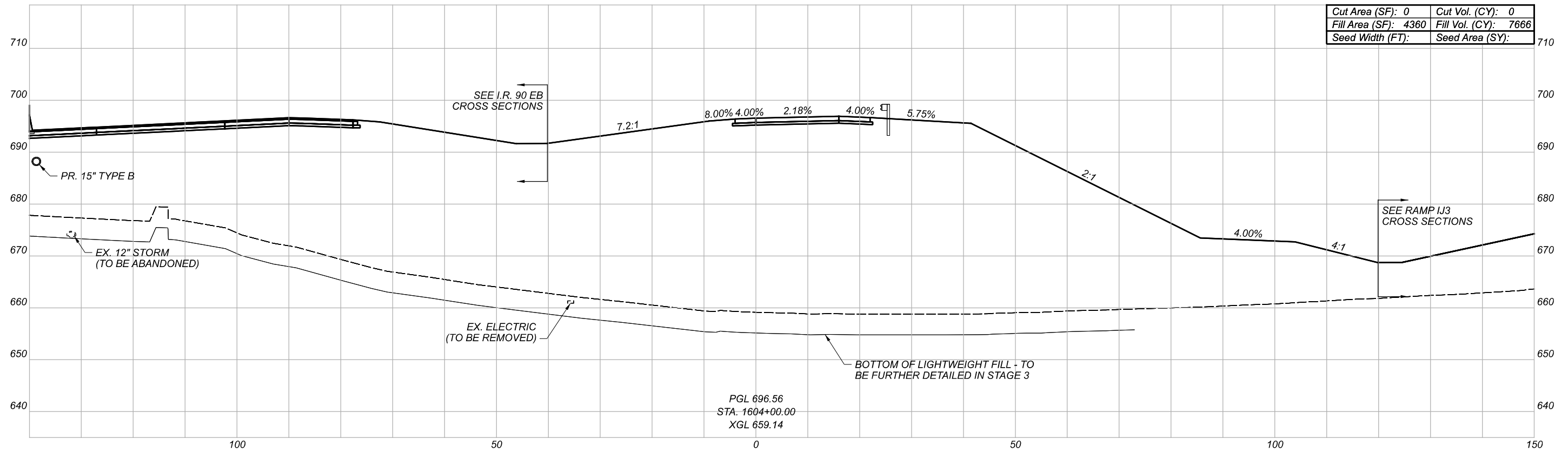

CROSS SECTIONS
RAMP B6

DESIGN AGENCY



DESIGNER

REVIEWER

PROJECT ID

82382

| Sheet Totals | | | SHEET | TOTAL |
|--------------|-----|------|-------|-------|
| Seeding | Cut | Fill | | |
| . | . | . | 671 | 2339 |

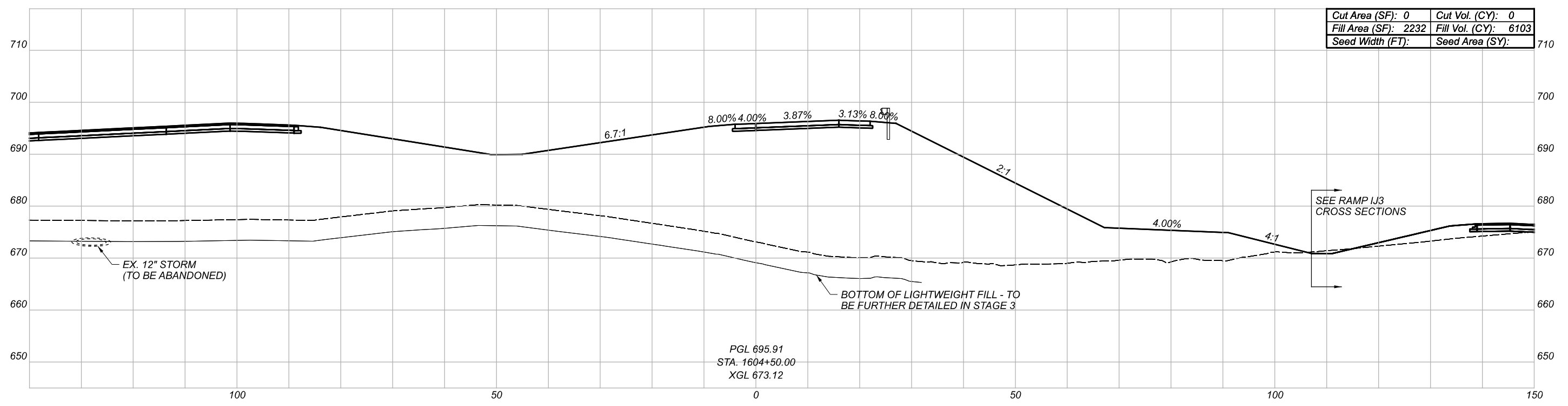
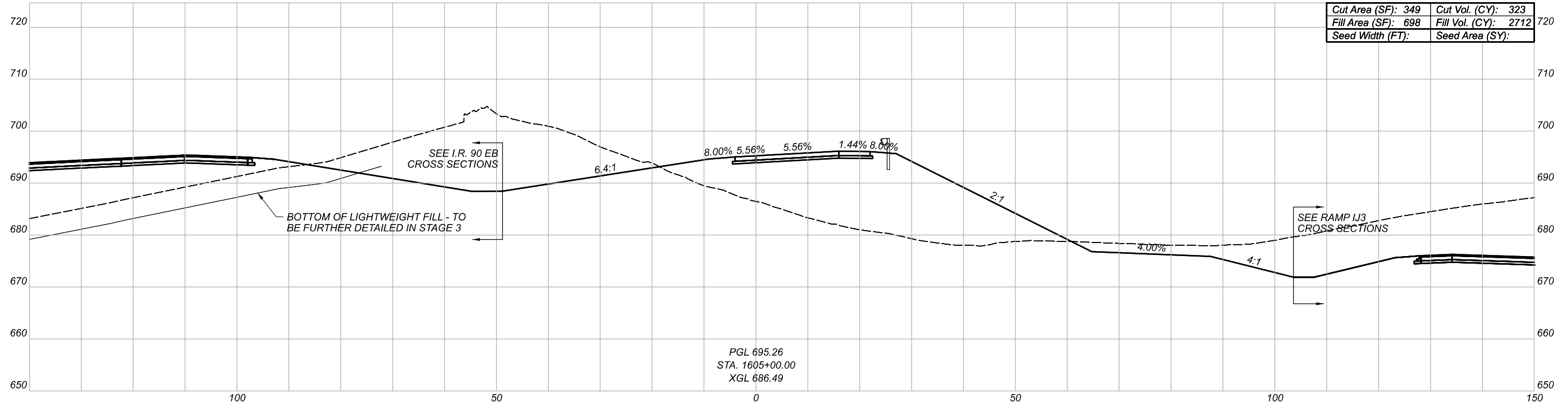

CROSS SECTIONS
RAMP B6

DESIGN AGENCY



DESIGNER

REVIEWER

PROJECT ID

82382

| Sheet Totals | | | SHEET | TOTAL |
|--------------|-----|------|-------|-------|
| Seeding | Cut | Fill | | |
| . | . | . | 672 | 2339 |

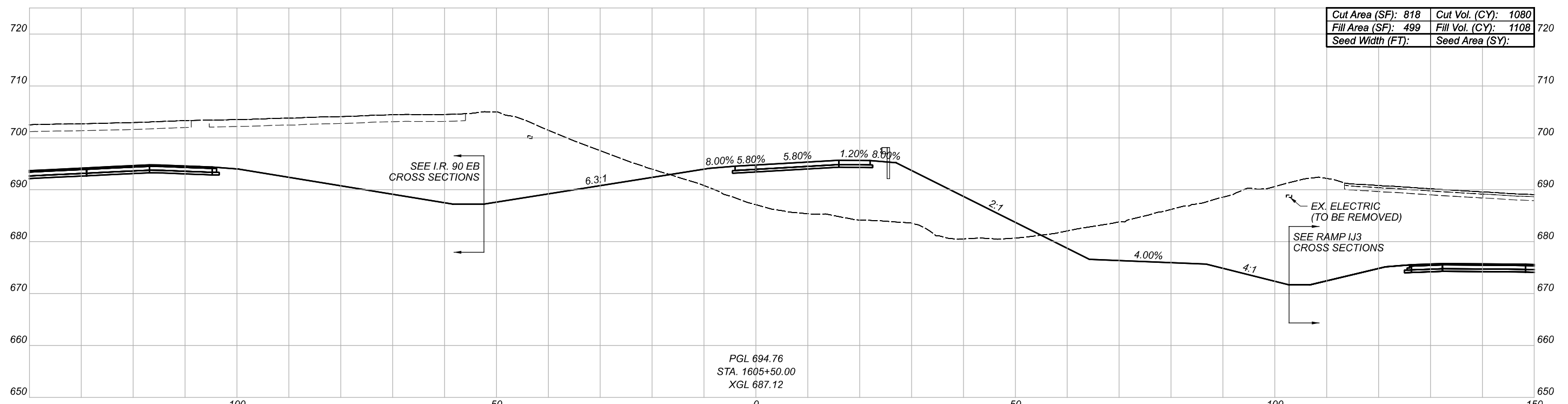
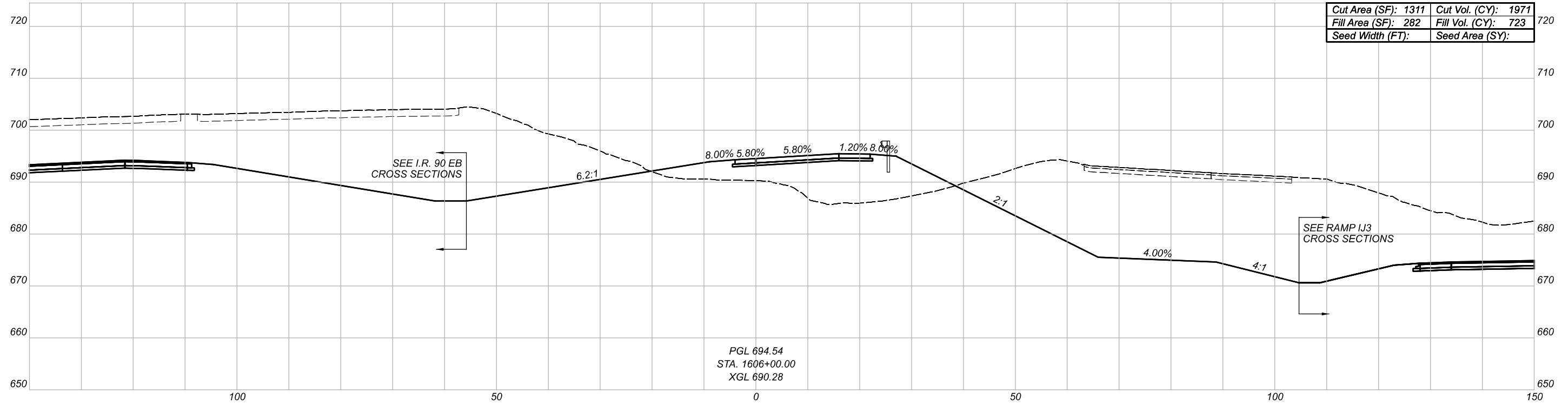

CROSS SECTIONS
 RAMP B6

DESIGN AGENCY



DESIGNER

REVIEWER

PROJECT ID

82382

| Sheet Totals | | | SHEET | TOTAL |
|--------------|-----|------|-------|-------|
| Seeding | Cut | Fill | 673 | 2339 |

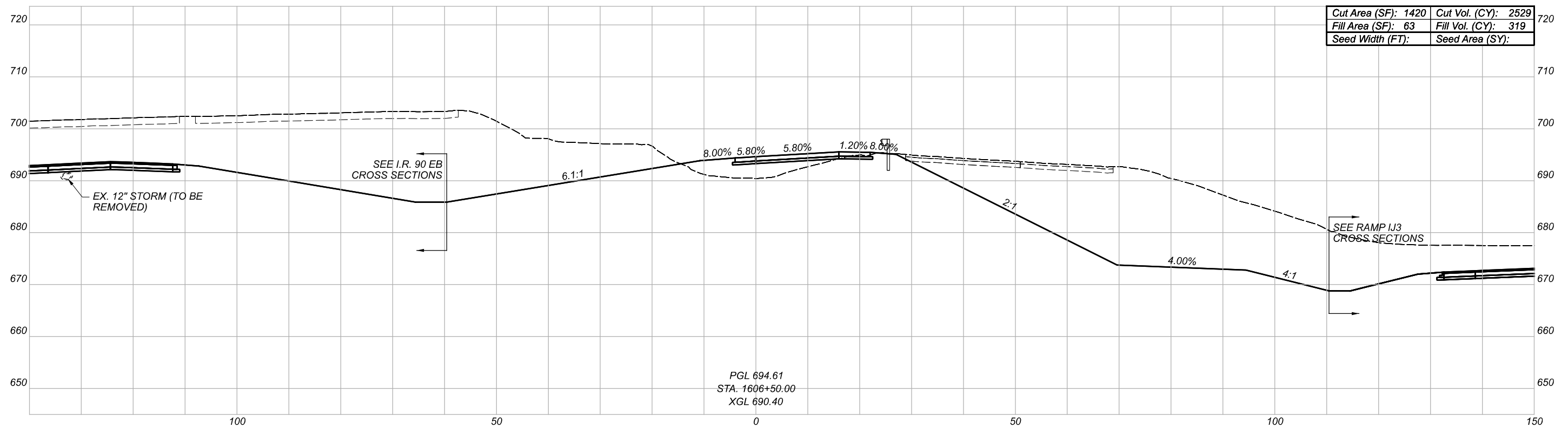
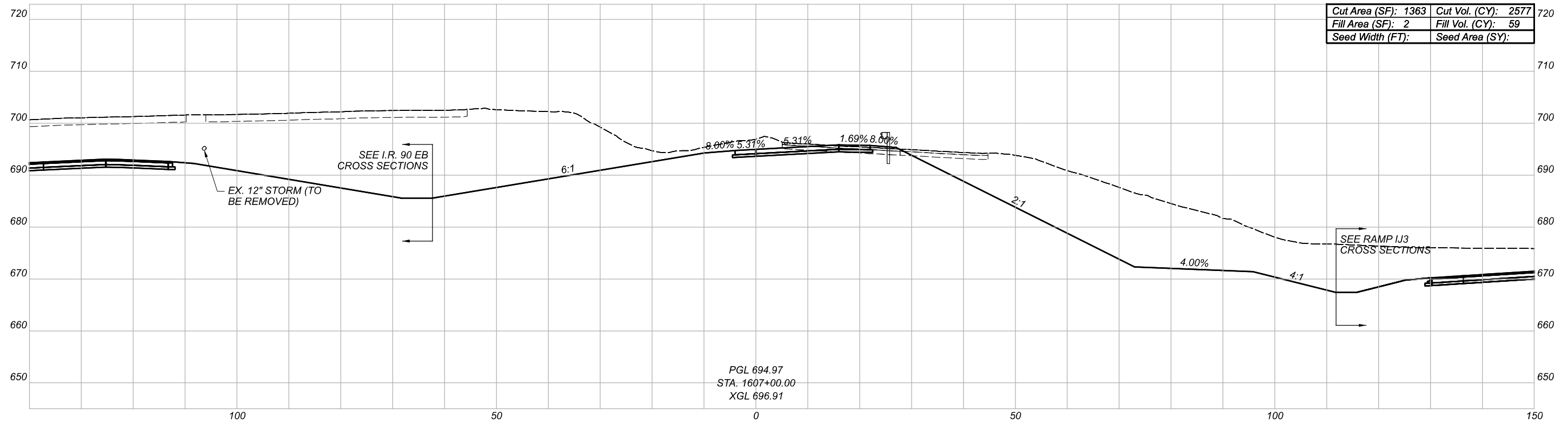

CROSS SECTIONS
RAMP B6

DESIGN AGENCY



DESIGNER

REVIEWER

PROJECT ID

82382

| Sheet Totals | | | SHEET | TOTAL |
|--------------|-----|------|-------|-------|
| Seeding | Cut | Fill | | |
| . | . | . | 674 | 2339 |

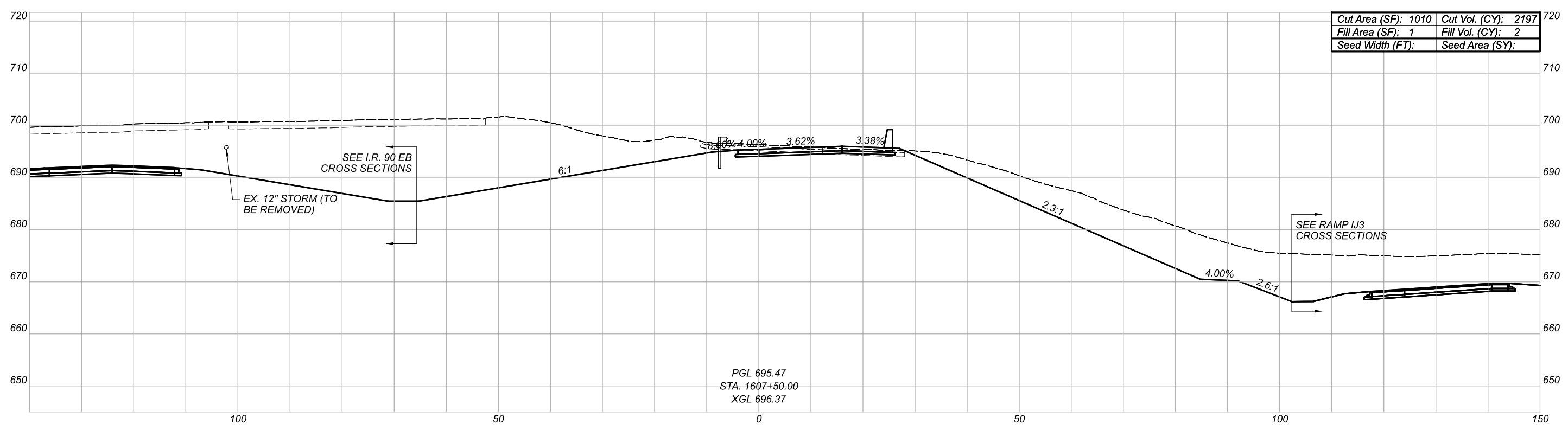
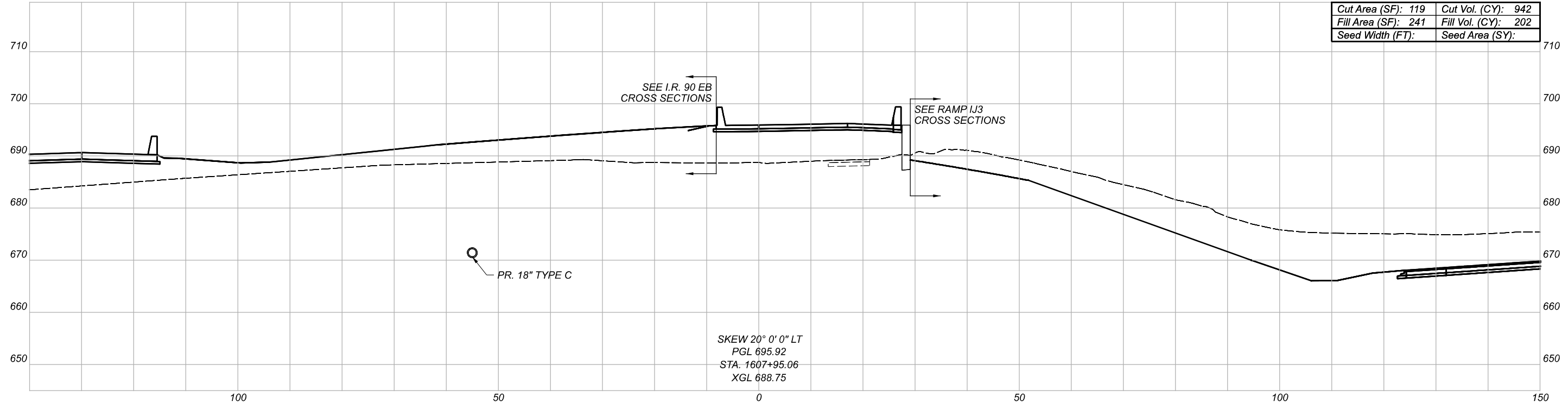

CROSS SECTIONS
RAMP B6

DESIGN AGENCY



DESIGNER

REVIEWER

PROJECT ID

82382

| Sheet Totals | | | SHEET | TOTAL |
|--------------|-----|------|-------|-------|
| Seeding | Cut | Fill | | |
| . | . | . | 675 | 2339 |

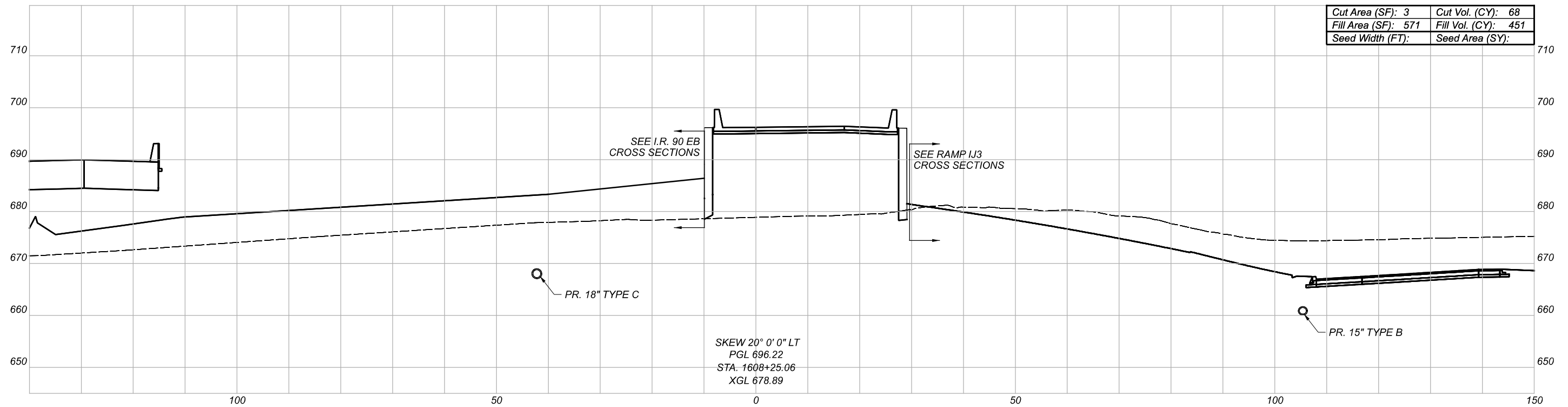
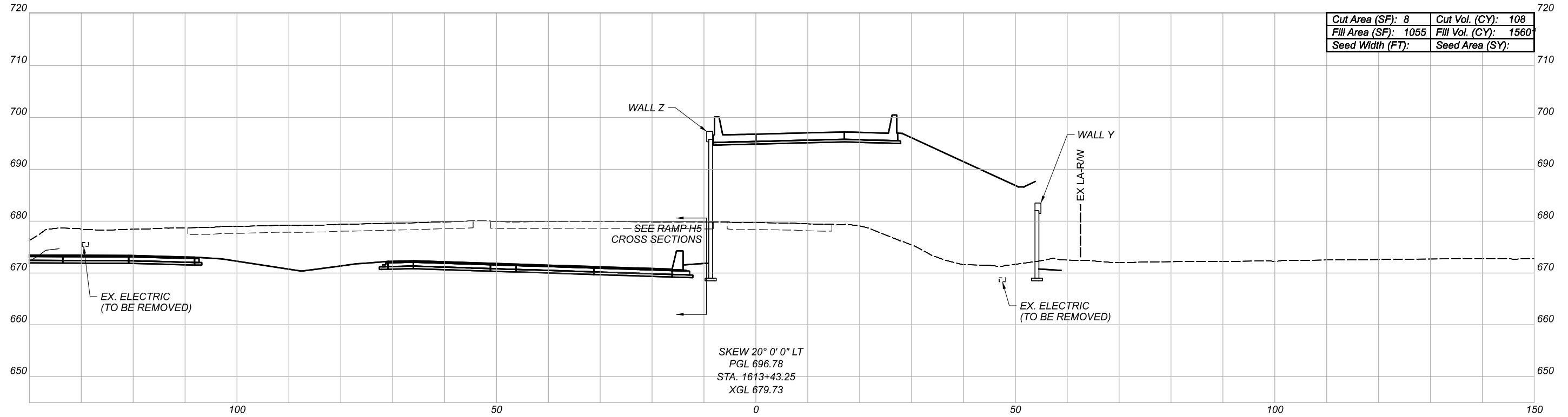

CROSS SECTIONS
RAMP B6

DESIGN AGENCY



DESIGNER

REVIEWER

PROJECT ID

82382

| Sheet Totals | | | SHEET | TOTAL |
|--------------|-----|------|-------|-------|
| Seeding | Cut | Fill | | |
| . | . | . | 676 | 2339 |

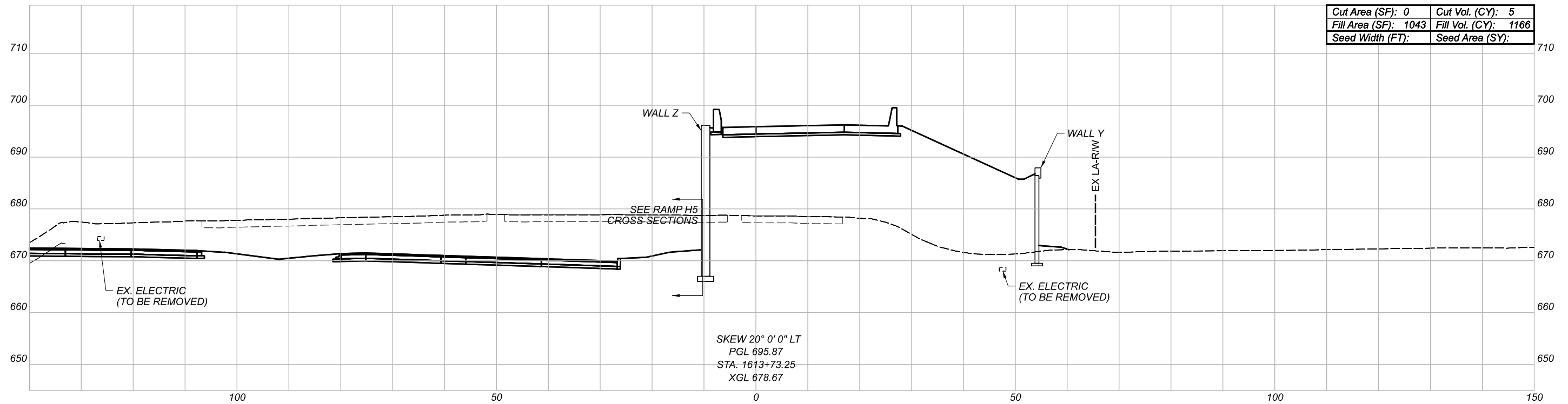
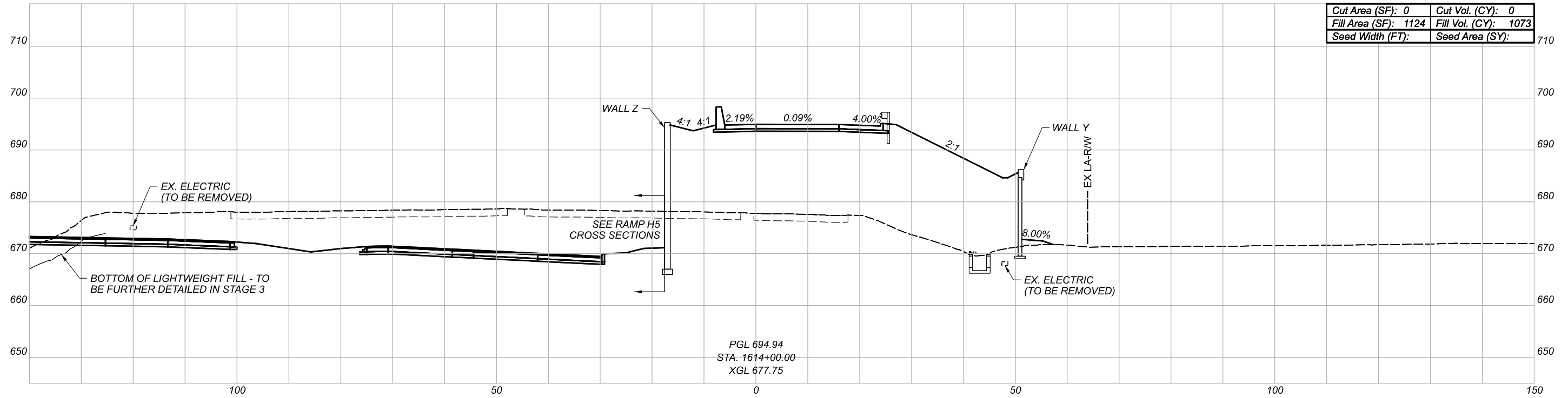

CROSS SECTIONS
RAMP B6

DESIGN AGENCY



DESIGNER

REVIEWER

PROJECT ID

82382

| Sheet Totals | | | SHEET | TOTAL |
|--------------|-----|------|-------|-------|
| Seeding | Cut | Fill | | |
| . | . | . | 677 | 2339 |

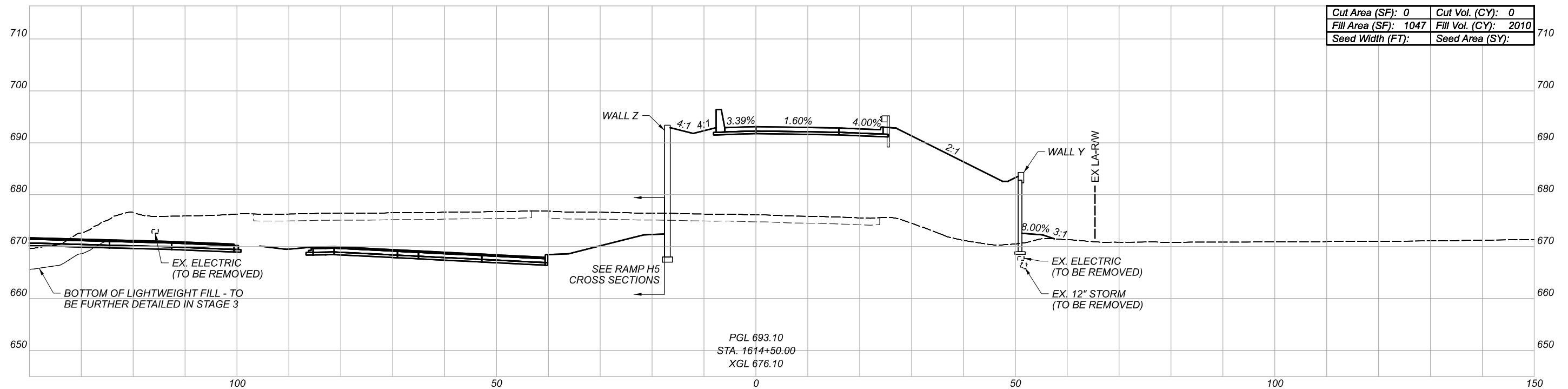
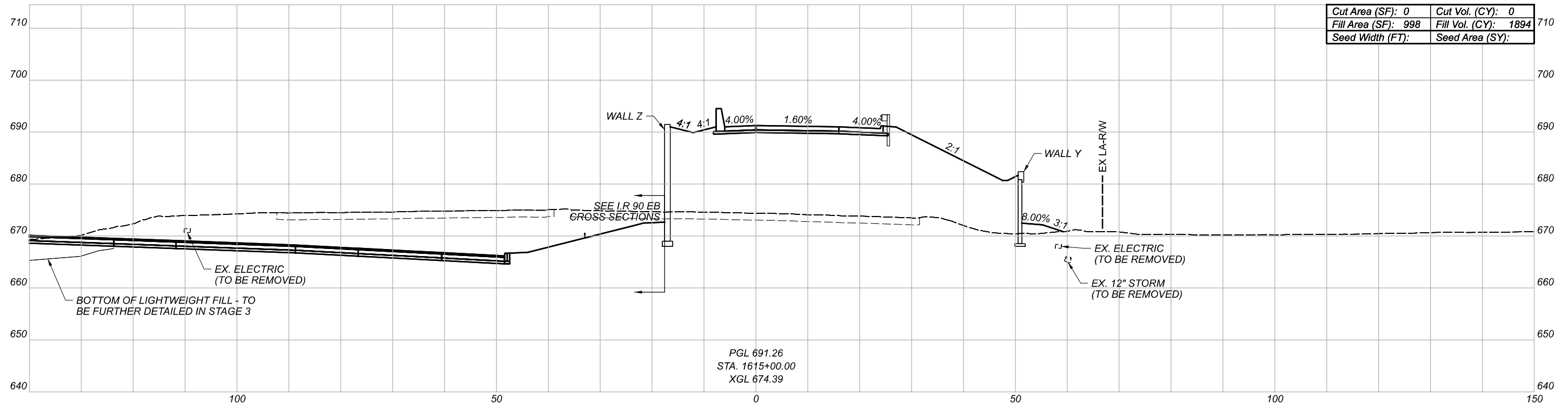

CROSS SECTIONS
 RAMP B6

DESIGN AGENCY



DESIGNER

REVIEWER

PROJECT ID

82382

| Sheet Totals | | | SHEET | TOTAL |
|--------------|-----|------|-------|-------|
| Seeding | Cut | Fill | | |
| . | . | . | 678 | 2339 |

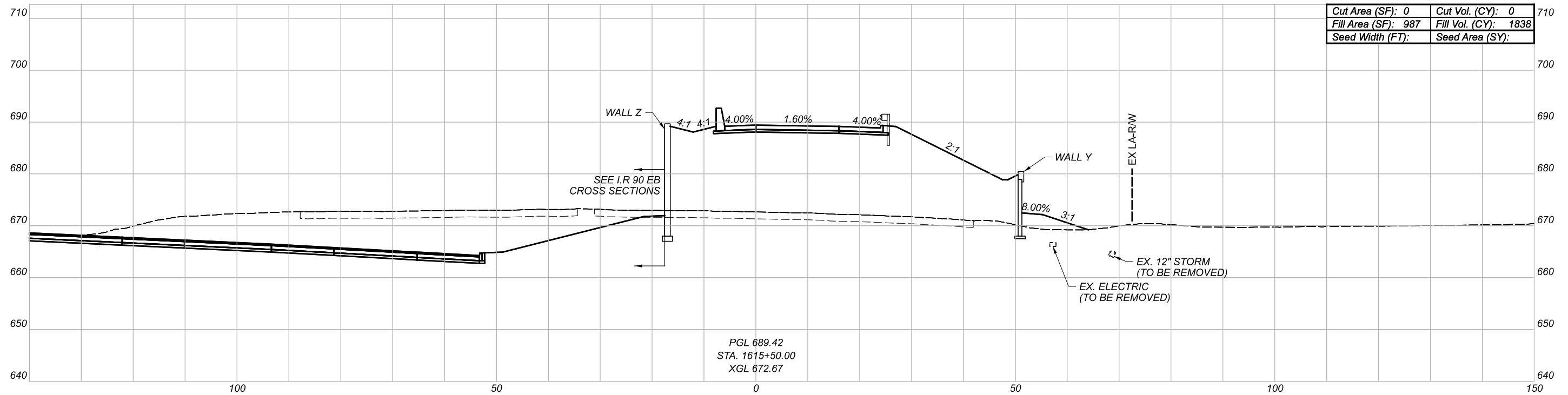
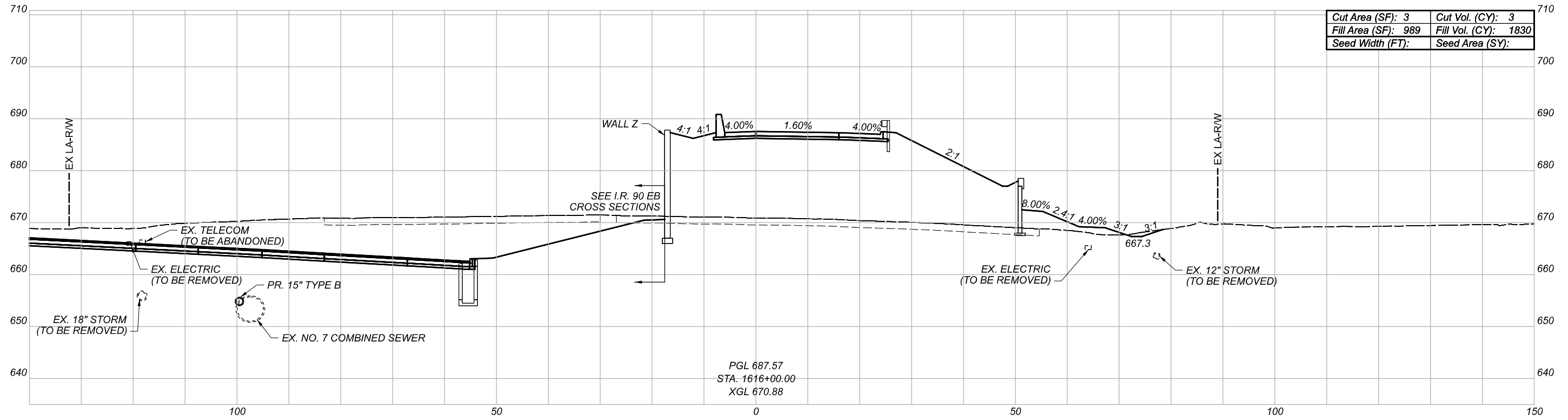

CROSS SECTIONS
 RAMP B6

DESIGN AGENCY



DESIGNER

REVIEWER

PROJECT ID

82382

| Sheet Totals | | | SHEET | TOTAL |
|--------------|-----|------|-------|-------|
| Seeding | Cut | Fill | | |
| . | . | . | 679 | 2339 |

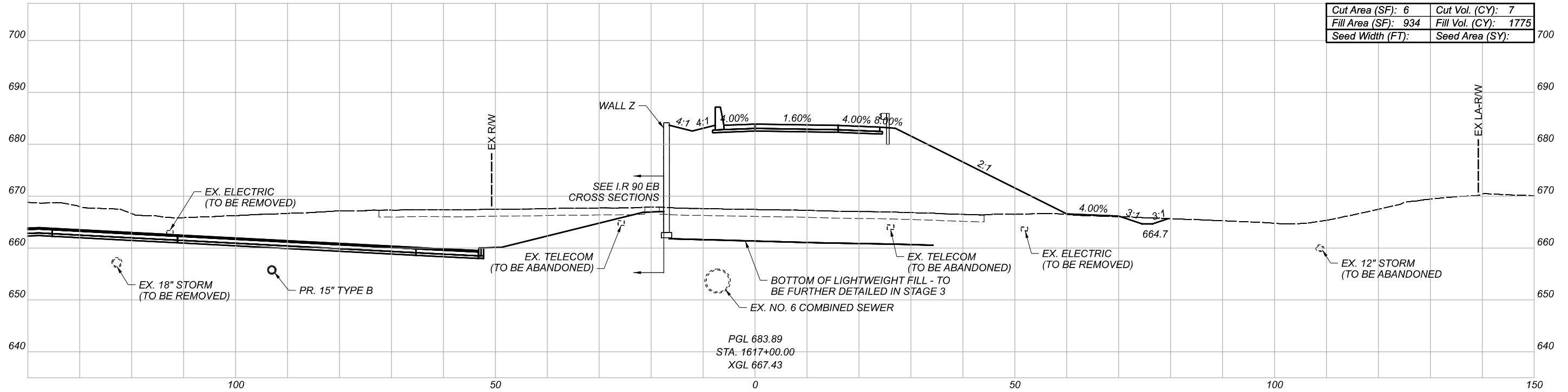

| | | | |
|------------------|-----|-----------------|------|
| Cut Area (SF): | 6 | Cut Vol. (CY): | 7 |
| Fill Area (SF): | 934 | Fill Vol. (CY): | 1775 |
| Seed Width (FT): | | Seed Area (SY): | |

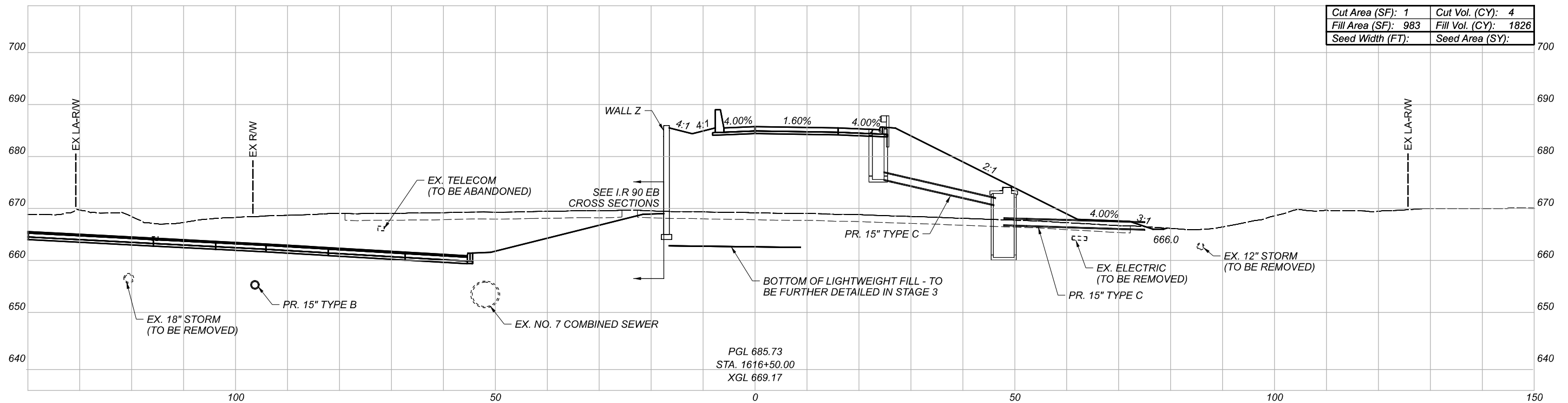

| | | | |
|------------------|-----|-----------------|------|
| Cut Area (SF): | 1 | Cut Vol. (CY): | 4 |
| Fill Area (SF): | 983 | Fill Vol. (CY): | 1826 |
| Seed Width (FT): | | Seed Area (SY): | |

CROSS SECTIONS
RAMP B6

DESIGN AGENCY



DESIGNER

REVIEWER

PROJECT ID

82382

| Sheet Totals | | | SHEET | TOTAL |
|--------------|-----|------|-------|-------|
| Seeding | Cut | Fill | | |
| . | . | . | 680 | 2339 |

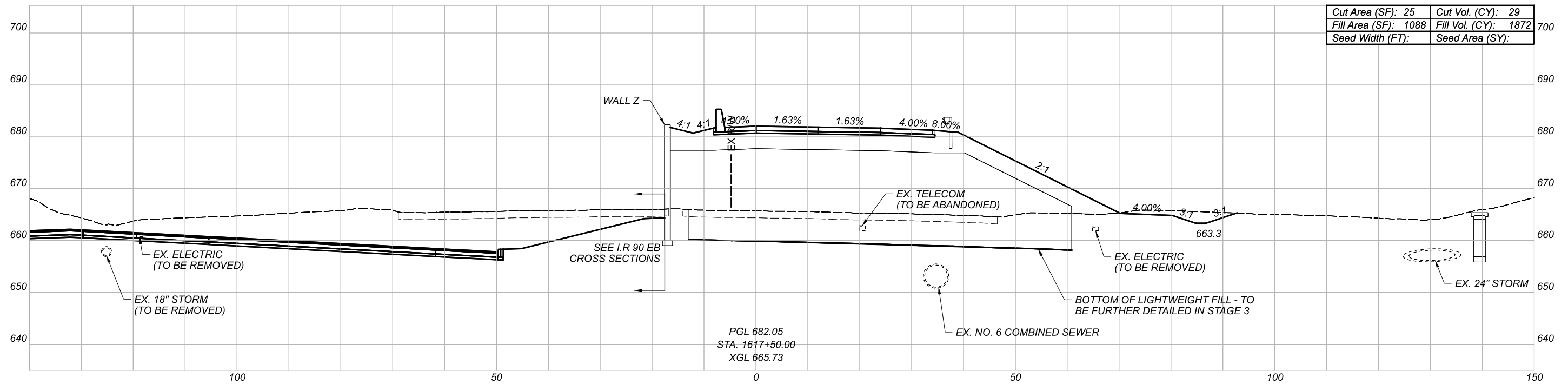
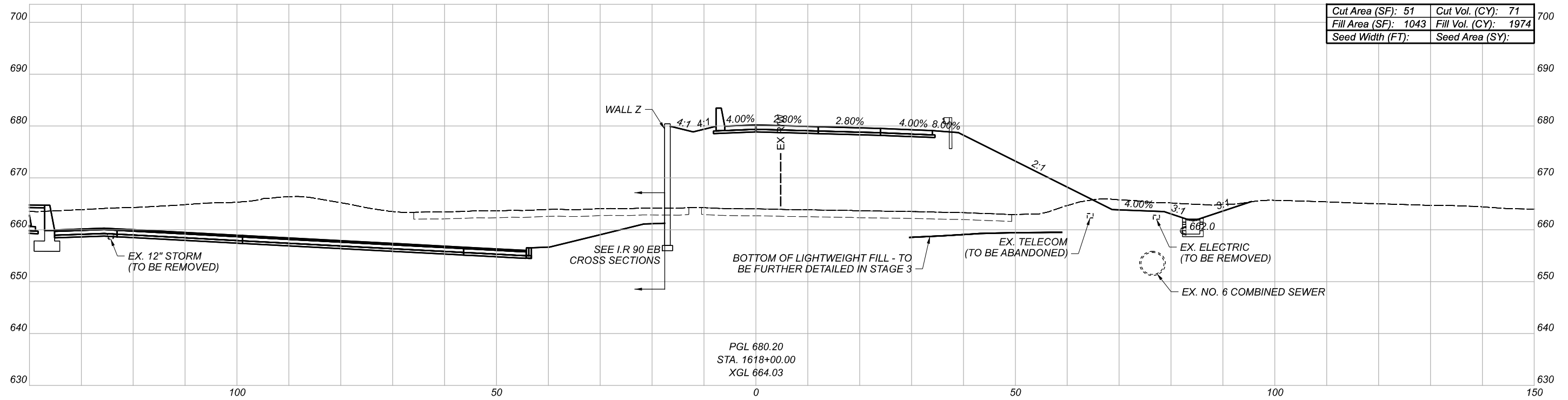

CROSS SECTIONS
 RAMP B6

DESIGN AGENCY



DESIGNER

REVIEWER

PROJECT ID

82382

| Sheet Totals | | | SHEET | TOTAL |
|--------------|-----|------|-------|-------|
| Seeding | Cut | Fill | 681 | 2339 |

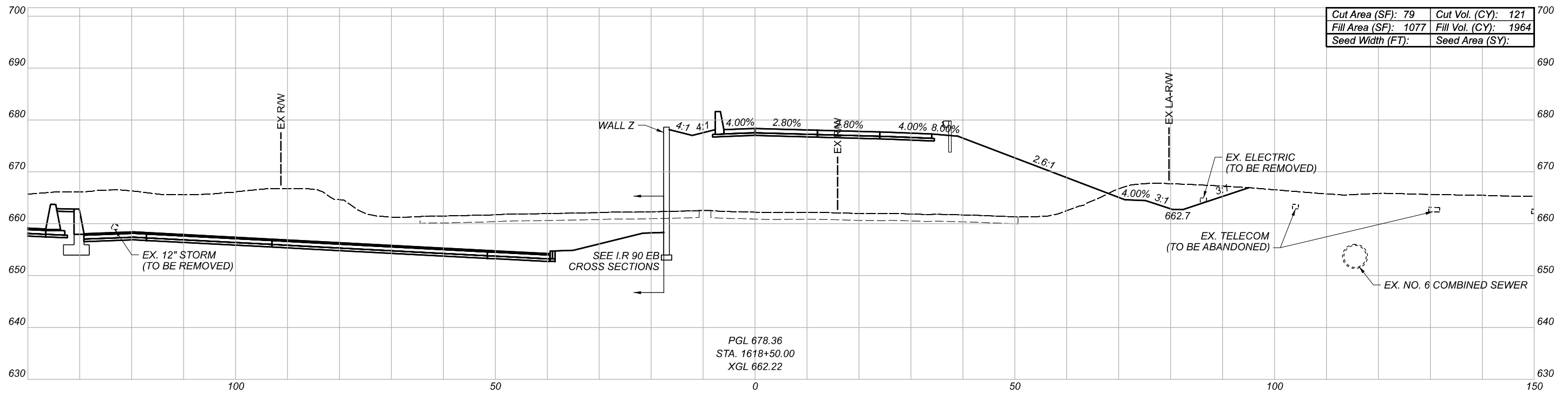
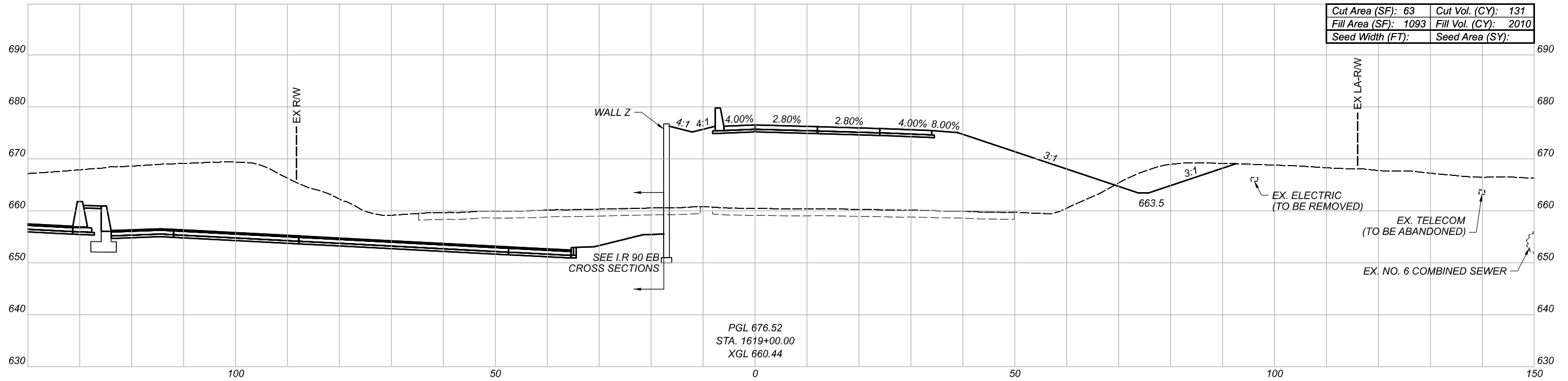

CROSS SECTIONS
 RAMP B6

DESIGN AGENCY



DESIGNER

REVIEWER

PROJECT ID

82382

| Sheet Totals | | | SHEET | TOTAL |
|--------------|-----|------|-------|-------|
| Seeding | Cut | Fill | | |
| . | . | . | 682 | 2339 |

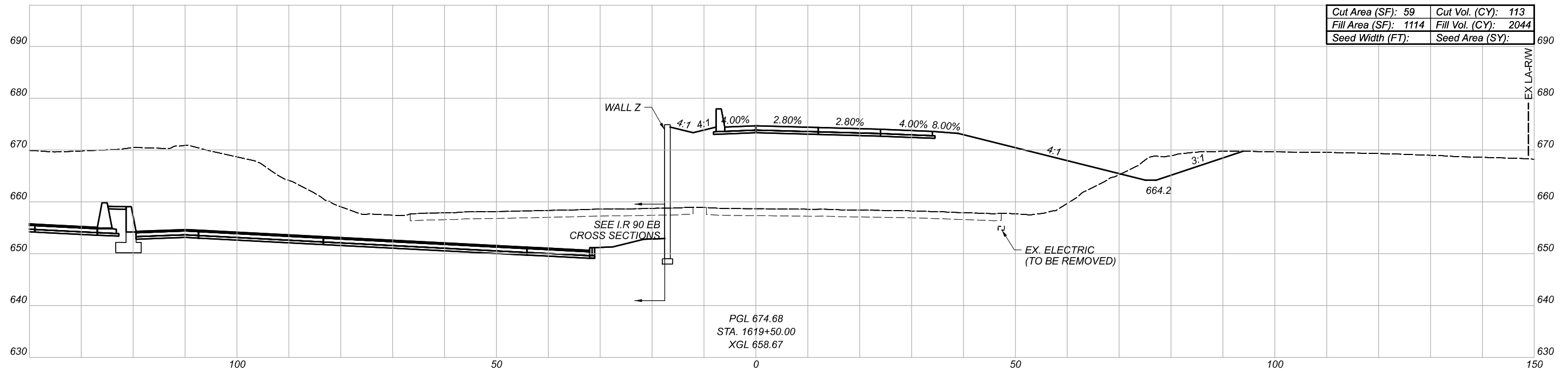
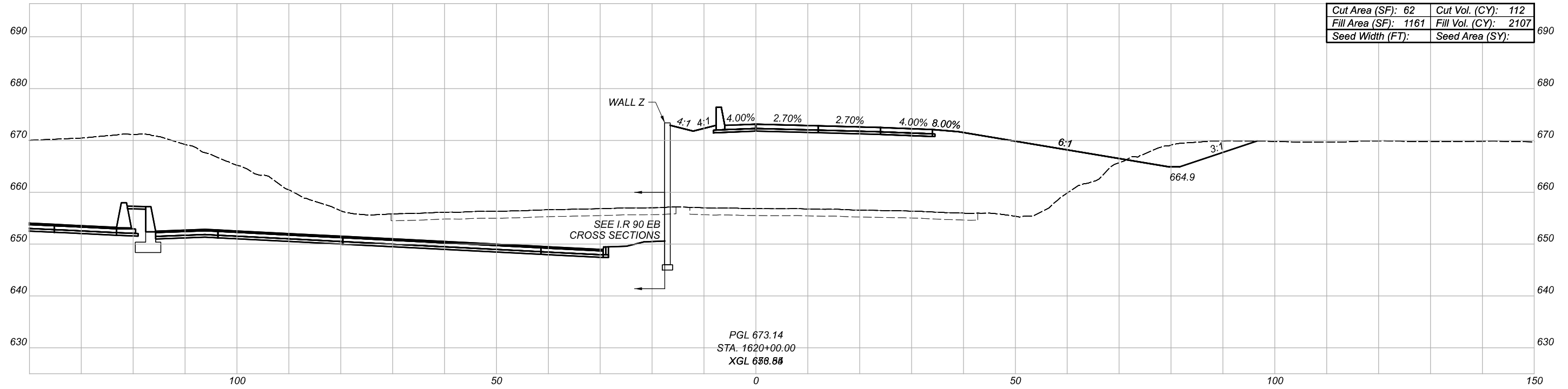

CROSS SECTIONS
 RAMP B6

DESIGN AGENCY



DESIGNER

REVIEWER

PROJECT ID

82382

| Sheet Totals | | | SHEET TOTAL | |
|--------------|-----|------|-------------|-------|
| Seeding | Cut | Fill | SHEET | TOTAL |
| . | . | . | 683 | 2339 |

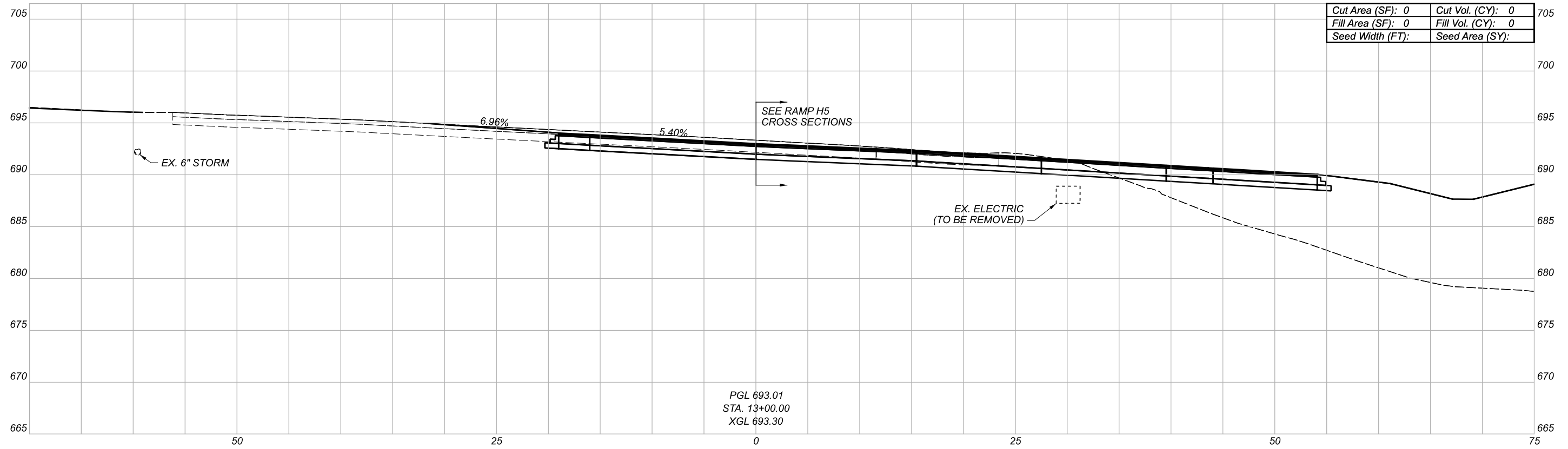

| | | | |
|------------------|---|-----------------|---|
| Cut Area (SF): | 0 | Cut Vol. (CY): | 0 |
| Fill Area (SF): | 0 | Fill Vol. (CY): | 0 |
| Seed Width (FT): | | Seed Area (SY): | |

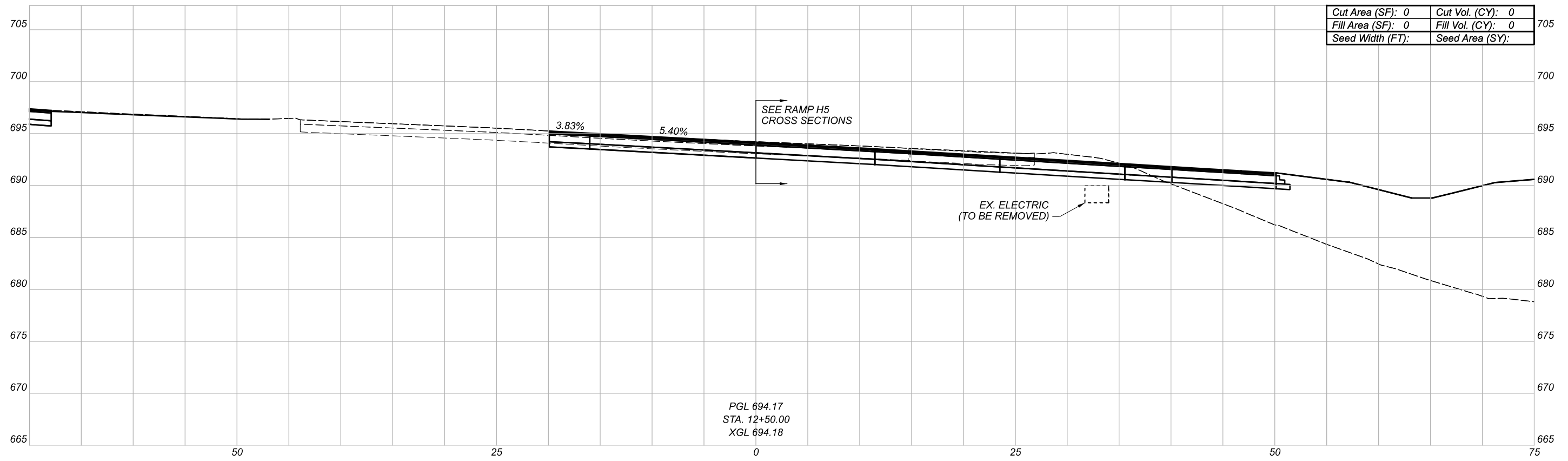

| | | | |
|------------------|---|-----------------|---|
| Cut Area (SF): | 0 | Cut Vol. (CY): | 0 |
| Fill Area (SF): | 0 | Fill Vol. (CY): | 0 |
| Seed Width (FT): | | Seed Area (SY): | |

CROSS SECTIONS
RAMP IH4

| | |
|---------------|-------|
| DESIGN AGENCY | |
| DESIGNER | -- |
| REVIEWER | -- |
| PROJECT ID | 82382 |

| Sheet Totals | | |
|--------------|-----|------|
| Seeding | Cut | Fill |
| . | . | . |

| | |
|-------|-------|
| SHEET | TOTAL |
| 684 | 2339 |

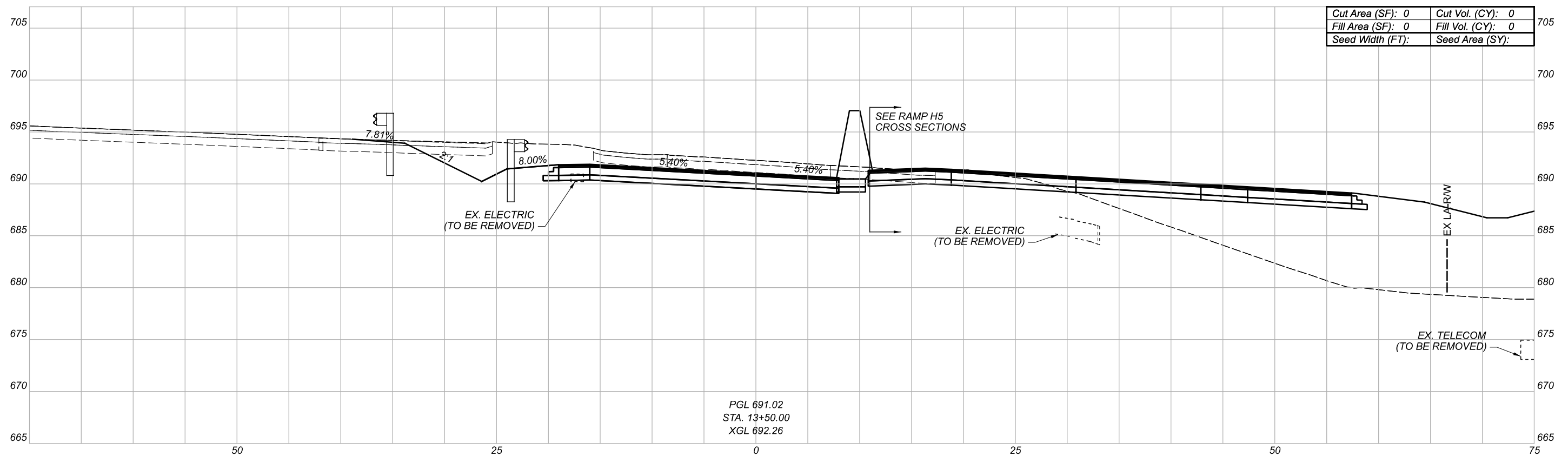
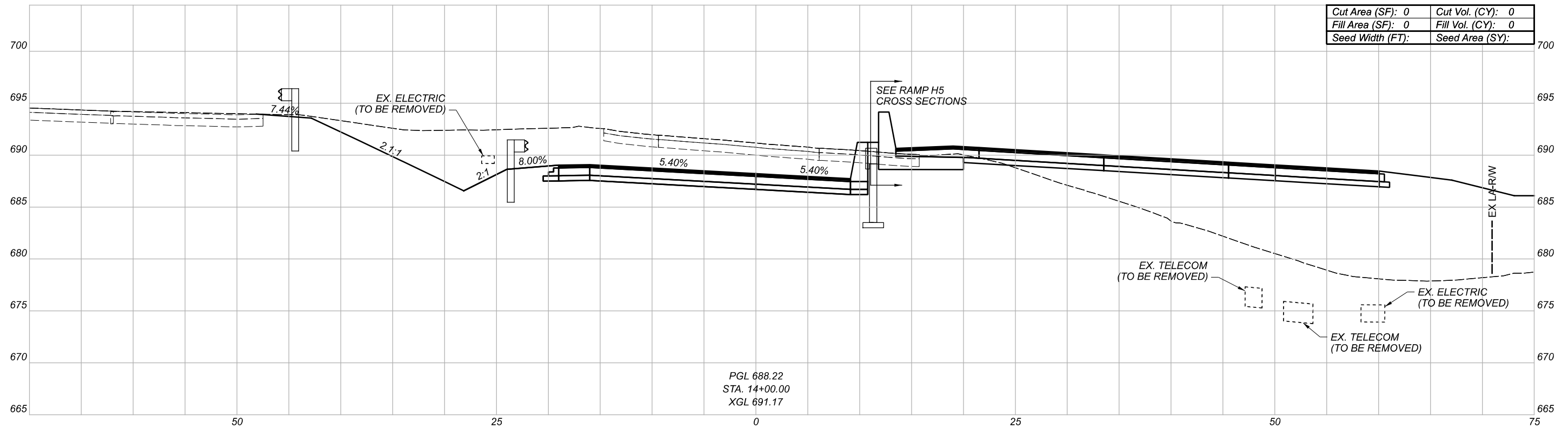

CROSS SECTIONS
RAMP IH4

| | |
|---------------------------------------|-------|
| DESIGN AGENCY | |
| Michael Baker INTERNATIONAL | |
| DESIGNER | -- |
| REVIEWER | -- |
| PROJECT ID | 82382 |

| Sheet Totals | | | SHEET | TOTAL |
|--------------|-----|------|-------|-------|
| Seeding | Cut | Fill | | |
| . | . | . | 685 | 2339 |

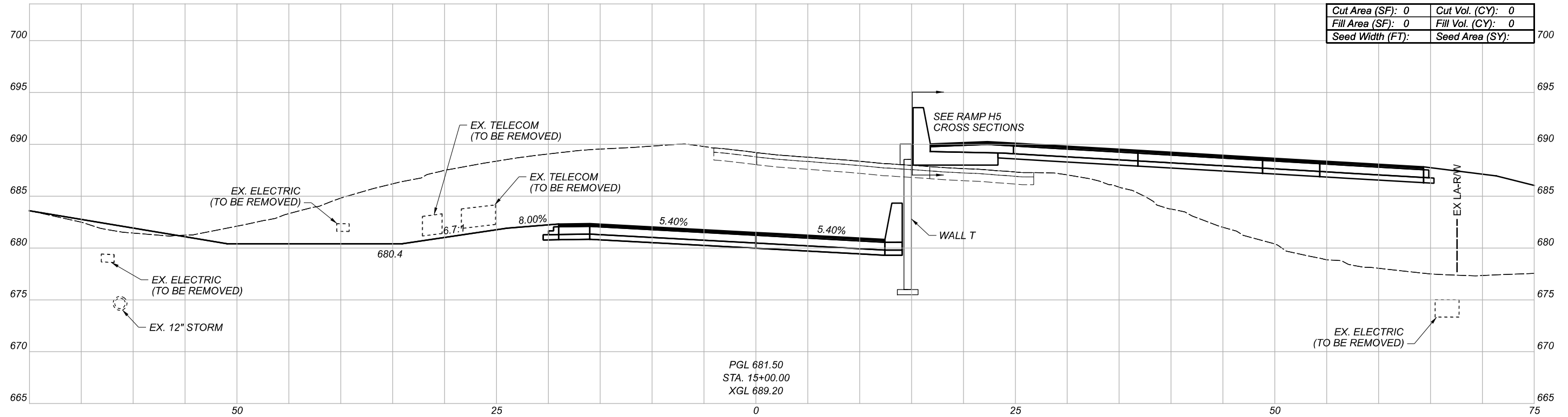

| | |
|-------------------|-------------------|
| Cut Area (SF): 0 | Cut Vol. (CY): 0 |
| Fill Area (SF): 0 | Fill Vol. (CY): 0 |
| Seed Width (FT): | Seed Area (SY): |

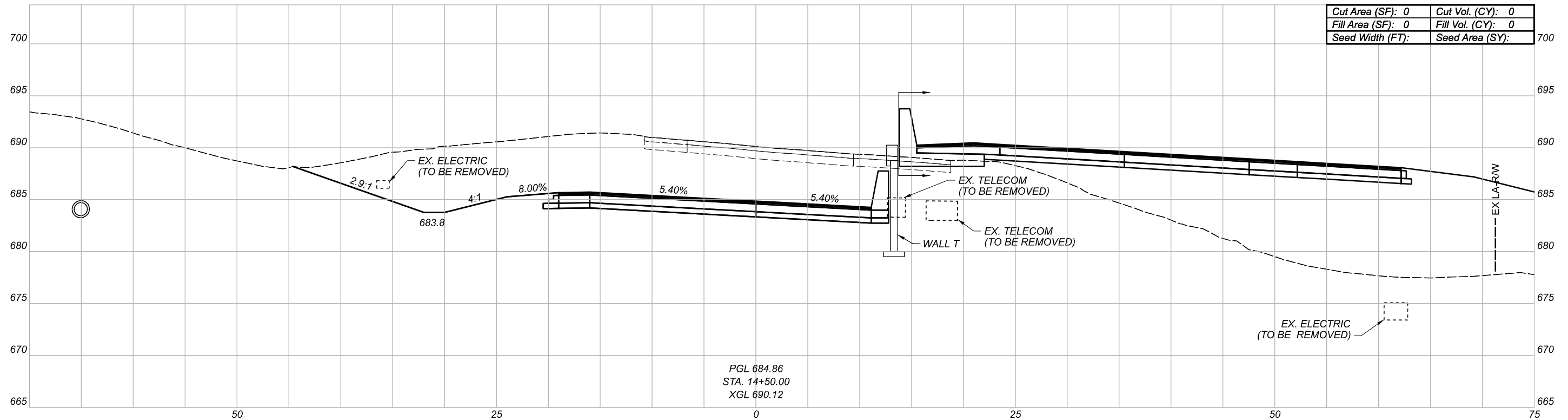

| | |
|-------------------|-------------------|
| Cut Area (SF): 0 | Cut Vol. (CY): 0 |
| Fill Area (SF): 0 | Fill Vol. (CY): 0 |
| Seed Width (FT): | Seed Area (SY): |

CROSS SECTIONS
RAMP IH4

| | |
|---------------------------------------|-------|
| DESIGN AGENCY | |
| Michael Baker INTERNATIONAL | |
| DESIGNER | -- |
| REVIEWER | -- |
| PROJECT ID | 82382 |

| Sheet Totals | | |
|--------------|-----|------|
| Seeding | Cut | Fill |
| . | . | . |

| | |
|-------|-------|
| SHEET | TOTAL |
| 686 | 2339 |

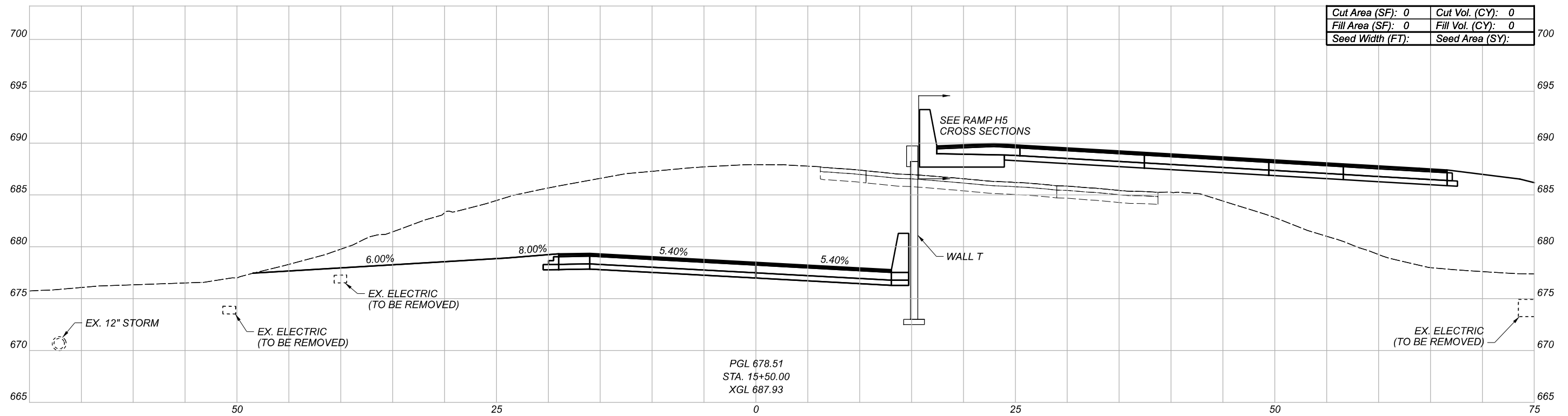
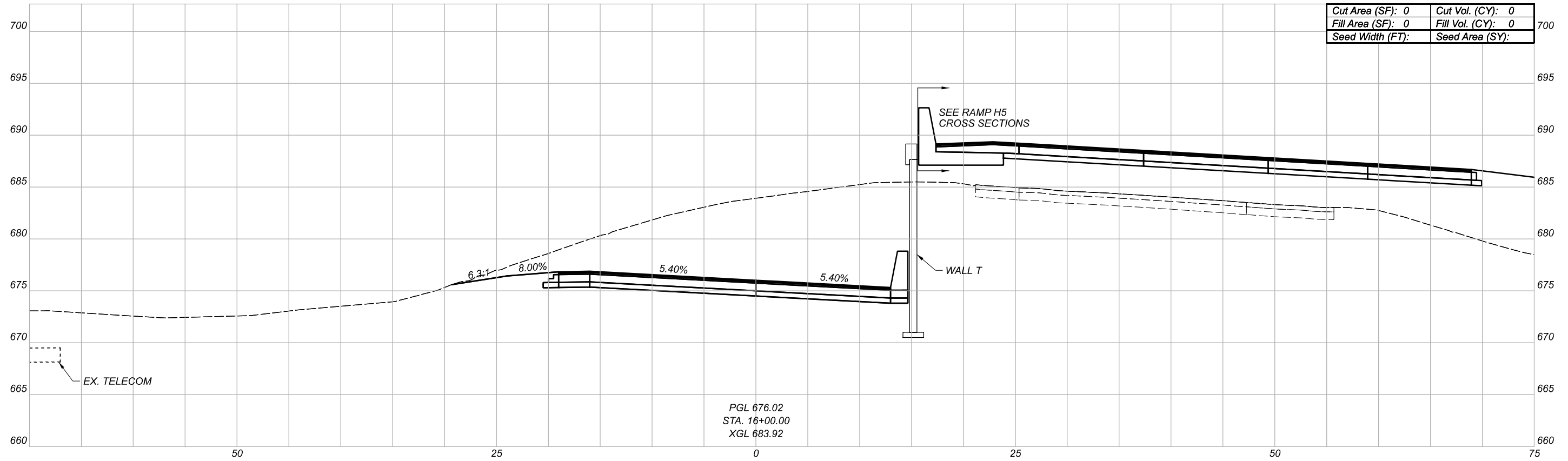

CROSS SECTIONS
RAMP IH4

DESIGN AGENCY

Michael Baker
INTERNATIONAL

DESIGNER

REVIEWER

PROJECT ID

82382

| Sheet Totals | | | SHEET | TOTAL |
|--------------|-----|------|-------|-------|
| Seeding | Cut | Fill | | |
| . | . | . | 687 | 2339 |

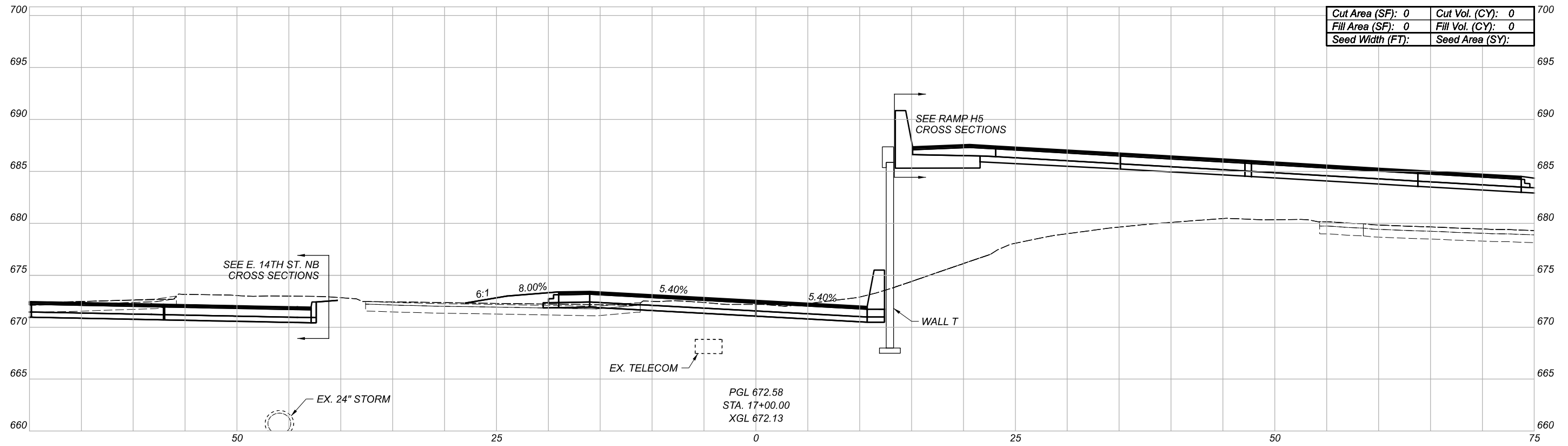

| | |
|-------------------|-------------------|
| Cut Area (SF): 0 | Cut Vol. (CY): 0 |
| Fill Area (SF): 0 | Fill Vol. (CY): 0 |
| Seed Width (FT): | Seed Area (SY): |

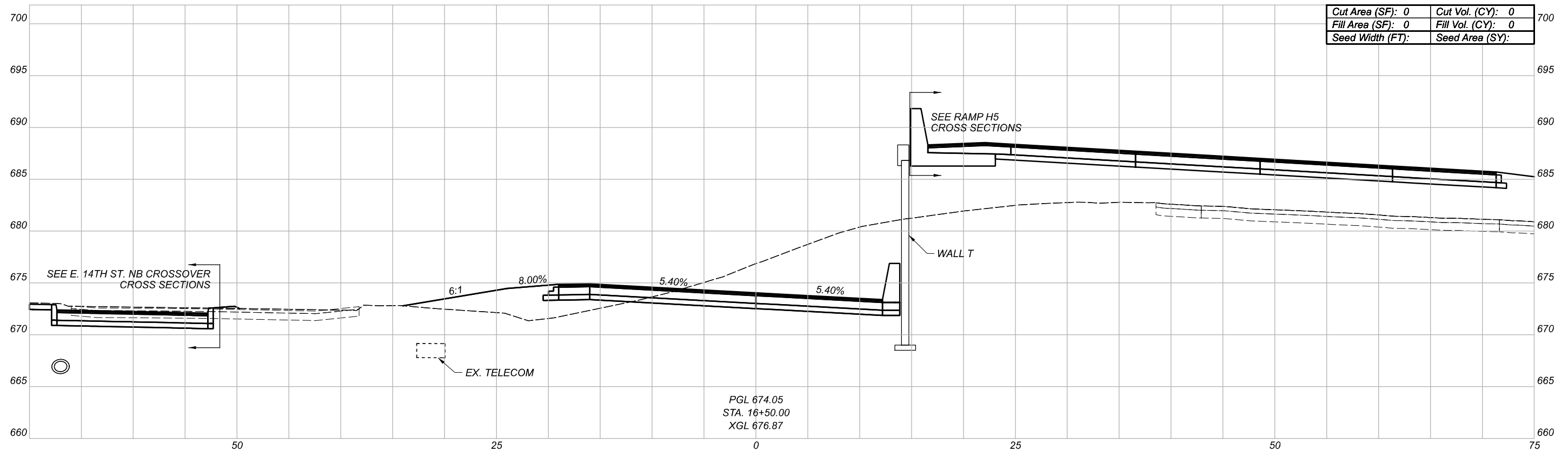

| | |
|-------------------|-------------------|
| Cut Area (SF): 0 | Cut Vol. (CY): 0 |
| Fill Area (SF): 0 | Fill Vol. (CY): 0 |
| Seed Width (FT): | Seed Area (SY): |

CROSS SECTIONS
RAMP IH4

| | |
|-----------------------------|-------|
| DESIGN AGENCY | |
| Michael Baker INTERNATIONAL | |
| DESIGNER | -- |
| REVIEWER | -- |
| PROJECT ID | 82382 |

| Sheet Totals | | |
|--------------|-------|------|
| Seeding | Cut | Fill |
| . | . | . |
| SHEET | TOTAL | |
| 688 | 2339 | |

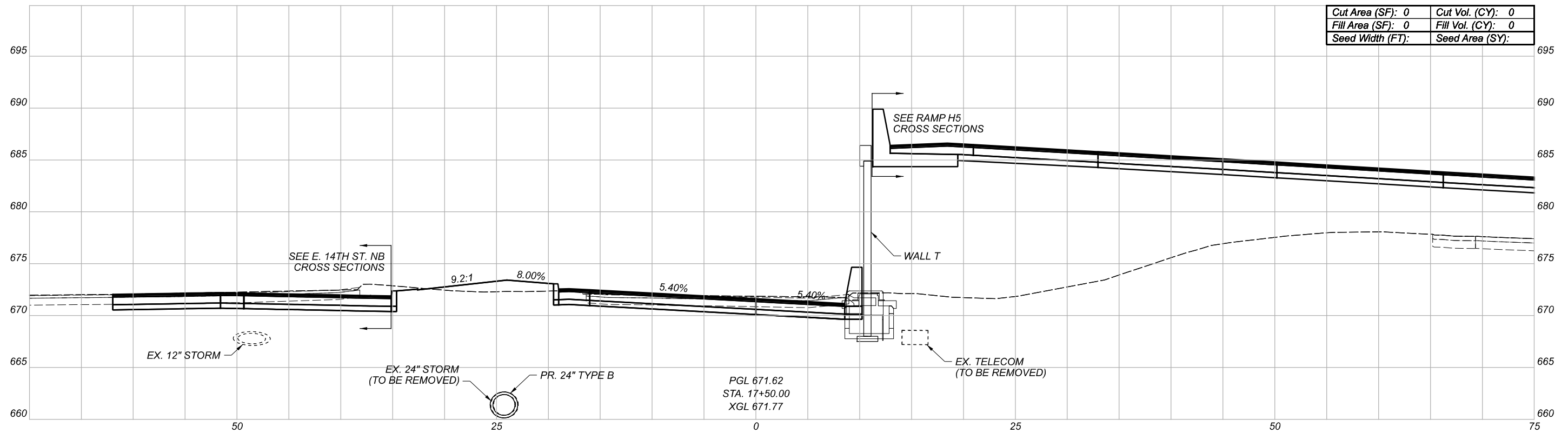
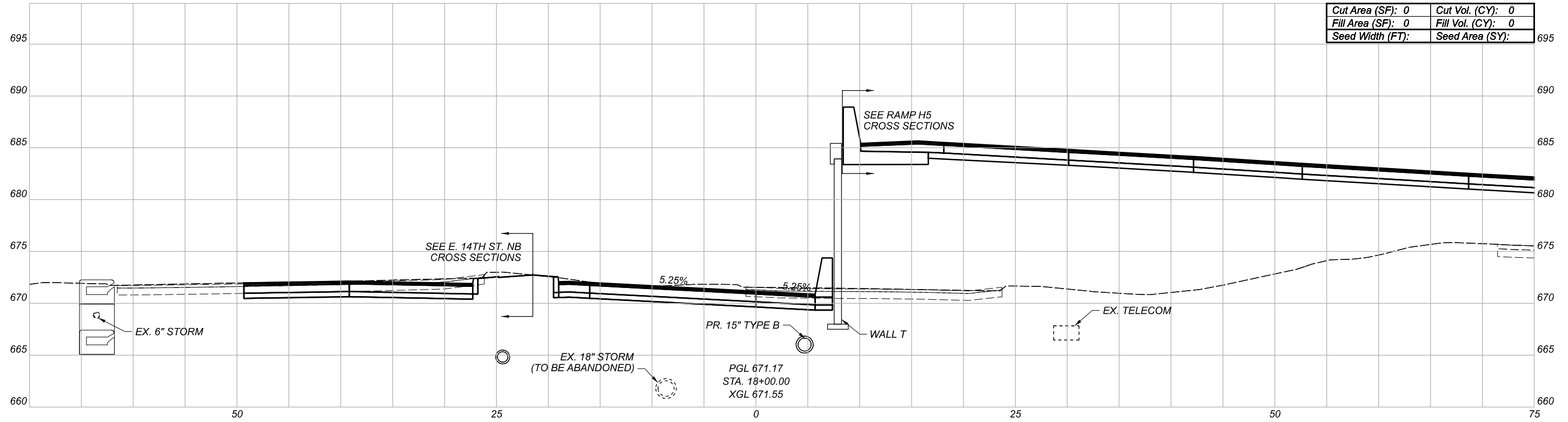

CROSS SECTIONS
RAMP IH4

DESIGN AGENCY

Michael Baker
INTERNATIONAL

DESIGNER

REVIEWER

PROJECT ID

82382

| Sheet Totals | | | SHEET | TOTAL |
|--------------|-----|------|-------|-------|
| Seeding | Cut | Fill | | |
| . | . | . | 689 | 2339 |

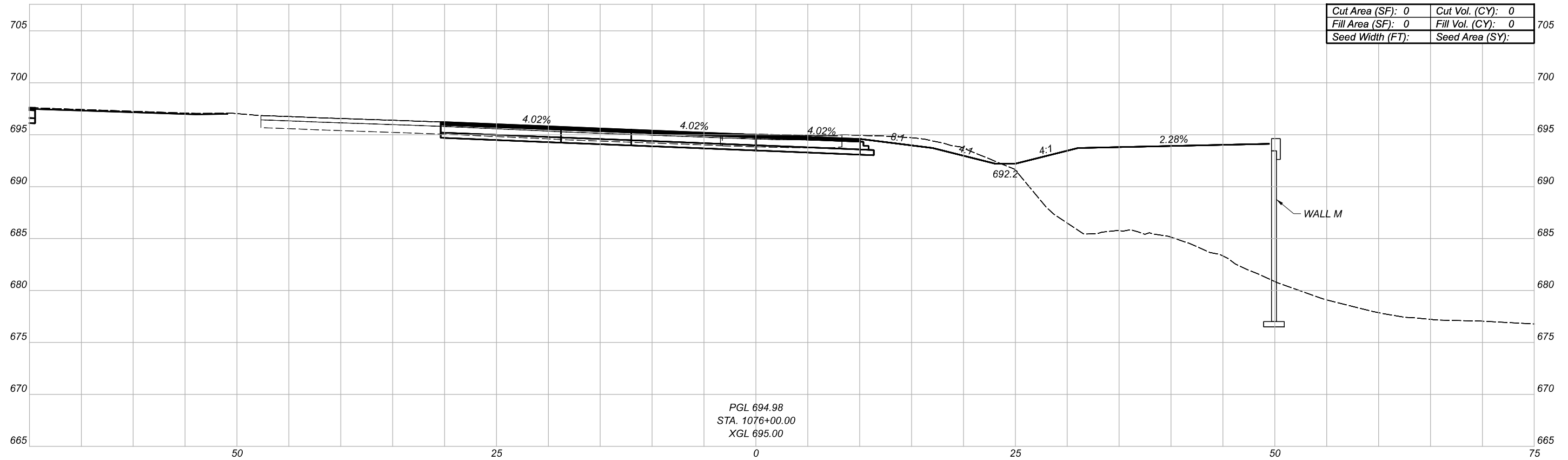
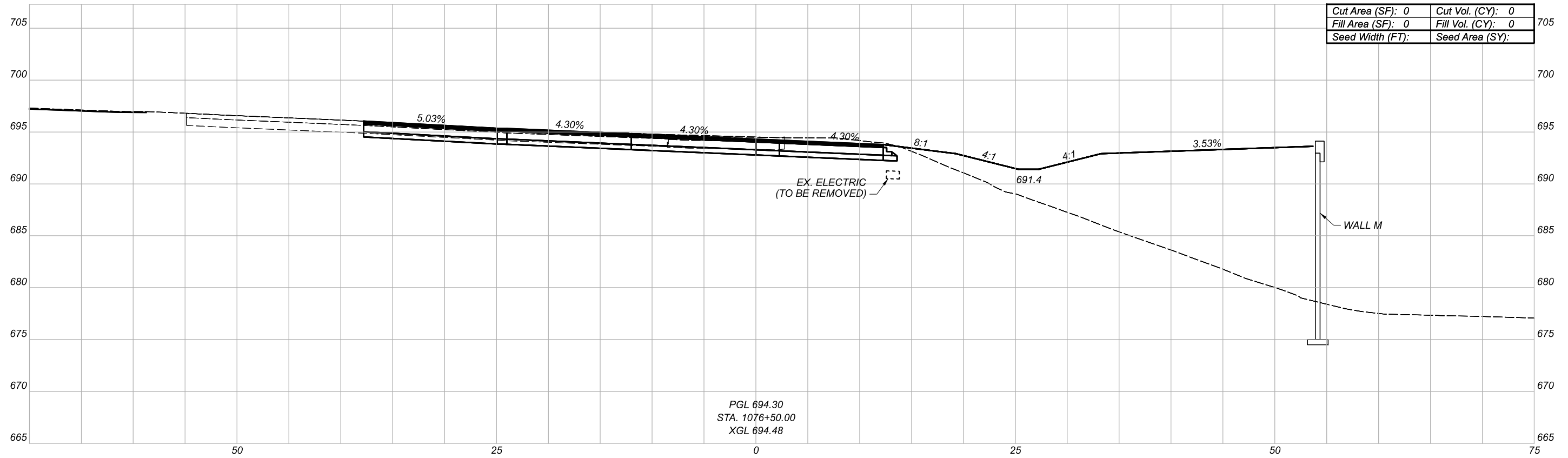

CROSS SECTIONS
RAMP IH5/H5

DESIGN AGENCY

Michael Baker
INTERNATIONAL

DESIGNER

REVIEWER

PROJECT ID

82382

| Sheet Totals | | | SHEET | TOTAL |
|--------------|-----|------|-------|-------|
| Seeding | Cut | Fill | | |
| . | . | . | 690 | 2339 |

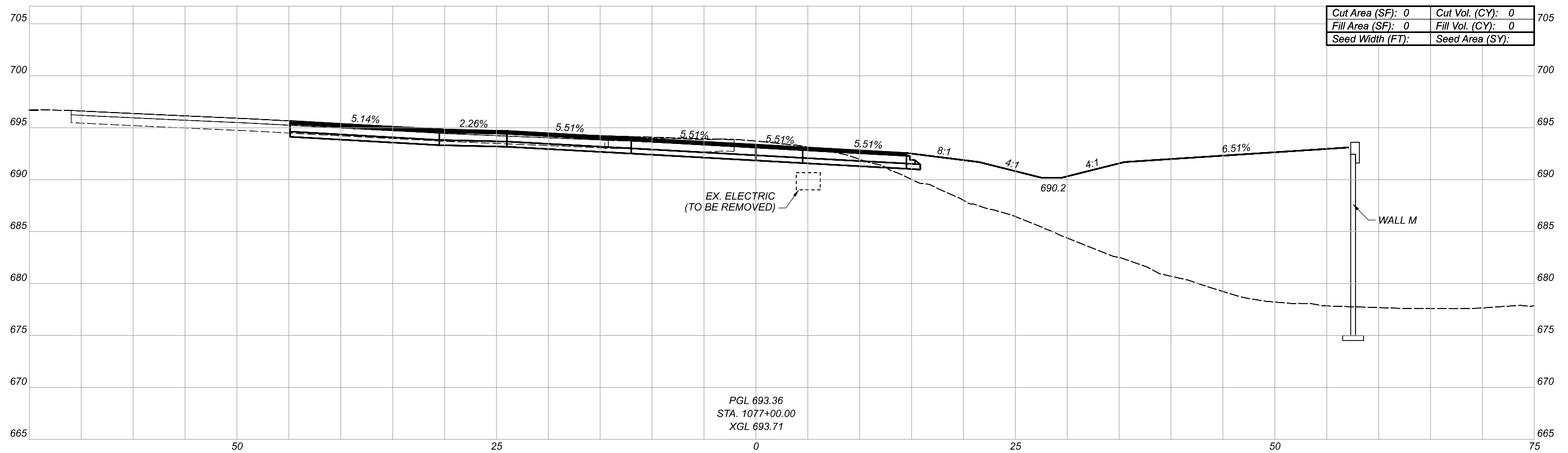
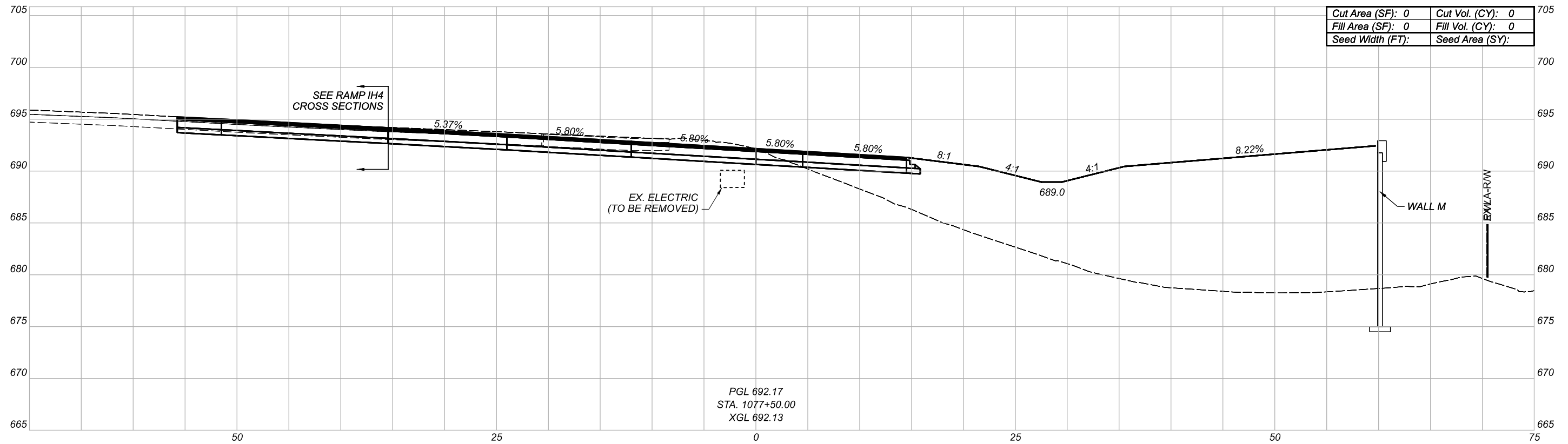

CROSS SECTIONS
RAMP IH5/H5

DESIGN AGENCY

Michael Baker
INTERNATIONAL

DESIGNER

REVIEWER

PROJECT ID

82382

| Sheet Totals | | | SHEET | TOTAL |
|--------------|-----|------|-------|-------|
| Seeding | Cut | Fill | | |
| . | . | . | 691 | 2339 |

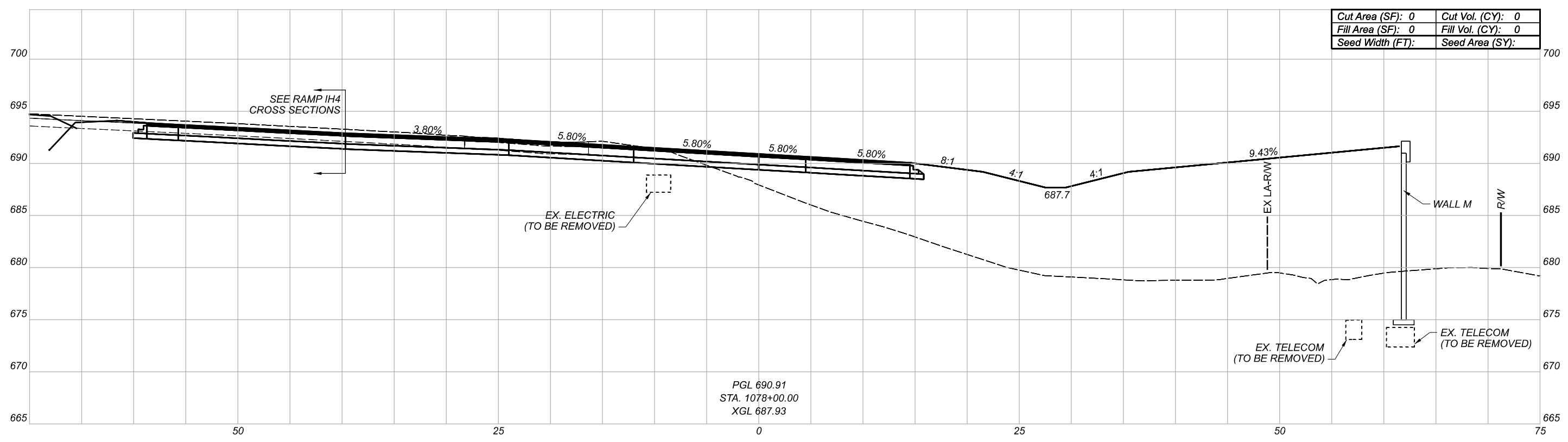
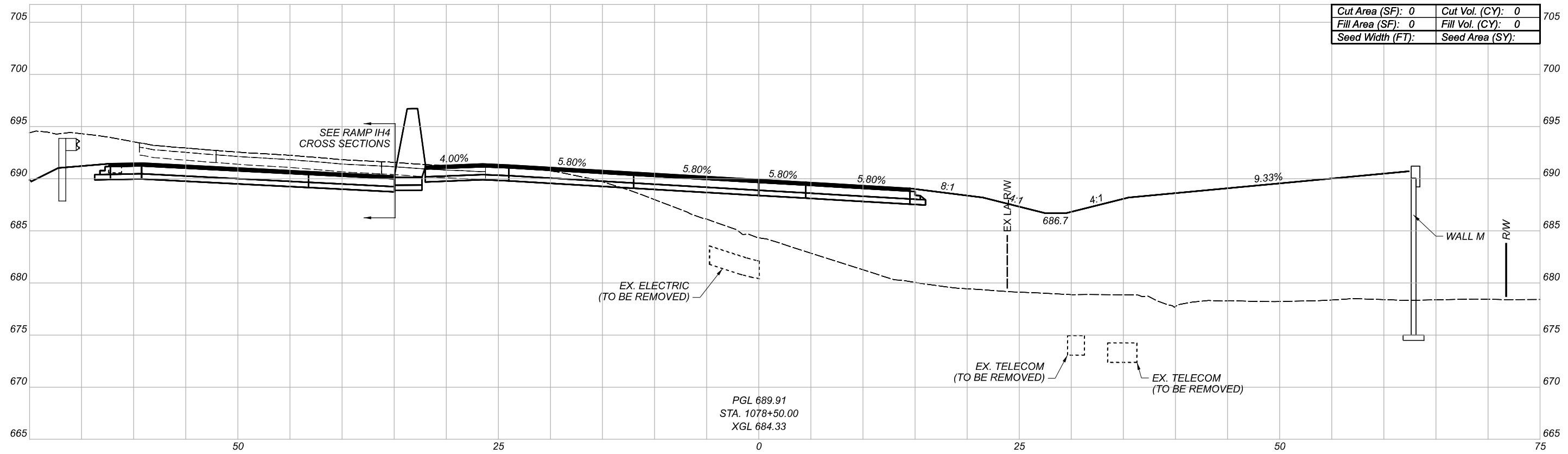

CROSS SECTIONS
RAMP IH5/H5

| | |
|-----------------------------|-------|
| DESIGN AGENCY | |
| Michael Baker INTERNATIONAL | |
| DESIGNER | -- |
| REVIEWER | -- |
| PROJECT ID | 82382 |

| Sheet Totals | | | SHEET | TOTAL |
|--------------|-----|------|-------|-------|
| Seeding | Cut | Fill | | |
| . | . | . | 692 | 2339 |

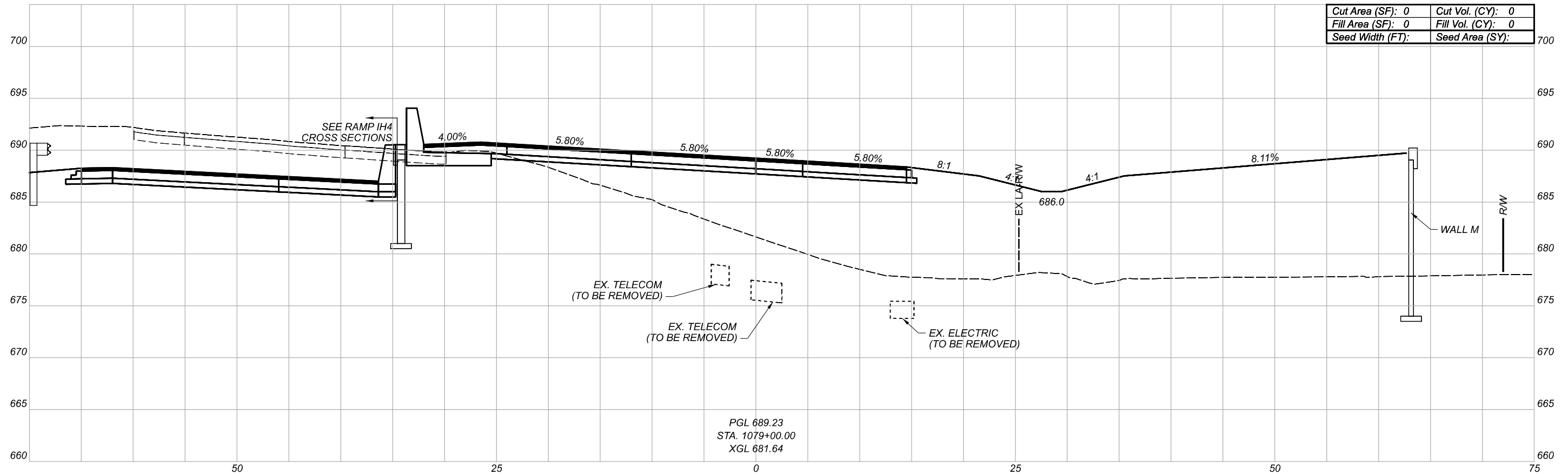
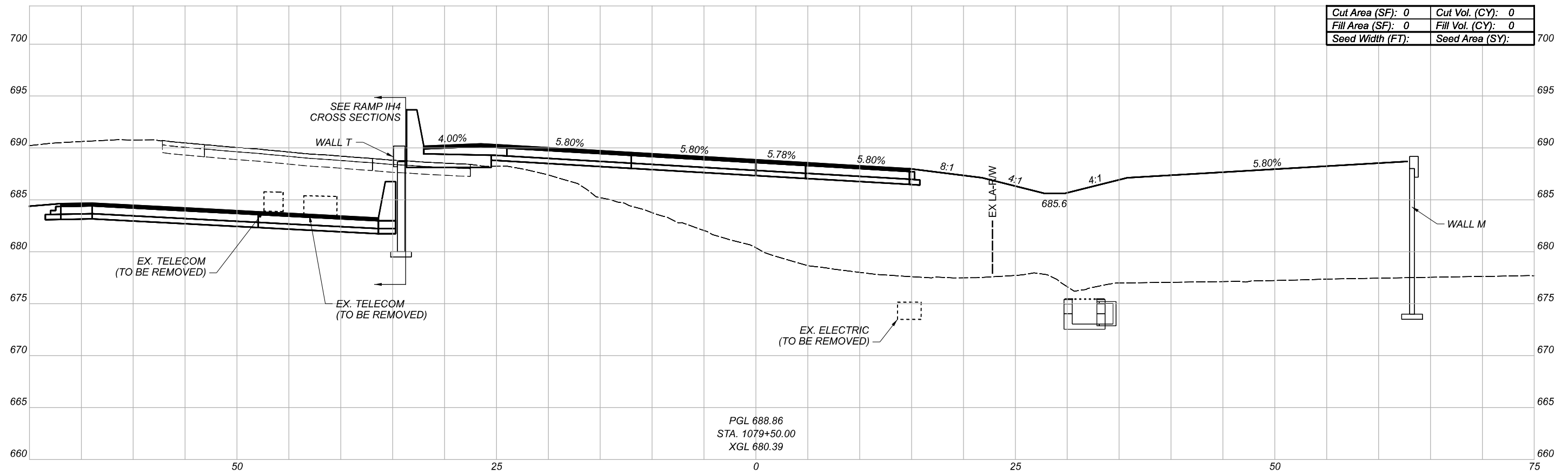

CROSS SECTIONS
RAMP IH5/H5

DESIGN AGENCY

Michael Baker
INTERNATIONAL

DESIGNER

REVIEWER

PROJECT ID

82382

| Sheet Totals | | | 82382 | |
|--------------|-----|------|-------|-------|
| Seeding | Cut | Fill | SHEET | TOTAL |
| . | . | . | 693 | 2339 |

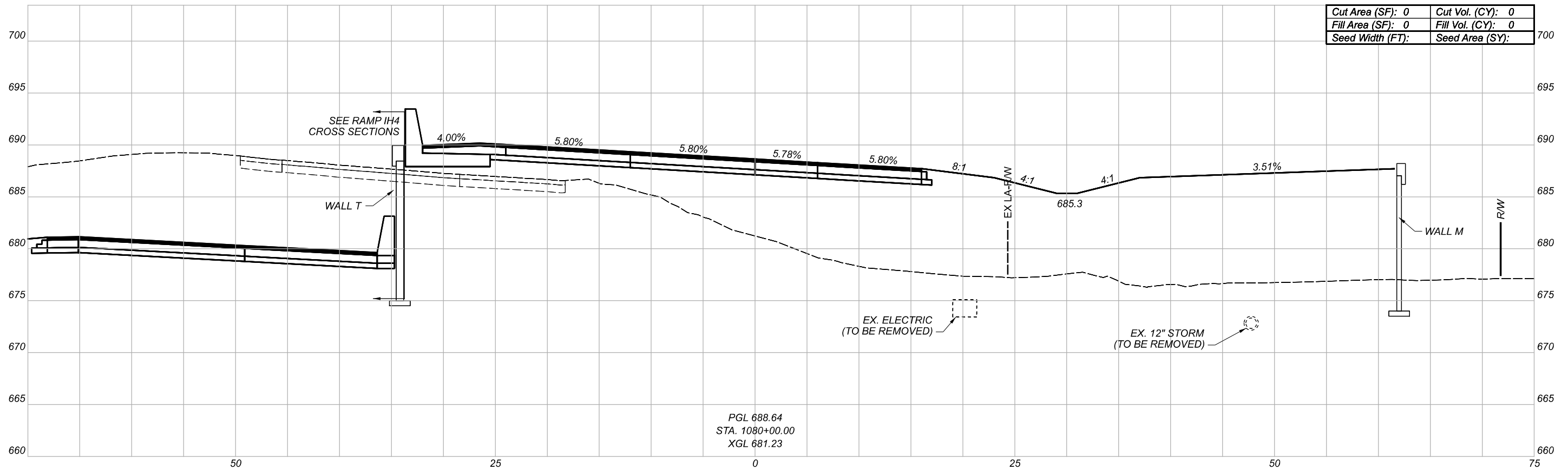
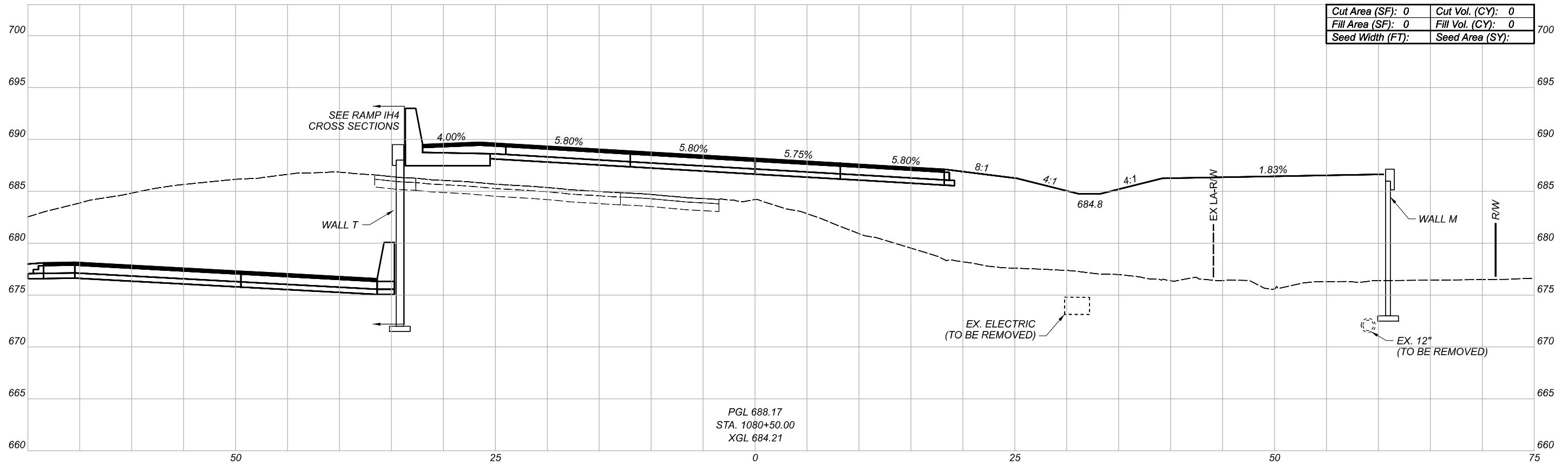

CROSS SECTIONS
RAMP IH5/H5

DESIGN AGENCY

Michael Baker
INTERNATIONAL

DESIGNER

REVIEWER

PROJECT ID

82382

| Sheet Totals | | | SHEET | TOTAL |
|--------------|-----|------|-------|-------|
| Seeding | Cut | Fill | | |
| . | . | . | 694 | 2339 |

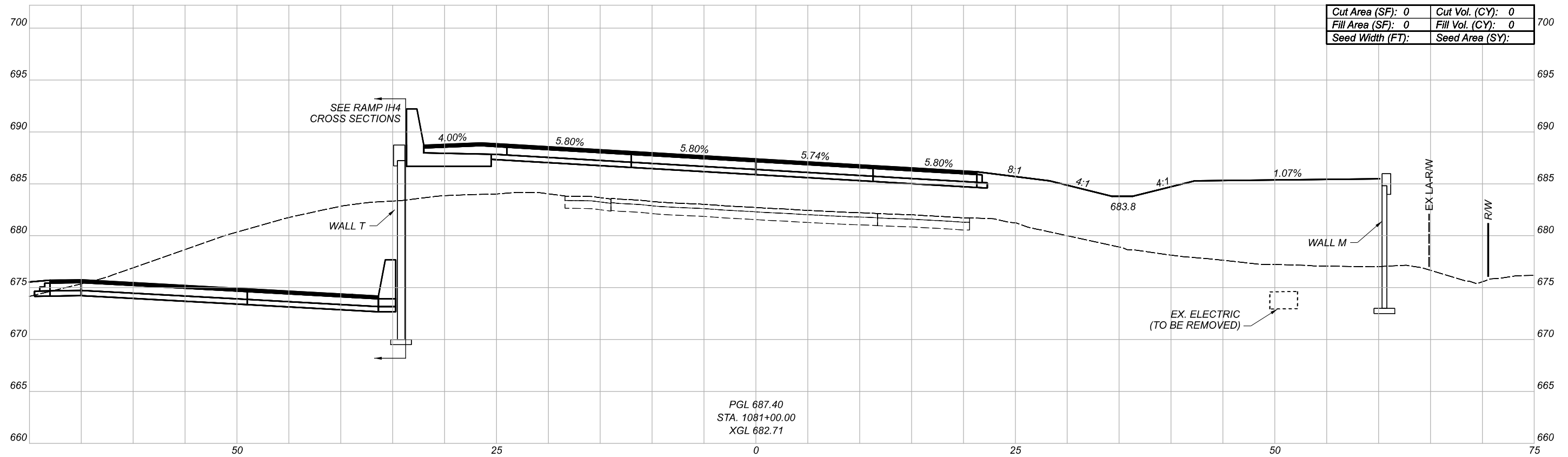
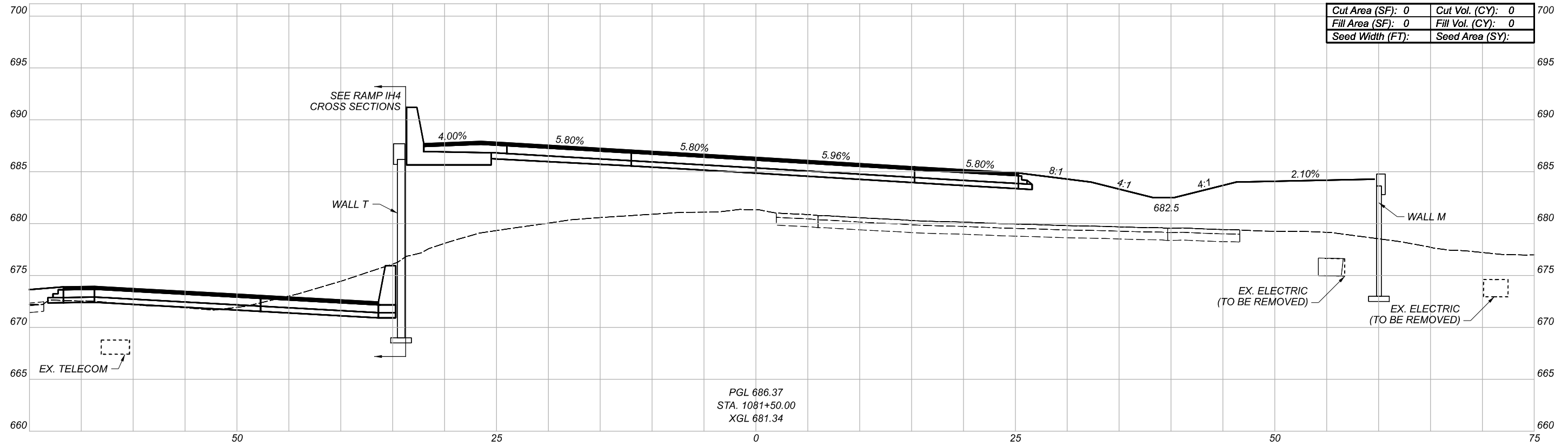

CROSS SECTIONS
RAMP IH5/H5

DESIGN AGENCY

Michael Baker
INTERNATIONAL

DESIGNER

REVIEWER

PROJECT ID

82382

| Sheet Totals | | | SHEET | TOTAL |
|--------------|-----|------|-------|-------|
| Seeding | Cut | Fill | | |
| . | . | . | 695 | 2339 |

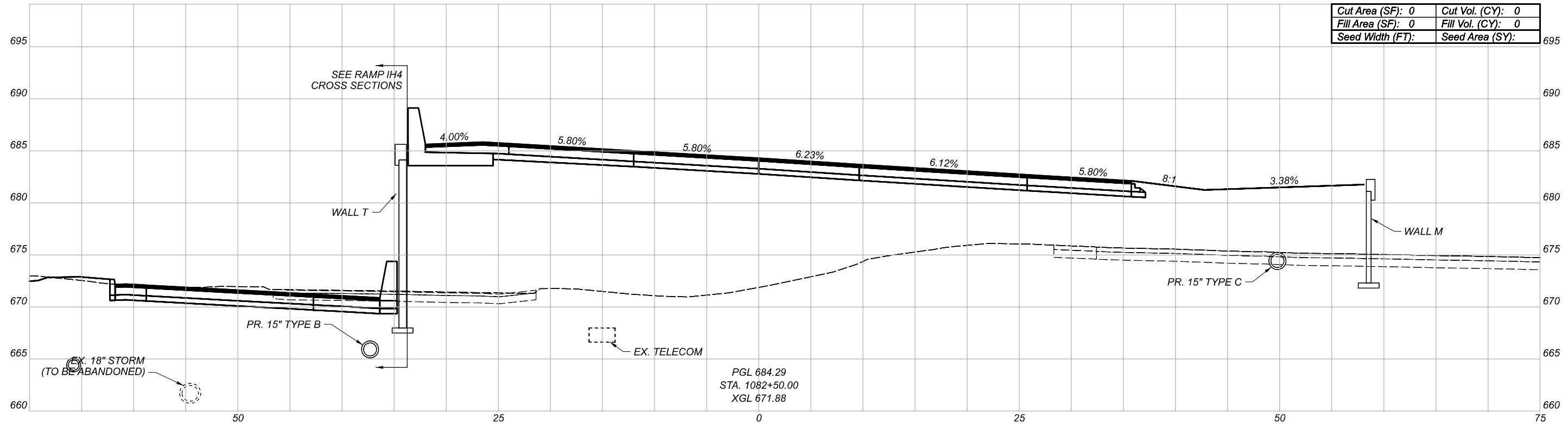

| | | | |
|------------------|---|-----------------|---|
| Cut Area (SF): | 0 | Cut Vol. (CY): | 0 |
| Fill Area (SF): | 0 | Fill Vol. (CY): | 0 |
| Seed Width (FT): | | Seed Area (SY): | |

PGL 684.29
 STA. 1082+50.00
 XGL 671.88

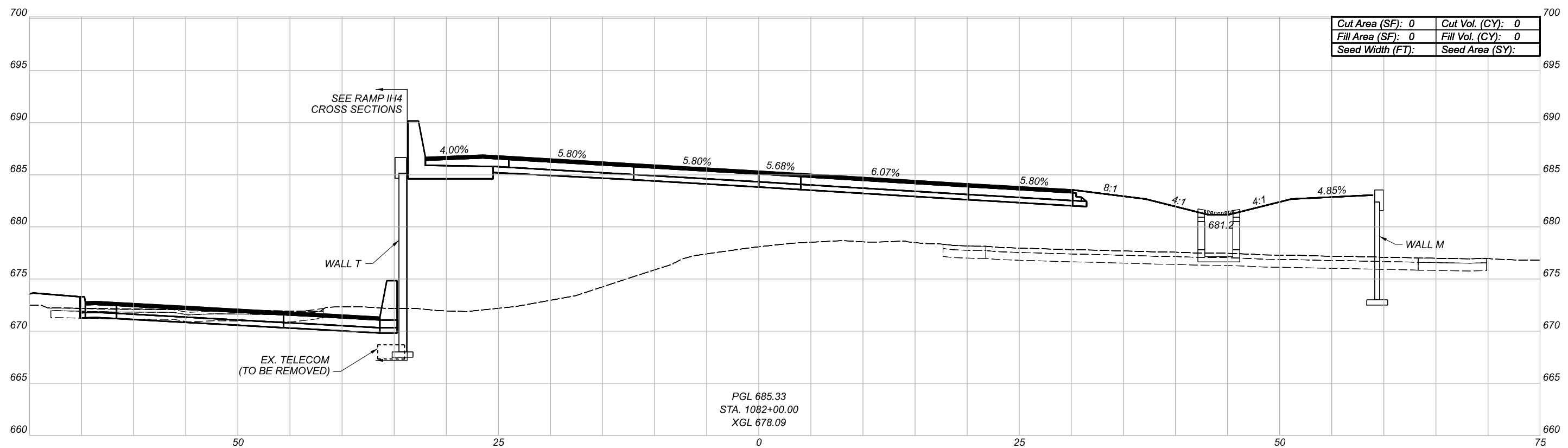

| | | | |
|------------------|---|-----------------|---|
| Cut Area (SF): | 0 | Cut Vol. (CY): | 0 |
| Fill Area (SF): | 0 | Fill Vol. (CY): | 0 |
| Seed Width (FT): | | Seed Area (SY): | |

PGL 685.33
 STA. 1082+00.00
 XGL 678.09

CROSS SECTIONS
 RAMP IH5/H5

| | |
|-----------------------------|-------|
| DESIGN AGENCY | |
| Michael Baker INTERNATIONAL | |
| DESIGNER | -- |
| REVIEWER | -- |
| PROJECT ID | 82382 |

| Sheet Totals | | | SHEET | TOTAL |
|--------------|-----|------|-------|-------|
| Seeding | Cut | Fill | | |
| . | . | . | 696 | 2339 |

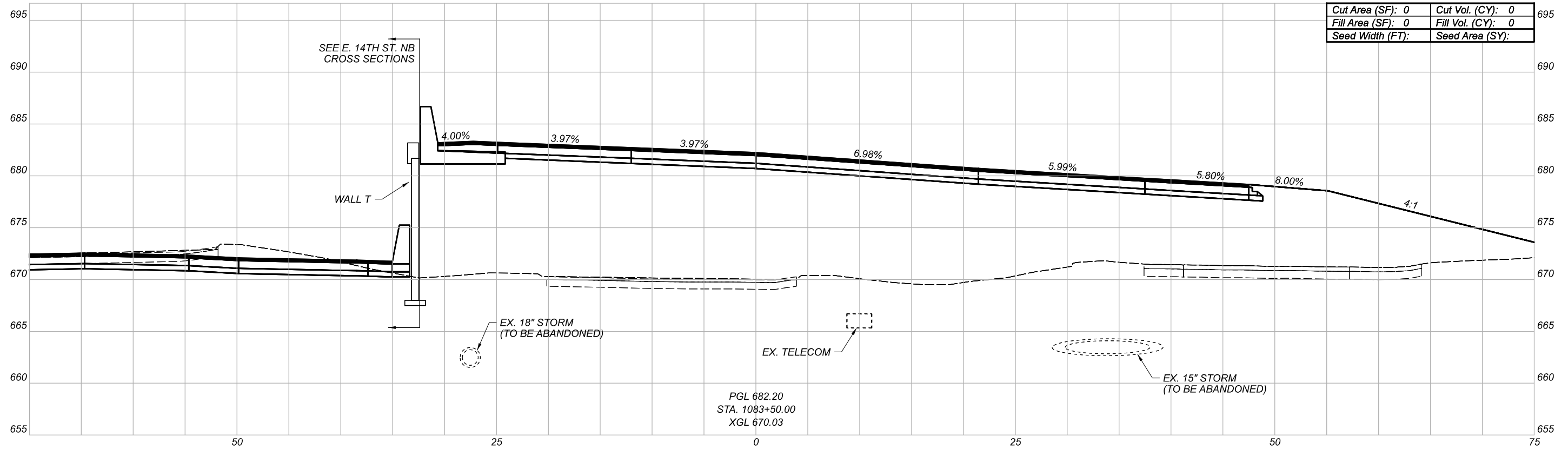

| | |
|-------------------|-------------------|
| Cut Area (SF): 0 | Cut Vol. (CY): 0 |
| Fill Area (SF): 0 | Fill Vol. (CY): 0 |
| Seed Width (FT): | Seed Area (SY): |

PGL 682.20
 STA. 1083+50.00
 XGL 670.03

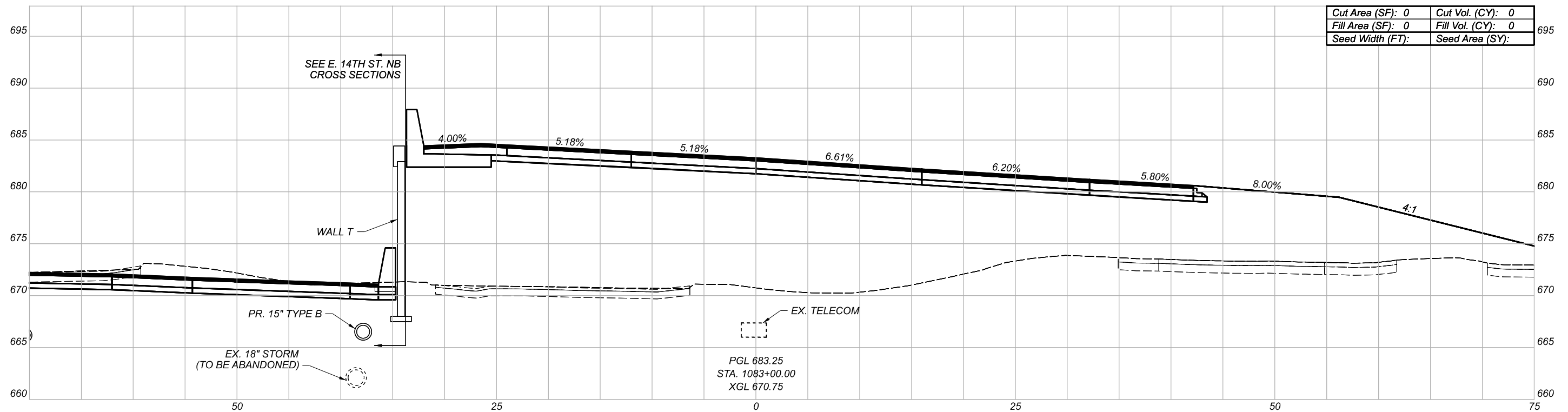

| | |
|-------------------|-------------------|
| Cut Area (SF): 0 | Cut Vol. (CY): 0 |
| Fill Area (SF): 0 | Fill Vol. (CY): 0 |
| Seed Width (FT): | Seed Area (SY): |

PGL 683.25
 STA. 1083+00.00
 XGL 670.75

CROSS SECTIONS
 RAMP IH5/H5

| | |
|-----------------------------|-------|
| DESIGN AGENCY | |
| Michael Baker INTERNATIONAL | |
| DESIGNER | -- |
| REVIEWER | -- |
| PROJECT ID | 82382 |

| | | |
|--------------|-------|------|
| Sheet Totals | | |
| Seeding | Cut | Fill |
| . | . | . |
| SHEET | TOTAL | |
| 697 | 2339 | |

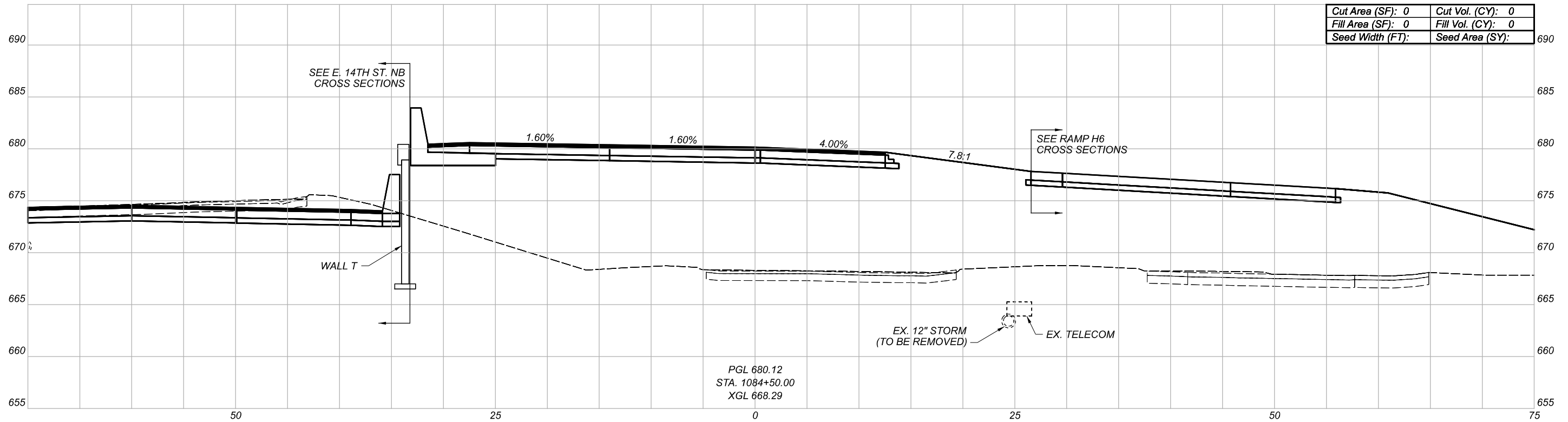

| | | | |
|------------------|---|-----------------|---|
| Cut Area (SF): | 0 | Cut Vol. (CY): | 0 |
| Fill Area (SF): | 0 | Fill Vol. (CY): | 0 |
| Seed Width (FT): | | Seed Area (SY): | |

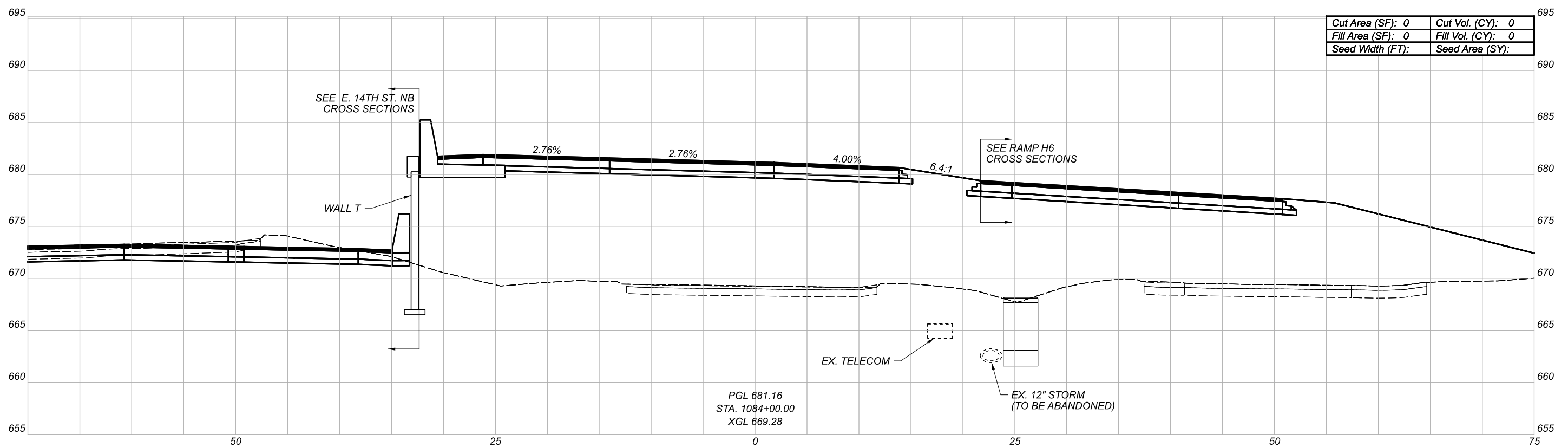

| | | | |
|------------------|---|-----------------|---|
| Cut Area (SF): | 0 | Cut Vol. (CY): | 0 |
| Fill Area (SF): | 0 | Fill Vol. (CY): | 0 |
| Seed Width (FT): | | Seed Area (SY): | |

CROSS SECTIONS
RAMP IH5/H5

DESIGN AGENCY

Michael Baker
INTERNATIONAL

DESIGNER

REVIEWER

PROJECT ID

82382

| Sheet Totals | | | SHEET | TOTAL |
|--------------|-----|------|-------|-------|
| Seeding | Cut | Fill | | |
| . | . | . | 698 | 2339 |

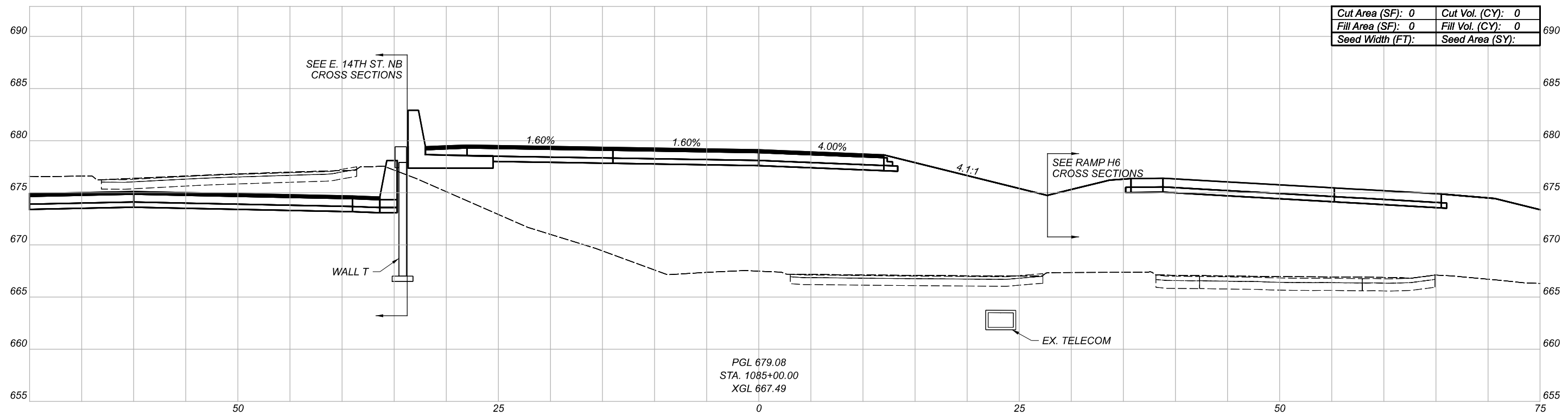
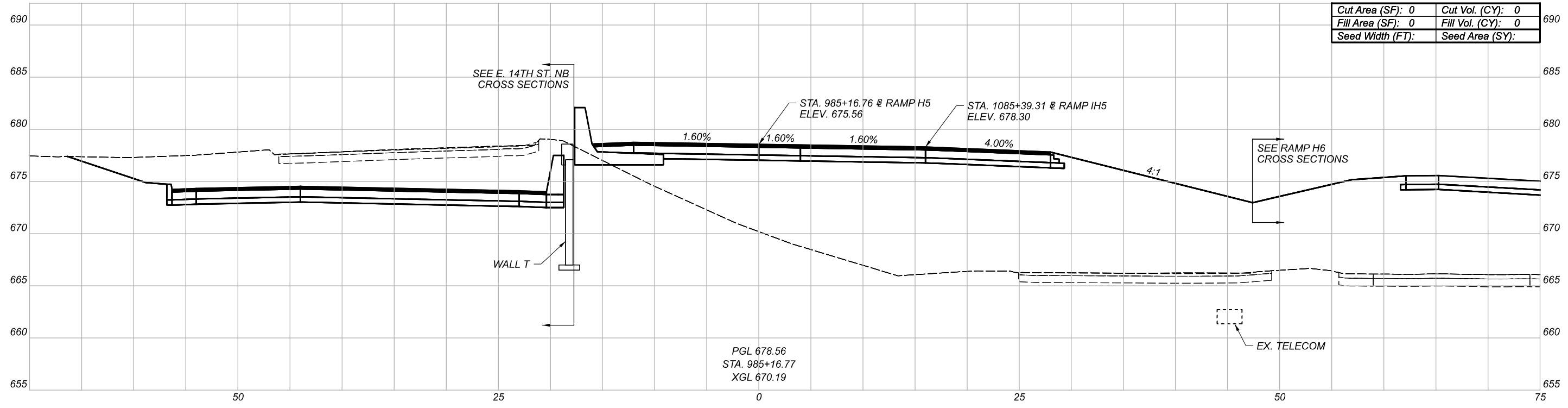

CROSS SECTIONS
RAMP IH5/H5

| | |
|---------------|-------|
| DESIGN AGENCY | |
| DESIGNER | -- |
| REVIEWER | -- |
| PROJECT ID | 82382 |

| Sheet Totals | | | SHEET | TOTAL |
|--------------|-----|------|-------|-------|
| Seeding | Cut | Fill | | |
| . | . | . | 699 | 2339 |

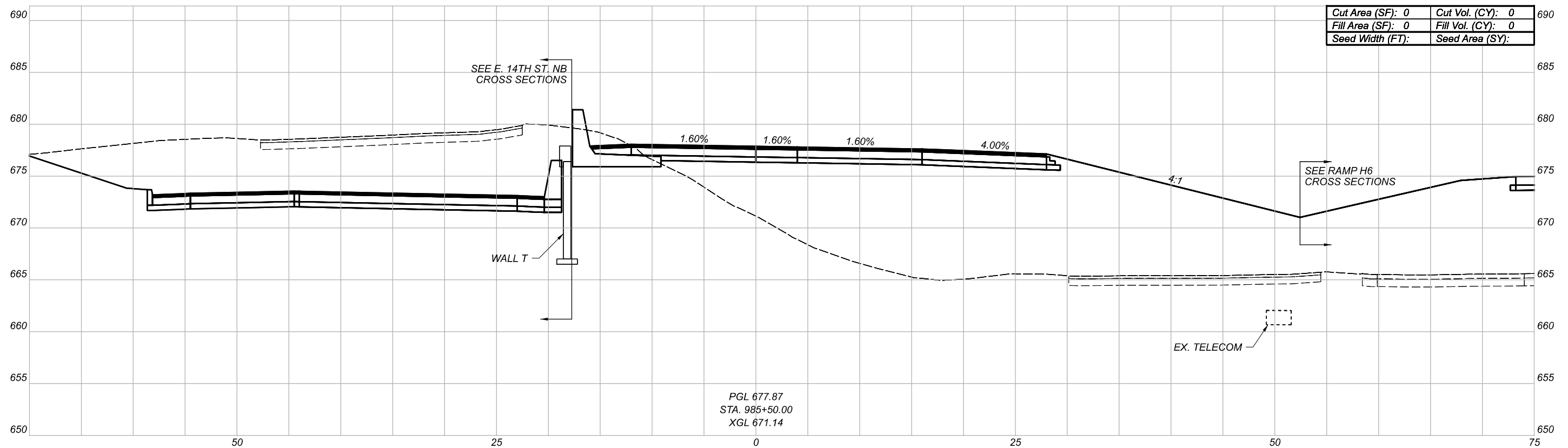
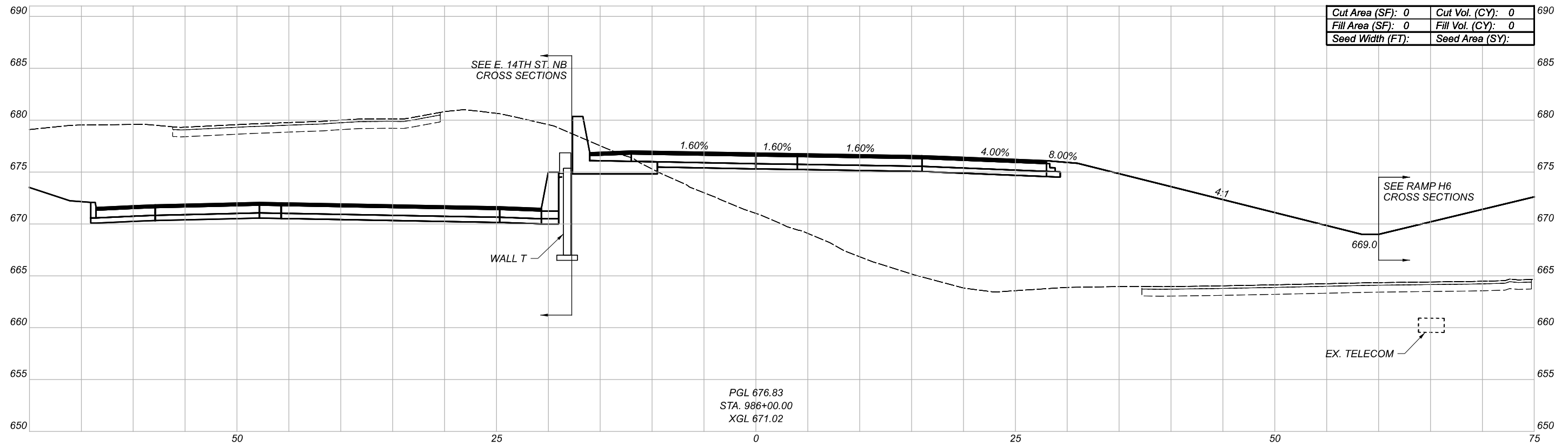

CROSS SECTIONS
RAMP IH5/H5

DESIGN AGENCY

Michael Baker
INTERNATIONAL

DESIGNER

REVIEWER

PROJECT ID

82382

| Sheet Totals | | | SHEET | TOTAL |
|--------------|-----|------|-------|-------|
| Seeding | Cut | Fill | | |
| . | . | . | 700 | 2339 |

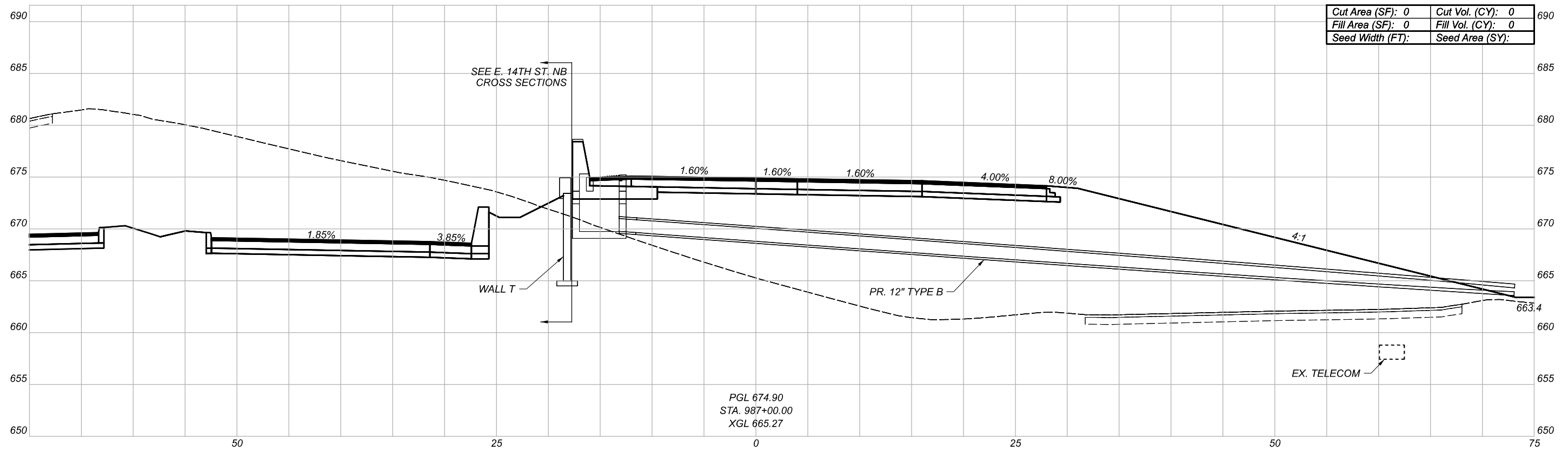

| | | | |
|------------------|---|-----------------|---|
| Cut Area (SF): | 0 | Cut Vol. (CY): | 0 |
| Fill Area (SF): | 0 | Fill Vol. (CY): | 0 |
| Seed Width (FT): | | Seed Area (SY): | |

PGL 674.90
 STA. 987+00.00
 XGL 665.27

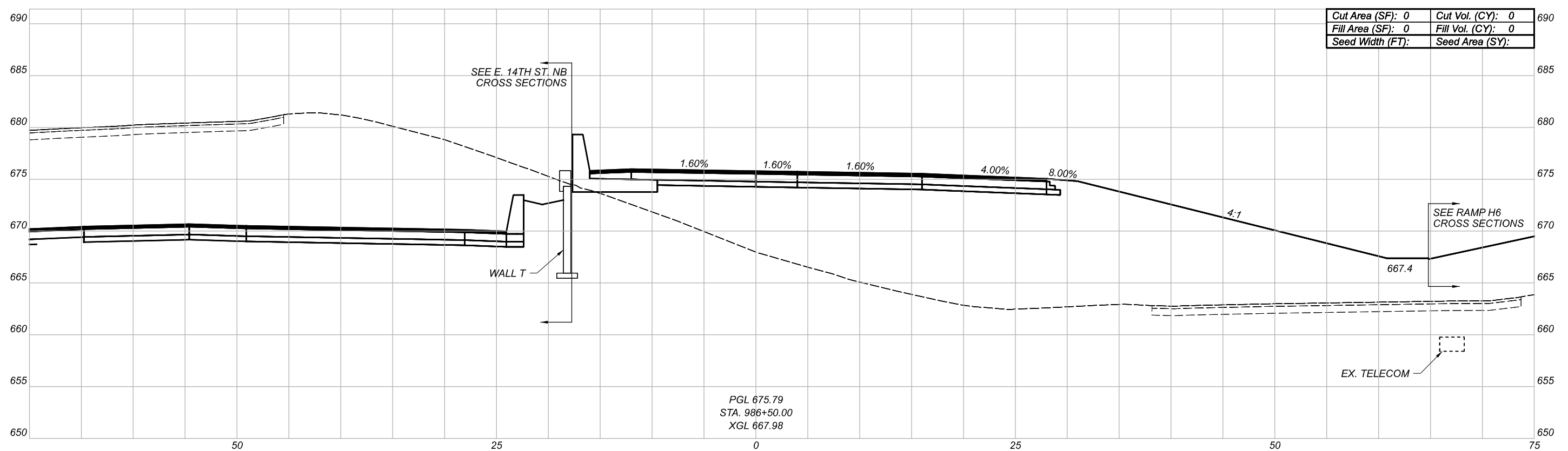

| | | | |
|------------------|---|-----------------|---|
| Cut Area (SF): | 0 | Cut Vol. (CY): | 0 |
| Fill Area (SF): | 0 | Fill Vol. (CY): | 0 |
| Seed Width (FT): | | Seed Area (SY): | |

PGL 675.79
 STA. 986+50.00
 XGL 667.98

CROSS SECTIONS
 RAMP IH5/H5

| | |
|-----------------------------|-------|
| DESIGN AGENCY | |
| Michael Baker INTERNATIONAL | |
| DESIGNER | -- |
| REVIEWER | -- |
| PROJECT ID | 82382 |

| | | |
|--------------|-------|------|
| Sheet Totals | | |
| Seeding | Cut | Fill |
| . | . | . |
| SHEET | TOTAL | |
| 701 | 2339 | |

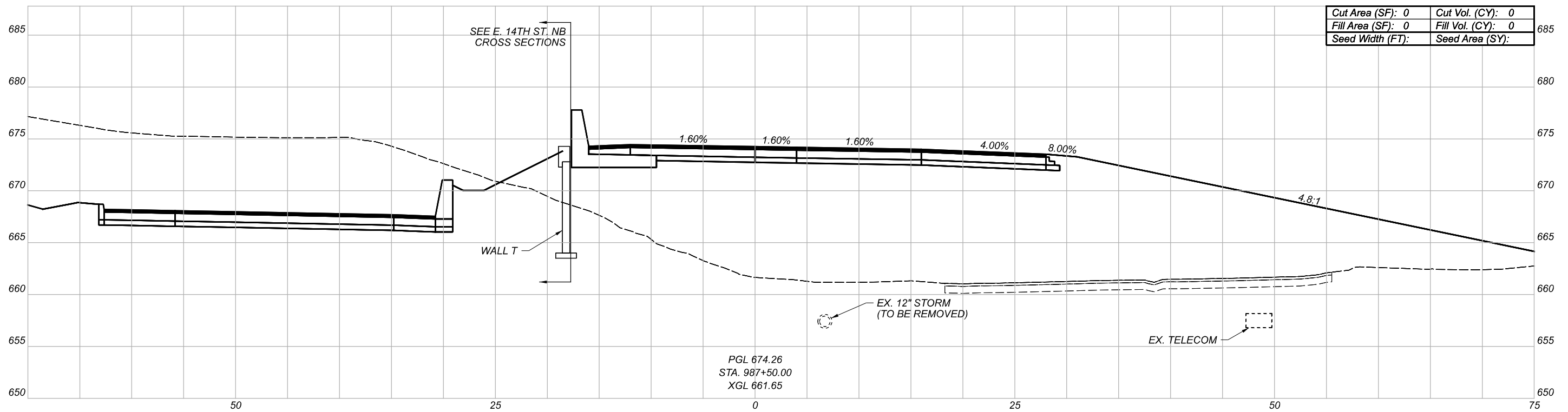
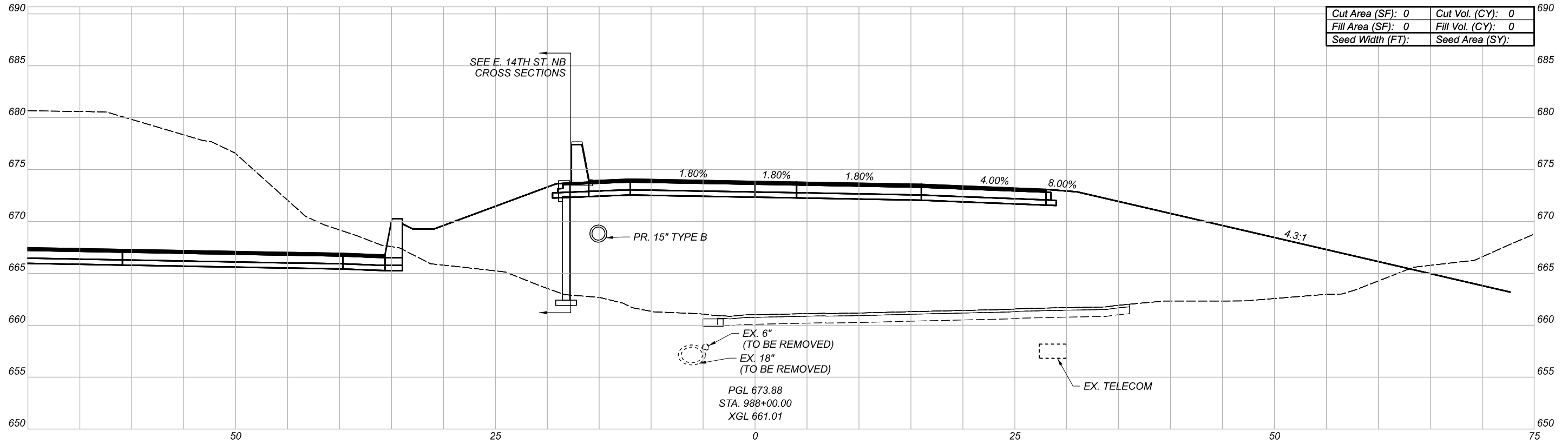

CROSS SECTIONS
RAMP IH5/H5

DESIGN AGENCY

Michael Baker
INTERNATIONAL

DESIGNER

REVIEWER

PROJECT ID

82382

| Sheet Totals | | | SHEET | TOTAL |
|--------------|-----|------|-------|-------|
| Seeding | Cut | Fill | | |
| . | . | . | 702 | 2339 |

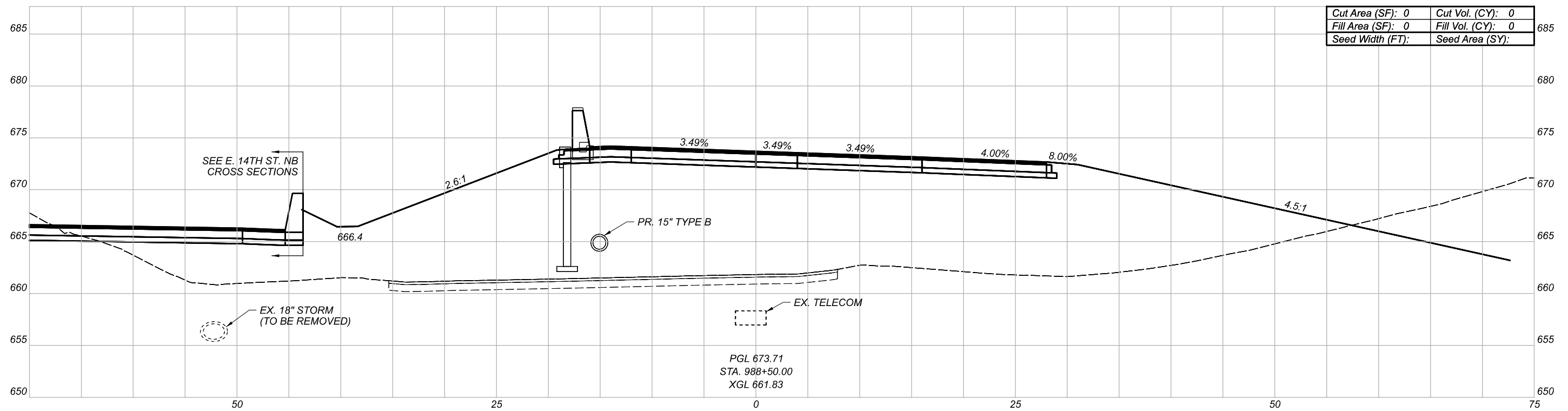
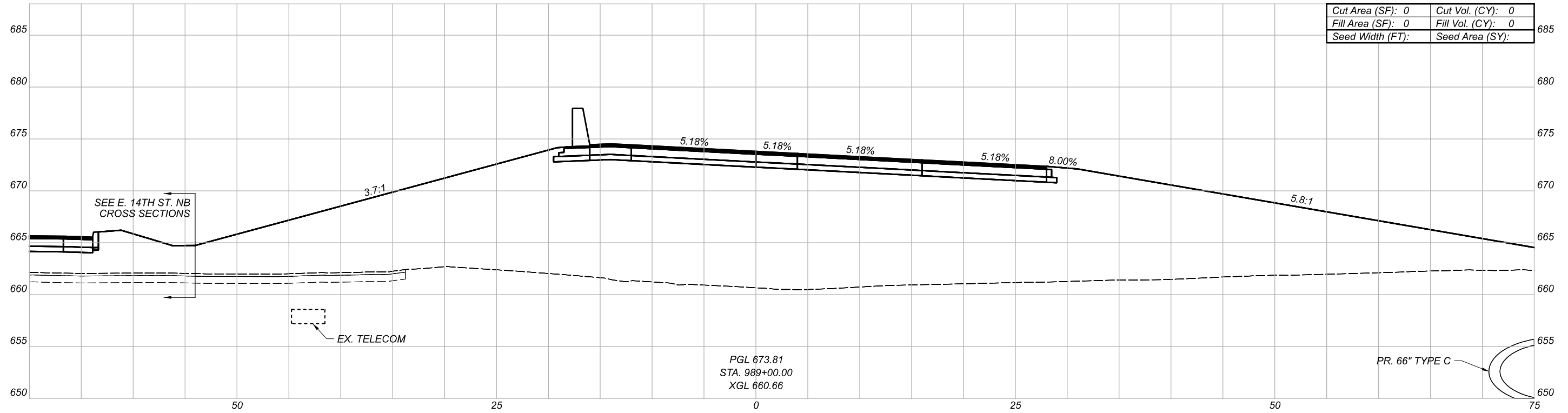

CROSS SECTIONS
RAMP IH5/H5

DESIGN AGENCY

Michael Baker
INTERNATIONAL

DESIGNER

REVIEWER

PROJECT ID

82382

| Sheet Totals | | | SHEET | TOTAL |
|--------------|-----|------|-------|-------|
| Seeding | Cut | Fill | | |
| . | . | . | 703 | 2339 |

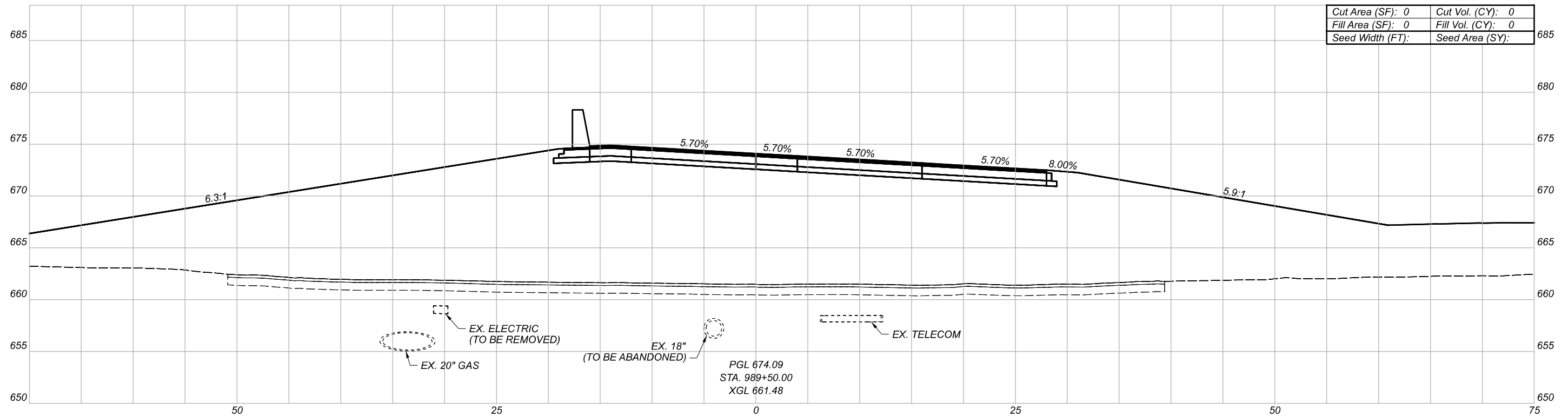

| | |
|-------------------|-------------------|
| Cut Area (SF): 0 | Cut Vol. (CY): 0 |
| Fill Area (SF): 0 | Fill Vol. (CY): 0 |
| Seed Width (FT): | Seed Area (SY): |

PGL 674.09
 STA. 989+50.00
 XGL 661.48

CROSS SECTIONS
 RAMP IH5/H5

| | |
|-----------------------------|-------|
| DESIGN AGENCY | --- |
| Michael Baker INTERNATIONAL | |
| DESIGNER | --- |
| REVIEWER | --- |
| PROJECT ID | 82382 |

| Sheet Totals | | |
|--------------|-----|------|
| Seeding | Cut | Fill |
| . | . | . |

| | |
|-------|-------|
| SHEET | TOTAL |
| 704 | 2339 |

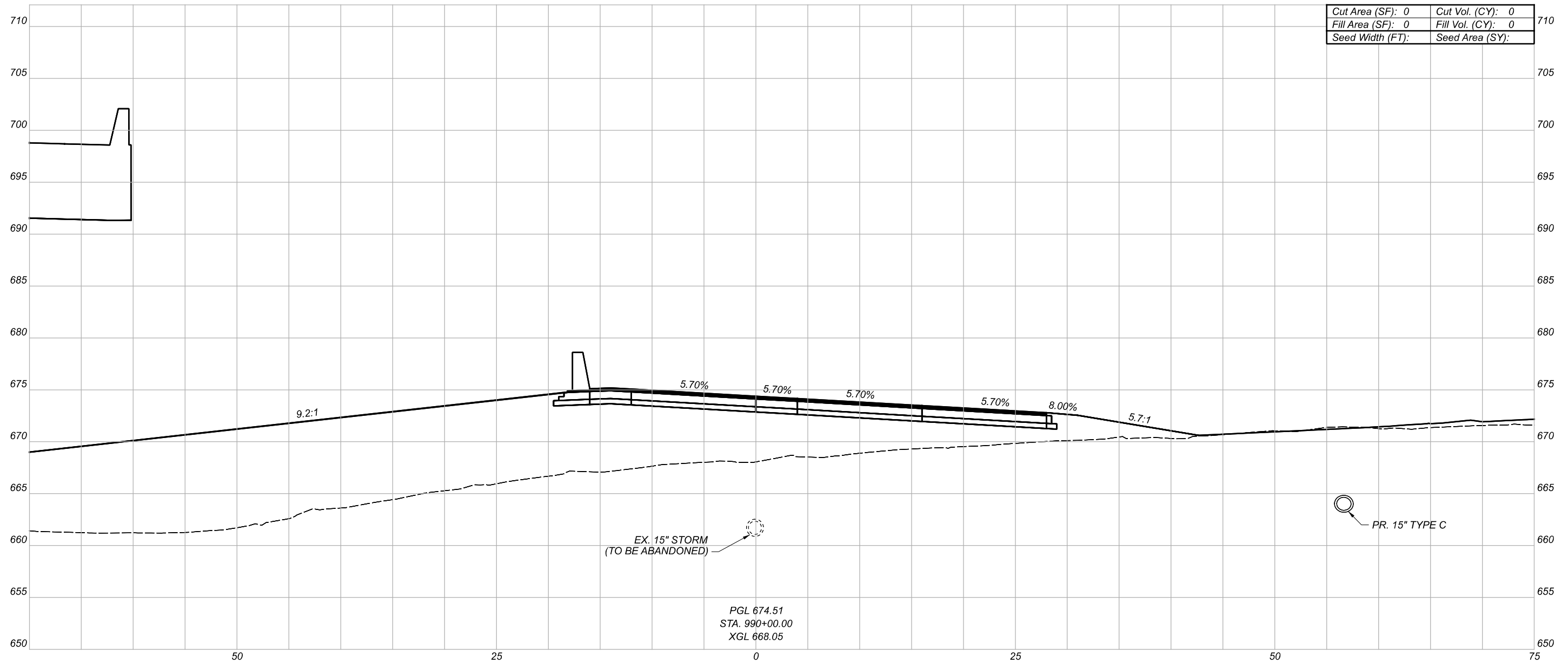

| | |
|-------------------|-------------------|
| Cut Area (SF): 0 | Cut Vol. (CY): 0 |
| Fill Area (SF): 0 | Fill Vol. (CY): 0 |
| Seed Width (FT): | Seed Area (SY): |

CROSS SECTIONS
RAMP IH5/H5

DESIGN AGENCY

Michael Baker
INTERNATIONAL

DESIGNER

REVIEWER

PROJECT ID

82382

| Sheet Totals | | | SHEET | TOTAL |
|--------------|-----|------|-------|-------|
| Seeding | Cut | Fill | | |
| . | . | . | 705 | 2339 |

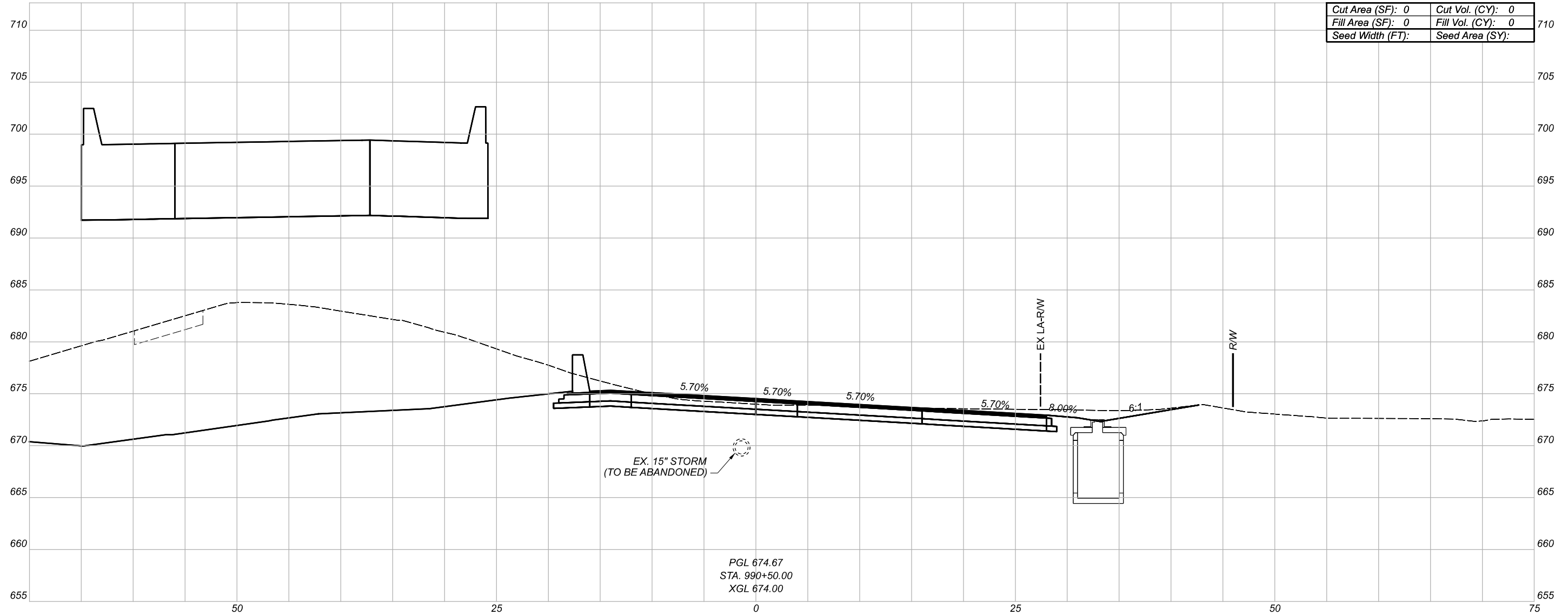

EX. 15" STORM
(TO BE ABANDONED)

PGL 674.67
 STA. 990+50.00
 XGL 674.00

CROSS SECTIONS
 RAMP IH5/H5

| | |
|---------------|-----------------------------|
| DESIGN AGENCY | |
| DESIGNER | Michael Baker INTERNATIONAL |
| REVIEWER | |
| PROJECT ID | 82382 |

| Sheet Totals | | | SHEET | TOTAL |
|--------------|-----|------|-------|-------|
| Seeding | Cut | Fill | | |
| . | . | . | 706 | 2339 |

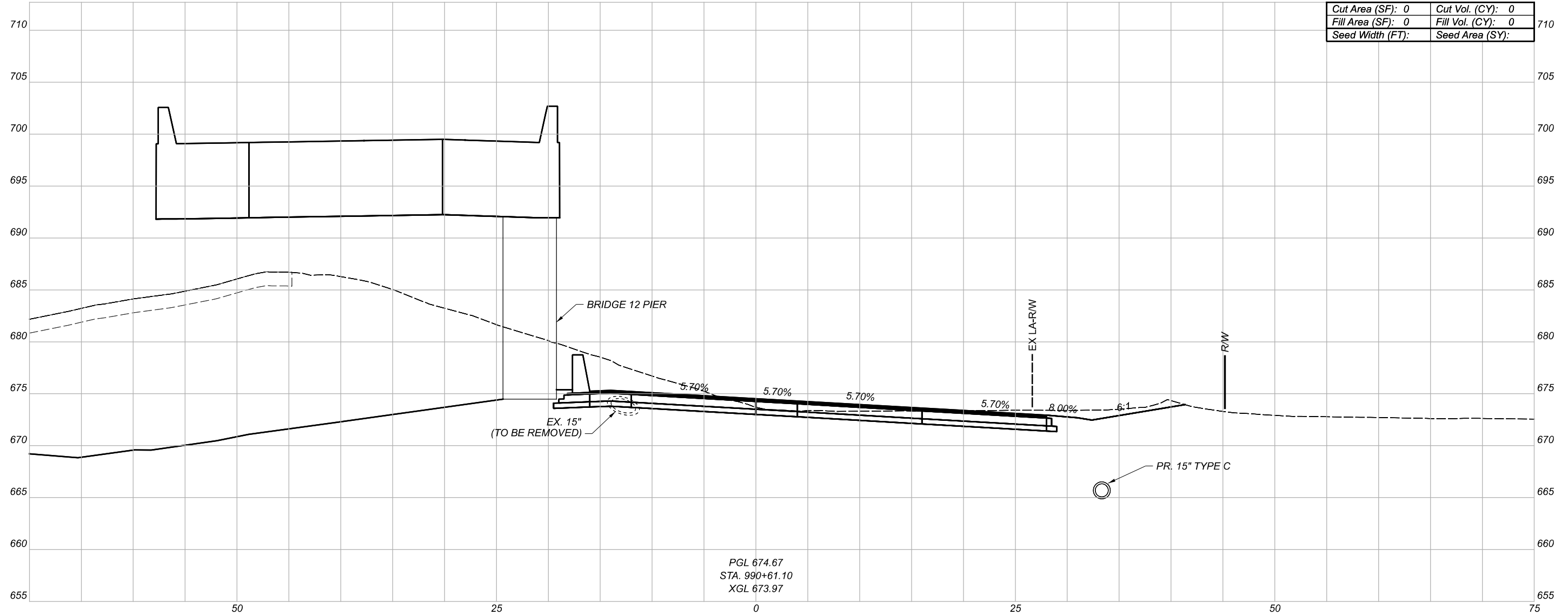

PGL 674.67
 STA. 990+61.10
 XGL 673.97

| | |
|-------------------|-------------------|
| Cut Area (SF): 0 | Cut Vol. (CY): 0 |
| Fill Area (SF): 0 | Fill Vol. (CY): 0 |
| Seed Width (FT): | Seed Area (SY): |

CROSS SECTIONS
 RAMP IH5/H5

| | |
|---------------------------------------|-------|
| DESIGN AGENCY | |
| Michael Baker INTERNATIONAL | |
| DESIGNER | -- |
| REVIEWER | -- |
| PROJECT ID | 82382 |
| SHEET | TOTAL |
| 707 | 2339 |

| Sheet Totals | | |
|--------------|-----|------|
| Seeding | Cut | Fill |
| . | . | . |

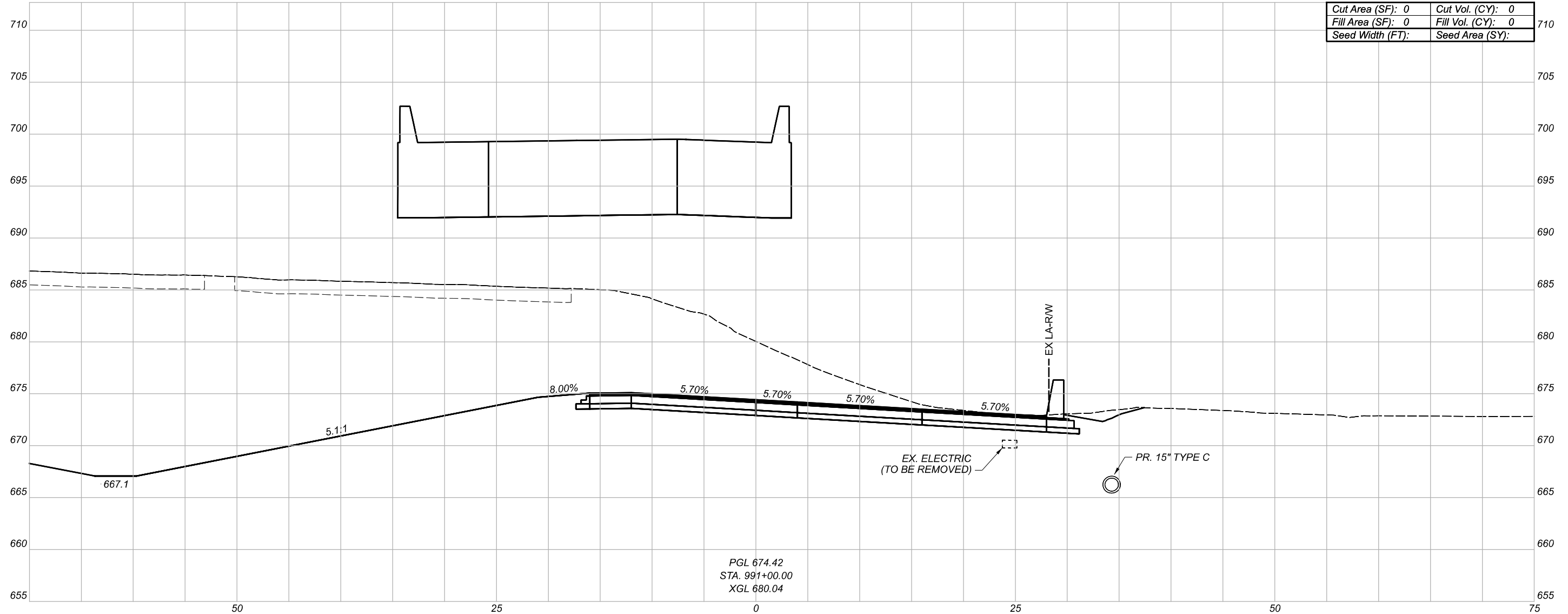

PGL 674.42
 STA. 991+00.00
 XGL 680.04

CROSS SECTIONS
 RAMP IH5/H5

| | |
|---------------|-----------------------------|
| DESIGN AGENCY | |
| DESIGNER | Michael Baker INTERNATIONAL |
| REVIEWER | |
| PROJECT ID | 82382 |

| Sheet Totals | | |
|--------------|-----|------|
| Seeding | Cut | Fill |
| . | . | . |

| | |
|-------|-------|
| SHEET | TOTAL |
| 708 | 2339 |

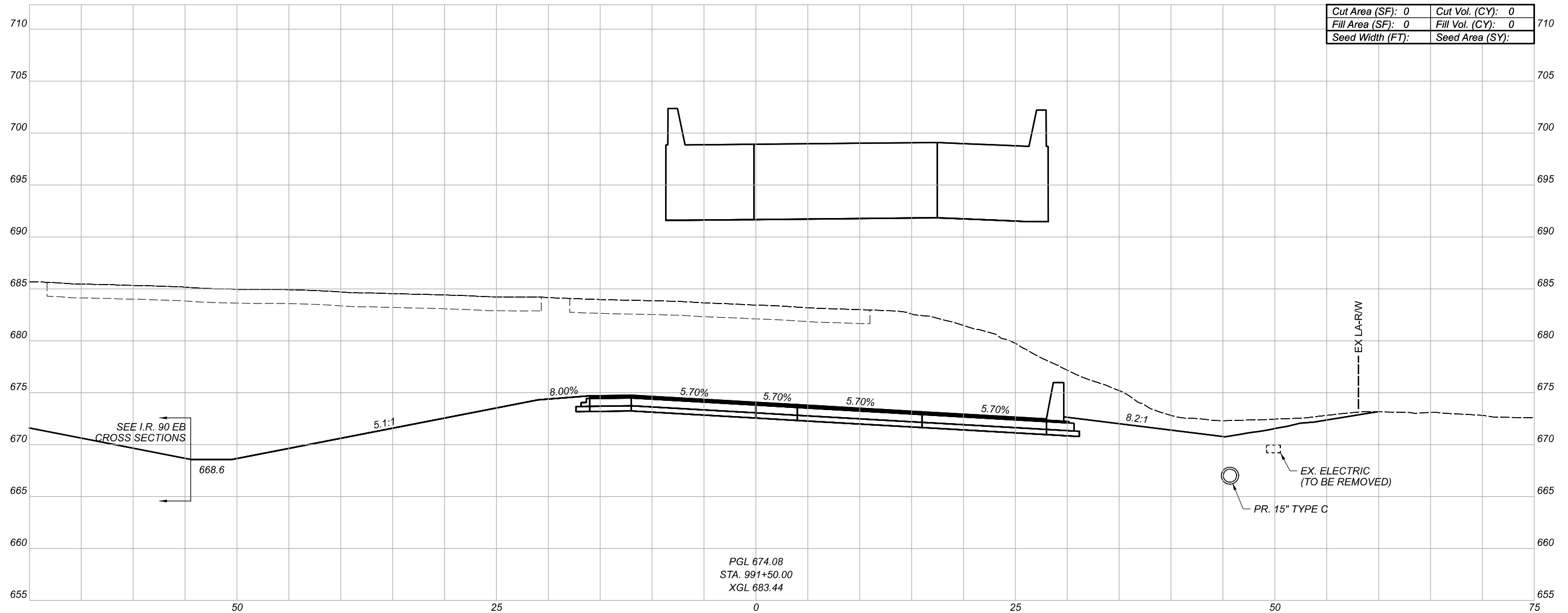

| | |
|-------------------|-------------------|
| Cut Area (SF): 0 | Cut Vol. (CY): 0 |
| Fill Area (SF): 0 | Fill Vol. (CY): 0 |
| Seed Width (FT): | Seed Area (SY): |

PGL 674.08
 STA. 991+50.00
 XGL 683.44

SEE I.R. 90 EB
 CROSS SECTIONS

668.6

5.1:1

8.00%

5.70%

5.70%

5.70%

5.70%

8.2:1

PR. 15" TYPE C

EX. ELECTRIC
 (TO BE REMOVED)

EX LA-RW

| Sheet Totals | | |
|--------------|-----|------|
| Seeding | Cut | Fill |
| . | . | . |

| | |
|---------------|-----------------------------|
| DESIGN AGENCY | Michael Baker INTERNATIONAL |
| DESIGNER | --- |
| REVIEWER | --- |
| PROJECT ID | 82382 |
| SHEET TOTAL | 709 2339 |

CROSS SECTIONS
 RAMP IH5/H5

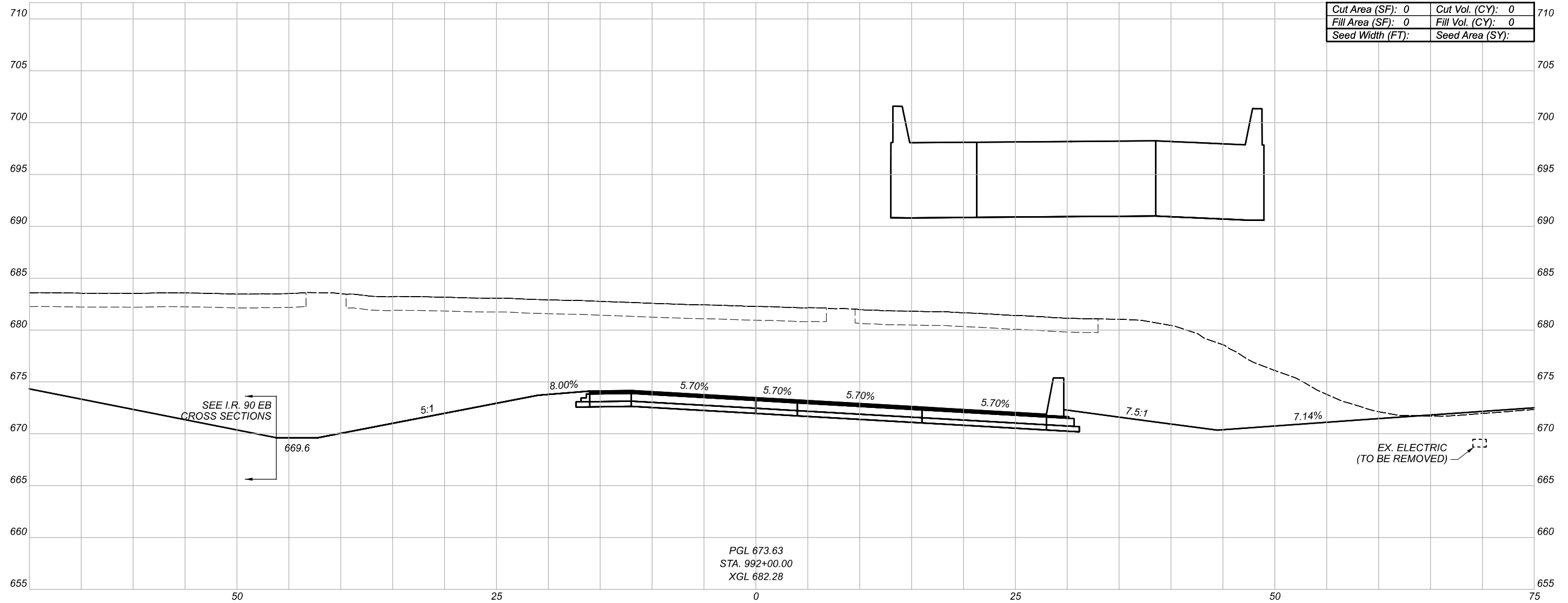

PGL 673.63
 STA. 992+00.00
 XGL 682.28

SEE I.R. 90 EB
 CROSS SECTIONS

EX. ELECTRIC
 (TO BE REMOVED)

CROSS SECTIONS
 RAMP IH5/H5

| | |
|---------------|-----------------------------|
| DESIGN AGENCY | |
| DESIGNER | Michael Baker INTERNATIONAL |
| REVIEWER | |
| PROJECT ID | 82382 |

| Sheet Totals | | | SHEET | TOTAL |
|--------------|-----|------|-------|-------|
| Seeding | Cut | Fill | | |
| . | . | . | 710 | 2339 |

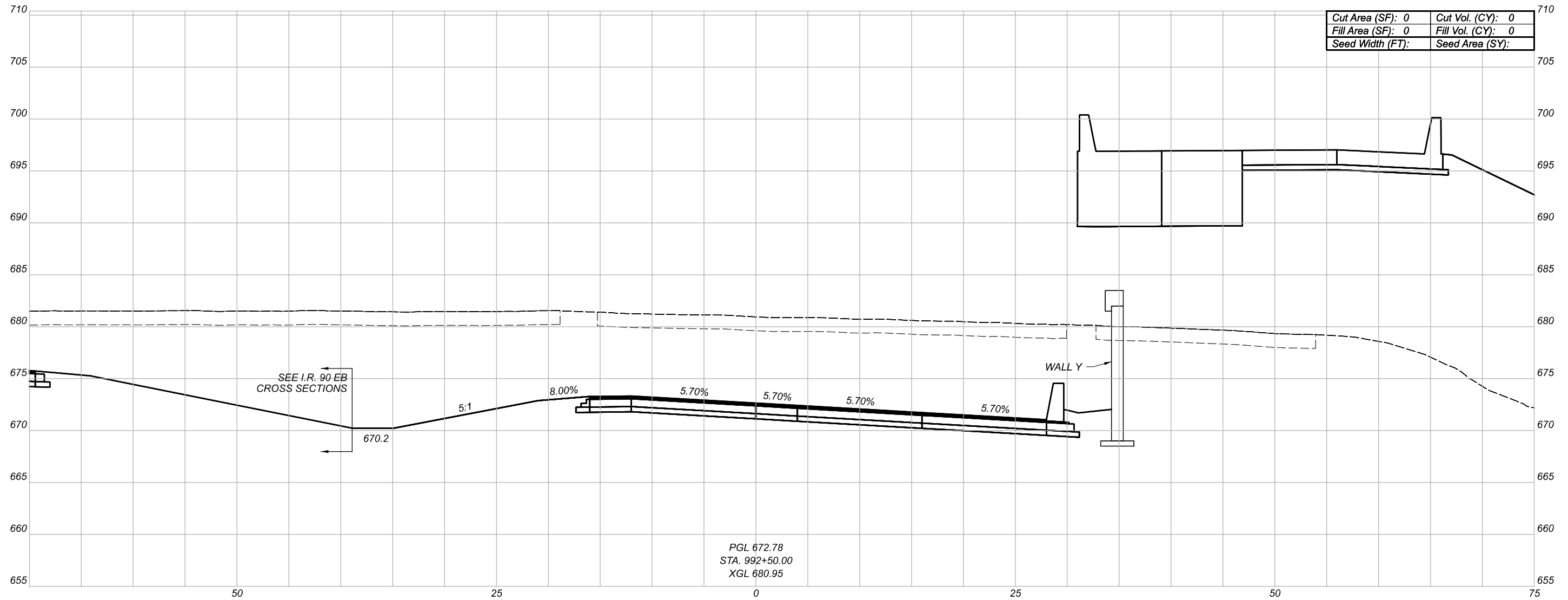

SEE I.R. 90 EB
CROSS SECTIONS

WALL Y

PGL 672.78
STA. 992+50.00
XGL 680.95

CROSS SECTIONS
RAMP IH5/H5

| | |
|---------------|-------|
| DESIGN AGENCY | |
| DESIGNER | -- |
| REVIEWER | -- |
| PROJECT ID | 82382 |

| Sheet Totals | | | SHEET | TOTAL |
|--------------|-----|------|-------|-------|
| Seeding | Cut | Fill | | |
| . | . | . | 711 | 2339 |

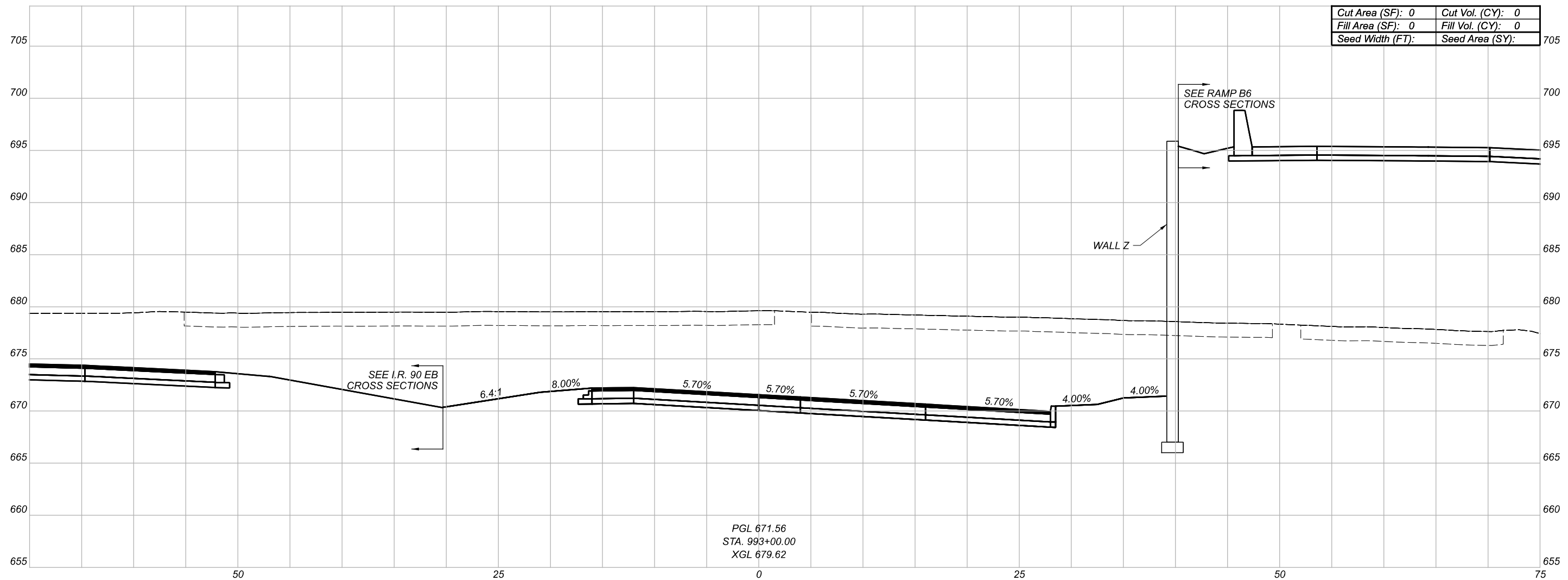

PGL 671.56
 STA. 993+00.00
 XGL 679.62

| | |
|-------------------|-------------------|
| Cut Area (SF): 0 | Cut Vol. (CY): 0 |
| Fill Area (SF): 0 | Fill Vol. (CY): 0 |
| Seed Width (FT): | Seed Area (SY): |

CROSS SECTIONS
 RAMP IH5/H5

| | |
|---------------|-----------------------------|
| DESIGN AGENCY | |
| DESIGNER | Michael Baker INTERNATIONAL |
| REVIEWER | |
| PROJECT ID | 82382 |

| Sheet Totals | | | SHEET | TOTAL |
|--------------|-----|------|-------|-------|
| Seeding | Cut | Fill | | |
| . | . | . | 712 | 2339 |

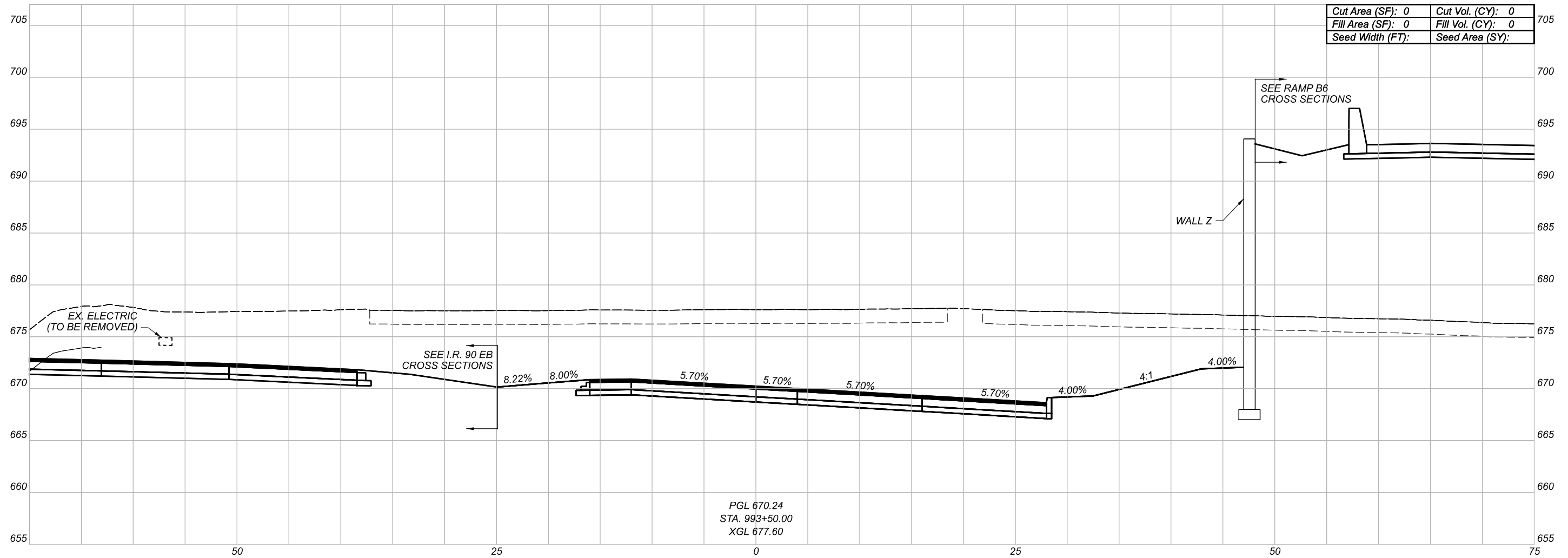

PGL 670.24
 STA. 993+50.00
 XGL 677.60

CROSS SECTIONS
 RAMP IH5/H5

DESIGN AGENCY

Michael Baker
 INTERNATIONAL

DESIGNER

REVIEWER

PROJECT ID

82382

| Sheet Totals | | | SHEET | TOTAL |
|--------------|-----|------|-------|-------|
| Seeding | Cut | Fill | | |
| . | . | . | 713 | 2339 |

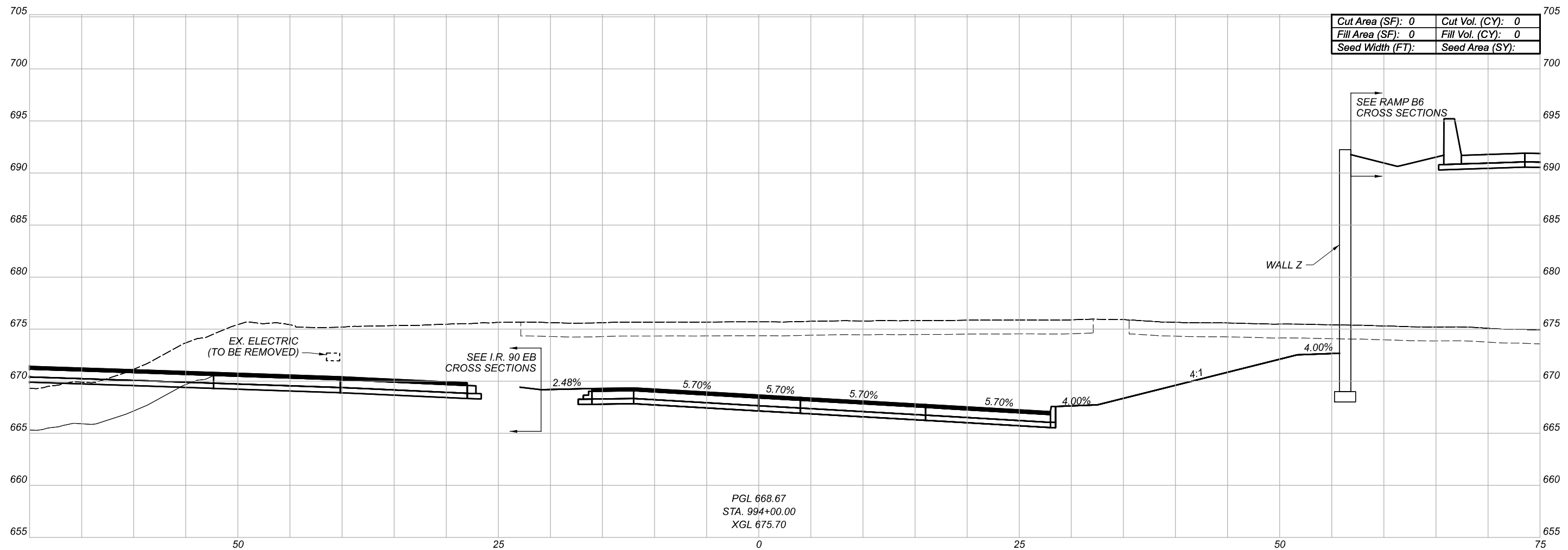

PGL 668.67
 STA. 994+00.00
 XGL 675.70

| | |
|-------------------|-------------------|
| Cut Area (SF): 0 | Cut Vol. (CY): 0 |
| Fill Area (SF): 0 | Fill Vol. (CY): 0 |
| Seed Width (FT): | Seed Area (SY): |

CROSS SECTIONS
 RAMP IH5/H5

| | |
|-----------------------------|-------|
| DESIGN AGENCY | |
| Michael Baker INTERNATIONAL | |
| DESIGNER | -- |
| REVIEWER | -- |
| PROJECT ID | 82382 |
| SHEET | 714 |
| TOTAL | 2339 |

| Sheet Totals | | |
|--------------|-----|------|
| Seeding | Cut | Fill |
| . | . | . |

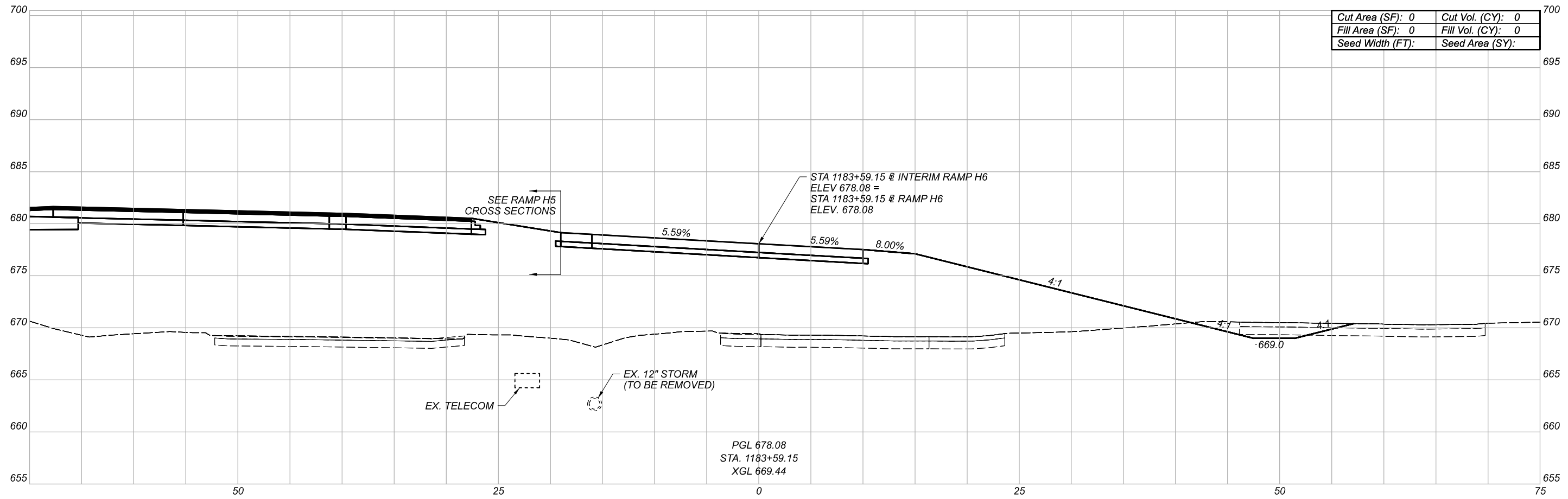

| | |
|-------------------|-------------------|
| Cut Area (SF): 0 | Cut Vol. (CY): 0 |
| Fill Area (SF): 0 | Fill Vol. (CY): 0 |
| Seed Width (FT): | Seed Area (SY): |

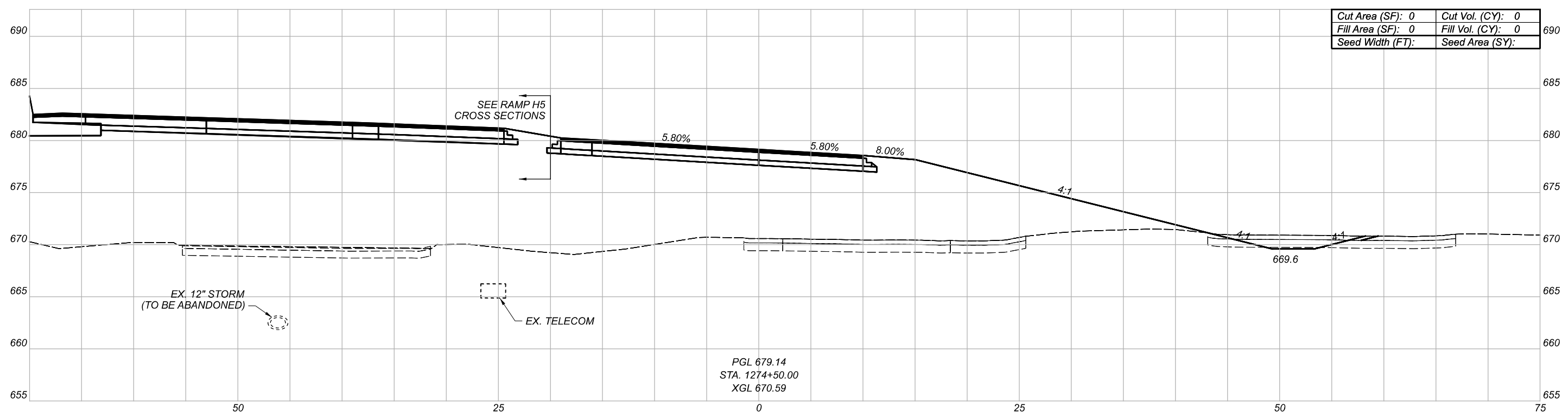

| | |
|-------------------|-------------------|
| Cut Area (SF): 0 | Cut Vol. (CY): 0 |
| Fill Area (SF): 0 | Fill Vol. (CY): 0 |
| Seed Width (FT): | Seed Area (SY): |

CROSS SECTIONS
RAMP IH6/H6

| | |
|---------------------------------------|-------|
| DESIGN AGENCY | |
| Michael Baker INTERNATIONAL | |
| DESIGNER | -- |
| REVIEWER | -- |
| PROJECT ID | 82382 |

| Sheet Totals | | | SHEET | TOTAL |
|--------------|-----|------|-------|-------|
| Seeding | Cut | Fill | | |
| . | . | . | 715 | 2339 |

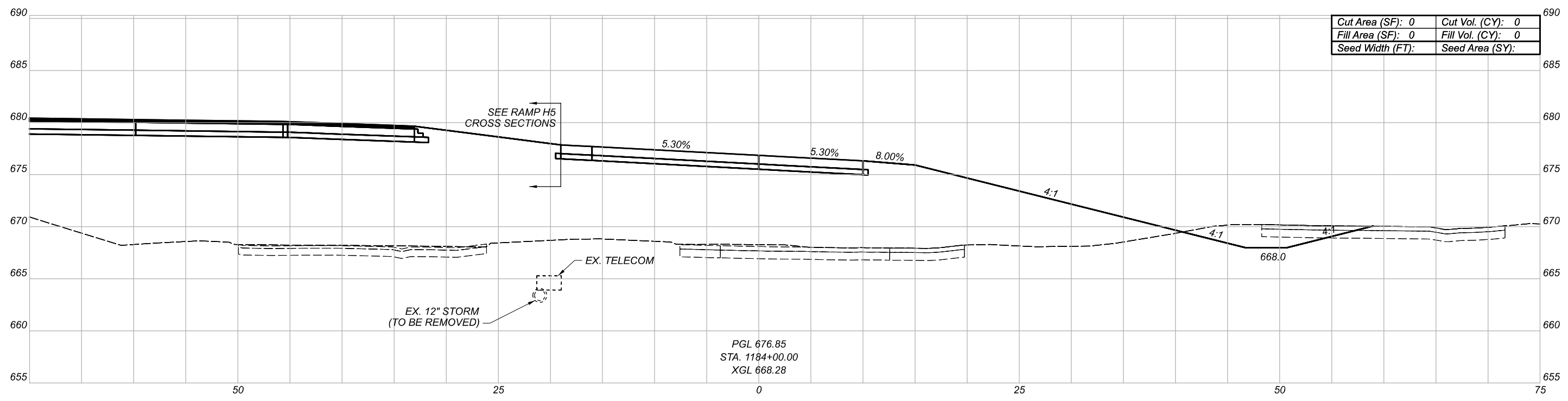
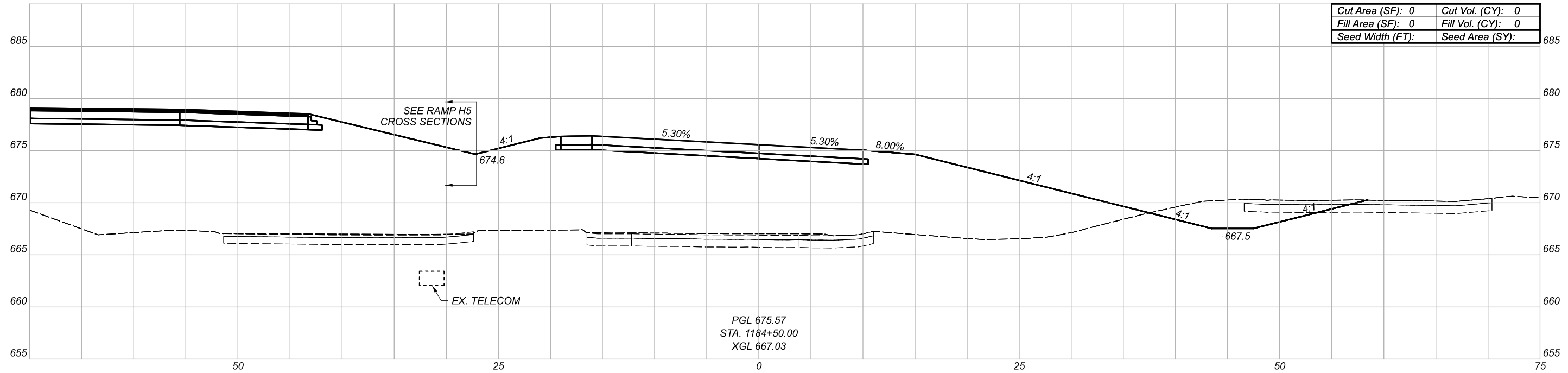

CROSS SECTIONS
RAMP IH6/H6

| | |
|---------------------------------------|-------|
| DESIGN AGENCY | |
| Michael Baker INTERNATIONAL | |
| DESIGNER | -- |
| REVIEWER | -- |
| PROJECT ID | 82382 |

| Sheet Totals | | | SHEET | TOTAL |
|--------------|-----|------|-------|-------|
| Seeding | Cut | Fill | | |
| . | . | . | 716 | 2339 |

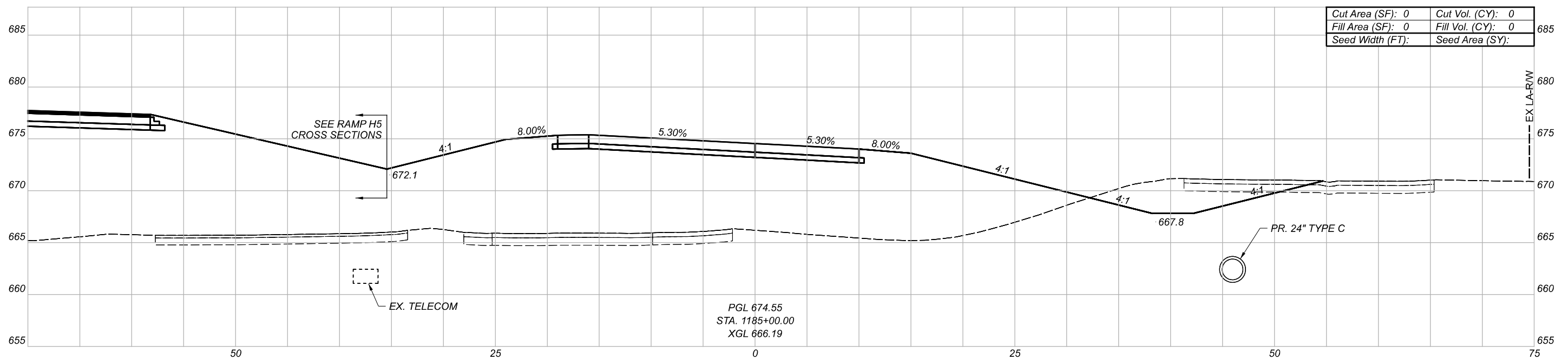
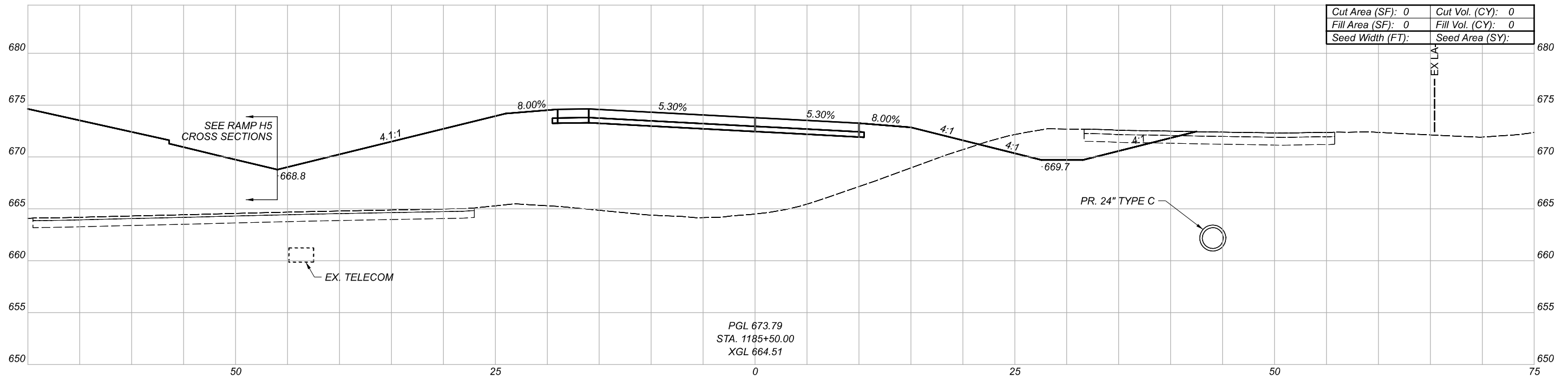

CROSS SECTIONS
RAMP IH6/H6

DESIGN AGENCY

Michael Baker
INTERNATIONAL

DESIGNER

REVIEWER

PROJECT ID

82382

| Sheet Totals | | | SHEET | TOTAL |
|--------------|-----|------|-------|-------|
| Seeding | Cut | Fill | | |
| . | . | . | 717 | 2339 |

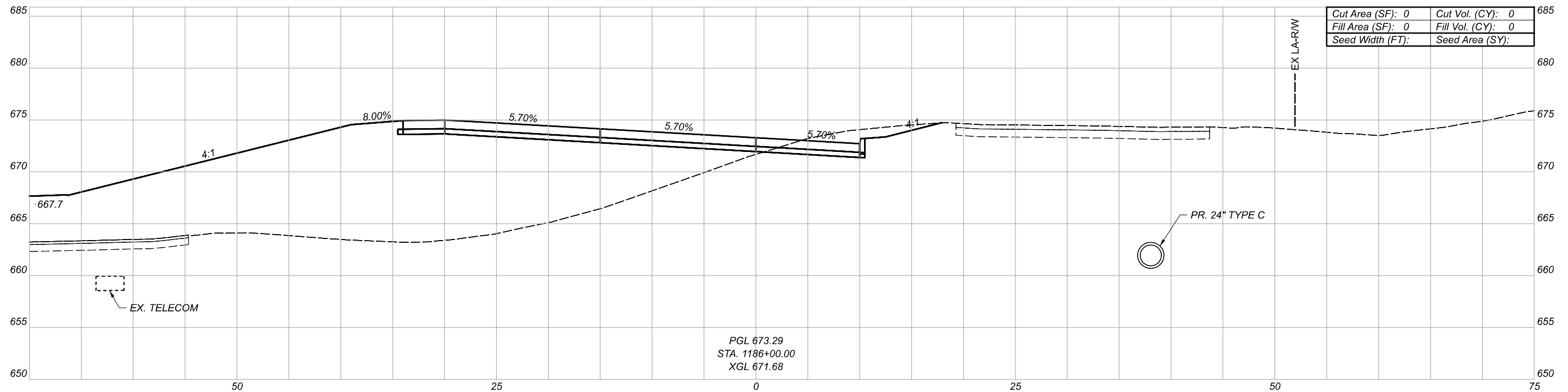
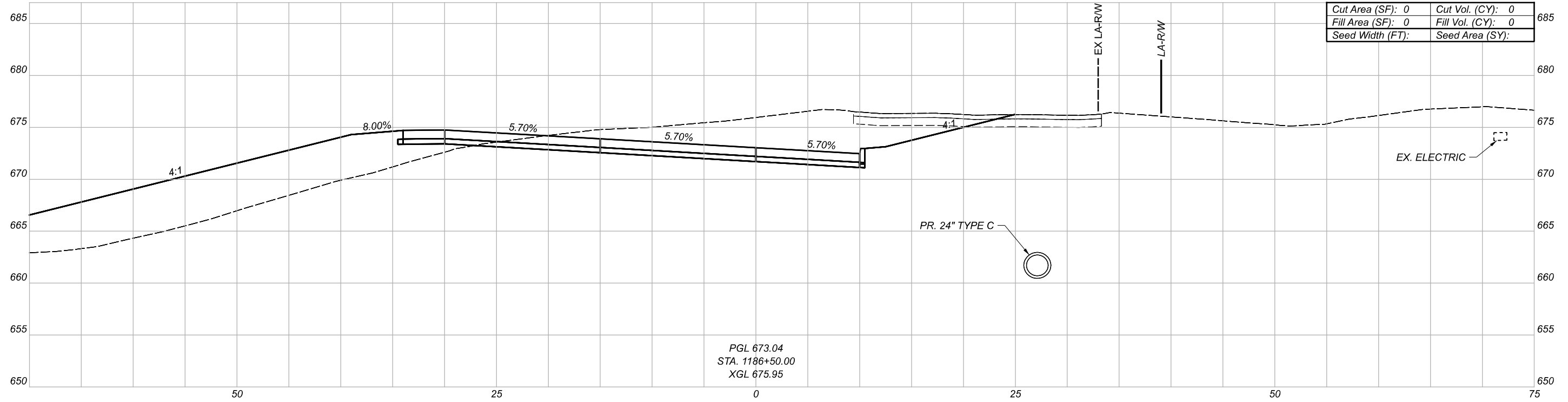

CROSS SECTIONS
 RAMP IH6/H6

DESIGN AGENCY

Michael Baker
 INTERNATIONAL

DESIGNER

REVIEWER

PROJECT ID

82382

| Sheet Totals | | | SHEET | TOTAL |
|--------------|-----|------|-------|-------|
| Seeding | Cut | Fill | 718 | 2339 |

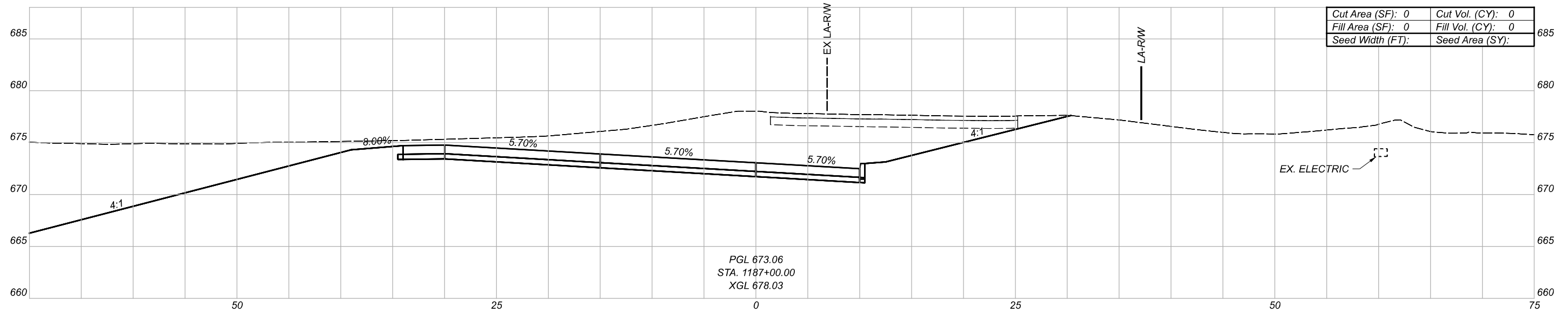
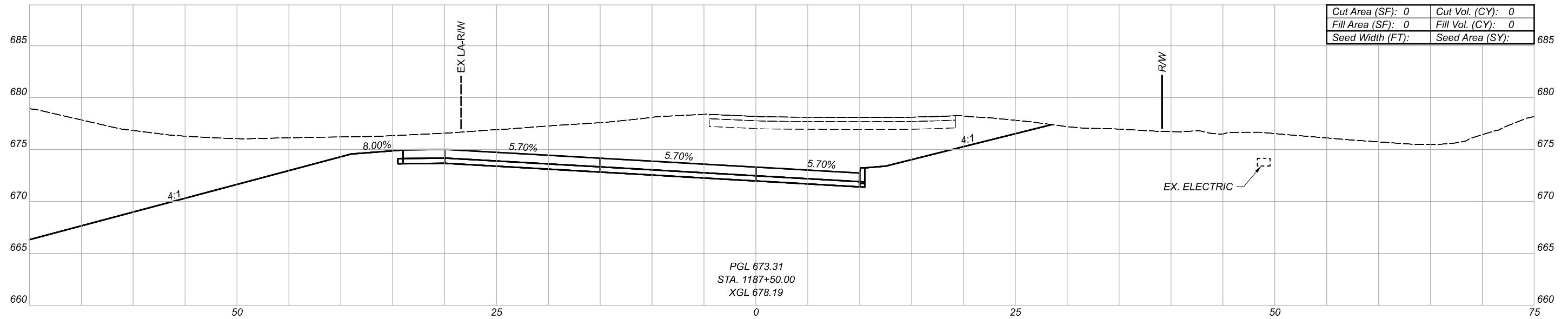
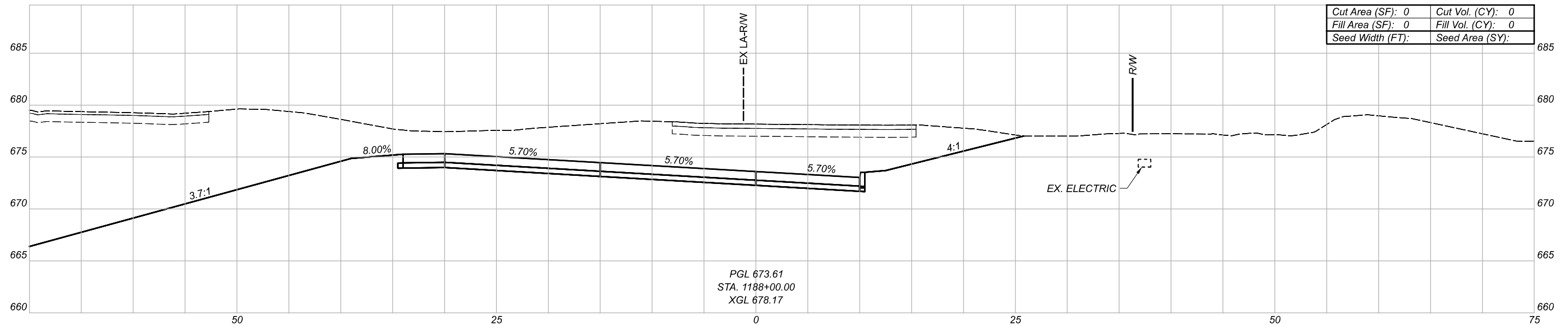

CROSS SECTIONS
 RAMP IH6/H6

DESIGN AGENCY

Michael Baker
 INTERNATIONAL

DESIGNER

REVIEWER

PROJECT ID

82382

| Sheet Totals | | | SHEET | TOTAL |
|--------------|-----|------|-------|-------|
| Seeding | Cut | Fill | | |
| . | . | . | 719 | 2339 |

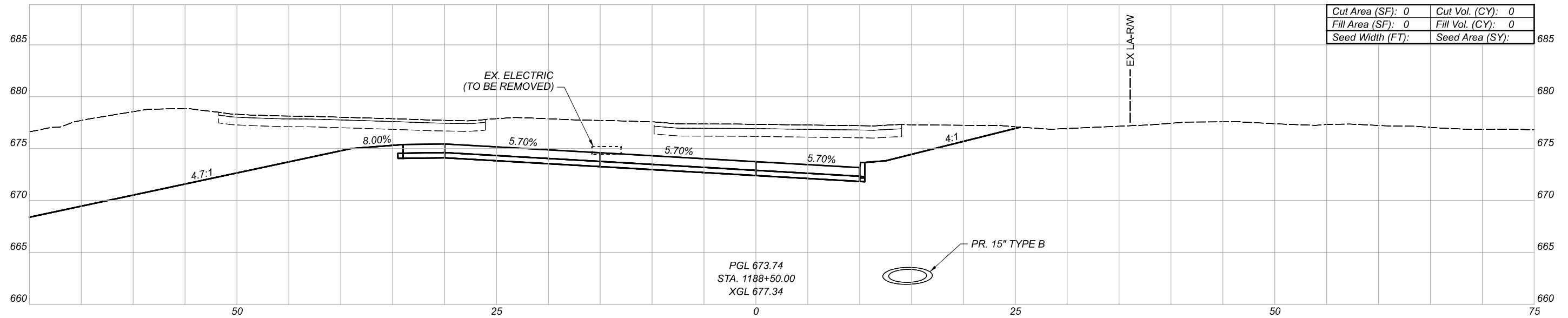
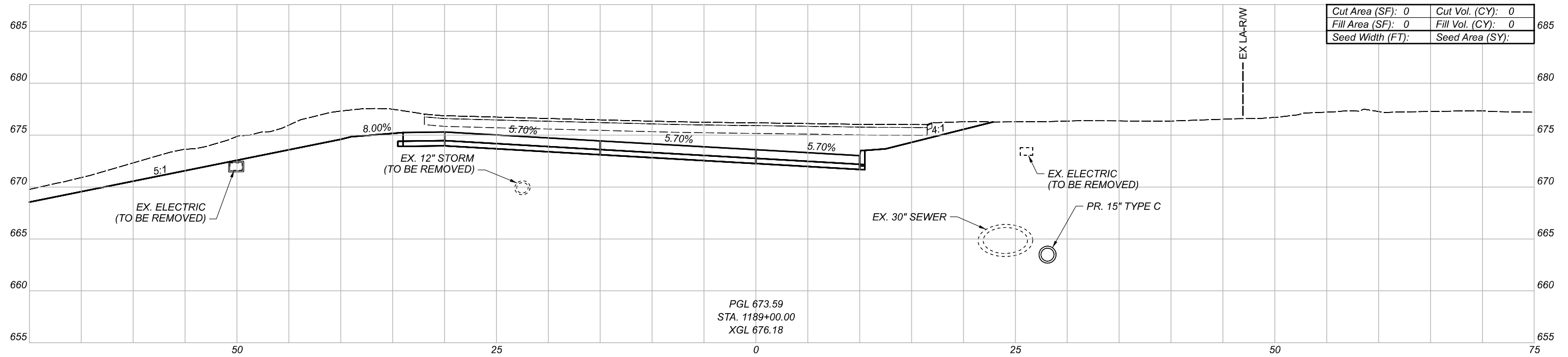

CROSS SECTIONS
RAMP IH6/H6

DESIGN AGENCY

Michael Baker
INTERNATIONAL

DESIGNER

REVIEWER

PROJECT ID

82382

| Sheet Totals | | | SHEET | TOTAL |
|--------------|-----|------|-------|-------|
| Seeding | Cut | Fill | | |
| . | . | . | 720 | 2339 |

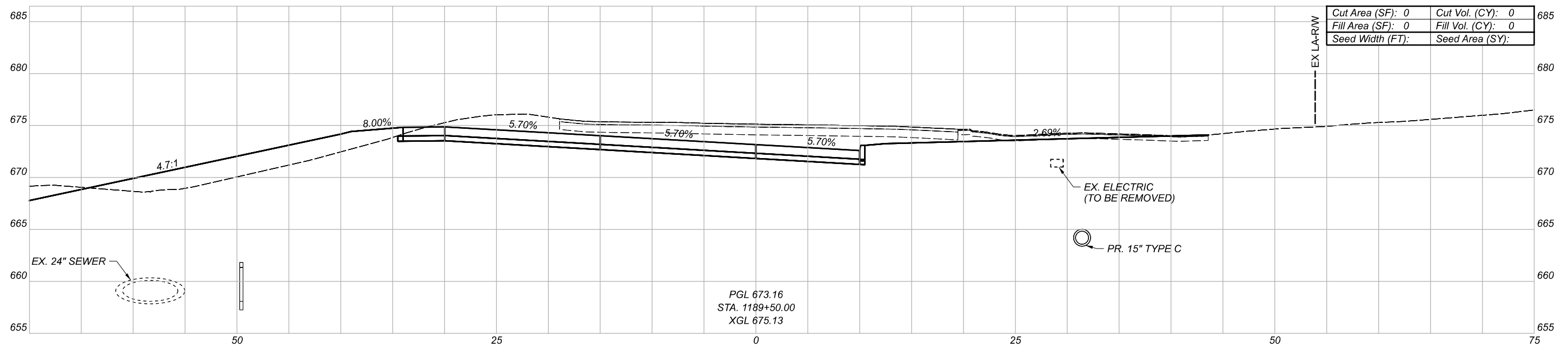

CROSS SECTIONS
RAMP IH6/H6

DESIGN AGENCY

Michael Baker
INTERNATIONAL

DESIGNER

REVIEWER

PROJECT ID

82382

| Sheet Totals | | | SHEET | TOTAL |
|--------------|-----|------|-------|-------|
| Seeding | Cut | Fill | | |
| . | . | . | 721 | 2339 |

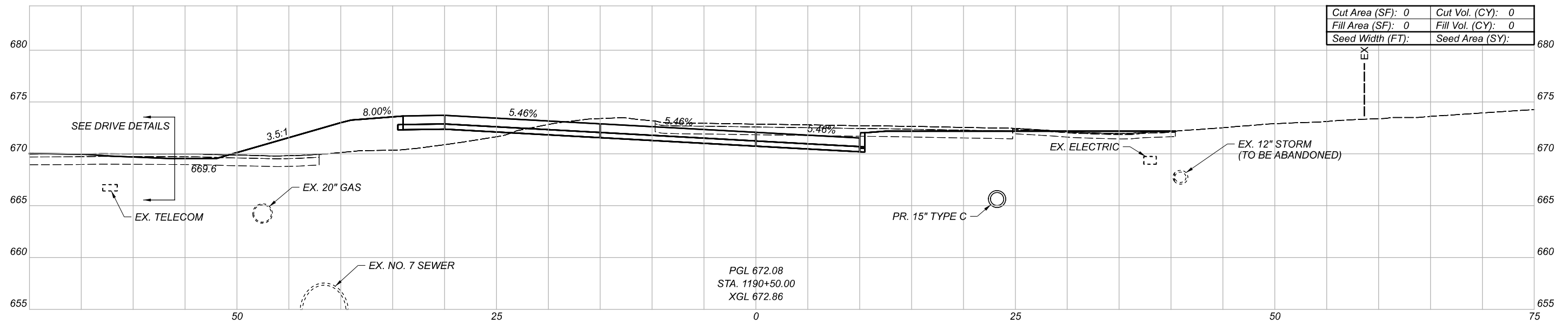
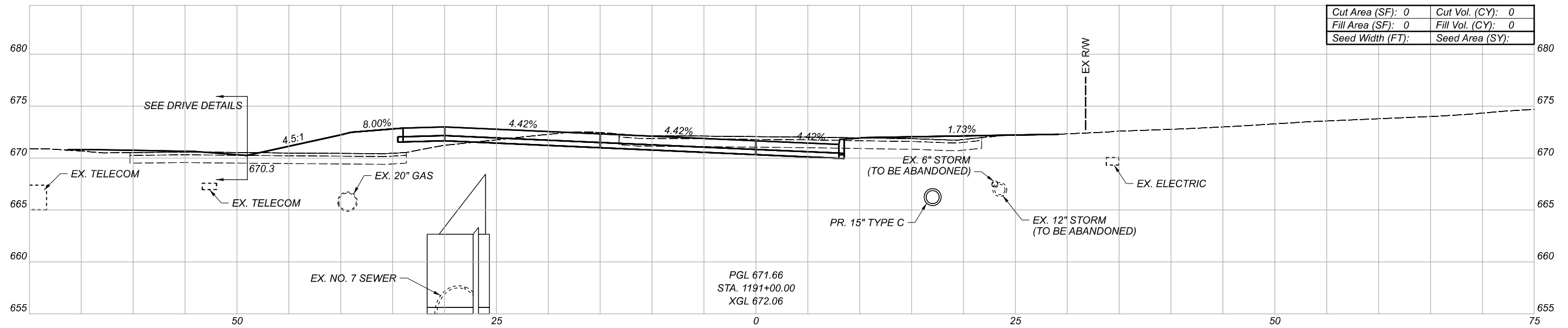

CROSS SECTIONS
 RAMP IH6/H6

DESIGN AGENCY

Michael Baker
 INTERNATIONAL

DESIGNER

REVIEWER

PROJECT ID

82382

| Sheet Totals | | | SHEET | TOTAL |
|--------------|-----|------|-------|-------|
| Seeding | Cut | Fill | | |
| . | . | . | 722 | 2339 |

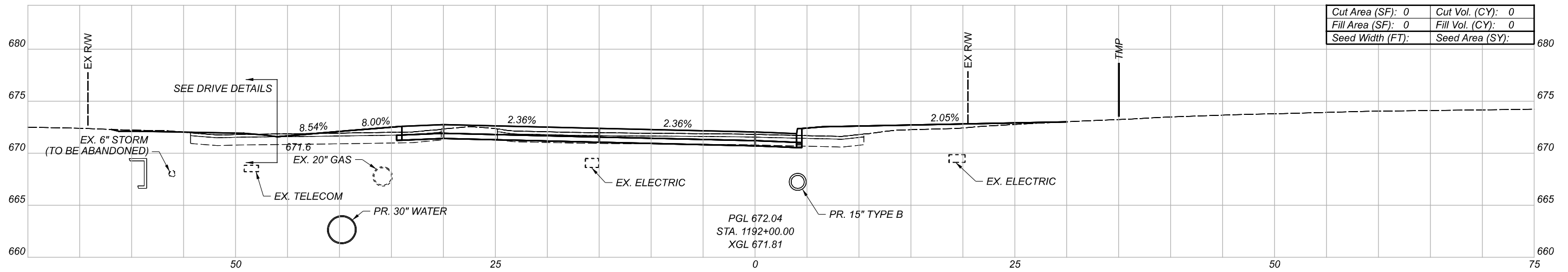

| | | | |
|------------------|---|-----------------|---|
| Cut Area (SF): | 0 | Cut Vol. (CY): | 0 |
| Fill Area (SF): | 0 | Fill Vol. (CY): | 0 |
| Seed Width (FT): | | Seed Area (SY): | |

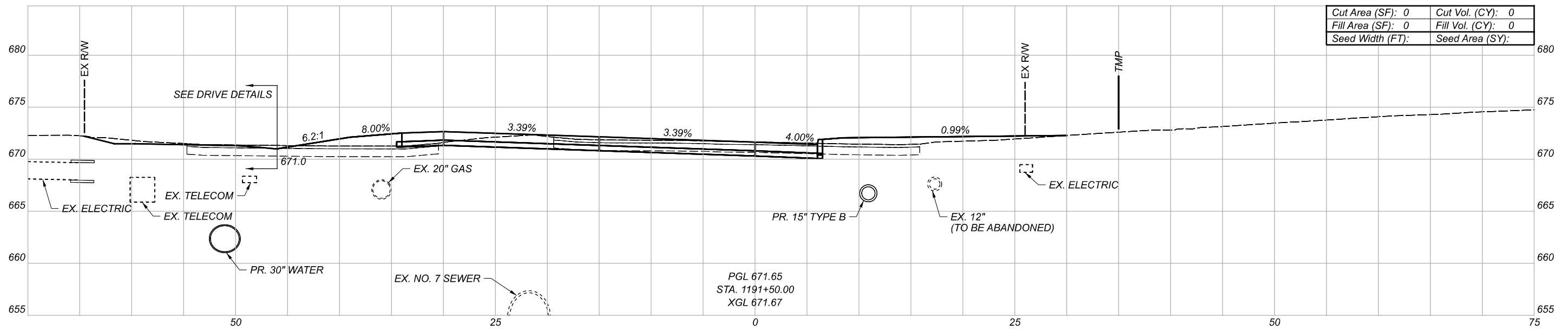

| | | | |
|------------------|---|-----------------|---|
| Cut Area (SF): | 0 | Cut Vol. (CY): | 0 |
| Fill Area (SF): | 0 | Fill Vol. (CY): | 0 |
| Seed Width (FT): | | Seed Area (SY): | |

CROSS SECTIONS
RAMP IH6/H6

DESIGN AGENCY

Michael Baker
INTERNATIONAL

DESIGNER

REVIEWER

PROJECT ID

82382

| Sheet Totals | | | SHEET | TOTAL |
|--------------|-----|------|-------|-------|
| Seeding | Cut | Fill | | |
| . | . | . | 723 | 2339 |

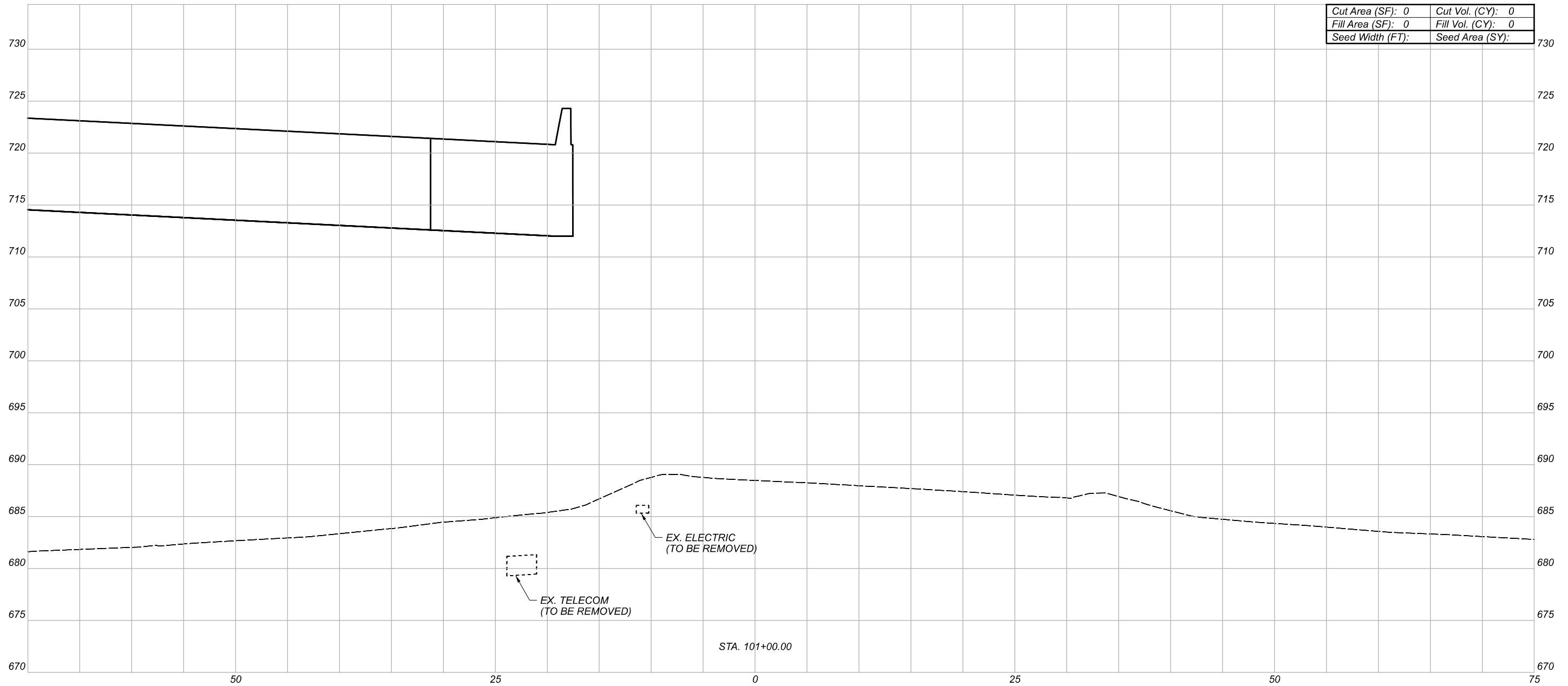

| | | | |
|------------------|---|-----------------|---|
| Cut Area (SF): | 0 | Cut Vol. (CY): | 0 |
| Fill Area (SF): | 0 | Fill Vol. (CY): | 0 |
| Seed Width (FT): | | Seed Area (SY): | |

CROSS SECTIONS
RAMP IJ3

DESIGN AGENCY

Michael Baker
INTERNATIONAL

DESIGNER

REVIEWER

PROJECT ID

82382

Sheet Totals

| Seeding | Cut | Fill |
|---------|-----|------|
| . | . | . |

| SHEET | TOTAL |
|-------|-------|
| 724 | 2339 |

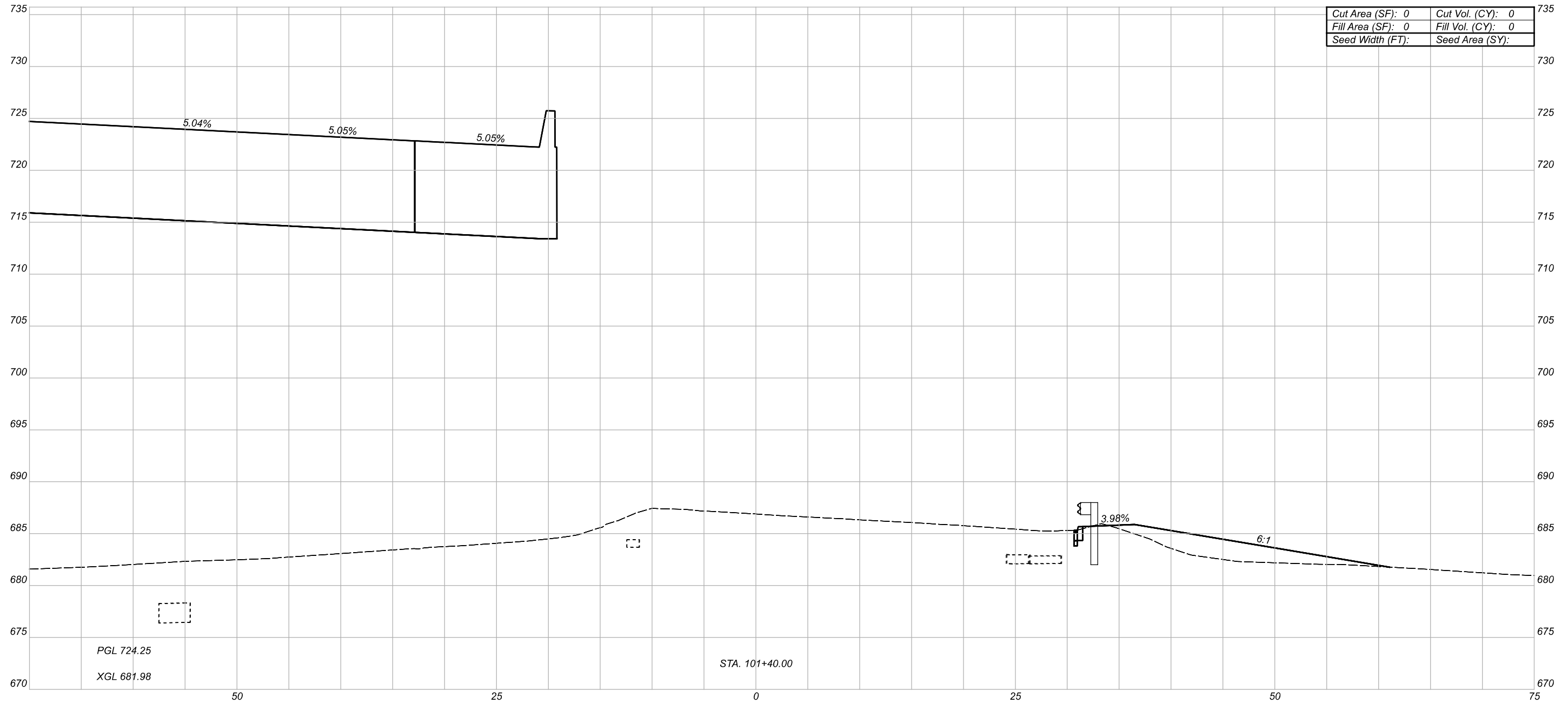

| | |
|-------------------|-------------------|
| Cut Area (SF): 0 | Cut Vol. (CY): 0 |
| Fill Area (SF): 0 | Fill Vol. (CY): 0 |
| Seed Width (FT): | Seed Area (SY): |

CROSS SECTIONS
RAMP IJ3

| | |
|---------------|-------|
| DESIGN AGENCY | |
| DESIGNER | -- |
| REVIEWER | -- |
| PROJECT ID | 82382 |

| | |
|-------|-------|
| SHEET | TOTAL |
| 725 | 2339 |

| Sheet Totals | | |
|--------------|-----|------|
| Seeding | Cut | Fill |
| . | . | . |

PGL 724.25
XGL 681.98

STA. 101+40.00

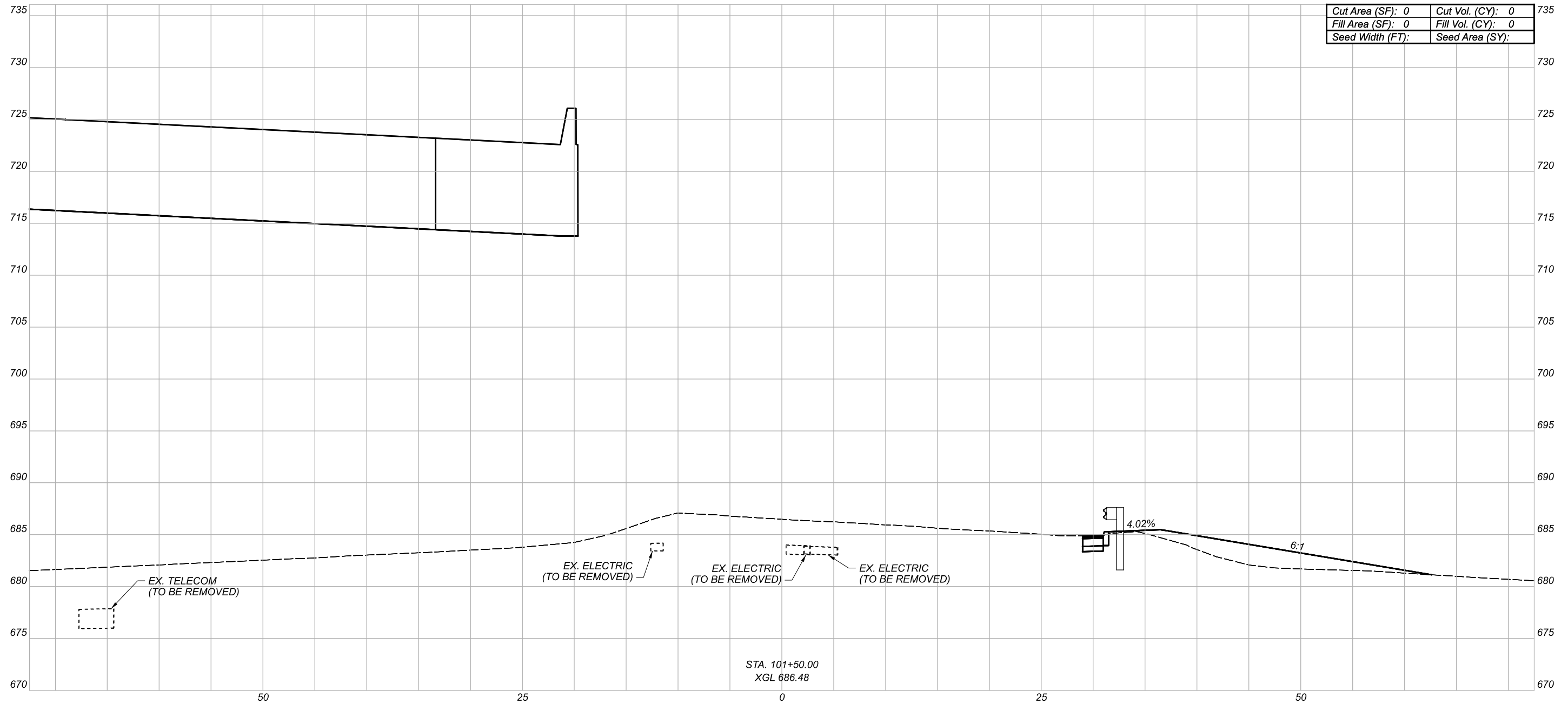

| | |
|-------------------|-------------------|
| Cut Area (SF): 0 | Cut Vol. (CY): 0 |
| Fill Area (SF): 0 | Fill Vol. (CY): 0 |
| Seed Width (FT): | Seed Area (SY): |

CROSS SECTIONS
RAMP IJ3

DESIGN AGENCY

Michael Baker
INTERNATIONAL

DESIGNER

REVIEWER

PROJECT ID

82382

| Sheet Totals | | | SHEET | TOTAL |
|--------------|-----|------|-------|-------|
| Seeding | Cut | Fill | | |
| . | . | . | 726 | 2339 |

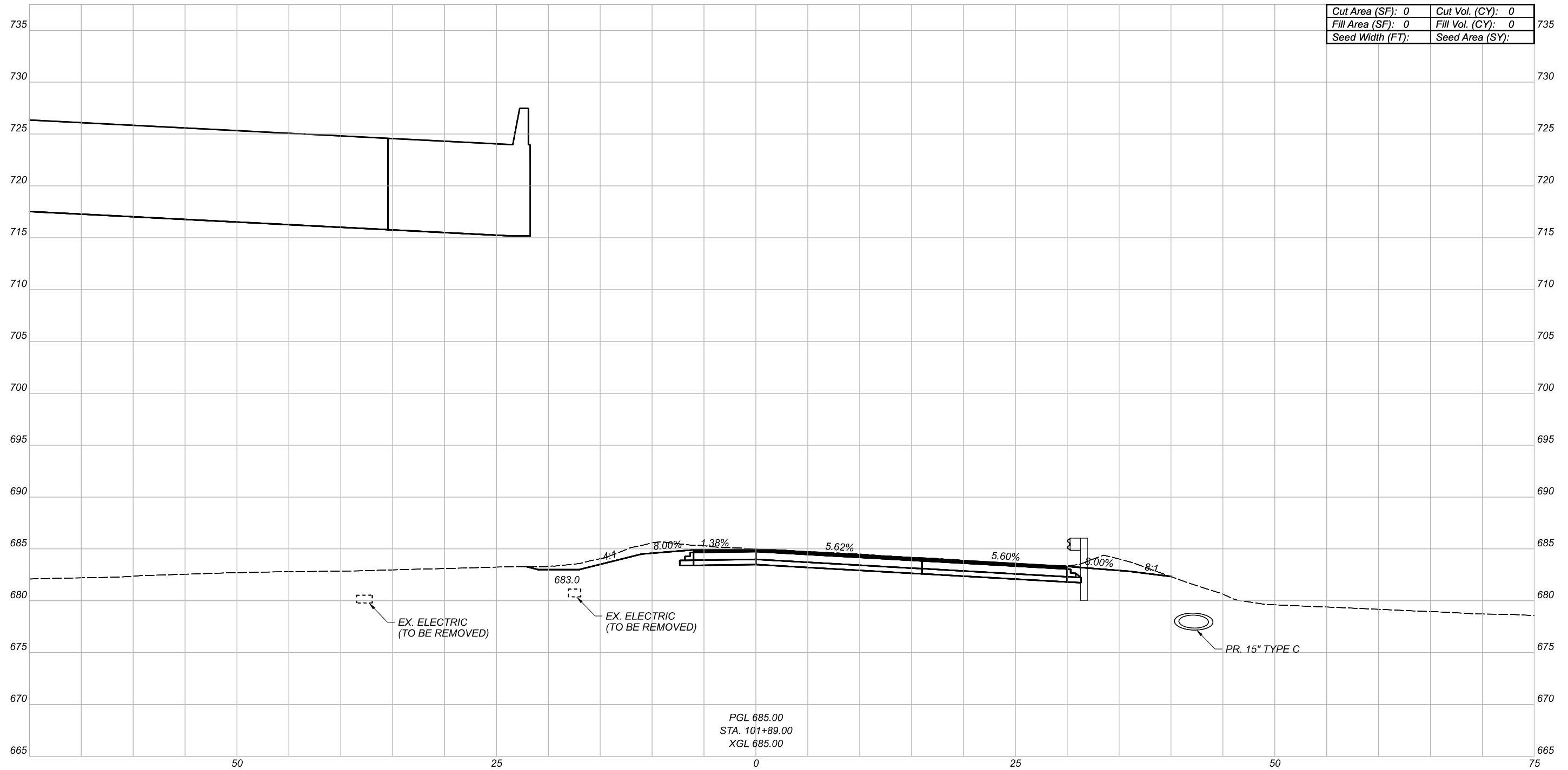

CROSS SECTIONS
RAMP IJ3

DESIGN AGENCY

Michael Baker
INTERNATIONAL

DESIGNER

REVIEWER

PROJECT ID

82382

| Sheet Totals | | | SHEET | TOTAL |
|--------------|-----|------|-------|-------|
| Seeding | Cut | Fill | | |
| . | . | . | 727 | 2339 |

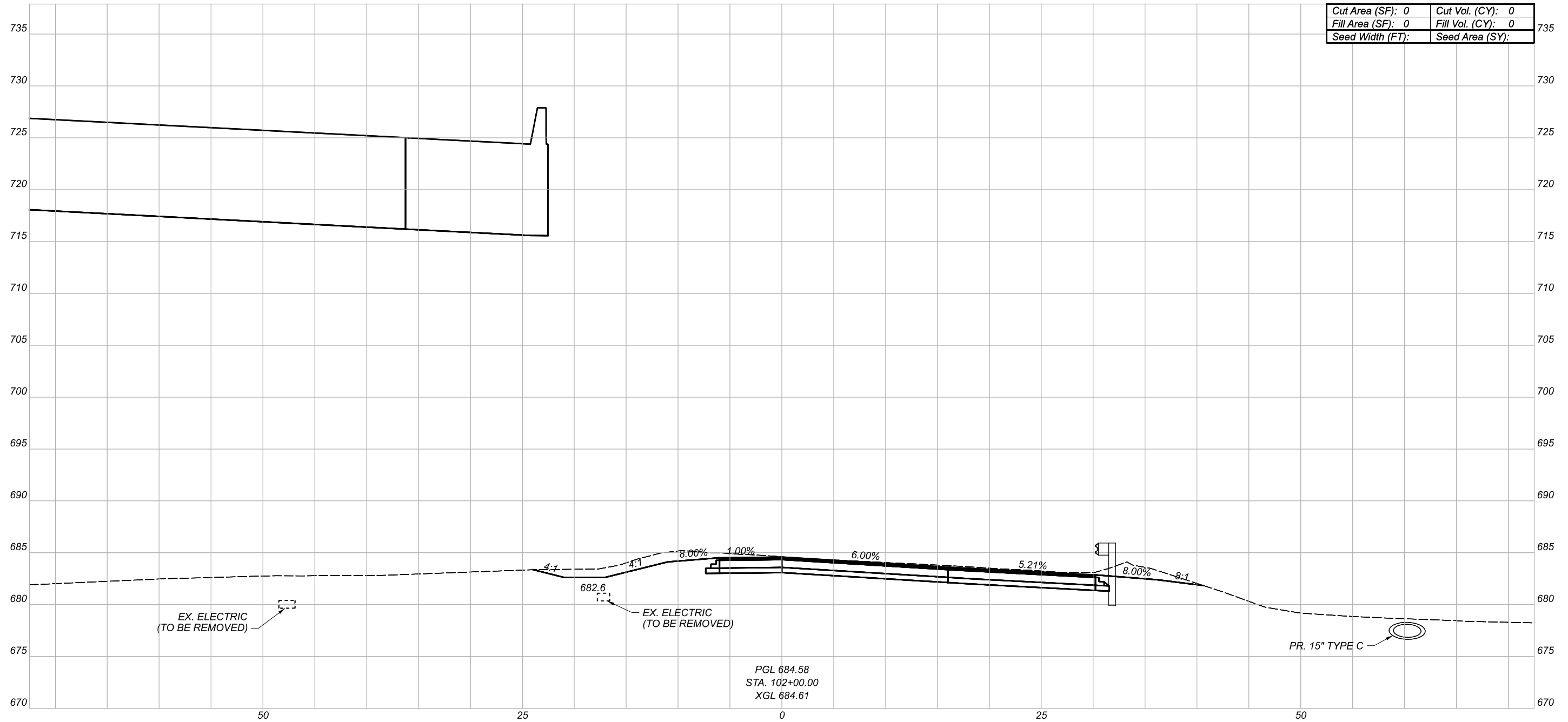

CROSS SECTIONS
RAMP IJ3

| | |
|----------------------|---------------|
| DESIGN AGENCY | |
| Michael Baker | INTERNATIONAL |
| DESIGNER | -- |
| REVIEWER | -- |
| PROJECT ID | 82382 |
| SHEET | 728 |
| TOTAL | 2339 |

| Sheet Totals | | |
|--------------|-----|------|
| Seeding | Cut | Fill |
| . | . | . |

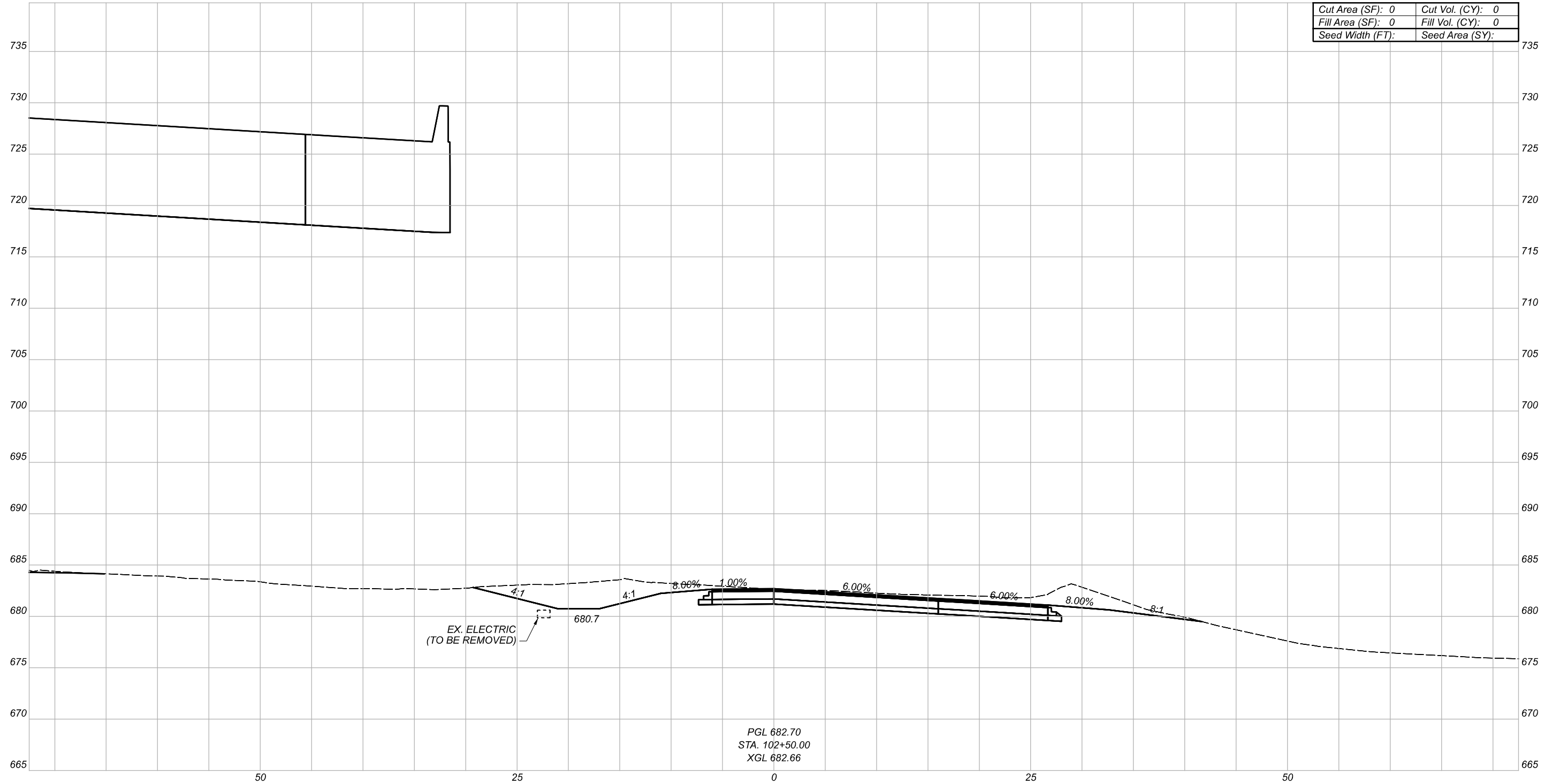

CROSS SECTIONS
RAMP IJ3

DESIGN AGENCY

Michael Baker
INTERNATIONAL

DESIGNER

REVIEWER

PROJECT ID

82382

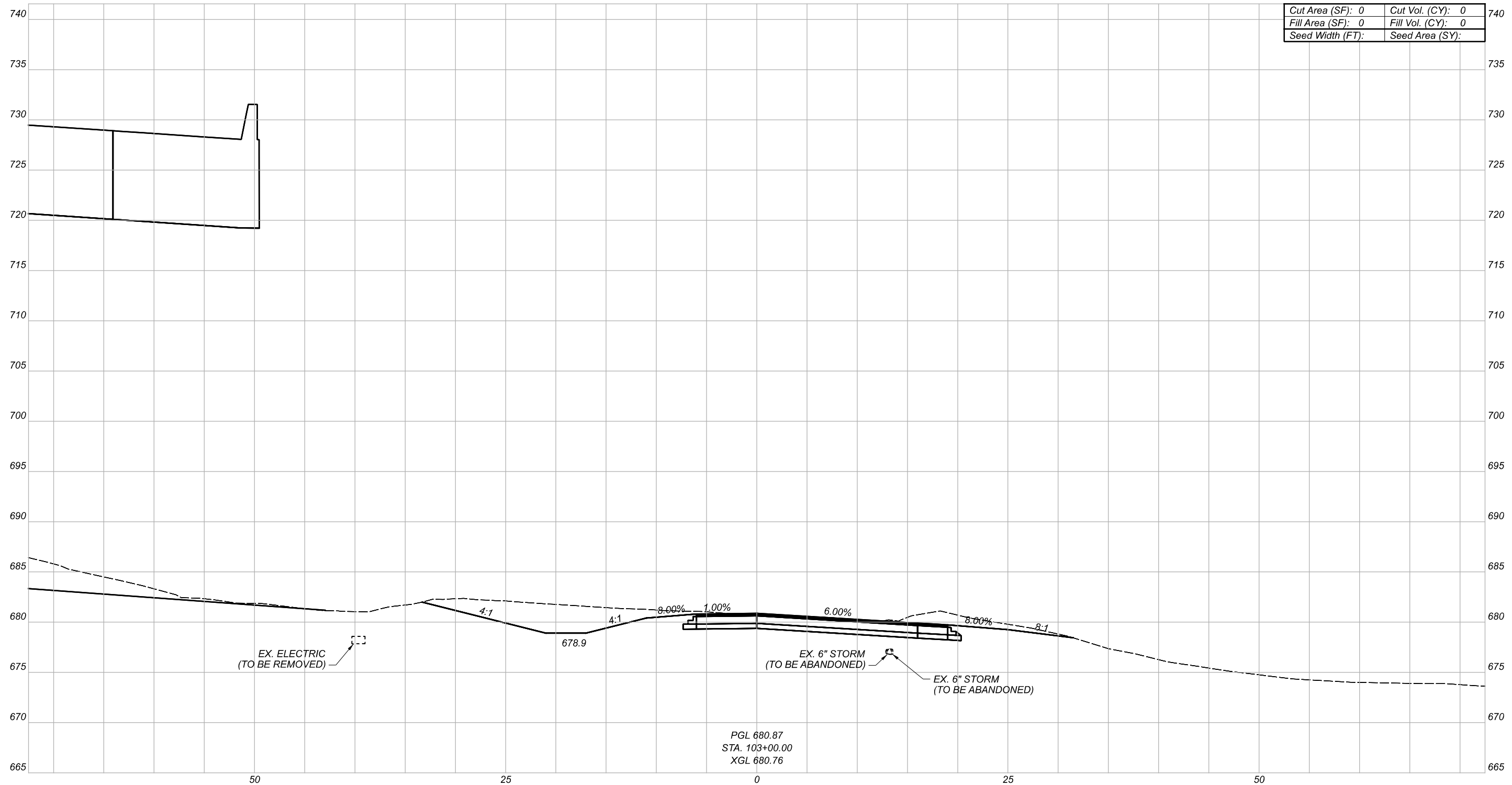

| | |
|-------------------|-------------------|
| Cut Area (SF): 0 | Cut Vol. (CY): 0 |
| Fill Area (SF): 0 | Fill Vol. (CY): 0 |
| Seed Width (FT): | Seed Area (SY): |

PGL 680.87
 STA. 103+00.00
 XGL 680.76

CROSS SECTIONS
 RAMP IJ3

| | |
|---------------------------------------|-------|
| DESIGN AGENCY | |
| Michael Baker INTERNATIONAL | |
| DESIGNER | -- |
| REVIEWER | -- |
| PROJECT ID | 82382 |

| Sheet Totals | | | SHEET | TOTAL |
|--------------|-----|------|-------|-------|
| Seeding | Cut | Fill | | |
| . | . | . | 730 | 2339 |

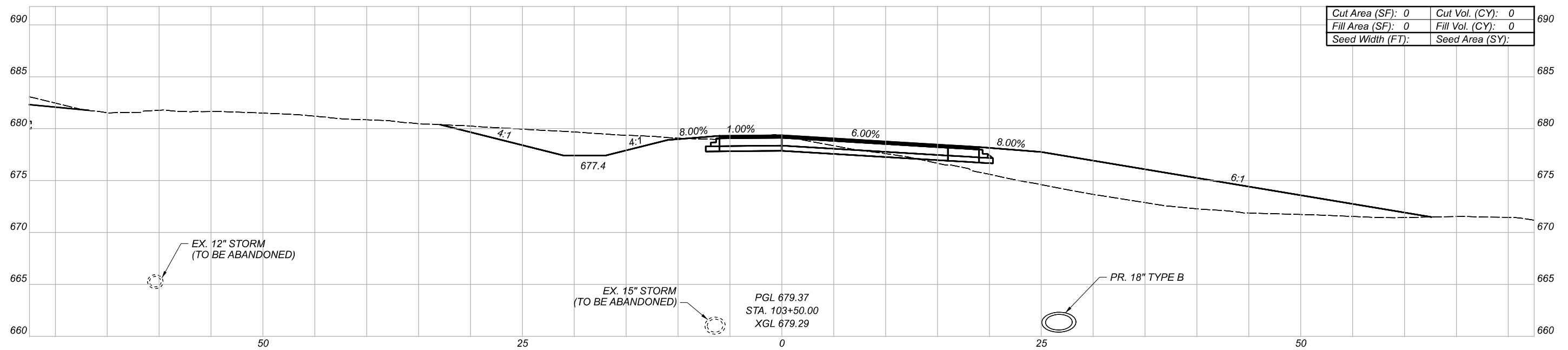
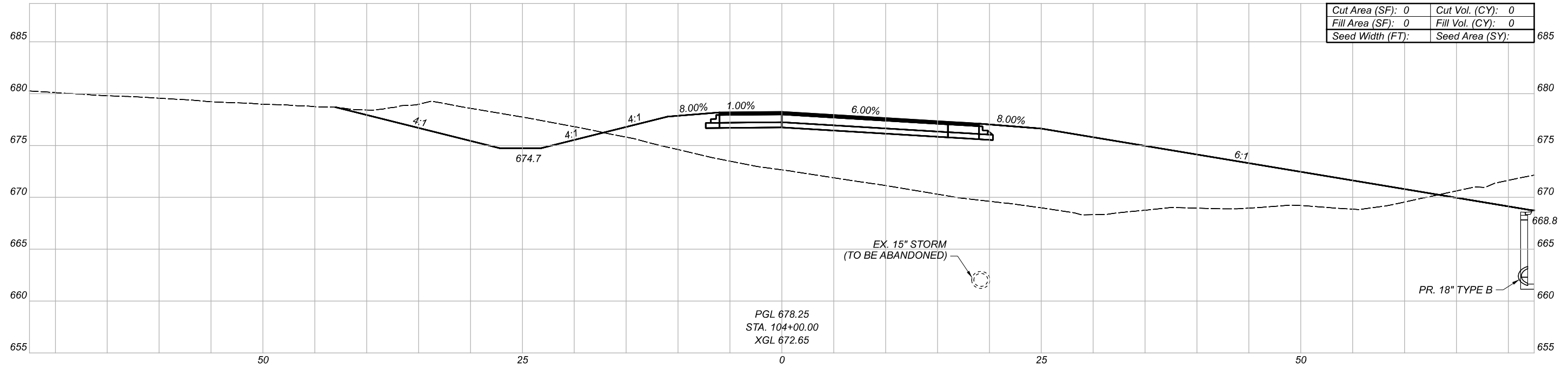

CROSS SECTIONS
RAMP IJ3

DESIGN AGENCY

Michael Baker
INTERNATIONAL

DESIGNER

REVIEWER

PROJECT ID

82382

| Sheet Totals | | | SHEET | TOTAL |
|--------------|-----|------|-------|-------|
| Seeding | Cut | Fill | | |
| . | . | . | 731 | 2339 |

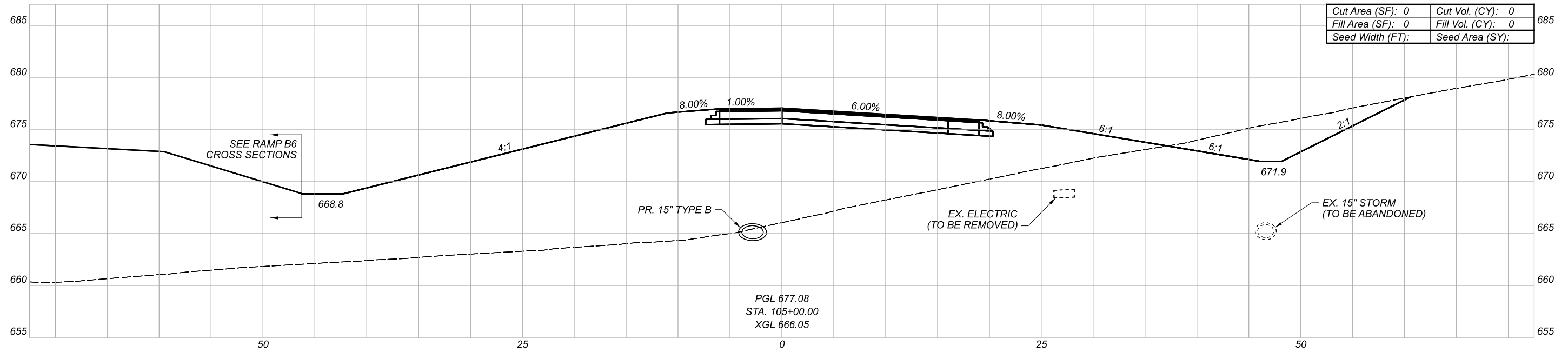

| | | | |
|------------------|---|-----------------|---|
| Cut Area (SF): | 0 | Cut Vol. (CY): | 0 |
| Fill Area (SF): | 0 | Fill Vol. (CY): | 0 |
| Seed Width (FT): | | Seed Area (SY): | |

PGL 677.08
 STA. 105+00.00
 XGL 666.05

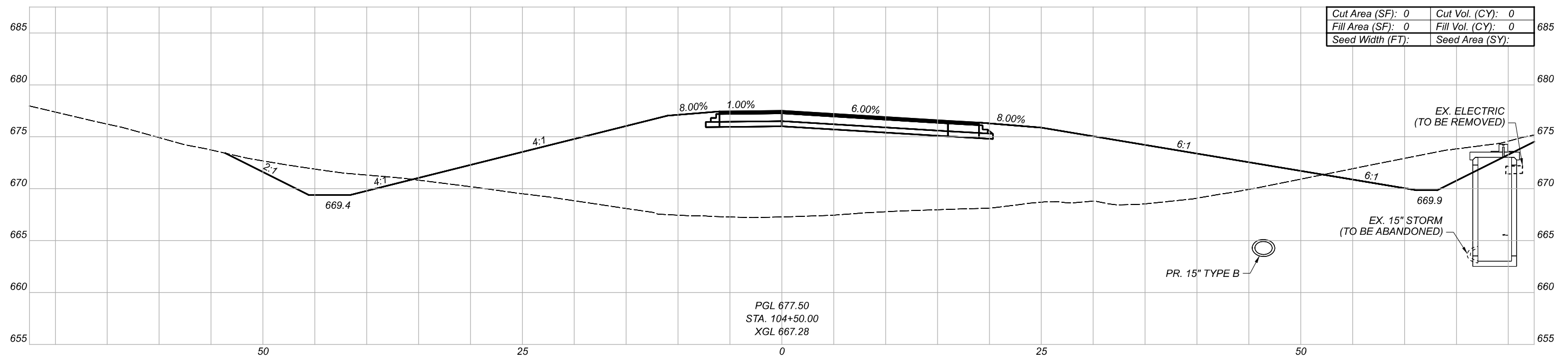

| | | | |
|------------------|---|-----------------|---|
| Cut Area (SF): | 0 | Cut Vol. (CY): | 0 |
| Fill Area (SF): | 0 | Fill Vol. (CY): | 0 |
| Seed Width (FT): | | Seed Area (SY): | |

PGL 677.50
 STA. 104+50.00
 XGL 667.28

CROSS SECTIONS
 RAMP IJ3

| | |
|-----------------------------|-------|
| DESIGN AGENCY | |
| Michael Baker INTERNATIONAL | |
| DESIGNER | -- |
| REVIEWER | -- |
| PROJECT ID | 82382 |

| Sheet Totals | | |
|--------------|-------|------|
| Seeding | Cut | Fill |
| . | . | . |
| SHEET | TOTAL | |
| 732 | 2339 | |

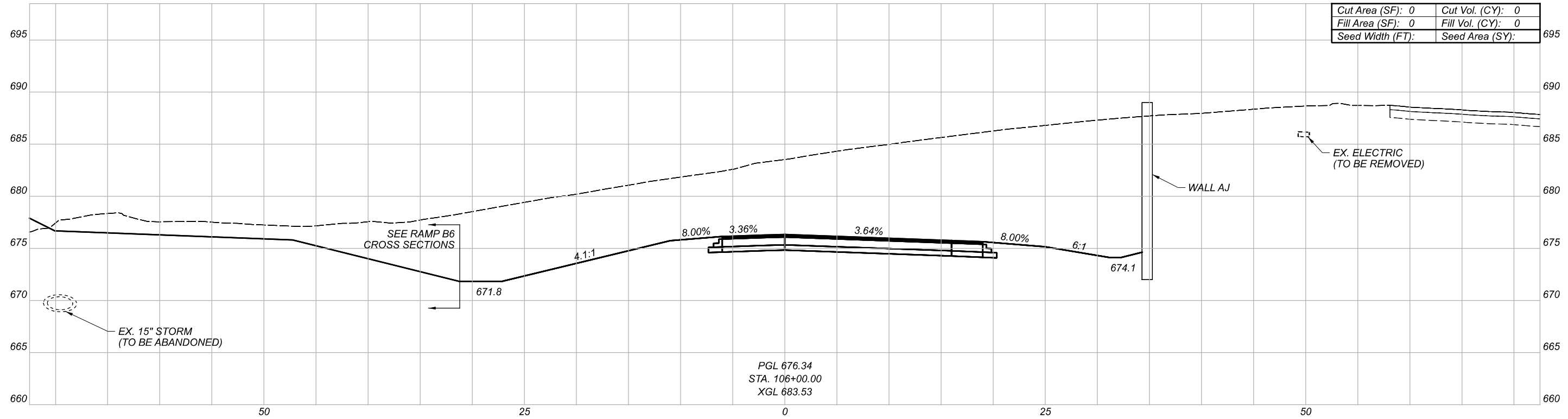

| | | | |
|------------------|---|-----------------|---|
| Cut Area (SF): | 0 | Cut Vol. (CY): | 0 |
| Fill Area (SF): | 0 | Fill Vol. (CY): | 0 |
| Seed Width (FT): | | Seed Area (SY): | |

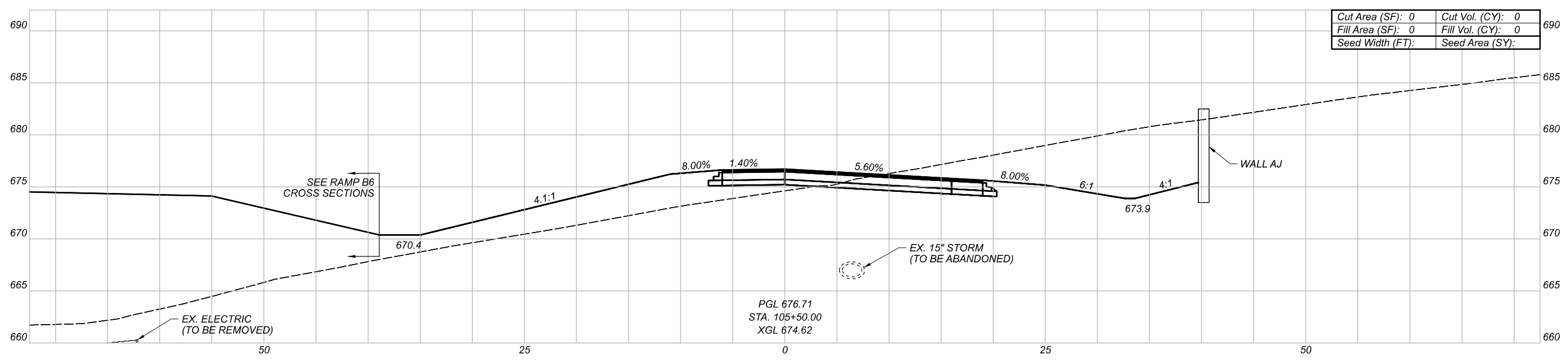

| | | | |
|------------------|---|-----------------|---|
| Cut Area (SF): | 0 | Cut Vol. (CY): | 0 |
| Fill Area (SF): | 0 | Fill Vol. (CY): | 0 |
| Seed Width (FT): | | Seed Area (SY): | |

CROSS SECTIONS
RAMP IJ3

| | |
|-----------------------------|-------|
| DESIGN AGENCY | |
| Michael Baker INTERNATIONAL | |
| DESIGNER | -- |
| REVIEWER | -- |
| PROJECT ID | 82382 |

| Sheet Totals | | | SHEET | TOTAL |
|--------------|-----|------|-------|-------|
| Seeding | Cut | Fill | | |
| . | . | . | 733 | 2339 |

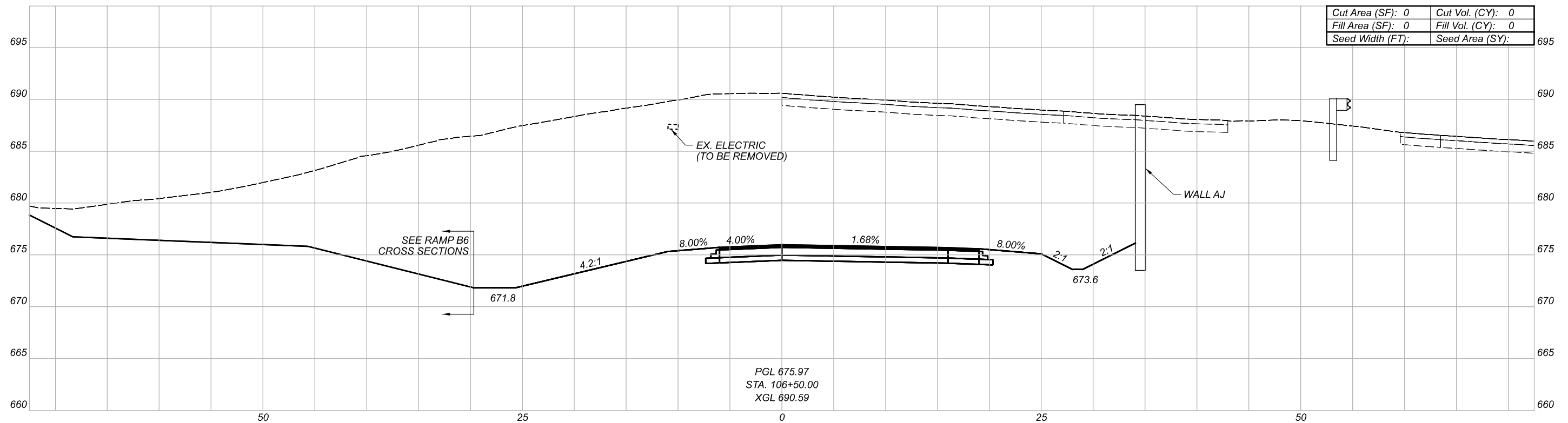
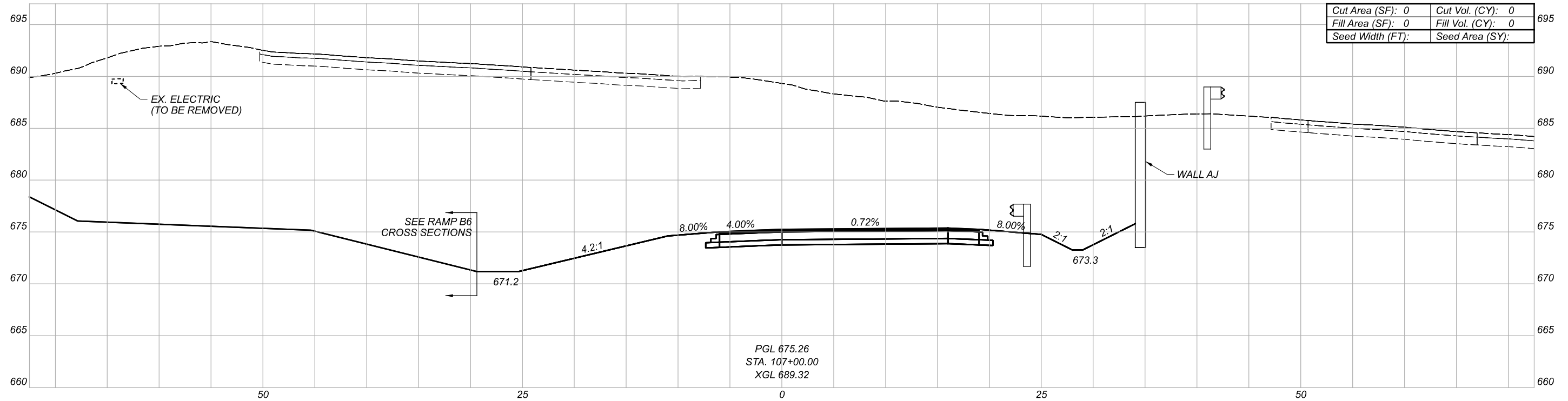

CROSS SECTIONS
RAMP IJ3

DESIGN AGENCY

Michael Baker
INTERNATIONAL

DESIGNER

REVIEWER

PROJECT ID

82382

| Sheet Totals | | | SHEET | TOTAL |
|--------------|-----|------|-------|-------|
| Seeding | Cut | Fill | | |
| . | . | . | 734 | 2339 |

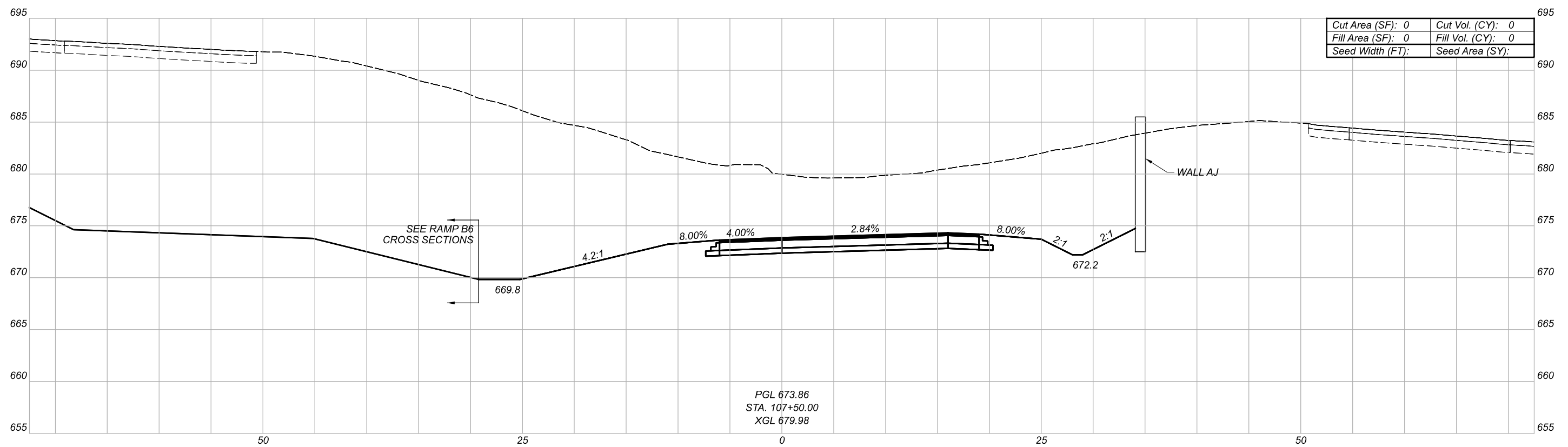
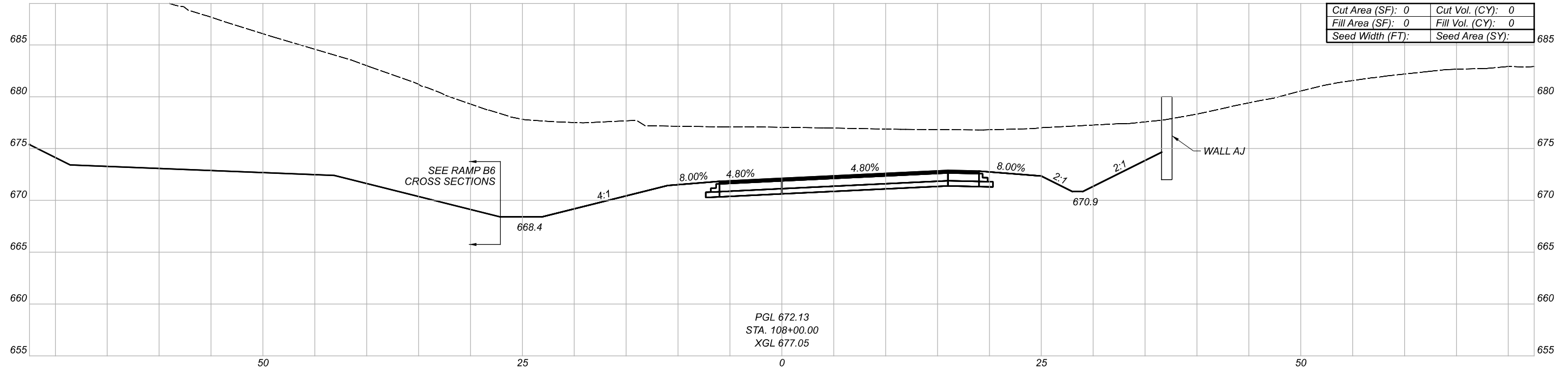

CROSS SECTIONS
RAMP IJ3

DESIGN AGENCY

Michael Baker
INTERNATIONAL

DESIGNER

REVIEWER

PROJECT ID

82382

| Sheet Totals | | | SHEET | TOTAL |
|--------------|-----|------|-------|-------|
| Seeding | Cut | Fill | | |
| . | . | . | 735 | 2339 |

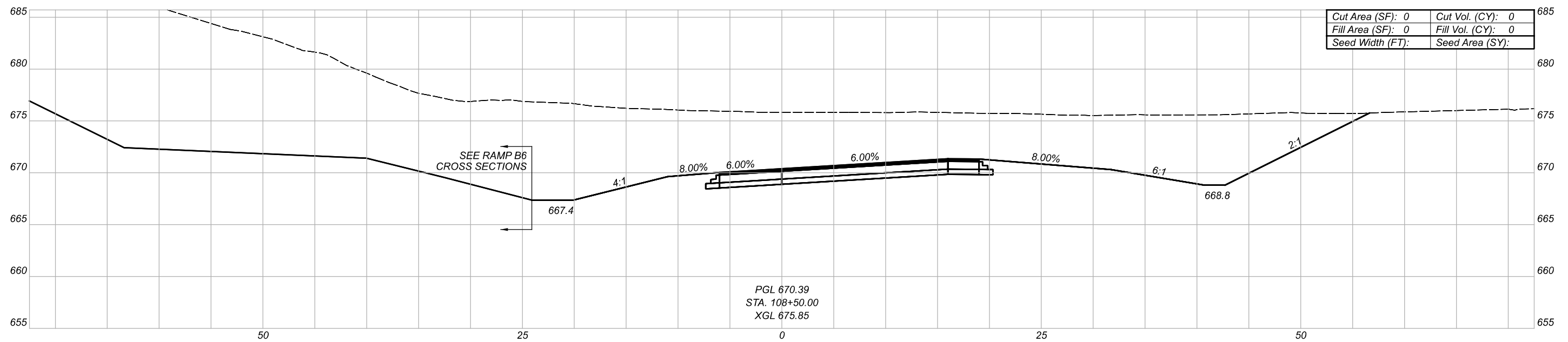
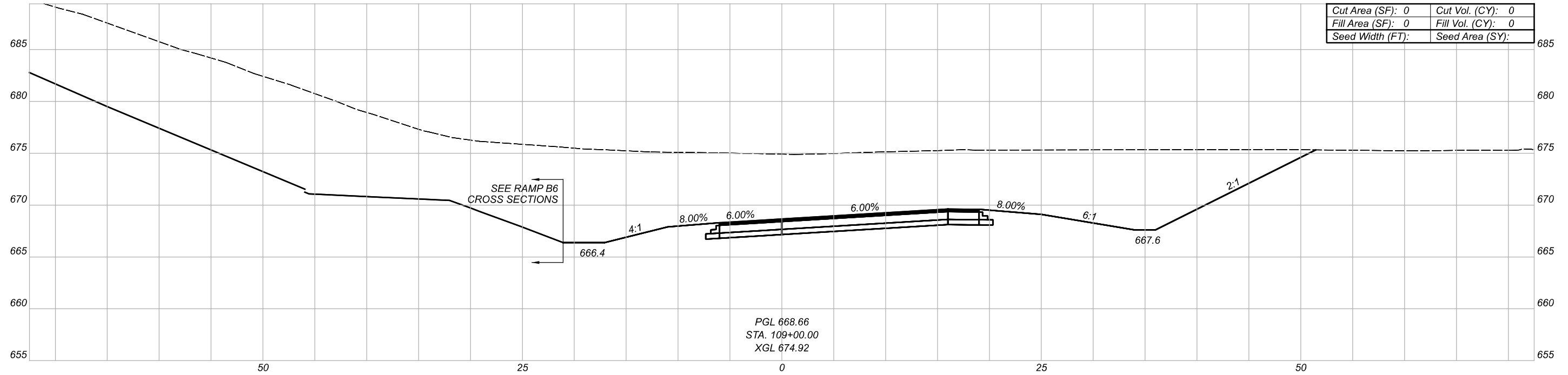

CROSS SECTIONS
RAMP IJ3

DESIGN AGENCY

Michael Baker
INTERNATIONAL

DESIGNER

REVIEWER

PROJECT ID

82382

| Sheet Totals | | | SHEET | TOTAL |
|--------------|-----|------|-------|-------|
| Seeding | Cut | Fill | | |
| . | . | . | 736 | 2339 |

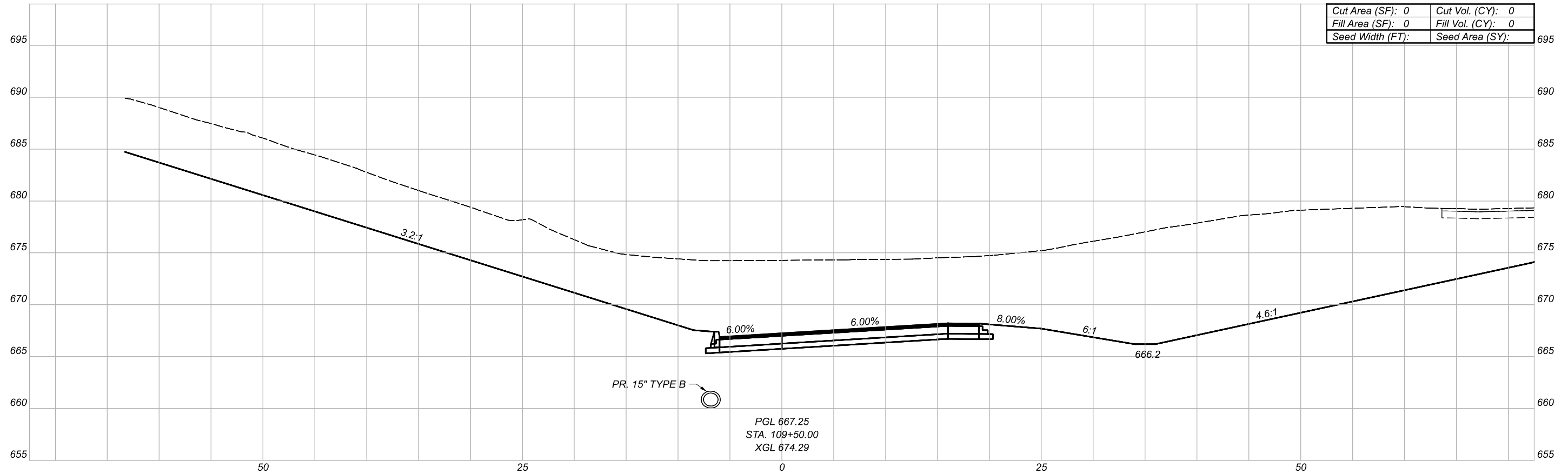

| | | | |
|------------------|---|-----------------|---|
| Cut Area (SF): | 0 | Cut Vol. (CY): | 0 |
| Fill Area (SF): | 0 | Fill Vol. (CY): | 0 |
| Seed Width (FT): | | Seed Area (SY): | |

CROSS SECTIONS
RAMP IJ3

DESIGN AGENCY

Michael Baker
INTERNATIONAL

DESIGNER

REVIEWER

PROJECT ID

82382

| Sheet Totals | | | SHEET | TOTAL |
|--------------|-----|------|-------|-------|
| Seeding | Cut | Fill | | |
| . | . | . | 737 | 2339 |

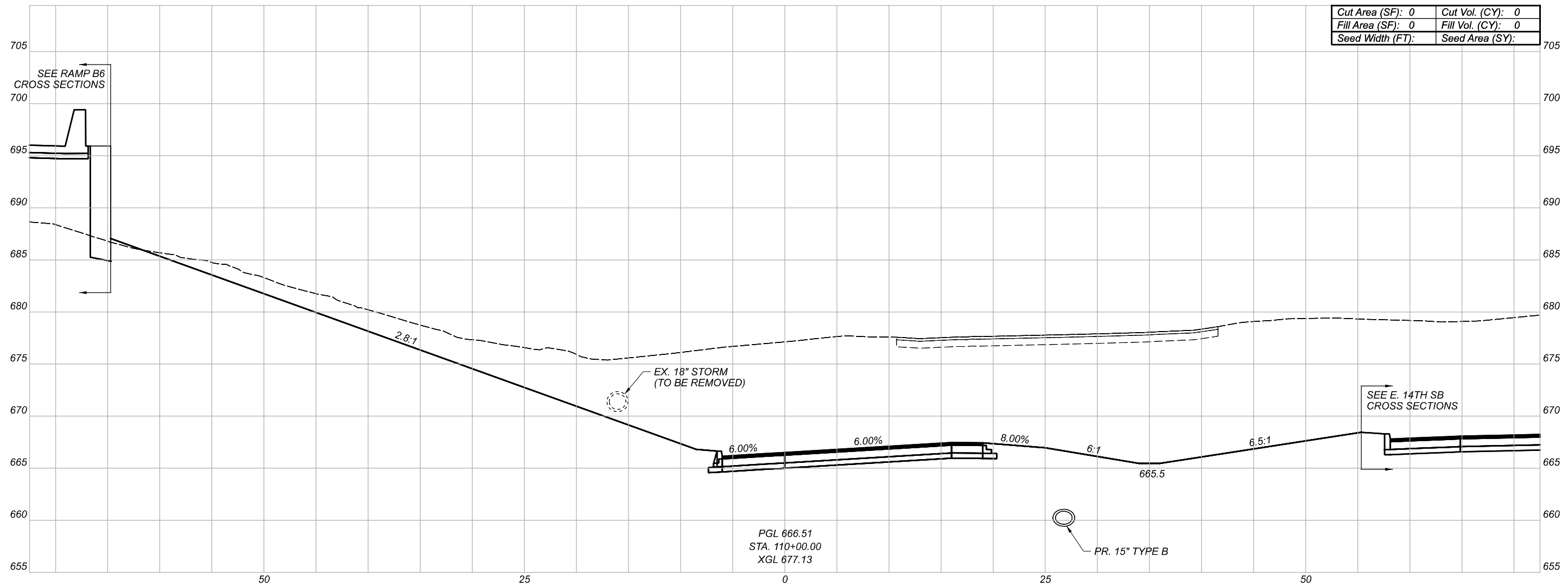

| | | | |
|------------------|---|-----------------|---|
| Cut Area (SF): | 0 | Cut Vol. (CY): | 0 |
| Fill Area (SF): | 0 | Fill Vol. (CY): | 0 |
| Seed Width (FT): | | Seed Area (SY): | |

CROSS SECTIONS
RAMP IJ3

| | |
|-----------------------------|-------|
| DESIGN AGENCY | |
| Michael Baker INTERNATIONAL | |
| DESIGNER | -- |
| REVIEWER | -- |
| PROJECT ID | 82382 |

| Sheet Totals | | | SHEET | TOTAL |
|--------------|-----|------|-------|-------|
| Seeding | Cut | Fill | | |
| . | . | . | 738 | 2339 |

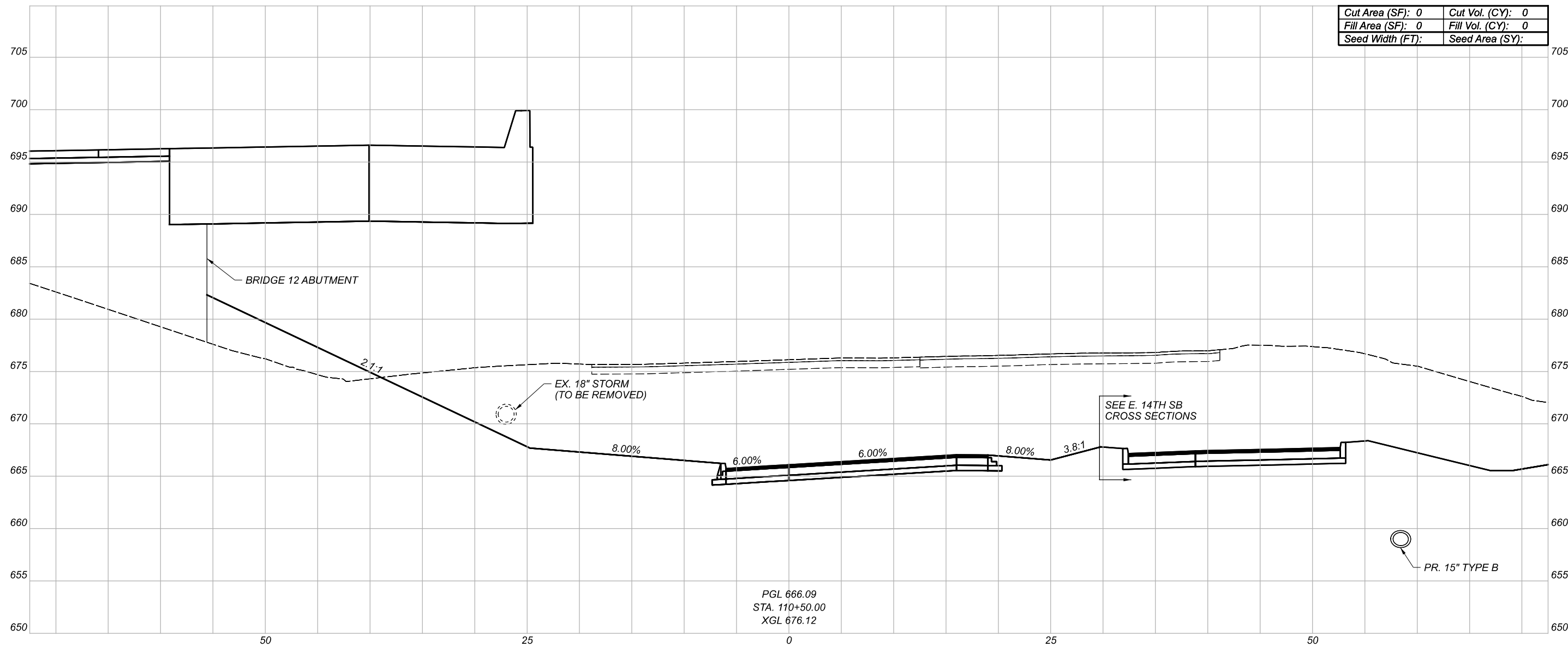

| | |
|-------------------|-------------------|
| Cut Area (SF): 0 | Cut Vol. (CY): 0 |
| Fill Area (SF): 0 | Fill Vol. (CY): 0 |
| Seed Width (FT): | Seed Area (SY): |

PGL 666.09
 STA. 110+50.00
 XGL 676.12

CROSS SECTIONS
 RAMP IJ3

| | |
|---------------------------------------|-------|
| DESIGN AGENCY | |
| Michael Baker INTERNATIONAL | |
| DESIGNER | -- |
| REVIEWER | -- |
| PROJECT ID | 82382 |

| Sheet Totals | | | SHEET | TOTAL |
|--------------|-----|------|-------|-------|
| Seeding | Cut | Fill | | |
| . | . | . | 739 | 2339 |