

SECTION A-A

1 Dowel location for curb & gutter

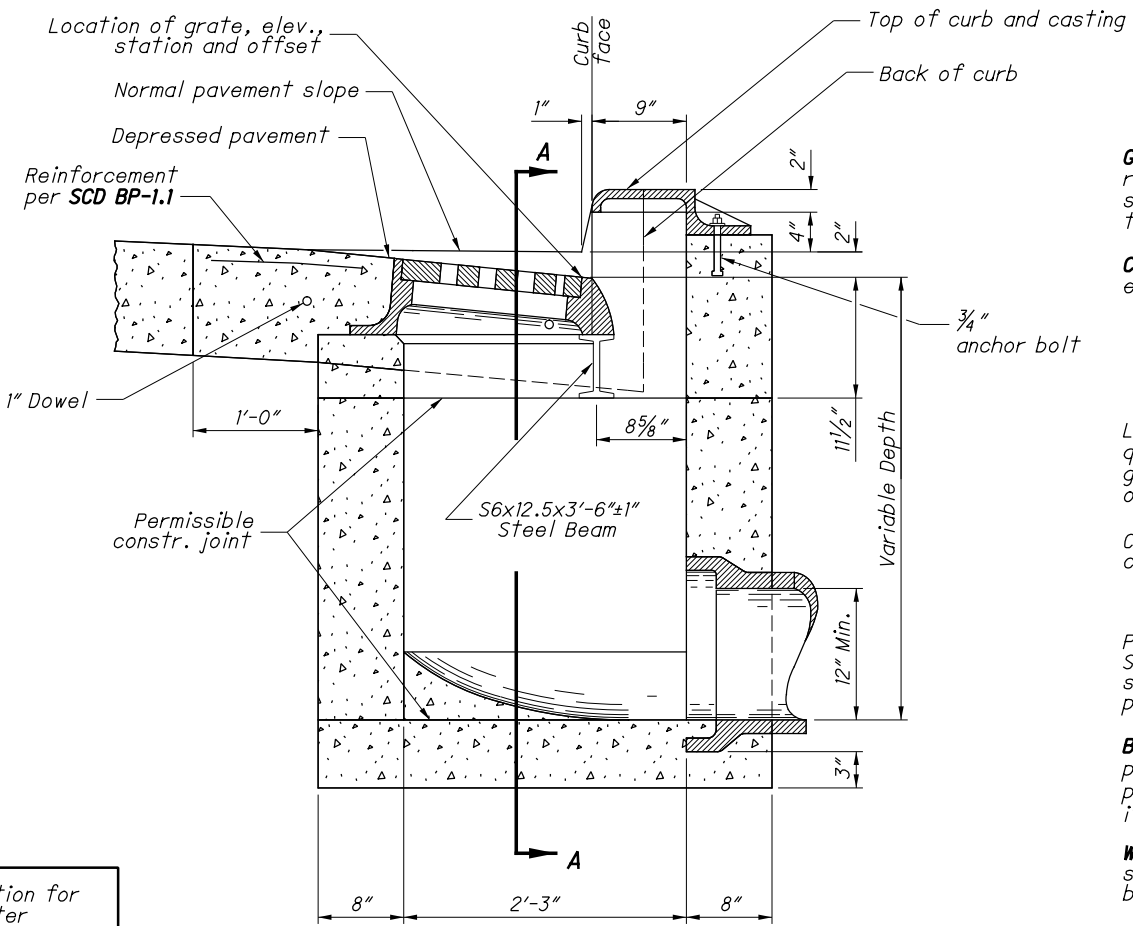

SECTION B-B WITH CURB (2" DEPRESSION)

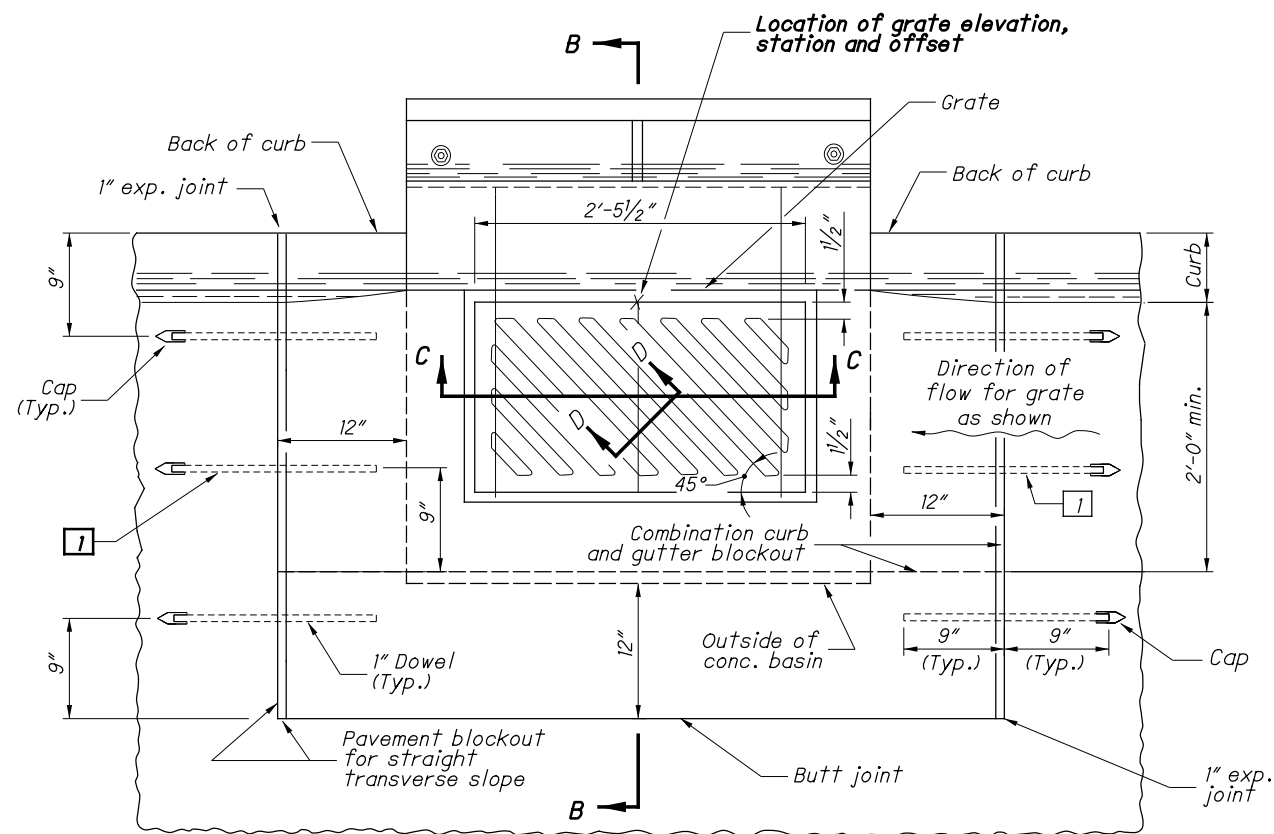

PLAN OF CATCH BASIN AND PAVEMENT JOINTS
 (For SECTIONS C-C and D-D, see Sht. 2/2)

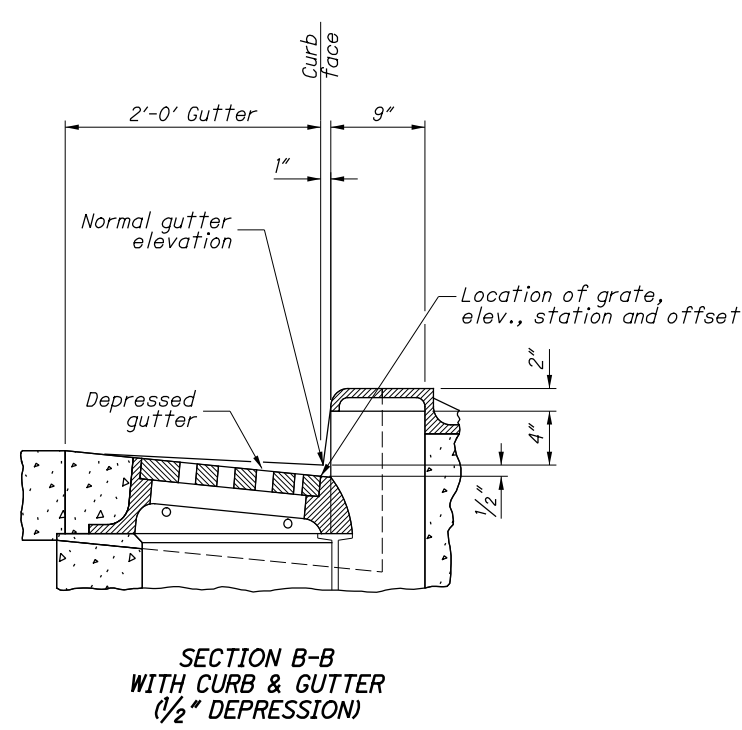

SECTION B-B WITH CURB & GUTTER (1/2" DEPRESSION)

NOTES

GRATES: Provide Grate "V" unless the plans specifically require the diagonal grate. If the diagonal grate is specified, place it so that the diagonal bars direct the drainage toward the curb.

CASTINGS: Provide a design essentially the same and equally as strong as the one shown. Minimum weight:

- Curb Casting 170 lbs.
- Standard Grate 127 lbs.
- Frame 320 lbs.
- Grate "V" 105 lbs.

Lighter weight frames and grates that meet the requirements of CMS 711.14 may also be provided. Provide grate openings and dimensions as shown here unless otherwise shown in the plans.

Cast the following text into the top of the curb casting:

"DUMP NO WASTE" and "DRAINS TO WATERWAY"

Print text in bold, capital letters at least 3/4" high. See example on Plan & Section. "WATERWAY" may be substituted with "STREAM", "RIVER", "LAKE", etc. Actual placement and logo may vary per manufacturer.

BEARING AREAS: Fit and finish the frame and grate to provide a firm and even seat. No projections are permitted on bearing areas, and the grate must seat in its frame without rocking.

WALLS: Provide Class QC1 concrete for cast-in-place structures. When used in place of concrete, construct brick side walls with 8" nominal thickness.

PRECAST CONSTRUCTION: Permitted, except for the apron. Provide concrete meeting the requirements of CMS 706.13. Provide precast walls at least 6" thick with sufficient reinforcement to permit shipping and placement without damage. Reduce the wall thickness from the outside. Mark the catch basin number on the structure.

MINIMUM DEPTH: The minimum depth is per the cover requirements for that pipe type.

OPENINGS: Ensure pipe openings are the O.D. of the pipe being supplied plus 2" when fabricated or field cut. Fill any voids per CMS 611.

STEPS: Provide steps where depth exceeds 6". Meet the requirements of SCD MH-1.

DOWELS: Furnish four 1"x18" dowels for concrete pavement or gutter blackout. See SCD BP-2.2 for dowel details.

BLOCKOUT: Pave blockouts with Class QC1 concrete in PCC pavement or gutter. Blockouts are paid for as part of the pavement or gutter with no deduction in pavement, curb or gutter quantities because of the castings. Cast a Class QC1 concrete apron in place, the size of the 2'-0" gutter blackout, in asphalt pavement (no dowels required) with the cost included in the catch basin bid price. Provide the 1" expansion joint in the curb for all curb types with no deduction made in curb quantities.

PAYMENT: All materials and labor, including excavation and backfilling, are paid for under Item 611 - Catch Basin, No. 3A.

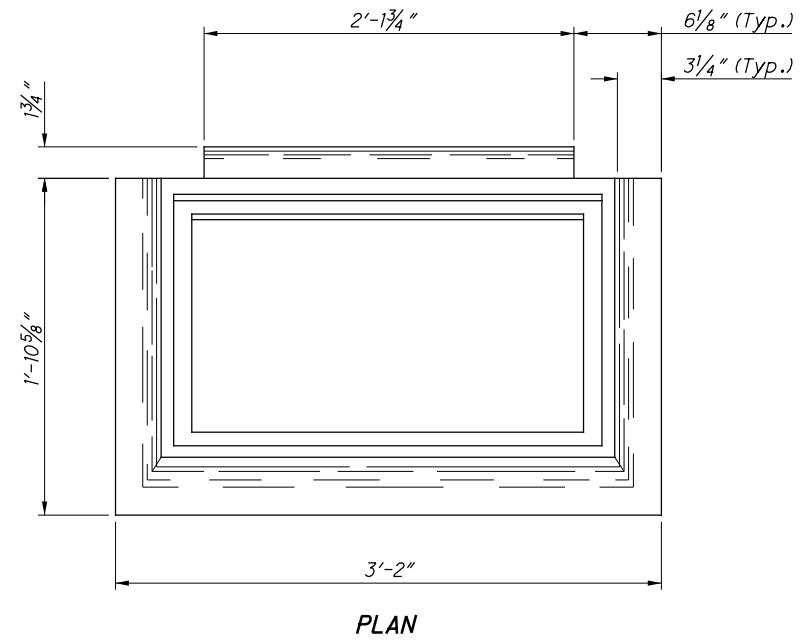

PLAN

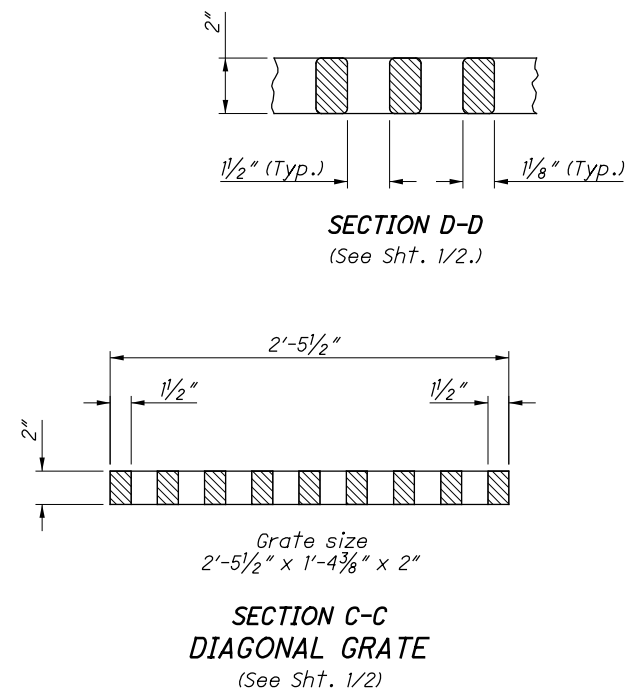

SECTION C-C
DIAGONAL GRATE
(See Sht. 1/2)

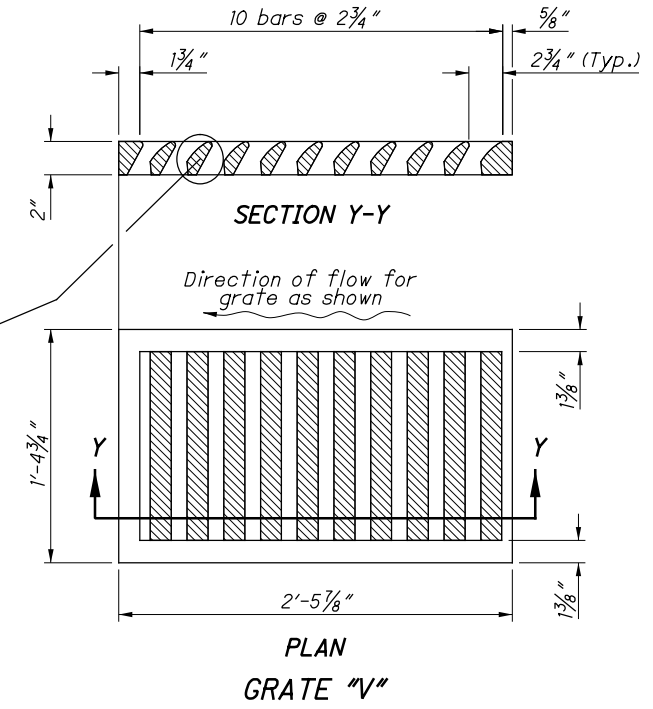
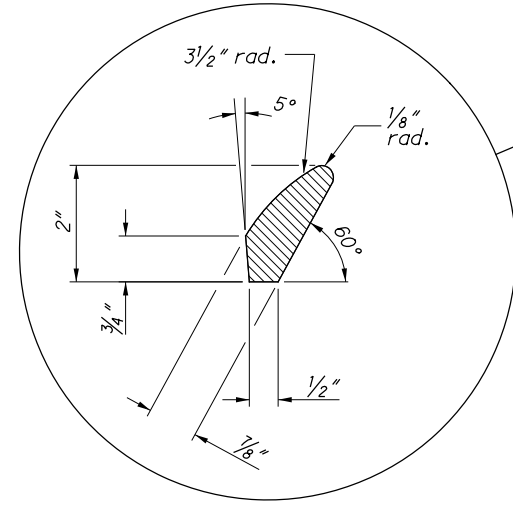

PLAN
GRATE "V"

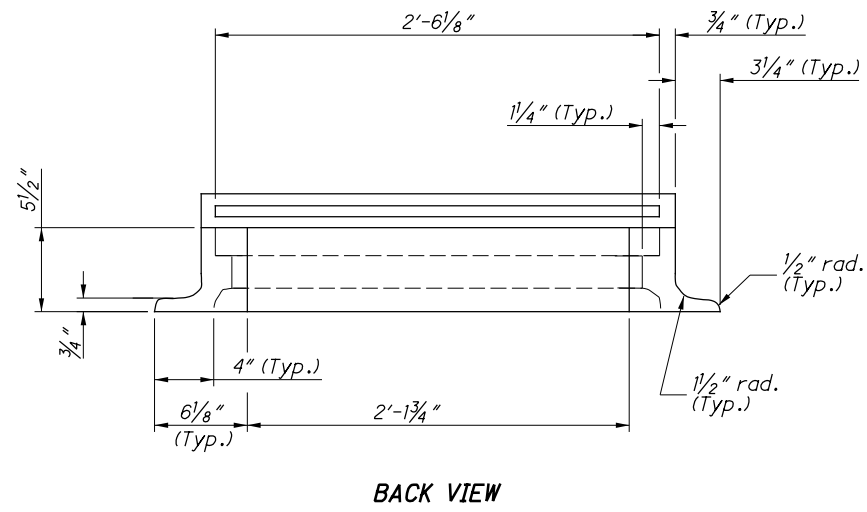

BACK VIEW

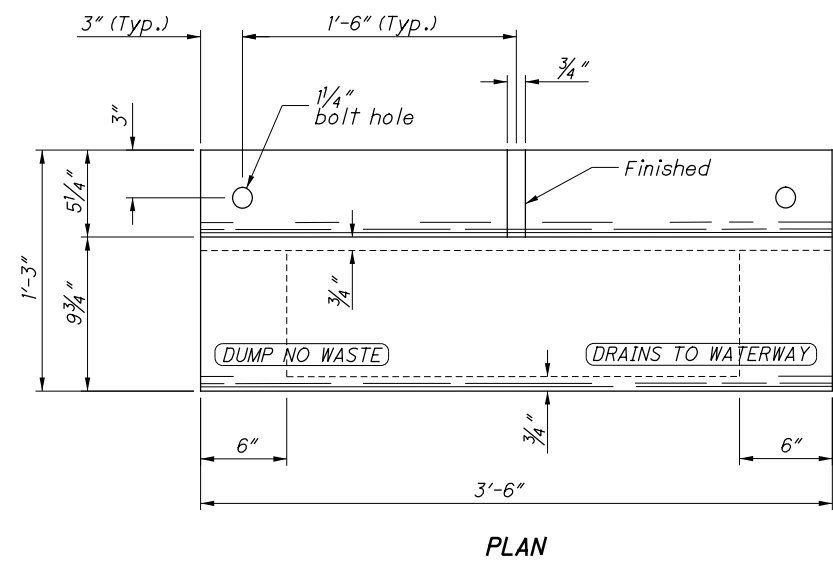

PLAN

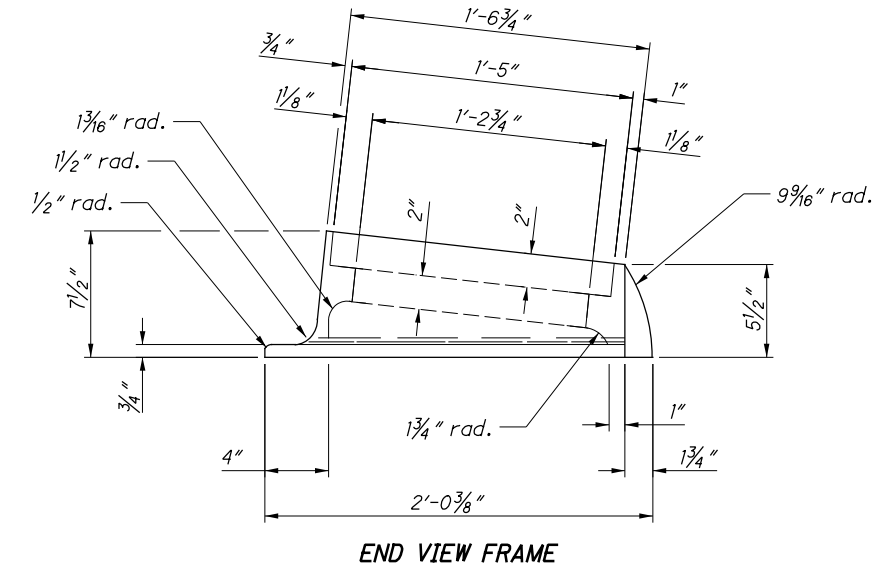

END VIEW FRAME

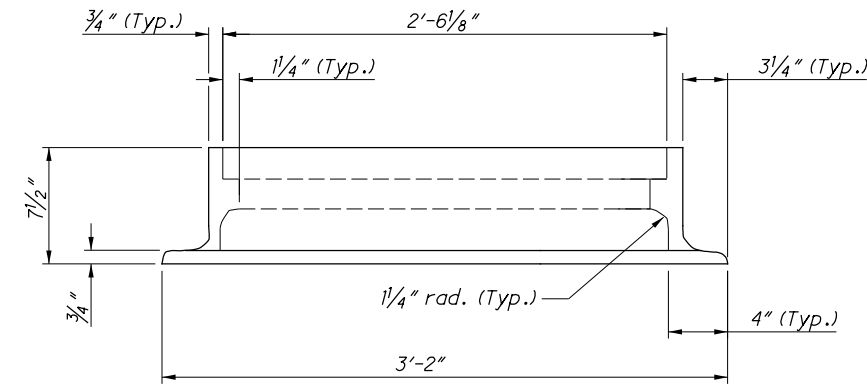

FRAME
FRONT VIEW

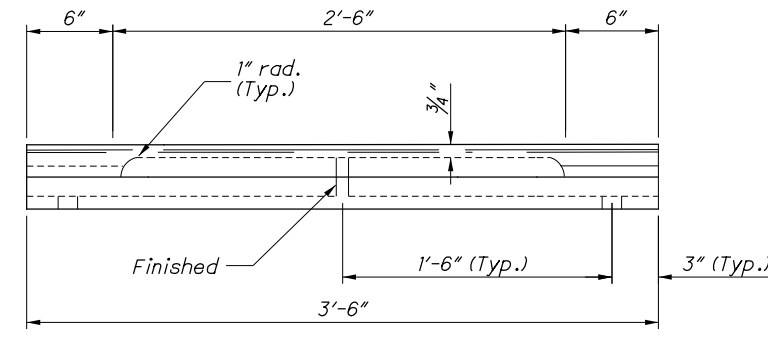

FRONT VIEW
CURB CASTING

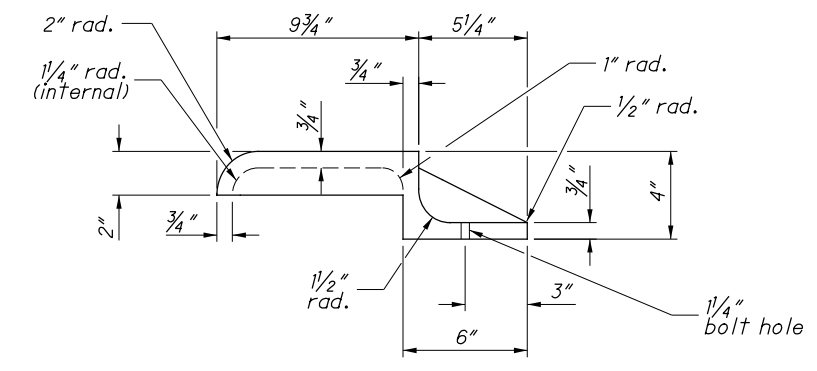

END VIEW
CURB CASTING

CB-3A