

DRAINAGE

CROSSINGS AND CONNECTIONS TO EXISTING PIPES AND UTILITIES

WHERE PLANS PROVIDE FOR A PROPOSED CONDUIT TO BE CONNECTED TO, OR CROSS OVER OR UNDER AN EXISTING SEWER OR UNDERGROUND UTILITY, THE CONTRACTOR SHALL LOCATE THE EXISTING PIPES OR UTILITIES BOTH AS TO LINE AND GRADE BEFORE STARTING TO LAY THE PROPOSED CONDUIT.

IF IT IS DETERMINED THAT THE ELEVATION OF THE EXISTING CONDUIT, OR EXISTING APPURTENANCE TO BE CONNECTED, DIFFERS FROM THE PLAN ELEVATION OR RESULTS IN A CHANGE IN THE PLAN CONDUIT SLOPE, THE ENGINEER SHALL BE NOTIFIED BEFORE STARTING CONSTRUCTION OF ANY PORTION OF THE PROPOSED CONDUIT WHICH WILL BE AFFECTED BY THE VARIANCE IN THE EXISTING ELEVATIONS.

IF IT IS DETERMINED THAT THE PROPOSED CONDUIT WILL INTERSECT AN EXISTING SEWER OR UNDERGROUND UTILITY IF CONSTRUCTED AS SHOWN ON THE PLAN, THE ENGINEER SHALL BE NOTIFIED BEFORE STARTING CONSTRUCTION OF ANY PORTION OF THE PROPOSED CONDUIT WHICH WOULD BE AFFECTED BY THE INTERFERENCE WITH AN EXISTING FACILITY.

PAYMENT FOR ALL THE OPERATIONS DESCRIBED ABOVE SHALL BE INCLUDED IN THE CONTRACT PRICE FOR THE PERTINENT 611 CONDUIT ITEM.

REVIEW OF DRAINAGE FACILITIES

BEFORE ANY WORK IS STARTED ON THE PROJECT AND AGAIN BEFORE FINAL ACCEPTANCE BY THE STATE, REPRESENTATIVES OF THE STATE AND THE CONTRACTOR, ALONG WITH LOCAL REPRESENTATIVES, SHALL MAKE AN INSPECTION OF ALL EXISTING SEWERS WHICH ARE TO REMAIN IN SERVICE AND WHICH MAY BE AFFECTED BY THE WORK. THE CONDITION OF THE EXISTING CONDUITS AND THEIR APPURTENANCE SHALL BE DETERMINED FROM FIELD OBSERVATIONS. RECORDS OF THE INSPECTION SHALL BE KEPT IN WRITING BY THE STATE.

ALL NEW CONDUITS, INLETS, CATCH BASINS, AND MANHOLES CONSTRUCTED AS A PART OF THE PROJECT SHALL BE FREE OF ALL FOREIGN MATTER AND IN A CLEAN CONDITION BEFORE THE PROJECT WILL BE ACCEPTED BY THE STATE.

ALL EXISTING SEWERS INSPECTED INITIALLY BY THE ABOVE MENTIONED PARTIES SHALL BE MAINTAINED AND LEFT IN A CONDITION REASONABLY COMPARABLE TO THAT DETERMINED BY THE ORIGINAL INSPECTION. ANY CHANGE IN THE CONDITION RESULTING FROM THE CONTRACTOR'S OPERATIONS SHALL BE CORRECTED BY THE CONTRACTOR TO THE SATISFACTION OF THE ENGINEER.

PAYMENT FOR ALL OPERATIONS DESCRIBED ABOVE SHALL BE INCLUDED IN THE CONTRACT PRICE FOR THE PERTINENT 611 CONDUIT ITEMS.

ITEM SPECIAL - FIELD INJECTION OF EXISTING JOINTS WITH HIGH DENSITY POLYURETHANE FOAM

- 1.0 DESCRIPTION
- 2.0 MATERIALS
- 3.0 MANUFACTURERS SHIPPING RECORD
- 4.0 EQUIPMENT
- 5.0 EXPERIENCE
- 6.0 DRILLING HOLES
- 7.0 SEALING THE INFRASTRUCTURE
- 8.0 FINISHING ACTIVITIES
- 9.0 METHOD OF MEASUREMENT
- 10.0 BASIS OF PAYMENT

1.0 DESCRIPTION: THIS WORK CONSISTS OF SEALING CONSTRUCTION JOINTS AND CRACKS 1/8 INCH THICK OR GREATER BY INJECTING HIGH DENSITY POLYURETHANE (HDP) AT THE SITE. SEE THIS SHEET FOR ADDITIONAL DESCRIPTION OF WORK TO BE COMPLETED.

2.0 MATERIALS: SUPPLY A CLOSED-CELL HIGH-DENSITY POLYURETHANE (MOUNTAIN GROUT HYDROPHOBIC POLYURETHANE OR APPROVED EQUAL) MEETING THE PROPERTIES SPECIFIED BELOW AS VERIFIED BY CERTIFIED DATA FROM AN INDEPENDENT TESTING LABORATORY. FOR APPROVAL AT LEAST 24 HOURS PRIOR TO THE BEGINNING OF WORK, SUPPLY THE CERTIFIED DATA TO THE PROJECT ENGINEER.

PROPERTY	ASTM TEST	REQUIRED VALUE
MATERIAL DENSITY	D1622	2.0 LB/CU FT
TENSILE STRENGTH	D1623 (NOTE 1)	29 PSI MINIMUM
SHEAR STRENGTH	C273	17 PSI MINIMUM
WATER ABSORPTION	D2127	LESS THAN 1% VOLUME

NOTE: FOR VERIFICATION PURPOSES, THE CONTRACTOR SHALL ALLOW THE PROJECT ENGINEER UNLIMITED ACCESS TO ALL EQUIPMENT, HDP MATERIAL DATA SHEETS AND ANY OTHER PRINTED HDP INFORMATION RELATED TO THE PROJECT.

3.0 MANUFACTURERS SHIPPING RECORD: PROVIDE MANUFACTURER BATCH NUMBERS AND SHIPPING INVOICES. MARK EACH CONTAINER OF ALL COMPONENTS AS FOLLOWS:

- A. NUMBER OF GALLONS (LITERS)
- B. NET WEIGHT OF MATERIAL
- C. BATCH NUMBER
- D. DATE OF PRODUCTION
- E. EFFECTIVE SHELF LIFE OF THE PRODUCT
- F. COMPANY NAME AND ADDRESS
- G. COMPONENT TRADE NAME AS GIVEN IN THE MATERIAL TEST DATA
- H. MSDS SHEETS.

4.0 EQUIPMENT: FOR REVIEW, SUBMIT AN INVENTORY OF ALL SEALING EQUIPMENT TO THE PROJECT ENGINEER. PROVIDE THE FOLLOWING EQUIPMENT AS A MINIMUM:

- A. PNEUMATIC OR ELECTRICAL DRILL CAPABLE OF DRILLING 3/8 TO 5/8 INCH DIAMETER HOLES (DEPENDING ON SIZE OF PACKERS) THROUGH THE INFRASTRUCTURE.
- B. PACKERS AND APPROPRIATE FITTINGS AS APPROVED BY THE MATERIAL SUPPLIER.
- C. PUMPING EQUIPMENT FOR DELIVERING MATERIAL INTO VOID AREAS WITH SUFFICIENT PRESSURES AS RECOMMENDED BY THE MATERIAL SUPPLIER. PUMPING EQUIPMENT SHALL BE ADEQUATELY MOBILE TO ALLOW FOR USE WHERE CALLED FOR IN THE PLANS.

5.0 EXPERIENCE: THE CONTRACTOR OR SUBCONTRACTOR PERFORMING THIS SPECIFIC WORK SHALL HAVE A MINIMUM OF TWO (2) YEARS EXPERIENCE USING HDP TO SEAL INFRASTRUCTURE LEAKS (AS DEMONSTRATED BY TEN (10) SUCCESSFULLY COMPLETED JOB REFERENCES). FOR EACH SUCCESSFULLY COMPLETED JOB REFERENCE, PROVIDE THE FOLLOWING:

- 1. PROJECT DESCRIPTION
- 2. CLIENT CONTACT INFORMATION
- 3. DATE COMPLETED
- 4. TOTAL COST OF JOB

6.0 DRILLING HOLES: PLOT AND RECORD A PATTERN OF INJECTION HOLES AROUND THE LEAKING AREA OF THE INFRASTRUCTURE WHERE THE SERIES OF HOLES SHALL BE DRILLED. SPACING OF HOLES SHALL NOT BE MORE THAN FOUR (4) FEET CENTER TO CENTER. DRILL HOLES OUTSIDE THE LEAKING AREAS TO BE USED AS SEEPAGE HOLES (I.E. WHEN HDP MATERIAL SEEPS FROM THESE SAME HOLES, THEN THE LEAKED AREA HAS BEEN EFFECTIVELY SEALED). FOR MORE DETAILS, SEE EQUIPMENT ON THIS SAME SHEET.

PRIOR TO DRILLING HOLES. SPRAY PAINT THE LIMITS OF THE LEAKING. HOLES DRILLED WITHIN THE PAINTED PERIMETER WILL BE INJECTION HOLES WHEREAS HOLES DRILLED OUTSIDE THE PAINTED PERIMETER WILL BE SEEPAGE HOLES. THE ENGINEER SHALL APPROVE THE PAINTED PERIMETER DESIGNATION PRIOR TO DRILLING HOLES.

7.0 SEALING THE INFRASTRUCTURE: INJECT HDP THROUGH THE DRILLED HOLES IN THE LEAKING AREA. CONTINUE INJECTING HDP UNTIL MATERIAL SEEPS FROM THE SEEPAGE HOLES.

VERIFY THAT ALL HDP COUNTERS (IF SO EQUIPPED) ARE SET AT ZERO PRIOR TO EACH SHIFT BEGINNING ITS PROJECT INJECTION.

8.0 FINISHING ACTIVITIES:

- A. REMOVAL OF EXCESS: REMOVE ANY EXCESS POLYURETHANE MATERIAL.
- B. FINAL USAGE RECORDS: RECORD THE FINAL AMOUNT OF HDP USED FOR EACH SHIFT BY COUNTING CONTAINERS OR RECORDING METER VALUES IF SO EQUIPPED. RESET ALL COUNTERS TO ZERO PRIOR TO THE NEXT SHIFT.

9.0 METHOD OF MEASUREMENT: THE DEPARTMENT WILL MEASURE THE ACTUAL POUNDS OF HDP MATERIAL USED BY COUNTING THE NUMBER OF CONTAINERS. IN THE PLANS, SUCH QUANTITY WAS ESTIMATED USING A HDP IN-SITU DENSITY OF 2 POUNDS/CU FT

10.0 BASIS OF PAYMENT: PAYMENT FOR ACCEPTED QUANTITIES COMPLETE IN PLACE WILL BE MADE AT CONTRACT PRICE FOR:

ITEM:	UNIT:	DESCRIPTION:
SPECIAL	POUND	FIELD INJECTION OF EXISTING PIPE JOINTS WITH HIGH DENSITY POLYURETHANE FOAM

ALL LABOR, EQUIPMENT, MATERIALS AND INCIDENTALS REQUIRED TO PLACE PROPERLY THE HDP SHALL BE INCLUDED IN THE COST OF THE BID ITEM.

CONCRETE REPAIR BY EPOXY INJECTION

CRACKS LESS THAN 1/8 INCH THICK SHALL BE REPAIRED USING EPOXY INJECTION FOLLOWING CMS 512.07. THE QUANTITIES PROVIDED IN THE PLANS FOR THIS ITEM ARE TO USED AS DIRECTED BY THE ENGINEER.

EROSION CONTROL

SEEDING AND MULCHING

THE FOLLOWING QUANTITIES ARE PROVIDED TO PROMOTE GROWTH AND CARE OF PERMANENT SEEDED AREAS:

659, SOIL ANALYSIS TEST	2 EACH
659, TOPSOIL	101 CU. YD.
659, REPAIR SEEDING AND MULCHING	46 SQ.YD.
659, INTER-SEEDING	46 SQ.YD.
659, COMMERCIAL FERTILIZER	0.13 TON
659, LIME	0.19 ACRES
659, WATER	6 M. GAL.

SEEDING AND MULCHING SHALL BE APPLIED TO ALL AREAS OF EXPOSED SOIL BETWEEN THE RIGHT-OF-WAY LINES, AND WITHIN THE CONSTRUCTION LIMITS FOR AREAS OUTSIDE THE RIGHT-OF-WAY LINES COVERED BY WORK AGREEMENT OR SLOPE EASEMENT. QUANTITY CALCULATIONS FOR SEEDING AND MULCHING ARE BASED ON THESE LIMITS.

TEMPORARY ACCESS FILL

COFFERDAMS AND EXCAVATION BRACING INSTALLED FOR THE PROJECT ARE FOR DEWATERING THE WORK AREA. COFFERDAMS AND EXCAVATION BRACING DESIGN, CONSTRUCTION, AND REIMBURSEMENT FOR DAMAGE IS BASED ON CMS 503. THE CONTRACTOR MUST COMPLY WITH THE IN-STREAM RESTRICTION IN THE SPECIAL PROVISIONS - WATERWAY PERMIT. ADDING FILL TO OR EXCAVATING FROM THE STREAM TO DEWATER THE WORK AREA REQUIRES A TEMPORARY ACCESS FILL (TAF) SUBMISSION PER THE SPECIAL PROVISIONS. FILLING THE EXCAVATED AREA AFTERWARDS IS CONSIDERED A PERMANENT FILL AND MAY VIOLATE THE WATERWAY PERMIT'S THRESHOLDS OF IMPACTS.

IF THE CONTRACTOR CHOOSES TO IMPACT THE STREAM DURING THE MONTHS OF APRIL THROUGH OCTOBER: ALL REQUIREMENTS OF CMS 503 APPLY, UNLESS STIPULATED ELSEWHERE IN THIS NOTE.

IF THE CONTRACTOR CHOOSES TO IMPACT THE STREAM AT ANY TIME IN THE MONTHS OF NOVEMBER THROUGH MARCH: EVEN IF THE ACTUAL WATER ELEVATION EXCEEDS 3 FEET ABOVE THE STATED ORDINARY HIGH WATER MARK, THE DEPARTMENT WILL NOT REIMBURSE THE CONTRACTOR FOR RESULTING DAMAGE TO THE WORK PROTECTED BY THE COFFERDAM. ALL OTHER REQUIREMENTS OF CMS 503 APPLY.

AS STATED IN THE SPECIAL PROVISIONS, THE TAF WILL NOT BE PAID AS A SEPARATE ITEM BUT WILL BE INCLUDED BY THE CONTRACT AS PART OF THE TOTAL PROJECT COST.

CALCULATED
RMS
CHECKED
SAC

GENERAL NOTES

CLI-28 / 124-
4.52 / 5.47 / 0.54

5
53

E:\0001\Project\02731\02731_CLI-28 & 124\Design\Roadway\Sheets\02731_GG001.dgn Sheet 2 9/30/2020 3:46:01 PM scook

SHEET NUM.											PART.	ITEM	ITEM	GRAND	UNIT	DESCRIPTION	SEE SHEET NO.
OFFICE CALCS			6		12	21	26	28		33	01/STR/BR	EXT	TOTAL				
																TRAFFIC CONTROL	
					1						1	621	00100	1	EACH	RPM	
					1						1	621	54000	1	EACH	RAISED PAVEMENT MARKER REMOVED	
					4						4	626	00110	4	EACH	BARRIER REFLECTOR, TYPE 2 BIDIRECTIONAL	
					56						56	630	03100	56	FT	GROUND MOUNTED SUPPORT, NO. 3 POST	
					8						8	630	80100	8	SF	SIGN, FLAT SHEET	
					1						1	630	84900	1	EACH	REMOVAL OF GROUND MOUNTED SIGN AND DISPOSAL	
					5						5	630	85100	5	EACH	REMOVAL OF GROUND MOUNTED SIGN AND REERECTION	
					3						3	630	86002	3	EACH	REMOVAL OF GROUND MOUNTED POST SUPPORT AND DISPOSAL	
					0.02		0.03	0.02			0.07	642	00104	0.07	MILE	EDGE LINE, 6", TYPE 1	
					0.01		0.01	0.01			0.03	642	00300	0.03	MILE	CENTER LINE, TYPE 1	
							38				38	642	00500	38	FT	STOP LINE, TYPE 1	
																STRUCTURE 20 FOOT SPAN AND UNDER (CLI-28-0452)	
					LS						LS	202	11000	LS		STRUCTURE REMOVED	
					LS						LS	503	11100	LS		COFFERDAMS AND EXCAVATION BRACING	5
					LS						LS	503	21300	LS		UNCLASSIFIED EXCAVATION	
					3,297						3,297	509	10000	3,297	LB	EPOXY COATED REINFORCING STEEL	
					8						8	511	46011	8	CY	CLASS QC1 CONCRETE, RETAINING/WINGWALL NOT INCLUDING FOOTING, AS PER PLAN	21
					29						29	511	46510	29	CY	CLASS QC1 CONCRETE, FOOTING	
					1						1	511	46610	1	CY	CLASS QC1 CONCRETE, HEADWALL	
					46						46	512	10100	46	SY	SEALING OF CONCRETE SURFACES (EPOXY-URETHANE)	
					85						85	512	33000	85	SY	TYPE 2 WATERPROOFING	
					110						110	512	33010	110	SY	TYPE 3 WATERPROOFING	
					27						27	516	13600	27	SF	1" PREFORMED EXPANSION JOINT FILLER	
					LS						LS	518	21230	LS		POROUS BACKFILL WITH GEOTEXTILE FABRIC	
					62						62	611	95601	62	FT	12' X 4' CONDUIT, TYPE A, 706.05, AS PER PLAN, DESIGN EARTH COVER 2' (CLI-28-0452)	21
																STRUCTURE 20 FOOT SPAN AND UNDER (CLI-28-0547)	
					LS						LS	503	11100	LS		COFFERDAMS AND EXCAVATION BRACING	5
					61						61	512	10100	61	SY	SEALING OF CONCRETE SURFACES (EPOXY-URETHANE)	
					100						100	512	10600	100	FT	CONCRETE REPAIR BY EPOXY INJECTION	
					520						520	519	11101	520	SF	PATCHING CONCRETE STRUCTURE, AS PER PLAN	27
					40						40	SPECIAL	69099400	40	LB	FIELD INJECTION OF EXISTING PIPE JOINTS WITH HIGH DENSITY POLYURETHANE FOAM	5
					17						17	843	50000	17	SF	PATCHING CONCRETE STRUCTURES WITH TROWELABLE MORTAR	
																STRUCTURE 20 FOOT SPAN AND UNDER (CLI-124-0054)	
					LS						LS	202	11000	LS		STRUCTURE REMOVED	
					LS						LS	503	11100	LS		COFFERDAMS AND EXCAVATION BRACING	5
					LS						LS	503	21300	LS		UNCLASSIFIED EXCAVATION	
					3,270						3,270	509	10000	3,270	LB	EPOXY COATED REINFORCING STEEL	
					7						7	511	46011	7	CY	CLASS QC1 CONCRETE, RETAINING/WINGWALL NOT INCLUDING FOOTING, AS PER PLAN	33
					29						29	511	46510	29	CY	CLASS QC1 CONCRETE, FOOTING	
					1						1	511	46610	1	CY	CLASS QC1 CONCRETE, HEADWALL	
					47						47	512	10100	47	SY	SEALING OF CONCRETE SURFACES (EPOXY-URETHANE)	
					101						101	512	33000	101	SY	TYPE 2 WATERPROOFING	
					132						132	512	33010	132	SY	TYPE 3 WATERPROOFING	
					28						28	516	13600	28	SF	1" PREFORMED EXPANSION JOINT FILLER	
					LS						LS	518	21230	LS		POROUS BACKFILL WITH GEOTEXTILE FABRIC	
					74						74	611	95601	74	FT	12' X 4' CONDUIT, TYPE A, 706.05, AS PER PLAN, DESIGN EARTH COVER 2' (CLI-124-0054)	33
																MAINTENANCE OF TRAFFIC	
				24							24	614	11110	24	HR	LAW ENFORCEMENT OFFICER WITH PATROL CAR FOR ASSISTANCE	
				LS							LS	614	12420	LS		DETOUR SIGNING	
																INCIDENTALS	
											LS	614	11000	LS		MAINTAINING TRAFFIC	
											LS	623	10000	LS		CONSTRUCTION LAYOUT STAKES AND SURVEYING	
											LS	624	10000	LS		MOBILIZATION	

GENERAL SUMMARY

CLI-28 / 124-
4.52 / 5.47 / 0.54

GENERAL NOTES

EXISTING STRUCTURE VERIFICATION

DETAILS AND DIMENSIONS SHOWN ON THESE PROPOSED PLANS PERTAINING TO THE EXISTING STRUCTURE HAVE BEEN OBTAINED FROM PLANS OF THE EXISTING STRUCTURE AND FROM FIELD OBSERVATIONS AND MEASUREMENTS. CONSEQUENTLY, SUCH DETAILS AND DIMENSIONS ARE INDICATIVE OF THE EXISTING STRUCTURE AND THE PROPOSED WORK, BUT THEY SHALL BE CONSIDERED TENTATIVE AND APPROXIMATE. THE CONTRACTOR IS REFERRED TO CMS SECTIONS 102.05, 105.02 AND 513.04. BASE THE CONTRACT BID PRICES UPON A RECOGNITION OF THE UNCERTAINTIES DESCRIBED ABOVE AND UPON A PREBID EXAMINATION OF THE EXISTING STRUCTURE. HOWEVER, THE DEPARTMENT WILL PAY FOR ALL PROJECT WORK BASED UPON ACTUAL DETAILS AND DIMENSIONS THAT HAVE BEEN VERIFIED IN THE FIELD.

DESIGN SPECIFICATIONS

THIS STANDARD DRAWING CONFORMS TO THE "LRFD BRIDGE DESIGN SPECIFICATIONS" ADOPTED BY THE AMERICAN ASSOCIATION OF STATE HIGHWAY AND TRANSPORTATION OFFICIALS, 2014, INCLUDING THE 2015 & 2016 INTERIM SPECIFICATIONS AND THE ODOT BRIDGE DESIGN MANUAL, 2007.

DESIGN DATA

THE FOLLOWING DESIGN DATA IS ASSUMED:

INTERNAL ANGLE OF FRICTION OF BACKFILL SOIL: $\phi = 30^\circ$ (GRANULAR), 18° (COHESIVE)
 TOTAL UNIT WEIGHT OF BACKFILL SOIL = 125 PCF
 INTERNAL ANGLE OF FRICTION (DRAINED), FOUNDATION SOIL, $\phi = 23^\circ$
 UNDRAINED SHEAR STRENGTH (COHESIVE), FOUNDATION SOIL, $S = 1500$ PSF (INLET)
 $S = 1000$ PSF (OUTLET)

UNIT WEIGHT OF CONCRETE = 150 PCF
 SLOPE OF BACKFILL = 2:1 (TYPE A & B HEADWALLS)
 HEIGHT OF LIVE LOAD SURCHARGE = 2 FT (TYPE C HEADWALLS)

CONCRETE CLASS QC1 - COMPRESSIVE STRENGTH 4000 PSI
 (FOOTING, WINGWALL AND FORESLOPE WALL)

REINFORCING STEEL - ASTM A615, A616, OR A617
 GRADE 60 MINIMUM YIELD STRENGTH
 60,000 PSI (ALL REINFORCING SHALL BE EPOXY COATED)

ITEM 202 - STRUCTURE REMOVED

THIS LUMP SUM PAY ITEM INCLUDES THE REMOVAL OF THE EXISTING CULVERT AND ALL EXISTING HEADWALLS, WINGWALLS, AND FOOTINGS.

PRECAST CONCRETE

OUTLET WINGWALL #1 SHALL BE CAST-IN-PLACE AND NOT CONSTRUCTED WITH PRECAST CONCRETE.

ITEM 511 - CLASS QC1 CONCRETE, RETAINING/WINGWALL NOT INCLUDING FOOTING, AS PER PLAN:

UNLESS THE PRECAST HEADWALL/WINGWALL SYSTEM IS ON THE APPROVED PRODUCTS LIST, THE DEPARTMENT WILL NOT PERMIT THE USE OF PRECAST HEADWALLS OR WINGWALLS. IF THE SYSTEM IS ON THE APPROVED PRODUCTS LIST, THEN THE FOLLOWING IS APPLICABLE (EXCEPT FOR OUTLET WINGWALL #1):

THE DEPARTMENT WILL PERMIT THE USE OF PRECAST CONCRETE IN LIEU OF CAST-IN-PLACE CONCRETE FOR HEADWALLS AND WINGWALLS IN ACCORDANCE WITH C&MS 602.03. THE DEPARTMENT WILL PAY FOR THE WINGWALL AND HEADWALL CONCRETE IN SQUARE YARD AS DETERMINED FROM PLAN DIMENSIONS USING THE WALL HEIGHTS ABOVE THE FOOTING AND LENGTH ALONG THE EXTERIOR FACES OF THE WALLS. THE DEPARTMENT WILL CONSIDER THE REINFORCING STEEL IN THE WINGWALLS AND HEADWALLS, INCLUDING THE REINFORCEMENT THAT EXTENDS INTO THE FOOTINGS, AS INCIDENTAL TO THE RETAINING/WINGWALL CONCRETE. THE TOTAL QUANTITY OF CAST-IN-PLACE WINGWALL AND HEADWALL CONCRETE IS 6 CU YD. THE TOTAL QUANTITY OF CAST-IN-PLACE WINGWALL AND HEADWALL REINFORCING STEEL IS 696 LBS.

FOUNDATION BEARING RESISTANCE

HEADWALL AND WINGWALL FOOTINGS, AS DESIGNED, PRODUCE A MAXIMUM SERVICE LOAD PRESSURE OF 3.0 KIPS PER SQUARE FOOT AND A MAXIMUM STRENGTH LOAD PRESSURE OF 5.7 KIPS PER SQUARE FOOT. THE FACTORED BEARING RESISTANCE IS 3.0 KIPS PER SQUARE FOOT.

PERFORMED EXPANSION JOINT FILLER

PERFORMED EXPANSION JOINT FILLER (PEJF) CONFORMING TO CMS 705.03, 1 INCH THICK, SHALL BE PLACED ABOVE THE FOOTING BETWEEN THE SIDES OF THE BOX CULVERT AND THE ENDS OF THE WINGWALLS. PAYMENT FOR MATERIALS AND INSTALLATION SHALL BE INCLUDED WITH ITEM 516 - 1" PERFORMED EXPANSION JOINT FILLER.

POROUS BACKFILL WITH GEOTEXTILE FABRIC

THIS ITEM SHALL BE PLACED 1'-6" THICK BEHIND THE WINGWALLS ONLY AND SHALL EXTEND TO 12" BELOW THE EMBANKMENT SURFACE. GEOTEXTILE FABRIC TYPE A SHALL BE PLACED BETWEEN THE POROUS BACKFILL AND REPLACED EXCAVATION ADJACENT TO THE STRUCTURE. IT SHALL TURN UNDER THE BOTTOM OF THE POROUS BACKFILL AND RETURN 6" ABOVE THE TOP ELEVATION OF THE WEEPHOLE.

WEEPHOLES SHALL BE PLACED 6" TO 12" ABOVE THE NORMAL WATER ELEVATION OR GROUND LINE AND SHALL HAVE A MAXIMUM SPACING OF 10'-0". A MINIMUM OF ONE WEEPHOLE SHALL BE PROVIDED PER WINGWALL.

ITEM 611 - 12' X 4' CONDUIT, TYPE A, 706.05, AS PER PLAN

THIS ITEM SHALL CONSIST OF PRECAST REINFORCED CONCRETE BOX SECTIONS WITH INTERIOR DIMENSIONS OF A 12' SPAN AND A 4' RISE. ALL OTHER REQUIREMENTS OF CMS SECTION 611 SHALL STILL BE APPLICABLE.

STRUCTURAL BACKFILL TYPE 1 THAT MEETS THE GRADATIONS OF ITEM 304 SHALL BE PLACED AS SHOWN IN THE DETAIL BELOW. QUANTITY SHALL BE BASED ON A TRENCH LENGTH OF 34 FEET, WHICH IS THE APPROXIMATE LENGTH OF THE PAVEMENT PLUS 4 FEET OF ADDITIONAL LENGTH PER SIDE, MEASURED ALONG THE CENTERLINE OF THE CULVERT. PAYMENT FOR STRUCTURAL BACKFILL TYPE 1 AND THE EXCAVATION REQUIRED FOR THE PLACEMENT OF THE STRUCTURAL BACKFILL SHALL BE INCLUDED IN ITEM 611 FOR PAYMENT.

ALL LABOR, TOOLS, MATERIALS, AND INCIDENTALS REQUIRED TO PROVIDE AND PLACE THE PROPOSED CULVERT SECTIONS SHALL BE INCLUDED IN THE CONTRACT PRICE BID FOR ITEM 611, 12' X 4' CONDUIT, TYPE A, 706.05, AS PER PLAN.

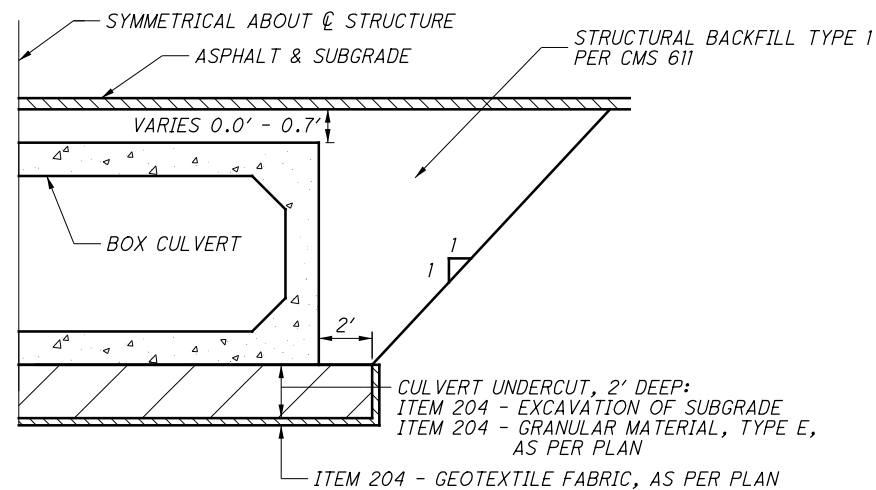

FORESLOPE WALL ANCHOR DOWELS

ANCHOR PER CMS 510 WITH NONSHRINK, NON-METALLIC GROUT CONFORMING TO CMS 705.20 AND TO A DEPTH SPECIFIED ON SHEETS 12/14 AND 13/14. PAYMENT FOR DOWEL HOLES, GROUT AND INSTALLATION SHALL BE INCLUDED WITH ITEM 511.

THREADED INSERTS OR NON-PROTRUDING MECHANICAL CONNECTORS CAPABLE OF DEVELOPING AT LEAST 125 PERCENT OF THE SPECIFIED YIELD STRENGTH OF THE REINFORCEMENT SHOWN ARE AN ACCEPTABLE ALTERNATIVE TO RESIN BONDING. MAINTAIN A MINIMUM COVER OF 3 INCHES AT THE BOTTOM OF THE CULVERT SLAB. MECHANICAL CONNECTORS SHALL HAVE AN "L-SHAPED" BAR INSIDE THE CULVERT WITH A MINIMUM HORIZONTAL LENGTH OF 12 INCHES. THE DEPARTMENT WILL CONSIDER PAYMENT FOR INSERTS OR MECHANICAL CONNECTORS AS INCIDENTAL TO ITEM 611.

SEALING OF FORESLOPE WALL AND WINGWALLS

ALL EXPOSED FORESLOPE WALL AND WINGWALL CONCRETE SHALL BE SEALED WITH EPOXY-URETHANE SEALER. THE LIMITS SHALL BE AS SHOWN IN THE DIAGRAMS BELOW. PAYMENT FOR THE EPOXY-URETHANE SEALER SHALL BE PER ITEM 512 - SEALING OF CONCRETE SURFACES.

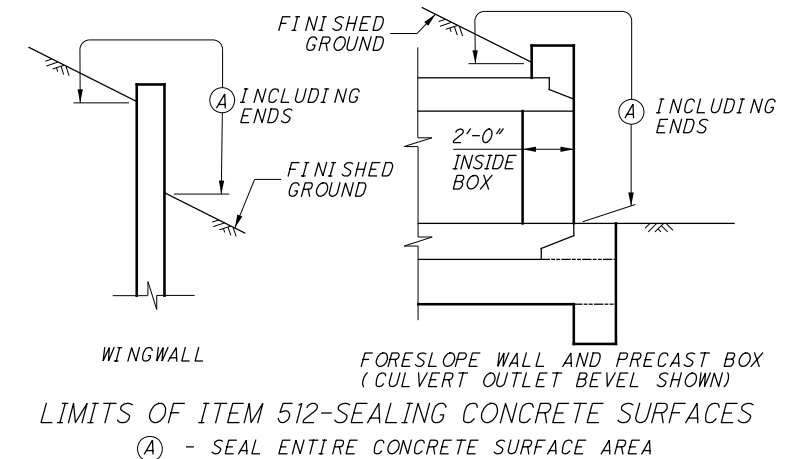

WATERPROOFING

TYPE 2 WATERPROOFING, PER CMS 512.09 AND 711.25, SHALL EXTEND VERTICALLY DOWN THE ENTIRE SIDES OF THE PRECAST CULVERT SECTIONS FOR ALL PORTIONS OF THE CULVERT WHICH SHALL BE IN CONTACT WITH THE BACKFILL. PAYMENT FOR THE MEMBRANE WATERPROOFING SHALL BE AT THE CONTRACT PRICE BID PER SQUARE YARD FOR ITEM 512 - TYPE 2 WATERPROOFING.

TYPE 3 WATER-PROOFING, PER CMS 512.10 AND 711.29 SHALL BE APPLIED TO THE ENTIRE TOP SURFACE OF THE PRECAST CULVERT SECTIONS AND SHALL EXTEND ONE FOOT VERTICALLY DOWN THE SIDES FOR ALL PORTIONS OF THE CULVERT WHICH SHALL BE IN CONTACT WITH THE BACKFILL. PAYMENT FOR THE MEMBRANE WATERPROOFING SHALL BE AT THE CONTRACT PRICE BID PER SQUARE YARD FOR ITEM 512 - TYPE 3 WATERPROOFING.

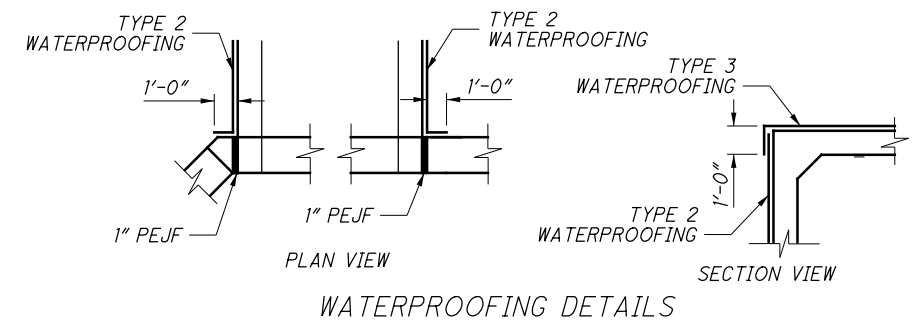



STRUCTURE CLI-28-0452 ESTIMATED QUANTITIES (CARRIED TO GENERAL SUMMARY)			
ITEM	QUANTITY	UNIT	DESCRIPTION
202	LUMP		STRUCTURE REMOVED
204	83	CU. YD.	EXCAVATION OF SUBGRADE
204	83	CU. YD.	GRANULAR MATERIAL, TYPE E, AS PER PLAN
204	152	SQ. YD.	GEOTEXTILE FABRIC, AS PER PLAN
503	LUMP		COFFERDAMS AND EXCAVATION BRACING
503	LUMP		UNCLASSIFIED EXCAVATION
509	3297	LB.	EPOXY COATED REINFORCING STEEL
511	8	CU. YD.	CLASS QC1 CONCRETE, RETAINING/WINGWALL NOT INCLUDING FOOTING, AS PER PLAN
511	29	CU. YD.	CLASS QC1 CONCRETE, FOOTING
511	1	CU. YD.	CLASS QC1 CONCRETE, HEADWALL
512	46	SQ. YD.	SEALING OF CONCRETE SURFACES (EPOXY-URETHANE)
512	85	SQ. YD.	TYPE 2 WATERPROOFING
512	110	SQ. YD.	TYPE 3 WATERPROOFING
516	27	SQ. FT.	1" PERFORMED EXPANSION JOINT FILLER
518	LUMP		POROUS BACKFILL WITH GEOTEXTILE FABRIC
611	62	FT.	12' x 4' CONDUIT, TYPE A, 706.05, AS PER PLAN, DESIGN EARTH COVER 2' (CLI-28-0452)

DESIGN AGENCY: Environmental Design Group
 DATE: 9/2020
 REVIEWED: BUB
 DRAWN: RMS
 CHECKED: SAC
 DESIGNED: BUB
 STRUCTURE FILE NUMBER: 1400363
 STRUCURE NOTES AND ESTIMATED QUANTITIES
 CLI-28-4.52
 UNNAMED TRIBUTARY TO SECOND CREEK
 CLI-28/124-4.52/0.54
 PID No. 102731
 10/14
 21/53

E:\ODOT\ProjectData\008\02731\CLI-28 & 124\Design\Drainage\Sheets\02731-DD00A.dgn Sheet 9/30/2020 3:46:11 PM scook

LEGEND

-  LIMITS OF MILLING AND FILLING STA 288+35.00 TO EXISTING BUTT JOINT (APPROXIMATE STA 289+07.00)
 -  FULL DEPTH PAVEMENT REPLACEMENT AND REPLACEMENT OF CURB & GUTTER. PAVEMENT TO BE AS SHOWN FOR S.R. 28 ON SHEET 2.
 -  LIMITS OF CULVERT REPAIR. SEE SHEET 22 (2/2) FOR MORE INFORMATION.
- OHWM = ORDINARY HIGH WATER MARK

ESTIMATED QUANTITIES

ITEM	QUANTITY	UNIT	DESCRIPTION
202	18	FT	PIPE REMOVED, 24" AND UNDER
202	1	EACH	CATCH BASIN REMOVED
203	93	CU. YD.	EXCAVATION (CULVERT BOTTOM)
204	93	CU. YD.	GRANULAR MATERIAL, TYPE E, AS PER PLAN
503	LUMP		COFFERDAMS AND EXCAVATION BRACING
512	61	SQ. YD.	SEALING OF CONCRETE SURFACES (EPOXY-URETHANE)
512	100	FT	CONCRETE REPAIR BY EPOXY INJECTION
519	520	SQ. FT.	PATCHING OF CONCRETE STRUCTURE, AS PER PLAN
611	18	FT	12" CONDUIT, TYPE C
611	1	EACH	CATCH BASIN, NO. 3A
642	0.03	MILE	EDGE LINE, 6", TYPE 1
642	0.01	MILE	CENTER LINE, TYPE 1
642	38	FT	STOP LINE, TYPE 1
843	17	SQ. FT.	PATCHING OF CONCRETE STRUCTURES WITH TROWELABLE MORTAR
SPECIAL	40	LB.	FIELD INJECTION OF EXISTING PIPE JOINTS WITH HIGH DENSITY POLYURETHANE FOAM

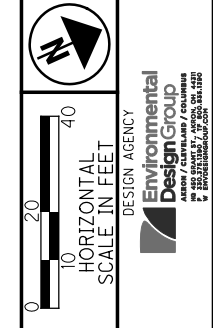

DESIGN AGENCY
Environmental Design Group
 1400398

REVIEWED DATE 9/2020
 BUB STRUCTURE FILE NUMBER 1400398

DRAWN RMS
 SAC CHECKED BUB

DESIGNED DATE 9/2020
 SAC CHECKED BUB

PROJECT EARTH DISTURBED AREA: 0.03 ACRES
 ESTIMATED CONTRACTOR EARTH DISTURBED AREA: 0.06 ACRES
 NOTICE OF INTENT EARTH DISTURBED AREA: NO NOI REQUIRED

EXISTING STRUCTURE
 TYPE: REINFORCED CONCRETE BOX
 SIZE: 14'W x 7'H
 LENGTH: 180'
 SKEW: 30° LEFT FORWARD
 ALIGNMENT: TANGENT
 DATE BUILT: 1964
 CONDITION: FAIR
 LATITUDE: N39° 18' 39"
 LONGITUDE: W83° 54' 30"

HYDRAULIC DESIGN DATA
 N/A

D-1
 CB-3A
 STA 289+49.50, 16.20' RT (S.R. 28)
 STA 238+62.42, 21.95' RT (U.S. 68)
 GRATE = 989.31
 INV 12" SE = 987.11
 18' - 12" TYPE C @ 2.50%

UNNAMED TRIBUTARY TO WEST FORK EAST FORK LITTLE MIAMI RIVER

CULVERT PLAN AND PROFILE
 CLI-28-5-47

CLI-28/124-4.52/5.47/0.54
 PID No. 102731

1 / 2

26
 53

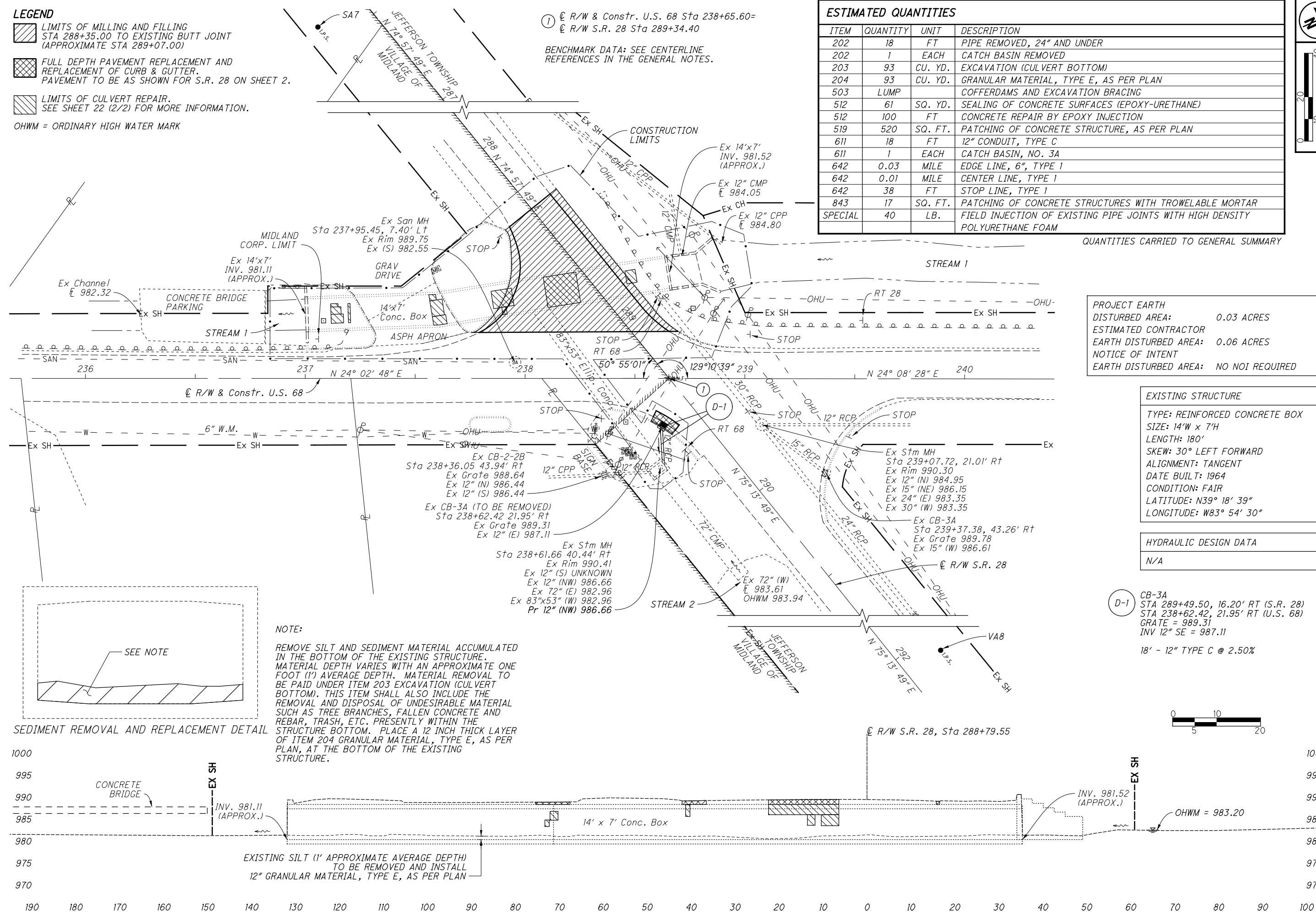

E:\0001\ProjectData\008\102731\CLI-28 & 124\Design\Roadway\Sheets\102731_GPO02.dgn Sheet 9/30/2020 3:46:16 PM scook

GENERAL NOTES

EXISTING STRUCTURE VERIFICATION

DETAILS AND DIMENSIONS SHOWN ON THESE PROPOSED PLANS PERTAINING TO THE EXISTING STRUCTURE HAVE BEEN OBTAINED FROM PLANS OF THE EXISTING STRUCTURE AND FROM FIELD OBSERVATIONS AND MEASUREMENTS. CONSEQUENTLY, SUCH DETAILS AND DIMENSIONS ARE INDICATIVE OF THE EXISTING STRUCTURE AND THE PROPOSED WORK, BUT THEY SHALL BE CONSIDERED TENTATIVE AND APPROXIMATE. THE CONTRACTOR IS REFERRED TO CMS SECTIONS 102.05, 105.02 AND 513.04. BASE THE CONTRACT BID PRICES UPON A RECOGNITION OF THE UNCERTAINTIES DESCRIBED ABOVE AND UPON A PREBID EXAMINATION OF THE EXISTING STRUCTURE. HOWEVER, THE DEPARTMENT WILL PAY FOR ALL PROJECT WORK BASED UPON ACTUAL DETAILS AND DIMENSIONS THAT HAVE BEEN VERIFIED IN THE FIELD.

DESIGN SPECIFICATIONS

THIS STANDARD DRAWING CONFORMS TO THE "LRFD BRIDGE DESIGN SPECIFICATIONS" ADOPTED BY THE AMERICAN ASSOCIATION OF STATE HIGHWAY AND TRANSPORTATION OFFICIALS, 2014, INCLUDING THE 2015 & 2016 INTERIM SPECIFICATIONS AND THE ODOT BRIDGE DESIGN MANUAL, 2007.

DESIGN DATA

THE FOLLOWING DESIGN DATA IS ASSUMED:

INTERNAL ANGLE OF FRICTION OF BACKFILL SOIL: $\phi = 30^\circ$ (GRANULAR), 18° (COHESIVE)
 TOTAL UNIT WEIGHT OF BACKFILL SOIL = 125 PCF
 INTERNAL ANGLE OF FRICTION (DRAINED), FOUNDATION SOIL, $\phi = 27^\circ$
 UNDRAINED SHEAR STRENGTH (COHESIVE), FOUNDATION SOIL, $S = 4000$ PSF
 UNIT WEIGHT OF CONCRETE = 150 PCF
 SLOPE OF BACKFILL = 2:1 (TYPE A & B HEADWALLS)
 HEIGHT OF LIVE LOAD SURCHARGE = 2 FT (TYPE C HEADWALLS)

CONCRETE CLASS QC1 - COMPRESSIVE STRENGTH 4000 PSI
 (FOOTING, WINGWALL AND FORESLOPE WALL)

REINFORCING STEEL - ASTM A615, A616, OR A617
 GRADE 60 MINIMUM YIELD STRENGTH
 60,000 PSI (ALL REINFORCING SHALL BE EPOXY COATED)

ITEM 202 - STRUCTURE REMOVED

THIS LUMP SUM PAY ITEM INCLUDES THE REMOVAL OF THE EXISTING CULVERT AND ALL EXISTING HEADWALLS, WINGWALLS, AND FOOTINGS.

PRECAST CONCRETE

OUTLET WINGWALL #2 SHALL BE CAST-IN-PLACE AND NOT CONSTRUCTED WITH PRECAST CONCRETE.

ITEM 511 - CLASS QC1 CONCRETE, RETAINING/WINGWALL NOT INCLUDING FOOTING, AS PER PLAN:

UNLESS THE PRECAST HEADWALL/WINGWALL SYSTEM IS ON THE APPROVED PRODUCTS LIST, THE DEPARTMENT WILL NOT PERMIT THE USE OF PRECAST HEADWALLS OR WINGWALLS. IF THE SYSTEM IS ON THE APPROVED PRODUCTS LIST, THEN THE FOLLOWING IS APPLICABLE (EXCEPT FOR OUTLET WINGWALL #2):

THE DEPARTMENT WILL PERMIT THE USE OF PRECAST CONCRETE IN LIEU OF CAST-IN-PLACE CONCRETE FOR HEADWALLS AND WINGWALLS IN ACCORDANCE WITH C&MS 602.03. THE DEPARTMENT WILL PAY FOR THE WINGWALL AND HEADWALL CONCRETE IN SQUARE YARD AS DETERMINED FROM PLAN DIMENSIONS USING THE WALL HEIGHTS ABOVE THE FOOTING AND LENGTH ALONG THE EXTERIOR FACES OF THE WALLS. THE DEPARTMENT WILL CONSIDER THE REINFORCING STEEL IN THE WINGWALLS AND HEADWALLS, INCLUDING THE REINFORCEMENT THAT EXTENDS INTO THE FOOTINGS, AS INCIDENTAL TO THE RETAINING/WINGWALL CONCRETE. THE TOTAL QUANTITY OF CAST-IN-PLACE WINGWALL AND HEADWALL CONCRETE IS 6 CU YD. THE TOTAL QUANTITY OF CAST-IN-PLACE WINGWALL AND HEADWALL REINFORCING STEEL IS 676 LBS.

FOUNDATION BEARING RESISTANCE

HEADWALL AND WINGWALL FOOTINGS, AS DESIGNED, PRODUCE A MAXIMUM SERVICE LOAD PRESSURE OF 4.0 KIPS PER SQUARE FOOT AND A MAXIMUM STRENGTH LOAD PRESSURE OF 22.4 KIPS PER SQUARE FOOT. THE FACTORED BEARING RESISTANCE IS 4.0 KIPS PER SQUARE FOOT

PREFORMED EXPANSION JOINT FILLER

PREFORMED EXPANSION JOINT FILLER (PEJF) CONFORMING TO CMS 705.03, 1 INCH THICK, SHALL BE PLACED ABOVE THE FOOTING BETWEEN THE SIDES OF THE BOX CULVERT AND THE ENDS OF THE WINGWALLS. PAYMENT FOR MATERIALS AND INSTALLATION SHALL BE INCLUDED WITH ITEM 516 - 1" PREFORMED EXPANSION JOINT FILLER.

POROUS BACKFILL WITH GEOTEXTILE FABRIC

THIS ITEM SHALL BE PLACED 1'-6" THICK BEHIND THE WINGWALLS ONLY AND SHALL EXTEND TO 12" BELOW THE EMBANKMENT SURFACE. GEOTEXTILE FABRIC TYPE A SHALL BE PLACED BETWEEN THE POROUS BACKFILL AND REPLACED EXCAVATION ADJACENT TO THE STRUCTURE. IT SHALL TURN UNDER THE BOTTOM OF THE POROUS BACKFILL AND RETURN 6" ABOVE THE TOP ELEVATION OF THE WEEPHOLE.

WEEPHOLES SHALL BE PLACED 6" TO 12" ABOVE THE NORMAL WATER ELEVATION OR GROUND LINE AND SHALL HAVE A MAXIMUM SPACING OF 10'-0". A MINIMUM OF ONE WEEPHOLE SHALL BE PROVIDED PER WINGWALL.

ITEM 611 - 12' X 4' CONDUIT, TYPE A, 706.05, AS PER PLAN

THIS ITEM SHALL CONSIST OF PRECAST REINFORCED CONCRETE BOX SECTIONS WITH INTERIOR DIMENSIONS OF A 12' SPAN AND A 4' RISE. ALL OTHER REQUIREMENTS OF CMS SECTION 611 SHALL STILL BE APPLICABLE.

STRUCTURAL BACKFILL TYPE 1 THAT MEETS THE GRADATIONS OF ITEM 304 SHALL BE PLACED AS SHOWN IN THE DETAIL BELOW. QUANTITY SHALL BE BASED ON A TRENCH LENGTH OF 30 FEET, WHICH IS THE APPROXIMATE LENGTH OF THE PAVEMENT PLUS 4 FEET OF ADDITIONAL LENGTH PER SIDE, MEASURED ALONG THE CENTERLINE OF THE CULVERT. PAYMENT FOR STRUCTURAL BACKFILL TYPE 1 AND THE EXCAVATION REQUIRED FOR THE PLACEMENT OF THE STRUCTURAL BACKFILL SHALL BE INCLUDED IN ITEM 611 FOR PAYMENT.

ALL LABOR, TOOLS, MATERIALS, AND INCIDENTALS REQUIRED TO PROVIDE AND PLACE THE PROPOSED CULVERT SECTIONS SHALL BE INCLUDED IN THE CONTRACT PRICE BID FOR ITEM 611, 12' X 4' CONDUIT, TYPE A, 706.05, AS PER PLAN.

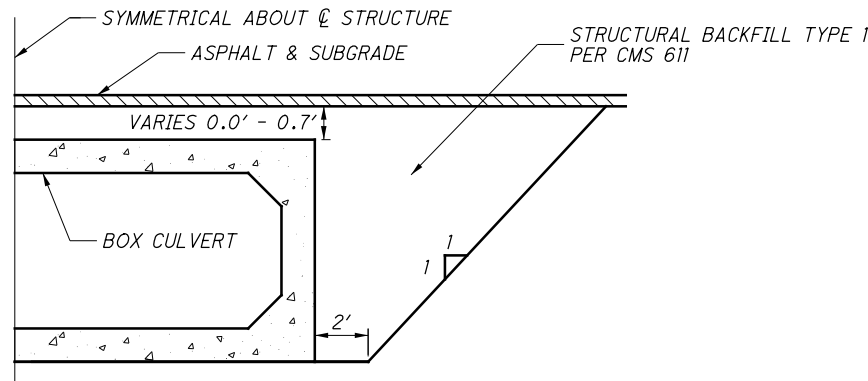

FORESLOPE WALL ANCHOR DOWELS

ANCHOR PER CMS 510 WITH NONSHRINK, NON-METALLIC GROUT CONFORMING TO CMS 705.20 AND TO A DEPTH SPECIFIED ON SHEETS 8/10 AND 9/10. PAYMENT FOR DOWEL HOLES, GROUT AND INSTALLATION SHALL BE INCLUDED WITH ITEM 511.

THREADED INSERTS OR NON-PROTRUDING MECHANICAL CONNECTORS CAPABLE OF DEVELOPING AT LEAST 125 PERCENT OF THE SPECIFIED YIELD STRENGTH OF THE REINFORCEMENT SHOWN ARE AN ACCEPTABLE ALTERNATIVE TO RESIN BONDING. MAINTAIN A MINIMUM COVER OF 3 INCHES AT THE BOTTOM OF THE CULVERT SLAB. MECHANICAL CONNECTORS SHALL HAVE AN "L-SHAPED" BAR INSIDE THE CULVERT WITH A MINIMUM HORIZONTAL LENGTH OF 12 INCHES. THE DEPARTMENT WILL CONSIDER PAYMENT FOR INSERTS OR MECHANICAL CONNECTORS AS INCIDENTAL TO ITEM 611.

SEALING OF FORESLOPE WALL AND WINGWALLS

ALL EXPOSED FORESLOPE WALL AND WINGWALL CONCRETE SHALL BE SEALED WITH EPOXY-URETHANE SEALER. THE LIMITS SHALL BE AS SHOWN IN THE DIAGRAMS BELOW. PAYMENT FOR THE EPOXY-URETHANE SEALER SHALL BE PER ITEM 512 - SEALING OF CONCRETE SURFACES.

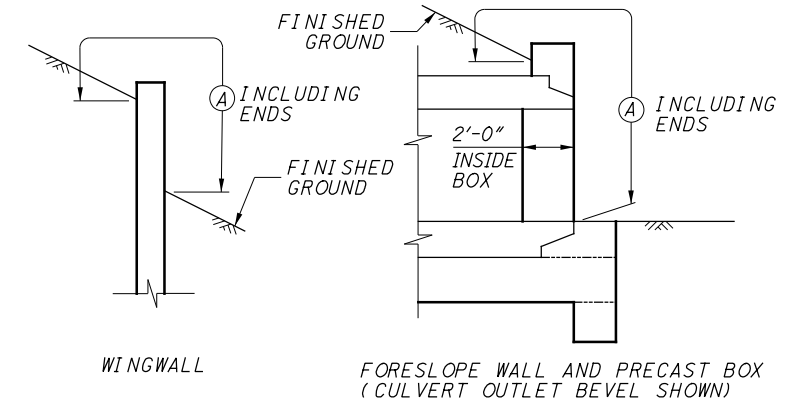

LIMITS OF ITEM 512-SEALING CONCRETE SURFACES

(A) - SEAL ENTIRE CONCRETE SURFACE AREA

WATERPROOFING

TYPE 2 WATERPROOFING, PER CMS 512.09 AND 711.25, SHALL EXTEND VERTICALLY DOWN THE ENTIRE SIDES OF THE PRECAST CULVERT SECTIONS FOR ALL PORTIONS OF THE CULVERT WHICH SHALL BE IN CONTACT WITH THE BACKFILL. PAYMENT FOR THE MEMBRANE WATERPROOFING SHALL BE AT THE CONTRACT PRICE BID PER SQUARE YARD FOR ITEM 512 - TYPE 2 WATERPROOFING.

TYPE 3 WATERPROOFING, PER CMS 512.10 AND 711.29 SHALL BE APPLIED TO THE ENTIRE TOP SURFACE OF THE PRECAST CULVERT SECTIONS AND SHALL EXTEND ONE FOOT VERTICALLY DOWN THE SIDES FOR ALL PORTIONS OF THE CULVERT WHICH SHALL BE IN CONTACT WITH THE BACKFILL. PAYMENT FOR THE MEMBRANE WATERPROOFING SHALL BE AT THE CONTRACT PRICE BID PER SQUARE YARD FOR ITEM 512 - TYPE 3 WATERPROOFING.

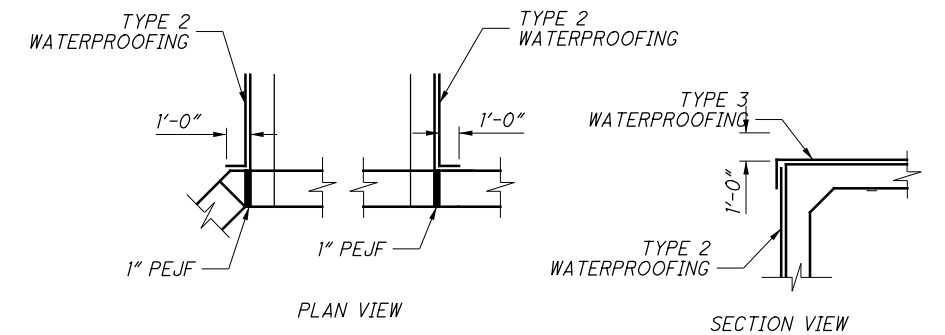

WATERPROOFING DETAILS

STRUCTURE CLI-124-0054 ESTIMATED QUANTITIES (CARRIED TO GENERAL SUMMARY)			
ITEM	QUANTITY	UNIT	DESCRIPTION
202	LUMP		STRUCTURE REMOVED
503	LUMP		COFFERDAMS AND EXCAVATION BRACING
503	LUMP		UNCLASSIFIED EXCAVATION
509	3270	LB.	EPOXY COATED REINFORCING STEEL
511	7	CU. YD.	CLASS QC1 CONCRETE, RETAINING/WINGWALL NOT INCLUDING FOOTING, AS PER PLAN
511	29	CU. YD.	CLASS QC1 CONCRETE, FOOTING
511	1	CU. YD.	CLASS QC1 CONCRETE, HEADWALL
512	47	SQ. YD.	SEALING OF CONCRETE SURFACES (EPOXY-URETHANE)
512	101	SQ. YD.	TYPE 2 WATERPROOFING
512	132	SQ. YD.	TYPE 3 WATERPROOFING
516	28	SQ. FT.	1" PREFORMED EXPANSION JOINT FILLER
518	LUMP		POROUS BACKFILL WITH GEOTEXTILE FABRIC
611	74	FT.	12' x 4' CONDUIT, TYPE A, 706.05, AS PER PLAN, DESIGN EARTH COVER 2' (CLI-124-0054)

DESIGN AGENCY: Environmental Design Group
 DATE: 9/2020
 REVIEWED: BJB
 DRAWN: RMS
 DESIGNED: SAC
 CHECKED: BJB
 STRUCTURE FILE NUMBER: 1402528
 STRUCTURE NOTES AND ESTIMATED QUANTITIES
 CLI-124-0.54
 UNNAMED TRIBUTARY TO EAST FORK LITTLE MIAMI RIVER
 CLI-28/124-4.52/5.47/0.54
 PID No. 102731
 6/10
 33/53

E:\ODOT\Project\08\02731\CL1-28 & 124\Design\Drawings\02731-DD003A.dgn Sheet 9/30/2020 3:46:22 PM scook