

DETAIL A

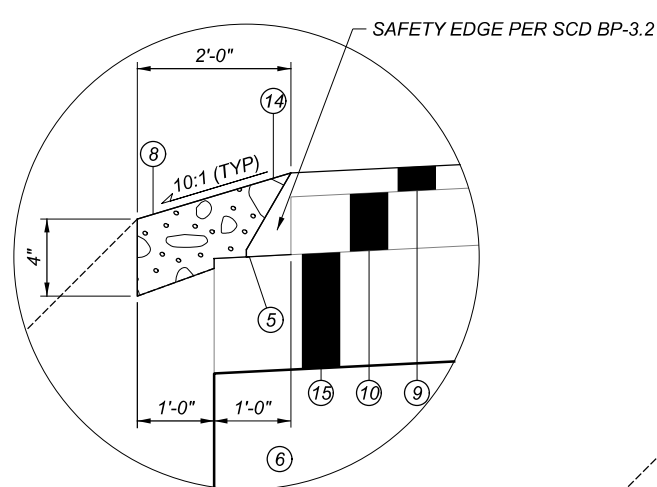

DETAIL B

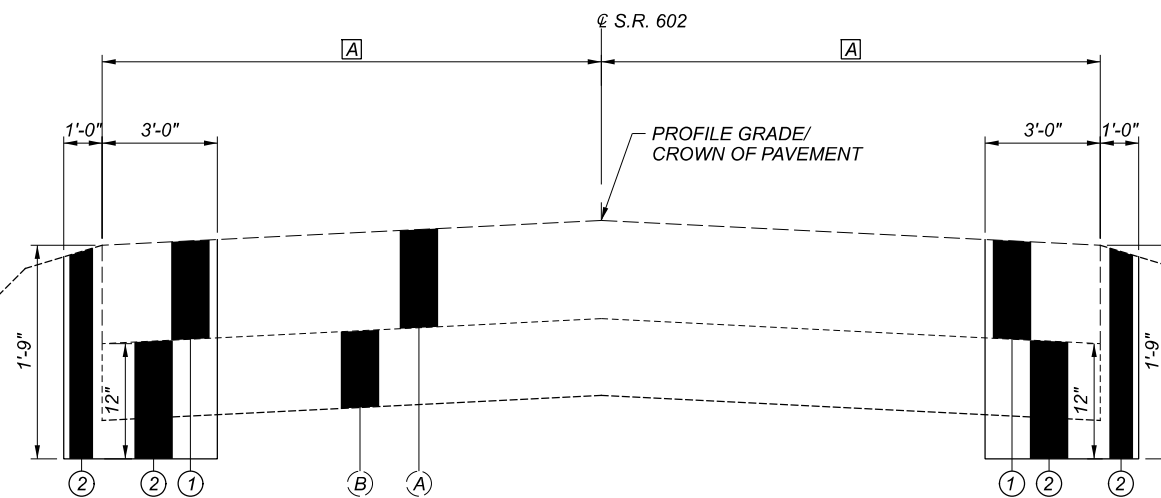

EXCAVATION TYPICAL SECTION

APPLIES TO: CRA-602-4.25 TO 13.64
APPROACH SLABS NOT SHOWN FOR CLARITY

[A] VARIES FROM 12'-6" TO 20'-0"
[B] VARIES FROM 13'-0" TO 20'-0";
SEE PAVEMENT AND SHOULDER
DATA SHEET

GUARDRAIL NOT SHOWN FOR CLARITY;
SEE GUARDRAIL DETAIL SHEETS

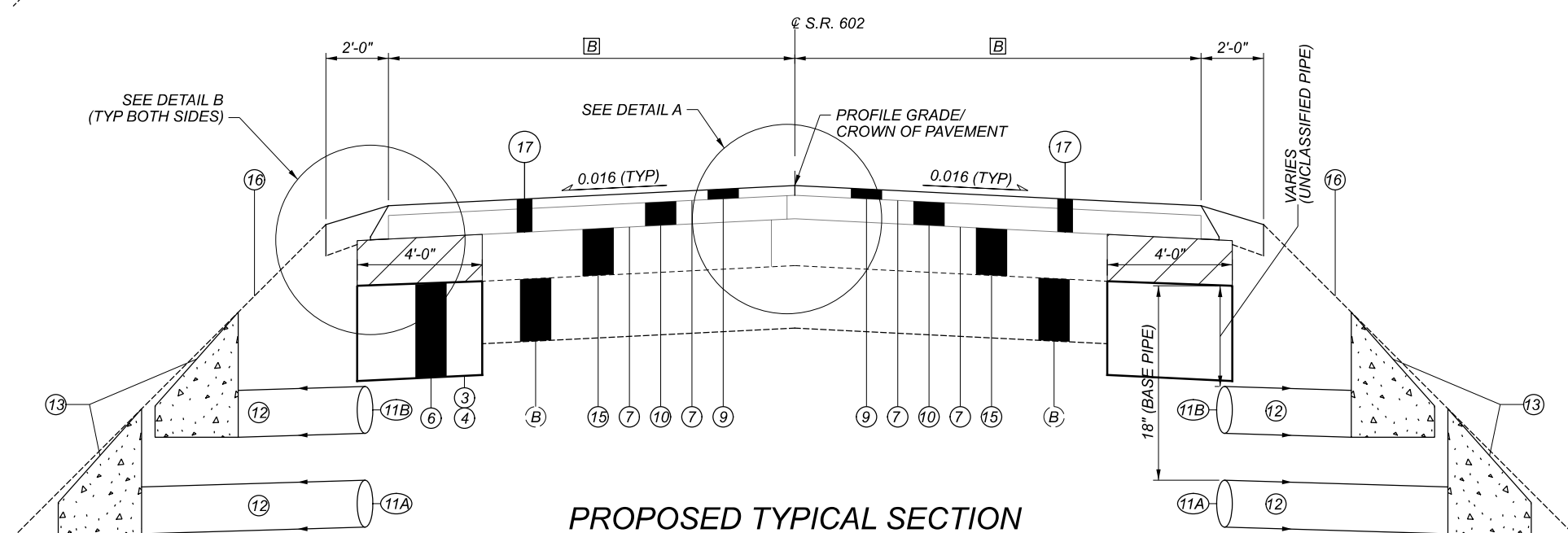

PROPOSED TYPICAL SECTION

APPLIES TO: CRA-602-4.25 TO 5.98
CRA-602-6.02 TO 9.49
CRA-602-9.51 TO 13.64

PROPOSED LEGEND

- ① ITEM 202 - PAVEMENT REMOVED (10.25"±)
- ② ITEM 203 - EXCAVATION (12" - 21" DEEP)
- ③ ITEM 204 - SUBGRADE COMPACTION
- ④ ITEM 204 - GEOGRID
- ⑤ ITEM 209 - PREPARING SUBGRADE FOR SHOULDER PAVING
- ⑥ ITEM 304 - AGGREGATE BASE (12" THICK)
- ⑦ ITEM 407 - TACK COAT (0.06 GAL/SY)
- ⑧ ITEM 408 - PRIME COAT, AS PER PLAN
- ⑨ ITEM 442 ASPHALT CONCRETE SURFACE COURSE, 9.5MM, TYPE A, (446), AS PER PLAN, PG64-22 (1.25")
- ⑩ ITEM 442 ASPHALT CONCRETE INTERMEDIATE COURSE, 19MM, TYPE A, (446), AS PER PLAN, PG64-22 (3.00")
- ⑪A ITEM 605 - 6" BASE PIPE UNDERDRAINS (SEE UNDERDRAIN DATA SHEET FOR LOCATIONS)
- ⑪B ITEM 605 - 6" UNCLASSIFIED PIPE UNDERDRAINS
- ⑫ ITEM 611 - 6" CONDUIT, TYPE F FOR UNDERDRAIN OUTLETS
- ⑬ ITEM 611 - PRECAST REINFORCED CONCRETE OUTLET
- ⑭ ITEM 617 - COMPACTED AGGREGATE (4.00" THICK)
- ⑮ ITEM 690 - SPECIAL - FULL DEPTH RECLAIMED BASE COURSE, 6.00 INCHES DEEP
- ITEM 690 - SPECIAL - EMULSIFIED ASPHALT
- ITEM 690 - SPECIAL - ADDITIONAL ADDITIVES (CEMENT, FLY ASH, LIME)
- ITEM 690 - SPECIAL - CORRECTIVE AGGREGATE FOR FDR (FINE, COARSE OR RAP)
- ITEM 690 - SPECIAL - MIXTURE DESIGN FOR FULL DEPTH RECLAIMED BASE COURSE
- ⑯ ITEM 209 - LINEAR GRADING (6' AVERAGE WIDTH)
- ⑰ ITEM 202 - PAVEMENT REMOVED, AS PER PLAN (4.25" THICK),
6" THICK ASPHALT CONCRETE GRINDINGS RETAINED FROM ITEM 202 - PAVEMENT REMOVED AS PER PLAN (4.25" THICK),
TO BE INCORPORATED INTO ITEM 690 - FULL DEPTH RECLAIMED BASE COURSE, 6.00 INCHES DEEP

EXISTING LEGEND

- (A) EXISTING ASPHALT PAVEMENT (10.25"±)
- (B) EXISTING MACADAM BASE (8.00"±)
- (C) EXISTING APPROACH SLAB (13.00"±)

VERTICAL DIMENSIONS SHOWN ON THIS SHEET EXAGGERATED BY A FACTOR OF 3.

TYPICAL SECTIONS

DESIGN AGENCY
DISTRICT 3

ENGINEERING
TEAM FOUR

DESIGNER
JNC

REVIEWER
NRF 12-06-21

PROJECT ID
102939

SHEET TOTAL
3 38

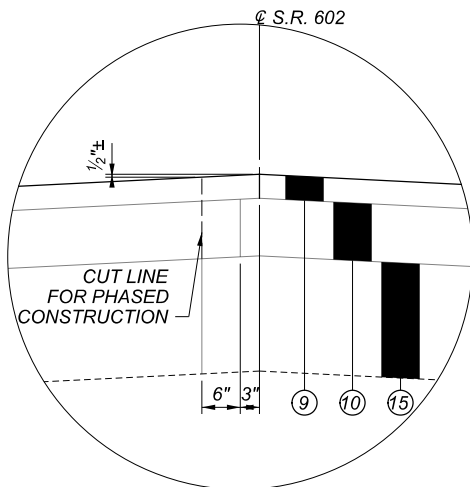

DETAIL A

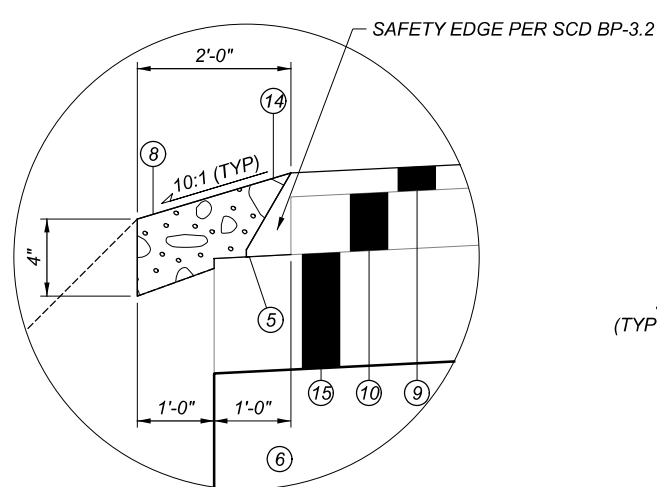

DETAIL B

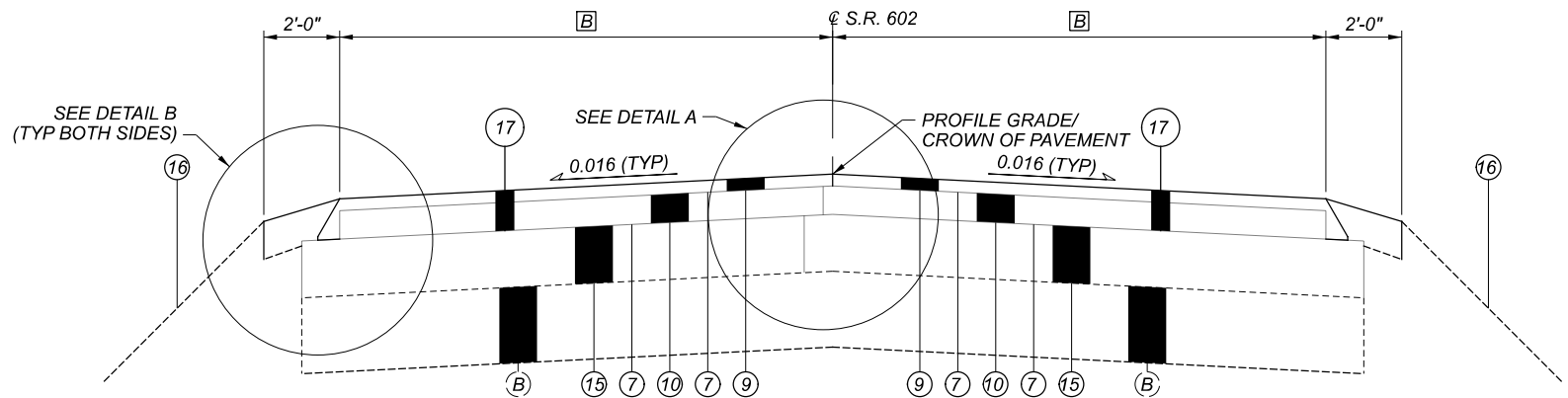

PROPOSED TYPICAL SECTION

APPLIES TO: 10' BEFORE AND AFTER CULVERTS AT THE FOLLOWING LOCATIONS:
 CRA-602-4.36 CRA-602-7.86 CRA-602-4.58 CRA-602-8.24
 CRA-602-4.93 CRA-602-8.43 CRA-602-5.68 CRA-602-8.93
 CRA-602-5.77 CRA-602-9.19 CRA-602-6.26 CRA-602-10.50
 CRA-602-6.74

[A] VARIES FROM 12'-6" TO 20'-0"

[B] VARIES FROM 13'-0" TO 20'-0";
SEE PAVEMENT AND SHOULDER DATA SHEET

GUARDRAIL NOT SHOWN FOR CLARITY;
SEE GUARDRAIL DETAIL SHEETS

PROPOSED LEGEND

- ① ITEM 202 - PAVEMENT REMOVED (10.25"±)
- ② ITEM 203 - EXCAVATION (12" - 21" DEEP)
- ③ ITEM 204 - SUBGRADE COMPACTION
- ④ ITEM 204 - GEOGRID
- ⑤ ITEM 209 - PREPARING SUBGRADE FOR SHOULDER PAVING
- ⑥ ITEM 304 - AGGREGATE BASE (12" THICK)
- ⑦ ITEM 407 - TACK COAT (0.06 GAL/SY)
- ⑧ ITEM 408 - PRIME COAT, AS PER PLAN
- ⑨ ITEM 442 ASPHALT CONCRETE SURFACE COURSE, 9.5MM, TYPE A, (446), AS PER PLAN, PG64-22 (1.25")
- ⑩ ITEM 442 ASPHALT CONCRETE INTERMEDIATE COURSE, 19MM, TYPE A, (446), AS PER PLAN, PG64-22 (3.00")
- ⑪A ITEM 605 - 6" BASE PIPE UNDERDRAINS (SEE UNDERDRAIN DATA SHEET FOR LOCATIONS)
- ⑪B ITEM 605 - 6" UNCLASSIFIED PIPE UNDERDRAINS
- ⑫ ITEM 611 - 6" CONDUIT, TYPE F FOR UNDERDRAIN OUTLETS
- ⑬ ITEM 611 - PRECAST REINFORCED CONCRETE OUTLET
- ⑭ ITEM 617 - COMPACTED AGGREGATE (4.00" THICK)
- ⑮ ITEM 690 - SPECIAL - FULL DEPTH RECLAIMED BASE COURSE, 6.00 INCHES DEEP
- ITEM 690 - SPECIAL - EMULSIFIED ASPHALT
- ITEM 690 - SPECIAL - ADDITIONAL ADDITIVES (CEMENT, FLY ASH, LIME)
- ITEM 690 - SPECIAL - CORRECTIVE AGGREGATE FOR FDR (FINE, COARSE OR RAP)
- ITEM 690 - SPECIAL - MIXTURE DESIGN FOR FULL DEPTH RECLAIMED BASE COURSE
- ⑯ ITEM 209 - LINEAR GRADING (6' AVERAGE WIDTH)
- ⑰ ITEM 202 - PAVEMENT REMOVED, AS PER PLAN (4.25" THICK)

6" THICK ASPHALT CONCRETE GRINDINGS RETAINED FROM ITEM 202 - PAVEMENT REMOVED AS PER PLAN (4.25" THICK), TO BE INCORPORATED INTO ITEM 690 - FULL DEPTH RECLAIMED BASE COURSE, 6.00 INCHES DEEP

EXISTING LEGEND

- (A) EXISTING ASPHALT PAVEMENT (10.25"±)
- (B) EXISTING MACADAM BASE (8.00"±)
- (C) EXISTING APPROACH SLAB (13.00"±)

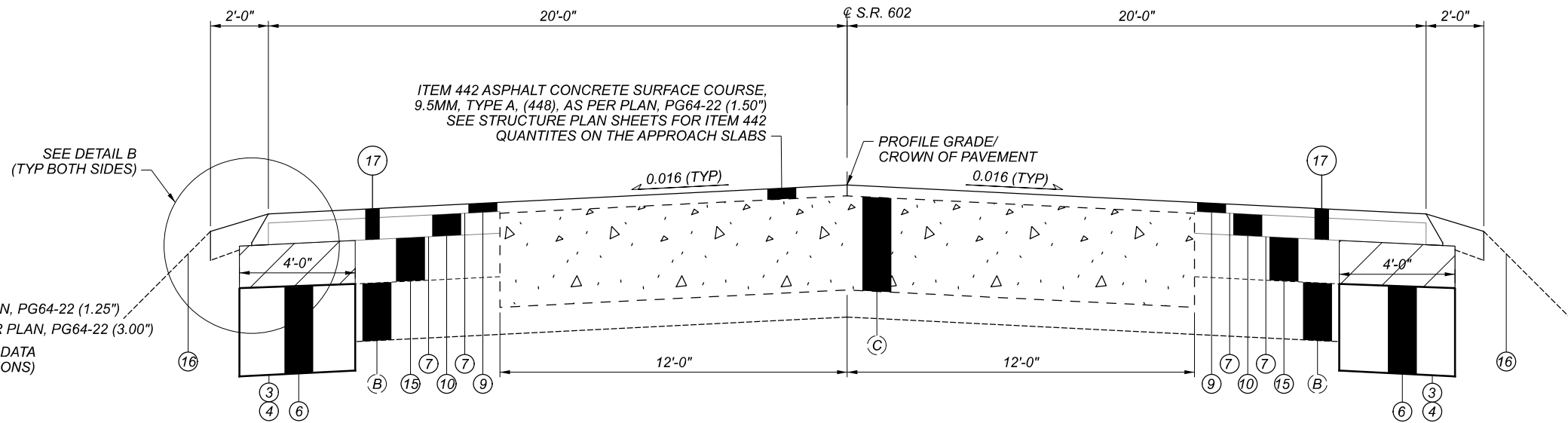

PROPOSED TYPICAL SECTION AT APPROACH SLABS, STRUCTURE CRA-602-0949

APPLIES TO: CRA-602-9.49 (25 FT) CRA-602-9.51 (25 FT)

VERTICAL DIMENSIONS SHOWN ON THIS SHEET EXAGGERATED BY A FACTOR OF 3.

TYPICAL SECTIONS

DESIGN AGENCY	DISTRICT 3
ENGINEERING TEAM FOUR	
DESIGNER	JNC
REVIEWER	NRF
PROJECT ID	102939
SHEET	TOTAL
4	38

UTILITIES

LISTED BELOW ARE ALL UTILITIES LOCATED WITHIN THE PROJECT LIMITS TOGETHER WITH THEIR RESPECTIVE OWNERS:

ELECTRIC AEP OHIO 2552 QUAKER ROAD BUCYRUS, OH 44820 419.563.1509	ELECTRIC NORTH-CENTRAL ELECTRIC CO-OP 13978 E C.R. 56 ATTICA, OH 44807 419.426.3072
GAS COLUMBIA GAS OF OHIO 1021 N. MAIN ST. MANSFIELD, OH 44903 419.528.1137	GAS ASPIRE ENERGY 300 TRACY BRIDGE ROAD ORRVILLE, OH 44667 330.682.7726
GAS ROVER PIPELINE 1300 MAIN STREET HOUSTON, TX 77002 501.322.9622	SEWER CRAWFORD COUNTY ENGINEER 815 WHETSTONE STREET BUCYRUS, OH 44820 419.562.7731
WATER NORTHERN OHIO RURAL WATER P.O. BOX 96 COLLINS, OH 44826 419.668.7213	COMMUNICATION FRONTIER COM 83 TOWNSEND AVENUE NORWALK, OH 44857 419.744.3613
COMMUNICATION LUMEN 175 ASHLAND ROAD, P.O. BOX 3555 MANSFIELD, OH 44907 419.755.7956	CABLE CHARTER COMMUNICATIONS 5520 WHIPPLE AVENUE NW NORTH CANTON, OH 44720 330.494.9200
TRAFFIC ODOT DISTRICT THREE 906 CLARK AVENUE ASHLAND, OH 44805 419.207.7045	

THE AFOREMENTIONED UTILITY COMPANIES AND AGENCIES HAVE VARIOUS FACILITIES IN THE AREA THAT WILL REMAIN IN PLACE DURING CONSTRUCTION.

EXTREME CAUTION SHOULD BE EXERCISED IN AREAS WITH UTILITIES. SECTIONS 105.07 AND 107.16 OF THE DEPARTMENT OF TRANSPORTATION CONSTRUCTION AND MATERIAL SPECIFICATIONS REQUIRE, AMONG OTHER THINGS, THAT THE CONTRACTOR COOPERATE WITH ALL UTILITIES LOCATED WITHIN THE LIMITS OF THIS CONSTRUCTION PROJECT AND TAKE RESPONSIBILITY FOR THE PROTECTION OF THE UTILITY PROPERTY AND SERVICES.

EXISTING PLANS

EXISTING PLANS ENTITLED AS LISTED BELOW MAY BE INSPECTED IN THE ODOT DISTRICT THREE OFFICE IN ASHLAND.

PLAN TITLE	DATE	
CRA-96-(5.00-5.43)	1960	INCLUDES STRUCTURE CRA-602-0600
CRA-602-(9.34)(12.02)(13.21)	1970	
CRA-602-0.00	1991	
CRA-602-6.00	2009	

WORK LIMITS

THE WORK LIMITS SHOWN ON THESE PLANS ARE FOR PHYSICAL CONSTRUCTION ONLY. PROVIDE THE INSTALLATION AND OPERATION OF ALL WORK ZONE TRAFFIC CONTROL AND WORK ZONE TRAFFIC CONTROL DEVICES REQUIRED BY THESE PLANS WHETHER INSIDE OR OUTSIDE THESE WORK LIMITS.

PROGRESSION OF WORK

GUARDRAIL SHALL BE REMOVED PRIOR TO ANY EMBANKMENT WORK AT THE GUARDRAIL RUN. GUARDRAIL WORK SHALL BE DONE AFTER WIDENING, PAVING, AND BERM WORK SO AS TO ESTABLISH PROPER GRADES FROM WHICH TO CONSTRUCT THE RAIL.

ROUTINE MAINTENANCE

BETWEEN THE TIME THAT BIDS ARE TAKEN AND THE START OF CONSTRUCTION, THE MAINTAINING AGENCY MAY ENTER UPON THE PROJECT AND PERFORM ROUTINE MAINTENANCE SUCH AS CRACK SEALING, PATCHING, AND BERM AND SHOULDER REPAIR. THE EFFECTS, IF ANY, OF THE PERFORMANCE OF ROUTINE MAINTENANCE SHALL BE CONSIDERED AS INHERENT IN WORK OF THE CHARACTER PROVIDED FOR IN THE PLAN AND THE RESULTING CONDITIONS SHALL NOT BE CONSIDERED AS DIFFERING MATERIALLY FROM THOSE EXISTING AT THE TIME BIDS WERE TAKEN.

PROFILE AND ALIGNMENT

PLACE THE PROPOSED PAVEMENT TO FOLLOW THE ALIGNMENT AND PROFILE OF THE EXISTING PAVEMENT, WHICH MAY BE FOLLOWED IN THE FIELD DURING PART-WIDTH CONSTRUCTION AS SHOWN IN THE DETAILS ON THE TYPICAL SECTIONS. PLACE THE PROPOSED ASPHALT CONCRETE LIFTS AS SHOWN ON THE TYPICAL SECTIONS.

ENVIRONMENTAL COMMITMENTS

THE PROJECT IS LOCATED WITHIN THE KNOWN HABITAT RANGES OF THE FEDERALLY ENDANGERED NORTHERN LONG-EARED AND INDIANA BAT, AND THE STATE ENDANGERED LITTLE BROWN AND TRICOLORED BATS. NO TREES SHALL BE REMOVED UNDER THIS PROJECT FROM APRIL 1 THROUGH SEPTEMBER 30. ALL NECESSARY TREE REMOVAL SHALL OCCUR FROM OCTOBER 1 THROUGH MARCH 31. THIS REQUIREMENT IS NECESSARY TO AVOID AND MINIMIZE IMPACTS TO THESE SPECIES AS REQUIRED BY THE ENDANGERED SPECIES ACT AND ORC 1531.25. FOR THE PURPOSES OF THIS NOTE, A TREE IS DEFINED AS A LIVE, DYING, OR DEAD WOODY PLANT, WITH A TRUNK THREE INCHES OR GREATER IN DIAMETER AT A HEIGHT OF 4.5 FEET ABOVE THE GROUND SURFACE, AND WITH A MINIMUM HEIGHT OF 13 FEET.

ODOT SHALL COMPLETE ALL FLOODPLAIN COORDINATION PRIOR TO THE START OF CONSTRUCTION.

ODOT WILL OBTAIN AND ADHERE TO ALL APPROPRIATE WATERWAY PERMITS PRIOR TO ANY WORK BELOW THE ORDINARY HIGH WATER MARK OF ANY WATERWAY AND ALL SPECIAL PROVISIONS FOR WATERWAY PERMITS WILL BE INCLUDED IN THE PROJECT PLANS.

ITEM 209 – PREPARING SUBGRADE FOR SHOULDER PAVING

PREPARE THE SHOULDER FOR PAVING A CONSISTENT SAFETY EDGE IN BOTH THICKNESS AND WIDTH.

PRIOR TO PAVING THE SAFETY EDGE, GRADE AN AREA 10 INCHES WIDE, BEGINNING AT THE EDGE OF THE PAVED ROADWAY, TO PROVIDE A LEVEL SURFACE FREE OF VEGETATION FOR CONSTRUCTION OF THE SAFETY EDGE. IF NECESSARY, EXCAVATE THE GRADED AREA TO THE DEPTH NECESSARY TO CONSTRUCT THE SAFETY EDGE. COMPACT THE GRADED SHOULDER ACCORDING TO 617.05 OR AS DIRECTED BY THE ENGINEER. THE GRADED SHOULDER BEYOND THE 10-INCH WIDE AREA FOR THE SAFETY EDGE SHALL BE GRADED AT A 10:1 SLOPE, OR AS DIRECTED BY THE ENGINEER. THE INTENT IS TO PROVIDE AN UNOBSTRUCTED AND POSITIVE FLOW OF STORM WATER FROM THE PAVEMENT TO THE DITCH.

SAFETY EDGE

IN ADDITION TO THE REQUIREMENTS OF 401.12, ATTACH A DEVICE TO THE SCREED OF THE PAVER THAT CONFINES THE MATERIAL AT THE END GATE AND EXTRUDES THE ASPHALT MATERIAL IN SUCH A WAY THAT RESULTS IN A COMPACTED WEDGE SHAPE PAVEMENT EDGE OF APPROXIMATELY 30 DEGREES (NOT STEEPER THAN 40 DEGREES). ENSURE THE DEVICE MAINTAINS CONTACT WITH THE EXISTING SURFACE, AND ALLOW FOR AUTOMATIC TRANSITION TO CROSS ROADS, DRIVEWAYS AND OBSTRUCTIONS. DO NOT USE CONVENTIONAL SINGLE PLATE STRIKE OFF.

CONSTRUCTION OF SAFETY EDGE CAN BE OMITTED AT LOCATIONS WHERE EXISTING WIDTH OF GRADED SHOULDER OR BERM IS LESS THAN 12". PROJECTS WITH VARYING CONDITIONS SHOULD USE SAFETY EDGE WHERE POSSIBLE. PLAN PREPARATION HAS MADE EVERY REASONABLE ATTEMPT TO IDENTIFY POSSIBLE SAFETY EDGE LOCATIONS.

USE THE TRANSTECH SHOULDER WEDGE MAKER, THE CARLSON SAFETY EDGE END GATE, THE ADVANT-EDGER, THE TROXLER SAFESLOPE OR A SIMILAR APPROVED-EQUAL DEVICE THAT PRODUCES THE SAME WEDGE CONSOLIDATION RESULTS. CONTACT INFORMATION FOR THESE WEDGE SHAPE COMPACTION DEVICES IS THE FOLLOWING:

TRANSTECH SYSTEMS, INC. 1594 STATE STREET SCHENECTADY, NY 12304 1-800-724-6306 www.transtechsys.com	ADVANT-EDGE PAVING EQUIPMENT LLC P.O. BOX 9163 NISKAYUNA, NY 12309-0163 518-280-6090 www.advantedgepaving.com
CARLSON SAFETY EDGE END GATE 18450 50TH AVENUE EAST TACOMA, WA 98446 253-875-8000	TROXLER ELECTRONICS LABORATORIES INC. 3008 E. CORNWALLIS RD. RESEARCH TRIANGLE PARK, NC 27709 1-877-TROXLER www.troxlerlabs.com

IF ELECTING TO USE A SIMILAR DEVICE, PROVIDE PROOF THAT THE DEVICE HAS BEEN USED ON PREVIOUS PROJECTS WITH ACCEPTABLE RESULTS OR CONSTRUCT A TEST SECTION PRIOR TO THE BEGINNING OF WORK AND DEMONSTRATE WEDGE COMPACTION TO THE SATISFACTION OF THE ENGINEER. SHORT SECTIONS OF HANDWORK WILL BE ALLOWED WHEN NECESSARY FOR TRANSITIONS AND TURNOUTS OR OTHERWISE AUTHORIZED BY THE ENGINEER.

IN ADDITION TO THE REQUIREMENTS OF 401.16, MAKE THE FIRST ROLLER PASS 8 TO 12 INCHES AWAY FROM TAPERED EDGE. DO NOT ROLL THE TAPER.

ITEM 202 - PAVEMENT REMOVED, AS PER PLAN (4.25" THICK)

THE DESCRIBED THICKNESS OF 4.25" SHALL BE CONSIDERED AN ESTIMATE; ACTUAL REMOVAL THICKNESS SHALL BE DETERMINED BASED ON FDR SWELL, AS DETERMINED DURING PERFORMANCE OF ITEM 690 – SPECIAL: MIXTURE DESIGN FOR FULL DEPTH RECLAIMED BASE COURSE. PAYMENT FOR PAVEMENT REMOVAL SHALL BE MADE AT THE CONTRACT PRICE PER SQUARE YARD FOR ITEM 202 – PAVEMENT REMOVED, AS PER PLAN (4.25").

RETAIN SUFFICIENT QUANTITY OF GRINDINGS FROM THIS WORK TO PROVIDE FOR FDR CONSTRUCTION OVER ITEM 304 – AGGREGATE BASE, AS DETAILED ON THE TYPICAL SECTIONS. PLACEMENT AND INCORPORATION OF GRINDINGS SHALL BE PAID FOR INCIDENTAL TO ITEM 690 – FULL DEPTH RECLAIMED BASE COURSE, 6.00 INCHES DEEP. DO NOT INCORPORATE ITEM 304 MATERIAL INTO THE FDR MIX.

ESTIMATED QUANTITY OF GRIDINGS TO BE RETAINED FOR FDR: 7306 CU YD

ITEM 204 – UNSTABLE OR UNSUITABLE FOUNDATION SOILS

IF UNSTABLE OR OTHERWISE UNSUITABLE FOUNDATION SOILS ARE ENCOUNTERED IN THE AREAS OF THE PROPOSED ROADBED, THEY SHALL BE REMOVED AND REPLACED. THE LOCATIONS AND DIMENSIONS WILL BE AS DETERMINED BY THE ENGINEER.

CONSTRUCT THE SUBGRADE AS FOLLOWS AND IN THE FOLLOWING SEQUENCE:

- EXCAVATE AND REPLACE UNSUITABLE SUBGRADE IDENTIFIED BY PROOF ROLLING. THE ENGINEER WILL IDENTIFY THE ACTUAL LIMITS OF EXCAVATION FOR UNSTABLE SUBGRADE BASED ON THE PROOF ROLLING RESULTS AND VISUAL OBSERVATIONS.
- EXCAVATE UNSTABLE SUBGRADE AS DIRECTED BY THE ENGINEER AND STABILIZE BY REPLACING WITH THE SPECIFIED MATERIALS ACCORDING TO C&MS 204.07. EXCAVATIONS WILL EXTEND 18 INCHES BEYOND THE IDENTIFIED UNSUITABLE AREAS.
- COMPACT THE REPLACED SUBGRADE ACCORDING TO C&MS 204.03.
- PROOF ROLL THE STABILIZED AREAS ACCORDING TO C&MS 204.06 TO VERIFY STABILITY.
- FINE GRADE THE SUBGRADE TO MATCH THE EXISTING GRADE.

THE QUANTITIES FOR EXCAVATING THE UNSUITABLE SUBGRADE AND UNSTABLE SUBGRADE ARE BOTH PAID UNDER ITEM 204, EXCAVATION OF SUBGRADE.

THE FOLLOWING CONTINGENCY QUANTITIES HAVE BEEN INCLUDED IN THE GENERAL SUMMARY TO BE USED AS DIRECTED BY THE ENGINEER. THE DEPARTMENT WILL PAY FOR QUANTITIES ACTUALLY USED ON THE PROJECT.

ITEM 204 - EMBANKMENT	2000 CU. YDS.
ITEM 204 - EXCAVATION OF SUBGRADE	2000 CU. YDS.
ITEM 204 – SUBGRADE COMPACTION	2000 SQ. YDS.
ITEM 204 – PROOF ROLLING	1 HOURS

ITEM 442 - ASPHALT CONCRETE SURFACE COURSE, 9.5MM, TYPE A (446), AS PER PLAN, PG64-22

ALL OPEN TRANSVERSE JOINTS SHALL BE TAPERED TO MEET EXISTING PAVEMENT BEFORE INTRODUCING TRAFFIC. A "BUMP" SIGN (W8-1-36) SHALL BE ERECTED ON EACH SIDE OF TRANSVERSE JOINTS LEFT OPEN OVER NIGHT, INCLUDING A SPEED ADVISORY SIGN. THESE SIGNS SHALL BE REMOVED IMMEDIATELY AFTER JOINT HAS BEEN CLOSED. PLACEMENT OF SIGNS SHALL BE INCLUDED IN THE UNIT PRICE BID FOR ITEM 614 MAINTAINING TRAFFIC.

CARE SHALL BE TAKEN TO MATCH EXISTING PAVEMENT ELEVATIONS AT EXISTING PAVED BERMS, DRIVES, INTERSECTIONS, ETC.

REQUIREMENTS OF 442 APPLY EXCEPT AS FOLLOWS: MIX DESIGN: FOR Ndes USE 50 GYRATIONS, FOR Nmax USE 75 GYRATIONS. CHOOSE OPTIMUM BINDER CONTENT AT DESIGN AIR VOIDS OF 3.5%. MINIMUM TOTAL PG BINDER CONTENT IS 6.3 PERCENT. MINIMUM VIRGIN PG BINDER CONTENT IS 5.2 PERCENT.

USE A PG 64-22 BINDER. WHEN AN AGGREGATE SOURCE IS SPECIALLY DESIGNATED WITH AN SR ON THE AGGREGATE GRAVITY LIST DO NOT USE THE AGGREGATE EXCEPT AS ALLOWED FOR MEDIUM TRAFFIC IN THE GUIDELINES FOR MAINTAINING ADEQUATE PAVEMENT FRICTION IN SURFACE PAVEMENT. QUALITY CONTROL: DO NOT PERFORM Nmax IN QUALITY CONTROL TESTING. DO NOT TAKE EXTRA ASPHALT BINDER SAMPLES AS OUTLINED IN CMS 442.05.

SEE ALSO THE REQUIREMENTS OF THE AC GAUGE OFFSET AND IDEAL-CT MIX DESIGN ACCEPTANCE NOTES IN THESE PLANS.

ITEM 442 - ASPHALT CONCRETE SURFACE COURSE, 9.5MM, TYPE A (446), AS PER PLAN, PG64-22 (SAFETY EDGE)

THE SAFETY EDGE SHALL BE INSTALLED AT THE SAME TIME AS THE SURFACE COURSE IS TO BE PLACED. THE SAFETY EDGE WILL NOT REQUIRE ANY DENSITY TESTING.

ITEM 442 - ASPHALT CONCRETE INTERMEDIATE COURSE, 19MM, TYPE A (446), AS PER PLAN, PG64-22

ALL OPEN TRANSVERSE JOINTS SHALL BE TAPERED TO MEET EXISTING PAVEMENT BEFORE INTRODUCING TRAFFIC. A "BUMP" SIGN (W8-1-36) SHALL BE ERECTED ON EACH SIDE OF TRANSVERSE JOINTS LEFT OPEN OVER NIGHT, INCLUDING A SPEED ADVISORY SIGN. THESE SIGNS SHALL BE REMOVED IMMEDIATELY AFTER JOINT HAS BEEN CLOSED. PLACEMENT OF SIGNS SHALL BE INCLUDED IN THE UNIT PRICE BID FOR ITEM 614 MAINTAINING TRAFFIC.

REQUIREMENTS OF 442 APPLY EXCEPT AS FOLLOWS: MIX DESIGN: FOR Ndes USE 50 GYRATIONS, FOR Nmax USE 75 GYRATIONS. CHOOSE OPTIMUM BINDER CONTENT AT DESIGN AIR VOIDS OF 3.5%. USE A PG 64-22 BINDER. MAXIMUM RECLAIMED ASPHALT CONCRETE PAVEMENT IS 30 PERCENT. APPLY 703.05 FOR COARSE AND FINE AGGREGATE EXCEPT GRADATION FOR FINE AGGREGATE DOES NOT APPLY. QUALITY CONTROL: DO NOT PERFORM Nmax IN QUALITY CONTROL TESTING. DO NOT TAKE EXTRA ASPHALT BINDER SAMPLES AS OUTLINED IN CMS 442.05.

SEE ALSO THE REQUIREMENTS OF THE AC GAUGE OFFSET AND IDEAL-CT MIX DESIGN ACCEPTANCE NOTES IN THESE PLANS.

DESIGN AGENCY	DISTRICT 3
ENGINEERING TEAM FOUR	
DESIGNER	JNC
REVIEWER	NRF
PROJECT ID	12-06-21
	102939
SHEET	TOTAL
5	38

ITEM 202 - ANCHOR ASSEMBLY REMOVED, TYPE A

THIS ITEM SHALL INCLUDE THE REMOVAL OF THE EXISTING TYPE A, ANCHOR ASSEMBLY INCLUDING ALL POSTS, HARDWARE, RAIL ELEMENTS, AND CONCRETE ANCHORS. ALL ITEMS REMOVED SHALL BECOME THE PROPERTY OF THE CONTRACTOR AND SHALL BE PROPERLY DISPOSED OF.

THE EXISTING CONCRETE ANCHOR AND CONCRETE AT POSTS SHALL BE REMOVED ENTIRELY. ALL HOLES REMAINING AFTER REMOVAL SHALL BE FILLED WITH GRANULAR MATERIAL OR EXCESS MATERIAL RESULTING FROM GUARDRAIL CONSTRUCTION. ALL FILL MATERIAL SHALL BE THOROUGHLY COMPACTED AND LEVELED, AS DIRECTED BY THE ENGINEER.

PAYMENT FOR ALL OF THE ABOVE SHALL BE INCLUDED IN THE UNIT BID PRICE FOR ITEM 202, ANCHOR ASSEMBLY REMOVED, TYPE A.

**ITEM 606 - ANCHOR ASSEMBLY, TYPE E
ITEM 606 - ANCHOR ASSEMBLY, MGS TYPE E (MASH 2016)**

THESE ITEMS SHALL CONSIST OF FURNISHING AND INSTALLING ANY OF THE GUARDRAIL END TERMINALS AS LISTED ON ROADWAY ENGINEERING'S WEB PAGE UNDER ROADSIDE SAFETY DEVICES FOR APPROVED GUARDRAIL END TREATMENTS, FOR AN ASSOCIATED GUARDRAIL TYPE. INSTALLATION SHALL BE AT THE LOCATIONS SPECIFIED IN THE PLANS, IN ACCORDANCE WITH THE MANUFACTURER'S SPECIFICATIONS.

THE FACE OF THE TYPE E IMPACT HEAD SHALL BE COVERED WITH A SHEET OF TYPE G REFLECTIVE SHEETING, PER CMS 730.19.

THE CONTRACTOR MAY USE A SALVAGED EXTRUDER WHEN ASSEMBLING THE ITEM 606 ANCHOR ASSEMBLY, TYPE E OR ITEM 606 ANCHOR ASSEMBLY, MGS TYPE E. ALL WELDS ON THE EXTERIOR OF THE SALVAGED EXTRUDER SHALL NOT BE DAMAGED AND THE FEEDER SHUTE SHALL NOT BE BENT.

REFER TO THE MANUFACTURER'S INSTRUCTIONS REGARDING THE INSTALLATION OF, AND THE GRADING AROUND, THE FOUNDATION TUBES AND GROUND STRUT. THE TOP OF ANY FOUNDATION TUBE SHOULD BE LESS THAN 4 INCHES ABOVE THE GROUND. THE PLACEMENT OF THE FOUNDATION TUBES SHOULD BE AN APPROPRIATE DEPTH BELOW THE LEVEL LINE IN ORDER TO MAINTAIN THE FINISHED GUARDRAIL HEIGHT OF 27 3/4 INCHES FROM THE EDGE OF THE SHOULDER. ON SITE GRADING IS REQUIRED IF THE TOP OF THE FOUNDATION TUBES OR TOP OF THE GROUND STRUT PROJECT MORE THAN 4 INCHES ABOVE THE GROUND LINE.

PAYMENT FOR THE ABOVE WORK SHALL BE MADE AT THE UNIT PRICE BID FOR ITEM 606, ANCHOR ASSEMBLY, TYPE E, EACH, AND SHALL INCLUDE ALL LABOR, TOOLS, EQUIPMENT AND MATERIALS NECESSARY TO CONSTRUCT A COMPLETE AND FUNCTIONAL ANCHOR ASSEMBLY SYSTEM, INCLUDING ALL RELATED TRANSITIONS, REFLECTIVE SHEETING, HARDWARE, GRADING, EMBANKMENT AND EXCAVATION NOT SEPARATELY SPECIFIED, AS REQUIRED BY THE MANUFACTURER.

ALL TYPE E ANCHOR ASSEMBLIES SUPPLIED ON THIS PROJECT SHALL MEET THE REQUIREMENTS OF MASH 2016 TESTING.

CONNECTION BETWEEN EXISTING AND PROPOSED GUARDRAIL

WHEN IT IS NECESSARY TO SPLICE PROPOSED GUARDRAIL TO EXISTING GUARDRAIL, ONLY THE EXISTING GUARDRAIL SHALL BE CUT, DRILLED, OR PUNCHED. THE CONNECTION SHALL BE MADE USING A W-BEAM, BEAM SPLICE AS SHOWN IN AASHTO M 180-12, EXCEPT THE BEAM WASHERS ARE NOT TO BE USED. PAYMENT SHALL BE INCLUDED IN THE CONTRACT PRICE FOR THE RESPECTIVE GUARDRAIL ITEMS.

ITEM 203 - EMBANKMENT, AS PER PLAN

THE INTENT OF ITEM 203 - EMBANKMENT, AS PER PLAN, IS TO REPAIR WASHED-OUT OR OTHERWISE DEFICIENT SHOULDER LOCATIONS IDENTIFIED ON THE GUARDRAIL DETAIL SHEETS AND AS DIRECTED BY THE ENGINEER. PLACE AND COMPACT ACCORDING TO C&MS 203, TO MATCH SURROUNDING SLOPES AND PROVIDE ACCEPTABLE SLOPE AND ELEVATION UNDERNEATH AND SURROUNDING EXISTING OR PROPOSED GUARDRAIL.

PERFORM THE ABOVE WORK PRIOR TO PERFORMING ITEM 209 - PREPARATION FOR SHOULDER PAVING AND PLACEMENT OF ITEM 617 - COMPACTED AGGREGATE.

PAYMENT SHALL INCLUDE ALL LABOR, EQUIPMENT, AND MATERIALS NECESSARY TO COMPLETE THE WORK DESCRIBED ABOVE. PAYMENT WILL BE MADE AT THE UNIT BID PRICE PER CUBIC YARD OF ITEM 203 - EMBANKMENT, AS PER PLAN.

ITEM 659 - SEEDING AND MULCHING

THE FOLLOWING QUANTITIES ARE PROVIDED TO PROMOTE GROWTH AND CARE OF PERMANENT SEEDED AREAS:

659	COMMERCIAL FERTILIZER	0.93	TON
659	LIME	1.38	ACRE
659	WATER	37	M GAL
659	REPAIR SEEDING AND MULCHING	334	SQ YD
659	INTERSEEDING	334	SQ YD
659	TOPSOIL	741	CU YD
659	SOIL ANALYSIS TEST	2	EACH
659	SEEDING AND MULCHING	6672	SQ YD

SEEDING AND MULCHING SHALL BE APPLIED TO ALL AREAS OF PLACED ITEM 203 - EMBANKMENT, AS PER PLAN, AND ITEM 670 - SLOPE EROSION PROTECTION. QUANTITY CALCULATIONS FOR SEEDING AND MULCHING ARE BASED ON THESE LIMITS. QUANTITIES ARE CARRIED TO THE GENERAL SUMMARY.

AC GAUGE OFFSET

FOLLOW 403, EXCEPT AS FOLLOWS:

- OFFSET THE AC GAUGE FOR EACH JMF FOR THE PROJECT PRIOR TO THE PROJECT'S START USING 403.06.A. AND THE MODIFIED SUPPLEMENT 1043 PROCEDURE BELOW.
- DURING S-1043.07 PROCESS, A RAP SAMPLE OBTAINED FROM THE JMF-DESIGNATED RAP PILE WILL BE EXTRACTED IN THE ASPHALT LEVEL 3 LAB TO VERIFY THE RAP AC %. THE RAP AC % WILL BE WITHIN 0.3% OF THE AVERAGE RAP AC % FROM THE JMF. IF RAP AC % IS OUTSIDE OF THE 0.3%, THE VERIFICATION PAN PROCESS WILL STOP, AND DISTRICT TESTING WILL ALLOW ONE OPPORTUNITY TO REWORK THE RAP PILE AT THE MIX PLANT AND RESAMPLE. RESAMPLING REQUIRES DISTRICT TESTING TO BE PRESENT. IF THE RESAMPLE IS STILL OUTSIDE OF THE 0.3%, THE JMF WILL BE RESCINDED AND NEED TO BE REDESIGNED.

FOLLOW 403.06 EXCEPT AS FOLLOWS:

- ENSURE ASPHALT BINDER CONTENT DOES NOT EXCEED TABLE 403.06.G-1. ADJUSTMENTS TO MIX PLANT CONTROL SETTINGS MUST BE SUBMITTED TO AND APPROVED BY DISTRICT TESTING PRIOR TO MAKING THE ADJUSTMENT. THE ADJUSTMENT CANNOT EXCEED +/- 0.2% FROM DESIGN AC % FROM JMF. DO NOT LOWER VIRGIN BINDER CONTENT OR INCREASE RAP PERCENT. ENSURE PLANT TICKET SHOWS THE ADJUSTMENT AND IS SET TO THE ADJUSTED TOTAL AC % AT ALL TIMES AFTERWARDS.
- RECORD THE DAILY VERIFICATION PAN RESULTS IN A SEPARATE WORKSHEET AND MAKE SURE IT'S POSTED IN THE PLANT FACILITY AND AVAILABLE TO THE MONITORS. INCLUDE THE DATE RAN, VERIFICATION PAN RESULT, AND INITIALS OF WHO RAN IT. ENSURE A PRINTOUT OF THE DAILY VERIFICATION PAN IS ALSO INCLUDED WITH THE TE-199.

FOLLOW SUPPLEMENT 1043 FOR AC GAUGE OFFSET, EXCEPT AS MODIFIED BELOW:

- FOLLOW 1043.07 EXCEPT AS FOLLOWS:
 - NOTIFY DISTRICT TESTING A MINIMUM OF ONE WEEK PRIOR TO MAKING VERIFICATION PANS.
 - DISTRICT TESTING WILL WITNESS A SOLVENT EXTRACTION FROM A SAMPLE FROM THE RAP PILE THAT IS TO BE USED IN THE JMF TO VERIFY THE RAP AC %. RAP AC % WILL BE WITHIN 0.3% OF RAP AC % DETERMINED IN JMF. IF OUTSIDE OF 0.3%, DO NOT PROCEED AND THE JMF WILL NEED TO BE REDESIGNED.
 - DISTRICT TESTING WILL WITNESS THE VERIFICATION PANS BEING BLENDED, MIXED, AND COMPACTED.
 - MAKE A MINIMUM OF THREE VERIFICATION PANS FOR THE JMF THAT ARE AT THE JMF ASPHALT BINDER CONTENT. MAKE ONE ADDITIONAL VERIFICATION PAN FOR EACH ADDITIONAL DISTRICT THE JMF WILL BE USED IN.
 - IN ADDITION, TURN POSSESSION OVER OF THE CALIBRATION AC GAUGE PANS USED TO DETERMINE THE FIT COEFFICIENT TO DISTRICT TESTING.
- FOR AC CONTENT PAY ACCEPTANCE, REPLACE 1043.08 WITH THE FOLLOWING: CALCULATE AN AC GAUGE OFFSET AMOUNT FOR EACH JMF AND MIX PLANT IN ACCORDANCE WITH THE FOLLOWING PROCEDURE PRIOR TO START OF ANY PRODUCTION FOR THE JMF. NOTIFY DISTRICT TESTING 24 HOURS PRIOR TO OFFSETTING GAUGE.

1. ENSURE PRINTER IS ON AND PLACE THE FIRST VERIFICATION PAN IN THE AC GAUGE AND RUN.
2. AFTER THE 16-MINUTE TEST, TAKE THE VERIFICATION PAN OUT AND TURN 180 DEGREES AND PLACE BACK IN AC GAUGE AND RUN.
3. REPEAT STEPS 1 AND 2 WITH SECOND AND THIRD VERIFICATION PANS.
4. FOR EACH RUN, TAKE THE JMF ASPHALT BINDER CONTENT MINUS THE AC GAUGE AC % TO OBTAIN THE OFFSET FOR THAT RUN.
5. AVERAGE ALL OFFSETS FOR A FINAL OFFSET.
6. RETAIN ALL OF THE VERIFICATION PANS. AFTER THE FINAL OFFSET IS DETERMINED, DISTRICT TESTING WILL CHOOSE TWO OF THE VERIFICATION PANS AND SEND ONE OF THESE TWO TO OMM TO EXTRACT AND REFLUX.
7. DISTRICT TESTING WILL USE THE TWO VERIFICATION PANS TO OFFSET THEIR AC GAUGE.

BEFORE THE BEGINNING OF A PRODUCTION DAY, RUN THE VERIFICATION PAN IN THE AC GAUGE AND ENSURE THE OFFSET AC GAUGE AMOUNT IS WITHIN 0.14% OF THE JMF ASPHALT BINDER CONTENT. DURING THE START OF PRODUCTION FOR THE JMF, SOLVENT EXTRACT THE FIRST TWO QC SAMPLES AND COMPARE TO THE OFFSET AC GAUGE. ENSURE SOLVENT EXTRACTION IS WITHIN 0.3% OF OFFSET AC GAUGE. IF MORE THAN 0.3% OFF, IMMEDIATELY RESAMPLE AND RUN AC GAUGE AND SOLVENT EXTRACT IMMEDIATELY. IF TWO CONSECUTIVE SAMPLES ARE MORE THAN 0.3% OFF, IMMEDIATELY STOP PRODUCTION, CONTACT MONITORING TEAM, AND INVESTIGATE THE REASON FOR THE PROBLEM. ONCE TWO CONSECUTIVE QC SAMPLES ARE WITHIN 0.3% OF OFFSET AC GAUGE, THE FINAL OFFSET GAUGE IS CONFIRMED. AFTER CONFIRMING THE AC GAUGE OFFSET AMOUNT PROCEED WITH DETERMINING AC CONTENTS OF PRODUCTION SAMPLES BY THE AC GAUGE ACCORDING TO 1043.09. ONLY DETERMINE ONE AC GAUGE OFFSET AMOUNT PER JMF. IF MORE THAN 30 DAYS HAS LAPSED SINCE THE JMF WAS LAST TESTED, RE-DO THE OFFSET PROCEDURE ABOVE WITH TWO VERIFICATION PANS (ONE FROM THE CONTRACTOR AND ONE FROM THE DISTRICT). IF AN AC GAUGE OFFSET AMOUNT IS LATER DETERMINED, BY AN INVESTIGATION OF BOTH THE CONTRACTOR AND THE DISTRICT, TO BE INCORRECT RE-DO THE OFFSET PROCEDURE. IN ADDITION, ALSO DETERMINE THE AC GAUGE OFFSET FOLLOWING THE CURRENT PROCEDURE AS OUTLINED IN SUPPLEMENT 1043 DATED JANUARY 21, 2022 AND PROVIDE THE INFORMATION TO THE DEPARTMENT. THIS AC GAUGE OFFSET NUMBER WILL NOT BE USED DURING QC TESTING.

IDEAL-CT MIX DESIGN ACCEPTANCE

FOLLOW ALL REQUIREMENTS OF THE SPECIFICATIONS WITH THE ADDITION OF THE FOLLOWING:

PERFORM THE IDEAL-CT FOR THE MIX DESIGN SUBMITTAL PER SUPPLEMENT 1033 ON THE JMF ASPHALT BINDER CONTENT DETERMINED FROM THE DESIGN AIR VOIDS AND ENSURE THE MINIMUM IN THE TABLE BELOW IS MET FOR THE MIX TYPE. THE IDEAL-CT ONLY NEEDS TO BE RAN FOR MIX DESIGN ACCEPTANCE.

PROVIDE RESULTS PER SUPPLEMENT 1033 WITH THE MIX DESIGN. SUPPLY SIX GYRATORY COMPACTED SPECIMENS TO THE HEIGHT MENTIONED IN SUPPLEMENT 1033 FOR THE MIX TYPE SPECIFIED. ALLOW MORE THAN TWO WEEKS FOR MIX DESIGN REVIEW AND PRELIMINARY APPROVAL DUE TO OMM VERIFYING THE MIX.

MIX TYPE	MINIMUM CT _{INDEX}
ITEM 442 (SUPERPAVE) 9.5 MM	80
ITEM 442 (SUPERPAVE) 19 MM (INTERMEDIATE)	60

ELECTRONIC TICKETING

PROVIDE ELECTRONIC MATERIAL TICKETS IN AN ELECTRONIC FORMAT DIRECTLY RECORDED FROM THE MATERIAL LOADING SOURCE FOR THE FOLLOWING MATERIALS:

- AGGREGATE
- ASPHALT CONCRETE
- PORTLAND CONCRETE

THIS NOTE IN NO WAY SUPERSEDES ANY OTHER COMMERCIAL REGULATIONS OR ANY OTHER LEGAL REQUIREMENTS REGULATING THE TRANSPORTATION OF COMMERCIAL MATERIALS.

AT THE PRE-CONSTRUCTION MEETING, SUBMIT AN ELECTRONIC TICKETING PLAN TO THE ENGINEER DESCRIBING THE PROPOSED ELECTRONIC TICKET DELIVERY METHOD. THE ELECTRONIC MATERIAL TICKET SHALL CONTAIN INFORMATION AS REQUIRED PER THE APPLICABLE MATERIAL SPECIFICATION FOR WEIGHT MEASUREMENT AND OTHER MATERIAL CHARACTERISTICS; PROVIDE AN EXAMPLE(S) OR A "MOCK-UP" OF THE PROPOSED ELECTRONIC TICKET TO SHOW THE DETAILS ON WHAT IS TO BE TRANSMITTED TO THE DEPARTMENT. NAMING OF THE ELECTRONIC MATERIAL TICKET FILES SHALL BE DISTINCT SUCH THAT THE TICKET'S REPRESENTED MATERIAL IS EASILY DETERMINED; INCLUDE THE PROPOSED NAMING CONVENTION. DELIVERY MAY BE THROUGH A PRODUCER WEBSITE UPLOAD ACCESSIBLE TO THE ENGINEER, ODOT PROJECT SPECIFIC SHAREPOINT DOCUMENTATION SITE UPLOAD, OR ANOTHER SECURE ELECTRONIC TRANSMITTAL MEANS. EMAILING OF A TICKET TO AN ODOT CONTACT IS ACCEPTABLE BUT IS NOT PREFERRED. THE ELECTRONIC TICKETING PLAN SHALL IDENTIFY A CONTINGENCY METHOD FOR MANUALLY CAPTURING AND DELIVERING TICKET INFORMATION IF ELECTRONIC TRANSMISSION IS TEMPORARILY UNAVAILABLE. AN ELECTRONIC TICKETING PLAN WHICH INCLUDES SOLELY THE USE OF DIGITAL PHOTOS OF PAPER TICKETS IS NOT ACCEPTABLE.

THE DEPARTMENT RECOGNIZES THAT VARIOUS DIGITAL TICKETING SYSTEMS MAY BE COMMERCIALY AVAILABLE AND USED TO ACCOMMODATE INDIVIDUAL CONTRACTORS AND MATERIAL SUPPLIER CAPABILITIES. THE CONTRACTOR MAY PROVIDE A DIGITAL TICKETING SYSTEM GIVING SECURE ACCESS TO ORGANIZED DIGITAL DATA. IF UTILIZED, THE DIGITAL TICKETING SYSTEM MAY ALSO BE ACCESSIBLE BY REAL-TIME MONITORING WITH A MOBILE COMMUNICATION DEVICE SUCH AS A TABLET, SMARTPHONE, ETC. THROUGH MOBILE DEVICE APPLICATIONS ("MOBILE APP") IF ACCEPTABLE TO THE DEPARTMENT. IF A DIGITAL TICKETING SYSTEM REQUIRES A MOBILE APP, THE MOBILE APP SHALL BE AT NO COST TO THE DEPARTMENT. THE DIGITAL DATA MUST BE ABLE TO BE EXPORTED IN A FORMAT USABLE BY THE ENGINEER UPON REQUEST (I.E. MICROSOFT WORD, MICROSOFT EXCEL, PDF FORMATS).

DELIVER EACH ELECTRONIC MATERIAL TICKET TO THE ENGINEER PRIOR TO THE PLACEMENT OF MATERIAL, BUT NOT PRIOR TO THE LOADING OF MATERIAL AT THE SOURCE.

PROVIDE THE ENGINEER A DAILY MATERIAL SUMMARY REPORT BY THE END OF THE DAY'S HAULING ACTIVITIES, OR AT A TIME AS APPROVED BY THE ENGINEER. THE DAILY MATERIAL SUMMARY REPORT INCLUDES SUMMARY INFORMATION LISTED FOR EACH MATERIAL AS OUTLINED IN THE RESPECTIVE MATERIAL SPECIFICATION.

COSTS FOR THE ELECTRONIC TICKETING SHALL BE INCIDENTAL TO THE RESPECTIVE ITEMS TO WHICH THE DELIVERED QUANTITIES BELONG.



FULL DEPTH RECLAMATION WITH EMULSIFIED ASPHALT

GENERAL. THIS WORK CONSISTS OF FULL DEPTH RECLAMATION (FDR) WITH EMULSIFIED ASPHALT BY PULVERIZING ALL OF THE EXISTING ASPHALT LAYERS AND MAY INCLUDE PORTIONS OF THE AGGREGATE BASE AND SUBGRADE MATERIAL TO A SPECIFIED DEPTH, WIDTH, AND GRADATION; MIXING EMULSIFIED ASPHALT, WATER, AGGREGATE, AND ADDITIVES WITH THE PULVERIZED MATERIAL; AND SPREADING AND COMPACTING THE MIXTURE.

JUST-IN-TIME TRAINING. PROVIDE A JUST-IN-TIME TRAINING (JITT) COURSE REGARDING DESIGN, CONSTRUCTION, AND TESTING OF FDR WITH EMULSIFIED ASPHALT FOR CONTRACTOR AND DEPARTMENT PROJECT STAFF. SUBMIT THE JITT INSTRUCTOR, COURSE CONTENT, TRAINING SITE, DATE, AND TIME, TO THE ENGINEER FOR APPROVAL. CONDUCT THE TRAINING CLASS AT A PROJECT FIELD LOCATION CONVENIENT FOR ALL PROJECT CONSTRUCTION PERSONNEL RESPONSIBLE FOR FDR OPERATIONS AND INSPECTION TO ATTEND.

HOLD THE JITT COURSE DURING NORMAL WORKING HOURS NOT MORE THAN 14 DAYS BEFORE THE START OF THE FDR OPERATION.

PROVIDE A JITT INSTRUCTOR EXPERIENCED IN THE CONSTRUCTION METHODS, MATERIALS, AND TEST METHODS ASSOCIATED WITH EMULSIFIED ASPHALT STABILIZED FDR. SUBMIT A COPY OF THE COURSE SYLLABUS, HANDOUTS AND PRESENTATION MATERIALS TO THE ENGINEER AT LEAST 5 DAYS BUSINESS DAYS BEFORE THE JITT COURSE DATE.

MATERIALS. FURNISH MATERIALS CONFORMING TO:

EMULSIFIED ASPHALT	702.04
WATER	499.02
PORTLAND CEMENT	701.04
LIME (QUICKLIME)	712.04.B
FLY ASH	701.13
CORRECTIVE AGGREGATE	703.02, 703.04, 703.16.C.2, 703.16.C.3

FURNISH EMULSIFIED ASPHALT MEETING THE REQUIREMENTS OF THE TABLE BELOW:

FDR EMULSIFIED ASPHALT MATERIAL SPECIFICATION

TEST	PROCEDURE	MINIMUM	MAXIMUM
VISCOSITY, SAYBOLT FUROL, @77° F (25° C), SFS	AASHTO T 59	20	100
SIEVE TEST, NO. 20 (850 µm), RETAINED ON SIEVE, %	AASHTO T 59		0.10
STORAGE STABILITY TEST, 24 HR., %	AASHTO T 59		1
DISTILLATION TEST, RESIDUE BY DISTILLATION, %	AASHTO T 59 ^[1]	64.0	
OIL DISTILLATE BY VOLUME, %	AASHTO T 59		1
PENETRATION, 77° F (25° C), 100 G, 5 S, DMM	AASHTO T 59	50	200

[1] MODIFIED AASHTO T 59 – DISTILLATION TEMPERATURE OF 350 ± 9° F (177 ± 5° C) WITH A 20-MINUTE HOLD.

DETERMINE FROM MIX DESIGN IF ADDITIVES ARE NECESSARY AND, IF SO, THE REQUIRED PERCENTAGE IN THE MIX.

DETERMINE FROM MIX DESIGN THE TYPE AND QUANTITY OF CORRECTIVE AGGREGATE THAT MAY BE REQUIRED. ENSURE THE CORRECTIVE AGGREGATE MEETS THE PERFORMANCE AND GRADATION REQUIREMENTS OF THE MIX DESIGN. CORRECTIVE AGGREGATE MAY BE FINE, COARSE, OR RECLAIMED ASPHALT PAVEMENT (RAP) FROM STOCKPILES. OBTAIN RAP FROM VERIFIABLE DEPARTMENT OR OHIO TURNPIKE COMMISSION PROJECTS. IF THE RAP IS NOT FROM ABOVE SOURCES, THE SOURCE IS UNKNOWN, OR MORE THAN ONE SOURCE OF RAP IS USED, PROCESS AND BLEND ALL THE RAP FOR THE PROJECT INTO A SINGLE UNIFORM STOCKPILE, TEST ACCORDING TO LEVEL 3 ASPHALT MIX DESIGN REQUIREMENTS, AND OBTAIN DISTRICT TESTING APPROVAL FOR USE. OBTAIN WRITTEN APPROVAL FROM OMM FOR USE OF UNUSUALLY LARGE, OLD RAP STOCKPILES OF UNKNOWN CONTENT, AGE, OR BOTH. ENSURE NO FOREIGN OR DELETERIOUS MATERIAL IS PRESENT IN RAP.

SUBMITTALS. PREPARE THE MIX DESIGN REPORT AS DESCRIBED IN THE PLANS AND SUBMIT TO THE ENGINEER FOR REVIEW AT LEAST 14 DAYS BEFORE WORK BEGINS. DO NOT BEGIN WORK WITHOUT APPROVAL OF THE MIX DESIGN REPORT BY THE ENGINEER. THE ENGINEER MAY REQUIRE ADDITIONAL SAMPLING IF THE REPORT IS NOT SATISFACTORY.

EQUIPMENT. PROVIDE EQUIPMENT THAT MEETS THE FOLLOWING REQUIREMENTS:

PROVIDE A SELF-PROPELLED RECLAIMER THAT IS CAPABLE OF FULLY PULVERIZING TO THE DEPTH REQUIRED, INCORPORATING THE EMULSIFIED ASPHALT AND WATER, AND MIXING THE MATERIALS TO PRODUCE A HOMOGENEOUS MATERIAL. ENSURE THE RECLAIMER HAS A MINIMUM RATING OF 600 HP (447 KW); IS CAPABLE OF RECLAIMING NOT LESS THAN 7.75 FT (2.36 M) WIDE AND 12 INCHES (300 MM) DEEP IN EACH PASS; THE ROTATIONAL SPEED OF THE CUTTING DRUM IS ADJUSTABLE INDEPENDENT OF THE MACHINE'S FORWARD SPEED; AND HAS AN ADDITIVE SYSTEM FOR EMULSIFIED ASPHALT WITH A FULL-WIDTH SPRAY BAR CONSISTING OF A POSITIVE DISPLACEMENT PUMP INTERLOCKED TO THE SELF-PROPELLED RECLAIMER'S GROUND SPEED SO THAT THE AMOUNT OF EMULSIFIED ASPHALT AGENT BEING ADDED IS AUTOMATICALLY ADJUSTED WITH CHANGES TO THE RECLAIMER'S GROUND SPEED. ENSURE THE ADDITIVE SYSTEM IS CAPABLE OF INCORPORATING UP TO 7 GALLONS PER SQUARE YARD (31.7 LM²) OF EMULSIFIED ASPHALT. ENSURE THE INDIVIDUAL VALVES ON THE SPRAY BAR ARE CAPABLE OF BEING TURNED OFF AS NECESSARY TO MINIMIZE EMULSIFIED ASPHALT OVERLAP ON SUBSEQUENT PASSES. VERIFY THAT THE RECLAIMER IS PROPERLY CALIBRATED TO DELIVER THE SPECIFIED EMULSIFIED ASPHALT CONTENT.

IF APPLYING DRY POWDER ADDITIVES, PROVIDE SPREADERS OR DISTRIBUTORS THAT ARE NON-PRESSURIZED MECHANICAL VANE-FEED, CYCLONE, OR SCREW TYPE CAPABLE OF PROVIDING A CONSISTENT, ACCURATE, AND UNIFORM DISTRIBUTION OF MATERIAL WHILE MINIMIZING DUST DURING CONSTRUCTION.

FULL DEPTH RECLAMATION WITH EMULSIFIED ASPHALT (CONTINUED)

PROVIDE A MOTOR GRADER WITH CROSS SLOPE INDICATOR FOR PRE-SHAPING, AERATING, SPREADING, AND FINAL SHAPING OF THE MATERIAL.

PROVIDE WATER TRUCK(S) FOR SUPPLYING WATER TO THE RECLAIMER OR ROADWAY FOR ADDITION OF MOISTURE AND FOR FINISH ROLLING THE FDR OPERATION. ENSURE THE WATER TRUCK(S) CAN PROVIDE A CONTROLLED AND CONSISTENT SPRAY WITHOUT ERODING OR OTHERWISE DAMAGING THE COMPACTED FDR STABILIZED BASE SURFACE.

PROVIDE VIBRATORY PAD FOOT ROLLER(S) WITH A FRONT MOUNTED BLADE FOR BACK-DRAGGING HAVING A MINIMUM STATIC WEIGHT OF 10 TONS (9 METRIC TONS) AND A MINIMUM EFFECTIVE WEIGHT OF 25 TONS (23 METRIC TONS). PROVIDE A VIBRATORY SINGLE OR TANDEM SMOOTH DRUM ROLLER(S) HAVING A MINIMUM STATIC WEIGHT OF 10 TONS (9 METRIC TONS) OR A PNEUMATIC TIRE ROLLER, WEIGHING AT LEAST 25 TONS, WITH MINIMUM TIRE PRESSURES OF 90 POUNDS PER SQUARE INCH (620 KPA) FOR INTERMEDIATE AND FINISH ROLLING. PERFORM ALL FINISH ROLLING IN STATIC MODE.

CONSTRUCTION.

A. ROADWAY PREPARATION. REMOVE VEGETATION FROM CRACKS, JOINTS, AND OTHER AREAS SUCH AS ALONG EDGES OF THE EXISTING PAVEMENT TO PREVENT CONTAMINATION OF THE PULVERIZED BITUMINOUS MATERIAL DURING THE RECLAIMING OPERATION. ENSURE THE SUBGRADE IS FIRM AND ABLE TO SUPPORT, WITHOUT YIELDING OR SUBSEQUENT SETTLEMENT, THE CONSTRUCTION EQUIPMENT AND COMPACTON OF THE FDR STABILIZED BASE. CORRECT SOFT OR YIELDING SUBGRADE BEFORE CONSTRUCTION PROCEEDS. PROTECT FROM DAMAGE ANY MANHOLES, VALVE COVERS, AND OTHER BURIED STRUCTURES/UTILITIES BEFORE PROCEEDING. PLACE GRINDINGS RETAINED DURING PERFORMANCE OF ITEM 202 - PAVEMENT REMOVED, AS PER PLAN (4.25" THICK) AS SHOWN ON THE TYPICAL SECTIONS. CONSTRUCT FDR IN A SERIES OF PARALLEL LANES SUCH THAT LONGITUDINAL AND TRANSVERSE JOINTS ARE MINIMIZED.

B. WEATHER. PERFORM WORK ONLY BETWEEN MAY 1 AND SEPTEMBER 30. ENSURE THE AIR TEMPERATURE IS A MINIMUM OF 50 °F (10 °C) AND RISING BEFORE INJECTING EMULSIFIED ASPHALT. PULVERIZATION MAY BE PERFORMED AT LOWER TEMPERATURES. DO NOT PERFORM WORK WHEN THE LOCAL WEATHER FORECAST PREDICTS TEMPERATURES AT OR BELOW 32 °F (0 °C) WITHIN 7 DAYS AFTER PLACEMENT OF THE MATERIAL. THE ENGINEER MAY RESTRICT WORK WHEN THE HEAT INDEX IS GREATER THAN 100 °F (38 °C).

C. TEST STRIP. CONSTRUCT A MINIMUM 500 FT LONG TEST STRIP, IN THE PRESENCE OF THE ENGINEER, ON THE FIRST DAY OF PRODUCTION, TO VERIFY THE CONSTRUCTION PROCESS AND DETERMINE THE SEQUENCE AND MANNER OF ROLLING NECESSARY TO OBTAIN THE SPECIFIED DENSITY REQUIREMENTS. THIS ALLOWS THE CONTRACTOR TO DEMONSTRATE THE APPROPRIATENESS OF THE EQUIPMENT, MATERIALS, AND PROCESSES PROPOSED. THIS INCLUDES VERIFYING THE OPTIMAL RATES FOR THE EMULSIFIED ASPHALT, WATER, AND ANY ADDITIVES RECOMMENDED IN THE MIX DESIGN. PLACE FDR AT THE DEPTH OF THE LIFT REQUIRED BY THE PROJECT.

OBTAIN THE MAXIMUM WET DENSITY FOLLOWING THE REQUIREMENTS OF QUALITY CONTROL SECTION G IN THIS NOTE. ENSURE THE MAXIMUM WET DENSITY IS WITHIN ORIGINAL MIX DESIGN TOLERANCES. MONITOR AND TEST COMPACTION FOLLOWING THE REQUIREMENTS OF QUALITY CONTROL SECTION H IN THIS NOTE.

A NEW TEST STRIP IS REQUIRED IF CHANGES ARE MADE OUTSIDE OF THE TOLERANCES OF THE ORIGINAL MIX DESIGN, EQUIPMENT, OR CONSTRUCTION METHODS. PRODUCTION MAY CONTINUE ONLY AFTER APPROVAL OF THE TEST STRIPS AT THE DISCRETION OF THE ENGINEER. THE TEST STRIPS WILL BE CONSIDERED PART OF THE COMPLETED WORK AND WILL REMAIN IN PLACE.

D. PULVERIZATION AND INITIAL SHAPING. PULVERIZE THE EXISTING PAVEMENT WITH THE SELF-PROPELLED RECLAIMER AND SHAPE WITH THE MOTOR GRADER TO CORRECT FOR PROFILE, CROWN, AND CONTOUR, ACCORDING TO THE PLANS, BEFORE THE ADDITION OF THE EMULSIFIED ASPHALT. ADD ANY REQUIRED WATER, CORRECTIVE AGGREGATE, OR BOTH DURING THIS OPERATION. CONTINUE MIXING UNTIL THE ENTIRE MIXTURE IS PULVERIZED AND GRADATION REQUIREMENTS ARE MET. MAKE THE FINAL CHECK FOR GRADATION REQUIREMENTS AT THE CONCLUSION OF MIXING OPERATIONS. SHAPE THE PULVERIZED MATERIAL TO WITHIN 1/2 INCH (15 MM) OF THE PROPOSED GRADE AND COMPACT TO PREVENT SATURATION OF PULVERIZED MATERIAL AND TO PROVIDE DEPTH CONTROL DURING PROCESSING. OVERLAP LONGITUDINAL JOINTS A MINIMUM OF 6 INCHES (150 MM) AND TRANSVERSE JOINTS A MINIMUM OF 2 FEET (0.6 M).

E. CORRECTIVE AGGREGATE (IF REQUIRED). IF REQUIRED BY THE MIX DESIGN, SPREAD CORRECTIVE AGGREGATES, AT THE APPROVED RATE, USING A SPREADER BOX, MECHANICAL SPREADER, CONVENTIONAL PAVER, OR BY TAIL GATING FROM END DUMPS AND SPREADING TO A UNIFORM THICKNESS WITH A MOTOR GRADER. BLEND THE CORRECTIVE AGGREGATE WITH THE PULVERIZED MATERIAL BY MEANS OF ADDITIONAL FULL DEPTH MIXING TO FORM A HOMOGENEOUS MIXTURE BEFORE APPLICATION OF THE EMULSIFIED ASPHALT.

F. APPLICATION OF ADDITIVES (IF REQUIRED). AFTER PULVERIZING, SPREAD ANY ADDITIVES REQUIRED BY THE MIX DESIGN UNIFORMLY ON THE SURFACE. BEFORE PLACING ADDITIVES, CALIBRATE THE EQUIPMENT USED TO MECHANICALLY SPREAD AND MIX THE ADDITIVES ACCORDING TO THE MANUFACTURER'S INSTRUCTIONS. AFTER CALIBRATION, VERIFY THE SPREAD RATE ACCORDING TO THE QUALITY CONTROL SECTION OF THIS NOTE.

FULL DEPTH RECLAMATION WITH EMULSIFIED ASPHALT (CONTINUED)

SPREAD DRY ADDITIVES USING A MECHANICAL SPREADER AT THE APPROVED RATE AND AT A CONSTANT SLOW RATE OF SPEED. SPREAD WITH THE DISTRIBUTION BAR AT A MAXIMUM HEIGHT OF 3 FEET (1 METER) ABOVE THE PULVERIZED LAYER. SURROUND THE DISTRIBUTION BAR WITH A CANVAS SHROUD THAT COVERS THE DISTRIBUTION BAR AND EXTENDS TO THE PULVERIZED SURFACE. MINIMIZE DUSTING WHEN SPREADING THE DRY ADDITIVES. CONTROL DUST ACCORDING TO 107.19. DO NOT SPREAD THE ADDITIVES WHEN WIND CONDITIONS CREATE BLOWING DUST THAT EXCEEDS THE LIMITS IN 107.19. DO NOT SPREAD THE ADDITIVES ON STANDING WATER.

BEGIN MIXING AS SOON AS POSSIBLE AND WITHIN 30 MINUTES AFTER SPREADING THE ADDITIVE. DO NOT SPREAD ADDITIVE THAT CANNOT BE MIXED DURING THE SAME DAY.

G. EMULSIFIED ASPHALT APPLICATION. BEFORE INJECTING EMULSIFIED ASPHALT AND COMPACTING THE MIXTURE, ENSURE THE PROCESSED MATERIAL'S GRADATION FALLS WITHIN THE APPROVED MIX DESIGN GRADATION LIMITS IN THE FDR MATERIAL GRADATION TABLE IN THIS NOTE, AND THE MOISTURE CONTENT IS WITHIN -1.0 TO +2.0 PERCENT OF THE DESIGN MOISTURE CONTENT. ADJUST THE MOISTURE CONTENT BY ADDING OR REMOVING WATER, AS REQUIRED. REGULARLY MONITOR THE DEPTH OF RECLAMATION AND EMULSIFIED ASPHALT APPLICATION RATE TO ENSURE THE PROPER PERCENTAGE OF EMULSIFIED ASPHALT IS BEING INCORPORATED. INCORPORATE EMULSIFIED ASPHALT AT THE RATE SPECIFIED IN THE MIX DESIGN. DETERMINE THE ACTUAL FINAL DRY UNIT WEIGHT DURING CONSTRUCTION.

H. COMPACTION. COMPACT THE FDR MATERIAL AS FOLLOWS:

BEGIN BREAKDOWN ROLLING IMMEDIATELY AFTER APPLYING EMULSIFIED ASPHALT AND MAINTAIN 500 FEET (150 M) OR LESS BETWEEN THE BREAKDOWN ROLLER AND RECLAIMER. PERFORM BREAKDOWN ROLLING WITH A PADFOOT ROLLER APPLYING HIGH AMPLITUDE AND LOW FREQUENCY VIBRATION OR WITH A PNEUMATIC ROLLER. CONTINUE COMPACTION UNTIL THE BREAKDOWN ROLLER WALKS OUT OF THE MATERIAL. WALKING OUT FOR THE PADFOOT ROLLER IS DEFINED AS LIGHT BEING CLEARLY EVIDENT BETWEEN ALL OF THE PADS AT THE MATERIAL-PADFOOT DRUM INTERFACE AND BEING NO MORE THAN 3/16 IN. (5 MM) DEEP. WALKING OUT FOR THE PNEUMATIC ROLLER IS DEFINED AS NO SIGNIFICANT WHEEL IMPRESSIONS BEING LEFT ON THE SURFACE.

AFTER THE COMPLETION OF BREAKDOWN ROLLING, SHAPE THE MATERIAL WITH A MOTOR GRADER. CUT THE RECYCLED MATERIAL NO DEEPER THAN NECESSARY TO REMOVE BREAKDOWN ROLLER MARKS FROM THE INITIAL COMPACTION AND TO ACHIEVE DESIRED CROSS SLOPE. SHAPE MATERIAL AS SOON AS POSSIBLE AFTER ADDITION OF EMULSIFIED ASPHALT BUT NO LATER THAN 3 HOURS AFTER EMULSIFIED ASPHALT ADDITION.

COMPACT THE SHAPED MATERIAL WITH INTERMEDIATE AND FINISH ROLLERS. THE NUMBER OF PASSES AND ORDER OF ROLLERS MAY BE ALTERED TO MEET COMPACTION REQUIREMENTS OF QUALITY CONTROL, PARAGRAPH H, THIS NOTE. DO NOT PERFORM FINISH ROLLING IN VIBRATORY MODE. IF NECESSARY, ADD A LIGHT SPRAY OF WATER TO THE SURFACE BY A WATER TRUCK TO AID IN IMPROVING FINAL DENSITY AND APPEARANCE. USE A SECOND WATER TRUCK IF WATER IS ALSO BEING ADDED AT THE RECLAIMER.

I. FINISHING. FINE GRADE THE FDR THE SAME DAY AS MIXING AND ENSURE IT IS WITHIN 1/2 INCH (15 MM) OF THE PLAN ELEVATION AT ANY LOCATION. CORRECT ANY DEVIATIONS GREATER THAN 1/2 INCH (15 MM).

TEST THE COMPLETED FDR FOR SMOOTHNESS IN EACH WHEEL PATH (3 FEET (1 M) FROM THE EDGE OF LANE) WITH A 10 FOOT (3 M) STRAIGHTEDGE AND RECORD THE VALUE EVERY 1000 FEET. FOR EACH VARIATION IN THE FDR THAT EXCEEDS 1/2 INCH (15 MM), CORRECT THE ENTIRE AREA AFFECTED BY REGRADING AND COMPACTING, OR IF NECESSARY, BY MEANS OF A SELF-PROPELLED MILLING MACHINE. DOCUMENT ALL TEST LOCATIONS AND SUBMIT RESULTS TO THE ENGINEER.

FURNISH A 10 FOOT (3 M) STRAIGHTEDGE ON THE PROJECT FOR USE BY THE ENGINEER.

J. CURING. BEFORE PLACING ANY SUBSEQUENT PAVEMENT LAYERS, CURE THE FDR FOR A MINIMUM OF THREE DAYS AND UNTIL ONE OF THE FOLLOWING CONDITIONS IS MET:
 1. THERE IS LESS THAN 3.0 PERCENT MOISTURE REMAINING IN THE MIXTURE, OR
 2. THE IN-PLACE MOISTURE CONTENTS HAVE REMAINED CONSTANT AT 50 PERCENT OR LESS OF THE DESIGN MOISTURE CONTENT FOR A CONTINUOUS PERIOD OF FIVE DAYS. ENSURE THE FDR IS SURFACED BEFORE NOVEMBER 1.

K. OPENING TO TRAFFIC. LOCAL TRAFFIC MAY BE ALLOWED ON THE SURFACE BEFORE PLACING THE NEXT COURSE. ENSURE THAT LOCAL TRAFFIC DOES NOT IMPEDE CURING OPERATIONS AND DOES NOT CAUSE ANY DAMAGE OR PERMANENT DEFORMATION. MAINTAIN THE FDR SURFACE IN A CONDITION SUITABLE FOR THE SAFE MOVEMENT OF TRAFFIC AND KEEP IT FREE FROM RUTTING, DISTORTION, POTHOLES, AND LOOSE AGGREGATE. REMOVE ANY LOOSE PARTICLES THAT DEVELOP ON THE FDR SURFACE. REPAIR DEFICIENCIES, AT NO ADDITIONAL COST, AS DIRECTED BY THE ENGINEER. REPAIR ANY DAMAGE BEFORE PLACING THE NEXT COURSE.



ITEM 614 – MAINTAINING TRAFFIC (GENERAL)

MAINTAIN ONE 10' LANE OF TRAFFIC AT ALL TIMES, UNLESS OTHERWISE SPECIFIED.

ROAD CLOSURE PERIODS AND ASSOCIATED DETOURS ARE PROVIDED IN THE PLANS. THE CONTRACTOR IS REQUIRED TO MAINTAIN ONE 10' MINIMUM LANE FOR LOCAL ACCESS DURING ALL CLOSURE PERIODS. THE CONTRACTOR SHALL PROVIDE FOR POSITIVE CONTROL AND DECONFLICTION OF LOCAL TRAFFIC USING FLAGGERS, SIGNALS, OR OTHER MEANS APPROVED BY THE ENGINEER. TRAFFIC SHALL BE DETOURED UNTIL INTERMEDIATE COURSE FOR A GIVEN SECTION HAS BEEN PLACED AND IS ABLE TO BEAR TRAFFIC.

SUBMIT, IN WRITING, A SCHEDULE OF OPERATIONS TO THE ENGINEER AND RECEIVE APPROVAL BEFORE WORK IS STARTED ON THE PROJECT. PRIOR TO BEGINNING WORK, COORDINATE THE MAINTENANCE OF TRAFFIC OPERATIONS WITH THE LOCAL STATE HIGHWAY PATROL.

ALL WORK AND TRAFFIC CONTROL DEVICES SHALL BE IN ACCORDANCE WITH C&MS 614 AND OTHER APPLICABLE PORTIONS OF THE SPECIFICATIONS, AS WELL AS THE OHIO MANUAL OF UNIFORM TRAFFIC CONTROL DEVICES, 2012, WITH THE LATEST REVISIONS. PAYMENT FOR ALL LABOR, EQUIPMENT AND MATERIALS SHALL BE INCLUDED IN THE LUMP SUM CONTRACT PRICE FOR ITEM 614, MAINTAINING TRAFFIC, UNLESS SEPARATELY ITEMIZED IN THE PLAN.

ITEM 614 – MAINTAINING TRAFFIC (TIME LIMITATION ON A DETOUR)

A MINIMUM OF ONE LANE OF TRAFFIC IN EACH DIRECTION SHALL BE MAINTAINED AT ALL TIMES, EXCEPT FOR A PERIOD NOT TO EXCEED THE CONSECUTIVE CALENDAR DAYS SHOWN ON THE TABLE BELOW, WHEN THROUGH TRAFFIC MAY BE DETOURED AS SHOWN ON SHEETS 12-14, AND LOCAL TRAFFIC MAINTAINED IN AT LEAST ONE DIRECTION. A DISINCENTIVE SHALL BE ASSESSED FOR EACH CALENDAR DAY THE ROADWAY REMAINS CLOSED TO TRAFFIC BEYOND THE SPECIFIED LIMIT, ACCORDING TO THE TABLE BELOW.

SEGMENT	MAXIMUM DURATION OF CLOSURE	DISINCENTIVE AMOUNT
CRA-602-4.25 TO 6.25	60 DAYS	\$4,500 / DAY
CRA-602-6.25 TO 9.20	60 DAYS	\$3,600 / DAY
CRA-602-9.20 TO 13.64	90 DAYS	\$5,500 / DAY

ITEM 614 – MAINTAINING TRAFFIC RESIDENTIAL AND AGRICULTURAL DRIVES

ACCESS TO ALL RESIDENTIAL AND AGRICULTURAL DRIVES SHALL BE MAINTAINED AT ALL TIMES WITH EITHER EXISTING / NEW PAVEMENT OR ITEM 410 – TRAFFIC COMPACTED SURFACE, TYPE A OR B EXCEPT FOR A MINIMAL PERIOD APPROVED BY THE ENGINEER FOR THE PLACEMENT OF ASPHALT CONCRETE PAVEMENT IN FRONT OF AND/OR ADJACENT TO THE DRIVE APRON. THE CONTRACTOR IS TO PROVIDE 7 CALENDAR DAY NOTICE TO THE AFFECTED PERSON(S) SO THEY CAN MAKE ALTERNATIVE PARKING ARRANGEMENTS. ASPHALT GRINDINGS THAT MEET THE REQUIREMENTS OF C&MS 703.18 MAY BE USED.

ITEM 614 – MAINTAINING TRAFFIC SIDE / CROSS ROADS

ACCESS TO ALL SIDE AND / OR INTERSECTING ROADS, INCLUDING ACCESS ACROSS S.R. 602, SHALL BE MAINTAINED AT ALL TIMES WITH EITHER EXISTING / NEW PAVEMENT OR ITEM 410 – TRAFFIC COMPACTED SURFACE, TYPE C, EXCEPT FOR MINIMUM PERIODS AS APPROVED BY THE ENGINEER TO ALLOW CONSTRUCTION ACTIVITIES WITHIN THE INTERSECTION.

MAINTAINING TRAFFIC PHASES

DURING EACH PHASE, LOCAL TRAFFIC SHALL BE MAINTAINED IN AT LEAST ONE DIRECTION.

- PH 1A: ROAD CLOSURE BETWEEN CRA-602-4.25 AND 6.25. MAINTAIN ONE 10' LANE FOR LOCAL TRAFFIC USING EXISTING WEST SIDE PAVEMENT. CONSTRUCT THE EAST SIDE.
- PH 1B: ROAD CLOSURE BETWEEN CRA-602-4.25 AND 6.25. MAINTAIN ONE 10' LANE FOR LOCAL TRAFFIC USING NEW / EXISTING EAST SIDE PAVEMENT. CONSTRUCT THE WEST SIDE. CONDUCT WORK ON STRUCTURE CRA-602-0600 DURING THIS PHASE.
- PH 2A: ROAD CLOSURE BETWEEN CRA-602-6.25 AND 9.20. MAINTAIN ONE 10' LANE FOR LOCAL TRAFFIC USING EXISTING WEST SIDE PAVEMENT. CONSTRUCT THE EAST SIDE.
- PH 2B: ROAD CLOSURE BETWEEN CRA-602-6.25 AND 9.20. MAINTAIN ONE 10' LANE FOR LOCAL TRAFFIC USING NEW / EXISTING EAST SIDE PAVEMENT. CONSTRUCT THE WEST SIDE.
- PH 3A: ROAD CLOSURE BETWEEN CRA-602-9.20 AND 13.64. MAINTAIN ONE 10' LANE FOR LOCAL TRAFFIC USING NEW / EXISTING WEST SIDE PAVEMENT. CONSTRUCT THE EAST SIDE. CONDUCT WORK ON THE EAST SIDE OF STRUCTURE CRA-602-0949 DURING THIS PHASE.
- PH 3B: ROAD CLOSURE BETWEEN CRA-602-9.20 AND 13.64. MAINTAIN ONE 10' LANE FOR LOCAL TRAFFIC USING EXISTING EAST SIDE PAVEMENT. CONSTRUCT THE WEST SIDE. CONDUCT WORK ON THE WEST SIDE OF STRUCTURE CRA-602-0949 DURING THIS PHASE.

DETOUR SIGNING

THE FOLLOWING QUANTITY IS INCLUDED FOR THE CONTRACTOR TO PROVIDE THE DETOUR SIGNING AS SHOWN IN THESE PLANS AND AS PER C&MS 614.06:

ITEM 614 – DETOUR SIGNING LUMP

DUST CONTROL

THE CONTRACTOR SHALL FURNISH AND APPLY WATER FOR DUST CONTROL AS DIRECTED BY THE ENGINEER. THE FOLLOWING ESTIMATED QUANTITIES HAVE BEEN INCLUDED FOR DUST CONTROL PURPOSES.

ITEM 616 – WATER 100 M. GAL

ITEM 614 – MAINTAINING TRAFFIC (LANE CLOSURE/REDUCTION REQUIRED)

LENGTH AND DURATION OF LANE CLOSURES AND RESTRICTIONS SHALL BE AT THE APPROVAL OF THE ENGINEER. IT IS THE INTENT TO MINIMIZE THE IMPACT TO THE TRAVELING PUBLIC. LANE CLOSURES OR RESTRICTIONS OVER SEGMENTS OF THE PROJECT IN WHICH NO WORK IS ANTICIPATED WITHIN A REASONABLE TIME FRAME, AS DETERMINED BY THE ENGINEER, SHALL NOT BE PERMITTED. THE LEVEL OF UTILIZATION OF MAINTENANCE OF TRAFFIC DEVICES SHALL BE COMMENSURATE WITH THE WORK IN PROGRESS.

ITEM 614 – MAINTAINING TRAFFIC (NOTICE OF CLOSURE SIGN)

NOTICE OF CLOSURE SIGNS (W20-H14) SHALL BE ERECTED BY THE CONTRACTOR PRIOR TO THE SCHEDULED ROAD OR RAMP CLOSURE IN ACCORDANCE WITH THE NOTICE OF CLOSURE TIME TABLE BELOW. THE SIGNS SHALL BE ERECTED ON THE RIGHT-HAND SIDE OF THE ROAD FACING TRAFFIC. THEY SHALL BE PLACED SO AS NOT TO INTERFERE WITH THE VISIBILITY OF ANY OTHER TRAFFIC CONTROL SIGNS. ON ROADWAYS, THEY SHOULD BE ERECTED AT OR NEAR THE POINT OF CLOSURE.

ITEM	NOTICE OF CLOSURE SIGN TIME TABLE	
	DURATION OF CLOSURE	SIGN DISPLAYED TO PUBLIC
RAMP AND ROAD CLOSURES	≥ 2 WEEKS	14 CALENDAR DAYS*
	> 12 HOURS & < 2 WEEKS	7 CALENDAR DAYS*
	< 12 HOURS	2 BUSINESS DAYS*

* DAYS PRIOR TO CLOSURE

THE SIGN SHALL DISPLAY THE DATE OF THE CLOSURE IN MMM-DD FORMAT AND THE NUMBER OF DAYS OF THE CLOSURE. THE LAST LINE OF THE W20-H14 SIGN LISTS THE NAME OF THE DEPARTMENT, i.e. "THE OHIO DEPT. OF TRANS."

ITEM 614 – MAINTAINING TRAFFIC (ESTIMATED QUANTITIES)

THE FOLLOWING ESTIMATED QUANTITIES HAVE BEEN INCLUDED IN THE GENERAL SUMMARY FOR USE AS DETERMINED BY THE ENGINEER FOR MAINTENANCE OF TRAFFIC. INCLUDE THE COST FOR THE REMOVAL OF ALL MAINTENANCE OF TRAFFIC MATERIALS IN THE CONTRACT BID PRICE FOR EACH ITEM BELOW. REMOVE THE MATERIALS AT THE DIRECTION OF THE ENGINEER WHEN NO LONGER OPERATIONALLY NEEDED, AND PRIOR TO PLACEMENT OF PERMANENT PAVEMENT.

ITEM 410 – TRAFFIC COMPACTED SURFACE, TYPE A OR B 442 CU YD
 ITEM 410 – TRAFFIC COMPACTED SURFACE, TYPE C 326 CU YD
 ITEM 614 – ASPHALT CONCRETE FOR MAINTAINING TRAFFIC 33 CU YD
 ITEM 616 – WATER 10 M. GAL

TEMPORARY PAVEMENT WEDGES

PROVIDE TEMPORARY PAVEMENT WEDGES AT ALL TIMES WHERE TRAFFIC IS REQUIRED TO TRAVEL FROM OR ONTO A SURFACE OF A DIFFERENT ELEVATION IN THE DIRECTION OF TRAVEL (JOINTS, MANHOLES, CATCH BASINS, VALVE BOXES, MONUMENT BOXES, ETC.). THE TAPER RATE OF THE TEMPORARY PAVEMENT WEDGES SHALL BE AS PER THE REQUIREMENTS IN THE CHART BELOW. REMOVE THE TEMPORARY PAVEMENT WEDGES PRIOR TO PLACING EACH PROPOSED PAVEMENT COURSE. CONSIDER PAYMENT FOR THIS WORK, INCLUDING ALL MATERIAL, LABOR, EQUIPMENT, AND INCIDENTALS NEEDED TO COMPLETE THIS WORK, AS INCIDENTAL TO ITEM 614 – ASPHALT CONCRETE FOR MAINTAINING TRAFFIC.

SPEED		DURATION	
		7 DAYS OR LESS	MORE THAN 7 DAYS
LESS THAN 45 MPH	45 MPH OR GREATER	36H:1V	60H:1V
		60H:1V	120H:1V

ONE WAY SIGNING

PROVIDE TEMPORARY ONE-WAY SIGNING IN FRONT OF EACH DRIVEWAY WITHIN ANY SEGMENT UNDER ONE-WAY LOCAL TRAFFIC. BELOW IS AN ESTIMATE OF REQUIRED SIGN INSTALLATIONS TO ACCOMPLISH THIS WORK. ALL LABOR, MATERIALS, AND EQUIPMENT REQUIRED TO ACCOMPLISH THE ABOVE SHALL BE CONSIDERED INCIDENTAL TO THE LUMP SUM BID FOR ITEM 614 – MAINTAINING TRAFFIC.

WORK ZONE MARKING SIGN: (R6-1L-36) ONE WAY 36 EACH
 WORK ZONE MARKING SIGN: (R6-1R-36) ONE WAY 25 EACH

MAINTENANCE OF LOCAL DETOUR ROUTE

A LOCAL DETOUR ROUTE, OTHER THAN THE OFFICIAL SIGNED ODOT DETOUR ROUTE, AS NOTED IN THESE PLANS, WILL BE SELECTED BY AGREEMENT BETWEEN ODOT AND LOCAL GOVERNMENTAL AGENCIES PRIOR TO THE HIGHWAY CLOSURE. DURING THE TIME THAT TRAFFIC IS DETOURED, THE CONTRACTOR SHALL MAINTAIN THIS ROUTE IN A CONDITION WHICH IS REASONABLY SMOOTH AND FREE FROM HOLES, RUTS, RIDGES, BUMPS, DUST, AND STANDING WATER. ONCE THE DETOUR IS REMOVED AND TRAFFIC RETURNED TO ITS NORMAL PATTERN, THE DESIGNATED LOCAL DETOUR ROUTE SHALL BE RESTORED TO A CONDITION THAT IS EQUIVALENT TO THAT WHICH EXISTED PRIOR TO ITS USE FOR THIS PURPOSE. ALL SUCH WORK SHALL BE PERFORMED WHEN AND AS DIRECTED BY THE ENGINEER. THE DESIGNATED LOCAL DETOUR ROUTE IS TO BE REVIEWED AND REPAIRED PRIOR TO THE ASPHALT CONTRACTOR OR SUBCONTRACTOR LEAVING THE PROJECT.

PAYMENT FOR THE WORK NECESSARY TO REPAIR THESE LOCAL ROADS WILL BE PERFORMED BY CHANGE ORDER.

ITEM 614 – PORTABLE CHANGEABLE MESSAGE SIGNS, AS PER PLAN

THE CONTRACTOR SHALL FURNISH, INSTALL, MAINTAIN AND REMOVE, WHEN NO LONGER NEEDED, A CHANGEABLE MESSAGE SIGN. THE SIGN SHALL BE OF A TYPE SHOWN ON A LIST OF APPROVED PCMS UNITS AVAILABLE ON THE OFFICE OF MATERIALS MANAGEMENT WEB PAGE. THE LIST CONTAINS CLASS A AND B UNITS WITH MINIMUM LEGIBILITY DISTANCES OF 800 FEET AND 650 FEET, RESPECTIVELY.

EACH SIGN SHALL BE TRAILER-MOUNTED AND EQUIPPED WITH A FUNCTIONAL DIMMING MECHANISM, TO DIM THE SIGN DURING DARKNESS, AND A TAMPER AND VANDAL PROOF ENCLOSURE. EACH SIGN SHALL BE PROVIDED WITH APPROPRIATE TRAINING AND OPERATION INSTRUCTIONS TO ENABLE ON-SITE PERSONNEL TO OPERATE AND TROUBLESHOOT THE UNIT. THE SIGN SHALL ALSO BE CAPABLE OF BEING POWERED BY AN ELECTRICAL SERVICE DROP FROM A LOCAL UTILITY COMPANY. THE PCMS SHALL BE DELINEATED IN ACCORDANCE WITH C&MS 614.03.

THE PROBABLE PCMS LOCATIONS AND WORK LIMITS FOR THOSE LOCATIONS ARE SHOWN ON SHEET(S) OF THE PLAN. PLACEMENT, OPERATION, MAINTENANCE AND ALL ACTIVATION OF THE SIGNS BY THE CONTRACTOR SHALL BE AS DIRECTED BY THE ENGINEER. THE PCMS SHALL BE LOCATED IN A HIGHLY VISIBLE POSITION YET PROTECTED FROM TRAFFIC. THE CONTRACTOR SHALL, AT THE DIRECTION OF THE ENGINEER, RELOCATE THE PCMS TO IMPROVE VISIBILITY OR ACCOMMODATE CHANGED CONDITIONS. WHEN NOT IN USE, THE PCMS SHALL BE TURNED OFF. ADDITIONALLY, WHEN NOT IN USE FOR EXTENDED PERIODS OF TIME, THE PCMS SHALL BE TURNED AWAY FROM ALL TRAFFIC.

THE ENGINEER SHALL BE PROVIDED ACCESS TO EACH SIGN UNIT AND SHALL BE PROVIDED WITH APPROPRIATE TRAINING AND OPERATION INSTRUCTIONS TO ENABLE ODOT PERSONNEL TO OPERATE AND TROUBLESHOOT THE UNIT, AND TO REVISE SIGN MESSAGES, IF NECESSARY.

ALL MESSAGES TO BE DISPLAYED ON THE SIGN WILL BE PROVIDED BY THE ENGINEER. A LIST OF ALL REQUIRED PRE-PROGRAMMED MESSAGES WILL BE GIVEN TO THE CONTRACTOR AT THE PROJECT PRECONSTRUCTION CONFERENCE. THE SIGN SHALL HAVE THE CAPABILITY TO STORE UP TO 99 MESSAGES. MESSAGE MEMORY OR PRE-PROGRAMMED DISPLAYS SHALL NOT BE LOST AS A RESULT OF POWER FAILURES TO THE ON-BOARD COMPUTER. THE SIGN LEGEND SHALL BE CAPABLE OF BEING CHANGED IN THE FIELD. THREE-LINE PRESENTATION FORMATS WITH UP TO SIX MESSAGE PHASES SHALL BE SUPPORTED. PCMS FORMAT SHALL PERMIT THE COMPLETE MESSAGE FOR EACH PHASE TO BE READ AT LEAST TWICE.

THE PCMS SHALL CONTAIN AN ACCURATE CLOCK AND PROGRAMMING LOGIC WHICH WILL ALLOW THE SIGN TO BE ACTIVATED, DEACTIVATED OR MESSAGES CHANGED AUTOMATICALLY AT DIFFERENT TIMES OF THE DAY FOR DIFFERENT DAYS OF THE WEEK.

THE PCMS UNIT SHALL BE MAINTAINED IN GOOD WORKING ORDER BY THE CONTRACTOR IN ACCORDANCE WITH THE PROVISIONS OF C&MS 614.07. THE CONTRACTOR SHALL, PRIOR TO ACTIVATING THE UNIT, MAKE ARRANGEMENTS, WITH AN AUTHORIZED SERVICE AGENT FOR THE PCMS, TO ASSURE PROMPT SERVICE IN THE EVENT OF FAILURE. ANY FAILURE SHALL NOT RESULT IN THE SIGN BEING OUT OF SERVICE FOR MORE THAN 12 HOURS, INCLUDING WEEKENDS. FAILURE TO COMPLY MAY RESULT IN AN ORDER TO STOP WORK AND OPEN ALL TRAFFIC LANES AND/OR IN THE DEPARTMENT TAKING APPROPRIATE ACTION TO SAFELY CONTROL TRAFFIC. THE ENTIRE COST TO CONTROL TRAFFIC, ACCRUED BY THE DEPARTMENT DUE TO THE CONTRACTOR'S NONCOMPLIANCE, WILL BE DEDUCTED FROM MONEYS DUE, OR TO BECOME DUE THE CONTRACTOR ON HIS CONTRACT.

THE CONTRACTOR SHALL BE RESPONSIBLE FOR 24-HOUR-PER-DAY OPERATION AND MAINTENANCE OF THESE SIGNS ON THE PROJECT FOR THE DURATION OF THE PHASES WHEN THE PLAN REQUIRES THEIR USE.

PAYMENT FOR THE ABOVE DESCRIBED ITEM SHALL BE AT THE CONTRACT UNIT PRICE. PAYMENT SHALL INCLUDE ALL LABOR, MATERIALS, EQUIPMENT, FUELS, LUBRICATING OILS, SOFTWARE, HARDWARE AND INCIDENTALS TO PERFORM THE ABOVE DESCRIBED WORK.

ITEM 614 – PORTABLE CHANGEABLE MESSAGE SIGN, AS PER PLAN 16 SIGN MONTH ASSUMING 2 PCMS SIGNS FOR 8 MONTHS

DESIGN AGENCY
DISTRICT 3



ENGINEERING
TEAM FOUR

DESIGNER
JNC

REVIEWER
NRF 12-06-21

PROJECT ID
102939

SHEET TOTAL
11 38

SHEET NUM.										PART.		ITEM	ITEM EXT	GRAND TOTAL	UNIT	DESCRIPTION	SEE SHEET NO.	
5	6	7	11	12	18	19	20	21	25	01/STR/PV	02/STR/BR							
					32,807					32,807			202	23000	32,807	SY	PAVEMENT REMOVED (10.25"+/-)	
					142,681					142,681			202	23001	142,681	SY	PAVEMENT REMOVED, AS PER PLAN (4.25"+/-)	5
								581		581			202	38000	581	FT	GUARDRAIL REMOVED	
								15		15			202	42000	15	EACH	ANCHOR ASSEMBLY REMOVED, TYPE A	
								4		4			202	47000	4	EACH	BRIDGE TERMINAL ASSEMBLY REMOVED	
					637					637			203	10000	637	CY	EXCAVATION	
								342		342			203	20001	342	CY	EMBANKMENT, AS PER PLAN	7
2,000					43,747					45,747			204	10000	45,747	SY	SUBGRADE COMPACTION	
2,000										2,000			204	13000	2,000	CY	EXCAVATION OF SUBGRADE	
2,000										2,000			204	20000	2,000	CY	EMBANKMENT	
1					22					23			204	45000	23	HOUR	PROOF ROLLING	
					43,747					43,747			204	51000	43,747	SY	GEOGRID	
	345									345			205	10050	345	CY	LIME STABILIZED EMBANKMENT	
								0.4		0.4			209	15000	0.4	STA	RESHAPING UNDER GUARDRAIL	
					19					19			209	60500	19	MILE	LINEAR GRADING	
					19					19			209	72050	19	MILE	PREPARING SUBGRADE FOR SHOULDER PAVING	
								175		175			606	15050	175	FT	GUARDRAIL, TYPE MGS	
								137.5		137.5			606	17000	137.5	FT	RAISING TYPE 5 GUARDRAIL	
								1		1			606	17700	1	EACH	REPLACE EXISTING GUARDRAIL BLOCKOUT	
								11		11			606	26100	11	EACH	ANCHOR ASSEMBLY, TYPE E	
								4		4			606	26150	4	EACH	ANCHOR ASSEMBLY, MGS TYPE E (MASH 2016)	
								4		4			606	34600	4	EACH	MGS BRIDGE TERMINAL ASSEMBLY, TYPE TST-2	
										LS			623	10001	LS		CONSTRUCTION LAYOUT STAKES AND SURVEYING, AS PER PLAN	6
	23									23			623	38501	23	EACH	MONUMENT ASSEMBLY, AS PER PLAN	6
	23									23			623	40900	23	EACH	MONUMENT, MISC.: LOCATING MONUMENT STONES	6
								8		8			626	00110	8	EACH	BARRIER REFLECTOR, TYPE 2 (BIDIRECTIONAL)	
																	EROSION CONTROL	
		2								2			659	00100	2	EACH	SOIL ANALYSIS TEST	
		741								741			659	00300	741	CY	TOPSOIL	
	528									528			659	00300	528	CY	TOPSOIL (4" THICK)	
		6,672								6,672			659	10000	6,672	SY	SEEDING AND MULCHING	
		334								334			659	14000	334	SY	REPAIR SEEDING AND MULCHING	
		334								334			659	15000	334	SY	INTER-SEEDING	
		0.93								0.93			659	20000	0.93	TON	COMMERCIAL FERTILIZER	
		1.38								1.38			659	31000	1.38	ACRE	LIME	
		37								37			659	35000	37	MGAL	WATER	
	4,752									4,752			670	00500	4,752	SY	SLOPE EROSION PROTECTION	
	LS									LS			832	15000	LS		STORM WATER POLLUTION PREVENTION PLAN	
	LS									LS			832	15002	LS		STORM WATER POLLUTION PREVENTION INSPECTIONS	
	LS									LS			832	15010	LS		STORM WATER POLLUTION PREVENTION INSPECTION SOFTWARE	
										150,000			832	30000	150,000	EACH	EROSION CONTROL	
																	DRAINAGE	
							14,257			14,257			605	13300	14,257	FT	6" UNCLASSIFIED PIPE UNDERDRAINS	
							84,903			84,903			605	14000	84,903	FT	6" BASE PIPE UNDERDRAINS	
							3,105			3,105			611	00510	3,105	FT	6" CONDUIT, TYPE F FOR UNDERDRAIN OUTLETS	
							207			207			611	99710	207	EACH	PRECAST REINFORCED CONCRETE OUTLET	
																	PAVEMENT	
					3,078					3,078			254	01000	3,078	SY	PAVEMENT PLANING, ASPHALT CONCRETE (1.25" DEEP)	
					18					18			254	01600	18	SY	PATCHING PLANED SURFACE	
					993					993			304	20000	993	CY	AGGREGATE BASE (12" THICK)	
					17,695					17,695			407	10000	17,695	GAL	TACK COAT	
					8,800					8,800			408	10001	8,800	GAL	PRIME COAT, AS PER PLAN	6
					5,785					5,785			442	00201	5,785	CY	ASPHALT CONCRETE SURFACE COURSE, 9.5 MM, TYPE A (446), AS PER PLAN, PG64-22	5
					11,900					11,900			442	10101	11,900	CY	ASPHALT CONCRETE INTERMEDIATE COURSE, 19 MM, TYPE A (446), AS PER PLAN, PG64-22	5
					2,456					2,456			617	10100	2,456	CY	COMPACTED AGGREGATE	
					153,615					153,615			SPECIAL	69098300	153,615	SY	FULL DEPTH RECLAIMED BASE COURSE, 6.00 INCHES DEEP	7
										LS			SPECIAL	69098400	LS		MIXTURE DESIGN FOR RECLAIMED BASE COURSE	9
					826					826			SPECIAL	69098800	826	TON	ADDITIONAL ADDITIVES (CEMENT, FLY ASH, LIME)	7
					5,128					5,128			SPECIAL	69098800	5,128	TON	CORRECTIVE AGGREGATE FOR FDR (FINE, COARSE OR RAP)	7
					345,624					345,624			SPECIAL	69098900	345,624	GAL	EMULSIFIED ASPHALT	7

GENERAL SUMMARY

DESIGN AGENCY
DISTRICT 3



ENGINEERING
TEAM FOUR

DESIGNER
JNC

REVIEWER
NRF 12-06-21

PROJECT ID
102939

SHEET TOTAL
 16 | 38

COUNTY	ROUTE	LOG POINT TO LOG POINT		LENGTH		PLAN SPLIT:										01/STR/PV																										
				MILE	FEET	TRAVELLED WAY WIDTH	LEFT SHOULDER WIDTH	RIGHT SHOULDER WIDTH	TOTAL PAVED WIDTH	PAVEMENT AREA	202		203	204		209	254		304	407	407	442		690				209		408	617											
											SY	SY	CY	SY	SY	HOURS	MILE	SY	SY	CY	GAL	GAL	CY	CY	SY	GAL	TON	TON	FT	R	SY	MILE	GAL	CY								
											SLM	FT	FT	FT	FT	SY	SY	SY	SY	SY	SY	SY	SY	SY	SY	SY	SY	SY	SY	SY	SY	SY	SY	SY	SY	SY						
CRA	602	4.25	4.50	0.25	1320	22	2	2	26	3814	880	3,814	27	1174	1,174	0.59	0.50			27	458		133	19	318	4107	9241	22	137	2.00	2.00	587	0.50	235	66							
CRA	602	4.50	5.00	0.50	2640	22	2	2	26	7627	1,760	7,627	53	2347	2,347	1.17	1.00			53	916		265	38	636	8214	18480	44	274	2.00	2.00	1174	1.00	470	131							
CRA	602	5.00	5.50	0.50	2640	22	2	2	26	7627	1,760	7,627	53	2347	2,347	1.17	1.00			53	916		265	38	636	8214	18480	44	274	2.00	2.00	1174	1.00	470	131							
CRA	602	5.50	5.97	0.47	2482	22	2	2	26	7170	1,655	7,170	50	2206	2,206	1.10	0.94			50	861		249	36	598	7721	17373	41	258	2.00	2.00	1103	0.94	442	123							
CRA	602	5.97	5.98	0.01	53	22	7	7	36	212	36	212	2	47	47	0.02	0.02			2	26		8	1	18	224	504	2	8	2.00	2.00	24	0.02	10	3							
SUSPEND AND RESUME PAVING OVER STRUCTURE CRA-602-0600																																										
CRA	602	6.02	6.04	0.02	125	22	7	7	36	500	84	500	3	112	112	0.06	0.05			3	60		18	2	42	528	1188	3	18	2.00	2.00	56	0.05	23	7							
CRA	602	6.04	6.50	0.46	2409	22	2	2	26	6961	1,607	6,961	49	2142	2,142	1.07	0.91			49	836		242	35	581	7496	16866	40	250	2.00	2.00	1071	0.91	429	119							
CRA	602	6.50	7.00	0.50	2640	22	2	2	26	7627	1,760	7,627	53	2347	2,347	1.17	1.00			53	916		265	38	636	8214	18480	44	274	2.00	2.00	1174	1.00	470	131							
CRA	602	7.00	7.50	0.50	2640	22	2	2	26	7627	1,760	7,627	53	2347	2,347	1.17	1.00			53	916		265	38	636	8214	18480	44	274	2.00	2.00	1174	1.00	470	131							
CRA	602	7.50	8.00	0.50	2640	22	2	2	26	7627	1,760	7,627	53	2347	2,347	1.17	1.00			53	916		265	38	636	8214	18480	44	274	2.00	2.00	1174	1.00	470	131							
CRA	602	8.00	8.50	0.50	2640	22	2	2	26	7627	1,760	7,627	53	2347	2,347	1.17	1.00			53	916		265	38	636	8214	18480	44	274	2.00	2.00	1174	1.00	470	131							
CRA	602	8.50	9.00	0.50	2640	22	2	2	26	7627	1,760	7,627	53	2347	2,347	1.17	1.00			53	916		265	38	636	8214	18480	44	274	2.00	2.00	1174	1.00	470	131							
CRA	602	9.00	9.45	0.45	2376	22	2	2	26	6864	1,584	6,864	48	2112	2,112	1.06	0.90			48	824		239	34	572	7392	16632	39	247	2.00	2.00	1056	0.90	423	118							
CRA	602	9.47	9.49	0.02	125	22	9	9	40	556	84	556	3	112	112	0.06	0.05			3	67		20	2	47	584	1314	4	20	2.00	2.00	56	0.05	23	7							
CRA	602	9.49	9.49	0.00	25		8	8	16	45	17	45	1	23	23	0.01	0.01			1	6		4	1	4	51	114	1	2	2.00	2.00	12	0.01	5	2							
SUSPEND AND RESUME PAVING OVER STRUCTURE CRA-602-0949																																										
CRA	602	9.51	9.51	0.00	25		8	8	16	45	17	45	1	23	23	0.01	0.01			1	6		2	1	4	51	114	1	2	2.00	2.00	12	0.01	5	2							
CRA	602	9.51	9.54	0.02	125	22	9	9	40	556	84	556	3	112	112	0.06	0.05			3	67		20	2	47	584	1314	4	20	2.00	2.00	56	0.05	23	7							
CRA	602	9.54	10.00	0.46	2438	22	2	2	26	7044	1,626	7,044	49	2168	2,168	1.08	0.92			49	846		245	35	587	7586	17068	40	253	2.00	2.00	1084	0.92	434	121							
CRA	602	10.00	10.50	0.50	2640	22	2	2	26	7627	1,760	7,627	53	2347	2,347	1.17	1.00			53	916		265	38	636	8214	18480	44	274	2.00	2.00	1174	1.00	470	131							
CRA	602	10.50	11.00	0.50	2640	22	2	2	26	7627	1,760	7,627	53	2347	2,347	1.17	1.00			53	916		265	38	636	8214	18480	44	274	2.00	2.00	1174	1.00	470	131							
CRA	602	11.00	11.50	0.50	2640	22	2	2	26	7627	1,760	7,627	53	2347	2,347	1.17	1.00			53	916		265	38	636	8214	18480	44	274	2.00	2.00	1174	1.00	470	131							
CRA	602	11.50	12.00	0.50	2640	22	2	2	26	7627	1,760	7,627	53	2347	2,347	1.17	1.00			53	916		265	38	636	8214	18480	44	274	2.00	2.00	1174	1.00	470	131							
CRA	602	12.00	12.50	0.50	2640	22	2	2	26	7627	1,760	7,627	53	2347	2,347	1.17	1.00			53	916		265	38	636	8214	18480	44	274	2.00	2.00	1174	1.00	470	131							
CRA	602	12.50	13.00	0.50	2640	22	2	2	26	7627	1,760	7,627	53	2347	2,347	1.17	1.00			53	916		265	38	636	8214	18480	44	274	2.00	2.00	1174	1.00	470	131							
CRA	602	13.00	13.50	0.50	2640	22	2	2	26	7627	1,760	7,627	53	2347	2,347	1.17	1.00			53	916		265	38	636	8214	18480	44	274	2.00	2.00	1174	1.00	470	131							
CRA	602	13.50	13.64	0.14	739	22	2	2	26	2136	493	2,136	15	658	658	0.33	0.28			15	257		75	11	178	2300	5176	13	77	2.00	2.00	329	0.28	132	37							
RAMP TO S.R. 96										541																																
EXTRA AREA FOR INTERSECTIONS										1528																																
EXTRA AREA FOR PAVED DRIVES										63																																
EXTRA AREA FOR AGGREGATE DRIVES										486																																
EXTRA AREA FOR EX. MAILBOX APPROACHES										460																																
TOTALS CARRIED TO GENERAL SUMMARY										145,759	32,807	142,681	993	43,747	43,747	22	19	3,078	18	993	17,695							5,785	11,900	153,615	345,624	826	5,128							19	8,800	2,456

* THESE QUANTITIES ARE PROVIDED FOR ESTIMATION PURPOSES ONLY. ACTUAL QUANTITIES WILL BE AS DETERMINED PER ITEM 609 - MIXTURE DESIGN FOR RECLAIMED BASE COURSE, WHICH SHALL BE PAID FOR ON A LUMP SUM BASIS. SEE THE "FULL DEPTH RECLAMATION WITH EMULSIFIED ASPHALT" NOTE IN THESE PLANS.

UNDERDRAIN LAYOUT & QUANTITIES - LEFT SIDE

COUNTY	ROUTE	PLAN SPLIT: LENGTH				01/STR/PV			
		LOG POINT		605		611			
		TO							
		LOG POINT			6" UNCLASSIFIED PIPE UNDERDRAINS	6" BASE PIPE UNDERDRAINS	6" CONDUIT, TYPE F FOR UNDERDRAIN OUTLETS	PRECAST REINFORCED CONCRETE OUTLET	
		SLM	MILE	FEET	FT	FT	FT	EACH	
CRA	602	4.25	4.33	0.08	422	422		30	2
CRA	602	4.33	5.44	1.11	5861		5,861	210	14
CRA	602	5.44	6.07	0.63	3326		3,326	105	7
CRA	602	6.07	11.24	5.17	27298		27,298	1020	68
CRA	602	11.24	11.75	0.51	2693	2,693		105	7
CRA	602	11.75	13.55	1.80	9504		9,504	360	24
CRA	602	13.55	13.64	0.09	475	475		30	2
TOTALS CARRIED TO GENERAL SUMMARY					3,591	45,989	1,860	124	

LEFT SIDE ESTIMATED OUTLET LOCATIONS

SLM	DIST. FROM PREVIOUS OUTLET [FT]	UNDERDRAIN TYPE	SLM	DIST. FROM PREVIOUS OUTLET [FT]	UNDERDRAIN TYPE
4.27		UNCLASSIFIED	9.06	422	BASE PIPE
4.33	317	UNCLASSIFIED	9.14	422	BASE PIPE
4.40	370	BASE PIPE	9.21	370	BASE PIPE
4.48	422	BASE PIPE	9.29	422	BASE PIPE
4.55	370	BASE PIPE	9.36	370	BASE PIPE
4.63	422	BASE PIPE	9.44	422	BASE PIPE
4.70	370	BASE PIPE	9.52	422	BASE PIPE
4.78	422	BASE PIPE	9.59	370	BASE PIPE
4.86	422	BASE PIPE	9.67	422	BASE PIPE
4.93	370	BASE PIPE	9.74	370	BASE PIPE
5.01	422	BASE PIPE	9.82	422	BASE PIPE
5.08	370	BASE PIPE	9.89	370	BASE PIPE
5.16	422	BASE PIPE	9.97	422	BASE PIPE
5.23	370	BASE PIPE	10.05	422	BASE PIPE
5.31	422	BASE PIPE	10.12	370	BASE PIPE
5.39	422	BASE PIPE	10.20	422	BASE PIPE
5.44	264	BASE PIPE	10.27	370	BASE PIPE
5.52	422	BASE PIPE	10.35	422	BASE PIPE
5.59	370	BASE PIPE	10.42	370	BASE PIPE
5.67	422	BASE PIPE	10.50	422	BASE PIPE
5.78	581	BASE PIPE	10.58	422	BASE PIPE
5.97	1003	BASE PIPE	10.65	370	BASE PIPE
6.05	422	BASE PIPE	10.73	422	BASE PIPE
6.11	317	BASE PIPE	10.80	370	BASE PIPE
6.18	370	BASE PIPE	10.88	422	BASE PIPE
6.26	422	BASE PIPE	10.95	370	BASE PIPE
6.33	370	BASE PIPE	11.03	422	BASE PIPE
6.41	422	BASE PIPE	11.11	422	BASE PIPE
6.48	370	BASE PIPE	11.18	370	BASE PIPE
6.56	422	BASE PIPE	11.26	422	UNCLASSIFIED
6.64	422	BASE PIPE	11.33	370	UNCLASSIFIED
6.71	370	BASE PIPE	11.41	422	UNCLASSIFIED
6.79	422	BASE PIPE	11.48	370	UNCLASSIFIED
6.86	370	BASE PIPE	11.56	422	UNCLASSIFIED
6.94	422	BASE PIPE	11.64	422	UNCLASSIFIED
7.02	422	BASE PIPE	11.71	370	UNCLASSIFIED
7.09	370	BASE PIPE	11.79	422	BASE PIPE
7.17	422	BASE PIPE	11.86	370	BASE PIPE
7.24	370	BASE PIPE	11.94	422	BASE PIPE
7.32	422	BASE PIPE	12.02	422	BASE PIPE
7.39	370	BASE PIPE	12.09	370	BASE PIPE
7.47	422	BASE PIPE	12.17	422	BASE PIPE
7.55	422	BASE PIPE	12.24	370	BASE PIPE
7.62	370	BASE PIPE	12.32	422	BASE PIPE
7.70	422	BASE PIPE	12.39	370	BASE PIPE
7.77	370	BASE PIPE	12.47	422	BASE PIPE
7.85	422	BASE PIPE	12.55	422	BASE PIPE
7.92	370	BASE PIPE	12.62	370	BASE PIPE
8.00	422	BASE PIPE	12.70	422	BASE PIPE
8.08	422	BASE PIPE	12.77	370	BASE PIPE
8.15	370	BASE PIPE	12.85	422	BASE PIPE
8.23	422	BASE PIPE	12.92	370	BASE PIPE
8.30	370	BASE PIPE	13.00	422	BASE PIPE
8.38	422	BASE PIPE	13.08	422	BASE PIPE
8.45	370	BASE PIPE	13.15	370	BASE PIPE
8.53	422	BASE PIPE	13.23	422	BASE PIPE
8.61	422	BASE PIPE	13.30	370	BASE PIPE
8.68	370	BASE PIPE	13.38	422	BASE PIPE
8.76	422	BASE PIPE	13.45	370	BASE PIPE
8.83	370	BASE PIPE	13.53	422	BASE PIPE
8.91	422	BASE PIPE	13.55	106	UNCLASSIFIED
8.98	370	BASE PIPE	13.63	422	UNCLASSIFIED

RIGHT SIDE ESTIMATED OUTLET LOCATIONS

SLM	DIST. FROM PREVIOUS OUTLET [FT]	UNDERDRAIN TYPE	SLM	DIST. FROM PREVIOUS OUTLET [FT]	UNDERDRAIN TYPE
4.27		UNCLASSIFIED	9.00	370	UNCLASSIFIED
4.34	370	UNCLASSIFIED	9.08	422	UNCLASSIFIED
4.42	422	UNCLASSIFIED	9.16	422	UNCLASSIFIED
4.50	422	UNCLASSIFIED	9.23	370	UNCLASSIFIED
4.57	370	BASE PIPE	9.31	422	UNCLASSIFIED
4.65	422	BASE PIPE	9.38	370	UNCLASSIFIED
4.72	370	BASE PIPE	9.46	422	UNCLASSIFIED
4.80	422	BASE PIPE	9.55	475	BASE PIPE
4.88	422	BASE PIPE	9.63	422	BASE PIPE
4.95	370	BASE PIPE	9.70	370	BASE PIPE
5.03	422	BASE PIPE	9.78	422	BASE PIPE
5.10	370	BASE PIPE	9.86	422	BASE PIPE
5.18	422	BASE PIPE	9.93	370	BASE PIPE
5.25	370	BASE PIPE	10.01	422	BASE PIPE
5.33	422	BASE PIPE	10.08	370	BASE PIPE
5.41	422	BASE PIPE	10.16	422	BASE PIPE
5.48	370	BASE PIPE	10.23	370	BASE PIPE
5.56	422	BASE PIPE	10.31	422	BASE PIPE
5.63	370	BASE PIPE	10.39	422	BASE PIPE
5.71	422	BASE PIPE	10.46	370	BASE PIPE
5.78	370	BASE PIPE	10.54	422	BASE PIPE
5.86	422	BASE PIPE	10.61	370	BASE PIPE
5.94	422	BASE PIPE	10.69	422	BASE PIPE
6.01	370	BASE PIPE	10.77	422	BASE PIPE
6.09	422	BASE PIPE	10.84	370	BASE PIPE
6.16	370	BASE PIPE	10.92	422	BASE PIPE
6.24	422	BASE PIPE	10.99	370	BASE PIPE
6.31	370	BASE PIPE	11.07	422	BASE PIPE
6.39	422	BASE PIPE	11.14	370	BASE PIPE
6.47	422	BASE PIPE	11.22	422	BASE PIPE
6.54	370	BASE PIPE	11.30	422	BASE PIPE
6.62	422	BASE PIPE	11.37	370	BASE PIPE
6.69	370	BASE PIPE	11.45	422	BASE PIPE
6.77	422	BASE PIPE	11.52	370	BASE PIPE
6.84	370	BASE PIPE	11.60	422	BASE PIPE
6.92	422	BASE PIPE	11.67	370	BASE PIPE
7.00	422	BASE PIPE	11.75	422	BASE PIPE
7.07	370	BASE PIPE	11.83	422	BASE PIPE
7.15	422	BASE PIPE	11.90	370	BASE PIPE
7.24	475	BASE PIPE	11.98	422	BASE PIPE
7.32	422	BASE PIPE	12.05	370	BASE PIPE
7.39	370	BASE PIPE	12.13	422	BASE PIPE
7.47	422	BASE PIPE	12.20	370	BASE PIPE
7.55	422	BASE PIPE	12.28	422	BASE PIPE
7.62	370	BASE PIPE	12.36	422	BASE PIPE
7.70	422	BASE PIPE	12.43	370	BASE PIPE
7.77	370	BASE PIPE	12.51	422	BASE PIPE
7.85	422	BASE PIPE	12.58	370	BASE PIPE
7.92	370	BASE PIPE	12.66	422	BASE PIPE
8.02	528	UNCLASSIFIED	12.73	370	BASE PIPE
8.09	370	UNCLASSIFIED	12.81	422	BASE PIPE
8.17	422	UNCLASSIFIED	12.89	422	BASE PIPE
8.25	422	UNCLASSIFIED	12.96	370	BASE PIPE
8.32	370	UNCLASSIFIED	13.04	422	BASE PIPE
8.40	422	UNCLASSIFIED	13.11	370	UNCLASSIFIED
8.47	370	UNCLASSIFIED	13.19	422	UNCLASSIFIED
8.55	422	UNCLASSIFIED	13.25	317	BASE PIPE
8.63	422	UNCLASSIFIED	13.32	370	BASE PIPE
8.70	370	UNCLASSIFIED	13.40	422	BASE PIPE
8.78	422	UNCLASSIFIED	13.47	370	BASE PIPE
8.85	370	UNCLASSIFIED	13.55	422	UNCLASSIFIED
8.93	422	UNCLASSIFIED	13.63	422	UNCLASSIFIED

UNDERDRAIN LAYOUT & QUANTITIES- RIGHT SIDE

COUNTY	ROUTE	PLAN SPLIT: LENGTH				01/STR/PV			
		LOG POINT		605		611			
		TO							
		LOG POINT			6" UNCLASSIFIED PIPE UNDERDRAINS	6" BASE PIPE UNDERDRAINS	6" CONDUIT, TYPE F FOR UNDERDRAIN OUTLETS	PRECAST REINFORCED CONCRETE OUTLET	
		SLM	MILE	FEET	FT	FT	FT	EACH	
CRA	602	4.25	4.55	0.30	1584	1,584		60	4
CRA	602	4.55	8.02	3.47	18322		18,322	360	24
CRA	602	8.02	9.53	1.51	7973	7,973		300	20
CRA	602	9.53	13.11	3.58	18902		18,902	405	27
CRA	602	13.11	13.21	0.10	528	528		30	2
CRA	602	13.21	13.53	0.32	1690		1,690	60	4
CRA	602	13.53	13.64	0.11	581	581		30	2
TOTALS CARRIED TO GENERAL SUMMARY					10,666	38,914	1245	83	

NOTE: THE LOCATIONS, LENGTHS, AND UNDERDRAIN TYPES SHOWN ON THIS SHEET ARE BASED ON AERIAL LIDAR DATA AND SHALL BE CONSIDERED APPROXIMATE. THE CONTRACTOR IS RESPONSIBLE FOR ENSURING THAT THE OUTLET LOCATIONS AND UNDERDRAIN TYPE INSTALLED AT EACH LOCATION ALLOW FOR POSITIVE DRAINAGE OUTLETTING NOT LESS THAN 6" ABOVE THE DITCHLINE.

THE OUTLET TYPES, SPACING, AND QUANTITIES SHOWN ARE CONSERVATIVE, AND ARE INTENDED TO ALLOW FOR ADJUSTMENT AND/OR LIMITED OMISSION OF OUTLET LOCATIONS AT THE DISCRETION OF THE ENGINEER, AS FIELD CONDITIONS INDICATE. SPACING OF OUTLETS AT 500' OR LESS IS PREFERRED, WITH 1000' MAXIMUM SPACING.