

## ACCESS PERMIT

THIS ACCESS PERMIT ("Permit") is made as of this 17<sup>th</sup> day of February, 2023 by and between THE BOARD OF PARK COMMISSIONERS OF THE CLEVELAND METROPOLITAN PARK DISTRICT ("Cleveland Metroparks") and Permittee designated below in consideration of Permittee's agreement to abide by the terms and conditions of this Permit.

1. Definitions.

a. "Permittee," "Reservation," "Park Manager," "Work," and "Term" shall have the definitions set forth on Exhibit A.

b. The "Permit Area" shall mean the area of the Reservation identified on the map attached hereto as Exhibit B.

2. Plans, Specifications, and Permits.

a. This Access Permit is necessary for Permittee to clear Right of Way and bid the Work. Prior to Permittee's selected contractor accessing the Permit Area, Permittee shall require that its contractor have an Access Permit in place with Cleveland Metroparks. If possible, as of the date of this agreement, Permittee shall provide the bidders of the Work with Cleveland Metroparks typical Access Permit. Otherwise, if project bidding documents are already final as of the date of this agreement, then Permittee's Project Engineer shall provide the contractor with a standard Cleveland Metroparks Access Permit document to process.

b. Prior to beginning the Work, Permittee shall submit its plans, specifications, and/or scope of work to Cleveland Metroparks for approval, which approval shall not be unreasonably withheld. Permittee's plans, specifications, and/or scope of work must comply with all applicable laws, ordinances, rules, regulations, and restrictions imposed by deed, easement, license and any other applicable legal instrument.

c. Prior to beginning the Work, Permittee shall obtain any and all necessary permits, authorizations, and other consents necessary to perform the Work.

3. Use of Permit Area.

a. Cleveland Metroparks grants Permittee permission to perform the Work in the Permit Area and to take such actions as described below as are necessary to perform the Work. Permittee may not undertake any other action without prior written approval of Cleveland Metroparks.

b. Permittee may remove from the Permit Area only that vegetation which is required for the Work. Permittee shall follow the Vegetation Removal Specifications set forth in Exhibit C.

c. Permittee shall remove from Cleveland Metroparks' property all topsoil and/or subsurface soil removed from the Permit Area unless Permittee requires such topsoil and/or dirt for backfilling and grading.

d. Permittee shall obtain approval from the Park Manager for all needed parking and storage in or around the Permit Area and shall adhere to any limitations, whether on time or location, on such parking and storage imposed by the Park Manager.

e. Permittee's work in the Permit Area shall not interfere with or restrict use of or access to the Reservation by Cleveland Metroparks' personnel or visitors. If traffic control measures or road closures are required, Permittee shall obtain approval for such traffic control measures or road closures from the Park Manager and work with the Park Manager and Cleveland Metroparks Rangers to secure traffic control measures or road closures in a manner that is least disruptive to Cleveland Metroparks' employees and visitors.

f. Permittee, at Permittee's sole cost and expense, shall repair and maintain any structure(s) associated with the Work in good condition throughout the Permit period, whether such repair or maintenance is required by reason of damage caused by human or natural causes. Permittee shall conduct such repairs and maintenance of its own accord, and at the request of Cleveland Metroparks. Permittee shall contact The Reservation Manager a minimum of two (2) calendar days prior to initiating the work on the structure(s). Repairs and/or maintenance shall include removal of graffiti and correction of any vandalism. In addition, if Permittee believes the design of the approved structure(s), or graphic presentations contained therein, require changes, Permittee shall propose the changes to Cleveland Metroparks for written approval at least ten (10) calendar days prior to implementation. All above-grade structures associated with the Work shall be removed completely and the Permit Area restored to its original condition at the termination of the Permit period, unless approved otherwise by Cleveland Metroparks by subsequent Permit or other valid legal instrument.

4. Use of Park Roadways.

a. Access for Permittee's vehicles entering the Permit Area shall be limited to the roadways identified in Exhibit A.

b. Cleveland Metroparks paved roadways and parking lots have a five (5) ton maximum gross vehicle weight limit. Permittee shall not allow any vehicle in excess of five (5) tons on any Cleveland Metroparks pavement. Should Permittee or Permittee's suppliers, subcontractors, partners or agents violate this provision, Permittee is responsible for all damages resulting from such vehicles, including cracking, faulting, displacement, rutting and disintegration, and is responsible for the cost of all necessary repairs.

c. Permittee must keep all Cleveland Metroparks roadways, trails and other public areas clear of construction debris, spillage and mud on a daily basis.

5. Restoration of Permit Area.

a. Permittee shall follow the Road, Trail, Vegetation and Seed Specifications set forth in Exhibit C unless the Parties agree to alternate methods of repairing or replacing trails, roads, and vegetative areas.

b. Permittee shall restore all other surfaces to conditions approved by Cleveland Metroparks.

6. Inspection. Cleveland Metroparks shall have the right with prior advance notice to enter into the Permit Area at any time to inspect the Work.

7. Indemnification. Permittee

as an agency of the State of Ohio, is self-insured and its liability may only be determined under Chapter 2743 of the Ohio Revised Code. Permittee, shall, however, require of its Project Contractor to obtain and maintain commercial general liability insurance together with other relevant insurance coverages as are required under Section 107.12 of Permittee's Construction and Materials Specifications (Online 2019 Edition as amended through January 17, 2020- Online version). Moreover, for purposes of that Section, this Access Permit shall be the equivalent of or an agreed substitution for a Temporary Easement such that the obligation to indemnify shall extend to Cleveland Metroparks as the fee owner of the property that is a political subdivision of the State of Ohio. However, Permittee's selected contractor shall enter into an Access Permit with Cleveland Metroparks that includes indemnification language, as is standard in Cleveland Metroparks' Access Permits.

8. Insurance. Permittee as an agency of the State of Ohio, is self-insured. Permittee shall cause to be maintained by its construction contractor the insurance detailed in Exhibit D, consistent with Section 107.12 of the ODOT Construction and Materials Specifications (Online Version updated to 1/1/7/20).

9. Termination by Cleveland Metroparks. If at any time Permittee ceases to use the Permit Area for the Work or if Permittee fails to comply with any provision of this Agreement and such failure continues for two (2) days after Cleveland Metroparks has provided notice of the failure, Cleveland Metroparks may terminate the Permit. If the failure cannot be corrected in two (2) days but Permittee can show Cleveland Metroparks that it has taken substantial steps to correct the failure, Cleveland Metroparks may accept those substantial steps as compliance with the terms of this Agreement and choose not to terminate. Upon termination of the Permit, Permittee shall return the Permit Area to the condition existing before being disturbed as set forth in Section 5.

10. Choice of Law; Jurisdiction. This Agreement shall be governed by the laws of the State of Ohio regardless of any choice of law principles. All actions arising from or relating to this Agreement or the Work or a claim of breach of this Agreement shall be instituted and prosecuted exclusively in a court of competent jurisdiction located in Franklin County, Ohio, as provided in Section 5501.22 of the Ohio Revised Code .

11. Publicity; Public Records. Permittee shall not discuss this Permit or its contents with the media, use Cleveland Metroparks' name or logos or issue any press release or other public statement related hereto, unless authorized in writing by Cleveland Metroparks, which authorization may be withdrawn by Cleveland Metroparks at any time. Permittee acknowledges that this Permit and other records in the possession or control of Cleveland Metroparks regarding the Work may be public records under Ohio Revised Code Section 149.43 and may be open to public inspection unless a legal exemption applies.

12. Miscellaneous. This Permit constitutes the entire agreement between the parties with respect to the subject matter hereof and supersedes all prior agreements, written or oral, with respect thereto. This Permit may not be modified except in writing signed by Cleveland Metroparks and Permittee. If any provision of this Permit shall be or become invalid or unenforceable, then this Permit shall be divisible, and the remainder of the Permit shall be valid and binding as though such provision were not included therein. Nothing herein creates any rights in or remedies on behalf of any third party. This Permit may be executed in counterparts, each of which shall be deemed an original and all of which shall constitute one instrument. By entering into this Permit, the Parties agree on behalf of themselves, their officers, employees, subcontractors, sub-grantees, agents or assigns, that this transaction may be conducted by electronic means by agreeing that all documents requiring signatures by the Parties may be

executed by electronic means, and that the electronic signatures affixed by the Parties to said documents shall have the same legal effect as if that signature was manually affixed to a paper version of the document. The Parties also agree to be bound by the provisions of Chapter 1306 of the Ohio Revised Code as it pertains to electronic transactions.

[SIGNATURE PAGE FOLLOWS]

BOARD OF PARK COMMISSIONERS OF THE  
CLEVELAND METROPOLITAN PARK DISTRICT

Date: 02.17.2023



Christopher J. Papp, P.E.  
Park District Civil Engineer

Approved as to legal for by Rosalina M. Fini,  
Chief Legal & Ethics Officer



Kyle G. Baker, Assistant Legal Counsel

OHIO DEPARTMENT OF TRANSPORTATION Date: 2/17/2023



Jack Marchbanks, PhD.  
Director  
By: Matthew Schulz, P.E.  
Real Estate Administrator

Approved as to legal form for ODOT

**For Use by ODOT Office of Chief  
Legal Counsel Only:**



Date reviewed: 02/08/2023

## EXHIBIT A

"Permittee" shall mean *Ohio Department of Transportation, 1980 West Broad Street, Columbus, Ohio 43223, having its District 12 offices at 5500 Transportation Boulevard, Garfield Heights, Ohio 44125. The local contact for Permittee will be Matthew Schulz, P.E., District 12 Real Estate Administrator who can be contacted at 5500 Transportation Boulevard, Garfield Heights, Ohio 44125, 216-584-2117, Matthew.Schulz@dot.ohio.gov.*

"Reservation" shall mean the *Rocky River Reservation* in the Cleveland Metropolitan Park District.

"Park Manager" shall mean *Rick Ditch* who can be contacted at 440-331-8287 & 440-679-1264, [rdd@clevelandmetroparks.com](mailto:rdd@clevelandmetroparks.com) and *Chad Heck* who can be contacted at 440-331-8732 & 440-679-1239, [rwh@clevelandmetroparks.com](mailto:rwh@clevelandmetroparks.com)

"Term" shall mean the time period commencing on the date Cleveland Metroparks receives this executed Permit and shall continue until *December 31, 2023*.

"Work" shall mean a *continuation of the work that was started in project CUY-10-0869 PID 22131. A Metroparks Access Permit was issued for that project on 11-06-2019. For this work, the project includes the repair and/or replacement of non-functioning downspouts on the bridge, the painting of Towers 4 through 7, and the repair of deteriorated steel members.*

*Final plans are also attached for reference.*

Permittee shall access the Permit Area using the following roadways: *Access to the bridge will be from Valley Parkway or from the top of the bridge.*

*There are no temporary or permanent alterations to park property at the SR-10 bridge site.*

*The access drives would be stone drives built per ODOT Construction & Material Specifications (2019). These drives would be removed upon completion of the work. Estimated five (5) workers will be needed to install the downspouts, with the following required equipment: aerial lift, backhoe, and utility truck. Times for parking would be 7:00 AM - 5:00 PM Monday-Friday.*

EXHIBIT B  
The Permit Area

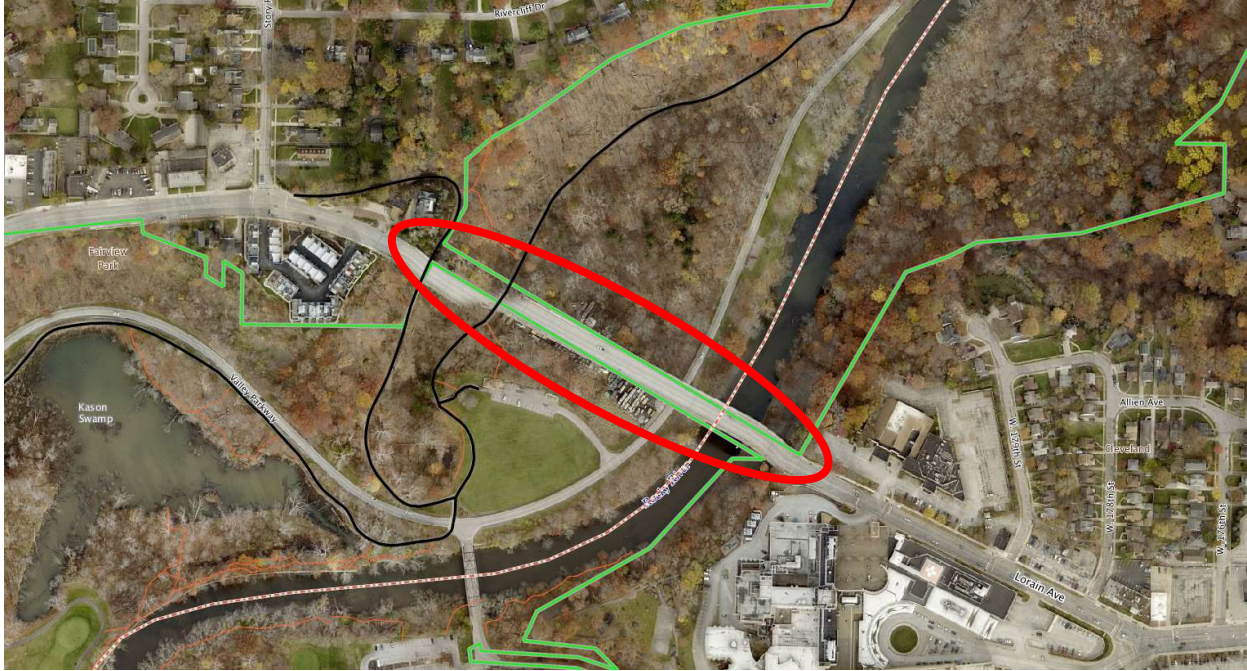

CUY-10 Bridge

## EXHIBIT C

### All Purpose Trail Specifications.

- All repair areas will be full width; partial width patches will not be permitted.
- After existing asphalt removed, existing subbase shall be inspected by Cleveland Metroparks and direction given as to re-grading and compaction or subbase replacement.
- Subbase shall be replaced as directed with not less than 6" ODOT CMS item 304 limestone aggregate (not slag), compacted, and placed on proof rolled subgrade.
- Installation of not less than 3" ODOT CMS item 448 Asphaltic Concrete.
- Asphalt joints shall be "butt" type, perpendicular to trail alignment and saw-cut full asphalt depth, no "feather" edges permitted, and sealed per ODOT CMS 705.04.
- Compliance of all materials with requirements of State of Ohio, Department of Transportation, and Construction & Material Specifications.
- It is advised that the Permittee video/photograph the access trails and roadways prior to commencing activities.

### Road and Parking Lot Specifications

- Repair area(s) will be delineated by paint lines as agreed by Cleveland Metroparks.
- Repair area will be milled per ODOT CMS 254 to a depth of three (3) inches, all edges will be vertical (no "feather edges" will be permitted), all cuttings will be completely removed.
- Tack coat per ODOT CMS 407 will be applied.
- Installation of not less than 3" ODOT CMS item 448 Asphaltic Concrete surface course to match prevailing pavement cross-slope.
- Full depth asphalt pavement repair, where required by Cleveland Metroparks, will include an additional 6" ODOT CMS 301 bituminous aggregate base and 6" ODOT CMS 304 subbase aggregate.
- Asphalt joints shall be sealed per ODOT CMS 705.04.
- All pavement striping damaged or destroyed by Permittee will be replaced per ODOT CMS 641 and 642.

### Seed Specifications

- All soil areas disturbed by Permittee's activities shall be seeded and mulched per ODOT CMS 659.
- The seed mixture for restoration of lawn and roadside areas shall be a mixture of 20% Kentucky 31 Fescue, 25% common Kentucky Bluegrass, 20% Manhattan Rye Grass, and 35% Creeping Red Fescue at the rate of eight (8) pounds per one thousand square feet (8:1000).
- When specifically required, other areas shall be seeded with ODOT CMS 659 Type 5B Native Wildflower and Grass Mixture or, in certain situations, a mix specified by Cleveland Metroparks Natural Resources Division.
- Mulching material shall conform to ODOT CMS 659.
- Topsoil shall conform to ODOT CMS 653.

### Vegetation Removal Specifications

- Permittee may remove from the Permit Area only that brush necessary to perform the Work and as approved by Cleveland Metroparks in a site visit prior to initiation of the Work.
- Permittee may remove only those trees (four (4) inches DBH or greater) as marked by Permittee and approved by Cleveland Metroparks in a site visit prior to initiation of the Work. Permittee



must replace all removed trees at a 2:1 ratio, species and size as specified by Cleveland Metroparks. Permittee shall provide deer protection for newly planted trees, using Cleveland Metroparks approved plastic mesh tree guards or wire fencing to protect the stem for a height of at least forty-eight (48) inches. Tree protectors should fit loosely around stems.

- Permittee shall not clear cut the Permit Area unless permitted in writing by Cleveland Metroparks.
- Permittee shall properly dispose of all removed vegetation within seven (7) calendar days of cutting the vegetation unless otherwise approved in writing by Cleveland Metroparks

#### Maintenance of Traffic Requirements

- All work impacting traffic on Cleveland Metroparks' thoroughfares shall comply the latest version of the Ohio Manual of Uniform Traffic Control Devices (OMUTCD).
- Any staging done on Cleveland Metroparks' property shall be done in a manner as to not impede traffic, parking, sight distances, or to present a hazard to the traveling public.
- Any damage incurred due to staging shall be restored to pre-work condition and to the satisfaction of the Cleveland Metroparks.

EXHIBIT D  
Insurance Requirements

[State or County Government Permittee:]

Permittee understands that insurance carried by Cleveland Metroparks will not include insurance related to the Activities. Permittee as an agency of the State of Ohio is self-insured and with the signing of this Permit is providing a certificate demonstrating that.

Permittee shall, consistent with Section 107.12 of the ODOT Construction and Materials Specifications (Online Version updated to 1/17/20), direct awarded contractor to provide a Certificate of Insurance prior to entering Cleveland Metroparks property that will maintain and pay for, or cause to be maintained and paid for:

- (i) commercial general liability insurance, including without limitation contractual liability coverage, products and completed operations coverage, and coverage for collapse, underground exposure, and explosion hazards; and
- (ii) commercial automobile liability insurance for owned, hired, and non-owned automobiles.

Such insurance (A) shall insure against claims for bodily injury (including death) and property damage, with each policy having a combined single limit of not less than \$1,000,000 per occurrence, (B) shall be primary to any insurance maintained by Cleveland Metroparks, and (C) shall name the Board of Park Commissioners of the Cleveland Metropolitan Park District as an additional insured.

Certificates of insurance evidencing the aforementioned coverage(s) shall be provided to Cleveland Metroparks prior to commencement of the work. Cleveland Metroparks reserves the right to request a full and complete copy of all insurance policies. Awarded contractors coverage may not be cancelled or materially changed until at least ten (10) days after written notice to Cleveland Metroparks. The aforementioned insurance coverage(s) shall be placed with an insurance company listed in the latest edition of “Best’s Insurance Guide and Key Ratings” with a policy rating of at least A-, X.

As is provided in Section 7 above, for purposes of Permittee’s Section 107.12 of its Construction and Materials Specifications that are incorporated into Permittee’s bridge repair construction contract (that states “**107.12 Responsibility for Damage Claims and Liability Insurance.** The Contractor shall indemnify and save harmless the State and all of its representatives, municipalities, counties, public utilities, any affected railroad or railway company, and any fee owner from whom a temporary Right-of-Way was acquired for the Project from all suits, actions, claims, damages, or costs of any character brought on account of any injuries or damages sustained by any person or property on account of any negligent act or omission by the Contractor or its subcontractors or agents in the prosecution or safeguarding of the Work.”), this Access Permit shall be considered to be the equivalent of or a substitution for a Temporary Right-of-Way such that the requirement for indemnification shall include Cleveland Metroparks which is both a political subdivision of the State of Ohio and the fee owner of property on and over which construction work is being allowed.

[Federal Permittee:]

Permittee shall maintain self-insurance for, or otherwise self-finance, claims for bodily injury (including death) and property damage related to this Permit, the Permit Area, and the Activities or Improvements in accordance with its customary practices.



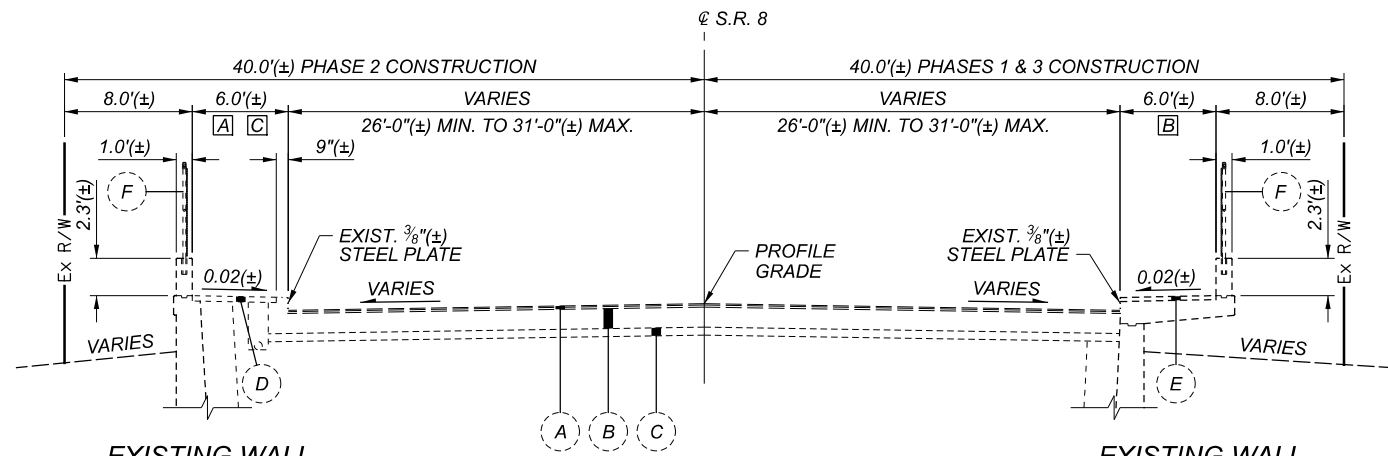

**EXISTING WALL**

STA. 39+24.25(±) TO STA. 41+75.00(±)

**EXISTING SECTION - S.R. 8**

STA. 22+92.25(±) TO STA. 23+17.25(±)  
 STA. 39+24.25(±) TO STA. 44+50.00(±)

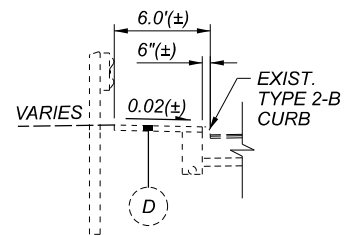

**SIDEWALK DETAIL C**

STA. 41+75.00(±) TO STA. 42+25.00(±)

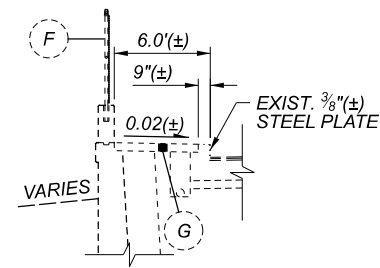

**SIDEWALK DETAIL A**

STA. 22+92.25(±) TO STA. 23+17.25(±)  
 STA. 39+24.25(±) TO STA. 39+49.25(±)

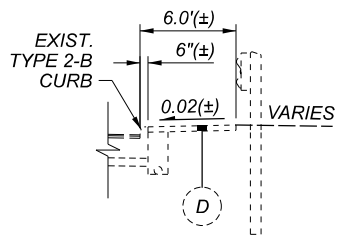

**SIDEWALK DETAIL B**

STA. 39+90.00(±) TO STA. 41+77.00(±)

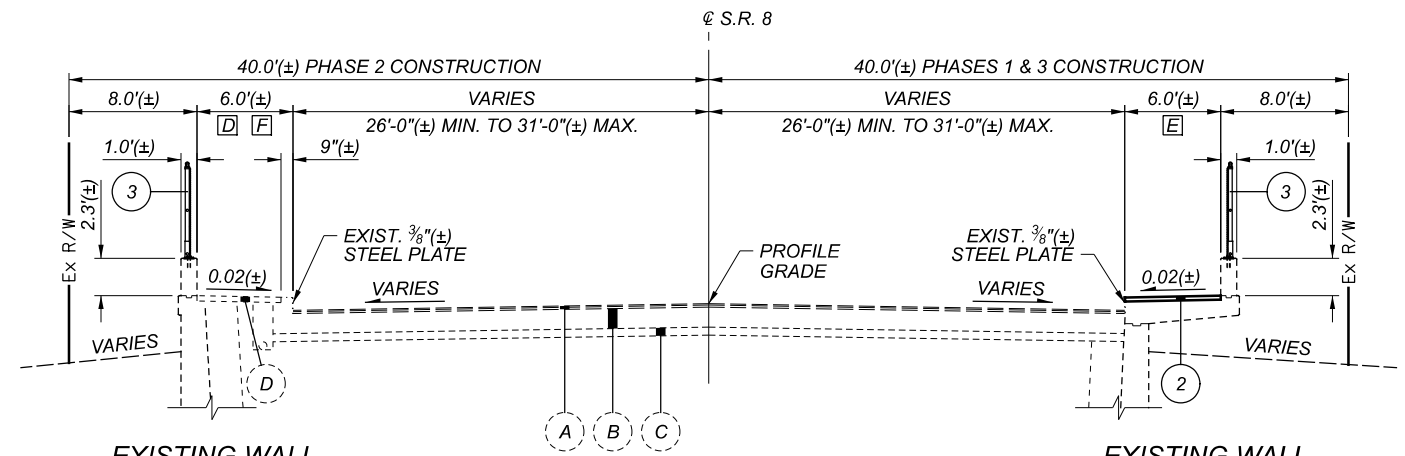

**EXISTING WALL**

STA. 39+49.25(±) TO STA. 41+75.00(±)

**NORMAL SECTION - S.R. 8**

STA. 22+92.25(±) TO STA. 23+17.25(±)  
 STA. 39+24.25(±) TO STA. 44+50.00(±)

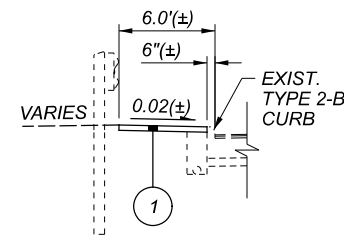

**SIDEWALK DETAIL F**

**SIDEWALK REPLACEMENT LIMITS**  
 STA. 41+75.00(±) TO STA. 41+95.00(±);  
 EXISTING SIDEWALK DETAIL C  
 STA. 41+95.00(±) TO STA. 42+25.00(±)

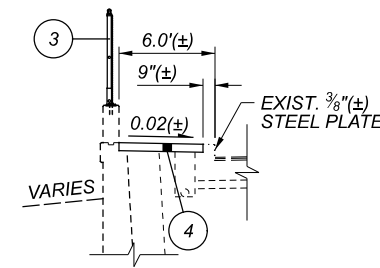

**SIDEWALK DETAIL D**

**SIDEWALK REPLACEMENT LIMITS**  
 STA. 23+02.25(±) TO STA. 23+17.25(±)  
 STA. 39+24.25(±) TO STA. 39+49.25(±);  
 EXISTING SIDEWALK DETAIL A  
 STA. 22+92.25(±) TO STA. 23+02.25(±)

**LEGEND**

- |   |  |
|---|--|
| (A) EXISTING 2"± ASPHALT CONCRETE   | (1) ITEM 608 - 4" CONCRETE WALK  |
| (B) EXISTING 8"± PORTLAND CEMENT CONCRETE BASE OR EXISTING 15"± REINFORCED CONCRETE APPROACH SLAB | (2) ITEM 511 - CLASS QC2 CONCRETE, SIDEWALK WEARING SURFACE, AS PER PLAN |
| (C) EXISTING 6"± SUBBASE  | (3) ITEM 607 - VANDAL PROTECTION FENCE, 6' STRAIGHT, COATED FABRIC       |
| (D) EXISTING 4"± CONCRETE WALK  | (4) ITEM 608 - 6" CONCRETE WALK  |
| (E) EXISTING 3"± CONCRETE WALK WEARING SURFACE  |  |
| (F) EXISTING CHAIN LINK FENCE   |  |
| (G) EXISTING 6"± CONCRETE WALK  |  |

**UTILITIES**

LISTED BELOW ARE ALL UTILITIES LOCATED WITHIN THE PROJECT CONSTRUCTION LIMITS TOGETHER WITH THEIR RESPECTIVE OWNERS:

**CUY-8-0226:**

AT&T OHIO  
13630 LORAIN AVE. – 2ND FLOOR  
CLEVELAND, OH 44111  
ATTN: PETER JANIS  
PHONE: 216-476-6142  
EMAIL: PJ8191@ATT.COM

CITY OF BEDFORD  
120 SOLON RD.  
BEDFORD, OH 44146  
ATTN: CLINT BELLAR  
PHONE: 440-735-6583  
EMAIL: CBELLAR@BEDFORDOH.GOV

CITY OF CLEVELAND DIVISION OF WATER  
1201 LAKESIDE AVE.  
CLEVELAND, OH 44114  
ATTN: FRED ROBERTS  
PHONE: 216-664-2444, EXT. 75590  
EMAIL: FRED\_ROBERTS@CLEVELANDWATER.COM

ENERGY TRANSFER COMPANY (FORMERLY SUNOCO PIPELINE)  
ATTN: ENCROACHMENT DEPARTMENT  
EMAIL: ENCROACHMENTS@ENERGYTRANSFER.COM

LUMEN (FORMERLY CENTURYLINK/LEVEL3)  
4000 CHESTER AVE.  
CLEVELAND, OH 44103  
ATTN: DOUG HOLLOWAY  
PHONE: 216-426-6010  
EMAIL: DOUG.HOLLOWAY@LUMEN.COM

**CUY-10-0869:**

DOMINION ENERGY  
320 SPRINGSIDE DR., SUITE 320  
AKRON, OH 44333  
ATTN: 2ND FLOOR RELOCATION DESIGN  
PHONE: 330-664-2409  
EMAIL: RELOCATION@DOMINIONENERGY.COM

FIRST ENERGY/CEI  
6896 MILLER RD.  
BRECKSVILLE, OH 44141  
ATTN: JOHN ZASSICK  
PHONE: 440-546-8706  
EMAIL: JMZASSICK@FIRSTENERGYCORP.COM

THE LOCATION OF THE UNDERGROUND UTILITIES SHOWN ON THE PLANS ARE AS OBTAINED FROM THE OWNERS AS REQUIRED BY SECTION 153.64 O.R.C.

IF ANY UTILITIES ARE DAMAGED DURING CONSTRUCTION ACTIVITIES, THE CONTRACTOR SHALL IMMEDIATELY NOTIFY THE ENGINEER AND THE APPROPRIATE UTILITY OWNER(S).

**CLEVELAND METROPARKS**

LISTED BELOW IS THE CONTACT FOR THE CLEVELAND METROPARKS, WHICH IS LOCATED BELOW BOTH BRIDGES ON THIS PROJECT.

RICK DITCH  
4101 FULTON PARKWAY  
CLEVELAND, OH 44144  
PHONE: 440-679-1264

**EXISTING SITE CONDITIONS**

FIRST ENERGY HIGH VOLTAGE ELECTRIC LINES AND AT&T CABLES RUN OVERHEAD THE LENGTH OF THE CUY-8-0226 BRIDGE. THE CONTRACTOR IS URGED TO VIEW THE SITE (PER CMS 102.05) BEFORE BIDDING SO HIS/HER MEANS AND METHODS WILL BE APPROPRIATE FOR THE SITE CONDITIONS. NO EXTRA COMPENSATION WILL BE GIVEN FOR ADJUSTMENTS TO MEANS AND METHODS FOR EXISTING SITE CONDITIONS.

**EXISTING PLANS**

EXISTING PLANS ENTITLED CUY-8-2.26 (1983, 2000, 2011, AND 2014) LORAIN ROAD VIADUCT, CUY-10-8.65, CUY-10-8.69, CUY-480-6.47/NAR PAINT, D12-BH FY2019 MISC. MAY BE INSPECTED IN THE ODOT DISTRICT 12 OFFICE IN GARFIELD HEIGHTS, OHIO.

**CONSTRUCTION NOISE**

ACTIVITIES AND LAND USE ADJACENT TO THIS PROJECT MAY BE AFFECTED BY CONSTRUCTION NOISE. IN ORDER TO MINIMIZE ANY ADVERSE CONSTRUCTION NOISE IMPACTS, DO NOT OPERATE POWER-OPERATED CONSTRUCTION-TYPE DEVICES BETWEEN THE HOURS OF 9:00 PM AND 7:00 AM. IN ADDITION, DO NOT OPERATE AT ANY TIME ANY DEVICE IN SUCH A MANNER THAT THE NOISE CREATED SUBSTANTIALLY EXCEEDS THE NOISE CUSTOMARILY AND NECESSARILY ATTENDANT TO THE REASONABLE AND EFFICIENT PERFORMANCE OF SUCH EQUIPMENT.

**WORK LIMITS**

THE WORK LIMITS SHOWN ON THESE PLANS ARE FOR PHYSICAL CONSTRUCTION ONLY. PROVIDE THE INSTALLATION AND OPERATION OF ALL WORK ZONE TRAFFIC CONTROL AND WORK ZONE TRAFFIC CONTROL DEVICES REQUIRED BY THESE PLANS WHETHER INSIDE OR OUTSIDE THESE WORK LIMITS.

**CONTINGENCY QUANTITIES**

THE CONTRACTOR SHALL NOT ORDER MATERIALS OR PERFORM WORK FOR ITEMS DESIGNATED BY PLAN NOTE TO BE USED "AS DIRECTED BY THE ENGINEER" UNLESS AUTHORIZED BY THE ENGINEER.

**CLEARING AND GRUBBING**

ALTHOUGH THERE ARE NO TREES OR STUMPS SPECIFICALLY MARKED FOR REMOVAL WITHIN THE LIMITS OF THE PROJECT, A LUMP SUM QUANTITY IS INCLUDED IN THE GENERAL SUMMARY FOR ITEM 201, CLEARING AND GRUBBING. ALL PROVISIONS AS SET FORTH IN THE SPECIFICATIONS UNDER THIS ITEM ARE INCLUDED IN THE LUMP SUM PRICE BID FOR ITEM 201, CLEARING AND GRUBBING.

**AIRWAY/HIGHWAY CLEARANCE FOR AIRPORTS AND HELIPORTS**

THE CUY-10-0869 BRIDGE ON THIS PROJECT HAS BEEN IDENTIFIED AS BEING WITHIN THE INFLUENCE AREA OF A PUBLIC USE AIRPORT OR HELIPORT. NO TEMPORARY STRUCTURES OR CONSTRUCTION EQUIPMENT AT MAXIMUM OPERATING HEIGHT SHALL EXCEED A HEIGHT OF 189 FT FOR THE CUY-10-0869 BRIDGE. IF ANY TEMPORARY STRUCTURES OR CONSTRUCTION EQUIPMENT WILL EXCEED THIS HEIGHT, FURTHER COORDINATION WITH THE FEDERAL AVIATION ADMINISTRATION (FAA), AND ODOT OFFICE OF AVIATION, WILL BE NECESSARY PRIOR TO ERECTING SUCH TEMPORARY STRUCTURES OR OPERATING SUCH EQUIPMENT ON THE PROJECT. THE CONTRACTOR WILL BE REQUIRED TO SUBMIT FORM 7460-1 TO THE FAA. NOTIFY THE ODOT OFFICE OF AVIATION WHEN SUBMITTING FAA FORM 7460-1.

NO TEMPORARY STRUCTURES OR CONSTRUCTION EQUIPMENT SHALL EXCEED THE PERMISSIBLE HEIGHT, UNTIL A COPY OF THE FAA APPROVAL AND THE ODOT OFFICE OF AVIATION PERMIT HAS BEEN FURNISHED TO THE PROJECT ENGINEER.

FEDERAL AVIATION ADMINISTRATION  
SOUTHWEST REGIONAL OFFICE  
OBSTRUCTION EVALUATION GROUP  
10101 HILLWOOD PARKWAY  
FORT WORTH, TX 76177  
FAX: (817) 222-5920  
HTTP://CEAAA.FAA.GOV

OHIO DEPARTMENT OF TRANSPORTATION  
OFFICE OF AVIATION  
2829 WEST DUBLIN-GRANVILLE ROAD  
COLUMBUS, OHIO 43235  
OHIO.AIRPORT.PROTECTION@DOT.OHIO.GOV

**ENDANGERED BAT SPECIES HABITAT REMOVAL**

THE PROJECT IS LOCATED WITHIN THE KNOWN HABITAT RANGES OF THE FEDERALLY ENDANGERED NORTHERN LONG-EARED AND INDIANA BAT, AND THE STATE ENDANGERED LITTLE BROWN AND TRICOLORED BATS. NO TREES SHALL BE REMOVED UNDER THIS PROJECT FROM APRIL 1 THROUGH SEPTEMBER 30. ALL NECESSARY TREE REMOVAL SHALL OCCUR FROM OCTOBER 1 THROUGH MARCH 31. THIS REQUIREMENT IS NECESSARY TO AVOID AND MINIMIZE IMPACTS TO THESE SPECIES AS REQUIRED BY THE ENDANGERED SPECIES ACT AND ORC 1531.25. FOR THE PURPOSES OF THIS NOTE, A TREE IS DEFINED AS A LIVE, DYING, OR DEAD WOODY PLANT, WITH A TRUNK 3 INCHES OR GREATER IN DIAMETER AT A HEIGHT OF 4.5 FEET ABOVE THE GROUND SURFACE, AND WITH A MINIMUM HEIGHT OF 13 FEET.

**ENVIRONMENTAL COMMITMENTS:**

1. THE OHIO DEPARTMENT OF TRANSPORTATION WILL OBTAIN ALL APPROPRIATE WATERWAY PERMITS PRIOR TO ANY WORK WITH THE JURISDICTIONAL BOUNDARY OF ANY WATERWAY, INCLUDING WETLANDS, AND ALL APPLICABLE WATERWAY PERMIT CONDITIONS WILL BE INCLUDED IN THE PLANS AND ADHERED TO DURING CONSTRUCTION.
2. THE PROJECT DESIGNER SHALL INCORPORATE THE ENDANGERED BAT SPECIES HABITAT REMOVAL NOTE INTO THE PLANS.
3. TREE REMOVAL AMM 3: ENSURE TREE REMOVAL IS LIMITED TO THAT SPECIFIED IN PROJECT PLANS BY CLEARLY MARKING CLEARING LIMITS. ENSURE THAT CONTRACTORS UNDERSTAND CLEARING LIMITS AND HOW THEY ARE MARKED IN THE FIELD.
4. THE CONTRACTOR WILL SUBMIT THE COMPLETED NOTIFICATION FORM TO OEPA AT LEAST 10 DAYS PRIOR TO DEMOLITION.
5. TREE REMOVAL AMM 1: MODIFY ALL PHASES/ASPECTS OF THE PROJECT (E.G., TEMPORARY WORK AREAS, ALIGNMENTS) TO AVOID TREE REMOVAL IN EXCESS OF WHAT IS REQUIRED TO IMPLEMENT THE PROJECT SAFELY.
6. TREE REMOVAL AMM 2(A) (OH PBO: A-1): TIME OF YEAR RESTRICTIONS FOR TREE REMOVAL WHEN BATS ARE NOT LIKELY TO BE PRESENT. TO AVOID IMPACTS TO SUMMER ROOSTING BATS, SWH WILL BE CLEARED ONLY BETWEEN OCTOBER 1 AND MARCH 31, WHEN THE SPECIES WOULD NOT BE PRESENT.

DESIGN AGENCY



DESIGNER

JAM

REVIEWER

MJL 10/24/22

PROJECT ID

113674

SHEET

TOTAL

3 | 82

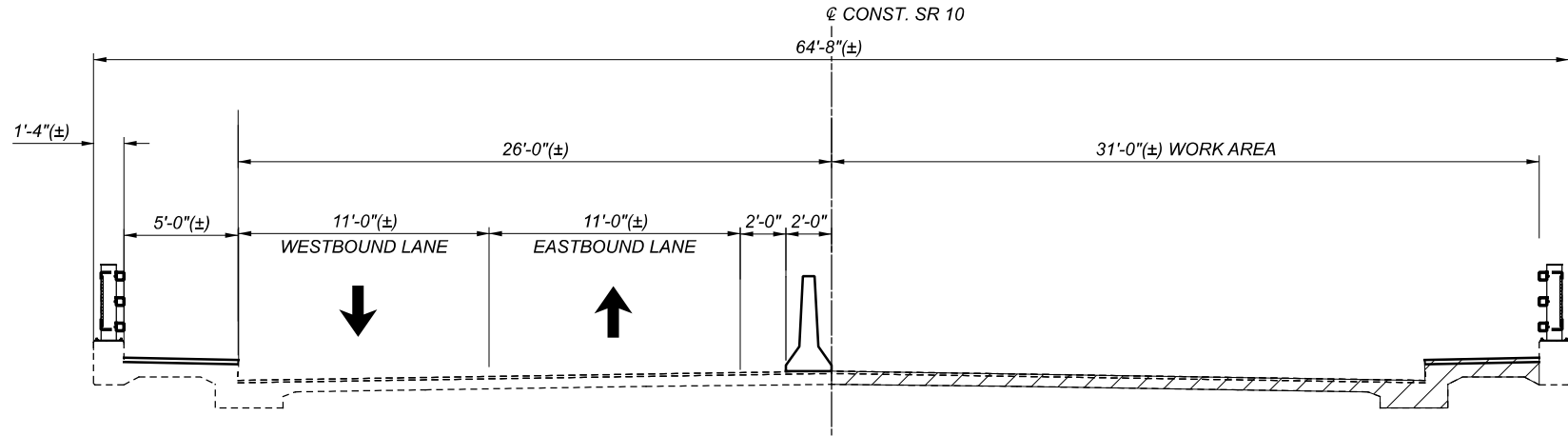

**TYPICAL MAINTENANCE OF TRAFFIC - BRIDGE NO. CUY-10-0869 - PHASE 1 & 3**  
 STA. 458+75 TO STA. 471+11

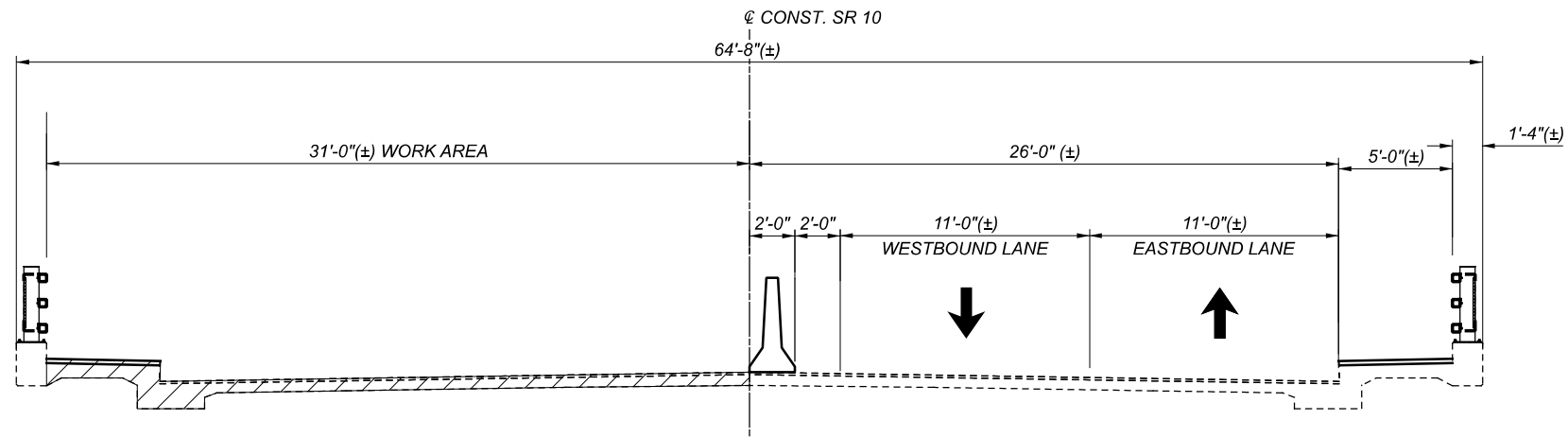

**TYPICAL MAINTENANCE OF TRAFFIC - BRIDGE NO. CUY-10-0869 - PHASE 2**  
 STA. 458+75 TO STA. 471+11

MAINTENANCE OF TRAFFIC

CONSTRUCTION PHASING:

PHASE 1: ONE LANE OF TRAFFIC MAINTAINED IN EACH DIRECTION ON THE WESTBOUND LANES WHILE THE EASTBOUND LANES ARE CONSTRUCTED. PEDESTRIANS ARE DETOURED TO THE WESTBOUND LANES.

PHASE 2: ONE LANE OF TRAFFIC MAINTAINED IN EACH DIRECTION ON THE EASTBOUND LANES WHILE THE WESTBOUND LANES ARE CONSTRUCTED. PEDESTRIANS ARE DETOURED TO THE EASTBOUND LANES.

PHASE 3: ONE LANE OF TRAFFIC MAINTAINED IN EACH DIRECTION ON THE WESTBOUND LANES WHILE THE FINAL STRIP SEAL IS INSTALLED. PEDESTRIANS ARE DETOURED TO THE WESTBOUND LANES. TRAFFIC IS RESTORED TO THE RECONSTRUCTED BRIDGE.

TEMPORARY TRAFFIC CONTROL NOTES:

1. A MINIMUM OF ONE LANE OF TRAFFIC IN EACH DIRECTION SHALL BE MAINTAINED AT ALL TIMES BY USE OF THE EXISTING PAVEMENT AND THE COMPLETED PAVEMENT USING ITEMS 410 AND 614.

2. LENGTH AND DURATION OF LANE CLOSURES AND RESTRICTIONS SHALL BE AT THE APPROVAL OF THE ENGINEER. IT IS THE INTENT TO MINIMIZE THE IMPACT TO THE TRAVELING PUBLIC. LANE CLOSURES OR RESTRICTIONS OVER SEGMENTS OF THE PROJECT IN WHICH NO WORK IS ANTICIPATED WITHIN A REASONABLE TIME FRAME, AS DETERMINED BY THE ENGINEER, SHALL NOT BE PERMITTED. THE LEVEL OF UTILIZATION OF MAINTENANCE OF TRAFFIC DEVICES SHALL BE COMMENSURATE WITH THE WORK IN PROGRESS.

3. NOTICE OF CLOSURE SIGNS (W20-H13) SHALL BE ERECTED BY THE CONTRACTOR PRIOR TO THE SCHEDULED ROAD CLOSURE IN ACCORDANCE WITH THE NOTICE OF CLOSURE TIME TABLE BELOW.

THE SIGNS SHALL BE ERECTED ON THE RIGHT-HAND SIDE OF THE ROAD FACING TRAFFIC. THEY SHALL BE PLACED SO AS NOT TO INTERFERE WITH THE VISIBILITY OF ANY OTHER TRAFFIC CONTROL SIGNS. ON ROADWAYS, THEY SHOULD BE ERECTED AT OR NEAR THE POINT OF CLOSURE.

NOTICE OF CLOSURE SIGN TIME TABLE

ITEM	DURATION OF CLOSURE	SIGN DISPLAYED TO PUBLIC
	=2 WEEKS	14 CALENDAR DAYS PRIOR TO CLOSURE
ROAD CLOSURES	> 12 HOURS	7 CALENDAR DAYS PRIOR TO CLOSURE
	< 2 WEEKS	
	<= 12 HOURS	2 BUSINESS DAYS PRIOR TO CLOSURE

THE SIGN SHALL DISPLAY THE DATE OF THE CLOSURE IN MM-DD FORMAT AND THE NUMBER OF DAYS OF THE CLOSURE. THE LAST LINE OF THE W20-H13 SIGN LISTS A PHONE NUMBER WHICH A MOTORIST MAY CALL FOR ADDITIONAL INFORMATION. THIS IS TO BE A SPECIFIC OFFICE WITHIN THE DISTRICT RATHER THAN THE GENERAL SWITCHBOARD NUMBER.

ITEM 614, LAW ENFORCEMENT OFFICER (WITH PETROL CAR) FOR ASSISTANCE DURING CONSTRUCTION OPERATIONS

USE OF LAW ENFORCEMENT OFFICERS (LEOS) BY CONTRACTORS OTHER THAN THE USES SPECIFIED BELOW WILL NOT BE PERMITTED AT PROJECT COST. LEOS SHOULD NOT BE USED WHERE THE OMUTCD INTENDS THAT FLAGGERS BE USED.

IN ADDITION TO THE REQUIREMENTS OF C&MS 614 AND THE OMUTCD, A UNIFORMED LEO WITH AN OFFICIAL PATROL CAR (CAR WITH TOP-MOUNTED EMERGENCY FLASHING LIGHTS AND COMPLETE MARKINGS OF THE APPROPRIATE LAW ENFORCEMENT AGENCY) SHALL BE PROVIDED FOR THE FOLLOWING TRAFFIC CONTROL TASKS:

DURING THE ENTIRE ADVANCE PREPARATION AND CLOSURE SEQUENCE WHERE COMPLETE BLOCKAGE OF TRAFFIC IS REQUIRED.

DURING A TRAFFIC SIGNAL INSTALLATION WHEN IMPACTING THE NORMAL FUNCTION OF THE SIGNAL OR THE FLOW OF TRAFFIC, OR WHEN TRAFFIC NEEDS TO BE DIRECTED THROUGH AN ENERGIZED TRAFFIC SIGNAL CONTRARY TO THE SIGNAL DISPLAY (E.G., DIRECTING MOTORISTS THROUGH A RED LIGHT).

IN ADDITION TO THE REQUIREMENT OF C&MS 614 AND THE OMUTCD, A UNIFORMED LEO WITH AN OFFICIAL PATROL CAR (CAR WITH TOP-MOUNTED EMERGENCY FLASHING LIGHTS AND COMPLETE MARKINGS OF THE APPROPRIATE LAW ENFORCEMENT AGENCY) SHOULD BE PROVIDED FOR THE FOLLOWING TRAFFIC CONTROL TASKS AS APPROVED BY THE ENGINEER:

FOR LANE CLOSURES: DURING INITIAL SET-UP PERIODS, TEAR DOWN PERIODS, SUBSTANTIAL SHIFTS OF A CLOSURE POINT OR WHEN NEW LANE CLOSURE ARRANGEMENTS ARE INITIATED FOR LONG-TERM LANE CLOSURES/SHIFTS (FOR THE FIRST AND LAST DAY OF MAJOR CHANGES IN TRAFFIC CONTROL SETUP).

"WITHOUT POSITIVE PROTECTION" MEANS USE OF DRUMS, CONES, SHADOW VEHICLE, ETC, WITHOUT PROTECTION FROM PORTABLE BARRIER OR OTHER RIGID BARRIER ALONG THE WORK AREA. THIS PHRASE DOES NOT APPLY TO CASES WHERE POSITIVE PROTECTION IS REQUIRED. MOBILE OPERATIONS ARE REGARDED AS "WITHOUT POSITIVE PROTECTION". FOR WORK ZONES USING A COMBINATION OF BARRIER AND TEMPORARY TRAFFIC CONTROL DEVICES (CONES, DRUMS, ETC), THE DESIGNATION SHALL BE BASED UPON THE TYPE OF DEVICES USED IN THE AREA THAT WORKERS ARE LOCATED.

IF MULTIPLE ACTIVE LOCALIZED QUALIFYING WORK AREAS OCCUR WITHOUT POSITIVE PROTECTION, PER MAINLINE TRAFFIC DIRECTION, PROVIDE A UNIFORMED LEO AND OFFICIAL PATROL CAR IN ADVANCE OF: THE FIRST ACTIVE WORK AREA THAT DRIVERS WILL ENCOUNTER; OR THE ACTIVE WORK AREA Laterally CLOSEST TO THE OPEN TRAVELED LANE; OR OTHER LOCATION AS APPROVED BY THE ENGINEER. THE UNIFORMED LEO AND OFFICIAL PATROL CAR MAY RELOCATE AMONG THE LISTED LOCATIONS AS APPROPRIATE AS THE OPERATIONS PROCEED IN THE LOCALIZED QUALIFYING WORK AREAS.

IN GENERAL, LEOS SHOULD BE POSITIONED IN ADVANCE OF AND ON THE SAME SIDE AS THE LANE RESTRICTION (OR AT THE POINT OF ROAD CLOSURE), AND TO MANUALLY CONTROL TRAFFIC MOVEMENTS THROUGH SIGNALIZED INTERSECTIONS IN WORK ZONES.

LEOS SHOULD NOT FORGO THEIR TRAFFIC CONTROL RESPONSIBILITIES TO APPREHEND MOTORISTS FOR ROUTINE TRAFFIC VIOLATIONS. HOWEVER, IF A MOTORIST'S ACTIONS ARE CONSIDERED TO BE RECKLESS, THEN PURSUIT OF THE MOTORIST IS APPROPRIATE.

THE LEOS WORK AT THE DIRECTION OF THE CONTRACTOR. THE CONTRACTOR IS RESPONSIBLE FOR SECURING THE SERVICES OF THE LEOS WITH THE APPROPRIATE AGENCIES AND COMMUNICATING THE INTENTIONS OF THE PLANS WITH RESPECT TO DUTIES OF THE LEOS. THE ENGINEER SHALL HAVE FINAL CONTROL OVER THE LEOS' DUTIES AND PLACEMENT, TREATMENT IN ACCORDANCE WITH MT-101.90 AND WILL RESOLVE ANY ISSUES THAT MAY ARISE BETWEEN THE TWO PARTIES.

ENSURE PROVIDED LEOS HAVE BEEN TRAINED APPROPRIATE TO THE JOB DECISIONS THEY ARE REQUIRED TO MAKE WHILE ON THE PROJECT, IN ACCORDANCE WITH C&MS 614.03.

IN ADDITION TO THE REQUIREMENT OF C&MS 614 AND THE OMUTCD, A UNIFORMED LEO WITH AN OFFICIAL PATROL CAR (CAR WITH TOP-MOUNTED EMERGENCY FLASHING LIGHTS AND COMPLETE MARKINGS OF THE APPROPRIATE LAW ENFORCEMENT AGENCY) SHOULD BE PROVIDED FOR THE FOLLOWING TRAFFIC CONTROL TASKS AS APPROVED BY THE ENGINEER:

FOR LANE CLOSURES: DURING INITIAL SET-UP PERIODS, TEAR DOWN PERIODS, SUBSTANTIAL SHIFTS OF A CLOSURE POINT OR WHEN NEW LANE CLOSURE ARRANGEMENTS ARE INITIATED FOR LONG-TERM LANE CLOSURES/SHIFTS (FOR THE FIRST AND LAST DAY OF MAJOR CHANGES IN TRAFFIC CONTROL SETUP). THE LEO SHALL REPORT IN TO THE CONTRACTOR PRIOR TO THE START OF THE SHIFT, IN ORDER TO RECEIVE INSTRUCTIONS REGARDING SPECIFIC WORK ASSIGNMENTS DURING HIS/HER THE LEO IS EXPECTED TO STAY AT THE PROJECT SITE FOR THE ENTIRE DURATION OF HIS/HER SHIFT. THE LEO SHALL REPORT TO THE CONTRACTOR AT THE END OF HIS/HER SHIFT. SHOULD IT BE NECESSARY TO LEAVE THE PROJECT SITE, THE LEO SHALL NOTIFY THE ENGINEER. THE CONTRACTOR SHALL PROVIDE THE LEO WITH A TWO-WAY COMMUNICATION DEVICE THAT SHALL BE RETURNED TO THE CONTRACTOR AT THE END OF HIS/HER SHIFT.

LEOS (WITH PATROL CAR) REQUIRED BY THE TRAFFIC MAINTENANCE TASKS ABOVE SHALL BE PAID FOR ON A UNIT PRICE (HOURLY) BASIS UNDER ITEM 614, LAW ENFORCEMENT OFFICER (WITH PATROL CAR) FOR ASSISTANCE. THE FOLLOWING ESTIMATED QUANTITIES HAVE BEEN CARRIED TO THE GENERAL SUMMARY.

ITEM 614, LAW ENFORCEMENT OFFICER WITH PATROL CAR FOR ASSISTANCE: 24 HOURS

THE HOURS PAID SHALL INCLUDE ANY MINIMUM SHOW-UP TIME REQUIRED BY THE LAW ENFORCEMENT AGENCY INVOLVED.

ITEM 614, WORK ZONE MARKINGS AND SIGNS

THE FOLLOWING ESTIMATED QUANTITIES HAVE BEEN CARRIED TO THE GENERAL SUMMARY FOR USE AT LOCATIONS IDENTIFIED BY THE ENGINEER FOR WORK ZONE PAVEMENT MARKINGS AND SIGNS PER THE REQUIREMENTS OF C&MS 614.04 AND 614.11.

ITEM 622, PORTABLE BARRIER, 50", AS PER PLAN

THIS WORK SHALL CONSIST OF FURNISHING, MAINTAINING, AND SUBSEQUENTLY REMOVING A 50-INCH PORTABLE BARRIER AT THE LOCATIONS SHOWN ON THE PLANS. FOR DETAILS, SEE SCD RM-4.1.

PORTABLE STEEL BARRIER IS AN APPROVED ALTERNATIVE TO PORTABLE CONCRETE BARRIER. FOR INFORMATION ON APPROVED VENDORS, SEE THE APPROVED PRODUCTS LIST MAINTAINED BY THE OFFICE OF ROADWAY ENGINEERING.

PORTABLE BARRIER, 32 INCHES HIGH WITH AN 18-INCH MINIMUM HEIGHT GLARE SCREEN MAY BE USED AT THE OPTION OF THE CONTRACTOR. THE GLARE SCREEN SHALL BE CONSTRUCTED USING ONE OF THE SCREENS PROVIDED ON THE APPROVED LIST, AVAILABLE ON THE OFFICE OF ROADWAY ENGINEERING WEBSITE.

PADDLE OR INTERMITTENT TYPE GLARE SCREENS SHALL BE DESIGNED USING A 20 DEGREE CUT-OFF ANGLE BASED ON TANGENT ALIGNMENT. THAT SPACING SHALL BE USED THROUGHOUT THE BARRIER LENGTH WITHOUT REGARD TO BARRIER CURVATURE.

THE GLARE SCREEN SYSTEM SHALL BE SECURELY FASTENED TO THE 32-INCH PORTABLE BARRIER USING THE HARDWARE AND PROCEDURES SPECIFIED BY THE MANUFACTURER.

FOR DIRECTIONS ON HOW TO INSTALL THE GLARE SCREEN AND THE BARRIER, SEE THE MANUFACTURER'S INSTRUCTIONS.

PAYMENT SHALL INCLUDE ALL LABOR, MATERIAL, AND EQUIPMENT NECESSARY TO PERFORM THE WORK AND SHALL BE PAID FOR AT THE CONTRACT PRICE PER FOOT FOR ITEM 622, PORTABLE BARRIER, 50", AS PER PLAN.

DESIGN AGENCY



DESIGNER	CAM
REVIEWER	SA 10/17/22
PROJECT ID	113674
SHEET	TOTAL
5	82

ITEM 614. WORK ZONE IMPACT ATTENUATOR FOR 24" WIDE HAZARDS (UNIDIRECTIONAL OR BIDIRECTIONAL)

THIS ITEM SHALL CONSIST OF FURNISHING AND INSTALLING A NON-GATING IMPACT ATTENUATOR. FURNISH AN IMPACT ATTENUATOR FROM THE OFFICE OF ROADWAY ENGINEERING'S APPROVED LIST FOR WORK ZONE IMPACT ATTENUATORS, FROM THE ROADWAY STANDARDS APPROVED PRODUCTS WEB PAGE.

INSTALLATION SHALL BE AT THE LOCATIONS SPECIFIED IN THE PLANS IN ACCORDANCE WITH THE MANUFACTURER'S SPECIFICATIONS.

THE CONTRACTOR SHALL REPAIR OR REPLACE A DAMAGED UNIT WITHIN 24 HOURS OF A DAMAGING IMPACT.

WHEN BIDIRECTIONAL DESIGNS ARE SPECIFIED, THE CONTRACTOR SHALL SUPPLY APPROPRIATE TRANSITIONS.

WHEN GATING IMPACT ATTENUATORS ARE DESIRED, THE CONTRACTOR SHALL SUBMIT DOCUMENTATION TO THE ENGINEER FOR ACCEPTANCE.

THE COST FOR THE ADDITIONAL BARRIER REQUIRED FOR A GATING IMPACT ATTENUATOR SHALL BE INCLUDED IN THE COST OF THE GATING IMPACT ATTENUATOR.

PAYMENT FOR THE ABOVE WORK SHALL BE MADE AT THE UNIT PRICE BID AND SHALL INCLUDE ALL LABOR, TOOLS, EQUIPMENT AND MATERIALS NECESSARY TO CONSTRUCT AND MAINTAIN A COMPLETE AND FUNCTIONAL IMPACT ATTENUATOR SYSTEM, INCLUDING ALL RELATED BACKUPS, TRANSITIONS, LEVELING PADS, HARDWARE AND GRADING, NOT SEPARATELY SPECIFIED, AS REQUIRED BY THE MANUFACTURER.

ALL WORK AND TRAFFIC CONTROL DEVICES SHALL BE IN ACCORDANCE WITH C&MS 614 AND C&MS 622 OF THE SPECIFICATIONS, AS WELL AS THE OHIO MANUAL OF UNIFORM TRAFFIC CONTROL DEVICES. PAYMENT FOR ALL LABOR, EQUIPMENT AND MATERIALS SHALL BE INCLUDED IN THE LUMP SUM CONTRACT PRICE FOR ITEM 614, MAINTAINING TRAFFIC, UNLESS SEPARATELY ITEMIZED IN THE PLAN.

MAINTENANCE OF TRAFFIC NOTES  
BRIDGE NO. CUY-10-0869  
OVER VALLEY PARKWAY & ROCKY RIVER

DESIGN AGENCY



DESIGNER  
CAM

REVIEWER  
SA 10/17/22

PROJECT ID  
113674

SHEET	TOTAL
6	82



REF NO.	MOT PHASE	STATION TO STATION		SIDE	614	614	614	614	614	622												
					WORK ZONE IMPACT ATTENUATOR, 24" WIDE HAZARDS, (UNIDIRECTIONAL) EACH	WORK ZONE CENTER LINE, CLASS I, DOUBLE SOLID MILE	WORK ZONE EDGE LINE, CLASS I, 4", WHITE MILE	WORK ZONE DOTTED LINE, CLASS I FT	WORK ZONE TRANSVERSE/DIAGONAL LINE, CLASS I FT	PORTABLE BARRIER, 50", AS PER PLAN FT												
PHASE 1																						
TEW1		451+69.00	454+22.00				0.05															
TDL1		451+69.00	455+60.00					391														
TEW2		455+60.00	473+00.00				0.33															
IA1		457+30.00	457+56.00		1																	
TCL1		457+08.00	458+83.00			0.03																
TCL2		457+08.00	473+00.00			0.30																
PCB1		457+56.00	472+27.00							1471.00												
TY1		457+08.00	458+83.00						41													
TCL3		471+67.00	473+00.00			0.03																
TY2		471+66.00	473+00.00						33													
TY3		473+90.00	476+00.00						39													
IA2		472+27.00	472+53.00		1																	
TDL1		473+00.00	473+90.00					90														
TCL4		473+90.00	476+00.00			0.04																
TCL5		473+90.00	476+00.00			0.04																
PHASE 2																						
TCL1		456+18.00	472+47.00			0.31																
TCL2		456+18.00	458+54.00			0.04																
TY1		456+18.00	458+54.00						40													
TDL1		456+00.00	458+54.00					254														
TEW1		456+72.00	473+00.00				0.31															
IA1		457+41.00	457+67.00		1																	
PCB1		457+67.00	472+00.00							1433.00												
TCL3		471+11.00	472+47.00			0.03																
TY2		471+11.00	472+47.00						22													
IA2		472+00.00	472+26.00		1																	
TDL2		473+00.00	473+90.00					90														
TDL3		473+00.00	473+90.00					90														
TEW2		473+90.00	476+42.00				0.05															
TCL4		473+90.00	476+42.00			0.05																
<b>TOTALS FROM THIS SHEET</b>					4	0.87	0.73	915	175	2904												
<b>TOTALS CARRIED TO GENERAL SUMMARY</b>					4	0.87	0.73	915	175	2904												

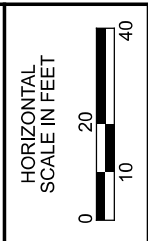
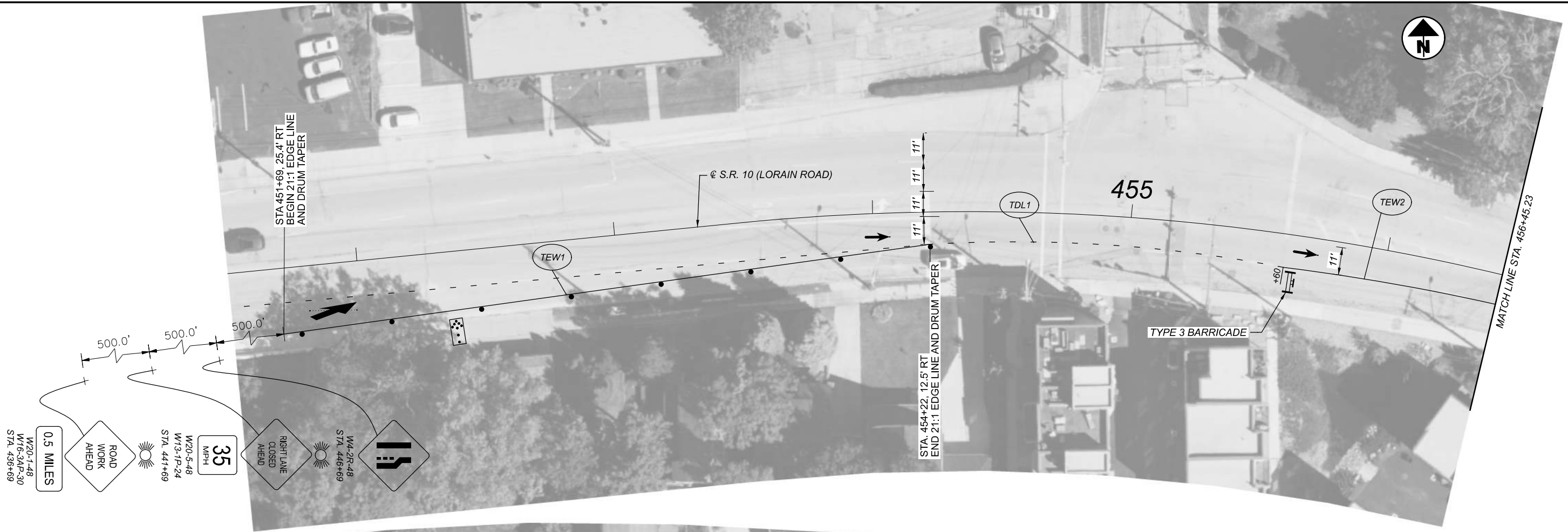



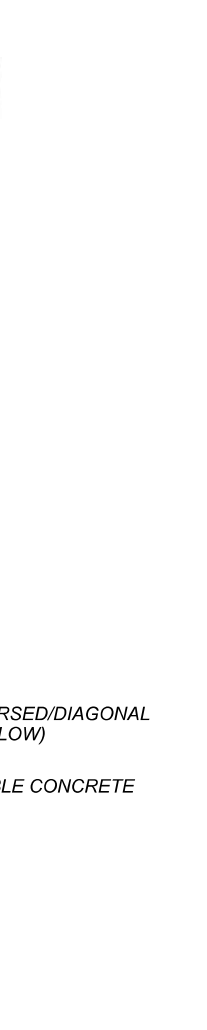
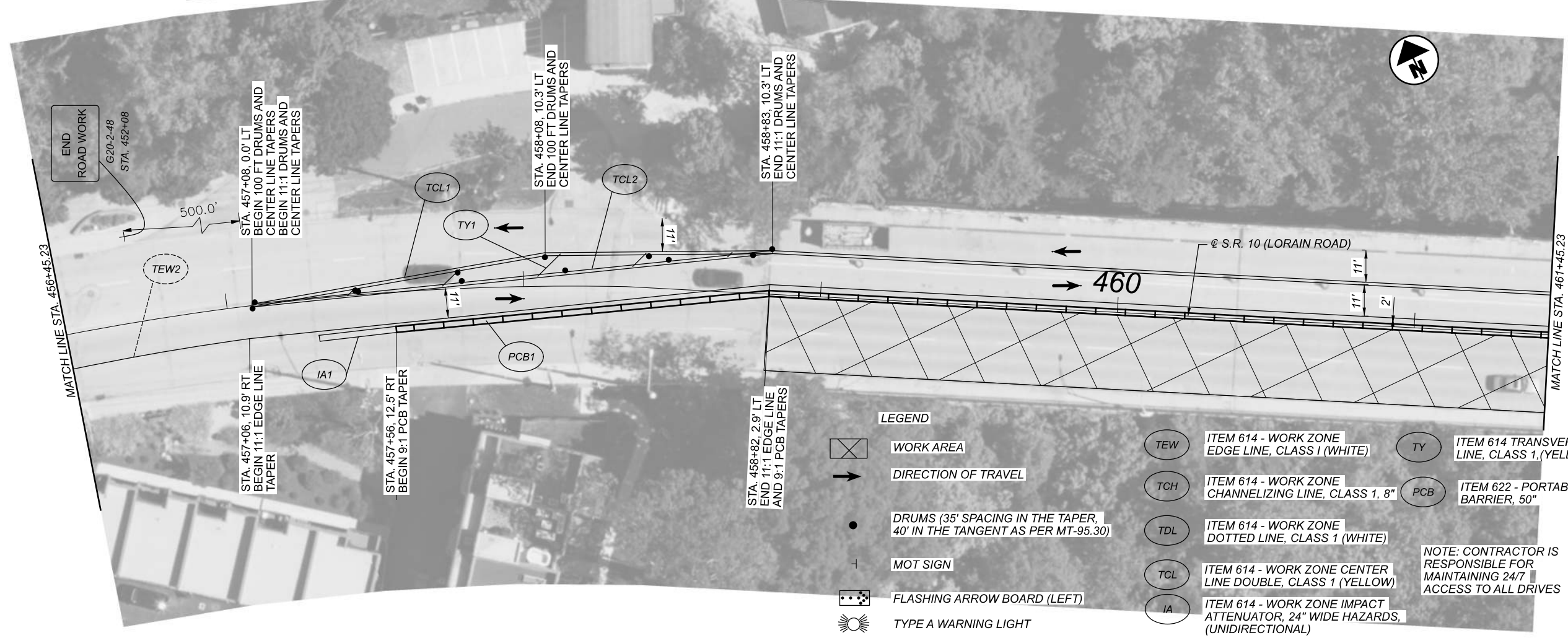









MAINTENANCE OF TRAFFIC CUY-10-0869  
 PHASES 1 & 3 - STA. 451+45 TO 461+45



LEGEND	
	WORK AREA
	DIRECTION OF TRAVEL
	DRUMS (35' SPACING IN THE TAPER, 40' IN THE TANGENT AS PER MT-95.30)
	MOT SIGN
	FLASHING ARROW BOARD (LEFT)
	TYPE A WARNING LIGHT
	ITEM 614 - WORK ZONE EDGE LINE, CLASS 1 (WHITE)
	ITEM 614 - WORK ZONE CHANNELIZING LINE, CLASS 1, 8"
	ITEM 614 - WORK ZONE DOTTED LINE, CLASS 1 (WHITE)
	ITEM 614 - WORK ZONE CENTER LINE DOUBLE, CLASS 1 (YELLOW)
	ITEM 614 - WORK ZONE IMPACT ATTENUATOR, 24" WIDE HAZARDS, (UNIDIRECTIONAL)
	ITEM 614 TRANSVERSED/DIAGONAL LINE, CLASS 1, (YELLOW)
	ITEM 622 - PORTABLE CONCRETE BARRIER, 50"

NOTE: CONTRACTOR IS RESPONSIBLE FOR MAINTAINING 24/7 ACCESS TO ALL DRIVES

DESIGN AGENCY	
DESIGNER	SDB
REVIEWER	SA 10/17/22
PROJECT ID	113674
SHEET	TOTAL
8	82

- LEGEND**
-  WORK AREA
  -  DIRECTION OF TRAVEL
  -  DRUMS (35' SPACING IN THE TAPER, 40' IN THE TANGENT AS PER MT-95.30)
  -  MOT SIGN
  -  FLASHING ARROW BOARD (LEFT)
  -  TYPE A WARNING LIGHT
  -  ITEM 614 - WORK ZONE EDGE LINE, CLASS 1 (WHITE)
  -  ITEM 614 - WORK ZONE CHANNELIZING LINE, CLASS 1, 8"
  -  ITEM 614 - WORK ZONE DOTTED LINE, CLASS 1 (WHITE)
  -  ITEM 614 - WORK ZONE CENTER LINE DOUBLE, CLASS 1 (YELLOW)
  -  ITEM 614 - WORK ZONE IMPACT ATTENUATOR, 24" WIDE HAZARDS, (UNIDIRECTIONAL)
  -  ITEM 614 TRANSVERSED/DIAGONAL LINE, CLASS 1, (YELLOW)
  -  ITEM 622 - PORTABLE CONCRETE BARRIER, 50"

NOTE: CONTRACTOR IS RESPONSIBLE FOR MAINTAINING 24/7 ACCESS TO ALL DRIVES

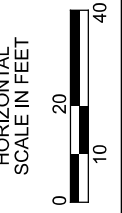
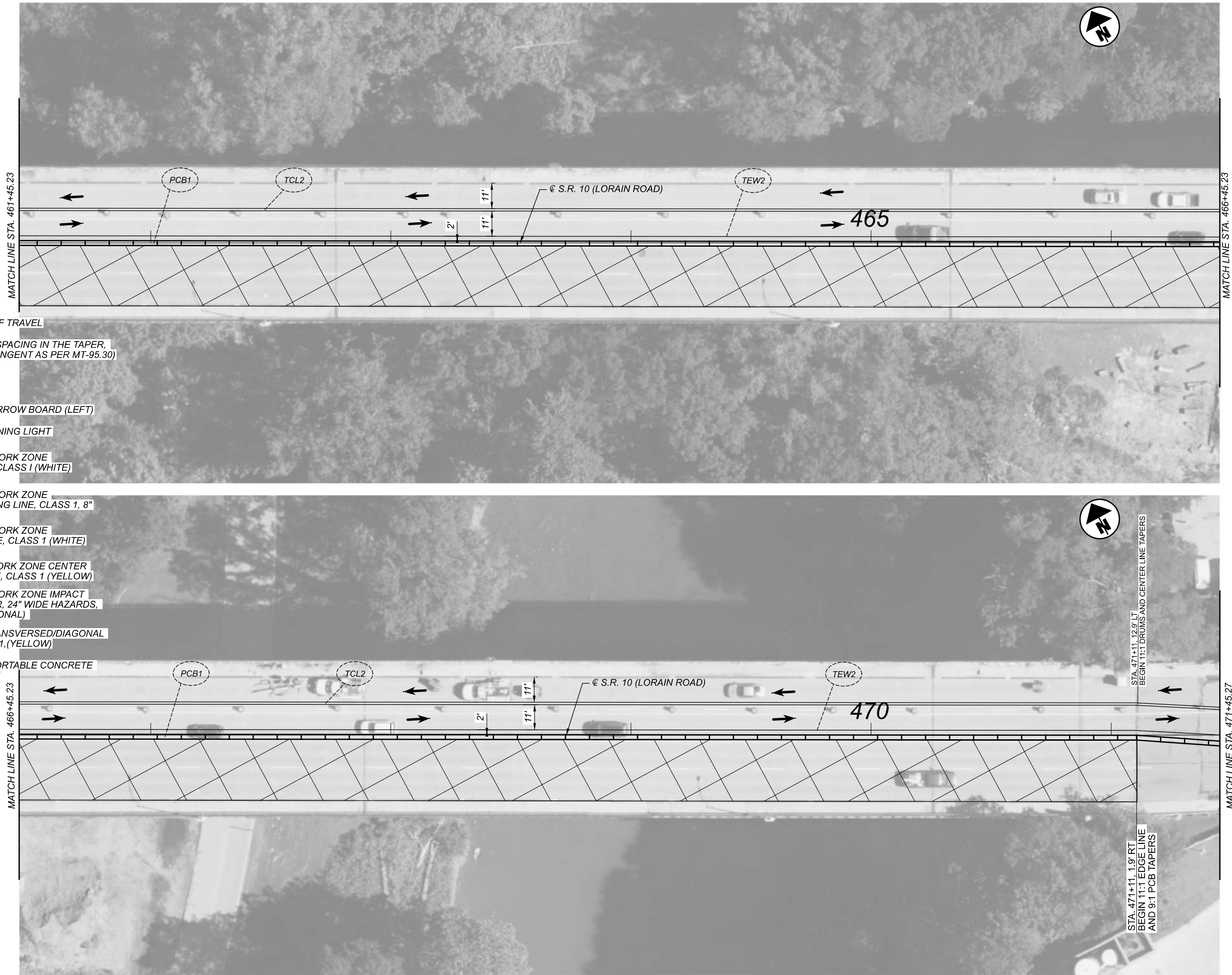

MAINTENANCE OF TRAFFIC CUY-10-0869  
 PHASES 1 & 3 - STA. 461+45 TO 471+45

DESIGN AGENCY



DESIGNER	SDB
REVIEWER	SA 10/17/22
PROJECT ID	113674
SHEET	TOTAL
9	82

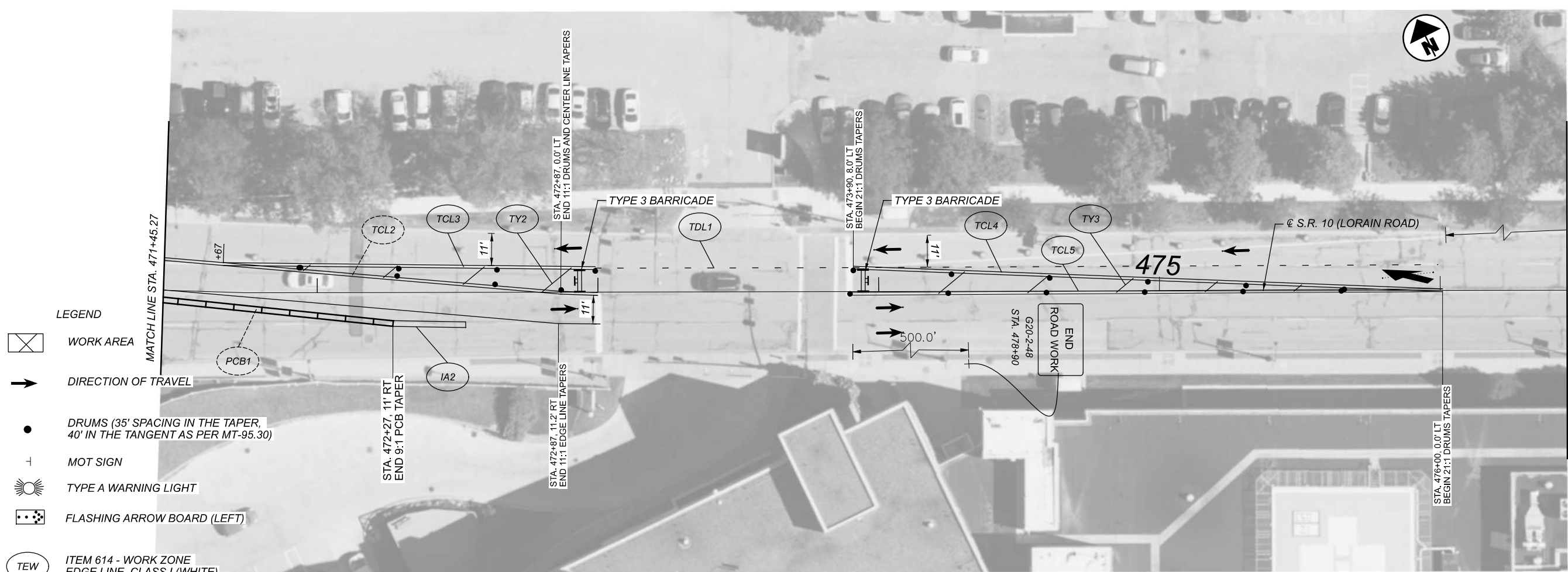

LEGEND

- WORK AREA
- DIRECTION OF TRAVEL
- DRUMS (35' SPACING IN THE TAPER, 40' IN THE TANGENT AS PER MT-95.30)
- MOT SIGN
- TYPE A WARNING LIGHT
- FLASHING ARROW BOARD (LEFT)

- ITEM 614 - WORK ZONE EDGE LINE, CLASS I (WHITE)
- ITEM 614 - WORK ZONE CHANNELIZING LINE, CLASS 1, 8"
- ITEM 614 - WORK ZONE DOTTED LINE, CLASS 1 (WHITE)
- ITEM 614 - WORK ZONE CENTER LINE DOUBLE, CLASS 1 (YELLOW)
- ITEM 614 - WORK ZONE IMPACT ATTENUATOR, 24" WIDE HAZARDS, (UNIDIRECTIONAL)
- ITEM 614 TRANSVERSED/DIAGONAL LINE, CLASS 1, (YELLOW)
- ITEM 622 - PORTABLE CONCRETE BARRIER, 50"

NOTE: CONTRACTOR IS RESPONSIBLE FOR MAINTAINING 24/7 ACCESS TO ALL DRIVES

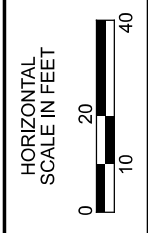

MAINTENANCE OF TRAFFIC CUY-10-0869  
 PHASES 1 & 3 - STA. 471+45 TO 476+93

DESIGN AGENCY



DESIGNER  
 SDB

REVIEWER  
 SA 10/17/22

PROJECT ID  
 113674

SHEET	TOTAL
10	82

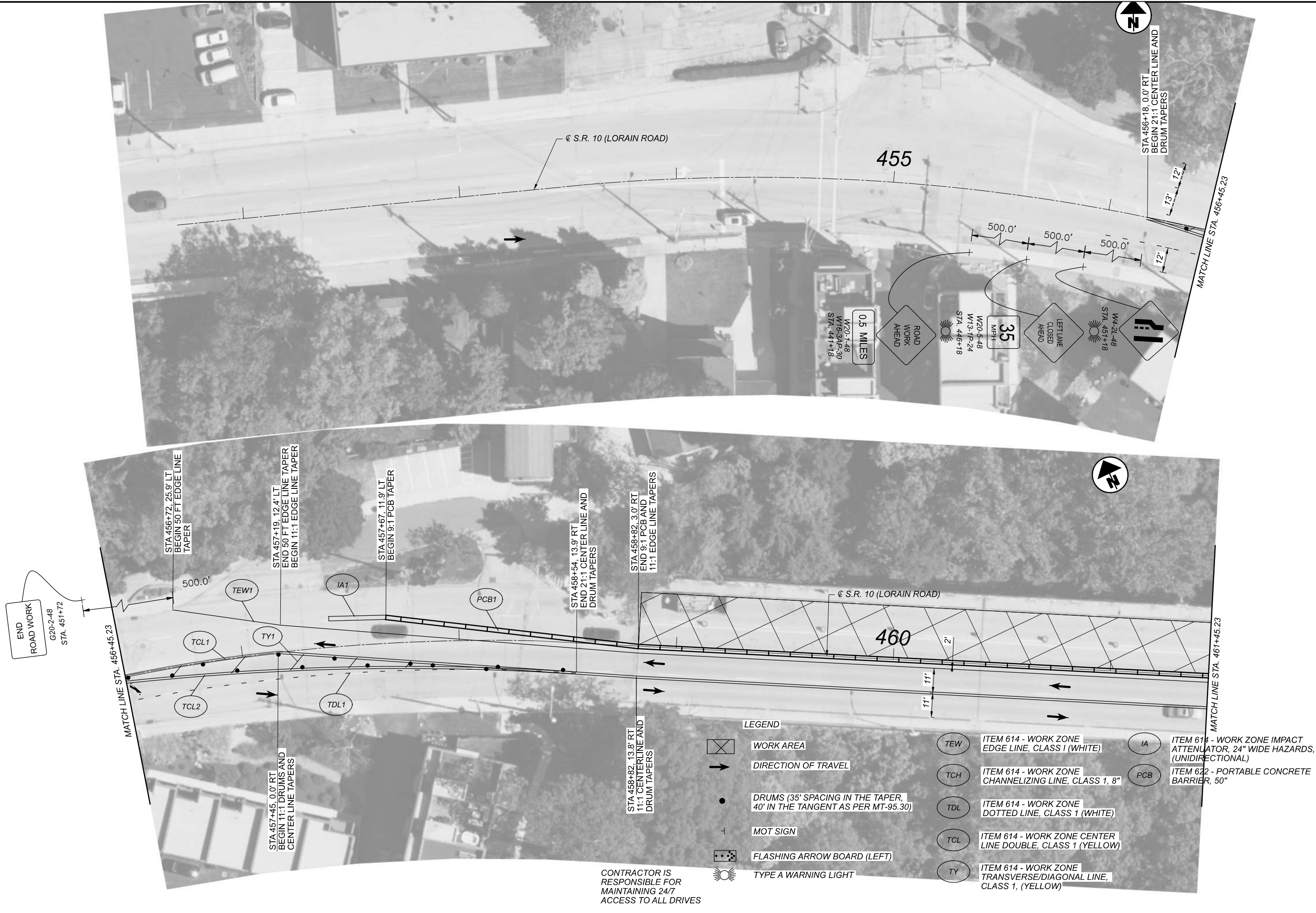





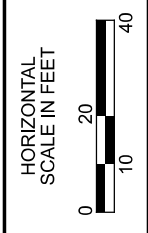







CONTRACTOR IS RESPONSIBLE FOR MAINTAINING 24/7 ACCESS TO ALL DRIVES

LEGEND	
	WORK AREA
	DIRECTION OF TRAVEL
	DRUMS (35' SPACING IN THE TAPER, 40' IN THE TANGENT AS PER MT-95.30)
	MOT SIGN
	FLASHING ARROW BOARD (LEFT)
	TYPE A WARNING LIGHT
	ITEM 614 - WORK ZONE EDGE LINE, CLASS 1 (WHITE)
	ITEM 614 - WORK ZONE CHANNELIZING LINE, CLASS 1, 8"
	ITEM 614 - WORK ZONE DOTTED LINE, CLASS 1 (WHITE)
	ITEM 614 - WORK ZONE CENTER LINE DOUBLE, CLASS 1 (YELLOW)
	ITEM 614 - WORK ZONE TRANSVERSE/DIAGONAL LINE, CLASS 1, (YELLOW)
	ITEM 614 - WORK ZONE IMPACT ATTENUATOR, 24" WIDE HAZARDS, (UNIDIRECTIONAL)
	ITEM 622 - PORTABLE CONCRETE BARRIER, 50"



MAINTENANCE OF TRAFFIC CUY-10-0869  
PHASE 2 - STA. 451+45 TO 461+45





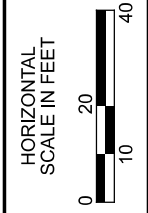
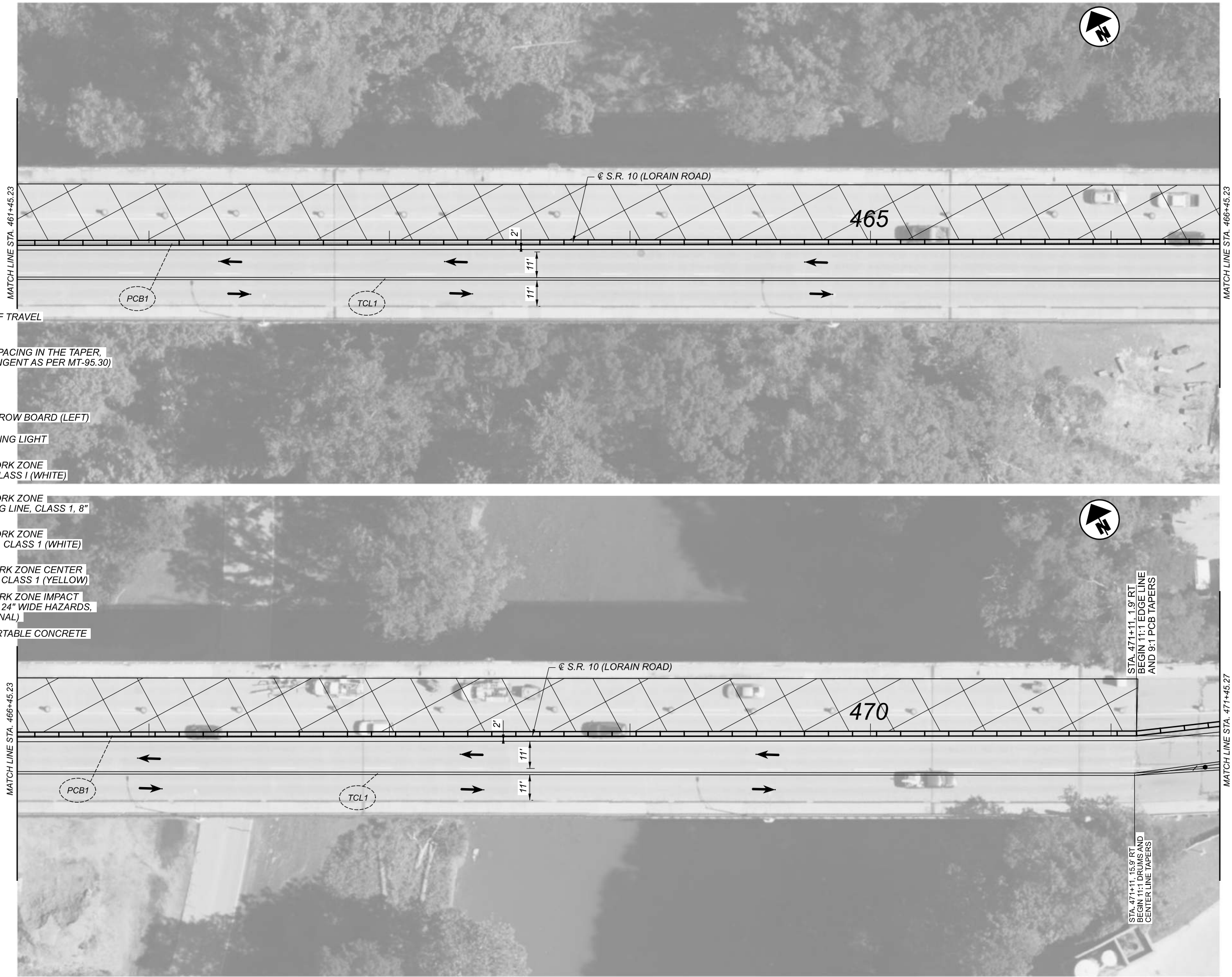







DESIGN AGENCY	
DESIGNER	SDB
REVIEWER	SA 10/17/22
PROJECT ID	113674
SHEET	TOTAL
11	82

- LEGEND**
-  WORK AREA
  -  DIRECTION OF TRAVEL
  -  DRUMS (35' SPACING IN THE TAPER, 40' IN THE TANGENT AS PER MT-95.30)
  -  MOT SIGN
  -  FLASHING ARROW BOARD (LEFT)
  -  TYPE A WARNING LIGHT
  -  ITEM 614 - WORK ZONE EDGE LINE, CLASS 1 (WHITE)
  -  ITEM 614 - WORK ZONE CHANNELIZING LINE, CLASS 1, 8"
  -  ITEM 614 - WORK ZONE DOTTED LINE, CLASS 1 (WHITE)
  -  ITEM 614 - WORK ZONE CENTER LINE DOUBLE, CLASS 1 (YELLOW)
  -  ITEM 614 - WORK ZONE IMPACT ATTENUATOR, 24" WIDE HAZARDS, (UNIDIRECTIONAL)
  -  ITEM 622 - PORTABLE CONCRETE BARRIER, 50"



**MAINTENANCE OF TRAFFIC CUY-10-0869  
 PHASE 2 - STA. 461+45 TO 471+45**

DESIGN AGENCY	
	
DESIGNER	SDB
REVIEWER	SA 10/17/22
PROJECT ID	113674
SHEET	TOTAL
12	82

- LEGEND**
-  WORK AREA
  -  DIRECTION OF TRAVEL
  -  DRUMS (35' SPACING IN THE TAPER, 40' IN THE TANGENT AS PER MT-95.30)
  -  MOT SIGN
  -  FLASHING ARROW BOARD (LEFT)
  -  TYPE A WARNING LIGHT
  -  ITEM 614 - WORK ZONE EDGE LINE, CLASS 1 (WHITE)
  -  ITEM 614 - WORK ZONE CHANNELIZING LINE, CLASS 1, 8"
  -  ITEM 614 - WORK ZONE DOTTED LINE, CLASS 1 (WHITE)
  -  ITEM 614 - WORK ZONE CENTER LINE DOUBLE, CLASS 1 (YELLOW)
  -  ITEM 614 - WORK ZONE TRANSVERSE/DIAGONAL, CLASS 1 (YELLOW)
  -  ITEM 614 - WORK ZONE IMPACT ATTENUATOR, 24" WIDE HAZARDS, (UNIDIRECTIONAL)
  -  ITEM 622 - PORTABLE CONCRETE BARRIER, 50"

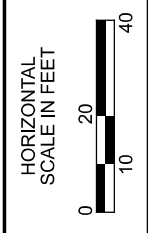
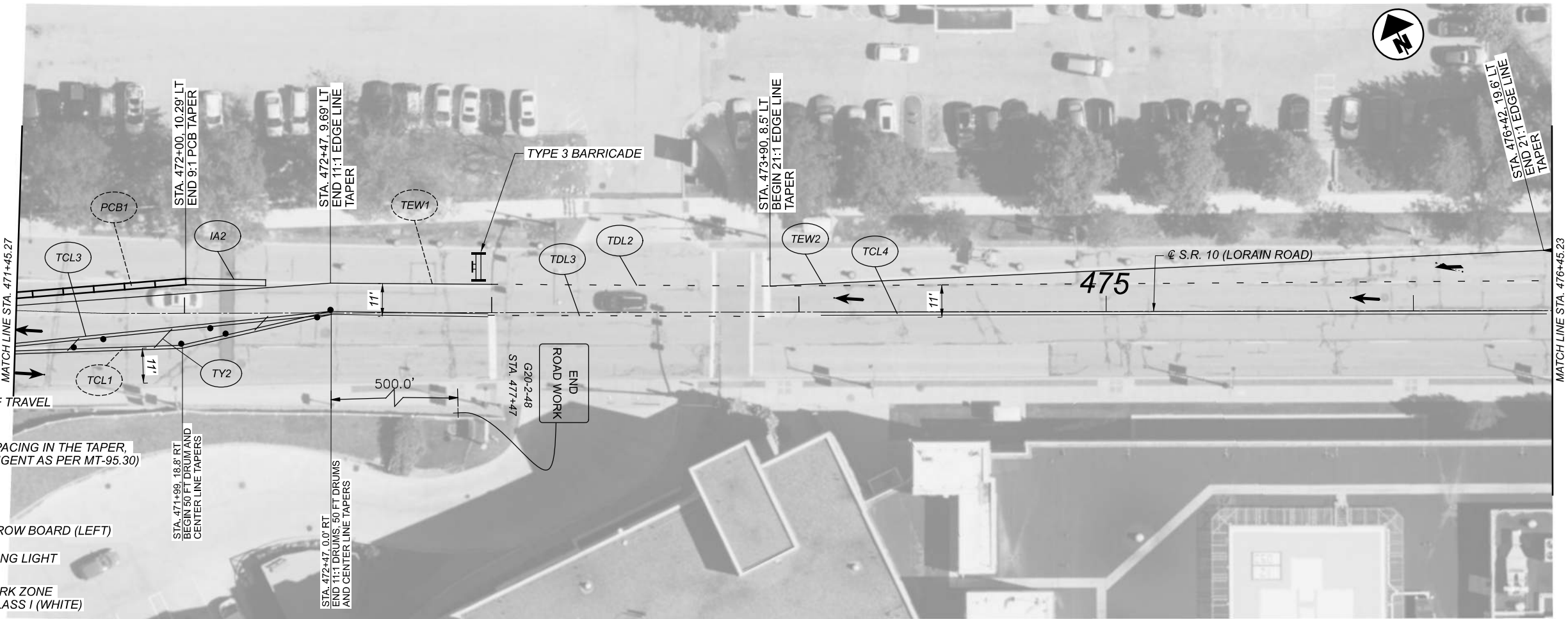

MAINTENANCE OF TRAFFIC CUY-10-0869  
 PHASE 2 - STA. 471+45 TO 476+93

DESIGN AGENCY	
	
DESIGNER	SDB
REVIEWER	SA 10/17/22
PROJECT ID	113674
SHEET	TOTAL
13	82

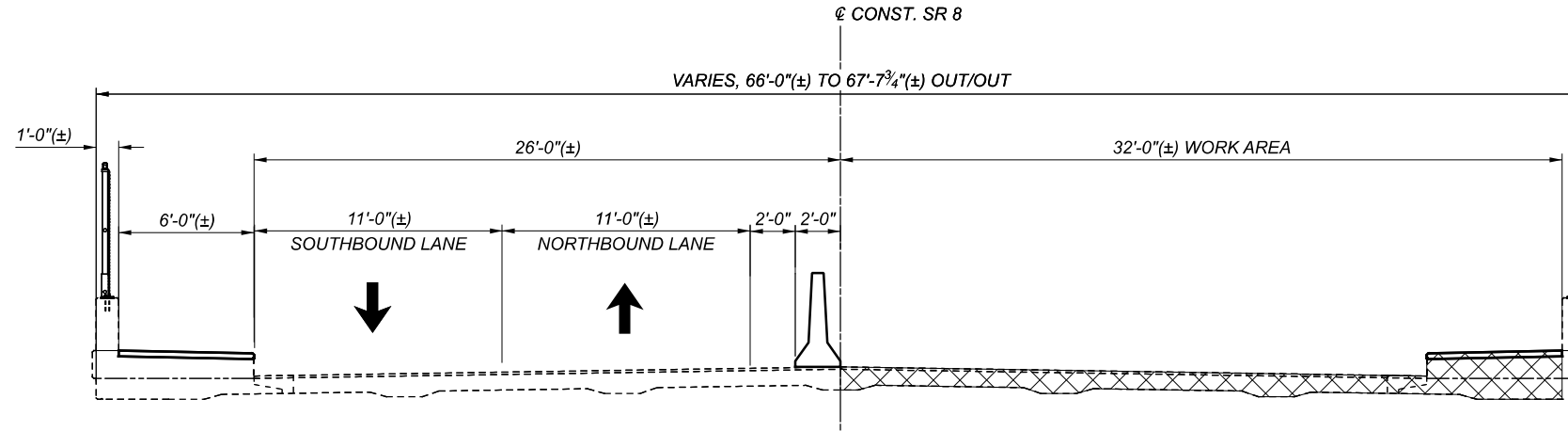

**TYPICAL MAINTENANCE OF TRAFFIC - BRIDGE NO. CUY-8-0226 - PHASE 1 & 3**  
 STA. 23+17.25 TO STA. 39+24.25

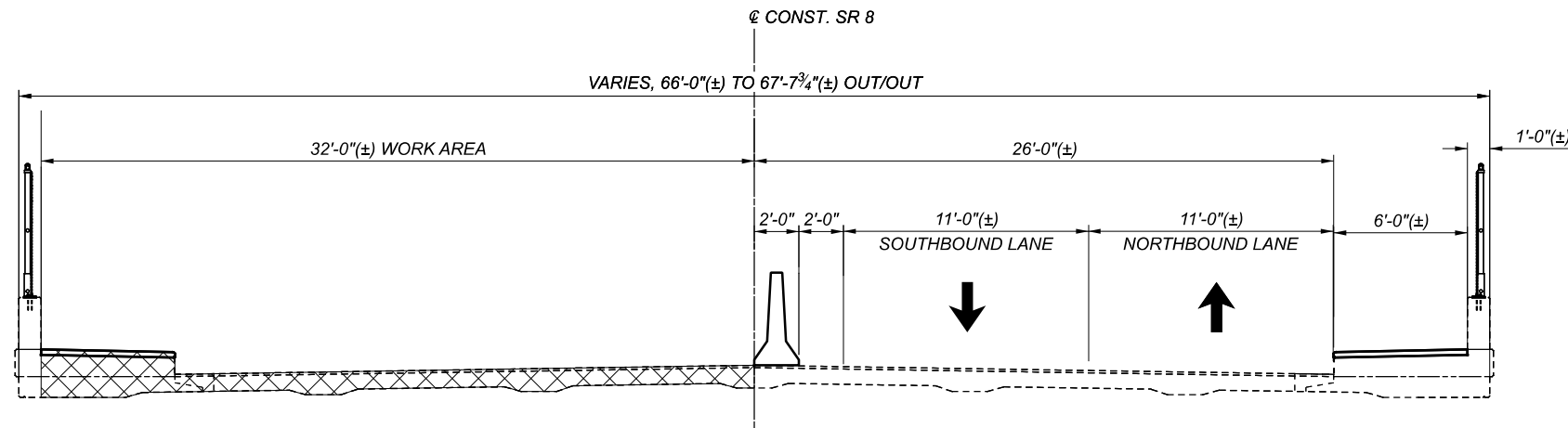

**TYPICAL MAINTENANCE OF TRAFFIC - BRIDGE NO. CUY-8-0226 - PHASE 2**  
 STA. 23+17.25 TO STA. 39+24.25



MAINTENANCE OF TRAFFIC

CONSTRUCTION PHASING:

PHASE 1: ONE LANE OF TRAFFIC MAINTAINED IN EACH DIRECTION ON THE SOUTHBOUND LANES WHILE THE NORTHBOUND LANES ARE CONSTRUCTED. PEDESTRIANS ARE DETOURED TO THE SOUTHBOUND LANES.

PHASE 2: ONE LANE OF TRAFFIC MAINTAINED IN EACH DIRECTION ON THE NORTHBOUND LANES WHILE THE SOUTHBOUND LANES ARE CONSTRUCTED. PEDESTRIANS ARE DETOURED TO THE NORTHBOUND LANES.

PHASE 3: ONE LANE OF TRAFFIC MAINTAINED IN EACH DIRECTION ON THE SOUTHBOUND LANES WHILE THE FINAL STRIP SEAL IS INSTALLED. PEDESTRIANS ARE DETOURED TO THE SOUTHBOUND LANES. TRAFFIC IS RESTORED TO THE RECONSTRUCTED BRIDGE.

TEMPORARY TRAFFIC CONTROL NOTES:

1. A MINIMUM OF ONE LANE OF TRAFFIC IN EACH DIRECTION SHALL BE MAINTAINED AT ALL TIMES BY USE OF THE EXISTING PAVEMENT AND THE COMPLETED PAVEMENT USING ITEMS 410 AND 614.

2. LENGTH AND DURATION OF LANE CLOSURES AND RESTRICTIONS SHALL BE AT THE APPROVAL OF THE ENGINEER. IT IS THE INTENT TO MINIMIZE THE IMPACT TO THE TRAVELING PUBLIC. LANE CLOSURES OR RESTRICTIONS OVER SEGMENTS OF THE PROJECT IN WHICH NO WORK IS ANTICIPATED WITHIN A REASONABLE TIME FRAME, AS DETERMINED BY THE ENGINEER, SHALL NOT BE PERMITTED. THE LEVEL OF UTILIZATION OF MAINTENANCE OF TRAFFIC DEVICES SHALL BE COMMENSURATE WITH THE WORK IN PROGRESS.

3. NOTICE OF CLOSURE SIGNS (W20-H13) SHALL BE ERECTED BY THE CONTRACTOR PRIOR TO THE SCHEDULED ROAD CLOSURE IN ACCORDANCE WITH THE NOTICE OF CLOSURE TIME TABLE BELOW.

THE SIGNS SHALL BE ERECTED ON THE RIGHT-HAND SIDE OF THE ROAD FACING TRAFFIC. THEY SHALL BE PLACED SO AS NOT TO INTERFERE WITH THE VISIBILITY OF ANY OTHER TRAFFIC CONTROL SIGNS. ON ROADWAYS, THEY SHOULD BE ERECTED AT OR NEAR THE POINT OF CLOSURE.

NOTICE OF CLOSURE SIGN TIME TABLE

ITEM	DURATION OF CLOSURE	SIGN DISPLAYED TO PUBLIC
	=2 WEEKS	14 CALENDAR DAYS PRIOR TO CLOSURE
ROAD CLOSURES	> 12 HOURS	7 CALENDAR DAYS PRIOR TO CLOSURE
	< 2 WEEKS	
	<= 12 HOURS	2 BUSINESS DAYS PRIOR TO CLOSURE

THE SIGN SHALL DISPLAY THE DATE OF THE CLOSURE IN MM-DD FORMAT AND THE NUMBER OF DAYS OF THE CLOSURE. THE LAST LINE OF THE W20-H13 SIGN LISTS A PHONE NUMBER WHICH A MOTORIST MAY CALL FOR ADDITIONAL INFORMATION. THIS IS TO BE A SPECIFIC OFFICE WITHIN THE DISTRICT RATHER THAN THE GENERAL SWITCHBOARD NUMBER.

ITEM 614, LAW ENFORCEMENT OFFICER (WITH PETROL CAR) FOR ASSISTANCE DURING CONSTRUCTION OPERATIONS

USE OF LAW ENFORCEMENT OFFICERS (LEOS) BY CONTRACTORS OTHER THAN THE USES SPECIFIED BELOW WILL NOT BE PERMITTED AT PROJECT COST. LEOS SHOULD NOT BE USED WHERE THE OMUTCD INTENDS THAT FLAGGERS BE USED.

IN ADDITION TO THE REQUIREMENTS OF C&MS 614 AND THE OMUTCD, A UNIFORMED LEO WITH AN OFFICIAL PATROL CAR (CAR WITH TOP-MOUNTED EMERGENCY FLASHING LIGHTS AND COMPLETE MARKINGS OF THE APPROPRIATE LAW ENFORCEMENT AGENCY) SHALL BE PROVIDED FOR THE FOLLOWING TRAFFIC CONTROL TASKS:

DURING THE ENTIRE ADVANCE PREPARATION AND CLOSURE SEQUENCE WHERE COMPLETE BLOCKAGE OF TRAFFIC IS REQUIRED.

DURING A TRAFFIC SIGNAL INSTALLATION WHEN IMPACTING THE NORMAL FUNCTION OF THE SIGNAL OR THE FLOW OF TRAFFIC, OR WHEN TRAFFIC NEEDS TO BE DIRECTED THROUGH AN ENERGIZED TRAFFIC SIGNAL CONTRARY TO THE SIGNAL DISPLAY (E.G., DIRECTING MOTORISTS THROUGH A RED LIGHT).

IN ADDITION TO THE REQUIREMENT OF C&MS 614 AND THE OMUTCD, A UNIFORMED LEO WITH AN OFFICIAL PATROL CAR (CAR WITH TOP-MOUNTED EMERGENCY FLASHING LIGHTS AND COMPLETE MARKINGS OF THE APPROPRIATE LAW ENFORCEMENT AGENCY) SHOULD BE PROVIDED FOR THE FOLLOWING TRAFFIC CONTROL TASKS AS APPROVED BY THE ENGINEER:

FOR LANE CLOSURES: DURING INITIAL SET-UP PERIODS, TEAR DOWN PERIODS, SUBSTANTIAL SHIFTS OF A CLOSURE POINT OR WHEN NEW LANE CLOSURE ARRANGEMENTS ARE INITIATED FOR LONG-TERM LANE CLOSURES/SHIFTS (FOR THE FIRST AND LAST DAY OF MAJOR CHANGES IN TRAFFIC CONTROL SETUP).

"WITHOUT POSITIVE PROTECTION" MEANS USE OF DRUMS, CONES, SHADOW VEHICLE, ETC, WITHOUT PROTECTION FROM PORTABLE BARRIER OR OTHER RIGID BARRIER ALONG THE WORK AREA. THIS PHRASE DOES NOT APPLY TO CASES WHERE POSITIVE PROTECTION IS REQUIRED. MOBILE OPERATIONS ARE REGARDED AS "WITHOUT POSITIVE PROTECTION". FOR WORK ZONES USING A COMBINATION OF BARRIER AND TEMPORARY TRAFFIC CONTROL DEVICES (CONES, DRUMS, ETC), THE DESIGNATION SHALL BE BASED UPON THE TYPE OF DEVICES USED IN THE AREA THAT WORKERS ARE LOCATED.

IF MULTIPLE ACTIVE LOCALIZED QUALIFYING WORK AREAS OCCUR WITHOUT POSITIVE PROTECTION, PER MAINLINE TRAFFIC DIRECTION, PROVIDE A UNIFORMED LEO AND OFFICIAL PATROL CAR IN ADVANCE OF: THE FIRST ACTIVE WORK AREA THAT DRIVERS WILL ENCOUNTER; OR THE ACTIVE WORK AREA Laterally CLOSEST TO THE OPEN TRAVELED LANE; OR OTHER LOCATION AS APPROVED BY THE ENGINEER. THE UNIFORMED LEO AND OFFICIAL PATROL CAR MAY RELOCATE AMONG THE LISTED LOCATIONS AS APPROPRIATE AS THE OPERATIONS PROCEED IN THE LOCALIZED QUALIFYING WORK AREAS.

IN GENERAL, LEOS SHOULD BE POSITIONED IN ADVANCE OF AND ON THE SAME SIDE AS THE LANE RESTRICTION (OR AT THE POINT OF ROAD CLOSURE), AND TO MANUALLY CONTROL TRAFFIC MOVEMENTS THROUGH SIGNALIZED INTERSECTIONS IN WORK ZONES.

LEOS SHOULD NOT FORGO THEIR TRAFFIC CONTROL RESPONSIBILITIES TO APPREHEND MOTORISTS FOR ROUTINE TRAFFIC VIOLATIONS. HOWEVER, IF A MOTORIST'S ACTIONS ARE CONSIDERED TO BE RECKLESS, THEN PURSUIT OF THE MOTORIST IS APPROPRIATE.

THE LEOS WORK AT THE DIRECTION OF THE CONTRACTOR. THE CONTRACTOR IS RESPONSIBLE FOR SECURING THE SERVICES OF THE LEOS WITH THE APPROPRIATE AGENCIES AND COMMUNICATING THE INTENTIONS OF THE PLANS WITH RESPECT TO DUTIES OF THE LEOS. THE ENGINEER SHALL HAVE FINAL CONTROL OVER THE LEOS' DUTIES AND PLACEMENT, TREATMENT IN ACCORDANCE WITH MT-101.90 AND WILL RESOLVE ANY ISSUES THAT MAY ARISE BETWEEN THE TWO PARTIES.

ENSURE PROVIDED LEOS HAVE BEEN TRAINED APPROPRIATE TO THE JOB DECISIONS THEY ARE REQUIRED TO MAKE WHILE ON THE PROJECT, IN ACCORDANCE WITH C&MS 614.03.

IN ADDITION TO THE REQUIREMENT OF C&MS 614 AND THE OMUTCD, A UNIFORMED LEO WITH AN OFFICIAL PATROL CAR (CAR WITH TOP-MOUNTED EMERGENCY FLASHING LIGHTS AND COMPLETE MARKINGS OF THE APPROPRIATE LAW ENFORCEMENT AGENCY) SHOULD BE PROVIDED FOR THE FOLLOWING TRAFFIC CONTROL TASKS AS APPROVED BY THE ENGINEER:

FOR LANE CLOSURES: DURING INITIAL SET-UP PERIODS, TEAR DOWN PERIODS, SUBSTANTIAL SHIFTS OF A CLOSURE POINT OR WHEN NEW LANE CLOSURE ARRANGEMENTS ARE INITIATED FOR LONG-TERM LANE CLOSURES/SHIFTS (FOR THE FIRST AND LAST DAY OF MAJOR CHANGES IN TRAFFIC CONTROL SETUP). THE LEO SHALL REPORT IN TO THE CONTRACTOR PRIOR TO THE START OF THE SHIFT, IN ORDER TO RECEIVE INSTRUCTIONS REGARDING SPECIFIC WORK ASSIGNMENTS DURING HIS/HER THE LEO IS EXPECTED TO STAY AT THE PROJECT SITE FOR THE ENTIRE DURATION OF HIS/HER SHIFT. THE LEO SHALL REPORT TO THE CONTRACTOR AT THE END OF HIS/HER SHIFT. SHOULD IT BE NECESSARY TO LEAVE THE PROJECT SITE, THE LEO SHALL NOTIFY THE ENGINEER. THE CONTRACTOR SHALL PROVIDE THE LEO WITH A TWO-WAY COMMUNICATION DEVICE THAT SHALL BE RETURNED TO THE CONTRACTOR AT THE END OF HIS/HER SHIFT.

LEOS (WITH PATROL CAR) REQUIRED BY THE TRAFFIC MAINTENANCE TASKS ABOVE SHALL BE PAID FOR ON A UNIT PRICE (HOURLY) BASIS UNDER ITEM 614, LAW ENFORCEMENT OFFICER (WITH PATROL CAR) FOR ASSISTANCE. THE FOLLOWING ESTIMATED QUANTITIES HAVE BEEN CARRIED TO THE GENERAL SUMMARY.

ITEM 614, LAW ENFORCEMENT OFFICER WITH PATROL CAR FOR ASSISTANCE: 24 HOURS

THE HOURS PAID SHALL INCLUDE ANY MINIMUM SHOW-UP TIME REQUIRED BY THE LAW ENFORCEMENT AGENCY INVOLVED.

ITEM 614, WORK ZONE MARKINGS AND SIGNS

THE FOLLOWING ESTIMATED QUANTITIES HAVE BEEN CARRIED TO THE GENERAL SUMMARY FOR USE AT LOCATIONS IDENTIFIED BY THE ENGINEER FOR WORK ZONE PAVEMENT MARKINGS AND SIGNS PER THE REQUIREMENTS OF C&MS 614.04 AND 614.11.

ITEM 622, PORTABLE BARRIER, 50", AS PER PLAN

THIS WORK SHALL CONSIST OF FURNISHING, MAINTAINING, AND SUBSEQUENTLY REMOVING A 50-INCH PORTABLE BARRIER AT THE LOCATIONS SHOWN ON THE PLANS. FOR DETAILS, SEE SCD RM-4.1.

PORTABLE STEEL BARRIER IS AN APPROVED ALTERNATIVE TO PORTABLE CONCRETE BARRIER. FOR INFORMATION ON APPROVED VENDORS, SEE THE APPROVED PRODUCTS LIST MAINTAINED BY THE OFFICE OF ROADWAY ENGINEERING.

PORTABLE BARRIER, 32 INCHES HIGH WITH AN 18-INCH MINIMUM HEIGHT GLARE SCREEN MAY BE USED AT THE OPTION OF THE CONTRACTOR. THE GLARE SCREEN SHALL BE CONSTRUCTED USING ONE OF THE SCREENS PROVIDED ON THE APPROVED LIST, AVAILABLE ON THE OFFICE OF ROADWAY ENGINEERING WEBSITE.

PADDLE OR INTERMITTENT TYPE GLARE SCREENS SHALL BE DESIGNED USING A 20 DEGREE CUT-OFF ANGLE BASED ON TANGENT ALIGNMENT. THAT SPACING SHALL BE USED THROUGHOUT THE BARRIER LENGTH WITHOUT REGARD TO BARRIER CURVATURE.

THE GLARE SCREEN SYSTEM SHALL BE SECURELY FASTENED TO THE 32-INCH PORTABLE BARRIER USING THE HARDWARE AND PROCEDURES SPECIFIED BY THE MANUFACTURER.

FOR DIRECTIONS ON HOW TO INSTALL THE GLARE SCREEN AND THE BARRIER, SEE THE MANUFACTURER'S INSTRUCTIONS.

PAYMENT SHALL INCLUDE ALL LABOR, MATERIAL, AND EQUIPMENT NECESSARY TO PERFORM THE WORK AND SHALL BE PAID FOR AT THE CONTRACT PRICE PER FOOT FOR ITEM 622, PORTABLE BARRIER, 50", AS PER PLAN.



ITEM 614. WORK ZONE IMPACT ATTENUATOR FOR 24" WIDE HAZARDS (UNIDIRECTIONAL OR BIDIRECTIONAL)

THIS ITEM SHALL CONSIST OF FURNISHING AND INSTALLING A NON-GATING IMPACT ATTENUATOR. FURNISH AN IMPACT ATTENUATOR FROM THE OFFICE OF ROADWAY ENGINEERING'S APPROVED LIST FOR WORK ZONE IMPACT ATTENUATORS, FROM THE ROADWAY STANDARDS APPROVED PRODUCTS WEB PAGE.

INSTALLATION SHALL BE AT THE LOCATIONS SPECIFIED IN THE PLANS IN ACCORDANCE WITH THE MANUFACTURER'S SPECIFICATIONS.

THE CONTRACTOR SHALL REPAIR OR REPLACE A DAMAGED UNIT WITHIN 24 HOURS OF A DAMAGING IMPACT.

WHEN BIDIRECTIONAL DESIGNS ARE SPECIFIED, THE CONTRACTOR SHALL SUPPLY APPROPRIATE TRANSITIONS.

WHEN GATING IMPACT ATTENUATORS ARE DESIRED, THE CONTRACTOR SHALL SUBMIT DOCUMENTATION TO THE ENGINEER FOR ACCEPTANCE.

THE COST FOR THE ADDITIONAL BARRIER REQUIRED FOR A GATING IMPACT ATTENUATOR SHALL BE INCLUDED IN THE COST OF THE GATING IMPACT ATTENUATOR.

PAYMENT FOR THE ABOVE WORK SHALL BE MADE AT THE UNIT PRICE BID AND SHALL INCLUDE ALL LABOR, TOOLS, EQUIPMENT AND MATERIALS NECESSARY TO CONSTRUCT AND MAINTAIN A COMPLETE AND FUNCTIONAL IMPACT ATTENUATOR SYSTEM, INCLUDING ALL RELATED BACKUPS, TRANSITIONS, LEVELING PADS, HARDWARE AND GRADING, NOT SEPARATELY SPECIFIED, AS REQUIRED BY THE MANUFACTURER.

ALL WORK AND TRAFFIC CONTROL DEVICES SHALL BE IN ACCORDANCE WITH C&MS 614 AND C&MS 622 OF THE SPECIFICATIONS, AS WELL AS THE OHIO MANUAL OF UNIFORM TRAFFIC CONTROL DEVICES. PAYMENT FOR ALL LABOR, EQUIPMENT AND MATERIALS SHALL BE INCLUDED IN THE LUMP SUM CONTRACT PRICE FOR ITEM 614, MAINTAINING TRAFFIC, UNLESS SEPARATELY ITEMIZED IN THE PLAN.

MAINTENANCE OF TRAFFIC NOTES

BRIDGE NO. CUY-8-0226

OVER HAWTHORN PKWY., BROADWAY AVE., TINKERS CREEK, & WHEELING & LAKE ERIE RR

DESIGN AGENCY



DESIGNER  
CAM













REVIEWER  
SA 10/17/22

PROJECT ID  
113674

SHEET TOTAL  
16 82

REF NO.	MOT PHASE	STATION TO STATION		SIDE	614	SPECIAL	614	614	614	614	614	614	622								
					WORK ZONE IMPACT ATTENUATOR, 24" WIDE HAZARDS, (UNIDIRECTIONAL)	FLASHING ARROW PANEL	WORK ZONE CENTER LINE, CLASS I, DOUBLE SOLID	WORK ZONE EDGE LINE, CLASS I, 4", WHITE	WORK ZONE CHANNELIZING LINE, CLASS I, 8"	WORK ZONE DOTTED LINE, CLASS I	WORK ZONE TRANSVERSE/DIAGONAL LINE, CLASS I, (YELLOW)	WORK ZONE ARROW, CLASS I	PORTABLE BARRIER, 50", AS PER PLAN								
					EACH	EACH	MILE	MILE	FT	FT	FT	EACH	FT								
PHASE 1																					
LA1		17+00.00	19+03.00									9									
TCH1		18+04.00	19+04.00						100												
TEW1		20+99.00	41+97.00			1		0.40													
TCL1		21+44.00	43+11.00				0.41														
TCL2		21+44.00	23+19.00				0.03														
TY1		21+44.00	23+19.00								48										
IA1			21+94.00		1																
PCB1		21+94.00	40+92.00										1898								
TDL1		39+73.00	43+11.00						338												
IA2		40+92.00			1																
PHASE 2																					
TCH1		16+14.00	19+04.00						290												
TCH2		16+14.00	19+04.00						290												
TDL1		19+04.00	20+86.00							182											
TCL1		20+86.00	43+00.00				0.42														
TY1		20+86.00	23+19.00								72										
TCL2		21+62.00	23+19.00				0.03														
TCH3		20+95.00	21+20.00						25												
TEW1		20+95.00	42+96.00					0.42													
IA1		21+59.00	21+85.00		1																
PCB1		21+85.00	40+55.00										1870								
IA2		40+55.00	40+81.00		1																
TCL3		39+58.00	41+08.00				0.03														
TY2		39+58.00	41+08.00								24										
TLD2		42+96.00	44+49.00							153											
TDL3		43+01.00	44+49.00							148											
TCH3		44+49.00	47+21.00						272												
TCH4		44+49.00	47+21.00						272												
<b>TOTALS FROM THIS SHEET</b>					4	1.00	0.92	0.82	1249	821	144	9	3768								
<b>TOTALS CARRIED TO GENERAL SUMMARY</b>					4	1.00	0.92	0.82	1249	821	144	9	3768								

LEGEND

-  WORK AREA
-  DIRECTION OF TRAVEL
-  DRUMS (35' SPACING IN THE TAPER, 40' IN THE TANGENT AS PER MT-95.30)
-  MOT SIGN
-  FLASHING ARROW BOARD (LEFT)
-  TYPE A WARNING LIGHT
-  ITEM 614 - WORK ZONE EDGE LINE, CLASS 1 (WHITE)
-  ITEM 614 - WORK ZONE CHANNELIZING LINE, CLASS 1, 8"
-  ITEM 614 - WORK ZONE DOTTED LINE, CLASS 1 (WHITE)
-  ITEM 614 - WORK ZONE CENTER LINE DOUBLE, CLASS 1 (YELLOW)
-  ITEM 614 - WORK ZONE TRANSVERSE/DIAGONAL LINE, CLASS 1 (YELLOW)
-  ITEM 614 - WORK ZONE IMPACT ATTENUATOR, 24" WIDE HAZARDS, (UNIDIRECTIONAL)
-  ITEM 622 - PORTABLE CONCRETE BARRIER, 50"

CONTRACTOR IS RESPONSIBLE FOR MAINTAINING 24/7 ACCESS TO ALL DRIVES

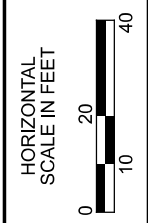
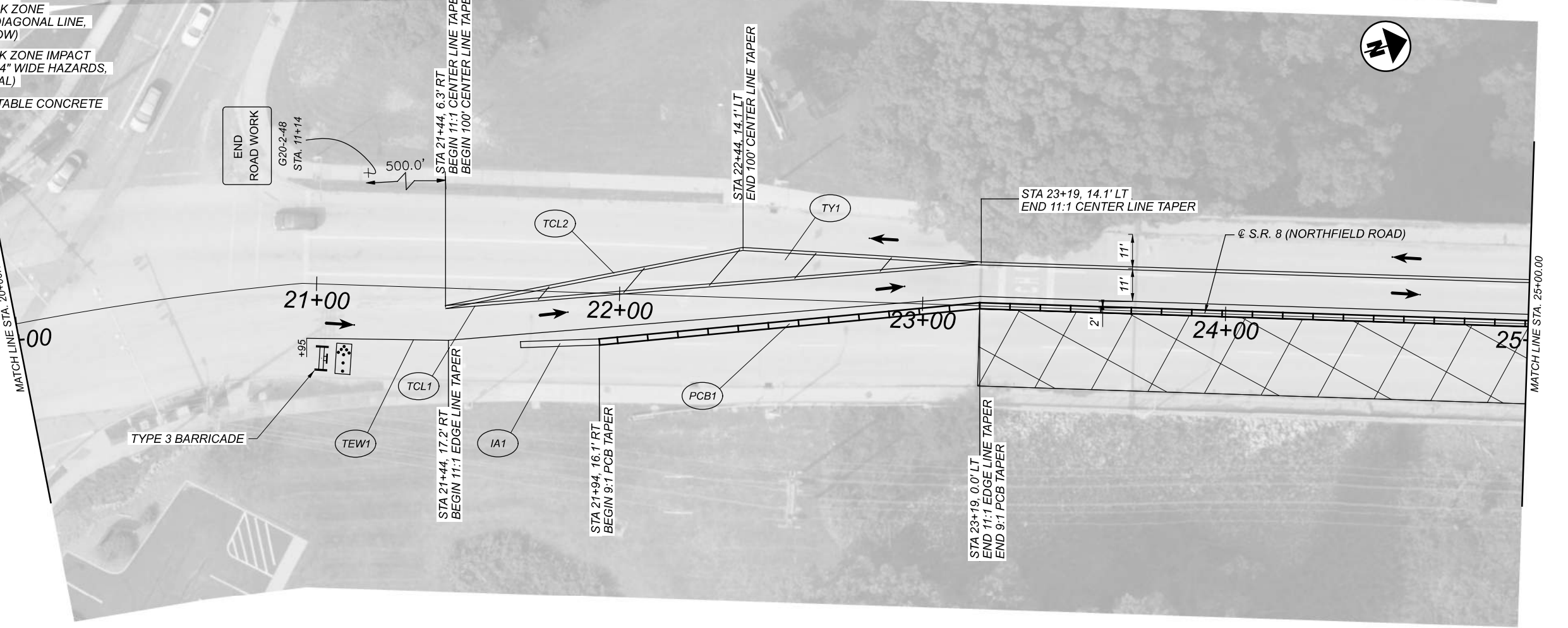
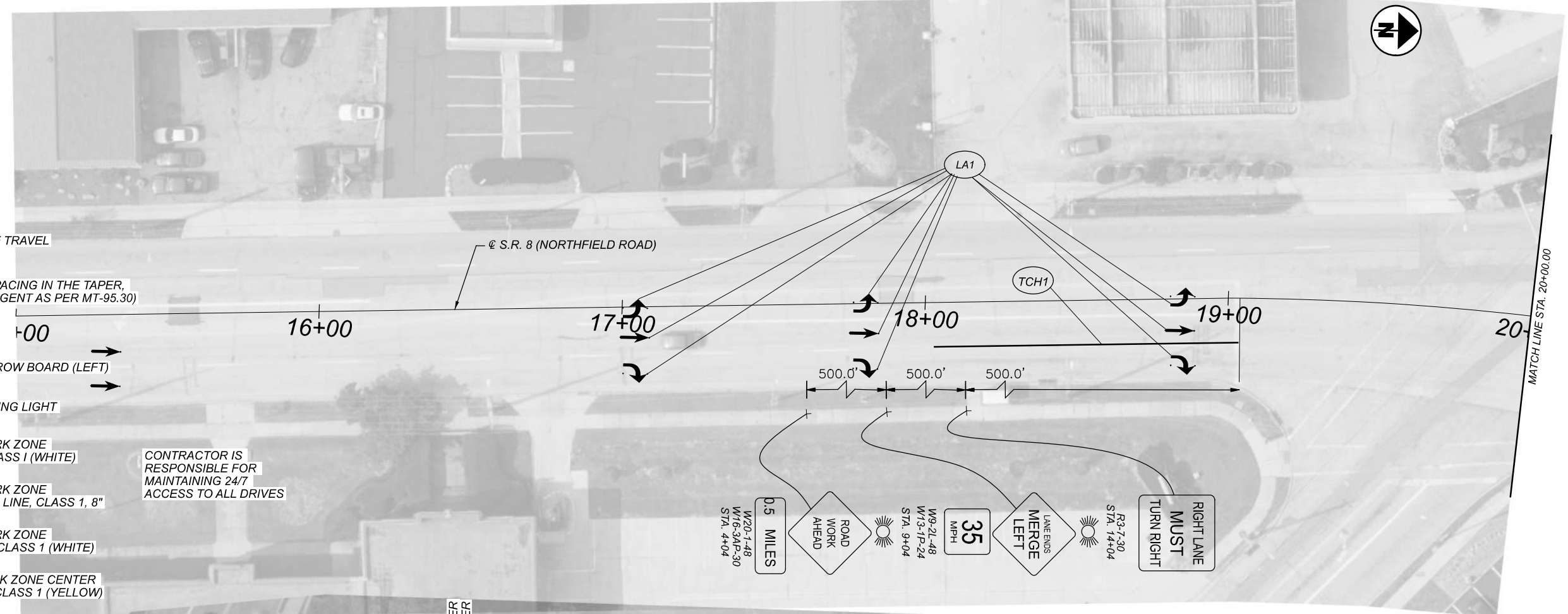

MAINTENANCE OF TRAFFIC CUY-8-0226  
 PHASES 1 & 3 - STA. 15+00 TO 25+00

DESIGN AGENCY	
DESIGNER	SDB
REVIEWER	SA 10/17/22
PROJECT ID	113674
SHEET	TOTAL
18	82

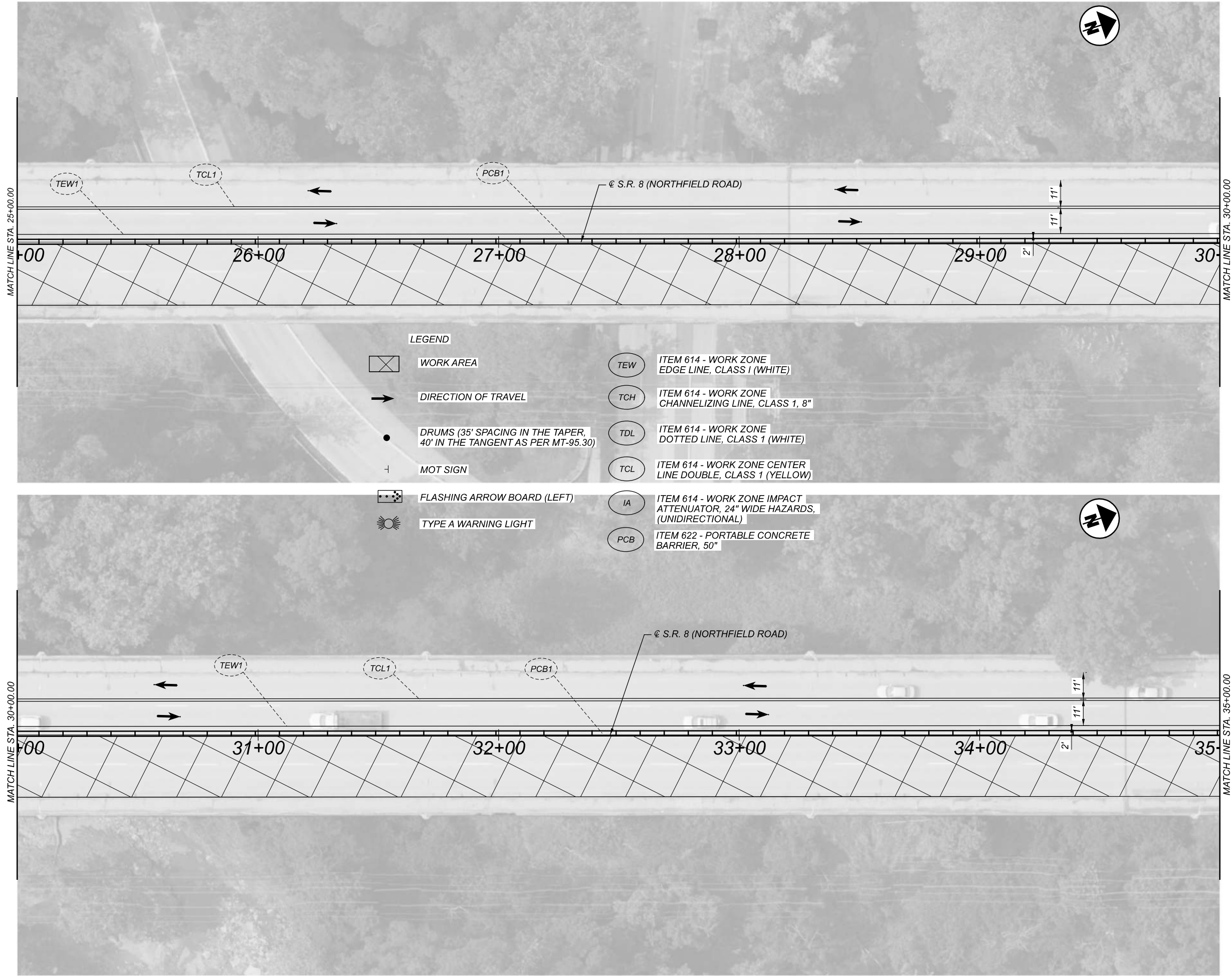

MAINTENANCE OF TRAFFIC CUY-8-0226  
 PHASES 1 & 3 - STA. 25+00 TO 35+00

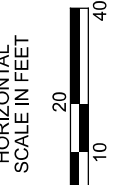

DESIGN AGENCY



DESIGNER

SDB

REVIEWER

SA 10/17/22













PROJECT ID

113674

SHEET TOTAL

19 82

LEGEND

-  WORK AREA
-  DIRECTION OF TRAVEL
-  DRUMS (35' SPACING IN THE TAPER, 40' IN THE TANGENT AS PER MT-95.30)
-  MOT SIGN
-  FLASHING ARROW BOARD (LEFT)
-  TYPE A WARNING LIGHT
-  ITEM 614 - WORK ZONE EDGE LINE, CLASS 1 (WHITE)
-  ITEM 614 - WORK ZONE CHANNELIZING LINE, CLASS 1, 8"
-  ITEM 614 - WORK ZONE DOTTED LINE, CLASS 1 (WHITE)
-  ITEM 614 - WORK ZONE CENTER LINE DOUBLE, CLASS 1 (YELLOW)
-  ITEM 614 - WORK ZONE IMPACT ATTENUATOR, 24" WIDE HAZARDS, (UNIDIRECTIONAL)
-  ITEM 622 - PORTABLE CONCRETE BARRIER, 50"

CONTRACTOR IS RESPONSIBLE FOR MAINTAINING 24/7 ACCESS TO ALL DRIVES

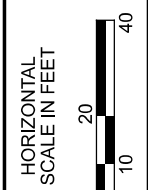
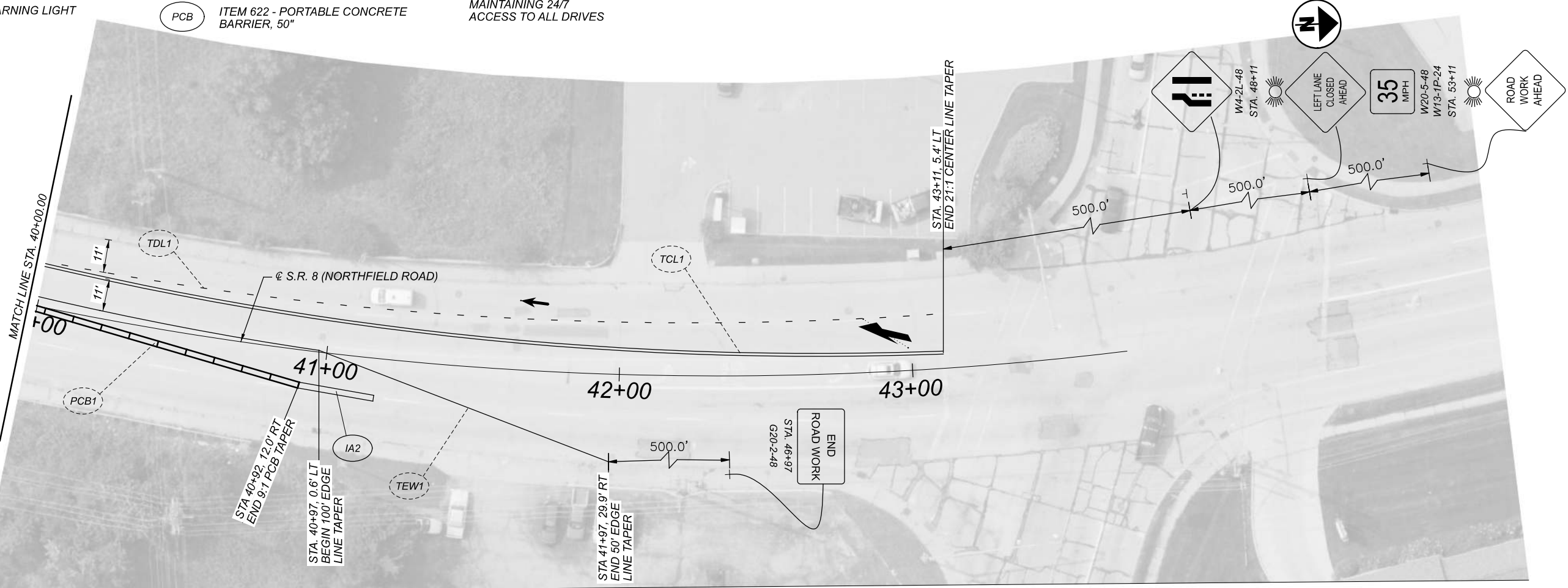
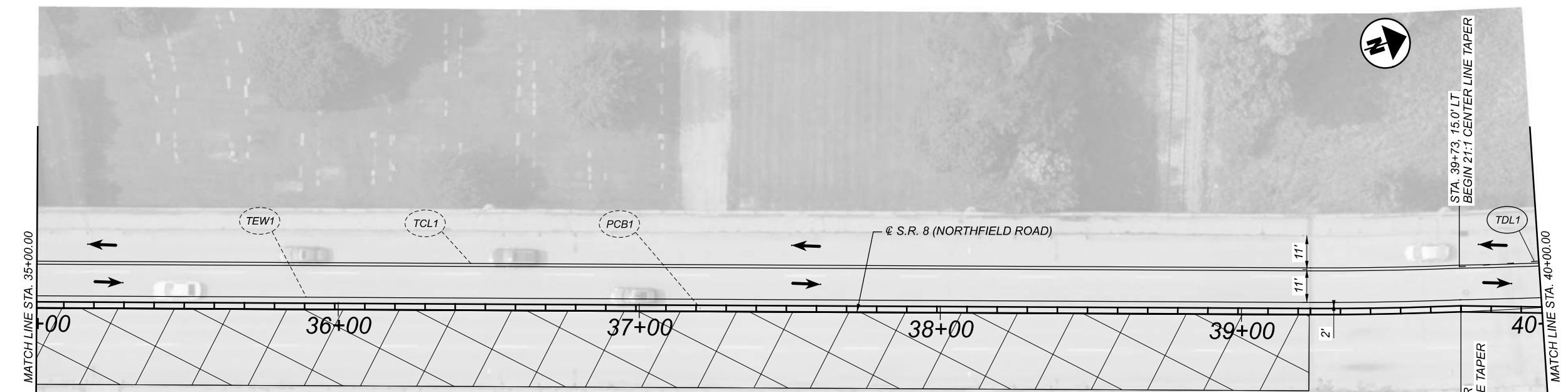

MAINTENANCE OF TRAFFIC CUY-8-0226  
 PHASES 1 & 3 - STA. 35+00 TO 45+00

DESIGN AGENCY



DESIGNER	SDB
REVIEWER	SA 10/17/22
PROJECT ID	113674
SHEET	TOTAL
20	82

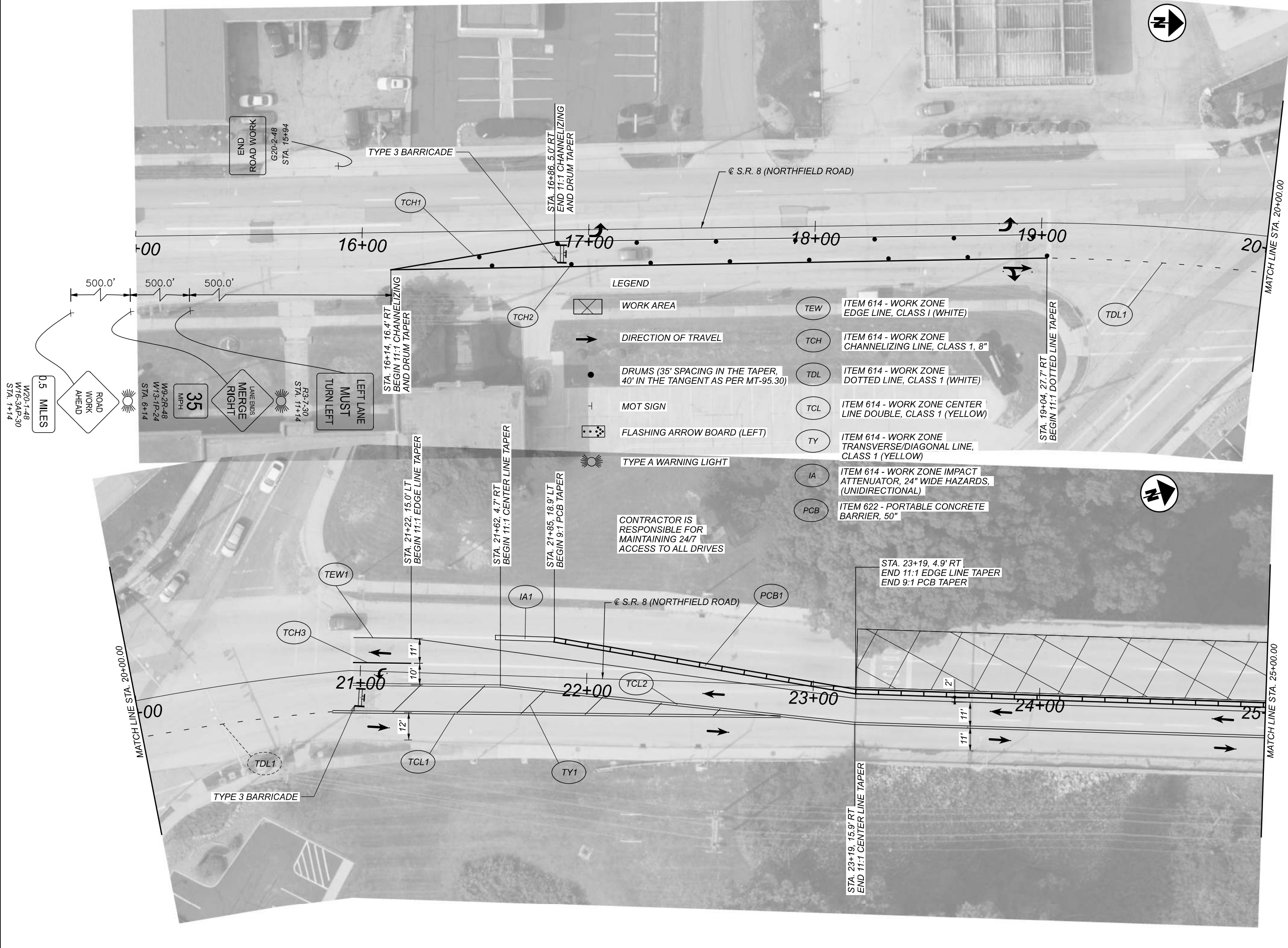

0.5 MILES  
 W20-1-48  
 W16-34P-30  
 STA. 1+14

ROAD WORK AHEAD  
 W9-2R-48  
 W13-1P-24  
 STA. 6+14

LANE ENDS MERGE RIGHT  
 35 MPH  
 R3-7-30  
 STA. 7+14

LEFT LANE MUST TURN LEFT  
 R3-7-30  
 STA. 7+14

LEGEND

- WORK AREA
- DIRECTION OF TRAVEL
- DRUMS (35' SPACING IN THE TAPER, 40' IN THE TANGENT AS PER MT-95.30)
- MOT SIGN
- FLASHING ARROW BOARD (LEFT)
- TYPE A WARNING LIGHT
- ITEM 614 - WORK ZONE EDGE LINE, CLASS I (WHITE)
- ITEM 614 - WORK ZONE CHANNELIZING LINE, CLASS 1, 8"
- ITEM 614 - WORK ZONE DOTTED LINE, CLASS 1 (WHITE)
- ITEM 614 - WORK ZONE CENTER LINE DOUBLE, CLASS 1 (YELLOW)
- ITEM 614 - WORK ZONE TRANSVERSE/DIAGONAL LINE, CLASS 1 (YELLOW)
- ITEM 614 - WORK ZONE IMPACT ATTENUATOR, 24" WIDE HAZARDS, (UNIDIRECTIONAL)
- ITEM 622 - PORTABLE CONCRETE BARRIER, 50"

CONTRACTOR IS RESPONSIBLE FOR MAINTAINING 24/7 ACCESS TO ALL DRIVES

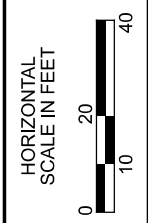

MAINTENANCE OF TRAFFIC CUY-8-0226  
 PHASE 2 - STA. 15+00 TO STA 25+00

DESIGN AGENCY



DESIGNER  
 SDB

REVIEWER  
 SA 10/17/22

PROJECT ID  
 113674

SHEET TOTAL  
 21 82

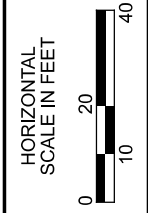

**MAINTENANCE OF TRAFFIC CUY-8-0226**  
**PHASE 2 STA. 25+00 TO 35+00**

DESIGN AGENCY	
DESIGNER	SDB
REVIEWER	SA 10/17/22
PROJECT ID	113674
SHEET	TOTAL
22	82



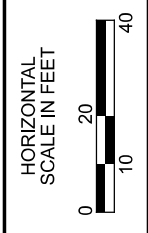
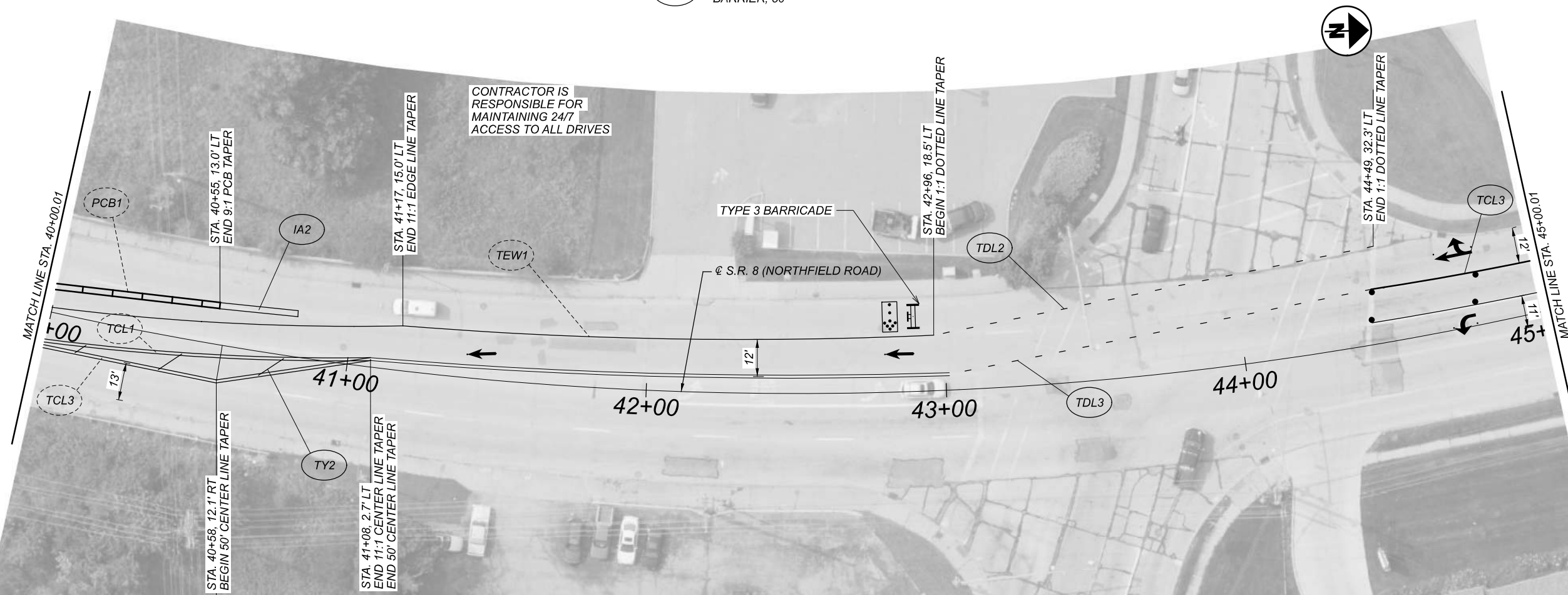
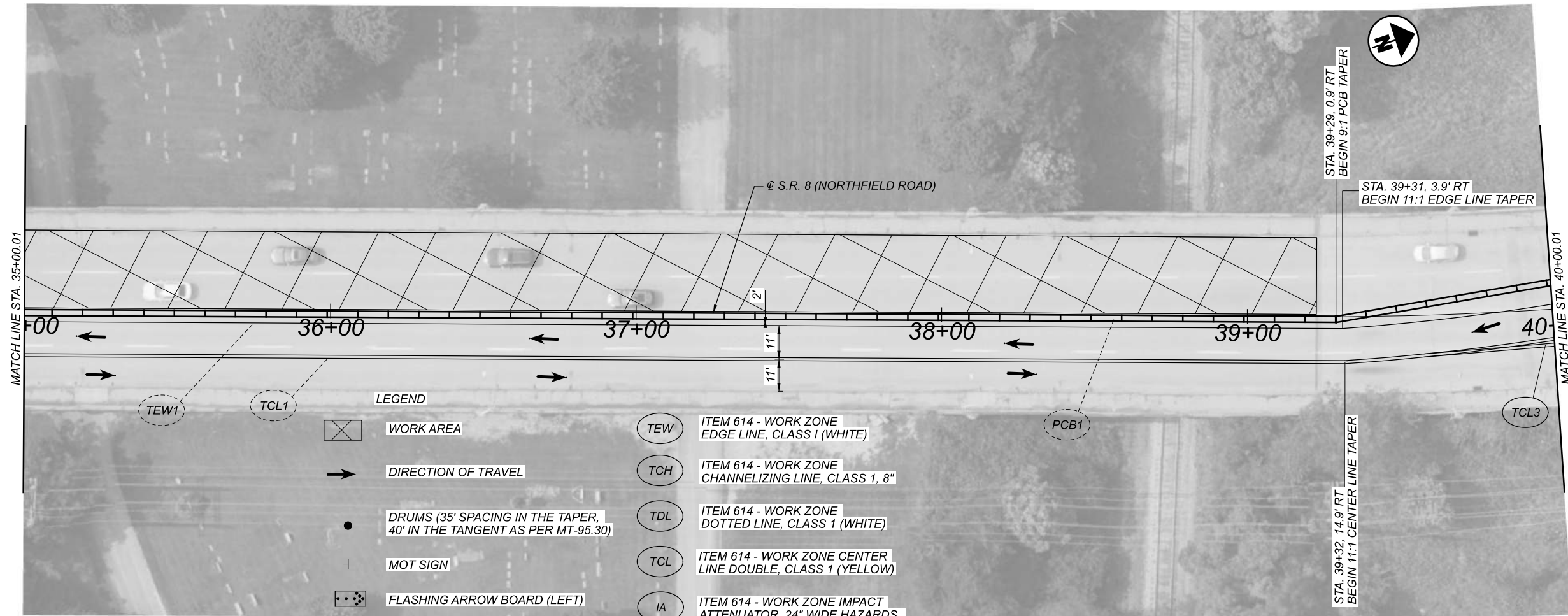





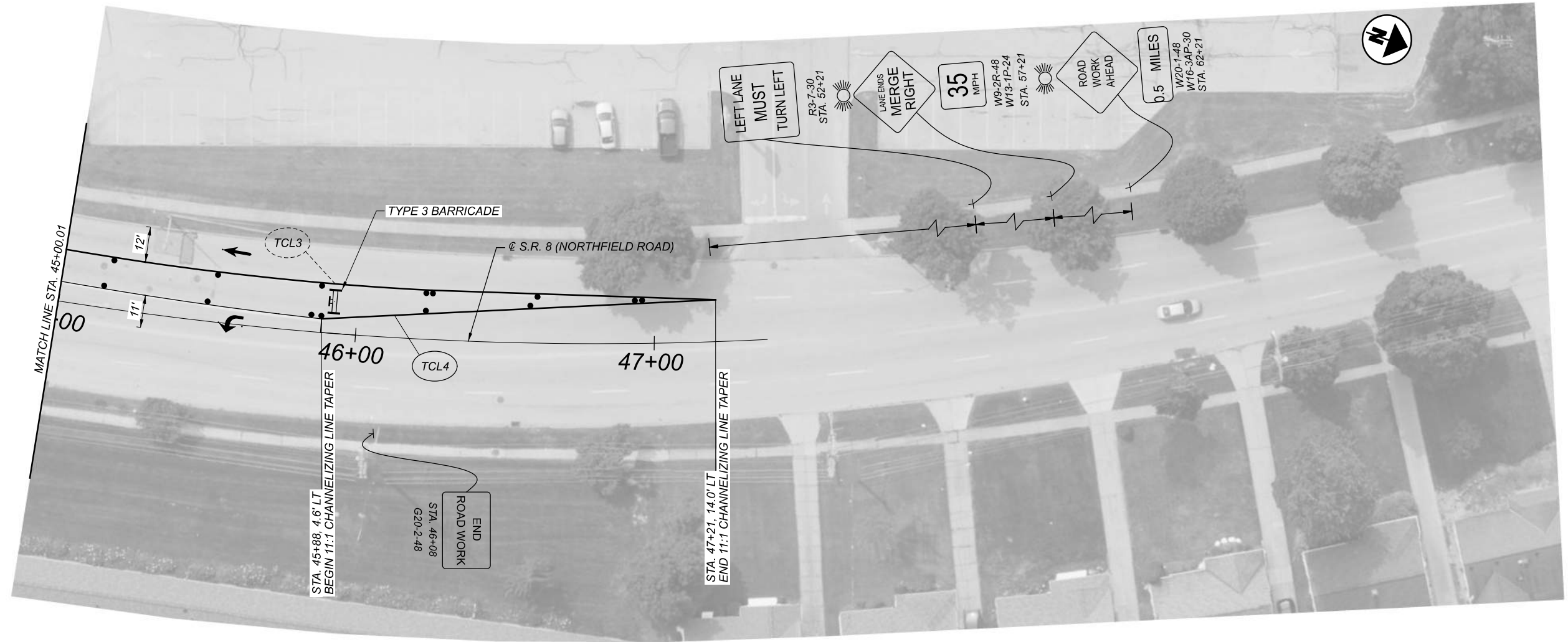







MAINTENANCE OF TRAFFIC CUY-8-0226  
 PHASE 2 - STA. 35+00 TO 45+00

DESIGN AGENCY	DLZ
DESIGNER	SDB
REVIEWER	SA 10/17/22
PROJECT ID	113674
SHEET	TOTAL
23	82



LEGEND

-  WORK AREA
-  DIRECTION OF TRAVEL
-  DRUMS (35' SPACING IN THE TAPER, 40' IN THE TANGENT AS PER MT-95.30)
-  MOT SIGN
-  FLASHING ARROW BOARD (LEFT)
-  TYPE A WARNING LIGHT
-  ITEM 614 - WORK ZONE EDGE LINE, CLASS 1 (WHITE)
-  ITEM 614 - WORK ZONE CHANNELIZING LINE, CLASS 1, 8"
-  ITEM 614 - WORK ZONE DOTTED LINE, CLASS 1 (WHITE)
-  ITEM 614 - WORK ZONE CENTER LINE DOUBLE, CLASS 1 (YELLOW)
-  ITEM 614 - WORK ZONE IMPACT ATTENUATOR, 24" WIDE HAZARDS, (UNIDIRECTIONAL)
-  ITEM 622 - PORTABLE CONCRETE BARRIER, 50"

CONTRACTOR IS RESPONSIBLE FOR MAINTAINING 24/7 ACCESS TO ALL DRIVES

MAINTENANCE OF TRAFFIC CUY-8-0226  
 PHASE 2 - STA. 45+00 TO 50+00

DESIGN AGENCY



DESIGNER  
 SDB

REVIEWER  
 SA 10/17/22

PROJECT ID  
 113674

SHEET	TOTAL
24	82



SHEET NUM.											PART.	ITEM	ITEM EXT	GRAND TOTAL	UNIT	DESCRIPTION	SEE SHEET NO.
7	17	26															
		6										202	32000	6	FT	CURB REMOVED	
		935										608	10000	935	SF	4" CONCRETE WALK	
		221										608	13000	221	SF	6" CONCRETE WALK	
		6										609	16001	6	FT	CURB, TYPE 2-B, AS PER PLAN	
																<b>STRUCTURE REPAIR (CUY-10-0869, SFN 1801325)</b>	
																FOR ESTIMATED QUANTITIES, SEE STRUCTURE PLANS	30
																<b>STRUCTURE REPAIR (CUY-8-0226, SFN 1801244)</b>	
																FOR ESTIMATED QUANTITIES, SEE STRUCTURE PLANS	61
																<b>MAINTENANCE OF TRAFFIC</b>	
4	4											614	12380	8	EACH	WORK ZONE IMPACT ATTENUATOR, 24" WIDE HAZARDS, (UNIDIRECTIONAL)	6, 16
	1											SPECIAL	61412760	1	EACH	FLASHING ARROW PANEL	
0.87	0.92											614	21000	1.79	MILE	WORK ZONE CENTER LINE, CLASS I, DOUBLE SOLID	
0.73	0.82											614	22000	1.55	MILE	WORK ZONE EDGE LINE, CLASS I, 4", WHITE	
	1,249											614	23000	1,249	FT	WORK ZONE CHANNELIZING LINE, CLASS I, 8"	
915	821											614	24000	1,736	FT	WORK ZONE DOTTED LINE, CLASS I	
175	144											614	25000	319	FT	WORK ZONE TRANSVERSE/DIAGONAL LINE, CLASS I	
	9											614	30000	9	EACH	WORK ZONE ARROW, CLASS I	
2,904	3,768											622	41011	6,672	FT	PORTABLE BARRIER, 50", AS PER PLAN	5, 15
																<b>INCIDENTALS</b>	
												614	11000	LS		MAINTAINING TRAFFIC	
												619	16010	15	MNTH	FIELD OFFICE, TYPE B	
												623	10000	LS		CONSTRUCTION LAYOUT STAKES AND SURVEYING	
												624	10000	LS		MOBILIZATION	

GENERAL SUMMARY

DESIGN AGENCY  
  
 DESIGNER  
 JG  
 REVIEWER  
 MJL 10/24/22  
 PROJECT ID  
 113674  
 SHEET TOTAL  
 25 82



CUY-8/10-02-26/08.69

MODEL: Sheet PAPER: 17x11 (in.) DATE: 10/28/2022 TIME: 8:43:19 PM USER: jmillar  
 X:\Projects\2021\12122100200 ODOT CUY-8 CUY-10\113674\400-Engineering\Structures\SFN\_1801325\_SFN\_1801325\_SP001.dgn

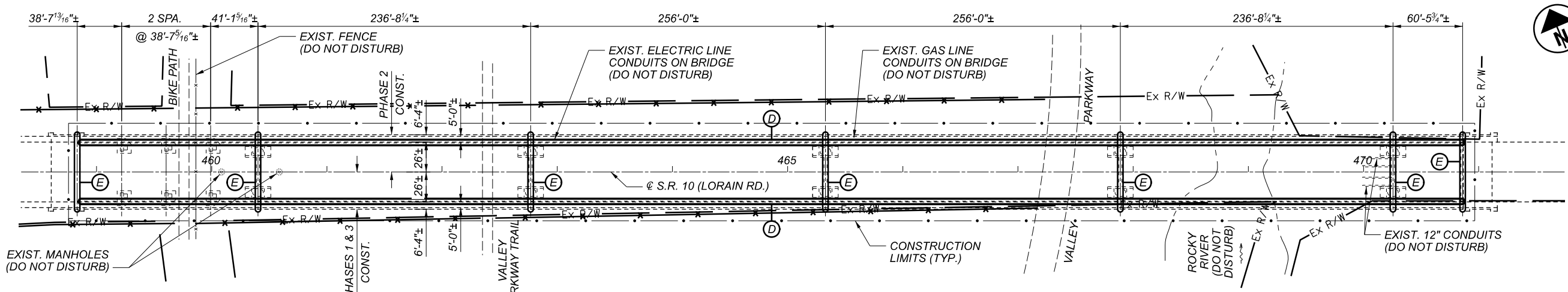

GENERAL PLAN

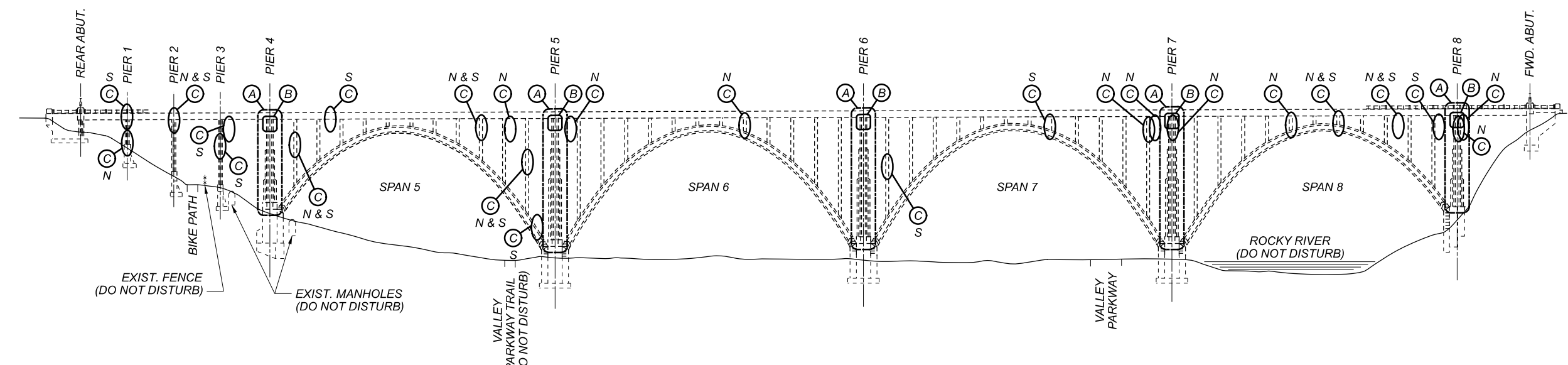

GENERAL ELEVATION

**LEGEND**

- (A) REPAIR AND PAINT STRUCTURAL STEEL IN PIER TOWER
- (B) ADD VENTED COVER PLATE AT TOP OF PIER TOWER
- (C) REPLACE DOWNSPOUT OR COLLECTOR PIPE ON NORTH (N) OR SOUTH (S) SIDE OF BRIDGE
- (D) CLEAN OUT ALL DRAINAGE TROUGHS, DOWNSPOUT PIPES, AND COLLECTOR PIPES
- (E) REPLACE EXPANSION JOINTS INCLUDING SIDEWALK AND CURB PLATE ASSEMBLIES

**DESIGN TRAFFIC**

CURRENT ADT (2022) = 12,841      DESIGN ADT (2052) = 14,767  
 CURRENT ADTT (2022) = 257      DESIGN ADTT (2052) = 296  
 DIRECTIONAL DISTRIBUTION = 0.60

**NOTES**

1. DETAILS ON THIS SHEET ARE TAKEN FROM EXISTING PLANS AND SHALL BE USED FOR INFORMATIONAL PURPOSES ONLY.
2. PERFORM ONLY THE WORK AS INDICATED IN THE LEGEND ON THIS SHEET.
3. EXISTING UTILITIES ARE TO REMAIN UNLESS NOTED OTHERWISE.

EXISTING STRUCTURE	PROPOSED STRUCTURE
<p>TYPE: OPEN SPANDREL STEEL ARCH WITH REINFORCED CONCRETE DECK AND SUBSTRUCTURE</p> <p>SPANS: 38'-7 13/16" (±), 2 @ 38'-7 5/16" (±), 41'-1 5/16" (±), 236'-8 1/4" (±), 2 @ 256'-0" (±), 236'-8 1/4" (±), 60'-5 3/4" (±) SUBSTRUCTURES</p> <p>ROADWAY: 52'-0" (±) FACE/FACE CURBS &amp; 5'-0" (±) SIDEWALK EACH SIDE</p> <p>LOADING: HS20-44 &amp; ALTERNATE MILITARY LOADING, FUTURE WEARING SURFACE = 0 KSF</p> <p>SKIEW: NONE</p> <p>WEARING SURFACE: 1 1/4" (±) LATEX MODIFIED CONCRETE</p> <p>APPROACH SLABS: 25'-0" (±) LONG (AS-1-81)</p> <p>ALIGNMENT: TANGENT</p> <p>CROWN: 0.0156 (±) FT/FT</p> <p>STRUCTURE FILE NUMBER: 1801325</p> <p>DATE BUILT: 1935</p> <p>DISPOSITION: MISCELLANEOUS STRUCTURE REPAIRS</p>	<p>PROPOSED WORK: REPAIR DETERIORATED STEEL MEMBERS INSIDE PIER TOWERS 4-8, ADD COVER PLATES ABOVE PIER TOWERS 4-8 REPLACE EXPANSION JOINTS, AND REPAIR DRAINAGE SYSTEM</p> <p>TYPE: OPEN SPANDREL STEEL ARCH WITH REINFORCED CONCRETE DECK AND SUBSTRUCTURE</p> <p>SPANS: 38'-7 13/16" (±), 2 @ 38'-7 5/16" (±), 41'-1 5/16" (±), 236'-8 1/4" (±), 2 @ 256'-0" (±), 236'-8 1/4" (±), 60'-5 3/4" (±) SUBSTRUCTURES</p> <p>ROADWAY: 52'-0" (±) FACE/FACE CURBS &amp; 5'-0" (±) SIDEWALK EACH SIDE</p> <p>VEHICULAR LIVE LOAD: HS20-44 &amp; ALTERNATE MILITARY LOADING</p> <p>FUTURE WEARING SURFACE: 0 KSF</p> <p>SKIEW: NONE</p> <p>WEARING SURFACE: 1 1/4" (±) LATEX MODIFIED CONCRETE</p> <p>APPROACH SLABS: 25'-0" (±) LONG (AS-1-81)</p> <p>ALIGNMENT: TANGENT</p> <p>CROWN: 0.0156 (±) FT/FT</p> <p>DECK AREA: 79,335 SF</p> <p>COORDINATES: LATITUDE 41°27'04.59" N          LONGITUDE 81°49'27.17" W</p>

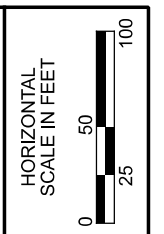

SITE PLAN  
 BRIDGE NO. CUY-10-0869  
 OVER VALLEY PARKWAY & ROCKY RIVER

SFN	1801325
DESIGN AGENCY	DLZ
DESIGNER	JAM
CHECKER	TA/JDA
REVIEWER	CJS
DATE	10/24/22
PROJECT ID	113674
SUBSET	1
TOTAL	30
SHEET	27
TOTAL	82

**REFER TO THE FOLLOWING STANDARD BRIDGE DRAWINGS:**

EXJ-4-87 REVISED 07/15/22  
 EXJ-6-17 REVISED 01/15/21

**AND TO THE FOLLOWING SUPPLEMENTAL SPECIFICATIONS:**

800 DATED 01/20/23

**DESIGN SPECIFICATIONS:**

THE EXISTING STRUCTURE WAS DESIGNED IN CONFORMANCE WITH THE "STANDARD SPECIFICATIONS FOR HIGHWAY BRIDGES" ADOPTED BY THE AMERICAN ASSOCIATION OF STATE HIGHWAY AND TRANSPORTATION OFFICIALS, 1977, INCLUDING THE 1978 THROUGH 1980 INTERIM SPECIFICATIONS AND THE OHIO SUPPLEMENT TO THESE SPECIFICATIONS.

**DESIGN LOADING INCLUDES:**

VEHICULAR LIVE LOAD: HS20-44 CASE II AND THE ALTERNATE MILITARY LOADING

**DESIGN DATA:**

CONCRETE CLASS QC2 - COMPRESSIVE STRENGTH 4.5 KSI (SUPERSTRUCTURE)

CONCRETE REINFORCEMENT:  
 EPOXY COATED STEEL REINFORCEMENT - MINIMUM YIELD STRENGTH 60 KSI

STRUCTURAL STEEL - YIELD STRENGTH 33 KSI (EXISTING U.N.O.)  
 STRUCTURAL STEEL - ASTM A36 - YIELD STRENGTH 36 KSI (EXIST. BEAMS FOR WIDENING)  
 STRUCTURAL STEEL - ASTM A709 GRADE 50 - YIELD STRENGTH 50 KSI (PROPOSED)

**MAINTENANCE OF TRAFFIC:**

MAINTENANCE OF TRAFFIC FOR THE STRUCTURE WORK SHALL BE COORDINATED WITH THE OVERALL PROJECT. REFER TO THE MAINTENANCE OF TRAFFIC NOTES AND DETAILS ELSEWHERE IN THE PLANS.

**EXISTING STRUCTURE VERIFICATION:**

DETAILS AND DIMENSIONS SHOWN ON THESE PLANS PERTAINING TO THE EXISTING STRUCTURE HAVE BEEN OBTAINED FROM PLANS OF THE EXISTING STRUCTURE AND FROM FIELD OBSERVATIONS AND MEASUREMENTS. CONSEQUENTLY, THEY ARE INDICATIVE OF THE EXISTING STRUCTURE AND THE PROPOSED WORK BUT THEY SHALL BE CONSIDERED TENTATIVE AND APPROXIMATE. THE CONTRACTOR IS REFERRED TO C&MS, SECTIONS 102.05, 105.02, AND 513.04.

BASE CONTRACT BID PRICES UPON A RECOGNITION OF THE UNCERTAINTIES DESCRIBED ABOVE AND UPON A PREBID EXAMINATION OF THE EXISTING STRUCTURE. HOWEVER, THE DEPARTMENT WILL PAY FOR ALL PROJECT WORK BASED UPON ACTUAL DETAILS AND DIMENSIONS THAT HAVE BEEN VERIFIED IN THE FIELD.

**EXISTING STRUCTURE PLANS:**

PLANS MAY BE EXAMINED BY THE PROSPECTIVE BIDDERS AT THE OHIO DEPARTMENT OF TRANSPORTATION, DISTRICT 12, 5500 TRANSPORTATION BOULEVARD, GARFIELD HEIGHTS, OH 44125, PHONE: 216-581-2100.

**ITEM 202 - PORTIONS OF STRUCTURE REMOVED, OVER 20 FOOT SPAN, AS PER PLAN:**

DESCRIPTION: WORK TO BE PAID FOR UNDER THIS ITEM SHALL INCLUDE THE REMOVAL OF EXISTING STRUCTURE COMPONENTS AS DETAILED IN THE PLANS AND AS DIRECTED BY THE ENGINEER. THE REMOVALS SHALL INCLUDE BUT NOT NECESSARILY BE LIMITED TO THE FOLLOWING:

1. STRIP SEAL EXPANSION JOINTS, INCLUDING EMBEDDED STEEL, AT THE ABUTMENTS AND ABOVE THE PIER TOWERS AS SHOWN IN THE PLANS.
2. PORTIONS OF EXISTING BRIDGE DECK SLAB AS SHOWN IN THE PLANS, INCLUDING SAW CUTTING.
3. PORTIONS OF EXISTING ABUTMENT BACKWALLS AS SHOWN IN THE PLANS, INCLUDING SAW CUTTING.
4. STRUCTURAL STEEL MEMBERS IN PIER TOWERS 4-8 AS SHOWN IN THE PLANS.
5. EXISTING STEEL DOWNSPOUT AND COLLECTOR PIPES AS SHOWN IN THE PLANS, INCLUDING ALL DIRT AND DEBRIS CONTAINED WITHIN.
6. MISCELLANEOUS ITEMS THAT ARE NOT SHOWN TO BE INCORPORATED INTO THE FINAL CONSTRUCTION AND ARE DIRECTED TO BE REMOVED BY THE ENGINEER.

THE PROVISIONS OF ITEM 202 APPLY EXCEPT AS SPECIFIED BY THE FOLLOWING NOTES. PERFORM WORK CAREFULLY DURING DECK REMOVALS TO PROTECT PORTIONS OF SUCH SYSTEMS THAT ARE TO BE SALVAGED AND INCORPORATED INTO THE PROPOSED STRUCTURE. THE DEPARTMENT WILL NOT PERMIT THE USE OF EXPLOSIVES, HEADACHE BALLS AND/OR HOE RAM TYPE OF EQUIPMENT. SUBMIT CONSTRUCTION PLANS ACCORDING TO C&MS 501.05.

PROTECTION OF STEEL SUPPORT SYSTEMS: BEFORE DECK SLAB CUTTING BEGINS, DRAW THE OUTLINE OF PRIMARY STEEL MEMBERS IN CONTACT WITH THE BOTTOM OF THE DECK ON THE SURFACE OF DECK. DRILL SMALL DIAMETER PILOT HOLES 2 INCHES OUTSIDE THESE LINES TO CONFIRM THE LOCATION OF FLANGE EDGES. DECK CUTS OVER OR WITHIN 2 INCHES OF FLANGE EDGES SHALL NOT EXTEND LOWER THAN THE BOTTOM LAYER OF CONCRETE REINFORCEMENT IN THE DECK SLAB. CUTS MADE OUTSIDE 2 INCHES OF FLANGE EDGES MAY EXTEND THE FULL DEPTH OF THE DECK. PERFORM WORK CAREFULLY DURING CUTTING OF THE DECK SLAB TO AVOID DAMAGING STEEL MEMBERS THAT ARE TO BE INCORPORATED INTO THE PROPOSED STRUCTURE. REPLACE OR REPAIR STEEL MEMBERS DAMAGED BY THE DECK SLAB CUTTING OPERATIONS AT NO COST TO THE PROJECT. AT LEAST 7 DAYS BEFORE PERFORMING REPAIR WORK, SUBMIT A PROPOSED REPAIR PLAN, DEVELOPED BY AN OHIO REGISTERED PROFESSIONAL ENGINEER TO THE ENGINEER. OBTAIN THE ENGINEER'S APPROVAL BEFORE PERFORMING REPAIR.

REMOVAL METHODS: THE CONTRACTOR MAY REMOVE CONCRETE BY CUTTING AND BY MEANS OF HAND OPERATED PNEUMATIC HAMMERS EMPLOYING POINTED OR BLUNTED CHISEL TYPE TOOLS. FOR REMOVALS OVER STRUCTURAL MEMBERS (STEEL GIRDER, ETC.), THE CONTRACTOR MAY USE A HAMMER HEAVIER THAN 35 POUNDS BUT NOT TO EXCEED 90 POUNDS UNLESS APPROVED BY THE ENGINEER. REMOVAL METHODS OVER STRUCTURAL MEMBERS SHALL ENSURE ADEQUATE DEPTH CONTROL AND PREVENT NICKING OR GOUGING THE PRIMARY STRUCTURAL MEMBERS. DUE TO THE POSSIBLE PRESENCE OF ATTACHMENTS (E.G., FINISHING MACHINE, SCUPPER AND FORM SUPPORTS, ETC.) TO EXISTING STRUCTURAL MEMBERS, PERFORM WORK CAREFULLY DURING DECK REMOVAL TO AVOID DAMAGING STRUCTURAL MEMBERS THAT ARE TO REMAIN. REPLACE OR REPAIR STRUCTURAL MEMBERS DAMAGED BY THE REMOVAL OPERATIONS AT NO COST TO THE PROJECT. AT LEAST 7 DAYS BEFORE PERFORMING REPAIR WORK, SUBMIT A PROPOSED REPAIR PLAN, DEVELOPED BY AN OHIO REGISTERED PROFESSIONAL ENGINEER TO THE ENGINEER. OBTAIN THE ENGINEER'S APPROVAL BEFORE PERFORMING REPAIR.

**ITEM 202 - PORTIONS OF STRUCTURE REMOVED, OVER 20 FOOT SPAN, AS PER PLAN (CONT.):**

CUT LINE CONSTRUCTION JOINT PREPARATION: SAW CUT BOUNDARIES OF PROPOSED CONCRETE REMOVALS 1 INCH DEEP. REMOVE CONCRETE TO A ROUGH SURFACE. LEAVE THE EXISTING CONCRETE REINFORCEMENT, IF REQUIRED IN THE PLANS, IN PLACE. INSTALL DOWEL BARS IF SPECIFIED. PRIOR TO CONCRETE PLACEMENT ABRASIVELY CLEAN JOINT SURFACES AND EXISTING EXPOSED REINFORCEMENT TO REMOVE LOOSE AND DISINTEGRATED CONCRETE AND LOOSE RUST. THOROUGHLY CLEAN THE JOINT SURFACE AND EXPOSED REINFORCEMENT OF ALL DIRT, DUST, RUST OR OTHER FOREIGN MATERIAL BY THE USE OF WATER, AIR UNDER PRESSURE, OR OTHER METHODS THAT PRODUCE SATISFACTORY RESULTS. EXISTING STEEL REINFORCEMENT DOES NOT HAVE TO HAVE A BRIGHT STEEL FINISH BUT REMOVE ALL PACK AND LOOSE RUST. THOROUGHLY DRENCH EXISTING CONCRETE SURFACES WITH CLEAN WATER AND ALLOW TO DRY TO A DAMP CONDITION BEFORE PLACING CONCRETE.

SUBSTRUCTURE CONCRETE REMOVAL: REMOVE CONCRETE BY MEANS OF APPROVED PNEUMATIC HAMMERS EMPLOYING POINTED AND BLUNT CHISEL TOOLS. THE DEPARTMENT WILL NOT PERMIT HYDRAULIC HOE-RAM TYPE HAMMERS. THE WEIGHT OF THE HAMMER SHALL NOT BE MORE THAN 35 POUNDS FOR REMOVAL WITHIN 18 INCHES OF PORTIONS TO BE PRESERVED. OUTSIDE THE 18-INCH LIMIT, THE CONTRACTOR MAY USE HAMMERS NOT EXCEEDING 90 POUNDS UPON THE APPROVAL OF THE ENGINEER. DO NOT PLACE PNEUMATIC HAMMERS IN DIRECT CONTACT WITH CONCRETE REINFORCEMENT THAT IS TO BE RETAINED IN THE REBUILT STRUCTURE.

MEASUREMENT & PAYMENT: THE DEPARTMENT WILL MEASURE THE QUANTITY OF REMOVALS ON A LUMP SUM BASIS. THE DEPARTMENT WILL PAY FOR THE ACCEPTED QUANTITIES OF REMOVALS AT THE CONTRACT PRICE FOR ITEM 202 - PORTIONS OF STRUCTURE REMOVED, OVER 20 FOOT SPAN, AS PER PLAN.

**ITEM 509 - CONCRETE REINFORCEMENT, REPLACEMENT OF EXISTING CONCRETE REINFORCEMENT, AS PER PLAN:**

REPLACE ALL EXISTING REINFORCING BARS DEEMED BY THE ENGINEER TO BE UNUSABLE BECAUSE OF CORROSION. THE DEPARTMENT WILL MEASURE THE REPLACEMENT CONCRETE REINFORCEMENT BY THE NUMBER OF POUNDS ACCEPTED IN PLACE. REPLACE ALL EXISTING STEEL REINFORCEMENT BARS WHICH ARE TO BE INCORPORATED INTO THE NEW WORK AND ARE DEEMED BY THE ENGINEER TO BE MADE UNUSABLE BY CONCRETE REMOVAL OPERATIONS WITH NEW CONCRETE REINFORCEMENT OF THE SAME SIZE, COATING, AND MATERIAL AT NO COST TO THE DEPARTMENT.

**ITEM 513 - STRUCTURAL STEEL MEMBERS, LEVEL UF, AS PER PLAN:**

ALL REQUIREMENTS OF C&MS 513 APPLY TO SHOP FABRICATED MEMBERS. PERFORM WORK FOR FIELD FABRICATED MEMBERS ACCORDING TO ITEM 513, EXCEPT AS MODIFIED HEREIN. THE DEPARTMENT WILL NOT REQUIRE THE CONTRACTOR PERFORMING FIELD FABRICATION TO BE PREQUALIFIED AS SPECIFIED IN S1078. SUBMIT A WRITTEN LETTER OF MATERIAL ACCEPTANCE IN ACCORDANCE WITH C&MS 501.06, TO THE ENGINEER. PROVIDE THE ENGINEER "AS-BUILT" DRAWINGS ACCORDING C&MS 513.06, EXCEPT C&MS 501.04 DOES NOT APPLY. UPON RECEIPT OF THE ENGINEER'S ACCEPTANCE, SUPPLY A COPY OF THE DRAWINGS, ACCORDING TO S1002 TO THE OFFICE OF MATERIAL MANAGEMENT FOR RECORD PURPOSES.

THE FOLLOWING MEMBERS ARE INCLUDED IN THIS ITEM: PIER TOWER CAP AND COLUMN ANGLES AND CHANNELS.

**ITEM 514 - FIELD PAINTING OF EXISTING STRUCTURAL STEEL, PRIME COAT, ITEM 514 - FIELD PAINTING STRUCTURAL STEEL, INTERMEDIATE COAT & ITEM 514 - FIELD PAINTING STRUCTURAL STEEL, FINISH COAT:**

FIELD PAINTING OF STRUCTURAL STEEL SHALL BE LIMITED TO THE PROPOSED STRUCTURAL STEEL INSTALLED AS PART OF THIS PROJECT.

THE COLOR OF THE FINISH COAT SHALL MATCH THE EXISTING PAINT COLOR.

SFN	1801325
DESIGN AGENCY	
	
DESIGNER	CHECKER
JAM	MJL
REVIEWER	
CJS 10/24/22	
PROJECT ID	
113674	
SUBSET	TOTAL
2	30
SHEET	
TOTAL	
28	82

**ITEM 516 - STRIP SEAL EXPANSION JOINT ANCHORED WITH ELASTOMERIC CONCRETE, AS PER PLAN:**

THIS ITEM OF WORK INCLUDES REPLACEMENT OF THE EXISTING DECK EXPANSION JOINTS AT THE ABUTMENTS AND OVER THE PIER TOWERS AS DETAILED IN THE PLANS.

ALL NEW CONCRETE AND REINFORCEMENT NEEDED FOR THE NEW ABUTMENT BACKWALLS, DECK, AND SIDEWALK AT/NEAR THE EXPANSION JOINTS IS INCLUDED IN THE UNIT PRICE BID FOR THIS ITEM. ALL REINFORCEMENT IS TO BE EPOXY COATED AND BE PER C&MS 509. ALL CONCRETE IS TO BE CLASS QC2 CONCRETE, SUPERSTRUCTURE, PER C&MS 511. ANY DOWELING NEEDED IS TO BE PER C&MS 510 USING NONSHRINK, NONMETALLIC GROUT.

PAYMENT AND MEASUREMENT FOR THIS ITEM OF WORK SHALL BE PER LINEAR FOOT OF JOINT COMPLETED IN PLACE. THE BID PRICE SHALL INCLUDE ALL LABOR, MATERIALS, EQUIPMENT, INCLUDING REPLACEMENT OF CONCRETE, SIDEWALK COVER PLATES, HMWM RESIN, AND INCIDENTALS NECESSARY TO COMPLETE THE EXPANSION JOINT REPLACEMENTS. THE DEPARTMENT WILL PAY FOR THE ACCEPTED QUANTITIES AT THE CONTRACT UNIT PRICE BID FOR ITEM 516 - STRIP SEAL EXPANSION JOINT ANCHORED WITH ELASTOMERIC CONCRETE, AS PER PLAN.

**ITEM 518 - STRUCTURE DRAINAGE, MISC.: 10" GALVANIZED STEEL PIPE, INCLUDING SPECIALS:**

DESCRIPTION: THIS WORK CONSISTS OF FURNISHING AND INSTALLING GALVANIZED STEEL COLLECTOR PIPES AND DOWNSPOUT PIPES AT LOCATIONS NOTED IN THE PLANS.

MATERIALS: STRUCTURAL STEEL FOR CLEANOUTS AND DOWNSPOUT SUPPORTS SHALL BE ASTM A709 GRADE 50, GALVANIZED IN ACCORDANCE WITH C&MS 711.02. STEEL PIPE FOR COLLECTORS AND DOWNSPOUTS SHALL BE ASTM A139 / A139M, GRADE B OR ASTM A53, GRADE B, 10" DIAMETER STANDARD WEIGHT PIPE, GALVANIZED ON EXTERIOR AND INTERIOR SURFACES IN ACCORDANCE WITH C&MS 711.02. U-BOLTS, THREADED EYE BOLTS, AND OTHER MISCELLANEOUS HARDWARE FURNISHED FOR PIPE SUPPORTS SHALL BE GALVANIZED BY THE MANUFACTURER. FURNISH MATERIALS IN CONFORMANCE WITH C&MS 518.

EXECUTION: FABRICATE ALL COMPONENTS IN CONFORMANCE WITH C&MS 518. PRIOR TO PREPARING SHOP DRAWINGS, OBTAIN FIELD MEASUREMENTS TO VERIFY AS-BUILT DIMENSIONS AS NEEDED TO ENSURE FIT-UP BETWEEN THE PROPOSED WORK AND PORTIONS OF EXISTING DOWNSPOUTS TO REMAIN. ALL SHOP JOINTS AND FIELD JOINTS IN COLLECTORS AND DOWNSPOUTS SHALL BE WELDED AND WATERTIGHT.

MEASUREMENT AND PAYMENT: THE DEPARTMENT WILL MEASURE THIS WORK BY THE NUMBER OF FEET ACCEPTED IN PLACE. THE BID PRICE SHALL INCLUDE ALL LABOR, MATERIALS, EQUIPMENT, AND INCIDENTALS NECESSARY TO COMPLETE THE WORK. THE DEPARTMENT WILL PAY FOR THE ACCEPTED QUANTITIES AT THE CONTRACT UNIT PRICE BID FOR ITEM 518 - STRUCTURE DRAINAGE, MISC.: 10" GALVANIZED STEEL PIPE, INCLUDING SPECIALS.

**ITEM 518 - STRUCTURE DRAINAGE, MISC.: PIER TOWER COVERINGS:**

THIS ITEM OF WORK INCLUDES THE CONSTRUCTION OF THE PIER TOWER CAP COVERS AS DETAILED IN THE PLANS FOR PIER TOWERS 4-8.

PAYMENT AND MEASUREMENT FOR THIS ITEM OF WORK SHALL BE PER THE NUMBER OF EACH COMPLETED IN PLACE. THE BID PRICE SHALL INCLUDE ALL LABOR, MATERIALS, EQUIPMENT, AND INCIDENTALS NECESSARY TO COMPLETE THE PIER TOWER CAP COVERS. THE DEPARTMENT WILL PAY FOR THE ACCEPTED QUANTITIES AT THE CONTRACT UNIT PRICE BID FOR ITEM 518 - STRUCTURE DRAINAGE, MISC.: PIER TOWER COVERINGS.

**ITEM 518 - STRUCTURE DRAINAGE, MISC.: BRIDGE DRAINAGE SYSTEM CLEANING:**

DESCRIPTION: THIS WORK CONSISTS OF REMOVING SEDIMENT AND DEBRIS FROM THE BRIDGE DECK, THE EXISTING GUTTER TROUGHS, AND ALL PORTIONS OF THE EXISTING BRIDGE DRAINAGE SYSTEM TO BE REUSED. ALL MATERIAL REMOVED SHALL BE DISPOSED OF AS PER C&MS 105.16 AND 105.17. ALL GUTTER TROUGHS, DOWNSPOUTS, AND COLLECTOR PIPES SHALL BE CLEANED OUT TO THE SATISFACTION OF THE ENGINEER.

**ITEM 518 - STRUCTURE DRAINAGE, MISC.: BRIDGE DRAINAGE SYSTEM CLEANING (CONT.):**

EXECUTION: REMOVE ACCUMULATED DIRT AND DEBRIS FROM THE GUTTER TROUGHS BY METHODS THAT DO NOT FLUSH THE MATERIALS INTO THE DOWNSPOUTS. REMOVE AND REINSTALL THE EXISTING GUTTER TROUGH GRATES AS REQUIRED TO COMPLETE THE WORK. AFTER THE SEDIMENT AND DEBRIS ARE REMOVED, THE EXISTING BRIDGE DRAINAGE SYSTEM SHALL BE FLUSHED WITH CLEAN WATER MAKING CERTAIN THE WATER FLOWS SMOOTHLY. THE CONTRACTOR SHALL PROVIDE ALL NECESSARY EQUIPMENT PRIOR TO BEGINNING WORK FOR THE PURPOSE OF EXAMINING THE PORTIONS OF THE EXISTING BRIDGE DRAINAGE SYSTEM TO REMAIN AFTER CLEANING TO VERIFY THE CONDITION OF ALL DOWNSPOUTS AND COLLECTOR PIPES. ALL GUTTER TROUGHS SHALL BE FREE OF SEDIMENT AND DEBRIS AT THE COMPLETION OF THE PROJECT. THE CONTRACTOR'S SUPERINTENDENT SHALL ACCOMPANY THE ENGINEER IN MAKING THE DETAILED EXAMINATION OF THE DRAINAGE SYSTEM. INCLUDE THE COST OF ANY FOLLOW-UP CLEANING REQUIRED TO SATISFY THIS REQUIREMENT IN THE UNIT COST BID.

MEASUREMENT AND PAYMENT: THE DEPARTMENT WILL MEASURE THIS WORK ON A LUMP SUM BASIS. THE BID PRICE SHALL INCLUDE ALL LABOR, MATERIALS, EQUIPMENT, AND INCIDENTALS NECESSARY TO COMPLETE THE BRIDGE DRAINAGE SYSTEM CLEANING. THE DEPARTMENT WILL PAY FOR THE ACCEPTED QUANTITIES AT THE CONTRACT UNIT PRICE BID FOR ITEM 518 - STRUCTURE DRAINAGE, MISC.: BRIDGE DRAINAGE SYSTEM CLEANING.

**ITEM SPECIAL - STRUCTURES: PIER TOWER CLEANOUT:**

DESCRIPTION: THIS WORK CONSISTS OF REMOVING DEBRIS AND ANIMAL WASTE FROM EXISTING PIER TOWERS 4-8. ALL MATERIAL REMOVED, INCLUDING THE HAZARDOUS ANIMAL WASTE, SHALL BE DISPOSED OF AS PER C&MS 105.16 AND 105.17. THE INTERIOR OF PIER TOWERS 4-8 SHALL BE CLEANED OUT TO THE SATISFACTION OF THE ENGINEER.

EXECUTION: REMOVE ACCUMULATED DEBRIS AND ANIMAL WASTE FROM THE INTERIOR OF PIER TOWERS 4-8 BY USING AN AIR COMPRESSOR TO FULLY CLEAN THE INTERIOR OF THE PIER TOWERS AFTER INSTALLATION OF THE PIER TOWER COVERINGS. THE INTERIOR OF PIER TOWERS 4-8 SHALL BE FREE OF DEBRIS AND ANIMAL WASTE AT THE COMPLETION OF THE PROJECT. INCLUDE THE COST OF ANY FOLLOW-UP CLEANING REQUIRED TO SATISFY THIS REQUIREMENT IN THE UNIT COST BID.

MEASUREMENT AND PAYMENT: THE DEPARTMENT WILL MEASURE THIS WORK ON A LUMP SUM BASIS. THE BID PRICE SHALL INCLUDE ALL LABOR, MATERIALS, EQUIPMENT, AND INCIDENTALS NECESSARY TO COMPLETE THE PIER TOWER CLEANOUT. THE DEPARTMENT WILL PAY FOR THE ACCEPTED QUANTITIES AT THE CONTRACT UNIT PRICE BID FOR ITEM SPECIAL - STRUCTURES: PIER TOWER CLEANOUT.

**ASBESTOS NOTIFICATION:**

A CERTIFIED ASBESTOS HAZARD EVALUATION SPECIALIST SURVEYED THE BRIDGE STRUCTURE SCHEDULED FOR DEMOLITION AND/OR REHABILITATION; THE SURVEY DETERMINED THAT NO ASBESTOS IS PRESENT ON THE BRIDGE STRUCTURE.

ODOT SHALL PROVIDE A COPY OF THE OHIO ENVIRONMENTAL PROTECTION AGENCY (OEPA) NOTIFICATION OF DEMOLITION AND RENOVATION FORM, PARTIALLY COMPLETED AND SIGNED BY THE BRIDGE OWNER, TO THE SUCCESSFUL BIDDER. THE CONTRACTOR SHALL COMPLETE THE FORM AND SUBMIT IT TO ONE OF THE ADDRESSES BELOW AT LEAST TEN (10) WORKING DAYS PRIOR TO THE START OF ANY DEMOLITION AND/OR RENOVATION.

ASBESTOS PROGRAM	OR	ASBESTOS PROGRAM
OHIO EPA, DAPC		OHIO EPA, DAPC
P.O. BOX 1049		50 W. TOWN ST., SUITE 700
COLUMBUS, OH 43216-1049		COLUMBUS, OH 43215

THE CONTRACTOR SHALL PROVIDE A COPY OF THE COMPLETED FORM TO THE ENGINEER AT LEAST TEN (10) WORKING DAYS PRIOR TO THE START OF ANY DEMOLITION AND/OR RENOVATION. THE FORM SHALL INCLUDE: 1) THE CONTRACTOR'S NAME AND ADDRESS, 2) THE SCHEDULED DATES FOR THE START AND COMPLETION OF THE BRIDGE REMOVAL AND 3) A DESCRIPTION OF THE PLANNED DEMOLITION WORK AND THE METHOD(S) TO BE USED. COPIES OF THE OEPA FORM AND BRIDGE INSPECTION REPORT ARE AVAILABLE FOR REVIEW AT THE ODOT DISTRICT 12 OFFICE, 5500 TRANSPORTATION BOULEVARD, GARFIELD HEIGHTS, OHIO 44125.

**ASBESTOS NOTIFICATION (CONT.):**

BASIS FOR PAYMENT: THE CONTRACTOR SHALL FURNISH ALL FEES, LABOR, AND MATERIAL NECESSARY TO COMPLETE AND SUBMIT THE OEPA NOTIFICATION FORM. PAYMENT FOR THIS WORK SHALL BE INCLUDED IN ITEM 202 - PORTIONS OF STRUCTURE REMOVED, OVER 20 FOOT SPAN, AS PER PLAN.

**SUMMARY OF PROPOSED REHABILITATION WORK:**

THE FOLLOWING LIST CONTAINS THE MAJOR ITEMS OF WORK INCLUDED IN THESE PLANS FOR THE REHABILITATION OF THIS STRUCTURE:

- CLEANOUT OF THE EXISTING DECK DRAINAGE GUTTER TROUGHS, DOWNSPOUTS, AND COLLECTOR PIPES AND REPLACEMENT OF SELECT DOWNSPOUT AND COLLECTOR PIPE LOCATIONS.
- REPLACEMENT OF THE EXISTING STRIP SEAL EXPANSION JOINTS AT THE ABUTMENTS AND ABOVE THE PIER TOWERS WITH NEW STRIP SEAL EXPANSION JOINTS, INCLUDING RECONSTRUCTION OF THE TOPS OF THE ABUTMENT BACKWALLS AND PORTIONS OF THE EXISTING DECK SLAB AT ALL LOCATIONS AND REPLACEMENT OF SIDEWALK AND CURB COVER PLATE ASSEMBLIES.
- REPLACEMENT AND PAINTING OF SELECT STRUCTURAL STEEL MEMBERS IN PIER TOWERS 4-8.
- CONSTRUCTION OF VENTED COVER PLATES AT THE TOPS OF PIER TOWERS 4-8.
- CLEANOUT OF THE DEBRIS FROM THE REHABILITATED PIER TOWERS 4-8.

**PLAN ABBREVIATIONS:**

@	= AT
ABUT.	= ABUTMENT
ADT	= AVERAGE DAILY TRAFFIC
ADTT	= AVERAGE DAILY TRUCK TRAFFIC
APPROX.	= APPROXIMATE
BRG.	= BEARING
¢	= CENTERLINE
CALC.	= CALCULATED
CHKD.	= CHECKED
C&MS	= CONSTRUCTION AND MATERIAL SPECIFICATIONS
CONST.	= CONSTRUCTION
DESC.	= DESCRIPTION
DIA., $\phi$	= DIAMETER
DIM.	= DIMENSION
EXIST.	= EXISTING
EXP.	= EXPANSION
FWD.	= FORWARD
JT.	= JOINT
MAX.	= MAXIMUM
MIN.	= MINIMUM
MISC.	= MISCELLANEOUS
NO.	= NUMBER
PROP.	= PROPOSED
R.	= RADIUS
REF.	= REFERENCE
SPA.	= SPACED
S.R.	= STATE ROUTE
TYP.	= TYPICAL
U.N.O.	= UNLESS NOTED OTHERWISE

CUY-8/10-02.26/08.69

MODEL: Sheet PAPER SIZE: 17x11 (in.) DATE: 10/29/2022 TIME: 8:43:20 PM USER: jmillier X:\Projects\2022\12122\100200 ODOT CUY-8 CUY-48 CUY-4 CUY-48 CUY-48 CUY-48 CUY-48 CUY-48 CUY-48 CUY-48 CUY-48 CUY-48 CUY-48 CUY-48 CUY-48 CUY-48 CUY-48 CUY-48 CUY-48 CUY-48

STRUCTURE GENERAL NOTES - 2  
BRIDGE NO. CUY-10-0869  
OVER VALLEY PARKWAY & ROCKY RIVER

SFN		1801325
DESIGN AGENCY		
		
DESIGNER	CHECKER	
JAM	MJL	
REVIEWER		
CJS	10/24/22	
PROJECT ID		113674
SUBSET	TOTAL	
3	30	
SHEET	TOTAL	
29	82	

CUY-8/10-02-26/08.69

MODEL: Sheet PAPER SIZE: 17x11 (in.) DATE: 10/28/2022 TIME: 8:43:21 PM USER: jmillar  
 X:\Projects\2021\12122100200 ODOT CUY-8 CUY-10\113674\400-Engineering\Structures\SFN\_1801325\_SFN\_1801325\_SC001.dgn

FUNDING	ESTIMATED QUANTITIES										
	ITEM	ITEM EXTENSION	TOTAL	UNIT	DESCRIPTION	REAR ABUTMENT	FORWARD ABUTMENT	PIERS	SUPER-STRUCTURE	GENERAL	REF. SHEET NUMBER
---	202	11203	LS		PORTIONS OF STRUCTURE REMOVED, OVER 20 FOOT SPAN, AS PER PLAN					LS	2, 28 / 30
	509	20001	690	LB	CONCRETE REINFORCEMENT, REPLACEMENT OF EXISTING CONCRETE REINFORCEMENT, AS PER PLAN	245	245		200		2 / 30
	513	10001	LS		STRUCTURAL STEEL MEMBERS, LEVEL UF, AS PER PLAN					LS	2 / 30
	514	00100	LS		SURFACE PREPARATION OF EXISTING STRUCTURAL STEEL					LS	
	514	00200	LS		FIELD PAINTING OF EXISTING STRUCTURAL STEEL, PRIME COAT					LS	
	514	00800	96,786	LB	FIELD PAINTING STRUCTURAL STEEL, INTERMEDIATE COAT				96,786		
	514	00850	96,786	LB	FIELD PAINTING STRUCTURAL STEEL, FINISH COAT				96,786		
	514	00504	60	MNHR	GRINDING FINS, TEARS, SLIVERS ON EXISTING STRUCTURAL STEEL			60			
	514	10000	15	EACH	FINAL INSPECTION REPAIR			15			
	516	12301	434	FT	STRIP SEAL EXPANSION JOINT ANCHORED WITH ELASTOMERIC CONCRETE, AS PER PLAN				434		3, 27-28 / 30
	518	51100	12	FT	8" PIPE DOWNSPOUT, INCLUDING SPECIALS				12		
	518	62100	340	FT	STRUCTURE DRAINAGE, MISC.: 10" GALVANIZED STEEL PIPE, INCLUDING SPECIALS				340		3, 29 / 30
	518	62200	5	EACH	STRUCTURE DRAINAGE, MISC.: PIER TOWER COVERINGS			5			3 / 30
	518	63300	LS		STRUCTURE DRAINAGE, MISC.: BRIDGE DRAINAGE SYSTEM CLEANING					LS	3 / 30
	SPECIAL	53000200	LS		STRUCTURES: PIER TOWER CLEANOUT					LS	3 / 30

**REINFORCING STEEL LIST**

MARK	NO.	LENGTH	WEIGHT	TYPE	DIMENSIONS					SERIES INC.
					A	B	C	D	E	
<b>ABUTMENTS</b>										
A401	4	4'-8"	12	STR						
A501	16	26'-11"	449	STR						
A502	4	4'-8"	19	STR						
		TOTAL	480	LBS						
<b>SUPERSTRUCTURE</b>										
S401	24	4'-8"	75	STR						
S501	48	26'-11"	1,348	STR						
S502	24	4'-8"	117	STR						
S601	48	26'-11"	1,941	STR						
		TOTAL	3,481	LBS						

**REINFORCING STEEL NOTES**

- SERIES BARS - EACH BAR VARIES BY TABULATED AMOUNT.
- ALL DIMENSIONS ARE OUT-TO-OUT.
- TYPE 'STR' INDICATES A STRAIGHT BAR.
- THE BAR SIZE NUMBER IS INDICATED IN THE 'MARK' COLUMN. THE FIRST ONE OR TWO DIGITS OF EACH MARK INDICATES THE BAR SIZE NUMBER. FOR EXAMPLE, A501 IS A #5 BAR SIZE AND P1101 IS A #11 BAR SIZE.
- ALL REINFORCING STEEL SHALL BE EPOXY COATED.

ESTIMATED QUANTITIES  
 BRIDGE NO. CUY-10-0869  
 OVER VALLEY PARKWAY & ROCKY RIVER

SFN	1801325
DESIGN AGENCY	
	
DESIGNER	CHECKER
JDA	JG
REVIEWER	
CJS	10/24/22
PROJECT ID	113674
SUBSET	TOTAL
4	30
SHEET	TOTAL
30	82



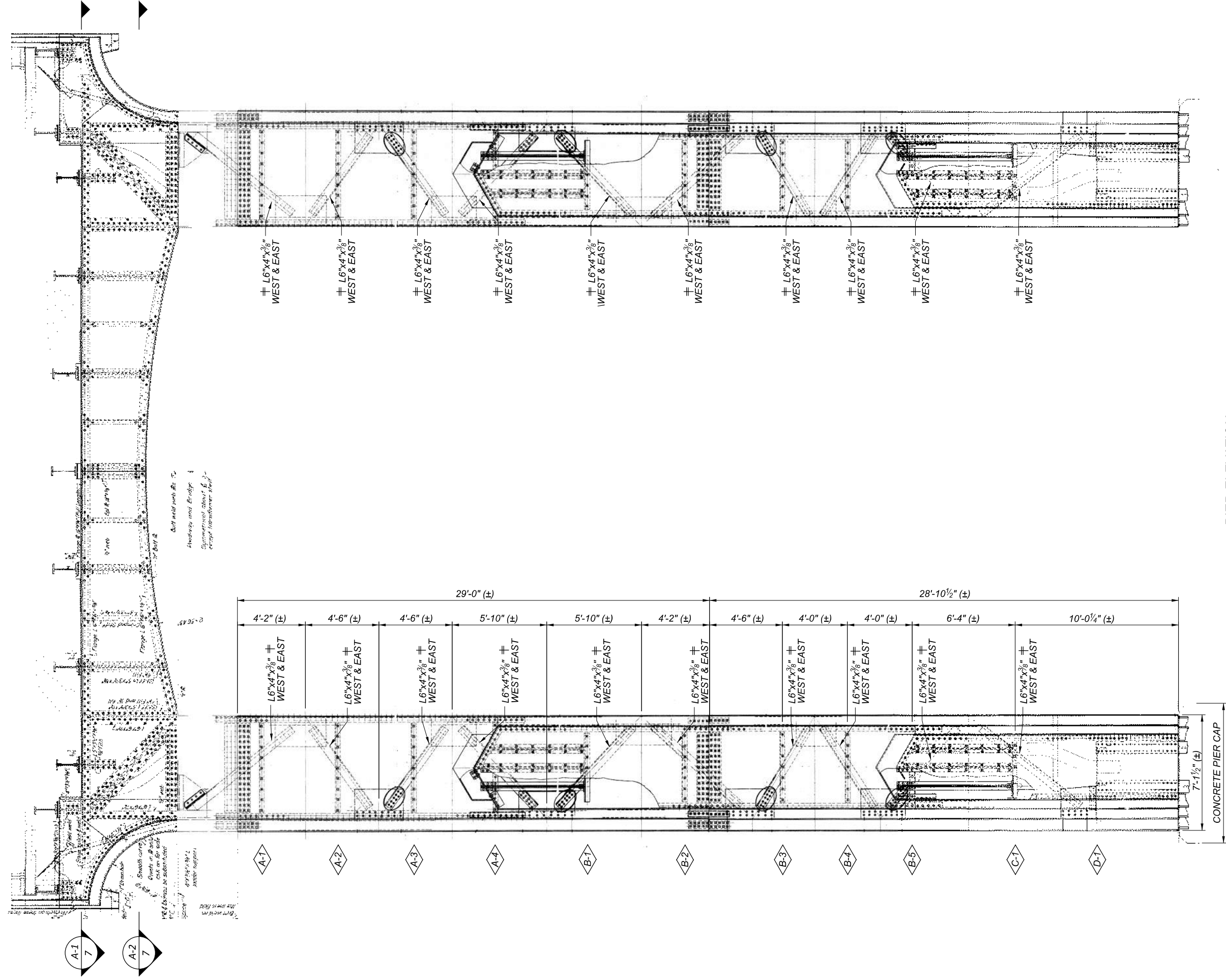

**PIER ELEVATION**  
 WEST ELEVATION SHOWN.  
 EAST ELEVATION SIMILAR BUT OPPOSITE HAND

**LEGEND**

- ◇ DENOTES DIAPHRAGM
- ≡ MEMBERS DENOTED ARE EXISTING MEMBERS TO BE REPLACED, BOTH EAST AND WEST FACE DIAGONALS.

**NOTES**

1. DETAILS ON THIS SHEET ARE TAKEN FROM THE ORIGINAL PLANS AND SHALL BE USED FOR INFORMATIONAL PURPOSES ONLY.
2. PHYSICAL INVENTORY OF MEASURED DETERIORATION TO DETERMINE MEMBERS NEEDING REPLACED WAS PERFORMED IN JULY 2022.
3. SEE SHEET 20 OF 30 FOR DIAPHRAGM MEMBER REPLACEMENTS.
4. CONTRACTOR SHALL STAGE REMOVAL AND REPLACEMENT OF MEMBERS TO PRESERVE THE INTEGRITY OF THE OVERALL PIER TOWER ELEMENT ACCORDING TO ODOT CMS ITEM 513.

**PIER TOWER 4 - REPAIR DETAILS - 1**  
 BRIDGE NO. CUY-10-0869  
 OVER VALLEY PARKWAY & ROCKY RIVER

SFN	
1801325	
DESIGN AGENCY	
<b>DLZ</b>	
DESIGNER	CHECKER
JDA	MJL
REVIEWER	
CJS 10/24/22	
PROJECT ID	
113674	
SUBSET	TOTAL
5	30
SHEET	TOTAL
31	82

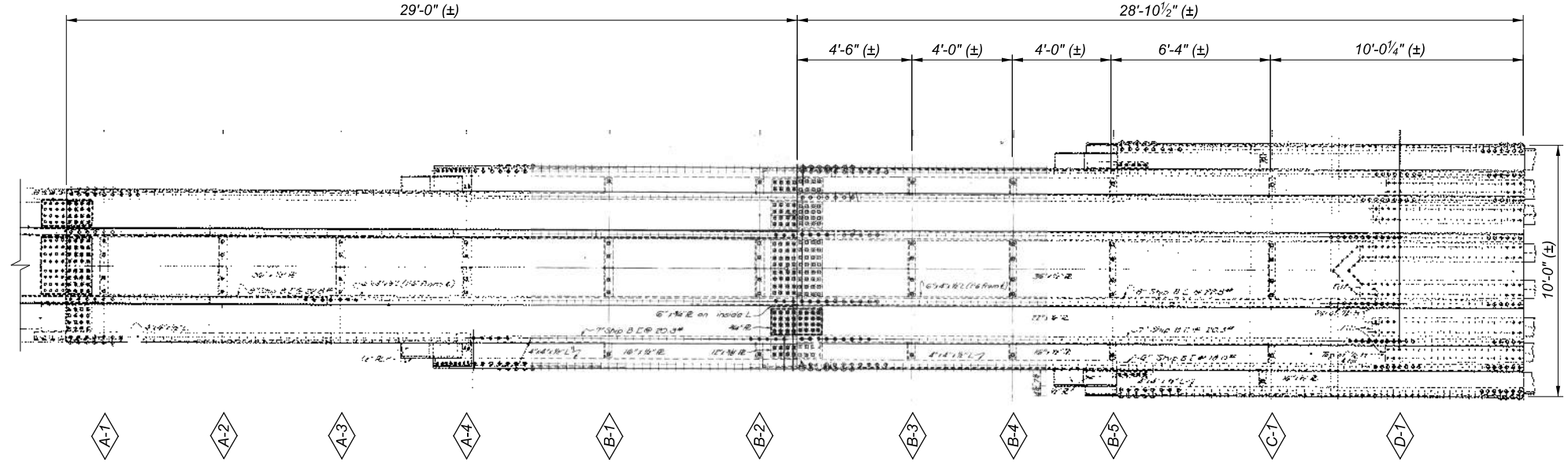

**SOUTH ELEVATION - PIER TOWER**  
 NORTH ELEVATION SIMILAR,  
 OPPOSITE HAND

**LEGEND**  
 ◇ DENOTES DIAPHRAGM

**NOTES**

1. PHYSICAL INVENTORY OF MEASURED DETERIORATION TO DETERMINE MEMBERS NEEDING REPLACED WAS PERFORMED IN JULY 2022.
2. SEE SHEET 20 OF 30 FOR DIAPHRAGM MEMBER REPLACEMENT.
3. CONTRACTOR SHALL STAGE REMOVAL AND REPLACEMENT OF MEMBERS TO PRESERVE THE INTEGRITY OF THE OVERALL PIER TOWER ELEMENT ACCORDING TO ODOT CMS ITEM 513.

SFN	
1801325	
DESIGN AGENCY	
DESIGNER	CHECKER
JDA	MJL
REVIEWER	
CJS 10/24/22	
PROJECT ID	
113674	
SUBSET	TOTAL
6	30
SHEET	TOTAL
32	82

**PIER TOWER 4 - REPAIR DETAILS - 2**  
 BRIDGE NO. CUY-10-0869  
 OVER VALLEY PARKWAY & ROCKY RIVER

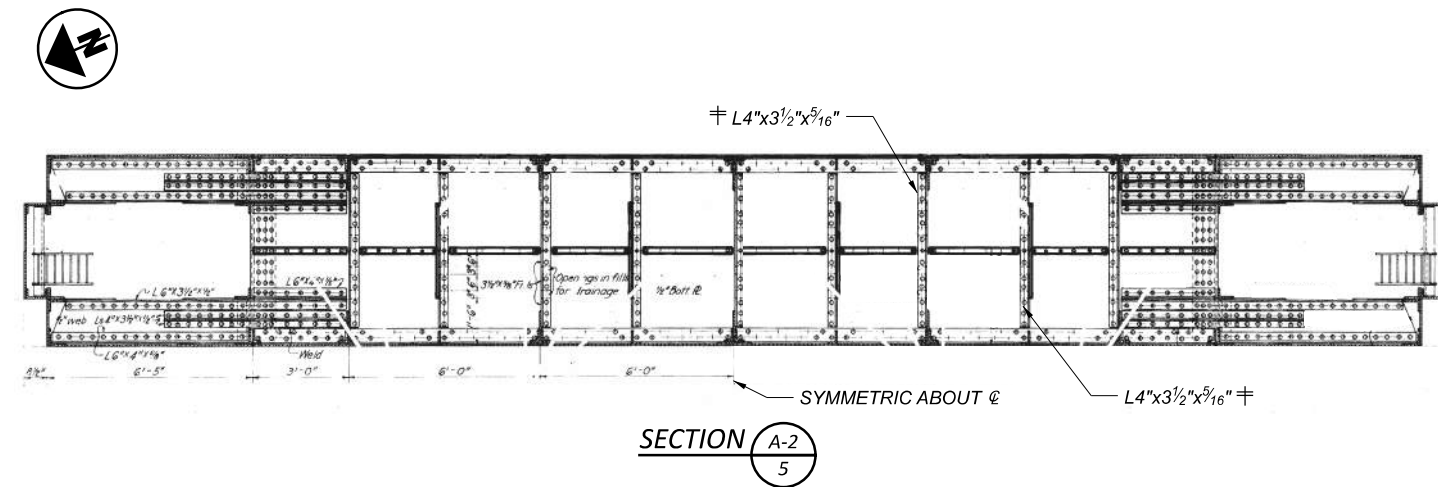
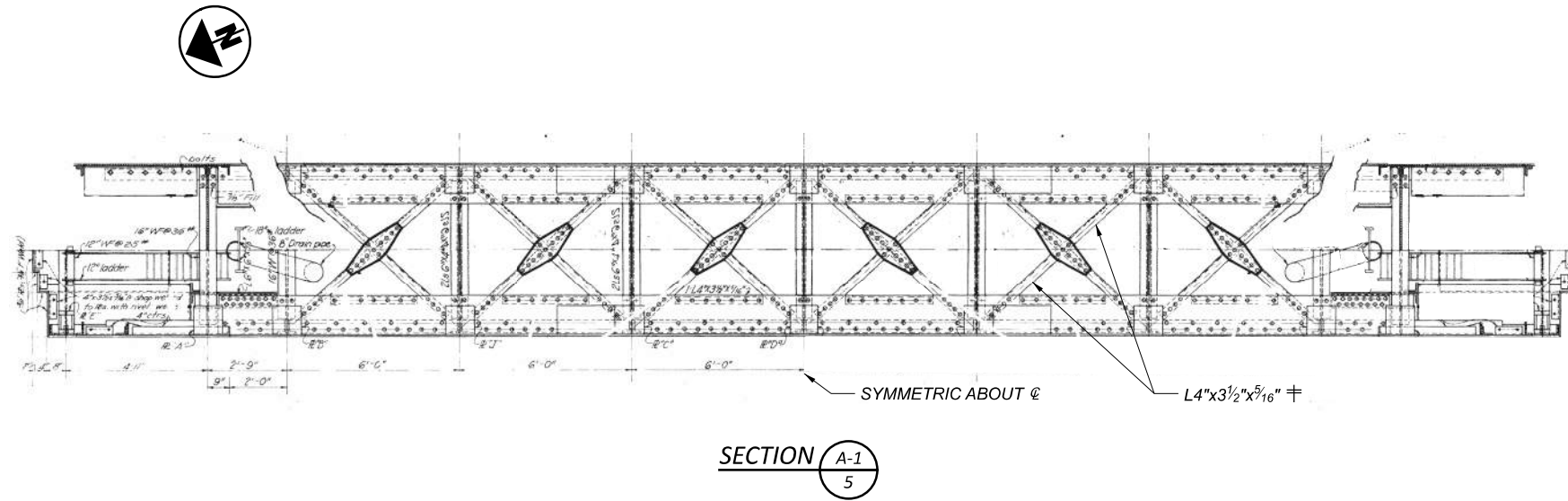

**LEGEND**

† MEMBERS DENOTED ARE EXISTING MEMBERS TO BE REPLACED.

**NOTES**

1. DETAILS ON THIS SHEET ARE TAKEN FROM THE ORIGINAL PLANS AND SHALL BE USED FOR INFORMATIONAL PURPOSES ONLY.
2. PHYSICAL INVENTORY OF MEASURED DETERIORATION TO DETERMINE MEMBERS NEEDING REPLACED WAS PERFORMED IN JULY 2022.
3. CONTRACTOR SHALL STAGE REMOVAL AND REPLACEMENT OF MEMBERS TO PRESERVE THE INTEGRITY OF THE OVERALL PIER TOWER ELEMENT ACCORDING TO ODOT CMS ITEM 513.



DESIGNER	CHECKER
JDA	MJL
REVIEWER	
CJS	10/24/22
PROJECT ID	
113674	
SUBSET	TOTAL
7	30
SHEET	
TOTAL	
33	82

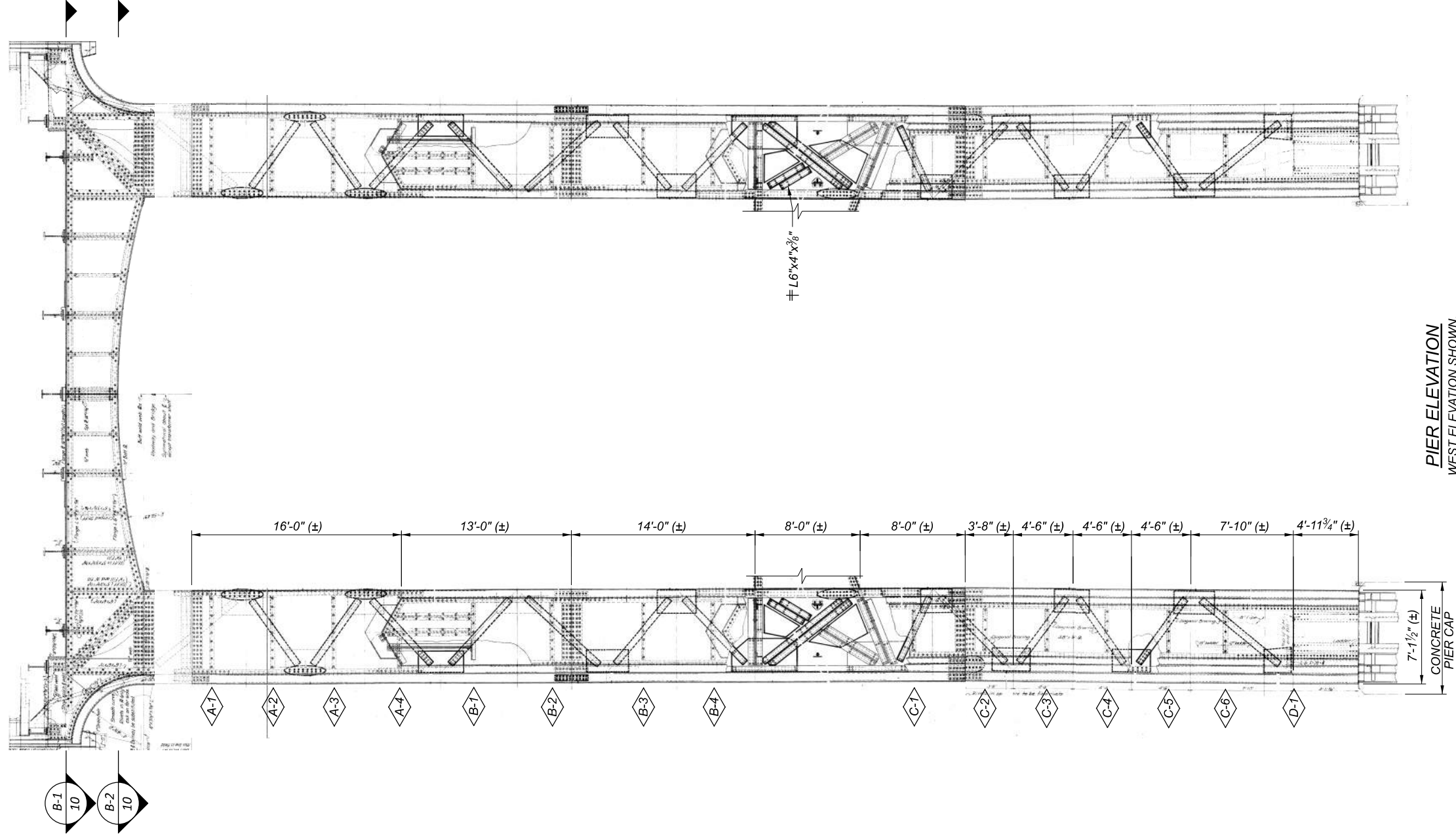

**PIER ELEVATION**  
 WEST ELEVATION SHOWN.  
 EAST ELEVATION SIMILAR BUT OPPOSITE HAND

**LEGEND**  
 ◇ DENOTES DIAPHRAGM  
 # MEMBERS DENOTED ARE EXISTING MEMBERS TO BE REPLACED,  
 BOTH EAST AND WEST FACE DIAGONALS.

**NOTES**

1. DETAILS ON THIS SHEET ARE TAKEN FROM THE ORIGINAL PLANS AND SHALL BE USED FOR INFORMATIONAL PURPOSES ONLY.
2. PHYSICAL INVENTORY OF MEASURED DETERIORATION TO DETERMINE MEMBERS NEEDING REPLACED WAS PERFORMED IN JULY 2022.
3. SEE SHEET 21 OF 30 FOR DIAPHRAGM MEMBER REPLACEMENTS.
4. CONTRACTOR SHALL STAGE REMOVAL AND REPLACEMENT OF MEMBERS TO PRESERVE THE INTEGRITY OF THE OVERALL PIER TOWER ELEMENT ACCORDING TO ODOT CMS ITEM 513.

**PIER TOWER 5 - REPAIR DETAILS - 1**  
 BRIDGE NO. CUY-10-0869  
 OVER VALLEY PARKWAY & ROCKY RIVER

SFN	
1801325	
DESIGN AGENCY	
DESIGNER	CHECKER
JDA	MJL
REVIEWER	
CJS 10/24/22	
PROJECT ID	
113674	
SUBSET	TOTAL
8	30
SHEET	TOTAL
34	82

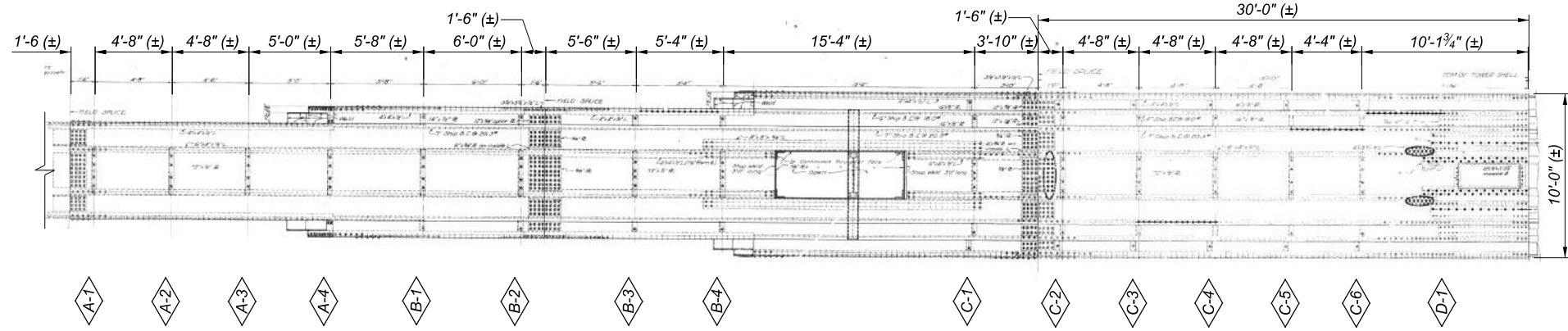

**SOUTH ELEVATION - PIER TOWER**  
 NORTH ELEVATION SIMILAR,  
 OPPOSITE HAND

**LEGEND**  
 ◇ DENOTES DIAPHRAGM

**NOTES**

1. DETAILS ON THIS SHEET ARE TAKEN FROM THE ORIGINAL PLANS AND SHALL BE USED FOR INFORMATIONAL PURPOSES ONLY.
2. PHYSICAL INVENTORY OF MEASURED DETERIORATION TO DETERMINE MEMBERS NEEDING REPLACED WAS PERFORMED IN JULY 2022.
3. SEE SHEET 21 OF 30 FOR DIAPHRAGM MEMBER REPLACEMENTS.
4. CONTRACTOR SHALL STAGE REMOVAL AND REPLACEMENT OF MEMBERS TO PRESERVE THE INTEGRITY OF THE OVERALL PIER TOWER ELEMENT ACCORDING TO ODOT CMS ITEM 513.

SFN	
1801325	
DESIGN AGENCY	
DESIGNER	CHECKER
JDA	MJL
REVIEWER	
CJS 10/24/22	
PROJECT ID	
113674	
SUBSET	TOTAL
9	30
SHEET	TOTAL
35	82

**PIER TOWER 5 - REPAIR DETAILS - 2**  
 BRIDGE NO. CUY-10-0869  
 OVER VALLEY PARKWAY & ROCKY RIVER

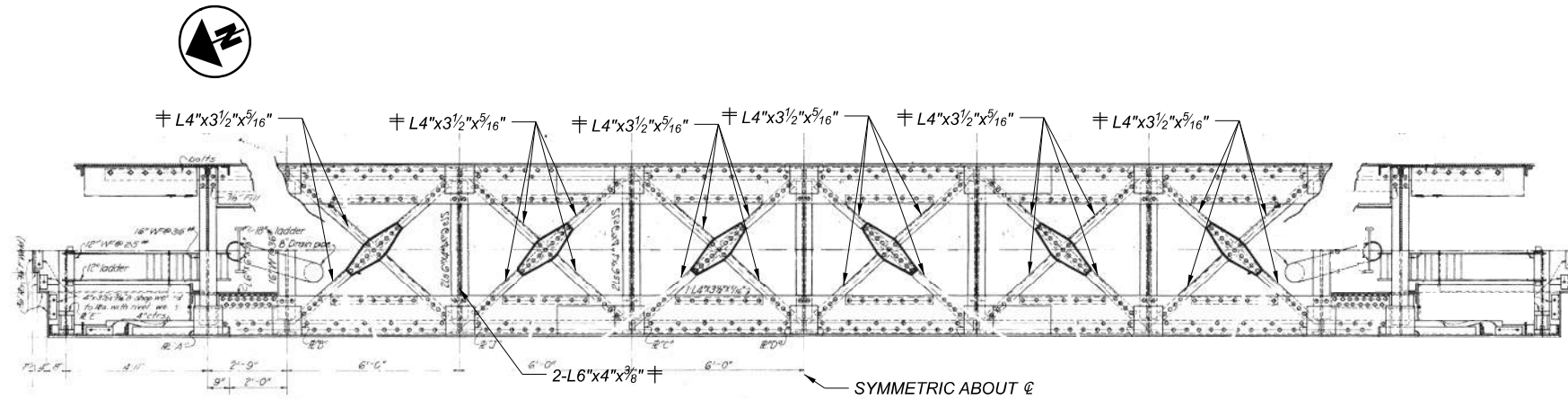

SECTION B-1  
8

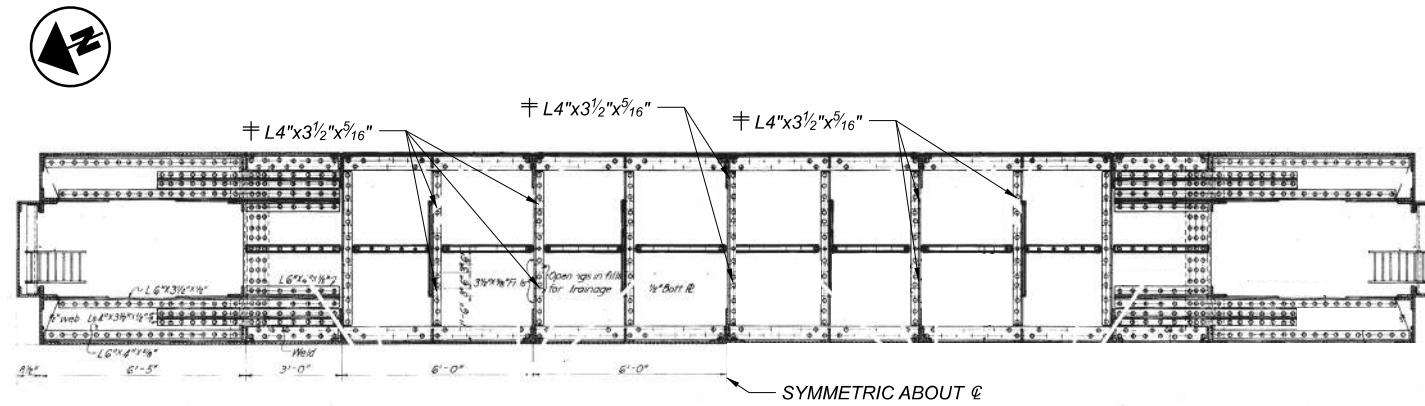

SECTION B-2  
8

**LEGEND**

‡ MEMBERS DENOTED ARE EXISTING MEMBERS TO BE REPLACED.

**NOTES**

1. DETAILS ON THIS SHEET ARE TAKEN FROM THE ORIGINAL PLANS AND SHALL BE USED FOR INFORMATIONAL PURPOSES ONLY.
2. PHYSICAL INVENTORY OF MEASURED DETEIORATION TO DETERMINE MEMBERS NEEDING REPLACED WAS PERFORMED IN JULY 2022.
3. CONTRACTOR SHALL STAGE REMOVAL AND REPLACEMENT OF MEMBERS TO PRESERVE THE INTEGRITY OF THE OVERALL PIER TOWER ELEMENT ACCORDING TO ODOT CMS ITEM 513.



DESIGNER	CHECKER
JDA	MJL
REVIEWER	
CJS	10/24/22
PROJECT ID	
113674	
SUBSET	TOTAL
10	30
SHEET	
TOTAL	
36	82

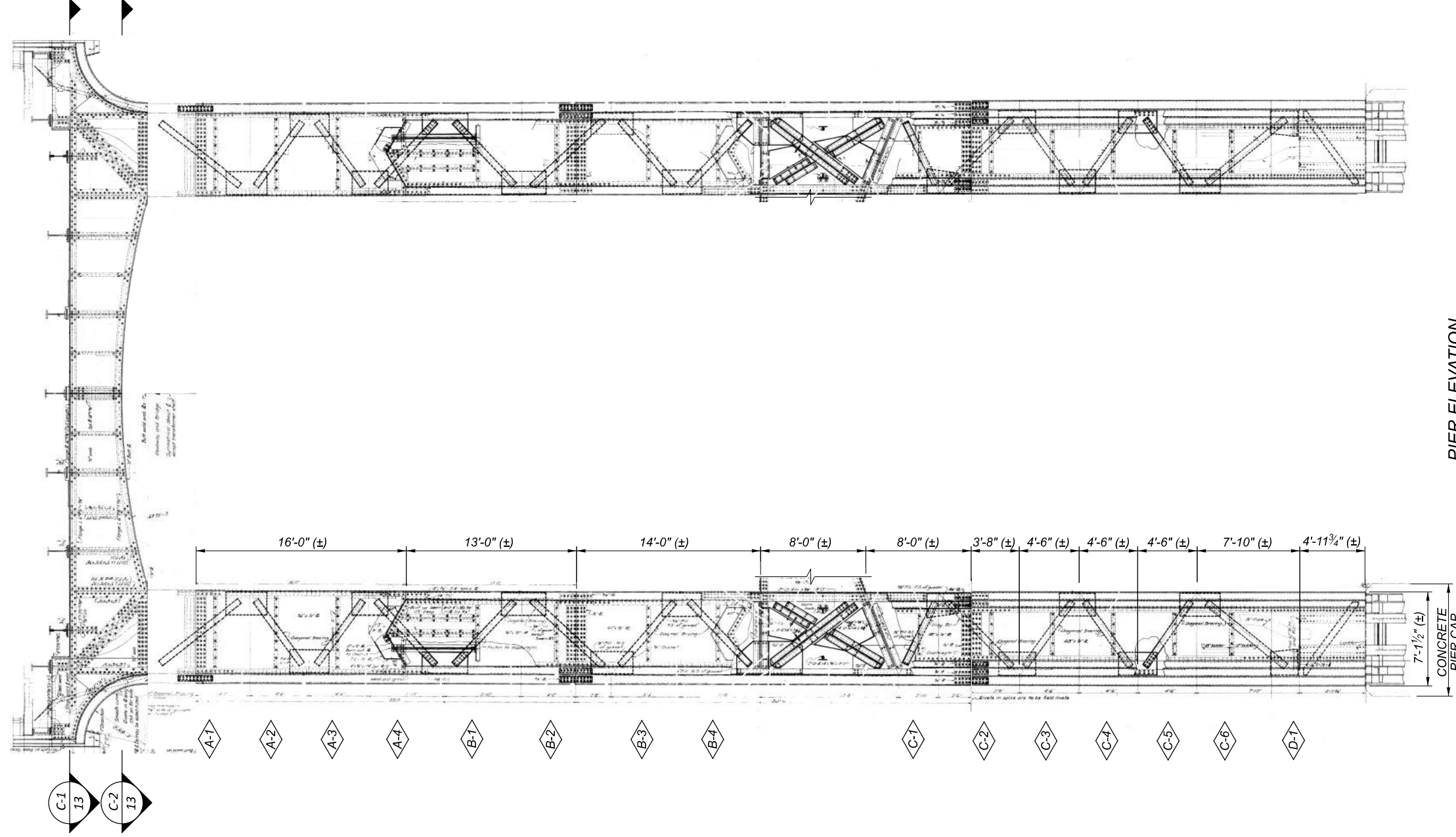

PIER ELEVATION  
 WEST ELEVATION SHOWN  
 EAST ELEVATION SIMILAR BUT OPPOSITE HAND

**LEGEND**

- ◇ DENOTES DIAPHRAGM
- ⊕ MEMBERS DENOTED ARE EXISTING MEMBERS TO BE REPLACED, BOTH EAST AND WEST FACE DIAGONALS.

**NOTES**

1. DETAILS ON THIS SHEET ARE TAKEN FROM THE ORIGINAL PLANS AND SHALL BE USED FOR INFORMATIONAL PURPOSES ONLY.
2. PHYSICAL INVENTORY OF MEASURED DETERIORATION TO DETERMINE MEMBERS NEEDING REPLACED WAS PERFORMED IN JULY 2022.
3. SEE SHEET 21 OF 30 FOR DIAPHRAGM MEMBER REPLACEMENTS.
4. CONTRACTOR SHALL STAGE REMOVAL AND REPLACEMENT OF MEMBERS TO PRESERVE THE INTEGRITY OF THE OVERALL PIER TOWER ELEMENT ACCORDING TO ODOT CMS ITEM 513.

SFN	
1801325	
DESIGN AGENCY	
DESIGNER	CHECKER
JDA	MJL
REVIEWER	
CJS 10/24/22	
PROJECT ID	
113674	
SUBSET	TOTAL
11	30
SHEET	TOTAL
37	82

**PIER TOWER 6 - REPAIR DETAILS - 1**  
 BRIDGE NO. CUY-10-0869  
 OVER VALLEY PARKWAY & ROCKY RIVER

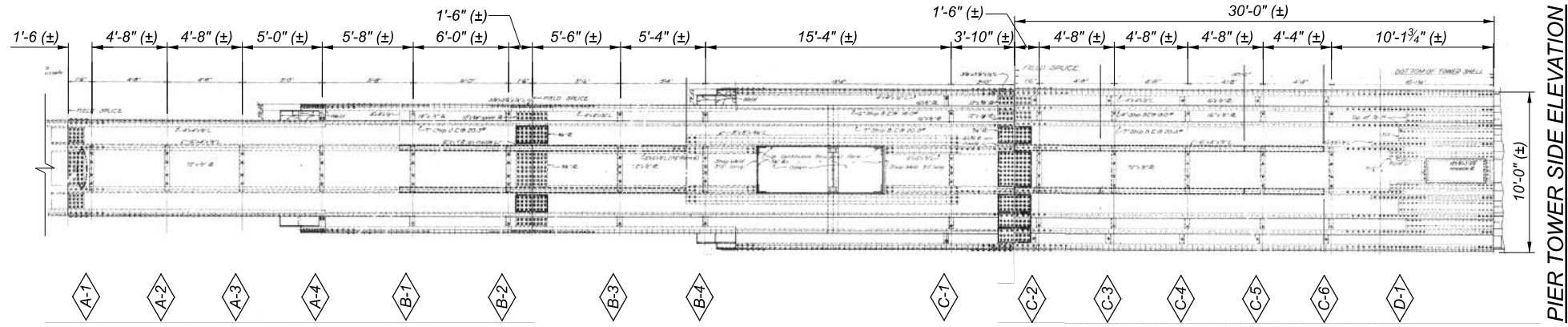

PIER TOWER SIDE ELEVATION

LEGEND  
 ◇ DENOTES DIAPHRAGM

NOTES

1. DETAILS ON THIS SHEET ARE TAKEN FROM THE ORIGINAL PLANS AND SHALL BE USED FOR INFORMATIONAL PURPOSES ONLY.
2. PHYSICAL INVENTORY OF MEASURED DETERIORATION TO DETERMINE MEMBERS NEEDING REPLACED WAS PERFORMED IN JULY 2022.
3. SEE SHEET 21 OF 30 FOR DIAPHRAGM MEMBER REPLACEMENTS.
4. CONTRACTOR SHALL STAGE REMOVAL AND REPLACEMENT OF MEMBERS TO PRESERVE THE INTEGRITY OF THE OVERALL PIER TOWER ELEMENT ACCORDING TO ODOT CMS ITEM 513.

PIER TOWER 6 - REPAIR DETAILS - 2  
 BRIDGE NO. CUY-10-0869  
 OVER VALLEY PARKWAY & ROCKY RIVER

SFN	1801325
DESIGN AGENCY	
DESIGNER	CHECKER
JDA	MJL
REVIEWER	
CJS 10/24/22	
PROJECT ID	
113674	
SUBSET	TOTAL
12	30
SHEET	TOTAL
38	82



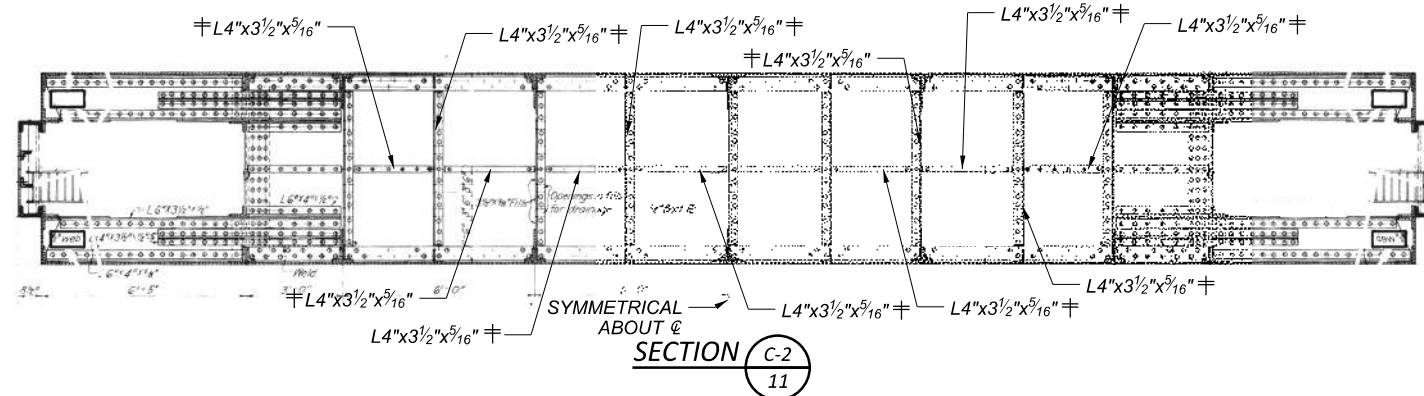
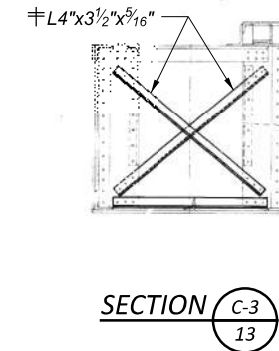
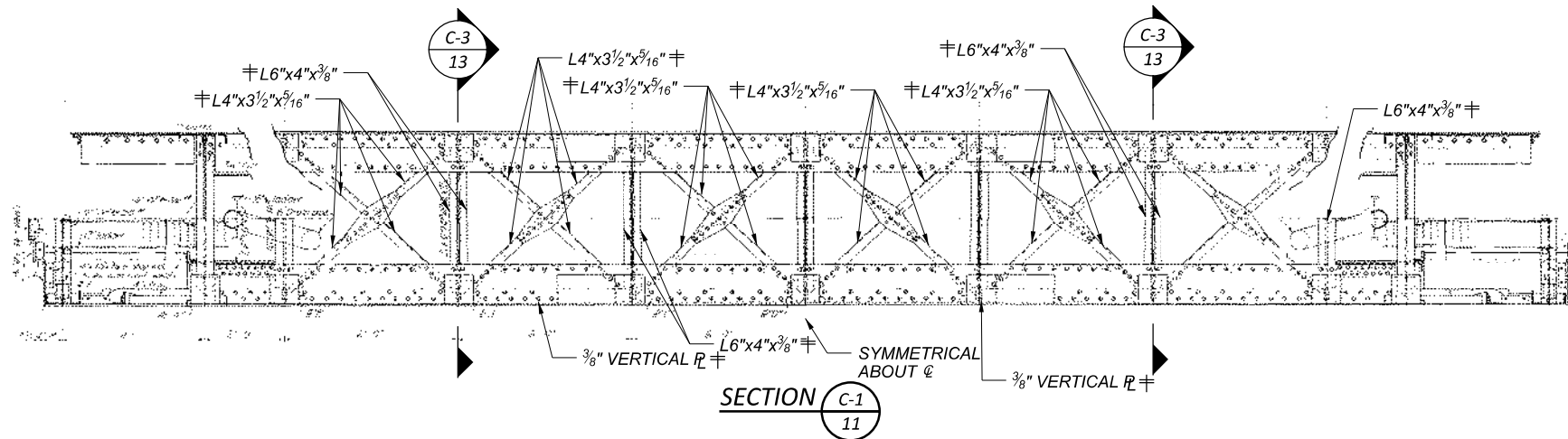

**LEGEND**

‡ MEMBERS DENOTED ARE EXISTING MEMBERS TO BE REPLACED.

**NOTES**

1. DETAILS ON THIS SHEET ARE TAKEN FROM THE ORIGINAL PLANS AND SHALL BE USED FOR INFORMATIONAL PURPOSES ONLY.
2. PHYSICAL INVENTORY OF MEASURED DETERIORATION TO DETERMINE MEMBERS NEEDING REPLACED WAS PERFORMED IN JULY 2022.
3. CONTRACTOR SHALL STAGE REMOVAL AND REPLACEMENT OF MEMBERS TO PRESERVE THE INTEGRITY OF THE OVERALL PIER TOWER ELEMENT ACCORDING TO ODOT CMS ITEM 513.



DESIGNER	CHECKER
JDA	MJL
REVIEWER	
CJS	10/24/22
PROJECT ID	113674
SUBSET	TOTAL
13	30
SHEET	TOTAL
39	82

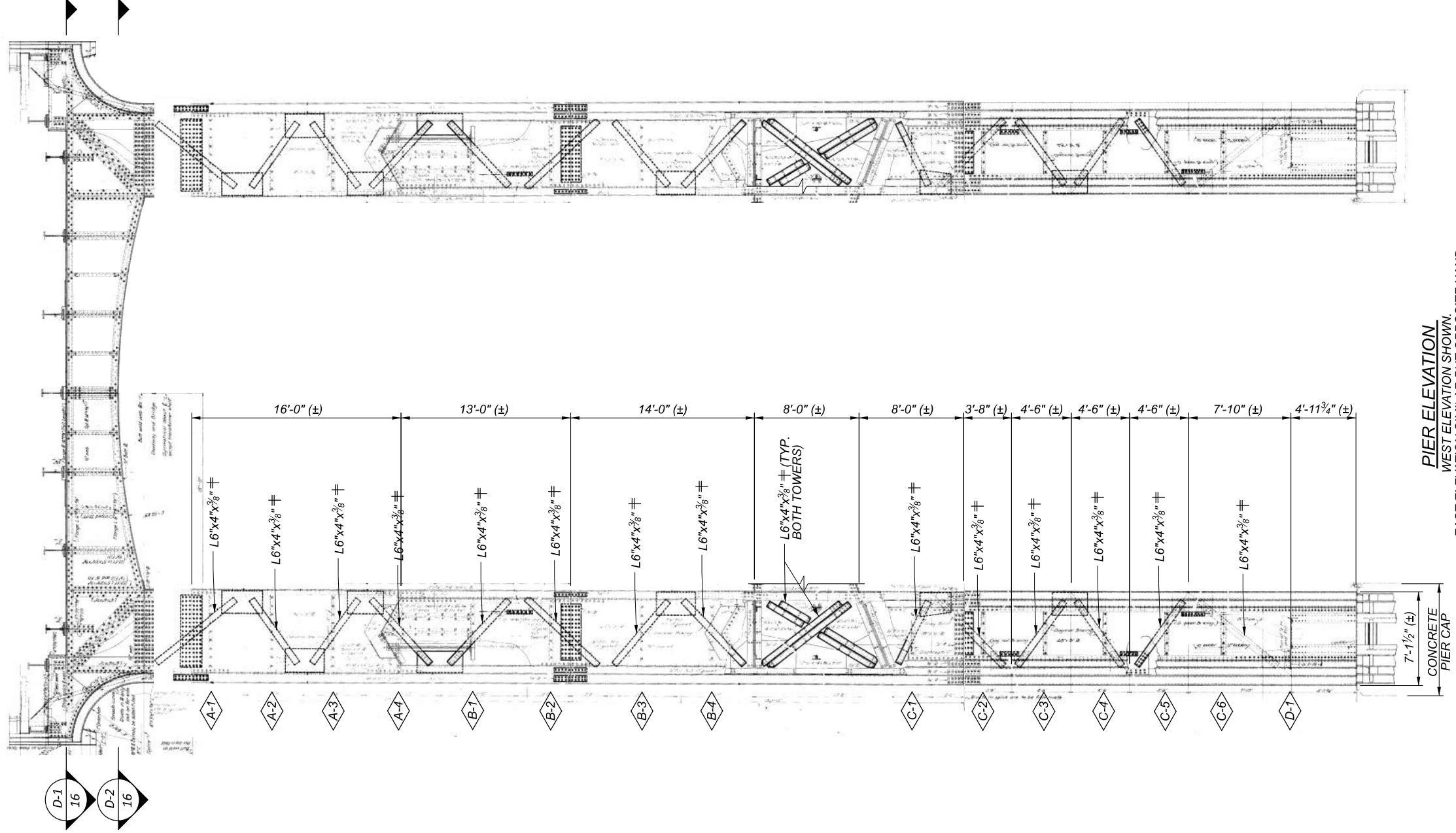

**PIER ELEVATION**  
 WEST ELEVATION SHOWN.  
 EAST ELEVATION SIMILAR BUT OPPOSITE HAND

**LEGEND**

- ◇ DENOTES DIAPHRAGM
- ≠ MEMBERS DENOTED ARE EXISTING MEMBERS TO BE REPLACED, BOTH EAST AND WEST FACE DIAGONALS.

**NOTES**

1. DETAILS ON THIS SHEET ARE TAKEN FROM THE ORIGINAL PLANS AND SHALL BE USED FOR INFORMATIONAL PURPOSES ONLY.
2. PHYSICAL INVENTORY OF MEASURED DETERIORATION TO DETERMINE MEMBERS NEEDING REPLACED WAS PERFORMED IN JULY 2022.
3. SEE SHEET 21 OF 30 FOR DIAPHRAGM MEMBER REPLACEMENTS.
4. CONTRACTOR SHALL STAGE REMOVAL AND REPLACEMENT OF MEMBERS TO PRESERVE THE INTEGRITY OF THE OVERALL PIER TOWER ELEMENT ACCORDING TO ODOT CMS ITEM 513.

SFN	
1801325	
DESIGN AGENCY	
DESIGNER	CHECKER
JDA	MJL
REVIEWER	
CJS 10/24/22	
PROJECT ID	
113674	
SUBSET	TOTAL
14	30
SHEET	TOTAL
40	82

**PIER TOWER 7 - REPAIR DETAILS - 1**  
 BRIDGE NO. CUY-10-0869  
 OVER VALLEY PARKWAY & ROCKY RIVER

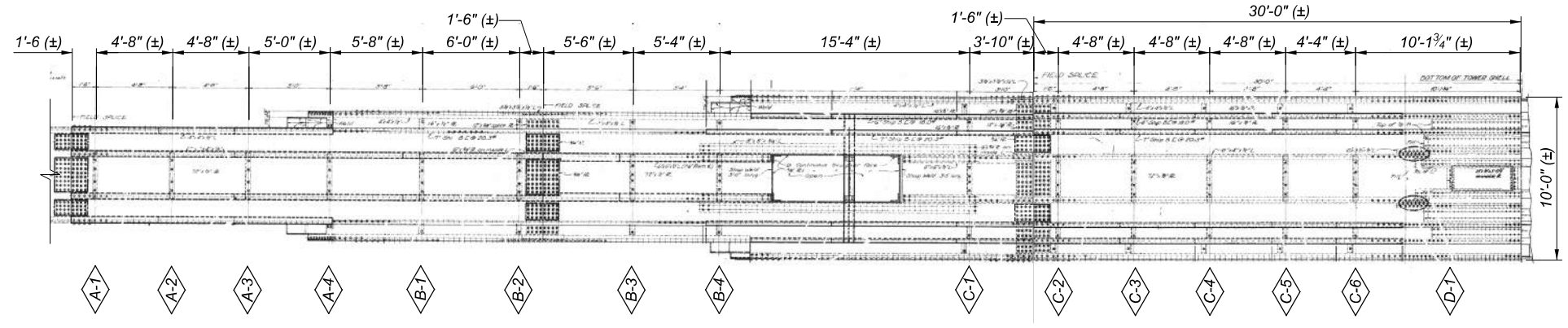

PIER TOWER SIDE ELEVATION

LEGEND  
 ◇ DENOTES DIAPHRAGM

NOTES

1. DETAILS ON THIS SHEET ARE TAKEN FROM THE ORIGINAL PLANS AND SHALL BE USED FOR INFORMATIONAL PURPOSES ONLY.
2. PHYSICAL INVENTORY OF MEASURED DETERIORATION TO DETERMINE MEMBERS NEEDING REPLACED WAS PERFORMED IN JULY 2022.
3. SEE SHEET 21 OF 30 FOR DIAPHRAGM MEMBER REPLACEMENTS.
4. CONTRACTOR SHALL STAGE REMOVAL AND REPLACEMENT OF MEMBERS TO PRESERVE THE INTEGRITY OF THE OVERALL PIER TOWER ELEMENT ACCORDING TO ODOT CMS ITEM 513.

SFN	1801325
DESIGN AGENCY	
DESIGNER	CHECKER
JDA	MJL
REVIEWER	
CJS	10/24/22
PROJECT ID	113674
SUBSET	TOTAL
15	30
SHEET	TOTAL
41	82

PIER TOWER 7 - REPAIR DETAILS - 2  
 BRIDGE NO. CUY-10-0869  
 OVER VALLEY PARKWAY & ROCKY RIVER

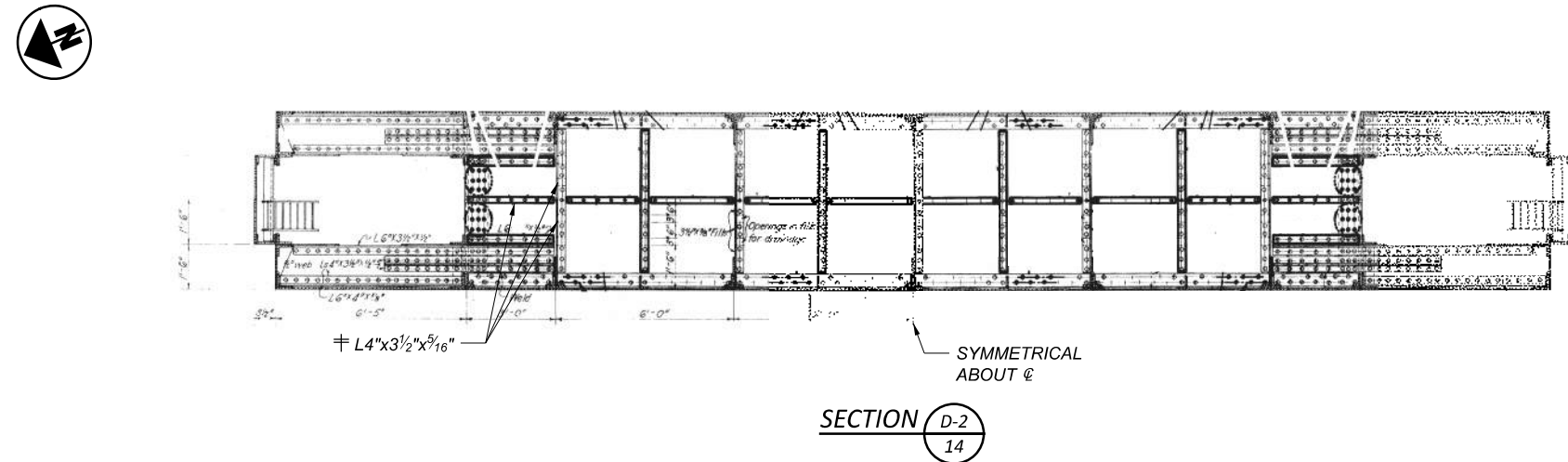
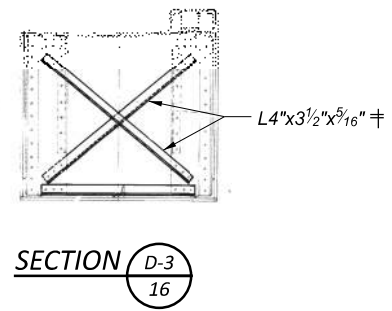
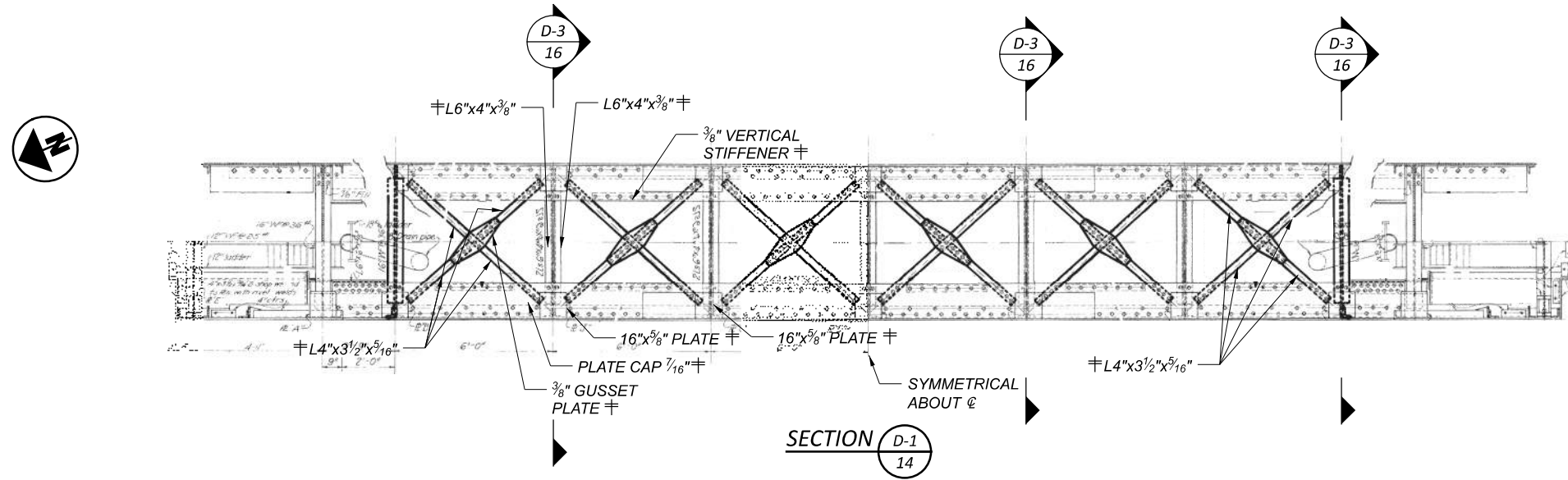

**LEGEND**

‡ MEMBERS DENOTED ARE EXISTING MEMBERS TO BE REPLACED.

**NOTES**

1. DETAILS ON THIS SHEET ARE TAKEN FROM THE ORIGINAL PLANS AND SHALL BE USED FOR INFORMATIONAL PURPOSES ONLY.
2. PHYSICAL INVENTORY OF MEASURED DETERIORATION TO DETERMINE MEMBERS NEEDING REPLACED WAS PERFORMED IN JULY 2022.
3. CONTRACTOR SHALL STAGE REMOVAL AND REPLACEMENT OF MEMBERS TO PRESERVE THE INTEGRITY OF THE OVERALL PIER TOWER ELEMENT ACCORDING TO ODOT CMS ITEM 513.



DESIGNER	CHECKER
JDA	MJL
REVIEWER	
CJS	10/24/22
PROJECT ID	
113674	
SUBSET	TOTAL
16	30
SHEET TOTAL	
42	82

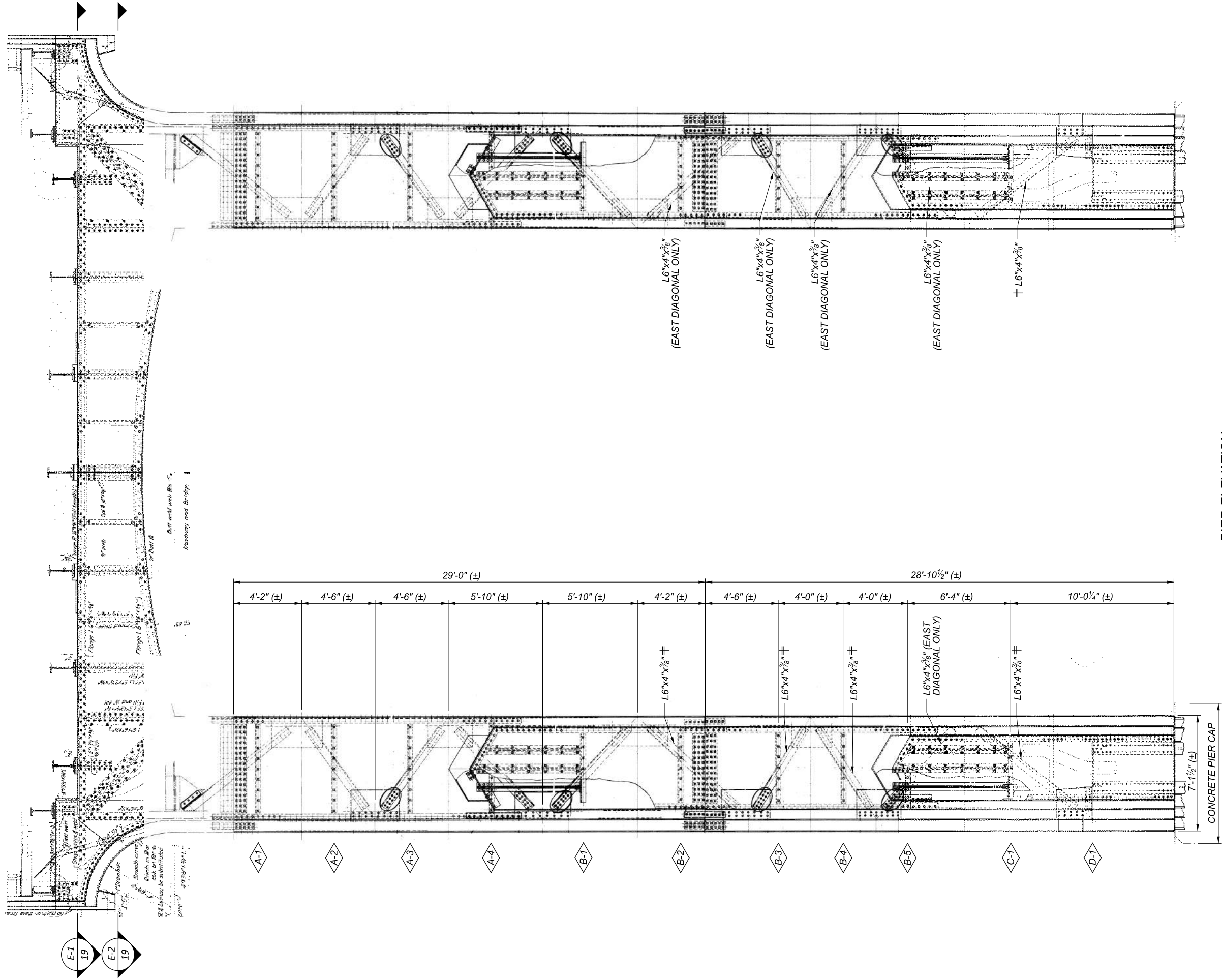

PIER ELEVATION  
 WEST ELEVATION SHOWN  
 EAST ELEVATION SIMILAR BUT OPPOSITE HAND

LEGEND  
 ◇ DENOTES DIAPHRAGM  
 † MEMBERS DENOTED ARE EXISTING MEMBERS TO BE REPLACED,  
 BOTH EAST AND WEST FACE DIAGONALS.

NOTES

1. DETAILS ON THIS SHEET ARE TAKEN FROM THE ORIGINAL PLANS AND SHALL BE USED FOR INFORMATIONAL PURPOSES ONLY.
2. PHYSICAL INVENTORY OF MEASURED DEGRADATION TO DETERMINE MEMBERS NEEDING REPLACED WAS PERFORMED IN JULY 2022.
3. SEE SHEET 20 OF 30 FOR DIAPHRAGM MEMBER REPLACEMENTS.
4. CONTRACTOR SHALL STAGE REMOVAL AND REPLACEMENT OF MEMBERS TO PRESERVE THE INTEGRITY OF THE OVERALL PIER TOWER ELEMENT ACCORDING TO ODOT CMS ITEM 513.

PIER TOWER 8 - REPAIR DETAILS - 1  
 BRIDGE NO. CUY-10-0869  
 OVER VALLEY PARKWAY & ROCKY RIVER

SFN	1801325
DESIGN AGENCY	
DESIGNER	CHECKER
JDA	MJL
REVIEWER	10/24/22
CJS	
PROJECT ID	113674
SUBSET	TOTAL
17	30
SHEET	TOTAL
43	82

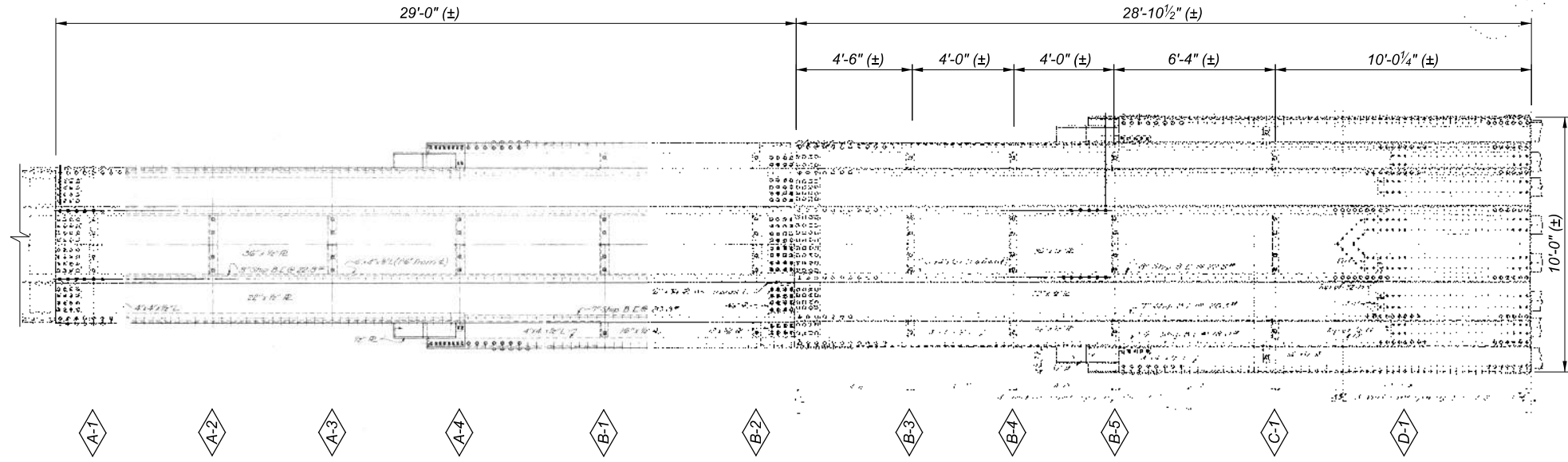

PIER TOWER SIDE ELEVATION

**LEGEND**  
 ◊ DENOTES DIAPHRAGM

**NOTES**

1. PHYSICAL INVENTORY OF MEASURED DETERIORATION TO DETERMINE MEMBERS NEEDING REPLACED WAS PERFORMED IN JULY 2022.
2. SEE SHEET 20 OF 30 FOR DIAPHRAGM MEMBER REPLACEMENT.
3. CONTRACTOR SHALL STAGE REMOVAL AND REPLACEMENT OF MEMBERS TO PRESERVE THE INTEGRITY OF THE OVERALL PIER TOWER ELEMENT ACCORDING TO ODOT CMS ITEM 513.

PIER TOWER 8 - REPAIR DETAILS - 2  
 BRIDGE NO. CUY-10-0869  
 OVER VALLEY PARKWAY & ROCKY RIVER

SFN	1801325
DESIGN AGENCY	
DESIGNER	CHECKER
JDA	MJL
REVIEWER	
CJS	10/24/22
PROJECT ID	
	113674
SUBSET	TOTAL
18	30
SHEET	TOTAL
44	82

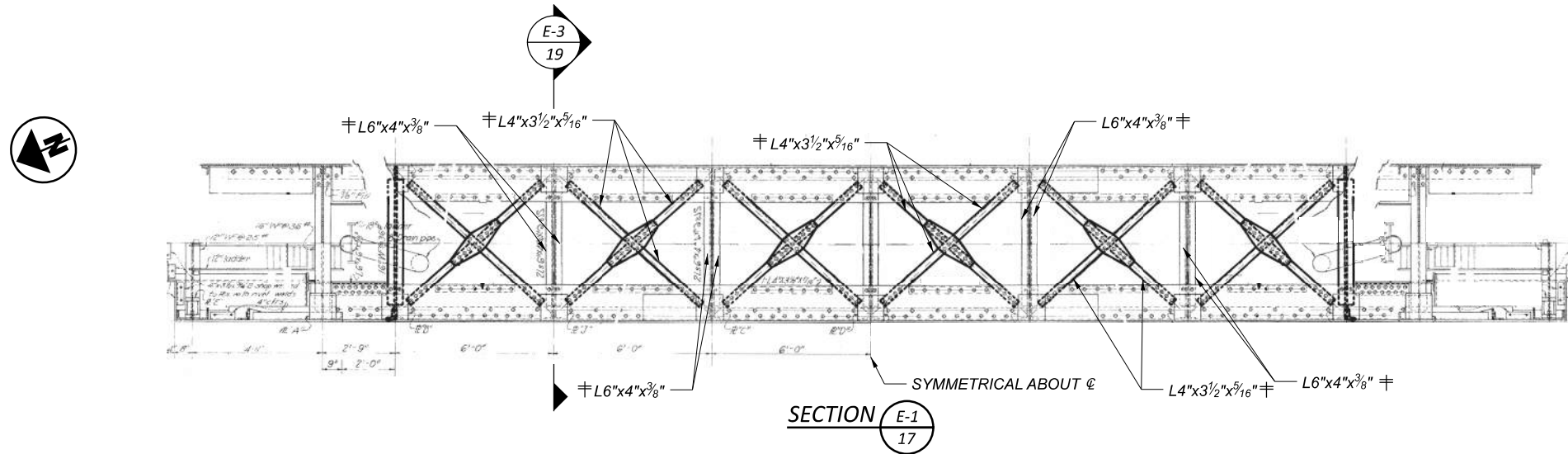

SECTION E-1  
17

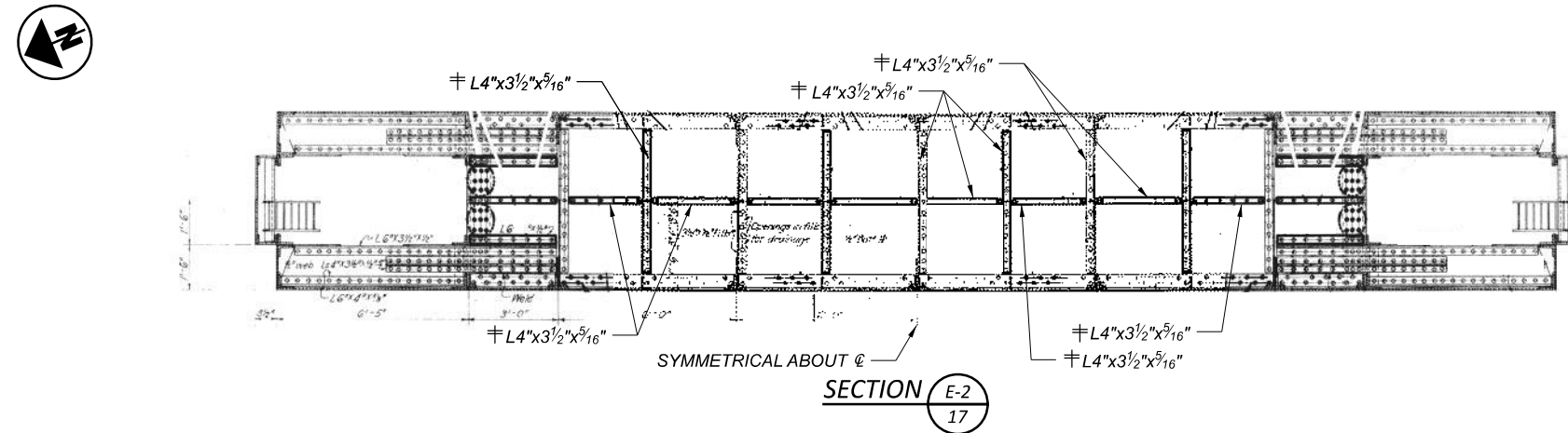

SECTION E-2  
17

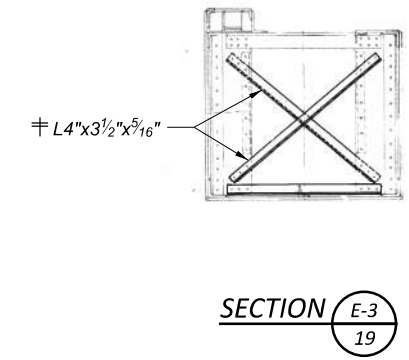

SECTION E-3  
19

**LEGEND**

‡ MEMBERS DENOTED ARE EXISTING MEMBERS TO BE REPLACED.

**NOTES**

1. DETAILS ON THIS SHEET ARE TAKEN FROM THE ORIGINAL PLANS AND SHALL BE USED FOR INFORMATIONAL PURPOSES ONLY.
2. PHYSICAL INVENTORY OF MEASURED DETERIORATION TO DETERMINE MEMBERS NEEDING REPLACED WAS PERFORMED IN JULY 2022.
3. CONTRACTOR SHALL STAGE REMOVAL AND REPLACEMENT OF MEMBERS TO PRESERVE THE INTEGRITY OF THE OVERALL PIER TOWER ELEMENT ACCORDING TO ODOT CMS ITEM 513.



DESIGNER	CHECKER
JDA	MJL
REVIEWER	
CJS 10/24/22	
PROJECT ID	
113674	
SUBSET	TOTAL
19	30
SHEET	TOTAL
45	82

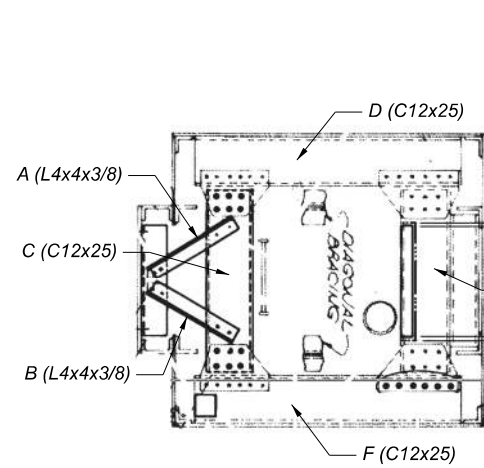

A-1 THRU A-4 DIAPHRAGMS

PIER 4, NORTH TOWER

	A	B	C	D	E	F	G	H
A-1							N/A	N/A
A-2							N/A	N/A
A-3							N/A	N/A
A-4							N/A	N/A
B-1								
B-2								
B-3	X	X	X	X			X	X
B-4	X	X	X	X	X	X	X	
B-5	X	X	X	X	X	X	X	X
C-1	X	X	X	X	X	X	X	X
D-1								

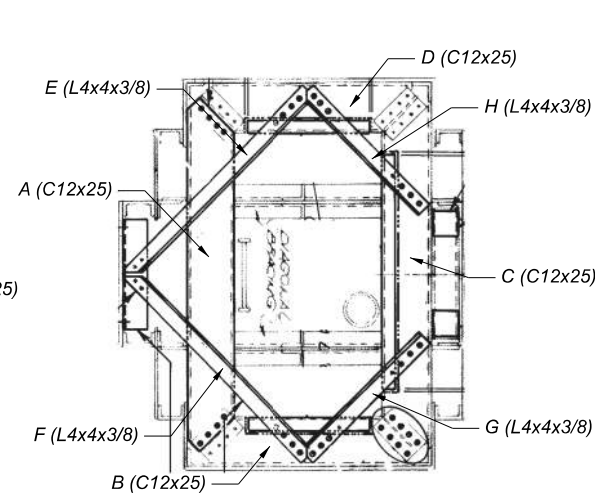

B-1 THRU B-5 DIAPHRAGMS

PIER 4, SOUTH TOWER

	A	B	C	D	E	F	G	H
A-1							N/A	N/A
A-2							N/A	N/A
A-3							N/A	N/A
A-4							N/A	N/A
B-1								
B-2								
B-3	X	X	X	X	X	X	X	X
B-4	X	X	X	X	X	X	X	X
B-5	X	X	X	X	X	X	X	
C-1	X	X	X	X	X	X		
D-1								

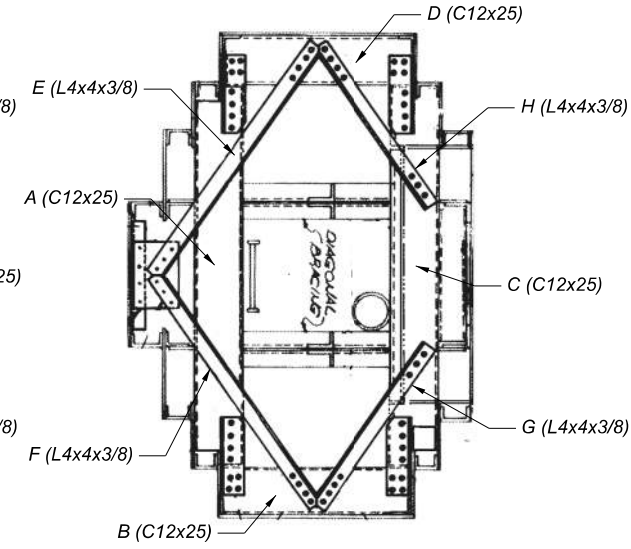

C-1 DIAPHRAGM

PIER 8, NORTH TOWER

	A	B	C	D	E	F	G	H
A-1			X	X	X	X	N/A	N/A
A-2			X	X	X	X	N/A	N/A
A-3			X	X	X	X	N/A	N/A
A-4			X	X	X	X	N/A	N/A
B-1			X	X	X	X		
B-2			X	X	X	X	X	X
B-3			X	X	X	X	X	X
B-4			X	X	X	X	X	X
B-5	X	X	X	X	X	X	X	X
C-1			X	X		X	X	X
D-1								

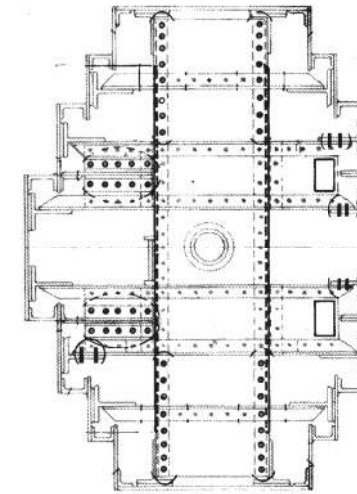

D-1 DIAPHRAGM

PIER 8, SOUTH TOWER

	A	B	C	D	E	F	G	H
A-1			X	X	X	X	N/A	N/A
A-2			X	X	X	X	N/A	N/A
A-3			X	X	X	X	N/A	N/A
A-4			X	X	X	X	N/A	N/A
B-1			X	X	X	X		
B-2	X	X	X	X	X	X	X	X
B-3	X	X	X	X	X	X	X	X
B-4	X	X	X	X	X	X	X	
B-5	X	X	X	X	X	X	X	
C-1	X	X	X	X	X	X	X	X
D-1								

**MEMBERS TO BE REPAIRED OR REPLACED**

X - REPLACE MEMBER

**NOTES**

1. DETAILS ON THIS SHEET ARE TAKEN FROM THE ORIGINAL PLANS AND SHALL BE USED FOR INFORMATIONAL PURPOSES ONLY.
2. PHYSICAL INVENTORY OF MEASURED DETERIORATION TO DETERMINE MEMBERS NEEDING REPLACED WAS PERFORMED IN JULY 2022.
3. CONTRACTOR SHALL STAGE REMOVAL AND REPLACEMENT OF MEMBERS TO PRESERVE THE INTEGRITY OF THE OVERALL PIER TOWER ELEMENT ACCORDING TO ODOT CMS ITEM 513.



DESIGNER	CHECKER
JDA	MJL
REVIEWER	
CJS	10/24/22
PROJECT ID	113674
SUBSET	TOTAL
20	30
SHEET	TOTAL
46	82





(TYP. ALL)

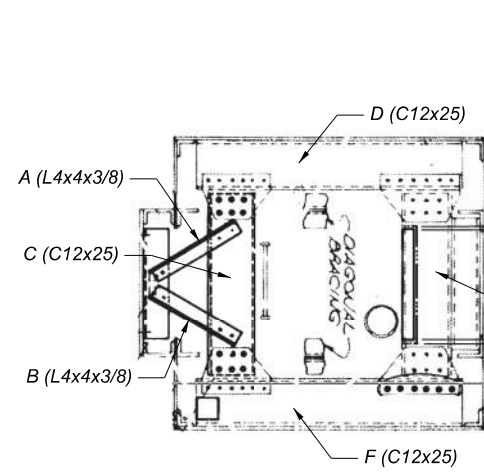

A-1 THRU A-4 DIAPHRAGMS

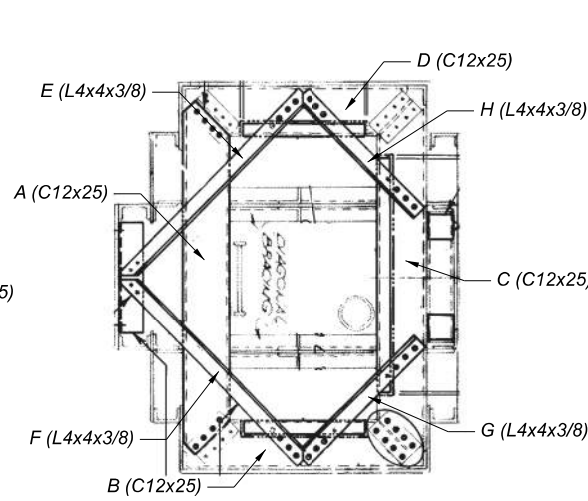

B-1 THRU B-4 DIAPHRAGMS

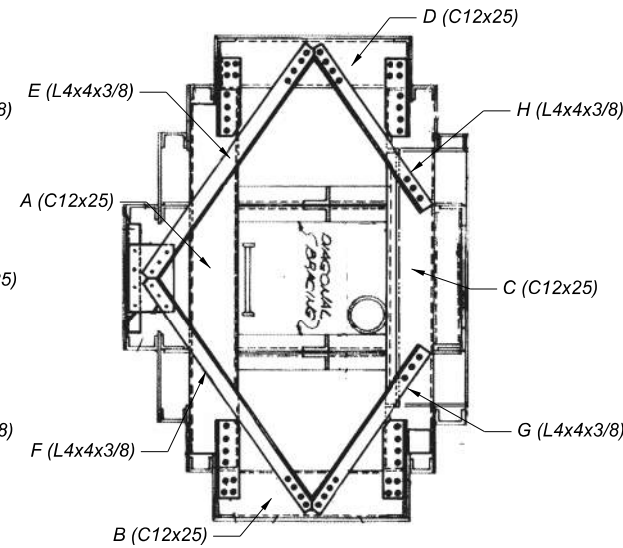

C-1 THRU C-6 DIAPHRAGMS

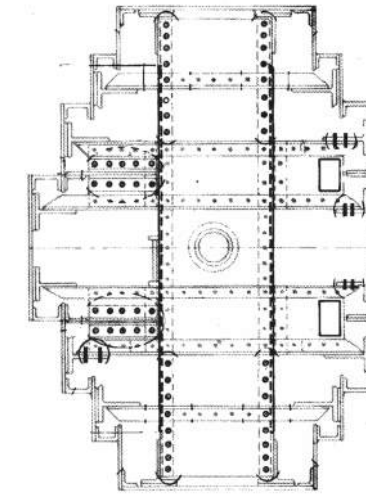

D-1 DIAPHRAGM

PIER 5, NORTH AND SOUTH TOWERS

	A	B	C	D	E	F	G	H
A-1		X					N/A	N/A
A-2		X					N/A	N/A
A-3		X					N/A	N/A
A-4		X			X		N/A	N/A
B-1		X			X			
B-2		X			X	X		
B-3		X			X			
B-4		X			X			
C-1		X			X			
C-2		X			X			
C-3		X			X			
C-4		X			X			
C-5		X			X			
C-6		X			X			
D-1								

PIER 6, NORTH AND SOUTH TOWERS

	A	B	C	D	E	F	G	H
A-1				X			N/A	N/A
A-2				X			N/A	N/A
A-3				X			N/A	N/A
A-4				X			N/A	N/A
B-1	X	X	X	X				
B-2	X	X	X	X				
B-3	X	X	X	X				
B-4	X	X	X	X				
C-1	X	X	X	X				
C-2	X	X	X	X				
C-3	X	X	X	X				
C-4	X	X	X	X				
C-5	X	X	X	X				
C-6	X	X	X	X				
D-1								

PIER 7, NORTH AND SOUTH TOWERS

	A	B	C	D	E	F	G	H
A-1	X	X	X	X	X	X	N/A	N/A
A-2	X	X	X	X	X	X	N/A	N/A
A-3	X	X	X	X	X	X	N/A	N/A
A-4	X	X	X	X	X	X	N/A	N/A
B-1	X	X	X	X	X	X	X	X
B-2	X	X	X	X	X	X	X	X
B-3	X	X	X	X	X	X	X	X
B-4	X	X	X	X	X	X	X	X
C-1	X	X	X	X	X	X	X	X
C-2	X	X	X	X	X	X	X	X
C-3	X	X	X	X	X	X	X	X
C-4	X	X	X	X	X	X	X	X
C-5	X	X	X	X	X	X	X	X
C-6	X	X	X	X	X	X	X	X
D-1								

**MEMBERS TO BE REPAIRED OR REPLACED**

X - REPLACE MEMBER

**NOTES**

1. DETAILS ON THIS SHEET ARE TAKEN FROM THE ORIGINAL PLANS AND SHALL BE USED FOR INFORMATIONAL PURPOSES ONLY.
2. PHYSICAL INVENTORY OF MEASURED DETERIORATION TO DETERMINE MEMBERS NEEDING REPLACED WAS PERFORMED IN JULY 2022.
3. CONTRACTOR SHALL STAGE REMOVAL AND REPLACEMENT OF MEMBERS TO PRESERVE THE INTEGRITY OF THE OVERALL PIER TOWER ELEMENT ACCORDING TO ODOT CMS ITEM 513.



DESIGNER	CHECKER
JDA	MJL
REVIEWER	
CJS	10/24/22
PROJECT ID	
113674	
SUBSET	TOTAL
21	30
SHEET	TOTAL
47	82

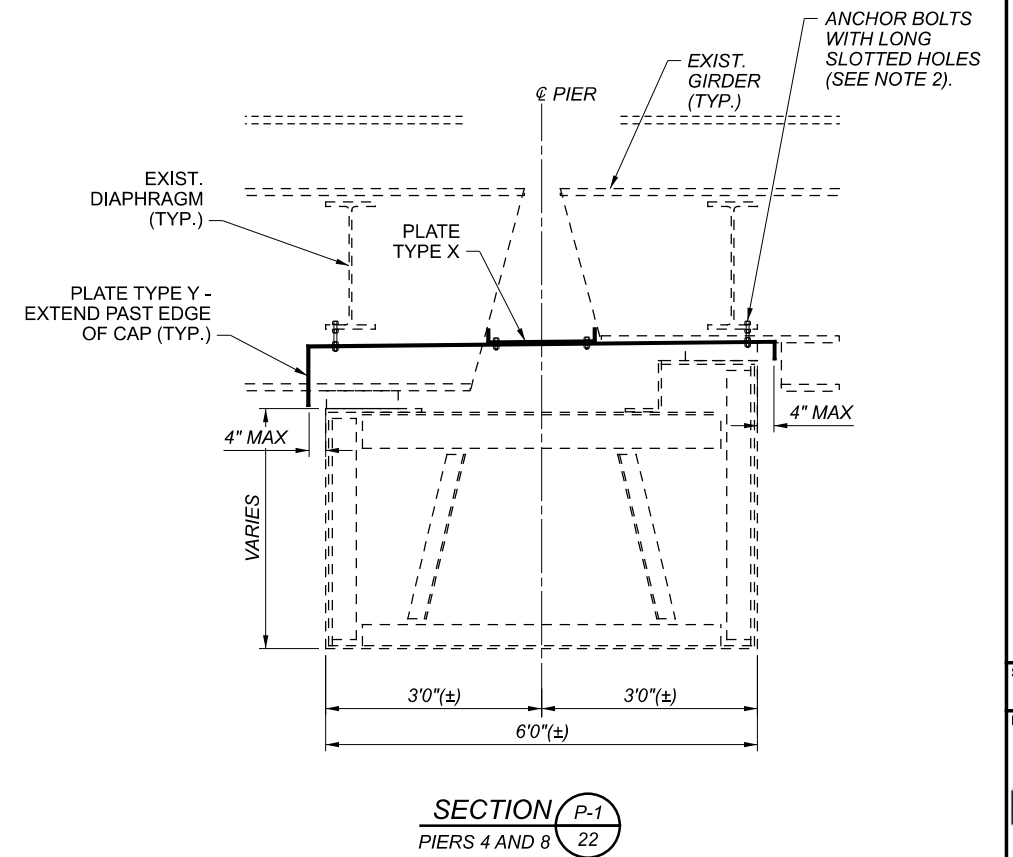
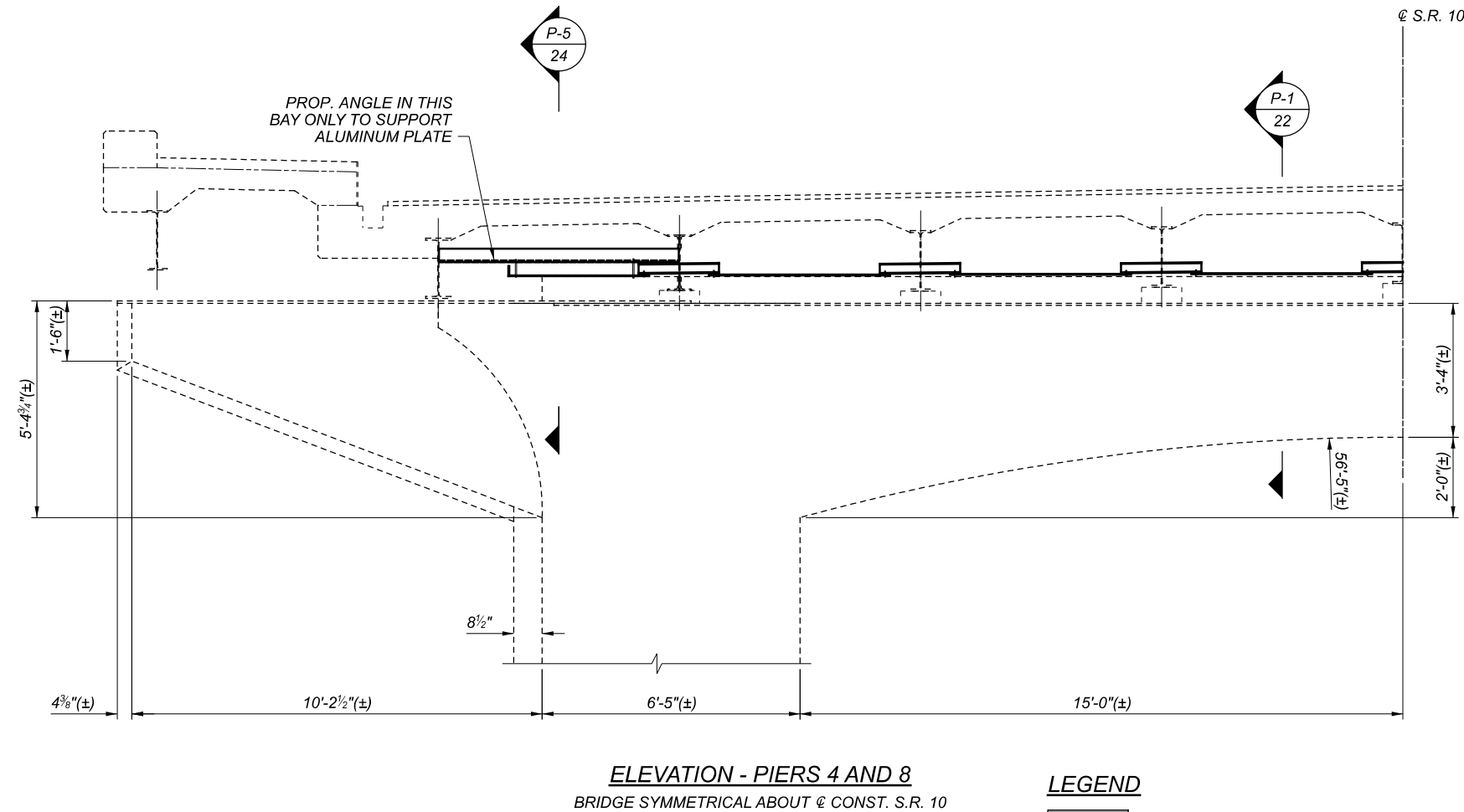
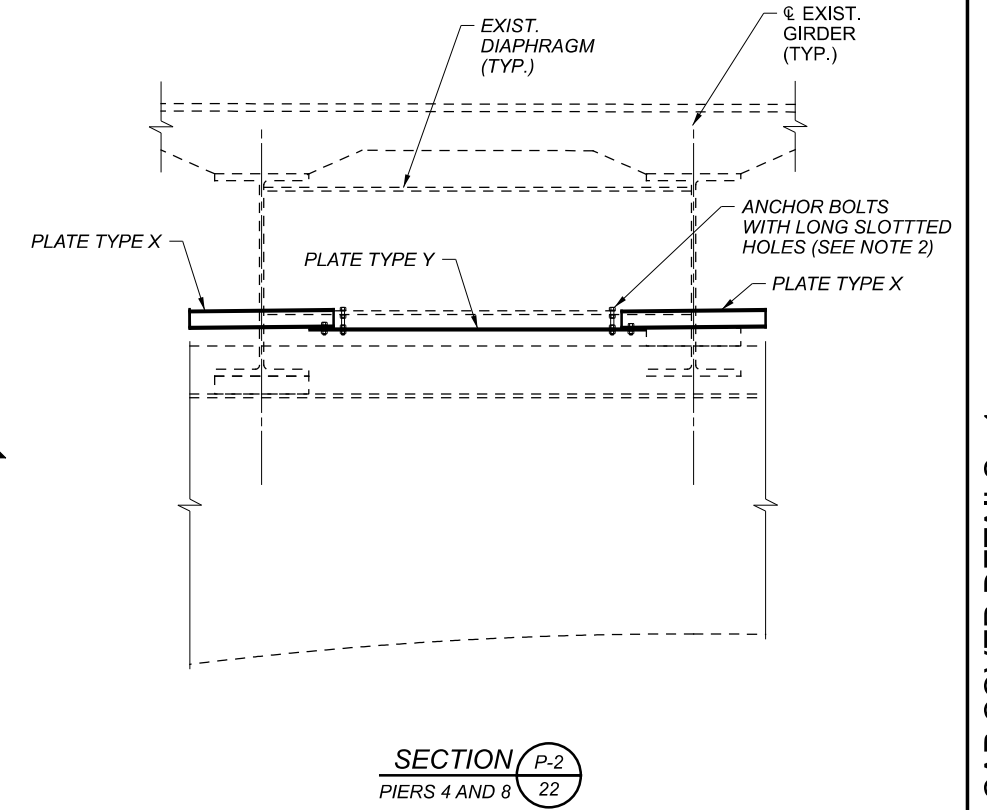
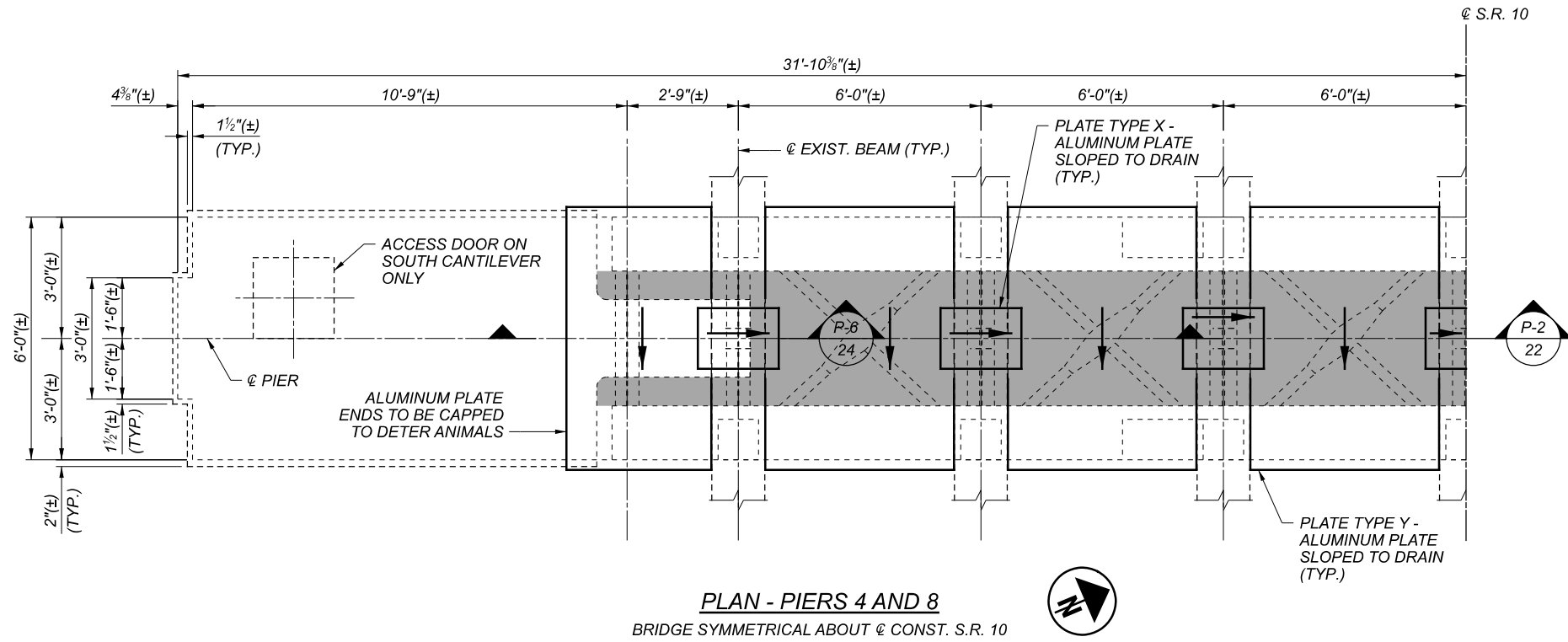

**LEGEND**

OPEN AREA IN PIER CAP TO BE COVERED

**NOTES**

1. PRIOR TO PREPARING SHOP DRAWINGS, OBTAIN FIELD MEASUREMENTS TO VERIFY DIMENSIONS AS NEEDED TO ENSURE PLATES FIT WITH BOLTED CONNECTIONS AND EXISTING ELEMENTS AND TO PROVIDE POSITIVE DRAINAGE AND PROTECTION AS NOTED.
2. HOLES FOR ANCHOR BOLTS SHALL BE SLOTTED PARALLEL TO THE EXISTING GIRDERS FOR CONNECTIONS WITH PLATE TYPE Y.
3. SEE SHEET 25/30 FOR PLATE TYPE X AND Y DETAILS.

DESIGNER	CHECKER
MDK	MJL
REVIEWER	
CJS	10/24/22
PROJECT ID	113674
SUBSET	TOTAL
22	30
SHEET	TOTAL
48	82

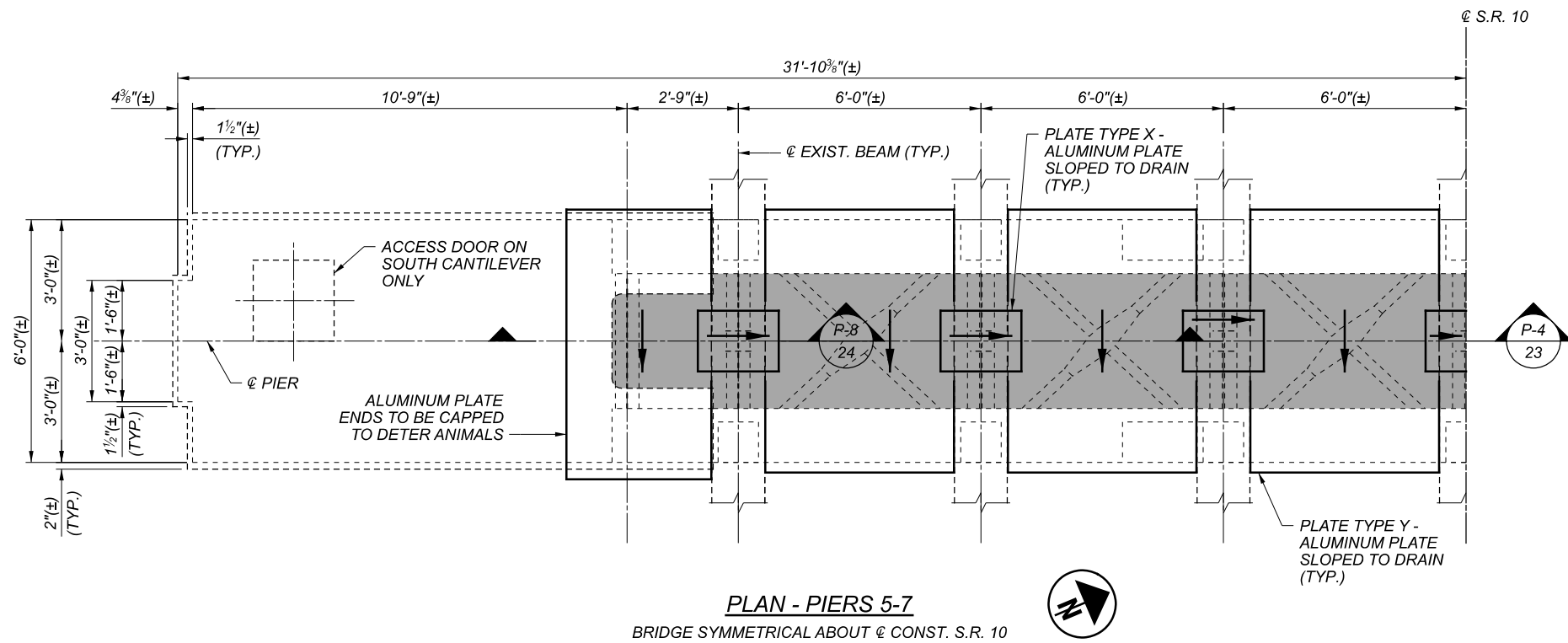

**PLAN - PIERS 5-7**  
 BRIDGE SYMMETRICAL ABOUT  $\text{\textcircled{C}}$  CONST. S.R. 10

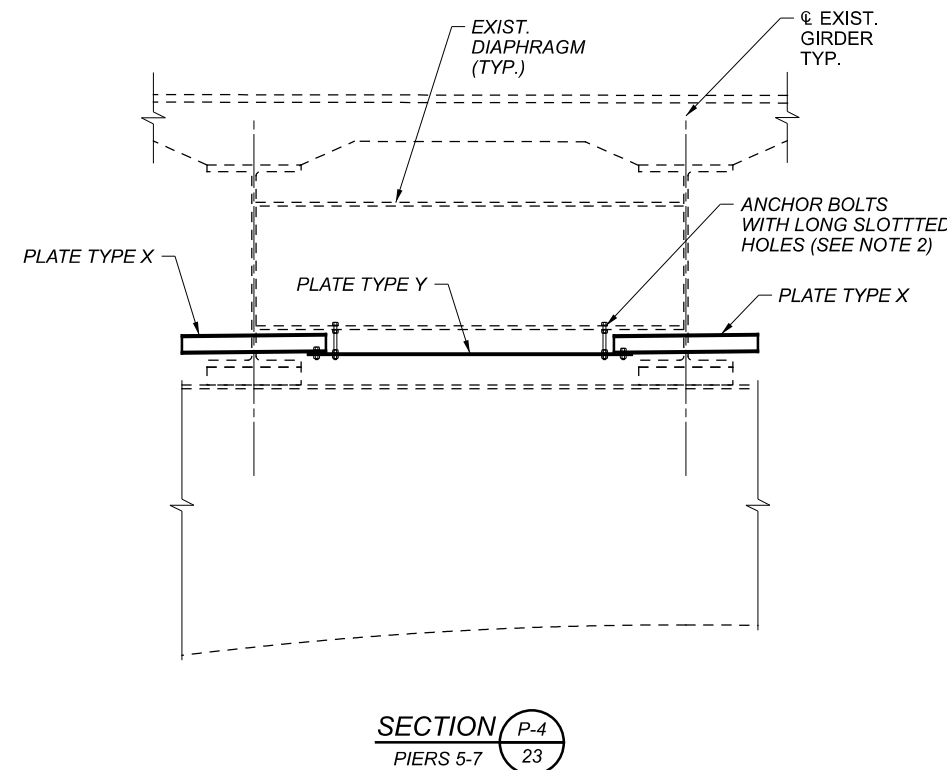

**SECTION P-4**  
 PIERS 5-7 23

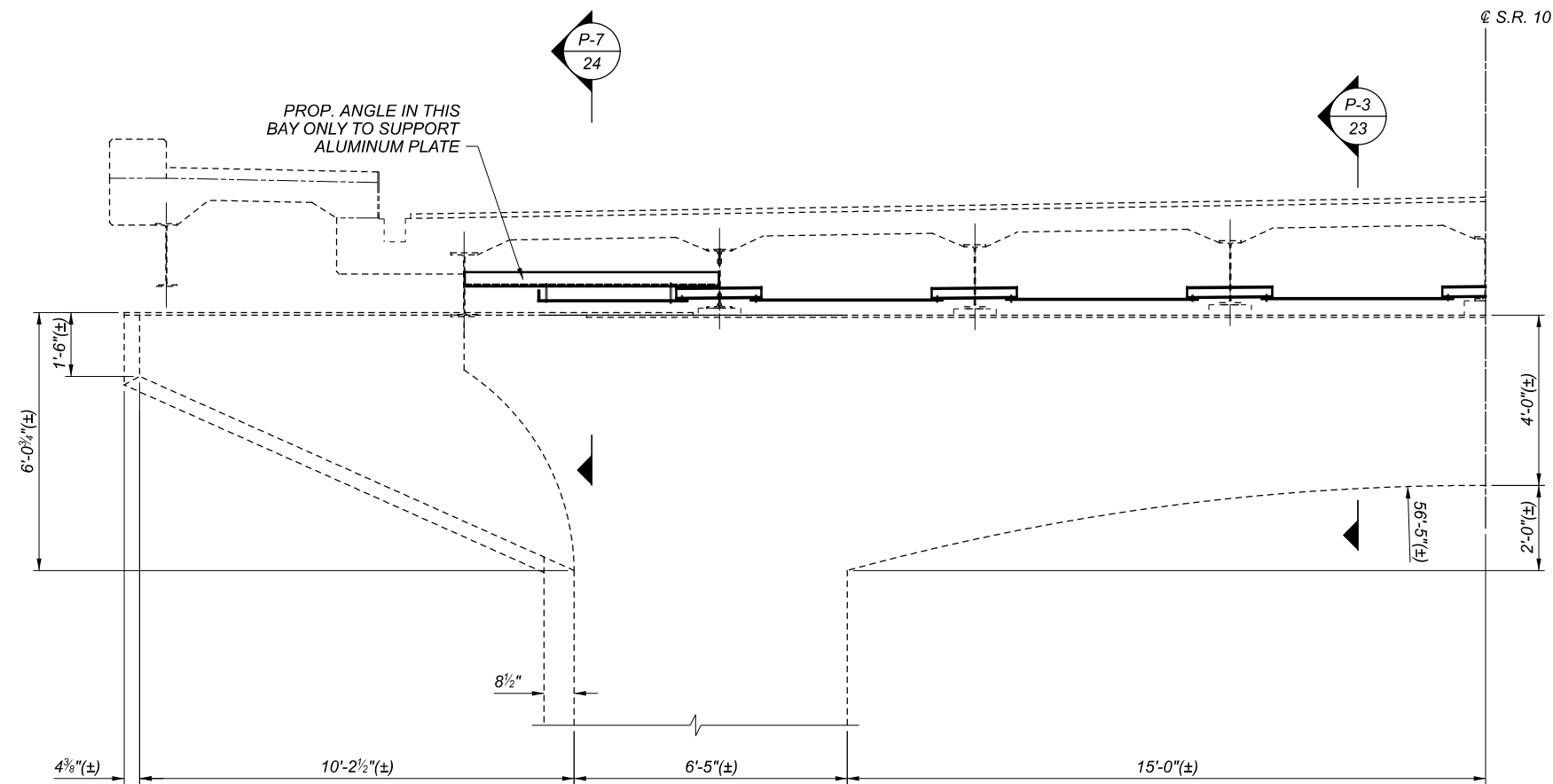

**ELEVATION - PIERS 5-7**  
 BRIDGE SYMMETRICAL ABOUT  $\text{\textcircled{C}}$  CONST. S.R. 10

**LEGEND**

OPEN AREA IN PIER CAP TO BE COVERED

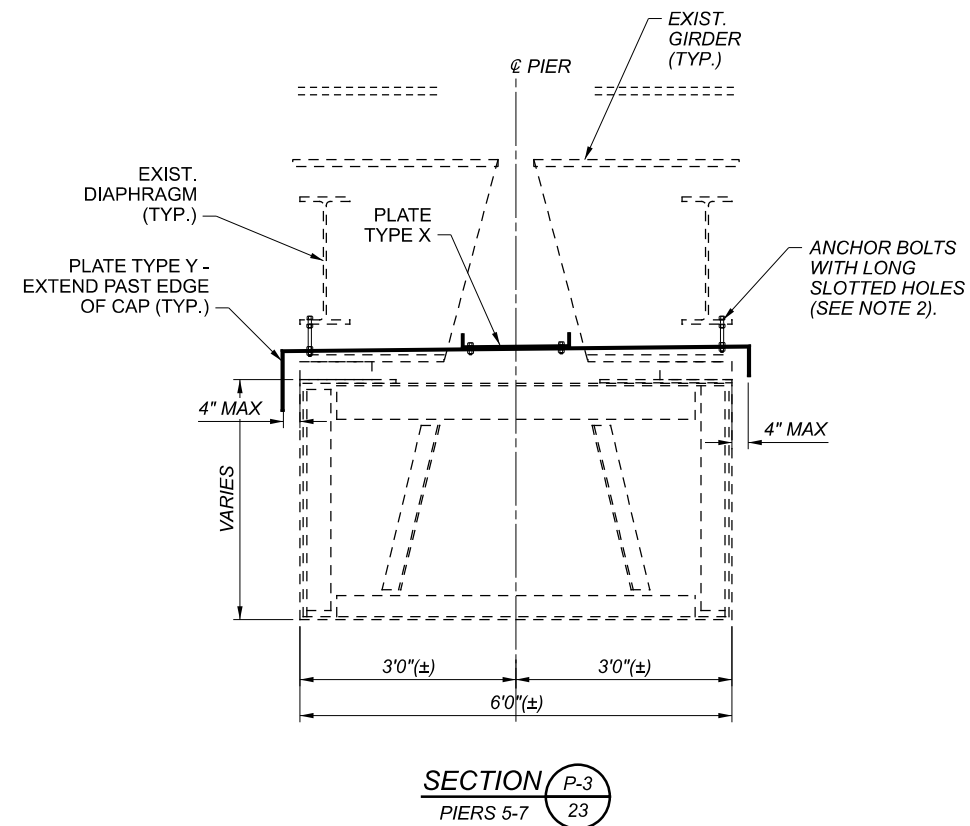

**SECTION P-3**  
 PIERS 5-7 23

**NOTES**

1. PRIOR TO PREPARING SHOP DRAWINGS, OBTAIN FIELD MEASUREMENTS TO VERIFY DIMENSIONS AS NEEDED TO ENSURE PLATES FIT WITH BOLTED CONNECTIONS AND EXISTING ELEMENTS AND TO PROVIDE POSITIVE DRAINAGE AND PROTECTION AS NOTED.
2. HOLES FOR ANCHOR BOLTS SHALL BE SLOTTED PARALLEL TO THE EXISTING GIRDERS FOR CONNECTIONS WITH PLATE TYPE Y.
3. SEE SHEET 25/30 FOR PLATE TYPE X AND Y DETAILS.

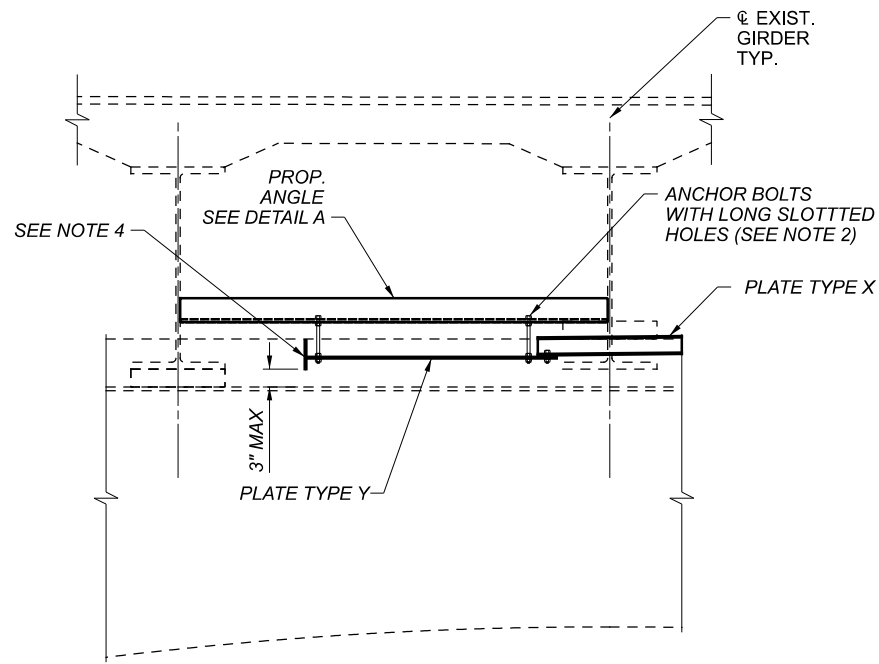

SECTION P-6  
PIERS 4 AND 8 22

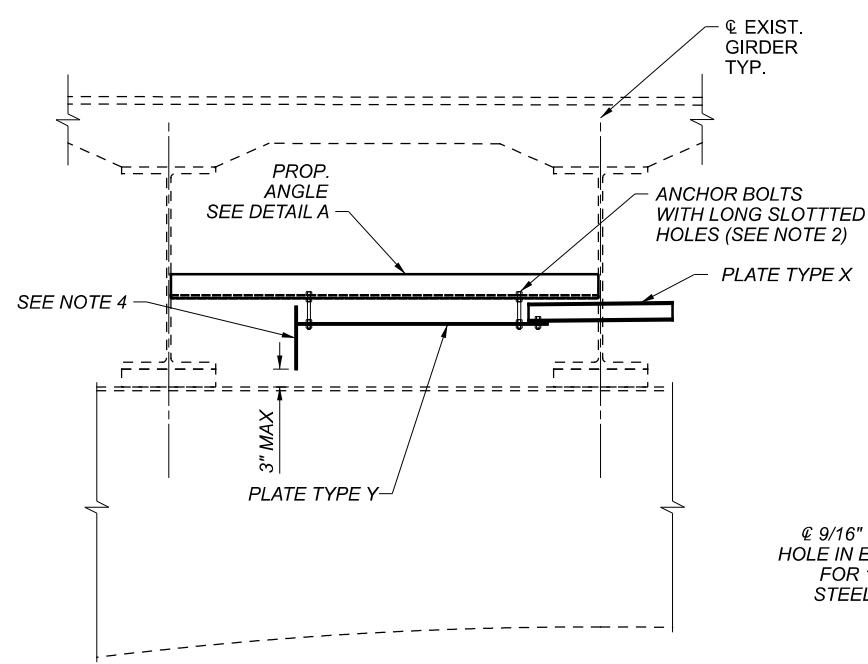

SECTION P-8  
PIERS 5-7 23

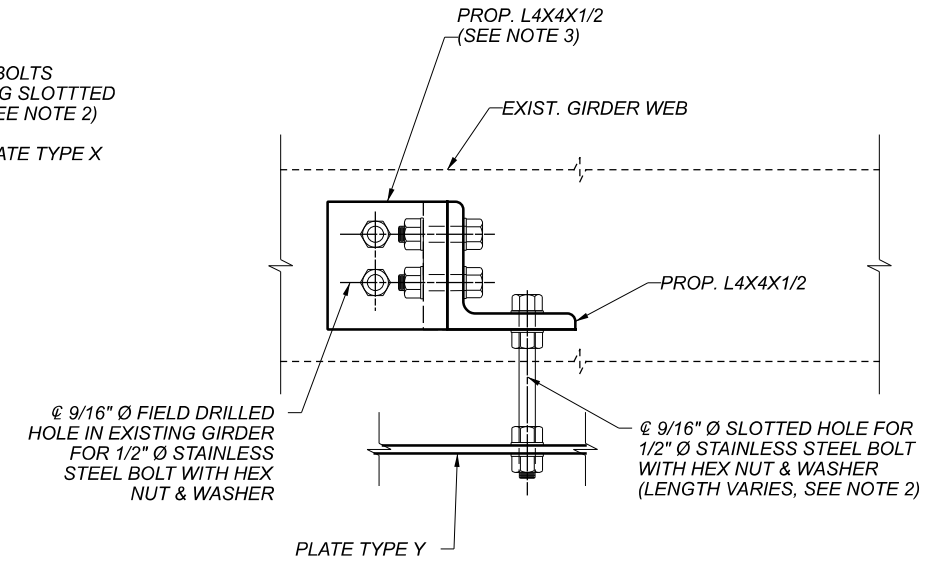

DETAIL A

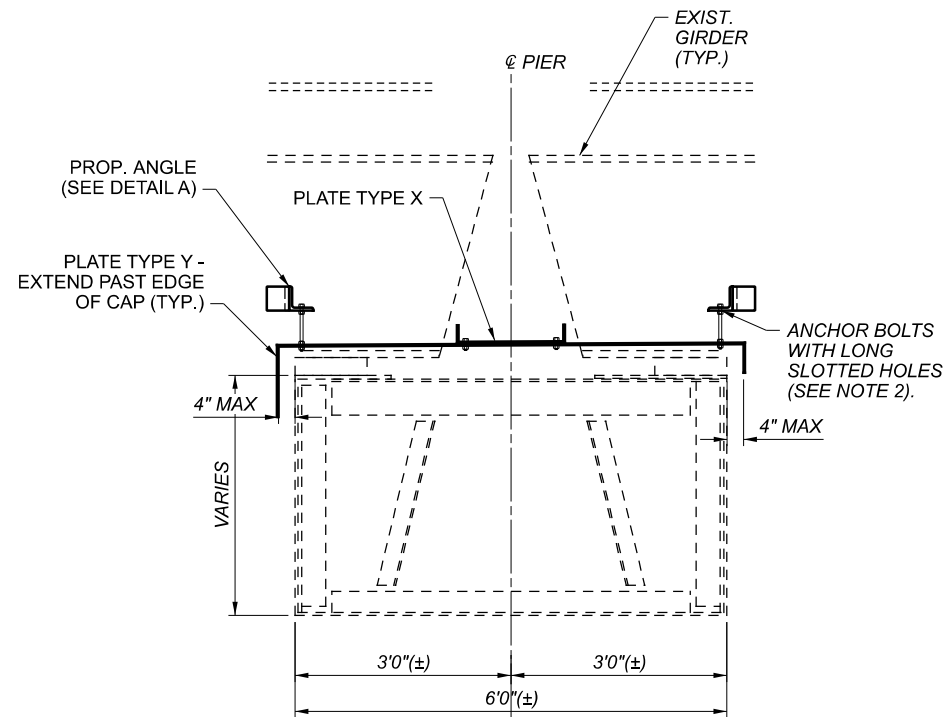

SECTION P-5  
PIERS 4 AND 8 22

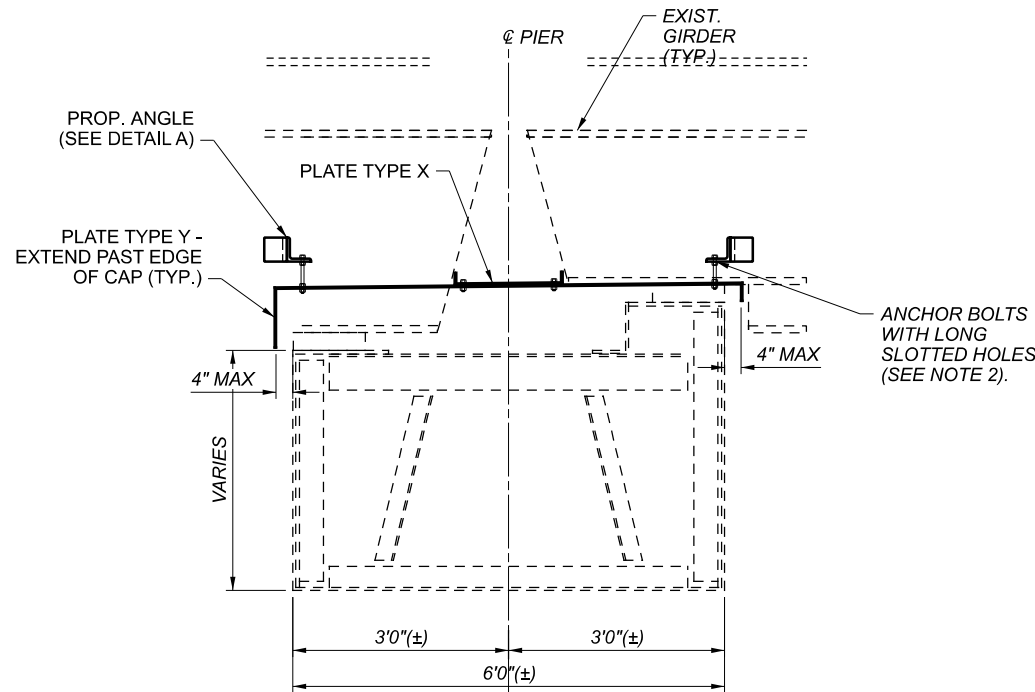

SECTION P-7  
PIERS 5-7 23

**NOTES**

1. PRIOR TO PREPARING SHOP DRAWINGS, OBTAIN FIELD MEASUREMENTS TO VERIFY DIMENSIONS AS NEEDED TO ENSURE PLATES FIT WITH BOLTED CONNECTIONS AND EXISTING ELEMENTS AND TO PROVIDE POSITIVE DRAINAGE AND PROTECTION AS NOTED.
2. HOLES FOR ANCHOR BOLTS SHALL BE SLOTTED PARALLEL TO THE EXISTING GIRDERS FOR CONNECTIONS WITH PLATE TYPE Y.
3. BOLTS THROUGH ANGLE SHALL HAVE A MINIMUM EDGE CLEARANCE OF 3/4" AND A MINIMUM CENTER TO CENTER SPACING OF 3 TIMES THE BOLT DIAMETERS.
4. PLATE TYPE Y ON EXTERIOR BAYS SHALL HAVE A "T" END FABRICATED ON ONE SIDE. DIMENSIONS OF THE "T" ENDS SHALL BE DETERMINED BASED ON FIELD MEASUREMENTS.

DESIGNER	CHECKER
MDK	MJL
REVIEWER	
CJS	10/24/22
PROJECT ID	
	113674
SUBSET	TOTAL
24	30
SHEET	TOTAL
50	82

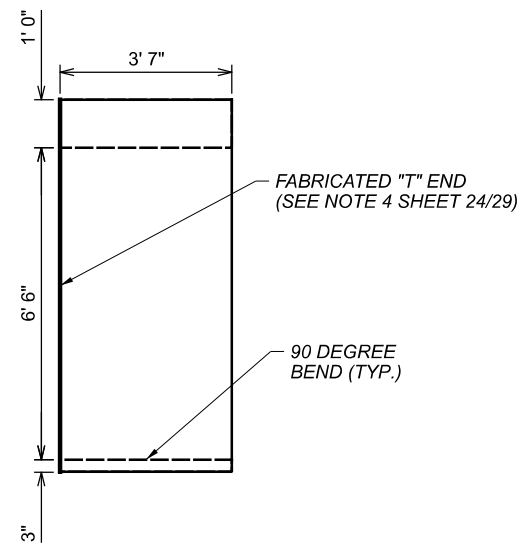

**PLATE TYPE Y** (AP-1)  
PIERS 4 AND 8  
EXTERIOR BAYS 25

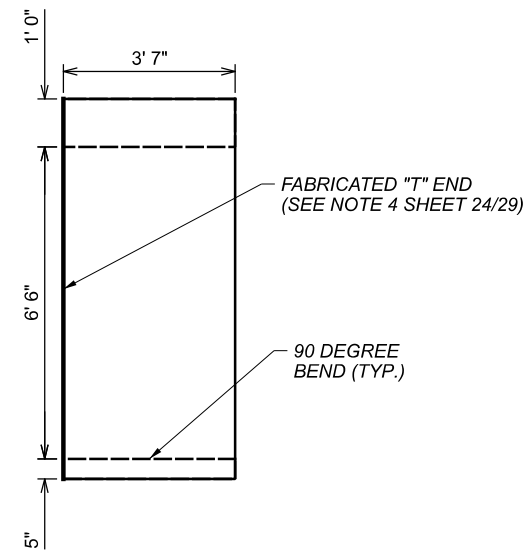

**PLATE TYPE Y** (AP-2)  
PIERS 5-7  
EXTERIOR BAYS 25

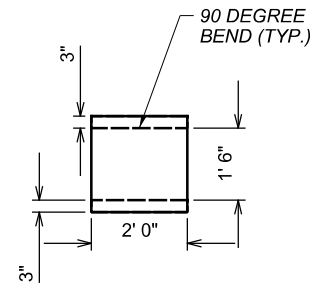

**PLATE TYPE X** (AP-5)  
25

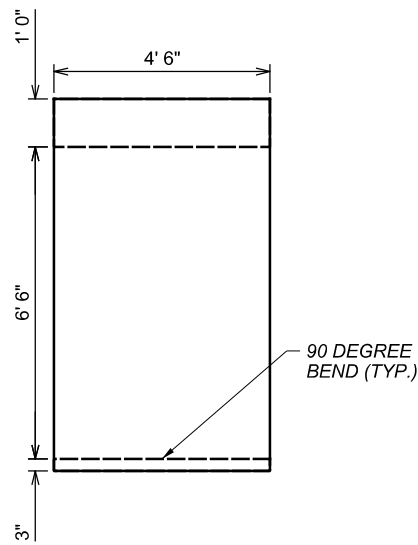

**PLATE TYPE Y** (AP-3)  
PIERS 4 AND 8  
INTERIOR BAYS 25

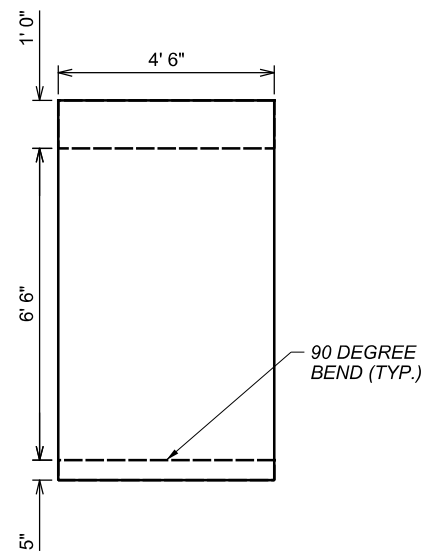

**PLATE TYPE Y** (AP-4)  
PIERS 5-7  
INTERIOR BAYS 25

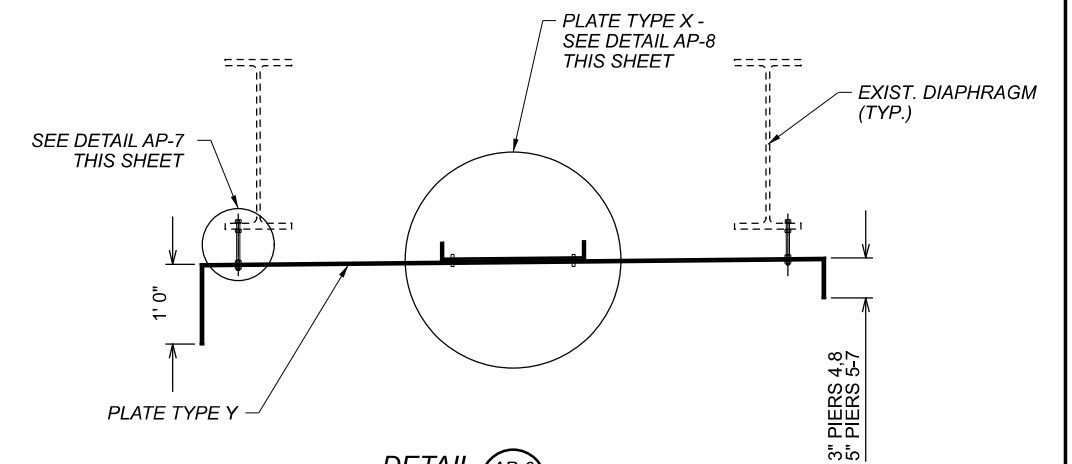

**DETAIL** (AP-6)  
25

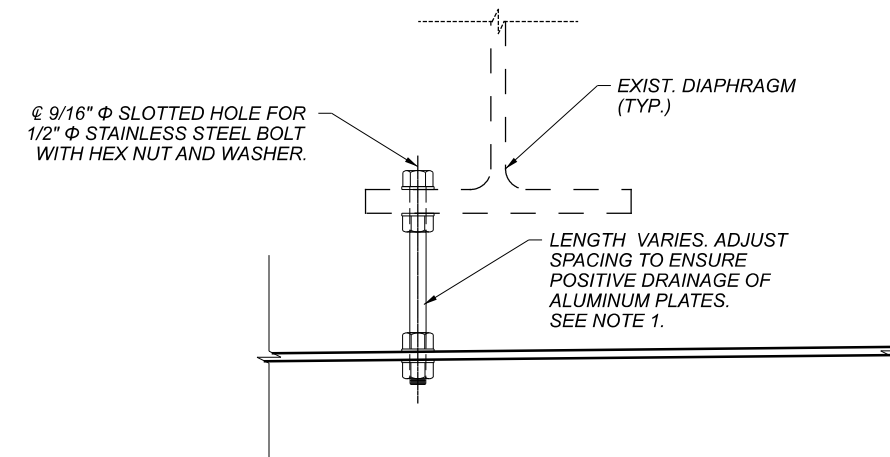

**DETAIL** (AP-8)  
25

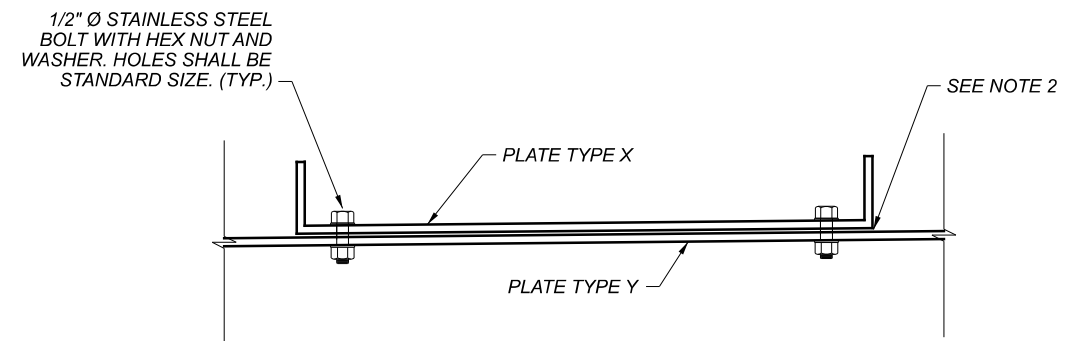

**DETAIL** (AP-8)  
25

**NOTES**

1. PRIOR TO PREPARING SHOP DRAWINGS, OBTAIN FIELD MEASUREMENTS TO VERIFY DIMENSIONS AS NEEDED TO ENSURE PLATES FIT WITH BOLTED CONNECTIONS AND EXISTING ELEMENTS AND TO PROVIDE POSITIVE DRAINAGE AND PROTECTION AS NOTED.
2. PLATES SHALL BE 1/4" THICK, IN ACCORDANCE WITH ASTM B 209.
3. PLATE TYPE X AND Y SHALL HAVE A SELF-ADHESIVE MEMBRANE ATTACHED TO THE BOTTOM OF THE SHEETS AS A METHOD TO PROVIDE VIBRATION DAMPENING.

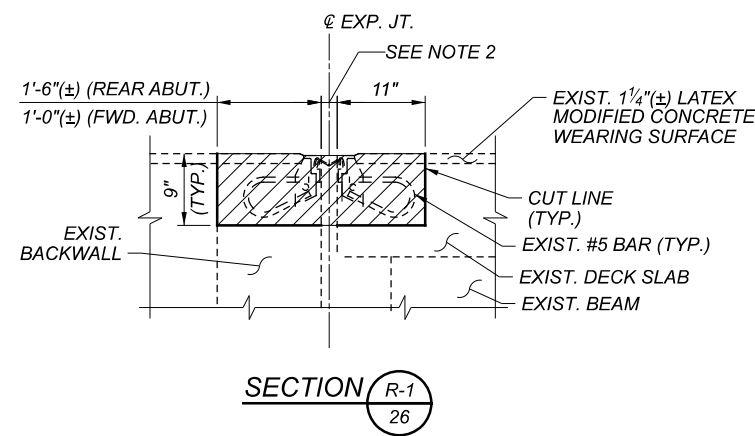
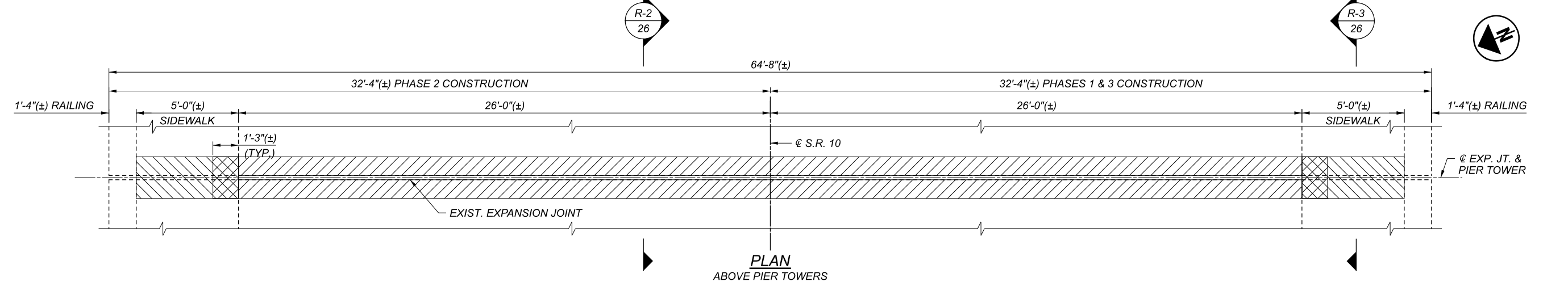
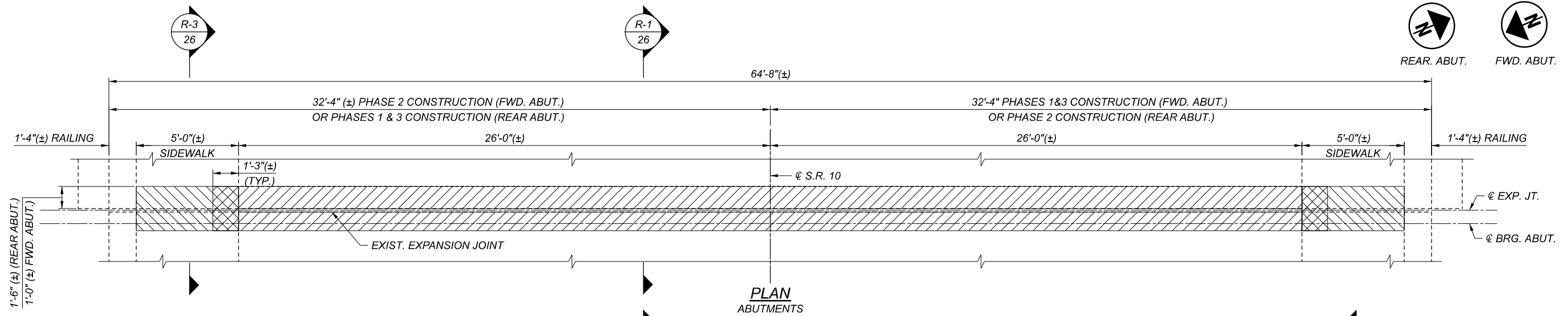

SECTION R-1  
ABUTMENTS  
(EXIST. REINFORCING STEEL NOT SHOWN FOR CLARITY)

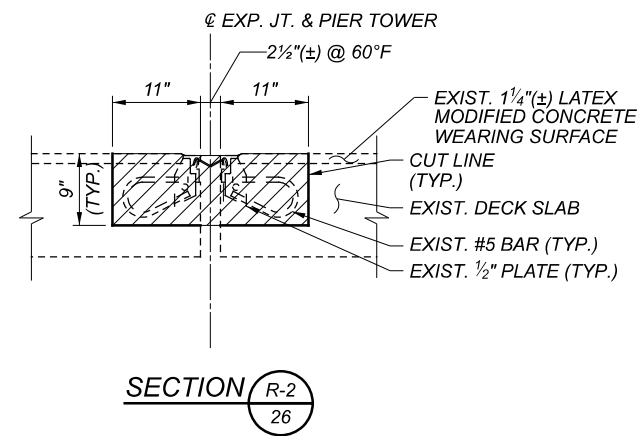

SECTION R-2  
PIER TOWERS  
(EXIST. REINFORCING STEEL NOT SHOWN FOR CLARITY)

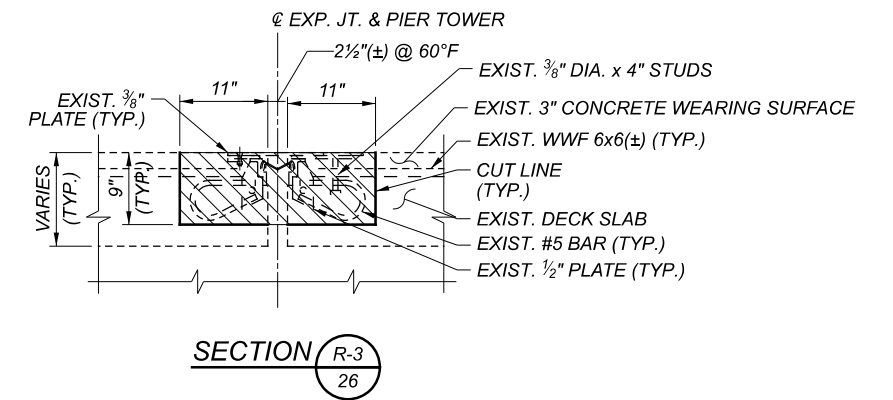

SECTION R-3  
SIDEWALK  
(EXIST. REINFORCING STEEL NOT SHOWN FOR CLARITY)  
PIER TOWERS SHOWN, ABUTMENTS SIMILAR

**LEGEND**

- ITEM 202 - PORTIONS OF STRUCTURE REMOVED, OVER 20 FOOT SPAN, AS PER PLAN (AREA OF SIDEWALK AND DECK OR BACKWALL REMOVAL)
- ITEM 202 - PORTIONS OF STRUCTURE REMOVED, OVER 20 FOOT SPAN, AS PER PLAN (AREA OF SIDEWALK REMOVAL)
- ITEM 202 - PORTIONS OF STRUCTURE REMOVED, OVER 20 FOOT SPAN, AS PER PLAN (AREA OF DECK OR BACKWALL REMOVAL)

**NOTES**

1. REMOVAL LIMITS SHOWN ARE THE MINIMUM REQUIRED TO COMPLETE THE WORK. SHOULD THE CONTRACTOR ELECT TO REMOVE GREATER PORTIONS TO FACILITATE THE WORK, THE CONTRACTOR SHALL REPLACE IN KIND THE DECK, SIDEWALK, AND/OR BACKWALL REINFORCING AS SHOWN IN THE ORIGINAL BRIDGE CONSTRUCTION CONTRACT PLANS AT NO ADDITIONAL COST TO THE DISTRICT.
2. EXPANSION JOINT OPENING AT FORWARD ABUTMENT IS 2" (±) AT ALL TEMPERATURES AND EXPANSION JOINT OPENING AT REAR ABUTMENT IS 2" (±) AT 60°F.

**EXPANSION JOINT REMOVAL DETAILS**  
**BRIDGE NO. CUY-10-0869**  
**OVER VALLEY PARKWAY & ROCKY RIVER**

SFN		1801325	
DESIGN AGENCY			
DESIGNER	CHECKER		
MHK	MJL		
REVIEWER		CJS 10/24/22	
PROJECT ID			
113674			
SUBSET	TOTAL		
26	30		
SHEET		TOTAL	
52		82	

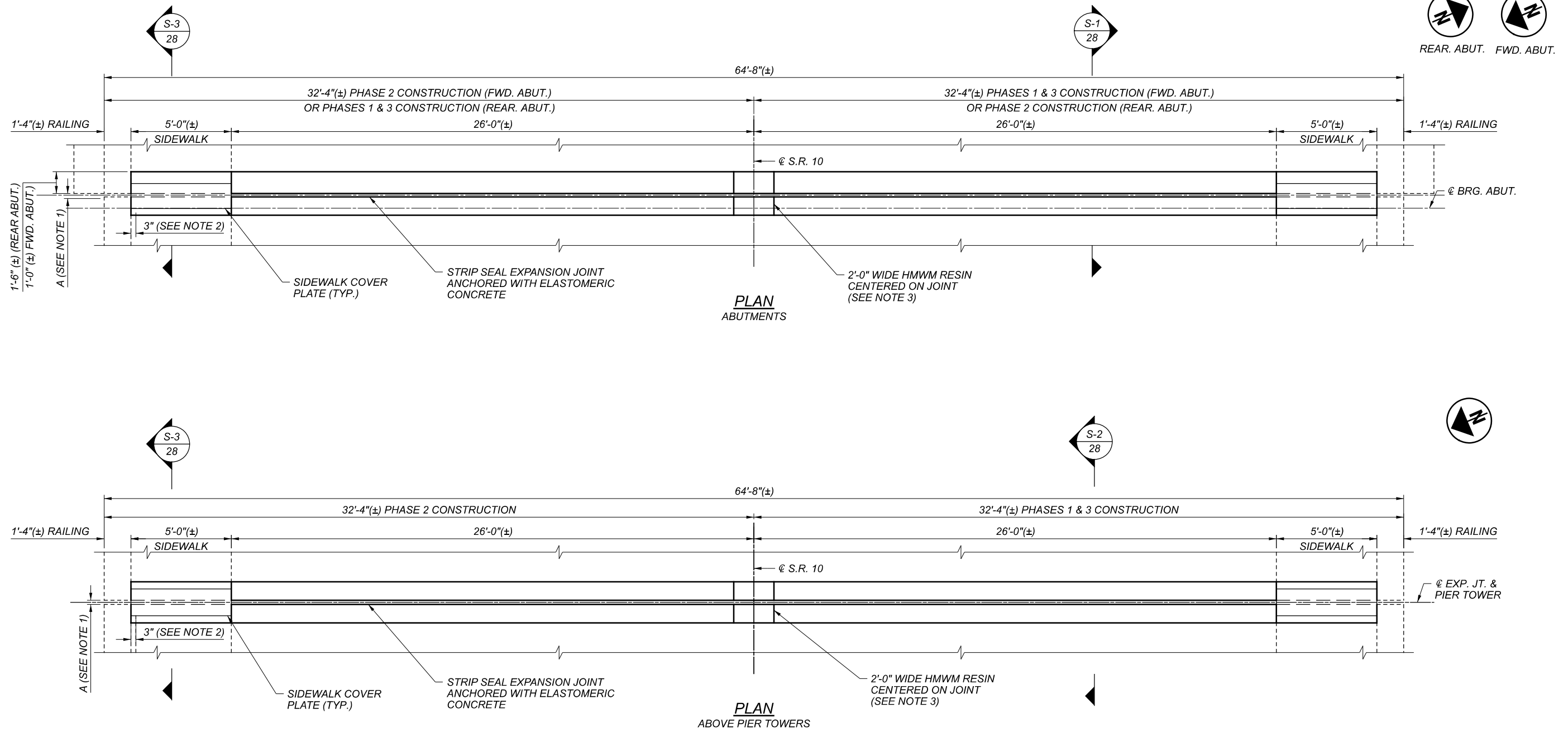

**NOTES**

1. FOR EXPANSION JOINT DIMENSION "A", SEE SHEET 28/30.
2. JOINT SEAL RETAINER TO END 3" FROM FACE OF RAILING.
3. THE 2'-0" OF HMWM CENTERED ON THE LONGITUDINAL C.J. IS INCLUDED FOR PAYMENT WITH ITEM 516 - STRIP SEAL EXPANSION JOINT ANCHORED WITH ELASTOMERIC CONCRETE, AS PER PLAN.

**EXPANSION JOINT REPAIR DETAILS - 1**  
**BRIDGE NO. CUY-10-0869**  
**OVER VALLEY PARKWAY & ROCKY RIVER**

SFN 1801325	
DESIGN AGENCY	
DESIGNER	CHECKER
MHK	MJL
REVIEWER	
CJS	10/24/22
PROJECT ID	
113674	
SUBSET	TOTAL
27	30
SHEET	TOTAL
53	82

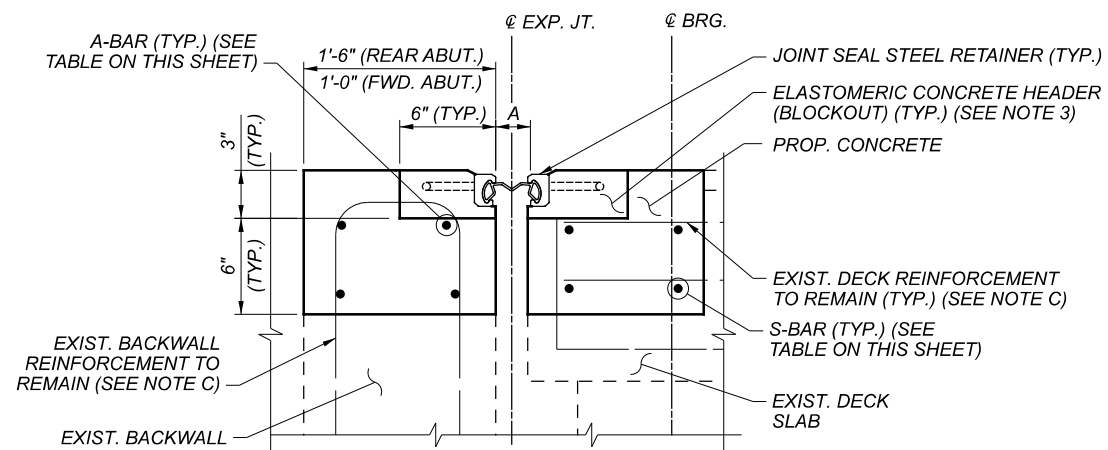

SECTION S-1  
27  
ABUTMENTS

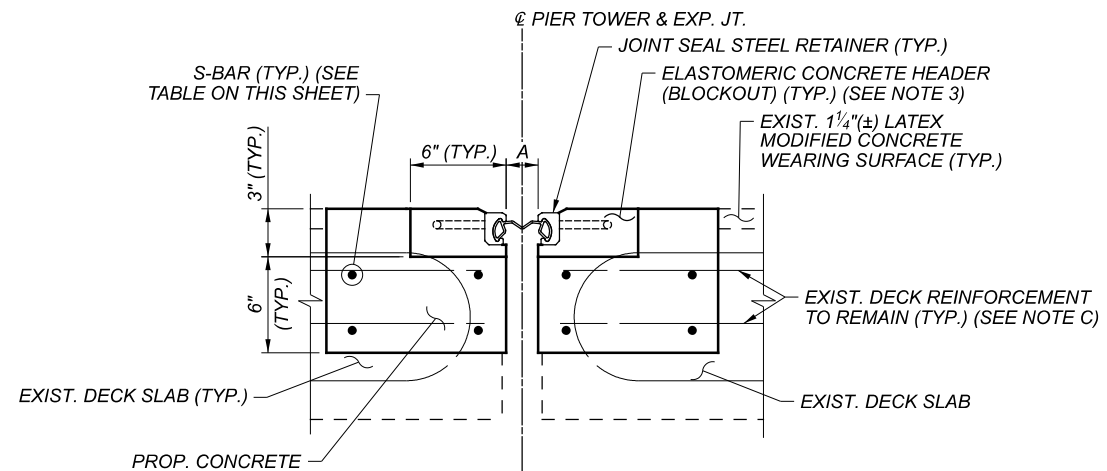

SECTION S-2  
27  
PIER TOWERS

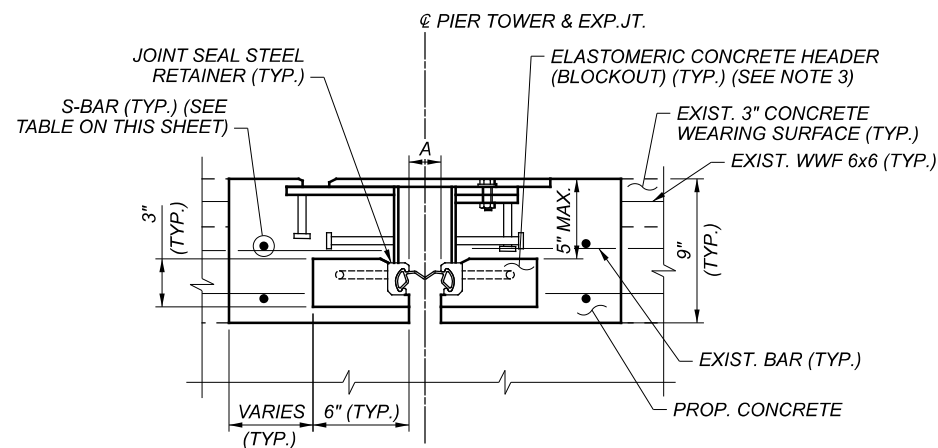

SECTION S-3  
27  
SIDEWALK  
(ABOVE PIER TOWER SHOWN, ABUTMENTS SIMILAR)

**DECK REINFORCING NOTES**

- A. PLACE THE RECONSTRUCTED EDGE OF DECK REINFORCING BARS PARALLEL TO THE EXPANSION JOINT AND 6" FROM THE PROPOSED EDGE OF DECK. ALL BARS TO BE SPACED AT EQUAL SPACES IN PROPOSED SECTION.
- B. COORDINATE THE INSTALLATION OF RECONSTRUCTED EDGE OF DECK REINFORCING WITH THE INSTALLATION OF PROPOSED EXPANSION JOINT ARMOR SO AS TO MINIMIZE INTERFERENCE BETWEEN JOINT ARMOR ANCHOR BARS AND EDGE OF DECK REINFORCING BARS.
- C. EXISTING REINFORCING STEEL TO REMAIN IN REMOVAL SECTIONS EXCEPT FOR REMOVALS AS NECESSARY TO ACCOMMODATE PROPOSED JOINT SYSTEM. INCLUDE FOR PAYMENT WITH ITEM 202 - PORTIONS OF STRUCTURE REMOVED, OVER 20 FOOT SPAN, AS PER PLAN.

**NOTES**

- 1. STRIP SEAL GLAND SIZE SHALL BE 3" THE JOINTS AT THE ABUTMENTS AND 4" FOR THE JOINTS ABOVE THE PIER TOWERS. INSTALL STRIP SEAL GLAND AT EACH EXPANSION JOINT IN ONE CONTINUOUS PIECE DURING PHASES 2 AND 3.
- 2. FOR ADDITIONAL EXPANSION JOINT NOTES AND DETAILS NOT SHOWN, SEE STANDARD DRAWING EXJ-4-87.
- 3. FOR ELASTOMERIC CONCRETE HEADER DETAILS, SEE STANDARD DRAWING EXJ-6-17.
- 4. INSTALL THREADED MECHANICAL CONNECTORS FOR HORIZONTAL REINFORCING STEEL PARALLEL TO PROPOSED EXPANSION JOINTS AT PHASE CONSTRUCTION JOINT. THREADED MECHANICAL CONNECTORS SHALL BE RICHMOND SCREW ANCHOR THREADED DOWEL BAR ASSEMBLY, LENTON REBAR SPLICING MECHANISM, OR APPROVED EQUAL. COST SHALL BE INCLUDED FOR PAYMENT WITH ITEM 516 - STRIP SEAL EXPANSION JOINT ANCHORED WITH ELASTOMERIC CONCRETE, AS PER PLAN.

RECONSTRUCTED EDGE OF DECK REINFORCING (PER JOINT)				
LOCATION	PHASE 1		PHASE 2	
	DECK / BACKWALL	SIDEWALK	DECK / BACKWALL	SIDEWALK
ABUTMENT	2-S601 (TOP) (DECK) 2-S501 (BOT.) (DECK) 4-A501 (BACKWALL)	1-S502 (TOP) 1-S401 (BOT.) 1-A502 (TOP) 1-A401 (BOT.)	2-S601 (TOP) (DECK) 2-S501 (BOT.) (DECK) 4-A501 (BACKWALL)	1-S502 (TOP) 1-S401 (BOT.) 1-A502 (TOP) 1-A401 (BOT.)
PIER TOWER	4-S601 (TOP) 4-S501 (BOT.)	2-S502 (TOP) 2-S401 (BOT.)	4-S601 (TOP) 4-S501 (BOT.)	2-S502 (TOP) 2-S401 (BOT.)

EXPANSION JOINT OPENINGS (DIM. "A")					
TEMP.	REAR ABUT.	PIER TOWER 1	PIER TOWERS 2-4	PIER TOWER 5	FWD. ABUT.
30°F	1 <sup>3</sup> / <sub>16</sub> "	2 <sup>1</sup> / <sub>2</sub> "	2 <sup>9</sup> / <sub>16</sub> "	2 <sup>7</sup> / <sub>16</sub> "	2"
40°F	1 <sup>3</sup> / <sub>4</sub> "	2 <sup>5</sup> / <sub>16</sub> "	2 <sup>5</sup> / <sub>16</sub> "	2 <sup>5</sup> / <sub>16</sub> "	2"
50°F	1 <sup>3</sup> / <sub>4</sub> "	2 <sup>3</sup> / <sub>16</sub> "	2 <sup>1</sup> / <sub>8</sub> "	2 <sup>3</sup> / <sub>16</sub> "	2"
60°F	1 <sup>11</sup> / <sub>16</sub> "	2"	1 <sup>15</sup> / <sub>16</sub> "	2 <sup>1</sup> / <sub>16</sub> "	2"
70°F	1 <sup>5</sup> / <sub>8</sub> "	1 <sup>7</sup> / <sub>8</sub> "	1 <sup>3</sup> / <sub>4</sub> "	1 <sup>7</sup> / <sub>8</sub> "	2"
80°F	1 <sup>9</sup> / <sub>16</sub> "	1 <sup>11</sup> / <sub>16</sub> "	1 <sup>9</sup> / <sub>16</sub> "	1 <sup>3</sup> / <sub>4</sub> "	2"
90°F	1 <sup>1</sup> / <sub>2</sub> "	1 <sup>9</sup> / <sub>16</sub> "	1 <sup>3</sup> / <sub>8</sub> "	1 <sup>5</sup> / <sub>8</sub> "	2"



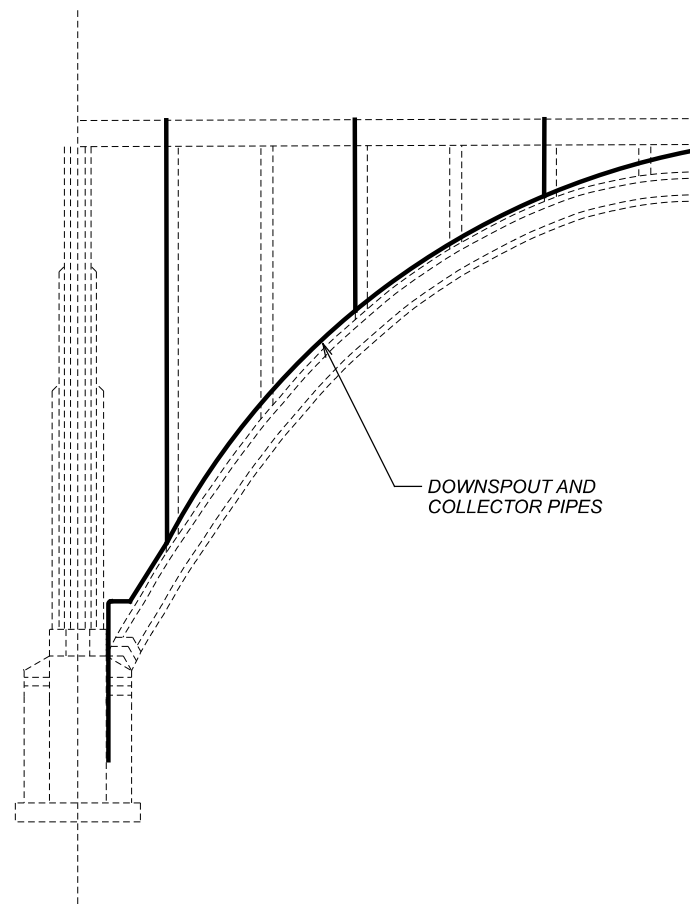

TYPICAL DRAINAGE IN ARCH SPANS

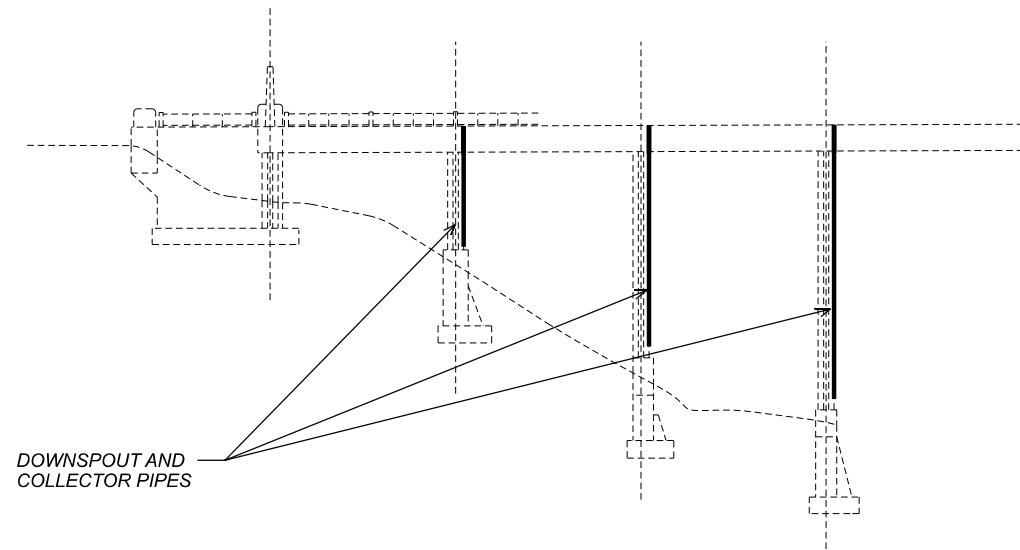

TYPICAL COLUMN DRAINAGE - PIERS 1, 2, AND 3

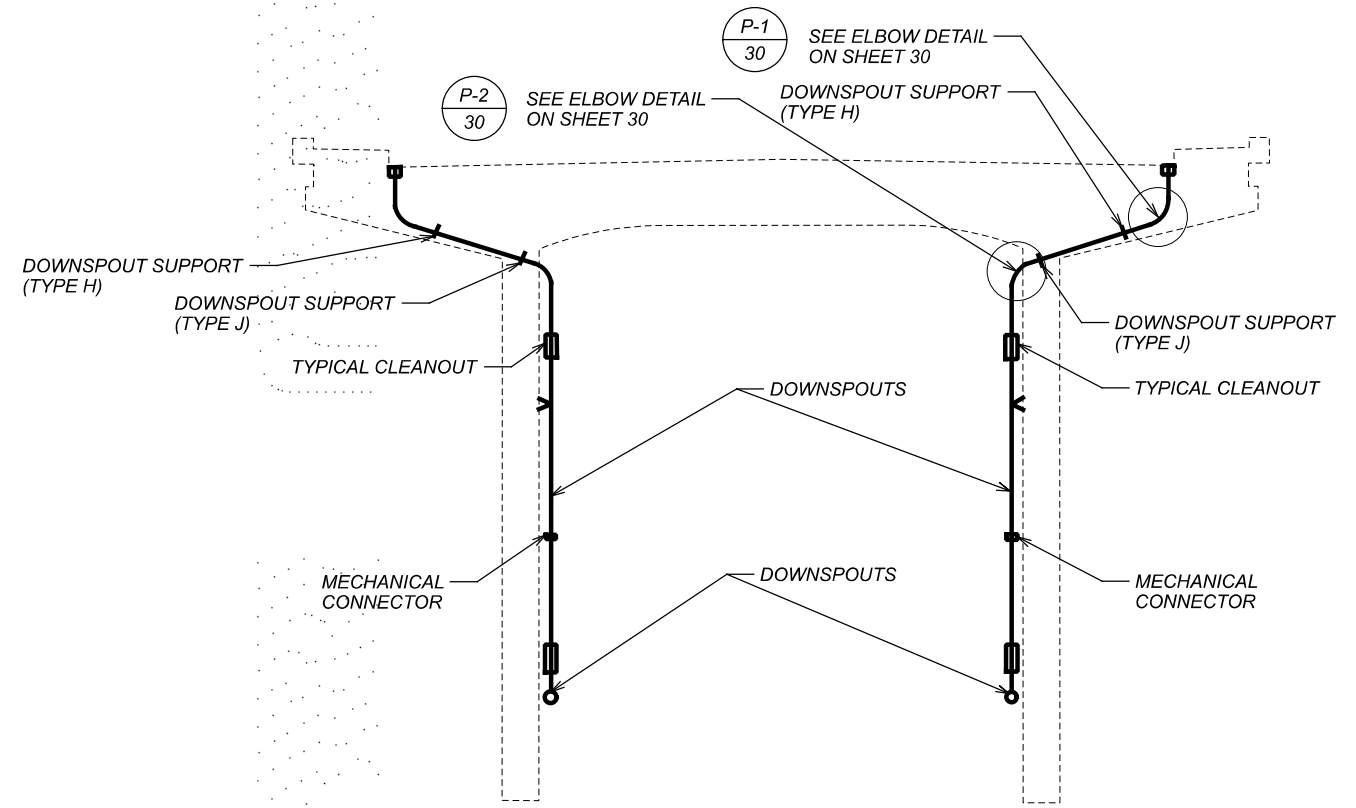

TYPICAL COLUMN DRAINAGE - ARCH SPANS

**NOTES**

- EXISTING DETAILS ON THIS SHEET ARE TAKEN FROM EXISTING PLANS AND SHALL BE USED FOR INFORMATION PURPOSES ONLY.
- THE DRAINAGE SYSTEM BELOW THE BRIDGE DECK AND ABOVE GROUND SHALL BE REPAIRED IN ACCORDANCE WITH THE DETAILS AND TABLE PROVIDED HEREIN AND AS DIRECTED BY THE ENGINEER.
- THE DETERIORATED SECTIONS OF THE DOWNSPOUT AND COLLECTOR PIPES SHALL BE NEATLY CUT OUT AND REPLACED WITH NEW SECTIONS OF GALVANIZED PIPE THAT ARE WELDED TO THE EXISTING. THE JOINTS SHALL BE GROUND SMOOTH ON THE OUTSIDE AND BARE STEEL SHALL BE TOUCHED UP WITH A ZINC RICH COATING PER CMS 711.02 AND ASTM A780-01 REPAIR METHOD A-2 (REPAIR USING PAINTS CONTAINING ZINC DUST). WORK TO BE INCLUDED WITH ITEM 518 FOR PAYMENT.



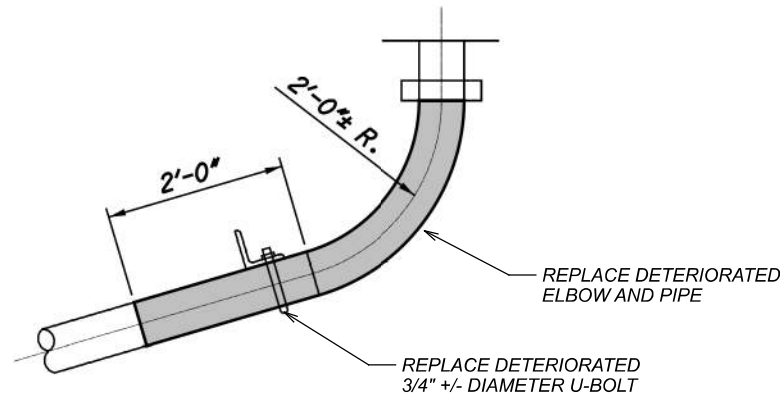

P-1  
29 ELBOW DETAIL - A

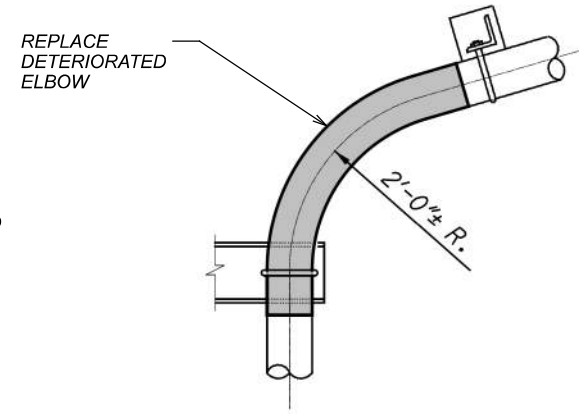

P-2  
29 ELBOW DETAIL - B

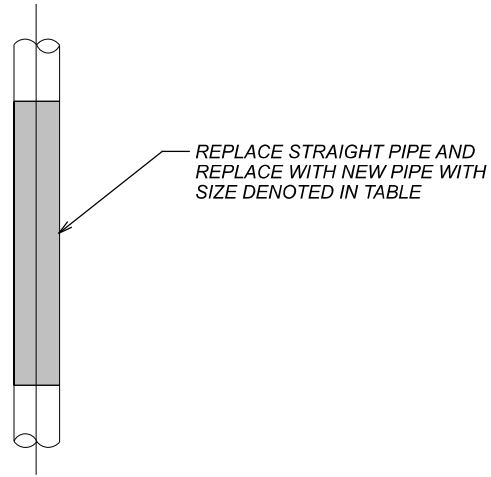

P-3  
30 DOWNSPOUT PIPE REPLACEMENT

LOCATIONS OF DRAINAGE REPAIRS

North(N) or South(S)	Span #	Pier # / Column #	Approx. Vertical Location	Pipe Diameter (in)	Length of Downspout to be replaced (ft)	Pipe Bend Desc.
S	N/A	1	Upper	10	10	
N	N/A	1	Lower	10	10	2 bend horizontal offset
N	N/A	2	Upper	10	10	1 bend
S	N/A	2	Upper	10	10	2 bend horizontal offset
S	N/A	3	Mid	10	70	1 bend
S	5	1	Mid	10*	10	1 10"x6" Y
N	5	1	Mid	10*	10	1 10"x6" Y
S	5	2-3	Upper	10	5	At collar
N	5	9	Upper	10	10	
N	5	9	Upper	8	10	
S	5	9	Upper	10	10	Bend out of Scupper
N	5	11	Mid	10	10	At coupler
S	5	11	Mid	10	10	At the Y
S	5	11	Lower	10	8	At pier base
N	6	8	Upper	10	10	1 10"x6" Y
S	7	1	Mid	10	5	By diaphragm
S	7	8	Upper	10	10	1 10"x6" Y
N	7	12	Upper	10	10	
N	8	7	Upper	10	5	
S	8	7	Upper	10	5	
N	8	5	Upper	10	10	
S	8	9-10	Upper	10	5	
N	N/A	7	Upper	10	3	
N	N/A	8	Upper	10	22	
N	N/A	8	Upper	10	12	
<b>Total</b>					<b>290</b>	

LOCATIONS OF DRAINAGE REPAIRS FROM FOLLOW-UP INSPECTION

North(N) or South(S)	Span #	Pier # / Column #	Approx. Vertical Location	Pipe Diameter (in)	Length of Downspout to be Replaced (ft)
S	N/A	3	Upper	10	10
N	5	10	Upper	10	10
S	5	11	Lower	10	10
N	6	1	Upper	10	10
N	7	12	Upper	10	10
S	8	11	Upper	10	10
<b>Total</b>					<b>60</b>

LEGEND

- INDICATES CONDUIT TO BE REMOVED AND REPLACED WITH SIZE DENOTED IN TABLE

NOTES

- REFER TO SHEET 29 OF 30 FOR DETAILS NOT SHOWN AND NOTES.

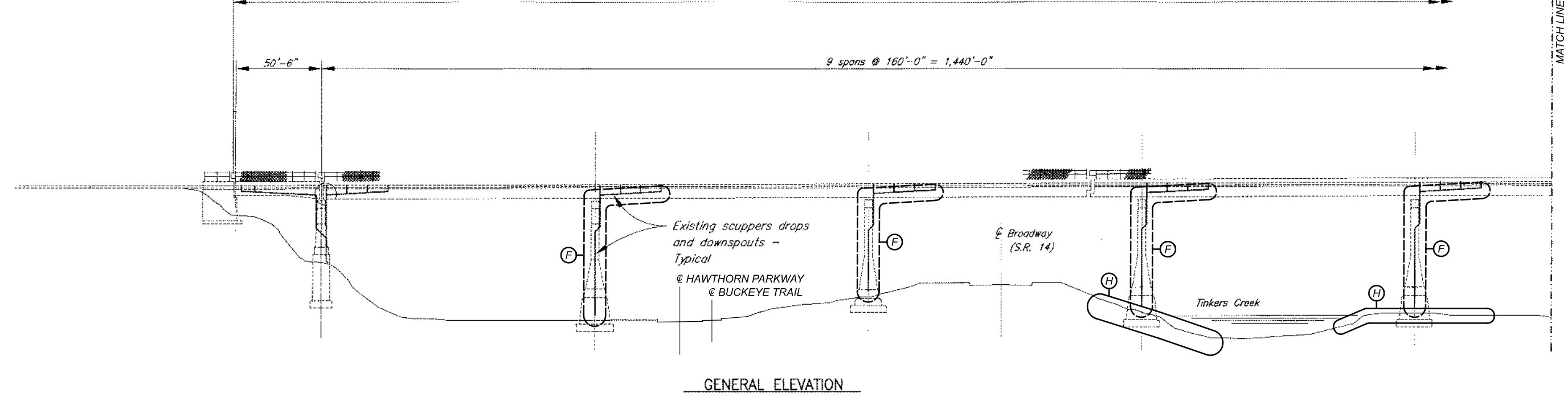
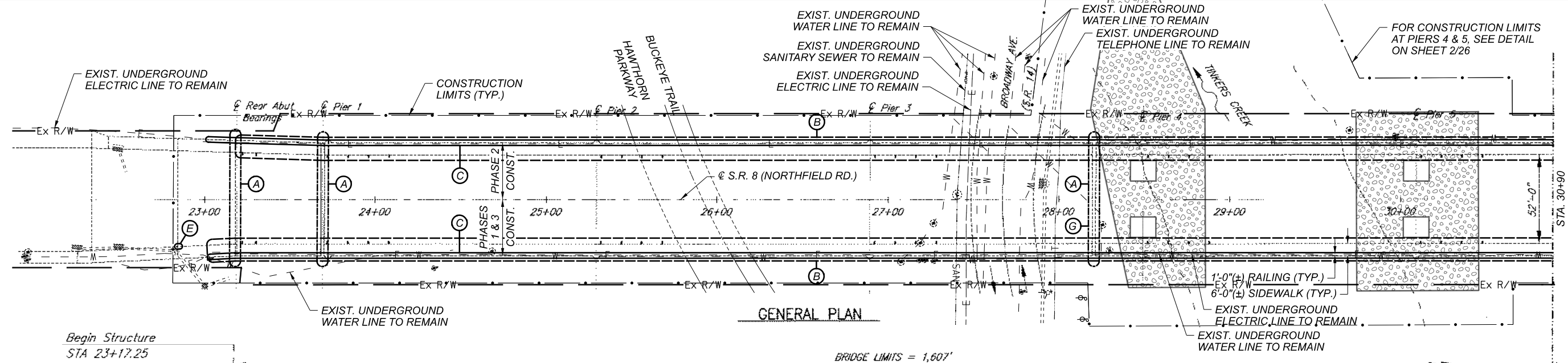

- LEGEND**
- (A) REPLACE EXPANSION JOINTS INCLUDING SIDEWALK AND CURB COVER PLATE ASSEMBLIES; CLEAN AND PAINT GIRDER ENDS AND CROSS FRAMES; REPLACE END CROSSFRAME AND DIAPHRAGM.
  - (B) REMOVE TOP OF CURB PLATES; REMOVE EXISTING WATERPROOFING MATERIAL AND REPLACE SIDEWALK WEARING SURFACE; CLEAN OUT ALL SCUPPERS
  - (C) PATCH AND REPAIR CRACKS ON CONCRETE RAILING; REPLACE CHAIN LINK FENCE
  - (D) REPLACE SIDEWALKS
  - (E) REPAIR INTEGRAL CURB CONCRETE
  - (F) REPLACE ALL COLLECTOR AND DOWNSPOUT PIPES FROM UNDERSIDE OF DECK TO OUTLET
  - (G) ADD ADDITIONAL STEEL PLATES TO STRENGTHEN SELECT STEEL STIFFENER PLATES
  - (H) ADD ROCK CHANNEL PROTECTION, TYPE A (PIER 4) OR TYPE B (PIER 5), WITH GEOTEXTILE FABRIC

**DESIGN TRAFFIC**

CURRENT ADT (2022) = 17,618      DESIGN ADT (2052) = 20,260  
 CURRENT ADTT (2022) = 350      DESIGN ADTT (2052) = 403  
 DIRECTIONAL DISTRIBUTION = 0.60

- NOTES**
1. DETAILS ON THIS SHEET ARE TAKEN FROM EXISTING PLANS AND SHALL BE USED FOR INFORMATIONAL PURPOSES ONLY.
  2. PERFORM ONLY THE WORK AS INDICATED IN THE LEGEND AND THESE NOTES ON THIS SHEET.
  3. EXISTING UTILITIES ARE TO REMAIN UNLESS NOTED OTHERWISE.
  4. SEAL ALL BRIDGE AND APPROACH SIDEWALK CONCRETE SURFACES WITH NON-EPOXY. SEAL ALL BRIDGE AND APPROACH RAILING CONCRETE SURFACES WITH EPOXY-URETHANE.

EXISTING STRUCTURE	PROPOSED STRUCTURE
<p>TYPE: CONTINUOUS STEEL GIRDER WITH REINFORCED CONCRETE DECK AND SUBSTRUCTURE</p> <p>SPANS: 50'-6" (±), 9 @ 160'-0" (±), 112'-0" (±) SUBSTRUCTURES</p> <p>ROADWAY: 52'-0" (±) FACE/FACE CURBS &amp; 6'-0" (±) SIDEWALK EACH SIDE</p> <p>LOADING: HS20-44 &amp; ALTERNATE MILITARY LOADING, FUTURE WEARING SURFACE = 0 KSF</p> <p>SKEW: NONE</p> <p>WEARING SURFACE: 1 1/4" (±) LATEX MODIFIED CONCRETE</p> <p>APPROACH SLABS: 25'-0" (±) LONG (AS-1-81)</p> <p>ALIGNMENT: TANGENT</p> <p>CROWN: 0.0156 (±) FT/FT</p> <p>STRUCTURE FILE NUMBER: 1801244</p> <p>DATE BUILT: 1985</p> <p>DISPOSITION: MISCELLANEOUS STRUCTURE REPAIRS</p>	<p>PROPOSED WORK: REPLACE EXPANSION JOINTS AND REPAIR DRAINAGE SYSTEM, SIDEWALKS, FENCE, PIERS, SUPERSTRUCTURE, AND APPROACH SLABS</p> <p>TYPE: CONTINUOUS STEEL GIRDER WITH REINFORCED CONCRETE DECK AND SUBSTRUCTURE</p> <p>SPANS: 50'-6" (±), 9 @ 160'-0" (±), 112'-0" (±) SUBSTRUCTURES</p> <p>ROADWAY: 52'-0" (±) FACE/FACE CURBS &amp; 6'-0" (±) SIDEWALK EACH SIDE</p> <p>VEHICULAR LIVE LOAD: HS20-44 &amp; ALTERNATE MILITARY LOADING</p> <p>FUTURE WEARING SURFACE: 0 KSF</p> <p>SKEW: NONE</p> <p>WEARING SURFACE: 1 1/4" (±) LATEX MODIFIED CONCRETE</p> <p>APPROACH SLABS: 25'-0" (±) LONG (AS-1-81)</p> <p>ALIGNMENT: TANGENT</p> <p>CROWN: 0.0156 (±) FT/FT</p> <p>DECK AREA: 105,897 SF</p> <p>COORDINATES: LATITUDE 41°22'59.07" N                      LONGITUDE 81°31'36.01" W</p>

**SITE PLAN - 1**  
**BRIDGE NO. CUY-8-0226**  
**OVER HAWTHORN PKWY., BROADWAY AVE., TINKERS CREEK, & WHEELING & LAKE ERIE RR**

SFN 1801244  
 DESIGN AGENCY  
**DLZ**  
 DESIGNER CHECKER  
 JAM /TA/JDA  
 REVIEWER  
 MJL 10/24/22  
 PROJECT ID  
 113674  
 SUBSET TOTAL  
 1 26  
 SHEET TOTAL  
 57 82



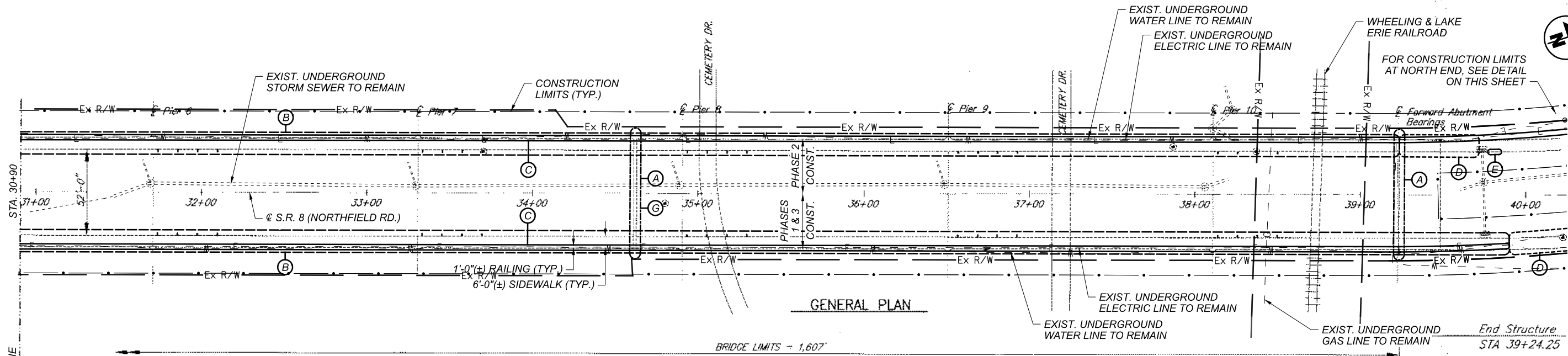

GENERAL PLAN

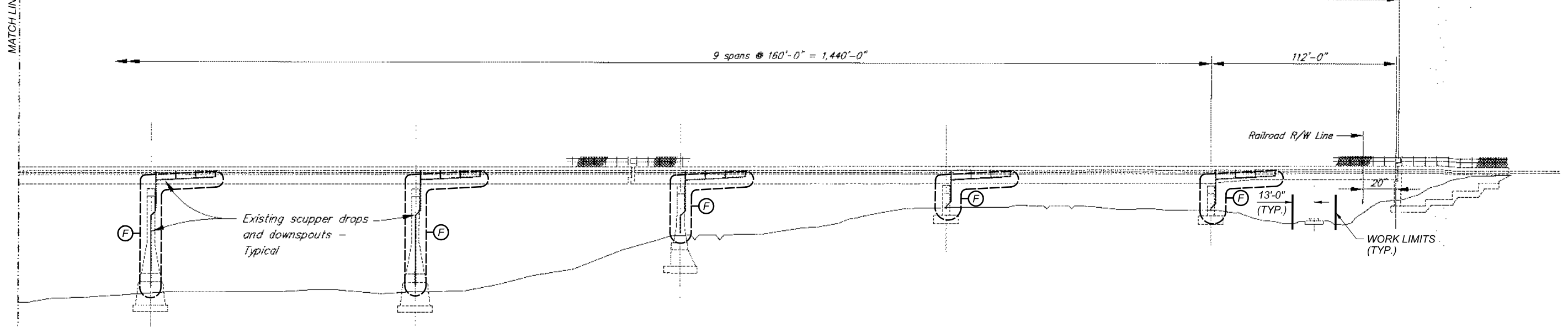

GENERAL ELEVATION

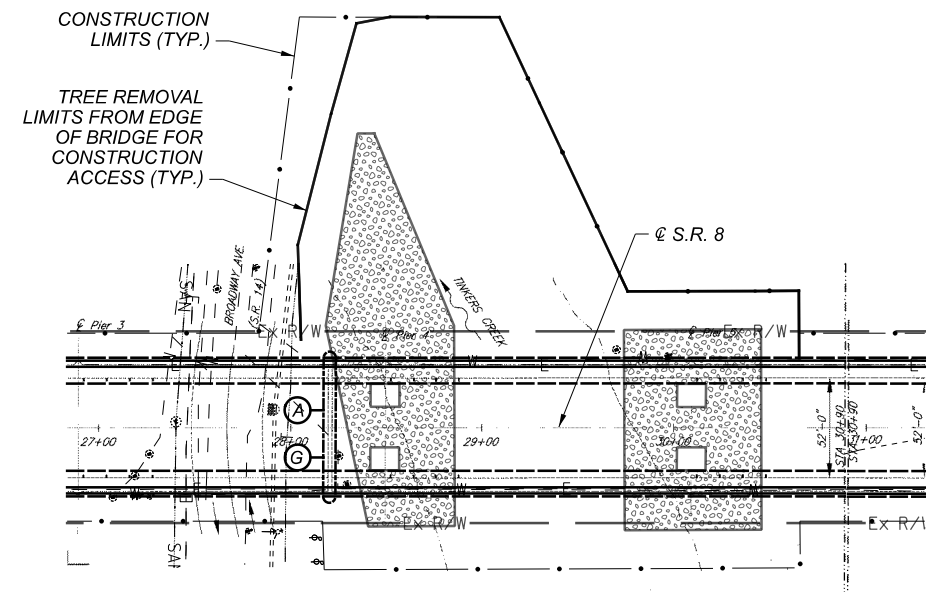

CONSTRUCTION LIMITS AT PIERS 4 & 5 DETAIL

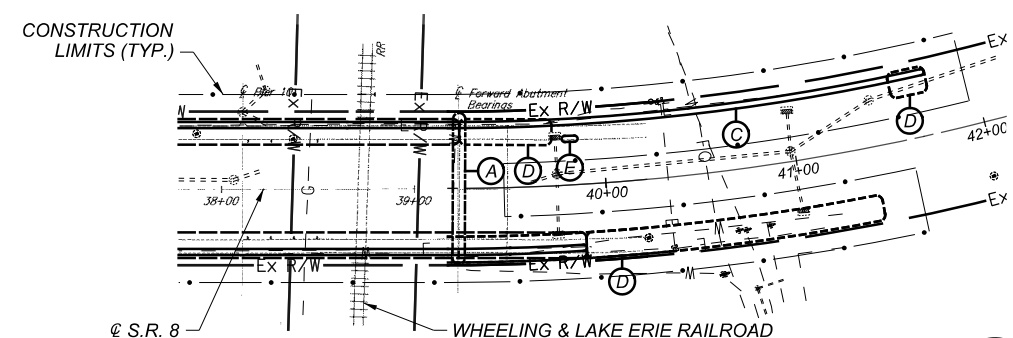

CONSTRUCTION LIMITS AT NORTH END DETAIL



NOTES

1. FOR LEGEND AND NOTES, SEE SHEET 1/26.

SITE PLAN - 2  
 BRIDGE NO. CUY-8-0226  
 OVER HAWTHORN PKWY., BROADWAY AVE., TINKERS CREEK, & WHEELING & LAKE ERIE RR

SFN	1801244
DESIGN AGENCY	DLZ
DESIGNER/CHECKER	JAM /TA/JDA
REVIEWER	MJL 10/24/22
PROJECT ID	113674
SUBSET	2
TOTAL	26
SHEET	58
TOTAL	82

**REFER TO THE FOLLOWING STANDARD BRIDGE DRAWINGS:**

EXJ-4-87	REVISED	07/15/22
EXJ-6-17	REVISED	01/15/21
VPF-1-90	REVISED	07/20/18

**AND TO THE FOLLOWING SUPPLEMENTAL SPECIFICATIONS:**

800	DATED	01/20/23
844	DATED	04/20/18

**DESIGN SPECIFICATIONS:**

THE EXISTING STRUCTURE WAS DESIGNED IN CONFORMANCE WITH THE "STANDARD SPECIFICATIONS FOR HIGHWAY BRIDGES" ADOPTED BY THE AMERICAN ASSOCIATION OF STATE HIGHWAY AND TRANSPORTATION OFFICIALS, 1977, INCLUDING THE 1978 THROUGH 1982 INTERIM SPECIFICATIONS AND THE OHIO SUPPLEMENT TO THESE SPECIFICATIONS.

**DESIGN LOADING INCLUDES:**

VEHICULAR LIVE LOAD: HS20-44 CASE II AND THE ALTERNATE MILITARY LOADING

**DESIGN DATA:**

CONCRETE CLASS QC2 - COMPRESSIVE STRENGTH 4.5 KSI (SUPERSTRUCTURE)

CONCRETE REINFORCEMENT:  
EPOXY COATED STEEL REINFORCEMENT - MINIMUM YIELD STRENGTH 60 KSI

STRUCTURAL STEEL - ASTM A588 - YIELD STRENGTH 50 KSI (EXISTING)  
STRUCTURAL STEEL - ASTM A709 GRADE 50 - YIELD STRENGTH 50 KSI (PROPOSED)

**MAINTENANCE OF TRAFFIC:**

MAINTENANCE OF TRAFFIC FOR THE STRUCTURE WORK SHALL BE COORDINATED WITH THE OVERALL PROJECT. REFER TO THE MAINTENANCE OF TRAFFIC NOTES AND DETAILS ELSEWHERE IN THE PLANS.

**CONSTRUCTION CLEARANCE:**

MAINTAIN A CONSTRUCTION CLEARANCE OF 13 FEET HORIZONTALLY FROM THE CENTER OF TRACKS AND 22 FEET VERTICALLY FROM A POINT LEVEL WITH THE TOP OF THE HIGHER RAIL, AND 6 FEET FROM THE CENTER OF TRACKS, AT ALL TIMES.

**EXISTING STRUCTURE VERIFICATION:**

DETAILS AND DIMENSIONS SHOWN ON THESE PLANS PERTAINING TO THE EXISTING STRUCTURE HAVE BEEN OBTAINED FROM PLANS OF THE EXISTING STRUCTURE AND FROM FIELD OBSERVATIONS AND MEASUREMENTS. CONSEQUENTLY, THEY ARE INDICATIVE OF THE EXISTING STRUCTURE AND THE PROPOSED WORK BUT THEY SHALL BE CONSIDERED TENTATIVE AND APPROXIMATE. THE CONTRACTOR IS REFERRED TO C&MS, SECTIONS 102.05, 105.02, AND 513.04.

BASE CONTRACT BID PRICES UPON A RECOGNITION OF THE UNCERTAINTIES DESCRIBED ABOVE AND UPON A PREBID EXAMINATION OF THE EXISTING STRUCTURE. HOWEVER, THE DEPARTMENT WILL PAY FOR ALL PROJECT WORK BASED UPON ACTUAL DETAILS AND DIMENSIONS THAT HAVE BEEN VERIFIED IN THE FIELD.

**EXISTING STRUCTURE PLANS:**

PLANS MAY BE EXAMINED BY THE PROSPECTIVE BIDDERS AT THE OHIO DEPARTMENT OF TRANSPORTATION, DISTRICT 12, 5500 TRANSPORTATION BOULEVARD, GARFIELD HEIGHTS, OH 44125, PHONE: 216-581-2100.

**ITEM 202 - PORTIONS OF STRUCTURE REMOVED, OVER 20 FOOT SPAN, AS PER PLAN:**

DESCRIPTION: WORK TO BE PAID FOR UNDER THIS ITEM SHALL INCLUDE THE REMOVAL OF EXISTING STRUCTURE COMPONENTS AS DETAILED IN THE PLANS AND AS DIRECTED BY THE ENGINEER. THE REMOVALS SHALL INCLUDE BUT NOT NECESSARILY BE LIMITED TO THE FOLLOWING:

- EXISTING FENCE ON THE BRIDGE RAILING AS SHOWN IN THE THE PLANS.
- COMPRESSION JOINTS OR STRIP SEAL EXPANSION JOINTS, INCLUDING EMBEDDED STEEL, AT THE ABUTMENTS, PIER 1, AND THE HINGED EXPANSION JOINTS AS SHOWN IN THE PLANS.
- PORTIONS OF EXISTING BRIDGE DECK SLAB AND RAILING AS SHOWN IN THE PLANS, INCLUDING SAW CUTTING.
- PORTIONS OF EXISTING ABUTMENT BACKWALLS AS SHOWN IN THE PLANS, INCLUDING SAW CUTTING.
- EXISTING STEEL CROSS FRAMES AND DIAPHRAGMS AT THE ABUTMENTS, AS SHOWN IN THE PLANS.
- EXISTING SIDEWALK WEARING SURFACE, WATERPROOFING MATERIAL BELOW THE EXISTING WEARING SURFACE, AND TOP OF THE EXISTING CURB PLATE AS SHOWN IN THE PLANS.
- EXISTING STEEL DOWNSPOUT AND COLLECTOR PIPE DRAINAGE SYSTEM AS SHOWN IN THE PLANS, INCLUDING ALL DIRT AND DEBRIS CONTAINED WITHIN.
- MISCELLANEOUS ITEMS THAT ARE NOT SHOWN TO BE INCORPORATED INTO THE FINAL CONSTRUCTION AND ARE DIRECTED TO BE REMOVED BY THE ENGINEER.

THE PROVISIONS OF ITEM 202 APPLY EXCEPT AS SPECIFIED BY THE FOLLOWING NOTES. PERFORM WORK CAREFULLY DURING DECK REMOVALS TO PROTECT PORTIONS OF SUCH SYSTEMS THAT ARE TO BE SALVAGED AND INCORPORATED INTO THE PROPOSED STRUCTURE. THE DEPARTMENT WILL NOT PERMIT THE USE OF EXPLOSIVES, HEADACHE BALLS AND/OR HOE RAM TYPE OF EQUIPMENT. SUBMIT CONSTRUCTION PLANS ACCORDING TO C&MS 501.05.

PROTECTION OF STEEL SUPPORT SYSTEMS: BEFORE DECK SLAB CUTTING BEGINS, DRAW THE OUTLINE OF PRIMARY STEEL MEMBERS IN CONTACT WITH THE BOTTOM OF THE DECK ON THE SURFACE OF DECK. DRILL SMALL DIAMETER PILOT HOLES 2 INCHES OUTSIDE THESE LINES TO CONFIRM THE LOCATION OF FLANGE EDGES. DECK CUTS OVER OR WITHIN 2 INCHES OF FLANGE EDGES SHALL NOT EXTEND LOWER THAN THE BOTTOM LAYER OF CONCRETE REINFORCEMENT IN THE DECK SLAB. CUTS MADE OUTSIDE 2 INCHES OF FLANGE EDGES MAY EXTEND THE FULL DEPTH OF THE DECK. PERFORM WORK CAREFULLY DURING CUTTING OF THE DECK SLAB TO AVOID DAMAGING STEEL MEMBERS THAT ARE TO BE INCORPORATED INTO THE PROPOSED STRUCTURE. REPLACE OR REPAIR STEEL MEMBERS DAMAGED BY THE DECK SLAB CUTTING OPERATIONS AT NO COST TO THE PROJECT. AT LEAST 7 DAYS BEFORE PERFORMING REPAIR WORK, SUBMIT A PROPOSED REPAIR PLAN, DEVELOPED BY AN OHIO REGISTERED PROFESSIONAL ENGINEER TO THE ENGINEER. OBTAIN THE ENGINEER'S APPROVAL BEFORE PERFORMING REPAIR.

REMOVAL METHODS: THE CONTRACTOR MAY REMOVE CONCRETE BY CUTTING AND BY MEANS OF HAND OPERATED PNEUMATIC HAMMERS EMPLOYING POINTED OR BLUNTED CHISEL TYPE TOOLS. FOR REMOVALS OVER STRUCTURAL MEMBERS (STEEL GIRDER, ETC.), THE CONTRACTOR MAY USE A HAMMER HEAVIER THAN 35 POUNDS BUT NOT TO EXCEED 90 POUNDS UNLESS APPROVED BY THE ENGINEER. REMOVAL METHODS OVER STRUCTURAL MEMBERS SHALL ENSURE ADEQUATE DEPTH CONTROL AND PREVENT NICKING OR GOUGING THE PRIMARY STRUCTURAL MEMBERS. DUE TO THE POSSIBLE PRESENCE OF ATTACHMENTS (E.G., FINISHING MACHINE, SCUPPER AND FORM SUPPORTS, ETC.) TO EXISTING STRUCTURAL MEMBERS, PERFORM WORK CAREFULLY DURING DECK REMOVAL TO AVOID DAMAGING STRUCTURAL MEMBERS THAT ARE TO REMAIN. REPLACE OR REPAIR STRUCTURAL MEMBERS DAMAGED BY THE REMOVAL OPERATIONS AT NO COST TO THE PROJECT. AT LEAST 7 DAYS BEFORE PERFORMING REPAIR WORK, SUBMIT A PROPOSED REPAIR PLAN, DEVELOPED BY AN OHIO REGISTERED PROFESSIONAL ENGINEER TO THE ENGINEER. OBTAIN THE ENGINEER'S APPROVAL BEFORE PERFORMING REPAIR.

**ITEM 202 - PORTIONS OF STRUCTURE REMOVED, OVER 20 FOOT SPAN, AS PER PLAN (CONT.):**

DECK REMOVALS - COMPOSITE DECK DESIGNS - STEEL SUPERSTRUCTURES: DUE TO THE PRESENCE OF WELDED STUDS TO THE EXISTING STRUCTURAL STEEL, SUBMIT A DETAILED PROCEDURE OF THE DECK REMOVAL WITH THE ENGINEERED DRAWINGS ACCORDING TO C&MS 501.05. DEPARTMENT ACCEPTANCE IS NOT REQUIRED. THE PROCEDURE SHALL INCLUDE ALL DETAILS, EQUIPMENT AND METHODS TO BE USED FOR REMOVAL OF THE CONCRETE OVER THE FLANGES AND AROUND THE STUDS. REPLACE OR REPAIR MAIN STEEL AND STUDS DAMAGED BY THE REMOVAL OPERATIONS AT NO COST TO THE PROJECT. AT LEAST 7 DAYS BEFORE PERFORMING REPAIR WORK, SUBMIT A PROPOSED REPAIR PLAN ACCORDING TO C&MS 501.05.C TO THE ENGINEER TO REPLACE OR REPAIR STRUCTURAL STEEL AND STUDS DAMAGED BY THE REMOVAL OPERATIONS. THE DEPARTMENT WILL NOT PAY FOR DAMAGE REPAIRS.

CUT LINE CONSTRUCTION JOINT PREPARATION: SAW CUT BOUNDARIES OF PROPOSED CONCRETE REMOVALS 1 INCH DEEP. REMOVE CONCRETE TO A ROUGH SURFACE. LEAVE THE EXISTING CONCRETE REINFORCEMENT, IF REQUIRED IN THE PLANS, IN PLACE. INSTALL DOWEL BARS IF SPECIFIED. PRIOR TO CONCRETE PLACEMENT ABRASIVELY CLEAN JOINT SURFACES AND EXISTING EXPOSED REINFORCEMENT TO REMOVE LOOSE AND DISINTEGRATED CONCRETE AND LOOSE RUST. THOROUGHLY CLEAN THE JOINT SURFACE AND EXPOSED REINFORCEMENT OF ALL DIRT, DUST, RUST OR OTHER FOREIGN MATERIAL BY THE USE OF WATER, AIR UNDER PRESSURE, OR OTHER METHODS THAT PRODUCE SATISFACTORY RESULTS. EXISTING STEEL REINFORCEMENT DOES NOT HAVE TO HAVE A BRIGHT STEEL FINISH BUT REMOVE ALL PACK AND LOOSE RUST. THOROUGHLY DRENCH EXISTING CONCRETE SURFACES WITH CLEAN WATER AND ALLOW TO DRY TO A DAMP CONDITION BEFORE PLACING CONCRETE.

SUBSTRUCTURE CONCRETE REMOVAL: REMOVE CONCRETE BY MEANS OF APPROVED PNEUMATIC HAMMERS EMPLOYING POINTED AND BLUNT CHISEL TOOLS. THE DEPARTMENT WILL NOT PERMIT HYDRAULIC HOE-RAM TYPE HAMMERS. THE WEIGHT OF THE HAMMER SHALL NOT BE MORE THAN 35 POUNDS FOR REMOVAL WITHIN 18 INCHES OF PORTIONS TO BE PRESERVED. OUTSIDE THE 18-INCH LIMIT, THE CONTRACTOR MAY USE HAMMERS NOT EXCEEDING 90 POUNDS UPON THE APPROVAL OF THE ENGINEER. DO NOT PLACE PNEUMATIC HAMMERS IN DIRECT CONTACT WITH CONCRETE REINFORCEMENT THAT IS TO BE RETAINED IN THE REBUILT STRUCTURE.

MEASUREMENT & PAYMENT: THE DEPARTMENT WILL MEASURE THE QUANTITY OF REMOVALS ON A LUMP SUM BASIS. THE DEPARTMENT WILL PAY FOR THE ACCEPTED QUANTITIES OF REMOVALS AT THE CONTRACT PRICE FOR ITEM 202 - PORTIONS OF STRUCTURE REMOVED, OVER 20 FOOT SPAN, AS PER PLAN.

**ITEM 509 - CONCRETE REINFORCEMENT, REPLACEMENT OF EXISTING CONCRETE REINFORCEMENT, AS PER PLAN:**

REPLACE ALL EXISTING REINFORCING BARS DEEMED BY THE ENGINEER TO BE UNUSABLE BECAUSE OF CORROSION. THE DEPARTMENT WILL MEASURE THE REPLACEMENT CONCRETE REINFORCEMENT BY THE NUMBER OF POUNDS ACCEPTED IN PLACE. REPLACE ALL EXISTING STEEL REINFORCEMENT BARS WHICH ARE TO BE INCORPORATED INTO THE NEW WORK AND ARE DEEMED BY THE ENGINEER TO BE MADE UNUSABLE BY CONCRETE REMOVAL OPERATIONS WITH NEW CONCRETE REINFORCEMENT OF THE SAME SIZE, COATING, AND MATERIAL AT NO COST TO THE DEPARTMENT.

**ITEM 512 - SEALING OF CONCRETE SURFACES (EPOXY-URETHANE):**

COMPLETE ALL CONCRETE CRACK REPAIR, PATCHING, AND FULL HEIGHT RECONSTRUCTION ON THE RAILING BEFORE SEALING. THE COLOR OF THE FINISH COAT FOR ALL SURFACES SHALL BE FEDERAL COLOR NUMBER 595B-27778 (LIGHT NEUTRAL, SEMIGLOSS).

SFN	1801244
DESIGN AGENCY	
DESIGNER	CHECKER
JAM	JDA
REVIEWER	
MJL 10/24/22	
PROJECT ID	
113674	
SUBSET	TOTAL
3	26
SHEET	
TOTAL	
59	82

**ITEM 514 - FIELD PAINTING OF EXISTING STRUCTURAL STEEL, PRIME COAT,  
ITEM 514 - FIELD PAINTING STRUCTURAL STEEL, INTERMEDIATE COAT &  
ITEM 514 - FIELD PAINTING STRUCTURAL STEEL, FINISH COAT:**

FIELD PAINTING OF STRUCTURAL STEEL SHALL BE LIMITED TO THE PROPOSED STRUCTURAL STEEL INSTALLED AS PART OF THIS PROJECT AND TO THE FOLLOWING AREAS OF EXISTING STEEL MEMBERS:

1. **ABUTMENTS:** ALL EXISTING STEEL SURFACES, INCLUDING EXISTING GIRDERS, CROSS FRAMES, PLATES, AND DIAPHRAGMS, FOR A DISTANCE OF TEN (10) FEET FROM THE ENDS OF THE GIRDERS, AS MEASURED ALONG THE GIRDERS.
2. **PIER 1 & HINGED EXPANSION JOINTS:** ALL EXISTING STEEL SURFACES, INCLUDING EXISTING GIRDERS, CROSS FRAMES, PLATES, AND DIAPHRAGMS, FOR A DISTANCE OF TEN (10) FEET IN BOTH DIRECTIONS (I.E., TWENTY (20) FEET IN TOTAL) FROM THE CENTERLINE OF PIER 1 OR THE CENTERLINE OF THE HINGES, AS MEASURED ALONG THE GIRDERS.

THE COLOR OF THE FINISH COAT SHALL MATCH THE EXISTING PAINT COLOR.

**ITEM 516 - STRIP SEAL EXPANSION JOINT ANCHORED WITH ELASTOMERIC CONCRETE, AS PER PLAN:**

THIS ITEM OF WORK INCLUDES REPLACEMENT OF THE EXISTING DECK EXPANSION JOINTS AT THE ABUTMENTS, PIER 1, AND AT THE HINGED EXPANSION JOINTS AS DETAILED IN THE PLANS.

ALL NEW CONCRETE AND REINFORCEMENT NEEDED FOR THE NEW ABUTMENT BACKWALLS, DECK, AND SIDEWALK AT/NEAR THE EXPANSION JOINTS IS INCLUDED IN THE UNIT PRICE BRID FOR THIS ITEM. ALL REINFORCEMENT IS TO BE EPOXY COATED AND BE PER C&MS 509. ALL CONCRETE IS TO BE CLASS QC2 CONCRETE, SUPERSTRUCTURE, PER C&MS 511. ANY DOWELING NEEDED IS TO BE PER C&MS 510 USING NONSHRINK, NONMETALLIC GROUT.

PAYMENT AND MEASUREMENT FOR THIS ITEM OF WORK SHALL BE PER LINEAR FOOT OF JOINT COMPLETED IN PLACE. THE BID PRICE SHALL INCLUDE ALL LABOR, MATERIALS, EQUIPMENT, INCLUDING REPLACEMENT OF CONCRETE, SIDEWALK COVER PLATES, HMWM RESIN, AND INCIDENTALS NECESSARY TO COMPLETE THE EXPANSION JOINT REPLACEMENTS. THE DEPARTMENT WILL PAY FOR THE ACCEPTED QUANTITIES AT THE CONTRACT UNIT PRICE BID FOR ITEM 516 - STRIP SEAL EXPANSION JOINT ANCHORED WITH ELASTOMERIC CONCRETE, AS PER PLAN.

**ITEM 518 - STRUCTURE DRAINAGE, MISC.: BRIDGE DRAINAGE SYSTEM CLEANING:**

**DESCRIPTION:** THIS WORK CONSISTS OF REMOVING SEDIMENT AND DEBRIS FROM THE BRIDGE DECK, THE EXISTING DECK SCUPPERS, AND ALL PORTIONS OF THE EXISTING BRIDGE DRAINAGE SYSTEM TO BE REUSED, INCLUDING THE MANHOLES THAT THE DRAINAGE SYSTEM OUTLETS INTO, AS SHOWN IN THE PLANS. ALL MATERIAL REMOVED SHALL BE DISPOSED OF AS PER C&MS 105.16 AND 105.17. ALL SCUPPERS, DOWNSPOUTS, COLLECTOR PIPES, AND MANHOLES SHALL BE CLEANED OUT TO THE SATISFACTION OF THE ENGINEER.

**EXECUTION:** REMOVE ACCUMULATED DIRT AND DEBRIS FROM THE SCUPPERS BY METHODS THAT DO NOT FLUSH THE MATERIALS INTO THE DOWNSPOUTS. CLEANOUT OF THE SCUPPERS ADJACENT TO PIERS 2 THROUGH 10 SHALL BE PERFORMED BEFORE STARTING WORK ON THE REPLACEMENT DRAINAGE SYSTEM. AFTER THE SEDIMENT AND DEBRIS ARE REMOVED, THE EXISTING BRIDGE DRAINAGE SYSTEM SHALL BE FLUSHED WITH CLEAN WATER MAKING CERTAIN THE WATER FLOWS SMOOTHLY. THE CONTRACTOR SHALL PROVIDE ALL NECESSARY EQUIPMENT PRIOR TO BEGINNING WORK FOR THE PURPOSE OF EXAMINING THE PORTIONS OF THE EXISTING BRIDGE DRAINAGE SYSTEM TO REMAIN AFTER CLEANING TO VERIFY THE CONDITION OF ALL DOWNSPOUTS, COLLECTOR PIPES, AND MANHOLES. ALL SCUPPERS SHALL BE FREE OF SEDIMENT AND DEBRIS AT THE COMPLETION OF THE PROJECT. THE CONTRACTOR'S SUPERINTENDENT SHALL ACCOMPANY THE ENGINEER IN MAKING THE DETAILED EXAMINATION OF THE DRAINAGE SYSTEM. INCLUDE THE COST OF ANY FOLLOW-UP CLEANING REQUIRED TO SATISFY THIS REQUIREMENT IN THE UNIT COST BID.

**ITEM 518 - STRUCTURE DRAINAGE, MISC.: BRIDGE DRAINAGE SYSTEM CLEANING (CONT.):**

MEASUREMENT AND PAYMENT: THE DEPARTMENT WILL MEASURE THIS WORK ON A LUMP SUM BASIS. THE BID PRICE SHALL INCLUDE ALL LABOR, MATERIALS, EQUIPMENT, AND INCIDENTALS NECESSARY TO COMPLETE THE BRIDGE DRAINAGE SYSTEM CLEANING. THE DEPARTMENT WILL PAY FOR THE ACCEPTED QUANTITIES AT THE CONTRACT UNIT PRICE BID FOR ITEM 518 - STRUCTURE DRAINAGE, MISC.: BRIDGE DRAINAGE SYSTEM CLEANING.

**ITEM 844 - CONCRETE PATCHING WITH GALVANIC ANODE PROTECTION, AS PER PLAN:**

THIS WORK CONSISTS OF PATCHING EXISTING REINFORCED CONCRETE IN ACCORDANCE WITH SUPPLEMENTAL SPECIFICATION 844, MODIFIED AS FOLLOWS:

WHERE THE AREA OF AN INDIVIDUAL REPAIR, AS DETERMINED IN THE FIELD AT THE TIME OF CONSTRUCTION, TOTALS LESS THAN FIVE (5) SQUARE FEET, THE INSTALLATION OF GALVANIC ANODES IS NOT REQUIRED, AND THE WORK SHALL BE PERFORMED IN ACCORDANCE WITH C&MS 519.

ANODE SPACING SHALL BE 24" FOR REPAIRS ON THE EXISTING BRIDGE RAILINGS.

**ASBESTOS NOTIFICATION:**

A CERTIFIED ASBESTOS HAZARD EVALUATION SPECIALIST SURVEYED THE BRIDGE STRUCTURE SCHEDULED FOR DEMOLITION AND/OR REHABILITATION; THE SURVEY DETERMINED THAT NO ASBESTOS IS PRESENT ON THE BRIDGE STRUCTURE.

ODOT SHALL PROVIDE A COPY OF THE OHIO ENVIRONMENTAL PROTECTION AGENCY (OEPA) NOTIFICATION OF DEMOLITION AND RENOVATION FORM, PARTIALLY COMPLETED AND SIGNED BY THE BRIDGE OWNER, TO THE SUCCESSFUL BIDDER. THE CONTRACTOR SHALL COMPLETE THE FORM AND SUBMIT IT TO ONE OF THE ADDRESSES BELOW AT LEAST TEN (10) WORKING DAYS PRIOR TO THE START OF ANY DEMOLITION AND/OR RENOVATION.

ASBESTOS PROGRAM	OR	ASBESTOS PROGRAM
OHIO EPA, DAPC		OHIO EPA, DAPC
P.O. BOX 1049		50 W. TOWN ST., SUITE 700
COLUMBUS, OH 43216-1049		COLUMBUS, OH 43215

THE CONTRACTOR SHALL PROVIDE A COPY OF THE COMPLETED FORM TO THE ENGINEER AT LEAST TEN (10) WORKING DAYS PRIOR TO THE START OF ANY DEMOLITION AND/OR RENOVATION. THE FORM SHALL INCLUDE: 1) THE CONTRACTOR'S NAME AND ADDRESS, 2) THE SCHEDULED DATES FOR THE START AND COMPLETION OF THE BRIDGE REMOVAL AND 3) A DESCRIPTION OF THE PLANNED DEMOLITION WORK AND THE METHOD(S) TO BE USED. COPIES OF THE OEPA FORM AND BRIDGE INSPECTION REPORT ARE AVAILABLE FOR REVIEW AT THE ODOT DISTRICT 12 OFFICE, 5500 TRANSPORTATION BOULEVARD, GARFIELD HEIGHTS, OHIO 44125.

**BASIS FOR PAYMENT:** THE CONTRACTOR SHALL FURNISH ALL FEES, LABOR, AND MATERIAL NECESSARY TO COMPLETE AND SUBMIT THE OEPA NOTIFICATION FORM. PAYMENT FOR THIS WORK SHALL BE INCLUDED IN ITEM 202 - PORTIONS OF STRUCTURE REMOVED, OVER 20 FOOT SPAN, AS PER PLAN.

**SUMMARY OF PROPOSED REHABILITATION WORK:**

THE FOLLOWING LIST CONTAINS THE MAJOR ITEMS OF WORK INCLUDED IN THESE PLANS FOR THE REHABILITATION OF THIS STRUCTURE:

1. MISCELLANEOUS REPAIRS TO THE SUPERSTRUCTURE, INCLUDING REPLACEMENT OF THE CROSS FRAMES AND DIAPHRAGMS AT BOTH ABUTMENTS AND THE ADDITION OF STEEL PLATES TO STRENGTHEN SELECT EXISTING STIFFENER PLATES AT THE HINGES.
2. CLEANOUT OF THE EXISTING DECK SCUPPERS, REPLACEMENT OF THE EXISTING DOWNSPOUT AND COLLECTOR PIPE DRAINAGE SYSTEM FROM THE UNDERSIDE OF THE DECK TO THE OUTLET AT PIERS 2-10, AND INSTALLATION OF CRUSHED AGGREGATE SLOPE PROTECTION BELOW SELECT PIPE OUTLETS.

**SUMMARY OF PROPOSED REHABILITATION WORK (CONT.):**

3. REPLACEMENT OF THE EXISTING COMPRESSION JOINTS AND STRIP SEAL EXPANSION JOINTS AT THE ABUTMENTS, PIER 1, AND THE HINGED EXPANSION JOINTS WITH NEW STRIP SEAL EXPANSION JOINTS, INCLUDING RECONSTRUCTION OF THE TOPS OF THE ABUTMENT BACKWALLS AND PORTIONS OF THE EXISTING DECK SLAB AT ALL LOCATIONS AND REPLACEMENT OF SIDEWALK AND CURB COVER PLATE ASSEMBLIES.
4. REPLACEMENT OF EXISTING SIDEWALK WEARING SURFACE, INCLUDING REMOVAL OF TOP OF CURB PLATES AND WATERPROOFING MATERIAL BELOW EXISTING WEARING SURFACE AND ADDITION OF SURFACE TREATMENT TO CURB PLATES.
5. REPAIR OF BRIDGE RAILINGS, INCLUDING CONCRETE CRACK REPAIR, PATCHING, AND FULL HEIGHT RAILING RECONSTRUCTION WHERE WARRANTED.
6. INSTALLATION OF NEW VANDAL PROTECTION FENCE.
7. PAINTING OF GIRDER ENDS AND CROSS FRAMES AT THE ABUTMENTS AND INTERMEDIATE EXPANSION JOINTS.
8. SUPERSTRUCTURE, SUBSTRUCTURE, AND APPROACH SIDEWALK AND RAILING CONCRETE SEALING.
9. ADDITION OF ROCK CHANNEL PROTECTION AT PIERS 4 AND 5.

**PLAN ABBREVIATIONS:**

@	= AT
ABUT.	= ABUTMENT
ADT	= AVERAGE DAILY TRAFFIC
ADTT	= AVERAGE DAILY TRUCK TRAFFIC
BOT.	= BOTTOM
BRG.	= BEARING
c/c	= CENTER-TO-CENTER
℄	= CENTERLINE
CALC.	= CALCULATED
CHKD.	= CHECKED
C.J.	= CONSTRUCTION JOINT
C&MS	= CONSTRUCTION AND MATERIAL SPECIFICATIONS
CONC.	= CONCRETE
CONST.	= CONSTRUCTION
DIA.	= DIAMETER
DIM.	= DIMENSION
E.F.	= EACH FACE
EL.	= ELEVATION
EXIST.	= EXISTING
EXP.	= EXPANSION
FWD.	= FORWARD
INC.	= INCREMENT
JT.	= JOINT
MAX.	= MAXIMUM
MIN.	= MINIMUM
MISC.	= MISCELLANEOUS
NO.	= NUMBER
O.D.	= OUTSIDE DIAMETER
PROP.	= PROPOSED
REF.	= REFERENCE
REINF.	= REINFORCED
SPA.	= SPACED
S.R.	= STATE ROUTE
STA.	= STATION
TYP.	= TYPICAL



FUNDING	ESTIMATED QUANTITIES											CALC. BY: JG	DATE: 10/27/22
	ITEM	ITEM EXTENSION	TOTAL	UNIT	DESCRIPTION	REAR ABUTMENT	FORWARD ABUTMENT	PIERS	SUPER-STRUCTURE	GENERAL	REF. SHEET NUMBER	CHKD. BY: MJL	DATE: 10/28/22
	202	11203	LS		PORTIONS OF STRUCTURE REMOVED, OVER 20 FOOT SPAN, AS PER PLAN					LS	3 / 26		
	509	20001	200	LB	CONCRETE REINFORCEMENT, REPLACEMENT OF EXISTING CONCRETE REINFORCEMENT, AS PER PLAN				200		3 / 26		
	511	34423	19,290	SF	CLASS QC2 CONCRETE, SIDEWALK WEARING SURFACE, AS PER PLAN				19,290		2, 64-66 / 82		
	511	34448	2	CY	CLASS QC2 CONCRETE, BRIDGE DECK (PARAPET)				2				
	512	10050	2,143	SY	SEALING OF CONCRETE SURFACES (NON-EPOXY)				2,143				
	512	10100	3,372	SY	SEALING OF CONCRETE SURFACES (EPOXY-URETHANE)	34	297		3,041				
	512	10600	482	FT	CONCRETE REPAIR BY EPOXY INJECTION				482				
	513	10201	7,730	LB	STRUCTURAL STEEL MEMBERS, LEVEL UF, AS PER PLAN				7,730		12 / 26		
	514	00050	10,400	SF	SURFACE PREPARATION OF EXISTING STRUCTURAL STEEL				10,400				
	514	00056	10,400	SF	FIELD PAINTING OF EXISTING STRUCTURAL STEEL, PRIME COAT				10,400				
	514	00060	10,400	SF	FIELD PAINTING STRUCTURAL STEEL, INTERMEDIATE COAT				10,400				
	514	00066	10,400	SF	FIELD PAINTING STRUCTURAL STEEL, FINISH COAT				10,400				
	514	00504	24	MNHR	GRINDING FINIS, TEARS, SLIVERS ON EXISTING STRUCTURAL STEEL				24				
	514	10000	13	EACH	FINAL INSPECTION REPAIR				13				
	516	12301	340	FT	STRIP SEAL EXPANSION JOINT ANCHORED WITH ELASTOMERIC CONCRETE, AS PER PLAN				340		15 / 26		
	518	51101	381	FT	8" PIPE DOWNSPOUT, INCLUDING SPECIALS, AS PER PLAN				381		17-20 / 26		
	518	51201	1,800	FT	PIPE DOWNSPOUT, INCLUDING SPECIALS, AS PER PLAN, 10"				1,800		17-20 / 26		
	518	63300	LS		STRUCTURE DRAINAGE, MISC.: BRIDGE DRAINAGE SYSTEM CLEANING					LS	4 / 26		
	SPECIAL	53001300	3,558	FT	STRUCTURES: CURB PLATE SURFACE COATING	36	314		3,208		7 / 26		
	601	20010	5	CY	CRUSHED AGGREGATE SLOPE PROTECTION			5					
	601	32004	1,500	CY	ROCK CHANNEL PROTECTION, TYPE A WITH GEOTEXTILE FABRIC			1,500					
	601	32104	700	CY	ROCK CHANNEL PROTECTION, TYPE B WITH GEOTEXTILE FABRIC			700					
	607	39901	3,540	FT	VANDAL PROTECTION FENCE, 6' STRAIGHT, COATED FABRIC, AS PER PLAN	34	310		3,196		15 / 26		
	844	10001	467	SF	CONCRETE PATCHING WITH GALVANIC ANODE PROTECTION, AS PER PLAN		51		416		11 / 26		

REINFORCING STEEL LIST										
MARK	NO.	LENGTH	WEIGHT	TYPE	DIMENSIONS					SERIES INC.
					A	B	C	D	E	
<b>ABUTMENTS</b>										
A501	12	25'-10"	323	STR						
A502	4	27'-5"	114	STR						
A601	4	6'-6"	39	2	0'-7"	5'-8"	0'-7"			
		TOTAL	476	LBS						
<b>SUPERSTRUCTURE</b>										
S601	73	25'-10"	2,833	STR						
S602	16	6'-6"	156	2	0'-7"	5'-8"	0'-7"			
S603	3	27'-5"	124	STR						
		TOTAL	3,113	LBS						

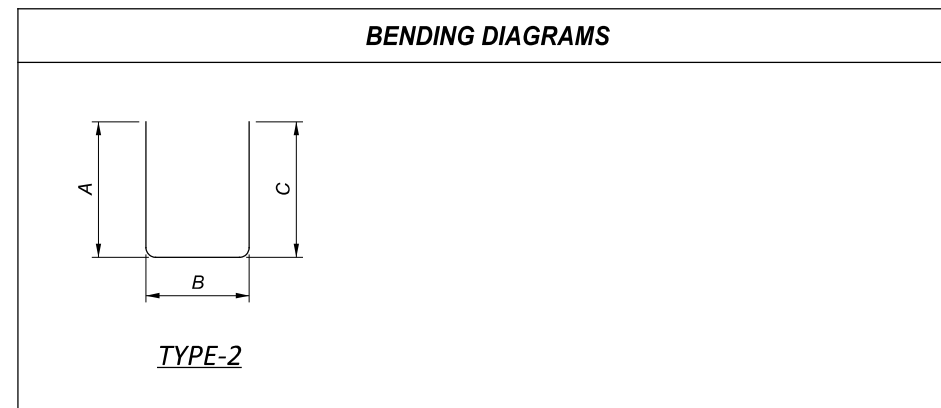

**REINFORCING STEEL NOTES**

- SERIES BARS - EACH BAR VARIES BY TABULATED AMOUNT.
- ALL DIMENSIONS ARE OUT-TO-OUT.
- TYPE 'STR' INDICATES A STRAIGHT BAR.
- THE BAR SIZE NUMBER IS INDICATED IN THE 'MARK' COLUMN. THE FIRST ONE OR TWO DIGITS OF EACH MARK INDICATES THE BAR SIZE NUMBER. FOR EXAMPLE, A501 IS A #5 BAR SIZE AND P1101 IS A #11 BAR SIZE.
- ALL REINFORCING STEEL SHALL BE EPOXY COATED.

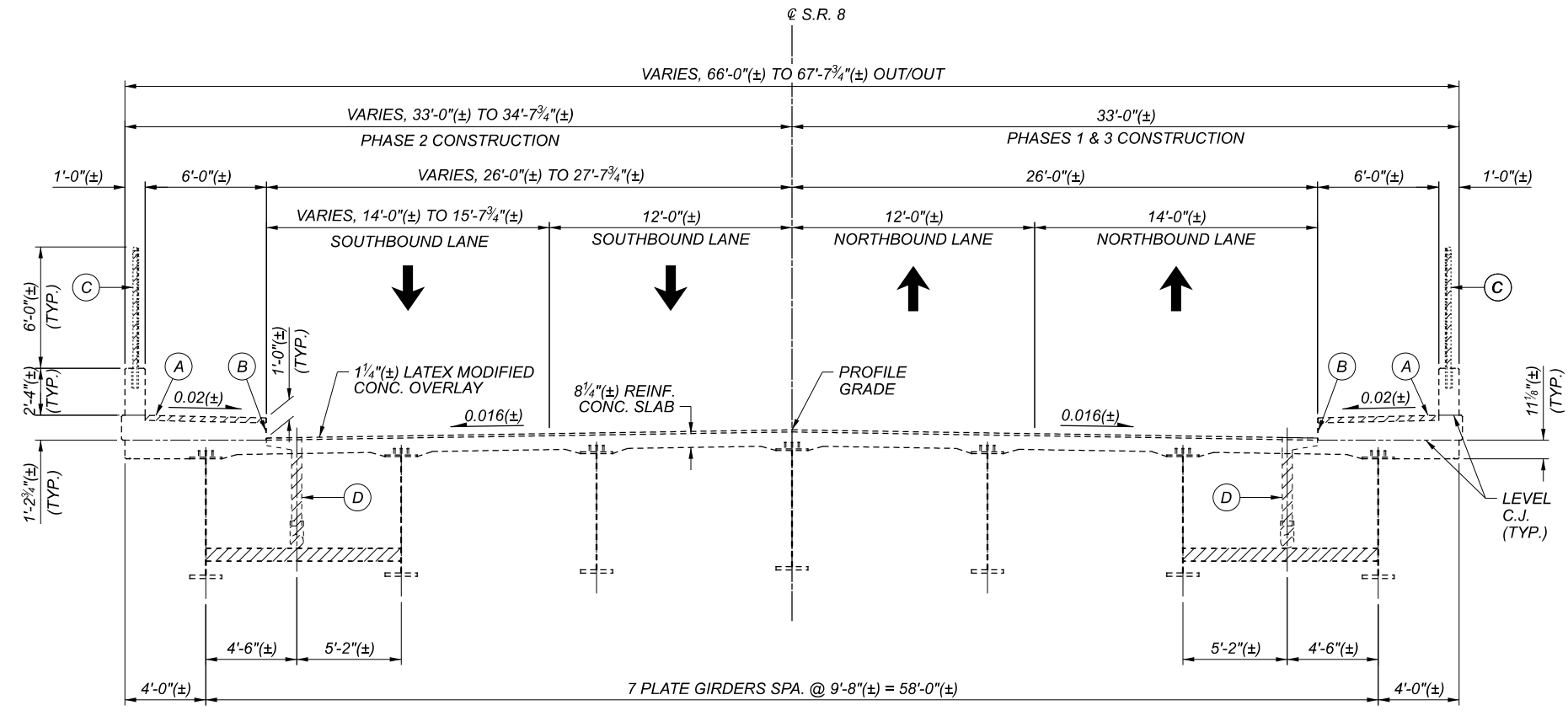

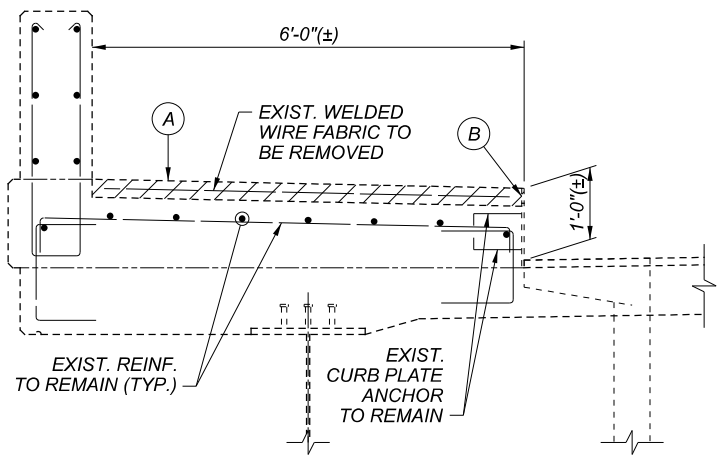

**EXISTING TRANSVERSE SECTION**  
 EXIST. CROSSFRAMES NOT SHOWN

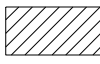

**TYPICAL REMOVAL SIDEWALK SECTION**  
 EXIST. FENCE & DECK REINFORCING STEEL NOT SHOWN

**LEGEND**

-  ITEM 202 - PORTIONS OF STRUCTURE REMOVED, OVER 20 FOOT SPAN, AS PER PLAN
- (A) REMOVE EXIST. 3" (±) CONCRETE SIDEWALK WEARING SURFACE, REMOVE EXISTING WATERPROOFING, PATCH CONCRETE BELOW EXISTING WATERPROOFING, AND ROUGHEN UNDERLYING CONCRETE SURFACE
- (B) REMOVE TOP 2 1/2" OF EXIST. 3/8" (±) THICK STEEL CURB PLATE
- (C) REMOVE EXISTING FENCE AND CUT FENCE POSTS FLUSH WITH THE TOP OF THE RAILING
- (D) REMOVE ALL COLLECTOR AND DOWNSPOUT PIPES IN SPANS 3-11 FROM UNDERSIDE OF DECK TO OUTLET AT CATCH BASIN

SFN	1801244
DESIGN AGENCY	
	
DESIGNER	CHECKER
JAM	JDA
REVIEWER	
MJL	10/24/22
PROJECT ID	113674
SUBSET	TOTAL
6	26
SHEET	TOTAL
62	82



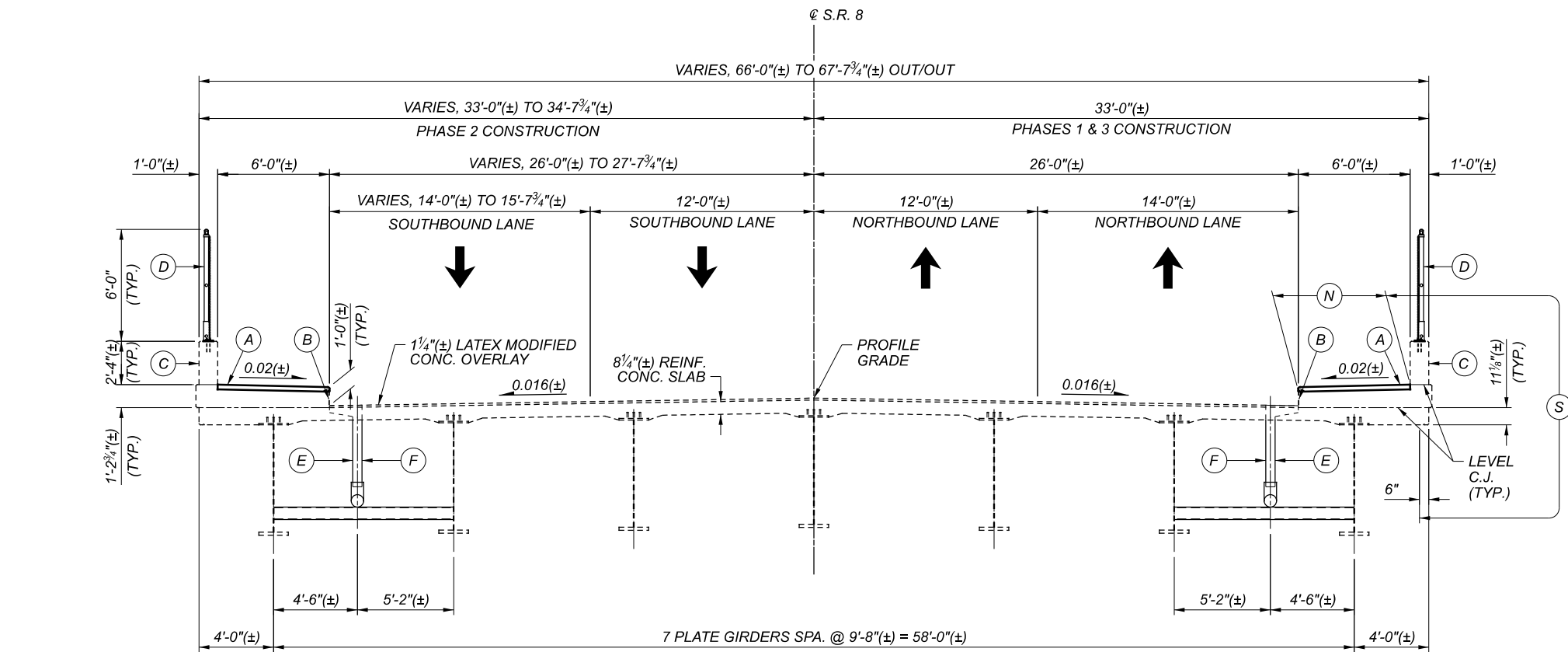

**PROPOSED TRANSVERSE SECTION**  
 EXIST. CROSSFRAMES NOT SHOWN

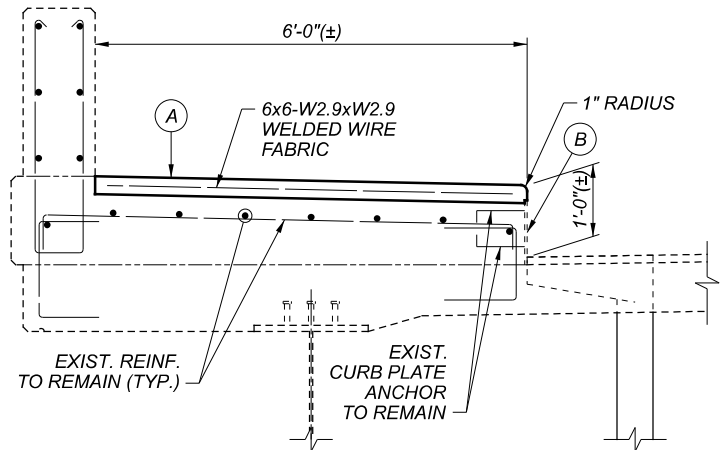

**LEGEND**

- (A) PROPOSED 3" CONCRETE SIDEWALK WEARING SURFACE
- (B) ADD POLYUREA SURFACE COATING TO MITIGATE FUTURE CORROSION OF THE CURB PLATE (SEE NOTE 1)
- (C) PATCH RAILING CONCRETE AND REPAIR CRACKS, SEE SHEETS 8-11/26 FOR ADDITIONAL INFORMATION
- (D) PROPOSED 6'-0" VPF-1-90 FENCE WITH BP-5 BASE PLATE, SEE SHEETS 22-26/26 FOR ADDITIONAL INFORMATION
- (E) CLEAN OUT EXIST. SCUPPERS, COLLECTOR, AND DOWNSPOUT PIPES IN SPANS 1 AND 2 AND ON PIER 1
- (F) PROPOSED COLLECTOR AND DOWNSPOUT PIPES IN SPANS 3-11, SEE SHEETS 17-20/26 FOR ADDITIONAL INFORMATION
- (N) LIMITS OF SEALING OF CONCRETE SURFACES (NON-EPOXY) (TYP.)
- (S) LIMITS OF SEALING OF CONCRETE SURFACES (EPOXY-URETHANE) (TYP.)

**NOTES**

1. THE ENTIRE FACE OF THE EXISTING CURB PLATES TO BE COATED WITH POLYUREA SURFACE COATING. ALL MATERIALS, EQUIPMENT, LABOR, AND INCIDENTALS REQUIRED TO COMPLETE THE COATING OF THE CURB PLATES SHALL BE INCLUDED FOR PAYMENT WITH ITEM SPECIAL - STRUCTURE: CURB PLATE SURFACE COATING.

SFN	1801244	
DESIGN AGENCY		
DESIGNER	JAM	CHECKER
		TA/JDA
REVIEWER	MjL 10/24/22	
PROJECT ID	113674	
SUBSET	7	TOTAL
		26
SHEET	63	TOTAL
		82

CUY-8/10-02.26/08.69

MODEL: Sheet PAPER: SIZE: 17x11 (in.) DATE: 10/28/2022 TIME: 8:46:29 PM USER: jmillar  
 X:\Projects\2021\12122100200 ODOT CUY-8 CUY-10\113674\400-Engineering\Structures\SFN\_1801244\_SFN\_1801244\_SD001.dgn

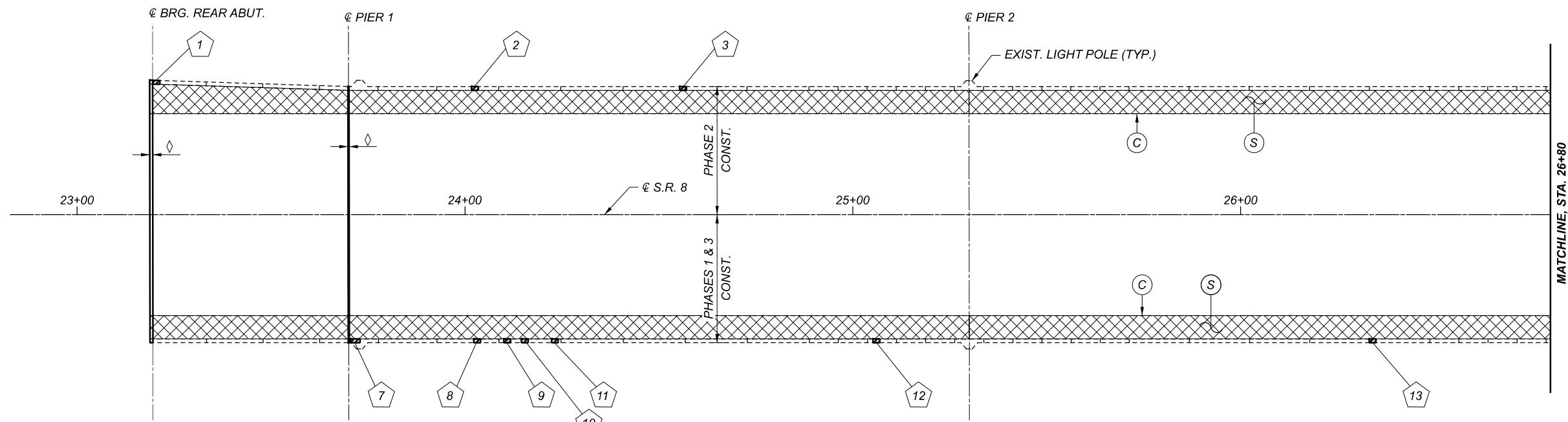



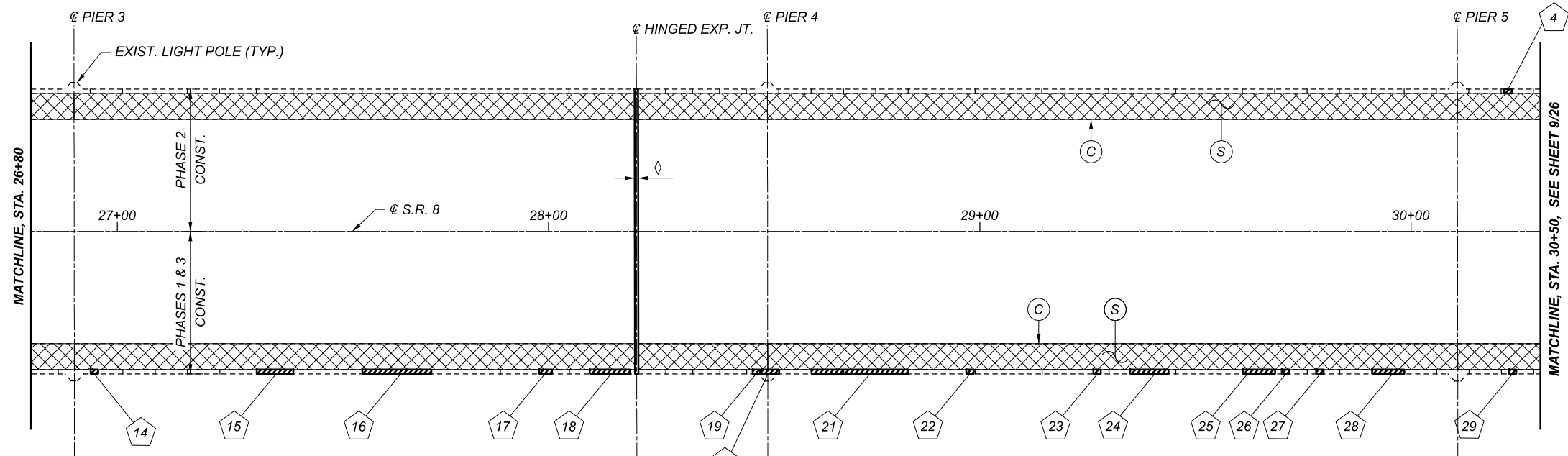

DECK PLAN



DECK PLAN

**LEGEND**

-  RAILING REPAIR LOCATION NUMBER
-  SIDEWALK WEARING SURFACE REPLACEMENT (SEE NOTE 2)
-  CURB PLATE SURFACE TREATMENT (SEE NOTE 2)
-  EXPANSION JOINT REHABILITATION (SEE NOTE 3)

**NOTES**

1. FOR RAILING REPAIR LOCATION DETAILS AND QUANTITIES, SEE SHEET 11/26.
2. FOR PROPOSED TRANSVERSE SECTION, SEE SHEET 7/26.
3. FOR EXPANSION JOINT REHABILITATION DETAILS, SEE SHEETS 13-16/26.

DECK PLAN - 1  
 BRIDGE NO. CUY-8-0226  
 OVER HAWTHORN PKWY., BROADWAY AVE., TINKERS CREEK, & WHEELING & LAKE ERIE RR

SFN	
1801244	
DESIGN AGENCY	
	
DESIGNER	CHECKER
JG	EAO
REVIEWER	
MJL 10/24/22	
PROJECT ID	
113674	
SUBSET	TOTAL
8	26
SHEET	TOTAL
64	82

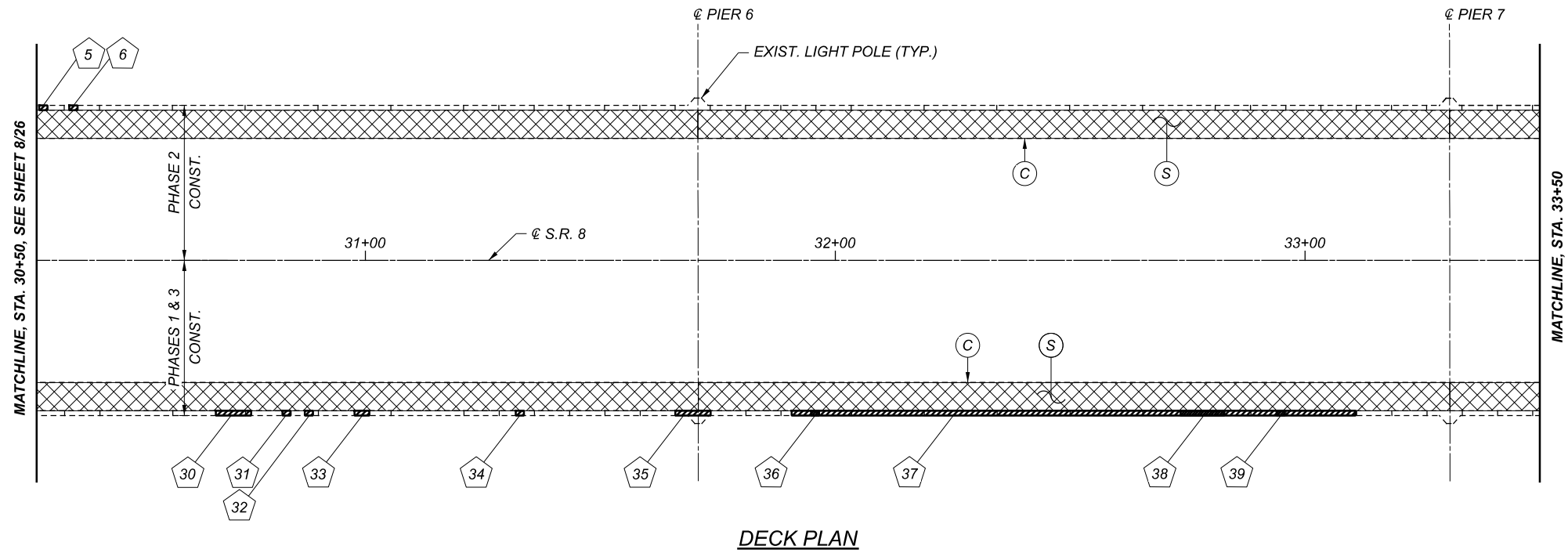



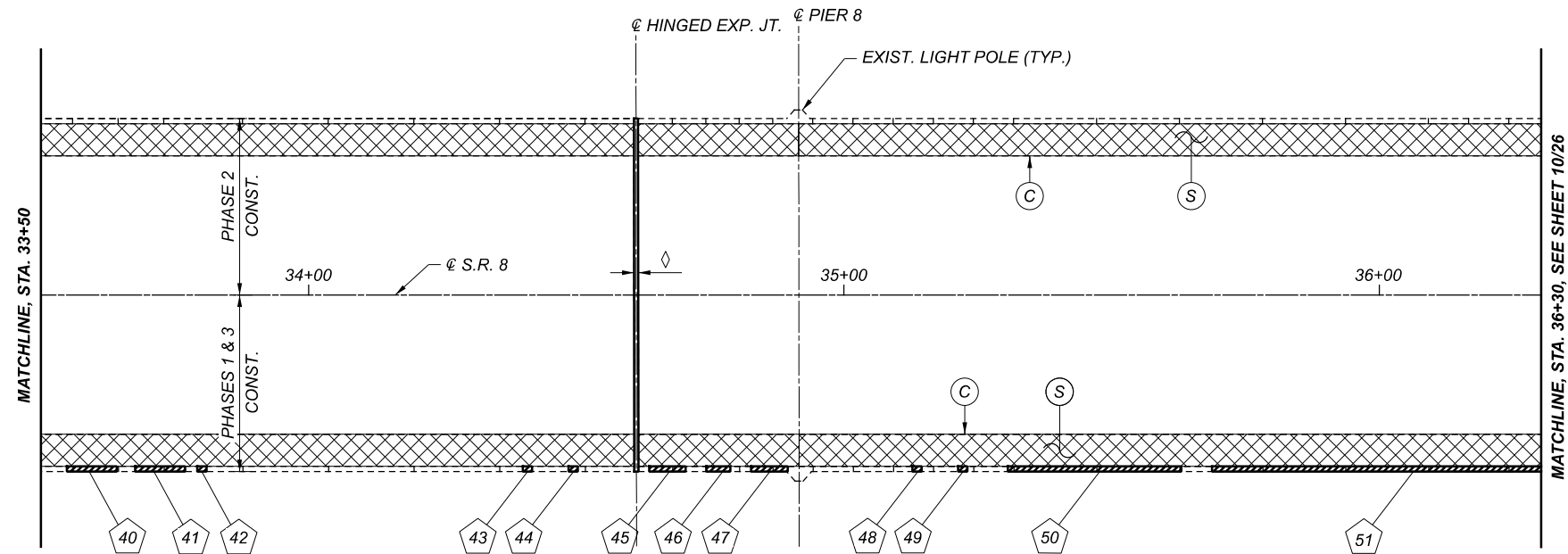

DECK PLAN



DECK PLAN

**LEGEND**

-  RAILING REPAIR LOCATION NUMBER
-  SIDEWALK WEARING SURFACE REPLACEMENT (SEE NOTE 2)
-  CURB PLATE SURFACE TREATMENT (SEE NOTE 2)
-  EXPANSION JOINT REHABILITATION (SEE NOTE 3)

**NOTES**

1. FOR RAILING REPAIR LOCATION DETAILS AND QUANTITIES, SEE SHEET 11/26.
2. FOR PROPOSED TRANSVERSE SECTION, SEE SHEET 7/26.
3. FOR EXPANSION JOINT REHABILITATION DETAILS, SEE SHEETS 13-16/26.



SFN 1801244

DESIGN AGENCY



DESIGNER CHECKER  
 JG EAO

REVIEWER  
 MJL 10/24/22

PROJECT ID  
 113674

SUBSET TOTAL  
 9 26

SHEET TOTAL  
 65 82

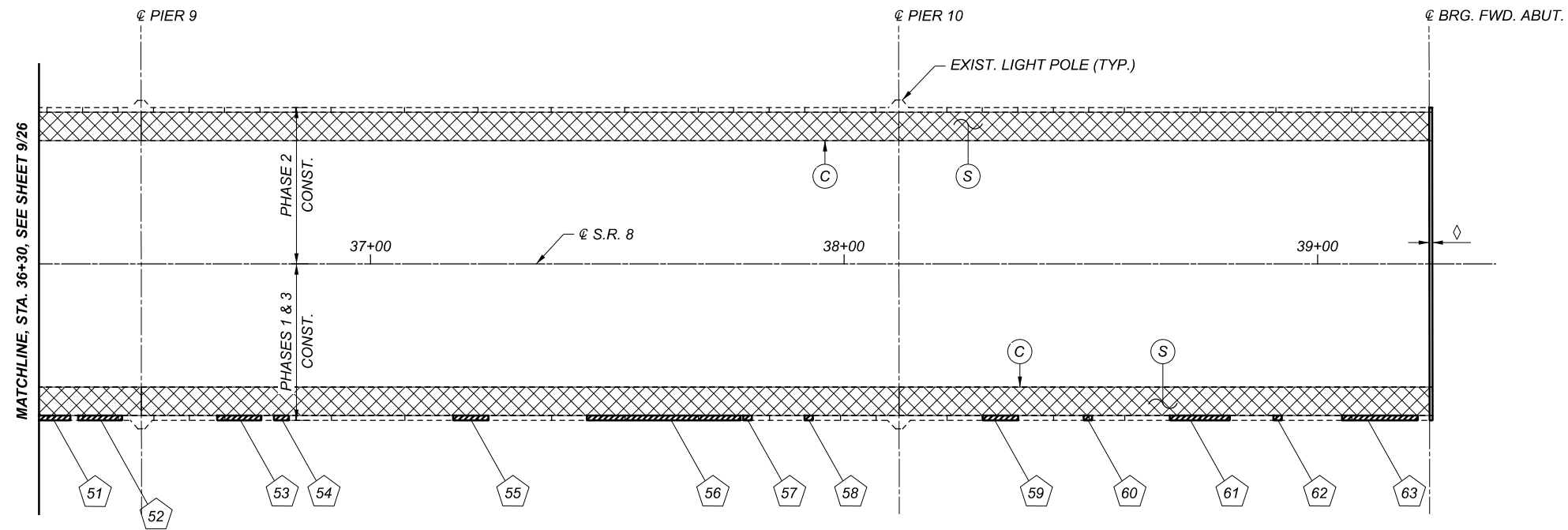

DECK PLAN

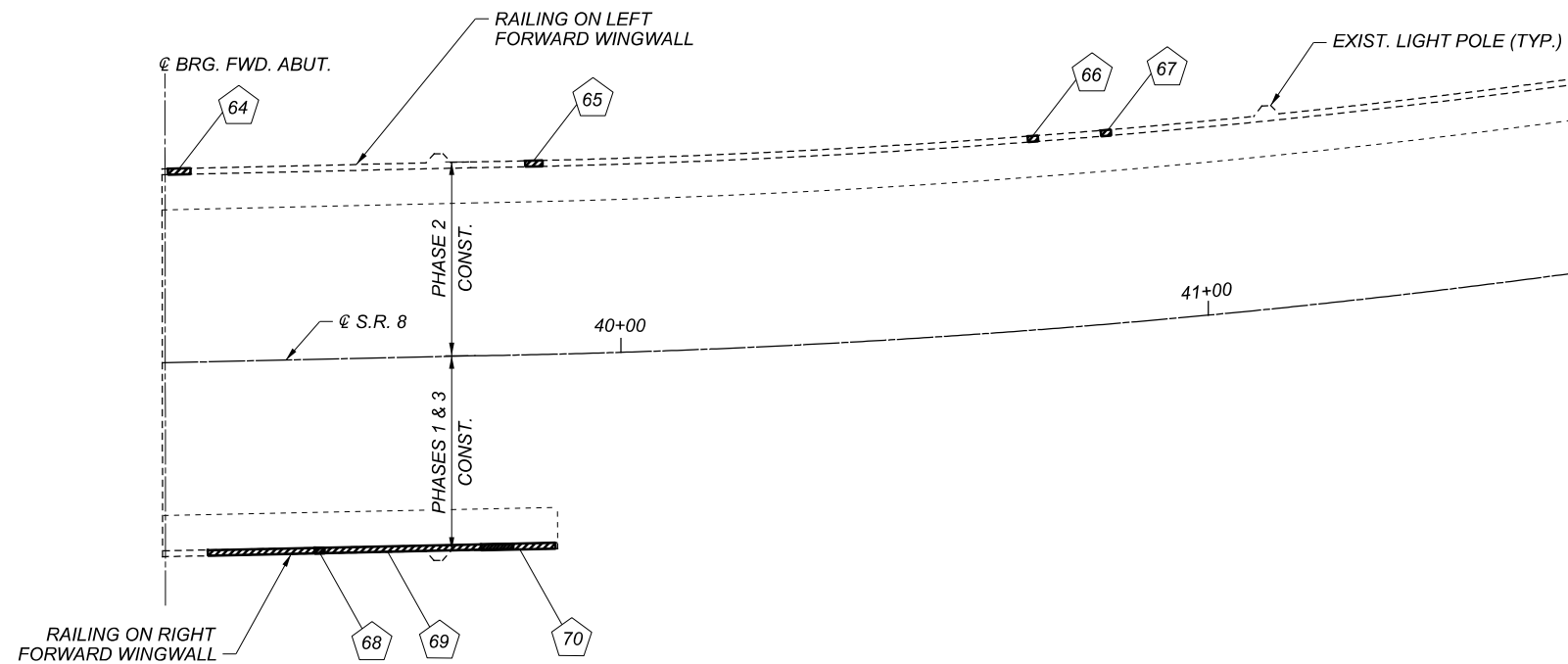

FORWARD APPROACH PLAN

**LEGEND**

- RAILING REPAIR LOCATION NUMBER
- SIDEWALK WEARING SURFACE REPLACEMENT (SEE NOTE 2)
- CURB PLATE SURFACE TREATMENT (SEE NOTE 2)
- EXPANSION JOINT REHABILITATION (SEE NOTE 3)

**NOTES**

1. FOR RAILING REPAIR LOCATION DETAILS AND QUANTITIES, SEE SHEET 11/26.
2. FOR PROPOSED TRANSVERSE SECTION, SEE SHEET 7/26.
3. FOR EXPANSION JOINT REHABILITATION DETAILS, SEE SHEETS 13-16/26.





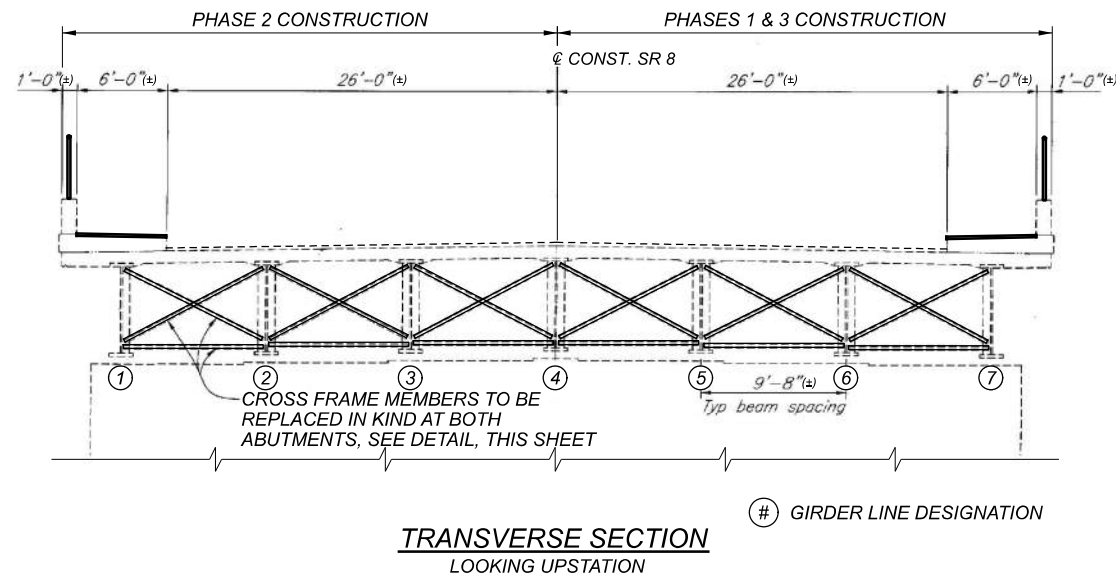

**TRANSVERSE SECTION**  
LOOKING UPSTATION

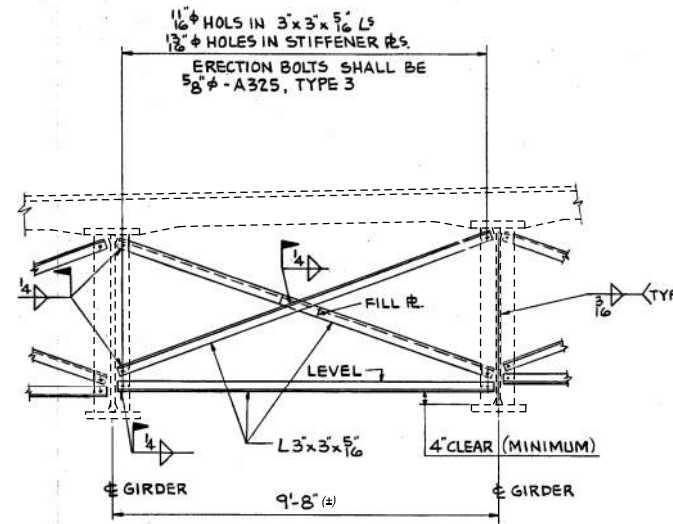

**TYPICAL END CROSSFRAME**

FOR GIRDERS G1 THRU G7  
 @ BOTH ABUTMENTS  
 INTERIOR BAY SHOWN  
 EXTERIOR BAY SIMILAR

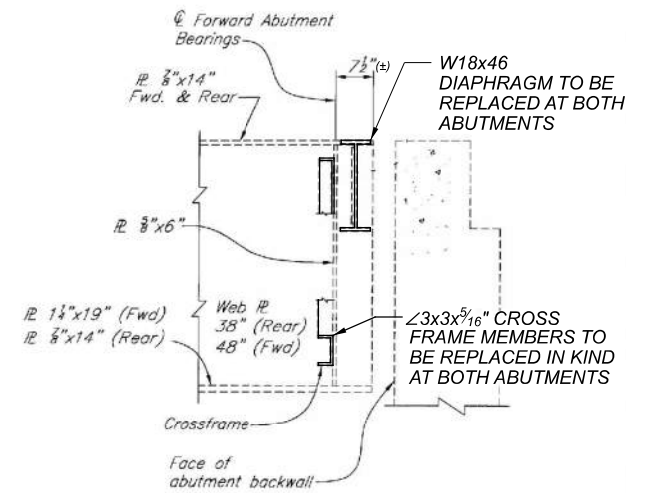

**FRAMING DETAIL AT ABUTMENTS**

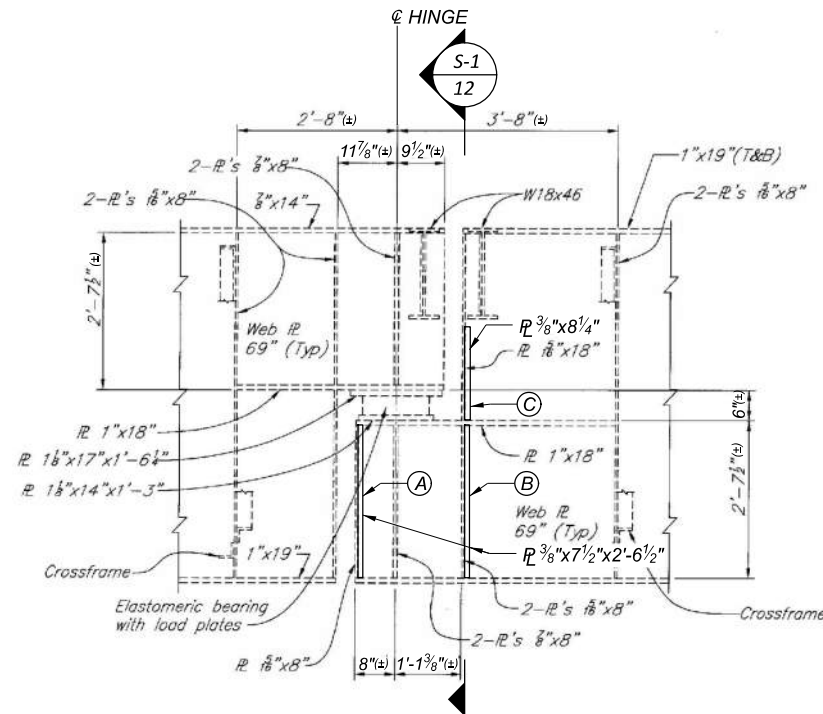

**FRAMING DETAIL AT HINGES**

**SPAN 4**

- (A) GIRDER 5, WEST
- (B) GIRDER 7, EAST
- (C) GIRDER 1, EAST
- GIRDER 2, WEST
- GIRDER 7, WEST
- GIRDER 7

**SPAN 8**

- (C) GIRDER 1, EAST

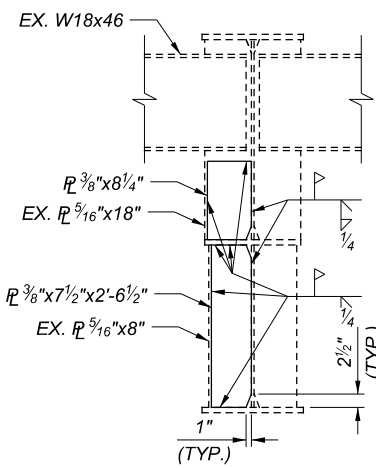

**SECTION S-1**  
12

**NOTES**

1. THE WORK PROPOSED ON THIS SHEET INCLUDES STEEL CROSSFRAME REPLACEMENT AND THE ADDITION OF STIFFENING PLATES AT THE LOCATIONS SHOWN.
2. ALL WORK SHOWN ON THIS SHEET SHALL BE PERFORMED WITHIN THEIR RESPECTIVE CONSTRUCTION PHASES SO THAT THERE IS NO LIVE LOAD PRESENT IN THE ADJACENT SPANS.
3. ALL MATERIALS, EQUIPMENT, LABOR, AND INCIDENTALS REQUIRED TO FABRICATE AND INSTALL THE PROPOSED CROSS FRAMES AND DIAPHRAGMS AT THE ABUTMENTS AND PROPOSED PLATES AT THE HINGES SHALL BE INCLUDED FOR PAYMENT WITH ITEM 513 - STRUCTURAL STEEL MEMBERS, LEVEL UF, AS PER PLAN.

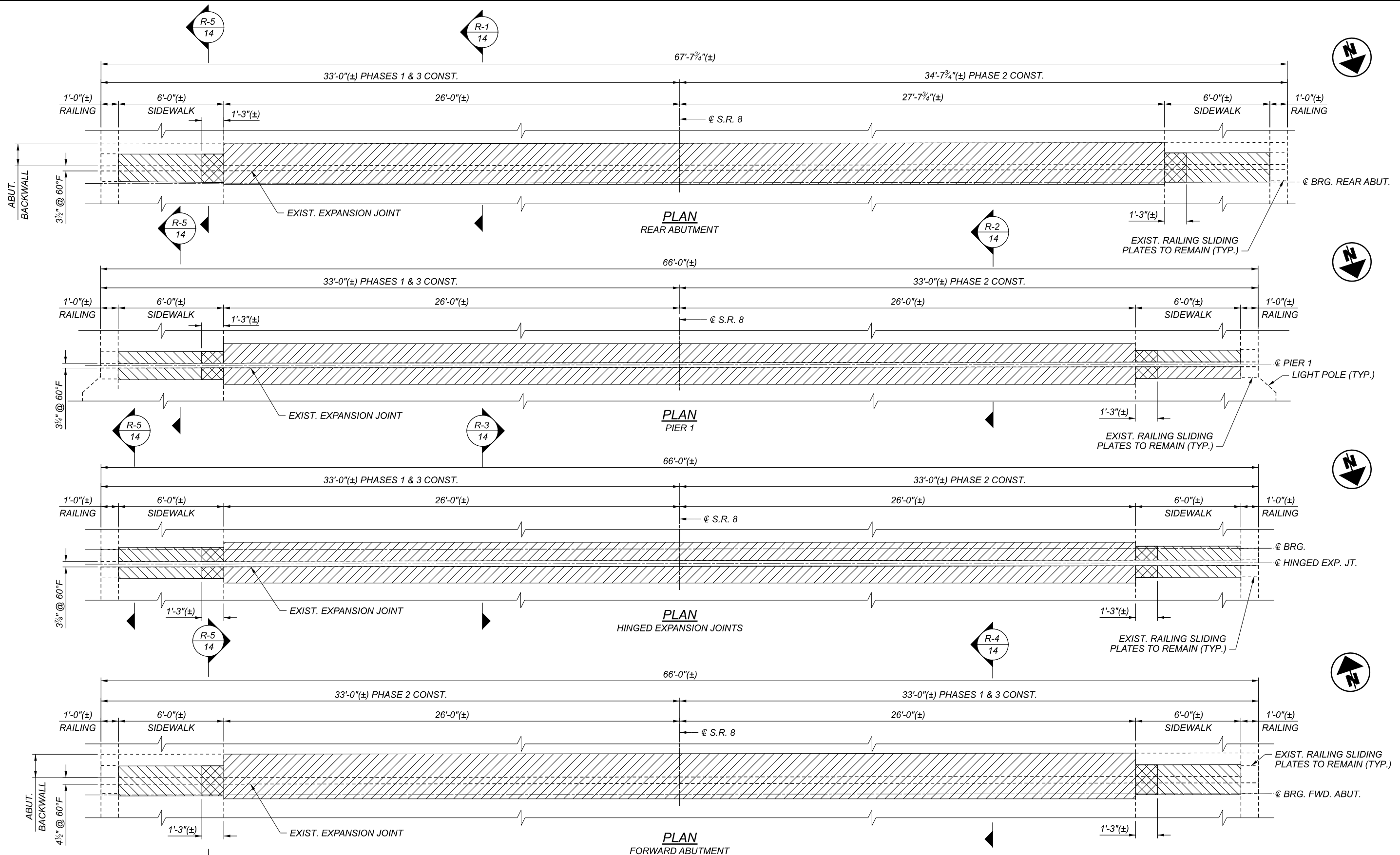

**LEGEND**

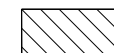
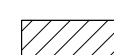
-  ITEM 202 - PORTIONS OF STRUCTURE REMOVED, OVER 20 FOOT SPAN, AS PER PLAN (AREA OF SIDEWALK AND DECK OR BACKWALL REMOVAL)
-  ITEM 202 - PORTIONS OF STRUCTURE REMOVED, OVER 20 FOOT SPAN, AS PER PLAN (AREA OF SIDEWALK REMOVAL)
-  ITEM 202 - PORTIONS OF STRUCTURE REMOVED, OVER 20 FOOT SPAN, AS PER PLAN (AREA OF DECK OR BACKWALL REMOVAL)

**EXPANSION JOINT REMOVAL DETAILS - 1**  
 BRIDGE NO. CUY-8-0226

OVER HAWTHORN PKWY., BROADWAY AVE., TINKERS CREEK, & WHEELING & LAKE ERIE RR

SFN 1801244	
DESIGN AGENCY	
	
DESIGNER	CHECKER
JG	JDA
REVIEWER	
MJL 10/24/22	
PROJECT ID	
113674	
SUBSET	TOTAL
13	26
SHEET	TOTAL
69	82

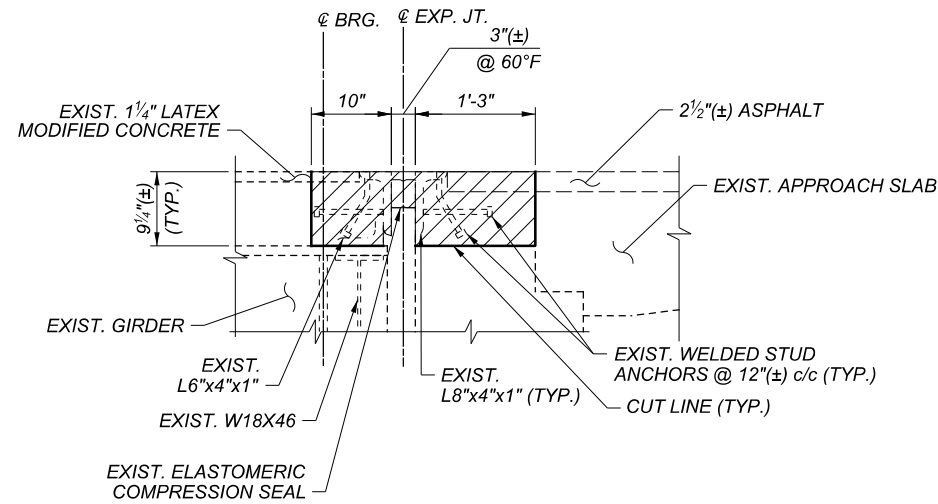

SECTION R-1  
13

REAR ABUTMENT  
EXIST. REINFORCING STEEL NOT SHOWN FOR CLARITY

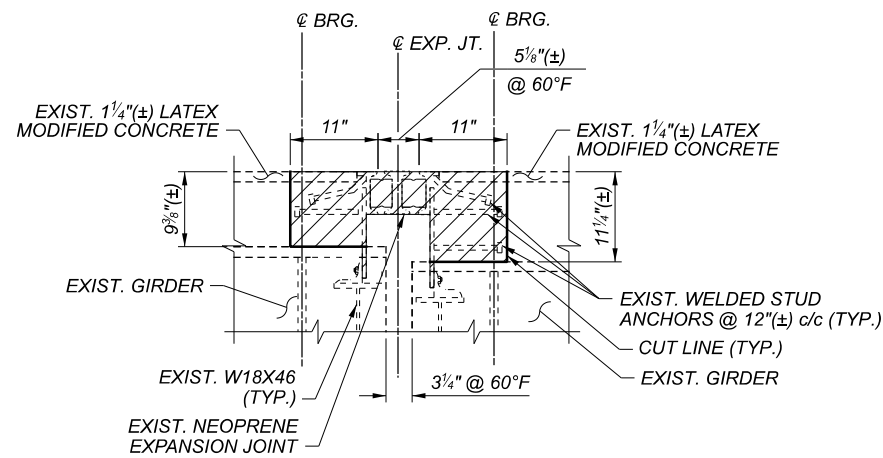

SECTION R-2  
13

TYPICAL REMOVAL AT PIER 1  
EXIST. REINFORCING STEEL NOT SHOWN FOR CLARITY

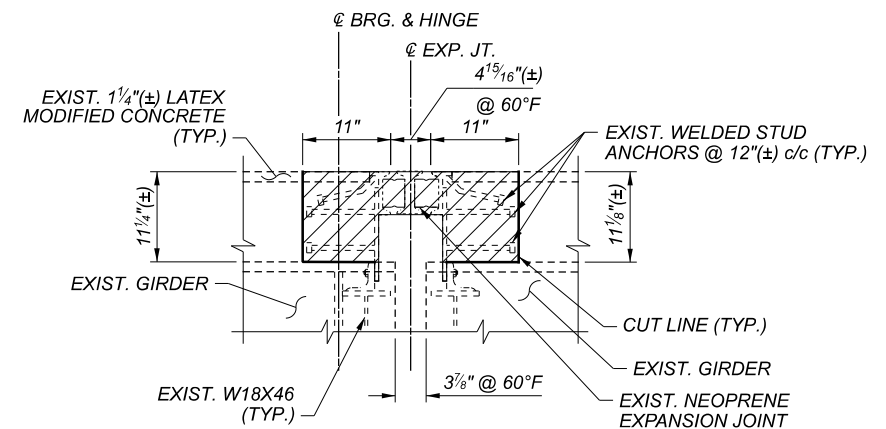

SECTION R-3  
13

TYPICAL REMOVAL AT HINGED EXPANSION JOINTS  
EXIST. REINFORCING STEEL NOT SHOWN FOR CLARITY

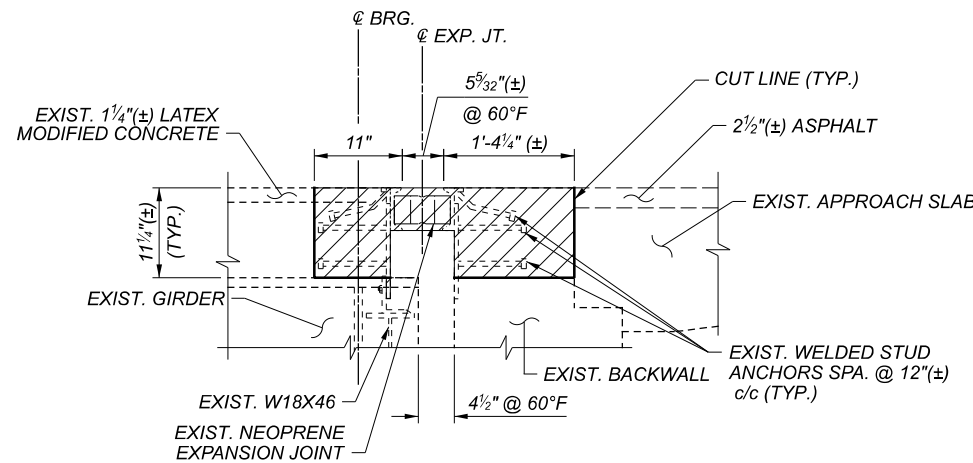

SECTION R-4  
13

TYPICAL REMOVAL AT FORWARD ABUTMENT  
EXIST. REINFORCING STEEL NOT SHOWN FOR CLARITY

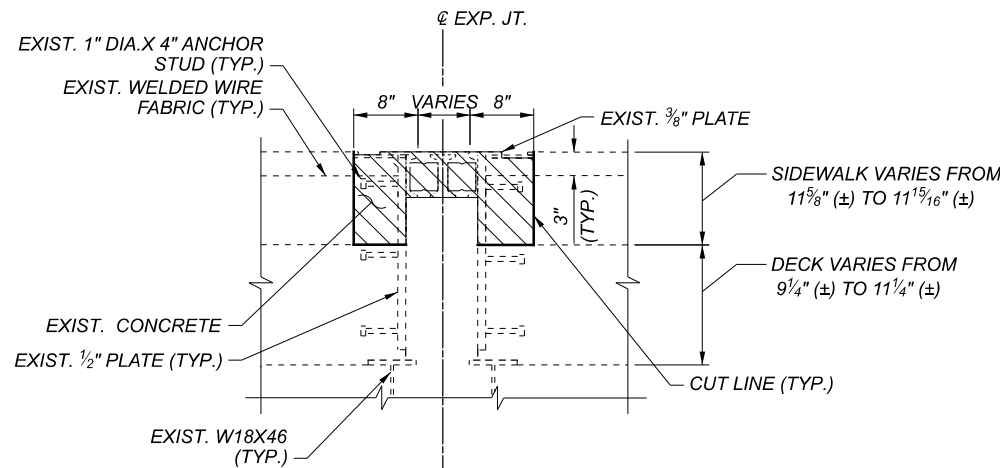

SECTION R-5  
13

TYPICAL REMOVAL AT SIDEWALK  
HINGED EXP. JT. & PIER 1 SHOWN, ABUTMENTS SIMILAR  
EXIST. REINFORCING STEEL NOT SHOWN FOR CLARITY

**LEGEND**

- ITEM 202 - PORTIONS OF STRUCTURE REMOVED, OVER 20 FOOT SPAN, AS PER PLAN (AREA OF SIDEWALK REMOVAL)
- ITEM 202 - PORTIONS OF STRUCTURE REMOVED, OVER 20 FOOT SPAN, AS PER PLAN (AREA OF DECK OR BACKWALL REMOVAL)

**NOTES**

1. REMOVAL LIMITS SHOWN ARE THE MINIMUM REQUIRED TO COMPLETE THE WORK. SHOULD THE CONTRACTOR ELECT TO REMOVE GREATER PORTIONS TO FACILITATE THE WORK, THE CONTRACTOR SHALL REPLACE IN KIND THE DECK, SIDEWALK, AND/OR BACKWALL REINFORCING AS SHOWN IN THE ORIGINAL BRIDGE CONSTRUCTION CONTRACT PLANS AT NO ADDITIONAL COST TO THE DISTRICT.
2. FOR DETAILS ON EXISTING REINFORCING STEEL TO REMAIN IN REMOVAL AREAS, SEE SHEET 16/26.



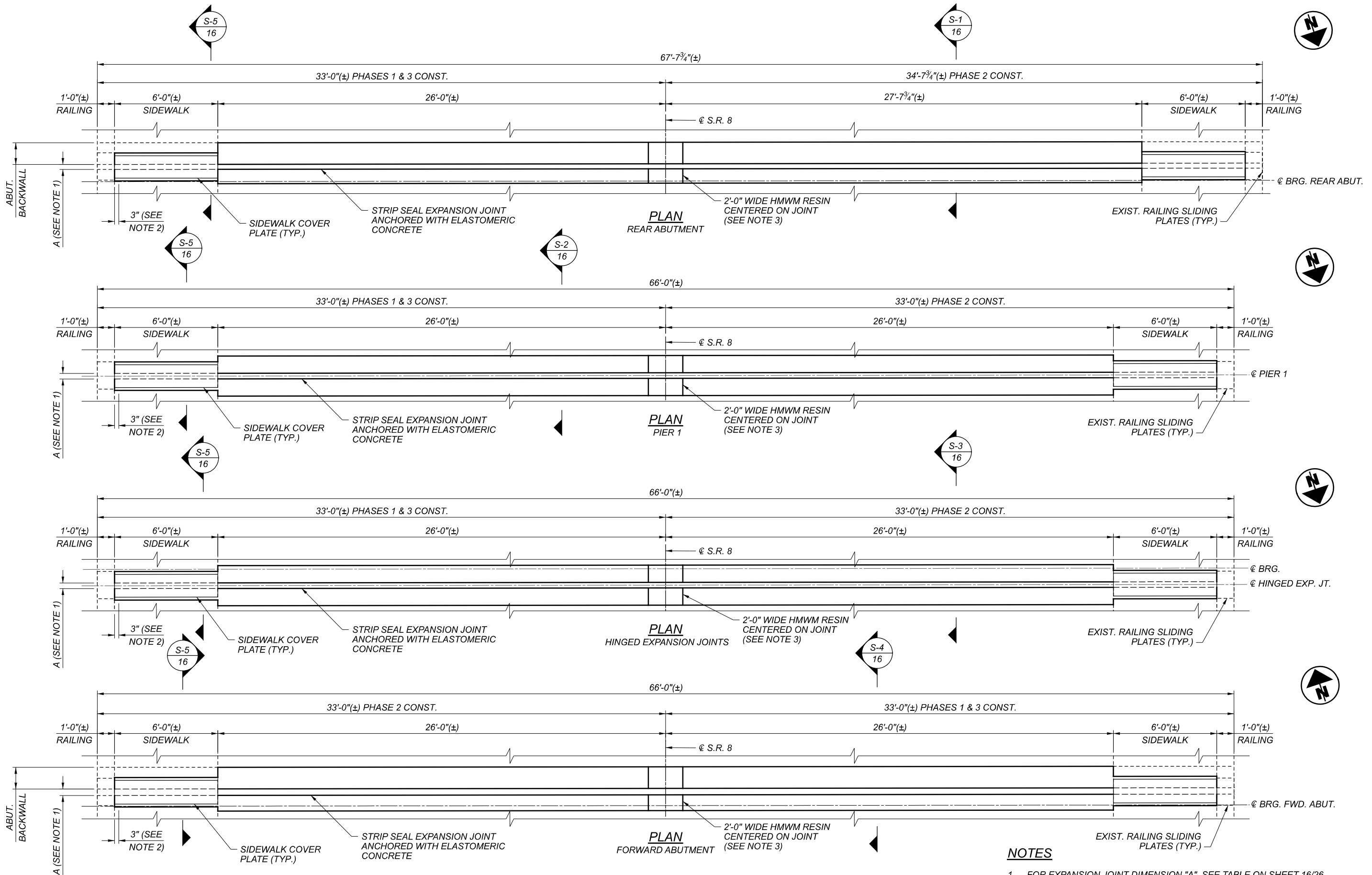

**NOTES**

- FOR EXPANSION JOINT DIMENSION "A", SEE TABLE ON SHEET 16/26.
- JOINT SEAL RETAINER TO END 3" FROM INSIDE FACE OF RAILING.
- THE 2'-0" OF HMWM CENTERED ON THE LONGITUDINAL C.J. IS INCLUDED FOR PAYMENT WITH ITEM 516 - STRIP SEAL EXPANSION JOINT ANCHORED WITH ELASTOMERIC CONCRETE, AS PER PLAN.

SFN	1801244
DESIGN AGENCY	
DESIGNER	MHK
CHECKER	JDA
REVIEWER	MJL
DATE	10/24/22
PROJECT ID	113674
SUBSET	15
TOTAL	26
SHEET	71
TOTAL	82

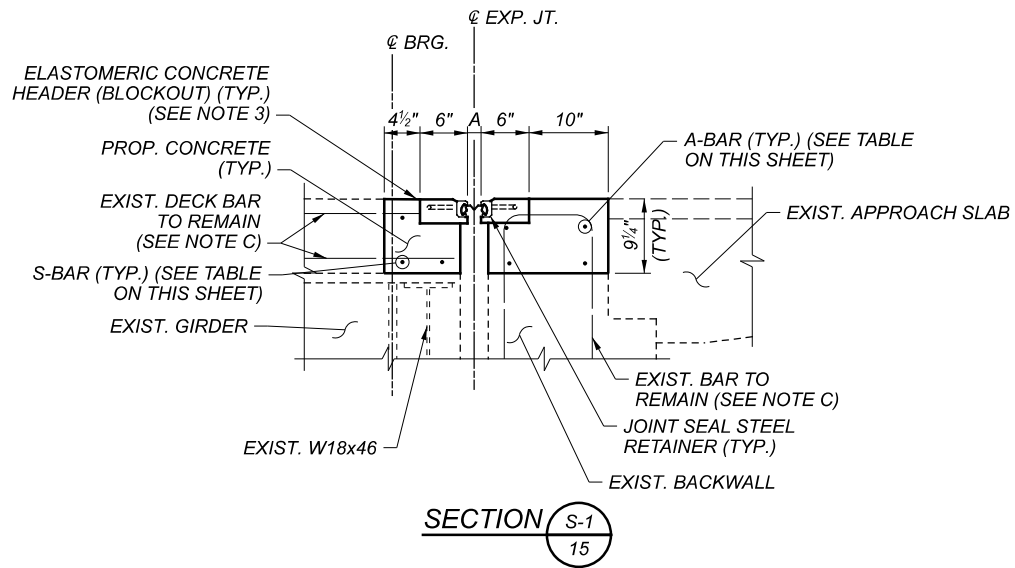

TYPICAL PROPOSED AT REAR ABUTMENT

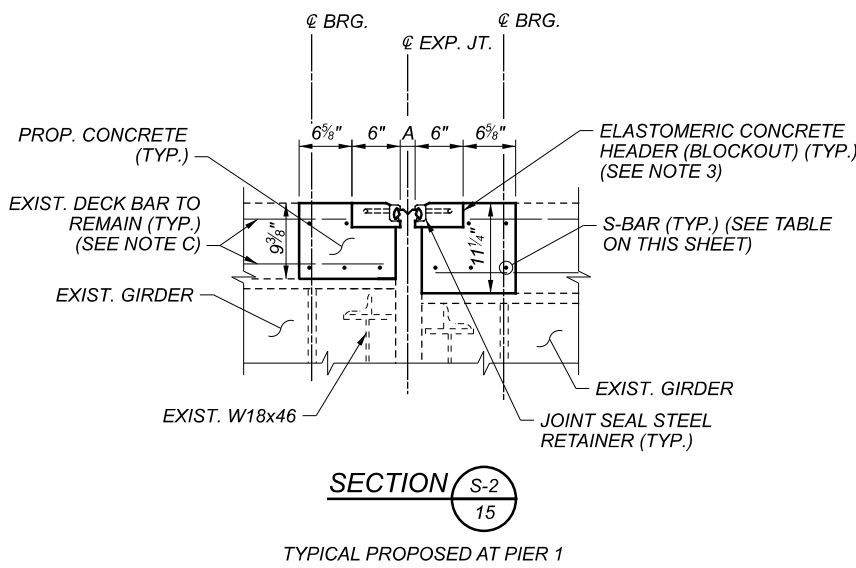

TYPICAL PROPOSED AT PIER 1

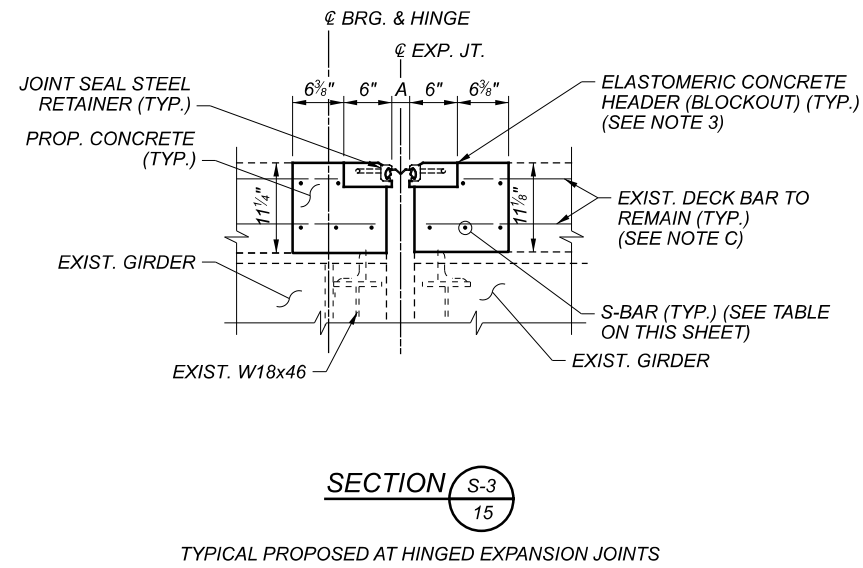

TYPICAL PROPOSED AT HINGED EXPANSION JOINTS

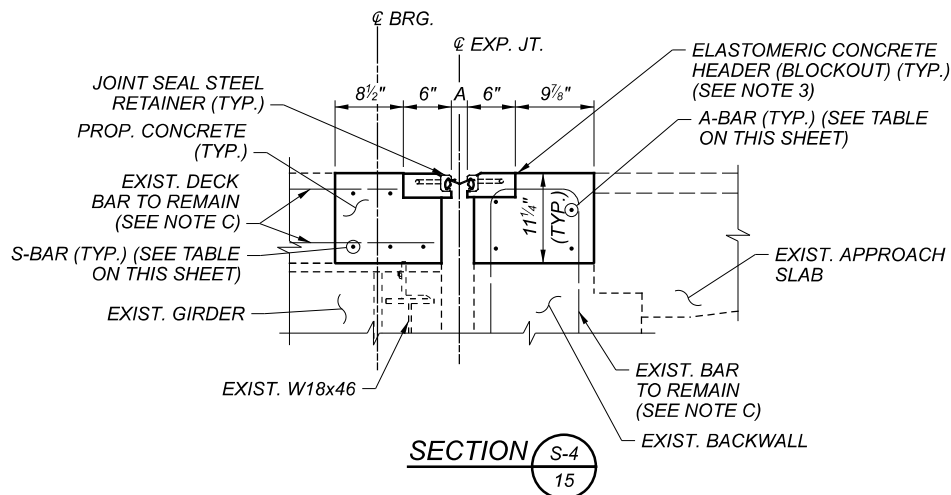

TYPICAL PROPOSED AT FORWARD ABUTMENT

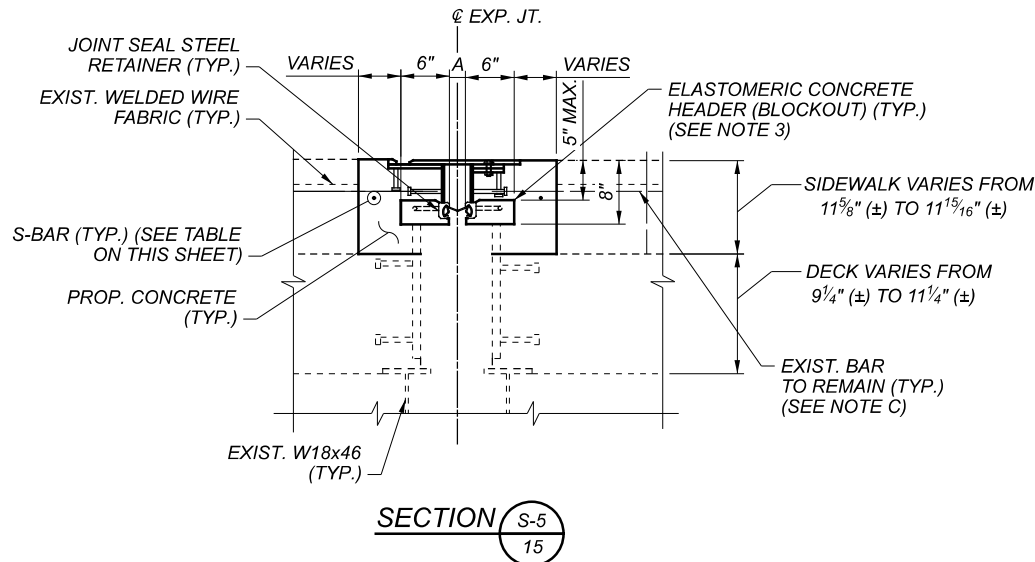

TYPICAL PROPOSED AT SIDEWALK HINGED EXP. JT. & PIER 1 SHOWN, ABUTMENTS SIMILAR

**DECK REINFORCING NOTES**

- A. PLACE THE RECONSTRUCTED EDGE OF DECK REINFORCING BARS PARALLEL TO THE EXPANSION JOINT AND 6" FROM THE PROPOSED EDGE OF DECK. ALL BARS TO BE SPACED AT EQUAL SPACES IN PROPOSED SECTION.
- B. COORDINATE THE INSTALLATION OF RECONSTRUCTED EDGE OF DECK REINFORCING WITH THE INSTALLATION OF PROPOSED EXPANSION JOINT ARMOR SO AS TO MINIMIZE INTERFERENCE BETWEEN JOINT ARMOR ANCHOR BARS AND EDGE OF DECK REINFORCING BARS.
- C. EXISTING REINFORCING STEEL TO REMAIN IN REMOVAL SECTIONS EXCEPT FOR REMOVALS AS NECESSARY TO ACCOMMODATE PROPOSED JOINT SYSTEM. INCLUDE FOR PAYMENT WITH ITEM 202 - PORTIONS OF STRUCTURE REMOVED, OVER 20 FOOT SPAN, AS PER PLAN.

**NOTES**

1. STRIP SEAL GLAND SIZE SHALL BE 3" FOR JOINT AT THE REAR ABUTMENT, 4" FOR THE JOINT AT PIER 1 AND THE JOINT AT THE FORWARD ABUTMENT, AND 5" FOR BOTH JOINTS AT THE HINGES. FOR THE 5" SINGLE GLAND STRIP SEAL JOINTS OVER BOTH HINGES, A DOUBLE GLAND JOINT CAN BE USED AS APPROVED BY THE ENGINEER. INSTALL STRIP SEAL GLAND AT EACH EXPANSION JOINT IN ONE CONTINUOUS PIECE DURING PHASES 2 AND 3.
2. FOR ADDITIONAL EXPANSION JOINT DETAILS NOT SHOWN, SEE STANDARD DRAWING EXJ-4-87.
3. FOR ELASTOMERIC CONCRETE HEADER DETAILS, SEE STANDARD DRAWING EXJ-6-17.
4. INSTALL THREADED MECHANICAL CONNECTORS FOR HORIZONTAL REINFORCING STEEL PARALLEL TO PROPOSED EXPANSION JOINTS AT PHASE CONSTRUCTION JOINT. THREADED MECHANICAL CONNECTORS SHALL BE RICHMOND SCREW ANCHOR THREADED DOWEL BAR ASSEMBLY, LENTON REBAR SPLICING MECHANISM, OR APPROVED EQUAL. COST SHALL BE INCLUDED FOR PAYMENT WITH ITEM 516 - STRIP SEAL EXPANSION JOINT ANCHORED WITH ELASTOMERIC CONCRETE, AS PER PLAN.

EXPANSION JOINT OPENINGS (DIM. "A")					
TEMP.	REAR ABUT.	PIER 1	HINGE 1	HINGE 2	FWD. ABUT.
30°F	1 3/16"	2 5/8"	3 3/16"	3 5/16"	2 9/16"
40°F	1 3/4"	2 3/8"	2 19/16"	2 19/16"	2 3/8"
50°F	1 3/4"	2 1/8"	2 9/16"	2 9/16"	2 1/8"
60°F	1 11/16"	1 7/8"	2 3/16"	2 3/16"	1 15/16"
70°F	1 5/8"	1 5/8"	1 13/16"	1 13/16"	1 3/4"
80°F	1 5/8"	1 3/8"	1 1/16"	1 1/16"	1 1/2"
90°F	1 9/16"	1 1/8"	1 1/16"	1 1/16"	1 9/16"

LOCATION	RECONSTRUCTED EDGE OF DECK REINFORCING			
	PHASE 1		PHASE 2	
	DECK / BACKWALL	SIDEWALK	DECK / BACKWALL	SIDEWALK
REAR ABUT.	3-S601 (DECK) 4-A501 (BACKWALL)	1-S602 1-A601	3-S603 (DECK) 4-A502 (BACKWALL)	1-S602 1-A601
PIER 1	10-S601	2-S602	10-S601	2-S602
HINGED EXP. JT.	10-S601	2-S602	10-S601	2-S602
FWD. ABUT.	5-S601 (DECK) 4-A501 (BACKWALL)	1-S602 1-A601	5-S601 (DECK) 4-A501 (BACKWALL)	1-S602 1-A601

CUY-8/10-02.26/08.69

MODEL: Sheet PAPER: 17x11 (in.) DATE: 10/28/2022 TIME: 8:46:55 PM USER: jmillar X:\Projects\2021\12122100200 ODOT CUY-8 CUY-10\113674\400-Engineering\Structures\SFN\_1801244\_SFN\_1801244\_SFN001.dgn

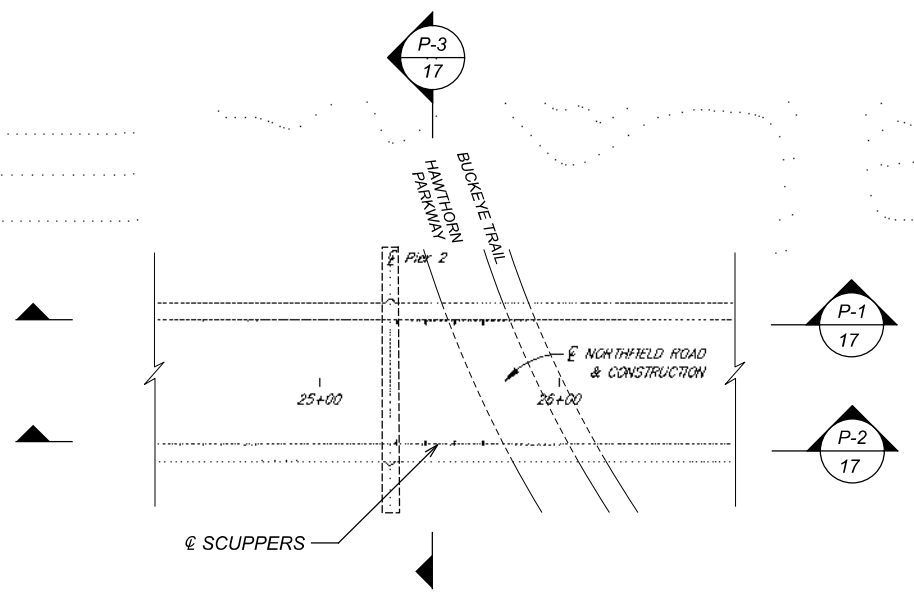

**PLAN - DECK DRAINAGE**  
(TYPICAL FOR PIERS 2, 3, 4, 5, 6, AND 7)  
PIER 2 SHOWN. OTHERS SIMILAR.

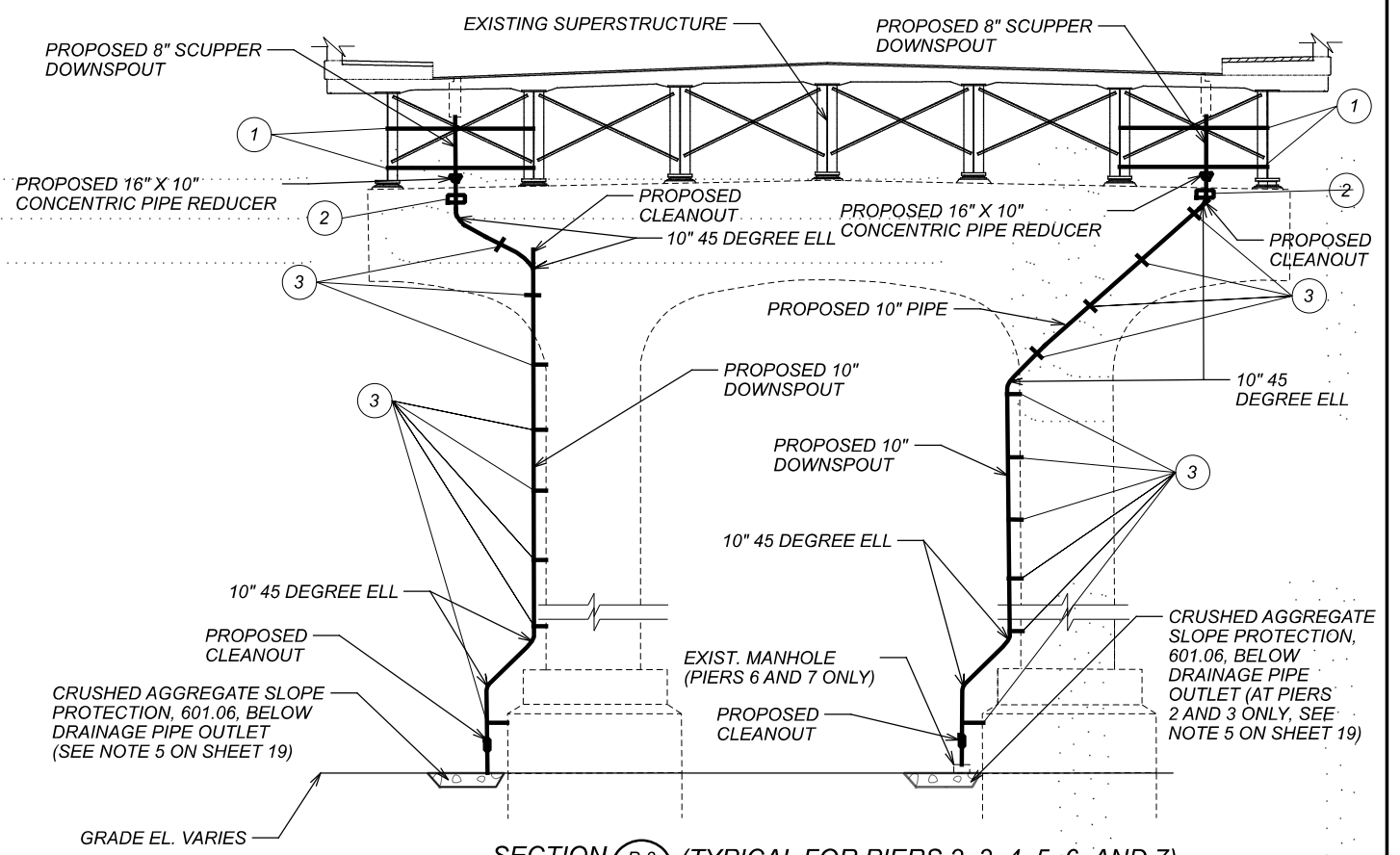

**SECTION P-3** (TYPICAL FOR PIERS 2, 3, 4, 5, 6, AND 7)

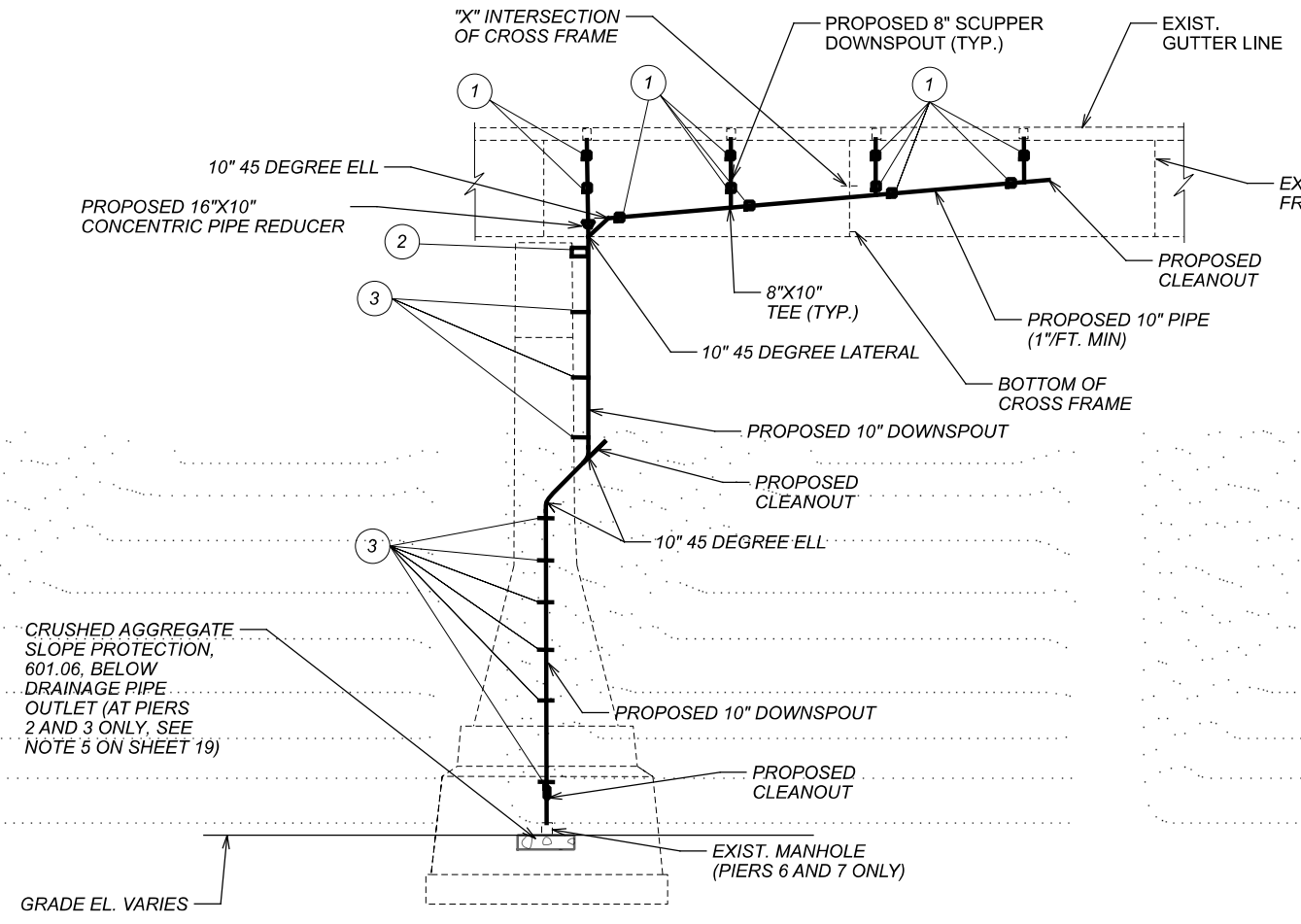

**SECTION P-1** (TYPICAL FOR PIERS 2, 3, 4, 5, 6, AND 7)

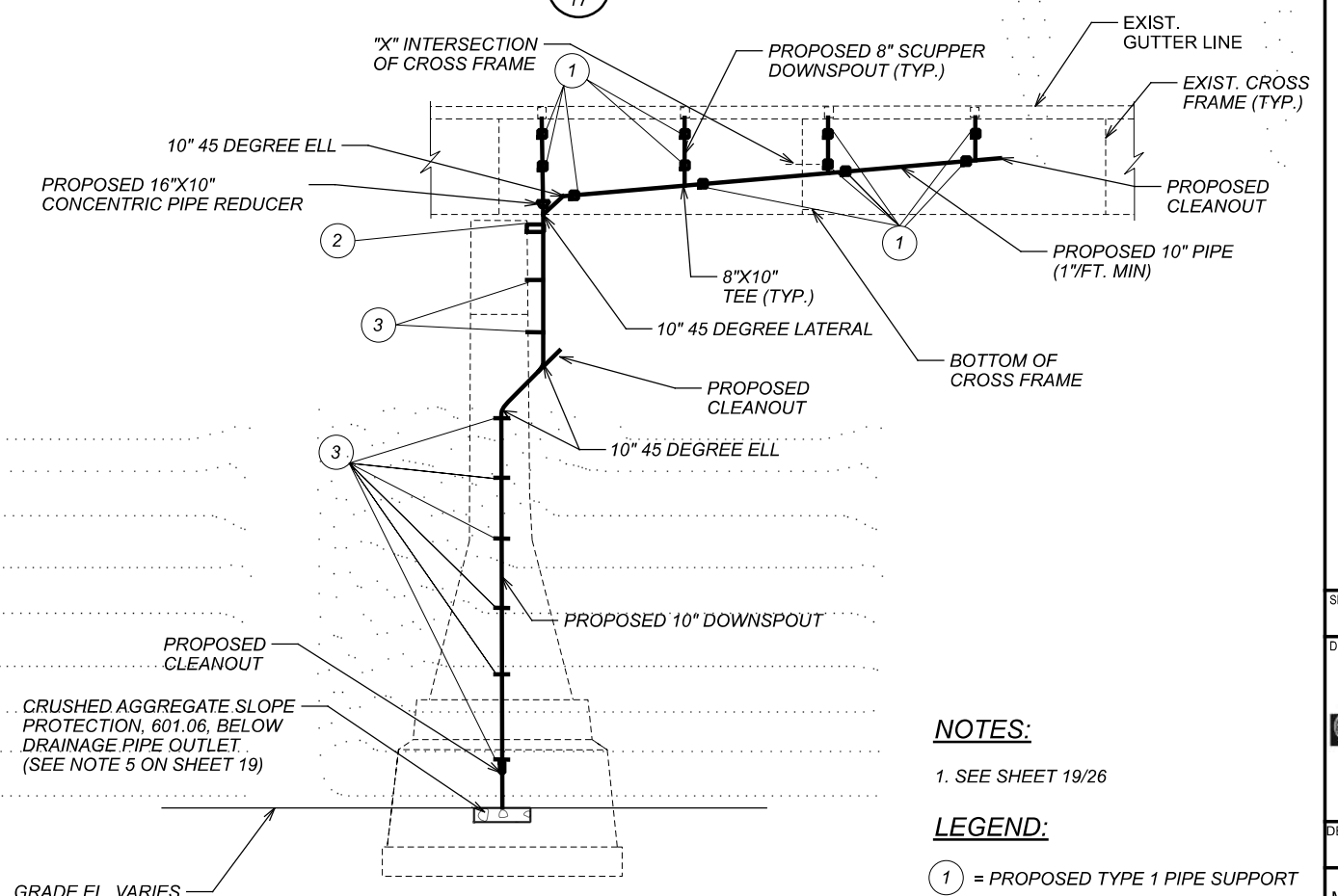

**SECTION P-2** (TYPICAL FOR PIERS 2, 3, 4, 5, 6, AND 7)

**NOTES:**

1. SEE SHEET 19/26

**LEGEND:**

- ① = PROPOSED TYPE 1 PIPE SUPPORT
- ② = PROPOSED TYPE 2 PIPE SUPPORT
- ③ = PROPOSED TYPE 3 PIPE SUPPORT

**DRAINAGE REPAIRS SCHEMATIC PLAN - 1**  
**BRIDGE NO. CUY-8-0226**  
**OVER HAWTHORN PKWY., BROADWAY AVE., TINKERS CREEK, & WHEELING & LAKE ERIE RR**

SFN	1801244
DESIGN AGENCY	
DESIGNER/CHECKER	SEB CJS
REVIEWER	MJL 10/24/22
PROJECT ID	113674
SUBSET	17 TOTAL 26
SHEET	73 TOTAL 82

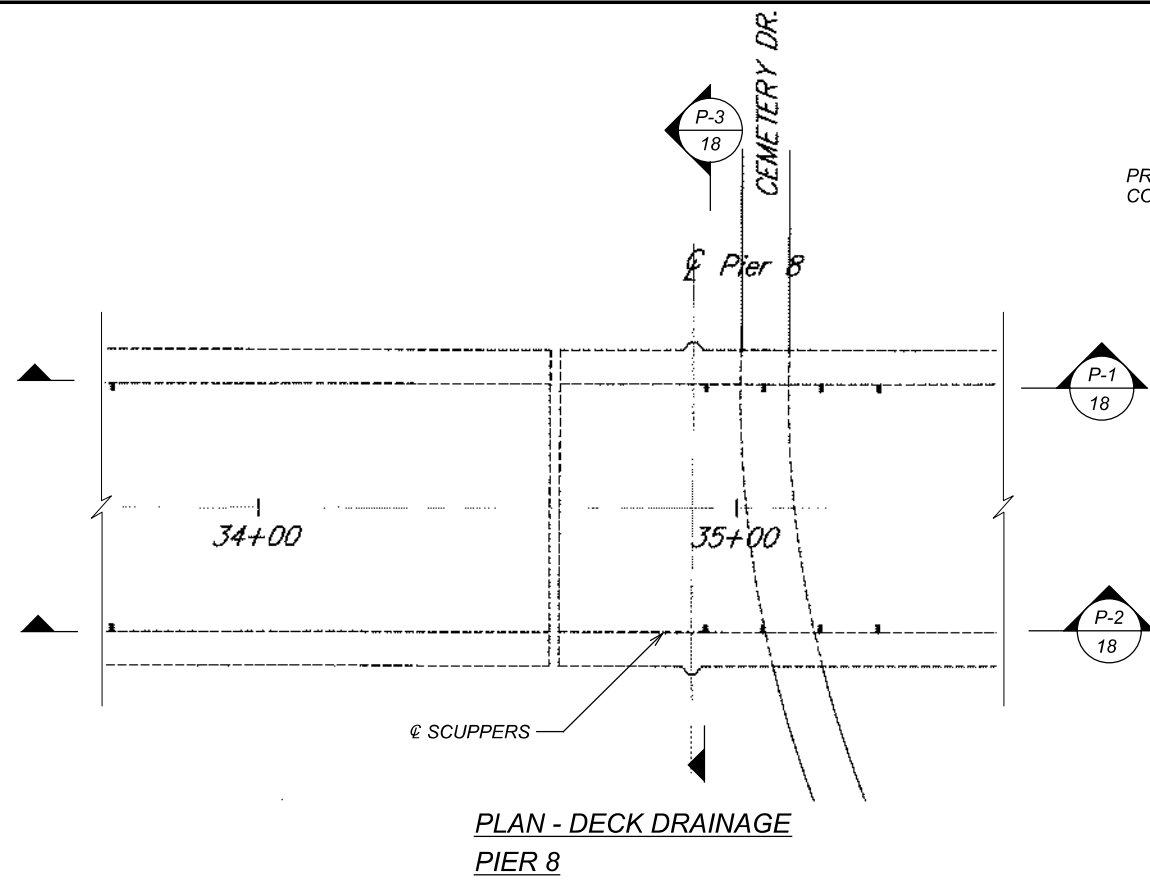

PLAN - DECK DRAINAGE  
PIER 8

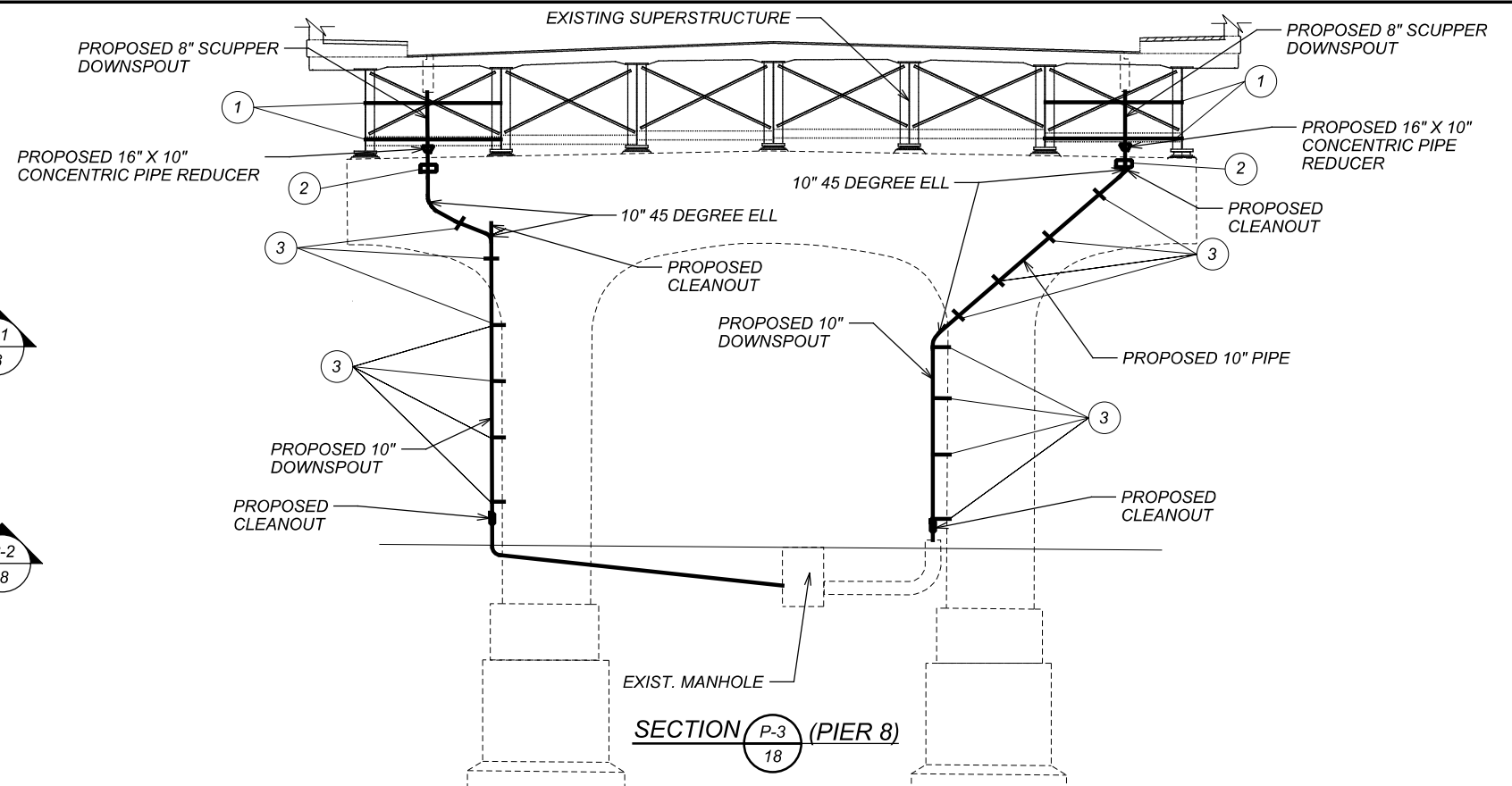

SECTION P-3 (PIER 8)

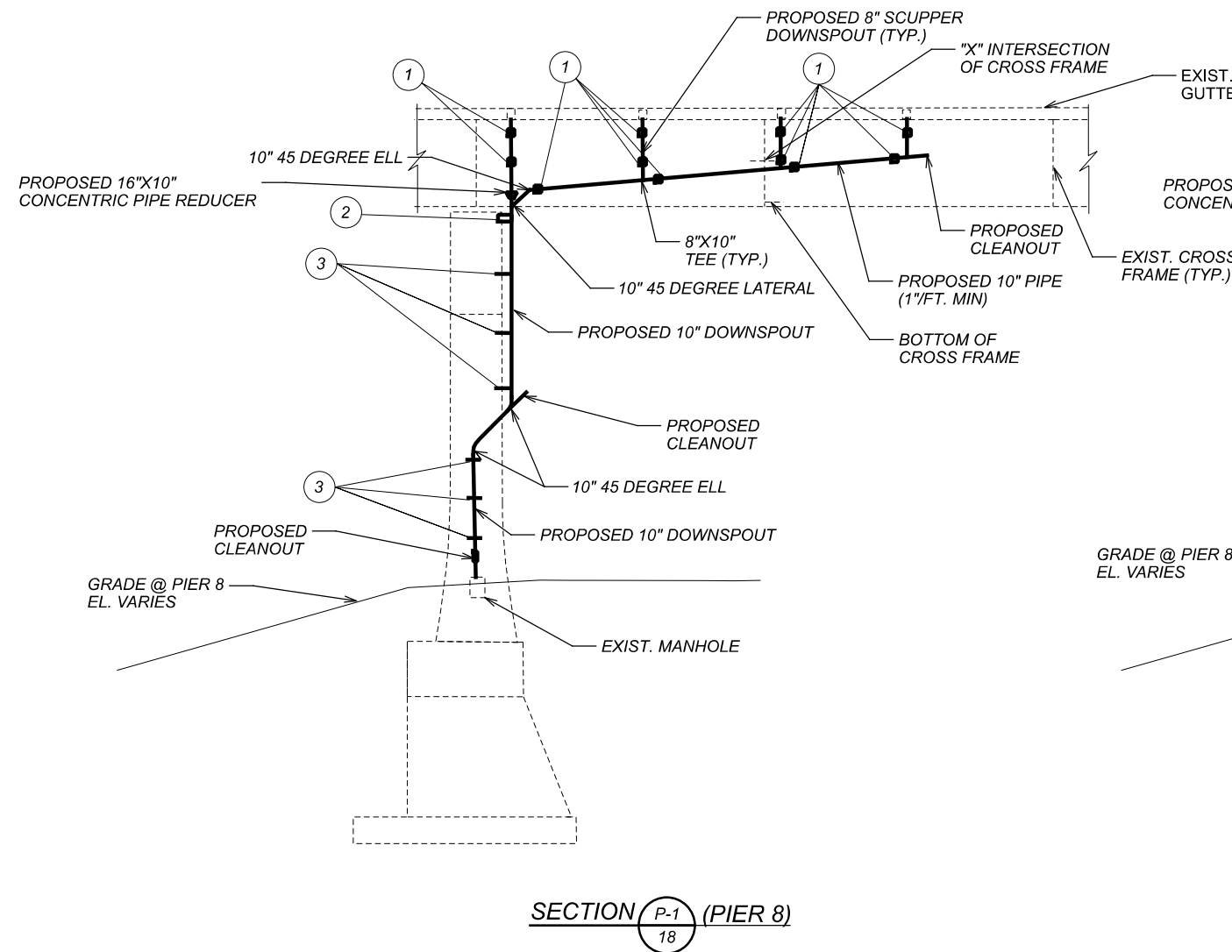

SECTION P-1 (PIER 8)

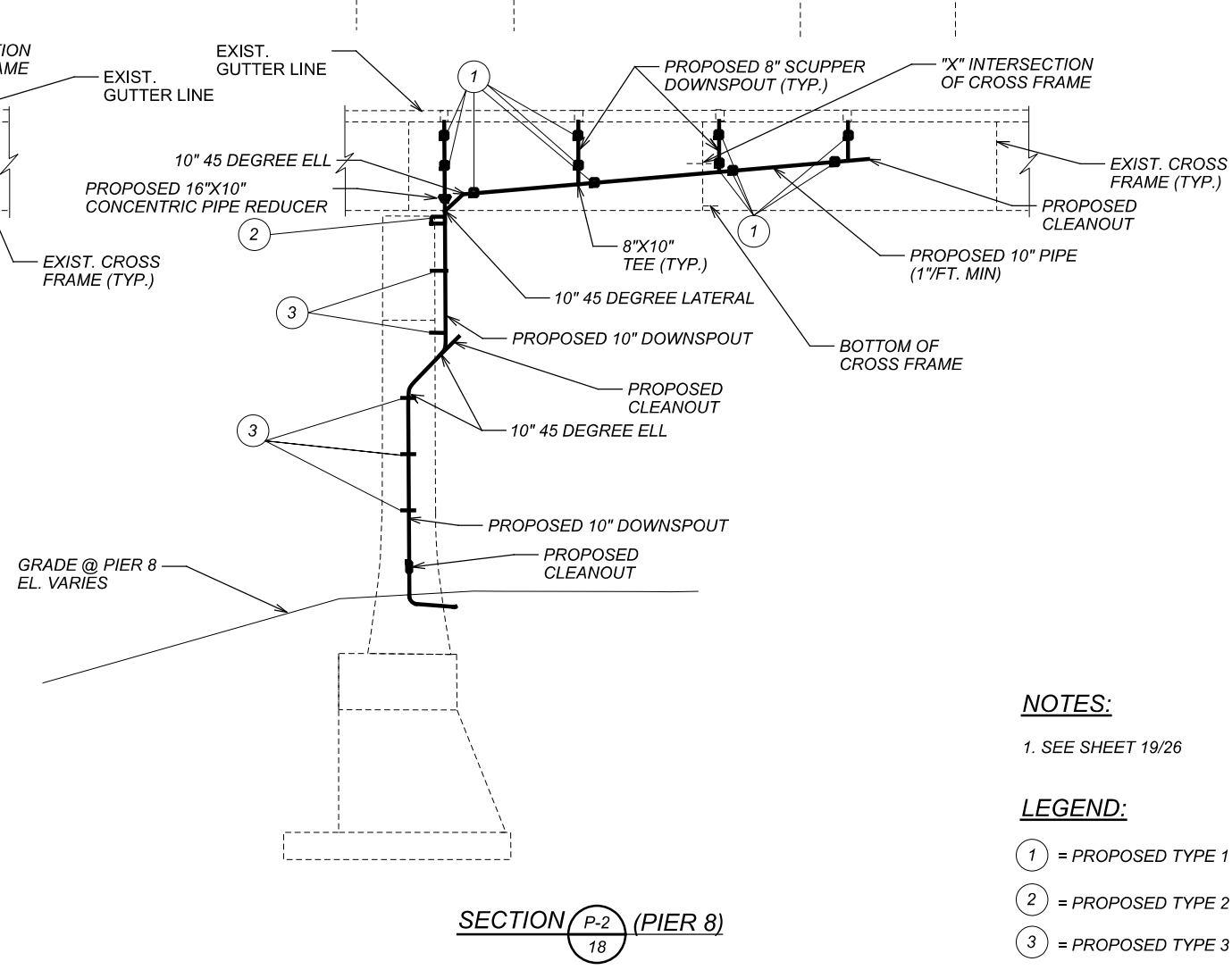

SECTION P-2 (PIER 8)

**NOTES:**

1. SEE SHEET 19/26

**LEGEND:**

- ① = PROPOSED TYPE 1 PIPE SUPPORT
- ② = PROPOSED TYPE 2 PIPE SUPPORT
- ③ = PROPOSED TYPE 3 PIPE SUPPORT



DESIGNER	CHECKER
SEB	CJS
REVIEWER	
MJL	10/24/22
PROJECT ID	
	113674
SUBSET	TOTAL
18	26
SHEET	TOTAL
74	82

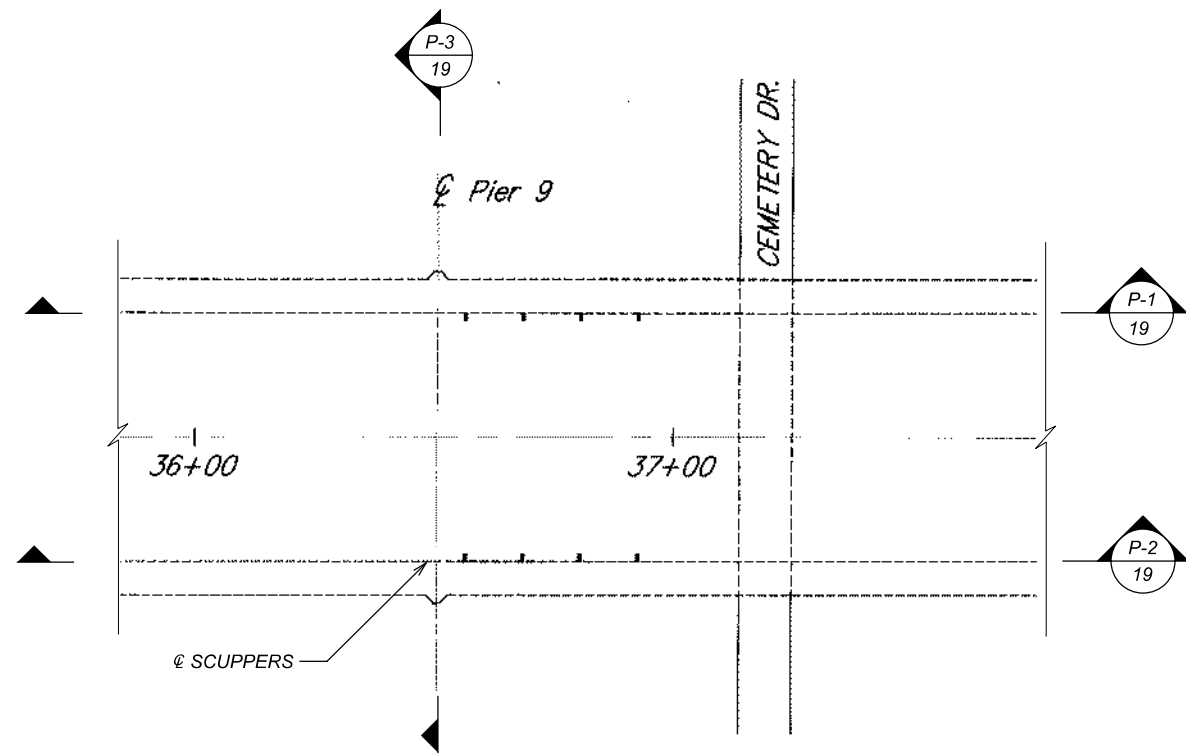

PLAN - DECK DRAINAGE  
TYPICAL FOR PIERS 9 AND 10  
PIER 9 SHOWN. PIER 10 SIMILAR.

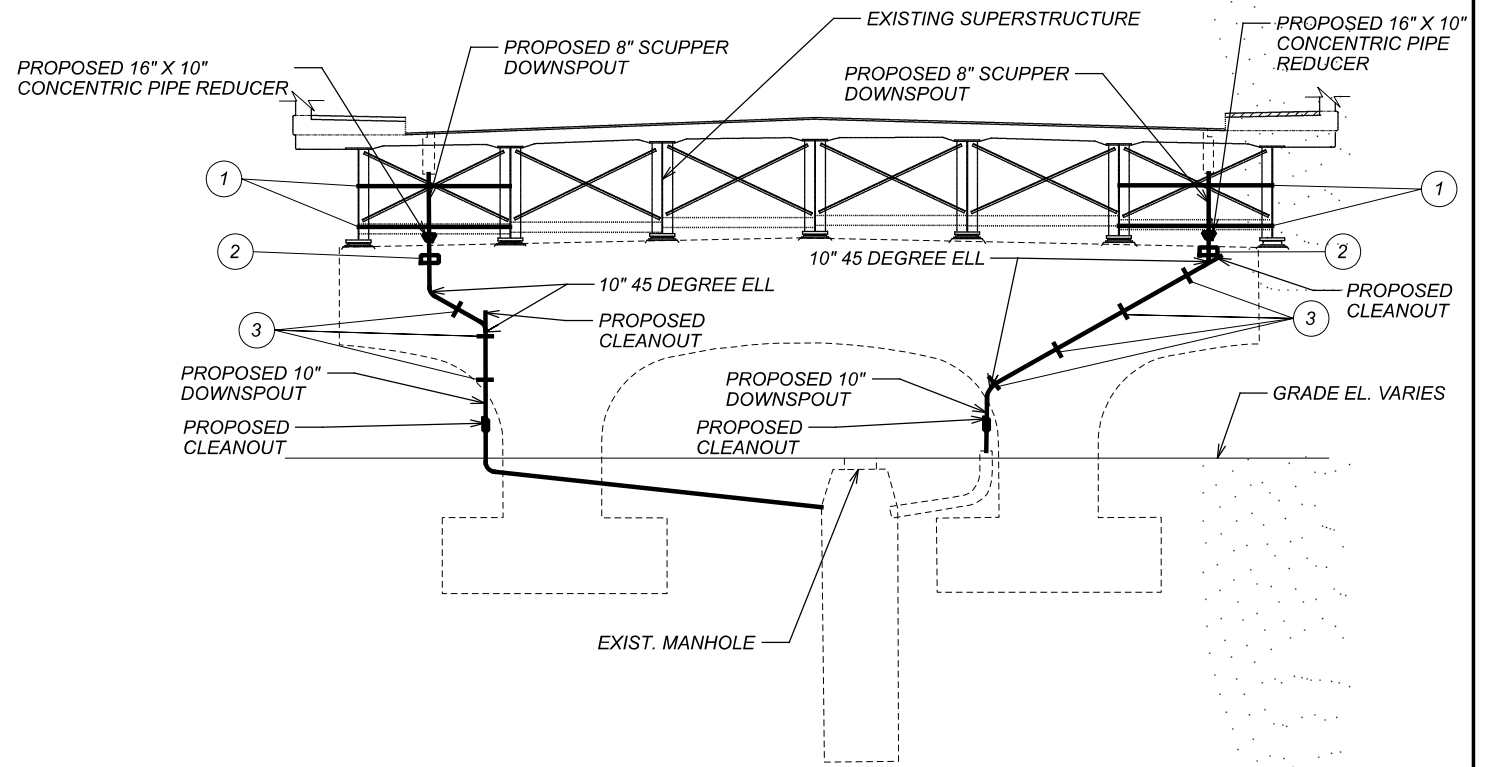

SECTION P-3 (TYPICAL FOR PIERS 9 AND 10)  
19

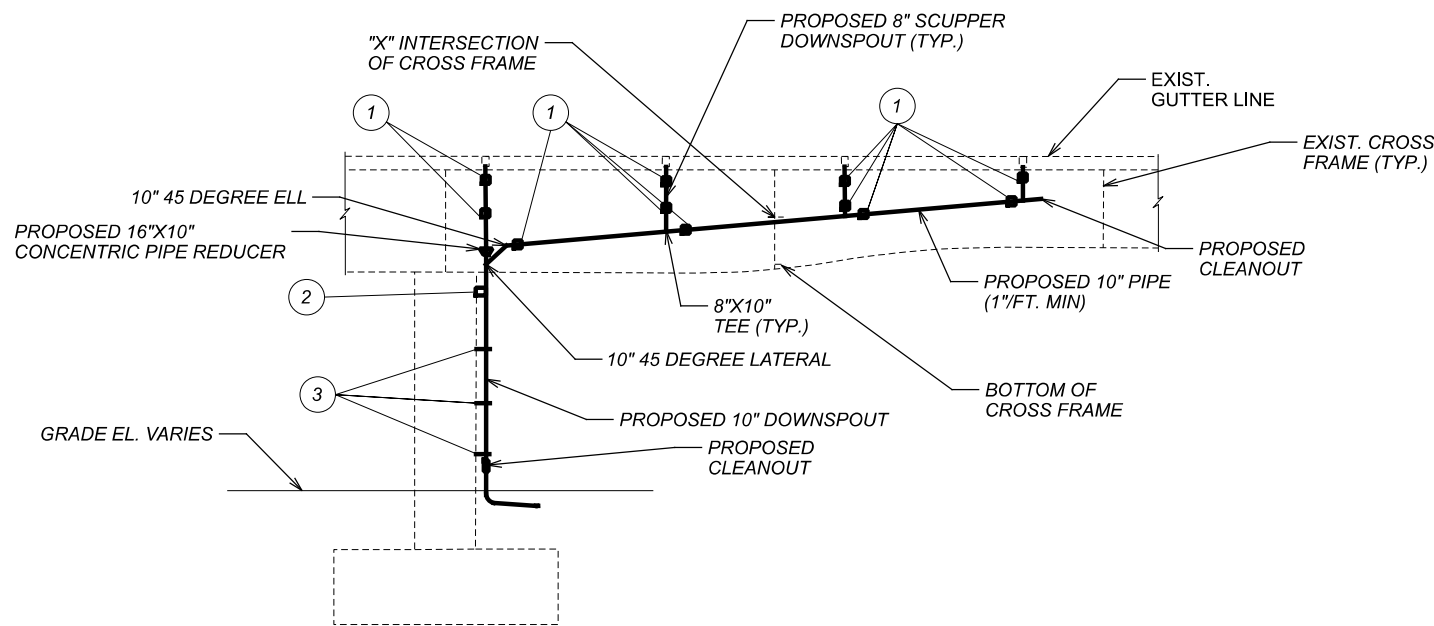

SECTION P-2 (TYPICAL FOR PIERS 9 AND 10)  
19 SIMILAR FOR SECTION P-1

**NOTES**

1. EXISTING SCUPPER DOWNSPOUTS, PIPES, AND HANGERS ARE NOT SHOWN FOR CLARITY AND WILL BE REMOVED TO THE EXISTING GROUND LEVEL. EXISTING SCUPPER SUPPORTS THAT ARE WELDED TO THE GIRDERS SHALL BE CUT OFF WITHOUT GOUGING THE WEB AND THE AREA GROUND SMOOTH.
2. CLEAN OUT ALL EXISTING SCUPPERS AND EXISTING COLLECTOR DOWNSPOUTS IN SPANS 1 AND 2 AND ON PIER 1 IN ACCORDANCE WITH ITEM 518 - STRUCTURE DRAINAGE, MISC.; SCUPPER CLEANOUT.
3. THIS WORK INCLUDES, BUT IS NOT LIMITED TO, REMOVAL OF THE DRAINAGE SYSTEM AND SUPPORTS FOR THE GIRDERS AND CONCRETE AND PIERS 2 THROUGH 10, DOWN TO THE EXISTING GROUND SURFACE.
4. THE PIPE AND FITTINGS SHALL BE FIBERGLASS REINFORCED THERMOSET RESIN PIPE (FRP) ACCORDING TO ASTM D 2996 BDP-12EA12122 WITH A 30,000 PSI (207 MPA) MINIMUM SHORT TIME RUPTURE STRENGTH HOOPS TENSILE STRESS, THE ACCELERATED UV WEATHERING PERFORMANCE REQUIREMENTS OF ASTM G154 (D4329-99). A MINIMUM WALL THICKNESS OF 0.125 IN. (3.18 MM) AND A MINIMUM OPERATING PRESSURE OF 50 PSI.
5. MINIMUM ROCK CHANNEL PROTECTION TO BE PROVIDED AT EACH DOWNSPOUT THAT DOES NOT LEAD INTO AN EXISTING MANHOLE SHALL BE APPROXIMATELY 4'-0" BY 4'-0" BY 1'-0" THICK AT PIERS 2, 3, 6, 7, 9, AND 10. SUBSTANTIAL ROCK PROTECTION IS ALREADY PROVIDED AT PIERS 4 AND 5 FOR SCOUR PROTECTION. SEE SHEET 21 FOR DETAILS.
6. SEE SHEET 20/27 FOR PIPE SUPPORT DETAILS.

**LEGEND:**

- ① = PROPOSED TYPE 1 PIPE SUPPORT
- ② = PROPOSED TYPE 2 PIPE SUPPORT
- ③ = PROPOSED TYPE 3 PIPE SUPPORT

SFN	1801244
DESIGN AGENCY	
DESIGNER	CHECKER
SEB	CJS
REVIEWER	
MJL 10/24/22	
PROJECT ID	
113674	
SUBSET TOTAL	
19	26
SHEET TOTAL	
75	82

CUY-8/10-02-26/08.69

MODEL: Sheet PAPER: 17X11 (in.) DATE: 10/29/2022 TIME: 8:47:59 PM USER: jmillar  
X:\Projects\2021\12122100200 ODOT CUY-8 CUY-8 CUY-8 CUY-8\Projects\2021\12122100200\Structures\SFN\_1801244.dgn

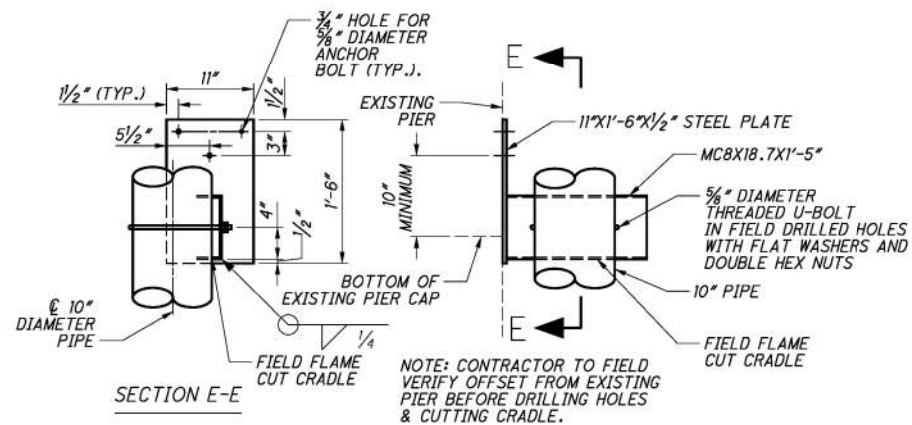

TYPE 2 PIPE SUPPORT

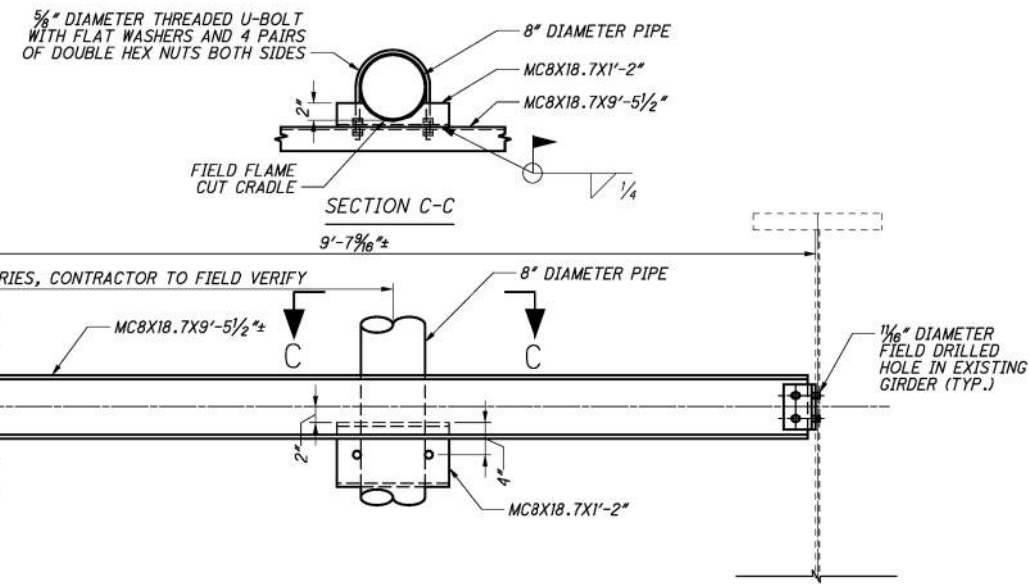

TYPE 1 PIPE SUPPORT

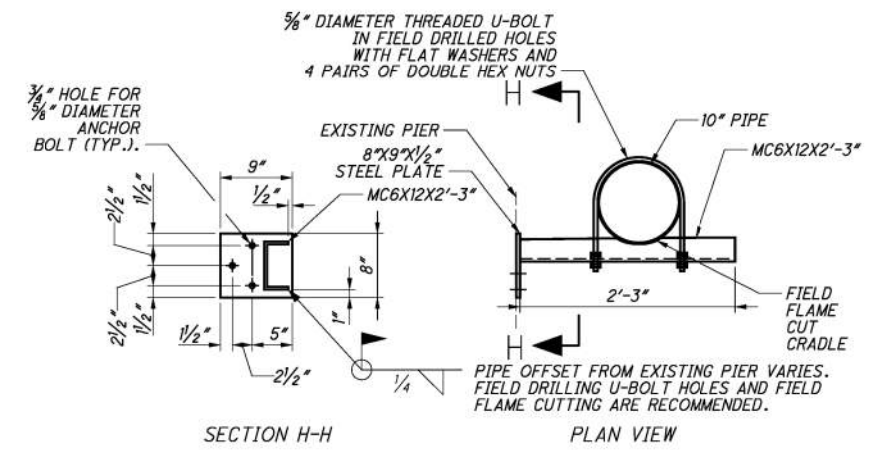

TYPE 3 PIPE SUPPORT

DRAINAGE REPAIR DETAILS  
BRIDGE NO. CUY-8-0226

OVER HAWTHORN PKWY., BROADWAY AVE., TINKERS CREEK, & WHEELING & LAKE ERIE RR

SFN  
1801244  
DESIGN AGENCY



DESIGNER	CHECKER
SEB	CJS
REVIEWER	
MJL	10/24/22
PROJECT ID	113674
SUBSET	TOTAL
20	26
SHEET	TOTAL
76	82

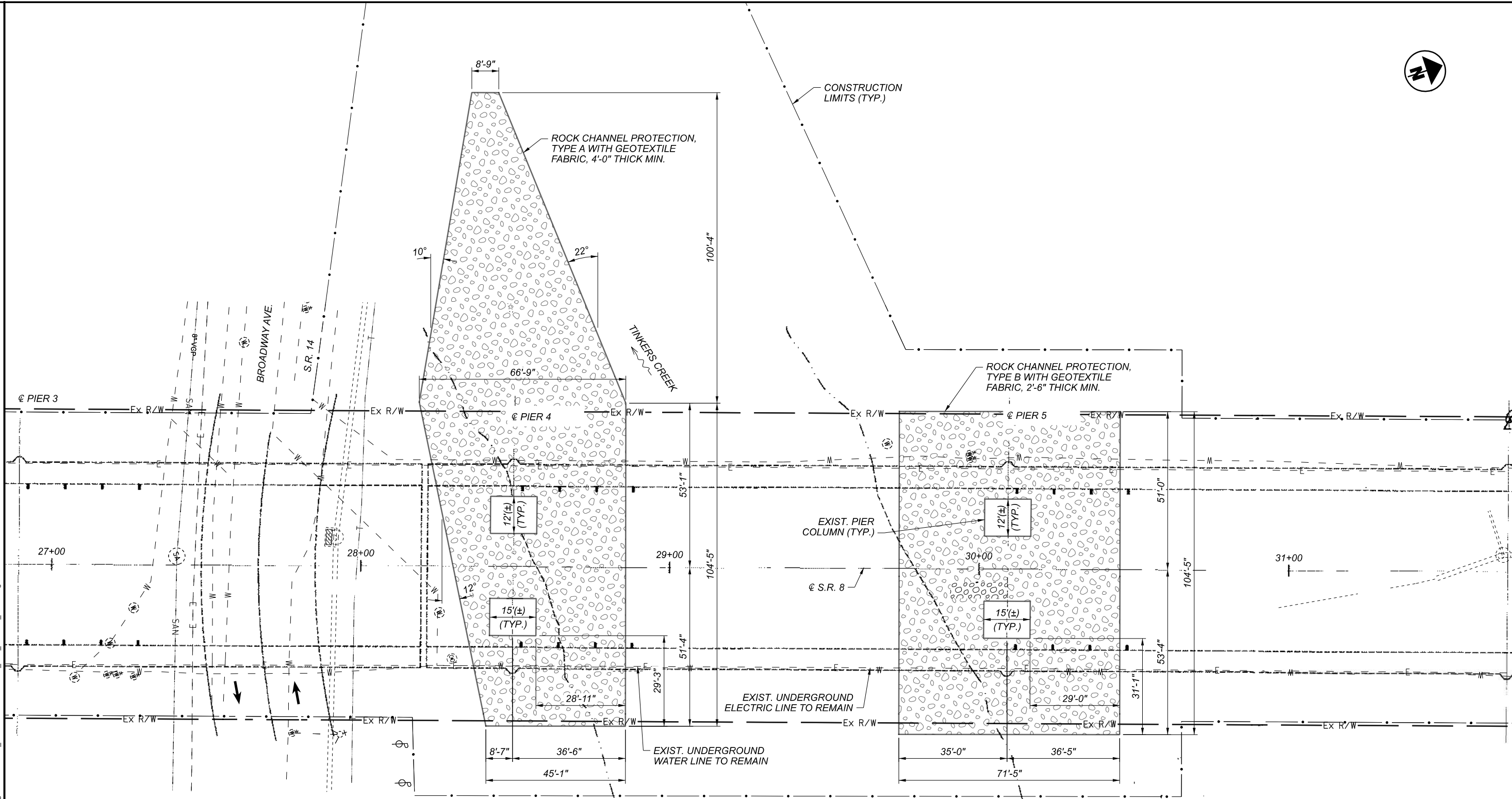

PLAN

NOTES

- 1. PLACE ROCK CHANNEL PROTECTION SUCH THAT THE TOP OF THE ROCK CHANNEL PROTECTION IS AT THE NORMAL BED LEVEL OF THE CREEK. IN SCOURED LOCATIONS, PLACE ROCK CHANNEL PROTECTION TO THE ORIGINAL GRADE.

ROCK CHANNEL PROTECTION DETAILS  
 BRIDGE NO. CUY-8-0226

OVER HAWTHORN PKWY., BROADWAY AVE., TINKERS CREEK, & WHEELING & LAKE ERIE RR

SFN  
1801244  
DESIGN AGENCY



DESIGNER CHECKER  
MHK CJS

REVIEWER  
MJL 10/24/22

PROJECT ID  
113674

SUBSET	TOTAL
21	26

SHEET	TOTAL
77	82



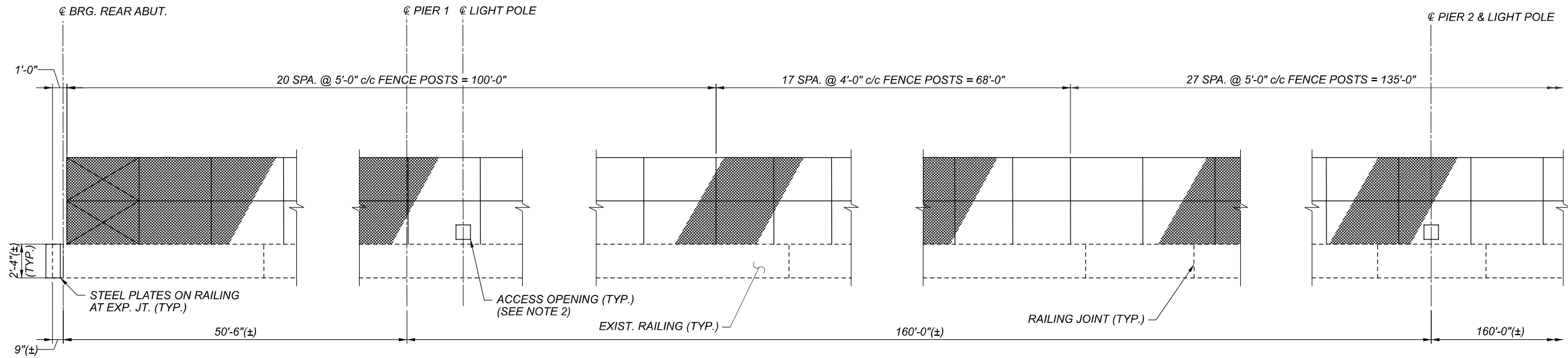

**SUPERSTRUCTURE FENCE ELEVATION**  
 LEFT SIDE SHOWN, RIGHT SIDE SIMILAR  
 INTERIOR VIEW

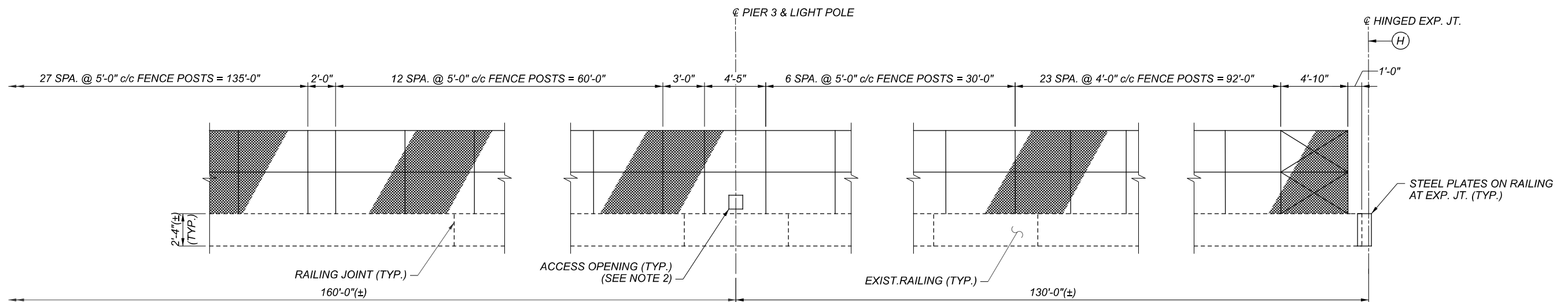

**SUPERSTRUCTURE FENCE ELEVATION**  
 LEFT SIDE SHOWN, RIGHT SIDE SIMILAR  
 INTERIOR VIEW

**LEGEND**

(H) FOR FENCE DETAIL AT EXPANSION JOINT, SEE DETAIL ON SHEET 26/26

**NOTES**

- FENCE ON SIDEWALK RAILINGS SHALL BE IN ACCORDANCE WITH STANDARD DRAWING VPF-1-90, 6'-0" STRAIGHT FENCE TYPE PS-4 WITH BP-5 BASE PLATES AND COATED FABRIC, COLOR BLACK.
- FOR FENCE ACCESS OPENING AT LIGHT POLE DETAIL, SEE STANDARD DRAWING VPF-1-90.

SFN		1801244	
DESIGN AGENCY			
<b>DLZ</b>			
DESIGNER	CHECKER		
JG	CJS		
REVIEWER			
MJL	10/24/22		
PROJECT ID			
113674			
SUBSET	TOTAL		
22	26		
SHEET			
78	82		



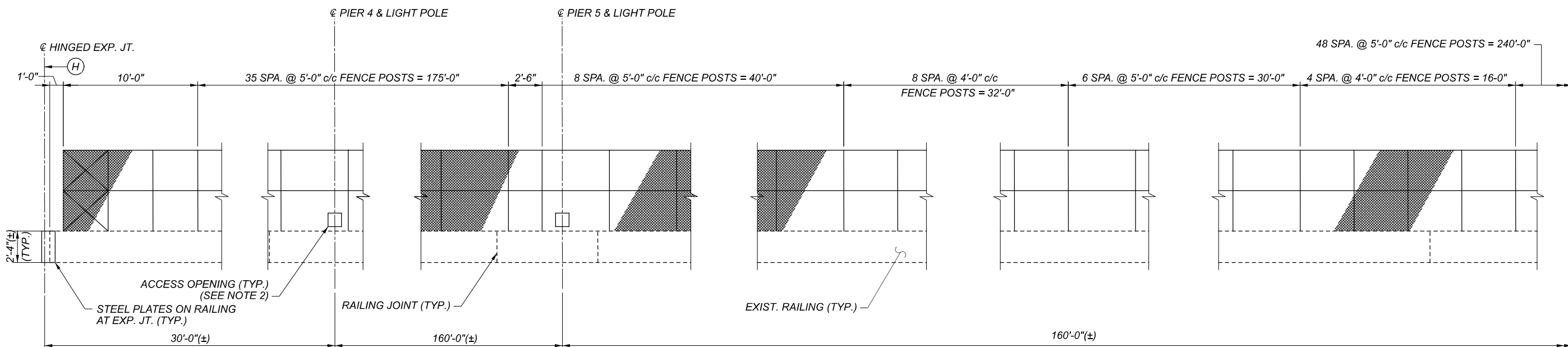

**SUPERSTRUCTURE FENCE ELEVATION**  
 LEFT SIDE SHOWN, RIGHT SIDE SIMILAR  
 INTERIOR VIEW

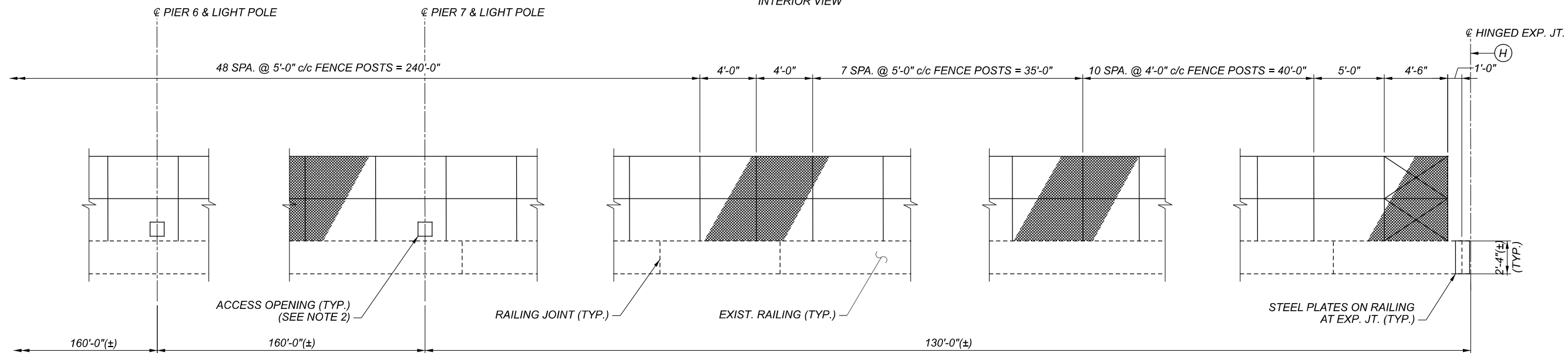

**SUPERSTRUCTURE FENCE ELEVATION**  
 LEFT SIDE SHOWN, RIGHT SIDE SIMILAR  
 INTERIOR VIEW

**LEGEND**

(H) FOR FENCE DETAIL AT EXPANSION JOINT, SEE DETAIL ON SHEET 26/26

**NOTES**

- FENCE ON SIDEWALK RAILINGS SHALL BE IN ACCORDANCE WITH STANDARD DRAWING VPF-1-90, 6'-0" STRAIGHT FENCE TYPE PS-4 WITH BP-5 BASE PLATES AND COATED FABRIC, COLOR BLACK.
- FOR FENCE ACCESS OPENING AT LIGHT POLE DETAIL, SEE STANDARD DRAWING VPF-1-90.

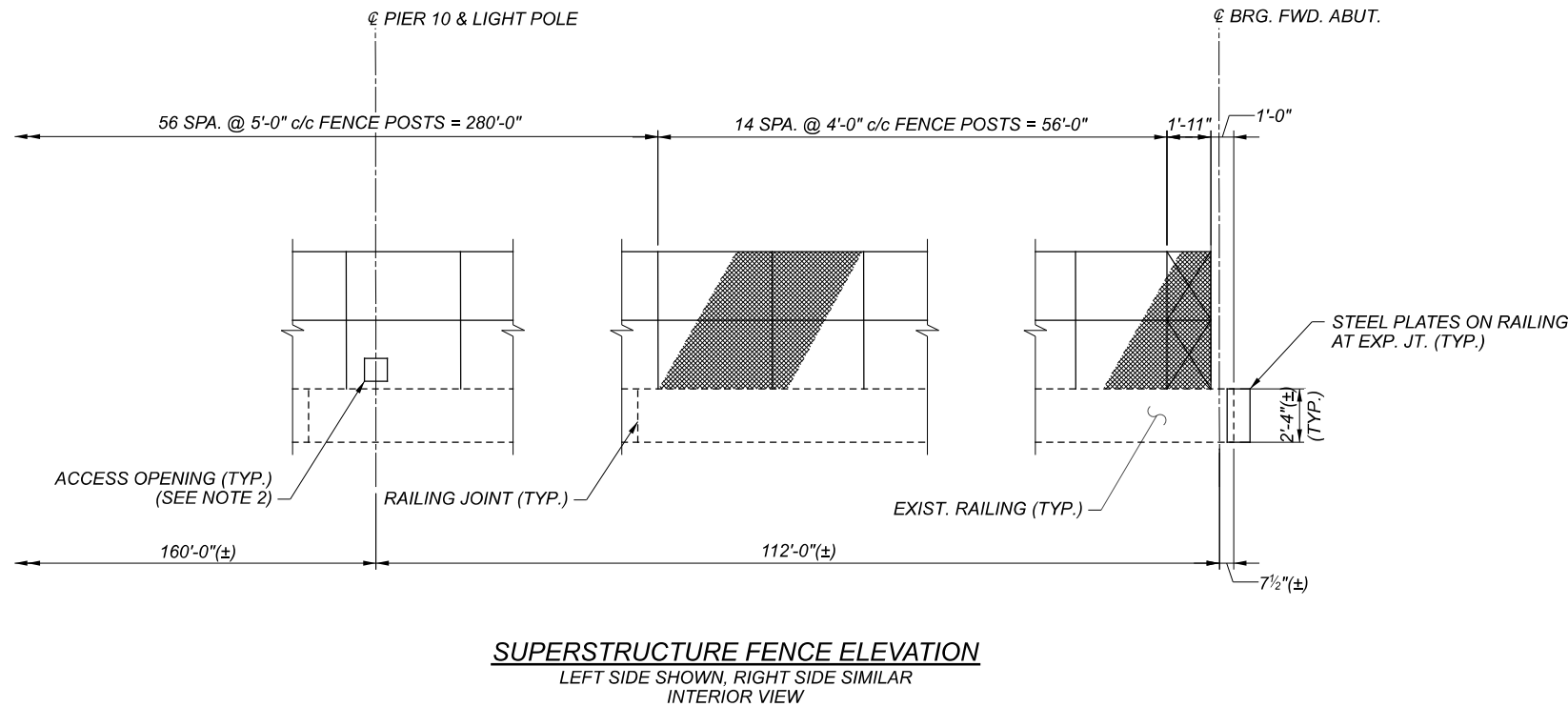
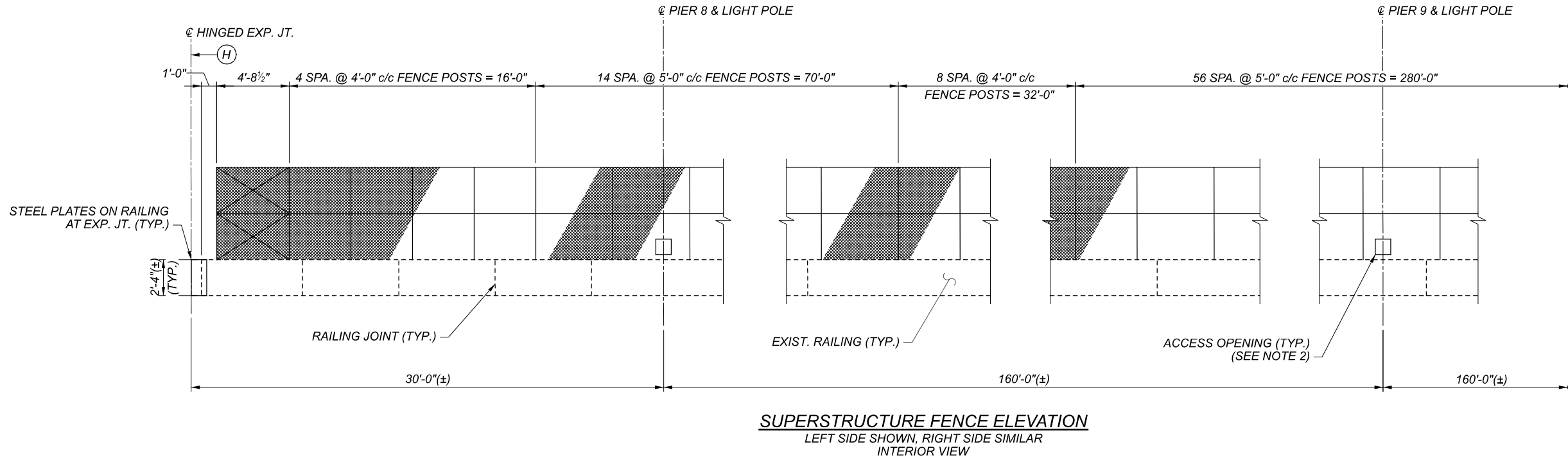

**LEGEND**

(H) FOR FENCE DETAIL AT EXPANSION JOINT, SEE DETAIL ON SHEET 26/26

**NOTES**

- FENCE ON SIDEWALK RAILINGS SHALL BE IN ACCORDANCE WITH STANDARD DRAWING VPF-1-90, 6'-0" STRAIGHT FENCE TYPE PS-4 WITH BP-5 BASE PLATES AND COATED FABRIC, COLOR BLACK.
- FOR FENCE ACCESS OPENING AT LIGHT POLE DETAIL, SEE STANDARD DRAWING VPF-1-90.

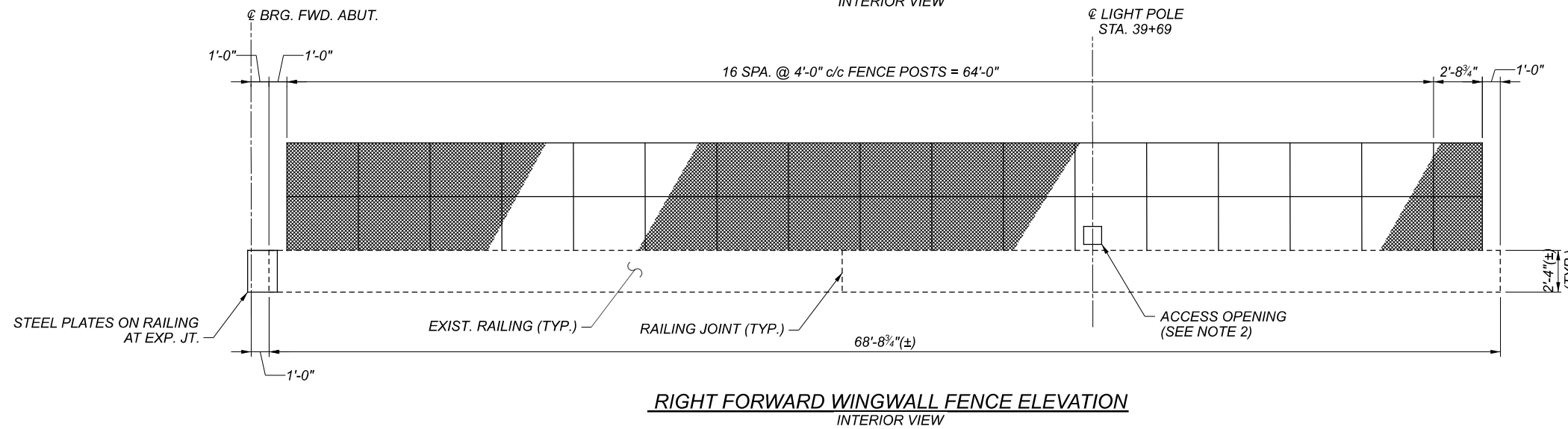
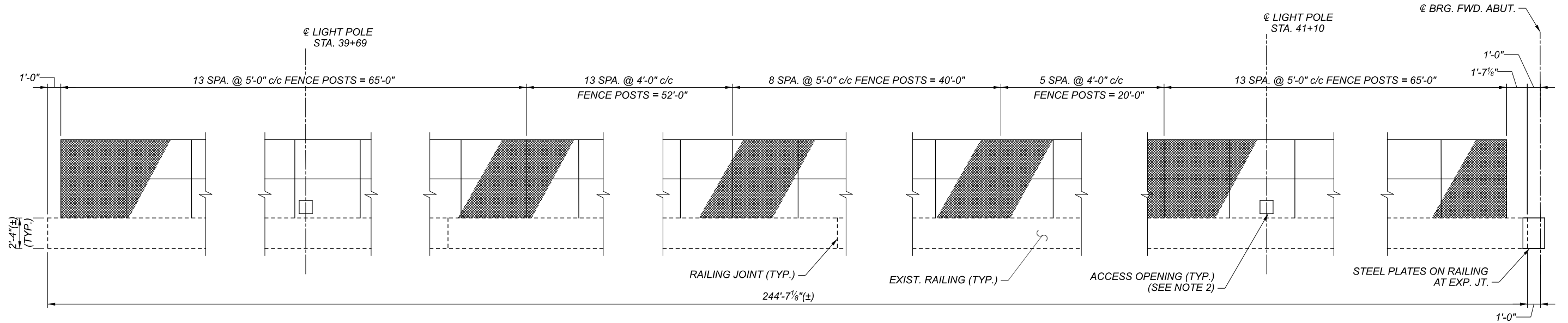
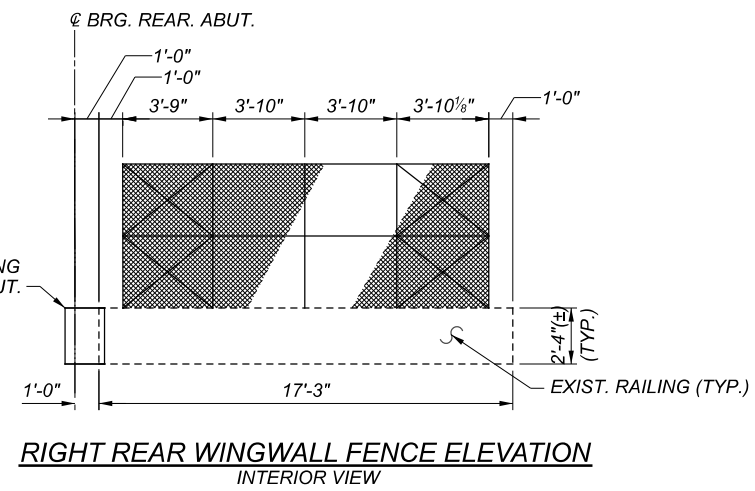
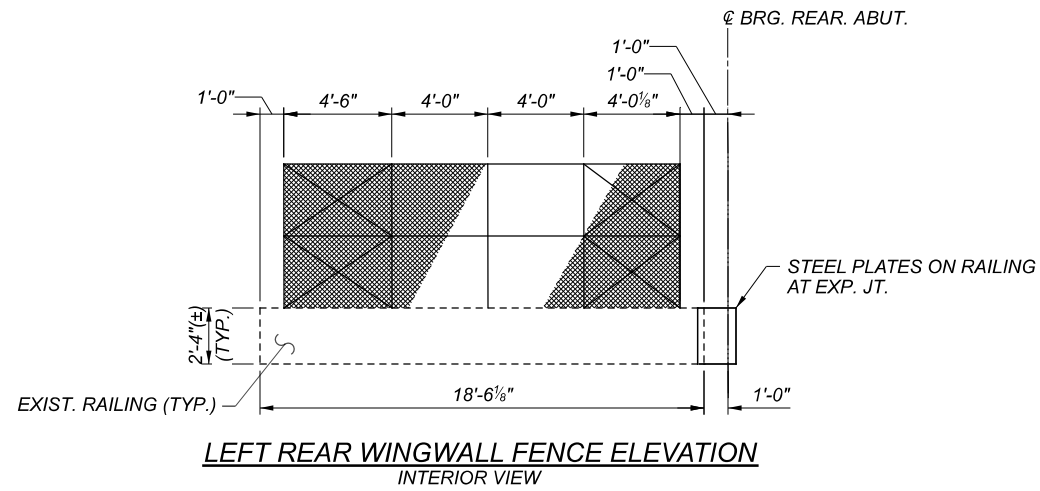

**NOTES**

1. FENCE ON SIDEWALK RAILINGS SHALL BE IN ACCORDANCE WITH STANDARD DRAWING VPF-1-90, 6'-0" STRAIGHT FENCE TYPE PS-4 WITH BP-5 BASE PLATES AND COATED FABRIC, COLOR BLACK.
2. FOR FENCE ACCESS OPENING AT LIGHT POLE DETAIL, SEE STANDARD DRAWING VPF-1-90.

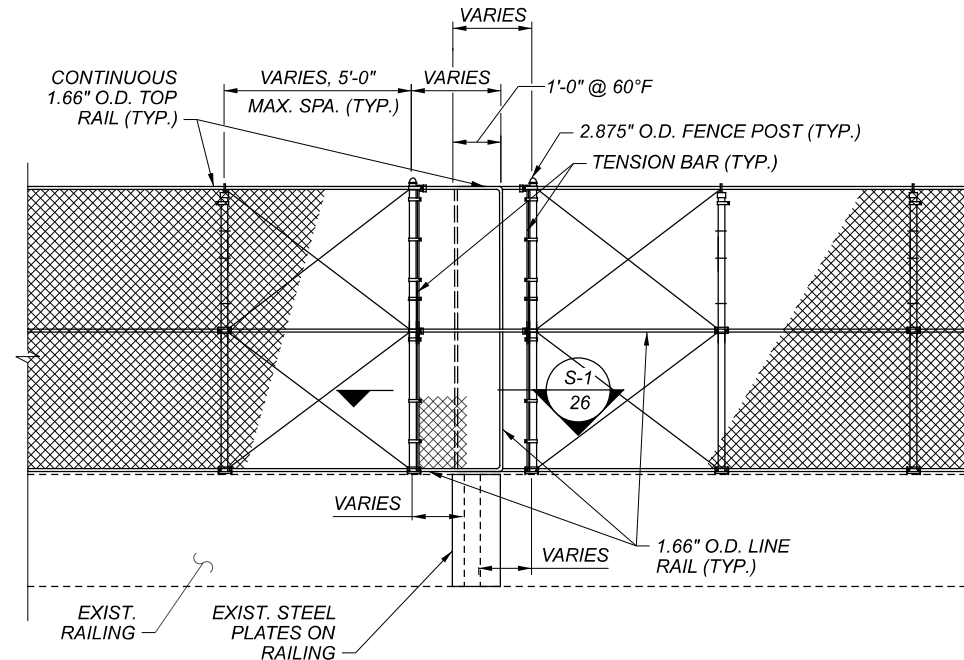
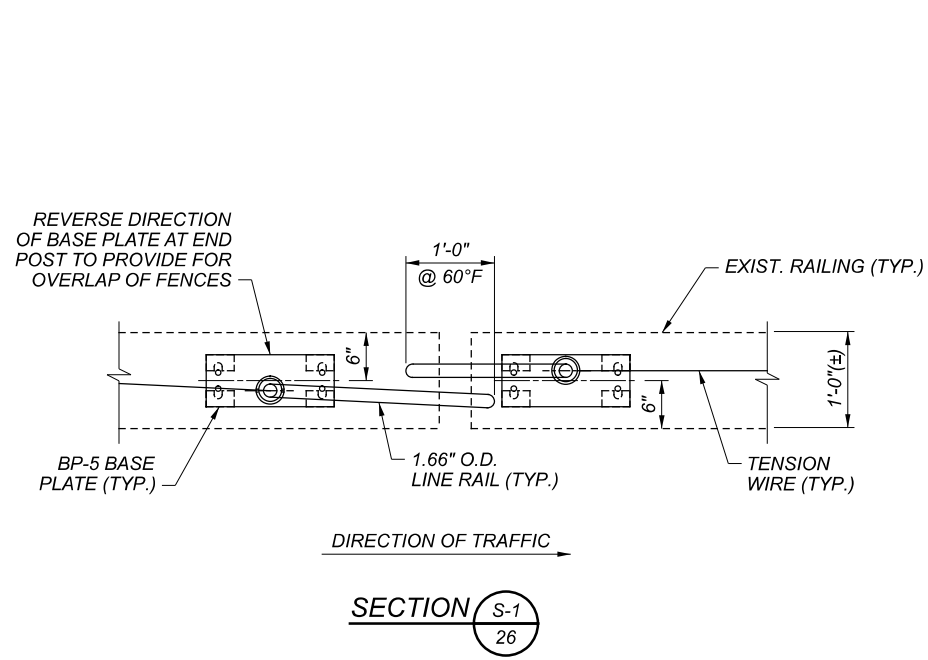

**TYPICAL FENCE DETAIL AT EXPANSION JOINT**

**NOTES**

- FOR ADDITIONAL FENCE DETAILS NOT SHOWN, SEE STANDARD DRAWING VPF-1-90.
- FOR LOCATIONS OF FENCE AT EXPANSION JOINTS, SEE SHEETS 22-25/26.