

COUNTY: SUMMIT

LOCATION: SR 18 @ MEDINA LINE RD.

S.L.M.: 0.00

24" STOP LINE: 42 L.F.

12" CROSSWALK LINE: L.F.

DOTTED LINE: L.F.

8" CHANNELIZING LINE: 300 L.F.

12" CHANNELIZING LINE: L.F.

24" TRANSVERSE LINE (WT): L.F.

24" TRANSVERSE LINE (YW): L.F.

SYMBOL: 5 - LEFT ARROWS

14 SF - ISLAND MARKING

MEDINA LINE RD.

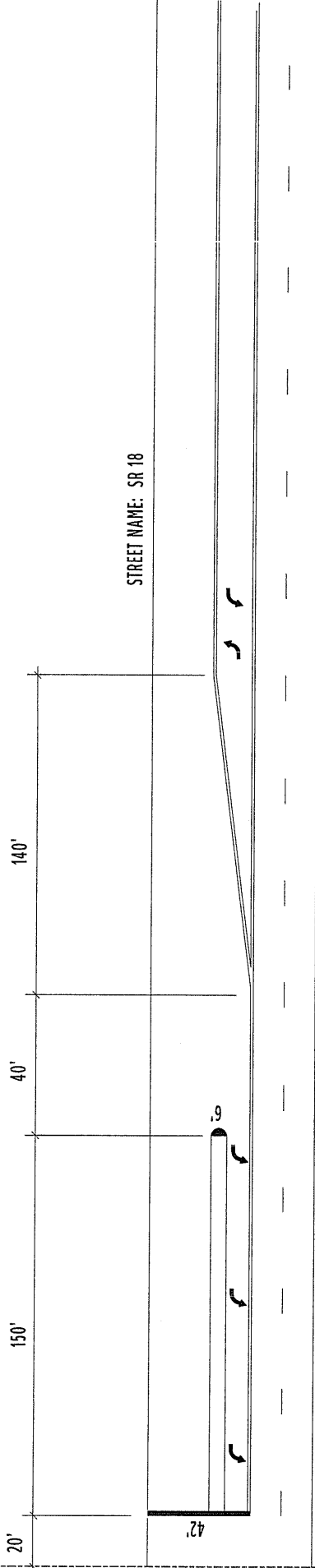

MEDINA COUNTY

SUMMIT COUNTY



COUNTY:	SUMMIT
LOCATION:	SR 18 @ HARMONY HILLS RD.
S.L.M.:	0.340
24" STOP LINE:	L.F.
12" CROSSWALK LINE:	L.F.
DOTTED LINE:	L.F.
8" CHANNELIZING LINE:	420 L.F.
12" CHANNELIZING LINE:	L.F.
24" TRANSVERSE LINE (WT):	L.F.
24" TRANSVERSE LINE (YW):	L.F.
SYMBOL:	11 - LEFT ARROWS

STREET NAME: SR 18

HARMONY HILLS

151 TRANS.

120'

300'

STREET NAME: SR 18

BUSINESS DRIVE



COUNTY:	SUMMIT	
LOCATION:	SR 18 @ CREEKRUN DR.	
S.L.M.:	0.60	
24" STOP LINE:	L.F.	
12" CROSSWALK LINE:	L.F.	
DOTTED LINE:	L.F.	
8" CHANNELIZING LINE:	120	L.F.
12" CHANNELIZING LINE:	L.F.	
24" TRANSVERSE LINE (WT):	L.F.	
24" TRANSVERSE LINE (YW):	L.F.	
SYMBOL:	7 - LEFT ARROWS	
	2 - RIGHT ARROWS	
	57 S.F. - ISLAND MARKING	

STREET NAME: SR 18

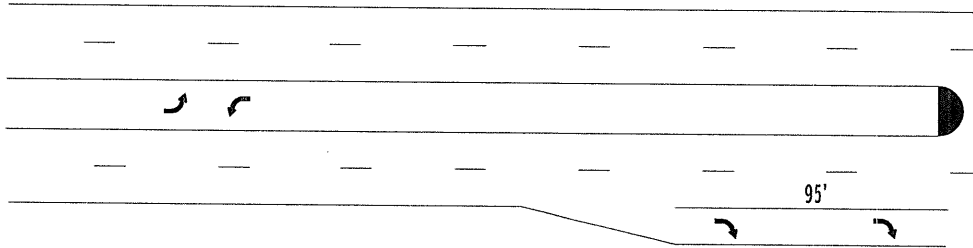

CREEK RUN

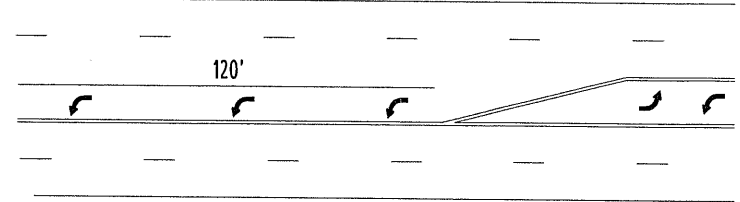



COUNTY:	SUMMIT
LOCATION:	SR 18 @ HAMETOWN RD.
S.I.M.:	0.864
24" STOP LINE:	L.F.
12" CROSSWALK LINE:	L.F.
DOTTED LINE:	L.F.
8" CHANNELIZING LINE:	175 L.F.
12" CHANNELIZING LINE:	L.F.
24" TRANSVERSE LINE (WT):	L.F.
24" TRANSVERSE LINE (YW):	L.F.
SYMBOL:	5 - LEFT ARROWS
	57 SF - ISLAND MAKING

STREET NAME: SR 18 _____

N. HAMETOWN

175'

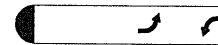



COUNTY:	SUMMIT	
LOCATION:	SR 18 @ S. HAMETOWN RD.	
S.I.M.:	1.005	
24" STOP LINE:	78	L.F.
12" CROSSWALK LINE:		L.F.
DOTTED LINE:		L.F.
8" CHANNELIZING LINE:	560	L.F.
12" CHANNELIZING LINE:		L.F.
24" TRANSVERSE LINE (WT):		L.F.
24" TRANSVERSE LINE (YW):		L.F.
SYMBOL:	2 - LEFT ARROWS	
	2 - RIGHT ARROWS	
	57 SF - ISLAND MARKING	

STREET NAME: SR 18

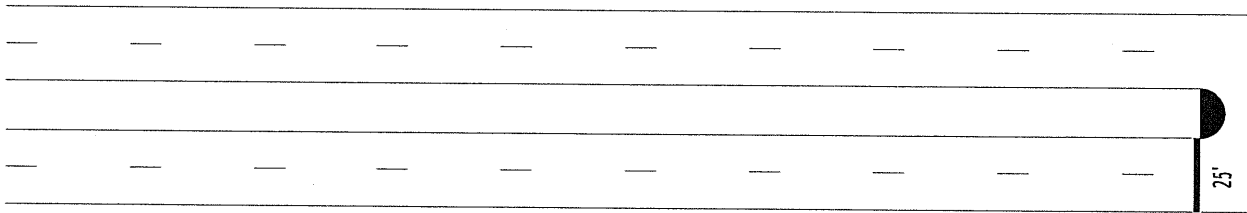

25'

S. HAMETOWN

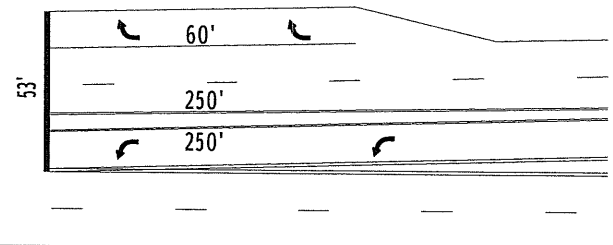

53'



COUNTY:	SUMMIT
LOCATION:	SR 18 @ S. HAMETOWN RD.
S.L.M.:	1.100
24" STOP LINE:	L.F.
12" CROSSWALK LINE:	L.F.
DOTTED LINE:	L.F.
8" CHANNELIZING LINE:	L.F.
12" CHANNELIZING LINE:	L.F.
24" TRANSVERSE LINE (WT):	L.F.
24" TRANSVERSE LINE (YW):	L.F.
SYMBOL:	6 - LEFT ARROWS

STREET NAME: SR 18

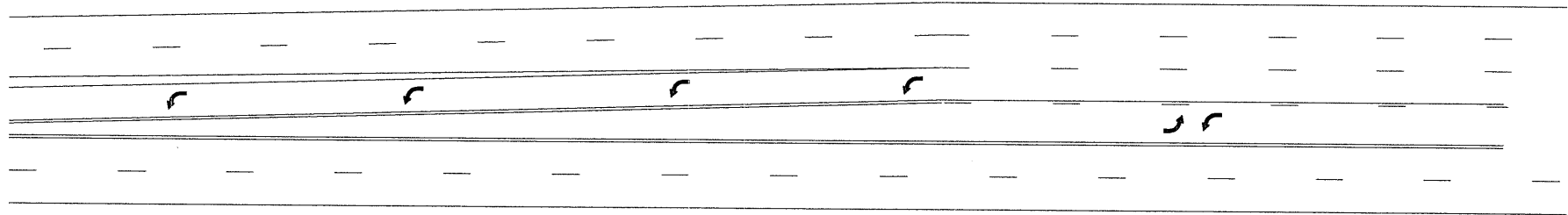

SCENIC VIEW DR.



COUNTY:	SUMMIT	
LOCATION:	SR 18 @ SCENIC VIEW DR.	
S.L.M.:	1.19	
24" STOP LINE:	L.F.	
12" CROSSWALK LINE:	L.F.	
DOTTED LINE:	L.F.	
8" CHANNELIZING LINE:	190	L.F.
12" CHANNELIZING LINE:	L.F.	
24" TRANSVERSE LINE (WT):	L.F.	
24" TRANSVERSE LINE (YW):	L.F.	
SYMBOL:	5 - LEFT ARROWS	

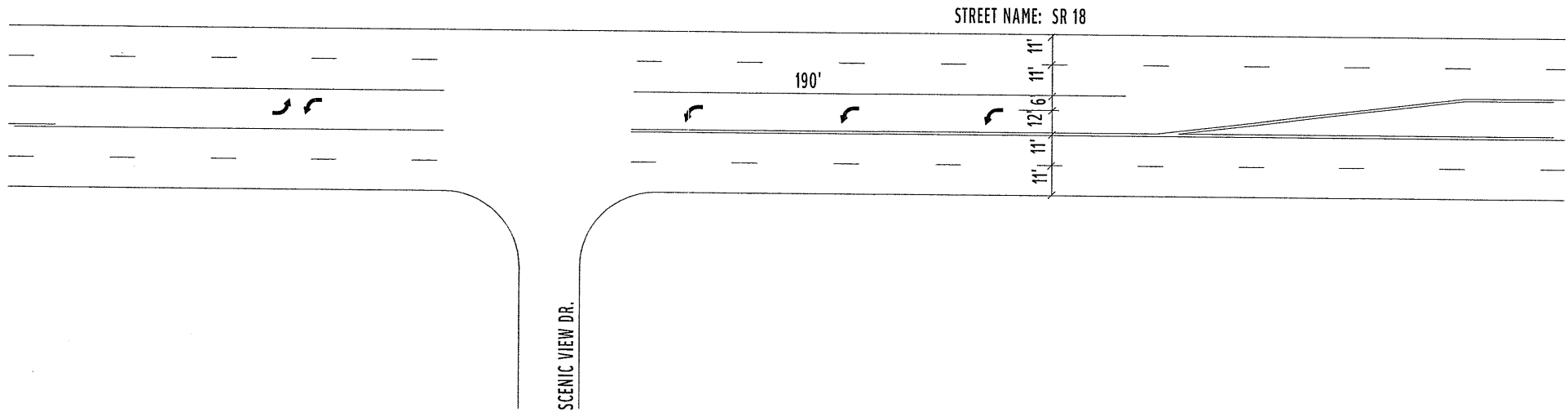



COUNTY:	SUMMIT	
LOCATION:	SR 18 @ HERITAGE WOODS DR.	
S.L.M.:	1.42	
24" STOP LINE:	95	L.F.
12" CROSSWALK LINE:		L.F.
DOTTED LINE:		L.F.
8" CHANNELIZING LINE:	560	L.F.
12" CHANNELIZING LINE:		L.F.
24" TRANSVERSE LINE (WT):		L.F.
24" TRANSVERSE LINE (YW):		L.F.
SYMBOL:	7 - LEFT ARROWS	

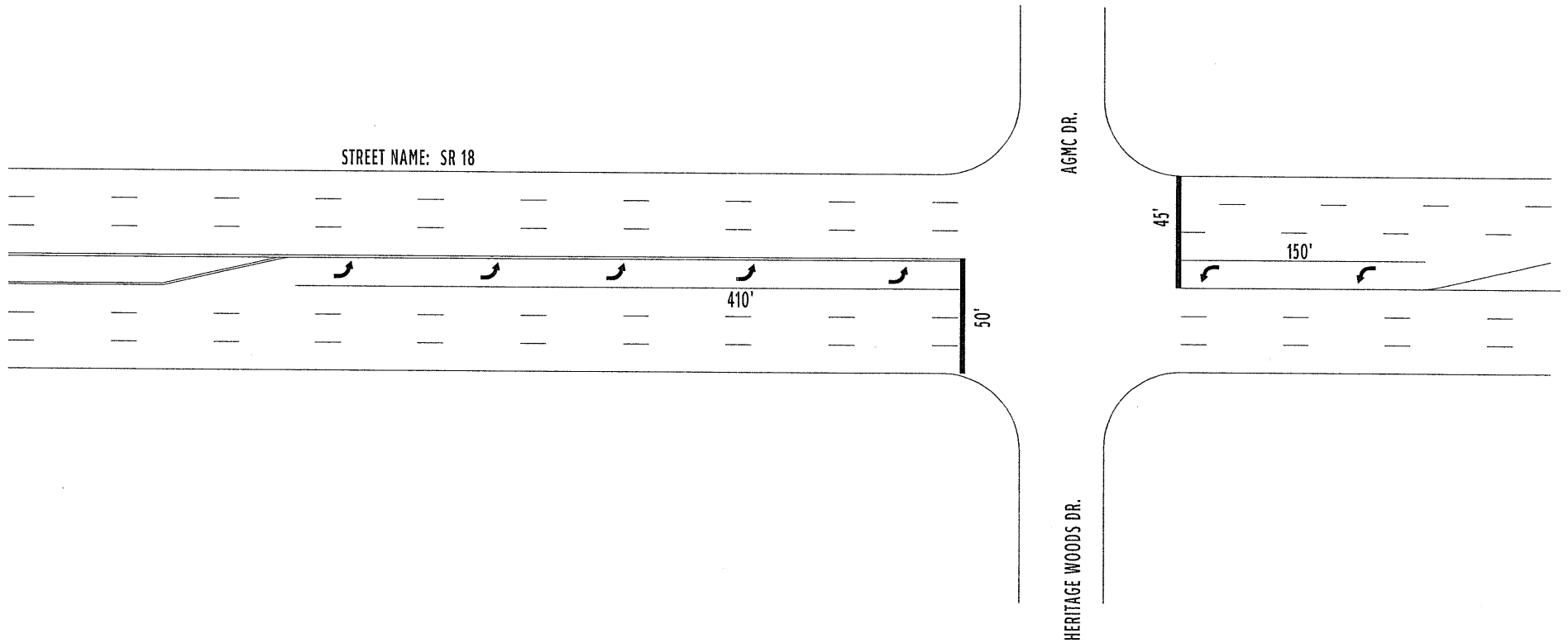



COUNTY:	SUMMIT	
LOCATION:	SR 18 @ MONTROSE W AVE.	
S.L.M.:	1.55	
24" STOP LINE:	110	L.F.
12" CROSSWALK LINE:		L.F.
DOTTED LINE:	225	L.F.
8" CHANNELIZING LINE:	1280	L.F.
12" CHANNELIZING LINE:		L.F.
24" TRANSVERSE LINE (WT):		L.F.
24" TRANSVERSE LINE (YW):		L.F.
SYMBOL:	7 - LEFT ARROWS	
	3 - RIGHT ARROWS	

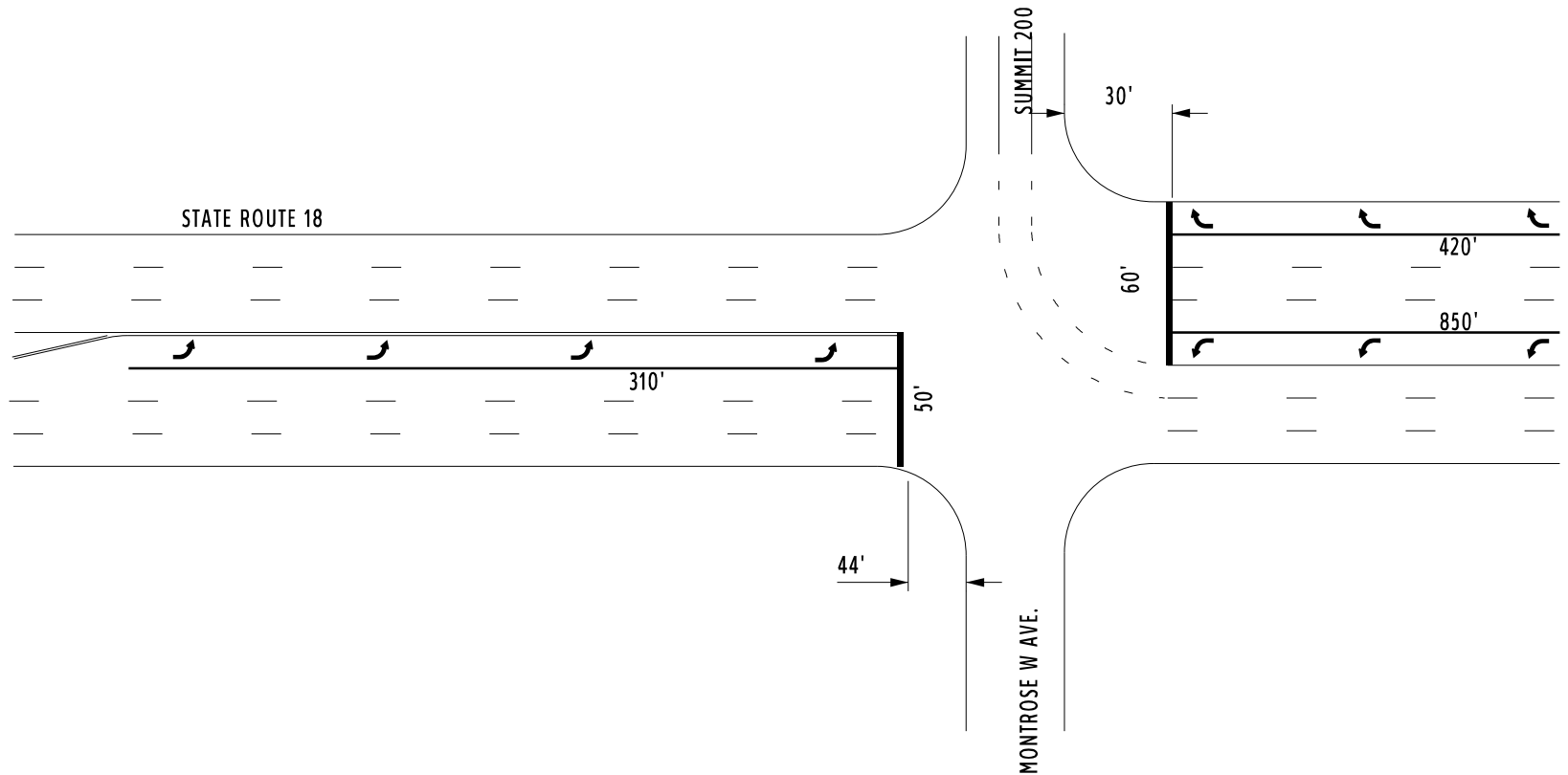



COUNTY:	SUMMIT
LOCATION:	SR 18 @ IR 77 SB RAMPS
S.L.M.:	1.67
24" STOP LINE:	L.F.
12" CROSSWALK LINE:	L.F.
DOTTED LINE:	550 L.F.
8" CHANNELIZING LINE:	220 L.F.
12" CHANNELIZING LINE:	L.F.
24" TRANSVERSE LINE (WT):	L.F.
24" TRANSVERSE LINE (YW):	L.F.
SYMBOL:	7 - LEFT ARROWS
	2 - RIGHT ARROWS

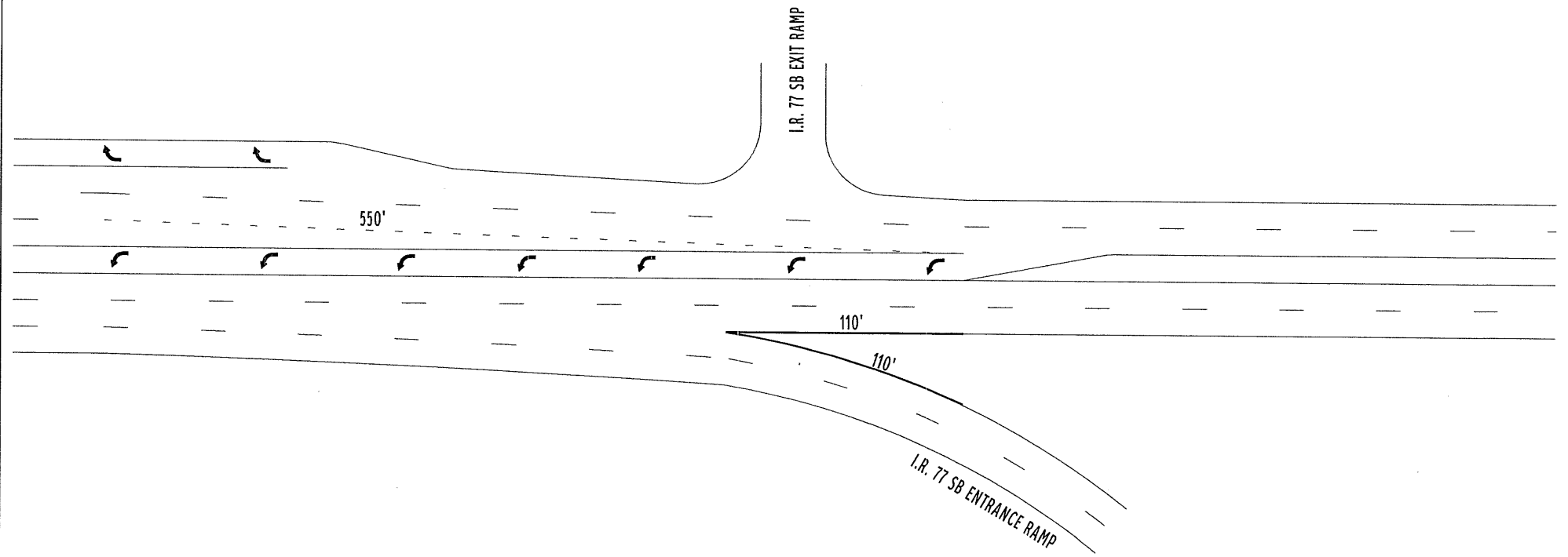

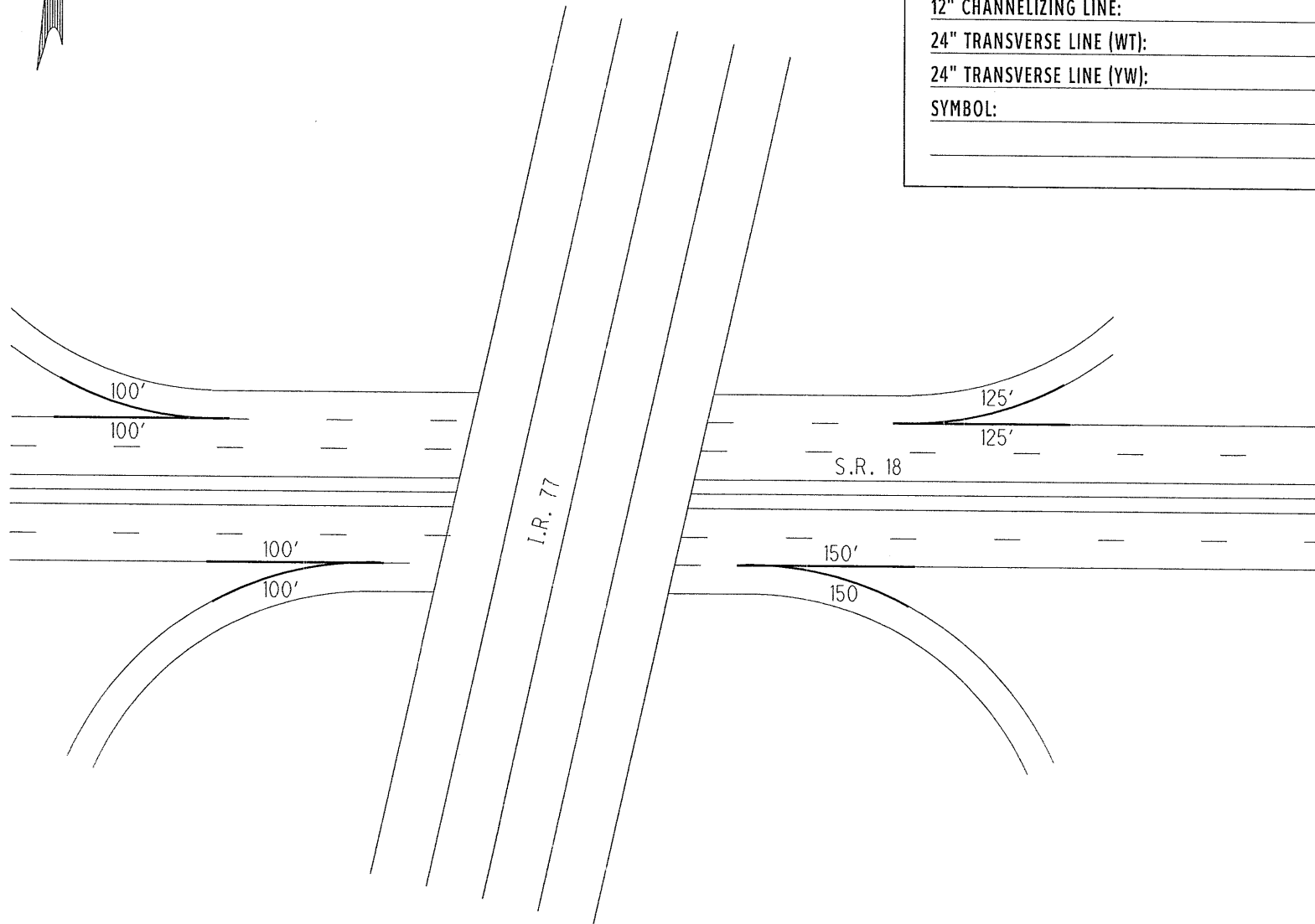

COUNTY:	SUMMIT
LOCATION:	SR 18 @ I.R. 77 UNDERPASS
S.I.M.:	1.88
24" STOP LINE:	L.F.
12" CROSSWALK LINE:	L.F.
DOTTED LINE:	L.F.
8" CHANNELIZING LINE:	950 L.F.
12" CHANNELIZING LINE:	L.F.
24" TRANSVERSE LINE (WT):	L.F.
24" TRANSVERSE LINE (YW):	L.F.
SYMBOL:	



COUNTY:	SUMMIT
LOCATION:	SR 18 @ I.R. 77 NB RAMPS
S.L.M.:	2.09
24" STOP LINE:	L.F.
12" CROSSWALK LINE:	L.F.
DOTTED LINE:	L.F.
8" CHANNELIZING LINE:	635 L.F.
12" CHANNELIZING LINE:	L.F.
24" TRANSVERSE LINE (WT):	L.F.
24" TRANSVERSE LINE (YW):	L.F.
SYMBOL:	5 - RIGHT ARROWS

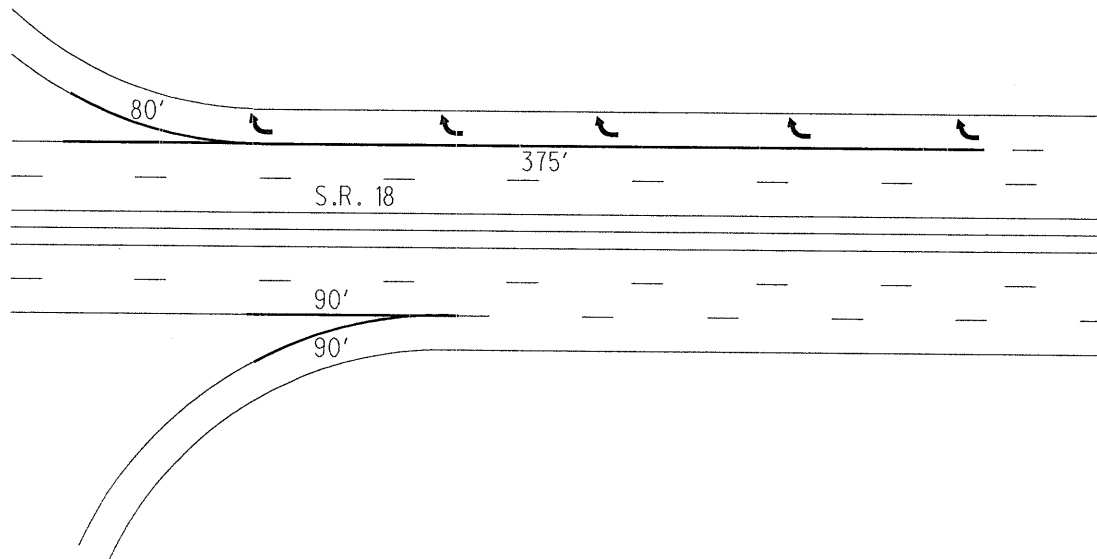



COUNTY:	SUMMIT	
LOCATION:	SR 18 @ SPRINGSIDE DR.	
S.L.M.:	2.20	
24" STOP LINE:	95	L.F.
12" CROSSWALK LINE:	620	L.F.
DOTTED LINE:		L.F.
8" CHANNELIZING LINE:	180	L.F.
12" CHANNELIZING LINE:		L.F.
24" TRANSVERSE LINE (WT):		L.F.
24" TRANSVERSE LINE (YW):		L.F.
SYMBOL:	6 - LEFT ARROWS	

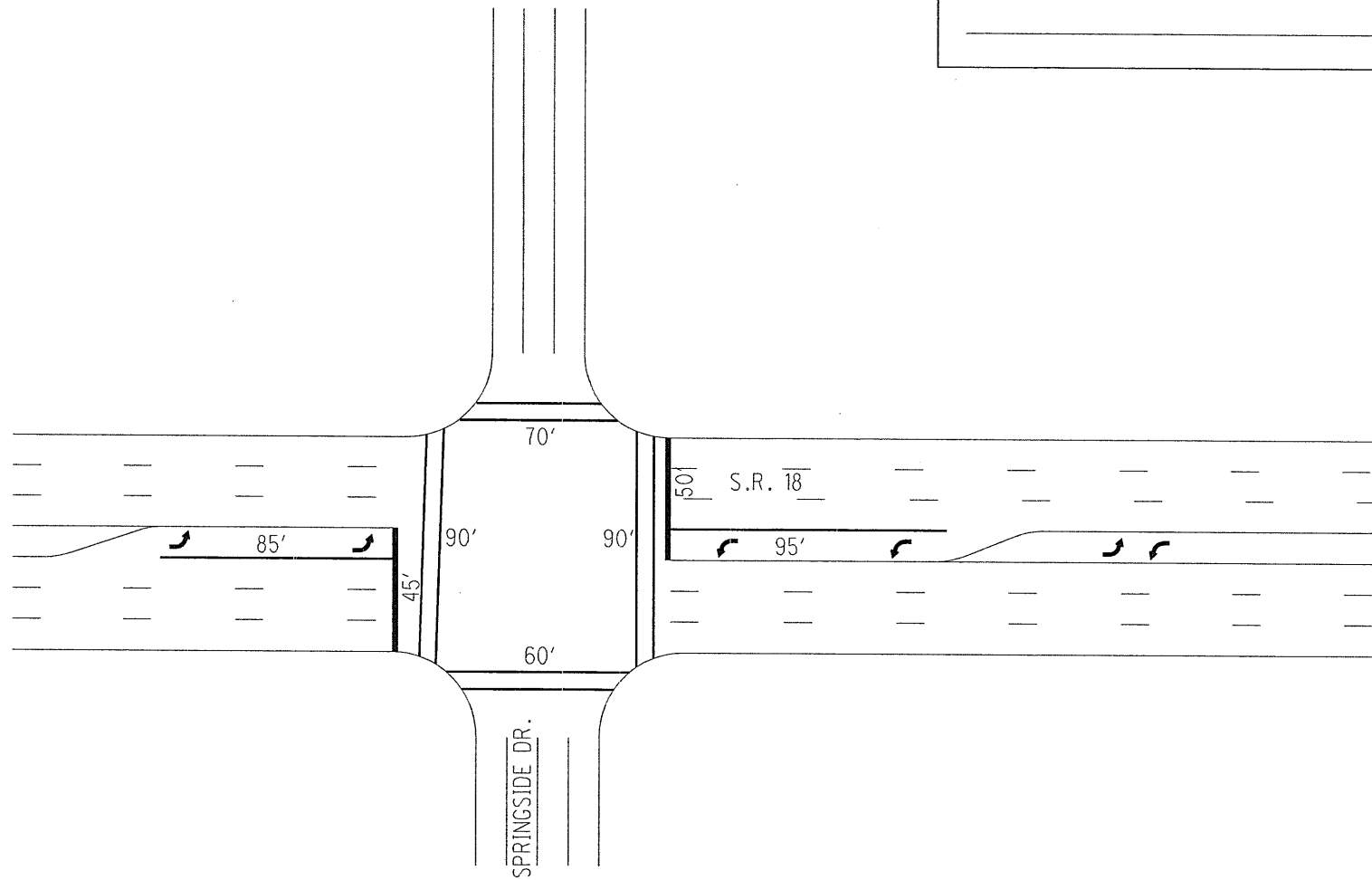



COUNTY:	SUMMIT	
LOCATION:	SR 18 @ ACME ENTRANCE	
S.L.M.:	2.35	
24" STOP LINE:	95	L.F.
12" CROSSWALK LINE:	450	L.F.
DOTTED LINE:		L.F.
8" CHANNELIZING LINE:	175	L.F.
12" CHANNELIZING LINE:		L.F.
24" TRANSVERSE LINE (WT):		L.F.
24" TRANSVERSE LINE (YW):		L.F.
SYMBOL:	4 - LEFT ARROWS	

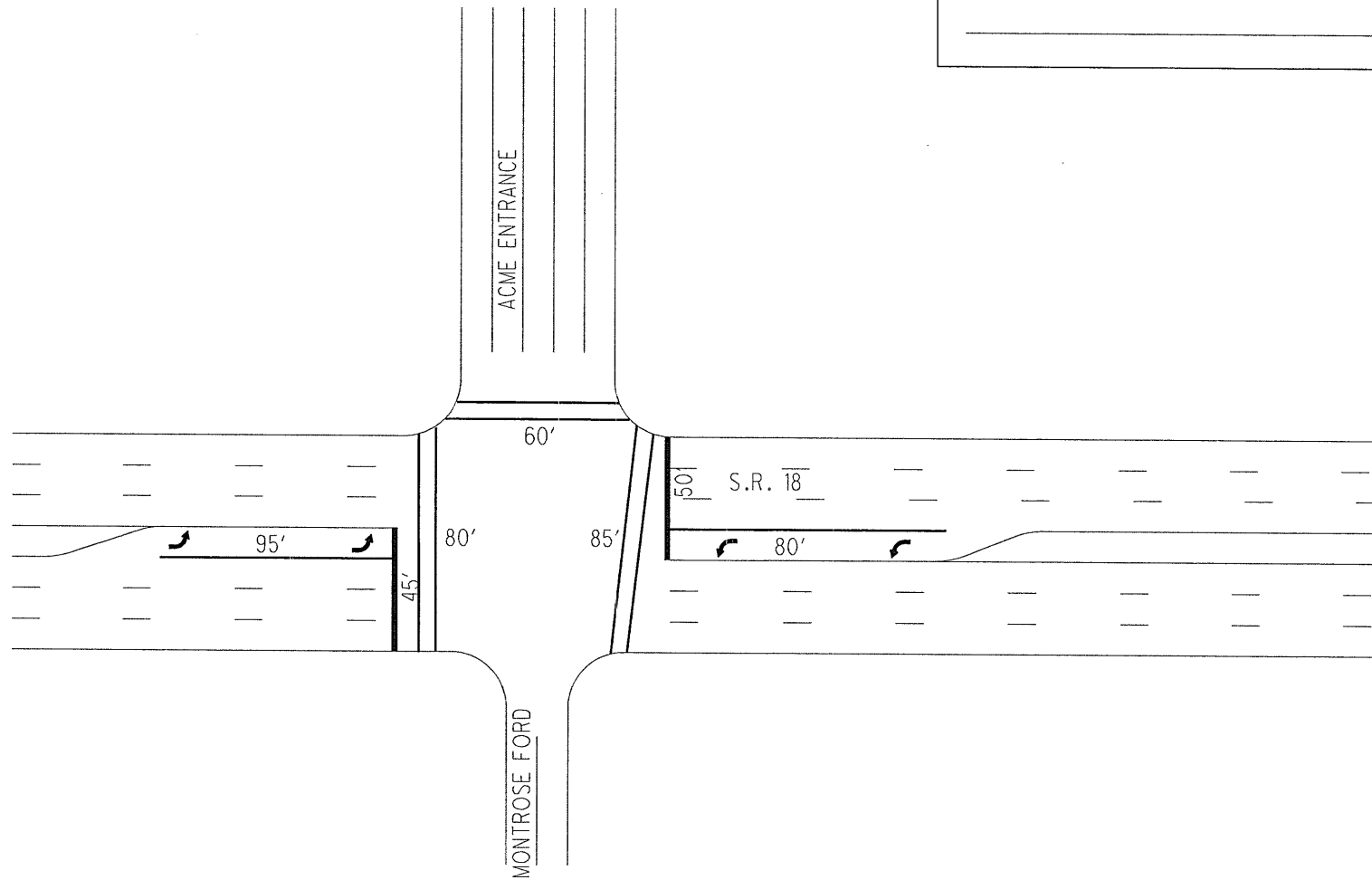

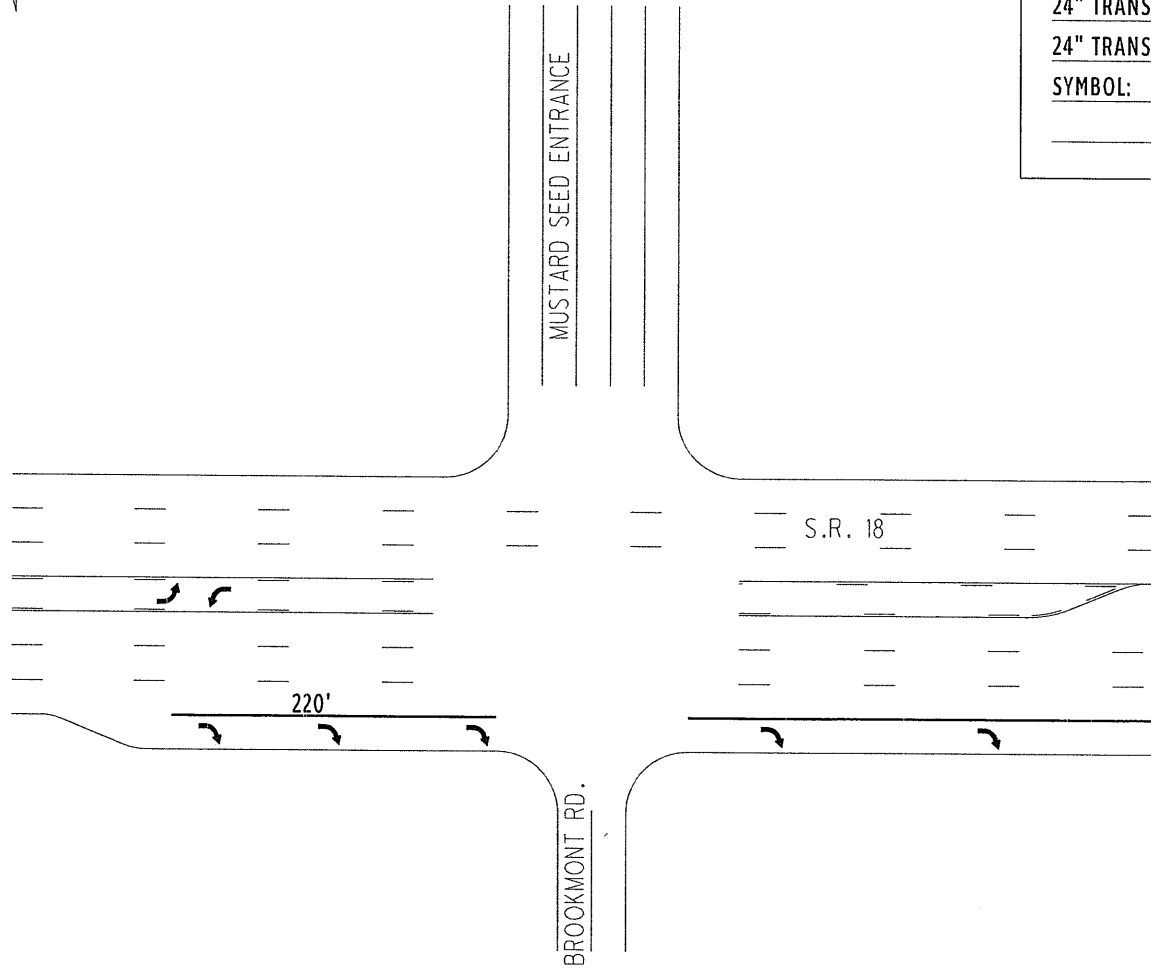

COUNTY:	SUMMIT	
LOCATION:	SR 18 @ MUSTARD SEED ENTRANCE	
S.L.M.:	2.49	
24" STOP LINE:	L.F.	
12" CROSSWALK LINE:	L.F.	
DOTTED LINE:	L.F.	
8" CHANNELIZING LINE:	220	L.F.
12" CHANNELIZING LINE:	L.F.	
24" TRANSVERSE LINE (WT):	L.F.	
24" TRANSVERSE LINE (YW):	L.F.	
SYMBOL:	2 - LEFT ARROWS	
	5 - RIGHT ARROWS	



COUNTY:	SUMMIT	
LOCATION:	SR 18 @ CLEVELAND MASSILLON RD.	
S.L.M.:	2.60	
24" STOP LINE:	100	L.F.
12" CROSSWALK LINE:	820	L.F.
DOTTED LINE:	650	L.F.
8" CHANNELIZING LINE:	855	L.F.
12" CHANNELIZING LINE:		L.F.
24" TRANSVERSE LINE (WT):		L.F.
24" TRANSVERSE LINE (YW):		L.F.
SYMBOL:	6 - LEFT ARROWS	
	3 - RIGHT ARROWS	

