

STANDARD DRAWINGS AND SUPPLEMENTAL SPECIFICATIONS

REFER TO THE FOLLOWING SUPPLEMENTAL SPECIFICATION(S):

844 DATED 1-17-25

DESIGN SPECIFICATIONS

THIS STRUCTURE CONFORMS TO THE 10th EDITION OF THE "LRFD BRIDGE DESIGN SPECIFICATIONS" ADOPTED BY THE AMERICAN ASSOCIATION OF STATE HIGHWAY AND TRANSPORTATION OFFICIALS, 2020 AND THE ODOT BRIDGE DESIGN MANUAL, 2020.

DESIGN DATA

CONCRETE CLASS QC1 - COMPRESSIVE STRENGTH 4.0 KSI

CONCRETE REINFORCEMENT:
UNCOATED STEEL REINFORCEMENT - MINIMUM YIELD STRENGTH 60 KSI

PLANS OF EXISTING BRIDGES

CONSTRUCTION PLANS FOR THE EXISTING BRIDGES ARE AVAILABLE FOR REFERENCE BY CONTACTING THE OHIO DEPARTMENT OF TRANSPORTATION, DISTRICT 8 OFFICE.

IT IS THE RESPONSIBILITY OF THE CONTRACTOR TO BECOME FAMILIAR WITH ALL PERTINENT EXISTING DRAWINGS AND DETAILS RELEVANT TO THIS PROJECT.

EXISTING STRUCTURE VERIFICATION

DETAILS AND DIMENSIONS SHOWN ON THESE PLANS PERTAINING TO THE EXISTING STRUCTURE HAVE BEEN OBTAINED FROM PLANS OF THE EXISTING STRUCTURE AND FROM FIELD OBSERVATIONS AND MEASUREMENTS. CONSEQUENTLY, THEY ARE INDICATIVE OF THE EXISTING STRUCTURE AND THE PROPOSED WORK BUT THEY SHALL BE CONSIDERED TENTATIVE AND APPROXIMATE. THE CONTRACTOR IS REFERRED TO C&MS SECTIONS 102.05, 105.02 AND 513.04. BASE CONTRACT BID PRICES UPON A RECOGNITION OF THE UNCERTAINTIES DESCRIBED ABOVE AND UPON A PREBID EXAMINATION OF THE EXISTING STRUCTURE. HOWEVER, THE DEPARTMENT WILL PAY FOR ALL PROJECT WORK BASED UPON ACTUAL DETAILS AND DIMENSIONS THAT HAVE BEEN VERIFIED IN THE FIELD.

ITEM 509, CONCRETE REINFORCEMENT, REPLACEMENT OF EXISTING CONCRETE REINFORCEMENT, AS PER PLAN

REPLACE ALL EXISTING REINFORCING BARS DEEMED BY THE ENGINEER TO BE UNUSABLE BECAUSE OF CORROSION. THE DEPARTMENT WILL MEASURE THE REPLACEMENT CONCRETE REINFORCEMENT BY THE NUMBER OF POUNDS ACCEPTED IN PLACE. REPLACE ALL EXISTING STEEL REINFORCEMENT BARS WHICH ARE TO BE INCORPORATED INTO THE NEW WORK AND ARE DEEMED BY THE ENGINEER TO BE MADE UNUSABLE BY CONCRETE REMOVAL OPERATIONS WITH NEW CONCRETE REINFORCEMENT OF THE SAME SIZE, COATING, AND MATERIAL AT NO COST TO THE DEPARTMENT.

ADDITIONAL QUANTITIES HAVE BEEN PROVIDED FOR DOWEL HOLES, IF NEEDED, TO EMBED THE REPLACEMENT REINFORCING INTO THE EXISTING STRUCTURE. PAYMENT FOR DOWEL HOLES SHALL BE MADE AT THE BID UNIT PRICE FOR ITEM 510, DOWEL HOLES WITH NONSHRINK, NONMETALLIC GROUT, AS PER PLAN.

ITEM 510, DOWEL HOLES WITH NONSHRINK, NONMETALLIC GROUT, AS PER PLAN

INSTALL DOWEL BARS ACCORDING TO THE MANUFACTURER'S INSTALLATION INSTRUCTIONS FOR BLACK REBAR PUBLISHED IN THE ICC-ES REPORTS LISTED BELOW.

THE HOLES FOR THE DOWEL BARS SHALL BE DRILLED WITH A HAMMER DRILL AND CARBIDE BIT. PRIOR TO THE INSTALLATION OF THE ANCHORS, THE HOLES SHALL BE CLEANED AND DRIED IN A MANNER CONSISTENT WITH THE MANUFACTURER'S REQUIREMENTS FOR DRY CONCRETE.

SELECT FROM ONE OF THE FOLLOWING APPROVED PRODUCTS:

HILTI HIT-HY 200 ADHESIVE ANCHORS
(ICC-ES REPORT ESR-3187)

DEWALT PURE110+ EPOXY ADHESIVE ANCHOR SYSTEM
(ICC-ES REPORT ESR-3298)

SIMPSON STRONG-TIE SET-3G EPOXY ADHESIVE ANCHORS
(ICC-ES REPORT ESR-4057)

ATC ULTRABOND HS-1CC ADHESIVE ANCHOR SYSTEM
(ICC-ES REPORT ESR-4094)

THE MANUFACTURER'S INSTALLATION INSTRUCTIONS PUBLISHED IN THE ICC-ES REPORTS FOR ACCEPTABLE PRODUCTS ARE AVAILABLE AT: WWW.ICC-ES.ORG/EVALUATION-REPORT-PROGRAM/REPORTS-DIRECTORY

PRIOR TO DRILLING HOLES, LOCATE EXISTING REINFORCING STEEL BARS IN THE AREA OF THE HOLE WITH THE AID OF A REINFORCING STEEL BAR LOCATOR (PACHOMETER). IF AN EXISTING BAR IS ENCOUNTERED AT THE SAME LOCATION AS A PROPOSED DOWEL HOLE, MOVE THE DOWEL TO EITHER SIDE OF THE EXISTING BAR. THE DEPARTMENT WILL PAY FOR DOWEL HOLES AND GROUTING WITH ITEM 510 - DOWEL HOLES WITH NONSHRINK, NONMETALLIC GROUT, AS PER PLAN.

ITEM 512, CONCRETE REPAIR BY EPOXY INJECTION, AS PER PLAN

NARROW CRACKS THAT ARE NOT NOTED IN THE PLANS TO BE EPOXY INJECTED SHALL BE GROUND SMOOTH BEFORE APPLYING EPOXY-URETHANE SEALER OR HMWM RESIN. BEFORE PERFORMING WORK, THE LOCATIONS OF CRACKS TO BE GROUND SMOOTH SHALL BE APPROVED BY THE ENGINEER.

ITEM SPECIAL- COMPOSITE FIBER WRAP SYSTEM (SINGLE LAYER)

THE INTENT OF THE FIBER WRAP IS TO PROTECT THE CONCRETE FROM CHLORIDE AND MOISTURE INGRESS TO PREVENT DETERIORATION AND IS NOT INTENDED TO PROVIDE ANY INCREASE IN STRUCTURAL CAPACITY.

THE FIBER-WRAP SYSTEM SHALL CONSIST OF A SINGLE LAYER OF FRP INSTALLED IN ACCORDANCE WITH THE MANUFACTURER'S REQUIREMENTS. THE CURED LAMINATE THICKNESS SHALL BE NO LESS THAN THE MANUFACTURER'S SPECIFIED MINIMUM THICKNESS FOR AN ICC-ES APPROVED SYSTEM AND SHALL FULLY COMPLY WITH PN 519, SECTION II.

THE DEPARTMENT WILL MEASURE THE FRP COMPOSITE WRAP SYSTEM BY THE NUMBER OF SQUARE FEET OF CONCRETE SURFACE WRAPPED. THE MINIMUM OVERLAP FOR THE FRP COMPOSITE WRAP SYSTEM SHALL BE AS SPECIFIED BY THE MANUFACTURER TO ENSURE PROPER INSTALLATION AND PERFORMANCE. FOR BIDDING PURPOSES, ASSUME A MINIMUM OVERLAP OF 6 INCHES.

ITEM SPECIAL- COMPOSITE FIBER WRAP SYSTEM (STRENGTHENING)

THIS WORK CONSISTS OF PREPARING EXISTING SOUND SURFACES AND DESIGNING THE SYSTEM TO MEET THE REQUIREMENTS IN THE PLANS, FURNISHING AND INSTALLING FIBER REINFORCED POLYMER (FRP) COMPOSITE WRAP SYSTEMS TO RETROFIT EXISTING CONCRETE PIER COLUMNS AT THE LOCATIONS SHOWN IN THE PLANS PER PN 519.

THE FRP SHALL BE DESIGNED TO PROVIDE A SYSTEM THAT DEVELOPS A MINIMUM EFFECTIVE LATERAL CONFINING PRESSURE OF 0.6 KSI. SUBMIT CALCULATIONS DEMONSTRATING THAT THE INSTALLED SYSTEM, INCLUDING LAYER CONFIGURATION AND MATERIAL PROPERTIES, ACHIEVES NOT LESS THAN 0.60 KSI OF EFFECTIVE CONFINEMENT. ENSURE THAT INSTALLATION PRACTICES, INCLUDING SURFACE PREPARATION, RESIN SATURATION, CONSOLIDATION, AND CURING, ARE PERFORMED IN ACCORDANCE WITH THE SYSTEM MANUFACTURER'S REQUIREMENTS.

THE DEPARTMENT WILL MEASURE THE FRP COMPOSITE WRAP SYSTEM BY THE NUMBER OF SQUARE FEET OF CONCRETE SURFACE WRAPPED.

**ITEM 519, PATCHING CONCRETE STRUCTURES, AS PER PLAN
ITEM 844, GALVANIC ANODE PROTECTION, AS PER PLAN**

FOLLOW ALL PROVISIONS OF C&MS 519 EXCEPT AS REQUIRED BY THIS NOTE.

THE QUANTITY GIVEN IN THE ESTIMATE QUANTITY TABLE HAS BEEN ESTIMATED FROM FIELD INSPECTION AND ORIGINAL PLANS. IT IS POSSIBLE THAT ADDITIONAL AREAS REQUIRING PATCHING MAY HAVE DEVELOPED SINCE THE MOST RECENT INSPECTION OF THE STRUCTURE. THEREFORE, THE CONTRACTOR SHALL SOUND THE SURROUNDING PERIMETER OF THE AREA TO BE PATCHED AND PATCH NEW AREAS APPROVED BY THE ENGINEER THAT HAVE NOT BEEN DETAILED IN THE PLANS. PAYMENT SHALL BE MADE PER SQ. FT. AT THE PRICE BID FOR THE ACTUAL AREA PATCHED AND SHALL INCLUDE ALL COST FOR LABOR, MATERIALS AND EQUIPMENT.

PRIOR TO THE SURFACE CLEANING SPECIFIED IN C&MS 519.04 AND WITHIN 24 HOURS OF PLACING PATCHING MATERIAL, BLAST CLEAN ALL SURFACES TO BE PATCHED INCLUDING THE EXPOSED STEEL REINFORCEMENT. ACCEPTABLE METHODS INCLUDE HIGH-PRESSURE WATER BLASTING WITH OR WITHOUT ABRASIVES IN THE WATER, ABRASIVE BLASTING WITH CONTAINMENT, OR VACUUM ABRASIVE BLASTING.

REMOVE THE FORMS WITHIN 24 HOURS AFTER PLACING CONCRETE AND FINISH ALL EXPOSED SURFACES BY RUBBING TO MATCH THE SURROUNDING SURFACE. APPLY MEMBRANE CURING ACCORDING TO C&MS 511.14, METHOD B, IMMEDIATELY AFTER RUBBING THE SURFACES.

REPAIR CONCRETE SHALL BE HYDRAULIC CEMENT-BASED MATERIAL WITH A ELECTRICAL RESISTIVITY LESS THAN 50,000 OHM-CM ACCORDING TO ASTM C 1760. DO NOT USE NON- CONDUCTIVE REPAIR MATERIALS SUCH AS MAGNESIUM AMMONIUM PHOSPHATE CONCRETE AND EPOXY MORTARS OR BONDING AGENTS. CONCRETE MIXES CONTAINING HIGH LEVELS OF SUPPLEMENTARY CEMENTITIOUS MATERIALS SUCH AS SILICA FUME, GROUND-GRANULATED BLAST FURNACE SLAG, LATEX, FLY ASH OR METAKAOLIN MAY NOT MEET THE RESISTIVITY REQUIREMENT.

THE GALVANIC ANODE SIZE AND SPACING IS BASED ON ACHIEVING A CURRENT DENSITY FOR THE EXTREMELY HIGH CORROSION RISK CATEGORY WITH A 20 YEAR INSTALLATION. SUPPLY ANODES WITH A MINIMUM CORE OF 160 GRAMS OF ZINC.

DESIGN AGENCY



DESIGNER
GTF

REVIEWER

CAH 02/17/26

PROJECT ID

123648

SHEET TOTAL

7 45

ESTIMATED QUANTITIES-STRUCTURE No.: BUT-129-2139 (SFN: 0903566) (02/NHS FUNDING SPLIT)

ITEM	EXTENSION	TOTAL	UNIT	DESCRIPTION	ABUT.	PIERS	SUPER.	GEN.	SEE SHEET
512	10100	77	SY	SEALING OF CONCRETE SURFACES (EPOXY-URETHANE)		77			
512	74000	42	SY	REMOVAL OF EXISTING COATINGS FROM CONCRETE SURFACES		42			
SPECIAL	51900100	310	SF	COMPOSITE FIBER WRAP SYSTEM (SINGLE LAYER)		310			7

ESTIMATED QUANTITIES-STRUCTURE No.: CLE-275-0896 (SFN: 1305697) (01/IMS FUNDING SPLIT)

ITEM	EXTENSION	TOTAL	UNIT	DESCRIPTION	ABUT.	PIERS	SUPER.	GEN.	SEE SHEET
512	10100	170	SY	SEALING OF CONCRETE SURFACES (EPOXY-URETHANE)		170			
512	74000	95	SY	REMOVAL OF EXISTING COATINGS FROM CONCRETE SURFACES		95			
SPECIAL	51900100	680	SF	COMPOSITE FIBER WRAP SYSTEM (SINGLE LAYER)		680			7
519	11101	170	SF	PATCHING CONCRETE STRUCTURE, AS PER PLAN		170			7
844	20001	142	EACH	GALVANIC ANODE PROTECTION, AS PER PLAN		142			7

ESTIMATED QUANTITIES-STRUCTURE No.: CLE-275-1008 (SFN: 1305719) (01/IMS FUNDING SPLIT)

ITEM	EXTENSION	TOTAL	UNIT	DESCRIPTION	ABUT.	PIERS	SUPER.	GEN.	SEE SHEET
512	10100	154	SY	SEALING OF CONCRETE SURFACES (EPOXY-URETHANE)		154			
512	74000	95	SY	REMOVAL OF EXISTING COATINGS FROM CONCRETE SURFACES		95			
SPECIAL	51900100	536	SF	COMPOSITE FIBER WRAP SYSTEM (SINGLE LAYER)		536			7
519	11101	116	SF	PATCHING CONCRETE STRUCTURE, AS PER PLAN		116			7
844	20001	113	EACH	GALVANIC ANODE PROTECTION, AS PER PLAN		113			7

ESTIMATED QUANTITIES-STRUCTURE No.: CLI-71-0031 (SFN: 1401416) (01/IMS FUNDING SPLIT)

ITEM	EXTENSION	TOTAL	UNIT	DESCRIPTION	ABUT.	PIERS	SUPER.	GEN.	SEE SHEET
509	20001	50	LB	CONCRETE REINFORCEMENT, REPLACEMENT OF EXISTING CONCRETE REINFORCEMENT, AS PER PLAN		50			7
509	25000	756	LB	UNCOATED STEEL REINFORCEMENT		756			
510	10001	192	EACH	DOWEL HOLES WITH NONSHRINK, NONMETALLIC GROUT, AS PER PLAN		192			7
511	43210	12	CY	CLASS QC1 CONCRETE, PIER		12			
511	71200	100	SF	CONCRETE, MISC.: REMOVAL OF LOOSE CONCRETE		100			15 - 17
512	10100	245	SY	SEALING OF CONCRETE SURFACES (EPOXY-URETHANE)		245			
512	10601	48	FT	CONCRETE REPAIR BY EPOXY INJECTION, AS PER PLAN		48			7
SPECIAL	51900100	1565	SF	COMPOSITE FIBER WRAP SYSTEM (SINGLE LAYER)		1565			7
SPECIAL	51900100	645	SF	COMPOSITE FIBER WRAP SYSTEM (STRENGTHENING)		645			7
519	11101	901	SF	PATCHING CONCRETE STRUCTURE, AS PER PLAN		901			7
844	20001	654	EACH	GALVANIC ANODE PROTECTION, AS PER PLAN		654			7

ESTIMATED QUANTITIES-STRUCTURE No.: CLI-71-0407 (SFN: 1401505) (01/IMS FUNDING SPLIT)

ITEM	EXTENSION	TOTAL	UNIT	DESCRIPTION	ABUT.	PIERS	SUPER.	GEN.	SEE SHEET
512	10100	410	SY	SEALING OF CONCRETE SURFACES (EPOXY-URETHANE)		410			
512	74000	78	SY	REMOVAL OF EXISTING COATINGS FROM CONCRETE SURFACES		78			
SPECIAL	51900100	1102	SF	COMPOSITE FIBER WRAP SYSTEM (SINGLE LAYER)		1102			7
519	11101	201	SF	PATCHING CONCRETE STRUCTURE, AS PER PLAN		201			7
844	20001	203	EACH	GALVANIC ANODE PROTECTION, AS PER PLAN		203			7

ESTIMATED QUANTITIES-STRUCTURE No.: CLI-71-0495 (SFN: 1401564) (01/IMS FUNDING SPLIT)

ITEM	EXTENSION	TOTAL	UNIT	DESCRIPTION	ABUT.	PIERS	SUPER.	GEN.	SEE SHEET
512	10100	199	SY	SEALING OF CONCRETE SURFACES (EPOXY-URETHANE)		199			
512	74000	78	SY	REMOVAL OF EXISTING COATINGS FROM CONCRETE SURFACES		78			
SPECIAL	51900100	1102	SF	COMPOSITE FIBER WRAP SYSTEM (SINGLE LAYER)		1102			7
519	11101	498	SF	PATCHING CONCRETE STRUCTURE, AS PER PLAN		498			7
844	20001	488	EACH	GALVANIC ANODE PROTECTION, AS PER PLAN		488			7

ESTIMATED QUANTITIES-STRUCTURE No.: CLI-71-0567 (SFN: 1401629) (01/IMS FUNDING SPLIT)

ITEM	EXTENSION	TOTAL	UNIT	DESCRIPTION	ABUT.	PIERS	SUPER.	GEN.	SEE SHEET
512	10100	199	SY	SEALING OF CONCRETE SURFACES (EPOXY-URETHANE)		199			
512	74000	78	SY	REMOVAL OF EXISTING COATINGS FROM CONCRETE SURFACES		78			
SPECIAL	51900100	1102	SF	COMPOSITE FIBER WRAP SYSTEM (SINGLE LAYER)		1102			7
519	11101	190	SF	PATCHING CONCRETE STRUCTURE, AS PER PLAN		190			7
844	20001	215	EACH	GALVANIC ANODE PROTECTION, AS PER PLAN		215			7



ESTIMATED QUANTITIES-STRUCTURE No.: CLI-71-1187 (SFN: 1401777) (01/IMS FUNDING SPLIT)										
ITEM	EXTENSION	TOTAL	UNIT	DESCRIPTION	ABUT.	PIERS	SUPER.	GEN.	SEE SHEET	
512	10100	215	SY	SEALING OF CONCRETE SURFACES (EPOXY-URETHANE)		215				
512	74000	94	SY	REMOVAL OF EXISTING COATINGS FROM CONCRETE SURFACES		94				
SPECIAL	51900100	1102	SF	COMPOSITE FIBER WRAP SYSTEM (SINGLE LAYER)		1102			7	
519	11101	99	SF	PATCHING CONCRETE STRUCTURE, AS PER PLAN		99			7	
844	20001	125	EACH	GALVANIC ANODE PROTECTION, AS PER PLAN		125			7	

ESTIMATED QUANTITIES-STRUCTURE No.: CLI-73-0232 (SFN: 1402102) (01/IMS FUNDING SPLIT)										
ITEM	EXTENSION	TOTAL	UNIT	DESCRIPTION	ABUT.	PIERS	SUPER.	GEN.	SEE SHEET	
512	10100	314	SY	SEALING OF CONCRETE SURFACES (EPOXY-URETHANE)		314				
512	74000	154	SY	REMOVAL OF EXISTING COATINGS FROM CONCRETE SURFACES		154				
SPECIAL	51900100	1448	SF	COMPOSITE FIBER WRAP SYSTEM (SINGLE LAYER)		1448			7	
519	11101	558	SF	PATCHING CONCRETE STRUCTURE, AS PER PLAN		558			7	
844	20001	503	EACH	GALVANIC ANODE PROTECTION, AS PER PLAN		503			7	

ESTIMATED QUANTITIES-STRUCTURE No.: GRE-675-0737 (SFN: 2903660) (01/IMS FUNDING SPLIT)										
ITEM	EXTENSION	TOTAL	UNIT	DESCRIPTION	ABUT.	PIERS	SUPER.	GEN.	SEE SHEET	
202	11200	LUMP	LS	PORTIONS OF STRUCTURE REMOVED		LUMP				
512	74000	133	SY	REMOVAL OF EXISTING COATINGS FROM CONCRETE SURFACES		133				
512	10100	228	SY	SEALING OF CONCRETE SURFACES (EPOXY-URETHANE)		228				
SPECIAL	51900100	848	SF	COMPOSITE FIBER WRAP SYSTEM (SINGLE LAYER)		848			7	
519	11101	95	SF	PATCHING CONCRETE STRUCTURE, AS PER PLAN		95			7	
844	20001	87	EACH	GALVANIC ANODE PROTECTION, AS PER PLAN		87			7	

ESTIMATED QUANTITIES-STRUCTURE No.: HAM-127-1464 (SFN: 3111474) (01/IMS FUNDING SPLIT)										
ITEM	EXTENSION	TOTAL	UNIT	DESCRIPTION	ABUT.	PIERS	SUPER.	GEN.	SEE SHEET	
512	10100	655	SY	SEALING OF CONCRETE SURFACES (EPOXY-URETHANE)		655				
512	74000	380	SY	REMOVAL OF EXISTING COATINGS FROM CONCRETE SURFACES		380				
SPECIAL	51900100	2473	SF	COMPOSITE FIBER WRAP SYSTEM (SINGLE LAYER)		2473			7	
519	11101	233	SF	PATCHING CONCRETE STRUCTURE, AS PER PLAN		233			7	
844	20001	239	EACH	GALVANIC ANODE PROTECTION, AS PER PLAN		239			7	

ESTIMATED QUANTITIES-STRUCTURE No.: HAM-71-0822R (SFN: 3115135) (01/IMS FUNDING SPLIT)										
ITEM	EXTENSION	TOTAL	UNIT	DESCRIPTION	ABUT.	PIERS	SUPER.	GEN.	SEE SHEET	
512	10100	77	SY	SEALING OF CONCRETE SURFACES (EPOXY-URETHANE)		77				
SPECIAL	51900100	690	SF	COMPOSITE FIBER WRAP SYSTEM (SINGLE LAYER)		690			7	
519	11101	46	SF	PATCHING CONCRETE STRUCTURE, AS PER PLAN		46			7	
844	20001	43	EACH	GALVANIC ANODE PROTECTION, AS PER PLAN		43			7	

ESTIMATED QUANTITIES-STRUCTURE No.: WAR-75-0722 (SFN: 8303541) (01/IMS FUNDING SPLIT)										
ITEM	EXTENSION	TOTAL	UNIT	DESCRIPTION	ABUT.	PIERS	SUPER.	GEN.	SEE SHEET	
512	10100	277	SY	SEALING OF CONCRETE SURFACES (EPOXY-URETHANE)		277				
512	74000	76	SY	REMOVAL OF EXISTING COATINGS FROM CONCRETE SURFACES		76				
SPECIAL	51900100	1808	SF	COMPOSITE FIBER WRAP SYSTEM (SINGLE LAYER)		1808			7	
519	11101	158	SF	PATCHING CONCRETE STRUCTURE, AS PER PLAN		158			7	
844	20001	150	EACH	GALVANIC ANODE PROTECTION, AS PER PLAN		150			7	

ESTIMATED QUANTITIES-STRUCTURE No.: WAR-75-0918 (SFN: 8303789) (01/IMS FUNDING SPLIT)										
ITEM	EXTENSION	TOTAL	UNIT	DESCRIPTION	ABUT.	PIERS	SUPER.	GEN.	SEE SHEET	
512	10100	187	SY	SEALING OF CONCRETE SURFACES (EPOXY-URETHANE)		187				
512	74000	65	SY	REMOVAL OF EXISTING COATINGS FROM CONCRETE SURFACES		65				
SPECIAL	51900100	1102	SF	COMPOSITE FIBER WRAP SYSTEM (SINGLE LAYER)		1102			7	
519	11101	121	SF	PATCHING CONCRETE STRUCTURE, AS PER PLAN		121			7	
844	20001	92	EACH	GALVANIC ANODE PROTECTION, AS PER PLAN		92			7	

ESTIMATED QUANTITIES-STRUCTURE No.: WAR-75-1146 (SFN: 8303886) (01/IMS FUNDING SPLIT)										
ITEM	EXTENSION	TOTAL	UNIT	DESCRIPTION	ABUT.	PIERS	SUPER.	GEN.	SEE SHEET	
512	10100	236	SY	SEALING OF CONCRETE SURFACES (EPOXY-URETHANE)		236				
512	74000	64	SY	REMOVAL OF EXISTING COATINGS FROM CONCRETE SURFACES		64				
SPECIAL	51900100	310	SF	COMPOSITE FIBER WRAP SYSTEM (SINGLE LAYER)		310			7	
519	11101	4	SF	PATCHING CONCRETE STRUCTURE, AS PER PLAN		4			7	

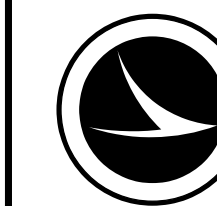

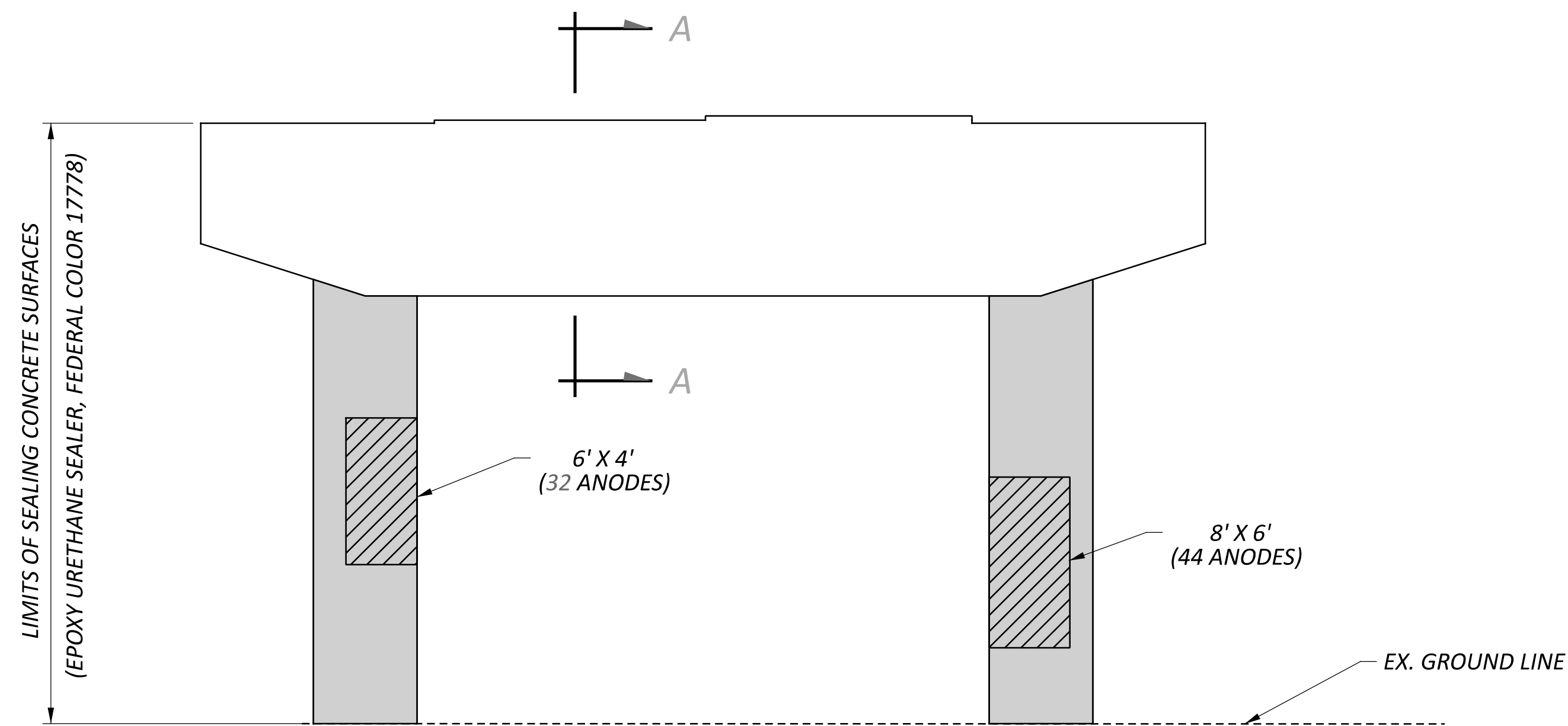

PIER 1 NORTH ELEVATION

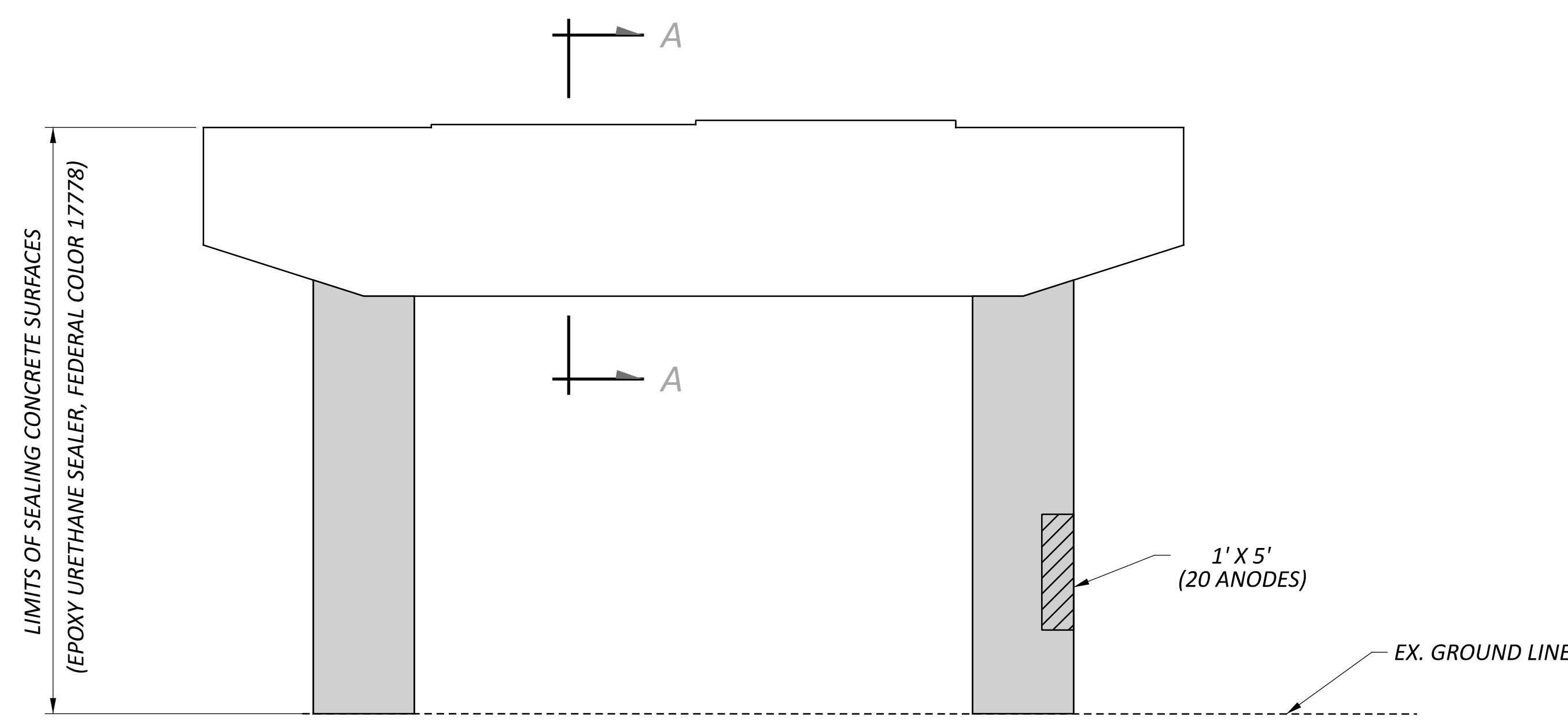

PIER 1 SOUTH ELEVATION

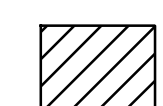
SUMMARY OF REPAIR AREAS			
PHYSICAL INVENTORY OF MEASURED QUANTITIES OF DETERIORATION WAS PERFORMED IN APRIL OF 2025.			
EXACT DIMENSIONS AND LOCATIONS OF REPAIRS SHALL BE DETERMINED BY THE ENGINEER IN THE FIELD FOR FINAL PAY QUANTITIES.			
TYPE	MEASURED QUANTITIES	ESTIMATING FACTOR*	ESTIMATED QUANTITIES
PIER 1 PATCHING 	77 SQ. FT.	1.5	116 SQ. FT.
PIER 1 ANODES			96

* - ESTIMATED QUANTITIES HAVE BEEN INCREASED BY 50% OVER MEASURED QUANTITIES TO ALLOW FOR ADDITIONAL DETERIORATION.

LEGEND

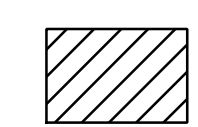
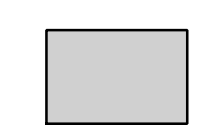
-  - AREA TO BE REPAIRED WITH ITEM 519 - PATCHING CONCRETE STRUCTURE, AS PER PLAN
-  - LIMITS OF SINGLE LAYER OF FIBER WRAP PER ITEM 519 - SPECIAL COMPOSITE FIBER WRAP SYSTEM

NOTES

- SEE STRUCTURE GENERAL NOTES FOR FIBER REINFORCED POLYMER SPECIFICATIONS AND ADDITIONAL DETAILS.
- STAGE PATCH REPAIR WIDTHS TO LIMIT REPAIRS TO 1/4 OF THE CIRCUMFERENCE AT A TIME.
- CONCRETE SEALING LIMITS AND LIMITS OF FIBER WRAP SHOWN FOR PIER 1 ARE SIMILAR TO THE LIMITS FOR PIER PIER 2
- INSTALL GALVANIC ANODES TO EXISTING REINFORCEMENT ALONG THE PERIMETER OF THE REPAIR AT A MAXIMUM SPACING OF 8"

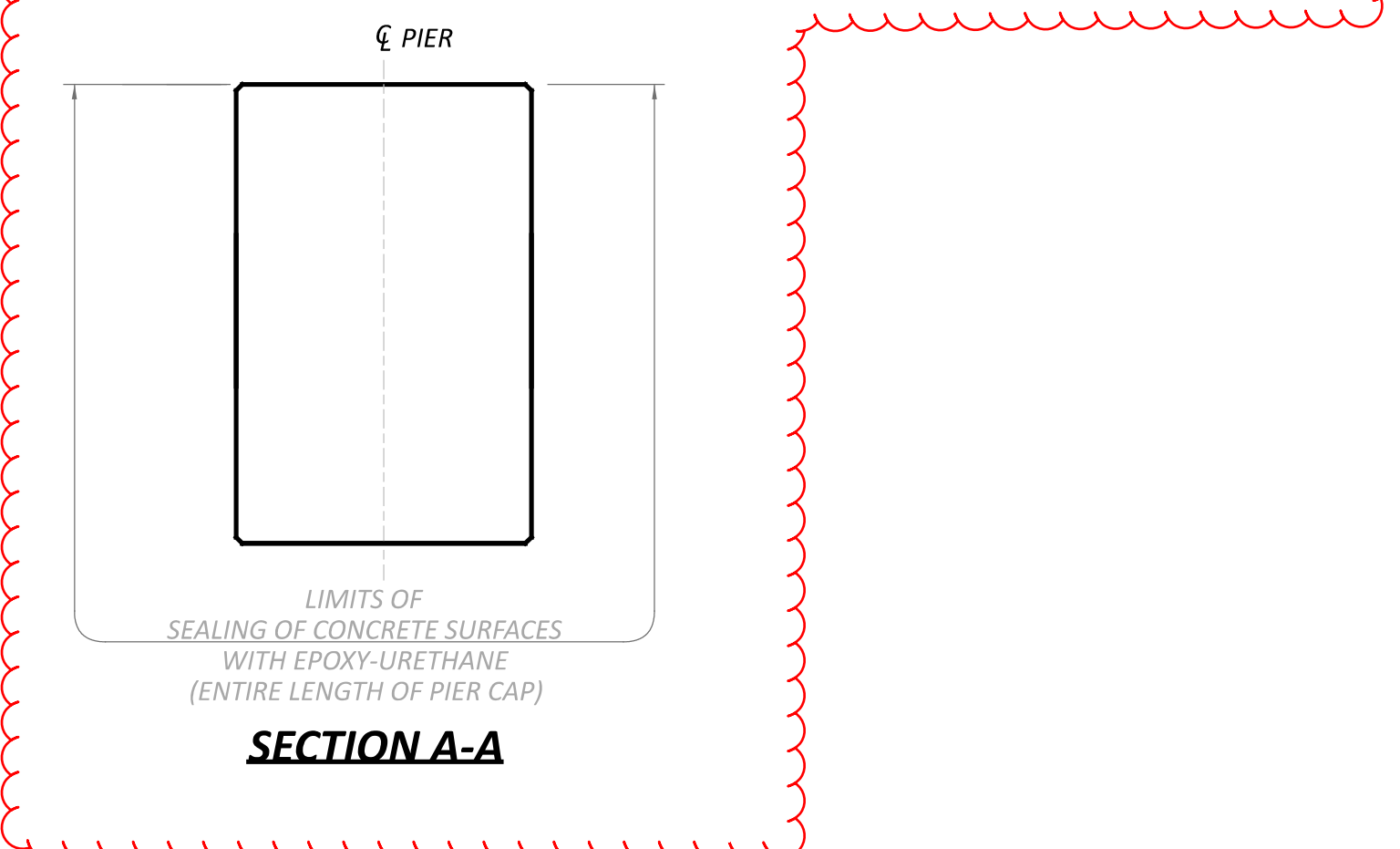

SFN	1305697
DESIGN AGENCY	
DESIGNER	CHECKER
GTF	BCP
REVIEWER	CAH 02/17/26
PROJECT ID	123648
SUBSET	TOTAL
1	2
SHEET	TOTAL
10	45

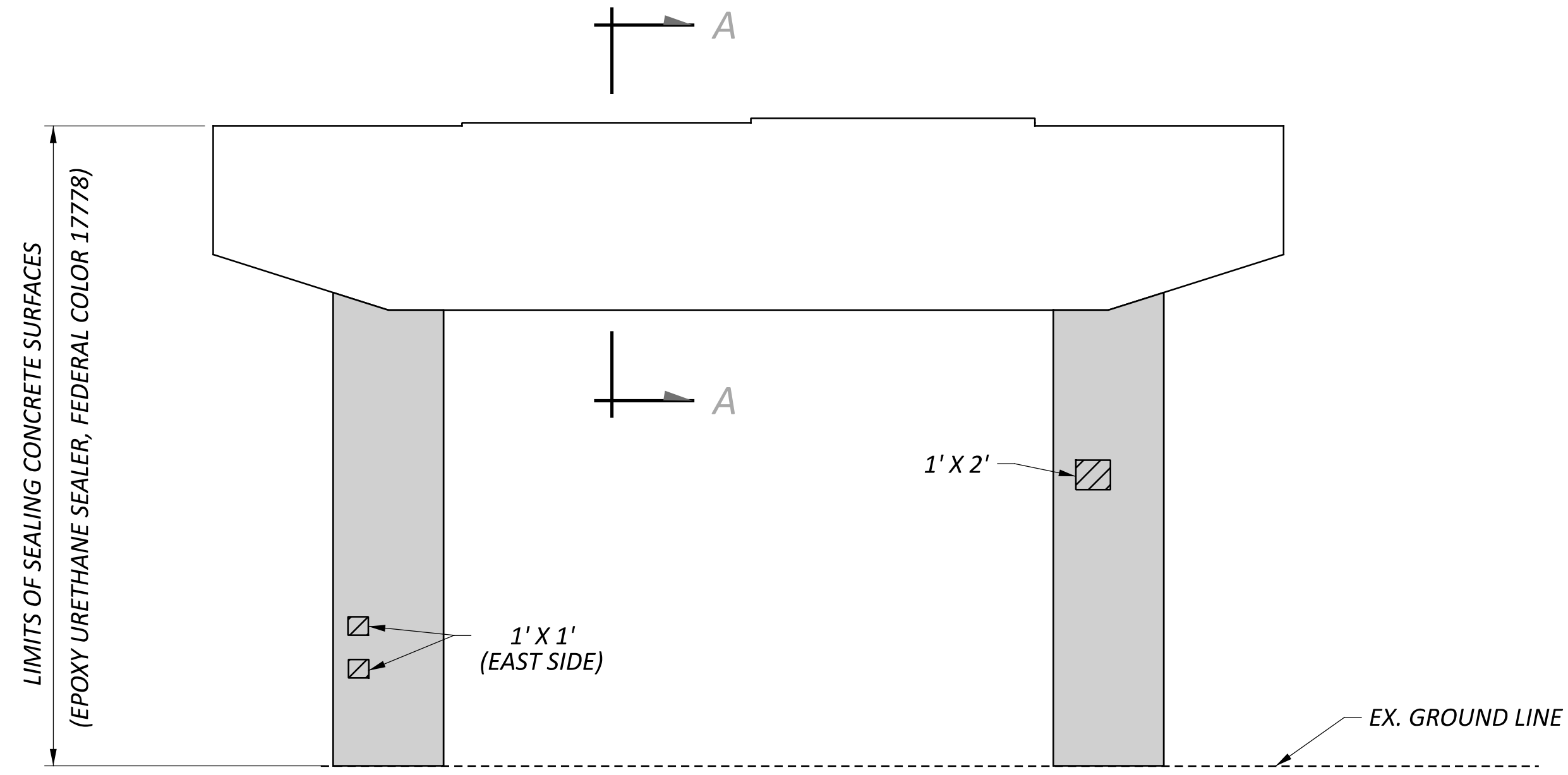

PIER 3 NORTH ELEVATION

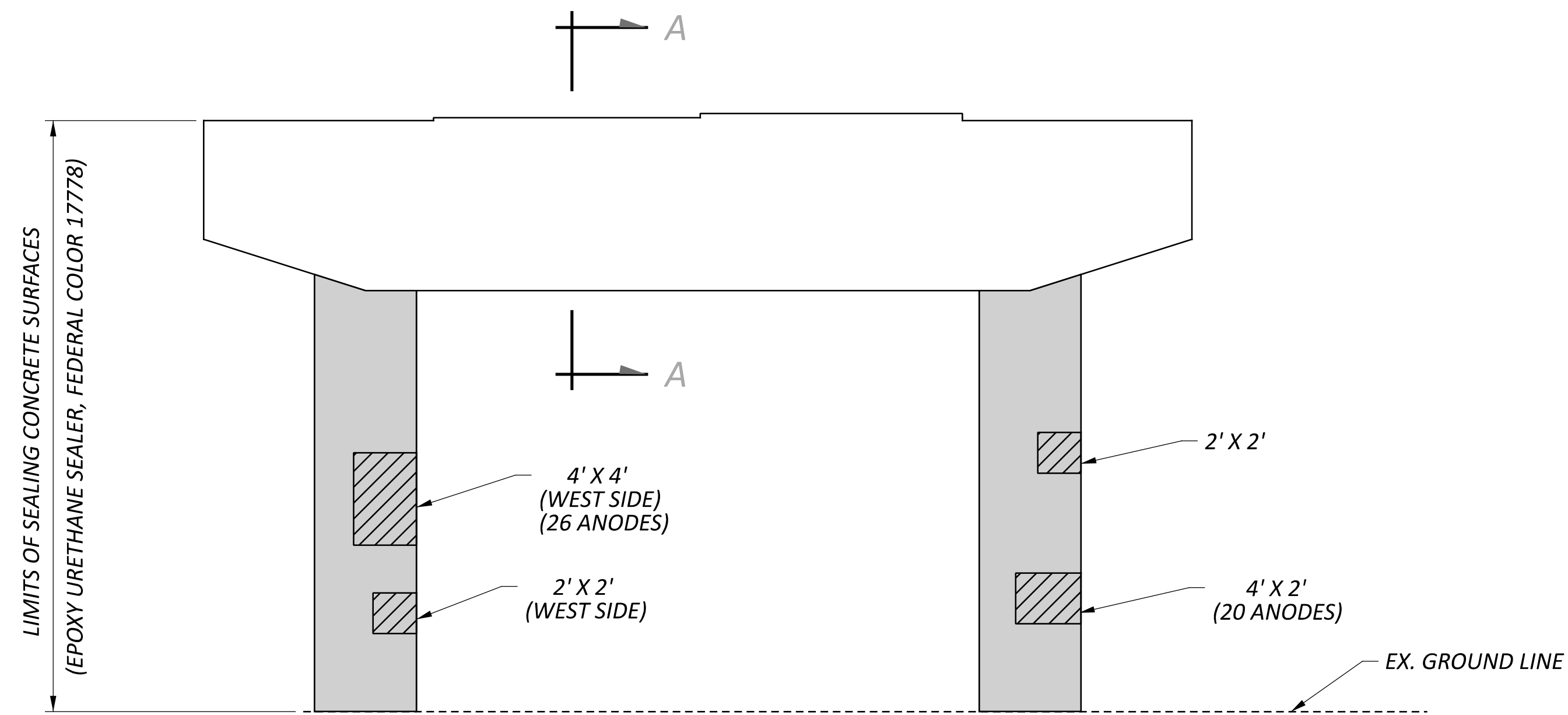

PIER 3 SOUTH ELEVATION

SUMMARY OF REPAIR AREAS			
PHYSICAL INVENTORY OF MEASURED QUANTITIES OF DETERIORATION WAS PERFORMED IN APRIL OF 2025.			
EXACT DIMENSIONS AND LOCATIONS OF REPAIRS SHALL BE DETERMINED BY THE ENGINEER IN THE FIELD FOR FINAL PAY QUANTITIES.			
TYPE	MEASURED QUANTITIES	ESTIMATING FACTOR*	ESTIMATED QUANTITIES
PIER 3 PATCHING	36 SQ. FT.	1.5	54 SQ. FT.
PIER 3 ANODES			46

* - ESTIMATED QUANTITIES HAVE BEEN INCREASED BY 50% OVER MEASURED QUANTITIES TO ALLOW FOR ADDITIONAL DETERIORATION.

LEGEND

- AREA TO BE REPAIRED WITH ITEM 519 - PATCHING CONCRETE STRUCTURE, AS PER PLAN
- LIMITS OF SINGLE LAYER OF FIBER WRAP PER ITEM 519 - SPECIAL COMPOSITE FIBER WRAP SYSTEM

NOTES

- SEE STRUCTURE GENERAL NOTES FOR FIBER REINFORCED POLYMER SPECIFICATIONS AND ADDITIONAL DETAILS.
- STAGE PATCH REPAIR WIDTHS TO LIMIT REPAIRS TO 1/4 OF THE CIRCUMFERENCE AT A TIME.
- CONCRETE SEALING LIMITS AND LIMITS OF FIBER WRAP SHOWN FOR PIER 3 ARE SIMILAR TO THE LIMITS FOR PIER PIER 2
- INSTALL GALVANIC ANODES TO EXISTING REINFORCEMENT ALONG THE PERIMETER OF THE REPAIR AT A MAXIMUM SPACING OF 8"

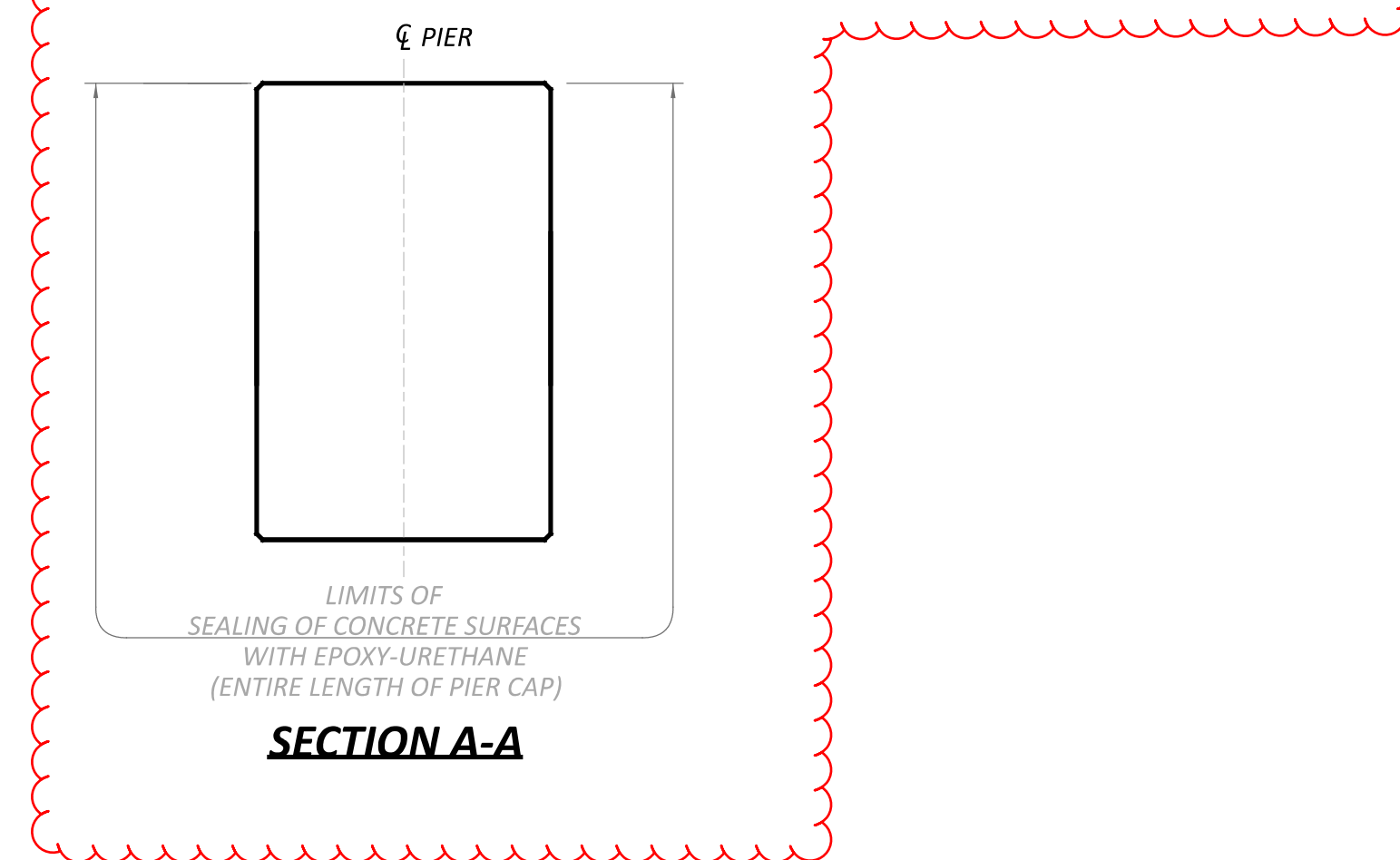

SFN	1305697
DESIGN AGENCY	
DESIGNER	CHECKER
GTF	BCP
REVIEWER	
CAH	02/17/26
PROJECT ID	123648
SUBSET	TOTAL
2	2
SHEET	TOTAL
11	45

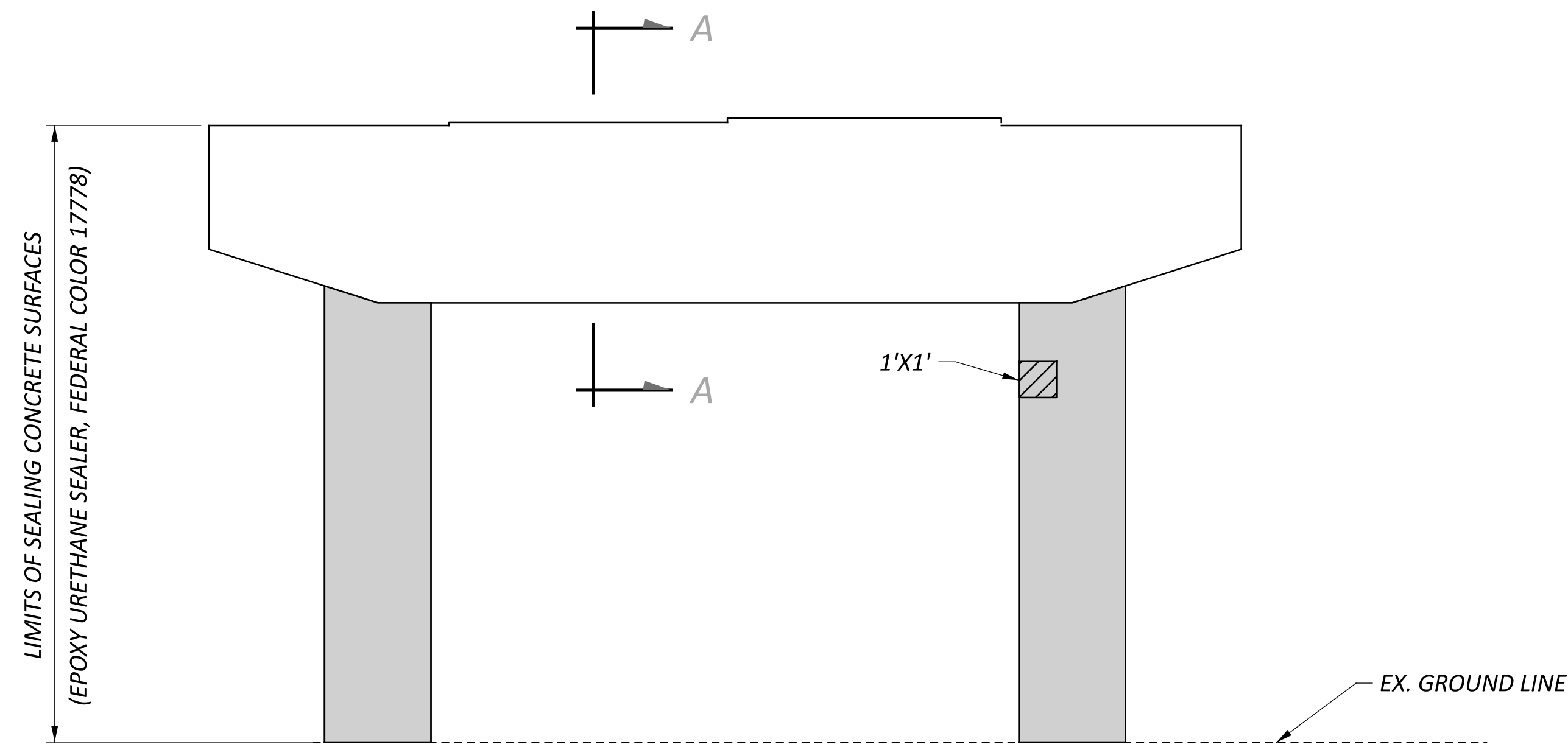

PIER 1 NORTH ELEVATION

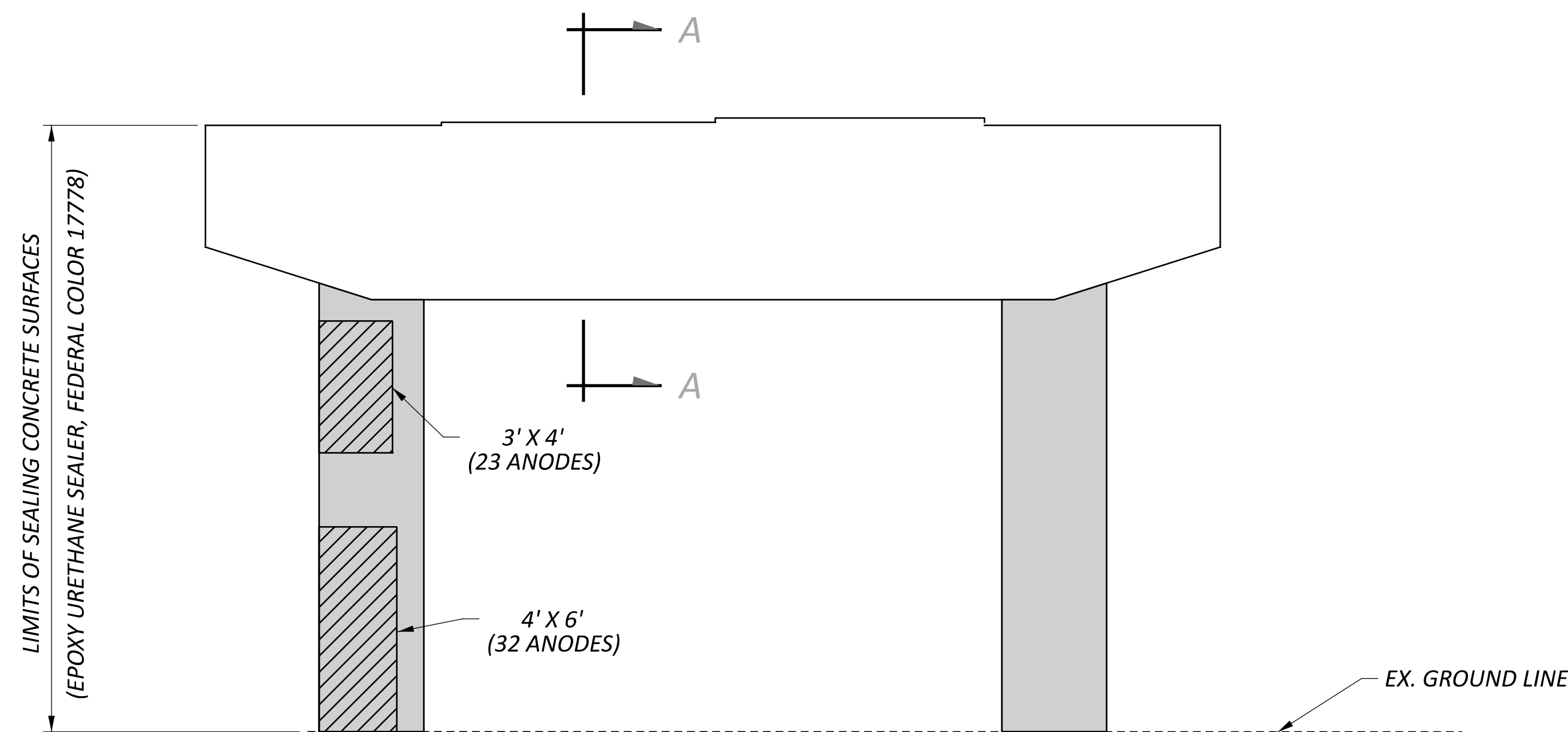

PIER 1 SOUTH ELEVATION

SUMMARY OF REPAIR AREAS			
PHYSICAL INVENTORY OF MEASURED QUANTITIES OF DETERIORATION WAS PERFORMED IN APRIL OF 2025.			
EXACT DIMENSIONS AND LOCATIONS OF REPAIRS SHALL BE DETERMINED BY THE ENGINEER IN THE FIELD FOR FINAL PAY QUANTITIES.			
TYPE	MEASURED QUANTITIES	ESTIMATING FACTOR*	ESTIMATED QUANTITIES
PIER 1 PATCHING	37 SQ. FT.	1.5	56 SQ. FT.
PIER 1 ANODES			55
* - ESTIMATED QUANTITIES HAVE BEEN INCREASED BY 50% OVER MEASURED QUANTITIES TO ALLOW FOR ADDITIONAL DETERIORATION.			

LEGEND

- AREA TO BE REPAIRED WITH ITEM 519 - PATCHING CONCRETE STRUCTURE, AS PER PLAN
- LIMITS OF SINGLE LAYER OF FIBER WRAP PER ITEM 519 - SPECIAL COMPOSITE FIBER WRAP SYSTEM

NOTES

1. SEE STRUCTURE GENERAL NOTES FOR FIBER REINFORCED POLYMER SPECIFICATIONS AND ADDITIONAL DETAILS.
2. STAGE PATCH REPAIR WIDTHS TO LIMIT REPAIRS TO 1/4 OF THE CIRCUMFERENCE AT A TIME.
3. INSTALL GALVANIC ANODES TO EXISTING REINFORCEMENT ALONG THE PERIMETER OF THE REPAIR AT A MAXIMUM SPACING OF 8"

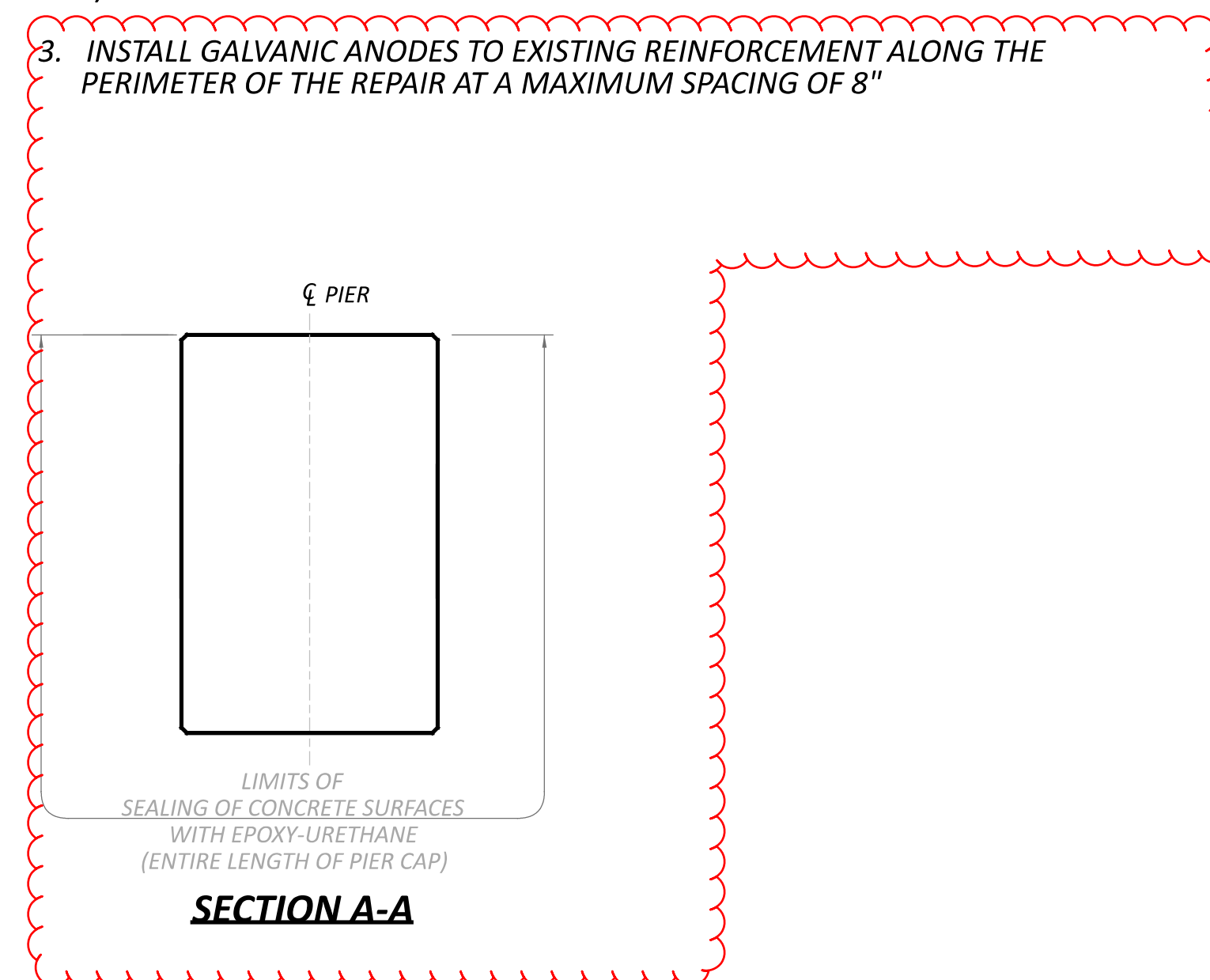

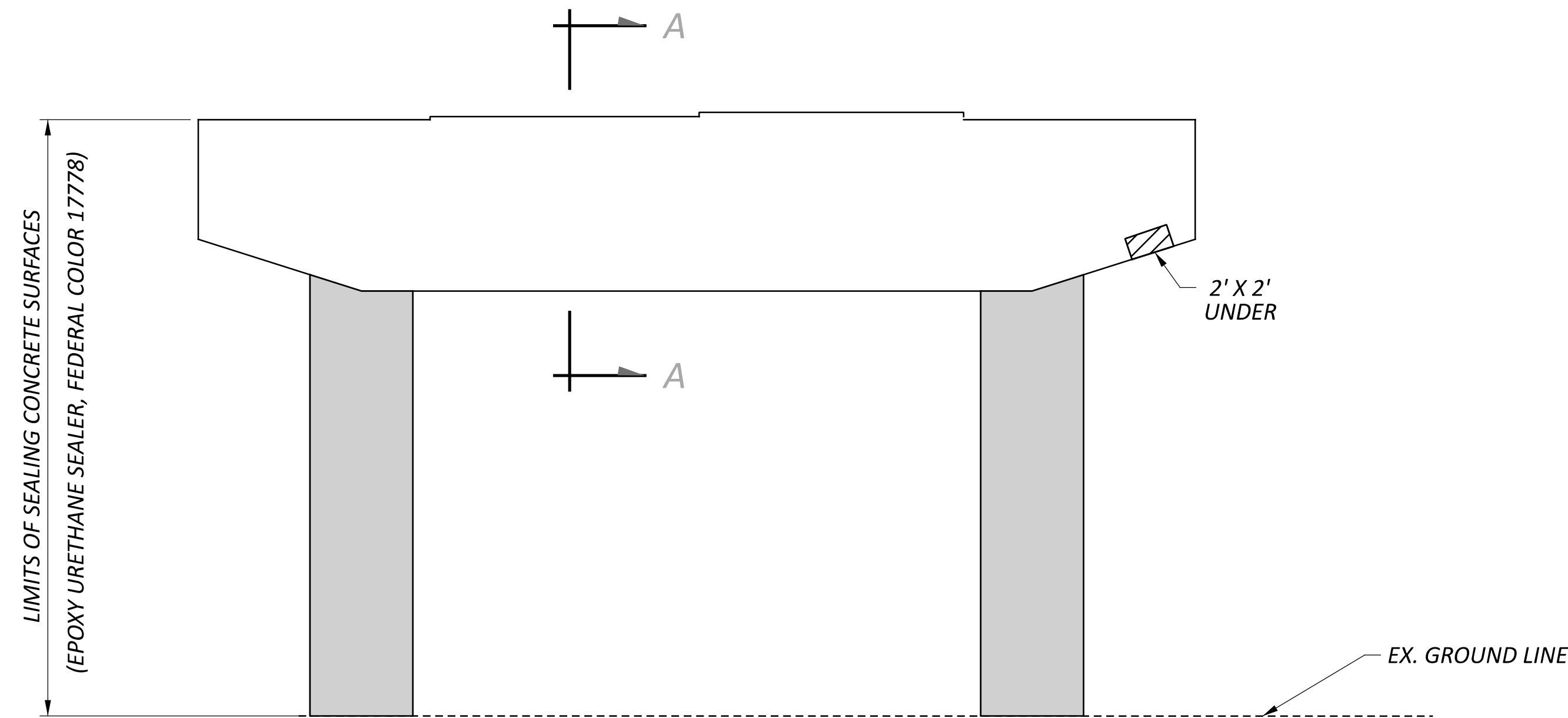

SFN 1305719	
DESIGN AGENCY	
DESIGNER	CHECKER
GTF	BCP
REVIEWER	
CAH 02/17/26	
PROJECT ID	
123648	
SUBSET	TOTAL
1	3
SHEET	TOTAL
12	45

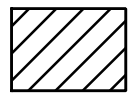

PIER 2 SOUTH ELEVATION

SUMMARY OF REPAIR AREAS			
PHYSICAL INVENTORY OF MEASURED QUANTITIES OF DETERIORATION WAS PERFORMED IN APRIL OF 2025.			
EXACT DIMENSIONS AND LOCATIONS OF REPAIRS SHALL BE DETERMINED BY THE ENGINEER IN THE FIELD FOR FINAL PAY QUANTITIES.			
TYPE	MEASURED QUANTITIES	ESTIMATING FACTOR*	ESTIMATED QUANTITIES
PIER 2 PATCHING 	4 SQ. FT.	1.5	6 SQ. FT.
PIER 2 ANODES			0
* - ESTIMATED QUANTITIES HAVE BEEN INCREASED BY 50% OVER MEASURED QUANTITIES TO ALLOW FOR ADDITIONAL DETERIORATION.			

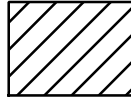
LEGEND

-  -AREA TO BE REPAIRED WITH ITEM 519 - PATCHING CONCRETE STRUCTURE, AS PER PLAN
-  -LIMITS OF SINGLE LAYER OF FIBER WRAP PER ITEM 519 - SPECIAL COMPOSITE FIBER WRAP SYSTEM

NOTES

1. SEE STRUCTURE GENERAL NOTES FOR FIBER REINFORCED POLYMER SPECIFICATIONS AND ADDITIONAL DETAILS.
2. STAGE PATCH REPAIR WIDTHS TO LIMIT REPAIRS TO 1/4 OF THE CIRCUMFERENCE AT A TIME.

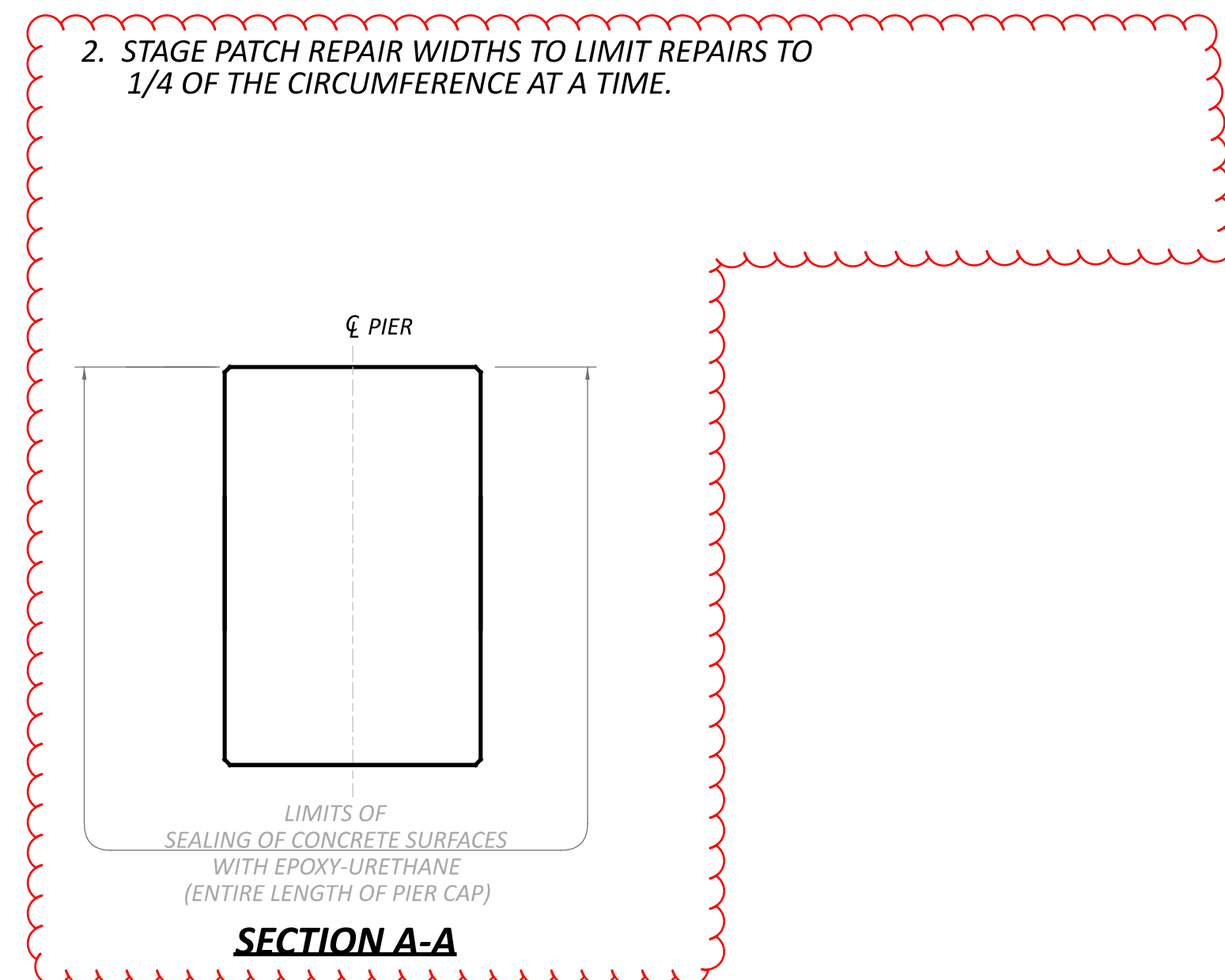

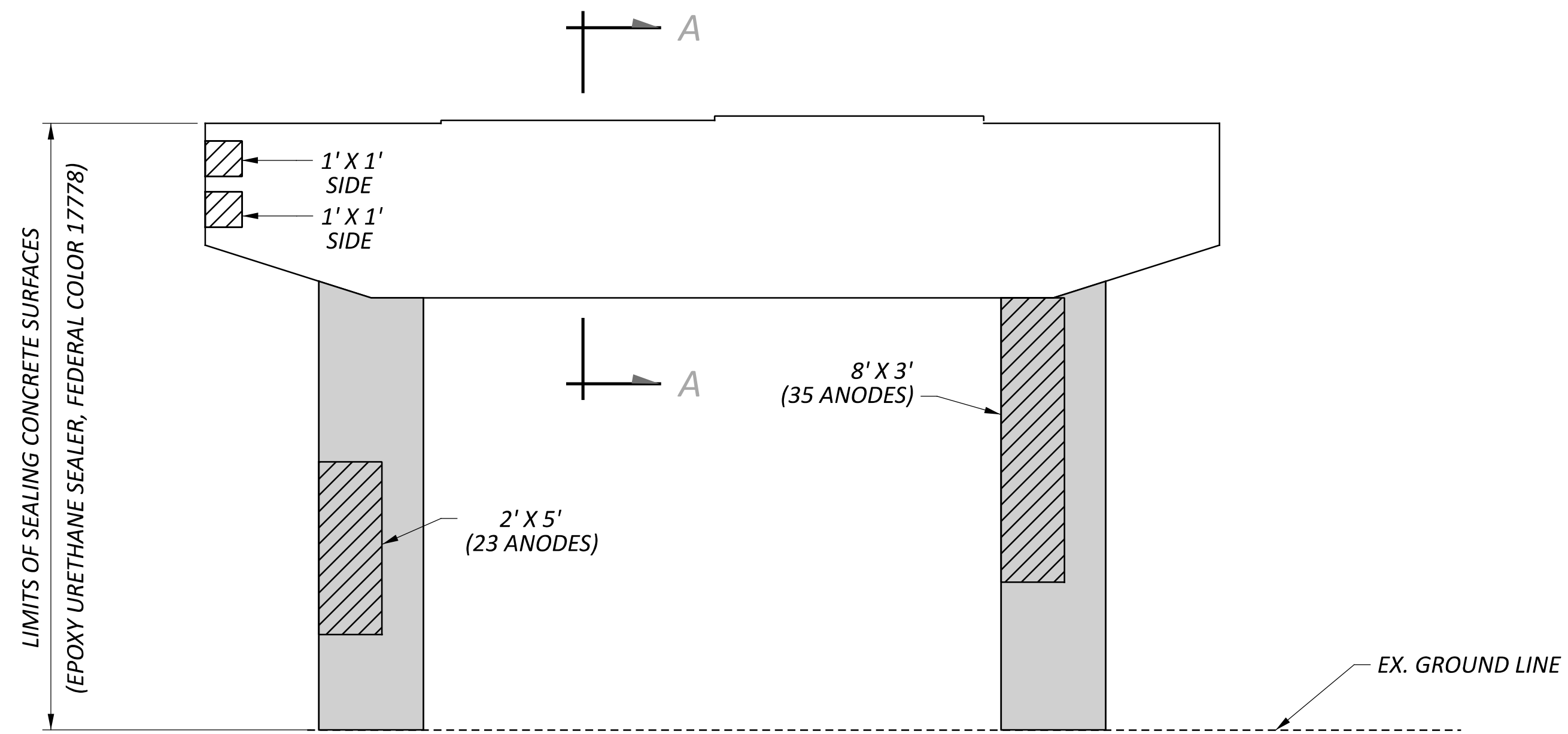

PIER 3 NORTH ELEVATION

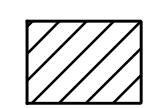
SUMMARY OF REPAIR AREAS			
PHYSICAL INVENTORY OF MEASURED QUANTITIES OF DETERIORATION WAS PERFORMED IN APRIL OF 2025.			
EXACT DIMENSIONS AND LOCATIONS OF REPAIRS SHALL BE DETERMINED BY THE ENGINEER IN THE FIELD FOR FINAL PAY QUANTITIES.			
TYPE	MEASURED QUANTITIES	ESTIMATING FACTOR*	ESTIMATED QUANTITIES
PIER 3 PATCHING 	36 SQ. FT.	1.5	54 SQ. FT.
PIER 3 ANODES			58
* - ESTIMATED QUANTITIES HAVE BEEN INCREASED BY 50% OVER MEASURED QUANTITIES TO ALLOW FOR ADDITIONAL DETERIORATION.			

LEGEND

 -AREA TO BE REPAIRED WITH ITEM 519 - PATCHING CONCRETE STRUCTURE, AS PER PLAN

 -LIMITS OF SINGLE LAYER OF FIBER WRAP PER ITEM 519 - SPECIAL COMPOSITE FIBER WRAP SYSTEM

NOTES

- SEE STRUCTURE GENERAL NOTES FOR FIBER REINFORCED POLYMER SPECIFICATIONS AND ADDITIONAL DETAILS.
- STAGE PATCH REPAIR WIDTHS TO LIMIT REPAIRS TO 1/4 OF THE CIRCUMFERENCE AT A TIME.
- INSTALL GALVANIC ANODES TO EXISTING REINFORCEMENT ALONG THE PERIMETER OF THE REPAIR AT A MAXIMUM SPACING OF 8"

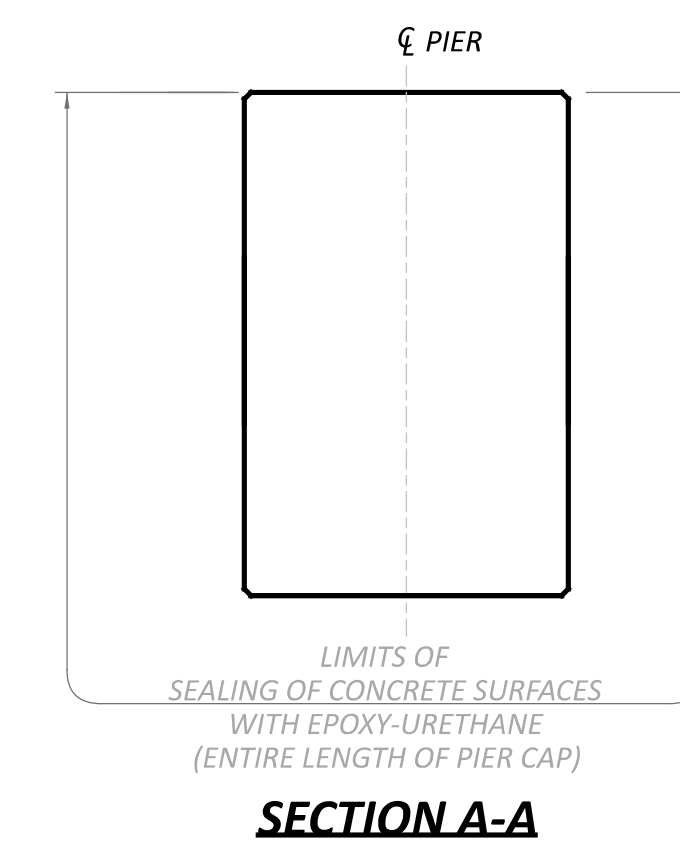

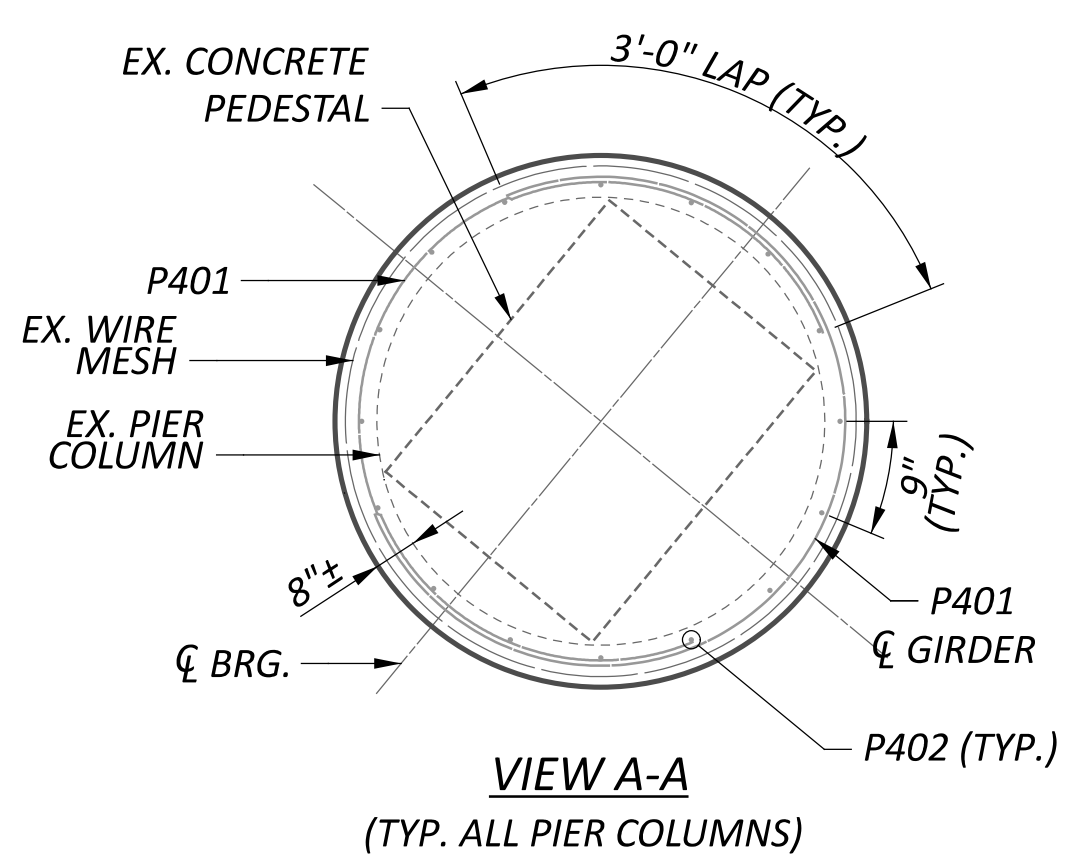
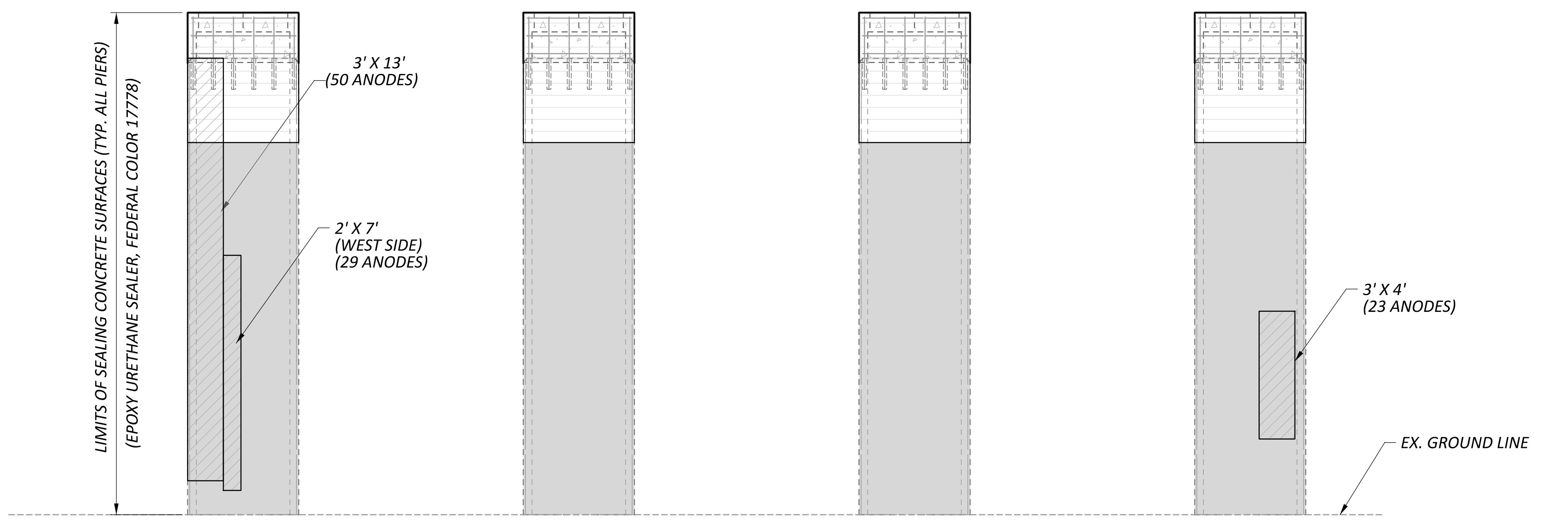
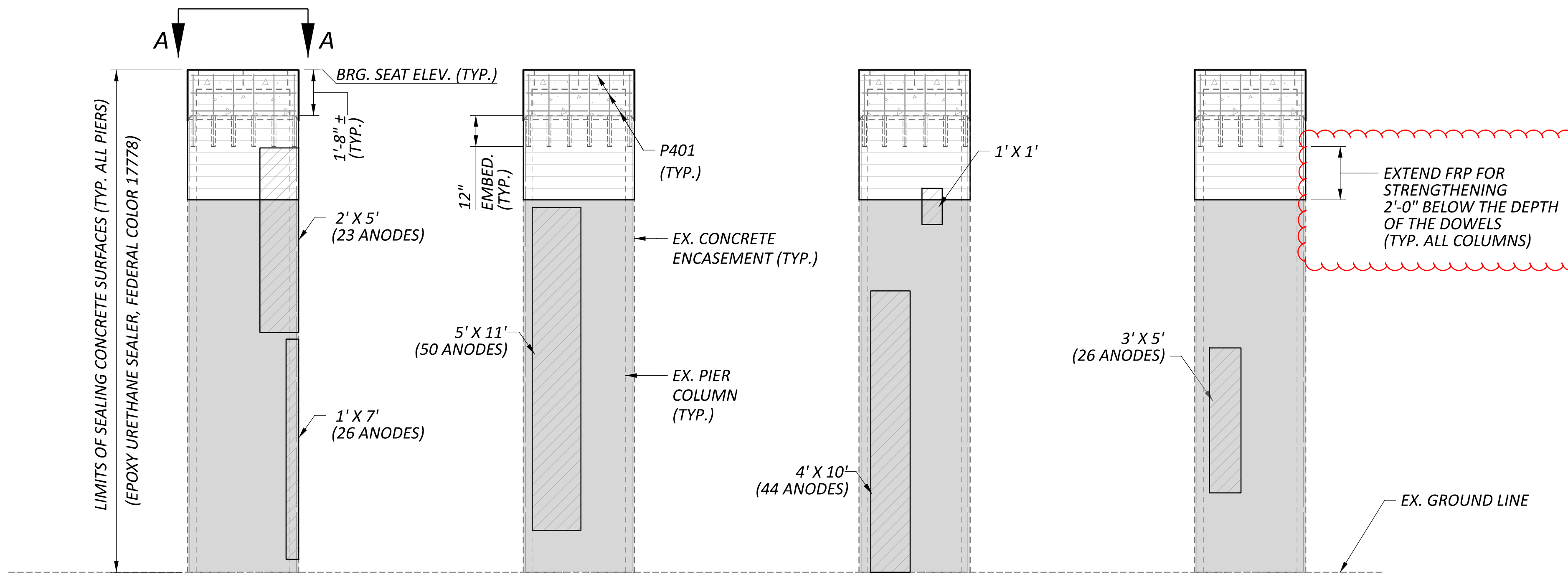

SUMMARY OF REPAIR AREAS			
PHYSICAL INVENTORY OF MEASURED QUANTITIES OF DETERIORATION WAS PERFORMED IN APRIL OF 2025.			
EXACT DIMENSIONS AND LOCATIONS OF REPAIRS SHALL BE DETERMINED BY THE ENGINEER IN THE FIELD FOR FINAL PAY QUANTITIES.			
TYPE	MEASURED QUANTITIES	ESTIMATING FACTOR*	ESTIMATED QUANTITIES
PIER 1 PATCHING	193 SQ. FT.	1.5	290 SQ. FT.
PIER 1 ANODES			271

* - ESTIMATED QUANTITIES HAVE BEEN INCREASED BY 50% OVER MEASURED QUANTITIES TO ALLOW FOR ADDITIONAL DETERIORATION.

LEGEND

- AREA TO BE REPAIRED WITH ITEM 519 - PATCHING CONCRETE STRUCTURE, AS PER PLAN
- LIMITS OF SINGLE LAYER OF FIBER WRAP PER ITEM 519 - SPECIAL COMPOSITE FIBER WRAP SYSTEM (SINGLE LAYER)
- LIMITS OF FIBER WRAP PER ITEM 519 - ITEM SPECIAL- COMPOSITE FIBER WRAP SYSTEM (STRENGTHENING)
- ITEM 511, CLASS QC1 CONCRETE

NOTES

- SEE STRUCTURE GENERAL NOTES FOR FIBER REINFORCED POLYMER SPECIFICATIONS AND ADDITIONAL DETAILS.
- STAGE PATCH REPAIR WIDTHS TO LIMIT REPAIRS TO 1/4 OF THE CIRCUMFERENCE AT A TIME.
- INSTALL GALVANIC ANODES TO EXISTING REINFORCEMENT ALONG THE PERIMETER OF THE REPAIR AT A MAXIMUM SPACING OF 8"

ITEM 511, CONCRETE, MISC.: REMOVAL OF LOOSE CONCRETE

THIS ITEM SHALL INCLUDE THE REMOVAL OF LOOSE AND DISINTEGRATED CONCRETE ON THE PORTIONS OF THE PIER COLUMNS AND SQUARE PEDESTALS THAT PROTRUDE FROM THE CONCRETE PIER COLUMN ENCASEMENT PRIOR TO VERTICAL EXTENSION OF CONCRETE PIER ENCASEMENT. REMOVE ALL LOOSE AND DISINTEGRATED CONCRETE IN SUCH A MANNER AND TO SUCH AN EXTENT TO EXPOSE INTACT CONCRETE. ONLY USE HAND TOOLS THAT GIVE RESULTS SATISFACTORY TO THE ENGINEER IN THE REMOVAL OF THE LOOSE AND DISINTEGRATED CONCRETE. PNEUMATIC HAMMERS WILL NOT BE PERMITTED FOR REMOVAL OF THE CONCRETE. ADEQUATELY SUPPORT REINFORCEMENT THAT IS LOOSE AND TIE BACK INTO PLACE.

THE REMOVAL OF LOOSE CONCRETE SHALL BE PAID FOR ON A SQUARE FOOT UNIT PRICE BASIS. THE FOLLOWING ESTIMATED QUANTITIES HAVE BEEN CARRIED TO THE STRUCTURES ESTIMATED QUANTITIES FOR REMOVAL OF LOOSE CONCRETE AT PIER 3.

ITEM 511, CONCRETE MISC.: REMOVAL OF LOOSE CONCRETE 66 SQ. FT.

MARK	NUMBER TOTAL	LENGTH	WEIGHT	TYPE	DIMENSIONS						
					A	B	C	D	E	R	INC
PIER 1 REINFORCING STEEL											
P401	24	9'-0"	145							1'-11"	
P402	64	2'-6"	107	STR							
SUB-TOTAL			252								

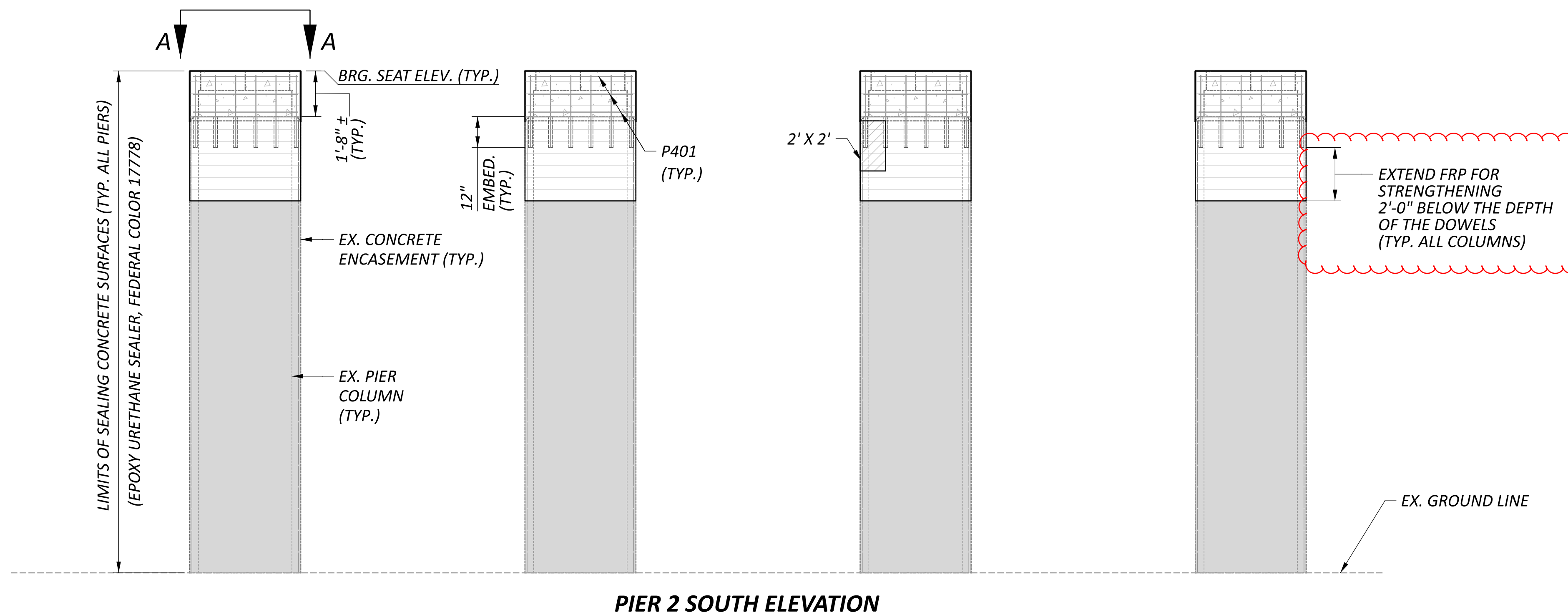

PIER 2 SOUTH ELEVATION

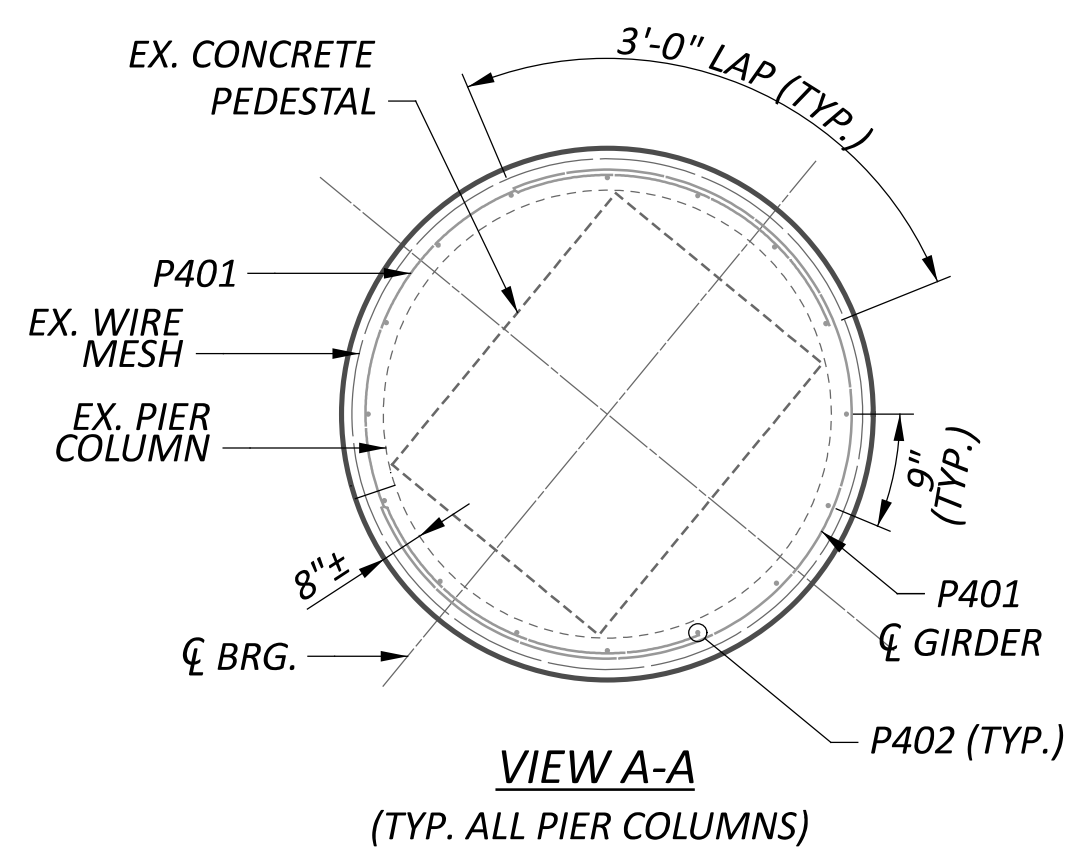

MARK	NUMBER	LENGTH	WEIGHT	TYPE	DIMENSIONS						
					A	B	C	D	E	R	INC
PIER 1 REINFORCING STEEL											
P401	24	9'-0"	145							1'-11"	
P402	64	2'-6"	107	STR							
SUB-TOTAL			252								

SUMMARY OF REPAIR AREAS			
PHYSICAL INVENTORY OF MEASURED QUANTITIES OF DETERIORATION WAS PERFORMED IN APRIL OF 2025.			
EXACT DIMENSIONS AND LOCATIONS OF REPAIRS SHALL BE DETERMINED BY THE ENGINEER IN THE FIELD FOR FINAL PAY QUANTITIES.			
TYPE	MEASURED QUANTITIES	ESTIMATING FACTOR*	ESTIMATED QUANTITIES
PIER 2 PATCHING	4 SQ. FT.	1.5	6 SQ. FT.
* - ESTIMATED QUANTITIES HAVE BEEN INCREASED BY 50% OVER MEASURED QUANTITIES TO ALLOW FOR ADDITIONAL DETERIORATION.			

LEGEND

- AREA TO BE REPAIRED WITH ITEM 519 - PATCHING CONCRETE STRUCTURE, AS PER PLAN
- LIMITS OF SINGLE LAYER OF FIBER WRAP PER ITEM 519 - SPECIAL COMPOSITE FIBER WRAP SYSTEM (SINGLE LAYER)
- LIMITS OF FIBER WRAP PER ITEM 519 - ITEM SPECIAL- COMPOSITE FIBER WRAP SYSTEM (STRENGTHENING)
- ITEM 511, CLASS QC1 CONCRETE

NOTES

- SEE STRUCTURE GENERAL NOTES FOR FIBER REINFORCED POLYMER SPECIFICATIONS AND ADDITIONAL DETAILS.
- STAGE PATCH REPAIR WIDTHS TO LIMIT REPAIRS TO 1/4 OF THE CIRCUMFERENCE AT A TIME.

ITEM 511, CONCRETE, MISC.: REMOVAL OF LOOSE CONCRETE

THIS ITEM SHALL INCLUDE THE REMOVAL OF LOOSE AND DISINTEGRATED CONCRETE ON THE PORTIONS OF THE PIER COLUMNS AND SQUARE PEDESTALS THAT PROTRUDE FROM THE CONCRETE PIER COLUMN ENCASEMENT PRIOR TO VERTICAL EXTENSION OF CONCRETE PIER ENCASEMENT. REMOVE ALL LOOSE AND DISINTEGRATED CONCRETE IN SUCH A MANNER AND TO SUCH AN EXTENT TO EXPOSE INTACT CONCRETE. ONLY USE HAND TOOLS THAT GIVE RESULTS SATISFACTORY TO THE ENGINEER IN THE REMOVAL OF THE LOOSE AND DISINTEGRATED CONCRETE. PNEUMATIC HAMMERS WILL NOT BE PERMITTED FOR REMOVAL OF THE CONCRETE. ADEQUATELY SUPPORT REINFORCEMENT THAT IS LOOSE AND TIE BACK INTO PLACE.

THE REMOVAL OF LOOSE CONCRETE SHALL BE PAID FOR ON A SQUARE FOOT UNIT PRICE BASIS. THE FOLLOWING ESTIMATED QUANTITIES HAVE BEEN CARRIED TO THE STRUCTURES ESTIMATED QUANTITIES FOR REMOVAL OF LOOSE CONCRETE AT PIER 3.

ITEM 511, CONCRETE MISC.: REMOVAL OF LOOSE CONCRETE 66 SQ. FT.

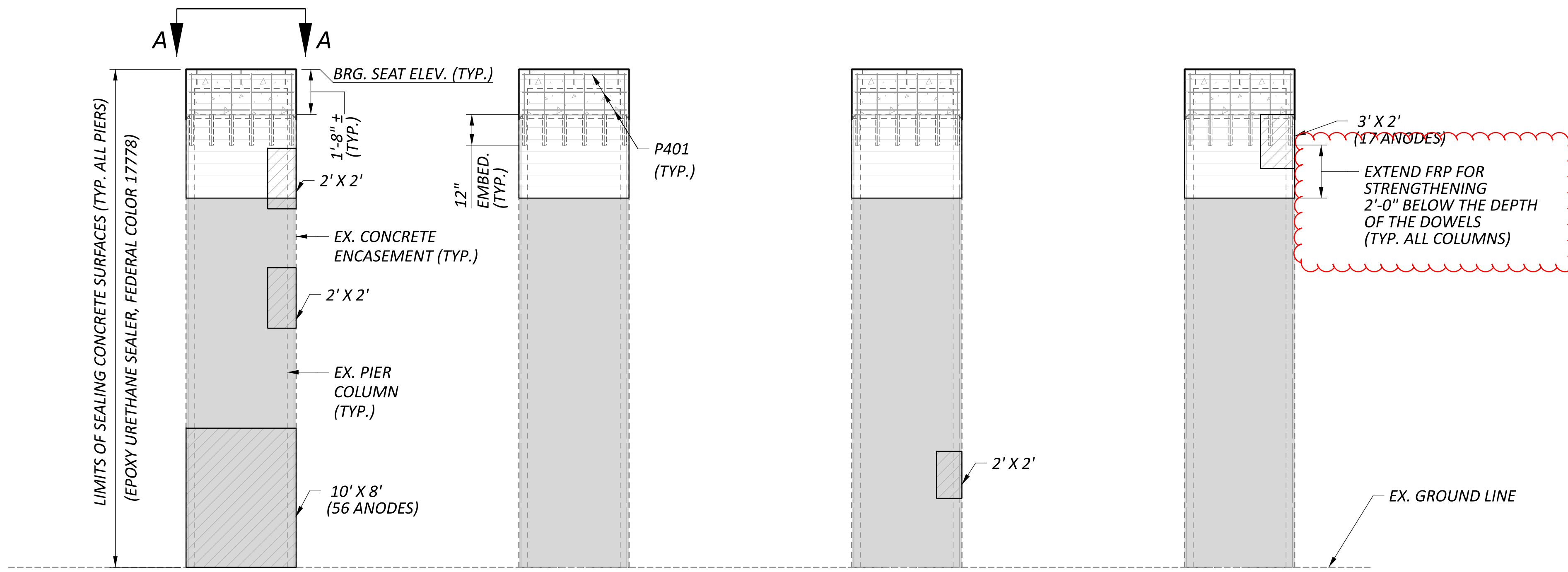

PIER 3 NORTH ELEVATION

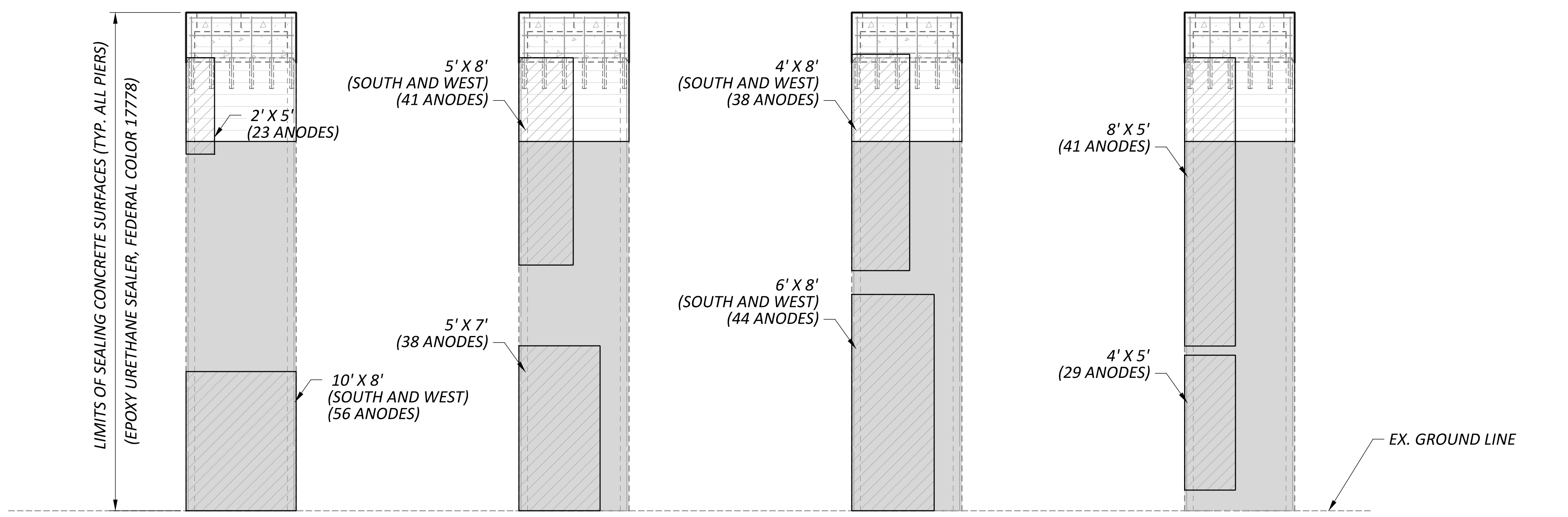

PIER 3 SOUTH ELEVATION

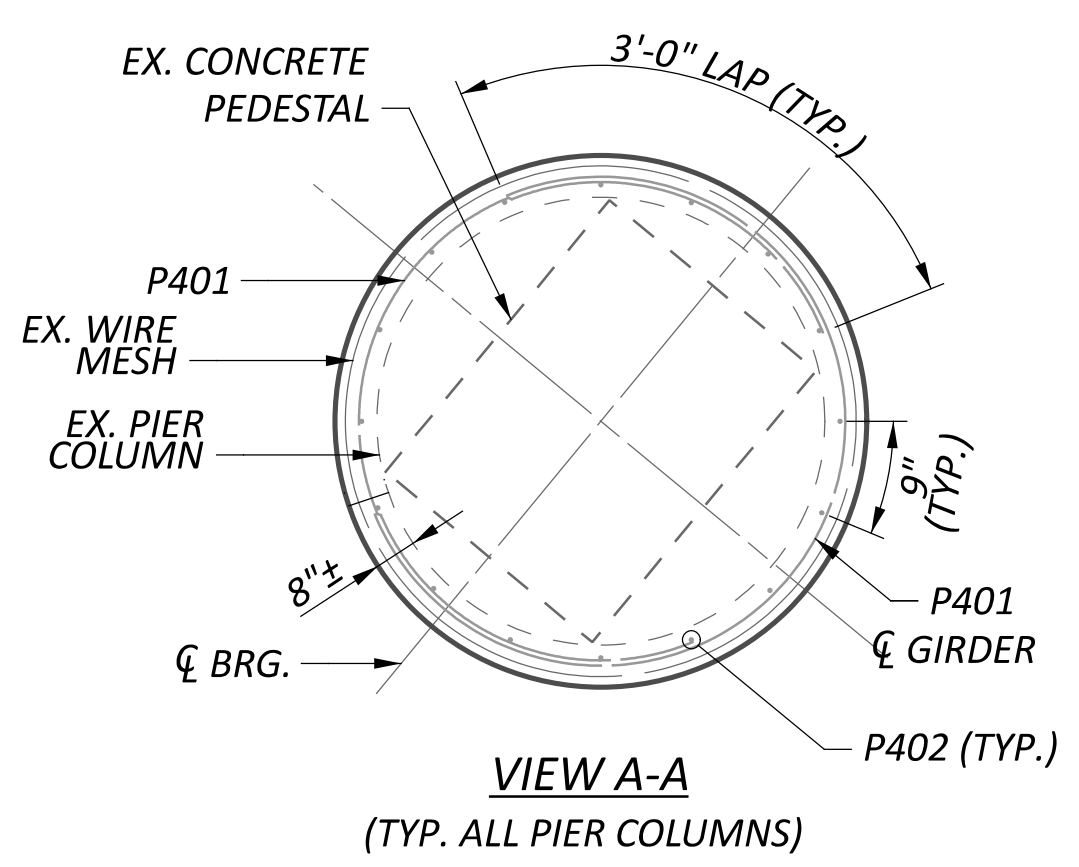

MARK	NUMBER	LENGTH	WEIGHT	TYPE	DIMENSIONS						
					A	B	C	D	E	R	INC
PIER 1 REINFORCING STEEL											
P401	24	9'-0"	145							1'-11"	
P402	64	2'-6"	107	STR							
SUB-TOTAL			252								

SUMMARY OF REPAIR AREAS			
PHYSICAL INVENTORY OF MEASURED QUANTITIES OF DETERIORATION WAS PERFORMED IN APRIL OF 2025.			
EXACT DIMENSIONS AND LOCATIONS OF REPAIRS SHALL BE DETERMINED BY THE ENGINEER IN THE FIELD FOR FINAL PAY QUANTITIES.			
TYPE	MEASURED QUANTITIES	ESTIMATING FACTOR*	ESTIMATED QUANTITIES
PIER 3 PATCHING	403 SQ. FT.	1.5	605 SQ. FT.
PIER 3 ANODES			383
* - ESTIMATED QUANTITIES HAVE BEEN INCREASED BY 50% OVER MEASURED QUANTITIES TO ALLOW FOR ADDITIONAL DETERIORATION.			

LEGEND

- AREA TO BE REPAIRED WITH ITEM 519 - PATCHING CONCRETE STRUCTURE, AS PER PLAN
- LIMITS OF SINGLE LAYER OF FIBER WRAP PER ITEM 519 - SPECIAL COMPOSITE FIBER WRAP SYSTEM (SINGLE LAYER)
- LIMITS OF FIBER WRAP PER ITEM 519 - ITEM SPECIAL- COMPOSITE FIBER WRAP SYSTEM (STRENGTHENING)
- ITEM 511, CLASS QC1 CONCRETE

NOTES

1. SEE STRUCTURE GENERAL NOTES FOR FIBER REINFORCED POLYMER SPECIFICATIONS AND ADDITIONAL DETAILS.
2. STAGE PATCH REPAIR WIDTHS TO LIMIT REPAIRS TO 1/4 OF THE CIRCUMFERENCE AT A TIME.
3. INSTALL GALVANIC ANODES TO EXISTING REINFORCEMENT ALONG THE PERIMETER OF THE REPAIR AT A MAXIMUM SPACING OF 8"

ITEM 511, CONCRETE, MISC.: REMOVAL OF LOOSE CONCRETE

THIS ITEM SHALL INCLUDE THE REMOVAL OF LOOSE AND DISINTEGRATED CONCRETE ON THE PORTIONS OF THE PIER COLUMNS AND SQUARE PEDESTALS THAT PROTRUDE FROM THE CONCRETE PIER COLUMN ENCASEMENT PRIOR TO VERTICAL EXTENSION OF CONCRETE PIER ENCASEMENT. REMOVE ALL LOOSE AND DISINTEGRATED CONCRETE IN SUCH A MANNER AND TO SUCH AN EXTENT TO EXPOSE INTACT CONCRETE. ONLY USE HAND TOOLS THAT GIVE RESULTS SATISFACTORY TO THE ENGINEER IN THE REMOVAL OF THE LOOSE AND DISINTEGRATED CONCRETE. PNEUMATIC HAMMERS WILL NOT BE PERMITTED FOR REMOVAL OF THE CONCRETE. ADEQUATELY SUPPORT REINFORCEMENT THAT IS LOOSE AND TIE BACK INTO PLACE.

THE REMOVAL OF LOOSE CONCRETE SHALL BE PAID FOR ON A SQUARE FOOT UNIT PRICE BASIS. THE FOLLOWING ESTIMATED QUANTITIES HAVE BEEN CARRIED TO THE STRUCTURES ESTIMATED QUANTITIES FOR REMOVAL OF LOOSE CONCRETE AT PIER 3.

ITEM 511, CONCRETE MISC.: REMOVAL OF LOOSE CONCRETE 66 SQ. FT.

SFN	1401416
DESIGN AGENCY	
DESIGNER	CHECKER
GTF	BCP
REVIEWER	
CAH	02/17/26
PROJECT ID	123648
SUBSET	TOTAL
3	3
SHEET	TOTAL
17	45

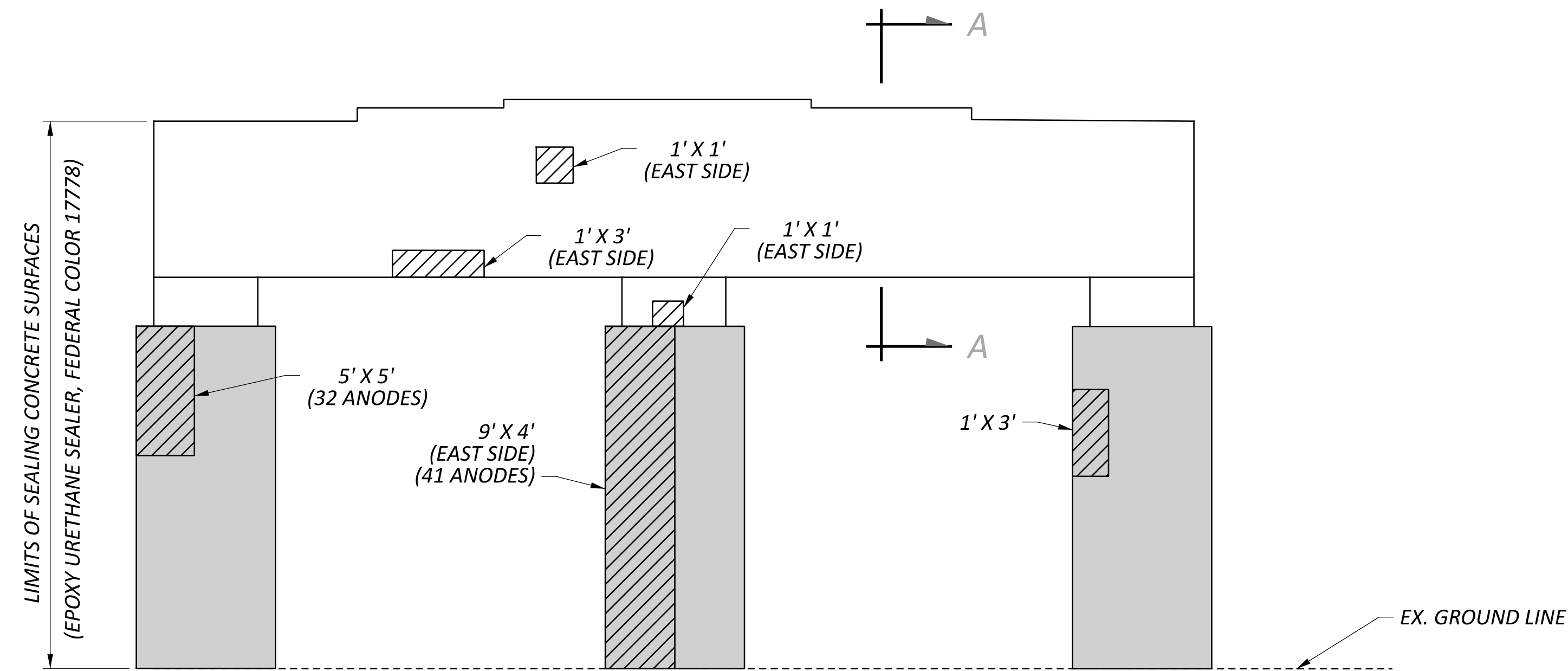

PIER 1 NORTH ELEVATION

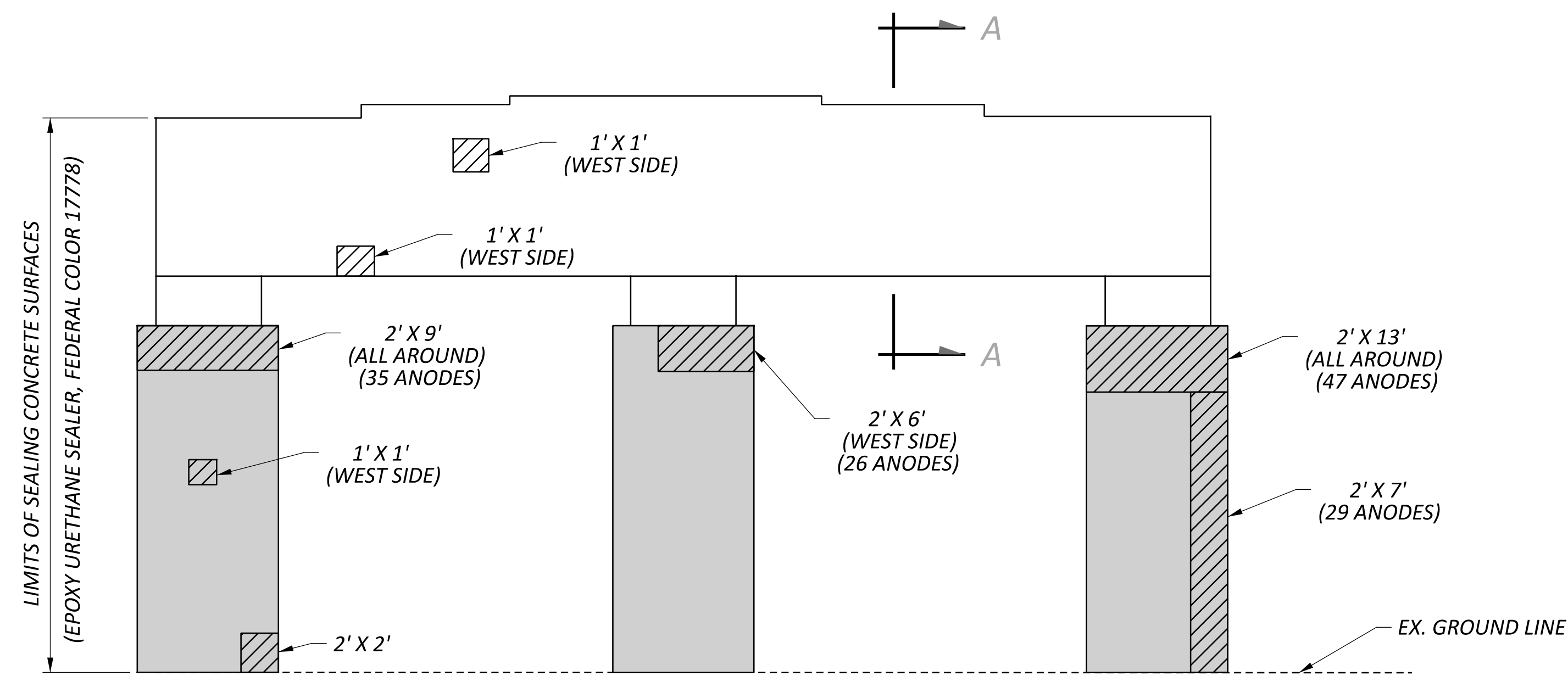

PIER 1 SOUTH ELEVATION

SUMMARY OF REPAIR AREAS			
PHYSICAL INVENTORY OF MEASURED QUANTITIES OF DETERIORATION WAS PERFORMED IN APRIL OF 2025.			
EXACT DIMENSIONS AND LOCATIONS OF REPAIRS SHALL BE DETERMINED BY THE ENGINEER IN THE FIELD FOR FINAL PAY QUANTITIES.			
TYPE	MEASURED QUANTITIES	ESTIMATING FACTOR*	ESTIMATED QUANTITIES
PIER 1 PATCHING	146 SQ. FT.	1.5	219 SQ. FT.
PIER 1 ANODES			210
* - ESTIMATED QUANTITIES HAVE BEEN INCREASED BY 50% OVER MEASURED QUANTITIES TO ALLOW FOR ADDITIONAL DETERIORATION.			

LEGEND

- AREA TO BE REPAIRED WITH ITEM 519 - PATCHING CONCRETE STRUCTURE, AS PER PLAN
- LIMITS OF SINGLE LAYER OF FIBER WRAP PER ITEM 519 - SPECIAL COMPOSITE FIBER WRAP SYSTEM

NOTES

- SEE STRUCTURE GENERAL NOTES FOR FIBER REINFORCED POLYMER SPECIFICATIONS AND ADDITIONAL DETAILS.
- STAGE PATCH REPAIR WIDTHS TO LIMIT REPAIRS TO 1/4 OF THE CIRCUMFERENCE AT A TIME.

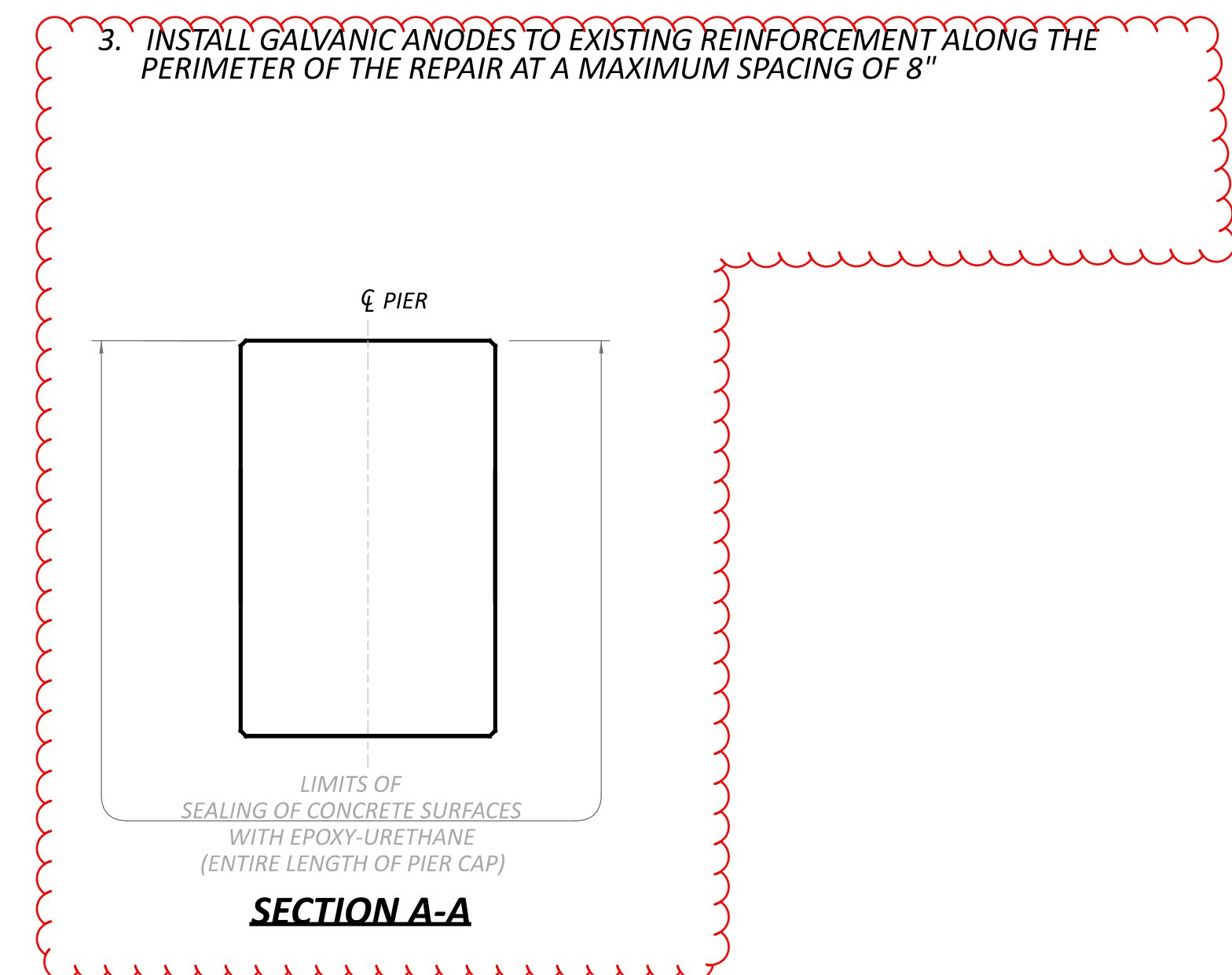

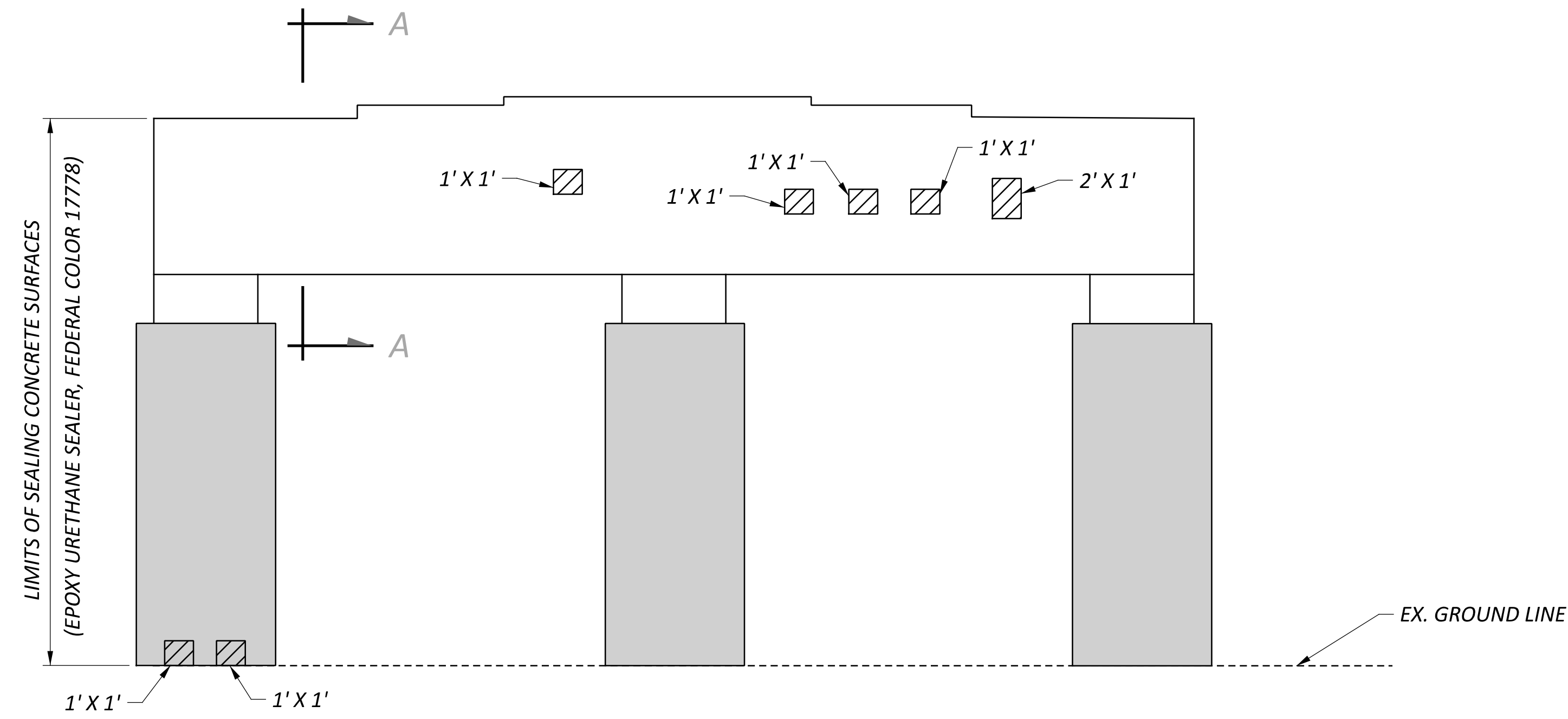

PIER 2 EAST ELEVATION

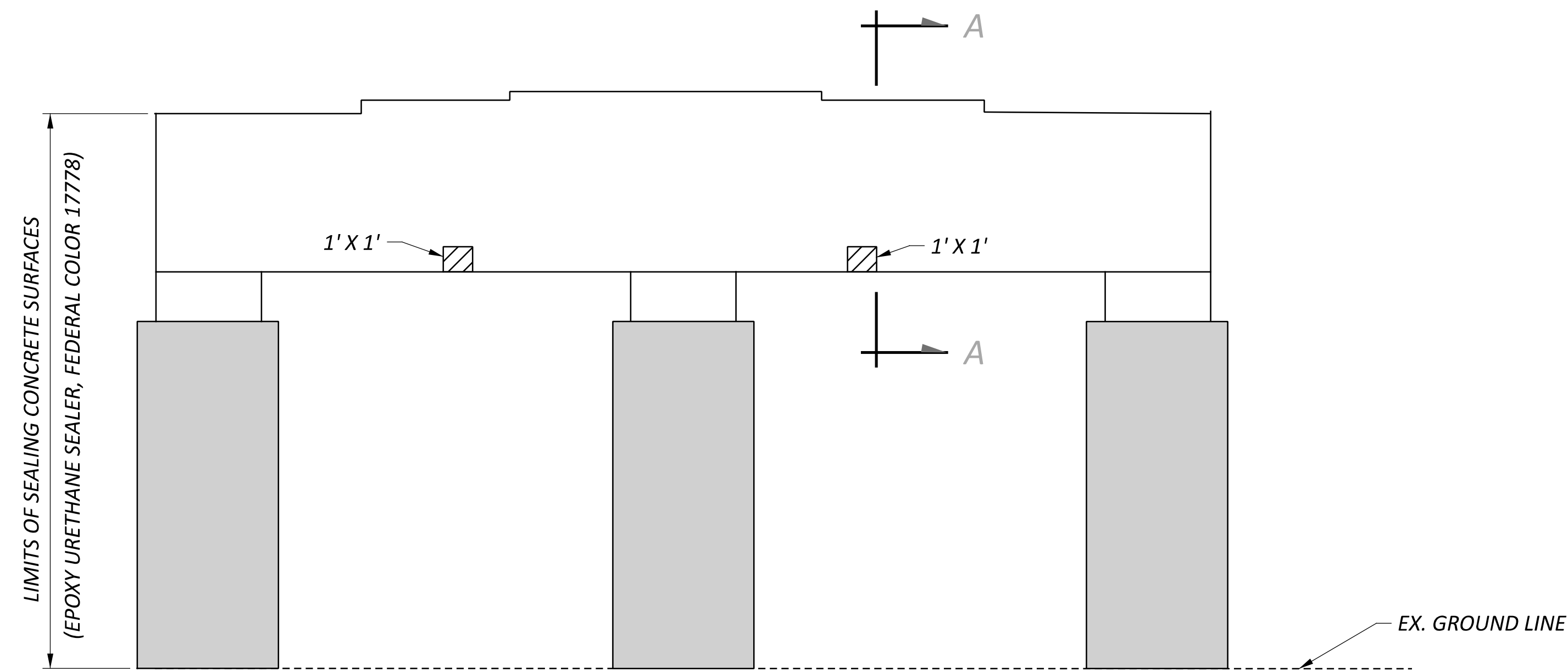

PIER 2 WEST ELEVATION

SUMMARY OF REPAIR AREAS			
PHYSICAL INVENTORY OF MEASURED QUANTITIES OF DETERIORATION WAS PERFORMED IN APRIL OF 2025.			
EXACT DIMENSIONS AND LOCATIONS OF REPAIRS SHALL BE DETERMINED BY THE ENGINEER IN THE FIELD FOR FINAL PAY QUANTITIES.			
TYPE	MEASURED QUANTITIES	ESTIMATING FACTOR*	ESTIMATED QUANTITIES
PIER 2 PATCHING	10 SQ. FT.	1.5	15 SQ. FT.
PIER 2 ANODES			
* - ESTIMATED QUANTITIES HAVE BEEN INCREASED BY 50% OVER MEASURED QUANTITIES TO ALLOW FOR ADDITIONAL DETERIORATION.			

LEGEND

- AREA TO BE REPAIRED WITH ITEM 519 - PATCHING CONCRETE STRUCTURE, AS PER PLAN
- LIMITS OF SINGLE LAYER OF FIBER WRAP PER ITEM 519 - SPECIAL COMPOSITE FIBER WRAP SYSTEM

NOTES

1. SEE STRUCTURE GENERAL NOTES FOR FIBER REINFORCED POLYMER SPECIFICATIONS AND ADDITIONAL DETAILS.
2. STAGE PATCH REPAIR WIDTHS TO LIMIT REPAIRS TO 1/4 OF THE CIRCUMFERENCE AT A TIME.

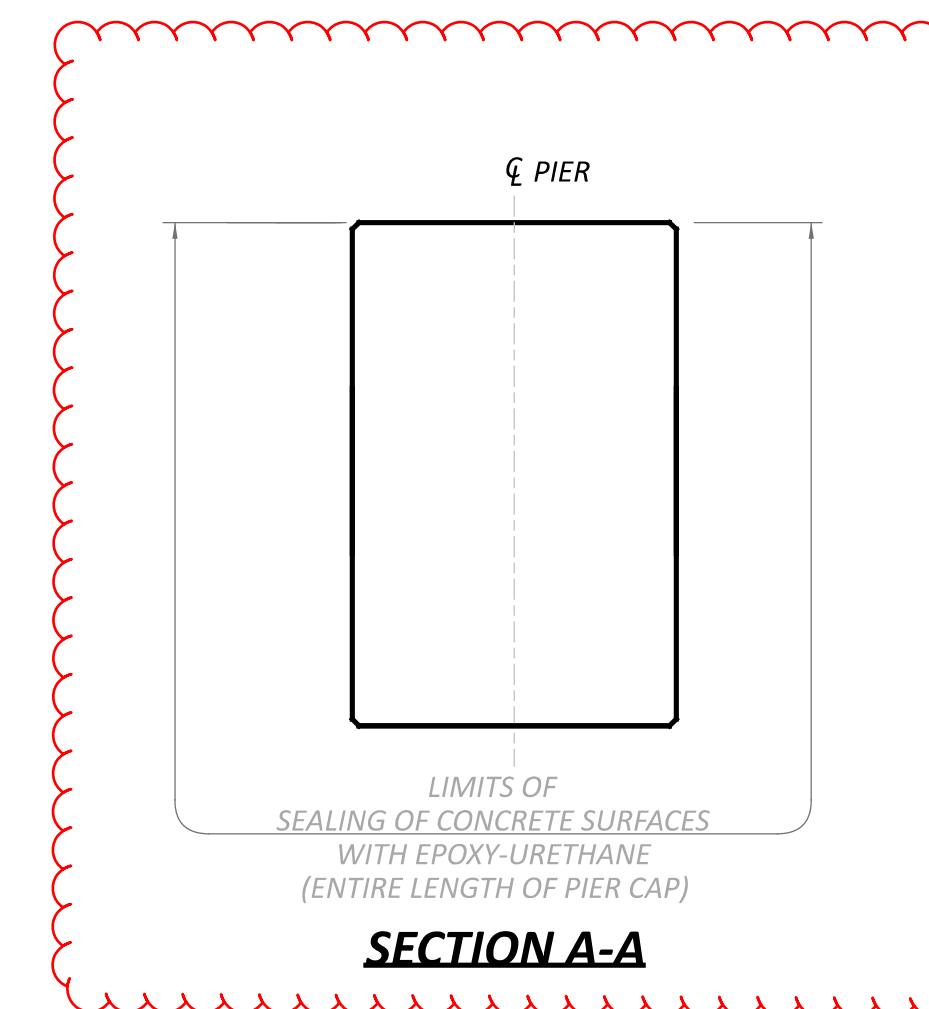

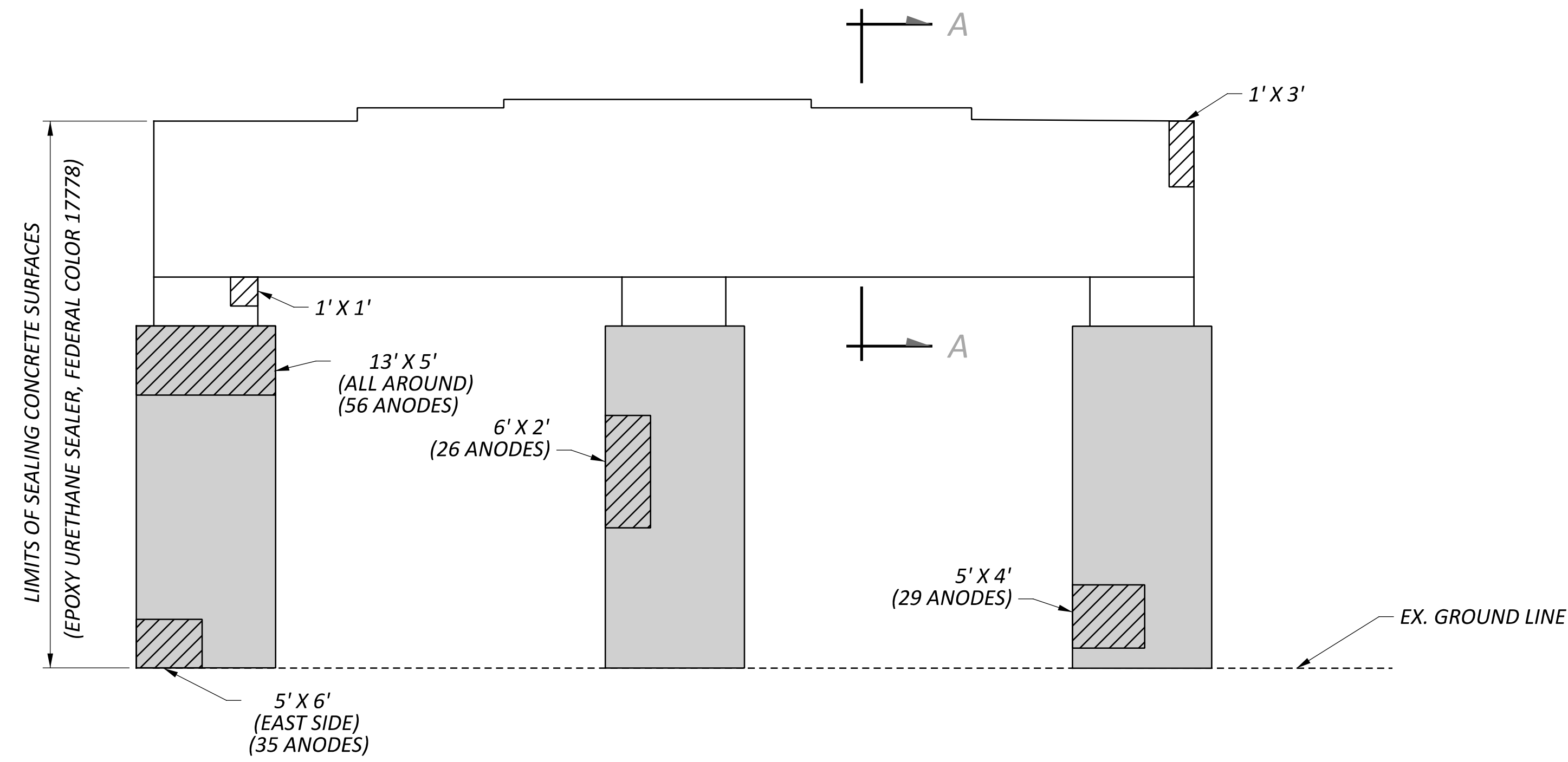

PIER 3 NORTH ELEVATION

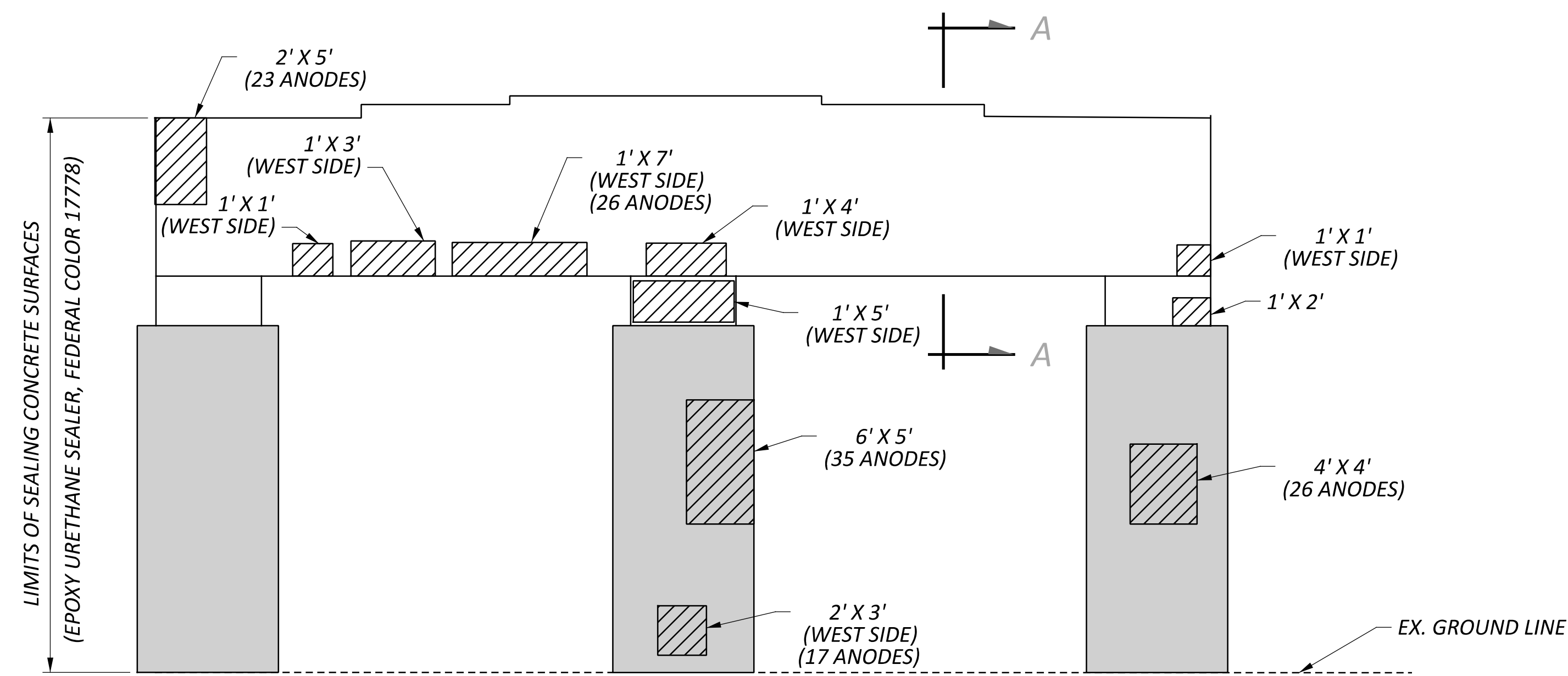

PIER 3 SOUTH ELEVATION

SUMMARY OF REPAIR AREAS			
PHYSICAL INVENTORY OF MEASURED QUANTITIES OF DETERIORATION WAS PERFORMED IN APRIL OF 2025.			
EXACT DIMENSIONS AND LOCATIONS OF REPAIRS SHALL BE DETERMINED BY THE ENGINEER IN THE FIELD FOR FINAL PAY QUANTITIES.			
TYPE	MEASURED QUANTITIES	ESTIMATING FACTOR*	ESTIMATED QUANTITIES
PIER 3 PATCHING	216 SQ. FT.	1.5	324 SQ. FT.
PIER 3 ANODES			293
* - ESTIMATED QUANTITIES HAVE BEEN INCREASED BY 50% OVER MEASURED QUANTITIES TO ALLOW FOR ADDITIONAL DETERIORATION.			

LEGEND

- AREA TO BE REPAIRED WITH ITEM 519 - PATCHING CONCRETE STRUCTURE, AS PER PLAN
- LIMITS OF SINGLE LAYER OF FIBER WRAP PER ITEM 519 - SPECIAL COMPOSITE FIBER WRAP SYSTEM

NOTES

- SEE STRUCTURE GENERAL NOTES FOR FIBER REINFORCED POLYMER SPECIFICATIONS AND ADDITIONAL DETAILS.
- STAGE PATCH REPAIR WIDTHS TO LIMIT REPAIRS TO 1/4 OF THE CIRCUMFERENCE AT A TIME.
- INSTALL GALVANIC ANODES TO EXISTING REINFORCEMENT ALONG THE PERIMETER OF THE REPAIR AT A MAXIMUM SPACING OF 8"

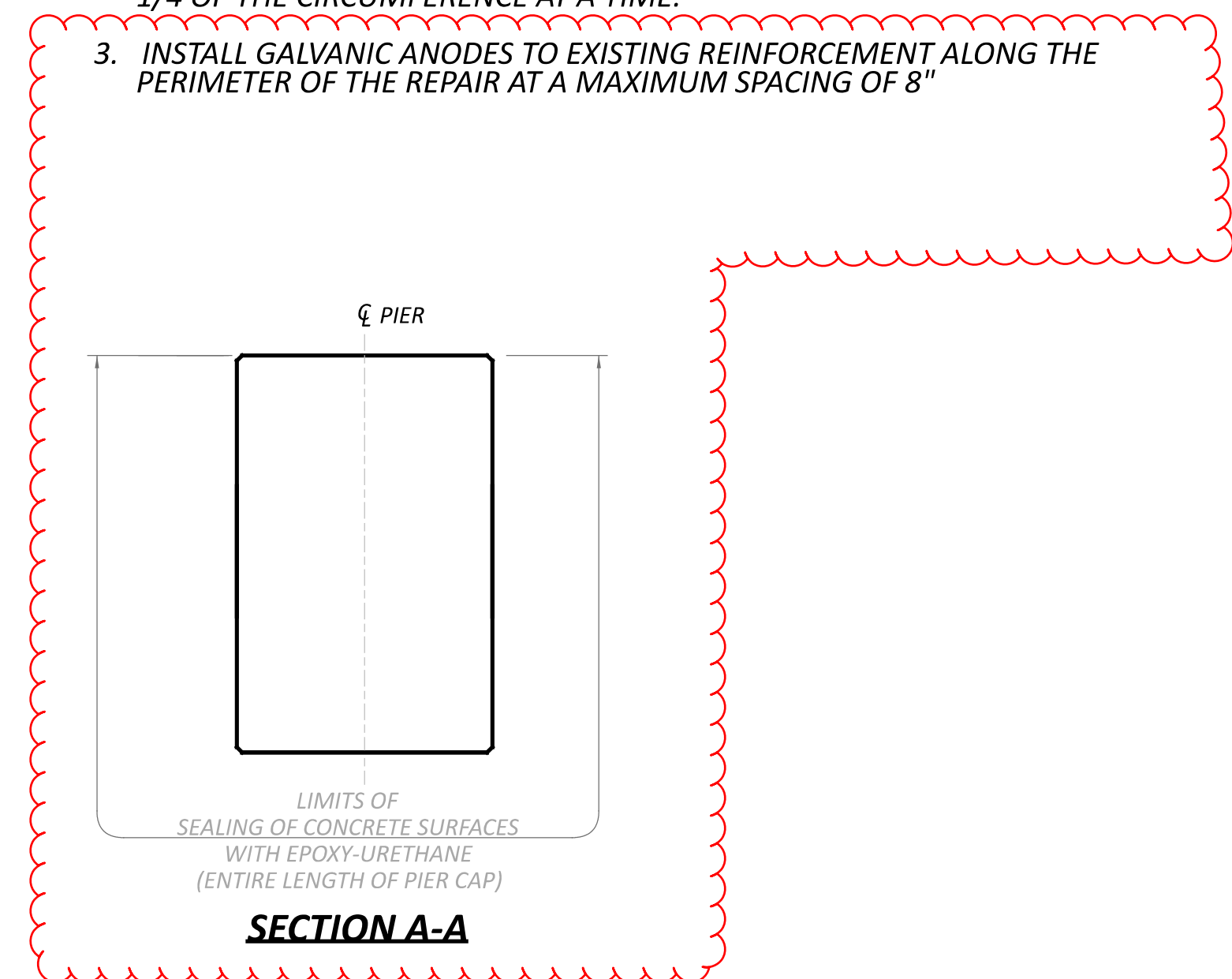

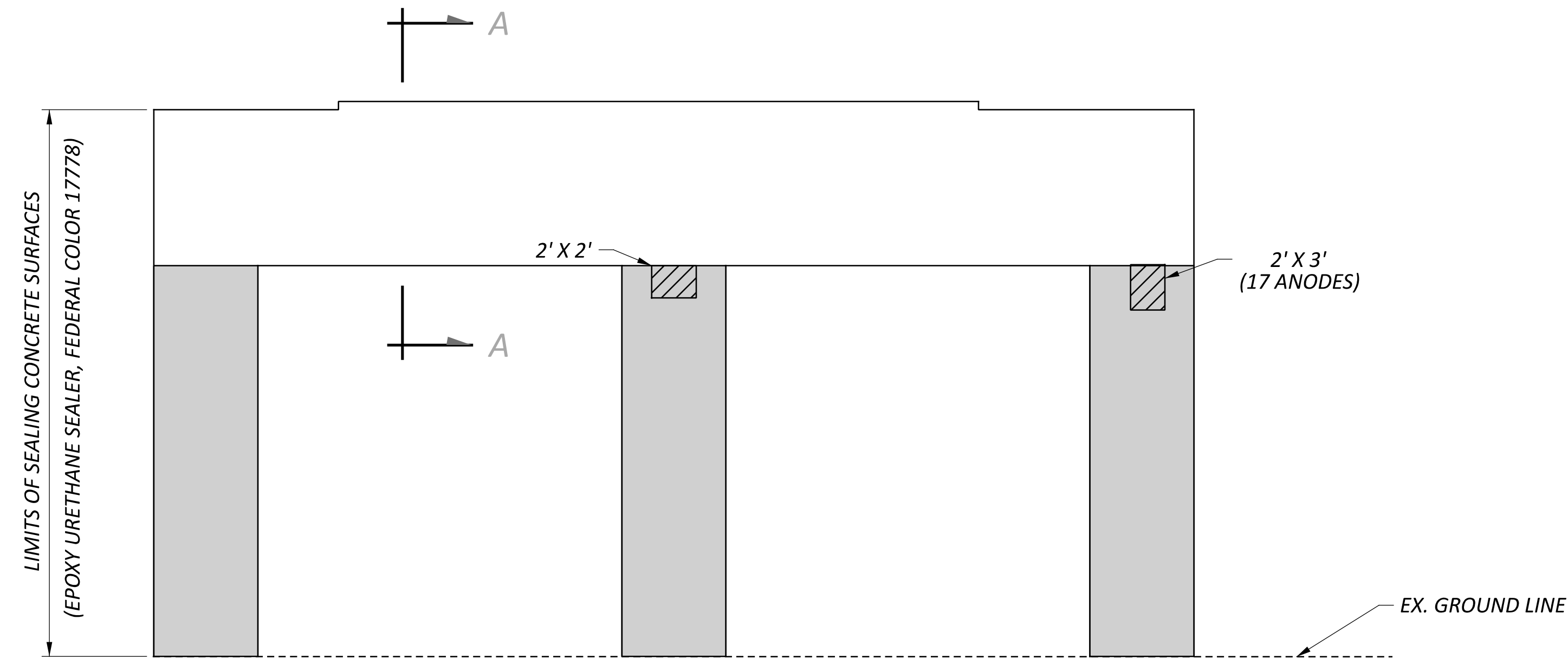

PIER 1 NORTH ELEVATION

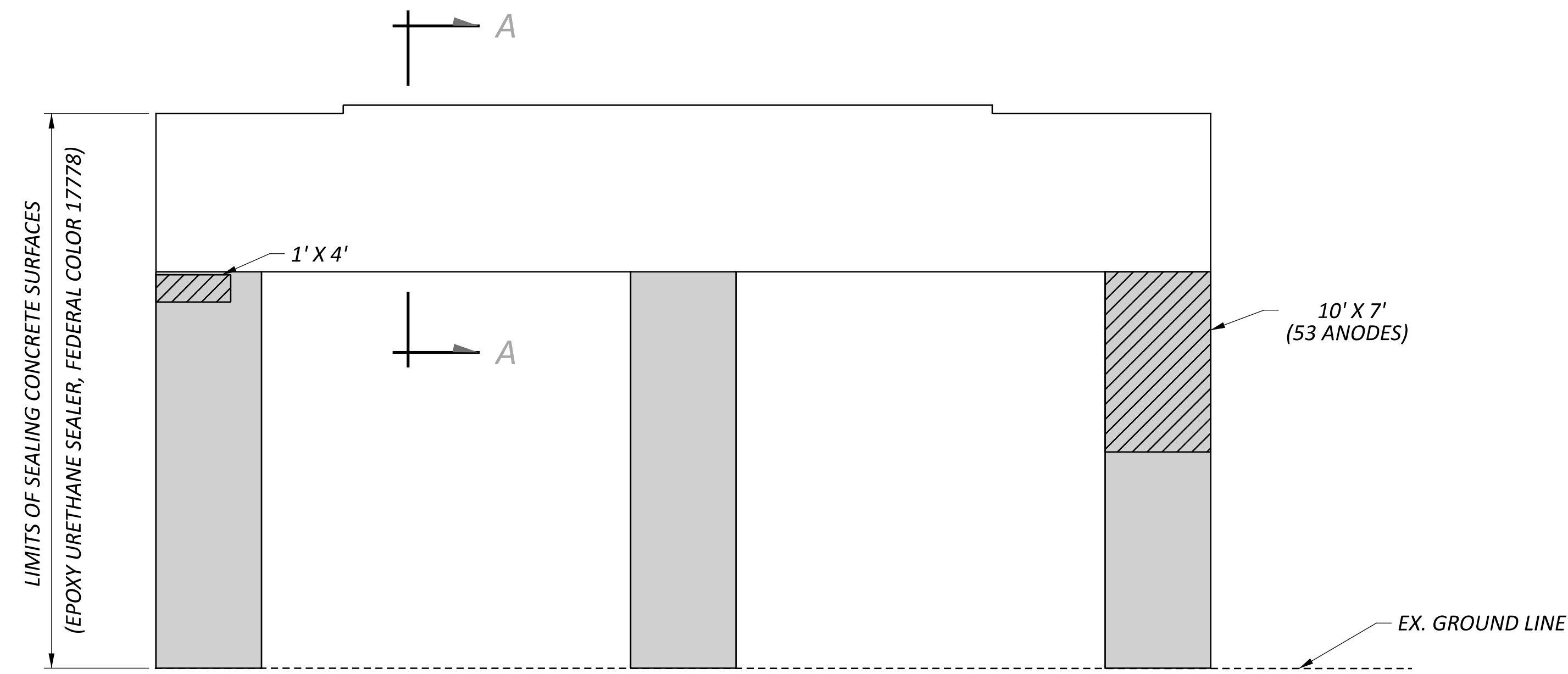

PIER 1 SOUTH ELEVATION

SUMMARY OF REPAIR AREAS			
PHYSICAL INVENTORY OF MEASURED QUANTITIES OF DETERIORATION WAS PERFORMED IN APRIL OF 2025.			
EXACT DIMENSIONS AND LOCATIONS OF REPAIRS SHALL BE DETERMINED BY THE ENGINEER IN THE FIELD FOR FINAL PAY QUANTITIES.			
TYPE	MEASURED QUANTITIES	ESTIMATING FACTOR*	ESTIMATED QUANTITIES
PIER 1 PATCHING	84 SQ. FT.	1.5	126 SQ. FT.
PIER 1 ANODES			70
* - ESTIMATED QUANTITIES HAVE BEEN INCREASED BY 50% OVER MEASURED QUANTITIES TO ALLOW FOR ADDITIONAL DETERIORATION.			

LEGEND

- AREA TO BE REPAIRED WITH ITEM 519 - PATCHING CONCRETE STRUCTURE, AS PER PLAN
- LIMITS OF SINGLE LAYER OF FIBER WRAP PER ITEM 519 - SPECIAL COMPOSITE FIBER WRAP SYSTEM

NOTES

- SEE STRUCTURE GENERAL NOTES FOR FIBER REINFORCED POLYMER SPECIFICATIONS AND ADDITIONAL DETAILS.
- STAGE PATCH REPAIR WIDTHS TO LIMIT REPAIRS TO 1/4 OF THE CIRCUMFERENCE AT A TIME.
- CONCRETE SEALING LIMITS AND LIMITS OF FIBER WRAP SHOWN FOR PIER 1 ARE SIMILAR TO THE LIMITS FOR PIER 2
- INSTALL GALVANIC ANODES TO EXISTING REINFORCEMENT ALONG THE PERIMETER OF THE REPAIR AT A MAXIMUM SPACING OF 8"

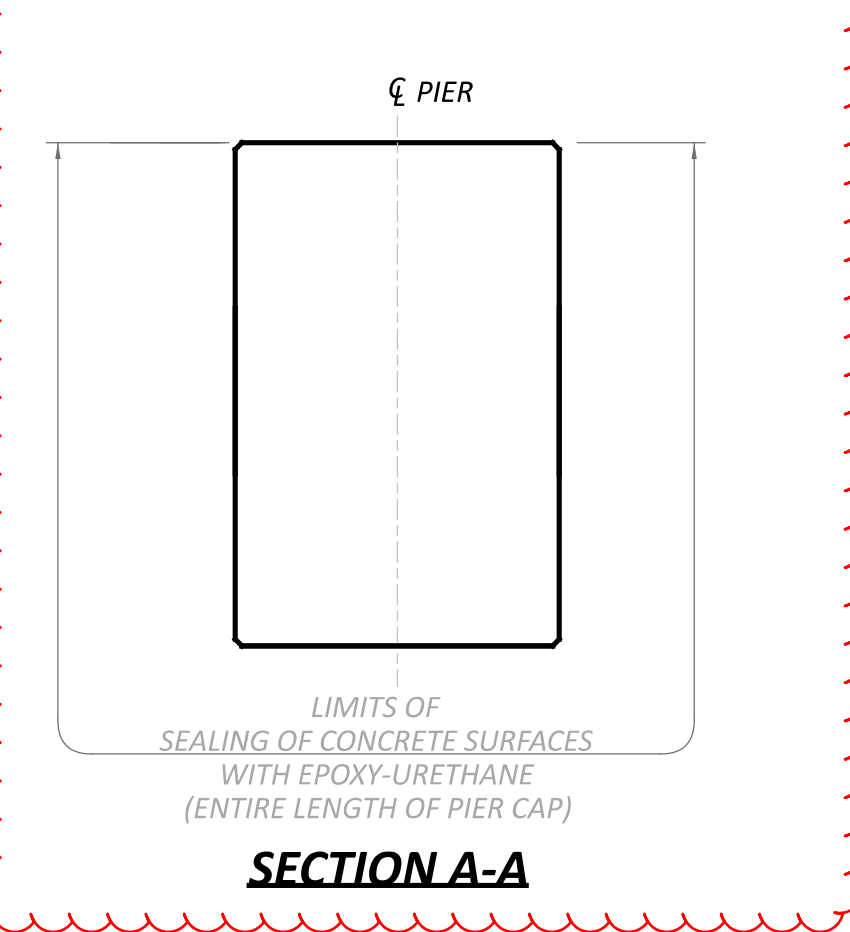

SFN	1401505
DESIGN AGENCY	
DESIGNER	CHECKER
GTF	BCP
REVIEWER	
CAH	02/17/26
PROJECT ID	123648
SUBSET	TOTAL
1	2
SHEET	TOTAL
21	45

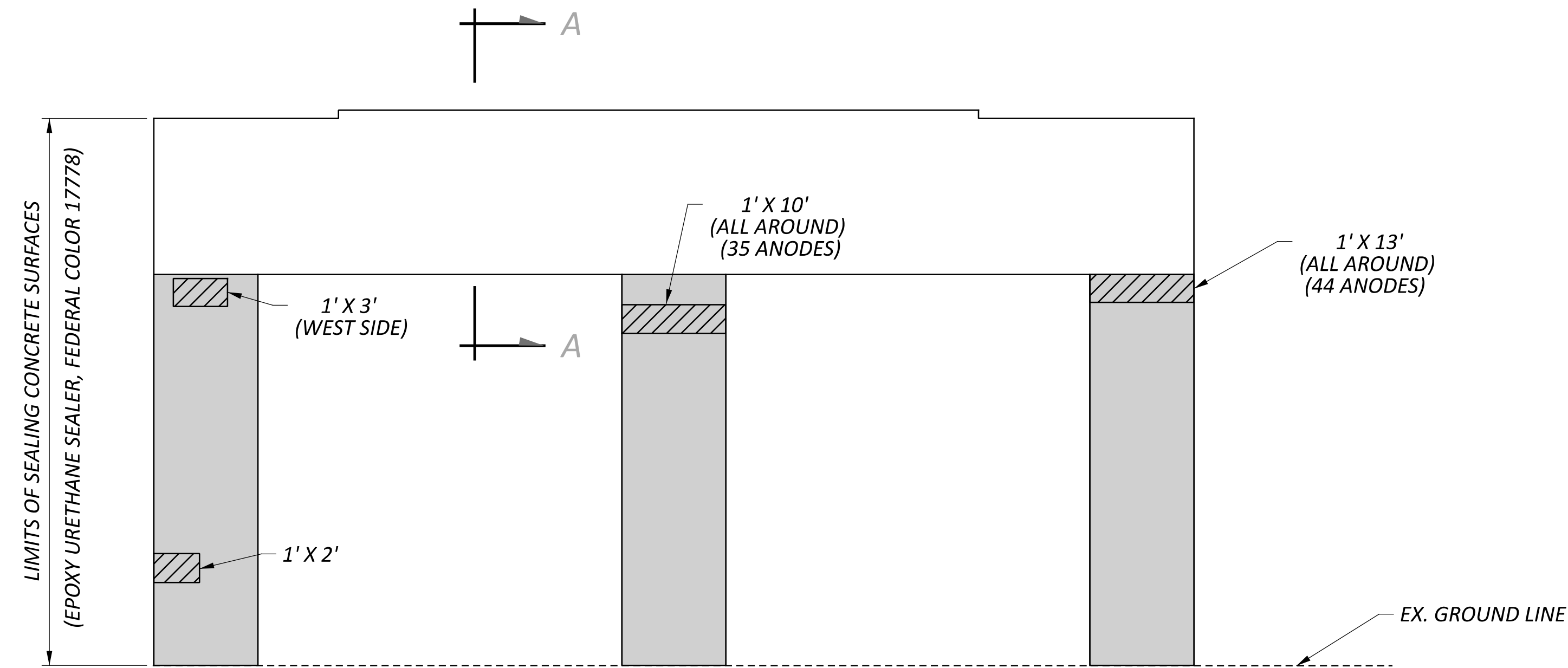

PIER 3 NORTH ELEVATION

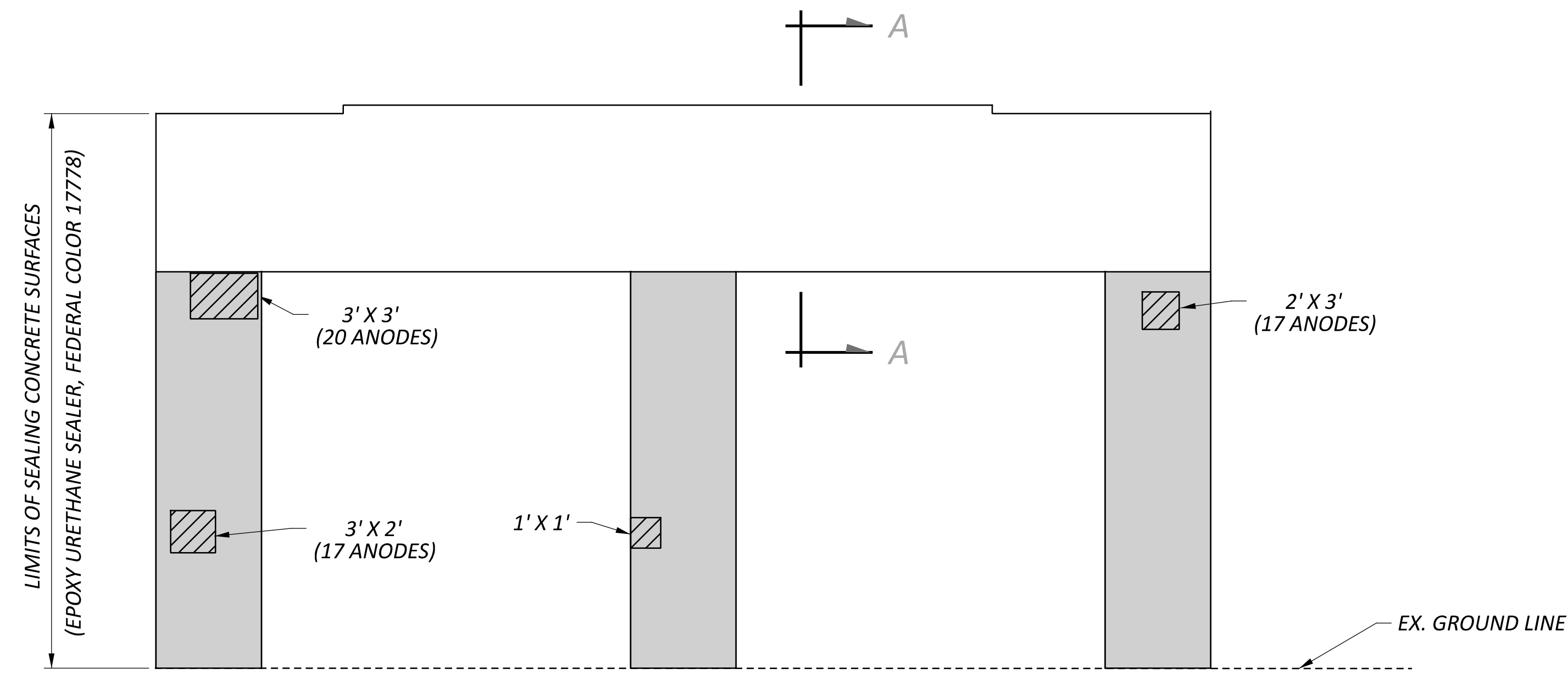

PIER 3 SOUTH ELEVATION

SUMMARY OF REPAIR AREAS			
PHYSICAL INVENTORY OF MEASURED QUANTITIES OF DETERIORATION WAS PERFORMED IN APRIL OF 2025.			
EXACT DIMENSIONS AND LOCATIONS OF REPAIRS SHALL BE DETERMINED BY THE ENGINEER IN THE FIELD FOR FINAL PAY QUANTITIES.			
TYPE	MEASURED QUANTITIES	ESTIMATING FACTOR*	ESTIMATED QUANTITIES
PIER 3 PATCHING	50 SQ. FT.	1.5	75 SQ. FT.
PIER 3 ANODES			133
* - ESTIMATED QUANTITIES HAVE BEEN INCREASED BY 50% OVER MEASURED QUANTITIES TO ALLOW FOR ADDITIONAL DETERIORATION.			

LEGEND

- AREA TO BE REPAIRED WITH ITEM 519 - PATCHING CONCRETE STRUCTURE, AS PER PLAN
- LIMITS OF SINGLE LAYER OF FIBER WRAP PER ITEM 519 - SPECIAL COMPOSITE FIBER WRAP SYSTEM

NOTES

- SEE STRUCTURE GENERAL NOTES FOR FIBER REINFORCED POLYMER SPECIFICATIONS AND ADDITIONAL DETAILS.
- STAGE PATCH REPAIR WIDTHS TO LIMIT REPAIRS TO 1/4 OF THE CIRCUMFERENCE AT A TIME.
- CONCRETE SEALING LIMITS AND LIMITS OF FIBER WRAP SHOWN FOR PIER 3 ARE SIMILAR TO THE LIMITS FOR PIER PIER 2
- INSTALL GALVANIC ANODES TO EXISTING REINFORCEMENT ALONG THE PERIMETER OF THE REPAIR AT A MAXIMUM SPACING OF 8"

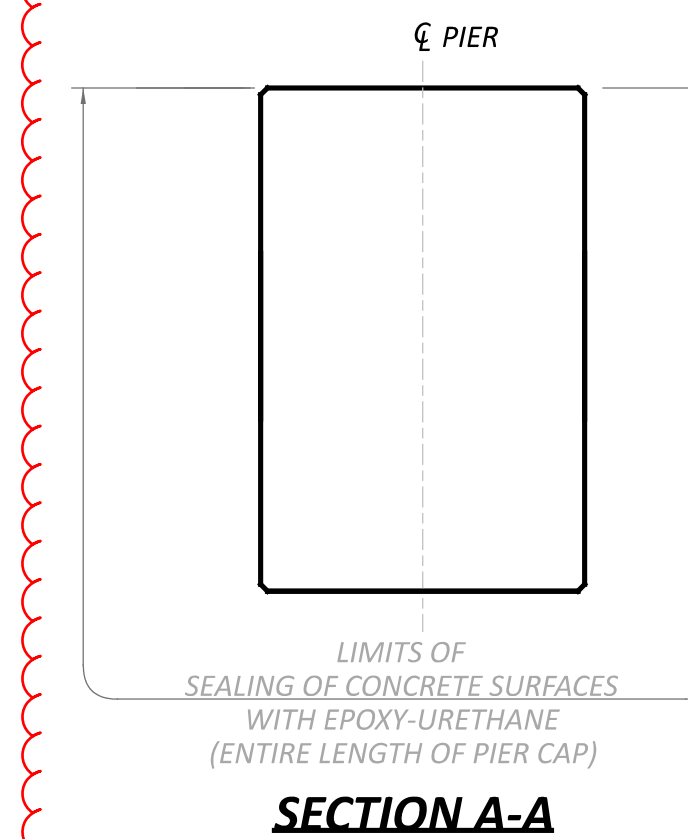

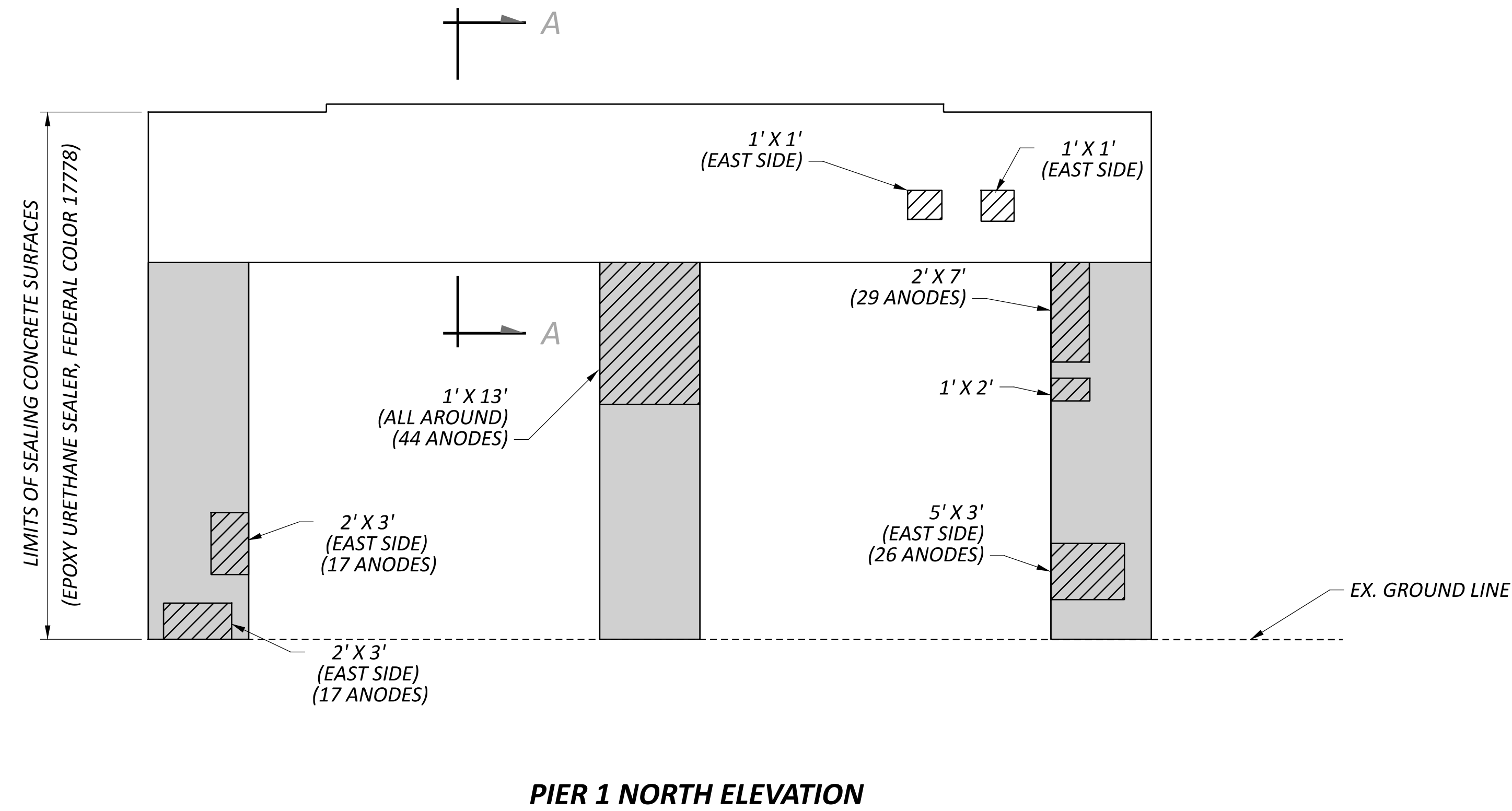

PIER 1 NORTH ELEVATION

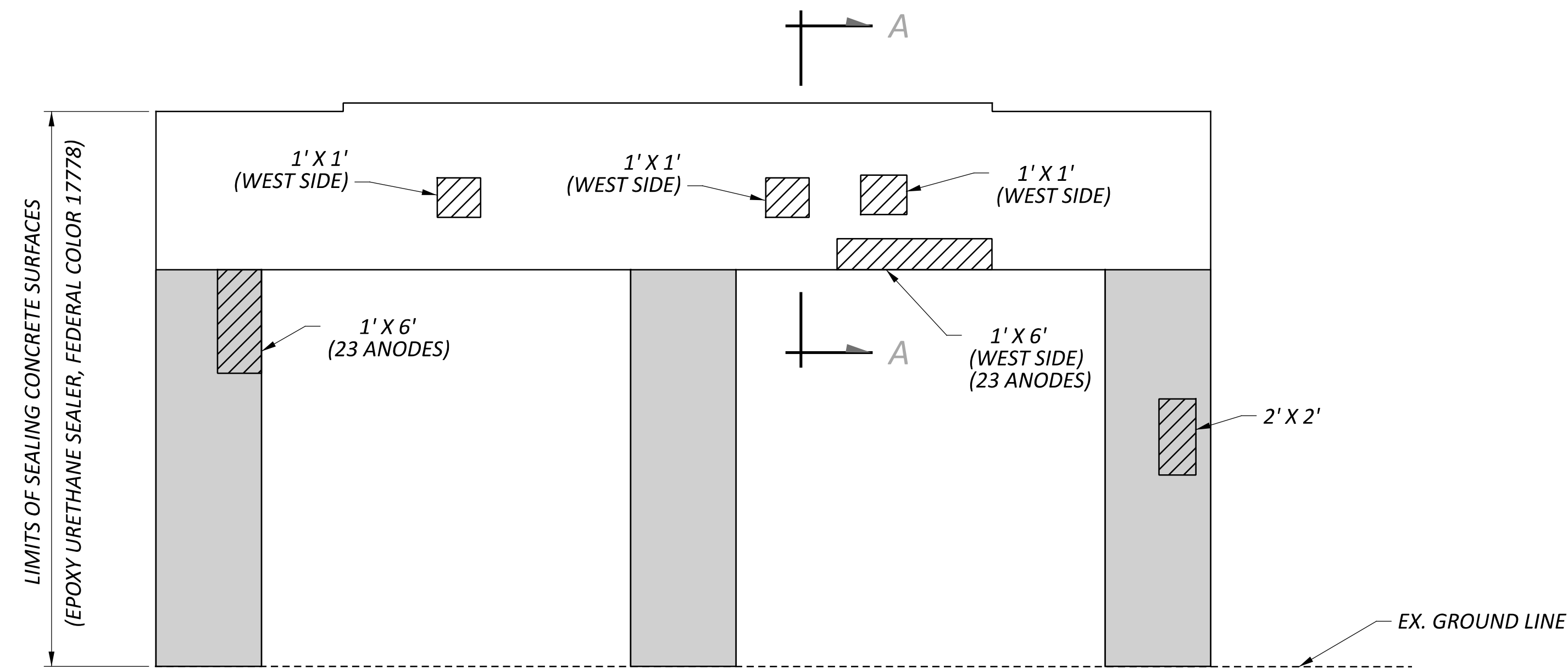

PIER 1 SOUTH ELEVATION

SUMMARY OF REPAIR AREAS			
PHYSICAL INVENTORY OF MEASURED QUANTITIES OF DETERIORATION WAS PERFORMED IN APRIL OF 2025.			
EXACT DIMENSIONS AND LOCATIONS OF REPAIRS SHALL BE DETERMINED BY THE ENGINEER IN THE FIELD FOR FINAL PAY QUANTITIES.			
TYPE	MEASURED QUANTITIES	ESTIMATING FACTOR*	ESTIMATED QUANTITIES
PIER 1 PATCHING	77 SQ. FT.	1.5	116 SQ. FT.
PIER 1 ANODES			156
* - ESTIMATED QUANTITIES HAVE BEEN INCREASED BY 50% OVER MEASURED QUANTITIES TO ALLOW FOR ADDITIONAL DETERIORATION.			

LEGEND

- AREA TO BE REPAIRED WITH ITEM 519 - PATCHING CONCRETE STRUCTURE, AS PER PLAN
- LIMITS OF SINGLE LAYER OF FIBER WRAP PER ITEM 519 - SPECIAL COMPOSITE FIBER WRAP SYSTEM

NOTES

- SEE STRUCTURE GENERAL NOTES FOR FIBER REINFORCED POLYMER SPECIFICATIONS AND ADDITIONAL DETAILS.
- STAGE PATCH REPAIR WIDTHS TO LIMIT REPAIRS TO 1/4 OF THE CIRCUMFERENCE AT A TIME.
- INSTALL GALVANIC ANODES TO EXISTING REINFORCEMENT ALONG THE PERIMETER OF THE REPAIR AT A MAXIMUM SPACING OF 8"

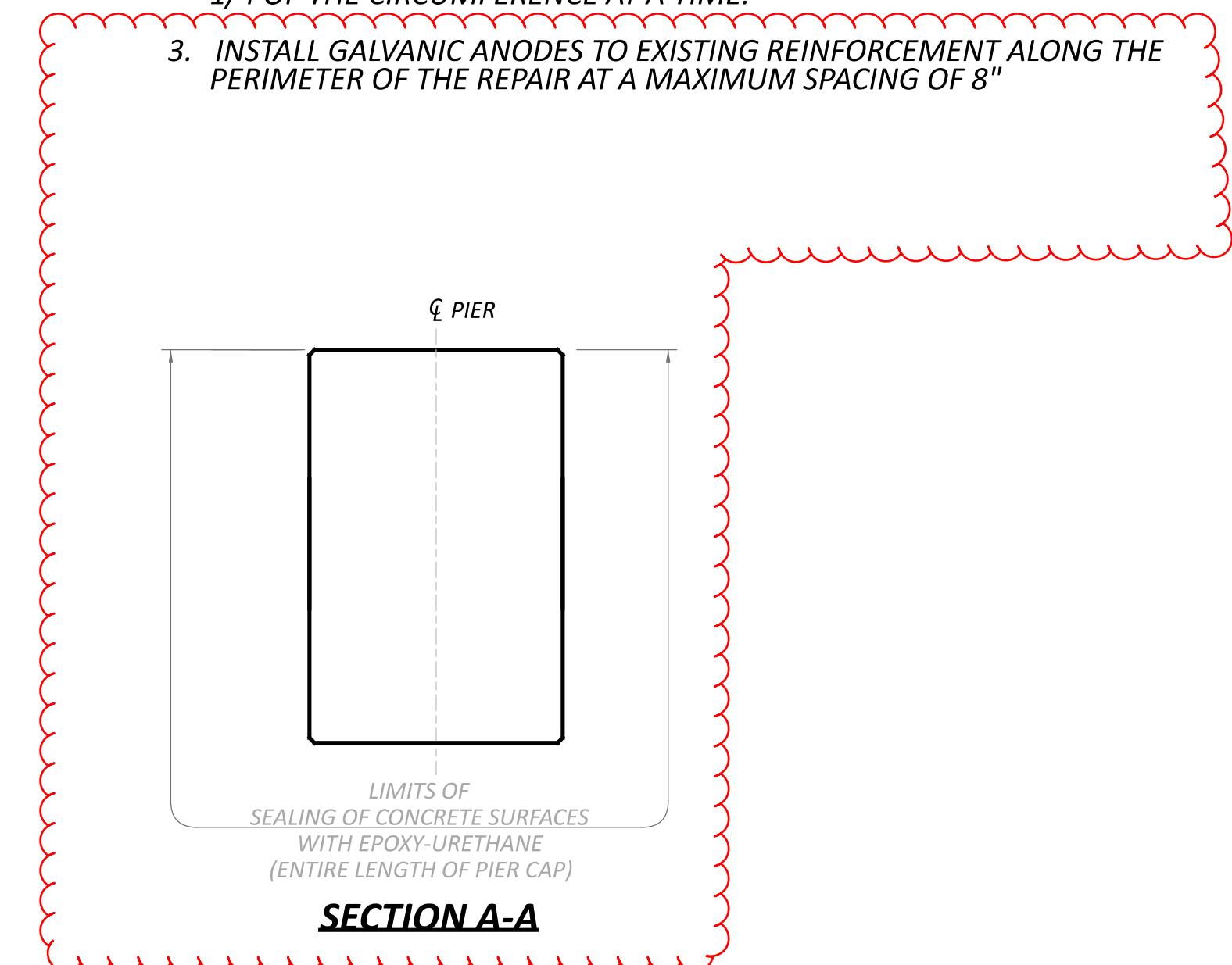

SFN	1401564
DESIGN AGENCY	
DESIGNER	CHECKER
GTF	BCP
REVIEWER	CAH 02/17/26
PROJECT ID	123648
SUBSET	TOTAL
1	3
SHEET	TOTAL
23	45

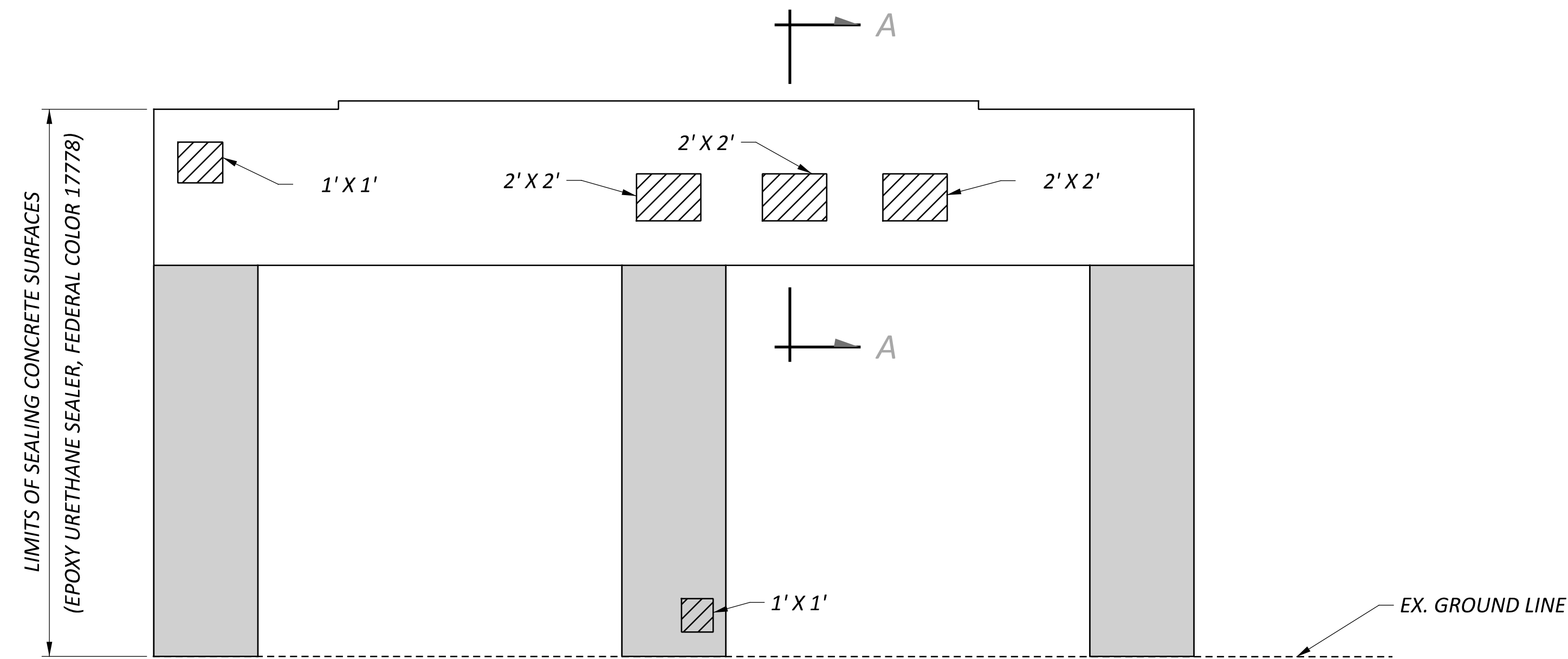

PIER 2 EAST ELEVATION

SUMMARY OF REPAIR AREAS			
PHYSICAL INVENTORY OF MEASURED QUANTITIES OF DETERIORATION WAS PERFORMED IN APRIL OF 2025.			
EXACT DIMENSIONS AND LOCATIONS OF REPAIRS SHALL BE DETERMINED BY THE ENGINEER IN THE FIELD FOR FINAL PAY QUANTITIES.			
TYPE	MEASURED QUANTITIES	ESTIMATING FACTOR*	ESTIMATED QUANTITIES
PIER 2 PATCHING	8 SQ. FT.	1.5	12 SQ. FT.
PIER 2 ANODES			

* - ESTIMATED QUANTITIES HAVE BEEN INCREASED BY 50% OVER MEASURED QUANTITIES TO ALLOW FOR ADDITIONAL DETERIORATION.

LEGEND

- AREA TO BE REPAIRED WITH ITEM 519 - PATCHING CONCRETE STRUCTURE, AS PER PLAN
- LIMITS OF SINGLE LAYER OF FIBER WRAP PER ITEM 519 - SPECIAL COMPOSITE FIBER WRAP SYSTEM

NOTES

1. SEE STRUCTURE GENERAL NOTES FOR FIBER REINFORCED POLYMER SPECIFICATIONS AND ADDITIONAL DETAILS.
2. STAGE PATCH REPAIR WIDTHS TO LIMIT REPAIRS TO 1/4 OF THE CIRCUMFERENCE AT A TIME.

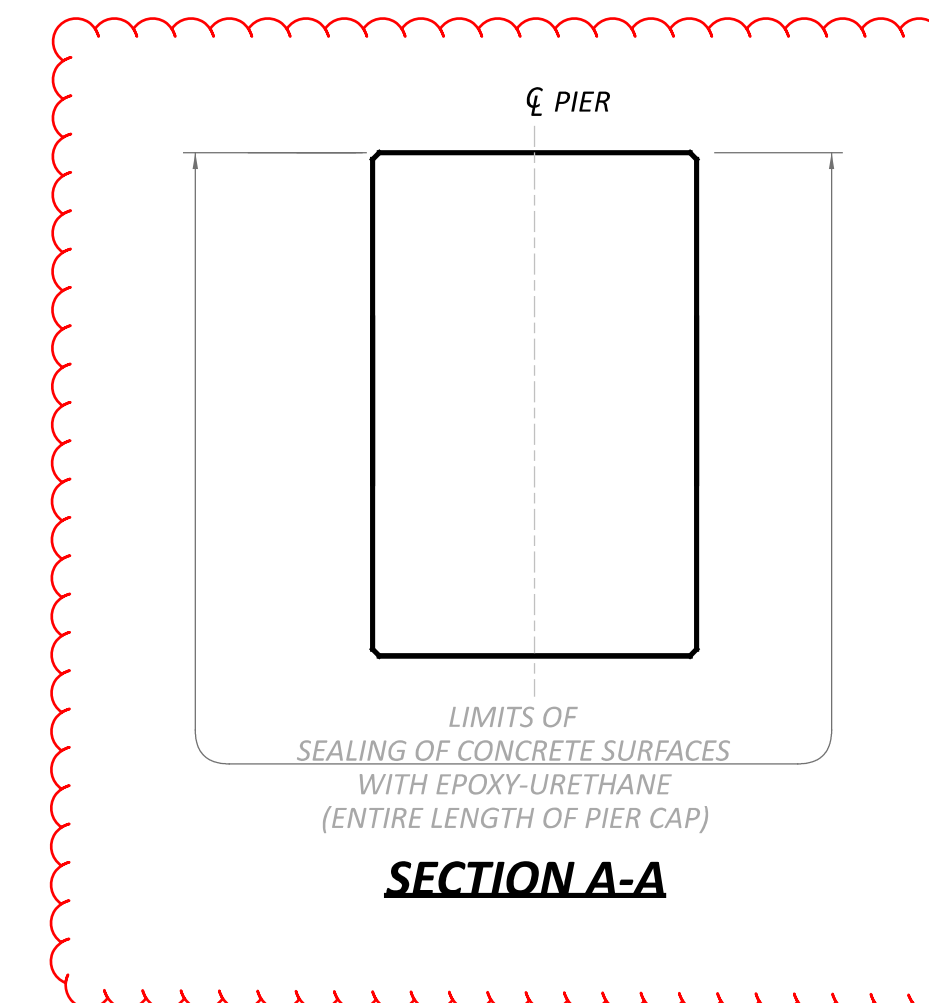

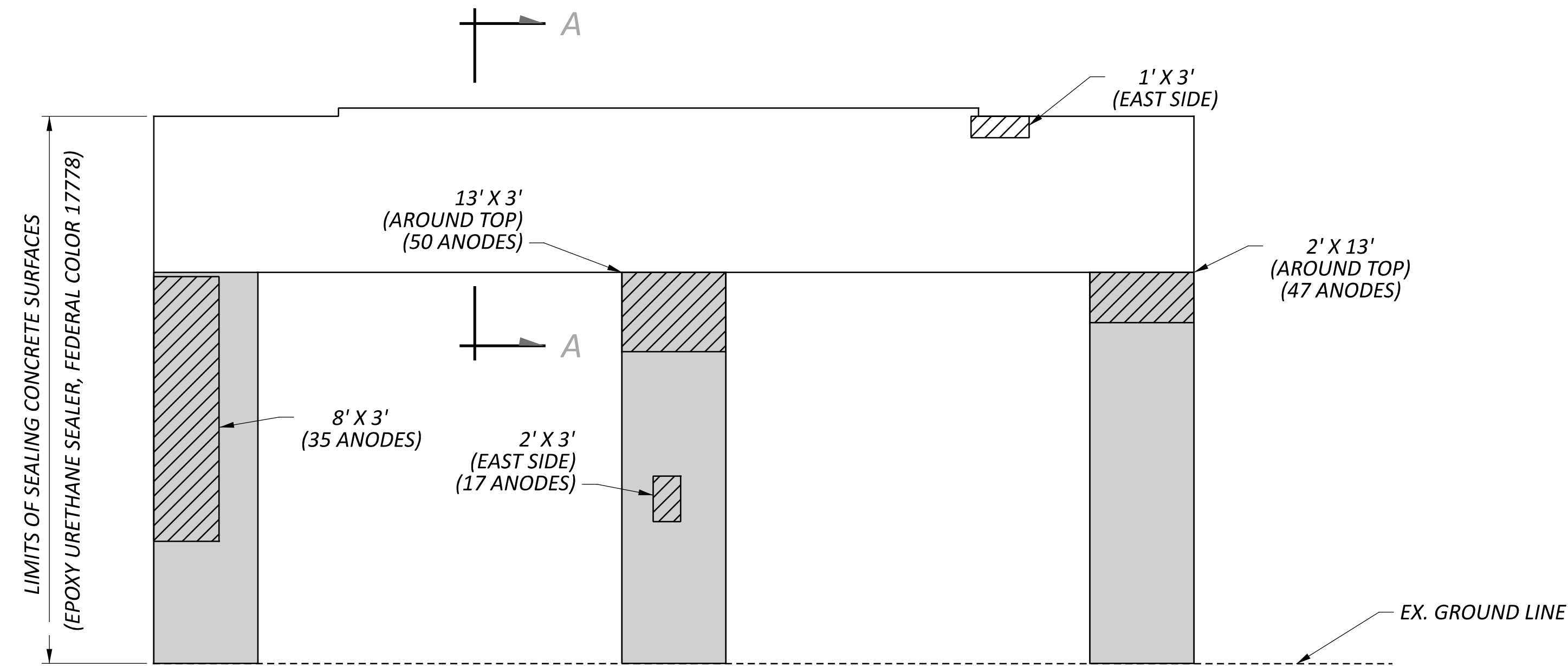

PIER 3 NORTH ELEVATION

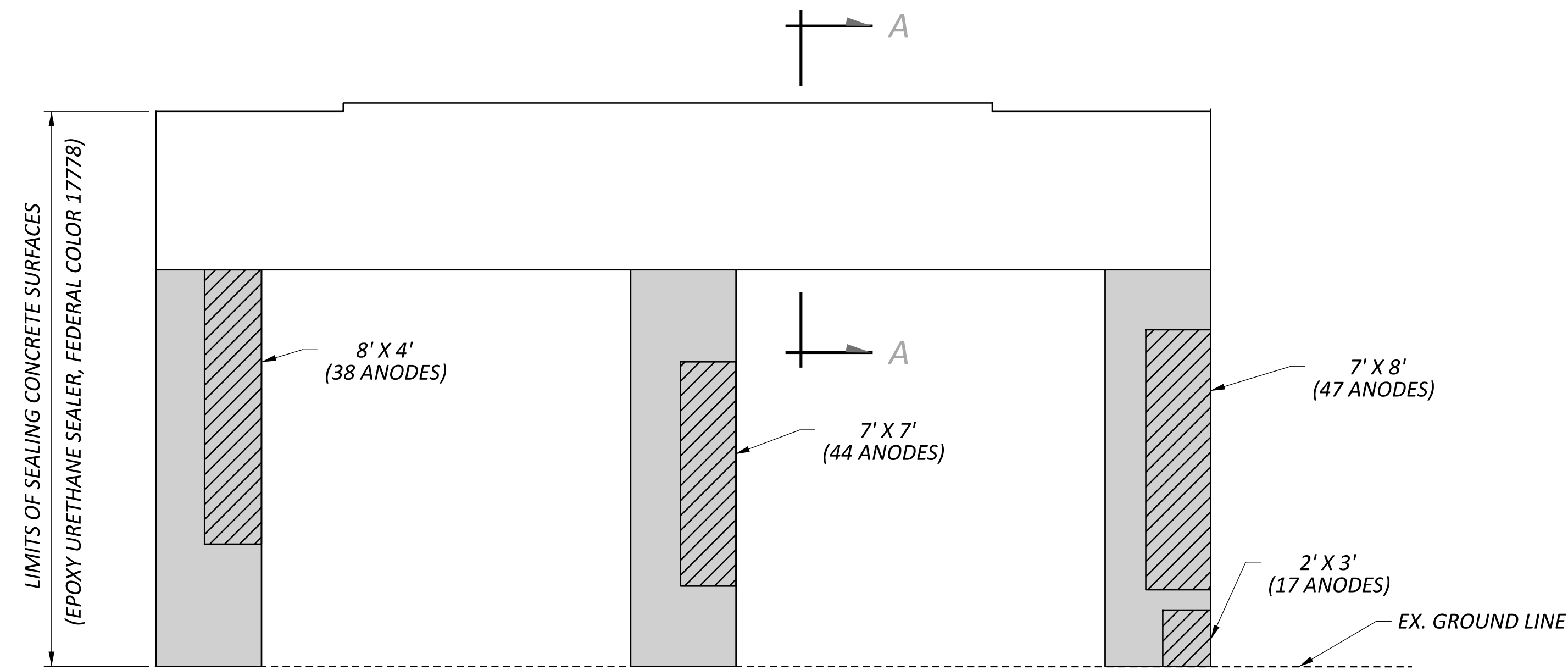

PIER 3 SOUTH ELEVATION

SUMMARY OF REPAIR AREAS			
PHYSICAL INVENTORY OF MEASURED QUANTITIES OF DETERIORATION WAS PERFORMED IN APRIL OF 2025.			
EXACT DIMENSIONS AND LOCATIONS OF REPAIRS SHALL BE DETERMINED BY THE ENGINEER IN THE FIELD FOR FINAL PAY QUANTITIES.			
TYPE	MEASURED QUANTITIES	ESTIMATING FACTOR*	ESTIMATED QUANTITIES
PIER 3 PATCHING	241 SQ. FT.	1.5	362 SQ. FT.
PIER 3 ANODES			295

* - ESTIMATED QUANTITIES HAVE BEEN INCREASED BY 50% OVER MEASURED QUANTITIES TO ALLOW FOR ADDITIONAL DETERIORATION.

LEGEND

- AREA TO BE REPAIRED WITH ITEM 519 - PATCHING CONCRETE STRUCTURE, AS PER PLAN
- LIMITS OF SINGLE LAYER OF FIBER WRAP PER ITEM 519 - SPECIAL COMPOSITE FIBER WRAP SYSTEM

NOTES

- SEE STRUCTURE GENERAL NOTES FOR FIBER REINFORCED POLYMER SPECIFICATIONS AND ADDITIONAL DETAILS.
- STAGE PATCH REPAIR WIDTHS TO LIMIT REPAIRS TO 1/4 OF THE CIRCUMFERENCE AT A TIME.
- INSTALL GALVANIC ANODES TO EXISTING REINFORCEMENT ALONG THE PERIMETER OF THE REPAIR AT A MAXIMUM SPACING OF 8"

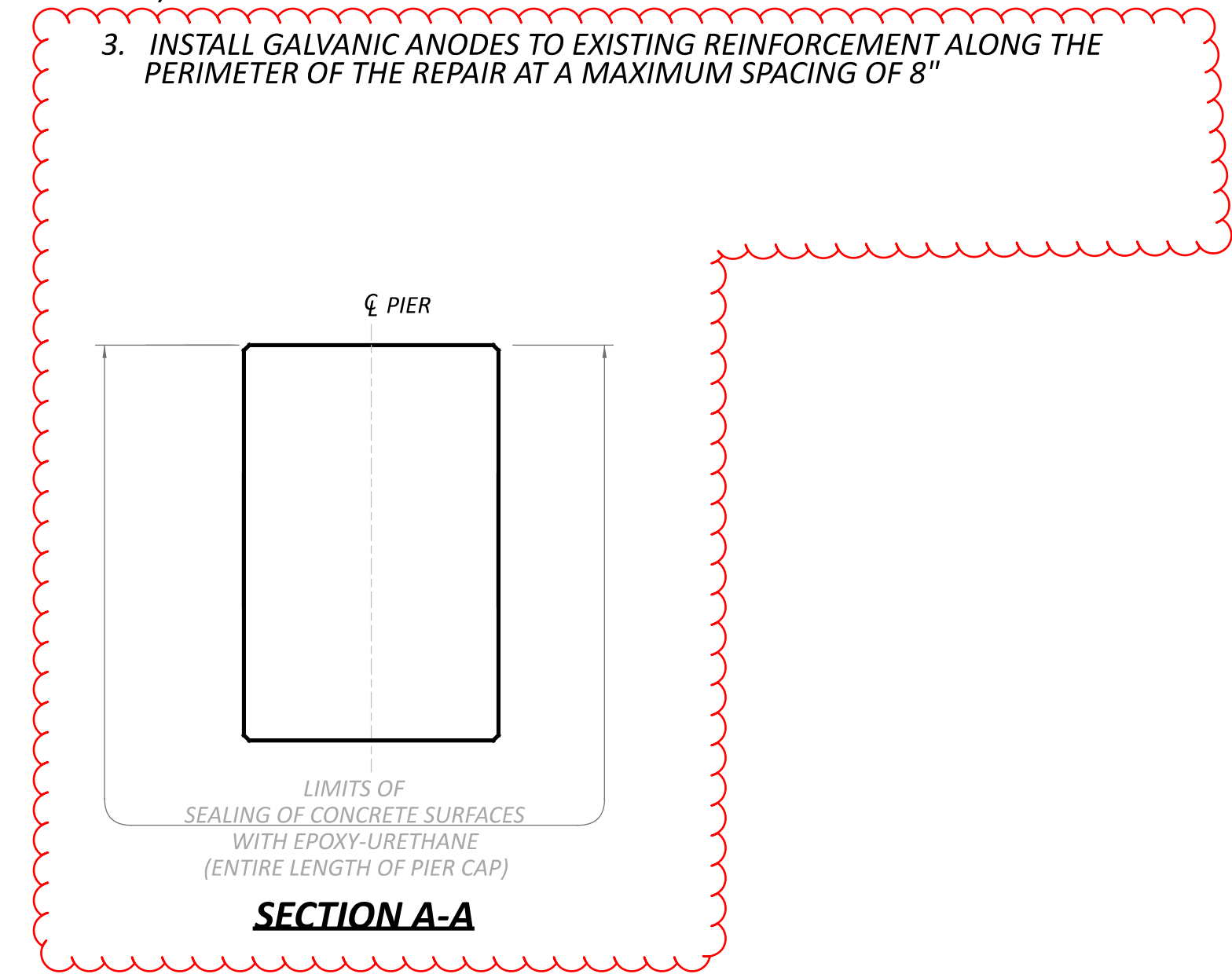

SFN	1401564
DESIGN AGENCY	
DESIGNER	CHECKER
GTF	BCP
REVIEWER	CAH 02/17/26
PROJECT ID	123648
SUBSET	TOTAL
3	3
SHEET	TOTAL
25	45

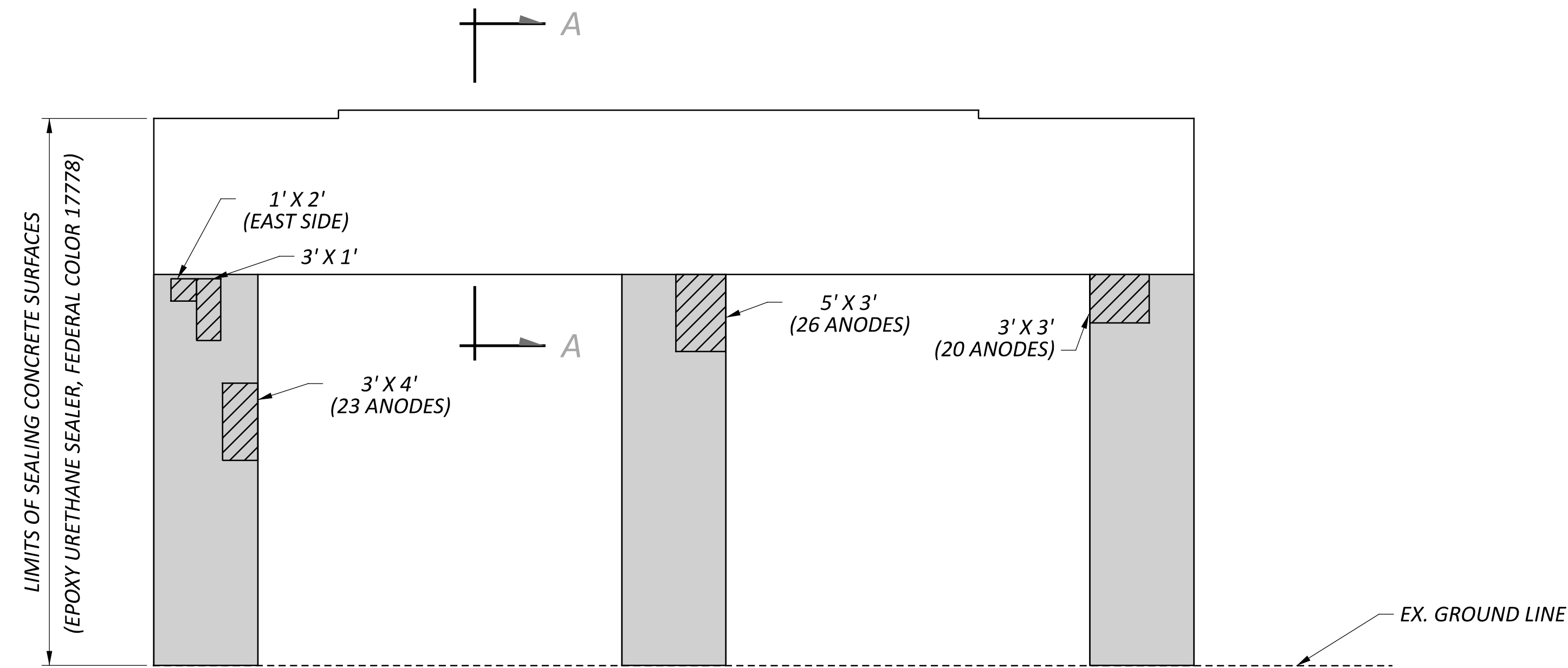

PIER 1 NORTH ELEVATION

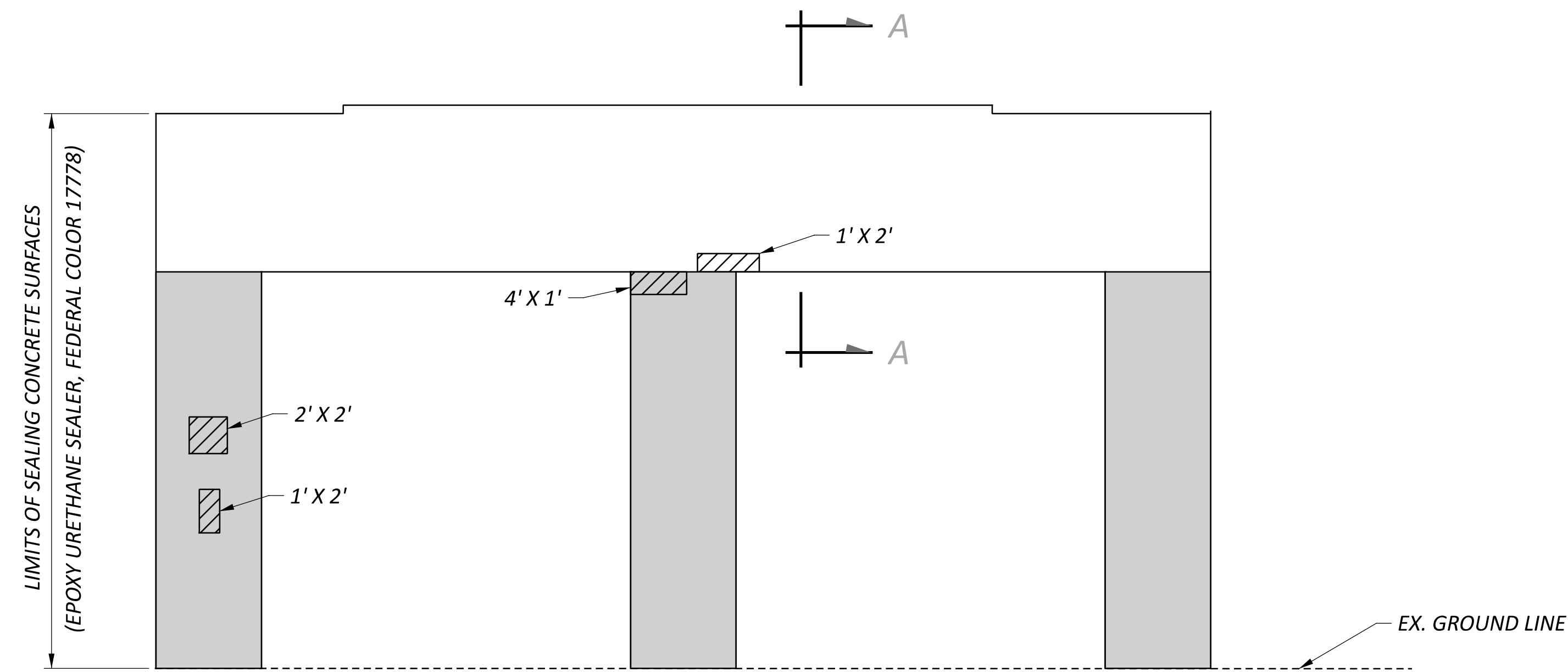

PIER 1 SOUTH ELEVATION

SUMMARY OF REPAIR AREAS			
PHYSICAL INVENTORY OF MEASURED QUANTITIES OF DETERIORATION WAS PERFORMED IN APRIL OF 2025.			
EXACT DIMENSIONS AND LOCATIONS OF REPAIRS SHALL BE DETERMINED BY THE ENGINEER IN THE FIELD FOR FINAL PAY QUANTITIES.			
TYPE	MEASURED QUANTITIES	ESTIMATING FACTOR*	ESTIMATED QUANTITIES
PIER 1 PATCHING	53 SQ. FT.	1.5	80 SQ. FT.
PIER 1 ANODES			69
* - ESTIMATED QUANTITIES HAVE BEEN INCREASED BY 50% OVER MEASURED QUANTITIES TO ALLOW FOR ADDITIONAL DETERIORATION.			

LEGEND

- AREA TO BE REPAIRED WITH ITEM 519 - PATCHING CONCRETE STRUCTURE, AS PER PLAN
- LIMITS OF SINGLE LAYER OF FIBER WRAP PER ITEM 519 - SPECIAL COMPOSITE FIBER WRAP SYSTEM

NOTES

- SEE STRUCTURE GENERAL NOTES FOR FIBER REINFORCED POLYMER SPECIFICATIONS AND ADDITIONAL DETAILS.
- STAGE PATCH REPAIR WIDTHS TO LIMIT REPAIRS TO 1/4 OF THE CIRCUMFERENCE AT A TIME.
- CONCRETE SEALING LIMITS AND LIMITS OF FIBER WRAP SHOWN FOR PIER 1 ARE SIMILAR TO THE LIMITS FOR PIER 2
- INSTALL GALVANIC ANODES TO EXISTING REINFORCEMENT ALONG THE PERIMETER OF THE REPAIR AT A MAXIMUM SPACING OF 8"

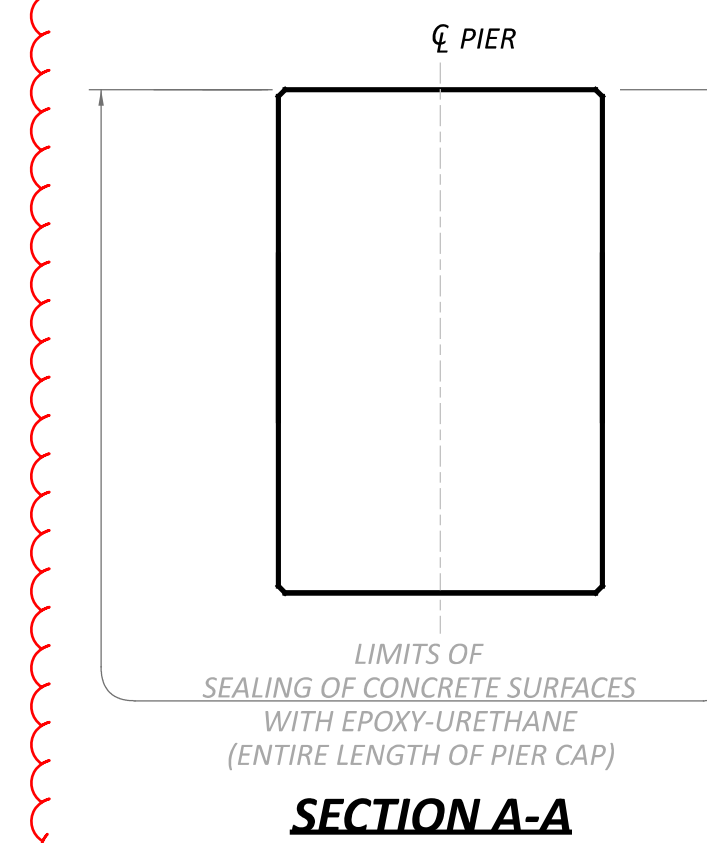

SFN	1401629
DESIGN AGENCY	
DESIGNER	CHECKER
GTF	BCP
REVIEWER	
CAH	02/17/26
PROJECT ID	123648
SUBSET	TOTAL
1	2
SHEET	TOTAL
26	45

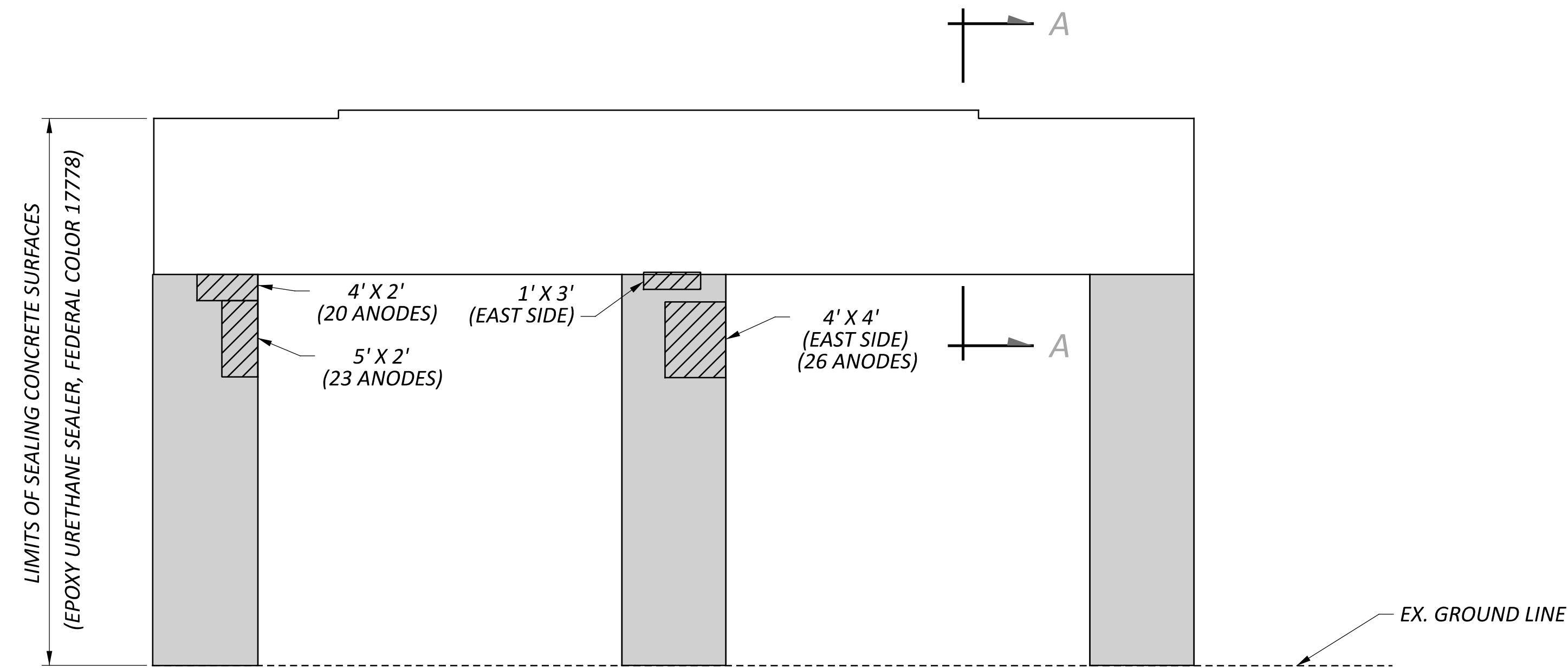

PIER 3 NORTH ELEVATION

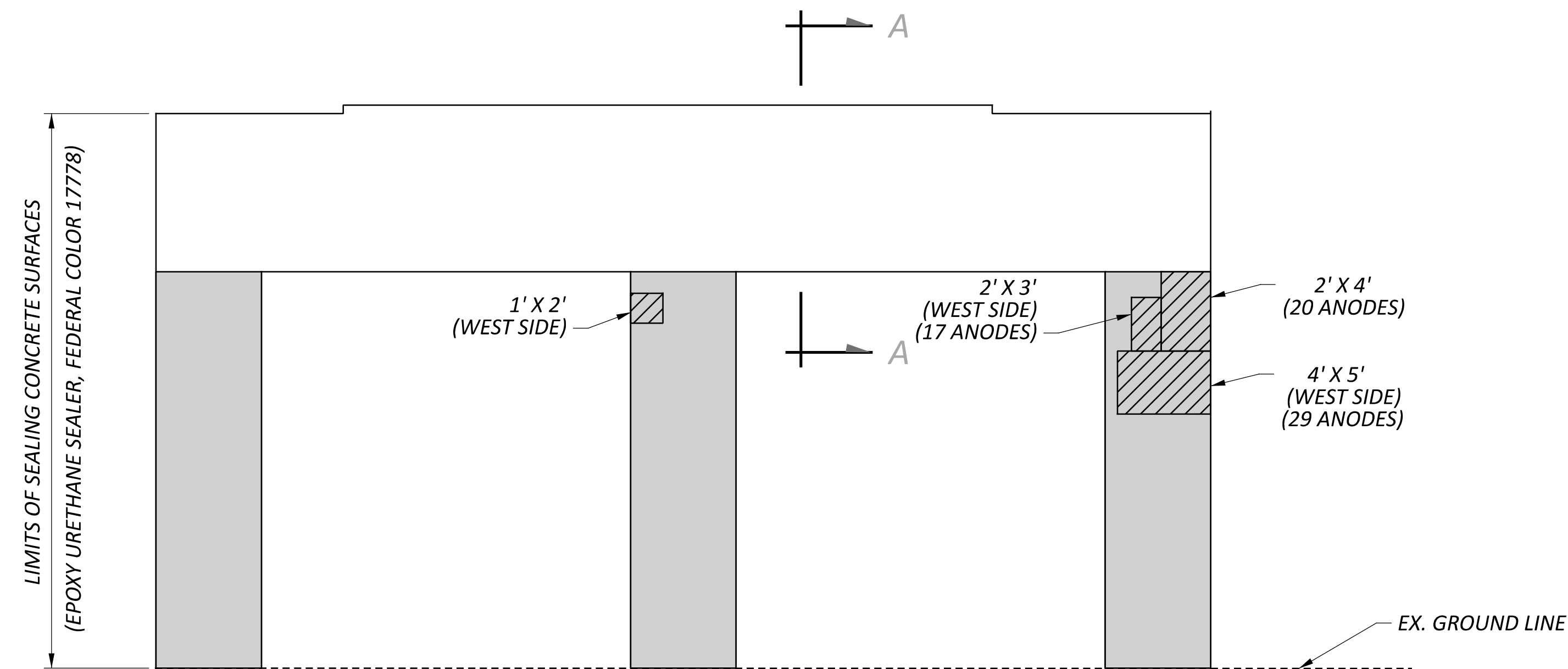

PIER 3 SOUTH ELEVATION

SUMMARY OF REPAIR AREAS			
PHYSICAL INVENTORY OF MEASURED QUANTITIES OF DETERIORATION WAS PERFORMED IN APRIL OF 2025.			
EXACT DIMENSIONS AND LOCATIONS OF REPAIRS SHALL BE DETERMINED BY THE ENGINEER IN THE FIELD FOR FINAL PAY QUANTITIES.			
TYPE	MEASURED QUANTITIES	ESTIMATING FACTOR*	ESTIMATED QUANTITIES
PIER 3 PATCHING	73 SQ. FT.	1.5	110 SQ. FT.
PIER 3 ANODES			135
* - ESTIMATED QUANTITIES HAVE BEEN INCREASED BY 50% OVER MEASURED QUANTITIES TO ALLOW FOR ADDITIONAL DETERIORATION.			

LEGEND

- AREA TO BE REPAIRED WITH ITEM 519 - PATCHING CONCRETE STRUCTURE, AS PER PLAN
- LIMITS OF SINGLE LAYER OF FIBER WRAP PER ITEM 519 - SPECIAL COMPOSITE FIBER WRAP SYSTEM

NOTES

- SEE STRUCTURE GENERAL NOTES FOR FIBER REINFORCED POLYMER SPECIFICATIONS AND ADDITIONAL DETAILS.
- STAGE PATCH REPAIR WIDTHS TO LIMIT REPAIRS TO 1/4 OF THE CIRCUMFERENCE AT A TIME.
- CONCRETE SEALING LIMITS AND LIMITS OF FIBER WRAP SHOWN FOR PIER 3 ARE SIMILAR TO THE LIMITS FOR PIER 2
- INSTALL GALVANIC ANODES TO EXISTING REINFORCEMENT ALONG THE PERIMETER OF THE REPAIR AT A MAXIMUM SPACING OF 8"

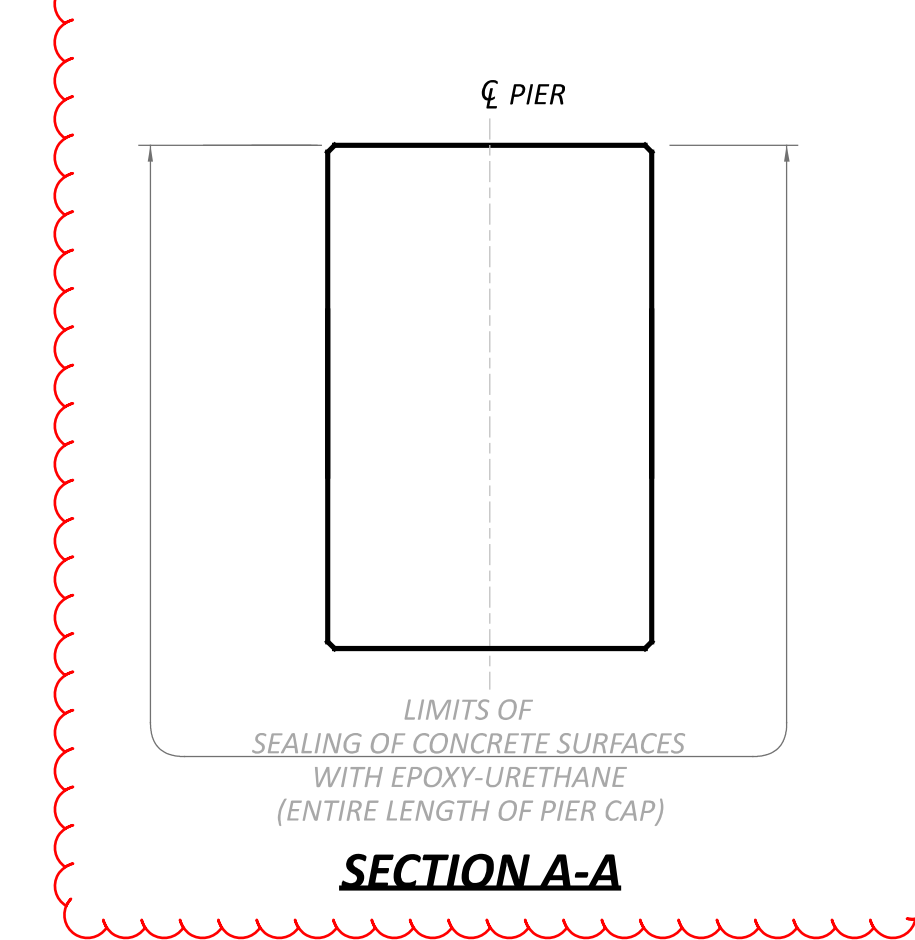

SFN	1401629
DESIGN AGENCY	
DESIGNER	CHECKER
GTF	BCP
REVIEWER	
CAH 02/17/26	
PROJECT ID	
123648	
SUBSET	TOTAL
2	2
SHEET	TOTAL
27	45

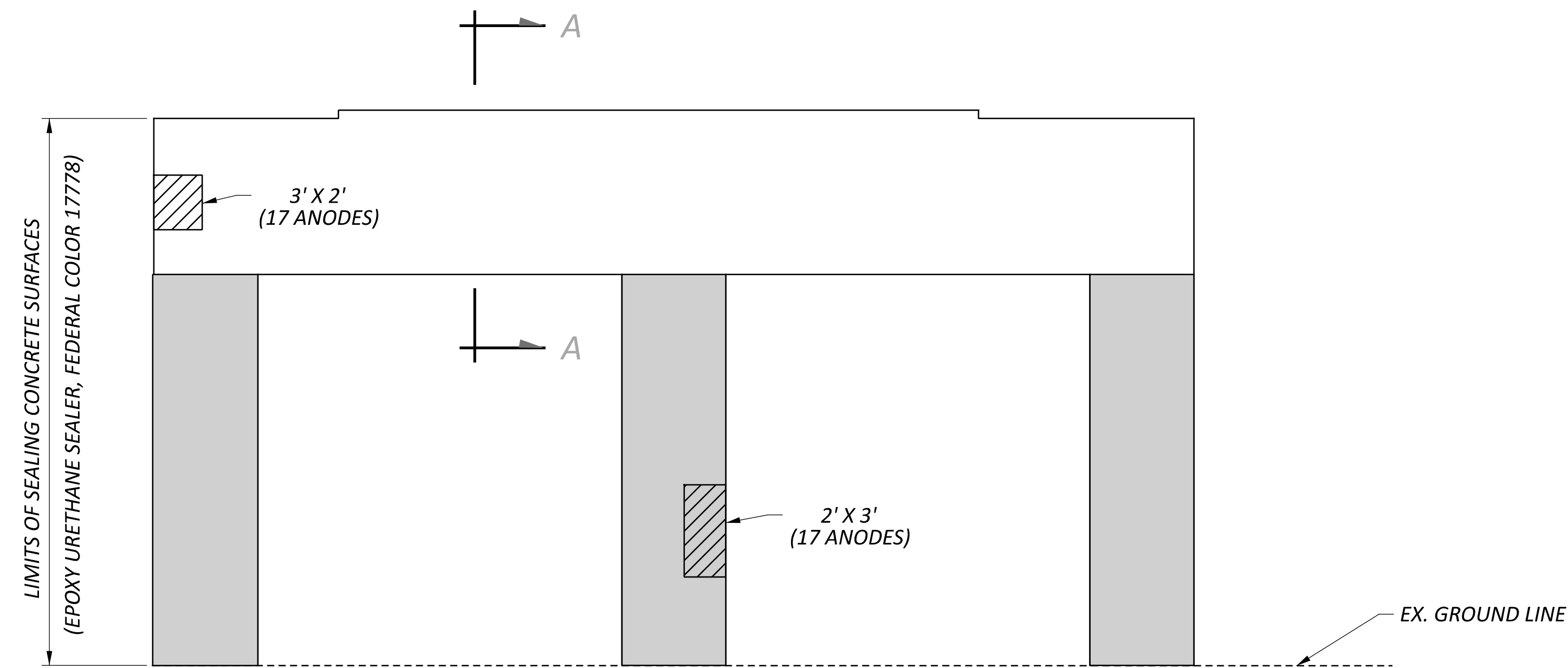

PIER 1 NORTH ELEVATION

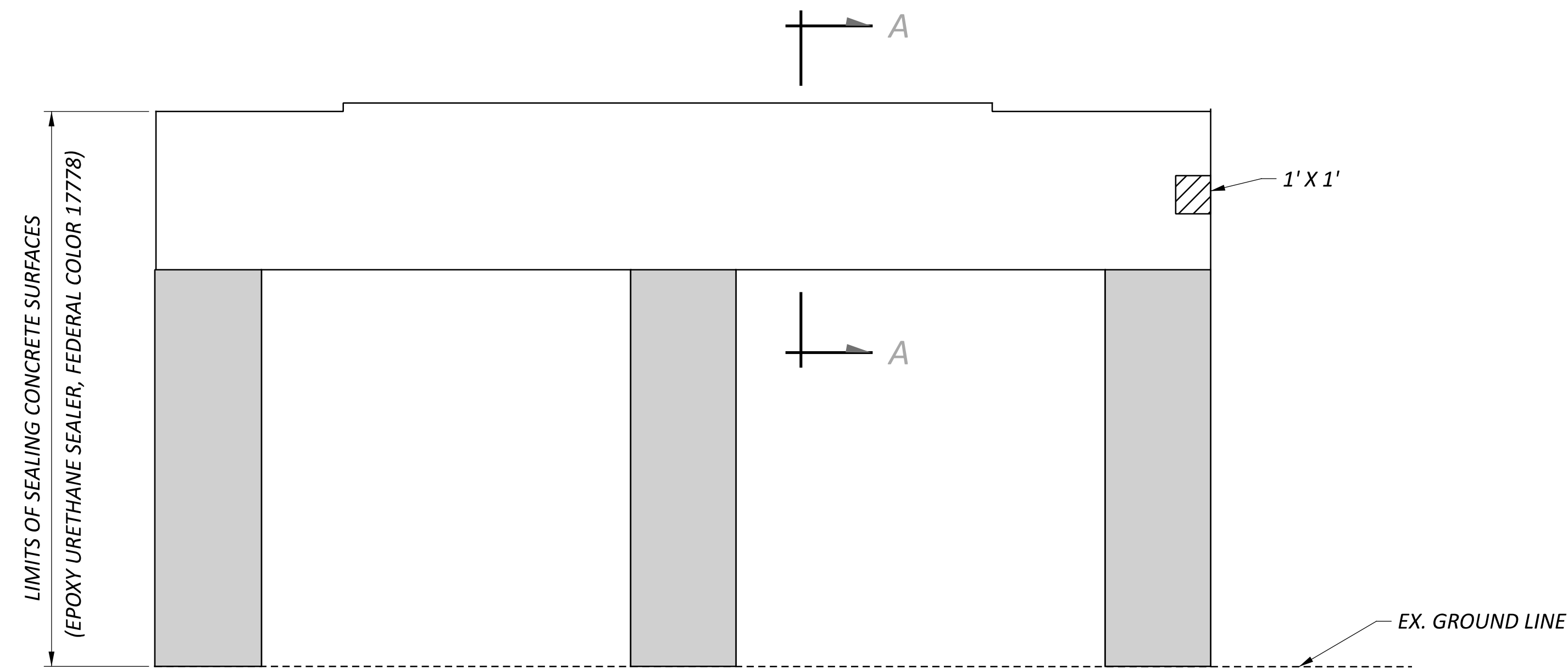

PIER 1 SOUTH ELEVATION

SUMMARY OF REPAIR AREAS			
PHYSICAL INVENTORY OF MEASURED QUANTITIES OF DETERIORATION WAS PERFORMED IN APRIL OF 2025.			
EXACT DIMENSIONS AND LOCATIONS OF REPAIRS SHALL BE DETERMINED BY THE ENGINEER IN THE FIELD FOR FINAL PAY QUANTITIES.			
TYPE	MEASURED QUANTITIES	ESTIMATING FACTOR*	ESTIMATED QUANTITIES
PIER 1 PATCHING	13 SQ. FT.	1.5	20 SQ. FT.
PIER 1 ANODES			34

* - ESTIMATED QUANTITIES HAVE BEEN INCREASED BY 50% OVER MEASURED QUANTITIES TO ALLOW FOR ADDITIONAL DETERIORATION.

LEGEND

-AREA TO BE REPAIRED WITH ITEM 519 - PATCHING CONCRETE STRUCTURE, AS PER PLAN

-LIMITS OF SINGLE LAYER OF FIBER WRAP PER ITEM 519 - SPECIAL COMPOSITE FIBER WRAP SYSTEM

NOTES

- SEE STRUCTURE GENERAL NOTES FOR FIBER REINFORCED POLYMER SPECIFICATIONS AND ADDITIONAL DETAILS.
- STAGE PATCH REPAIR WIDTHS TO LIMIT REPAIRS TO 1/4 OF THE CIRCUMFERENCE AT A TIME.
- INSTALL GALVANIC ANODES TO EXISTING REINFORCEMENT ALONG THE PERIMETER OF THE REPAIR AT A MAXIMUM SPACING OF 8"

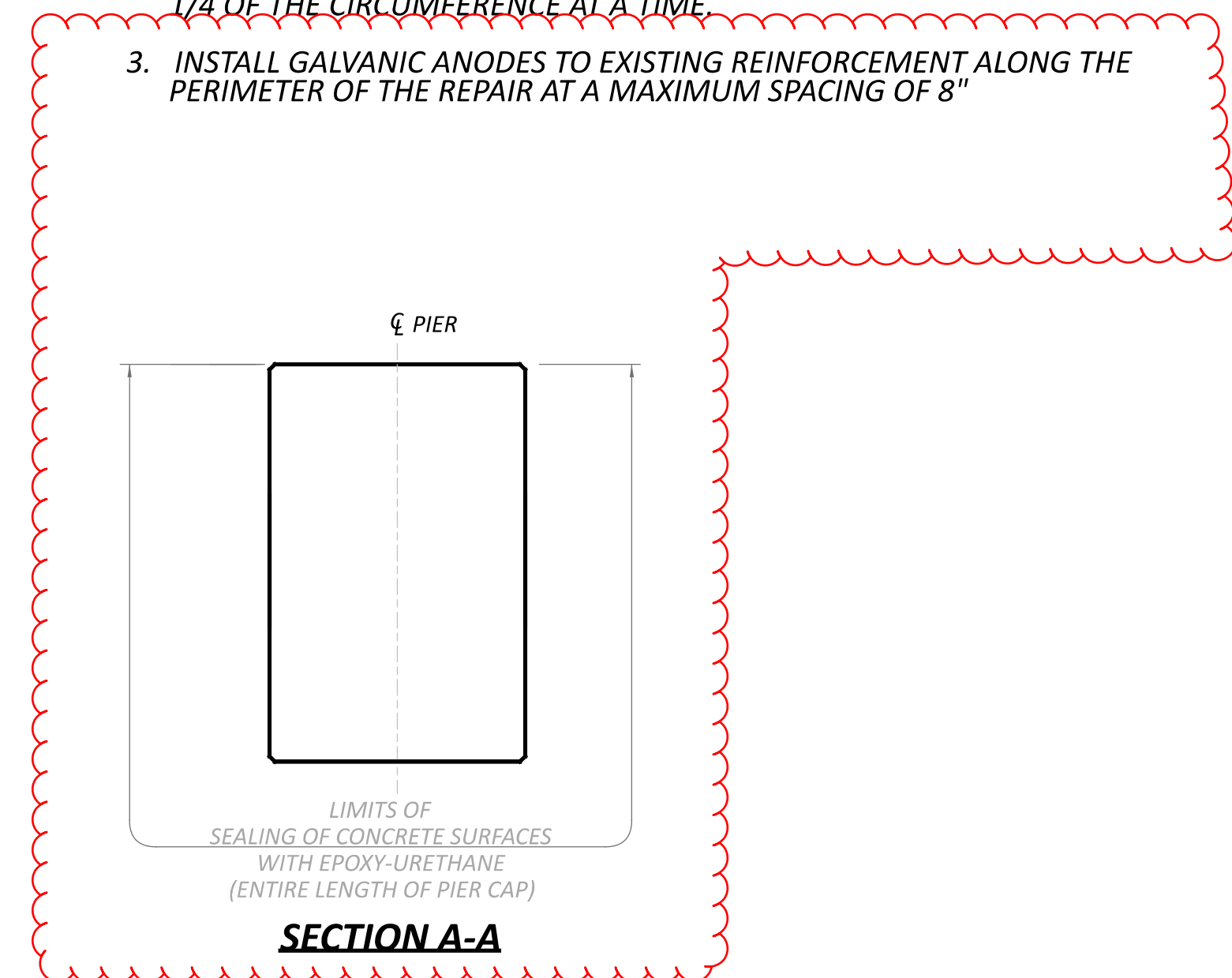

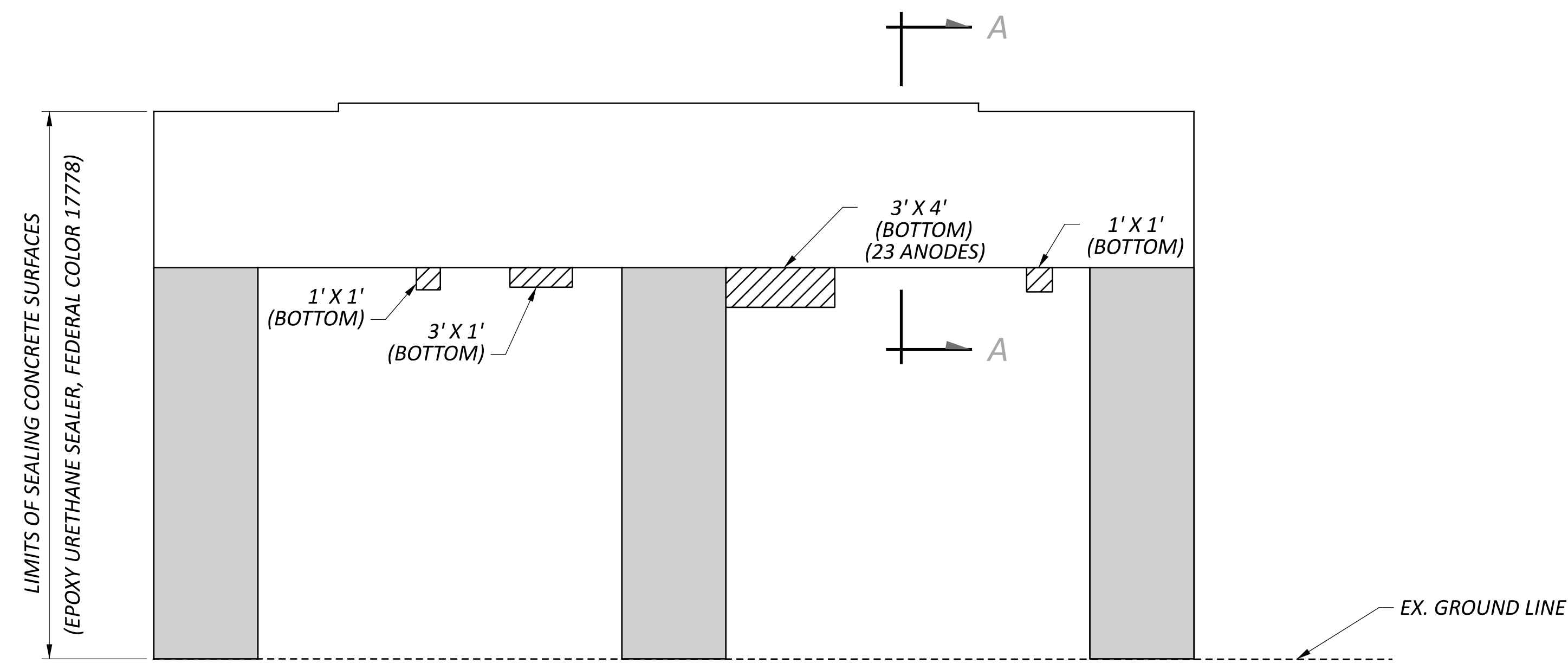

PIER 2 NORTH ELEVATION

SUMMARY OF REPAIR AREAS			
PHYSICAL INVENTORY OF MEASURED QUANTITIES OF DETERIORATION WAS PERFORMED IN APRIL OF 2025.			
EXACT DIMENSIONS AND LOCATIONS OF REPAIRS SHALL BE DETERMINED BY THE ENGINEER IN THE FIELD FOR FINAL PAY QUANTITIES.			
TYPE	MEASURED QUANTITIES	ESTIMATING FACTOR*	ESTIMATED QUANTITIES
PIER 2 PATCHING	17 SQ. FT.	1.5	26 SQ. FT.
PIER 2 ANODES			23
* - ESTIMATED QUANTITIES HAVE BEEN INCREASED BY 50% OVER MEASURED QUANTITIES TO ALLOW FOR ADDITIONAL DETERIORATION.			

LEGEND

- AREA TO BE REPAIRED WITH ITEM 519 - PATCHING CONCRETE STRUCTURE, AS PER PLAN
- LIMITS OF SINGLE LAYER OF FIBER WRAP PER ITEM 519 - SPECIAL COMPOSITE FIBER WRAP SYSTEM

NOTES

1. SEE STRUCTURE GENERAL NOTES FOR FIBER REINFORCED POLYMER SPECIFICATIONS AND ADDITIONAL DETAILS.
2. STAGE PATCH REPAIR WIDTHS TO LIMIT REPAIRS TO 1/4 OF THE CIRCUMFERENCE AT A TIME.
3. INSTALL GALVANIC ANODES TO EXISTING REINFORCEMENT ALONG THE PERIMETER OF THE REPAIR AT A MAXIMUM SPACING OF 8"

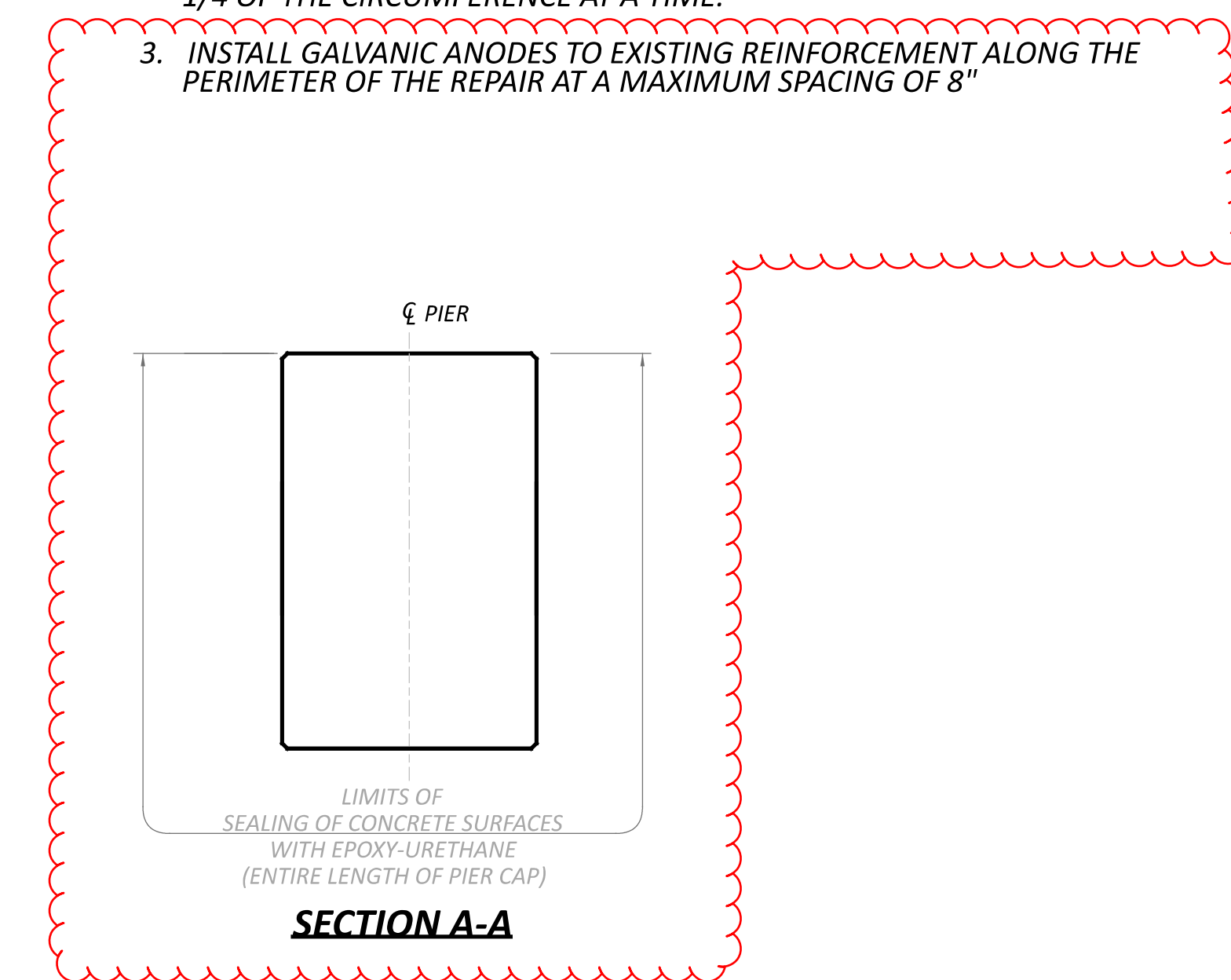

SFN	1401777
DESIGN AGENCY	
DESIGNER	CHECKER
GTF	BCP
REVIEWER	CAH 02/17/26
PROJECT ID	123648
SUBSET	TOTAL
2	3
SHEET	TOTAL
29	45

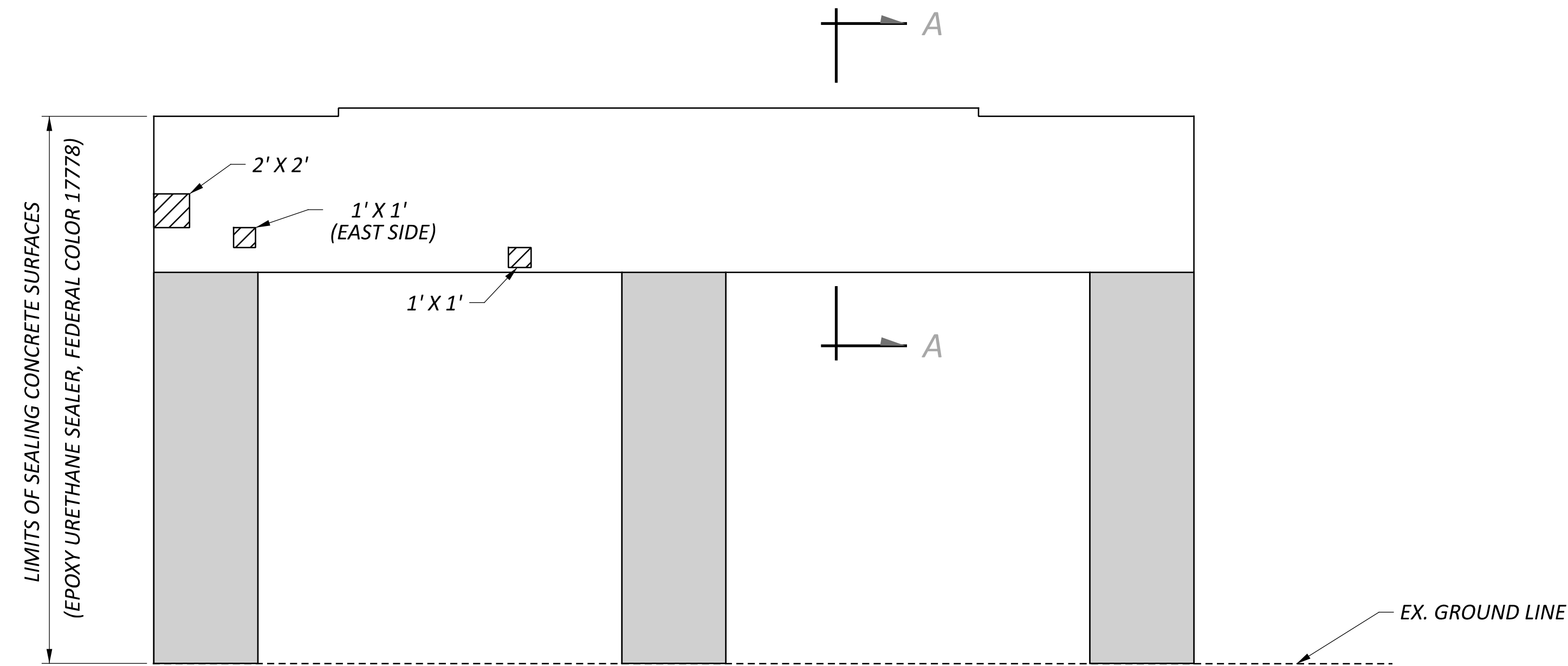

PIER 3 NORTH ELEVATION

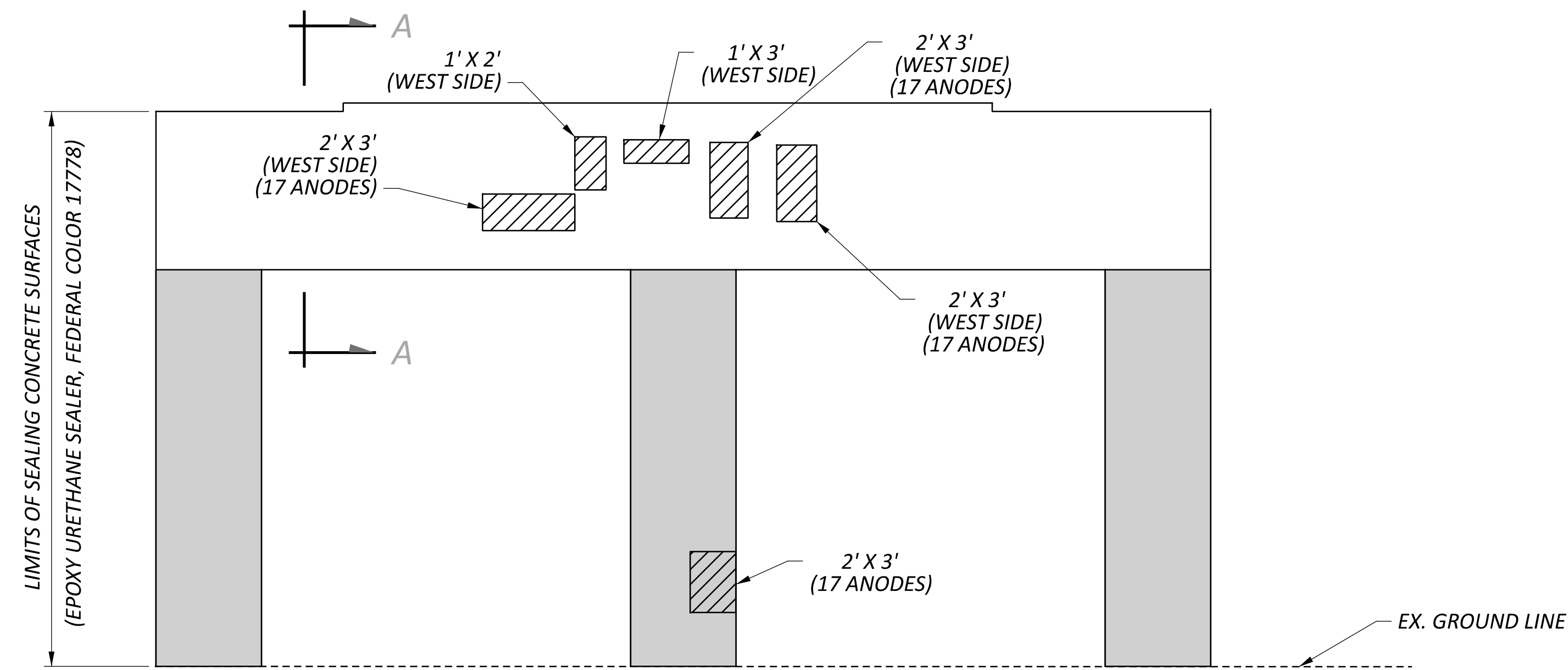

PIER 3 SOUTH ELEVATION

SUMMARY OF REPAIR AREAS			
PHYSICAL INVENTORY OF MEASURED QUANTITIES OF DETERIORATION WAS PERFORMED IN APRIL OF 2025.			
EXACT DIMENSIONS AND LOCATIONS OF REPAIRS SHALL BE DETERMINED BY THE ENGINEER IN THE FIELD FOR FINAL PAY QUANTITIES.			
TYPE	MEASURED QUANTITIES	ESTIMATING FACTOR*	ESTIMATED QUANTITIES
PIER 3 PATCHING	35 SQ. FT.	1.5	53 SQ. FT.
PIER 3 ANODES			51
* - ESTIMATED QUANTITIES HAVE BEEN INCREASED BY 50% OVER MEASURED QUANTITIES TO ALLOW FOR ADDITIONAL DETERIORATION.			

LEGEND

- AREA TO BE REPAIRED WITH ITEM 519 - PATCHING CONCRETE STRUCTURE, AS PER PLAN
- LIMITS OF SINGLE LAYER OF FIBER WRAP PER ITEM 519 - SPECIAL COMPOSITE FIBER WRAP SYSTEM

NOTES

- SEE STRUCTURE GENERAL NOTES FOR FIBER REINFORCED POLYMER SPECIFICATIONS AND ADDITIONAL DETAILS.
- STAGE PATCH REPAIR WIDTHS TO LIMIT REPAIRS TO 1/4 OF THE CIRCUMFERENCE AT A TIME.
- INSTALL GALVANIC ANODES TO EXISTING REINFORCEMENT ALONG THE PERIMETER OF THE REPAIR AT A MAXIMUM SPACING OF 8"

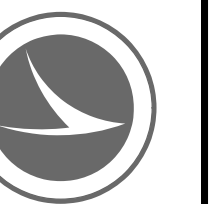
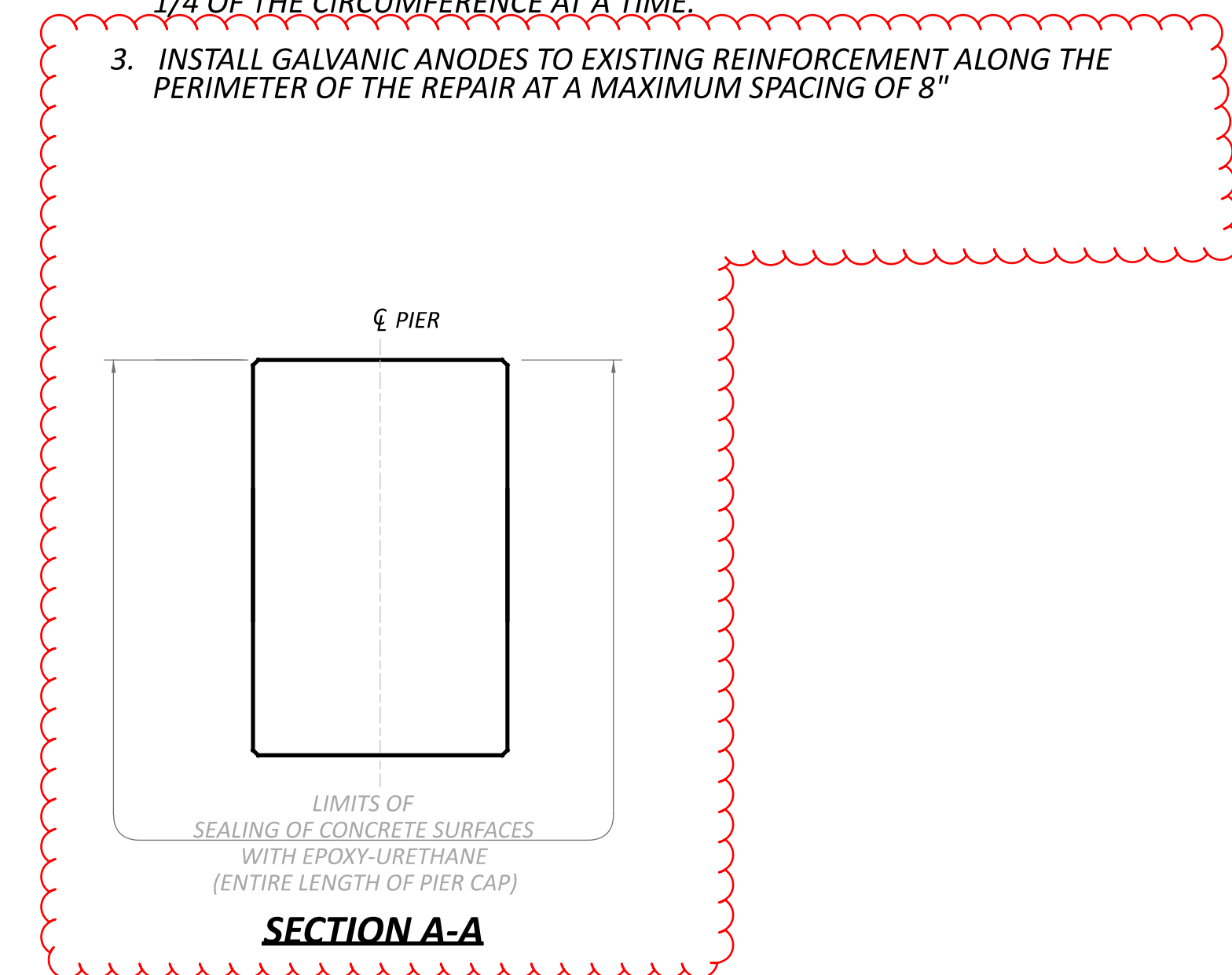

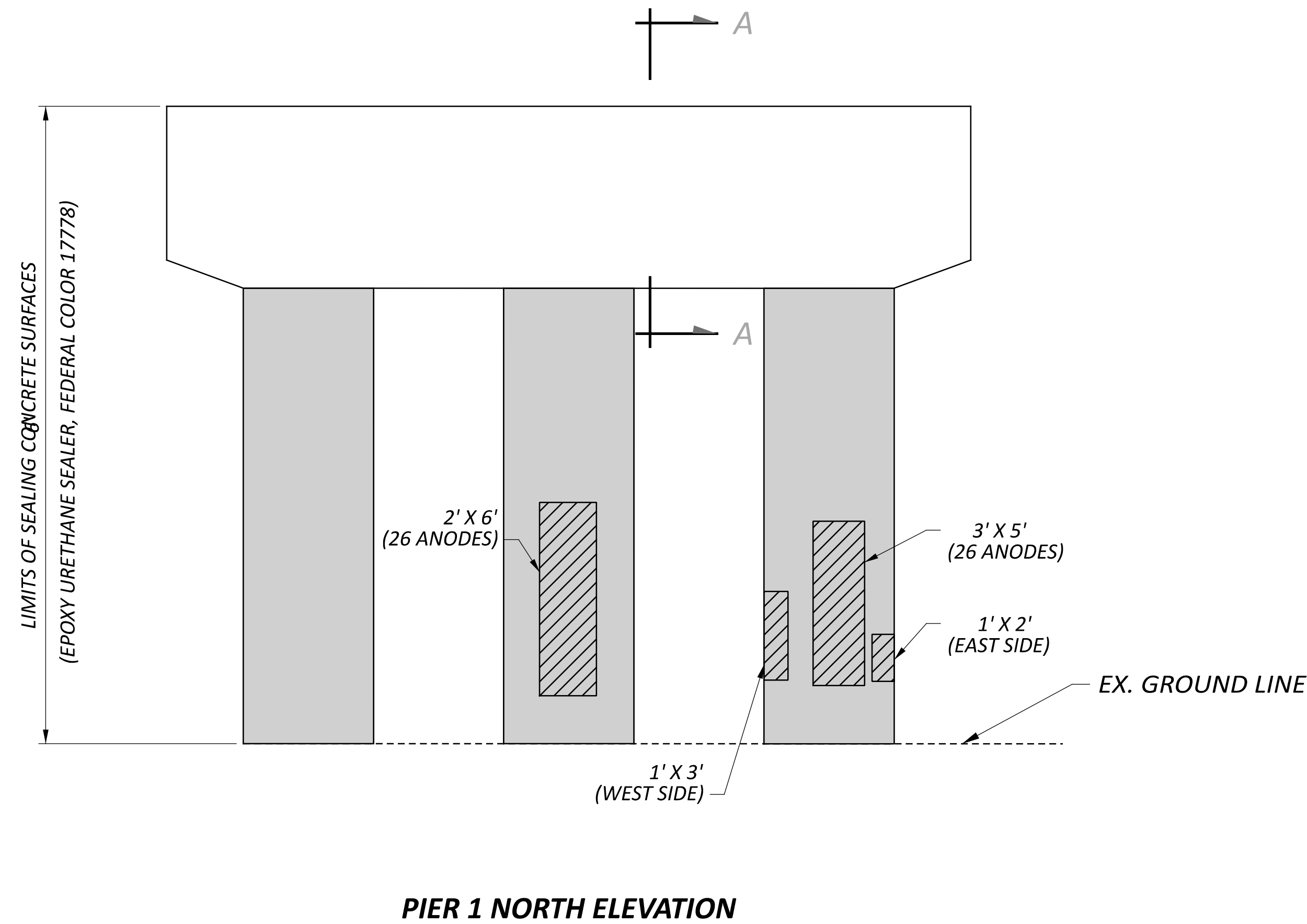

SUMMARY OF REPAIR AREAS			
PHYSICAL INVENTORY OF MEASURED QUANTITIES OF DETERIORATION WAS PERFORMED IN APRIL OF 2025.			
EXACT DIMENSIONS AND LOCATIONS OF REPAIRS SHALL BE DETERMINED BY THE ENGINEER IN THE FIELD FOR FINAL PAY QUANTITIES.			
TYPE	MEASURED QUANTITIES	ESTIMATING FACTOR*	ESTIMATED QUANTITIES
PIER 1 PATCHING	32 SQ. FT.	1.5	48 SQ. FT.
PIER 1 ANODES			52
* - ESTIMATED QUANTITIES HAVE BEEN INCREASED BY 50% OVER MEASURED QUANTITIES TO ALLOW FOR ADDITIONAL DETERIORATION.			

LEGEND

- AREA TO BE REPAIRED WITH ITEM 519 - PATCHING CONCRETE STRUCTURE, AS PER PLAN
- LIMITS OF SINGLE LAYER OF FIBER WRAP PER ITEM 519 - SPECIAL COMPOSITE FIBER WRAP SYSTEM

NOTES

1. SEE STRUCTURE GENERAL NOTES FOR FIBER REINFORCED POLYMER SPECIFICATIONS AND ADDITIONAL DETAILS.
2. STAGE PATCH REPAIR WIDTHS TO LIMIT REPAIRS TO 1/4 OF THE CIRCUMFERENCE AT A TIME.
3. REMOVE ABANDONED ELECTRICAL CONTROL PANEL FROM THE COLUMN DOWN TO GRADE. CAP THE CONDUIT AS IT GOES INTO THE GROUND. WORK SHALL BE PAID UNDER ITEM 202, PORTIONS OF STRUCTURE REMOVED.
4. INSTALL GALVANIC ANODES TO EXISTING REINFORCEMENT ALONG THE PERIMETER OF THE REPAIR AT A MAXIMUM SPACING OF 8"

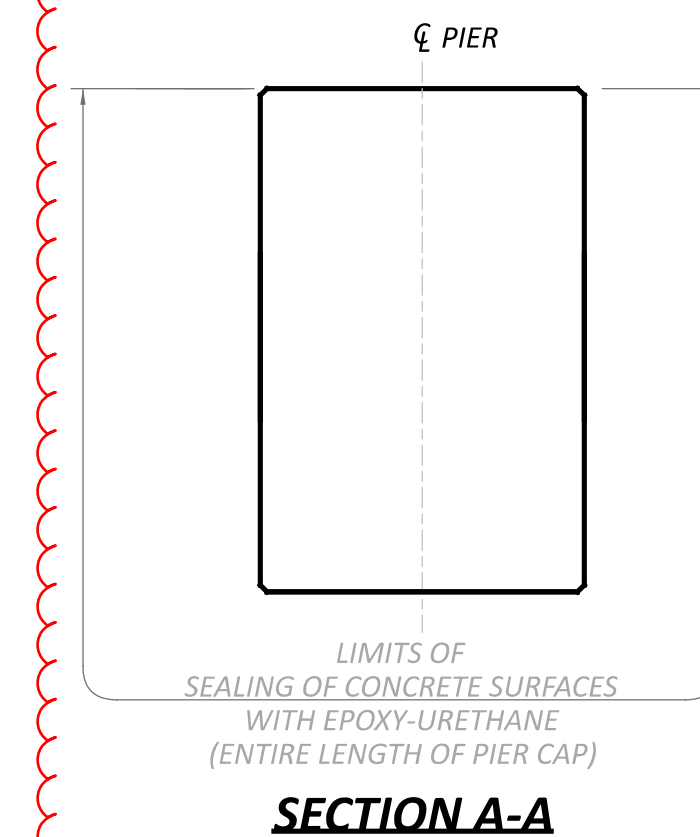

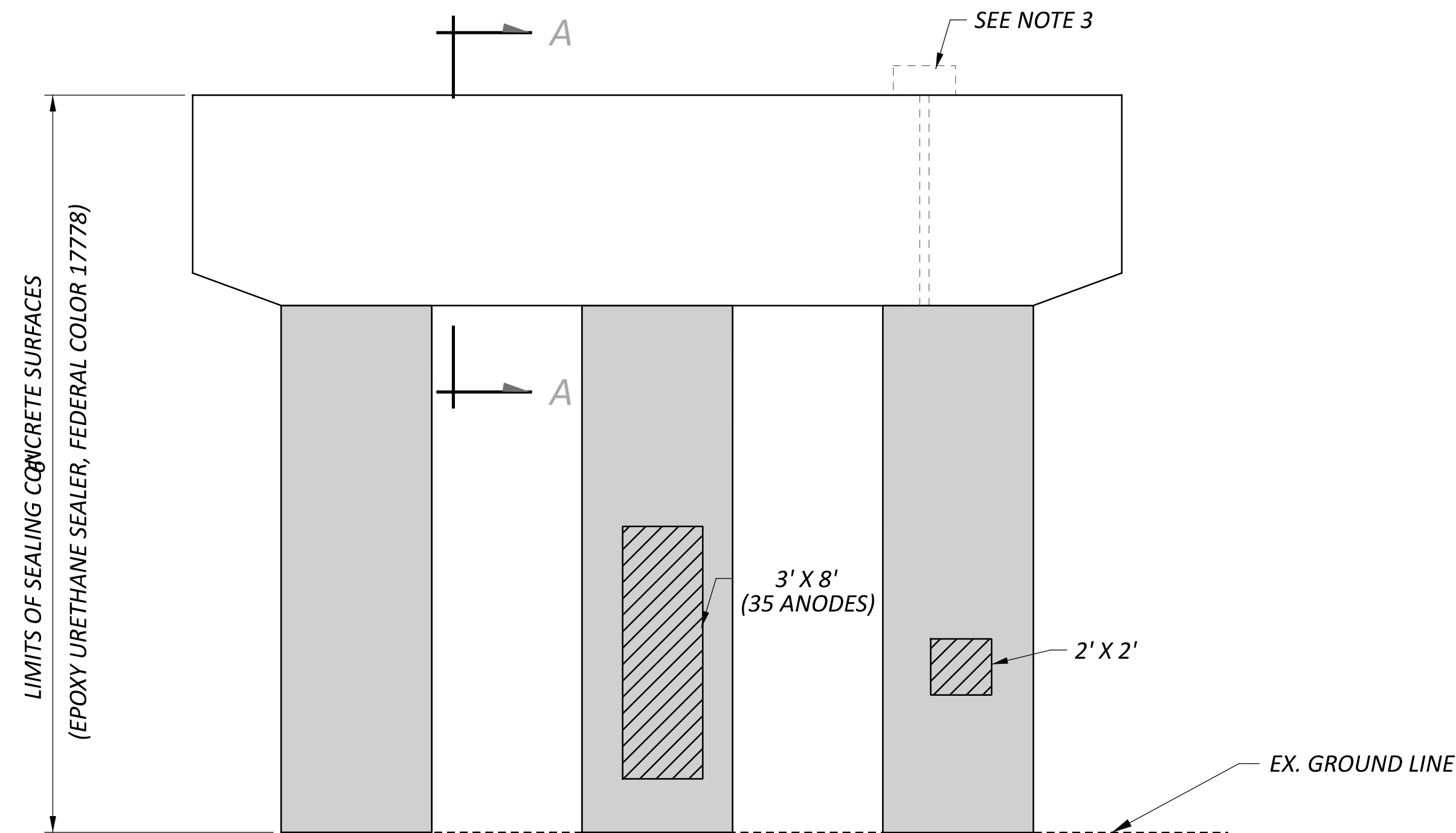

PIER 2 NORTH ELEVATION

SUMMARY OF REPAIR AREAS			
PHYSICAL INVENTORY OF MEASURED QUANTITIES OF DETERIORATION WAS PERFORMED IN APRIL OF 2025.			
EXACT DIMENSIONS AND LOCATIONS OF REPAIRS SHALL BE DETERMINED BY THE ENGINEER IN THE FIELD FOR FINAL PAY QUANTITIES.			
TYPE	MEASURED QUANTITIES	ESTIMATING FACTOR*	ESTIMATED QUANTITIES
PIER 2 PATCHING	28 SQ. FT.	1.5	42 SQ. FT.
PIER 2 ANODES			35
* - ESTIMATED QUANTITIES HAVE BEEN INCREASED BY 50% OVER MEASURED QUANTITIES TO ALLOW FOR ADDITIONAL DETERIORATION.			

LEGEND

- AREA TO BE REPAIRED WITH ITEM 519 - PATCHING CONCRETE STRUCTURE, AS PER PLAN
- LIMITS OF SINGLE LAYER OF FIBER WRAP PER ITEM 519 - SPECIAL COMPOSITE FIBER WRAP SYSTEM

NOTES

1. SEE STRUCTURE GENERAL NOTES FOR FIBER REINFORCED POLYMER SPECIFICATIONS AND ADDITIONAL DETAILS.
2. STAGE PATCH REPAIR WIDTHS TO LIMIT REPAIRS TO 1/4 OF THE CIRCUMFERENCE AT A TIME.
3. REMOVE THE ABANDONED ELECTRICAL CONTROL PANEL FROM THE TOP OF THE PIER CAP AND THE CONDUIT ATTACHED TO THE COLUMN DOWN TO GRADE IN ACCORDANCE WITH CMS 202. CAP THE EXISTING CONDUIT WHERE IT ENTERS THE GROUND IN ACCORDANCE WITH CMS 625.

INCLUDE ALL LABOR, TOOLS, EQUIPMENT, AND INCIDENTALS NECESSARY TO COMPLETE THIS WORK AS PART OF THE PAYMENT FOR ITEM 519 - SPECIAL COMPOSITE FIBER WRAP SYSTEM

4. INSTALL GALVANIC ANODES TO EXISTING REINFORCEMENT ALONG THE PERIMETER OF THE REPAIR AT A MAXIMUM SPACING OF 8"

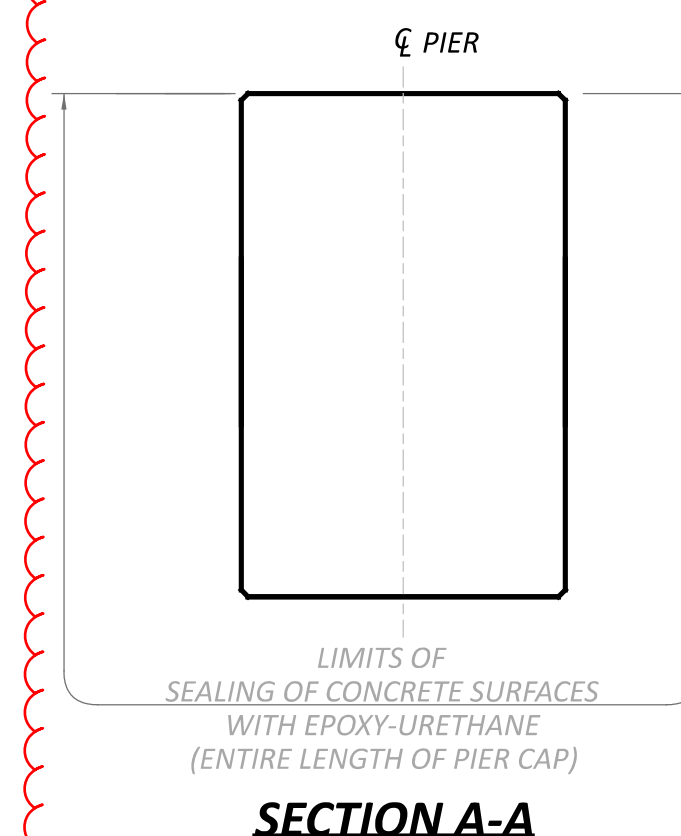

SFN 2903660	
DESIGN AGENCY	
DESIGNER GTF	CHECKER BCP
REVIEWER CAH 02/17/26	
PROJECT ID 123648	
SUBSET 2	TOTAL 3
SHEET 32	TOTAL 45

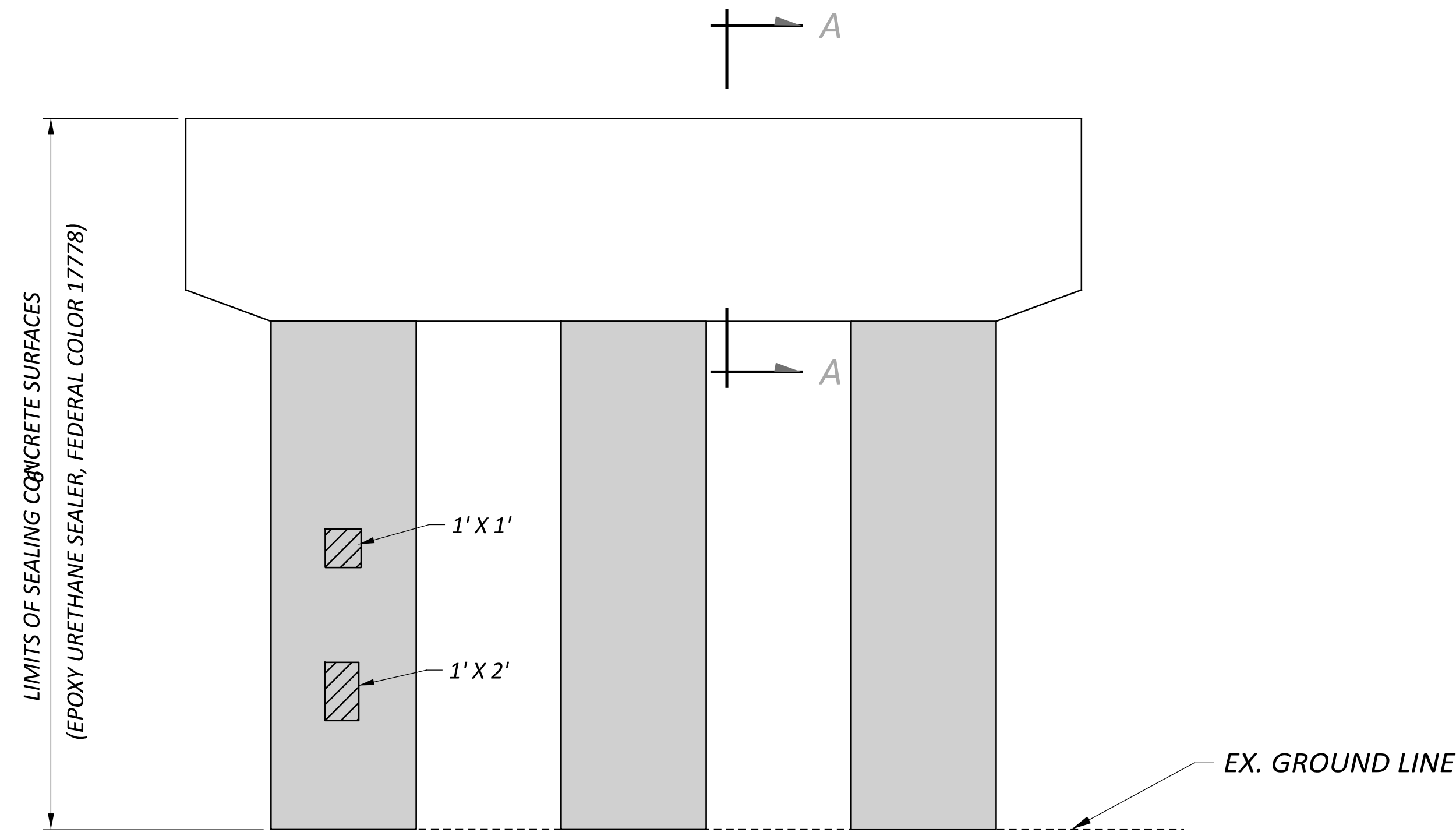

PIER 3 SOUTH ELEVATION

SUMMARY OF REPAIR AREAS			
PHYSICAL INVENTORY OF MEASURED QUANTITIES OF DETERIORATION WAS PERFORMED IN APRIL OF 2025.			
EXACT DIMENSIONS AND LOCATIONS OF REPAIRS SHALL BE DETERMINED BY THE ENGINEER IN THE FIELD FOR FINAL PAY QUANTITIES.			
TYPE	MEASURED QUANTITIES	ESTIMATING FACTOR*	ESTIMATED QUANTITIES
PIER 3 PATCHING	3 SQ. FT.	1.5	5 SQ. FT.
PIER 3 ANODES			
* - ESTIMATED QUANTITIES HAVE BEEN INCREASED BY 50% OVER MEASURED QUANTITIES TO ALLOW FOR ADDITIONAL DETERIORATION.			

LEGEND

- AREA TO BE REPAIRED WITH ITEM 519 - PATCHING CONCRETE STRUCTURE, AS PER PLAN
- LIMITS OF SINGLE LAYER OF FIBER WRAP PER ITEM 519 - SPECIAL COMPOSITE FIBER WRAP SYSTEM

NOTES

1. SEE STRUCTURE GENERAL NOTES FOR FIBER REINFORCED POLYMER SPECIFICATIONS AND ADDITIONAL DETAILS.
2. STAGE PATCH REPAIR WIDTHS TO LIMIT REPAIRS TO 1/4 OF THE CIRCUMFERENCE AT A TIME.

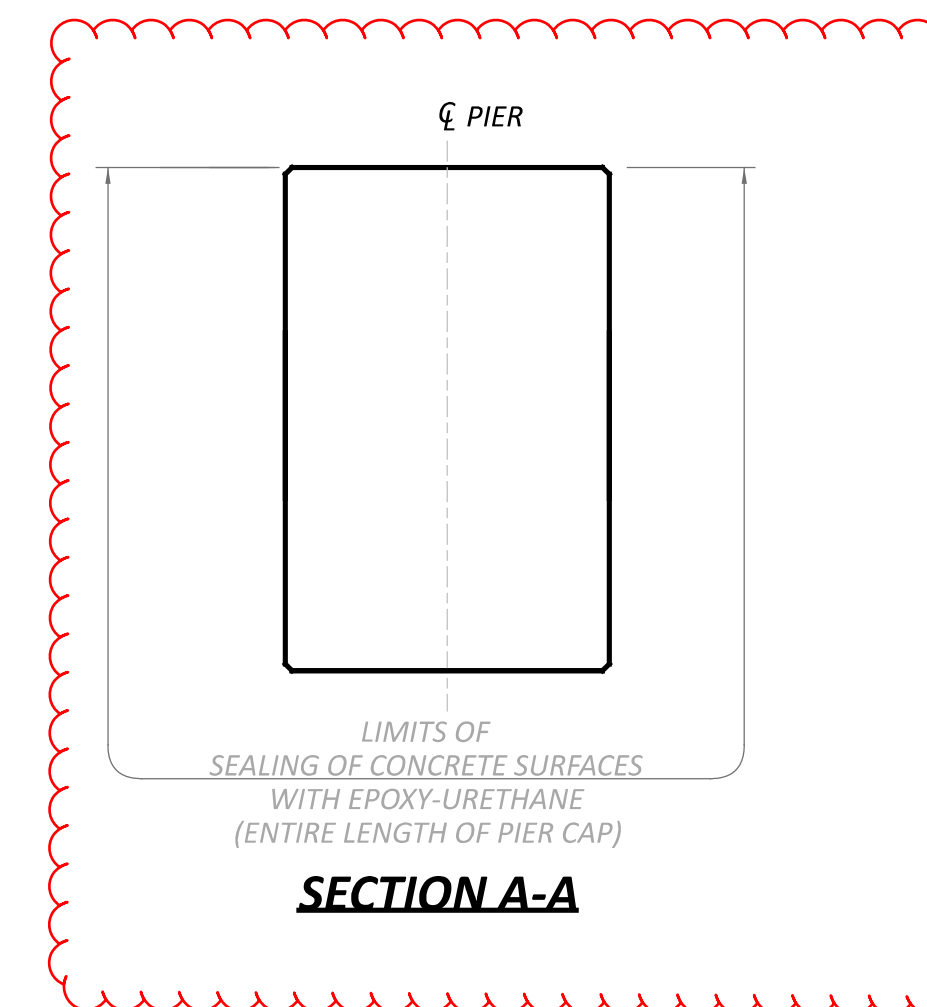

SFN	2903660
DESIGN AGENCY	
DESIGNER	CHECKER
GTF	BCP
REVIEWER	
CAH 02/17/26	
PROJECT ID	
123648	
SUBSET	TOTAL
3	3
SHEET	TOTAL
33	45

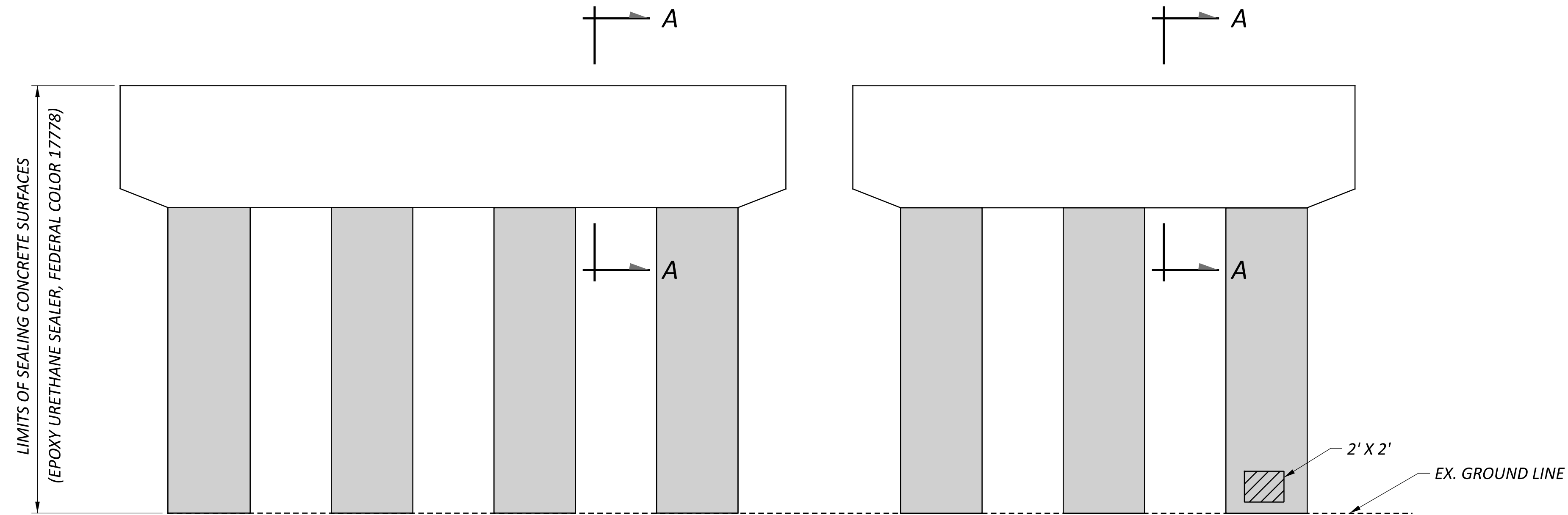

PIER 1 EAST ELEVATION

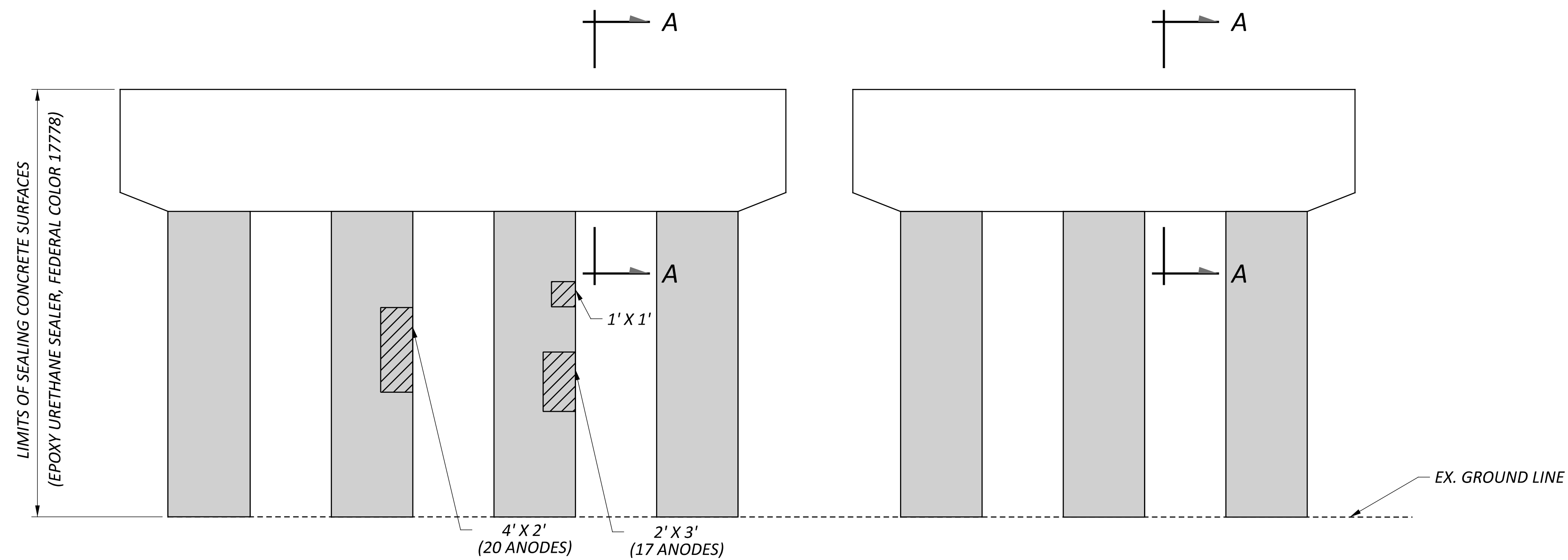

PIER 1 WEST ELEVATION

SUMMARY OF REPAIR AREAS			
PHYSICAL INVENTORY OF MEASURED QUANTITIES OF DETERIORATION WAS PERFORMED IN APRIL OF 2025.			
EXACT DIMENSIONS AND LOCATIONS OF REPAIRS SHALL BE DETERMINED BY THE ENGINEER IN THE FIELD FOR FINAL PAY QUANTITIES.			
TYPE	MEASURED QUANTITIES	ESTIMATING FACTOR*	ESTIMATED QUANTITIES
PIER 1 PATCHING	19 SQ. FT.	1.5	29 SQ. FT.
PIER 1 ANODES			37
* - ESTIMATED QUANTITIES HAVE BEEN INCREASED BY 50% OVER MEASURED QUANTITIES TO ALLOW FOR ADDITIONAL DETERIORATION.			

LEGEND

- AREA TO BE REPAIRED WITH ITEM 519 - PATCHING CONCRETE STRUCTURE, AS PER PLAN
- LIMITS OF SINGLE LAYER OF FIBER WRAP PER ITEM 519 - SPECIAL COMPOSITE FIBER WRAP SYSTEM

NOTES

- SEE STRUCTURE GENERAL NOTES FOR FIBER REINFORCED POLYMER SPECIFICATIONS AND ADDITIONAL DETAILS.
- STAGE PATCH REPAIR WIDTHS TO LIMIT REPAIRS TO 1/4 OF THE CIRCUMFERENCE AT A TIME.
- INSTALL GALVANIC ANODES TO EXISTING REINFORCEMENT ALONG THE PERIMETER OF THE REPAIR AT A MAXIMUM SPACING OF 8"

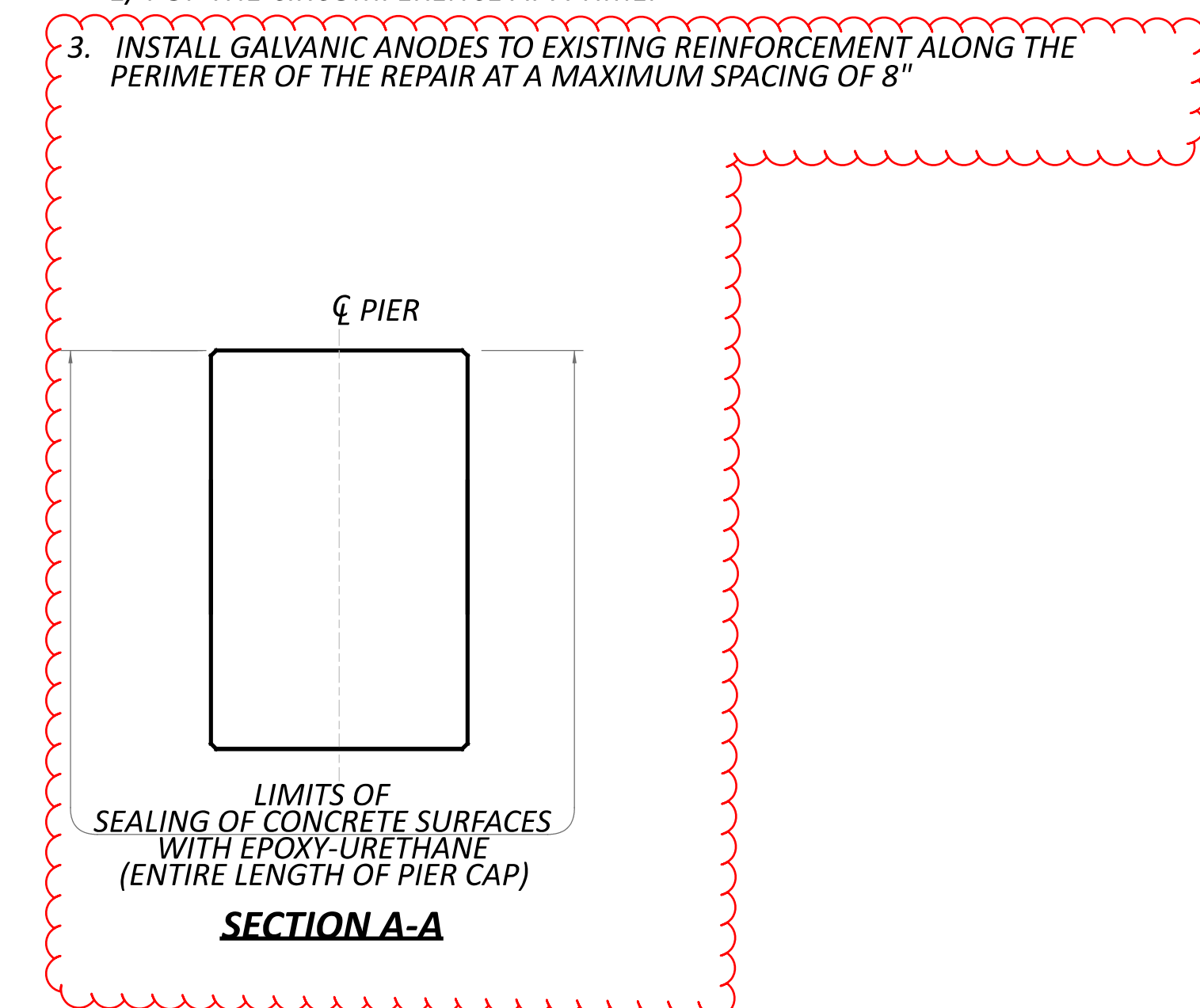

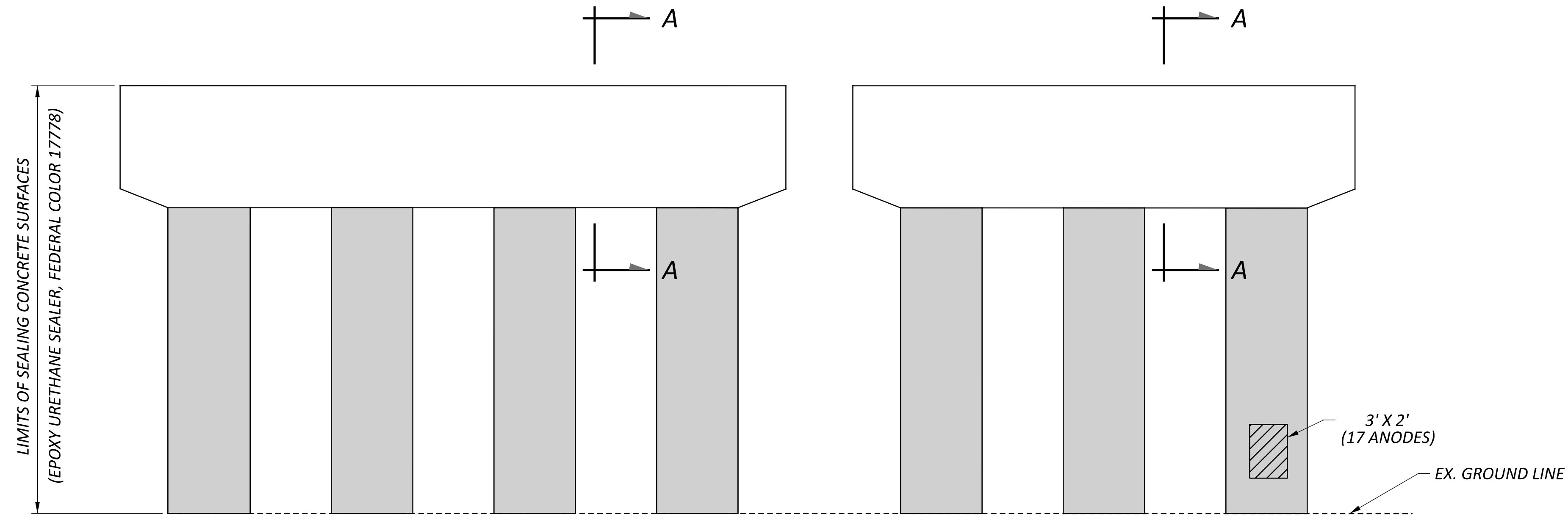

PIER 2 SOUTH ELEVATION

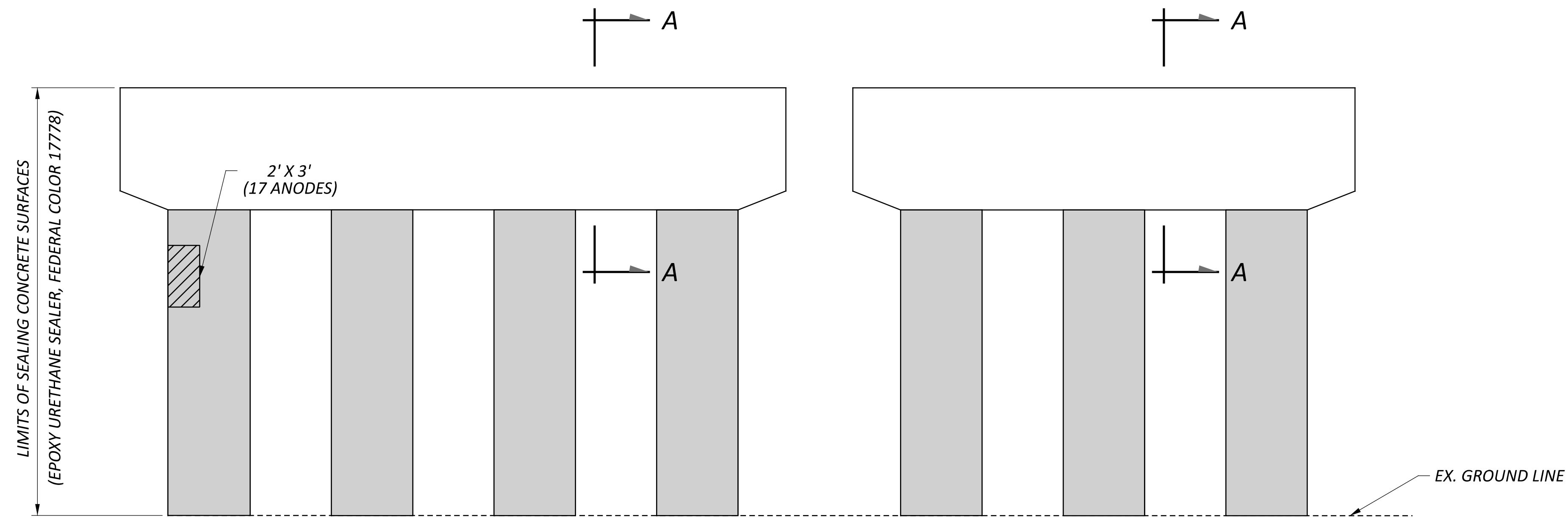

PIER 2 WEST ELEVATION

SUMMARY OF REPAIR AREAS			
PHYSICAL INVENTORY OF MEASURED QUANTITIES OF DETERIORATION WAS PERFORMED IN APRIL OF 2025.			
EXACT DIMENSIONS AND LOCATIONS OF REPAIRS SHALL BE DETERMINED BY THE ENGINEER IN THE FIELD FOR FINAL PAY QUANTITIES.			
TYPE	MEASURED QUANTITIES	ESTIMATING FACTOR*	ESTIMATED QUANTITIES
PIER 2 PATCHING	12 SQ. FT.	1.5	18 SQ. FT.
PIER 2 ANODES			34

* - ESTIMATED QUANTITIES HAVE BEEN INCREASED BY 50% OVER MEASURED QUANTITIES TO ALLOW FOR ADDITIONAL DETERIORATION.

LEGEND

- AREA TO BE REPAIRED WITH ITEM 519 - PATCHING CONCRETE STRUCTURE, AS PER PLAN
- LIMITS OF SINGLE LAYER OF FIBER WRAP PER ITEM 519 - SPECIAL COMPOSITE FIBER WRAP SYSTEM

NOTES

- SEE STRUCTURE GENERAL NOTES FOR FIBER REINFORCED POLYMER SPECIFICATIONS AND ADDITIONAL DETAILS.
- STAGE PATCH REPAIR WIDTHS TO LIMIT REPAIRS TO 1/4 OF THE CIRCUMFERENCE AT A TIME.
- INSTALL GALVANIC ANODES TO EXISTING REINFORCEMENT ALONG THE PERIMETER OF THE REPAIR AT A MAXIMUM SPACING OF 8"

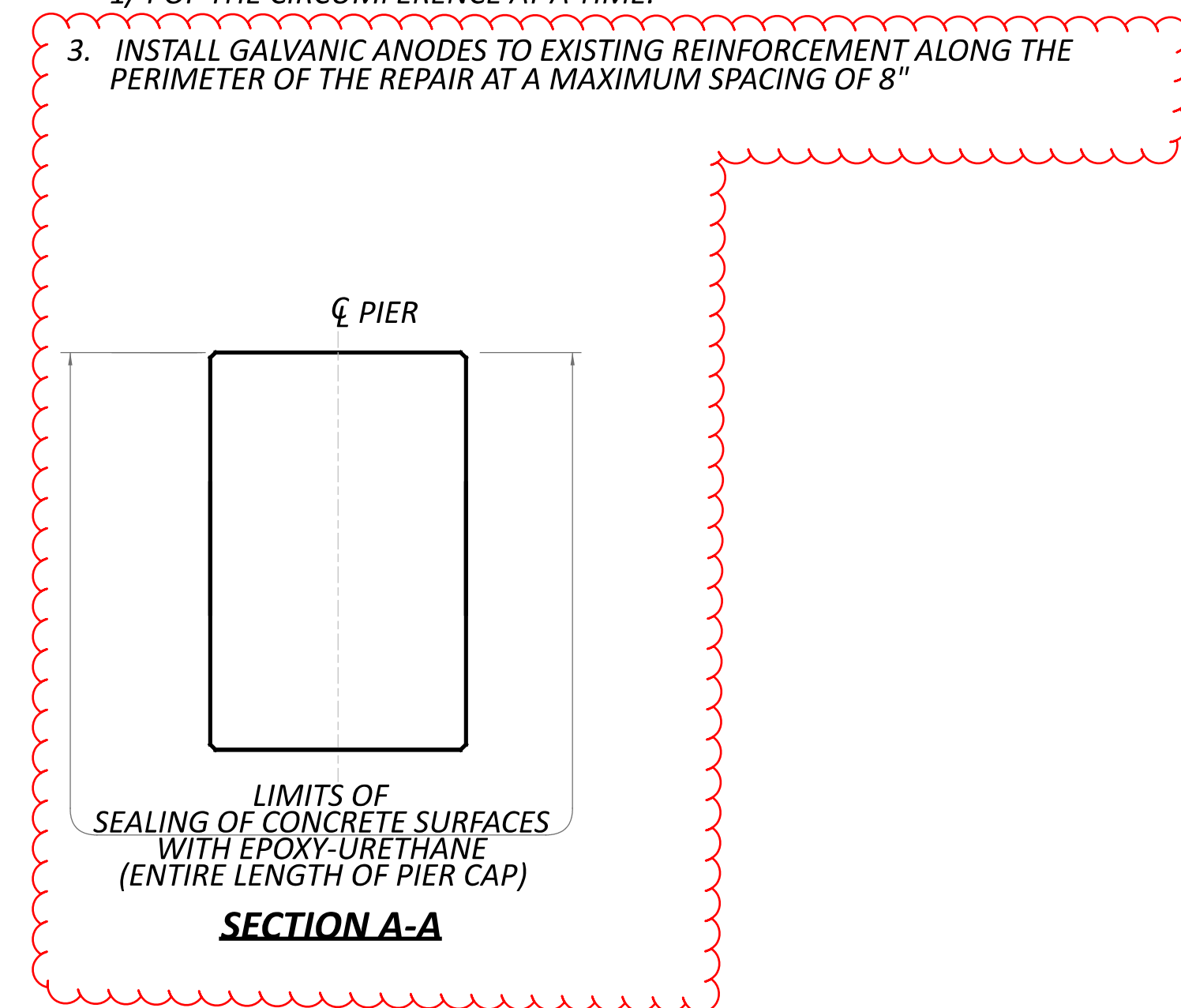

SFN 3111474	
DESIGN AGENCY	
DESIGNER	CHECKER
GTF	BCP
REVIEWER	
CAH 02/17/26	
PROJECT ID	
123648	
SUBSET	TOTAL
2	3
SHEET	TOTAL
35	45

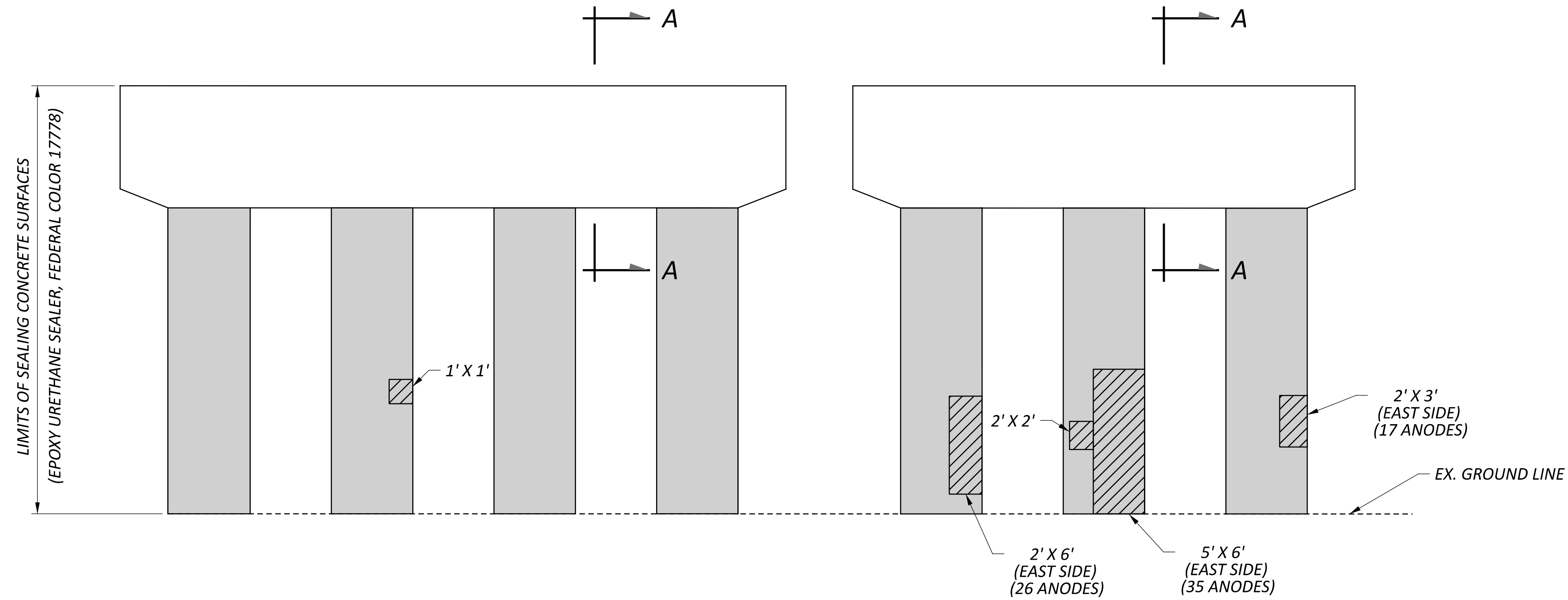

PIER 3 NORTH ELEVATION

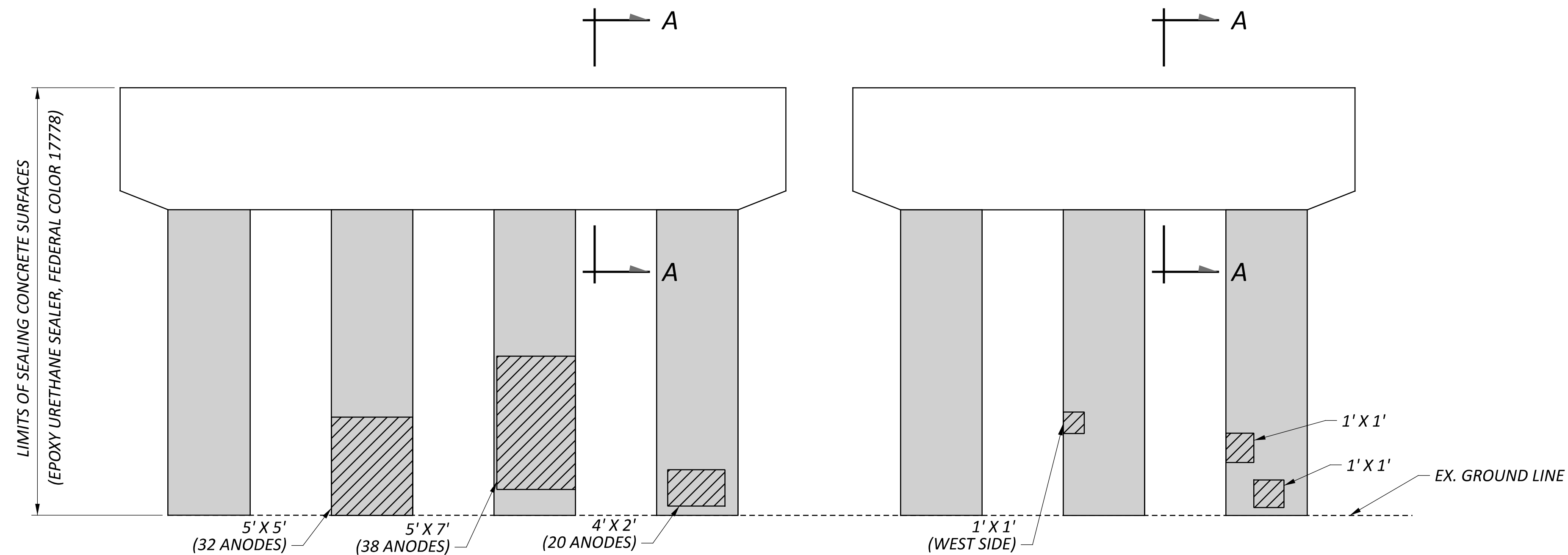

PIER 3 SOUTH ELEVATION

SUMMARY OF REPAIR AREAS			
PHYSICAL INVENTORY OF MEASURED QUANTITIES OF DETERIORATION WAS PERFORMED IN APRIL OF 2025.			
EXACT DIMENSIONS AND LOCATIONS OF REPAIRS SHALL BE DETERMINED BY THE ENGINEER IN THE FIELD FOR FINAL PAY QUANTITIES.			
TYPE	MEASURED QUANTITIES	ESTIMATING FACTOR*	ESTIMATED QUANTITIES
PIER 3 PATCHING	124 SQ. FT.	1.5	186 SQ. FT.
PIER 3 ANODES			168

* - ESTIMATED QUANTITIES HAVE BEEN INCREASED BY 50% OVER MEASURED QUANTITIES TO ALLOW FOR ADDITIONAL DETERIORATION.

LEGEND

- AREA TO BE REPAIRED WITH ITEM 519 - PATCHING CONCRETE STRUCTURE, AS PER PLAN
- LIMITS OF SINGLE LAYER OF FIBER WRAP PER ITEM 519 - SPECIAL COMPOSITE FIBER WRAP SYSTEM

NOTES

- SEE STRUCTURE GENERAL NOTES FOR FIBER REINFORCED POLYMER SPECIFICATIONS AND ADDITIONAL DETAILS.
- STAGE PATCH REPAIR WIDTHS TO LIMIT REPAIRS TO 1/4 OF THE CIRCUMFERENCE AT A TIME.
- INSTALL GALVANIC ANODES TO EXISTING REINFORCEMENT ALONG THE PERIMETER OF THE REPAIR AT A MAXIMUM SPACING OF 8"

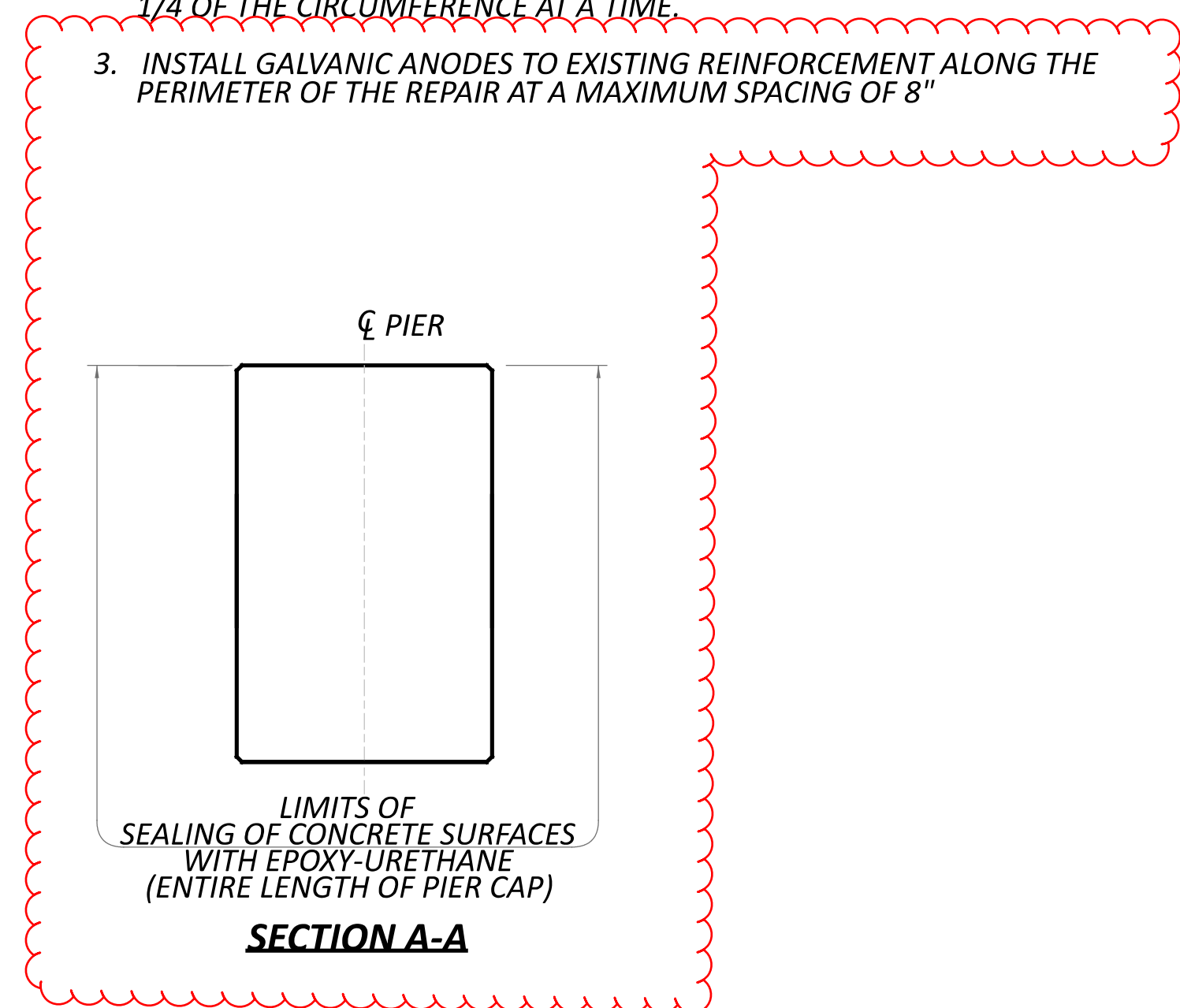

SFN	3111474
DESIGN AGENCY	
DESIGNER	CHECKER
GTF	BCP
REVIEWER	CAH 02/17/26
PROJECT ID	123648
SUBSET	TOTAL
3	3
SHEET	TOTAL
36	45

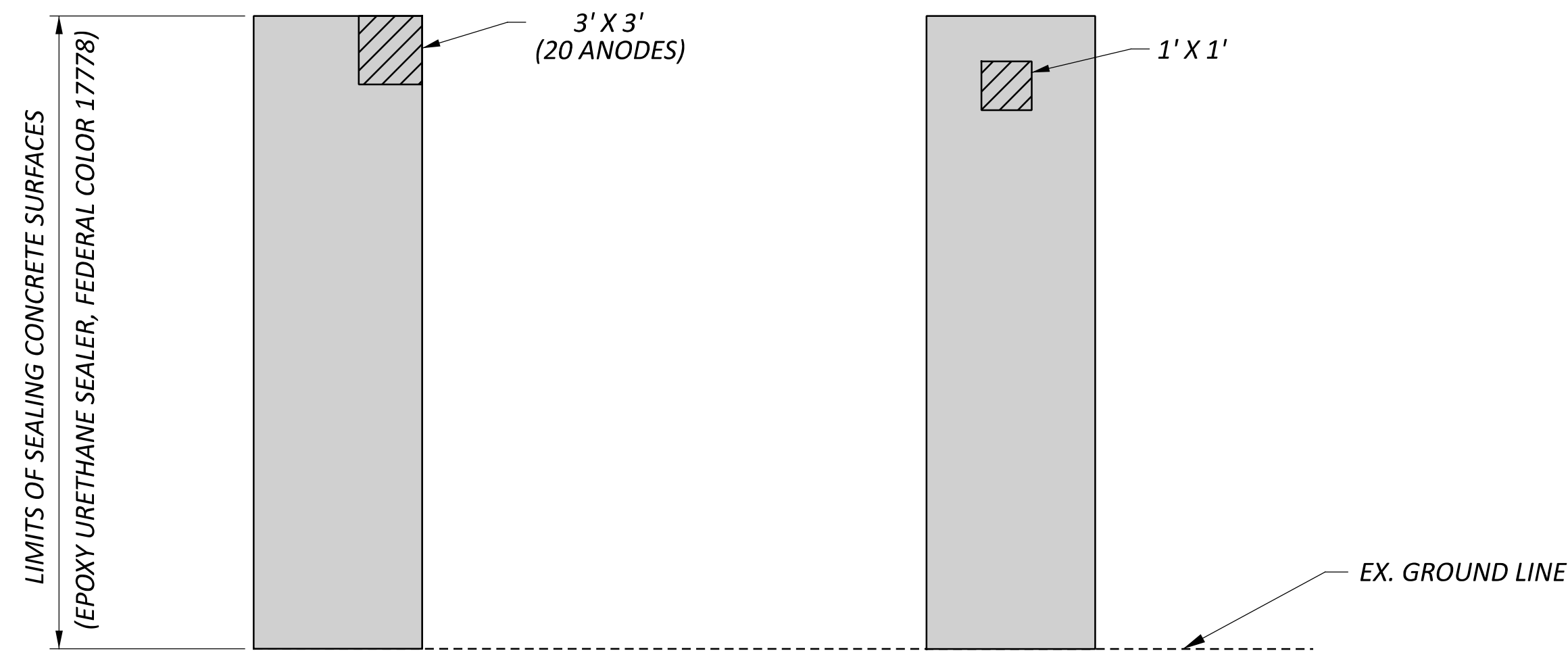

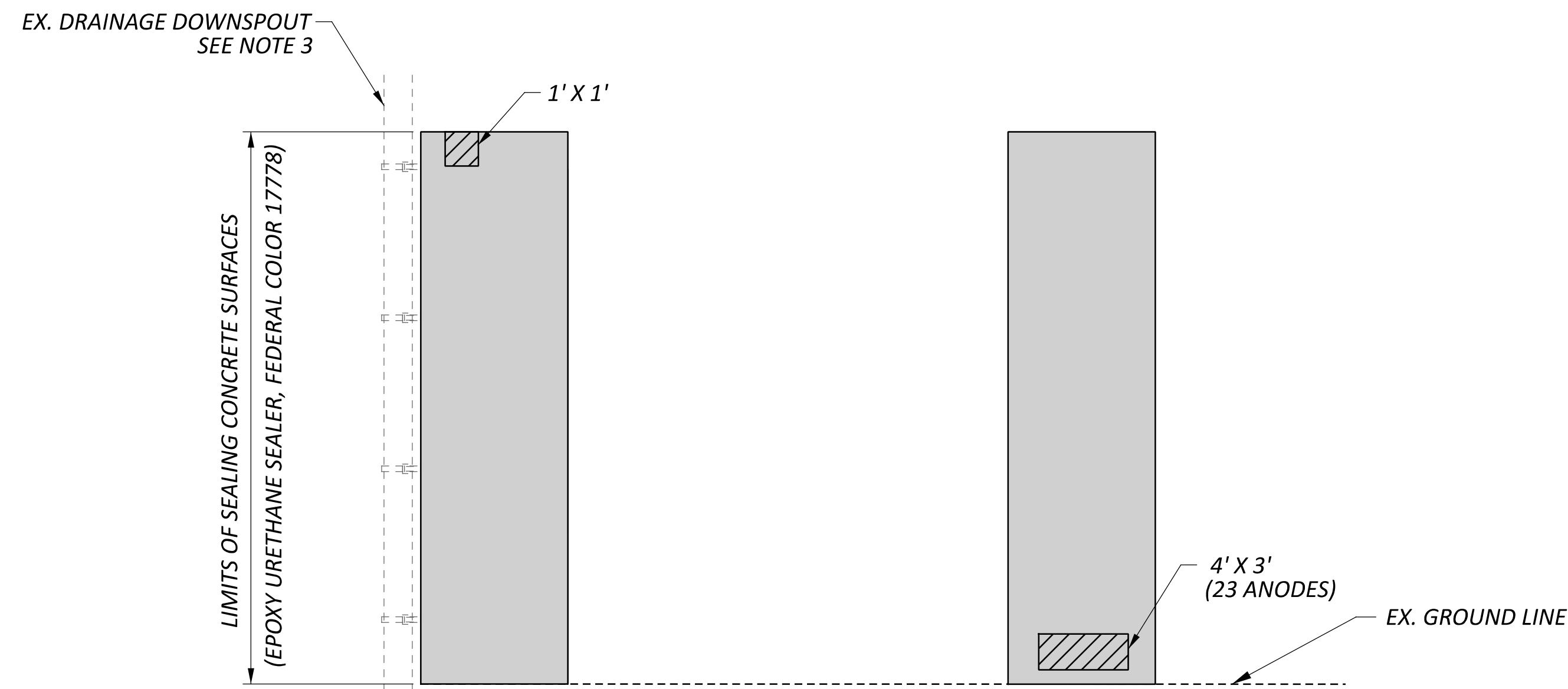

PIER 2 EAST ELEVATION

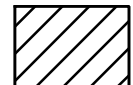

PIER 2 SOUTH ELEVATION

SUMMARY OF REPAIR AREAS			
PHYSICAL INVENTORY OF MEASURED QUANTITIES OF DETERIORATION WAS PERFORMED IN APRIL OF 2025.			
EXACT DIMENSIONS AND LOCATIONS OF REPAIRS SHALL BE DETERMINED BY THE ENGINEER IN THE FIELD FOR FINAL PAY QUANTITIES.			
TYPE	MEASURED QUANTITIES	ESTIMATING FACTOR*	ESTIMATED QUANTITIES
PIER 2 PATCHING 	23 SQ. FT.	1.5	35 SQ. FT.
PIER 2 ANODES			43
* - ESTIMATED QUANTITIES HAVE BEEN INCREASED BY 50% OVER MEASURED QUANTITIES TO ALLOW FOR ADDITIONAL DETERIORATION.			

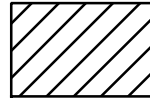
LEGEND

-  - AREA TO BE REPAIRED WITH ITEM 519 - PATCHING CONCRETE STRUCTURE, AS PER PLAN
-  - LIMITS OF SINGLE LAYER OF FIBER WRAP PER ITEM 519 - SPECIAL COMPOSITE FIBER WRAP SYSTEM

NOTES

- SEE STRUCTURE GENERAL NOTES FOR FIBER REINFORCED POLYMER SPECIFICATIONS AND ADDITIONAL DETAILS.
- STAGE PATCH REPAIR WIDTHS TO LIMIT REPAIRS TO 1/4 OF THE CIRCUMFERENCE AT A TIME.
- TEMPORARILY DISMANTLE EXISTING SCUPPER DOWNSPOUTS AND RE-INSTALL USING NEW SUPPORTS DRILLED THROUGH THE FIBER REINFORCED POLYMER (FRP) SYSTEM. PROTECT THE FRP SYSTEM FROM DAMAGE DURING DRILLING AND INSTALLATION. ANY DAMAGE TO THE FRP SHALL BE REPAIRED AT THE CONTRACTOR'S EXPENSE TO THE SATISFACTION OF THE ENGINEER.

ALL HARDWARE AND FASTENERS FOR THE SCUPPER SUPPORTS SHALL CONFORM TO THE REQUIREMENTS OF CMS 514 - SCUPPERS AND DOWNSPOUTS. PERFORM ALL WORK IN ACCORDANCE WITH THE REQUIREMENTS OF CMS 519.04 - CONSTRUCTION REQUIREMENTS AND THE PROJECT PLANS. INCLUDE ALL LABOR, MATERIALS, TOOLS, EQUIPMENT, AND INCIDENTALS NECESSARY TO COMPLETE THIS WORK AS PART OF THE PAYMENT FOR ITEM 519 - SPECIAL COMPOSITE FIBER WRAP SYSTEM.



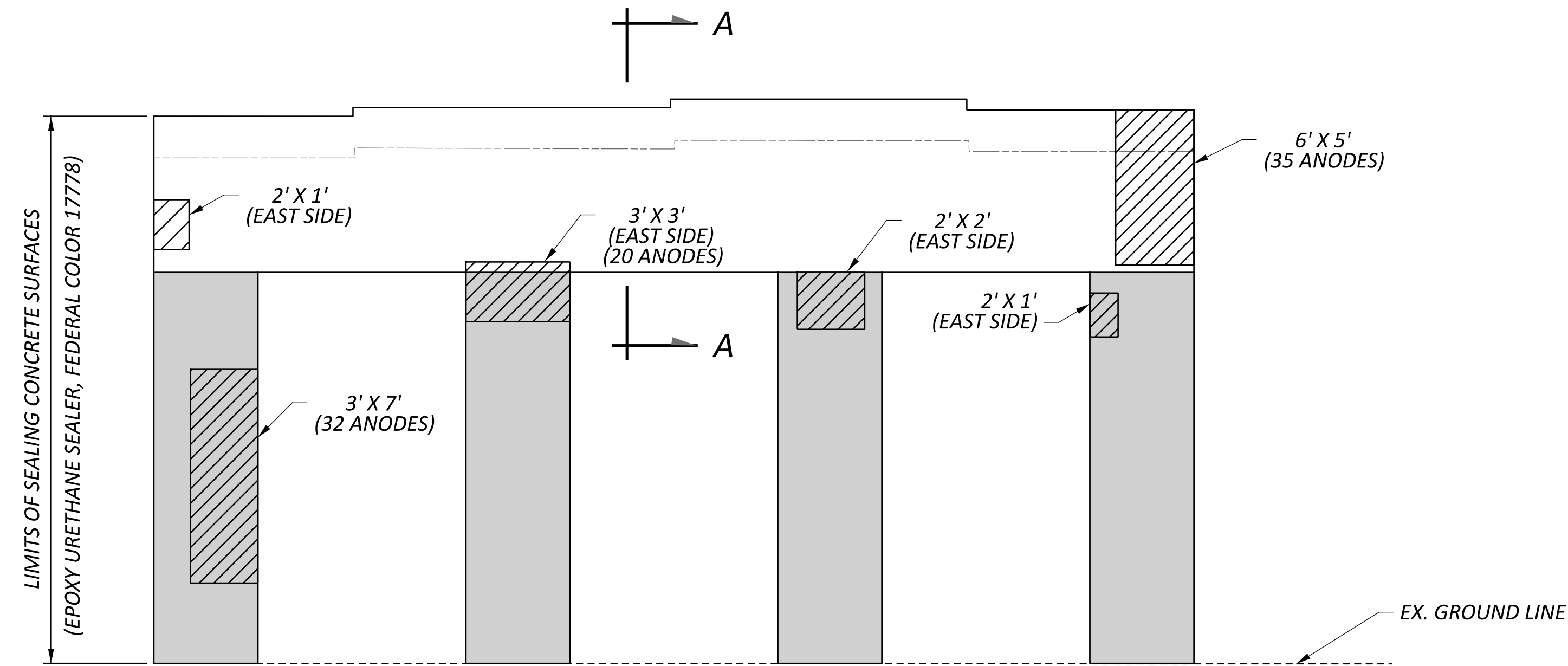

PIER 1 NORTH ELEVATION

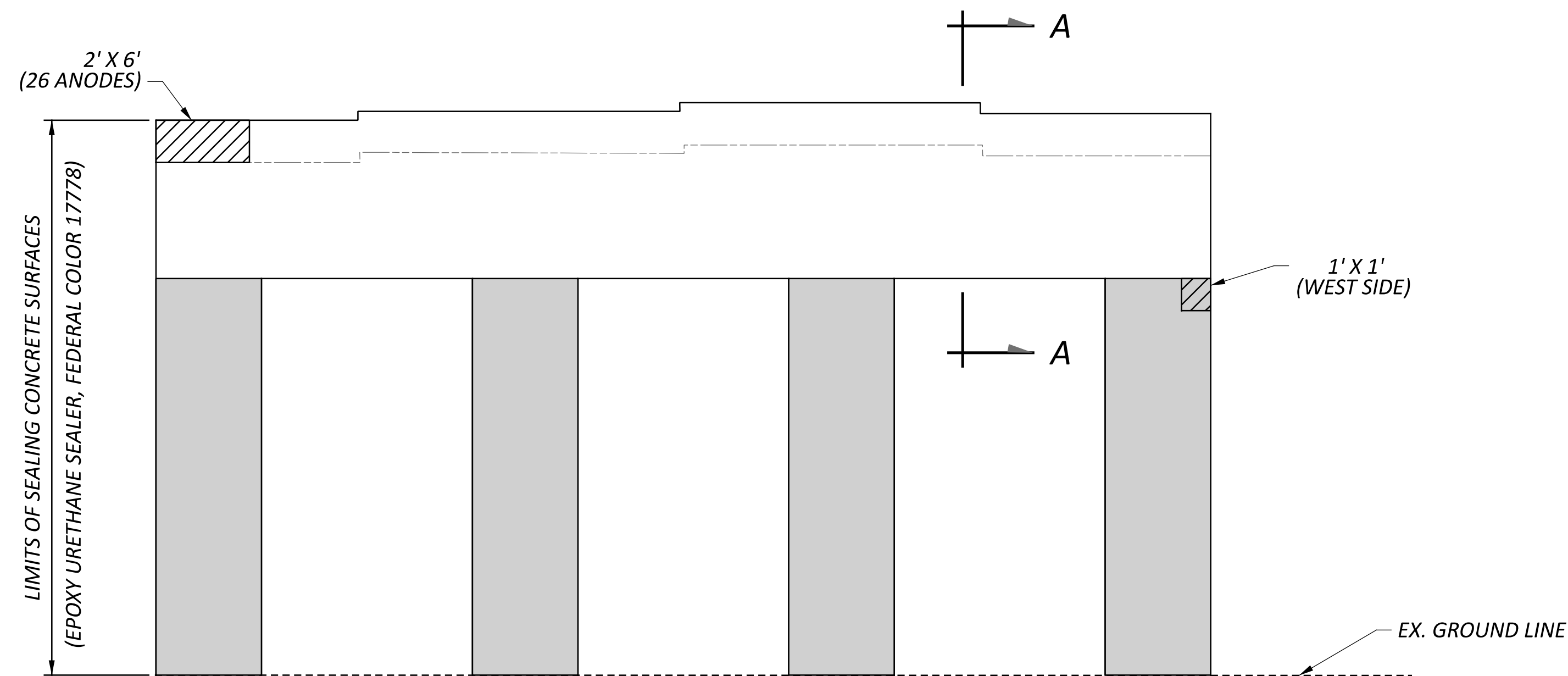

PIER 1 SOUTH ELEVATION

SUMMARY OF REPAIR AREAS			
PHYSICAL INVENTORY OF MEASURED QUANTITIES OF DETERIORATION WAS PERFORMED IN APRIL OF 2025.			
EXACT DIMENSIONS AND LOCATIONS OF REPAIRS SHALL BE DETERMINED BY THE ENGINEER IN THE FIELD FOR FINAL PAY QUANTITIES.			
TYPE	MEASURED QUANTITIES	ESTIMATING FACTOR*	ESTIMATED QUANTITIES
PIER 1 PATCHING	81 SQ. FT.	1.5	122 SQ. FT.
PIER 1 ANODES			113
* - ESTIMATED QUANTITIES HAVE BEEN INCREASED BY 50% OVER MEASURED QUANTITIES TO ALLOW FOR ADDITIONAL DETERIORATION.			

LEGEND

- AREA TO BE REPAIRED WITH ITEM 519 - PATCHING CONCRETE STRUCTURE, AS PER PLAN
- LIMITS OF SINGLE LAYER OF FIBER WRAP PER ITEM 519 - SPECIAL COMPOSITE FIBER WRAP SYSTEM

NOTES

- SEE STRUCTURE GENERAL NOTES FOR FIBER REINFORCED POLYMER SPECIFICATIONS AND ADDITIONAL DETAILS.
- STAGE PATCH REPAIR WIDTHS TO LIMIT REPAIRS TO 1/4 OF THE CIRCUMFERENCE AT A TIME.
- STAGE PIER CAP ENDS TO 1/4 PIER END CAP DIAMETER TO ENSURE THE FASCIA BEARINGS HAVE ADEQUATE BEARING AND REINFORCING DEVELOPMENT.
- INSTALL GALVANIC ANODES TO EXISTING REINFORCEMENT ALONG THE PERIMETER OF THE REPAIR AT A MAXIMUM SPACING OF 8"

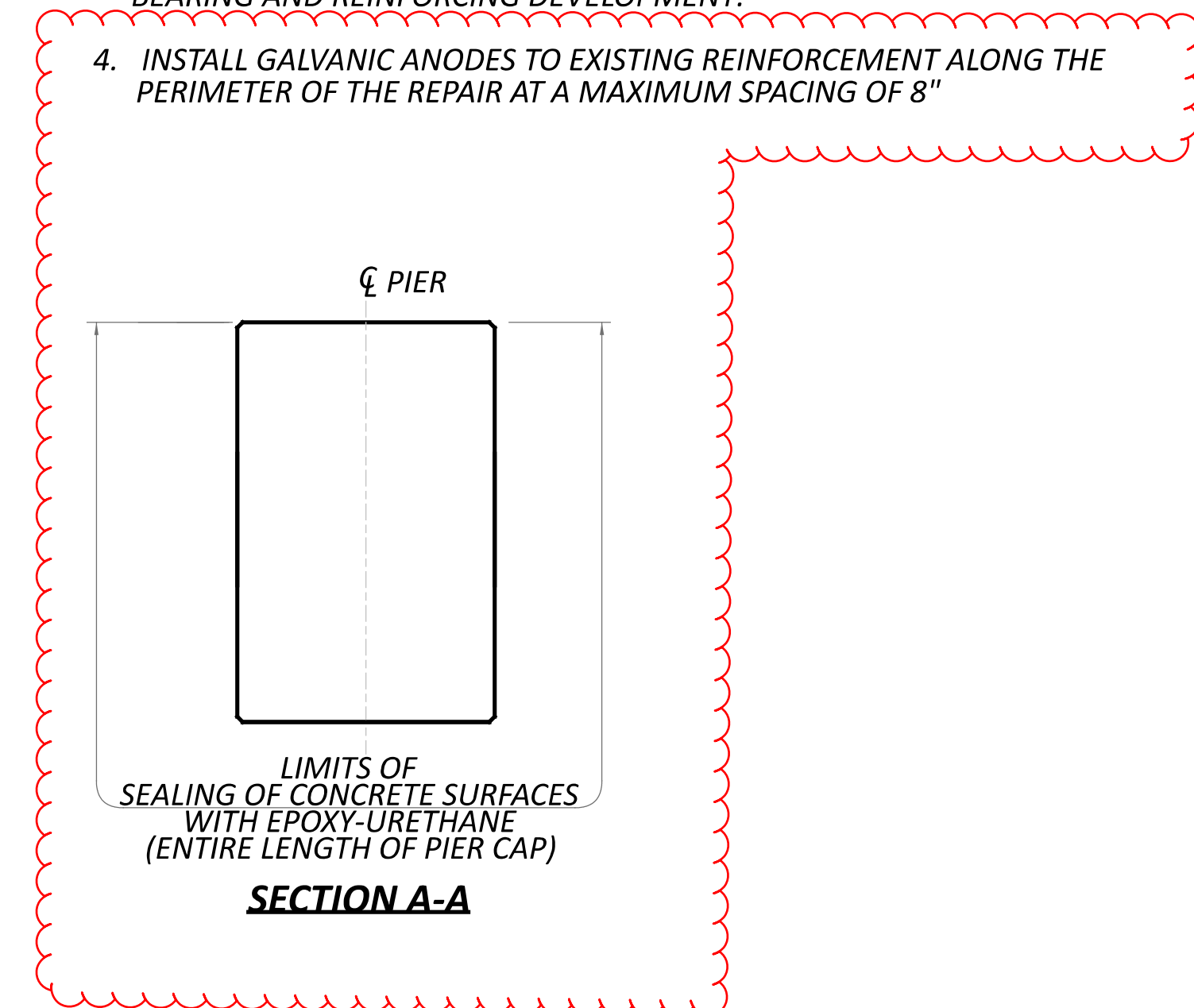

SFN	8303541
DESIGN AGENCY	
DESIGNER	CHECKER
GTF	BCP
REVIEWER	
CAH	02/17/26
PROJECT ID	123648
SUBSET	TOTAL
1	3
SHEET	TOTAL
39	45

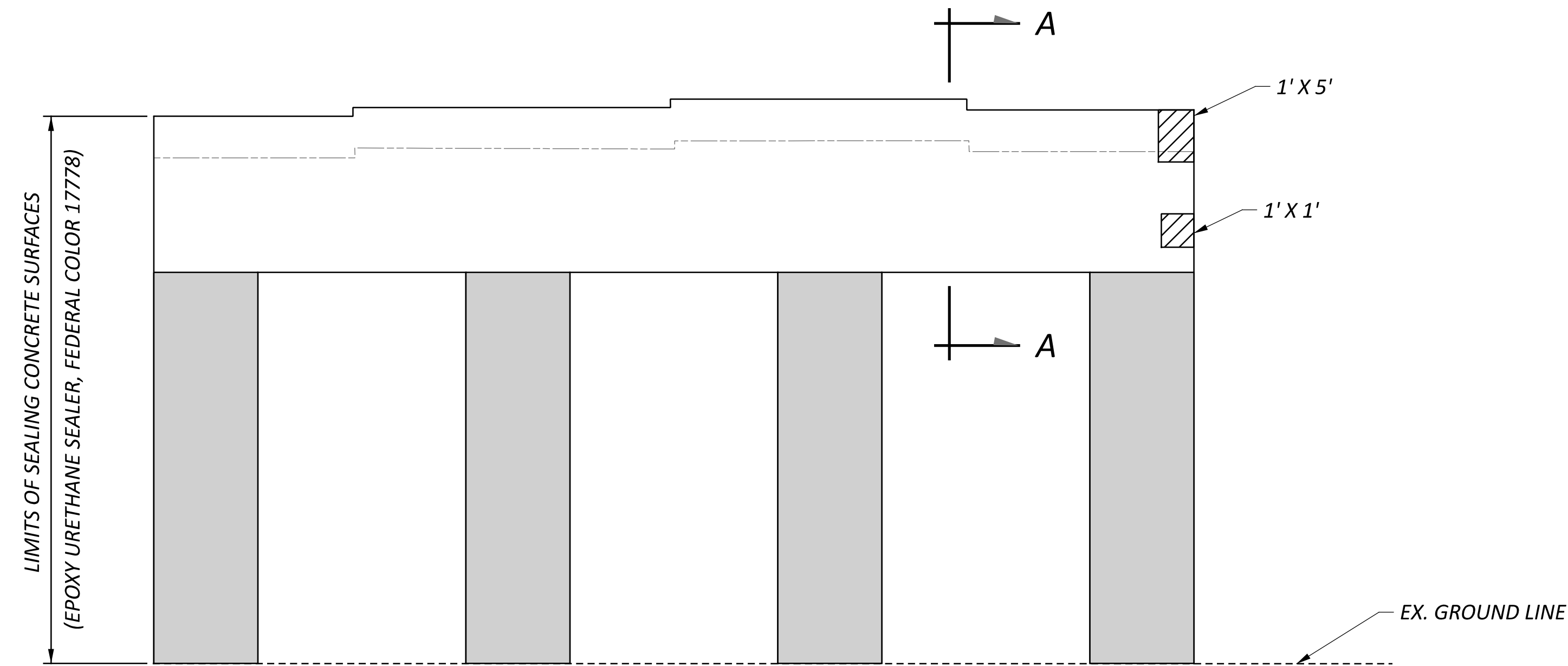

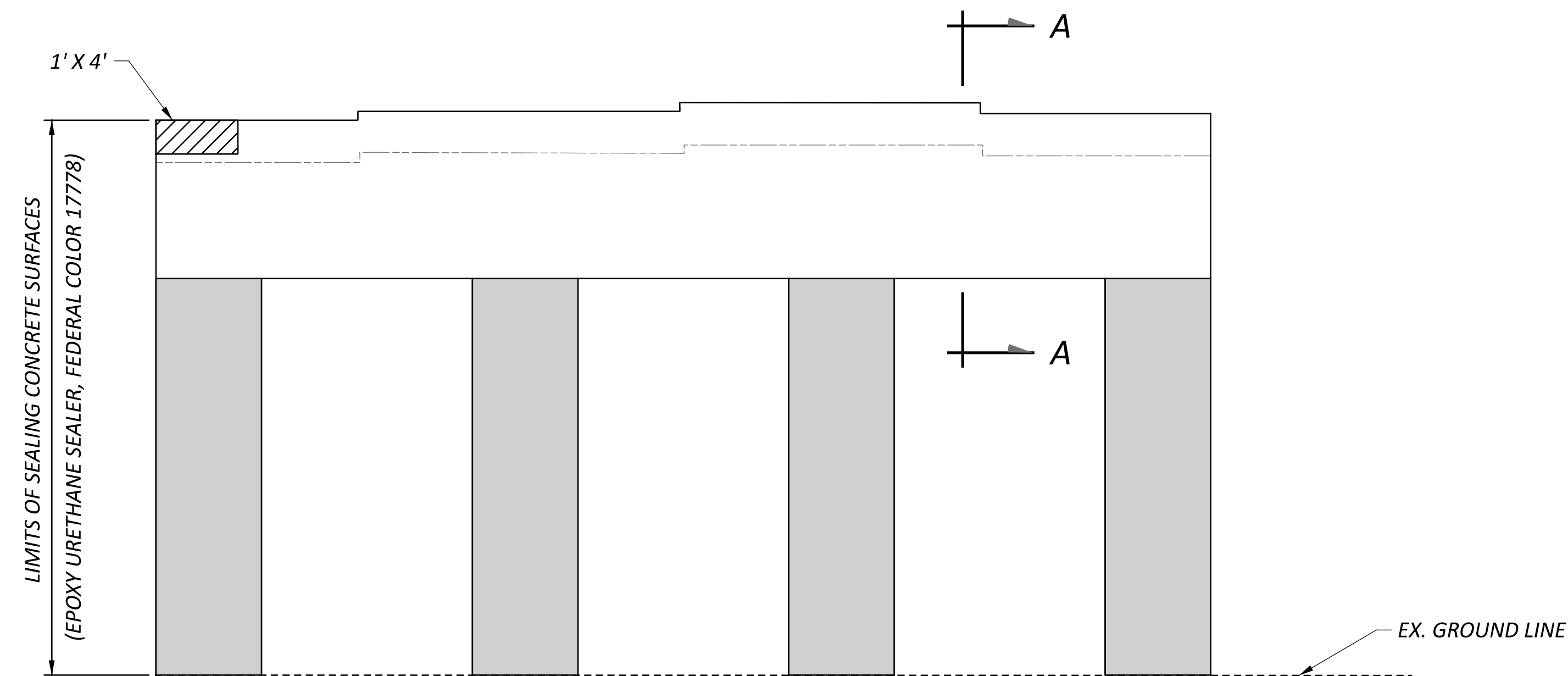

PIER 2 NORTH ELEVATION

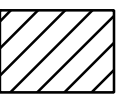

PIER 2 SOUTH ELEVATION

SUMMARY OF REPAIR AREAS			
PHYSICAL INVENTORY OF MEASURED QUANTITIES OF DETERIORATION WAS PERFORMED IN APRIL OF 2025.			
EXACT DIMENSIONS AND LOCATIONS OF REPAIRS SHALL BE DETERMINED BY THE ENGINEER IN THE FIELD FOR FINAL PAY QUANTITIES.			
TYPE	MEASURED QUANTITIES	ESTIMATING FACTOR*	ESTIMATED QUANTITIES
PIER 2 PATCHING 	10 SQ. FT.	1.5	15 SQ. FT.
* - ESTIMATED QUANTITIES HAVE BEEN INCREASED BY 50% OVER MEASURED QUANTITIES TO ALLOW FOR ADDITIONAL DETERIORATION.			

LEGEND

-  -AREA TO BE REPAIRED WITH ITEM 519 - PATCHING CONCRETE STRUCTURE, AS PER PLAN
-  -LIMITS OF SINGLE LAYER OF FIBER WRAP PER ITEM 519 - SPECIAL COMPOSITE FIBER WRAP SYSTEM

NOTES

1. SEE STRUCTURE GENERAL NOTES FOR FIBER REINFORCED POLYMER SPECIFICATIONS AND ADDITIONAL DETAILS.
2. STAGE PATCH REPAIR WIDTHS TO LIMIT REPAIRS TO 1/4 OF THE CIRCUMFERENCE AT A TIME.
3. STAGE PIER CAP ENDS TO 1/4 PIER END CAP DIAMETER TO ENSURE THE FASCIA BEARINGS HAVE ADEQUATE BEARING AND REINFORCING DEVELOPMENT.

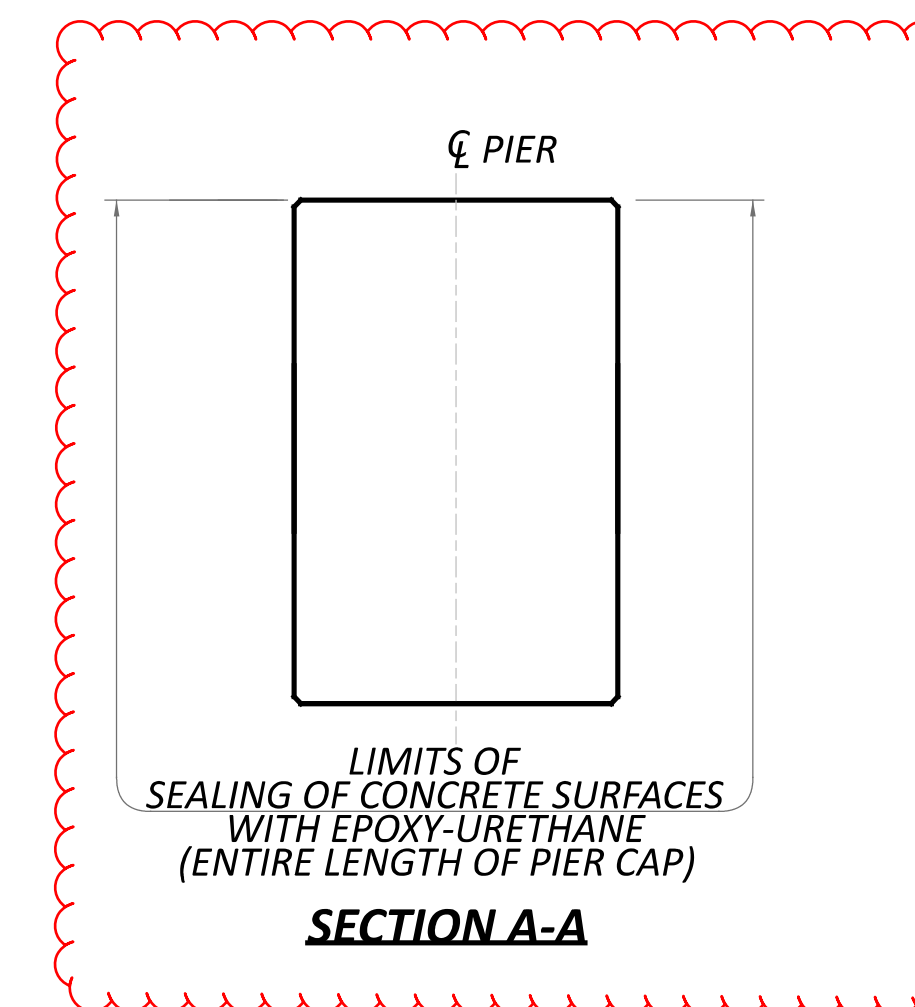

SFN 8303541	
DESIGN AGENCY	
	
DESIGNER	CHECKER
GTF	BCP
REVIEWER	
CAH 02/17/26	
PROJECT ID	
123648	
SUBSET	TOTAL
2	3
SHEET	TOTAL
40	45

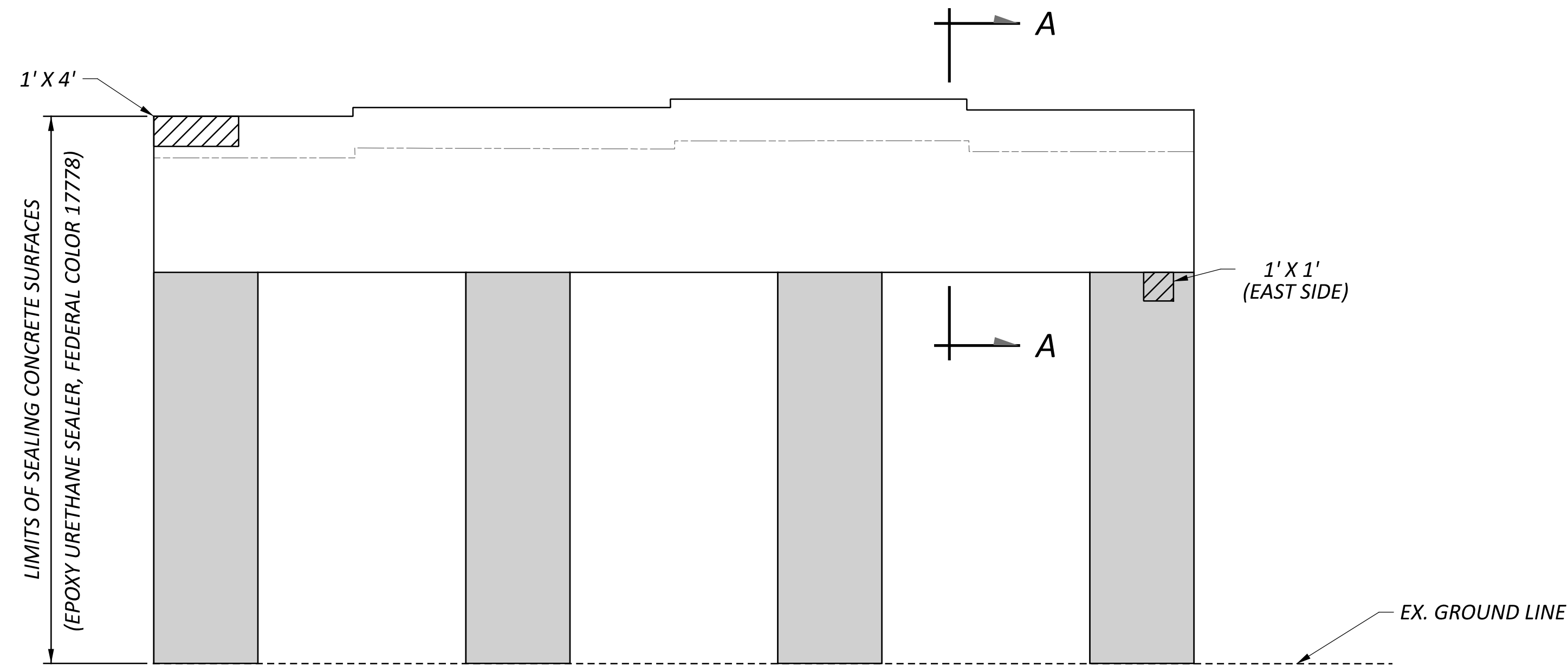

PIER 3 NORTH ELEVATION

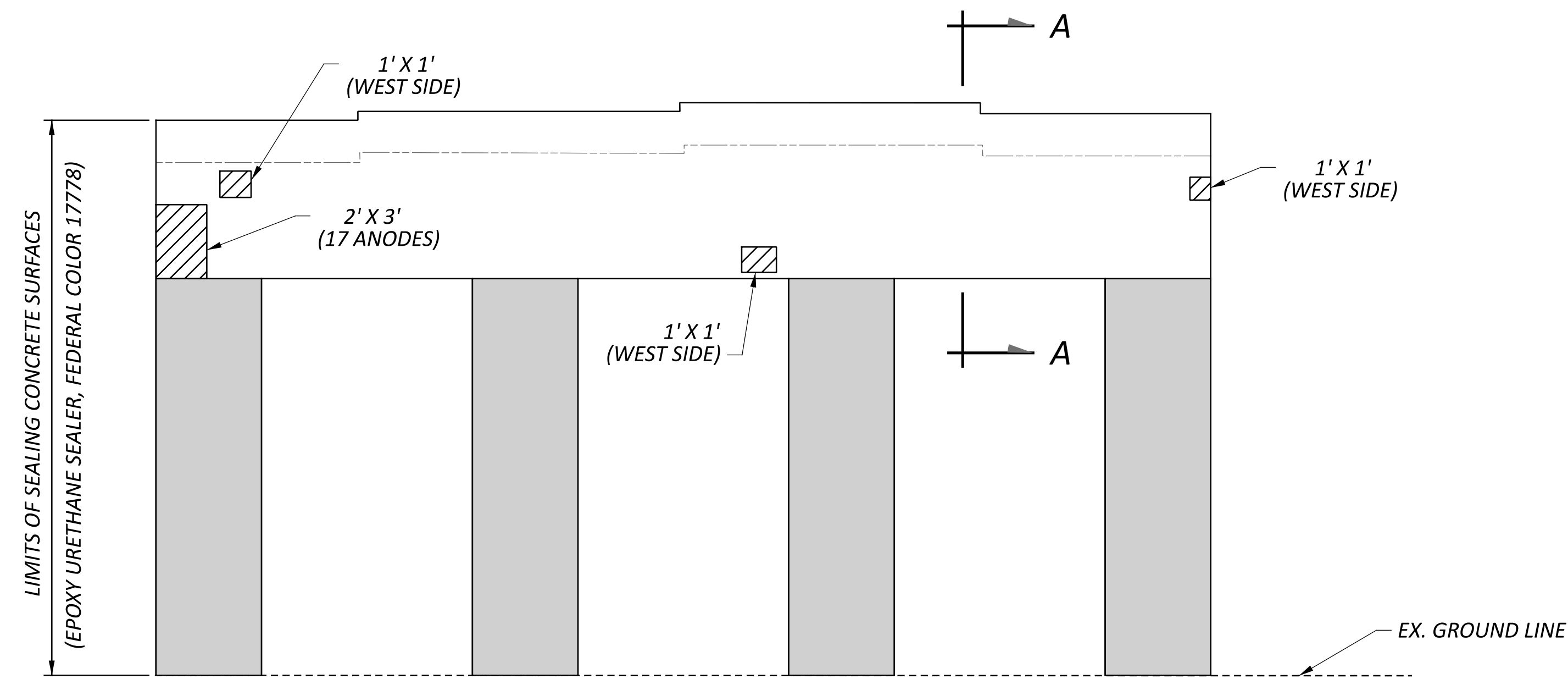

PIER 3 SOUTH ELEVATION

SUMMARY OF REPAIR AREAS			
PHYSICAL INVENTORY OF MEASURED QUANTITIES OF DETERIORATION WAS PERFORMED IN APRIL OF 2025.			
EXACT DIMENSIONS AND LOCATIONS OF REPAIRS SHALL BE DETERMINED BY THE ENGINEER IN THE FIELD FOR FINAL PAY QUANTITIES.			
TYPE	MEASURED QUANTITIES	ESTIMATING FACTOR*	ESTIMATED QUANTITIES
PIER 3 PATCHING	14 SQ. FT.	1.5	21 SQ. FT.
PIER 3 ANODES			17
* - ESTIMATED QUANTITIES HAVE BEEN INCREASED BY 50% OVER MEASURED QUANTITIES TO ALLOW FOR ADDITIONAL DETERIORATION.			

LEGEND

- AREA TO BE REPAIRED WITH ITEM 519 - PATCHING CONCRETE STRUCTURE, AS PER PLAN
- LIMITS OF SINGLE LAYER OF FIBER WRAP PER ITEM 519 - SPECIAL COMPOSITE FIBER WRAP SYSTEM

NOTES

- SEE STRUCTURE GENERAL NOTES FOR FIBER REINFORCED POLYMER SPECIFICATIONS AND ADDITIONAL DETAILS.
- STAGE PATCH REPAIR WIDTHS TO LIMIT REPAIRS TO 1/4 OF THE CIRCUMFERENCE AT A TIME.
- STAGE PIER CAP ENDS TO 1/4 PIER END CAP DIAMETER END TO ENSURE THE FASCIA BEARINGS HAVE ADEQUATE BEARING AND REINFORCING DEVELOPMENT.
- INSTALL GALVANIC ANODES TO EXISTING REINFORCEMENT ALONG THE PERIMETER OF THE REPAIR AT A MAXIMUM SPACING OF 8"

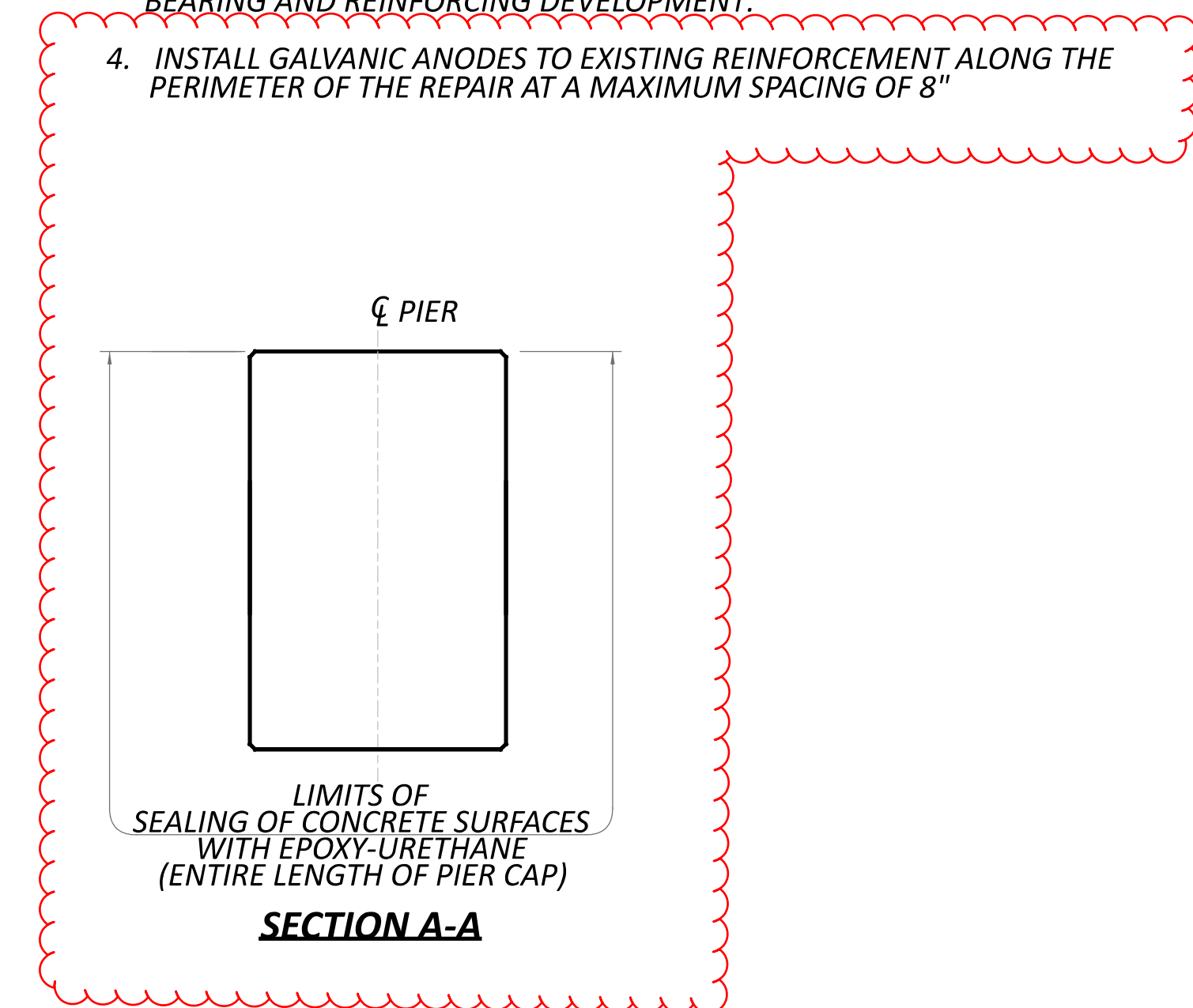

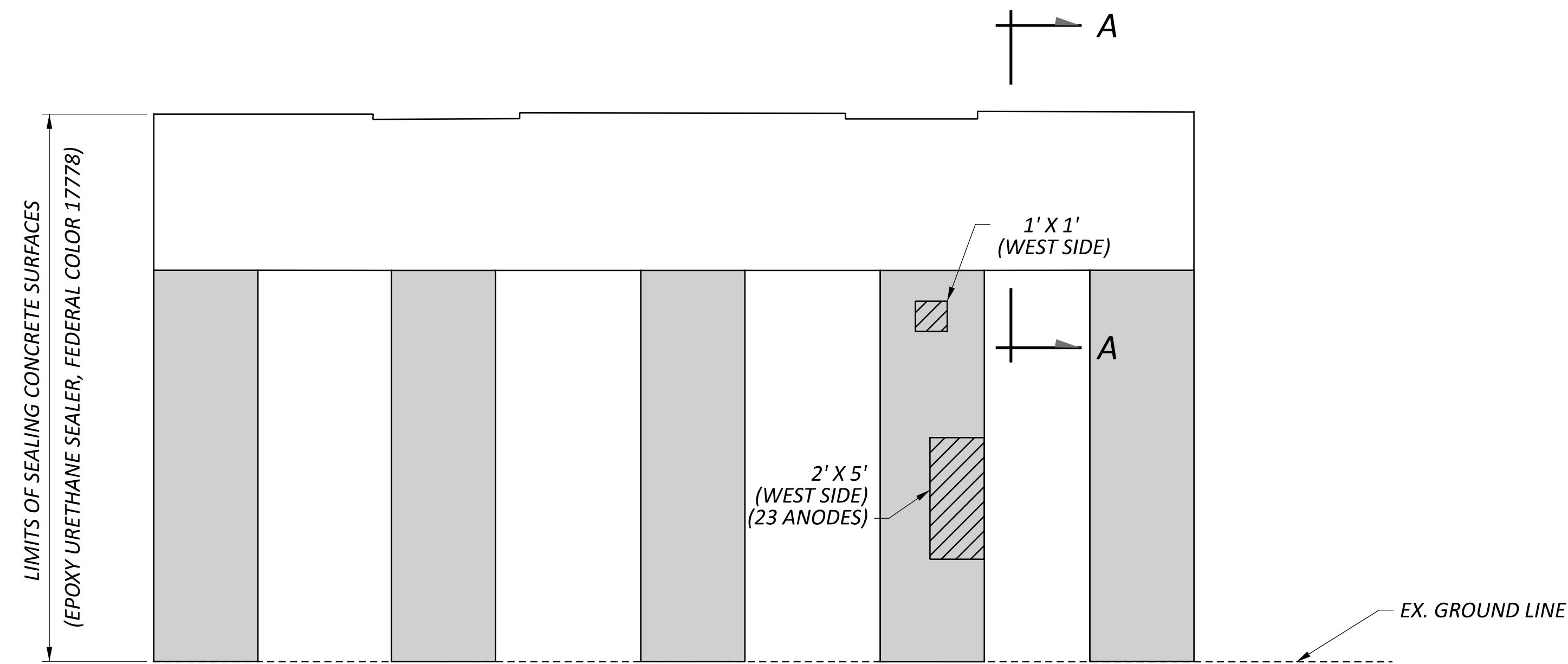

PIER 3 NORTH ELEVATION

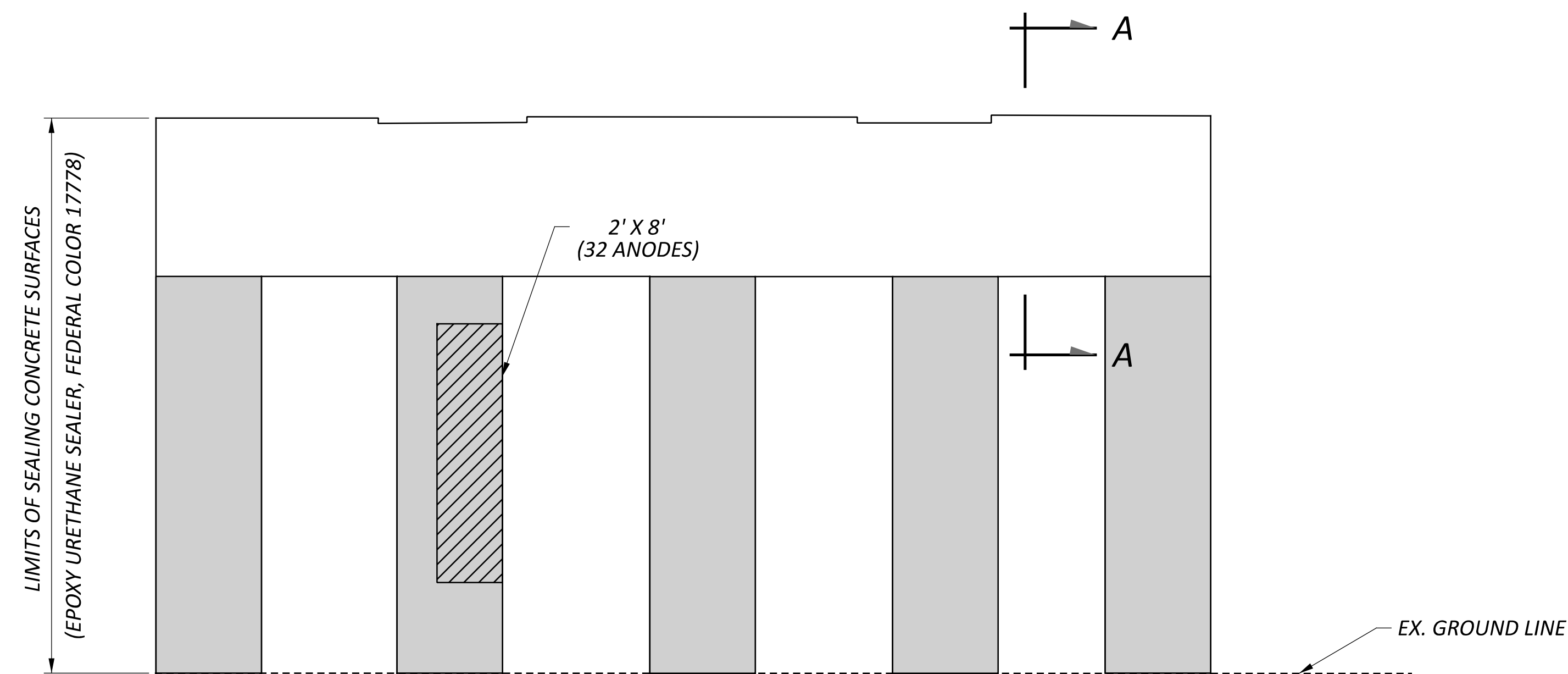

PIER 3 SOUTH ELEVATION

SUMMARY OF REPAIR AREAS			
PHYSICAL INVENTORY OF MEASURED QUANTITIES OF DETERIORATION WAS PERFORMED IN APRIL OF 2025.			
EXACT DIMENSIONS AND LOCATIONS OF REPAIRS SHALL BE DETERMINED BY THE ENGINEER IN THE FIELD FOR FINAL PAY QUANTITIES.			
TYPE	MEASURED QUANTITIES	ESTIMATING FACTOR*	ESTIMATED QUANTITIES
PIER 3 PATCHING	27 SQ. FT.	1.5	41 SQ. FT.
PIER 3 ANODES			55

* - ESTIMATED QUANTITIES HAVE BEEN INCREASED BY 50% OVER MEASURED QUANTITIES TO ALLOW FOR ADDITIONAL DETERIORATION.

LEGEND

- AREA TO BE REPAIRED WITH ITEM 519 - PATCHING CONCRETE STRUCTURE, AS PER PLAN
- LIMITS OF SINGLE LAYER OF FIBER WRAP PER ITEM 519 - SPECIAL COMPOSITE FIBER WRAP SYSTEM

NOTES

- SEE STRUCTURE GENERAL NOTES FOR FIBER REINFORCED POLYMER SPECIFICATIONS AND ADDITIONAL DETAILS.
- STAGE PATCH REPAIR WIDTHS TO LIMIT REPAIRS TO 1/4 OF THE CIRCUMFERENCE AT A TIME.
- INSTALL GALVANIC ANODES TO EXISTING REINFORCEMENT ALONG THE PERIMETER OF THE REPAIR AT A MAXIMUM SPACING OF 8"

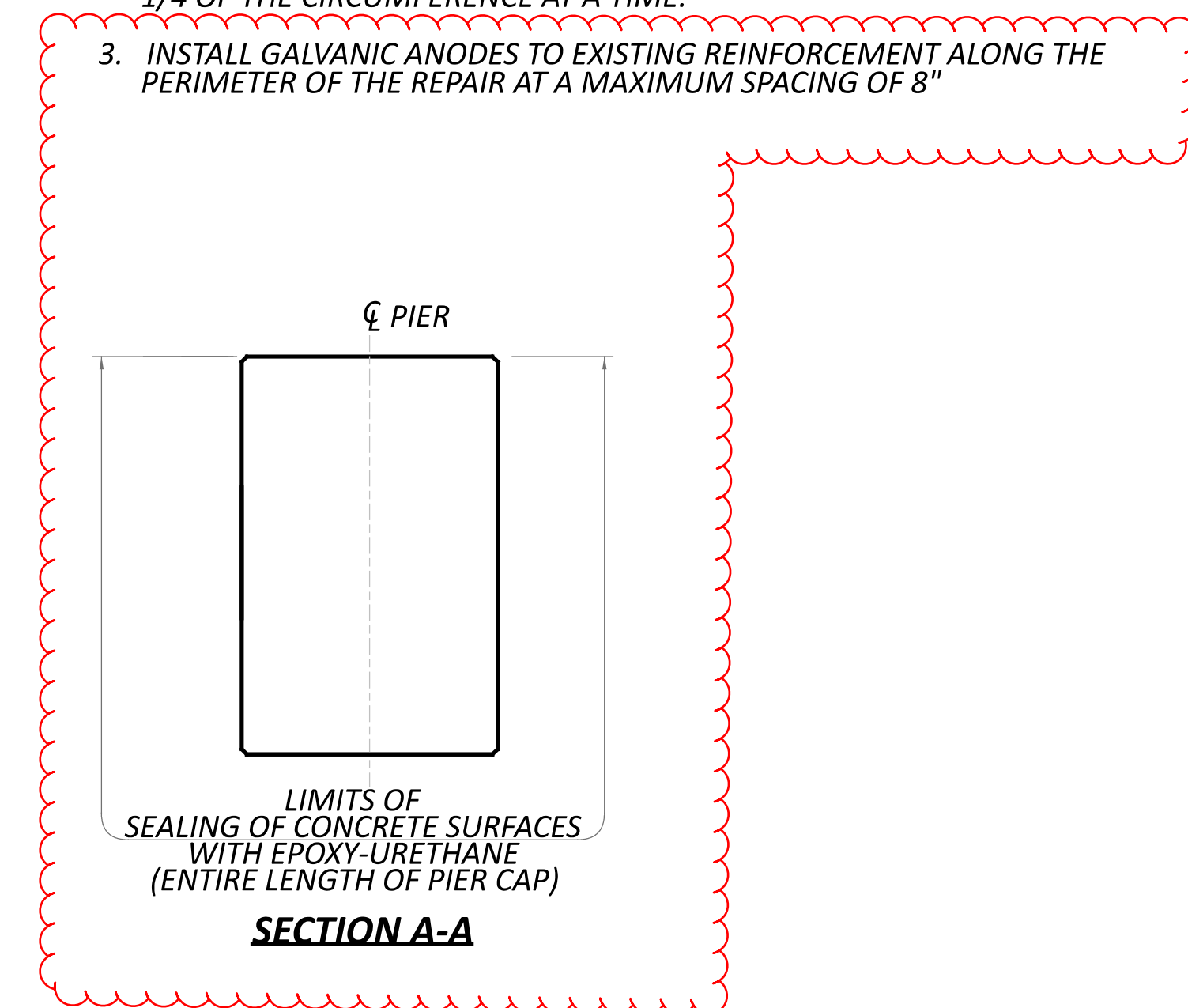

SFN	8303789
DESIGN AGENCY	
DESIGNER	CHECKER
GTF	BCP
REVIEWER	
CAH	02/17/26
PROJECT ID	123648
SUBSET	TOTAL
3	3
SHEET	TOTAL
42	45

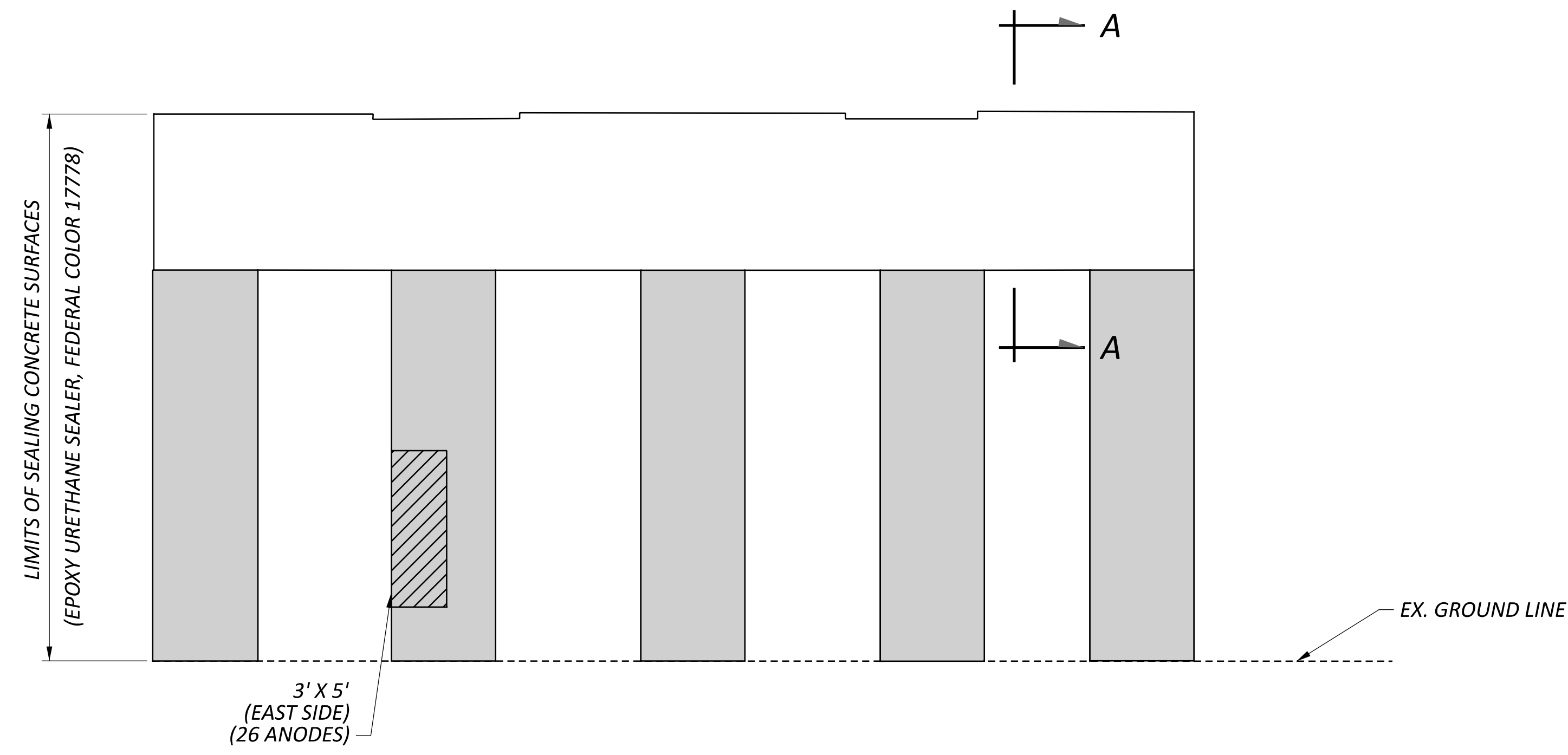

PIER 1 NORTH ELEVATION

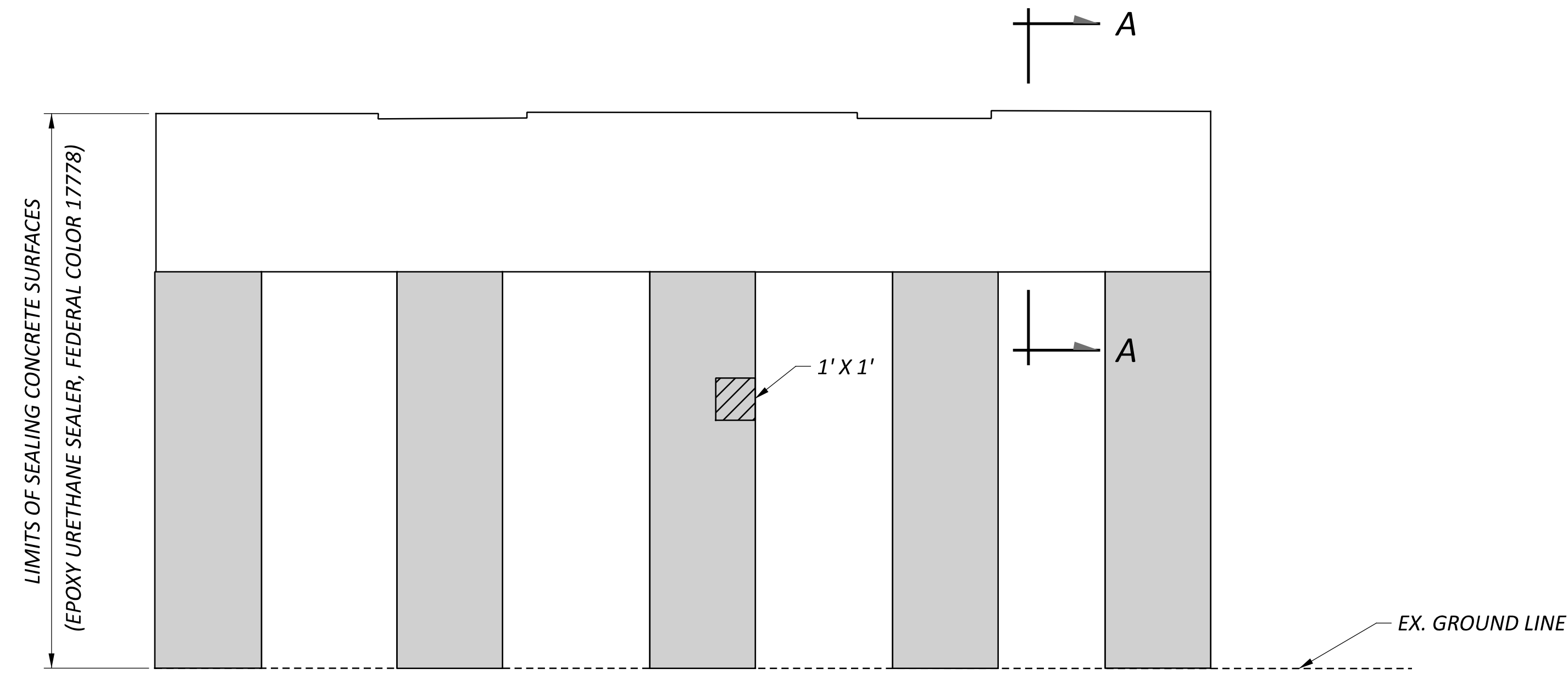

PIER 1 SOUTH ELEVATION

SUMMARY OF REPAIR AREAS			
PHYSICAL INVENTORY OF MEASURED QUANTITIES OF DETERIORATION WAS PERFORMED IN APRIL OF 2025.			
EXACT DIMENSIONS AND LOCATIONS OF REPAIRS SHALL BE DETERMINED BY THE ENGINEER IN THE FIELD FOR FINAL PAY QUANTITIES.			
TYPE	MEASURED QUANTITIES	ESTIMATING FACTOR*	ESTIMATED QUANTITIES
PIER 1 PATCHING	16 SQ. FT.	1.5	24 SQ. FT.
PIER 1 ANODES			26
* - ESTIMATED QUANTITIES HAVE BEEN INCREASED BY 50% OVER MEASURED QUANTITIES TO ALLOW FOR ADDITIONAL DETERIORATION.			

LEGEND

- AREA TO BE REPAIRED WITH ITEM 519 - PATCHING CONCRETE STRUCTURE, AS PER PLAN
- LIMITS OF SINGLE LAYER OF FIBER WRAP PER ITEM 519 - SPECIAL COMPOSITE FIBER WRAP SYSTEM

NOTES

- SEE STRUCTURE GENERAL NOTES FOR FIBER REINFORCED POLYMER SPECIFICATIONS AND ADDITIONAL DETAILS.
- STAGE PATCH REPAIR WIDTHS TO LIMIT REPAIRS TO 1/4 OF THE CIRCUMFERENCE AT A TIME
- INSTALL GALVANIC ANODES TO EXISTING REINFORCEMENT ALONG THE PERIMETER OF THE REPAIR AT A MAXIMUM SPACING OF 8"

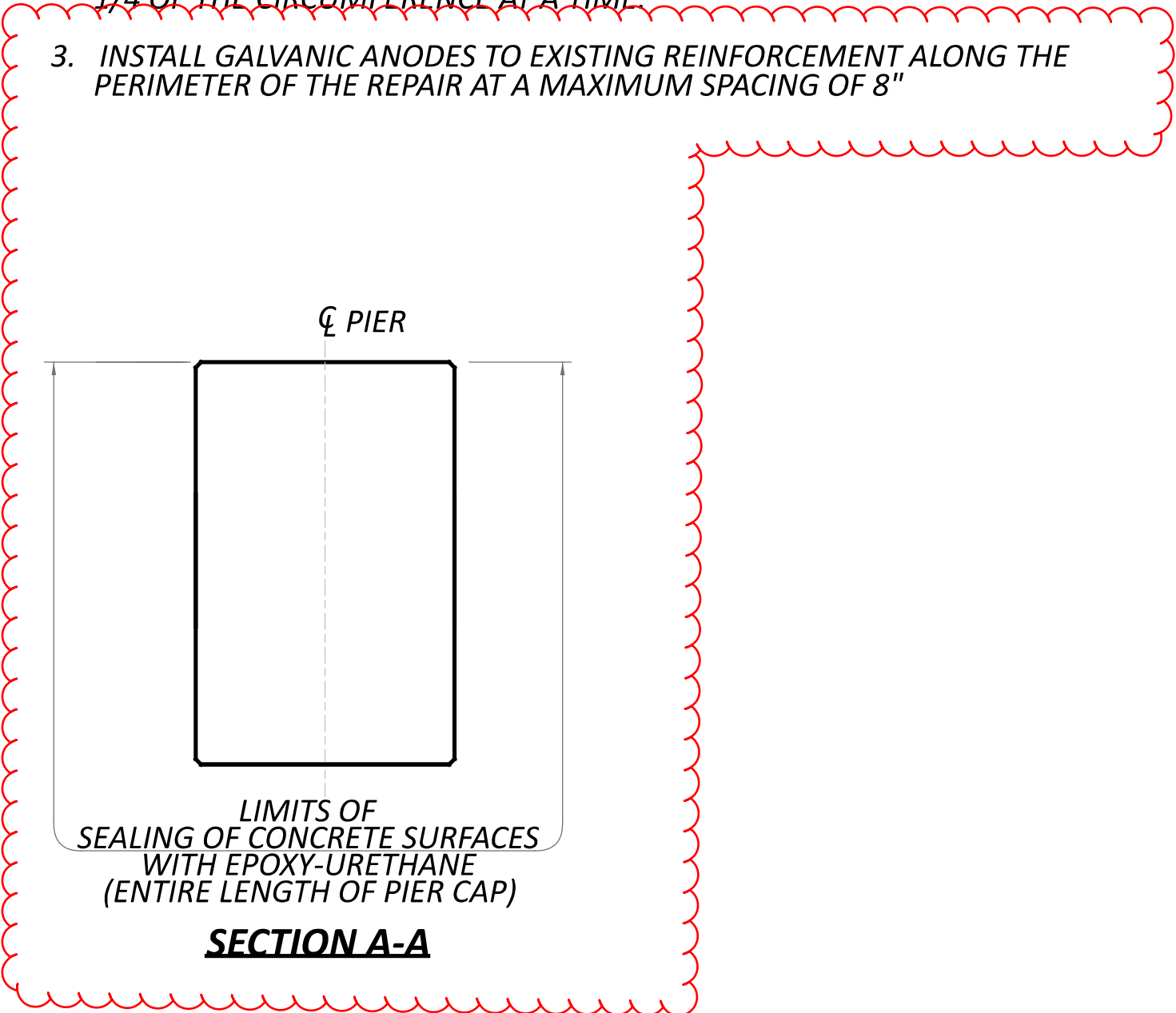

SFN	8303789
DESIGN AGENCY	
DESIGNER	CHECKER
GTF	BCP
REVIEWER	CAH 02/17/26
PROJECT ID	123648
SUBSET	TOTAL
1	3
SHEET	TOTAL
43	45

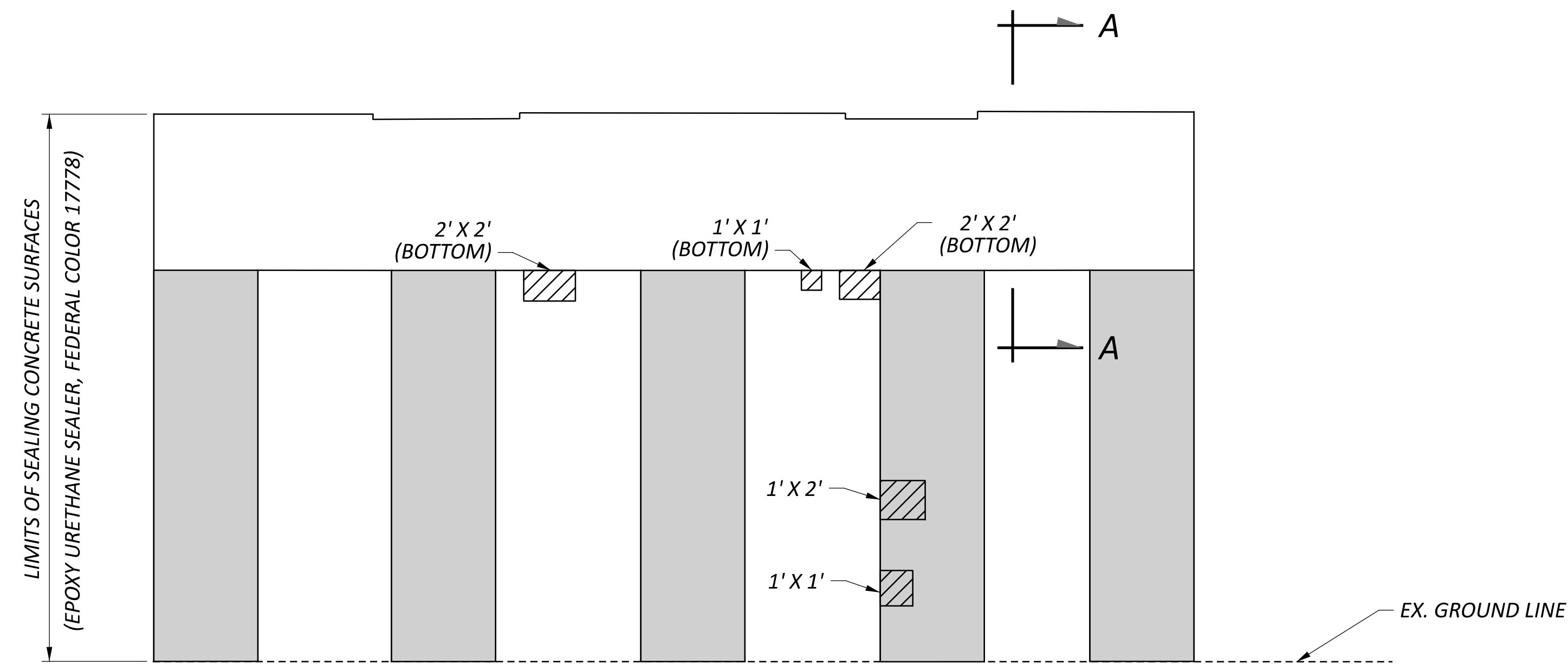

PIER 2 NORTH ELEVATION

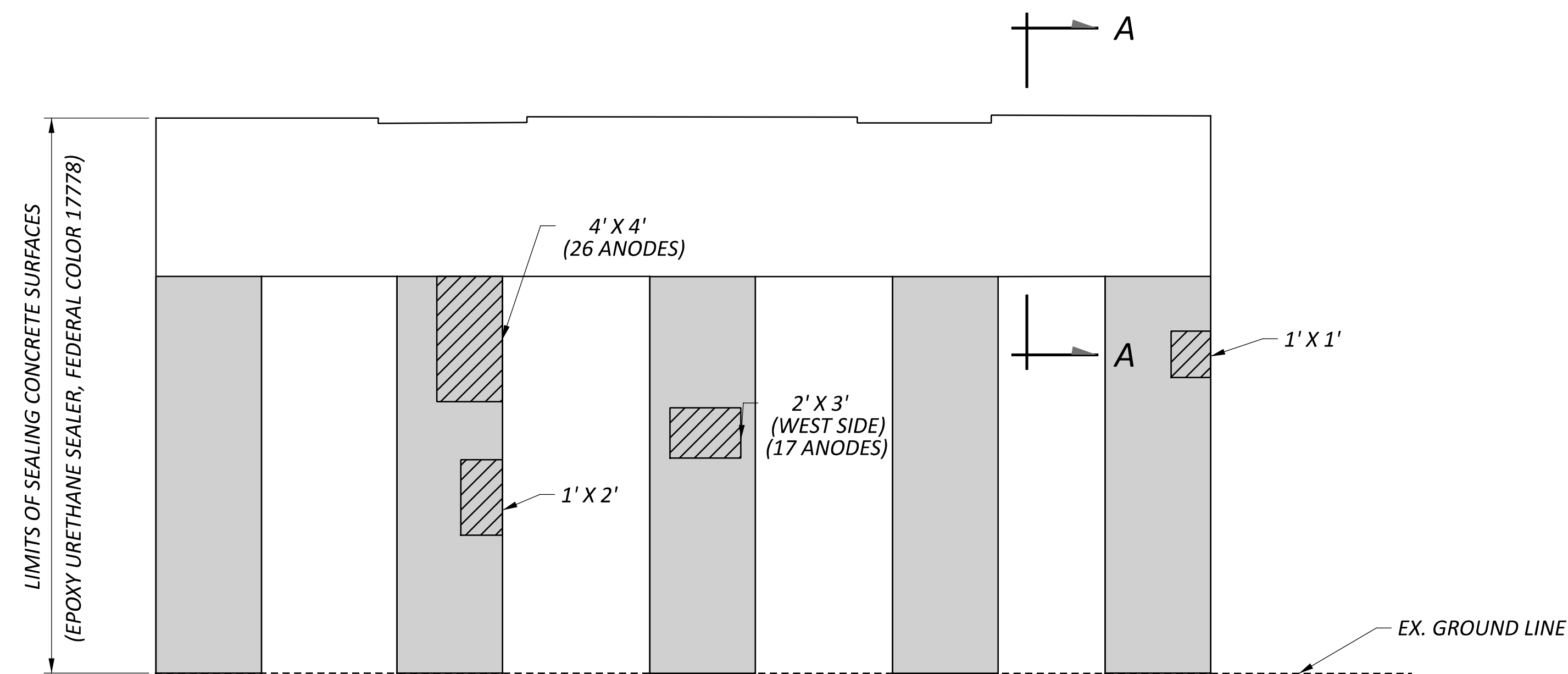

PIER 2 SOUTH ELEVATION

SUMMARY OF REPAIR AREAS			
PHYSICAL INVENTORY OF MEASURED QUANTITIES OF DETERIORATION WAS PERFORMED IN APRIL OF 2025.			
EXACT DIMENSIONS AND LOCATIONS OF REPAIRS SHALL BE DETERMINED BY THE ENGINEER IN THE FIELD FOR FINAL PAY QUANTITIES.			
TYPE	MEASURED QUANTITIES	ESTIMATING FACTOR*	ESTIMATED QUANTITIES
PIER 2 PATCHING	37 SQ. FT.	1.5	56 SQ. FT.
PIER 2 ANODES			43
* - ESTIMATED QUANTITIES HAVE BEEN INCREASED BY 50% OVER MEASURED QUANTITIES TO ALLOW FOR ADDITIONAL DETERIORATION.			

LEGEND

- AREA TO BE REPAIRED WITH ITEM 519 - PATCHING CONCRETE STRUCTURE, AS PER PLAN
- LIMITS OF SINGLE LAYER OF FIBER WRAP PER ITEM 519 - SPECIAL COMPOSITE FIBER WRAP SYSTEM

NOTES

- SEE STRUCTURE GENERAL NOTES FOR FIBER REINFORCED POLYMER SPECIFICATIONS AND ADDITIONAL DETAILS.
- STAGE PATCH REPAIR WIDTHS TO LIMIT REPAIRS TO 1/4 OF THE CIRCUMFERENCE AT A TIME.
- INSTALL GALVANIC ANODES TO EXISTING REINFORCEMENT ALONG THE PERIMETER OF THE REPAIR AT A MAXIMUM SPACING OF 8"

