

Sheet Number	Sign Reference Number	Reference Sub Location	County	Route	SJM/Ramp ID	Side	Travel Direction	Support Type	Sign Legend	Sign Code	SIZE		630	630	630	630	630	630	630	630	630	630	Comments		
											Width (inches)	Height (inches)	Ground Mounted Structural Beam Support, S4x7.7	Ground Mounted Structural Beam Support, W6x9	Ground Mounted Structural Beam Support, W8x18	Ground Mounted Structural Beam Support, W10x12	Ground Mounted Structural Beam Support, W10x22	Ground Mounted Structural Beam Support, W12x30	Breakaway Structural Beam Connection	Sign, Flat Sheet	Sign, Ground Mounted Extrusheet	Sign Backing Assembly		Ground Mounted Structural Beam Support Foundation	
												in	in	FT	FT	FT	FT	FT	FT	EACH	SQ FT	SQ FT	EACH	EACH	
19	S-1	A	HOC	33	0.00	LT	EB	GM	ENTERING Hocking County	I-H2h	72	48	30.0							2		24.0		2	Remove and reerect Fairfield Co sign
19	S-2	A	HOC	33	0.10	RT	EB	GM	HOCKING COUNTY CR 30 Fairfield Rd (RT Arrow)	D3-H6c	96	24	27.5									16.0		2	
19	S-3	A	HOC	33	0.22	RT	EB	GM	Clear Creek Rd 1/3 MILE	D3-H4	120	84				44.5			2			70.0		2	
19	S-4	A	HOC	33	0.28	RT	EB	GM	Clear Creek Metro Park (RT Arrow)	D7-H1	96	36	29.0						2			24.0		2	New location
19	S-5	A	HOC	33	0.56	RT	EB	GM	HOCKING COUNTY CR 116 Clear Creek Rd (RT Arrow)	D3-H6c	96	24		32.5								16.0		2	GREEN BACKGROUND
19		B	HOC	33	0.56	RT	EB	GM	CLEAR CREEK METRO PARK (RT Arrow)	D7-H1	96	36										24.0			BROWN BACKGROUND
19	S-6	A	HOC	33	0.63	RT	EB	GM	Opossum Hollow Rd 1/3 MILE	D3-H4	132	84			36.5							77.0		2	
19	S-7	A	HOC	33	0.87	RT	EB	GM	Opossum Hollow Rd (RT Arrow)	D3-H3a	168	60				51.0						70.0		2	
19	S-8	A	HOC	33	0.97	RT	EB	GM	GOOD HOPE TOWNSHIP TR 129 Opossum Hollow Rd (RT Arrow)	D3-H6c			27.5						2			0.0		2	Remove and reerect on new supports
19	S-9	A	HOC	33	1.15	RT	EB	GM	Rockbridge Rd Bailey Rd 1/2 MILE	D3-H4	180	84				45.5			2			105.0		2	
20	S-10	A	HOC	33	1.32	RT	EB	GM	ENTERING Hocking Hills Region	D7-H3	144	60				42.0			2			60.0		2	
20	S-11	A	HOC	33	1.54	RT	EB	GM	(LT Arrow) Rockbridge Rd Bailey Rd (RT Arrow)	D3-H3a (mod)	216	72				42.5			2			108.0		2	
20	S-12	A	HOC	33	1.67	RT	EB	GM	(LT Arrow) HOCKING COUNTY CR 10 Rockbridge Rd	D3-H6c	96	24		36.0								16.0		2	
20		B	HOC	33	1.67	RT	EB	GM	HOCKING COUNTY CR 27 Bailey Rd (RT Arrow)	D3-H6c	96	24										16.0			
20	S-13	A	HOC	33	1.83	RT	EB	GM	Buena Vista Rd (RT Arrow)	D3-H3a (mod)	204	36		35.5								51.0		2	install pr. in front of ex
20	S-14	A	HOC	33	1.98	RT	EB	GM	HOCKING COUNTY CR 34 Buena Vista Rd (RT Arrow)	D3-H6c	96	24	27.0						2			16.0		2	
20	S-15	A	HOC	33	2.12	RT	EB	GM	JUNCTION SR 374 1/2 MILE	M2-H2a	96	96				45.0						64.0		2	Install pr. 15' in front of ex.
20	S-16	A	HOC	33	2.31	RT	EB	GM	(LT Arrow) Rockbridge	D1-H1	168	36		37.0					2			42.0		2	
20	S-17	A	HOC	33	2.35	RT	EB	GM	(LT Arrow) Rockbridge Rd Logan Rd (RT Arrow)	D3-H3a (mod)	216	72			41.5				2			108.0		2	
20	S-17	A	HOC	33	2.35	RT	EB	GM	Lane Use Control Sign (L-T-TR)	R3-H8cg	48	30							10.00			1			
20	S-18	A	HOC	33	2.44	RT	EB	GM	(LT Arrow) HOCKING COUNTY CR 10 Rockbridge Rd	D3-H6c	96	24	31.0						2			16.0		2	
20		B	HOC	33	2.44	RT	EB	GM	GOOD HOPE TOWNSHIP TR 56 Logan Rd (RT Arrow)	D3-H6c	96	24										16.0			
21	S-19	A	HOC	33	2.50	RT	EB	GM	(ODNR Logo) Rock House Cantwell Cliffs NEXT RIGHT	E3-H1	192	72				44.7			2			96.0		2	with FSS M1-5-3 and M5-1R
21		A	HOC	33	2.50	RT	EB	GM	SR 374	M1-5-3	36	30									7.50				
21		A	HOC	33	2.50	RT	EB	GM	ADV RT Arrow	M5-1R	30	21									4.38				
21	S-20	A	HOC	33	2.64	RT	EB	GM	SOUTH SR 374 (RT Arrow)	M2-H3	48	60	30.0						2			20.0		2	New sign
21	S-21	A	HOC	33	2.68	RT	EB	GM	REST AREA 1 MILE	D5-H1	120	60				40.5			2			50.0		2	
21	S-22	A	HOC	33	2.84	RT	EB	GM	Logan 7 Athens 34	E7-H1	156	60				39.5			2			65.0		2	
21	S-23	A	HOC	33	2.90	RT	EB	GM	Darl Rd Miller Rd 1/2 MILE	D3-H4	132	84				43.0			2			77.0		2	install pr. in front of ex.
21	S-24	A	HOC	33	3.36	RT	EB	GM	(LT Arrow) Darl Rd Miller Rd (RT Arrow)	D3-H3a (mod)	156	72				42.5			2			78.0		2	
21	S-25	A	HOC	33	3.46	RT	EB	GM	(LT Arrow) Good Hope Township TR 567 Darl Rd	D3-H6c	96	24	33.0						2			16.0		2	
21		B	HOC	33	3.46	RT	EB	GM	Hocking County CR 33 Miller Rd (RT Arrow)	D3-H6c	96	24										16.0			
21	S-26	A	HOC	33	3.59	RT	EB	GM	REST AREA (Diag RT Arrow)	D5-H2	120	60				38.5						50.0		2	
21	S-27	A	HOC	33	3.64	RT	EB	GM	EXIT 166	E1-H5P	96	30										20.0			
21		B	HOC	33	3.64	RT	EB	GM	HOCKING COUNTY 33A SR 180 Laurelville EXIT 3/4 MILE	E1-H1	180	108				42.5			2			135.0		2	
22	S-28	A	HOC	33	3.73	RT	EB	GM	REST AREA (Diag RT Arrow) (gore sign)	D5-H2a	72	72		38.0					2			36.0		2	
22	S-29	A	HOC	33	3.86	RT	EB	GM	EXIT 166	E1-H5P	96	30										20.0			
22		B	HOC	33	3.86	RT	EB	GM	HOCKING COUNTY 33A SR 180 Laurelville EXIT 1/2 MILE	E1-H1	180	108					31.5		2			135.0		2	
22	S-30	A	HOC	33	3.90	RT	EB	GM	(LT Arrow) Dalton Rd Risch Rd (RT Arrow)	D3-H3a (mod)	168	72				45.5			2			84.0		2	
22	S-31	A	HOC	33	4.04	RT	EB	GM	GOOD HOPE TOWNSHIP TR 124 Risch Rd (RT Arrow)	D3-H6c	96	24	31.5						2			16.0		2	
22		B	HOC	33	4.04	RT	EB	GM	(LT Arrow) FALLS TOWNSHIP TR 503 Dalton Rd	D3-H6c	96	24										16.0			
22	S-32	A	HOC	33	4.10	RT	EB	GM	EXIT 166	E1-H5P	96	30										20.0			BROWN BACKGROUND
22		B	HOC	33	4.10	RT	EB	GM	(ODNR Logo) Lake Logan State Park Rock House	E6-H3	156	72					51.6		2			78.0		2	BROWN BACKGROUND
22		C	HOC	33	4.10	RT	EB	GM	Hocking College Logan Campus	E3-H1	156	48										52.0			GREEN BACKGROUND
22	S-33	A	HOC	33	4.18	RT	EB	GM	PARK & RIDE EXIT 166	D4-H2b	108	72				39.5			2			54.0		2	
22	S-34	A	HOC	33	4.29	RT	EB	GM	EXIT 166	E1-H5P	96	30										20.0			
SUBTOTALS														266.5	179.0	254.0	426.0	127.8	0.0	50	21.88	2093.0	1	66	

I:\Project\10\102334_D10EXSIGNFY2022\Design\102334_Gensum_Removal_and_Proposed_Subsummaries.dgn Sheet 12/13/2021 09:10:01 AM tcamden

Sheet Number	Sign Reference Number	Reference Sub Location	County	Route	SLM/Ramp ID	Side	Travel Direction	Support Type	Sign Legend	Sign Code	SIZE		630	630	630	630	630	630	630	630	630	630	630	630	630	630	630	Comments	
											Width (inches)	Height (inches)																	
											in	in	FT	FT	FT	FT	FT	FT	FT	EACH	SQ FT	SQ FT	EACH	EACH					
22		B	HOC	33	4.29	RT	EB	GM	HOCKING COUNTY 33A SR 180 Laurelville (Diag RT Arrow)	E1-H3	180	120																	
22	S-35	A	HOC	33	4.41	RT	EB	GM	EXIT 166 (gore sign)	E5-H1a	84	60	32.0								2		35.0		2			Add exit number	
22	S-36	A	HOC	33	5.45	RT	EB	GM	Logan 4 Nelsonville 18 Athens 31	E7-H1	192	84											50.5			112.0		2	
23	S-37	A	HOC	33	6.16	RT	EB	GM	Logan NEXT 3 EXITS	E7-H4	132	60									2		55.0				2		
23	S-38	A	HOC	33	6.23	RT	EB	GM	OSHP DRUG ACTIVITY IMPAIRED DRIVERS CALL #677	D12-H22	120	48		37.0										40.0			2		
23	S-39	A	HOC	33	6.51	RT	EB	GM	SR 93 Downtown Logan	E1-H1	216	72			42.5											108.0		2	
23	S-40	A	HOC	33	6.79	RT	EB	GM	EXIT 170	E1-H5P	96	30														20.0			
23		B	HOC	33	6.79	RT	EB	GM	SR 664 Logan Bremen 1 MILE	E1-H1	132	144														132.0		2	
23	S-41	A	HOC	33	7.04	RT	EB	GM	EXIT 170	E1-H5P	96	30														20.0			BROWN BACKGROUND
23		B	HOC	33	7.04	RT	EB	GM	(ODNR Logo) Hocking Hills State Park Old Man's Cave	E3-H1	204	84						49.6	2							119.0			Moved from SLM 7.13; BROWN BKGD
23		C	HOC	33	7.04	RT	EB	GM	TOURIST INFO CENTER	D5-H7c (mod)	204	36														51.0		2	BLUE BACKGROUND
23	S-42	A	HOC	33	7.13	RT	EB	GM	Hospital NEXT RIGHT	D12-H17b	108	48		35.0												36.0		2	New location (Remove from LOGO)
23	S-43	A	HOC	33	7.28	RT	EB	GM	EXIT 170	E1-H5P	96	30														20.0			
23		B	HOC	33	7.28	RT	EB	GM	SR 664 Logan Bremen 1/2 MILE	E1-H1	132	144										2				132.0		2	
23	S-44	A	HOC	33	7.64	RT	EB	GM	EXIT 170	E1-H5P	96	30														20.0			
23		B	HOC	33	7.64	RT	EB	GM	SR 664 Logan Bremen (Diag RT Arrow)	E1-H3	168	120										2				140.0		2	
23	S-45	A	HOC	33	7.80	RT	EB	GM	EXIT 170 (gore sign)	E5-H1a	84	60	34.0													35.0		2	
24	S-46	A	HOC	33	9.47	RT	EB	GM	EXIT 172	E1-H5P	96	30														20.0			
24		B	HOC	33	9.47	RT	EB	GM	SR 93 Logan McArthur 1/2 MILE	E1-H1	156	144														156.0		2	
24		C	HOC	33	9.47	RT	EB	GM	Historic District	SPEC	156	24														26.0			
24	S-47	A	HOC	33	9.61	RT	EB	GM	Logan CORP LIMIT	I-H2a	108	48		36.5												36.0		2	remove and store Home of Katie FSS
24	S-48	A	HOC	33	9.86	RT	EB	GM	EXIT 172	E1-H5P	96	30														20.0			
24		B	HOC	33	9.86	RT	EB	GM	SR 93 Logan McArthur (Diag RT Arrow)	E1-H3	192	120														160.0		2	
24	S-49	A	HOC	33	9.98	RT	EB	GM	EXIT 172 (gore sign)	E5-H1a	84	60	33.5									2				35.0		2	install pr. 6' in front of ex.
24	S-50	A	HOC	33	10.64	RT	EB	GM	EXIT 174	E1-H5P	96	30														20.0			
24		B	HOC	33	10.64	RT	EB	GM	SR 328 Logan 1 MILE	E1-H1	108	108			55.0							2				81.0		2	
24	S-51	A	HOC	33	11.18	RT	EB	GM	EXIT 174	E1-H5P	96	30														20.0			
24		B	HOC	33	11.18	RT	EB	GM	SR 328 Logan 1/2 MILE	E1-H1	108	108														81.0		2	
24	S-52	A	HOC	33	11.50	RT	EB	GM	EXIT 174	E1-H5P	96	30														20.0			
24		B	HOC	33	11.50	RT	EB	GM	SR 328 Logan (Diag RT Arrow)	E1-H1	144	96			44.0											96.0		2	
25	S-53	A	HOC	33	11.66	RT	EB	GM	EXIT 174 (gore sign)	E5-H1a	84	60	32.6													35.0		2	
25	S-54	A	HOC	33	12.75	RT	EB	GM	Nelsonville 11 Athens 34	E7-H1	180	60														75.0		2	
25	S-55	A	HOC	33	13.92	RT	EB	GM	EXIT 177	E1-H5P	96	30														20.0			
25		B	HOC	33	13.92	RT	EB	GM	SR 595 HOCKING COUNTY 25 New Straitsville Haydenville 1 MILE	E1-H1	252	144														252.0		3	
25	S-57	A	HOC	33	14.41	RT	EB	GM	EXIT 177	E1-H5P	96	30														20.0			
25		B	HOC	33	14.41	RT	EB	GM	SR 595 HOC COUNTY 25 New Straitsville Haydenville 1/2 MILE	E1-H1	252	144														252.0		3	
25	S-58	A	HOC	33	14.70	RT	EB	GM	EXIT 177	E1-H5P	96	30														20.0			
25		B	HOC	33	14.70	RT	EB	GM	SR 595 HOC CO 25 New Straitsville Haydenville (Diag RT Arrow)	E1-H3	252	156														273.0		3	
25	S-59	A	HOC	33	14.86	RT	EB	GM	EXIT 177 (gore sign)	E5-H1a	84	60	32.7													35.0		2	
25	S-60	A	HOC	33	15.88	RT	EB	GM	Nelsonville 7 Athens 20	E7-H1	180	60														75.0		2	
26	S-61	A	HOC	33	15.68	RT	WB	GM	EXIT 177	E1-H5P	96	30														20.0			
26		B	HOC	33	15.68	RT	WB	GM	SR 595 HOC COUNTY 25 New Straitsville Haydenville 1/2 MILE	E1-H1	252	144														252.0		3	
26	S-62	A	HOC	33	15.34	RT	WB	GM	EXIT 177	E1-H5P	96	30														20.0			
26		B	HOC	33	15.34	RT	WB	GM	SR 595 HOC CO 25 New Straitsville Haydenville (Diag RT Arrow)	E1-H1	252	156														273.0		3	
26	S-63.1	A	HOC	33	15.18	RT	WB	GM	EXIT 177 (gore sign)	E5-H1a	84	60	31.7													35.0		2	
26	S-63.2	A	HOC	33	14.53	RT	WB	GM	Logan 6 Columbus 52	E7-H1	180	60														75.0		2	
26	S-64	A	HOC	33	13.37	RT	WB	GM	Logan NEXT 3 EXITS	E7-H4	132	60														55.0		2	
26	S-65	A	HOC	33	13.28	RT	WB	GM	SR 93 Downtown Logan	E6-H2	216	72														108.0		2	
26	S-66	A	HOC	33	12.99	RT	WB	GM	EXIT 174	E1-H5P	96	30														20.0			
26		B	HOC	33	12.99	RT	WB	GM	SR 328 Logan 1 MILE	E1-H1	108	108			50.5											81.0		2	
SUBTOTALS													196.5	108.5	192.0	214.5	406.2	574.9	50	0.0	3992.0	0	71						

I:\ProjectData\10\12334_D10\EXSIGN\FY2022\Design\12334_Gensum_Removal_and_Proposed_Subsummaries.dgn Sheet 12/13/2021 09:10:22 AM tcamden

Sheet Number	Sign Reference Number	Reference Sub Location	County	Route	SLM/Ramp ID	Side	Travel Direction	Support Type	Sign Legend	Sign Code	SIZE		630 Ground Mounted Structural Beam Support, 54x7.7	630 Ground Mounted Structural Beam Support, W6x9	630 Ground Mounted Structural Beam Support, W8x18	630 Ground Mounted Structural Beam Support, W10x12	630 Ground Mounted Structural Beam Support, W10x22	630 Ground Mounted Structural Beam Support, W12x30	630 Breakaway Structural Beam Connection	630 Sign, Flat Sheet	630.0 Sign, Ground Mounted Extrusheet	630 Sign Backing Assembly	630 Ground Mounted Structural Beam Support Foundation	Comments			
											Width (inches) in	Height (inches) in															
26	S-67	A	HOC	33	12.52	RT	WB	GM	EXIT 174	E1-H5P	96	30															
26		B	HOC	33	12.52	RT	WB	GM	SR 328 Logan 1/2 MILE	E1-H1	108	108				49.0			2				2				
26	S-68	A	HOC	33	12.13	RT	WB	GM	EXIT 174	E1-H5P	96	30															
26		B	HOC	33	12.13	RT	WB	GM	SR 328 Logan (Diag RT Arrow)	E1-H1	144	96			38.5				2				2				
27	S-69	A	HOC	33	11.96	RT	WB	GM	EXIT 174 (gore sign)	E5-H1a	84	60	31.9						2				2				
27	S-70	A	HOC	33	11.00	RT	WB	GM	EXIT 172	E1-H5P	96	30															
27		B	HOC	33	11.00	RT	WB	GM	SR 93 Logan McArthur 1 MILE	E1-H1	156	144						62.5					2				
27		C	HOC	33	11.00	RT	WB	GM	Historic District	SPEC	156	24															
27	S-71	A	HOC	33	10.83	RT	WB	GM	ENTERING Hocking Hills Region	D7-H3a	144	60				45.0								2			
27	S-72	A	HOC	33	10.59	RT	WB	GM	EXIT 172	E1-H5P	96	30															
27		B	HOC	33	10.59	RT	WB	GM	SR 93 Logan McArthur 1/2 MILE	E1-H1	156	144						49.0	2					2			
27		C	HOC	33	10.59	RT	WB	GM	FAIRGROUNDS	SPEC	156	24															
27	S-73	A	HOC	33	10.24	RT	WB	GM	EXIT 172	E1-H5P	96	30															
27		B	HOC	33	10.24	RT	WB	GM	SR 93 Logan McArthur (Diag RT Arrow)	E1-H1	192	120						56.5	2					2			
27	S-74	A	HOC	33	10.13	RT	WB	GM	Logan CORP LIMIT	I-H2a	108	48		39.5											2	remove and store Home of Katie FSS	
28	S-75	A	HOC	33	10.07	RT	WB	GM	EXIT 172 (gore sign)	E5-H1a	84	60		32.1					2								
28	S-76	A	HOC	33	9.15	RT	WB	GM	EXIT 170	E1-H5P	96	30															
28		B	HOC	33	9.15	RT	WB	GM	SR 664 Logan Bremen 1 MILE	E1-H1	132	144						61.0							2		
28	S-77	A	HOC	33	8.92	RT	WB	GM	Lancaster 17 Columbus 48	E7-H1	180	60				37.5			2								
28	S-78	A	HOC	33	8.73	RT	WB	GM	EXIT 170	E1-H5P	96	30														BROWN BACKGROUND	
28		B	HOC	33	8.73	RT	WB	GM	(ODNR Logo) Hocking Hills State Park Old Man's Cave	E6-H2 (BRN)	204	84						55.2	2						2	BROWN BACKGROUND	
28		C	HOC	33	8.73	RT	WB	GM	TOURIST INFO CENTER	SPEC (BLU)	204	36														BLU BKGD, moved from SLM 8.98	
28	S-79	A	HOC	33	8.64	RT	WB	GM	EXIT 170	E1-H5P	96	30															
28		B	HOC	33	8.64	RT	WB	GM	SR 664 Logan Bremen 1/2 MILE	E1-H1	132	144						64.5	2						2		
28	S-80	A	HOC	33	8.54	RT	WB	GM	EXIT 170	E1-H5P (BRN)	96	30														BROWN BACKGROUND	
28		B	HOC	33	8.54	RT	WB	GM	(ODNR Logo) Lake Logan State Park	E6-H2 (BRN)	156	48			44.9				2						2	BROWN BACKGROUND	
28		C	HOC	33	8.54	RT	WB	GM	HOSPITAL	SPEC (BLU)	156	24														BLUE BACKGROUND	
29	S-81	A	HOC	33	8.27	RT	WB	GM	EXIT 170	E1-H5P	96	30															
29		B	HOC	33	8.27	RT	WB	GM	SR 664 Logan Bremen (Diag RT Arrow)	E1-H1	168	120						48.4		2					2	New location 75' E of existing	
29	S-82	A	HOC	33	8.13	RT	WB	GM	EXIT 170 (gore sign)	E5-H1a	84	60	33.0						2								
29	S-83	A	HOC	33	6.25	RT	WB	GM	OSHP DRUG ACTIVITY IMPAIRED DRIVERS CALL #677	D12-H22	120	48			40.0											2	New location 50' E of EX. (behind GR)
29	S-84	A	HOC	33	5.92	RT	WB	GM	EXIT 166	E1-H5P	96	30															
29		B	HOC	33	5.92	RT	WB	GM	SR 180 HOCKING COUNTY 33A Laurelville 1 MILE	E1-H1	180	108						61.0								2	
29	S-85	A	HOC	33	5.70	RT	WB	GM	EXIT 166	E1-H5P (BRN)	96	30														BROWN BACKGROUND	
29		B	HOC	33	5.70	RT	WB	GM	(ODNR Logo) Lake Logan State Park Rock House	E6-H3	156	72						48.9							2	BROWN BACKGROUND	
29		C	HOC	33	5.70	RT	WB	GM	Hocking College Logan Campus	E3-H1	156	48															GREEN BACKGROUND
29	S-86	A	HOC	33	5.53	RT	WB	GM	PARK & RIDE EXIT 166	D4-H2b	108	72				41.9										2	
30	S-87	A	HOC	33	5.42	RT	WB	GM	EXIT 166	E1-H5P	96	30															
30		B	HOC	33	5.42	RT	WB	GM	SR 180 HOCKING COUNTY 33A Laurelville 1/2 MILE	E1-H1	180	108						60.1								2	
30	S-88	A	HOC	33	4.99	RT	WB	GM	EXIT 166	E1-H5P	96	30															
30		B	HOC	33	4.99	RT	WB	GM	SR 180 HOCKING COUNTY 33A Laurelville (Diag RT Arrow)	E1-H1	180	120						45.4		2						2	
30	S-89	A	HOC	33	4.83	RT	WB	GM	EXIT 166 (gore sign)	E5-H1a	96	60	30.6						2							2	
30	S-90	A	HOC	33	4.67	RT	WB	GM	REST AREA 3/4 MILE	D5-H1	120	60		34.7					2							2	
30	S-91	A	HOC	33	4.15	RT	WB	GM	(LT Arrow) Risch Rd Dalton Rd (RT Arrow)	D3-H3a (mod)	168	72					36.7		2							2	
30	S-92	A	HOC	33	4.03	RT	WB	GM	(LT Arrow) GOOD HOPE TOWNSHIP TR 124 Risch Rd	D3-H6c	96	24	31.9						2							2	
30		B	HOC	33	4.03	RT	WB	GM	FALLS TOWNSHIP TR 503 Dalton Rd (RT Arrow)	D3-H6c	96	24															
30	S-93	A	HOC	33	3.98	RT	WB	GM	REST AREA (Diag RT Arrow)	D5-H2	120	60			38.2				2							2	
30	S-94	A	HOC	33	3.93	RT	WB	GM	Darl Rd Miller Rd 1/2 MILE	D3-H4	132	84				44.0			2							2	
30	S-95	A	HOC	33	3.87	RT	WB	GM	REST AREA (Diag RT Arrow)	D5-H2a	72	72	35.8						2							2	
31	S-96	A	HOC	33	3.66	RT	WB	GM	Lancaster 12 Columbus 42	E7-H1	180	60				43.2										2	
31	S-97	A	HOC	33	3.57	RT	WB	GM	(LT Arrow) Miller Rd Darl Rd (RT Arrow)	D3-H3a (mod)	156	72				43.9			2							2	
SUBTOTALS													163.2	184.5	83.4	341.2	142.7	469.8	42	0.0	3075.0	0	62				

I:\ProjectData\10\12334_D10EXSIGNFY2022_Design\12334_Gensum_Removal_and_Proposed_Subsummaries.dgn Sheet 12/13/2021 09:10:41AM tcamden

Sheet Number	Sign Reference Number	Reference Sub Location	County	Route	SJM/Ramp ID	Side	Travel Direction	Support Type	Sign Legend	Sign Code	SIZE		630	630	630	630	630	630	630	630.0	630	630	Comments				
											Width (inches)	Height (inches)	Ground Mounted Structural Beam Support, S4x7.7	Ground Mounted Structural Beam Support, W6x9	Ground Mounted Structural Beam Support, W8x18	Ground Mounted Structural Beam Support, W10x12	Ground Mounted Structural Beam Support, W10x22	Ground Mounted Structural Beam Support, W12x30	Breakaway Structural Beam Connection	Sign, Flat Sheet	Sign, Ground Mounted Extrusheet	Sign Backing Assembly		Ground Mounted Structural Beam Support Foundation			
												in	in	FT	FT	FT	FT	FT	FT	EACH	SQ FT	SQ FT	EACH	EACH			
31	S-98	A	HOC	33	3.46	RT	WB	GM	(LT Arrow) HOCKING COUNTY CR 33 Miller Rd	D3-H6c	96	24	35.4						2		16.0		2				
31		B	HOC	33	3.46	RT	WB	GM	GOOD HOPE TOWNSHIP TR 567 Darl Rd (RT Arrow)	D3-H6c	96	24									16.0						
31	S-99	A	HOC	33	3.13	RT	WB	GM	JUNCTION SR 374 1/2 MILE	M2-H2a	96	96				46.3					64.0		2				
31	S-100	A	HOC	33	2.90	RT	WB	GM	(ODNR Logo) Cantwell Cliffs NEXT LEFT	E6-H3	168	60				40.4			2		70.0		2				
31	S-101	A	HOC	33	2.64	RT	WB	GM	SOUTH SR 374 (LT Arrow)	M2-H3	48	60	36.2								20.0		2				
31	S-102	A	HOC	33	2.56	RT	WB	GM	(LT Arrow) Logan Rd Rockbridge Rd (RT Arrow)	D3-H3a (mod)	216	72					50.3				108.0		2				
31	S-103	A	HOC	33	2.50	RT	WB	GM	Rockbridge (RT Arrow)	D1-H15	180	36									45.0			Install on ex. Suppts, 13.33" font			
31	S-104	A	HOC	33	2.45	RT	WB	GM	(LT Arrow) GOOD HOPE TOWNSHIP TR 56 Logan Rd	D3-H6c	96	24	34.4								16.0		2				
31		B	HOC	33	2.45	RT	WB	GM	HOCKING COUNTY CR 10 Rockbridge Rd (RT Arrow)	D3-H6c	96	24									16.0						
32	S-105	A	HOC	33	2.33	RT	WB	GM	Buena Vista Rd 1/3 MILE	D3-H4	120	84				47.8					70.0		2				
32	S-106	A	HOC	33	2.27	RT	WB	GM	Lancaster 10 Columbus 39	E7-H1 mod	144	48				44.1					48.0		2				
32	S-107	A	HOC	33	2.09	RT	WB	GM	(LT Arrow) Buena Vista Rd	D3-H3a (mod)	156	60				42.6					65.0		2				
32	S-108	A	HOC	33	1.98	RT	WB	GM	(LT Arrow) HOCKING COUNTY CR 34 Buena Vista Rd	D3-H6c	96	24	26.4						2		16.0		2				
32	S-109	A	HOC	33	1.76	RT	WB	GM	(LT Arrow) Bailey Rd Rockbridge Rd (RT Arrow)	D3-H3a (mod)	216	72					48.4				108.0		2				
32	S-110	A	HOC	33	1.66	RT	WB	GM	(LT Arrow) HOCKING COUNTY CR 27 Bailey Rd	D3-H6c	96	24	35.0								16.0		2				
32		B	HOC	33	1.66	RT	WB	GM	HOCKING COUNTY CR 10 Rockbridge Rd (RT Arrow)	D3-H6c	96	24									16.0						
32	S-111	A	HOC	33	1.58	RT	WB	GM	Clear Creek Metro Park Camp Wyandot 1 MILE	E3-H1	156	96					51.1				104.0		2	BROWN BACKGROUND			
32	S-112	A	HOC	33	1.50	RT	WB	GM	Opossum Hollow Rd 1/2 MILE	D3-H4 (mod)	132	84				48.1			2		77.0		2				
32	S-113	A	HOC	33	1.09	RT	WB	GM	(LT Arrow) Opossum Hollow Rd	D3-H3a	168	60				39.6			2		70.0		2				
33	S-114	A	HOC	33	0.98	RT	WB	GM	(LT Arrow) GOOD HOPE TOWNSHIP TR 129 Opossum Hollow Rd	D3-H6c	96	24	31.0						2		16.0		2				
33	S-115	A	HOC	33	0.91	RT	WB	GM	Clear Creek Rd 1/3 MILE	D3-H4	192	60				42.9					80.0		2				
33	S-116	A	HOC	33	0.66	RT	WB	GM	(LT Arrow) Clear Creek Rd	D3-H3a (mod)	228	36				43.9					57.0		2	GREEN BACKGROUND			
33		B	HOC	33	0.66	RT	WB	GM	(LT Arrow) Clear Creek Metro Park	E6-H2 BRN	228	36									57.0			BROWN BACKGROUND			
33	S-117	A	HOC	33	0.57	RT	WB	GM	(LT Arrow) HOCKING COUNTY CR 116 Clear Creek Rd	D3-H6c	96	24				38.6			2		16.0		2	GREEN BACKGROUND			
33		B	HOC	33	0.57	RT	WB	GM	(LT Arrow) CLEAR CREEK METRO PARK	D7-H1 MOD	96	36									24.0			BROWN BACKGROUND			
33	S-118	A	HOC	33	0.45	RT	WB	GM	Fairfield Rd 1/3 MILE	D3-H4	156	60				44.9			2		65.0		2				
33	S-119	A	HOC	33	0.21	RT	WB	GM	(LT Arrow) Fairfield Rd	D3-H3a	192	36				42.2			2		48.0		2				
33	S-120	A	HOC	33	0.11	RT	WB	GM	(LT Arrow) HOCKING COUNTY CR 30 Fairfield Rd	D3-H6c	96	24	31.7								16.0		2				
34	S-121	A	HOC	37000	0.04	RT	WB	GM	(LT Arrow) Laurelville 17 Enterprise 1 (RT Arrow)	D1-H16a	120	48				44.6					40.0		2	Exit Ramp US 33 WB to SR 180			
34		B	HOC	37000	0.04	RT	WB	GM	WEST	M3-4	24	12							2.00		1		Exit Ramp US 33 WB to SR 180				
34		C	HOC	37000	0.04	RT	WB	GM	SR 180	M1-5-3	30	24							5.00				Exit Ramp US 33 WB to SR 180				
34		D	HOC	37000	0.04	RT	WB	GM	LT Arrow	M6-1L	21	15							2.19				Exit Ramp US 33 WB to SR 180				
34		E	HOC	37000	0.04	RT	WB	GM	HOCKING COUNTY CR 33A	M1-H6a	24	24							4.00		1		Exit Ramp US 33 WB to SR 180				
34		F	HOC	37000	0.04	RT	WB	GM	RT Arrow	M6-1R	21	15							2.19				Exit Ramp US 33 WB to SR 180				
34	S-122	A	HOC	37002	0.06	RT	EB	GM	(LT Arrow) Enterprise 1 Laurelville 17 (RT Arrow)	D1-H16a	120	48				42.9					40.0		2	Exit Ramp US 33 EB to SR 180			
34		B	HOC	37002	0.06	RT	EB	GM	HOCKING COUNTY CR 33A	M1-H6a	24	24							4.00	4.0	1		Exit Ramp US 33 EB to SR 180				
34		C	HOC	37002	0.06	RT	EB	GM	LT Arrow	M6-1L	21	15							2.19	2.2			Exit Ramp US 33 EB to SR 180				
34		D	HOC	37002	0.06	RT	EB	GM	WEST	M3-4	24	12							2.00	2.0	1		Exit Ramp US 33 EB to SR 180				
34		E	HOC	37002	0.06	RT	EB	GM	SR 180	M1-5-3	30	24							5.00	5.0			Exit Ramp US 33 EB to SR 180				
34		F	HOC	37002	0.06	RT	EB	GM	RT Arrow	M6-1R	21	15							2.19	2.2			Exit Ramp US 33 EB to SR 180				
												SUBTOTALS				230.1	38.6	43.9	526.4	149.8	0.0	18	30.8	1435.4	4	48	

Sheet Number	Sign Reference Number	Reference Sub Location	County	Route	S/LM/Ramp ID	Side	Travel Direction	Support Type	Sign Legend	Sign Code	SIZE		630	630	630	630	630	630	630	630.0	630	630	Comments		
											Width (inches)	Height (inches)	Ground Mounted Structural Beam Support, S4x7.7	Ground Mounted Structural Beam Support, W6x9	Ground Mounted Structural Beam Support, W8x18	Ground Mounted Structural Beam Support, W10x12	Ground Mounted Structural Beam Support, W10x22	Ground Mounted Structural Beam Support, W12x30	Breakaway Structural Beam Connection	Sign, Flat Sheet	Sign, Ground Mounted Extrusheet	Sign Backing Assembly		Ground Mounted Structural Beam Support Foundation	
												in	in	FT	FT	FT	FT	FT	FT	EACH	SQ FT	SQ FT	EACH	EACH	
37	S-143		HOC	CR 25	0.11	RT	WB	GM	WEST (UP Arrow) 33 EAST (ADV RT Arrow)	M2-H4	108	36	32.3									2	27.0	2	
37	S-144	A	HOC	CR 25	0.06	RT	WB	GM	(UP Arrow) Columbus 54	D1-H1a	96	24		39.1									16.0	2	
37		B	HOC	CR 25	0.06	RT	WB	GM	Athens 20 (RT Arrow)	D1-H1a	96	24											16.0		
37	S-145	A	HOC	595	0.18	RT	NB	GM	WEST (UP Arrow) US 33 EAST (RT Arrow)	M2-H4	108	36	36.1										27.0	2	
37	S-146	A	HOC	595	0.28	RT	NB	GM	US 33 WEST Columbus (LT Arrow)	E1-H3	108	84				47.3							63.0	2	
37	S-147	A	HOC	595	0.36	RT	SB	GM	EAST (UP Arrow) US 33 (ADV RT Arrow)	M2-H4	108	36	34.6									2	27.0	2	
37		B	HOC	595	0.36	RT	SB	GM	HOCKING COUNTY CR 33 B Hocking Dr (RT Arrow)	D3-H6c mod	108	24											18.0		Width adjusted to match "A"
37	S-148	A	HOC	595	0.31	RT	SB	GM	EAST (UP Arrow) US 33 WEST (RT Arrow)	M2-H4	108	36	33.5										27.0	2	
37	S-149	A	HOC	595	0.29	RT	SB	GM	(UP Arrow) Athens 20	D1-H1a mod	108	24	32.8										18.0	2	Wider than standard
37		B	HOC	595	0.29	RT	SB	GM	Columbus 54 (RT Arrow)	D1-H1a mod	108	24											18.0		Wider than standard
37	S-150		HOC	595	0.20	SB	GM		US 33 EAST Athens (LT Arrow)	E1-H3	84	84				43.1							49.0	2	
38	S-151		MOE	7	12.43	RT	NB	GM	New Martinsville West Virginia NEXT RIGHT	E1-H1	168	60				38.8					2	70.0	2		
38	S-152		MOE	7	12.58	RT	NB	GM	New Martinsville West Virginia (Diag RT Arrow)	E1-H3	168	72				40.9					2	84.0	2		
38	S-153		MOE	7	12.71	RT	NB	GM	EXIT (gore sign)	E1-H5	72	60	33.7								2	30.0	2		
38	S-154		MOE	7	13.01	RT	SB	GM	New Martinsville West Virginia NEXT LEFT	E1-H1	168	60				37.5					2	70.0	2		
38	S-155		MOE	7	12.90	RT	SB	GM	BRIDGE NEXT LEFT	SPEC	84	48	31.2								2	28.0	2		
38	S-156		MOE	7	12.76	RT	SB	GM	New Martinsville West Virginia (LT Arrow)	E1-H3	168	72				39.3					2	84.0	2		
38	S-157		WAS	32	10.42	RT	EB	GM	(LT Arrow) Parkersburg WV	D1-H1	72	12										6.00			Remove OH and replace with GM
38			WAS	32	10.42	RT	EB	GM	TO	M4-5	24	12										2.00	1		
38			WAS	32	10.42	RT	EB	GM	77	M1-1	24	24										4.00			
38			WAS	32	10.42	RT	EB	GM	(LT Arrow)	M6-1L	21	15										2.19			
38			WAS	32	10.42	RT	EB	GM	TO	M4-5	24	12										2.00	1		
38			WAS	32	10.42	RT	EB	GM	68	M1-6 (WV)	24	24										4.00			West Virginia Sign Code
38			WAS	32	10.42	RT	EB	GM	(LT Arrow)	M6-1L	21	15										2.19			
SUBTOTALS														234.2	39.1	0.0	246.9	0.0	0.0	16	22.4	672.0	2	28	
GRAND TOTALS														1347.6	670.1	573.3	2127.3	826.5	1044.7	186	143.5	12048.8	14	315	

I:\ProjectData\10\112334 - D10E XSIGNFY2022\Design\112334_Sign Elevations.dgn SheetViews 12/13/2021 7:59:11 AM tcamden

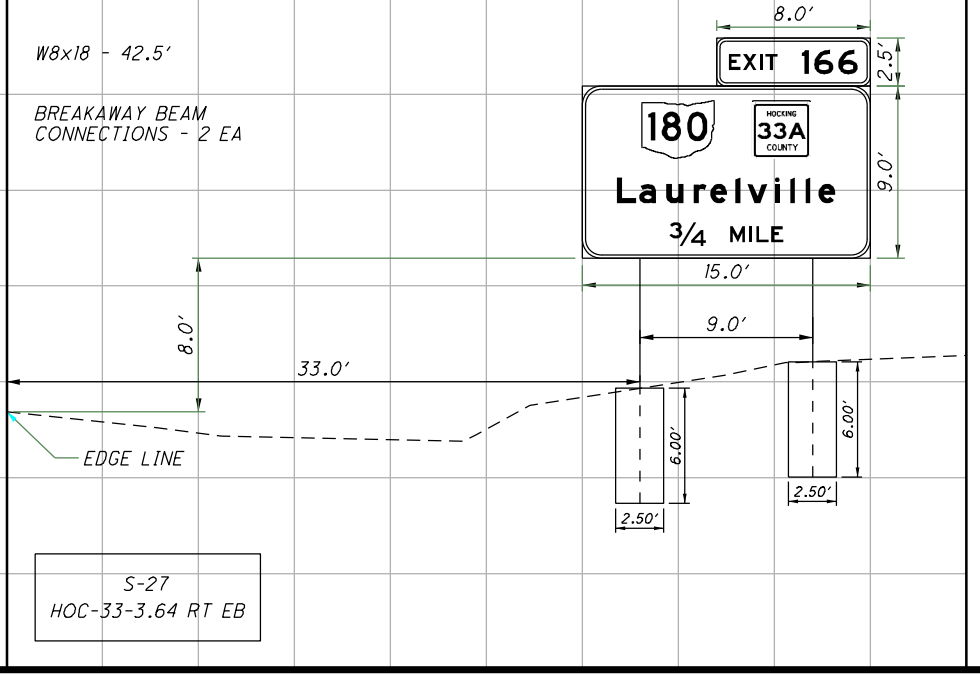
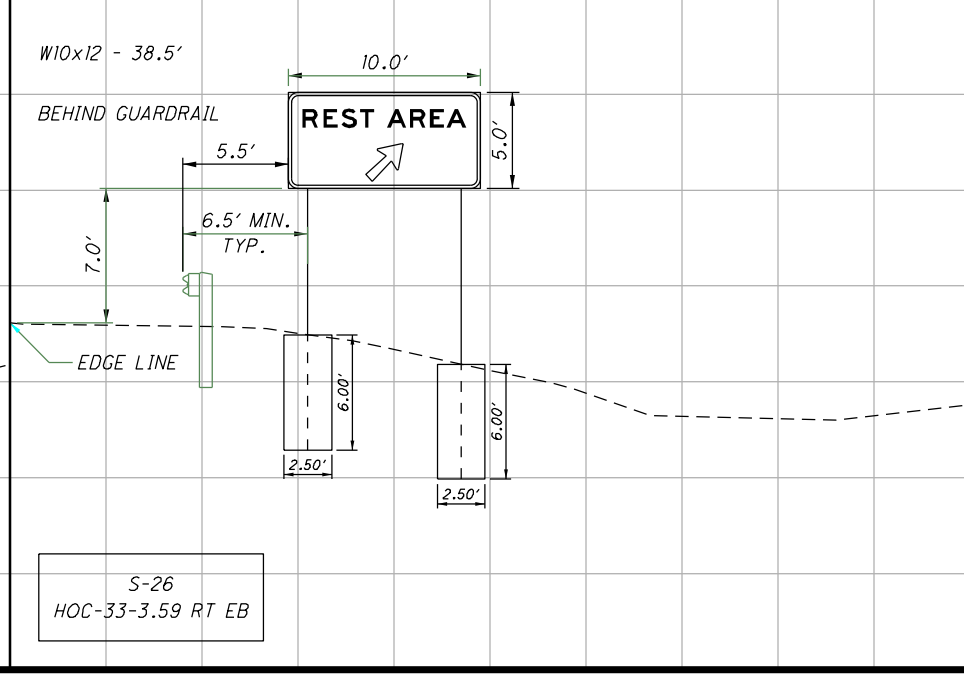
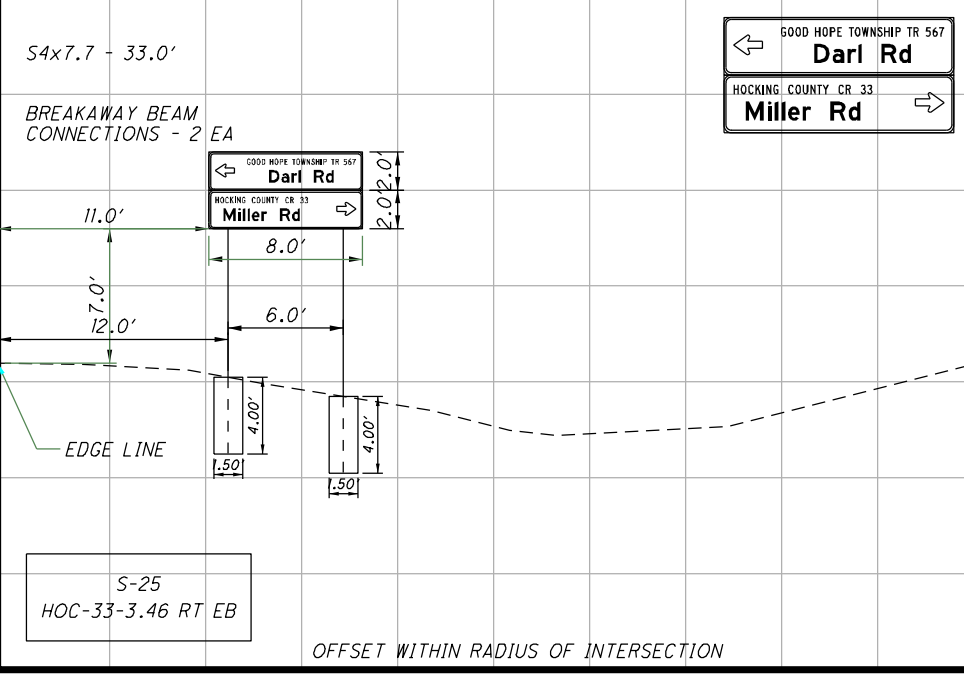
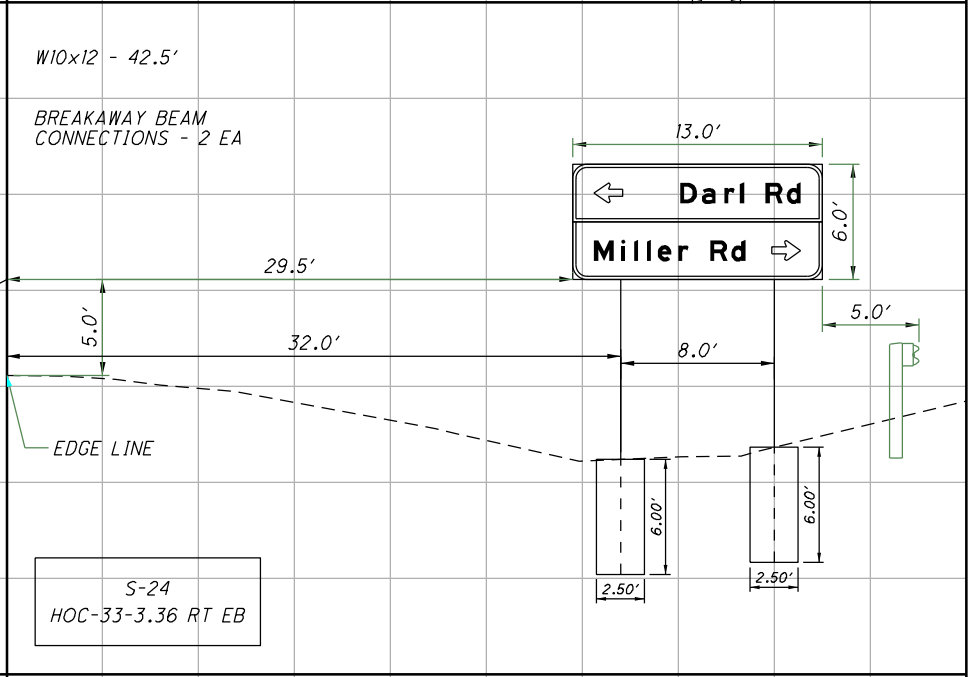
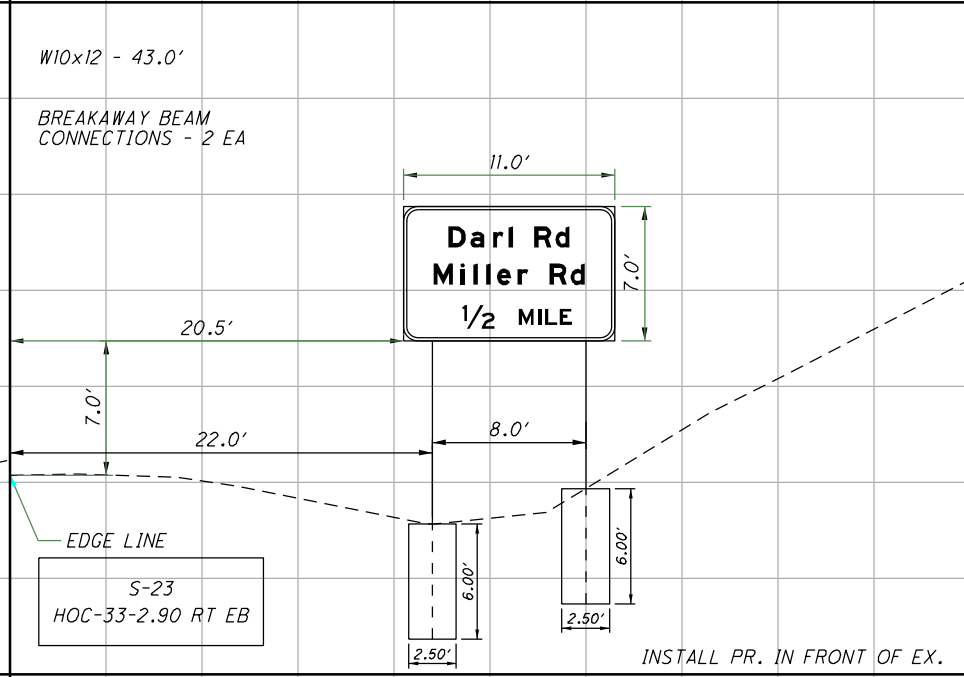
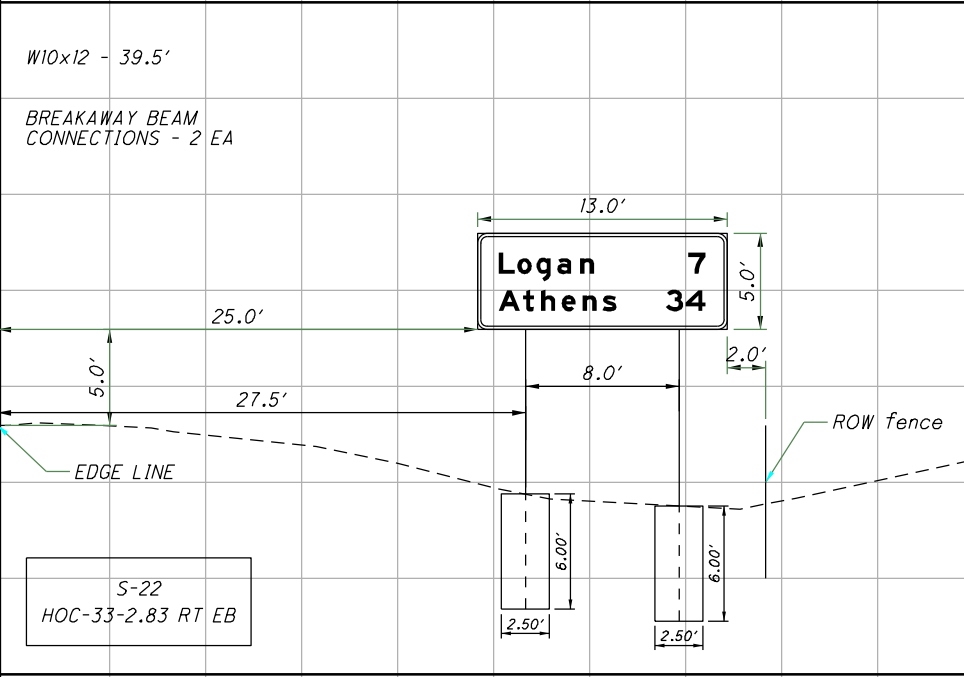
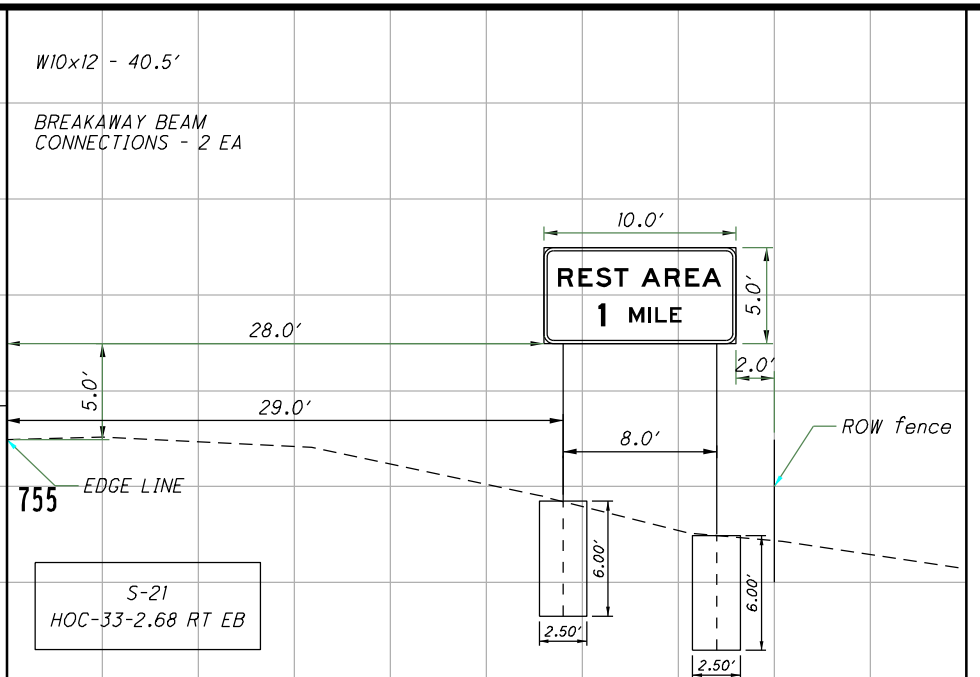
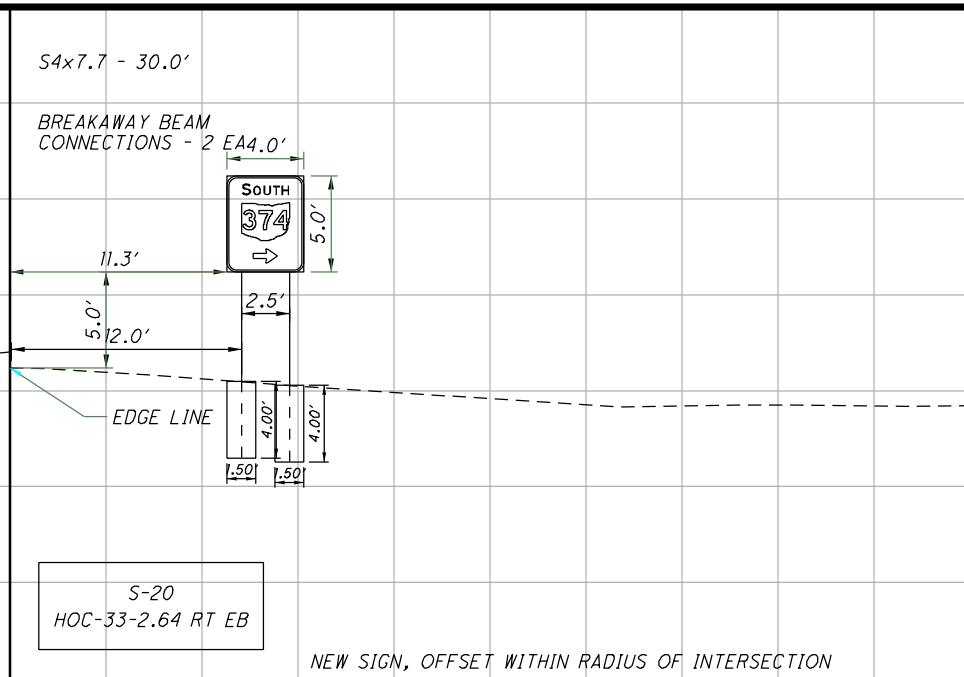
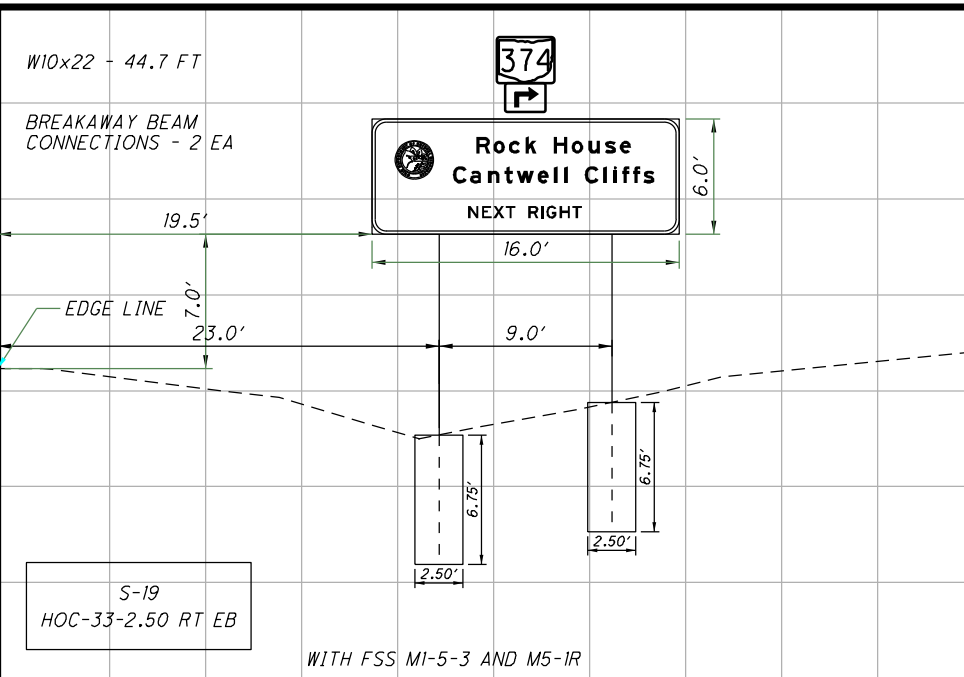

CALCULATED
SSE
CHECKED
TEC

HOC-33/ LEAD IN GROUND MOUNT SIGN ELEVATIONS (3/19)

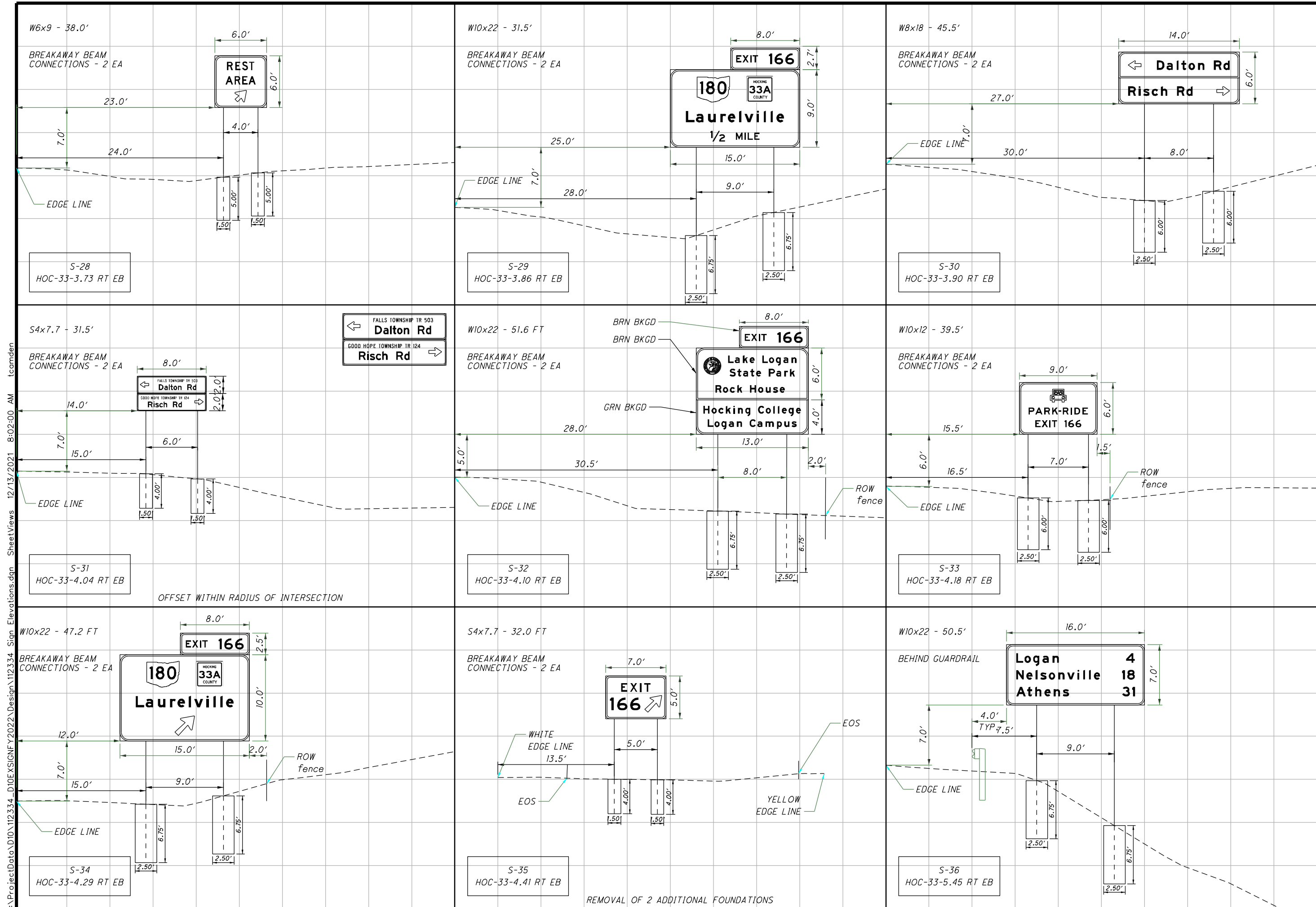

I:\ProjectData\10\112334 - D10E XSIGNFY2022\Design\112334 - Sign Elevations.dgn SheetViews 12/13/2021 8:02:00 AM tcomden

I:\ProjectData\10\112334 - D10E XSIGNFY2022\Design\112334 - Sign Elevations.dgn SheetViews 12/13/2021 8:04:07 AM tcomden

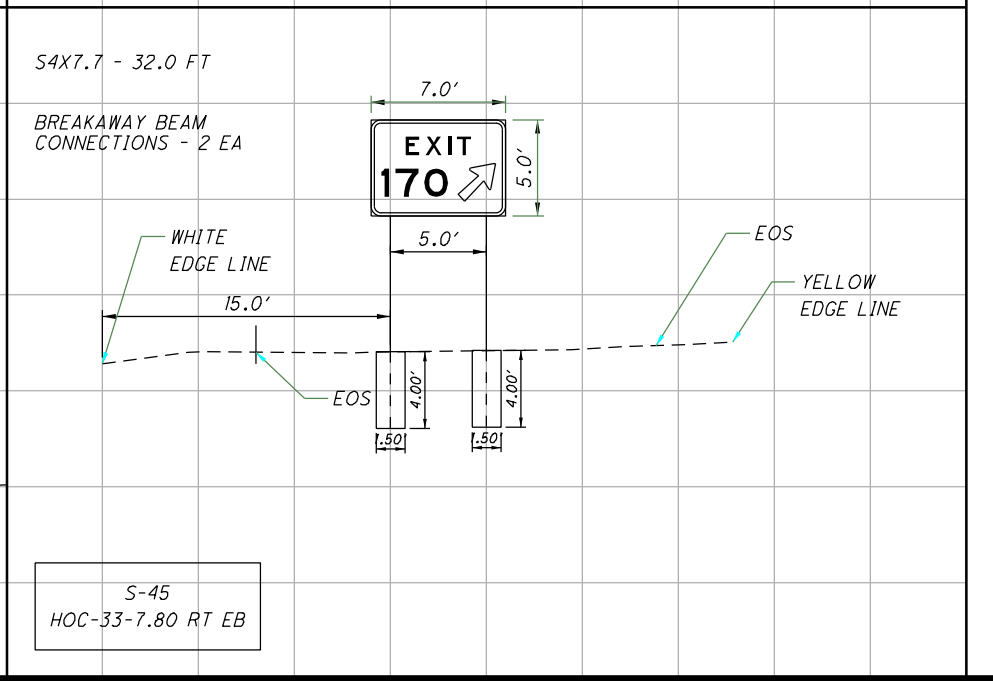
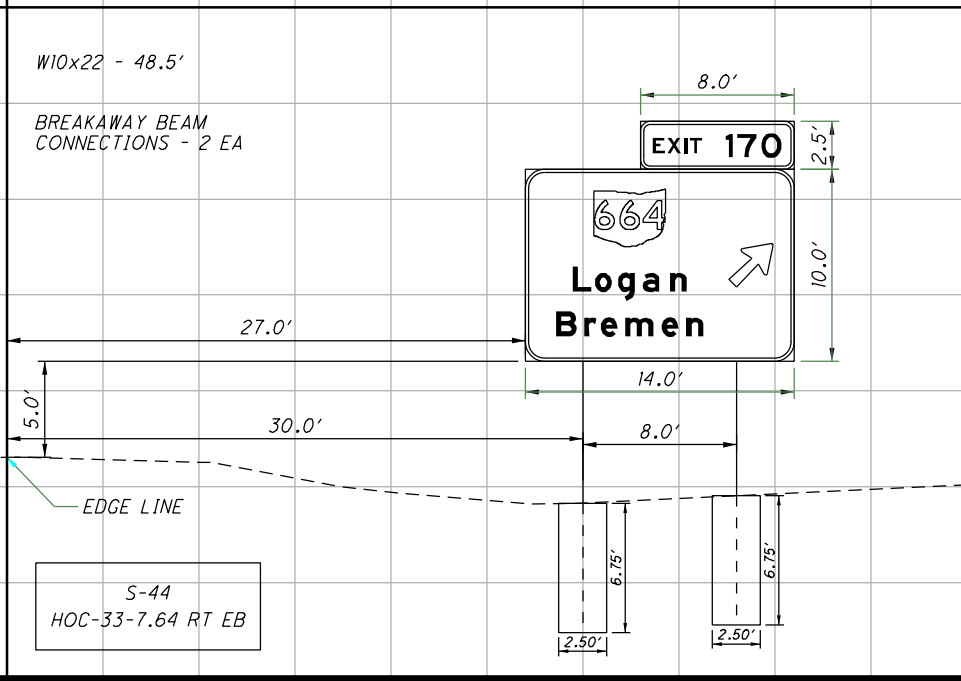
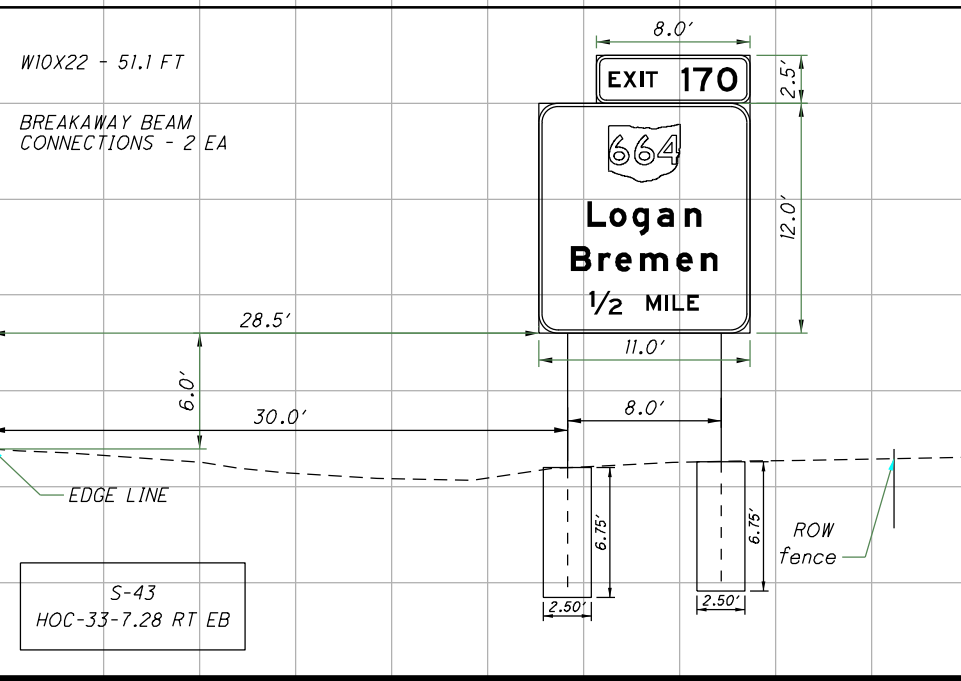
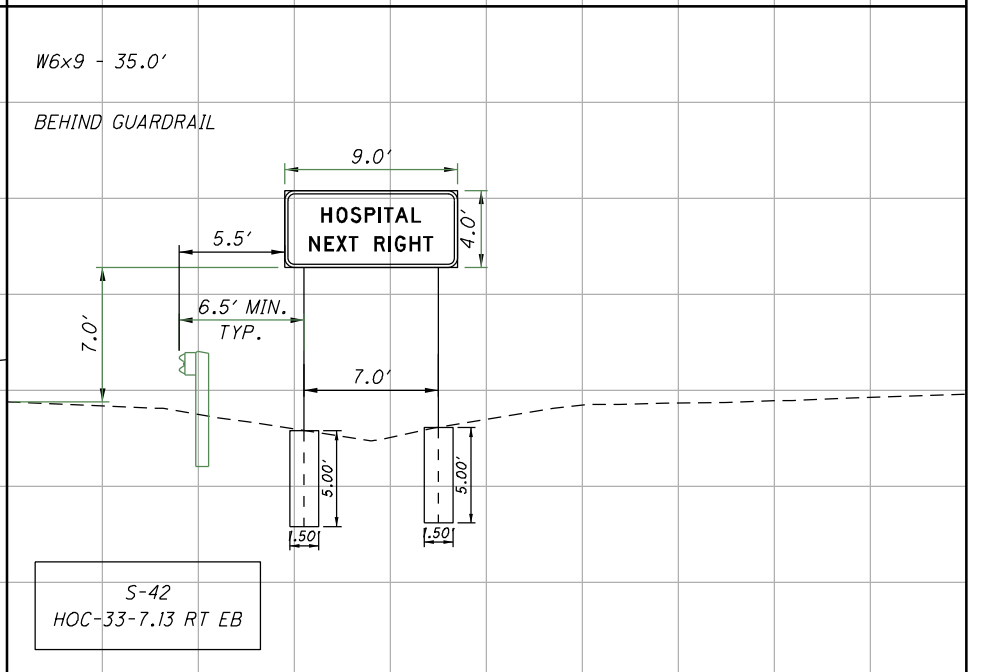
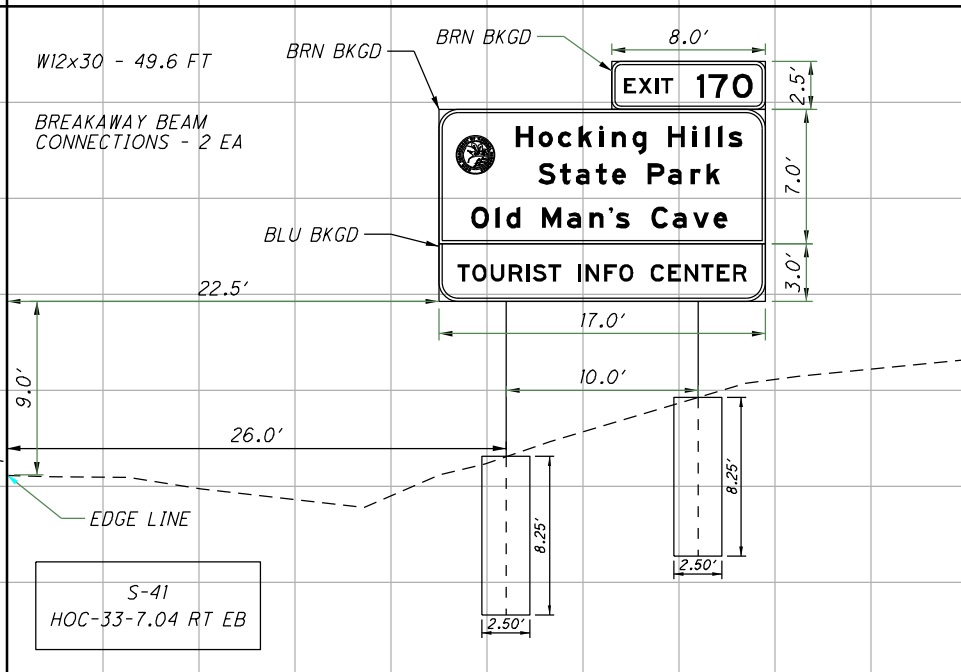
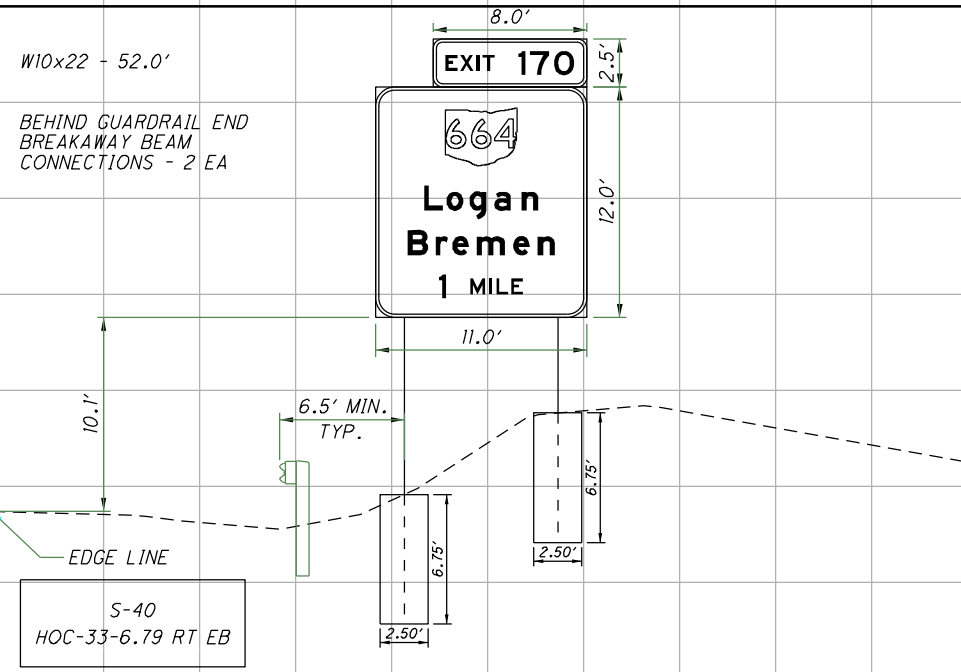
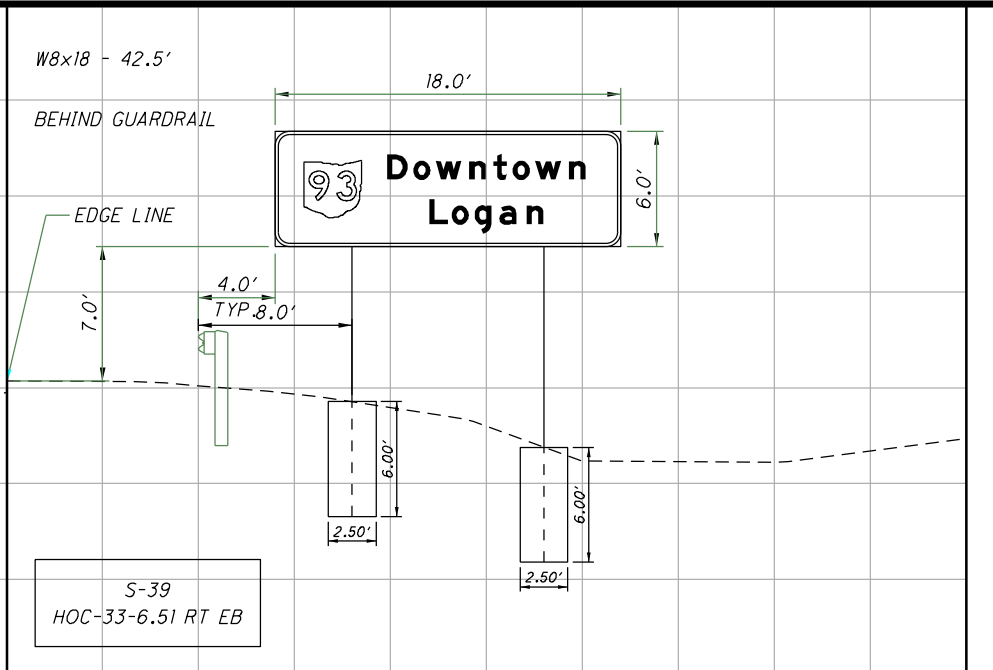
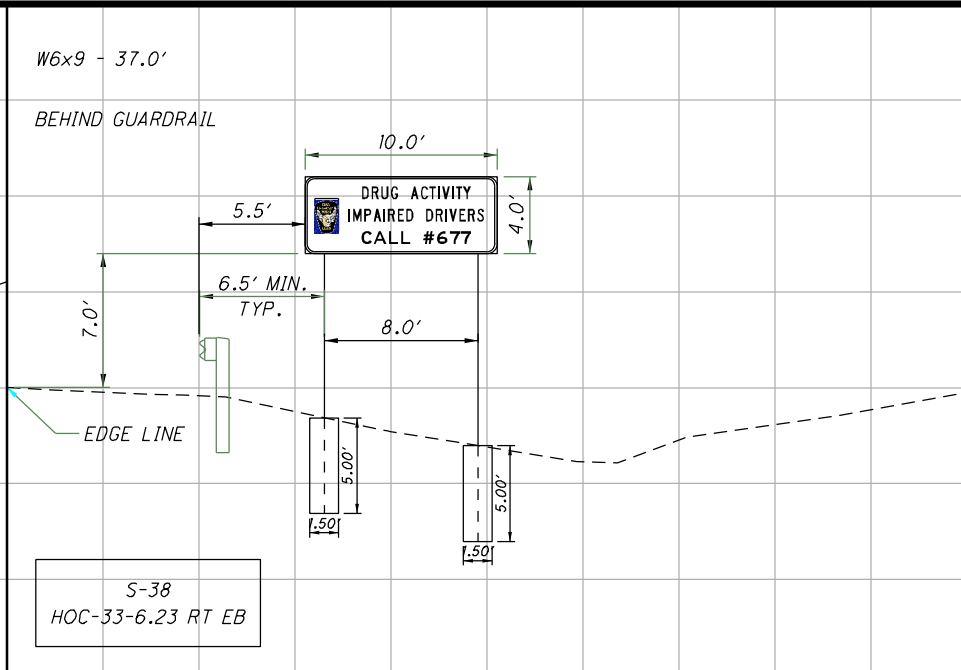
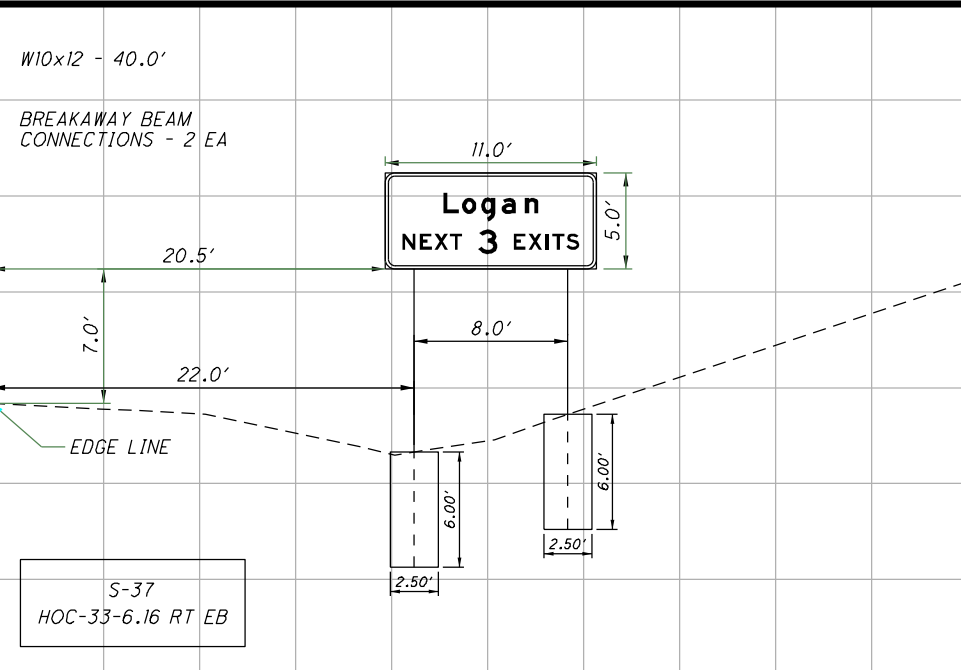

CALCULATED SSE CHECKED TEC

HOC-33/LEAD IN GROUND MOUNT SIGN ELEVATIONS (5/19)

I:\ProjectData\10\112334_D10E\XSIGN\FY2022\Design\112334_Sign Elevations.dgn SheetViews 12/13/2021 8:13:25 AM tcomden

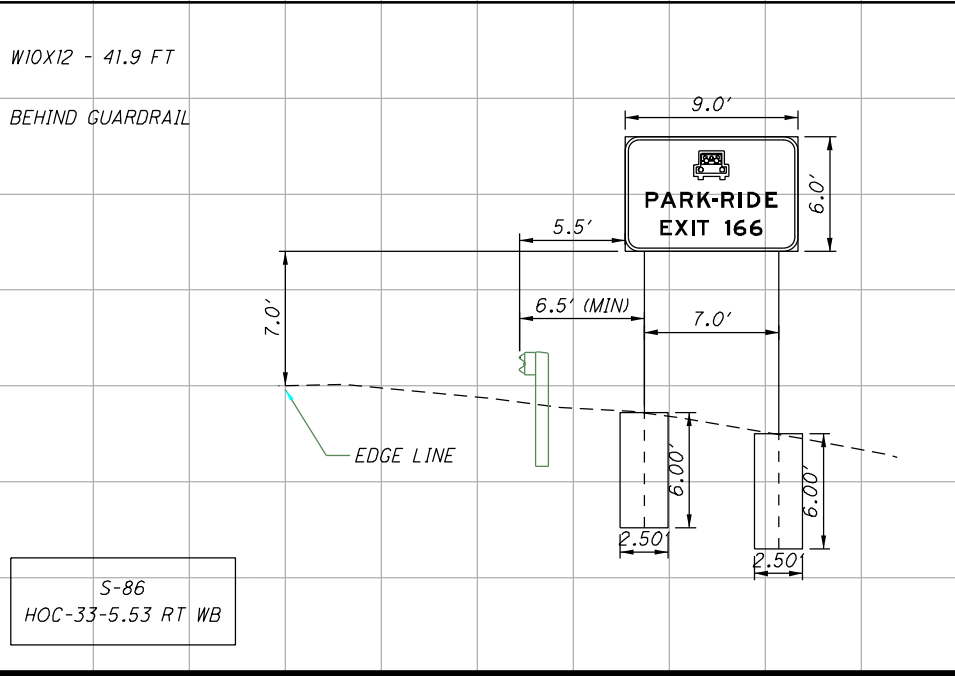
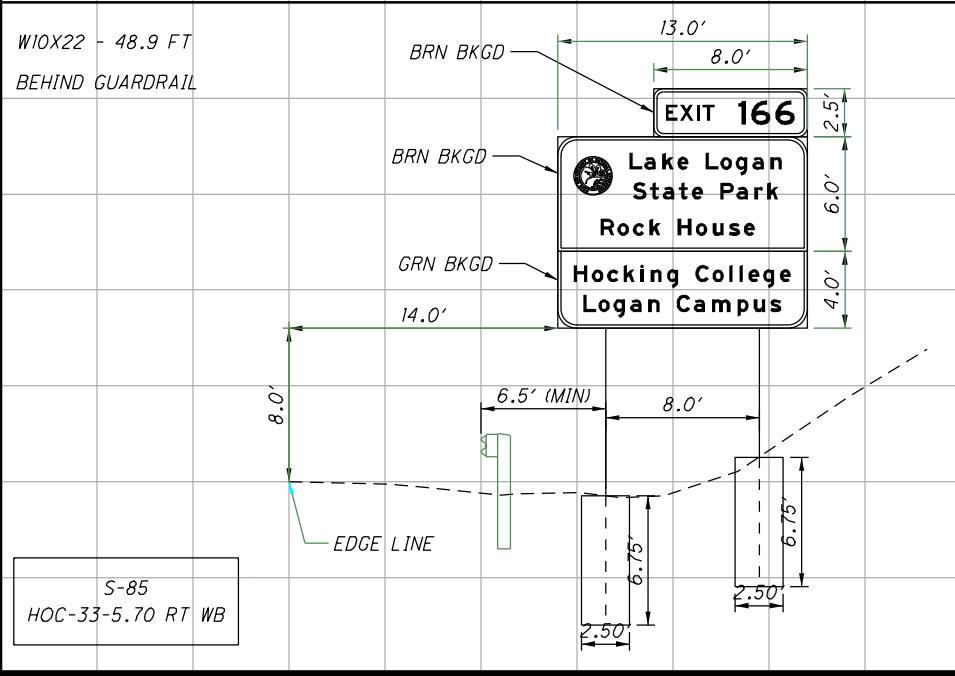
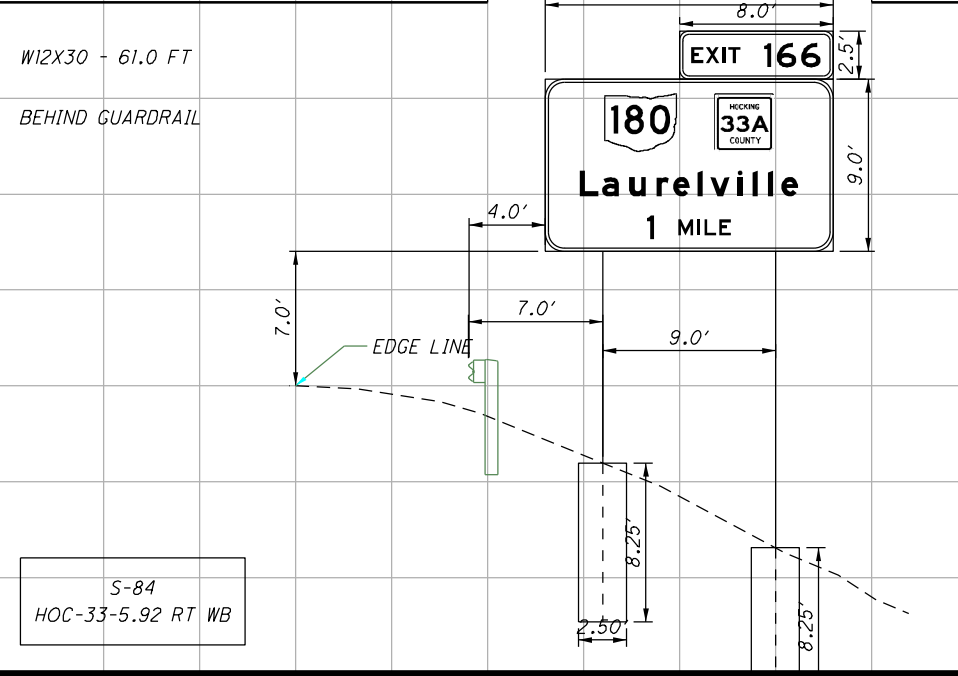
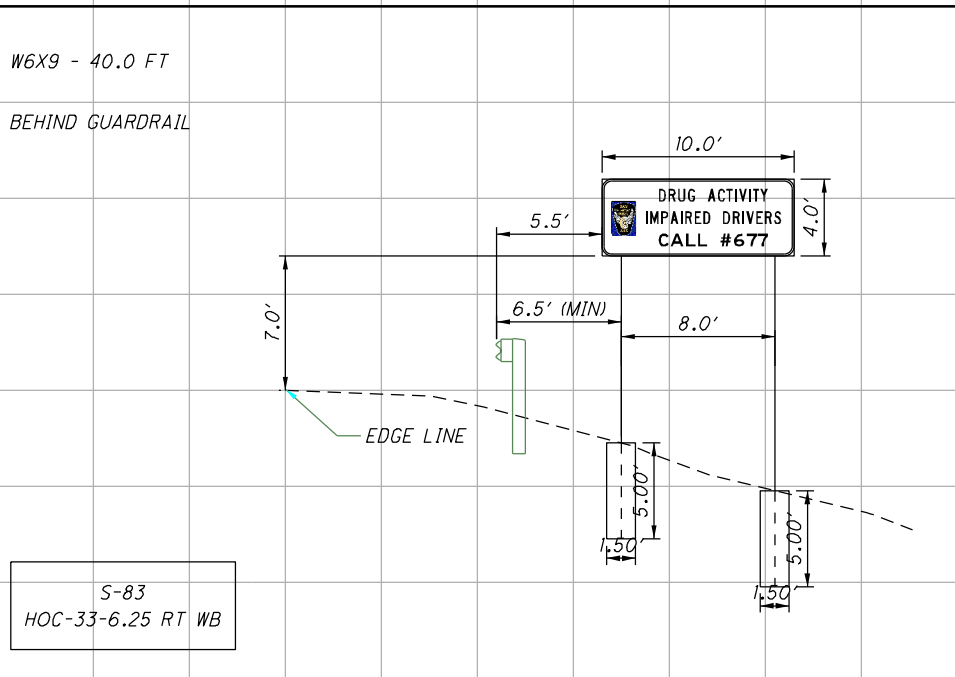
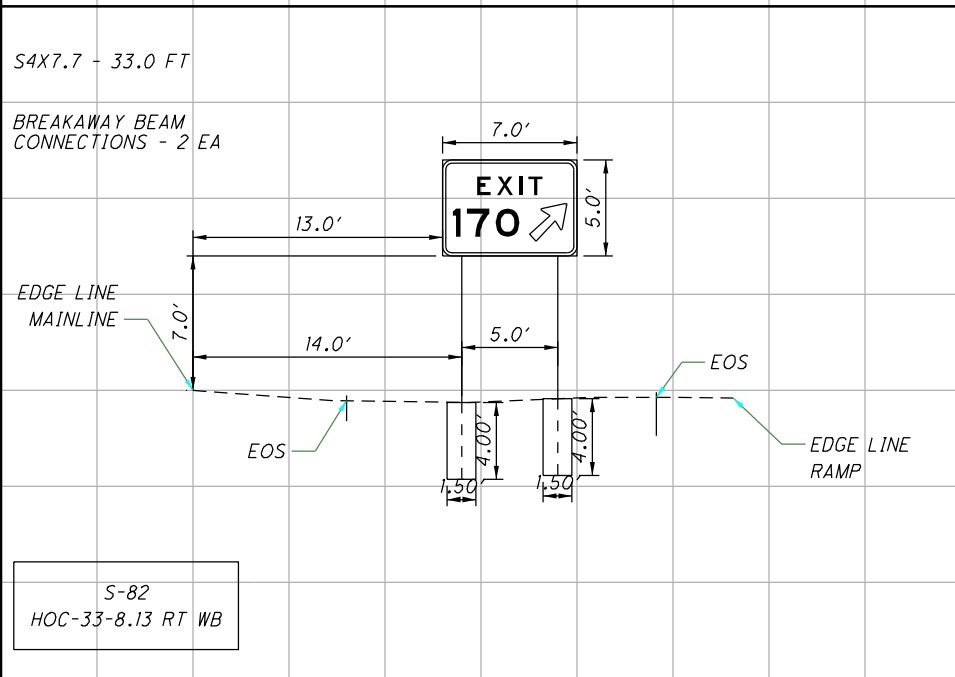
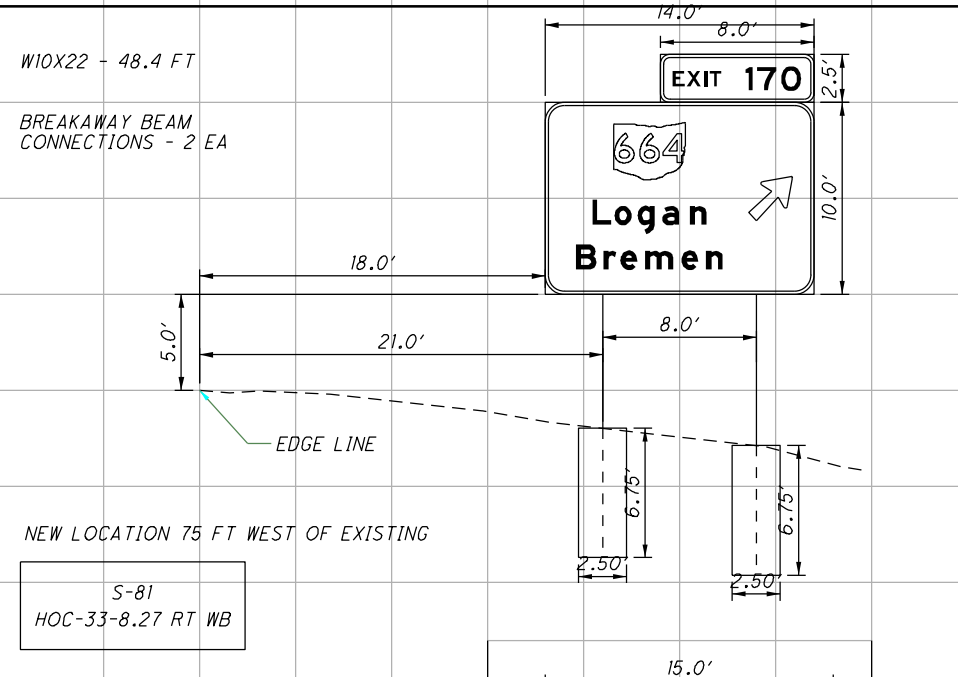

CALCULATED
SSE
CHECKED
TEC

HOC-33/ LEAD IN GROUND MOUNT SIGN ELEVATIONS (11 / 19)

I:\ProjectData\10\112334 - D10E XSIGNFY2022\Design\112334 - Sign Elevations.dgn SheetViews 12/13/2021 8:14:38 AM tcomden

