

STATE OF OHIO
DEPARTMENT OF TRANSPORTATION

FAY-SYS SIGN REPLACE-FY20

FAYETTE COUNTY

PROJECT DESCRIPTION

REPLACE VARIOUS FLATSHEET SIGNS, SIGN REFLECTOR & SUPPORTS IN FAYETTE COUNTY.

EARTH DISTURBED AREAS

PROJECT EARTH DISTURBED AREA: N/A*
ESTIMATED CONTRACTOR EARTH DISTURBED AREA: N/A*
NOTICE OF INTENT EARTH DISTURBED AREA: N/A*
* SIGNING PROJECT

LIMITED ACCESS

THIS IMPROVEMENT IS ESPECIALLY DESIGNED FOR THROUGH TRAFFIC AND HAS BEEN DECLARED A LIMITED ACCESS HIGHWAY OR FREEWAY BY ACTION OF THE DIRECTOR IN ACCORDANCE WITH THE PROVISIONS OF SECTION 5511.02 OF THE OHIO REVISED CODE.

2019 SPECIFICATIONS

THE STANDARD SPECIFICATIONS OF THE STATE OF OHIO, DEPARTMENT OF TRANSPORTATION, INCLUDING SUPPLEMENTAL SPECIFICATIONS LISTED IN THE PLANS AND CHANGES LISTED IN THE PROPOSAL SHALL GOVERN THIS IMPROVEMENT.

TRAFFIC NOT REROUTED

I HEREBY APPROVE THESE PLANS AND DECLARE THAT THE MAKING OF THIS IMPROVEMENT WILL NOT REQUIRE THE CLOSING TO TRAFFIC OF THE HIGHWAY AND THAT PROVISIONS FOR THE MAINTENANCE OF TRAFFIC AND SAFETY WILL BE AS SET FORTH ON PLANS AND ESTIMATES.

PLANS CERTIFIED BY:
NAME: *[Signature]* DATE: 1/23/2022
DISTRICT 6
OHIO DEPT. OF TRANSPORTATION

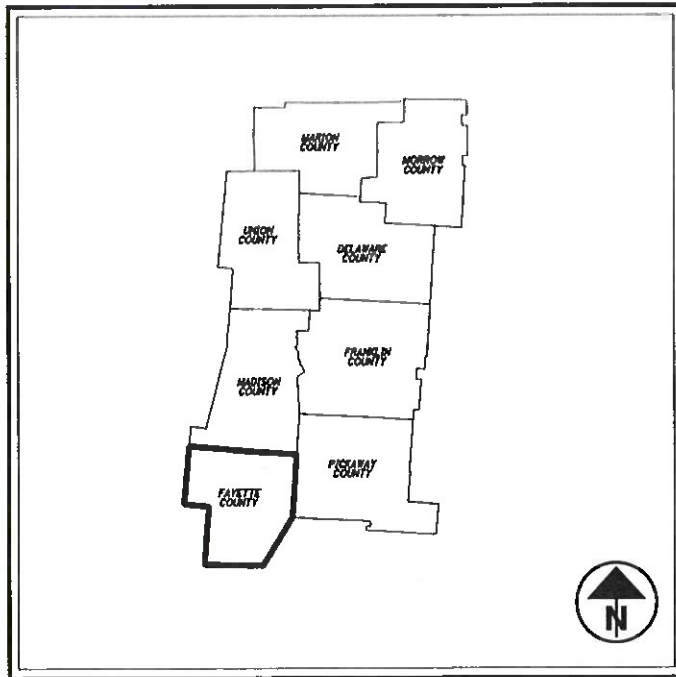

LOCATION MAP

FAYETTE COUNTY LATITUDE: 39°35'31" LONGITUDE: -83°27'52"

- PORTION TO BE IMPROVED _____
- INTERSTATE HIGHWAY _____
- FEDERAL ROUTES _____
- STATE ROUTES _____
- COUNTY & TOWNSHIP ROADS _____
- OTHER ROADS _____

DESIGN DESIGNATION

- CURRENT ADT (2019) _____ VARIES
- DESIGN YEAR ADT (2034) _____ VARIES
- DESIGN HOURLY VOLUME (2034) _____ VARIES
- DIRECTIONAL DISTRIBUTION _____ VARIES
- TRUCKS (24 HOUR B&C) _____ VARIES
- DESIGN SPEED _____ VARIES
- LEGAL SPEED _____ VARIES
- DESIGN FUNCTIONAL CLASSIFICATION: _____
- VARIES
- NHS PROJECT _____ VARIES

DESIGN EXCEPTIONS

NONE

UNDERGROUND UTILITIES
Contact Two Working Days Before You Dig



OHIO811, 8-1-1, or 1-800-362-2764
(Non-members must be called directly)

PLAN PREPARED BY:



INDEX OF SHEETS:

TITLE	1
GENERAL NOTES	2
MAINTAINENCE OF TRAFFIC NOTES	3 - 4
GENERAL SUMMARY	5
TRAFFIC CONTROL SUBSUMMARY	6 - 7
SIGNING PLANS & QUANTITIES	8 - 88

STANDARD CONSTRUCTION DRAWINGS				SUPPLEMENTAL SPECIFICATIONS	SPECIAL PROVISIONS
MT-95.30	1/17/20	TC-22.20	1/17/14	800	1/17/20
MT-95.32	4/19/19	TC-41.10	7/19/13	821	4/20/12
MT-95.50	7/21/17	TC-41.20	10/18/13	832	10/19/18
MT-98.10	1/20/17	TC-41.30	10/18/13		
MT-98.11	4/19/19	TC-41.40	10/18/13		
MT-98.20	4/19/19	TC-41.41	07/19/19		
MT-98.22	1/20/17	TC-41.50	10/18/13		
MT-98.28	1/20/17	TC-42.10	10/18/13		
MT-105.10	7/19/13	TC-42.20	10/18/13		
		TC-51.12	1/15/16		
		TC-52.10	10/18/13		
		TC-52.20	7/20/18		
		TC-73.20	1/17/20		

ENGINEERS SEAL:

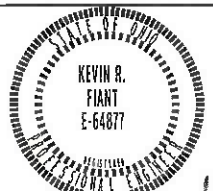

SIGNED: *Kevin R. Fiant*
DATE: 1-23-2022

FEDERAL PROJECT NO. 107556
CONSTRUCTION PROJECT NO. NONE
RAILROAD INVOLVEMENT NONE
FAY-SYS SIGN REPLACE-FY20
1/88

FAY - Sys Sign Replace FY20
200258 PID - 107556
Dist 6 4/23/2020
Contract Proposal Available @
www.contacts.dot.state.oh.us/home

GENERAL:

ALL TRAFFIC CONTROL DEVICES SHALL BE FURNISHED, ERECTED, MAINTAINED, AND REMOVED BY THE CONTRACTOR IN ACCORDANCE WITH THE OHIO MANUAL OF UNIFORM TRAFFIC CONTROL DEVICES.

CONTRACTORS EQUIPMENT - OPERATION AND STORAGE:

THE CONTRACTOR'S EQUIPMENT SHALL BE OPERATED IN THE DIRECTION OF TRAFFIC WHERE PRACTICAL. EQUIPMENT SHALL HAVE AT LEAST ONE AMBER FLASHING LIGHT. WHEN PARKED ALONG THE HIGHWAY, THE EQUIPMENT SHALL BE LOCATED EITHER A MINIMUM OF THIRTY FEET FROM THE EDGE OF PAVEMENT OR SIX FEET BEHIND GUARDRAIL WITH A MINIMUM OF 125 FEET OF GUARDRAIL PRECEDING THE EQUIPMENT. ALL OTHER EQUIPMENT, INCLUDING PRIVATE VEHICLES, SHALL BE STORED AT AN APPROVED CONTRACTOR'S STORAGE AREA. THE CONTRACTOR SHALL NOT PARK EQUIPMENT ON THE RIGHT-OF-WAY WITHOUT APPROVAL OF THE PROJECT ENGINEER. ALL STAGING AREAS IN THE RIGHT-OF-WAY WILL BE APPROVED BY THE PROJECT ENGINEER.

ALL VEHICLES AND EQUIPMENT SHALL BE KEPT IN PROPER REPAIR. ALL EQUIPMENT SHALL BE KEPT SUFFICIENTLY SECURE SO AS TO PREVENT LITTERING OR LEAKAGE OF FLUID. THE CONTRACTOR IS REQUIRED AND SHALL BE HELD RESPONSIBLE FOR THE CLEAN UP AND REMEDIATION OF ANY AND ALL SPILLS TO THE STANDARDS SET BY THE E.P.A. AND SHALL BE AT THE CONTRACTOR'S EXPENSE.

ESTIMATED QUANTITIES:

THE QUANTITIES SHOWN IN THE GENERAL SUMMARY ARE ESTIMATED QUANTITIES AND VARIANCES CAN BE EXPECTED IN THE ACTUAL QUANTITIES USED DURING THE LIFE OF THIS CONTRACT.

CONTINGENCY QUANTITIES:

CONTINGENCY REPAIR QUANTITIES ARE CONTAINED WITHIN THIS PLAN. THESE CONTINGENCY QUANTITIES ARE ONLY TO BE USED WITHIN THE LIMITS OF THE WORK DEFINED IN THIS PROJECT. THE CONTRACTOR SHALL NOT ORDER MATERIALS OR PERFORM WORK FOR ITEMS DESIGNATED BY PLAN NOTE TO BE USED "AS DIRECTED BY THE ENGINEER" UNLESS AUTHORIZED BY THE ENGINEER. THE ACTUAL WORK LOCATIONS AND QUANTITIES USED FOR SUCH ITEMS SHALL BE INCORPORATED INTO THE FINAL CHANGE ORDER GOVERNING COMPLETION OF THIS PROJECT.

PLAN DETAILS:

PLAN VIEW DETAILS HAVE BEEN PROVIDED IN THIS PLAN TO SHOW STATION PLACEMENT FOR PROPOSED SIGNS. THE CONTRACTOR SHALL USE EXISTING LANDMARKS SUCH AS EXISTING SIGNS AND INTERSECTIONS STATION EQUATIONS TO ACCURATELY PLACE PROPOSED SIGNS.

ITEM 630 - REMOVAL ITEMS:

ALL EXISTING EXTRUSHEET AND FLAT SHEET SIGNS SHALL REMAIN IN PLACE UNTIL THE PROPOSED EXTRUSHEET AND FLAT SHEET SIGNS HAVE BEEN ERECTED IN PLACE. WHERE A NEW SIGN IS TO BE INSTALLED IN THE SAME GENERAL LOCATION AS THE EXISTING SIGN, SEEK TO PLACE THE NEW SIGN BEHIND THE EXISTING SIGN. THE EXISTING SIGN SHOULD BE IN PLAIN VIEW UNTIL IT IS READY FOR REMOVAL AND THE NEW SIGN WILL BE IN PLAIN VIEW.

REMOVAL OF GROUND MOUNTED SIGN & RE-ERECTION, AS PER PLAN:

THE CONTRACTOR SHALL REMOVE THE EXISTING SIGN ASSEMBLY TAKING CARE NOT TO DAMAGE THE SIGN OR ANY BRACKETS USED TO SECURE THE SIGN(S). THE CONTRACTOR SHALL RE-USE THE EXISTING SIGN ASSEMBLY TO RE-ERECT THE SIGN(S) AT ITS PREVIOUS LOCATION UNLESS OTHERWISE NOTED IN THE PLANS. STREET NAME SIGN ASSEMBLIES MAY INCLUDE MULTIPLE STREET NAME SIGNS ON ONE BRACKET BUT WILL BE PAID AS ONE (1) EACH FOR THE ENTIRE ASSEMBLY. ALL MATERIAL, LABOR, AND EQUIPMENT NECESSARY TO COMPLETE THE WORK DESCRIBED ABOVE IS TO BE INCLUDED IN THE UNIT BID PRICE FOR ITEM 630 REMOVAL OF GROUND MOUNTED SIGN & RE-ERECTION, AS PER PLAN

SIGNING, MISC: REMOVAL OF POST REFLECTOR

THIS ITEM SHALL CONSIST OF REMOVING & DISPOSING OF THE EXISTING SIGN POST REFLECTOR IN PREPARATION FOR THE INSTALLATION OF NEW SIGN POST REFLECTORS. ALL MATERIAL, LABOR, AND EQUIPMENT NECESSARY TO COMPLETE THE WORK DESCRIBED ABOVE IS TO BE INCLUDED IN THE UNIT BID PRICE FOR ITEM 630 - SIGNING, MISC: REMOVAL OF POST REFLECTOR.

ITEM 630 - GROUND MOUNTED SUPPORT, NO. 2 POST:

ITEM 630 - GROUND MOUNTED SUPPORT, NO. 3 POST:
ALL OF THE PROPOSED GROUND MOUNTED NO. 3 SUPPORTS WITHIN THIS PROJECT ARE REQUIRED TO BE MADE AS SHOWN BELOW. PAYMENT FOR THE ABOVE WORK SHALL BE MADE AT THE UNIT PRICE BID FOR ITEM 630 - GROUND MOUNTED SUPPORT AND SHALL INCLUDE ALL LABOR, TOOLS, EQUIPMENT AND MATERIALS NECESSARY TO CONSTRUCT A COMPLETE AND FUNCTIONAL SIGN SUPPORT.

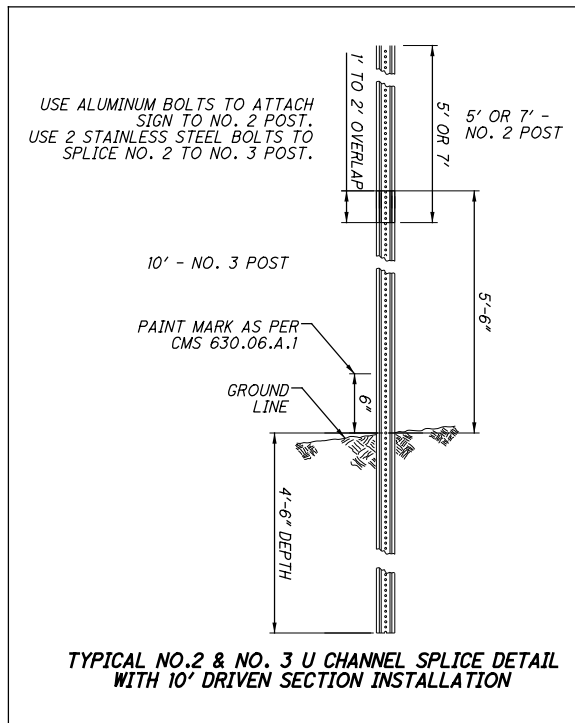

ITEM 630 - SIGNS, (FLAT SHEET AND EXTRUSHEET):

THE CONTRACTOR IS RESPONSIBLE FOR REPLACEMENT OF PERMANENT TRAFFIC CONTROL SIGNS DAMAGED OR REMOVED DURING CONSTRUCTION. ANY SIGNS REMOVED FROM THEIR EXISTING LOCATION SHALL BE TEMPORARILY REPLACED IMMEDIATELY. THE CONTRACTOR WILL BE CHARGED IF IT BECOMES NECESSARY FOR THE TRANSPORTATION DIVISION TO PERFORM SIGN REPLACEMENT WORK. THE CONTRACTOR SHALL ASSUME ALL LIABILITY FOR MISSING, DAMAGED AND IMPROPERLY PLACED SIGNS. WHERE THE PLANS CALL FOR A PERMANENT SIGN TO BE COVERED, THE CONTRACTOR SHALL DO SO IN SUCH A MANNER AS TO AVOID DAMAGING THE PERMANENT SIGN WHEN THE COVER IS REMOVED. THE COVER SHALL BE TOTALLY OPAQUE. THE USE OF ADHESIVE TAPE APPLIED DIRECTLY TO A SIGN FACE IS STRICTLY PROHIBITED.

FOR SIGN POSITION UNLESS OTHERWISE DIRECTED BY THE ENGINEER THE FOLLOWING CONDITIONS SHALL APPLY. WHERE PHYSICAL CONDITIONS PERMIT, SIGNS SHALL HAVE THE CORRECT LATERAL AND VERTICAL CLEARANCE WITH RESPECT TO THE EDGE OF PAVEMENT IN ACCORDANCE WITH THE MINIMUM DISTANCE SHOWN ON THE STANDARD DRAWING. THE STATIONS ARE APPROXIMATE TO SHOW THE ORDER OF SIGNS IN RELATIONSHIP TO EACH OTHER AND ARE NOT TO BE CONSIDERED EXACT LOCATIONS.

SIGNS INDICATED AS NEW INSTALLATIONS SHALL BE LOCATED AS APPROVED BY THE ENGINEER. WHERE A NEW SIGN IS TO BE INSTALLED IN THE SAME GENERAL LOCATION AS THE EXISTING SIGN, SEEK TO PLACE THE NEW SIGN BEHIND THE EXISTING SIGN. THE EXISTING SIGN SHOULD BE IN PLAIN VIEW UNTIL IT IS READY FOR REMOVAL AND THE NEW SIGN WILL BE IN PLAIN VIEW. AFTER INSTALLATION ALL SIGNS SHALL BE INSPECTED AS PER CMS 630.13.

EXISTING SIGNS NOT SHOWN ON THE SCHEMATIC SHEETS OR LISTED ON THE SUB SUMMARY AS WORK LOCATIONS SHALL NOT BE DISTURBED.

ALL EXTRUSHEET SIGNS SHALL BE LAID OUT AND FABRICATED AS PROPOSED IN THE CONTRACT. IN NO CASE SHALL ANY SIGN LEGENDS BE CHANGED WITHOUT PRIOR NOTIFICATION TO THE DISTRICT SIX PRODUCTION DEPARTMENT. CERTIFIED DRAWINGS AS PER CMS 630.03 SHALL BE SUBMITTED TO THE PROJECT ENGINEER.

ITEM 630 - SIGN, FLAT SHEET, AS PER PLAN

ALL NEW OR REPLACEMENT, W8-13, "BRIDGE ICES BEFORE ROAD" SIGNS IDENTIFIED IN THE PLANS SHALL BE HINGED AND PAID FOR UNDER ITEM 630 - SIGN, FLAT SHEET, AS PER PLAN.

UTILITIES IMPACT:

IT IS EXPECTED THAT THE PROJECT WILL NOT HAVE ANY IMPACT ON EXISTING UTILITIES. THE CONTRACTOR SHALL CONTACT OURS AHEAD OF ANY POST INSTALLATION TO VERIFY THERE ARE NO CONFLICTS WITH ANY UTILITIES. IN THE EVENT THERE IS A CONFLICT THE CONTRACT SHALL ADJUST POLE PLACEMENT TO AVOID CONFLICT.

UTILITY NOTIFICATION

THE OHIO DEPARTMENT OF TRANSPORTATION HAS UTILITY FACILITIES (HIGHWAY LIGHTING, TRAFFIC SIGNALS, AND ITS) WITHIN THE LIMITS OF THIS PROJECT.

UTILITIES:

THE ODOT CONTRACTOR IS REQUIRED TO CONTACT OUPS A MINIMUM OF 48 HOURS EXCLUDING WEEKENDS AND HOLIDAYS TO PERMIT ALL UNDERGROUND UTILITIES AN OPPORTUNITY TO MARK THEIR LINES. IT IS ALSO THE ODOT CONTRACTOR'S RESPONSIBILITY TO CONTACT ALL NON-MEMBERS OF OUPS DIRECTLY A MINIMUM OF 48 HOURS' NOTICE EXCLUDING WEEKENDS AND HOLIDAYS TO PROVIDE THEM WITH THE SAME OPPORTUNITY.

WATERSHED PROTECTION:

THE WORK ASSOCIATED WITH THIS PROJECT IS BEING PERFORMED WITHIN THE DIRECT DRAINAGE AREA OF A WATERSHED. IT IS ESSENTIAL THAT ALL ACTIVITIES ASSOCIATED WITH THIS WORK BE PERFORMED IN A MANNER CONSISTENT WITH BEST WATERSHED MANAGEMENT PRACTICES INCLUDING, BUT NOT LIMITED TO;

AREAS OF DISTURBED GROUND SHALL HAVE APPROPRIATE EROSION AND SEDIMENT CONTROLS. IF HAZARDOUS/TOXIC MATERIALS INCLUDING BUT NOT LIMITED TO FUELS, OILS, BITUMEN'S, PAINTS, SEALANTS OR OTHER CHEMICALS, ARE STORED ON SITE, THEY SHALL BE STORED IN A DOUBLE-CONTAINMENT MANNER. ALL EQUIPMENT REPAIRS, MAINTENANCE, AND MECHANICAL WORK THAT COULD RESULT IN THE RELEASE OF HAZARDOUS/TOXIC MATERIALS SHALL BE PERFORMED IN AN APPROPRIATELY CONTAINED AREA, PREFERABLY OFF SITE OR AN APPROPRIATE OFF-SITE FACILITY.

IN THE EVENT THAT ANY HAZARDOUS/TOXIC MATERIALS INCLUDING BUT NOT LIMITED TO FUELS, OILS, BITUMEN'S, PAINTS, SEALANTS, OR OTHER CHEMICALS ARE SPILLED INTO ANY RIVER, THE CONTRACTOR SHALL IMMEDIATELY NOTIFY THE OHIO ENVIRONMENTAL PROTECTION AGENCY. THE CONTRACTOR SHOULD BE PREPARED TO PROVIDE DETAILED INFORMATION RELATIVE TO THE TYPE AND QUANTITY OF MATERIAL THAT HAS BEEN SPILLED AS WELL AS THE EXACT LOCATION AND THE EXACT TIME AT WHICH THE SPILL OCCURRED.

THE CONTRACTOR SHALL BE SOLELY RESPONSIBLE FOR INFORMING ALL SUBCONTRACTORS AND OTHER AGENTS OF THESE RESPONSIBILITIES, PRECAUTIONS, AND PROHIBITIONS.

WATER QUALITY PROTECTION:

NO TOXIC OR HAZARDOUS MATERIALS SUCH AS SEALANTS, PAINT, SOLVENTS, CLEANING AGENTS, EARTHEN MATERIALS, WASTE-WATER, FUELS OR DEBRIS OF ANY KIND SHALL BE DISCHARGED TO ANY STREAMS, DRAINAGE COURSES, OR BODIES OF WATER. ALL ASPHALT OR CONCRETE GRINDINGS, EXCESS ASPHALTIC OR CONCRETE MATERIALS OR ANY OTHER DEBRIS GENERATED DURING RESURFACING OR OTHER SIMILAR ACTIVITIES SHALL BE NOT BE DISPOSED OF WITHIN A FLOOD PLAIN BELOW THE 100-YEAR FLOOD ELEVATION. THE CONTRACTOR SHALL TAKE GREAT CARE TO MINIMIZE THE POTENTIAL TO CONTAMINATE THE PUBLIC DRINKING WATER SUPPLY, ALL PROJECT RELATED REFUELING AND MAINTENANCE ACTIVITIES SHALL BE PERFORMED IN AN ENVIRONMENTALLY RESPONSIBLE MANNER AND ALL PRECAUTIONS NECESSARY TO PREVENT LIQUIDS USED TO REPAIR, CLEAN, SEAL, OR TREAT ANY BRIDGE STRUCTURE (I.E. PAINT, SEALER, SOLVENT) FROM ENTERING STREAMS, WETLANDS OR OTHER WATERS OF THE UNITED STATES AND TAKE THE APPROPRIATE ACTIONS IN THE EVENT OF A RELEASE. THE CONTRACTOR IS REQUIRED AND SHALL BE HELD RESPONSIBLE FOR THE CLEAN UP AND REMEDIATION OF ANY AND ALL SPILLS.

I:\ProjectData\107556_FAY_PIC_FLAT_SHEET\Design\Roadway\Sheets\107556_TN01.dgn 107756_TN01\27/2020 3:52:08 PM vpotel

CALCULATED
VHP
CHECKED
XXX

GENERAL NOTES

FAY-SYS SIGN
REPLACE-FY20

GENERAL:

ALL TRAFFIC CONTROL DEVICES SHALL BE FURNISHED, ERECTED, MAINTAINED, AND REMOVED BY THE CONTRACTOR IN ACCORDANCE WITH THE OHIO MANUAL OF UNIFORM TRAFFIC CONTROL DEVICES (CURRENT EDITION). COPIES ARE AVAILABLE FROM,

THE OHIO DEPARTMENT OF TRANSPORTATION
THE OFFICE OF TRAFFIC ENGINEERING,
1980 WEST BROAD STREET
COLUMBUS, OHIO 43223

THE CONTRACTOR SHALL NOT ORDER MATERIALS OR PERFORM WORK LISTED IN THE GENERAL SUMMARY FOR ITEMS DESIGNATED BY PLAN NOTE TO BE USED "AS DIRECTED BY THE ENGINEER" UNLESS AUTHORIZED BY THE ENGINEER.

CONSTRUCTION OPERATIONS SHALL NOT BEGIN UNTIL ALL TRAFFIC CONTROL IS IN PLACE AND APPROVED BY ODOT PERSONNEL. THE CONSTRUCTION INSPECTOR SHALL APPROVE ALL TEMPORARY TRAFFIC CONTROL DEVICES FOR CONDITION AND LOCATION BEFORE THE CONTRACTOR WILL BE ALLOWED TO BEGIN WORK. IF THE CONTRACTOR DOES NOT COMPLY WITH THE STANDARDS, HIS PERMIT SHALL BE REVOKED AND ALL WORK SHALL BE TERMINATED.

LENGTH AND DURATION OF LANE CLOSURES AND RESTRICTIONS SHALL BE AT THE APPROVAL OF THE ENGINEER. IT IS THE INTENT TO MINIMIZE THE IMPACT TO THE TRAVELING PUBLIC. LANE CLOSURES OR RESTRICTIONS OVER SEGMENTS OF THE ROADWAY, IN WHICH NO WORK IS ANTICIPATED WITHIN A REASONABLE TIME FRAME, AS DETERMINED BY THE ENGINEER, SHALL NOT BE PERMITTED. THE LEVEL OF UTILIZATION OF MAINTENANCE OF TRAFFIC DEVICES SHALL BE COMMENSURATE WITH THE WORK IN PROGRESS.

WHEN IT IS NECESSARY TO CLOSE ONE LANE OF TRAFFIC ADJACENT TO THE WORK, THE CLOSURE SHALL BE ACCOMPLISHED BY THE APPLICATION OF TRAFFIC CONTROL DEVICES AS SHOWN ON ODOT STANDARD DRAWINGS MT 95.30, MT 95.31, MT 95.32 AND MT 97.10. ALL ADVANCE-WARNING SIGNS FOR ANY CONDITION, WHICH RESTRICTS TRAFFIC, SHALL BE ERECTED BEFORE ANY SUCH RESTRICTION IS PUT INTO EFFECT. ALL SUCH SIGNS SHALL BE COVERED OR REMOVED FROM THE VIEW OF TRAFFIC WHEN THEY ARE NOT APPLICABLE, AS DETERMINED BY THE ENGINEER.

FOR WORK, WHICH IS CONFINED TO THE SHOULDER, TRAFFIC CONTROL SHALL CONFORM TO FIGURES 6H-1(TA-1) AND 6H-3(TA-3) OF THE OHIO MANUAL OF UNIFORM TRAFFIC CONTROL DEVICES (OMUTCD). IF THE CONTRACTOR FAILS TO COMPLY WITH THE PROVISIONS FOR TRAFFIC CONTROL AS SET FORTH IN THESE PLANS AND PROVISIONS AND THE OMUTCD AND THE FAILURE RESULTS IN A CONDITION AT THE WORK SITE, WHICH IS UNSAFE FOR TRAFFIC, THE ENGINEER HAS THE AUTHORITY TO SUSPEND WORK UNTIL THE CONTRACTOR COMPLIES WITH THE NECESSARY REQUIREMENTS.

TWO WAY, ONE LANE TRAFFIC SHALL BE MAINTAINED BY USE OF THE EXISTING PAVEMENT AND MAY BE PERMITTED SUBJECT TO THE APPROVAL OF THE ENGINEER.

USE OF STANDARD DRAWINGS

IT MAY BE NECESSARY TO EXTEND THE ADVANCE WARNING AND BUFFER ZONES BEYOND THE MINIMUM DISTANCES SHOWN ON THE STANDARD DRAWINGS. THIS MAY BE DUE TO HORIZONTAL ALIGNMENT, VERTICAL ALIGNMENT, RAMP LOCATIONS, OR OTHER SIGHT OBSTRUCTIONS. LOCATIONS OF THE TAPER ZONES MAY BE ADJUSTED AS DIRECTED BY THE ENGINEER, BUT TAPER LENGTHS MUST MEET THE MINIMUM STANDARDS. TAPERS SHOULD BE PLACED IN TANGENT SECTIONS WHENEVER POSSIBLE. ADDITIONAL YIELD SIGNS MAY BE REQUIRED FOR RAMPS WITHIN 1,000 FEET OF A WORK ZONE. PAYMENT SHALL BE INCLUDED IN THE LUMP SUM CONTRACT PRICE FOR ITEM 614 - MAINTAINING TRAFFIC.

FOR ANY MULTILANE HIGHWAY, DEVICE SPACING SHALL BE A MAXIMUM OF 40' CENTER ON CENTER IN THE TAPERS AND 80' CENTER ON CENTER IN THE TANGENT SECTIONS.

NOTIFICATION OF CONSTRUCTION INITIATION

AT LEAST FOURTEEN DAYS PRIOR TO STARTING INITIAL CONSTRUCTION ACTIVITIES, THE CONTRACTOR SHALL ADVISE THE DISTRICT OFFICE OF COMMUNICATIONS VIA EMAIL AT D06.PIO@DOT.OHIO.GOV, THE DISTRICT WORK ZONE TRAFFIC MANAGER VIA EMAIL AT D06.MOT@DOT.OHIO.GOV AND THE CENTRAL OFFICE SPECIAL HAUL PERMITS SECTION VIA EMAIL AT HAULING.PERMITS@DOT.OHIO.GOV OF THE ANTICIPATED START DATE OF ANY CONSTRUCTION ACTIVITIES INCLUDING BUT NOT LIMITED TO THE PLACING OF WORK ZONE SIGNS. THE NOTIFICATION SHALL ALSO INCLUDE THE PROJECT NUMBER, PID, NAME AND PHONE NUMBER OF THE CONTRACTOR, A POINT OF CONTACT AND THE ANTICIPATED IMPACT ON TRAFFIC. THE CONTRACTOR WILL IMMEDIATELY INFORM THE DISTRICT OFFICE OF COMMUNICATIONS AND THE DISTRICT WORK ZONE TRAFFIC MANAGER OF ANY AND ALL DELAYS AND/OR CHANGES REGARDING THE CONSTRUCTION INITIATION DATE.

NOTIFICATION OF TRAFFIC RESTRICTIONS

THROUGHOUT THE DURATION OF THE PROJECT, THE CONTRACTOR SHALL NOTIFY THE PROJECT ENGINEER IN WRITING OF ALL TRAFFIC RESTRICTIONS AND UPCOMING MAINTENANCE OF TRAFFIC CHANGES. THE CONTRACTOR SHALL ENSURE THE WRITTEN NOTIFICATION IS SUBMITTED IN A TIMELY MANNER TO ALLOW THE PROJECT ENGINEER TO MEET THE REQUIRED TIME FRAMES SET FORTH IN THE TABLE BELOW. THIS NOTIFICATION SHALL BE RECEIVED BY THE PROJECT ENGINEER PRIOR TO THE PHYSICAL SETUP OF ANY APPLICABLE SIGNS OR MESSAGE BOARDS.

INFORMATION SHOULD INCLUDE BUT IS NOT LIMITED TO ALL CONSTRUCTION ACTIVITIES THAT IMPACT OR INTERFERE WITH TRAFFIC AND SHOULD LIST THE SPECIFIC LOCATION, TYPE OF WORK, ROAD STATUS, DATE AND TIME OF RESTRICTION, DURATION OF RESTRICTION, NUMBER OF LANES MAINTAINED, DETOUR ROUTES IF APPLICABLE, AND ANY OTHER INFORMATION REQUESTED BY THE PROJECT ENGINEER.

ITEM	DURATION OF CLOSURE	NOTIFICATION DUE TO DISTRICT 6 COMMUNICATIONS OFFICE
RAMP AND ROAD CLOSURES	>= 2 WEEKS	14 BUSINESS DAYS PRIOR TO CLOSURE
	> 12 HOURS AND < 2 WEEKS	7 BUSINESS DAYS PRIOR TO CLOSURE
	< 12 HOURS	TO CLOSURE? BUSINESS DAYS PRIOR
LANE CLOSURES/ RESTRICTIONS	>= 2 WEEKS	7 BUSINESS DAYS PRIOR TO CLOSURE
	< 2 WEEKS	2 BUSINESS DAYS PRIOR TO CLOSURE

ANY UNFORESEEN CONDITIONS NOT SPECIFIED IN THE PLANS REQUIRING TRAFFIC RESTRICTIONS SHALL ALSO BE REPORTED TO THE PROJECT ENGINEER USING THE NOTIFICATION TIME FRAME TABLE.

LANES OPEN DURING HOLIDAYS AND SPECIAL EVENTS

NO WORK SHALL BE PERFORMED AND THE SAME NUMBER OF LANES AS WERE AVAILABLE AT THE START OF THE PROJECT SHALL BE OPEN TO TRAFFIC DURING THE FOLLOWING DESIGNATED HOLIDAYS AND EVENTS:

HOLIDAYS:

CHRISTMAS	FOURTH OF JULY
NEW YEAR'S EVE	LABOR DAY
MEMORIAL DAY	THANKSGIVING

THE PERIOD OF TIME THAT THE LANES ARE TO BE OPEN DEPENDS ON THE DAY OF THE WEEK ON WHICH THE HOLIDAY FALLS. THE FOLLOWING SCHEDULE SHALL BE USED TO DETERMINE THIS PERIOD:

DAY OF HOLIDAY	TIME ALL LANES MUST BE OPEN TO TRAFFIC
SUNDAY	12:00 NOON FRIDAY THROUGH 5:00 AM MONDAY
MONDAY	12:00 NOON FRIDAY THROUGH 5:00 AM TUESDAY
TUESDAY	12:00 NOON MONDAY THROUGH 5:00 AM WEDNESDAY
WEDNESDAY	12:00 NOON TUESDAY THROUGH 5:00 AM THURSDAY
THURSDAY	12:00 NOON WEDNESDAY THROUGH 5:00 AM FRIDAY
THANKSGIVING	12:00 NOON TUESDAY THROUGH 5:00 AM MONDAY
FRIDAY	12:00 NOON THURSDAY THROUGH 5:00 AM MONDAY
SATURDAY	12:00 NOON FRIDAY THROUGH 5:00 AM MONDAY

SPECIAL EVENTS:

NO EXTENSIONS OF TIME SHALL BE GRANTED FOR DELAYS IN MATERIAL DELIVERIES, UNLESS SUCH DELAYS ARE INDUSTRY WIDE, OR FOR LABOR STRIKES, UNLESS SUCH STRIKES ARE AREA WIDE.

SHOULD THE CONTRACTOR FAIL TO MEET ANY OF THESE REQUIREMENTS, THE CONTRACTOR SHALL BE ASSESSED A DISINCENTIVE IN THE AMOUNT OF \$100 FOR EACH MINUTE THE ABOVE DESCRIBED LANE CLOSURE RESTRICTIONS ARE VIOLATED.

COORDINATION WITH ADJACENT PROJECTS

THE CONTRACTOR SHALL COORDINATE WORK WITH ODOT AND THE CONTRACTORS ON THE ADJACENT PROJECTS. A LIST OF ODOT CONSTRUCTION PROJECTS WITHIN FAYETTE COUNTY SHALL BE PROVIDED AT THE PRE-CONSTRUCTION MEETING. COORDINATION SHALL BE MADE TO PREVENT CONFLICTING ADVANCE WARNING SIGNS, CONFLICTING DETOUR ROUTES, OVERLAPING/CONFLICTING LANE CLOSURES, AND TO ENSURE THAT A MINIMUM DISTANCE OF 2 MILES BETWEEN ADJACENT LANE CLOSURES IS MAINTAINED. THIS IS NOT AN EXHAUSTIVE LIST OF COORDINATION ITEMS THAT MAY NEED TO BE RESOLVED BETWEEN PROJECTS. THE DEPARTMENT RESERVES THE RIGHT TO DECIDE WHICH PROJECT'S ACTIVITIES TAKE PRECEDENCE. PROJECTS THAT HAVE ACTIVITIES DELAYED DUE TO CONFLICTS WILL CONSIDER THIS AN EXCUSABLE, NON-COMPENSABLE DELAY PER 108.06.B. ON PROJECTS THAT HAVE ACTIVITIES DELAYED DUE TO CONFLICTS WHERE THE CONTRACTOR FAILED TO MEET THE NOTIFICATION REQUIREMENTS, THE DELAYS SHALL NOT BE CONSIDERED EXCUSABLE OR COMPENSABLE.

ATTENDANCE AT DEPARTMENT ORDERED TRAFFIC COORDINATION MEETINGS BETWEEN ADJACENT PROJECTS SHALL BE CONSIDERED MANDATORY FOR EACH PROJECT'S SUPERINTENDENT AND WORKSITE TRAFFIC SUPERVISOR (WTS)*, AND INCIDENTAL TO THE LUMP SUM MAINTENANCE OF TRAFFIC PAYMENT ITEM. *IF REQUIRED BY THE PROJECT

TRUCK MOUNTED ATTENUATOR (TMA) TWO LANE ROADS:

WHEN WORKING IN A CLOSED LANE OR SHOULDER ON A TWO LANE HIGHWAY WITHOUT TEMPORARY OR PERMANENT TRAFFIC BARRIERS SEPARATING THE WORK AREA FROM THE TRAVELED LANE, A TRUCK MOUNTED ATTENUATOR (TMA) SHALL BE PROVIDED TO PROTECT EACH WORK AREA IN ACCORDANCE WITH OMUTCD TYPICAL APPLICATION (TA) 4, TA-6 AND TA-17, ALONG WITH STANDARD CONSTRUCTION DRAWING (SCD) MT-97.10. THE TMA SHALL BE PLACED IN SUCH A WAY TO ADEQUATELY PROTECT THE WORKERS INSIDE THE WORK ZONE. THE TMA IS NOT INTENDED TO BE USED AS OR SUBSTITUTED FOR THE FLAGGERS AND/OR WARNING SIGNS AND DEVICES. THE TMA SHALL MEET NCHRP 350 TEST LEVEL 3 CRITERIA FOR STANDARD AND OPTIONAL TESTS AT 100 KM/H (62 MPH) FOR DESIGN IMPACTS. THE COST FOR PROVIDING THE TMA SHALL INCLUDE ALL MATERIAL, LABOR, EQUIPMENT, AND HARDWARE REPLACEMENT AND IS TO BE INCLUDED IN THE LUMP SUM BID PRICE FOR ITEM 614 MAINTAINING TRAFFIC.

WORK SITE LIGHTING:

FLOODLIGHTING OF THE WORK SITE FOR OPERATIONS CONDUCTED DURING NIGHTTIME PERIODS SHALL BE ACCOMPLISHED SO THAT THE LIGHTS DO NOT CAUSE GLARE TO THE DRIVERS ON THE ROADWAY. TO ENSURE THE ADEQUACY OF THE FLOODLIGHT PLACEMENT, THE CONTRACTOR, AND THE ENGINEER SHALL DRIVE THROUGH THE WORK SITE EACH NIGHT WHEN THE LIGHTING IS IN PLACE AND OPERATIVE PRIOR TO COMMENCING ANY WORK. IF GLARE IS DETECTED, THE LIGHT PLACEMENT AND SHIELDING SHALL BE ADJUSTED TO THE SATISFACTION OF THE ENGINEER BEFORE WORK PROCEEDS. PAYMENT FOR ALL LABOR, EQUIPMENT, AND MATERIALS SHALL BE INCLUDED IN THE LUMP SUM CONTRACT PRICE FOR ITEM 614, MAINTAINING TRAFFIC.

I:\ProjectData\07556_FAY_PIC_FLAT\Design\Roadway\Sheets\07556_TN01.dgn 1/27/2020 3:52:09 PM vpd\tel

PERMITTED LANE CLOSURE TIMES AND DISINCENTIVE:

ALL LANES OF TRAFFIC IN EACH DIRECTION SHALL BE MAINTAINED AT ALL TIMES, EXCEPT FOR THE ALLOWABLE TIMES SHOWN IN THE LANE VALUE CONTRACT TABLE & PERMITTED LANE CLOSURE TABLE. THE CONTRACTOR SHALL BE ASSESSED A DISINCENTIVE AS DESIGNATED IN THE TABLES LOCATED BELOW FOR EACH UNIT OF TIME A LANE/RAMP/SHOULDER IS CLOSED BY THE CONTRACTOR'S ACTION WHILE NOT OTHERWISE PERMITTED BY THE CONTRACT. AT NO TIME SHALL ANY RAMP BE CLOSED. IF A RAMP CLOSURE IS REQUIRED THE CONTRACTOR SHALL COORDINATE THE CLOSURE AND SUBSEQUENT DETOUR WITH DISTRICT 06 WORK ZONE TRAFFIC MANAGER. ALL COSTS ASSOCIATED WITH THE CLOSURE SHALL BE INCLUDED IN THE UNIT BID PRICE FOR ITEM 614 - MAINTAINING TRAFFIC.

UNAUTHORIZED LANE USE:

THE PERMITTED LANE CLOSURE TIMES LISTED BELOW SHALL BE SUBJECT TO DISINCENTIVES AS PER THE UNAUTHORIZED LANE USE TABLE BELOW FOR ANY TIME PERIOD OR PORTION THEREOF IN WHICH THE MINIMUM NUMBER OF OPEN LANES IS VIOLATED. FOR U.S. ROUTE 35, INTERSTATE 71, & STATE ROUTE 435 THE CONTRACTOR SHALL USE THE LANE VALUE CONTRACT TABLE FOR ALLOWABLE HOURS & DISINCENTIVES.

UNAUTHORIZED LANE USE TABLE	
ALL TWO-LANE ROUTES	\$25.00 PER MINUTE PER LANE
ALL OTHER ROUTES	\$100.00 PER MINUTE PER LANE

PERMITTED LANE CLOSURE TABLE		
LOCATION	HOURS OF WORK	NOTES
TWO-LANE HIGHWAY	8:00 AM - 4:00 PM & 6:00 PM - 6:00 AM	MAINTAIN AT LEAST ONE SHARED LANE
ALL OTHER ROUTES	9:00 PM - 5:00 AM	MAINTAIN AT LEAST ONE PER DIRECTION. ONLY SINGLE OR DOUBLE LANE CLOSURES ALLOWED ON SECTIONS WITH 5 LANES PER DIRECTION OR LESS. ONLY TRIPLE LANE CLOSURES ALLOWED ON SECTIONS WITH 6 LANES PER DIRECTION.

LANE VALUE CONTRACT TABLE						
Section (SLM)	Existing Number of Lanes per Direction	Lane closures are NOT permitted:				Disincentive Amounts per minute per lane
		Lane Reduction	Mon to Fri	Sat	Sun	
FAY-35						
FAY-435 (4.37) to SR 739 (17.23)	2	2 to 1	No Restriction	No Restriction	No Restriction	
Shoulder closures are permitted any time except 5AM-9AM & 3PM-6PM Monday-Friday						

LANE VALUE CONTRACT TABLE						
FAY-71						
Section	Existing Number of Lanes per Direction	Lane closures are NOT permitted:				Disincentive Amounts per minute per lane
		Lane Reduction	Mon to Thur	Fri to Sat	Sun	
Green County Line (0.00) to SR 41 (9.45) Northbound	3	3 to 2	No Restriction	No Restriction	No Restriction	\$160
Green County Line (0.00) to SR 41 (9.45) Southbound	3	3 to 2	No Restriction	No Restriction	No Restriction	\$160
SR 41 (9.45) to Madison County Line (14.65) Northbound	2	2 to 1	9AM-7PM	7AM-7PM	9AM-10PM	\$235
SR 41 (9.45) to Madison County Line (14.65) Southbound	2	2 to 1	9AM-7PM	7AM-10PM	9AM-7PM	\$235
Short term shoulder closures are permitted any time except 6AM-9AM and 3PM-6PM Monday-Friday.						

LANE VALUE CONTRACT TABLE						
Section (SLM)	Existing Number of Lanes per Direction	Lane closures are NOT permitted:				Disincentive Amounts per minute per lane
		Lane Reduction	Mon to Fri	Sat	Sun	
FAY-435						
US 35 (0.00) to West Lancaster Road (1.38)	2	2 to 1	No Restriction	No Restriction	No Restriction	\$25
West Lancaster Road (1.38) to Factory Shops Blvd (1.96)	2	2 to 1	6AM-9AM & 4PM-6PM	6AM-9AM & 4PM-6PM	6AM-9AM & 4PM-6PM	\$105
Factory Shops Blvd (1.96) to US 35 (2.48) Westbound	2	2 to 1	No Restriction	No Restriction	No Restriction	\$65
Factory Shops Blvd (1.96) to US 35 (2.48) Eastbound	1	1 shared lane	6AM-9AM & 4PM-6PM	6AM-9AM & 4PM-6PM	6AM-9AM & 4PM-6PM	\$100
US 35 (2.48) to SR 729 (3.97)	1	1 shared lane	6AM-9AM & 4PM-6PM	6AM-9AM & 4PM-6PM	6AM-9AM & 4PM-6PM	\$25
Shoulder closures are permitted any time except 5AM-9AM & 3PM-6PM Monday-Friday						

CALCULATED
VHP
CHECKED
XXX

MAINTENANCE OF TRAFFIC NOTES

FAY-SYS SIGN REPLACE-FY20

I:\ProjectData\07556_FAY_PIC_FLAT_SHEET\Design\Roadway\Sheets\07556_TG001.dgn 07556_TG001 2/26/2020 10:02:00 AM vpatel

SHEET NUM.										PART.		ITEM	ITEM	GRAND	UNIT	DESCRIPTION	SEE SHEET NO.
5	6									01/SAF/OT		EXT	TOTAL				
TRAFFIC CONTROL																	
490	1,071											630	02100	1,561	FT	GROUND MOUNTED SUPPORT, NO. 2 POST	
730	1,575											630	03100	2,305	FT	GROUND MOUNTED SUPPORT, NO. 3 POST	
178	128											630	08600	306	EACH	SIGN POST REFLECTOR	
28	6											630	79500	34	EACH	SIGN SUPPORT ASSEMBLY, POLE MOUNTED	
3,790.7	3,112.5											630	80100	6,903.2	SF	SIGN, FLAT SHEET	
242.0	36.0											630	80101	278.0	SF	SIGN, FLAT SHEET, AS PER PLAN	2
26	45											630	80600	71	EACH	SIGN, DOUBLE FACED, MILE MARKER	
4	5											630	82000	9	EACH	SIGN BACKING ASSEMBLY	
692	641											630	84900	1,333	EACH	REMOVAL OF GROUND MOUNTED SIGN AND DISPOSAL	
8	23											630	85101	31	EACH	REMOVAL OF GROUND MOUNTED SIGN AND REERECTION, AS PER PLAN	2
90	36											630	86002	126	EACH	REMOVAL OF GROUND MOUNTED POST SUPPORT AND DISPOSAL	
28	6											630	87500	34	EACH	REMOVAL OF POLE MOUNTED SIGN AND DISPOSAL	
177	128											630	97700	305	EACH	SIGNING, MISC.:MISC: REMOVAL OF POST REFLECTOR	2
INCIDENTALS																	
												LS	614	11000	LS	MAINTAINING TRAFFIC	
												LS	623	10000	LS	CONSTRUCTION LAYOUT STAKES AND SURVEYING	
												LS	624	10000	LS	MOBILIZATION	

GENERAL SUMMARY

FAY-SYS SIGN REPLACE-FY20

CALCULATED
VHP
CHECKED

I:\ProjectData\107556_FAY_PIC_FLATSHEET\Design\Roadway\Sheets\107556_IS000.dgn 107556_IS001 2/26/2020 9:57:44 AM vpatel

SHEET NO.	ROUTE	NOTE	630	630	630	630	630	630	630	630	630	630	630	630	630	630	630	630		
			GROUND MOUNTED SUPPORT, No. 2 POST	GROUND MOUNTED SUPPORT, No. 3 POST	SIGN POST REFLECTOR, RED	SIGN POST REFLECTOR, WHITE	SIGN POST REFLECTOR, YELLOW	SIGN BACKING ASSEMBLY	SIGN SUPPORT ASSEMBLY, POLE MOUNTED	SIGN, FLAT SHEET	SIGN, FLAT SHEET, AS PER PLAN	SIGN, DOUBLE FACED, MILE MARKER	REMOVAL OF GROUND MOUNTED SIGN & DISPOSAL	REMOVAL OF GROUND MOUNTED SIGN & RE-ERECTION, AS PER PLAN		REMOVAL OF GROUND MOUNTED POST SUPPORT AND DISPOSAL		REMOVAL OF POLE MOUNTED SIGN & DISPOSAL	SIGNING, MISC: REMOVAL OF POST REFLECTOR	
			FT	FT	EACH		EACH	EACH	SQ FT	SQ FT	EACH	EACH	EACH		EACH		EACH	EACH		
FAYETTE COUNTY																				
15	US-22		21.0	30.0	10				243.2		7	44		5				10		
16	US-22		7.0	10.0	2				238.8			49						2		
17	US-22		7.0	20.0				9	195.6		1	32		1		9				
18	US-22		7.0	20.0				19	127.4		1	22		1		19				
19	US-22		21.0	30.0	4		2		171.1		3	41						6		
20	US-22		7.0	10.0	15				217.5		6	46		1				15		
30	US-35		84.0	120.0	4	4			207.0	32.0		28		11				8		
31	US-35		70.0	100.0	4	4			159.5	96.0		34		14				8		
32	US-35		42.0	60.0	5	4			246.8	32.0		32		8				9		
33	US-35		49.0	70.0	7	4		4	313.9	32.0		39		12				11		
34	US-35		70.0	100.0	4	4			133.5			32		15				8		
38	SR-38		28.0	45.0	2		11		190.2		1	33	3					12		
39	SR-38		14.0	25.0	17				164.5			29	4	1				17		
40	SR-38		14.0	20.0	3		12		149.3		3	39		3				15		
41	SR-38		7.0	10.0	3		6		151.1	9.0	4	44	1	1				9		
42	SR-38				1		12		106.3	9.0		32		1				13		
49	I-71				8	8			305.0	16.0		42		12				16		
50	I-71		42.0	60.0	6	6			362.0	16.0		41		4				12		
51	I-71				4	2			108.0			33						6		
TOTALS CARRIED TO GENERAL SUMMARY			490.0	730.0	99	36	43	4	28	3790.7	242.0	26	692	8	90		28	177		
					178															

CALCULATED
VHP
CHECKED
XXX

TRAFFIC CONTROL SUB-SUMMARY

**FAY-SYS SIGN
REPLACE-FY20**

I:\ProjectData\07556_FAY_PIC_FLATSHEET\Design\Roadway\Sheets\07556_IS000.dgn 107556_IS002 2/26/2020 9:56:26 AM vpatel

SHEET NO.	ROUTE	NOTE	630	630	630	630	630	630	630	630	630	630	630	630	630	630	630	630	630	630		
			GROUND MOUNTED SUPPORT, No. 2 POST	GROUND MOUNTED SUPPORT, No. 3 POST	SIGN POST REFLECTOR, RED	SIGN POST REFLECTOR, WHITE	SIGN POST REFLECTOR, YELLOW	SIGN BACKING ASSEMBLY	SIGN SUPPORT ASSEMBLY, POLE MOUNTED	SIGN, FLAT SHEET	SIGN, FLAT SHEET, AS PER PLAN	SIGN, DOUBLE FACED, MILE MARKER	REMOVAL OF GROUND MOUNTED SIGN & DISPOSAL	REMOVAL OF GROUND MOUNTED SIGN & RE-ERECTION, AS PER PLAN	REMOVAL OF GROUND MOUNTED POST SUPPORT AND DISPOSAL	REMOVAL OF POLE MOUNTED SIGN & DISPOSAL	SIGNING, MISC: REMOVAL OF POST REFLECTOR					
			FT	FT	EACH			EACH	SQ FT	SQ FT	EACH	EACH	EACH	EACH	EACH		EACH		EACH	EACH		
FAYETTE COUNTY																						
54	SR-207		14.0	20.0	12				180.5		3	31				1			12			
55	SR-207				6				123.2		2	24							6			
59	SR-435		7.0	10.0	7				285.4	9.0	1	46							7			
60	SR-435		28.0	50.0			4		188.9		1	40	4			11						
61	SR-435		28.0	45.0					148.6		2	34				2						
67	SR-729		14.0	25.0	12		2	1	213.1		4	42				2			14			
68	SR-729			5.0	13		3		195.3	9.0	1	39	4			1			16			
69	SR-729		35.0	55.0	10		3		250.7	18.0	3	39	4			3			13			
70	SR-729				6				133.1			32	10			2			6			
71	SR-729		21.0	30.0	6				157.5		4	31				3			6			
76	SR-734			10.0	9			6	189.7		5	37	1					6	9			
77	SR-734		28.0	40.0	6		4		170.0		6	39				4			10			
84	SR-753				8		2		214.8		4	46				2			10			
85	SR-753				12				194.0		5	45							12			
86	SR-753		7.0	15.0	1				182.6		2	42				3			1			
87	SR-753		14.0	20.0	1		5		166.4		2	39				2			6			
88	SR-753								118.7			35										
CONTINGENCY QUANTITY			875.0	1250.0																		
TOTALS CARRIED TO GENERAL SUMMARY			1071.0	1575.0	109		19	5	6	3112.5	36.0	45	641	23		36		6	128			
					128																	

CALCULATED
VHP
CHECKED
XXX

TRAFFIC CONTROL SUB-SUMMARY

**FAY-SYS SIGN
REPLACE-FY20**

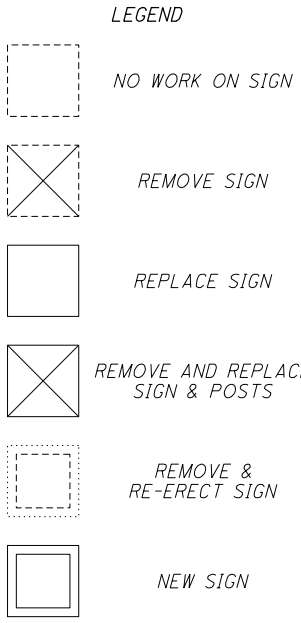

NOTES
1. SEE SHEETS 15-20 FOR QUANTITIES

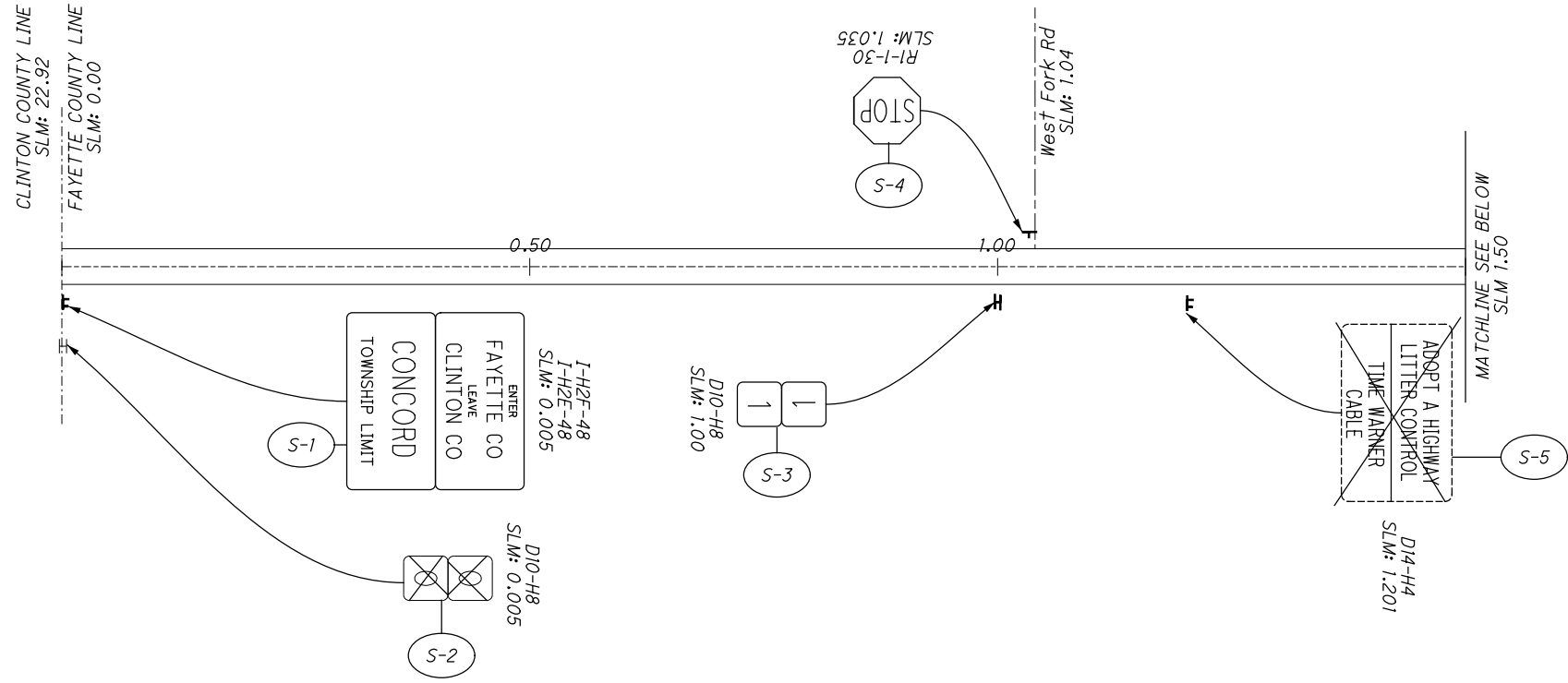
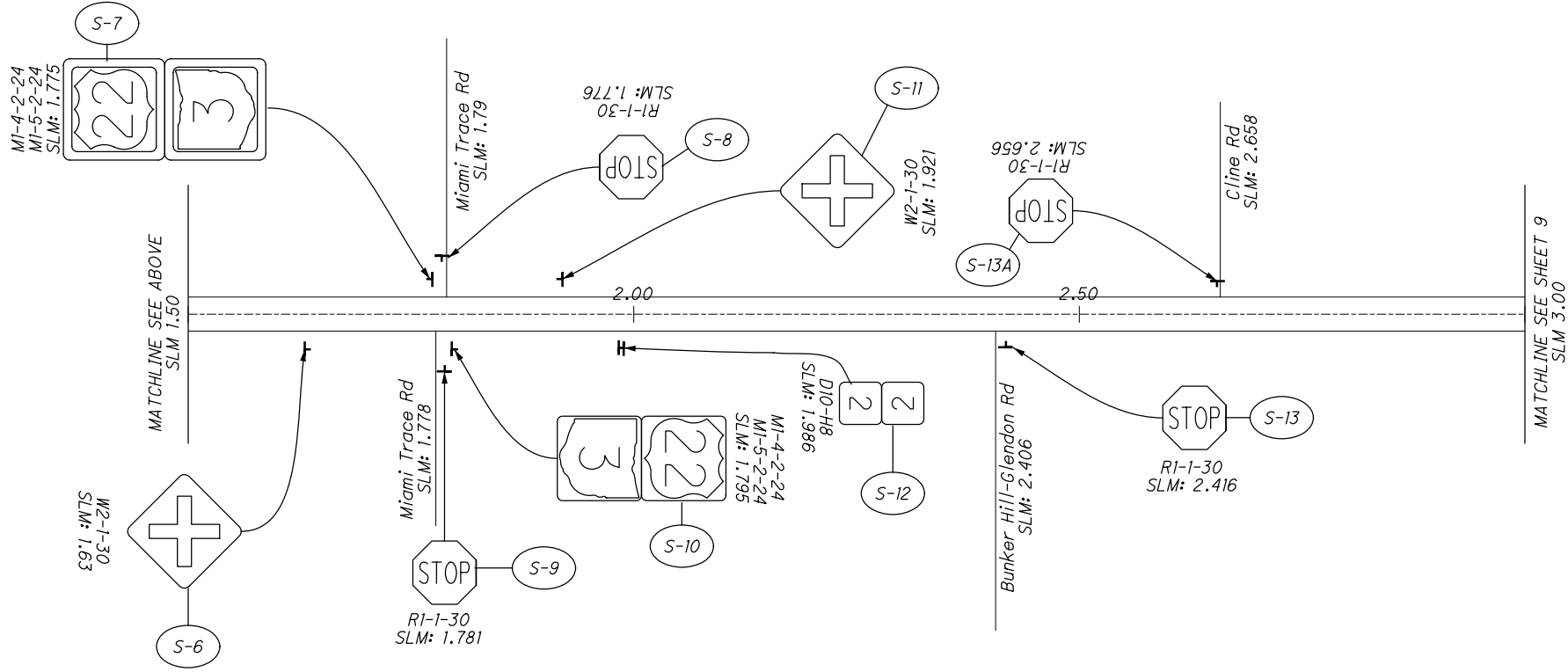

SEE SHEET 8 FOR LEGEND
SEE SHEETS 15 - 20 FOR QUANTITIES

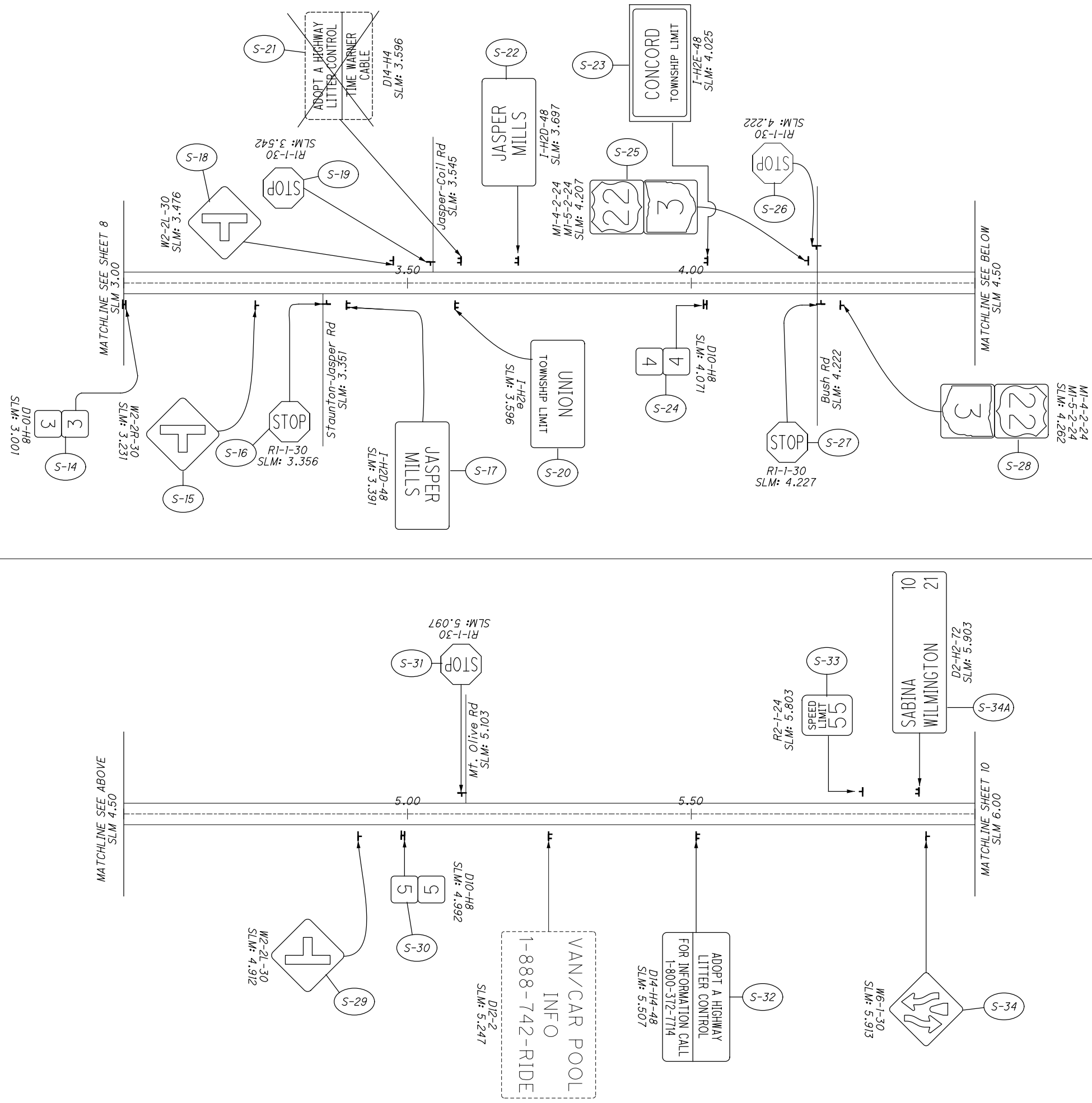

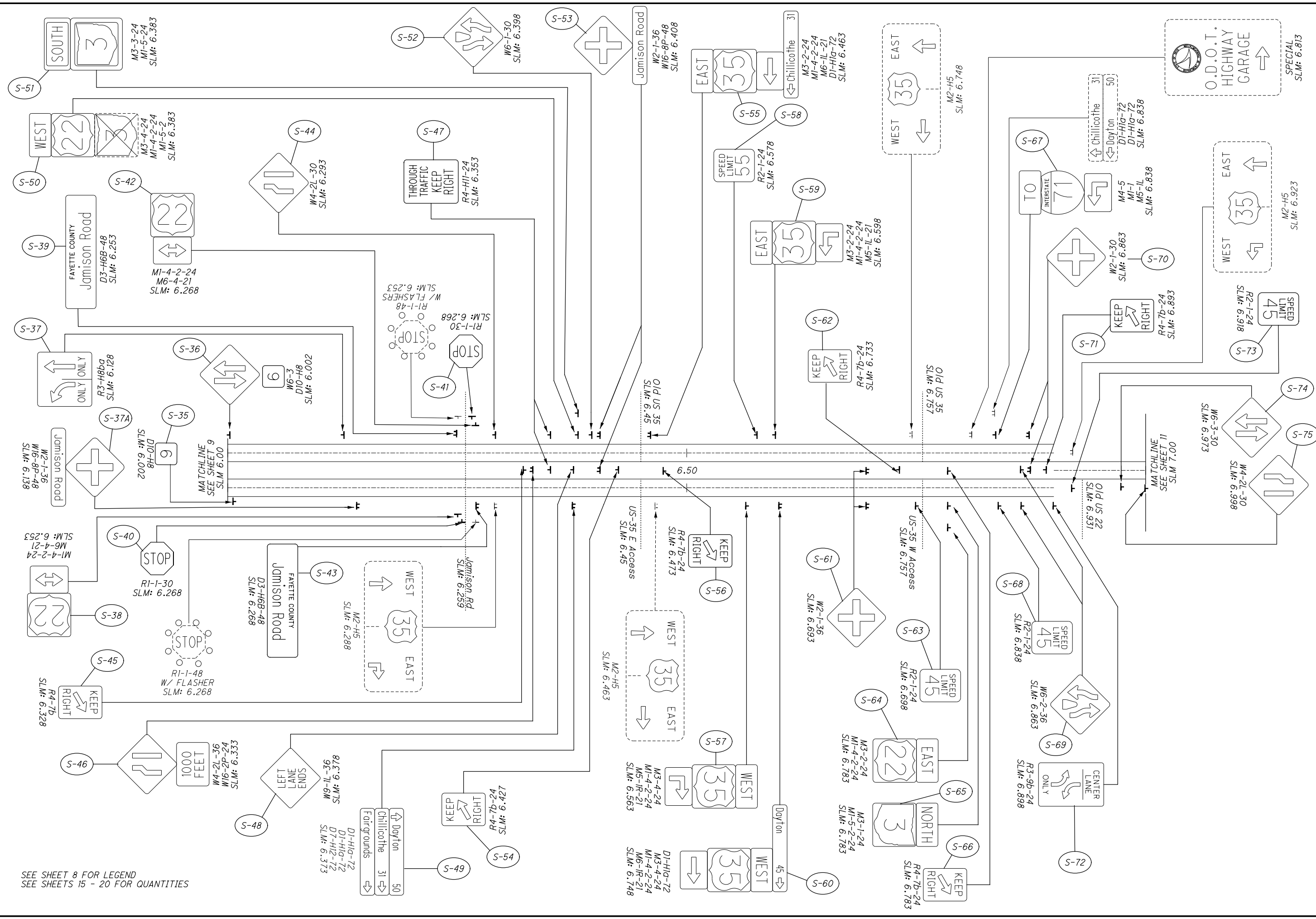

SEE SHEET 8 FOR LEGEND
 SEE SHEETS 15 - 20 FOR QUANTITIES



**FAY-SYS SIGN
 REPLACE-FY20**

SIGN PLAN

FAY-22: SLM 6.00 - 7.00

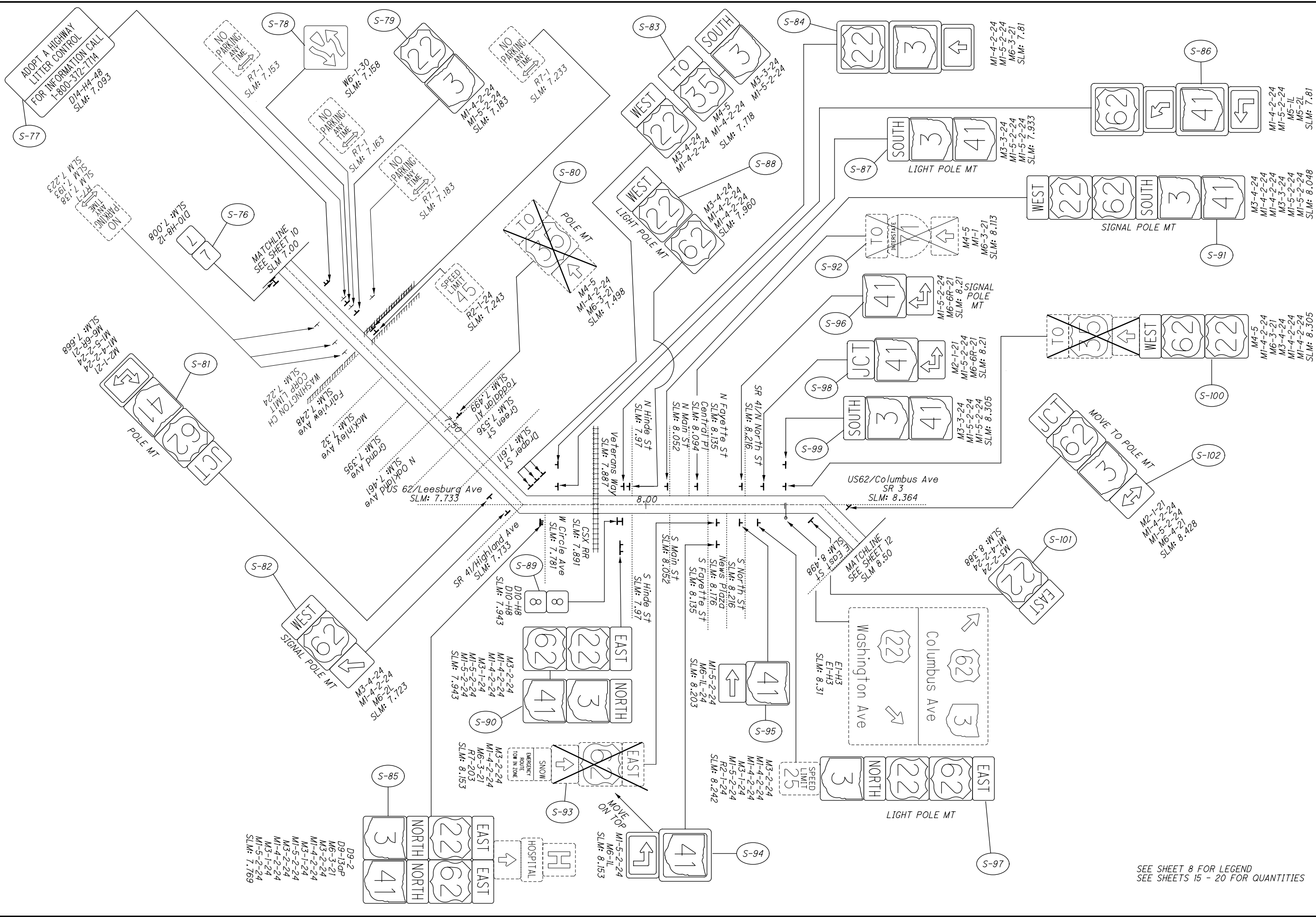

CALCULATED
CHECKED

SIGN PLAN
FAY-22: SLM 7.00 - 8.50

FAY-SYS SIGN REPLACE-FY20
11
88

SEE SHEET 8 FOR LEGEND
SEE SHEETS 15 - 20 FOR QUANTITIES

SEE SHEET 8 FOR LEGEND
SEE SHEETS 15 - 20 FOR QUANTITIES

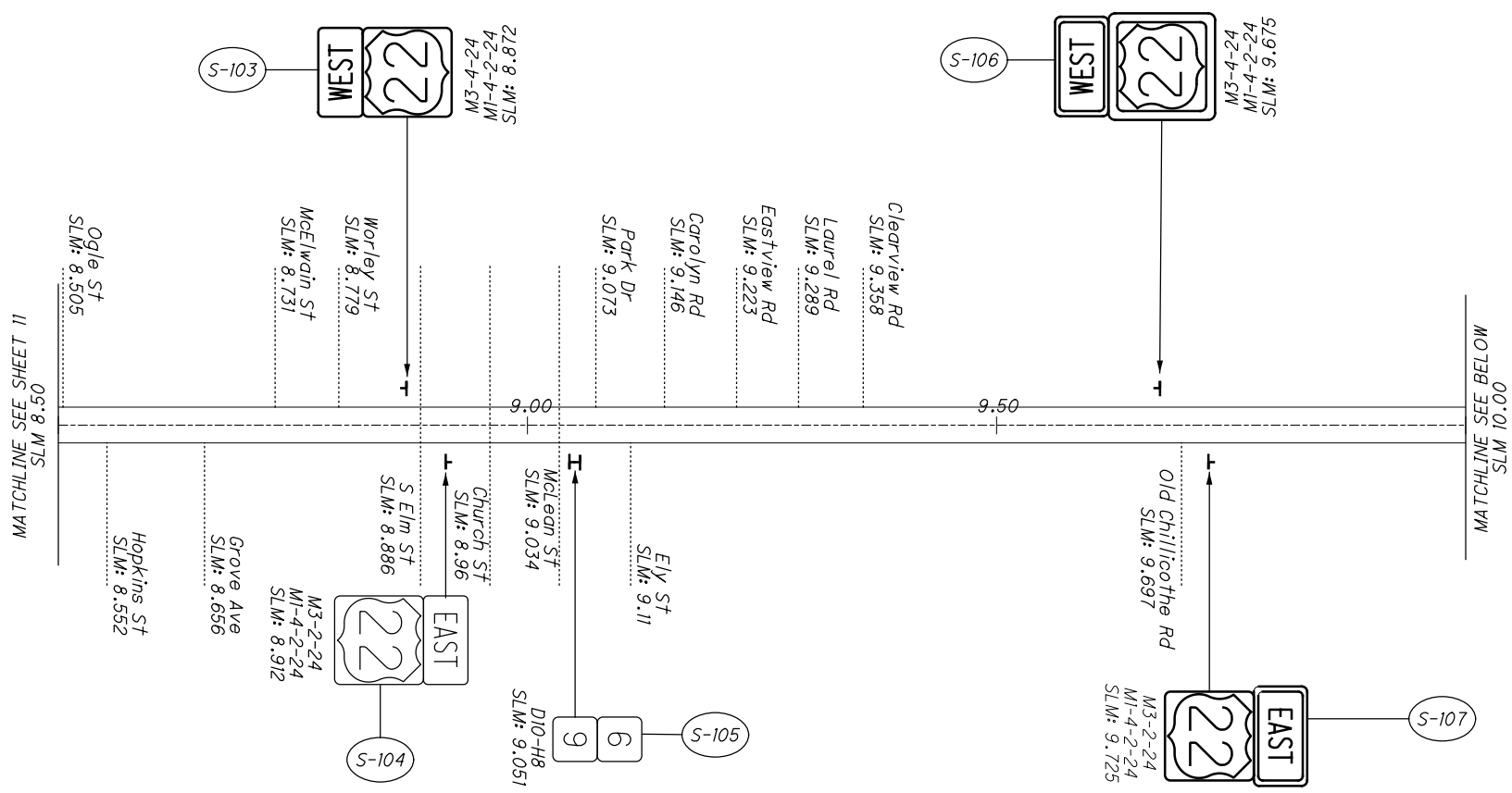
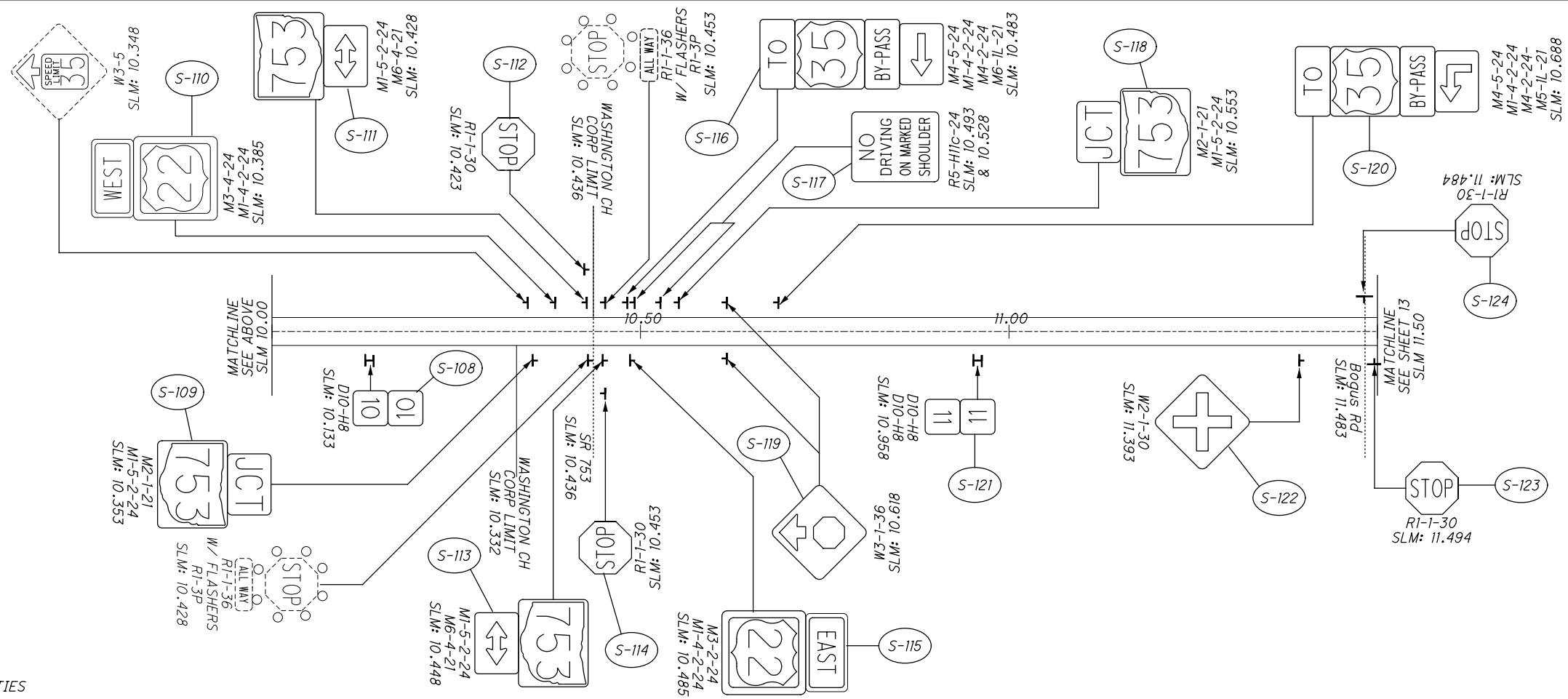

**FAY-SYS SIGN
REPLACE-FY20**

**SIGN PLAN
FAY-22: SLM 8.50 - 11.50**

\\P:\ProjectData\107556_FAY_PIC_FLAT_SHEET\Design\Roadway\Sheets\107556_IP001.dgn 107556_IP006 1/27/2020 3:52:25 PM vpatel

SEE SHEET 8 FOR LEGEND
SEE SHEETS 15 - 20 FOR QUANTITIES

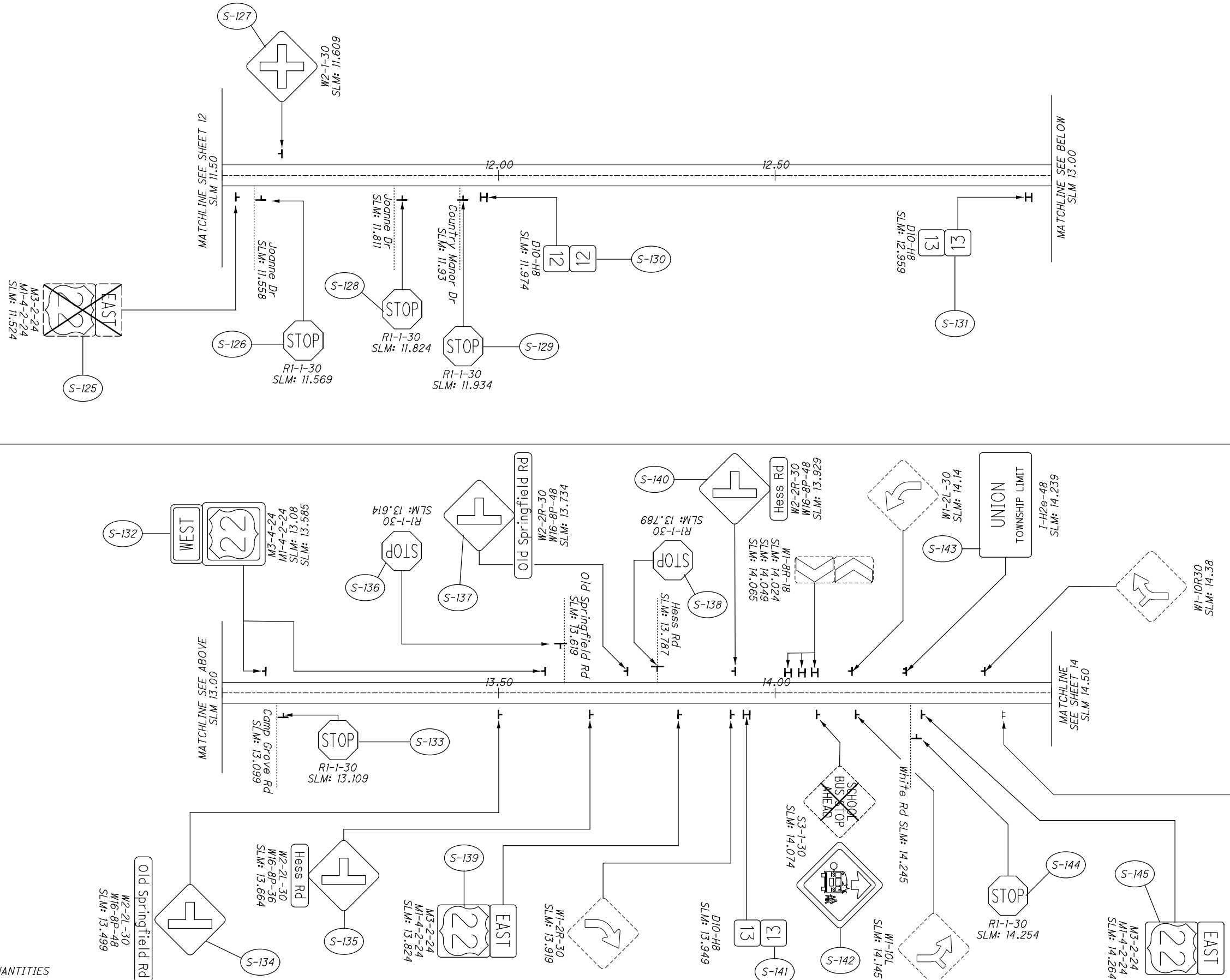

CALCULATED

CHECKED



SIGN PLAN
FAY-22: SLM 11.50 - 14.50

FAY-SYS SIGN
REPLACE-FY20

VAN/CAR POOL
INFO
1-888-742-RIDE
D12-2
SLM: 14.409

SEE SHEET 8 FOR LEGEND
SEE SHEETS 15 - 20 FOR QUANTITIES

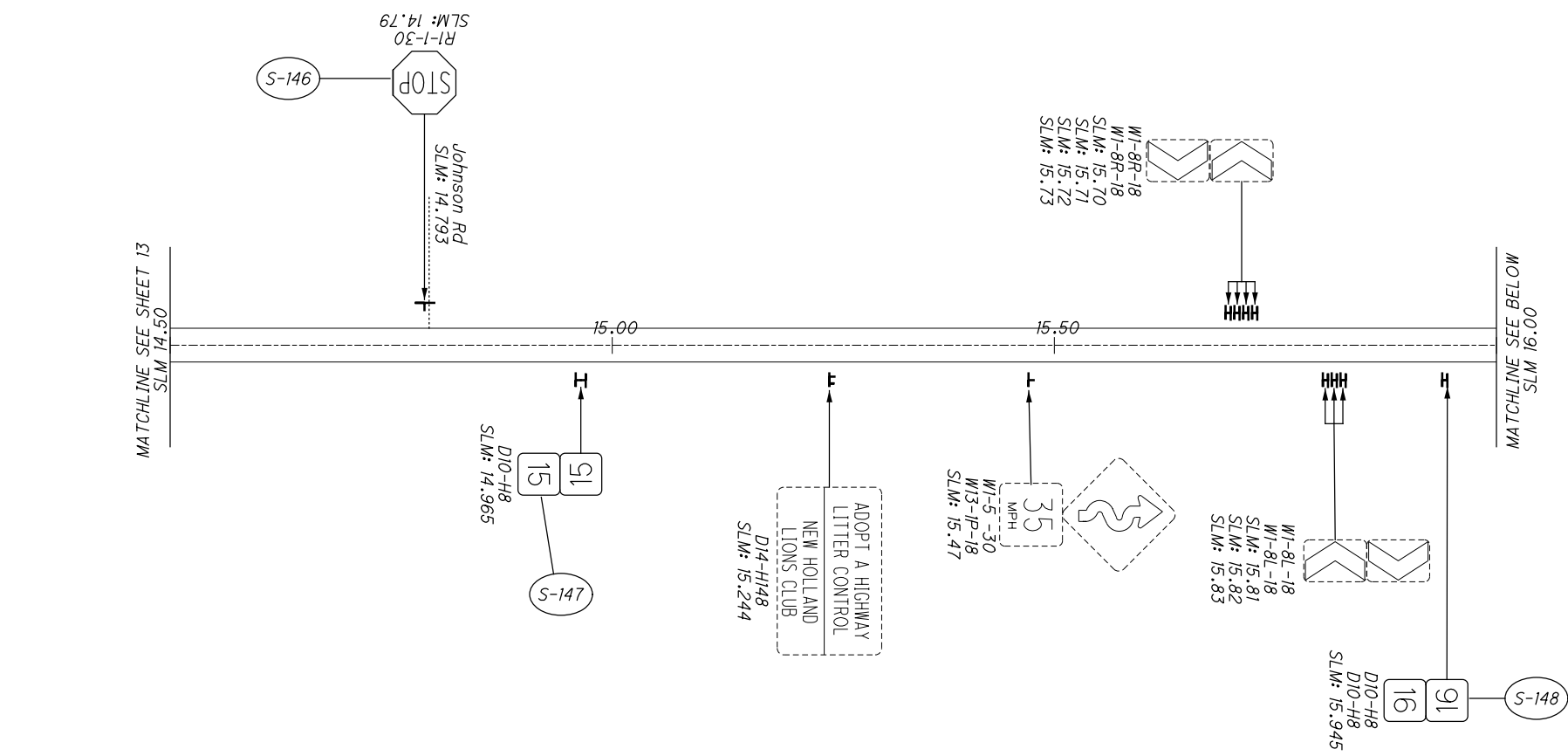
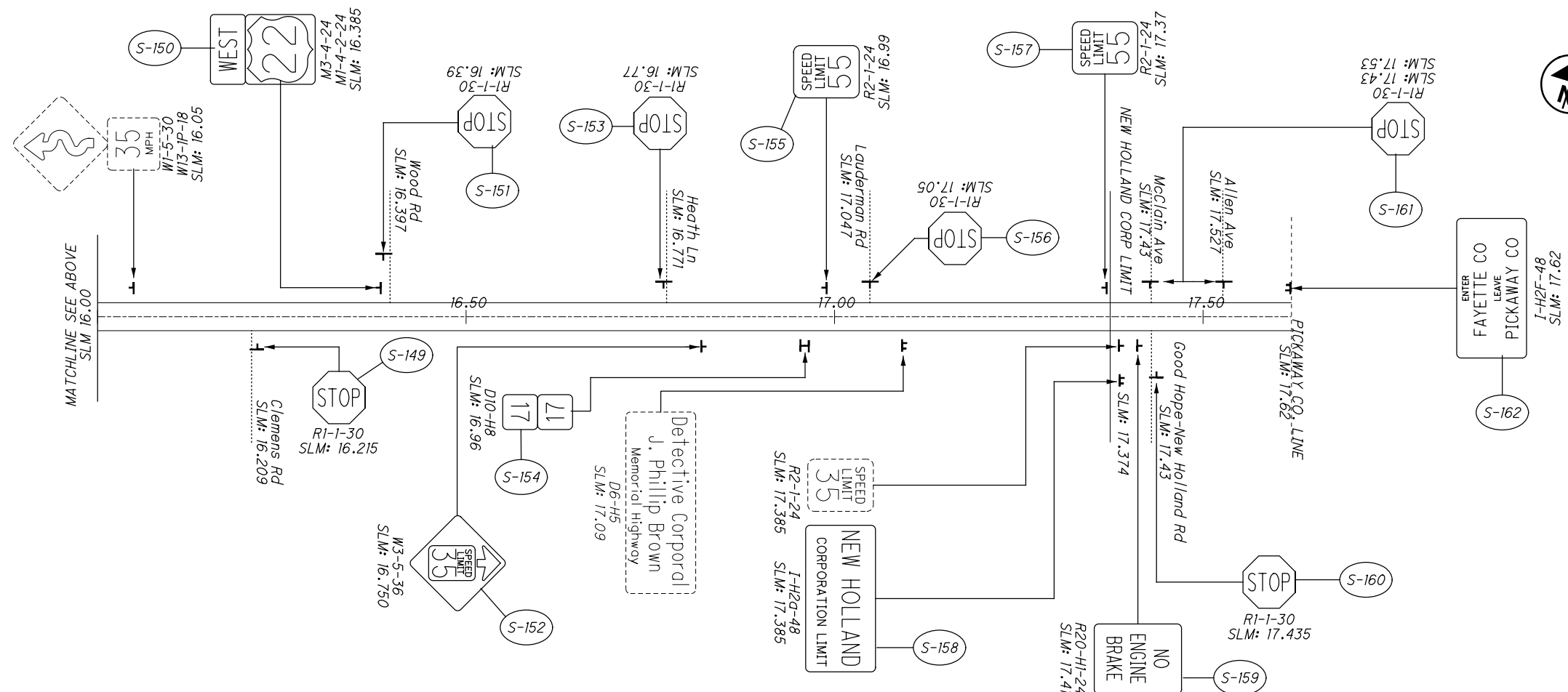

FAY-SYS SIGN
REPLACE-FY20

SIGN PLAN
FAY-22: SLM 14.50 - 17.62

CALCULATED	0
CHECKED	

0 500 1000
HORIZONTAL SCALE IN FEET

I:\ProjectData\07556_FAY_PIC_FLAT_SHEET\Design\Roadway\Sheets\07556_T000.dgn 107556_T0002_22 1/21/2020 3:52:30 PM vpatel

SHEET NO.	REFERENCE NUMBER	LOCATION (SLM)	SIDE	NOTE	CODE	SIZE (INCHES)	630.0	630.0	630	630	630	630	630	630	630	630	630	630	630	630	630	630	630	630	HINGED	
							GROUND MOUNTED SUPPORT, No. 2 POST FT	GROUND MOUNTED SUPPORT, No. 3 POST FT	SIGN POST REFLECTOR, RED EACH		SIGN POST REFLECTOR, WHITE EACH	SIGN POST REFLECTOR, YELLOW EACH	SIGN BACKING ASSEMBLY EACH	SIGN SUPPORT ASSEMBLY, POLE MOUNTED EACH	SIGN, FLAT SHEET SQ FT	SIGN, FLAT SHEET, AS PER PLAN SQ FT	SIGN, DOUBLE FACED, MILE MARKER EACH	REMOVAL OF GROUND MOUNTED SIGN & DISPOSAL EACH	REMOVAL OF GROUND MOUNTED SIGN & RE-ERECTION, AS PER PLAN EACH	REMOVAL OF GROUND MOUNTED MAJOR SIGN & DISPOSAL EACH	REMOVAL OF GROUND MOUNTED POST SUPPORT AND DISPOSAL EACH	REMOVAL OF STRUCTURE MOUNTED SIGN AND DISPOSAL EACH	REMOVAL OF POLE MOUNTED SIGN & DISPOSAL EACH	SIGNING, MISC: REMOVAL OF POST REFLECTOR EACH		
10	S-38	6.253	RIGHT		M6-4	21 X 15								2.2			1									
10	S-39	6.253	LEFT	Jamison Road	D3-H6B	72 X 24								12.0			1									
10	S-40	6.268	RIGHT		R1-1	30 X 30								9.0											1	
10	S-41	6.268	LEFT		R1-1	30 X 30								9.0											1	
10	S-42	6.268	LEFT	22	M1-4-2	24 X 24								4.0			1									
10	S-42	6.268	LEFT		M6-4	21 X 15								2.2			1									
10	S-43	6.268	RIGHT	Jamison Road	D3-H6B	72 X 24								12.0			1									
10	S-44	6.293	LEFT		W4-2L	36 X 36								9.0			1									
10	S-45	6.238	RIGHT		R4-7B	24 X 30								5.0			1									
10	S-46	6.333	MEDIAN		W4-2L	36 X 36								9.0			1									
10	S-46	6.333	MEDIAN	1000	W16-2P	24 X 18								3.0			1									
10	S-47	6.353	LEFT		R4-H11	24 X 30								5.0			1									
10	S-47	6.353	MEDIAN		R4-H11	24 X 30								5.0			1									
10	S-48	6.387	MEDIAN		W9-1L	36 X 36								9.0			1									
10	S-49	6.373	RIGHT	Dayton 50	D1-H1A	72 X 12								6.0			1									
10	S-49	6.373	RIGHT	Chillicothe 31	D1-H1A	72 X 12								6.0			1									
10	S-49	6.373	RIGHT	Fairground	D7-H15	72 X 12								6.0			1									
10	S-50	6.383	LEFT		M3-4	24 X 12								2.0			1									
10	S-50	6.383	LEFT	22	M1-4-2	24 X 24								4.0			1									
10	S-50	6.383	LEFT	3	M1-5-2	24 X 24											1									
10	S-51	3.383	LEFT		M3-3	24 X 12	7.0	10.0						2.0			1									
10	S-51	3.383	LEFT	3	M1-5-2	24 X 24								4.0			1									
10	S-52	6.398	LEFT		W6-1	36 X 36								9.0			1									
10	S-53	6.408	LEFT		W2-1	30 X 30								6.3			1									
10	S-53	6.408	LEFT	Jamison Road	W16-8P	30 X 8								1.7			1									
10	S-53	6.408	MEDIAN		W2-1	30 X 30								6.3			1									
10	S-53	6.408	MEDIAN	Jamison Road	W16-8P	30 X 8								1.7			1									
10	S-54	6.427	MEDIAN		R4-7B	24 X 30								5.0			1									
10	S-55	6.463	LEFT		M3-2	24 X 12								2.0			1									
10	S-55	6.463	LEFT	35	M1-4-2	24 X 24								4.0			1									
10	S-55	6.463	LEFT		M6-1L	21 X 15								2.2			1									
10	S-55	6.463	LEFT	Chillicothe 31	D1-H1A	72 X 12								6.0			1									
10	S-56	6.473	MEDIAN		R4-7B	24 X 30								5.0			1									
10	S-57	6.563	RIGHT		M3-4	24 X 12								2.0			1									
10	S-57	6.563	RIGHT	35	M1-4-2	24 X 24								4.0			1									
10	S-57	6.563	RIGHT		M5-1R	21 X 15								2.2			1									
10	S-58	6.578	LEFT	55	R2-1	24 X 30								5.0			1									
10	S-59	6.598	LEFT		M3-2	24 X 12								2.0			1									
10	S-59	6.598	LEFT	35	M1-4-2	24 X 24								4.0			1									
10	S-59	6.598	LEFT		M5-1L	21 X 15								2.2			1									
10	S-60	6.748	RIGHT	Dayton 45	D1-H1A	72 X 12								6.0			1									
10	S-60	6.748	RIGHT		M3-4	24 X 12								2.0			1									
10	S-60	6.748	RIGHT	35	M1-4-2	24 X 24								4.0			1									
10	S-60	6.748	RIGHT		M6-1R	21 X 15								2.2			1									
10	S-61	6.693	RIGHT		W2-1	30 X 30								6.3			1									
10	S-61	6.693	MEDIAN		W2-1	30 X 30								6.3			1									
10	S-62	6.733	MEDIAN		R4-7B	24 X 30								5.0			1									
10	S-63	6.698	RIGHT	45	R2-1	24 X 30								5.0			1									
10	S-64	6.783	RIGHT		M3-2	24 X 12								2.0			1									
10	S-64	6.783	RIGHT	22	M1-4-2	24 X 24								4.0			1									
TOTALS CARRIED TO SUB-SUMMARY, SHEET 6							7.0	10.0	2					238.8			49								2	

SIGN PLAN QUANTITIES
FAYETTE COUNTY - US 22

FAY-SYS SIGN
REPLACE-FY20

CALCULATED
VHP
CHECKED
XXX

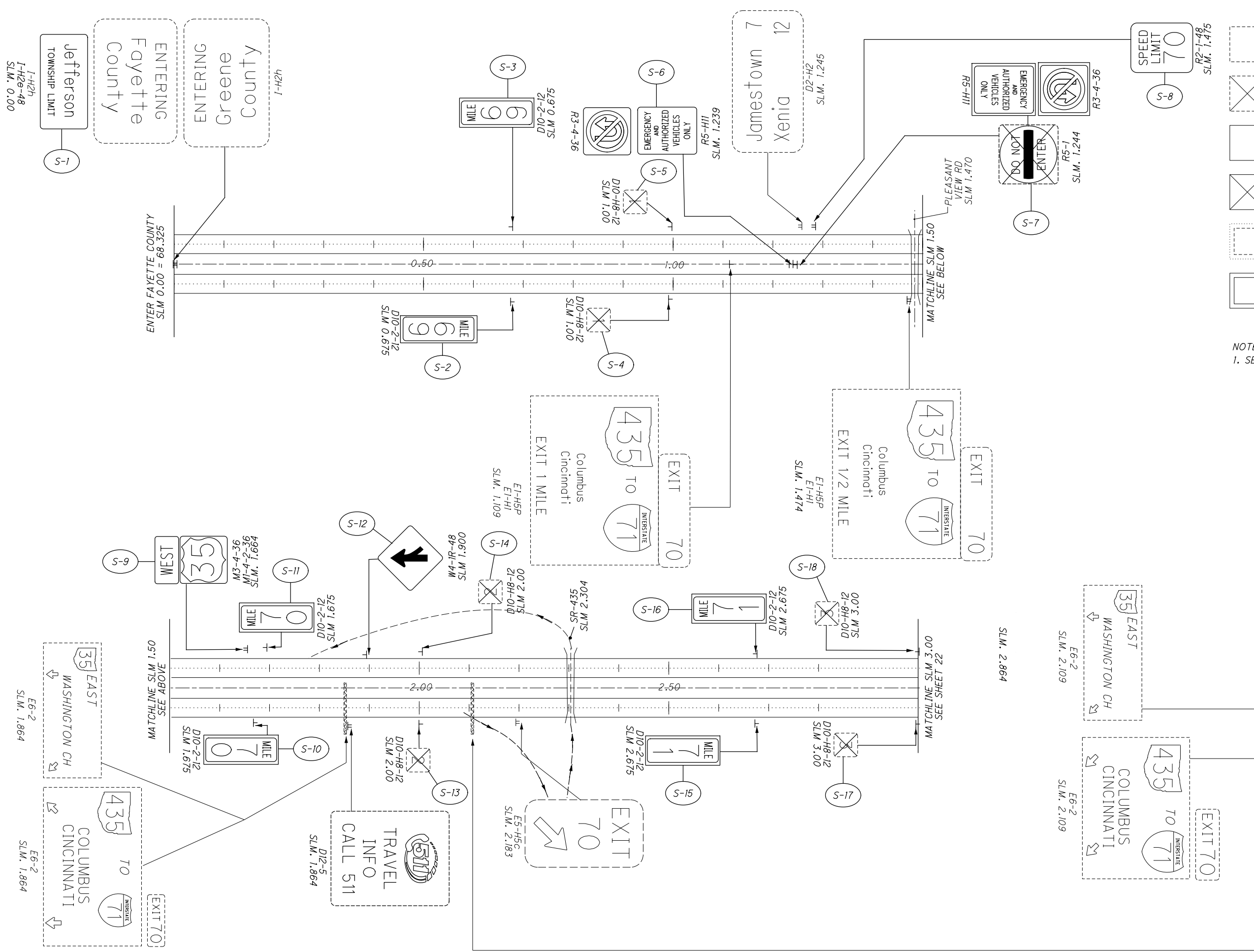

LEGEND

- NO WORK ON SIGN
- REMOVE SIGN
- REPLACE SIGN
- REMOVE AND REPLACE SIGN & POSTS
- REMOVE & RE-ERECT SIGN
- NEW SIGN

NOTES
1. SEE SHEETS 30 -34 FOR QUANTITIES

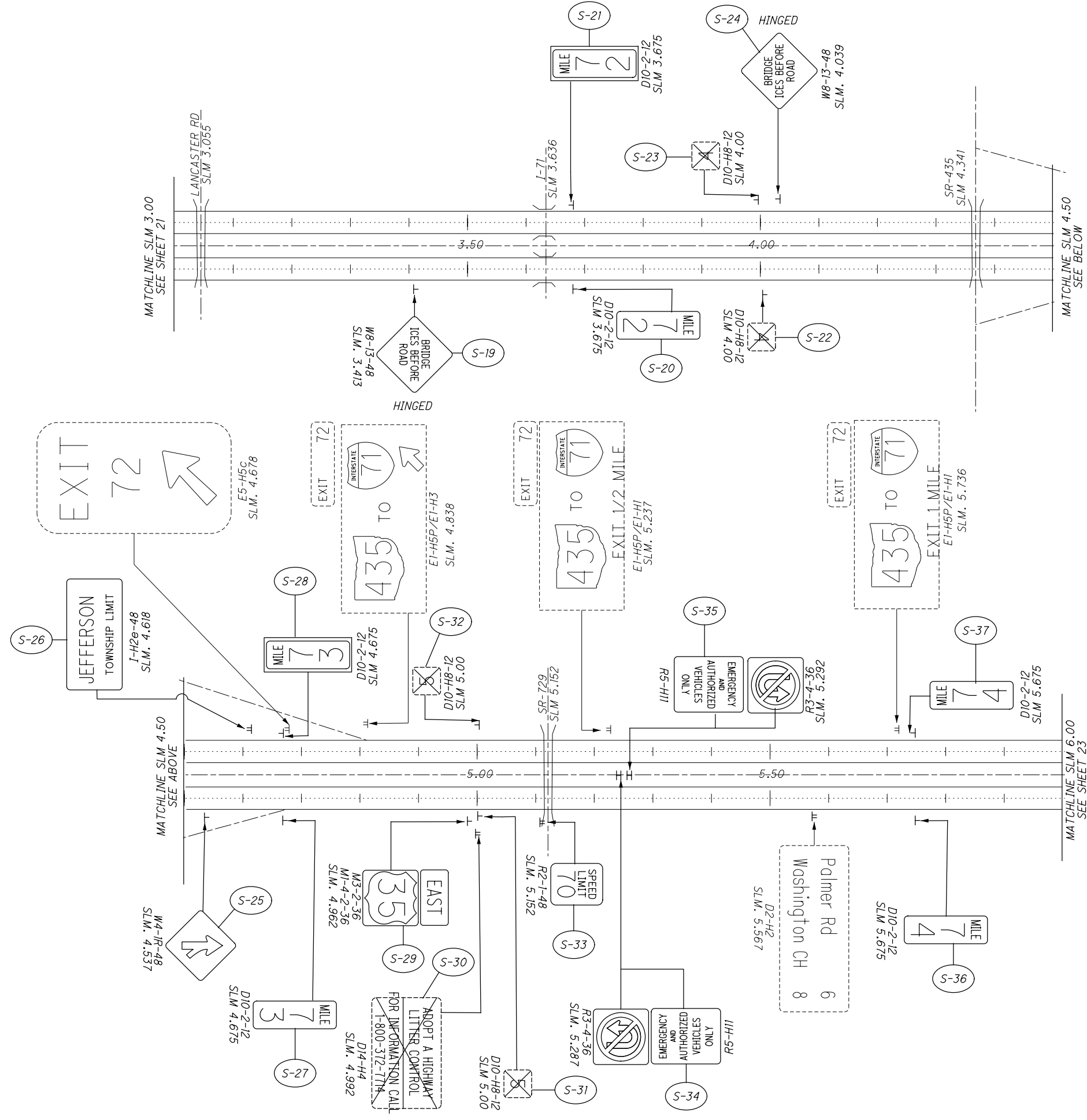

SEE SHEET 21 FOR LEGEND
SEE SHEETS 30 -34 FOR QUANTITIES



SIGN PLAN
FAY-35: SLM 3.00 - 6.00

FAY-SYS SIGN
REPLACE-FY20

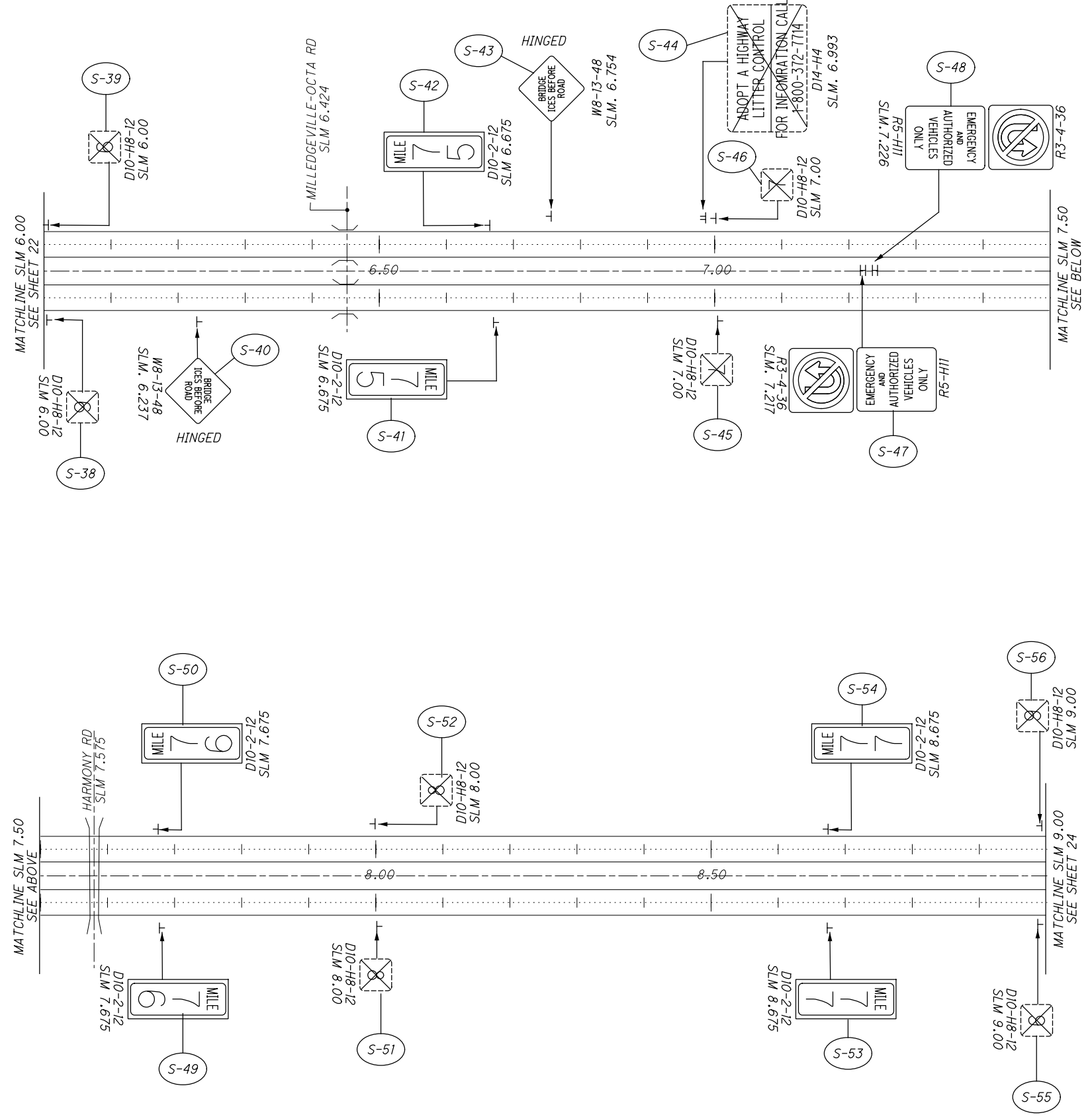

SEE SHEET 21 FOR LEGEND
SEE SHEETS 30 -34 FOR QUANTITIES

CALCULATED
CHECKED

0 500 1000
HORIZONTAL SCALE IN FEET

SIGN PLAN
FAY-35: SLM 6.00 - 9.00

FAY-SYS SIGN REPLACE-FY20

SEE SHEET 21 FOR LEGEND
SEE SHEETS 30 -34 FOR QUANTITIES



CALCULATED
CHECKED

FAY-SYS SIGN SIGN PLAN

FAY-35: SLM 9.00 - 12.00

24
88

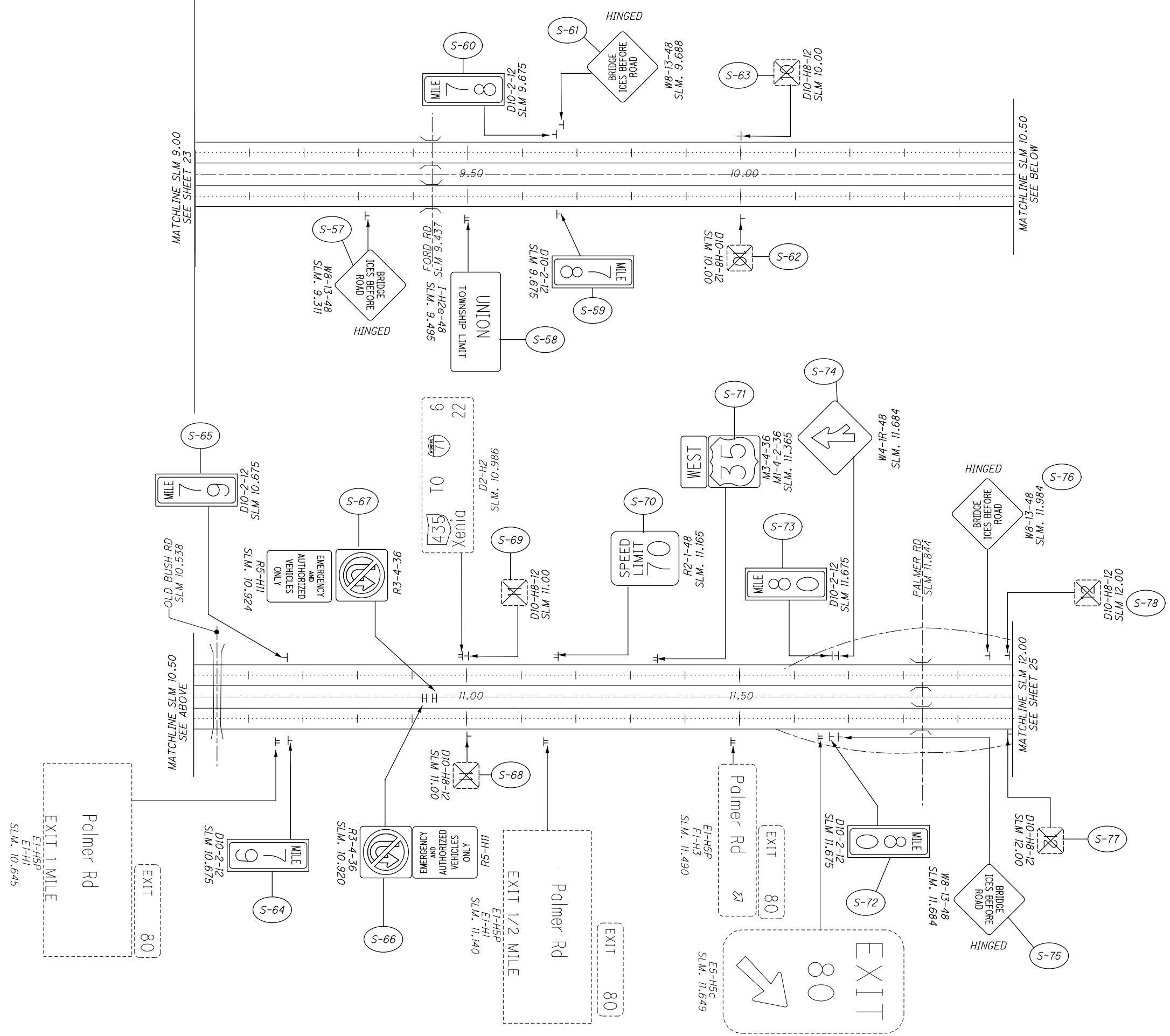

SEE SHEET XX FOR LEGEND
SEE SHEET XX FOR QUANTITIES

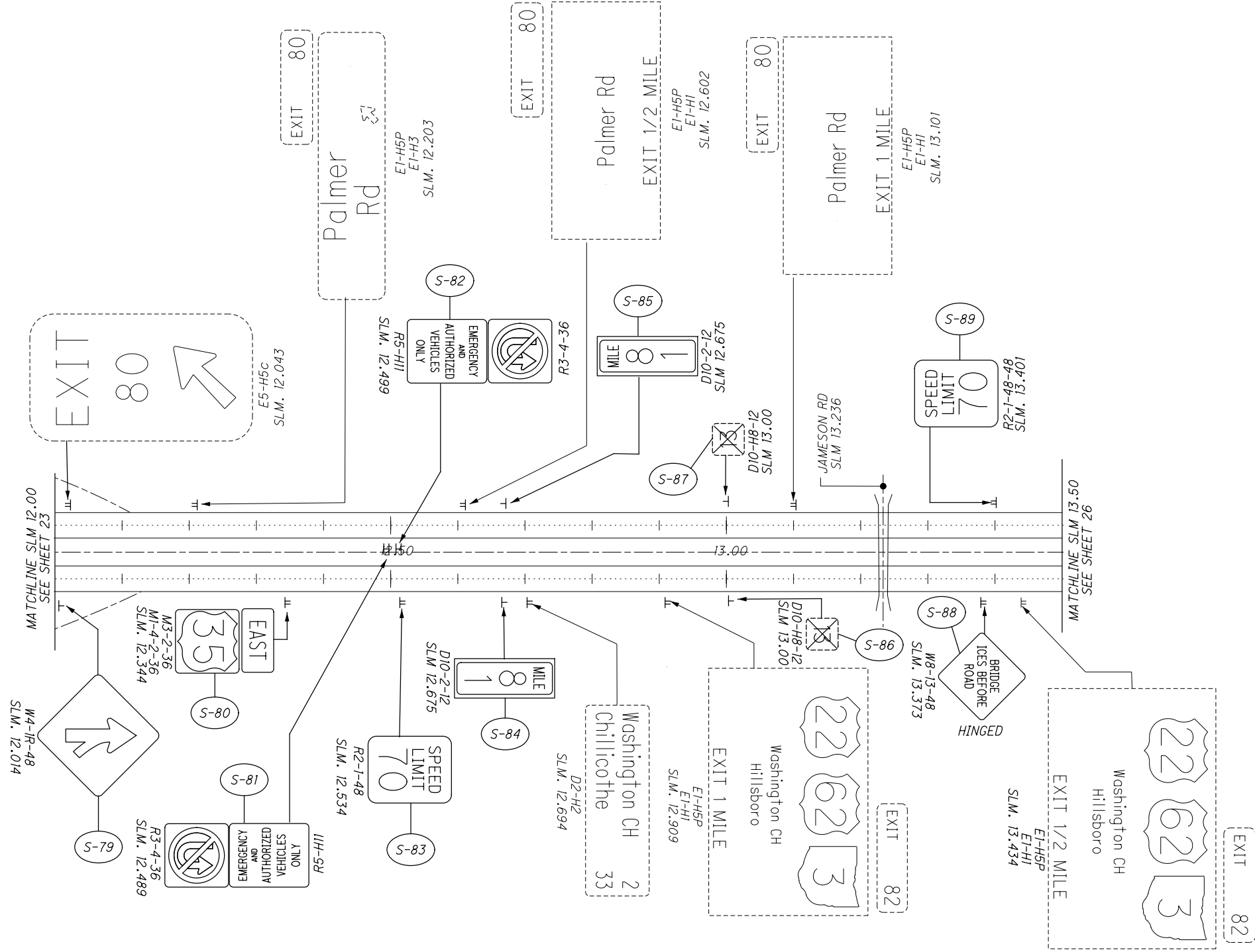

SEE SHEET 21 FOR LEGEND
SEE SHEETS 30 -34 FOR QUANTITIES

CALCULATED

CHECKED

0 500 1000
HORIZONTAL SCALE IN FEET

SIGN PLAN
FAY -35: SLM 12.00 - 13.50

SIGN
REPLACE-FY20

SEE SHEET 21 FOR LEGEND
SEE SHEETS 30 -34 FOR QUANTITIES



CALCULATED

CHECKED

FAY -35: SLM 13.50 - 15.00

FAY-SYS SIGN REPLACE-FY20

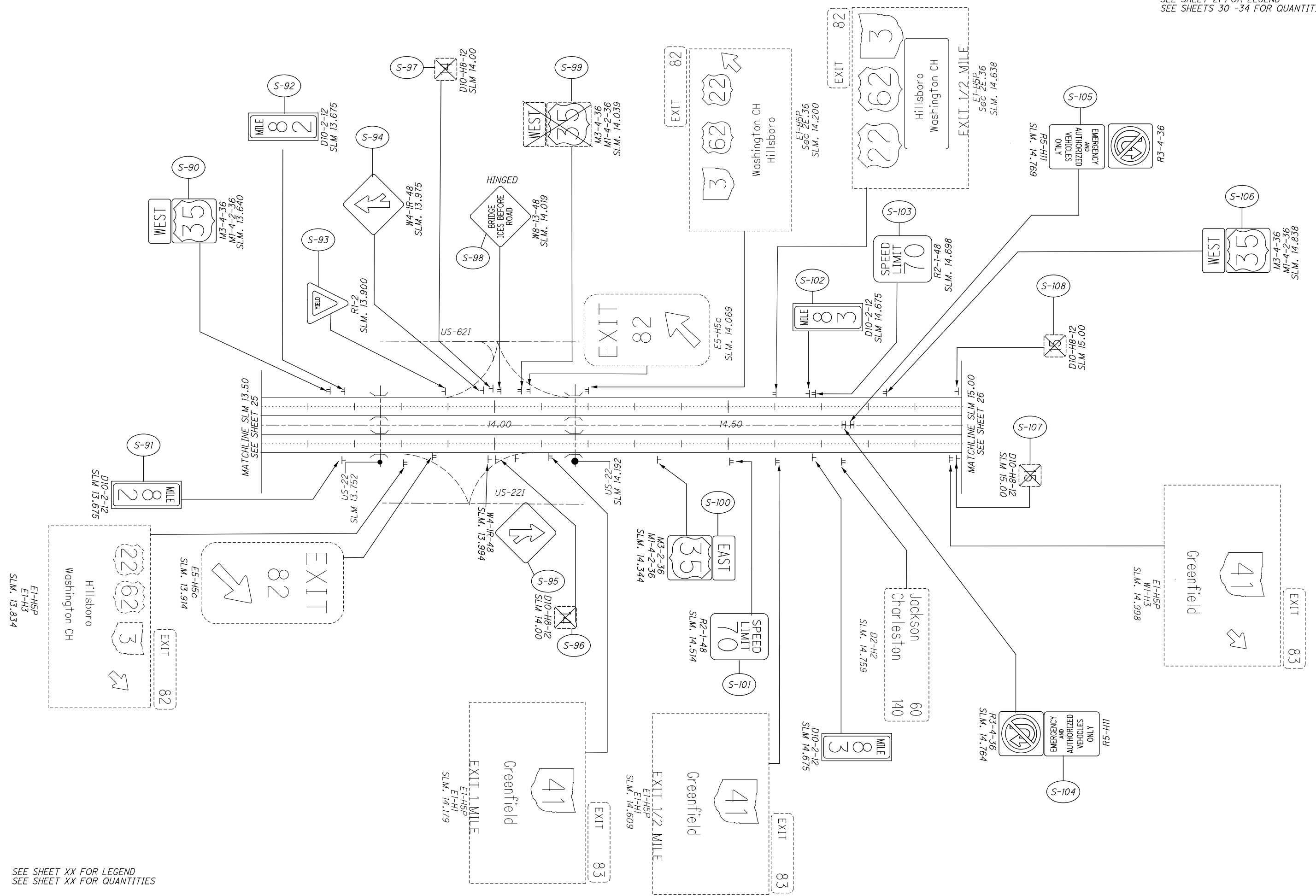

SEE SHEET XX FOR LEGEND
SEE SHEET XX FOR QUANTITIES

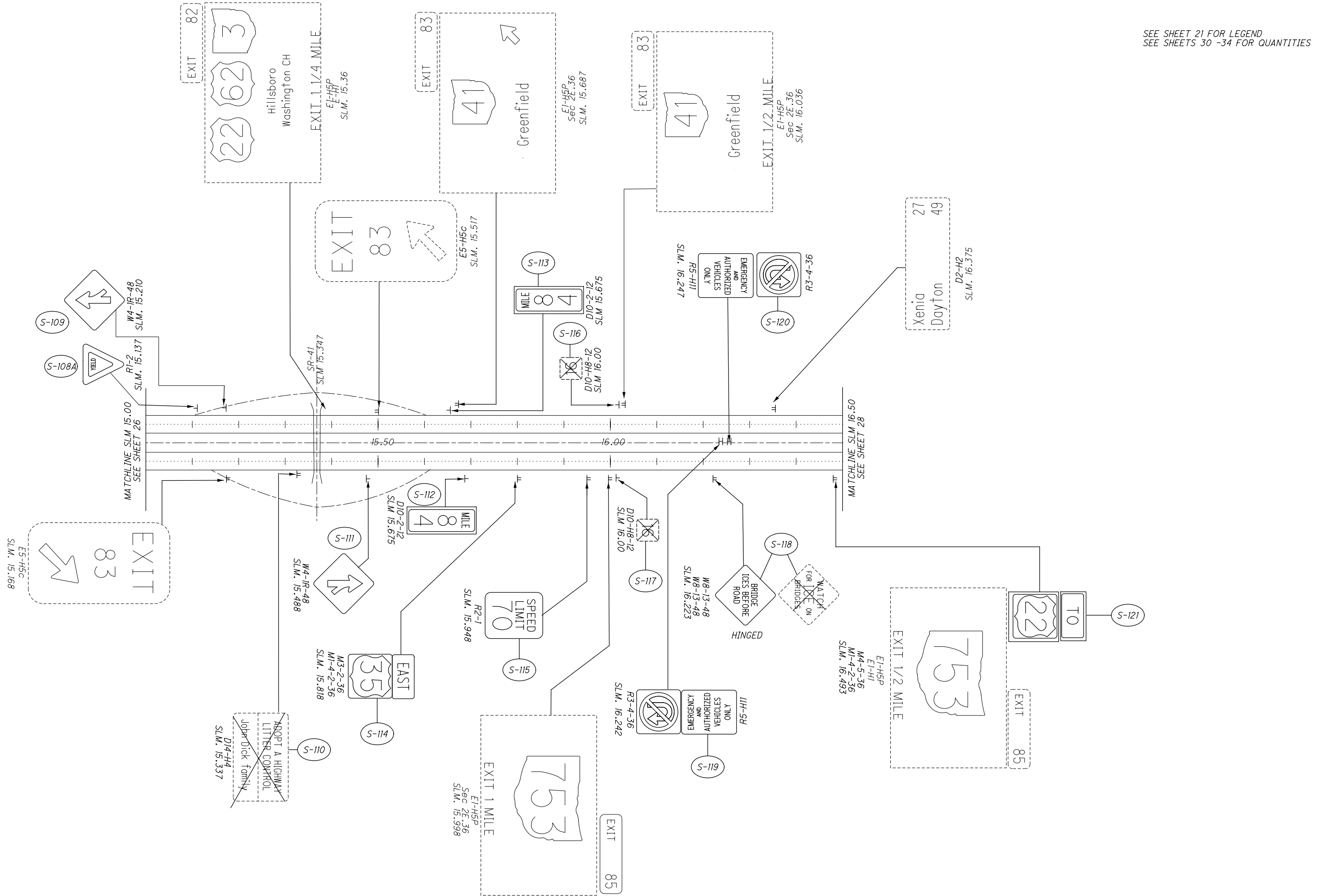

SEE SHEET 21 FOR LEGEND
SEE SHEETS 30 -34 FOR QUANTITIES

CALCULATED 0 500 1000
CHECKED

HORIZONTAL SCALE IN FEET

SIGN PLAN
FAY -35: SLM 15.00 -16.50

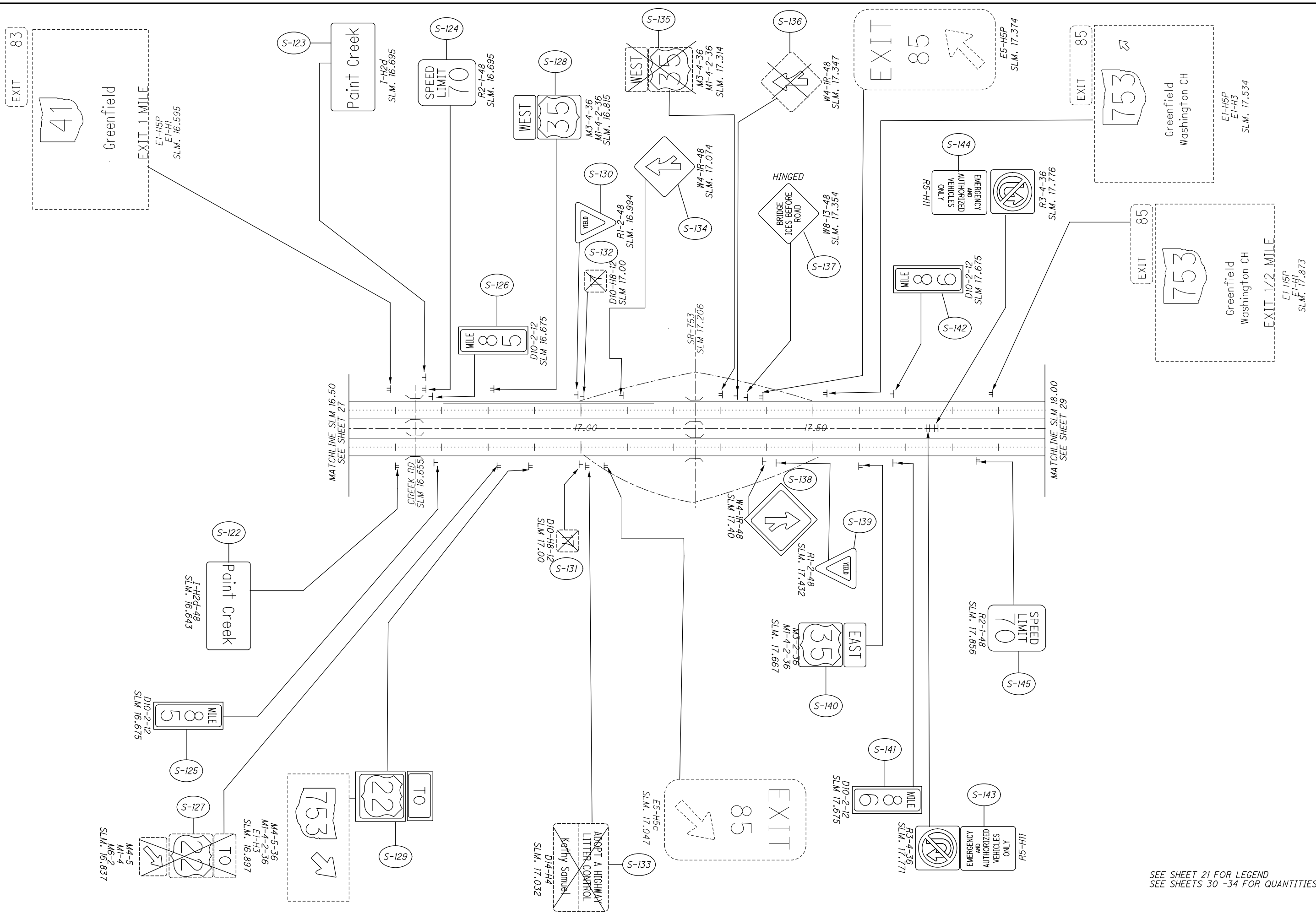

SEE SHEET 21 FOR LEGEND
SEE SHEETS 30 -34 FOR QUANTITIES

CALCULATED 0 500 1000
CHECKED

HORIZONTAL SCALE IN FEET

FAY-SYS SIGN PLAN
FAY-35: SLM 16.50 - 18.00

FAY-SYS SIGN REPLACE-FY20

28
88

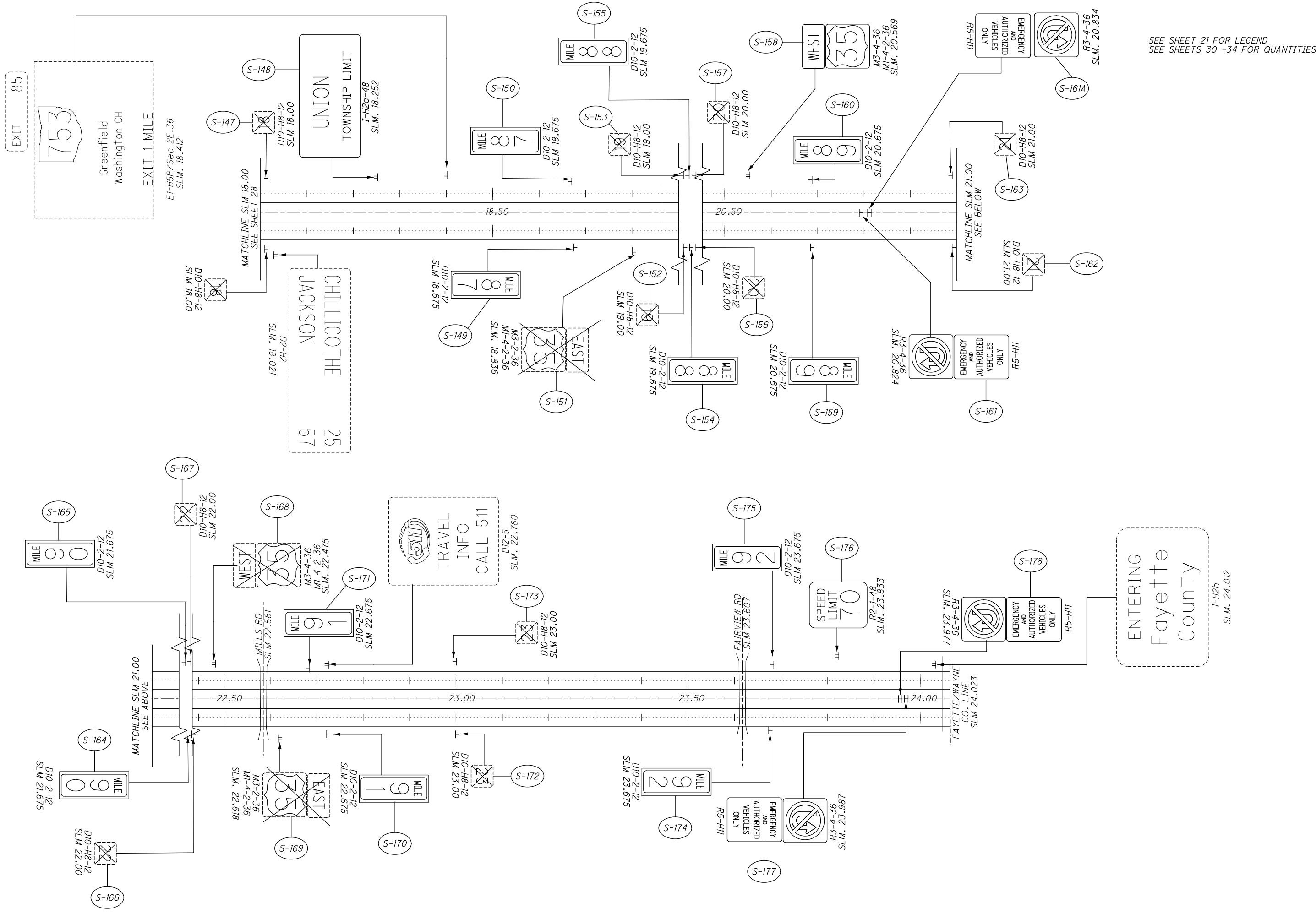

SEE SHEET 21 FOR LEGEND
SEE SHEETS 30 -34 FOR QUANTITIES

CALCULATED 0 500 1000
CHECKED

HORIZONTAL SCALE IN FEET



FAY-SYS SIGN PLAN
FAY-35: SLM 18.00 - 24.02

FAY-SYS SIGN REPLACE-FY20

I:\ProjectData\07556_FAY_PIC_FLATSHEET\Design\Roadway\Sheets\07556_T0002.dgn 107556_T0001_35 1/21/2020 3:52:42 PM vpatel

SHEET NO.	REFERENCE SHEET	LOCATION (SLM)	SIDE	NOTE	CODE	SIZE (INCHES)	630	630	630	630	630	630	630	630	630	630	630	630	630	630	630	630	630	HINGED			
							GROUND MOUNTED SUPPORT, No. 2 POST FT	GROUND MOUNTED SUPPORT, No. 3 POST FT	SIGN POST REFLECTOR, RED EACH		SIGN POST REFLECTOR, WHITE EACH	SIGN POST REFLECTOR, YELLOW EACH	SIGN BACKING ASSEMBLY EACH	SIGN SUPPORT ASSEMBLY, POLE MOUNTED EACH	SIGN, FLAT SHEET SQ FT	SIGN, FLAT SHEET, AS PER PLAN SQ FT	SIGN, DOUBLE FACED, MILE MARKER EACH	REMOVAL OF GROUND MOUNTED SIGN & DISPOSAL EACH	REMOVAL OF GROUND MOUNTED SIGN & RE-ERECTION, AS PER PLAN EACH	REMOVAL OF GROUND MOUNTED MAJOR SIGN & DISPOSAL EACH	REMOVAL OF GROUND MOUNTED POST SUPPORT AND DISPOSAL EACH	REMOVAL OF STRUCTURE MOUNTED SIGN AND DISPOSAL EACH	REMOVAL OF POLE MOUNTED SIGN & DISPOSAL EACH			SIGNING, MISC: REMOVAL OF POST REFLECTOR EACH	
21	S-1	0.000	MEDIAN	JEFFERSON	I-H2e	48 X 24								8.0			1										
21	S-2	0.675	RIGHT	69	D10-2	12 X 36	7.0	10.0						3.0													
21	S-3	0.675	LEFT	69	D10-2	12 X 36	7.0	10.0						3.0													
21	S-4	1.000	RIGHT		D10-H8	12 X 12											1				1						
21	S-5	1.000	LEFT		D10-H8	12 X 12											1				1						
21	S-6	1.239	MEDIAN		R3-4	36 X 36			1					9.0										1			
21	S-6	1.239	MEDIAN		R5-H11	30 X 24				1				5.0										1			
21	S-7	1.244	MEDIAN		R5-1	48 X 48											1							1			
21	S-7	1.244	MEDIAN		R3-4	36 X 36			1					9.0										1			
21	S-7	1.244	MEDIAN		R5-H11	30 X 24				1				5.0										1			
21	S-8	1.475	LEFT	70	R2-1	48 X 60								20.0			1										
21	S-9	1.664	LEFT	WEST	M3-4	36 X 18								4.5			1										
21	S-9	1.664	LEFT	35	M1-4-2	36 X 36								9.0			1										
21	S-10	1.675	RIGHT	70	D10-2	12 X 36	7.0	10.0						3.0													
21	S-11	1.675	LEFT	70	D10-2	12 X 36	7.0	10.0						3.0													
21	S-12	1.900	LEFT		W4-1R	48 X 48								16.0			1										
21	S-13	2.000	RIGHT		D10-H8	12 X 12											1				1						
21	S-14	2.000	LEFT		D10-H8	12 X 12											1				1						
21	S-15	2.675	RIGHT	71	D10-2	12 X 36	7.0	10.0						3.0													
21	S-16	2.675	LEFT	71	D10-2	12 X 36	7.0	10.0						3.0													
21	S-17	3.000	RIGHT		D10-H8	12 X 12											1				1						
21	S-18	3.000	LEFT		D10-H8	12 X 12											1				1						
22	S-19	3.413	RIGHT		W8-13	48 X 48								16.0			1							YES			
22	S-20	3.675	RIGHT	72	D10-2	12 X 36	7.0	10.0						3.0													
22	S-21	3.675	LEFT	72	D10-2	12 X 36	7.0	10.0						3.0													
22	S-22	4.000	RIGHT		D10-H8	12 X 12											1				1						
22	S-23	4.000	LEFT		D10-H8	12 X 12											1				1						
22	S-24	4.039	LEFT		W8-13	48 X 48								16.0			1							YES			
22	S-25	4.537	RIGHT		W4-1R	48 X 48								16.0			1										
22	S-26	4.618	LEFT	JEFFERSON	I-H2E	48 X 24								8.0			1										
22	S-27	4.675	RIGHT	73	D10-2	12 X 36	7.0	10.0						3.0													
22	S-28	4.675	LEFT	73	D10-2	12 X 36	7.0	10.0						3.0													
22	S-29	4.962	RIGHT	EAST	M3-2	36 X 18								4.5			1										
22	S-29	4.962	RIGHT	35	M1-4-2	36 X 36								9.0			1										
22	S-30	4.992	RIGHT		D14-H4	30 X 48											1				1						
22	S-31	5.000	RIGHT		D10-H8	12 X 12											1				1						
22	S-32	5.000	LEFT		D10-H8	12 X 12											1				1						
22	S-33	5.152	RIGHT	70	R2-1	48 X 60								20.0			1										
22	S-34	5.287	MEDIAN		R3-4	36 X 36			1					9.0			1							1			
22	S-34	5.287	MEDIAN		R5-H11	30 X 24				1				5.0			1							1			
22	S-35	5.292	MEDIAN		R3-4	36 X 36			1					9.0			1							1			
22	S-35	5.292	MEDIAN		R5-H11	30 X 24				1				5.0			1							1			
22	S-36	5.675	RIGHT	74	D10-2	12 X 36	7.0	10.0						3.0													
22	S-37	5.675	LEFT	74	D10-2	12 X 36	7.0	10.0						3.0													
TOTALS CARRIED TO SUB-SUMMARY, SHEET 6							84.0	120.0	4	4					207.0	32.0		28			11				8		

SIGN PLAN QUANTITIES
FAYETTE COUNTY - US 35
FAY-SYS SIGN
REPLACE-FY20

CALCULATED
VHP
CHECKED
XXX

I:\ProjectData\07556_FAY_PIC_FLATSHEET\Design\Roadway\Sheets\07556_I0002.dgn 07556_I0002_35 2/26/2020 9:52:37 AM vpatel

SHEET NO.	REFERENCE SHEET	LOCATION (SLM)	SIDE	NOTE	CODE	SIZE (INCHES)	630	630	630	630	630	630	630	630	630	630	630	630	630	630	630	630	HINGED		
							GROUND MOUNTED SUPPORT, No. 2 POST FT	GROUND MOUNTED SUPPORT, No. 3 POST FT	SIGN POST REFLECTOR, RED EACH	SIGN POST REFLECTOR, WHITE EACH	SIGN POST REFLECTOR, YELLOW EACH	SIGN BACKING ASSEMBLY EACH	SIGN SUPPORT ASSEMBLY, POLE MOUNTED EACH	SIGN, FLAT SHEET SQ FT	SIGN, FLAT SHEET, AS PER PLAN SQ FT	SIGN, DOUBLE FACED, MILE MARKER EACH	REMOVAL OF GROUND MOUNTED SIGN & DISPOSAL EACH	REMOVAL OF GROUND MOUNTED SIGN & RE-ERECTION, AS PER PLAN EACH	REMOVAL OF GROUND MOUNTED MAJOR SIGN & DISPOSAL EACH	REMOVAL OF GROUND MOUNTED POST SUPPORT AND DISPOSAL EACH	REMOVAL OF STRUCTURE MOUNTED SIGN AND DISPOSAL EACH	REMOVAL OF POLE MOUNTED SIGN & DISPOSAL EACH			SIGNING, MISC: REMOVAL OF POST REFLECTOR EACH
23	S-38	6.000	RIGHT		D10-H8	12 X 12																			
23	S-39	6.000	LEFT		D10-H8	12 X 12																			
23	S-40	6.237	RIGHT		W8-13	48 X 48																			
23	S-41	6.675	RIGHT	75	D10-2	12 X 36	7.0	10.0						3.0										YES	
23	S-42	6.675	LEFT	75	D10-2	12 X 36	7.0	10.0						3.0											
23	S-43	6.754	LEFT		W8-13	48 X 48																			
23	S-44	6.993	LEFT		D14-H4	30 X 48								10.0										YES	
23	S-45	7.000	RIGHT		D10-H8	12 X 12																			
23	S-46	7.000	LEFT		D10-H8	12 X 12																			
23	S-47	7.217	MEDIAN		R3-4	36 X 36								9.0											
23	S-47	7.217	MEDIAN		R5-H11	30 X 24								5.0											
23	S-48	7.226	MEDIAN		R3-4	36 X 36								9.0											
23	S-48	7.226	MEDIAN		R5-H11	30 X 24								5.0											
23	S-49	7.675	RIGHT	76	D10-2	12 X 36	7.0	10.0						3.0											
23	S-50	7.675	LEFT	76	D10-2	12 X 36	7.0	10.0						3.0											
23	S-51	8.000	LEFT		D10-H8	12 X 12																			
23	S-52	8.000	RIGHT		D10-H8	12 X 12																			
23	S-53	8.675	LEFT	77	D10-2	12 X 36								3.0											
23	S-54	8.675	RIGHT	77	D10-2	12 X 36								3.0											
23	S-55	9.000	LEFT		D10-H8	12 X 12																			
23	S-56	9.000	RIGHT		D10-H8	12 X 12																			
24	S-57	9.311	RIGHT		W8-13	48 X 48																			
24	S-58	9.495	RIGHT		I-H2E	48 X 24								8.0											
24	S-59	9.675	RIGHT	78	D10-2	12 X 36	7.0	10.0						3.0											
24	S-60	9.675	LEFT	78	D10-2	12 X 36	7.0	10.0						3.0											
24	S-61	9.688	LEFT		W8-13	48 X 48																			
24	S-62	10.000	RIGHT		D10-H8	12 X 12																			
24	S-63	10.000	LEFT		D10-H8	12 X 12																			
24	S-64	10.675	RIGHT	79	D10-2	12 X 36	7.0	10.0						3.0											
24	S-65	10.675	LEFT	79	D10-2	12 X 36	7.0	10.0						3.0											
24	S-66	10.920	MEDIAN		R3-4	36 X 36								9.0											
24	S-66	10.920	MEDIAN		R5-H11	30 X 24								5.0											
24	S-67	10.924	MEDIAN		R3-4	36 X 36								9.0											
24	S-67	10.924	MEDIAN		R5-H11	30 X 24								5.0											
24	S-68	11.000	RIGHT		D10-H8	12 X 12																			
24	S-69	11.000	LEFT		D10-H8	12 X 12																			
24	S-70	11.165	LEFT	70	R2-1	48 X 60								20.0											
24	S-71	11.365	LEFT	WEST	M3-4	36 X 18								4.5											
24	S-71	11.365	LEFT	35	M1-4-2	36 X 36								9.0											
24	S-72	11.675	LEFT	80	D10-2	12 X 36	7.0	10.0						3.0											
24	S-73	11.675	RIGHT	80	D10-2	12 X 36	7.0	10.0						3.0											
24	S-74	11.684	LEFT		W4-1R	48 X 48																			
24	S-75	11.684	RIGHT		W8-13	48 X 48																			
24	S-76	11.984	LEFT		W8-13	48 X 48																			
24	S-77	12.000	RIGHT		D10-H8	12 X 12																			
24	S-78	12.000	LEFT		D10-H8	12 X 12																			
TOTALS CARRIED TO SUB-SUMMARY, SHEET 6							70.0	100.0	4	4				159.5	96.0			34			14			8	

CALCULATED VHP	CHECKED XXX	SIGN PLAN QUANTITIES FAYETTE COUNTY - US 35	FAY-SYS SIGN REPLACE-FY20	31
				88

I:\ProjectData\07556_FAY_PIC_FLAT_SHEET\Design\Roadway\Sheets\07556_T0002.dgn 07556_T0003.35 1/27/2020 3:52:44 PM vpatel

SHEET NO.	REFERENCE SHEET	LOCATION (SLM)	SIDE	NOTE	CODE	SIZE (INCHES)	630	630	630	630	630	630	630	630	630	630	630	630	630	630	630	630	HINGED		
							GROUND MOUNTED SUPPORT, No. 2 POST FT	GROUND MOUNTED SUPPORT, No. 3 POST FT	SIGN POST REFLECTOR, RED EACH	SIGN POST REFLECTOR, WHITE EACH	SIGN POST REFLECTOR, YELLOW EACH	SIGN BACKING ASSEMBLY EACH	SIGN SUPPORT ASSEMBLY, POLE MOUNTED EACH	SIGN, FLAT SHEET SQ FT	SIGN, FLAT SHEET, AS PER PLAN SQ FT	SIGN, DOUBLE FACED, MILE MARKER EACH	REMOVAL OF GROUND MOUNTED SIGN & DISPOSAL EACH	REMOVAL OF GROUND MOUNTED SIGN & RE-ERECTION, AS PER PLAN EACH	REMOVAL OF GROUND MOUNTED MAJOR SIGN & DISPOSAL EACH	REMOVAL OF GROUND MOUNTED POST SUPPORT AND DISPOSAL EACH	REMOVAL OF STRUCTURE MOUNTED SIGN AND DISPOSAL EACH	REMOVAL OF POLE MOUNTED SIGN & DISPOSAL EACH			SIGNING, MISC: REMOVAL OF POST REFLECTOR EACH
25	S-79	12.014	RIGHT		W4-1R	48 X 48							16.0			1									
25	S-80	12.344	RIGHT	EAST	M3-2	36 X 18							4.5			1									
25	S-80	12.344	RIGHT	35	M1-4-2	36 X 36							9.0			1									
25	S-81	12.489	MEDIAN		R3-4	36 X 36			1				9.0			1						1			
25	S-81	12.489	MEDIAN		R5-H11	30 X 24				1			5.0			1						1			
25	S-82	12.499	MEDIAN		R3-4	36 X 36			1				9.0			1						1			
25	S-82	12.499	MEDIAN		R5-H11	30 X 24				1			5.0			1						1			
25	S-83	12.534	RIGHT		R2-1	48 X 60							20.0												
25	S-84	12.675	RIGHT	81	D10-2	12 X 36	7.0	10.0					3.0												
25	S-85	12.675	LEFT	81	D10-2	12 X 36	7.0	10.0					3.0												
25	S-86	2.000	RIGHT		D10-H8	12 X 12										1			1						
25	S-87	2.000	LEFT		D10-H8	12 X 12										1			1						
25	S-88	13.373	RIGHT		W8-13	48 X 48								16.0		1							YES		
25	S-89	13.401	LEFT	70	R2-1	48 X 60							20.0			1									
26	S-90	13.640	LEFT	WEST	M3-4	36 X 18							4.5			1									
26	S-90	13.640	LEFT	35	M1-4-2	36 X 36							9.0			1									
26	S-91	13.675	RIGHT	82	D10-2	12 X 36	7.0	10.0					3.0												
26	S-92	13.675	LEFT	82	D10-2	12 X 36	7.0	10.0					3.0												
26	S-93	13.900	LEFT		R1-2	60 X 60 X 60			1				10.8			1						1			
26	S-94	13.975	LEFT		W4-1R	48 X 48							16.0			1									
26	S-95	13.994	RIGHT		W4-1R	48 X 48							16.0			1									
26	S-96	14.000	RIGHT		D10-H8	12 X 12										1			1						
26	S-97	14.000	LEFT		D10-H8	12 X 12										1			1						
26	S-98	14.019	LEFT		W8-13	48 X 48								16.0		1							YES		
26	S-99	14.039	LEFT		M3-4	36 X 18										1			1						
26	S-99	14.039	LEFT		M1-4-2	36 X 36										1			1						
26	S-100	14.344	RIGHT	EAST	M3-2	36 X 18							4.5			1									
26	S-100	14.344	RIGHT	35	M1-4-2	36 X 36							9.0			1									
26	S-101	14.514	RIGHT		R2-1	48 X 60							20.0			1									
26	S-102	14.675	RIGHT	83	D10-2	12 X 36	7.0	10.0					3.0												
26	S-103	14.675	LEFT	83	D10-2	12 X 36	7.0	10.0					3.0												
26	S-104	14.764	MEDIAN		R3-4	36 X 36			1				9.0			1						1			
26	S-104	14.764	MEDIAN		R5-H11	30 X 24				1			5.0			1						1			
26	S-105	14.769	MEDIAN		R3-4	36 X 36			1				9.0			1						1			
26	S-105	14.769	MEDIAN		R5-H11	30 X 24				1			5.0			1						1			
26	S-106	14.838	LEFT	WEST	M3-4	36 X 18							4.5			1									
26	S-106	14.838	LEFT	35	M1-4-2	36 X 36							9.0			1									
26	S-107	15.000	RIGHT		D10-H8	12 X 12										1			1						
26	S-108	15.000	LEFT		D10-H8	12 X 12										1			1						
TOTALS CARRIED TO SUB-SUMMARY, SHEET 6							42.0	60.0	5	4			246.8	32.0		32		8			9				

CALCULATED VHP	CHECKED XXX	SIGN PLAN QUANTITIES FAYETTE COUNTY - US 35	FAY-SYS SIGN REPLACE-FY20	32
				88

I:\ProjectData\07556_FAY_PIC_FLATSHET\Design\Roadway\Sheets\07556_T0002.dgn 107556_T0005_35 1/27/2020 3:52:46 PM vpotel

SHEET NO.	REFERENCE SHEET	LOCATION (SLM)	SIDE	NOTE	CODE	SIZE (INCHES)	630	630	630	630	630	630	630	630	630	630	630	630	630	630	630	630				
							GROUND MOUNTED SUPPORT, No. 2 POST	GROUND MOUNTED SUPPORT, No. 3 POST	SIGN POST REFLECTOR, RED	SIGN POST REFLECTOR, WHITE	SIGN POST REFLECTOR, YELLOW	SIGN BACKING ASSEMBLY	SIGN SUPPORT ASSEMBLY, POLE MOUNTED	SIGN, FLAT SHEET	SIGN, FLAT SHEET, AS PER PLAN	SIGN, DOUBLE FACED, MILE MARKER	REMOVAL OF GROUND MOUNTED SIGN & DISPOSAL	REMOVAL OF GROUND MOUNTED SIGN & RE-ERECTION, AS PER PLAN	REMOVAL OF GROUND MOUNTED MAJOR SIGN & DISPOSAL	REMOVAL OF GROUND MOUNTED POST SUPPORT AND DISPOSAL	REMOVAL OF STRUCTURE MOUNTED SIGN AND DISPOSAL	REMOVAL OF POLE MOUNTED SIGN & DISPOSAL			SIGNING, MISC: REMOVAL OF POST REFLECTOR	HINGED
							FT	FT	EACH		EACH	EACH	SQ FT	SQ FT	EACH	EACH	EACH	EACH	EACH	EACH	EACH	EACH			EACH	
29	S-146	18.000	RIGHT		D10-H8	12 X 12													1							
29	S-147	18.000	LEFT		D10-H8	12 X 12													1							
29	S-148	18.252	LEFT	UNION	I-H2E	48 X 24							8.0						1							
29	S-149	18.675	RIGHT	87	D10-2	12 X 36							3.0						1							
29	S-150	18.675	LEFT	87	D10-2	12 X 36							3.0						1							
29	S-151	18.836	RIGHT		M3-2	36 X 18													1							
29	S-151	18.836	RIGHT		M1-4-2	36 X 36													1							
29	S-152	19.000	RIGHT		D10-H8	12 X 12													1							
29	S-153	19.000	LEFT		D10-H8	12 X 12													1							
29	S-154	20.675	RIGHT	88	D10-2	12 X 36	7.0	10.0					3.0													
29	S-155	20.675	LEFT	88	D10-2	12 X 36	7.0	10.0					3.0													
29	S-156	20.000	RIGHT		D10-H8	12 X 12													1							
29	S-157	20.000	LEFT		D10-H8	12 X 12													1							
29	S-158	20.569	LEFT	WEST	M3-4	36 X 18							4.5						1							
29	S-158	20.569	LEFT	35	M1-4-2	36 X 36							9.0						1							
29	S-159	20.675	RIGHT	89	D10-2	12 X 36	7.0	10.0					3.0													
29	S-160	20.675	LEFT	89	D10-2	12 X 36	7.0	10.0					3.0													
29	S-161	20.824	MEDIAN		R3-4	36 X 36				1			9.0					1				1				
29	S-161	20.824	MEDIAN		R5-H11	30 X 24					1		5.0					1				1				
29	S-161A	20.834	MEDIAN		R3-4	36 X 36				1			9.0					1				1				
29	S-161A	20.834	MEDIAN		R5-H11	30 X 24					1		5.0					1				1				
29	S-162	21.000	RIGHT		D10-H8	12 X 12													1							
29	S-163	21.000	LEFT		D10-H8	12 X 12													1							
29	S-164	21.675	RIGHT	90	D10-2	12 X 36	7.0	10.0					3.0													
29	S-165	21.675	LEFT	90	D10-2	12 X 36	7.0	10.0					3.0													
29	S-166	22.000	RIGHT		D10-H8	12 X 12													1							
29	S-167	22.000	LEFT		D10-H8	12 X 12													1							
29	S-168	22.475	LEFT		M3-4	36 X 18													1							
29	S-168	22.475	LEFT		M1-4-2	36 X 36													1							
29	S-169	22.618	RIGHT		M3-2	36 X 18													1							
29	S-169	22.618	RIGHT		M1-4-2	36 X 36													1							
29	S-170	22.675	RIGHT	91	D10-2	12 X 36	7.0	10.0					3.0													
29	S-171	22.675	LEFT	91	D10-2	12 X 36	7.0	10.0					3.0													
29	S-172	23.000	RIGHT		D10-H8	12 X 12													1							
29	S-173	23.000	LEFT		D10-H8	12 X 12													1							
29	S-174	23.675	RIGHT	92	D10-2	12 X 36	7.0	10.0					3.0													
29	S-175	23.675	LEFT	92	D10-2	12 X 36	7.0	10.0					3.0													
29	S-176	22.833	LEFT	70	R2-1	48 X 60							20.0						1							
29	S-177	23.987	RIGHT		R3-4	36 X 36				1			9.0						1				1			
29	S-177	23.987	RIGHT		R5-H11	30 X 24					1		5.0						1				1			
29	S-178	23.977	LEFT		R3-4	36 X 36				1			9.0						1				1			
29	S-178	23.977	LEFT		R5-H11	30 X 24					1		5.0						1				1			
TOTALS CARRIED TO SUB-SUMMARY, SHEET 6							70.0	100.0	4	4			133.5			32			15			8				

CALCULATED
VHP
CHECKED
XXX

SIGN PLAN QUANTITIES
FAYETTE COUNTY - US 35

FAY-SYS SIGN
REPLACE-FY20

34
88

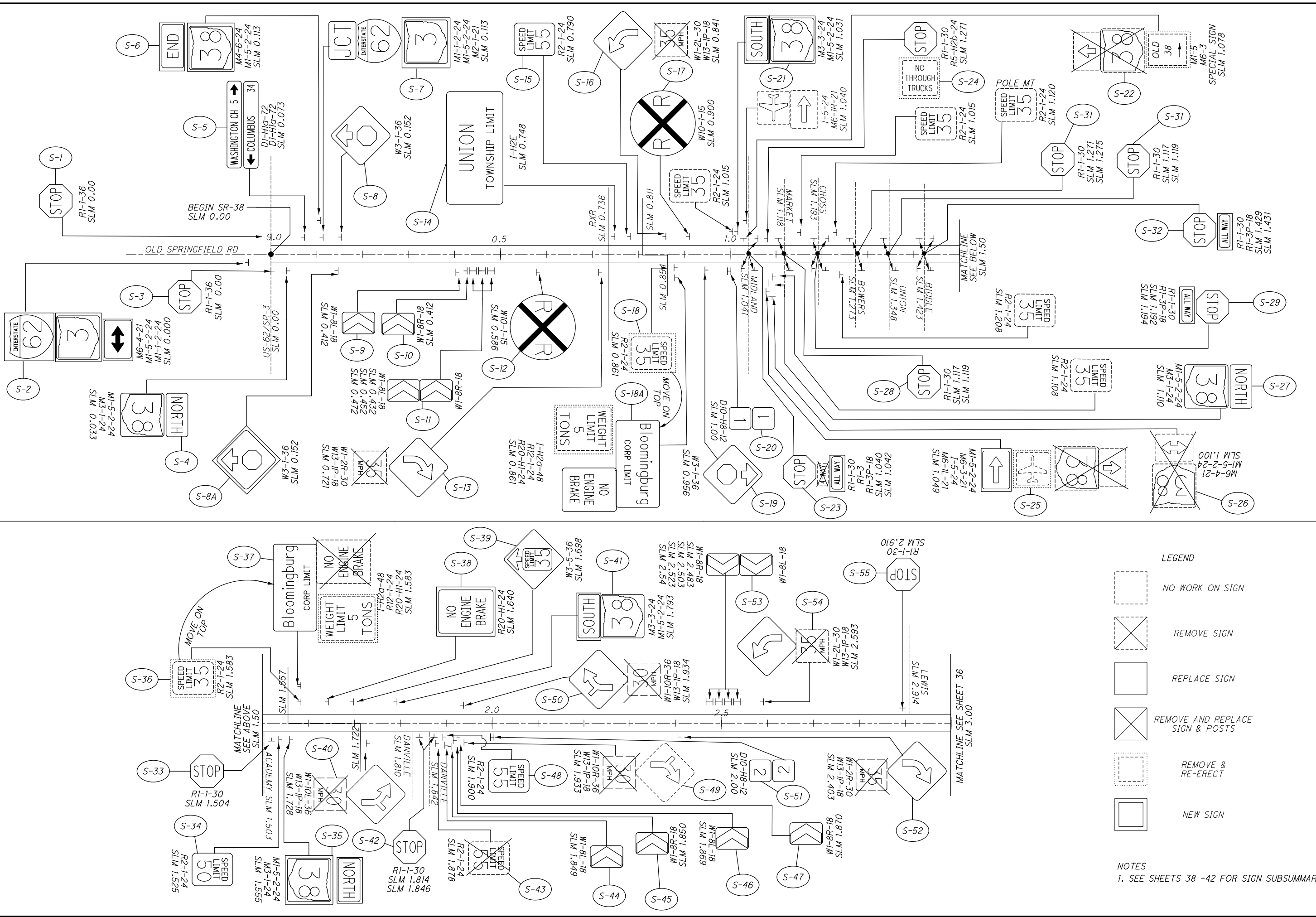

LEGEND

- NO WORK ON SIGN
- REMOVE SIGN
- REPLACE SIGN
- REMOVE AND REPLACE SIGN & POSTS
- REMOVE & RE-ERECT
- NEW SIGN

NOTES
1. SEE SHEETS 38 -42 FOR SIGN SUBSUMMARY

CALCULATED 0 500 1000
CHECKED

HORIZONTAL SCALE IN FEET

SIGN PLAN
FAY-38: SLM 0.00 - 3.00

FAY-SYS SIGN
REPLACE-FY20

35
88

I:\ProjectData\07556_FAY_PIC_FLAT_SHEET\Design\Roadway\Sheets\07556_TP003.dgn 107556_TP003_38 1/27/2020 3:52:48 PM vpatel

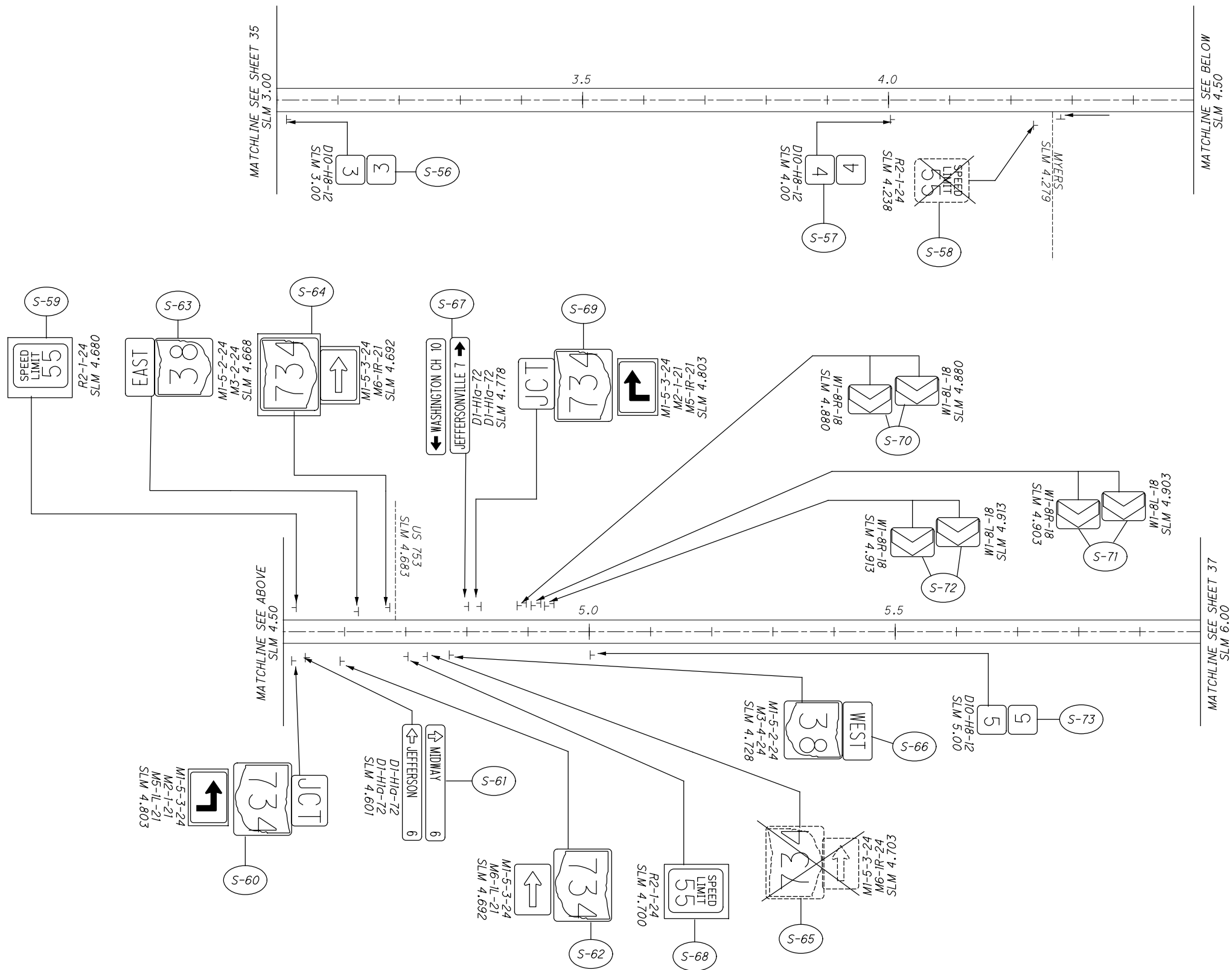

SEE SHEET 35 FOR LEGEND
SEE SHEETS 38 - 42 FOR QUANTITIES

CALCULATED	0	500	1000
CHECKED			

HORIZONTAL SCALE IN FEET

SIGN PLAN
FAY-38: SLM 3.00 - 6.00

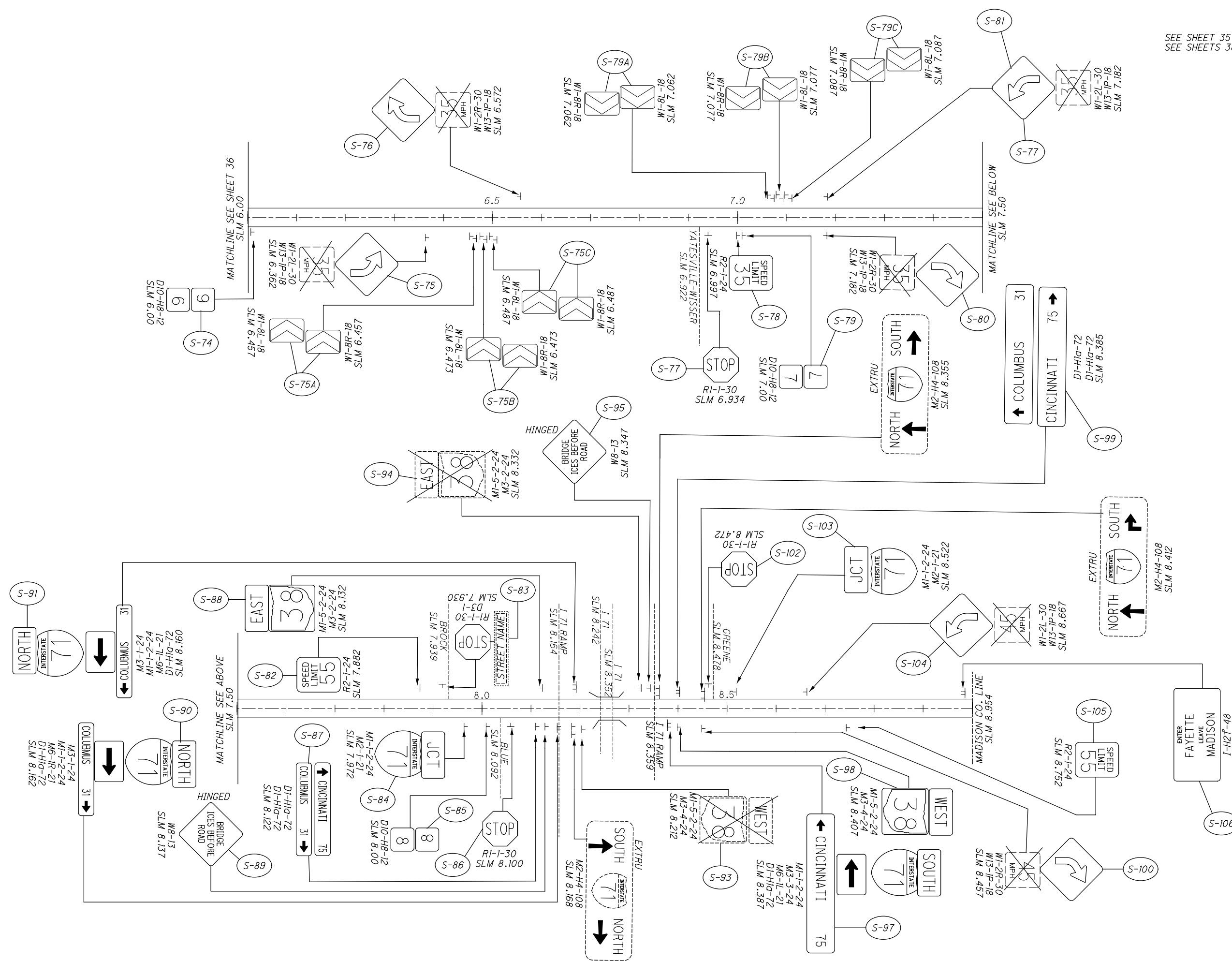

SEE SHEET 35 FOR LEGEND
SEE SHEETS 38 - 42 FOR QUANTITIES

CALCULATED
CHECKED

0 500 1000
HORIZONTAL SCALE IN FEET

SIGN PLAN
FAY-38: SLM 6.00 - 8.95

FAY-SYS SIGN REPLACE-FY20

37
88

SHEET NO.	REFERENCE SHEET	LOCATION (SLM)	SIDE	NOTE	CODE	SIZE (INCHES)	630	630	630	630	630	630	630	630	630	630	630	630	630	630	630	630
							GROUND MOUNTED SUPPORT, No. 2 POST FT	GROUND MOUNTED SUPPORT, No. 3 POST FT	SIGN POST REFLECTOR, RED EACH			SIGN POST REFLECTOR, WHITE EACH	SIGN POST REFLECTOR, YELLOW EACH	SIGN BACKING ASSEMBLY EACH	SIGN SUPPORT ASSEMBLY, POLE MOUNTED EACH	SIGN, FLAT SHEET SQ FT	SIGN, FLAT SHEET, AS PER PLAN SQ FT	SIGN, DOUBLE FACED, MILE MARKER EACH	REMOVAL OF GROUND MOUNTED SIGN & DISPOSAL EACH	REMOVAL OF GROUND MOUNTED SIGN & RE-ERECTION, AS PER PLAN EACH	REMOVAL OF GROUND MOUNTED MAJOR SIGN & DISPOSAL EACH	REMOVAL OF GROUND MOUNTED POST SUPPORT AND DISPOSAL EACH
35	S-41	1.793	LEFT		M3-3	24 X 12							2.0									
35	S-41	1.793	LEFT	35	M1-5-2	24 X 24							4.0		1							
35	S-42	1.814	RIGHT		R1-1	30 X 30			1				6.3		1						1	
35	S-42	1.846	RIGHT		R1-1	30 X 30			1				6.3		1						1	
35	S-43	1.878	RIGHT		R2-1	24 X 30									1		1					
35	S-44	1.849	RIGHT		W1-8L	18 X 24						1	3.0		1							1
35	S-45	1.850	RIGHT		W1-8R	18 X 24						1	3.0		1							1
35	S-46	1.869	RIGHT		W1-8L	18 X 24						1	3.0		1							1
35	S-47	1.870	RIGHT		W1-8R	18 X 24						1	3.0		1							1
35	S-48	1.900	RIGHT	48	R2-1	24 X 30							5.0		1							
35	S-49	1.933	RIGHT		W1-10R	36 X 36							9.0		1							
35	S-49	1.933	RIGHT		W13-1P	18 X 18									1							
35	S-50	1.934	LEFT		W1-10R	36 X 36							9.0		1							
35	S-50	1.934	LEFT		W13-1P	18 X 18									1							
35	S-51	2.000	RIGHT	2	D10-H8	12 X 12										1						
35	S-52	2.403	RIGHT		W1-2R	30 X 30							6.3				1					
35	S-52	2.403	RIGHT		W13-1P	18 X 18									1							
35	S-53	2.438	LEFT		W1-8R	18 X 24						1	3.0				1					1
35	S-53	2.438	LEFT		W1-8L	18 X 24						1	3.0				1					1
35	S-53	2.503	LEFT		W1-8R	18 X 24						1	3.0				1					1
35	S-53	2.503	LEFT		W1-8L	18 X 24						1	3.0				1					1
35	S-53	2.523	LEFT		W1-8R	18 X 24						1	3.0				1					1
35	S-53	2.523	LEFT		W1-8L	18 X 24						1	3.0				1					1
35	S-53	2.540	LEFT		W1-8R	18 X 24						1	3.0				1					1
35	S-53	2.540	LEFT		W1-8L	18 X 24						1	3.0				1					1
35	S-54	2.593	LEFT		W1-2L	30 X 30							6.3				1					
35	S-54	2.593	LEFT		W13-1P	18 X 18									1							
35	S-55	2.910	LEFT		R1-1	30 X 30			1				6.3				1					1
36	S-56	3.000	RIGHT	3	D10-H8	12 X 12									1	1						
36	S-57	4.000	RIGHT	4	D10-H8	12 X 12									1	1						
36	S-58	4.238	RIGHT		R2-1	24 X 30									1			1				
36	S-59	4.680	LEFT		R2-1	24 X 30	7.0	10.0					5.0									
36	S-60	4.803	RIGHT	734	M1-5-3	30 X 24							5.0				1					
36	S-60	4.803	RIGHT		M2-1	21 X 15							2.2				1					
36	S-60	4.803	RIGHT		M5-1L	21 X 15							2.2									
36	S-61	4.601	RIGHT	MIDWAY, 6	D1-H1A	72 X 12							6.0				1					
36	S-61	4.601	RIGHT	JEFFERSON, 6	D1-H1A	72 X 12							6.0				1					
36	S-62	4.692	RIGHT	734	M1-5-3	30 X 24							5.0				1					
36	S-62	4.692	RIGHT		M6-1L	21 X 15							2.2				1					
36	S-63	4.668	LEFT	38	M1-5-2	24 X 24							4.0				1					
36	S-63	4.668	LEFT		M3-2	24 X 12							2.0				1					
36	S-64	4.692	LEFT	734	M1-5-3	30 X 24	7.0	10.0					5.0									
36	S-64	4.692	LEFT		M6-1R	21 X 15							2.2									
36	S-65	4.703	RIGHT	734	M1-5-3	30 X 24											1			1		
36	S-65	4.703	RIGHT		M6-1R	21 X 15											1					
36	S-66	4.728	RIGHT	38	M1-5-2	24 X 24							4.0									
36	S-66	4.728	RIGHT		M3-4	24 X 12							2.0									

CALCULATED	VHP	CHECKED	XXX
SIGN PLAN QUANTITIES FAYETTE COUNTY - SR 38			
FAY-SYS SIGN REPLACE-FY20			
40			
88			

TOTALS CARRIED TO SUB-SUMMARY, SHEET 6

14.0 20.0 3 12 149.3 3 39 3 15

SHEET NO.	REFERENCE SHEET	LOCATION (SLM)	SIDE	NOTE	CODE	SIZE (INCHES)	630.0	630.0	630	630	630	630	630.0	630	630	630	630	630	630	630	630	630	HINGED		
							GROUND MOUNTED SUPPORT, No. 2 POST	GROUND MOUNTED SUPPORT, No. 3 POST	SIGN POST REFLECTOR, RED	SIGN POST REFLECTOR, WHITE	SIGN POST REFLECTOR, YELLOW	SIGN BACKING ASSEMBLY	SIGN SUPPORT ASSEMBLY, POLE MOUNTED	SIGN, FLAT SHEET	SIGN, FLAT SHEET, AS PER PLAN	SIGN, DOUBLE FACED, MILE MARKER	REMOVAL OF GROUND MOUNTED SIGN & DISPOSAL	REMOVAL OF GROUND MOUNTED SIGN & RE-ERECTION, AS PER PLAN	REMOVAL OF GROUND MOUNTED MAJOR SIGN & DISPOSAL	REMOVAL OF GROUND MOUNTED POST SUPPORT AND DISPOSAL	REMOVAL OF STRUCTURE MOUNTED SIGN AND DISPOSAL	REMOVAL OF POLE MOUNTED SIGN & DISPOSAL			SIGNING, MISC: REMOVAL OF POST REFLECTOR
							FT	FT	EACH	EACH	EACH	EACH	SQ FT	SQ FT	EACH	EACH	EACH	EACH	EACH	EACH	EACH	EACH			EACH
37	S-94	8.332	LEFT	38	M1-5-2	24 X 24											1					1			
37	S-94	8.332	LEFT		M3-2	24 X 12											1								
37	S-95	8.347	LEFT		W8-13	36 X 36								9			1						YES		
	S-96			NOT-USED																					
37	S-97	8.387	RIGHT		M1-1-2	24 X 24							4.0				1								
37	S-97	8.387	RIGHT		M3-3	24 X 12							2.0				1								
37	S-97	8.387	RIGHT		M6-1L	21 X 15							2.2				1								
37	S-97	8.387	RIGHT	CINCINNATI, 75	D1-H1A	72 X 12							6.0				1								
37	S-98	8.4.07	RIGHT	38	M1-5-2	24 X 24							4.0				1								
37	S-98	8.4.07	RIGHT		M3-2	24 X 12							2.0				1								
37	S-99	8.385	LEFT	COLUMBUS, 31	D1-H1A	72 X 12							6.0				1								
37	S-99	8.385	LEFT	CINCINNATI, 75	D1-H1A	72 X 12							6.0				1								
37	S-100	8.457	RIGHT		W1-2R	30 X 30							6.3				1								
37	S-100	8.457	RIGHT		W13-1P	18 X 18											1								
	S-101			NOT-USED																					
37	S-102	8.471	LEFT		R1-1	30 X 30			1				6.3				1						1		
37	S-103	8.522	LEFT	"WHITE ON BLUE"	M2-1	21 X 15							2.2				1								
37	S-103	8.522	LEFT	71	M1-1-2	24 X 24							4.0				1								
37	S-104	8.667	LEFT		W1-2L	30 X 30							6.3				1								
37	S-104	8.667	LEFT		W13-1P	18 X 18											1								
37	S-105	8.752	RIGHT	55	R2-1	24 X 30							5.0				1								
37	S-106	8.954	LEFT	ENTER FAYETTE, LEAVE MADISON	I-H2F	24 X 48							8.0				1								
37	S-75A	6.457	RIGHT		W1-8L	18 X 24																	1		
37	S-75A	6.457	RIGHT		W1-8R	18 X 24																	1		
37	S-75B	6.473	RIGHT		W1-8L	18 X 24																	1		
37	S-75B	6.473	RIGHT		W1-8R	18 X 24																	1		
37	S-75C	6.487	RIGHT		W1-8L	18 X 24																	1		
37	S-75C	6.487	RIGHT		W1-8R	18 X 24																	1		
37	S-79A	7.062	LEFT		W1-8R	18 X 24																	1		
37	S-79A	7.062	LEFT		W1-8L	18 X 24																	1		
37	S-79B	7.077	LEFT		W1-8R	18 X 24																	1		
37	S-79B	7.077	LEFT		W1-8L	18 X 24																	1		
37	S-79C	7.087	LEFT		W1-8R	18 X 24																	1		
37	S-79C	7.087	LEFT		W1-8L	18 X 24																	1		
TOTALS CARRIED TO SUB-SUMMARY, SHEET 6									1		12		106.3	9			32			1				13	

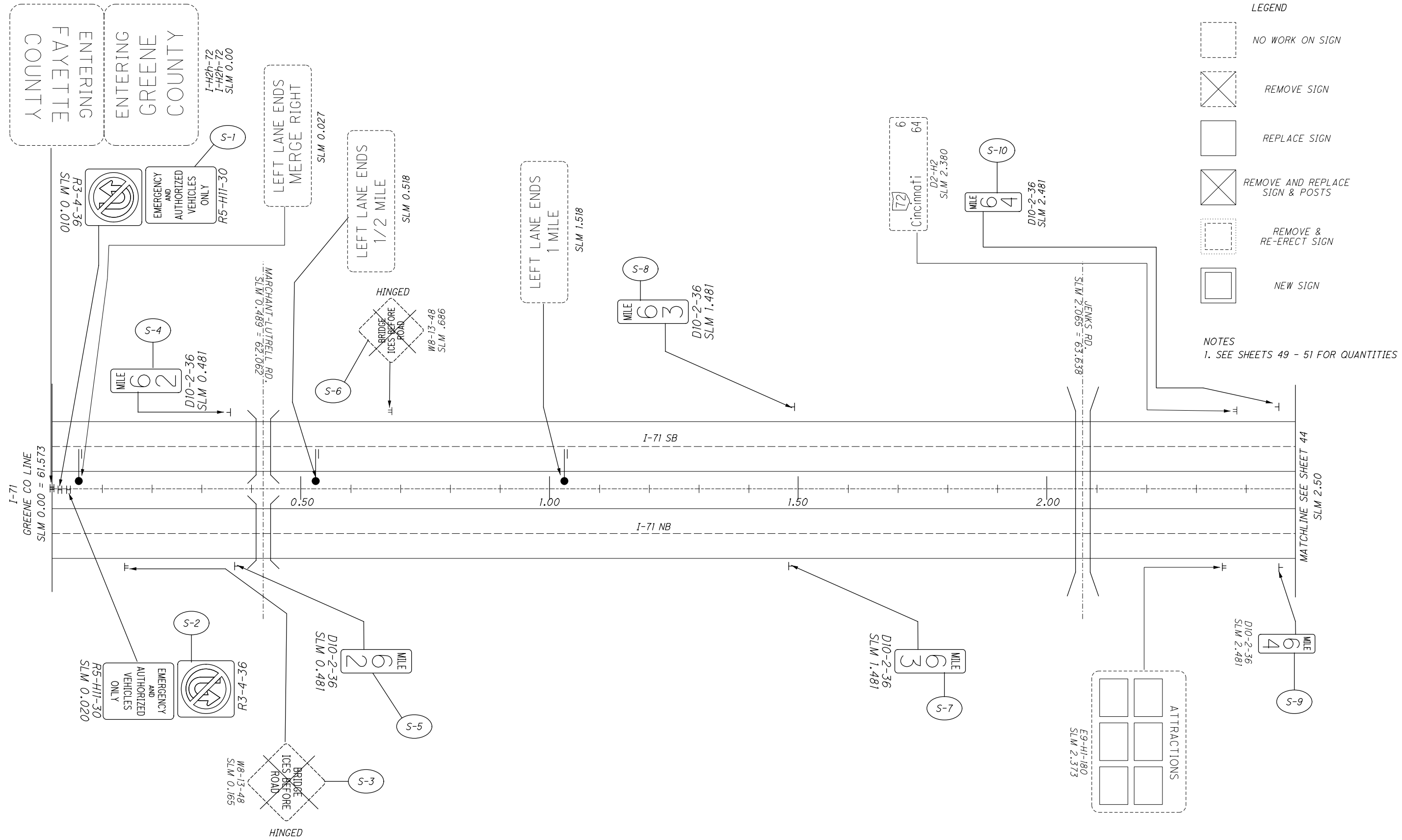

ENTERING FAYETTE COUNTY

ENTERING GREENE COUNTY

I-H2h-72
I-H2h-72
SLM 0.00

LEGEND

- NO WORK ON SIGN
- REMOVE SIGN
- REPLACE SIGN
- REMOVE AND REPLACE SIGN & POSTS
- REMOVE & RE-ERECT SIGN
- NEW SIGN

NOTES

1. SEE SHEETS 49 - 51 FOR QUANTITIES

SEE SHEET 43 FOR LEGEND
SEE SHEETS 49 - 51 FOR QUANTITIES

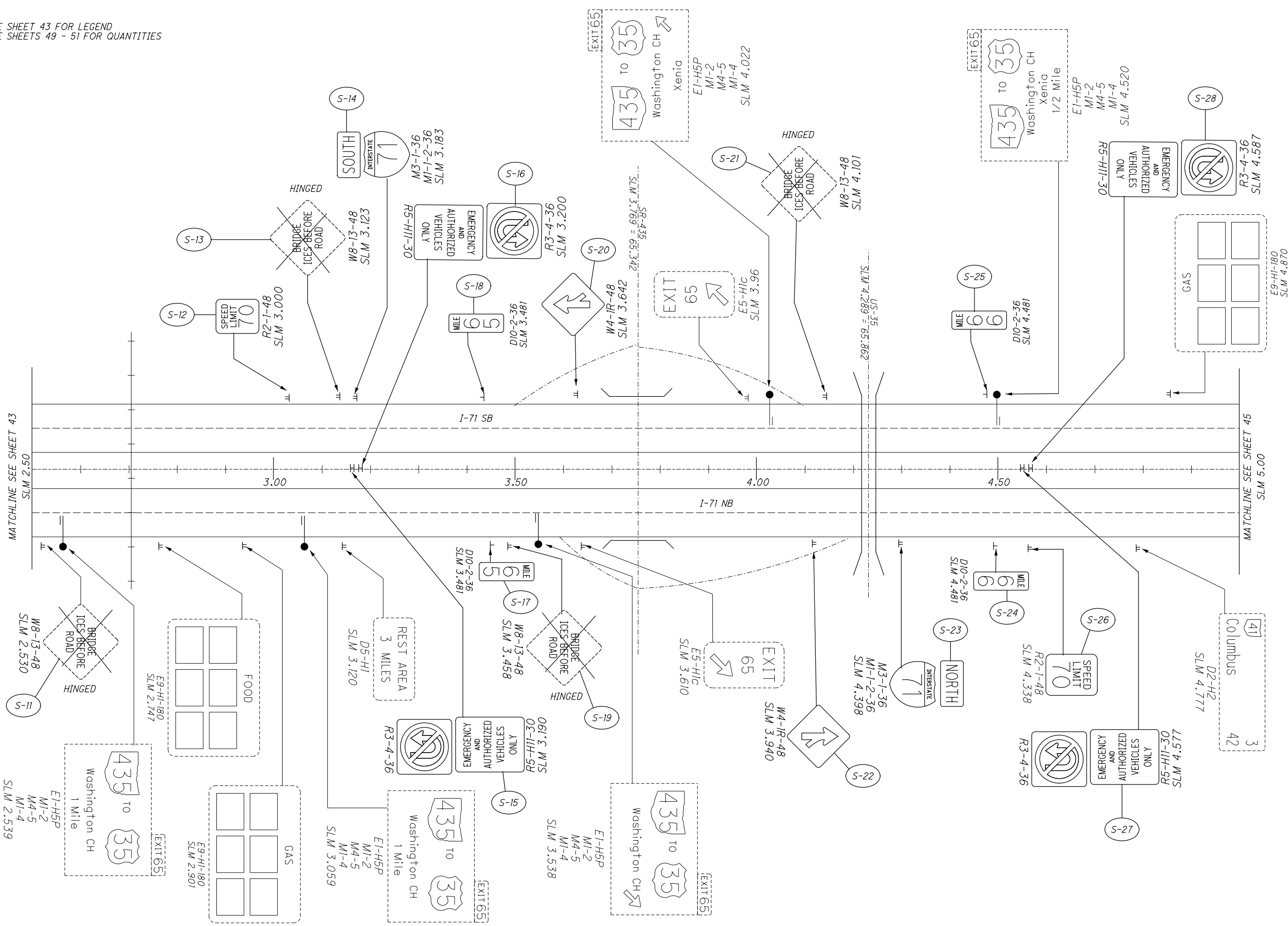

CALCULATED _____
CHECKED _____

SIGN PLAN
FAY-71: SLM 2.50 - 5.00

FAY-SYS SIGN
REPLACE-FY20

44
88

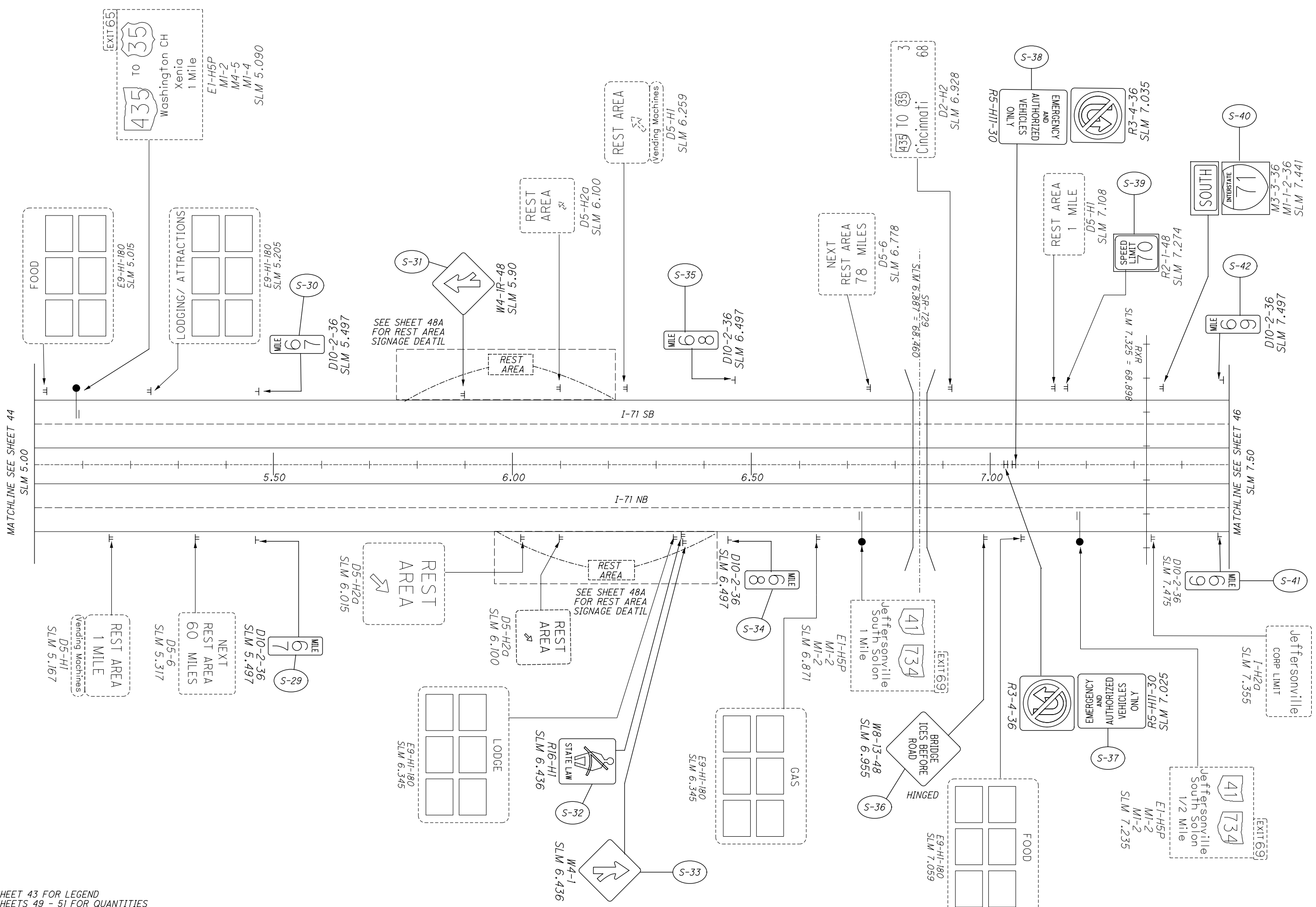

SEE SHEET 43 FOR LEGEND
SEE SHEETS 49 - 51 FOR QUANTITIES

CALCULATED 0 500 1000
CHECKED
HORIZONTAL SCALE IN FEET

SIGN PLAN
FAY-71: SLM 5.00 - 7.50

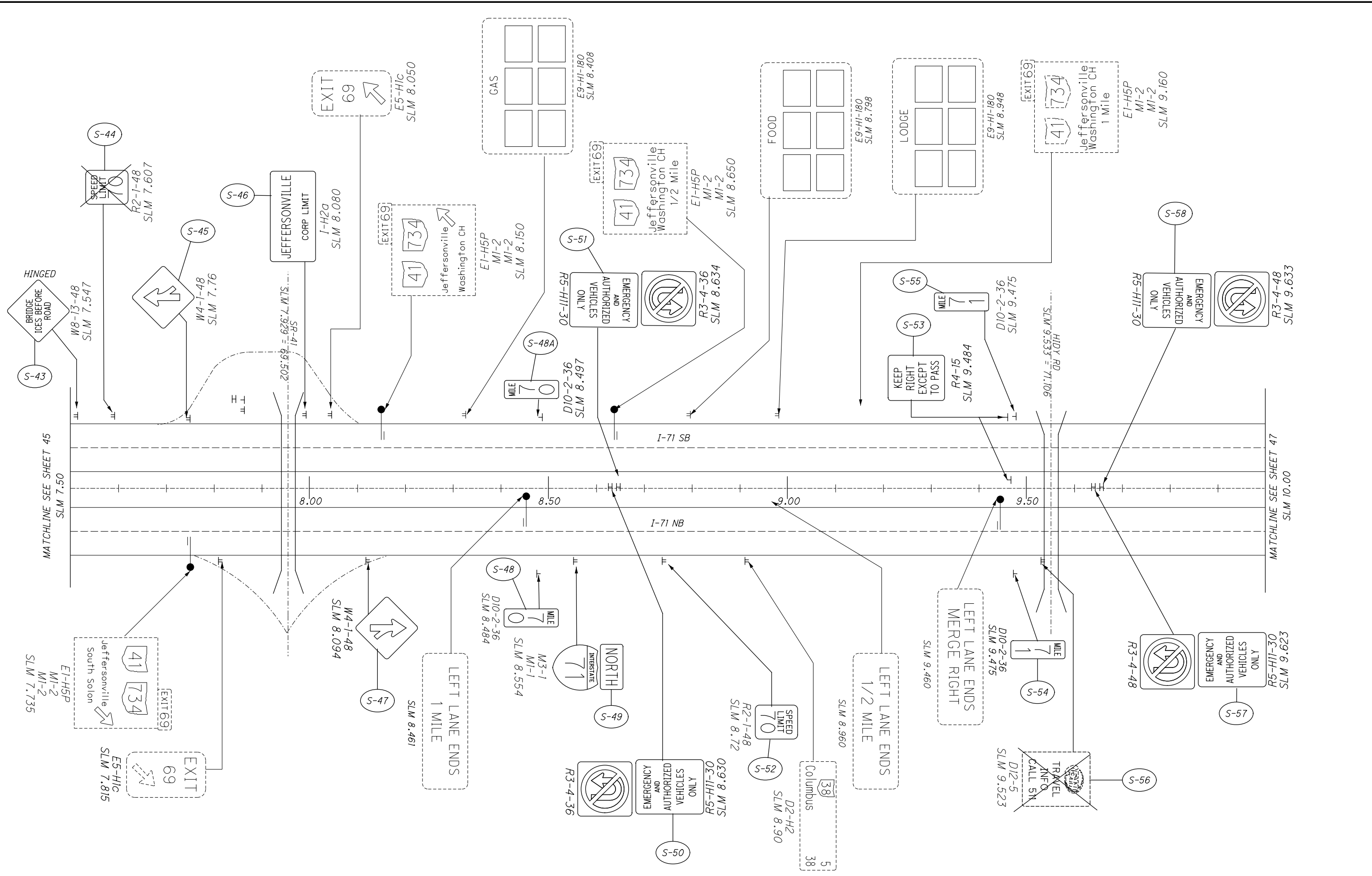

SEE SHEET 43 FOR LEGEND
SEE SHEETS 49 - 51 FOR QUANTITIES

CALCULATED 0 500 1000
CHECKED
HORIZONTAL SCALE IN FEET

SIGN PLAN
FAY-71: SLM 7.50 - 10.00

FAY-SYS SIGN REPLACE-FY20

SEE SHEET 43 FOR LEGEND
SEE SHEETS 49 - 51 FOR QUANTITIES

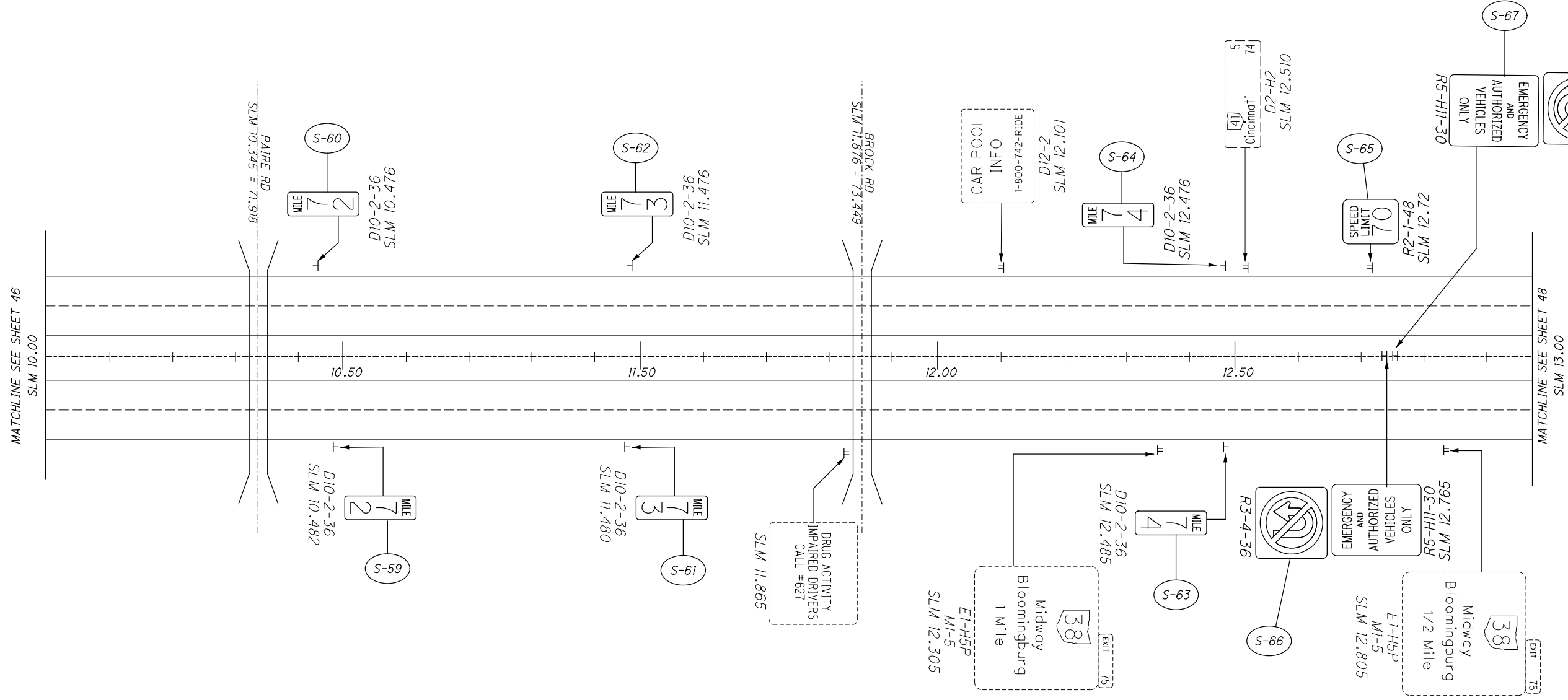

I:\Project+Data\I07556_FAY_PIC_FLATSHEET\Design\Roadway\Sheets\I07556_IP005.dgn I07556_IP006_71 1/27/2020 3:52:58 PM vpatel

SEE SHEET 43 FOR LEGEND
SEE SHEETS 49 - 51 FOR QUANTITIES

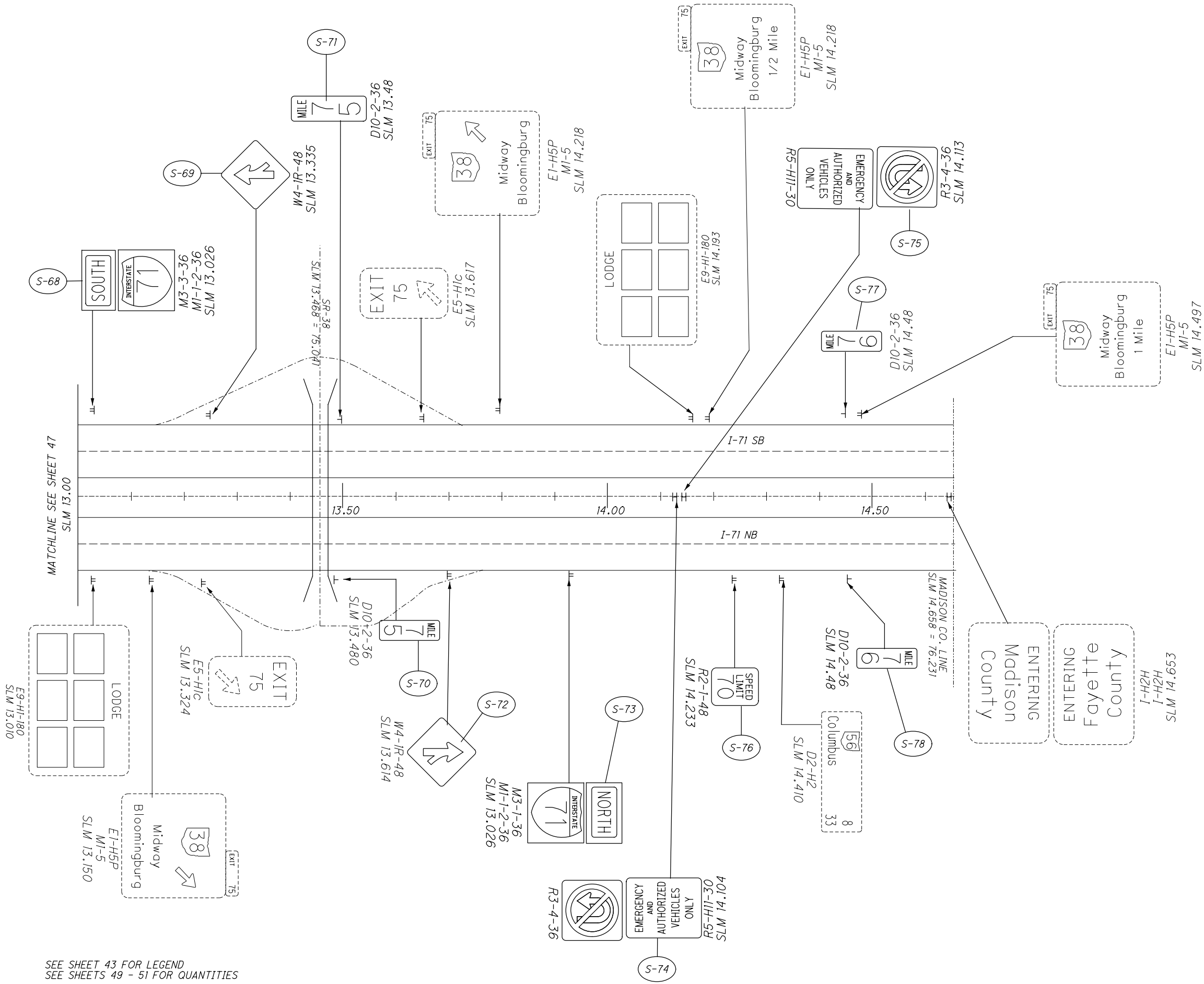

I:\ProjectData\07556_FAY_PIC_FLATSHEET\Design\Roadway\Sheets\07556_T0005.dgn 07556_T0001.TI 2/26/2020 9:36:47 AM vpatel

SHEET NO.	REFERENCE SHEET	LOCATION (SLM)	SIDE	NOTE	CODE	SIZE (INCHES)	630	630	630	630	630	630	630	630	630	630	630	630	630	630	630	630	630			
							GROUND MOUNTED SUPPORT, No. 2 POST FT	GROUND MOUNTED SUPPORT, No. 3 POST FT	SIGN POST REFLECTOR, RED EACH		SIGN POST REFLECTOR, WHITE EACH	SIGN POST REFLECTOR, YELLOW EACH	SIGN BACKING ASSEMBLY EACH	SIGN SUPPORT ASSEMBLY, POLE MOUNTED EACH	SIGN, FLAT SHEET SQ FT	SIGN, FLAT SHEET, AS PER PLAN SQ FT	SIGN, DOUBLE FACED, MILE MARKER EACH	REMOVAL OF GROUND MOUNTED SIGN & DISPOSAL EACH	REMOVAL OF GROUND MOUNTED SIGN & RE-ERECTION, AS PER PLAN EACH	REMOVAL OF GROUND MOUNTED MAJOR SIGN & DISPOSAL EACH	REMOVAL OF GROUND MOUNTED POST SUPPORT AND DISPOSAL EACH	REMOVAL OF STRUCTURE MOUNTED SIGN AND DISPOSAL EACH	REMOVAL OF POLE MOUNTED SIGN & DISPOSAL EACH	SIGNING, MISC: REMOVAL OF POST REFLECTOR EACH	HINGED	
43	S-1	0.010	MEDIAN		R3-4	36 X 36			1					9.0			1						1			
43	S-1	0.010	MEDIAN		R5-H11	30 X 24				1				5.0			1						1			
43	S-2	0.020	MEDIAN		R3-4	36 X 36			1					9.0			1						1			
43	S-2	0.020	MEDIAN		R5-H11	30 X 24				1				5.0			1						1			
43	S-3	0.165	RIGHT		W8-13	48 X 48											1			2				YES		
43	S-4	0.481	LEFT	62	D10-2	12 X 36								3.0			1									
43	S-5	0.481	RIGHT	62	D10-2	12 X 36								3.0			1									
43	S-6	0.686	LEFT		W8-13	48 X 48											1			2				YES		
43	S-7	1.481	RIGHT	63	D10-2	12 X 36								3.0			1									
43	S-8	1.481	LEFT	63	D10-2	12 X 36								3.0			1									
43	S-9	2.481	RIGHT	64	D10-2	12 X 36								3.0			1									
43	S-10	2.481	LEFT	64	D10-2	12 X 36								3.0			1									
44	S-11	2.530	RIGHT		W8-13	48 X 48											1			2				YES		
44	S-12	3.000	LEFT	70	R2-1	48 X 60								20.0			1									
44	S-13	3.123	LEFT		W8-13	48 X 48											1			2				YES		
44	S-14	31.830	LEFT		M3-1	36 X 18								4.5												
44	S-14	31.830	LEFT	71	M1-1-2	36 X 36								9.0												
44	S-15	3.190	MEDIAN		R3-4	36 X 36			1					9.0									1			
44	S-15	3.190	MEDIAN		R5-H11	30 X 24				1				5.0									1			
44	S-16	3.200	MEDIAN		R3-4	36 X 36			1					9.0									1			
44	S-16	3.200	MEDIAN		R5-H11	30 X 24				1				5.0									1			
44	S-17	3.481	RIGHT	65	D10-2	12 X 36								3.0			1									
44	S-18	3.481	LEFT	65	D10-2	12 X 36								3.0			1									
44	S-19	3.458	RIGHT		W8-13	48 X 48											1			2				YES		
44	S-20	3.642	LEFT		W4-1R	48 X 48								16.0			1									
44	S-21	4.101	LEFT		W8-13	48 X 48											1			2				YES		
44	S-22	3.940	RIGHT		W4-1R	48 X 48								16.0			1									
44	S-23	4.398	RIGHT		M3-1	36 X 18								4.5			1									
44	S-23	4.398	RIGHT		M1-1-2	36 X 36								9.0			1									
44	S-24	4.481	RIGHT	66	D10-2	12 X 36								3.0			1									
44	S-25	4.481	LEFT	66	D10-2	12 X 36								3.0			1									
44	S-26	4.338	RIGHT	70	R2-1	48 X 60								20.0			1									
44	S-27	4.577	MEDIAN		R3-4	36 X 36			1					9.0			1						1			
44	S-27	4.577	MEDIAN		R5-H11	30 X 24				1				5.0			1						1			
44	S-28	4.587	MEDIAN		R3-4	36 X 36			1					9.0			1						1			
44	S-28	4.587	MEDIAN		R5-H11	30 X 24				1				5.0			1						1			
45	S-29	5.497	RIGHT	67	D10-2	12 X 36								3.0			1									
45	S-30	5.497	LEFT	67	D10-2	12 X 36								3.0			1									
45	S-31	5.900	LEFT		W4-1R	48 X 48								16.0			1									
45	S-32	6.438	RIGHT		R16-H1	48 X 60								20.0			1									
45	S-33	6.436	RIGHT		W4-1R	48 X 48								16.0			1									
45	S-34	6.497	RIGHT	68	D10-2	12 X 36								3.0			1									
45	S-35	6.497	LEFT	68	D10-2	12 X 36								3.0			1									
45	S-36	6.955	RIGHT		W8-13	48 X 48											1			16.0				YES		
45	S-37	7.025	MEDIAN		R3-4	36 X 36			1					9.0			1						1			
45	S-37	7.025	MEDIAN		R5-H11	30 X 24				1				5.0			1						1			
45	S-38	7.035	MEDIAN		R3-4	36 X 36			1					9.0			1						1			
45	S-38	7.035	MEDIAN		R5-H11	30 X 24				1				5.0			1						1			
TOTALS CARRIED TO SUB-SUMMARY, SHEET 6									8	8					305.0	16.0		42			12			16		

CALCULATED VHP CHECKED XXX

SIGN PLAN QUANTITIES

FAYETTE COUNTY - IR 71

FAY-SYS SIGN REPLACE-FY20

49
88

I:\ProjectData\07556_FAY_PIC_FLATSHEET\Design\Roadway\Sheets\07556_T0005.dgn 07556_T0002_71 1/27/2020 3:53:00 PM vpatel

SHEET NO.	REFERENCE SHEET	LOCATION (SLM)	SIDE	NOTE	CODE	SIZE (INCHES)	630	630	630	630	630	630	630	630	630	630	630	630	630	630	630	630	HINGED			
							GROUND MOUNTED SUPPORT, No. 2 POST FT	GROUND MOUNTED SUPPORT, No. 3 POST FT	SIGN POST REFLECTOR, RED EACH		SIGN POST REFLECTOR, WHITE EACH	SIGN POST REFLECTOR, YELLOW EACH	SIGN BACKING ASSEMBLY EACH	SIGN SUPPORT ASSEMBLY, POLE MOUNTED EACH	SIGN, FLAT SHEET SQ FT	SIGN, FLAT SHEET, AS PER PLAN SQ FT	SIGN, DOUBLE FACED, MILE MARKER EACH	REMOVAL OF GROUND MOUNTED SIGN & DISPOSAL EACH	REMOVAL OF GROUND MOUNTED SIGN & RE-ERECTION, AS PER PLAN EACH	REMOVAL OF GROUND MOUNTED MAJOR SIGN & DISPOSAL EACH	REMOVAL OF GROUND MOUNTED POST SUPPORT AND DISPOSAL EACH	REMOVAL OF STRUCTURE MOUNTED SIGN AND DISPOSAL EACH			REMOVAL OF POLE MOUNTED SIGN & DISPOSAL EACH	SIGNING, MISC: REMOVAL OF POST REFLECTOR EACH
45	S-39	7.214	LEFT		R2-1	48 X 60																				
45	S-40	7.441	LEFT		M3-3	36 X 18	14.0	20.0																		
45	S-40	7.441	LEFT		M1-1-2	36 X 36																				
45	S-41	7.475	RIGHT	69	D10-2	12 X 36																				
45	S-42	7.497	LEFT	69	D10-2	12 X 36																				
46	S-43	7.547	LEFT		W8-13	48 X 48																				
46	S-44	7.607	LEFT	70	R2-1	48 X 60																				
46	S-45	7.760	LEFT		W4-1	48 X 48																				
46	S-46	8.080	LEFT	JEFFERSONVILLE	I-H2A	72 X 36																				
46	S-47	8.094	RIGHT		W4-1R	48 X 48																				
46	S-48	8.484	RIGHT	70	D10-2	12 X 36																				
46	S-48A	8.497	LEFT	70	D10-2	12 X 36																				
46	S-49	8.554	RIGHT		M3-1	36 X 18																				
46	S-49	8.554	RIGHT	71	M1-1-2	36 X 36																				
46	S-50	8.630	MEDIAN		R3-4	36 X 36																				
46	S-50	8.630	MEDIAN		R5-H11	30 X 24																				
46	S-51	8.634	MEDIAN		R3-4	36 X 36																				
46	S-51	8.634	MEDIAN		R5-H11	30 X 24																				
46	S-52	8.720	RIGHT		R2-1	48 X 60																				
46	S-53	9.484	MEDIAN		R4-16	48 X 60																				
46	S-53	9.484	LEFT		R4-16	48 X 60																				
46	S-54	9.475	RIGHT	71	D10-2	12 X 36																				
46	S-55	9.475	LEFT	71	D10-2	12 X 36																				
46	S-56	9.523	RIGHT		D12-5	66 X 78																				
46	S-57	9.623	MEDIAN		R3-4	36 X 36																				
46	S-57	9.623	MEDIAN		R5-H11	30 X 24																				
46	S-58	9.633	MEDIAN		R3-4	36 X 36																				
46	S-58	9.633	MEDIAN		R5-H11	30 X 24																				
47	S-59	10.482	RIGHT	72	D10-2	12 X 36																				
47	S-60	10.476	LEFT	72	D10-2	12 X 36																				
47	S-61	11.480	RIGHT	73	D10-2	12 X 36																				
47	S-62	11.476	LEFT	73	D10-2	12 X 36																				
47	S-63	12.485	RIGHT	74	D10-2	12 X 36																				
47	S-64	12.476	LEFT	74	D10-2	12 X 36																				
47	S-65	12.720	LEFT		R2-1	48 X 60																				
47	S-66	12.765	MEDIAN		R3-4	36 X 36																				
47	S-66	12.765	MEDIAN		R5-H11	30 X 24																				
47	S-67	12.775	MEDIAN		R3-4	36 X 36																				
47	S-67	12.775	MEDIAN		R5-H11	30 X 24																				
48	S-68	13.026	LEFT		M3-3	36 X 18	14.0	20.0																		
48	S-68	13.026	LEFT		M1-1-2	36 X 36																				
48	S-69	13.335	LEFT	71	W4-1	48 X 48																				
48	S-70	13.480	RIGHT	75	D10-2	12 X 36																				
48	S-71	13.480	LEFT	75	D10-2	12 X 36																				
48	S-72	13.614	RIGHT		W4-1	48 X 48																				
48	S-73	13.026	RIGHT		M3-1	36 X 18	14.0	20.0																		
48	S-73	13.026	RIGHT	71	M1-1-2	36 X 36																				
TOTALS CARRIED TO SUB-SUMMARY, SHEET 6							42.0	60.0	6	6							362.0	16.0			41			4		12

SIGN PLAN QUANTITIES
FAYETTE COUNTY - IR 71

FAY-SYS SIGN
REPLACE-FY20

CALCULATED
VHP
CHECKED
XXX

50
88

I:\ProjectData\07556_FAY_PIC_FLAT_SHEET\Design\Roadway\Sheets\07556_T0003_71\1/27/2020_3:53:01PM vpotel

SHEET NO.	REFERENCE SHEET	LOCATION (SLM)	SIDE	NOTE	CODE	SIZE (INCHES)	630	630	630	630	630	630	630	630	630	630	630	630	630	630	630	630	630	630		
							GROUND MOUNTED SUPPORT, No. 2 POST FT	GROUND MOUNTED SUPPORT, No. 3 POST FT	SIGN POST REFLECTOR, RED EACH	SIGN POST REFLECTOR, WHITE EACH	SIGN POST REFLECTOR, YELLOW EACH	SIGN BACKING ASSEMBLY EACH	SIGN SUPPORT ASSEMBLY, POLE MOUNTED EACH	SIGN, FLAT SHEET SQ FT	SIGN, FLAT SHEET, AS PER PLAN SQ FT	SIGN, DOUBLE FACED, MILE MARKER EACH	REMOVAL OF GROUND MOUNTED SIGN & DISPOSAL EACH	REMOVAL OF GROUND MOUNTED SIGN & RE-ERECTION, AS PER PLAN EACH	REMOVAL OF GROUND MOUNTED MAJOR SIGN & DISPOSAL EACH	REMOVAL OF GROUND MOUNTED POST SUPPORT AND DISPOSAL EACH	REMOVAL OF STRUCTURE MOUNTED SIGN AND DISPOSAL EACH	REMOVAL OF POLE MOUNTED SIGN & DISPOSAL EACH	SIGNING, MISC: REMOVAL OF POST REFLECTOR EACH	HINGED		
48	S-74	14.104	MEDIAN		R3-4	36 X 36			1				9.0			1								1		
48	S-74	14.104	MEDIAN		R5-H11	30 X 24				1			5.0			1									1	
48	S-75	14.113	MEDIAN		R3-4	36 X 36			1				9.0			1									1	
48	S-75	14.113	MEDIAN		R5-H11	30 X 24				1			5.0			1									1	
48	S-76	14.233	RIGHT	70	R2-1	48 X 60							20.0			1										
48	S-77	14.480	LEFT	76	D10-2	12 X 36							3.0			1										
48	S-78	14.480	RIGHT	76	D10-2	12 X 36							3.0			1										
REST AREA I-71 NB																										
48A	S-79	6.085	RIGHT		R7-1	12 X 18							1.5			1										
48A	S-79	6.103	RIGHT		R7-1	12 X 18							1.5			1										
48A	S-79	6.121	RIGHT		R7-1	12 X 18							1.5			1										
48A	S-79	6.139	RIGHT		R7-1	12 X 18							1.5			1										
48A	S-80	6.160	RIGHT		R7-1	12 X 18							1.5			1										
48A	S-80	6.160	RIGHT		R7-1	12 X 18							1.5			1										
48A	S-81	6.180	RIGHT		R7-1	12 X 18							1.5			1										
48A	S-81	6.180	RIGHT		R7-1	12 X 18							1.5			1										
48A	S-82	6.200	RIGHT		R7-1	12 X 18							1.5			1										
48A	S-82	6.200	RIGHT		R7-1	12 X 18							1.5			1										
48A	S-83	6.220	RIGHT		R7-1	12 X 18							1.5			1										
48A	S-83	6.220	RIGHT		R7-1	12 X 18							1.5			1										
48A	S-84	6.240	RIGHT		R7-1	12 X 18							1.5			1										
48A	S-84	6.240	RIGHT		R7-1	12 X 18							1.5			1										
48A	S-85	6.240	RIGHT		R3-4	36 X 36			1				9.0			1									1	
48A	S-86	6.395	RIGHT		R7-1	12 X 18							1.5			1										
48A	S-86	6.415	RIGHT		R7-1	12 X 18							1.5			1										
48A	S-86	6.435	RIGHT		R7-1	12 X 18							1.5			1										
48A	S-86	6.455	RIGHT		R7-1	12 X 18							1.5			1										
48A	S-86	6.475	RIGHT		R7-1	12 X 18							1.5			1										
48A	S-87	6.008	LEFT		R3-4	36 X 36			1				9.0			1									1	
48A	S-87	6.008	LEFT		R7-1	12 X 18							1.5			1										
48A	S-87	6.028	LEFT		R7-1	12 X 18							1.5			1										
48A	S-87	6.048	LEFT		R7-1	12 X 18							1.5			1										
48A	S-87	6.068	LEFT		R7-1	12 X 18							1.5			1										
48A	S-87	6.088	LEFT		R7-1	12 X 18							1.5			1										
TOTALS CARRIED TO SUB-SUMMARY, SHEET 6									4	2			108.0			33								6		

CALCULATED VHP	CHECKED XXX	SIGN PLAN QUANTITIES FAYETTE COUNTY - IR 71	FAY-SYS SIGN REPLACE-FY20	51
				88

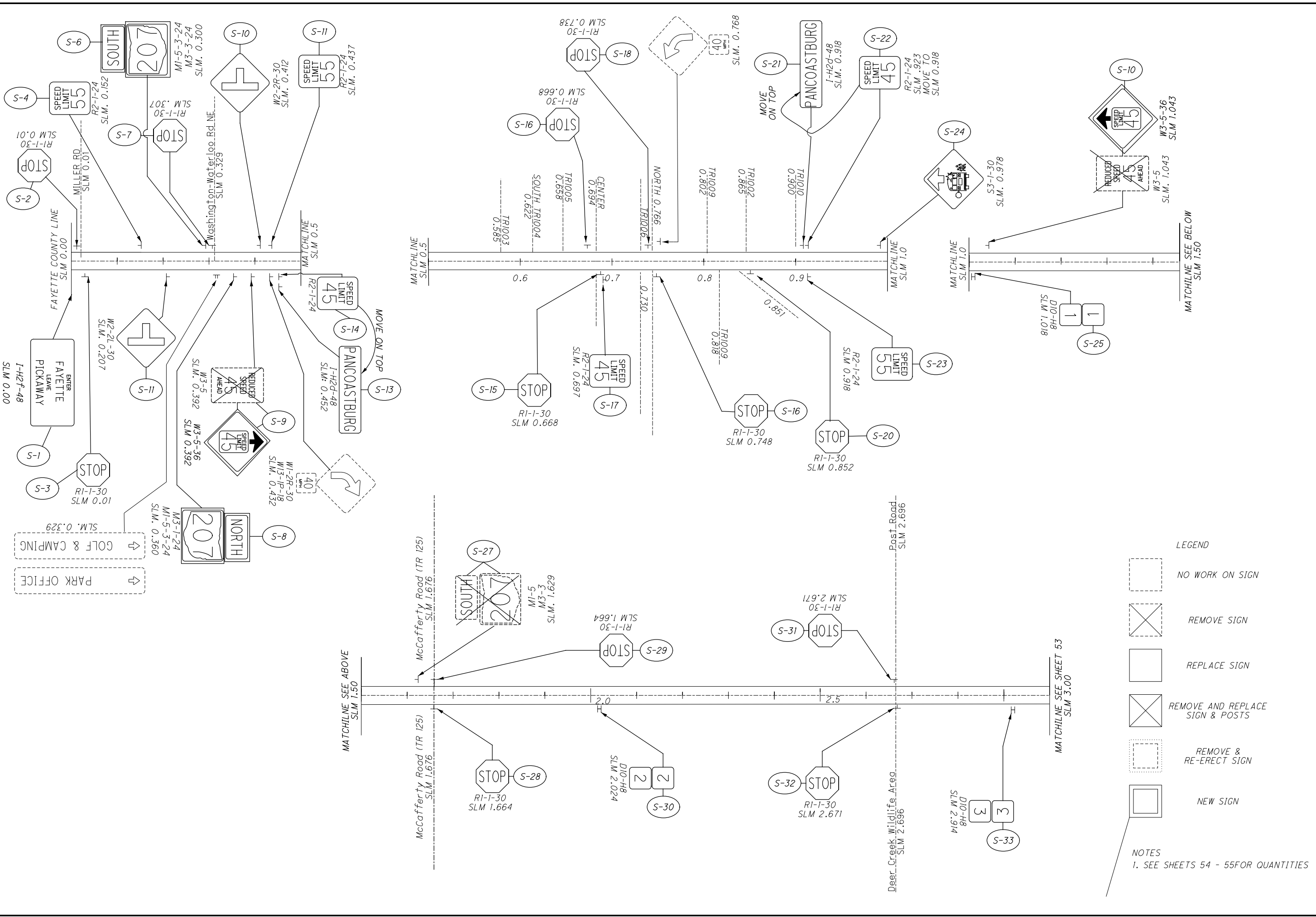

LEGEND

- NO WORK ON SIGN
- REMOVE SIGN
- REPLACE SIGN
- REMOVE AND REPLACE SIGN & POSTS
- REMOVE & RE-ERECT SIGN
- NEW SIGN

NOTES
1. SEE SHEETS 54 - 55 FOR QUANTITIES

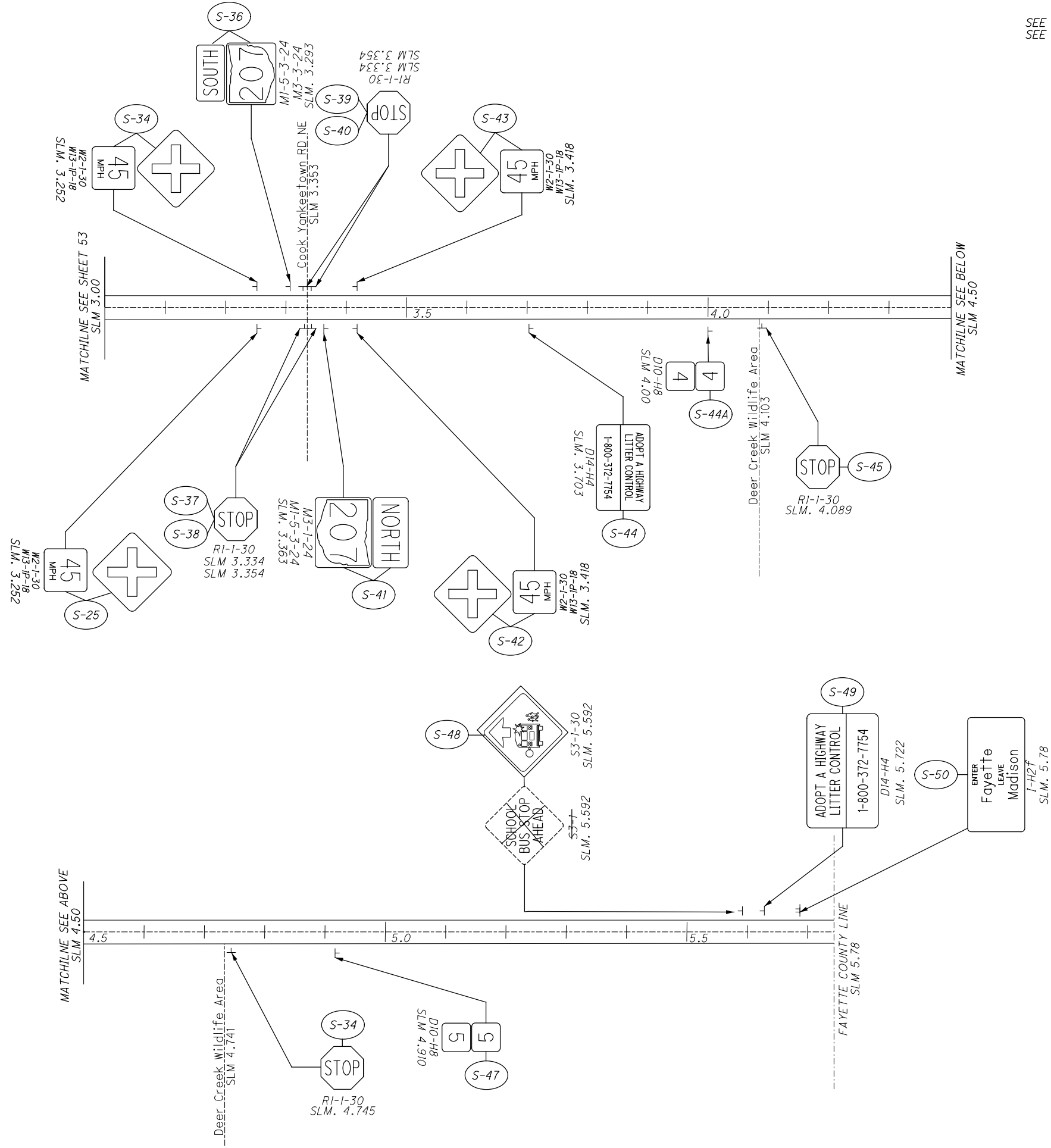

SEE SHEET 52 FOR LEGEND
SEE SHEETS 54 - 55 FOR QUANTITIES

CALCULATED
CHECKED

0 500 1000
HORIZONTAL SCALE IN FEET

N

SIGN PLAN
FAY-207: SLM 3.00 - 5.78

FAY-SYS SIGN
REPLACE-FY20

I:\ProjectData\07556_FAY_PIC_FLAT_SHEET\Design\Roadway\Sheets\07556_I0006.dgn 107556_I0001.207 1/27/2020 3:53:04 PM vpatel

SHEET NO.	REFERENCE SHEET	LOCATION (SLM)	SIDE	NOTE	CODE	SIZE (INCHES)	630	630	630	630	630	630	630	630	630	630	630	630	630	630	630	630	630	HINGED	
							GROUND MOUNTED SUPPORT, No. 2 POST	GROUND MOUNTED SUPPORT, No. 3 POST	SIGN POST REFLECTOR, RED	SIGN POST REFLECTOR, WHITE	SIGN POST REFLECTOR, YELLOW	SIGN BACKING ASSEMBLY	SIGN SUPPORT ASSEMBLY, POLE MOUNTED	SIGN, FLAT SHEET	SIGN, FLAT SHEET, AS PER PLAN	SIGN, DOUBLE FACED, MILE MARKER	REMOVAL OF GROUND MOUNTED SIGN & DISPOSAL	REMOVAL OF GROUND MOUNTED SIGN & RE-ERECTION, AS PER PLAN	REMOVAL OF GROUND MOUNTED MAJOR SIGN & DISPOSAL	REMOVAL OF GROUND MOUNTED POST SUPPORT AND DISPOSAL	REMOVAL OF STRUCTURE MOUNTED SIGN AND DISPOSAL	REMOVAL OF POLE MOUNTED SIGN & DISPOSAL	SIGNING, MISC: REMOVAL OF POST REFLECTOR		
							FT	FT	EACH		EACH	EACH	SQ FT	SQ FT	EACH	EACH	EACH	EACH	EACH	EACH	EACH	EACH	EACH		
52	S-1	0.000	RIGHT	ENTER FAYETTE, LEAVE PICKAWAY	I-H2F	24 X 48							8.0			1									
52	S-2	0.010	LEFT		R1-1	30 X 30							6.3			1								1	
52	S-3	0.010	RIGHT		R1-1	30 X 30							6.3			1								1	
52	S-4	0.152	LEFT	55 MPH	R2-1	24 X 30							5.0			1									
52	S-5	0.207	RIGHT		W2-2L	30 X 30							6.3			1									
52	S-6	0.300	LEFT	207	M1-5-3	30 X 24	7.0	10.0					5.0												
52	S-6	0.300	LEFT		M3-3	24 X 12							2.0												
52	S-7	0.307	LEFT		R1-1	30 X 30							6.3			1								1	
52	S-8	0.36	RIGHT	207	M1-5-3	30 X 24	7.0	10.0					5.0												
52	S-8	0.36	RIGHT		M3-1	24 X 12							2.0												
52	S-9	0.392	RIGHT	45 MPH	W3-5	36 X 36							9.0			1									
52	S-10	0.412	LEFT		W2-2R	30 X 30							6.3			1									
52	S-11	0.437	LEFT	55 MPH	R2-1	24 X 30							5.0			1									
52	S-13	0.452	RIGHT	PANCOASTBURG	I-H2d	48 X 24							8.0			1									
52	S-14	0.452	RIGHT	45 MPH	R2-1	24 X 30							5.0			1									
52	S-15	0.668	RIGHT		R1-1	30 X 30							6.3			1								1	
52	S-16	0.738	LEFT		R1-1	30 X 30							6.3			1								1	
52	S-17	0.697	RIGHT	45 MPH	R2-1	24 X 30							5.0			1									
52	S-18	0.738	LEFT		R1-1	30 X 30							6.3			1								1	
52	S-19	0.748	RIGHT		R1-1	30 X 30							6.3			1								1	
52	S-20	0.852	RIGHT		R1-1	30 X 30							6.3			1								1	
52	S-21	0.918	LEFT	PANCOASTBURG	I-H2d	48 X 24							8.0			1									
52	S-22	0.923	LEFT	45 MPH	R2-1	24 X 30							5.0			1									
52	S-23	0.918	RIGHT	55 MPH	R2-1	24 X 30							5.0			1									
52	S-24	0.978	LEFT		S3-1	30 X 30							6.3			1									
52	S-25	1.018	RIGHT	1	D10-H8	12 X 12									1	1									
52	S-26	1.043	LEFT	45 MPH	W3-5	36 X 36							9.0			1									
52	S-27	1.629	LEFT	207	M3-3	24 X 12										1								1	
52	S-27	1.629	LEFT		M1-5-3	30 X 24										1									
52	S-28	1.664	LEFT		R1-1	30 X 30							6.3			1								1	
52	S-29	1.664	RIGHT		R1-1	30 X 30							6.3			1								1	
52	S-30	2.024	RIGHT	2	D10-H8	12 X 12									1	1									
52	S-31	2.671	LEFT		R1-1	30 X 30							6.3			1								1	
52	S-32	2.671	RIGHT		R1-1	30 X 30							6.3			1								1	
52	S-33	2.914	RIGHT	3	D10-H8	12 X 12									1	1									
TOTALS CARRIED TO SUB-SUMMARY, SHEET 7							14.0	20.0	12					180.5		3	31			1				12	

SIGN PLAN QUANTITIES FAYETTE COUNTY - SR 207	FAY-SYS SIGN REPLACE-FY20
CALCULATED VHP CHECKED XXX	

I:\ProjectData\07556_FAY_PIC_FLAT_SHEET\Design\Roadway\Sheets\07556_T0006.dgn 107556_T0002_207 1/27/2020 3:53:04 PM vpatel

SHEET NO.	REFERENCE SHEET	LOCATION (SLM)	SIDE	NOTE	CODE	SIZE (INCHES)	630	630	630	630	630	630	630	630	630	630	630	630	630	630	630	630	HINGED		
							GROUND MOUNTED SUPPORT, No. 2 POST FT	GROUND MOUNTED SUPPORT, No. 3 POST FT	SIGN POST REFLECTOR, RED EACH		SIGN POST REFLECTOR, WHITE EACH	SIGN POST REFLECTOR, YELLOW EACH	SIGN BACKING ASSEMBLY EACH	SIGN SUPPORT ASSEMBLY, POLE MOUNTED EACH	SIGN, FLAT SHEET SQ FT	SIGN, FLAT SHEET, AS PER PLAN SQ FT	SIGN, DOUBLE FACED, MILE MARKER EACH	REMOVAL OF GROUND MOUNTED SIGN & DISPOSAL EACH	REMOVAL OF GROUND MOUNTED SIGN & RE-ERECTION, AS PER PLAN EACH	REMOVAL OF GROUND MOUNTED MAJOR SIGN & DISPOSAL EACH	REMOVAL OF GROUND MOUNTED POST SUPPORT AND DISPOSAL EACH	REMOVAL OF STRUCTURE MOUNTED SIGN AND DISPOSAL EACH			REMOVAL OF POLE MOUNTED SIGN & DISPOSAL EACH
53	S-34	3.252	RIGHT		W2-1	30 X 30								6.3			1								
53	S-34	3.252	RIGHT	45 MPH	W13-1P	18 X 18								2.3			1								
53	S-35	3.252	RIGHT		W2-1	30 X 30								6.3			1								
53	S-35	3.252	RIGHT	45 MPH	W13-1P	18 X 18								2.3			1								
53	S-36	3.293	LEFT		M3-3	24 X 12								2.0			1								
53	S-36	3.293	LEFT	207	M1-5-3	30 X 24								5.0			1								
53	S-37	3.334	RIGHT		R1-1	30 X 30				1				6.3			1						1		
53	S-38	3.354	RIGHT		R1-1	30 X 30				1				6.3			1						1		
53	S-39	3.322	LEFT		R1-1	30 X 30				1				6.3			1						1		
53	S-40	3.322	LEFT		R1-1	30 X 30				1				6.3			1						1		
53	S-41	3.363	RIGHT		M3-1	24 X 12								2.0			1								
53	S-41	3.363	RIGHT	207	M1-5-3	30 X 24								5.0			1								
53	S-42	3.418	LEFT		W2-1	30 X 30								6.3			1								
53	S-42	3.418	LEFT	45 MPH	W13-1P	18 X 18								2.3			1								
53	S-43	3.418	RIGHT		W2-1	30 X 30								6.3			1								
53	S-43	3.418	RIGHT	45 MPH	W13-1P	18 X 18								2.3			1								
53	S-44	3.703	RIGHT		D14-H4	30 X 48								10.0			1								
53	S-44A	4.000	RIGHT	4	D10-H8	12 X 12										1	1								
53	S-45	4.089	RIGHT		R1-1	30 X 30				1				6.3			1						1		
53	S-46	4.745	RIGHT		R1-1	30 X 30				1				6.3			1						1		
53	S-47	4.910	RIGHT	5	D10-H8	12 X 12										1	1								
53	S-48	5.592	LEFT		S3-1	30 X 30								9.0			1								
53	S-49	5.722	LEFT	1-800-372-7754	D14-H4	30 X 48								10.0			1								
53	S-59	5.780	LEFT	ENTER FAYETTE, LEAVE MADISON	I-H2f	24 X 48								8.0			1								
TOTALS CARRIED TO SUB-SUMMARY, SHEET 7														123.2			2		24					6	

CALCULATED
VHP
CHECKED
XXX

SIGN PLAN QUANTITIES
FAYETTE COUNTY - SR 207

FAY-SYS SIGN
REPLACE-FY20

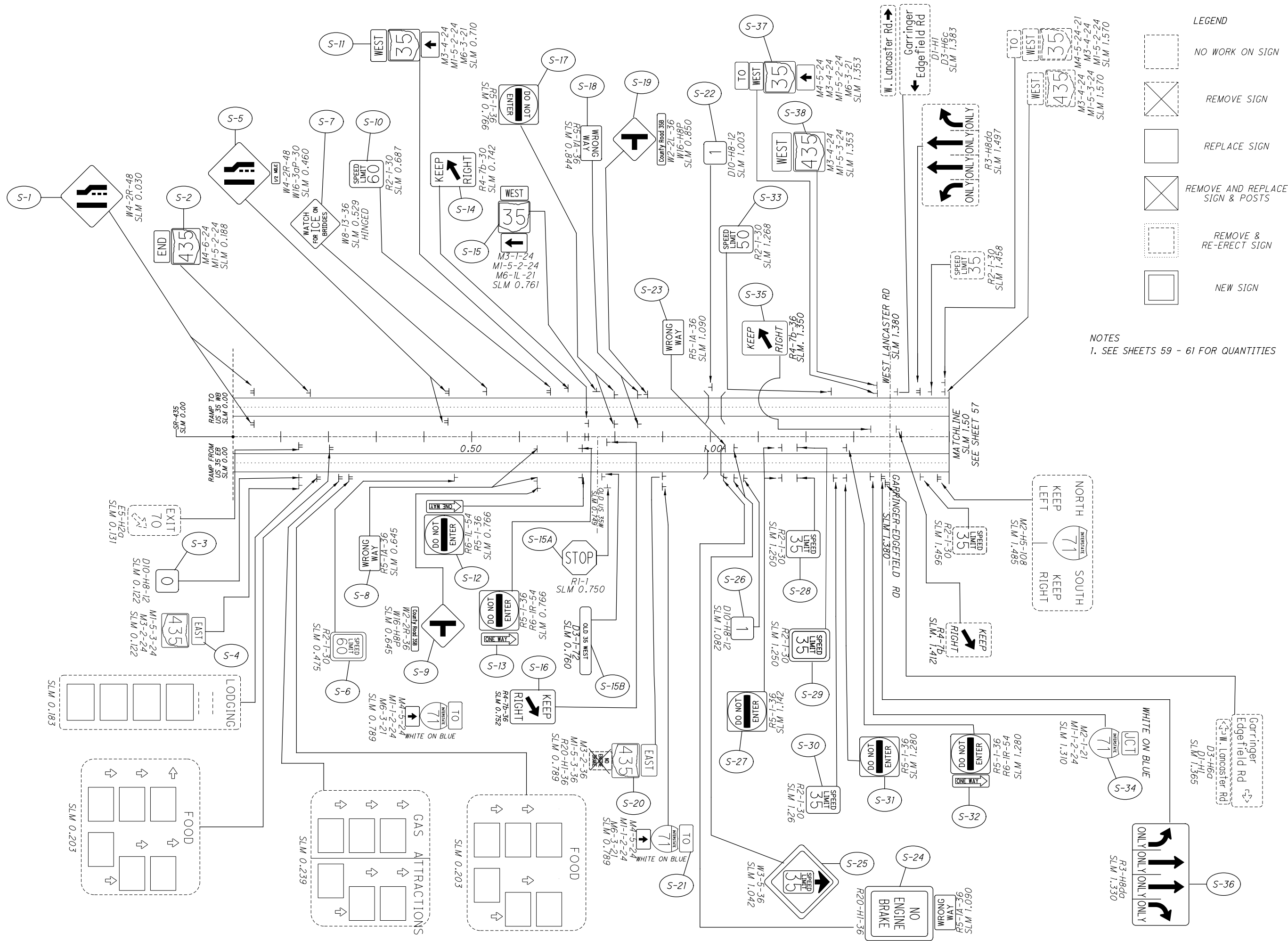

NOTES
 1. SEE SHEETS 59 - 61 FOR QUANTITIES

- LEGEND
- NO WORK ON SIGN
 - REMOVE SIGN
 - REPLACE SIGN
 - REMOVE AND REPLACE SIGN & POSTS
 - REMOVE & RE-ERECT SIGN
 - NEW SIGN

CALCULATED 0 250 500
 HORIZONTAL SCALE IN FEET
 CHECKED

SIGN PLAN
FAY-435: SLM 1.50 - 2.00

FAY-SYS SIGN
REPLACE-FY20
 56
 88

I:\ProjectData\07556_FAY_PIC_FLATSHEET\Design\Roadway\Sheets\07556_TP002_435_1/27/2020_3:53:06 PM vpatel

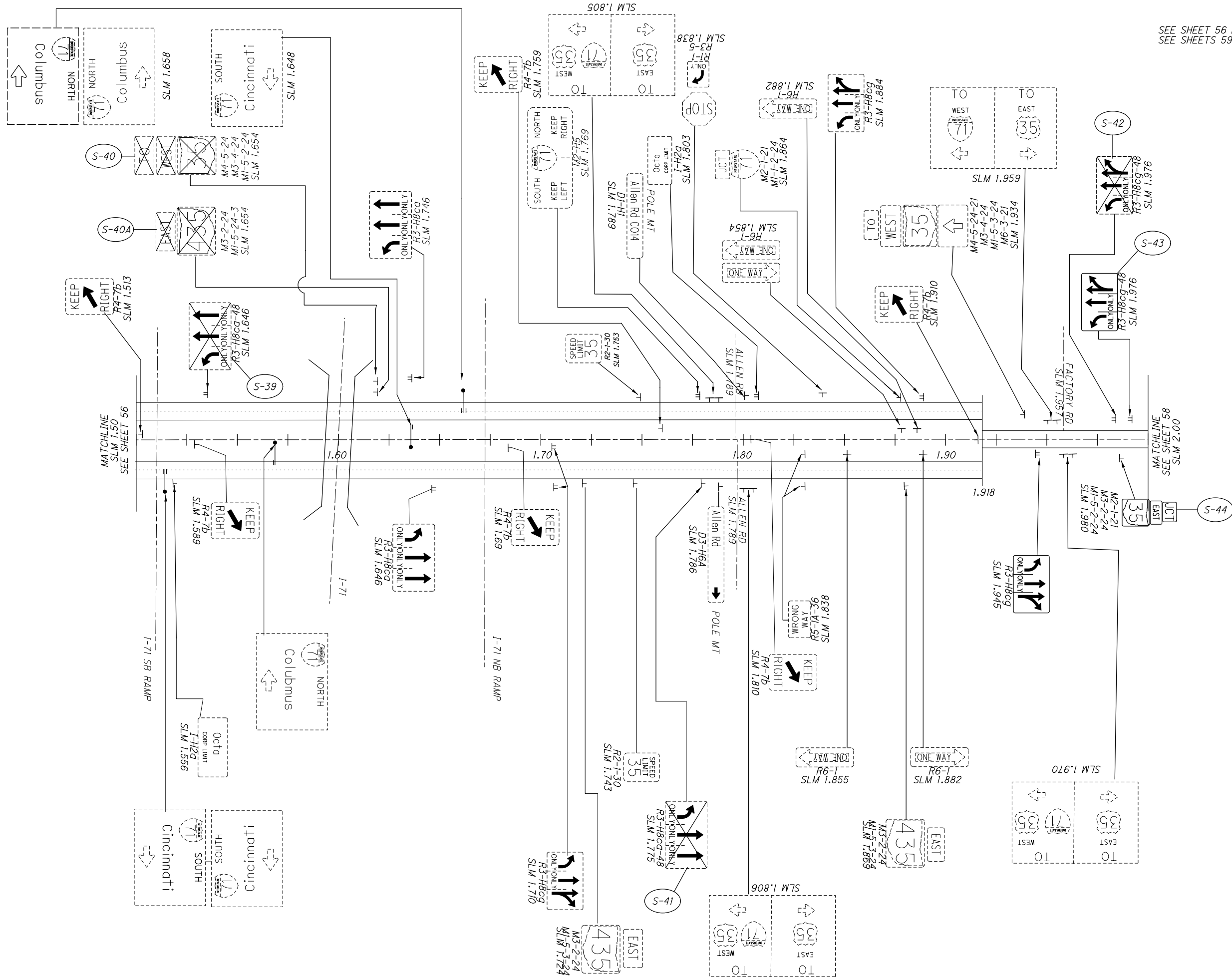

SEE SHEET 56 FOR LEGEND
SEE SHEETS 59 - 61 FOR QUANTITIES



CALCULATED 0 500 1000
CHECKED
HORIZONTAL SCALE IN FEET

SIGN PLAN
FAY-435: SLM 0.00 - 1.50

FAY-SYS SIGN
REPLACE-FY20

SEE SHEET 56 FOR LEGEND
SEE SHEETS 59 - 61 FOR QUANTITIES



CALCULATED
CHECKED

SIGN PLAN FAY-435: SLM 2.00 - 4.08

FAY-SYS SIGN REPLACE-FY20

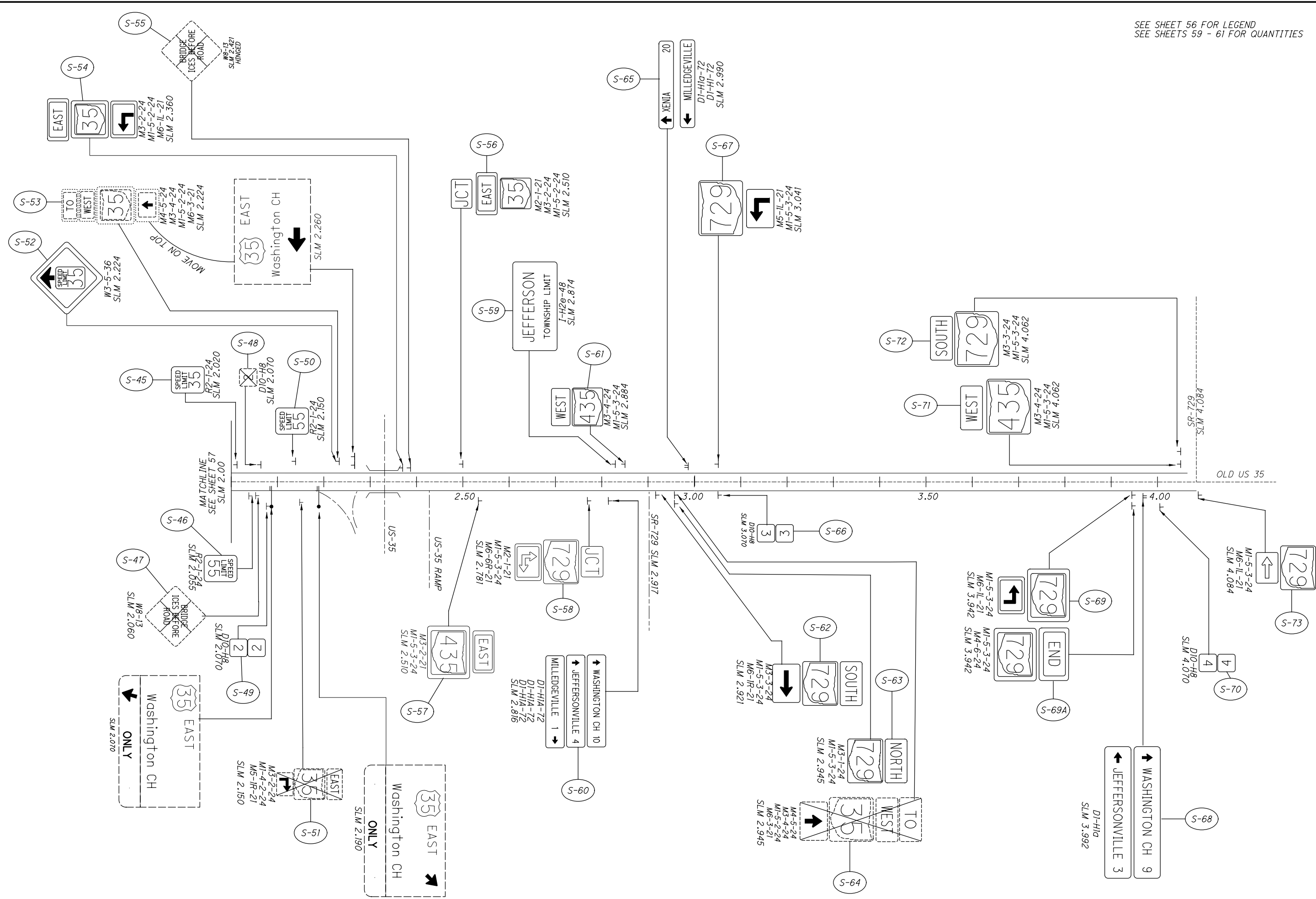

I:\ProjectData\07556_FAY_PIC_FLAT_SHEET\Design\Roadway\Sheets\07556_T0007.dgn 07556_T0001_435 1/27/2020 3:53:08 PM vpdtef

SHEET NO.	REFERENCE SHEET	LOCATION (SLM)	SIDE	NOTE	CODE	SIZE (INCHES)	630	630	630	630	630	630	630	630	630	630	630	630	630	630	630	HINGED	
							GROUND MOUNTED SUPPORT, No. 2 POST FT	GROUND MOUNTED SUPPORT, No. 3 POST FT	SIGN POST REFLECTOR, RED EACH			SIGN POST REFLECTOR, WHITE EACH	SIGN POST REFLECTOR, YELLOW EACH	SIGN BACKING ASSEMBLY EACH	SIGN SUPPORT ASSEMBLY, POLE MOUNTED EACH	SIGN, FLAT SHEET SQ FT	SIGN, FLAT SHEET, AS PER PLAN SQ FT	SIGN, DOUBLE FACED, MILE MARKER EACH	REMOVAL OF GROUND MOUNTED SIGN & DISPOSAL EACH	REMOVAL OF GROUND MOUNTED SIGN & RE-ERECTION, AS PER PLAN EACH	REMOVAL OF GROUND MOUNTED MAJOR SIGN & DISPOSAL EACH		REMOVAL OF GROUND MOUNTED POST SUPPORT AND DISPOSAL EACH
56	S-1	0.030	LEFT		W4-2R	36 X 36							9.0				1						
56	S-1	0.030	MEDIAN		W4-2R	36 X 36							9.0				1						
56	S-2	0.188	LEFT		M4-6	24 X 12							2.0				1						
56	S-2	0.188	LEFT	435	M1-5-3	30 X 24							5.0				1						
56	S-3	0.122	RIGHT	0	D10-H8	12 X 12										1	1						
56	S-4	0.122	RIGHT		M1-5-3	30 X 24							5.0				1						
56	S-5	0.460	LEFT		W4-2R	36 X 36							9.0				1						
56	S-5	0.460	LEFT	1/2 MILE	W16-3AP	30 X 12							2.5				1						
56	S-5	0.460	MEDIAN		W4-2R	36 X 36							9.0				1						
56	S-5	0.460	MEDIAN	1/2 MILE	W16-3AP	30 X 12							2.5				1						
56	S-6	0.475	RIGHT	60	R2-1	30 X 36							7.5				1						
56	S-7	0.529	LEFT		W8-13	36 X 36								9.0			1					YES	
56	S-8	0.645	LEFT		R5-1A	42 X 30							8.8				1					1	
56	S-8	0.645	MEDIAN		R5-1A	42 X 30							8.8									1	
56	S-9	0.645	RIGHT		W2-2R	36 X 36							9.0				1						
56	S-9	0.645	RIGHT		W16-H8P	48 X 8							2.7				1						
56	S-9	0.645	MEDIAN		W2-2R	36 X 36							9.0				1						
56	S-9	0.645	MEDIAN		W16-H8P	48 X 8							2.7				1						
56	S-10	0.687	LEFT	60	R2-1	30 X 36							7.5				1						
56	S-11	0.710	LEFT		M3-4	24 X 12							2.0				1						
56	S-11	0.710	LEFT	35	M1-5-2	24 X 24							4.0				1						
56	S-11	0.710	LEFT		M6-3	21 X 15							2.2				1						
56	S-12	0.766	RIGHT		R6-1L	54 X 18							6.8				1						
56	S-12	0.766	RIGHT		R5-1	36 X 36							9.0				1						
56	S-13	0.766	MEDIAN		R5-1	36 X 36							9.0				1						
56	S-13	0.766	MEDIAN		R6-1R	54 X 18							6.8				1						
56	S-14	0.742	MEDIAN		R4-7B	36 X 48							12.0				1						
56	S-15	0.761	LEFT		M3-1	24 X 12							2.0				1						
56	S-15	0.761	LEFT	35	M1-5-2	24 X 24							4.0				1						
56	S-15	0.761	LEFT		M6-1L	21 X 15							2.2				1						
56	S-15A	0.750	RIGHT		R1-1	30 X 30							6.3				1					1	
56	S-15B	0.760	RIGHT	ODL 35 WEST	D3-1	72 X 12							6.0				1						
56	S-16	0.752	MEDIAN		R4-7B	36 X 48							12.0				1						
56	S-17	0.766	LEFT		R5-1	36 X 36							9.0				1						
56	S-17	0.766	MEDIAN		R5-1	36 X 36							9.0				1						
56	S-18	0.844	LEFT		R5-1A	42 X 30							8.8				1					1	
56	S-18	0.844	MEDIAN		R5-1A	42 X 30							8.8				1					1	
56	S-19	0.850	LEFT		W2-2L	36 X 36							9.0				1						
56	S-19	0.850	LEFT		W16-H8P	48 X 8							2.7				1						
56	S-20	0.789	RIGHT		M3-2	24 X 12							2.0				1						
56	S-20	0.789	RIGHT		M1-5-2	24 X 24							4.0				1						
56	S-20	0.789	RIGHT		R20-H1	36 X 48											1						
56	S-21	0.789	RIGHT		M4-5	24 X 12							2.0				1						
56	S-21	0.789	RIGHT	71	M1-1-2	24 X 24							4.0				1						
56	S-21	0.789	RIGHT		M6-3	21 X 15							2.2				1						
56	S-22	1.003	LEFT	1	D10-H8	12 X 12							1.0				1						
56	S-23	1.090	MEDIAN		R5-1A	42 X 30							8.8				1					1	
56	S-24	1.090	RIGHT		R20-H1	36 X 48	7.0	10.0					12.0										
56	S-24	1.090	RIGHT		R5-1A	42 X 30							8.8									1	
TOTALS CARRIED TO SUB-SUMMARY, SHEET 7							7.0	10.0	7					285.4	9.0	1	46						7

**SIGN PLAN QUANTITIES
FAYETTE COUNTY - SR 435**

**FAY-SYS SIGN
REPLACE-FY20**

CALCULATED
VHP
CHECKED
XXX

I:\ProjectData\07556_FAY_PIC_FLAT_SHEET\Design\Roadway\Sheets\07556_T0007.dgn 10/27/2020 3:53:10 PM vpatel

SHEET NO.	REFERENCE SHEET	LOCATION (SLM)	SIDE	NOTE	CODE	SIZE (INCHES)	630		630		630		630		630		630		630		630		630				CALCULATED VHP	CHECKED XXX																		
							GROUND MOUNTED SUPPORT, No. 2 POST		GROUND MOUNTED SUPPORT, No. 3 POST		SIGN POST REFLECTOR, RED		SIGN POST REFLECTOR, WHITE		SIGN POST REFLECTOR, YELLOW		SIGN BACKING ASSEMBLY		SIGN SUPPORT ASSEMBLY, POLE MOUNTED		SIGN, FLAT SHEET		SIGN, FLAT SHEET, AS PER PLAN		SIGN, DOUBLE FACED, MILE MARKER				REMOVAL OF GROUND MOUNTED SIGN & DISPOSAL		REMOVAL OF GROUND MOUNTED SIGN & RE-ERECTION, AS PER PLAN		REMOVAL OF GROUND MOUNTED MAJOR SIGN & DISPOSAL		REMOVAL OF GROUND MOUNTED POST SUPPORT AND DISPOSAL		REMOVAL OF STRUCTURE MOUNTED SIGN AND DISPOSAL		REMOVAL OF POLE MOUNTED SIGN & DISPOSAL		SIGNING, MISC: REMOVAL OF POST REFLECTOR				HINGED	
							FT	FT			EACH	EACH	EACH	SQ FT	SQ FT	EACH	EACH	EACH	EACH	EACH	EACH	EACH	EACH	EACH	EACH	EACH			EACH	EACH																
58	S-54	2.360	LEFT		M3-2	24 X 12	7.0	10.0					2.0																																	
58	S-54	2.360	LEFT	35	M1-5-2	24 X 24							4.0																																	
58	S-54	2.360	LEFT		M6-1L	21 X 15							2.2																																	
58	S-55	2.241	LEFT		W8-13	36 X 36												1											YES																	
58	S-56	2.510	LEFT		M2-1	21 X 15							2.2				1																													
58	S-56	2.510	LEFT		M3-2	24 X 12			5.0				2.0																																	
58	S-56	2.510	LEFT	35	M1-5-2	24 X 24							4.0				1																													
58	S-57	2.510	RIGHT		M3-2	24 X 12	7.0	10.0					2.0																																	
58	S-57	2.510	RIGHT	435	M1-5-3	30 X 24							5.0																																	
58	S-58	2.781	RIGHT		M2-1	21 X 15							2.2				1																													
58	S-58	2.781	RIGHT	729	M1-5-3	30 X 24							5.0				1																													
58	S-58	2.781	RIGHT		M6-6R	21 X 15							2.2																																	
58	S-59	2.874	LEFT	JEFFERSON	I-H2E	24 X 48							8.0				1																													
58	S-60	2.816	RIGHT	WASHINGTON CH, 10	D1-H1A	72 X 12							6.0				1																													
58	S-60	2.816	RIGHT	JEFFERSONVILLE, 4	D1-H1A	72 X 12							6.0				1																													
58	S-60	2.816	RIGHT	MILLEDGEVILLE, 1	D1-H1A	72 X 12							6.0				1																													
58	S-61	2.884	LEFT		M3-4	24 X 12							2.0				1																													
58	S-61	2.884	LEFT	435	M1-5-3	30 X 24							5.0				1																													
58	S-62	2.921	RIGHT		M3-3	24 X 12							2.0				1																													
58	S-62	2.921	RIGHT	729	M1-5-3	30 X 24							5.0				1																													
58	S-62	2.921	RIGHT		M6-1R	21 X 15							2.2				1																													
58	S-63	2.945	RIGHT		M3-1	24 X 12							2.0				1																													
58	S-63	2.945	RIGHT	729	M1-5-3	30 X 24							5.0				1																													
58	S-64	2.945	RIGHT		M4-5	24 X 12											1																													
58	S-64	2.945	RIGHT		M3-4	24 X 12											1																													
58	S-64	2.945	RIGHT	35	M1-5-2	24 X 24											1																													
58	S-64	2.945	RIGHT		M6-3	21 X 15											1																													
58	S-65	2.990	LEFT	XENIA, 20	D1-H1A	72 X 12							6.0				1																													
58	S-65	2.990	LEFT	MILLEDGEVILLE	D1-H1	72 X 12							6.0				1																													
58	S-66	3.070	RIGHT	3	D10-H8	12 X 12										1	1																													
58	S-67	3.041	LEFT		M5-1L	21 X 15							2.2				1																													
58	S-67	3.041	LEFT	729	M1-5-3	30 X 24							5.0				1																													
58	S-68	3.992	RIGHT	WASHINGTON CH, 9	D1-H1A	72 X 12							6.0				1																													
58	S-68	3.992	RIGHT	JEFFERSONVILLE, 3	D1-H1A	72 X 12							6.0				1																													
58	S-69	3.942	RIGHT	729	M1-5-3	30 X 24	7.0	10.0					5.0																																	
58	S-69	3.942	RIGHT		M6-1L	21 X 15							2.2																																	
58	S-69A	3.942	RIGHT		M4-6	24 X 12	7.0	10.0					2.0																																	
58	S-69A	3.942	RIGHT	435	M1-5-3	30 X 24							5.0																																	
58	S-70	4.070	RIGHT	4	D10-H8	12 X 12										1	1																													
58	S-71	4.062	LEFT		M3-4	24 X 12							2.0				1																													
58	S-71	4.062	LEFT	435	M1-5-3	30 X 24							5.0				1																													
58	S-72	4.062	LEFT		M3-3	24 X 12							2.0				1																													
58	S-72	4.062	LEFT	729	M1-5-3	30 X 24							5.0				1																													
58	S-73	4.084	RIGHT		M6-1L	21 X 15							2.2				1																													
58	S-73	4.084	RIGHT	729	M1-5-3	30 X 24							5.0				1																													
TOTALS CARRIED TO SUB-SUMMARY, SHEET 7							28.0	45.0					148.6			2	34				2												61	88												

SIGN PLAN QUANTITIES
FAYETTE COUNTY - SR 435

FAY-SYS SIGN
REPLACE-FY20

SEE ABOVE FOR LEGEND
SEE SHEETS 67 - 71 FOR QUANTITIES

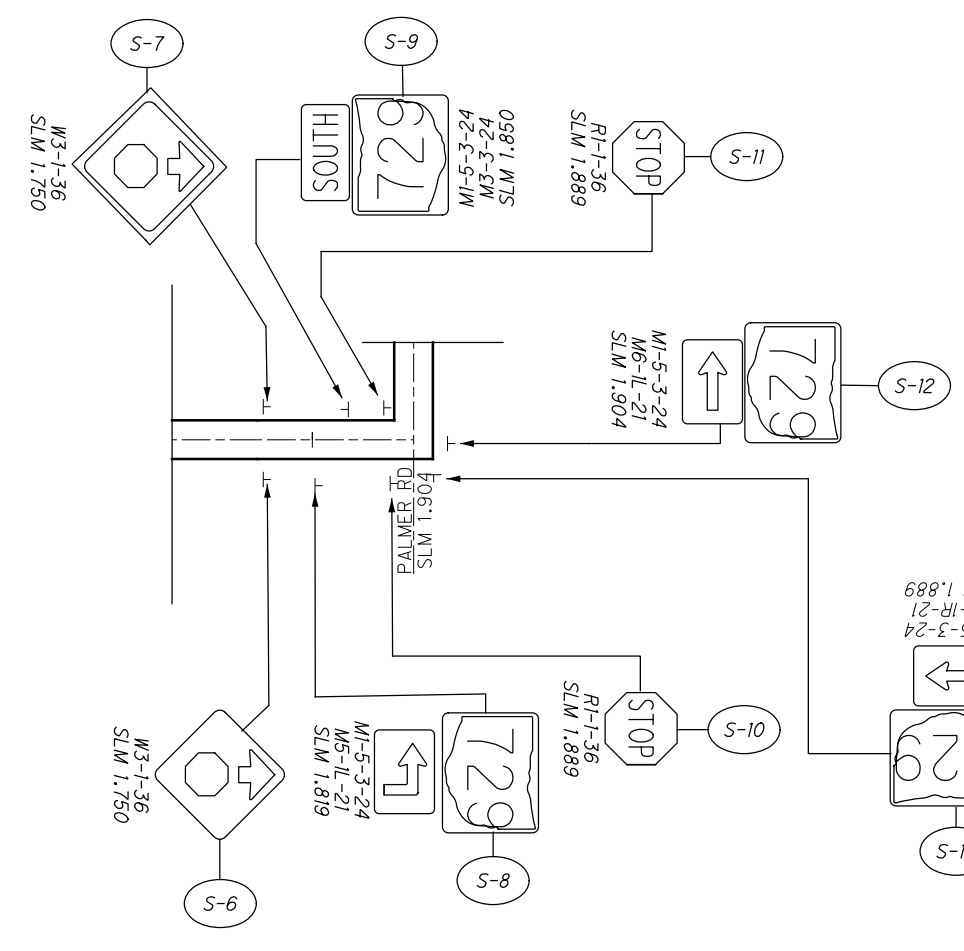
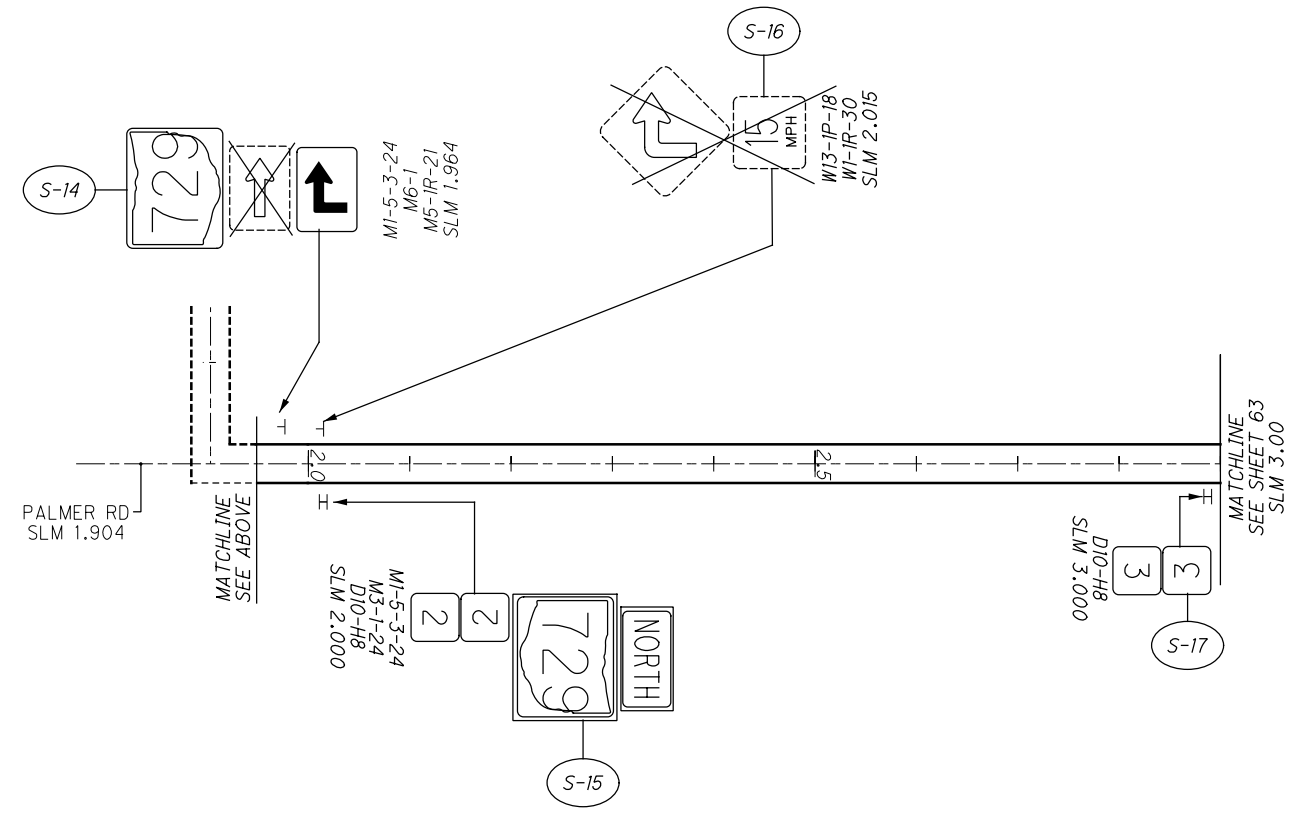
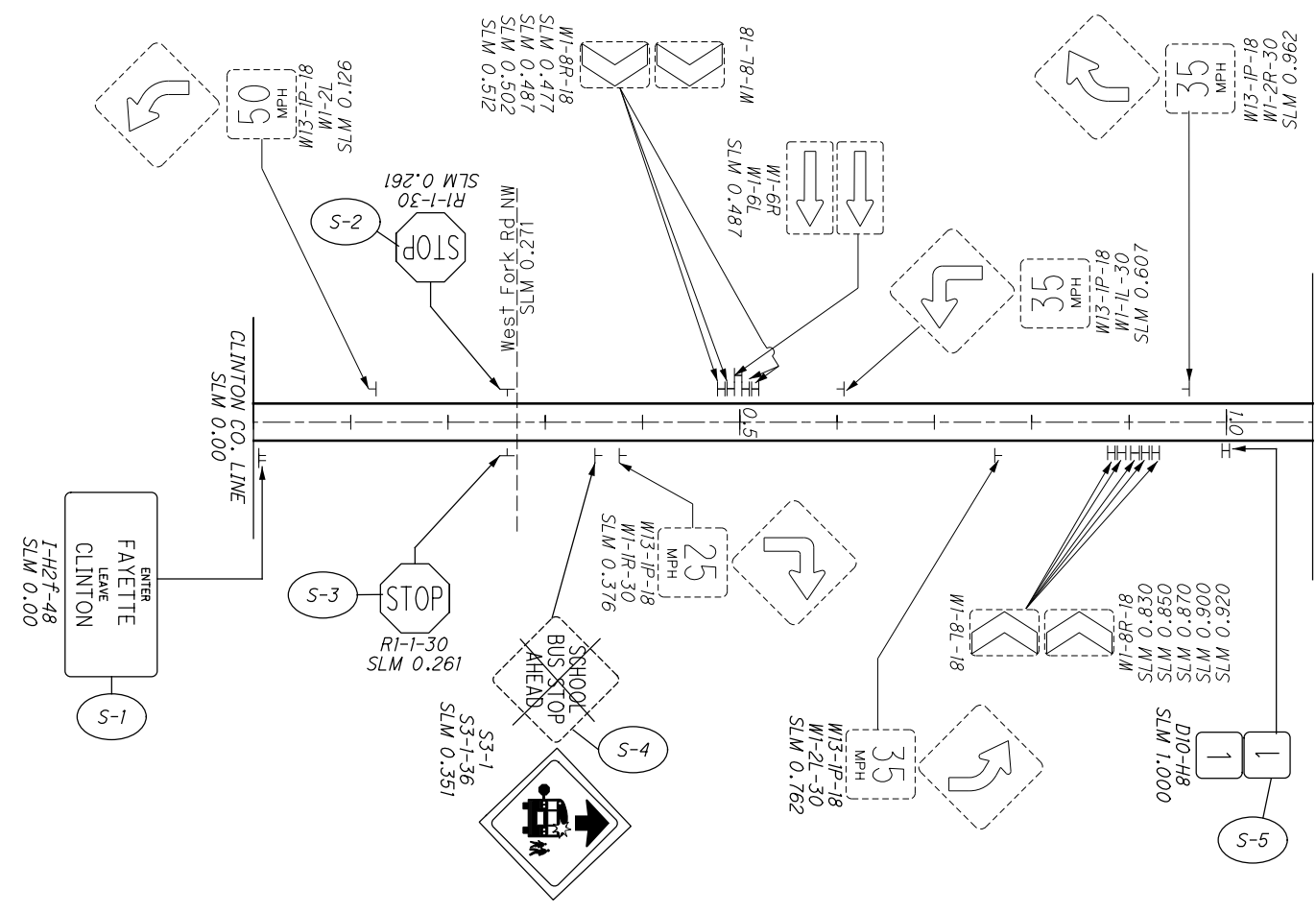

LEGEND

- NO WORK ON SIGN
- REMOVE SIGN
- REPLACE SIGN
- REMOVE AND REPLACE SIGN & POSTS
- REMOVE & RE-ERECT SIGN
- NEW SIGN

NOTES
1. SEE SHEETS 67 - 71 FOR QUANTITIES



SIGN PLAN
FAY-729: SLM 0.00 - 3.00

FAY-SYS SIGN
REPLACE-FY20

SEE SHEET 62 FOR LEGEND
SEE SHEETS 67 - 71 FOR QUANTITIES

SEE SHEET 62 FOR LEGEND
SEE SHEETS 67 - 71 FOR QUANTITIES

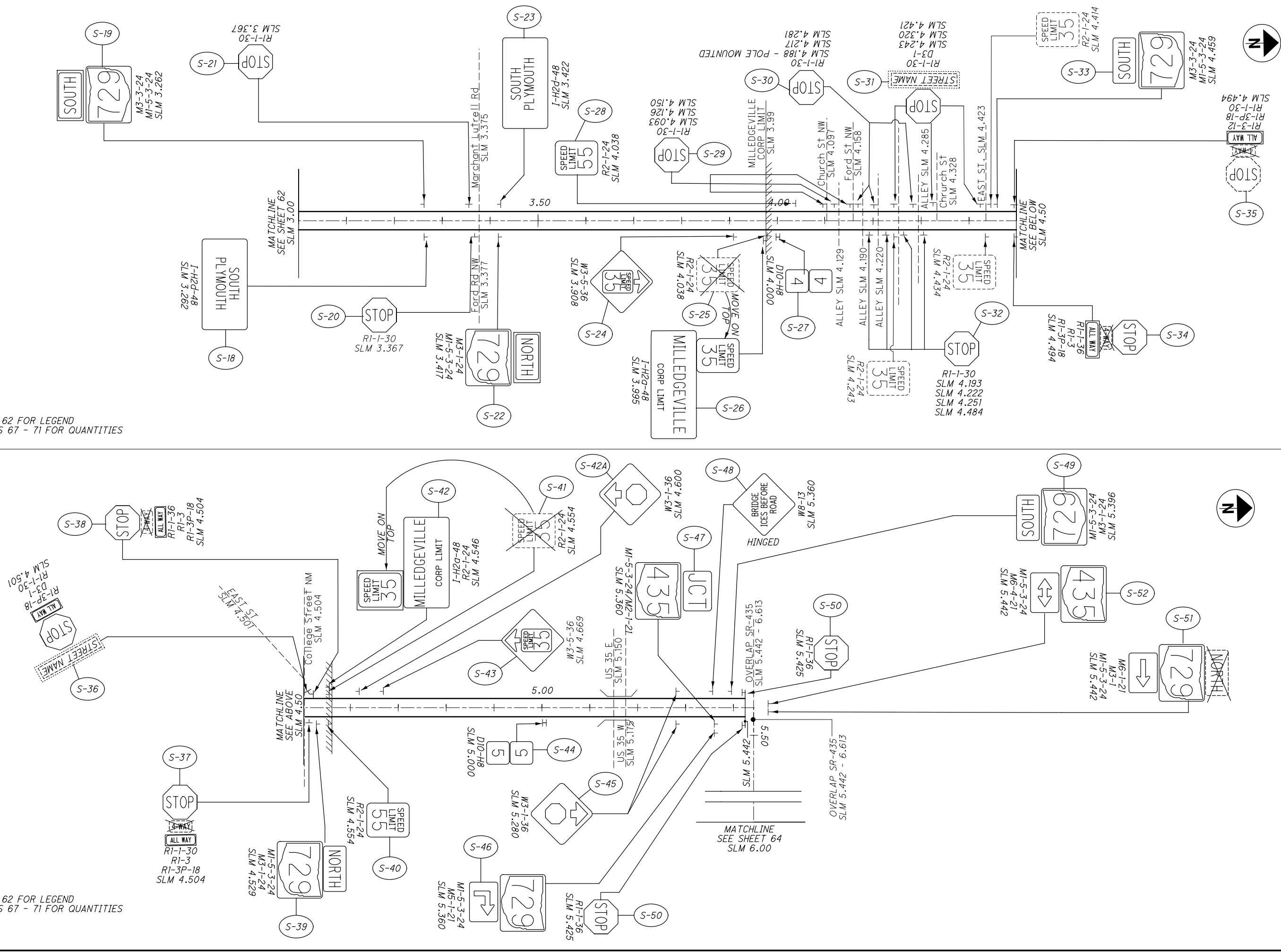

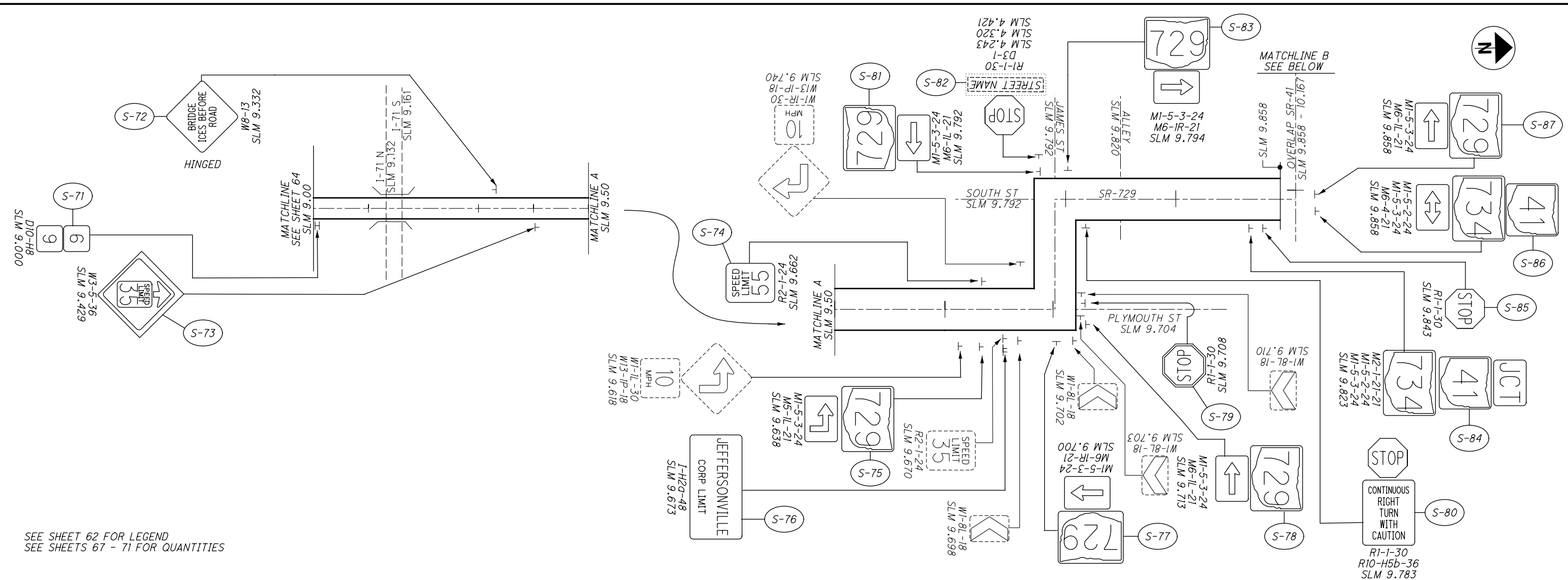
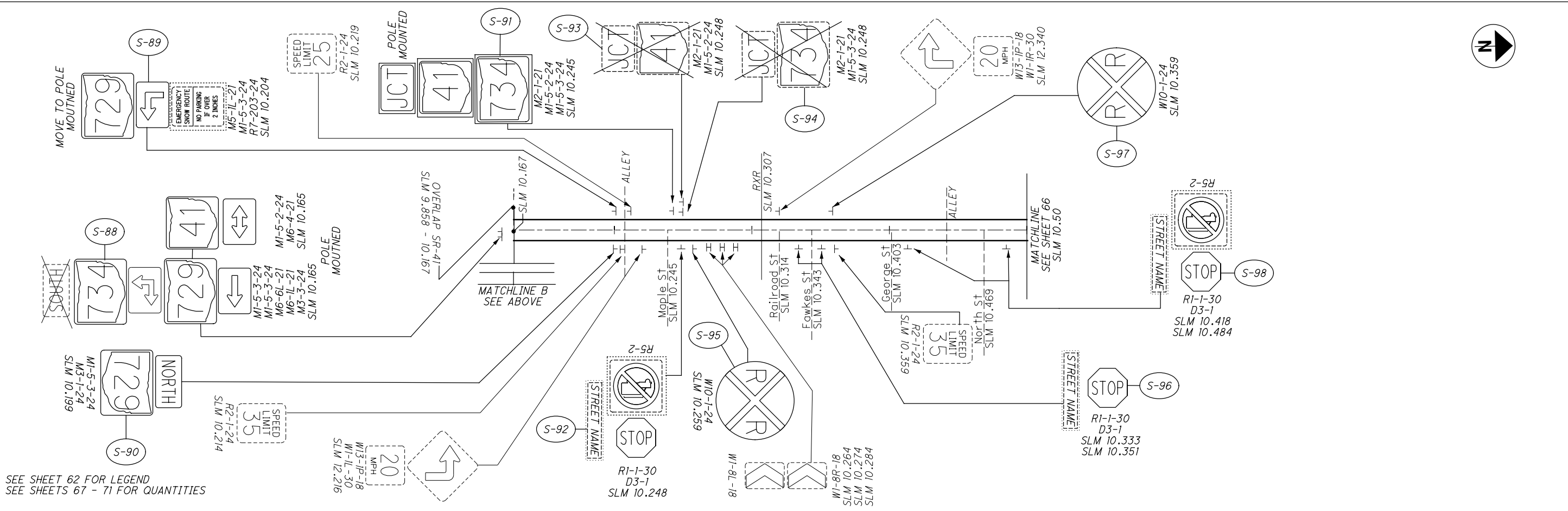

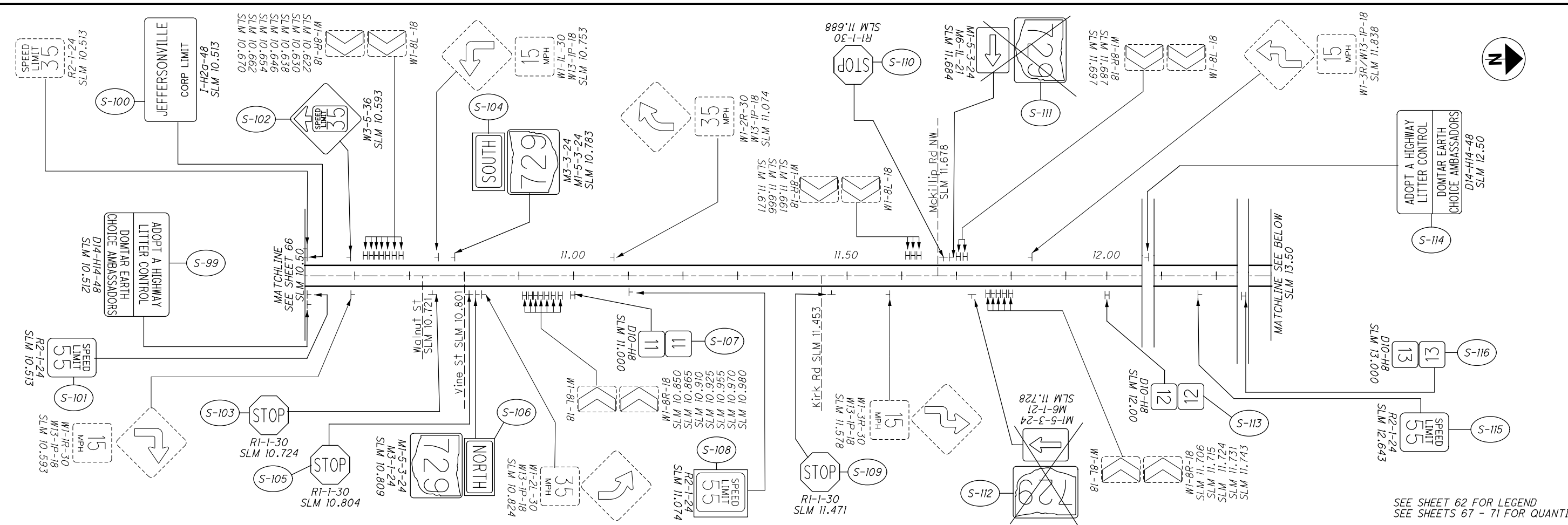

SEE SHEET 62 FOR LEGEND
SEE SHEETS 67 - 71 FOR QUANTITIES

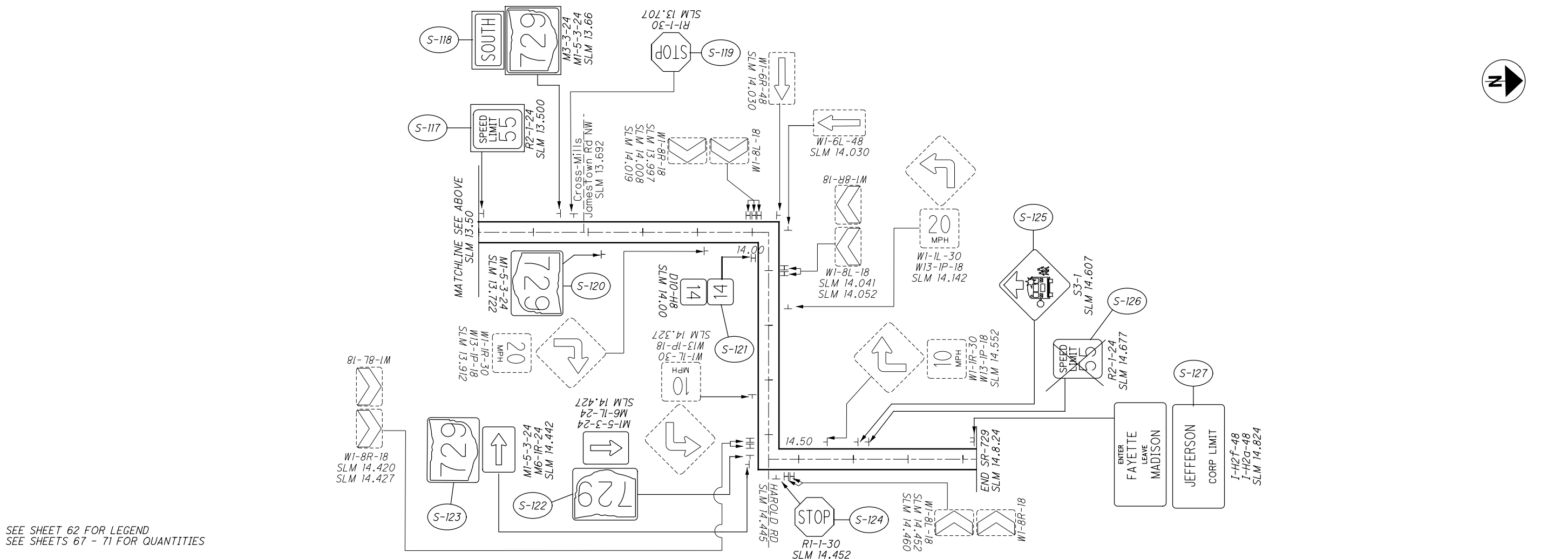

SEE SHEET 62 FOR LEGEND
SEE SHEETS 67 - 71 FOR QUANTITIES



I:\ProjectData\07556_FAY_PIC_FLATSHEET\Design\Roadway\Sheets\07556_I0008.dgn 07556_I0001_T29 1/27/2020 3:53:16 PM vpatel

SHEET NO.	REFERENCE SHEET	LOCATION (SLM)	SIDE	NOTE	CODE	SIZE (INCHES)	630	630	630	630	630	630	630	630	630	630	630	630	630	630	630	630	630		
							GROUND MOUNTED SUPPORT, No. 2 POST FT	GROUND MOUNTED SUPPORT, No. 3 POST FT	SIGN POST REFLECTOR, RED EACH		SIGN POST REFLECTOR, WHITE EACH	SIGN POST REFLECTOR, YELLOW EACH	SIGN ATTACHMENT ASSEMBLY EACH	SIGN SUPPORT ASSEMBLY, POLE MOUNTED EACH	SIGN, FLAT SHEET SQ FT	SIGN, FLAT SHEET, AS PER PLAN SQ FT	SIGN, DOUBLE FACED, MILE MARKER EACH	REMOVAL OF GROUND MOUNTED SIGN & DISPOSAL EACH	REMOVAL OF GROUND MOUNTED SIGN & RE-ERECTION, AS PER PLAN EACH	REMOVAL OF GROUND MOUNTED MAJOR SIGN & DISPOSAL EACH	REMOVAL OF GROUND MOUNTED POST SUPPORT AND DISPOSAL EACH	REMOVAL OF STRUCTURE MOUNTED SIGN AND DISPOSAL EACH	REMOVAL OF POLE MOUNTED SIGN & DISPOSAL EACH	SIGNING, MISC: REMOVAL OF POST REFLECTOR EACH	HINGED
62	S-1	0.000	RIGHT	ENTER FAYETTE, LEAVE CLINTON	I-H2F	24 X 48								8.0			1								
62	S-2	0.261	LEFT	WEST FORK RD	R1-1	30 X 30								6.3			1						1		
62	S-3	2.610	RIGHT	WEST FORK RD	R1-1	30 X 30								6.3			1						1		
62	S-4	0.351	RIGHT		S3-1	30 X 30											1								
62	S-4	0.351	RIGHT		S3-1	30 X 30								6.3											
62	S-5	1.000	RIGHT	1	D10-H8	12 X 12											1	1							
62	S-6	1.819	RIGHT		W3-1	36 X 36								9.0			1						1		
62	S-7	1.750	LEFT		W3-1	36 X 36	7.0	10.0						9.0									1		
62	S-8	1.819	RIGHT	729	M1-5-3	30 X 24								5.0			1								
62	S-8	1.819	RIGHT		M5-1L	21 X 15								2.2			1								
62	S-9	1.850	LEFT	729	M1-5-3	30 X 24								5.0			1								
62	S-9	1.850	LEFT		M3-3	24 X 12								2.0			1								
62	S-10	1.889	RIGHT		R1-1	36 X 36								9.0			1						1		
62	S-11	1.889	LEFT		R1-1	36 X 36								9.0			1						1		
62	S-12	1.904	RIGHT	729	M1-5-3	30 X 24								5.0			1								
62	S-12	1.904	RIGHT		M6-1L	21 X 15								2.2			1								
62	S-13	1.889	RIGHT	729	M1-5-3	30 X 24								5.0			1								
62	S-13	1.889	RIGHT		M6-1R	21 X 15								2.2			1								
62	S-14	1.964	LEFT	729	M1-5-3	30 X 24								5.0			1								
62	S-14	1.964	LEFT		M6-1R	21 X 15								5.0			1								
62	S-14	1.964	LEFT		M5-1R	21 X 15								2.2											
62	S-15	2.000	RIGHT	729	M1-5-3	30 X 24	7.0	10.0						5.0			1								
62	S-15	2.000	RIGHT		M3-1	24 X 12								2.0			1								
62	S-15	2.000	RIGHT	2	D10-H8	12 X 12											1	1							
62	S-16	2.015	LEFT		W13-1P	18 X 18											1				1				
62	S-16	2.015	LEFT		W1-1R	30 X 30											1								
62	S-17	3.000	RIGHT	3	D10-H8	12 X 12											1	1							
63	S-18	3.262	RIGHT	SOUTH PLYMOUTH	I-H2D	48 X 24								8.0			1								
63	S-19	3.262	LEFT	729	M1-5-3	30 X 24								5.0			1								
63	S-19	3.262	LEFT		M3-3	24 X 12								2.0											
63	S-20	3.367	RIGHT		R1-1	30 X 30								6.3			1						1		
63	S-21	3.367	LEFT		R1-1	30 X 30								6.3			1						1		
63	S-22	3.417	RIGHT	729	M1-5-3	30 X 24								5.0			1								
63	S-22	3.417	RIGHT		M3-1	24 X 12								2.0			1								
63	S-23	3.422	LEFT	SOUTH PLYMOUTH	I-H2D	48 X 24								8.0			1								
63	S-24	3.908	RIGHT		W3-5	36 X 36								9.0			1								
63	S-25	4.038	RIGHT	"MOVE ON TOP"	R2-1	24 X 30											1				1				
63	S-26	3.995	RIGHT	MILLEDGEVILLE	I-H2A	48 X 24		5.0						8.0			1								
63	S-26	3.995	RIGHT	35	R2-1	24 X 30							1.00	5.0											
63	S-27	4.000	RIGHT	4	D10-H8	12 X 12											1	1							
63	S-28	4.038	LEFT	55	R2-1	24 X 30								5.0			1								
63	S-29	4.093	LEFT		R1-1	30 X 30								6.3			1						1		
63	S-29	4.126	LEFT		R1-1	30 X 30								6.3			1						1		
63	S-29	4.150	LEFT		R1-1	30 X 30								6.3			1						1		
63	S-30	4.188	LEFT		R1-1	30 X 30								6.3			1						1		
63	S-30	4.217	LEFT		R1-1	30 X 30								6.3			1						1		
63	S-30	4.281	LEFT		R1-1	30 X 30								6.3			1						1		
TOTALS CARRIED TO SUB-SUMMARY, SHEET 7							14.0	25.0	12					213.1			4	42			2			14	

SIGN PLAN QUANTITIES
FAYETTE COUNTY - SR 729
FAY-SYS SIGN
REPLACE-FY20

CALCULATED
VHP
CHECKED
XXX

SHEET NO.	REFERENCE SHEET	LOCATION (SLM)	SIDE	NOTE	CODE	SIZE (INCHES)	630	630	630	630	630	630	630	630	630	630	630	630	630	630	630	630					
							GROUND MOUNTED SUPPORT, No. 2 POST FT	GROUND MOUNTED SUPPORT, No. 3 POST FT	SIGN POST REFLECTOR, RED EACH	SIGN POST REFLECTOR, WHITE EACH	SIGN POST REFLECTOR, YELLOW EACH	SIGN ATTACHMENT ASSEMBLY EACH	SIGN SUPPORT ASSEMBLY, POLE MOUNTED EACH	SIGN, FLAT SHEET SQ FT	SIGN, FLAT SHEET, AS PER PLAN SQ FT	SIGN, DOUBLE FACED, MILE MARKER EACH	REMOVAL OF GROUND MOUNTED SIGN & DISPOSAL EACH	REMOVAL OF GROUND MOUNTED SIGN & RE-ERECTION, AS PER PLAN EACH	REMOVAL OF GROUND MOUNTED MAJOR SIGN & DISPOSAL EACH	REMOVAL OF GROUND MOUNTED POST SUPPORT AND DISPOSAL EACH	REMOVAL OF STRUCTURE MOUNTED SIGN AND DISPOSAL EACH	REMOVAL OF POLE MOUNTED SIGN & DISPOSAL EACH	SIGNING, MISC: REMOVAL OF POST REFLECTOR EACH	HINGED			
63	S-31	4.234	LEFT		R1-1	30 X 30			1					6.3			1							1			
63	S-31	4.234	LEFT		D3-1	VAR											1										
63	S-31	4.320	LEFT		R1-1	30 X 30			1					6.3			1							1			
63	S-31	4.320	LEFT		D3-1	VAR											1										
63	S-31	4.421	LEFT		R1-1	30 X 30			1					6.3			1							1			
63	S-31	4.421	LEFT		D3-1	VAR											1										
63	S-32	4.193	RIGHT		R1-1	30 X 30			1					6.3			1							1			
63	S-32	4.222	RIGHT		R1-1	30 X 30			1					6.3			1							1			
63	S-32	4.251	RIGHT		R1-1	30 X 30			1					6.3			1							1			
63	S-32	4.484	RIGHT		R1-1	30 X 30			1					6.3			1							1			
63	S-33	4.459	LEFT	729	M1-5-3	30 X 24								5.0			1										
63	S-33	4.459	LEFT		M3-3	24 X 12								2.0			1										
63	S-34	4.494	RIGHT		R1-1	30 X 30			1					6.3			1							1			
63	S-34	4.494	RIGHT		R1-3	12 X 6											1										
63	S-34	4.494	RIGHT		R1-3P	18 X 6								0.8													
63	S-35	4.494	LEFT		R1-3	12 X 6											1										
63	S-35	4.494	LEFT		R1-3P	18 X 6								0.8													
63	S-36	4.501	LEFT		R1-1	30 X 30			1					6.3			1							1			
63	S-36	4.501	LEFT		R1-3P	18 X 6								0.8													
63	S-36	4.501	LEFT		D3-1	VAR											1										
63	S-37	4.504	RIGHT		R1-1	30 X 30			1					6.3			1							1			
63	S-37	4.504	RIGHT		R1-3	12 X 6											1										
63	S-37	4.504	RIGHT		R1-3P	18 X 6								0.8													
63	S-38	4.504	LEFT		R1-1	30 X 30			1					6.3			1							1			
63	S-38	4.504	LEFT		R1-3	12 X 6											1										
63	S-38	4.504	LEFT		R1-3P	18 X 6								0.8													
63	S-39	4.529	RIGHT	729	M1-5-3	30 X 24								5.0			1										
63	S-39	4.529	RIGHT		M3-1	24 X 12								2.0			1										
63	S-40	4.552	RIGHT	55	R2-1	24 X 30								5.0			1										
63	S-41	4.554	LEFT	"MOVE ON TOP"	R2-1	24 X 30											1						1.00				
63	S-42	4.546	LEFT	MIDDLEGEVILLE	I-H2D	48 X 24								8.0			1										
63	S-42	4.546	LEFT	35	R2-1	24 X 30								5.0													
63	S-42A	4.600	LEFT		W3-1	36 X 36								9.0			1							1			
63	S-43	4.669	LEFT		W3-5	36 X 36								9.0			1										
63	S-44	5.000	RIGHT	5	D10-H8	12 X 12										1											
63	S-45	5.280	LEFT		W3-1	36 X 36								9.0			1							1			
63	S-45	5.280	RIGHT		W3-1	36 X 36								9.0			1							1			
63	S-46	5.360	RIGHT	729	M1-5-3	30 X 24								5.0			1										
63	S-46	5.360	RIGHT		M5-1R	21 X 15								2.2			1										
63	S-47	5.360	LEFT	729	M1-5-3	30 X 24								5.0			1										
63	S-47	5.360	LEFT		M2-1	21 X 15								2.2			1										
63	S-48	5.360	LEFT		W8-13	36 X 36											1										
63	S-49	5.396	LEFT	729	M1-5-3	30 X 24								5.0			1										
63	S-49	5.396	LEFT		M3-1	24 X 12								2.0			1										
63	S-50	5.425	LEFT		R1-1	30 X 30			1					6.3										1			
63	S-50A	5.425	RIGHT		R1-1	36 X 36			1					9.0										1			
63	S-51	5.442	LEFT		M6-1L	21 X 15								2.2			1										
63	S-51	5.442	LEFT		M3-1	24 X 12											1										
63	S-51	5.442	LEFT	729	M1-5-3	30 X 24								5.0			1										
63	S-52	5.442	LEFT	435	M1-5-3	30 X 24								7.9			1										
63	S-52	5.442	LEFT		M6-4	21 X 15								2.2			1										
TOTALS CARRIED TO SUB-SUMMARY, SHEET 7								5.0	13		3				195.3	9.0	1	39	4		1					16	

CALCULATED
VHP
CHECKED
XXX

SIGN PLAN QUANTITIES
FAYETTE COUNTY - SR 729

FAY-SYS SIGN
REPLACE-FY20

SHEET NO.	REFERENCE SHEET	LOCATION (SLM)	SIDE	NOTE	CODE	SIZE (INCHES)	630	630	630	630	630	630	630	630	630	630	630	630	630	630	630	630	630	630	
							GROUND MOUNTED SUPPORT, No. 2 POST FT	GROUND MOUNTED SUPPORT, No. 3 POST FT	SIGN POST REFLECTOR, RED EACH			SIGN POST REFLECTOR, WHITE EACH	SIGN POST REFLECTOR, YELLOW EACH	SIGN ATTACHMENT ASSEMBLY EACH	SIGN SUPPORT ASSEMBLY, POLE MOUNTED EACH	SIGN, FLAT SHEET SQ FT	SIGN, FLAT SHEET, AS PER PLAN SQ FT	SIGN, DOUBLE FACED, MILE MARKER EACH	REMOVAL OF GROUND MOUNTED SIGN & DISPOSAL EACH	REMOVAL OF GROUND MOUNTED SIGN & RE-ERECTION, AS PER PLAN EACH	REMOVAL OF GROUND MOUNTED MAJOR SIGN & DISPOSAL EACH	REMOVAL OF GROUND MOUNTED POST SUPPORT AND DISPOSAL EACH	REMOVAL OF STRUCTURE MOUNTED SIGN AND DISPOSAL EACH	REMOVAL OF POLE MOUNTED SIGN & DISPOSAL EACH	SIGNING, MISC: REMOVAL OF POST REFLECTOR EACH
64	S-53	6.617	RIGHT		M6-1R	21 X 15								2.2											
64	S-53	6.617	RIGHT	729	M1-5-3	30 X 24								5.0											
64	S-53	6.617	RIGHT	435	M1-5-3	30 X 24								5.0											
64	S-53	6.617	RIGHT		M6-1R	21 X 15								2.2											
64	S-53	6.617	RIGHT		W1-7	96 X 48	14.0	20.0				1		32.0										2	
64	S-54	6.617	RIGHT		R1-1	36 X 36							1	9.0											
64	S-55	6.617	LEFT		R1-1	36 X 36								9.0											
64	S-56	6.635	RIGHT		M3-1	24 X 12								2.0											
64	S-56	6.635	RIGHT	729	M1-5-3	30 X 24	7.0	10.0						5.0											
64	S-57	6.661	LEFT	WASHINGTON CH, 9	D1-H1A	72 X 12								6.0											
64	S-57	6.661	LEFT	MILLEDGEVILLE	D1-H1	72 X 12								6.0											
64	S-57	6.661	LEFT	XENIA, 21	D1-H1A	72 X 12								6.0											
64	S-58	6.702	LEFT	729	M1-5-3	30 X 24								5.0											
64	S-58	6.702	LEFT		M5-1R	21 X 15								2.2											
64	S-59	6.742	LEFT	435	M1-5-3	30 X 24								5.0											
64	S-59	6.742	LEFT		M2-1	21 X 15								2.2											
64	S-60	6.802	RIGHT		W3-1	36 X 36								9.0											
64	S-61	6.802	LEFT		W3-1	36 X 36								9.0											
64	S-62	6.912	RIGHT	"MOVE ON TOP"	R20-H1	24 X 30								5.0											
64	S-63	6.912	RIGHT	JEFFERSON	I-H2E	24 X 48		5.0						8.0											
64	S-64	7.000	RIGHT	7	D10-H8	12 X 12																			
64	S-65	7.448	RIGHT		R1-1	30 X 30								6.3											
64	S-65	7.448	RIGHT		R5-2	24 X 24																			
64	S-66	7.714	RIGHT		R1-1	30 X 30								6.3											
64	S-67	8.000	RIGHT	8	D10-H8	12 X 12																			
64	S-68	8.224	LEFT		M1-5-3	30 X 24																			
64	S-69	8.240	LEFT		R1-1	30 X 30								6.3											
64	S-70	8.941	RIGHT		W8-13	36 X 36										9.0									YES
65	S-71	9.000	RIGHT	9	D10-H8	12 X 12																			
65	S-72	9.332	LEFT		W8-13	36 X 36										9.0									YES
65	S-73	9.429	RIGHT		W3-5	36 X 36	7.0	10.0						9.0											
65	S-74	9.662	LEFT	55	R2-1	24 X 30								5.0											
65	S-75	9.638	RIGHT	729	M1-5-3	30 X 24								5.0											
65	S-75	9.638	RIGHT		M5-1L	21 X 15								2.2											
65	S-76	9.673	RIGHT	JEFFERSONVILLE	I-H2A	48 X 24								8.0											
65	S-77	9.700	RIGHT	729	M1-5-3	30 X 24								5.0											
65	S-77	9.700	RIGHT		M6-1R	21 X 15								2.2											
65	S-78	9.713	RIGHT	729	M1-5-3	30 X 24								5.0											
65	S-78	9.713	RIGHT		M6-1L	21 X 15								2.2											
65	S-79	9.708	RIGHT		R1-1	30 X 30	7.0	10.0						6.3											
65	S-80	9.783	RIGHT		R1-1	30 X 30								6.3											
65	S-80	9.783	RIGHT		R10-H5B	36 X 48								12.0											
65	S-81	9.792	LEFT	729	M1-5-3	30 X 24								5.0											
65	S-81	9.792	LEFT		M6-1L	21 X 15								2.2											
65	S-82	4.243	LEFT		R1-1	30 X 30								6.3											
65	S-82	4.243	LEFT		D3-1	VAR																			
65	S-82	4.320	LEFT		R1-1	30 X 30								6.3											
65	S-82	4.320	LEFT		D3-1	VAR																			
65	S-82	4.421	LEFT		R1-1	30 X 30								9.0											
65	S-82	4.421	LEFT		D3-1	VAR																			
TOTALS CARRIED TO SUB-SUMMARY, SHEET 7							35.0	55.0	10				3		250.7	18.0	3	39	4		3			13	

I:\ProjectData\07556_FAY_PIC_FLAT\SHEET\Design\Roadway\Sheets\07556_T0004.dgn 07556_T0004_T29 1/27/2020 3:53:18 PM vpd\tel

SHEET NO.	REFERENCE SHEET	LOCATION (SLM)	SIDE	NOTE	CODE	SIZE (INCHES)	630	630	630	630	630	630	630	630	630	630	630	630	630	630	630	630	630		
							GROUND MOUNTED SUPPORT, No. 2 POST FT	GROUND MOUNTED SUPPORT, No. 3 POST FT	SIGN POST REFLECTOR, RED EACH			SIGN POST REFLECTOR, WHITE EACH	SIGN POST REFLECTOR, YELLOW EACH	SIGN ATTACHMENT ASSEMBLY EACH	SIGN SUPPORT ASSEMBLY, POLE MOUNTED EACH	SIGN, FLAT SHEET SQ FT	SIGN, FLAT SHEET, AS PER PLAN SQ FT	SIGN, DOUBLE FACED, MILE MARKER EACH	REMOVAL OF GROUND MOUNTED SIGN & DISPOSAL EACH	REMOVAL OF GROUND MOUNTED SIGN & RE-ERECTION, AS PER PLAN EACH	REMOVAL OF GROUND MOUNTED MAJOR SIGN & DISPOSAL EACH	REMOVAL OF GROUND MOUNTED POST SUPPORT AND DISPOSAL EACH	REMOVAL OF STRUCTURE MOUNTED SIGN AND DISPOSAL EACH	REMOVAL OF POLE MOUNTED SIGN & DISPOSAL EACH	SIGNING, MISC: REMOVAL OF POST REFLECTOR EACH
65	S-83	9.794	LEFT	729	M1-5-3	30 X 24										5.0									
65	S-84	9.794	LEFT		M6-1R	21 X 15										2.2									
65	S-84	9.823	RIGHT		M2-1	21 X 15										2.2						1.00			
65	S-84	9.823	RIGHT	41	M1-5-2	24 X 24										4.0									
65	S-85	9.823	RIGHT	734	M1-5-3	30 X 24										5.0									
65	S-86	9.843	RIGHT		R1-1	36 X 36				1						9.0									
65	S-86	9.858	RIGHT	41	M1-5-2	24 X 24										4.0									1
65	S-86	9.858	RIGHT	734	M1-5-3	30 X 24										5.0									
65	S-87	9.858	RIGHT		M6-4	21 X 15										2.2									
65	S-87	9.858	RIGHT	729	M1-5-3	30 X 24										5.0									
65	S-88	9.858	RIGHT		M6-1L	21 X 15										2.2									
65	S-88	10.165	RIGHT		M3-3	24 X 12																			
65	S-88	10.165	RIGHT	734	M1-5-3	30 X 24										5.0									
65	S-88	10.165	RIGHT		M6-6L	21 X 15										2.2									
65	S-88	10.165	RIGHT	729	M1-5-3	30 X 24										5.0									
65	S-88	10.165	RIGHT		M6-1L	21 X 15										2.2									
65	S-88	10.165	RIGHT	41	M1-5-2	24 X 24										4.0									
65	S-89	10.165	RIGHT		M6-4	21 X 15										2.2									
65	S-89	10.204	LEFT		M5-1L	21 X 15										2.2									
65	S-89	10.204	LEFT	729	M1-5-3	30 X 24										5.0									
65	S-90	10.204	LEFT		R7-203	24 X 30																			
65	S-90	10.199	RIGHT	729	M1-5-3	30 X 24										5.0						1			
65	S-91	10.199	RIGHT		M3-1	24 X 12										2.0									
65	S-91	10.245	LEFT		M2-1	21 X 15										2.2									
65	S-91	10.245	LEFT	41	M1-5-2	24 X 24										4.0									
65	S-92	10.245	LEFT	734	M1-5-3	30 X 24										5.0									
65	S-92	10.248	RIGHT		R1-1	30 X 30				1						6.3						1			1
65	S-92	10.248	RIGHT		R5-2	24 X 24																1			
65	S-93	10.248	RIGHT		D3-1	VAR																1			
65	S-93	10.248	LEFT		M2-1	21 X 15																1			1
65	S-94	10.248	LEFT	41	M1-5-2	24 X 24																1			
65	S-94	10.248	LEFT		M2-1	21 X 15																1			1
65	S-95	10.248	LEFT	734	M1-5-2	24 X 24																1			
65	S-96	10.259	RIGHT	R X R	W10-1	15 RADIUS										4.9						1			
65	S-96	10.333	RIGHT		R1-1	30 X 30				1						6.3						1			1
65	S-96	10.333	RIGHT		D3-1	VAR																1			
65	S-96	10.351	RIGHT		R1-1	30 X 30				1						6.3						1			1
65	S-97	10.351	RIGHT		D3-1	VAR																1			
65	S-98	10.359	LEFT		W10-1	15 RADIUS										4.9						1			
65	S-98	10.418	LEFT		R1-1	30 X 30				1						6.3						1			1
65	S-98	10.418	LEFT		D3-1	VAR																1			
65	S-98	10.418	LEFT		R5-2	24 X 24																1			
65	S-98	10.484	LEFT		R1-1	30 X 30				1						6.3						1			1
65	S-98	10.484	LEFT		D3-1	VAR																1			
65	S-98	10.484	LEFT		R5-2	24 X 24																1			

TOTALS CARRIED TO SUB-SUMMARY, SHEET 7

6

133.1

32

10

2

6

CALCULATED
VHP
CHECKED
XXX

**SIGN PLAN QUANTITIES
FAYETTE COUNTY - SR 729**

**FAY-SYS SIGN
REPLACE-FY20**

SHEET NO.	REFERENCE SHEET	LOCATION (SLM)	SIDE	NOTE	CODE	SIZE (INCHES)	630	630	630	630	630	630	630	630	630	630	630	630	630	630	630	630		
							GROUND MOUNTED SUPPORT, No. 2 POST FT	GROUND MOUNTED SUPPORT, No. 3 POST FT	SIGN POST REFLECTOR, RED EACH	SIGN POST REFLECTOR, WHITE EACH	SIGN POST REFLECTOR, YELLOW EACH	SIGN ATTACHMENT ASSEMBLY EACH	SIGN SUPPORT ASSEMBLY, POLE MOUNTED EACH	SIGN, FLAT SHEET SQ FT	SIGN, FLAT SHEET, AS PER PLAN SQ FT	SIGN, DOUBLE FACED, MILE MARKER EACH	REMOVAL OF GROUND MOUNTED SIGN & DISPOSAL EACH	REMOVAL OF GROUND MOUNTED SIGN & RE-ERECTION, AS PER PLAN EACH	REMOVAL OF GROUND MOUNTED MAJOR SIGN & DISPOSAL EACH	REMOVAL OF GROUND MOUNTED POST SUPPORT AND DISPOSAL EACH	REMOVAL OF STRUCTURE MOUNTED SIGN AND DISPOSAL EACH	REMOVAL OF POLE MOUNTED SIGN & DISPOSAL EACH		SIGNING, MISC: REMOVAL OF POST REFLECTOR EACH
66	S-99	10.512	RIGHT	DOMTAR EARTH CHOICE AMBASSADORS	D14-H14	30 X 48								10.0			1							
66	S-100	10.513	LEFT	JEFFERSONVILLE	I-H2A	48 X 24								8.0			1							
66	S-101	10.513	RIGHT	55	R2-1	24 X 30								5.0			1							
66	S-102	10.593	LEFT		W3-5	36 X 36								9.0			1							
66	S-103	10.724	RIGHT		R1-1	30 X 30				1				6.3			1					1		
66	S-104	10.783	LEFT		M3-3	24 X 12								2.0										
66	S-104	10.783	LEFT	729	M1-5-3	30 X 24								5.0			1							
66	S-105	10.804	RIGHT		R1-1	30 X 30				1				6.3			1					1		
66	S-106	10.809	RIGHT	729	M1-5-3	30 X 24								5.0			1							
66	S-106	10.809	RIGHT		M3-1	24 X 12								2.0										
66	S-107	11.000	RIGHT	11	D10-H8	12 X 12										1	1							
66	S-108	11.074	RIGHT	55	R2-1	24 X 30	7.0	10.0						5.0										
66	S-109	11.471	RIGHT		R1-1	30 X 30				1				6.3			1					1		
66	S-110	11.668	LEFT		R1-1	30 X 30				1				6.3			1					1		
66	S-111	11.684	LEFT		M1-5-3	30 X 24											1							
66	S-111	11.684	LEFT		M6-1L	21 X 15											1							
66	S-112	11.728	RIGHT		M1-5-3	30 X 24											1				1			
66	S-112	11.728	RIGHT		M6-1R	21 X 15											1							
66	S-113	12.000	RIGHT	12	D10-H8	12 X 12										1	1							
66	S-114	12.500	LEFT	DOMTAR EARTH CHOICE AMBASSADORS	D14-H14	30 X 48								10.0			1							
66	S-115	12.643	RIGHT		R2-1	24 X 30								5.0			1							
66	S-116	13.000	RIGHT	13	D10-H8	12 X 12										1	1							
66	S-117	13.500	LEFT	55	R2-1	24 X 30	7.0	10.0						5.0										
66	S-118	13.660	LEFT		M3-3	24 X 12								2.0										
66	S-118	13.660	LEFT	729	M1-5-3	30 X 24	7.0	10.0						5.0										
66	S-119	13.707	LEFT		R1-1	30 X 30				1				6.3			1					1		
66	S-120	13.722	RIGHT		M1-5-3	30 X 24								5.0			1							
66	S-121	14.000	RIGHT	14	D10-H8	12 X 12										1	1							
66	S-122	14.427	RIGHT	729	M1-5-3	30 X 24								5.0			1							
66	S-122	14.427	RIGHT		M6-1L	21 X 15								2.2			1							
66	S-123	14.442	RIGHT	729	M1-5-3	30 X 24								5.0			1							
66	S-123	14.442	RIGHT		M6-6R	21 X 15								2.2			1							
66	S-124	14.452	RIGHT		R1-1	30 X 30				1				6.3			1					1		
66	S-125	14.607	LEFT		S3-1	30 X 30								6.3			1							
66	S-126	14.677	LEFT		R2-1	24 X 30											1				1			
66	S-127	14.824	LEFT	ENTER FAYETTE LEAVE MADISON	I-H2F	24 X 48								8.0			1							
66	S-127	14.824	LEFT	JEFFERSON	I-H2A	48 X 24								8.0			1							
TOTALS CARRIED TO SUB-SUMMARY, SHEET 7							21.0	30.0	6						157.5		4	31			3			6

SIGN PLAN QUANTITIES	FAYETTE COUNTY - SR 729				
FAY-SYS SIGN REPLACE-FY20	<table border="1" style="width: 60px; margin: auto;"> <tr><td style="text-align: center;">CALCULATED</td><td style="text-align: center;">VHP</td></tr> <tr><td style="text-align: center;">CHECKED</td><td style="text-align: center;">XXX</td></tr> </table>	CALCULATED	VHP	CHECKED	XXX
CALCULATED	VHP				
CHECKED	XXX				
71	88				

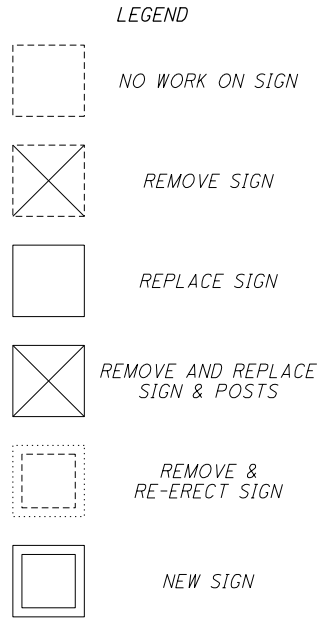

NOTES
1. SEE SHEETS 76 - 77 FOR QUANTITIES

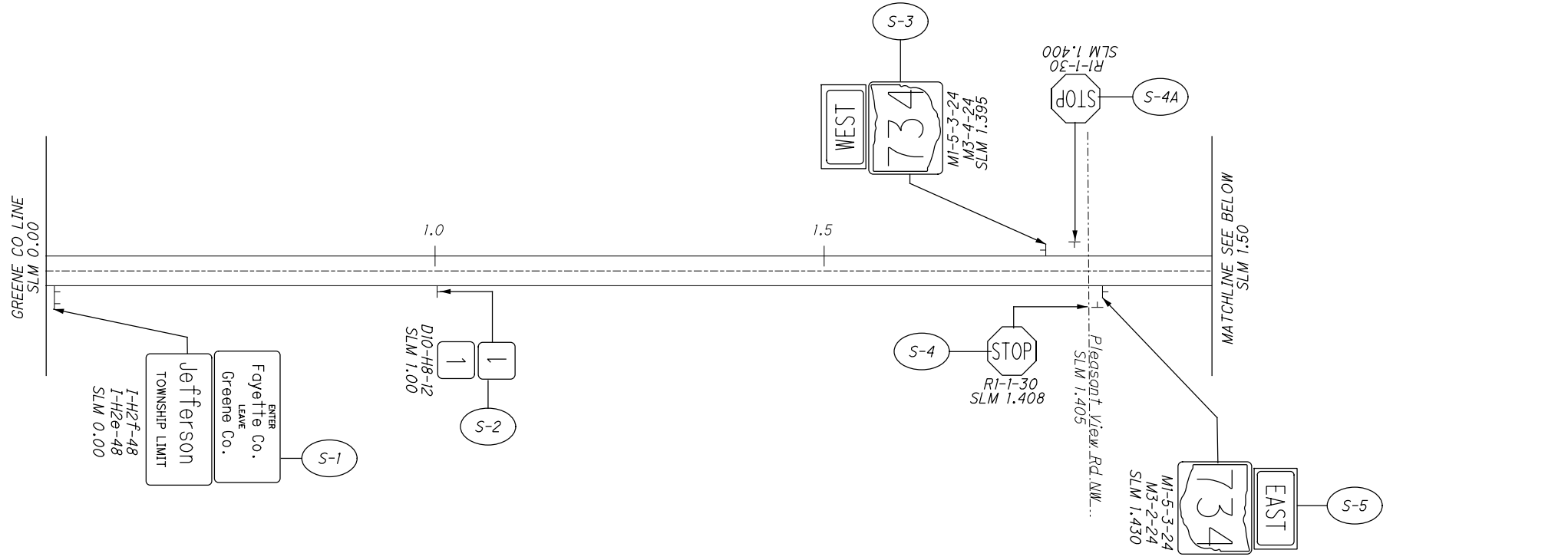
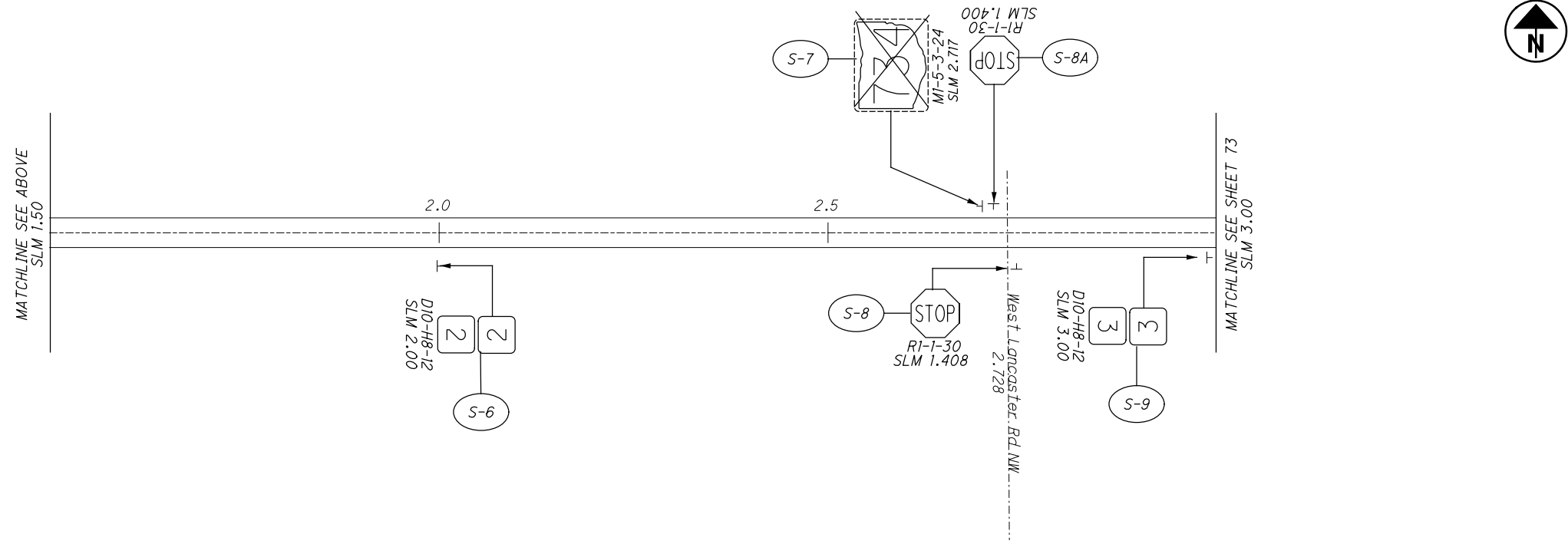

SEE SHEET 72 FOR LEGEND
SEE SHEETS 76 - 77 FOR QUANTITIES

SEE SHEET 72 FOR LEGEND
SEE SHEETS 76 - 77 FOR QUANTITIES

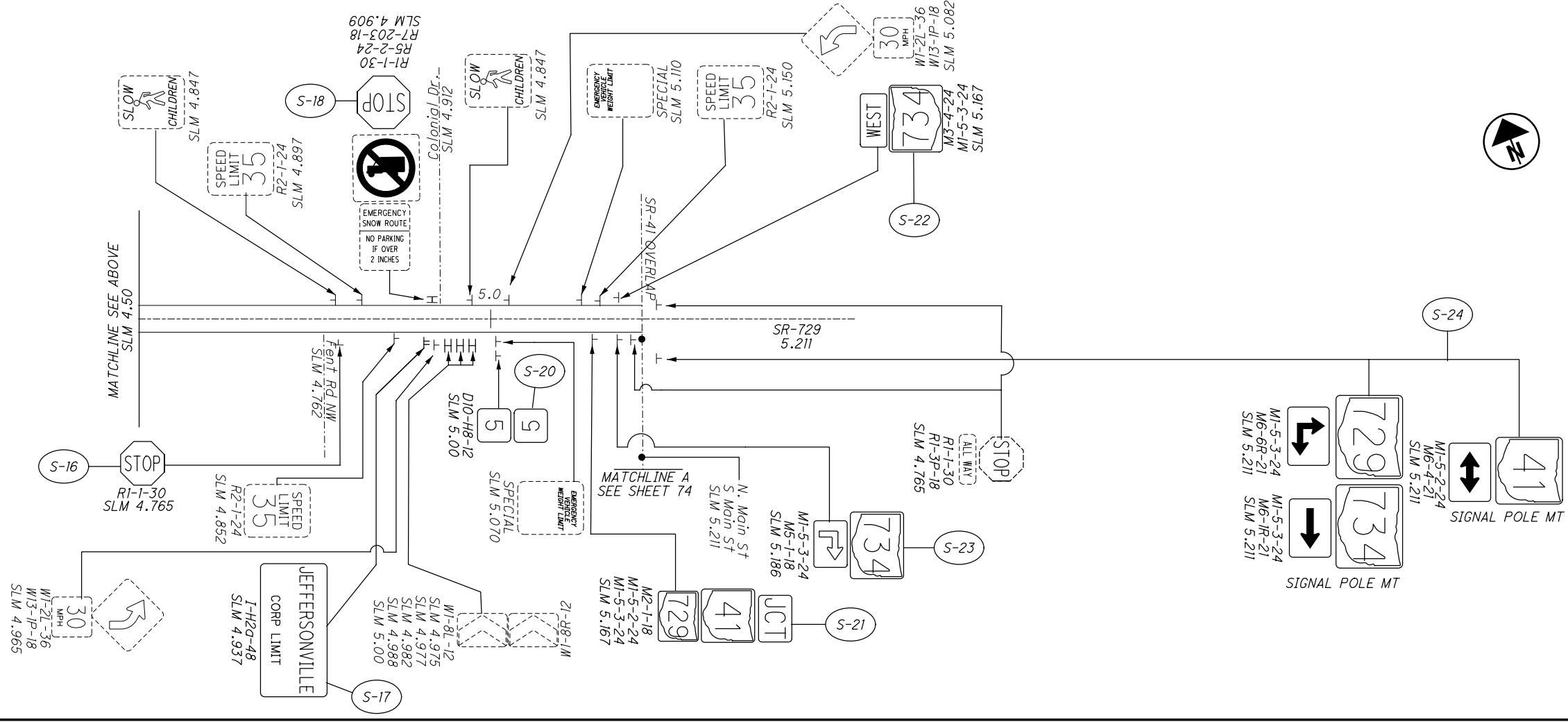
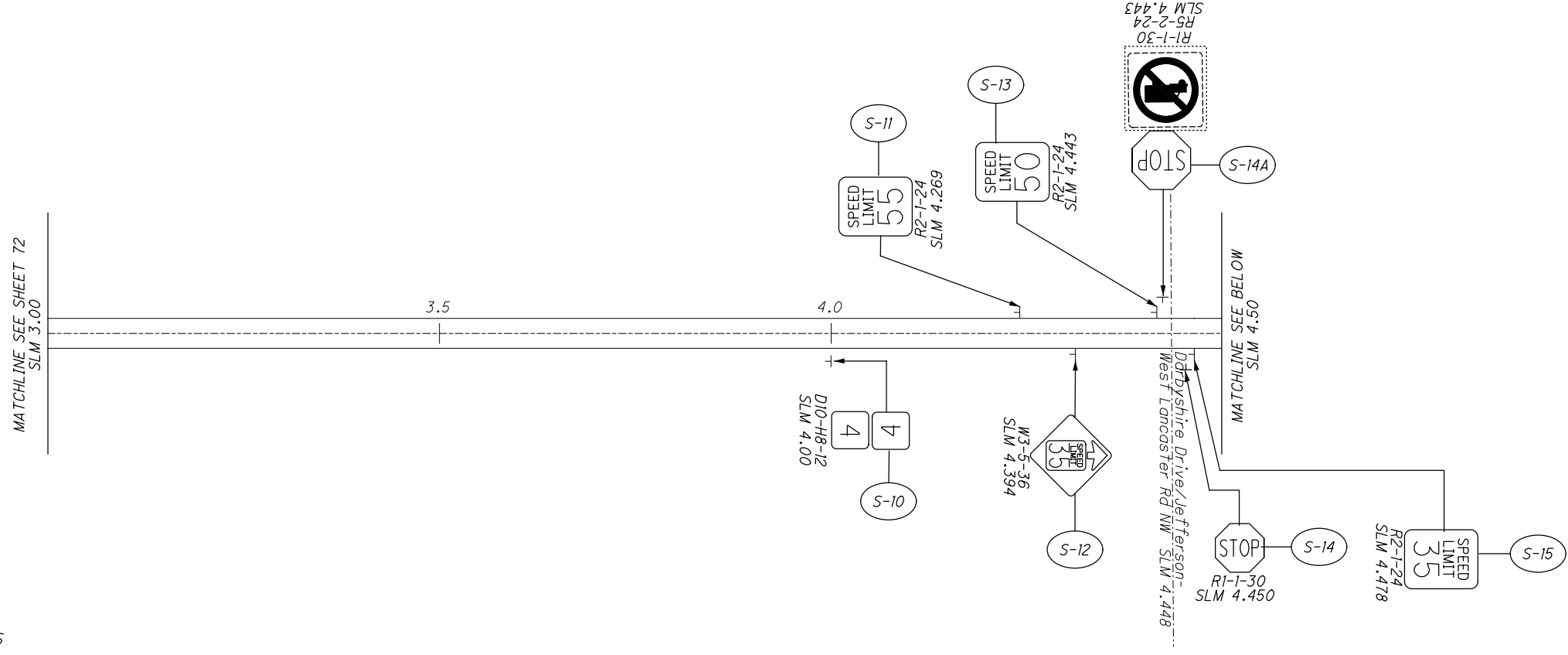

SEE SHEET 72 FOR LEGEND
SEE SHEETS 76 - 77 FOR QUANTITIES

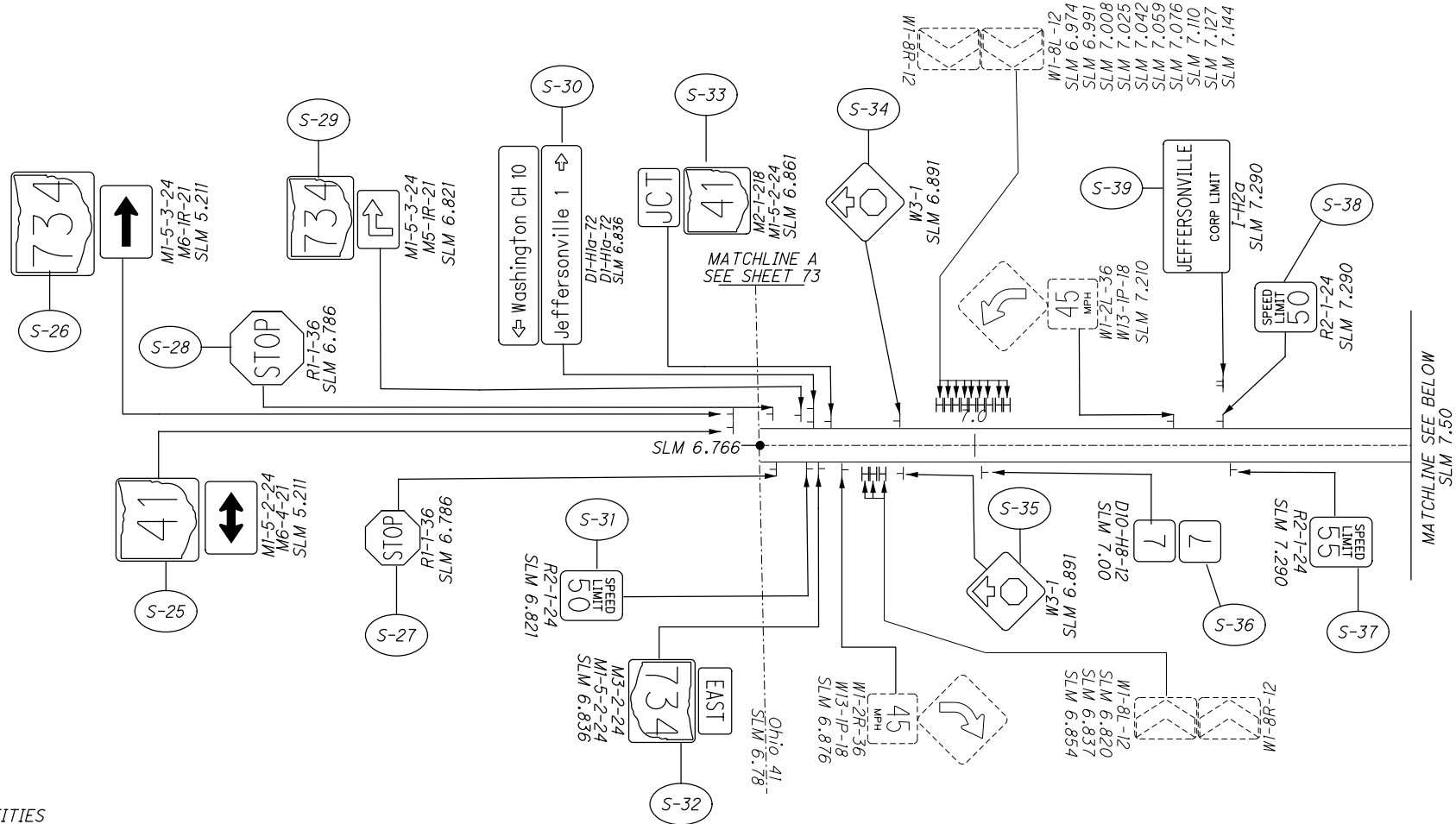

SEE SHEET 72 FOR LEGEND
SEE SHEETS 76 - 77 FOR QUANTITIES

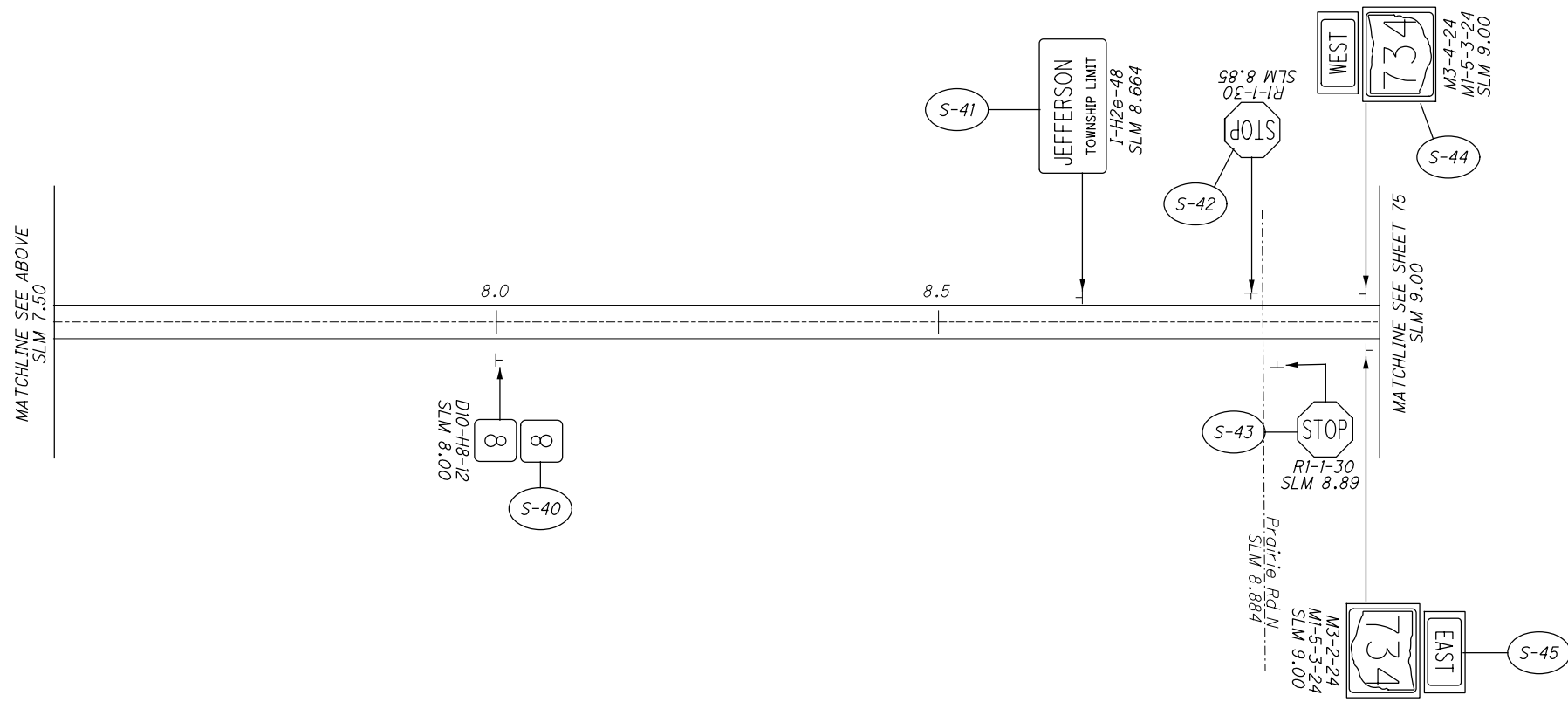

CALCULATED	0
CHECKED	



SIGN PLAN
FAY-734 SLM: 6.00 - 9.00

FAY-SYS SIGN REPLACE-FY20

SEE SHEET 72 FOR LEGEND
SEE SHEETS 76 - 77 FOR QUANTITIES

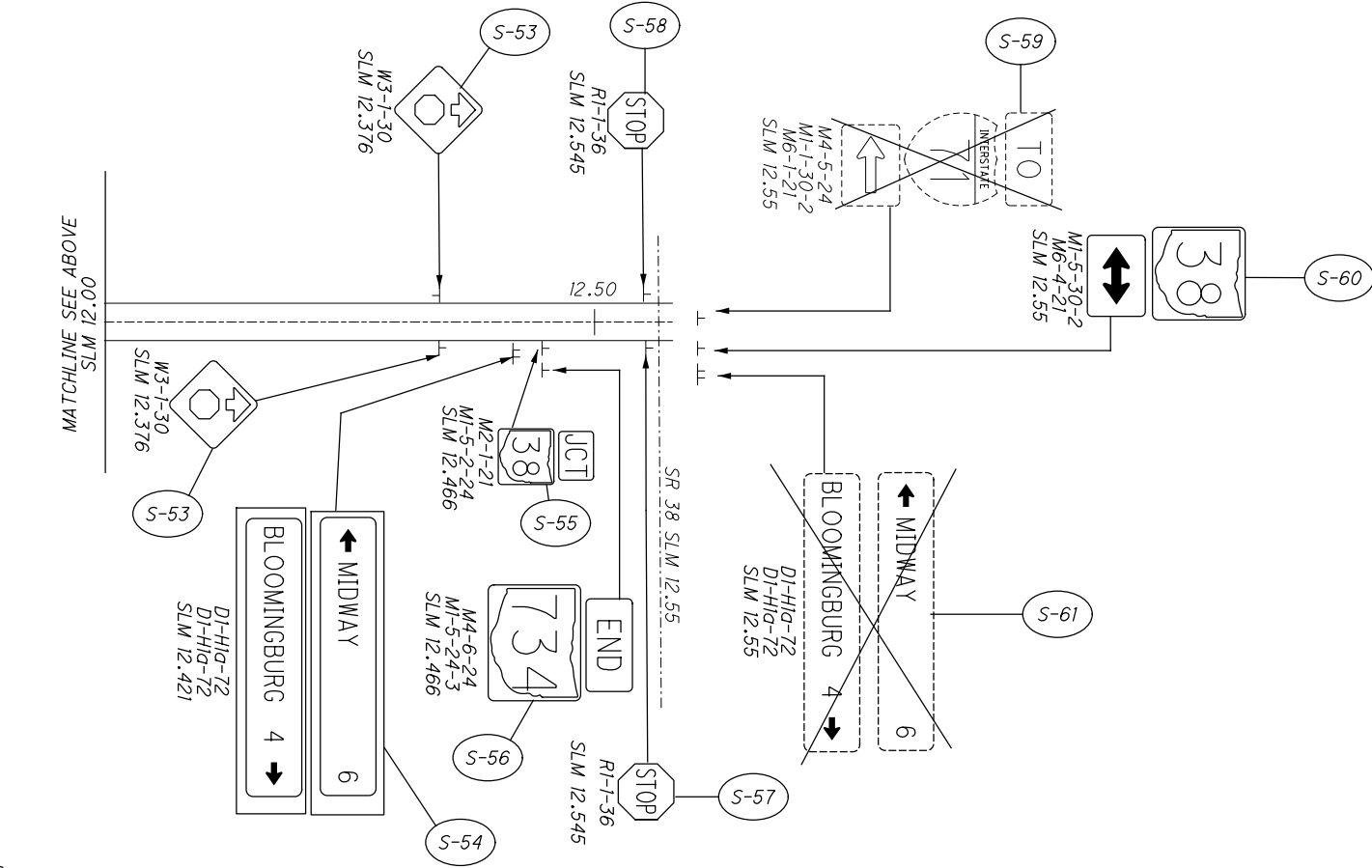

SEE SHEET 72 FOR LEGEND
SEE SHEETS 76 - 77 FOR QUANTITIES

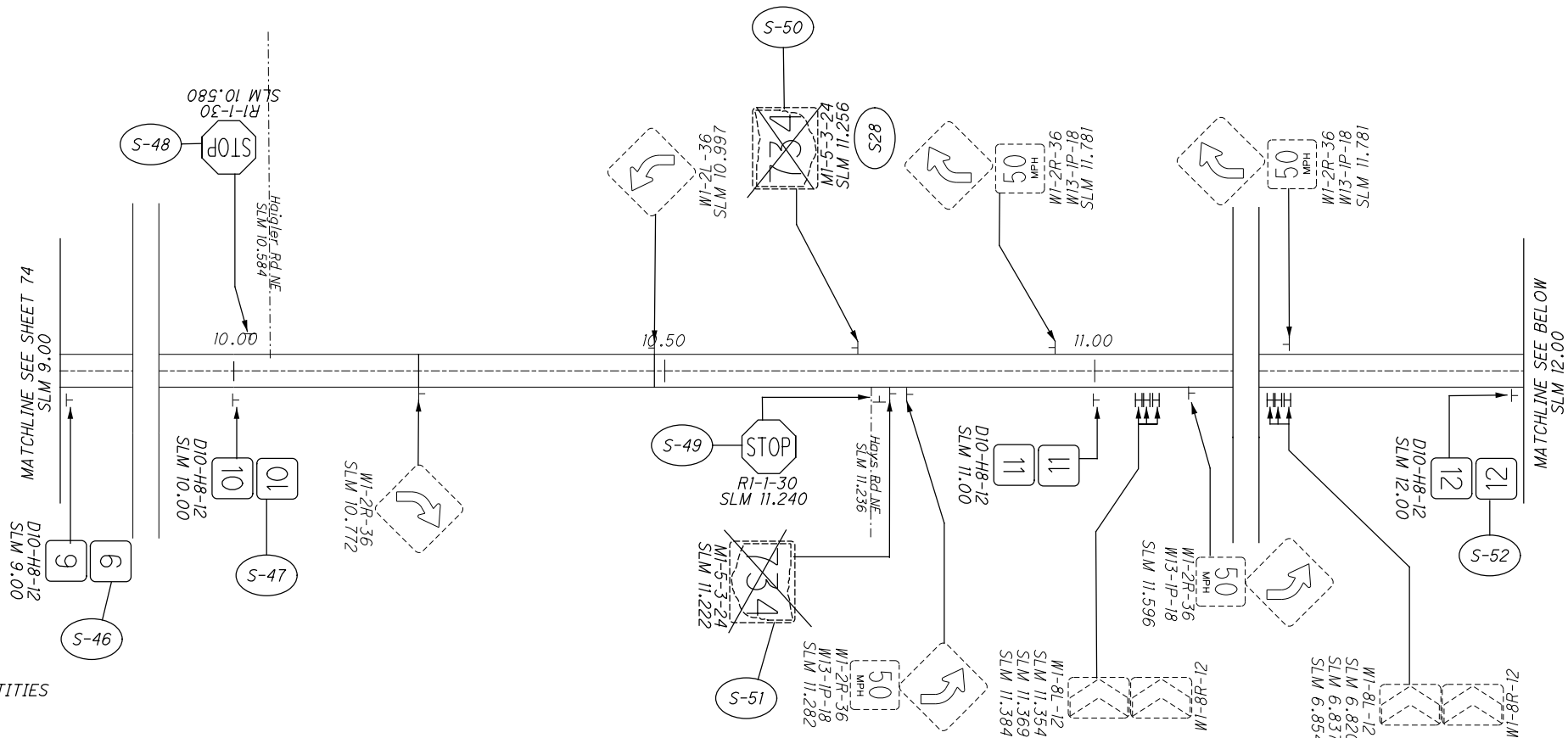

I:\Project\07556_FAY_PIC_FLAT_SHEET\Design\Roadway\Sheets\07556_I0001.dgn 1/27/2020 3:53:24 PM vpatel

SHEET NO.	REFERENCE SHEET	LOCATION (SLM)	SIDE	NOTE	CODE	SIZE (INCHES)	630	630	630	630	630	630	630	630	630	630	630	630	630	630	630	630							
							GROUND MOUNTED SUPPORT, No. 2 POST	GROUND MOUNTED SUPPORT, No. 3 POST	SIGN POST REFLECTOR, RED	SIGN POST REFLECTOR, WHITE	SIGN POST REFLECTOR, YELLOW	SIGN BACKING ASSEMBLY	SIGN SUPPORT ASSEMBLY, POLE MOUNTED	SIGN, FLAT SHEET	SIGN, FLAT SHEET, AS PER PLAN	SIGN, DOUBLE FACED, MILE MARKER	REMOVAL OF GROUND MOUNTED SIGN & DISPOSAL	REMOVAL OF GROUND MOUNTED SIGN & RE-ERECTION, AS PER PLAN	REMOVAL OF GROUND MOUNTED MAJOR SIGN & DISPOSAL	REMOVAL OF GROUND MOUNTED POST SUPPORT AND DISPOSAL	REMOVAL OF STRUCTURE MOUNTED SIGN AND DISPOSAL	REMOVAL OF POLE MOUNTED SIGN & DISPOSAL	SIGNING, MISC: REMOVAL OF POST REFLECTOR	HINGED					
							FT	FT	EACH	EACH	EACH	EACH	SQ FT	SQ FT	EACH	EACH	EACH	EACH	EACH	EACH	EACH	EACH	EACH	EACH					
72	S-1	0.000	RIGHT	Enter Fayette Co., Leave Greene CO.	I-H2F	24 X 48								8.0		1													
72	S-1	0.000	RIGHT	Jefferson	I-H2E	24 X 48								8.0		1													
72	S-2	1.000	RIGHT	1	D10-H8	12 X 12										1													
72	S-3	1.395	LEFT	734	M1-5-3	30 X 24								5.0		1													
72	S-3	1.395	LEFT		M3-4	24 X 12								2.0															
72	S-4	1.408	RIGHT		R1-1	30 X 30			1					6.3									1						
72	S-5	1.430	RIGHT	734	M1-5-3	30 X 24								5.0		1													
72	S-5	1.430	RIGHT		M3-2	24 X 12								2.0															
72	S-6	2.000	RIGHT	2	D10-H8	12 X 12										1	1												
72	S-7	2.717	LEFT	734	M1-5-3	30 X 24										1	1												
72	S-8	1.408	RIGHT		R1-1	30 X 30			1					6.3			1						1						
72	S-8A	1.400	LEFT		R1-1	30 X 30			1					6.3			1						1						
72	S-9	3.000	RIGHT	3	D10-H8	12 X 12										1	1												
73	S-10	4.000	RIGHT	4	D10-H8	12 X 12										1	1												
73	S-11	4.296	LEFT	55	R2-1	24 X 30								5.0			1												
73	S-12	4.394	RIGHT	35	W3-5	36 X 36								9.0			1												
73	S-13	4.443	LEFT	50	R2-1	24 X 30								5.0			1												
73	S-14	4.450	RIGHT		R1-1	30 X 30			1					6.3			1						1						
73	S-14A	4.443	LEFT	"LOW"	R1-1	30 X 30		10.0	1					6.3			1						1						
73	S-14A	4.443	LEFT		R5-2	24 X 24												1											
73	S-15	4.478	RIGHT	55	R2-1	24 X 30								5.0			1												
73	S-16	4.765	RIGHT		R1-1	30 X 30			1					6.3			1						1						
73	S-17	4.937	RIGHT	JEFFERSONVILLE	I-H2A	48 X 24								8.0			1												
73	S-18	4.909	LEFT		R1-1	30 X 30			1					6.3			1						1						
	S-19			NOT USED																									
73	S-20	5.000	RIGHT	5	D10-H8	12 X 12										1	1												
73	S-21	5.167	RIGHT		M2-1	21 X 15								2.2			1												
73	S-21	5.167	RIGHT	41	M1-5-2	24 X 24								4.0			1												
73	S-21	5.167	RIGHT	729	M1-5-3	30 X 24								5.0			1												
73	S-22	5.167	LEFT		M3-4	24 X 12								2.0			1												
73	S-22	5.167	LEFT	734	M1-5-3	30 X 24								5.0			1												
73	S-23	5.186	RIGHT	734	M1-5-3	30 X 24								5.0			1												
73	S-23	5.186	RIGHT		M5-1L	21 X 15								2.2			1												
73	S-24	5.211	RIGHT	41	M1-5-2	24 X 24							1	4.0									1						
73	S-24	5.211	RIGHT		M6-4	21 X 15							1	2.2									1						
73	S-24	5.211	RIGHT	729	M1-5-3	30 X 24							1	5.0									1						
73	S-24	5.211	RIGHT		M6-6R	21 X 15							1	2.2									1						
73	S-24	5.211	RIGHT	734	M1-5-2	24 X 24							1	4.0									1						
73	S-24	5.211	RIGHT		M6-1R	21 X 15							1	2.2									1						
74	S-25	5.211	LEFT	41	M1-5-2	24 X 24								4.0			1												
74	S-25	5.211	LEFT		M6-4	21 X 15								2.2			1												
74	S-26	5.211	LEFT	734	M1-5-3	30 X 24								5.0			1												
74	S-26	5.211	LEFT		M6-1R	21 X 15								2.2			1												
74	S-27	6.786	RIGHT		R1-1	36 X 36			1					9.0			1						1						
74	S-28	6.786	LEFT		R1-1	36 X 36			1					9.0			1						1						
74	S-29	6.821	LEFT	732	M1-5-3	30 X 24								5.0			1												
74	S-29	6.821	LEFT		M5-1R	21 X 15								2.2			1												

**SIGN PLAN QUANTITIES
FAYETTE COUNTY - SR 734**

TOTALS CARRIED TO SUB-SUMMARY, SHEET 7

10.0

9

6

189.7

5

37

1

6

9

SHEET NO.	REFERENCE SHEET	LOCATION (SLM)	SIDE	NOTE	CODE	SIZE (INCHES)	630	630	630	630	630	630	630	630	630	630	630	630	630	630	630	630	630	630		
							GROUND MOUNTED SUPPORT, No. 2 POST	GROUND MOUNTED SUPPORT, No. 3 POST	SIGN POST REFLECTOR, RED	SIGN POST REFLECTOR, WHITE	SIGN POST REFLECTOR, YELLOW	SIGN BACKING ASSEMBLY	SIGN SUPPORT ASSEMBLY, POLE MOUNTED	SIGN, FLAT SHEET	SIGN, FLAT SHEET, AS PER PLAN	SIGN, DOUBLE FACED, MILE MARKER	REMOVAL OF GROUND MOUNTED SIGN & DISPOSAL	REMOVAL OF GROUND MOUNTED SIGN & RE-ERECTION, AS PER PLAN	REMOVAL OF GROUND MOUNTED MAJOR SIGN & DISPOSAL	REMOVAL OF GROUND MOUNTED POST SUPPORT AND DISPOSAL	REMOVAL OF STRUCTURE MOUNTED SIGN AND DISPOSAL	REMOVAL OF POLE MOUNTED SIGN & DISPOSAL	SIGNING, MISC: REMOVAL OF POST REFLECTOR	HINGED		
74	S-30	6.836	LEFT	WASHINGTON CH, 10	D1-H1A	72 X 12	FT	FT	EACH	EACH	EACH	SQ FT	SQ FT	EACH	EACH	EACH	EACH	EACH	EACH	EACH	EACH	EACH	EACH	EACH	EACH	
74	S-30	6.836	LEFT	JEFFERSONVILLE, 1	D1-H1A	72 X 12						6.0				1										
74	S-31	6.821	RIGHT	50	R2-1	24 X 30						6.0				1										
74	S-32	6.836	RIGHT	734	M1-5-3	30 X 24						5.0				1										
74	S-32	6.836	RIGHT		M3-2	24 X 12						5.0				1										
74	S-33	6.861	LEFT		M1-5-2	24 X 24						2.0				1										
74	S-33	6.861	LEFT		M2-1	21 X 15						4.0				1										
74	S-34	6.891	LEFT		W3-1	30 X 30					1	2.2				1										
74	S-35	6.891	RIGHT		W3-1	30 X 30					1	6.3				1							1			
74	S-36	7.000	RIGHT	7	D10-H8	12 X 12						6.3				1	1									
74	S-37	7.290	RIGHT	55	R2-1	24 X 30						6.3				1										
74	S-38	7.290	LEFT	50	R2-1	24 X 30						5.0				1										
74	S-39	7.290	LEFT	JEFFERSONVILLE	I-H2A	48 X 24						5.0				1										
74	S-40	8.000	RIGHT	8	D10-H8	12 X 12						8.0				1	1									
74	S-41	8.664	LEFT	JEFFERSON	I-H2E	24 X 48						8.0				1										
74	S-42	8.850	LEFT		R1-1	30 X 30			1			6.3				1							1			
74	S-43	8.890	RIGHT		R1-1	30 X 30			1			6.3				1							1			
74	S-44	9.000	LEFT		M3-4	24 X 12	7.0	10.0				2.0														
74	S-44	9.000	LEFT	734	M1-5-3	30 X 24						5.0														
74	S-45	9.000	RIGHT		M3-2	24 X 12	7.0	10.0				2.0														
74	S-45	9.000	RIGHT	734	M1-5-3	30 X 24						5.0														
75	S-46	9.000	RIGHT	9	D10-H8	12 X 12									1	1										
75	S-47	10.000	RIGHT	10	D10-H8	12 X 12									1	1										
75	S-48	10.850	LEFT		R1-1	30 X 30			1			6.3											1			
75	S-49	11.240	RIGHT		R1-1	30 X 30			1			6.3											1			
75	S-50	11.256	LEFT		M1-5-3	30 X 24										1			1							
75	S-51	11.000	RIGHT	11	D10-H8	12 X 12									1	1										
75	S-52	12.000	RIGHT	12	D10-H8	12 X 12									1	1										
75	S-53	12.376	RIGHT		W3-1	30 X 30					1	6.3				1							1			
75	S-53A	12.376	RIGHT		W3-1	30 X 30					1	6.3				1							1			
75	S-54	12.421	RIGHT	MIDWAY, 6	D1-H1A	72 X 12	14.0	20.0				6.0				1										
75	S-54	12.421	RIGHT	BLOOMINGBURG, 4	D1-H1A	72 X 12						6.0				1										
75	S-55	12.466	LEFT		M2-1	21 X 15						2.2				1										
75	S-55	12.466	LEFT	38	M1-5-2	24 X 24						4.0				1										
75	S-56	12.466	RIGHT		M4-6	24 X 12						2.0				1										
75	S-56	12.466	RIGHT	734	M1-5-3	30 X 24						5.0				1										
75	S-57	12.545	RIGHT		R1-1	36 X 36			1			9.0				1							1			
75	S-58	12.545	LEFT		R1-1	36 X 36			1			9.0				1							1			
75	S-59	12.550	LEFT		M4-5	24 X 12										1										
75	S-59	12.550	LEFT	71	M1-1-2	24 X 24										1			1							
75	S-59	12.550	LEFT		M6-1L	21 X 15										1										
75	S-60	12.550	RIGHT		M1-5-2	24 X 24						4.0				1										
75	S-60	12.550	RIGHT		M6-4	21 X 15						2.2				1										
75	S-61	12.550	RIGHT	MIDWAY, 6	D1-H1A	72 X 12										1			2							
75	S-61	12.550	RIGHT	BLOOMINGBURG, 4	D1-H1A	72 X 12										1										
TOTALS CARRIED TO SUB-SUMMARY, SHEET 7							28.0	40.0	6		4		170.0		6	39		4			10					

**SIGN PLAN QUANTITIES
FAYETTE COUNTY - SR 734**

CALCULATED
VHP
CHECKED
XXX

**FAY-SYS SIGN
REPLACE-FY20**

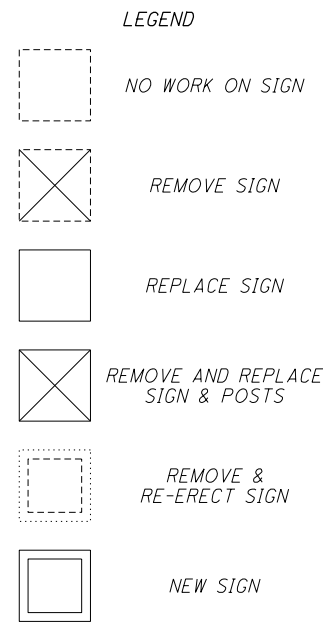

NOTES
1. SEE SHEETS 84 - 88 FOR QUANTITIES

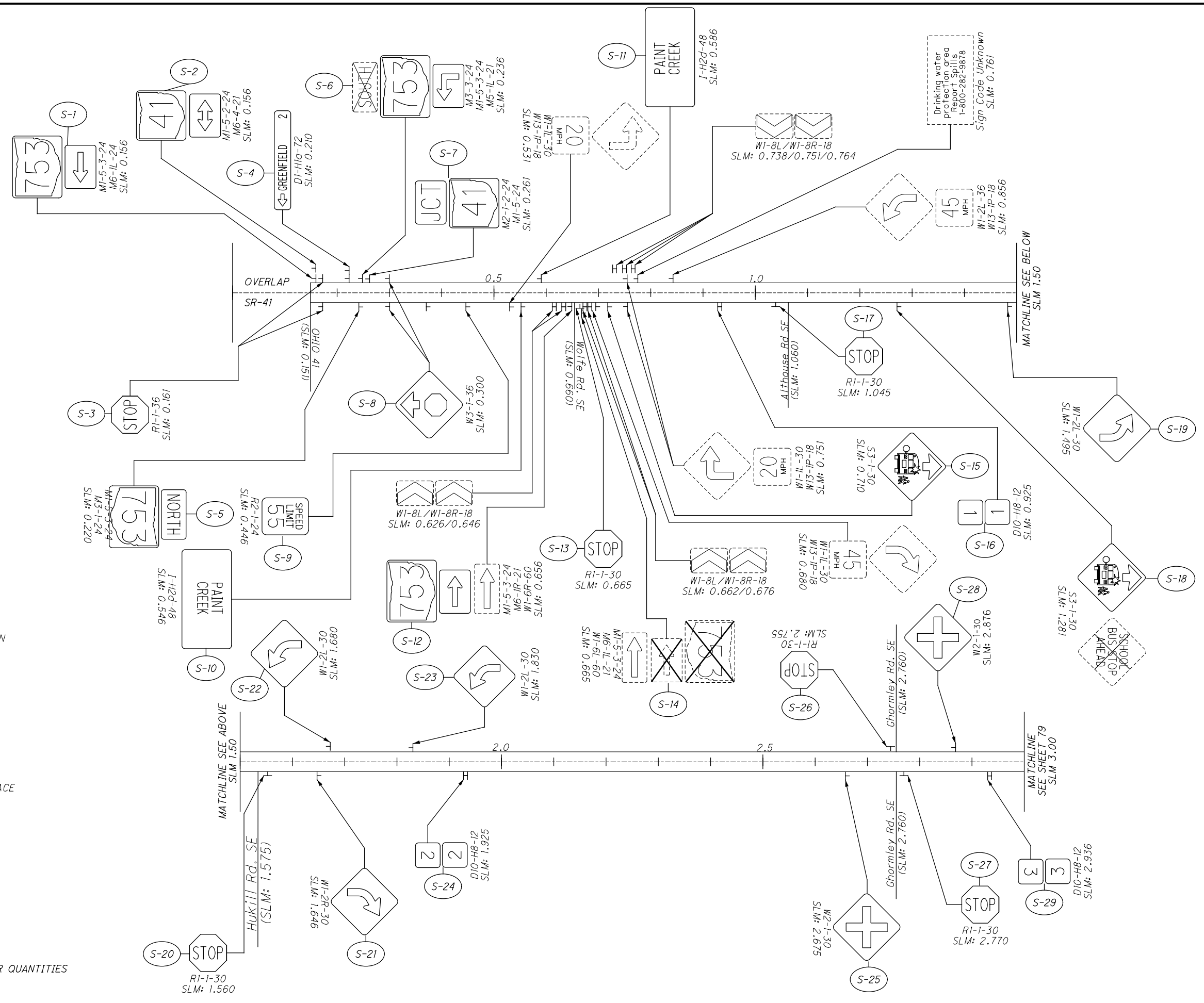

CALCULATED
CHECKED

SIGN PLAN
FAY-753: SLM 0.00 - 3.00

FAY-SYS SIGN
REPLACE-FY20

SEE SHEET 78 FOR LEGEND
SEE SHEETS 84 - 88 FOR QUANTITIES

CALCULATED
CHECKED

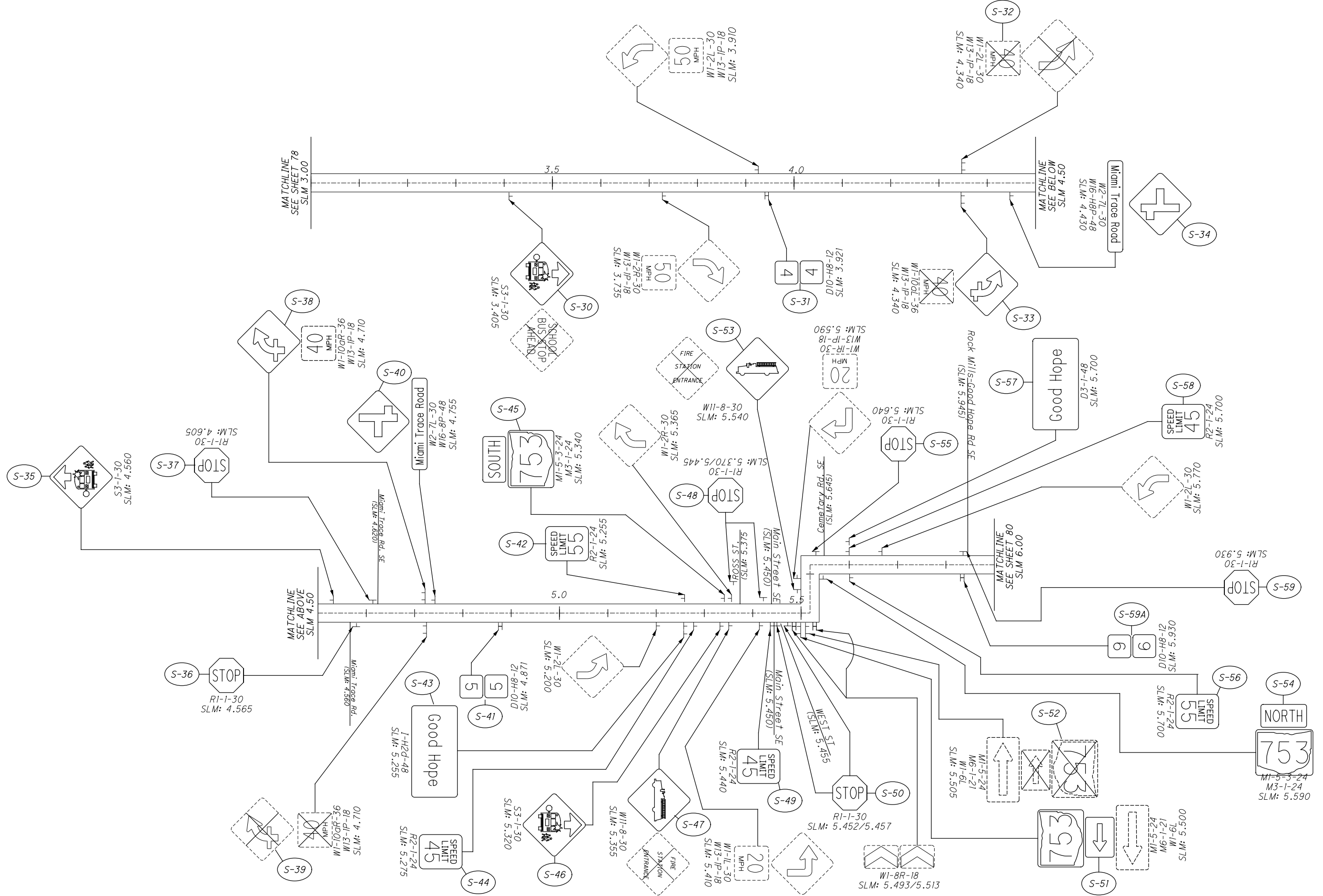

SIGN PLAN
FAY-753: SLM 3.00 - 6.00

FAY-SYS SIGN
REPLACE-FY20

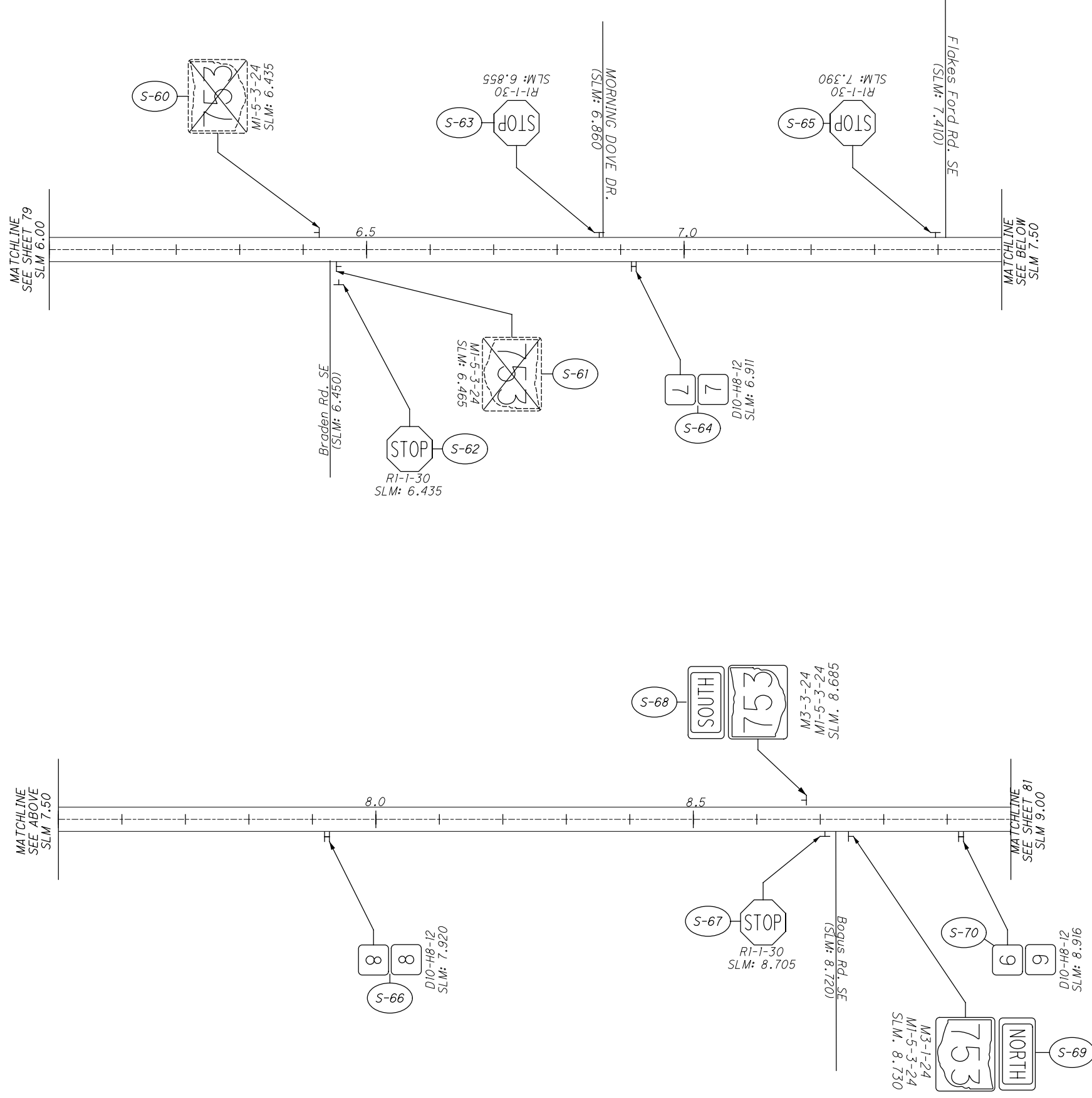

SEE SHEET 78 FOR LEGEND
SEE SHEETS 84 - 88 FOR QUANTITIES

CALCULATED
CHECKED

SIGN PLAN
FAY-753: SLM 6.00 - 9.00

FAY-SYS SIGN
REPLACE-FY20

I:\ProjectData\07556_FAY_PIC_FLAT\Design\Roadway\Sheets\07556_TP004_753_1/27/2020_3:53:28 PM vpatel

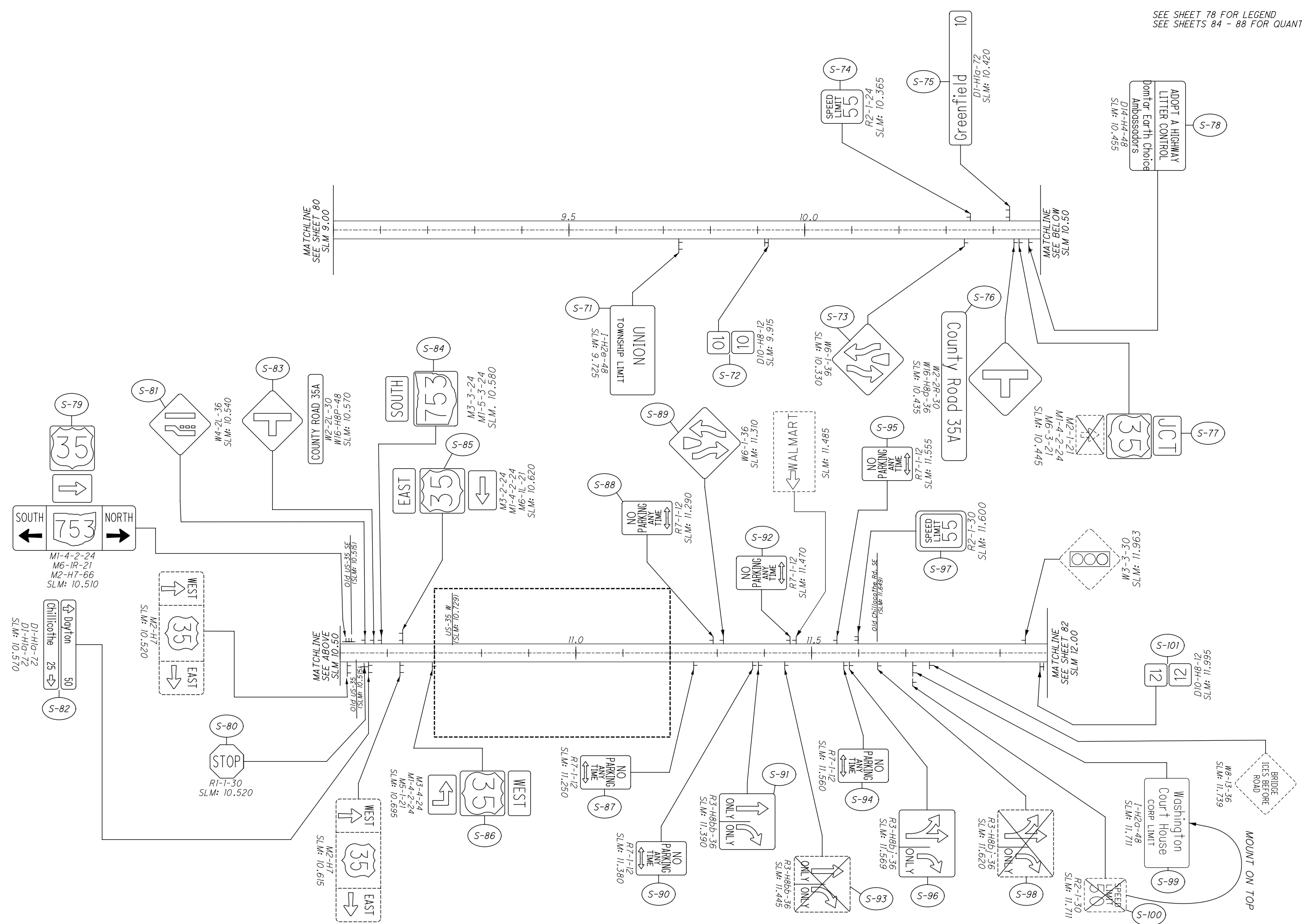

SEE SHEET 78 FOR LEGEND
SEE SHEETS 84 - 88 FOR QUANTITIES

CALCULATED
CHECKED

SIGN PLAN FAY-753: SLM 9.00 - 12.00

FAY-SYS SIGN REPLACE-FY20

81
88

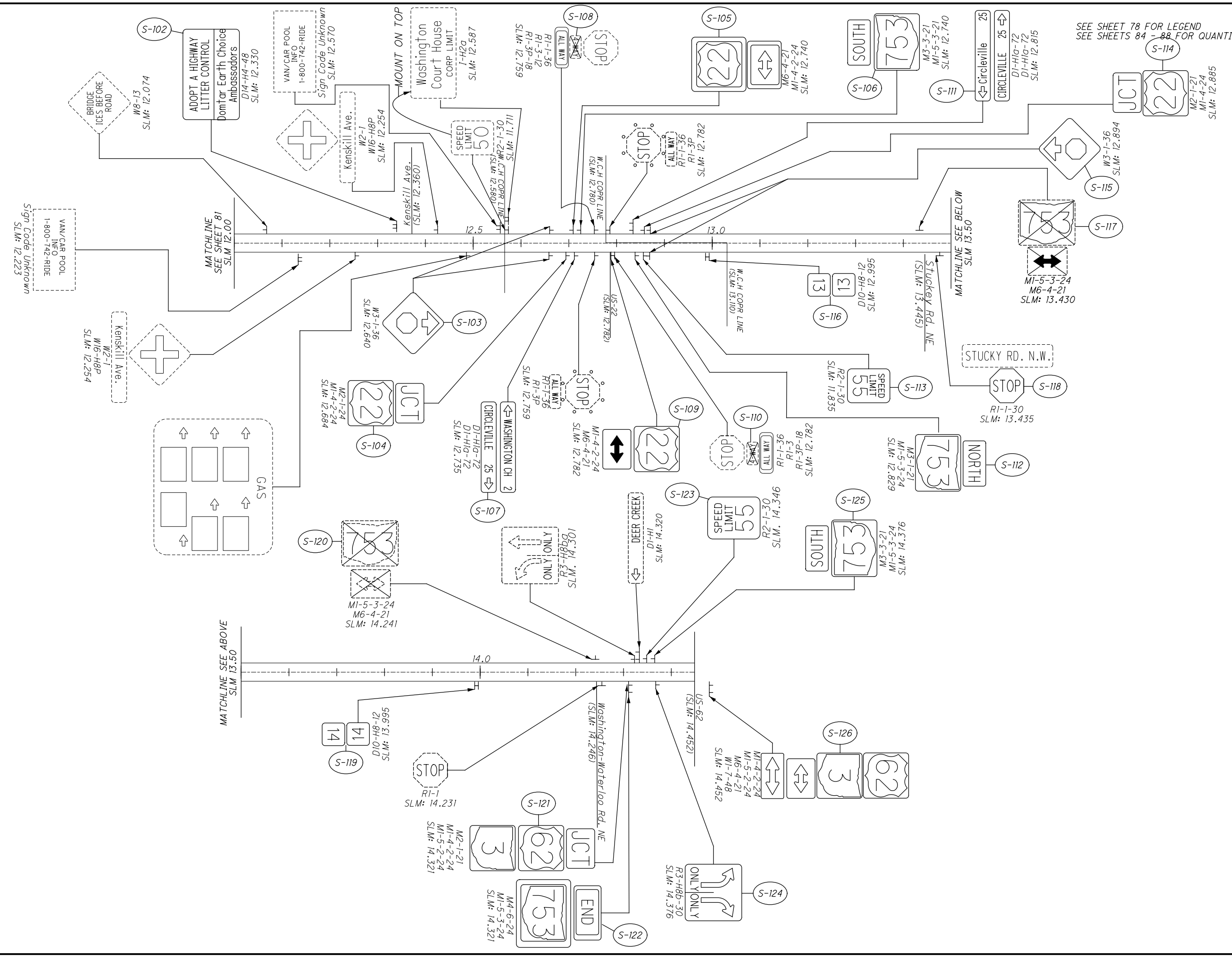

SEE SHEET 78 FOR LEGEND
SEE SHEETS 84 - 88 FOR QUANTITIES

CALCULATED
CHECKED

SIGN PLAN
FAY-753: SLM 12.00 - 14.45

FAY-SYS SIGN
REPLACE-FY20

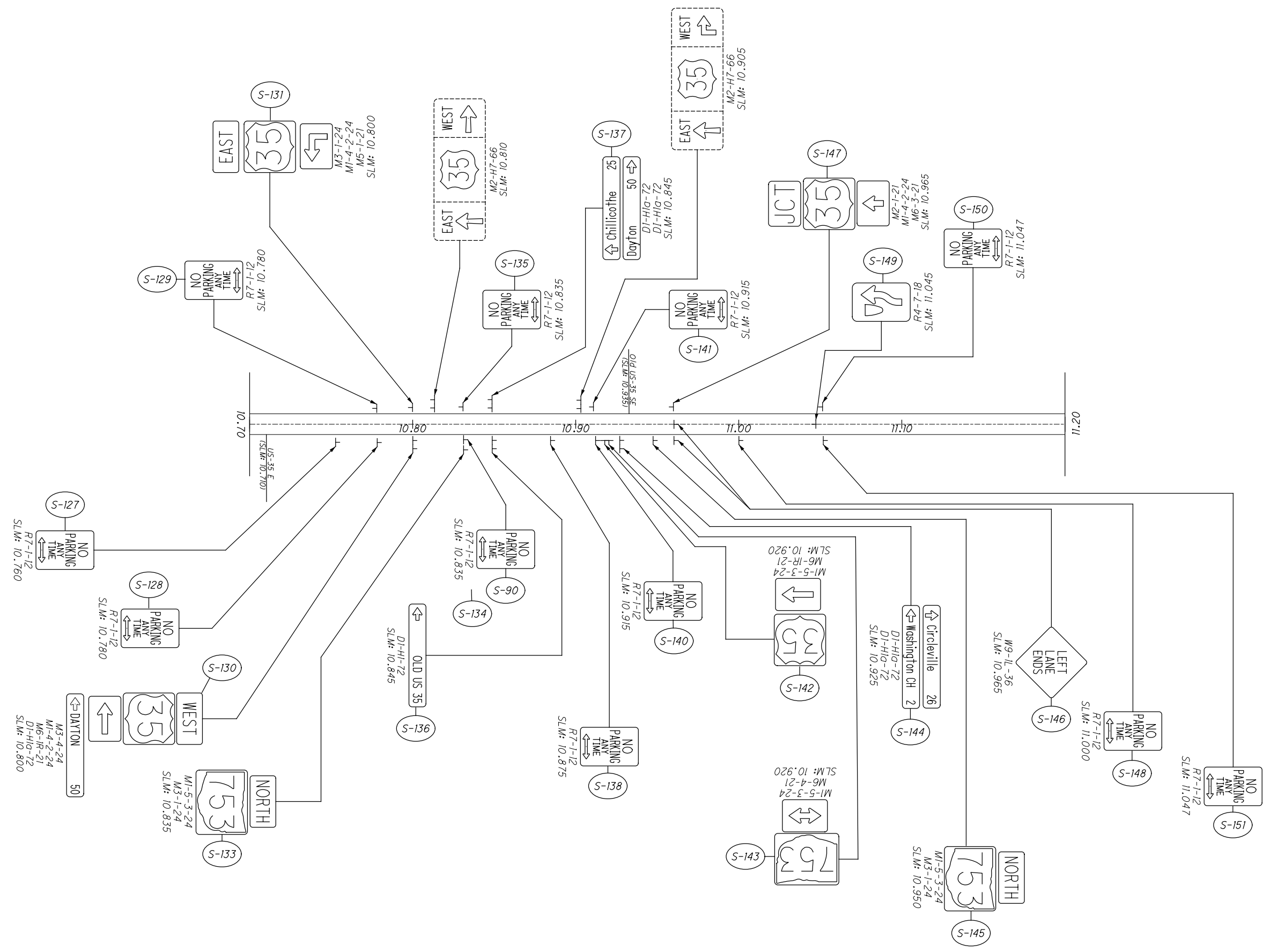

CALCULATED
CHECKED

SIGN PLAN
FAY-753: SLM 10.70 - 11.20

FAY-SYS SIGN
REPLACE-FY20

I:\ProjectData\07556_FAY_PIC_FLATSHEET\Design\Roadway\Sheets\07556_T000.dgn 107556_T000_753 1/27/2020 3:53:31PM vpatel

SHEET NO.	REFERENCE SHEET	LOCATION (SLM)	SIDE	NOTE	CODE	SIZE (INCHES)	630	630	630	630	630	630	630	630	630	630	630	630	630	630	630	630	630	HINGED	
							GROUND MOUNTED SUPPORT, No. 2 POST FT	GROUND MOUNTED SUPPORT, No. 3 POST FT	SIGN POST REFLECTOR, RED				SIGN POST REFLECTOR, WHITE		SIGN POST REFLECTOR, YELLOW	SIGN BACKING ASSEMBLY EACH	SIGN SUPPORT ASSEMBLY, POLE MOUNTED EACH	SIGN, FLAT SHEET SQ FT	SIGN, FLAT SHEET, AS PER PLAN SQ FT	SIGN, DOUBLE FACED, MILE MARKER EACH	REMOVAL OF GROUND MOUNTED SIGN & DISPOSAL EACH	REMOVAL OF GROUND MOUNTED SIGN & RE-ERECTION, AS PER PLAN EACH	REMOVAL OF GROUND MOUNTED MAJOR SIGN & DISPOSAL EACH		
78	S-1	0.156	LEFT	753	M1-5-3	30 X 24							5.0				1								
78	S-1	0.156	LEFT		M6-1L	21 X 15							2.2				1								
78	S-2	0.156	LEFT	41	M1-5-2	24 X 24							4.0				1								
78	S-2	0.156	LEFT		M6-4	21 X 15							2.2				1								
78	S-3	0.161	LEFT		R1-1	30 X 30				1			6.3				1							1	
78	S-3	0.161	RIGHT		R1-1	36 X 36				1			9.0				1								1
78	S-4	0.210	LEFT	GREENFIELD, 2	D1-H1A	72 X 12							6.0				1								
78	S-5	0.220	RIGHT	753	M1-5-2	24 X 24							4.0				1								
78	S-5	0.220	RIGHT		M3-1	24 X 12							2.0				1								
78	S-6	0.236	LEFT		M3-3	24 X 12							2.0				1								
78	S-6	0.236	LEFT	753	M1-5-3	30 X 24							5.0				1								
78	S-6	0.236	LEFT		M5-1L	21 X 15							2.2				1								
78	S-7	0.261	LEFT		M2-1	21 X 15							2.2				1								
78	S-7	0.261	LEFT	41	M1-5-2	24 X 24							4.0				1								
78	S-8	0.300	LEFT		W3-1	36 X 36					1		9.0				1								1
78	S-8	0.300	RIGHT		W3-1	36 X 36					1		9.0				1								1
78	S-9	0.446	RIGHT	55	R1-1	30 X 30				1			6.3				1								1
78	S-10	0.546	RIGHT	PAINTE CREEK	I-H2D	48 X 24							8.0				1								
78	S-11	0.586	LEFT	PAINTE CREEK	I-H2D	48 X 24							8.0				1								
78	S-12	0.656	RIGHT	753	M1-5-3	30 X 24							5.0				1								
78	S-12	0.656	RIGHT		M6-1R	21 X 15							2.2				1								
78	S-12	0.665	RIGHT		M1-5-3	30 X 24							5.0				1								
78	S-13	0.665	RIGHT		R1-1	30 X 30				1			6.3				1								1
78	S-14	0.665	RIGHT		M6-1L	21 X 15											1								
78	S-14	0.665	RIGHT	753	M1-5-3	30 X 24											1								
78	S-15	0.710	RIGHT		S3-1	30 X 30							6.3				1								
78	S-16	0.925	RIGHT	1	D10-H8	12 X 12										1	1								
78	S-17	1.045	RIGHT		R1-1	30 X 30				1			6.3				1								1
78	S-18	1.281	RIGHT		S3-1	30 X 30							6.3				1								
78	S-18	1.281	RIGHT		S3-1	30 X 30							6.3				1								
78	S-19	1.495	RIGHT		W1-2L	30 X 30							6.3				1								
78	S-20	1.560	RIGHT		R1-1	30 X 30				1			6.3				1								1
78	S-21	1.646	RIGHT		W1-2R	30 X 30							6.3				1								
78	S-22	1.680	LEFT		W1-2L	30 X 30							6.3				1								
78	S-23	1.830	LEFT		W1-2L	30 X 30							6.3				1								
78	S-24	1.925	RIGHT	2	D10-H8	12 X 12										1	1								
78	S-25	2.675	RIGHT		W2-1	30 X 30							6.3				1								
78	S-26	2.755	LEFT		R1-1	30 X 30				1			6.3				1								1
78	S-27	2.770	RIGHT		R1-1	30 X 30				1			6.3				1								1
78	S-28	2.876	LEFT		W2-1	30 X 30							6.3				1								
78	S-29	2.936	RIGHT	3	D10-H8	12 X 12										1	1								
79	S-30	3.405	RIGHT		S3-1	30 X 30							6.3				1								
79	S-31	3.921	RIGHT	4	D10-H8	12 X 12										1	1								
79	S-32	4.340	LEFT		W1-2L	30 X 30											1				2				
79	S-32	4.340	LEFT	40	W13-1P	18 X 18											1								
79	S-33	4.340	RIGHT		W1-10AL	36 X 36							9.0				1								
79	S-33	4.340	RIGHT	30	W13-1P	18 X 18											1								
79	S-34	4.430	RIGHT		W2-7L	30 X 30							6.3												
79	S-34	4.430	RIGHT	Miami Trace Road	W16-H8P	48 X 8							2.7												
TOTALS CARRIED TO SUB-SUMMARY, SHEET 7										8		2		214.8		4	46			2			10		

SIGN PLAN SUB-SUMMARY - SR753
FAYETTE COUNTY - SR 753

FAY-SYS SIGN
REPLACE-FY20

CALCULATED VHP
CHECKED XXX

I:\ProjectData\07556_FAY_PIC_FLATSHEET\Design\Roadway\Sheets\07556_T000.dgn 107556_T0002_753 1/27/2020 3:53:32 PM vpd\tel

SHEET NO.	REFERENCE SHEET	LOCATION (SLM)	SIDE	NOTE	CODE	SIZE (INCHES)	630	630	630	630	630	630	630	630	630	630	630	630	630	630	630	630	630									
							GROUND MOUNTED SUPPORT, No. 2 POST	GROUND MOUNTED SUPPORT, No. 3 POST	SIGN POST REFLECTOR, RED	SIGN POST REFLECTOR, WHITE	SIGN POST REFLECTOR, YELLOW	SIGN BACKING ASSEMBLY	SIGN SUPPORT ASSEMBLY, POLE MOUNTED	SIGN, FLAT SHEET	SIGN, FLAT SHEET, AS PER PLAN	SIGN, DOUBLE FACED, MILE MARKER	REMOVAL OF GROUND MOUNTED SIGN & DISPOSAL	REMOVAL OF GROUND MOUNTED SIGN & RE-ERECTION, AS PER PLAN	REMOVAL OF GROUND MOUNTED MAJOR SIGN & DISPOSAL	REMOVAL OF GROUND MOUNTED POST SUPPORT AND DISPOSAL	REMOVAL OF STRUCTURE MOUNTED SIGN AND DISPOSAL	REMOVAL OF POLE MOUNTED SIGN & DISPOSAL	SIGNING, MISC: REMOVAL OF POST REFLECTOR	HINGED								
							FT	FT	EACH		EACH	EACH	EACH	SQ FT	SQ FT	EACH	EACH	EACH	EACH	EACH	EACH	EACH	EACH	EACH	EACH	EACH						
79	S-35	4.560	LEFT		S3-1	30 X 30								6.3			1															
79	S-36	4.565	RIGHT		R1-1	30 X 30								6.3			1															
79	S-37	4.605	LEFT		R1-1	30 X 30			1					6.3			1															
79	S-38	4.710	LEFT		W1-10AR	36 X 36								9.0			1															
79	S-39	4.710	RIGHT		W1-10AR	36 X 36											1															
79	S-39	4.710	RIGHT		W13-1P	18 X 18											1															
79	S-40	4.755	LEFT		W2-7L	30 X 30								6.3			1															
79	S-40	4.755	LEFT		W16-8P	30 X 8								1.7			1															
79	S-41	4.871	RIGHT	5	D10-H8	12 X 12										1	1															
79	S-42	5.255	LEFT	55	R2-1	24 X 30								5.0			1															
79	S-43	5.255	RIGHT	Good Hope	I-H2D	48 X 24								8.0			1															
79	S-44	5.275	RIGHT	45	R2-1	24 X 30								5.0			1															
79	S-45	5.340	LEFT	753	M1-5-3	30 X 24								5.0			1															
79	S-45	5.340	LEFT		M3-1	24 X 12								2.0			1															
79	S-46	5.320	RIGHT		S3-1	30 X 30								6.3			1															
79	S-47	5.355	RIGHT		W11-8	30 X 30								6.3			1															
79	S-48	5.370	LEFT		R1-1	30 X 30			1					6.3			1															
79	S-48	5.445	LEFT		R1-1	30 X 30			1					6.3			1															
79	S-49	5.440	RIGHT	45	R2-1	24 X 30								5.0			1															
79	S-50	5.452	RIGHT		R1-1	30 X 30								6.3			1															
79	S-50	5.457	RIGHT		R1-1	30 X 30			1					6.3			1															
79	S-51	5.500	RIGHT	753	M1-5-3	30 X 24								5.0			1															
79	S-51	5.500	RIGHT		M6-1L	21 X 15								2.2			1															
79	S-52	5.505	RIGHT	753	M1-5-3	30 X 24											1															
79	S-52	5.505	RIGHT		M6-1L	21 X 15											1															
79	S-53	5.540	LEFT		W11-8	30 X 30								6.3			1															
79	S-54	5.590	RIGHT	753	M1-5-3	30 X 24								5.0			1															
79	S-54	5.590	RIGHT		M3-1	24 X 12								2.0			1															
79	S-55	5.640	LEFT		R1-1	30 X 30				1				6.3			1															
79	S-56	5.700	RIGHT	55	R2-1	24 X 30								5.0			1															
79	S-57	5.700	LEFT	Good Hope	I-H2D	48 X 24								8.0			1															
79	S-58	5.700	LEFT	45	R2-1	24 X 30								5.0			1															
79	S-59	5.930	LEFT		R1-1	30 X 30				1				6.3			1															
79	S-59A	5.930	RIGHT	6	D10-H8	12 X 12											1	1														
80	S-60	6.435	LEFT	753	M1-5-3	30 X 24											1															
80	S-61	6.465	RIGHT	753	M1-5-3	30 X 24											1															
80	S-62	6.435	RIGHT		R1-1	30 X 30				1				6.3			1															
80	S-63	6.855	LEFT		R1-1	30 X 30				1				6.3			1															
80	S-64	6.911	RIGHT	7	D10-H8	12 X 12											1	1														
80	S-65	7.390	LEFT		R1-1	30 X 30				1				6.3			1															
80	S-66	7.920	RIGHT	8	D10-H8	12 X 12											1	1														
80	S-67	8.705	RIGHT		R1-1	30 X 30				1				6.3			1															
80	S-68	7.685	LEFT		M3-3	24 X 12								2.0																		
80	S-68	7.685	LEFT	753	M1-5-3	30 X 24								5.0			1															
80	S-69	8.730	RIGHT		M3-1	24 X 12								2.0																		
80	S-69	8.730	RIGHT	753	M1-5-3	30 X 24								5.0			1															
80	S-70	8.916	RIGHT	9	D10-H8	12 X 12												1	1													
TOTALS CARRIED TO SUB-SUMMARY, SHEET 7									12					194.0		5	45								12							

**SIGN PLAN SUB-SUMMARY - SR753
FAYETTE COUNTY - SR 753**

**FAY-SYS SIGN
REPLACE-FY20**

CALCULATED
VHP
CHECKED
XXX

SHEET NO.	REFERENCE SHEET	LOCATION (SLM)	SIDE	NOTE	CODE	SIZE (INCHES)	630	630	630	630	630	630	630	630	630	630	630	630	630	630	630	630	630	HINGED			
							GROUND MOUNTED SUPPORT, No. 2 POST FT	GROUND MOUNTED SUPPORT, No. 3 POST FT	SIGN POST REFLECTOR, RED EACH	SIGN POST REFLECTOR, WHITE EACH	SIGN POST REFLECTOR, YELLOW EACH	SIGN BACKING ASSEMBLY EACH	SIGN SUPPORT ASSEMBLY, POLE MOUNTED EACH	SIGN, FLAT SHEET SQ FT	SIGN, FLAT SHEET, AS PER PLAN SQ FT	SIGN, DOUBLE FACED, MILE MARKER EACH	REMOVAL OF GROUND MOUNTED SIGN & DISPOSAL EACH	REMOVAL OF GROUND MOUNTED SIGN & RE-ERECTION, AS PER PLAN EACH	REMOVAL OF GROUND MOUNTED MAJOR SIGN & DISPOSAL EACH	REMOVAL OF GROUND MOUNTED POST SUPPORT AND DISPOSAL EACH	REMOVAL OF STRUCTURE MOUNTED SIGN AND DISPOSAL EACH	REMOVAL OF POLE MOUNTED SIGN & DISPOSAL EACH	SIGNING, MISC: REMOVAL OF POST REFLECTOR EACH				
81	S-71	9.725	RIGHT	UNION	I-H2E	24 X 48							8.0														
81	S-72	9.915	RIGHT	10	D10-H8	12 X 12																					
81	S-73	10.330	RIGHT		W6-1	36 X 36							9.0														
81	S-74	10.365	LEFT		R2-1	24 X 30							5.0														
81	S-75	10.420	LEFT	Greenfield, 10	D1-H1A	72 X 12							6.0														
81	S-76	10.435	RIGHT		W2-2R	36 X 36							9.0														
81	S-76	10.435	RIGHT	County Road 35A	W16-H8P	48 X 8							2.7														
81	S-77	10.445	RIGHT		M2-1	21 X 15							2.2														
81	S-77	10.445	RIGHT	35	M1-4-2	24 X 24							4.0														
81	S-77	10.445	RIGHT		M6-3	21 X 15																					
81	S-78	10.455	LEFT	Domtar Earth Choice Ambassadors	D14-H4	30 X 48							10.0														
81	S-79	10.510	LEFT	35	M1-4-2	24 X 24							4.0														
81	S-79	10.510	LEFT		M6-1R	21 X 15							2.2														
81	S-79	10.510	LEFT	753	M2-H7	66 X 24							11.0														
81	S-80	10.520	RIGHT		R1-1	30 X 30			1				6.3											1			
81	S-81	10.540	LEFT		W4-2L	36 X 36							9.0														
81	S-82	10.570	RIGHT	Dayton, 50	D1-H1A	72 X 12							6.0														
81	S-82	10.570	RIGHT	Chillicothe, 25	D1-H1A	72 X 12							6.0														
81	S-83	10.570	LEFT		W2-2L	30 X 30							6.3														
81	S-83	10.570	LEFT	County Road 35A	W16-H8P	48 X 8							2.7														
81	S-84	10.580	LEFT		M3-3	24 X 12							2.0														
81	S-84	10.580	LEFT	753	M1-4-3	30 X 24							5.0														
81	S-85	10.620	LEFT		M3-2	24 X 12							2.0														
81	S-85	10.620	LEFT	35	M1-4-2	24 X 24							4.0														
81	S-85	10.620	LEFT		M6-1L	21 X 15							2.2														
81	S-86	10.695	RIGHT		M3-4	24 X 12							2.0														
81	S-86	10.695	RIGHT	35	M1-4-2	24 X 24							4.0														
81	S-86	10.695	RIGHT		M5-1L	21 X 15							2.2														
81	S-87	11.250	RIGHT		R7-1	12 X 18							1.5														
81	S-88	11.290	LEFT		R7-1	12 X 18							1.5														
81	S-89	11.310	LEFT		W6-1	36 X 36							9.0														
81	S-90	11.380	RIGHT		R7-1	12 X 18							1.5														
81	S-91	11.390	RIGHT		R3-H8BB	30 X 30							6.3														
81	S-92	11.470	LEFT		R7-1	12 X 18							1.5														
81	S-93	11.445	RIGHT		R3-H8BB	30 X 30																					
81	S-94	11.560	RIGHT		R7-1	12 X 18							1.5														
81	S-95	11.550	LEFT		R7-1	12 X 18							1.5														
81	S-96	11.569	RIGHT		R3-H8BJ	36 X 30							7.5														
81	S-97	11.600	LEFT		R2-1	24 X 30	7.0	10.0					5.0														
81	S-98	11.620	RIGHT		R3-H8BJ	36 X 30																					
81	S-99	11.711	RIGHT		I-H2A	48 X 24							8.0														
81	S-99	11.711	RIGHT	50	R2-1	24 X 30							5.0														
81	S-100	11.711	RIGHT	55	R2-1	24 X 30																					
81	S-101	11.995	LEFT	12	D10-H8	12 X 12																					
TOTALS CARRIED TO SUB-SUMMARY, SHEET 7							7.0	15.0	1					182.6		2	42					3				1	

SIGN PLAN SUB-SUMMARY - SR753
FAYETTE COUNTY - SR 753
FAY-SYS SIGN REPLACE-FY20

CALCULATED
VHP
CHECKED
XXX

I:\ProjectData\07556_FAY_PIC_FLATSHEET\Design\Roadway\Sheets\07556_T000.dgn 107556_T0004_753 1/27/2020 3:53:34 PM vpatel

SHEET NO.	REFERENCE SHEET	LOCATION (SLM)	SIDE	NOTE	CODE	SIZE (INCHES)	630	630	630	630	630	630	630	630	630	630	630	630	630	630	630	630	HINGED			
							GROUND MOUNTED SUPPORT, No. 2 POST FT	GROUND MOUNTED SUPPORT, No. 3 POST FT	SIGN POST REFLECTOR, RED EACH		SIGN POST REFLECTOR, WHITE EACH	SIGN POST REFLECTOR, YELLOW EACH	SIGN BACKING ASSEMBLY EACH	SIGN SUPPORT ASSEMBLY, POLE MOUNTED EACH	SIGN, FLAT SHEET SQ FT	SIGN, FLAT SHEET, AS PER PLAN SQ FT	SIGN, DOUBLE FACED, MILE MARKER EACH	REMOVAL OF GROUND MOUNTED SIGN & DISPOSAL EACH	REMOVAL OF GROUND MOUNTED SIGN & RE-ERECTION, AS PER PLAN EACH	REMOVAL OF GROUND MOUNTED MAJOR SIGN & DISPOSAL EACH	REMOVAL OF GROUND MOUNTED POST SUPPORT AND DISPOSAL EACH	REMOVAL OF STRUCTURE MOUNTED SIGN AND DISPOSAL EACH			REMOVAL OF POLE MOUNTED SIGN & DISPOSAL EACH	SIGNING, MISC: REMOVAL OF POST REFLECTOR EACH
82	S-102	12.330	LEFT	Domtar Earth Choice Ambasssadors	D14-H4	30 X 48								10.0			1									
82	S-103	12.640	RIGHT		W3-1	36 X 36								9.0			1									
82	S-104	12.684	RIGHT		M2-1	21 X 15								2.2			1							1		
82	S-104	12.684	RIGHT	22	M1-4-2	24 X 24								4.0			1									
82	S-105	12.740	LEFT		M6-4	21 X 15	7.0	10.0						2.2												
82	S-105	12.740	LEFT	22	M1-5-2	24 X 24								4.0												
82	S-106	12.740	LEFT		M3-3	24 X 12								2.0			1									
82	S-106	12.740	LEFT	753	M1-5-3	30 X 24								5.0			1									
82	S-107	12.735	RIGHT	WASHINGTON CH, 2	D1-H1A	72 X 12								6.0			1									
82	S-107	12.735	RIGHT	CIRCLEVILLE, 25	D1-H1A	72 X 12								6.0			1									
82	S-108	12.759	LEFT		R1-3P	18 X 6								0.8												
82	S-108	12.759	LEFT		R1-3P	18 X 6											1									
82	S-109	12.782	RIGHT	22	M1-4-2	24 X 24								4.0			1									
82	S-109	12.782	RIGHT		M6-4	21 X 15								2.2			1									
82	S-110	12.782	RIGHT		R1-3P	18 X 6											1									
82	S-110	12.782	RIGHT		R1-3P	18 X 6								0.8												
82	S-111	12.815	LEFT		D1-H1A	72 X 12								6.0			1									
82	S-111	12.815	LEFT		D1-H1A	72 X 12								6.0			1									
82	S-112	12.829	RIGHT		M3-1	24 X 12								2.0			1									
82	S-112	12.829	RIGHT	753	M1-5-3	30 X 24								5.0			1									
82	S-113	11.835	RIGHT	55	R2-1	24 X 30								5.0			1									
82	S-114	12.885	LEFT		M2-1	21 X 15								2.2			1									
82	S-114	12.885	LEFT	22	M1-4-2	24 X 24								4.0			1									
82	S-115	12.894	LEFT		W3-1	36 X 36								9.0			1							1		
82	S-115	12.894	RIGHT		W3-1	36 X 36								9.0			1							1		
82	S-116	12.995	RIGHT	13	D10-H8	12 X 12										1	1									
82	S-117	13.430	LEFT	753	M1-5-3	30 X 24											1									
82	S-117	13.430	LEFT		M6-4	21 X 15											1									
82	S-118	13.435	RIGHT		R1-1	30 X 30				1			6.3				1							1		
82	S-119	13.995	RIGHT	14	D10-H8	12 X 12										1	1									
82	S-120	14.241	LEFT	753	M1-5-3	30 X 24											1							1		
82	S-120	14.241	LEFT		M6-4	21 X 15											1									
82	S-121	14.321	RIGHT		M2-1	21 X 15								2.2			1									
82	S-121	14.321	RIGHT	62	M1-4-2	24 X 24								4.0			1									
82	S-121	14.321	RIGHT	3	M1-5-2	24 X 24								4.0			1									
82	S-122	14.321	RIGHT		M4-6	24 X 12	7.0	10.0						2.0												
82	S-122	14.321	RIGHT	753	M1-5-3	30 X 24								5.0												
82	S-123	14.346	LEFT	55	R2-1	24 X 30								5.0												
82	S-124	14.376	RIGHT		R3-H8BD	30 X 30								6.3			1									
82	S-125	14.376	LEFT		M3-3	24 X 12								2.0			1									
82	S-125	14.376	LEFT	753	M1-5-3	30 X 24								5.0			1									
82	S-126	14.452	RIGHT	62	M1-4-2	24 X 24								4.0			1									
82	S-126	14.452	RIGHT	3	M1-5-2	24 X 24								4.0			1									
82	S-126	14.452	RIGHT		M6-4	21 X 15								2.2			1									
82	S-126	14.452	RIGHT		W1-7	48 X 24								8.0			1							2		
TOTALS CARRIED TO SUB-SUMMARY, SHEET 7							14.0	20.0	1		5			166.4	2	39		2				6				

**SIGN PLAN SUB-SUMMARY - SR753
FAYETTE COUNTY - SR 753**

**FAY-SYS SIGN
REPLACE-FY20**

CALCULATED
VHP
CHECKED
XXX

SHEET NO.	REFERENCE SHEET	LOCATION (SLM)	SIDE	NOTE	CODE	SIZE (INCHES)	630	630	630	630	630	630	630	630	630	630	630	630	630	630	630	630	630	CALCULATED VHP	CHECKED XXX	
							GROUND MOUNTED SUPPORT, No. 2 POST	GROUND MOUNTED SUPPORT, No. 3 POST	SIGN POST REFLECTOR, RED	SIGN POST REFLECTOR, WHITE	SIGN POST REFLECTOR, YELLOW	SIGN BACKING ASSEMBLY	SIGN SUPPORT ASSEMBLY, POLE MOUNTED	SIGN, FLAT SHEET	SIGN, FLAT SHEET, AS PER PLAN	SIGN, DOUBLE FACED, MILE MARKER	REMOVAL OF GROUND MOUNTED SIGN & DISPOSAL	REMOVAL OF GROUND MOUNTED SIGN & RE-ERECTION, AS PER PLAN	REMOVAL OF GROUND MOUNTED MAJOR SIGN & DISPOSAL	REMOVAL OF GROUND MOUNTED POST SUPPORT AND DISPOSAL	REMOVAL OF STRUCTURE MOUNTED SIGN AND DISPOSAL	REMOVAL OF POLE MOUNTED SIGN & DISPOSAL	SIGNING, MISC: REMOVAL OF POST REFLECTOR			HINGED
							FT	FT	EACH			EACH	EACH	SQ FT	SQ FT	EACH	EACH	EACH	EACH	EACH	EACH	EACH	EACH			EACH
83	S-127	10.760	RIGHT		R7-1	12 X 18							1.5				1									
83	S-128	10.780	RIGHT		R7-1	12 X 18							1.5				1									
83	S-129	10.780	LEFT		R7-1	12 X 18							1.5				1									
83	S-130	10.800	RIGHT		M3-4	24 X 12							2.0				1									
83	S-130	10.800	RIGHT	353	M1-4-2	24 X 24							4.0				1									
83	S-130	10.800	RIGHT		M6-1L	21 X 15							2.2				1									
83	S-130	10.800	RIGHT	DAYTON, 50	D1-HIA	72 X 12							6.0				1									
83	S-131	10.800	LEFT		M3-1	24 X 12							2.0				1									
83	S-131	10.800	LEFT	35	M1-4-2	24 X 24							4.0				1									
83	S-131	10.800	LEFT		M5-1L	21 X 15							2.2				1									
	S-132			NOT USED																						
83	S-133	10.835	RIGHT	753	M1-5-3	30 X 24							5.0													
83	S-133	10.835	RIGHT		M3-1	24 X 12							2.0				1									
83	S-134	10.835	RIGHT		R7-1	12 X 18							1.5				1									
83	S-135	10.835	LEFT		R7-1	12 X 18							1.5				1									
83	S-136	10.845	RIGHT	OLD US 35	D1-HIA	72 X 12							6.0				1									
83	S-137	10.845	LEFT	Chillicothe, 25	D1-HIA	72 X 12							6.0				1									
83	S-137	10.845	LEFT	DAYTON, 50	D1-HIA	72 X 12							6.0				1									
83	S-138	10.875	RIGHT		R7-1	12 X 18							1.5				1									
	S-139			NO USED																						
83	S-140	10.915	RIGHT		R7-1	12 X 18							1.5				1									
83	S-141	10.915	LEFT		R7-1	12 X 18							1.5				1									
83	S-142	10.920	RIGHT	35	M1-5-2	24 X 24							4.0				1									
83	S-142	10.920	RIGHT		M6-1R	21 X 15							2.2				1									
83	S-143	10.620	RIGHT	753	M1-5-3	30 X 24							5.0				1									
83	S-143	10.620	RIGHT		M6-4	21 X 15							2.2				1									
83	S-144	10.925	RIGHT	Circleville, 26	D1-HIA	72 X 12							6.0				1									
83	S-144	10.925	RIGHT	Washington CH, 2	D1-HIA	72 X 12							6.0				1									
83	S-145	10.950	RIGHT	753	M1-5-3	30 X 24							5.0				1									
83	S-145	10.950	RIGHT		M3-1	24 X 12							2.0				1									
83	S-146	10.955	RIGHT		W9-1L	36 X 36							9.0				1									
83	S-147	10.965	LEFT		M2-1	21 X 15							2.2				1									
83	S-147	10.965	LEFT	35	M1-4-2	24 X 24							4.0				1									
83	S-147	10.965	LEFT		M6-3	21 X 15							2.2				1									
83	S-148	11.000	RIGHT		R7-1	12 X 18							1.5				1									
83	S-149	11.045	LEFT		R4-7	24 X 30							5.0				1									
83	S-150	11.047	LEFT		R7-1	12 X 18							1.5				1									
83	S-151	11.047	RIGHT		R7-1	12 X 18							1.5				1									
TOTALS CARRIED TO SUB-SUMMARY, SHEET 7													118.7				35									

SIGN PLAN SUB-SUMMARY - SR753
FAYETTE COUNTY - SR 753

FAY-SYS SIGN
REPLACE-FY20