

ITEM 254 PAVEMENT PLANING, AS PER PLAN (VARIABLE DEPTH) 0" - 2":

THIS ITEM IS INTENDED TO BE USED FOR THE LID REPLACEMENT OF THE TWO TYPE 2A INLETS AT STATIONS 777+95L & 777+95R. IT IS INTENDED TO RESTORE THE OPENING FOR THE INLET. SEE DETAIL SHEET 21.

ITEM 611 - INLET MISC.: TYPE NO. 2A REPLACEMENT TOP:

THIS ITEM SHALL BE TO REPLACE THE TOP SLAB AND CONCRETE APRON FOR THE TYPE 2A-11 INLETS. THE SLAB REPLACEMENT SHALL INCLUDE A NEW CASTING AND LID. THE CONCRETE APRON AND SHOULDER AREA SHALL BE CONSTRUCTED AS SHOWN IN THE DETAIL ON SHEET 21. THE APRON DEPRESSED AREA SHALL BE MILLED TO A VARIABLE DEPTH SUCH THAT THE OPENING SHALL BE RESTORED TO 4" ONCE THE 1 1/2" OVERLAY IS PLACED. THIS ITEM SHALL BE AS PER STANDARD CONSTRUCTION DRAWING I-1.2 AND SHALL INCLUDE ALL LABOR, TOOLS, EQUIPMENT AND MATERIALS NECESSARY TO CONSTRUCT A COMPLETE TYPE 2A PAVEMENT INLET AS SHOWN IN THE STANDARD CONSTRUCTION DRAWING.

ITEM SPECIAL - PIPE CLEANOUT, 24" AND UNDER:

THIS WORK SHALL CONSIST OF REMOVING SEDIMENT AND DEBRIS FROM THE EXISTING DRAINAGE CONDUITS AS DIRECTED BY THE ENGINEER.

ALL MATERIAL REMOVED SHALL BE DISPOSED OF AS PER 105.16 AND 105.17. ALL SEWERS SHALL BE CLEANED OUT TO THE SATISFACTION OF THE ENGINEER.

CLEANOUT OF THE PIPE SHALL BE PAID FOR AT THE UNIT PRICE BID FOR ITEM SPECIAL - PIPE CLEANOUT, 24" AND UNDER. THIS PRICE SHALL INCLUDE THE COST FOR MATERIAL, EQUIPMENT, LABOR, AND ALL INCIDENTALS REQUIRED TO COMPLETE THE CLEANOUT.

A QUANTITY OF 200' OF ITEM SPECIAL - PIPE CLEANOUT, 24" & UNDER IS CARRIED TO THE GENERAL SUMMARY.

CALCULATED
MAK
CHECKED
JRA

DRAINAGE NOTES

FRA - 161 - 14.02

SHEET	REFERENCE NO.	STATION	LOCATION	SIDE	202		254		611			622		REMARKS
					REMOVAL MISC.: EXISTING METAL BARRIER, TYPE TC-41.21 EACH	PAVEMENT PLANING, AS PER PLAN (VARIABLE DEPTH) 0" - 2" SQ YD	CATCH BASIN ADJUSTED TO GRADE EACH	INLET ADJUSTED TO GRADE, AS PER PLAN EACH	INLET MISC.: TYPE 2A REPLACEMENT TOP	CONCRETE BARRIER, SINGLE SLOPE, TYPE B1 FT				
21	CB-1	777+95	SR 161	L		8				1				I-1.2A-11
21	CB-2	777+95	SR 161	R		8				1				I-1.2A-11
21	CB-3	783+50	SR 161	R					1					I-1.2A-14
22	CB-4	795+58	SR 161	L				1						CB-6
27	B-1	773+50	SR 161	C	1						10			
QUANTITIES CARRIED TO GENERAL SUMMARY					1	16	1	1	2		10			

DRAINAGE ESTIMATED QUANTITIES

I:\ProjectData\FRA-161-14.02\Design\Roadway\Sheets\07792_DP001.dgn_Sheet101 11/23/2020 9:22:58 AM mkatong



0 5 10 20
HORIZONTAL
SCALE IN FEET

CALCULATED
MAK
CHECKED
JRA

**DRAINAGE PLAN
TRENCH DRAIN**

FRA-161-14.02

23
76

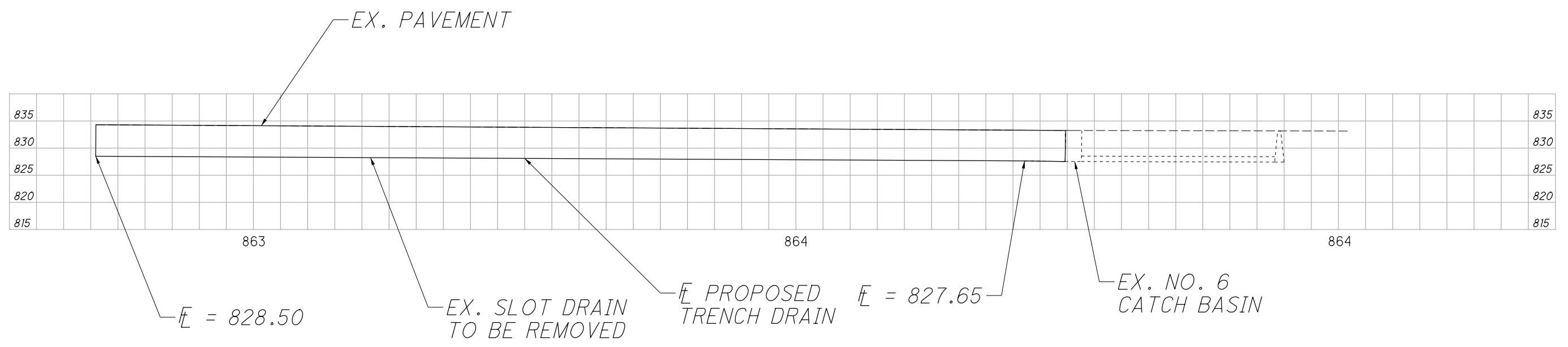
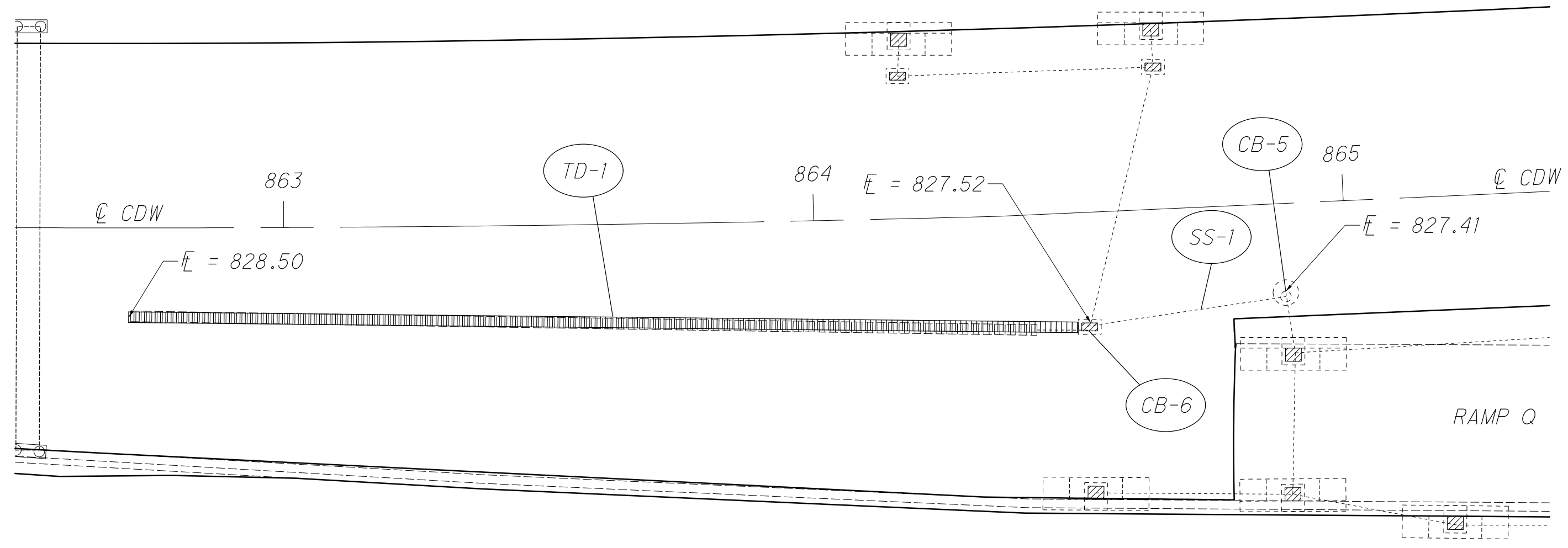

FOR QUANTITIES, SEE SHEET NO. 24

REF. NO.	BEGIN STATION	END STATION	202				611		839						REMARKS
			SPECIAL - PIPE CLEANOUT, 24" AND UNDER FT	REMOVAL MISC: SLOT DRAIN FT			CATCH BASIN MISC.: CLEANOUT EACH		TRENCH DRAIN WITH STANDARD GRATE, AS PER PLAN FT						
TD-1	862+66	864+52		171				180							
SS-1	864+52	864+88	36												
CB-5	864+52						1								
CB-6	864+88						1								
			36	171			2	180							

QUANTITIES CARRIED TO GENERAL SUMMARY

CALCULATED MAK
CHECKED JRA

**DRAINAGE PLAN
TRENCH DRAIN QUANTITIES**

FRA - 161 - 14.02

ITEM 203 EMBANKMENT, AS PER PLAN:

QUANTITIES FOR ITEM 203 - EMBANKMENT HAVE BEEN PROVIDED THROUGHOUT THIS PLAN TO BUILD UP FORE-SLOPES AND ENSURE PROPER GRADING FOR THE PROPOSED ANCHOR ASSEMBLIES. THIS ITEM OF WORK INCLUDES ANY CLEARING AND GRUBBING NECESSARY TO PLACE THE EMBANKMENT AT THE LOCATIONS SPECIFIED OR DIRECTED. THE CONTRACTOR SHALL BE PREPARED TO USE EMBANKMENT AT THE LOCATIONS SPECIFIED IN THE PLANS AND ANY OTHER AREAS "AS DIRECTED BY THE ENGINEER".

SEE DETAIL ON SHEET 34.

ITEM 251 - PARTIAL DEPTH PAVEMENT REPAIR (ASPHALT CONCRETE BASE), AS PER PLAN 3":

ITEM 251 - PARTIAL DEPTH PAVEMENT REPAIR (ASPHALT CONCRETE BASE), AS PER PLAN 4.5":

REPAIR AREAS SHALL BE DETERMINED BY THE PROJECT ENGINEER BEFORE THE BEGINNING OF WORK. REPAIR AREAS SHALL CONSIST OF REMOVING 3" OR 4.5" OF PAVEMENT AND PLACING 3" OR 4.5" OF ITEM 301 - ASPHALT CONCRETE BASE, PG64-22. WORK SHALL BE PERFORMED PRIOR TO RESURFACING AND REPAIR AREAS ARE TO BE INCLUDED INTO GENERAL RESURFACING. SEE CHART ON SHEET 39.

ITEM 254 - PAVEMENT PLANING, ASPHALT CONCRETE 1.5":

ITEM 254 - PAVEMENT PLANING, ASPHALT CONCRETE, AS PER PLAN 1.7" - 3.0":

THE CONTRACTOR SHALL BE TOTALLY RESPONSIBLE FOR ANY AND ALL DAMAGE THAT MAY RESULT TO CASTINGS FROM THE PLANING OPERATION. THE DEPTH OF PLANING CLOSE TO THE CASTINGS SHALL BE AS DIRECTED, TO ACHIEVE A SMOOTH RIDING FINISHED PAVEMENT. GREAT CARE SHALL BE TAKEN TO PREVENT THE REMOVAL THE EXISTING PAVEMENT CROSS-SLOPE (CROWN) DURING THE PLANING OPERATIONS.

BUTT JOINTS SHALL BE PROVIDED AT THE BEGINNING AND END OF PAVING LIMITS AND AT THE APPROACH SLABS OF ALL STRUCTURES NOT BEING PAVED.

AT NO TIME SHALL TRAFFIC BE EXPOSED TO PLANED PAVEMENT WITHIN THE TRAVELED WAY/LANE(S). AT NO TIME OUTSIDE OF THE WORK SHIFT SHALL THE SHOULDERS BE LEFT AT A HIGHER ELEVATION THAN THE DRIVING LANES. PLANED OUTSIDE SHOULDERS MAY BE EXPOSED TO TRAFFIC FOR FIVE (5) CALENDAR DAYS.

FAILURE TO COMPLY SHALL SUBJECT THE CONTRACTOR TO LIQUIDATED DAMAGES AS PER SECTION 108.07 OF CMS.

ITEM 442 - ASPHALT SURFACE COURSE, 12.5MM, TYPE A (446), AS PER PLAN (MAINLINE PAVING/CD ROAD PAVING):

GREAT CARE SHALL BE TASKEN TO MAINTAIN THE EXISTING PAVEMENT CROSS-SLOPE (CROWN), INTERSECTION CROSS-SLOPES (CROWN), AS WELL AS ALL LONGITUDINAL SLOPES DURING THE PAVING OPERATIONS.

LOCATE LONGITUDINAL JOINTS IN THE SURFACE COURSE SUBJECT TO THE FOLLOWING REQUIREMENTS:

PLACE THE MAINLINE PAVEMENT SURFACE COURSE WITH A SINGLE COLD LONGITUDINAL JOINT. WHERE THE NUMBER OF MAINLINE JOINS EXCEEDS 2 (BU TNOT 4) LANES, A SINGLE COLD JOINT IS STILL REQUIRED. A COLD LONGITUDINAL JOINT IS PERMITTED BETWEEN THE SHOULDER AND MAILINE PAVEMENT. NO OTHER COLD JOINTS ARE PERMITTED IN THE SURFACE COURSE OF MAINLINE PAVEMENT.

JOINT CORING IN ACCORDANCE WITH 446.04 IS NOT REQUIRED FOR COLD LONGITUDINAL JOINTS PLACED OVER VOID REDUCING ASPHALT MEMBRANE (VRAM). CONSTRUCT COLD LONGITUDINAL JOINTS OVER VRAM USING THE SAME TECHNIQUES, EQUIPMENT, AND ROLLER PATTERNS USED ON THE REST OF THE MAT. OBTAIN 10 MAT CORES FOR EACH LOT OF MATERIAL IN ACCORDANCE WITH 446.04. PAY FACTORS FOR EACH LOT OF MATERIAL WILL BE DETERMINED ACCORDING TO TABLE 446.04-2.

ITEM 442 - ANTI-SEGREGATION EQUIPMENT:

THE QUANTITY FOR THIS ITEM IS IN CUBIC YARDS AND IS EQUAL TO THE AMOUNT OF SURFACE COURSE (EXCLUDING SHOULDERS) ON MAINLINE SR-161, CD ROADS AND RAMPS

ITEM 442 - ASPHALT SURFACE COURSE, 12.5MM, TYPE A (446), AS PER PLAN, PG76-22M (RAMP PAVING):

GREAT CARE SHALL BE TASKEN TO MAINTAIN THE EXISTING PAVEMENT CROSS-SLOPE (CROWN), INTERSECTION CROSS-SLOPES (CROWN), AS WELL AS ALL LONGITUDINAL SLOPES DURING THE PAVING OPERATIONS.

DUE TO THE HIGH STRESS CHARACTERISTICS OF THE ASPHALT RAMPS IN THIS PLAN, APPENDIX B OF THE PAVEMENT DESIGN MANUAL APPLIES. ITEM 442 ON THE RAMPS SHALL REQUIRE A PG72-22M BINDER.

ITEM 606 - ITEM 606 - ANCHOR ASSEMBLY, (MGS) TYPE B:

THIS ITEM SHALL CONSIST OF FURNISHING AND INSTALLING ANY OF THE GUARDRAIL END TERMINALS FOR TYPE MGS GUARDRAIL AS LISTED ON ROADWAY ENGINEERING'S WEB PAGE UNDER ROADSIDE SAFETY DEVICES FOR APPROVED GUARDRAIL END TREATMENTS. INSTALLATION SHALL BE AT THE LOCATIONS SPECIFIED IN THE PLANS, IN ACCORDANCE WITH THE MANUFACTURER'S SPECIFICATIONS.

THE FACE OF THE TYPE B IMPACT HEAD SHALL BE COVERED WITH TYPE G REFLECTIVE SHEETING, PER CMS 730.19.

REFER TO THE MANUFACTURER'S INSTRUCTIONS REGARDING THE INSTALLATION OF, AND THE GRADING AROUND, THE FOUNDATION TUBES AND GROUND STRUT. THE TOP OF ANY FOUNDATION TUBE SHOULD BE LESS THAN 4 INCHES ABOVE THE GROUND. THE PLACEMENT OF THE FOUNDATION TUBES SHOULD BE AN APPROPRIATE DEPTH BELOW THE LEVEL LINE IN ORDER TO MAINTAIN THE FINISHED GUARDRAIL HEIGHT OF 31 INCHES FROM THE EDGE OF THE SHOULDER.

ON-SITE GRADING IS REQUIRED IF THE TOP OF THE FOUNDATION TUBES OR TOP OF THE GROUND STRUT DOES PROJECT MORE THAN 4 INCHES ABOVE THE GROUND LINE.

THE PAYMENT LIMIT (LENGTH) FOR THE PROPOSED ANCHOR ASSEMBLY, (MGS) TYPE B, SHALL BE 40'-7 1/2" (TO THE STANDARD MGS CONNECTION) AS DETAILED BELOW.

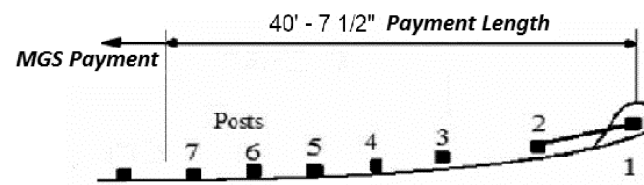

PAYMENT FOR THE ABOVE WORK SHALL BE MADE AT THE UNIT PRICE BID FOR ITEM 606, ANCHOR ASSEMBLY, (MGS) TYPE B, EACH, AND SHALL INCLUDE ALL LABOR, TOOLS, EQUIPMENT AND MATERIALS NECESSARY TO CONSTRUCT A COMPLETE AND FUNCTIONAL ANCHOR ASSEMBLY SYSTEM, INCLUDING REFLECTIVE SHEETING AND ALL RELATED HARDWARE, GRADING, EMBANKMENT AND EXCAVATION NOT SEPARATELY SPECIFIED, AS REQUIRED BY THE MANUFACTURER.

ITEM 606 - GUARDRAIL, MISC.: ALTERNATIVE GUARDRAIL PLACEMENT:

THIS ITEM SHALL BE USED WHEN THE CONTRACTOR IS REQUIRED TO USE AN ALTERNATE METHOD TO SET POSTS TO PREVENT DAMAGE TO AN UNDERGROUND OBSTACLE, SUCH AS A UTILITY. THE USE OF THIS ITEM WILL BE AS DEEMED NECESSARY BY THE ENGINEER. THIS ITEM SHALL INCLUDE ALL LABOR, EQUIPMENT, AND MATERIAL NEEDED TO SET AND BACKFILL POSTS WHILE MEETING THE REQUIREMENTS OF THE APPLICABLE GUARDRAIL ITEM BEING PERFORMED. APPLICABLE GUARDRAIL ITEMS INCLUDE BUT ARE NOT LIMITED TO SETTING POSTS (AND SLEEVES) FOR TYPE 5, TYPE MGS, BARRIER DESIGN, ANCHOR ASSEMBLIES, AND BRIDGE TERMINAL ASSEMBLIES. PAYMENT SHALL BE AT THE UNIT BID PRICE OF EACH AND SHALL BE PAID FOR IN ADDITION TO THE APPLICABLE GUARDRAIL PLACEMENT ITEM LISTED ABOVE.

THE FOLLOWING ESTIMATED QUANTITIES HAVE BEEN PROVIDED:
ITEM 606 - GUARDRAIL, MISC.: ALTERNATIVE GUARDRAIL PLACEMENT = 50 FT

GRADING AND EROSION CONTROL:

AREAS DISTURBED BY GUARDRAIL ACTIVITIES AND AREAS WHERE EMBANKMENT HAVE BEEN PLACED SHALL BE REPAIRED WITH THE QUANTITIES, AS SHOWN ON SHEET NO. 31.

ITEM 606 - CURVED RAIL ELEMENTS:

ALL RADII OF CURVED RAIL ARE ESTIMATED AND ACTUAL RADII OF PROPOSED RAIL SHALL BE DETERMINED IN THE FIELD BY THE CONTRACTOR PRIOR TO ORDERING. LENGTH OF CURVED RAIL ELEMENTS, WHERE CALLED FOR IN A RUN, SHALL BE INCLUDED IN THE TOTAL LENGTH OF RUN SHOWN IN THE GUARDRAIL COLUMN AND THE CURVED RAIL ELEMENT TOTAL ARE INCLUDED WITH THE GUARDRAIL TOTALS ON THE GENERAL SUMMARY SHEET.

ITEM 606 - ITEM 606 - ANCHOR ASSEMBLY, MGS TYPE E, AS PER PLAN (MASH 2016):

THIS ITEM SHALL CONSIST OF FURNISHING AND INSTALLING ANY OF THE GUARDRAIL END TERMINALS FOR TYPE MGS GUARDRAIL AS LISTED ON ROADWAY ENGINEERING'S WEB PAGE UNDER ROADSIDE SAFETY DEVICES FOR APPROVED GUARDRAIL END TREATMENTS. INSTALLATION SHALL BE AT THE LOCATIONS SPECIFIED IN THE PLANS, IN ACCORDANCE WITH THE MANUFACTURER'S SPECIFICATIONS.

WHEN THE FACE OF THE ADJACENT (ATTACHED) GUARDRAIL IS LESS THAN 4' OFFSET FROM THE PROPOSED EDGE LINE, THE PROPOSED TYPE E ANCHOR ASSEMBLY SHALL BE INSTALLED USING A 25:1 FLARE RATE (24" OFFSET DESIGN) AS DETAILED IN THE SHOP DRAWINGS AND AS DIRECTED BY THE ENGINEER.

THE FACE OF THE TYPE E IMPACT HEAD SHALL BE COVERED WITH A SHEET OF TYPE G REFLECTIVE SHEETING, PER CMS 730.19.

REFER TO THE MANUFACTURER'S INSTRUCTIONS REGARDING THE INSTALLATION OF, AND THE GRADING AROUND, THE FOUNDATION TUBES AND GROUND STRUT. THE TOP OF ANY FOUNDATION TUBE SHOULD BE LESS THAN 4 INCHES ABOVE THE GROUND. THE PLACEMENT OF THE FOUNDATION TUBES SHOULD BE AN APPROPRIATE DEPTH BELOW THE LEVEL LINE IN ORDER TO MAINTAIN THE FINISHED GUARDRAIL HEIGHT OF 31 INCHES FROM THE EDGE OF THE SHOULDER.

ON-SITE GRADING IS REQUIRED IF THE TOP OF THE FOUNDATION TUBES OR TOP OF THE GROUND STRUT DOES PROJECT MORE THAN 4 INCHES ABOVE THE GROUND LINE.

THE PAYMENT LIMIT (LENGTH) FOR THE PROPOSED ANCHOR ASSEMBLY, (MGS) TYPE E, AS PER PLAN SHALL BE 53'-1 1/2" (TO THE STANDARD MGS CONNECTION) AS DETAILED BELOW.

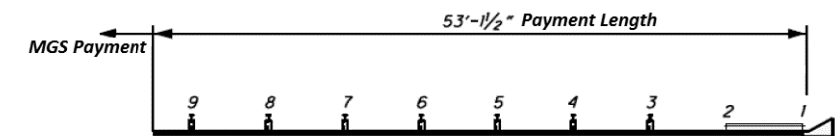

PAYMENT FOR THE ABOVE WORK SHALL BE MADE AT THE UNIT PRICE BID FOR ITEM 606, ANCHOR ASSEMBLY, MGS TYPE E, EACH, AND SHALL INCLUDE ALL LABOR, TOOLS, EQUIPMENT AND MATERIALS NECESSARY TO CONSTRUCT A COMPLETE AND FUNCTIONAL ANCHOR ASSEMBLY SYSTEM, INCLUDING ALL RELATED TRANSITIONS, REFLECTIVE SHEETING, HARDWARE, GRADING, EMBANKMENT AND EXCAVATION NOT SEPARATELY SPECIFIED, AS REQUIRED BY THE MANUFACTURE.

ITEM 608 WALKWAY, MISC.: CURB RAMP, CITY OF COLUMBUS (TYPE C):

ITEM 608 8" CONCRETE WALK, AS PER PLAN:

ITEM 608 DETECTABLE WARNING, AS PER PLAN, TYPE E:

THIS ITEM SHALL BE AS PER ITEM 608 AND SUPPLEMENTAL SPECIFICATION 1550, OF THE CITY OF COLUMBUS CONSTRUCTION AND MATERIAL SPECIFICATIONS, LATEST EDITION.

THE SPECS CAN BE DOWNLOADED FROM THE CITY OF COLUMBUS WEB SITE: <https://www.columbus.gov/publicservice/Design-and-Construction/document-library/Standard-Drawings/>

FIRE HYDRANTS:

THE CONTRACTOR SHALL BE RESPONSIBLE FOR OBTAINING ANY PERMITS AND FEES THAT ARE REQUIRED FOR THE USE OF ANY FIRE HYDRANTS. A SIAMESE VALVE IS TO BE USED ON THE HYDRANT OUTLET IF A HOSE IS TO BE LEFT CONNECTED AND UNATTENDED. THIS PERMIT CAN BE OBTAINED FROM THE CITY OF COLUMBUS.

CALCULATED
MAK
CHECKED
DKR

GENERAL NOTES

FRA - 161 - 14.02

LANE VALUE CONTRACT:

THE CONTRACTOR SHALL BE ASSESSED A DISINCENTIVE AS DESIGNATED IN THE LANE VALUE CONTRACT TABLE FOR EACH UNIT OF TIME A LANE/SHOULDER/RAMP IS CLOSED BY THE CONTRACTOR'S ACTION WHILE NOT OTHERWISE PERMITTED BY THE LANE VALUE CONTRACT TABLE BELOW.

LANE VALUE CONTRACT TABLE						
SECTION	EXISTING NUMBER OF LANES PER DIRECTION	LANE CLOSURES ARE NOT PERMITTED				DISINCENTIVE AMOUNTS PER MINUTE PER LANE
		LANE REDUCTION	MON TO FRI	SAT.	SUN	
HUNTLEY ROAD (10.85) TO STRAWBERRY FARMS BLVD (15.24)	2	2 TO 1	5AM-9AM & 3PM-6PM	NO RESTRICTIONS	NO RESTRICTIONS	\$50
STRAWBERRY FARMS BLVD (15.24) TO LITTLE TURTLE WAY (17.31) MAINLINE	2	2 to 1	5AM-9AM & 3PM-6PM	NO RESTRICTIONS	NO RESTRICTIONS	\$50
I-270 (15.70) TO LITTLE TURTLE WAY (17.31) CD	3	3 to 2	5AM-9AM & 3PM-6PM	NO RESTRICTIONS	NO RESTRICTIONS	\$75
		3 to 1	5AM-8PM	6AM-7PM	8AM-7PM	
LITTLE TURTLE WAY (17.31) TO JUST WEST OF HAMILTON ROAD (18.25)	3	3 to 2	5AM-9AM & 3PM-6PM	NO RESTRICTIONS	NO RESTRICTIONS	\$75
		3 TO 1	5AM-8PM	6AM-7PM	8AM-7PM	
JUST WEST OF HAMILTON ROAD (18.25) TO JUST WEST OF HARLEM ROAD (19.49) EASTBOUND	3	3 to 2	5AM-9AM & 3PM-6PM	NO RESTRICTIONS	NO RESTRICTIONS	\$75
		3 TO 1	5AM-8PM	6AM-7PM	8AM-7PM	
JUST WEST OF HAMILTON ROAD (18.25) TO JUST WEST OF HARLEM ROAD (19.49) WESTBOUND	2	2 TO 1	5AM-7PM	8AM-7PM	8AM-7PM	\$75
JUST WEST OF HARLEM ROAD (19.49) TO LICKING COUNTY LINE (23.71)	2	2 TO 1	5AM-7PM	8AM-7PM	8AM-7PM	\$75

SHORT TERM CLOSURES ARE NOT PERMITTED 6AM-9AM AND 3PM-6PM MONDAY-FRIDAY

**Ramp Closure Restrictions
State Route 161 in Franklin County**

Secondary Route: Westerville Rd (SR-3) SLM along 161:					
Ramp	Movement	No Closures Allowed		Detour Routes	
		Mon to Fri	Sat to Sun	Primary Route	Secondary Route
A	SR-3 to SR-161WB	No Restriction	No Restriction	SR-3 to Old Dublin Granville Rd to SR-161	
B	SR-161WB to SR-3	6AM-9AM & 3PM-7PM	No Restriction	SR-161 to Old Dublin Granville Rd to SR-3	
C	SR-3 to SR-161EB	6AM-9AM & 3PM-7PM	No Restriction	SR-3 to I-270 E to SR-161	SR-3 to Moorse Rd to I-270N to SR-161*
D	SR-161EB to SR-3	No Restriction	No Restriction	SR-161E to Old Dublin Granville Rd to SR-3	

**Ramp Closure Restrictions
Interstate Route 270 in Franklin County**

Secondary Route: State Route 161 SLM along 270: 30.53 (East Side)					
Ramp	Movement	No Closures Allowed		Detour Routes	
		Mon to Fri	Sat to Sun	Primary Route	Secondary Route
A	OH-161 WB to I-270 NB	5AM-10PM	7AM-9PM	OH-161 W to 270 S (Ramp H) to oh-317 to 270 N	None
B	I-270 NB to OH-161 WB	5AM-7PM	8AM-7PM	270 N to OH-161 E (Ramp C) to Sunbury Rd. to OH-161 W	270 N to OH-3 to 270 S to OH-161 W (Ramp G)
C	I-270 NB to OH-161 EB	5AM-12AM	7AM-9PM	270 N to OH-3 to 270 S to OH-161 E (Ramp F)	None
D	OH-161 EB to I-270 NB	5AM-9AM & 3PM-7PM	No Restriction	OH-161 E to Sunbury Rd. to 270 N (Ramp A)	OH-161 E to 270 S (Ramp E) to OH-317 to 270 N
E	OH-161 EB to I-270 SB	5AM-8PM	8AM-7PM	OH-161 E to Sunbury Rd. to 270 S (Ramp H)	OH-161 E to 270 N (Ramp D) to OH-3 to 270 S
F	I-270 SB to OH-161 EB	5AM-12AM	7AM-9PM	270 S to OH-317 to 270 N to OH-161 E (Ramp C)	None
G	I-270 SB to OH-161 WB	5AM-9AM & 3PM-7PM	No Restriction	270 S to OH-317 to 270 N to OH-161 W (Ramp B)	None
H	OH-161 WB to I-270 SB	5AM-9PM	7AM-9PM	OH-161 E to 270 N (Ramp A) to OH-3 to 270 S	None

Secondary Route: Sunbury Rd SLM along 161:					
Ramp	Movement	No Closures Allowed		Detour Routes	
		Mon to Fri	Sat to Sun	Primary Route	Secondary Route
J	SR-161 WB TO SUNBURY RD	5AM to 9PM	8AM to 8PM	SR-161 WB to Ramp B to Westerville Rd. SB to Ramp C to SR-161 EB to Ramp L to Sunbury Rd.	
K	SUNBURY RD TO SR-161 EB	5AM to 9PM	8AM to 7PM	Ramp M to SR-161 WB to Ramp B to Westerville Rd. SB to Ramp C to SR-161 EB	
L	SR161 EB TO SUNBURY RD	6AM to 7PM	8AM to 7PM	Ramp S (Little Turtle Way exit) to Ramp U then Ramp R to SR-161 to Sunbury Rd.	
M	SUNBURY RD TO SR-161 WB	6AM to 7PM	8AM to 7PM	Ramp K to SR-161 EB to Ramp S (Little Turtle Way exit) to Ramp U then Ramp R to SR-161 WB	
N	SUNBURY RD TO I-270 ACCESS RD	5AM to 9PM	8AM to 8PM	Ramp K to SR-161 EB to Ramp S (Little Turtle Way exit) to Ramp U to I-270 Access Rd	
P	I-270 ACCESS RD TO SUNBURY RD	5AM to 9PM	8AM to 8PM	I-270 Access Rd to Ramp T then to Ramp S (Little Turtle Way exit) to Ramp U then Ramp R to SR-161 WB to Sunbury Rd.	
Q	SUNBURY RD TO I-270 ACCESS RD	5AM to 9PM	8AM to 8PM	Ramp K to SR-161 EB to Ramp S (Little Turtle Way exit) to Ramp U then Ramp R to SR-161 WB	

I:\ProjectData\07792_FRA-161-14.02_Design\Roadway\Sheets\07792_MN001.dgn Sheet04 11/19/2020 6:20:59 AM mkatona

CALCULATED
MAK
CHECKED
DKR

MAINTENANCE OF TRAFFIC GENERAL NOTES

FRA - 161 - 14.02

I:\ProjectData\07792_FRA-161-14.02\Design\Roadway\Sheets\07792_GG00.dgn_Sheet10 11/19/2020 8:42:19 AM mkatona

SHEET NUM.										PART.				ITEM	ITEM EXT	GRAND TOTAL	UNIT	DESCRIPTION	SEE SHEET NO.
8-9	11-13	17-18	19	20	24	37-40	41	59	63	01/NHS/PV	02/S>2/PV	03/BRO/BR	04/S>2/PV						
ROADWAY																			
						926.25				926.25				202	38001	926.25	FT	GUARDRAIL REMOVED, AS PER PLAN	7
						2				2				202	42011	2	EACH	ANCHOR ASSEMBLY REMOVED, TYPE E, AS PER PLAN	7
						1				1				202	42051	1	EACH	ANCHOR ASSEMBLY REMOVED, TYPE B, AS PER PLAN	7
						7				7				202	47001	7	EACH	BRIDGE TERMINAL ASSEMBLY REMOVED, AS PER PLAN	7
			200		36					236				SPECIAL	20270110	236	FT	PIPE CLEANOUT, 24" AND UNDER	7
				1						1				202	98100	1	EACH	REMOVAL MISC.: EXISTING METAL BARRIER, TYPE TC-41.21	7
					171					171				202	98200	171	FT	REMOVAL MISC.: SLOT DRAIN	7
						281.5			8.5	290				203	20001	290	CY	EMBANKMENT, AS PER PLAN	7
						10.5				10.5				209	15000	10.5	STA	RESHAPING UNDER GUARDRAIL	
		8.75								7.27	1.48			209	60500	8.75	MILE	LINEAR GRADING	
						675				675				606	15050	675	FT	GUARDRAIL, TYPE MGS	
						295				295				606	15100	295	FT	GUARDRAIL, TYPE MGS WITH LONG POSTS	
						1				1				606	26050	1	EACH	ANCHOR ASSEMBLY, MGS TYPE B	
						1				1				606	26151	1	EACH	ANCHOR ASSEMBLY, MGS TYPE E, AS PER PLAN (MASH 2016)	8
						1				1				606	26550	1	EACH	ANCHOR ASSEMBLY, MGS TYPE T	
						4				4				606	35000	4	EACH	BRIDGE TERMINAL ASSEMBLY, TYPE 1	
						3				3				606	35100	3	EACH	BRIDGE TERMINAL ASSEMBLY, TYPE 2	
50										50				606	98000	50	FT	GUARDRAIL, MISC.: ALTERNATIVE GUARDRAIL PLACEMENT	8
										110				608	15001	110	SF	8" CONCRETE WALK, AS PER PLAN	8
										2				608	98200	2	EACH	WALKWAY, MISC.: CURB RAMP, CITY OF COLUMBUS (TYPE C)	8
										4				608	53021	4	SF	DETECTABLE WARNING, AS PER PLAN TYPE E	8
				10						10				622	10100	10	FT	CONCRETE BARRIER, SINGLE SLOPE, TYPE B1	
		130									130			SPECIAL	90010000	130	FT	KWIK KURB, REMOVE AND REPLACE	7
EROSION CONTROL																			
	3									3				616	10000	3	MGAL	WATER	
						89				89				659	00300	89	CY	TOPSOIL	
						845				845				659	10000	845	SY	SEEDING AND MULCHING	
						42				42				659	14000	42	SY	REPAIR SEEDING AND MULCHING	
						42				42				659	15000	42	SY	INTER-SEEDING	
						0.11				0.11				659	20000	0.11	TON	COMMERCIAL FERTILIZER	
						0.17				0.17				659	31000	0.17	ACRE	LIME	
						5				5				659	35000	5	MGAL	WATER	
										2,500	500			832	30000	3,000	EACH	EROSION CONTROL	
DRAINAGE																			
				1						1				611	98630	1	EACH	CATCH BASIN ADJUSTED TO GRADE	
					2					2				611	98690	2	EACH	CATCH BASIN, MISC.:CLEANOUT	8
				1						1				611	99150	1	EACH	INLET ADJUSTED TO GRADE	
				2						2				611	99500	2	EACH	INLET, MISC.: TYPE 2A REPLACEMENT TOP	19
					180					180				839	30000	180	FT	TRENCH DRAIN WITH STANDARD GRATE	
PAVEMENT																			
						6,537				5,301		1,236		251	01041	6,537	SY	PARTIAL DEPTH PAVEMENT REPAIR (ASPHALT CONCRETE BASE), AS PER PLAN, 3"	8
						39						39		251	01041	39	SY	PARTIAL DEPTH PAVEMENT REPAIR (ASPHALT CONCRETE BASE), AS PER PLAN, 4.5"	8
		216,983								187,980	29,003			254	01000	216,983	SY	PAVEMENT PLANING, ASPHALT CONCRETE 1.5"	
		1,466								1,466				254	01001	1,466	SY	PAVEMENT PLANING, ASPHALT CONCRETE, AS PER PLAN ,VARIABLE DEPTH 1.7" - 3.0"	8
				8						8				254	01001	8	SY	PAVEMENT PLANING, ASPHALT CONCRETE, AS PER PLAN, VARIABLE DEPTH (0.0" - 2.0")	19
		18,567								16,119	2,448			407	20000	18,567	GAL	NON-TRACKING TACK COAT	
		8,443								8,443				442	00100	8,443	CY	ANTI-SEGREGATION EQUIPMENT	
		592								592				442	10000	592	CY	ASPHALT CONCRETE SURFACE COURSE, 12.5 MM, TYPE A (446) 1.5"	
		7,703								7,703				442	10001	7,703	CY	ASPHALT CONCRETE SURFACE COURSE, 12.5 MM, TYPE A (446), AS PER PLAN, PG64-22	8
		744								744				442	10001	744	CY	ASPHALT CONCRETE SURFACE COURSE, 12.5 MM, TYPE A (446), AS PER PLAN, PG76-22M	8
		139								118	21			617	10101	139	CY	COMPACTED AGGREGATE, AS PER PLAN	8
3										2.5	0.5			617	25000	3	MGAL	WATER	
		33,307								33,307				872	10000	33,307	FT	VOID REDUCING ASPHALT MEMBRANE (VRAM)	

GENERAL SUMMARY

FRA - 161 - 14.02

CALCULATED
MAK
CHECKED
DKR

