

STATE OF OHIO DEPARTMENT OF TRANSPORTATION

GAL-7-19.94

GREEN TOWNSHIP
GALLIA COUNTY



LOCATION MAP

LATITUDE: 82°13'22" LONGITUDE: 38°46'56"



PORTION TO BE IMPROVED	-----	=====
INTERSTATE HIGHWAY	-----	=====
FEDERAL ROUTES	-----	=====
STATE ROUTES	-----	=====
COUNTY & TOWNSHIP ROADS	-----	=====
OTHER ROADS	-----	=====

DESIGN DESIGNATION

CURRENT ADT (2025)	-----	6,600
DESIGN YEAR ADT (2045)	-----	6,800
DESIGN HOURLY VOLUME (2045)	-----	750
DIRECTIONAL DISTRIBUTION	-----	63.4%
TRUCKS (24 HOUR B&C)	-----	7%
DESIGN SPEED	-----	55
LEGAL SPEED	-----	55
DESIGN FUNCTIONAL CLASSIFICATION:		
RURAL ARTERIAL	-----	
NHS PROJECT	-----	YES

DESIGN EXCEPTIONS

NONE

ADA DESIGN WAIVERS

NONE

UNDERGROUND UTILITIES
Contact Two Working Days
Before You Dig

OHIO811.org
Before You Dig

OHIO811, 8-1-1, or 1-800-362-2764
(Non members must be called directly)

PLAN PREPARED BY:
OHIO DEPARTMENT OF
TRANSPORTATION PLANNING
AND ENGINEERING - DISTRICT 10

INDEX OF SHEETS:

TITLE SHEET	1
TYPICAL SECTION	2
GENERAL NOTES	3-4
MAINTENANCE OF TRAFFIC	5-7
GENERAL SUMMARY	8-9
CALCULATIONS	10
PLAN AND PROFILE (S.R. 7)	11-12
PLAN AND PROFILE (FIELD DRIVE)	13
CROSS SECTIONS	14-24
CULVERT DETAILS	25
DRILLED SHAFT PROFILE	26
DRILLED SHAFT DETAILS	27-31
GEOTECHNICAL PROFILE - LANDSLIDE	32-48

STANDARD CONSTRUCTION DRAWINGS				SUPPLEMENTAL SPECIFICATIONS	SPECIAL PROVISIONS
BP-3.1	1/19/24	MT-96.20	7/21/23	800-2023 7/19/24	
		MT-96.26	1/18/19	832 7/21/23	
DM-1.1	7/17/20	MT-97.10	4/19/19	902 7/19/19	
DM-1.2	7/16/21	MT-101.70	4/21/23		
DM-4.3	1/15/16	MT-101.75	7/21/23		
DM-4.4	1/15/16	MT-101.90	7/17/20		
MGS-1.1	7/16/21	TC-65.10	1/17/14		
MGS-2.1	1/19/18	TC-65.11	1/19/24		
MGS-2.3	1/20/23				
MGS-4.2	7/19/13				
MGS-4.3	1/18/13				
RM-4.2	4/17/20				
MT-96.11	7/21/23				

FEDERAL PROJECT NUMBER
E240998

RAILROAD INVOLVEMENT
NONE

PROJECT DESCRIPTION
A LANDSLIDE REPAIR CONSISTING OF A 446FT
DRILLED SHAFT RETAINING WALL AND CULVERT
REPLACEMENT.

EARTH DISTURBED AREAS

PROJECT EARTH DISTURBED AREA:	0.32 ACRES
ESTIMATED CONTRACTOR EARTH DISTURBED AREA:	0.10 ACRES
NOTICE OF INTENT EARTH DISTURBED AREA:	0.42 ACRES

2023 SPECIFICATIONS

THE STANDARD SPECIFICATIONS OF THE STATE OF OHIO, DEPARTMENT OF TRANSPORTATION, INCLUDING SUPPLEMENTAL SPECIFICATIONS LISTED IN THE PLANS, CHANGES LISTED IN THE PROPOSAL, AND THE SUPPLEMENTAL SPECIFICATION 800 VERSION INDICATED ON THE PROPOSAL SHALL GOVERN THIS IMPROVEMENT.

I HEREBY APPROVE THESE PLANS AND DECLARE THAT THE MAKING OF THIS IMPROVEMENT WILL NOT REQUIRE THE CLOSING TO TRAFFIC OF THE HIGHWAY AND THAT PROVISIONS FOR THE MAINTENANCE AND SAFETY OF TRAFFIC WILL BE AS SET FORTH ON THE PLANS AND ESTIMATES.

Rich Oster
District 10 Deputy Director

Pamela Boratyn
Director, Department of Transportation

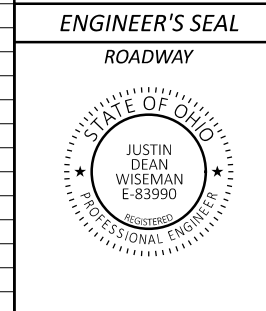

TITLE SHEET

DESIGN AGENCY	
DESIGNER	JDW
REVIEWER	XXX MM-DD-YY
PROJECT ID	115533
SHEET TOTAL	P.01 P.48

GAL-7-19.94

MODEL: Sheet PAPER: 17x11 (in.) DATE: 10/23/2024 TIME: 7:54:31 AM USER: jwiseman pwc:\ohio\dot-pw\dot-bentley.com\shhdot-pw-02\Documents\01 Active Projects\District 10\Gallia\115533\400-Engineering\Roadway\Sheets\115533_GT001.dgn

CL PAVEMENT OFFSET FROM CL ROW SR 7

STATION	OFFSET
1066+00.00	0.67' LT
1066+25.00	0.47' LT
1066+50.00	0.29' RT
1066+75.00	0.23' RT
1067+00.00	0.67' RT
1067+25.00	1.03' RT
1067+50.00	1.50' RT
1067+75.00	1.58' RT
1068+00.00	1.70' RT
1068+25.00	1.71' RT
1068+50.00	1.29' RT
1068+75.00	1.55' RT
1069+00.00	1.40' RT
1069+25.00	1.27' RT
1069+50.00	0.78' RT
1069+75.00	1.33' RT
1070+00.00	0.80' RT
1070+25.00	0.90' RT
1070+50.00	0.11' RT
1070+75.00	0.06' LT
1071+00.00	0.20' LT
1071+25.00	0.33' LT
1071+50.00	0.72' LT
1071+75.00	0.56' LT
1072+00.00	0.53' LT

NOTES:

- # - STRIPE LANES AT 12.5' WIDTH (MATCH EXISTING)
- * - MAXIMUM LIFT THICKNESS 1.5"
- ** - MAXIMUM LIFT THICKNESS 6"; MINIMUM LIFT THICKNESS 3"

EXISTING LEGEND

- (A) 9" EXISTING PORTLAND CONCRETE
- (B) 15" EXISTING ASPHALT CONCRETE
- (C) EXISTING DRIVEWAY ASPHALT CONCRETE

PROPOSED LEGEND

- 1 ITEM 441 - 1.5" ASPHALT CONCRETE SURFACE, TYPE 1, (448), PG64-22*
- 2 ITEM 441 - 1.5" ASPHALT CONCRETE INTERMEDIATE COURSE, TYPE 1, (448)*
- 3 ITEM 441 - ASPHALT CONCRETE INTERMEDIATE COURSE, TYPE 1 (449), (VARIABLE THICKNESS)*
- 4 ITEM 441 - 3" ASPHALT CONCRETE SURFACE COURSE, TYPE 1, (449), (DRIVEWAYS)*
- 5 ITEM 301 - 9" ASPHALT CONCRETE BASE, PG64-22**
- 6 ITEM 304 - 6" AGGREGATE BASE
- 7 ITEM 304 - AGGREGATE BASE (VARIABLE THICKNESS)
- 8 ITEM 407 - NON-TRACKING TACK COAT
- 9 ITEM 254 - PAVEMENT PLANING, ASPHALT CONCRETE, AS PER PLAN
- 10 ITEM 202 - PAVEMENT REMOVED (PAYMENT UNDER ITEM 203 - EXCAVATION)
- 11 ITEM 617 - 3" COMPACTED AGGREGATE & ITEM 408 - PRIME COAT (0.4 GAL/SY)
- 12 ITEM 659 - SEEDING AND MULCHING
- 13 ITEM 204 - SUBGRADE COMPACTION
- 14 ITEM 605 - 4" BASE PIPE UNDERDRAIN
- 15 ITEM 606 - GUARDRAIL, TYPE MGS
- 16 ITEM 606 - GUARDRAIL, TYPE MGS WITH LONG POSTS
- 17 ITEM 518 - POROUS BACKFILL WITH GEOTEXTILE FABRIC

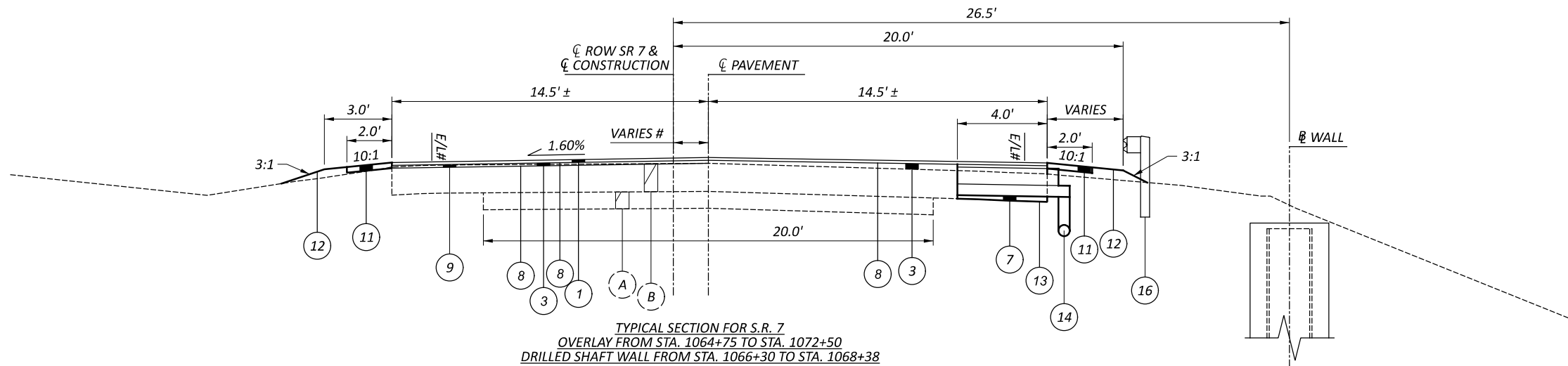

TYPICAL SECTION FOR S.R. 7
OVERLAY FROM STA. 1064+75 TO STA. 1072+50
DRILLED SHAFT WALL FROM STA. 1066+30 TO STA. 1068+38

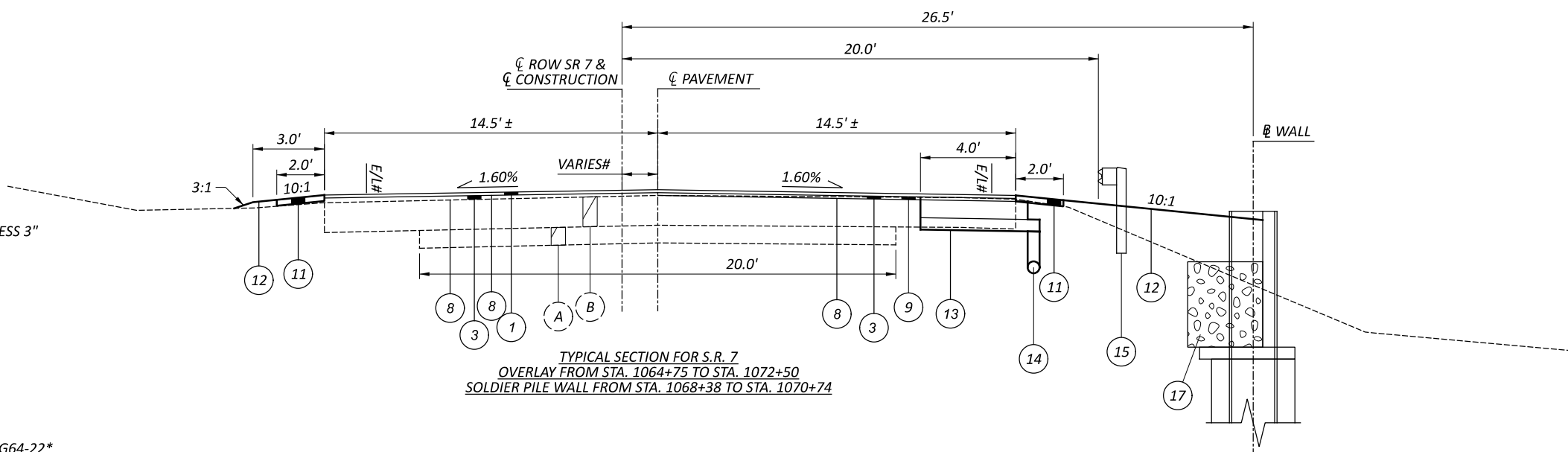

TYPICAL SECTION FOR S.R. 7
OVERLAY FROM STA. 1064+75 TO STA. 1072+50
SOLDIER PILE WALL FROM STA. 1068+38 TO STA. 1070+74

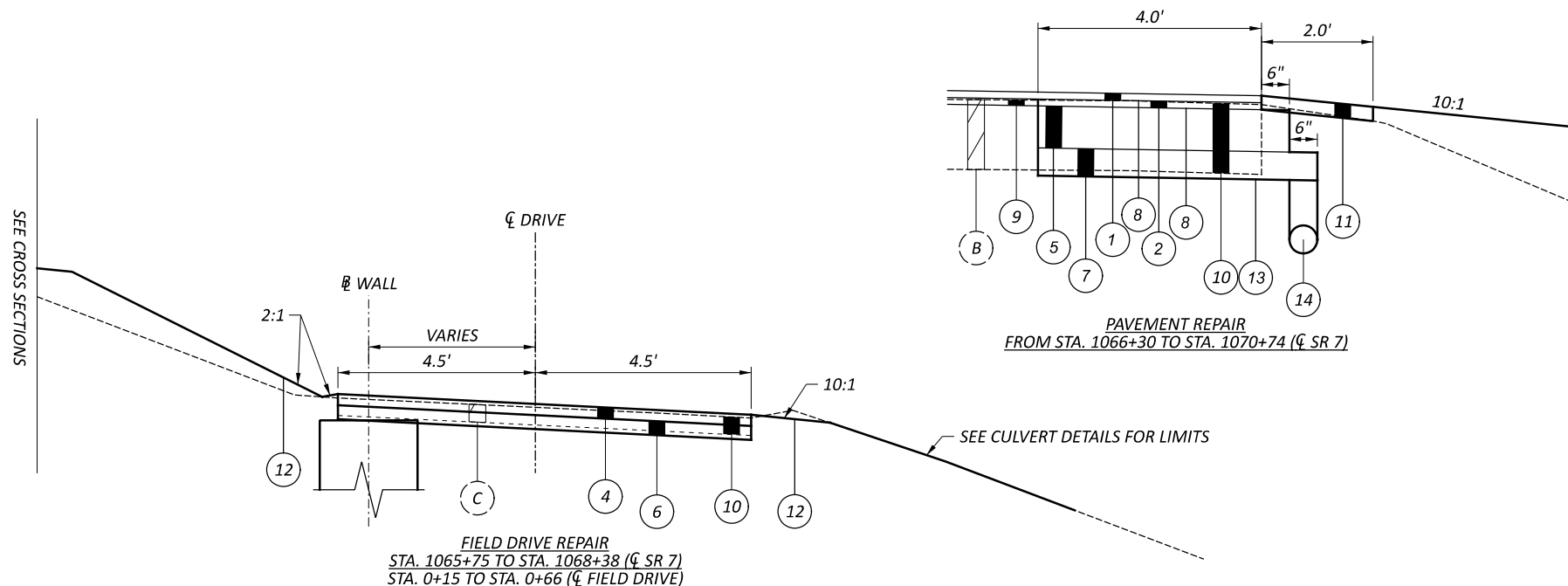

FIELD DRIVE REPAIR
STA. 1065+75 TO STA. 1068+38 (CL SR 7)
STA. 0+15 TO STA. 0+66 (CL FIELD DRIVE)

TYPICAL SECTION

DESIGN AGENCY



DESIGNER

JDW

REVIEWER

XXX MM-DD-YY

PROJECT ID

115533

SHEET TOTAL

P.02 P.48

UTILITIES

UTILITIES WERE NOT MARKED AT THE TIME OF THE SURVEY. LISTED BELOW ARE ALL UTILITIES LOCATED WITHIN THE PROJECT CONSTRUCTION LIMITS TOGETHER WITH THEIR RESPECTIVE OWNERS:

AMERICAN ELECTRIC POWER
38831 SR 7
REEDSVILLE, OH 45769
CLARKE SAUNDERS 614-312-5807

A&T
160 NORTH SIXTH STREET
ZANESVILLE, OH 43701
BARRETT TAMASOVICH 740-454-3552

COLUMBIA GAS OF OHIO
843 PIATT AVENUE
CHILLICOTHE, OH 45601
TIFFANY WOODYARD 740-772-9131

SUDDENLINK
1737 EAST SEVENTH STREET
PARKERSBURG, WV 26101
BILL BROWN 304-865-4067

CITY OF GALLIPOLIS
518 2ND AVENUE
GALLIPOLIS, OH 45631
740-441-6006

CLEARING AND GRUBBING

THE DEPARTMENT HAS NOT MARKED INDIVIDUAL TREES AND STUMPS FOR REMOVAL. UNLESS SPECIFICALLY DESIGNATED AS "DO NOT DISTURB" IN THE PLANS, REMOVE ALL TREES AND STUMPS WITHIN THE CONSTRUCTION LIMITS UNDER THE LUMP SUM BID FOR ITEM 201 CLEARING AND GRUBBING.

ITEM 659 - SEEDING AND MULCHING

SEEDING AND MULCHING SHALL BE APPLIED TO ALL AREAS OF EXPOSED SOIL BETWEEN THE RIGHT-OF-WAY LINES, AND WITHIN THE CONSTRUCTION LIMITS FOR AREAS OUTSIDE THE RIGHT-OF-WAY LINES COVERED BY WORK AGREEMENT OR SLOPE EASEMENT. QUANTITY CALCULATIONS FOR SEEDING AND MULCHING ARE BASED ON THESE LIMITS.

CONTINGENCY QUANTITIES

THE CONTRACTOR SHALL NOT ORDER MATERIALS OR PERFORM WORK FOR ITEMS DESIGNATED BY PLAN NOTE TO BE USED "AS DIRECTED BY THE ENGINEER" UNLESS AUTHORIZED BY THE ENGINEER. THE ACTUAL WORK LOCATIONS AND QUANTITIES USED FOR SUCH ITEMS SHALL BE INCORPORATED INTO THE FINAL CHANGE ORDER GOVERNING COMPLETION OF THIS PROJECT.

WORK LIMITS

THE WORK LIMITS SHOWN ON THESE PLANS ARE FOR PHYSICAL CONSTRUCTION ONLY. PROVIDE THE INSTALLATION AND OPERATION OF ALL WORK ZONE TRAFFIC CONTROL DEVICES REQUIRED BY THESE PLANS WHETHER INSIDE OR OUTSIDE THESE WORK LIMITS.

NOTIFICATION OF TRAFFIC RESTRICTIONS

THROUGHOUT THE DURATION OF THE PROJECT, THE CONTRACTOR SHALL NOTIFY THE PROJECT ENGINEER IN WRITING OF ALL TRAFFIC RESTRICTIONS AND UPCOMING MAINTENANCE OF TRAFFIC CHANGES. THE CONTRACTOR SHALL ENSURE THE WRITING OF ALL TRAFFIC RESTRICTIONS AND UPCOMING MAINTENANCE OF TRAFFIC CHANGES. THE CONTRACTOR SHALL ENSURE THE WRITTEN NOTIFICATION IS SUBMITTED IN A TIMELY MANNER TO ALLOW THE PROJECT ENGINEER TO MEET THE REQUIRED TIME FRAMES SET FORTH IN THE TABLE BELOW TO INFORM THE SPECIAL HAULING PERMITS SECTION (HAULING.PERMITS@DOT.OHIO.GOV) AND THE DISTRICT PUBLIC INFORMATION OFFICE (PIO). THIS NOTIFICATION SHALL BE RECEIVED BY THE PROJECT ENGINEER PRIOR TO THE PHYSICAL SETUP OF ANY APPLICABLE SIGNS OR MESSAGE BOARDS.

INFORMATION SHOULD INCLUDE, BUT IS NOT LIMITED TO, ALL CONSTRUCTION ACTIVITIES THAT IMPACT OR INTERFERE WITH TRAFFIC AND SHALL LIST THE SPECIFIC LOCATION, TYPE OF WORK, ROAD STATUS, DATE AND TIME OF RESTRICTION, DURATION OF RESTRICTION, NUMBER OF LANES MAINTAINED, NUMBER OF LANES CLOSED, MINIMUM VERTICAL CLEARANCE, MINIMUM WIDTH OF DRIVABLE PAVEMENT, DETOUR ROUTES, IF APPLICABLE, AND ANY OTHER INFORMATION REQUESTED BY THE PROJECT ENGINEER.

NOTIFICATION TIME TABLE		
ITEM	DURATION OF CLOSURE	NOTICE DUE TO PERMITS AND PIO
RAMP & ROAD CLOSURES	>= 2 WEEKS	21 CALENDAR DAYS PRIOR TO CLOSURE
	> 12 HOURS & < 2 WEEKS	14 CALENDAR DAYS PRIOR TO CLOSURE
	< 12 HOURS	4 CALENDAR DAYS PRIOR TO CLOSURE
LANE CLOSURES & RESTRICTIONS	>= 2 WEEKS	14 CALENDAR DAYS PRIOR TO CLOSURE
	< 2 WEEKS	5 BUSINESS DAYS PRIOR TO CLOSURE
START OF CONSTRUCTION & TRAFFIC PATTERN CHANGES	N/A	14 CALENDAR DAYS PRIOR TO IMPLEMENTATION

ANY UNFORESEEN CONDITIONS NOT SPECIFIED IN THE PLANS REQUIRING TRAFFIC RESTRICTIONS SHALL ALSO BE REPORTED TO THE PROJECT ENGINEER USING THE NOTIFICATION TIME TABLE.

THE PROJECT ENGINEER WILL FORWARD THIS INFORMATION TO THE FOLLOWING:

DISTRICT PUBLIC INFORMATION OFFICER (PIO):
ASHLEY RITTENHOUSE
FAX: (740) 373-3953
EMAIL: ASHLEY.RITTENHOUSE@DOT.OHIO.GOV

DISTRICT PERMIT SECTION:
STEPHEN WELLS
FAX: (740) 373-3953
EMAIL: STEPHEN.WELLS@DOT.OHIO.GOV

CENTRAL OFFICE SPECIAL HAUL PERMITS SECTION:
FAX: (614) 728-4099
EMAIL: HAULING.PERMITS@DOT.OHIO.GOV

THE PIO WILL, IN TURN, NOTIFY THE PUBLIC, THE LOCAL EMERGENCY SERVICES, AFFECTED SCHOOLS AND BUSINESSES, AND ANY OTHER IMPACTED LOCAL PUBLIC AGENCY OF THE ABOVE MENTIONED ITEMS VIA MEDIA SOURCES.

ITEM 524 - DRILLED SHAFTS, 36" DIAMETER, ABOVE BEDROCK, AS PER PLAN

ITEM 524 - DRILLED SHAFTS, 42" DIAMETER, ABOVE BEDROCK, AS PER PLAN

ITEM 524 - DRILLED SHAFTS, 42" DIAMETER, INTO BEDROCK, AS PER PLAN

THIS WORK CONSISTS OF FURNISHING AND INSTALLING DRILLED SHAFTS FOR SOLDIER PILE AND LAGGING WALLS. THE DRILLED SHAFTS ARE REINFORCED WITH SOLDIER PILES INSTEAD OF REINFORCING STEEL CAGES. THE SOLDIER PILES EXTEND ABOVE THE TOP OF THE DRILLED SHAFT. FURNISH AND INSTALL DRILLED SHAFTS IN ACCORDANCE WITH CMS 524 EXCEPT AS MODIFIED AND SUPPLEMENTED BELOW.

EXCAVATE THE HOLE FOR THE DRILLED SHAFTS WITHIN 3 INCHES OF THE PLAN LOCATION IN THE HORIZONTAL PLANE. IF FIELD CONDITIONS INDICATE GREATER DEPTHS, NOTIFY THE ENGINEER FOR FURTHER EVALUATION.

PLACE THE SOLDIER PILE VERTICALLY WITHIN THE HOLE SO IT IS NOT INCLINED MORE THAN 1" BETWEEN THE TOP AND BOTTOM. PLACE THE SOLDIER PILE SO THAT THE FLANGES ARE PARALLEL TO THE CENTERLINE OF CONSTRUCTION. DO NOT ALLOW THE ORIENTATION OF THE FLANGES TO VARY BY MORE THAN 10 DEGREES. SUPPORT THE SOLDIER PILE SO THAT IT DOES NOT MOVE DURING CONCRETE PLACEMENT.

USE CLASS QC1 CONCRETE ACCORDING TO CMS 511. PLACE CONCRETE TO THE ELEVATION FOR THE BOTTOM OF THE PRECAST LAGGING. THE CONTRACTOR MAY PLACE CONCRETE USING THE FREE FALL METHOD PROVIDED THE DEPTH OF WATER IS LESS THAN 6 INCHES AND THE CONCRETE FALLS WITHOUT STRIKING THE SIDES OF THE HOLE. POURING CONCRETE ALONG THE WEB OF THE SOLDIER PILE IS ACCEPTABLE.

CHECK THE POSITION, THE VERTICAL ALIGNMENT AND ORIENTATION OF THE SOLDIER PILE IMMEDIATELY AFTER CONCRETE PLACEMENT. MAKE CORRECTIONS AS NECESSARY TO MEET THE ABOVE TOLERANCES.

PLACE PRECAST LAGGING SO THAT THE SOLDIER PILE FLANGE OVERLAPS THE END OF THE LAGGING BY AT LEAST 3 INCHES AT BOTH ENDS OF THE LAGGING.

SEQUENCE OF INSTALLATION
THE INSTALLATION SEQUENCE SHALL BE SUCH THAT NO KING PILE IS INSTALLED ADJACENT TO EITHER AN OPEN KING PILE EXCAVATION OR A KING PILE IN WHICH THE CONCRETE HAS LESS THAN A 48 HOUR CURE. INSTALLING THE SHAFTS IN AN ALTERNATING SEQUENCE OR ANY OTHER SEQUENCE THAT MEETS THIS CRITERIA IS PERMISSIBLE.

PROTECTION OF UNATTENDED OPEN SHAFTS
CARE SHALL BE EXERCISED AS TO COVER UNATTENDED OPEN SHAFTS. TEMPORARY COVERS SHALL BE OF ADEQUATE STRENGTH TO PREVENT A PERSON OR ANIMAL FROM FALLING IN. NO DRILLED SHAFT EXCAVATION SHALL BE LEFT UN-POURED OVERNIGHT

THE CONTRACTOR SHALL BE RESPONSIBLE FOR THE MEANS AND METHODS USED TO CONSTRUCT THE DRILLED SHAFTS AND PLACE CONCRETE PANELS. ANY TEMPORARY GRADING, EXCAVATION, EMBANKMENT, AGGREGATE, DRAINAGE, SHEETING, ETC. NEEDED TO COMPLETE THE WORK AREA SHALL BE INCLUDED IN THE BID PRICE FOR THE DRILLED SHAFTS. THE COST OF ANY EXCAVATION AND SUBSEQUENT REPLACEMENT OF EMBANKMENT (PER ITEM 203 EMBANKMENT) SHALL BE INCLUDED IN THE VARIOUS BID ITEMS FOR THE DRILLED SHAFTS AND CONCRETE PANELS. NO SEPARATE PAYMENT WILL BE MADE.

PAYMENT IS FULL COMPENSATION FOR CONSTRUCTING THE DRILLED SHAFTS, INCLUDING FURNISHING AND PLACING CONCRETE AND REMOVAL OF CONCRETE FROM AROUND THE SOLDIER PILE IN ORDER TO PLACE PRECAST LAGGING. PAYMENT FOR SOIL OVERBURDEN DRILLING, WHICH IS GROUND LEVEL TO THE TOP OF THE SHAFT, SHALL BE INCLUSIVE OF ITEM 524 DRILLED SHAFTS, 36" DIAMETER, ABOVE BEDROCK AS PER PLAN AND ITEM 524 DRILLED SHAFTS, 42" DIAMETER, ABOVE BEDROCK AS PER PLAN.

MEASUREMENT FOR PAYMENT FOR DRILLED SHAFTS ABOVE BEDROCK, AS PER PLAN, WILL BE MEASURED ALONG THE AXIS OF THE DRILLED SHAFT FROM THE TOP OF THE SHAFT TO THE TOP OF BEDROCK, AS DETERMINED BY THE ENGINEER. MEASUREMENT FOR PAYMENT FOR DRILLED SHAFTS INTO BEDROCK, AS PER PLAN, WILL BE LIMITED TO THE DISTANCE BETWEEN THE TOP OF BEDROCK AND THE BOTTOM OF THE DRILLED SHAFT, AS DETERMINED BY THE ENGINEER.

CONNECTION BETWEEN EXISTING AND PROPOSED GUARDRAIL

WHEN IT IS NECESSARY TO SPLICE PROPOSED GUARDRAIL TO EXISTING GUARDRAIL, ONLY THE EXISTING GUARDRAIL SHALL BE CUT, DRILLED, OR PUNCHED. THE CONNECTION SHALL BE MADE USING A W-BEAM, BEAM SPLICE AS SHOWN IN AASHTO M 180-12, EXCEPT THE BEAM WASHERS ARE NOT TO BE USED. PAYMENT SHALL BE INCLUDED IN THE CONTRACT PRICE FOR THE RESPECTIVE GUARDRAIL ITEMS.

ITEM 254 - PAVEMENT PLANING, ASPHALT CONCRETE, AS PER PLAN

DUE TO THE ACTIVE NATURE OF THE LANDSLIDE, PAVEMENT OVERLAYS HAVE BEEN PLACED AFTER THE SURVEY WAS PERFORMED. IT IS ANTICIPATED THAT PAVEMENT PLANING MAY BE NECESSARY TO OBTAIN THE PROPOSED CROSS-SLOPE.

DESIGN AGENCY



DESIGNER

JDW

REVIEWER

XXX MM-DD-YY

PROJECT ID

115533

SHEET TOTAL

P.03 P.48

ITEM 614, MAINTAINING TRAFFIC

A MINIMUM OF ONE LANE OF TRAFFIC SHALL BE MAINTAINED AT ALL TIMES BY USE OF THE EXISTING PAVEMENT, THE COMPLETED PAVEMENT, ITEM 615 PAVEMENT FOR MAINTAINING TRAFFIC, AND ITEM 615 ROADS FOR MAINTAINING TRAFFIC.

LENGTH AND DURATION OF LANE CLOSURES AND RESTRICTIONS SHALL BE AT THE APPROVAL OF THE ENGINEER. IT IS THE INTENT TO MINIMIZE THE IMPACT TO THE TRAVELING PUBLIC. LANE CLOSURES OR RESTRICTIONS OVER SEGMENTS OF THE PROJECT IN WHICH NO WORK IS ANTICIPATED WITHIN A REASONABLE TIME FRAME, AS DETERMINED BY THE ENGINEER, SHALL NOT BE PERMITTED. THE LEVEL OF UTILIZATION OF MAINTENANCE OF TRAFFIC DEVICES SHALL BE COMMENSURATE WITH THE WORK IN PROGRESS.

ALL WORK AND TRAFFIC CONTROL DEVICES SHALL BE IN ACCORDANCE WITH C&MS 614 AND OTHER APPLICABLE PORTIONS OF THE SPECIFICATIONS, AS WELL AS THE OHIO MANUAL OF UNIFORM TRAFFIC CONTROL DEVICES. PAYMENT FOR ALL LABOR, EQUIPMENT AND MATERIALS SHALL BE INCLUDED IN THE LUMP SUM CONTRACT PRICE FOR ITEM 614, MAINTAINING TRAFFIC, UNLESS SEPARATELY ITEMIZED IN THE PLAN.

ITEM 614, WORK ZONE IMPACT ATTENUATOR FOR 24" WIDE HAZARDS (BIDIRECTIONAL)

THIS ITEM SHALL CONSIST OF FURNISHING AND INSTALLING A NON-GATING IMPACT ATTENUATOR. FURNISH AN IMPACT ATTENUATOR FROM THE OFFICE OF ROADWAY ENGINEERING'S APPROVED LIST FOR WORK ZONE IMPACT ATTENUATORS, FROM THE ROADWAY STANDARDS APPROVED PRODUCTS WEB PAGE.

INSTALLATION SHALL BE AT THE LOCATIONS SPECIFIED IN THE PLANS IN ACCORDANCE WITH THE MANUFACTURER'S SPECIFICATIONS.

THE CONTRACTOR SHALL REPAIR OR REPLACE A DAMAGED UNIT WITHIN 24 HOURS OF A DAMAGING IMPACT.

WHEN BIDIRECTIONAL DESIGNS ARE SPECIFIED, THE CONTRACTOR SHALL SUPPLY APPROPRIATE TRANSITIONS.

WHEN GATING IMPACT ATTENUATORS ARE DESIRED, THE CONTRACTOR SHALL SUBMIT DOCUMENTATION TO THE ENGINEER FOR ACCEPTANCE.

THE COST FOR THE ADDITIONAL BARRIER REQUIRED FOR A GATING IMPACT ATTENUATOR SHALL BE INCLUDED IN THE COST OF THE GATING IMPACT ATTENUATOR.

PAYMENT FOR THE ABOVE WORK SHALL BE MADE AT THE UNIT PRICE BID AND SHALL INCLUDE ALL LABOR, TOOLS, EQUIPMENT AND MATERIALS NECESSARY TO CONSTRUCT AND MAINTAIN A COMPLETE AND FUNCTIONAL IMPACT ATTENUATOR SYSTEM, INCLUDING ALL RELATED BACKUPS, TRANSITIONS, LEVELING PADS, HARDWARE AND GRADING, NOT SEPARATELY SPECIFIED, AS REQUIRED BY THE MANUFACTURER.

ITEM 614, BARRIER REFLECTORS AND/OR OBJECT MARKERS

BARRIER REFLECTORS AND/OR OBJECT MARKERS SHALL BE INSTALLED ON ALL PORTABLE BARRIER (PB) USED FOR TRAFFIC CONTROL. BARRIER REFLECTORS, OBJECT MARKERS AND THEIR INSTALLATION SHALL CONFORM TO CMS 626, EXCEPT THAT THE SPACING SHALL BE 50 FEET

LIGHTING

LIGHTING SHALL BE PROVIDED AT EACH END OF THE LANE CLOSURE FOR THE CLOSING OF ONE LANE OF A TWO LANE HIGHWAY.

LIGHTING SHALL BE BY CONVENTIONAL METHODS, WITH LUMINAIRE ARMS ATTACHED TO THE SIGNAL SUPPORTS. AREA ILLUMINATION SHALL BE PROVIDED BY USING AN 8000-LUMEN LED, 150 WATT MINIMUM HIGH PRESSURE SODIUM LUMINARIES OR 250 WATT MINIMUM MERCURY LUMINARIES. THE MINIMUM HEIGHT OF THE LUMINAIRE SHALL BE 27 FT FROM THE GROUND SURFACE.

PAYMENT FOR LIGHTING SHALL INCLUDE DELIVERY, ERECTION, MAINTENANCE AND REMOVAL AS CALLED FOR IN THE PLANS. PAYMENT SHALL BE PER EACH.

ITEM 614 - WORK ZONE LIGHTING SYSTEM 1 EACH QUANTITY CARRIED TO THE GENERAL SUMMARY.

SEQUENCE OF CONSTRUCTION

PHASE 1:

1. WHILE USING FLAGGERS, INSTALL PORTABLE BARRIERS, IMPACT ATTENUATORS, SIGNALS, DELINEATORS, AND SIGNS TO PERFORM PART-WIDTH CONSTRUCTION OF THE PROPOSED CONDUIT AND PAVEMENT FOR MAINTAINING TRAFFIC. WORK PERFORMED SHALL BE IN ACCORDANCE WITH SCD'S MT-96.11, MT-96.20, MT-96.26, MT-97.10, MT-101.70, AND MT-101.75.
2. REMOVE PAVEMENT AND INSTALL PROPOSED CONDUIT, WHILE MAINTAINING DRAINAGE THROUGH THE EXISTING CONDUIT.
3. PLACE LOW STRENGTH MORTAR BACKFILL AND PLACE PROPOSED PAVEMENT TO MATCH EXISTING PROFILE AND INSTALL TEMPORARY PAVEMENT.

PHASE 2:

1. WHILE USING FLAGGERS, MOVE PORTABLE BARRIERS, IMPACT ATTENUATORS, DELINEATORS, SIGNS, AND PLACE PAVEMENT MARKINGS FOR INSTALLING THE DRILLED SHAFT WALL. WORK PERFORMED SHALL BE IN ACCORDANCE WITH SCD'S MT-96.11, MT-96.20, MT-96.26, MT-97.10, MT-101.70, AND MT-101.75.
2. CONSTRUCT DRILLED SHAFT, SOLDIER PILE WALL.
3. COMPLETE PART-WIDTH CONSTRUCTION OF CULVERT, PERTINENT LOW STRENGTH MORTAR BACKFILL, PLUG AND FILL EXISTING CONDUIT, AND PAVEMENT REPLACEMENT.
4. PERFORM PAVEMENT REPAIR.

PHASE 3:

1. WHILE USING FLAGGERS, REMOVE PORTABLE BARRIERS, INSTALL BARRELS, DELINEATORS, AND SIGNS TO PLACE PAVEMENT OVERLAY, PAVEMENT MARKINGS AND GUARDRAIL. WORK PERFORMED SHALL BE IN ACCORDANCE WITH SCD'S MT-96.11, MT-96.20, MT-96.26, MT-97.10, MT-101.70, AND MT-101.75.
2. COMPLETE PAVEMENT REPLACEMENT, OVERLAY, FINAL MARKINGS, AND INSTALL GUARDRAIL.
3. USING FLAGGERS REMOVE MAINTENANCE OF TRAFFIC DEVICES.

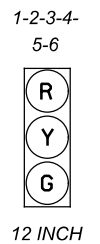

SIGNAL INDICATORS

COLOR SEQUENCE CHART

INDICATORS FACINGS	No	Ø1			Ø2			Ø3		
		1	2	3	1	2	3	1	2	3
NORTH BOUND SR 7	1	G	Y	R	R	R	R	R	R	R
	2	G	Y	R	R	R	R	R	R	R
SOUTH BOUND SR 7	3	R	R	R	G	Y	R	R	R	R
	4	R	R	R	G	Y	R	R	R	R
DRIVEWAY AT STA. 1071+10	5	R	R	R	R	R	R	G	Y	R
	6	R	R	R	R	R	R	G	Y	R

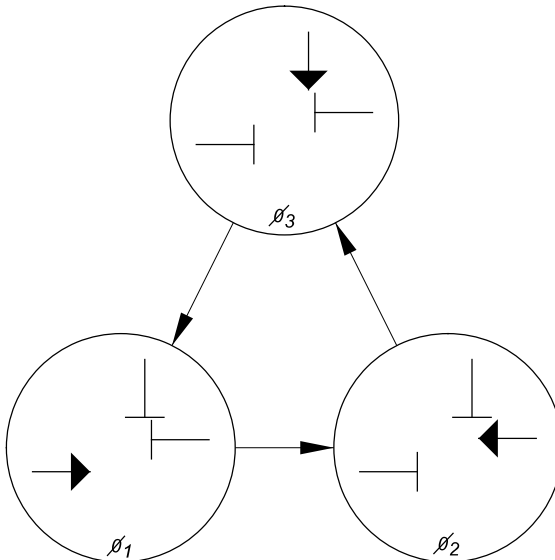

PHASING DIAGRAM

TIMING CHART

INTERVAL	Ø1			Ø2			Ø3		
	1	2	3	1	2	3	1	2	3
GREEN	36			36			3		
YELLOW CHANGE		3			3			3	
ALL RED CLEARANCE			24			24			18
CYCLE LENGTH	150								

DESIGN AGENCY



DESIGNER

JDW

REVIEWER

XXX MM-DD-YY

PROJECT ID

115533

SHEET TOTAL

P.05 P.48

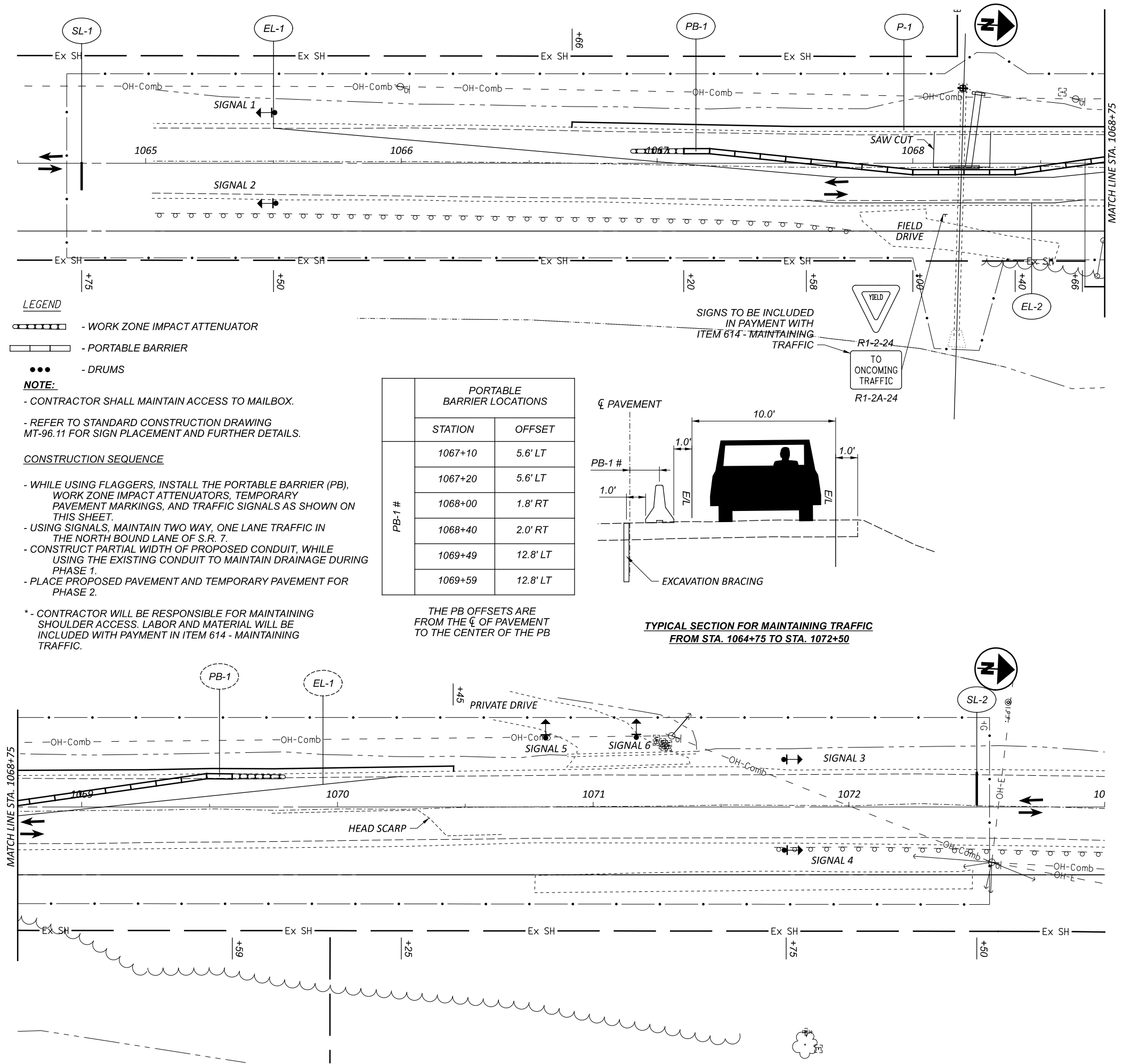

- LEGEND**
- WORK ZONE IMPACT ATTENUATOR
 - PORTABLE BARRIER
 - DRUMS

NOTE:

- CONTRACTOR SHALL MAINTAIN ACCESS TO MAILBOX.
- REFER TO STANDARD CONSTRUCTION DRAWING MT-96.11 FOR SIGN PLACEMENT AND FURTHER DETAILS.

CONSTRUCTION SEQUENCE

- WHILE USING FLAGGERS, INSTALL THE PORTABLE BARRIER (PB), WORK ZONE IMPACT ATTENUATORS, TEMPORARY PAVEMENT MARKINGS, AND TRAFFIC SIGNALS AS SHOWN ON THIS SHEET.
- USING SIGNALS, MAINTAIN TWO WAY, ONE LANE TRAFFIC IN THE NORTH BOUND LANE OF S.R. 7.
- CONSTRUCT PARTIAL WIDTH OF PROPOSED CONDUIT, WHILE USING THE EXISTING CONDUIT TO MAINTAIN DRAINAGE DURING PHASE 1.
- PLACE PROPOSED PAVEMENT AND TEMPORARY PAVEMENT FOR PHASE 2.

* - CONTRACTOR WILL BE RESPONSIBLE FOR MAINTAINING SHOULDER ACCESS. LABOR AND MATERIAL WILL BE INCLUDED WITH PAYMENT IN ITEM 614 - MAINTAINING TRAFFIC.

PB-1 #	PORTABLE BARRIER LOCATIONS	
	STATION	OFFSET
	1067+10	5.6' LT
	1067+20	5.6' LT
	1068+00	1.8' RT
	1068+40	2.0' RT
	1069+49	12.8' LT
	1069+59	12.8' LT

THE PB OFFSETS ARE FROM THE ζ OF PAVEMENT TO THE CENTER OF THE PB

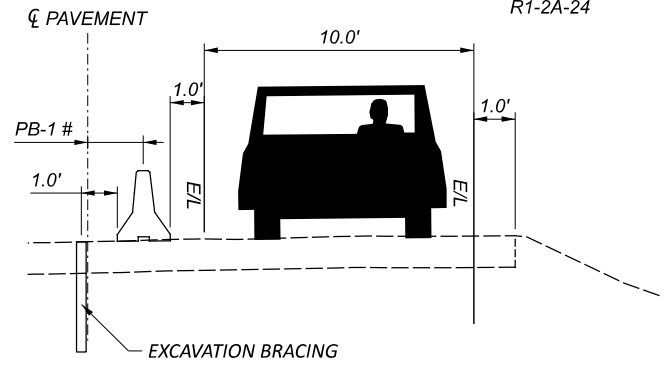

REF NO.	STATION		SIDE	ITEM	UNIT	TOTALS CARRIED TO GENERAL SUMMARY	
	FROM	TO				QUANTITY	AMOUNT
EL-1	1066+50	1070+25	LT/RT				
EL-2	1067+58	1068+66	RT				
SL-1	1064+75		RT				
SL-2	1072+50		LT				
PB-1	1067+10	1069+59	LT/RT			250	
P-1	1066+66	1070+45	RT				
				ROADS FOR MAINT. TRAFFIC	LUMP		LUMP
				PAVEMENT FOR MAINT. TRAFFIC, TYPE B	SY		85
				PORTABLE BARRIER	FEET		250
				WORK ZONE EDGE LINE, CLASS 1	MILE	0.09	
				WORK ZONE STOP LINE	FEET	12	
				OBJECT MARKER, TWO WAY	EACH	5	
				BARRIER REFLECTOR, TYPE 1	EACH	5	
				WORK ZONE IMPACT ATTEN.	EACH	2	
				WORK ZONE STOP LINE	FEET	12	
				EXCAVATION BRACING	LINEAL FEET	24	
				MAINTAINING TRAFFIC	ITEM 614		0.11
				MAINTAINING TRAFFIC	ITEM 615		85
				MAINTAINING TRAFFIC	ITEM 622		250
TOTALS CARRIED TO GENERAL SUMMARY							

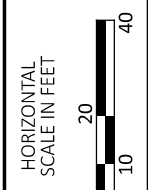

MAINTENANCE OF TRAFFIC
PHASE 1

DESIGN AGENCY

DESIGNER: JDW
 REVIEWER: XXX MM-DD-YY
 PROJECT ID: 115533
 SHEET: P.06 TOTAL: P.48

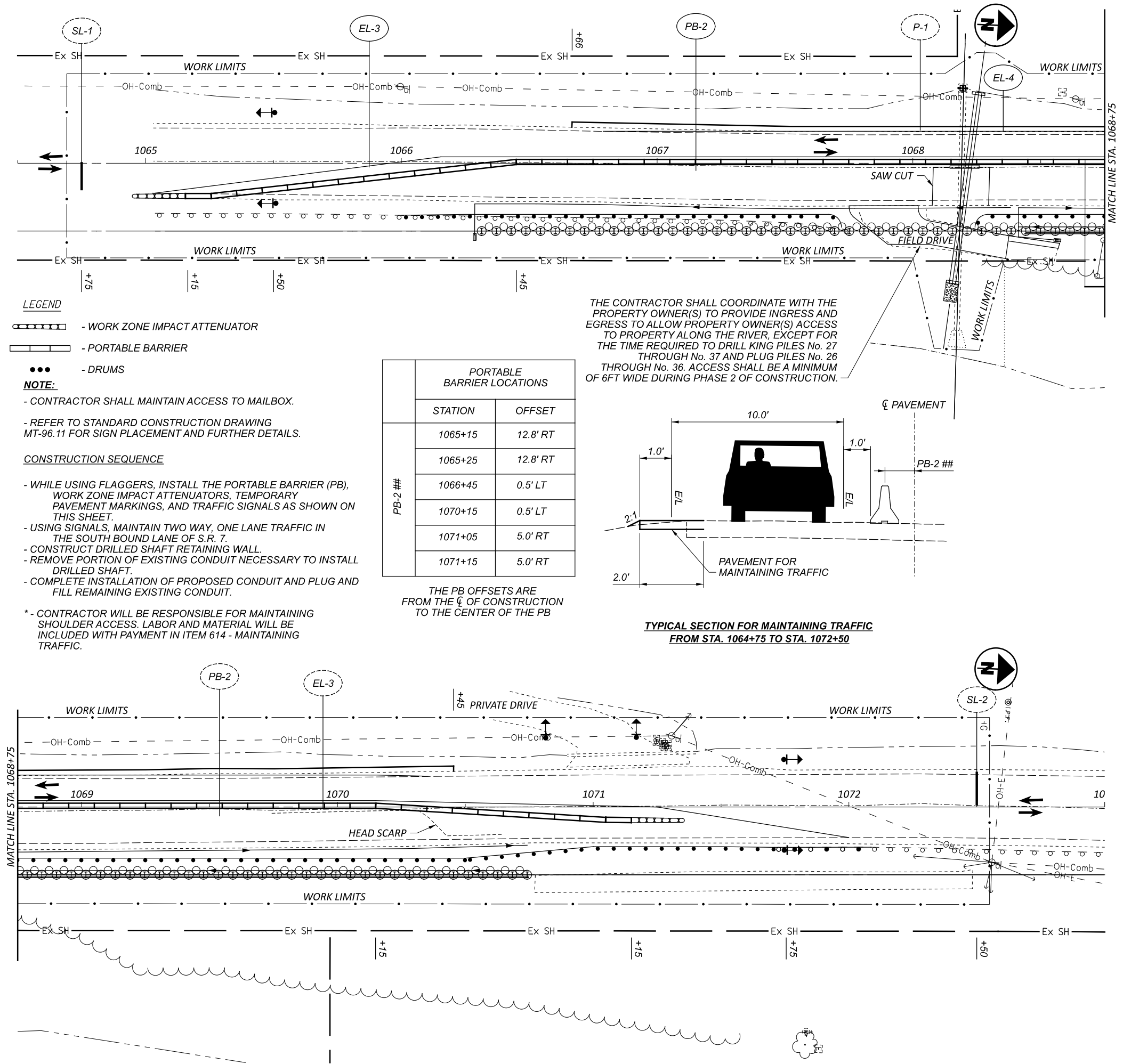

REF NO.	STATION		SIDE	ITEM	UNIT	AMOUNT	TOTAL
	FROM	TO					
EL-3	1065+50	1070+25	LT/RT	WORK ZONE IMPACT ATTEN.	EACH	2	2
EL-4	1066+78	1070+35	RT	BARRIER REFLECTOR TYPE 1	EACH	12	12
PB-2	1067+10	1069+59	LT/RT	OBJECT MARKER TWO WAY	EACH	12	12
P-1	1067+81	1068+57	RT	ROADS FOR MAINT TRAFFIC	LUMP	600	600
TOTALS CARRIED TO GENERAL SUMMARY							

MAINTENANCE OF TRAFFIC PHASE 2

HORIZONTAL SCALE IN FEET

DESIGN AGENCY

DESIGNER
JDW

REVIEWER
XXX MM-DD-YY

PROJECT ID
115533

SHEET TOTAL
P.07 P.48

SHEET NUM.										PART.			ITEM	ITEM EXT	GRAND TOTAL	UNIT	DESCRIPTION	SEE SHEET NO.
10	12	13	25	30						01/NHS/06	02/NHS/17							
										LUMP	LUMP		201	11000	LS		ROADWAY	3
			76	62						76	62		202	23001	138	SY	PAVEMENT REMOVED, AS PER PLAN	13, 25
			5								5		202	35100	5	FT	PIPE REMOVED, 24" DIAMETER AND UNDER	
	214									214			202	38000	214	FT	GUARDRAIL REMOVED	
	2									2			202	42206	2	EACH	ANCHOR ASSEMBLY REMOVED	
				1							1		202	58100	1	EACH	CATCH BASIN REMOVED	
				93							93		SPECIAL	20270000	93	FT	FILL AND PLUG EXISTING CONDUIT 24"	25
	1									1			202	98100	1	EACH	REMOVAL MISC.:STAND PIPE	12
				1							1		202	98100	1	EACH	REMOVAL MISC.:CONCRETE OUTLET APRON	25
156										156			203	10000	156	CY	EXCAVATION	
236										236			203	20000	236	CY	EMBANKMENT	
273			76							349			204	10000	349	SY	SUBGRADE COMPACTION	
254										254			254	01001	254	SY	PAVEMENT PLANING, ASPHALT CONCRETE, AS PER PLAN VARIABLE DEPTH	3
	200									200			606	15050	200	FT	GUARDRAIL, TYPE MGS	
	337.5									337.5			606	15100	337.5	FT	GUARDRAIL, TYPE MGS WITH LONG POSTS	
	2									2			606	20050	2	EACH	ROUNDED END SECTION	
	2									2			606	26550	2	EACH	ANCHOR ASSEMBLY, MGS TYPE T	
																	EROSION CONTROL	
				3							3		601	32100	3	CY	ROCK CHANNEL PROTECTION, TYPE B WITH FILTER	
1,544										1,544			659	10000	1,544	SY	SEEDING AND MULCHING	
0.21										0.21			659	20000	0.21	TON	COMMERCIAL FERTILIZER	
0.32										0.32			659	31000	0.32	ACRE	LIME	
4.17										4.17			659	35000	4.17	MGAL	WATER	
										3,000	2,000		832	30000	5,000	EACH	EROSION CONTROL	
																	DRAINAGE	
				56							56		511	52110	56	CY	CLASS QC MS CONCRETE	
				1.2							1.2		602	20000	1.2	CY	CONCRETE MASONRY	
	443									443			605	06000	443	FT	4" BASE PIPE UNDERDRAINS	
				75							75		611	13200	75	FT	30" CONDUIT, TYPE A	
	2									2			611	99710	2	EACH	PRECAST REINFORCED CONCRETE OUTLET	
																	PAVEMENT	
56				16						56	16		301	56000	72	CY	ASPHALT CONCRETE BASE, PG64-22, (449)	
56			26	11						82	11		304	20000	93	CY	AGGREGATE BASE	
207				4						207	4		407	20000	211	GAL	NON-TRACKING TACK COAT	
138										138			408	10000	138	GAL	PRIME COAT	
106										106			441	50000	106	CY	ASPHALT CONCRETE SURFACE COURSE, TYPE 1, (448), PG64-22	
9				3						9	3		441	50200	12	CY	ASPHALT CONCRETE INTERMEDIATE COURSE, TYPE 1, (448)	
68										68			441	70200	68	CY	ASPHALT CONCRETE INTERMEDIATE COURSE, TYPE 1, (449)	
			7							7			441	70500	7	CY	ASPHALT CONCRETE SURFACE COURSE, TYPE 1, (449), (DRIVEWAYS)	
29										29			617	10100	29	CY	COMPACTED AGGREGATE	
																	TRAFFIC CONTROL	
20										20			621	00100	20	EACH	RPM	
20										20			621	54000	20	EACH	RAISED PAVEMENT MARKER REMOVED	
	12									12			626	00110	12	EACH	BARRIER REFLECTOR, TYPE 2(BIDIRECTIONAL)	
0.3										0.3			642	00104	0.3	MILE	EDGE LINE, 6", TYPE 1	
0.15										0.15			642	00300	0.15	MILE	CENTER LINE, TYPE 1	
																	RETAINING WALLS	
				3,706						3,706			507	00400	3,706	FT	STEEL PILES, MISC.:SOLDIER PILES, W27X146	3,4,26-31
20										20			511	46511	20	CY	CLASS QC1 CONCRETE, FOOTING, AS PER PLAN	4
137										137			518	21200	137	CY	POROUS BACKFILL WITH GEOTEXTILE FABRIC	
										233			518	40000	233	FT	6" PERFORATED CORRUGATED PLASTIC PIPE	
	233									38			518	40012	38	FT	6" NON-PERFORATED CORRUGATED PLASTIC PIPE	

GENERAL SUMMARY

DESIGN AGENCY



DESIGNER
JDW

REVIEWER
XXX MM-DD-YY

PROJECT ID
115533

SHEET TOTAL
P.08 P.48

SHEET NUM.										PART.			ITEM	ITEM EXT	GRAND TOTAL	UNIT	DESCRIPTION	SEE SHEET NO.
5	6	7	25	27	30	31				01/NHS/06	02/NHS/17							
						950				950			524	94703	950	FT	RETAINING WALLS (CONTINUED) DRILLED SHAFTS, 36" DIAMETER, ABOVE BEDROCK, AS PER PLAN	3,4,26-31
					2,664					2,664			524	94803	2,664	FT	DRILLED SHAFTS, 42" DIAMETER, ABOVE BEDROCK, AS PER PLAN	3,4,26-31
					780					780			524	94805	780	FT	DRILLED SHAFTS, 42" DIAMETER, INTO BEDROCK, AS PER PLAN	3,4,26-31
						3				3			524	95000	3	FT	DRILLED SHAFTS, MISC.:EXTENSION	3,4,26-31
						950				950			524	95000	950	FT	DRILLED SHAFTS, MISC.:36" PERMANENT CASING	3,4,26-31
					2,664					2,664			524	95000	2,664	FT	DRILLED SHAFTS, MISC.:42" PERMANENT CASING	3,4,26-31
				1,320						1,320			SPECIAL	53051010	1,320	SF	RETAINING WALL, PRECAST CONCRETE LAGGING	3,4,26-31
			LUMP								LUMP		503	11100	LS		MISCELLANEOUS STRUCTURE COFFERDAMS AND EXCAVATION BRACING	
																	MAINTENANCE OF TRAFFIC	
1	2	2								4			614	12384	4	EACH	WORK ZONE IMPACT ATTENUATOR, 24" WIDE HAZARDS, (BIDIRECTIONAL)	
	5	12								1			614	12740	1	EACH	WORK ZONE LIGHTING SYSTEM	
										17			614	13310	17	EACH	BARRIER REFLECTOR, TYPE 1(BIDIRECTIONAL)	
	5	12								17			614	13360	17	EACH	OBJECT MARKER, TWO WAY	
	0.11	0.2								0.31			614	22010	0.31	MILE	WORK ZONE EDGE LINE, CLASS I, 6"	
	24									24			614	26000	24	FT	WORK ZONE STOP LINE, CLASS I	
	LUMP	LUMP								LUMP	LUMP		615	10000	LS		ROADS FOR MAINTAINING TRAFFIC	
	85									85			615	25000	85	SY	PAVEMENT FOR MAINTAINING TRAFFIC, CLASS B	
	250	600								850			622	41100	850	FT	PORTABLE BARRIER, UNANCHORED	
																	INCIDENTALS	
										LUMP	LUMP		614	11000	LS		MAINTAINING TRAFFIC	
										LUMP	LUMP		623	10000	LS		CONSTRUCTION LAYOUT STAKES AND SURVEYING	
										LUMP	LUMP		624	10000	LS		MOBILIZATION	

GENERAL SUMMARY

DESIGN AGENCY



DESIGNER
JDW

REVIEWER
XXX MM-DD-YY

PROJECT ID
115533

SHEET TOTAL
P.09 | P.48

ITEM 441 - ASPHALT CONCRETE SURFACE COURSE, TYPE 1, (448), PG64-22

(OVERLAY)
 STA. 1064+75 TO STA. 1072+50
 775 FT x AVG. 29.5 FT x (1.5 IN/12)/27 = 105.8 CY

A TOTAL OF 106 CY TO BE CARRIED TO THE GENERAL SUMMARY.

ITEM 441 - ASPHALT CONCRETE INTERMEDIATE COURSE, TYPE 1, (448)

(PAVEMENT REPAIR)
 STA. 1066+28 TO STA. 1070+74
 446 FT x 4.0 FT x (1.5 IN/12)/27 = 8.3 CY

A TOTAL OF 9 CY TO BE CARRIED TO THE GENERAL SUMMARY.

ITEM 441 - ASPHALT CONCRETE INTERMEDIATE COURSE, TYPE 1, (449)

(LEVELING COURSE - LEFT LANE)
 STA. 1066+25 TO STA. 1067+00
 75 FT x AVG. 14.1 FT x (AVG. 1.9 IN/12)/27 = 6.2 CY
 STA. 1067+00 TO STA. 1068+08
 108 FT x AVG. 12.5 FT x (1.5 IN/12)/27 = 6.3 CY
 STA. 1068+08 TO STA. 1068+30
 SEE CULVERT DETAILS
 STA. 1068+30 TO STA. 1069+00
 70 FT x AVG. 12.4 FT x (AVG. 2.6 IN/12)/27 = 7.0 CY
 STA. 1069+00 TO STA. 1070+00
 100 FT x AVG. 13.0 FT x (1.5 IN/12)/27 = 6.0 CY
 STA. 1070+00 TO STA. 1070+50
 50 FT x AVG. 13.9 FT x (AVG. 2.1 IN/12)/27 = 4.5 CY

(LEVELING COURSE - RIGHT LANE)
 STA. 1066+25 TO STA. 1068+08
 183 FT x AVG. 12.4 FT x (AVG. 2.6 IN/12)/27 = 18.2 CY
 STA. 1068+08 TO STA. 1068+30
 SEE CULVERT DETAILS
 STA. 1068+30 TO STA. 1068+75
 45 FT x AVG. 12.5 FT x (AVG. 1.9 IN/12)/27 = 3.3 CY
 STA. 1068+75 TO STA. 1069+50
 75 FT x AVG. 12.5 FT x (1.5 IN/12)/27 = 4.3 CY
 STA. 1069+50 TO STA. 1070+75
 125 FT x AVG. 11.3 FT x (AVG. 2.6 IN/12)/27 = 11.3 CY

A TOTAL OF 68 CY TO BE CARRIED TO THE GENERAL SUMMARY.

ITEM 304 - AGGREGATE BASE (PAVEMENT REPAIR)

STA. 1066+28 TO STA. 1070+74
 446 FT x 5.0 FT x (6 IN/12)/27 = 41.3 CY

(VARIABLE THICKNESS)
 STA. 1066+28 TO STA. 1068+75
 247 FT x 4.0 FT x (AVG. 3.0 IN/12)/27 = 9.1 CY
 STA. 1069+50 TO STA. 1070+74
 124 FT x 4.0 FT x (AVG. 3.0 IN/12)/27 = 4.6 CY

A TOTAL OF 56 CY TO BE CARRIED TO THE GENERAL SUMMARY.

ITEM 301 - ASPHALT CONCRETE BASE, PG64-22 (PAVEMENT REPAIR)

STA. 1066+28 TO STA. 1070+74
 446 FT x 4.5 FT x (9 IN/12)/27 = 55.8 CY

A TOTAL OF 56 CY TO BE CARRIED TO THE GENERAL SUMMARY.

ITEM 407 - NON-TRACKING TACK COAT RATE = 0.08 GAL/SY (APPLIED ONTO EXISTING PAVEMENT)

(OVERLAY - APPLIED TO EXISTING PAVEMENT)
 STA. 1064+75 TO STA. 1066+28
 153 FT x 29.5 FT / 9 x 0.08 = 40.1 GAL.
 STA. 1066+28 TO STA. 1068+08
 180 FT x 25.5 FT / 9 x 0.08 = 40.8 GAL.
 STA. 1068+30 TO STA. 1070+74
 244 FT x 25.5 FT / 9 x 0.08 = 55.3 GAL.
 STA. 1070+74 TO STA. 1072+50
 176 FT x 29.5 FT / 9 x 0.08 = 46.2 GAL.

RATE = 0.05 GAL/SY (APPLIED ONTO LEVELING COURSES)

(APPLIED TO PAVEMENT REPAIR, ASPHALT CONC. BASE)
 STA. 1066+28 TO STA. 1070+74
 446 FT x 4.5 FT / 9 x 0.05 = 11.2 GAL.

(OVERLAY - APPLIED TO PAVEMENT REPAIR, INTERMEDIATE)
 STA. 1066+28 TO STA. 1070+74
 446 FT x 4.0 FT / 9 x 0.05 = 9.9 GAL.

(OVERLAY - APPLIED TO PAVEMENT FOR CULVERT REPLACEMENT)
 STA. 1068+08 TO STA. 1068+30
 22 FT x 25.5 FT / 9 x 0.05 = 3.1 GAL.

A TOTAL OF 207 GAL TO BE CARRIED TO THE GENERAL SUMMARY.

ITEM 204 - SUBGRADE COMPACTION (PAVEMENT REPAIR)

STA. 1066+28 TO STA. 1070+74
 446 FT x 5.5 FT / (9 SY/SF) = 272.6 SY

A TOTAL OF 273 SY TO BE CARRIED TO THE GENERAL SUMMARY.

ITEM 642 - EDGE LINE

STA. 1064+75 TO STA. 1072+50
 2 X 775 FT / 5280 FT = 0.30 MILE

A TOTAL OF 0.30 MILE TO BE CARRIED TO THE GENERAL SUMMARY.

ITEM 642 - CENTERLINE

STA. 1064+75 TO STA. 1072+50
 775 FT / 5280 FT = 0.15 MILE

A TOTAL OF 0.15 MILE TO BE CARRIED TO THE GENERAL SUMMARY.

ITEM 511 - CLASS QC1 CONCRETE, FOOTING, AS PER PLAN

STA. 1068+44 TO STA. 1070+74
 230 FT x 4.0 FT x (6 IN / (12 IN/FT)) / (27 CF/CY) = 19.2 CY

A TOTAL OF 20 CY TO BE CARRIED TO THE GENERAL SUMMARY.

ITEM 254 - PAVEMENT PLANING, ASPHALT CONCRETE, AS PER PLAN

(VARIABLE THICKNESS)
 STA. 1064+75 TO STA. 1072+50
 775 FT x AVG. 29.5 FT x 10% / 9 = 254.0 SY

A TOTAL OF 254 SY TO BE CARRIED TO THE GENERAL SUMMARY.

SHEET NO.	EARTHWORK, SEEDING AND MULCHING		
	ITEM 203	ITEM 203	ITEM 659
	EXCAVATION	EMBANKMENT	SEEDING AND MULCHING
	CY	CY	SY
14	3	5	77
15	12	14	163
16	14	6	151
17	17	11	135
18	49	23	262
19	14	27	144
20	14	27	130
21	18	65	224
22	12	47	161
23	3	11	97
24	0	0	0
TOTALS	156	236	1544

SEEDING AND MULCHING

THE FOLLOWING QUANTITIES ARE PROVIDED TO PROMOTE GROWTH AND CARE OF PERMANENT SEEDED AREAS:

659 - SEEDING AND MULCHING = 1544 SQ. YD.

659 - COMMERCIAL FERTILIZER 1544 SY x 1 TON/7410 SY = 0.209 TON

659 - LIME 1544 SQ. YD. x 9 / 43,560 = 0.32 ACRES

659 - WATER 1544 SY x 0.0027M. GAL/SY = 4.17 M. GAL.

TOTALS TO BE CARRIED TO THE GENERAL SUMMARY.

ITEM 621 - RPM / RPM REMOVED

STA. 1064+75 TO STA. 1072+50
 775 FT / 40 FT SPACING = 20 EA

A TOTAL OF 20 EA TO BE CARRIED TO THE GENERAL SUMMARY.

ITEM 408 - PRIME COAT

STA. 1064+75 TO STA. 1072+50
 2 x 775 FT x 2 FT / (9 SY/SF) X (0.4 GAL/SY) = 137.8 GAL

A TOTAL OF 138 GAL TO BE CARRIED TO THE GENERAL SUMMARY.

ITEM 617 - COMPACTED AGGREGATE

STA. 1064+75 TO STA. 1072+50
 2 x 775 FT x 2 FT x (3 IN / 12) / 27 = 228.7 CY

A TOTAL OF 29 CY TO BE CARRIED TO THE GENERAL SUMMARY.

ITEM 518 - POROUS BACKFILL W/ FABRIC				
STATION BASELINE OF WALL	HEIGHT	DEPTH	AREA	VOLUME
	FEET	FEET	SQ. FT.	CU. FT.
13+63.36				
	1.07	3.5	3.745	
	4.53	3.5	15.855	56.35
13+69.11				
	4.53	3.5	15.855	
	4.53	3.5	15.855	3464.32
15+87.61				
	4.53	3.5	15.855	
	1.13	3.5	42.9	168.92
15+93.36				
TOTAL (CY) CARRIED TO GENERAL SUMMARY				137



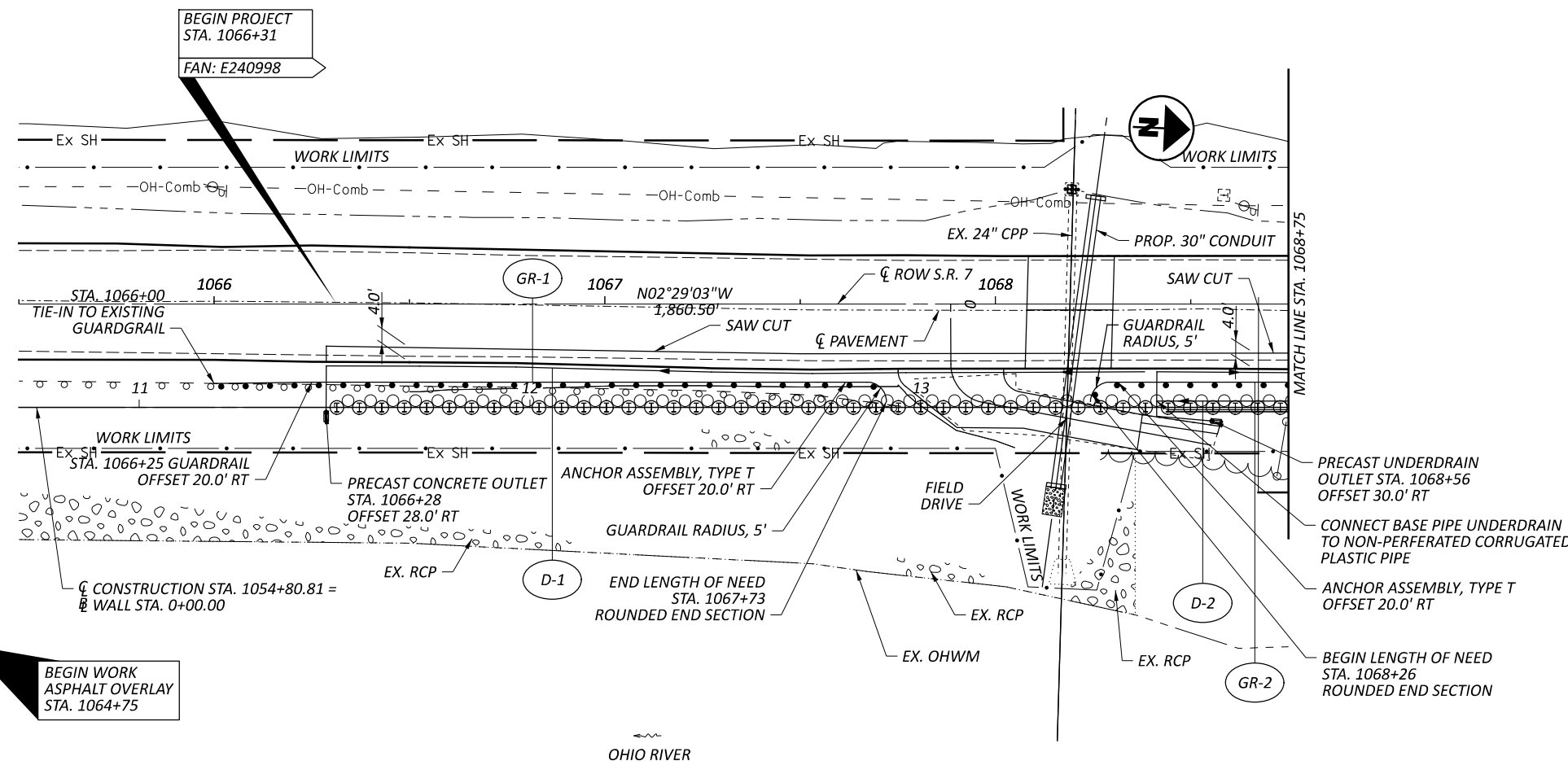

NOTE:

USE GUARDRAIL, TYPE MGS WITH LONG POSTS FROM STA. 1066+00 TO STA. 1067+73 AND FROM STA. 1068+26 TO STA. 1068+50

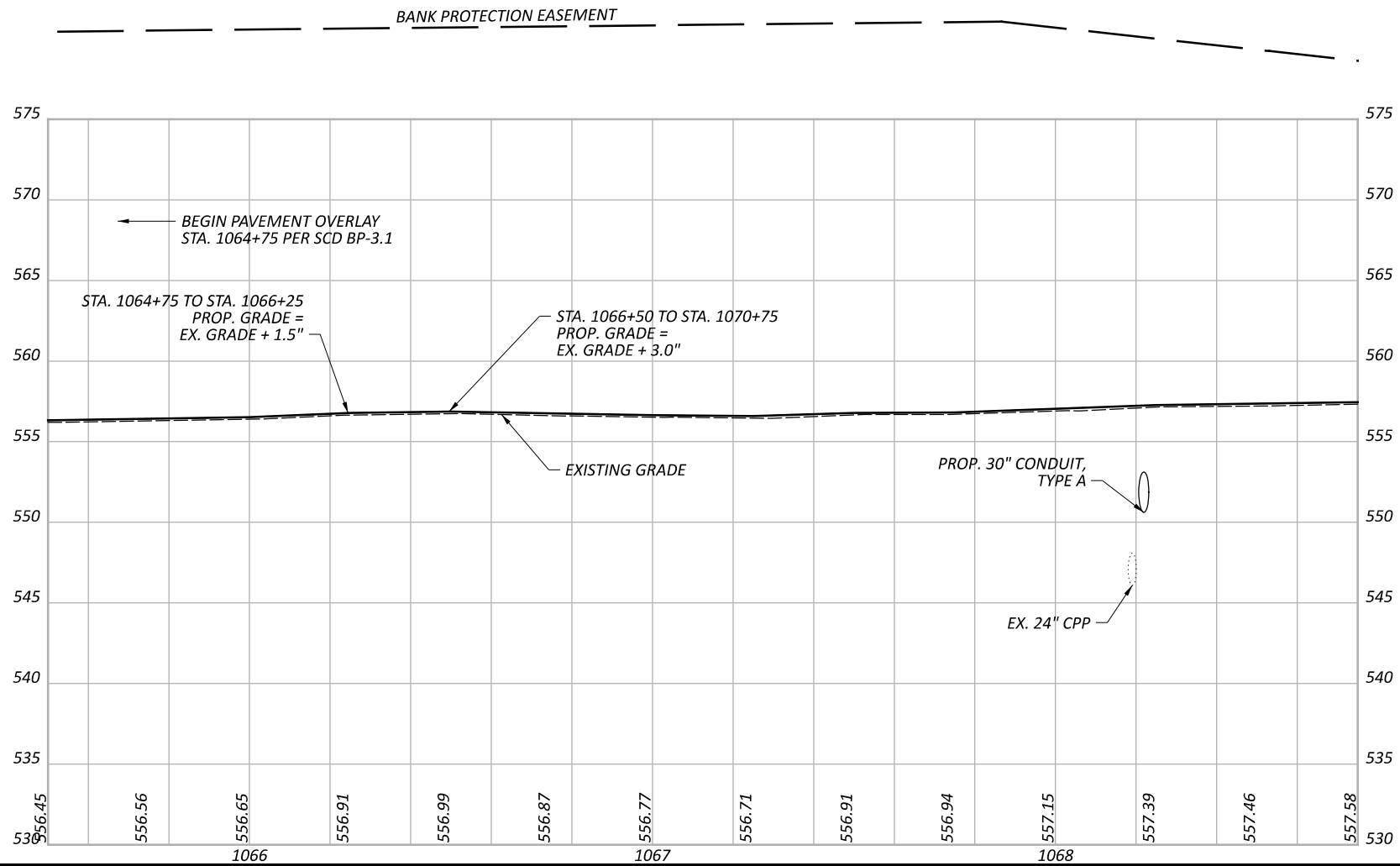
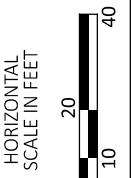

PLAN AND PROFILE
 STA 1065+50 TO STA 1068+75

DESIGN AGENCY



DESIGNER
 JDW

REVIEWER

XXX MM-DD-YY

PROJECT ID
 115533

SHEET TOTAL
 P.11 P.48

NOTE:
 USE GUARDRAIL, TYPE MGS WITH LONG POSTS
 FROM STA. 1070+50 TO STA. 1072+09

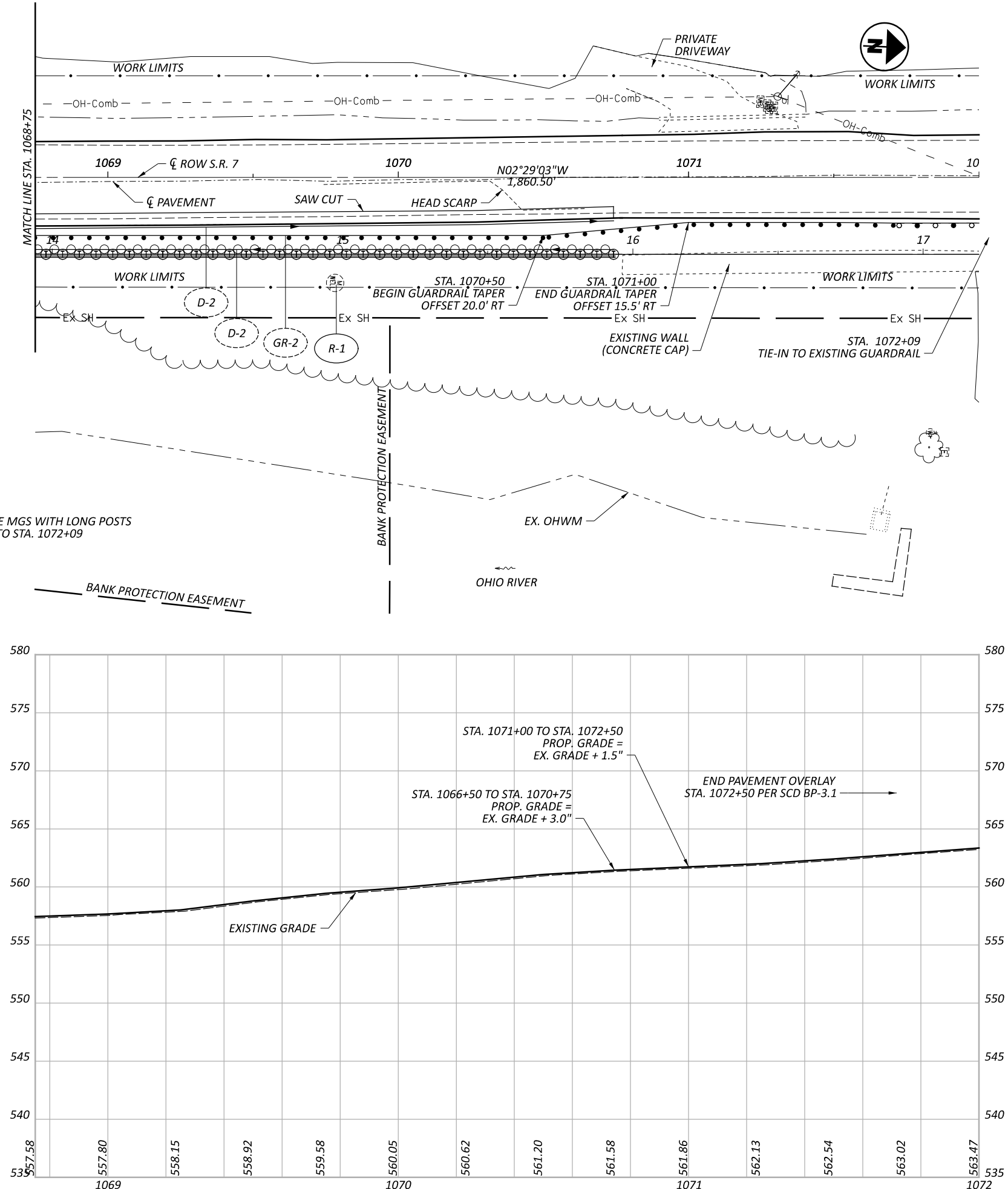

REF NO.	STATION		SIDE	QUANTITY	UNIT	TOTAL
	FROM	TO				
D-1	1066+28	1068+38	RT	1	EACH	1
D-2	1068+41	1070+74	RT	1	EACH	1
GR-1	1066+00	1067+73	RT	176	FT	176
GR-2	1068+24	1072+09	RT	38	FT	38
R-1	1069+78		RT	1	EACH	1
TOTALS CARRIED TO GENERAL SUMMARY				1		1
				202	REMOVAL, MISC. STAND PIPE	202
				202	GUARDRAIL REMOVED	202
				202	ANCHOR ASSEMBLY REMOVED	202
				518	6" PERF. CORR. PLASTIC PIPE	518
				518	6" NON-PERF. CORR. PLASTIC PIPE	518
				605	4" BASEPIPE UNDERDRAIN	605
				606	GUARDRAIL, TYPE MGS	606
				606	GUARDRAIL, TYPE MGS W/LONG POSTS	606
				606	ANCHOR ASSEMBLY, TYPE T	606
				606	ROUNDED END SECTION	606
				611	PRECAST RE-INFORCED CONC. OUTLET	611
				626	BARRIER REFLECTOR, TYPE 2	626

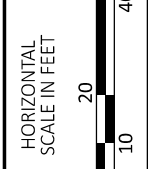

PLAN AND PROFILE
 STA 1068+75 TO STA 1072+00

SEEDING	
END WIDTH	SO. YDS.
	49

10	
28	
10	
77	

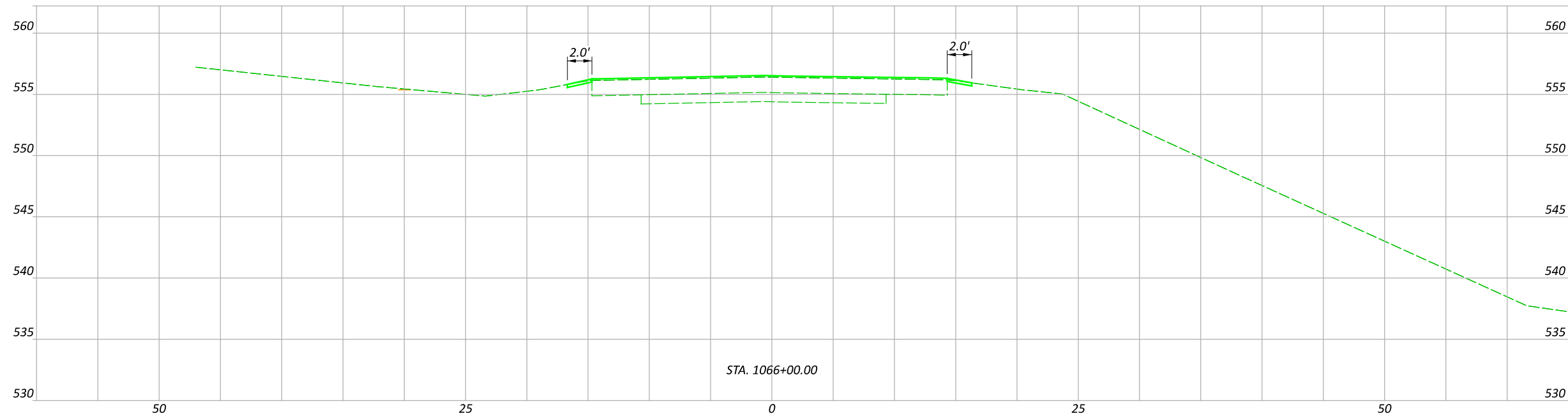
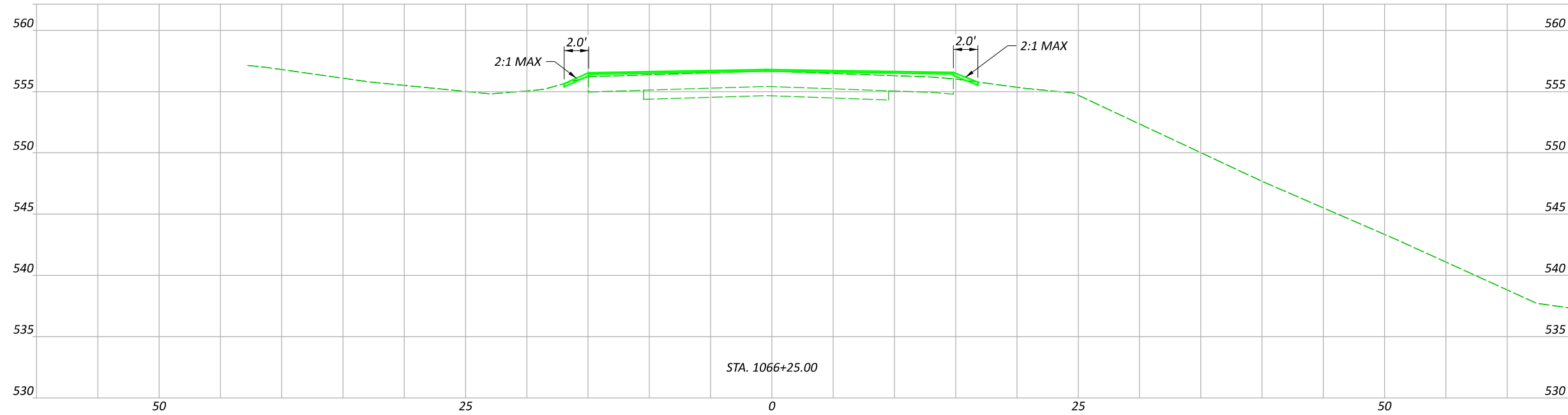

END AREA		VOLUME	
CUT	FILL	CUT	FILL
		3	5
0	0		
		0	0
0	0		
		3	5

CROSS SECTIONS
 FROM STA. 1066+00 TO STA. 1066+25

DESIGN AGENCY

 DESIGNER
 JDW
 REVIEWER
 XXX MM-DD-YY
 PROJECT ID
 115533
 SHEET TOTAL
 P.14 P.48

SEEDING	
END WIDTH	SO. YDS.
	85

31

78

25

163

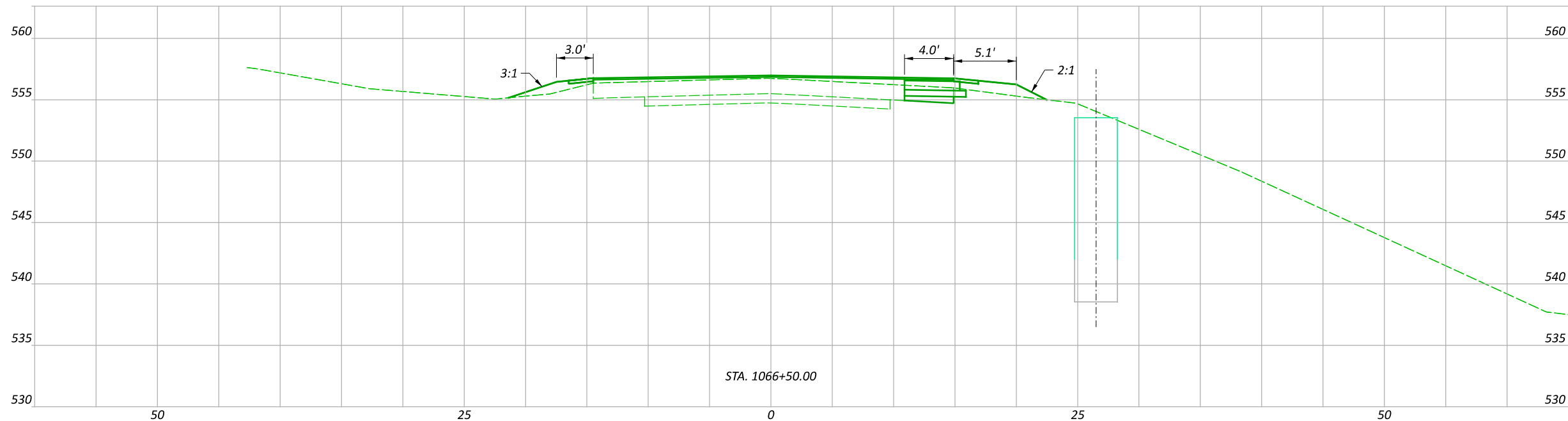
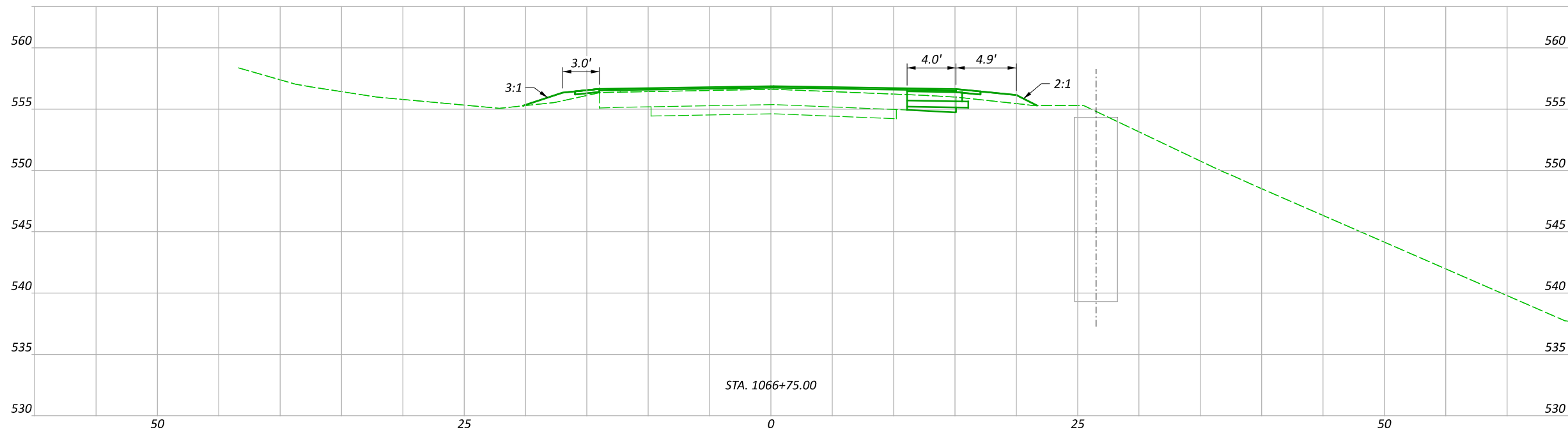

END WIDTH	END AREA		VOLUME	
	CUT	FILL	CUT	FILL
85			6	6
31	6	7		
78			6	8
25	6	10		
163			12	14

CROSS SECTIONS
 FROM STA. 1066+50 TO STA. 1066+75

DESIGN AGENCY



DESIGNER
 JDW

REVIEWER
 XXX MM-DD-YY

PROJECT ID
 115533

SHEET TOTAL
 P.15 P.48

SEEDING	
END WIDTH	SO. YDS.
73	
26	
78	
30	
151	

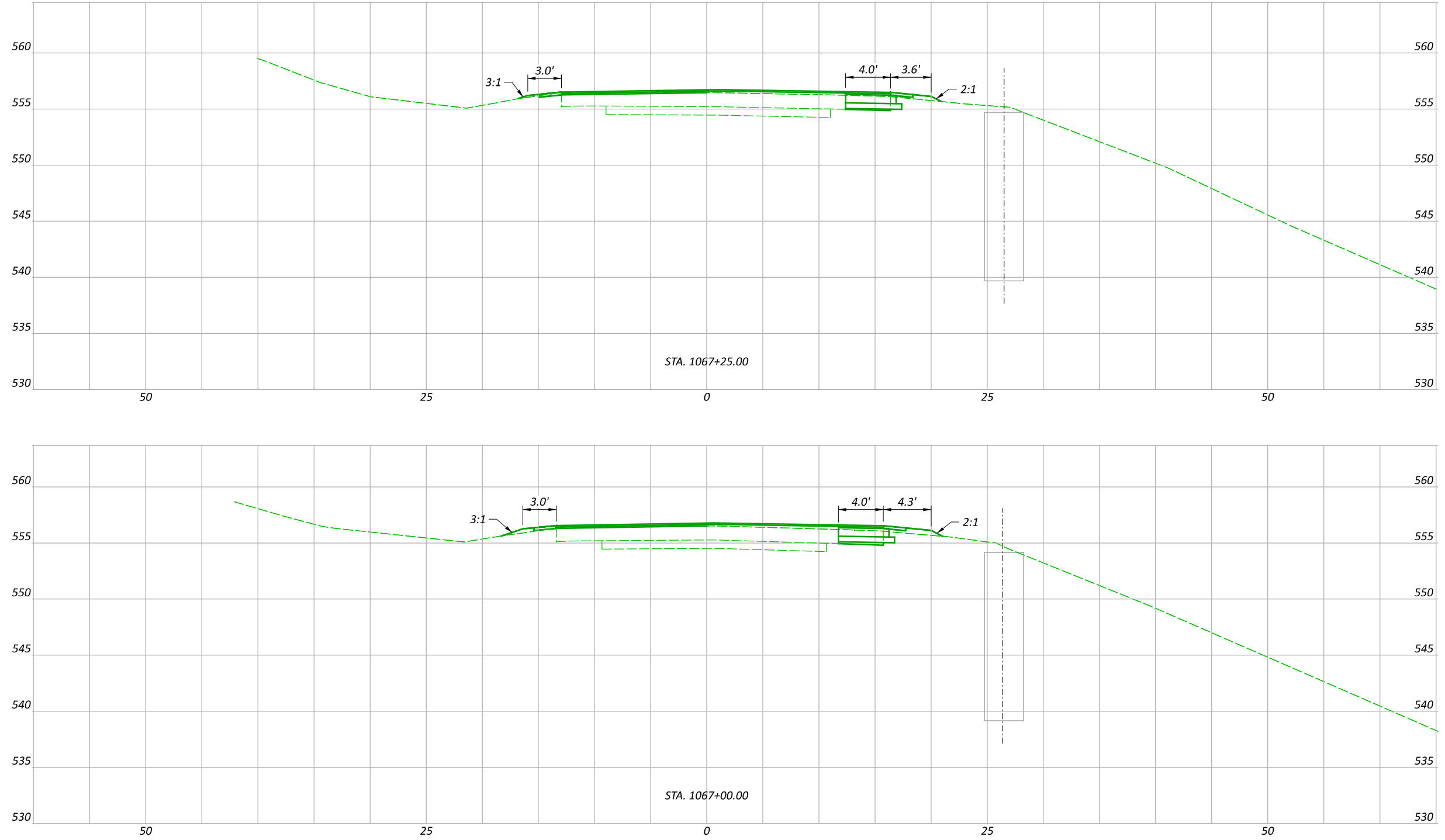

END AREA		VOLUME	
CUT	FILL	CUT	FILL
		7	3
7	2		
		7	3
6	4		
		14	6

CROSS SECTIONS
 FROM STA. 1067+00 TO STA. 1067+25

DESIGN AGENCY

 DESIGNER
 JDW
 REVIEWER
 XXX MM-DD-YY
 PROJECT ID
 115533
 SHEET TOTAL
 P.16 P.48

SEEDING	
END WIDTH	SO. YDS.
62	

26

73

26

135

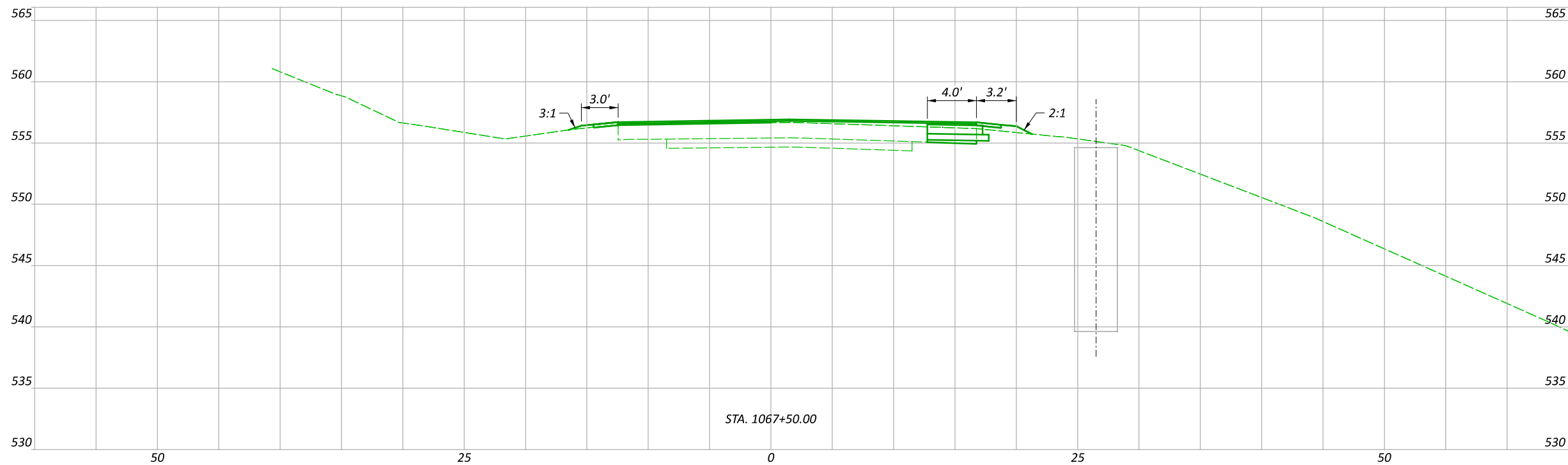
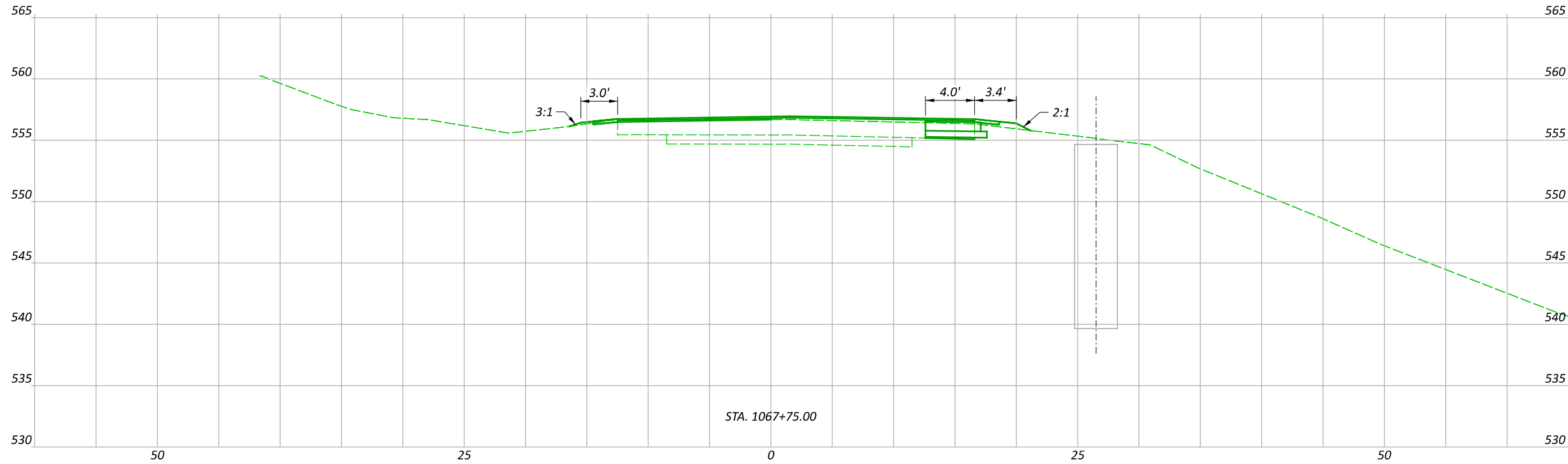

END WIDTH	END AREA		VOLUME	
	CUT	FILL	CUT	FILL
62			10	8
73	7	3	7	3
135	6	3	17	11
TOTAL			P.17	P.48

CROSS SECTIONS
 FROM STA. 1067+50 TO STA. 1067+75

DESIGN AGENCY



DESIGNER
 JDW

REVIEWER
 XXX MM-DD-YY

PROJECT ID
 115533

SHEET TOTAL
 P.17 P.48

SEEDING	
END WIDTH	SO. YDS.
	138

71

124

18

262

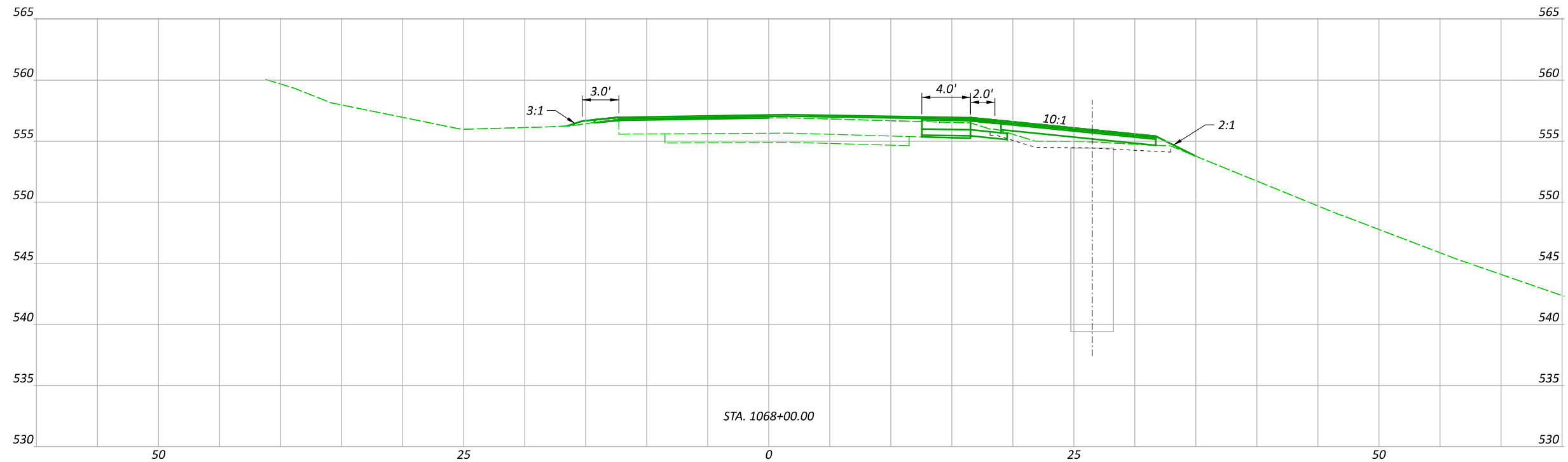
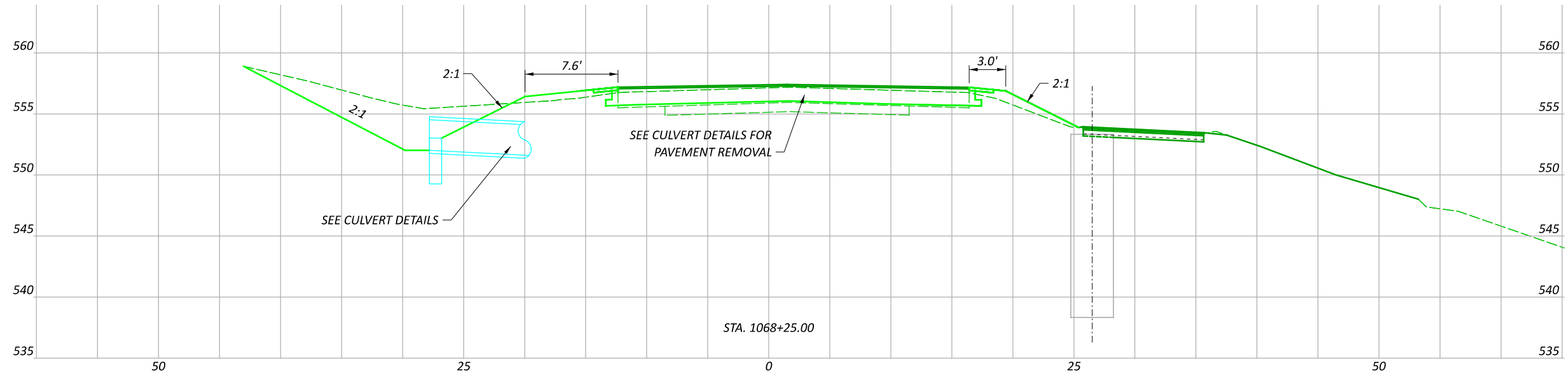

END	AREA		VOLUME	
	CUT	FILL	CUT	FILL
			23	12
41		10		
		26	11	
14		13		
		49	23	

CROSS SECTIONS
 FROM STA. 1068+00 TO STA. 1068+25

DESIGN AGENCY



DESIGNER
 JDW
 REVIEWER
 XXX MM-DD-YY
 PROJECT ID
 115533
 SHEET TOTAL
 P.18 P.48

SEEDING	
END WIDTH	SO. YDS.
25	70
74	
28	
144	

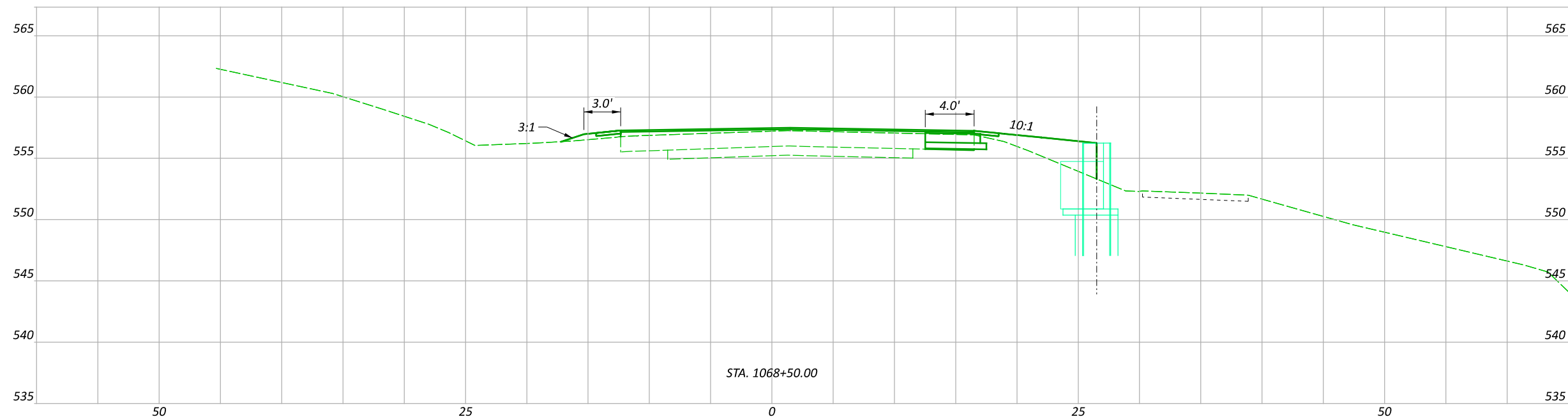
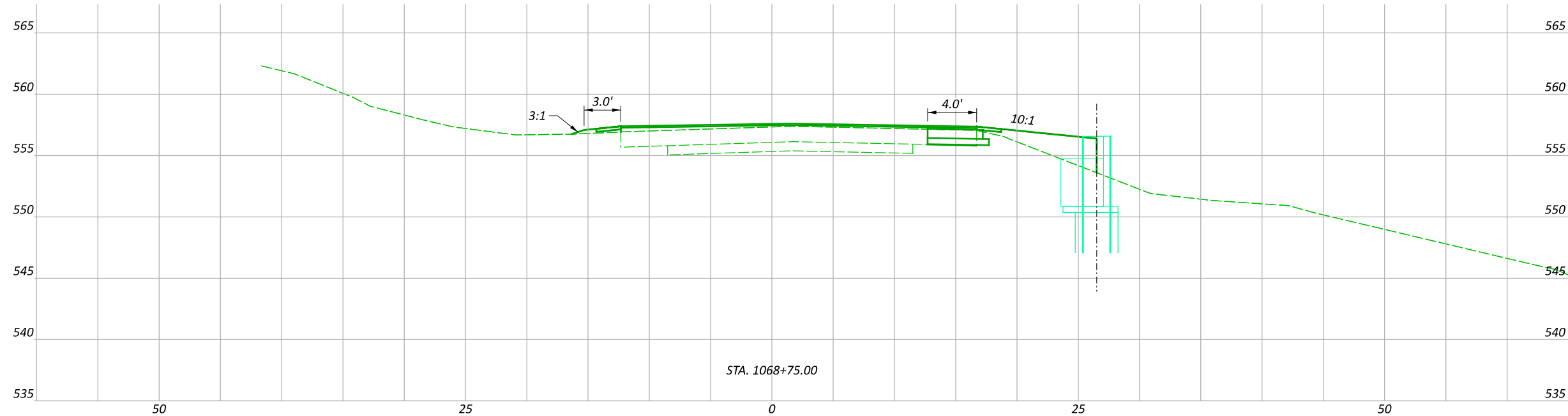

END	AREA		VOLUME	
	CUT	FILL	CUT	FILL
			7	13
25	7	15		
74			7	14
28	7	15		
144			14	27

CROSS SECTIONS
 FROM STA. 1068+50 TO STA. 1068+75

DESIGN AGENCY



DESIGNER
 JDW

REVIEWER
 XXX MM-DD-YY

PROJECT ID
 115533

SHEET TOTAL
 P.19 P.48

SEEDING	
END WIDTH	SQ. YDS.
66	
21	
64	
25	
130	

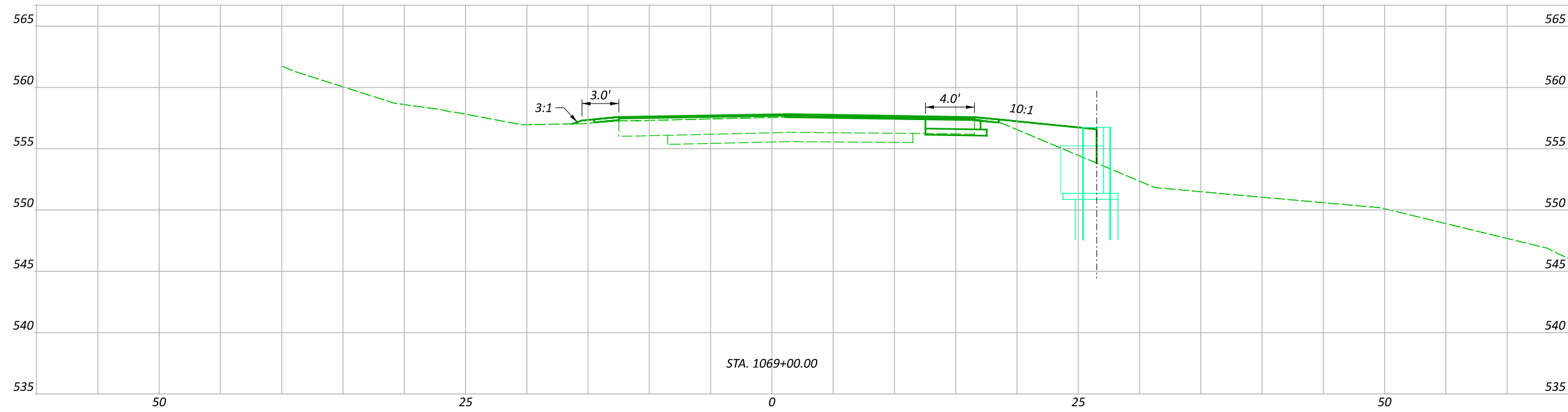
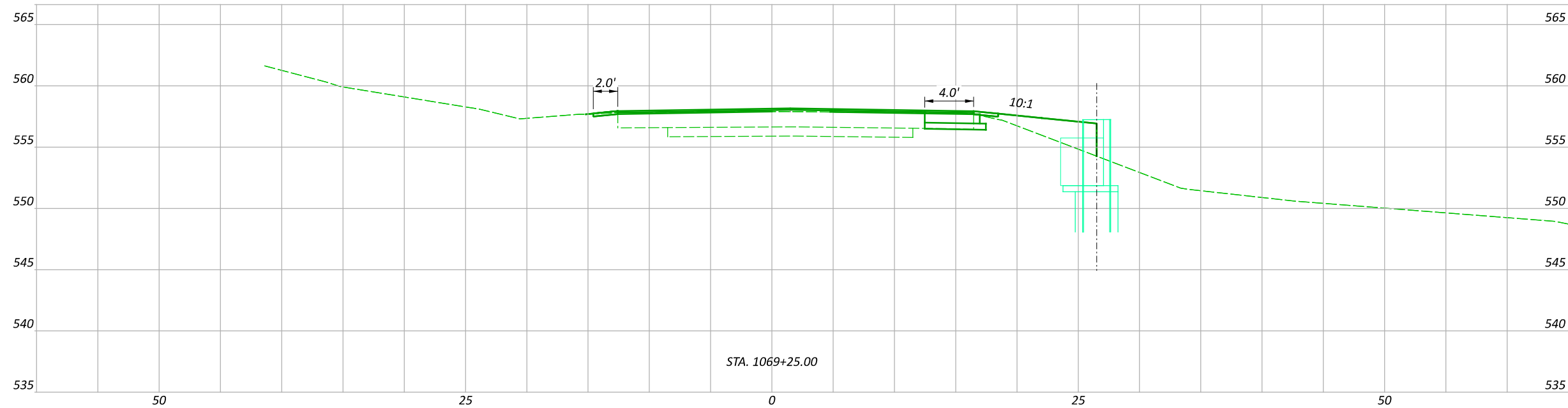

END WIDTH	END AREA		VOLUME	
	CUT	FILL	CUT	FILL
66			7	15
21			7	12
64			7	12
25			7	12
130			14	27

CROSS SECTIONS
 FROM STA. 1069+00 TO STA. 1069+25

DESIGN AGENCY

 DESIGNER: JDW
 REVIEWER: XXX MM-DD-YY
 PROJECT ID: 115533
 SHEET: P.20 TOTAL: P.48

SEEDING	
END WIDTH	SQ. YDS.
77	
27	
74	
26	
73	
26	
224	

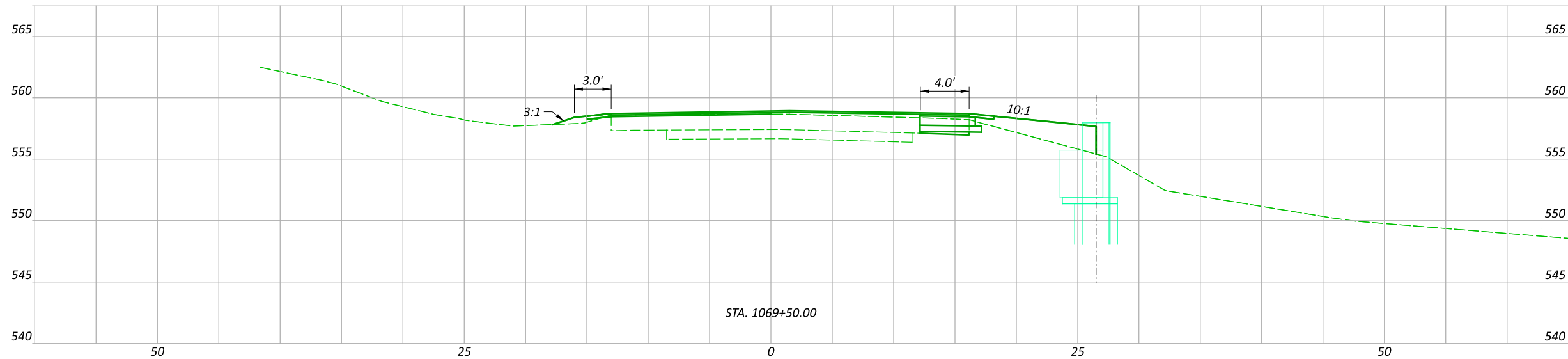
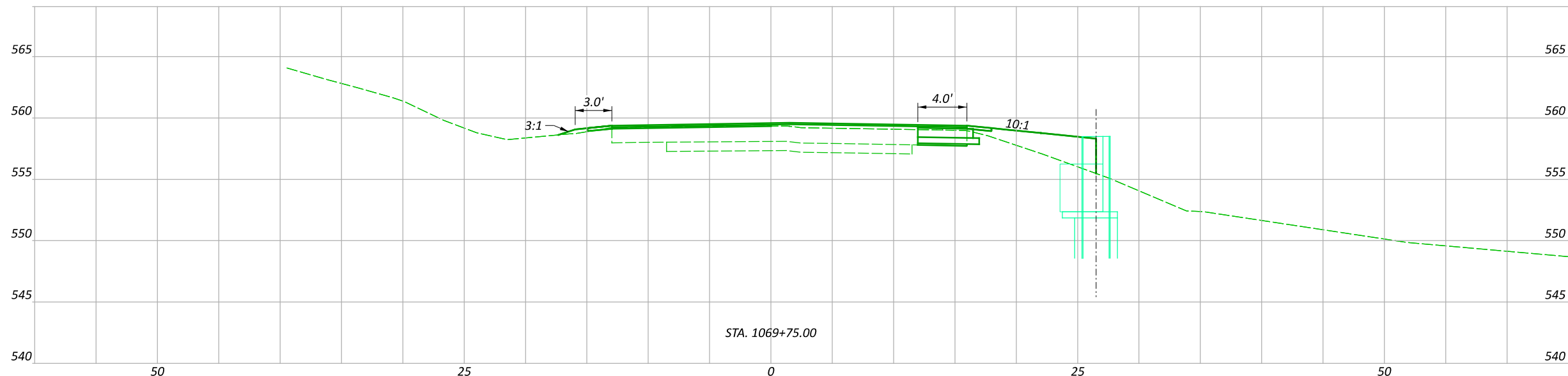
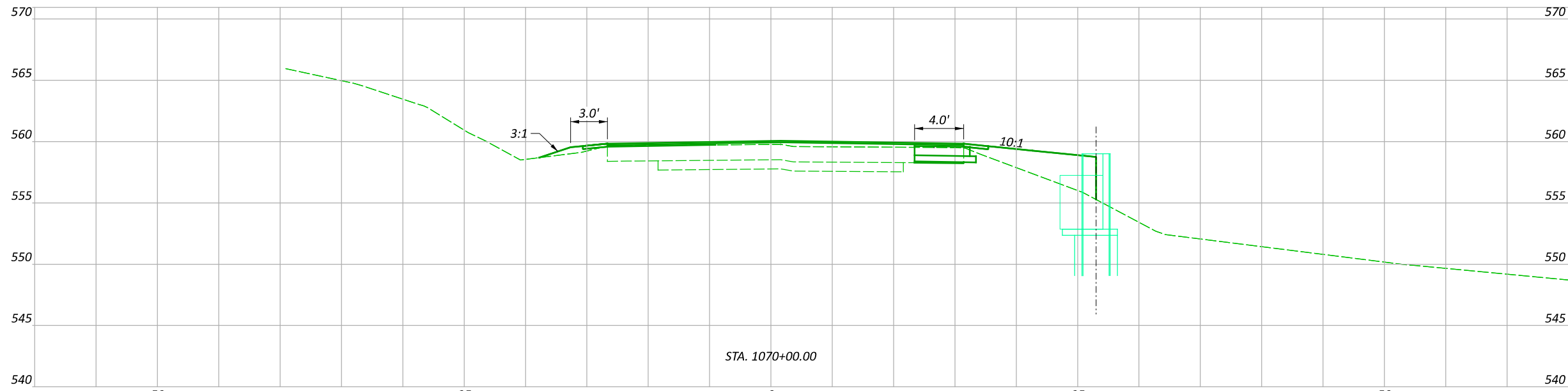

END AREA		VOLUME	
CUT	FILL	CUT	FILL
		6	25
6	29		
		6	22
6	18		
		6	18
6	19		
		18	65
P.21	TOTAL P.48		

CROSS SECTIONS
 FROM STA. 1069+50 TO STA. 1070+00

DESIGN AGENCY



DESIGNER

JDW

REVIEWER

XXX MM-DD-YY

PROJECT ID

115533

SHEET TOTAL

P.21 P.48

SEEDING	
END WIDTH	SO. YDS.
	81

29

80

28

161

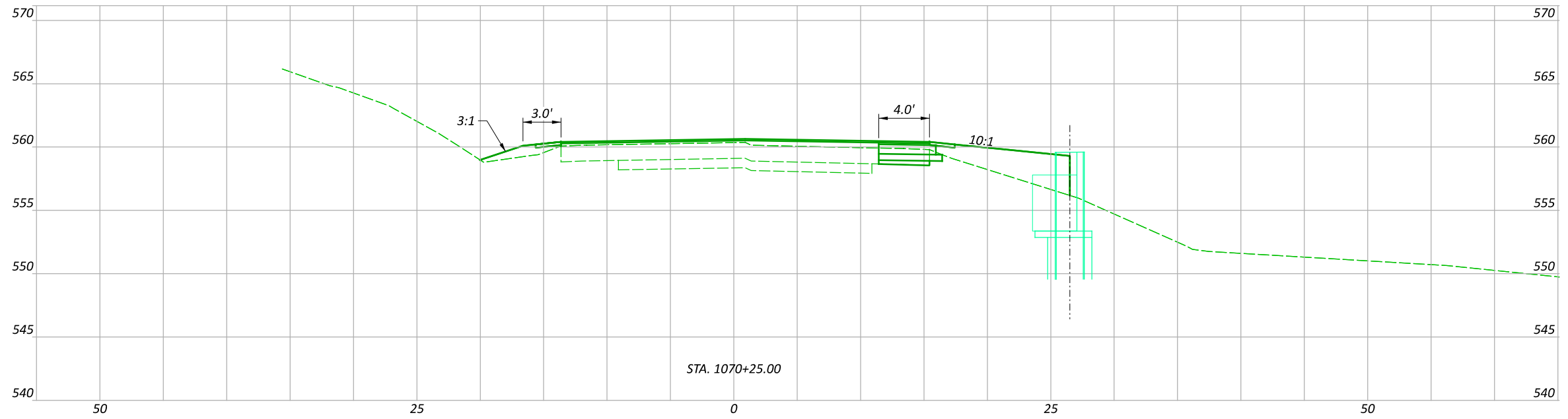
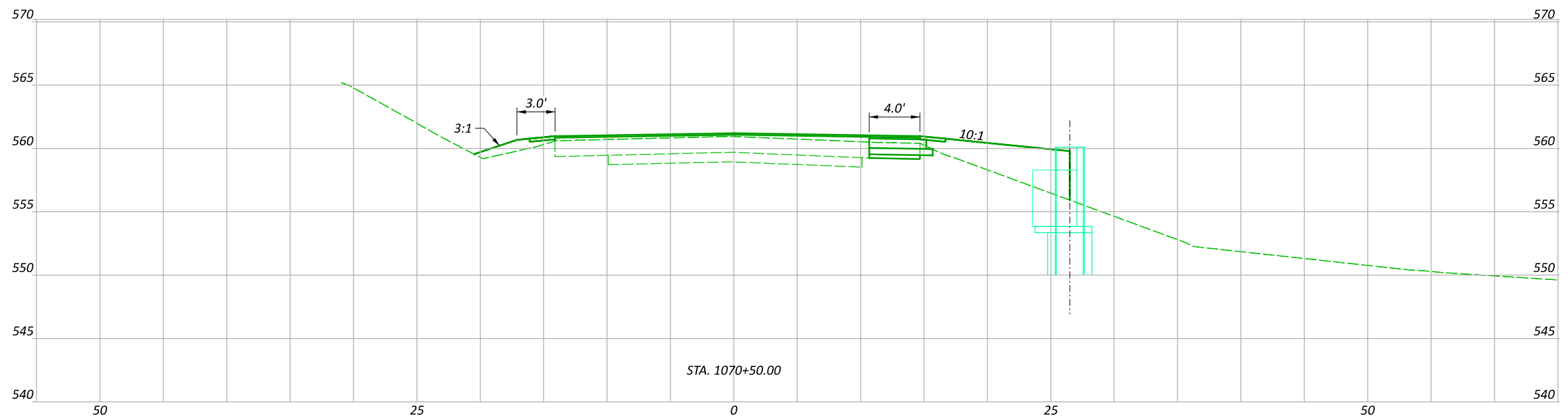

END AREA	VOLUME	CUT		FILL	
		CUT	FILL	CUT	FILL
				6	23
6	27				
				6	24
6	23				
		12	47		

CROSS SECTIONS
 FROM STA. 1070+25 TO STA. 1070+50

DESIGN AGENCY



DESIGNER
 JDW

REVIEWER
 XXX MM-DD-YY

PROJECT ID
 115533

SHEET TOTAL
 P.22 P.48

SEEDING	
END WIDTH	SQ. YDS.
14	
10	
28	
10	
55	
29	
97	

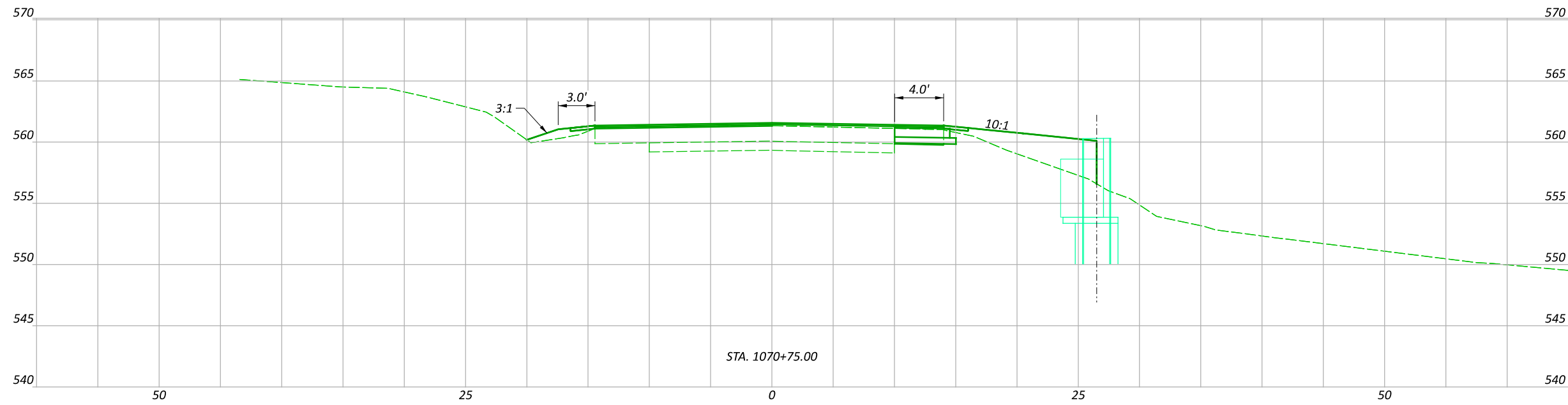
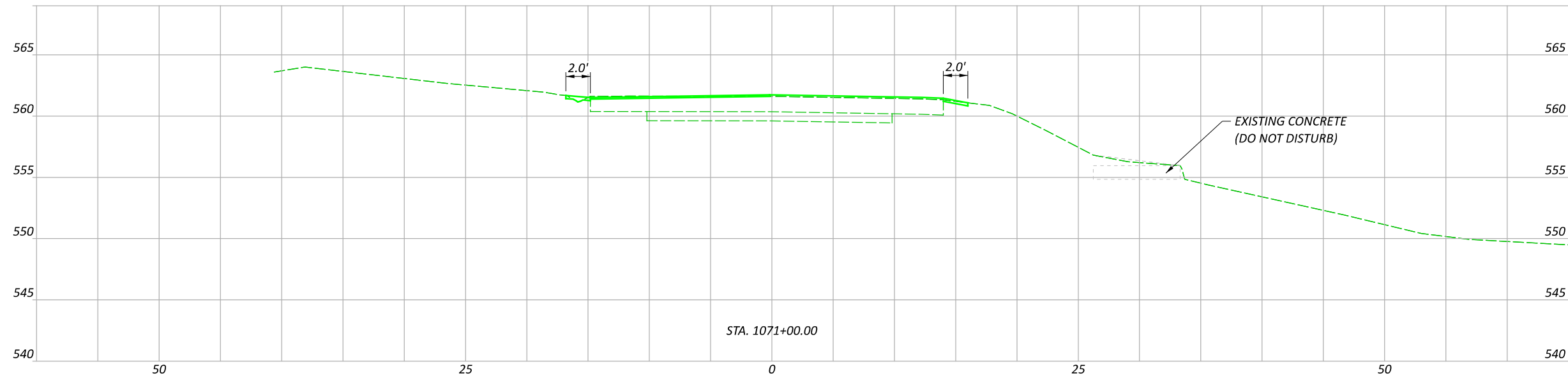
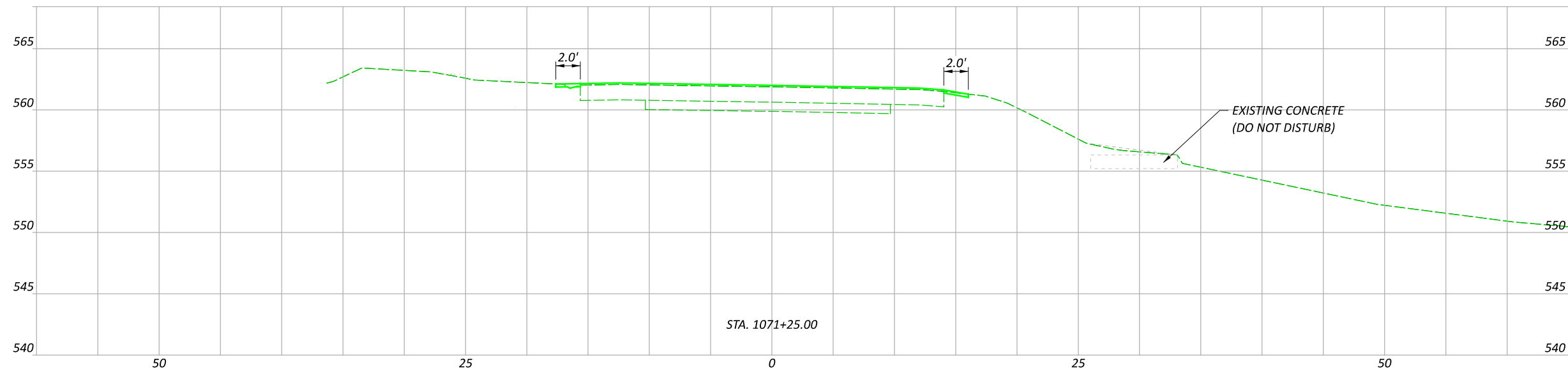

END AREA		VOLUME	
CUT	FILL	CUT	FILL
0	0	0	0
0	0	0	0
0	0	3	11
6	22	3	11
		TOTAL	TOTAL
		P.23	P.48

CROSS SECTIONS
 FROM STA. 1070+75 TO STA. 1071+25

DESIGN AGENCY

 DESIGNER
 JDW
 REVIEWER
 XXX MM-DD-YY
 PROJECT ID
 115533
 SHEET TOTAL
 P.23 P.48

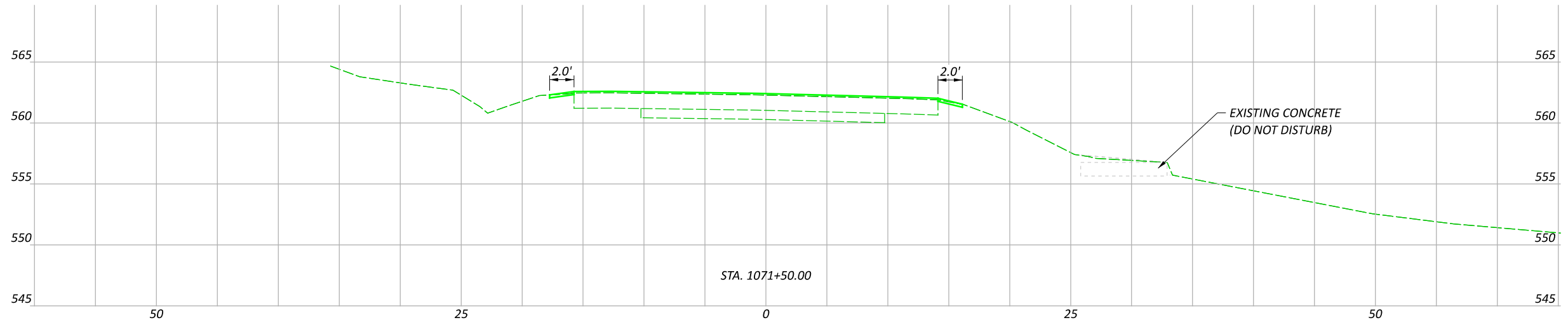
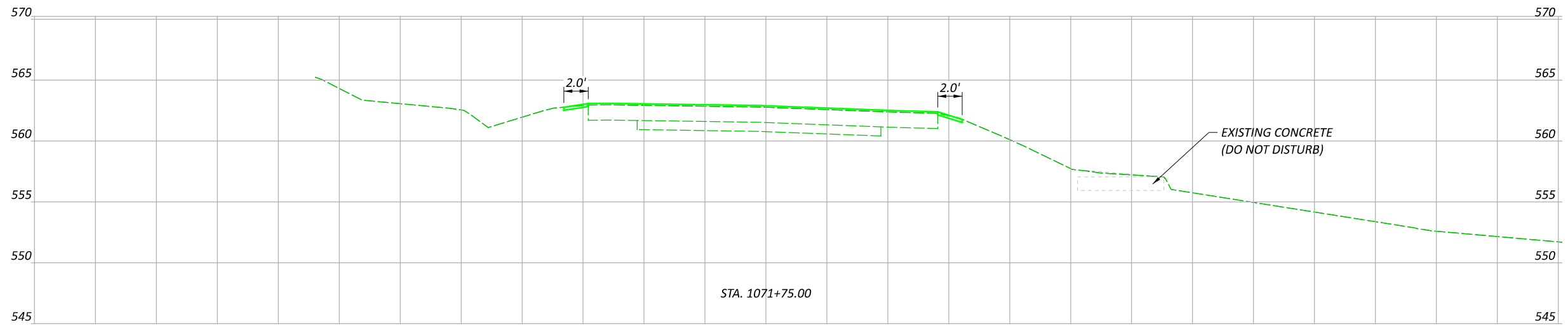
SEEDING	
END WIDTH	SO. YDS.
0	0



	END AREA		VOLUME	
	CUT	FILL	CUT	FILL
	0	0	0	0
TOTAL	0	0	0	0

CROSS SECTIONS
FROM STA. 1071+50 TO STA. 1071+75

DESIGN AGENCY



DESIGNER

JDW

REVIEWER

XXX MM-DD-YY

PROJECT ID

115533

SHEET TOTAL

P.24 | P.48

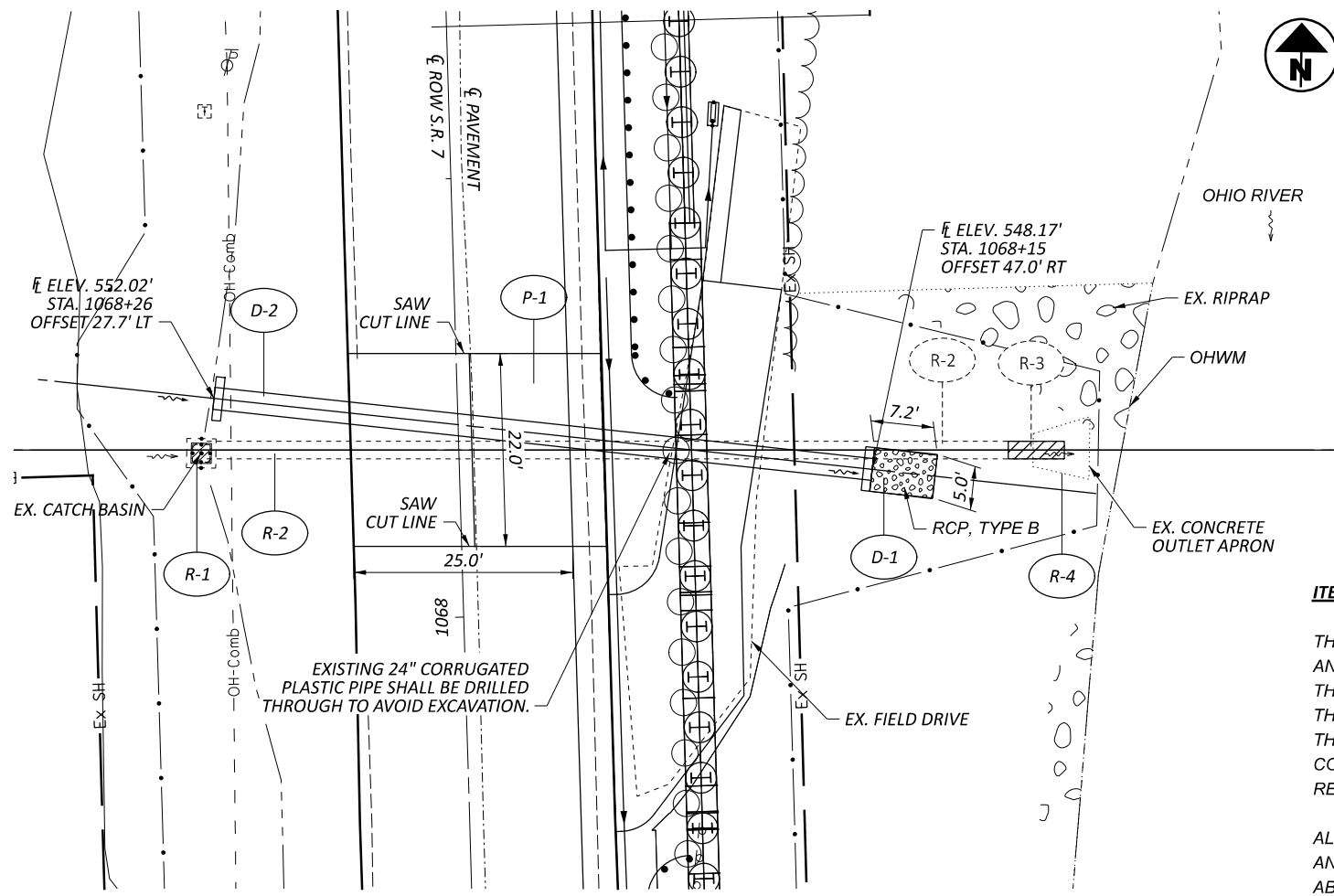

ITEM 601 - RCP, TYPE B WITH FILTER, AS PER PLAN

WORK SHALL BE DONE IN ACCORDANCE WITH CMS 601 FOR ITEM 601 - RCP, TYPE B WITH FILTER, APP. EXCEPT THE MATERIAL SHALL BE OBTAINED FROM THE EXISTING RIPRAP THAT IS EXCAVATED TO INSTALL THE PROPOSED CONDUIT AND OR THE EXISTING CONCRETE APRON.

ITEM 202 - REMOVAL, MISC.: CONCRETE OUTLET APRON

EXISTING CONCRETE OUTLET APRON SHALL BE BROKEN AND LEFT IN PLACE UNLESS IT IS NEEDED FOR ITEM 601 - ROCK CHANNEL PROTECTION TYPE B WITH FILTER, AS PER PLAN. EACH BROKEN PIECE SHALL NOT EXCEED 2 FOOT IN SIZE. EXPOSED CONCRETE REINFORCING IN THE CONCRETE SHALL BE REMOVED, SUCH THAT NO PIECE OF REINFORCING EXTENDS BEYOND 2 INCHES FROM THE CONCRETE SURFACE.

ITEM 202 - PAVEMENT REMOVED, AS PER PLAN

THIS ITEM CONSISTS OF REMOVING THE EXISTING ASPHALT AND CONCRETE PAVEMENT FROM STA. 1068+08 TO STA. 1068+30. THE DEPTH OF THE PAVEMENT MAY VARY. SOIL BORINGS INDICATE THE ASPHALT PAVEMENT TO BE APPROXIMATELY 15" THICK AND THE CONCRETE PAVEMENT TO BE APPROXIMATELY 10". THE CONTRACTOR SHALL REMOVE PAVEMENT AS SHOWN, REGARDLESS OF THE DEPTH ENCOUNTERED IN THE FIELD.

ALL EQUIPMENT, MATERIALS, INCIDENTALS, PAVEMENT SAWING, AND LABOR REQUIRED TO PERFORM THE WORK OUTLINED ABOVE SHALL BE INCLUDED FOR PAYMENT UNDER:

ITEM 202 - PAVEMENT REMOVED, AS PER PLAN - SY

CALCULATIONS:
ITEM 441 - ASPHALT CONCRETE INTERMEDIATE COURSE, TYPE 1, (448) PG64-22, 1.5"

$25.0 \text{ FT} \times 22.0 \text{ FT} \times (T=1.5 \text{ IN})/12/27 = 2.5 \text{ CU. YDS.}$

ITEM 301 - ASPHALT CONCRETE BASE PG64-22, (449) 9"

$25.5 \text{ FT} \times 22.0 \text{ FT} \times (T=9 \text{ IN})/12/27 = 15.6 \text{ CU. YDS.}$

ITEM 304 - AGGREGATE BASE, 6"

$26.0 \text{ FT} \times 22.0 \text{ FT} \times (T=6 \text{ IN})/12/27 = 10.6 \text{ CU. YDS.}$

ITEM 511 - CLASS QC MS CONCRETE (12.3 FT LT TO 16.4 FT RT)

$(A=51.8 \text{ SQ. FT.}) \times (L=12.3'+16.4')/27 = 55.1 \text{ CU. YDS.}$

ITEM 407 - NON-TRACKING TACK COAT

$25.0 \text{ FT} \times 22.0 \text{ FT} / 9 \times 0.05 = 3.1 \text{ GAL}$

ITEM 601 - ROCK CHANNEL PROTECTION, TYPE B, W/ FILTER

$7.2 \text{ FT} \times 5.0 \text{ FT} \times 2.0 \text{ FT} / 27 = 2.7 \text{ CY}$

ITEM 202 - PAVEMENT REMOVED, APP

$25.0 \text{ FT} \times 22.0 \text{ FT} / (9 \text{ SF/SY}) = 61.1 \text{ SY}$

ESTIMATED QUANTITIES

REF.	ITEM	QUANTITY	UNIT	DESCRIPTION
R-1	202	1	EACH	CATCH BASIN REMOVED
R-4	202	1	EACH	REMOVAL, MISC.: CONC. OUTLET APRON
R-2	202	93	FT	FILL AND PLUG EXISTING CONDUIT, 24"
R-3	202	5	FT	PIPE REMOVED, 24" DIAMETER AND UNDER
P-1	202	62	SY	PAVEMENT REMOVED, APP
P-1	301	16	CY	9" ASPHALT CONC. BASE PG64-22
P-1	304	11	CY	6" AGGREGATE BASE
P-1	407	4	GAL	NON-TRACKING TACK
P-1	441	3	CY	1.5" ASPHALT CONC. INT. COURSE (448)
D-1	601	3	CY	RCP, TYPE B WITH FILTER, APP
D-2	602	1.2	CY	CONCRETE MASONRY
D-2	611	75	FT	30" CONDUIT, TYPE A
D-2	503	LUMP	LS	COFFERDAMS AND EXCAVATION BRACING
P-1	511	56	CY	CLASS QC MS CONCRETE

HYDRAULIC DATA

DRAINAGE AREA = 12.2 ACRES
 Q (4%) = 20.7 CFS V (4%) = 13.1 FT/S HW (4%) = 554.3 FT
 Q (10%) = 17.7 CFS V (10%) = 12.6 FT/S HW (10%) = 554.1 FT
 ORDINARY HIGH WATER MARK: N/A
 DESIGN SERVICE LIFE: 20 YEARS
 ABRASION LEVEL: N/A
 pH: 7

EXISTING STRUCTURE

TYPE: CORRUGATED PLASTIC PIPE
 SIZE: 24"
 SKEW: 01° 39' 59" L.F.
 ALIGNMENT: TANGENT
 DATE BUILT: UNKNOWN
 CONDITION: POOR
 CFN: 1981270

PROPOSED STRUCTURE

TYPE: 75' - 30" CONDUIT, TYPE A
 SKEW: 07° 49' 34" L.F.
 ALIGNMENT: TANGENT
 CFN: 1996556

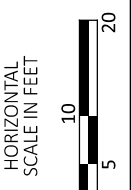
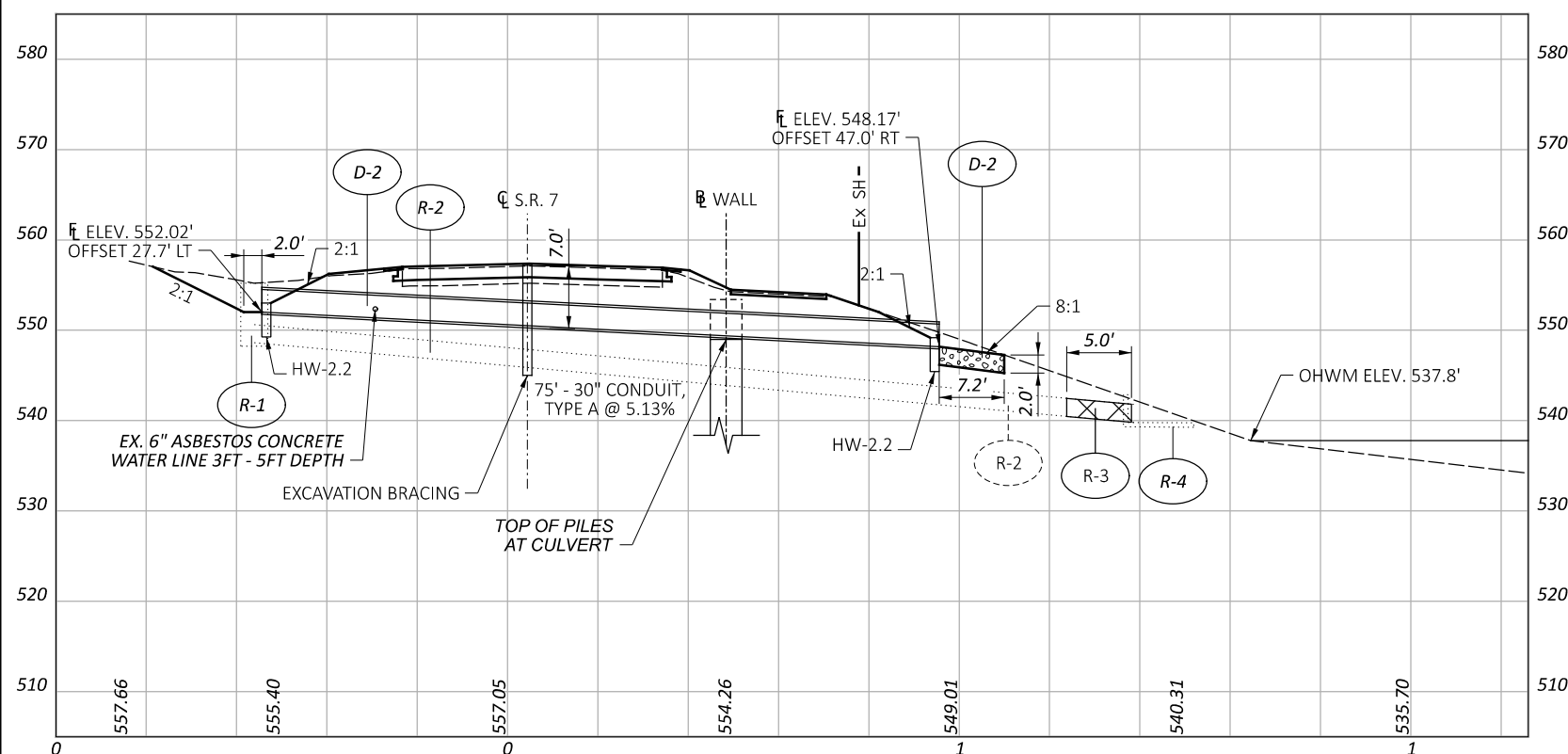

CULVERT DETAILS
 STA. 1068+21

DESIGN AGENCY



DESIGNER
 JDW

REVIEWER

XXX MM-DD-YY

PROJECT ID
 115533

SUBSET TOTAL
 0 0

SHEET TOTAL
 P.25 P.48

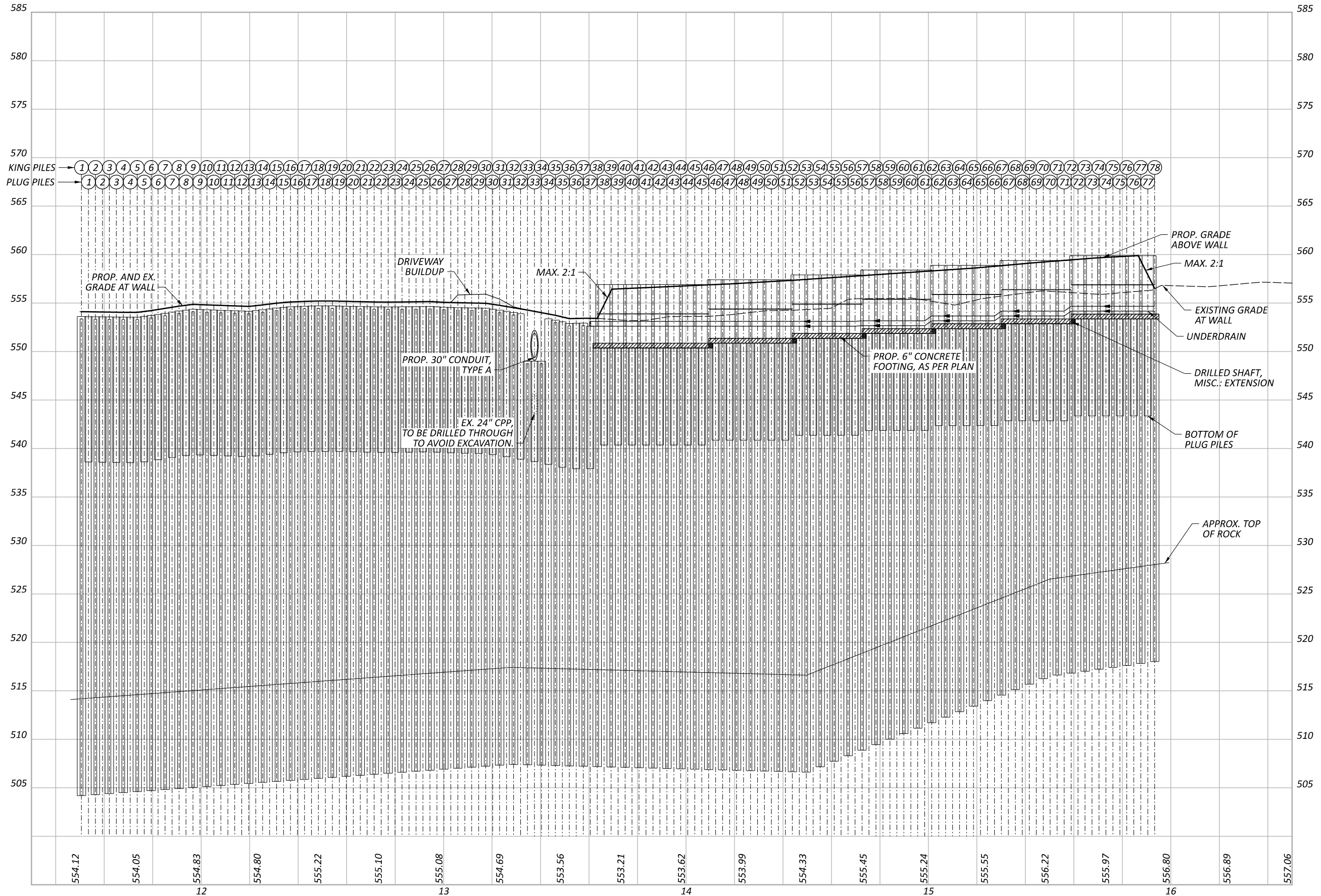

DRILLED SHAFT DETAILS
WALL PROFILE

DESIGN AGENCY



DESIGNER
JDW
 REVIEWER
XXX MM-DD-YY
 PROJECT ID
115533
 SHEET TOTAL
P.26 P.48

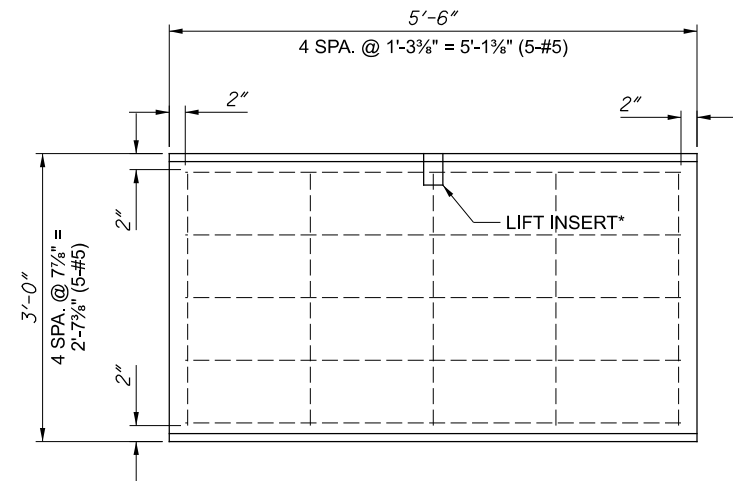

PRE-CAST CONCRETE PANEL A

TOTAL REQUIRED = 80, QUANTITY CARRIED TO GENERAL SUMMARY

1" CHAMFER ON FACE (TYP.)

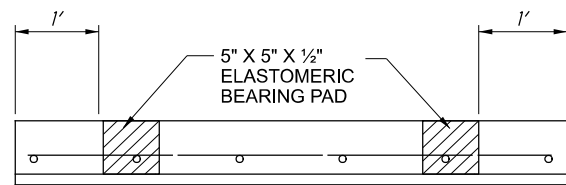
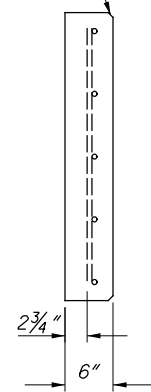

ELASTOMERIC BEARING PAD TYPICAL DETAIL.**

NOTES:

- * PRECAST PANEL MANUFACTURER TO DESIGN LIFT INSERT. MANUFACTURER TO DETERMINE NUMBER OF INSERTS FOR EACH PANEL.
- ** PRICE OF ELASTOMERIC BEARING PADS SHALL BE INCLUDED IN THE UNIT PRICE OF THE PRECAST CONCRETE PANELS.

CALCULATIONS

ITEM 530 - SPECIAL - RETAINING WALL, PRECAST CONCRETE LAGGING
 A = 80 EACH X (3.0 FT X 5.5 FT) = 1,320 SF

A TOTAL OF 1,320 SF TO BE CARRIED TO THE GENERAL SUMMARY.

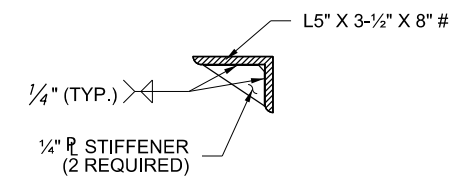
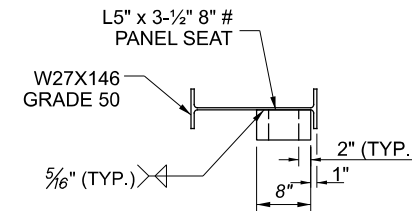
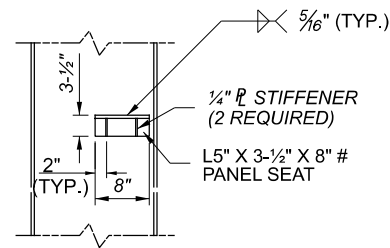

PANEL SEAT DETAIL.

PANEL SEAT, STIFFENERS FOR PANEL SEAT STEEL IS INCLUDED IN PAYMENT FOR ITEM 507 - SOLDIER PILE, MISC.: SOLDIER PILES W27X146.

NOTE:
 THE PANEL SEAT MAY BE NON-PERFORMED IF THE CONCRETE FOOTING IS PLACED PRIOR TO THE PRECAST CONCRETE LAGGING.

IF THE PRECAST CONCRETE LAGGING IS TO BE PLACED PRIOR TO THE CONCRETE FOOTING THEN THE PANELS SEATS SHALL BE PLACED ON EACH BEAM, FOR EITHER SIDE OF THE PRECAST CONCRETE LAGGING.

DESIGN AGENCY



DESIGNER

JDW

REVIEWER

XXX MM-DD-YY

PROJECT ID

115533

SHEET TOTAL

P.27 P.48

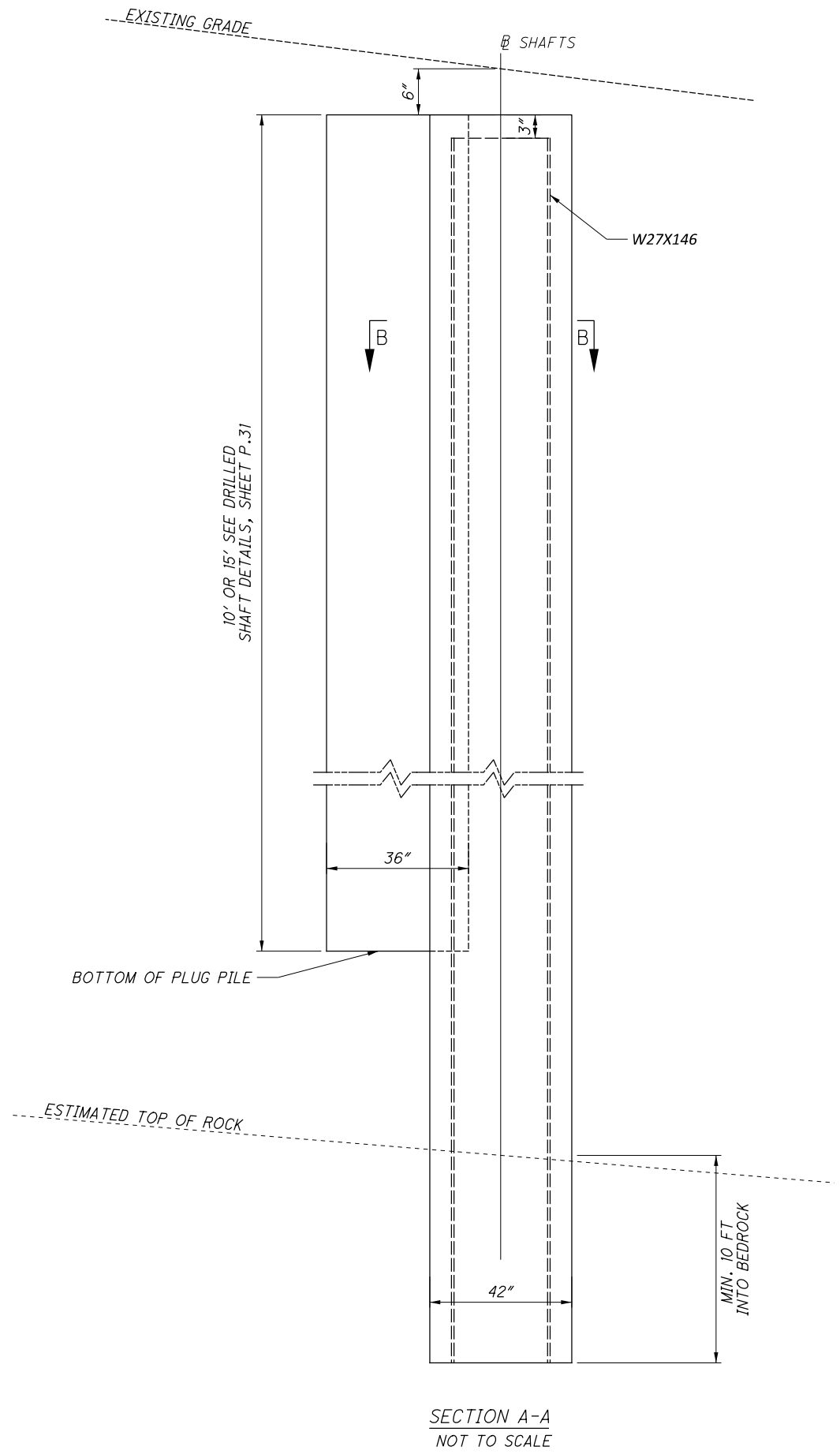
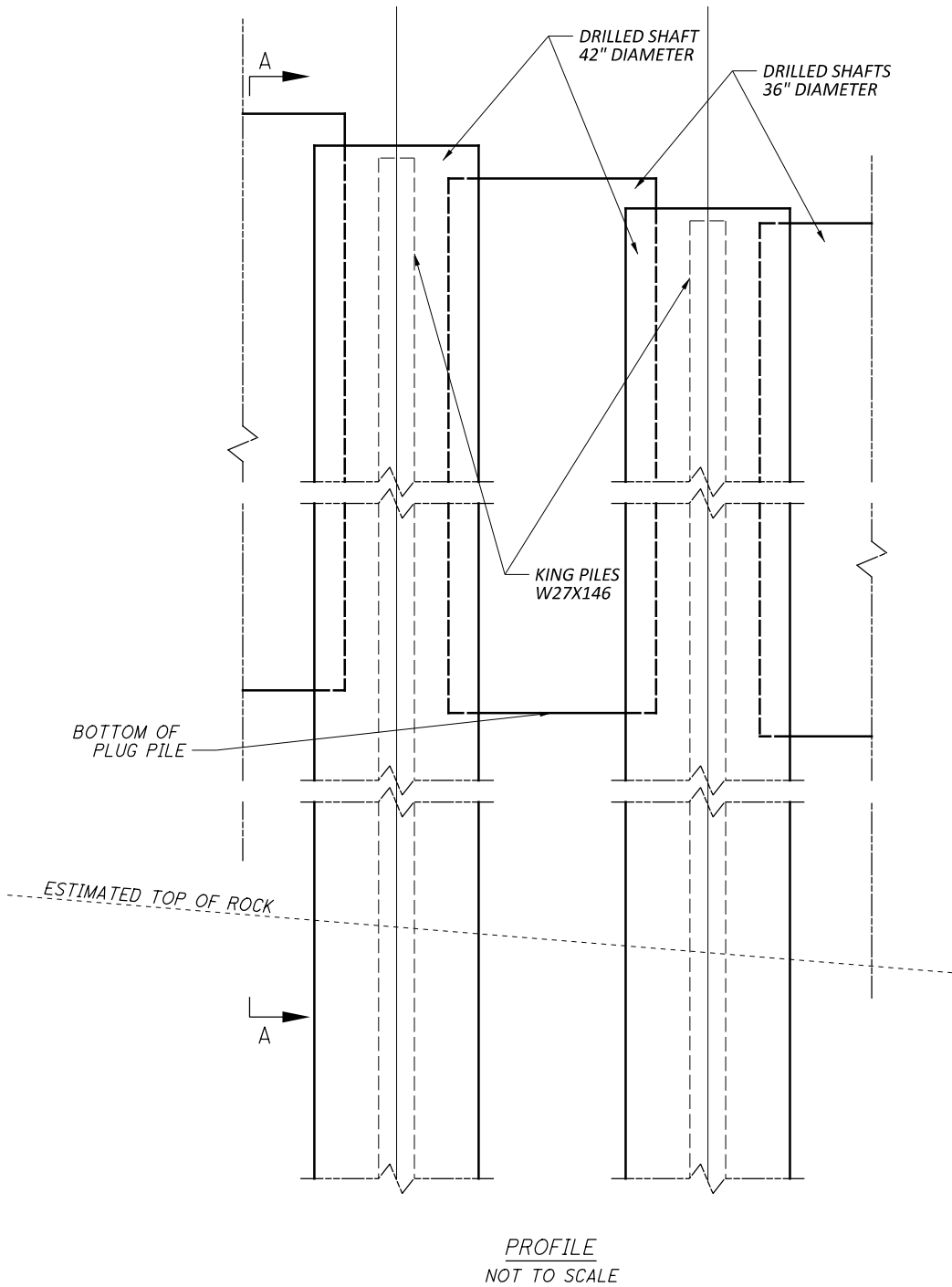
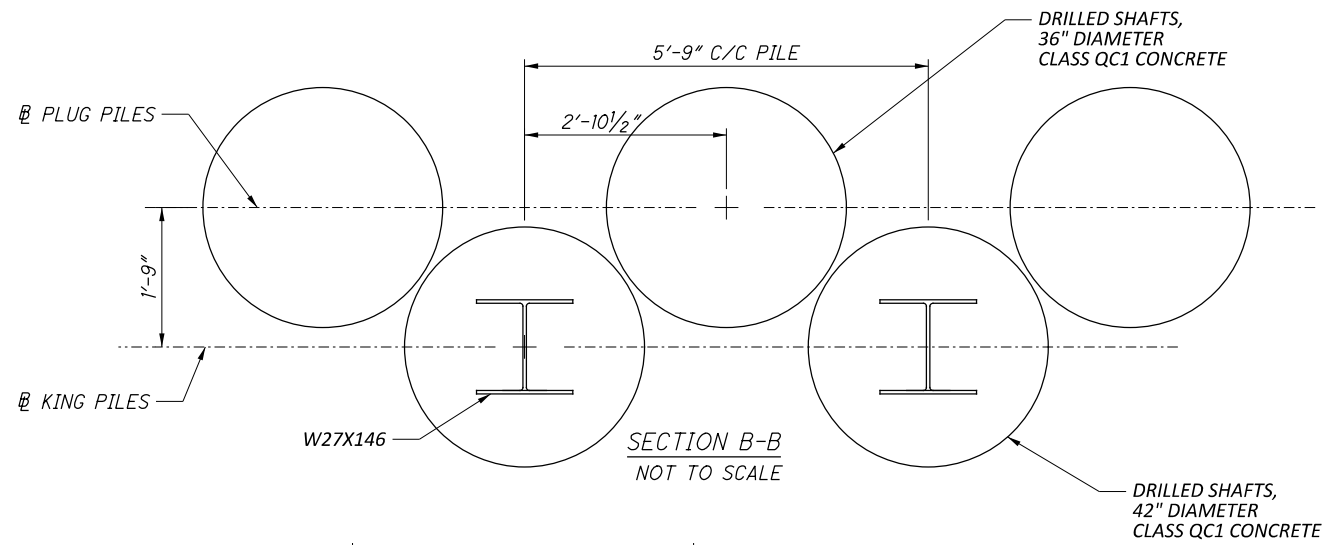

DRILLED SHAFT DETAILS

DESIGN AGENCY



DESIGNER

JDW

REVIEWER

XXX MM-DD-YY

PROJECT ID

115533

SHEET

P.28

TOTAL

P.48

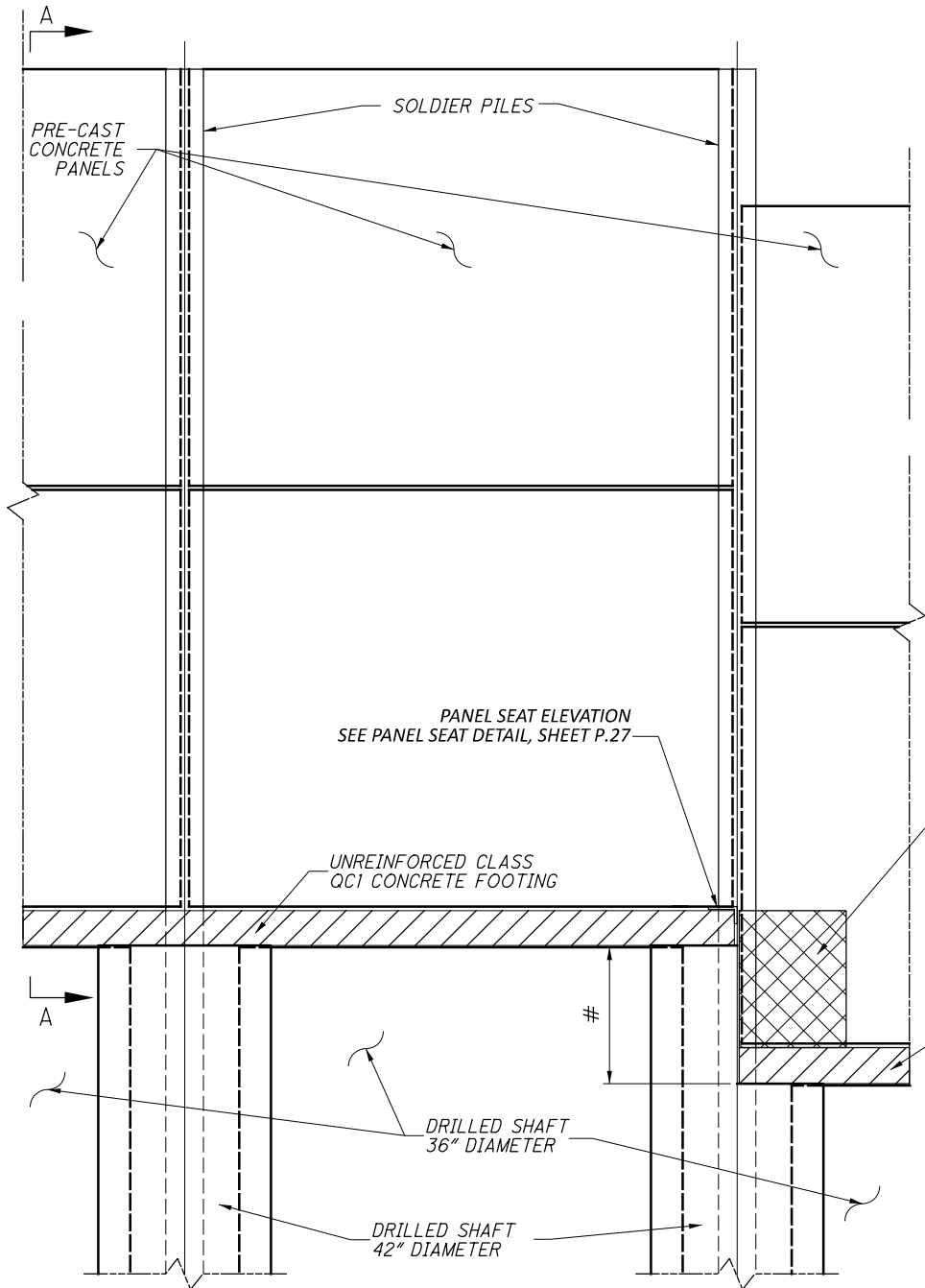
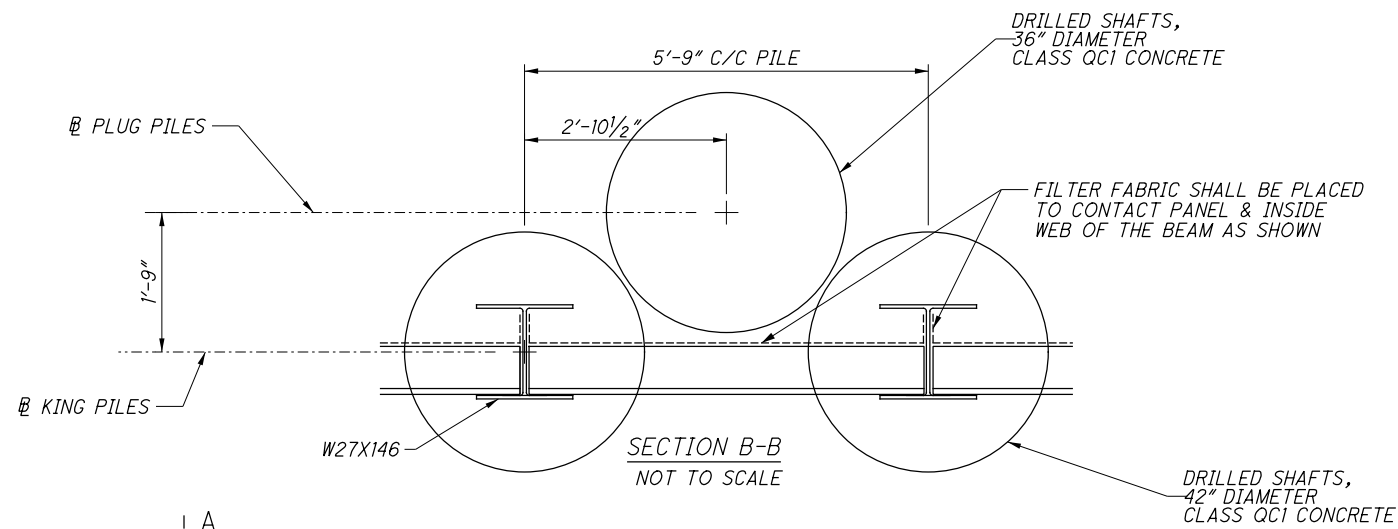

BLOCK OUT DRILLED SHAFT CONCRETE WITH FOAM INSULATION OR SIMILAR TO PROVIDE SUPPORT TO THE LOWER PANEL. THE COST TO BLOCK OUT THE DRILLED SHAFT WILL BE INCLUDED FOR PAYMENT UNDER ITEM 524 - DRILLED SHAFT, 42" DIAMETER, ABOVE BEDROCK, AS PER PLAN.

NOTE:
 # - ITEM 524 - DRILLED SHAFTS, MISC.: EXTENSION. QUANTITIES ARE INCLUDED IN DRILLED SHAFT DETAILS, SHEET P.30

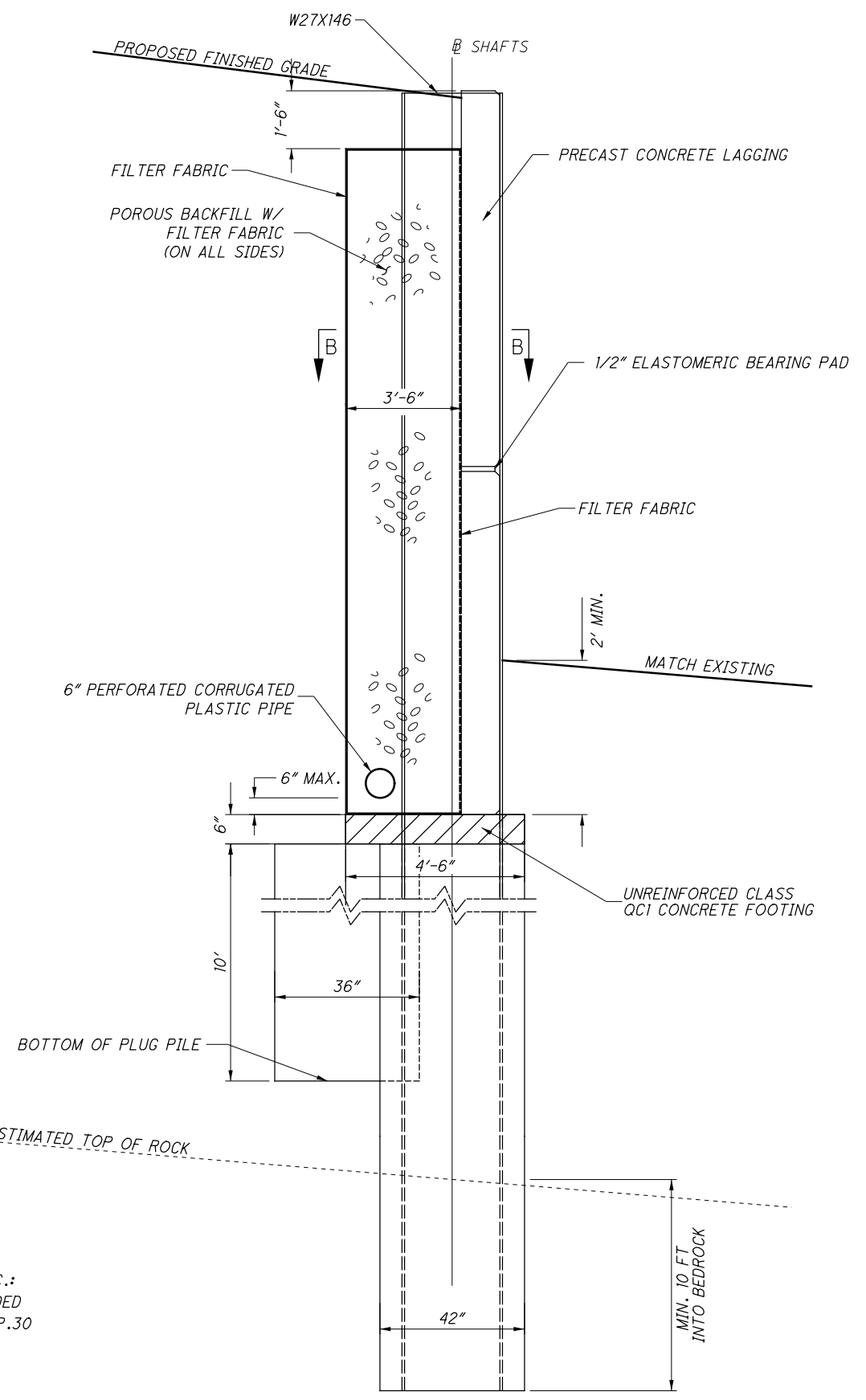

DRILLED SHAFT DETAILS

DESIGN AGENCY



DESIGNER
 JDW
 REVIEWER
 XXX MM-DD-YY
 PROJECT ID
 115533
 SHEET TOTAL
 P.29 | P.48

DRILLED SHAFT SUMMARY (PLUG PILE)

SHAFT No.	CENTERLINE DRILLED SHAFT (PLUG PILE) STA.	CENTERLINE OFFSET	BOTTOM ELEVATION OF SHAFT	TOP ELEVATION OF SHAFT	ITEM 524: 36" DIA. DRILLED SHAFTS	
					ABOVE BEDROCK	ITEM 524: DRILLED SHAFTS, MISC.: 36" STEEL CASING
1	11+53.48	24.75 RT	538.60	553.60	15.00	15.00
2	11+59.23	24.75 RT	538.60	553.60	15.00	15.00
3	11+64.98	24.75 RT	538.60	553.60	15.00	15.00
4	11+70.73	24.75 RT	538.50	553.50	15.00	15.00
5	11+76.48	24.75 RT	538.60	553.60	15.00	15.00
6	11+82.23	24.75 RT	538.80	553.80	15.00	15.00
7	11+87.98	24.75 RT	539.10	554.10	15.00	15.00
8	11+93.73	24.75 RT	539.30	554.30	15.00	15.00
9	11+99.48	24.75 RT	539.30	554.30	15.00	15.00
10	12+05.23	24.75 RT	539.30	554.30	15.00	15.00
11	12+10.98	24.75 RT	539.20	554.20	15.00	15.00
12	12+16.73	24.75 RT	539.20	554.20	15.00	15.00
13	12+22.48	24.75 RT	539.20	554.20	15.00	15.00
14	12+28.23	24.75 RT	539.40	554.40	15.00	15.00
15	12+33.98	24.75 RT	539.60	554.60	15.00	15.00
16	12+39.73	24.75 RT	539.60	554.60	15.00	15.00
17	12+45.48	24.75 RT	539.70	554.70	15.00	15.00
18	12+51.23	24.75 RT	539.70	554.70	15.00	15.00
19	12+56.98	24.75 RT	539.70	554.70	15.00	15.00
20	12+62.73	24.75 RT	539.70	554.70	15.00	15.00
21	12+68.48	24.75 RT	539.60	554.60	15.00	15.00
22	12+74.23	24.75 RT	539.60	554.60	15.00	15.00
23	12+79.98	24.75 RT	539.60	554.60	15.00	15.00
24	12+85.73	24.75 RT	539.60	554.60	15.00	15.00
25	12+91.48	24.75 RT	539.60	554.60	15.00	15.00
26	12+97.23	24.75 RT	539.60	554.60	15.00	15.00
27	13+02.98	24.75 RT	539.60	554.60	15.00	15.00
28	13+08.73	24.75 RT	539.50	554.50	15.00	15.00
29	13+14.48	24.75 RT	539.50	554.50	15.00	15.00
30	13+20.23	24.75 RT	539.40	554.40	15.00	15.00
31	13+25.98	24.75 RT	539.10	554.10	15.00	15.00
32	13+31.73	24.75 RT	538.90	553.90	15.00	15.00
33	13+37.48	24.75 RT	539.00	549.00	10.00	10.00
34	13+43.23	24.75 RT	538.40	553.40	15.00	15.00
35	13+48.98	24.75 RT	538.10	553.10	15.00	15.00
36	13+54.73	24.75 RT	537.90	552.90	15.00	15.00
37	13+60.48	24.75 RT	537.61	552.61	15.00	15.00
38	13+66.23	24.75 RT	540.36	550.36	10.00	10.00
39	13+71.98	24.75 RT	540.36	550.36	10.00	10.00
40	13+77.73	24.75 RT	540.36	550.36	10.00	10.00
41	13+83.48	24.75 RT	540.36	550.36	10.00	10.00
42	13+89.23	24.75 RT	540.36	550.36	10.00	10.00
43	13+94.98	24.75 RT	540.36	550.36	10.00	10.00
44	14+00.73	24.75 RT	540.36	550.36	10.00	10.00
45	14+06.48	24.75 RT	540.36	550.36	10.00	10.00
46	14+12.23	24.75 RT	540.86	550.86	10.00	10.00
47	14+17.98	24.75 RT	540.86	550.86	10.00	10.00
48	14+23.73	24.75 RT	540.86	550.86	10.00	10.00
49	14+29.48	24.75 RT	540.86	550.86	10.00	10.00
50	14+35.23	24.75 RT	540.86	550.86	10.00	10.00
51	14+40.98	24.75 RT	540.86	550.86	10.00	10.00
52	14+46.73	24.75 RT	541.36	551.36	10.00	10.00
53	14+52.48	24.75 RT	541.36	551.36	10.00	10.00
54	14+58.23	24.75 RT	541.36	551.36	10.00	10.00
55	14+63.98	24.75 RT	541.36	551.36	10.00	10.00
56	14+69.73	24.75 RT	541.36	551.36	10.00	10.00
57	14+75.48	24.75 RT	541.86	551.86	10.00	10.00
58	14+81.23	24.75 RT	541.86	551.86	10.00	10.00
59	14+86.98	24.75 RT	541.86	551.86	10.00	10.00
60	14+92.73	24.75 RT	541.86	551.86	10.00	10.00
61	14+98.48	24.75 RT	541.86	551.86	10.00	10.00
62	15+04.23	24.75 RT	542.36	552.36	10.00	10.00
63	15+09.98	24.75 RT	542.36	552.36	10.00	10.00
64	15+15.73	24.75 RT	542.36	552.36	10.00	10.00
65	15+21.48	24.75 RT	542.36	552.36	10.00	10.00
66	15+27.23	24.75 RT	542.36	552.36	10.00	10.00
67	15+32.98	24.75 RT	542.86	552.86	10.00	10.00
68	15+38.73	24.75 RT	542.86	552.86	10.00	10.00
69	15+44.48	24.75 RT	542.86	552.86	10.00	10.00
70	15+50.23	24.75 RT	542.86	552.86	10.00	10.00
71	15+55.98	24.75 RT	542.86	552.86	10.00	10.00
72	15+61.73	24.75 RT	543.36	553.36	10.00	10.00
73	15+67.48	24.75 RT	543.36	553.36	10.00	10.00
74	15+73.23	24.75 RT	543.36	553.36	10.00	10.00
75	15+78.98	24.75 RT	543.36	553.36	10.00	10.00
76	15+84.73	24.75 RT	543.36	553.36	10.00	10.00
77	15+90.48	24.75 RT	543.36	553.36	10.00	10.00
TOTAL					950.00	950.00

DRILLED SHAFT DETAILS

PROJECT DESCRIPTION

THE PROJECT CONSISTS OF REPAIRING A LANDSLIDE UTILIZING A 446 FT DRILLED SHAFT RETAINING WALL AND DUMPED ROCK FILL.

HISTORIC RECORDS

NO HISTORICAL GEOTECHNICAL RECORDS WERE FOUND FOR THIS PROJECT. HISTORICAL DOCUMENTATION FOR SR7 INDICATES THAT ACTIVE SLOPE INSTABILITY HAS BEEN PRESENT THROUGHOUT THE AREA PRIOR TO THE 1930'S.

GEOLOGY

THE PROJECT IS LOCATED WITHIN THE NON-GLACIATED MARIETTA PLATEAU PHYSIOGRAPHIC REGION WHICH IS CHARACTERIZED AS A HIGH RELIEF DISSECTED PLATEAU. THIN RESIDUAL SOILS ARE LOCATED ALONG THE RIDGE TOPS AND HILLSIDES, AND THIN TO THICK COLLUVIAL SOILS ARE LOCATED AT THE BASE OF THE HILLS. ALONG MAJOR STREAM VALLEYS LACUSTRINE DEPOSITS WITH OUTWASH SOILS ARE PRESENT. THE OHIO DEPARTMENT OF NATURAL RESOURCES (ODNR) INTERACTIVE GEOLOGIC MAP INDICATES THAT THE MAJORITY OF THE PROJECT AREA IS COMPRISED OF ALLUVIAL SOILS, ASSOCIATED WITH THE OHIO RIVER VALLEY, AT THE GROUND SURFACE. THE OVERBURDEN SOILS ARE UNDERLAIN BY PENNSYLVANIAN-AGED SHALE, SILTSTONE, SANDSTONE, CONGLOMERATE, AND SUBORDINATE AMOUNTS OF LIMESTONE, CLAY, FLINT, AND COAL FROM THE CONEMAUGH GROUP.

RECONNAISSANCE

INITIAL FIELD RECONNAISSANCE WAS COMPLETED BY DISTRICT PERSONNEL ON JULY 12, 2021. THE ROADWAY WAS NOTED AS BEING PATCHED AND WAVY. CRACKING WAS NOTED WITHIN THE PAVEMENT INDICATING A HEAD SCARP DUE TO SLOPE INSTABILITY BELOW THE ROADWAY. AT THE WEST END OF THE PAVEMENT PATCH AND EXTENDING FURTHER WEST DUMP ROCK PLACED FOR RIVERBANK STABILIZATION IS PRESENT. AT THE EAST END OF THE PAVEMENT PATCH, A CONCRETE CAP IS PRESENT BEING SUPPORTED BY STEEL PILES. THE BASE OF THE CAP HAS BEEN EXPOSED AT THE WESTERN END ALLOWING FOR THE PILES TO BE VISIBLE. A PAVED DRIVEWAY IS PRESENT WITHIN THE AREA OF THE PAVEMENT PATCH LEADING TO A GRASSY FIELD BELOW THE ROADWAY. THE EASTERN END OF THE PROJECT HAS A STEEP, SHORT EMBANKMENT SUPPORTING THE ROADWAY. ABOVE THE ROADWAY IS A GENTLY RISING GRASSY HILLSIDE TRANSITIONING INTO A STEEPER WOODED SLOPE. THE RIPARIAN CORRIDOR AT THE EDGE OF THE OHIO RIVER IS WOODED. GENERALLY, THE SURROUNDING LAND USE IS FALLOW, GRASSY, AGRICULTURAL LAND.

SUBSURFACE EXPLORATION

MULTIPLE PHASES WERE PERFORMED FOR THE GEOTECHNICAL EXPLORATION. INITIALLY FOUR (4) BORINGS, B-001-0-21 THROUGH B-004-0-21, WERE COMPLETED BETWEEN AUGUST 3 AND 19, 2021, UTILIZING A TRUCK MOUNTED CME 55 ROTARY DRILL, USING 3 1/4-INCH I.D. HOLLOW STEM AUGERS. AN ADDITIONAL BORING, B-003-1-22, WAS COMPLETED BETWEEN MAY 31 AND JUNE 7, 2022, UTILIZING A TRUCK MOUNTED CME 850R, USING 3 1/4-INCH I.D. HOLLOW STEM AUGERS. AUGERS WERE ADVANCED THROUGH THE OVERBURDEN SOILS INTO WEATHERED BEDROCK WITH DISTURBED SAMPLES COLLECTED IN ACCORDANCE WITH THE STANDARD PENETRATION TEST (AASHTO T206) AT CONTINUOUS AND 2.5-FOOT INTERVALS. THE HAMMER SYSTEMS USED WERE CALIBRATED ON APRIL 15, 2020, WITH AN AVERAGE DRILL ROD ENERGY RATIO (ER) OF 84% FOR THE CME 55 AND ON APRIL 19, 2021, WITH THE ER CAPPED AT 90% FOR THE CME 850 AS PER SGE 404.3. THE BORINGS WERE ADVANCED INTO BEDROCK AND SAMPLED (AASHTO T225) USING AN N SERIES WIRELINE CORE BARREL, WATER METHOD.

AN ELECTRICAL RESISTIVITY IMAGING (ER) SURVEY WAS COMPLETED WITHIN THE VICINITY OF THE CONCRETE CAP AS AN ATTEMPT TO DELINEATE THE EXTENT OF THE CAP. A SECOND ER SURVEY WAS CONDUCTED TO HELP DETERMINE THE LOCATION OF A CULVERT AND THE CULVERT OUTLET WITHIN THE PROJECT AREA. THE ER DATA WAS COLLECTED WITH AN ADVANCED GEOSCIENCES INC. (AGI) SUPERSTING R8 CONTROL UNIT. FOR THE FIRST ER SURVEY, 34 ELECTRODES WERE SPACED APPROXIMATELY 5 FEET APART, WHILE THE SECOND SURVEY UTILIZED 24 ELECTRODES SPACED APPROXIMATELY 5 FEET APART. THE ELECTRODES WERE USED TO MEASURE THE POTENTIAL FIELD WITH DIPOLE-DIPOLE AND STRONG GRADIENT ARRAYS. THE DATA WAS PROCESSED, AND SURFACE ELEVATION CORRECTED USING AGI'S EARTHIMAGER 2D SOFTWARE.

EXPLORATION FINDINGS

BORINGS B-001-0-21 THROUGH B-004-0-21 WERE COMPLETED WITHIN THE EXISTING ROADWAY ENCOUNTERING 12 TO 18-INCHES OF ASPHALT UNDERLAIN BY 8 TO 10-INCHES OF CONCRETE. BENEATH THE SURFACE MATERIALS THE BORINGS ENCOUNTERED PREDOMINANTLY COHESIVE SOILS CONSISTING OF SANDY SILT (A-4a), SILT (A-4b), SILT AND CLAY (A-6a), SILTY CLAY (A-6b), AND CLAY (A-7-6) RANGING FROM VERY SOFT TO HARD IN CONSISTENCY AND DAMP TO WET IN CONDITION. MODERATELY ORGANIC SOILS WERE ENCOUNTERED IN B-001-0-21 BETWEEN ELEVATIONS (EL.) 547.8 AND 542.8 FEET (FT) AND WITHIN B-003-0-21 BETWEEN EL. 546.0 AND 544.5 FT. ADDITIONALLY, NON-COHESIVE SOILS WERE ENCOUNTERED WITHIN ISOLATED AREAS WITHIN THESE BORINGS. MEDIUM DENSE SILT (A-4b) WAS ENCOUNTERED BETWEEN EL. 529.1 AND 522.8 FT IN WET CONDITION WITHIN B-001-0-21. WITHIN B-002-0-21 VERY DENSE STONE FRAGMENTS WITH SAND AND SILT (A-2-4) AND LOOSE COARSE AND FINE SAND (A-3a) WERE ENCOUNTERED BETWEEN EL. 533.1 AND 531.3 FT AND 525.3 AND 523.8 FT, RESPECTIVELY. BEDROCK WAS ENCOUNTERED IN ALL FOUR BORINGS BETWEEN EL. 517.8 AND 529.5 FT WHICH WAS SLIGHTLY VARIABLE, BUT, GENERALLY, RAISED TO THE EAST. THE FIRST ENCOUNTERED BEDROCK CONSISTED OF SANDSTONE WHICH WAS TYPICALLY HIGHLY TO MODERATELY WEATHERED AND WEAK TO SLIGHTLY STRONG. B-003-0-21 FIRST ENCOUNTERED A MODERATELY WEATHERED, VERY WEAK SHALE INSTEAD OF SANDSTONE. B-004-0-21 ENCOUNTERED A SILTSTONE LAYER BENEATH THE SANDSTONE, WHICH WAS MODERATELY WEATHERED, SLIGHTLY STRONG, AND CONTAINED CLAY SEAMS. CLAYSTONE WAS ENCOUNTERED IN ALL FOUR BORINGS BETWEEN EL. 515.3 AND 520.4 FT WITH A SLIGHTLY VARIABLE SURFACE. THIS STRATUM WAS TYPICALLY MODERATELY WEATHERED AND VERY WEAK. UNCONFINED COMPRESSIVE STRENGTH TESTING RESULTS RANGED FROM 27 TO 33 AND FROM 88 TO 338 PSI WITH CONFINING PRESSURE ADDED. ALL BORINGS WERE TERMINATED WITHIN CLAYSTONE. B-001-0-21 AND B-004-0-21 WERE REPORTED AS BEING DRY PRIOR TO INTRODUCTION OF CORE WATER. B-002-0-21 AND B-003-0-21 ENCOUNTERED FREE WATER WHILE DRILLING AT EL. 525.3 AND 527.0 FT., RESPECTIVELY WITH B-002-0-21 HAVING A WATER LEVEL AT COMPLETION, INCLUDING CORE WATER, AT EL. 538.6 FT.

LEGEND		ODOT CLASS	CLASSIFIED MECH./VISUAL	
DESCRIPTION				
	STONE FRAGMENTS WITH SAND AND SILT	A-2-4	1	1
	COARSE AND FINE SAND	A-3a	3	3
	SANDY SILT	A-4a	8	2
	SILT	A-4b	5	6
	SILT AND CLAY	A-6a	10	15
	SILTY CLAY	A-6b	9	18
	CLAY	A-7-6	5	11
	TOTAL		41	56
	BOULDERS	VISUAL		
	CLAYSTONE	VISUAL		
	SANDSTONE	VISUAL		
	SHALE	VISUAL		
	SILTSTONE	VISUAL		
	PAVEMENT OR BASE = X = APPROXIMATE THICKNESS	VISUAL		
	SOD AND TOPSOIL = X = APPROXIMATE THICKNESS	VISUAL		
	BORING LOCATION - PLAN VIEW.			
	DRIVE SAMPLE AND/OR ROCK CORE BORING PLOTTED TO VERTICAL SCALE ONLY. HORIZONTAL BAR INDICATES A CHANGE IN STRATIGRAPHY.			
WC	INDICATES WATER CONTENT IN PERCENT.			
N ₆₀	INDICATES STANDARD PENETRATION RESISTANCE NORMALIZED TO 60% DRILL ROD ENERGY RATIO.			
X/D"	NUMBER OF BLOWS FOR STANDARD PENETRATION TEST (SPT): X/D" = NUMBER OF BLOWS (UNCORRECTED) FOR D" OF PENETRATION AT REFUSAL.			
	INDICATES WATER AT COMPLETION.			
	INDICATES FREE WATER ELEVATION.			
	INDICATES A PLASTIC MATERIAL WITH A MOISTURE CONTENT EQUAL TO OR GREATER THAN THE LIQUID LIMIT MINUS 3.			
	INDICATES A NON-PLASTIC MATERIAL WITH A MOISTURE CONTENT GREATER THAN 25 % OR GREATER THAN 19 % WITH A WET APPEARANCE.			
	INDICATES UNIT WEIGHT OF ROCK.			
LOI	INDICATES ORGANIC CONTENT BY LOSS ON IGNITION, AASHTO T267.			
QU	INDICATES UNCONFINED COMPRESSION TEST, ASTM D7012. (ROCK)			
SS	INDICATES A SPLIT SPOON SAMPLE.			
NQ	"N" SERIES ROCK CORE BARREL OF "Q" WIRELINE BIT SIZE.			
NP	INDICATES A NON-PLASTIC SAMPLE.			
TR	INDICATES TOP OF ROCK ELEVATION.			

EXPLORATION FINDINGS CONTINUED, SEE SHEET 2.

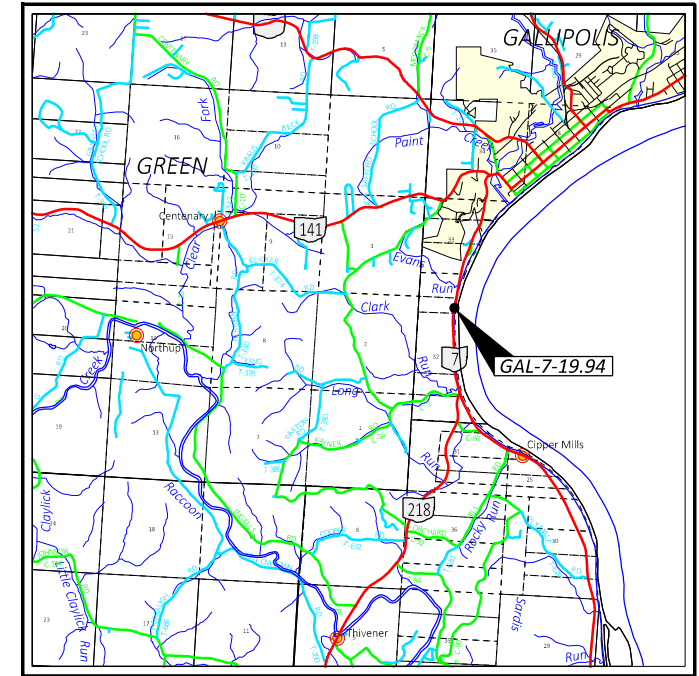

LOCATION MAP
SCALE IN MILES

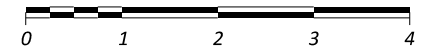

PARTICLE SIZE DEFINITIONS

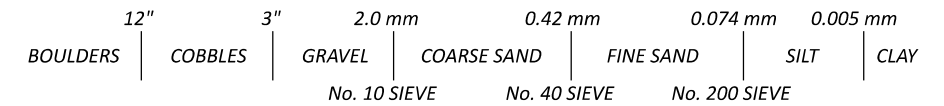

INDEX OF SHEETS				
EXPLORATION NOTES CONT., SHEET 2.				
LOCATION FROM STA.	TO STA.	PLAN VIEW SHEET	PROFILE SHEET	CROSS SECTION SHEET
SR 7				
106+00	117+50	3	3	-
117+50	122+50	4	4	-
	121+85.55	-	-	5
BORING LOGS & ROCK CORE REPORTS, SHEETS 6 - 16.				
INCLINOMETER AND ER LINES DATA, SHEET 17.				

- RECON. - AM 07/12/21
- DRILLING - KAM 08/03/21 - 08/11/21
- AMJ 08/11/21 - 08/19/21
- DML 05/31/22 - 06/07/22
- DRAWN - AJC 08/23/24
- REVIEWED - SAT 08/23/24

GAL-7-19.94

MODEL: Sheet PAPER SIZE: 17x11 (in.) DATE: 10/23/2024 TIME: 7:41:29 AM USER: wiseman pww\ohiodot-pw-bentley.com\ohiodot-pw-02\Documents\01.Active Projects\District 10\Gallia\115533\400-Engineering\Geotechnical\Sheets\115533_YC001.dgn

GEOTECHNICAL PROFILE - LANDSLIDE

DESIGN AGENCY	
DESIGNER	AJC
REVIEWER	SAT 08/23/24
PROJECT ID	115533
SUBSET	TOTAL
1	17
SHEET	TOTAL
P.32	P.48

EXPLORATION FINDINGS (CONT.)

BORINGS B-001-0-21 THROUGH B-004-0-21 WERE COMPLETED WITHIN THE EXISTING ROADWAY ENCOUNTERING 12 TO 18-INCHES OF ASPHALT UNDERLAIN BY 8 TO 10-INCHES OF CONCRETE. BENEATH THE SURFACE MATERIALS THE BORINGS ENCOUNTERED PREDOMINANTLY COHESIVE SOILS CONSISTING OF SANDY SILT (A-4a), SILT (A-4b), SILT AND CLAY (A-6a), SILTY CLAY (A-6b), AND CLAY (A-7-6) RANGING FROM VERY SOFT TO HARD IN CONSISTENCY AND DAMP TO WET IN CONDITION. MODERATELY ORGANIC SOILS WERE ENCOUNTERED IN B-001-0-21 BETWEEN ELEVATIONS (EL.) 547.8 AND 542.8 FEET (FT) AND WITHIN B-003-0-21 BETWEEN EL. 546.0 AND 544.5 FT. ADDITIONALLY, NON-COHESIVE SOILS WERE ENCOUNTERED WITHIN ISOLATED AREAS WITHIN THESE BORINGS. MEDIUM DENSE SILT (A-4b) WAS ENCOUNTERED BETWEEN EL. 529.1 AND 522.8 FT IN WET CONDITION WITHIN B-001-0-21. WITHIN B-002-0-21 VERY DENSE STONE FRAGMENTS WITH SAND AND SILT (A-2-4) AND LOOSE COARSE AND FINE SAND (A-3a) WERE ENCOUNTERED BETWEEN EL. 533.1 AND 531.3 FT AND 525.3 AND 523.8 FT, RESPECTIVELY. BEDROCK WAS ENCOUNTERED IN ALL FOUR BORINGS BETWEEN EL. 517.8 AND 529.5 FT WHICH WAS SLIGHTLY VARIABLE, BUT, GENERALLY, RAISED TO THE EAST. THE FIRST ENCOUNTERED BEDROCK CONSISTED OF SANDSTONE WHICH WAS TYPICALLY HIGHLY TO MODERATELY WEATHERED AND WEAK TO SLIGHTLY STRONG. B-003-0-21 FIRST ENCOUNTERED A MODERATELY WEATHERED, VERY WEAK SHALE INSTEAD OF SANDSTONE. B-004-0-21 ENCOUNTERED A SILTSTONE LAYER BENEATH THE SANDSTONE, WHICH WAS MODERATELY WEATHERED, SLIGHTLY STRONG, AND CONTAINED CLAY SEAMS. CLAYSTONE WAS ENCOUNTERED IN ALL FOUR BORINGS BETWEEN EL. 515.3 AND 520.4 FT WITH A SLIGHTLY VARIABLE SURFACE. THIS STRATUM WAS TYPICALLY MODERATELY WEATHERED AND VERY WEAK. UNCONFINED COMPRESSIVE STRENGTH TESTING RESULTS RANGED FROM 27 TO 33 AND FROM 88 TO 338 PSI WITH CONFINING PRESSURE ADDED. ALL BORINGS WERE TERMINATED WITHIN CLAYSTONE. B-001-0-21 AND B-004-0-21 WERE REPORTED AS BEING DRY PRIOR TO INTRODUCTION OF CORE WATER. B-002-0-21 AND B-003-0-21 ENCOUNTERED FREE WATER WHILE DRILLING AT EL. 525.3 AND 527.0 FT., RESPECTIVELY WITH B-002-0-21 HAVING A WATER LEVEL AT COMPLETION, INCLUDING CORE WATER, AT EL. 538.6 FT.

BORING B-003-1-22 WAS COMPLETED BELOW THE ROADWAY, TOWARD THE RIVER, WITHIN THE GRASSY FIELD ENCOUNTERING 12-INCHES OF TOPSOIL UNDERLAIN BY COHESIVE SOILS CONSISTING OF SANDY SILT (A-4a) AND SILTY CLAY (A-6b) IN STIFF TO VERY STIFF CONSISTENCY AND DAMP CONDITION. MEDIUM DENSE SILT (A-4b) WAS ENCOUNTERED AT EL. 529.3 FT. UNDERLAIN BY VERY LOOSE COARSE AND FINE SAND (A-3a) WHICH CONTAINED ELEVATED HYDROSTATIC HEAD CONDITIONS RESULTING IN HEAVING SANDS THAT EXTENDED TO EL. 518.3 FT. SEVERELY WEATHERED CLAYSTONE BEDROCK WHICH WAS VERY WEAK TO WEAK WAS FIRST ENCOUNTERED AT EL. 514.8 FT. AND WAS SPLIT SPOON SAMPLED TO EL. 505.8 FT WHERE IT BECAME HIGHLY TO MODERATELY WEATHERED AND WAS CORED. COMPRESSIVE STRENGTH TEST RESULTS OF 14 AND 48 PSI WERE OBTAINED FROM REPRESENTATIVE SAMPLES. SANDSTONE WAS ENCOUNTERED AT EL. 489.3 FT. IN MODERATELY WEATHERED CONDITION AND STRONG WITH AN UNCONFINED COMPRESSIVE STRENGTH TEST RESULT OF 8,255 PSI INTO WHICH THE BORING WAS TERMINATED. UPON COMPLETION OF SAMPLING ACTIVITIES AN INCLINOMETER CASING WAS INSTALLED WITHIN THE BOREHOLE. READING OF THE INCLINOMETER INDICATES A FAILURE ZONE AROUND EL. 526 FT.

THE ER SURVEYS WERE COMPLETED BELOW THE ROADWAY IN AN ATTEMPT TO LOCATE THE EXTENT OF THE PREVIOUSLY INSTALLED STRUCTURE LOCATED AT THE EAST END OF THE PROJECT AND A CULVERT OUTLET WITHIN THE PROJECT AREA. BASED ON THE RESULTS OF THE FIRST ER LINE, IT DOES NOT APPEAR THAT THE CAP AND PILES EXTEND SOUTH BEYOND WHAT IS EXPOSED AT THE SURFACE. THE RESULTS OF THE SECOND ER LINE WERE ABLE TO DELINEATE THE OUTLET OF THE EXISTING CULVERT TO BE ROUGHLY 83.09 FT EAST OF STA.1071+05 S.R. 7 AT EL 424 FT.

SPECIFICATIONS

THIS GEOTECHNICAL EXPLORATION WAS PERFORMED IN ACCORDANCE WITH THE STATE OF OHIO, DEPARTMENT OF TRANSPORTATION, OFFICE OF GEOTECHNICAL ENGINEERING, SPECIFICATIONS FOR GEOTECHNICAL EXPLORATIONS, DATED JULY 2021.

AVAILABLE INFORMATION

THE SOIL, BEDROCK, AND GROUNDWATER INFORMATION COLLECTED FOR THIS SUBSURFACE EXPLORATION THAT CAN BE CONVENIENTLY DISPLAYED ON THE GEOTECHNICAL PROFILE SHEETS HAS BEEN PRESENTED. GEOTECHNICAL REPORTS, IF PREPARED, ARE AVAILABLE FOR REVIEW ON THE OFFICE OF CONTRACT SALES WEBSITE.

BEDROCK TEST SUMMARY				
EXPLOR. ID	SAMPLE DEPTH	SAMPLE ELEVATION	LITHOLOGY	QU (psi)
B-001-0-21	41.6' - 42.0'	514.7' - 514.3'	CLAYSTONE	27
B-001-0-21	45.3' - 45.7'	511.0' - 510.6'	CLAYSTONE	185
B-001-0-21	55.0' - 55.4'	501.3' - 500.9'	CLAYSTONE	88
B-003-0-21	44.4' - 44.8'	513.6' - 513.2'	CLAYSTONE	33
B-003-0-21	45.0' - 45.4'	513.0' - 512.6'	CLAYSTONE	338
B-003-1-22	54.6' - 55.0'	497.7' - 497.3'	CLAYSTONE	48
B-003-1-22	57.4' - 57.8'	494.9' - 494.5'	CLAYSTONE	14
B-003-1-22	63.9' - 64.3'	488.4' - 488.0'	SANDSTONE	8,255

ORGANIC CONTENT BY LOSS ON IGNITION TEST				
EXPLOR. ID	SAMPLE ID	SAMPLE DEPTH	SAMPLE ELEVATION	LOI (%)
B-001-0-21	SS-4	8.50' - 10.00'	547.8' - 546.3'	4.2
B-001-0-21	SS-5	11.00' - 12.50'	545.3' - 543.8'	4.2
B-003-0-21	SS-7	12.00' - 13.50'	546.0' - 544.5'	6.2

DESIGN AGENCY



DESIGNER

AJC

REVIEWER

SAT 08/23/24

PROJECT ID

115533

SUBSET TOTAL

2 17

SHEET TOTAL

P.33 P.48

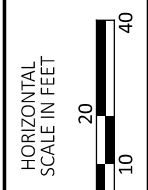
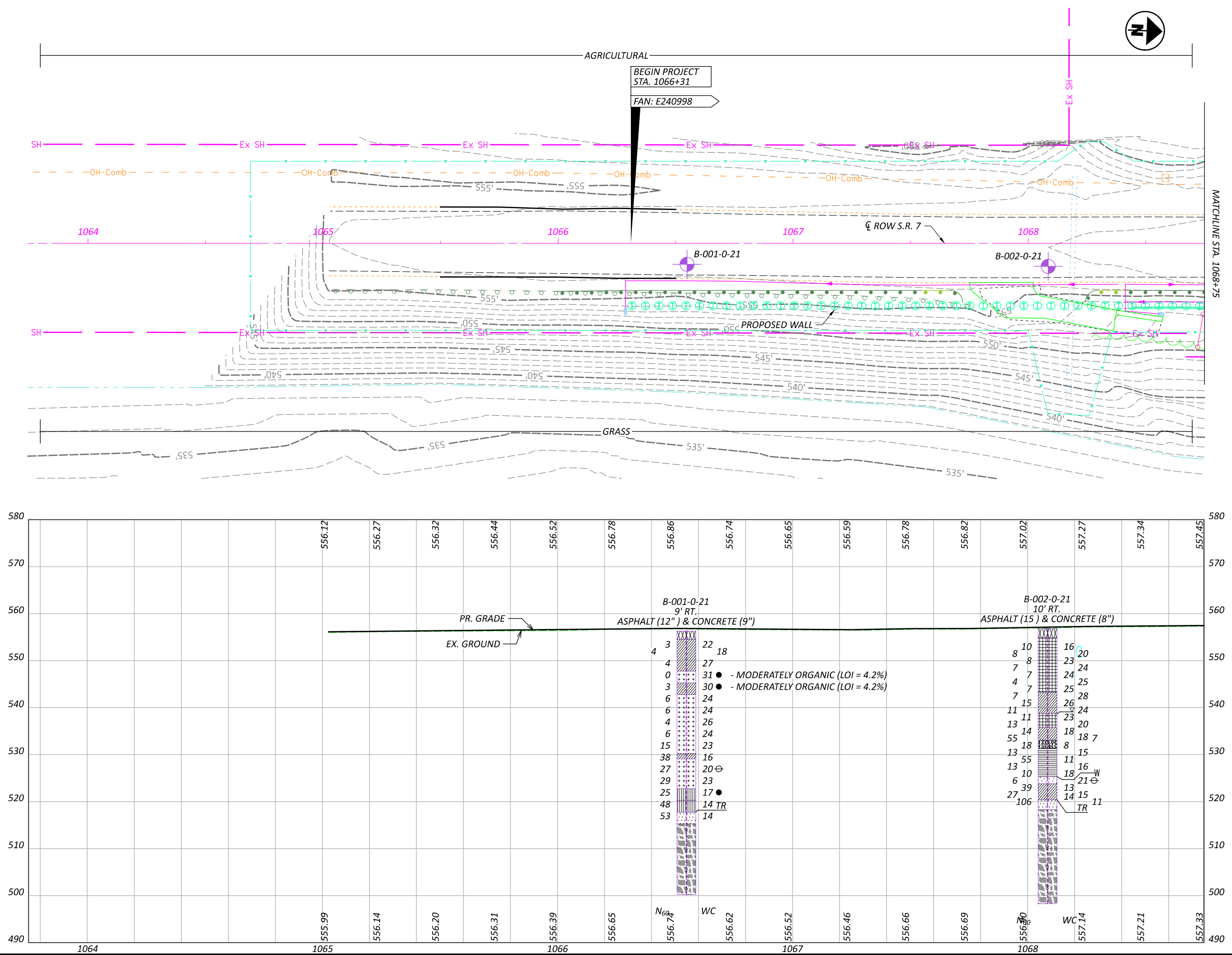

GEOTECHNICAL PROFILE - LANDSLIDE
 STA. 1063+75 TO STA. 1068+75 - S.R. 7

DESIGN AGENCY	
DESIGNER	
AIC	
REVIEWER	
SAT 08/23/24	
PROJECT ID	
115533	
SUBSET	TOTAL
3	17
SHEET	TOTAL
P.34	P.48

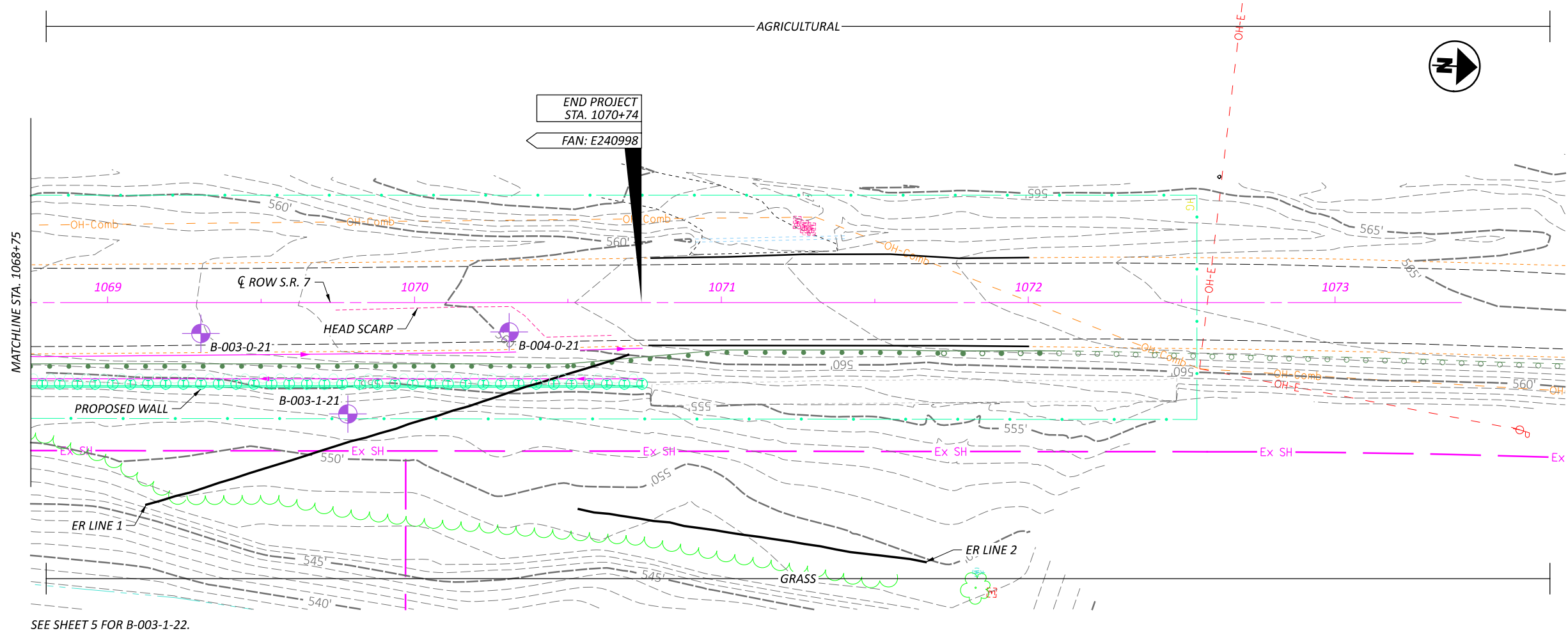

SEE SHEET 5 FOR B-003-1-22.

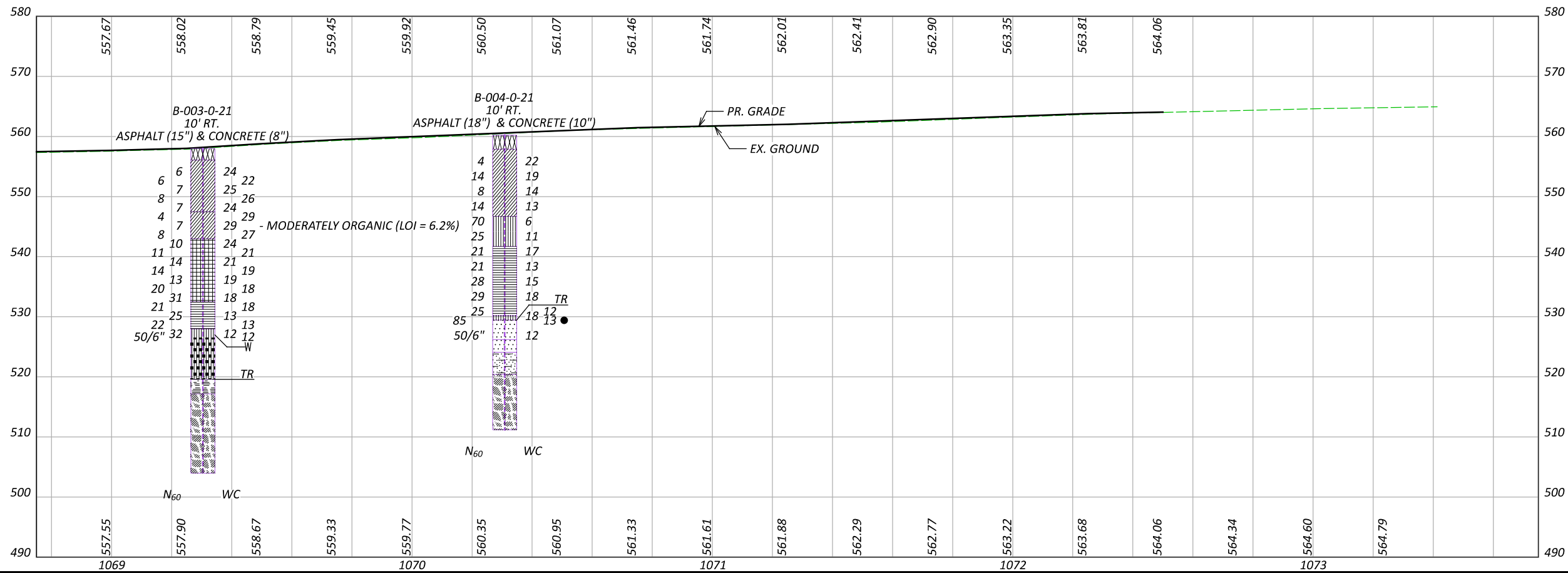

AGRICULTURAL

END PROJECT
 STA. 1070+74
 FAN: E240998



GEOTECHNICAL PROFILE - LANDSLIDE
 STA. 1068+75 TO STA. 1073+75 - S.R. 7

DESIGN AGENCY



DESIGNER

AJC

REVIEWER

SAT 08/23/24

PROJECT ID

115533

SUBSET TOTAL

4 17

SHEET TOTAL

P.35 P.48

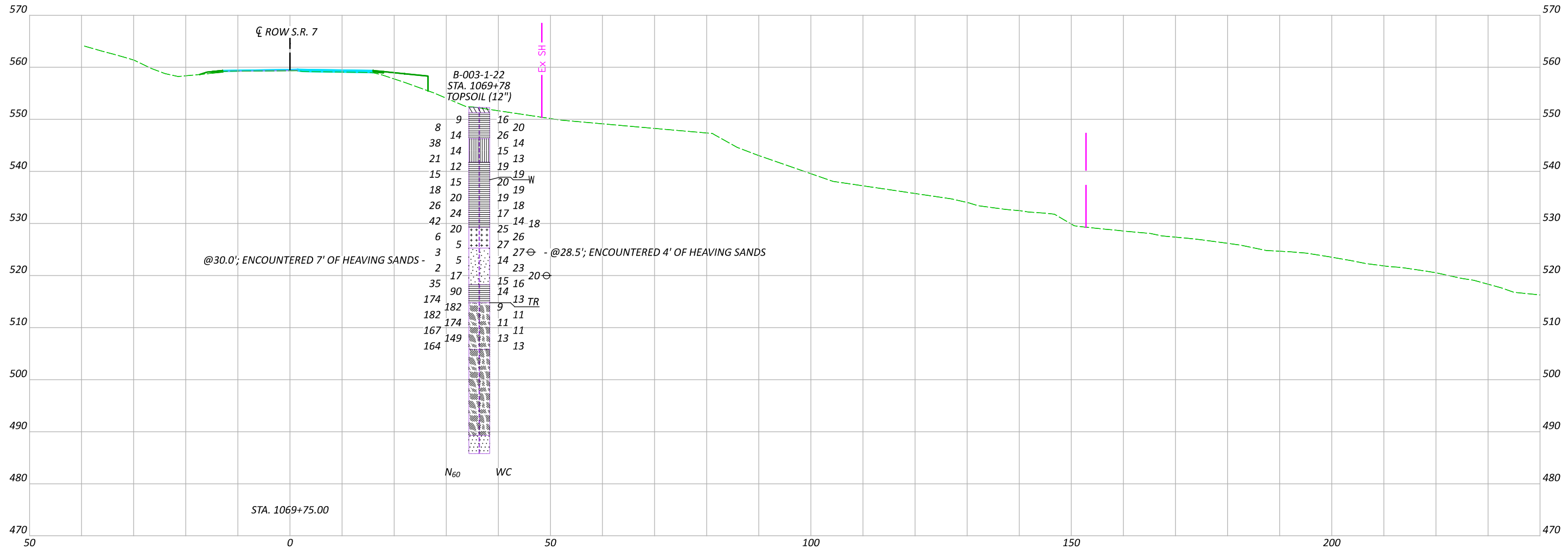

GEOTECHNICAL PROFILE - LANDSLIDE
 CROSS SECTION STA. 1069+75 - S.R. 7

DESIGN AGENCY



DESIGNER
AJC

REVIEWER
SAT 08/23/24

PROJECT ID
115533

SUBSET	TOTAL
5	17

SHEET	TOTAL
P.36	P.48

GAL-7-19.94

MODEL SHEET PAPER SIZE: 17x11 (in.) DATE: 10/23/2024 TIME: 7:41:59 AM USER: wiseman
 p:\ohiodot-pw\entire\ohiodot-pw-02\Documents\01_Active Projects\District 10\Gallia\115533\400-Engineering\Geotechnical\Sheets\115533_YL001.dgn

PROJECT: GAL-7-19.94
 TYPE: LANDSLIDE
 PID: 115533 SFN:
 START: 8/11/21 END: 8/19/21

DRILLING FIRM / OPERATOR: ODOT / CAREY
 SAMPLING FIRM / LOGGER: ODOT / AJ
 DRILLING METHOD: 3.25" HSA / NQ2
 SAMPLING METHOD: SPT / NQ2

DRILL RIG: CME 55 TRUCK
 HAMMER: CME AUTOMATIC
 CALIBRATION DATE: 4/15/20
 ENERGY RATIO (%): 84

STATION / OFFSET: 1066+55.9' RT.
 ALIGNMENT: CL SR 7
 ELEVATION: 556.3 (ft) EOB: 56.0 ft.
 LAT / LONG: 38.781706, -82.222695

EXPLORATION ID
 B-001-0-21
 PAGE
 1 OF 1

MATERIAL DESCRIPTION AND NOTES

DEPTH (ft)	ELEV. (ft)	DESCRIPTION	SPT/ RQD	N ₆₀	REC (%)	SAMPLE ID	HP (tsf)	GR	CS	FS	SI	CL	LL	PL	PI	WC	ODOT CLASS (GI)
1	556.3	ASPHALT (12") & CONCRETE (9")															
2	554.5	SOFT, RED AND BROWN, SILT AND CLAY, LITTLE GRAVEL, LITTLE SAND, MOIST	0	3	44	SS-1	0.50	15	3	8	31	43	37	22	15	22	A-6a (10)
3			1	4	50	SS-2	0.50	-	-	-	-	-	-	-	-	-	18
4		@3.5'; DAMP	1	2													
5			0	4	50	SS-3	0.50	-	-	-	-	-	-	-	-	-	27
6		@6.0'; MOIST	1	2													
7			0	0	94	SS-4	0.25	0	1	13	61	25	27	18	9	31	A-4b (8)
8	547.8	VERY SOFT, GRAY OXIDIZING TO BROWN, SILT, SOME CLAY, LITTLE SAND, MODERATELY ORGANIC (LOI = 4.2%), WET	0	0													
9			0	3	78	SS-5	0.50	7	2	8	48	35	33	20	13	30	A-6a (9)
10		SOFT, GRAY OXIDIZING TO BROWN, SILT AND CLAY, LITTLE SAND, TRACE GRAVEL, MODERATELY ORGANIC (LOI = 4.2%), MOIST	0	2													
11	545.3		0	6	100	SS-7	0.50	0	0	2	70	28	29	21	8	24	A-4b (8)
12		MEDIUM STIFF, BROWN, SILT, SOME CLAY, TRACE SAND, MOIST	0	2													
13	542.8		0	6	67	SS-6	0.50	-	-	-	-	-	-	-	-	-	24
14		@18.5'; SOFT	0	2													
15			0	6	100	SS-8	0.50	-	-	-	-	-	-	-	-	-	26
16		@21.0'; VERY STIFF	1	1													
17			1	6	100	SS-9	2.50	0	0	5	71	24	28	19	9	24	A-4b (8)
18		HARD, RED AND GRAY, SILT AND CLAY, TRACE SAND, TRACE GRAVEL, DAMP	2	5													
19			2	15	100	SS-10	3.00	-	-	-	-	-	-	-	-	-	23
20		MEDIUM DENSE, GRAY, SILT, "AND" SAND, LITTLE CLAY, WET	6	13													
21	530.3		6	38	83	SS-11	4.50	3	0	3	38	56	37	23	14	16	A-6a (10)
22	529.1	VERY STIFF, BROWN AND GRAY, MODERATELY WEATHERED, WEAK, LAMINATED TO VERY THIN BEDDED, SLIGHTLY ARENACEOUS.	9	10													
23			9	27	56	SS-12	-	0	10	29	50	11	NP	NP	NP	20	A-4b (5)
24		VERY STIFF, BROWN AND GRAY, SANDY SILT, "AND" STONE FRAGMENTS, LITTLE CLAY, DAMP	5	9													
25			5	29	50	SS-13	-	-	-	-	-	-	-	-	-	-	23
26		SANDSTONE, BROWN AND GRAY, MODERATELY WEATHERED, WEAK, LAMINATED TO VERY THIN BEDDED, SLIGHTLY ARENACEOUS.	4	7													
27	522.8		4	25	78	SS-14	-	8	16	39	21	16	18	13	5	17	A-4a (0)
28		CLAYSTONE, RED WITH GRAY, MODERATELY WEATHERED, VERY WEAK, MEDIUM BEDDED, BLOCKY, GOOD; RQD 63%, REC 88%. @ 41.6' - 42.0'; $\gamma = 135$ pcf; $Q_u = 27$ psi	8	17													
29			8	48	89	SS-15	3.00	36	2	14	32	16	23	15	8	14	A-4a (3)
30		@45.3' - 45.7'; $\gamma = 144$ pcf; $Q_u = 185$ psi, (ASTM 7012 METHOD C WITH CONFINING PRESSURE) @46.0'; GRAY @46.7'; RED WITH GRAY.	12	15													
31	517.8		12	53	100	SS-16	4.50	-	-	-	-	-	-	-	-	-	14
32		@48.2'; HIGH ANGLE FRACTURE - SLICKENSIDED.	7	23													
33			7	77	97	NQ2-1											CORE
34		@53.9'; HIGH ANGLE FRACTURE - SLICKENSIDED.	5	57													
35			5	67	67	NQ2-2											CORE
36		@55.0' - 55.4'; $\gamma = 143$ pcf; $Q_u = 88$ psi, (ASTM 7012 METHOD C WITH CONFINING PRESSURE)	5	55													
37	500.3		5	100	100	NQ2-3											CORE

NOTES: LAT/LONG/ELEV FROM DISTRICT SURVEY GRADE INSTRUMENTS. HOLE DRY BEFORE CORING.
 ABANDONMENT METHODS, MATERIALS, QUANTITIES: AUGER CUTTINGS MIXED WITH 25 LB. BENTONITE CHIPS



DESIGNER
 AIC

REVIEWER
 SAT 08/23/24

PROJECT ID
 115533

SUBSET TOTAL
 6 17

SHEET TOTAL
 P.37 P.48

**GEOTECHNICAL PROFILE - LANDSLIDE
 BORING LOG FOR B-001-0-21**

GAL-7-19.94

MODEL SHEET PAPER SIZE: 17x11 (in.) DATE: 10/23/2024 TIME: 7:42:10 AM USER: wiseman
 pw:\ohiodot-pw.bentley.com\ohiodot-pw-02\Documents\01_Active Projects\District 10\Galila\115533\400-Engineering\Geotechnical\Sheets\115533_YU002.dgn

PROJECT: GAL-7-19.94
 TYPE: LANDSLIDE
 PID: 115533 SFN:
 START: 8/9/21 END: 8/11/21

DRILLING FIRM / OPERATOR: ODOT / CAREY
 SAMPLING FIRM / LOGGER: ODOT / MCLEISH
 DRILLING METHOD: 3.25" HSA / NQ2
 SAMPLING METHOD: SPT / NQ2

DRILL RIG: CME 55 TRUCK
 HAMMER: CME AUTOMATIC
 CALIBRATION DATE: 4/15/20
 ENERGY RATIO (%): 84

STATION / OFFSET: 1068+09, 10' RT.
 ALIGNMENT: CL SR 7
 ELEVATION: 556.8 (ft) EOB: 58.5 ft.
 LAT / LONG: 38.782127, -82.222714

EXPLORATION ID: B-002-0-21
 PAGE: 1 OF 1

MATERIAL DESCRIPTION AND NOTES

DEPTH (ft)	ELEV. (ft)	REMARKS	SPT/ROD	N ₆₀	REC (%)	SAMPLE ID	HP (tsf)	GR	CS	FS	SI	CL	LL	PL	WC	ODOT CLASS (GI)	BACK FILL
1	556.8	ASPHALT (15') & CONCRETE (8')															
2	554.9	MEDIUM STIFF, REDDISH BROWN, CLAY, AND GRAVEL AND STONE FRAGMENTS, SOME SILT, LITTLE SAND, (NOT ENOUGH MATERIAL TO TEST), DAMP	2	10	28	SS-1	0.50									A-7-6 (V)	
3		@4.5'; NOT ENOUGH MATERIAL TO TEST	3	8	33	SS-2	0.50									A-7-6 (V)	
4		@6.0'; LITTLE GRAVEL AND STONE FRAGMENTS, MOIST	1	8	100	SS-3	0.50	10	8	11	28	43	42	21	21	A-7-6 (12)	
5		@10.5'; SOFT	1	7	100	SS-4	0.50									A-7-6 (V)	
6		@12.0'; MEDIUM STIFF, REDDISH BROWN AND GRAYISH BROWN	2	7	56	SS-5	0.50									A-7-6 (V)	
7		MEDIUM STIFF, GRAYISH BROWN, SILT AND CLAY, LITTLE SAND, TRACE STONE FRAGMENTS, MOIST	0	4	78	SS-6	0.50	13	6	8	29	44	41	22	19	A-7-6 (11)	
8		@15.0'; STIFF	1	7	100	SS-7	0.50									A-7-6 (V)	
9		STIFF, BROWN, CLAY, SOME SILT, LITTLE SAND, DAMP	2	11	100	SS-8	0.50	3	3	11	43	40	36	21	15	A-6a (10)	
10		STIFF, BROWN, SILT AND CLAY, SOME SAND, TRACE STONE FRAGMENTS, DAMP	1	15	100	SS-9	2.00									A-6a (V)	
11		STIFF, BROWN, SILT AND CLAY, SOME SAND, TRACE STONE FRAGMENTS, DAMP	2	11	100	SS-10	1.00									A-6a (V)	
12		STIFF, BROWN, SILT AND CLAY, SOME SAND, TRACE STONE FRAGMENTS, DAMP	3	11	100	SS-11	2.00	0	5	6	35	54	46	24	22	A-7-6 (14)	
13		STIFF, BROWN, SILT AND CLAY, SOME SAND, TRACE STONE FRAGMENTS, DAMP	2	13	100	SS-12	2.00									A-7-6 (V)	
14		STIFF, BROWN, SILT AND CLAY, SOME SAND, TRACE STONE FRAGMENTS, DAMP	2	14	100	SS-13	2.00									A-6a (V)	
15		VERY DENSE, BROWN, STONE FRAGMENTS WITH SAND AND SILT, LITTLE CLAY, DAMP	9	55	100	SS-14A	2.00	8	10	11	34	37	36	23	13	A-6a (8)	
16		VERY DENSE, BROWN, STONE FRAGMENTS WITH SAND AND SILT, LITTLE CLAY, DAMP	12	18	28	SS-14B	2.75	47	9	13	20	11	25	21	4	A-2-4 (0)	
17		VERY STIFF, BROWN, SILTY CLAY, LITTLE SAND, TRACE STONE FRAGMENTS, DAMP	6	18	50	SS-15	3.00									A-2-4 (V)	
18		@27.0'; SOME STONE FRAGMENTS	3	13	33	SS-16	2.50	9	8	10	35	38	40	22	18	A-6b (11)	
19		@28.5' - 30.0'; STIFF	9	55	50	SS-17	3.00									A-6b (V)	
20		LOOSE, BROWN, COARSE AND FINE SAND, LITTLE STONE FRAGMENTS, LITTLE SILT, TRACE CLAY, WET	10	13	22	SS-18	1.00									A-6b (V)	
21		VERY STIFF, REDDISH BROWN, SILT AND CLAY, LITTLE SAND, TRACE STONE FRAGMENTS, DAMP	2	10	6	SS-19	3.50									A-6b (V)	
22		SANDSTONE, GRAY, MODERATELY WEATHERED, WEAK, VERY FINE GRAINED.	3	4	100	SS-20	-	11	26	47	10	6	NP	NP	NP	A-3a (0)	
23		CLAYSTONE, GRAY, MODERATELY WEATHERED, VERY WEAK, MEDIUM, BLOCKY, GOOD; RQD 52%, REC 86%.	9	39	44	SS-21	3.00									A-6a (V)	
24		@40.4'; VARIEGATED RED, GRAY AND YELLOWISH BROWN.	3	27	56	SS-22	3.00	8	4	7	36	45	33	21	12	A-6a (9)	
25		@44.8'; GRAY, CONTAINS LITHIC FRAGMENTS.	19	106	100	SS-23A	2.75									A-6a (V)	
26		@46.7'; RED WITH GRAY.	27	49	100	SS-23B	-									Rock (V)	
27																	
28																	
29																	
30																	
31																	
32																	
33																	
34																	
35																	
36																	
37																	
38																	
39																	
40																	
41																	
42																	
43																	
44																	
45																	
46																	
47																	
48																	
49																	
50																	
51																	
52																	
53																	
54																	
55																	
56																	
57																	
58																	

NOTES: LAT/LONG/ELEV FROM OGE HANDHELD GPS UNIT. HOLE COLLAPSED AT 30.9 FT AFTER PULLING AUGERS
 ABANDONMENT METHODS, MATERIALS, QUANTITIES: AUGER CUTTINGS MIXED WITH 50 LB. BENTONITE CHIPS

DESIGN AGENCY:

DESIGNER: AIC

REVIEWER: SAT 08/23/24

PROJECT ID: 115533

SUBSET: 7 TOTAL: 17

SHEET: P.38 TOTAL: P.48

**GEOTECHNICAL PROFILE - LANDSLIDE
 BORING LOG FOR B-002-0-21**

STANDARD ODOT BORING LOG (11 X 17) - OH DOT GDT - 8/20/24 11-34 - X:\GINT\PROJ\PROJECTS\2021\COMPLET\FTF600888.GPJ

GAL-7-19.94

MODEL SHEET PAPER SIZE: 17x11 (in.) DATE: 10/23/2024 TIME: 7:42:22 AM USER: wiseman
 pw:\ohiodot-pw-bentley.com\ohiodot-pw-02\Documents\01.Active Projects\District 10\Galila\115533\400-Engineering\Geotechnical\Sheets\115533_YL003.dgn

PROJECT: GAL-7-19.94 DRILLING FIRM / OPERATOR: ODOT / CAREY ODOT / CAREY EXPLORATION ID B-003-0-21
 TYPE: LANDSLIDE SAMPLING FIRM / LOGGER: ODOT / MCLEISH ODOT / MCLEISH
 PID: 115533 SFN: DRILLING METHOD: 3.25" HSA / NQ2 SPT / NQ2 DEPTHS 1-53 ELEV. 558.0
 START: 8/4/21 END: 8/9/21 SPT / NQ2
 DRILL RIG: CME 55 TRUCK STATION / OFFSET: 1069+30, 10' RT. CL SR 7
 HAMMER: CME AUTOMATIC ALIGNMENT: ELEVATION: 558.0 (ft) EOB: 54.0 ft
 CALIBRATION DATE: 4/15/20 ENERGY RATIO (%): 84 LAT / LONG: 38.782462, -82.222730
 REC SAMPLE HP GRADATION (%) ATTERBERG ODOT CLASS (GI)
 ID (tsf) GR CS FS SI CL LL PL PI WC
 (%) N₆₀ (%) ID (tsf) GR CS FS SI CL LL PL PI WC

DEPTH	ELEV.	MATERIAL DESCRIPTION AND NOTES	SPT/RQD	REC (%)	SAMPLE ID	HP (tsf)	GR	CS	FS	SI	CL	LL	PL	PI	WC	ODOT CLASS (GI)	BACK FILL
1	558.0	ASPHALT (15") & CONCRETE (8")															
2	556.1	MEDIUM STIFF, REDDISH BROWN, SILT AND CLAY, LITTLE SAND, TRACE GRAVEL AND STONE FRAGMENTS, MOIST	1	28	SS-1	0.50	6	3	12	31	48	35	20	15	24	A-6a (10)	
3			2	44	SS-2	0.50	-	-	-	-	-	-	-	-	22	A-6a (V)	
4			2	50	SS-3	0.50	-	-	-	-	-	-	-	-	25	A-6a (V)	
5			3	56	SS-4	1.50	2	2	6	45	45	33	19	14	26	A-6a (10)	
6			1	100	SS-5	1.50	-	-	-	-	-	-	-	-	24	A-6a (V)	
7			2	100	SS-6	0.25	-	-	-	-	-	-	-	-	29	A-6a (V)	
8	547.5	SOFT, GRAYISH BROWN, SILT AND CLAY, LITTLE SAND, TRACE STONE FRAGMENTS, MOIST	0	89	SS-7	0.25	1	3	11	43	42	36	21	15	29	A-6a (10)	
9			2	82	SS-8	0.25	-	-	-	-	-	-	-	-	27	A-6a (V)	
10			4	89	SS-9	0.50	3	1	2	21	73	58	20	38	24	A-7-6 (20)	
11			3	100	SS-10	1.50	-	-	-	-	-	-	-	-	21	A-7-6 (V)	
12			4	89	SS-11	1.00	-	-	-	-	-	-	-	-	21	A-7-6 (V)	
13			6	56	SS-12	1.50	1	1	3	32	63	43	21	22	19	A-7-6 (13)	
14			2	100	SS-13	1.50	-	-	-	-	-	-	-	-	19	A-7-6 (V)	
15			3	83	SS-14	2.00	-	-	-	-	-	-	-	-	18	A-7-6 (V)	
16	532.5	MEDIUM STIFF, RED, SILTY CLAY, TRACE SAND, TRACE STONE FRAGMENTS, DAMP	2	78	SS-16	2.00	2	1	2	33	62	37	21	16	18	A-6b (10)	
17			6	94	SS-17	2.00	-	-	-	-	-	-	-	-	13	A-6b (V)	
18			8	100	SS-18	2.50	-	-	-	-	-	-	-	-	13	A-6b (V)	
19			8	78	SS-19	2.00	25	8	25	21	21	19	14	5	12	A-4a (1)	
20			11	100	SS-20	-	-	-	-	-	-	-	-	-	12	A-4a (V)	
21			12														
22			50														
23																	
24																	
25																	
26																	
27																	
28																	
29																	
30																	
31	527.0	VERY STIFF, BROWN AND GRAY, SANDY SILT, SOME STONE FRAGMENTS, SOME CLAY, DAMP	0	50	NQ2-1											CORE	
32																	
33																	
34																	
35																	
36																	
37																	
38																	
39																	
40																	
41	517.2	SHALE, GRAY, MODERATELY WEATHERED, VERY WEAK, LAMINATED TO VERY THIN BEDDED, POORLY FISSILE, BLOCKY, GOOD; RQD 0%, REC 100%.	23	100	NQ2-2											CORE	
42																	
43																	
44																	
45																	
46																	
47																	
48																	
49																	
50																	
51																	
52																	
53																	
54	504.0	CLAYSTONE, VARIEGATED YELLOWISH BROWN, GRAY AND RED, MODERATELY WEATHERED, VERY WEAK, MEDIUM BEDDED, BLOCKY, GOOD; RQD 44%, REC 85%.	38	68	NQ2-4											CORE	

NOTES: LAT/LONG/ELEV FROM OGE HANDHELD GPS UNIT.
 ABANDONMENT METHODS, MATERIALS, QUANTITIES: AUGER CUTTINGS MIXED WITH 50 LB. BENTONITE CHIPS

DESIGN AGENCY:

DESIGNER: AIC

REVIEWER: SAT 08/23/24

PROJECT ID: 115533

SUBSET: 8 TOTAL: 17

SHEET: P.39 TOTAL: P.48

GEOTECHNICAL PROFILE - LANDSLIDE BORING LOG FOR B-003-0-21

STANDARD ODOT BORING LOG (11 X 17) - OH DOT GDT - 8/20/24 11-34 - X:\GINT\PROJECTS\2021\COMPL\FTF600888.GPJ

PROJECT: GAL-7-19.94 LANDSLIDE		DRILLING FIRM / OPERATOR: ODOT / MCINTOSH		STATION / OFFSET: 1069+78.36' RT. CL SR 7		EXPLORATION ID B-003-1-22										
TYPE: LANDSLIDE		SAMPLING FIRM / LOGGER: ODOT / LEWIS		ALIGNMENT: 552.3 (ft) EOB: 66.5 ft.		PAGE 1 OF 2										
PID: 115533 SFN:		DRILLING METHOD: 3.75" HSA / NQ2		ELEVATION: 552.3 (ft) EOB: 66.5 ft.												
START: 5/31/22 END: 6/7/22		SAMPLING METHOD: SPT / NQ2		LAT / LONG: 38.782596, -82.222645												
MATERIAL DESCRIPTION AND NOTES				GRADATION (%)												
DEPTH (ft)	ELEV. (ft)	REMARKS	REC (%)	SPT/ RQD	N ₆₀	HP ID (tsf)	GR	CS	FS	SI	CL	LL	PL	WC	ODOT CLASS (GI)	INCL.
1	552.3	TOPSOIL (12")														
2	551.3	VERY STIFF, RED, SILTY CLAY, LITTLE STONE FRAGMENTS, LITTLE SAND, DAMP	56	3	9	SS-1	19	4	8	32	37	35	17	18	16	A-6b (10)
3			78	2	8	SS-2									20	A-6b (V)
4			56	3	14	SS-3									26	A-6b (V)
5	546.3		67	4	38	SS-4	31	1	32	22	14	24	18	6	14	A-4a (0)
6		VERY STIFF, RED AND BROWN, SANDY SILT, SOME STONE FRAGMENTS, LITTLE CLAY, DAMP	44	5	14	SS-5	26	1	26	27	20	24	16	8	15	A-4a (2)
7			33	6	21	SS-6									13	A-4a (V)
8			39	7	12	SS-7									19	A-6b (V)
9	541.8	STIFF, BROWN AND GRAY, SILTY CLAY, LITTLE STONE FRAGMENTS, TRACE SAND, DAMP	72	8	15	SS-8	14	2	4	24	56	40	20	20	19	A-6b (12)
10			39	9	15	SS-9									20	A-6b (V)
11			61	10	18	SS-10									19	A-6b (V)
12			39	11	20	SS-11									19	A-6b (V)
13			44	12	26	SS-12	2	0	1	36	61	39	19	20	18	A-6b (12)
14	538.4		50	13	24	SS-13									17	A-6b (V)
15			72	14	42	SS-14									14	A-6b (V)
16			83	15	20	SS-15A									18	A-6b (V)
17			83	16	4	SS-15B	0	0	33	63	4	NP	NP	NP	25	A-4b (6)
18			56	17	6	SS-16									26	A-4b (V)
19			33	18	5	SS-17									27	A-4b (V)
20			67	19	3	SS-18	0	2	80	14	4	NP	NP	NP	27	A-3a (0)
21			6	20	5	SS-19									14	A-3a (V)
22			28	21	2	SS-20									23	A-3a (V)
23			67	22	17	SS-21	3	28	52	14	3	NP	NP	NP	20	A-3a (0)
24			83	23	35	SS-22A									15	A-3a (V)
25			78	24	90	SS-23	2	3	4	39	52	39	18	21	14	A-6b (12)
26			78	25	26	SS-24									13	A-6b (V)
27			78	26	174	SS-25									9	Rock (V)
28			56	27	182	SS-26									11	Rock (V)
29			78	28	182	SS-27									11	Rock (V)
30			61	29	174	SS-28									11	Rock (V)
31			89	30	167	SS-29									11	Rock (V)
32			89	31	149	SS-30									13	Rock (V)
33			78	32	164	SS-31									13	Rock (V)
34			100	33	0	NQ2-1										CORE
35			100	34	0	NQ2-2										CORE
36			96	35	0	NQ2-3										CORE
37			63	36	25	NQ2-4										CORE
38			100	37	42	NQ2-5										CORE
39			96	38	75	NQ2-6										CORE
40			96	39	0	NQ2-7										CORE
41				40												CORE
42				41												CORE
43				42												CORE
44				43												CORE
45				44												CORE
46				45												CORE
47				46												CORE
48				47												CORE
49				48												CORE
50				49												CORE
51				50												CORE
52				51												CORE
53				52												CORE
54				53												CORE
55				54												CORE
56				55												CORE
57				56												CORE
58				57												CORE
59				58												CORE
60				59												CORE

GEOTECHNICAL PROFILE - LANDSLIDE
BORING LOG FOR B-003-1-22

DESIGN AGENCY	
	
DESIGNER	AJC
REVIEWER	SAT
PROJECT ID	115533
SUBSET	TOTAL
9	17
SHEET	TOTAL
P.40	P.48

STANDARD ODOT BORING LOG (11 X 17) - OH DOT GDT - R/2124 07-49 - X:\GINT\PROJECTS\2022 COMPLETION\971 GP1

GAL-7-19.94

MODEL SHEET PAPER SIZE: 17x11 (in.) DATE: 10/23/2024 TIME: 7:42:44 AM USER: wiseman
 pw:\ohiodot-pw.bentley.com\ohiodot-pw-02\Documents\01.Active Projects\District 10\Gallia\115533\400-Engineering\Geotechnical\Sheets\115533_YL005.dgn

PID: 115533	SFN:	PROJECT: GAL-7-19.94	STATION / OFFSET: 1069+78.36' RT.	START: 5/31/22	END: 6/7/22	PG 2 OF 2	B-003-1-22					
MATERIAL DESCRIPTION AND NOTES		ELEV.	DEPTHS	SPT/ RQD	REC N ₆₀ (%)	HP (tsf)	GRADATION (%)	ATTERBERG	WC	ODOT CLASS (GI)	INCL.	
CLAYSTONE , REDDISH BROWN, HIGHLY TO MODERATELY WEATHERED, VERY WEAK TO WEAK, THIN BEDDED; RQD 20%, REC 94%. <i>(continued)</i> @60.1' - 60.2': SLICKENSIDED HIGH ANGLE FRACTURE @61.0': BROWNISH BLACK @61.7': LIGHT GRAY, WEAK. SANDSTONE , GRAYISH BLACK, MODERATELY WEATHERED, STRONG, VERY FINE GRAINED, ARGILLACEOUS; RQD 56%, REC 100%. @ 63.9' - 64.3': $\gamma = 166$ pcf; $Q_u = 8,255$ psi		492.3	61	21	100							
			62								CORE	
		489.3	63	81	100							CORE
			64									
		485.8	65	17	100						CORE	
			66									
			EOB									

NOTES: LAT/LONG/ELEV FROM DISTRICT SURVEY GRADE INSTRUMENTS.
 ABANDONMENT METHODS, MATERIALS, QUANTITIES: TREMIED 120 GAL. BENTONITE CEMENT GROUT

DESIGN AGENCY	
DESIGNER	AJC
REVIEWER	SAT
SAT	08/23/24
PROJECT ID	115533
SUBSET	TOTAL
10	17
SHEET	TOTAL
P.41	P.48

**GEOTECHNICAL PROFILE - LANDSLIDE
 BORING LOG FOR B-003-1-22 (CONT.)**

STANDARD ODOT SOIL BORING LOG (11 X 17) - OH DOT GDT - 8/21/24 07:49 - X:\GINT\PROJECTS\2022 COMPLETION\0971.GPJ

GAL-7-19.94

MODEL SHEET PAPER SIZE: 17x11 (in.) DATE: 10/23/2024 TIME: 7:42:52 AM USER: wiseman
 pw:\ohiodot-pw.bentley.com\ohiodot-pw-02\Documents\01.Active Projects\District 10\Gallia\115533\400-Engineering\Geotechnical\Sheets\115533_YU006.dgn

PROJECT: GAL-7-19.94	DRILLING FIRM / OPERATOR: ODOT / CAREY	STATION / OFFSET: 1070+31, 10' RT.	EXPLORATION ID: B-004-0-21
TYPE: LANDSLIDE	SAMPLING FIRM / LOGGER: ODOT / MCLEISH	ALIGNMENT: CL SR 7	
PID: 115533 SFN:	DRILLING METHOD: 3.25" HSA / NQ2	ELEVATION: 560.2 (ft) EOB: 49.0 ft.	PAGE 1 OF 1
START: 8/3/21 END: 8/4/21	SAMPLING METHOD: SPT / NQ2	LAT / LONG: 38.782737, -82.222746	

DEPTH (ft)	ELEV. (ft)	MATERIAL DESCRIPTION AND NOTES	SPT/ RQD	REC (%)	SAMPLE ID	HP (tsf)	GRADATION (%)							WC	ODOT CLASS (GI)	BACK FILL
							GR	CS	FS	SI	CL	LL	PL			
1	560.2	ASPHALT (18") & CONCRETE (10')														
2	557.9	SOFT, REDDISH BROWN, SILT AND CLAY, LITTLE SAND, TRACE STONE FRAGMENTS, MOIST	4	28	SS-1	0.25	3	2	12	44	39	18	11	22	A-6a (8)	
3																
4			1	6	SS-2	2.00	-	-	-	-	-	-	-	19	A-6a (V)	
5			5	6	SS-2	2.00	-	-	-	-	-	-	-			
6			5	6	SS-2	2.00	-	-	-	-	-	-	-			
7			5	6	SS-2	2.00	-	-	-	-	-	-	-			
8																
9			4	33	SS-3	1.00	-	-	-	-	-	-	14	A-6a (V)		
10			2	4	SS-3	1.00	-	-	-	-	-	-				
11			4	44	SS-4	1.50	-	-	-	-	-	-	13	A-6a (V)		
12			5	44	SS-4	1.50	-	-	-	-	-	-				
13																
14	546.7	HARD, BROWN, SANDY SILT, SOME CLAY, DRY	31	70	SS-5	-	0	12	21	43	24	27	18	9	A-4a (6)	
15			29													
16			21													
17			5	25	SS-6	-	2	17	14	39	28	30	20	10	A-4a (6)	
18			7													
19			11													
20			3	83	SS-7	2.00	3	5	6	30	56	40	23	17	A-6b (11)	
21			6	21	SS-7	2.00	3	5	6	30	56	40	23	17	A-6b (11)	
22			9													
23																
24			5	21	SS-8	2.50	1	0	2	31	66	35	18	17	A-6b (11)	
25			6													
26			9													
27			12													
28																
29			3	28	SS-9	2.50	-	-	-	-	-	-	-	15	A-6b (V)	
30			8													
31	530.2	MEDIUM STIFF TO STIFF, RED AND BROWN, SANDY SILT, SOME CLAY, TRACE STONE FRAGMENTS, MOIST	25	28	SS-11	-	-	-	-	-	-	-	-	12	A-6b (V)	
32			7													
33			11													
34	529.5	SANDSTONE, GRAYISH BROWN, HIGHLY WEATHERED, WEAK TO SLIGHTLY STRONG, FINE TO MEDIUM GRAINED.	3	85	SS-12A	1.00	8	3	26	41	22	21	14	7	A-4a (6)	
35			19													
36			42													
37	526.2	SANDSTONE, BROWN AND GRAY, MODERATELY WEATHERED, SLIGHTLY STRONG, FINE TO MEDIUM GRAINED, THIN TO MEDIUM BEDDED, MICACEOUS, BLOCKY, GOOD; RQD 0%; REC 100%.														
38																
39	524.1	SILTSTONE, BLuish GRAY, MODERATELY WEATHERED, SLIGHTLY STRONG, THIN BEDDED, BLOCKY, GOOD; RQD 0%; REC 100%.	0	100	NQ2-1										CORE	
40																
41																
42																
43																
44																
45																
46																
47																
48																
49	511.2		32	100	NQ2-3										CORE	

NOTES: LAT/LONG/ELEV FROM OGE HANDHELD GPS UNIT. HOLE DRY BEFORE CORING.
 ABANDONMENT METHODS, MATERIALS, QUANTITIES: AUGER CUTTINGS MIXED WITH 50 LB. BENTONITE CHIPS

DESIGN AGENCY

 DESIGNER
 AIC
 REVIEWER
 SAT 08/23/24
 PROJECT ID
 115533
 SUBSET TOTAL
 11 17
 SHEET TOTAL
 P.42 P.48

**GEOTECHNICAL PROFILE - LANDSLIDE
 BORING LOG FOR B-004-0-21**

STANDARD ODOT BORING LOG (11 X 17) - OH DOT GDT - 8/20/24 11-34 - X:\GINT\PROJ\PROJECTS\2021\COMPLET\FTF600888.GPJ



Office of Geotechnical Engineering

B-001-0-21



Run #:	Depth	Recovery	RQD
NQ2-1	41.0'	58/60	46/60
NQ2-2	46.0'	40/60	34/60
GAL-7-19.94 PID 115533			



Office of Geotechnical Engineering

B-001-0-21

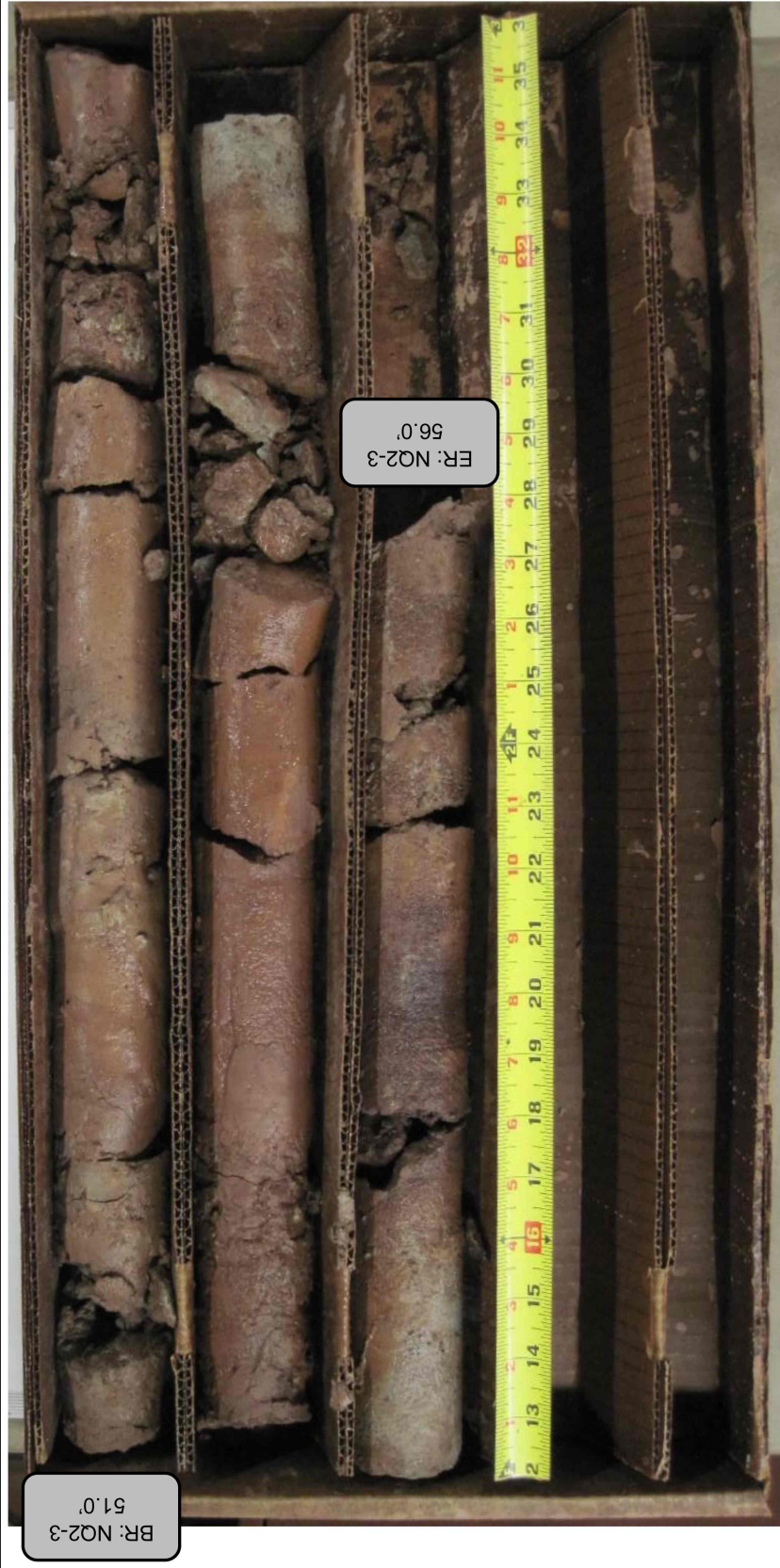

Run #:	Depth	Recovery	RQD
NQ2-3	51.0'	60/60	33/60
	56.0'	100%	55%
GAL-7-19.94 PID 115533			

DESIGN AGENCY



DESIGNER
AJC

REVIEWER
SAT 08/23/24

PROJECT ID
115533

SUBSET	TOTAL
12	17

SHEET	TOTAL
P.43	P.48



Office of Geotechnical Engineering

B-002-0-21

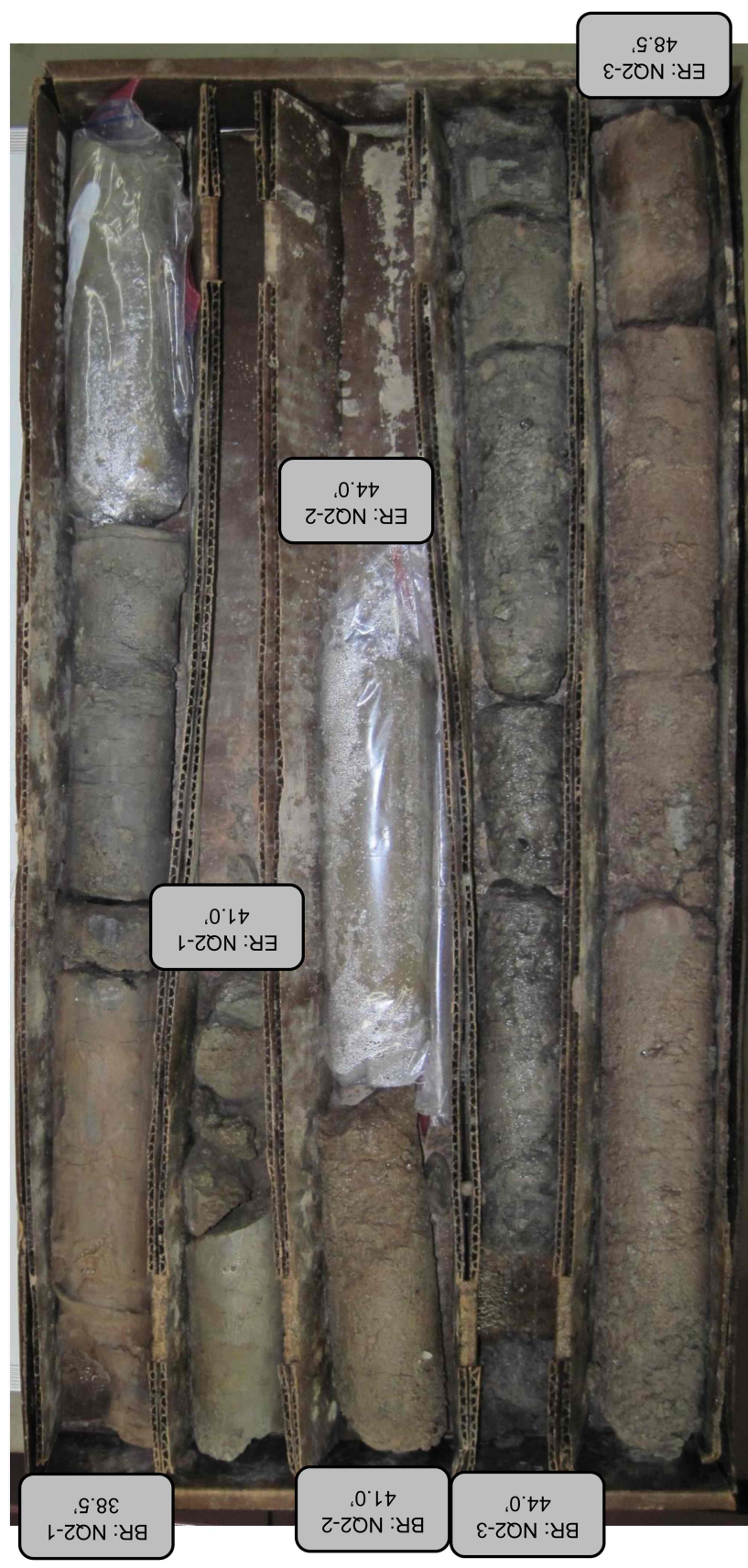

Run #:	Depth	Recovery	RQD
NQ2-1	38.5'	29/30	23/30
NQ2-2	41.0'	14/36	14/36
NQ2-3	44.0'	45/54	31/54
GAL-7-19.94 PID 115533			
		97%	77%
		39%	39%
		83%	57%



Office of Geotechnical Engineering

B-002-0-21



Run #:	Depth	Recovery	RQD
NQ2-4	48.5'	24/24	14/24
NQ2-5	50.5'	24/24	0/24
NQ2-6	52.5'	24/24	7/24
NQ2-7	54.5'	23/24	18/24
NQ2-8	56.5'	22/24	17/24
GAL-7-19.94 PID 115533			
		100%	58%
		100%	0%
		100%	29%
		96%	75%
		92%	71%

DESIGN AGENCY



DESIGNER

AJC

REVIEWER

SAT 08/23/24

PROJECT ID

115533

SUBSET TOTAL

13 17

SHEET TOTAL

P.44 P.48



Office of Geotechnical Engineering

B-003-0-21



Run #:	Depth	Recovery	RQD
NQ2-1	34.0'	30/60	0/60
NQ2-2	39.0'	60/60	14/60
GAL-7-19.94 PID 115533			



Office of Geotechnical Engineering

B-003-0-21



Run #:	Depth	Recovery	RQD
NQ2-3	44.0'	55/60	32/60
NQ2-4	49.0'	41/60	23/60
GAL-7-19.94 PID 115533			

DESIGN AGENCY



DESIGNER

AJC

REVIEWER

SAT 08/23/24

PROJECT ID

115533

SUBSET TOTAL

14 17

SHEET TOTAL

P.45 P.48



Office of Geotechnical Engineering

B-003-1-22



Run #:	Depth	Recovery	RQD
NQ2-1	46.5'	24/24	0/24
NQ2-2	48.5'	24/24	0/24
NQ2-3	50.5'	23/24	0/24
NQ2-4	52.5'	15/24	64/24
NQ2-5	54.5'	24/24	10/24

GAL-7-19.94 PID 115533



Office of Geotechnical Engineering

B-003-1-22



Run #:	Depth	Recovery	RQD
NQ2-6	56.5'	23/24	18/24
NQ2-7	58.5'	23/24	0/24
NQ2-8	60.5'	24/24	5/24
NQ2-9	62.5'	24/24	19.5/24
NQ2-10	64.5'	24/24	4/24

GAL-7-19.94 PID 115533



Office of Geotechnical Engineering

B-004-0-21



BR: NQ2-1
34.0'

39.0'

ER: NQ2-2
44.0'

Run #:	Depth	Recovery	RQD
NQ2-1	34.0'	60/60	0/60
NQ2-2	39.0'	60/60	24/60
GAL-7-19.94 PID 115533			
		100%	0%
		100%	40%



Office of Geotechnical Engineering

B-004-0-21



BR: NQ2-3
44.0'

ER: NQ2-3
49.0'

Run #:	Depth	Recovery	RQD
NQ2-3	44.0'	60/60	19/60
GAL-7-19.94 PID 115533			
		100%	32%

Borehole : B-003-1-22
 Project : Inclinometer
 Location : GAL-7-19.94
 Northing :
 Easting :
 Collar :

Spiral Correction : N/A
 Collar Elevation : 0.0 feet
 Borehole Total Depth : 66.0 feet
 A+ Groove Azimuth :
 Base Reading : 2022 Jun 10 06:13
 Applied Azimuth : -5.0 degrees

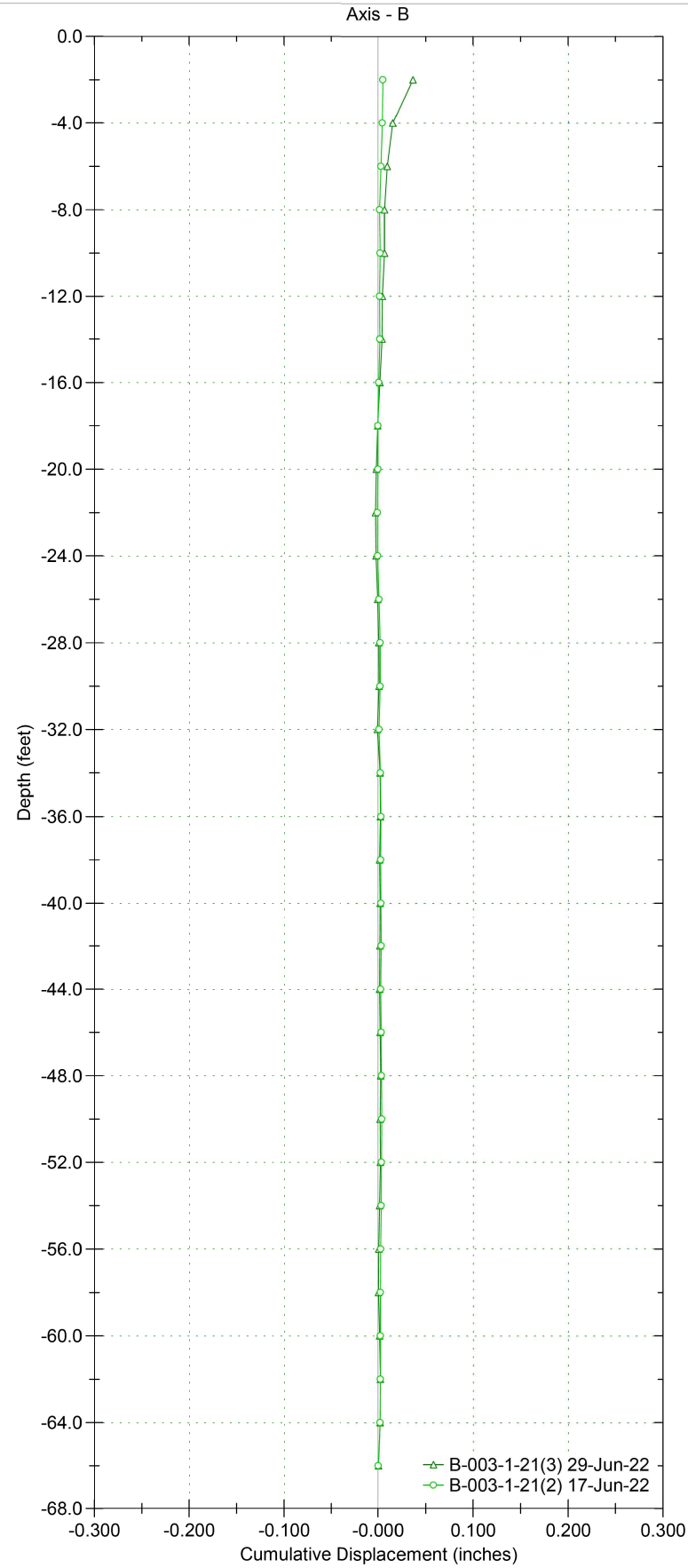
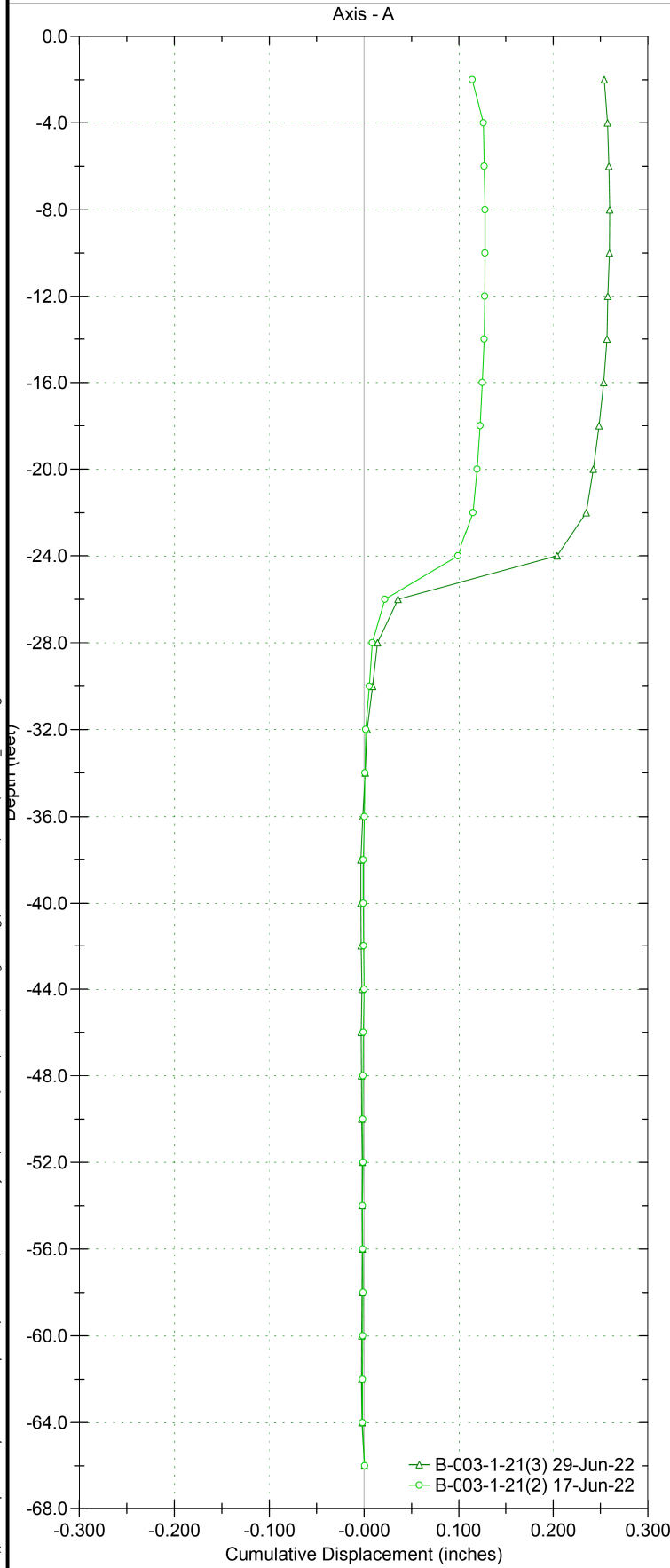

GAL-7-19.94 ER Survey Line 1 Inverted Resistivity Section

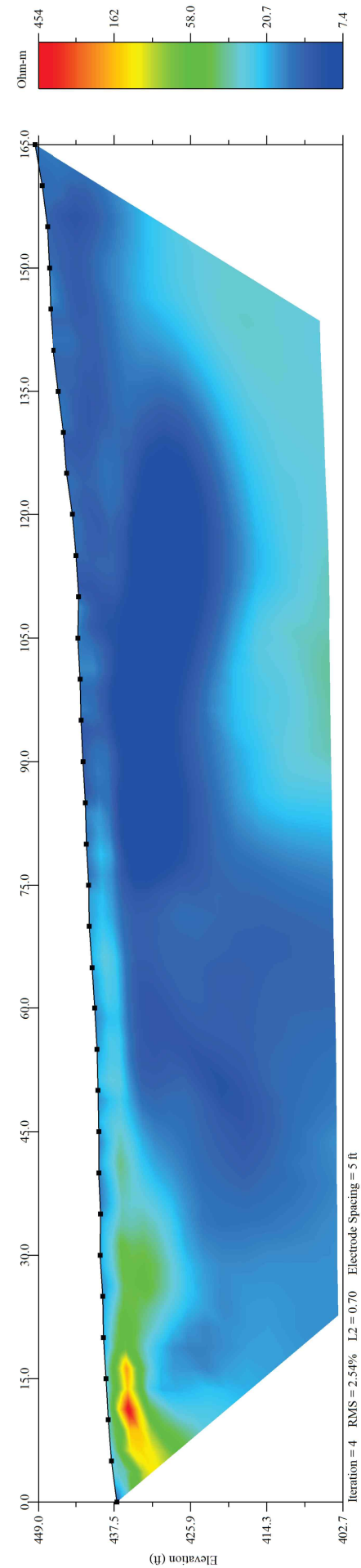

GAL-7-19.94 ER Survey Line 2 Inverted Resistivity Section

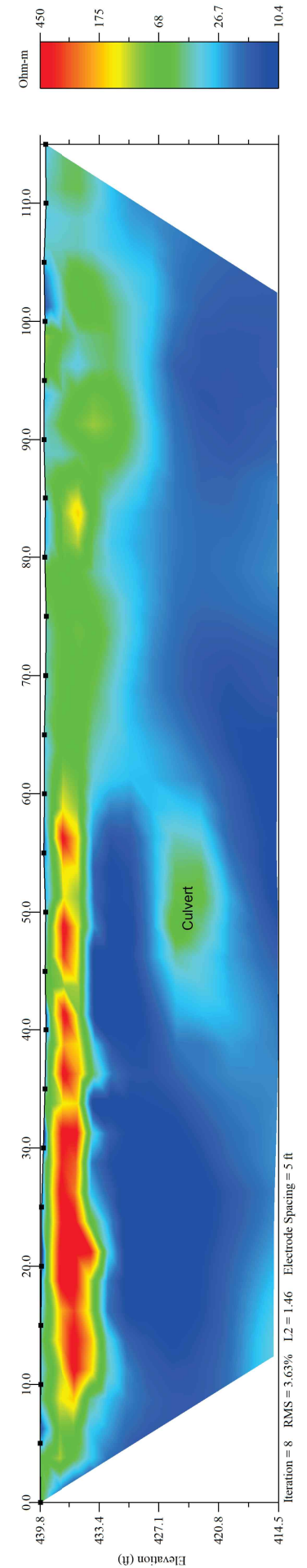

DESIGN AGENCY

DESIGNER

AJC

REVIEWER

SAT 08/23/24

PROJECT ID

115533

SUBSET TOTAL

17 17

SHEET TOTAL

P.48 P.48